

Popular Radio

Edited by **KENDALL BANNING**

25¢

***MAY • 1925**

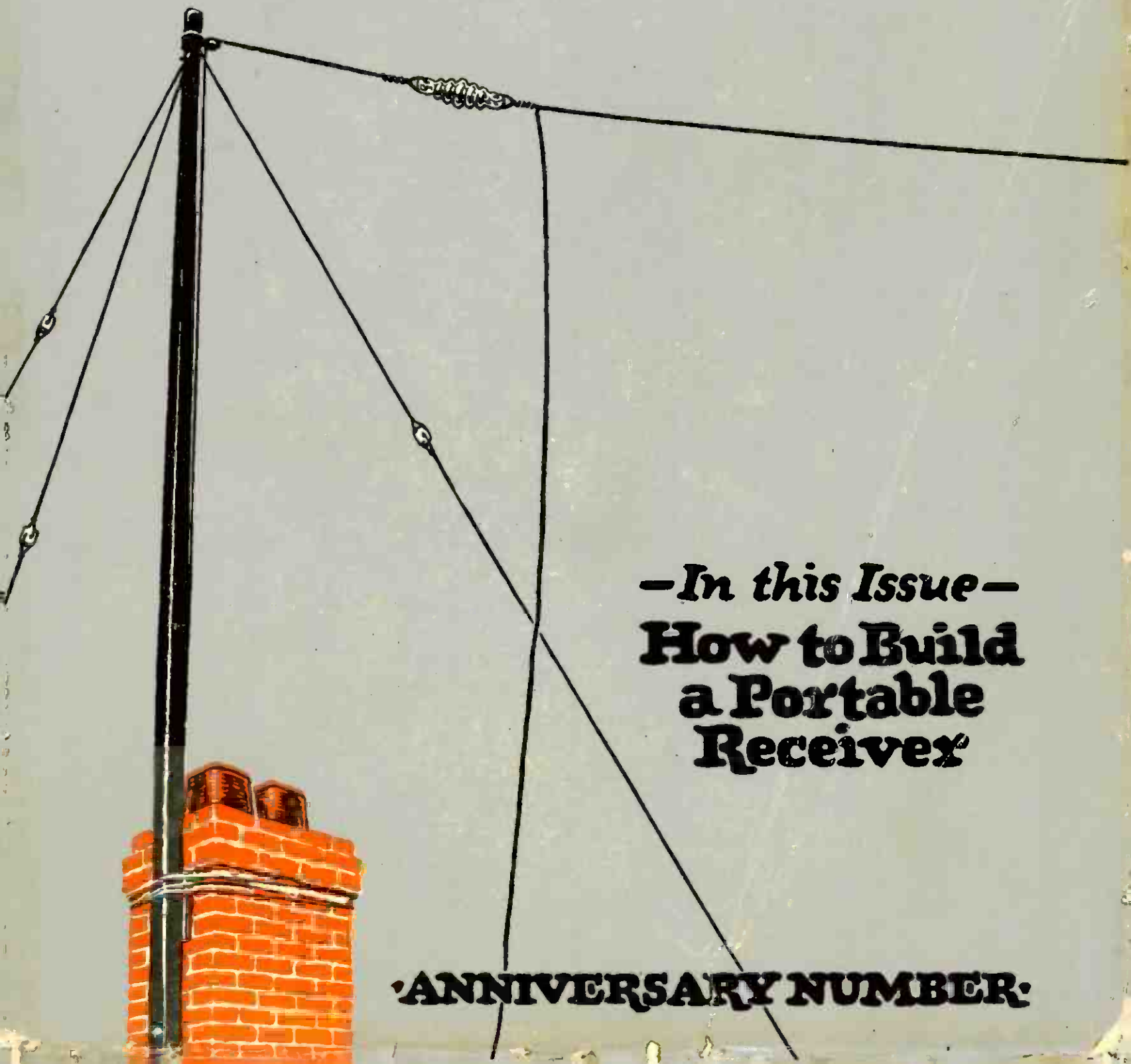

-In this Issue-
**How to Build
a Portable
Receiver**

ANNIVERSARY NUMBER



The
AC
Radio
Tube

McCULLOUGH
AC

McCULLOUGH SALES CO.

Distributors McCullough AC Tubes

963 Liberty Avenue

Pittsburgh, Pennsylvania

A Decade of RADIO HISTORY in

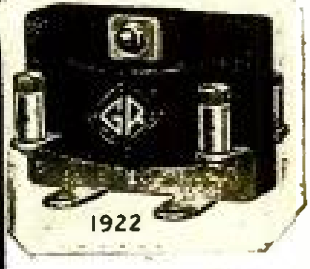
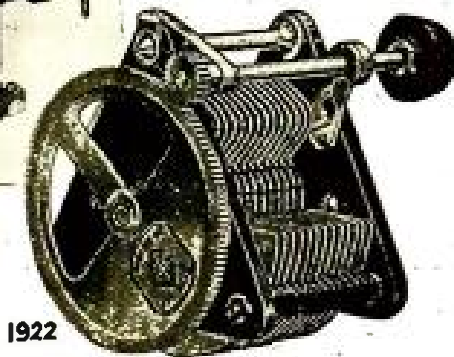
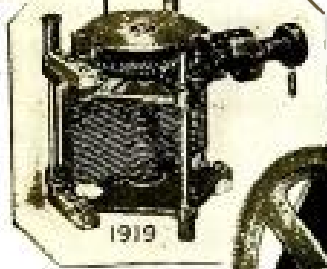
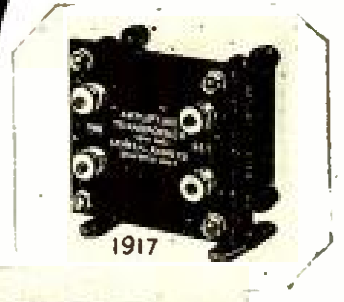
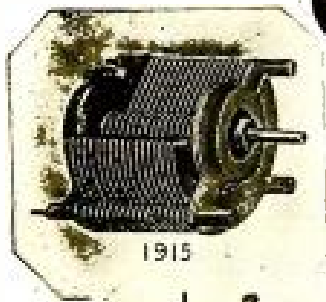

CONDENSER *and* TRANSFORMER DESIGN

The *first* condenser known as a "low loss" condenser was introduced commercially by the General Radio Company in 1915. This instrument was the type 101 condenser and designed for laboratory use. There are a large number of these condensers still in use in the leading radio laboratories of the country.

In 1919 the General Radio Company announced the type 222 Precision Condenser, which today is universally accepted the world over as the laboratory standard for accurate capacity measurements. When several of these condensers were destroyed in the Japanese earthquake, orders were cabled for their immediate replacement. The type 222 was the *first* low loss condenser with geared vernier, and *first* to have metal end plates and grounded rotor.

In 1922 the type 247 condensers were released. They were the *first* of the now so popular soldered plate type. Unlike the type 101 and 222 condensers they were not designed for laboratory standards but for constant use in radio sets. The design represents the best balance between dielectric, eddy current and conductivity losses with full attention to mechanical construction.

Beside contributing so liberally to condenser design the General Radio Company was the *first* to offer for use in radio reception an audio frequency amplifying transformer with closed core. This popularly known transformer was the type 166A released in 1917. It was followed in 1922 by the type 231-A which was then so far in advance that even today it is a leader of the lower ratio type.

The latest achievement of the General Radio Company and perhaps one of the most important is the new type 285 audio transformer. The outstanding features of this instrument are its unusually high and even amplification over the entire musical range.

The General Radio Company has been instrumental in contributing many other developments to the art of radio. Its laboratory equipment may be found in nearly all of the higher educational institution laboratories of the country: The Army, Navy, and Bureau of Standards laboratories as well as such well-known commercial laboratories as those of the General Electric Company, Westinghouse, and Bell Telephone have been for a decade extensive users of General Radio precision apparatus.

For complete description of General Radio parts write for Bulletin 920-U.

General Radio Company
Cambridge, Massachusetts

POPULAR RADIO

EDITED by KENDALL BANNING



CONTENTS for MAY, 1925

(Cover design by Frank B. Masters)

VOLUME VII	NUMBER 5
One of the Two Inventors of the New Radio Picture System	FRONTISPIECE
The New Bartlane System of Radio Transmission of Pictures	<i>Edmund H. Hansen</i> Page 407
Can Man Release the Enormous Energy in the Atom?	<i>T. F. Wall</i> 412
The Men Who Made Radio	420
Sixth Installment	
Factors That Affect Antenna Capacity	<i>Oliver Lodge</i> 422
Article No. 13	
How to Wire Your House to Have Radio in Every Room	<i>Raymond Francis Yates</i> 426
Simple "How-to-build" Articles for Beginners	<i>Laurence M. Cockaday</i> 430
No. 8: How to Build a Single-tube, Four-circuit Tuner	
Points on Joints	<i>Frank A. Rumball</i> 434
How Radio Is Being Used to Foretell the Coming of Storms	<i>Marshall D. Bewick</i> 436
How to Get the Most Out of Your Ready-made Receiver	<i>S. Gordon Taylor</i> 439
No. 5: The De Forest Reflex	
The "Radio Rights" of Authors	<i>Will Irwin</i> 452
Handy Tools for Radio Fans: No. 3	454
The Hydrometer	
How to Build the Portable "Town and Country" Receiver	<i>S. Gordon Taylor</i> 455
Ohm's Law in a Nutshell	<i>J. W. Goostree</i> 468
Chalk Talks in Radio, No. 1	

DEPARTMENTS

What Readers Ask	<i>Laurence M. Cockaday</i> 470
In the World's Laboratories	<i>E. E. Free</i> 476
Hints for Amateurs	<i>Albert G. Craig</i> 484
The Broadcast Listener	<i>Raymond Francis Yates</i> 486
"Trouble Shooting"	<i>S. Gordon Taylor</i> 490
What's New in Radio Apparatus	<i>Technical Editor</i> 495
Broadcasts	<i>David Lay</i> 500

VOLUME VII

MAY, 1925

NUMBER 5

Published monthly by Popular Radio, Inc., 627 West 43rd St., New York, N. Y., telephone number Chickering 1906; Douglas H. Cooke, President and Treasurer; Kendall Banning, Vice-President; L. M. Cockaday, Secretary; Joseph T. Cooney, Asst. Treasurer. Price 25 cents a copy; subscription \$3.00 a year in the U. S., Canada and all countries within the domestic postal zone; elsewhere \$3.50 a year, payable in advance. The International News Company, Ltd., No. 5 Bream's Bldg., London, E. C. 4, sole distributors in England. Entered as second class matter April 7, 1922, at the Post Office at New York, N. Y., under the act of March 3, 1879. Copyright, 1925, and title registered as a trade-mark by Popular Radio, Inc. Copyright in Great Britain by Popular Radio, Inc., 6 Henrietta St., Covent Garden, W. C., London, England.

Printed in U. S. A.

LAURENCE M. COCKADAY, *Technical Editor*
E. E. FREE, Ph.D., *Contributing Editor* JOHN V. L. HOGAN, *Contributing Editor*

For advertising rates address

E. R. CROWE & COMPANY, INC.

New York: 25 Vanderbilt Avenue

Chicago: 225 North Michigan Avenue

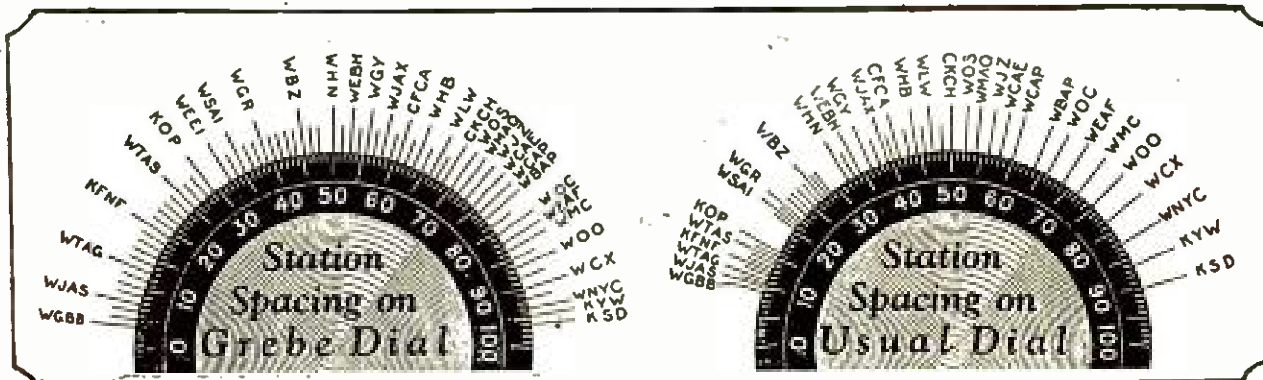

Why Tuning is So Easy with the Grebe

S-L-F (straight line frequency) *Condensers*—exclusively Grebe—make unnecessary the crowding of short-wave stations to the lower dial numbers.

On the Grebe dial all stations have equal spacing. There is as much leeway in tuning-in a short as a long-wave station. Sharp tuning is quick, easy and certain.

Each station is found on the same settings on all dials.

With other exclusive Grebe features—such as *Binocular Coils* and *Volume Control*—the *Synchrophase* presents the very latest in radio receiver development.

Unlike sets made of assembled parts, every detail of the *Synchrophase* is designed and built in our factory in order that we may control the quality and workmanship. For this reason all parts co-ordinate perfectly and make possible the unsurpassed performance of the *Synchrophase*.

The cabinet is beautifully designed and built of solid mahogany, highly polished and with delicately embossed gold escutcheons.

Ask your dealer for a demonstration

A. H. Grebe & Co., Inc.
Van Wyck Blvd., Richmond Hill, N. Y.

Western Branch: 443 So. San Pedro Street, Los Angeles, Cal.

GREBE
SYNCHROPHASE
— TRADE MARK —



TRADE MARK
REG. U.S. PAT. OFF.

All Grebe apparatus is covered by patents granted and pending.

This Company owns and operates Station WAHG



Only perfection in every detail can give perfection to the whole.

Locher H.



Synchrophase with Battery base

PAGES WITH THE EDITOR

WITH this number—May, 1925—POPULAR RADIO celebrates its third anniversary.

* * *

RAPID as the progress of the magazine has been since its first issue, its growth during the past year has been so marked and so substantial as to furnish ample proof of the soundness both of its editorial and of its business policies.

* * *

THESE policies may be summarized thus:

* * *

1. THE reading pages of POPULAR RADIO must be at all times scrupulously honest and beyond reach of the commercial influences. No article or item or picture must be inserted or omitted as the result of pressure from manufacturers, dealers, press agents or others who have special, selfish interests to serve. "The reading pages of POPULAR RADIO are not for sale."

* * *

2. POPULAR RADIO prints only advertisements of radio goods and services; it accepts no general, or non-radio advertising.

* * *

3. POPULAR RADIO accepts no advertising in which sets, parts, or supplies are offered at cut-rates, nor advertisements of jobbers or mail-order houses in which premiums are offered as an inducement to purchase a set or kit.

* * *

4. POPULAR RADIO carries no "fly-by-night" advertising—advertising of concerns unable to pay for their space on due dates.

* * *

5. POPULAR RADIO prints only advertisements of apparatus that has been tested and approved by POPULAR RADIO LABORATORY.

THAT some of these policies have been initiated and maintained in the face of great obstacles—including wilful misrepresentation of competitors—many of our friends have occasion to know. Yet POPULAR RADIO has maintained them from the beginning with the knowledge that sound policies and sound principles must in the end prevail. And they did!

* * *

ALL of these policies have stood the test. And they will continue to stand the test because they serve the interests of the reader—and because they are honest.

* * *

THE outward token of this progress has been evident to all in the mere physical size of the magazine—in its increase in number of reading pages, in its extraordinary growth in advertising patronage and in its rise in circulation. Gratifying as this material success has been, the Editor finds particular gratification in the magazine's growth in the regard in which it is held by its readers—by broadcast listeners, radio amateurs, radio novices, inventors, scientists—and by the radio industry generally.

* * *

ONE of the most important reasons for this growth may be found not only in the character of the contributions, but also in the character of the scientists, inventors and writers who made them—men who are known the world over. To them the credit for this success is given in full measure.

* * *

AMONG the contributors during the past year are numbered many, of course, who have written for POPULAR RADIO from the beginning; some of them indeed, may be listed as "regulars"—Sir Oliver Lodge, Dr. Lee De Forest, (Continued on page 6)



"HIS MASTER'S VICE"

Here is a "radio hound" designed by the famous cartoonist R. M. Brinkerhoff. "If you squeeze him just above the floating rib," Bob writes to the Editor, "he gives a bark that sounds like static!"

Only specialists can make *good* fixed condensers

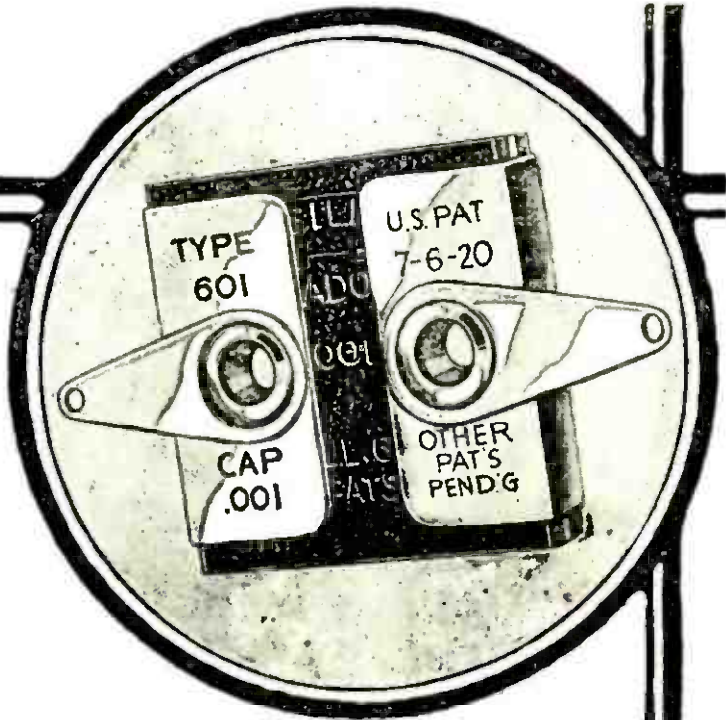

THE small fixed condensers in your radio set are there to help you get clear reception. If these little condensers are not made *most accurately* the quality of reception you get—even though your set may be excellent in all other respects—will be greatly impaired.

You will find that nearly all sets made—in fact over 90% of them—are equipped with Dubilier Micadons. This is the name by which all Dubilier fixed condensers are known.

Be sure your set—whether you buy it or build it—is equipped with Micadons. They are made by *specialists*.

Dubilier

CONDENSER AND RADIO CORPORATION

PAGES WITH THE EDITOR

(Continued from page 4)

Laurence M. Cockaday, Dr. Reginald A. Fessenden, C. Francis Jenkins, to specify only a few.

* * *

BUT to the list of contributors during 1924 have been added such eminent scientists as Dr. Willis R. Whitney, Dr. E. F. Northrup, Prof. J. R. MacGregor-Morris, Prof. Gordon D. Robinson, Robert H. Marriott, Dr. Robert A. Millikan, Edouard Belin, H. Grindell-Matthews, Major General Charles McK. Saltzman, William G. H. Finch, Camille Flammarion, Capt. Paul S. Edwards, Prof. A. M. Low, Leon Deloy, Dr. Edwin E. Slosson and a host of others who stand pre-eminent in the radio art and science.

* * *

To these gentlemen, as well as to the growing army of readers and advertisers who have made the third birthday of POPULAR RADIO a memorable and happy occasion, the Editor extends greetings—and gratitude.

* * *

"FIRST of all I want to say you have the most wonderful magazine on the market, every number is useful from beginning to end. In fact it could not be better. I have never tried one of your How-to-build articles without obtaining the exact results quoted in the text."

—LEO VOLKENRATH, *Huntington, W. Va.*

* * *

"WHAT do you think of a \$40.00 return from a 25-cent investment?" inquiries L. B. C. McMann of Toronto. "That's what happened to me when I bought a copy of POPULAR RADIO at a newsstand. From the excellent instructions given, I built a three-tube Cockaday receiver—although I had never before attempted to build a radio set.

* * *

"WHEN I had finished the job, it looked so good to me I decided to enter it in a radio contest that was then on. And to my surprise it carried off first prize—a large-sized loudspeaker. I have since remodeled the set on the hook-up given in the July number, using the Precision Coil (I had formerly wound my own) and 17 and 23 plate AB condensers. Although I still use only three tubes, I have tuned in 84 different stations in 23 states including Oakland, Calif., all on the loudspeaker. Needless to say, I like my set better than any I have heard, regardless of price."

* * *

FROM the Land of the Rising Sun, where (strangely enough) POPULAR RADIO is finding a steadily increasing number of readers, comes this friendly and altogether delightful message from Masanori Suguira, of Shiba-Ku-Tokyo. In order that it may lose none of its original flavor, the Editor is taking the liberty of sharing it with his readers, just as it came:

* * *

"You are living so far from us that though we Japanese,—expecially I—hope to friend with you very much, the Pacific Ocean too

large to stretch out my hand for shake hand. But,—God gives us kindly wave—and we become able to show all our friendship by it, not by ship, and very often. So, by Jove! I will exert my best for anything what you please, and also, if any good chance come upon me, I will write you about something interest News in Japan for only as my mere entertainment to you. So, please give me a letter, too.

* * *

"At first, I was buying your famous magazine through the Japanese Book-seller's hand, but I would like to know more about Radio in your country. So that, I send this letter. Dear Genelemen! Please,—please tell and teach me about News or other els, connect with it. I will wait it with my all hopes. From further Japan,—I wish and pray for your healthy and happiness. Last, I am begging your pardon for my poor English and Writing. Good-bye!"

* * *

How many of us Americans could write as good a letter as that in Japanese?

* * *

ONE of the outstanding features of the particular class of radio experimenters and broadcast listeners who read POPULAR RADIO is that it is a class which *buys* radio apparatus.

* * *

No more conclusive evidence of this fact can be found than in the actual results obtained by advertisers in POPULAR RADIO—advertisers of radio apparatus who have learned by experience to gauge the quality of a magazine's circulation by the buying propensities of its readers.

* * *

HERE, for example, is one—and a representative one—of scores of letters from advertisers: "We believe that we are getting more consumer and dealer inquiries as a result of POPULAR RADIO than any two other radio mediums combined," writes the Plymouth Electric Company of New Haven, Conn.

* * *

ANOTHER letter comes from the Haynes-Griffin Radio Service, Inc., of New York. "It is particularly interesting to note the number of inquiries from POPULAR RADIO readers that have been developed into actual orders," writes Mr. John W. Griffin, the president. "While some of the trade papers have occasionally brought us a larger number of inquiries than did POPULAR RADIO, we have found right along that the *actual orders* which resulted were far greater from POPULAR RADIO inquiries than they have been from any publication in the radio field."

Mendall Banning
Editor, POPULAR RADIO

**EVEREADY HOUR
EVERY TUESDAY AT 9 P. M.**
(Eastern Standard Time)

For real radio enjoyment tune in the "Eveready Group." Broadcast through stations—

WEAF New York	WCAE	Pittsburgh
WJAR Providence	WGR	Buffalo
WEEI Boston	WOC	Davenport
WEAR Cleveland	WCCO	Minneapolis
WWJ Detroit		St. Paul
WFI Philadelphia	WSAI	Cincinnati

*The proven
Dry Cell for all
Radio Dry Cell
Tubes*

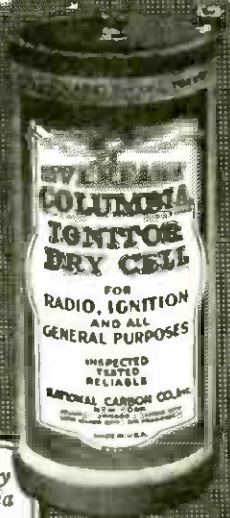

Eveready Columbia Ignitor Dry Cell "A" Battery for all Dry Cell Tubes 1½ volts

Recommend good batteries

IN AN effort to reduce the first cost of a radio set, a newcomer in radio often buys inferior batteries. You know such "saving" is really wasteful. Tell your friends who are about to buy receivers that the best batteries obtainable will prove to be the most economical. Tell them to buy Eveready Radio Batteries—they last longer and, because they are greatly superior, they give complete satisfaction.

Manufactured and guaranteed by
NATIONAL CARBON COMPANY, Inc.
New York San Francisco
Canadian National Carbon Co., Limited, Toronto, Ont.

EVEREADY Radio Batteries

- they last longer



No. 770
45-volt
Extra
Large
Vertical
Price
\$4.75
For use
on multi-
tube sets



No. 767
45-volt
Large
Horizontal
Price
\$3.75
With
variable
taps



Two Strikes Three Balls!

The pitcher has completed that slow, leisurely, tantalizing wind-up. That long, lithe, million-dollar arm has flashed back. A moment . . . and the ball, a white, hissing streak, is catapulting toward the catcher's waiting mitt.

And the winning or losing of a World Series depends on whether or not the batter has his eye on the ball.

A Cunningham Tube always has its eye on the ball. It stands ready to transmute an electrical impulse, traveling at a speed which would make the speed of a baseball seem a snail's pace, into music, a President's message—what you will.

Since 1915 - Standard for all sets

Types C-301A: C-299: C-300, C-11: C-12,
In the Orange and Blue Carton

Price . . . \$3.00 each



Cunningham

RADIO TUBES

E. J. Cunningham Inc.

HOME OFFICE:

Chicago

182 Second Street, San Francisco

New York

PATENT NOTICE: Cunningham tubes are covered by patents dated 2-18-08, 2-18-12, 12-30-13, 10-23-17, 10-23-17, and others issued and pending.



Why POPULAR RADIO Is Popular

POPULAR RADIO is a publication alive with all the spirit and the thrills that ride the Hertzian waves and bring the broadcast news and joys of the world into the fireside circle of the home. POPULAR RADIO deserves to be popular!

J. Augustus Mafum



ONE OF THE TWO INVENTORS OF THE NEW RADIO PICTURE SYSTEM

Mr. Bartholomew of "The London Daily Mirror" is here shown inspecting the tape which is the key to a photograph sent by radio from New York. The tape when run through a receiving apparatus reproduces the picture.

Popular Radio

VOLUME VII

MAY, 1925

NUMBER 5



THE NEW BARTLANE SYSTEM OF RADIO Transmission of Pictures

Within the past few months the transmission of pictures by radio has been put on a commercial basis. The Jenkins, the Belin and other systems have already been described in this magazine; this Bartlane system, which has been in course of development for several years, is here described for the first time

By EDMUND H. HANSEN

IN THE past year many methods of transmitting pictures have been brought to the attention of the public. These were systems whereby very delicate currents were handled in the most careful manner in order not to destroy the photo characteristics of the original photographs. Commercial application of these photographic transmission devices has been retarded by the skill required of the operators, and by the ability of the transmission lines to handle the delicate currents.

For several years there has been under development a method that will find a ready application to every-day use. This is the Bartlane system, which name was coined by combining the names of two inventors, Bartholomew and McFarlane.

Mr. Bartholomew has been for many years head of the art department and a director of the *Daily Mirror* of Lon-

don. With Captain McFarlane, a well-known English research engineer, he has been working since 1920 to put photograph transmission for the *Mirror* on a commercial basis. In 1921, with the co-operation of the British Post Office, a picture was successfully sent by cable to Halifax and then re-transmitted to England.

In most of the present day methods a direct system is employed. By this is meant that both sending and receiving stations are electrically linked together and are in synchronism one with the other. The current carrying the photograph is usually a very weak modulated carrier that is very similar in strength and character to radio signals.

In transmitting signals of this nature it is necessary that high-grade telephone lines be employed that entail an expense that is not always justified for

every day use. In the Bartlane system a tape similar to that employed in page-printer work is used.

Automatic telegraphy is accomplished by first punching a paper tape, in which each letter and number has a distinct arrangement of punch holes. The punching is done by means of a machine with a typewriter keyboard and a set of five punching magnets. Not more than five punchmarks are made for any one letter or number. In the center of the tape is a synchronizing hole. This tape is then fed into a transmitting machine which sends impulses of changing polarities by radio, cable or telegraph lines. These currents actuate magnets



THIS PICTURE CROSSED THE ATLANTIC BY WAY OF THE ETHER

Although the Bartlane pictures do not pick up all the photographic tones, they give an illusion that is satisfactory for newspaper reproduction.

The picture above is a typical example.

on the receiving typewriter and print the message directly on a blank.

In the Bartlane system instead of having an operator at a keyboard a set of five "tints" actuate the punching machine magnets that punch from one to five holes. These tint plates are made by exposing the photographic negative and tint plate for varying periods of time. Plate number one, for instance, would be exposed for two seconds, plate number two for four seconds and so on for the five plates.

These plates are of zinc or copper, and when developed they carry a certain value of halftone characteristic that acts as an insulating surface on some of the plates. These five tint plates are fastened to a rotating cylinder which is motor driven and synchronized with the tape-punching equipment. Each of the tint plates has an electrical contact finger that operates its individual punch magnet when a part of the tint plate which has no insulating surface touches a contact finger.

Let us analyze this coding action still further by taking a portion of the original negative and tracing the complete operation.

In the positive photograph a portion of the background is heavy black which appears as clear white in the negative and permits a maximum of light to effect the tint plate. When developed, the insulation on the plate, where the clear white occurs, is chemically removed.

As there is a maximum of light on each of the five tint plates when they are exposed to the clear white of the negative, this particular part of the picture will be represented on each of the tint plates by a clean surface which permits all five contact fingers to make electrical connection and thus cause five punch holes to be made across the tape.

Now let us consider another part of the surface that is only four-fifths as black.

When the tint plates are developed



THE TRANSMITTING APPARATUS

The five tint plates that operate the tape puncher are being adjusted by Mr. McFarlane preparatory to transmitting a picture by radio. The tape and puncher are shown on the table and at the right the controller that starts the synchronous motors that operate the picture recorder and the puncher.

it will be found that one of them is still covered by the insulating compound, and instead of five there will be only four holes punched. The picture is graded into the five different tints by exposing the plates a proportionate period of time. A sixth or pure white tint is obtained by using a value where no holes are punched in the tape. This can be explained better when we consider the receiving end.

The tape although it is punched in accordance with the various shades that appear in a picture that is to be transmitted is nevertheless the conventional form of page-printer tape. In consequence, it is only necessary to file the tape in a radio, telegraph or cable office to have a picture transmitted. The ordinary radio-telegraph transmitter is the simple means employed to send the picture. And, for wire transmission

no carefully built and well-balanced land lines are needed. The standard telegraph circuit is entirely satisfactory. Free from inductive and swinging effects, the tape is reproduced at the receiving end by another punching machine on which an exact reproduction of the transmitting tape is made.

In all other methods of sending photographs by radio or wire the very serious problems of synchronizing the sending and receiving machine is apparent. In the Bartlane method each time that a certain value of the negative is recorded on the tape by a punch hole, a punch mark is made at the same time in the center of the tape for synchronizing. In the transmission of the tape the synchronizing holes are automatically transmitted and the received tape therefore carries the synchronizing holes in their proper relationship to the

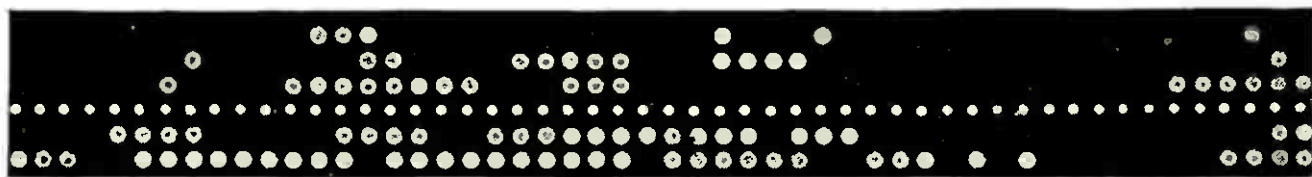
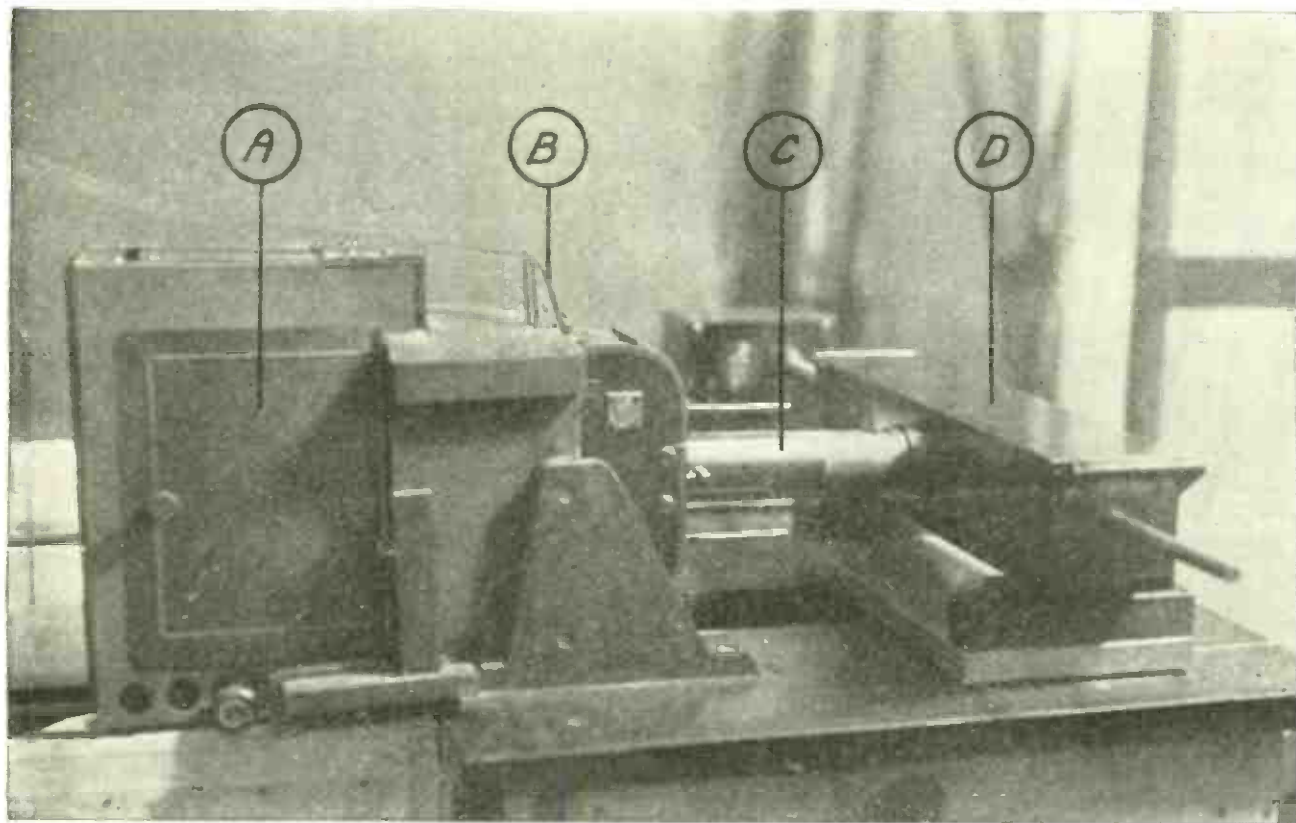

THE PICTURE REPRODUCER AND ITS TAPE

FIGURE 1: *The tape carries six lines of punch holes as shown in the picture above. The small holes fit into a sprocket arrangement so that the tape will run in synchronism with its duplicate at the transmitting end. The large holes are for controlling the tone values that are transmitted. The tape runs through the machine shown above at B so that the light from the arc inside the box A passes through the holes in the tape. This light then travels through a set of lenses in the cylinder C and reproduces the picture on a photographic film inside the light-proof compartment D. The film is then developed and the photograph printed.*

punches that indicate the photographic tone values.

After transmission there is at the receiving end a duplicate of the original tape that may be in London or Paris. This received tape must then be converted into a photograph.

In the apparatus shown in Figure 1 a beam of light is passed through the lenses on to the tape. The amount of light that is permitted to pass through the tape at any moment depends, of course, on the number of holes that pass by the beam at the particular moment.

That part of the tape that represents the black background has five holes and

will therefore allow the greatest amount of light to pass. When this light is focused by means of a series of lenses upon a photographic film, it will print an exact reproduction of the original negative. The part of the tape that has four holes gives a lesser amount of light and in consequence another light tone value. In other words the printing light varies as the number of holes in the tape. Where no holes are punched and no light passes, the recording film will show clear white.

As there is no relay or galvanometer action in this system, the speed at which the photograph can be repro-

duced is determined by the breaking point of the tape, and the intensity of the light which is thrown on the tape in conjunction with the speed of the film itself to light action. The usual time is two minutes.

The receiving cylinder is coupled with the sprocket wheel over which the tape passes and makes an absolute method of synchronizing as shown in Figure 1.

The Bartlane system has a wide use as tape transmission is employed almost universally with a standard tape; and there is no concern about transmission troubles. Furthermore, since the transmitted pictures possess true photographic characteristics, they lend themselves to retouching.

In transmitting the speed may be greatly increased by sending "takes" or

parts of the tape over different circuits. For instance there are several page-printer circuits between New York and Chicago, a tape can be divided into four sections, for instance, and be transmitted over as many different circuits thus speeding up the time of transmission four times.

Photographs have been sent by this method between England and Germany, across the Atlantic and between cities in the United States. In fact, pictures taken at the Carpentier-Dempsey fight were cabled to London and published a few hours later.

The Bartlane machines are quite simply made and they are small besides, which means that they can be easily transported and set up ready for operation in a few hours.

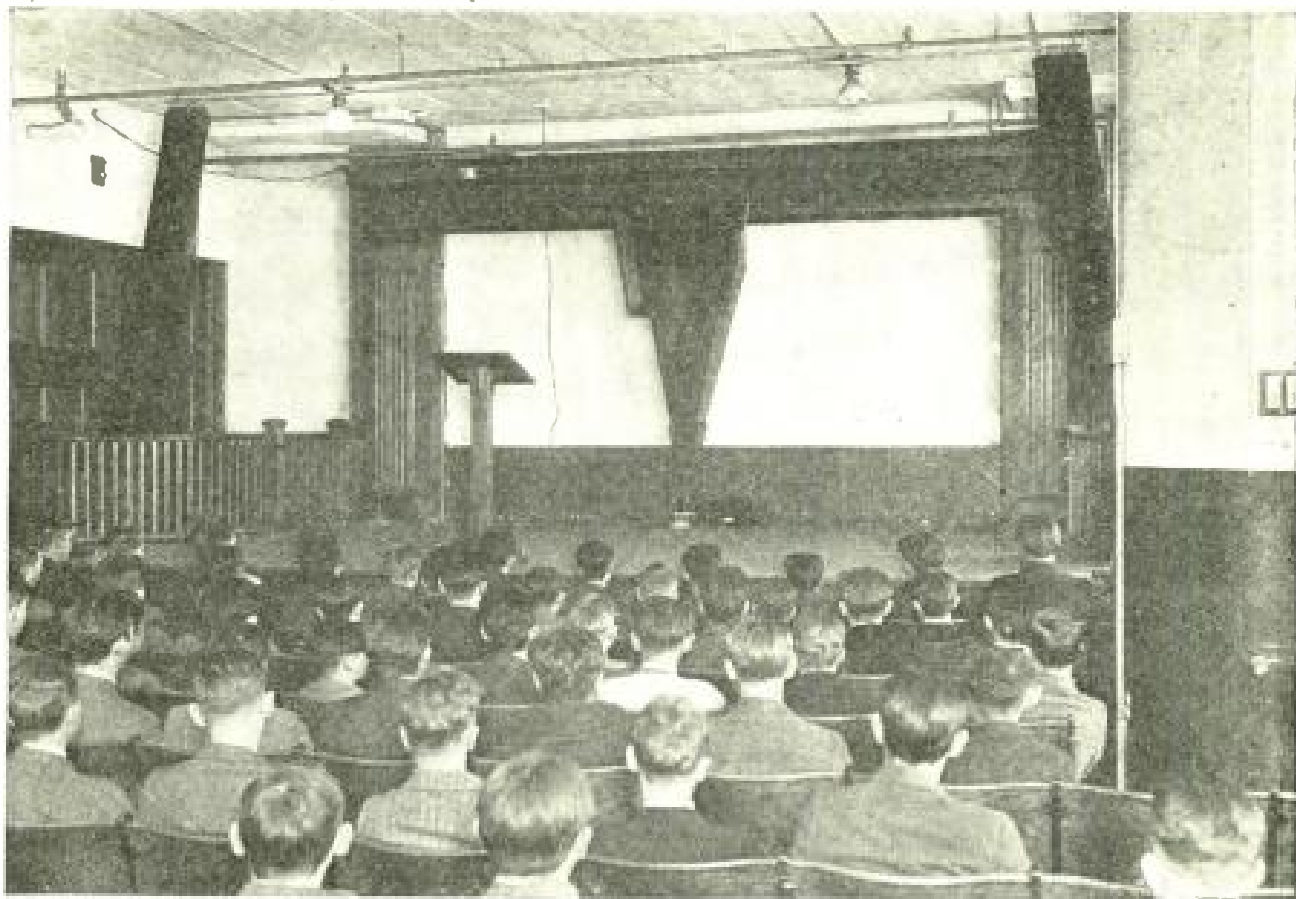

Kadel & Herbert

RADIO TAKES THE CENTER OF THE STAGE

This giant loudspeaker was built by the students of the Brooklyn (N. Y.) Technical School to supplement part of the daily assembly exercises with radio programs. The horn stands 8½ feet high and is used in connection with an eight-tube super-heterodyne receiver.

414



From a picture made for POPULAR RADIO

THIS SMALL COIL MAY BREAK UP ATOMS

FIGURE 1: *The author is here shown with one of the dwarf solenoids used in his high-frequency current experiments in which he is attempting to pull atoms apart and release their energy.*

CAN MAN RELEASE THE ENORMOUS Energy in the Atom?

A recent announcement by Professor Wall that he was endeavoring to disrupt the atom had one unexpected result. Many persons got the idea that his attempt might be dangerous, that the whole world might go up in dust. They begged him to desist. Such fears are groundless. Atoms are aggregates of electrons and protons. It is conceivable that these can be divorced, more or less completely, in several ways. The magnetic attack planned by Professor Wall is merely one of these ways.

—EDITOR

By T. F. WALL, D.Sc., D.Eng.

IT IS not many years ago since the atoms of matter were considered to be the final indivisible units (or bricks) from which lumps of matter were built up. This view was emphasized by the fact that the atoms were known to be the smallest particles of matter which ever took part in chemical reactions. It was thought that atoms could not be subdivided and were, in fact, the ultimate limit

of minuteness to be found anywhere in nature. During the last few decades, however, investigations of physicists have revealed a series of amazing facts regarding the constitution of the atom and have led to totally new conceptions as to what are the ultimate particles of matter. Information has also been obtained as to the relative sizes of the atoms and the units of which the atom is composed.

It is now known that, instead of being the ultimate indivisible particle of matter as was for so long believed, the atom is a complex structure and comprises within its boundaries a series of minute particles of electricity called electrons, which revolve in their orbits at a terrific speed. In comparison with these electrons the atoms are of enormous magnitude. Some conception of the relative sizes was suggested by Sir Oliver Lodge when he compared an electron in the atom with a fly in a cathedral.

Whatever the nature of the element may be, each one of its atoms comprises a central nucleus and a number of electrons rotating around the nucleus like planets around the sun. The nucleus of the atom is considered to be a complex structure comprising positive and negative electricity, the amount of positive charge being greater than the amount of negative charge, so that the nucleus has a charge that is positive in effect. This nucleus occupies a minute spot at the center of the atom, and circling round it are a number of electrons in their respective orbits, the number of electrons being the same as the effective number of units in the positive charge of the nucleus.

For example, the atom of hydrogen in its normal or uncharged state comprises a nucleus with a single positive effective charge and one electron, which revolves round it at the colossal speed of nearly 1,500 miles a second. An atom of mercury in its normal state comprises a nucleus with an effective positive charge of 80 units and 80 electrons circling round it at varying distances from the nucleus. In an atom of gold the nucleus has an effective positive charge of 79 units and 79 electrons circling round it. Now, the one distinctive characteristic of the atoms of the elements is the amount of the effective positive charge of the nucleus. If, in any way, the amount of this nucleus charge can be changed, *the nature of the element will also become changed.*

The fact just stated is of profound sig-

nificance, for it means nothing less than the answer to the age-old problem of the transmutation of the elements. It is, in fact, believed that this is the way in which the reported transmutation of mercury into gold has recently been performed by Prof. A. Miethe of Charlottenburg.

There seems to be no valid reason to doubt the truth of this report, as the scientific facts of the structure of the atom as outlined here are fully in accord with the result which has been claimed.

It is of interest to note that the transmutation referred to was the result of an accidental and incidental effect which came to light when a totally different investigation was being carried out. This investigation was an attempt to invent an intensely brilliant mercury vapor lamp. During the experiments the lamp was over-run, and it was observed that a dark deposit was being formed on the side of the lamp tube on this account. Prof. Miethe was asked to discover a means to prevent the formation of this deposit. He found, on examination, that the deposit actually contained a minute quantity of gold.

Now, it is well-known that minute

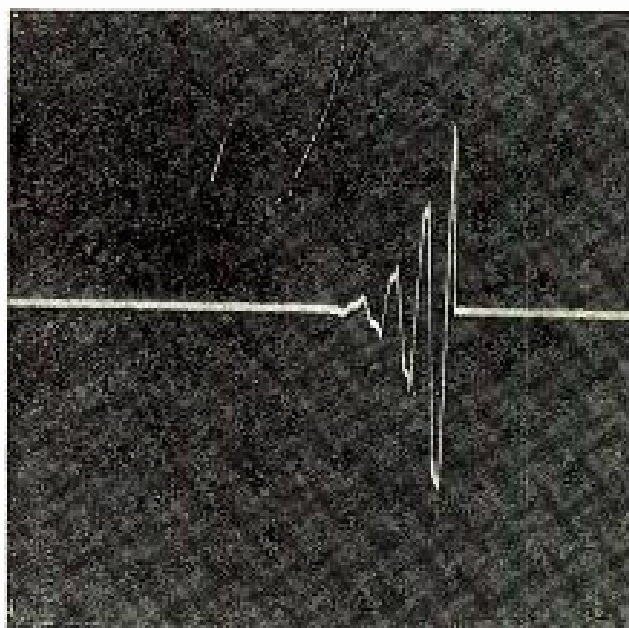

HOW THE ENORMOUS CURRENTS WERE PHOTOGRAPHED

FIGURE 2: The longest vertical line in this oscillograph represents a current of 24,000 amperes, which may be found sufficient to disrupt mercury atoms in Dr. Wall's experiments.

traces of gold exist in mercury in the natural state as an impurity; and in order to ensure that the gold detected was not due to any traces of gold originally present, mercury of the utmost purity was used. The experiment of over-running the vapor lamp was repeated and again gold was found in the deposit.

In the light of what has been said already, it will be understood now what is believed to have happened. The current which passes through the mercury vapor is (as every electric current is) a stream of electrons. In the cases of some of the atoms of the mercury vapor an electron of the current has penetrated to the nucleus so that its effective positive charge has been reduced from 80 to 79, and consequently its nature has been changed from mercury to gold. In this connection it is very significant to remember that traces of gold appear naturally as an impurity in mercury and that this suggests that the transmutation may be actually taking place in nature under suitable conditions—possibly a lightning flash may be sufficient to effect the transmutation. This also suggests the likelihood that the alchemists of old were led to the belief that mercury

could be changed into gold because they were aware that the two metals were found together in nature.

The investigation on which I am engaged is essentially an attempt to disturb the electronic structure of the atoms by the device of subjecting them to a very intense magnetic field. As the electrons, circling round in their orbits, are equivalent to electric currents, they give rise to magnetic fields inside the atoms, and the intensity of these inherent magnetic fields has been calculated to be enormously greater than that of any artificially produced magnetic field hitherto obtained. If, however, by special means, it becomes possible to produce, artificially, magnetic fields of an intensity which is comparable with that of the inherent magnetic fields within the atoms, and if the artificial field is impressed on the atoms, a mutual action will take place between the two fields in consequence of which the electrons will be disturbed in their orbits. If the disturbances so produced are large enough, say, to drag out an electron from the neighborhood of the nucleus, some scientists confidently believed that a relatively immense amount of energy would be released.

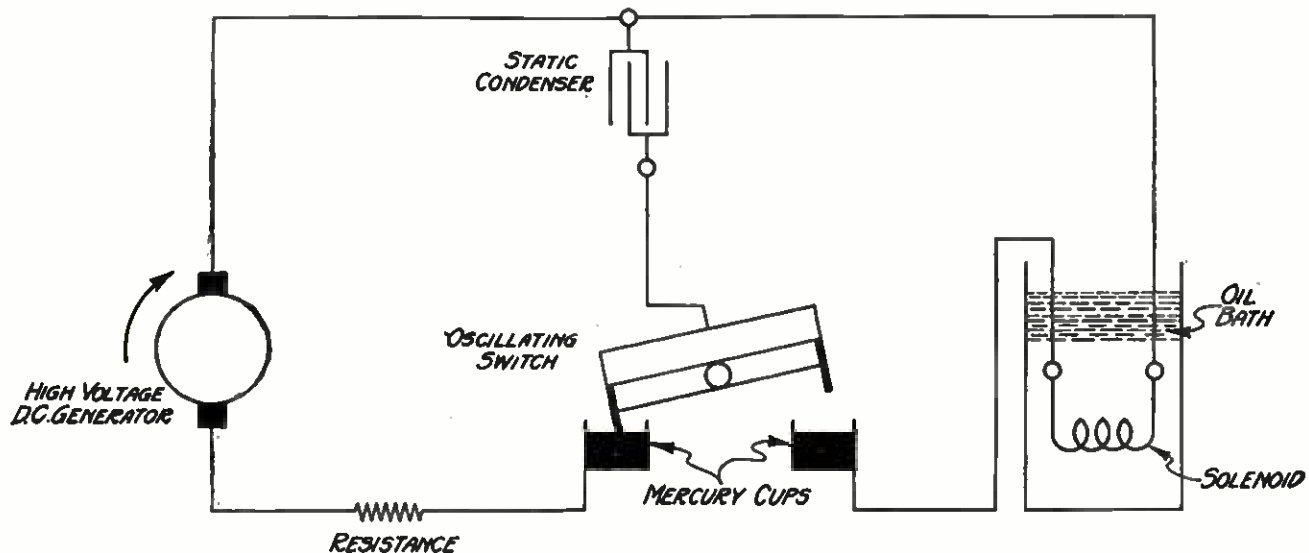

HOW THE POWERFUL MAGNETIC FIELD IS PRODUCED WITH THE AID OF THE ROCKING SWITCH

FIGURE 3: The static condenser shown in this diagram is charged by the generator up to the point of discharge. At this instant, the oscillating switch connects the condenser with the solenoid circuit into which the condenser discharges. This discharge builds up around the solenoid a tremendous magnetic field that may prove to be great enough to split atoms.

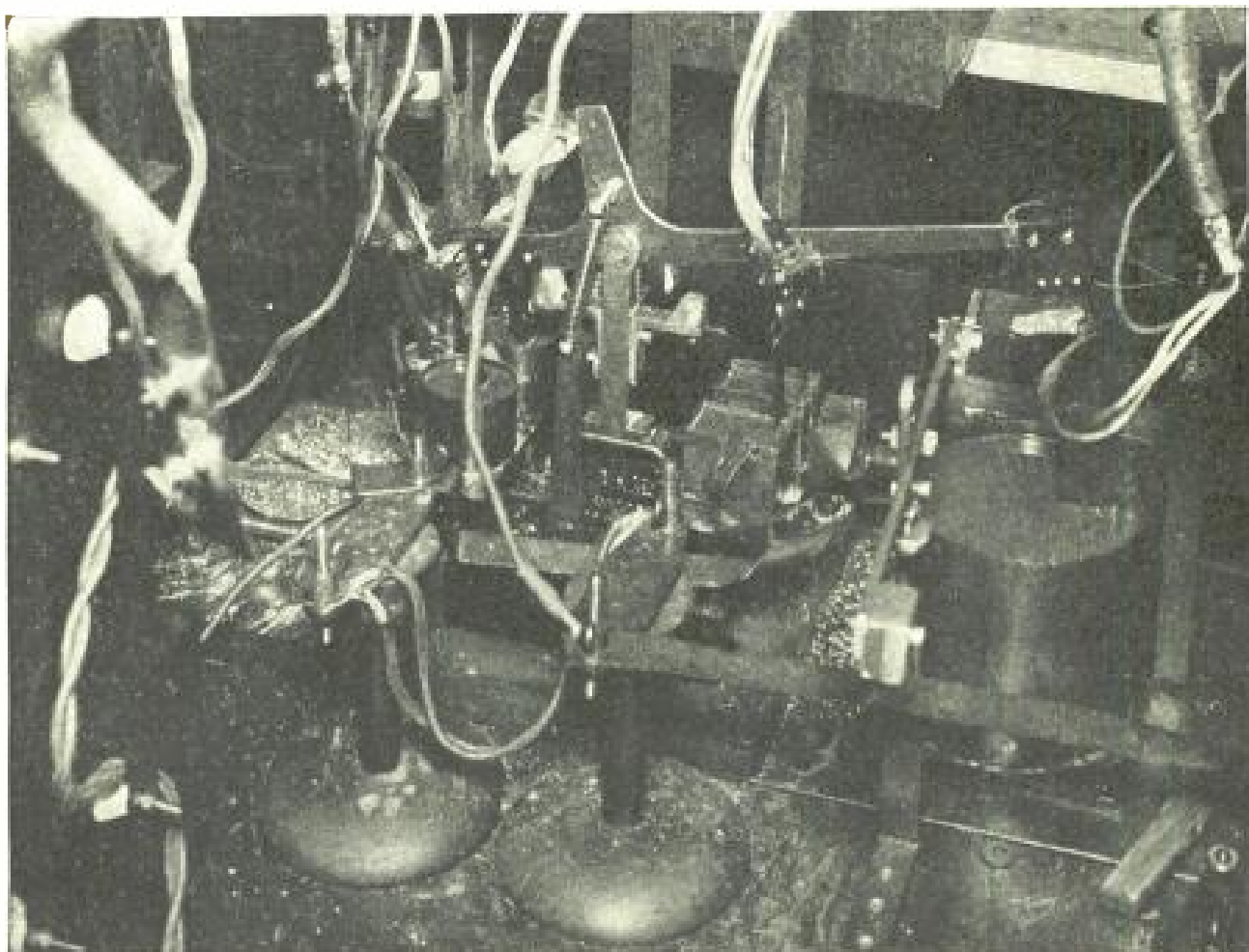

From a picture made for POPULAR RADIO

HOW THE ROCKING SWITCH WORKS

FIGURE 4: *This gives a close view of the rocking switch that makes contacts in the small tanks that are filled with mercury. These contacts are made alternately, thereby allowing the solenoid to be subjected to intense high-frequency currents at intervals.*

If the structure of the nucleus itself can be broken up, the whole of the atomic energy may thereby become available for providing power of some kind.

Many eminent authorities have given vivid illustrations of the immense stores of energy which are believed to be locked up in the atom. These views may perhaps be crystallized by stating:

If the stores of atomic energy could be successfully tapped in a practicable form they would be amply sufficient to supplant all the present forms of fuel, and to operate all the machinery of the world for an indefinite period.

It is obvious, therefore, that the problem is one of supreme international importance and its far-reaching significance cannot easily be exaggerated.

In my experiments I have concentrated

upon two approaches to my problem:

(1) The artificial generation of magnetic fields of an intensity immensely greater than any hitherto produced; and,

(2) The development of a suitable automatic device by means of which this intense magnetic field may be, at regular intervals, applied to and removed from a piece of magnetic material—steel being used in the first instance.

In my opinion, the only practicable way of producing magnetic fields of the necessary high intensity is to use the discharge current from high capacity static condensers charged to a high voltage. It is, of course, well known to all workers in radio telegraphy, that if static condensers are discharged through a coil of sufficiently low resistance, an oscillatory current is produced which gradually dies

away until eventually the condensers are completely discharged. This fact is the essence of my method.

A small coil or solenoid is wound with a known number of turns of low resistance wire, the actual size of one coil used being shown in Figure 1.

Static condensers of great capacity are charged to a high voltage by means of a high-tension direct current generator and the condensers are then discharged through the small solenoid. Currents of enormous strength may be obtained if the solenoid is correctly designed as regards its resistance and inductance. The current is an oscillating one and lasts only for a minute fraction of a second, and therefore it is practicable to use tremendously powerful currents without danger of burning out the solenoid; as for a given current, the amount of heat generated is directly proportional to the time for which the current flows. If, therefore, the time of flow is sufficiently small, the current may be indefinitely large without creating a high temperature.

The most intense magnetic field which has been produced heretofore by artificial means has a strength of about 100,000 gauss. *The author has, however, already produced in the core of a solenoid, similar to that shown in Figure 1, a mag-*

netic field of about 1,300,000 gauss intensity.

By means of a modification of the apparatus now being effected, it is expected that a magnetic field of nearly 10,000,000 gauss will soon be obtainable.

In Figure 2 is shown an oscillographic record of the condenser discharge current through the solenoid when a steel tube was used as the core on which the solenoid was wound. The forked appearance of the peaks of the waves is due to the reaction of the magnetic properties of the steel on the solenoid circuit. The scale of the oscillogram of Figure 2 is such that the height of the first peak denotes a current of 24,000 amperes.

It is interesting to estimate what horsepower would be necessary to drive the current of 24,000 amperes through this solenoid winding if the current were obtained, say, by connecting the coil to the terminals of a direct current machine. The coil has a resistance of 0.088 ohm, and hence, in order that a direct current of 24,000 amperes may flow in the winding, a direct p.d. of $24,000 \times 0.088 = 2,100$ volts would have to be applied to the terminals. The power supplied to the coil would, therefore, be $2,100 \times 24,000 = 50,000,000$ watts or 50,000 kilowatts—that is, 67,100 horse-power.

What May Happen If Atomic Energy Is Released—

- 1: *The present cumbersome engines in our automobiles, railroad engines, and in our factories, may be replaced by small atomic generators and small electric motors that will occupy small space—and the costs of fuel may be reduced by 90 percent:*
- 2: *The carrying capacity of ocean liners may be increased 100 percent by the substitution of atomic generators for the propulsion of gigantic machinery used today:*
- 3: *The costs of manufacturing and of exporting and importing may be vastly reduced—and the costs of living may come down proportionately.*

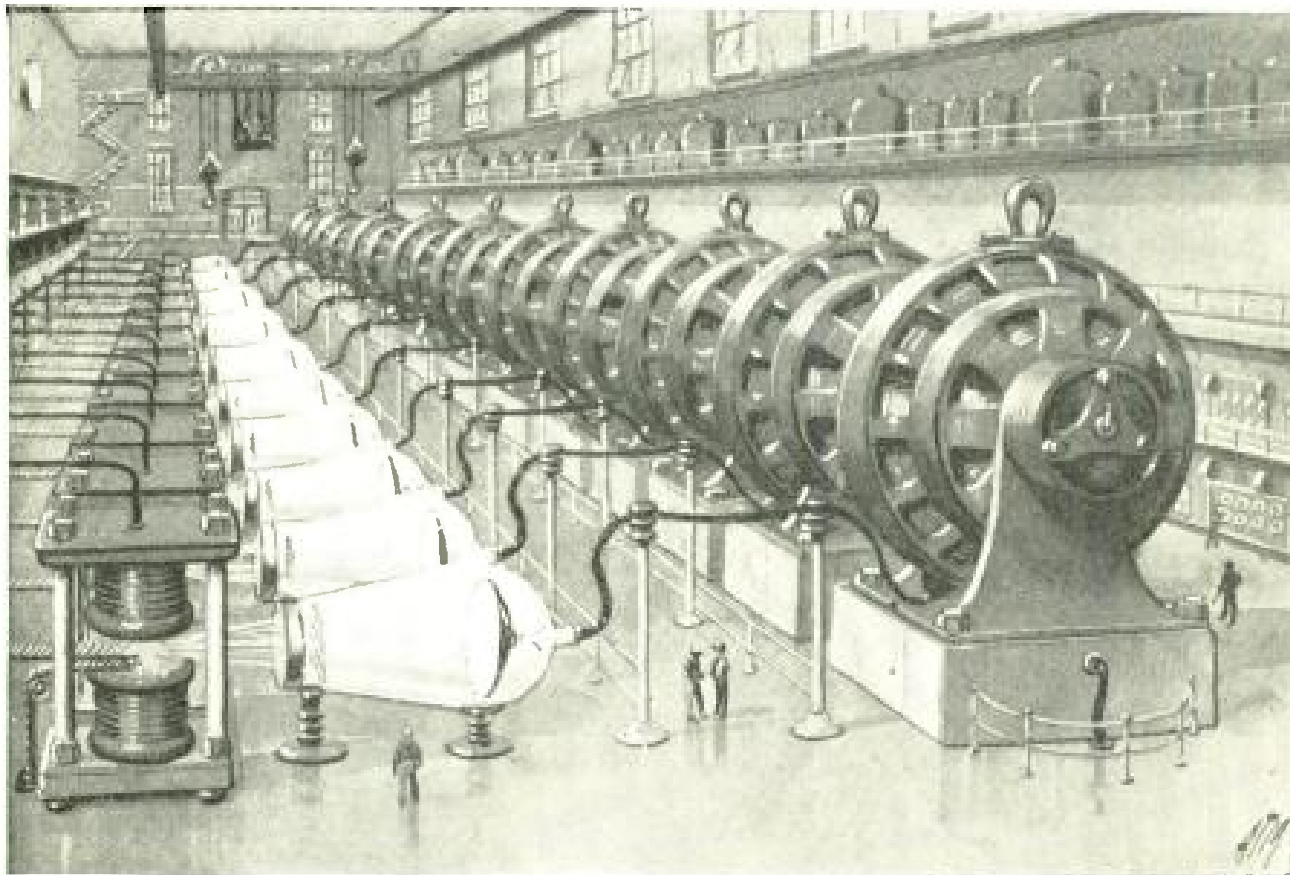

From a drawing made for POPULAR RADIO by Arthur Merrick

WHAT AN ATOM-SPLITTING POWER PLANT OF THE FUTURE MAY LOOK LIKE

Powerful magnetic fields may be used some day to split matter into "particles" of electric energy which will be absorbed by great tubes with grids and plates like radio vacuum-tube detectors. These tubes may behave like great rectifying devices that will deliver electrical energy to rows of dynamos that will supply a whole metropolis with light, heat and power.

When it is remembered that the maximum power generated by most of the largest electric power plants is only 100,000 kilowatts, some idea of the significance of the method of supplying current to the solenoid will be realized.

It has been calculated that the intensity of the inherent magnetic fields within the atoms and due to the revolving electrons is of the order of 100,000,000 gauss. The highest intensity of the magnetic fields which are at present obtainable through my apparatus is of the order of about three percent of the intensity of the inherent atomic fields. A single application of this intensity of artificial field may therefore be too small to produce an appreciable disturbance of the electronic orbits, hence the second part of the method has been to develop an automatic method of applying and removing this

artificial field at regular intervals. This has been achieved by means of a rocking-lever switch driven at a slow speed through gearing from a small electric motor.

Contacts arranged at the ends of the rocking lever alternately dip into mercury cups fixed under each end of the lever. By means of a spring moving across the dead-center position, the rocking-lever is caused to move over to its respective extreme positions by a very quick movement, so that the danger of sparking at the mercury cup contacts is reduced to a minimum. On one side the lever connects, through the corresponding mercury cup, the high tension D.C. generator to the high-capacity static condensers thus charging them. When the condensers are fully charged, the lever snaps over to the other side and so, through the correspond-

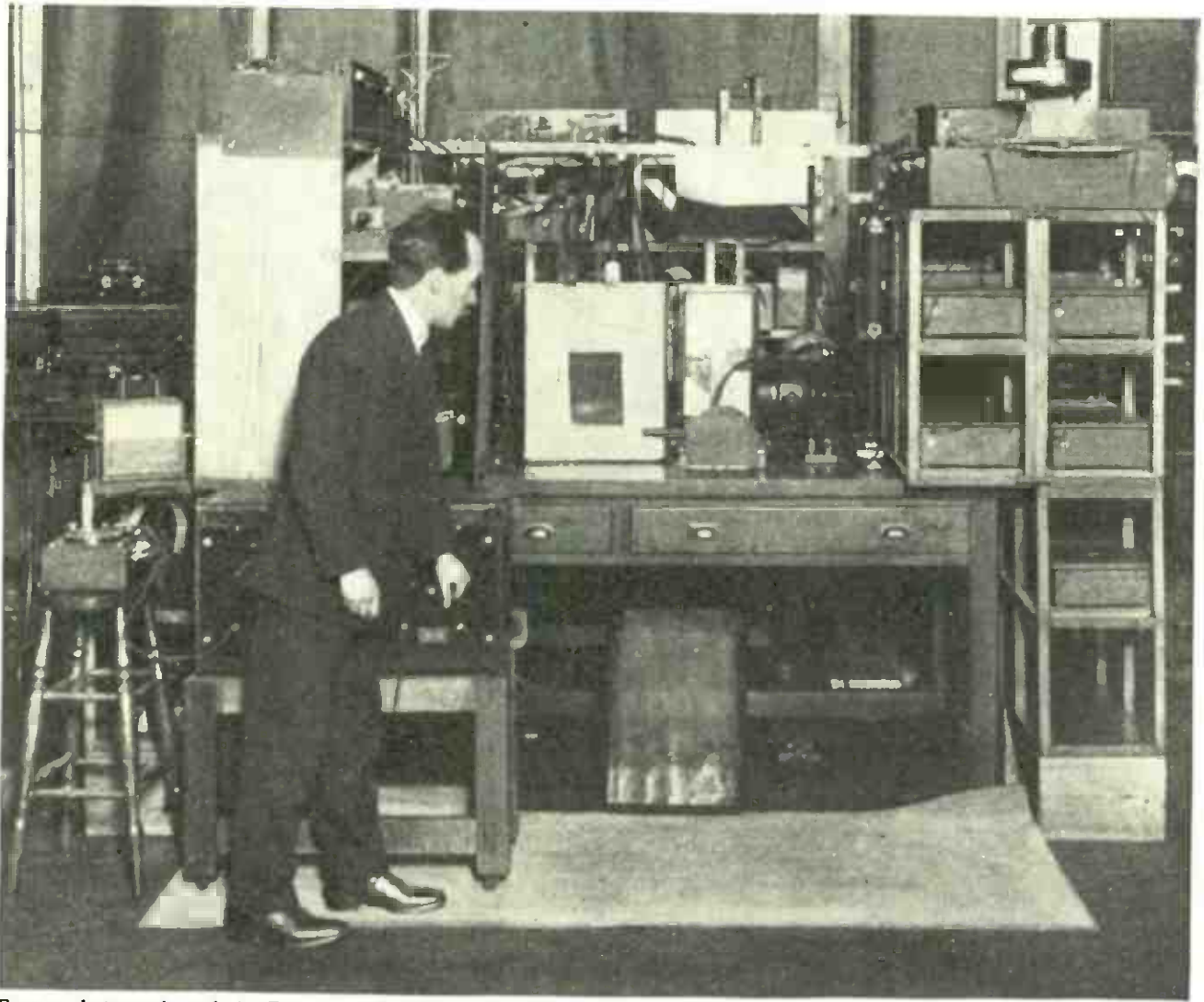

From a photograph made for POPULAR RADIO

HOW THE AUTHOR OPERATES HIS "ATOM SPLITTER"

FIGURE 5: *This picture shows part of the Wall apparatus. In the center of the table is the oil tank that contains the solenoid that is the heart of the entire device for producing gigantic magnetic fields.*

ing mercury cup, connects the solenoid to the charged condensers thus causing a current discharge through the solenoid winding.

The rocking-lever switch permits of the repeated application to, and removal from the specimen, of the intense magnetic fields at regular intervals, the purpose being to produce a cumulative effect by this repeated application until the atomic structure breaks down. A very close analogy to this repeated application of a force to produce a cumulative action is seen in the well-known mechanical case of the repeated application of a relatively small stress to a metal. Although a single application of the stress may produce no

appreciable effect on the structure of the metal, the continuous repetition of the stress will eventually rupture it.

A diagrammatic sketch of the general arrangement is shown in Figure 3, and in Figure 4 a photographic view of the rocking-lever switch is shown.

The solenoid coil is deeply immersed in a large oil bath, which is seen on the bench in Figure 5. The purpose of this is to ensure that the coil shall be cooled as effectively as possible. The main difficulty so far experienced from the tremendously heavy currents in the solenoid winding has not been overheating but the mechanical strain on the individual turns due to the mutual attraction between ad-

jacent turns carrying current in the same direction. This was so great that on one occasion a turn was ruptured when the current was flowing, with the consequence that the circuit was opened and a heavy flash developed under the oil. This produced violent pressure in the oil bath, which burst the tank and flooded the laboratory with oil.

The question naturally arises as to the form in which the atomic energy would manifest itself if these experiments achieve their ultimate object.

It is not possible to give a satisfactory answer to this question at present. In order to enable the procedure to be watched as closely as possible, the author has decided to subject a piece of magnetic material (steel) to the test in the first place. The reason for this is that, as the magnetic properties of steel are known to be due to the peculiar arrangement of the electrons in the atoms of the steel, it is reasonable to suppose that if a disturbance of the electronic orbits is obtained by this method, it will at once manifest itself by a change of the magnetic characteristics of the steel. It is a distinctive feature of this investigation that the first or preliminary stage is to detect any incipient breakdown of the atomic structure by the consequent change in the magnetic properties of the substance which is being subjected to the intense magnetic field.

It is quite possible that some very definite and more or less permanent effect on the inherent magnetic qualities of the steel will be one of the results of the

investigation. If this expectation is realized, it may lead to commercial applications of the greatest importance. Moreover, it is confidently anticipated that the results will throw new light on all the intricate problems of magnetic permeability.

The ultimate aim, however, of the undertaking is definitely to break down the atomic structure and to make available for practical purposes the stores of energy which it is believed are now latent in the atom.

The supremely important problem will then arise as to how the released energy could be controlled.

This problem, of course, cannot be settled yet, but it appears to me that, if the use of intense magnetic fields provides the means for releasing the energy, the control of the released energy may also be possible by the use of intense magnetic fields. If this supposition proves to be well-founded the system of control would be likely to become extremely easy to manipulate. Further, it is probable that the energy could in this way be concentrated in the form of a beam or ray and transmitted in any desired direction in a manner similar to that in which a searchlight is operated.

It is then legitimate to forecast that, instead of generating power by the present wasteful method of first generating heat by burning fuel and then converting the heat into steam, the power would be directly available from the stores in the atoms of matter.

A Simple Crystal Receiver with a Zero Coupling and High Selectivity

THE next number of POPULAR RADIO—for June—will tell how to build a crystal receiver that requires no batteries and is remarkable for its clarity, on account of the carborundum detector used in it, and for selectivity through its loose-coupler. Its selectivity is due to the low coupling obtainable between the antenna and secondary circuits. It is also easily adapted to the three-stage amplifier that was described in the March, 1925, issue of this magazine.



Brown Brothers

The MEN WHO

6th Installment

THE FIRST MAN TO SEND PICTURES BY RADIO

EDOUARD BELIN, French scientist, is credited with being the first person to put a system of radio picture transmission to practical use. The system which he invented can be adapted to use on cable and telephone lines as most of these transmission devices can be.



Western Electric

THE INVENTOR OF THE PLATE MODULATOR

AN American inventor, R. A. HEISING, who was engaged for many years in research work in wire telephony, devised a modulation system for radio telephony in 1915 which has since been so completely developed that it is employed in practically all modern broadcasting stations.

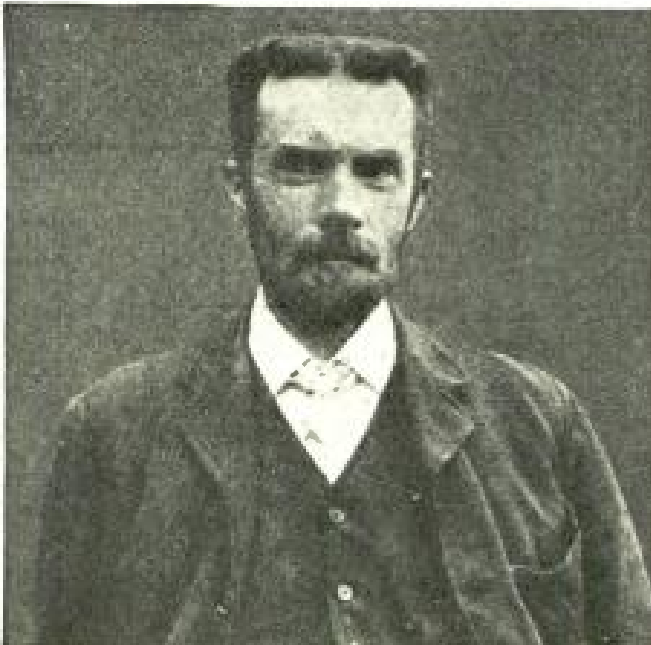

Courtesy of the *Electrician* (London)

THE CREATOR OF THE HEAVISIDE LAYER THEORY

It is perhaps paradoxical that a recluse, OLIVER HEAVISIDE, should be the propounder of a broad visioned hypothesis of the atmosphere above the earth, which is called the Heaviside Layer theory. Heaviside, who died recently, possessed a notable sense of humor and was one of Great Britain's foremost mathematicians. His theory, which explained how radio waves seem to follow the curvature of the earth, was one of a number which he developed on mathematical bases.

MADE RADIO

THE DISCOVERER OF THE CARBORUNDUM DETECTOR

ONE of the first radio crystal detectors that was put to practical use was discovered by GENERAL HENRY H. C. DUNWOODY in 1906. He selected crystals from electrical furnaces in which carborundum is made and tested them to determine their power of rectifying minute radio-frequency currents. Such carborundum crystals are still in use in perfected crystal holders.



Harris & Ewing

A PIONEER IN MULTIPLE RADIO

AFTER years in research to discover means of controlling the transmission of electromagnetic waves, ADOLPH SLABY got his final clue from the work of Marconi in England in 1896. Soon afterwards, in close co-operation with Count von Arco, Dr. Slaby devised and patented a system which was known as syn-tonic multiple spark telegraphy. This invention was intended to make possible the simultaneous transmission of two or more messages between a pair of radio stations. Theoretically the system was limited only by the possible number of wavelengths, each of which can be allotted to a single message.



Courtesy of Telefunken Company

ONE OF THE EARLY RADIO TELEPHONE EXPERIMENTERS

BEFORE 1900 JOHN STONE STONE is reported to have transmitted speech by electromagnetic waves that were propagated by an arc lamp generator. He was one of the early experimenters in telephony without wires and was concerned primarily with problems of interference. He has patented more than one hundred radio inventions in the United States.



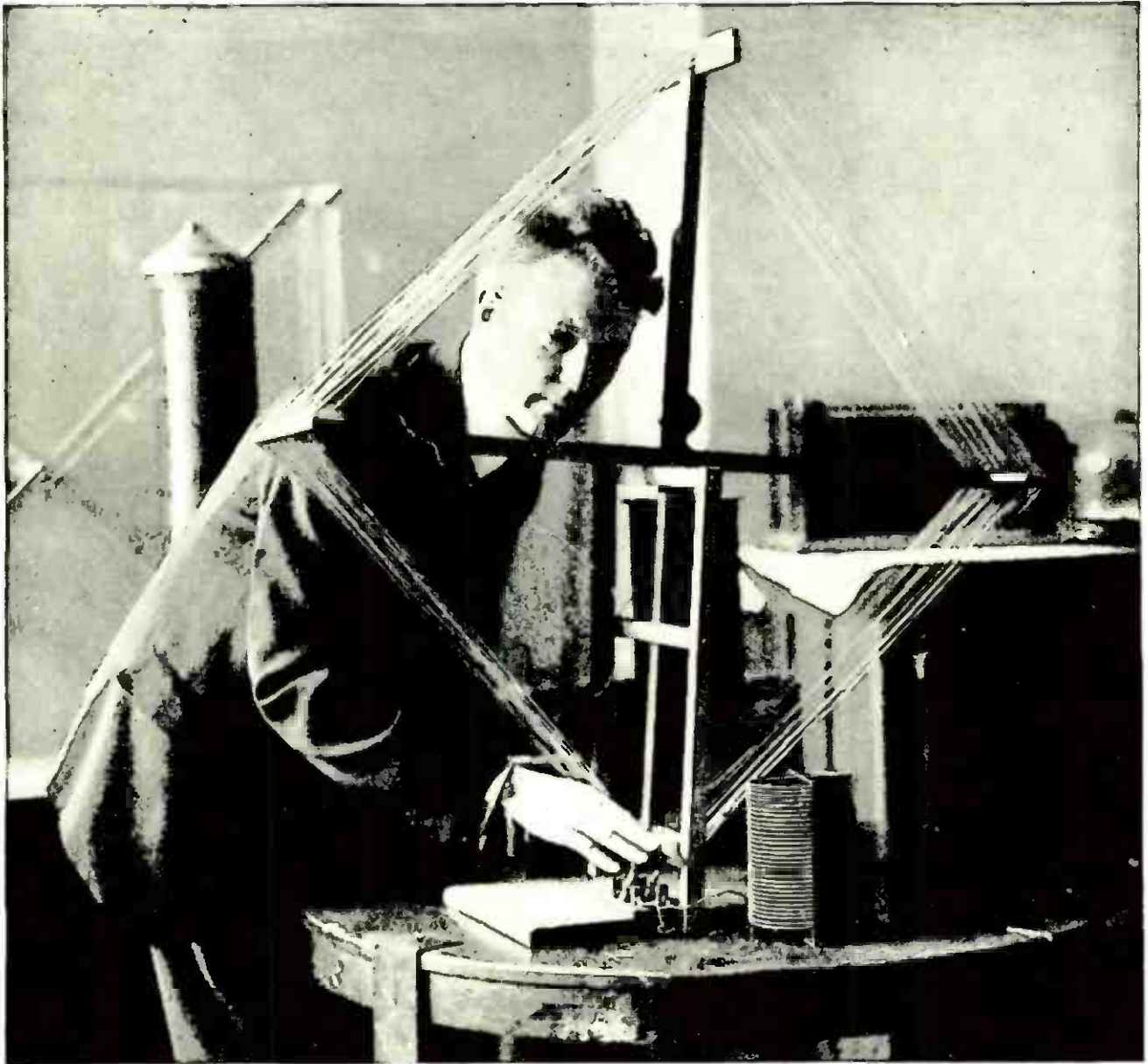

Sport-Commercial

A LOOP ANTENNA OF VERY LOW CAPACITY

This antenna, although built up of a great stretch of wire, is of low electrostatic capacity, largely on account of its shape. In this type of antenna the electromagnetic portion of the radio wave is what acts upon the wires to make them a receiving device.

FACTORS THAT AFFECT ANTENNA CAPACITY

Article No. 13

The importance of electrostatic capacity in an antenna and the considerations of height and length of antennas are explained in this article that is of particular value to those who want to improve their aerial circuits.

By SIR OLIVER LODGE, F.R.S., D.Sc., LL.D.

WHEN you want to make a condenser of great capacity, you naturally make the area big and the thickness small. You therefore take a number of sheets of tinfoil and interleave them with, say, sheets of tissue

paper that have been soaked in molten paraffin.

You then connect the alternate sheets of tinfoil so that half of them may be charged plus and half of them minus; say half of them insulated, half of them earthed.

Now, having a great capacity, you may supply a considerable quantity of electricity to the insulated half without the potential rising much. But, it now becomes necessary to employ a different set of units. The electrostatic unit of quantity that we have been employing hitherto is too small, and the electrostatic unit of potential is too big, for convenience. The electrostatic unit is 300 volts; and we should more commonly be dealing with one or two or a dozen volts. Quantity, again, or charge, would naturally now be supplied by a current, a current of so many amperes or milliamperes, lasting for a given time.

Suppose that, having constructed a condenser, as described above, we pump into it 10 milliamperes every 100 seconds, or, what is the same thing, one ampere for one second, we should have accumulated in it a practical unit of quantity called a "coulomb;" which, electrostatically, is enormous.

If we found that the condenser potential had only risen by one volt, and were sure that it had not leaked, we should know that it must have an immense capacity, a capacity which is called a farad; very much greater than we ever have to deal with in practice.

But if, instead of pumping in an ampere for a second, we supplied another condenser with a microampere for a second, and found that equally to have risen one volt, we should naturally say that its capacity was a microfarad. But if, instead of rising one volt, it had risen 100 volts, we should know that the capacity was 1/100th of a microfarad. For, as always, capacity is measured by the ratio of the quantity supplied, to the rise of potential created.

One coulomb by one volt equals one farad.

But the full treatment of these practical or engineering units does not belong to electrostatics. Electrostatic capacity is most easily expressed as a length. The capacity of every condenser can be expressed as a length; since $\frac{A}{4\pi}$, that is an area divided by a thickness, is necessarily a length.

If we ask what length corresponds to a microfarad, we shall find that the answer is 9 kilometers. That can be remembered, and the explanation sought later.

1 mfd. = 9 kilometers = 9×10^5 centimeters.

Imagine an isolated sphere 18 kilometers or about 12 miles in diameter; its electrostatic capacity is a microfarad.

In radio work the chief area that we have to treat electrostatically is the antenna. If you imagine this as a great horizontal plate, or network of wires so close together that they practically form a plate, of area A , and at height h above the earth (the earth being either sufficiently conducting in itself, or being supplied with a sufficient network of wires buried in the soil to make it conducting), then we can apply the usual formula, and say that the capacity of that antenna is $\frac{A}{4\pi h}$. For instance, suppose the antenna is 500 meters long, 100 meters wide, elevated 10 meters above the earth, its capacity will be $\frac{50,000}{4\pi}$, or, say, about 800 meters.

This is a large capacity, but not a large fraction of a microfarad, about 1/12th of a microfarad. However, it would be a large antenna that would have such a capacity.

An amateur antenna is not likely to be of this shape. It may be only a single isolated wire. Now a wire is a cylindrical conductor; and its geometry is not so simple as that of a sphere. A formula can easily be given for its capacity; but it involves logarithms. (You will find such formulas in my article,



From a photograph made for POPULAR RADIO

TWO ANTENNAS OF WIDELY DIFFERENT CAPACITIES

The higher antenna in this picture may have the lower electrostatic capacity because of its isolation from surrounding buildings, while the lower antenna, which is close to the roof, is likely to be of greater capacity than the one above it.

“Capacity Calculations,” in POPULAR RADIO for February, 1924.)

The thickness of the antenna wires does not very much matter. The material does not matter at all, so far as capacity is concerned. What chiefly matters is the length of the antenna, and also its proximity to neighboring objects, like buildings. Its capacity increases whenever those are near it. In that case, though it is insulated, it is not

isolated. Such capacity has no particular advantage and no particular disadvantage. An antenna is not wanted as a condenser, but as a radiator. The loftier it is, therefore, and the freer from obstruction, the more effective it will be in radiating its waves away into space. An ideal antenna would be an elevated wire of sufficient conducting power, reaching up to a great height, and then expanding into a sort of ca-

capacity area; the higher the effective capacity the better. Expansion at the top is not often feasible, however. Great height is not often feasible either. The antenna at the Eiffel Tower is one of the most ideal in this respect, and accordingly has remarkable radiating-power.

To calculate the capacity of a single isolated wire, of the length l and diameter d , one can work out the arithmetic of the following expression, which is obtained in the same manner as that of the spherical condensers above, only the geometry is less simple:

$$\frac{l}{2 \log_e \frac{2l}{d}},$$

or, what is the same thing,

$$\frac{.217 l}{\log_{10} 2l/d}$$

To indicate how this comes about, we may note briefly that the force from a charged wire of infinite, *i.e.* great, length, does not vary inversely as the square of the distance, but inversely as the distance. Accordingly the potential no longer varies inversely as the distance, but as the logarithm of the dis-

tance. That is how logarithms come in.

When quantity is divided by potential in order to get capacity, they stay in. The gradient of $\log r$ is $\frac{1}{r}$; just as the gradient of $\frac{1}{r}$ is $\frac{1}{r^2}$. The significance of this cryptic remark will become apparent after sufficient study.

On doing the arithmetic of the above expression, in what units will the answer come out?

In the same units as were put in; that is, in whatever units the length was expressed. For the denominator portion is merely a number. We must be sure that the length and diameter are expressed in the same unit; so that the length part cancels; otherwise you cannot take a logarithm. You can only take a logarithm of a number. A tabular logarithm, *i.e.* one given in the ordinary tables, which are to the base ten, must be multiplied by 2.3026, or say 2.3, in order to convert them into natural logarithms, such as occur in nature. For nature knows nothing about the base ten—which in the last resort is dependent upon the accident of our having ten fingers, and on early historical methods of counting. It is in many respects inconvenient, but it is too late to change.



Kadel & Herbert

BLINDNESS IS NO HANDICAP TO THESE FANS

Those who complain of difficulty in building their own sets can learn a lesson from these sightless boys, who are being educated at the Perkins Institute for the Blind near Boston, Mass.

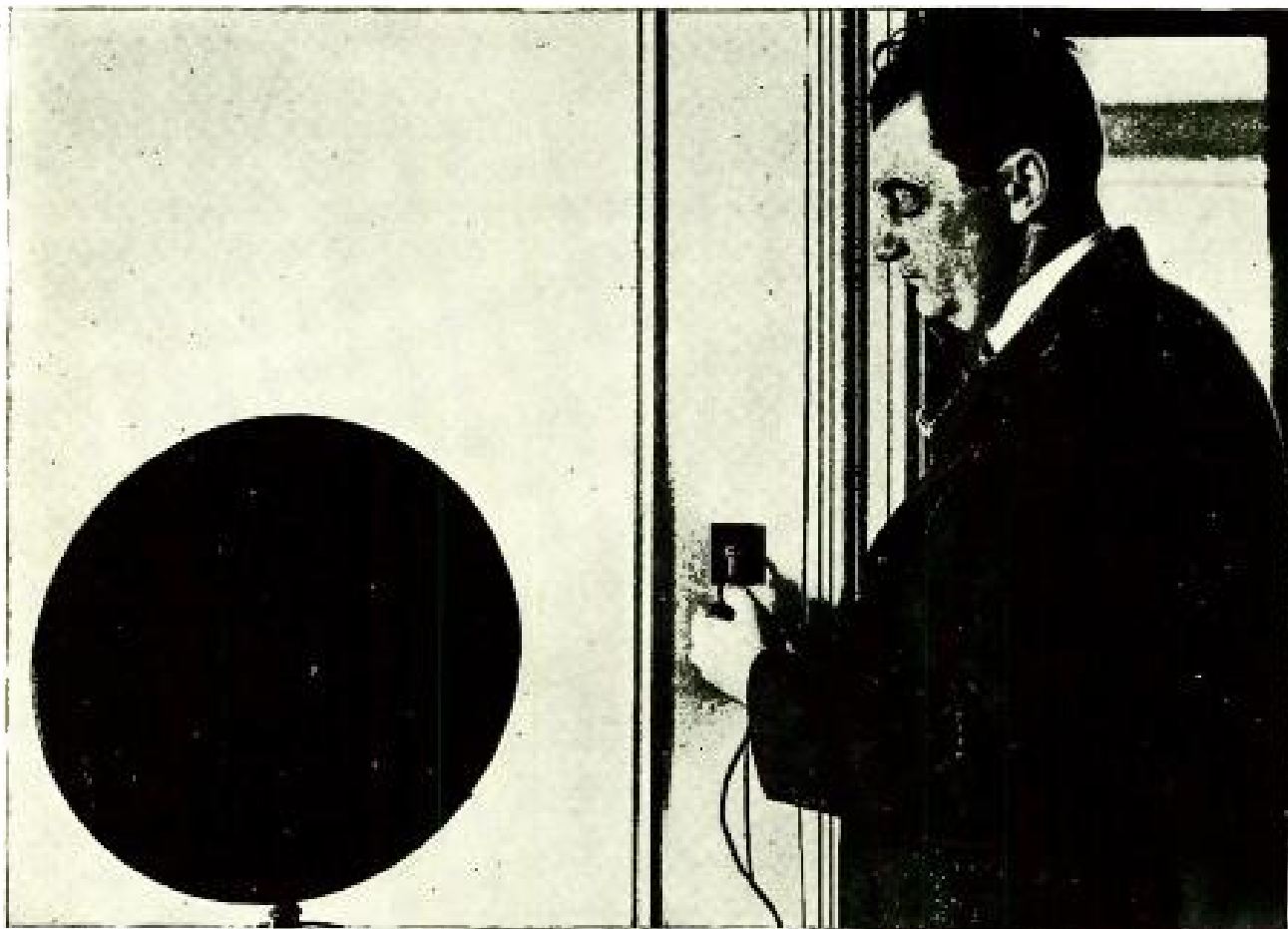

From a photograph made for POPULAR RADIO

THE LOUDSPEAKER IS CONNECTED THE SAME AS TO THE SET
A neat jack socket is attached to the wall as shown above the author's hand in the picture. The wiring is concealed in the wall and runs to the jacks in other rooms and to the receiving set which has been already tuned in at its permanent location.

HOW TO WIRE YOUR HOUSE TO HAVE Radio in Every Room

This system, which does away with moving a receiving set from room to room, is installed in the author's residence. He can get his programs at a particular place in his home by carrying a loudspeaker to a socket on a wall and plugging in. At the same time another member of the family can plug in at a socket elsewhere in the house.

By RAYMOND FRANCIS YATES

RADIO need no longer be an indoor sport that is confined to one room. In fact, some architects of apartment houses in our large cities have realized the limitations on radio in the house, and they have accordingly drafted their plans to make provision for wiring every room in the house with loudspeaker outlets.

We pipe water and electricity all over the house, so why should we not have our

radio programs "piped" around the house in similar fashion? We should—but we have not thought out a way to do it.

Perhaps you have abandoned this idea because you thought it would require a young power house in tubes to realize it. However, the average installation of this nature would require nothing more than a good ordinary three-tube set providing only one loudspeaker or one phone was

plugged in at a time in one of the rooms. If more than one was used, so that Pa and Ma and all the rest of the family could have their music when and where they wanted it, the addition of a couple more "lungs" in the form of a two-stage amplifier would be entirely sufficient to saturate the whole house from cellar to attic with local stations at least.

The task of wiring a house for this radio installation is as simple as the diagram in Figure 1 indicates.

Buy a couple of packages of annunciator wire, a few single-circuit jacks and you are all set.

Examine the house to see just where you can drop your wires between the partitions without meeting obstructing stud-dings and supports. In fact, you may even have to do a little sounding on the walls to make sure that you drop your lines between the 2 by 4's in the right

spots, and a trip around the attic and some experimenting with a weight on a string will help you to do this.

Having made sure where you can make a hole, drill it. Then go upstairs in the attic and drop down a nail on the end of a string. Someone downstairs peeks into the hole until he sees the elusive nail and catches hold of it and the string and then passes them through the wall into the room. Now you attach your wire to the string and pull it through.

After you have brought the wires through, they should be soldered to the jack.

Jacks can be mounted in small bakelite or hard rubber panels provided with a holding screw in each corner. If black does not match the woodwork, perhaps brown will do better. The screws can be round head or flat head, and if flat head, you must remember to countersink the

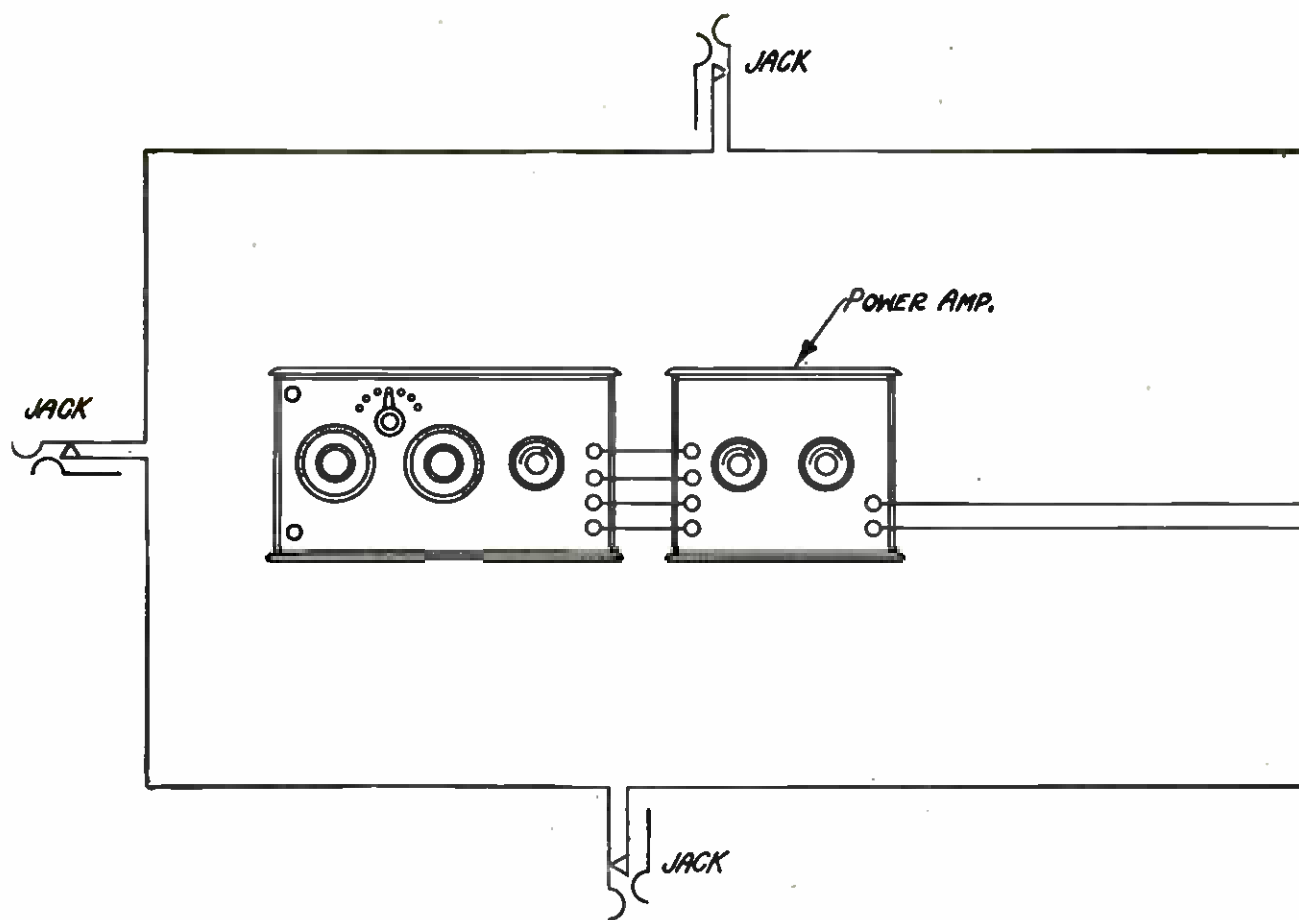

HOW THE CONNECTIONS ARE MADE

FIGURE 1: The cabinet at the right contains a two-stage amplifier that is added to the set to produce good volume in three loudspeakers. The jacks are all connected in series with the set, which means that care must be taken in soldering the connections to the jack so that they will not be open circuited.

NA

holes if you want to have a decent-looking job.

Wood for the jack panels should be well seasoned and dry enough to prevent undue leaking. The safe thing to do is to use a substance of proved insulating value.

Every house presents a different problem, depending upon the way it is built, the layout of the rooms, the location of the radio set and the number of rooms to be supplied with the service. These factors make it difficult to give more specific instructions regarding the complete installation. The installer must therefore use his good judgment.

Another wiring scheme is to use exposed wiring, neatly camouflaged. Only a single wire is necessary—one to the jack and one from it. This single wire can be very easily run along the top of the baseboard that is found around the walls or along the picture molding. For the baseboard, white cotton covered wire can be used and later you may stain or paint it to match the color of the wood on which it is fastened.

Take every precaution to avoid the electric light wires if the radio wires are installed between the partitions. Cross-

ing at close range should be avoided if possible, and where impossible, heavy insulation should be used on the radio wires. The radio wires should not be run parallel with the electric light wires at close range, especially if the house wires carry alternating current. Under such circumstances there would be strong likelihood of an alternating current, low-frequency hum in the loudspeaker or phones. The water pipes and gas pipes are also good things to avoid touching. These may cause partial grounds or inductive effects that will interfere with reception.

A big storage battery with its nauseating gases and biting acid has no more license to remain in the living room than a fly has in the milk. It really belongs down cellar with the coal and the dog. Those who look at Figure 2 will understand that it is not a bad idea to put it down cellar. It can be put on a shelf with the battery charger and wires can be run upstairs to the set. By arranging an ordinary two-pole, single-throw switch so that one blade will be connected in series with the low-potential side of the charger and the battery, and the other blade in series with the lighting circuit and the charger, you can connect or dis-

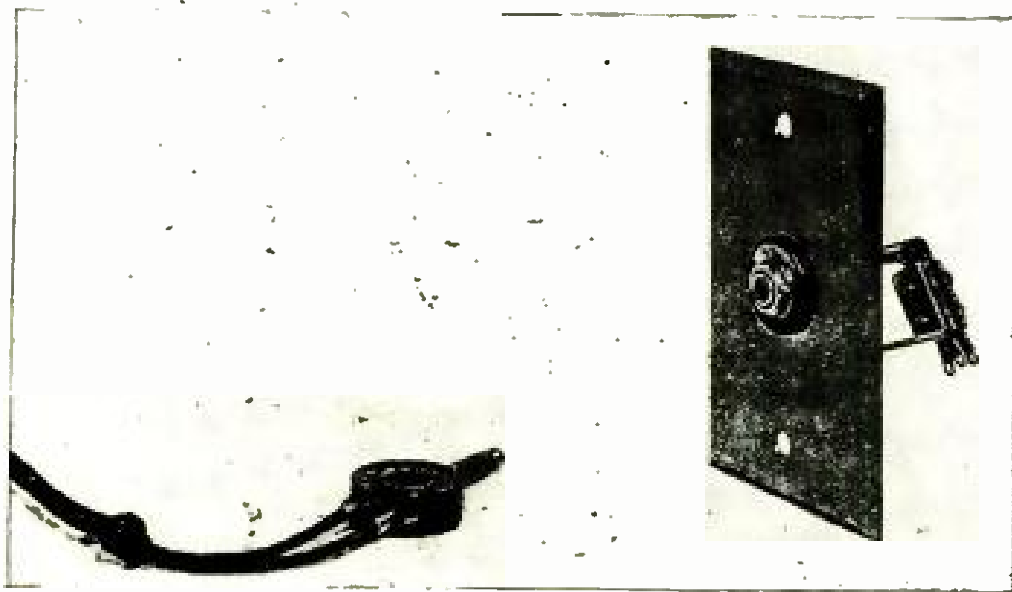

From a photograph made for POPULAR RADIO

THE WALL JACK AND PLUG

A jack that has a panel like the one above can be fastened to a wall without detracting from the appearance of a room. At the right you will note the three lugs to two of which you solder your connections. Do not make wire connections to the jack by trying to screw the metal parts of the jack down upon the wires.

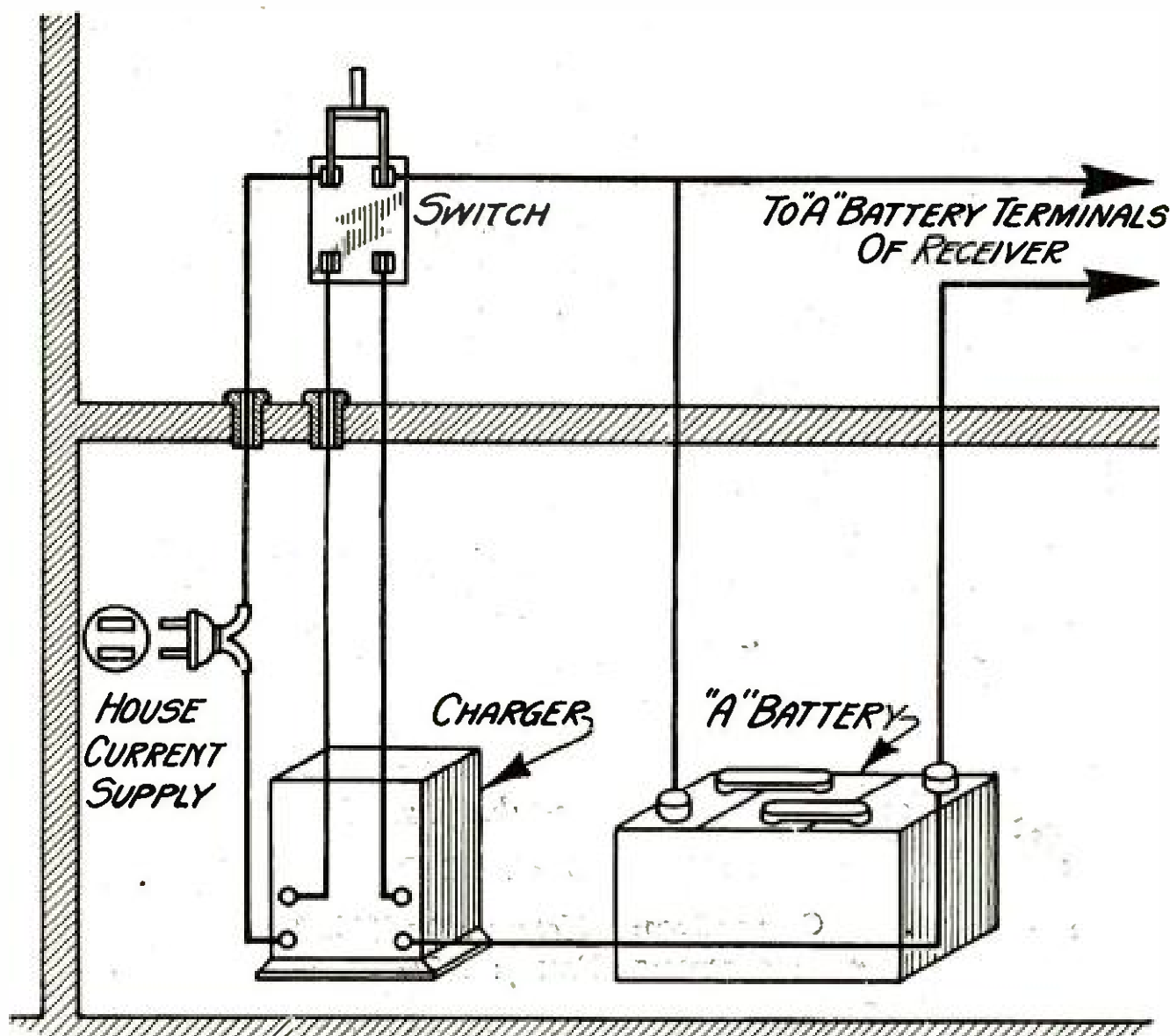

HOW TO INSTALL THE STORAGE BATTERY AND CHARGER IN THE CELLAR

FIGURE 2: Before you connect your battery to the charger in the cellar, turn off the filament switch on the set and cut off the rheostats by twisting them all the way to the left. This precaution will prevent any likelihood of grounding the battery through the wires that run to the receiver. By closing the DPST switch shown in the diagram you connect the high-potential side of the charger to the house current and the low-potential side to the battery which then begins to receive a charge.

connect the battery to the charger by one movement of the switch. In doing this it will be well to remember to disconnect your tubes from the battery just for safety's sake, since a surge in the power line might ruin them.

As an additional precaution it will be a good idea not only to open the filament switch, but to turn your rheostat all the way to the left so that they too are disconnected from your receiver circuit and tubes.

If you have a storage "B" battery you

can connect it to the charger in the same way and put it down cellar with its big brother the "A" battery. Such an arrangement makes not only for neatness and compactness but for efficiency.

This radio home idea is bound to grow because it is practical and offers conveniences that no other system will allow. Why carry a heavy receiving set around the house when it is only necessary to carry a loudspeaker or a pair of phones that are provided with an ordinary jack?

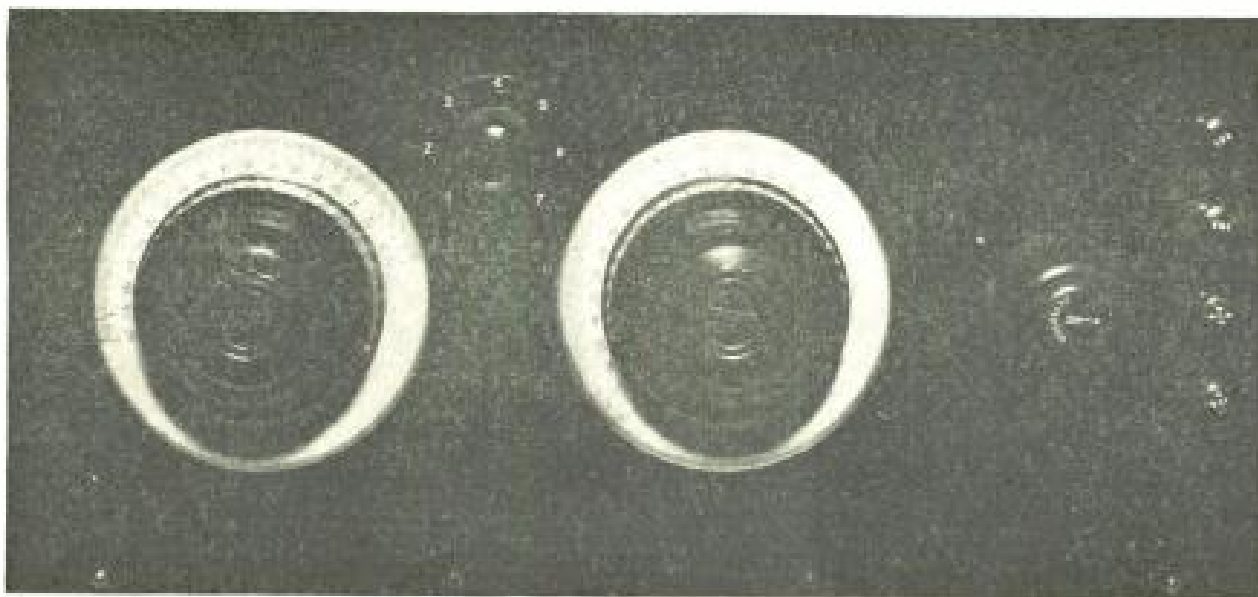

From a photograph made for POPULAR RADIO

THE PANEL ARRANGEMENT OF THE RECEIVER

The headphone and "A" battery connections are shown at the right. The two large dials control the condensers and the small dial varies the wavelength of the antenna circuit.

Simple "How-to-Build" Articles for Beginners No. 8

How to a build a single-tube, four-circuit tuner

By LAURENCE M. COCKADAY

COST OF PARTS: *Not more than \$32.00*

APPROXIMATE RANGE: *1,500 miles*

HERE ARE THE ITEMS YOU WILL NEED—

- | | |
|--|--|
| A, B, C and D—primary, secondary stabilizer and loading coils of the improved Precision "Cockaday" coil; | H—mica, fixed condenser, .0001 mfd.; |
| E—Bremer-Tully variable condenser, .0005 mfd., equipped with improved accuracy dials; | I—Bradleyleak; |
| F—Bremer-Tully variable condenser, .00025 mfd., equipped with improved accuracy dials; | J—Benjamin Cle-Ra-Tone socket; |
| G—mica, fixed condenser, .00025 mfd.; | K—Amsco Dubl-Wundr; |
| | L—Jones inductance switch; |
| | M—composition panel, 7 by 15 inches; |
| | N—baseboard, $9\frac{3}{8}$ by $13\frac{3}{4}$ inches; |
| | O and P—small composition connecting blocks; |
| | Q—small brass brackets. |

THIS receiving unit is a four-circuit tuner especially adapted for use with a UV-200 or C-300 tube.

The first article of this series told how to build a four-circuit tuner for use with a C-299 or UV-199 tube. The present article, however, gives the proper constants for using the larger "soft" variety of tube which will give much better distance and clearer local reception.

The unit that is described herewith was built and carefully tested out in POPULAR RADIO Laboratory and was found to give very satisfactory results. The construction of the unit is extremely easy and its operation is very simple.

Take this magazine to a dealer and ask him to give you the parts that are included in the list in the introduction to this article. Then take the parts home and drill the panel as shown in Figure 2.

which gives the correct spacing for all the holes that are used to mount the instruments.

Then, mount the instruments in their correct positions on the panel and on the baseboard as shown in Figure 1 and in the two pictures of the set. Next, wire up the instruments as indicated in the picture diagram, Figure 1.

If you follow the instructions shown there, you cannot make a mistake; all the connections are clearly indicated and the instruments are marked with the same designating letters that appear in the text and in the list of parts.

When you have finished wiring up, all you have to do is to connect the "A" and "B" batteries and the aerial and ground connections—then you are ready to tune in.

Set the receiver on a table and make the connections as follows:

Connect the aerial to binding post No. 1;

Connect the ground to binding post No. 2;

Connect the negative "B" battery to binding post No. 3;

Connect the "B" battery positive to binding post No. 4;

Connect the "A" battery negative to binding post No. 8;

Connect the "A" battery positive to binding post No. 7.

Finally connect the telephone cords to binding posts Nos. 5 and 6; this completes the connections and you are ready to listen in.

Turn up the filament of the vacuum-tube by rotating the small knob on the

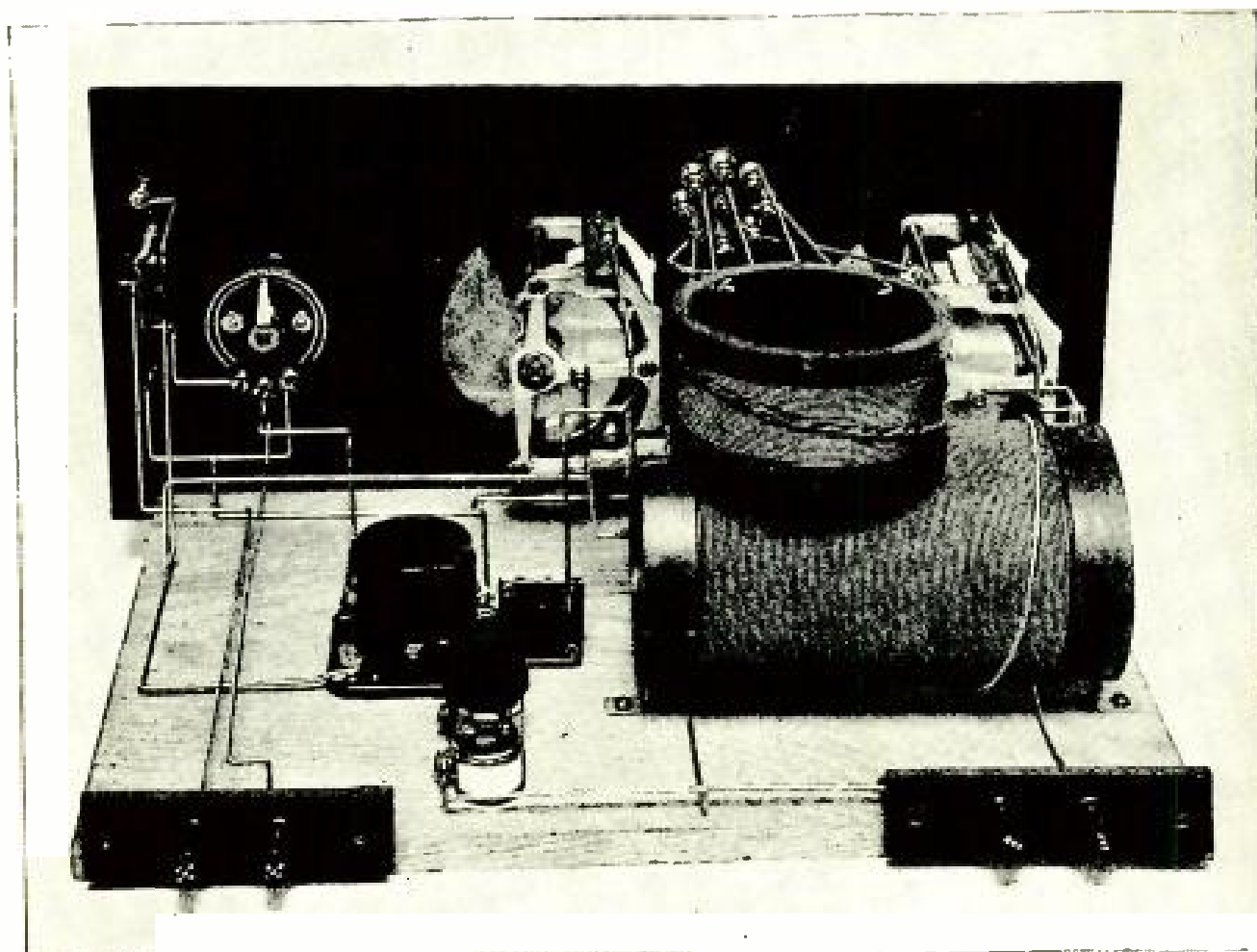

From a photograph made for POPULAR RADIO

THE REAR VIEW OF THE RECEIVER

Study this view in connection with the picture diagram of the hook-up on page 432. The location and connecting points of each wire appear clearly and you can determine just how to bend the wires to get the shortest connection with the proper clearance.

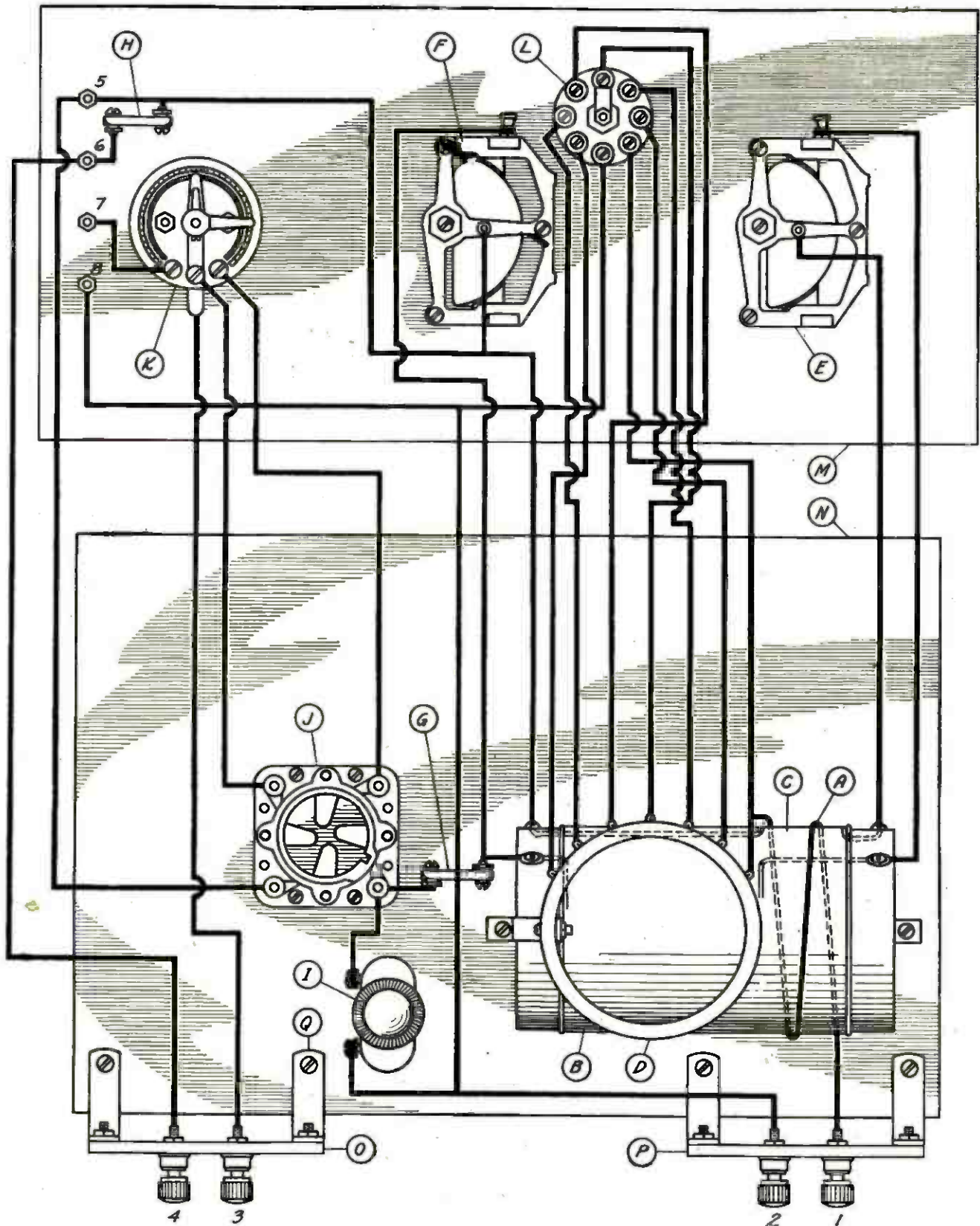

THE "PICTURE DIAGRAM" OF THE HOOK-UP

FIGURE 1: This illustration shows the exact manner in which the instruments are placed on the panel and baseboard and how the wires run in relation to them. The upper rectangle shows the back of the panel, and the lower one shows the baseboard. All the parts are lettered to correspond with the designations in the text and in the list of parts.

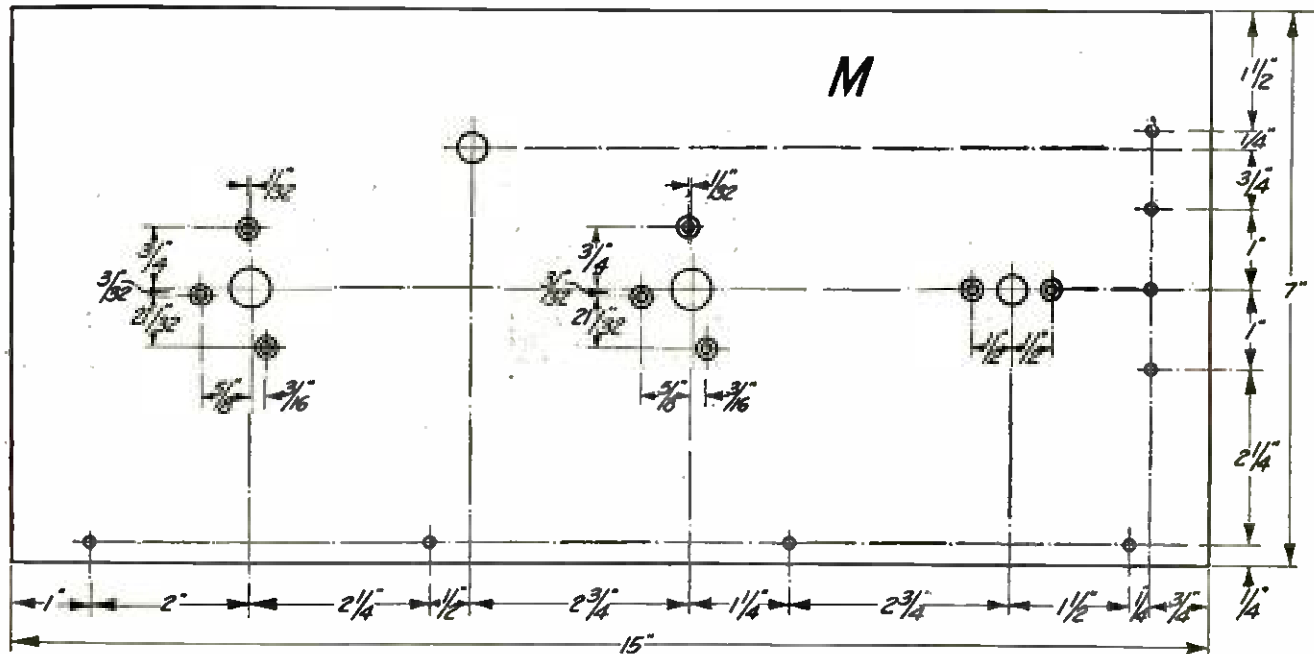

THE DRILLING PLAN FOR THE PANEL

FIGURE 2: This drawing shows where to drill the holes for mounting the instruments. The correct spacings are given for the holes. The holes outlined with a double circle should be countersunk. Always start drilling holes in the panel with a small drill—one-sixteenth is a desirable size. Never attempt the drilling without using a sheet of paper with the holes properly marked on it and then pasted on the panel.

potentiometer-rheostat K until the filament is lighted to the correct brilliancy. Then, rotate the two condensers E and F simultaneously by keeping the settings of each condenser the same throughout the tuning process until you pick up the sought-for signals.

Then, rotate the knob of the inductance switch L until the signals come in loudest.

Next, adjust the grid-leak I until you obtain the best tone and clarity. Make the final adjustment of this instrument while listening to a distant station.

The proper voltage for the "B" battery will be found to be either $16\frac{1}{2}$ or 18 volts. The proper "A" battery voltage will be obtained from a six-volt storage battery.

The correct type of antenna to use is a single or double wire antenna with a horizontal section of between 100 and 150 feet in length.

If the set is built correctly, the operator, when he becomes familiar with the tuning characteristics of the receiver, will find that he gets exceptional volume and clarity with the utmost selectivity.

An Amplifier for the New Single-tube, Four-circuit Tuner

FOR those builders who may want to add amplification to the set that is described in the foregoing, the three-stage amplifier that was described in the March issue of POPULAR RADIO is recommended. The proper way to connect this amplifier to the four-circuit receiver is explained in the "TROUBLE SHOOTING" Department in this issue.

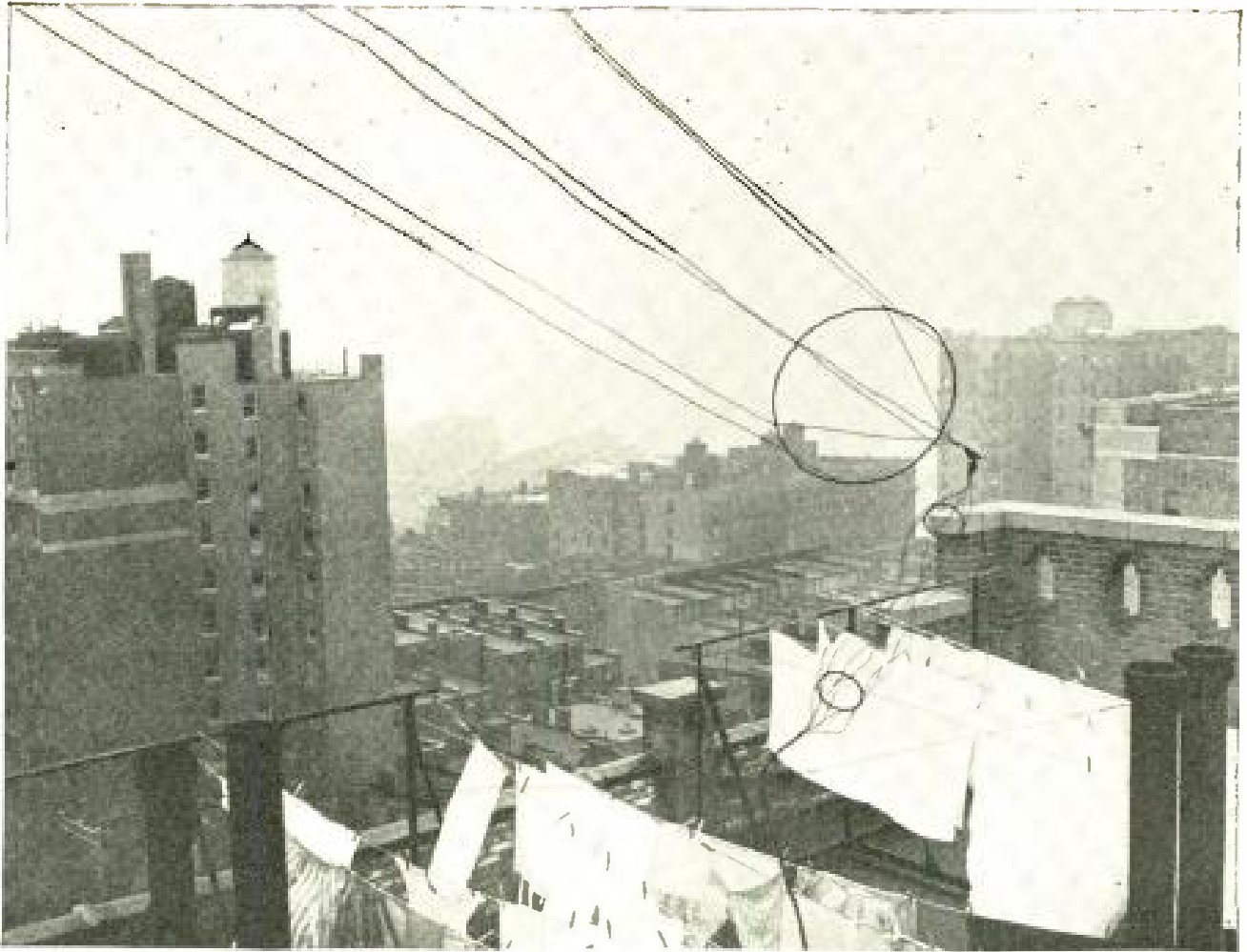

From a photograph made for POPULAR RADIO

THE BEST OF ANTENNAS GET WEAK JOINTS

This well-erected antenna may be the seat of all receiver trouble through some flaw in its numerous connections. It is a simple matter to lower the wires and inspect them regularly for trouble.

POINTS ON JOINTS

Often loudspeaker "sizzles" arise in defective joints in the antenna and ground circuits. This article tells how to keep them in condition and explains the proper method of making and testing joints

By FRANK A. RUMBALL

A RADIO set itself and its individual parts are often blamed for trouble that is really due to the ground conductor, the antenna or to poor connections somewhere between them and the set. In their haste to begin, many radio constructors regard the antenna system (which consists of the aerial and the ground conductor) as of little importance because it is out-of-doors and out of sight.

Besides being heedless of these outside

wires, they hurry with the connections. One result of this is that they get weak signals and are bothered with disagreeable and distracting noises that interfere with reception and proper tuning. Too often they attribute these troubles to the set itself, whereas the set really would work satisfactorily if given a fair chance.

A poor contact somewhere in the wiring will weaken the signals and a loose connection will often cause crackling in

the receivers. In splicing wires, therefore, you should first rub them clean and bright with emery cloth or sandpaper. Then the splicing should be done. Take care that the wires are held tightly together so that they do not rub or slip. It is always best to solder the joint so that no corrosion will occur and become a partial insulator.

Corrosion often occurs when clamps are used to connect the ground wire to a water pipe where rust is likely to form under the clamp. This possibility can be greatly lessened or entirely eliminated by careful installation.

If your set is grounded to a water pipe make sure to sandpaper the pipe as well as the wire.

When you drive a pipe or rod into the earth for a ground connection, be sure that it is not too short. It should be not less than four or five feet long, and preferably six or seven feet. In any case it must be long enough so that the lower end is in damp earth at all times. For long-distance reception several rods driven close together and connected with wires may be used. A network of buried wires, or even a large sheet of copper or zinc is efficient.

A high antenna is as conducive to good results as is a good ground. It should be, if possible, from 40 to 60 feet high, and as long as possible up to 200 feet. For a long antenna a single wire is sufficient, but when length is unobtainable on account of lack of space, two to four wires may be used with advantage.

If your receiver develops some trouble that you cannot immediately detect, examine not only the set itself, but every connection in the whole antenna and ground system. See that the ground con-

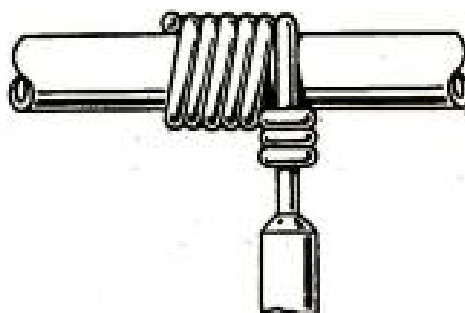
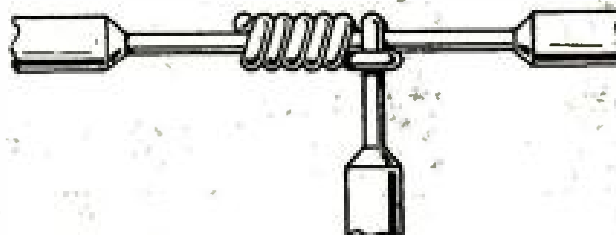

HOW TO MAKE JOINTS PROPERLY

The upper drawing shows how two conductors are twisted around each other with a pair of flat-nosed pliers. The middle picture shows a good way to attach a lead-in that locks around the antenna wire by the looping of the wire at the right. The lower diagram demonstrates an excellent way to make a ground contact that is extra tight because of the three locking loops on the wire that leads down.

ductor is in moist ground, or, if a pipe is used, see that it is clean and makes perfect contact with the ground wire. It may even be advisable to undo any doubtful joints and to resplice them.

Be sure that the antenna is properly insulated. Nothing should be neglected in "trouble-shooting" or when you look for a source of trouble.

Chalk Talks in Radio

TURN to page 468 of this number and read the first of a series of short, practical, informative articles that are written for the radio novice. The subject of Chalk Talk No. 1 is "Ohm's Law in a Nutshell."



New York Edison Co.

THE APPARATUS THAT "HEARS" ATMOSPHERIC DISTURBANCES

This picture shows the "storm detector" installed in the operating room of a power plant in New York. The switches above the cabinet connect with the antenna and, when the set is not in operation, with the ground.

THROUGH the use of a simple radio apparatus, a large electric light and power company is making storms announce their own approach. This applies particularly to electric storms although atmospheric disturbances accompanied by heavy winds will affect this same apparatus.

Formerly the New York Edison Company in New York employed a lookout man to observe the arrival of storms. He lost that job when the storm de-

How radio is being used
to foretell the coming of

STORMS

By MARSHALL D. BEUICK

tor was introduced recently, and he is engaged in other duties. Any other power company that is confronted with the problem of preparing for the arrival of storms at any season of the year when the station load rises suddenly as a result of thousands of consumers throwing on their electric lights at one time, may employ the storm detector to solve their problem. The apparatus is not costly, and its operation is automatic.

The old coherer, which all radio amateurs of fifteen years apprenticeship will recall, is the principle instrument in the storm detector system used in New York. This old type of detector, used successfully by Marconi in his first transatlantic radio-telegraph tests, has survived because it is still necessary where automatic announcing of the reception of signals is a requirement. There is no tuning element in the storm detector hook-up and all that is needed is a relay, two dry battery current sources, an ordinary electric bell, a switch, a fixed condenser, a spark gap, an antenna and a coherer, the construction of which will be described in the following.

At the Waterside plant of the New York Edison Company the static discharges in the atmosphere created by electric storms in the neighborhood or by other storms that charge the air and clouds are picked up by the antenna on the roof. These rush down the lead-in, jump the gap G (shown in Figure 1), charge the coherer D, which becomes conductive and closes the circuit that then magnetizes the coils of the relay.

The relay R then closes the bell circuit, whereupon the bell rings. The clapper of the bell strikes the coherer tube which is jarred so that it becomes of high resistance or is restored ready for the reception of the next static charge. This process is repeated each time a burst of static comes down from the antenna, and thus the approaching storm announces its arrival as much as a half hour before it descends upon a locality to shroud it in darkness. Meantime, the firemen have time to stoke up their fires and the engineers to throw in more generators to be prepared for an additional lighting load. When the storm is upon the city, the bell rings almost continuously.

Radio-telephone and radio-telegraph signals cannot operate the storm detector because they are too feeble to jump the gap shown in the hook-up diagram. Also extremely weak static charges cannot pass. But, as these are not indicative of a threatening storm, there is no need of catching them through the coherer.

The coherer (the combination of the coherer tube and the decoherer which is the bell-clapper) is made with a small hollow tube of glass (about one-quarter of an inch in diameter) containing metal

filings. Iron filings can be used, although nickel is preferable. The filings are held in the tube by two plugs that also act as contacts as shown in the drawing. Ordinarily, these filings are non-conductive because they are too loosely packed in the tube to allow a battery current to pass. But an electrostatic charge will agitate these filings and make them cling together end to end or cohere, much the same way as a magnet will make a small pile of pins cluster together. The filings are then in a condition to allow a current to pass. But, since this passage of current rings the bell, the filings are knocked apart by the bell-clapper and the bell stops ringing. The ringing cannot take place again until the filings cohere through the agency of another charge from the antenna.

In making a coherer, be sure that the plugs fit the tube snugly. Also make certain that you have a bright metal face to press against the filings in the tube; otherwise the plugs will not make contact through the filings when they cohere. The position of the plugs can be determined by experiment. Push the plugs in firmly, but not so hard that

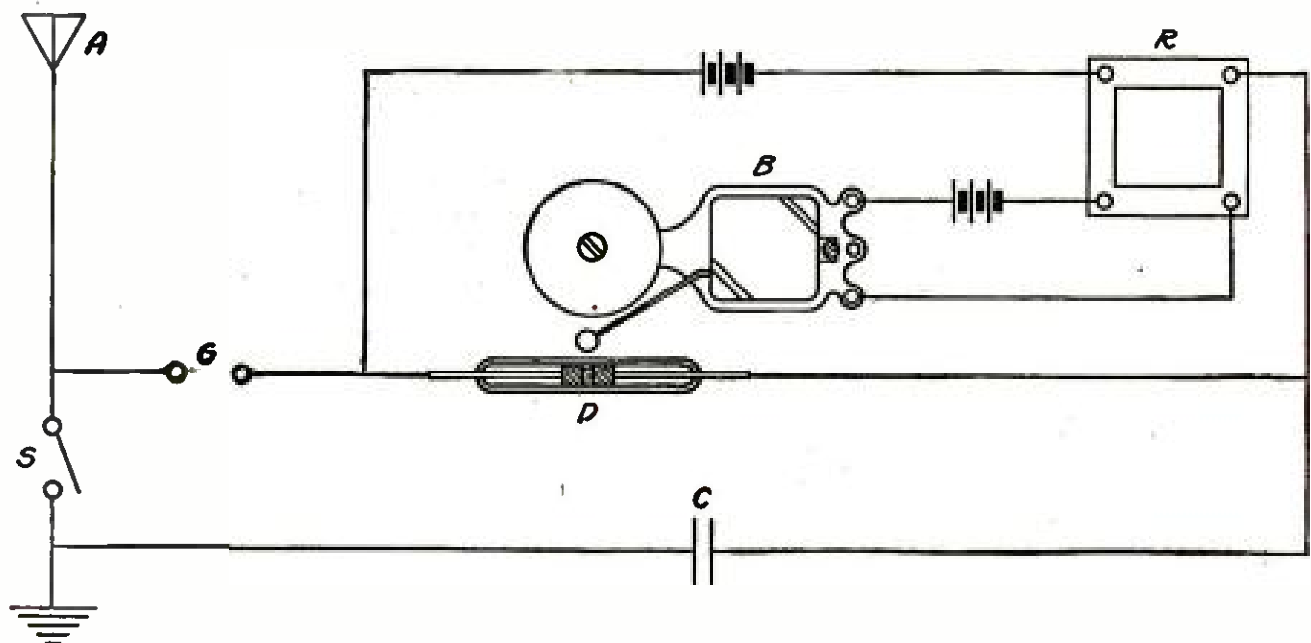

HOW THE STORM DETECTOR IS WIRED

FIGURE 1: This hook-up includes the coherer D, the relay R and the special gap G which is closer in actual construction than the diagram indicates.

they ring the bell. The clapper must tap the tube only lightly when the bell rings.

The condenser C is connected in the circuit to prevent the grounding of the relay circuit, and yet allow for the passage to the ground of radio-frequency currents that actuate the coherer.

The switch S is used to ground the antenna when a storm has arrived and there is no longer a necessity for receiving signals. Besides this protects the apparatus from any likelihood of damage from lightning.

At the Waterside station a distant storm will announce itself by operating the signal bell, which is the decoherer, at intervals of about ten minutes. As the storm nears the city, the signal interval increases. The station operators can then approximate from their experience with the apparatus, about when they may expect the storm to hit the city. Sometimes the signals are erratic, and by observing this behavior in the bell sig-

nals, the operators can ascertain whether or not the storm is going to skirt the metropolitan area and perhaps pass out to sea without darkening the city.

The gap G shown in Figure 1 can be made from two brass balls separated by the thickness of a sheet of paper. This should be inspected from time to time to clear out any dust, and perhaps once a year the nickel filings should be changed. Oxidation will take place at a slow rate on the nickel reducing its conductivity so that the coherer will not operate properly. There is nothing to bother with outside these things except occasionally to replace the batteries when they become polarized. If you use iron filings in the coherer tube, they must be changed more frequently, particularly in damp climates.

The storm detector can be built by any electrical mechanic, and housed in a glass wall-cabinet as shown in the picture. A dustproof cabinet with a glass door is desirable.



NEA

A BROADCASTING STATION IN A HIGH SCHOOL

A unique scheme for combining instruction with pleasure has been put into effect in Dayton, Ohio, where two of the high schools own and operate transmitting stations. The lower grades are equipped with receiving sets and can listen in on special programs arranged by the pupils in the higher grades. Plans are afoot to use radio in connection with regular instruction.



From a photograph made for POPULAR RADIO

THE RECEIVER SET UP FOR RECEPTION

The loop antenna fits into the top of the receiver and connects with the set as it is slipped into place. It can be rotated, of course, in order that the antenna wires cut the electrostatic plane of the incoming waves at the proper angle for reception.

HOW TO GET THE MOST OUT OF YOUR READY-MADE RECEIVER

No. 5: THE DE FOREST REFLEX

This series of articles explains the theory, operation, equipment and care of standard receiving sets

This series does not indorse the product of any manufacturer or make comparisons between receivers. The sets already described include: No. 1, the Eagle Neutrodyne; No. 2, the Radiola Superheterodyne; No. 3, the Melco Supreme Receiver; No. 4, the Crosley Trirdyn.

By S. GORDON TAYLOR

IN this receiver the radio-frequency amplification consists of both the tuned and the untuned types.

Untuned radio frequency amplification

has the advantage that a good degree of amplification is obtained without adding operating controls to the receiver.

On the other hand, the selectivity of this

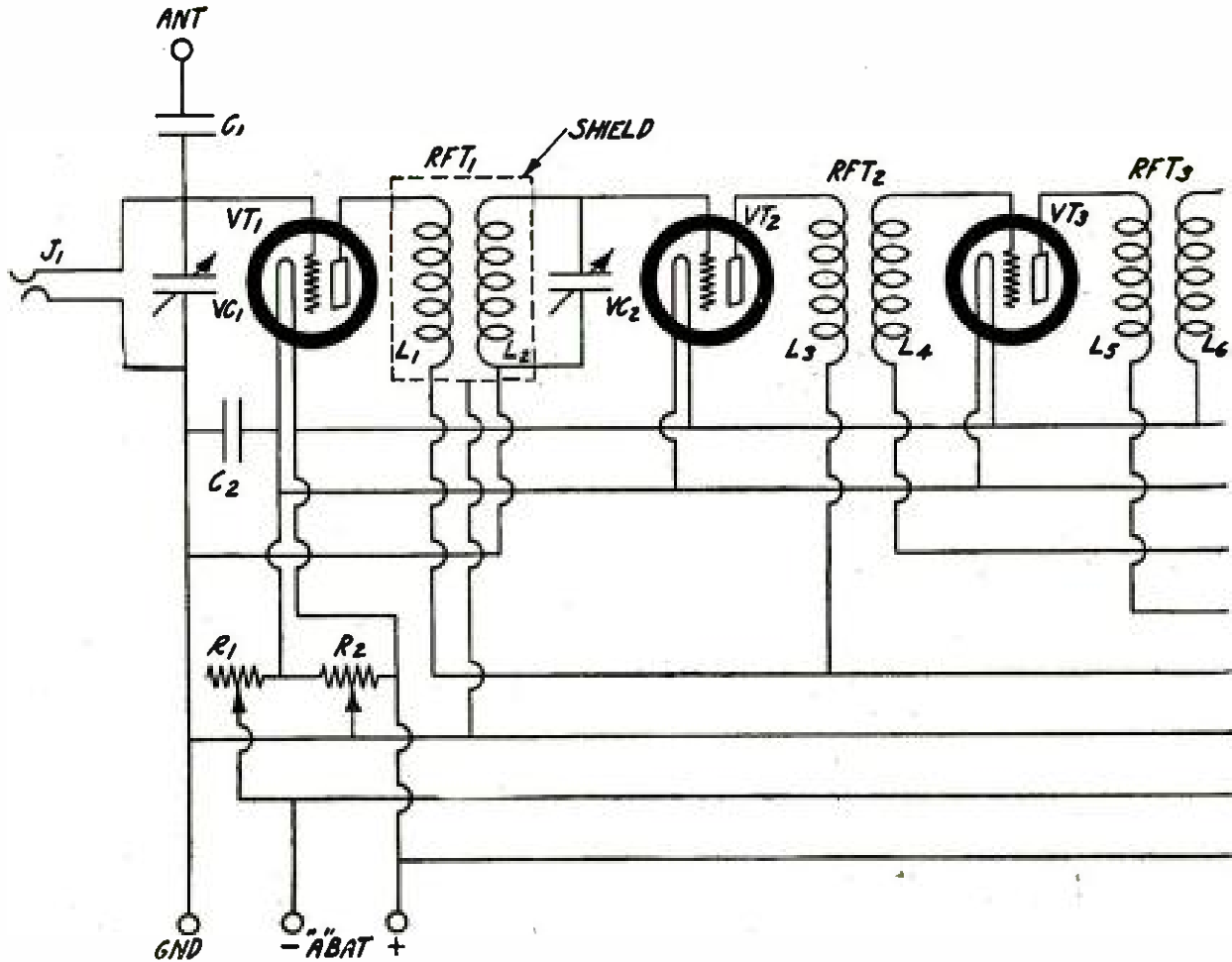

WIRING DIAGRAM OF THE DE FOREST REFLEX RECEIVER

FIGURE 1: All the designating letters in this hook-up are referred to and explained in the text.

type of amplification is lower than that of the tuned type for the simple reason that the untuned transformers are designed to cover the entire range of broadcast wavelengths, therefore they cannot amplify one particular wavelength to the exclusion of other wavelengths. In other words, the amplifier will amplify signals of any wavelength from approximately 225 to 550 meters, and amplify them all at the same time, although not all in quite the same degree. It therefore becomes necessary to segregate the desired signals before they reach the untuned amplifier. This is one of the purposes that is served by the tuned-radio-frequency amplification as used in the De Forest receiver before the stage of the untuned type.

Ordinarily not more than two stages of radio-frequency amplification are used in the standard manufactured receivers.

However, this amount is hardly sufficient to provide suitable results unless an outdoor antenna, or at least a fairly long indoor antenna, is used. Moreover, difficulty is encountered in using a loop antenna with two stages of ordinary tuned-radio-frequency amplification because of the interaction between the magnetic fields of the loop and the coils of the radio-frequency stages.

In the De Forest receiver, however, this has been made possible, and the added untuned stage provides the required additional amplification for loop operation.

The use of a loop antenna eliminates the necessity for both an outdoor antenna and a ground connection; and, where provision is made for the batteries within the receiver cabinet, all wiring is concealed and the receiver is thus a compact unit. This is true of the De

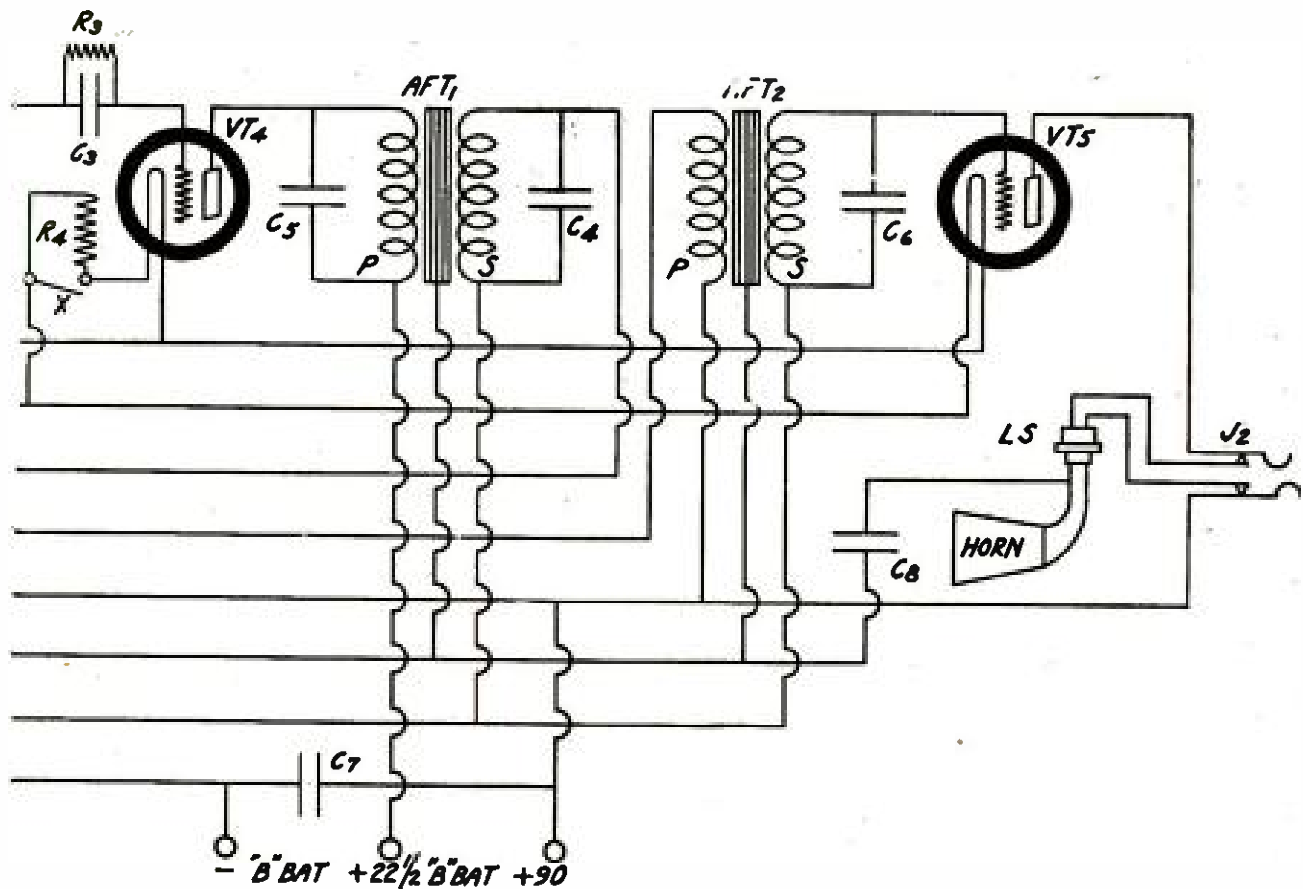

Forest receiver. Even the loudspeaker is concealed inside the cabinet and the absence of any outside connections permits the receiver to be moved about at will from room to room.

The theory of the operation of the De Forest receiver can best be followed step by step by referring to the schematic wiring diagram shown in Figure 1.

The incoming signal from a broadcasting station is intercepted by the loop. The amount of energy thus picked up is necessarily small as compared with that intercepted by an outdoor antenna, but it is sufficient to provide good reception where suitable radio-frequency amplification is provided which is the case with this receiver.

The variable condenser VC1 tunes the loop to resonance with the incoming signal. The tuning action is accomplished by turning the dial attached to this condenser, by which means the capacity of the condenser is altered and the variations of capacity result in variations of

the frequency or wavelength of the loop circuit.

From the loop circuit, which is also the grid circuit of VT1, the energy is impressed on the grid of VT1 (the grid is the zig-zag line shown in the circle that represents the vacuum tube). Another common name for this circuit is the "input" circuit of the vacuum tube. The energy to be amplified by the tube is impressed on this circuit and the amplified energy is taken out from the plate, or "output" circuit. The plate is the rectangular figure shown in the vacuum tube. Thus we see that the first stage of amplification is tuned by VC1.

Coil L1 is placed in the output circuit of VT1 and through this coil the amplified signal energy flows. By the process of electromagnetic induction, this energy is transferred to coil L2, which is in the input circuit of VT2. Here tuning is again made possible by means of VC2 which tunes this circuit to resonance with the incoming signal in the same

way that the input circuit of VT1 is tuned. The signal, which is then further amplified by VT2 is next transferred by induction from L3 in the output circuit of VT2, to L4 in the input circuit of VT3. VT3 and its circuits represent the untuned stage. Its output is transferred to the input or grid circuit of VT4 by means of coils L5 and L6.

The vacuum tube has no power in itself to amplify energy. What the tube really does is to act as a sort of throttle or trigger which permits, through the governing action of the grid, comparatively large impulses of energy to flow from the plate battery. The resulting output energy from this battery is in the form of a fluctuating or pulsating current. Its fluctuations correspond to the frequency of the energy that is intercepted by the antenna and impressed on

the grids of the amplifier tubes. In effect this fluctuating current may be considered as an alternating current.

High frequency currents have no effect on headphones or loudspeakers. Before the signals can be heard in these instruments, therefore, it is necessary that some sort of rectifying action take place to transform the alternating current into a direct current such as would be obtained if one half of each alternation were successfully choked out, leaving a pulsating direct current. These pulsations correspond exactly with the frequency variations of the voice or music which is being received.

It is the purpose of the detector tube VT4, to perform this so called "rectifying" action. The condenser C3 and the resistance (grid-leak) R3 assist in this action.

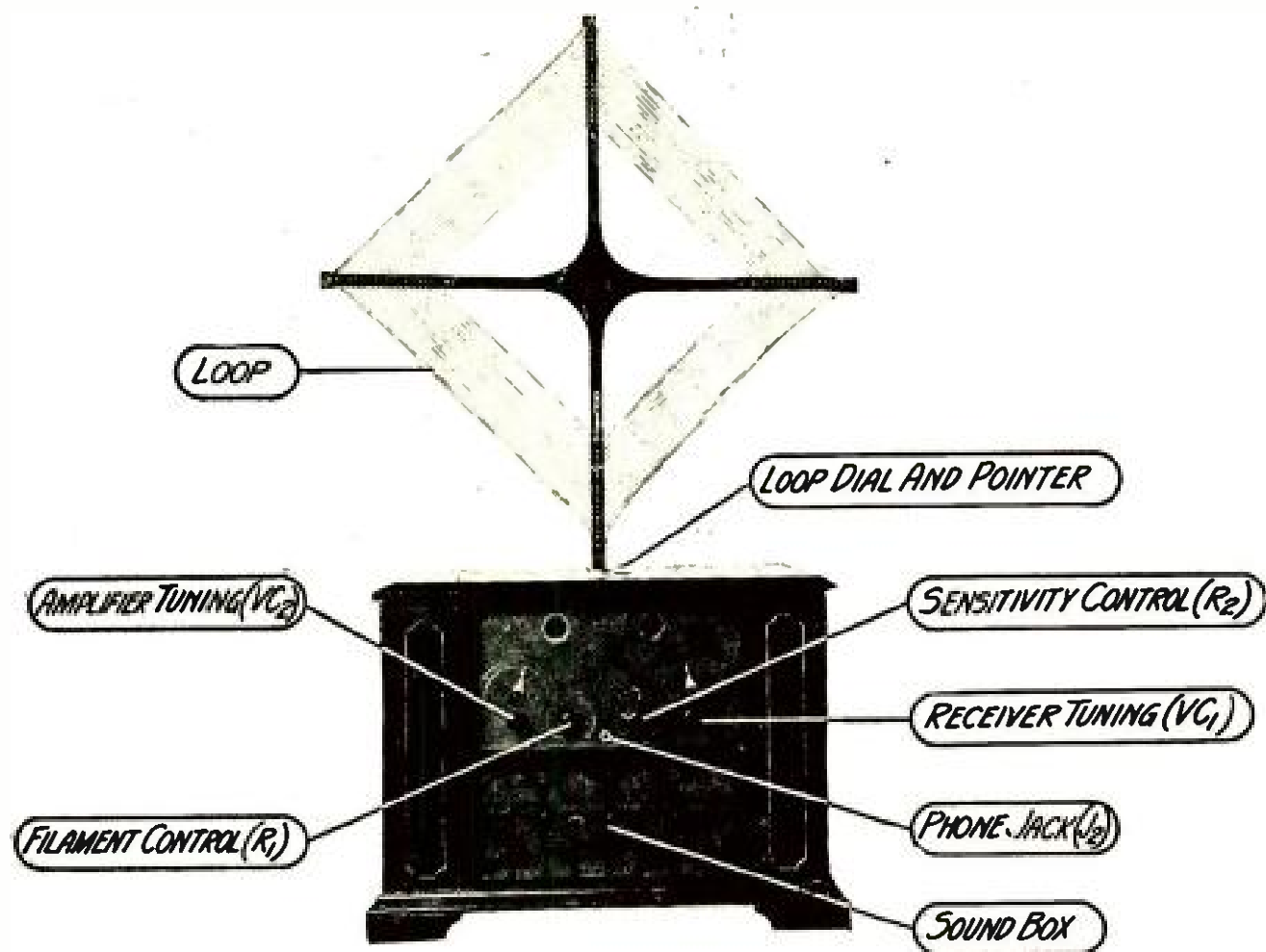

THE PANEL VIEW OF THE RECEIVER

FIGURE 2: The three principal controls are the amplifier tuning knob, the sensitivity control and the receiver tuning knob. The loop antenna, of course, enters into the tuning process. The filament control is varied little after it is once set.

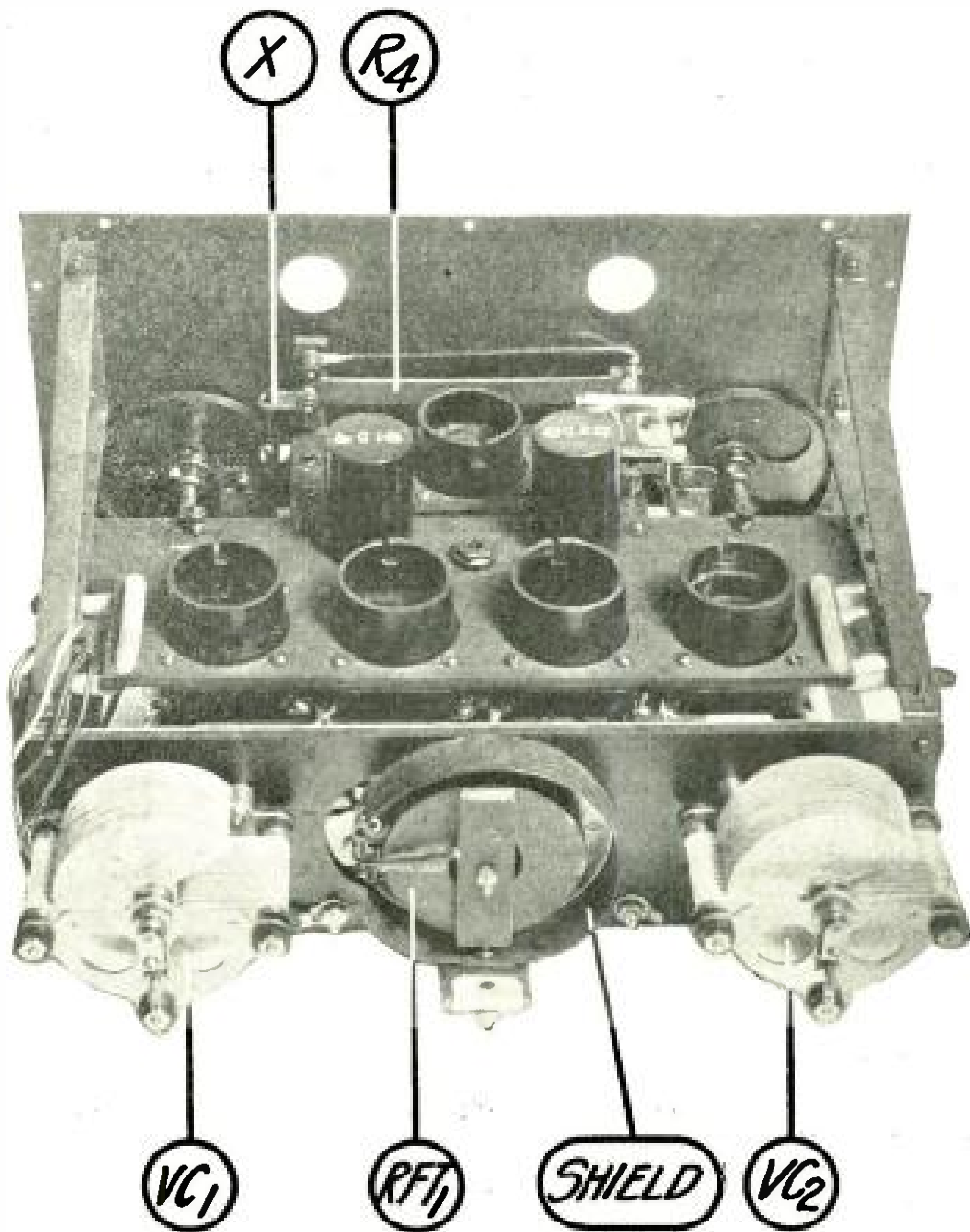

THE REAR VIEW OF THE SET WHEN REMOVED FROM THE CABINET

FIGURE 3: This view shows the principal parts and indicates how accessible the removal elements are. The tubes have been purposely left out of the sockets to permit more of the receiver to be seen.

Up to this point the weak intercepted energy has been thrice amplified and has been changed into a form which lends itself to the operation of the headphones. The detector output is at audio frequencies, but is nothing but an electrical current. It is the function of the headphones to transform this electrical energy into sound energy, thus making it audible to the human ear.

The amplification preceding the detector has been provided for the purpose of increasing or building up the weak

signals from distant stations and also, to a certain extent, the greater energy from local stations. Its purpose is to increase sensitivity rather than volume. Therefore the output of the detector, VT4, would still not be sufficient for satisfactory operation of a loudspeaker. Two stages of audio-frequency amplification are provided, the sole purpose of which is to build up the audio-frequency energy or, in other words, to produce great enough volume to satisfactorily operate a loudspeaker.

It will be noted that while five amplifier stages have been mentioned and also a detector tube, the receiver includes only five tubes. This discrepancy is accounted for by the fact that one of the amplifier tubes, VT3, is used as both a radio-frequency and an audio-frequency amplifier. This is made possible by the so called "reflex" principle which permits a tube to amplify two different frequencies at the same time—one radio frequency and one audio frequency.

This simply means that the received signal, after passing the detector, flows through the primary of the audio-fre-

quency transformer AFT1, is transferred to the secondary of this transformer by induction, and is then applied for the second time to the grid circuit of VT3. In the plate circuit of VT3 there are two coils, L5 and the primary of AFT2. Now the radio-frequency currents that result from the first passage of the signal current through VT3 acted on coil L5 but had no effect on the other coil, due to differences in construction and characteristics of the two coils. When the signal current (at audio frequencies this time) passes through VT3 for the second time the action is the reverse. It acts

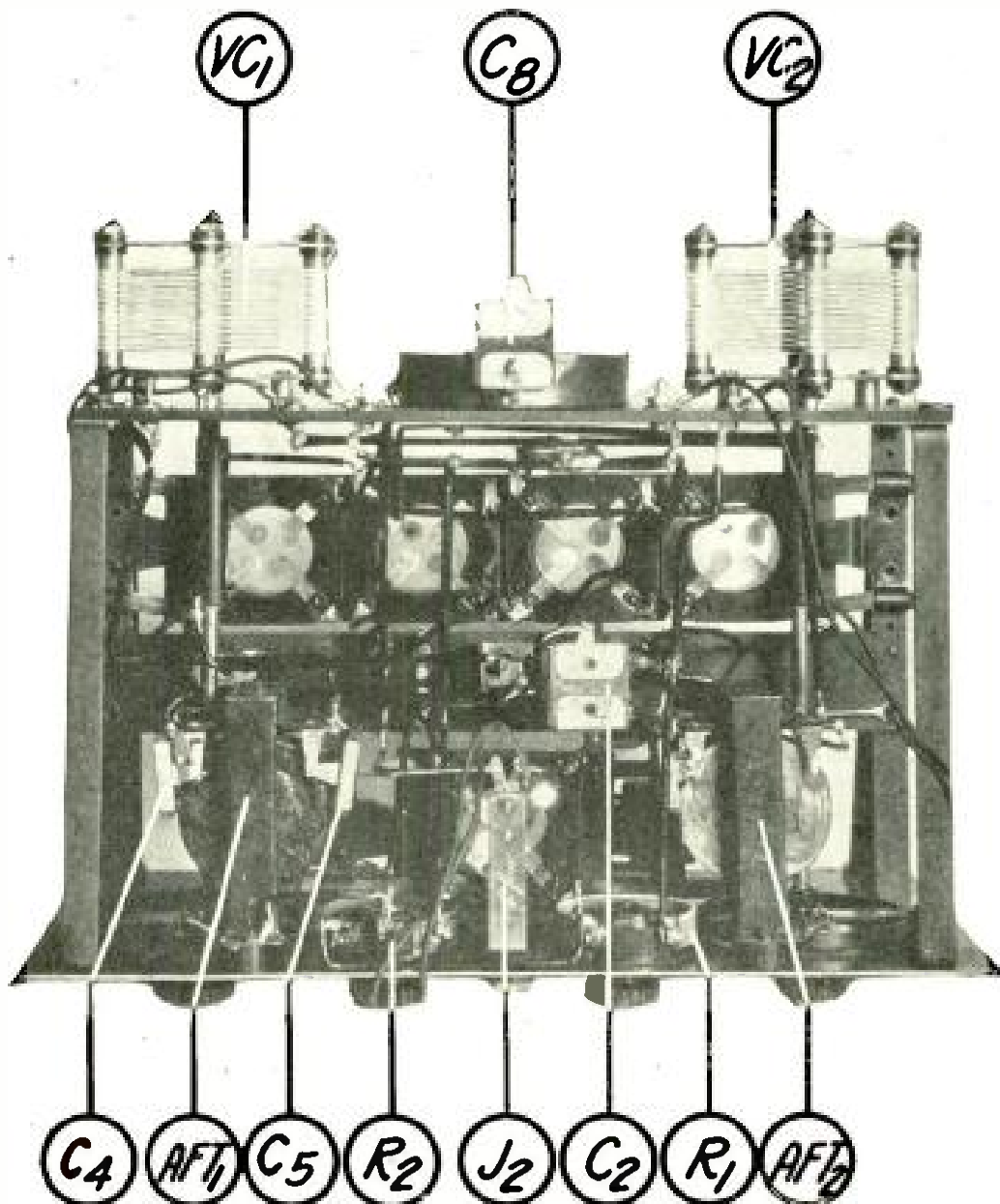

THE VIEW OF THE SET FROM THE BOTTOM

FIGURE 4: This picture shows that most of the wiring in the set is at the bottom of the frame. Any necessary repairs can therefore be easily made.

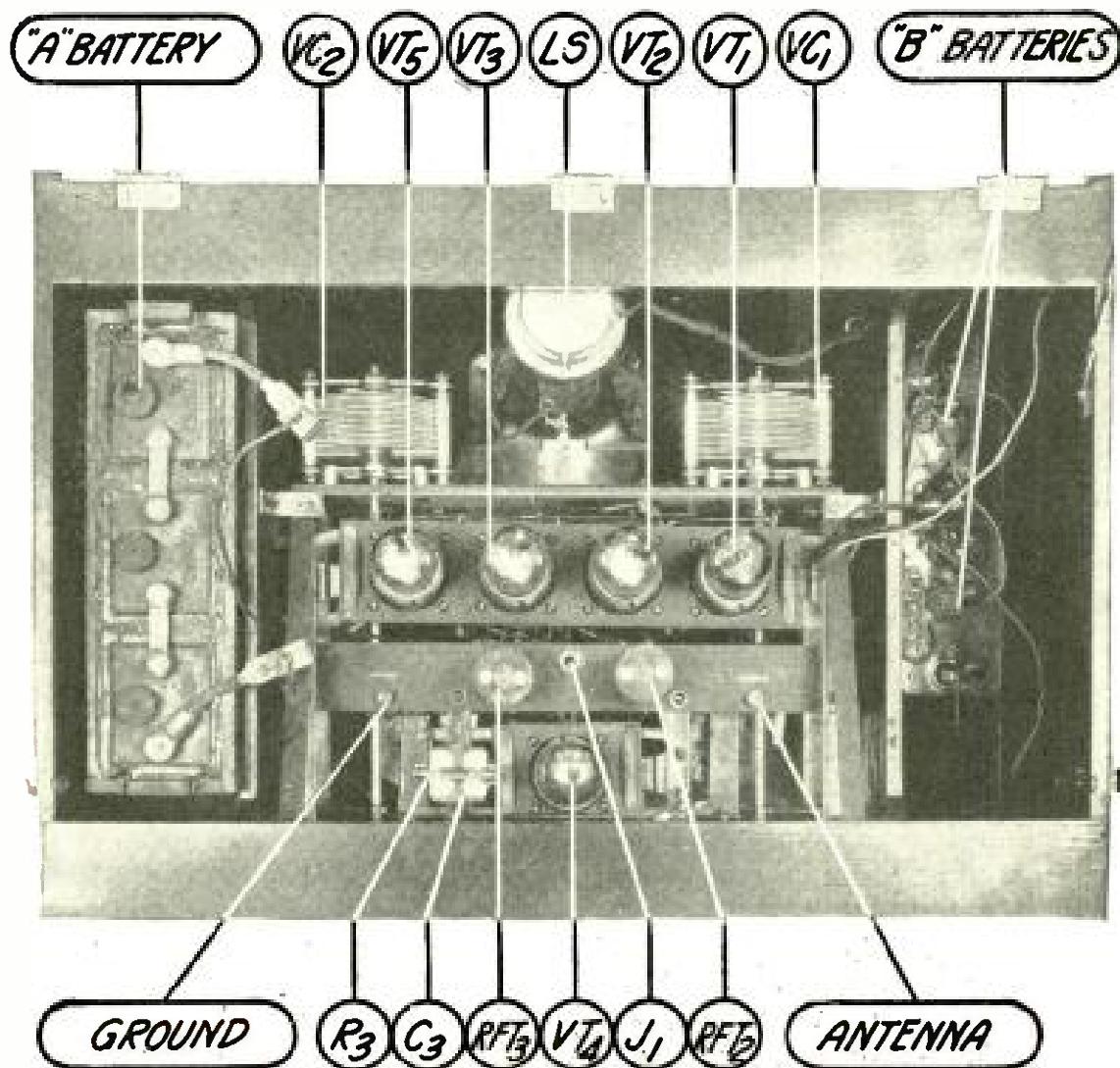

VIEW OF THE RECEIVER FROM ABOVE

FIGURE 5: The set in this picture is shown in its cabinet with the batteries beside it in their compartments. The white circle at the top is part of the loudspeaker.

upon the coil of AFT2 but not on L5, passing through the latter harmlessly. By induction the energy is then transferred from the primary of AFT2 to the secondary of AFT2 and is thus impressed on the grid of VT5. The output of VT5 then passes through the loudspeaker and results in signals of great volume.

Construction of the Receiver

The D-17 receiver is self-contained in every sense of the word. The loop antenna is plugged into the jack J1 that is provided in the receiver, and projects up through the top of the cabinet. The loudspeaker is in the lower part of the cabinet from which the sound is emitted through the grill work that covers the

lower half of the cabinet. The batteries are concealed within the cabinet, in compartments provided at either end.

The receiver proper is mounted on the black panel set into the upper half of the front of the cabinet, and two sub-panels are fastened to the front panel by means of brackets. The loudspeaker mechanism is mounted on the inside rear wall of the cabinet. It is an inverted horn that is similar to that in a phonograph. Knobs are provided on the front panel for the tuning and control of the set. The knob with pointer attached, at the left-hand side of the panel is the adjustment knob for VC2, shown in Figure 1. This control tunes the second stage of radio-frequency amplification. The corresponding knob at the right-

hand side of the panel controls VC1, the purpose of which is to tune the loop antenna and the first radio-frequency stage. The center knob marked "Filament" is for accurate control of the current supply that lights the filaments of the tubes. The "Sensitivity" knob to the right of this controls the potential of the grid of the first radio-frequency amplifier tube. The jack at the bottom of the panel is used in case it is desired to make use of headphones in place of the loudspeaker. It may also be used to plug in another loudspeaker, in place of the one in the set.

To use headphones the "sensitivity" knob should be turned all the way back in an anti-clockwise direction, otherwise the volume of sound will be unbearable.

The radio-frequency amplifier transformers RFT2 and RFT3 are removable and are equipped with five base pins which fit into corresponding receptacles in the receiver.

Receivers with two stages of tuned-

radio-frequency amplification have a tendency to oscillate too freely when a loop is used. To prevent this in the De Forest receiver a metal shield is placed around the radio-frequency transformer RFT1. This shield is shown in Figure 3.

The Antenna

The use of a ground connection in this receiver in conjunction with the loop usually results in improved reception.

If you make a ground connection, use a wire that is attached to some well-grounded metallic object, such as a water pipe, a steam radiator, or a pipe driven into the ground. This connection is fastened to the binding post marked "Ground," in Figure 5.

If an outside antenna is to be used, the connection recommended is somewhat different. The end of a piece of insulated wire is bared and attached to the "antenna" binding post inside the receiver. The wire is then run out

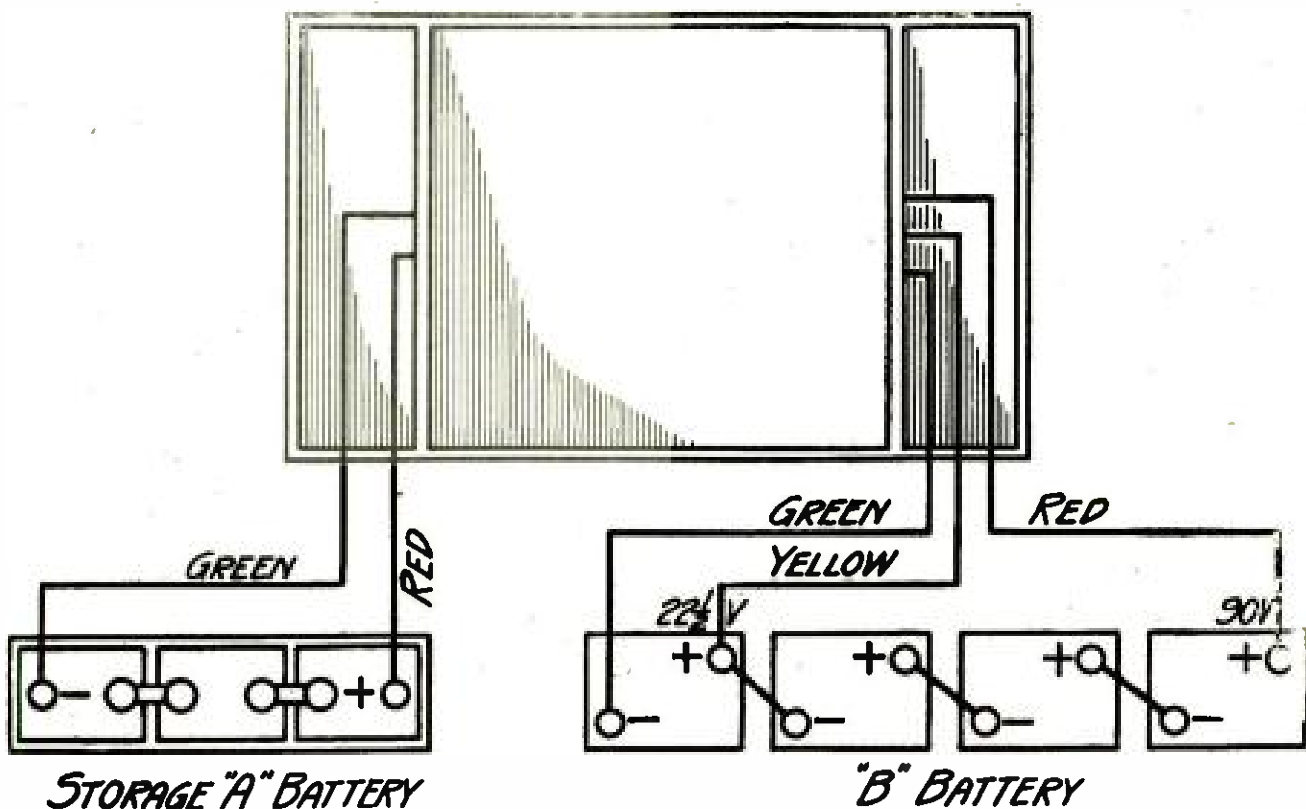

THE BATTERY HOOK-UP

FIGURE 6: This diagram shows how to connect battery renewals. Check up before using the set with new batteries to make sure your positive and negative battery terminals attach to positive, (+) and negative (-) posts in the cabinet.

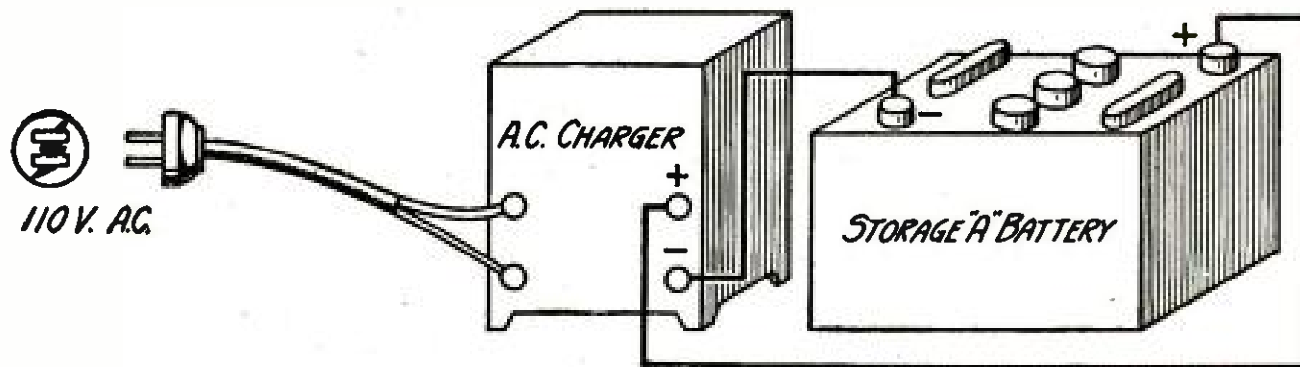

HOW TO CONNECT THE STORAGE BATTERY TO THE CHARGER

FIGURE 7: The A.C. charger is provided with a plug that fits any electric light socket. Be certain that you connect the positive (+) terminal of the battery to the positive (+) terminal of the charger. The terminals are always marked on every charger and every storage battery.

through one of the holes in the rear wall of the cabinet. This wire should be long enough to extend out about a foot from the cabinet. The lead from the outside antenna is then simply wrapped around this insulated wire. Be sure that there is no metallic connection between the antenna wire and the piece of insulated wire. Several turns of the antenna lead should first be wrapped around the other for a trial. Then a few more turns should be added until the proper number is found to give the best results. The number of turns of one wire around the other determines the amount of energy that will be transferred from the antenna to the receiver. Figures 10 and 11 show the method of connecting the antenna and ground to the receiver. The loop antenna is used even though an outdoor antenna and a ground connection are employed.

The Vacuum Tubes That Are Used

This receiver is rather unique in that it is designed for use with:

- (1) Five dry cell tubes—DV-3.
- (2) Five storage battery tubes—DV-2.
- (3) Four storage battery tubes for amplifiers and one dry cell tube for detector.

The dry cell tubes are not as satisfactory as those that operate on a stor-

age battery. When dry-cell tubes are used the filament current is obtained from three standard dry cells that are connected in series as shown in Figure 9.

Where there are facilities for charging a storage battery, the use of DV-2 tubes is recommended. These tubes are supplied with the receiver (unless DV-3 tubes are requested). UV 201-A or C 301-A tubes may also be used in place of the DV-2's if desired. These also operate on a storage battery.

In the third combination DV-2 tubes are used as the amplifiers, but a DV-3 is used for the detector, because for this purpose it is approximately equal to the DV-2, and it consumes 15 percent less filament current.

To make this arrangement possible a special resistance R-4 has been incorporated in the detector circuit to make possible the use of this dry-cell tube with the higher voltage of the storage battery. When a DV-2 is used as a detector this resistance is short-circuited by swinging up the little metal arm (shown as X in Figures 1 and 3), so that it connects the two binding posts provided for this purpose.

It is best to use the DV-2's in all five sockets. The second best choice is DV-2's for the amplifiers and DV-3 for the detector. The use of dry-cell tubes (DV-3) throughout is the third alternative.

The Batteries Needed

An "A" battery is required for lighting the filaments of the tubes. Where DV-2 or similar tubes are used—the "A" battery must be of the storage type. Dry cells are, of course, used in conjunction with the smaller tubes.

Special storage batteries are designed to fit in the battery compartment of the De Forest receiver. These batteries have rated capacity of 50 ampere hours and a fully charged battery of this type will operate the receiver for approximately 40 hours where five DV-2 or other large tubes are used.

The table that follows shows comparative life of various sizes of "B" batteries when used with this receiver.* The sizes that are referred to are the three standard sizes, the "large" size which is the one most commonly used in radio, such as the Burgess No. 2,156 or No. 2,158, or the Eveready No. 766 (these are all blocks of 22½ volts each).

It will be noted that greatest life of "B" batteries is obtained by using the "large" size, and by keeping the "Filament" knob at the lowest setting consistent with good results. In the case of the particular receiver that was used in making these tests the best "filament" setting was found to lie between 8 and 9 on the dial, therefore settings of 8, 8½ and 9 were used in making the battery consumption measurements.

With the "Filament" knob set at 9, and using small size "B" batteries, the battery life was shortest, therefore this is used as the unit of

*Most of the standard "large" size batteries (whether 22½ volt or 45 volt) will not fit the space provided in this receiver. However, the Burgess No. 2-158, which is "large" size will fit because of its vertical construction.

"Filament" Dial Setting	"B" Battery Size		
	"Small"	"Medium"	"Large"
9	1	3.6	16.6
8½	1.6	5.5	23
8	2.3	8.3	33.3

measurement and is called 1 in the table. By referring to the top row of figures it will be seen that under the same conditions of use, "medium" size batteries will have a life 3.6 times that of the "small" size.

The conclusions to be drawn from this tabulation are:

1. "Large" size "B" batteries are most economical. Their first cost is approximately twice that of the "small" size but their life is about 16 times as great.
2. The lowest setting of the "Filament" control knob that will give good results is the most economical. In reception from powerful local stations the setting of this knob may be quite low and still provide plenty of volume on the loudspeaker.

A battery charger that operates on house electric current is almost indispensable. They are made for alternating or direct current. You should find out the kind of current in your house before you purchase one.

Proper connections for such a charger are shown in Figure 7.

Where the house supply is 110 volt direct current, a resistance of four ordinary 50 watt electric bulbs (connected as shown in Figure 8) should

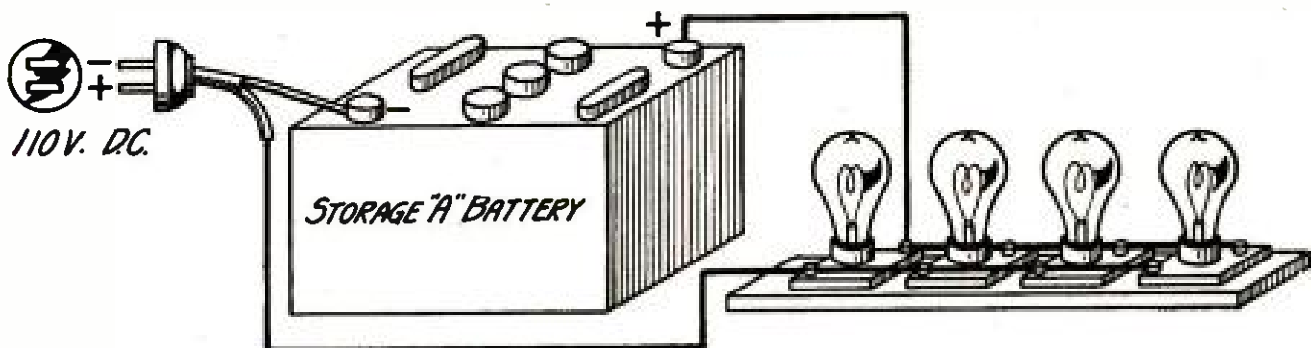

HOW TO CONNECT THE BATTERY AND LAMP BANK

FIGURE 8: You must be first certain that the positive (+) terminal of your direct current house supply connects, through the lamp bank, with the positive binding post of your battery. Determine the polarity of your house current, then mark the socket you intend to use regularly for charging so that you will always know at a glance which is the positive side of the socket.

be used for storage battery charging.

To charge the battery remove it from the receiver, and determine the condition of its charge with a hydrometer.

(The battery should be removed from the cabinet to prevent harmful effects sometimes caused by "gassing" in a closed compartment.)

This is an instrument that indicates the specific gravity of the solution in the battery. Inasmuch as the specific gravity varies with the state of charge, the reading of this instrument supplies a direct indication of the degree of charge left in the battery. When the hydrometer reading is 1,285, it indicates a fully charged battery. When the reading drops to 1,185, it is time to re-charge the battery. Never let your battery get below 1,185 as this condition tends to shorten the life of the battery.

The first time a battery is put into operation it discharges quite rapidly. A battery rated at 50 ampere hours may give only 20 hours of service on the first charge. This is no cause for worry, however, because a battery does not deliver its full capacity until it has been charged and discharged two or three times.

Another type of battery that is known as the "B" battery is required for this receiver. Ordinarily, a special type of dry-cell "B" battery is used with radio receivers, although storage "B" batteries are also obtainable. However, the storage type takes up considerable room and cannot be fitted into the "B" battery compartment of this receiver.

The most practical battery for this receiver is the Burgess No. 2158. Four of these are connected in series as shown in Figure 6.

The life of a "B" battery of given voltage increases with the size of the battery. This increase is by no means proportionate to the increase in size, however. A large size 45 volt battery, which is only about twice the size of the so-called "medium" size battery actually has approximately four times the

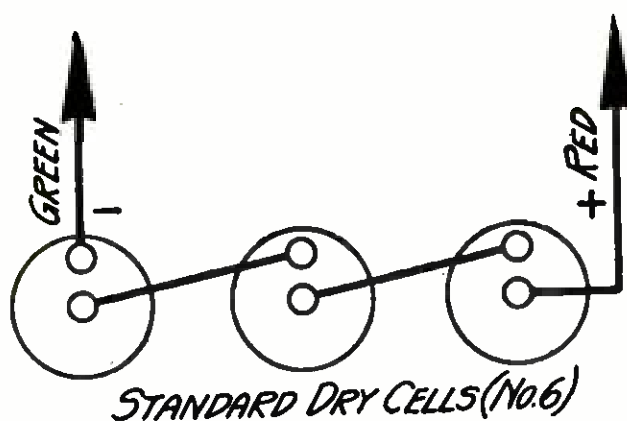

THE SERIES CONNECTION FOR DRY-CELLS

FIGURE 9: If you use dry-cell tubes, you will have to have a dry battery to operate them. The diagram above shows the proper way to connect the cells for this receiver.

life. It is quite evident, therefore, that the large type will be much more economical in the long run and it is estimated that its eventual cost is less than half the cost of the smaller type, even though the initial cost may be higher.

How to Operate the Receiver

When the receiver has been set up and the battery connections made as shown in Figure 6, the receiver is ready for operation. Where DV-2 tubes are used throughout, the knob marked "filament" should be turned in a clockwise direction until the pointer is opposite $8\frac{1}{2}$ on its scale. The "sensitivity" control is turned approximately half way in a clockwise direction. With the left-hand tuning control—marked "amplifier tuning"—set at approximately 70, the right-hand knob marked "receiver tuning" should be slowly rotated from 50 to 90.

If nothing is brought in during this operation, the "amplifier tuning" control should be moved about five degrees and the "receiver tuning" control again slowly rotated about twenty degrees above and below the setting of the "amplifier tuning" control. This process is continued until a station is picked up.

Once a station is heard, these two controls are slightly readjusted to bring the

signals in with maximum volume. Then the "sensitivity" control is moved in a clockwise direction to further increase the volume. In this latter adjustment, it will be found when a certain point is reached, reception will become somewhat noisy and distorted; that shows the receiver is about to oscillate. This means that the sensitivity knob has been turned too far in a clockwise direction. Turning it back slightly will remedy this trouble.

After a station is once properly tuned in, it is well to try slight variation of the filament control knob. In doing this the "sensitivity" control must be readjusted after each adjustment of the filament control knob. If the filament control is turned slightly in an anti-clockwise direction, the "sensitivity" control will have to be turned in the opposite direction and vice versa. A setting of the filament knob will be found where results are maximum and the knob should be left set at this point.

Another adjustment necessary is in the operation of the loop. When the edge of the loop is pointing directly toward the station from which signals

are being received, the greatest amount of energy will be picked up by the loop and the signals will be, of course, the loudest. If the loop is turned at right angles to this station, however, much less energy will be picked up; and, if the broadcasting station be a distant one, its signals may be lost entirely. In tuning for distant stations, it is therefore advisable to point the loop in approximately the direction in which the stations lie before trying to tune them in.

Another method of tuning the receiver is by what is known as the "beat" method. To do this, the "sensitivity" control is turned about three-fourths in a clockwise direction. When the dials are rotated, a whistle will be heard when the dial settings of a broadcasting station are passed over. The two dials should then be set to a point where this whistle has maximum volume. Then the "sensitivity" control knob should be turned in an anti-clockwise direction until the whistle disappears and the signals are clearly heard. Or it is sometimes better to clear up the tone by slightly detuning the amplifier tuning control.

A Typical Tuning Chart for the De Forest D-17

Wavelength	Amplifier Tuning	Receiver Tuning	Loop Switch	Loop Direction
252 meters	10	11	Down	300
263 "	11.5	13.5	Down	300
273 "	13	16.5	Down	20
286 "	16	21	Down	20
302 "	19	25	Down	270
316 "	22	30	Down	40
360 "	33	43	Down	20
370 "	36	22	Up	270
380 "	38.5	25	Up	200
390 "	40.5	27	Up	260
395 "	41.5	28	Up	320
405 "	44	31	Up	300
426 "	49	35	Up	260
448 "	56	42	Up	270
455 "	58	44	Up	20
469 "	65	47	Up	300
492 "	72	54	Up	20
517 "	78	62	Up	240
535 "	87	68	Up	270

At this point slight readjustment of the tuning control knobs and the loop will bring the signals up to maximum strength.

If the stations you seek operate on wavelengths below 400 meters, the switch on the loop should be turned down until it makes contact with the low point. For wavelengths above 400 meters, the switch should be turned up for best results.

Where dry-cell tubes are used throughout, the same tuning process as described above holds good except that it will usually be found necessary to keep the "sensitivity" control turned almost all the way in a clockwise direction.

Charting the Receiver.

As each broadcasting station is tuned in, a record should be made of the settings of the two tuning controls, whether the loop switch is up or down, and also the direction of the loop. You will then have a permanent record of all the stations you pick up and an index that will show you how to get the stations. Such a record is shown on page 450.

If this record is made up using the loop only without antenna or ground connections, it will only hold good when used again under the same conditions. This is particularly true of the "receiver tuning" control. In any case, the "am-

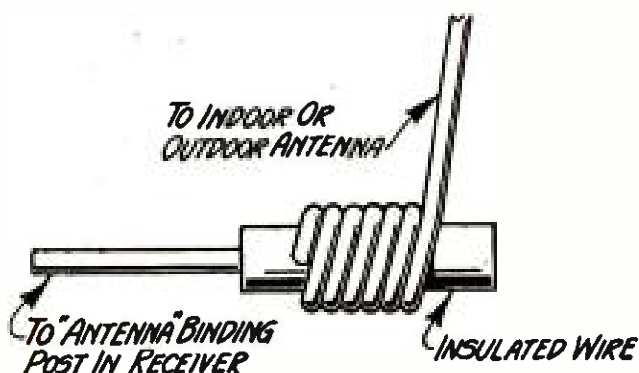

HOW TO CONNECT AN OUTDOOR ANTENNA TO THE RECEIVER

FIGURE 10: If you use another antenna in place of the one that comes with the set, wrap the bare antenna lead-in wire around the insulation of a wire that connects with the set as shown above. Do not make a metallic connection between these wires.

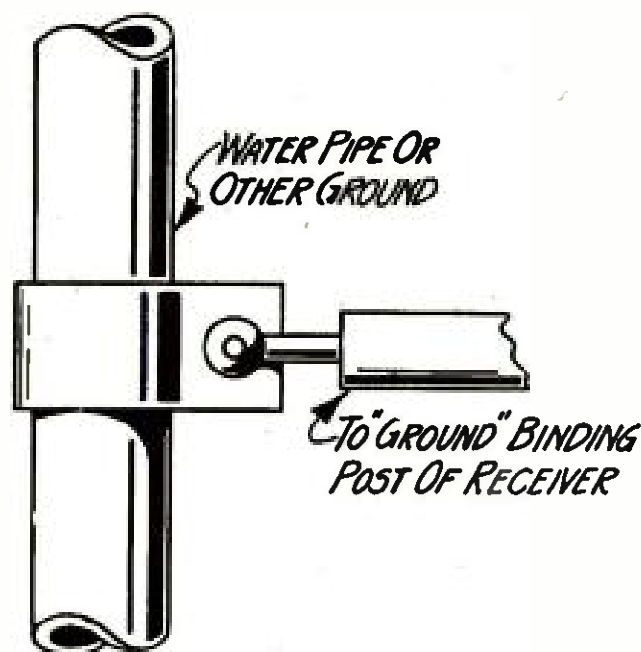

HOW TO MAKE A GROUND CONNECTION

FIGURE 11: If you decide to use a ground wire with this set, connect it to a pipe with a ground clamp in the manner indicated in the diagram above.

plifier tuning" control will always have the same setting for any given station, because it is not affected by the external conditions of antenna, ground or loop.

Before charting the receiver, therefore, it is well to try the use of an antenna and ground, as previously described and determine the combination which gives the best results under your particular conditions. After this has once been done, these connections should be permanently made and the receiver charted. The settings shown on the chart will then apply as long as the same conditions are maintained.

Perhaps the most practical arrangement is to make up two charts, one for tuning without either a ground or an antenna and another for receiving with a ground or an antenna or both.

The next article in this series will tell how to operate a five-tube, tuned-radio-frequency receiver. This set is the Atwater-Kent, model 20, cabinet receiver.

The editors will welcome suggestions for receivers that readers would like to see explained in future articles in this ready-made receiver series.



International

AMERICA'S WRITERS SEEK INCOME FROM THE BROADCASTING OF THEIR WORKS

An imposing delegation of nationally-known authors (of which Will Irwin, the contributor of this article, was one) journeyed to Washington a few weeks ago to urge the passage of the Perkins Bill, authorizing the U. S. to enter the International Copyright Union as one of the methods of obtaining protection from the new medium of "publication."

The "Radio Rights" of Authors

Why the creators of literary and dramatic works believe that their rights and their revenues are being threatened—and what they propose to do about it

By WILL IRWIN

THE present copyright law—enacted I believe in 1891—was excellent in its time. Now it is as out of date as a traffic control law passed in 1891. We have revised the traffic laws; for the automobile and the airplane have arrived. In the publishing business, the popular magazine, the moving picture and the radio have arrived; but we are still dragging on with the same old copyright law. Applied literally and strictly, it would work havoc with the income of every creative artist in the country. That it is not always applied literally we owe partly to the good-will and decency of the publishing class, and partly to such extra-legal forces as the Authors' League of America. This is an unnatural situation—a

private organization enforcing a natural right because the law does not protect that right. Yet it is the quandary in which the profession of authorship finds itself today.

In 1891 there were few periodicals. The cinema still slumbered in the womb of time. The first principle of the radio was as yet unknown. The law, as drawn, had its eye only on book publication. True, the four standard magazines of the time—*Harper's*, *Century*, *Scribner's* and *Atlantic*—often published serially matter written for eventual book publication. But the editors of these magazines were old-fashioned gentlemen of the publishing business. Law or no law, the author could always get an honest arrangement from them.

The Act of 1891 and its subsequent interpretation by the courts laid down three principles vital to the present discussion. First, a work of literature or music or art enjoyed no protection until it was copyrighted. Second, such works could not be copyrighted until they had been printed or otherwise reproduced. Finally, the rights conferred by copyright could not be divided. He who owned the copyright owned all the rights of reproduction. Taking my own branch of creative work for example; printing a book is an expensive process. An author cannot afford that expense—should not be asked to afford it—with the mere object of establishing his legal ownership to his own work. In ninety-nine cases out of a hundred, the publisher, as soon as the first two books are published, secures the copyright in his own name. Some, it is true, are copyrighted in the name of the author. But this goes by favor, not by legal right.

The Act of 1891 was scarcely on the statute books when what my trade calls "subsidiary rights" became important. The popular magazines arose. Where first-class literary copy was published in magazine form by thousands of words in 1890, it was published by hundreds of thousands of words in 1900 and by millions in 1920. More and more, successful works of fiction tended to be dramatized for the "legitimate" stage. Then came the movies. As they began to find themselves, they discovered that, for reasons too complex to state here, the best material for picture plays was furnished by popular works of fiction. The newspaper syndicates invented "second serialization." By that process, a novel already published in book form and possibly in magazine form, is, after its sales have run down, parcelled out among the newspapers for republication. A popular

piece of fiction with an appealing idea—Fanny Hurst's *Humoresque* for example—may run through all these forms. But still, the publisher of books or magazines who first prints such a piece of work owns automatically all these rights. If after getting his own bit he hands back to the original creator the other rights, he does it out of the justice of his heart or for fear of boycott by the Authors' League. I have no room to give examples showing how badly this creaky system works. But I could fill this periodical for a year with the instances I have known during twenty-five years of writing.

Now, out of the air comes radio, a means of communicating ideas of which no man dreamed in 1891. And against the appropriation of creative ideas by radio we seem to have no protection whatever. So far, this new thing affects only the composers of music; but already it is a serious situation for them. It may soon become serious for us all. A drama is a thing of two dimensions; sight and speech. The moving picture has succeeded with dramas of one dimension alone. What prevents the radio from succeeding with the other dimension alone? Further, wireless transmission of photography has arrived. Probably, wireless transmission of moving photography will come next. And one imagines dramas played in New York, flashing on a screen and simultaneously speaking from a horn in the drawing-rooms of San Francisco, Seattle, Chicago. The actors, the property-man, the electricians will all get their bit out of such performances; everyone will be paid except the author, who made the thing they are transmitting.

What we authors ask in the new copyright bill is merely a man's natural right of property in the work of his hand and his brain.

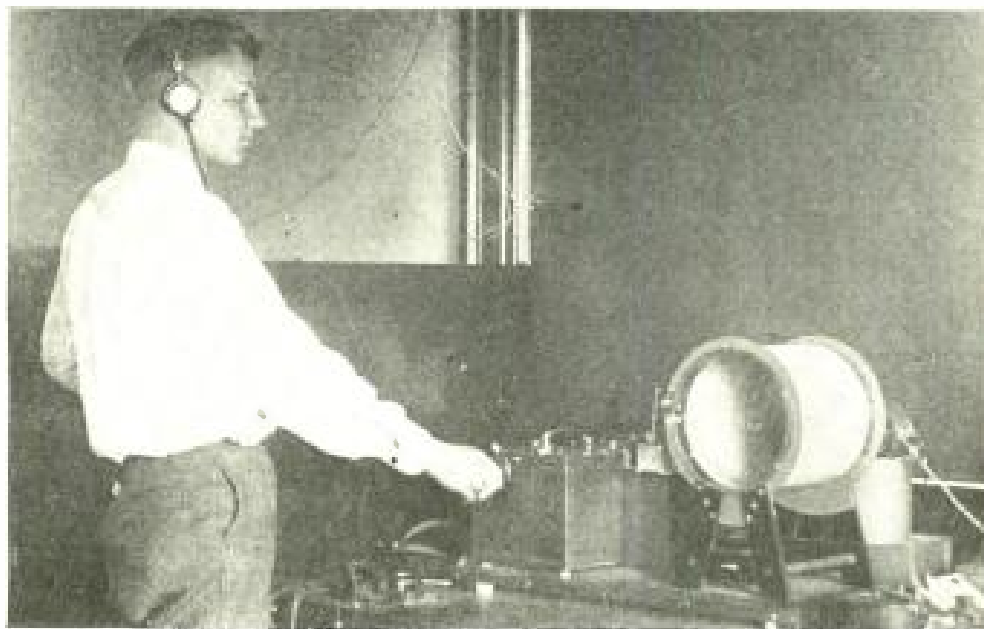

Pacific & Atlantic

CHECKING UP THE WAVELENGTH OF BROADCASTING STATIONS

In the radio laboratory of the United States Bureau of Standards at Washington, D. C. the wavemeter apparatus (shown in the picture) is used to measure the frequency of incoming signals from transmitting stations.

Handy Tools for Radio Fans: No. 3

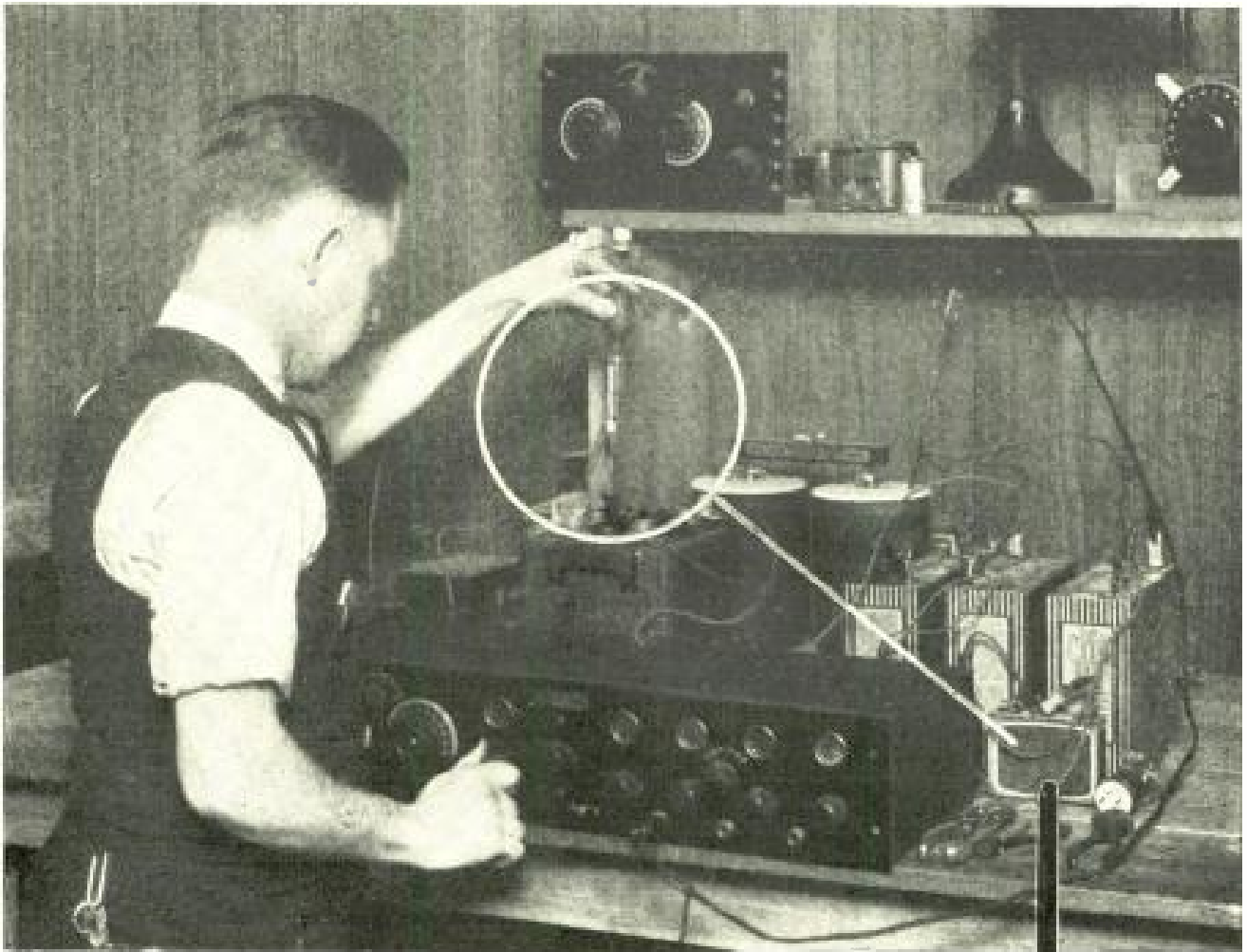

From a photograph made for POPULAR RADIO

THE HYDROMETER

*An accessory that every radio set owner
should have*

EVERY one who owns a receiver should have a reliable hydrometer. This instrument tells you immediately the condition of the "A" battery—whether it is charged or not.

The hydrometer is inserted into the vent cap of each cell and the bulb is squeezed and released to draw the electrolyte up into the outer glass cylinder. This causes the small float to rise. The specific gravity of the solution determines how high or low the floating gauge will be in the electrolyte. The float rises to a greater or lesser degree as the solution contains greater or lesser amounts of acid. This gives an accurate indication of the amount of charge in the battery.

The "fully charged" reading of the hydrometer for the ordinary lead storage battery is 1,280 and the "fully discharged" reading is about 1,150.

Never let your batteries get below 1,175.



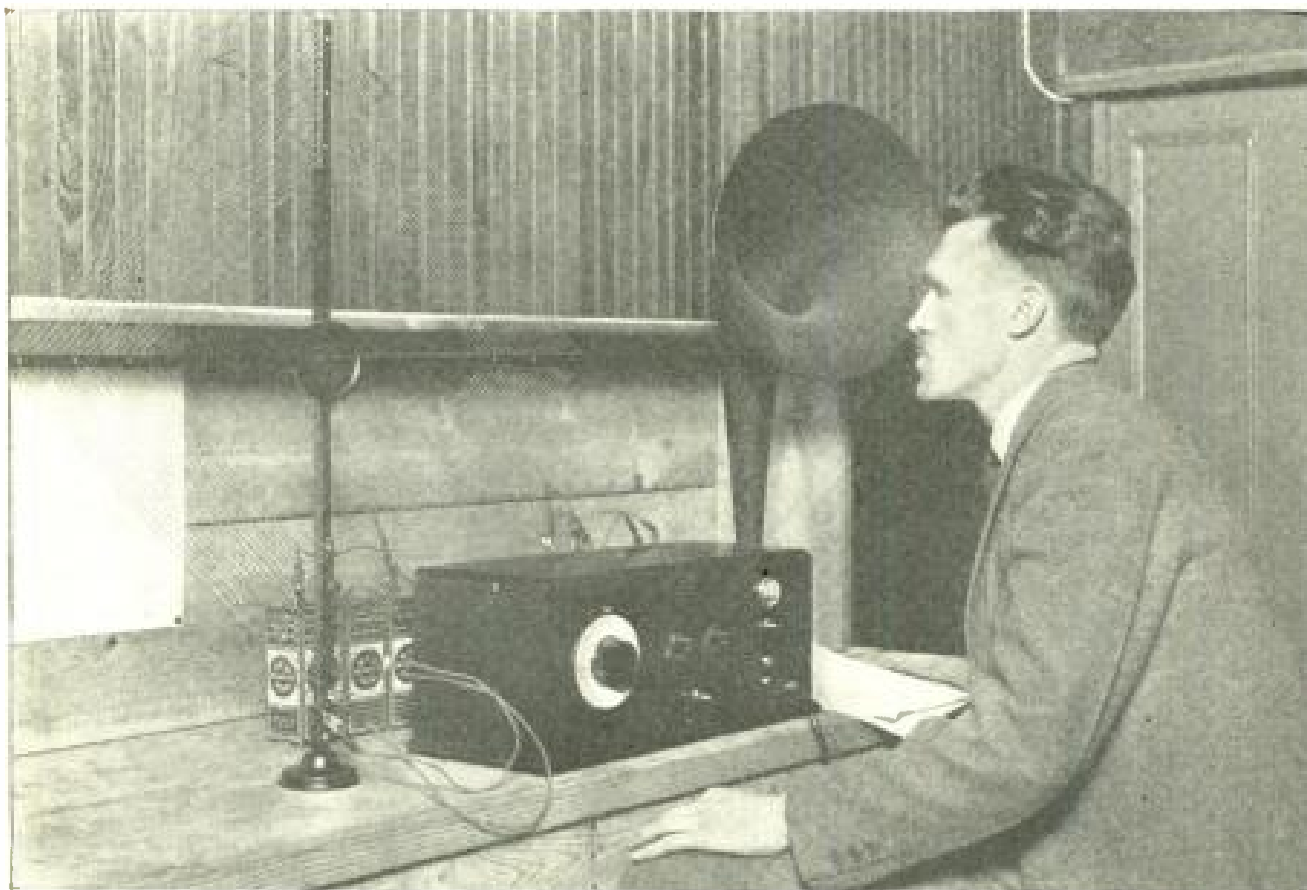

From a photograph made for POPULAR RADIO

HOW THE COMPLETED RECEIVER LOOKS

The simplicity of tuning this receiver is apparent at a glance. The large dial at the left controls the condenser. The two smaller knobs are for the rheostats that control the current supply to the tube filaments. The large dial has a small tuning chart on it where station tuning positions may be noted.

HOW TO BUILD THE PORTABLE "Town and Country" Receiver

The single-control set described in this article is an all-around receiver for the home, besides embracing a portable feature that makes it an unburdensome companion for the summer vacation in camp, on a cruise or on a motor tour

By S. GORDON TAYLOR

COST OF PARTS: *Not more than \$60.00*
RECEIVING RANGE: *1,500 miles*

HERE ARE THE ITEMS YOU WILL NEED—

- | | |
|--|--|
| <p>A—Remler square plate variable condenser Type No. 630, .00035 mfd. capacity, complete with dial, indicator, etc.;</p> <p>B—Amsco 20-ohm rheostat equipped with knob;</p> <p>C—Amsco 400-ohm potentiometer equipped with knob;</p> | <p>D and E—Cutler-Hammer filament battery switches;</p> <p>F—Hoyt "Bezel Hole Mounting" voltmeter, range 0 to 6 volts;</p> <p>G—Adams jack Type No. 502, 3-prong, double circuit;</p> <p>H—Adams jack type No. 501, 2-prong, single circuit, open;</p> |
|--|--|

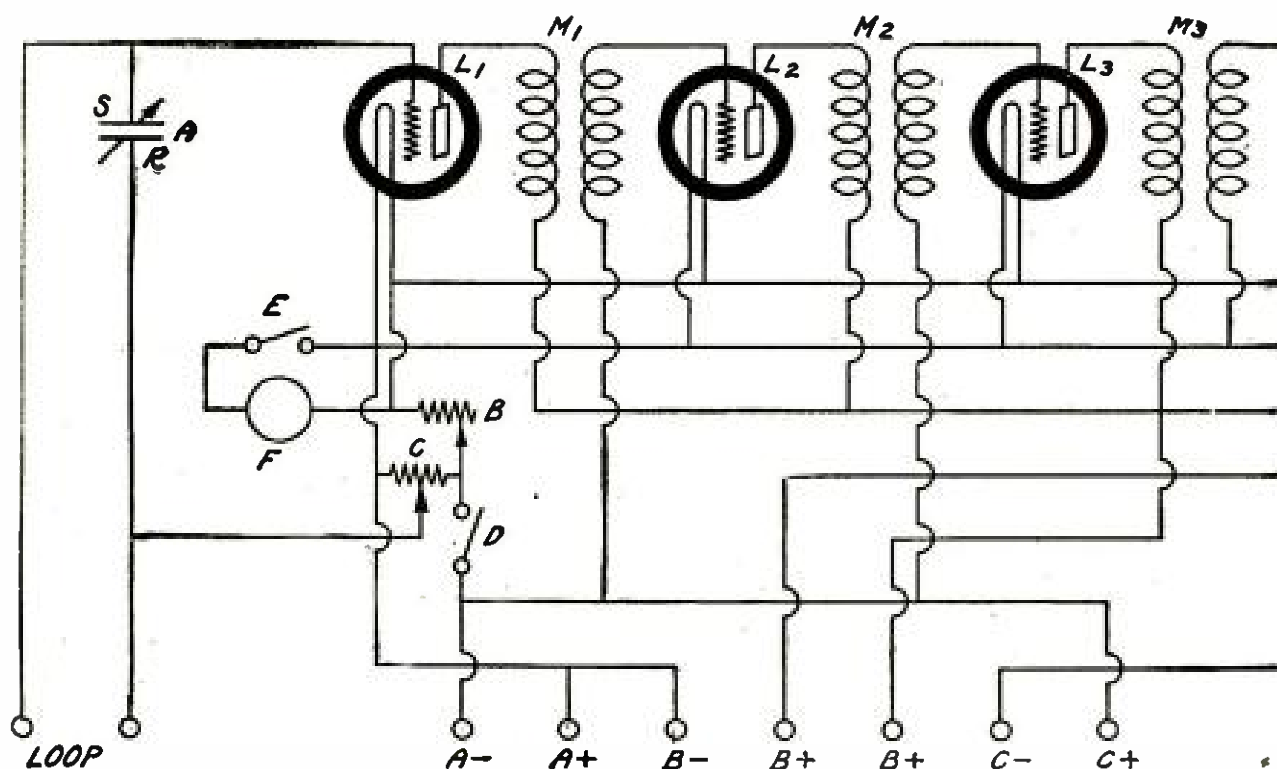

I—Dubilier mica fixed condenser, .00025 mfd. with clips for grid-leak;
 J—Daven grid-leak, 4 megohms;
 K—Dubilier mica fixed condenser, .00025 mfd. capacity;
 L1, L2, L3, L4, L5 and L6—Benjamin Cle-Ra-Tone sockets for UV-199 vacuum tubes;
 M1, M2 and M3—Dubilier "Duratran" radio-frequency transformers;

N1 and N2—Pacent "Audioformers" Type No. 26, audio-frequency transformers;
 O—sub-base;
 P—binding post sub-panel;
 Q—brass brackets;
 R—cabinet;
 S—Eby binding posts;
 T—composition panel;
 Round or square tinned bus wire, screws, soldering lugs, etc.

FOR those who are thinking about taking along a radio set on their vacations, the portable receiver described here is especially suitable.

There are two difficulties that most radio enthusiasts encounter in deciding upon making their radio set a traveling companion.

First, the portable receiver that is contained in a suitcase is suitable for the vacation, but it is usually unsuitable for use at home, because its appearance does not lend itself well to a living room.

Second, the standard receivers designed for home use are not adaptable for use on a vacation trip, because of their cumbersome size, the necessity for an outdoor antenna and usually for a storage battery.

The pressing need seems to be for an "all purpose" receiver that has the fine appearance of a standard receiver, is sufficiently sensitive to provide good loudspeaker volume without the use of an outdoor antenna or a ground connection, is small in size, light in weight and that operates on dry-cells. If we add to these requirements simplicity of control, by means of a single dial; ability to bring in stations half-way across the continent; good selectivity and tone quality, we have the requirements that are met by the "Town and Country Receiver" that is described in this article.

This set suits the home as well as any standard receiver. A standard loudspeaker, standard "B" batteries, dry-cells for filament lighting, and a loop

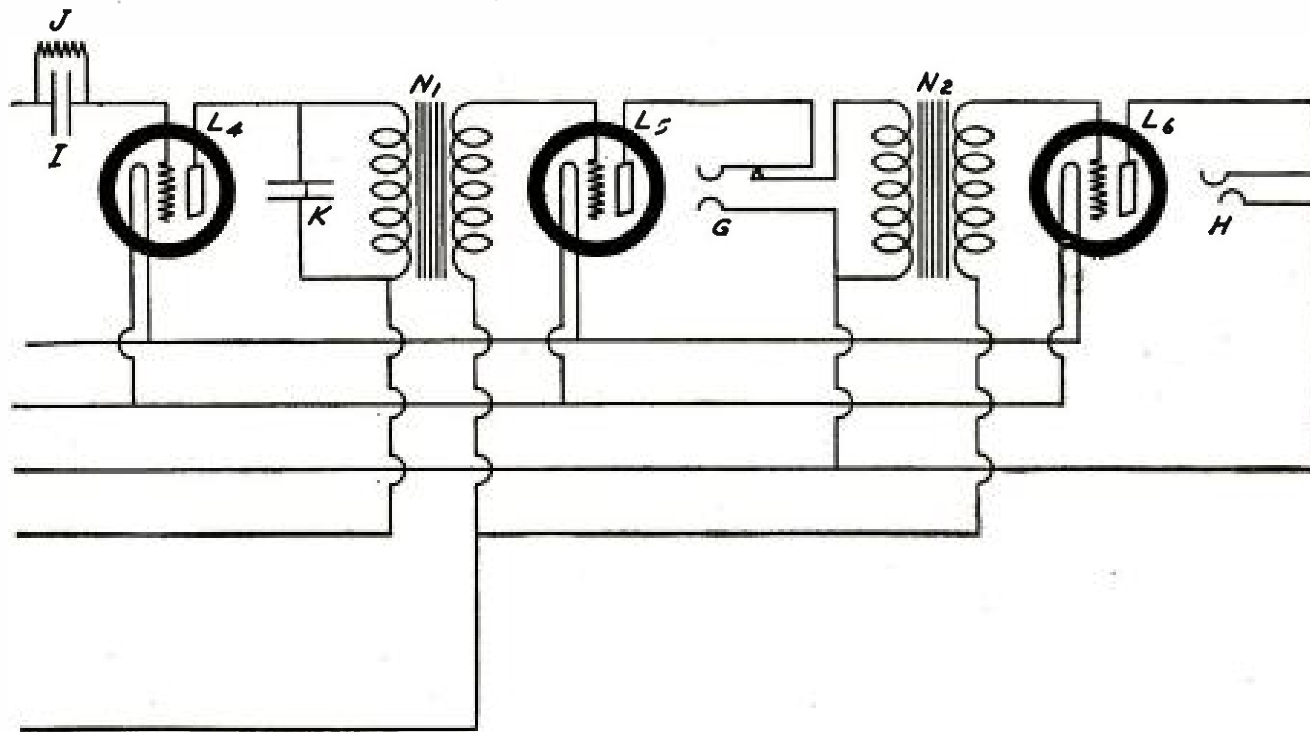

THE COMPLETE CIRCUIT DIAGRAM

FIGURE 1: This is the hook-up for the new "Town and Country" receiver. It will be noticed that all the symbols for the instruments bear designating letters which reappear in the list of parts on page 455, and throughout the text and the following illustrations. This eliminates the possibility of mistakes in construction and wiring up.

antenna are used with it. No ground or antenna wires are needed and all battery connections as well as the connections to the loop are made at the rear of the receiver, which eliminates unsightly wiring.

A carrying case with one compartment for the receiver itself, one for the batteries, and a third for a small built-in loudspeaker may be employed with this set to make it portable. When a folding loop is used,* it may be folded and slipped into one of the compartments when you travel.

Tuning with this set is accomplished with a single dial. In New York City the broadcasting stations of the East and Midwest can be brought in with ample loudspeaker volume, and when operated at a situation in the Middle West, the receiver is capable of picking up anything in the United States.

Six vacuum tubes, either UV-199's or C-299's, are used in this set which has three stages of transformer-coupled, ra-

dio-frequency amplification, a vacuum tube detector and two stages of transformer-coupled, audio-frequency amplification. The loop antenna is tuned by the variable condenser at the left end of the panel.

The potentiometer, to the right of the tuning dial, controls oscillation and the rheostat, to the right of the potentiometer controls the filament supply current. The small push-pull switch below cuts off the batteries when the receiver is not in use. At the right-hand end of the panel there is a voltmeter which gives the filament-voltage reading to aid in the proper adjustment of the rheostat to provide just the right voltage for proper operation of the tubes. Below this is another switch provided for cutting off the voltmeter from the circuit after the proper filament adjustment has been obtained, thus preventing additional current drain on the batteries caused by the voltmeter. Directly under this latter switch are the two jacks—the top one for headphones and the lower for the loudspeaker.

* The Suportenna Loop was used with the receiver described.

The Parts Used in Building the Set

In all the diagrams in this article all parts bear designating letters by which the prospective builder of a set may easily determine how to mount the instruments in the correct places and connect them properly in the electric circuit. The same designating letters are used in the text and in the list of parts at the beginning of the article.

Q The list of parts there given includes the exact instruments used in the set from which these specifications were made up. The experienced amateur, however, will be able to pick out other reliable makes of instruments which may be used with equally good results. But, we recommend that the novice follow the list, for the diagrams in this article will tell him ex-

actly where to bore the holes and exactly where to place the connections.

If instruments other than the ones listed are used, the only change that will be necessary will be the use of different spacings for the holes that are to be drilled in the panel for mounting the instruments.

How to Construct the Set

After procuring all the instruments and materials for building the set, the panel should be prepared. If a standard panel, 7 by 18 inches, is unobtainable, a piece of composition stock may be cut down to this size and the edges squared up smoothly with a file.

The centers for boring the holes (which are necessary for mounting the instruments) should

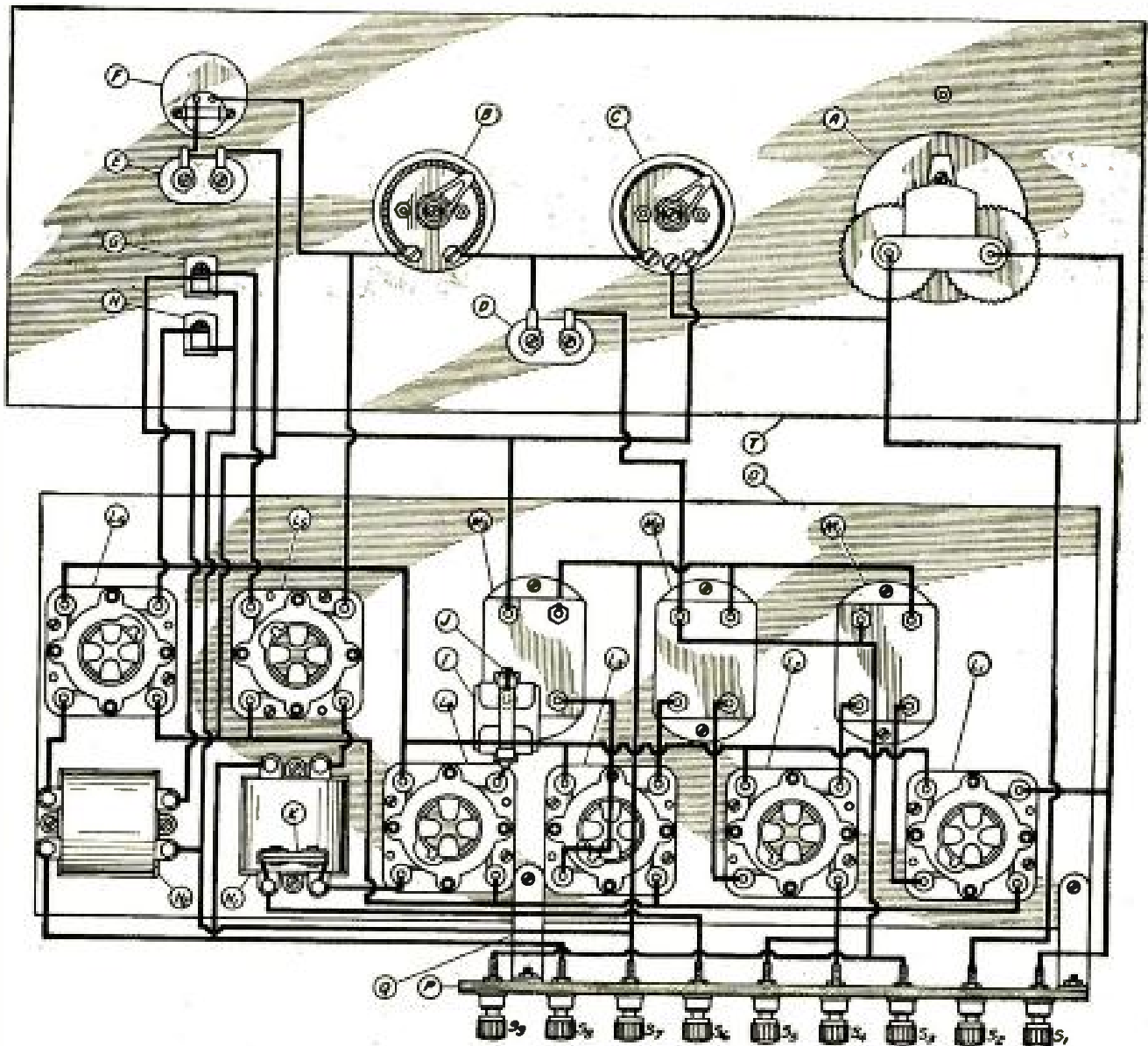

THE WORKING PLAN FOR CONNECTING UP THE INSTRUMENTS

FIGURE 2: The upper rectangle represents the panel and on it the instruments are drawn just as they appear. The lower rectangle represents the baseboard; the instruments are drawn in about their relative positions. The heavy black lines show the way to wire up the mounted instruments.

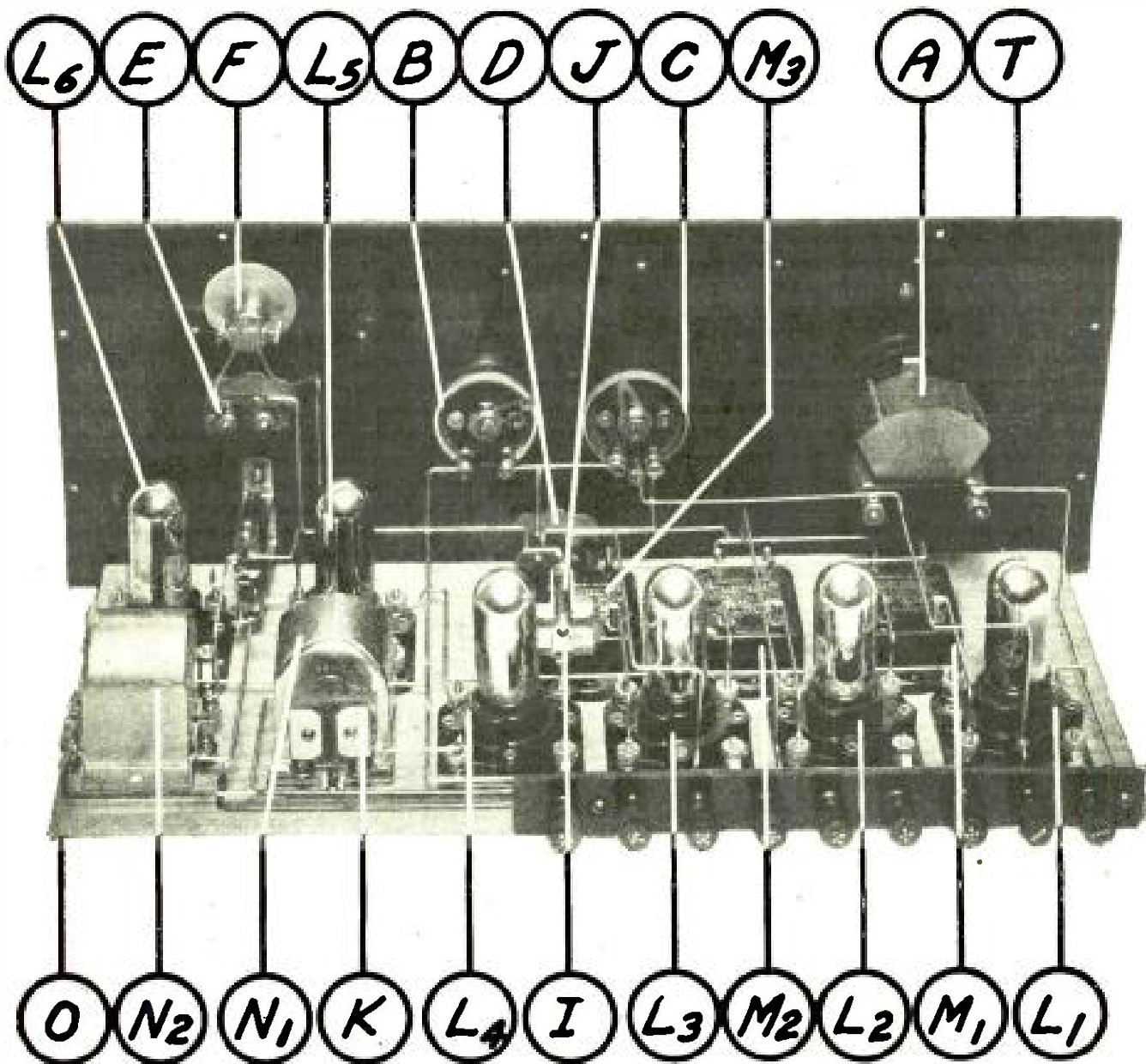

VIEW OF THE SET FROM THE REAR

FIGURE 3: This picture shows the general arrangement of all the instruments fastened to the panel or base. The exact locations for the instruments are shown in Figure 5.

be laid out on the panel as shown in Figure 8. Lay out all center holes on a piece of paper the same size as the panel. Fasten this paper directly on the panel and with a sharp-pointed instrument punch the center holes through this paper into the panel. The panel layout which comes with the set of blueprints, which may be obtained from POPULAR RADIO, can be used instead of this paper template.

Start to drill your holes with a small drill one-sixteenth of an inch in diameter or less, so that you can center them more easily.

The holes that are outlined in the panel diagram with a double circle should be counter-sunk, so that the flat-head machine screws used for fastening the instruments will set flush with the panel. All the rest of the holes in the panel are straight-drill holes. Sizes for the diameter of these holes are determined by measuring the size of the screws and shafts

of instruments that must go through the holes. The large hole for mounting the voltmeter may be made with a cutter or by first drilling a quarter-inch hole in the panel and enlarging it with a rat-tail file.

The panel may be left with its original shiny-black finish, if care has been exercised, so that it has not been scratched during the drilling. Or, when the panel is drilled, the builder may give it a dull finish with fine sandpaper that should be rubbed lengthwise on the face of the panel until its gloss is removed. This process should be repeated, except that light machine oil should be applied during the second rubbing. Then rub the panel dry with a piece of cheesecloth. A dull permanent finish will be the result.

After the panel has been prepared you are now ready to mount the instruments on it.

The variable condenser A is first mounted

by means of three machine screws, which are provided with the instrument. To do this the knob is unscrewed from the dial to permit the removal of the paper dial. Then the set-screw in the bushing of the metal dial is loosened so that the dial may be slipped off the condenser shaft. The condenser is then mounted on the panel and the metal dial is slipped over the protruding shaft-end and fastened on it with the set-screw.

The paper dial is put in place with the zero mark directly under the small projection on the edge of the metal dial and the knob is then screwed on again.

Next the small celluloid indicator is slipped on the screw that is provided for this purpose and the large washer is slipped on next and the screw inserted through the hole provided in the panel. It is tightened up by means of the small nut and spring washer which are placed behind the panel.

The potentiometer C and rheostat B are next mounted by means of two screws to each instrument and the knobs are attached. It will be noted that these two instruments are

mounted with the binding posts at the bottom.

Following this, the two switches D and E are mounted in their respective places as shown in Figure 2.

The last instrument to be mounted on the panel is the voltmeter F. One of the small screws at the rear of this instrument is removed. This permits the cross bar to be slipped out whereby the large metal washer can then be removed. The voltmeter is then slipped through the hole in the panel, the washer replaced behind the panel and the bar slipped back into place and tightened by means of the two screws which press against the large metal washer.

Now prepare the baseboard O. It should be cut from one-half inch hard wood to the size shown in Figure 5. Be sure that it is squared up properly when it will be ready for the mounting of the instruments.

Next mount the six sockets L1, L2, L3, L4, L5 and L6 in their respective places as shown in Figure 5. These are fastened to the baseboard O by means of two screws to each socket.

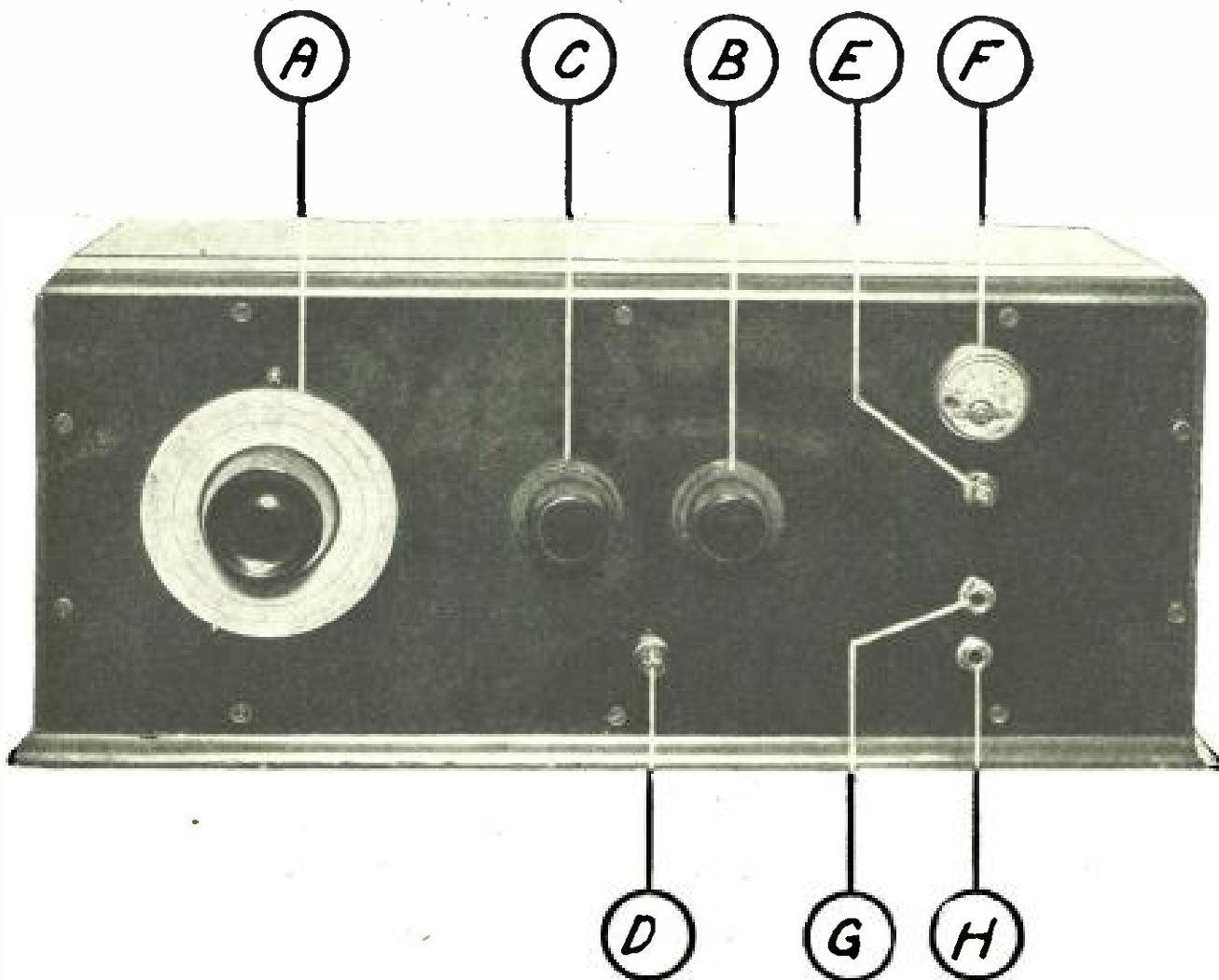

THE PANEL VIEW OF THE RECEIVER

FIGURE 4: This gives an idea of how the set looks from the front, and as the dial, the voltmeter and knobs are marked with letters which correspond to the instruments to which they are attached, the prospective operator will have no trouble in locating the various tuning controls as they are explained in the instructions for tuning.

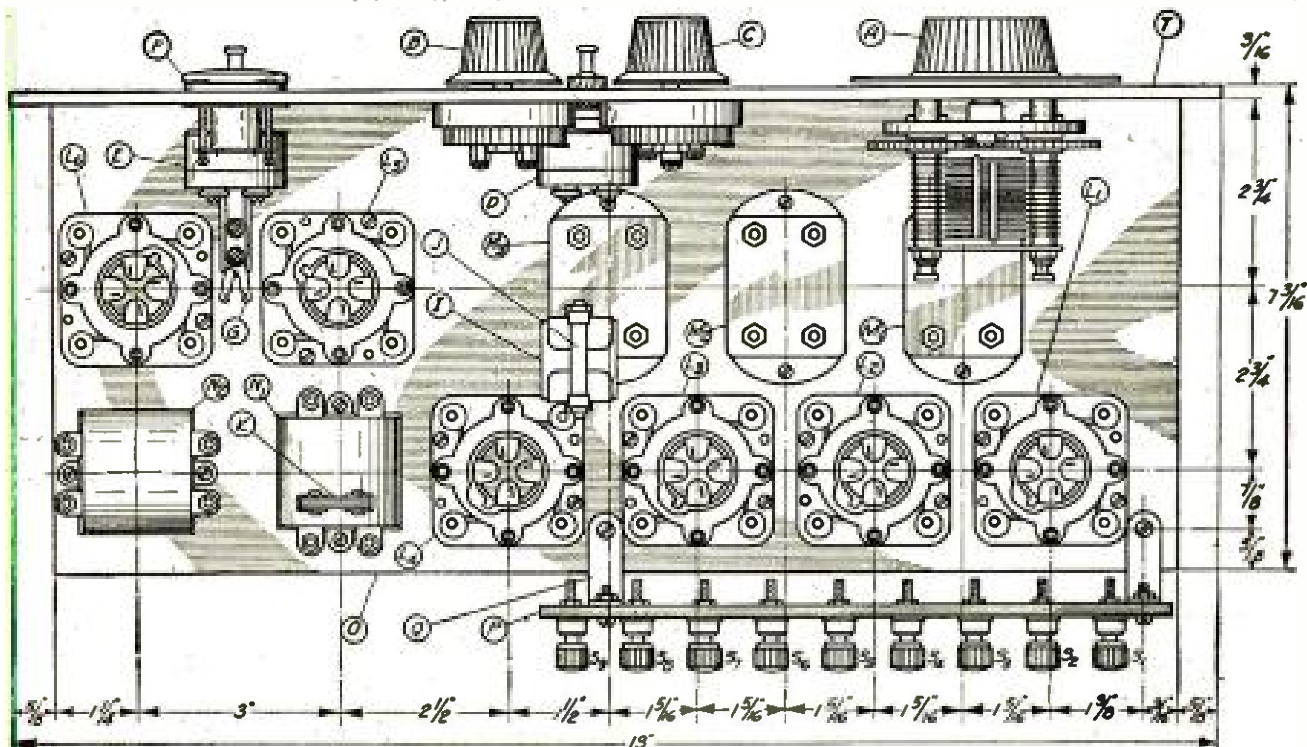

THE WORKING DIAGRAM FOR CONSTRUCTION

FIGURE 5: Here are shown the correct positions for the instruments that are mounted on the baseboard and the panel. The positions are given, center for center, for all instruments.

Then mount the radio-frequency transformers M1, M2 and M3 by means of two wood screws to each instrument.

Next the audio-frequency transformers N1 and N2 are mounted with two wood screws to fasten each instrument.

In mounting these instruments on the baseboard, it is essential that the position of their binding posts be exactly as shown in Figure 5, otherwise, difficulty will be encountered when it comes to wiring up the receiver.

The last job on the sub-base is to prepare and mount the binding post sub-panel P by means of the brass brackets Q. Constructional data on these three accessories appear in Figure 10. This sub-panel should be mounted in the position as shown in Figure 5 after the Eby binding posts Nos. 1 to 9 have been fastened in the holes provided for them.

This completes the mounting of the instruments on the base and it can now be fastened to the panel by means of three wood screws inserted through the holes drilled for them in the panel.

All is now in readiness for wiring the receiver.

How to Wire the Set

The set has been designed for compactness and with a view to keeping grid and plate leads as short as possible. This has been accomplished not only in the layout of the instruments, but also by placing each socket in positions that bring the grid and plate con-

nections nearest to the corresponding connections of the accompanying equipment. Round tinned bus wire has been used throughout. Spaghetti tubing was limited to the three leads running from binding posts 6, 7 and 8, to the transformers N1 and N2. These were the only leads that presented a possibility of short circuit through jarring, etc. The use of straight-shank soldering lugs was found satisfactory for the filament connections of the six sockets and on the two connections of each of the switches, D and E.

The filament circuit is first wired by connecting a length of bus wire to the "F" binding posts at the rear of each of the first four sockets, then continuing this wire through the space between socket L4 and transformer N1, to the "F" binding posts at the rear of sockets L5 and L6. This wire is then connected to binding post 4 at the rear of the receiver. If soldering lugs are fastened to each of these six binding posts, connections will be simplified. Repeat this operation, connecting the six front "F" binding posts of the sockets in the same manner. From this wire, connect another to the left-hand binding post of the rheostat B (looking from the rear of the receiver) and still another to the right-hand connection of the voltmeter F. The left-hand positive lead from the voltmeter is connected to the left-hand binding post of the switch E.

The next connection is that from "F" on transformer M1 to "F" on transformer M2, thence to the right-hand terminal on switch D. From this terminal another wire goes to binding post 3 at the rear of the receiver, and this binding post is also connected to binding post 9.

The left-hand post on switch D is connected to the right-hand post on the rheostat B, which is also connected to the left-hand binding post of the potentiometer C. Finally, the right-hand post of the potentiometer is connected to the "F" post on transformer M3 and from there to the right-hand post on switch E, also to binding post 4 at the rear of the receiver, through the wire connecting this post to the rear "F" terminals on the sockets. Thus the filament wiring of the filament circuit is completed.

Now connect "G" on transformer M1 to "G" on socket L2 and "P" on transformer M1 to "P" on socket L1. Do the same with transformer M2, connecting its "G" to "G" on socket L3 and its "P" to "P" on socket L2. In the case of transformer M3 its "G" binding post is slipped up through one of the holes in condenser I and the condenser is made secure by a drop of solder across the top of this hole and the binding post of the transformer. A small brass bolt is slipped through the other hole of the condenser and is securely fastened by means of a nut. Connection is made from this bolt to the post marked "G" on socket L4. "P" of transformer M3 is connected to "P" on socket L3. The grid-leak

may now be slipped between the clips provided on the condenser.

The "B" binding posts of transformers M1, M2 and M3 are next connected together and from this connector another is run back to binding post 7 at the rear of the receiver, completing the radio-frequency transformer connections.

The variable condenser A is next connected up by running a wire from its right-hand binding post (looking from the rear) to the "G" terminal of socket L1, and then on to binding post 1 at the rear of the receiver. The left-hand terminal of the condenser A is connected to the middle binding post of the potentiometer C, and also to post 2 at the rear of the receiver.

The audio-frequency amplifier is next to be wired. "G" of transformer N1 is connected to "G" of socket L5, and "P" of this transformer is connected to "P" of socket L4. "P" of socket L5 is connected to the top prong of jack G. The bottom prong of this jack is then connected to the bottom prong of jack H, thence to the "B+" terminal of transformer N2 and on to post 7 at the rear of the receiver. The middle prong of jack G is connected to the "P" terminal of transformer N2 and the

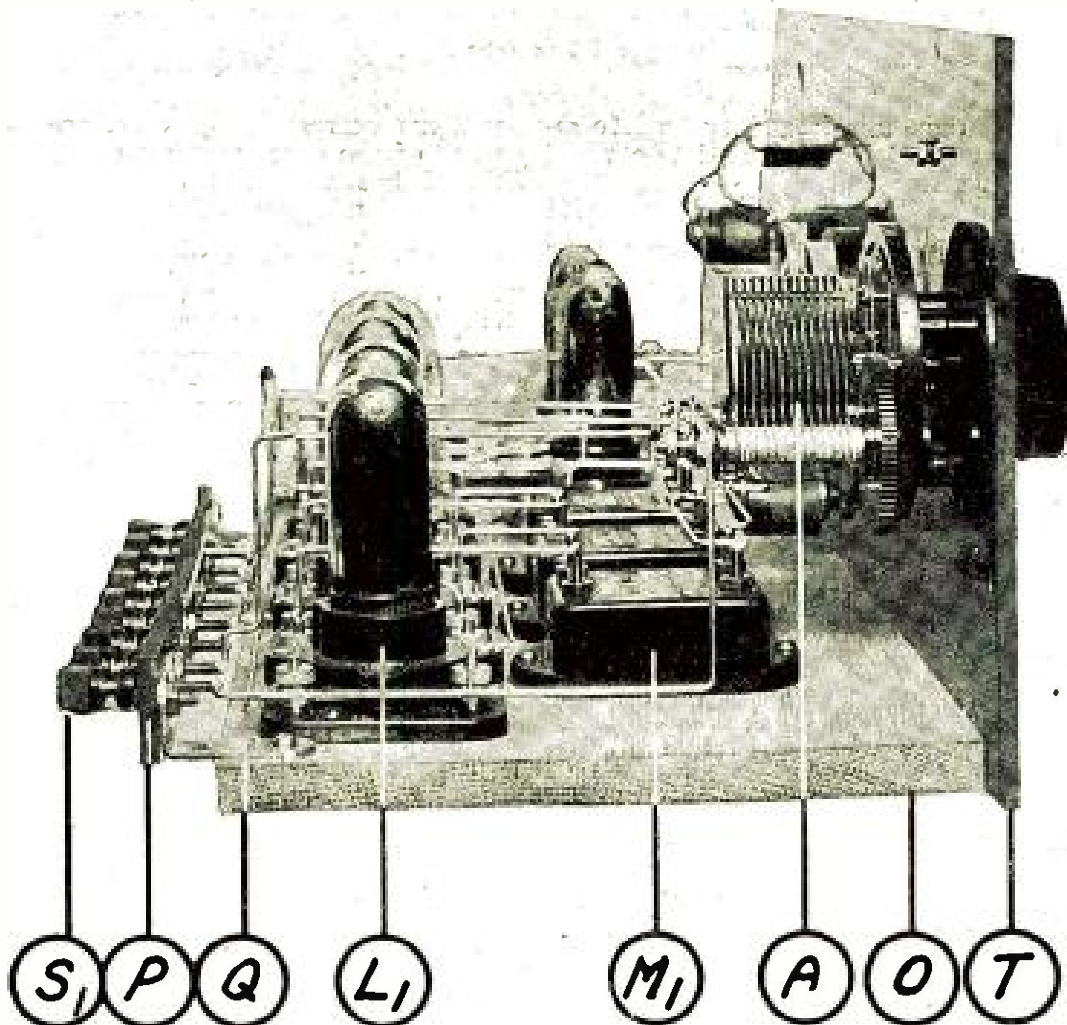

VIEW OF THE SET AS SEEN FROM THE LEFT

FIGURE 6: This illustration shows the general manner of mounting the sockets, binding-post strip, transformers and the radio-frequency transformers.

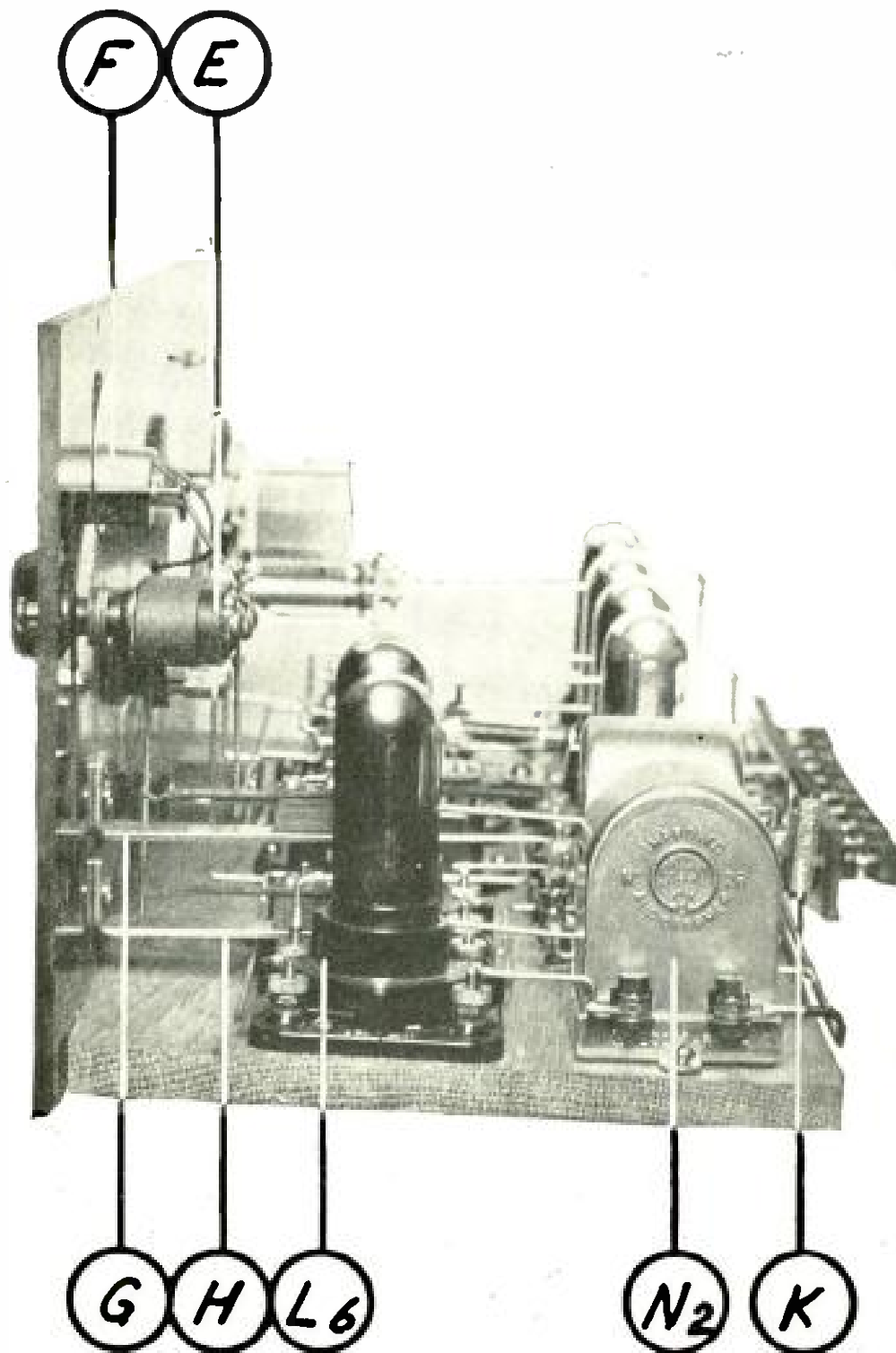

VIEW OF THE SET AS SEEN FROM THE RIGHT

FIGURE 7: This end view indicates the manner in which the audio-frequency transformers, the voltmeter and the rheostats are mounted.

top terminal of jack H is connected to "P" of socket L6.

"F—" of transformer N1 is then connected to "F—" of transformer N2 and from this connection another wire is run to post 8 at the rear of receiver. "B +" of transformer N1 is connected to post 6 at the rear. Connecting "G" of transformer N2 to "G" of socket L6 finishes the wiring of these instruments.

The last job is to connect together binding posts 4 and 5 at the rear of the receiver and to connect the fixed condenser K by means of

two small bolts through the holes, one bolt being connected to "P" of transformer N1 and the other to "B +" of this same transformer.

In all of the foregoing description it is important to note that the term "rear" means the back of the receiver, where the binding post sub-panel is located. When reference is made to "left-hand" and "right-hand" terminals, we assume that we are looking at the receiver from the rear. Also when symbols are included in parenthesis, they stand for symbols stamped on the instruments. Where parenthesis are not

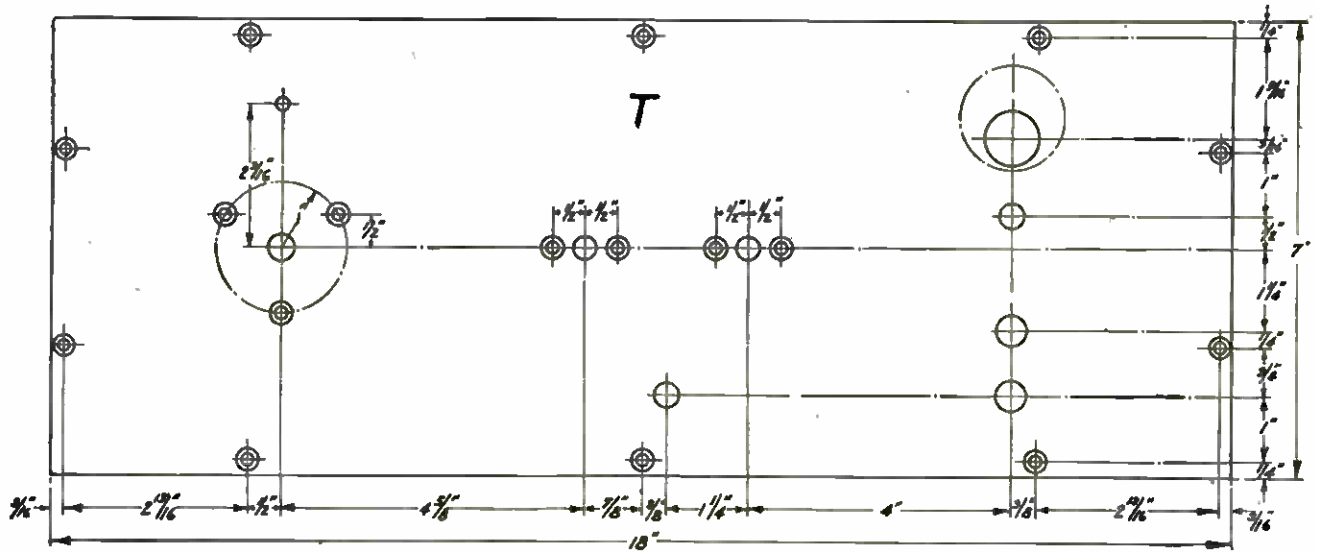

THE DRILLING PLAN FOR THE PANEL

FIGURE 8: This drawing shows where to drill the holes for mounting the instruments. The correct spacings are given for the holes. The holes outlined with a double circle should be countersunk. Always start drilling holes in the panel with a small drill—one-sixteenth is a desirable size. Never attempt the drilling without using a sheet of paper with the holes properly marked on it and then pasted on the panel.

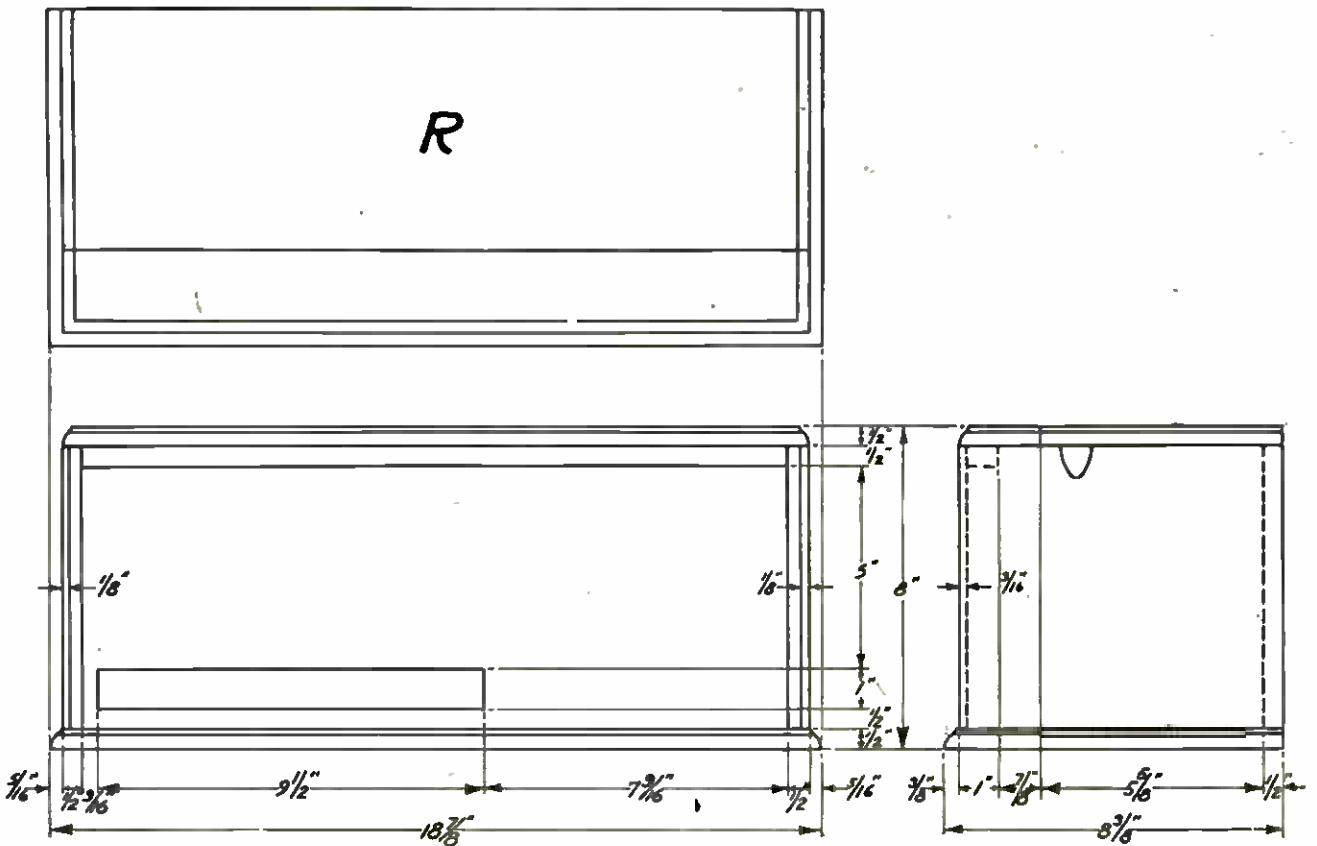

THE DIMENSIONS FOR THE CABINET

FIGURE 9: This diagram (which contains the top, front, and side measurements for the walnut cabinet) may be turned over for construction to a competent cabinet maker who can build it from these directions exactly the right size for the panel.

used, the symbols are those given above in the list of parts, and in the diagrams, to indicate the various instruments.

How to Install the Set

The completed receiver is slipped into the

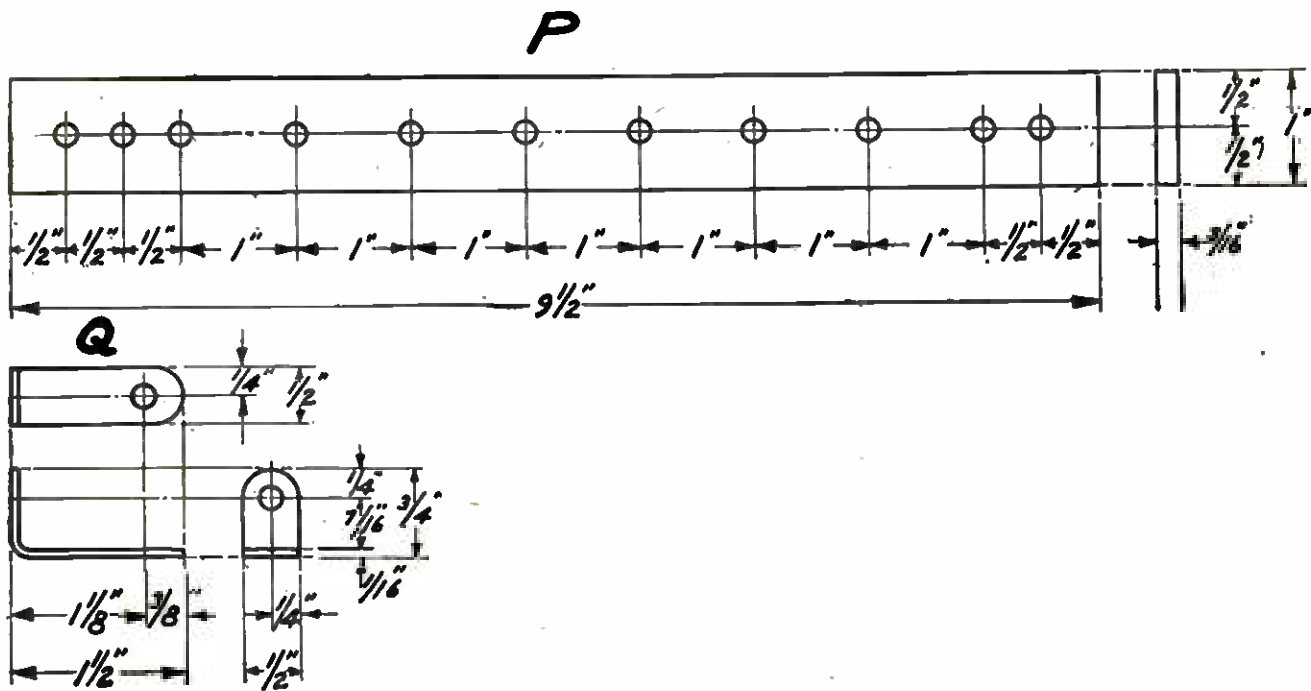

DETAILS OF THE CONNECTION BLOCKS AND THE SMALL BRASS BRACKETS

FIGURE 10: This drawing gives the necessary data for making the insulated blocks or strips on which the binding posts are to be mounted. It also gives the dimensions for the small brass brackets that are used to fasten the blocks to the baseboard.

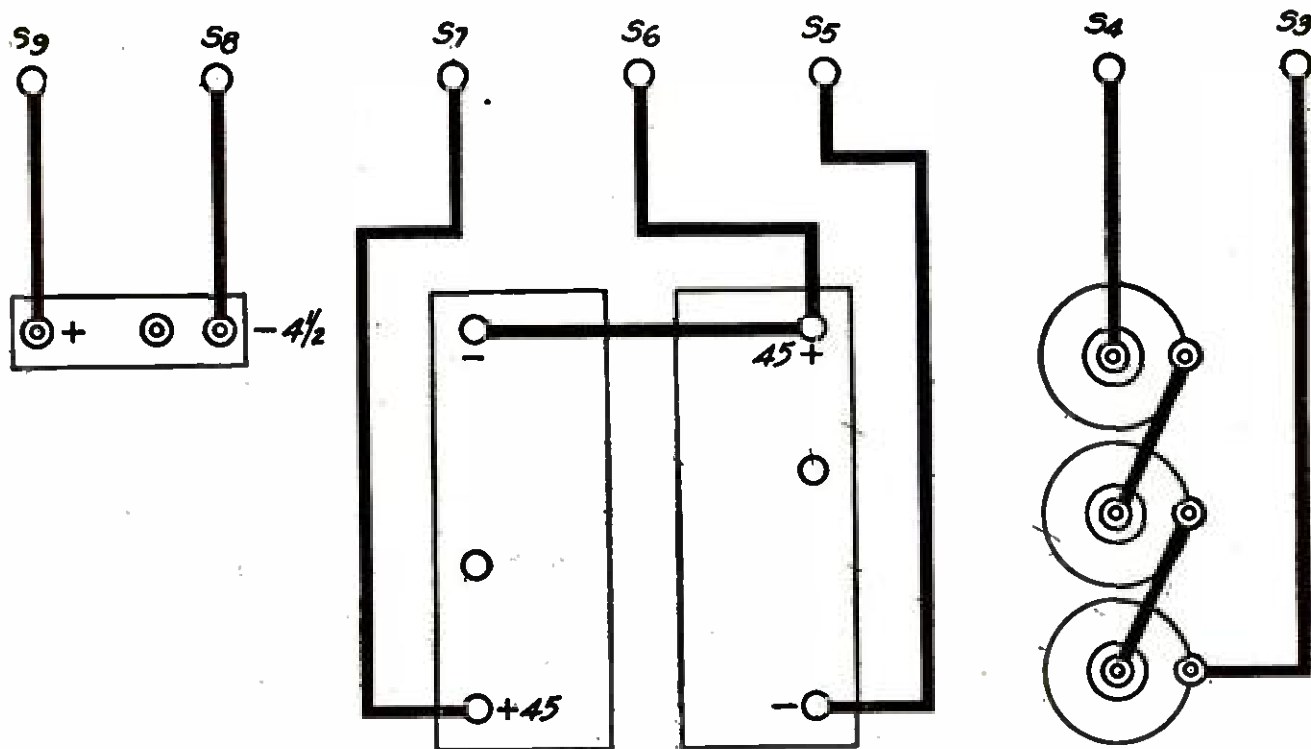

HOW TO HOOK UP THE BATTERIES

FIGURE 11: This drawing prevents you from making mistakes in connecting the batteries to the terminals. If you follow these instructions the set will be hooked up correctly because the terminals shown in the wiring diagrams are marked with designations that correspond with the numbers given here.

cabinet and is made fast by means of screws inserted through the holes around the edge of the panel. The binding post sub-panel at the rear of the receiver will, of course, slip through

the hole provided in the back of the cabinet as shown in Figure 9.

To connect up the receiver Figure 11 should be followed. Binding post 1 is connected to the

this same battery. The best tap can be determined after the set is in operation.

Connect post 7 to the 90-volt tap of the "B" battery.

Connect post 8 to the negative terminal of the 4½-volt "C" battery.

Connect post 9 to the positive terminal of the "C" battery.

Now, after being sure that the switch D is pushed all the way in, and that the rheostat B is turned all the way off, in a counter-clockwise direction, insert a UV-199 or C-299 tube in each socket.

Now pull out the switches D and E and then turn rheostat knob in a clockwise direction until the hand of the voltmeter indicates a filament voltage of 3 or slightly more. Insert the loudspeaker plug in jack H and the receiver is ready for operation.

How to Operate the Receiver

After adjusting the rheostat to the proper setting as indicated by the voltmeter (3 volts) the switch E should be pushed in thereby cutting the voltmeter out of the circuit. This is done to prevent unnecessary drain on the "A" battery, which occurs when a small meter of this type is permitted to remain in the circuit continuously.

With the knob C turned about three-fourths of a turn in a clockwise direction, the dial A should be slowly rotated, started at zero. Somewhere on this dial a broadcasting station will undoubtedly be heard. If not, with the potentiometer C turned a little further, move the dial A again in a clockwise direction. When a station is heard, dial A should be adjusted for maximum volume and the potentiometer knob turned to the point where the signal comes in loud and clear. If this knob is turned too far in a clockwise direction the signal will be distorted, due to oscillation of the receiver.

If a whistling sound is heard during the rotation of the tuning dial, it indicates an oscillating condition of the receiver and that it is tuned to a station. The potentiometer should be turned back to a point where the whistling stops and the broadcasting station becomes audible. At this point a slight adjustment of the dial A will be necessary to bring the station in with maximum volume.

Assuming that a station has been tuned in clearly, the loop should be turned in an effort to make the signal still louder. This is done to take advantage of the directional effect of the loop, volume being greatest when one edge of the loop is pointing toward the station which is transmitting the signals which are tuned in. As the loop is rotated, slight readjustment of dial A will be necessary.

The next operation is to vary the setting of rheostat B slightly, readjusting potentiometer C at the same time to keep the signals at maximum volume. In this way, the rheostat setting which gives the best results may be determined. After this point is found, the switch E should be pulled out and the voltmeter reading noted. Thereafter, best results will be obtained with the voltmeter at this same setting. In no case should the voltmeter reading be higher than 3½ volts and will usually be in the neighborhood of 3. When the voltmeter switch is pulled out the signals which were tuned in may be blotted out. This may be disregarded as the signals will come in again when the voltmeter is cut out of the circuit.

It will be found that stations operating at approximately 400 meters will require the potentiometer to be turned all the way in a clockwise direction while the lower and higher wavelengths will require different settings of this instrument. This is due to the fact that the receiver oscillates more freely on the low wavelengths and high wavelengths. A little practice will demonstrate the extreme simplicity of the tuning operation.

Working Blueprints of This Receiver

IN order to accommodate readers who may desire actual-size diagrams of this Portable "Town and Country" Receiver, a set of three blueprints has been prepared, consisting of—

One panel pattern (actual size);

One instrument layout;

One picture diagram of all parts, showing the wiring.

This set of three prints will be forwarded, postage prepaid, upon receipt of \$1.10.

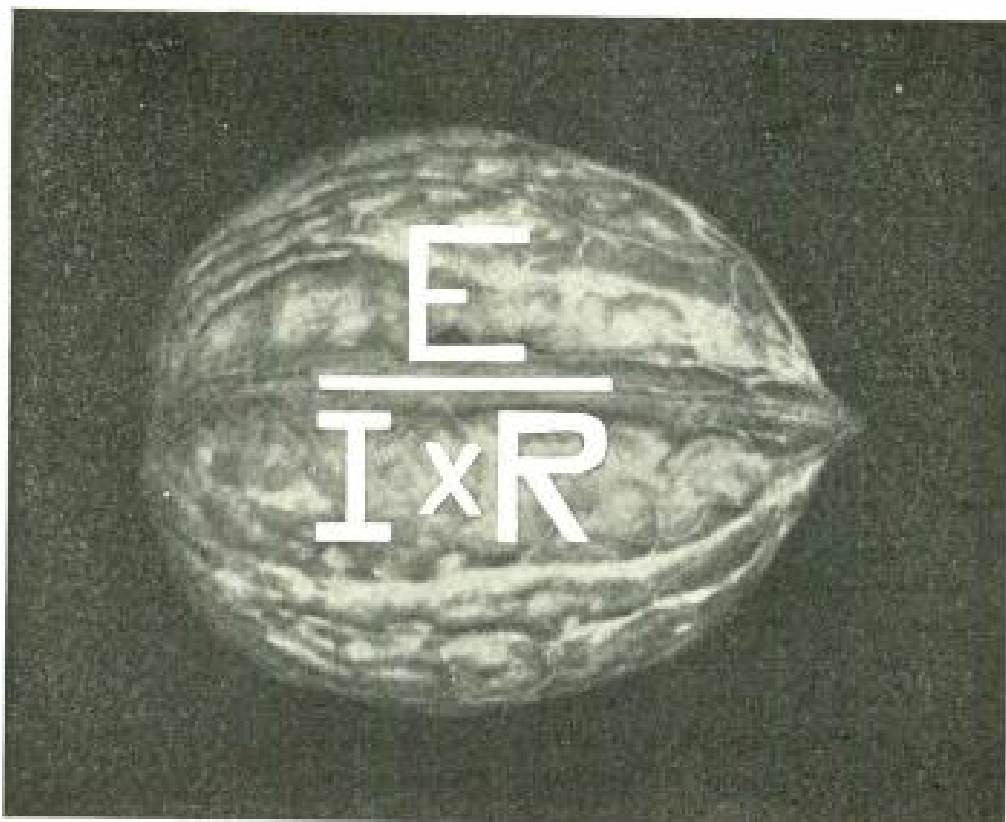

OHM'S LAW IN A NUTSHELL

Chalk Talks in Radio—No. 1

The first of a series of short, informative articles that are written for the radio novice. Keep them for reference

By J. W. GOOSTREE

IN order to understand the fundamentals of radio, we must first learn the electrical sign language—the symbols that are used in the formulas.

The big dynamo, the little dry cell, or any other generator of electricity, has two poles.

The *positive* pole is designated thus: +

The *negative* pole is designated thus: —

The electro-motive force or voltage generated by dynamos and batteries leaves the generator from the positive terminal, and, after transversing the external circuit, returns to the negative terminal.

The external circuit may be wire, coils of wire, or the earth. But whatever it is, it resists the passage of the electro-motive force to some extent. This resistance varies according to the kind of substance, to its length, and to its temperature.

When *any* amount of voltage passes over a circuit of *any* resistance, electric current is present in that circuit. The amount of current in amperes is equal to the voltage flowing, divided by the resistance, or

Amperes = Electro-motive Force ÷ Resistance.

The unit of electro-motive force is the volt. The symbol for it is *E*.

The unit of resistance is the ohm, and its symbol is R .

The unit of current is the ampere, and its symbol is I .

Here, then, is Ohm's law in a nutshell:

$$E = I \times R, I = E \div R, R = E \div I$$

In order to remember Ohm's law, we will use a nutshell which forms a horizontal line where the two halves of the shell meet.

In the upper half of the shell we will place the symbol E (volts) and below the line we will place the symbol I (current), and R (resistance) and between the "I" and "R" we will place the sign of multiplication, \times .

Now, the complete symbol appears as shown in the picture like this:

$$\frac{E}{I \times R}$$

When any letter is covered with the finger tip the remaining part of the symbol is a complete formula for finding the value of the part covered.

I covered leaves $\frac{E}{R}$ or, volts divided by the resistance equals I (current).

E covered leaves $I \times R$, current times the resistance equals E (electro-motive force).

R covered leaves $\frac{E}{I}$.

Electric-motive force divided by the current = resistance R .

¶ The next chalk talk will give Watt's law in a nutshell.

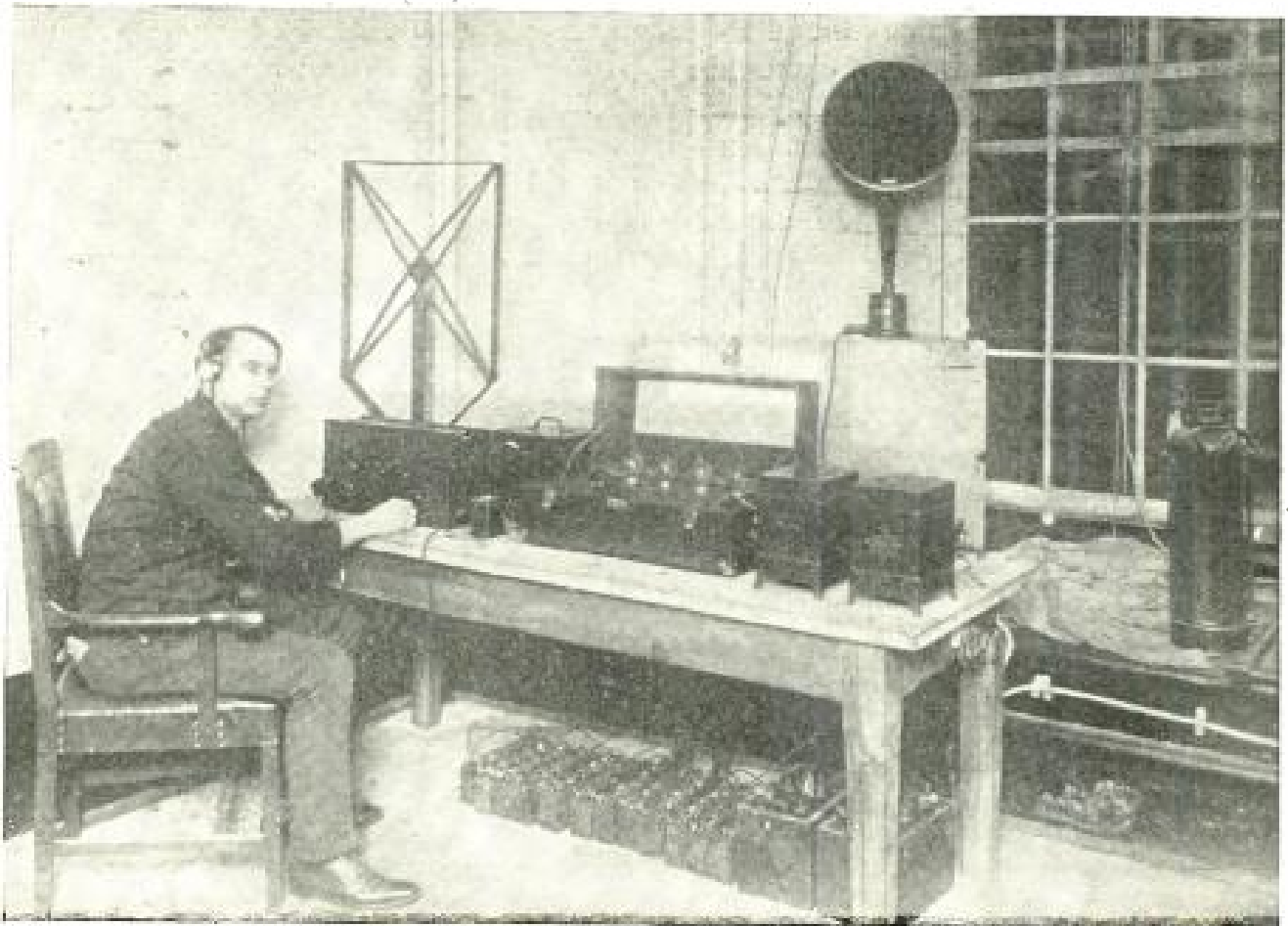

Wide World

RADIO GOES TO PRISON

Several of the inmates of Auburn Prison have been extended the privilege of having radio sets installed in their cells. Several of the prisoners are said to go to sleep with their earphones on their heads! In this picture one of the inmates is shown with a high-powered set that can be heard by many of the men in their cells.

WHAT READERS ASK



CONDUCTED BY LAURENCE M. COCKADAY

In justice to our regular subscribers a nominal fee of fifty cents per question is charged to non-subscribers to cover the cost of this service, and this sum must be inclosed with the letter of inquiry. Subscribers' inquiries should be limited to one question or one subject.

Two Stages of Audio-frequency Amplification Added to the Tuned-plate Regenerative Receiver

QUESTION: Kindly show in a wiring diagram how to add two stages of amplification to the tuned-plate receiver published recently in your magazine. I have been getting fine results with the one-tube set but would like to add more amplification so that I can use it with a loudspeaker. Will two stages be enough?

WALTER J. BREMY

ANSWER: A two-stage amplifier will enable you to use a loudspeaker with the type of tuner that you have. A wiring diagram show-

ing the complete receiver with the amplification added has been drawn for you in Figure 1. The parts that will be necessary for the complete set are as follows:

- L1 and L2—primary and secondary coils of an ordinary, tapped variocoupler;
- VAR—variometer;
- VC1 and VC2—variable condensers, .0005 mfd.;
- GC—mica, fixed condenser, .00025 mfd.;
- C1—mica, fixed condenser, .0005 mfd.;
- GL—variable, grid-leak;
- R1—filament rheostat, 6 ohms;
- R2 and R3—filament rheostats, 20 ohms;
- AFT1 and AFT2—audio-frequency, amplifying transformers;
- J1 and J2—double-circuit jacks;
- J3—single-circuit jacks.

We recommend the use of a soft tube for the detector such as the UV-200 or the C-300 tube. For the two amplifying tubes, use a hard

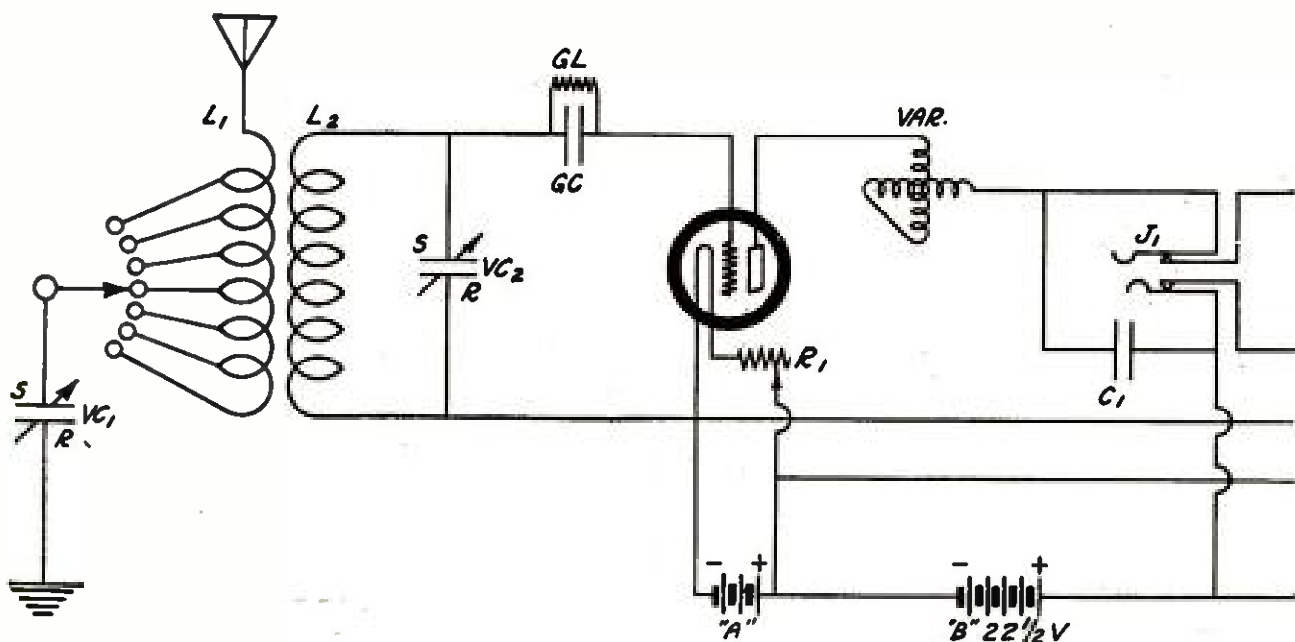

tube such as the UV-201-a or the C-301-a. The antenna tuning is controlled by the taps on the primary coil of the variocoupler and the variable condenser VC1. The secondary tuning is controlled by the variable condenser VC2. Regeneration is controlled by the variometer VAR. The connections for the "A," "B" and "C" batteries are plainly indicated in the wiring diagram.

Which Four-circuit Tuner to Build

QUESTION: I have a number of friends who are using the Improved Four-circuit Tuner, the Three-tube Four-circuit Tuner and one friend who is using your newest Four-circuit Tuner with resistance-coupled amplifier. I have listened in on a number of them but can't decide which to build. I am writing therefore to find out which you consider the best from standpoints of clarity of reception, selectivity, and distance range. I am particularly interested in a five-tube set.

H. B.

ANSWER: The Four-circuit Tuner with resistance-coupled amplifier is the latest and most highly developed of these receivers. An article giving detailed information on its construction appeared in the October, 1924, issue of POPULAR RADIO. Blueprints for this receiver have also been prepared for our readers and they are available for \$1.10 through POPULAR RADIO.

A Comparison of Amplifiers

QUESTION: Will the resistance-coupled amplifier described in connection with the Improved DX Regenerative Receiver function as well and give as good reproduction as the resistance-coupled amplifier used in the latest Four-circuit Tuner described in your October issue? I intend to build the new DX Regenerative Receiver and want to know the proper amplifier to incorporate in the set.

J. S. D.

ANSWER: We recommend that you build the Improved DX Regenerative Receiver exactly as described all the way through including the amplifier. This amplifier is fundamentally, from an electrical viewpoint, the same as that used in the Four-circuit Tuner, although the mechanical arrangement of the parts is somewhat different. If you follow the information given in the article about the DX Regenerative Receiver, you can build a set that will give truthful reproduction if a good loudspeaker is used with it.

Making Connections to a Part or Instrument in a Receiving Set

QUESTION: Do you recommend connecting wires to radio instruments by bending a loop in the connecting wire and fastening it underneath the binding posts of the instrument, or soldering the

HOW TO ADD AUDIO-FREQUENCY AMPLIFICATION TO A TUNED-PLATE RECEIVER

FIGURE 1: This is the hook-up for the tuned-plate receiver similar to that which was described in POPULAR RADIO for September, 1924. This circuit has two stages of audio-frequency amplification.

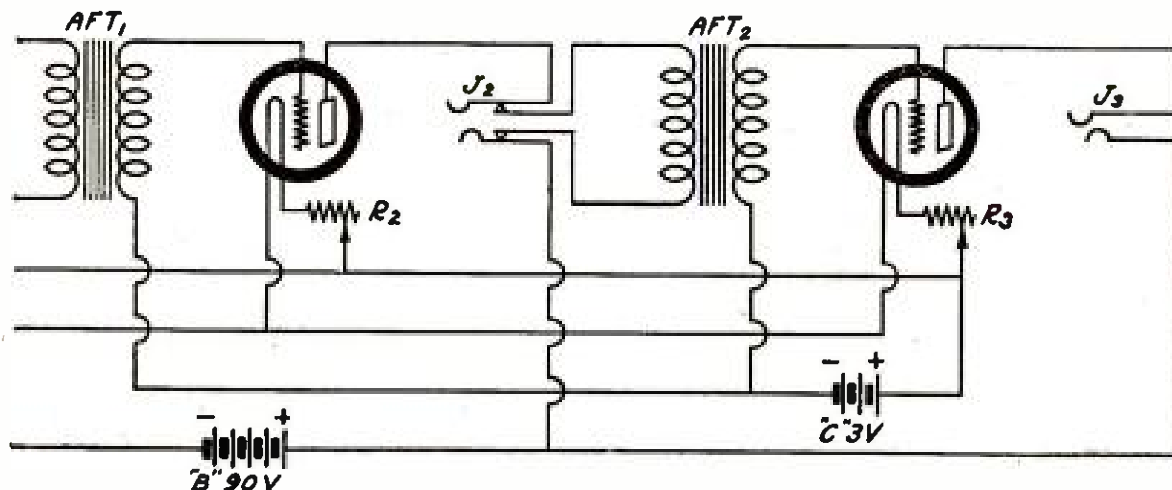

straight end of the wire directly to the soldering lugs?

H. M. P.

ANSWER: The best way to do this is by the second scheme you mentioned—to fasten your connection directly to the soldering lug with a soldered joint. This is the most permanent and highest conductivity joint.

Round or Square Bus Wire for Connections

QUESTION: Which do you recommend for use in making connections between the various instruments in a radio receiver, round bus wire or square bus wire? I have been using square bus wire for the last two years but just recently bought some of the round kind because my dealer was out of the other kind.

JOHN V. STANTON

ANSWER: Electrically there is very little choice between the two kinds of bus wire. However, we prefer the round bus wire, because it is easier to handle. The round bus wire can be bent in any direction, but the square bus wire makes a neat job only when it is bent at right angles to the square sides. It takes a much longer time to cut and bend the square type of wire than it does with the round; and when your job is completed, its general appearance is the same regardless of the kind of wire that you have used.

A Straight Inductively-coupled Vacuum-tube Circuit

QUESTION: I have a standard vario-coupler, a 23-plate variable condenser, a combination Bradley leak and condenser, a UV-200 vacuum tube and socket and a pair of phones. Can you give me a wiring diagram for a straight audion circuit that will include these parts?

JOHN REARDON

ANSWER: In Figure 2, you will find the circuit suitable for the instruments you have on hand. The diagram is self-explanatory and you will only need two other parts beside what you have now. These are the filament rheostat at 6 ohms and a mica, fixed condenser of .0005 mfd. capacity. The "A" battery should be a standard 6-volt storage battery and the "B" battery a 22½-volt dry-cell as shown in the diagram. The antenna circuit is tuned by means of the tapped switch and the secondary circuit is tuned by means of the variable condenser VC. The coupling between the antenna and secondary circuits is varied by rotating the coil L2. This circuit will give you exceptionally good quality of reception on the headphones.

A Receiver That Can Be Used at Home or in the Country

QUESTION: Is there any make of receiver or is there one that I could build, which I could use in my home in the city during the winter months and that would

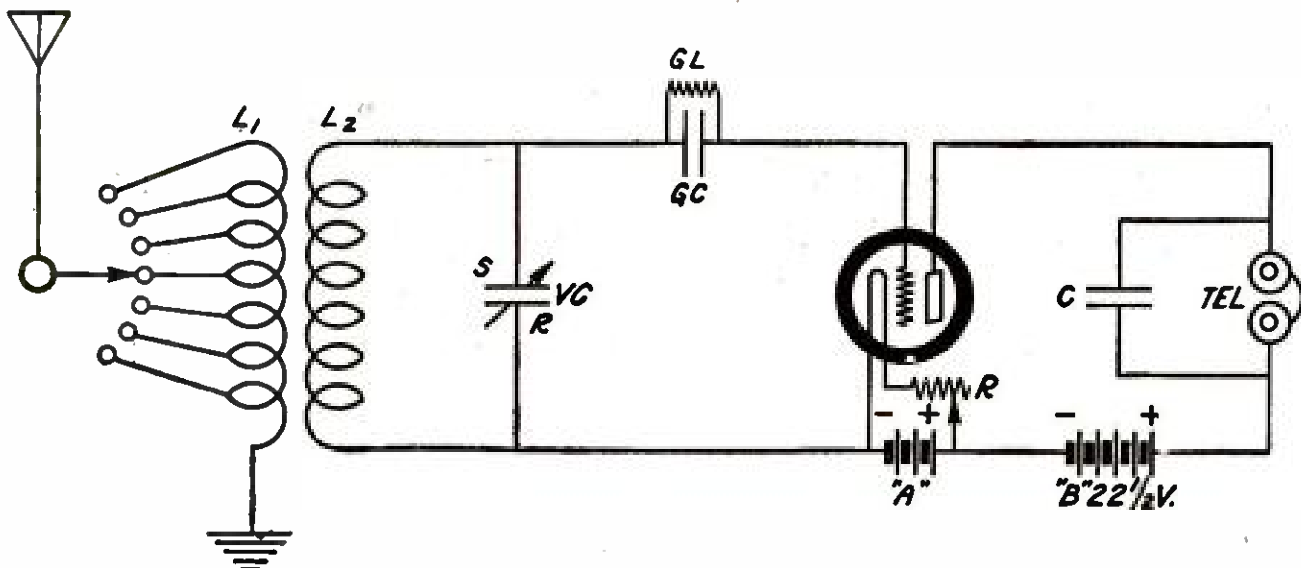

A STRAIGHT INDUCTIVELY-COUPLED HOOK-UP

FIGURE 2: A simple, single-tube circuit is shown in the diagram above that embraces a variocoupler and variable condenser for tuning.

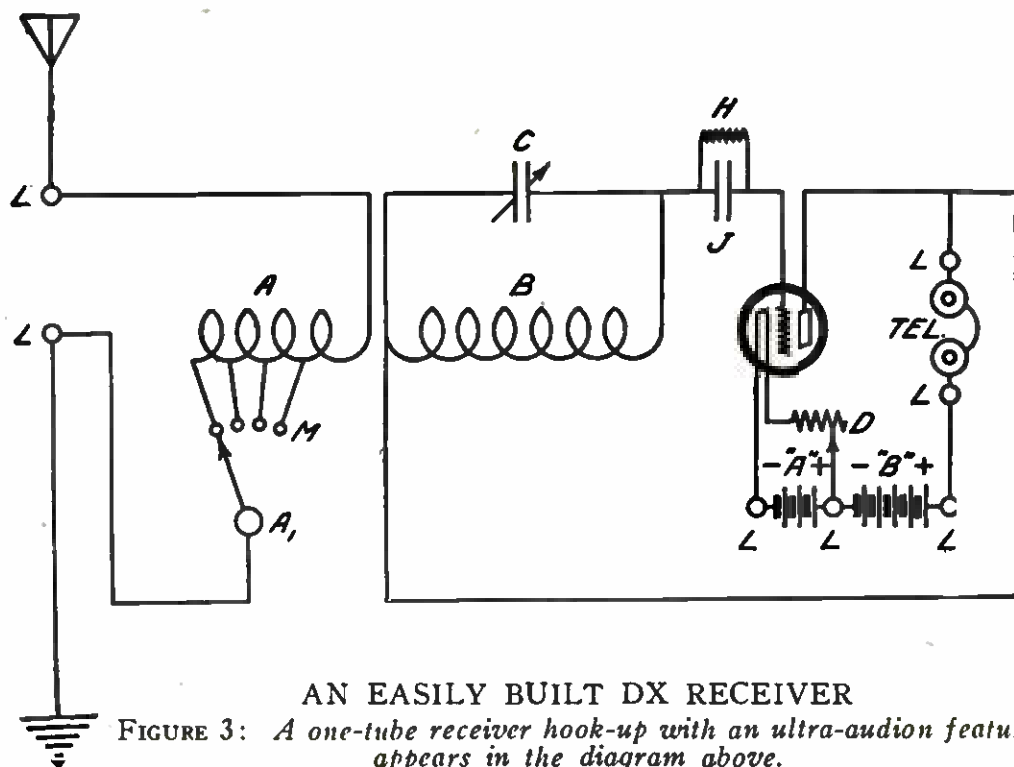

AN EASILY BUILT DX RECEIVER

FIGURE 3: A one-tube receiver hook-up with an ultra-audion feature appears in the diagram above.

be suitable for carrying to my bungalow in the country where I could use it during the summer? The type of receiver I should want would have to operate on dry-cells.

GEORGE S. MOORE

ANSWER: We recommend that you study the article on the Portable Receiver that is described in this issue. This set is just the thing that you are looking for and it operates on a small loop antenna.

A Simplified DX-type Receiver

QUESTION: I would like to build a receiver similar to the one in the April, 1924 issue except that I would rather use the ultra-audion circuit than use the tickler. Please give me a diagram for such a set with one tube? Also, can you show a tapped coil for the primary?

H. J. THOMPSON

ANSWER: In Figure 3, you will find the diagram that you have requested. This circuit was described in detail in a "How to Build" article in the April, 1923 issue of POPULAR RADIO. If you will consult this article, you will find all the specifications necessary for the coils, condensers and other accessories. This set will give you very good results on the headphones for distance reception as it tunes sharply. It has sensitivity and is easy to operate as the tuning is done entirely with the variable condenser C.

Small Tubes for the Eight-tube Superheterodyne Reflex

QUESTION: Is it possible to use a small tube such as the UV-199 tubes or WD-12 tubes with the Superheterodyne Reflex Receiver that was described in the January issue of POPULAR RADIO?

WALTER S. JOHNSON

ANSWER: It is possible to build a receiver that is suitable for the use of these small tubes, but the results will not be as good as with the larger tubes. We recommend the use of either UV-201-a or the C-301-a tubes.

Low-loss Sockets with Low-loss Coils and Condensers

QUESTION: Is there any use in using expensive low-loss condensers and coils unless the sockets that are used with the same parts are also of good enough quality to hold down the losses?

D. B.

ANSWER: This is a very important although little thought of item in amateur-constructed receiving sets. There is no use in using good tuning apparatus unless the socket that is used in the radio-frequency parts of the circuit is also efficient. It pays to buy the most efficient socket that is obtainable to go with the other high-grade instruments, as the radio-frequency

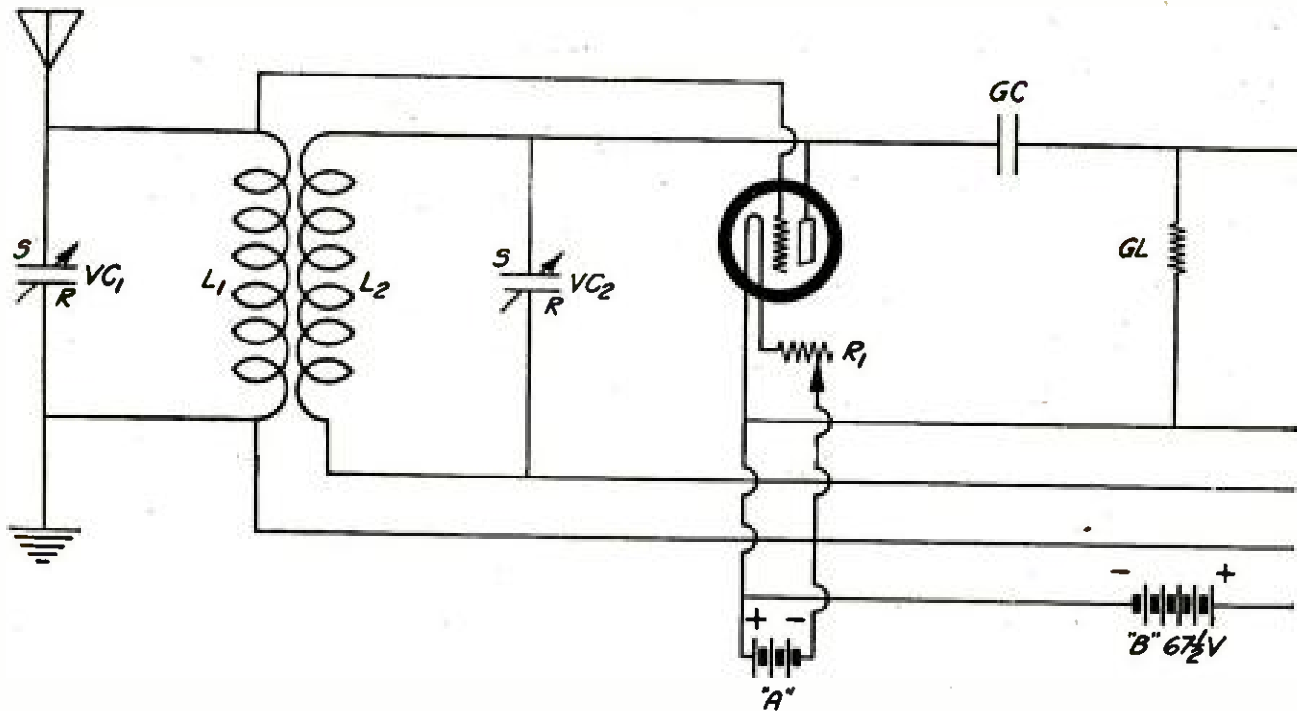

voltages across the socket terminals are of the same order as those across the tuning instruments and therefore, what might be saved in the other instruments, would be lost in the socket unless the socket is also of high efficiency.

GC—mica, fixed condenser, .00025 mfd.;
 C—mica, fixed condenser, .02 mfd.;
 GL—variable grid-leak;
 R1, R2, and R3—filament rheostats, 20 ohms;
 R4—non-inductive resistance, .05 megohm;
 R5—grid-leak, .25 megohm;
 TEL—telephones.

British Tuned-plate Receiver

QUESTION: Kindly give me a diagram of the popular British, tuned-plate, regenerative receiver which employs one stage of regenerative radio-frequency amplification, a vacuum-tube detector and one stage of resistance-coupled amplification. I want to use this set with headphones for distance reception of the British broadcasting stations. My brother in England who is using a tuned-plate receiver of three tubes is able to receive a number of our American stations on the headphones.

HOWARD SMITH

ANSWER: You will find a diagram of connections for the receiver in Figure 4. This receiver when properly adjusted is extremely sensitive and the tone quality on the headphones should be exceptionally good. A short antenna of not more than 50 or 75 feet should be used with it. The parts required for this receiver are the following:

L1—honeycomb coil, size L-35;
 L2—honeycomb coil, size L-50;
 VC1 and VC2—variable condensers, .0005 mfd.;

With this receiver use hard tubes similar to the UV-201-a, the DV-3 or the C-301-a tubes. The two coils, L1 and L2, are mounted in a double honeycomb coil mounting, so that one coil, L2, may swing as on a hinge. This controls the regenerative coupling between the plate circuit and the grid circuit. Tuning of the antenna-grid circuit is accomplished by means of the variable condenser VC1. Tuning of the plate circuit is accomplished by means of the variable condenser VC2. The set will be found extremely critical and will produce high amplification on distant signals.

Efficient Coils Should Be Used with Efficient Condensers

QUESTION: I have an old receiving set that consists of a regenerative detector and two stages of audio-frequency amplification. I use the old combination type of variocoupler and a cheap variable condenser that connects across the secondary. Thinking that I would get more efficient results if I had a better condenser, I bought an expensive one of the low-loss type from a reliable manufacturer. After connecting it in the circuit, I noticed no appreciable increase in signal strength

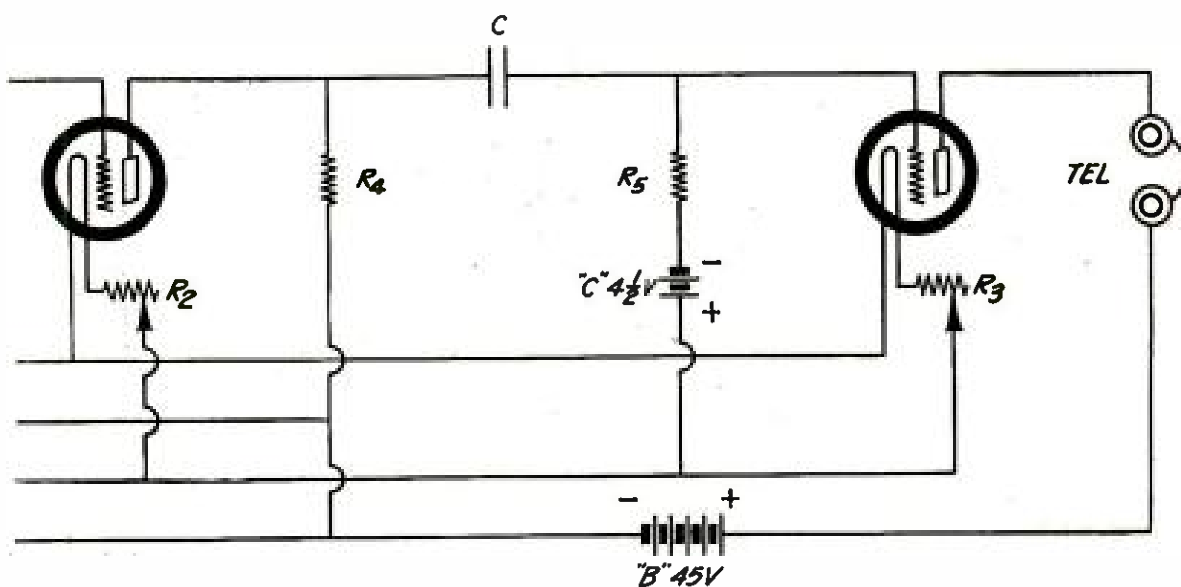

A BRITISH TYPE OF RECEIVER

FIGURE 4: Here is the circuit arrangement of a popular tuned-plate, regenerative receiver used by English fans.

over what I was getting with the cheap condenser. Why is this?

JOHN ANDREWS

ANSWER: In the first place, losses in a receiving set, especially in the radio-frequency parts of the circuit, may be due to low efficiency in the condensers, in the coils, or in the sockets. A receiver with either a poor coil or a poor socket would not work noticeably better with a good or a poor condenser. What you should do is to obtain a new high-efficiency coil or coupler and an efficient tube socket. Then, you will notice a great difference between the cheap condenser and the more expensive one.

The Difference Between Radio and Audio-frequencies

QUESTION: What is the difference between audio and radio-frequencies? Just where does audio-frequency leave off and radio-frequency begin?

MACK ROGAN

ANSWER: The term audio-frequency applied to radio and engineering in general means the frequency of alternating currents, which can be used to produce audible tones in telephone receivers. The audible range of sound of the human ear is approximately between 16 cycles and 20,000 cycles. Some peoples' ears exceed these limits and still other ears are limited to a smaller frequency. Currents, therefore, which range in frequency between the two limits stated, are generally called audio-frequency currents. Radio-frequency currents

oscillate much faster than the highest audio-frequency currents. As used in radiotelephony and radiotelegraphy, these currents range between 30,000 cycles and 5,000,000 cycles. Currents, therefore, below 20,000 cycles are termed audio-frequency currents. Currents above this value are termed radio-frequency currents.

"B" Batteries for the Four-circuit Tuner

QUESTION: May I use the small type "B" batteries with the Four-circuit Tuner?

T. E. McLAUGHLIN

ANSWER: The smaller batteries do not have great enough ampere-hour capacity to be suitable for use with this type of circuit. You will get much better results if you use the larger type. Besides, you will find them more economical in the long run.

Solid or Stranded Wire for Receiving Antennas

QUESTION: Would you advise me to get solid or stranded wire for the antenna? Which would work better, No. 14 solid or No. 14 stranded?

H. E. OSGOOD

ANSWER: Use the stranded wire. It offers greater surface area and is more flexible. It will give better results and stay up longer.



CONDUCTED BY DR. E. E. FREE

Lightning Flashes Heard Around the World

THE pioneer work of Mr. Watson-Watt on the source and causes of the crashing variety of static has already been noted in this department.* These experiments have been continued and extended by the British authorities and an additional account of some of them was given recently by Dr. R. L. Smith-Rose of the National Physical Laboratory, at Teddington, England.†

The most important conclusion which emerges from the new data is that lightning flashes are apparently quite powerful enough to send out radio impulses audible in ordinary receivers clear around the earth. On the average, there is about one static crash per second audible in the ordinary sensitive receiver. The frequency of thunderstorms over the entire earth is sufficient, Dr. Smith-Rose thinks, "to account for all the atmospherics heard in a wireless receiver."

The investigations of Dr. C. T. R. Wilson, in England; of Dr. H. Norinder, in Sweden; of Mr. F. W. Peek, Jr., in the United States, and of others, indicate that the potential of a lightning flash may be as high as 100,000,000 volts and that the quantity of electricity involved may be of the order of 20 coulombs. The recent investigations which Dr. Smith-Rose is reporting indicate a very short time for the static crash—probably about two one-thousandths of a second. This gives an amperage of about 10,000 amperes and a radiation of some 20,000 kilometer-amperes, the average height of the lightning flash being about two kilometers.

When one compares this radiation with the 0.2 kilometer-ampere, or less, characteristic of an ordinary broadcasting station and with the 240 kilometer-amperes attained by the largest present-day radio station, it is evident that the wave sent out by a lightning flash may easily

be strong enough to disturb reception all over the world. Some of the static crashes which you hear these spring nights may be radio messages from some thunderstorm as far off as Australia or China.

A Telegraph Code Composed of Artificial Vowel Sounds

At a recent meeting of the Physical Society of London Dr. W. H. Eccles and Mr. C. F. A. Wagstaffe presented a paper that suggested a most interesting method of sending code telegraph messages in which the code employed is not of the usual dot-and-dash variety but consists of a succession of vowel sounds like "ah," "oo," "ee" and so on.* The idea is of a language composed mainly of vowels; as, indeed, some of the Polynesian languages are. This would be easier to understand when heard, and no doubt easier to learn, than are any of the present types of sound-signal code used for telegraphy.

It would be possible, of course, to have some one familiar with this language speak the code sounds into a microphone in the usual broadcasting manner, but the suggestion of Dr. Eccles and Mr. Wagstaffe is much more ingenious than this. They propose to produce the vowel sounds themselves by an electrical method.

Readers of this Department will remember that some months ago Dr. Harvey Fletcher and Dr. John C. Steinberg, of the American Telephone and Telegraph Company Laboratories, devised an electric machine which could produce vowel sounds and could even be made to say recognizable words such as "papa" and "mama."† A similar production of artificial vowel sounds was accomplished in England by

* "Demonstration of an Electrical Method of Producing Vowel Sounds and Its Application to Wireless Telegraphy," by W. H. Eccles and C. F. A. Wagstaffe. *Proceedings of the Physical Society* as reported in the *Chemical News* (London), vol. 130, pages 43-44 (January 16, 1925).

† "The Papa Machine," *POPULAR RADIO* for May, 1924, page 510.

* "Static Poses for its Portrait," *POPULAR RADIO* for February, 1924, pages 205-206.

† "Atmospherics," by R. L. Smith-Rose. *World Power* (London), vol. 3, pages 20-25 (January, 1925).

Sir William Paget, who used tuned whistles or even a noise blown into his two hands when they were clasped together in certain positions.

The reason why these experiments were so successful is that the sound which we recognize as a vowel is produced, in reality, by a fundamental tone on which are superposed two other tones having a constant interval of pitch between them. For example, said Dr. Eccles, the sound "ah" may be produced by the combination of a fundamental tone of 250 vibrations a second (250 cycles) with two other tones having a pitch difference of 500 cycles; say a tone of 800 cycles and a tone of 1,300 cycles.

Accordingly, if one sends out from a broadcasting station a carrier wave modulated with these three tones—250 cycles, 800 cycles and 1,300 cycles—the result heard in the receiver will be the vowel sound "ah." Other vowels can be produced in the same way, the pitch difference between the two accessory tones being the thing which characterizes each recognized vowel.

But it is not necessary, Dr. Eccles suggested, to send out a modulated wave at all. Instead one may send, for example, a carrier wave of 100,800 cycles and another carrier wave of 101,300 cycles. At the receiving station these

can be combined, on the usual heterodyne principle, with a locally-generated oscillation of 100,000 cycles. The result will be *two* audio-frequency notes; one of 800 cycles, the other of 1,300 cycles. The difference of these two is the needed 500 cycles. If they be combined, then, with a 250-cycle note, also generated at the receiving station, what is heard is the vowel "ah," even though no one at either the transmitting station or anywhere else has spoken this vowel and even though no microphone or modulation of any kind has been employed.

A series of carrier waves of varying frequencies may be employed thus to produce various vowel sounds, or a smaller number of carrier waves may be used and combinations arranged between them to give the desired differences in pitch, or one carrier wave may be employed and modulations of high or of low frequency may be superposed on it. All this may be controlled by a keyboard, so that when a certain key is pressed at the transmitting station the ear at the receiving station hears what sounds like the spoken vowel corresponding to that key.

It is unfortunate that consonantal sounds cannot be produced in the same way. If they could, one would need merely to write phonetically on a typewriter properly connected to the transmitting circuits and the recipient

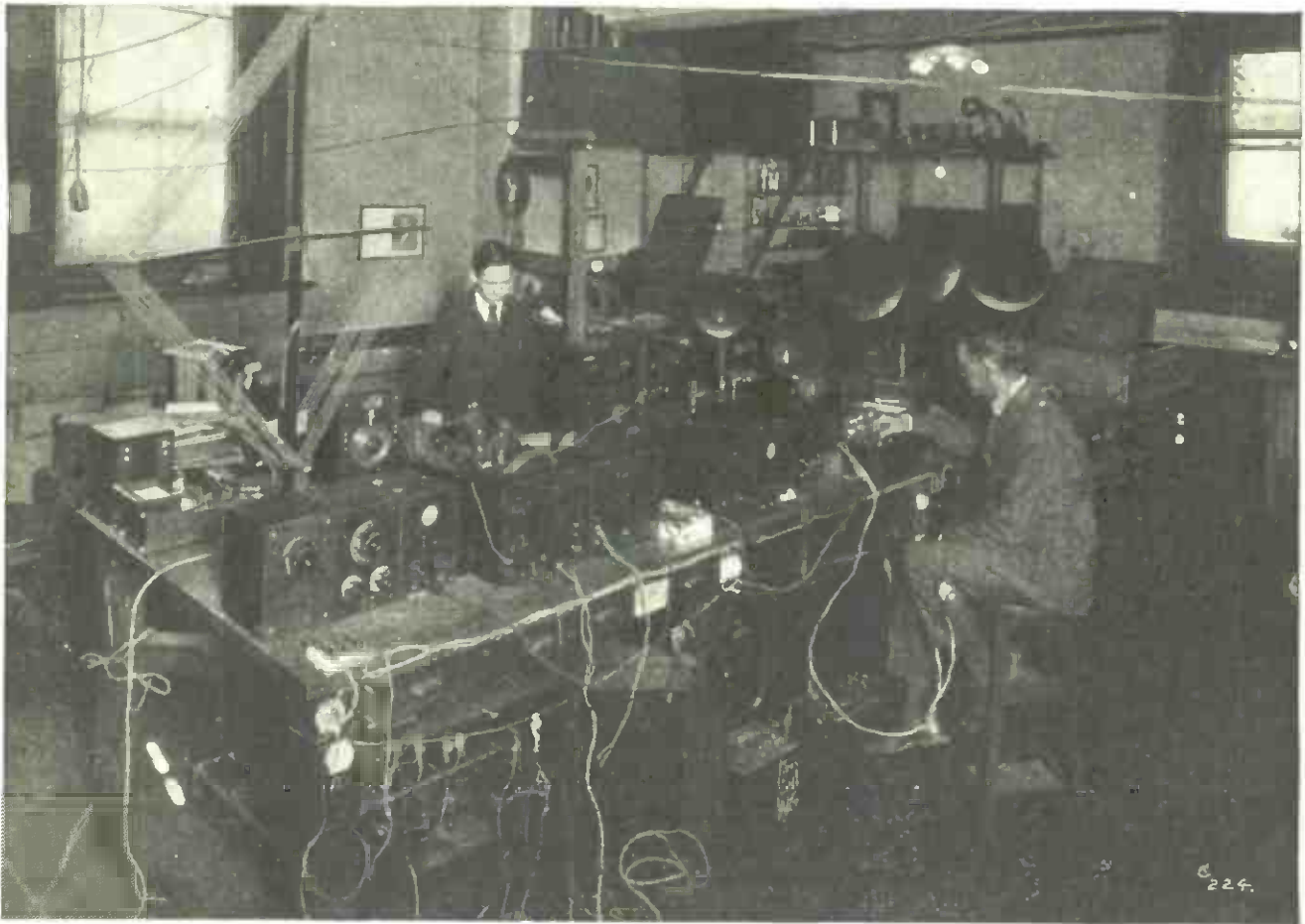

Radio Corporation of America

TESTING LOUDSPEAKERS FOR "STUTTERS"

The ideal loudspeaker would reproduce every frequency to which the human ear responds. The next best thing to this state of perfection is the proper production of the vowel and consonant sounds on which oral language is based.

would hear speech. It is by no means impossible that this actually will be possible some day. But the sounds of the consonants are much more complicated (in general) than are the vowel sounds. Dr. Fletcher's "papa machine" could say only a few of them and these with considerable imperfection. Dr. Eccles does not suggest their use at all. He would rely upon a code language consisting entirely of vowels.

The Sun's Energy Returning to Normal

It is known to most newspaper readers that the Smithsonian Institution, in Washington, D. C. has been engaged for a number of years in regular daily measurements of the amount of energy received by the earth from the sun in the form of light and heat. It is also well known that for the past three years this energy of solar radiation has been about two percent below normal. Recent irregularities of weather, the unusual warmth of the water of the North Atlantic, and a number of other exceptional features of present earth conditions have been ascribed, more or less probably, to this deficiency of solar radiation.

It appears, however, that this deficiency is not to be permanent. Dr. C. G. Abbot, who has been in charge of this investigation, reports that the solar radiation (as received by the earth) has increased again and is already back to its normal average.* It appears therefore—what was suspected by the astronomers as soon as Dr. Abbot's first results were announced—that our sun is really a "variable star," that is, a star the light and heat of which alter a little from time to time according to a more or less regular cycle.

These facts have an especial importance for radio. There is no longer room for doubt

* "The Present State of the Solar Radiation Investigations of the Smithsonian Institution," by Charles G. Abbot. Paper presented before the meeting of the American Astronomical Society, Washington, D. C., January 1, 1925. An account of the whole series of measurements of solar radiation has been published recently as Publication 2818 of the Smithsonian Institution, Washington, D. C., issued February 17, 1925.

that the phenomena of radio transmission, mysterious as they still remain, have a most intimate relation to the numerous radiations—heat, light, ultra-violet, electrons and others—which the earth is receiving continually from the sun. The fundamental causes of static, the truth about the Heaviside Layer theory, the reasons for good and bad transmission under different conditions of earth-illumination; these are only a few of the radio problems whose solutions must involve a knowledge, more or less complete, of things that are happening ninety-three million miles away on the surface of the star to which we are attached.

It is fundamental and careful investigations like those which Dr. Abbot has carried out—and which, happily, he is continuing—that will give us some day the keys to these radio mysteries.

Rocks Do Absorb Radio Waves

THERE has always been a general idea that when radio waves are compelled to pass through soil or rock, a part of the wave energy is lost by absorption, a greater part than is lost when the waves pass through a vacuum or through air. This has now been established, as an experimental fact, by the work of the United States Bureau of Mines on underground radio.

In continuation of previous experiments* on the use of radio as a signalling system for mine rescue work, Mr. J. J. Jakosky and Mr. D. H. Zellers of that Bureau have measured the detector plate current as affected by a transmitted signal at different distances from the detector and with three different wavelengths; 295 meters, 450 meters and 540 meters.† When the transmission was through the air, both stations being above ground, the effect of the transmitted signal was substantially greater at a given distance than when the transmission

* For accounts of these experiments see POPULAR RADIO for June, 1924, page 624 and for October, 1924, page 412.

† "Factors Retarding Transmission of Radio Signals Underground, and some Further Experiments and Conclusions," by J. J. Jakosky and D. H. Zellers. United States Bureau of Mines (Washington, D. C.). Reports of Investigations (mimeographed), number 2651. 12 pages, issued November, 1924.

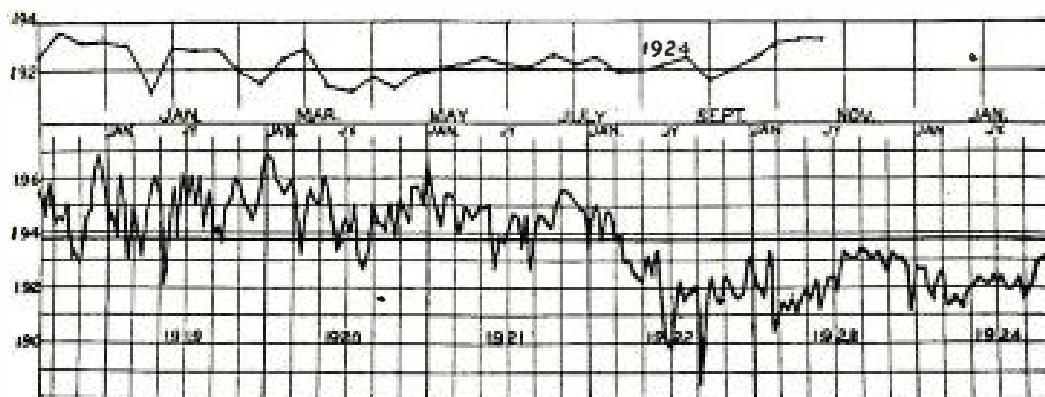

Smithsonian Institution

WHIMS OF THE SUN THAT MAY AFFECT RADIO TRANSMISSION

This chart shows how the radiant energy received by the earth from the sun has fluctuated during the past three years.



Gilliams Service

A UNIQUE RADIO LABORATORY

Experiments with the broadcasting of pictures by radio are being conducted from the studio of the Nauen station in Germany, shown above. Concerts, lectures and addresses are broadcast regularly from here with exceptionally high-powered transmitters.

was through the earth, from stations located underground.

There was encountered, also, an interesting variation with the wavelength. Above ground the shorter waves fell off least with increasing distance (up to a distance of 250 feet). Below ground this was reversed. It was then the long waves which were least absorbed, the 295-meter wave being absorbed the most.

Beware of Chemicals for Charging Storage Batteries!

THE newest radio swindle is the sale of mysterious solutions or chemicals or salts which are alleged to serve, when added to a storage battery, to recharge the battery without subjecting it to the usual process of passing an electric current through it for the necessary time.* All the samples of such chemicals which have been examined by competent authorities have turned out, so far as we can learn, to be entirely without value. It is extremely doubtful whether anything of this kind ever could

* Some tests of such solutions and a warning against them is contained in the *Technical News Bulletin* of the United States Bureau of Standards, number 94, issued February 10, 1925, in the form of mimeographed sheets.

be developed, the whole idea being quite contrary to what we know of electrochemistry.

The fact that these solutions do sometimes cause what seems to be a rejuvenation of a run-down battery is easily explainable. The active material in the usual type of lead-plate storage battery is a lead compound contained in the tiny grooves on the plate. When a battery is discharging this active compound is reacting chemically with the solution in the battery and is producing the current. On the other hand, when a battery is being charged the active compound is being re-formed on the plate. A battery is run-down and needs a re-charge as soon as the majority of the active compound has been used up by reaction with the solution.

Now any run-down battery usually has a little of the active compound left on the plate. If the old acid is poured out of the battery and some new acid put in, this residue of active compound will begin to react with the new acid and the battery will give a little more current. It will not give much more current for the part of the active compound still left behind is small and it is soon exhausted altogether.

That is the secret of the transient increase of current produced by most of the battery "renewer" liquids now being sold. They are

merely some new acid. Others contain a common chemical, sodium sulphate or "Glauber's salt." This has a good deal the same effect, an effect well known to chemists for years.

None of these things do a battery any good. Most of them do it harm. Until the chemists discover something altogether new about storage batteries—which is not in the least likely to happen—the only way to re-charge a storage battery will be the good old-fashioned way of running an electric current into it.

The Government Studies Rectifiers

A PUBLICATION which fills a real need has appeared from the laboratories of the Bureau of Standards.* It discusses, both experimentally and theoretically, the characteristics of the various types of rectifiers now so much used by radio fans to convert the usual alternating-current house supply of electricity into direct current for the home charging of radio storage batteries.

There are descriptions of the aluminum rectifier, of the tantalum rectifier, of the various types of vacuum-tube rectifiers and of the mechanical or "vibrating" rectifiers. The general theories are described, performance curves are given and some notes are included concerning the connection of the different types

* "Theory and Performance of Rectifiers," by H. D. Holler and J. P. Schrodt, *United States Bureau of Standards* (Washington, D. C.), Technologic Paper number 265 (part of vol. 18), pages 465-527 October 9, 1924).

of rectifiers into circuits of different electric and magnetic properties.

The pamphlet, being itself a condensation of much scattered information, is not suitable for further compression. Every radio experimenter will find it valuable. It can be obtained from the Superintendent of Documents, Washington, D. C. at a price of twenty cents. Send coin or a money order and quote the title and number given in the footnote below. Stamps or checks are not accepted.

Will Radio "Teletypes" Replace the Mails?

LAST October POPULAR RADIO published an article suggesting that automatic devices operated either by radio or by wire might some day replace a large part of the expensive and time-consuming correspondence needed in the conduct of modern business.* In a remarkable paper submitted to the Institution of Electrical Engineers five days before the appearance of the issue of POPULAR RADIO referred to, and delivered before that institution on December 18, 1924, Mr. Donald Murray makes the same suggestion in a much more definite manner and with a wealth of engineering detail.†

What Mr. Murray suggests is the general use in business offices of the printing telegraph or "teletype." These machines are already rea-

* "Will Radio Write Our Letters?" by Thomas Elway. POPULAR RADIO, vol. 6, pages 372-376 (October, 1924).

† "Speeding up the Telegraphs: A Forecast of the New Telegraphy," by Donald Murray. Cited from an advance proof for publication in the *Proceedings of the Institution of Electrical Engineers* (London).

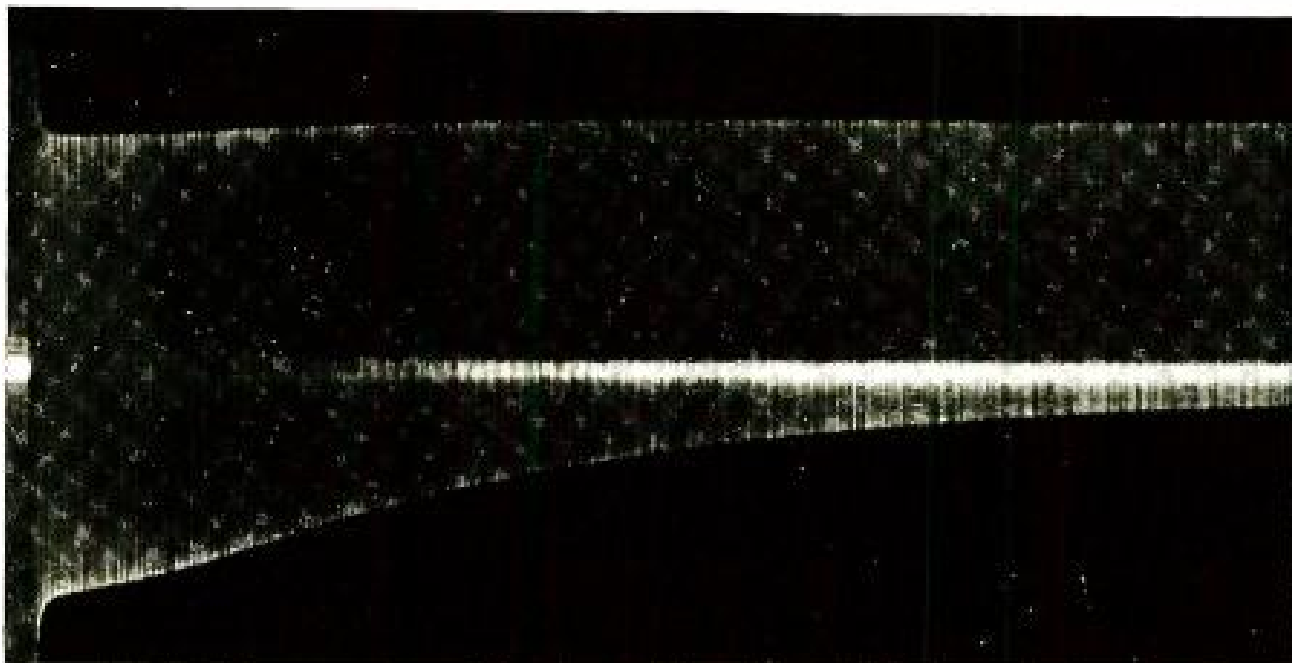

Bureau of Standards

A "PICTURE" OF A RECTIFIER IN ACTION

This oscillogram is a study of the time required for an oxide film to form on the electrode of an aluminum rectifier. At the end of 15 seconds the electrode was almost entirely coated as is indicated at the right where the smooth white line begins. When this condition of the electrode is reached electrons will flow from but not to the electrode. On this phenomenon is based the action of aluminum rectifiers that are sometimes used on A.C. as "B" battery substitutes.

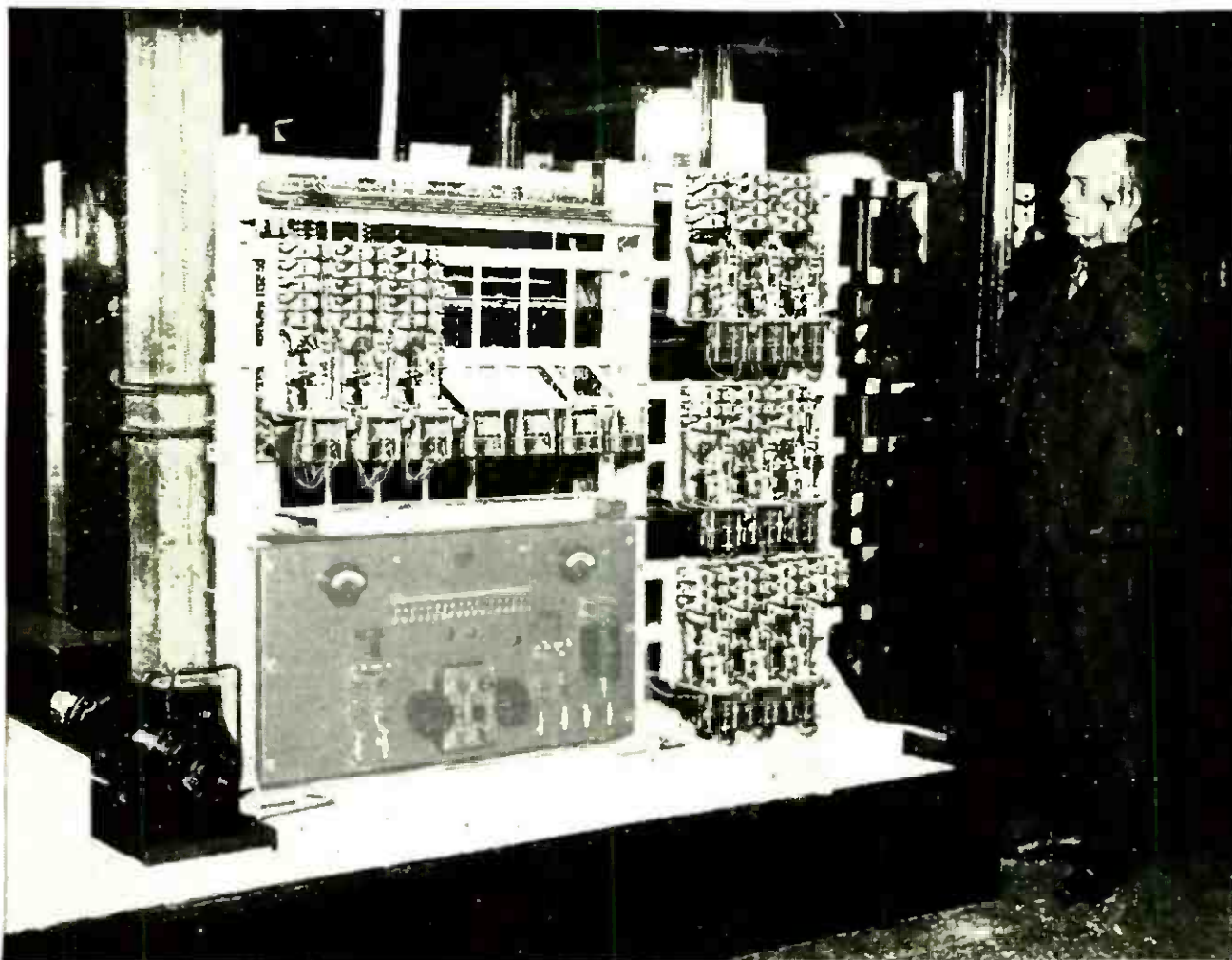

Harris & Ewing

A RADIO MAIL SERVICE OF TOMORROW?

When the typist of the future sits at her typewriter in Chicago and "mails" a letter, as she writes it, through a radio teletype system that operates another typewriter at some distant place, an automatic "central" (like the one shown above), will connect the two typewriters so that they will print the same correspondence. The apparatus in the picture, which automatically controls 50 telephones, is located in the Smithsonian Institution at Washington, D. C.

sonably perfect and are in common use, both for radio transmission and wire transmission.† They can be installed, Mr. Murray believes, much as telephones are now. Automatic exchanges can be provided and the machines can be arranged, without difficulty, so that the sending and receiving machine operate synchronously without attention by the operator. The result would be the transmission of written messages from office to office with all the speed and convenience of the present transmission of spoken messages by telephone.

The stenographer in one office would simply "call" the machine in the office for which the message was intended, just as a call is now made by telephone. When the automatic exchange had established the connection, the sending stenographer would type the message on an apparatus like an ordinary typewriter. Simultaneously, the receiving machine in the other office would make a typed copy of the

† See, for example, "A New and Remarkable Long-distance Typing Machine," by William G. H. Finch. *POPULAR RADIO*, vol. 6, pages 257-266 (September, 1924).

message. A "carbon" would be kept, of course, by the sending machine.

It must be confessed that this plan, revolutionary as it is, appears entirely practicable. No new or unknown apparatus is required. It is reported, indeed, that test installations are about to be made. Possibly Mr. Elway's predictions of a radio—or, strictly speaking, an electrified—correspondence system are closer to realization than even he dreamed.

New Data on Vacuum-tube Filaments

THE results of research work in electronic emission from tungsten, molybdenum and tantalum are published in an article by engineers of the General Electric Company,* who conduct researches in the manufacture of radio vacuum tubes and incandescent lamps. Their findings will interest tube "cranks."

* "Electron Emission from Tungsten, Molybdenum and Tantalum," by S. Duschman, et al. *The Physical Review*, vol. 25, no. 3, pages 338-360 (March, 1925).

Important New Experiments With Short Waves

A FEW months ago Senatore Marconi described in an address before the Royal Society of Arts, in London, the first series of his experiments on the use of short radio waves directed by reflectors, the method commonly known as the "Beam System" of radio.* In another address before the same society on December 11, 1924, he gave some interesting details of the continuation of these same experiments.†

The previous experiments had indicated, it will be remembered, that waves in the neighborhood of 100 meters could be sent out more or less perfectly in a given direction and that these directed beams would reach, under favorable conditions, from England to South America, to the United States and even to Australia. It was found, however, that the daylight range of these waves was much less than their range at night; a result in perfect agreement with all other data as to the differences between night time and daytime radio transmission.

In August, 1924, Senatore Marconi began additional experiments between the transmitting station at Poldhu, England, and his yacht, the S.S. *Elettra*, to see whether this daytime deficiency of the short waves could be overcome. Comparative tests were carried out with waves of 92, 60, 47 and 32 meters.

Surprisingly enough, it was found that the shorter waves showed much greater daylight ranges than did the longer ones. While the

Elettra was at Beyruth, at the eastern end of the Mediterranean, the 32-meter waves were received regularly all day while the 92-meter ones were lost altogether during a large fraction of the daylight.

Encouraged by these successes, Senatore Marconi arranged a series of tests on 32 meters between the Poldhu station and especially installed receivers at Montreal, New York, Rio de Janeiro, Buenos Ayres, Sydney (Australia), Bombay and Karachi (India), and Cape Town (South Africa). All tests were successful, the daylight absorption of these short waves, either with or without the directed-beam reflectors, proving to be far less than the similar absorption of the waves of 92-meter wavelength or of the still longer ones. The power used at Poldhu was usually 12 kilowatts although powers between 9 kilowatts and 15 kilowatts were used in some of the tests.

Senatore Marconi does not suggest any theoretical explanation for these really remarkable results, remarking merely that for some time now the practical utilization of long-distance radio has been considerably in advance of theoretical knowledge concerning it.

From the practical viewpoint the importance of these new tests lies in the promise of radio communication over most of the earth's surface during all hours of the twenty-four and with transmitting stations much less powerful, less bulky and less costly than those needed for the very long waves which are now preferred. It is conceivable, also, the Senatore suggests, that the use of much shorter waves in broadcasting may make it possible for the English fans to hear American stations at what he characterizes as "reasonable hours," the reception of American broadcasts in England being possible at present only at a time in the morning when all right-thinking Englishmen are comfortably in bed.

* See "Marconi's New Short-Wave Tests," POPULAR RADIO for October, 1924, page 408, and "New Directional Antenna Described by Marconi," POPULAR RADIO for November, 1924, page 508.

† "Radio Communications," by Senatore Guglielmo Marconi, *Journal of the Royal Society of Arts* (London), vol. 73, pages 121-133 (December 26, 1924).

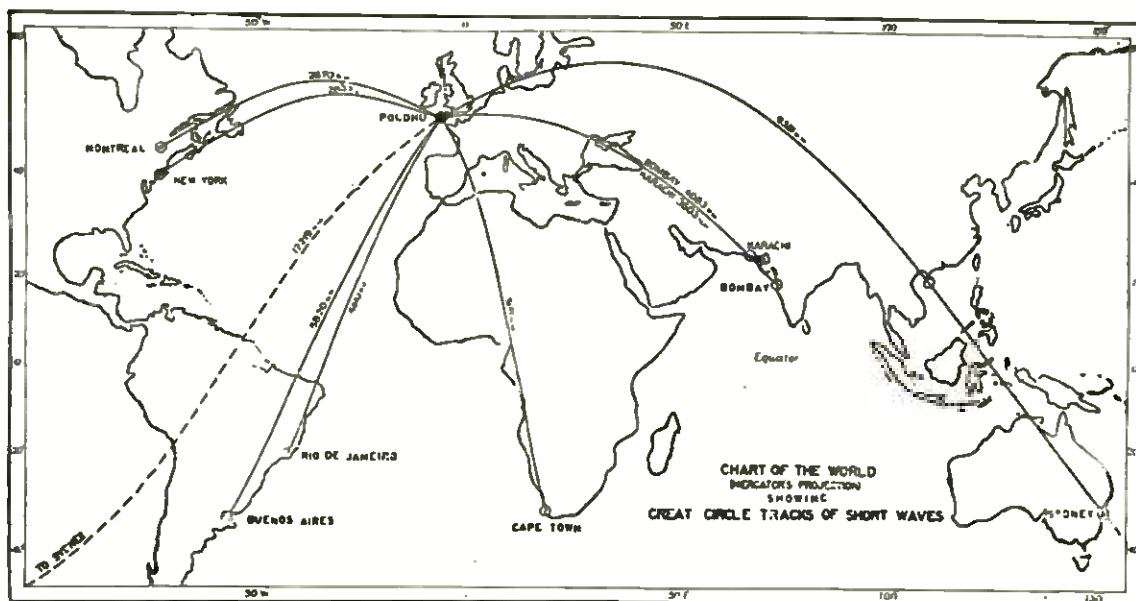

Journal of the Royal Society of Arts

WHERE THE "BEAM" SYSTEM TESTS WERE MADE

Recently Senator Marconi made public the results of his tests with short-wave transmitters, the waves of which were absorbed less in daytime operation over the areas shown above than were longer waves.

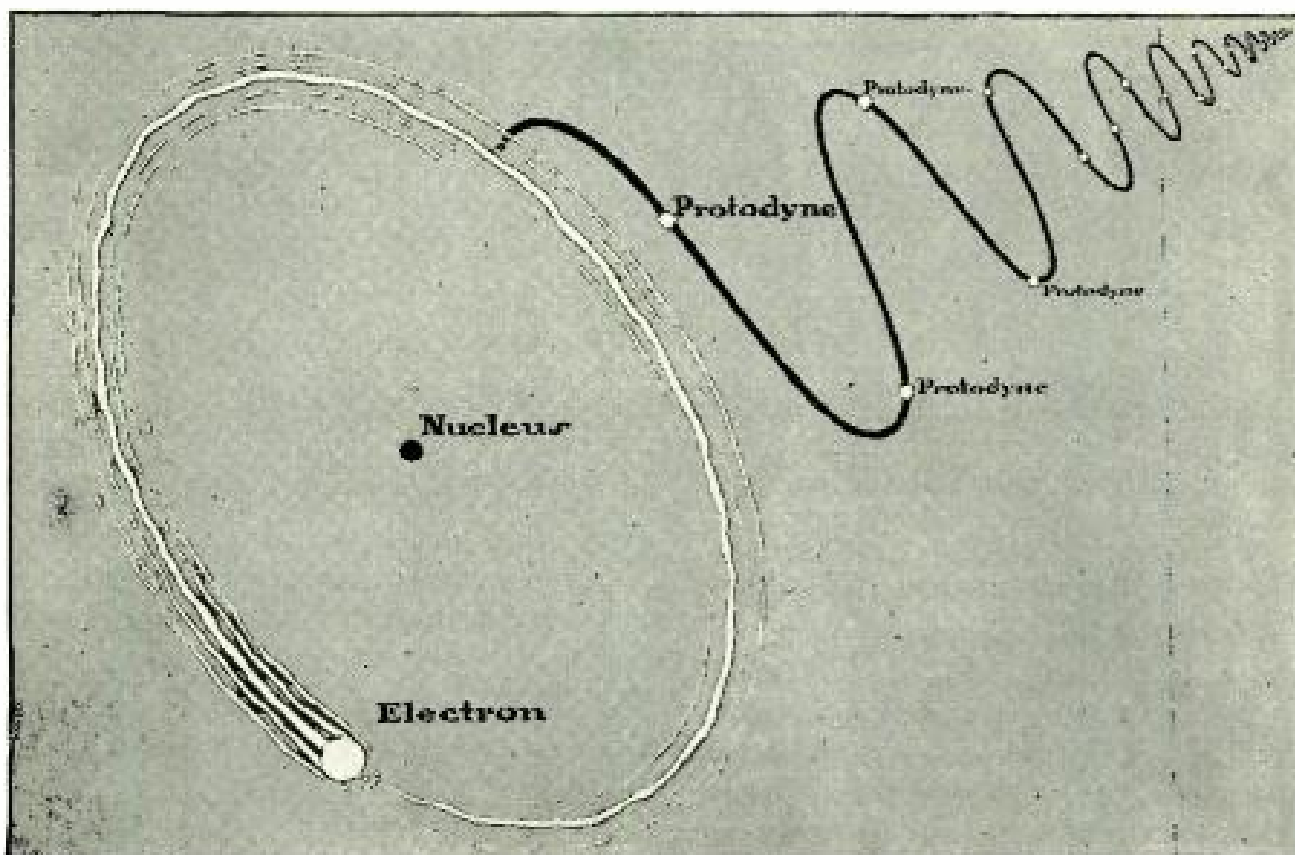

From a drawing for POPULAR RADIO by Arthur Merrick

HOW "PROTODYNES" OF LIGHT SHOOT OFF FROM ELECTRONS

According to a new theory of the character of light, particles, which are even smaller than electrons, travel into space at the same speed of light, but in an undulating manner indicated by the black, wavy line in the picture. Former theories of the transmission of light were based on a belief that light traveled by waves that moved in straight lines.

Another Theory of Particles Smaller than Electrons

READERS of this department will remember the theories of minute particles of light, particles astoundingly smaller than the electron, which theories have been associated mainly with the name of the distinguished French physicist, the Duke de Broglie.* Now we have a new form of this idea, propounded by the distinguished Spanish physicist, Dr. J. Comas Solá, of the astronomical observatory at Barcelona.†

It is possible, Dr. Solá thinks, that light consists of an immense number of very tiny particles thrown out by the electrons of matter whenever these electrons move about inside the atoms. He calls these particles "protodynes." They are not shot out in straight lines, as bullets would be from a gun. Instead, they go out in wavy lines; as if, Dr. Solá states, one shook a rope so that waves were made in it, at the same time moving the rope along its

* See for example, "Is There a New Universe Still Smaller than the Electrons?" POPULAR RADIO for July, 1924 page 82.

† "A New Emission Theory of Light and of Radiant Energy in General." In Spanish and French. *Scientia* (Bologna, Italy), vol. 36, pages 375-382 and Supplement, pages 112-118 (December, 1924).

length at an immense speed; the speed, in fact, of light.

This idea of a waviness in the long line of flying particles provides an explanation for such phenomena as those of the interference of light, phenomena which have always inclined the physicists to prefer a wave theory of light to any of the numerous theories of emitted particles—the "bullets of light" theories—which have been suggested from time to time.

Is the theory of Dr. Solá an important step in advance? No one can be sure. The whole matter of the nature of radiant energy, from light rays to radio waves, is now in a most unsatisfactory condition. The simple wave theory which satisfied the physicists for so long has broken down under the weight of our new knowledge of the atom and under the modifications necessitated by Einstein's theory of relativity. On the other hand, a theory of light particles shot out from luminous bodies as bullets are shot from guns has its own difficulties. For the present the question is open.

It is quite to be expected, however, that we will discover, some day, *some* kind of smaller particles inside the electron. Whether these will prove to have been foreshadowed in the "protodynes" of Dr. Solá time alone will tell.



CONDUCTED BY ALBERT G. CRAIG

How to Trace Noises in Your Receiver

OFTEN static is not to blame for all the grinding and sizzling noises in a radio receiver. A loose contact or partly worn-out "B" batteries frequently create disturbances that sound exactly like static. A sure way to find out whether the grinding and crackling sounds are generated in the receiver itself or in the antenna is to try disconnecting both the antenna and the ground. If the noises cease at once, you may be sure that there is nothing wrong with either the receiver or the batteries. Should disconnecting the antenna and ground have no effect on the noises, you can be positive that something is wrong with your own equipment. Test your batteries for the proper voltage, and make a careful search for the bad contact.

Does Your Receiver Squeal?

REGENERATIVE receivers are not to blame for all the squealing and howling. Poorly designed receivers that embrace radio-frequency amplification often cause more interference than the regenerative sets. If a squeal is heard when you tune your receiver to a wave where no station is transmitting and the squeal changes in pitch as you change one of the dials, you may be sure that your receiver is radiating and causing interference. When this happens, turn the rheostat down until the squeal stops. This tendency on the part of improperly balanced receivers

to oscillate and cause interference usually shows up on the lower wavelengths which is one of the reasons for the vast amount of squealing and howling heard on waves below 360 meters.

Fit Your Binding-post Panel Before Mounting It

WHILE the appearance of the back of the radio cabinet is not considered important, it is a satisfaction to be able to show your friends a careful workmanlike job of a binding-post panel that fits snugly into the oblong hole cut in the back of the cabinet. It is better to cut the hole in the cabinet before you start building the set and then by filing you can make the binding-post panel fit exactly in the opening. After that it is easy to screw the binding-post panel to the baseboard so that it will meet the opening in the back of the cabinet when you have the receiver finished.

Do Not Overload the Detector Tube

RECEIVERS which employ two stages of tuned-radio-frequency frequently distort the music and speech from local stations. This occurs because the first two tubes amplify the powerful local signals beyond the point where the detector tube rectifies properly. The simplest way to remedy this trouble is to cut out the radio-frequency amplifying tubes on local stations,

or if the wiring arrangement will not permit this, receiving local stations on a short indoor antenna will solve your problem.

Use a Piece of Paper While Soldering

It is a good idea to keep a scrap of paper handy while you are soldering the connections in a radio receiver. Slip the paper underneath each connection while you are soldering. Then, if a drop of soldering paste, rosin or solder falls from the joint, it will fall on the paper instead of smearing up the baseboard, panel or some piece of apparatus. Often a drop of solder will fall down and spread out in such a way that it may produce a short circuit when the set is hooked up.

Drill Panels in Horizontal Position

WHILE the radio builder naturally places his panel flat on the bench while he drills it, sometimes the bench is so cluttered up with tools and miscellaneous parts that it seems more convenient to clamp the panel vertically in the bench vise. This practice should be avoided because there is always a tendency for the holes to drift downward away from the center punch mark just as the drill starts to cut in. The error produced in this way is usually less than 1/32 of an inch, but this is often enough to prevent for instance, the mounting of a condenser.

Watch Out for Kinked Wire

UNLESS he has had some experience in handling coiled wire, the beginner is very likely to get his coil of antenna wire hopelessly tangled up. Antenna wire is springy and has a natural tendency to twist itself into loops. If these loops are pulled out by force, a sharp kink in the wire will result. These kinks have no particular effect on the reception of radio signals but the wire is weakened considerably at the kink and breaks in the first high wind or sleet storm.

How to Avoid Split Panels and Baseboards

SOMETIMES after you have drilled all the holes in a panel and start assembling the instruments, the panel cracks when you tighten up the screws. This trouble is ordinarily due to drilling the holes too small. All holes in composition panels should be large enough so that the screws fit loosely to prevent binding. Baseboards also are often split by the screws used to hold the various instruments in place. This is particularly likely to happen if there are several screws near together which are in line with the same grain in the wood. Avoid this by staggering the screws as much as possible.

Voltmeter or Hydrometer?

ALTHOUGH a test with a hydrometer is the only sure way to tell the state of charge of a storage battery of the lead, acid type, a voltmeter is also a fairly good indicator if you know how to use it. The instruction cards that accompany most storage batteries give the voltage which each cell should have when fully charged with the charging current still on, but these instructions usually neglect to mention that this maximum voltage depends on the charging rate. If you wish to rely on a voltmeter to tell you the condition of your storage battery, check your voltmeter readings with a hydrometer until you are sure of the voltages that indicate charge and discharge for your own particular battery and the charging rate you are using.

Make Your Ground-lead Short

WHEREVER possible the ground-lead should be kept as short as possible. Extended ground leads not only broaden the tuning of a set, but they add resistance to the antenna circuit. The receiver should be located as near the ground connection as the arrangement of the furniture in a room permits.



"THE BROADCAST LISTENER" AT WORK

Here is a snapshot of Raymond F. Yates at work—which consists principally of listening in on broadcast programs and writing his comments about them. He made his reputation as the world's first radio critic under the name of "Pioneer" in "The Herald-Tribune" of New York, and he is now conducting this department regularly for POPULAR RADIO—EDITOR.

The BROADCAST LISTENER

*Comments on radio programs, methods and technique
—from the point of view of the average fan*

By RAYMOND FRANCIS YATES

The Sentimental Announcer

TO date, we have not become a member of the Graham McNamee Association although we are willing to concede certain things to that silvery-voiced young man that we do not concede to the average the-next-number-on-our-program-will-be announcer. If you were one of those unfortunates who was stabbed in the very solar plexus of your emotional complex by that masterful drama "Where Are My Children," you probably "fill-up" every time Mr. McNamee approaches the microphone of the great WEAF chain.

Our Psychology Department reports back to us that the sentimental Mr. McNamee was very probably influenced in his younger days by Pollyanna and Laura Gene Libby and that he both harbors and caters to a secret ambition to write another "Lasca." Mr. McNamee's

puritan ambitions are a matter of his own business entirely and we certainly know that we may remain engaged for many years to come keeping our own door-yard clean. However, we feel constrained to put in one vote against Mr. McNamee's practicing poetic prose while he is outside the privacy of his own chambers. For months now, he has caused us almost nightly to bury our head in the largest pillow on the day bed and cry as though our little heart would break. Mr. McNamee can express the most mundane thought imaginable and yet as you listen a whole garden of Ophelia roses takes root, grows and blossoms and finally the velvety, fragrant petals are fluttering to the floor of the room where you are. If the young man under discussion bleeds long enough, and he usually does, a little nymph, dressed according to the best traditions, trips out from under the sewing table or the bookcase and dances

the dance of the Ophelia roses, kicking artistically among the petals. By this time, you are probably well over your crying spell and you begin tripping about clumsily with the little nymph. Of course, after your storm of ecstasy has subsided, and you regain your senses, you will, if there is any manhood in you at all, go right down cellar and search through the family tool box for the "heavy, blunt instrument."

* * *

A Handbook for Announcers

As these smart little paragraphs go to press, we are hard at work upon a new book to be called the "Handbook of Sweet Phrases for Ultra-humane Announcers." Each copy will be dipped in violet water and the frontispiece will be given over to the picture of a gorgeous group of orchids done in the most exquisite colors.

* * *

Listeners Who Send Telegrams

MR. A. NEAL, of Pando, Colo., joins us in taking a big, swift wordy kick at that diligent disturber of ethereal peace, the telegram sender and the telegram reader:

"Dear Sir: My pet aversion is the practice of broadcasting stations reading the telegrams that are of absolutely no interest to anyone but the senders. It seems they put up the price of a wire solely for the gratification of hearing their names mentioned on the air. What interest have I, or several thousand other listeners in "Programs coming over fine at Oskosh. Please play 'Follow the Swallow.'"

"Incidentally one of the unique features that I have had the pleasure of listening in on, was recently broadcast by WBAP, the Fort Worth Star Telegram. It was a negro camp meeting

held on the outskirts of the city and it was certainly something far removed from the rut that studios usually run in. It was splendid."

There are few things that tickle the yokel more than to have his question printed in the local newspaper "Forum" or his name flung far and wide on the radio while he sits spell-bound and awed listening to it. As a matter of fact, we cannot blame the telegram senders for any country the size of the United States is bound to have in its population a large number of the type of people who just naturally itch to send missives that will eventually be given publicity on the air. The real offender, is the blundering studio manager who permits his still more blundering announcer to solicitate such matter and air the thoughts expressed. This simply goes to show that most of our studios are, after all, pretty loosely managed by men who do not have the artistic sense of a soda fountain brakeman.

* * *

The Sudden Breaking Up of Programs

THOMAS R. HUGHES, an old customer of ours back in *The New York Tribune* days, writes to tell us how badly WJY treated a concert of the American Orchestral Society:

"After rather lengthy intermission, during which the announcer did his best to keep us in good humor, we listened to a really magnificent piano concerto played by a competent artist and the full orchestra. Right in the middle of it, right in the middle of a phrase in fact, while I and doubtlessly tens of thousands of others were enjoying to fullest advantage the wonderful music, came a jarring and very abrupt full stop. To lovers of real



Wm. Miller & Son

THE FIRST GROUP OF RADIO ANNOUNCERS TO ORGANIZE

Not to be outdone as "joiners" by the broadcast listeners, broadcast artists and others directly and indirectly connected with the maintenance of broadcast programs, the announcers have, in self-protection, formed an organization of their own. The officers, shown above, are (from left to right) Harold W. Arlin (KDKA), "Roxy" Samuel L. Rothafel, Arthur F. Edcs (WBZ), Harold J. Manchester (WDWF) and Thruston Seabury (WCAP).

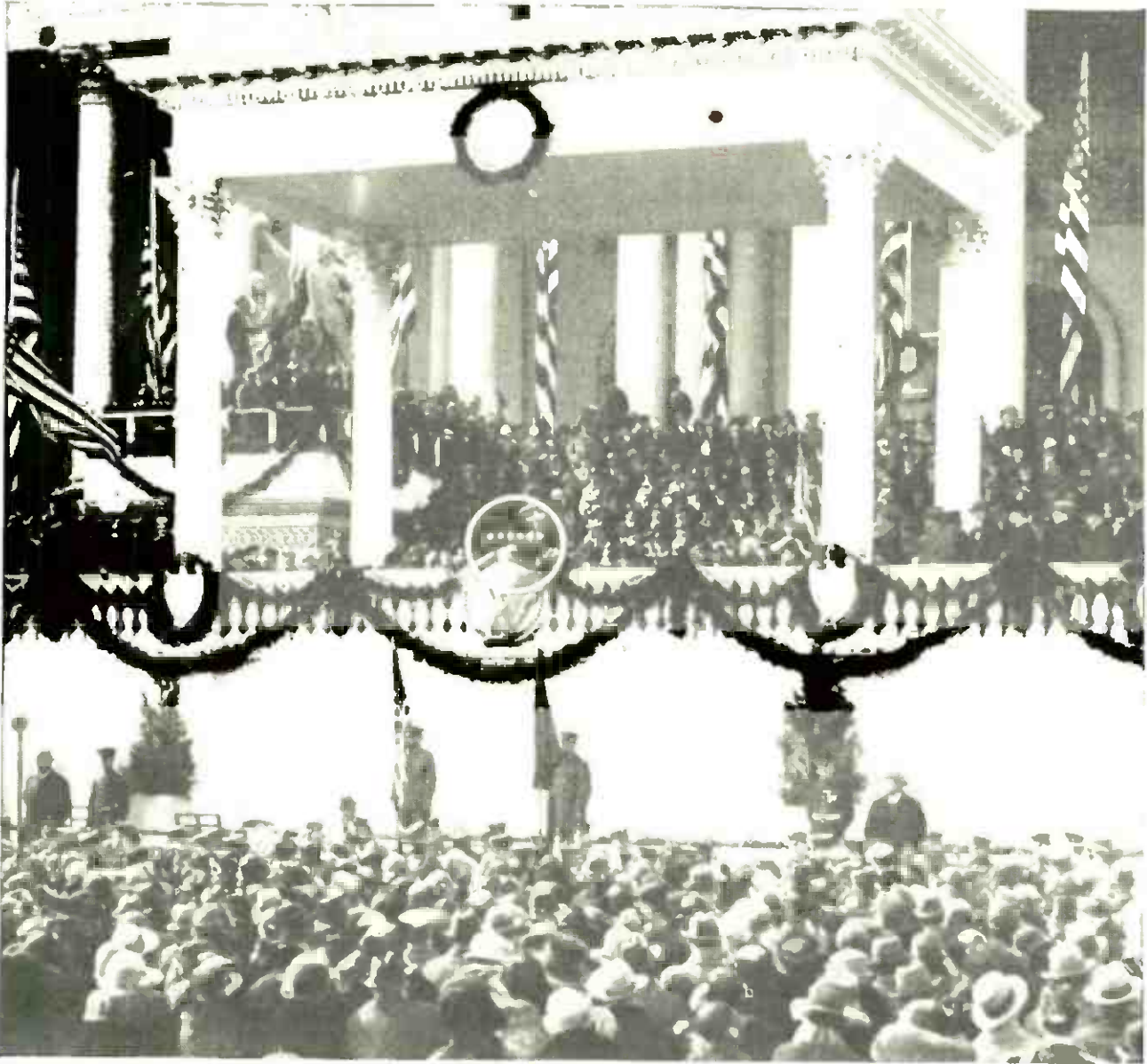

Underwood & Underwood

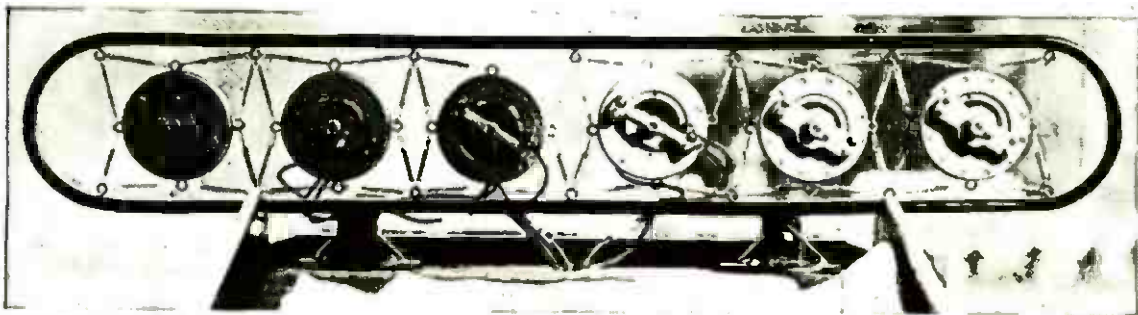

Underwood & Underwood

HOW THE PRESIDENT'S INAUGURAL ADDRESS WAS BROADCAST

The six "mikes" in the lower picture were located directly in front of President Coolidge when he read his address. In the upper picture, within the circle, is the President in front of the Capitol delivering the speech that was transmitted by wire to five distant broadcasting stations as well as to the Washington local station WCAP.

music, it was a mental shock. Immediately came the voice of the announcer without a word of apology or explanation. 'This ends the concert of the American Orchestral Society. You will now listen to the after dinner speeches at the ——— Hotel, New York City.'

We hope that we shall not be accused of working off a bad case of dyspepsia if we agree with Mr. Hughes in his righteous indignation and further add that too many of our better managed studios permit far too many boob mistakes to pass without explanatory comment. Broadcasting is getting to be a

pretty big boy now and it's about time we expected better table manners, less rowdyism and better general deportment. If our large army of telegram senders would spend their money sending wires that would reprimand, we could have an occasional pink edition of this department where nothing but pure wholesome flattery would be passed out.

* * *

The Stage and Radio

MAXINE BROWN's publicity man made a big thing of it when that young lady abandoned musical comedy to become associated with the program-makers of station WTAS, Chicago. That is all very fine and very lovely, but how we do wish some of our radio entertainers would abandon the microphone for Al Reeves.

* * *

Too Many Lectures

It is impossible to turn to the radio in these highly competitive days of the art without uncovering anywhere from one to five very thin lectures on such remote subjects as "How the Farmer Sends Eggs to the Market" or "Garden Planning in a Small Plot." During the past few weeks we have sampled some of the thinnest stuff in the history of our laboratory and it would seem that the epidemic of grade F rhetoric rages the merrier as broadcasting grows older. There are two things in the world that we do not like to hear. One is egg coal rushing down a chute and the other is an intellectual adventurer of the type found at afternoon teas, unloading a ten-page crop of encyclopedian notes.

If there is one thing the radio needs to save it from losing the little respect it has merited, it is speechmakers and lecturers with the power to say something that will register in intelligent or even bourgeois quarters. Our own objection to the average lecture has extended all the way from muttering unkind things under the breath to a complete loss of self-control.

* * *

"Regular Features"

WHILE it would make us feel very sad to have our readers think that there is not a charitable hair in this old gray head, we are not one to be torn between duty and diplomacy. If ripe red raspberries are in order, red ripe raspberries it is, even though it pains us as much as it does the recipient. Anyway it is about time that somebody said something nasty about the bales and bales of "regular features"

broadcast every day. About every second event you tune nowadays has a familiar sound.

It was bound to happen sooner or later that a few of the stations would stack up a tidy little pile of "regular features," pull down the cover of the roll-top desk and go off on a nice long vacation. No. 1 solid 24-karat "regular feature" program was exposed in New York a few weeks ago while the personnel of this department chuckled and chortled childishly between softly modulated outbreaks of "I told you so" and "Well, well, the old boy's dope isn't so bad after all." You know we prophesied long, long ago that regular features would some day grow so numerous that the mental task of studio managers would be reduced from thinking just a little bit to not thinking at all.

* * *

A New Radio Gas Mask

WE are happy to announce that we have made a discovery that may do a great deal toward making radio a little easier to bear during some of its worst moments. Our discovery, the details of which were laid before the board of directors late in the afternoon of preparing this copy, relates to the problem of permitting radio listeners to form their own opinions concerning the actions of various radio performers. The invention takes the form of an attachment somewhat on the style of the gas masks. This is added to the announcer with marvellous results. After the device has been applied (it is a long tube running from the mouth and ending in a receptacle resembling a waste can) announcers will find it impossible to flatter the work of artists and near-artists while they are within range of the microphone. This will permit millions of radio listeners to either condemn or endorse the various performers without being influenced by the crystal-clear *pfui* spouted by over-enthusiastic studio men. Of course, the announcer will be able to utter flattering words, but instead of going out on the ether, they will be caught in the filter of the device and carried down to the receptacle. This will permit intelligent listeners everywhere to form their own private opinion about Lucrezia Borax's "By the Waters of Minnetonka" or Jimmy Jones' harmonica solo of "Turkey in the Straw."

We almost forgot to mention that the waste matter caught in the receptacle, due to its unctuous nature, may be collected daily and sent to the playgrounds throughout the city where it will be found valuable in greasing the children's slides.

What Do You Think About Radio Programs?

READERS are invited to send in letters of comment—especially letters that contain constructive criticism that point the way to new and better broadcast features—to *The Broadcast Listener*.



“TROUBLE SHOOTING”

CONDUCTED BY S. GORDON TAYLOR

EVERY radio receiver requires a careful balancing of all of its parts if the best results are to be obtained. Two receivers made from exactly the same design may give widely different results, owing to variations in the parts used, the skill of the experimenters and the locations of the receiver. This department is conducted for the special benefit of readers who have built the radio receivers described in POPULAR RADIO and who want to profit from the experience of others in operating them—to learn the little kinks that get the maximum results.

Additional Facts About the Four-circuit Receiver

EMPHASIS in this department has frequently been laid on the advisability of using a large antenna with the Four-circuit Receiver. Despite this advice, there are many builders of this circuit who are still trying to obtain maximum results with a small antenna. Some of these persons say that they know that their antennas are all right because they had good results with other receivers.

An antenna that may give the best results with another type of receiver may be of little use with a Four-circuit Receiver, because, to obtain proper selectivity with the average receiver, a single wire not over 100 feet in length is about the longest that can be used. But, the selectivity of the Four-circuit Receiver is often increased by a long antenna.

If you cannot build an antenna longer than 100 feet, construct it of four wires that should be spaced three or four feet apart. Take off the lead-in at one end, where you should join the four wires. The other ends are left open.

If you can get a 150-foot stretch, you may use two wires although three will be better. If the length is over 150 feet, two wires should be ample; three would give only slight improvement.

A communication from Ralph MacUmbert, owner of a Four-circuit Receiver in Rochester, N. Y., suggests improvements that have been previously published in the “Trouble Shooting” department, but for the benefit of those who have not seen them, we publish his letter in part as follows:

“I followed your advice as to the antenna. I now have two wires each 100 feet long and the results are well worth getting up on the roof in zero weather for. My main trouble was a loose connection in the coil. After I had tightened the coil connections, improved the antenna and last of all cut the plate voltage on the detector tube, all was merry.

“I tuned stations on the loudspeaker, and the best part of it is that I had to use the fifth tube on only one station. Four tubes are plenty and these reports of no volume on the Cockaday are bunk.

“I have had four large sets, including a superdyne and a neutrodyne, and when I say that the Cockaday “Four-circuit” beats everything I have ever heard, I am not talking to hear myself.

“I didn’t reach ‘the coast’ because I did not ‘fish’ for stations.”

How to Test Fixed Condensers

IN the “Trouble Shooting” department in a recent issue suggestions were offered for testing fixed condensers with a battery and headphones. It was stated that no click would be

heard in the phones unless the condenser were defective. This statement should be amended, because, when the testing circuit is first completed, there should be a slight click in the

phones. If the condenser is in good condition, however, this click should be faint as compared with the click obtained through connecting the phones directly across the battery without the condenser in the circuit.

One manufacturer suggests a test with a

flashlight bulb or buzzer instead of the phones. If either of these is connected in series with a condenser and battery, it will operate only in case the condenser is short circuited. If it fails to operate it is an indication that the condenser is not "shorted."

Combinations With the Three-stage Amplifier

(This amplifier was described in POPULAR RADIO for March, 1925)

SOME readers who constructed the three-stage, audio-frequency amplifier intended it for use with one particular detector unit, while others built the amplifier as a utility apparatus for connecting to any one-tube receiver.

The tone quality and volume of this amplifier have proved so satisfactory that many builders want to combine it with the single-tube, Four-circuit Receiver described in this issue.

To assist beginners in connecting these two units, we publish pictures in Figures 1 and 2. You will note that a separate 22½-volt "B" battery is used in conjunction with the detector. It is important that this be entirely separate from the amplifier "B" batteries, otherwise results will not be satisfactory, and it is highly probable that the potentiometer winding will be burned out.

The two units are set up end to end (as shown in Figure 1), with the amplifier at the right. The four binding posts at the right-hand side of the tuner are then connected directly across to the corresponding binding posts on the left-hand side of the amplifier unit. The two binding posts at the left-hand side of the back of the tuner are connected to the antenna and ground respectively, and the two at the right, rear, connect to the negative and positive sides of the detector "B" battery. Re-

sults are usually best if the right-hand one of the latter two is connected to the 18-volt tap of the battery. These directions are given looking at the receiver from the front.

Finally, the 1st and 2nd posts from the bottom, at the right-hand end of the amplifier are connected to the negative and positive terminals, respectively, of the storage "A" battery and the 3rd and 4th posts connect to the negative and positive terminals of the 90-volt "B" battery which is provided for the amplifier.

With these connections completed the receiver is ready for operation. The detector filament is lighted by turning the detector rheostat about half-way in a clockwise direction. The battery switch on the amplifier panel is then pulled out and the three amplifier rheostats are also turned about half-way in a clockwise direction. The headphones may then be plugged into the first jack or, if desired, the loudspeaker may be plugged into the second or third jacks. Finally, after a station has been tuned in as well as possible, the four rheostats should be adjusted again to a point where volume and tone quality are best. The potentiometer is also adjusted to provide maximum detector volume.

It should be borne in mind that greatest economy in operation is obtained with the rheostats turned on (clockwise) as little as possible, but enough to permit maximum volume. The setting of the potentiometer is of no

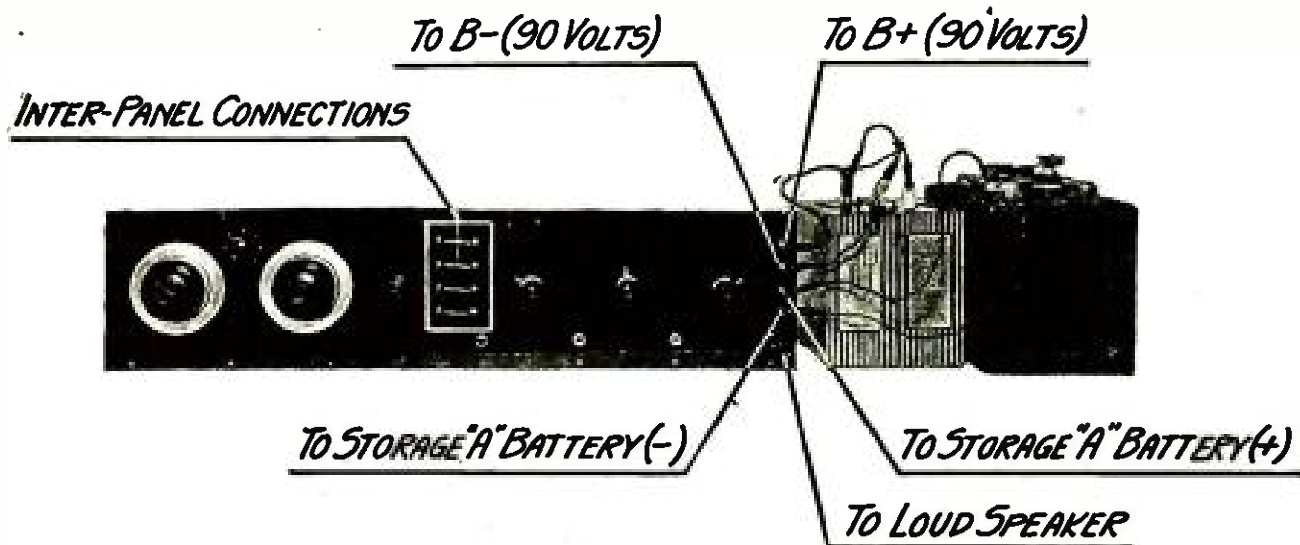

HOW TO CONNECT AN AMPLIFIER TO THE ONE-TUBE, FOUR-CIRCUIT TUNER

FIGURE 1: The receiver described in the "Simple How-to-build" article on page 430 of this issue, may be connected to the three-stage amplifier as shown in the picture diagram above. These two units were designed to permit the use of a single "A" battery to supply both instruments.

DA

importance in this single instance, however.

The operation of this receiver is the same as that of the Four-circuit Receiver (five-tube) described in the October, 1924 issue. Further

information on control and operation can therefore be obtained by referring to that issue—or to the "Trouble Shooting" department of the January, 1925 issue.

The "B" Batteries for the Eight-tube, Cockaday, Reflex Superheterodyne Receiver

(This set was described in POPULAR RADIO for January, 1925)

THE use of "B" battery eliminators with this receiver does not work out successfully in all cases. Sometimes such a device results in howling and squealing which is not noticeable when dry-cell or storage "B" batteries are used.

The use of storage "B" batteries with this receiver—or with any superheterodyne receiver—is recommended for the reason that the current drain on this battery is necessarily high when seven or more tubes are used. Storage "B" batteries that have a capacity of 1,200 milliampere hours or more will give good service because they maintain a more constant voltage

than do the batteries of the dry-cell type under such a heavy current drain. When they do run down, they can be recharged in a few hours at a cost of a few cents. By thus eliminating the cost entailed in replacing dry-cell "B" batteries, the storage "B" batteries pay for themselves within a few months, even though their initial cost may be considerably in excess of that of the dry-cell type.

In any case test regularly the voltage of the "B" batteries. When dry-cell batteries run down to a point where the voltage drops to about 37 (in the case of a 45-volt battery) it is time to replace them. If you let them run down too much you will find tuning difficult, and in some cases you will hear only the whistle of the carrier waves of stations.

Data About the Craig Reflex Receiver

(This set was described in POPULAR RADIO for February, 1925)

IF readers find difficulty in obtaining the coils specified for use in this receiver, there is no way out of the difficulty except to make the coils. We know of no coils on the market other than the make that was suggested that will meet the specifications for this circuit.

A receiver that was similar to this was described in the April, 1924 issue. The coils that were used in it can be used in the new receiver also. The only change necessary to use these coils with the receiver described in the February issue is the substitution of a .001 mfd. variable condenser for the .0005 mfd. instrument at F in the diagram on pages 160-161 of the February issue.

Figures 3 and 4 show the constructional de-

tails for the coils. To construct the coupler, which consists of coils A and B, as shown in Figure 3, first cut the composition tube for the primary coil A to size and drill the holes for the rear bearing of the coupler AA, the two angle brackets AB and one hole for the shaft in the front of the tube. Cut away the material above this latter hole so that the shaft can be slipped down into place later on. Wind the coil with No. 22 DSC wire, beginning $\frac{1}{2}$ inch from the top of the tube. Taps are taken off at the 3rd, 7th, 12th, 19th, 28th, 40th and 56th turns.

Cut the composition tube for the secondary coil B to size and drill the holes for the shaft and the two machine screws that are shown. Wind 21 turns of No. 22 DSC wire on one side of the shaft hole, beginning $\frac{1}{8}$ of an inch from the edge of the tube. Then bring the

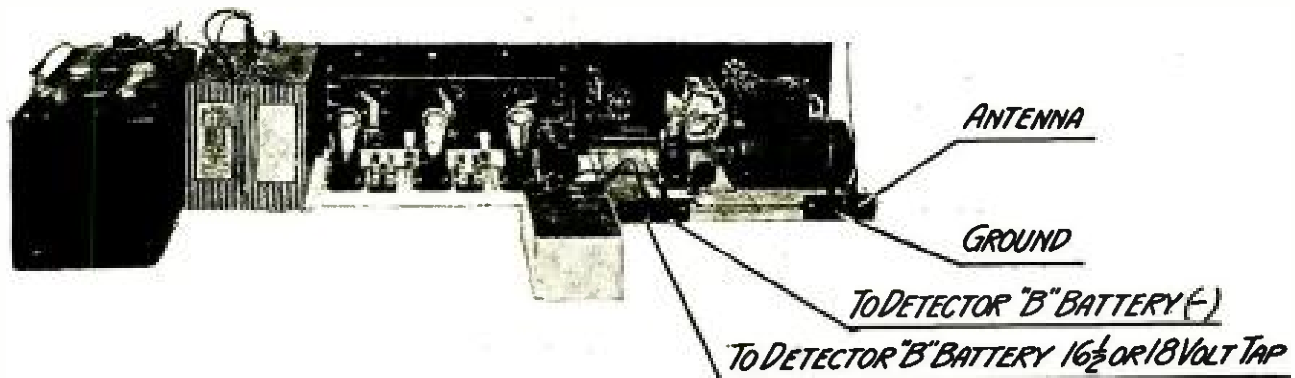

VIEW OF THE CONNECTED UNITS FROM THE REAR

FIGURE 2: A separate 22½-volt "B" battery is provided for the detector as shown by the connections to the battery in the center of the picture.

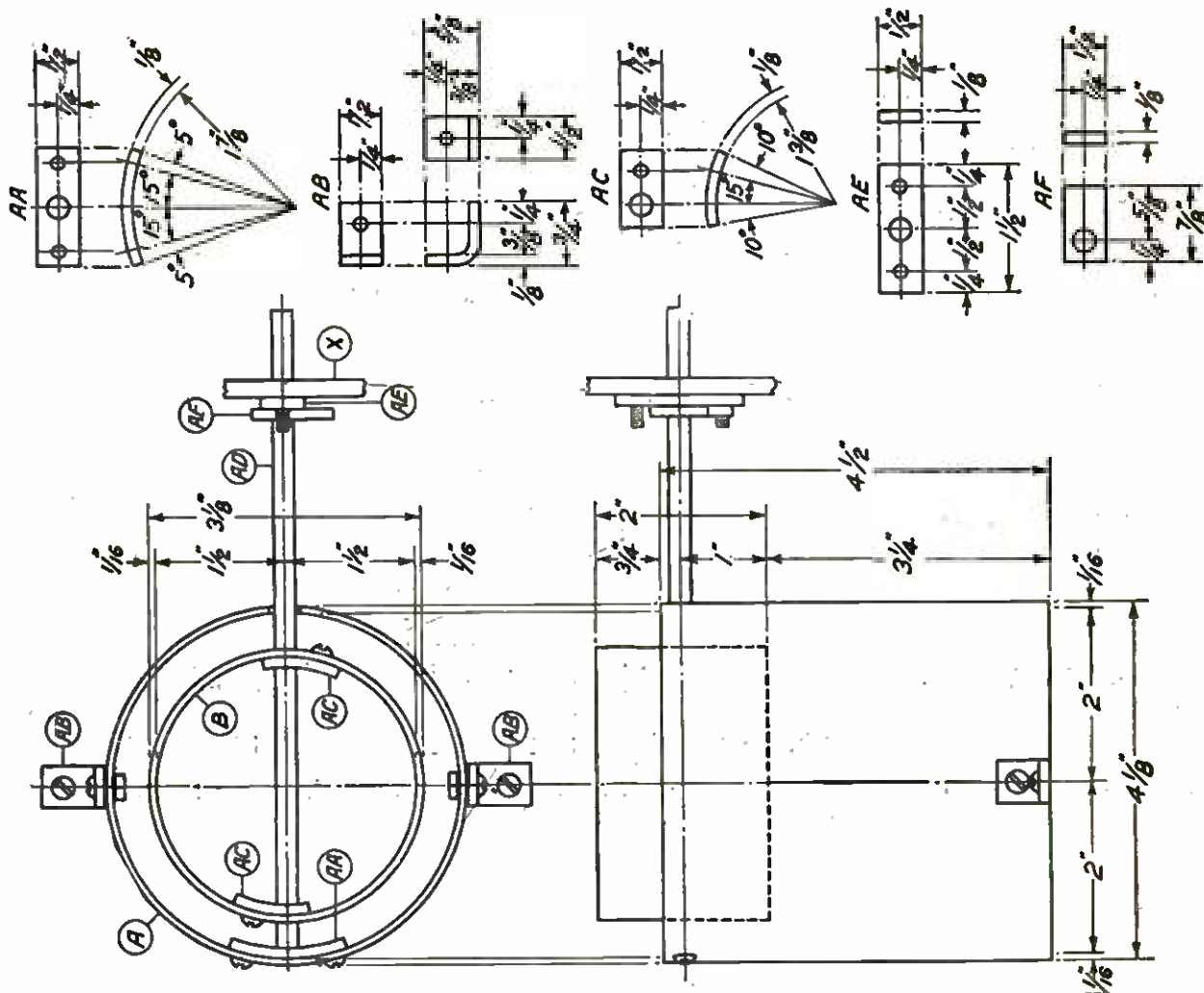

WORKING DRAWING FOR THE HOME-MADE COUPLER

FIGURE 3: This home-made coupler may be used to replace the coils A and B that were designated for use in the Craig Reflex Receiver. No changes in the circuit or instruments are required in making this substitution.

wire over and wind 21 more turns on the other side of the shaft hole. Make the rear bearing AA, the front bearing AE, the arm AF, which strikes the stops, the two pieces AC, for connecting the rotor and shaft, the two angle brackets AB, all out of 1/8 by 1/2-inch strip brass. The shaft AD consists of a piece of 1/4-inch brass rod 7 1/2 inches long (see Figure 3).

To assemble the coupler fasten the rear bear-

ing AA and the two angle brackets AB to the primary tube A with 6-32 inch brass machine screws. Fasten the two lugs AC to the rotor or secondary tube B with machine screws, then pass the shaft AD through the holes in the rotor and solder it to the lugs AC.

Next, construct the radio-frequency transformer C and D as shown in Figure 4 on the next page.

Cut the composition tube for the primary

New Developments in Vacuum Tubes

THERE are current many rumors about the manufacture of vacuum tubes and disputes about tube patents. And, new types of tubes are appearing at frequent intervals, yet in some quarters there has arisen a cry of monopoly. What the tube situation is today is important to the fan who is the buyer of tubes. In the June issue of POPULAR RADIO, Dan C. Wilkerson will explain some new phases of tube manufacture with an eye to showing what the future offers in better tubes.

coil C to size, and drill two holes for the mounting bracket AG. Wind 28 turns of No. 22 DSC wire centrally on the tube and take off a tap on the opposite side of the tube half-way between the 25th and 26th turns. The width of the winding will be about $\frac{3}{4}$ of an inch.

The secondary coil D is a 75-turn Pacent duo-lateral coil. Make the mounting bracket

AG out of $\frac{1}{8}$ by $\frac{1}{2}$ -inch brass strip. Cut two small clamping strips AH out of composition sheet. Assemble the transformer by passing two brass machine screws first through the tube C, then through the bracket AG and one of the clamping strips AH. Place the duo-lateral coil in position and fasten the other clamping strip AH down with nuts on the machine screws.

Operation Facts on the Seven-tube Superheterodyne Receiver

(This set was described in POPULAR RADIO for December, 1924)

THE balancing condenser is not properly adjusted in the "super" if the set does not tune in low-wave stations without whistling and distortion. When this occurs go through the balancing process again by following the instructions in the descriptive article in the December issue—or those in the "Trouble Shooting" department in the March, 1925 issue.

When WD-12 tubes are used in the first five sockets, the use of 45 volts connected to binding post No. 5, instead of $61\frac{1}{2}$ volts, sometimes gives better results. It is therefore well to try different voltages to determine the best for any particular receiver. If this voltage is too high, it will be difficult to tune stations in clearly, regardless of their wavelengths, and

the set will be inclined to produce excessive howling.

It is important that the sockets used in this receiver be of the vibrationless type such as those specified in the descriptive article or some other arrangement may be made whereby the tubes are not subject to vibration. If this is not done the microphonic effect will be troublesome. The vibration of the diaphragm of the loudspeaker makes the elements of the tubes vibrate which results in a loud, continuous howl that cannot be changed by any adjustment of the tuning controls. Sometimes this trouble can be overcome by moving the loudspeaker farther from the receiving set and turning its mouth away. However, the use of the vibrationless sockets provides a much more satisfactory means of overcoming the possibility of such trouble.

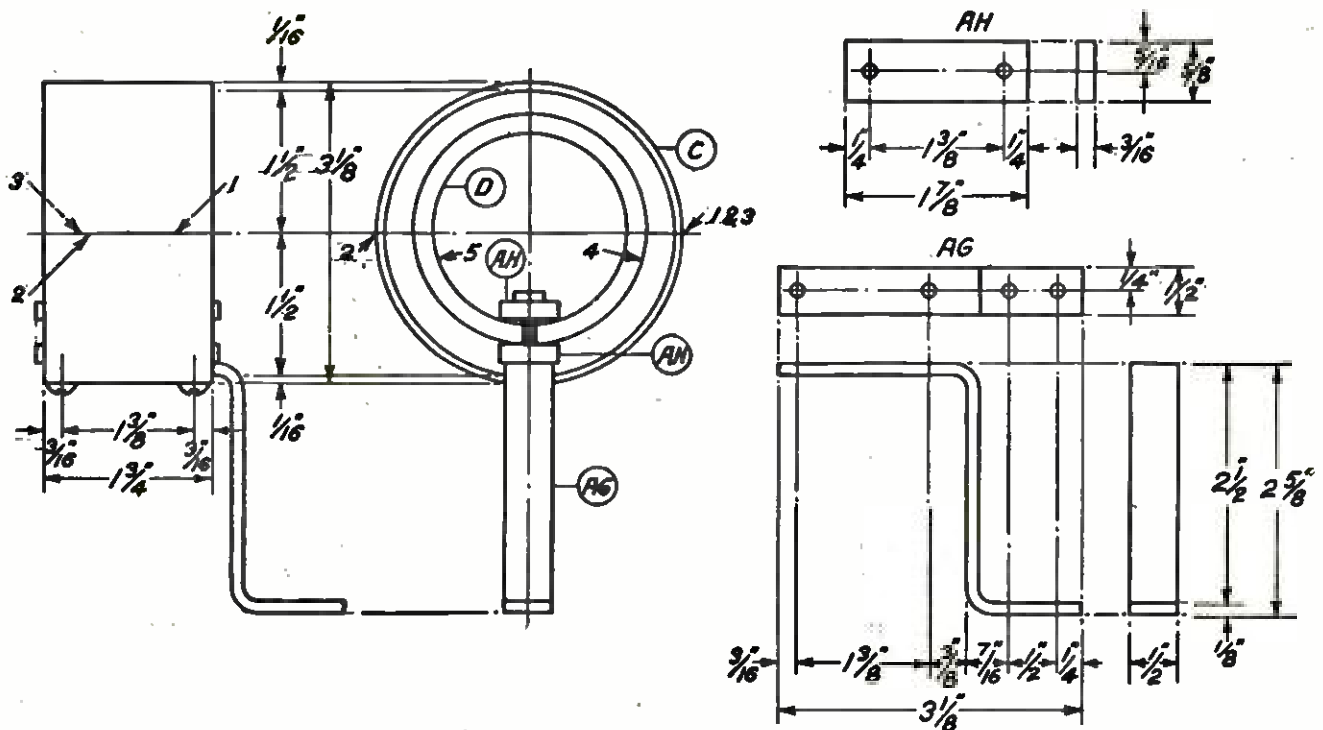

WORKING PLAN OF THE TRANSFORMER

FIGURE 4: This radio-frequency transformer may be used instead of the one that is specified for the Craig receiver that was described in the February, 1925 issue. The only change in the hook-up will be the use of a .001 mfd. variable condenser in place of a .0005 mfd. condenser for tuning this transformer.



THIS department is conducted by POPULAR RADIO LABORATORY for the purpose of keeping the radio experimenter and the broadcast listener informed concerning the newest inventions and the approved developments in radio equipment. Only such apparatus as has been tested and endorsed by the Laboratory is noted in these columns.

MISCELLANEOUS ACCESSORIES

Reddy Hot Soldering kit; E. D. Fahlberg Mfg. Co.
 "Fahnestock" antenna connector; Fahnestock Electric Co.
 "Fahnestock" ground clamp; Fahnestock Electric Co.
 "Fahnestock" clips; Fahnestock Electric Co.
 "Faustel" balkite "B" plate current supply; Faustel Products Co., Inc.
 "Fleming" connector unit; Fleming Mfg. Co.
 Lead-in bushing; M. M. Fleron & Son, Inc.
 Vernier adjusters; M. M. Fleron & Son, Inc.
 Refillable lightning arrester; M. M. Fleron & Son, Inc.
 Loudspeaker extension unit; Four-Way Co.
 "Freas" battery tester; Francis L. Freas Glass Works.
 "Freas" No. 1 hydrometer set; Francis L. Freas Glass Works.
 "Freas" clearview hydrometer set; Francis L. Freas Glass Works.
 "Freas" radio "B" hydrometer set; Francis L. Freas Glass Works.
 Radio aerial mast fittings; Freidag Mfg. Co.
 "Frost" ground clamp; Herbert H. Frost, Inc.
 "Frost" protector; Herbert H. Frost, Inc.
 "Frost" extension cord; Herbert H. Frost, Inc.
 No. 14. rubber-covered wire shielded with metallic braid; Herbert H. Frost, Inc.

Catalog house for retailer; W. E. Fuctterer Radio Supply Co.
 Allen dial vernier; General Eng. & Model Works.
 Laboratory instruments; General Radio Co.
 Wavemeter; General Radio Co.
 Binding posts; General Radio Co.
 Filter; General Radio Co.
 Jack binding post; Globe Phone Mfg. Co.
 "Goodrich" radiophone car cushions; B. F. Goodrich Rubber Co.
 "Goodrich" hard-rubber tubes; B. F. Goodrich Rubber Co.
 Spaghetti tubing; B. F. Goodrich Rubber Co.
 Battery mats; B. F. Goodrich Rubber Co.
 "Gray" lightning arrester; Gray Products, Inc.

PHONOGRAPH ATTACHMENTS

Phonograph adapters; M. M. Fleron & Son, Inc.
 "N & K" imported phonograph unit; Th. Goldschmidt Corp.

AN EXCELLENT TUNING CONTROL

Name of instrument: A vernier dial.

Description: A vernier dial which is controlled with a knob that is attached to a small gear. This gear is meshed with a half-ring gear that is marked in divisions from 0 to 100. This ring-gear also turns the shaft of the instrument. The piece of metal, from which this gear is cut, rotates with the instrument to which it is attached. The unit makes a pleasing appearance.

Usage: In connection with a tuning unit as a tuning control.

Outstanding features: Neat in appearance. Good workmanship. Makes tuning easier.

Maker: Apex Electric Mfg. Co.

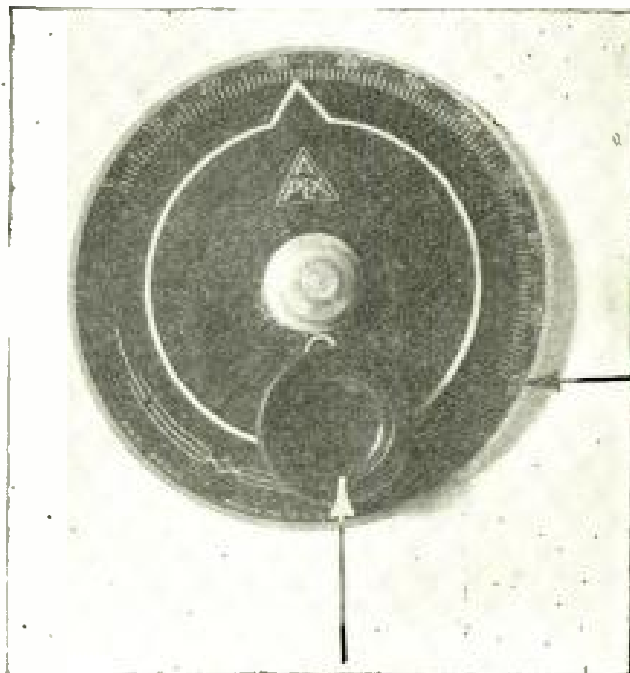

Has vernier knob and 100 degree scale.

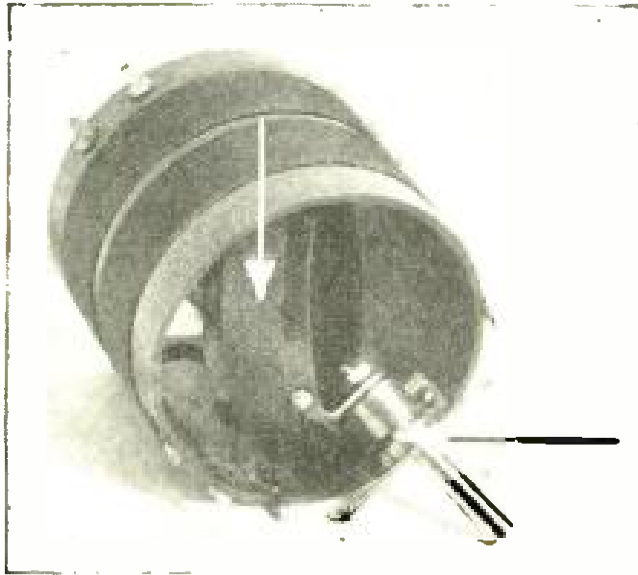

Smooth acting bearing and rotatable coil.

TUNING INDUCTANCE UNITS

Variocoupler; Federal Telephone & Telegraph Co.
"Ferbend" wave trap; Ferbend Electric Co.
"Fischer" coupler; G. H. Fischer & Co.
"Champ" variometer; G. H. Fischer & Co.
Coast Coil; Foote Radio Co.
Masterpiece coil and condenser; Chas. Freshman Co., Inc.
Variocoupler; General Radio Co.
Variometer; General Radio Co.
Low-loss coils; General Radio Co.
Reflex coils; General Radio Winding Co.
Variometer; General Radio Winding Co.
Variocoupler; General Radio Winding Co.
Neutroflex coils; General Radio Winding Co.
"Gen-Win" master tuning coils; General Radio Winding Co.
"Gen-Win" "Cockaday" unit; General Radio Winding Co.
"Gen-Win" low-loss tuner; General Radio Winding Co.
Variometers; Gilfillan Bros., Inc.
Variocouplers; Gilfillan Bros., Inc.
"Globe" low-loss tuner; Globe Radio Equipment Co.
"Goodman" short-wave tuner; L. W. Goodman.
"Grebe" clarifier; A. H. Grebe & Co., Inc.

INSULATORS

Stand-off insulator; M. M. Fleron & Son, Inc.
Porcelain insulators; M. M. Fleron & Son, Inc.
"Formica" insulation; Formica Insulation Co.
Insulators; General Radio Co.

A NEW STYLE MICA, FIXED CONDENSER

Name of instrument: Mica, fixed condenser.
Description: An improved fixed condenser in which the method of holding compression on the elements consists of a metal strip stamped in position around the bakelite end pieces. The terminals are brought out to two triangularly-shaped connections and fastened with eyelets. These condensers have supports for the grid-leak. The instrument is equipped with soldering lugs.

Usage: In any receiving circuit where another fixed condenser is necessary.

Outstanding features: Efficient. Accurate. Rigid construction. Neat appearance.

Maker: Dubilier Condenser & Radio Corporation.

A COMPACT OSCILLATOR COUPLER

Name of instrument: Inductive coupling unit.
Description: This small inductance instrument consists of three sets of windings that are brought out to separate terminals and wound with green, silk-covered wire on bakelite tubing. Two of the coils are stationary, while the third one is rotatable, so that the coupling between it and the other coils may be varied. The rotor coil is fitted on a small one-quarter-inch shaft with a smooth acting bearing and is equipped with a plate for attaching to a panel.

Usage: In a radio-frequency circuit as a coupling device.

Outstanding features: Compactness. Neat workmanship. Excellent for an oscillator such as used in the superheterodyne.

Maker: Remler Radio Manufacturing Co.

RECEIVING SETS

"Faraway" radio receiver; Faraway Radio Co.
"Federal" receivers; Federal Telephone & Telegraph Co.
"Freed-Eisemann" NR-6 receiver; Freed-Eisemann Radio Corp.
"Freshman" masterpiece receiver; Chas. Freshman Co., Inc.
"Garod" broadcast receivers (Hazeltine Neutrodyne Circuit); Garod Corp.
"Voclectic" portable receiver; General American Radio Corp.
"Gilfillan" neutrodyne; Gilfillan Bros., Inc.
Phodyne receiver; Golden-Leutz, Inc.
"Grebe" broadcast receiver; A. H. Grebe & Co., Inc.
"Grebe" synchrophase receiver; A. H. Grebe & Co., Inc.

VARIABLE CONDENSERS

Variable condenser; Federal Telephone & Telegraph Co.
"Freshman" selective variable condensers; Chas. Freshman Co., Inc. Gardiner & Hepburn, Inc.
"Garod" straightline condenser; Garod Corp.
"Low-loss variable condenser; General Instrument Corp.
"No-loss" variable condenser; General Instrument Corp.
Variable condenser; General Radio Co.
Air condensers; Gilfillan Bros., Inc.
"Grewol" vari-grid; Grewol Mfg. Co.
"No-Los" variable condenser; B. Grosser Sons Co., Inc.

SETS IN KIT FORM

Knockdown neutrodyne; Freed-Eisemann Radio Corp.
"Freshman" tuned-radio-frequency kit; Chas. Freshman Co., Inc.

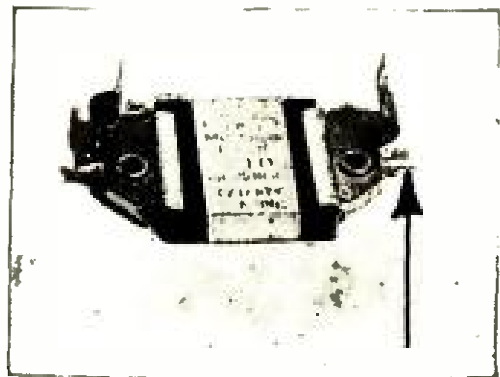

Equipped with soldering lugs.

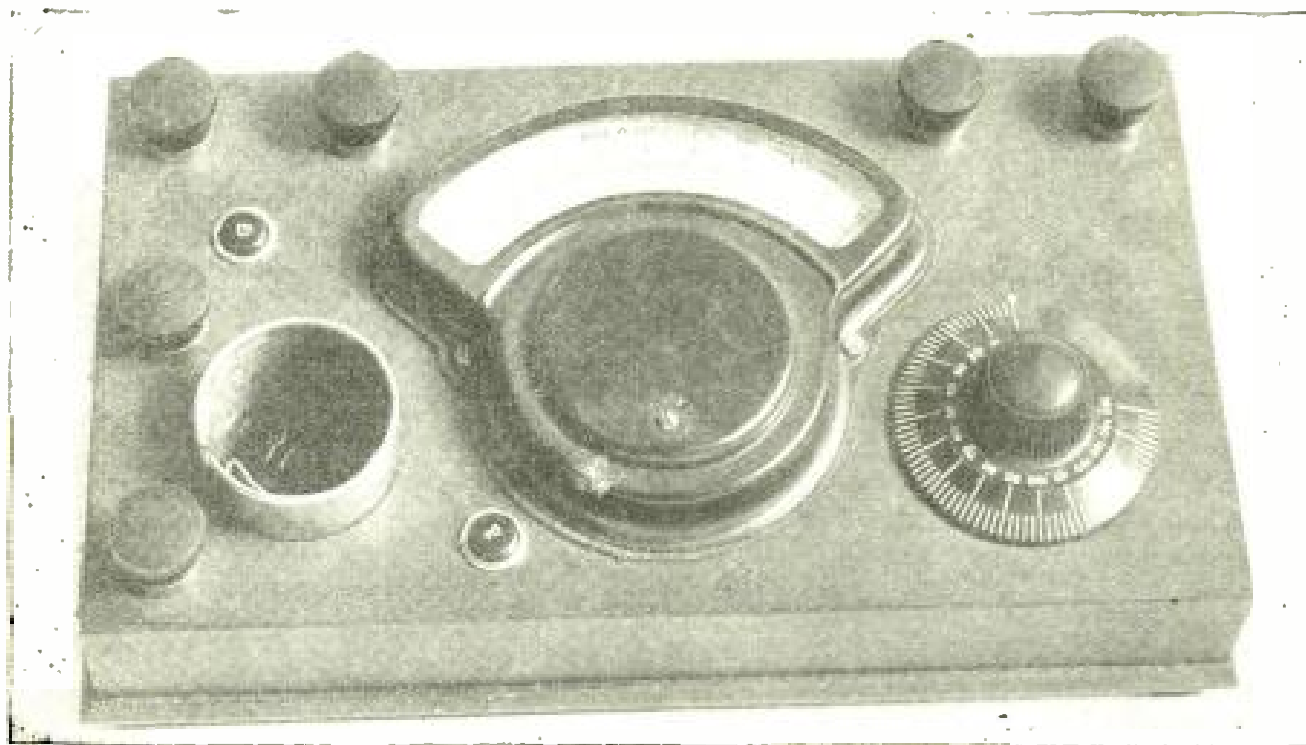

Complete tube-testing outfit that indicates plate and filament voltage, plate current and combined plate and grid current.

A NEW TUBE TESTER

Name of instrument: A tube tester.

Description: This instrument consists of a triple reading meter in combination with a socket, a rheostat and two push buttons with suitable connections for "A" and "B" batteries. The tube to be tested is inserted in the socket and the rheostat is then turned on. With suitable "A" and "B" batteries connected, the meter in the center may be caused to give the "B" battery voltage on one scale, the grid voltage on another scale and the plate current on the third scale. By this method, the tube characteristics may be easily determined.

Usage: An instrument for determining the electrical characteristics of vacuum tubes.

Outstanding features: A complete tube testing set in handy form. Neat in appearance. Simple to operate. Accurate.

Maker: Hoyt Electrical Instrument Works.

SOCKETS AND ADAPTERS

"Federal" sockets; Federal Telephone & Telegraph Co.

Porcelain sockets; M. M. Fleron & Son, Inc.

"Frost" shock-absorber 3-gang socket; Herbert H. Frost, Inc.

"Frost" adapter; Herbert H. Frost, Inc.

"Frost" bakelite sockets; Herbert H. Frost, Inc.

Sockets; General Radio Co.

Combination socket and rheostat; General Radio Co.

Sockets; Gilfillan Bros., Inc.

Adapters; Gilfillan Bros., Inc.

"Goodrich" V. T. Socket; B. F. Goodrich Rubber Co.

LOUDSPEAKERS

"Fibertone" horn and base; Fiber Products Co.

"N & K" imported loudspeaker; Th. Goldschmidt Corp.

"G. G. H." Reproducer; Grigsby-Grunow-Hinds Co.

SWITCHES

Anti-capacity switch; Federal Telephone & Telegraph Co.

"Frost" push-pull battery switch; Herbert H. Frost, Inc.

"Frost" Pan-Tab juck switch; Herbert H. Frost, Inc.

"Frost" bakelite toggle switches; Herbert H. Frost, Inc.

Panel switches; General Radio Co.

Switches; Gilfillan Bros., Inc.

Double-pole, double-throw switch; Globe Phone Mfg. Co.

Single-pole, double-throw switch; Globe Phone Mfg. Co.

AUDIO-FREQUENCY TRANSFORMERS

Maximum audio-frequency transformer; Fairmont Elec. & Mfg. Co.

No. 65 transformer; Federal Telephone & Telegraph Co.

"Supertran" transformer; Ford Mica Co.

Audio-frequency transformer; General Radio Co.

Amplifier unit; General Radio Co.

Detector-amplifier unit; Gilfillan Bros., Inc.

Audio-frequency transformer; Gilfillan Bros., Inc.

BATTERY CHARGERS AND RECTIFIERS

"Fansteel" bakelite battery charger; Fansteel Products Co., Inc.

"Fore" battery charger; Fore Electrical Mfg. Co.

Unitron battery charger; Forest Electric Co.

"FF" battery charger; France Mfg. Co.

"France" super charger; France Mfg. Co.

Tungar battery charger; General Electric Co.

PANELS

"Fibroc" bakelite panels; Fibroc Insulation Co.

"Electrasote" radio panels; M. M. Fleron & Son, Inc.

"Formica" panels; Formica Insulation Co.

Hard-rubber radio panels; B. F. Goodrich Rubber Co.

PHONE PLUGS

"Federal" plug; Federal Telephone & Telegraph Co.

"4-Way" switch plug; Four-Way Co.

"Frost" plugs; Herbert H. Frost, Inc.

"Frost" loop aerial plug; Herbert H. Frost, Inc.

"Comsco" bull-dog grip plug; General Instrument Corp.

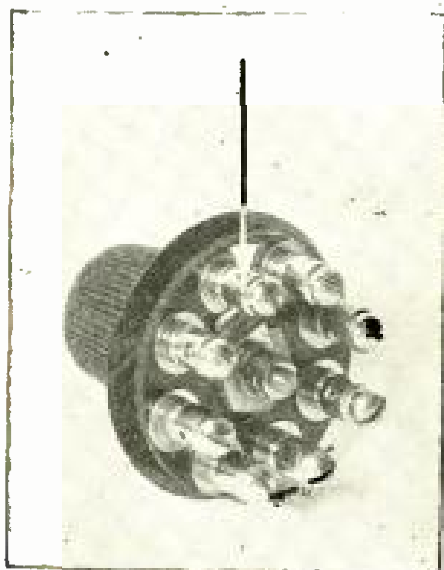

Equipped with binding posts.

A LABOR SAVING ACCESSORY

Name of instrument: Inductance switch.

Description: A compact switch which eliminates the necessity for drilling holes in panels for taps used in a tapped, inductance control. The center shaft and knob are connected to a lever which makes contact with seven electrodes and one dead electrode for grounding. The taps from the coil are attached to the small binding posts connected to each electrode. The insulating material is of bakelite. The plate which is attached to the front of the panel is marked with numbers which correspond to the taps and shows the operator which tap he is using when he turns the knob.

Usage: In connection with an inductance for cutting in and out turns of wire.

Outstanding features: Compactness. Ease of attachment. Neat appearance.

Maker: Jos. W. Jones Radio Mfg. Co., Inc.

RHEOSTATS

Rheostat; Framingham Co.

Tube control units; Herbert H. Frost, Inc.

"Frost" bakelite rheostat; Herbert H. Frost, Inc.

"Frost" metal frame rheostat; Herbert H. Frost, Inc.

Rheostats; General Instrument Corp.

Rheostats; General Radio Co.

Combination rheostat and socket; General Radio Co.

Rheostat; Gilfillan Bros., Inc.

GRID LEAKS AND RESISTANCES

Noiseless tested grid leak; Chas. Freshman Co., Inc.

POWER AMPLIFIERS

Power amplifier; General Radio Co.

HEADSETS

"Frost" Fones; Herbert H. Frost, Inc.

"Globe" phones; Globe Phone Mfg. Co.

"N & K" phones; Th. Goldschmidt Corp.

DIALS

Dials; Chas. Freshman Co., Inc.

Knobs and dials; General Radio Co.

Geared vernier dials; General Radio Co.

TUBES

Magic-Tron Vacuum Tube, type 201-A; F. & C. Corp.

MICA FIXED CONDENSERS

Micadensers; Ben Franklin Radio Mfg. Co.

A DIAL THAT CAN BE LOGGED

Name of instrument: Vernier dial.

Description: A vernier tuning control made entirely of metal except for the insulating knob, which is attached to a small gear that is meshed with a large half-ring gear. There are three sections on the dial for writing in call letters at the place where they are tuned in.

Usage: In connection with a tuning unit as a tuning control.

Outstanding features: Neat in appearance. Good workmanship. Can be logged and makes tuning easier.

Maker: Phenix Radio Corp.

JACKS

"Federal" jacks; Federal Telephone & Telegraph Co.

"Frost" Pan-Tab jacks; Herbert H. Frost, Inc.

"Frost" Jac-box; Herbert H. Frost, Inc.

"Frost" loop aerial jack; Herbert H. Frost, Inc.

CRYSTAL DETECTORS

"Variotector;" Foote Radio Co.

"Giant" crystals; Foote Radio Co.

"Freshman" adjustable crystal detector; Chas. Freshman Co., Inc.

Fixed reflex detector; Grewol Mfg. Co.

"Grewol" 2 in 1 crystal; Grewol Mfg. Co.

POTENTIOMETERS

Potentiometers; General Radio Co.

Potentiometer; Gilfillan Bros., Inc.

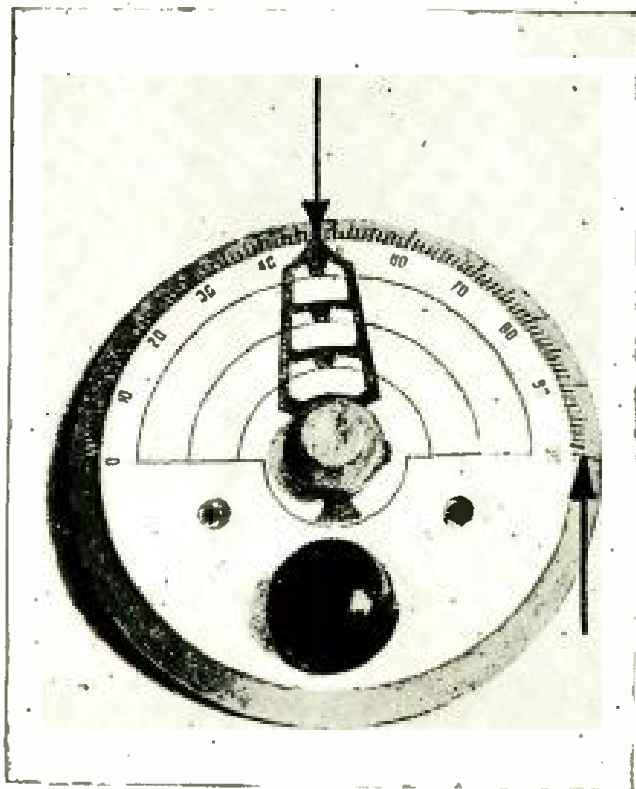

Equipped with multiple station indicator, 100 degree scale.

A HANDY VERNIER CONDENSER

Name of instrument: A small variable condenser.

Description: This small and useful condenser is made with the same precision as the larger instrument and is constructed in a similar manner and of the same material. It contains the modern metal-end-plate construction with two insulating bars for holding the stator plate.

Usage: In any radio-frequency circuit for vernier tuning or in places where small capacities may be used.

Outstanding features: High efficiency. Compactness. Neatly made.

Maker: Gardiner and Hepburn, Inc.

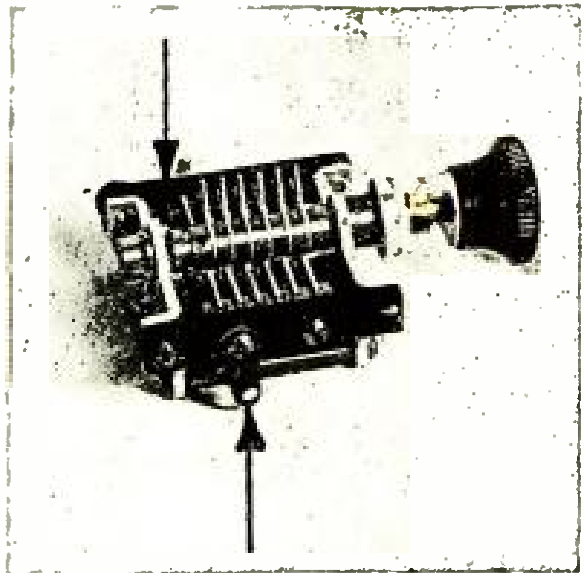

Has hard-rubber insulating strip. Equipped with soldering lugs.

RADIO-FREQUENCY TRANSFORMERS

"Federal" R.F. transformer; Federal Telephone & Telegraph Co.

Tuned air-core transformer; General Radio Winding Co.

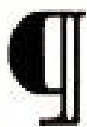

This list of apparatus approved by the POPULAR RADIO LABORATORY will be continued as a part of the WHAT'S NEW IN RADIO APPARATUS department until all instruments, parts and complete sets have been included. The listing is alphabetical by manufacturers' names and the installment in this issue goes only through the letters F and G.

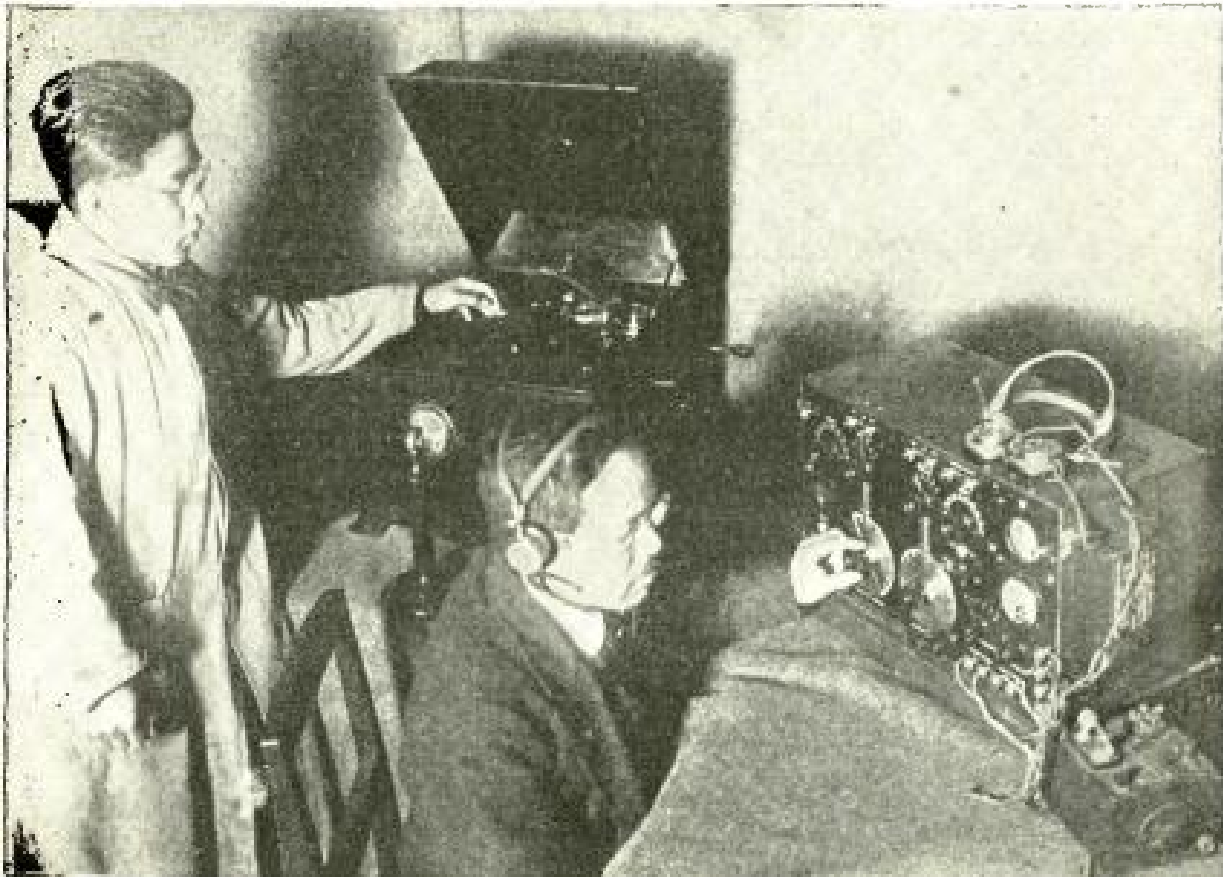

Henry Miller

THE JAPANESE STUDY BROADCASTING

The Japanese Government has recently organized in Tokyo the "Communication Officials Training Institute." two members of which are shown above, making broadcasting tests with a phonograph as the orchestra.



BROADCASTS

CONDUCTED BY DAVID LAY

ITEMS of general interest that you ought to know; bits of useful information that every radio fan ought to know.

New Aircraft Set Heard in England

AN improved radio set of the type designed for the air cruiser *Shenandoah* has received messages from a distance of 6,000 miles and is also having its signals received at great distances. A report by the Naval Communication Officer at Quantico, Va. says stations in England and France and several ships at sea near the Equator have reported receiving its signals. A wavelength of 88 meters is used.

* * *

More Than a Million Radio Licenses in Britain

IN Great Britain the number of people who have taken out radio receiving licenses has now passed 1,000,000. Thousands of them have gone from crystal to tube sets recently, it is reported. The import restrictions on radio apparatus were dropped at the beginning of the year, but British manufacturers have entered into arrangements with the retailers to restrict the trade to radio goods of British make.

* * *

University Credits by Radio

A COURSE of twelve lectures, with additional reading assignments, for which university credit will be given to those who enroll, has been started by station WSUI, which is the 500-watt radio station of the University of Iowa. These lectures are on modern English, current social and business problems, appreciation of literature and music and the American constitutional system.

* * *

Will the Kilocycle Supersede the Meter?

WITH the issuance of wavelengths in meters and tenths of meters, the career of the meter as a unit measure of wavelengths may soon be ended. Will fans go to the trouble of say-

ing 399.8 meters when they can say 750 kilocycles, or will they try to remember that WOO operates on 508.2 meters when it is much easier to recall the figure "590," the kilocycle equivalent? In making the Class "B" reassignments wavelength allocations are brought closer together by using tenths of meters, but this system is awkward. For ordinary use one can employ the kilocycle equivalents in even numbers, just as radio engineers have been urging. Probably all wavelengths will continue to be given out as they have been, paralleling the frequencies in kilocycles, but it is now believed that the use of the kilocycles of frequencies will become more popular in designating channels in the ether. Lest we forget, the rough formula for changing one to the other is briefly as follows: Frequency in kilocycles equals the velocity divided by the wavelength in meters. For example:

$$1,000 \text{ K/cs} = \frac{300,000}{300 \text{ m.}} \text{ or vice versa.}$$

* * *

Broadcast Fraud Warnings

RADIO is being used for the first time by the Bureau of Pensions in an attempt to apprehend an alleged impostor now operating in Ohio in violation of Federal statutes. The individual sought is said to have been posing as an agent of the Pensions Bureau, defrauding old soldiers. Attempts to apprehend him were made through the WHK broadcasting station at Cleveland and the WLW station at Cincinnati. Messages giving his identity and warning veterans against being victimized were broadcast at the same time.

* * *

A Radio Station Near the South Pole

RADIO fans who pick up the signal LRT will be in communication with the world's southernmost radio station, which is about to be set up in the South Orkney Islands, where the Argentine Government maintains a meteorological observatory.

"This Is WWJ"

Radio with the Detroit News is a tradition—a tradition based upon more than a quarter of a century of experimental work inaugurated by the late James E. Scripps, founder of the News itself.

The News began broadcasting away back in September 1920. Today Radio the world over, admires WWJ for the clear, even, mechanical perfection of its message. And the Detroit News Orchestra is everywhere an accepted standard of sound, musical excellence. Hear it, at its very best, through The Superspeaker.

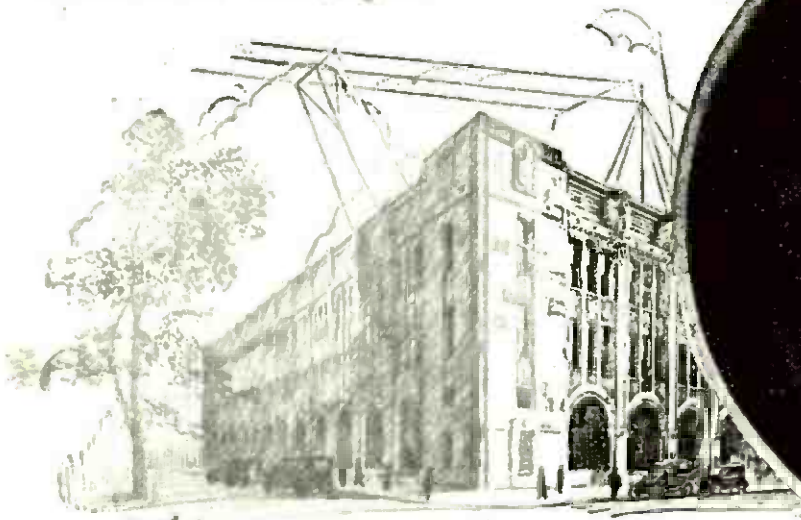

"COAST to Coast on the Loudspeaker" is your ultimate hope from a modern Radio Set.

But this is 100% performance and needs the 100% loudspeaker—The Jewett Superspeaker, nothing less!

The throat is as straight as an organ pipe. No extra batteries are needed.

Compare It—You'll Buy

Jewett Radio & Phonograph Co.
5668 Telegraph Road Pontiac, Michigan

The
Superspeaker
Trademark Registered

All apparatus advertised in this magazine has been tested and approved by POPULAR RADIO LABORATORY

Another Famous TOWER

Equal to the BEST
regardless of price

Tower
 Scientific
LOUD-SPEAKER
\$8.50



Surely a Wonderful TOWER TRIUMPH

Unquestionably the greatest Loud Speaker Value ever offered, giving the quality and volume to be found in the most expensive speakers, but priced within the reach of all.

The many features include magnets that lift 2 lbs. 10oz., diaphragm of specially constructed material, perfect non-vibrating fibre horn, finished in beautiful golden bronze with 10" bell.

On sale at all good dealers
from coast to coast.



Tower's Scientific Phones are tested and approved by Government licensed Radio Operators, thus guaranteeing uniform tone, quality and accuracy.

The Woolworth Bldg., New York City, is the tallest office building in the world being 792 feet high, containing 60 stories, and having an estimated weight of 206,000,000 lbs.

THE TOWER MFG. CORP.
98 Brookline Ave. Dept. J Boston, Mass.

Worlds Greatest Loud Speaker Value

All apparatus advertised in this magazine has been tested and approved by POPULAR RADIO LABORATORY

Lacault Scores Again!

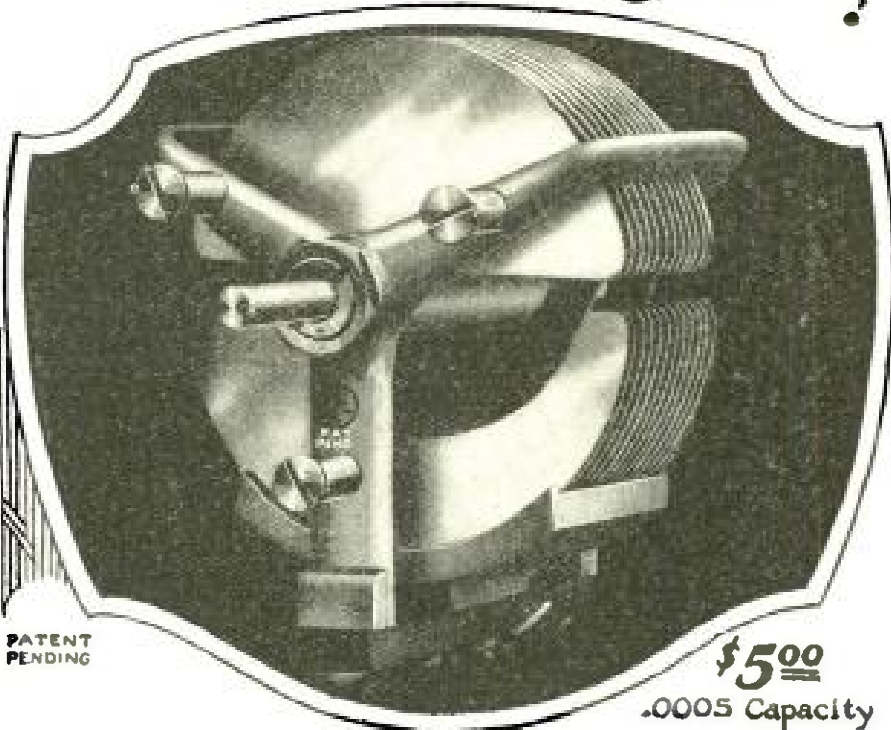

PATENT
PENDING

\$5⁰⁰
.0005 Capacity

The new Ultra-Lowloss condenser is the latest radio improved device designed by R. E. Lacault, formerly Associate Editor of Radio News, the originator of Ultradyne Receivers and now Chief Engineer of Phenix Radio Corporation.

ULTRA-LOWLOSS CONDENSER

LIKE every Lacault development, this new Ultra-Lowloss Condenser represents the pinnacle of ultra efficiency—overcomes losses usually experienced in other condensers.

Special design and cut of stator plates produces a straight line frequency curve, separates the stations of various wave lengths evenly over the dial range, making close tuning positive and easy.

With one station of known frequency located on the dial, other stations separated by the same number of kilocycles are the same number of degrees apart on the dial.

In the Lacault Ultra-Lowloss Condenser losses are reduced to a minimum by use of only one small strip of insulation, by the small amount of high resistance metal in the field and frame, and by a special monoblock mounting of fixed and movable plates.

At your dealer's, otherwise send purchase price and you will be supplied postpaid.



ULTRA-VERNIER
TUNING CONTROL

Simplifies radio tuning. Pencil-record a station on the dial—thereafter, simply turn the finder to your pencil mark to get that station instantly. Easy—quick to mount. Eliminates fumbling, guessing. Furnished clockwise or anti-clockwise in gold or silver finish. Gear ratio 20 to 1.

Silver \$2.50 Gold \$3.50

Design of lowloss coils furnished free with each condenser for amateur and broadcast frequencies showing which will function most efficiently with the condenser.



This seal on a radio product is your assurance of satisfaction and guarantee of Lacault designs.

To Manufacturers Who Wish to Improve Their Sets

The Ultra-Lowloss Condenser offers manufacturers the opportunity to greatly improve the present operation of their receiving sets.

Mr. Lacault will gladly consult with any manufacturer regarding the application of this condenser to his circuit for obtaining efficiency.

PHENIX RADIO CORPORATION, 116 East 25th Street, New York

All apparatus advertised in this magazine has been tested and approved by POPULAR RADIO LABORATORY

GOLDEN-LEUTZ

PLIO-6

TRADE MARK REG.

"The Perfect Broadcast Receiver"

A New Superior Broadcast Receiver

Simple—Long Range—Highest Quality
Non Radiating — Non Regenerative

\$ 60⁰⁰

*Two Stages Tuned Radio Frequency-Detector
and Three Stages of Audio
Frequency Amplification*

**COMPLETELY
CONSTRUCTED
Without Accessories**



PLIO-6
Front View Showing Simplicity
of Control

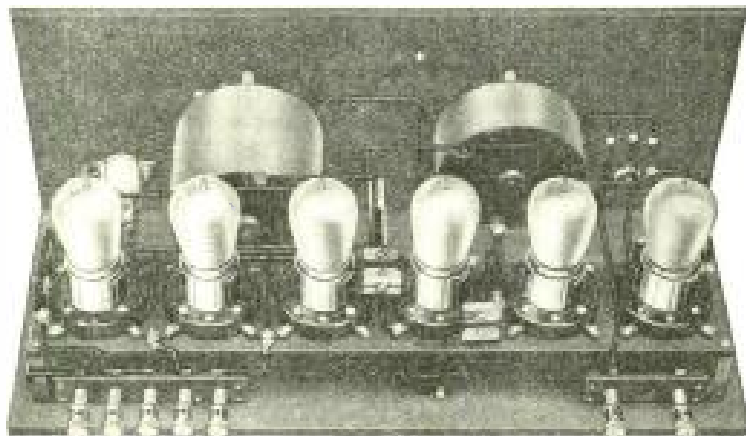

PLIO-6
Interior View Showing Compact
and Efficient Design

*If your local dealer
cannot supply you
with the PLIO-6,
write to us direct.*

Sent C. O. D. Subject to Examination

OUR GUARANTEE

We guarantee every Golden-Leutz "Plio-6" to be one of the finest broadcast receivers that can be manufactured using 6 tubes or less and to be satisfactory to you in every reasonable way.

GOLDEN-LEUTZ, Inc.

476 BROADWAY

NEW YORK CITY

Licensed under Hogan Patent No. 1,014,002

Use this Loop for better reception

It's a highly efficient antenna
and
a beautiful piece of furniture

Specifications

Hexloop is made of solid mahogany with a fine brown finish. Base is separate and massively built—heavy enough so that loop can be easily rotated without danger of its falling over. Hexloop is 36 inches high and 30 inches wide.

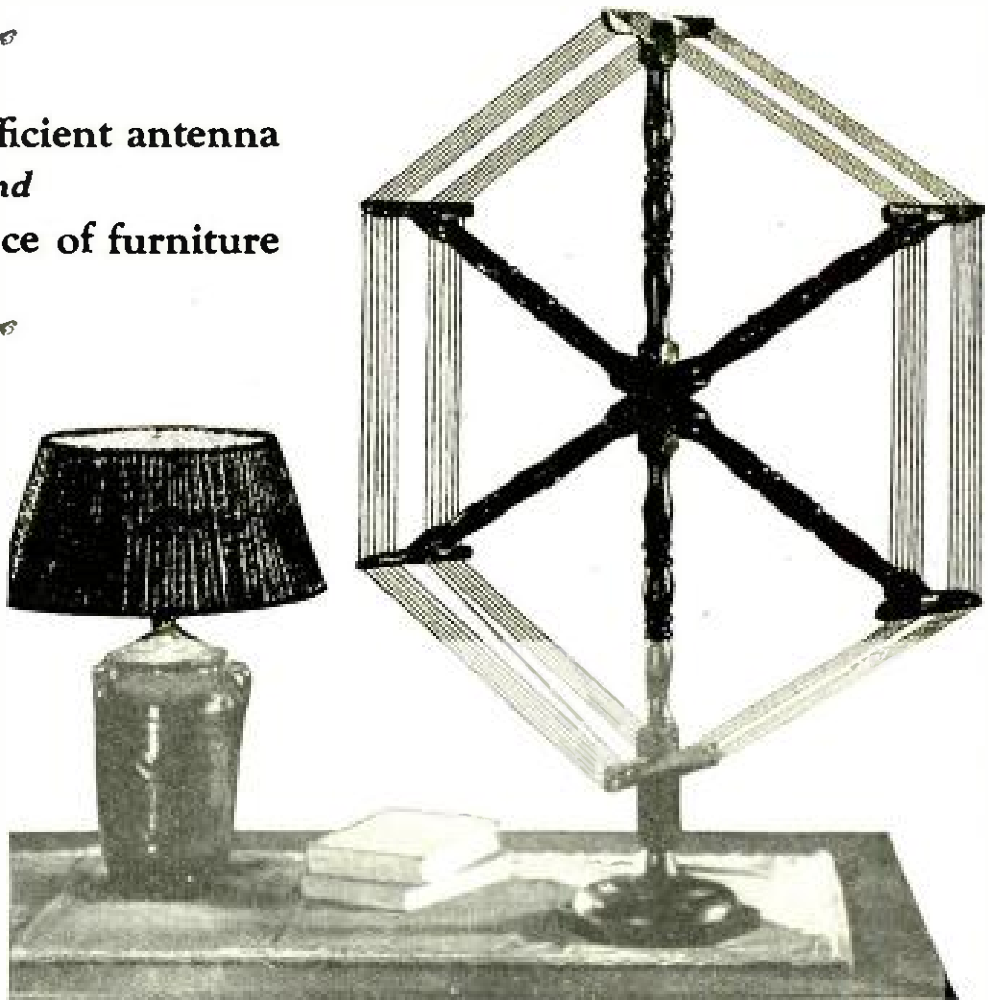

Hexloop—a new idea in loop antennae—highly efficient electrically and very attractive.

Hexloop does not detract from the appearance of your radio set and in spite of its size, it is not objectionably conspicuous. Hexloops' design is taken from an authentic model from the Colonial Period.

On sets where a loop can be used, Hexloop will give exceptional results. It has the necessary size to be a good antenna and there is just the right amount of winding, so that the entire broadcast range is nicely covered when tuning is done with a .0005 variable condenser.

Hexloop is a low resistance loop, therefore its directional characteristic is very pronounced.

Hexloop is wound with braided brown silk covered stranded wire that won't sag because there are several strands of stiffening wire wound with the soft copper lengths.

Built of solid mahogany—beautifully finished, Hexloop presents a handsome appearance that will fit in any surroundings.

All factors of performance, appearance and cost considered, Hexloop is the best loop value today.

Your dealer can get Hexloop for you or we will ship direct.

Hexloop can be had completely assembled from your dealer for \$20 or for \$18 you can buy a complete set of parts for this fine loop and by following a few simple instructions you can assemble it yourself without difficulty.

We only ship sets of parts direct, but we can assure you that if you order these parts you can assemble Hexloop in a few moments and get the same results as if it were purchased completely assembled.

HEXLOOP IS RIGHT—ELECTRICALLY—MECHANICALLY—ARCHITECTURALLY

R. B. Scribner Company

216 West 34th Street

∴

New York City

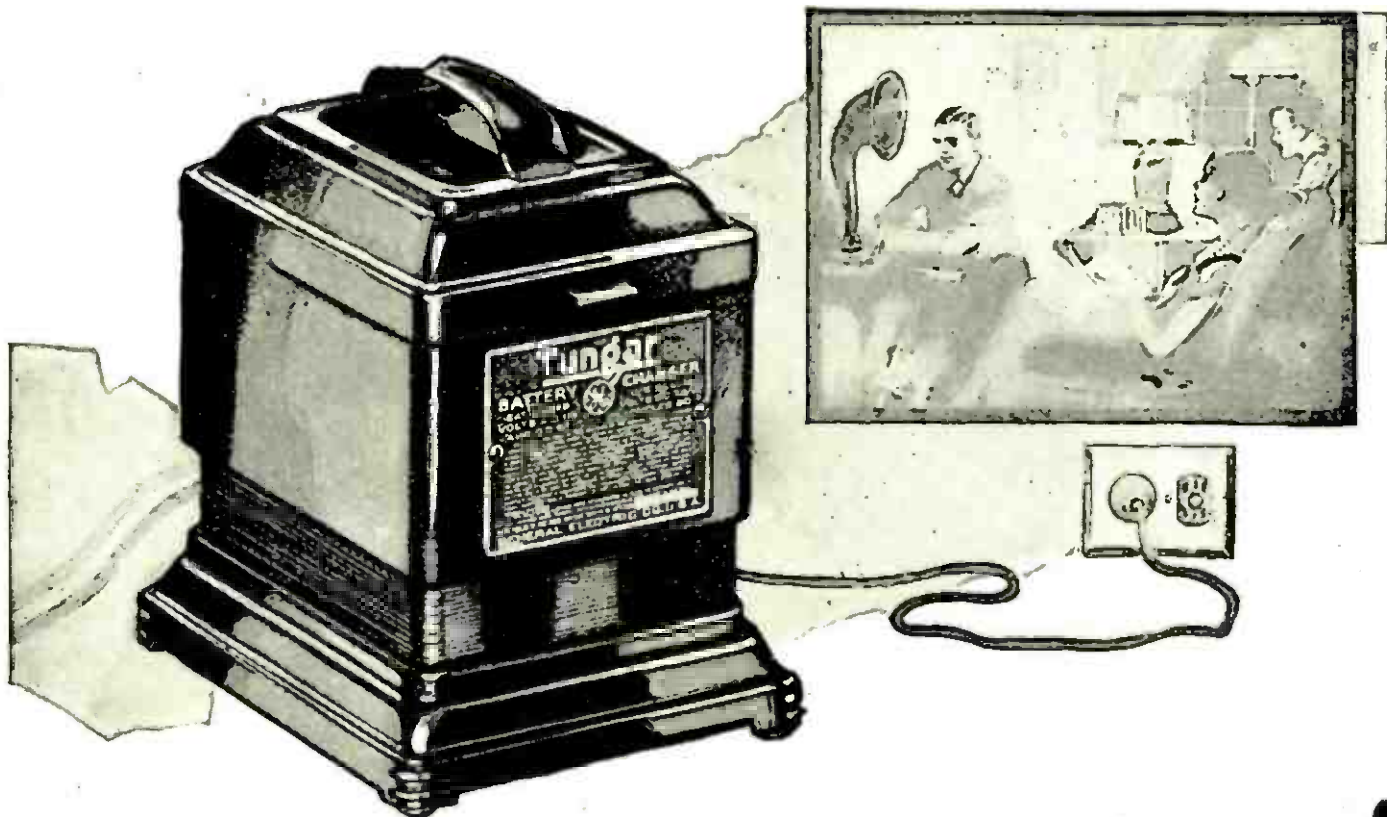

KEEP reception clear!

Keep it clear. Keep it loud—with all the volume your set should have. Keep the battery at top notch—fully charged—peppy.

The Tungar charges your storage battery overnight while you sleep—and at a cost of hardly more than five cents. It's easy! Just two clips—and a plug for the house current. Or you can make a permanent connection, and just throw a switch. Keep your set at its best all the time—with a Tungar.



The Tungar is a G-E product, developed in the great Research Laboratories of General Electric.

The New Model Tungar charges Radio A and B storage batteries, and auto batteries. Two ampere size (East of the Rockies) . . . \$18.00

A Tungar is also available in five ampere size, design unchanged (East of the Rockies) . . . \$28.00

60 cycles—110 volts

Tungar

REG. U.S.

PAT. OFF.

BATTERY CHARGER

Tungar—a registered trademark—is found only on the genuine. Look for it on the name plate.

Merchandise Division

General Electric Company, Bridgeport, Conn.

GENERAL ELECTRIC

Write your own
ideas of a perfect
Radio Receiver
and the
ARAGAIN
will check on
every point



DESCRIPTION

THE ARAGAIN receiver consists of a two-stage ARAGAIN radio frequency amplifying system, detector and two-stage audio frequency amplifier. - -

ARAGAIN radio frequency transformers are so designed that capacity coupling between the plate or primary circuit and the grid or secondary circuit is reduced to the absolute minimum. These transformers are precision instruments, and are housed in cases of the best high frequency insulating material.

The detector circuit is standard, except that it requires no manual adjustment, being automatically adjusted and balanced to the most sensitive point, requiring no adjustment by the operator.

There are only four moving parts, the three tuning dials and the modulator which controls the volume.

All ARAGAINS are wired with bi-metallic radio conductor, which is an unusually heavy bus bar of pure electrolytic copper surrounded with an envelope of pure gold, which forms the radio frequency conductor.

Scientifically designed and constructed. Tested and sealed before shipping. Housed in heavy, hand rubbed, brown mahogany cabinet of attractive design.

\$180 f. o. b.
Niagara Falls

ARAGAIN
REG. U. S. PAT. OFF.

What Other Set Can Meet This Test? The Absolute ARAGAIN Gets Them All

Selects 4 Stations Inside 1 Degree

AND along with this perfect selectivity, it delivers a great volume of real music, neither the high notes nor the low notes are slighted; nothing is added and nothing is subtracted from the quality of speech and music transmitted.

The ARAGAIN Radio Receiver is the result of four years of constant research work by an electrical engineer. He brought to bear on the problem all his years of experience in handling electrical energy; analyzed his problem; studied all parts and material offered; and after three years work produced the ARAGAIN.

For more than a year ARAGAIN has been demonstrating to owners and engineers its consistently splendid performance. It is meeting with favor because the ARAGAIN amplifying circuit produces UNUSUAL results. Skilled craftsmen produce the ARAGAIN, and only the finest quality of material is used in its construction.

**Do You Want Exceptional Clarity—Exceptional
Volume—Exceptional Selectivity?**

Laboratory tests and demonstrations prove absolutely that the ARAGAIN amplifies the signal to which it is tuned, and eliminates others, including the powerful local stations.

ARAGAIN will give you all these. Stop experimenting. Write for our booklet about "Absolute Aragain—the Set of Satisfaction."

AUTOMETAL CORPORATION
311 FALLS ST., NIAGARA FALLS, N.Y.

Some territory still open for jobbers and dealers



Assemble It Yourself

THE time is past when radio "fans" are satisfied with fair results—"cheap sets," limited distance, imperfect reception. They demand the best.

King Neutrodyne Kits meet the most exacting requirements.

A few hours of interesting work and the kit is assembled—absolutely the highest quality—the best in radio.

Dealers:

A complete line of Radio.

A liberal margin of profit.

Quick turn-over possibilities.

The King Dealer's plan will tell you about these in detail.

Write today!

Send for Catalog

KING QUALITY PRODUCTS, Inc.
Buffalo, N. Y.

KING
NEUTRODYNE
Perfected Radio

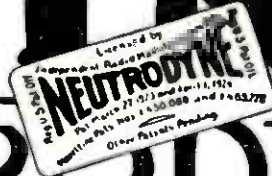

Bringing Distant Stations Closer



NEARBY stations thunder in because the antenna gathers in an ample supply of energy.

Distant stations lose energy on their way to your set. Conserving these faint signals through perfect insulation of your antenna is just like moving your set toward a station.

PYREX all-weather insulators improve reception by cutting down antenna leakage.

PYREX is the trade-mark of a special composition possessing distinctive electrical characteristics. It is not an ordinary glass.

PYREX Broadcast Insulators retail for 45c.

Insist on obtaining PYREX

CORNING GLASS WORKS

Industrial and Equipment Division, Corning, N. Y.

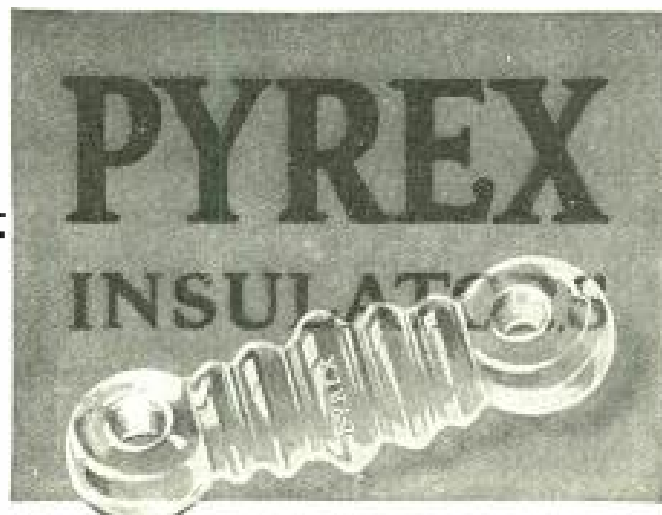



Camco Cannon-Ball, \$3.50

The quick pull and quick release of the cores in the Camco Cannon-Ball efficient coils help produce clear, sharp reception always. If you want tone, volume and quality, a Camco Cannon-Ball Headset will meet your wishes. Light as a good headset should be—comfortable on any type of head. Inspect the Camco Cannon-Ball Head set at your dealers or write for folder, "RADIO AS YOU LIKE IT."

Camco Cannon-Ball: Cases, highly polished aluminum; Magnets, chrome magnet steel; Cores, special alloy; Core Heads, Formica; Diaphragms, silicon steel; Wire, copper enamel insulation; Terminals, outside, positive side marked plus; Caps, black composition; Resistance, about 2,000 ohms D. C.; Turns, 4,500 per coil, 18,000 per set; Impedance, about 20,000 ohms at 1,000 cycles; Cords, black mercerized cotton, 5 feet long; Headbands, adjustable type, wire covered with black braid; Weight, complete with headband and cord, 10 ounces.

Compare Camco Cannon-Ball and Camco Grand Headsets. Then choose the one you like best. Both are sold on a MONEY-BACK GUARANTEE.

CANNON & MILLER COMPANY, Inc.



Grand, \$4.75

DEALERS: Ask your jobber about Camco products or write for complete details.

SPRINGWATER, N. Y.

Wonderful Volume with Clearness AMPL-TONE



\$3.00

Phonograph makers have spent years perfecting the acoustic properties of their phonographs. Use an AMPL-TONE Unit and make a real Loud Speaker in an instant.
After all, speakers are as good as their unit. We make a real unit at a real price. Money gladly returned if you are not entirely satisfied.

The UNION FABRIC CO.
DERBY, CONN.

Makers of the Excellent French AMPL-TONE Headset
Please send me an AMPL-TONE Unit for which I enclose \$3.00

Name

Address

State

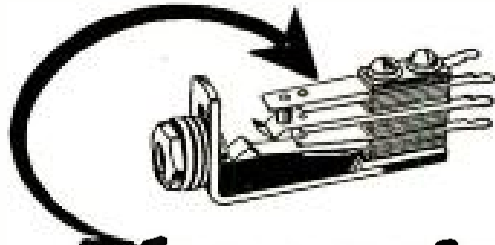

The spring's the thing!

Don't underestimate the importance of good jacks.
Don't buy jacks because they're cheap.
Over 25 leading set manufacturers use only Pacent Jacks. They have that most important essential—*fine springs* that keep the tension constant and the contact perfect.

Write for catalog of complete Pacent Line
PACENT ELECTRIC COMPANY, Inc.
91 Seventh Avenue, New York City

Washington
Minneapolis
Boston
San Francisco
Chicago
Birmingham

Pacent
RADIO ESSENTIALS

Philadelphia
St. Louis
Buffalo
Jacksonville
Detroit

Canadian Licensees: R. H. White Radio Co., Hamilton, Ont.

DONT IMPROVISE - PACENTIZE

The two outstanding parts in radio!

Give low losses and amplification without distortion to any set

QUALITY and distance are what a radio set must give. To insure Quality, amplification without distortion is essential. And to insure Distance, low losses are essential. That is radio in a nutshell.

People in whose sets Acme Transformers are used, are sure of hearing concerts "loud and clear" so a whole roomful of people can enjoy them.

The Acme A-2 Audio Amplifying Transformer is the part that gives quality. It is the result of 5 years of research and experimenting. It gives amplification without distortion to any set. Whether you have a neutrodyne, superheterodyne, regenerative or reflex the addition of the Acme A-2 will make it better.

To get the thrill of hearing

distant stations loud and clear, your set must have low losses, for it is low losses that give sharp tuning to cut through the locals, and it is low losses that allow the little energy in your antenna to come to the amplifier undiminished. That's what the Acme condenser will do for any set. And it will do it for years because the ends can't warp, the bearings can't stick and the dust can't get in and drive up the losses several hundred per cent.

The Acme Reflex (trade-mark) owes its success and its continued popularity to these two outstanding parts in the radio industry, for low losses and amplification go hand in hand.

Use these two parts in the set you build. Insist on them in the set you buy.

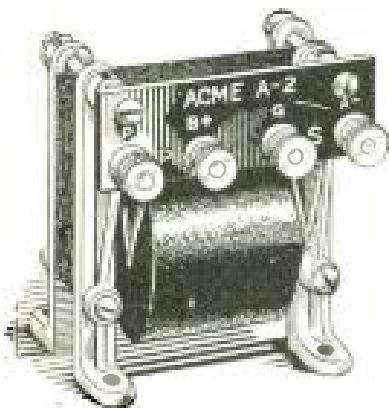

Acme A-2 Audio Frequency Amplifying Transformer

Send 10 cents for 40-page book, "Amplification without Distortion"

WE HAVE prepared a 40-page book called "Amplification without Distortion." It contains 19 valuable wiring diagrams. In clear non-technical language it discusses such subjects as, Radio Essentials and Set-building; How to make a loop; Audio frequency amplifying apparatus and circuits; Instructions for constructing and operating Re-

flex amplifiers; How to operate Reflex receivers; Antenna tuning circuits for Reflex sets; "D" Coil added to Acme four tube reflex; "D" coil tuned R. F. and Reflex diagrams; and several more besides. It will help you build a set or make your present set better. Send us 10 cents with coupon below and we will mail you a copy at once.

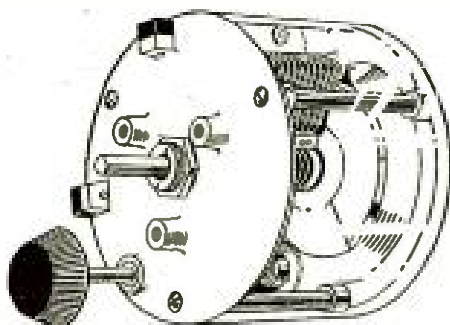

Acme Low-Loss Condenser

ACME APPARATUS COMPANY
Transformer and Radio Engineers and Manufacturers
Dept. C4, Cambridge, Mass.

SEND THIS COUPON

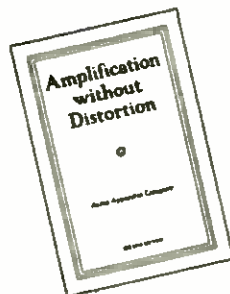

ACME APPARATUS COMPANY, Dept. C4, Cambridge, Mass.	
Gentlemen:— I am enclosing 10 cents (U. S. stamps or coin) for a copy of your book "Amplification without Distortion."	
Name.....
Street.....
City.....	State.....

ACME ~for amplification



More Money For You in **RADIO**

THE amazing expansion of Radio has opened up hundreds of wonderful new positions on land and sea. Big salaries, fascinating, easy work, short hours, and a wonderful future are offered to ambitious men who get into Radio now.

Take advantage of these wonderful opportunities to step into a big paying position in this great new field. You can stay at home and work up to a position paying up to \$10,000 a year, or Radio offers you an opportunity to travel and see the world, with all expenses paid, and a fine salary besides. One of our recent graduates secured a position one week after graduating, paying a salary of \$300 a month. Hundreds of others report equal success.

Easy to Learn Radio at Home

Thousands of Certified Radio-tricians are wanted to design Radio sets; to make new Radio improvements, to manufacture Radio equipment and to install it; to maintain and operate great broadcasting stations and home Radio sets; to repair and sell Radio apparatus; to go into business for themselves; to operate aboard ship and at land stations. You can easily and quickly qualify in your spare time at home through the help of the National Radio Institute—first school to teach Radio successfully by mail, established 1914. No previous experience or training needed. Prominent Radio Experts will help you in every problem, giving you personal attention. You learn by actually doing, as we furnish free with course circuits and parts for building latest receiving sets, making the work thoroughly practical. You learn quickly and easily—right at home.

This is an absolutely complete course which qualifies you for the real "big pay jobs" in Radio and our big Employment Department helps you get one.

Send for FREE BOOK

No other field today offers such great opportunities as Radio. Take your choice of the many wonderful openings everywhere. Prepare now to step into the most interesting and best paid profession today. Read about the opportunities open now—the different kinds of work—the salaries paid. Write today for the 32-page book that tells how America's Radio correspondence school (government recognized) can teach you to become a Certified Radio-trician in your spare time, and also Special Offer to those who act at once. Mail the coupon or write a letter NOW.

National Radio Institute, Dept. 32GB, Washington, D. C.

NATIONAL RADIO INSTITUTE, Dept. 32GB
Washington, D. C.

Without obligation send me your book, "Rich Rewards in Radio," which tells all about the opportunities in Radio, how spare time study at home will qualify me quickly as a Certified Radio-trician so I can get one of the splendid positions, and how your Employment Service helps me to secure a big pay job. Please write plainly.

Name.....Age.....

Street.....

City.....State.....

New and Improved

\$5⁵⁰



Authorized Cockaday Coil!

No more loose winding—special new feature holds coil windings fast. Built throughout of moulded hard rubber, not affected by atmospheric conditions. Wound with No. 18 D. S. C. copper wire.

The only coil specified by L. M. Cockaday in his New Four Circuit Tuner with Resistance Coupled Amplification because it meets all his specifications. Described in October POPULAR RADIO as Cockaday Precision Coil. Hundreds have substituted this quality coil for those of inferior make and are amazed at the improved reception, selectivity and general D-X results.

At your dealers, otherwise send purchase price and you will be supplied postpaid
In Canada \$7.75. Canadian Distributor, Perkins, Ltd.
Montreal—Toronto—Winnipeg

PRECISION COIL CO., Inc.
209-B Centre St., New York City

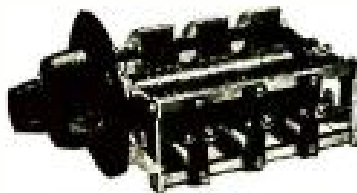

SINGLE DIAL CONTROL

A Late Development

LOMBARDI MULTI-UNIT CONDENSER

MR. COCKADAY, Technical Editor of Popular Radio, states that among other great advantages, single control insures

1. Simplified tuning
2. No body capacity
3. Improved appearance

Therefore set manufacturers are including Multi-Unit condensers in their new models.

They are also sold through retail channels to exacting amateur constructors.

Licensed under Hogan Single Control Patent #1,014,002

Literature Sent on Request

Lombardi Radio Mfg. Co.
67-71 Minerva Street Derby, Conn.
(Special Jobber and Dealer Proposition)

ATWATER KENT RADIO



To own an Atwater Kent ~

WHAT a wonderful, delightful difference it makes—just think what it means—in one evening the thrills of a lifetime are crowded into a few short hours.

Set its dials and the melodies of a famous orchestra flood your home; another touch and you hear a lecture from miles away—turn again and you have the news of the day or the sweet

voice of a renowned singer generously broadcasting for your entertainment.

Choose whatever program you will, with an ATWATER KENT you are master of the air.

There is an ATWATER KENT well within your means: it combines every feature that assures radio satisfaction for years to come—Any ATWATER KENT dealer will help you in your selection.

ATWATER KENT MANUFACTURING COMPANY. 4712 Wissahickon Ave., Phila., Pa.

THINK WHAT IS BACK OF IT

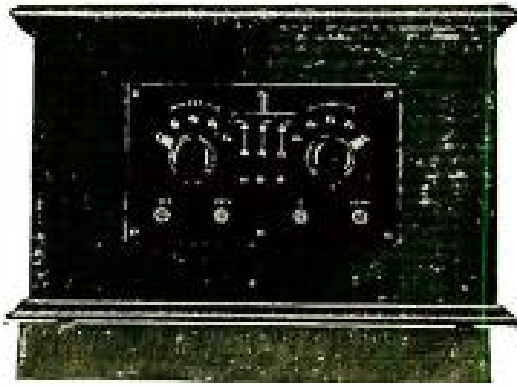

KIC-O "B" Multi-Power Unit— the power behind better radio reception

How did the concert come in last night? Did you have to disappoint your guests because of poor reception due to an unsatisfactory "B" battery? Then let the new KIC-O Multi-Power Unit end your radio troubles now.

This new unit combines one Multi-Polar recharger and one heavy capacity nickel-zinc alkaline storage "B" battery into a compact, durable, well-built power unit that will last for years.

Its ease of operation will please even the most exacting radio fan. Just attach to any electric light socket and forget it. When you desire to receive, throw the panel switch down. For recharging throw the switch up. No bother, no worry—a simple twist of the wrist.

Each unit bears a printed guarantee of protection against electrical and mechanical defects.

Write today for full description which tells why KIC-O Multi-Power Units are better than dry cells, "B" eliminators and acid "B" batteries.

PRICES
PZ indicates panel type with switches
CZ is plain type without switches

Voltage	M. A. H.	Type	
		PZ	CZ
130	2500	\$38.00	\$35.00
100	2500	27.50	24.50
70	2500	21.50	18.50
45	2500	16.00	14.50
22½	2500	7.50

MULTI-POWER UNITS
(No recharger required)

130 volts.....	\$43.50
100 volts.....	35.00

KIC-O CHARGERS

Type K-1 Single Unmounted.....	\$1.50
Type K-2 Single Mounted.....	3.50
Type K-3 Multi-Polar Mounted.....	5.00
KIC-O Special Charger Chemicals (One Cell).....	.50

KIMLEY ELECTRIC CO., Inc., 2667 Main St., Buffalo, N. Y.

U.S. TOOL
TRADE MARK

TYPE 6

WHETHER it be capacity or a mechanical feature, every attribute of perfection is embodied in U. S. Tool. Certainty of satisfaction leads editors to recommend it, manufacturers to use it and amateur set-builders to eventually select it.

FACTORY GUARANTEE

Write for Literature or Inquire at Your Dealer's

U.S. Tool Company, Inc.
AMPERE, N. J.

The LARGEST RADIO STORES in AMERICA

THE HOUSE OF QUALITY AND SERVICE

Hookups!
All the latest and best Kits in our new **RADIO CATALOG**

FREE

Just Out! Our new 1925, ninety-six page Radio Catalog including all the best and latest Kits, Parts and Accessories. Also our new 32 page bargain section—write for your FREE copy to-day!

Save Money! We buy up manufacturers' jobbers, and dealers surplus and bankrupt stocks—but only brand-new fully guaranteed, nationally advertised apparatus. Our enormous buying power permits us to pay spot cash and get rock-bottom prices—even way below manufacturer's costs. That's why our catalog is crammed with thousands of wonderful Radio Bargains.

CHICAGO SALVAGE STOCK STORES

509 So. State St., CHICAGO, ILL., Dept. P. R. 6

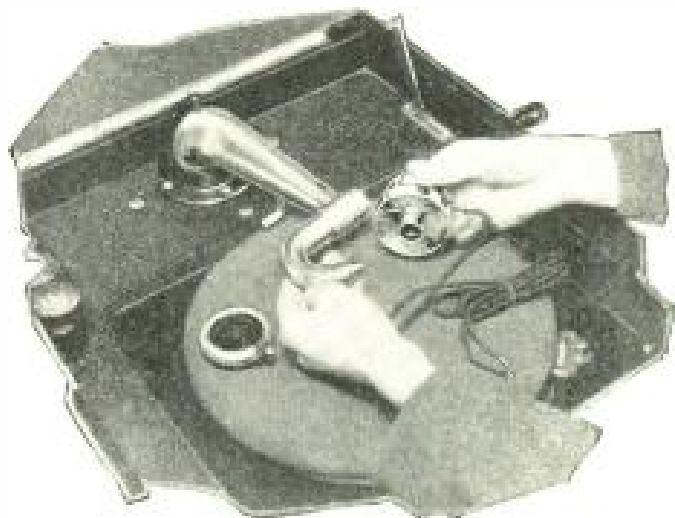

From Phonograph to Radio in a Jiffy—

Phonographic reproduction is justly famous for its accuracy and tone. But your own Phonograph will excell its best prior performance when you connect it with your Radio set by a Jewett Vemco Unit.

Slips on or off in a Jiffy—no tools needed.

A Phonograph one minute, a Radio loudspeaker the next.

But be sure the unit is a Vemco—the leader of all Radio-Phonographic equipment!



The same reproducer we use in the world-famous Superspeaker—Adjustable for volume control—A real musical instrument built by experienced musical instrument people—Standard model fits Victrola tone arm—simple adapters for other phonographs.

“THERE IS NO SUBSTITUTE FOR THE BEST”

JEWETT RADIO &
PHONOGRAPH COMPANY
5668 Telegraph Road • Pontiac, Mich.

The Jewett Vemco Unit

All apparatus advertised in this magazine has been tested and approved by POPULAR RADIO LABORATORY

For Better Radio Hammarlund PRECISION CONDENSER

Copyright March 17, 1925

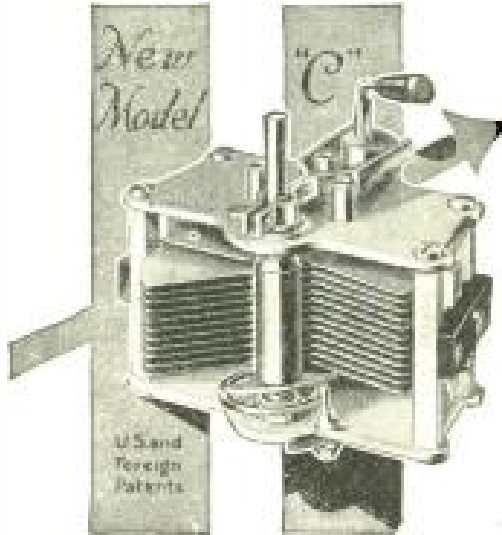

THE more you know about the technical requirements of radio, the more you appreciate the technical refinements of the Hammarlund New Model "C" Condenser.

It is an instrument of laboratory precision sold at a popular price by the better radio dealers. All capacities; plain and vernier.

Write for Descriptive Folder

HAMMARLUND MANUFACTURING CO.
424-438 West 33rd Street, New York

9 points of superiority

- 1—Soldered brass plates, chemically treated against corrosion; perfect alignment.
- 2—Stator plates specially shaped for easy tuning of low waves.
- 3—Adjustable ball-bearing rotor shaft, grounded through metal end-plates.
- 4—Soldered clock-spring pigtail, with automatic stop.
- 5—Minimum dielectric, losses too small to be measured.
- 6—Rugged, compact construction; cannot warp.
- 7—Micrometer cam-vernier moves all plates; knob or lever control; no backlash.
- 8—Takes any size dial.
- 9—The product of 14 years' experience, making precision instruments.



New York to Cuba in One Night

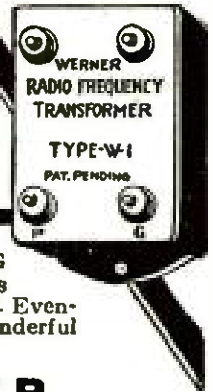

Get 46 stations in ONE EVENING including New York, Dallas, Los Angeles, and Porto Rico; the N. Y. Evening World did it in testing the wonderful sensitivity of the new principle

WERNER Radio Frequency TRANSFORMERS For All Circuits

The success of a really selective receiver depends on highly sensitive WERNER TRANSFORMERS. Insist on getting them, if your dealer can't supply you send your order to us.

Price \$4.00, All Types

Send for Diagrams

A wonderful interesting book "Radio" Frequency Amplification" contains popular and technical information with many up-to-date R. F. circuit diagrams of greatest interest to both radio user and engineer.

25c. postpaid

New Diagram Leaflet sent FREE

P. Werner Radio Mfg. Co.
204-206 Ninth St., Brooklyn, N. Y.

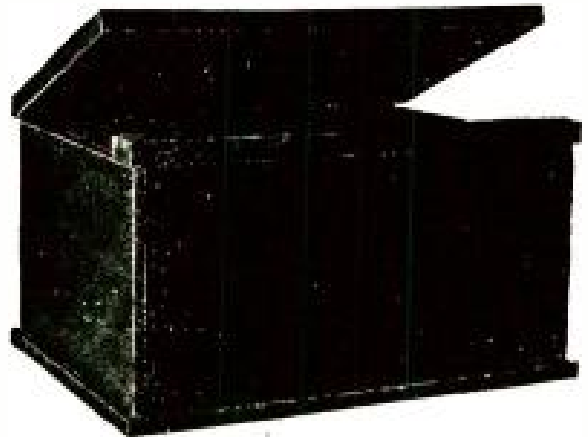

RADIO CABINETS

STRONG AND RIGID.

Remember that we pay mail and express charges—it makes quite a difference when comparing prices.

SPECIFICATIONS

Hardwood, rubbed mahogany finish. Top hinged, ends of top splined to prevent warping.

Panel Size	Depth	Price
7 x 14	10	\$3.00
7 x 18	10	3.25
7 x 21	10	3.50
7 x 24	10	3.75
7 x 26	10	4.50
7 x 27	9	5.00
7 x 28	10	6.00

Mail and express prepaid East of the Mississippi River. We also make Radio Desks and Tables.

SEND FOR FREE CATALOGUE.

THE SOUTHERN TOY COMPANY, Inc.
Dept. P. Hickory, N. C.



Boys' radio interest knows no "off season"

The harder the battle the sweeter the triumph. That's part of every live boy's code. And when it comes to radio, the greater the difficulties the more he strives to overcome them, or failing that, to succeed in spite of them. This spirit of boydom, together with the unquenchable enthusiasm, boys have for radio, is the radio manufacturer's bridge across the summer doldrums.

No matter where a boy goes—to camp, the mountains or the shore—he's sure to have two things with him: his appetite and his radio set. And each trip to the general store has a double purpose—soda for the appetite, and some new device for the beloved radio. The desire for one is as unremitting as the desire for the other. The volume of sales for both is amazing.

THE AMERICAN BOY is guide

and authority to 500,000 radio-hungry boys averaging 15½ to 16 years old. These boys are sons of well-to-do parents, possessors of substantial allowances with which to buy desired objects. And all through the summer this great army of boys will be buying radio equipment.

Advertise your radio products to them. Tell them not only of the goodness and up-to-dateness of your products—tell them of your distribution, and how they can get your goods wherever they spend the summer. Start them using your name—and thinking about radio in terms of your name. Keep your name and your product constantly before them in the one great publication they know to be their own—THE AMERICAN BOY.

Copy reaching us by May 10th will appear in July.

The American Boy
The Dugest, Brightest, Best Magazine for Boys in All the World
 Detroit Michigan



TYPE P

Black Enamel Finish. 3 holes in Flange for Panel Mounting. 2 ins. diameter.

List Prices

0-7 volts \$1.25 0-50 volts \$1.25
0-100 volts \$1.50



TYPE N

Handsome Nickel Rim with Black Bezel Clamp Style Mounting.

List Prices

0-7 volts \$1.75 0-50 volts \$1.75
0-100 volts \$2.00

DONGAN

VOLTMETERS

NECESSARY FOR EFFICIENT RADIO RECEPTION

Set Manufacturers and Fans now realize that efficient radio performance depends on correct tube and B battery voltage. Only in that way can you enjoy good radio all the time.

Dongan Voltmeters will keep an accurate check on your set operation. Accuracy over the entire range of scale, definite readings that can be relied upon feature Dongan Voltmeters—designed and manufactured by a company who has specialized for 15 years in the production of high-grade electrical instruments.

Dongan High-Resistance Voltmeters possess sufficient ohms per volt to insure efficient operation and are ruggedly built to give years of service.

Manufacturers Prices quoted on request.

Four Types for all purposes

Capacities from 0-7 to 0-100 volts

DONGAN QUALITY AUDIO TRANSFORMERS

are built in ratios, 2-1, 3 1-2-1, 6-1

DONGAN ELECTRIC MANUFACTURING CO.

2983 Franklin St., Detroit, Mich.

Transformers of Merit for 15 Years

The Key to Simplified Tuning

E-Z-TOON

(EASY TUNE)

Radio Dials

Users Say:

February 27th, 1925

"I have installed the E-Z-TOON dials on a Regenerative receiver and they have already proven themselves greatly superior to the mechanical verniers used up to this time. They certainly make the tuning in of DX stations a pleasure and simplify this process immeasurably." Hans Helle, 3107 Bedford Ave., Brooklyn, N. Y.

E-Z-Toon Dials are two dials in one with an 80 to 1 fine smooth vernier adjustment. Place a set of them on your set and you will marvel at its selectivity. 3 in. Dials, Blk., \$2.00; Mahog., \$2.20. 4 in. Dials, Blk., \$2.25; Mahog., \$2.45. 2 in. Non-Vernier Dials, Blk., 40c.; Mahog., 45c each. All Vernier Dials are made with Zero mark on either right or left side.

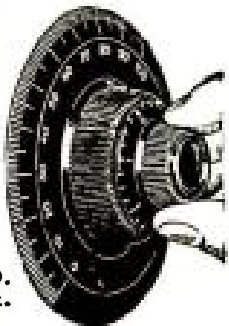

E-Z-TOON RADIO CO.
3236 W. Washington St.
Indianapolis, Ind.

The Key to Simplified Tuning

Our King Type Cabinet

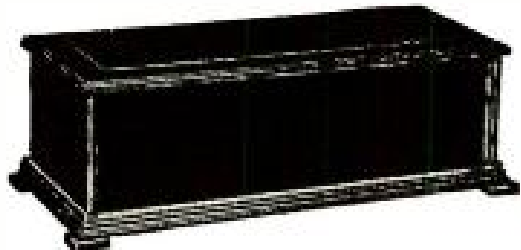

Our cabinets are made of carefully selected lumber. They are beautifully finished and hand rubbed. The workmanship is of as high grade as in the best furniture. If not entirely satisfied with cabinets received from us, money will be refunded. Black walnut cabinets have piano hinges and lid holders. Imitation walnut cabinets have regular hinges, no lid holders. Send for circular showing our De Luxe Type, also our Beauty Type.

No.	For Panel	Deep, In.	Imitation Walnut	Genuine Walnut
King 621	6 x 21	7	\$4.60	\$6.80
King 714	7 x 14	7	4.20	6.70
King 718	7 x 18	7	4.35	6.80
King 721	7 x 21	7	4.90	7.40
King 724	7 x 24	7	5.35	8.00
King 726	7 x 26	7	5.80	8.50
King 728	7 x 28	7	6.60	10.00
King 730	7 x 30	7	7.00	11.00
King 71810	7 x 18	10	5.70	9.00
King 72110	7 x 21	10	6.25	9.50
King 72410	7 x 24	10	6.70	10.00
King 72610	7 x 26	10	7.25	10.50
King 72810	7 x 28	10	8.00	12.00
King 73010	7 x 30	10	8.20	12.50
King 836	8 x 36	10	8.75	12.00
King 840	8 x 40	10	9.25	12.50
King 921	9 x 21	10	7.50	9.25
King 924	9 x 24	10	8.60	10.50

F. O. B. WAUKESHA, WIS.

UTILITY CABINET COMPANY

Waukesha

Phone-721

Wisconsin

DUPLEX CONDENSERS

DUPLEX STANDARD



"None other so good."
Conforms to Bureau of Standards specifications for lowest losses and best electrical characteristics. Skeleton metal end-plates and automatic take-up for bearing wear are among its features. Absolute satisfaction guaranteed!

DUPLEX JUNIOR



Lacks some of the costly refinements of DUPLEX Standard, but is "the best value for the price." Die cast rotor, milled stator posts, and other features usually found only in highest priced condensers. Electrical and mechanical perfection guaranteed.

In Matched Sets For Uniform Dial Settings

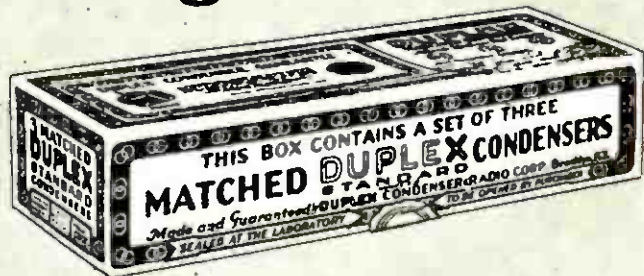

This most recent **DUPLEX** achievement — **DUPLEX Standard** condensers, specially tested, matched and guaranteed to have identical capacity curves, packed in sealed kits of three — has been enthusiastically welcomed everywhere by radio set builders, both professional and amateur. It is the *only* kit that affords uniform dial settings for Neutrodynes and all other tuned radio frequency circuits. There is only *one* number to log — not three — when you use a **DUPLEX Matched KIT**.

Instructive literature sent on request

DUPLEX CONDENSER & RADIO CORP.

50 Flatbush Ave. Extension, Brooklyn, New York

AMPLION

The World's Standard
Loud Speaker



The Amplion "Dragon" Model AR-19, \$42.50. Other Amplion Loud Speakers, \$13.50, \$24, \$27.50. Phonograph units in two sizes. Prices slightly higher in far west. Knob at rear of Amplion unit permits adjusting the mechanism to each set.

The "Floating Diaphragm" explains it!

The "Floating Diaphragm" of Special Metal is one of the outstanding *exclusive* features which account for the supreme and *lasting* sensitivity, purity, clarity and natural tone of The Amplion — qualities which have given it the coveted position of the world's largest selling loud speaker.

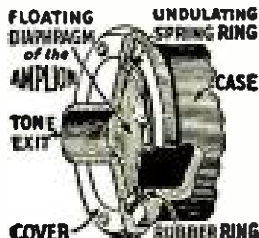

You will note in the cross sectional view that the diaphragm, insulated from contact with metal by rubber, rests on a narrow ledge —lightly held there by a spring ring with enough pressure to prevent "clatter" when extreme volume is desired. Diaphragm thus "floats" free from strain, stress or undue tension and free to vibrate in exact accord with the variations of current flowing through electromagnetic system. As a consequence, faithful reproduction is obtained throughout the entire musical scale—WITHOUT DISTORTION.

A treat awaits you, if you have yet to hear Radio over The Amplion.* Write today for literature—and name of dealer.

THE AMPLION CORPORATION
OF AMERICA

Executive Offices:

Suite X, 280 Madison Avenue, New York City

Canadian Distributors:

BURNDEPT OF CANADA, Ltd.,
130 Richmond Street West, Toronto

* Alfred Graham & Co., London,
England, patentees



Make Money Building This Set for Friends

Here is a 4-tube set with 5-tube volume, and a wonderfully sweet tone. It is not reflexed, but employs the circuit (with improvements) which made the Greene Concert Selector such a favorite in the east.

The secret is the L+K Variable Clarifying Selector and the VT25, Variotransformer, so widely praised by radio authorities. The Selector is a patented aerial tuner that gives needle-point selectivity. The VT25 is a variable transformer, operating without a condenser, that gives the amplification of two ordinary fixed R. F. transformers. Both will improve any standard hook-up.

We'll supply all the parts and charts and free expert advice to build this excellent set. Get just one set working in your neighborhood and you'll soon be good and busy on very profitable work. Write for Free diagram spread and particulars on this ELKAY SUPER-SELECTOR SET.

Address The Langbein-Kaufman Radio Company
511 Chapel St. Dept. P New Haven, Conn.

An L+K Product

TUNERS



SETS, KITS

PERSIL RADIO SERVICE

2114 Mapes Ave.

New York

Cockaday's Latest!

Have you written for our special offer including the Korach Loop, of the

8-Tube Superheterodyne Reflex

- 1 G. I. .0005 Condenser (Isolantite)..... \$5.50
- 1 G. I. .001 Condenser (Isolantite)..... 6.00
- 1 Set Haynes-Griffin Transformers..... 20.00
- 1 Precision Autodyne Coupler..... 3.50
- 1 Karas Harmonik A. F. Trans..... 7.00
- 1 Amplex Grid-Denser .0005..... 1.25
- 1 Benjamin Cle-ra-tone Socket..... 1.00
- 7 Federal Sockets No. 16 (\$1.20 each)..... 8.40
- 1 Patent D. C. Jack: 1 Patent S. C. Jack..... 1.10
- 2 Na-ald 4-inch Dials..... 1.50
- 1 Amso Rhoostat—2 Ohms..... 1.35
- 1 Amso Potentiometer—400 Ohms..... 1.50
- 2 Daven Resisto-Coupler Mounting..... 2.50
- 1 Daven Grid Leak Mounting..... .35
- 6 Daven Resistors—.5 Megohms, 5 Megohms, .005 Meg., .25 Meg.... 3.50
- 7 N. Y. Mica Condensers: .0001 Mid., .006 Mid., .00025 with clips... 4.15
- 1 Duratran R. F. Transformer..... 4.00
- 1 Walbert "A" Battery Switch..... .50
- 7 Eby Binding Posts..... 1.40
- 1 Sub-panel, bakelite 1" x 9", bus bar, brackets..... .45

Complete Kit..... \$74.95

WIRED In Special Mahogany Cabinet \$99.00

5-Tube Cockaday, 4-Circuit Tuner

KIT Resistance Coupled; Parts exactly as Specified. Blue Prints, Bus Wire, etc. \$67.00

WIRED In Genuine Mahogany Cabinet \$85.00

Craig 4-Tube Reflex Kit

PARTS as mentioned in magazine, including Blue Prints, panel, bus bar, and baseboard only \$47.50
WRITE FOR OFFER OF THIS KIT WITH SODIUM TUBE

WIRED In Genuine Walnut or Mahogany Cabinet \$74.50

Delivered Free Anywhere. Canada, Add 3% to Order. One-third Must Accompany All Orders. Insured if you wish. Write for Illustrated Circular of Above Receivers.

What Last Season PROVED TO Radio Manufacturers!

It proved that there is mighty little market for cheap looking radio equipment.

It proved that good material and workmanship are every day more essential to secure the confidence of the dealer—and build real business.

Service trouble ate up what little profit the dealer made on many really cheap sets—and he will sell no more of them!

The season proved that cheap substitutes for Formica panels are one of the most costly things a manufacturer can use.

Such expedients create a sales resistance that is far more costly in the end than good panels are in the beginning. That's why so many manufacturers who tried them are giving them up. Last year was the biggest Formica ever had in radio.

This year the volume will be done on sets that have Formica *base panels*—as well as Formica front panels, with their wonderful finish and permanent beauty.

Formica is one of the most lasting and unchanging materials in the world.

THE FORMICA INSULATION COMPANY

4641 Spring Grove Avenue, Cincinnati, Ohio

SALES OFFICES

50 Church Street.....New York, N. Y.	1026 Second Avenue...Minneapolis, Minn.
9 South Clinton St.....Chicago, Ill.	725 Bulletin Bldg.....Philadelphia, Pa.
516 Caxton Bldg.....Cleveland, Ohio	708 Title Building.....Baltimore, Md.
1142 Granite Bldg.....Rochester, N. Y.	585 Mission Street....San Francisco, Cal.
422 First Avenue.....Pittsburg, Pa.	419 Ohio Building.....Toledo, Ohio
6 Beacon Street.....Boston, Mass.	309 Plymouth Bldg....New Haven, Conn.
55 Calle Obispo.....Habana, Cuba	Whitney Central Bldg...New Orleans, La.
289 Victoria St..Toronto, Ontario, Canada	

Write for Booklet "What Formica Is"

- | | |
|---|--|
| <p>1 Formica is used by 125 leading makers—and has for years been used by more makers than all other materials.</p> <p>2 Formica will last forever.</p> <p>3 Formica, in appearance, is the finest of all panel materials and always remains so.</p> <p>4 Formica's electrical qualities of every kind far exceed any possible requirement.</p> | <p>5 Formica has high mechanical strength and will not break in use.</p> <p>6 Formica will not sag from heat or cold flow under pressure. It retains its dimensions. Everything you fasten to it stays tight and precisely where you put it.</p> <p>7 Formica panels are sold in neat craft paper envelopes which assure you that you are getting the genuine.</p> <p>8 Formica is one of the most widely approved materials in radio.</p> |
|---|--|

FORMICA

Made from Anhydrous Bakelite Resins

SHEETS TUBES RODS

Hear the Formica Orchestra every Tuesday evening from 9 to 10 Central Standard Time over WLW.

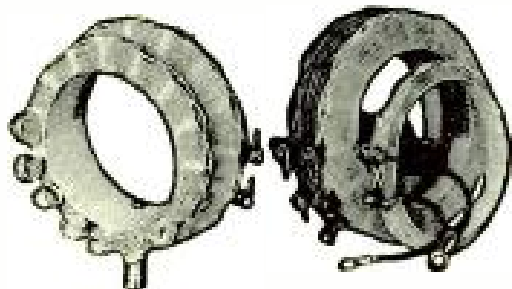

Coils for Roberts Circuit, No. 18
Price \$8.00 a Set

An entirely new system of Radio Reception

Sickles Diamond-Weave Coils have been specified for use in the Hoyt System of Signal Augmentation, by the inventor, Francis R. Hoyt. We have a limited number of blue printed copies of Mr. Hoyt's original laboratory notes on this new system of radio reception, together with nine circuit sketches, which will be sent free to you upon receipt of this coupon and four cents for postage.

The F. W. Sickles Co.
Springfield, Mass.

Please send information of Hoyt System

Name.....

Address.....

SICKLES

DIAMOND-WEAVE COILS

Patented Aug. 21, 1923

For Craig, Roberts and Hoyt Circuits

Sickles Coils were chosen by Albert G. Craig in designing his remarkable new Reflex Receiver using the new Sodian detector, and are specified by him, for this circuit in the February issue of POPULAR RADIO. This coil set, No. 20, is priced at \$4.50.

For the very popular Roberts Circuit the Sickles Coil Set No. 18 (\$8.00) is standard equipment. Unit No. 1 has primary and secondary coils. Unit No. 2 has primary, secondary, neutralizing coil and tickler. Broad variation in coupling adjustments is provided for. Tickler is provided with 180 degree dial control.

Coils for the Hoyt Circuit at \$10.00 a set, for the Knockout Reflex Circuit at \$4.00 a pair, the Tuned Radio Frequency coil at \$2.00 and the Acme Reflex Circuit at \$4.50 a set, are among the standard Sickles coils. We manufacture special coils also for manufacturers' requirements.

Send for descriptive catalog

The F. W. Sickles Co.

339 Worthington Street
SPRINGFIELD, MASS.

"Take No Chances—Use Como"
COMO DUPLEX

The World's Standard Push Pull Transformer

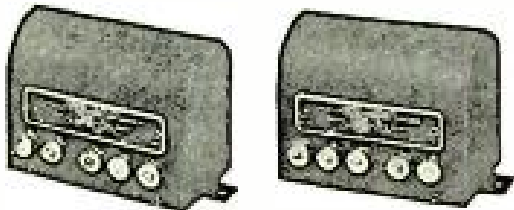

PRICE \$12.50 per pair
For maximum volume without distortion

What Prominent Writers on Radio Subjects say About Como.

Lewis B. Hagerman, Technical Editor, *Chicago Post*: "Actual Tests show this transformer to be far superior to any others of similar makes."

R. J. Robbins, *New York Sun*: "After consideration of several well-known makes of push pull transformers which are available 'COMO DUPLEX' was selected as most satisfactory."

C. White, *Radio World*: "'COMO DUPLEX' is infinitely superior—most other push pull transformers seem to be ordinary transformers with a center tap brought out as a makeshift."

E. P. Gordon, *Open Road*: "A system of audio-amplification which is becoming increasingly popular. Its use . . . will give surprising results in both quality and volume, and is thoroughly recommended by this department."

NEED WE SAY MORE?

COMO APPARATUS COMPANY

Manchester, New Hampshire
For Sale at Leading Dealers

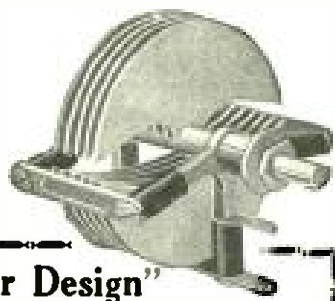

"Good Condenser Design"

What makes a good condenser? Send for this free folder and post yourself on today's requirements. This article is full of meat. It makes plain all the electrical as well as the mechanical qualities of a good condenser.

If you are planning to build a receiving set or to bring your present one up to date, go to your dealer and ask to see the new

Premier "CROFOOT" Variable Condenser

"CROFOOT" has all the necessary electrical and mechanical features. It is a real low loss instrument. It has the lowest minimum capacity yet attained—.000005 M. F. and the greatest tuning ratio—1 to 74. Made entirely of brass and hard rubber giving remarkably low skin resistance and low insulation leakage; a feature identified by the "red stripe." A sturdy, smooth acting, compact and graceful instrument. Mounts with one hole. Ratios 1 to 19, 1 to 42, 1 to 53 and 1 to 74. Price from \$2.75 to \$3.75. Vernier attachment with dial 75 cents additional.

FREE Hook-Up Diagrams

Ask your dealer for a complete set of Premier diagrams covering all types of hook-ups. If he cannot supply them send his name and receive a set with bulletin.

Premier Electric Company
3807 RAVENSWOOD AVE., CHICAGO

PREMIER

Quality Radio Parts



The new Sangamo Mica Condenser, actual size; accuracy guaranteed within 10 per cent. of marked capacity, and guaranteed to sustain that accuracy. Solidly molded in smooth brown bakelite, this condenser sets a new standard of neat compactness.

Announcing

an accurate fixed condenser of Sangamo Quality



High accuracy, sustained in service, has been inseparably identified with the name Sangamo for over a quarter of a century. It has won world-wide renown for Sangamo Meters. Linked with a reputation for accuracy too great to be jeopardized by the least deviation from its high standards, the name "Sangamo" is synonymous with success.

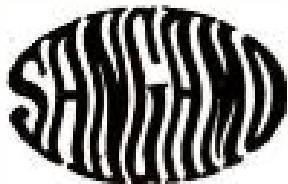

FIXED condensers are important units in a radio receiver, and should be carefully chosen for *sustained accuracy*. A poorly made fixed condenser varies with every temperature and humidity change. In reflex and other circuits where capacity is a critical factor, accuracy in the fixed condenser may make the great difference between a set that performs perfectly, and one that is as uncertain as the weather.

Sangamo Mica Fixed Condensers are guaranteed to be accurate to within 10 per cent. under all temperature and humidity conditions. Neither the intense heat of soldering, nor the dampness of the rainy season will impair the accuracy of these condensers. Even at the seashore where the salt air creeps in to change the capacity of exposed condensers, the accuracy of the Sangamo is not affected in the least.

Sangamo Condensers are made in all standard capacities, and sold at very reasonable prices. Also supplied with grid leak clips.

Sangamo Electric Company

Springfield, Illinois

1310-2

RADIO DIVISION, 50 Church Street, New York • Offices in all Principal Cities

All apparatus advertised in this magazine has been tested and approved by POPULAR RADIO LABORATORY

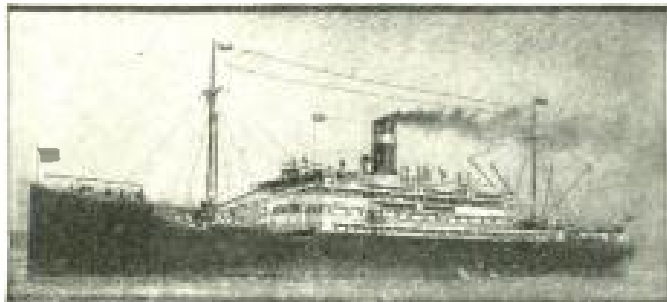

"S. S. Santa Teresa of the Grace Line. The Radio Operators are graduates of the Radio Institute of America."

Radio — the career for you!

Sailing on ocean steamers—with good pay and excellent quarters — at liberty whenever the ship is in port—big opportunity for advancement—all these help to make radio operating a lucrative and highly respected profession.

Thorough Training Essential for Success

Only skilled men can succeed in radio. But with the course of instruction offered by the Radio Institute of America, success depends only on your own application to study. Have you perseverance? Then follow the footsteps of 7,000 successful Radio Institute graduates.

Study Radio In Spare Time

Even though employed at present you can qualify for your U. S. Govt. Commercial Radio License in a few months of home study. Radio Institute is conducted by the Radio Corporation of America, assuring you of a thorough up-to-date Home Study Course. Mail the coupon now for more information.

Radio Institute of America

(formerly Marconi Institute)

Established in 1909

322 A Broadway, New York City

CUT HERE

RADIO INSTITUTE OF AMERICA
322 A Broadway, New York City

Please send me full information about your Home Study Course of radio instruction.

- I am interested in the complete course including code.
- I am interested in the technical course without code.

Name.....

Address.....

"By merit raised to an eminence"—Milton

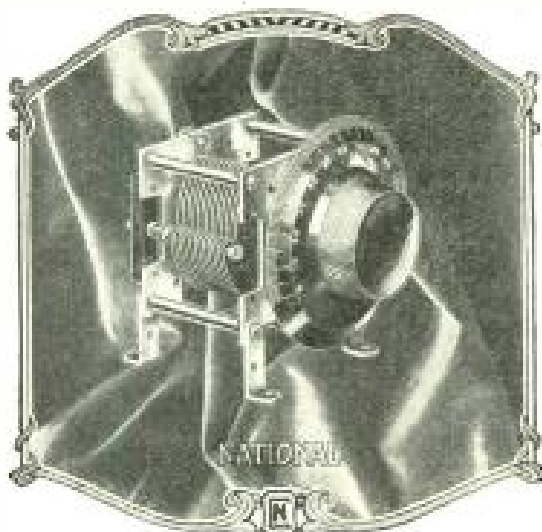

NATIONAL Velvet Vernier CONDENSERS and DIALS

are used by Lieutenant Frederick H. Schnell

(Traffic Manager, American Radio Relay League) for communication with amateurs on wave lengths from 20 to 125 meters from the Pacific Fleet during the cruise to Australia and return.

If your dealer is not yet stocked with NATIONALS send us his name. We will see that you are supplied.

Here are the prices:—TRANSMITTING CONDENSERS—

.00025 (23 plates) \$11 .00046 (43 plates) \$16

RECEIVING CONDENSERS—

Capacity—maximum—MF .001 .0005 .00035 .00025

3 3/4" Bakelite Dial \$7.25 \$6.25 \$6.00 \$5.75

4" " " 7.50 6.50 6.25 6.00

NATIONAL COMPANY, INC.

110 Brookline Street, Cambridge, Mass.

Sole licensees for the Manufacture of the National Regenerator under the Browning-Drake patents.

with the \$100 Guarantee



Absolutely warranted to protect your set from lightning, with a guarantee to pay you \$100 or repair your set, should it be damaged by lightning through any fault of the FIL-KO-ARRESTER.

Listed as standard under the re-examination service of National Board of Fire Underwriters.

If your dealer has none, send his name with remittance direct to Dept. PR-625

DX Instrument Co.
Harrisburg, Pa.



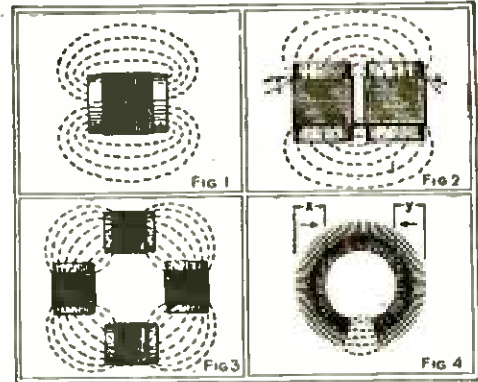
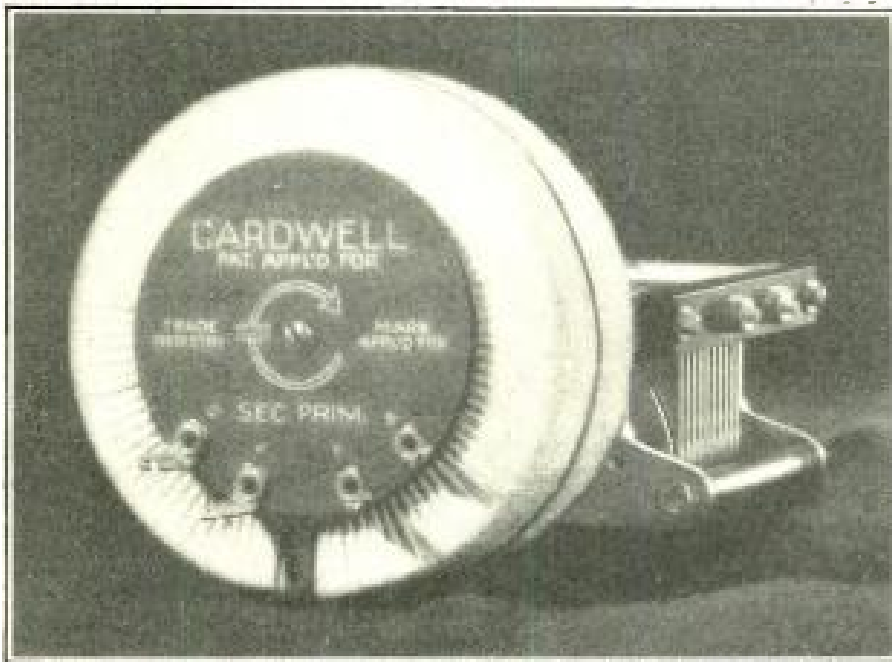

General Theory of the Toro-Tran

Figure 1 shows how the field of the ordinary coil extends into space and increases losses due to stray field. Figure 2 shows a "double series" winding, which restricts the field somewhat. Figure 3 shows a "four series" winding and the field almost enclosed. In Figure 4 (the Toro-Tran) the field is entirely enclosed and the losses due to stray fields are eliminated. Note that a stray signal passing through the coil at "X"—not introduced from the aerial or the tube—is balanced out at "Y" by the reversed polarity of the winding. This rejects undesirable signals, while the concentrated internal field builds up the tuned signal. Hence maximum distance and selectivity.

-and now the TORO-TRAN!

CARDWELL, whose pioneer "low-loss" condenser established new standards of radio efficiency, is now introducing the Toro-Tran*—the ideal *balanced* coupling inductance for all radio frequency work.

*TRADE MARK
Registry applied for

The Toro-Tran eliminates signal energy picked up by ordinary coils from nearby stations. It eliminates magnetic feed-back in multi-stage radio frequency circuits, thus removing the most active factor in causing howling and distortion, and thereby increasing selectivity and distance. It rejects almost entirely the interference effects caused by electrical power

machinery, elevators, door-bells, arc stations, etc.

The Toro-Tran winding confines the field to the inside of the coil, a small area, and thus avoids one of the greatest causes of loss known to radio receivers—that of stray magnetic fields, which result in the absorption of signal energy and reduce the efficiency of the receiver tremendously.

Note these unusual advantages in assembly and operation

1. Compactness. The coils do not require spacing or angular mounting. They occupy less space than your condensers.
2. Permit exact nullification for tube and stray capacity without guesswork or tedious testing.
3. Closed magnetic field eliminates magnetic feed-back in tuned radio frequency amplifiers.

4. Low distributed capacity, due to air spacing of each winding and to low voltage-drop per turn of small diameter wire.
5. Maximum coupling and high ratio of voltage increase due to concentrated field with zero leakage.
6. Absence of all supporting insulation in the field of the coil. This is one of

the greatest loss factors in the ordinary circuit and is not remedied by "skeleton" or so-called "low-loss" windings.

7. Ease of neutralizing oscillation due to tube capacity by means of rotating control, which anyone can "balance."

8. Low capacity between primary and secondary, affording maximum transfer of energy to succeeding grid circuit.

The Toro-Tran has a lower "circuit resistance" (i.e., effective resistance as assembled in a set and not as isolated in the laboratory for theoretical measurements) than any inter-stage tuned transformer made and has a correspondingly higher amplification factor, its ratio exceeding ten.

To appreciate the many remarkable advantages of the Toro-Tran, write for our two free booklets: "The Torodyne Circuit" and "The Most Interesting Radio Frequency Transformer Ever Invented."

Toro-Trans are ready to mount in any tuned radio frequency circuit. Replace your ordinary coils

with Toro-Trans. You will be astonished with the results. Most .00035 mfd. variable condensers will tune them, but by using Cardwell Condensers you get maximum efficiency.

Order from your dealer or direct

CARDWELL TORO-TRAN WITH BALANCING POTENTIODON	\$ 4.00
Cardwell .00035 Condenser for tuning	4.75
Cardwell .00035 Vernier Condenser	6.25
Cardwell .00035 Dual Condenser (two-in-one)	8.00
Cardwell .00035 Triple Condenser (three-in-one)	12.00
Cardwell Audio-Trans (compound audio transformers)	10.00

The Allen D. Cardwell Manufacturing Corp.
81 Prospect Street, Brooklyn, N. Y.

NEW

VERNIER With Low Losses

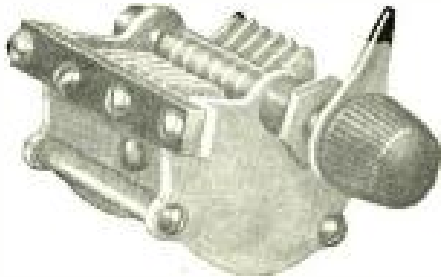

Actual Size
Actual Price

\$1.50

If your dealer can't
supply you, write
us direct.



A perfect vernier makes for perfect reception. "Continental" has made that possible with the new *Junior*—a miniature low loss condenser of advanced design and precision workmanship. Shunted across the standard condenser it makes the perfect vernier, with none of the faults of friction attachments or geared dials. Long Distance Stations come sailing through local broadcast with increased volume and amazing clarity.

CONTINENTAL
LOW LOSS

JUNIOR CONDENSER

GARDINER & HEPBURN, Inc.

611 WIDENER BUILDING,

PHILADELPHIA, PA.

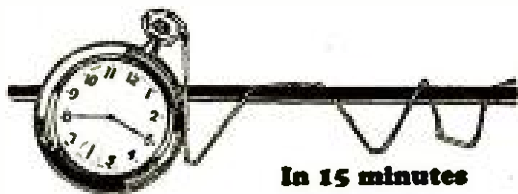

In 15 minutes
after the

LIBERTY Sealed Five

is delivered to your home
you can be hearing
wonderful programs from
local and distant stations



Manufactured by

LIBERTY

TRANSFORMER CO., INC.

123 North Sangamon St. CHICAGO, ILL.

\$3⁵⁰

**PRECISION
AUTODYNE
COUPLER**

Again Precision leads! L. M. Cockaday specified in the January issue of POPULAR RADIO the new Precision Autodyne Coupler for his 8-Tube Superheterodyne Reflex Receiver.

The Autodyne Coupler is a new development for use in connection with a vacuum tube for producing a continuously variable alternate current. Used as a laboratory vacuum tube oscillator, the frequency of which may be calibrated and thus the apparatus used as a standard, also as an oscillator and detector in some of the more specialized forms of the Super-Heterodyne.

At your dealers—otherwise send purchase price and you will be supplied postpaid.

Made by the makers of the genuine "Cockaday" Coil.
In Canada, \$5.00

Canadian Distributor
Perkins Ltd., Montreal-Toronto-Winnipeg

Precision Coil Company, Inc.
209-B Centre St., New York City



“I selected it for its high insulating qualities

It cuts down the losses in the circuit”

THOSE were the exact words of a prize-winner in a radio set-building prize contest, when asked why he used a Radion Panel. Like thousands of others, he had found by experience that there is nothing quite like Radion for real results.

Our engineers developed Radion Panels *especially to order* for radio. Losses from surface leakage and dielectric absorption are exceptionally low. And low losses mean clearer reception, more volume and more distance.

Easy to work—moisture proof—resists warping

RADION is easy to cut, drill and saw. You need not have the

slightest fear of chipping. Radion resists warping. It's strong. It's moisture proof. It comes in eighteen stock sizes and two kinds, black and mahoganite.

Radio dealers have the exact size you want. The use of Radion by the manufacturers of ready-built sets is almost invariably a sign of general good quality in that set.

*Send for booklet,
“Building Your Own Set”*

OUR new booklet, “Building Your Own Set,” giving wiring diagrams, front and rear views, showing new set with slanting panel, sets with the new Radion built-in horn, lists of parts and directions for building the most popular circuits—mailed for ten cents.

AMERICAN HARD RUBBER COMPANY
Dept. B5, 11 Mercer Street, New York City
Chicago Office: Conway Building

Pacific Coast Agent: Goodyear Rubber Company, San Francisco, Portland

RADION

The Supreme Insulation

PANELS

Dials, Sockets, Binding Post Panels, etc.

AMERICAN HARD RUBBER CO.
Dept. B5, 11 Mercer St., New York City

Please send me your new booklet “Building Your Own Set” for which I enclose 10 cents (stamps or coin).

Name.....

Address.....

BURGESS RADIO BATTERIES

Quality at Every Price

Cabinet or table space many times determine the size and type of radio batteries selected by the user.

Burgess manufactures a battery for every radio circuit and tube. Your choice of any one of many types involves no sacrifice of economy or service hours. The value and quality of Burgess Radio Batteries are constant — your satisfaction assured.

Ask Any Radio Engineer

Write to 217 Burgess Engineering Building, Madison, Wisconsin, for the Burgess Radio Compass. It is amusing, unusual and useful.

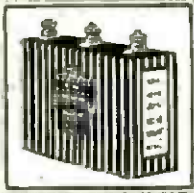

One of several sizes of Vertical 'B' Batteries.

Burgess 'C' Batteries improve reception economically.



Standard Burgess Radio No. 6 'A' Battery. "Over Twice the Life."

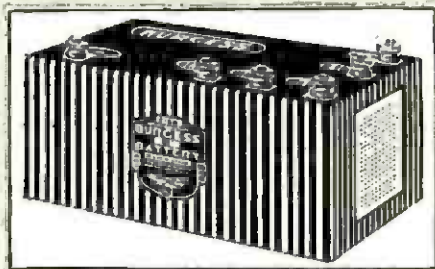

Burgess black shape 'B' Batteries are made in numerous types and voltages.

BURGESS BATTERY COMPANY
 Engineers DRY BATTERIES Manufacturers
 Flashlight • Radio • Ignition • Telephone
 General Sales Office: Harris Trust Bldg., Chicago
 Laboratories and Works: Madison, Wisc.
 In Canada: Niagara Falls and Winnipeg

Not
Too Little
Resistance
To
Overdrain
the
Battery

Not
Too Much
Resistance
To Give
Meaningless
High
Readings

No. 45 VOLTAMMETER

This combination is exceedingly useful for testing the amperage of dry cell "A" batteries and for voltage measurement of "B" batteries, both dry cell and storage. It combines the essential features of our No. 24 and No. 34 C meters.

0-35 amp. scale, 1 amp. divisions
 0-50 volt scale, 1 volt divisions

List Price \$3.75

THE
STERLING MFG. CO.
Cleveland, Ohio.

Has
the
Bulge
on
them
all



Sterling

VOLTAMMETER
 a combination ammeter and voltmeter

**-the Panel
SUPER Fine**

NO other material known possesses the many combined advantages for radio paneling as does Dilecto. It has every endorsement of dealer and manufacturer, because it is practically indestructible.

THE CONTINENTAL FIBRE COMPANY
 Factory: Newark, Delaware

NEW YORK, 270 Madison Ave.
 CHICAGO, Wrigley Bldg.
 PITTSBURGH, Farmers Bank Bldg.
 SAN FRANCISCO, 75 Fremont St.
 LOS ANGELES, 307 S. Hill St.
 SEATTLE, 1041 Sixth Av. So.

Look for the Red Stripe

Offices and Agents throughout the world.

Dilecto

Prest-O-Lite

RADIO CHART

Package of Tubes	No. of Tubes	Type of Tubes (See last column)	Total Rated Ampere Drain	Recommended Prest-O-Lite "A" Batteries	
				Order by Following Type	Days between Charge
5-Volt Tubes C-300 and UV-200 are interchangeable C-301A, DV-2 and UV-201A are interchangeable	1	6X4-200	1	66 WHR	22
	2	6Y-201A	1/2	67 WHR	16
	2	11Y-200 11Y-201A	1/4	61 WHR	33
				66 WHR	22
	3	6Y-201A	3/4	65 WHR	29
				67 WHR	22
	3	11Y-200 11Y-201A	1 1/2	611 RHR	21
				69 WHR	14
	4	6Y-201A	1	69 WHR	22
				67 WHR	16
	4	11Y-200 11Y-201A	1 3/4	613 RHR	22
				611 WHR	15
	5	6Y-201A	1 1/2	661 WHR	22
			67 WHR	17	
			611 WHR	19	
			613 WHR	13	
			611 WHR	21	
			69 WHR	14	
			69 WHR	21	
			67 WHR	15	
			67 WHR	22	
			67 WHR	13	
			67 WHR	19	
			67 WHR	16	
		For sets using current at a rate higher than 2 amperes.	2 1/4	67 WHR	13
			2 1/2	67 WHR	19
				67 WHR	16

Copyright, 1925
The Prest-O-Lite Co., Inc.



How to fit storage batteries to your set

It pays to buy wisely—to select batteries that bring out the best in your set and are of the right capacity to give fine reception at charging intervals best suited to your convenience.

The new Prest-O-Lite Radio Chart tells you how to select such batteries. The part of the master chart shown here covers "A" Batteries for 5-volt tube sets. Use either of the two sizes recommended for your set, depending on the days of service you wish between chargings (based on the average use of your set of three hours a day). You will find the larger capacity battery more desirable unless facilities are provided for frequent and easy recharging. For "B" Batteries, and "A" Batteries for peanut tubes, see the complete chart at your dealer's.

Special structure plates, high porosity separators and scientific internal construction make Prest-O-Lite Batteries dependable sources of the even, unvarying current absolutely necessary for volume, clarity and distance.

Prest-O-Lite Batteries are made to give long, faithful service. They're easy to recharge—and offer you truly remarkable savings. Though standard in every respect, they are priced as low as \$4.75 and up. See them at your dealer's—or write for "How to fit a storage battery to your set—and how to charge it."

THE PREST-O-LITE CO., INC.
INDIANAPOLIS, IND.
New York San Francisco
In Canada: Prest-O-Lite Company of Canada, Ltd.
Toronto, Ont.



Best for Reflex

and Crystal Sets
FRESHMAN

Double Adjustable
Crystal Detector

No more searching for the sensitive spot.
—Merely turn the knob as you would a dial.

For base or panel mounting, complete with Freshman Super - Crystal

\$1.50



Noiseless Grid Leak

40c
each in any value
from 1/4 to 10

FRESHMAN SUPERIOR

You can depend upon them to remain accurate at all times

Made of high resistance material impregnated throughout (not coated paper). Unaffected by climatic conditions. Will not deteriorate. Clamped between solid knurled ferrules assuring rigid construction and firm contact at all times.

ANTENELLA

No Aerial or Antenna Needed

The Complete Efficient and Economical Aerial

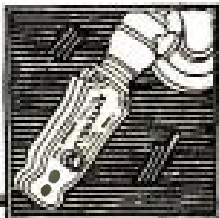

Why pay \$10 or more to have an aerial spoil the appearance of your home? Antennella eliminates all unsightly wiring, lightning arresters, etc., and precludes the possibility of dangerous grounding on a power line. It also stops "canary bird" re-radiation from nearby oscillating sets interfering.

ANTENELLA

is not only a real distance getter, but also overcomes troublesome static.

At your Dealer, otherwise send purchase price and you will be supplied postpaid.

Chas. Freshman Co. Inc.
Radio Receivers and Parts
FRESHMAN BUILDING
240-248 WEST 40TH ST - NEW YORK, N.Y.

ATTENTION DEALERS

Send for our 172 page catalog



The finest and largest exclusive
Radio Catalog in the
United States

Schneitter Radio Company

Dept. G.

St. Joseph, Missouri

The NEW B & P Micrometer Type LOW LOSS TUNER

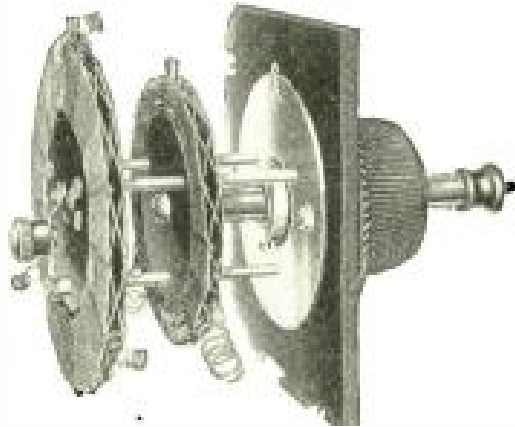

The famous micrometer adjustment which made the B & P condenser the precision instrument of its kind has been applied to a 3 circuit tuner. Amazing—are the results!

Micrometer adjustment of the tickler coil permits a fineness and sharpness of tuning yielding a degree of selectivity and a measure of volume never before obtained in 3 circuit regeneration. The B & P tuner is beyond comparison with any tuner that has ever come within your experience. \$8.00 complete. Write for circular or see your dealer

BARRETT & PADEN

1314 Sedgwick Street

Chicago

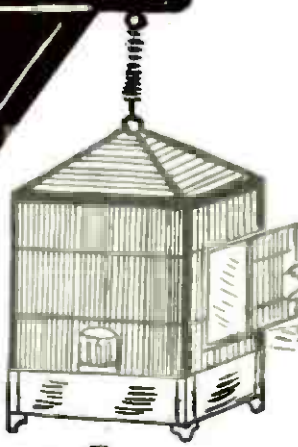

THE GREATEST SENSATION IN THE RADIO INDUSTRY



SUPERTRON, always a good tube, is now better than ever. Supertron is making Radio History, by being the first to make the tube price what it should be. A national advertising campaign will tell the whole world that the best tube should retail for not more than \$2.00. That includes a fair profit to the manufacturer and the trade, and amply provides for a guarantee and service to the public with complete satisfaction.

\$2.00

ALL TYPES

They will all follow Supertron, but the Industry and the public will always appreciate Supertron, because Supertron did it.

NO ARGUMENT GUARANTEE

Distributors, Jobbers, Dealers, Factory Representatives and Public—we welcome you. Write Now.

REG. U.S. PAT. OFF.
SUPERTRON
A GOOD TUBE.

SUPERTRON MFG. CO., Inc., 32 UNION SQUARE, NEW YORK CITY



**Finer
Selectivity**

Equip your receiving set with Apex Vernier Dials. They will greatly increase the efficiency of any set. Make Tuning positive—bring in distant stations. Your dealer has them. If not, send \$2.00 for Royal Brass Finish—\$2.50 for Satin Silver Finish, or \$3.50 for De Luxe Gold Plated (24k).

Apex Super 5
This highly efficient tuned radio frequency receiver is most advanced in design and construction. An instrument that meets every critical expectation of the radio enthusiast.

Housed in a highly finished walnut cabinet, complete with Jones Multi-plug Battery Cable. All settings highly gold plated. Sells for \$95 complete excepting accessories.

At All Good Dealers
Apex Elec. Mfg. Co.
1410 W. 59th Street
Dept. 502 Chicago



ZENITH RADIO

Trade
Mark
Reg.

Tunes straight through the locals, gets distance. Brings in more stations—clearly and with volume—in a given length of time than any other set. Direct comparisons invited. Zenith receiving sets cost more, but they do more.—The exclusive choice of MacMillan for his North Polar Expedition.

Seven Models—\$100 to \$475

Models 4R and 3R licensed under Armstrong U. S. Patent No. 1,113,149. They are NON-RADIATING.

Zenith 4R - - \$100
Zenith 3R - - \$175

Super-Zenith VII - - \$240
Super-Zenith VIII - - \$260
Super-Zenith IX - - \$355
Super-Zenith X - - \$475

Only dealers who are equipped to give service handle Zenith. Ask your nearest Zenith dealer for a demonstration.

Zenith Radio Corporation
332 S. Michigan Avenue, Chicago

AMPLEX

GRID-DENSER

Peps Up Sets!

GET JUST the correct value of capacity in your set by substituting GRID-DENSERS for your present fixed condensers. A GRID-DENSER makes possible those fine variations of capacity which is all the difference between mediocre and long distance reception.

Cockaday, Haynes, Sleeper all specify GRID-DENSERS. Write at once for the FREE book of hook-ups and you'll see why.

In either the .0005 with or without gridleak clips or .001 type or type N (neutralizing) **\$1.25**

AMPLEX INSTRUMENT LABS.
88 W. Broadway, Dept. P-5, N. Y. C.

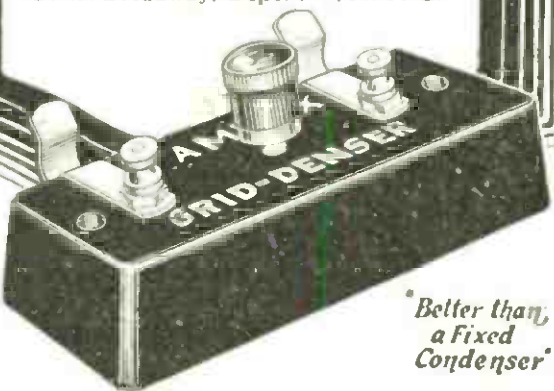

**Better than
a Fixed
Condenser**

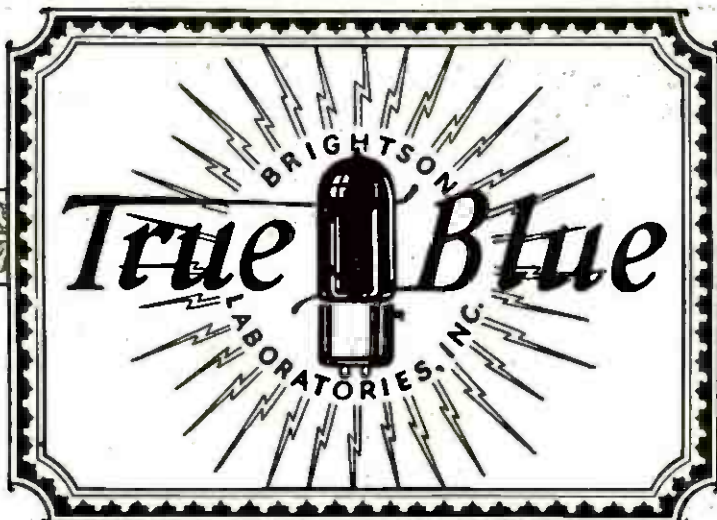

**The
Finest Radio Tube
in the World—Now Only \$3.50**

Formerly \$6.00

Selling direct to the dealers and for the dealers, eliminating the wholesaler — anticipating greatly increased production, permits this new price. You can now enjoy the uniformity, noiselessness, crystal tone, long life, beauty and quality of True Blue Tubes — at a little more than ordinary tubes cost.

Our Guarantee of All True Blue Tubes

1. Interchangeable uniformity.
2. Noiseless operation without shock absorbers.
3. Two to three times longer filament life.
4. No corrosion losses—silver contacts.
5. No conductive losses—non conductive color bakelite bases.
6. All superiorities guaranteed in writing.
7. All tubes handsomely cased.

New Characteristics of Power Plus Type

1. 6 volt amplification and double volume from 3 volt sockets.
2. Storage battery operation. amperage, .2 at 4 volts. amp.
3. Less B battery consumption than 3 volt tubes.

Do not confuse Power Plus Tubes with other tubes fitting 3 volt sockets. Power Plus Tubes have four times the plate and grid area and twice the filament length of 3 volt tubes. They are not merely little tubes improved, they are big tubes which replace little tubes. Standard socket True Blue Tubes take 6 volts and 1/4 ampere. Both types are now only \$3.50.

How True Blue Tubes Are Cased

Standard True Blue Tubes are cased one, three, and five to a set. They fit the standard sockets. Power Plus Tubes are cased one, three, six and eight to a set. They fit three volt sockets. Be sure and state type and number of tubes when ordering.

Mail us your check or money order giving us your dealer's name. We will supply you direct with 10 day return privilege.

BRIGHTSON LABORATORIES, INC. 16 W. 34th St., New York, N. Y.



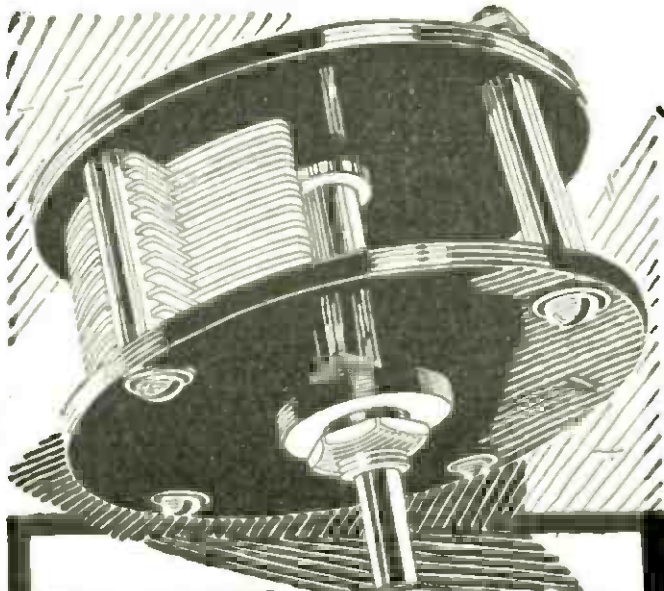

RATHBUN HONEST CONDENSERS

**Actual
Performance
Is the real test
Of any Condenser.**

**Judged
On this basis
The RATHBUN
Is the equal
Of any — and
At any price.**

**There is
No Better Value.**

RATHBUN MANUFACTURING CO., Inc.
Jamestown New York

A New System of Radio Reception

Rathbun Single Hole Mounting Superior Condensers have been specified for use in the Hoyt System of Signal Augmentation, by the inventor Francis R. Hoyt. We have a limited number of Blue Printed copies of Mr. Hoyt's original laboratory notes on this new system of radio reception, together with nine circuit sketches, which will be sent free to you upon receipt of this coupon and 4 cents for postage.

NAME

ADDRESS

RATHBUN
SINGLE-HOLE MOUNTING
SUPERIOR CONDENSERS



Atlas

TRADE MARK

RADIO REPRODUCTION
Gives the Best That's in Your Set

Tone-Quality.
Clarity of reproduction.
Sensitivity to signals.
Harmonizer adjustment.
Ample volume.
ATLAS products are guaranteed.

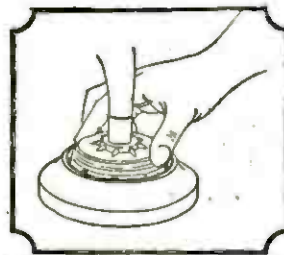

MULTIPLE ELECTRIC PRODUCTS CO., Inc.
375 Ogden St., Newark, N. J.
New York Philadelphia
Boston Baltimore Detroit
Pittsburgh Chicago
St. Louis San Francisco
Marconi Wireless Telegraph Co.
of Canada, Ltd.
Sole Canadian Distributors

GUARANTEED ACCURACY
to within

1/3 of 1%!

More Than Matched



COMPLETE KIT OF SIX COILS —

VICTOREEN QUALITY \$ **37.00**

A complete Super Heterodyne Kit for the particular radio fan who desires simplicity—selectivity—range consistent with quality of reception which has never been equalled.

List of parts and descriptive literature on request.

Complete Set of Four Blue Prints \$1.00

VICTOREEN RADIO, INC.

6538 Carnegie Ave. Cleveland, Ohio



Everyone Interested in RADIO Should Write for this FREE Radio Book



Write for your
FREE
copy
to-day

BE SURE

To consult our FREE 80-page catalog BEFORE making your purchase. You will be amazed how much you can save on **KNOCK-DOWN KITS** and standard quality parts. Remember **W. R. S. Sells DIRECT TO YOU at WHOLESALE PRICES.**

W. R. S. kits contain every authorized part for building the circuit you wish to build. You can start in to build the second you get the kit—when you finish—RESULTS are there. No more hours of trouble shooting—no more hunting for this or that missing part—everything is there! Down to the last screw—nut—wire—packed in sealed cartons that eliminate all difficulty and doubt in the purchase and assembly of proper materials. Hundreds of Popular Radio readers have already bought from this institution. Never a complaint lodged with us. We live up to our advertising statements.

Complete Parts Exactly as Specified and Approved by Mr. Cockaday Cockaday 8-Tube Super-Het Kit Cockaday Super-Het Built in Cabinet

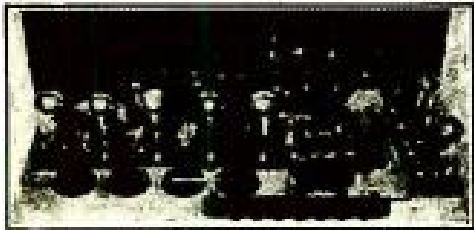

- 1 General Instrument .0005 mfd. NO LOSS with Isolantite insulation.
- 1 General Instrument .001 mfd. NO LOSS with Isolantite insulation.
- 1 Hayes Griffin Input Transformer (new type)
- 3 Hayes Griffin Intermediate Transformers (new type)
- 1 Precision Autodyne Coupler
- 1 Karas Harmonic Audio Frequency Transformer
- 1 Amplex Grid-Senser
- 1 Resistor Charting Socket
- 7 Federal Sockets No. 16
- 1 Patent Double Circuit Jack
- 1 Patent Single Circuit Jack
- 2 HAALD 4 Inch Dials
- 1 Amsco Rheostat 2 ohm
- 1 Amsco Rheostat 400 ohm
- 2 Daven Resistor-Coupler Mounts
- 1 Daven Grid Leak Mounting
- 2 Daven Resistors .5 megohm (500,000 ohm)
- 1 Daven Resistor .5 megohm
- 1 Daven Resistor .005 megohm (5,000 ohm)
- 2 Daven Resistors .25 megohm (250,000 ohm)
- 2 New York Mica Condensers .0001 mfd.
- 4 New York Mica Condensers .006 mfd.
- 1 New York Mica Condenser .00025 mfd. with grid leak mounts
- 1 Durabran Radio Frequency Transformer
- 1 Walbert "A" Battery Switch
- 7 Eby Marked Binding Posts
- 1 7 x 24 drilled and engraved Bakelite mirror-finished panel
- 1 Mahogany Baseboard
- 1 Drilled binding post panel
- 1 Box assorted screws, nuts, washers, lugs, etc.
- 40 feet of extra heavy No. 12 tinned bus bar wire
- 1 Set of angle brackets for mounting (nest panel)
- 1 Special Cockaday bracket for mounting Amplex grid-senser
- 1 Set of three Popular Radio blueprints covering complete constructional details for building this receiver

For full description of this Kit refer to Page 37 of our catalog

ON APPROVAL

You take no risk whatever in sending us your orders. If you so instruct us we will ship you any article by express subject to examination; so you may examine it before acceptance or payment.

QUICK SHIPMENTS

We pay transportation—our records prove every order shipped the same day as received.

SEND NO MONEY IN ADVANCE
Send no money in advance unless you prefer to send with order. We ask no deposit. You run no risk. We take all the risk of pleasing you.



Our Cockaday 8-tube Super-Het, built by expert engineers of the exact same parts as listed; in a beautiful piano-hinged cabinet, constructed of the best materials, and the most exacting workmanship, with such an extraordinary low price, is considered to be the best super-heterodyne on the market today.

Each receiver is tested for long distance, as well as local reception, and is thoroughly inspected, and must meet the most exacting demands before being shipped.

Cockaday 8-tube set, without tubes or batteries \$99.50
This Super-Het with 1 Kerach Tuned Loop and 8 C 301 A's or U. V. 201 A tubes \$132.00

Parts Hard to Get FRESHMAN IN STOCK 5-TUBE SET

- Remier Var. Condenser Type 630 .00035 mfd.
- Amsco 20 ohm Rheostat
- Amsco 400 Potentiometer
- Curtis-Hammer filament battery switch
- Rayl Bezel-Role Mounting voltmeter, 0 to 6 volts
- Adams Jack Type No. 502
- Dublier mica-fixed condenser .00025G mfd.
- Dublier mica-fixed condenser .00025 mfd.
- Dublier Durabran radio-frequency transformers
- Daven grid leak, 4 meg.
- Resonance Clear-tone Sockets for UV-199 tubes
- Patent Audiometers, Type No. 26 audio-frequency transformers
- Precision Cockaday Coil
- Remier Tuning Var. Condenser .005 mfd.
- Brumer Tuning Var. Condenser .00025 mfd.
- Improved Accuracy Dials
- N. Y. Mica Fixed Condenser .00025 mfd.
- N. Y. Mica Fixed Condenser .0001 mfd.
- New Type Bradleys
- Benjamin Clear-tone Sockets
- Amsco Built-Wound
- Jones Inductance Switch

AT "WRS" MONEY SAVING PRICES

**McLAUGHLIN 1 CONTROL
SUPERHETERODYNE
COMPLETE FACTORY
SEALED KITS IN STOCK**

**CRAIG 4-TUBE REFLEX
RECEIVER**

Write for our Catalog for complete description of this 4-tube marvel.



5-Tube Genuine Factory Built
Freshman Set in Mahogany
Cabinet ready for use (without
tubes or batteries)

\$37.50

**CAPT. PAUL EDWARDS'
SUPER-HETERODYNE**

Complete parts for this receiver
in stock; at "WRS" money-
saving prices.

WHOLESALE RADIO SERVICE CO. New York City

Mail Order Dept. P. R.
9 Church St.

THE *Summit* TOROIDAL

RADIO FREQUENCY TRANSFORMER

is the World's Best Tuned Radio Frequency Transformer, acknowledged by leading engineers as the last word in transformer development. Positively self neutralized and self balanced, having no stray fields, leakages or feed backs. The Summit Toroidal Transformers will not howl or squeak, result—superior quality reception.

Transformers are individually tested for grounds, short circuits, coupling, ratio and resonance before leaving the factory and balanced within one per cent. (1%)

In Genuine Bakelite housings—mated sets of three—\$10.00.

*Distributors and Jobbers
Wanted*

**SUMMIT RADIO MFG.
CO., Inc.**

481 Broad Street
Newark, N. J.

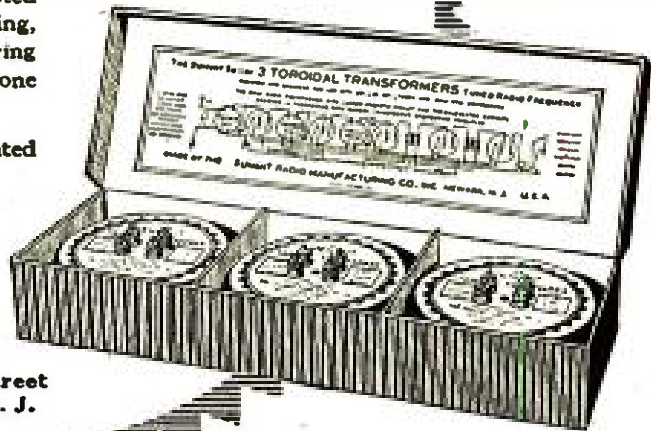

Pat. applied for

Popular Radio for 5 Months

Just Wrap a Dollar Bill Around the Coupon Below

We want more subscriptions, and so we will enter your subscription for 5 months, if you will fill out the coupon below, wrap a \$1.00 bill around it and mail it to us promptly.

This offer should interest the casual reader, the newcomer into the ranks of radio fans and all POPULAR RADIO readers who are not now subscribers. *This offer is only open to new subscribers.*

DO YOU WANT TO BUILD A SET?

You will get more out of Radio when you build your own set. POPULAR RADIO has made it possible for the beginner, with no previous knowledge of radio, to build any type of receiving set desired with the assurance of getting perfect results.

"HOW TO BUILD YOUR RADIO RECEIVER"

The most complete and authoritative collection of material on Receiver Construction yet published in book form. All working details given; lists of parts required; complete hook-ups and circuit diagrams.

TUNE-IN ON ONE OF THESE

You may have a copy of "How to Build Your Radio Receiver" FREE with a 7 months' subscription to POPULAR RADIO for \$2.00. Or your subscription for POPULAR RADIO for 12 months and your copy of "How to Build Your Radio Receiver" both for \$3.00. (See page 60.)

SIMPLIFIED BLUEPRINTS

POPULAR RADIO'S latest aid to receiving set builders show in ACTUAL SIZE every detail of the construction of 7 popular sets. (See page 70.)

Subscribe to POPULAR RADIO for 12 months and you may have your choice of any one set of Simplified Blueprints, at the regular subscription price of \$3.00.

POPULAR RADIO

627 West 43d Street

New York City

POPULAR RADIO, Dept. 57
627 West 43rd Street, New York City.

Enclosed is remittance of \$.... as payment, in full, of subscription offer for POPULAR RADIO as checked below.

- 5 months for \$1.00 (new subscription only).
- 7 months and "How to Build Your Radio Receiver" for \$2.00.
- 12 months and "How to Build Your Radio Receiver" for \$3.00.
- 12 months and Set of "Simplified Blueprints" No. for \$3.00.
- 24 months for \$5.00.

NAME

ADDRESS

CITY STATE

DE FOREST

Leads again

Another jump ahead!

First in 1925

Greatest thing De Forest ever did,
D-17 Radiophone.

New, self-contained and complete.

Tube detector.

Built-in De Forest Speaker.

Loop antenna—no aerial, no ground.

Remarkable distance-getter.

Purest and finest tone.

Movable, convenient, very
simple to operate.

Write or phone for the name of the nearest specially qualified De Forest agent, and arrange for a demonstration in your own home. You should know the newest, greatest thing in radio—the De Forest D-17.

Price range, \$125 to \$195

F. O. B. Jersey City

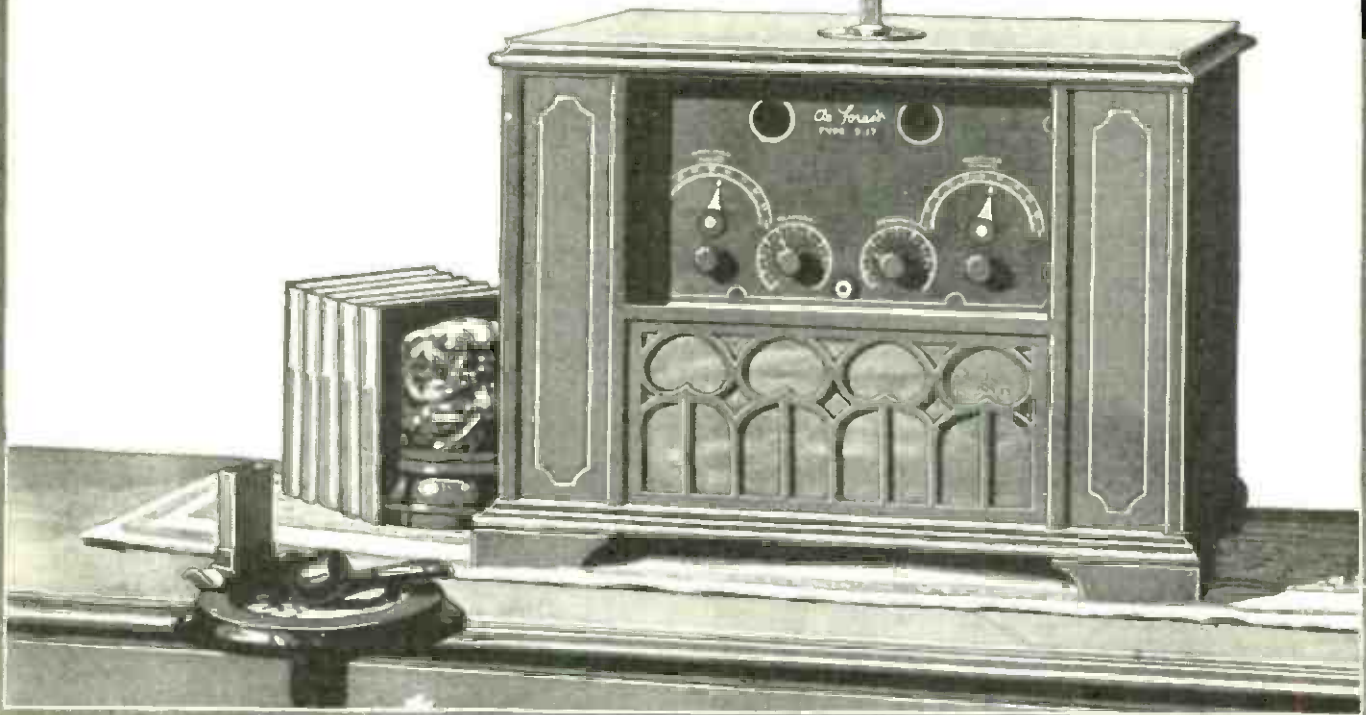
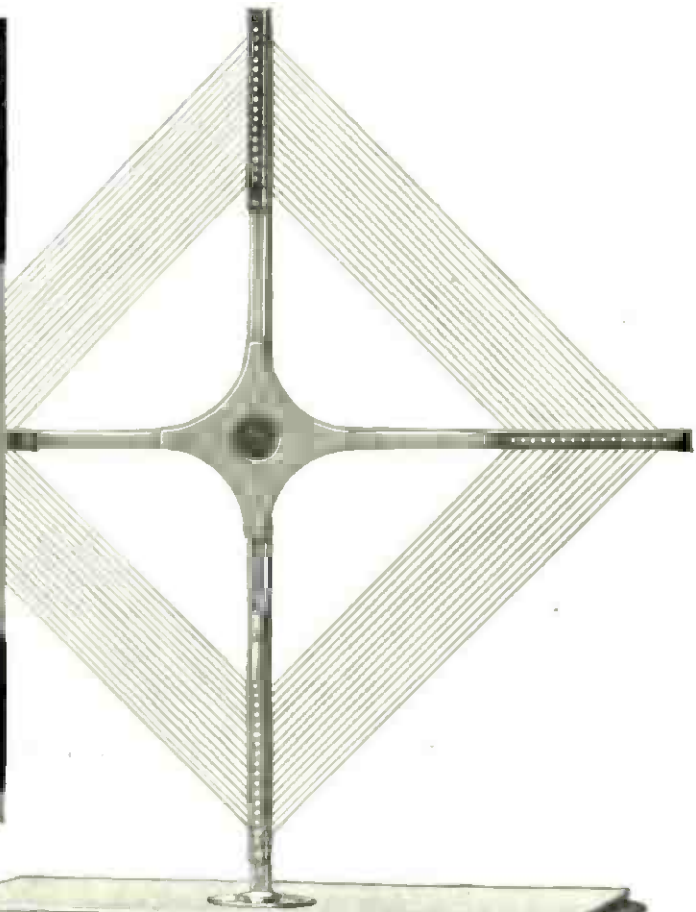

THE NEW DE FOREST D-17

REG. U.S. PAT. OFF.

De Forest Radio Company, Jersey City, N. J.

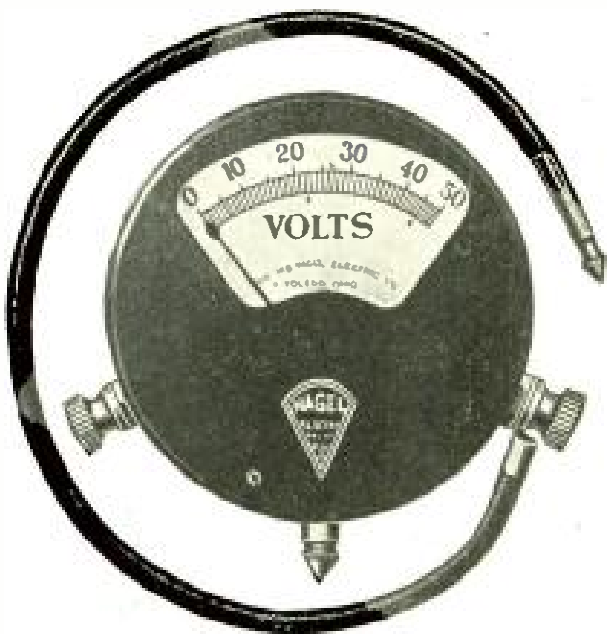

No. 22—About three-quarters actual size

60 Ohms per volt!

The correct resistance for a radio battery measuring instrument—no more because it is not necessary. But it must not be less, otherwise there is danger of draining your battery. Nagel Voltmeters and Voltammeters offer the radio fan a pocket type measuring instrument built to the highest standard—safe to use by

touch contact or under continuous service. They're fairly priced too. Ask your dealer or write The W. G. Nagel Electric Co., Hamilton Street, Toledo, Ohio.



NAGEL

Manufacturers of
**DRY CELL TESTERS • AMMETERS
 HIGH-RESISTANCE VOLTMETERS
 and VOLTAMMETERS • BAKELITE
 HOT MOULDED INSULATIONS**

RUBICON Kits cut cost

Go the coming summer weather one better by building a Super—at a saving. Write for the free folder on RUBICON Kits. It tells just what's needed. Check off the parts you have. Then from your dealer, or from us direct, get the Kit that fits your needs.

Postcard brings free folder



RUBICON COMPANY
 29 N. Sixth St.
 Philadelphia

IF YOUR SET HAS A NONOISE VARIABLE GRID-LEAK



*its maker has used the best
materials obtainable*

Here is a real variable Grid-Leak. The NONOISE is variable through a resistance range of $\frac{1}{2}$ to 7 megohms. It can be varied smoothly and silently without loss of the signal. No two sets are exactly alike, therefore the NONOISE that can be adjusted to the performance of your set gives the best results. No matter how good your set may be, a NONOISE will improve it.

Price 85 cents

If your dealer cannot supply you we will be pleased to fill your order. *Don't send any money.* Just drop us a postcard and the NONOISE will be sent Parcel Post, collect. Pay the postman upon delivery.

RADIO FOUNDATION INC.
 150 East 53rd Street New York City

Geared 80-1

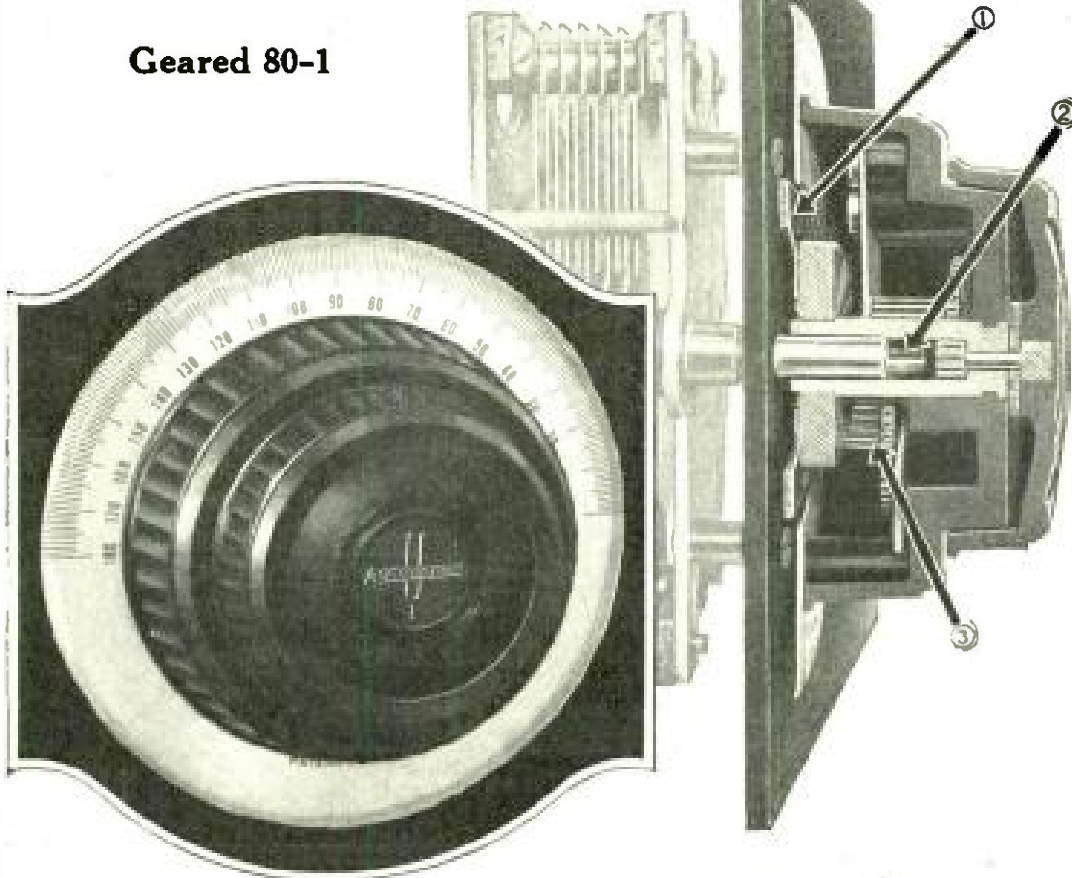

For Natural Reproduction

Even a genius cannot draw flawless music from an untuned violin. Just so—even the best radio receiver cannot reproduce clear, natural music if it is not sharply tuned.

(1) **Friction Clutch**—the heart of Accuratune Controls. Automatically locks gear train for coarse adjustment and throws train into operation for fine adjustment.

(2) **Long center bushing** gives maximum shaft-bearing surface and prevents all wobble.

Every detail of Accuratune Micrometer Controls is designed for extremely close, precise tuning... with perfect ease! Sensitive sets are simpler to handle—DX stations can be tuned-in easier—locals much clearer with more volume.

Accuratune Micrometer Controls may be applied instantly to any condenser shaft and replace ordinary dials without set alterations.

At your dealers, otherwise send price (\$3.50) and you will be supplied postpaid.

(3) **New gear mesh** assures perfect alignment of the new brass gear train.

European Branch Office:
GASTON E. MARBAIX
27 Anning St.
London, E. C. 2

Write for descriptive folder

MYDAR RADIO COMPANY, 9-B, Campbell St., Newark, N. J.

ACCURATUNE

REGISTERED GEARED 80-1 U.S. PAT. OFF.
MICROMETER CONTROLS

All apparatus advertised in this magazine has been tested and approved by POPULAR RADIO LABORATORY

NA

SUPPORTENA

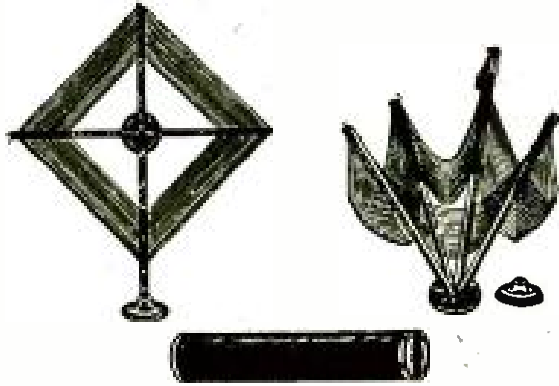

PATENT APPLIED FOR

THE FINAL WORD IN FOLDING LOOPS

The Slider permits tapping at every one of the 16 Turns!!

Indispensable for Superheterodynes.

Any Tube Set Now Made Portable.

\$9.00

Twelve Hook-ups Showing how to use it, with Different Types of Receivers.

Perfected by Radio's Master Loop Craftsmen.

J. NAZELEY CO.

571 Hudson Street

NEW YORK



\$3.50
each

RADIO Storage "B" Battery

12 Cells 24 Volts Lasts Indefinitely—Pays for Itself

Economy and performance unheard of before. Recharged at a negligible cost. Approved and listed as Standard by leading Radio Authorities, including Pop. Radio Laboratories, Pop. Sci. Inst. Standards, Radio News Lab., Lefax, Inc., and other important institutions. Equipped with Solid Rubber Case, an insurance against acid and leakage. Extra heavy glass jars. Heavy rugged plates. Order yours today!

SEND NO MONEY Just state number of batteries wanted and we will ship day order is received. **Extra Offer:** 4-batteries in series (96 volts), \$13. Pay expressman after examining batteries. 5 per cent discount for cash with order. Mail your order now!

WORLD BATTERY COMPANY

1219 So. Wabash Ave., Dept. 77, Chicago, Ill.

Makers of the Famous World Radio "A" Storage Battery
Prices: 6-volt, 100 Amp. \$12.50; 120 Amp. \$14.50; 140 Amp. \$16.00.
All equipped with Solid Rubber Base.

World FOR **RADIO**
STORAGE BATTERIES



KORA - WEAJ - WEN - WJS - HHI - KQG - KEAF - WJY - KOP

WITH better and more powerful broadcast-

ing— and with a sensitive, responsive Telomonic III receiver—

the fascination of radio continues this year, regardless of the calendar.

Write to Danziger-Jones, Inc., Dept. A, 25 Waverly Place, New York for booklet, "The Kit of a Thousand Possibilities."

TELOS
RADIO

Make More Money by Building Radio Sets with **INSULINE**



Ready Drilled and
Engraved Panels

for
**All
Popular
Circuits**

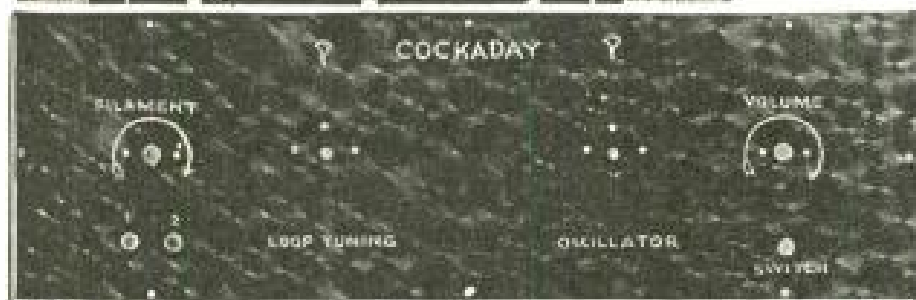

We stock ready drilled and engraved panels for all popular and demanded circuits. With these panels it is now possible for every amateur set builder to give his product that "Quality factory made flavor." Thousands of amateurs are now engaged in building sets for the people in their community. And making real money too.

Enter this New Well Paid Field on Your Full or Spare Time

As an amateur you are qualified to build a better and more efficient set than most people. Get around to your neighbors for their orders and build these sets with INSULINE Panels. It's lots easier than you think. If your work requires an odd size panel, we can cut and drill it to your individual requirements at a slight additional cost. Plain Panels stocked in all standard sizes and colors. Black, Mahogany and Frieze Finish. Don't lose any more time. Get busy today. If your dealer can't supply you, send us his name with your order and we will supply you direct.

WRITE FOR PARTICULARS

Radio Panel and Parts Corp.

INSULATING CO. OF AMERICA

59 Warren Street (INSULINE BLDG.) New York City



First in the Field—Specializing in Cockaday Kits

S. HAMMER RADIO CO., 303 Atkins Ave. Brooklyn, New York

Cockaday Sets Now Made Easier to Build by Our New "READY-TO-WIRE" Plan

50% OF YOUR TIME WORK AND WORRY SAVED!

All you need do is to connect bus-bar according to diagram, solder and your set is finished. These Kits are sent to you completely mounted and assembled on a Veneered Mahogany baseboard and genuine bakelite panel, drilled and engraved; in a solid Mahogany Cabinet. Genuine parts used as listed below; exactly as specified by Mr. L. M. Cockaday. COMPARE OUR OFFER!

5 TUBE NEW COCKADAY KIT # 4 CIRCUIT TUNER WITH RESISTANCE COUPLED AMPLIFIER

- | | |
|--|--|
| 1 "Precision" Cockaday Coil Set..... \$5.50 | 3 "Improved" DC Jacks..... \$2.40 |
| 1 "Cardwell" Vari. Cond. .0005 5.00 | 1 "Improved" SC Jack..... .60 |
| 1 "Cardwell" Vari. Cond. .00035 4.75 | 1 "Improved" Battery Switch..... .80 |
| 2 "Accuratune" Dials..... 7.00 | 1 "Precise" Transformer..... 5.00 |
| 1 "Amplex" GRID-DENSER. 1.25 | 3 "Electrad" 1/2 meg. leaks... 1.50 |
| 1 "N.Y." Fixed Cond. .00025... .35 | 3 "Electrad" Mountings..... 1.05 |
| 9 "N.Y." Fixed Cond. .005 5.40 | 8 Rajah Binding Posts..... 1.60 |
| 5 "Benjamin Cle-ra-tone" Sockets..... 5.00 | 7 Switch Points—2 stops..... .15 |
| 1 "Bradleyeak"..... 1.85 | 1 Baseboard..... .75 |
| 3 "Bradleyohms" No. 25..... 6.00 | 3 Sub-Panels (Genuine Bakelite)..... 4.40 |
| 1 "Amsco Dubl-Wundr"..... 2.00 | Bus Bar, Brackets, Screws..... .75 |
| 4 "Amperites" No. 1-A with mountings..... 4.40 | Genuine Bakelite Panel, Drilled and Engraved..... 3.00 |
| 1 Switch Lever..... .30 | |

KIT PRICE .. \$66.80

WIRED COMPLETE In \$85.00
Genuine Mahogany Cabinet

Cockaday's new improved D. X. Regenerative Receiver supplied with exact parts as specified, in exactly the same manner as above outlined with Genuine Bakelite Panel, drilled and engraved..... **\$46.00**

Write for Circular about these Parts and Kits. Also for our Radio Catalog.

Transportation Prepaid. One-third must accompany all C. O. D. orders. Not insured unless insurance charges included

8 TUBE NEW COCKADAY KIT # SUPERHETERODYNE REFLEX RECEIVER

- | | |
|--|--|
| 1 General Instrument .0005 Condenser (Isolantite Insulation)..... \$5.50 | 2 Daven Resisto - Coupler Mountings..... \$2.50 |
| 1 General Instrument .001 Condenser (Isolantite Insulation)..... 6.00 | 2 Daven Resistors .5 Megohms. 1.00 |
| 1 Haynes Griffin input transformer (new type)..... 5.00 | 1 Daven Resistor 5. Megohms.. .50 |
| 3 Haynes Griffin intermediate transformers (new type)..... 15.00 | 1 Daven Resistor .005 Megohms 1.00 |
| 1 Precision Autodyne Coupler. 3.50 | 2 Daven Resistors .25 Megohms 1.00 |
| 1 Karas Harmonik Audio Frequency Transformer..... 7.00 | 2 New York Mica Condensers .0001 Mfd..... .70 |
| 1 Amplex Grid-Denser .0005 1.25 | 4 New York Mica Condensers .006 Mfd..... 3.00 |
| 1 Benjamin Cle-ra-tone Socket. 1.00 | 1 New York Mica Condenser .00025 with clips..... .45 |
| 7 Federal Sockets No. 16..... 8.40 | 1 Duratran Radio Frequency Transformer..... 4.00 |
| 1 Patent Double Jack..... .60 | 1 Walbert "A" Battery Switch..... .50 |
| 1 Patent Single Jack..... .50 | 7 Eby Binding Posts..... 1.40 |
| 2 Na-Ald 4 inch Dials..... 1.50 | 1 Sub-Panel 1x9 Genuine Bakelite..... .15 |
| 1 Amsco Rheostat 2 Ohms..... 1.35 | 1 Baseboard (Hardwood)..... .35 |
| 1 Amsco Potentiometer 400 Ohms..... 1.50 | Genuine Bakelite Panel, Drilled and Engraved..... 3.00 |
| 1 Daven Grid Leak Mounting..... .35 | |

KIT PRICE .. \$78.00

WIRED COMPLETE IN GENUINE MAHOGANY CABINET \$110.00
INCLUDING KORACH LOOP

COCKADAYS Authorized ANTENNA COUPLER for \$2.00 the 8 Tube Super-Het for use with outdoor aerial

for super-fine tuning

MAJOR TUNER will end those "interference blues." A set built with the MAJOR TUNER gets only one station at a time—the one you want to get and no other.

MAJOR TUNER is the most advanced form of three circuit Low-Loss tuner. It is packed with complete picture wiring diagrams and full instructions.

(If your dealer cannot supply you, write us.) **\$4**

BEL-TONE RADIO CO.
161 Jamaica Ave., Brooklyn, N. Y.



KORACH
Tuned Loop
Tuning Feature
Directional
Can Be Logged
Collapsible

Patent Applied For

Approved, Recommended and used on the famous COCKADAY 8-TUBE SUPERHETERODYNE REFLEX. The Editorial on page four of Feb. POPULAR RADIO tells how Cockaday, using the Korach Loop, logged the following Foreign Stations: 2BD, Aberdeen, Scotland; 5NO, Newcastle, Eng.; 2PY, Plymouth, Eng.; ESP, Paris, France; 2LO, London, Eng.; PTT, Madrid, Spain; WKA2, Porto Rico and CYC, Mexico City. Positively the last word in loop construction. Exclusive features give you selectivity and distance unheard of before with loop aerials. Operates successfully on all sets designed for loop construction. If your dealer cannot supply you, order direct from us. Price \$16.50. Send \$2.00 as good faith deposit with your order, balance C. O. D. Parcel Post. Satisfaction guaranteed.

KORACH RADIO COMPANY
309 So. LaSalle St. Dept. 10 Chicago, Ill.

Full Particulars on Request
Dealers and Jobbers: Write at once for attractive proposition

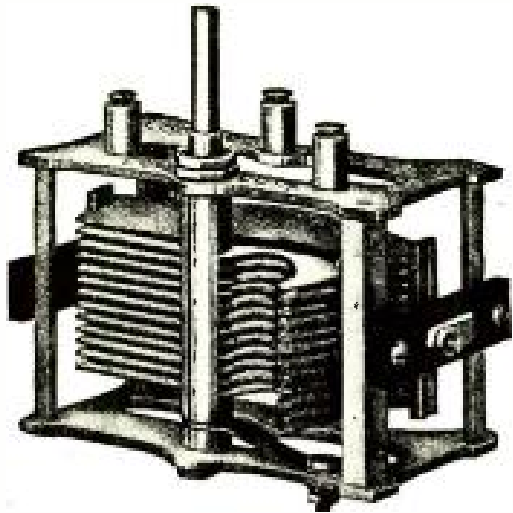

Open Tuning on Low Waves

No bunching of stations at the lower end of the dials when you use this new Chelten Variable Condenser. They are spread out so you can tune them in clear and strong. New Chelten plate shape does it. Frame of Duraluminum. Rotor shafts solid brass with milled slots for soldered-in plates.

Cat No.		Brass Plates	Aluminum Plates
913-13	plate—0.000250 M. F.	\$4.10	\$3.25
919-19	" —0.000350 M. F.	4.25	3.35
925-25	" —0.000500 M. F.	4.50	3.50

Chelten Midget



Connected to main condenser, the CHELTEN MIDGET VERNIER Condenser permits finer adjustment than ordinary vernier. Much sharper tuning is possible. \$1.50. Also is used in tuned Radio Frequency Circuits as a STABILIZER.

Chelten Microfarad Jr.

Designed especially for NEUTRALIZING tube capacities. Can be varied to suit change of tubes. Always holds adjustment, which can be altered only with key. \$1.75.

AT YOUR DEALER'S OR DIRECT
BY PARCEL POST

CHELTEN ELECTRIC CO.
Stenton Avenue and Rockland Street
PHILADELPHIA

Radio Authority Tests B-T Condensers

"Just a condenser" no longer satisfies the dyed-in-the-wool fan. Nowadays he wants a lot of information about resistances, etc. *He demands efficiency.*

B-T Condensers were recently subjected to a resistance test at Armour Institute of Technology, part of the report from the laboratory reads as follows:

"When B-T Condensers were in the circuit, the current was 1 to 2 percent greater than that obtained with our Laboratory Standard Condenser. It was necessary to add about .1 ohm resistance to bring the current down to the same value as that obtained with the "Standard." *The equivalent resistance of B-T Condensers is therefore less than that of the standard by approximately .1 ohm.*"

This test was made by Prof. G. M. Wilcox, Prof. of Physics at "Armour."

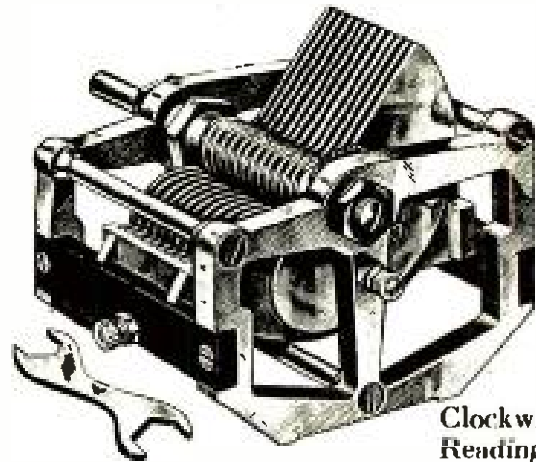

Clockwise
Reading

The B-T "NAMELESS" is a combination of efficient-low-loss apparatus and a circuit designed to take full advantage of such efficiency. By purchasing a "NAMELESS" Kit proper balance of coils and condensers is assured. "NAMELESS" Kits may be purchased at all high grade radio stores. Ask your dealer for late bulletins describing the "NAMELESS" or send direct.

Pioneers of "Better Tuning"

BREMER-TULLY MFG. CO.
532 S. Canal St., Chicago

Best For Any Set

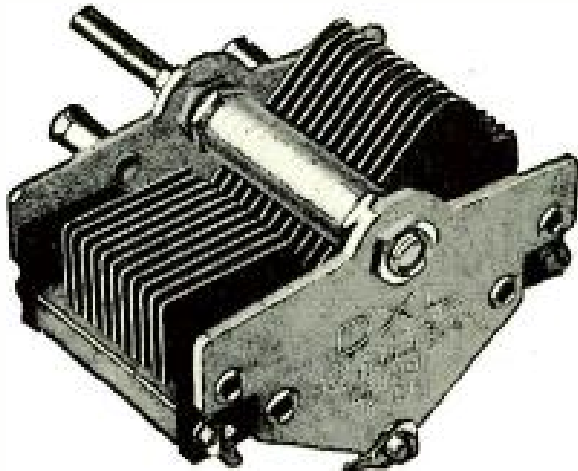

Selected for use
in the Better Sets

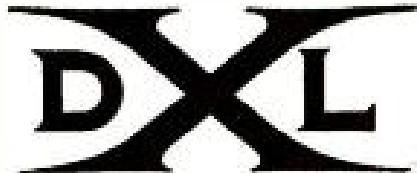

TRADE

MARK

Straight Line Low Loss Condensers

The better sets, being designed for the coming season, require the finest quality parts. Many manufacturers are choosing D X L Condensers for their straight line frequency and low power loss features. A most casual examination or the most exhaustive tests will prove to the satisfaction of any radio engineer that D X L Condensers practically eliminate losses of power and accomplish the highest known degree of selectivity.

Prices are within the reach of those set manufacturers who appreciate value.

JOBBERS

The recognized quality of D X L Products plus a protective sales policy assures a consistent year 'round business for a few jobbers in each territory. A sales representative will explain details at your convenience.

FANS: Brand New—D X L BALANCED R. F. Kit, oscillation controlled—now ready \$18.50. Write for details.

Set Manufacturers

planning R. F. Sets will be interested in New D X L Principles, applied to the famous tuned R. F. Circuits.

D X L RADIO CORPORATION
5767 Stanton Ave.
DETROIT, MICH.

GET THESE SIMPLIFIED BLUEPRINTS FREE

You can have your choice of any one of seven POPULAR RADIO Simplified Blueprints with your new or renewal subscription for POPULAR RADIO, accompanied by remittance of \$3.00. These Blueprints will make it possible for you to build a tested and approved set, while POPULAR RADIO for 12 months will keep you in touch with the progress being made in radio.

You, as a reader of POPULAR RADIO, know the many entertaining, interesting and instructive articles that are published each month. Every issue some new item is sure to attract your attention. We promise that throughout the coming months POPULAR RADIO will hold more and more of interest for Radio Fans.

Ease, Economy and Accuracy in Construction

Simplified Blueprints were prepared under the personal supervision of Laurence M. Cockaday. They make it possible for anyone, without previous knowledge of radio, to construct a highly efficient radio receiver. Each set of Blueprints consists of 3 prints as follows.

Panel Pattern

This Blueprint is the EXACT size of the actual set. So accurate that you need merely lay it on your panel and drill as indicated. You can readily appreciate the convenience of this Blueprint. No scaling or measuring to do, no danger of ruining the panel through faulty calculation.

Instrument Layout

Here again you have an actual size print of each instrument and binding post and its exact location both on the panel and within the cabinet. Even the cabinet structure is clearly shown.

Wiring Diagram

The unusual feature of this Blueprint is that it is an actual size picture diagram of the finished set. Each instrument and other parts appear in exact size and the wires are so clearly traced from one contact to another that you can connect all terminals accurately without even knowing how to read a hook-up diagram.

Set No. 2—"Non-regenerative Tuned Radio Frequency Receiver" (Simplified Neutrodyne, four tubes, three dials) as described in April, 1924, POPULAR RADIO.

Set No. 3—"Cockaday Distortionless Audio-frequency Amplifier" (four tubes, combination of resistance-coupled and push-pull amplification) as described in May, 1924, POPULAR RADIO.

Set No. 4—"Cockaday Four-circuit Tuner with Resistance-coupled Amplifier" (five tubes, distortionless, two dials, automatic vacuum tube control) as described in October, 1924, POPULAR RADIO.

Set No. 6—"Cockaday 8-Tube Super-heterodyne Reflex Receiver" as described in January, 1925, POPULAR RADIO.

Set No. 7—"Craig 4-Tube Reflex Receiver with Sodiun Detector Tube" as described in February, 1925, POPULAR RADIO.

Set No. 8—"Cockaday Improved DX Regenerative Receiver" (four tubes, distortionless, automatic filament control) as described in March, 1925, POPULAR RADIO.

Set No. 9—"The Portable Town and Country Receiver" (six tubes, three stages of transformer-coupled, radio-frequency amplification, loop antenna) as described in May, 1925, POPULAR RADIO.

Use coupon below: indicate which set of Blueprints you want.

POPULAR RADIO

Dept. 59

627 West 43rd Street New York City

POPULAR RADIO, Dept. 59

627 West 43rd Street, New York City

Enclosed is my remittance of \$..... in full payment for subscription, with Blueprints as checked below. FREE.

- | | |
|---|--|
| <input type="checkbox"/> Set No. 2—Non-regenerative Tuned Radio-frequency Receiver. | <input type="checkbox"/> Set No. 6—Cockaday 8-Tube Super-heterodyne Reflex Receiver. |
| <input type="checkbox"/> Set No. 3—Cockaday Distortionless Audio-frequency Amplifier. | <input type="checkbox"/> Set No. 7—Craig 4-Tube Reflex Receiver with Sodiun Detector Tube. |
| <input type="checkbox"/> Set No. 4—Cockaday Four-circuit Tuner with Resistance-coupled Amplifier. | <input type="checkbox"/> Set No. 8—Cockaday Improved DX Regenerative Receiver. |
| <input type="checkbox"/> Set No. 9—Portable Town and Country Receiver. | |

Name.....
Street.....
City..... State.....

Balkite Battery Charger.
Charges 6 volt "A" storage batteries.

Price \$19.50
West of Rockies \$20
In Canada \$27.50

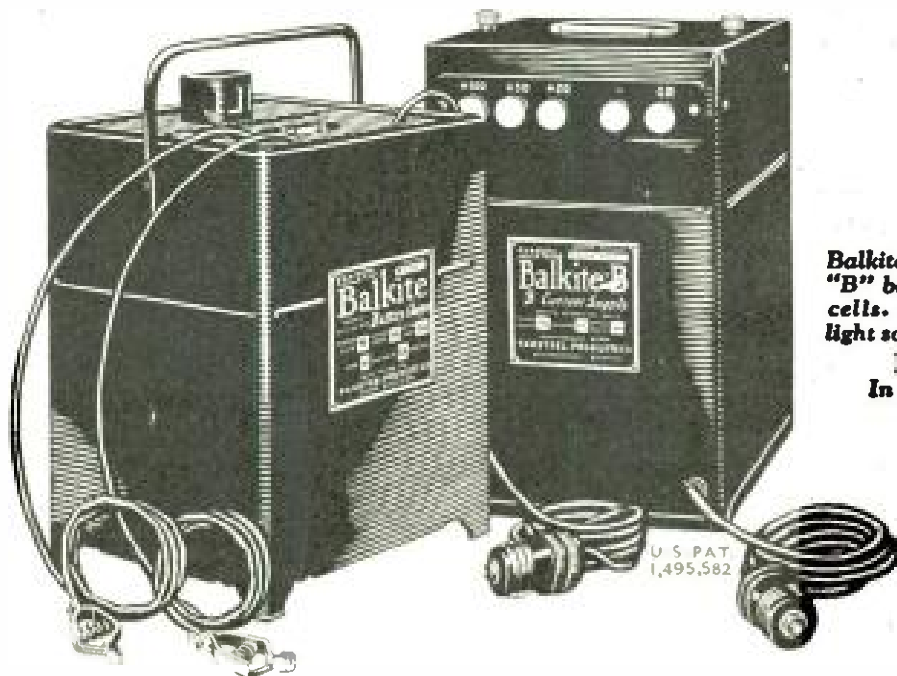

Balkite "B"—replaces "B" batteries and dry cells. Operates from light socket.

Price \$55
In Canada \$75

A uniform, constant power supply for both "A" and "B" circuits

Here at last is a convenient and unfailing power supply for your radio set. Balkite Radio Power Units furnish constant uniform voltage to both circuits, and will give your radio set greater clarity, power and range. The Balkite Battery Charger keeps your "A" storage battery charged. Balkite "B" replaces "B" batteries entirely and supplies plate current from the light socket.

Based on the same principle, both the Balkite Battery Charger and Balkite "B" are entirely noiseless. They have no bulbs or moving parts, and nothing to break, adjust or get out of order. They have a very low current consumption, are simple and efficient in operation, and can be put in use at any time by merely connecting to a light socket. Both are guaranteed to give satisfaction.

Sold by leading radio dealers everywhere

FAN STEEL
Balkite *Radio Power Units*

BALKITE BATTERY CHARGER — BALKITE "B" PLATE CURRENT SUPPLY

Manufactured by FANSTEEL PRODUCTS COMPANY, Inc., North Chicago, Illinois

All apparatus advertised in this magazine has been tested and approved by POPULAR RADIO LABORATORY

Free Booklet

—mail coupon below



Clearer Reception this easy way

THE important thing is to have clean, perfect contact between tubes and sockets. Otherwise disturbing noises will continue.

You can always have clean, perfect contact by using Na-Ald Sockets—the *only* sockets with these 3 essential features:

- (1) *Lowest losses.* Laboratory tests proved that of 13 best known makes Na-Ald Sockets were the *only* ones having losses lower than a good low loss condenser.
- (2) *Low capacity.* The same test showed that Na-Ald has the lowest capacity of any socket—very essential for short wave length reception.
- (3) *Positive side-scraping* contact (not just side pressure) that cleans corrosion from tube terminals.

Use Na-Ald Sockets in the set you build or buy, if not already installed by the manufacturer. De Luxe 75c; others, 35c and 50c.

ALDEN MANUFACTURING COMPANY
Also makers of the famous Na-Ald Dials
Dept. C6, Springfield, Mass.



ALDEN MANUFACTURING COMPANY,
Dept. C6, Springfield, Mass.

Please send free copy of booklet, "What to Build," showing tested and selected circuits.

Name

Address

City State

Obsolete

Take the
"GUESS"
Out of Tube
Control \$ 1.10
Everywhere

with

AMPERITE—the Self-Adjusting rheostat, takes care of tube current better than any expert operator could regulate it. No more hand rheostats or filament meters necessary. Brings the most out of each individual tube automatically. Simplifies wiring, doubles tube life, lowers set cost. Approved by all leading laboratories. Used in every popular construction circuit.

RADIALL COMPANY
Dept. P.R.-8, 50 Franklin St., New York City



Write for
FREE
Hook-ups

AMPERITE
REG. U.S. PAT. OFF.
"means right amperes"

Globe LOW-LOSS TUNERS

Make the perfect
radio set

QUALITY—VOLUME—DISTANCE

No Metal
No Eddy Current
Losses

Little Insulation
Low Distributed Capacity

Large Wire
Self Supporting

Anti-Capacity Windings
Low R F Resistance



Patented Dec. 9, 1924

GET ORIGINAL GLOBE COILS

PRICES:

Standard Tuner (Broadcast Range)	\$7.00
Short Wave (50-200 Meters)	\$7.00
For Superdyne Circuit	\$8.50
R F Transformers	\$6.00

Circular on Request. Dealers and Jobbers Write

Globe Radio Equipment Co.
217 WEST 125th ST., N. Y. C.

The New

NAVY MODEL C-10 SUPER-HETERODYNE

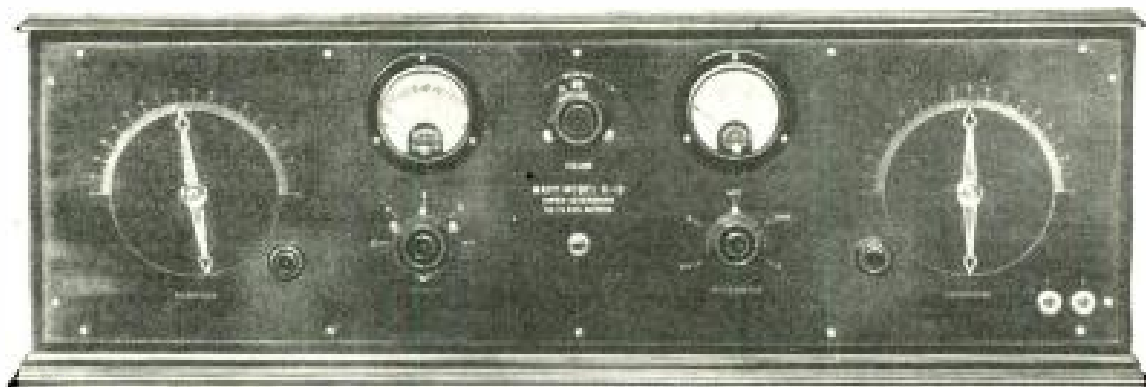

Only 2 Main Tuning Adjustments for 10 Tubes
Panel Size Only 28 3/16" x 8"

A POWERFUL 10 TUBE BROADCAST RECEIVER

Total Amplification 1,500,000 Times
Wave Length Range 50 to 600 Meters

We believe this new design by Charles R. Leutz has a range and degree of selectivity far in advance of any receiver, and represents final superiority over any receiver now being manufactured, or even contemplated, for broadcast reception.

Descriptive Literature Mailed on Request

Experimenters Information Service, Inc.

476 Broadway

New York City, N. Y.

*Designers of the Highest
Class Radio Apparatus
in the World*

Experimenters

Information Service, Inc.

476 Broadway, New York, N. Y.

Please forward literature on the New
Navy Model C-10. No charge.

Name

Address City State

3 Summer DX Kits OF THE BEST POSSIBLE QUALITY OBTAINABLE

Each of these four hookups offers the utmost Summer reception possible at the price. The high reputation and quality of every item from Morison—guarantees best results. Write today.

COCKADAY'S 8 TUBE SUPER-HETERODYNE REFLEX RECEIVER

1 General Instrument Low-Loss Condenser (isolantite insulation) .005 mfd.	\$5.50
1 General Instrument Low-Loss Condenser (isolantite insulation) .001 mfd.	6.00
1 Set of 4 Matched Haynes-Griffin Intermediate Transformers	20.00
1 Precision Autodyne Coupler	3.50
1 Karas-Harmonic Audio-Frequency Transformer	7.00
1 Amplex Grid-denser .0005 mfd.	1.25
1 Benjamin Cle-r-a-tone Socket	1.00
7 Federal Sockets No. 16	ca. \$1.20
1 Patent Double Circuit Jack	.60
1 Patent Single Circuit Jack	.50
2 Na-aid 4 inch Dials No. 3043	ea. .75
1 Amsco 2 Ohm Rheostat	1.35
1 Amsco Potentiometer 400 Ohms	1.50
2 Daven Resisto coupler mountings	ea. \$1.00
1 Daven Grid-leak Mounting	.85
2 Daven Resistor .5 Megohms	ea. 1.00
1 Daven Resistor 5 Megohms	.50
1 Daven Resistor .005 Megohm	1.00
2 Daven Resistor .25 Megohm	ea. 1.00
1 Radion Panel 7x24 ins.	3.00
2 .0001 N. Y. Coil Mica Condensers	ea. .35
4 .005 N. Y. Coil Mica Condensers	ea. .75
1 .00025 N. Y. Coil Mica Condenser with Grid-leak Mounting	.45
1 Duratran Radio-Frequency Transformer	4.00
1 Walbert A Battery Switch	.50
1 Baseboard 9 3/8 x 22 3/4 x 1-2 ins	.75
1 Connection Block 1 x 9 x 3-16 ins	.25
7 Eby Binding Posts	ea. .16
1 Material for making brackets	1.05
1 Korach Tuned Loop	16.50
1 Mahogany Cabinet	12.50
	\$104.90

IMPROVED D.X. REGENERATIVE RECEIVER

1 New York Coil D.X. Coupler	\$5.00
1 Rathbun .0005 Condenser	3.50
2 Kurz Kesh 4 in. Dials	1.00
2 Dubilier Type 640 .00025 Cond.	.45
1 Dubilier Type 640 .005 Cond.	.70
2 Dubilier Type 640 .02 Cond.	2.00
1 Gen'l. Radio No. 285 Audio Trans.	4.00
2 Brandleyohm No. 25	7.00
1 Cico Double Cir. Jack	4.00
1 Cico Single Cir. Jack	.90
1 Cico Battery Switch	.80
1 Radion Panel 7 x 24	.90
1 Amperite No. 1A	8.00
1 General Inst. 6 Ohm Rheo.	1.10
1 General Inst. 20 Ohm Rheo.	1.25
1 Filkoicak	1.59
1 Benj. Socket	2.00
3 Walbert Sockets	ea. \$1.00
2 Daven Mfgs. No. 50	1.00
1 Durham Metalized Leak .25 Meg.	.75
1 Durham Metalized Leak .5 Meg.	2.25
1 Baseboard 8 x 22	.35
8 Plain Eby Posts	.70
1 H. R. Strip 1 in. x 3 1/2 in.	.60
1 H. R. Strip 1 in. x 9 in.	.50
4 Brackets	.75
1 7 x 24 x 8 Mahogany Cabinet	.15
	1.20
	.15
	.25
	.20
	12.50
	\$58.55

4 CIRCUIT TUNER WITH RESISTANCE COUPLED AMPLIFIER

1 Set "Precision" Cockaday Coils	\$5.50
1 Cardwell Variable Condenser (.0005 mfd.)	5.00
1 Cardwell Variable Condenser (.00035 mfd.)	4.75
2 Accuratone Micrometer Control Dials	ea. \$3.50
1 Amplex Grid-denser	7.00
1 Bradleyesk	1.25
3 Bradley ohms No. 25	ea. \$2.00
1 Amsco Dubl-Wundr combination Potentiometer-Rheostat	6.00
4 Amperites No. 1-A with mountings	ea. \$1.10
3 Improved double-circuit Jacks	ea. \$1.00
1 Improved single-circuit Jack	3.00
1 Precise Audio Frequency Amplifier No. 285A	.70
3 1-2 in. Megohm Electrad Certified Grid-leaks	ea. 5.00
3 Electrad Certified Grid-leak Mounting	ea. .50
1 Improved Filament Battery Switch	1.60
	1.05
	1.00
	\$45.50

PARTS FOR 2 TUBE ROBERTS REFLEX

1 Set Sicklea Coils No. 18	\$8.00
2 Hammarlund .0005 Mfd. Var. Cond. at \$5.00	10.00
1 Karas Harmonic Audio-Trans.	7.00
2 Benjamin Standard Sockets	2.00
2 Amsco 20 Ohm Rheostats at \$1.25	2.50
1 MARGO Neutralizing Cond.	1.25
3 4 in. E. Z. Toon Dials	at \$2.25
1 Carter Jack Switch No. 2	6.75
1 Federal Single Circuit Jack No. 1421	1.00
1 Amsco Switch Lever with 7 points, 2 Stops	.60
1 Dubilier 601G Fixed Cond. .00025	.40
1 Dubilier 601 Fixed Cond. .002	.45
1 Dubilier 601 Fixed Cond. .005	.40
1 Daven .2 Meg. Grid-leak	.60
1 7 x 21 Radion Panel	2.65
1 Eby Mounted Binding Post Strip	1.25
1 Doz. Lengths Bus Bar	.25
1 Screws and Nuts	.60
Complete with Blue Print	\$41.50



WHOLESALE RETAIL
15 East 40th Street, New York City

You May Well Be Proud of Your

JOS. W. JONES

TRADE MARK

Standardized, Precision-Made Receiving Set

*Rich, Sweet Tone! Luxurious Volume!—
Bona Fide Selectivity! A Beautiful Cabinet!*

—and distance? Well, you'll be certain it is a local station 'till you hear the announcer gives its name!

Best of all, it's standardized—built of the famous Jones Precision Parts—which means utter dependability; no embarrassing moments of "indispositions" when guests are to be entertained.

The price will first surprise and then delight you!

Jos. W. Jones Radio Dealers invite you to come and

GET THE PROOF!
Hear a Demonstration

Jos. W. Jones Radio Mfg. Co., Inc.
42 West 25th Street, New York City

AP COILS & COILS



MODIFIED LORENZE
EFFICIENT RADIO COILS
Require

A Specialized Organization for Economical Production

We make Coils only. Our entire resources are devoted to Radio Coils. For that reason we are able to render Radio Set Manufacturers an unequalled coil service.

Regardless of your own facilities you will undoubtedly find this service profitable to you. Ask us for estimates and samples.

ACME PRODUCTS CO

107 W. Canton St. Boston, Mass.

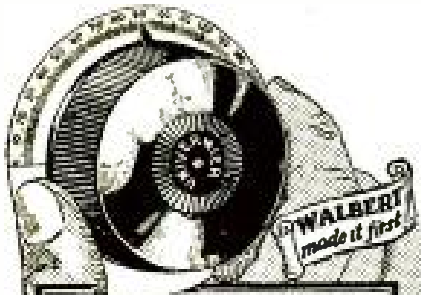

**WALBERT
UNIVERNIER**

The original geared tuning dial 12-to-1 Ratio. Helps you find the station you want—then clears it up. Puts entire range of your set under continuous vernier control. Positive smooth action. No slipping. No friction. Cannot destroy accuracy of low-loss condenser bearings. Promise yourself a real surprise. Replace your dials with UNIVERNIERS to-night. Black knob and silver-plated dial, \$1.25. Mahogany knob and gold finished dial.

\$1.50

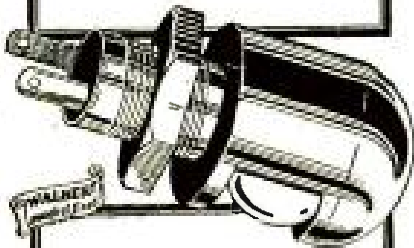

**WALBERT
PANELITE**

Now you can place your set in that convenient out-of-the-way corner and not have to strain your eyes while tuning. Light-up your panel with the new Walbert Panelite. Also acts as "tell-tale" light. Complete with low-current bulb. Hooks-up with your "A" Battery Circuit. Single hole mounting.

\$1.00

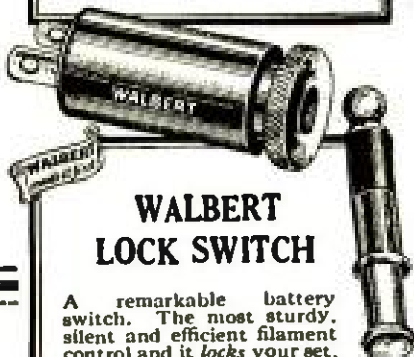

**WALBERT
LOCK SWITCH**

A remarkable battery switch. The most sturdy, silent and efficient filament control and it locks your set, too! One hole mounting. Requires less room behind panel than any other switch. Shockproof. Costs no more than a plain battery switch.

50c.

Extra key with key ring attachment **20c**

\$1000 for a NAME!

26 Prizes for the 26 best names suggested. You can win one of them! Just tell us what you would call the new auxiliary unit recently perfected by our engineers—a simple, forceful name that best describes the FACTS given below.

Prizes Are As Follows: For the best name: \$100 in cash, and one \$35.00 auxiliary unit. For the 25 next best names: One \$35.00 auxiliary unit for each name suggested. Should two or more persons submit the name selected as best, second best, etc., each will be awarded the prize for which they are tied.

Rules of Contest: Contest is open to everybody. You do not have to own a radio set or buy an auxiliary unit. Send in as many names as you choose. Each name may win a prize. Contest opens March 20, 1925, and closes promptly at midnight April 30, 1925. Announcement of prize awards will be made immediately thereafter.

Facts—Read Them Carefully: These facts state briefly and accurately what this auxiliary unit has done—what we positively guarantee it will do when hooked up with your set or any set:

1. Increase the selectivity of your set as you would have it.
2. Give you absolute control over local interference.
3. Give your set the clarity and tonal qualities of a perfect musical instrument.
4. Give you amazing power—power to pierce greater distances with more volume.
5. Positively eliminate all radiation.
6. Permits effective use of shorter indoor aerial thereby greatly reducing static.
7. Make your set better, no matter how good it now is.
8. Anybody can connect this unit in a few minutes.

Furthermore this auxiliary unit:

9. Will not alter the dial readings of your set.
10. Will not make your set unstable no matter how many stages of AF or RF amplification it already has.

These are facts. We unreservedly guarantee their accuracy. More than that, we will gladly demonstrate them to you at our expense. With your permission we will send this unit to you for a 7 days' test with your set. It must convince you by performance. It must do all we have said. It must fulfill your expectations or you may return the unit, and we will promptly refund your money.

Now—with Spring here—is the time to make this test. The auxiliary unit works perfectly summer or winter. Send in the test application blank today.

JOBBER AND DEALERS Write us for further details, prices and discounts on this new unit.

**WALBERT
MANUFACTURING COMPANY**

TEST APPLICATION

WALBERT MANUFACTURING COMPANY, 933 Wrightwood Ave., Chicago, Ill. GENTLEMEN: Enclosed please find check for \$35.00. Send me the auxiliary unit for a 7 days' performance test. Should the auxiliary unit fail to meet with my expectations I will return it to you at your expense and you will immediately refund my money. If I am a prize winner, you will refund my money.

Name..... Address.....
City..... State.....

All apparatus advertised in this magazine has been tested and approved by POPULAR RADIO LABORATORY

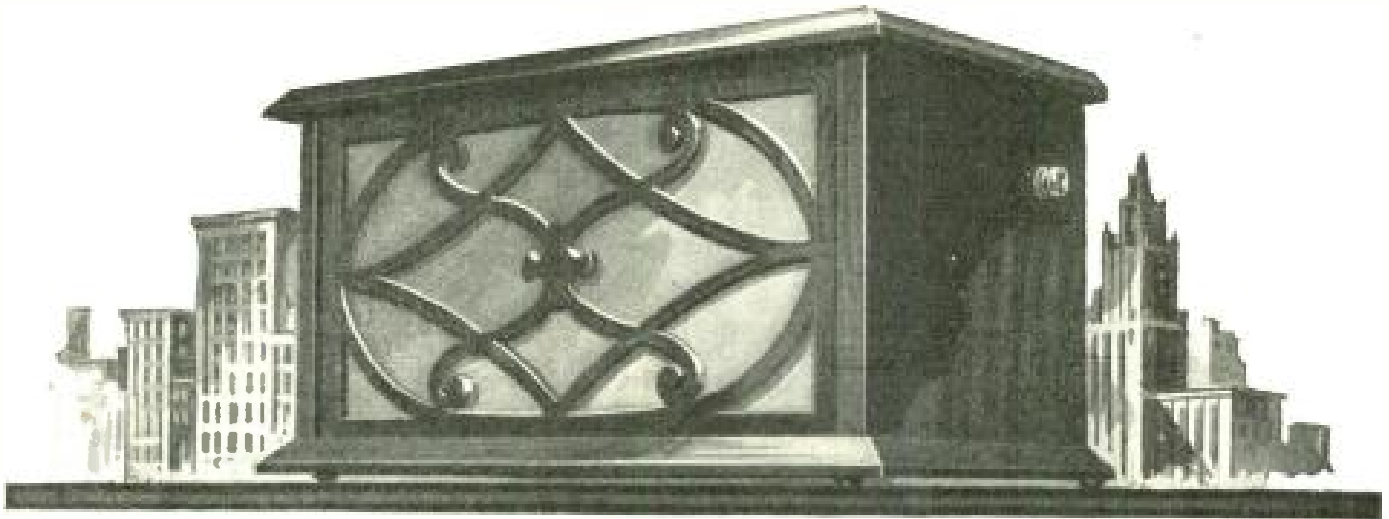

Bel-Canto—The Biggest Thing in Radio!

No matter what instrument you purchase—violin or piano or loud speaker, the first essential is tone quality—next volume—then design. It will pay you to hear a BEL-CANTO.



Gooseneck Fibre Horn with Adjustable Unit, \$15.00

THE ONLY PATENTED CABINET SPEAKER

The BEL-CANTO has exceptional volume and a mellow, brilliant tone quality. Our secret is a *flexible reed tone chamber*, an exclusive BEL-CANTO feature. The BEL-CANTO Cabinet Loud Speaker is a real musical instrument—a truly "beautiful singer." Workmanship is of the best—solid wood throughout—beautifully finished.

Price only \$17.50, a fraction of its comparative cost

Your dealer can get it for you, or we will ship prepaid on receipt of price

JOBBERs—Write us today about out-of-town territory

West of Rockies—Prices are \$18.00, \$15.50, \$10.50



The original Bel-Canto Fibre Horn with Adjustable Unit, \$10.00

BEL-CANTO RADIO AND TELEPHONE EQUIPMENT CO., Incorporated
872 Broadway, New York City

No. 248
E-5841
Underwriters App.

"Little Joe" Lightning Arrester

Especially designed for Radio Work. Made of Porcelain, small, neat rugged and serviceable. Can be suspended on antenna or fastened to wall.

Ask Your Dealer
M'fd by CIRCLE F MFG. CO.
Trenton, New Jersey

SILVER CIRCUIT DESIGNS

are responsible for the marvelous reception records that the SILVER 7-TUBE SUPERS and the SILVER 4-TUBE RECEIVERS have set—Records that back up every claim made for Silver Circuit Designs—Records that explain why the "WHO'S WHO" of Radio unanimously approve Silver Circuit Designs.

You cannot find more advanced designs. Silver Circuits are the results of years of research and experiment with hundreds of models... Research supervised by McMurdo Silver, Assoc. I. R. E., who is unsurpassed in Radio design. Your order for any of Mr. Silver's designs will be filled by SILVER-MARSHALL, Inc., without delay.

DESIGNS TO ORDER

Blueprints and Complete Building Instructions for the Silver Super 25c
McMurdo Silver's Book—"THE PORTABLE SUPER HETERODYNE" 50c
Complete Building Instructions for the Silver 4-Tube Receiver 25c

FREE "THE WHY OF SILVER CIRCUITS"
SEND FOR IT TODAY

Silver-Marshall, Inc.

110 S. Wabash Ave., Dept. A., CHICAGO

Thorola

THE
SPEAKING
LIKENESS

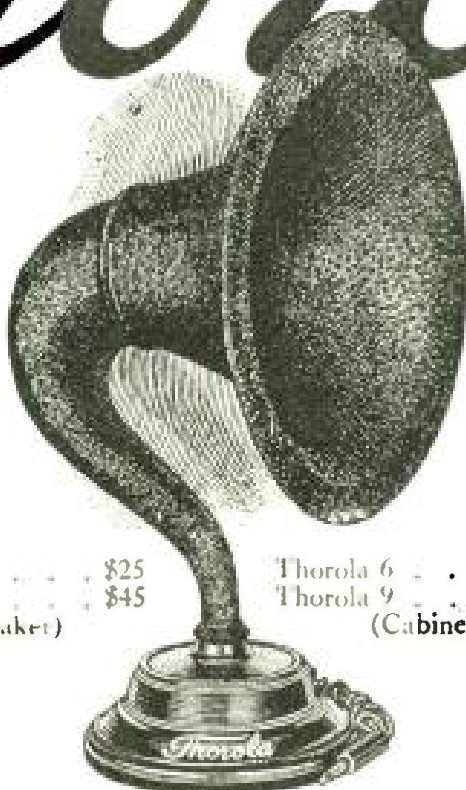

Thorola 4 \$25
Thorophone \$45
(Powerplus Speaker)

Thorola 6 \$15
Thorola 9 \$40
(Cabinet Speaker)

In No Other Speaker

No other speaker has a reproducing unit which lends itself so readily to scientific precision in manufacture. The greater size of the Thorola unit permits closer adherence to acoustic laws, just as a concert grand is truer in tone than a toy piano.

No other speaker duplicates the Thorola Controlled Mica Diaphragm, which first brought radio the most highly perfected method of musical reproduction.

No other speaker has the Separix, which enables Thorola to separate each note distinctly from every other note, preserving intact all the shadings and overtones which make the difference between music and noise!

And Thorola has the horn of Thorite, a compound devel-

oped only in Thorola laboratories to overcome the natural resonance and consequent interference experienced with horn materials made by Nature. Thorite is most scientific—and most beautiful.

Then there is the exclusive Thorola Synchronizer. It virtually “tunes” each Thorola with each particular receiver, putting this loud speaker in perfect balance in the circuit. No other way assures perfect harmony.

It takes every one of these great advancements; it takes all the facilities and knowledge of America’s pioneers in the loud speaker art to give Thorola its superiority.

The difference is decisive. Thorola today is the accepted sign that radio is being heard at its best.

The Thorola 10-day Refund Warranty is a guarantee to every user that Thorola will fulfill every claim.

No external battery. Plug in same as head phones.

REICHMANN COMPANY, 1725-39 W. 74th Street, CHICAGO



Do You Hear Each Instrument Distinctly?

With the unique design of Rauland-Lyric comes a peculiar excellence. There is brought before you, as a noted critic remarked, "the very personality of each artist," as he explores the resources of his instrument. Such a quality, indeed, as to render insignificant, in any radio set, the added cost of Rauland-Lyric Amplification.

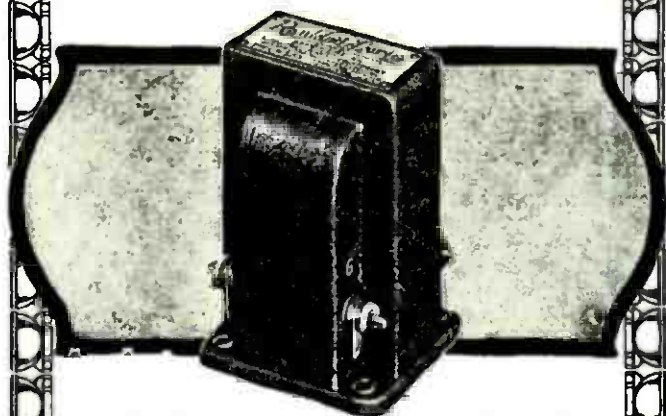

Rauland-Lyric is a laboratory-grade audio transformer designed especially for music lovers. The price is nine dollars. Descriptive circular with amplification curve will be mailed on request. All-American Radio Corporation, 2686 Coyne St., Chicago.

Rauland-Lyric

AN
ALL-AMERICAN
TRADE MARK
TRANSFORMER

The Choice of Noted Music Critics

BUILD A NEW SET

GET THIS BOOK

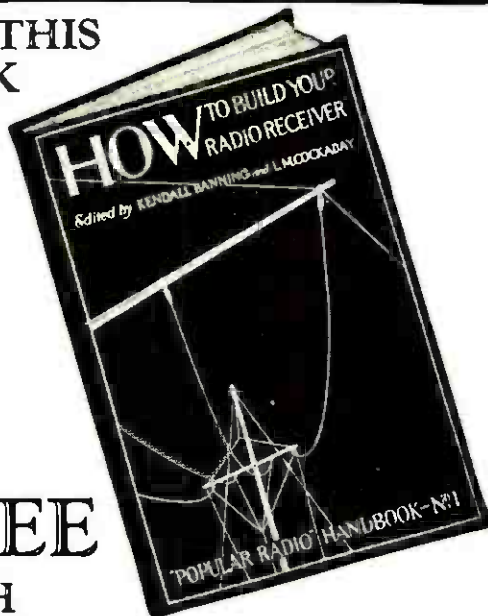

FREE WITH

Popular Radio

Kendall Banning, Editor, and Laurence M. Cockaday, Technical Editor of POPULAR RADIO, have compiled a book that will prove to any one that he can build a set which will give distance, selectivity and tone volume, and at the same time a very definite basic knowledge of radio.

BUILD YOUR OWN SET AND SAVE MONEY

In "How to Build Your Radio Receiver," you will find complete specifications, constructional diagrams, photographs and instructions for building all of the following sets:

- A \$5 Crystal Set
- The Haynes Single Tube Receiver
- A Two-Stage Audio-frequency Amplifier
- The Cockaday 4-Circuit Tuner
- A 5-Tube Tuned Radio-frequency Receiver
- The "Improved" Cockaday 4-Circuit Tuner
- The Regenerative Super-Heterodyne Receiver

ADVISORY SERVICE ALSO FREE

POPULAR RADIO maintains a big modern laboratory with a trained staff of investigators under the personal supervision of Mr. Cockaday. This Laboratory is always available through our Technical Service Bureau to answer, free of charge, by personal letter any problems you encounter which are not answered in either the "Handbook" or the magazine.

In POPULAR RADIO each month you will find the very latest news of the radio field as well as helpful suggestions and instructive and entertaining articles on radio and allied scientific phenomena.

30 DAY OFFER

You can secure a copy of "How to Build Your Radio Receiver" FREE, and have all the privileges of the Technical Service Bureau without additional expense, if you will send a remittance of \$3.00 in full payment of 12 months' subscription for POPULAR RADIO. (Or as an alternative, you may have the book and privileges of the Technical Service Bureau with POPULAR RADIO for 7 months only—for \$2.00. A two dollar bill will do.)

Remember you take no chance—we will refund your money in full if you are not more than satisfied.

POPULAR RADIO

627 West 43d St. New York City

POPULAR RADIO, Dept. 55
627 West 43d St., New York City, N. Y.

Enclosed remittance of \$3.00 is payment in full for a 12 months' subscription for POPULAR RADIO, with advisory service and copy of "How to Build Your Radio Receiver" FREE.

Name.....

Address.....

City.....State.....

Check here if you want the \$2.00 offer of POPULAR RADIO with "How to Build Your Radio Receiver" and Technical Service Bureau privileges for 7 months only.



FIVE POINTS OF RADIO QUALITY

All Developed to the Utmost Degree

in *Air-Way*

Receiving Sets

TONE, SELECTIVITY, DISTANCE,
VOLUME and APPEARANCE

are the five fundamental requirements of radio receiving sets to meet the demands of the buying public, and render satisfactory profits to the dealer.

AIR-WAY receiving sets are designed to and do meet these requirements to the satisfaction of the most discriminating buyer.

Their appearance attracts the buyer's attention and their performance meets his approval. Consequently they are satisfactory and profitable to the dealer, because they sell easily and stay sold, without the necessity of continuous service to keep them in satisfactory operation.

Model
51

PRICE
\$125.00



Model 51 is a five-tube tuned radio frequency set embodying the latest developments in this type of receiver, and includes such strictly up-to-date elements as Spider-web coils, Low-loss condensers, etc.

It is the ideal set for the D-X'fan who wants to pick up stations all over North America, but still demands reception with pleasant audibility and clarity of tone.

Mounted in a five-ply walnut cabinet of attractive design and handsome finish. PRICE, \$125.00.

AIR-WAY Model 41



A four-tube set with one stage of tuned radio frequency, detector and two stages of audio frequency amplification that meets all the requirements of the buyer of modest means.

We offer this set for the consideration of the dealer and buyer as absolutely the best radio value now on the market; in which is combined coast-to-coast reception, perfect tone qualities, and the utmost simplicity of tuning in connection with the required degree of selectivity.

Price \$65.00

We invite correspondence from every established radio dealer, regardless of the lines he may now be handling, and have a most attractive proposition to offer. Write for it today.

AIR-WAY ELECTRIC APPLIANCE CORPORATION

TOLEDO

OHIO

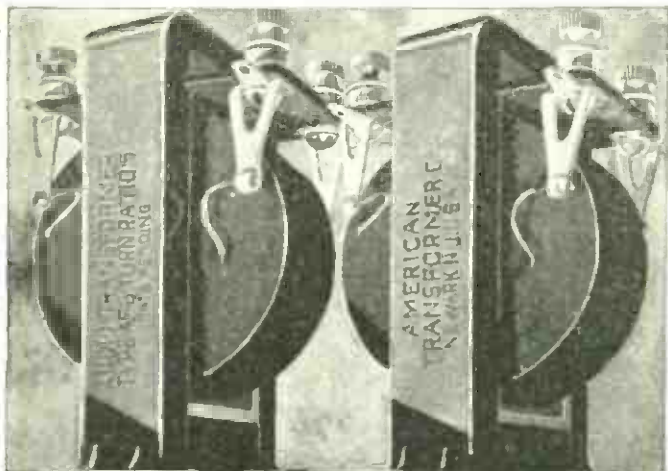

Build or Rebuild with AmerTrans

ONE of the reasons why Amertrans are preferred for fine sets is their strong, even amplification. They are made to be used by the pair as smooth working twin transformers.

AmerTrans amplify extreme tones with naturalness and uniformity. They are high in quality, produce great volume and can always be depended on to deliver the utmost in audio amplification.

AmerTran is made in two types, one quality—AF6, ratio 5:1 and AF7, ratio 3½:1. Price either model, \$7.00 at your dealer's.

Buy them by the Pair!

AMERICAN TRANSFORMER COMPANY

175 Emmet St., Newark, N. J.

"Transformer builders for over 24 years"

A New System of Radio Reception!

Francis R. Hoyt, inventor of the Hoyt System of Signal Augmentation, has specified AmerTrans for use in this new system. We have a limited number of Blue Printed copies of Mr. Hoyt's original laboratory notes on this new system of radio reception, together with nine circuit sketches, which will be sent free to you upon receipt of this coupon and 4 cents for postage.

NAME.....
ADDRESS.....

AMERTRAN
TRADE MARK REG. U. S. PAT. OFF.



The New "35-D" Super Radio Cabinet

Panel at top 7x26". Depth 10½". Filler strips for panel 7x18, 7x21 or 7x24. Built-in spruce horn back of silk lined grille. Horn fits all standard units. Two compartments each side of horn, ample for complete dry cell set. Door in back. Built of genuine select mahogany—latest lacquer hand rubbed piano finish. Equipment includes extra ½" mounting board, full continuous piano hinge, two folding lid supports and rubber feet under bottom. Write for illustrated price list.

Jobbers and dealers, write for discounts

BLANDIN PHONOGRAPH COMPANY, INC.

1500 16th ST. :: :: RACINE, WIS.

Don't Buy

L. M. Cockaday's 8 Tube Super-Heterodyne

Latest and best Reflex Receiver, complete parts, as described in January issue of POPULAR RADIO

The Sangamo

7 Tube Super-Heterodyne Kit

The famous non-radiating receiver by Jackson H. Pressley, chief engineer of the U. S. Signal Corps.

or Any of the Following Standard Parts

Nathaniel Baldwin Dubilier Benjamin
Weston Plugs Hammarlund Cutler Hammer
Jones Improved Jacks Thordarson Karas
Erls Jefferson Turn It
American Brand N. Y. Coil Tungara

Until You GET OUR PRICES

Our Catalog tells the Story. Write for it

HEINS & BOLET

Radio and Electrical Supply Corp.
Wholesale—Retail

44 Park Place, New York

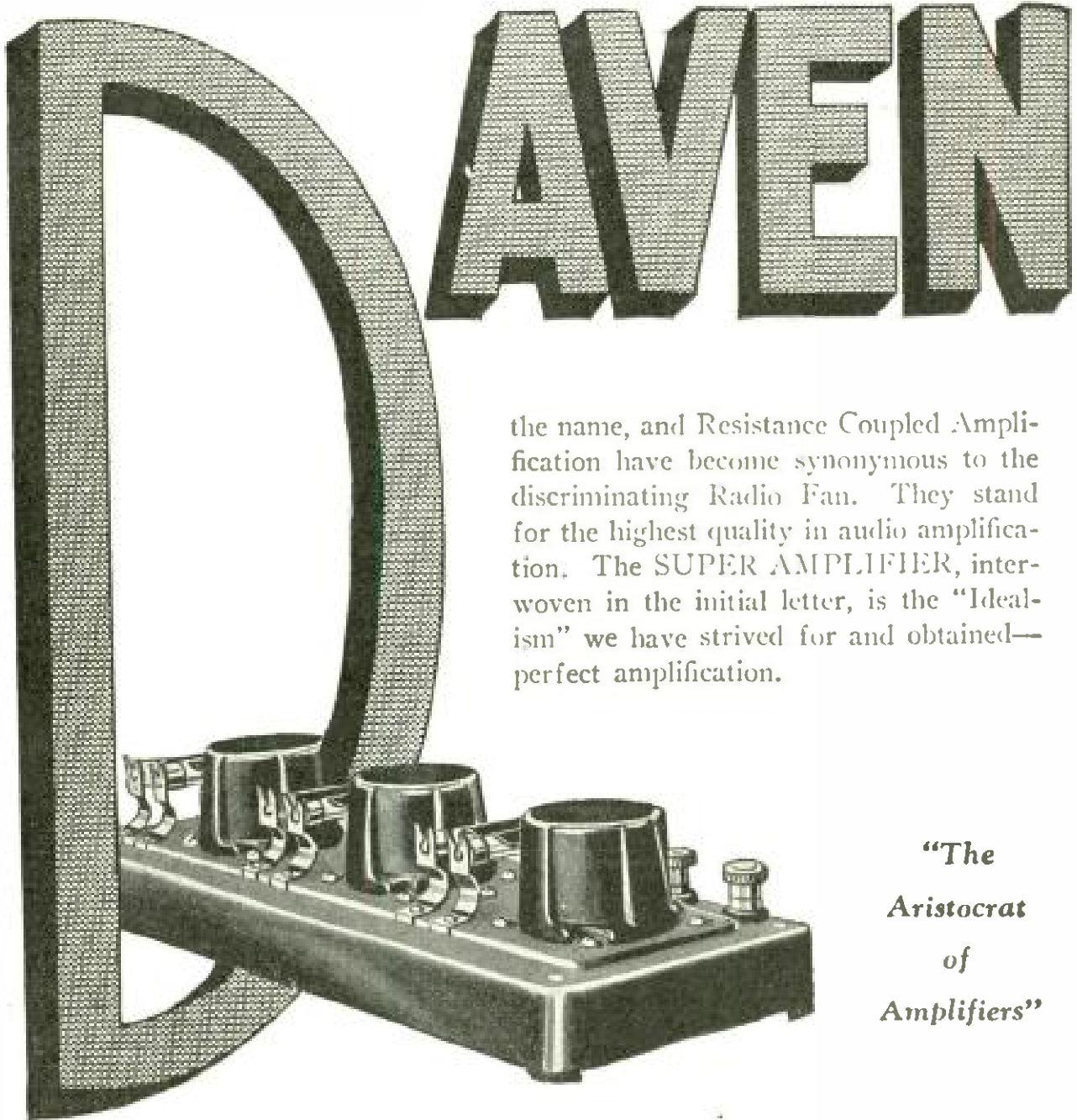

the name, and Resistance Coupled Amplification have become synonymous to the discriminating Radio Fan. They stand for the highest quality in audio amplification. The SUPER AMPLIFIER, interwoven in the initial letter, is the "Idealism" we have strived for and obtained—perfect amplification.

*"The
Aristocrat
of
Amplifiers"*

The SUPER AMPLIFIER is easily attached to your favorite tuner—it simplifies construction and amplifies with a volume and quality not obtainable with any other amplification device—there is nothing "just as good." It costs less to install and adds greatly to the life of your "B" Batteries.

The DAVEN RESISTANCE COUPLED KITS are for those who desire Resistance Coupled Amplification, but who would rather build their own than buy the complete, ready-to-attach SUPER AMPLIFIER. Sold in three and four-stage kits with complete instructions for assembly.

Obtain from your Dealer the "RESISTOR MANUAL," our complete handbook on Resistance Coupled Amplification. Price 25c. Postpaid 35c.

DAVEN RADIO CORPORATION

"Resistor Specialists"

Newark,

DAVEN RADIO

New Jersey

All apparatus advertised in this magazine has been tested and approved by POPULAR RADIO LABORATORY

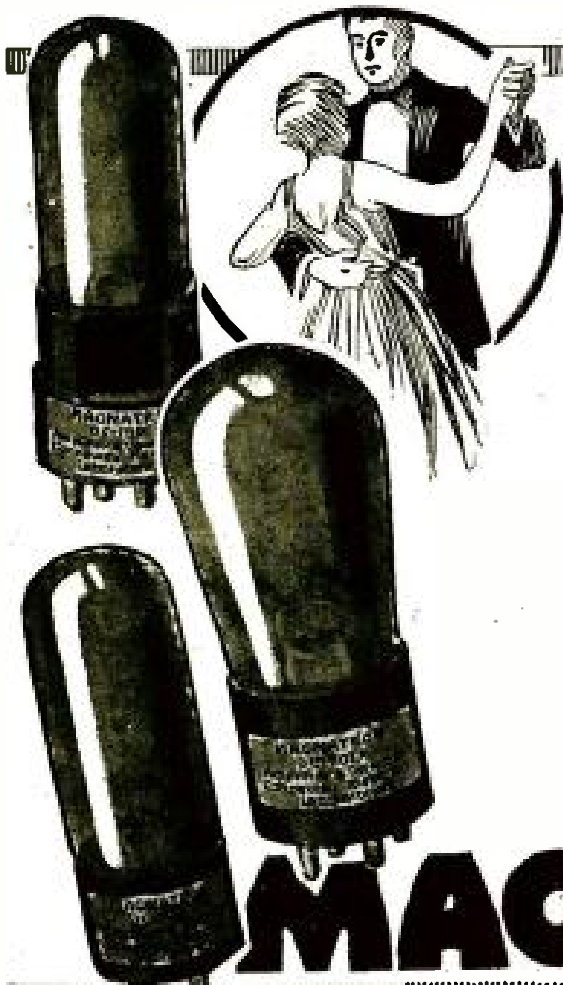

pep up your set with good tubes

"I DIDN'T think that tubes made such a difference—until I changed to MAGNATRONS." That's what one enthusiastic MAGNATRON user wrote us.

You, too, will be pleasantly surprised by the way that MAGNATRONS "pep" up a set and give it a new lease on life.

The many improvements which have been made in MAGNATRONS have placed them in the very front front rank of vacuum tubes.

MAGNATRON DC-199, 201A, and DC-199 with large base sell for only \$3 each at your dealers.

CONNEWAY ELECTRIC LABS.
309 Fifth Ave., New York.
Factories: Hoboken, N. J.

MAGNATRONS

8-TUBE COCKADAY SUPER \$95.00

This set is built exactly as described in the January issue of POPULAR RADIO, of specified parts, completely assembled and wired. It is mounted in a beautiful solid walnut cabinet.

If you prefer, this set may be mounted in a magnificent walnut finished console. The price is \$155.00.

For those who prefer to wire the set themselves a kit of parts is offered at \$78.00. This includes all parts for the set except the cabinet. A solid walnut cabinet may be had for \$13.00 if ordered with the kit.

Accessories Used With the Super

- Western Electric 540AW Speaker..... \$35.00
- Atlas Model 101 Speaker..... 25.00
- 8 Radiotrons, tested and matched for your super..... 24.00
- Korach Tapped Loop Antenna..... 16.50
- Philco A Battery, 90 A. H..... 18.00
- 3 Large size Eveready B Batteries.... 14.25

Write Now for Immediate Service

OSTERMEIER RADIO & ELECTRIC CO.

1720 SO. DOUGLAS AVE.
SPRINGFIELD, ILL.

We will build any set described in POPULAR RADIO.

GET YOUR SET OF SIMPLIFIED BLUE PRINTS FREE

You know how helpful, interesting and practical POPULAR RADIO is. You fully appreciate that at \$3.00 a year it is a real bargain. Consequently you should find it easy to convince one, two or more of your friends, who are not now subscribers, of the unusual value when any one of these seven sets of Simplified Blueprints (described on page 70) is offered free with their twelve months' subscription for POPULAR RADIO at the regular price of \$3.00.

In addition to the Blueprints given to your friends we will allow you one set free for each new subscription you send us with a \$3.00 remittance. Five new subscriptions and remittance of \$15.00 would entitle you to five sets free.

Only one set of Blueprints free with a renewal subscription whether your own or a friend's.

POPULAR RADIO, INC., Dept. 53,
627 West 43d Street, New York City

Enclosed is my remittance of \$ covering annual subscriptions for POPULAR RADIO (names on sheet attached). Send me set(s) checked below.

- Set No. 2
- Set No. 3
- Set No. 4
- Set No. 6
- Set No. 7
- Set No. 8
- Set No. 9

(See page 70 for description of Sets)

Name.....

Address.....

Foreign postage 50c. extra. No extra for Canada.

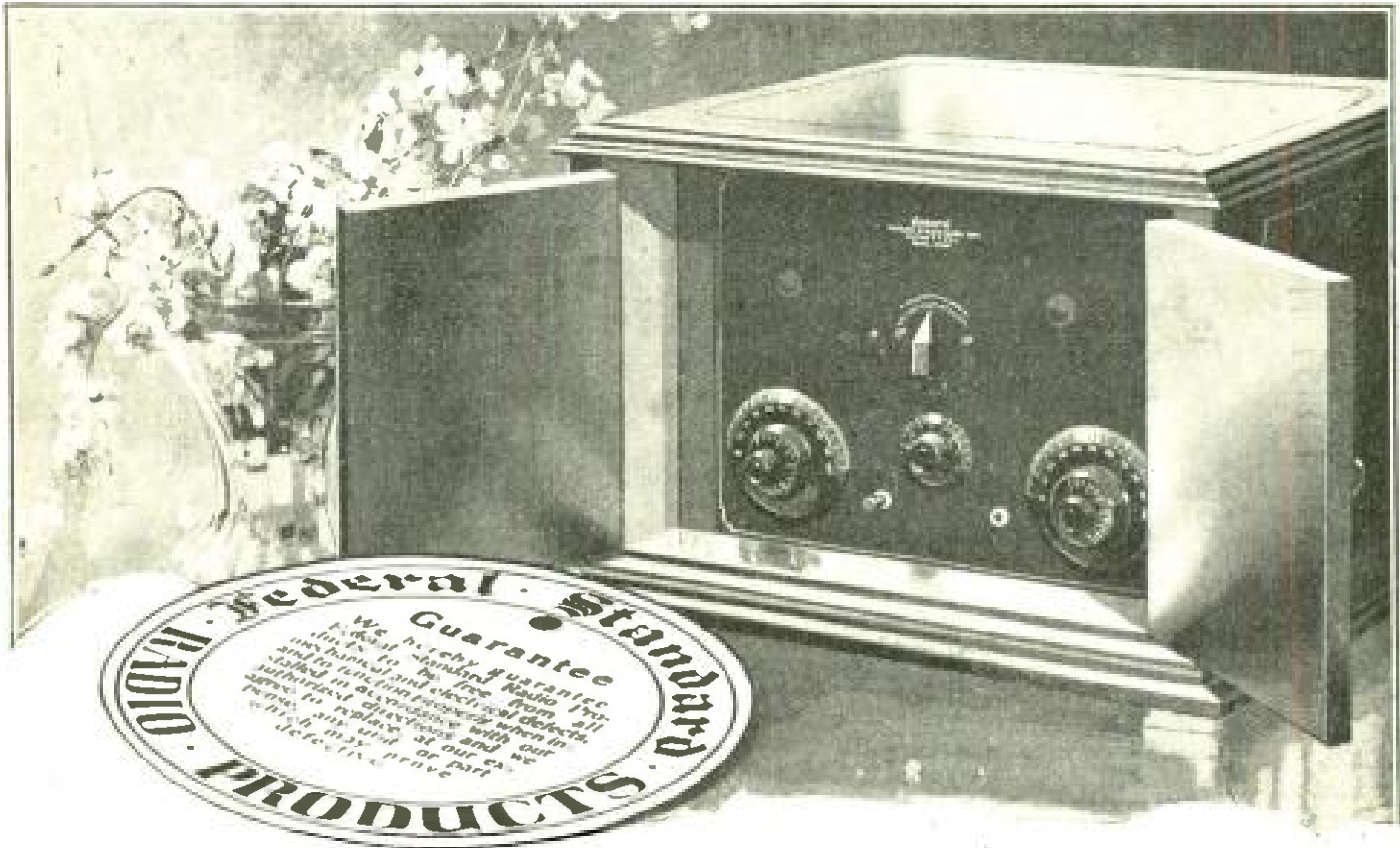

Cash in – Crash in!

This is a profit making invitation!

FFEDERAL has determined to lead in radio just as it *has* led in the electrical field for over a quarter century.

This means money profit for every radio jobber and dealer who ride in on the wave of buying that Federal is creating. Don't hesitate. Federal has the money, ability, and experience to set its own place in the market—and it *has* set positive *leadership* as its rightful place. The Federal franchise will become increasingly valuable and more exclusive as Federal

presses toward its goal. Get in now if you want to lead with Federal.

Write Federal for further information. Learn all about the *new* Federal equipment.

Learn what stands behind the *new* Federal guarantee. Learn how the *new* Federal overcomes service expense. Learn the exceptional advantages offered by the *new* Federal enclosed amplifying unit—and ball-bearing suspension. Learn what sales these points give you in your demonstrations. Learn what the *new* Federal gives in distance range, in selectivity and *absolute* tonal purity. Write us today for all facts—if you want radio *leadership* in your community.



FEDERAL TELEPHONE MFG. CORP.
BUFFALO, N. Y.

Federal

Standard **RADIO** Products

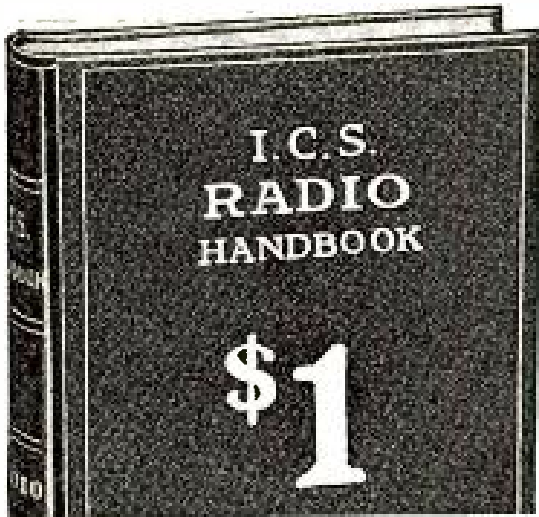

Do you understand Super-Regeneration?

This unique book shows the way to work out practical circuits
514 PAGES—100,000 SOLD—ONLY \$1

Compiled by HARRY F. DART, E.E.
Formerly with the Western Electric Co.,
and U. S. Army Instructor of Radio
Technically edited by F. H. DOANE

SUPER-REGENERATION! Do you know that big money will be made by the first one to design a practical Super-Regenerative set? This marvelous circuit can be made to do with two tubes as much as a six or eight tube super-heterodyne. But it's not yet commercialized. It's where the super-heterodyne was until recently. Why don't you find out how to make Super-Regeneration formulas? See pages 377 to 383, I. C. S. Radio Handbook, for details of the circuit and how to attack its problems.

This I. C. S. Radio Handbook explains electricity, electrical terms and formulas, antennas, batteries, motors and generators, vacuum tubes, transmitting and receiving principles and practice, radio and audio frequency amplification, condensers, battery chargers, filters, codes, license rules. Many other features.

Just mail the coupon with a dollar bill and your name and address, and we will send you this 514-page I. C. S. Radio Handbook by return mail. Note the other good books listed below and the low prices.

INTERNATIONAL CORRESPONDENCE SCHOOLS
Box 8253-E. Scranton, Penna.

I enclose \$..... for which send me, post-paid, the Handbooks marked X, at \$1 each.

RADIO HANDBOOK, 514 PAGES, \$1

- Automobile Handbook, 354 pages..... \$1
- Electrical Handbook, 414 pages..... \$1
- Chemistry Handbook, 348 pages..... \$1
- Pharmacy Handbook, 324 pages..... \$1
- Traffic Man's Handbook, 386 pages..... \$1
- Building Trades Handbook, 409 pages..... \$1
- Machine Shop Handbook, 335 pages..... \$1
- Salesman's Handbook, 352 pages..... \$1
- Advertising Handbook, 445 pages..... \$1
- Bookkeeper's Handbook, 302 pages..... \$1
- Civil Engineer's Handbook, 411 pages..... \$1
- Steam Engineer's Handbook, 298 pages..... \$1

Name.....

Address.....

Enclose \$1.50 for each book if you want the Leatheroid binding. All of the above books can be had in this binding except two—Traffic and Building Trades.

ARROW BATTERY SLASHES Prices TO CONSUMERS

Prices Smashed!
Quality Not Sacrificed

ONLY

Here is real battery quality, guaranteed to you, at prices that will astound the entire battery-buying public. Order direct from factory. Put the Dealer's Profit in your own pocket. You actually save much more than half, and so that you can be convinced of true quality and performance, we give a **Written Two-Year Guarantee**

Here is your protection! No need to take a chance. Our battery is right—and the price is the lowest ever made. Convince yourself. Read the prices!
Special 2-Volt Radio Storage Battery, \$3.75
Special 4-Volt Radio Storage Battery, 6.00
6-Volt, 60 Amp. Radio Storage Battery, 7.00
6-Volt, 80 Amp. Radio Storage Battery, 8.00
6-Volt, 100 Amp. Radio Storage Battery, 9.50
6-Volt, 120 Amp. Radio Storage Battery, 11.50
6-Volt, 140 Amp. Radio Storage Battery, 13.00

We ask for no deposit. Simply send name and address and style wanted. Battery will be shipped the day we receive your order Express C. O. D., subject to your examination on arrival. Our guarantee accompanies each battery. We allow 6% discount for cash in full with order. You cannot lose! Act quick. Send your order today—NOW.

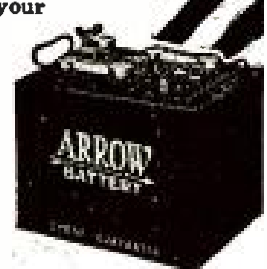

Arrow Battery Co.
1215 South Wabash Ave.
Dept. 7 Chicago, Ill.

This NEW Super Horn Brings Magic Clearness to Radio

The new Kellogg *Symphony* Reproducer is a new-type horn recently developed by our experts—based on the magnetic diaphragm principle.

It brings to radio a marvelous tone quality, a beauty you have never heard before. Attaches to any set and can be adjusted for the particular "volume" requirements of the set.

At all radio dealers. Ask for it by name. See it, hear it—compare!

KELLOGG SWITCHBOARD & SUPPLY CO.
Chicago, Illinois

Kellogg Symphony Reproducer Price \$20

With Every Kellogg Radio Part, Use—is the Test

FREAS Battery Testers

Now's the time your batteries need watching

BECAUSE you use your radio less now than in December is exactly the reason your batteries are likely to suffer from neglect. Test them frequently, at regular intervals — you'll need them often this summer.

The Freas Hydrometer is absolutely dependable in its readings. A finely gauged precision instrument, yet sturdily built for long service. Made from model test and approved by the U. S. Bureau of Standards.



FREE BOOKLET Major J. S. Hatcher tells you how to insure best reception results from your batteries. Postal brings his booklet to you.

JOBBER:
Write for our attractive proposition.

FRANCIS L. FREAS GLASS WORKS
America's Largest Hydrometer Manufacturers
CONSHOHOCKEN • PENNSYLVANIA

75c

THE McLAUGHLIN ONE-CONTROL SUPERHETERODYNE

As illustrated and described in the feature article on single-control receivers in the April issue of POPULAR RADIO.

Uses only one 45-volts
"B" battery

Wonderful tone quality

Amazingly selective

Coast to Coast Reception

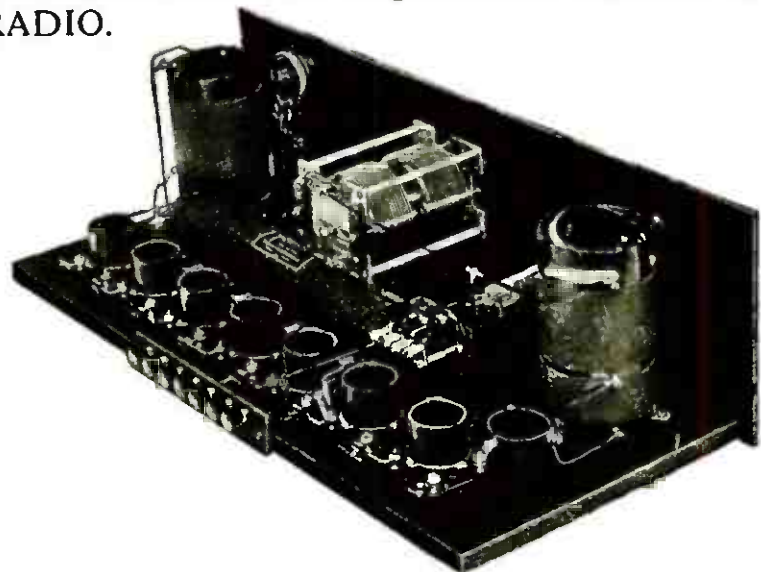

Showing the parts and their arrangement which make this set the outstanding development in radio receivers

All "Official" McLaughlin parts are contained in the complete U-NI-DIAL Kit

For full information write direct to

U-NI-DIAL Radio Company, 35 Greenwood Avenue, East Orange, N. J.

The New Haynes De Luxe Super-Heterodynes

The latest and most improved of all super-heterodynes! All the important improvements, all the latest advances in design are incorporated in Mr. Haynes' new sets.

Send for complete information and price lists. No charge or obligation of any kind. It will be sent at once. Use the handy coupon below.

MODEL A

Uses 9 storage battery tubes. A special type of tuned radio frequency amplification, used ahead of the straight super-heterodyne, gives a new and remarkable degree of sensitivity and selectivity. Distance range limited only by location and atmospheric conditions.

Every day this splendid new set is bringing more and more praise from hundreds of satisfied owners.

BLUEPRINTS OF BOTH MODELS

Ready now! Complete working blueprints showing construction in detail. Everything made so plain and easy-to-understand that you can't possibly go wrong. Included in each set is: Instrument layout; picture wiring diagram; panel drilling; schematic wiring diagram and battery connections.

Price, complete set for either model, \$1.25

MODEL B

Uses 6 dry cell and 3 storage battery tubes with marked reduction in A and B battery consumption. Special tuned radiofrequency amplification gives extreme sensitivity with the highest degree of selectivity.

Many other new and important features.

HAYNES-GRIFFIN RADIO SERVICE, Inc.

Mail Order Department
250 W. 49th Street, New York City

HAYNES-GRIFFIN RADIO SERVICE, Inc.
250 W. 49th Street, New York, N. Y.

Please send me complete information and prices on the new Haynes De Luxe Super-Heterodyne—

MODEL A MODEL B

Name.....

Address.....



SIMPLEX SR 5 \$57

If they're on the air Simplex will get them. Five tube, tuned radio frequency, non-oscillating. Every piece of apparatus of guaranteed Simplex Standard. Low loss. Genuine mahogany, hand-rubbed cabinet.

Write for details

SIMPLEX RADIO CO.

Manufacturers

1015 Ridge Ave. Philadelphia

STORAD

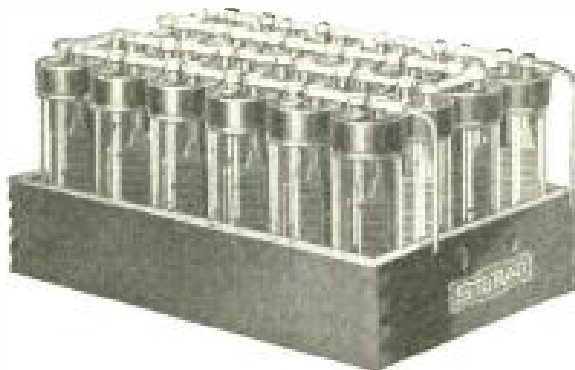

Batteries With a Reputation

STORAD Batteries have a reputation for giving reliable service under severe requirements of modern receiving sets. When you buy STORADS you may be sure that you have solved your "B" circuit power problem once and for all.

Made in Two Sizes

No. 4524—4½ amp. hr.—24 volts

No. 4548—4½ amp. hr.—48 volts

Literature sent on request or ask your Dealer.

Distributor's Territory still available.
Write for information.

The Cleveland Engineering Laboratories Co.
2118 Superior Viaduct, N. W., Cleveland, Ohio.

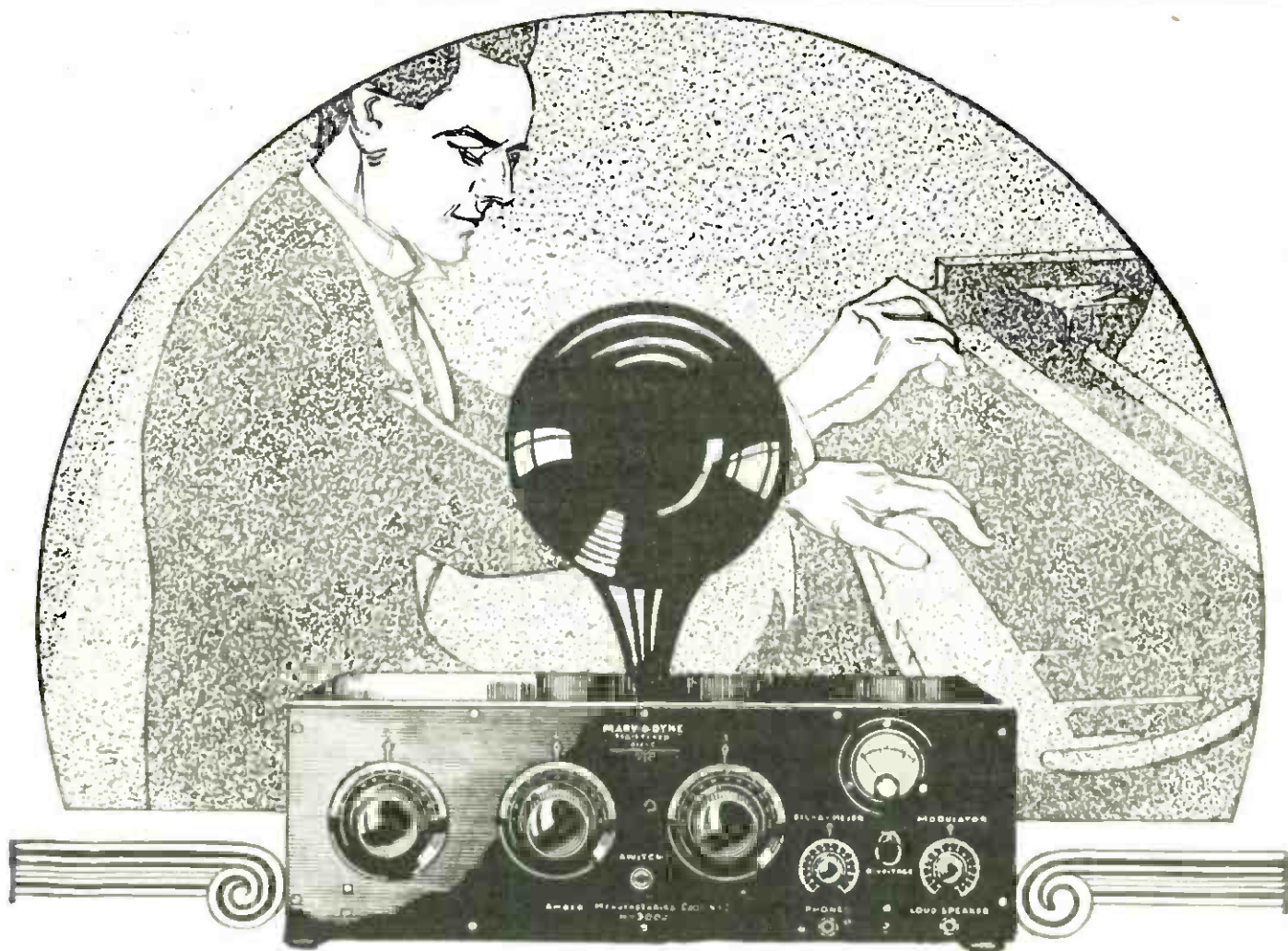

YOU buy a radio receiving set primarily for the entertainment it will bring to you, for the tone quality that will make the artists fairly step out of the loudspeaker. On that point the Improved MARV-O-DYNE, model 612-C, will fulfill your fondest expectations.

And when you purchase an Improved MARV-O-DYNE you have the additional satisfaction of knowing that your set incorporates more really useful improvements than any other of its type. There's the Fil-a-meter, for instance, an exclusive device which keeps the tubes always at their best operating point. The genu-

ine Weston meter which is a part of the Fil-a-meter can also be used for testing the B batteries by simply pushing a button.

The units entering into each MARV-O-DYNE are the best that money can buy. Take note of the Stromberg-Carlson transformers, the Haig and Haig Straitline condensers, the solid bakelite which is used throughout.

And yet this Improved MARV-O-DYNE costs only \$110! (West of the Rockies and in Canada, \$120.) If your dealer cannot show you this leader among sets, write us at once.

AMBER MANUFACTURING CORP., 115 West Broadway, New York

The Improved Amber
MARV O DYNE
The set with the  *Fil-a-meter!*

All apparatus advertised in this magazine has been tested and approved by POPULAR RADIO LABORATORY

LET COCKADAY HELP YOU BUILD A SET

WITH

SIMPLIFIED BLUEPRINTS



AURENCE M. COCKADAY has personally supervised the preparation of *Simplified Blueprints* of seven of POPULAR RADIO's most popular circuits. Each set consists of three separate *Actual Size* Blueprints; first a Panel Pattern; second, an Instrument Layout; and third, a Picture Wiring Diagram all simplified in the fullest sense of the word *because*

The Panel Pattern can be laid on the panel and all holes drilled as indicated. No scaling to do and so accurate there is no danger of ruining the panel through faulty calculation.

The Instrument Layout placed on the sub-base permits you to indicate by pinpricks the exact location of every screw.

The Picture Wiring Diagram gives every instrument in exact size and position with every wire clearly indicated from one contact to the other. With no knowledge of radio symbols you can assemble every part and complete your wiring with no chance of error.

Priced at \$1.10 per Set of Three Prints

Set No. 2—"Non-Regenerative Tuned Radio-Frequency Receiver" (Simplified Neutrodyne, four tubes, three dials, as described in the April 1924 issue of POPULAR RADIO).

Set No. 3—"Cockaday Distortionless Audio-Frequency Amplifier" (four tubes, combination of resistance-coupled and push-pull amplification, as described in the May 1924 issue of POPULAR RADIO).

Set No. 4—"Cockaday Four-Circuit Tuner with Resistance-Coupled Amplifier" (five tubes, distortionless, two dials, automatic vacuum tube control, as described in the October 1924 issue of POPULAR RADIO).

Set No. 6—"The Cockaday 8-tube Super-heterodyne Reflex Receiver" (eight tubes, two tuning dials,

loop, non-radiating, distortionless, as described in January 1925 issue of POPULAR RADIO).

Set No. 7—"The Craig 4-Tube Reflex Receiver with the New Sodian Detector" (four tubes, two tuning dials, short antenna, non-radiating as described in February 1925 issue of POPULAR RADIO).

Set No. 8—"The Improved Cockaday DX Regenerative Receiver" (four tubes, one tuning dial, one regeneration dial, short or long indoor or outdoor antenna, resistance coupled amplification as described in March 1925 issue of POPULAR RADIO.)

Set No. 9—"Portable Town and Country Receiver" (six tubes, three stages of transformer-coupled, radio-frequency amplification, loop antenna, tuned by variable condenser as described in May 1925 issue of POPULAR RADIO.)

Full constructional and parts details for these Receiving Sets will be found in the issue of POPULAR RADIO indicated. Back issues of POPULAR RADIO will be furnished at the rate of 35c a copy

Popular Radio

627 West 43d Street

Dept. 54

New York City

POPULAR RADIO, Inc., Dept. 54 627 West 43d St., New York City		Date.....
Enclosed is my remittance of \$..... for which kindly send me Blueprint Set (s) consisting of Panel Pattern, Instrument Layout and Wiring Diagram as checked below:		
<input type="checkbox"/> Set Number 2	<input type="checkbox"/> Set Number 6	
<input type="checkbox"/> Set Number 3	<input type="checkbox"/> Set Number 7	
<input type="checkbox"/> Set Number 4	<input type="checkbox"/> Set Number 8	
<input type="checkbox"/> Set No. 9		
Name		
Address		
City.....	State.....	

DEALERS

Write for terms on these fast selling Blueprints. An attractive Display Chart free with orders.

This Wonderful Loud Speaker at Direct Factory Price \$9⁸⁵



FULL SIZE

Bell — 12 $\frac{1}{4}$ inches.
Height — 19 $\frac{1}{2}$ inches.
Diaphragm — Finest made—no chattering.
All metal throughout.

If we sold you this horn through dealers, the price would be at least \$18. Of that the dealer gets 40 per cent. The jobber gets another 20 per cent. Our factory-direct-to-you method saves you all these middlemen's profits. Moreover you get a full-size horn whose beauty of tone and handsome finish will delight you. All metal construction; Florentine brown stipple finish. No wood, paper-mache or cheap substitute.

Guaranteed — Try it 5 Days Free

Try it 5 days. Then if for any reason you wish to return it, we'll refund you every cent of your money, without quibble or question.

5-Tube \$75 Receiver

This Dexter Radio Receiver has a range of 1500 to 3000 miles. Two stages radio frequency; detector; two stages audio amplification. Laboratory tested parts wired to Naval standards. Genuine mahogany cabinet. Every set individually tested. You can't buy its equal at retail below \$75. **TRY IT 5 DAYS FREE**—if you don't find it the clearest, full-toned receiver costing up to \$75 you've ever heard, return it. We'll refund your money.

\$48⁵⁰

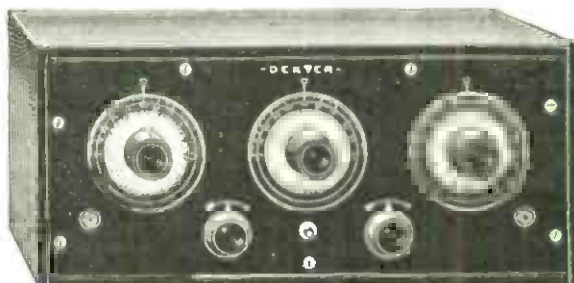

Special Offer—Dexter Receiver, Loud Speaker, Exide A Battery 80 amp; Two Ray-O-Vac 45 volt B Batteries: 5 tubes, tested and guaranteed perfect; 100 feet finest strand aerial wire; 50 feet heavy insulated lead-in and ground wire; Weston plug; two insulators; ground clamp; fixture wire —all complete **\$89.50**
Or—Dexter 5-Tube Receiver and Dexter Loud Speaker—special combination offer. **\$57.00**
Send no money—pay postman or expressman.

Deal With Responsible Manufacturers Direct

The Dexter Metal Mfg. Co. is 37 years old. Your banker can tell you about our financial standing. We've a long record for dealing honestly and fairly and every word printed here has our full responsibility behind it.

DEXTER METAL MANUFACTURING COMPANY

ESTABLISHED 1888

10-14 S. 18th Street, Philadelphia, Pa.

Address Radio Engineering Division J

An Ideal Home Battery Charger

Simple to use
Convenient
Fireproof

ULTRA

Charges All Storage Batteries "A" or "B" 2 to 48 volts

HANDY CHARGER

The Ultra Handy Charger is very simple to use. Just connect the sturdy clips to battery and plug the cord into a light socket—then turn on current. There are no complicated adjustments

No bulbs nor liquid.
No breakable glass.
No fast wearing parts.

No auxiliaries necessary.
No frequent adjustments.
No sticking contacts.

For all batteries, "A" and "B", both 24 and 48 volts. Charges quickly—5 to 7 amperes per hour to a 6-volt battery—"B" batteries at recommended rate.

There is no danger of fire even if allowed to run for several days.

The taper charge makes it impossible to over-charge the battery—as the charge in the battery increases the current in the charger decreases.

Save yourself the inconvenience of sending batteries out to be charged. Charge them at home when your radio set is not in use. Keeping batteries fully charged improves the reception and lengthens the life of the batteries.

Ask your dealer for a demonstration or write us for literature.

\$18.00

east of the Rockies

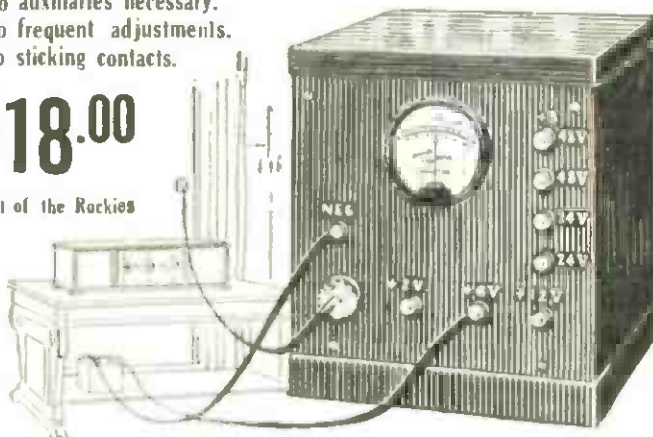

INTERSTATE ELECTRIC CO.

4339 Duncan Ave., St. Louis, Mo

FREE PARTS for COCKADAY RECEIVERS

NOW YOU CAN BUILD ONE OF THESE POPULAR RECEIVERS

READ THIS UNIQUE OFFER

If you want to build your own set, here is your opportunity to secure FREE all the parts you need for any one of these three popular POPULAR RADIO Receivers. Call on all your radio friends, and on anyone who has a set and tell them of the many special features of POPULAR RADIO.

These liberal offers will make it possible for you to secure an order from every one you call upon. For each subscription with remittance you send us you will receive credits as per the following scale:

POPULAR RADIO			
4 Months for	\$1.00 counts	16 credits	
6	1.50	25	..
8	2.00	33	..
12	3.00	50	..
24	5.00	75	..

CREDITS Needed for Parts Required for the Cockaday Improved DX Receiver

(Described and Illustrated in POPULAR RADIO for March, 1925)

Quantity	Item	Credits
1	Primary, Secondary and tickler coils of the New York Coil Co. (DX Coupler)	200
2	Kurz-Kasch 4-inch dials @ 40	80
1	Rathbun variable condenser .0005 mfd.	180
2	Dubilier mica fixed condensers Type No. 640, .00025 mfd. @ 18	36
1	Dubilier mica fixed condenser Type No. 640, .005 mfd.	28
2	Dubilier mica fixed condensers Type No. 640, .02 mfd. @ 80	160
1	General radio type 285 amplifying transformer	280
2	Bradleyohms No. 25 @ 80	160
1	Cico double-circuit jack	16
1	Cico single-circuit jack	15
1	Cico filament battery switch	26
1	Composition panel 7 by 24 inches	120
1	Amperite No. 1A automatic filament current adjuster	44
1	General instrument filament rheostat (6 ohms) equipped with knob and dial	90
1	General instrument filament rheostat (20 ohms) equipped with knob and dial	90
1	Fill-Ko-Leak	80
1	Benjamin Cle-ra-tone socket	40
3	Walbert sockets @ 20	60
2	Daven mountings No. 50 @ 14	28
1	Durham metallized filament grid-leak .5 meg.	20
1	Durham metallized filament grid-leak .25 meg.	20
Total		1,773

CREDITS Needed for Parts Required for the NEW Cockaday 4-Circuit Tuner with Resistance-Coupled Amplifier

(Described and Illustrated in POPULAR RADIO for October, 1924)

Quantity	Item	Credits
1	"Precision" Cockaday Coils	220
1	"Cardwell" variable condenser (.0005 mfd.)	200
1	"Cardwell" variable condenser (.00035 mfd.)	190
2	"Accuratune" micrometer control dials @ 140	280
1	"New York" mica fixed condenser (.00025 mfd.)	14
9	"New York" mica fixed condensers (.005 mfd.) @ 24	216
1	"Amplex" grid-denser	50
1	"Bradleyleak"	74
3	"Bradleyohms" No. 25	240
5	"Benjamin" Cle-ra-tone sockets for UV201A tubes	200
1	"Amsco Dubl-Wundr" combination potentiometer-rheostat	80
1	"Amsco" switch lever	12
4	"Amperites" No. 1-A, with mountings	176
3	"Improved" double-circuit jacks	120
1	"Improved" single-circuit jack	28
1	"Improved" filament battery switch	40
1	"Precise" audio-frequency transformer No. 285-A	200
3	"Electrad" Certified grid leaks. 1/2 megohm @ 20	60
3	"Electrad" Certified grid leak mountings @ 14	42
7	Switch points @ 1	6
2	Stops @ 1	2
1	Composition panel 7' x 24' x 3/16"	120
1	"Rajah" snap terminals @ 8	64
Total		2,634

CREDITS Needed for Parts Required for the "Portable Town and Country Receiver"

(Described and Illustrated in POPULAR RADIO for May, 1925)

Quantity	Item	Credits
1	"Remler" square plate variable condenser Type No. 630, .00035 mfd. complete with dial and indicator	200
1	"Amsco" 20-ohm rheostat equipped with knob	50
1	"Amsco" 400-ohm potentiometer equipped with knob	60
2	Cutler-Hammer filament battery switches @ 24	48
1	"Hoyt" Bezel-Hole Mounting voltmeter, 0 to 6 volts	90
1	"Adams" jack, Type No. 502, 3-prong double circuit	28
1	"Adams" jack, Type No. 501, 2-prong, single circuit, open	24
1	"Dubilier" mica-fixed condenser, .00025 mfd., with clips for grid-leak	18
1	"Dubilier" mica-fixed condenser, .00025 mfd.	14
3	"Dubilier" Duratran radio-frequency transformers @ 160	480
1	"Daven" grid-leak, 4 megohms	20
6	"Benjamin" Cle-ra-tone sockets for UV-199 vacuum tubes @ 40	240
2	"Pacent" Audioformers, Type No. 26 audio-frequency transformers @ 200	400
1	Binding post sub-panel, 9 1/2" x 1"	10
9	Eby binding posts @ 6	54
1	Composition panel 18" x 7"	90
Total		1,826

Popular Radio Department 51, 627 West 43rd Street, New York City

All apparatus advertised in this magazine has been tested and approved by POPULAR RADIO LABORATORY

ATTENTION, SET MANUFACTURERS!!

Our special "Selector" Variable Condenser with self-balanced coils attached is the equipment you have been waiting for—at a price you can afford to pay.

To enable you to successfully manufacture a five-tube, popular-priced radio receiver consisting of two stages of tuned radio frequency, detector and two stages audio, combining selectivity, volume, true tone, distant reception and simplicity.

Our "Selector" Low Loss Grounded Rotor Variable Condenser, "The Manufacturer's Special," answers the demand for a ruggedly constructed efficiency instrument at an exceptionally low price.

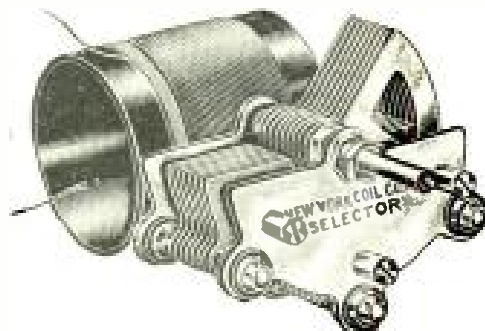

Condenser and Transformer as shown, List Price \$3.75
Get manufacturers price and descriptive literature

LIST PRICE: \$2.75 .0005 (23 plate) \$2.50 .00035 (17 plate)

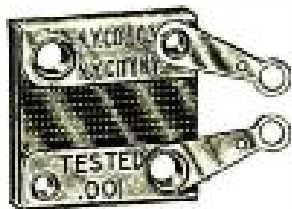

New York Precision Mica Fixed Condensers
Choice of Leading Manufacturers and Radio Engineers
All Capacities

PRICE: 35c to 75c

NEW YORK COIL COMPANY 338 PEARL STREET
New York City, N. Y.

PACIFIC COAST—Marshank Sales Co., 926 Insurance Exchange Building, Los Angeles Calif.,
also San Francisco, Portland.



ONLY
\$25

RHAMSTINE ★
"B"
RECTIFIER

Better than "B" Batteries

Dealers Note

This is the lowest priced, completely assembled source of "B" current on the market. Write for dealer proposition before some one else gets it.

Better "B" Current!

Forever rid yourself of "B" battery troubles—from the annoyance of weak signals due to run down batteries—from the snap and crackle sometimes thought to be "static" that results from chemical action in the cells—and enjoy better and smoother reception by using the Rhamstine* "B" RECTIFIER.

Two controls, one for the Detector and one for the Amplifiers makes it possible for you to feed just the right voltage to get best results. Operates on 110 volts A.C. 60 cycles.

The Rhamstine* "B" RECTIFIER plugs into your electric light circuit and delivers a dependable, steady, economical power that makes broadcast receiving a genuine pleasure. It is easy to operate, works equally well with all types of sets, cannot possibly burn out tubes, has no hum, no acid, and will last indefinitely.

SEND NO MONEY

Mail the coupon today, pay on delivery and try the Rhamstine* "B" RECTIFIER on your own set and under any and all conditions. If it doesn't do everything claimed for it—if you are not entirely satisfied in every respect, return it and Rhamstine* will refund your money. This is the same hard and fast guarantee that thousands of Rhamstine* Needle-phones have been sold under. It is your protection and assurance of satisfaction. Mail the coupon right now!

J. THOS. RHAMSTINE ★

MAIL THIS COUPON TODAY

J. Thos. Rhamstine*,
Woodbridge-at-Bcaubien, Detroit, Mich. (5)
Send me your "B" RECTIFIER by express C. O. D. subject to inspection, at \$25. It is distinctly understood that if I am not entirely satisfied, I will return it within 5 days and receive a refund of the purchase price.

Name.....

Address.....

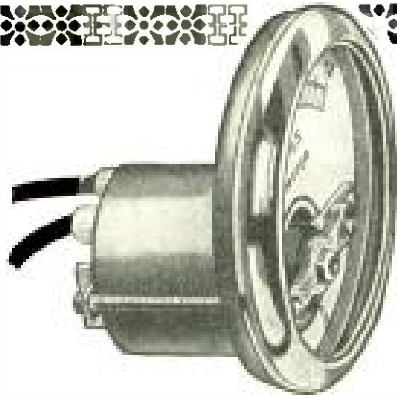

Hoyt Peep-hole meters
0 to 6 Volts

Hoyt meters are recommended by leading radio engineers

The Hoyt Voltmeter is designed to fit any Radio panel peep-hole. The barrel where it fits into the hole is 25/32" in diameter and the all-over diameter is 1 1/2". To control the filament voltage on your tubes, you need a voltmeter. For reading the amount of current drawn, an ammeter is used.

Hoyt Peep-Hole Meters

are built in all usual ranges. Most sets of modern designs—reflex, regenerative, heterodyne, neutrodyne—

NEED A VOLTMETER.—READING
0 to 6 Volts.

A variable grid leak that "stays put" \$1⁰⁰

Volt-X is a ballbearing, screw adjusting grid leak with an expansion contact and resistance unit that cannot wear out.

Volt-X Grid Leaks are positive and smooth in action. Fit into any standard leak mounting and get the best results from your tubes.

At your dealer's or write direct.

Range from one-half to fifteen megohms. For the balance of Super-Het and other circuits. 30,000-150,000 ohms. \$1³⁰ With Grid Leak Mounting



BURTON & ROGERS MFG. CO.
26 Brighton Ave. Boston, Mass.

DO YOU LIKE TO EXPLORE THE AIR?

DO YOU KNOW

- the wave lengths of the principal stations?
- where they are located on the map?
- who owns them?
- by what time they broadcast?

You will get much more enjoyment out of your radio receiver if you know the answers to these and other pertinent questions.

To receive the full benefit of your set you should have a complete log of the principal broadcasting stations and a convenient place to note your dial readings when you "pick-up" any of them.

A Complete Atlas and Station Log

The "POPULAR RADIO International Radio Atlas and Log" will supply you with the answers to all of the above and many other broadcasting questions.

This most useful and practical Atlas, consists of 16 pages, size 12" x 15" printed on good paper, from clear type in two colors and contains a complete series of double page maps, including—The World—The United States—Canada—North and South America, showing location of principal broadcasting, leading commercial and governmental radio stations. In addition these maps show time zones and Radio Districts with Headquarters and also the district zoning of the American Radio Relay League.

There is also included in this Atlas a list of all United States and Canadian stations, alphabetically arranged, giving signals, wave lengths, kilocycles, ownership and other important data, with space for logging three dial readings.

The Leading Radio Monthly

In POPULAR RADIO each month you will find the very latest news of the radio field with many entertaining, inter-

POPULAR RADIO
627 West 43d Street New York City

esting and instructive articles of interest to Radio Fans. With POPULAR RADIO and the "POPULAR RADIO International Radio Atlas and Log" you will have available the two most useful adjuncts to full enjoyment of your radio receiver.

SPECIAL FREE OFFER

You may have a copy of the "POPULAR RADIO International Radio Atlas and Log" free, with POPULAR RADIO for (8) eight months

For Only \$2.00

Pin \$2.00 in bills to the coupon below.

If you are a subscriber, your subscription will be extended eight months.

Date.....

POPULAR RADIO, Dept. 52,
627 West 43d St., New York City.

Enclosed is my remittance of \$2.00 for which you are to enter my subscription (extend my subscription) for (8) eight months for POPULAR RADIO and send FREE a copy of the "POPULAR RADIO International Radio Atlas and Log."

Name.....

Address.....

City..... State.....

Hommel Refers all Inquiries for Radio Apparatus to his Local Dealers

We advertise nationally and locally and get many consumers' inquiries. These are turned over to our dealers. We have many letters from dealers thanking us for the sales that resulted.

Our central location, prominence, extremely attractive display room and show window bring consumers into our store. These, too, we refer to our dealers.



Hommel never Retailers !

He wholesales only—he will not compete with his dealers. This means he gives his dealers material even when it is scarce because he will not sell it over a retail counter. He is noted for prompt shipments, gives liberal discounts and plays fair at all times. **BUY FROM HOMMEL AND GET THE INQUIRIES.**

Send for Hommel's Encyclopedia of Radio Apparatus 266-P.

WHOLESALE

EXCLUSIVELY

LUDWIG HOMMEL & CO

929 PENN AVENUE



PITTSBURGH, PA.

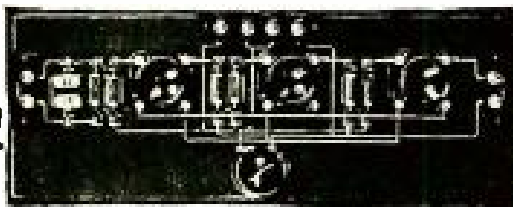

NEW!

Resistance-Coupled Amplifier Kit for only - - - **\$5.00**

3 stage Resistance-Coupled Amplifier as constructed with Electrad Kit No. 1. Price - **\$5.00**

Write for free diagrams and instructions

ELECTRAD, Inc.

428 Broadway

New York City



Solid Rubber Case

You Save 50%

World 6-Volt Storage Batteries are famous for their guaranteed quality and service. Backed by years of successful manufacture and thousands of satisfied users. You save 50% and get a

2-Year Guarantee Bond in Writing
World Battery owners "tell their friends." That's our best proof of performance. Send your order in today.

RADIO BATTERIES
6-Volt, 100-Amperes \$12.25
6-Volt, 120-Amperes 14.25
6-Volt, 140-Amperes 15.00

AUTO BATTERIES
6-Volt, 11-Plate \$12.25
6-Volt, 13-Plate 14.25
12-Volt, 7-Plate 17.00

SEND NO MONEY
Just state battery wanted and we will ship day order is received, by Express C. O. D., subject to your examination on arrival.
Extra Offer: 5% discount for cash in full with order. Buy now and get a guaranteed battery at 50% saving to you.

Approved and Listed as Standard by Leading Authorities

including Radio News Laboratories, Popular Science Institute of Standards, Popular Radio Laboratories, Radio Broadcast Laboratories and Lefax, Inc.

Solid Rubber Container

New Standard equipment on all World Storage Batteries. No more leakage or breakage of jars or rotting of box.

WORLD BATTERY COMPANY
1219 S. Wabash Ave., Dept. 3 Chicago, Ill.



PRECISE INSTRUMENTS

GIVE BEST RESULTS—THEY HAVE NO EQUAL



Laboratory
Instruments
at Commercial
Prices

Precise Super-Multiformer No. 1700

The one great advancement that has been made in Superheterodyne design since the original conception of the circuit. 1 instrument that does the work of 4—replacing all long-wave transformers. Like all other PRECISE instruments, this Super-Multiformer is made in strict accordance with the specifications of our Research Engineer, J. L. McLaughlin. This, plus PRECISE standards of skill and workmanship is your guarantee of best results. \$20.00.

Precise Audio Transformer No. 285

In performance this is the most amazing transformer on the market today. The first choice of radio experts everywhere. There is no other like it for volume and perfect reproduction. \$5.00.



Precise Manufacturing Corporation, Rochester, New York

BRANCHES • 53 W. Jackson Blvd., Chicago and 821 Market St., San Francisco
Eastern Sales Office—Precise Mfg. Corp., 3-5 Waverly Place, New York City
Southern Representative—Saal Products Sales, Inc., 35 Warren Street, New York City
CANADIAN DISTRIBUTORS • Perkins Electric, Ltd., • Toronto • Montreal • Winnipeg

ASK COCKADAY—HE KNOWS

WHY BOTHER WITH MISINFORMATION
WHEN YOU CAN GET THE ADVICE OF AN EXPERT?

POPULAR RADIO maintains for the benefit of its readers a Technical Service Bureau and Laboratory, under the personal supervision of Laurence M. Cockaday which will, without charge, answer by personal letter any question, problem or request for information submitted by a subscriber. This service is, however, also available to readers, other than subscribers, at the very nominal rate of 50 cents the inquiry.

In writing please confine your questions to one general

subject, writing on one side of the paper only, and enclose a self-addressed and stamped envelope.

It is possible that your individual problem has been covered in an issue of POPULAR RADIO, and so as an aid to you we endeavor to keep a supply of back numbers in stock. The condensed index below gives a few of the subjects that have appeared recently, look this list over and if the information you want is covered, we will be pleased to supply back numbers at 35c. a copy.

August, 1924

- How to build a single dry-cell tube, four-circuit tuner.
- How to build a two tube reflex receiver.
- Helpful hints for the broadcast listener

September, 1924

- How to build a single dry-cell tube reflex receiver.
- How to build a multi-wave tuner.
- How to improve broadcast reception.

October, 1924

- How to Build the (Cockaday) Four Circuit Tuner with a Resistance-coupled Amplifier.
- How to Select a Ready-made Receiver.
- How to Build a Detector-amplifier.
- A Radio Set to Pack in Your Suitcase.
- Harnessing the Radio and the Movie.

November, 1924

- How to Locate Interference from Power Lines.
- Cockaday Article for Beginners.
- How to Build a Low-loss Tuner for Short-wave Reception.
- The New Type of Superheterodyne.

December, 1924

- How to Build a Non-radiating 7-tube Superheterodyne Receiver.
- Cockaday Article for Beginners.
- How to Get the Most Out of Your Ready-made Receiver.

January, 1925

- How to Build the Cockaday 8-tube Super heterodyne Reflex Receiver.
- How to Improve Broadcast Reception.
- Cockaday Article for Beginners.

February, 1925

- How to Get on a Radio Program.
- A Loudspeaker for a Crystal Set.
- How to Build a 4-tube Reflex Receiver with the New Sodiion Detector.
- Cockaday Article for Beginners.

March, 1925

- How to Build the Improved DX Regenerative Receiver.
- Factors that Govern the Capacity of Condensers.
- What "Induction" Means to Your Set.
- A Five Meter Vacuum-tube Transmitter and Receiver.

April, 1925

- Single Control Receivers.
- How to Improve Broadcast Reception, VI: Increasing the Selecting Power of Your Receiver.
- How to get the Most out of Your Ready-made Receiver.
- Quartz Crystal as a New Wavelength Standard.

POPULAR RADIO

Dept. 58

627 West 43rd St., New York City

All apparatus advertised in this magazine has been tested and approved by POPULAR RADIO LABORATORY

The New

McCULLOUGH

AC

Radio Tube



The first
radio tube to
eliminate the
"A" Battery

JOBBER!

We are ready to place a
limited number of job-
bers franchises. Inves-
tigate Now!

Transformer Type L Suitable for McCullough Tubes

RADIO FOUNDATION INC.

25 WEST BROADWAY

NEW YORK CITY

Exclusive Selling Agents for

McCULLOUGH SALES CO.

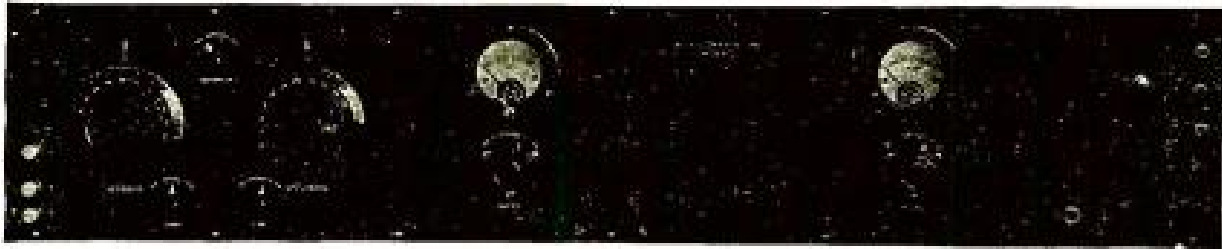

**The Famous E. I. S. Model
with 3,000-Mile Range**

Super-Heterodyne C-7

For any Circuit

Prompt shipment can be made on tested, standard apparatus of the following manufacture:

- E. I. S., Inc.**
General Radio
Ultradyn **Willard**
Sangamo Electric
Benjamin Electric
Allen Cardwell
Dubilier **Formica**
Western **Magnavox**
Jewell **Amer Tran**
Western Electric
Radio Corporation
Music Master **Acme**
Cutler Hammer **Frost**
Federal **Kellogg**

Few broadcast receivers yet devised can surpass the C-7 in range, in audibility, or in selectivity. Telephone range of 3,000 miles. Seven tubes give 10-tube results. Signals too weak for most receivers are regenerated and heterodyned through the radio frequency amplifier until heard clearly.

All material we furnish is endorsed and recommended by the Experimenters' Information Service, designers of this remarkable receiver.

Our Price List Saves You Money

FREE INFORMATION—Write for descriptive matter and price list. Our service is as near as your mail box.

FULL STOCK ON HAND—Immediate shipment can be made on laboratory tested apparatus.

NORDEN, HAUCK, INC.
Engineers

Office and Laboratories: 1617 Chestnut St., Philadelphia

For Quality **CORBETT'S CABINETS** For Quality

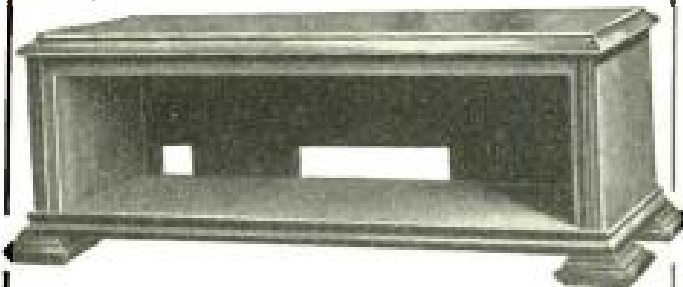

**COCKADAY FOUR CIRCUIT
COCKADAY SUPER-HETERODYNE**

*Built to Specifications in Popular Radio
(Rear slots not included in other cabinets.)*

Size	Mahog. any finish	Walnut or Mahogany	Size	Mahog. any finish	Walnut or Mahogany	Size	Mahog. any finish	Walnut or Mahogany
7x12-8	\$4.30	\$5.25	7x26-8	\$6.35	\$7.80	7x27-9	\$7.00	\$8.70
7x14-8	4.50	5.50	7x28-8	6.90	8.50	7x18-10	6.10	7.45
7x16-8	5.00	6.20	7x30-8	7.50	9.20	7x21-10	6.60	8.00
7x21-8	5.50	6.75	7x36-8	8.60	10.60	7x24-10	7.00	8.60
7x24-8	6.00	7.25	7x40-8	9.60	11.85	7x30-10	9.00	10.80

COCKADAY CABINET for either set..... 7.50 9.20

Charges Paid to Mississippi River

Nicely moulded top and base with shaped supports, nickel ball tip stop hinges. Carefully hand rubbed piano finish in Deep rich Adam Brown Mahogany. Accurately made of best kiln dried lumber and well packed.

For full length piano hinge and lid stay instead of nickel stop hinges add 4c per panel inch. Mounting boards 35c, above 24" panel 50c.

WRITE FOR BOOKLET offering best values in radio furniture and our special wood panels to match cabinets. Set Manufacturers inquiries solicited for special cabinets and panels.

TERMS: CASH WITH ORDER or C. O. D.

CORBETT CABINET MFG. COMPANY
St. Marys, Penna.

Prominent Set Builders

Now **DURHAM** Use

Grid Leaks

- Crosley, Ltd.
 DeForest, Ltd.
 Eagle Neutrodyne
 Eismann
 Howard
 Thompson
 Zenith



Qualities that won the above contracts will produce better results for you. Before using your set again—slip in a DURHAM.

50c Metallized Fixed Leaks 18 sizes; under 1/4 meg., 75c; over 1/4 meg., 50c.] Used in above sets

At dealers or postpaid Glass Sealed Variable Leaks 3 sizes fit all sets; 75c each for 1/10, 5 and 10 megs. **75c**

DURHAM & CO., Inc.
1936 Market St., Philadelphia

Canadian Distributors:
Da Forest Radio Corp., Ltd., Toronto

Be A Master ^{OF} THE Air

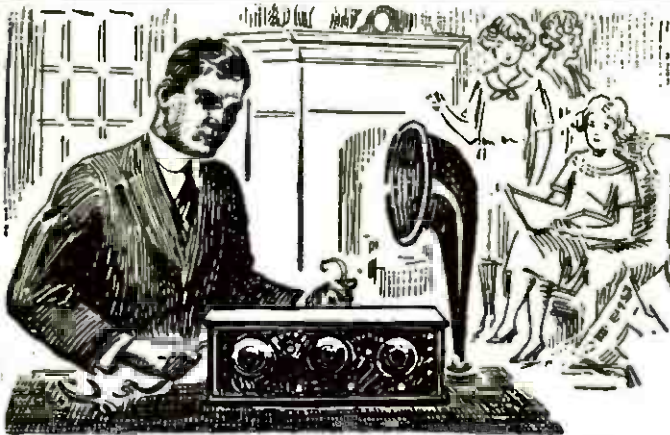

Pleasant Home Study

During the next few months you can, by devoting a few hours each week in pleasant home study, qualify yourself to get into the biggest paying field of all time. My practical, understandable course of instruction enables you to be a Master of the Air. Every problem in radio becomes an open book to you. *Be a Master of the Air and you will be a master of your future.*

\$3,000 to \$10,000
A Year as a Radio Expert

15,000 ships, hundreds and hundreds of Radio stations, with new ones springing up every day, are all keenly competing for the services of the radio-trained man. So enormous is the call for the radio expert that the man who knows his business in this field is in a position to *command* the size of his salary. On land or sea, in Government or private service, there are boundless fine paying opportunities for the man who understands radio problems and how to solve them.

RADIO ^{where} Knowledge is Power

—And Power is Cash

I show you how to construct, install, operate, repair and sell radio equipment. Instead of being a spectator in this big game with big stakes, you become an active player. I qualify you to handle every branch of radio. There is nothing theoretical or practical that is not presented to you in complete, concise form. You are standing face to face with the greatest money-making chance ever presented to you. Will you turn your back on it or will you decide now, once for all, that you will get your share of the millions being divided among radio-trained men? Right in your own neighborhood you can make easy profits. Neighbors and friends will gladly give orders for sets and pay for advice on radio problems.



A. G. MOHAUPT, B. A., M. S.
Head of the Radio Association of America, Graduate Electrical Engineer, University of Wisconsin. Former Radio Instructor for U. S. Government. Author of "Practice and Theory of Modern Radio."
I give my personal attention to every student taking my course. Your individual problems and questions are answered by myself. I work with you at every stage of the course, guiding you, directing you to your goal to be a Radio Engineer in the big pay class. My course prepares you to successfully pass Gov't examination for Operator's License.

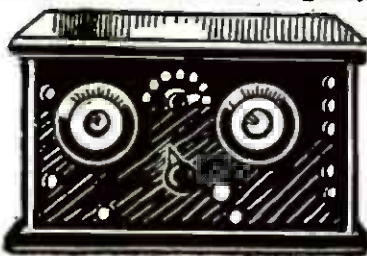

FREE 1000 Mile Radio Outfit

This set, when completed, has a range of over a thousand miles. I give it free with my course. I give you practical training by having you work on this set. The knowledge you gain is not mere book knowledge but is usable, practical experience. When you have finished my course, you can sell this set at a price that will more than pay the cost of the course.

QUICK PRACTICAL TRAINING

Everything in my course is clearly and simply stated so that you can easily understand every point I bring out. No previous experience or education is required. I give you fundamental and practical training in every angle of radio. There is no time to lose. Now is the best time to pass the other fellow by. Mail coupon today and get full information on my course, also details of the thousand mile set that I give free.

A. G. MOHAUPT, Radio Engineer
RADIO ASSOCIATION OF AMERICA
4513 Ravenswood Ave., Dept. 55, Chicago, Ill.

MAIL COUPON

A. G. MOHAUPT, Radio Engineer,
Radio Association of America,
4513 Ravenswood Ave., Dept. 55, Chicago

Please send me details of your Home Study Course—also your Free "Radio Facts" and information on how I can get a FREE 1,000 mile Radio Set.

Name

Address

City State

The Allen-Bradley Line of Perfect Radio Devices



BRADLEYDENSER



BRADLEYSTAT



BRADLEYLEAK



BRADLEYOHM



BRADLEYOMETER

BRADLEY-
NIER

BRADLEYSWITCH



A distinctive series of radio units
for set builders who seek superlative results

EVERY amateur yearns for perfection in his radio receiver. Better quality, greater volume, and closer selectivity are the requirements of discriminating radio enthusiasts, and the circuits which meet these requirements are inevitable favorites.

The experienced set builder has learned the value of fine radio parts, and he knows the important part they play in getting maximum results from a selective circuit. Hence, it is not strange that the Allen-Bradley line has gained increasing popularity with the introduction of the super-selective hook-ups. In fact, for stepless, noiseless, perfect control, Allen-Bradley Radio Devices have no peers. Your set will be a better set if you use them. Let us send you an illustrated folder about the Allen-Bradley line.

Allen-Bradley Co.

Electric Controlling Apparatus

276 Greenfield Ave., Milwaukee, Wis.

Manufacturers of graphite disc rheostats for over twenty years

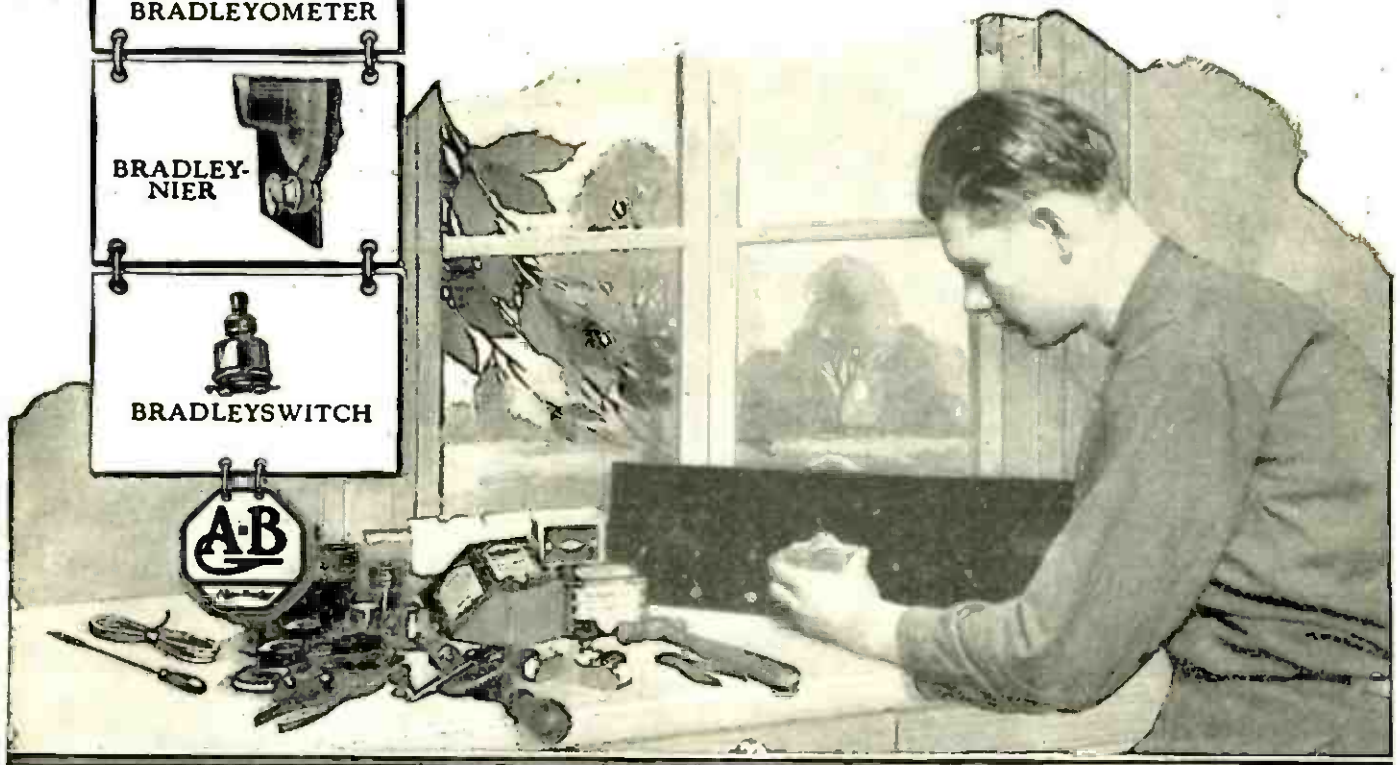

All apparatus advertised in this magazine has been tested and approved by POPULAR RADIO LABORATORY

THE NEW CROSLLEY 52-SPECIAL

\$35

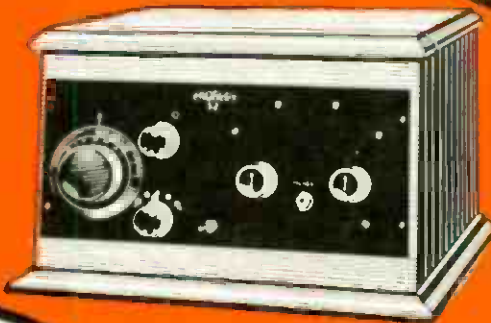

*Similar to
the well-known
Crosley 52 at \$30
in handsome large
cabinet with
Sloping Panel*

The tremendous demand for the Crosley three tube 52 has encouraged us to offer this circuit in a new, attractive cabinet with sloping panel, the Crosley 52 Special. This Cabinet is large enough to hold all dry cell batteries. It thus becomes self contained, a beautiful piece of furniture which can take its place in the living rooms of the most discriminating. The sloping panel makes operation easier and greatly adds to the appearance of the set.

Of course, the popular Crosley 52 will be continued. It has given uniformly satisfactory loud speaker service in all parts of the country. Continual coast to coast reception and even foreign stations on the loud speaker have been frequently reported. You can purchase a Crosley 52 or 52 Special from most any good dealer. All Crosley Radios are licensed under Armstrong Regenerative U. S. Patent 1,113,149. Write for Catalog.

Prices quoted without accessories. West of Rockies—add 10%

THE CROSLLEY RADIO CORPORATION

POWEL CROSLLEY, Jr., President

516 SASSAFRAS STREET,

CINCINNATI, OHIO

Crosley owns and operates Broadcasting Station WLW

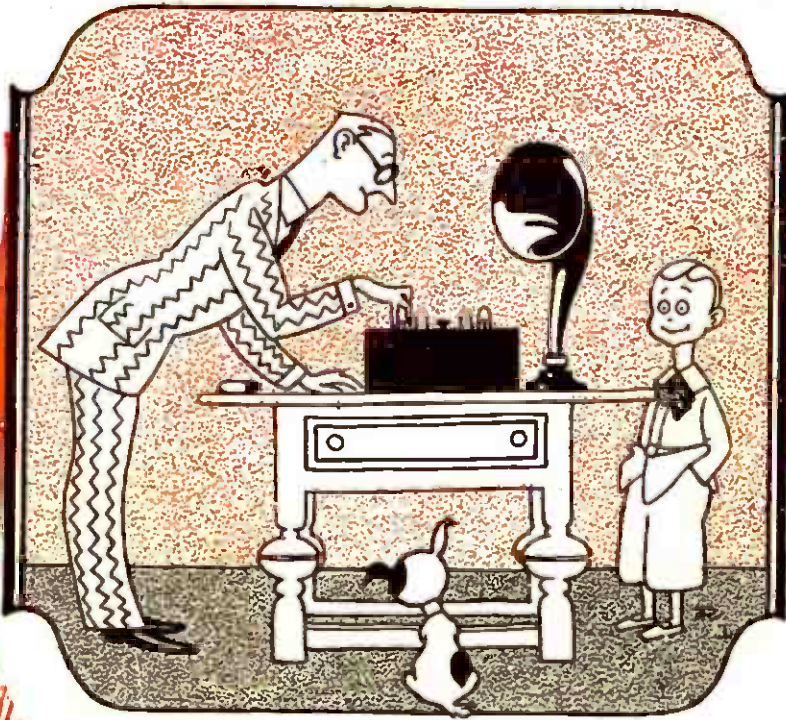

Put in the best!

To get the best out of a set—put the best into it. In some parts of the circuit, quality is more important than in others. It is most important in the tubes. They should be genuine RADIOTRONS.

The volume—the clearness—the quietness and the economy of operation—these depend on many things—but first of all upon the Radiotrons.

No matter what the job of the tube in the set, there's a Radiotron to fit it. You will always find it makes a difference if you demand a Radiotron—ask for it by name—and look on the tube for the word Radiotron and the RCA mark.

\$3 WD-11
WD-12
UV-199
UV-200
UV-201-a

Radiotrons with these model numbers are only genuine when they bear the name Radiotron and the RCA mark.

Radio Corporation of America

Sales Offices: Suite No. 45

233 Broadway, New York

10 So. La Salle St., Chicago, Ill.

28 Geary St., San Francisco, Cal.

Radiotron

REG. U.S. PAT. OFF.

PRODUCED ONLY BY RCA

