

\$2.00

Popular Radio

JULY 1923

20¢



In this Number
**How to Install
Your Radio
on Your Boat**

Get Long Range with RCA radio- frequency transformers



Model UV-1714
\$6.50



Model UV-1716
\$8.50

- To make a small inside loop reach as far as an outside antenna.
- To increase tremendously the range of an outdoor aerial without distortion.
- To amplify singly or in cascade; complete shielding prevents interaction of fields.
- To cover a broad band of wave lengths and pick up stations of every class.

*Particularly Adapted for Use
with RCA Radiotron Tubes*

Insist on RCA audio and
radio-frequency transformers
at your dealer



*This symbol of quality
is your protection*

Radio  **Corporation**
of America

Sales Dept. Suite 2067
233 Broadway
New York

District Sales Offices
10 So. LaSalle Street Chicago, Illinois
433 California Street San Francisco, California

Brandes



TWO OUT *and the* BASES FULL!

The count stands three and two and the next pitch tells the story—did he fan or walk, or did he sew up the game with a clean single?

Never a chance of being interrupted at an exciting moment by trouble in your headset. Never a chance of losing any part of the program which your set picks up—if you have a Brandes *Matched Tone* Headset.

Brandes tells the story clearly—every word of it. Brandes gets everything out of your set—and gets it all the time.

C. BRANDES, Inc., 237 Lafayette Street, N. Y.
Distributors in Australia and New Zealand: International Electric Co., Wellington, N. Z.
Made in Canada and England by Canadian Brandes Ltd., Toronto and London
Distributed in Canada by Perkins Electric Ltd., Toronto—MONTREAL—Winnipeg

Matched Tone

TRADE MARK REG. U.S. PAT. OFF.

Radio Headsets

POPULAR RADIO

EDITED by KENDALL BANNING



CONTENTS for JULY, 1923

(Cover design by Frank B. Masters)

VOLUME IV	NUMBER 1
What Radio Is Bringing to Humanity.....	Philip Gibbs.....Page 1
A Radio Set for a Tireless Business Man.....	2
How to Install Your Radio Set on Your Boat.....	Wm. F. Crosby..... 3
The Scientist Who Discovered the Electron.....	17
A Portrait of Sir Joseph J. Thomson	
My Speech to a Tomato Can.....	Clare Briggs..... 18
The Shortest Radio Waves Ever Produced by Man.....	Ernest F. Nichols..... 22
The Ratio in Size Between Your Antenna and Your Coil.....	Oliver Lodge..... 30
The Fourth of a Series of Articles Written for the Radio Amateur	
Useful Facts and Foolish Fallacies About Your Earphones.....	Raymond F. Yates..... 34
A Measurement Chart.....	Raoul J. Hoffman..... 39
For Determining the Capacity of Your Antenna—No. 4.	
Four Ways to Get Good Modulation—Part II.....	J. H. Morecroft..... 42
How to Make a Dry-Cell Tube Regenerative Set.....	Spencer Boyd..... 49
The New Signal Code.....	Louis Cohen..... 56
How to Keep Up Your Storage Battery.....	Henry Strahlman..... 60
What the New Broadcast Schedule Means to You.....	John V. L. Hogan..... 64

DEPARTMENTS

Broadcasts.....	71
What Readers Ask.....	74
Listening In.....	80
Hints for Amateurs.....	85
"Stations I Have Heard".....	87

VOLUME IV

JULY, 1923

NUMBER 1

Published monthly by Popular Radio, Inc., 9 East 40th Street, New York, N. Y., telephone number Vanderbilt 9985; H. B. Emerson, President; E. R. Crowe, Vice-President; F. C. Hemberger, Treasurer. Price, 20 cents a copy; subscription \$2.00 a year in the U. S., Canada and all countries within the domestic postal zone; elsewhere \$2.25 a year, payable in advance. The International News Company, Ltd., No. 5 Bream's Bldg., London, E. C. 4, sole distributors in England. Entered as second-class matter April 7, 1922, at the Post Office at New York, N. Y., under the act of March 3, 1879. Copyright, 1923, and title registered as a trade-mark by Popular Radio, Inc. Printed in U. S. A.

E. E. FREE, Ph.D., *Contributing Editor* LAURENCE M. COCKADAY, R.E., *Technical Editor*

New York: 9 East 40th St.

For advertising rates address E. R. CROWE & CO.

Chicago: 645 North Michigan Ave.

“Allow the ear to hear
what it likes,
the eye to see
what it likes.”

Kuan-Yi-Wu.



The Grebe Receiver

delights both
ear and eye,
for the ear enjoys
the eye good music,
beautiful
craftsmanship.

Doctor Mu.

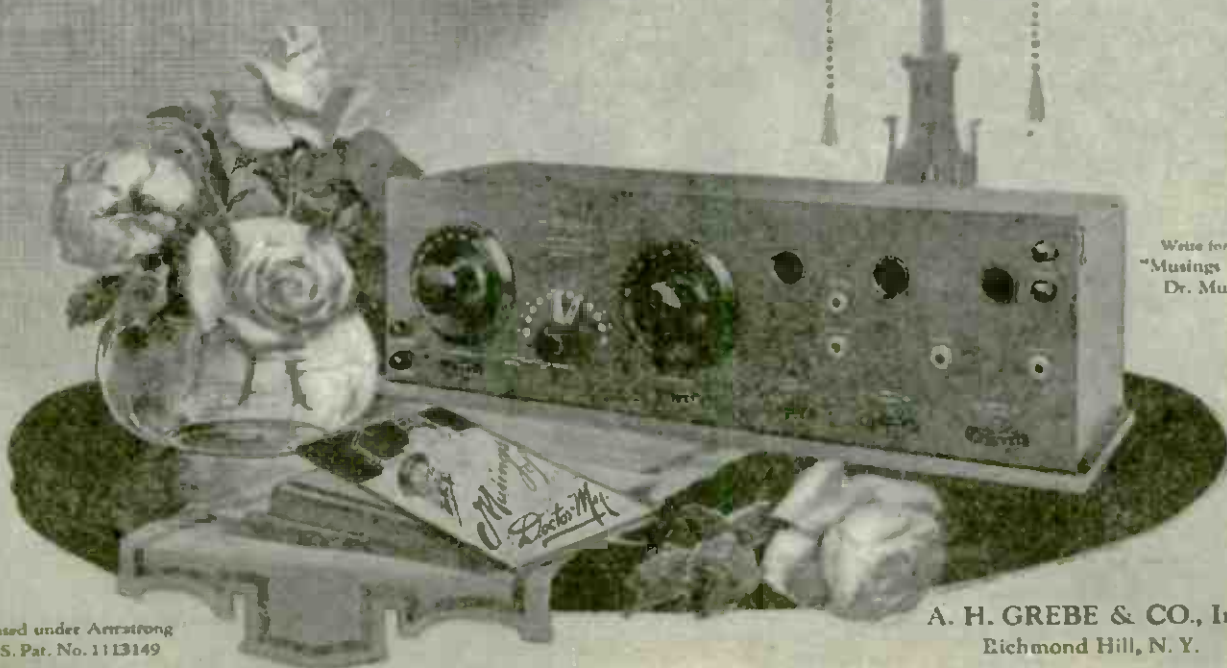
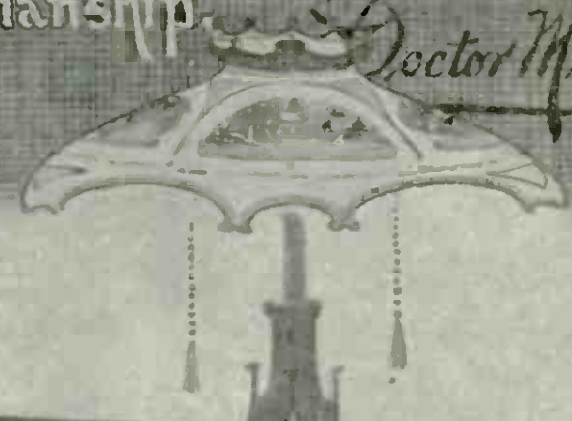
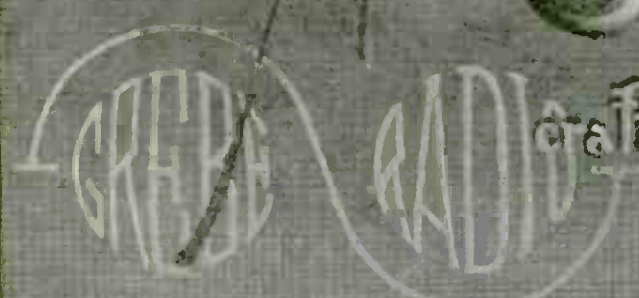

Write for
"Musings of
Dr. Mu."

Licensed under Arratrong
U. S. Pat. No. 1113149

A. H. GREBE & CO., Inc.
Richmond Hill, N. Y.

A PAGE WITH THE EDITOR

THE new Four-Circuit Tuner—not only announced for the first time in the May number of POPULAR RADIO but described in specific detail by the inventor, Laurence M. Cockaday—“went over with a bang” in the words of one ardent reader. Certainly no receiving set has been acclaimed so universally or so promptly or so enthusiastically in the whole history of radio.

* * *

AND despite the becoming modesty of its inventor, who insisted upon naming his brain-child the “Four-Circuit Tuner,” the set has, properly enough, assumed the name of its father, and is usually referred to as “the Cockaday set.” Which is fair enough!

* * *

“THE Cockaday set is the greatest asset to the radio public today,” writes C. J. Hauff, of New York. And Mr. Hauff’s comment is quoted here not because it is exceptional but because it is representative of the comment that reaches us by mail, telegraph, telephone and radio.

* * *

MR. HAUFF is not commenting from hearsay, either. He is one of the army of real fans who actually built the Cockaday set within a few hours from the time his May copy of POPULAR RADIO reached them.

* * *

It was not until four whole days after the May issue was published, however, that Mr. Hauff reported:

“Right after I finished building the set I picked up KDKA, KYW, WDAP, WBZ, WOC, WHAS and CFCA, although the local broadcasting stations were broadcasting at the time. And I also picked up amateur transmission from the 1st, 2d, 3d, 4th, 5th, 8th and 9th Districts and from numerous Canadian stations.”

* * *

ON the morning after the May number was published, Mr. Cockaday received six telephone calls from fans who had stayed up all night to build the new set and who wanted to report that it was “working fine.”

* * *

FROM L. B. Barret, of Bangor, Maine, comes this unusual report of his experience with his new Cockaday set:

“Last night, while listening to WGY on the loudspeaker, I removed the antenna—but I still heard the voices. I then removed the ground, yet I could yet hear the voices on the earphones. No ground—no antenna—yet the voices were still audible. I consider that remarkable!”

* * *

FOR the benefit of those of our subscribers who change their addresses and who (naturally) do not want to miss any copies of

POPULAR RADIO, our Subscription Manager offers the following word of advice:

In sending a notification of change of address, a subscriber should give both the old and the new address. In order to have the change become effective with the next issue, the notification must be received by the Subscription Department not later than the first of the month preceding the date of next issue.

* * *

“RADIO is just now the great boon of the boy. The ether is his plaything and he sports with its waves as in a swimming hole. The excellent popular-science journals that have done so much to teach and stimulate the American boy have crowded the dime novel off his bedroom shelf.”

—SATURDAY EVENING POST

POPULAR RADIO rises to acknowledge the compliment, blushing to the roots of its conventional hair.

* * *

WHEN POPULAR RADIO took the initiative among the radio magazines and undertook to have its circulation records *certified*, it entered upon a policy that met with the instant endorsement of advertisers and advertising agencies alike. For after all, an advertiser pays for *circulation*; in justice to him as well as in his protection, the circulation figures should be more than a mere matter of assertion or hearsay; they should be a matter of open, certified record.

* * *

THIS policy is now being further extended—and again in the protection of the advertiser. From the advertising manager comes this significant announcement:

“With its October issue, this magazine guarantees an average net sale of 100,000 copies a month, or pro-rata *refund* to all advertisers.”

“For this circulation, the rate will be \$200 a page, \$100 a half page, and \$50 a quarter page.”

“POPULAR RADIO was the first magazine in its field to publish a certified statement of past circulation. It is now the first to guarantee future circulation—to agree to deliver to advertisers the circulation they pay for.”

* * *

“SQUIERCASTING is certainly a good term to apply to wired wireless,” writes Henry J. Conant of New York. “But why not be a regular sport and call it *Sqwirecasting*?”

Honestly now, Henry, do you think that General Sqwire would regard this as such an all-fuiered good term for wuiered wuierless?

* * *

To “see ourselves as ithers see us” is not an invariable comfort. Here, however, is a copy of a confidential report on POPULAR RADIO that was recently sent by a disinterested investigator
(Continued on page 8)

Please mention POPULAR RADIO when answering advertisements.



The Dubilier By-Pass Condenser used in the Freed-Eisemann Set to bring in the stations clearly and free from noises.

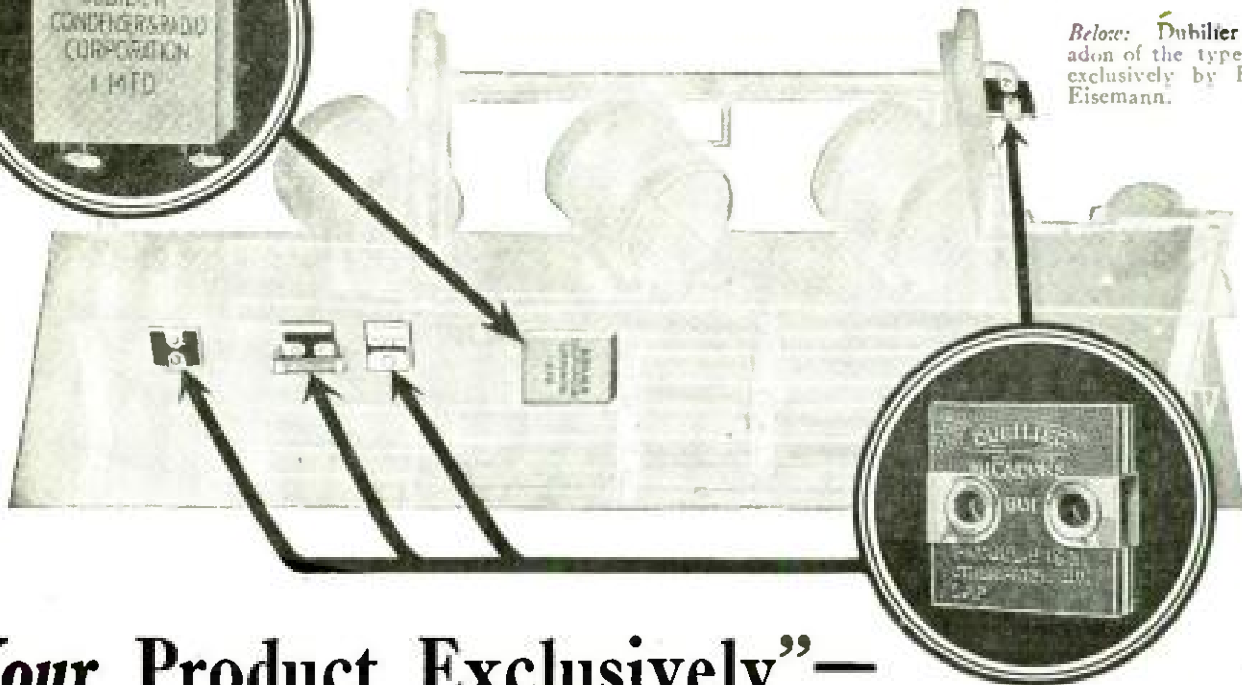

Below: Dubilier Micadon of the type used exclusively by Freed-Eisemann.

“Your Product Exclusively”—

IN the Freed-Eisemann five-tube Neutrodyne receiver Dubilier Micadons are used exclusively.

“We conducted experiments which caused us to decide on *your product exclusively*,” writes the Freed-Eisemann Radio Corporation to the Dubilier Condenser and Radio Corporation.

In order to balance capacities in the Neutrodyne circuit and to avoid losses, only condensers *permanent in capacity* can be used.

Because Dubilier Micadons alone meet these requirements they are used not only in the

well-known Freed-Eisemann set but in Paragon, Zenith, Fada, De Forest and other sets which have won the approval of the radio public.

Unless a set is equipped with Dubilier Micadons, there is unnecessary howling and whistling. The broadcasting station is not heard at its best.

Price 35 cents to \$1.50 each.

At all good dealers.

DUBILIER CONDENSER AND RADIO CORPORATION

48-50 West Fourth Street, N. Y.

BRANCH OFFICES IN THE FOLLOWING CITIES:

Los Angeles, Cal.	Huntington, W. Va.
St. Louis, Mo.	Washington, D. C.
Atlanta, Ga.	Chicago, Ill.
	Pittsburgh, Pa.

Distributed in Canada by Canadian General Electric Company, Ltd., Toronto

DUBILIER PRODUCTS

A PAGE WITH THE EDITOR

(Continued from page 6)

tor to one of the world's foremost scientists who has consistently refused to contribute to the magazines—but who, happily, made an exception in our case:

"POPULAR RADIO is the most conservative, dignified and authoritative magazine of radio, simply not to be compared with — — and other magazines which are simply the yellow journals of radio. It is the only magazine which consistently obtains specially prepared material from such persons as Elihu Thomson, Prof. J. H. Morecroft, Senator Marconi, Dr. Lee De Forest, John Hays Hammond, Jr., Charles P. Steinmetz, Sir Oliver Lodge and probably half a dozen equally as well known in the field. At the same time it is the most successful and highest-circulating magazine of any published and actually goes to a very discriminating audience. All this is simply to show that it keeps good company and I honestly believe that it hurts no one's standing to be seen in it."

WE have only one flaw to pick in this otherwise perfect recommendation. While we concur in the opinion that to contribute to our pages can "hurt" not even the most exacting scientist, we can even go so far, under pressure: as to admit that it will make him famous! Too many real scientists are known only to a small group of fellow-workers; who *should* be known to a large public—particularly to that discriminating part of it that read POPULAR RADIO.

THE avalanche of inquiries that keep pouring into the office of the Technical Editor from readers who have problems to solve, furnish gratifying evidence of the increasing value of the Technical Editor's advice. But despite the additions to our technical staff the questions from readers are increasing in even greater ratio—with the result that we have been at a loss as to just how we can be of service to so many of our good friends all at once!

IF we could only line up all of our correspondents so that they could *see* each other we could at least show the reasons for the delays in answering their letters and amiably advise them that "the line forms on the right; please do not shove."

By the time that this issue goes to press; however, the Editor hopes and believes that the pile of unanswered letters will have been materially reduced if not eliminated altogether. For we have called in not merely *one* additional technical expert, but a staff of several experts who will remain on the job until all the hold-over correspondence has been cleaned up.

"If you can't answer my inquiry promptly," writes a ruffled reader, "I know plenty of

radio editors who will be only too glad to." Well, so do we. That is one reason why POPULAR RADIO takes such particular care in preparing its replies—and that care takes time.

PERHAPS that suggests *one* of the reasons why more and more readers are turning to POPULAR RADIO for technical advice!

THIS cheerful burst of song comes from Toronto, Can. The Editor appreciates both its theme and its technical excellence:

*A happier boy in all this land
You could not find, when in my hand
I hold that wonderful—yes, quite so—
That wonderful POPULAR RADIO!*

S. B. PETCH

ON page 280 of our April number we published a picture of an interesting and highly efficient receiving set that was designed for the special use of lighthouse keepers; information came to the Editor that this apparatus was designed by the Bureau of Standards. Mr. A. W. Tupper, assistant engineer of the Bureau of Lighthouses, notifies us, however, that the set was designed by his bureau. POPULAR RADIO gladly re-locates the credit for the design of this excellent receiver.

"I HAVE built fifteen sets of different designs and tried many hook-ups," writes E. H. Severnson of Binghamton, N. Y., "but I am getting better results from the DX set described in your January number than from any set or hook-up that I have ever tried."

If you see it in POPULAR RADIO, it's so!

JUST exactly what do *you* like best in POPULAR RADIO? For what specific feature or features do you select it in preference to the many radio magazines?

To find out the answer, we recently sent out 3,500 questionnaires to a selected list of subscribers. Of the first 650 replies that reached us (several of them by telephone and telegraph) we have made a careful, detailed analysis. The results conclusively show that—

BUT just look through this number and decide for yourself what effect these replies have had on the magazine. Unless the results *show*, our trouble and expense in meeting your desires are in vain!

Kendall Banning

Editor, POPULAR RADIO

Please mention POPULAR RADIO when answering advertisements.

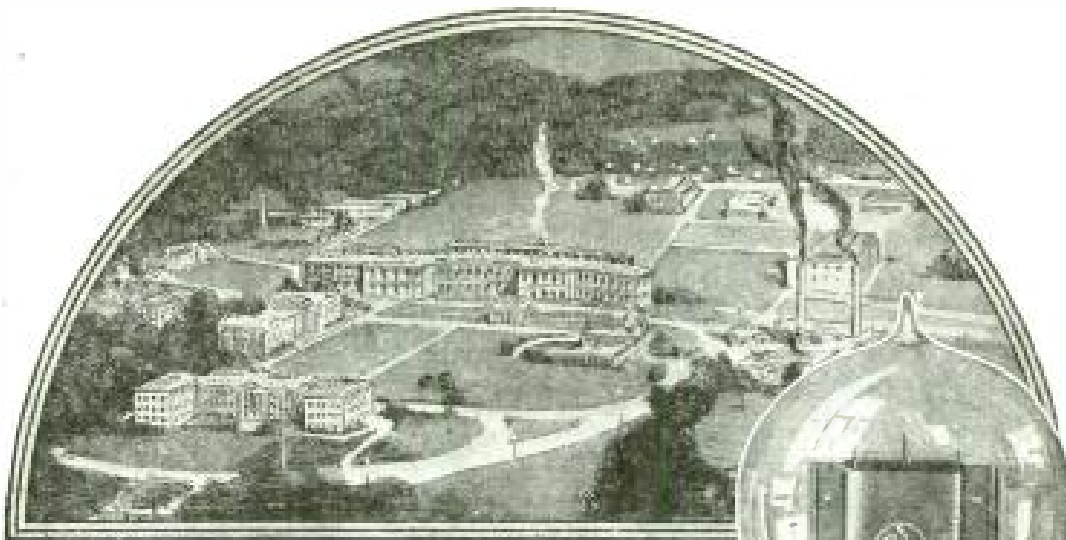

One of the World's Largest Manufacturers with unlimited resources Builds Cunningham Tubes

FORTY-THREE years ago the carbon filament electric lamp, at that time considered the finest development in the electrical art, came into general use.

The important and ever-growing demand resulted in the building and expansion of mighty factories, and the improvement of factory methods, until today the tungsten filament gas-filled lamp yields eight times the candle power for the same electric input.

In recent years these same highly skilled manufacturers have been devoting a part of their factories, and applying their engineering talent gained through years of experience, to the production of vacuum tubes.

The new Cunningham type C-301-A, Amplifier and Detector represents a combination of these years of manufacturing experience, and the engineering ability contributed by that great scientific organization, the Research Laboratory of the General Electric Company.

The low filament current of only one-fourth of an ampere and the extremely high mutual conductance of 700 micro-ohms, make the C-301-A the most efficient vacuum tube ever built for amateur and entertainment use in radio.

*A Specially
Designed Tube
For Every
Radio Use*

Patent Notice: *Cunningham tubes are covered by patents dated 11-7-05, 1-15-07, 2-18-08, and others issued and pending. Licensed for amateur, experimental and entertainment use in radio communication. Any other use will be an infringement.*

E. J. Cunningham Inc.

Home Office:
248 First Street
San Francisco, Calif.

Eastern Representative:
Chicago, Illinois

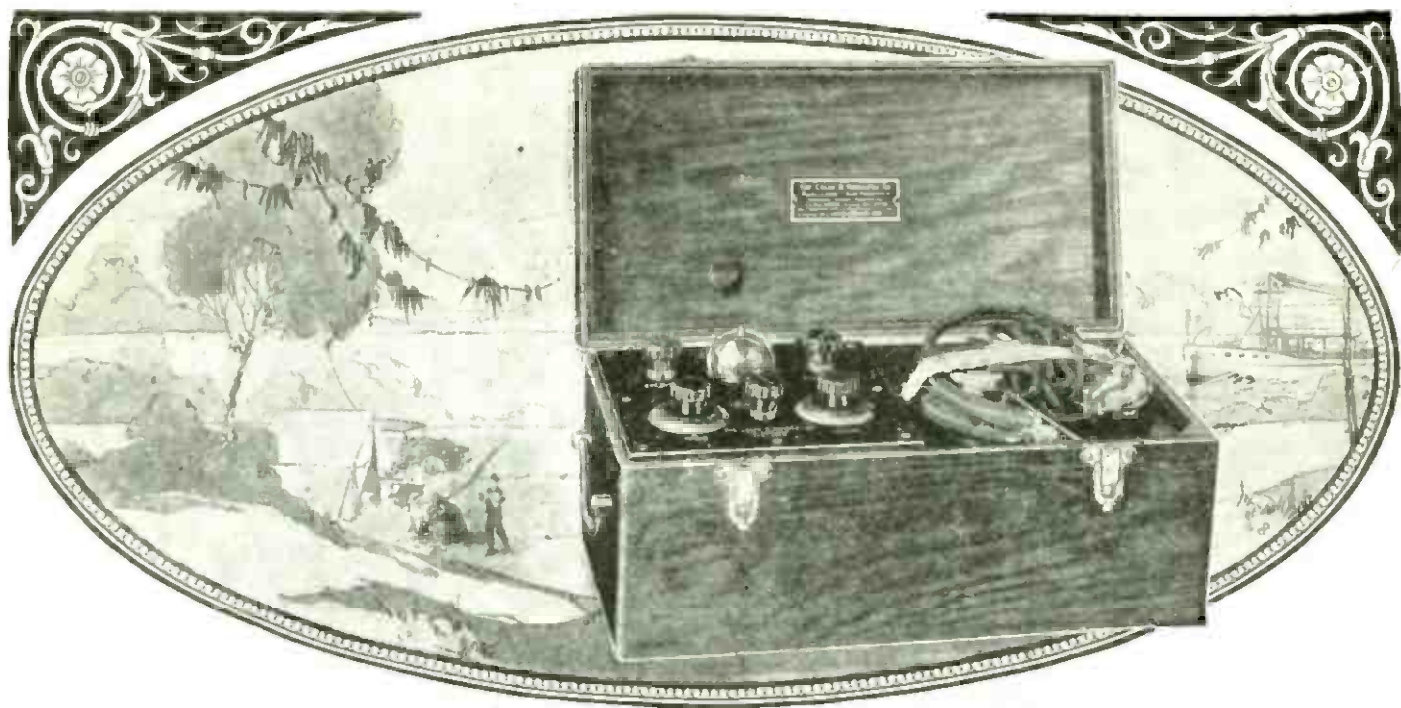

Take This Radio Set on Your Outings!

A New Kennedy Achievement—Light, Compact, Portable, Highly Efficient

Here is the ideal Summer Radio Set! Just the thing to take with you on your vacation—auto touring, boating, camping, or to your summer cottage. A handy, compact set, so easily transported from place to place that you can take it with you wherever you go—yet so exquisitely finished that you will be glad to have it in your home.



Enjoy Radio concerts at your summer cottage.



A welcome addition to the camper's kit.



Take it with you wherever you go.

All Kennedy Receiving Sets are regenerative—licensed under Armstrong U.S. Patent No. 1,113,149.

Reduces Interference

This new set is the latest triumph of the Kennedy Engineering staff. It has all the beauty, refinement and perfection of detail that distinguishes the Kennedy line and makes it the "Royalty of Radio." It is simple to operate, yet highly selective, with unusual freedom from interference—the ideal summer set.

No Storage Battery Needed

The Kennedy "Portable" is designed for use with any standard tube, including the dry-cell type. When dry-cell tube is used, the set is entirely self-contained, space being provided in the sturdy, beautiful oak cabinet for dry batteries and phones. Size 15x7½x7, weight 17 lbs. Complete, with tube, dry batteries and phones, \$75.00.

See the nearest Kennedy dealer for demonstration, or write for descriptive literature on this and other Kennedy sets.

THE COLIN B. KENNEDY COMPANY
SAINT LOUIS SAN FRANCISCO

KENNEDY

The Royalty of Radio





Underwood & Underwood

What Radio Is Bringing to Humanity

"Looking ahead, it is impossible to avoid the conviction that radio is going to create a revolution in the means of transmitting news and views, and that it will be a powerful aid to the education of humanity."

—SIR PHILIP GIBBS

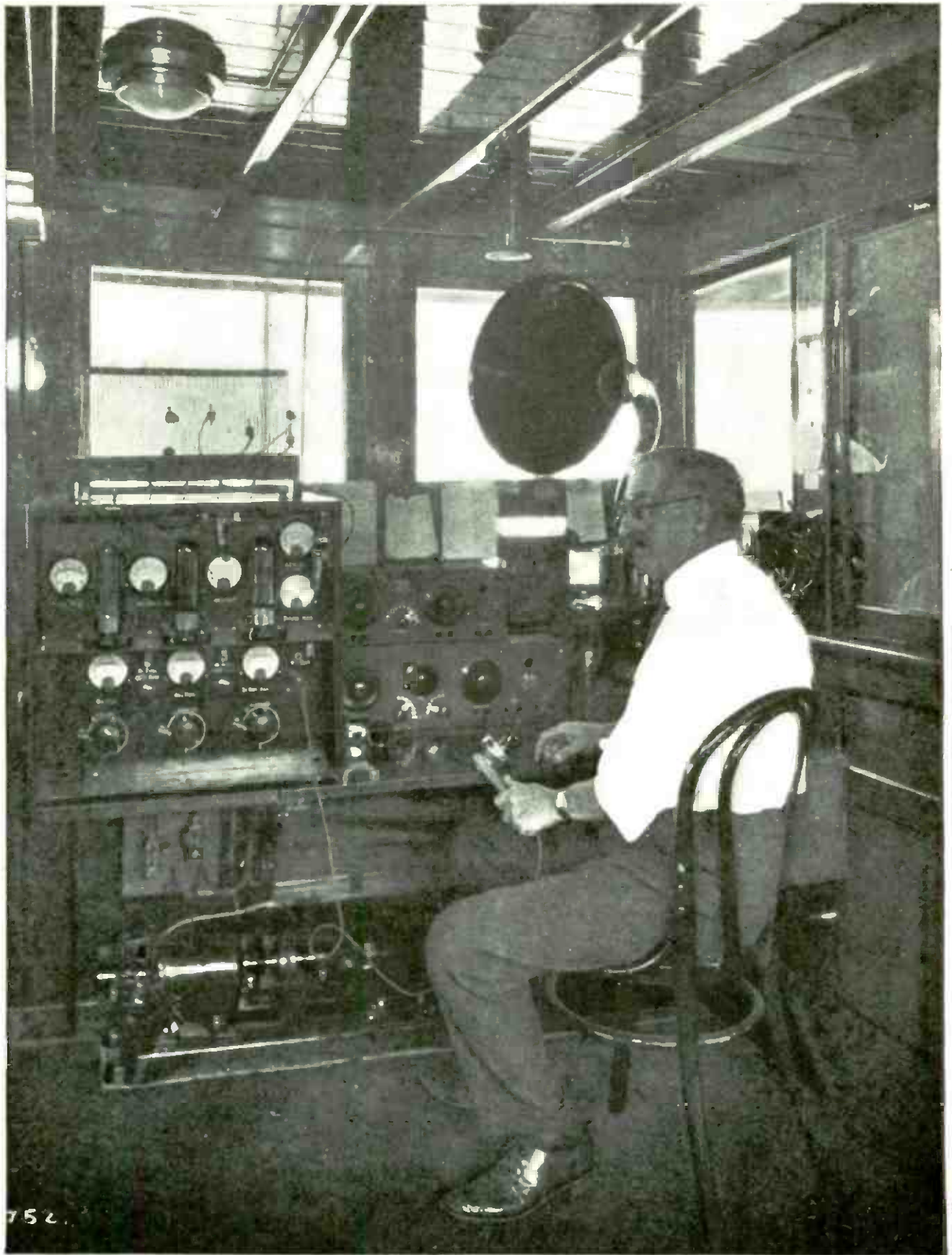

Ed via Levick

A Radio Set for a Tireless Business Man

When Henry B. Joy starts out on a cruise in his 65-foot motor yacht "Spray" he settles down to a period of uninterrupted work in his radio cabin—which comes pretty close to a radio fan's idea of what a radio set ought to be.

Popular Radio

VOLUME IV

JULY, 1923

NUMBER 1



How to Install Your Radio Set ON YOUR BOAT

Take your radio set with you on your vacation! Don't put it aside merely because you have heretofore regarded it only as a medium of indoor entertainment. How to set it up in your canoe, row-boat, launch, sailboat or yacht is here described in specific and practical terms by an experienced radio expert.

By WILLIAM F. CROSBY

A RADIO set installed on the small motor boat or cruiser will probably furnish one of the most popular methods of enjoying the broadcasting during the summer. The obstacles that have heretofore made this form of entertainment impractical have now been overcome.

On the larger motor yachts the installation of a radio set is a simple matter. In the case of the small cruiser, however, difficulties arise that heretofore have made the use of a radio set almost impossible. But the development of the one-and-a-half-volt tube during the last year has changed this situation, and the installation of such a set employing these tubes is both feasible and practical. There is now no reason why the owner of the small boat should not have a small set on his boat. Most of small-boat owners have a decided mechanical bent, and if the directions for making and installing a set given in this article are followed out, no difficulty should arise.

It will be best, at the very start, to eliminate the crystal detector set.

In the first place, the rolling of the boat, combined with the vibrations of the engine, would certainly knock the crystal detector out of adjustment continually. The crystal set will, on the other hand, be suitable for a canoe trip. It must be remembered, however, that the range of a crystal set is strictly limited, and if a lengthy cruise is contemplated, the results will not be satisfactory.

A small set, only seven inches by ten inches, may easily be made up and mounted on a panel. It should contain a vacuum tube and "A" and "B" batteries (if a one-and-a-half-volt tube is used). This set will work well on the small open motor boat, provided that the set is not used while the boat is running. It should be used only in the evening, or when the boat is anchored in some snug cove. The antenna wire may be kept on a reel and one of the crew may row ashore with

one end of it and fasten it up in a tree. The other end of the antenna may be attached to the set on the boat. With an antenna of this kind, about 100 feet long and a good vacuum tube set, results will be as good, if not better than with the same set at home.

The ground connection on any boat is a comparatively simple problem, but there are a few little kinks that may be well to bear in mind.

For ordinary work, merely the connecting of the ground wire to the propeller shaft will do very well, but better results will be obtained by having a sheet of copper fastened to the outside of the hull, well below the water line.

Solder should *not* be used on the copper sheet, however, if the boat is to be used in salt water, as there will be an electrolytic action between the copper and the solder that will soon eat the solder away. In a boat that has galvanized iron fittings or fastenings there

will also be some chemical action on the copper plate; in a case of this kind a zinc plate would be better. The zinc plate, though, will have to be kept a good distance from the bronze propeller and the shaft because, if it is left near the propeller and the shaft, the zinc plate will soon be eaten away.

If a copper plate is used, use copper tacks to hold it to the hull; if a zinc plate is used, galvanized iron tacks should be used for fastening.

For making contact to this plate, a strip of similar metal should be run from just under the sheer moulding to the ground plate. The top end of the metal strip may be run through a small slot in the side of the boat to the inside where an ordinary binding post may easily be attached, which in turn will have a piece of wire running to the set. (See Figure 1A). This metal strip, in case it runs down the outside of the hull, may be let in flush with the planking and painted over, so that you



A PRACTICAL INSTALLATION FOR A LAUNCH

The details of the antenna construction are clearly shown in this view of Fred Mueller's boat on Lake Worth, Texas; it has picked up stations from Denver to Atlanta. The circuit is shown in Figure 3, (pages 14 and 15).



Kadel & Herbert

MUSICAL INTERLUDES BETWEEN BITES

A receiving set that employs radio frequency and a loop antenna is perhaps the most suitable for a small boat or canoe. This installation was made by William Nigey, while on a fishing trip on the Belgrade Lakes in Maine.

will not be able to see it at all.

So much for the ground connection.

There are many small cruisers which could be easily equipped with radio if the owners only knew of the advantages to be gained. Many of them already have a phonograph on board, but the old records become rather tiresome when an extended cruise is taken. With a radio set on board, different programs may be secured every hour of the day and night, and if a long cruise is taken, it will prove both interesting and entertaining to hear the different broadcasting stations in the various sections of the country. There are many low-power broadcasting stations in the smaller cities that have a range of only a few miles. These stations may be picked up easily with a radio set on a cruiser, and the log book of such a cruise would show the call letters of a great many stations that the owner

never before knew were in existence. Then there will always be the large stations to come booming in over the little ones at any time.

What is the best type of receiver for this work? What is the best antenna that can be erected on a small boat? Where can we locate the set?

These and many more questions at once come to the boat owner when he has decided to install a set.

First, let us consider the antenna.

Most small cruisers have short masts erected on the cabin tops; in order to give the antenna all the length possible, it would be advisable to erect a topmast—if possible, a portable topmast. This may be done by fitting either the forward or after side of the mast with what is called a "track," such as is used on sailing yachts in place of mast hoops. Once this track is in place, it is not much of a job to fit the top-

mast in place, and by arranging a small pulley at the top of the permanent mast, the topmast may be lowered or raised at will. Side guy wires may be arranged to work with it, and the antenna itself used to act as a fore and aft guy.

The antenna should be made of stranded copper wires, so that it may be easily rolled up and stowed away. At the forward end a good sized screw eye may be secured to the stem head and the antenna may be connected direct to this, after a small porcelain cleat has been arranged to insulate it. If the boat is extremely small two wires should be used, arranged on spreaders about two feet long, with a spreader at the top of the mast and another fastened at the stern end of the awn-

ing frame. Thus the antenna will run from the stem head up to the top of the mast and down again to the after end of the awning, in a sort of inverted V.

The lead-in should be arranged so that it comes from the forward end or from the after end and not from the middle. In this way a fair-sized antenna may be put up on a small boat and the reception of long distance stations should not be difficult.

If the lead-in from the antenna comes into the cabin, it should be carefully insulated. Remember that salt water is a good conductor of electricity and unless this wire is arranged so that it puts all of the received energy where it is wanted (in the set) the receiving range will be considerably reduced. In fact the signal may be completely absorbed by damp woodwork and nothing whatever will be heard. A long porcelain tube, run through the side of the cabin, will do the trick.

The receiving set may be run from the storage battery that is already on board. A great many small cruisers have batteries for either starting the engine or for running the electric lights. However, there is one point that must be looked into carefully; if the type of vacuum tube is used that requires a storage battery, care must be used that the battery on board is not more than six volts. Some of these batteries are of the twelve-volt type. If this is the case it will be necessary to use only half of the cells in the battery. This may easily be done. There is a vent cap for each cell and therefore it will be easy to locate the first three cells. A connection may be made to the third cell and from one of the outer cells and the voltage will be correct for the ordinary vacuum tube of six volts.

If the cruiser is of medium size, it will be practical to make a receiver with a two-stage amplifier that uses a loudspeaker so that everyone on board may hear the broadcasting. The loudspeaker should be mounted on a small shelf in-



Edwin Levick

A PORTABLE MARINE SET—

I Sets intended for use on small boats must be easily transported and easily set up and taken down—unless one owns a private boathouse in which to lock up valuables!



Edwin Levick

—AS IT APPEARS INSTALLED AND IN OPERATION

2 *Many claims are made for the spiral antenna, which has its distinct uses and advantages. Just how useful it would be in a canoe in any but the most calm weather is a question. But who would venture out in a canoe in a storm, anyway?*

side of the cabin (as shown in Figure 1-B) in such a way that the bell of the horn comes out of an opening in the bulkhead. This will keep the whole set and the loudspeaker inside of the cabin, yet make the music plainly audible in the cockpit where the listeners usually sit.

If the storage battery is of the kind that is being continually charged while the engine is running, it will not be possible to use the set while the boat is in motion. However, a separate battery may be installed for this purpose,

with a double-pole, double-throw switch arranged so that the batteries may be changed over for charging. If the set is used at the same time that the battery is on charge there is danger of burning out the tubes.

The type of set to build depends on the size of the boat and just how much room is available. The first set to be described is a small one, designed for a small boat, that can make use of a shore antenna.

Here compactness is the first consideration and it will be necessary to

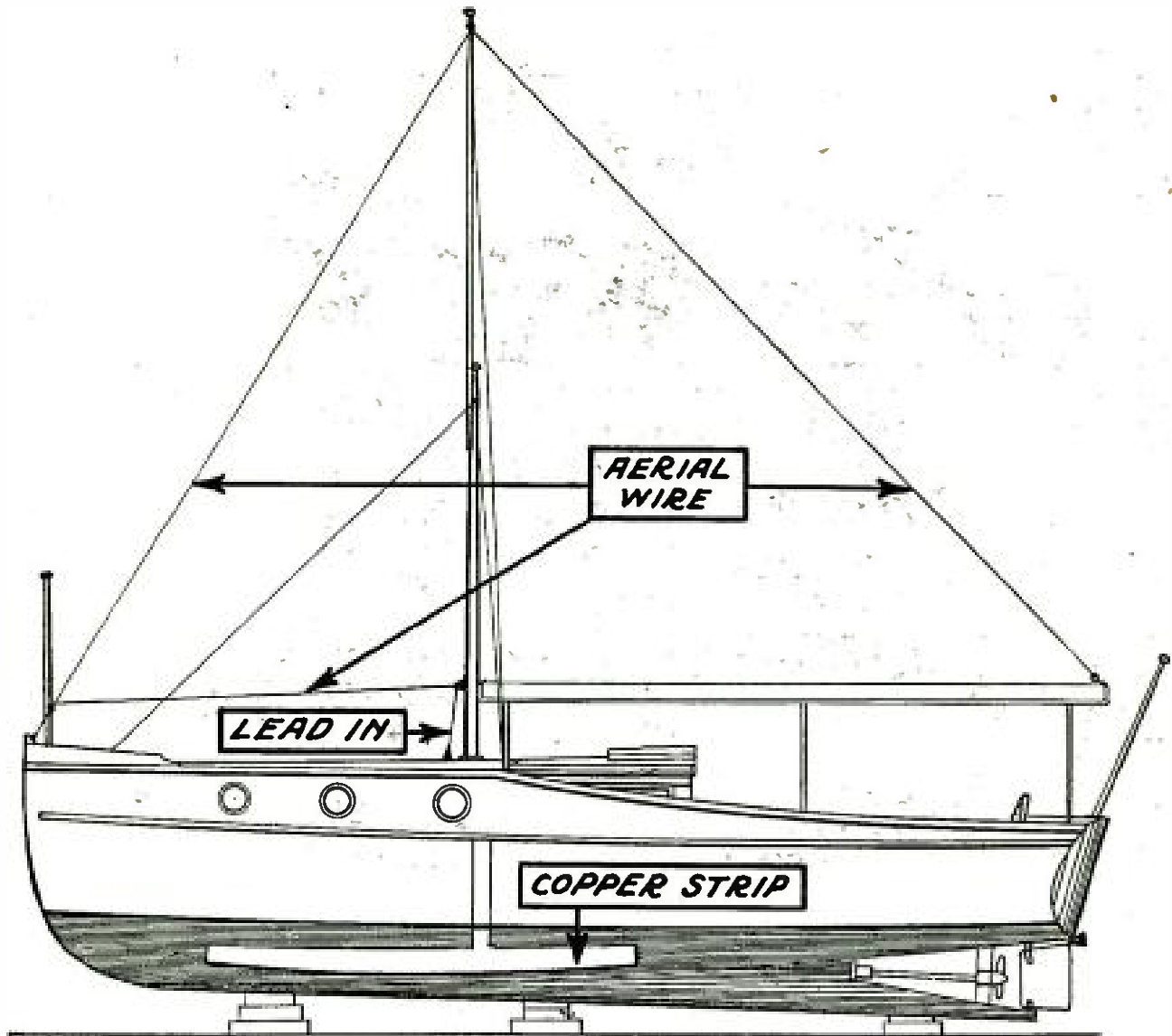

HOW TO INSTALL AN AERIAL AND A GROUND ON A YACHT

The antenna starts at the deck insulator, runs to the insulator at the bow, thence to the top of the collapsible mast, and ends up at the insulator at the rear of the awning.

use a dry-cell tube. The writer has made several of these small sets and has found them to give good satisfaction. In Figure 2, letter A indicates the primary and B the secondary coil. These coils are of the simplest construction; they consist of 13 and 35 turns respectively, wound on a composition or a cardboard tube about three and a half inches in diameter. Both windings are wound on the same tube and are spaced about a quarter of an inch apart. Be sure to see that both windings are wound in the same direction.

The secondary coil is tuned with the aid of the 23-plate variable condenser C. The grid leak and condenser is

shown at D. The numeral 1 indicates the grid of the tube, 2 the plate, and the two filament leads are marked 3. The letter E is the small fixed condenser (.002 mfd.); F shows the telephones and G the rheostat. "A" and "B" are the batteries.

One advantage of this set is the fact that it may be built in its entirety within a small space. A panel only 7 inches high and 10 inches long will suffice, and with a suitable cabinet the batteries may be placed within it; the only external connections are the leads for the antenna and the ground and the cords to the receivers.

The binding posts for the antenna and the ground connections may be ar-

ranged inside of the set in such a way that the wires leading to them are run out of the back of the set, thus doing away with all unsightly external connections.

To tune the set, merely turn on the filament and turn the dial of the variable condenser around until the loudest music is heard. A final adjustment of the rheostat may be necessary to get the best results. Remember that a dry-cell tube does not light up as brilliantly as the ordinary six-volt tube, so do not try to overload your tube; its life will be shortened considerably if it is burned too brightly.

The receiving set for a canoe or an extremely small boat of any kind, in which it is not possible to erect any sort of an antenna, had better be of the radio frequency type; as such a set cannot be easily made at home, it is best to purchase outright one of the many makes of really good loop antenna receivers. One of the small types of reflex sets should be ideal for this purpose; with a small loudspeaker it

should give nearly the same volume of sound that a phonograph will give. Such a set is portable and takes up little space.

The cruiser, however, may be equipped with a set that can be built entirely at home. A good regenerator with a two-stage amplifier will be suitable. The type of tuner, however, is a problem that will require some thought. Just what is wanted? The answer is compactness, simplicity and reasonable cost.

The single-circuit receiver, for several good reasons, will be eliminated at the start.

The two-variometer and variocoupler hook-up makes a fine set, but such an outfit takes up too much room. This leaves but one choice in the way of a receiving set—the three-coil honeycomb outfit. (See Figure 3.)

With such a set all-the-year-round enjoyment may be obtained, as it may be taken ashore in the winter and used in the owner's home; if it is properly built and operated it will give fine re-

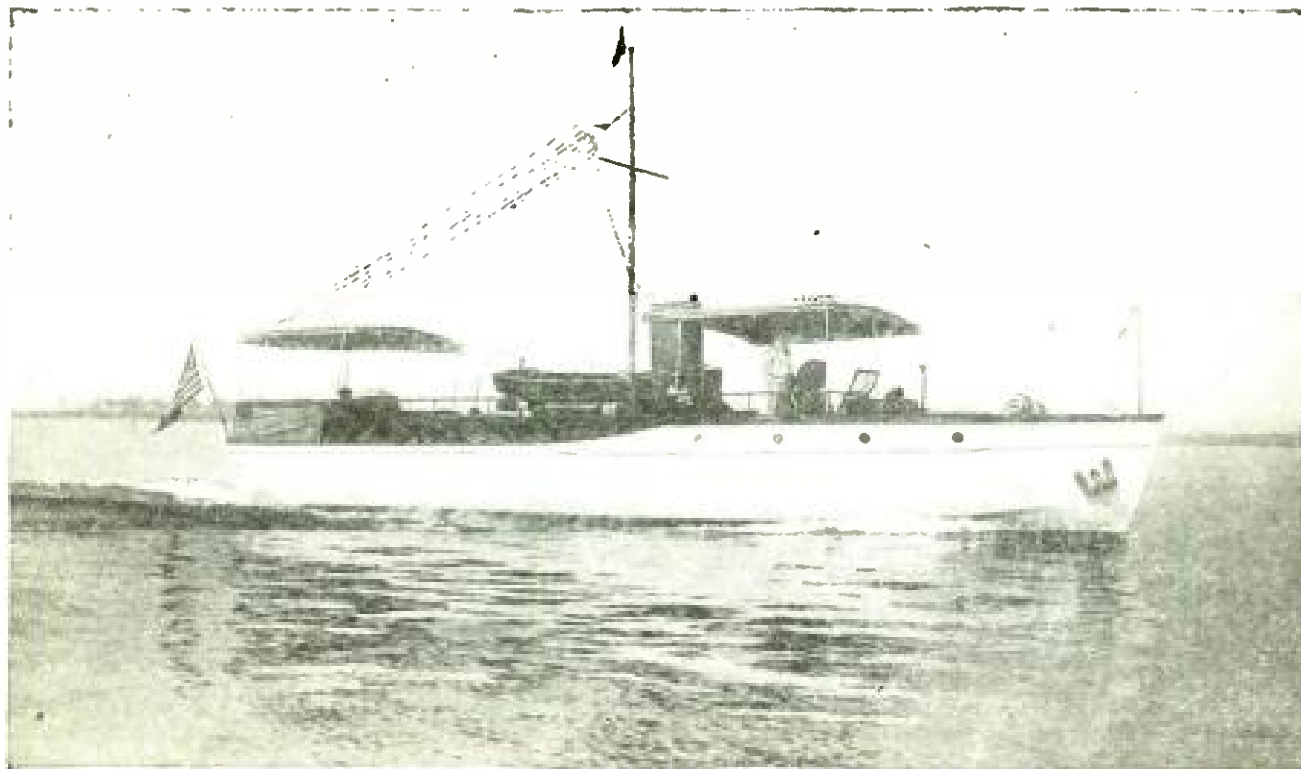

Edwin Levick

A CAGE ANTENNA FOR BOTH RECEIVING AND SENDING

Efficient as this type of aerial is, it cannot be recommended for use on boats less than 50 feet in length.

sults with good sensitivity and sharpness of tuning.

The main advantage of such a set, however, lies in the fact that it will enable the operator to tune his set to any wavelength, and if, through any legislation in the future, the broadcasting should be pushed up on a higher wavelength, the set may still be used; the only additional materials that will be required are a few of the larger-sized honeycomb coils. A number of the long wave commercial stations frequently send at a slow rate of speed, and after some practice the radio fan should be able to read at a fairly good speed. Arlington time signals and weather reports may also be picked up direct.

This set has three coils that are mounted on the outside of the panel by means of a triple-coil mounting. The coils are made in such a way that they may be plugged in and out at will, thus extending the wavelength range over wide bands. The coils are wound on a special machine for this work;

owing to the peculiar construction they are called honeycomb coils. The dualateral coil is practically the same thing under a different name.

Two condensers are used in this set in order to give the finer tuning adjustments, as changing the coils gives only rough tuning. The condensers should be of the vernier type in order to get the best results; furthermore, they will give more accurate tuning and allow the operator to bring in distant stations that might ordinarily be passed over. One of these condensers is used to tune the primary circuit and the other condenser is used for the secondary. No additional tuning apparatus is necessary.

It should be remembered that inductive coupling between the coils in the triple-coil mounting is varied by swinging the coils closer together or further apart. The tendency of the beginner is to jam the three coils right up close together all of the time. This is a mistake; it will broaden out the tuning to such an extent that all

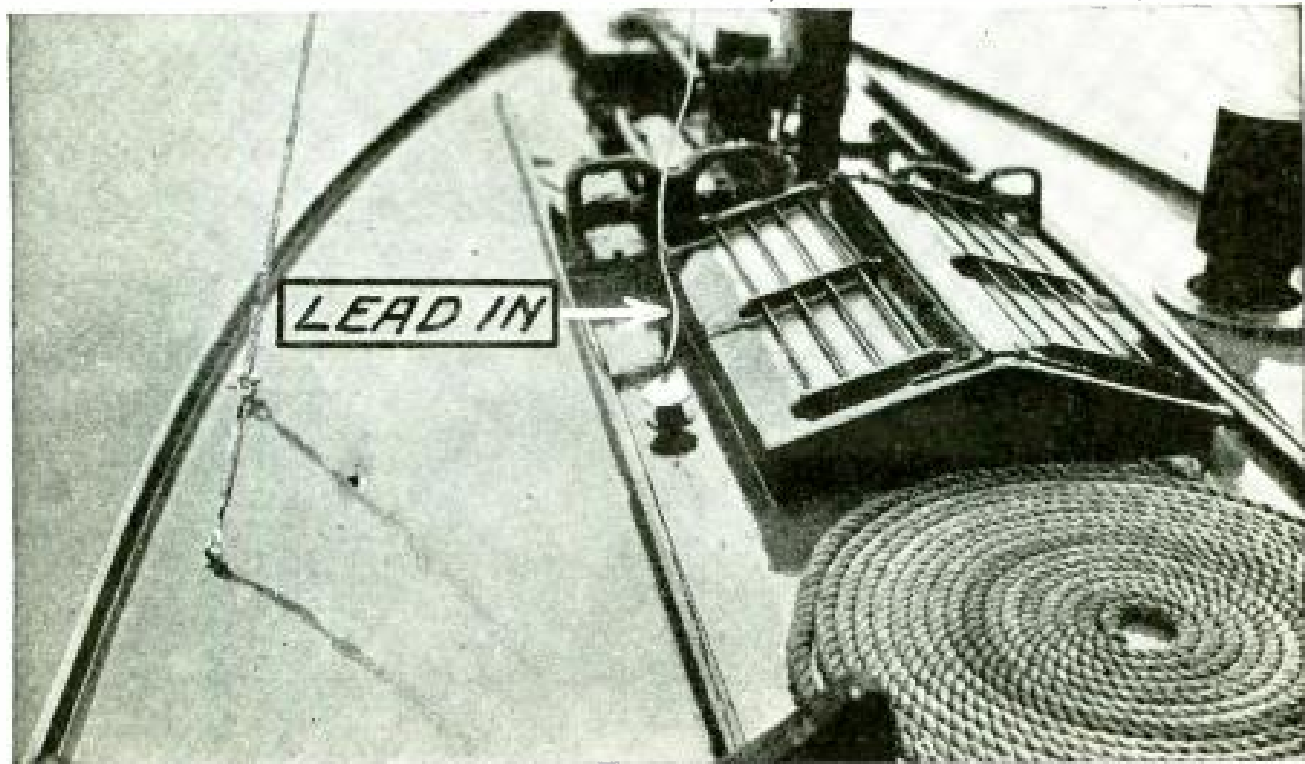

William Washburn Nutting

HOW THE LEAD-IN WIRE IS FASTENED TO THE DECK INSULATOR
The insulator has a terminal inside the cabin, where it is fastened to the antenna binding post of the receiving set.

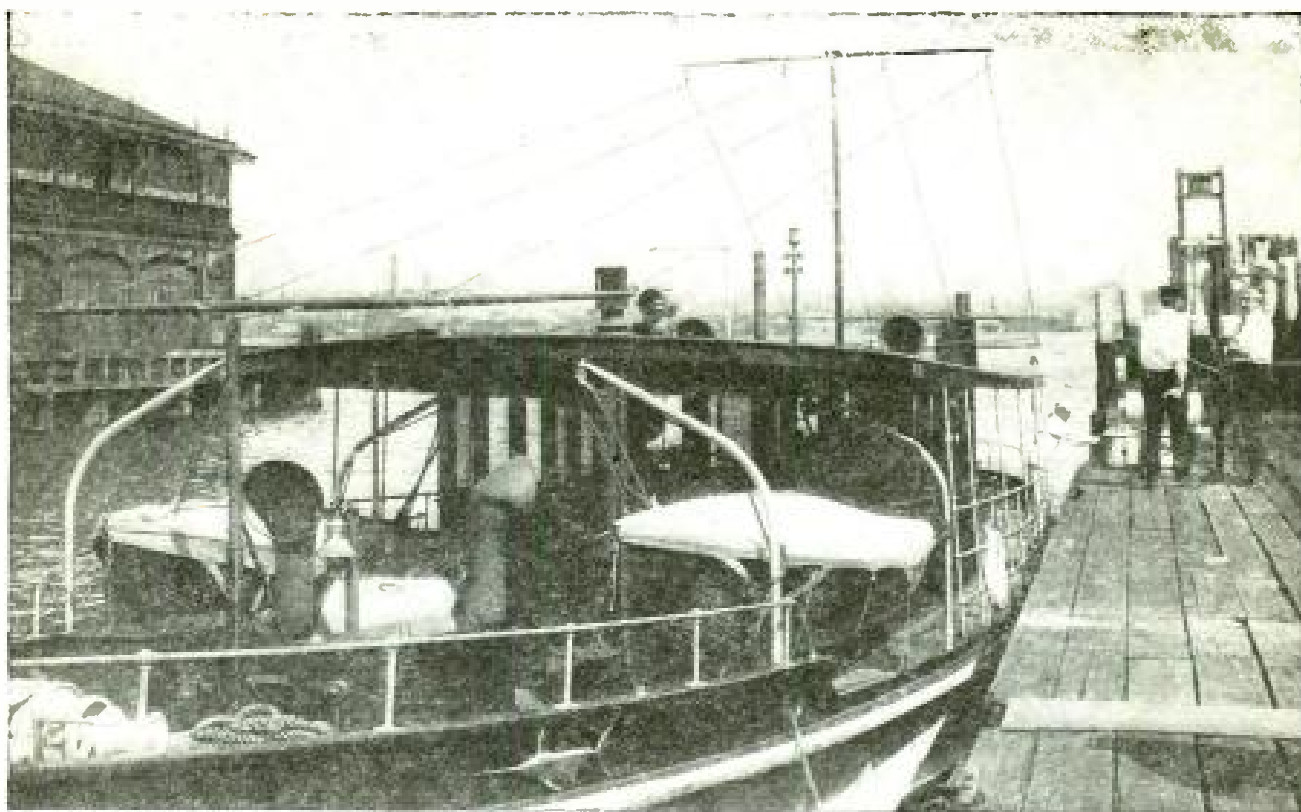

Edwin Levick

A GOOD ANTENNA FOR A CRUISER

Like the cage-type of antenna shown on page 9, this antenna is suitable for both receiving and transmitting, and is probably superior because of its higher capacity and greater length. It is arranged in the shape of an inverted V.

sorts of interference will be experienced, both from commercial and amateur stations. The coils should be carefully manipulated (swung back and forth on their hinges) so that there is quite a distance between them; the condensers should be used to bring the signals up to their maximum intensity.

The circuit is simple as is illustrated in the diagram. Figure 3. The coils are shown at the left of the drawing and are represented as A, the primary, B the secondary and C the tickler. For all ordinary broadcasting work these should be honeycomb or duolateral coils, L-50 for the primary and secondary and L-75 for the tickler. If at first the set does not function properly it will be wise to reverse the wires to the tickler.

The secondary condenser is shown at D and it should consist of 23 plates; E is the primary condenser of 43 plates, one side of which is connected to the bottom end of the primary coil and the other side to the ground binding

post. Be sure to get condensers that have a good firm connection to the rotary plates, as this is the weak spot in many of the condensers that are on the market at present. F stands for the grid leak and condenser of the ordinary type, and 1 is the grid of the vacuum tubes and 2 is the plate. The two filament leads are shown at the two figures 3. H is the rheostat. A vernier rheostat might help a little at this point, if one of the highly critical tubes is used. The "A" battery may be three dry-cells connected in parallel, if the small one-and-half-volt tubes are used; if six-volt tubes are used a six-volt storage battery must be employed.

The receivers are plugged in at the points marked I and J. A double circuit jack I, is used in the detector circuit and first stage and a single circuit jack J is used in the last stage of amplification.

Two amplifying transformers (K) are used and two extra sockets and rheostats.

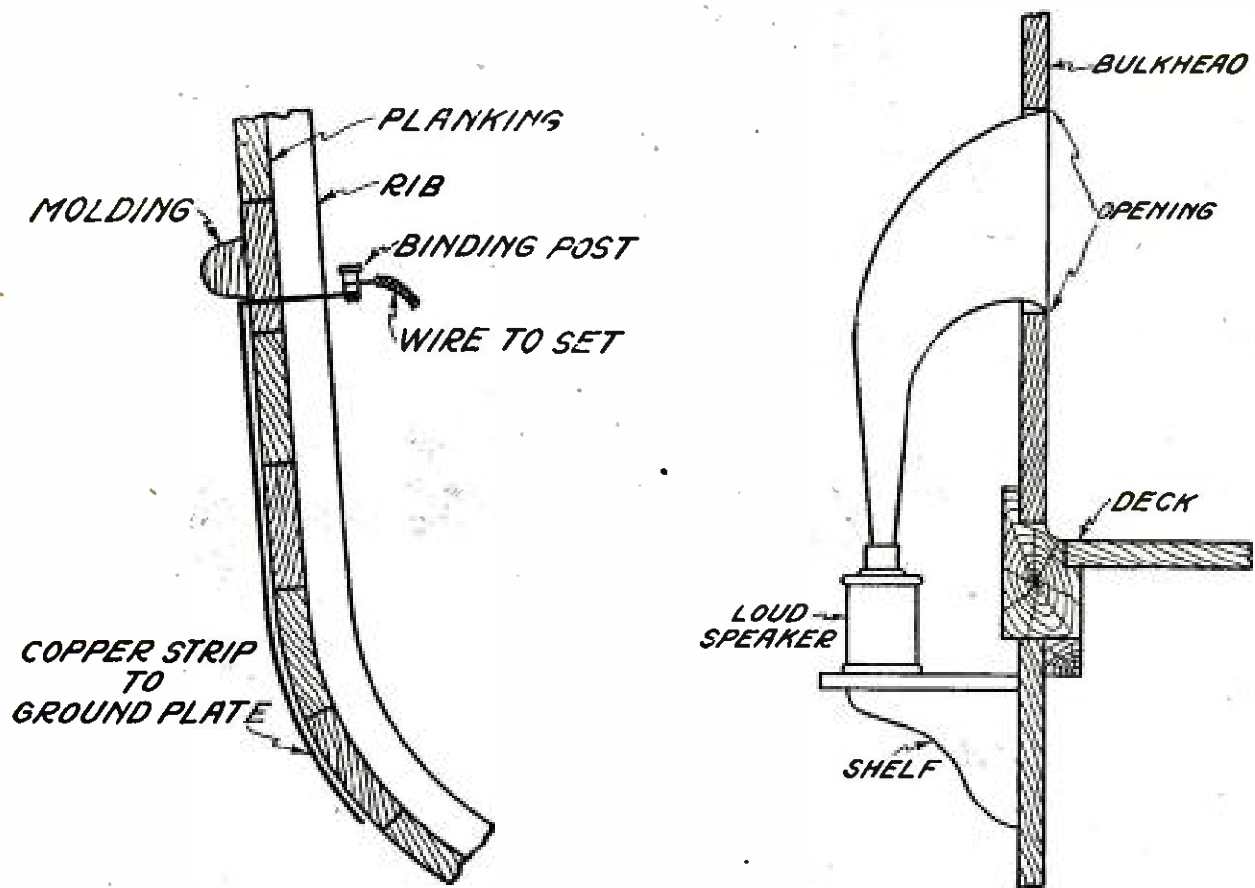

HOW THE GROUND MAY BE CONSTRUCTED

FIGURE 1A: This diagram shows the method of fastening the copper strip to the planking and of bringing it through just beneath the molding to a binding post to which is connected the ground lead of the set.

A NOVEL WAY OF INSTALLING A LOUDSPEAKER

FIGURE 1B: In order that those seated in the cockpit may hear the entertainment, the instrument may be mounted on a shelf inside the cabin, with the mouth projecting out of the bulkhead.



William Washburn Nutting

THE RECEIVING SET INSTALLED IN THE CABIN OF A SMALL YACHT
 Notice the installation of the loudspeaker—which is one of several methods of using it on a boat. (Compare this arrangement with that shown above, Figure 1B.)

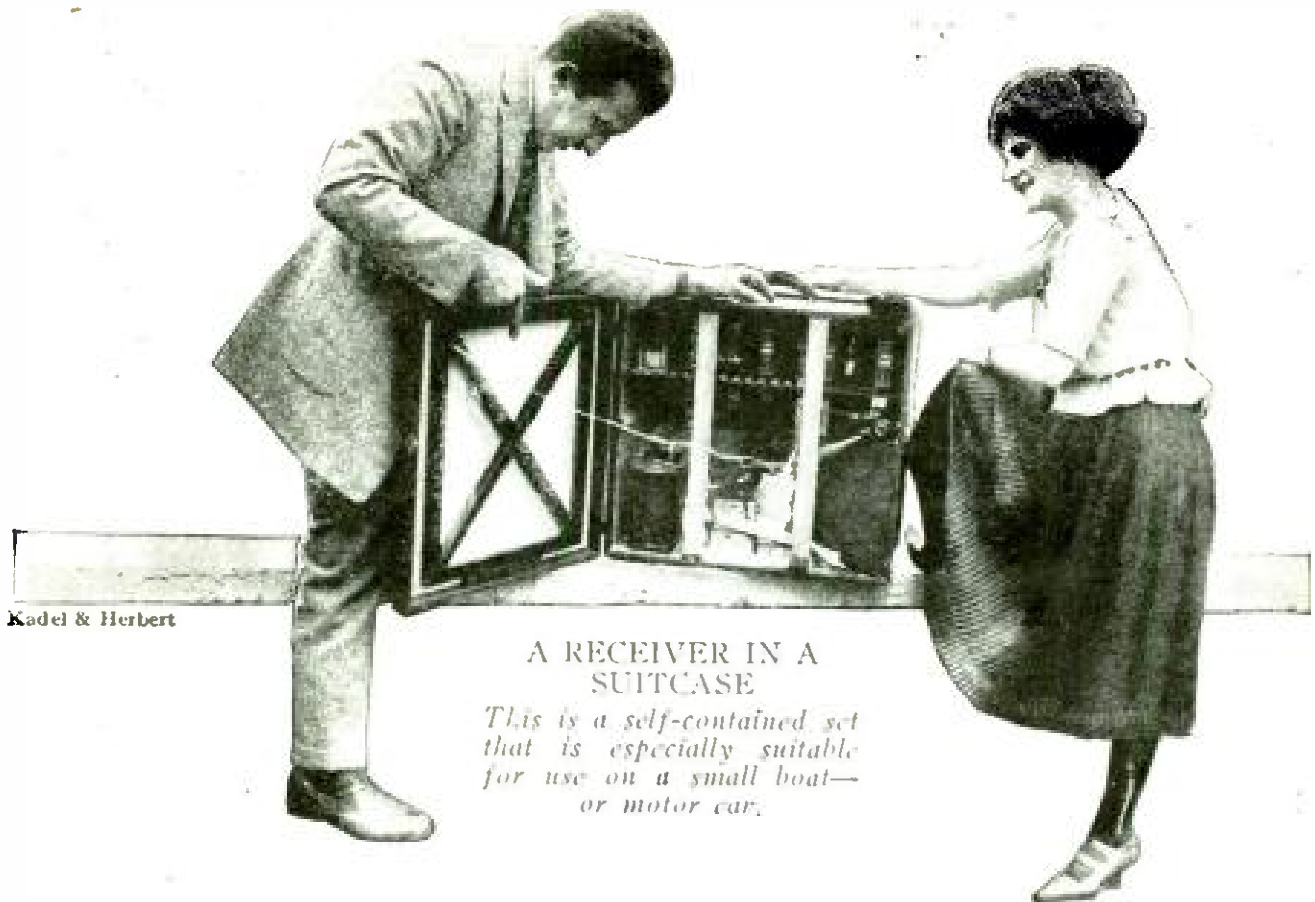

Kadel & Herbert

A RECEIVER IN A SUITCASE

This is a self-contained set that is especially suitable for use on a small boat—or motor car.

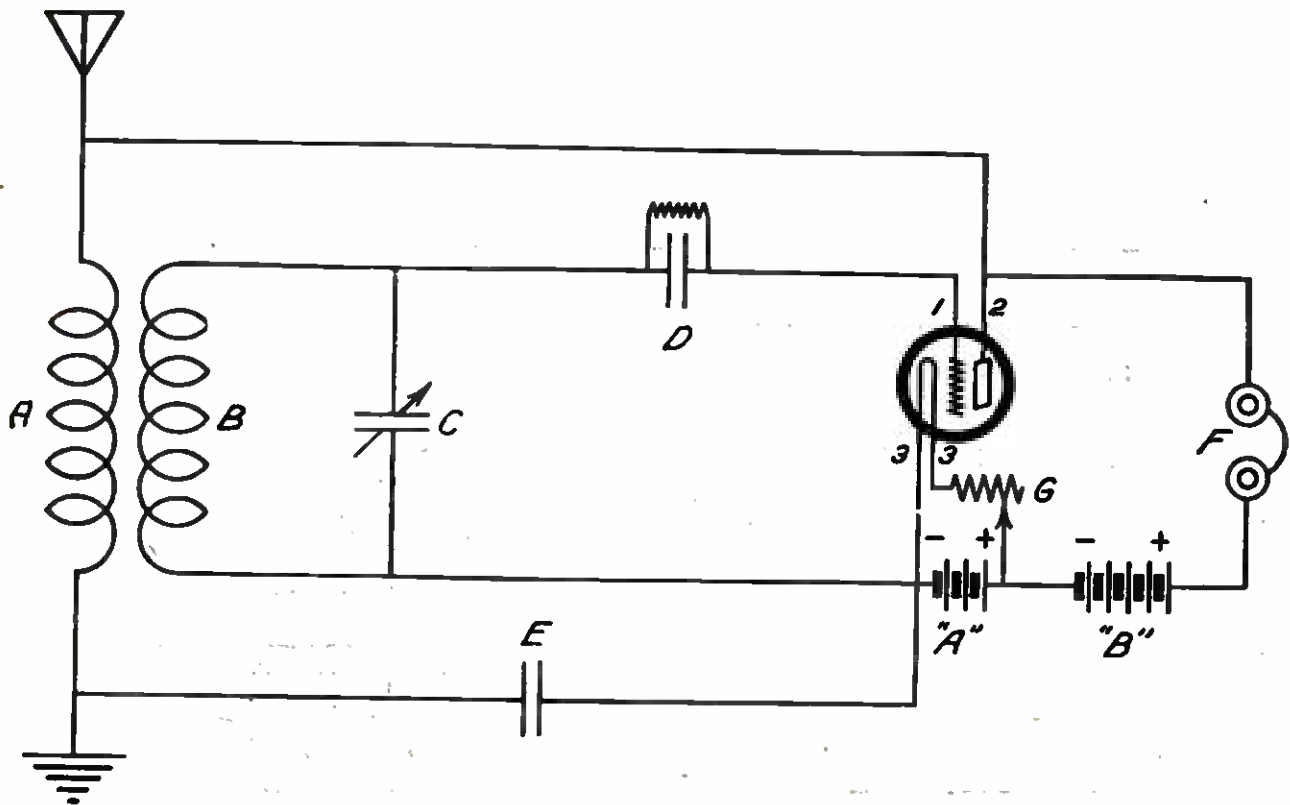
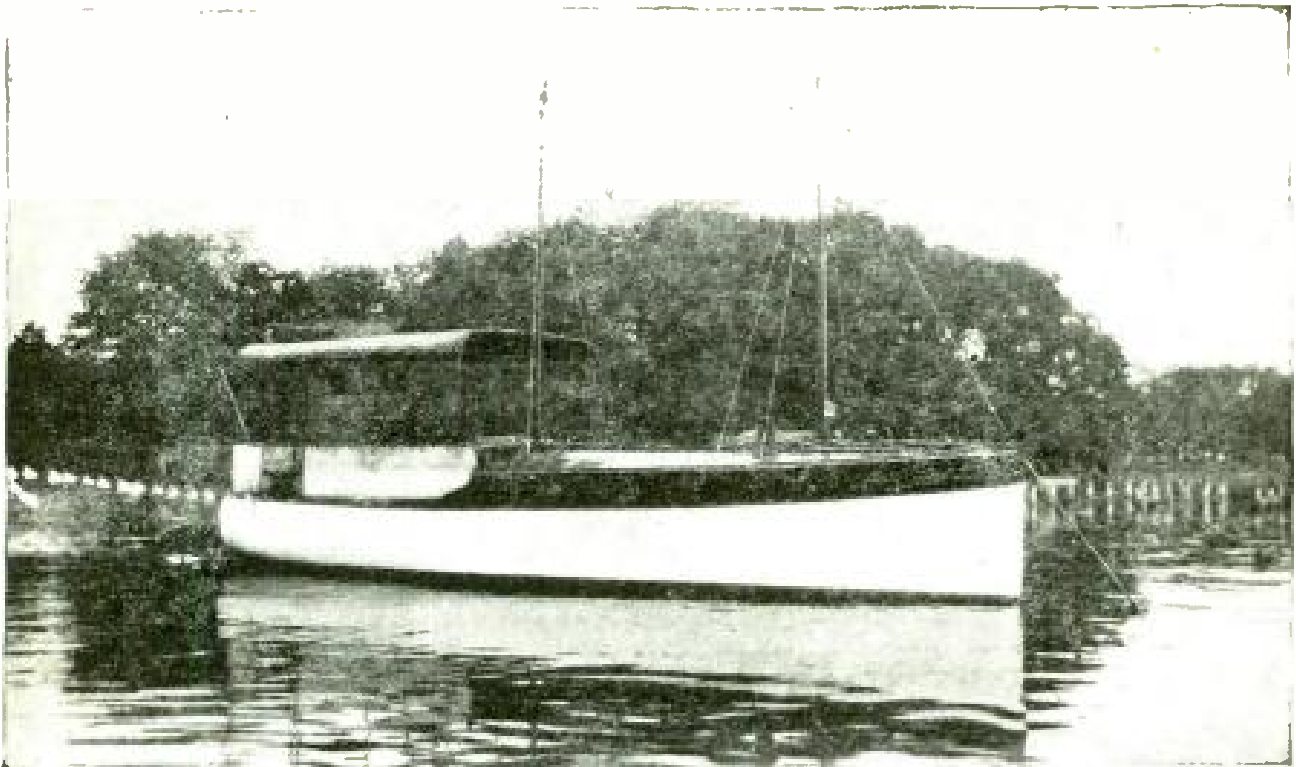

FIGURE 2: A circuit-diagram of a single-tube receiving set that uses a shore antenna and works on dry-cells, showing the connections for the instruments.



William Washburn Nutting

A THREE-WIRE ANTENNA ON A SMALL CRUISER

The wires are supported by three wooden spreaders that are fastened to the awning, the mainmast and the foremast. In this case the lead-in is taken off at the lower spreader aft.

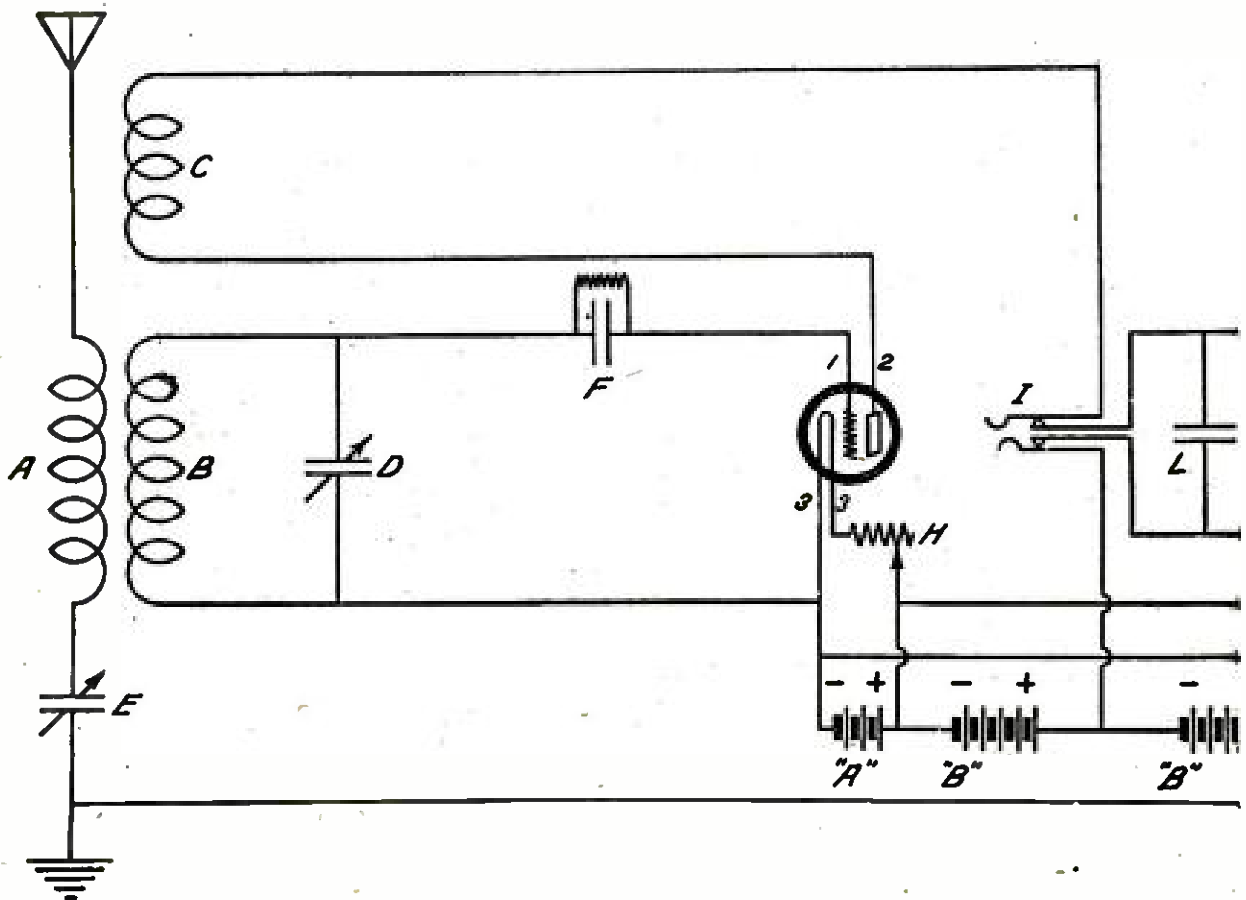

In any radio set the wiring should be done as neatly as possible. Try to keep the length of the wires as short as possible. Wiring that is laid out in neat angles looks pretty, but the straight-line wire, that covers the distance between two points in the shortest route, is by far the most efficient. In the amplifier, the wire from S-1 of the amplifying transformers to the grid of the tubes should be made as short as possible.

Do not use wire that is too light, and do not use wire that is too heavy. About size No. 20 will be suitable.

Another field for the marine radio set is in the houseboat. Here we have practically the same conditions as in the larger yacht on which any kind of a good set may be used. Remember that the same ground connections will have to be made, as were described in the first part of this article.

As a suggestion for the loudspeaker on this type of boat, where comfort is the first requisite, it would not be much of an undertaking to arrange the set in the main salon and have the boat wired up for numerous loudspeaker connections. A plug may be provided on the upper deck so that one of the crew can bring up the loudspeaker and plug it in whenever the owner so desires. Other plugs may be arranged

below, wherever necessary, so that the loudspeaker may be moved about at will and in stormy weather none of the delicate parts will be exposed to the elements.

The antenna is a simple proposition for such a boat; it is usually installed in the same way that a shore antenna would be put up—simply a pole fore and aft with two-foot spreaders, well insulated and with a lead-in wire dropping from one end. On any boat under fifty feet in length it would be best to use two wires, but for boats longer than this one wire will be suitable.

Lightning arresters should be arranged on any boat in the same manner as in shore installations.

There is no reason why radio should not be used just as much in the summer as in the winter; in fact on the water or in a bungalow, the radio set would do a great deal to fill the hours of vacation with real enjoyment. During the summer of 1922 good reception was the rule nearly every night. Of course, during thunder storms the set should not be used on account of the static, but these storms are usually of short duration and the set may be put into operation soon after the storm is over.

Still another form of antenna for a boat might be included in this list—

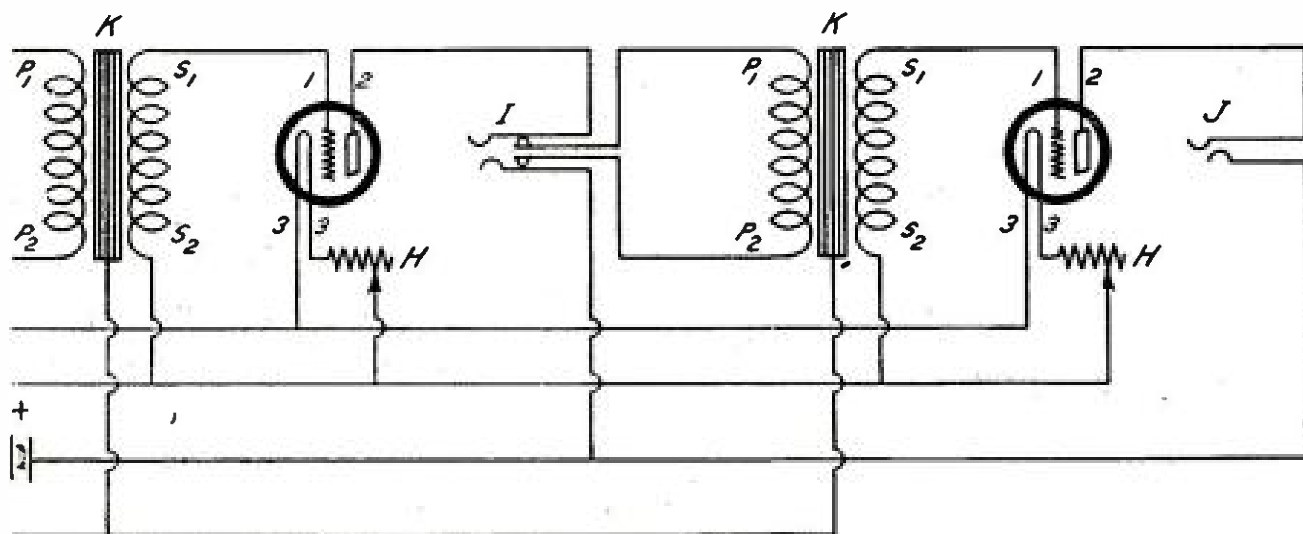

FIGURE 3: The circuit-diagram of a triple-coil set with two stages of audio frequency amplification. This set may be used with a loudspeaker.

the type used successfully on the Great Lakes during the past summer.

A piece of well-insulated rubber covered wire was dragged from the stern of a moving boat and connected to the set in place of the usual antenna. Results were really astonishing; often they were even better than with the usual overhead antenna. The wire, of course, was insulated from the surrounding water; the rubber insulation did not permit any of the water to get into the wire. The end of the wire (where it had been cut off) was incased in a small glass bottle and sealed in with paraffin.

If you own a small boat or canoe, get one of the many types of radio frequency sets that are now on the market and use it with a loop, or else get a tube set that operates on a one-and-a-half-volt tube and that employs an antenna fastened from boat to shore. The small cabin cruiser may have a

good set stowed away somewhere in a locker with an antenna stretched from stem to stern. The large yacht or houseboat may go the absolute limit in regard to equipment with a complete radio installation.

Some of the newer and larger yachts are equipped with sets of the finest manufacture, with licensed operators on board. Such yachts usually carry a regular commercial operator, a complete transmitting set and a sensitive receiver. The operator takes care of the tuning so that the owner and his guests may listen to the broadcasting on the after deck, and loudspeakers are installed for this purpose.

¶ *If you have a boat, no matter how small it is, equip it with radio and treat yourself and your friends to some really good music, while anchored in some snug cove for the night, or in the daytime. That is the best way to enjoy a cruise.*

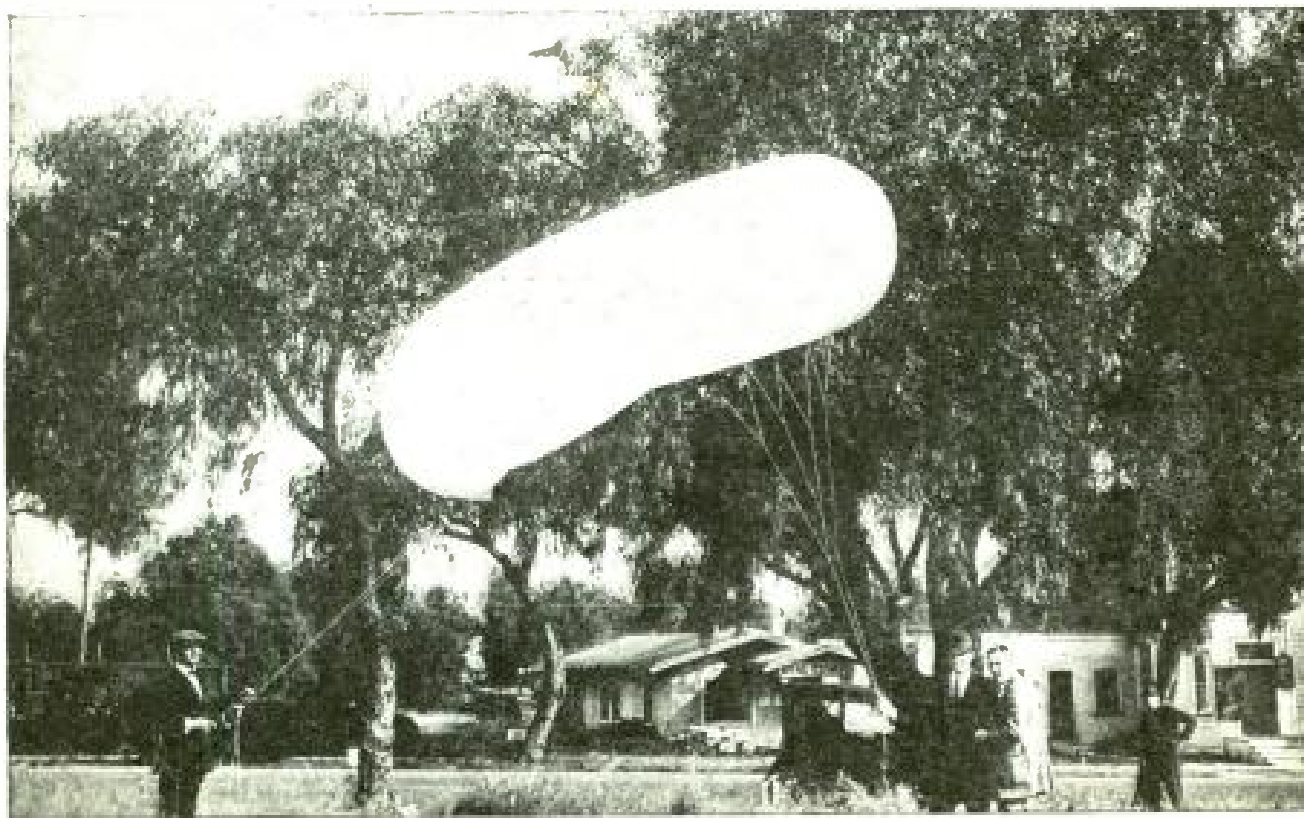

A BALLOON "MAST" FOR AN ANTENNA

When Marconi made his first successful experiments in transatlantic radio about twenty years ago, he attained the necessary height for his antenna wire by attaching it to a captive balloon. R. W. Coburn and Roy Knabenshue of California believe that this is a practical idea for use today; here is shown one of the first of the small balloons they have built for this purpose.



From a photograph by Hoppé, London

The Scientist Who Discovered the Electron

SIR JOSEPH J. THOMSON, Master of Trinity College of Cambridge, England, a student of the positive rays of electricity, is not only one of the most distinguished of living physicists but more than any one scientist he discovered how atoms are built up, what matter and electricity are made of, and what are the fundamental facts that underlie both physics and chemistry. Sir Joseph delivered recently at the Franklin Institute in Philadelphia a course of lectures which were among the most important scientific events of the year. By special arrangement with the Franklin Institute, following an interview by the editors of this magazine with Sir Joseph himself, POPULAR RADIO will shortly publish the first of a series of articles concerning some of Sir Joseph's most recent conclusions about electrons and atoms.





"WHEN A FELLER NEEDS A FRIEND"

"I had an uncomfortable feeling that the thing wasn't turned on; that somebody was playing a joke on me."

My Speech to a Tomato Can

When the Editor arranged to have "Briggs," the famous cartoonist, broadcast his maiden speech, he knew that POPULAR RADIO would get a frank confession of "how it feels." This is it!

By CLARE BRIGGS

SOME day, when I get around to it, I shall draw a cartoon on *what an announcer for the radio thinks about*. As he sits there night after night, introducing to a vast unseen audience famous men and women, listening to wonderful music, is his appreciation dulled? Is he no longer impressed with the marvel of sending his voice out to hundreds of thousands of listeners scattered over millions of square miles? Is it all just part of the day's work, or could a man *ever* get over the wonder and novelty of the thing?

I wonder!

Well, anyway, having talked to a radio audience myself, I am qualified to tell the world how the radio performer feels. And those of you who have been curious to know what that feeling is, need be

curious no longer if you will but follow my instructions. It's very simple:

Get an old tomato can, suspend it horizontally from the end of a pump handle, and talk to it.

It feels just like that to talk to a radio audience!

A pump handle may be rather hard to locate in this age and a water spigot positively will not do. I'd suggest—let me see—tying the garden rake across the top of the hall hat tree and hanging the tomato can on the end of that. The important thing is to get the can at about the level of your face—that is the purpose of the suspension.

Of course, you have to imagine that half a million people are listening to what you say, but that will be no harder than it was for me to convince myself that

anyone heard me, aside from a dozen or more people in the room, when I talked into WJZ's scientific tomato can at the Westinghouse plant in Newark.

I had a most uncomfortable feeling that the thing wasn't turned on; that someone was playing a joke on me.

In fact I didn't realize what happened until two days later when I began to get letters from people who had heard me hundreds of miles away. One friend had heard me at a summer camp up on the coast of Maine. The full weight of responsibility which had rested on my shoulders those few minutes that I "had the air" then first occurred to me.

It's an *awful* responsibility, this talking over the radio. Occasionally, when I have worn threadbare all the old excuses about a previous engagement, the pressure of business and the like, I have to address a gathering of some kind. You can always tell when your stuff isn't going over. An old-time audience is not without means of self protection. It can shuffle feet and chairs, cough and blow noses, and drop silverware (if it's a banquet). I flatter myself that I have never had an audience actually get up and walk out on me, nor have I ever been forcibly ejected from the premises.

But a radio audience has no comeback.



From a photograph made for POPULAR RADIO

"WHAT A BROADCASTER THINKS ABOUT"

"Not the least disconcerting forethought was that my family would be grouped around the set at home, snickering at Dad's homely utterances."

IT HAPPENS IN THE BEST REGULATED FAMILIES

APRIL 1922

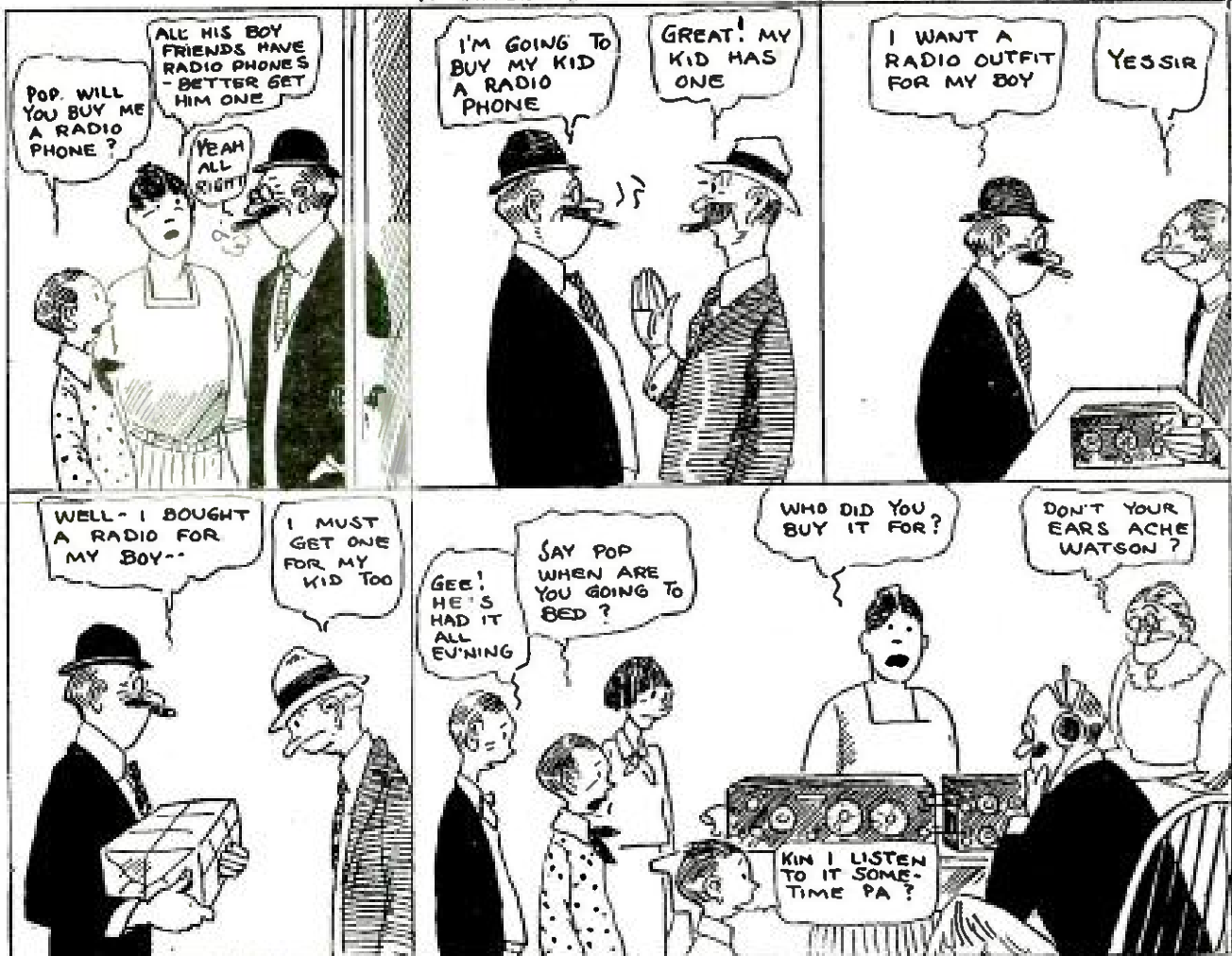

©1922, New York Tribune, Inc.

"IT HAPPENS IN THE BEST REGULATED FAMILIES"

"I have a notion that I ought not to make cartoons about any subject of which I have not first-hand knowledge," the author admits. So he bought a set—and drew this record of the results.

They've got to take what you hand them, or hang up. I suppose there is nothing so good goes over the radio but that a few listeners hang up, and nothing so bad but that a few simple souls continue to listen in. If there were only some kind of a meter to hang up before the radio performer which showed exactly how many persons are listening in! In justice to the great listening public, I think the inventors ought to get busy on such a device. Give the radio audience a comeback.

Now the radio performer can only imagine, as he steps up to the tomato can, that he hears the clatter of thousands of radio receivers being "hung up."

That tomato can transmitter is an austere and unencouraging device. You can't even be sure the darned thing is working, and if it is, whether the audience

(for which it is a single, sensitive ear) is smiling or gnashing its teeth. The poor performer can only sweat blood and imagine the worst.

I've been asked if I was nervous. Gosh, yes! If ever a feller needed a friend, I did then. I had been working myself up into a state of nervous excitement for a week before. What if my voice or delivery didn't "take," just as some good stage actors don't film well in the movies. I made up my mind that the razz-berry crop would be good this year.

I knew a little bit about radio before I went to WJZ. In fact that's one of the things that made me nervous—I knew *such* a little bit. I am not of a mechanical turn of mind. The one mechanical stunt at which I possess some genius is shutting off the alarm clock in the morn-

ing without having to wake myself up.

But I have a notion that I ought not make cartoons about any subject of which I have not first-hand knowledge. I also have a theory that the best cartoons are those which depict the everyday happenings in the average home. Radio has suddenly become an intimate part of the home life of the country. So, as a mere matter of business precaution, I had a radio set installed. When I was invited to speak from WJZ I felt that I really ought to take the opportunity to round out my radio experience. Immediately after accepting I regretted my business prudence in installing the set in my home. For not the least disconcerting forethought was that my family would be grouped around that home set, snickering as Dad's homely utterances came to their ears *via* nothing. (Nothing is technically correct, I believe. Dr. Steinmetz says there is no ether, and ether from ether leaves nothing.)

You may well imagine, then, the feelings of curiosity, expectancy and foreboding with which I journeyed to the Westinghouse plant. I suppose all radio fans have wondered what the inside of the studio looks like, what kind of a chap the announcer is and whether he wears a mustache. I'll settle the most important point first; he doesn't.

I was wrong about the studio, too. It looks like a studio—nothing more. There was no complicated electrical apparatus in sight—just a couple of pianos, several phonographs, at one end of the room a library table, divans and chairs grouped about a big fireplace. The only mysterious thing in sight was the pump-handle-tomato-can apparatus and beside it a cabinet shaped like a phonograph which contains some of the electrical apparatus.

I arrived a good hour before my scheduled talk, but already several people were present and the announcer (I recog-

nized his voice at once) was repeating baseball scores into the tomato can. It was a hot summer evening and those in the studio had laid aside all unnecessary clothing, giving the gathering a most informal aspect. Pretty soon the perspiring man in the chair next to me, without coat or collar, was introduced to the tomato can as a famous tenor. The practical appearing young person in the next chair, who might have been someone's stenographer, turned out to be a Spanish prima-donna!

One after another the tenor, the prima donna and a jazz band did their bit. Then I approached the tomato can for my turn. And what do you suppose I was thinking of?

There flashed into my mind the almost forgotten incident of the first time I ever talked into a telephone. I was five years old and wise enough to let my elders know before they placed the receiver to my skeptical ears, that they couldn't fool me into believing that I could actually speak to and hear someone a mile away!

I felt again as though someone were trying to "kid" me; that I was the victim of some kind of a hoax. Even here, inside a real broadcasting station and listening first-hand to one of the concerts which I had heard over my radio set, it was hard to believe these sounds got beyond the four walls of that room.

* * *

Up on the roof.

The stars are shining and the wires of the big antenna are silhouetted against the moon. The air is perfectly still; not a sound from the wires or a flash of sparks; not a sign that down below a singer is singing and that out in the night thousands of people are listening to her song. Uncanny!

* * *

Wonder what an announcer thinks about?

To prepare himself for his work as a poet. Gelett Burgess graduated from the Massachusetts Institute of Technology as a Civil Engineer—and then became a humorist! His experience in both roles was called upon when he put up his radio set. Just what happened is the subject of an article by him to appear shortly in POPULAR RADIO.

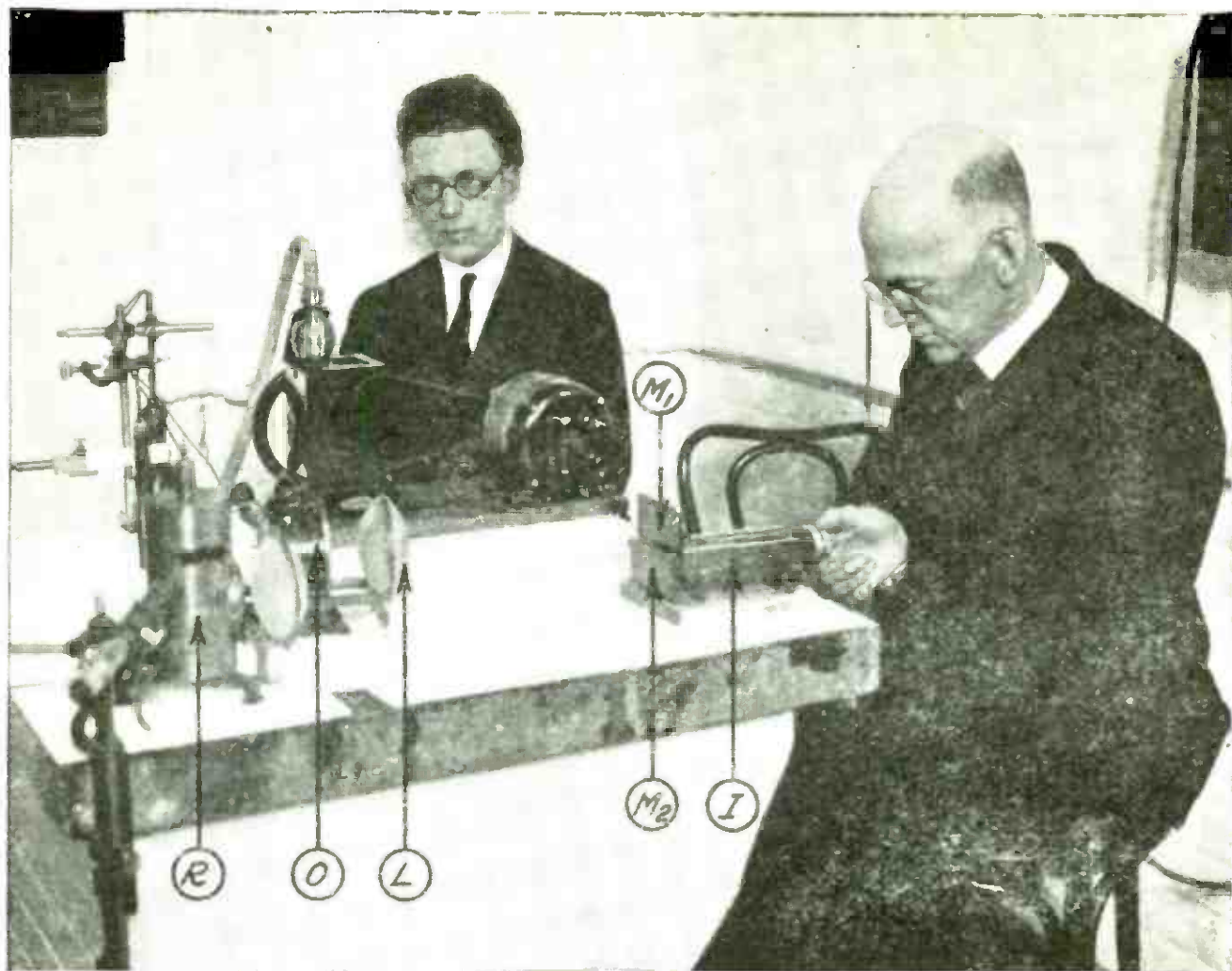

From a photograph made for POPULAR RADIO

SENDING AND RECEIVING RADIO WAVES 1/100TH OF AN INCH LONG
 FIGURE 1: At the right is Dr. Nichols, formerly president of Dartmouth College and director of the laboratory of pure science at the Nela Laboratories of Cleveland, and his associate, Dr. J. D. Tear. O shows the transmitter, R the receiver, L the condensing lens, and M_1 and M_2 the reflecting mirrors of the wavemeter I.

The SHORTEST RADIO WAVES

Ever Produced by Man

In this remarkable article, which constitutes a real and valuable addition to the literature of science, the author describes in specific detail and for the first time his experiments with wave impulses so short that they span at last the gap between heat waves and radio waves.

By ERNEST FOX NICHOLS, D. Sc., LL.D.

THERE is no more fascinating chapter in the whole history of science than that dealing with the evolution of the various theories of light and the progress of our experimental knowledge with which these theories must square.

For nearly three hundred years there was strife among physicists—"philosophers" they were then called—as to

whether light was due to countless myriads of minute imponderable corpuscles shot out along straight lines in every direction from a source of light, or whether light was an orderly wave motion spreading out radially in all directions in a universal imponderable medium called the ether.

Young's discovery of the interference

of two beams of light made in the first year of the last century was a decisive experiment in favor of the wave theory and would doubtless have convinced all scientists had it not been for the very great authority of Sir Isaac Newton which had come down through a century and a half. Newton in his day was unfortunately an advocate of the corpuscular theory. What was known of light at that time seemed more easily explained by corpuscles than waves. Newton was beyond question one of the greatest and most progressive thinkers of all time, and had he been alive would have been among the first to recognize the convincing evidence of Young's experiment. But Newton dead proved a most formidable obstacle to progress.

Young not only proved the wave theory but actually measured the wavelengths of light of different colors showing a progressive increase as we go from violet through blue, green, and yellow to the extreme red. Thus the wavelength of yellow light situated about midway in the orderly spaced band of color which we call the normal spectrum is approximately 1/50,000th of an inch. From this time on to the middle of the century, increasing and more convincing evidence of the wave theory slowly accumulated until Foucault found the velocity of light in water less than in air by an amount in exact accordance with the requirement of the wave theory, while the corpuscular theory required just the reverse, i. e., a greater velocity in water than air.

Thus the wave theory was finally and firmly established.

Fifteen years later, Maxwell proposed a new theory concerning the nature of light waves which he based on Faraday's experiments. Maxwell's theory at the time it was proposed proved as abstruse and baffling for the physicists of his day as we find Einstein's generalized theory of relativity in ours. In fact, Maxwell was the Einstein of his generation and succeeded in puzz-

ling everybody. Maxwell's theory asserted that light was an electric wave disturbance in the ether caused by astoundingly rapid vibrations of electric charges in the source of light. One of the chief difficulties in believing that light waves were electric waves was that in those days nobody had any electric waves to compare them with nor any indication that electric waves were possible.

In the next decade the Berlin Academy of Sciences became interested in Maxwell's theory and offered a prize to anyone who would give experimental proof of its fundamental assumption. Not long after this prize was offered, Von Helmholtz called the attention of one of his most promising students to it. That student was Heinrich Hertz who later not only obtained electric waves some two feet long in the laboratory but went further and performed with them a number of experiments demonstrating that these waves, like light, were reflected from surfaces, bent from their course by prisms, and that they traveled through space with the velocity of light.

Hertz's successors worked in two different directions. Righi, the Italian, and a number of other physicists worked toward shorter and shorter electric waves and repeated with them more and more of the classical experiments with light. Sir Oliver Lodge, Guglielmo Marconi, a brilliant young Italian experimenter, and others were inspired by the idea of making electric waves a means of signalling and communication. They worked toward longer and longer waves because long waves carry further and are not so easily scattered by obstacles. As we know, Marconi won in the long-wave contest and from his success we now have radio telegraphy, and with the advent of the vacuum tube, we have the greater marvel of radio telephony. Thus Hertz worked indefatigably to discover electric waves in order to prove that Maxwell was right,

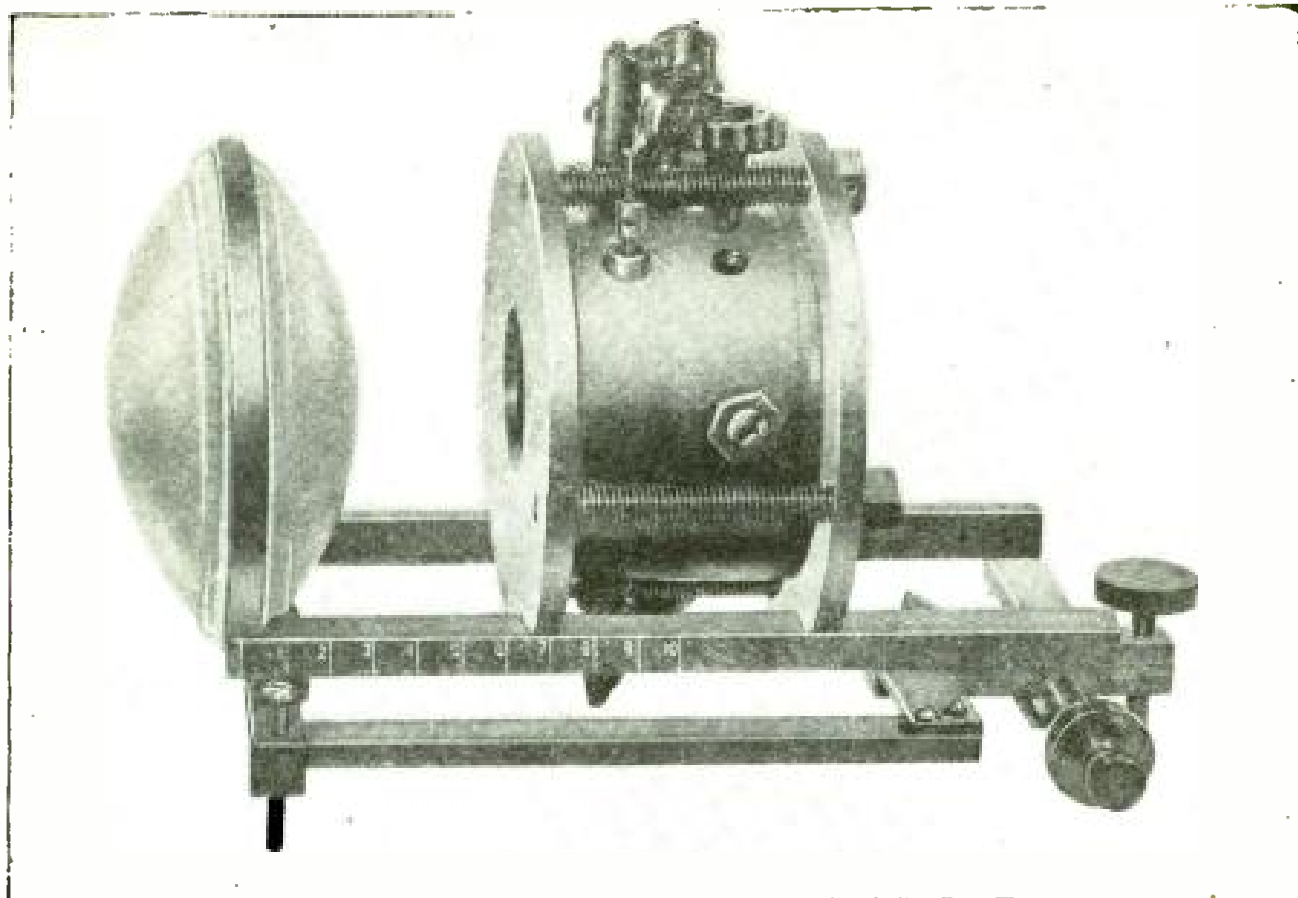

From a photograph made for POPULAR RADIO

THE TRANSMITTER UNIT FOR PRODUCING MICROSCOPIC WAVES

FIGURE 2: *This is the delicate machine for sending out the new waves. Notice the concentrating lens of paraffin which is brought into proper focus by rotating the small knob at the lower right hand portion of the instrument.*

that light waves *were* electric waves. His discovery with its consequences is but one of an accumulating number of instances in which astoundingly practical results have followed directly from the most abstruse workings of the scientific imagination.

Alongside of the discovery and development of electric waves, great progress was being made in the investigation of light and heat waves. Explorers pushing out into the dark spectrum below the longest visible red waves had extended the known region to a wavelength of about 1/10,000th of an inch, or five times the wavelength of yellow light. At this point our illustrious countryman, Professor Langley, began his labors in 1883 and extended the known wavelength region fourfold. Fourteen years later a new method for sifting out and isolating the long wave radiation from the total output of a light source

such as a candle flame or a Welsbach gas mantle was discovered by Rubens and Nichols. This method led to an extension toward long waves of more than ten times Langley's outer limit. Another twofold extension was accomplished by a further advance in method due to Rubens and Wood, and finally in 1911 heat waves 1/75 of an inch in length had been successfully isolated, measured, and their properties studied. But there was still an unbridged gulf between the shortest electric waves and the longest heat waves, for the followers of Hertz and Righi had been stopped in their progress toward shorter waves at waves about 1/3 of an inch in length.

In some experiments now in progress at the Nela Research Laboratories at Cleveland, Dr. J. D. Tear and I, by the devising of new instruments and methods of experimentation, have suc-

ceeded in generating and working with electric waves as short as 1/100th of an inch.

Stripped of all accessories and reduced to its essentials, the apparatus used appears in Figure 1. O is the sender unit (better seen in Figure 2). It consists of an oscillator box with necessary adjustments and a paraffin condensing lens. I is a reflection interferometer or wavemeter and R the receiver, with its condensing lens of paraffin.

Figure 3 is a diagram showing the essential parts of the oscillator in which H_1 , H_2 represent two very small cylinders of tungsten separated at the middle by a very short spark gap G, the whole submerged in kerosene. These tungsten cylinders sealed in the thin closed ends of the glass tubes T_1 , T_2 form a Hertzian doublet, which serves as the oscillator or wave source. The doublet is energized by charges communicated to it by the high potential leads V_1 , V_2 from an induction coil. Charges leak across air gaps A_1 , A_2 until H_1 , H_2 are charged to a sufficient potential difference to

break down the kerosene insulation in the spark gap G, when a spark passes, and an oscillating discharge of short duration ensues causing the emission of a short-wave train such as indicated in the diagram. The wavelength of the emitted radiation depends on the dimensions and mounting of the tungsten cylinders H_1 , H_2 . For the shortest waves obtained the cylinders were 1/250th of an inch in both diameter and length.

The divergent radiation from the oscillator is gathered into a kind of searchlight beam by the paraffin lens L, and, after reflection from the wave meter I, Figure 1, is picked up by a similar lens and brought to a focus on the sensitive surfaces of the suspended system inside the receiver case R. This receiver is of new design and depends on the following principles for its operation:

(1) Whenever electric waves fall on the surface of a conductor, they cause weak oscillating currents of the same frequency in the surface layers of the conductor. Due to the resistance of the conductor, these currents are converted

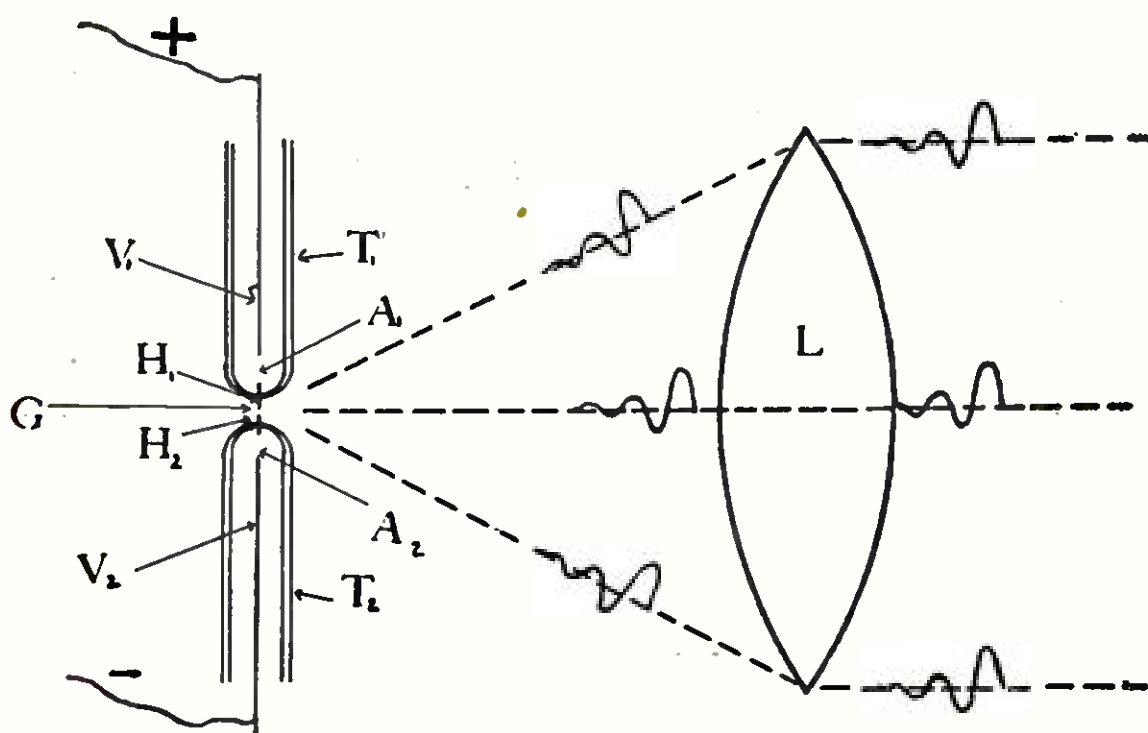

HOW THE OSCILLATOR WORKS

FIGURE 3: The transmitter is really an extremely small adaptation of the famous Hertz oscillator. The ingenious method of exciting the oscillator is described in the text on this page.

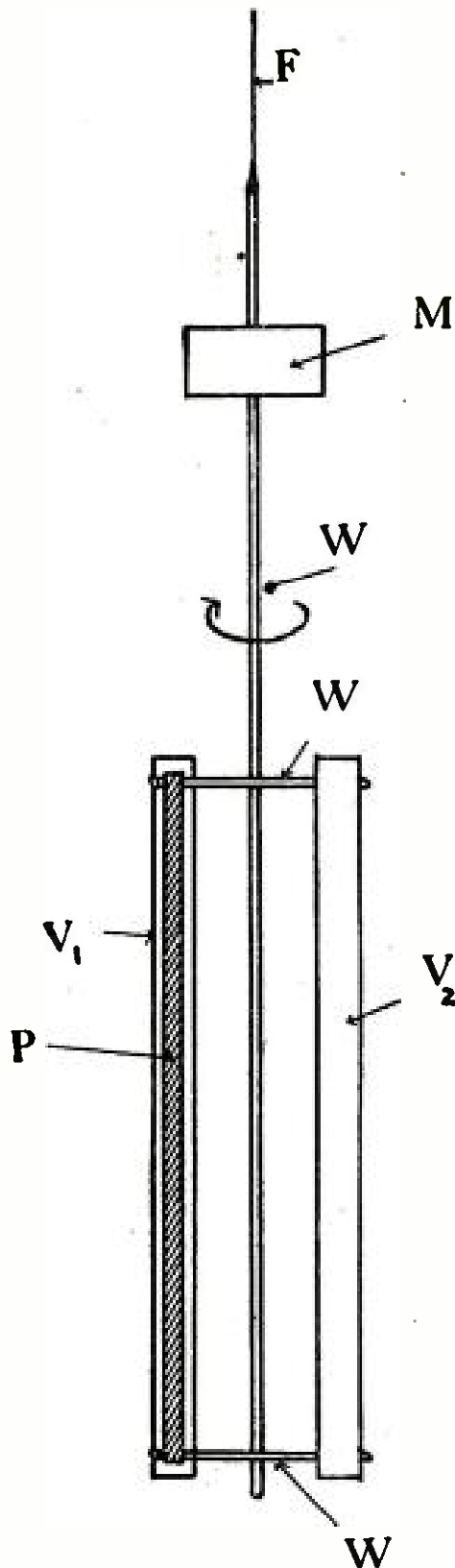

THE RECEIVER SUSPENSION
(Greatly enlarged)

FIGURE 4: This part of the receiver, which is suspended by a quartz fiber, is an ultra sensitive detector and depends on the discovery of Sir William Crookes, that a slightly warmed surface in a partial vacuum suffers a small repulsive force, for its operation.

into heat, and the conductor is very slightly warmed.

(2) The most sensitive means known for measuring small differences of temperature was discovered by the late Sir William Crookes who found that a slightly warmed surface in a partial vacuum suffers a small repulsive force.

With these two principles in mind the construction of the receiver suspension shown diagrammatically in Figure 4 will be easily understood. The skeleton of the system is formed of very thin whips of drawn glass *W*. The central axis is suspended from the top of the receiver case *R*, (Figure 1) by a very fine quartz fiber *F*. The suspension is thus free to turn but its turning is faintly resisted by the twisting of the fiber. *V*₁ and *V*₂ are small thin strips of mica attached to the cross arms. Just in front of *V*₁ and just behind *V*₂ is a still narrower mica strip thinly coated by a deposit of metallic platinum *P*. When electric waves fall on this system, the strips *P*, are warmed and the Crookes force tends to rotate the suspension against the torsion of the quartz fiber. Under properly controlled conditions, experiment has shown that the angle through which the quartz fiber is twisted is proportional to the intensity of the electric waves falling on the receiving surfaces. Just to the left of the receiver *R* in Figure 1 is a telescope by which the rotation of the suspension is read in the mirror *M* seen through a small window in the receiver case. The weight of this suspended system complete is less than a milligram or less than one thirty-thousandth of an ounce, and the temperature differences measured by the rotation of the system were certainly smaller than one ten millionth of a degree.

The wavemeter *I*, (Figure 1) makes use of the phenomenon of interference for wavelength measurements. The beam of radiation from the sender falls in equal parts on the two parallel mirrors *M*₁, *M*₂. When *M*₁ is slightly be-

hind M_2 as shown, a wave train reflected from the upper mirror has a longer path to follow from sender to receiver than the same train reflected by the lower mirror, and hence it is delayed and when the two halves of the beam are reunited at the receiver, the separated wave trains may no longer match. By varying the distance by which the plane of the mirror M_1 is behind that of M_2 , wave crests in one beam can be made to fall on the earlier wave crests of the other, and thus the two beams reinforce each other. On the other hand, wave crests of one can be brought together with the wave troughs of the other, and the two made to weaken each other. Observed positions of the mirror M_1 for reinforcements and neutralizations thus give a direct means for measuring the wavelength of the radiation.

As this wavemeter tells little concerning the wave form, a whole new wavemeter was devised. This instrument, shown in Figure 5, is in the form of a staircase made of a pile of eight exactly equal brass blocks. The back corners of the blocks rest against a

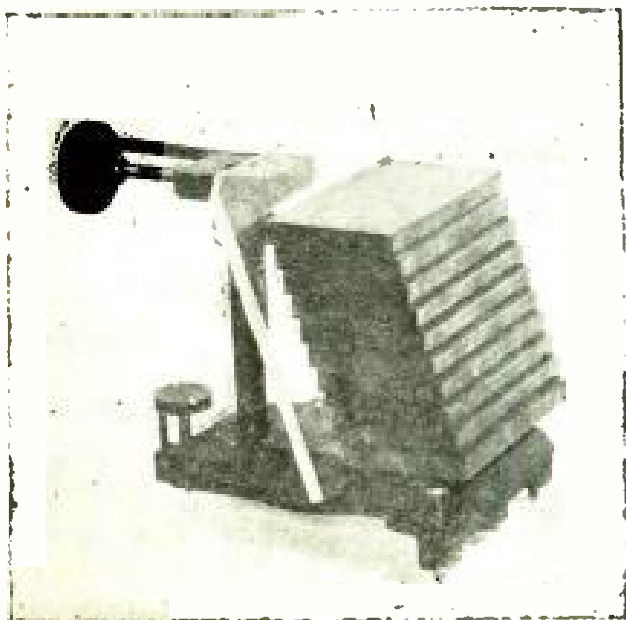

From a photograph made for POPULAR RADIO

THE NEW ECHELON INTERFEROMETER AND ANALYZER

FIGURE 5: The special instrument that has been devised in the experimental laboratory for the special purpose of studying and measuring the new wave.

slanting plate of glass the tilt of which and consequently the width of tread of the steps can be regulated and measured by a micrometer screw seen at the top. The way a single wave-train from the sender is divided up after reflection from the risers of the steps is shown diagrammatically in Figure 6, B. A shows the outline of the steps, and C is the wave form obtained when the short individual wave trains are brought together again at the receiver. By varying the width of the steps, this instrument gives a complete analysis of the wave trains showing both length and form.

The simplicity of the principles involved in these experiments and the homely character of the apparatus used may easily conceal the almost vanishing smallness of the effects measured and the great experimental difficulties which had to be overcome.

With the instruments and methods indicated we have not only artificially manufactured and measured electric waves 1/100th of an inch long but have used our electric wave receiver to de-

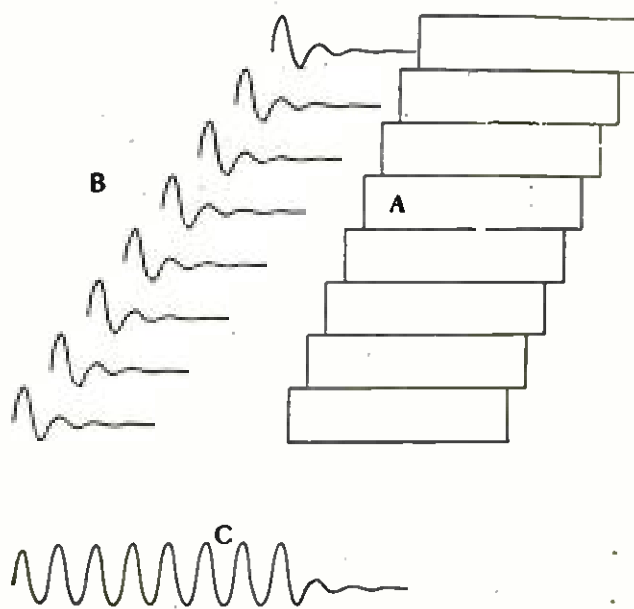
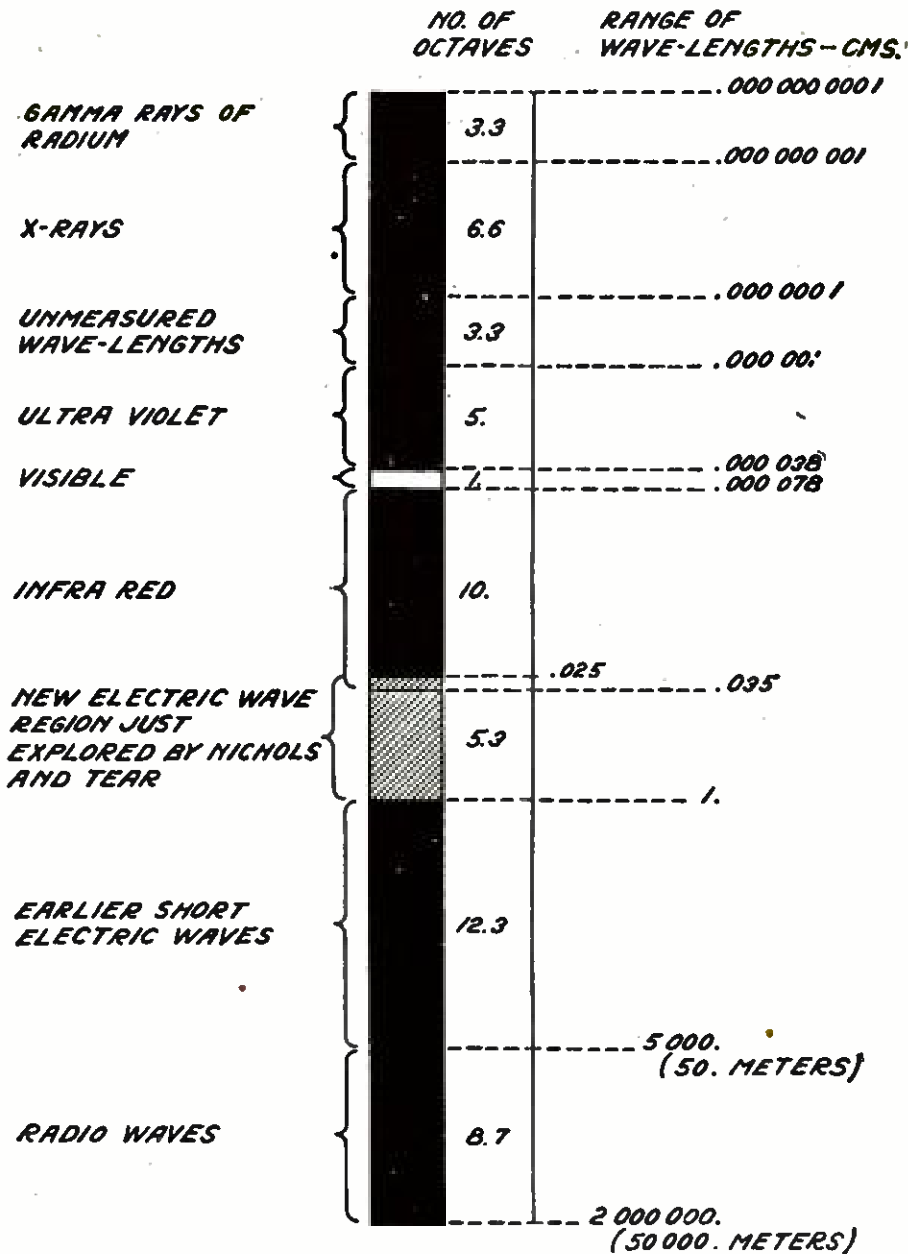

DIAGRAM ILLUSTRATING HOW THE ANALYZER WORKS.

FIGURE 6: The analyzer A breaks up a single wave front into separate wave trains B. The wave form obtained by re-combining the trains is shown at C.



THE COMPLETE ELECTRIC WAVE SPECTRUM
(Plotted in octaves)

FIGURE 7: The chart shows the wavelength relations and names of the various spectral regions. Notice how narrow is the band of visible light, which affects our human vision; this is shown in white. The new band of waves (shown in gray) links up the complete spectrum from the gamma rays of radium to the enormous waves employed in radio.

tect and remeasure the 1/75 of an inch heat waves obtained from hot bodies. Thus, for the first time, waves from hot bodies and artificially generated electric waves of the same length have been obtained, compared, and found identical in character. This experiment then supplies the last link in a long chain of experimental evidence connecting light with electric waves and furnishes a final proof of Maxwell's electromagnetic theory of light.

It is finally clear that not only radiations emitted by highly heated bodies including infra red, visible, and ultra violet waves are electric waves but so also are X-rays and the gamma rays from radium. Thus the true electric wave spectrum is expanded to an enormous extent for a twenty thousand meter radio wave is twenty million billion times as long as a short gamma wave.

Of the many new things thus revealed

none is more surprising than the very narrow limitations of the eye in perceiving electric waves as light. Its entire range from furthest violet to deepest red is only from a wavelength of fifteen millionths of an inch to one of thirty-one millionths of an inch. It is not possible to show such small detail and such vast extent as is embodied in the electric wave spectrum by any chart laid out in simple proportions, for if we represented the length of the visible spectrum by a quarter inch space, then the whole ultra violet, X-ray, and gamma ray spectra are crowded into another quarter inch space at the left, and on the right the infra red spectrum reaches out to the longer electric waves which extend to long radio waves at a distance of 100,000 miles away—surely an unwieldy chart!

The electric wave spectrum can be manageably mapped, however, if we lay it out on a chart by octaves like the keyboard of a piano, remembering that the wavelength of the sound of the first C above middle C has a wavelength one-half that of middle C, and that the first C below middle C has a wavelength

which is twice as long as middle C.

In Figure 7 such a chart of the electric wave spectrum is shown. On the left are the historic names of the different regions of the spectrum, and braces are attached to show their extent on the black strip representing the spectrum itself. Beyond, the number of octaves of wavelengths is shown for each region, and furthest to the right the wavelengths corresponding to the approximate regional boundaries are given in centimeters. On this chart the length of the visible spectrum becomes our measuring rod for it is very nearly an octave in extent, a single octave out of the more than fifty-five octaves shown on the electric wave spectrum in the present chart.

With the chart before us, it is also interesting to note that we get ultra violet, visible, and infra red waves from heated bodies but not X-rays, gamma rays, nor what used to be called electric waves. Electric pulses or partial waves we get from electric disturbances in the atmosphere called "static," and gamma rays are of natural origin in the disintegration of radioactive substances.

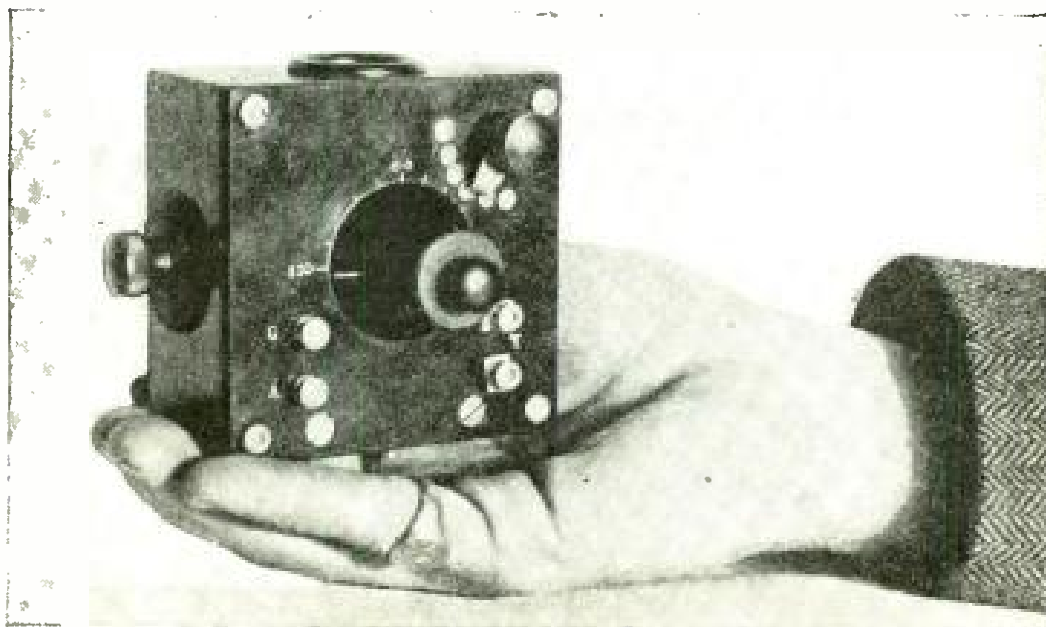

International

IS THIS THE SMALLEST REGENERATIVE SET IN THE WORLD?

Although this miniature set measures only 3½ by 3¼ inches in size and is literally small enough to fit in the palm of your hand, it is not only a vacuum tube set but it employs a regenerative circuit. It has picked up amateur sending over a distance of 800 miles. It was built by Roslyn Russel, a Niagara Falls amateur.

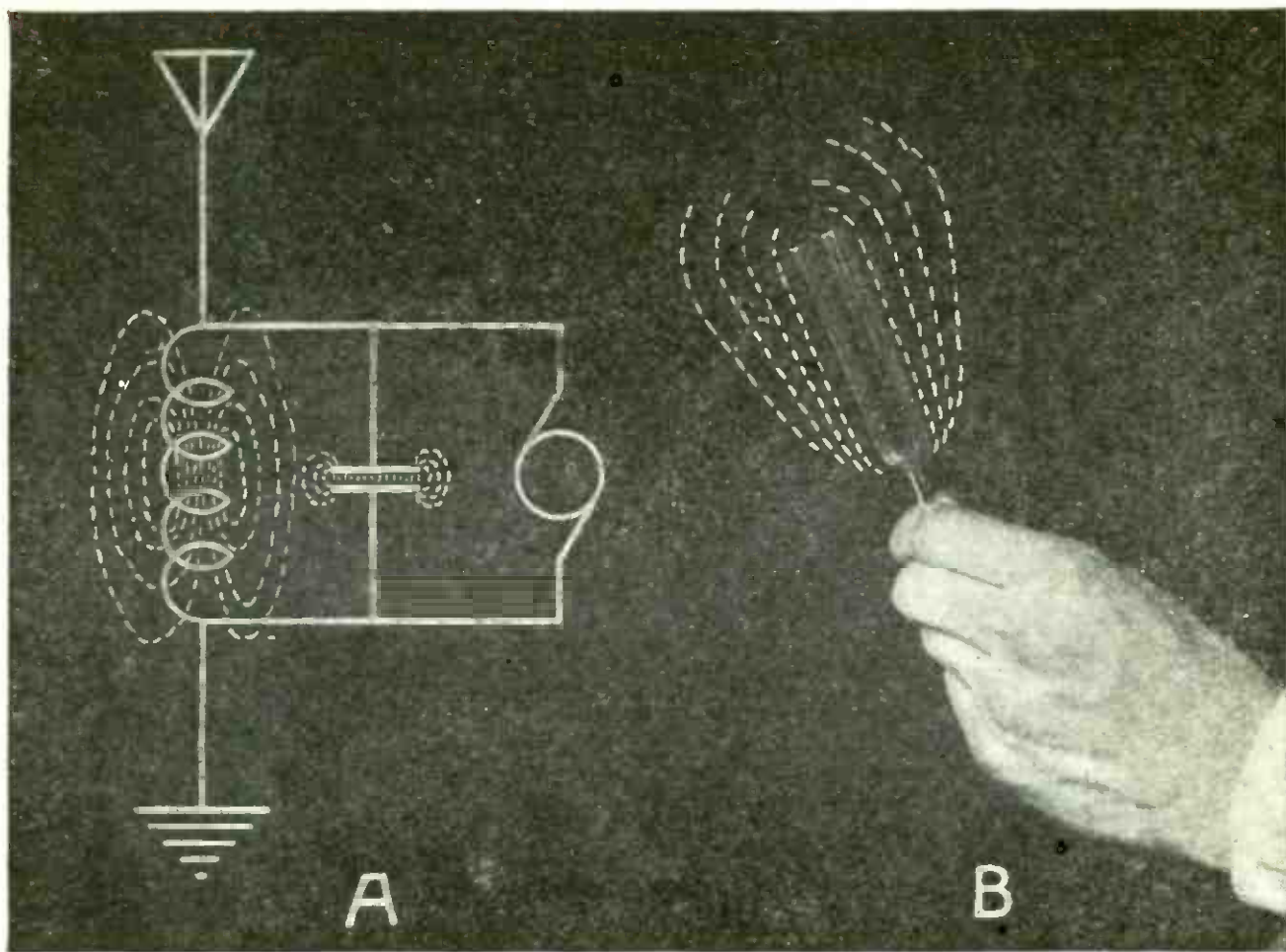

From a diagram made for POPULAR RADIO

THE SIMILARITY BETWEEN THE VIBRATIONS OF AN ELECTRICAL CIRCUIT AND OF A TUNING FORK

In case B the fork is set into vibration by striking against some rigid object and sound waves are given off. In case A, the oscillatory antenna circuit is set into electrical vibration by an impulse from the generator (shown as a circle), and electric waves are propagated. In both cases the energy alternates from a static form to a kinetic form during each oscillation.

THE RATIO IN SIZE BETWEEN Your Antenna and Your Coil

The Fourth of a Series of Articles Written for POPULAR RADIO

"I propose here to interpolate, among calculated and practical considerations, a little theoretical point of some interest. For radio fans and amateurs surely like to think occasionally of the ether whose properties they are utilizing."—AUTHOR

By SIR OLIVER LODGE, F.R.S., D.Sc., LL.D.

IN electromagnetic waves the electric energy and the magnetic energy are equal. Or in more general terms, in every wave or system of waves, the kinetic and the potential energies are equal. This is obvious, because the energy alternates from one form to the other. At one instant it is static; at

the next it is kinetic. Hence the two energies must be equal.

So it is also with the discharge of a Leyden jar, or any other capacity area. At one instant it is charged electrically, and at the next (that is, after a quarter swing) it is momentarily discharged, and all the energy is con-

tained in the rushing current. Then once more the energy piles itself up statically in the opposite direction, and then swings back again. So it is, even in a swinging pendulum: the potential energy at the end of the swing is equal to the kinetic energy in the middle. So it is, also, in a vibrating spring.

Consider, then, a spring with a load on it, which you can set vibrating. At the extremity of the swing the energy can be called "elastic energy," or the energy of recoil. It is static. It depends on the elasticity of the spring: it does not depend on the inertia of the load. It does not depend on inertia at all; it would be the same if the spring was bent an equal amount and not loaded.

But now let the spring go, and consider what happens as the load is rushing past the middle position. The whole energy is now the energy of movement. It depends wholly on inertia, that is, on the massiveness of the load: it does not depend on the elasticity of the spring at all. It would be just the same for the same moving load if the spring were instantaneously abolished.

This energy may be called "inertia energy," or the energy of current or movement.

The elastic and the inertia energies must be equal. The spring adapts itself to them. Its rate of vibration is thereby determined. If it is a very stiff spring with a small load it will vibrate with extreme rapidity. It must—in order that the motion energy can equal the elastic energy. If, on the other hand, it is a weak spring heavily loaded, it will vibrate very slowly; because, since the energy is small, the motion of a massive body must be slow.

All this is elementary and simple mechanics. But now apply it to the electrical analogue. Are we to regard a Hertz vibrator, or a radio transmitting station, as represented by a stiff spring

and a light load, or a feeble spring and a heavy load?

Or again, should we not rather try to arrange it so that the spring is moderately stiff and the load moderately massive, the one being adapted to the requirements of the other, and neither being over-balanced by the other?

Now in the electrical case, the oscillating thing is a group of electrons. They are very highly charged, but they are certainly not massive. They possess a kind of inertia due to the magnetic field which surrounds them when they are in motion. But the magnetic field due to a moving charge is but feeble, unless the charge is great and the motion exceedingly fast.

Now the electrons, though not massive, are highly charged, and they are presumably moving very quickly. Hence their current or magnetic energy is by no means negligible. But to bring it up to the required amount we must magnify it by coiling up the path of the electrons into a close spiral, so that all the magnetic fields reinforce each other, and give a large combined result. In that way, by the use of a sufficient coil, we may make the inertia what we please, and obtain the required amount of kinetic energy.

Now what about the static energy?

Here we must regard the ether as strained. And the ether's rigidity is excessively high. We know that; because of the rate at which light travels. Its elasticity compared with its density is accurately determined as equal to the square of the velocity of light; that is to say the ratio of the two is excessively great. A very small amount of distortion will account for a great amount of energy. But, to make room for all the electrons which are to take part in the discharge, an extensive area is required. If we use only a small area, we can hardly get any charge in it. It is like trying to bend a very stiff spring.

A tuning fork, for instance, can be

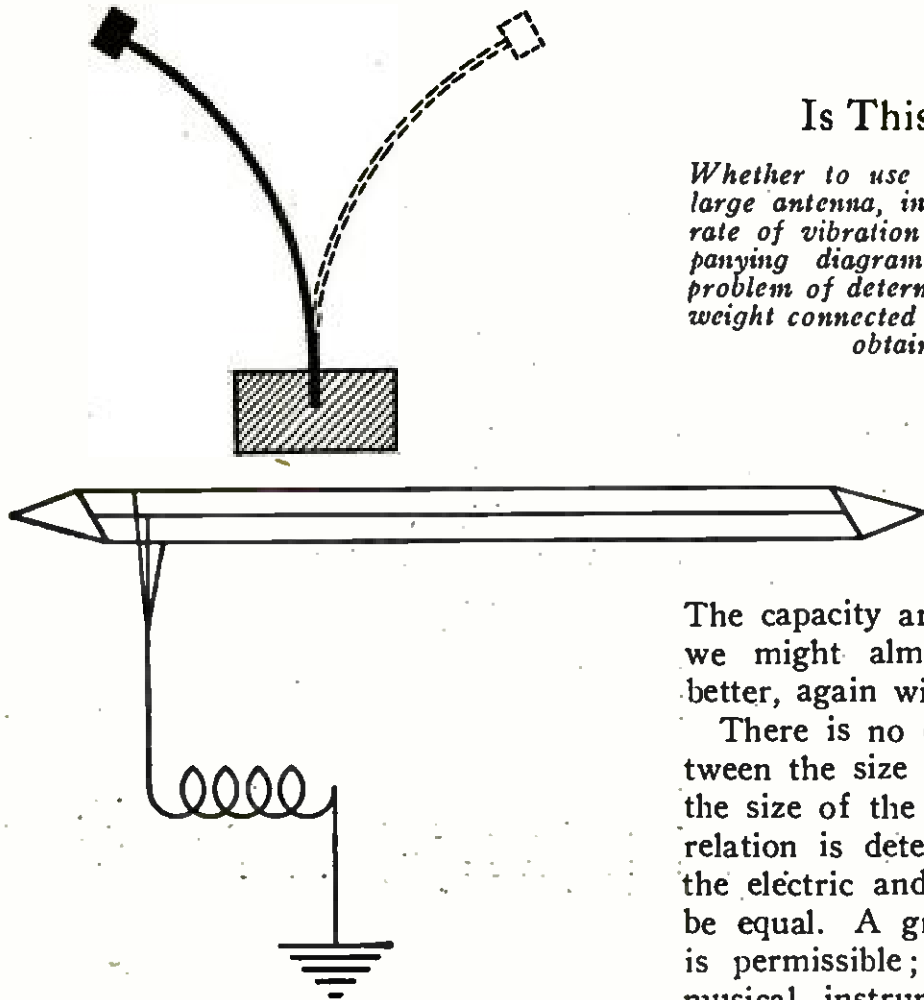

A

excited by a blow, or by a succession of timed impulses in synchronism with its natural period—which is practically what a violin bow does. Such a bow grips and releases a string or a spring in a synchronous and therefore effective manner. But a tuning fork hardly yields to a steady pull. The amount a small force can thus bend the prong of a stiff fork is insignificant. To be able to bend it sufficiently the spring must be long. And the greater the rigidity of the material the longer it must be. That means that in order to get an effective capacity area, it must be of large extent. It must be the most visible and conspicuous item in a radio station. On the other hand, the coil responsible for the magnetic energy may be quite small—we might even say the smaller the better, within certain limits.

Is This Ratio Better—

Whether to use a small coil connected to a large antenna, in order to obtain a specified rate of vibration (as is shown in the accompanying diagram A), is analogous to the problem of determining whether to use a small weight connected to a large spring in order to obtain a similar result.

The capacity area should be quite big—we might almost say the bigger the better, again within certain limits.

There is no doubt a best relation between the size of the capacity area and the size of the inductance coil, and this relation is determined by the fact that the electric and magnetic energies must be equal. A great margin of variation is permissible; just as is the case in musical instruments, which may vary from the stiffness of a tuning fork to the laxness of the column of air in a flute, with all manner of strings and reeds as intermediaries.

So it is with a radio station. One may be working with a small capacity and a large inductance, while another one may be working with a great capacity and a small inductance; and yet both may have the same period of vibration; and will have, if the product of capacity and inductance is the same for both.

But there is sure to be a best relation between the two things; which, however overridden in practice, it may be instructive to consider.

And it is specially instructive to realize that the great size of the antenna, as compared with the small size of the coil which is in circuit with it, is an immediate consequence of the relation which exists between the two properties of the ether—its elasticity and its density. One is incomparably bigger

—Than This Ratio?

Or should the experimenter use a large coil connected to a small antenna, as shown at B, in order to obtain the same results as in diagram A? The problem is comparable to that of determining whether to use a large weight on a small spring to attain the same rate of vibration as a small weight on a large spring.

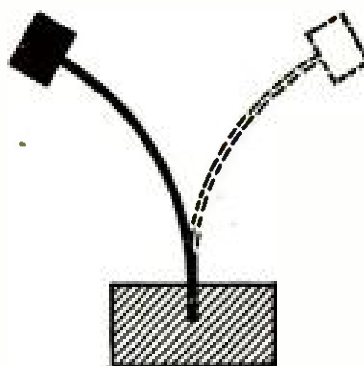

than the other. The ratio, in c.g.s. measure, is 10^{21} . Hence, we may say that the ratio between the size of an antenna—which depends on the ether's elasticity—and the size of the little coil—which depends on the ether's density—should also be of something like the order 10^{21} .

No, it can hardly be as big as that, even with the best possible arrangement. But it is legitimate to regard that as a sort of ideal, and to emphasize the importance of a big, as well as of a high, antenna, and of a small compact coil.

The size of the antenna has to be fixed by practical and often financial considerations. The size of the coil is at our disposal, and must be determined by the rapidity of vibration—that is, the wavelength that we want. And it must be adjusted so as to give this wavelength when worked in

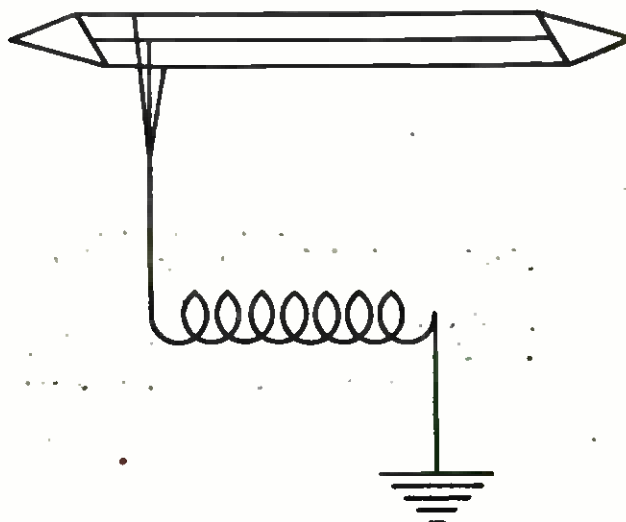

B

combination with the given antenna.

That, then, is the problem before us. Given an antenna of definite capacity, and required a certain wavelength, whether for receiving or for transmitting—but especially we will consider receiving—what sized coil shall we use, and what wire shall we wind it with?

Formulas that Help You Design Your Coils

THE next article from the pen of Sir Oliver Lodge will deal with the theoretical considerations that are involved in coil design. The article will contain formulas for size, inductance and shape for coils for various wavelength bands. It deals with the subject from an entirely new viewpoint—and does it by means of a linear method of calculation of inductance and capacity. It will be an important addition to these articles of practical helpfulness to the amateur which have been contributed to

POPULAR RADIO by this distinguished scientist.

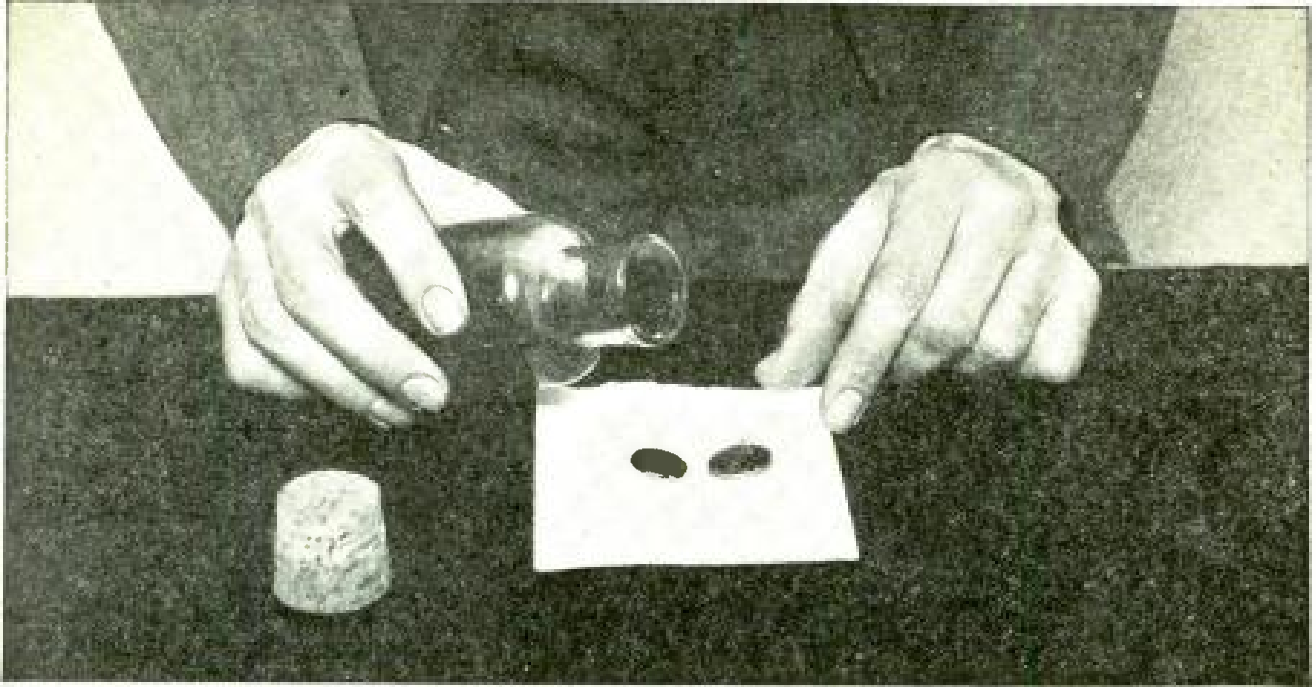

From a photograph made for POPULAR RADIO

A SIMPLE TEST OF YOUR RECEIVERS

An improvised battery for testing the phones may be made in a few seconds. Merely place a penny and a nickel side by side on a piece of blotting paper and pour a little vinegar in between them. Then touch one phone terminal to the penny and scrape the other terminal on the nickel. A scratching sound will be heard in the phones if they are sensitive and in good working order.

USEFUL FACTS AND FOOLISH FALLACIES ABOUT Your Earphones

Poor headsets offset the values of the best receiving apparatus. This article tells how to select good ones—and how to keep them in good condition.

By RAYMOND FRANCIS YATES

THIS article has really been prepared in a fit of rage. It happened this way. The writer was browsing around in a radio shop one day and happened to overhear a conversation between a salesman and an affable old gentleman who was being initiated into the mysteries of the art. He had purchased everything that was necessary for the construction of his first set with the exception of the headphones, and he appeared to be dimly conscious that this was about the most important part of his shopping. The clerk was one of those young wise-acs of the cake-eating, bun-dusting

variety. He had a ready answer for any question and spoke with the authority of a Marconi. The old gentleman was just technically innocent enough to be gullible and he absorbed everything the young wizard told him as gospel truth.

"Yes, this is a good phone," our friend assured him. "It ought to be sensitive, it has a resistance of 3,500 ohms. . . . Yes, this other phone is better looking, but it is only wound to 2,000 ohms. You see, a 2,000 ohm phone cannot pass as much current as the 3,500 ohm phone and—"

The result of that conversation is this

article. The writer does not wish to take the position of an austere technician, but he does wish to point out some facts about phones that are not generally known.

The headset is not only a little understood, but a much abused instrument. Yet how important the headset is! Without the headset we could hear nothing.

"Use a loudspeaker," you say.

But a loudspeaker is nothing but a telephone. It is the headset that converts the weak electrical impulses that surge through our radio receivers into audible sounds. Within them a mysterious transformation takes place. We have weak electrical currents. Presto! We have sounds. It is evident that we could not hear without headsets, and if we were to reduce a radio set to its very simplest elements we would have nothing but the detector and the headset. This should certainly impress us with the importance of this device.

In radio we deal with very weak currents. So weak, indeed, that if we interpose any great obstacle in their path they

fade away into nothing, joining that vast store of wasted energy which lies safely beyond the reach of man. We take these weak struggling currents and convert the highest possible percentage of their energy into sound. When they enter the telephone receivers they enter for better or for worse. If the receivers are not correctly designed and carefully manufactured, part of the current will be irretrievably lost. Whether we shall or not hear DX (long distance) stuff does not depend altogether upon how sharply our circuits may be tuned or how perfectly our various other instruments are made. A long-distance signal may be detected only to be lost in the headset.

The radio telephone receiver is one of the most sensitive indicating instruments known to science, and it should be manufactured in a way that befits its high scientific station. We gain some idea of its sensitivity when we learn that a good headset will give an audible indication if a current that is only .0000000016 ampere passes through it.

What an infinitesimal amount of

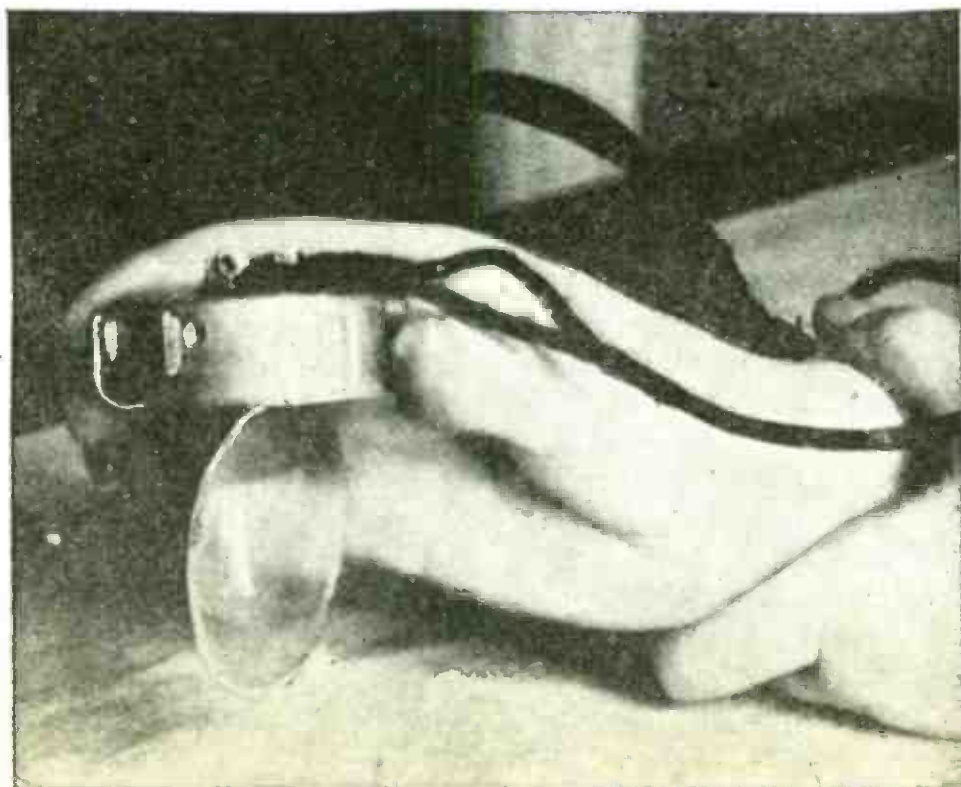

From a photograph made for POPULAR RADIO

HOW TO TEST THE MAGNETS OF YOUR EARPHONES

If the magnets are in good condition, they are capable of lifting up the diaphragm.

energy! Yet the telephone must have a certain degree of ruggedness even though it is called upon to detect currents that would make many sensitive electrical indicating instruments turn green with envy.

In the telephone we have two coils of very small wire wound about a steel core. Clamped tightly above these soft iron cores there is a diaphragm. The permanent magnets within the receiver case are in the proper magnetic relationship to the soft iron cores to allow the cores normally to exert a magnetic pull on the diaphragm. When a variable current passes through the coils or bobbins the magnetic pull of the diaphragm varies, and the diaphragm vibrates in sympathy with the current fluctuation. Since the diaphragm is in contact with the air it causes an atmospheric disturbance and sets up the sound waves which we hear.

So much for the theory of the telephone.

Now let us go into the matter of resistance, inasmuch as this was the point which goaded the writer into preparing this manuscript.

First and foremost, let us never be hoodwinked into purchasing a pair of phones because they have a high resistance. If there ever was a radio dumb-bell it is the chap who believes that the sensitivity of phones is measured in ohms. We measure light in candlepower; heat in British Thermal Units; energy in foot-pounds, and current in amperes.

But, we do not measure the sensitivity of phones in ohms.

In fact there is no advantage in giving the resistance of telephones. Most of us know that a given coil of wire will offer a greater resistance to alternating current than to direct current. In the parlance of alternating current phenomena, the word "impedance" is used; this impedance varies with the frequency of the current. With a frequency of 400 cycles, a certain receiver may have an impedance of 3,000 ohms, and this may

jump up to 5,000 ohms at 1,000 cycles.

Of course, the direct current resistance would be much lower than either one of these figures. If resistance were the only thing that counted, how simple a matter it would be to wind the bobbins of a telephone with some high resistance wire like German silver. In fact, there is a case on record where one manufacturer, either through ignorance or a deliberate attempt to defraud, wound his bobbins with German silver wire. They showed a beautiful resistance, but what they did to weak radio currents was a shame to say. It was a case of cold-blooded murder for everything but the heaviest currents.

Let us pass on, then, firm in our conviction that the resistance has little to do with the sensitivity of a headset.

Among other important items, the sensitivity of a headset depends upon the number of ampere-turns in a given space that the bobbins contain. It is the object of the conscientious headset manufacturer to crowd or concentrate as many turns of wire as possible into a minimum space. Some headsets have as many as 10,000 turns of No. 40 wire, and all this is crowded into a space that amounts to a fraction of a cubic inch. The phone manufacturer who knows his business does not wind his receivers merely to obtain a certain resistance. Each bobbin is wound with the number of turns of wire essential to get the best results.

Hereafter, when we buy receivers let us be more careful about their appearance and their reputation than their resistance. Let us see that the cases are carefully made with machined threads, that the caps have soft velvety surfaces that will not abrade the skin. Let us see that the diaphragms are perfectly flat and that the inside of the receiver is carefully protected from moisture. Let us see that the delicate windings of the bobbins have been protected with a covering. Let us also see that the pole faces have been carefully ground so that the receiver cap fits tightly. Then, if

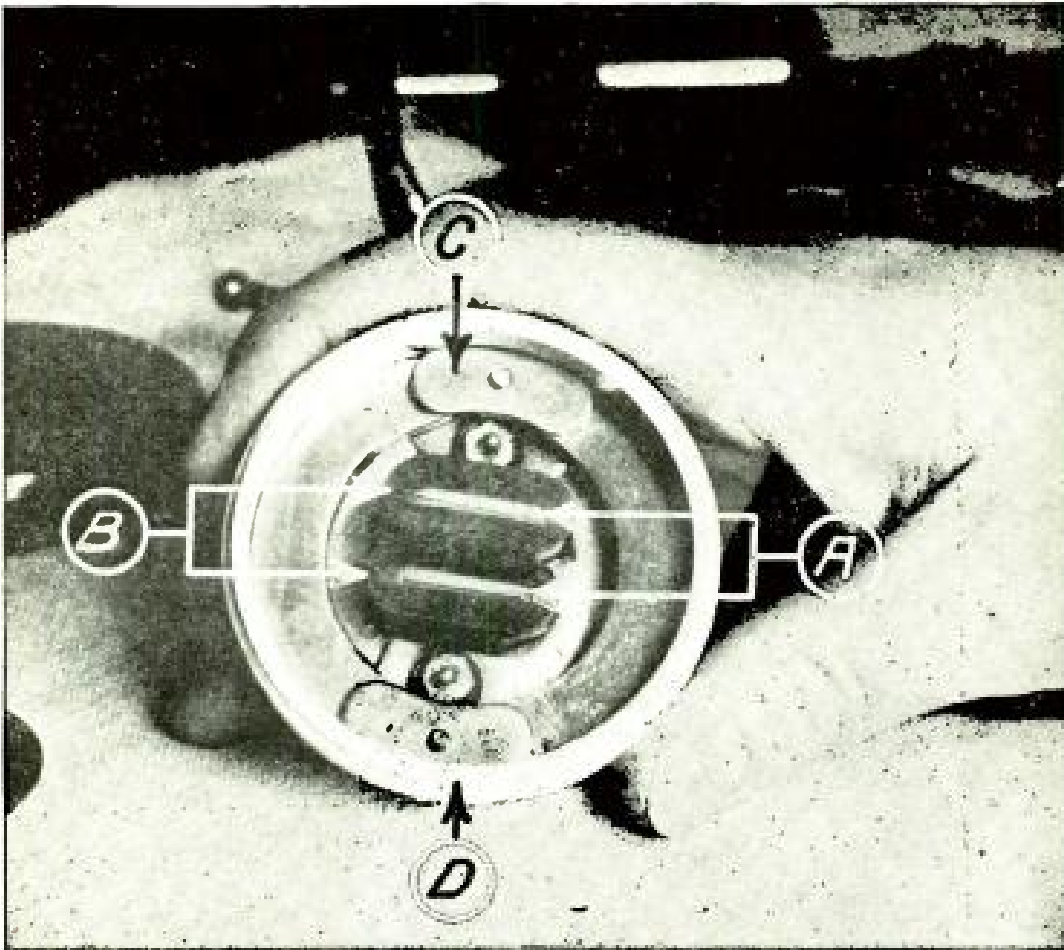

From a photograph made for POPULAR RADIO

THE INSIDE OF YOUR EARPHONES

The permanent magnets C, are fastened snugly inside the metallic case D, and have attached to their poles two pole pieces A, upon which are wound the bobbin coils B. It is the electric current flowing through the bobbin coils which causes the magnetic variations in the pole pieces that moves the diaphragm and produces sound waves.

we wish to test them on the spot, there is a way of doing that; it is indeed a poor phone that will not give an audible sound with the following little experiment. If we moisten a piece of paper on our tongues and place it between a penny and a nickel, a click will be heard in the phones when we bring the tips in contact with the coins. The two coins form the terminals of a miniature battery. If no sound is heard the phones are practically useless for radio and should not be purchased.

The ideal phone is the phone that will give maximum sensitivity and clear reproduction over a wide band of audio frequencies. The frequency of the sounds that reach us on the wings of radio are multitudinous. In the orchestra we have the high pitched violins, the low pitched trombone and other instruments repre-

senting a wide scale of vibration. The tiny diaphragm of our receivers is expected to be sensitive to all of these sounds; quite a job indeed. Every metal mass such as the diaphragm of a receiver has a natural period of vibration of its own; this means that it is particularly sensitive to a certain definite frequency. Of course, it will respond to other frequencies, but not so well. A good headset then is one that will give maximum sensitivity and clarity of tone over a wide band of frequencies. A certain type of receiver may have an exceptionally high sensitivity over a very narrow band of frequencies. This type of headset would not be suitable for radio, though many such headsets are on the market. The headset that brings maximum results produces a comparatively flat curve when it is subjected to these tests.

Good receivers must also be matched in tone—each receiver must be the sound mate of the other. Even though two receivers have identically the same physical appearance as far as the eye can see, they do not always have the same acoustic properties, and therefore do not always emit the same tone. Therefore, it is the duty of the careful manufacturer to see that each pair of receivers that he places in a headset are matched. This assures us of faultless reception, which would not be possible with two receivers emitting different tones.

And now a few words about the proper care of phones.

Some fans handle their phones with absolutely no respect for their delicacy. They quite forget that the abuse they heap upon them will sooner or later affect their sensitivity. Phones should not be dropped or handled roughly, as sudden shocks demagnetize the permanent magnets and they are apt to knock the receivers out of the adjustment made at the factory. The pole faces of a receiver should be able to hold the diaphragm on edge. If they cannot do this they should be sent back to the factory and remagnetized.

Care should also be taken in removing

the caps of a receiver, and this should be done only when absolutely necessary. The diaphragm should be handled with the greatest care, and it should be slid off the case and not picked up with the fingernails. This is sure to bend it—and a bent diaphragm means an inefficient receiver.

Care should also be taken not to bend or twist the cord too much since this will eventually cause it to break. If we do happen to remove the receiver cap and diaphragm, we must take care to see that no particles of dust are allowed to remain in the case.

Alert headset manufacturers have recognized the necessity of building into their phones an impedance that would match the impedance of the vacuum tubes and amplifying transformers that are used with them. There is an old electrical law that tells us that maximum efficiency in an electrical circuit fed by a battery or generator will be obtained only when the external resistance (the resistance outside of the generator or battery) is the same as the internal resistance of the battery or generator.

So it is with telephones, transformers and tubes; their impedance should be matched.

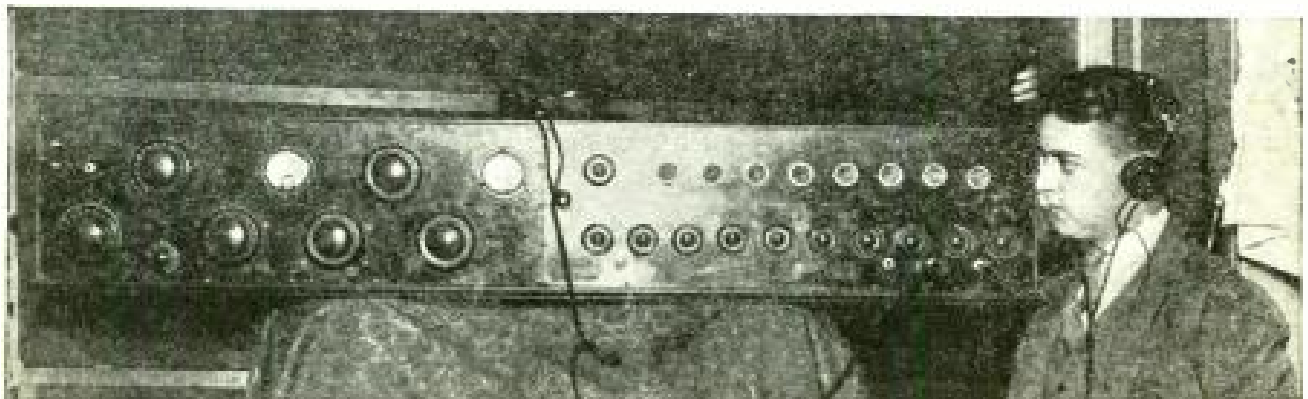

Kadel & Heroert

A SET THAT PICKS UP EUROPE EVERY NIGHT

With ten tubes used in the famous Armstrong super-heterodyne circuit (which has been called the most sensitive circuit yet developed) R. R. Mayo of New York finds that there is not much "DX" that he cannot get. Using an outdoor antenna, he picks up the European stations not only under favorable conditions but almost every night. Detailed instructions for building a super-heterodyne set will soon be published in POPULAR RADIO.

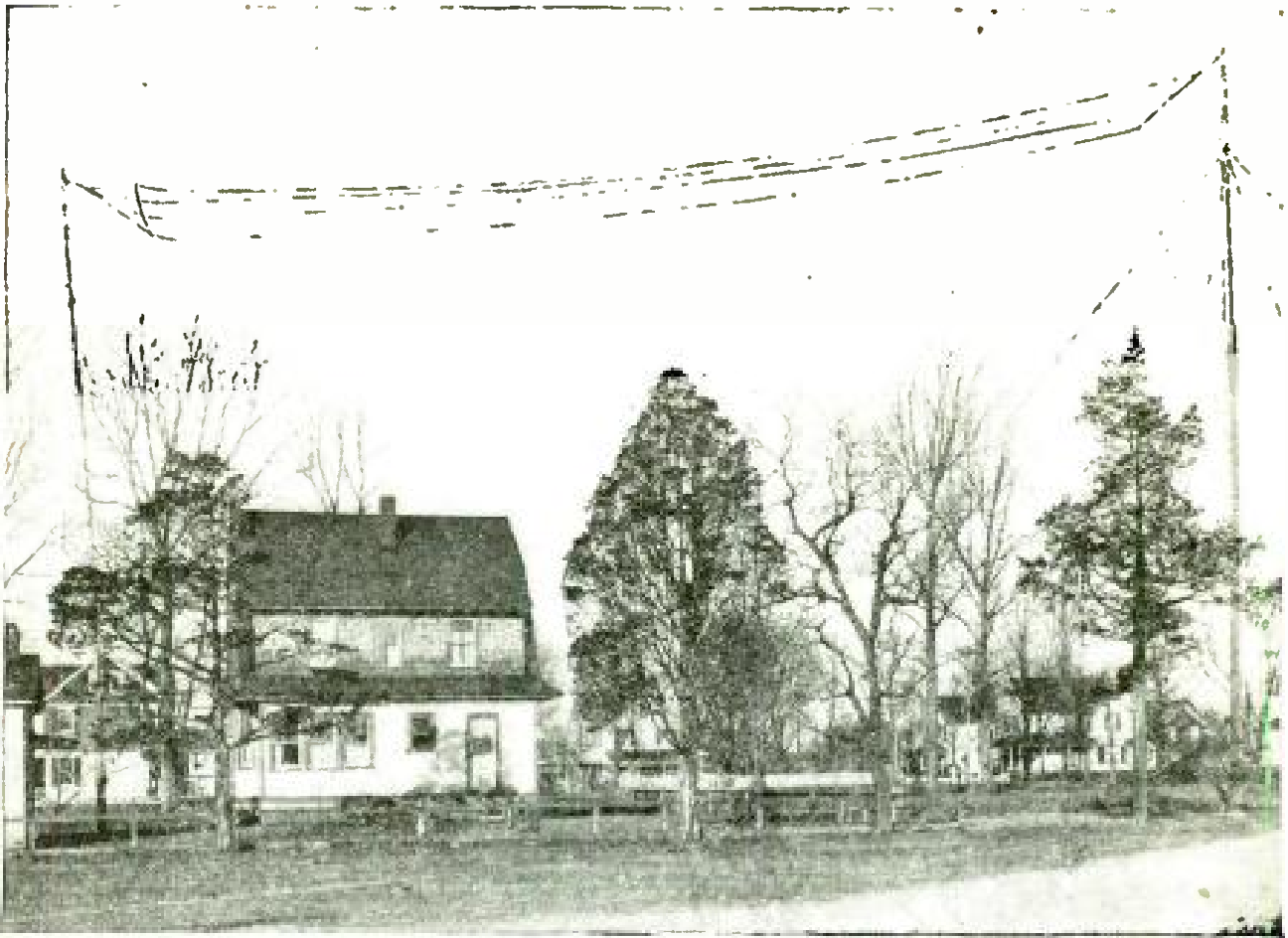

From a photograph made for POPULAR RADIO of Station 2ZL

KNOW THE CAPACITY OF YOUR AERIAL!

Everyone who uses either a receiving or transmitting set employs an antenna of some kind, and the value of his set is largely dependent upon the efficiency of it.

A MEASUREMENT CHART FOR DETERMINING THE CAPACITY OF YOUR ANTENNA

ARTICLE No. 4

POPULAR RADIO has already published charts for calculating the correct inductance for coils in a radio set, and charts for calculating the dimensions for these coils. In using these charts it is imperative that the capacity of the antenna, with which the coils are used, be known. This chart enables you to calculate the capacity of your antenna so that you may use the preceding charts more readily.

By RAOUL J. HOFFMAN, A. M. E.

ONE of the most important, but extremely uncertain, of calculations in radio engineering and design is the determination of the constants of the antenna system.

Under the term "antenna system" we understand the total construction outside of the set, connected to it in order to transmit to or receive signals from a distant radio station. These include the

antenna proper, grounds, fire-escapes, bedsprings, or any other aerial system used to radiate or collect energy.

In the first article of this series* we showed that for a certain wavelength we require a certain amount of capacity and a certain amount of inductance. To use the charts in the first article, however, we were required to know the amount of

*Published in the February, 1923, issue.

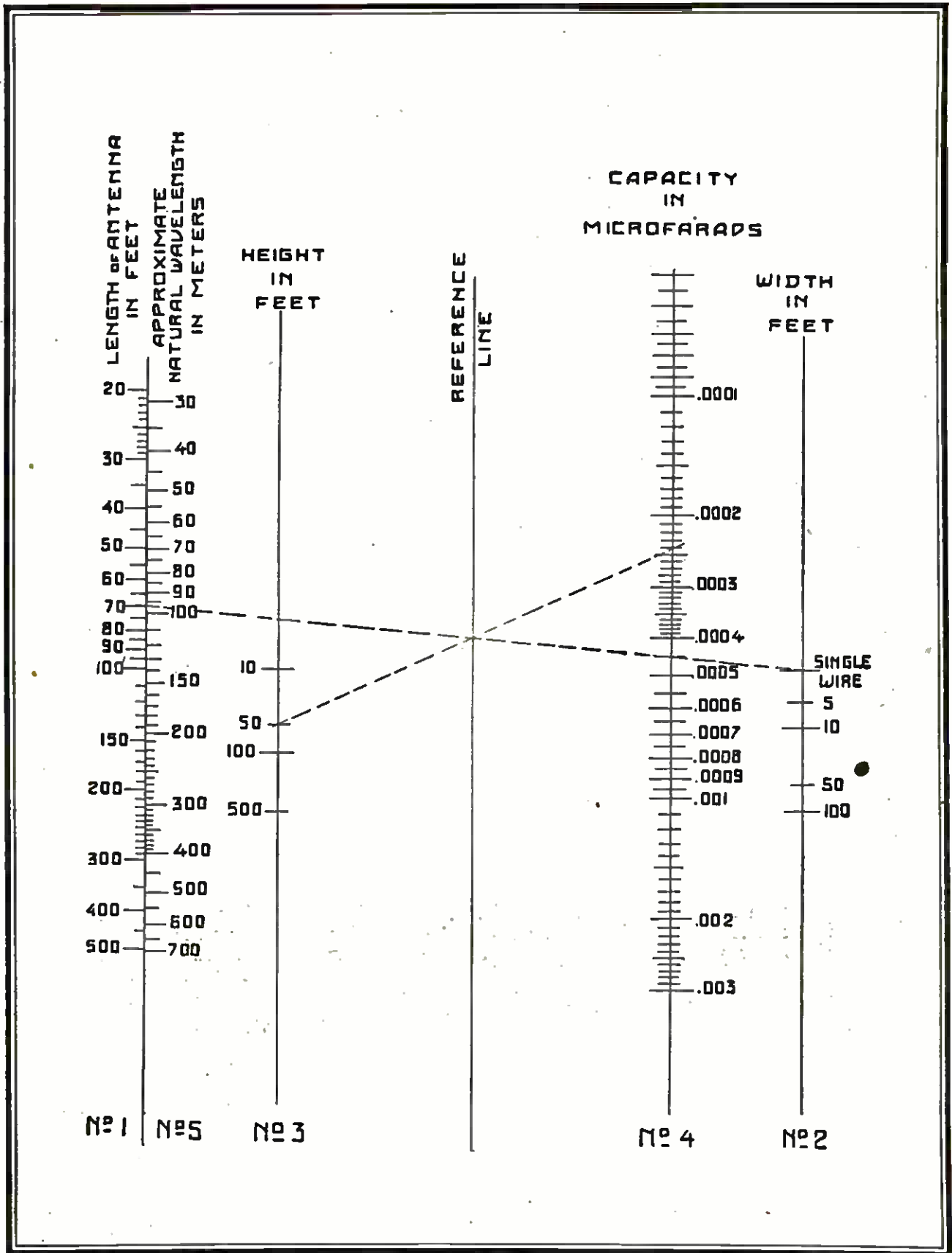

How to Use the Chart for Determining the Capacity of Your Antenna

With a ruler, connect the effective length of your antenna (scale No. 1) with the width of the antenna (scale No. 2). Then connect the effective height of the antenna (scale No. 3) with the intersection of the first line and the reference line. Carry the line out over scale No. 4—which will indicate the capacity of the antenna.

capacity incorporated in the design of our antenna, in order to calculate the correct coil to use with our antenna for a given wavelength.

In this article, then, we are introducing a chart that gives us the capacity of our antenna, with the requisite amount of accuracy to calculate the proper inductance for the coil to use with it.

To take advantage of simplicity, without deviating from accuracy—and the practical radio engineer always welcomes simplicity—we will neglect the inductance of the antenna, as it is small in comparison with the inductance of the coil to be used with it. This will not materially affect our calculations.

The chart (shown with this article) for calculating the capacity and fundamental wavelength of our antenna system is derived from data obtained from many experimental tests and laboratory experiments on vertical and horizontal antennas.

We will readily see by trying a few calculations on imaginary antennas (with the aid of the chart) that the longer and wider (or the more wires used) our antenna is constructed, the more capacity it will have, and the higher up it is suspended the less capacity it will have.

The chart has five scales.

Scale No. 1 indicates the effective length of the antenna (figuring the full length of the horizontal part and half the length of the vertical part.)

Scale No. 2 contains the width of the antenna; (it also indicates the imaginary width to use for the single wire antenna). When more than one wire is used, the width will be the distance between the outer wires. The wires should be spaced

not closer than two feet and not farther apart than four feet in order to be effective.

Scale No. 3 indicates the value of the effective height from the ground.

Scale No. 4 gives the resultant capacity in microfarads.

Scale No. 5 gives the approximate natural fundamental wavelength of the antenna, which corresponds to the values on the *Scale No. 1*, and in accordance with the standard formula:

$$\lambda = 1.38 l$$

wherein λ = the natural wavelength of the antenna in meters,
and l = the length of the antenna in feet.

Let us work out the following example in order to understand clearly how to use the chart:

We have an antenna with a 45-foot horizontal, single-wire stretch, a 40-foot vertical lead-in, and a 10-foot ground connection.

Taking the full amount for the horizontal wire (45 feet) and half the amount for the vertical part

$$\frac{(40 + 10)}{2} = 25 \text{ ft.}$$

We will have an effective length of $(45 + 25) = 70$ feet.

Connecting 70 on *Scale No. 1* with the mark "single wire" on *Scale No. 2*, and then connecting the point of intersection (of this line we have drawn with the reference line) with the effective height of the antenna $(40 + 10) = 50$ feet, on *Scale No. 3*, we may read the resulting capacity of the antenna on *Scale No. 4*.

The approximate natural wavelength of this antenna would be about 97 meters.

Save These Hoffman Charts!

By means of the "radio slide rule" originated by the author of the above article radio amateurs everywhere have been able to save a vast amount of time and at the same time insure accuracy in their calculations in the design of radio apparatus. The ingenious charts reproduced in this series constitute an equally valuable contribution to the science of radio. The previous articles contain charts for *Determining the Constants of Radio Circuits and Calculating Capacities of Condensers in Series*, in February, 1923; *For Determining the Dimensions of Your Coil* in March, 1923 and *For Determining the Capacity of a Condenser* in May, 1923.

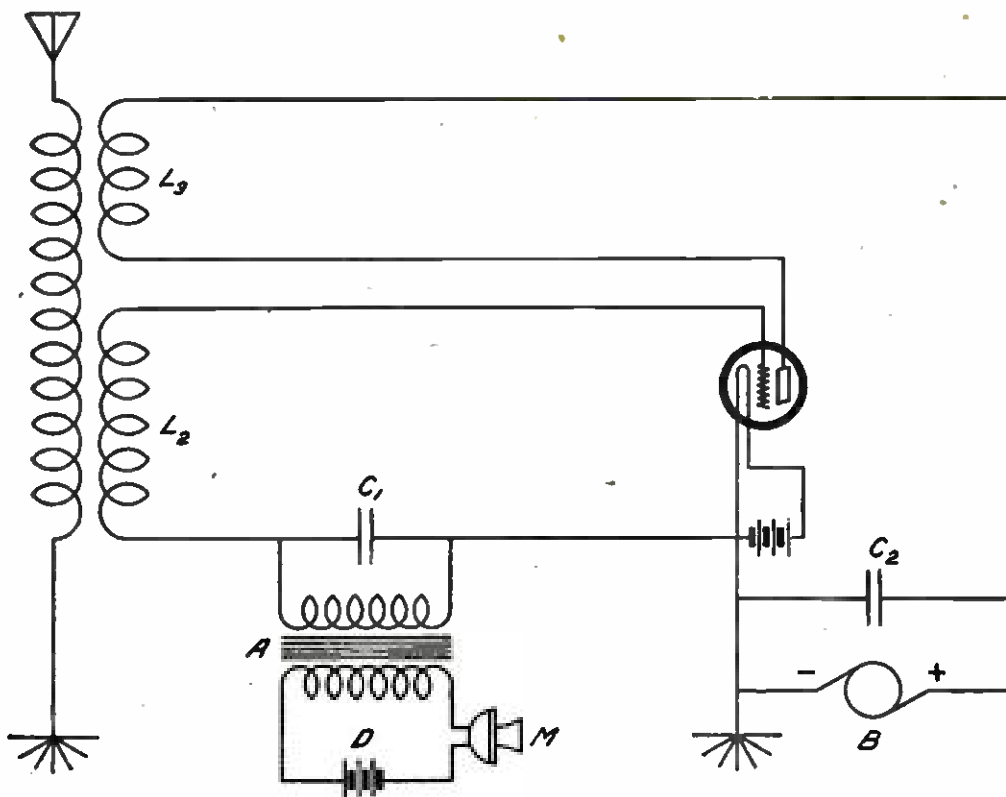

FIGURE 1

The circuit diagram for a low power single-tube telephone transmitter that employs the grid method of modulation.

FOUR WAYS TO GET GOOD MODULATION

PART II

The four standard methods may be listed as (1), the use of the microphone in the antenna circuit for low-power transmission*; (2), the use of a magnetic transformer*; (3), grid modulation and (4), Heising modulation. The latter two of these methods are here described by one of the foremost authorities in this field—

PROF. J. H. MORECROFT

WHEN a vacuum tube is used to generate the high-frequency power sent off from the antenna by a radio telephone transmitter, the very rigid control which the grid potential exerts over the plate current offers a ready means for modulating the plate current—and the plate current controls the amount of power which the tube supplies to the antenna.

An arrangement suitable for a small transmitter that uses one tube is shown

*See POPULAR RADIO for May, 1923

in Figure 1. When proper coupling is used between coils L_1 , L_2 , and L_3 the tube will oscillate and supply alternating current to the antenna, the frequency of which is approximately that fixed by the inductance and capacity of the antenna circuit.

The amount of plate current which the D. C. generator B, supplies to the tube is determined by the potential of the grid of the tube, and this potential is controlled in turn by the voice currents set up by microphone M, acting on the grid

through transformer A. The condenser C_1 , is advisable as it facilitates the oscillation of the tube; it must not be more than about .001 microfarad, however, otherwise distortion of the speech will result.

In some sets there is also connected across the secondary of transformer A, (called the "modulation transformer") a resistance of about one megohm; it is supposed to improve the quality of the speech. The condenser C_2 , is advisable, not only to facilitate the setting up of oscillations but also to protect the insulation of the armature of machine B, which is subjected to high-frequency dielectric losses if not shunted by this condenser.

The modulation transformer A, must be especially designed for the microphone and tube with which it is to be used. It generally has a fairly high transformation ratio, sometimes as much as twenty-five to one.

The primary coil, in series with the microphone, must be of low resistance, as low as that of the microphone itself or lower; if not, the variation in microphone resistance, brought about by the voice waves, will not materially affect the current from battery D, and if this current does not fluctuate there will be no voltage induced in the secondary coil

and so the tube output will not be controlled.

It might seem advisable to wind the transformer with an extremely high ratio (say five hundred to one), so that even with but little fluctuation in the primary current sufficient voltage will be induced in the secondary to properly modulate the antenna output. Such a high ratio would require a great many turns of fine wire in the secondary, however; this would be sure to bring about speech distortion as the consonants, the high-frequency waves of the voice, would not be repeated through the transformer.

The voltage transformation ratio of a transformer is not the same for all frequencies; if the secondary has a great many turns this ratio decreases very rapidly for the higher voice frequencies.

This effect is suggested in Figure 2 which gives the ratio of transformation for such a transformer; for the high voice frequencies the ratio is much less than for the lower ones, so that the high-frequency consonants would not come through the transformer with their proper relative magnitude and the voltage affecting the grid potential would be deficient in consonant sounds. The power radiated from the antenna would

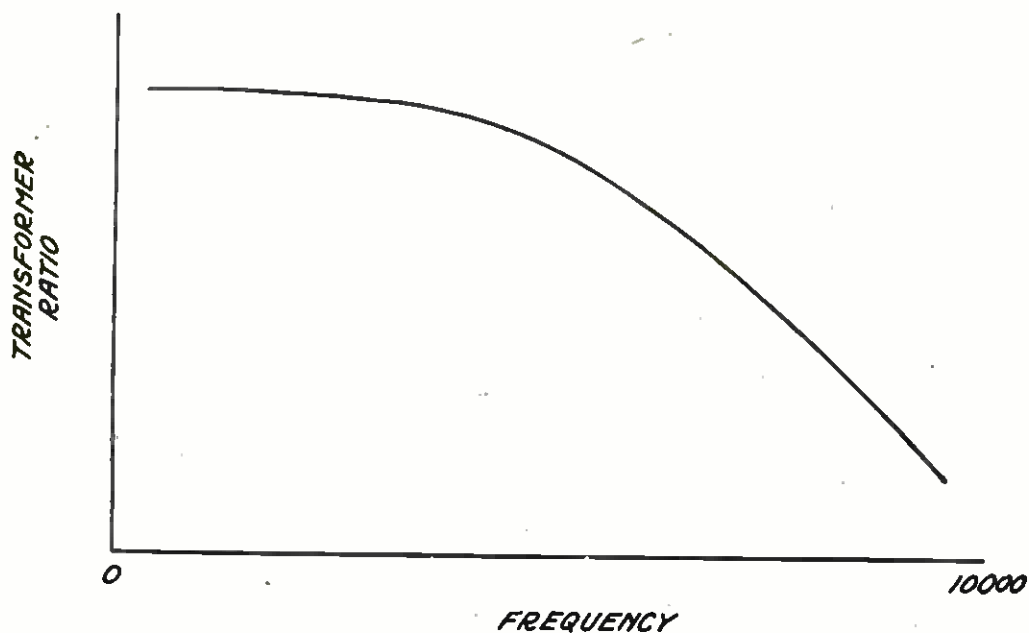

FIGURE 2

Curve showing how the voltage transformation ratio, for a modulation transformer which has a great many secondary turns, decreases with an increase of frequency.

thus be deficient in the high-frequency sounds of the voice and the speech received by the listener would be drummy and indistinct, no matter how good the receiving set might be.

It is to be pointed out however, that even if the quality of the speech sent out by the broadcast station is excellent, an improper adjustment of a regenerative receiving set will always make it seem poor. A transmitting station is frequently blamed for poor speech quality when actually the quality is spoiled right in the receiving set itself; we shall analyze this point later.

The scheme given in Figure 1, which we have just examined, called *grid modulation*, is not all that might be desired because even with the best adjustment it is impossible to obtain a high percentage of modulation (which causes wide variations in the antenna current) without getting poor quality.

As long as we are content to change the amplitude of the antenna current by perhaps 25 percent (or in other words get 25 percent modulation) the quality of received speech is fair, but when it

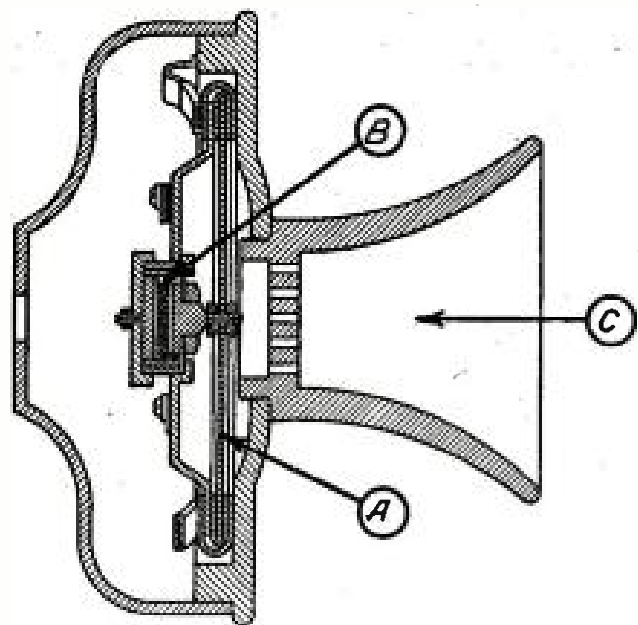

HOW SOUND WAVES ACT ON THE CARBON GRAIN MICROPHONE

The sound waves enter the mouthpiece C, and vibrate the diaphragm A, which causes the carbon grains B, to be compressed and released, thus varying the current that flows through the microphone.

is pointed out that in radio telephone transmission *it is the change in amplitude of the antenna current brought about by the voice and not the actual antenna current*, which determines how far the signal will carry, it is evident that some scheme that will permit greater modulation is to be desired.

Such a one is indicated in Figure 3; in Europe it is called *plate modulation* or *choke-coil modulation*, but in the United States it is styled the Heising scheme of modulation, because Heising was responsible for its development in this country.

This Heising method of modulating the antenna current is almost universally used in the better class broadcasting stations of today; although it is expensive to install and maintain compared to the other schemes, the quality of speech obtained when it is properly adjusted makes it far superior to any other method so far devised.

Many radio enthusiasts seem to object strenuously to this scheme because they have to "waste" half their tubes; only half of them are oscillating to produce antenna power and their antenna current is much less than when they connect all their tubes in parallel to act as oscillators to supply power to the antenna, and modulate by the grid method.

With all the tubes acting as oscillators the antenna current is about 50 percent greater than when connected for the Heising modulation scheme; hence it seems as though the Heising scheme must be inferior to the other. But we have to again emphasize the fact that such a judgment is based on a misconception as to what radio telephony really is; as stated before the reading of the antenna ammeter is no criterion at all regarding the usefulness of a set to transmit telephone signals—it is the *variation of antenna current* produced by the voice that measures the station's efficiency and *not the antenna current itself*.

One transmitting station that has two amperes of current in the antenna as read

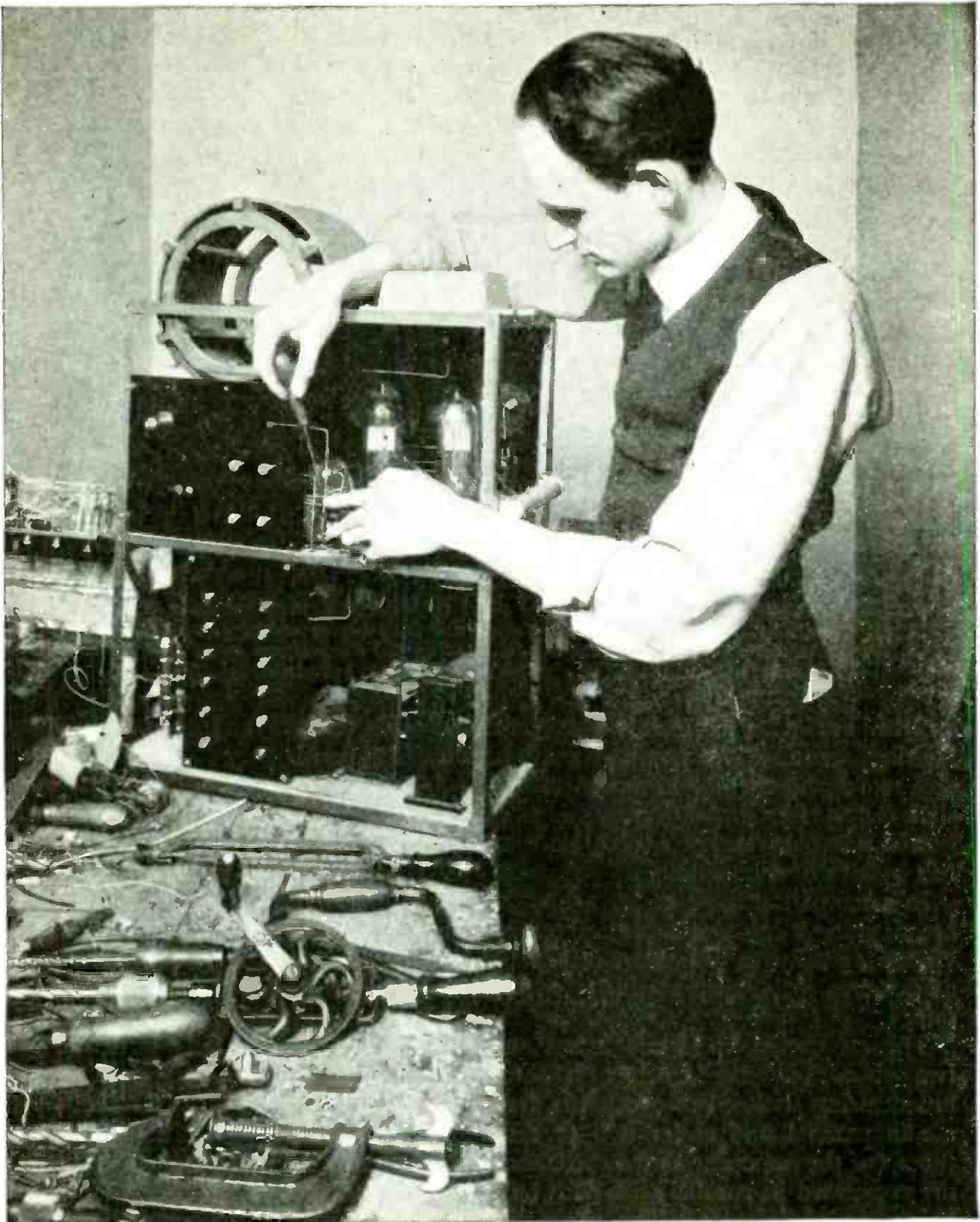

From a photograph made for POPULAR RADIO

BUILDING A SET THAT EMPLOYS THE HEISING SCHEME OF MODULATION

In this type of set one tube is used as an oscillator and another tube (of the same power) is used as a modulator. The circuit diagram for this set is shown in Figure 3, which indicates how to connect the two tubes in the correct way.

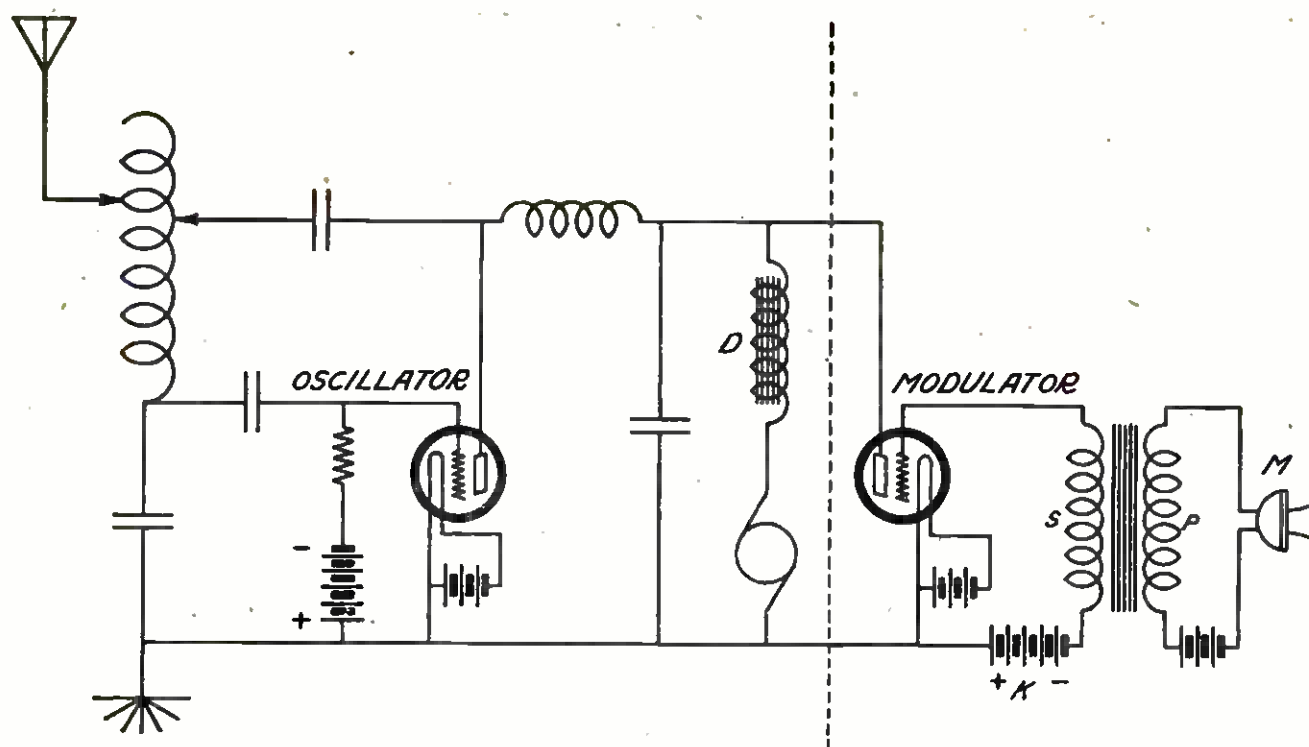

FIGURE 3

This diagram shows how to wire up a set employing Heising modulation. All the apparatus shown at the left of the dotted line is in the oscillator circuit and the apparatus at the right of this line is connected in the modulation circuit. This is the scheme of modulation used at all the larger broadcasting stations.

on the hot wire ammeter, using the Heising modulation scheme, should be able to telephone twice as far as is possible for another station that has a much greater antenna current with a less perfect system of modulation.

In some of the large stations used for broadcasting it has sometimes seemed advisable actually to use more tubes for modulators than were used for oscillators.

The set shown in Figure 3 has only two tubes; in the average 500-watt broadcasting station two oscillators operate in parallel and either two or three tubes (of the same size as the oscillators) are connected in parallel with each other to act as modulators. The connection scheme shown in Figure 3 was used extensively during the war for Signal Corps sets and for the sets used on naval vessels. The circuit is divided by the dash line to indicate the two parts; all the apparatus to the left is used to make the oscillator function to furnish the high-frequency power to the antenna while that to the right is the required addition

to the circuit to speech-modulate the antenna power.

The two tubes, oscillator and modulator, both draw their plate current through the iron-core choke coil D; for the ordinary five-watt tubes this coil should have an inductance of about two henries. The grid biasing batteries and filament current of both tubes are so adjusted that the plate current of each is equal and equal to about half the total possible plate current, fixed by the amount of electron emission from the filaments.

In Figure 4 is shown the static characteristics of the two tubes (supposedly the same for each); the grid of each tube is so adjusted in potential that the current taken by each is equal in amount to AC of Figure 4, this equality of currents to be obtained when the oscillator tube is oscillating and no speech is acting on the microphone of the modulator. This means that the grid battery K of the modulator must have the voltage OB and that the grid battery voltage of the oscillator, plus whatever resistance

drop there is in the grid leak due to the grid current taken by the oscillator, is also equal to OB.

As the amount of grid current flowing in the oscillator tube depends upon the adjustments of inductance, coupling, etc., the proper amount of grid battery for the oscillator cannot be obtained when the oscillator is not operating; an ammeter should be put in the plate circuits after the set starts to oscillate and the amount of grid battery adjusted to give equality of plate currents (the currents in the two plate circuits will not then be equal when the set ceases to oscillate). The amount of plate current in the oscillator, AC, corresponds to a certain definite amount of power in the antenna.

If the grid of the modulator tube is now made to go up and down in potential, about the point B of Figure 4, the plate current of this tube must go correspondingly up and down. As both tubes get their plate currents through coil D, however, and as this has sufficient choking action (the technician says it has sufficient *reactance*) to maintain the current through itself essentially constant, the plate current of the oscillator must

go down and up by the same amount that the modulator current goes up and down. The sum of the two currents must continually be equal to twice the current AC.

This means that if the modulator current decreases to the value AE, (Figure 4,) the oscillator plate current must rise to AG so that AE plus AG is equal to twice AC. As stated before, the power in the antenna depends directly upon the amount of plate current supplied to the oscillator tube so that it is evident that the microphone M, controlling, through the modulation transformer S-P, the grid potential of the modulator tube, actually controls the amount of alternating current in the antenna. Moreover the control exercised by this connection scheme is such that the fluctuation in amplitude of the antenna current represents the voice waves actuating the microphone M, more faithfully than is the case for any other modulation scheme so far tried.

In the large broadcasting stations the microphone does not directly control the potential of the modulator tube grids, so it is necessary to use some intermediate

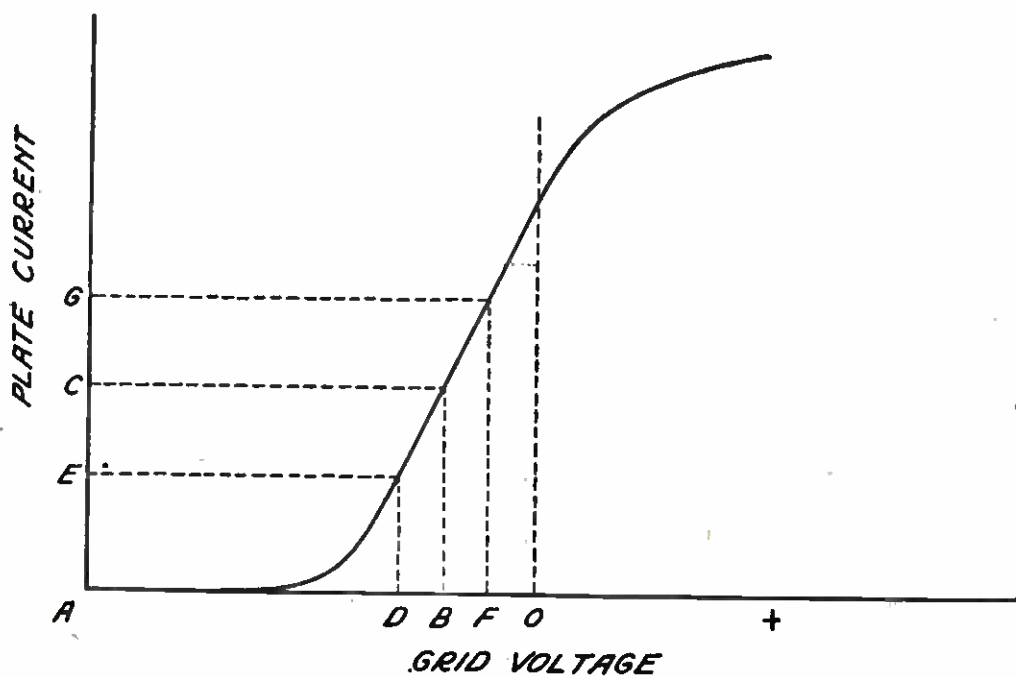

FIGURE 4

The characteristic curve for the tube. This chart is shown in order to make clear the action of the modulator and oscillator tubes as explained by the author in the text. The curve actually shows the increase of plate current caused by an increase of voltage applied to the grid circuit.

tubes for amplifying. Thus the microphone into which the broadcaster talks works into an ordinary resistance-coupled, two- or three-tube speech-amplifier which controls the grid potential of a five-watt tube; this tube controls the grid potential of a fifty-watt tube, which, in turn, acts directly on the grids of the modulator.

In this manner have the skilled re-

searchers in this branch of radio communication developed that wonderful system of control by which the microwatts, sent out by the voice, control, accurately and instantaneously, the kilowatts of power necessary for communicating the hundreds and thousands of miles which are now easily covered by all of the best radio telephone stations.

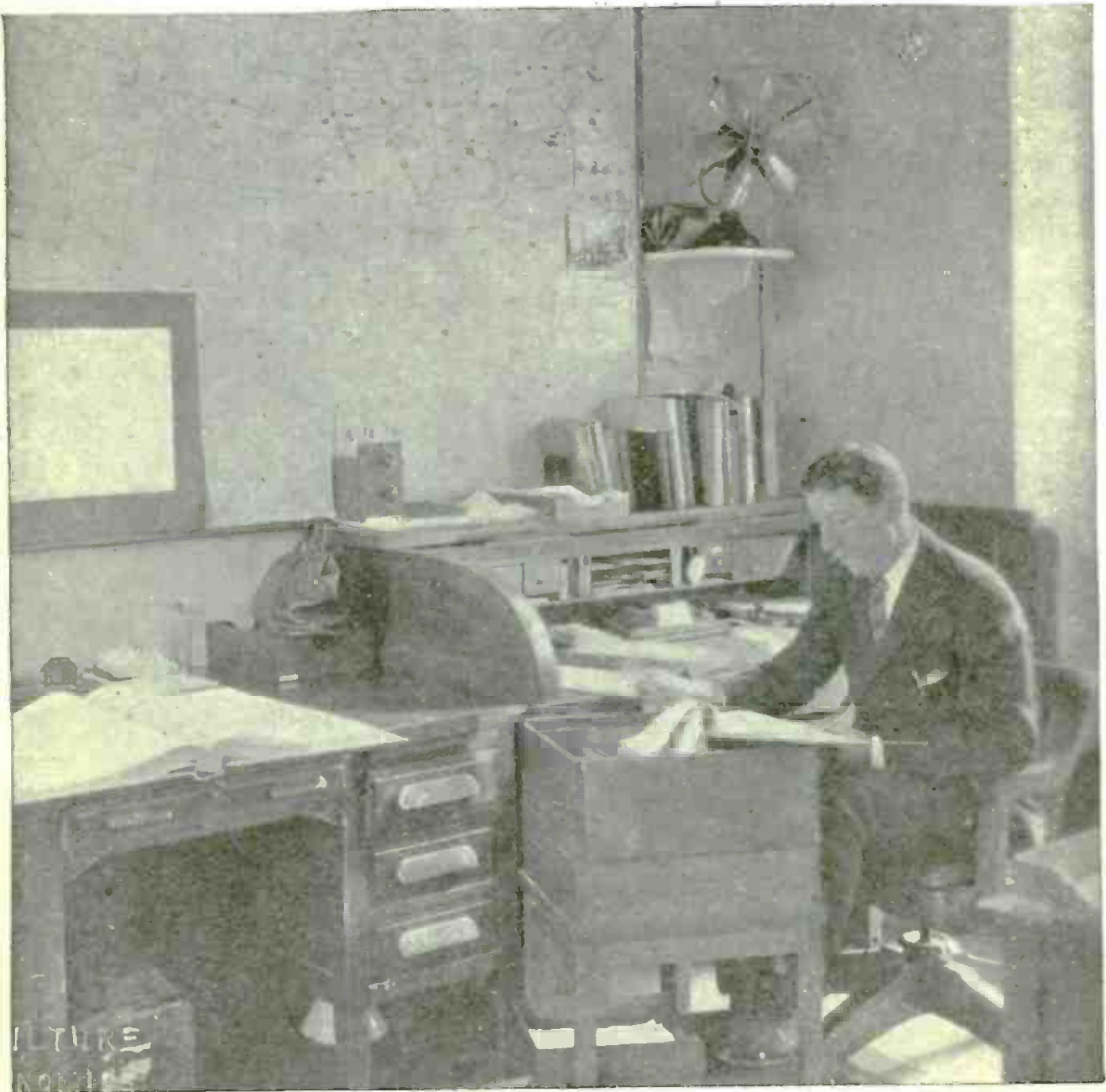

How Uncle Sam Is Helping the Farmer by Radio

No better demonstration of the practical usefulness of radio can be offered than the remarkable service which the Department of Agriculture is rendering, directly and indirectly to the farmers, through the newly created Radio Market News Service. Just what this service is and how it operates will be told by Harry A. Mount in a near issue of POPULAR RADIO.



THE AUTHOR SHOWS THE SIMPLICITY OF TUNING
An unusual feature of this home-made set is the fact that it requires only one dry-cell for its operation.

HOW TO MAKE A DRY-CELL TUBE REGENERATIVE SET

At a Cost of Less Than \$16.00

This is a peculiarly suitable receiver for the novice to begin with—particularly the beginner who wants to make every part of the set himself and thus learn from actual experience how a receiver works and how to work it.

BY SPENCER W. BOYD

THE writer recently made a vacuum tube set, with tube and batteries, that cost under \$16.00. The set works splendidly. Located in Atlanta, it has received clearly, even through heavy summer static, stations at Pittsburg, Detroit, Chicago and Shreveport, La.

The set is operated in connection with a single-wire antenna 100 feet long and 20 feet high, and no amplification is used. A regenerative circuit is employed with two home-made variometers for tuning. A saving in cost is made by using a WD-11 tube,

which requires only one dry-cell for the filament instead of a storage battery.

The Parts that are Needed

A list of materials needed to construct this set is here given:

1 vacuum tube, type WD-11.....	\$6.50
1 rheostat.....	1.00
1 dry-cell "A" battery.....	.35
1 22½-volt "B" battery.....	1.75
2 knobs and dials 3 inches in diameter with ⅛-inch bushing.....	1.50
7 binding posts.....	.70
1 .001 mfd. phone condenser.....	.35
1 grid leak and condenser.....	.35
150 feet No. 26 S.C.C. wire.....	.50
6 collars and set-screws for ⅛-inch rod	.30
1 ⅛-inch rod, 8 inches long.....	.10

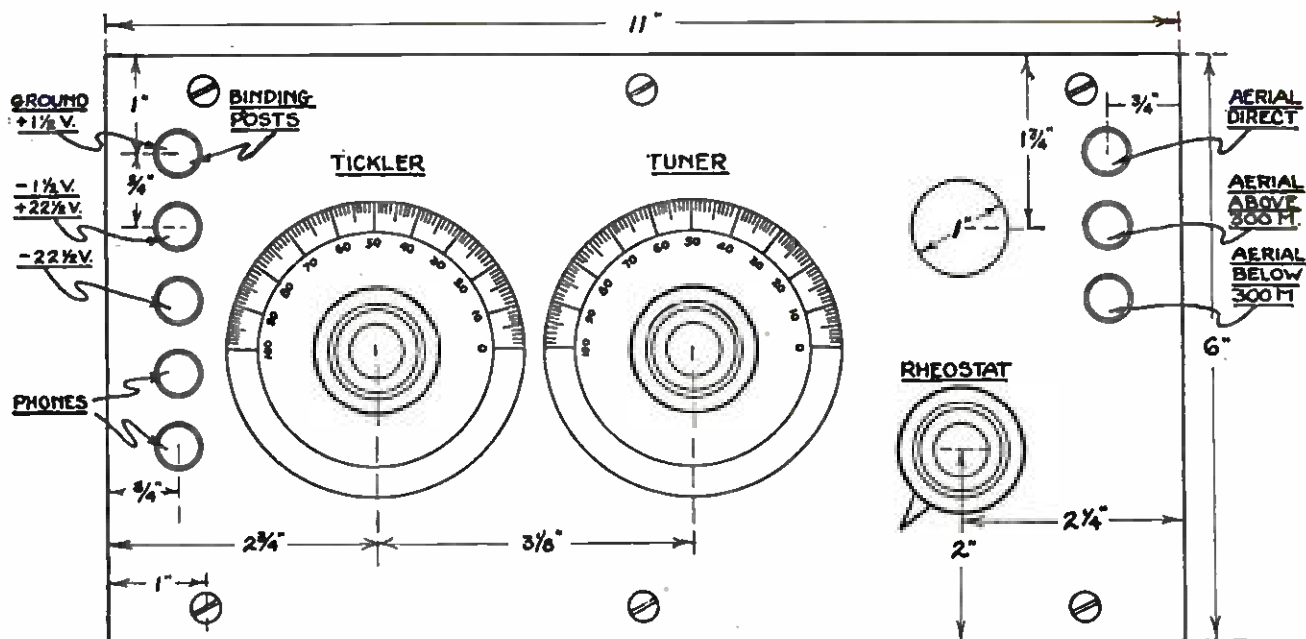

THE PANEL LAYOUT OF THE SET

FIGURE 1: This diagram shows arrangement of the dials, knobs and the binding posts for the connections to the antenna, ground, batteries and to the telephones.

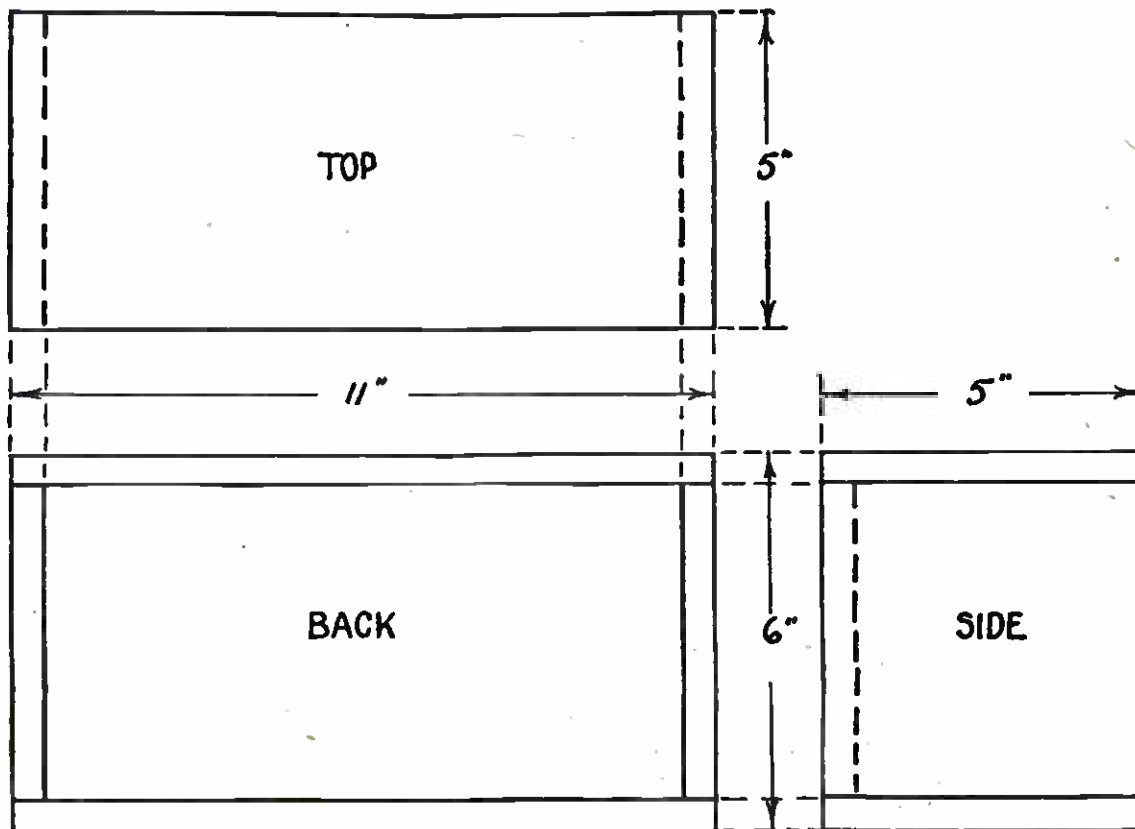

THE DIMENSIONS OF THE CABINET

FIGURE 2: This may be made at home from a plank of hardwood—or the diagram may be sent to a carpenter who can build it to order.

- 1 piece 1/2-inch oak, 5 inches by 4 feet
 - 1 piece 1/4-inch 3-ply wood, 6 inches by 11 inches
 - 1 smaller piece
 - Nuts, bolts and screws
 - 1 cardboard tube 3 1/4 inches in diameter and 6 inches long
 - 2 cardboard tubes 2 3/4 inches in diameter and 1 1/4 inches long
 - 1 cardboard tube 1 7/8 inches in diameter and 2 inches long
 - Tinfoil, sheet copper, angle brackets, paraffin, stain and shellac, totalling. 2.00
- Total..... \$15.80

The phones and the material for an antenna are not mentioned in the above list; almost everyone who is likely to build this set will already have them. Good phones cost about \$8.00, and the required antenna equipment should not cost over \$1.50.

All of the listed materials are easily obtainable—except perhaps the copper sheeting, of which a piece about 6 inches by 12 inches is required. But this may be taken from a worn-out copper tank, such as all plumbing shops have. The copper should be extremely thin, so that it may be cut easily with small scissors.

The wood can be purchased at a furniture factory or lumber yard. The oak should be cut the required width and thickness; the expense is small and a great deal of trouble is saved.

How to Build the Set

The cabinet is made from the oak and measures (outside dimensions) 11 inches long by 6 inches high by 5 inches deep. Details are shown in Figure 2. The front is left open and the panel, when it is attached, is screwed flat to it. When the cabinet is finished, give it a light coat of stain and then one of shellac.

If you wish to spend more time you can easily make a more elaborate cabinet, but this one is satisfactory.

The panel (Figure 1) is made from the larger piece of 3-ply wood. Bore all the holes and then give it several coats of dark stain. When this has dried, wax the cabinet with floor wax and polish it well.

The tuning element consists of two variometers, the stators of which are both wound on the same tube so that they are inductively coupled.

Three tubes should be obtained, one 6 inches long and 3 1/4 inches in diameter and two 1 1/4 inches long and 2 3/4 inches in diameter. If tubes the right size cannot be obtained you can make them either by cutting down larger ones or by using thin cardboard rolled several times about a form. In any case give them two coats of shellac and shrink them in a hot oven.

The stator tube with six groups of windings, lettered A, B, C, D, E and F, all of which are wound with No. 26 S.C.C. wire, is shown in Figure 3.

Wind D and E with one wire to form the stator of the right hand variometer. D and E should be wound first; begin at the left and wind to the right in the direction indicated. D consists of seventeen turns and begins 2 1/8 inches from the right end of the tube. E also consists of seventeen turns and begins 1 1/8 inches from the right end.

Now put on A, B, C and F.

A and B each consist of seventeen turns; they start 1/2 inch and 2 inches respectively

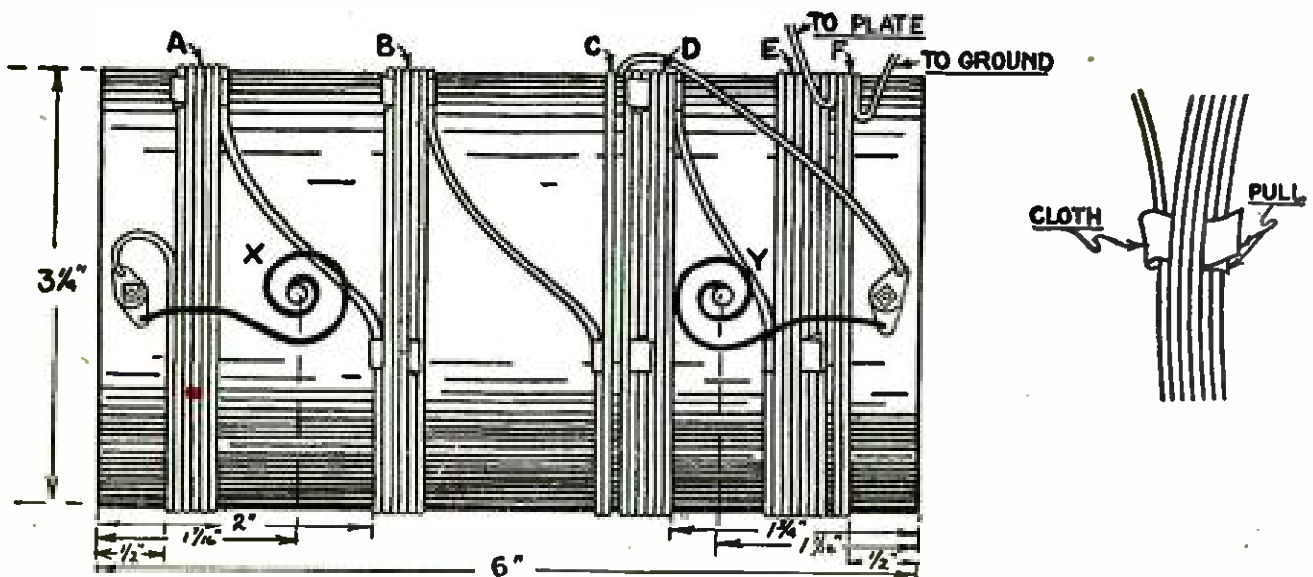

HOW TO MAKE THE TUNER

FIGURE 3: This drawing shows how to space the stator windings on the tube and how to fasten the ends of the windings with a small bit of cloth.

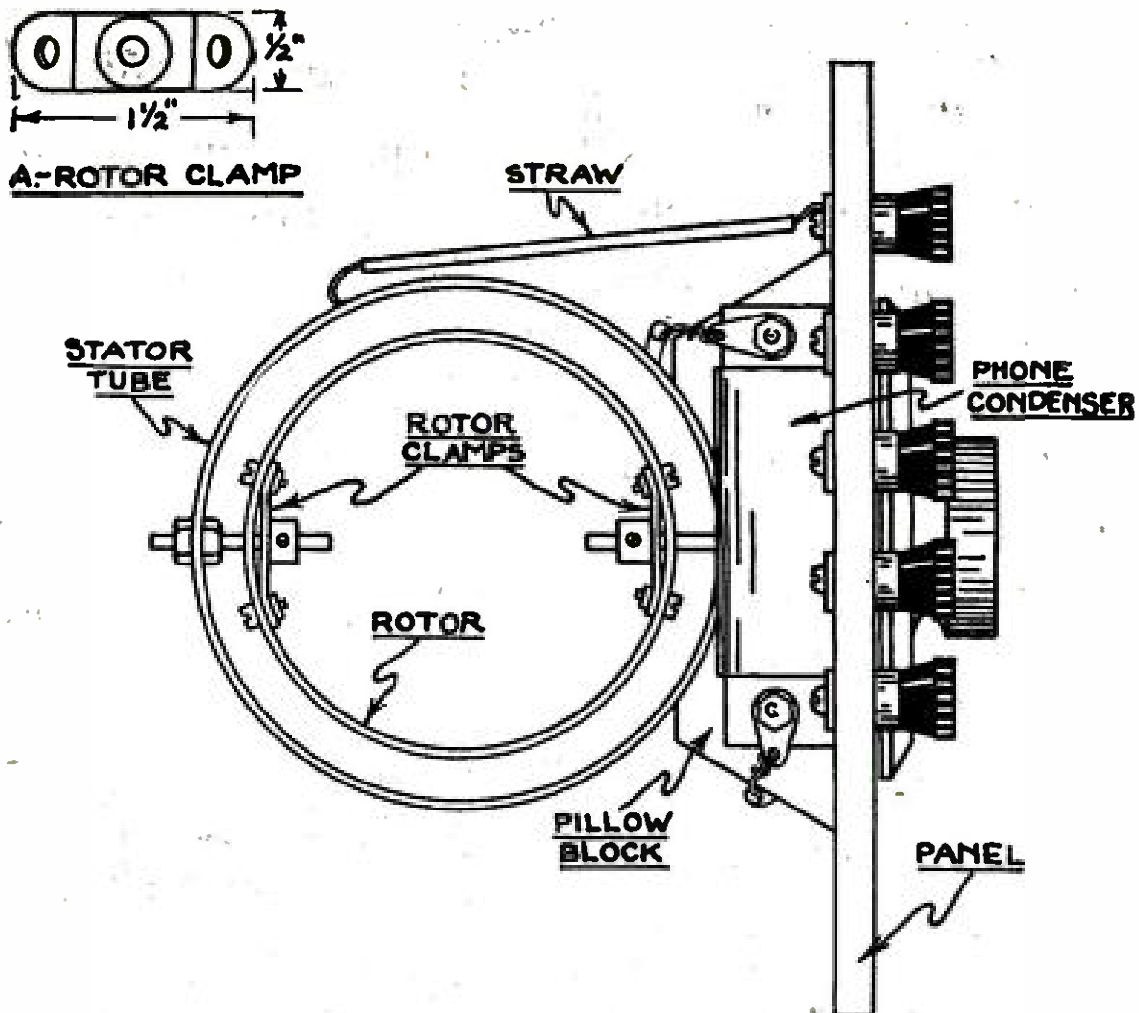

HOW TO MOUNT THE COILS AND THE CONDENSER AND THE BINDING POSTS

FIGURE 4: The rotors of the variometers are fastened to the shafts by means of two ingenious rotor clamps which are tightened on the shaft by set-screws.

from the left end of the tube. C and F each consist of six turns and are wound as close as possible to D and E. When the wire is led from one coil to another it is held in place by a loop of cloth as shown in Figure 3, except the wire from C to F which is led through holes in the tube and under D and E.

Now punch the holes in the tube as shown. X and Y are $\frac{1}{8}$ -inch holes and form the rear bearings for the rotor pivots. Holes in the panel form the front bearings. Cut two $\frac{1}{2}$ -inch holes in the front of the tube directly opposite X and Y. Shellac the tube lightly to hold the wire in place.

The two rotors are exactly alike, each being composed of thirty-eight turns of wire on one of the $1\frac{1}{4}$ -inch by $2\frac{3}{4}$ -inch tubes. When you wind the rotors leave a $\frac{1}{8}$ -inch space clear of wire in the middle of the tubes for the rods to pass through. Wind the wire in the same direction as you did on the larger tube. Run the ends of the wire through holes in the tubes to fasten them, and shellac the wire to hold it in place.

The four rotor clamps are each made from a collar with a set-screw and a $\frac{1}{2}$ -inch by $1\frac{1}{2}$ -inch piece of thin sheet metal. Bore three holes in each piece of metal as shown in Fig-

ure 4 and solder the collars directly above the middle ones. Bolt the clamps inside the rotors (Figure 4).

The bolts should pass through the open spaces that were left when the coil was wound, and the clamps lined up. Be sure that the insulation of the wire is not damaged by the bolt heads.

Use 6-inch pieces of flexible insulated wire to make the rotor connections in front and run these through the $\frac{1}{2}$ -inch holes in the stator tube. Use wire pigtails (Figure 3) for the connections in the rear. Solder them to the $\frac{1}{8}$ -inch rods on which the rotors are pivoted. Clamp these rods in the rotor clamps, and solder one end of the winding of each rotor to each clamp.

Mount each rotor in the large tube on two short rods cut from the long $\frac{1}{8}$ -inch rod (Figure 4). Make two pillow blocks from $\frac{1}{2}$ -inch wood to hold the stator tube. Screw one block at each end of the tube; the tube should be held $\frac{1}{2}$ inch clear of the panel.

If you do not buy a tube socket you can make it as follows:

Use a piece of $\frac{1}{4}$ -inch 3-ply wood, 3 inches by $3\frac{1}{2}$ inches, for the base of the socket (Figure 5). Cut out a space in front to make

HOW TO MAKE AND MOUNT THE SOCKET

FIGURE 5: This diagram is given for the benefit of those who want to make the whole outfit themselves. A regular socket for the tube may, however, be procured at any radio shop.

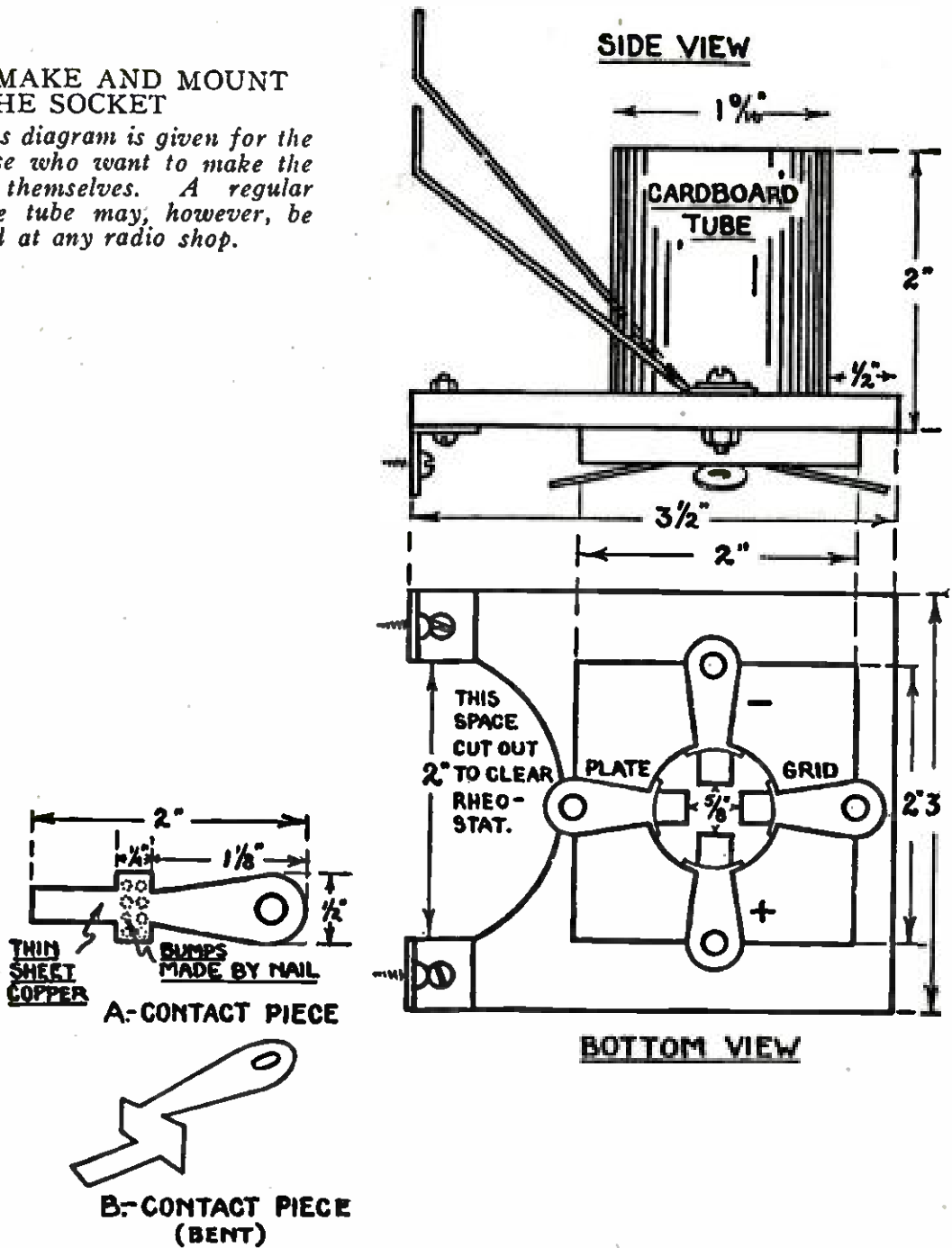

room for the rheostat; cut a 1 5/8-inch hole in it and mount a short cardboard cylinder for a tube guard. Fasten the frame to the panel by means of two angle brackets and two metal strips, one of which should be shorter than the other in order to clear the antenna binding posts.

Take a piece of 3-ply wood 2 inches square and bore holes in it to fit the prongs of the tubes. Now screw it under the cardboard tube. Make the holes a little larger than the prongs. Contact with the vacuum tube is made with the contact pieces; cut them from the copper and bend them as shown in Figure 5, and insert them in the holes. They should grip the prongs firmly when the tube is inserted. Bore holes in the ends of contact pieces so that the connecting wires may be bolted to them.

The antenna condenser (Figure 7) is made from three pieces of thin wrapping paper 1 1/4

inches by 2 inches, two pieces of tinfoil 1 inch by 2 1/2 inches and one piece 1 inch by 1/2 inch. Solder a wire to one end of each piece of tinfoil. Lay the condenser out as shown, roll it up and dip it in melted paraffin and then press it under a weight.

Cut a piece of the sheet copper about 5 1/4 inches by 9 inches with a tab left on one corner, and tack it to the back of the panel. The tab should be fastened under the ground binding post, so that the copper will form a shield for the instruments. Cut that portion of the sheet which is around each hole in the panel so as to make it clear of all the binding posts, except the grounded one.

How to Assemble the Set

When these details are completed, the set may be assembled. The position of the instruments is shown in Figure 1.

Screw all the instruments to the back of the

panel with wood screws, which should be sawed off flush so as not to break the outside finish of the panel. When mounting the instrument be sure that no metal part that is not supposed to be grounded touches the copper shield.

Mount the rheostat first; then screw on the pillow blocks and upon these screw the stator tube. Before fastening on the tube slip a collar with set screw over each of the $\frac{1}{8}$ -inch rods that project from the front of the tube. When the tube is mounted the rods should extend $\frac{1}{2}$ inch through the panel.

Now screw the tube socket directly behind the rheostat. Fasten the antenna condenser a little above and to the left (figuring from the back) of the stator tube.

The phone condenser is supported by two angle brackets (Figure 4); fasten these under the two required binding posts. If a condenser is purchased that measures $2\frac{1}{4}$ inches between its terminals it will fit perfectly.

The hook-up for the set is shown in Figure 6.

Connect the small piece of tinfoil in the condenser with the low wavelength binding post, the middle piece with the set, and the other piece with the high wavelength binding post. In Figure 1 a third binding post is shown, but it is not necessary; it cuts out the condenser entirely and is for use only in connection with an exterior variable condenser. If you own a variable condenser of .001 mfd. capacity you can use it; in this case no other antenna condenser is necessary.

No. 26 wire may be used for connections,

but heavier wire (about No. 18) is better. Cover the connecting wires with varnished-cambric tubing. If this cannot be procured paper straws, such as are furnished in soda fountains can be used.

Do not solder any connections; soldered connections are not advisable in a home-made set, for if any part of the set ever needs to be changed or removed all the connections have to be melted. It is better to solder a copper tab to the end of every connection wire. These tabs offer a large surface for contact and are easily fastened under the binding posts and bolted to the terminals.

Cut two spring washers from thin metal, slip one over each of the $\frac{1}{8}$ -inch rods that project from the panel, and fasten the knobs and dials on top. The dials, together with the collars back of the panel, should be adjusted so that the rotors can turn freely in the stator tube. Fasten the dials at such a position on the rods so that when the scales are at 100 the rotor windings will be parallel with the stator windings; any current passing through the variometers will then traverse both windings in the same direction.

Fasten the panel on the cabinet with six $\frac{3}{4}$ -inch round-head screws; the set is then complete with the exception of the connections of the batteries, phones, antenna and ground. These are shown in Figures 1 and 6.

How to Operate the Set

The tuning of a set cannot well be described in an article; skill in tuning can only be ac-

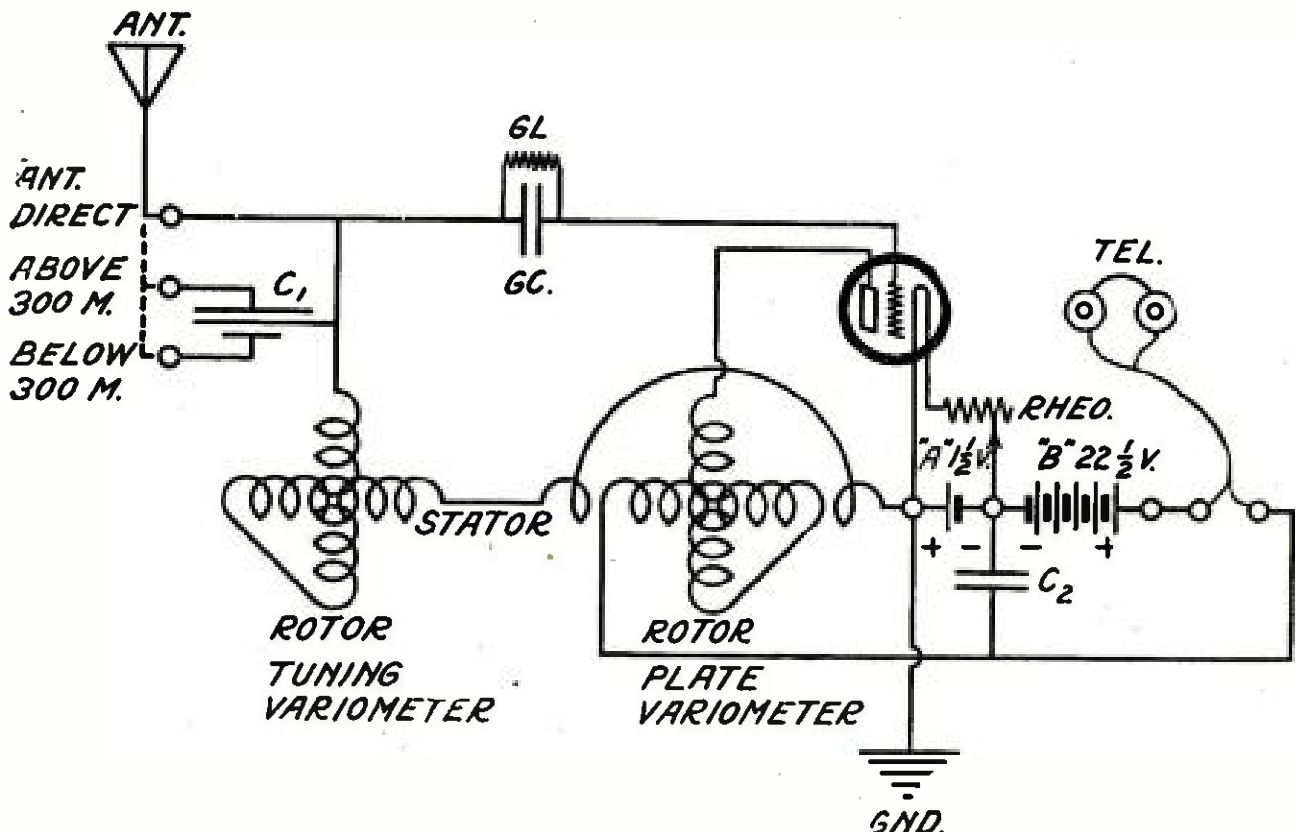

HOW THE SET SHOULD BE WIRED UP

FIGURE 6: The instruments are here shown diagrammatically in their proper parts in the circuit. The wires connecting them together should be run from one instrument to the other in the shortest path without touching any other instrument.

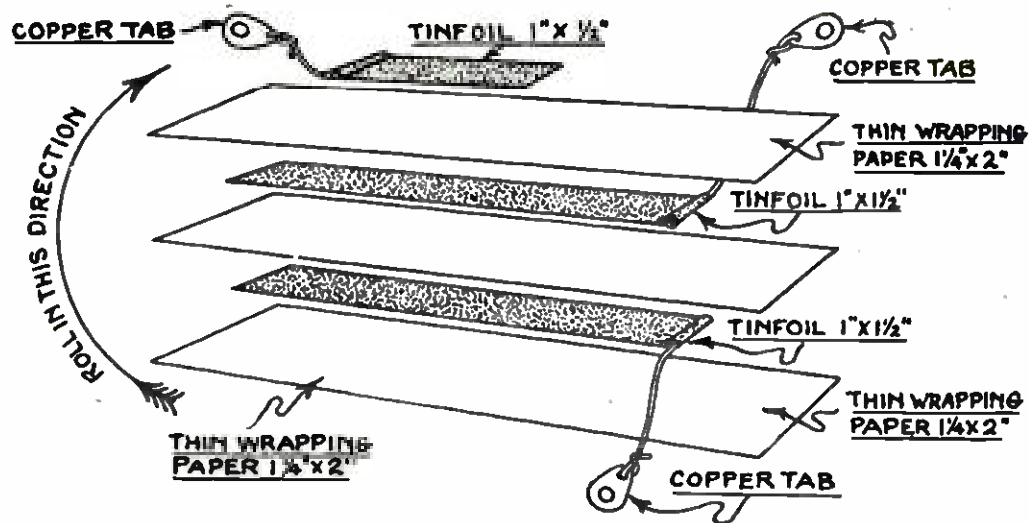

HOW TO PREPARE THE CONDENSER FOR ASSEMBLY

FIGURE 7: The layers of tinfoil and paper should be cut to the sizes shown and placed one on top of the other.

quired by practice. A good plan is to locate a friend who owns a set of his own and have him help you. Do not expect to be able to tune in at first any desired station immediately.

If you experience any trouble in making the tube oscillate when the antenna is connected to the high wavelength binding post, you will probably find that your antenna condenser is of too high capacity; you may have to experiment with it to suit your antenna. Adjust it so that a signal that is received on the low-wave binding post with the dials at 100 will be received with the same intensity on the high-wave post with the dials at about zero if the rheostat position has remained fixed.

The construction of the set here described will enable you to start in on long distance reception without great expense. Later on you may add audio frequency amplification; any type of audio frequency amplifier can be used with this set. It is a simple set for a be-

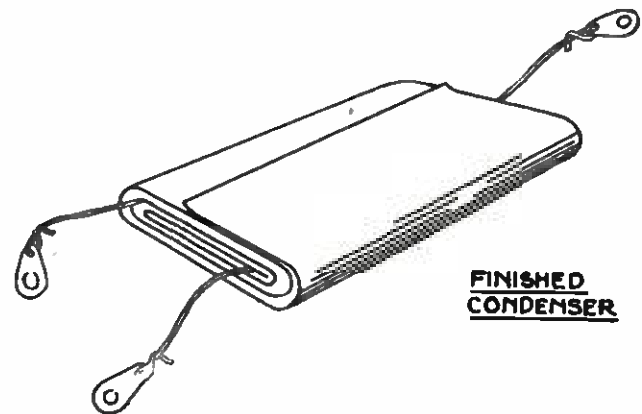

THE FINISHED CONDENSER

After the connecting tabs are fastened to the tinfoil plates the condenser should be rolled up and it will present an appearance as shown here.

giner; yet in this way it can be converted easily into a set for the more advanced fan.

How to Build and Operate the Five-tube Loop Antenna Set

IN the next issue of POPULAR RADIO—August—will appear a full description of how to construct the newest Cockaday set—a five-tube inductively tuned receiver that consists of two stages of radio frequency amplification with compensating condensers, a vacuum tube detector, and two stages of audio frequency amplification. As it operates effectively on either a loop or a short indoor antenna, it reduces to a minimum the interference due to static, and is, therefore, an ideal set for use in summer.



From a photograph made for POPULAR RADIO

THE CIVILIAN RADIO EXPERT OF THE ARMY

Dr. Louis Cohen, the associate of Major General Squier of the Signal Corps, who advised with his chief in the development of the code that promises to speed up transmission between 200 and 300 percent.

The NEW SIGNAL CODE

The most radical change proposed since the Morse alphabet was devised 80 years ago; what it is and how it works

By LOUIS COHEN, Ph.D.

IN the art of electrical communication we are concerned with the production and transmission of signals and the character and combination of the signals for the interpretation of intelligence; therefore a comprehensive study of electrical communication must take account of these two aspects of the art which are so closely related and interdependent.

The methods and means which are employed for the production and transmis-

sion of signals should necessarily depend upon the character of the signals transmitted; a change in one will necessarily involve a change in the other. Any study looking toward the increase in efficiency of electrical communication must take into consideration these two aspects of the problem, and this, of course, is true, irrespective of the methods employed for the transmission of the signals, whether it is radio, line telegraphy or submarine

telegraphy. In the different methods of signal transmission, different equipment and methods have to be employed, but in each case the development of any new methods and means for the production of signals will depend on the character of the signals, and any development, therefore, should logically proceed along these two lines simultaneously; a change in one may require a change in the other.

As a matter of fact, the efforts of engineers have been directed heretofore exclusively to the development and improvement of methods for the production of signals without any regard to a possible change in the character of the signals themselves. In all methods of communication, radio or line telegraphy, we are still using the Morse code, based on the combination of the dot and dash in exactly the same form as proposed by Morse some eighty years ago. It looks as if engineers have taken it for granted that no possible improvement on the Morse code could be made, and they therefore have not given the subject any attention whatsoever. It is remarkable, indeed, that so much engineering ingenuity should have been spent on improving, in the minutest detail, the methods of production of signals, and no consideration at all given to any possible change in the character of the signals themselves.

A new method of signaling has recently been described by Major General George O. Squier. In it the dot and dash signals of the Morse alphabet are differentiated by a difference in *intensity*, instead of a difference in *time-interval*, as is the practice now.

The difference in the two methods is of greatest importance in effecting economy in time of signaling. In the present practice, every dash signal occupies a time-interval three times that of a dot signal, and in the Squier method the dash signal does not require any more time than the dot signal. General Squier accomplishes this by the use of an alternating current in which each half cycle, or even multiple thereof, represents a dot

or a dash, the two being distinguished by a difference in intensity. In the case of land lines or submarine telegraphy, an alternating current of the desired frequency is directly impressed on the line and the signaling accomplished by varying the intensities of the half cycles, or multiples thereof. For radio signaling the carrier high-frequency current is modulated by a low-frequency alternating current, and here again the modulating alternating current is varied in amplitude to produce the desired signals. It is clear that in the case of submarine telegraphy only low-frequencies can be transmitted, and therefore to obtain any speed at all in signaling it will be necessary to make every half cycle represent a signal, a dot or a dash. On the other hand, in line telegraphy, where higher frequencies may be employed, considerable speed in signaling may be obtained by using several half cycles for each signal; that is to say, we could use, say, a 60-cycle alternating current or even 100-cycle alternating current, if desired, and assign for each signal a certain number of half cycles, depending upon the speed of signaling desired. The advantage of using several half cycles for each signal is that greater accuracy is thereby insured, because even if during the time-interval of each signal anything should occur to disturb the character of the signal, there is the possibility that some of the half cycles would retain their character, and the signal could therefore still be interpreted. The same reasoning applies also to radio signaling. Here again we can modulate the carrier high-frequency current by a low-frequency alternating current of any desired frequency and assign to each signal a certain number of half cycles, depending upon the modulating frequency employed and the speed of signaling desired.

It is believed that this method offers, among others, two great advantages:

First, an increase in speed of signaling; which means of course an increase in the efficiency of the system.

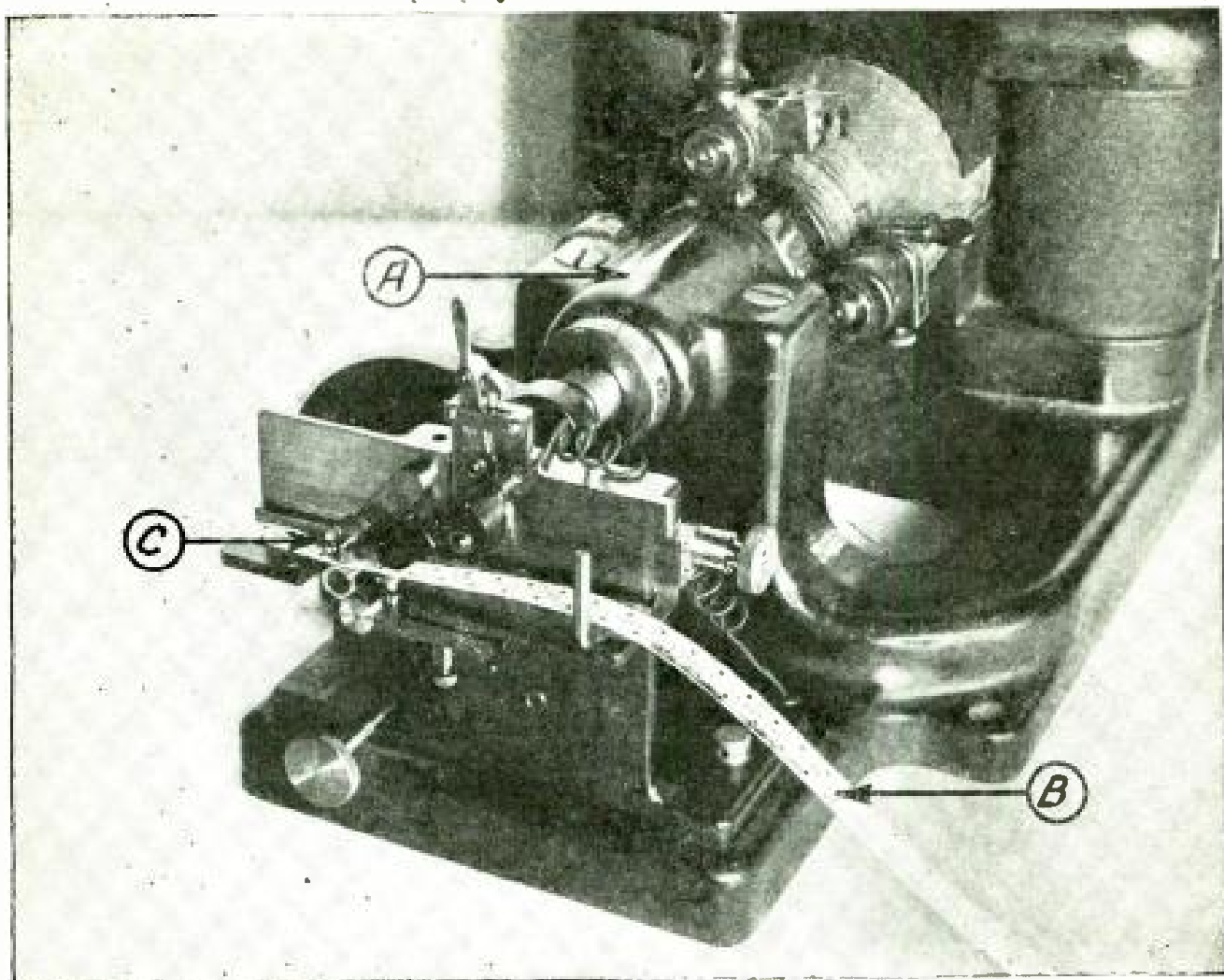

A MECHANICAL TRANSMITTER FOR THE NEW SQUIER CODE

A shows the driving motor; B shows the tape; C shows the roller. This apparatus may be used in connection with either radio, line telegraph or submarine cable.

Second, greater reliability and accuracy.

If we remember that by this method we can assign, say six or eight or even ten half cycles for each signal, the possibilities of errors in interpreting the signals are greatly reduced. Even in the case of static disturbances some of the half cycles of each signal may be affected in character, but there is still the possibility that some of the half cycles will retain their identity, thus enabling the operator to recognize the signals.

It is true, of course, that in varying the amplitude of each succeeding half cycle, or changing the amplitude of a group of oscillations, a transient effect is produced which must be carefully taken into consideration. This is a problem which can be investigated and is now

being investigated, mathematically, and it is hoped the results will be available before long. But it must be remembered that the change in amplitude required in order to distinguish between a dot and a dash need not be large, a change of the order of magnitude of ten percent will probably be sufficient, and therefore the transient effect produced by this small change in amplitude will not be large. Hence it would appear that the general considerations of this method, as outlined by General Squier, will not be upset seriously by these transient effects accompanying the changes in amplitude in signaling.

Another advantage of this method is that a much higher degree of selectivity can be obtained. In the present method the variations produced by the dot and

dash signaling are irregular in their character; the time-interval required for the dot and the dash are of the ratio of 3 to 1, and therefore no tuning to the signaling frequency is at all possible. But in the method proposed by General Squier, the signaling frequency is fixed, and the character of the signals is uniform, the variations following practically sine-wave form, and therefore it should be possible to tune both mechanically and electrically to the signaling frequency, which in the case of radio signaling would be the modulating frequency. We can by this method, in the case of radio signaling, effect a double tuning, first tuning by the usual means to the carrier frequency, and then again tuning mechanically and electrically to the low modulating frequency. It would seem that this method should offer possibilities of remarkably sharp selectivity, which is, of course, an advantage which can hardly be overestimated.

This method also offers a solution to the problem of multiplexing. There does not seem to be any reason why we could not, with advantage, modulate the carrier frequency by several different modulating frequencies and transmit several messages simultaneously on the same carrier frequency. At the receiving stations the messages could be easily separated by tuning to the modulating frequencies. This is a matter which is of pressing importance in radio signaling because of the limited number of wave channels available for transmission of intelligence. At the present time, when the demand for radio transmission is increasing from day to day, the problem of finding enough wave channels to satisfy all the demands is an urgent one.

Now it would seem that by changing the character of the alphabet, adopting the method proposed by General Squier,

the speed of signaling would be increased and also the use of one carrier frequency for transmission of several messages would be made possible, and thus the number of wave channels available for handling the radio traffic of the world would be increased.

A question may be raised in regard to the methods for interpreting the signals at the receiving end. The present methods will not do, since the operator could not differentiate the small difference in intensity between the dot and dash by receiving the signals in the ordinary telephone. The difficulties, however, are not of any serious consequence. In the first place, it must be remembered that if any great speed in signaling is desired, mechanical sending and receiving must be resorted to, and this method lends itself readily for machine operation, the signals being transmitted by tape in the usual way and received at the other end either by recording the signals, or by having them operate a page printer. But even if, for some reason, it is desired to transmit the signals by hand and receive them by audition, this can be accomplished in various ways. One of the methods which has been suggested is to have the two signals of different intensities; that is, the dot and the dash operate local circuits in which audible notes of different character are continuously generated, and thus the operator will hear two notes of different character which he could learn quickly to interpret as the dot and the dash.

From an engineering standpoint, therefore, this new method of signaling does not offer any serious problems which could not be met by present day engineering practice; at the same time it offers the advantages of increased speed, higher efficiency, and greater selectivity.



HOW A RECEIVED MESSAGE APPEARS

By remembering that the long impulses represent the dashes of the old code and that the short impulses represent the dots of the old code, any one who knows the Morse alphabet can decipher this phrase.



From a photograph made for POPULAR RADIO

TAKE YOUR HYDROMETER READING ONCE A WEEK

The full charge hydrometer reading of a lead acid cell should be between 1.250 and 1.300, and the battery should never be discharged below a reading of 1.18.

How to Keep Up Your STORAGE BATTERY

By HENRY STRAHLMAN

AMONG the questions that the radio amateur asks most frequently are: What is a storage battery? What is it used for? How does it store up electricity?

As the proper maintenance of the amateur's radio equipment is largely dependent upon an intelligent understanding of the workings of this important device, his questions may be answered simply as follows:

First: A storage battery is a device for storing energy at one time for use at another time. Energy is first put into it in the form of electricity and is delivered from it in the same form. The process of putting energy into a battery

is termed "charging." When the battery is delivering energy, it is "discharging."

Second: A storage battery is used to light the filament of one or more vacuum tubes of a radio receiving set.

Third: A storage battery does not store up electricity; it stores up a chemical action which, when the battery is connected, generates electricity. A lead-acid battery consists of a number of cells; each cell has a number of positive and negative plates. Both plates have as their backbone a cast grid made of a stiff lead alloy. These grids act merely as supports for the active material in the plates. These plates differ only in the composition of the active material with which

they are filled. The positive plates are filled with brown peroxide of lead and gray spongy lead in the negatives. There is also the electrolyte, which is the solution in the battery and which consists of a definite mixture of sulphuric acid and distilled or other "pure water." When the current is taken from a battery, a certain part of the solution combines with the plates, leaving the solution weaker.

For purposes of illustration, consider a six volt, sixty ampere hour battery of the lead acid type, which has been discharged and needs recharging.

Such a battery may be recharged in several ways. If you have direct current, you may use a thirty-two candle power lamp, connected in multiple as shown in figure 1. If you have alternating current, a number of rectifiers that are on the market will serve the purpose, such as the Tungar bulb rectifier or the magnetic rectifiers. These rectify the alternating current and turn it into direct current, as all storage batteries must be charged with the direct current.

Before you put the battery on charge, make sure which is the positive and which is the negative terminal of the battery. The positive is marked "Pos." or $+$ or is painted red; the negative is marked "Neg." or $-$, or is painted black. The polarity of the charging wires (if they are not marked), may be determined by placing them in a glass of water to which a teaspoonful of salt has been added; if you do this make sure that the wires are not too close together. Fine bubbles of colorless gas will collect on the negative wire under water.

The positive terminal of the battery must connect with the positive wire of the charging circuit and the negative terminal of the battery must connect with the negative wire of the charging circuit.

The battery is now on charge. The direct current flows through the plates and the solution, causing a chemical action which takes off that part of the solution that had combined with the material in the plates during the dis-

charge and returns it to the solution again. Great care should be taken that the charging rate is not greater than the correct charging rate of the battery. (This is usually shown on the manufacturer's nameplate).

In other words, let us assume that the charging rate of the battery is five amperes, and the battery is a sixty ampere hour type. Therefore we will charge it for twelve hours. For example: 5 amperes \times 12 hours = 60 ampere hours. However, this should be determined by means of a hydrometer or hydrometer syringe. By inserting the end of the syringe in the filling holes of the battery

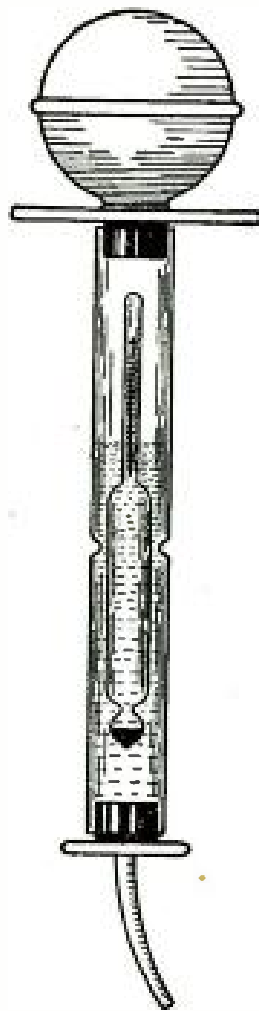

The battery solution is drawn up into the outer glass tube of the hydrometer syringe by means of the rubber bulb at the upper end. The narrow part of the floating indicator is graduated, much like a thermometer, to read in "specific gravity." The point where the surface of the liquid crosses the scale on the float gives the correct reading.

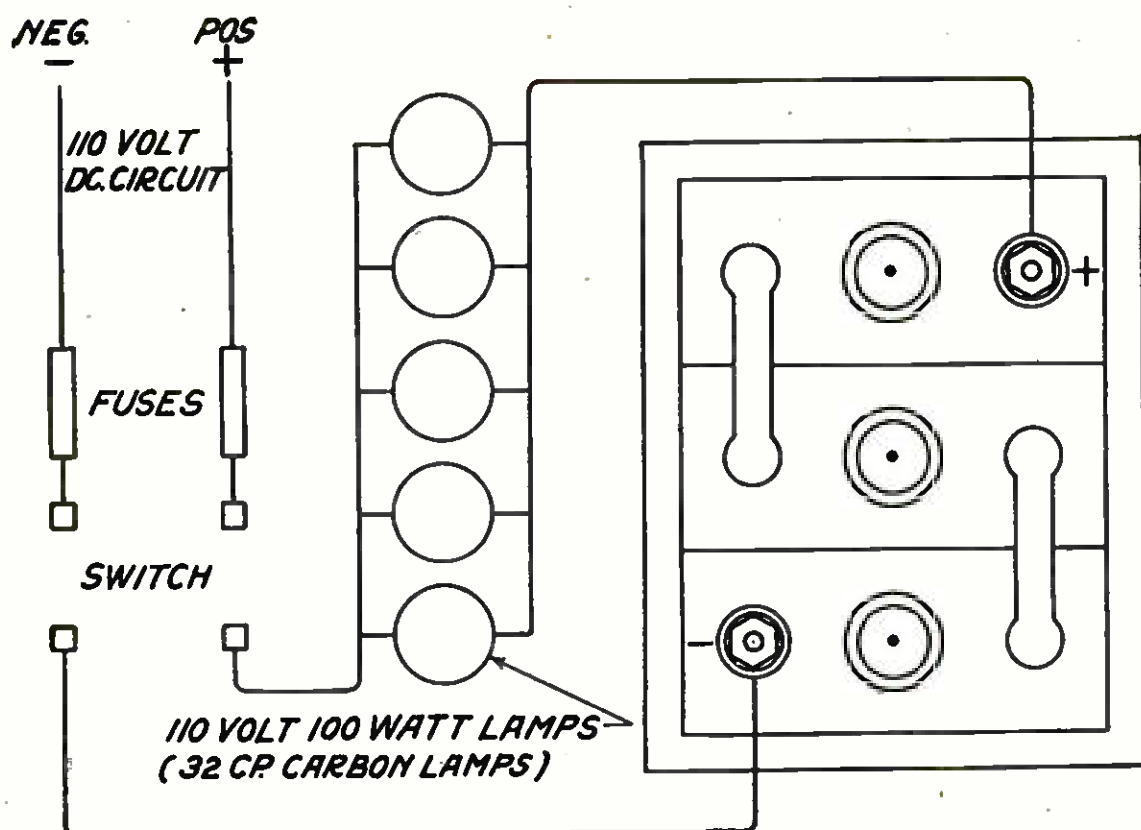

A CIRCUIT FOR CHARGING YOUR BATTERIES FROM THE D. C. LIGHTING MAINS

This diagram illustrates the connections that should be used with a 110-volt D. C. lighting circuit through a bank of lamps. Be sure that the positive terminal of the lighting main is connected to the positive terminal of your battery.

and by drawing up enough solution to float the glass bulb inside of the instrument, the reading of the scale at the surface of the liquid gives the strength of the solution, which must be between 1.250 and 1.300 when the battery is fully charged.

Another way of making sure that a battery is fully charged is to leave it on charge for two or three hours after each cell has started to gas or bubble. However, everyone should have a battery hydrometer to test his battery.

Upon discharging the battery, let us assume that we are using a detector and one step of amplification. The two vacuum tubes used are drawing about two amperes between them. The battery has but sixty ampere hours of current; therefore $60 \div 2 = 30$ ampere hours. This means that we can only draw two amperes for thirty hours.

The battery is now fully discharged and must be recharged immediately.

However, a battery of sixty ampere hours' capacity that has two amperes drawn out of it should never be discharged for more than twenty-five hours. This leaves some life in the battery, which lengthens the total life of it.

Hydrometer readings should be taken at least once every week and pure distilled water should be added to the solution at least once every week, so that the plates are always covered. The full charge hydrometer reading of a lead-acid cell should be between 1.250 and 1.300 and the battery should never be discharged below a hydrometer reading of 1.18. The lead-acid cell has a fully charged voltage of 2.2 volts and discharged voltage of 1.8 volts.

Another type of battery is the Edison cell battery. The positive or nickel plate consists of one or more perforated steel tubes, heavily nickel plated and filled with alternate layers of nickel hydroxide and pure metallic nickel in thin flakes. The

tube is drawn from a perforated ribbon of steel, nickel plated, and reinforced with eight steel bands, equidistant apart, which prevent the tube from expanding away from and breaking contact with its contents.

The negative or iron plate consists of a grid of cold rolled steel, nickel plated, that holds a number of rectangular pockets filled with powdered iron oxide. These pockets are made up of a finely perforated steel, nickel plated. After the pockets are filled, they are inserted in the grid and subjected to great pressure between dies which corrugate the surface of pockets and force them into good contact with the grid. The electrolyte consists of a 21 percent solution of potash in distilled water with a small percent of

lithia. The density of the electrolyte does not change on charge or discharge. The Edison cell has a fully charged voltage of 1.2 volts and a discharge voltage of .9 volt. The Edison cell may be overcharged or over-discharged, or even short-circuited, without injury to the plates. The lead cell, if allowed to remain idle, will lose its charge, and if left in a discharged or a partially discharged condition for any length of time, deterioration of the plates will take place. The Edison cell will retain its charge for a long time and is not damaged by being left in a discharged condition.

Never leave your storage battery discharged for any length of time, and do not try to use it when it is run down, or it will become permanently injured.



Harris & Ewing

RADIO ENTERS CONGRESS

Just why Representative Louis T. McFadden of Pennsylvania should take upon himself the distinction of being the first member of Congress to install a receiving set in his workroom in the Capitol is made clear when it is known that he is chairman of the Banking and Currency Committee of the House. Were it not for the fact that Station WWX, operated by the U. S. Post Office, sends out the latest quotations, he would have to wait until they came lumbering in on the old-fashioned ticker!



International

THE RADIO EXPERTS WHO FRAMED THE NEW RULES

The failure of the last Congress to pass the White Radio Bill prompted Secretary Hoover to re-assemble this National Radio Committee to work out new schedules to meet the emergency. And it did!

What the New Broadcasting Schedule Means to *You*

How order and system are being introduced into the ether and how interference is being eliminated, told by a nationally-known engineer who helped to frame the new rulings—

JOHN V. L. HOGAN

IF you are a broadcast listener, you have probably wondered how things would be changed by the Department of Commerce regulations made as a result of Secretary Hoover's radio conference last March.

You have read about the new wavelengths that have been opened to broadcasting, and about the new classification of stations. The changed rules went

into effect on May 15; since then you have been able to find out something of the way the new organization of stations works. However, the real value of the plan will not be evident until the winter months are with us again, for then long distance reception will be free from summer-time static interference and wave absorption.

Perhaps the greatest change made by

the use of extra wavelengths is in the reduction of interference between broadcasting stations.

To get some idea of this, can you imagine a great hall containing a dozen or two stages, with bands playing on some of them, lecturers speaking from others and soloists performing on still others? Can you imagine yourself walking about such a huge auditorium, trying to enjoy the music of one orchestra, or the speech of one orator, amid the pandemonium created by all the rest? Can you conceive that anyone would try to provide instruction or amusement in this way for a building full of people? Certainly the only listeners who would hear anything satisfactorily would be those nearest each attraction, for by each of them this particular one would be heard louder than any of the others and to some extent would drown out the interfering sounds. People who were standing about equally distant from two bands, however, would not hear enough of either to be worth much; and persons located near one speaker would be entirely "out of luck" if they wanted to hear a man who was talking at the other end of the room.

If you will think of the United States as such a huge auditorium, each broadcasting station as a performer and each radio receiver as a listener, you will have a fair picture of the broadcasting situation as it was when Secretary Hoover called the National Radio Conference in Washington on March 20. The comparison is not exact, of course, but the fact is that on March 17 there were in the United States 560 broadcasting transmitters licensed to operate on the 833 kc.* per second (360

*The Second National Radio Conference, which met with Secretary Hoover in March, introduced a method of designating radio waves which is somewhat new to the radio public. This is the use of frequency in kilocycles (abbreviated kc.), instead of wavelength in meters. The frequency of the radio wave is the same as the frequency of the alternating current which flows in the radio transmitting or receiving set.

The reason that kilocycles have been adopted by the Department of Commerce is that the necessary separation of the frequency of transmitting stations to

meter wave). This means that in so far as they worked at the same time, and at their official wave-frequency, they were all "in the same hall" and the only way to hear one to the exclusion of others was to move up near to it!

You realize, of course, that each wave-frequency (such as that of 833 kc.) represents a single path or channel for radio communication. As a practical matter, the channels cannot be narrowed down to a single frequency-value, and for radio telephony one must ordinarily have for each path or group or band of wave-frequencies about 10 kc. wide. Such frequency-bands are usually called by their central or *average* frequency, so that the one named 833 kc. really extends from 5 kc. less (828) to 5 kc. more (838). When a number of standard radio transmitters radiate waves of the same frequency, no receiver can select one station's signals from those of the others, no matter how sharply selective that receiver may be.

Thus broadcasting stations that use the same wave-frequency are almost literally in the same room, for no matter how carefully you tune your receiver you cannot discriminate between them except to the extent that the nearest and most powerful stations will be the loudest ones heard.

To help out the interference situation some forty of the best broadcasting stations were moved out of the

prevent interference is the same, no matter what the frequency may be. This necessary separation is variable and quite misleading when expressed in meters. Thus the number of radio messages that can be transmitted simultaneously without interference can be correctly judged from the kilocycles but not from the meters. For example, the amateurs will in the future work in a band of wavelengths from 150 to 200 meters, but this is a frequency band from 2,000 to 1,500 kilocycles. This is an enormously wider band when considered from the viewpoint of kilocycles than, for example, the band having the same width in meters from 1,000 to 1,050 meters, which is 300 to 286 kilocycles. While it is possible to carry on fifty simultaneous radio telephone communications between 150 and 200 meters, only one could be carried on between 1,000 and 1,050 meters.

To convert meters into kilocycles, divide 300,000 by the number of meters; to obtain meters from kilocycles, divide 300,000 by the number of kilocycles. For example, 100 meters = 3,000 kilocycles, 300 meters = 1,000 kilocycles, 1,000 meters = 300 kilocycles, 3,000 meters = 100 kilocycles.

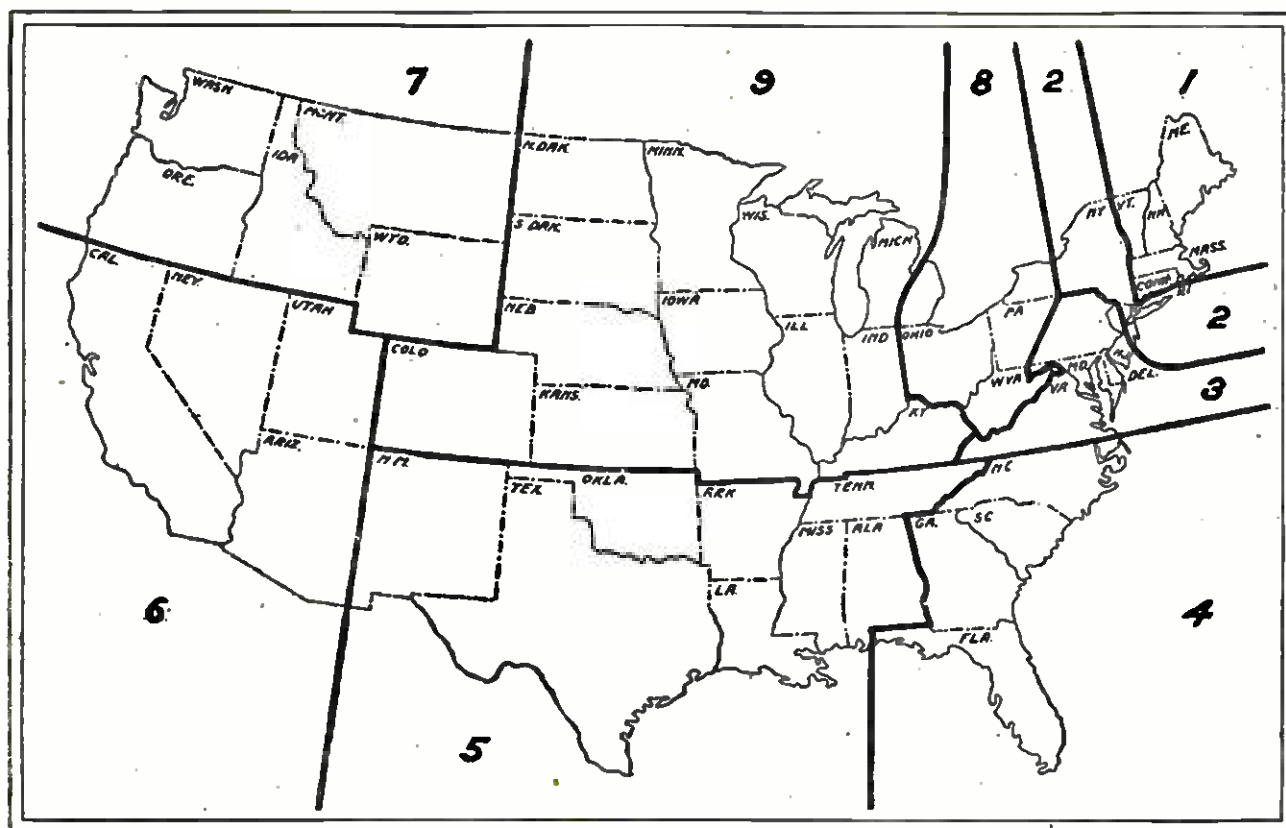

UNCLE SAM'S NINE RADIO DISTRICTS

The call letters of licensed amateurs are preceded by the numeral that indicates the district in which they are located. Thus "3ZY" would be located in the 3rd District.

general 833 kc. group and given a second wave-frequency of their own (750 kc., or 400 meters wavelength). This was more or less equivalent to putting these stations in a building of their own, where they would not be disturbed by the crowd of 833 kc. broadcasters. Nevertheless, even forty orchestras are too many for one building and forty powerful broadcasting stations are too many for one wave-frequency. To hear any one of them you must either move up near to the town in which it is located or else ask the other stations to keep still.

One may easily ask how such a chaotic and disorganized condition could have grown up in radio broadcasting, for it seems evident that only a relatively few stations could operate simultaneously at the same wave-frequency even though they were spread over so large a territory as the United States. The answer is not very simple, but perhaps the principal factor is that when the Department of Commerce decided

to limit broadcasting to a single wave-frequency (or, in our figurative phrase, to "put all the stations in the same building") no one had any idea that so many people would want to broadcast.

For a time after the first few stations were licensed things went very well. KDKA at Pittsburgh did not interfere badly with WJZ at Newark or KYW at Chicago; it was only when two and three and even a dozen or more stations crowded into the same locality that real trouble developed. Even if the government authorities had realized the demands that broadcasting would make upon them they probably could have done little more than assign the two wave-frequencies that they did grant, namely 833 and 750 kc. (360 and 400 meters), for most of the other useful radio channels were already in use and could not easily be pre-empted for broadcasting.

The biggest job that the radio conference had before it was to find more

wave-frequency bands for broadcasting. The government departments had the exclusive right to use a wide range of waves from 500 to 187 kc. (600 to 1,600 meters), and they were willing to throw open a part of it to other uses, but so few broadcast receivers would operate at wave-frequencies below 500 kc. that it would not have been fair to the listeners to have extended the waves in that direction. On the other hand, only few broadcast receivers can receive waves of frequencies higher than 1,500 kc., so that a similar upper limit was fixed at the corresponding wavelength of 200 meters.

The job of getting useful groups of wave-frequencies for broadcasting was done along with that of minimizing interference between various kinds of radio services, by clearing out (as far as possible) all non-broadcasting activities from the 500 to 1,500 kc. range. By international agreement, 500 kc. (600 meters) is a marine and aircraft radiotelegraph wave, and it is largely used for distress calls; 50 kc. had to be allowed to protect it from interference, so the lowest frequency that could be adopted for broadcasting was 550 kc. (545 meters wavelength). By arranging to stop the use of 667 kc. (450 meters) in ship telegraph traffic services between the hours of 7 and 11 P. M., and by transferring to other waves a number of stations whose services would not be handicapped by the change, the conference was able to get a practically unbroken range of broadcasting waves from 550 kc. up to 1,000 kc.

At 1,000 kc. (300 meters) there is another wave-frequency used for ship and aircraft services, but by agreeing to minimize transmission at this frequency it was possible to carry the broadcasting waves on up to 1,350 kc. (222 meters). Bearing in mind that wavebands 10 kc. wide are needed for ordinary radio telephony, it is clear that the range from 550 to 1,350 kc. allows something like eighty independent

channels for broadcasting. This means that under the new plan eighty properly located broadcast stations could be operated simultaneously all day long without interference, whereas the old plan permitted only two stations to work under the same conditions.

In order to operate still more than eighty stations simultaneously, advantage was taken of the fact that many BX plants (as we may call broadcasting stations) have limited power. Two of the most powerful stations would hardly interfere with each other if one were on the Atlantic coast and the other on the Pacific, even though both used the same wave-frequency. Thus, and particularly among the lower powered stations, waves may be duplicated if the stations to which they are assigned have locations that are well-separated.

In following the recommendations of the conference the Department of Commerce has established three classes of BX stations.

Class A includes the low-powered group with a limited distance range; to this class the wave-frequencies from 1,050 kc. (286 meters) to 1,350 kc. (222 meters) have been assigned.

Class B covers the stations of 500 watts power or over, with strict requirements as to quality of program and transmission; the wave-frequencies from 550 kc. (546 meters) to 1,040 kc. (288 meters) are set aside for these high grade plants.

Class C, for the present, includes stations that will use the old 833 kc. frequency which lies about in the center of a reserved range of wave-frequencies from 800 kc. (375 meters) to 870 kc. (345 meters). Class C stations are those whose management desire to continue to use the old "360 meter" wave, regardless of whether they operate on high or low power.

The principles followed in assigning the Class B wavelengths are simple, but in themselves automatically min-

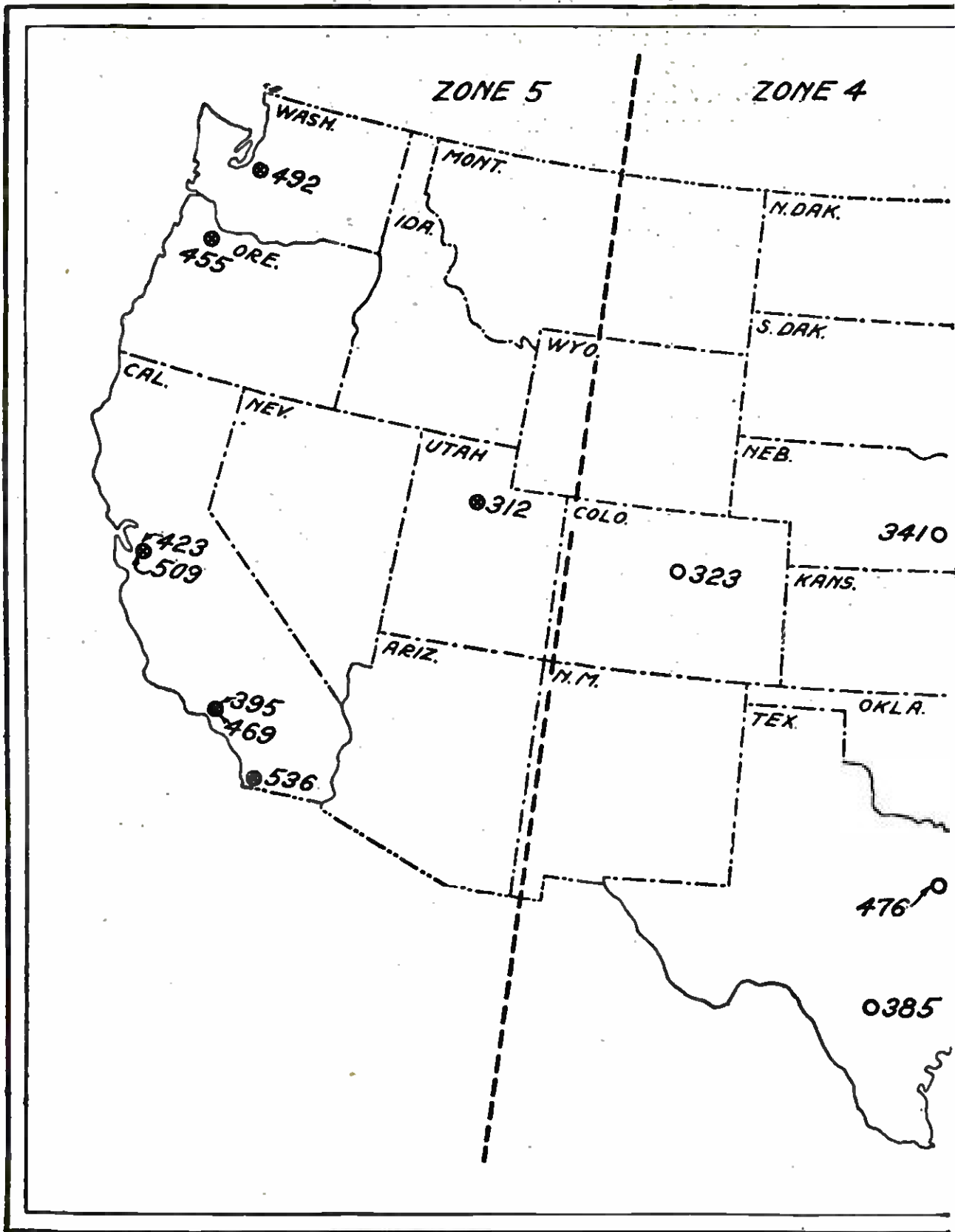

The Five New Broadcasting Zones of the United States—

To each of the five zones has been assigned ten of the wavebands which have been set aside for the Class B (high-powered) stations; the frequencies of any two stations within each zone have been kept at least 50 kilocycles apart.

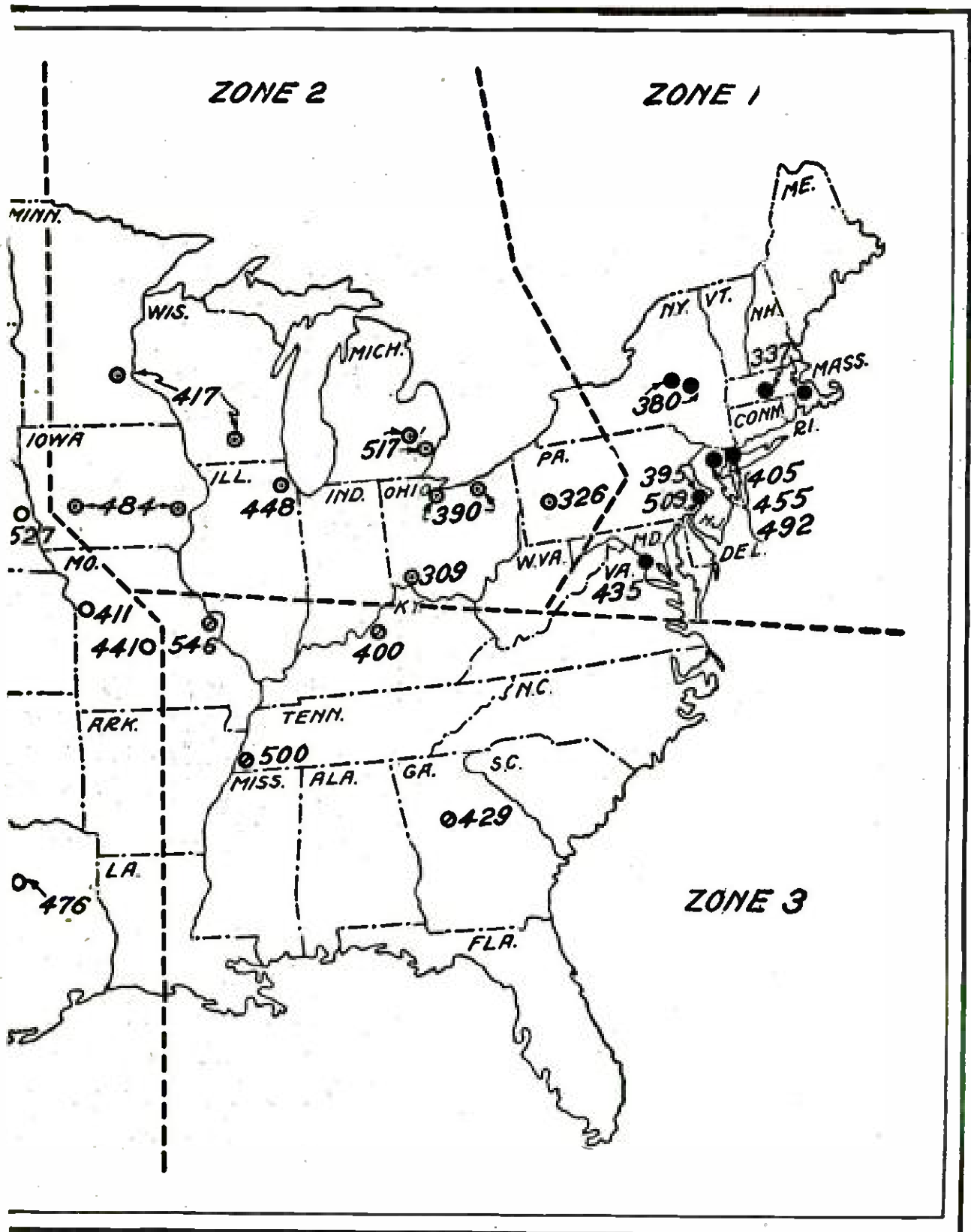

—and the New Wavelengths Assigned to the Leading Cities
The frequencies used by any two stations located in adjacent zones have also been separated by at least 20 kc. The remaining wavebands for the Class A (low-powered) stations will be distributed throughout the zones by the Radio District Inspectors.

imize interference to a large extent. The United States is to be divided into five radio broadcasting zones; each zone is to be assigned ten of the fifty wavebands available for Class B stations. The frequencies of adjacent stations within any zone are to be at least 50 kc. apart, and the frequencies of stations in adjacent zones are to be at least 20 kc. apart. The remaining wavebands for class A stations are to be distributed among the radio inspection districts on a basis that will keep stations using each specific frequency as far apart (geographically) as may be possible.

The important Class B wavelengths and the localities to which they have been assigned are given in the following table, and those not reserved are shown on the accompanying map.

FREQUENCY	WAVELENGTH	LOCALITY	ZONE
550 kc.	546 meters	St. Louis, Mo.	3
560 kc.	536 meters	San Diego, Cal.	5
570 kc.	527 meters	Omaha, Neb.	4
580 kc.	517 meters	Dearborn and Detroit, Mich.	2
590 kc.	509 meters	San Francisco, Cal.	5
590 kc.	509 meters	Philadelphia, Pa.	1
600 kc.	500 meters	Memphis, Tenn.	3
610 kc.	492 meters	Seattle, Wash.	5
610 kc.	492 meters	New York, N. Y. and Newark, N. J.	1
620 kc.	484 meters	Davenport and Des Moines, Iowa	2
630 kc.	476 meters	Dallas and Fort Worth, Texas	4
640 kc.	469 meters	Los Angeles, Cal.	5
640 kc.	469 meters	Reserved	1
650 kc.	462 meters	Reserved	3
660 kc.	455 meters	Portland, Oregon	5
660 kc.	455 meters	New York, N. Y. and Newark, N. J.	1
670 kc.	448 meters	Chicago, Ill.	2
680 kc.	441 meters	Jefferson City, Mo.	4
690 kc.	435 meters	Washington, D. C.	1
700 kc.	429 meters	Atlanta, Ga.	3
710 kc.	423 meters	San Francisco, Cal.	5
720 kc.	417 meters	Madison, Wis. and Minneapolis, Minn.	2
730 kc.	411 meters	Kansas City, Mo.	4
740 kc.	405 meters	New York, N. Y. and Newark, N. J.	1
750 kc.	400 meters	Louisville, Ky.	3
760 kc.	395 meters	Los Angeles, Cal.	5
760 kc.	395 meters	Philadelphia, Pa.	1
770 kc.	390 meters	Cleveland and Toledo, Ohio	2
780 kc.	385 meters	San Antonio, Texas	4
790 kc.	380 meters	Schenectady and Troy, N. Y.	1
800 kc.	375 meters	Reserved	3
(810) kc.	(370) meters	Reserved	5
(820) kc.	(366) meters	Reserved	2
(830) kc.	(361) meters	Reserved	4
(840) kc.	(357) meters	Reserved	1
(850) kc.	(353) meters	Reserved	3
(860) kc.	(349) meters	Reserved	5
870 kc.	345 meters	Reserved	2
880 kc.	341 meters	Lincoln, Neb.	4
890 kc.	337 meters	Springfield and Wellesley Hills, Mass.	1
900 kc.	333 meters	Reserved	3
910 kc.	330 meters	Reserved	5

920 kc.	326 meters	Pittsburgh, Pa.	2
930 kc.	323 meters	Denver, Col.	4
940 kc.	319 meters	Reserved	1
950 kc.	316 meters	Reserved	3
960 kc.	312 meters	Salt Lake City, Utah	5
970 kc.	309 meters	Cincinnati, Ohio	2
980 kc.	306 meters	Reserved	4
990 kc.	303 meters	Reserved	1
1000 kc.	300 meters	Reserved	3
(1010) kc.	(297) meters	Reserved	5
(1020) kc.	(294) meters	Reserved	2
(1030) kc.	(291) meters	Reserved	4
(1040) kc.	(288) meters	Reserved	1

The Class A wave frequencies and their assignment to inspection districts are shown below:

FREQUENCY	WAVELENGTH	LOCALITY
1350 kc.	222 meters	4th, 5th and 8th districts
1340 kc.	224 meters	All districts
1330 kc.	226 meters	All districts
1320 kc.	227 meters	1st, 6th and 9th districts
1310 kc.	229 meters	All districts
1300 kc.	231 meters	All districts
1290 kc.	233 meters	2nd, 5th and 7th districts
1280 kc.	234 meters	All districts
1270 kc.	236 meters	All districts
1260 kc.	238 meters	1st, 3rd and 6th districts
1250 kc.	240 meters	All districts
1240 kc.	242 meters	All districts
1230 kc.	244 meters	2nd, 4th and 9th districts
1220 kc.	246 meters	All districts
210 kc.	248 meters	All districts
200 kc.	250 meters	5th, 7th and 8th districts
1190 kc.	252 meters	All districts
1180 kc.	254 meters	All districts
1170 kc.	256 meters	1st, 3rd and 6th districts
1160 kc.	258 meters	All districts
1150 kc.	261 meters	All districts
1140 kc.	263 meters	2nd, 5th and 7th districts
1130 kc.	266 meters	All districts
1120 kc.	268 meters	All districts
1110 kc.	270 meters	4th, 7th and 8th districts
1100 kc.	273 meters	All districts
1090 kc.	275 meters	All districts
1080 kc.	278 meters	1st, 6th and 9th districts
1070 kc.	280 meters	All districts
1060 kc.	283 meters	All districts
1050 kc.	286 meters	3rd, 8th and 9th district

So much for the new plan, which has already proven itself a great thing for radio broadcasting. Whistling "beat" interference, for instance, has practically been eliminated.

It is not easy to keep so many stations exactly on their official wave-frequencies, and when one trespasses upon the neighboring waveband interference is created. Again, some receivers are incapable of selecting between wave-frequencies only 10 or 20 kc. apart, and users of such apparatus are having a little trouble.

Nothing, however, has come up or is likely to come up that will seriously interfere with the execution of the conference plan, and it is generally agreed that the new organization of wave-frequencies marks a great step in the advance of radio.

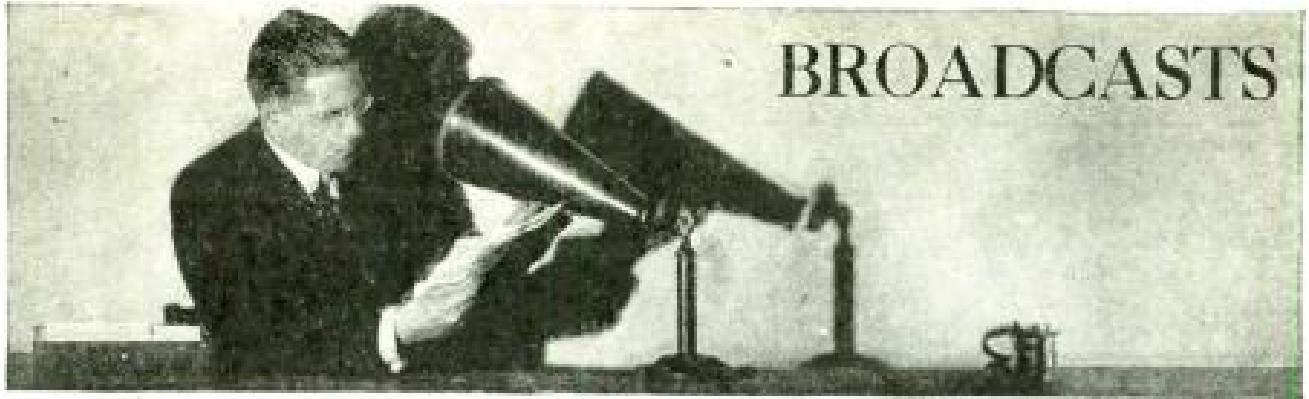

ITEMS of general interest that you ought to know; bits of useful information that every radio fan ought to know.

Radio "Dictation" for Students of Shorthand

THE latest difficulty that radio has done away with is the difficulty of the shorthand student to find someone patient enough to dictate to him. All he need do now is to plug in the headphones and copy down whatever is being broadcast.

* * *

Radio Equipment for the Fishing Fleet

Two hundred schooners of the French fishing fleet have been equipped with radio apparatus ranging from one-quarter to one kilowatt capacity.

* * *

Uncle Sam is Using Radio for Educational Purposes

THE U. S. Department of Education has set its stamp of approval on radio as a means for extension work. Twice a week, on Mondays and Thursdays at 6.45 P. M., it has lectures broadcast to listeners all over the country. Such subjects as the money value of education, visual aids to education, the necessity for education in a democracy, the economic loss due to illiteracy, have already been given.

* * *

Steel Skyscrapers Play Havoc with Radio Waves

ONE of the few obstacles that the ingenuity of radio engineers has not yet been able to surmount is the impossibility of radio transmission from the lower section of New York City due to the absorption or deflection of radio waves by the tall steel buildings. Two of the three stations on the island have not been able to operate successfully at all; even the third station experiences trouble in transmitting in certain directions.

* * *

A New Use for Antenna Towers

THE U. S. Navy Department has placed instruments on the top of one of the 700-foot towers of station NOF at Arlington, Va., to record wind direction and wind velocity for the purpose of obtaining data with which to direct airplane flights. Captive balloons were formerly used for this purpose but as these had to be brought down from time to time it was impossible to obtain continuous records.

Radio Unites Two Cousins

ANOTHER phase of radio's many services is indicated in the way station CFCA, Toronto, succeeded in re-uniting Walter Hales and Leonard Stanway, two cousins who had been separated for ten years. The two men came from England in 1913—Hales went to Massachusetts and Stanway to Toronto—and had been unable to locate each other since. Last winter Hales decided to try the help of radio and he asked CFCA to broadcast the following message: "Walter Hales of Orange, Massachusetts, is trying to locate his cousin, Leonard Stanway." This message was picked up by a friend of Stanway, and within a few days Hales received a letter from his cousin.

* * *

What France Demands of Radio Fans

IN France the amateur who wishes even a receiving set has to pay an annual fee of ten francs, promise to keep secret all intercepted messages, and agree to cease operations whenever the government so instructs.

* * *

A New Long-Distance Record for a Concert

STILL another record in long-distance broadcasting was set up by station WHAZ in Troy, N. Y., when the words and music of its radio concerts were heard distinctly on four successive nights by a station at Invercargill, New Zealand, which is nearly 10,000 miles away.

* * *

High-Speed Sending in the Army

RECENT experiments conducted by the Army have proved the possibility of clearing up the traffic jam at the Army Message Center in Washington by the use of transmitting machines that will send 100 or even 200 words a minute.

* * *

Reverse English by Radio

THOSE who had never heard English spoken backward were given an opportunity to do this recently when WGY broadcast part of a pallophotophone speech with the film reversed. The pallophotophone is an instrument used in connection with radio which photographs or records sound on a motion picture film—as described in POPULAR RADIO in February.

Pilotless Planes for Future War

SOME indication of the spectacular part that radio is destined to play in warfare may be drawn from recent experiments at Etampes, France, with radio-controlled airplanes. The test flight was made with planes equipped with automatic stabilizers. While such aircraft may some day be utilized as bombers, it has been proposed to use them for the more peaceful purpose of transporting mail to Africa.

* * *

Radio Waves Check Crime Waves in China

THE radio service that now connects Peking with Tientsin has finally baffled the Chinese bandits who have been accustomed to make bullets out of the telephone wires that until recently have furnished the only line of communication between these cities. Until the oriental outlaws conceive of some way of converting radio waves into the munitions of banditry, the present system seems to be fairly immune from pillage.

* * *

The Radio Eyes of the Fleet

WHILE technical experts are arguing as to whether or not the gun elevations of the battleships of our first line fleet may be increased without violating the international agreement on armament, other experts point out that what is needed far more is an increase of radio-equipped airplanes. Not only would these be of great value against a fleet operating behind a smoke screen, but without them an increase of range would be no gain, since the limit of visibility for a rangefinder located in a fighting-top is eleven miles, or approximately the present range.

The World's Long Distance Amateur Record?

A NEW record in DX transmission was established when signals sent out by E. W. Rouse, station 5IM, Galveston, Texas, were picked up by a ship operator 100 miles south of Ceylon—and approximately 11,000 miles away—half way around the globe.

* * *

Germany's One Broadcasting Station

GERMANY boasts of only one radio broadcasting station. The service which it renders is extremely limited, moreover, owing to the fact that a license to own a receiving set in Germany costs \$120—a price which is practically prohibitive.

* * *

The Navy Helps Out on Commercial Radio Messages

ALTHOUGH the Navy is an important link in the U. S. radio chain about the world, it never competes with commercial stations. It handles commercial messages under careful restrictions at a rate not less than the commercial rate and only when its assistance is needed to maintain traffic. As soon as the Secretary of Commerce notifies a navy station that a commercial station is prepared to take over its work, the navy station withdraws its service.

* * *

Radio Gives Its Name to a Town

THE home of the Navy's powerful radio station NAA, commonly thought of as Arlington because of its location near the great National Cemetery, is registered in the U. S. *Postal Guide* as Radio, Virginia. It claims the honor of being the first town in the country to take its name from the popular art.



International

RADIO BREAKS INTO A SAFE

One of the most unusual tests to which radio has been submitted was held recently in Stamford, Conn., when officials of the Stamford Trust Company allowed themselves to be locked into the bank's safe, equipped with a complete receiving set. Through the steel and concrete walls, not only orchestra music from WJZ in Newark, N. J., but the voice of the announcer came in clearly.



Kadel & Herbert

RADIO MESSAGES ON ELECTRIC CARS

Recent tests show that radio communication on carrier waves can be carried on successfully between central power stations and moving street cars. It is not improbable that trolley cars may be fitted with radio sets for use in case of emergency.

Why British Broadcasters Get Gray Hair

IN order to run a notice of their programs in the daily papers, British broadcasting stations are now obliged to buy the necessary space at regular advertising rates; it is calculated that to obtain adequate notice in this way costs a station about \$500 a day.

* * *

Broadcasting Niagara Falls

THE harnessing of the human voice and of orchestral concerts are only the beginnings of radio's possibilities; one of the latest achievements to be recorded is the broadcasting of the voice of Niagara Falls. By placing a microphone in the deep recess of the famous Cave of the Winds, it is possible "to hear the mysterious rush and roar of Niagara, the subtle orchestration of infinitely shaded sounds."

* * *

Singing from Four Cities at the Same Time

WHEN Anna Case sang at the Metropolitan Opera House recently, her voice was broadcast from four radio stations at once—from WEAf in New York, WMAQ in Chicago, WGY in Schenectady and KDKA in Pittsburgh. Her voice was carried to the four microphones over the telephone wires, and was projected into the ether almost simultaneously.

A Room and a Bath—and a Radio

ONE of the largest hotels in Minneapolis has decided that it cannot honestly advertise as being equipped with "all the modern conveniences" unless it includes radio service. Three sets, therefore, have been installed in an upper story and each room is furnished with a connection to one of these sets. A guest only has to plug in to be given radio entertainment.

* * *

Ether Waves Among the Alps

THE latest nation to take up radio is Switzerland, where the manufacturers can hardly turn out instruments fast enough to keep up with the demand. The nearest important broadcasting station is the Eiffel Tower, 300 miles away, but with the Alpine summits to give height to their antennas, the Swiss do not find difficulty in receiving programs.

* * *

The Broadcasting Wave in South America

With the successful opening of broadcasting stations in Buenos Ayres, Montevideo, Rio de Janeiro and other cities, radio enthusiasm in South America seems to have really come to stay. American dealers report that radio apparatus is being bought in all the countries; in Argentina alone there are 25,000 receiving sets as compared to approximately 100 a year ago.

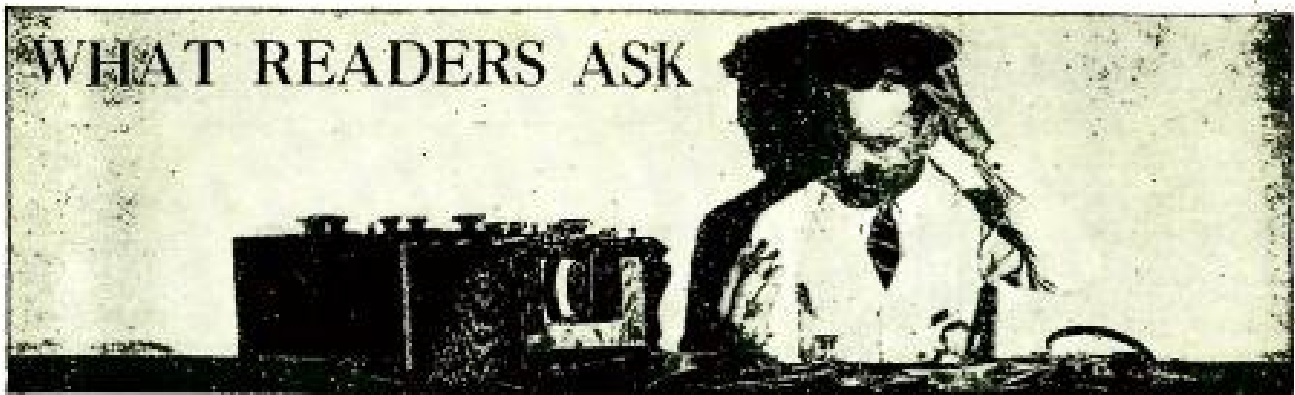

THIS department is conducted for the benefit of our readers who want expert help in unravelling the innumerable kinks that puzzle the amateur who installs and operates his own radio apparatus. If the mechanism of your equipment bothers you—if you believe that you are not getting the best results from it—ask THE TECHNICAL EDITOR.

THE flood of inquiries that has poured in upon the Technical Editor has not only furnished evidence of the need of this department, it has also necessitated a system of handling the correspondence that will insure the selection of and answer to only those questions that are of the widest application and that are, consequently, of the greatest value to the greatest number of our readers. Our correspondents are, accordingly, asked to co-oper-

ate with us by observing the following requests:

1. Confine each letter of inquiry to one specific subject.
2. Enclose a stamped and self-addressed envelope with your inquiry.
3. Do *not* ask how far your radio set should receive. To answer this inquiry properly involves a far more intimate knowledge of conditions than it is possible to incorporate in your letter.

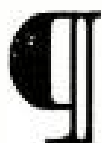

In justice to our regular subscribers, the Technical Editor is compelled to restrict this special service to those whose names appear on our subscription list. A nominal fee of 50 cents is charged to non-subscribers to cover the costs of this service and this sum must be enclosed with the letter of inquiry.

QUESTION: I am getting wonderful "DX" on my four-circuit tuner right here in the city; I tune through the local stations and am having so much enjoyment out of the circuit that I want to take the set with me on my vacation. Would it be possible to use WD-11, WD-12, or UV-199 tubes in this set. I have no means of charging a storage battery in my country place and will have to use a dry-cell tube. Will you please let me know if these tubes can be used?

B. R. F.

ANSWER: These tubes function nicely in the circuit referred to, and any of them will give good results. You will need a "C" battery in the grid circuits of the amplifiers, however, to get maximum signals and clear modulation.

* * *

QUESTION: When I place my hand near the variable condenser in the antenna tuning circuit of my receiver I

get a howl. When I tune in a distant station I have to place my hand a certain distance from the dial to keep it tuned in. If I move my hand or take it away the signals disappear and the howl comes back. Isn't there some way to overcome this trouble?

FRED S. HACKETT

ANSWER: Connect the rotary plates of the condenser in question to the wire that leads to the ground, and the stationary plates to the wire that leads to the antenna; your trouble should then be eliminated. In other words, reverse the connections to your condenser. This reduces the body capacity of the set by placing the shaft of the condenser at ground potential.

* * *

QUESTION: Should the grid leak be connected across the grid condenser or from the grid to the filament?

A. D. ROBERTS

ANSWER: In the majority of circuits the best results will be obtained if the grid condenser is connected from the grid direct to the filament.

QUESTION: Is it possible to use radio frequency amplification with a crystal detector? I have a simple crystal set at present and have had such good results during the last winter that I hate to give up the crystal. Please tell me where I can obtain a hook-up that uses one bulb and the crystal.

HERBERT LANGDEN

ANSWER: On page 467, Figure 1, of the June issue of POPULAR RADIO you will find a circuit for using the tube and crystal in a simple reflex radio frequency set. It should give you loud signals.

* * *

QUESTION: I have heard much lately about the different ratios for amplifying transformers, but I am not really clear as to just how they should be used. Will you kindly tell me where the different ratios—10 to 1, 5 to 1, 3½ to 1 and so forth—should be used in the circuit?

S. RATHBERN

ANSWER: The high ratios should be used in the first stage of amplification and the lower ratios in the succeeding stages.

* * *

QUESTION: What resistance should be used in the rheostat for the new UV-199 tube? I have purchased three of these tubes and I would like to operate them all on the one rheostat. I am going to use two 1½-volt dry-cells in series for

lighting the filament. Will you please let me know if this will be feasible, and if so what is the correct resistance to use?

A. C. DILLINGAST

ANSWER: This scheme is perfectly feasible. The rheostat for the three tubes should have a resistance of thirty ohms.

* * *

QUESTION: Will one stage of radio frequency amplification bring in signals when a loop antenna is used and the distance is fifty miles or less?

G. H. WAGNER

ANSWER: Yes, if a reliable detector is used with it. It will not operate a loudspeaker unless audio frequency amplification is added, however.

* * *

QUESTION: Will you show me how to add one stage of audio frequency amplification to my three-coil receiving set? I obtained the original hook-up from Figure 1 on page 59 in the May, 1922, issue of POPULAR RADIO.

HENRY S. AIRES

ANSWER: In Figure 1 you will find the complete circuit. The extra parts you will need are:

- J1—double-circuit jack;
- J2—single-circuit jack;
- C—mica fixed condenser, .0005 mfd.;
- R2—rheostat, 6 ohms;
- AFT—audio frequency amplifying transformer;
- extra "B" batteries;
- tube socket.

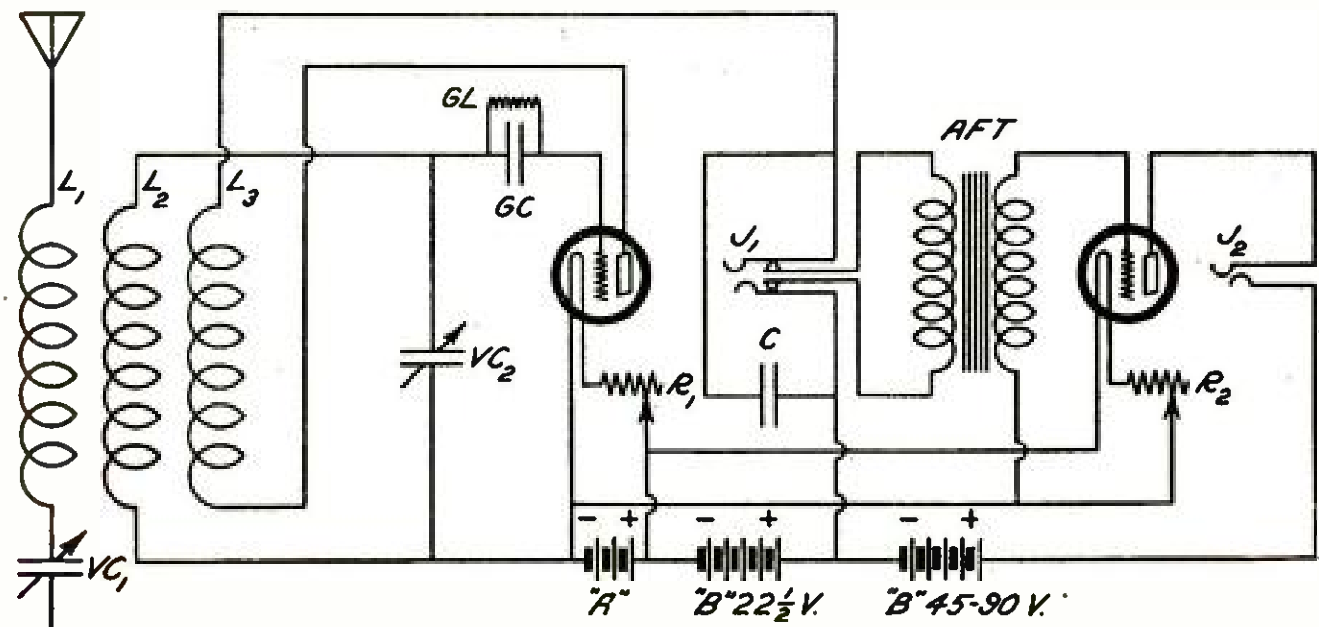

FIGURE 1

A hook-up for one stage of audio frequency amplification added to the triple-coil set.

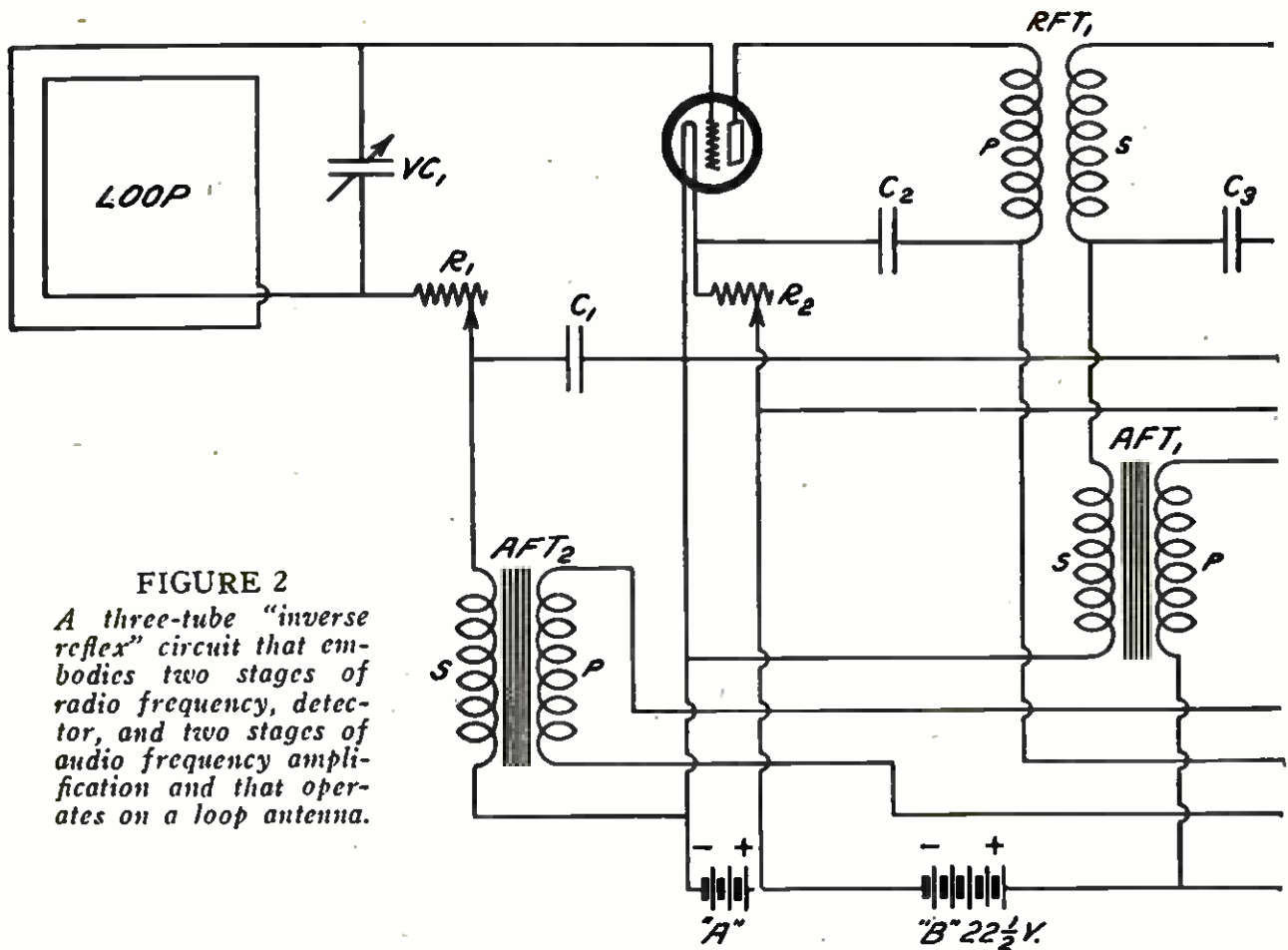

FIGURE 2

A three-tube "inverse reflex" circuit that embodies two stages of radio frequency, detector, and two stages of audio frequency amplification and that operates on a loop antenna.

QUESTION: Please give me the hook-up of the "inverse reflex" circuit for three tubes. Show the proper connections for a loop if it is possible to use one with this circuit.

FLOYD MURDIN

ANSWER: The circuit you need is given in Figure 2. The designations on this diagram refer to the following parts:

- VC1—variable condenser, .0005 mfd.;
- C1—fixed condenser, .0025 mfd.;
- C2, C3, C4, and C5—fixed condensers, .001 mfd.;
- RFT1 and RFT2—radio frequency amplifying transformers;
- AFT1 and AFT2—audio frequency amplifying transformers;
- R1—Variable resistance, 300 ohms;
- R2, R3 and R4—filament rheostats;
- GC—fixed condenser, .00025 mfd.;
- GL—grid leak resistance, 2 megohms.

The "A" battery potential will depend on the type of tubes used and the "B" battery potentials are indicated on the diagram.

* * *

QUESTION: Is it good to stick the windings of a coil together with collodion? I have heard that shellac is harmful and thought that this might also apply to the collodion.

E. FRED KENNEDY

ANSWER: If you cover the windings with any kind of insulating paint or varnish it will increase the distributed capacity and this will interfere with the sharp tuning of the set. For best results leave the coils dry.

* * *

QUESTION: What is the reason that some tubes require the rheostat on the positive side of the filament and some on the negative side? Also why is it that the grid return in some cases is connected to the "A" battery positive and in most cases for amplification is shown connected to the "A" battery negative?

J. L. WILLIAMS

ANSWER: This is done in order to get the correct free grid potential for the tube so that it will operate on the right portion of the characteristic curve for that tube. Detection takes place at the lower portion of the curve where the change in slope is great, and amplification is more efficient and less distortion takes place when the straight portion of the curve is used. By changing the position of the rheostats the grid can be made more positive or more negative so that the operation of the tube will be shifted to the portion of the curve where the best results can be obtained.

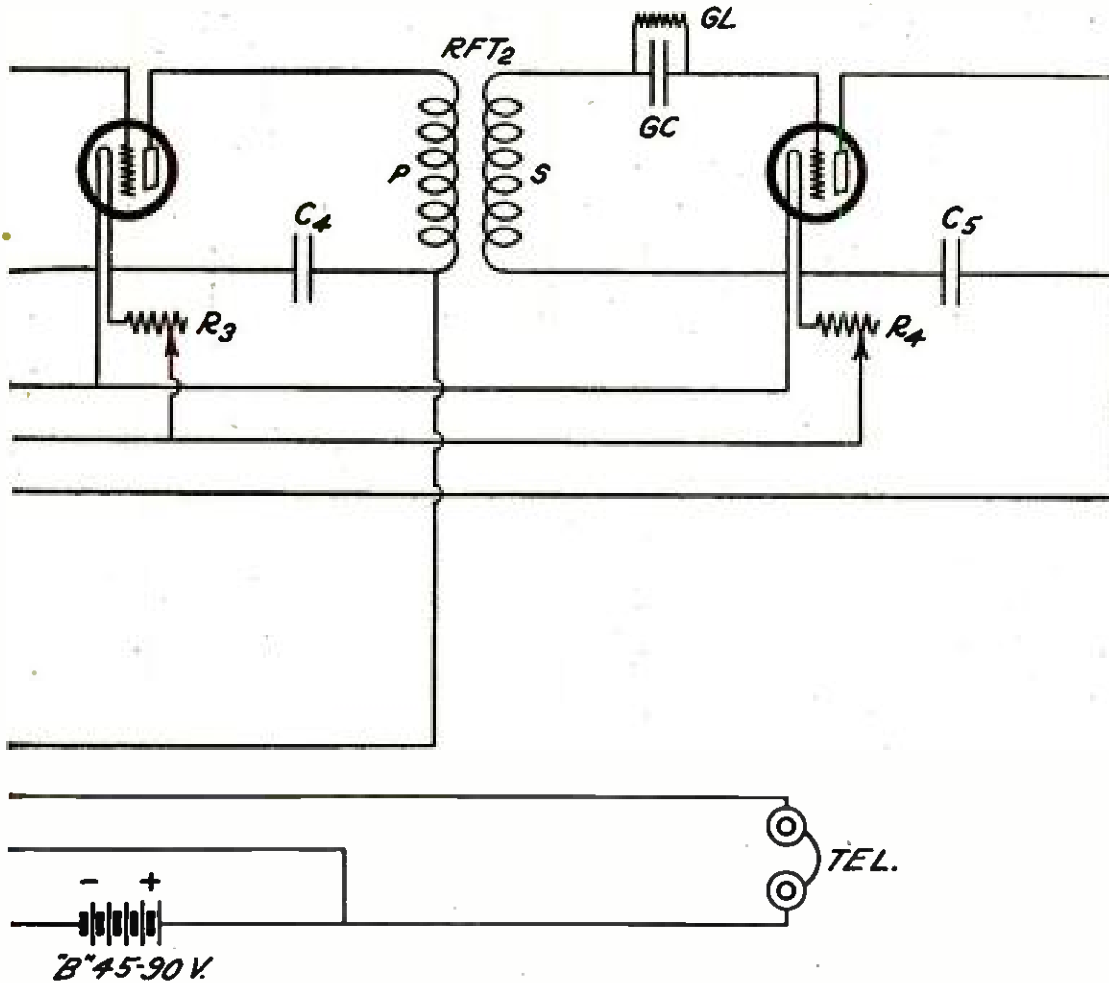

QUESTION: I want a hook-up that will show how to add one stage of amplification to my single-tube set. How many volts should be used on the plate?

ROBT. G. GIBSON

ANSWER: The circuit you need is shown in Figure 3. This amplification may be added to any set, whether it uses a crystal or a vacuum tube detector. The "B" battery you should use may be anything up to about 90 volts; it depends upon the type of tube you have on hand.

QUESTION: With four-circuit tuner described on page 358 of the May issue of POPULAR RADIO, would it be better to place the filament rheostats in the negative leg of the filaments rather than in the positive leg, if I use UV-201-A tubes for the amplifiers.

ANDREW SCOTT

ANSWER: When this type of tube is used for an amplifier this would be better; when it is used for a detector the rheostat should be left in the positive leg for best results.

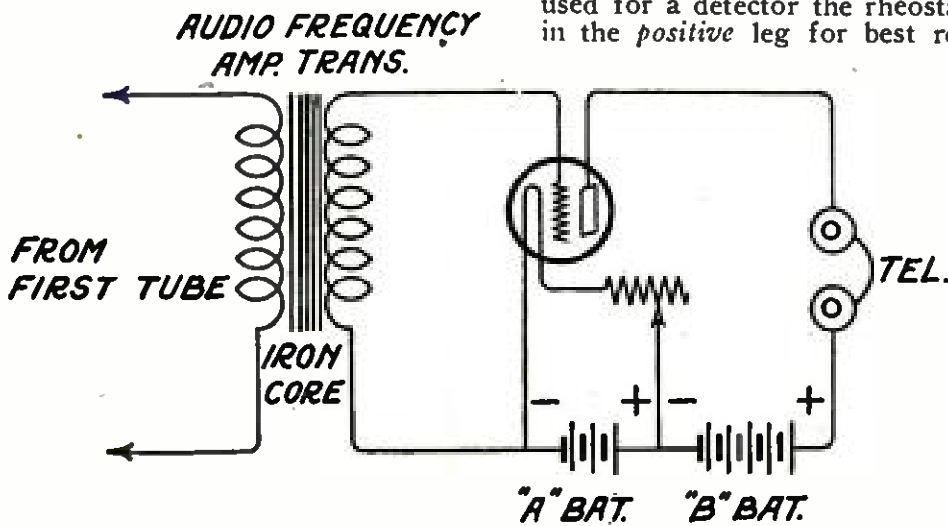

FIGURE 3

One stage of audio frequency amplification that can be added to any crystal or vacuum tube set.

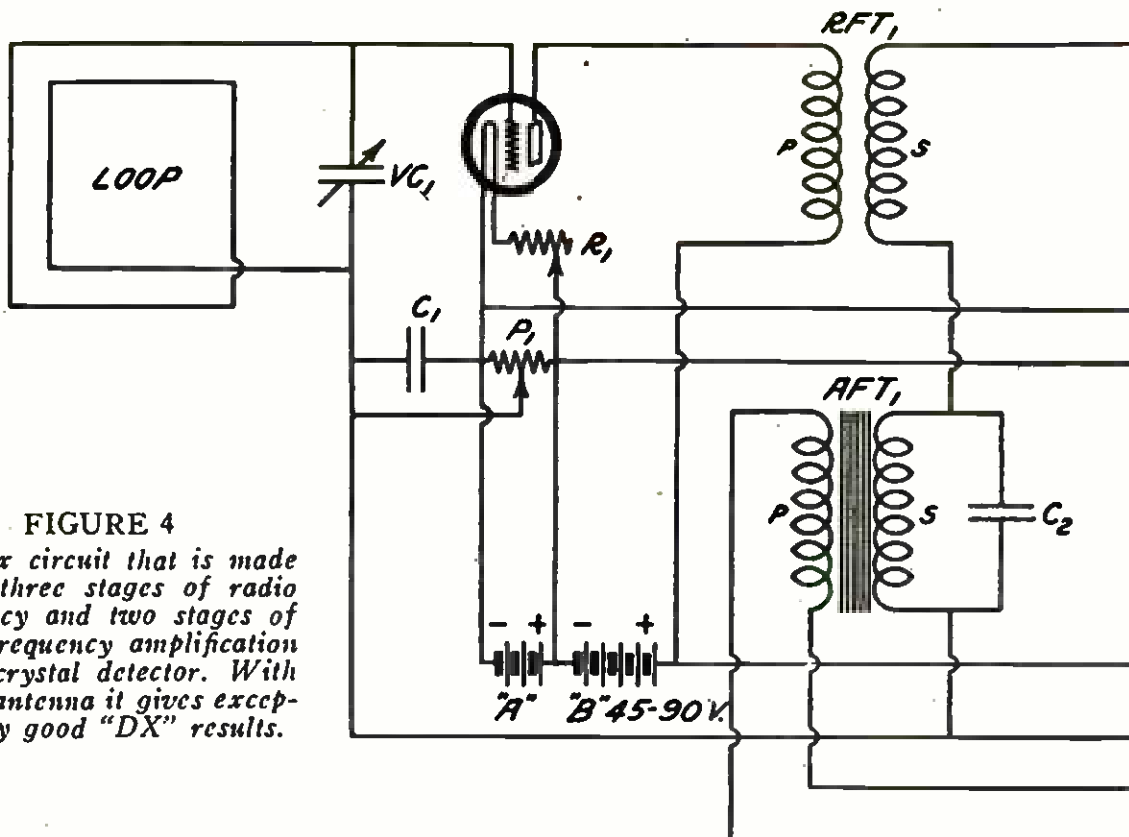

FIGURE 4

A reflex circuit that is made up of three stages of radio frequency and two stages of audio frequency amplification and a crystal detector. With a loop antenna it gives exceptionally good "DX" results.

QUESTION: Will you draw me a diagram of one of the most successful reflex circuits? I do not wish to use more than three tubes and a crystal detector, unless I can get much louder results by using additional tubes. Please include also a list of the parts necessary together with their constants.

RUSSELL KNIGHTON

ANSWER: A diagram for a three-tube and crystal detector circuit is shown in Figure 4. The parts for the set are:

- VC1—variable condenser, .0005 mfd.;
- C1—fixed condenser, .005 mfd.;
- C2—fixed condenser, .0015 mfd.;
- C3—fixed condenser, .0015 mfd.;
- C4—fixed condenser, .0015 mfd.;
- C5—fixed condenser, .002 mfd.;
- C6—fixed condenser, .002 mfd.;
- R1, R2, and R3—filament rheostats;
- RFT1, RFT2, RFT3—radio frequency amplifying transformers;
- AFT1, AFT2—audio frequency amplifying transformers;
- DET—crystal detector.

A suitable loop antenna for this hook-up would be a spiral loop, three feet square, with the turns spaced $\frac{3}{4}$ -inch apart.

* * *

QUESTION: When I wiggle my phone cords I hear a crackling sound. At first I thought that one of the terminals of the phones was loose, but

upon investigating I find that they were connected properly. What is the trouble?

THOS. NELSON

ANSWER: The trouble is in your phone cords. Inside of the silk covering there are a few strands of braided tinsel and you have at some time pulled or twisted the cords so that these strands have broken through or they have worn out and now touch and separate when you move them. Get a new set of phone cords at the local dealer and connect them in place of the damaged ones.

* * *

QUESTION: How often should I have to charge my 6-volt, 60-ampere storage battery if I use it on a three-tube set, about three hours a night and four nights a week?

JOHN B. GRILLIN

ANSWER: If your tubes draw approximately one ampere per tube, the three tubes will take three ampere-hours an hour. For three hours a night, this will be nine ampere-hours an evening. For four nights this will be 36 ampere-hours. In this case your battery will need to be charged about once every two weeks.

* * *

QUESTION: Please send me a hook-up for the following parts:

- 1 Workrite variocoupler;
 - 1 High-tone buzzer;
 - 1 push button switch;
 - 1 dry-cell;
- } for
} buzzer
} test

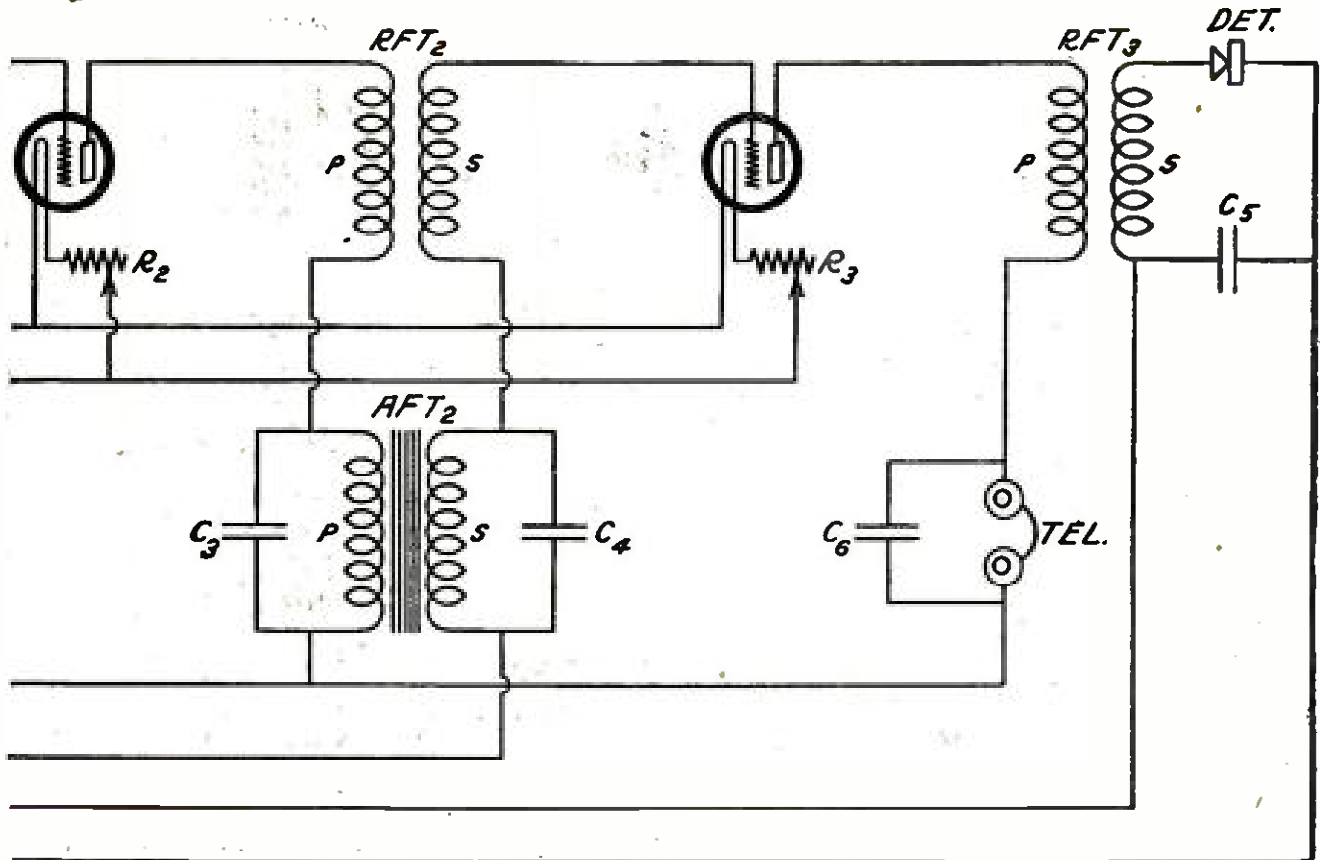

- 1 Micon condenser, .001 mfd.;
- 1 Amrad variometer;
- 1 Foote tested mineral detector;
- 1 pair Teleradio phones;
- 1 detector stand.

I would like to use all these parts if possible, as I wish to change the set

to a vacuum tube circuit when I become more familiar with tuning.

A. GREENLEAF.

ANSWER: A crystal circuit which employs the instruments you describe is shown in Figure 5. This set may be easily converted into a single-tube circuit by the addition of a variable condenser, a tube and tube socket, and a rheostat, grid condenser and grid leak.

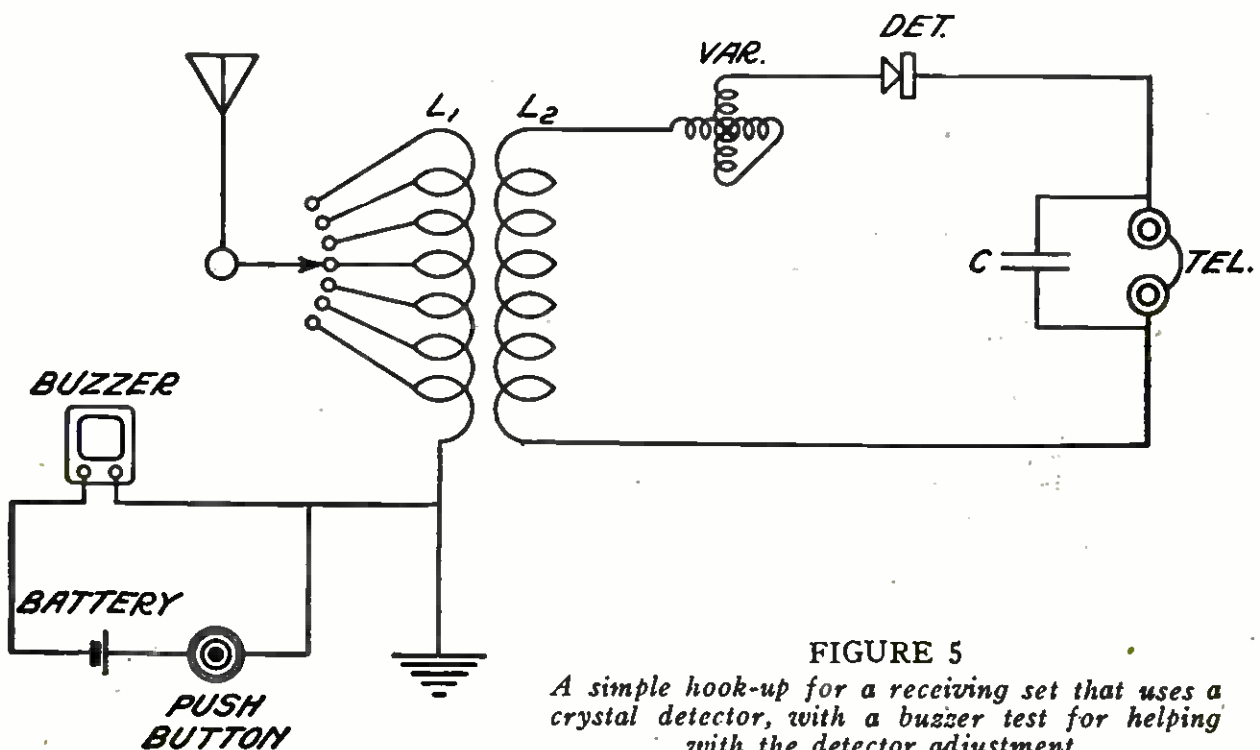

FIGURE 5

A simple hook-up for a receiving set that uses a crystal detector, with a buzzer test for helping with the detector adjustment.



HELP your neighbor. If you have discovered any little Kink that helps to eliminate trouble in your radio apparatus, or if while experimenting with the connections of your set you should run across some interesting phenomenon, or if you should discover some new hook-up that gives better results—send it to the "Listening In" page.

An Indian Guyed by Radio

FROM the wilds of Quebec comes the following delightful acknowledgment of the joy with which radio is being hailed by the backwoodsman whose life has, up to now, been largely cut off from civilization. The letter was addressed to station WGY in Schenectady, New York, and is reproduced just as it was received:

i am gide for hunter man wot come at dis place Lac-des isle for hunting deer. dese hunter man bring it wit him a machine for heer you spik sunday nite also tuesday nite i hear song bout my old modder dats long tim i dont see my modder and i ting dats dame fine song also i heer oder song i dont no de nam. tuesday nite storie for de small boy and girl bout mak de star shine for dem if dey is good boy and girl. hunter man laff lik hell an tole me ax you how we make some moon shine.

i hear you spik just de same lik your at me place i ting you have good machine i lissen more nex week.

tank you and much oblige
gide Camille Poirier
Chemis p. o., Quebec, Canada

* * *

Experience Adds 1000 Miles to My Receiving Range

WHEN that new receiving set of yours is not coming up to expectations do not condemn it; do not be tempted to blame the dealer for selling you a poor set, but keep at it until you have secured the necessary familiarity with the tuning of your apparatus. The chances are that the trouble is not with

your set, but with you—as this amateur in Ithaca, N. Y., confesses:

I shall probably remember for some time my first attempt to operate a vacuum tube circuit. Everything seemed hooked up all right, or so I thought, but when I lighted up the filament and prepared to listen, not a sound did I hear. My trouble, I soon found, was one familiar to novices, a "B" battery connected up in the wrong way; and after I had remedied this I was rewarded by signals from Arlington.

I soon tired of this straight audion hook-up, however, and passed on to the regenerative circuit. Then began more trouble. First, the bulb would not oscillate, but this difficulty was finally overcome and mediocre results were obtained within a comparatively short time.

Still there did not seem to be much to hear. For a long time I heard nothing but a few 600 meter stations; I could pick up no amateurs at all. Then one night I heard for the first time an amateur station located about five miles away, then one about fourteen miles distant, and later others still farther away came in. But I could not get stations that could in any true sense be called distant.

These experiences took place about two years ago. Last summer—not the best weather for radio by any means—I succeeded in getting stations that I had never thought of hearing the winter before, despite the poorer conditions that prevailed. A number of distant broadcasting stations were picked up, the most distant being WSB, the *Atlanta Journal*. One night in the middle of the summer I heard 5LA, an amateur station in New Orleans, about one thousand miles away, which established a new record for my set. And all this has been done with the same apparatus that I had experienced so much trouble with at first and pronounced "no good" because of the limited results secured.

L. DONALD KOONS

A New and Remarkable Low-Amperage Vacuum Tube

HERE is a description of what may be regarded as one of the most important developments of vacuum tube construction of the past year:

One of the recent developments in vacuum tube construction is the new UV-199 which consumes 70 percent less current than any of the small or so-called "peanut-tube" variety. It operates with the filament current supplied from an ordinary flashlight battery.

This new type tube has the X-L tungsten filament, which according to radio engineers is considered as great an advance over the old tungsten filament for vacuum tubes in radio work as the tungsten incandescent lamp is over the carbon lamp in the field of electrical illumination.

The filament wire in the new tube is exceedingly small. It is but one-fourth the diameter of an ordinary hair. However, this is not an indication of any weakness for this tungsten wire has the strength of the best steel piano wire.

The filament of this tube consumes .18 watt, or approximately 1/27 of the energy used in the UV-201 tube. Yet the characteristics when used in a radio set are, if anything, slightly better.

It is interesting to note that more than fourteen different chemical elements are utilized in this tube.

This new radiotron tube is an excellent radio frequency amplifier, because the capacity between elements is lower than that of the UV-201-A tube. It operates satisfactorily in all circuits which were used with the old UV-201 tube and should give slightly superior results, especially in radio frequency amplification.

The UV-199 tube requires so little filament energy that the ordinary No. 6 dry-cells give remarkably long service. For instance, three No. 6 dry-cells in series will operate one of the UV-199 tubes one hour a day for a whole year.

It should be understood that this UV-199 tube will not deliver as much energy as an amplifier that the UV-201-A will. The UV-201-A is a remarkably powerful tube and has electron emission, mutual conductance and amplification far above any other receiving tube. It must not be expected that with a filament expenditure of only .18 watt that as powerful results can be obtained as an amplifier as with the expenditure of 1.25 watts.

On account of the low filament current required by this tube it is essential to have the filament rheostat of sufficient resistance. For operation from three dry-cells, the filament rheostat resistance should be at least thirty ohms per tube. If a six-volt storage battery is used, the resistance should be at least sixty ohms. In multi-tube sets the sockets for the

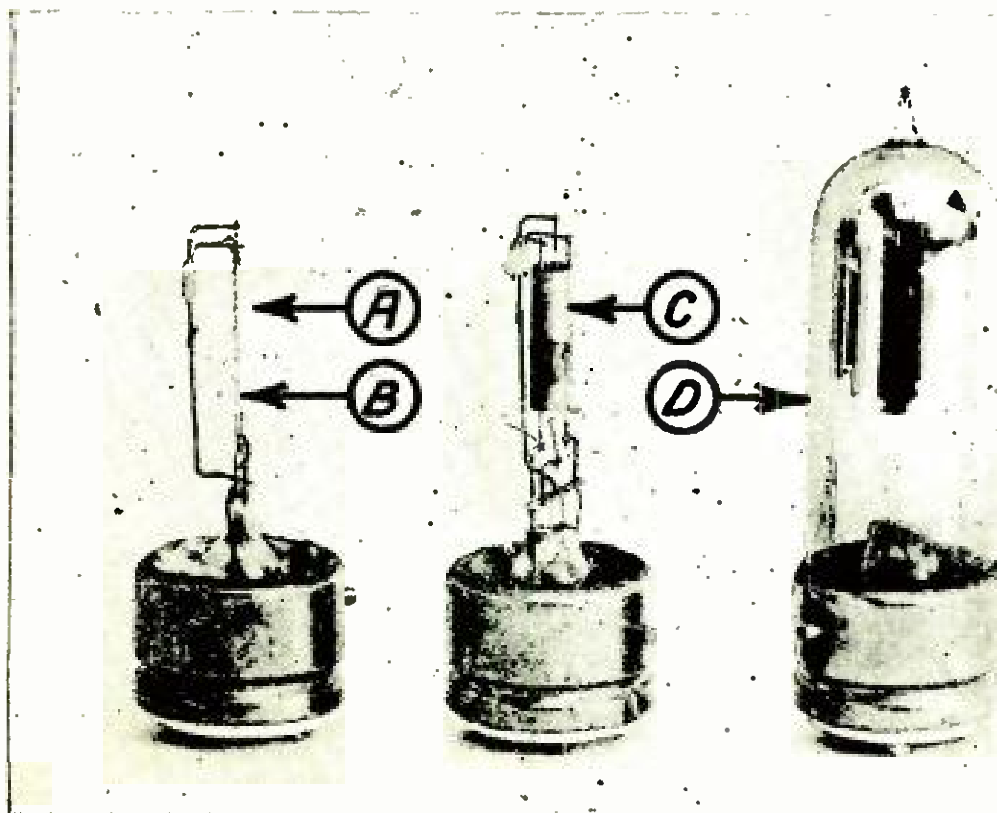

General Electric

THE CONSTRUCTION OF THE NEW TUBE

A is the tiny spiral grid, B the thoriated filament, C the cylindrical plate, and D the necessary glass bulb. Although this tube requires only .06 ampere, in its operating characteristics it is not a "peanut" tube.

tubes should be cushion mounted so as to minimize the effect of vibration. This is necessary where more than one tube is used. The tube sockets may be set on small pieces of sponge-rubber and in this way all microphonic noises will be eliminated.

C. L. BEACH

* * *

How Broadcasting Affects the Artist

THE nervous strain of broadcasting is a factor with which the inexperienced artist does not always reckon. Some idea of it may be derived from the following item which comes to us from a man who has had a great deal of experience both with artists and with broadcasting:

As everyone knows, the radio apparatus is so sensitive that the slightest sounds are con-

veyed and amplified to an appreciable degree of intensity, so much so that anything extraneous to the actual broadcasting event is most likely to spoil the result. Therefore, silence is imposed upon all in the studio while broadcasting is in progress. Silence is difficult to maintain for any period and when so required constitutes an additional strain upon the nervous system—the very thought that you must not make a sound other than to sing or play; that you must make no movement unless it can be accomplished silently; that you cannot clear your throat, ask for a sip of water, whisper, blow your nose or even breathe deeply. This kind of silence is more awful than darkness, just as a lull before a storm is more impressive than the storm itself. Tension engendered by absolute repose is a severe strain. Broadcasting enjoins these two unnatural factors upon the artist.

Silence and an invisible audience compose a two-handed encumbrance that requires a very robust temperament to overcome.

C. E. LE MASSENA

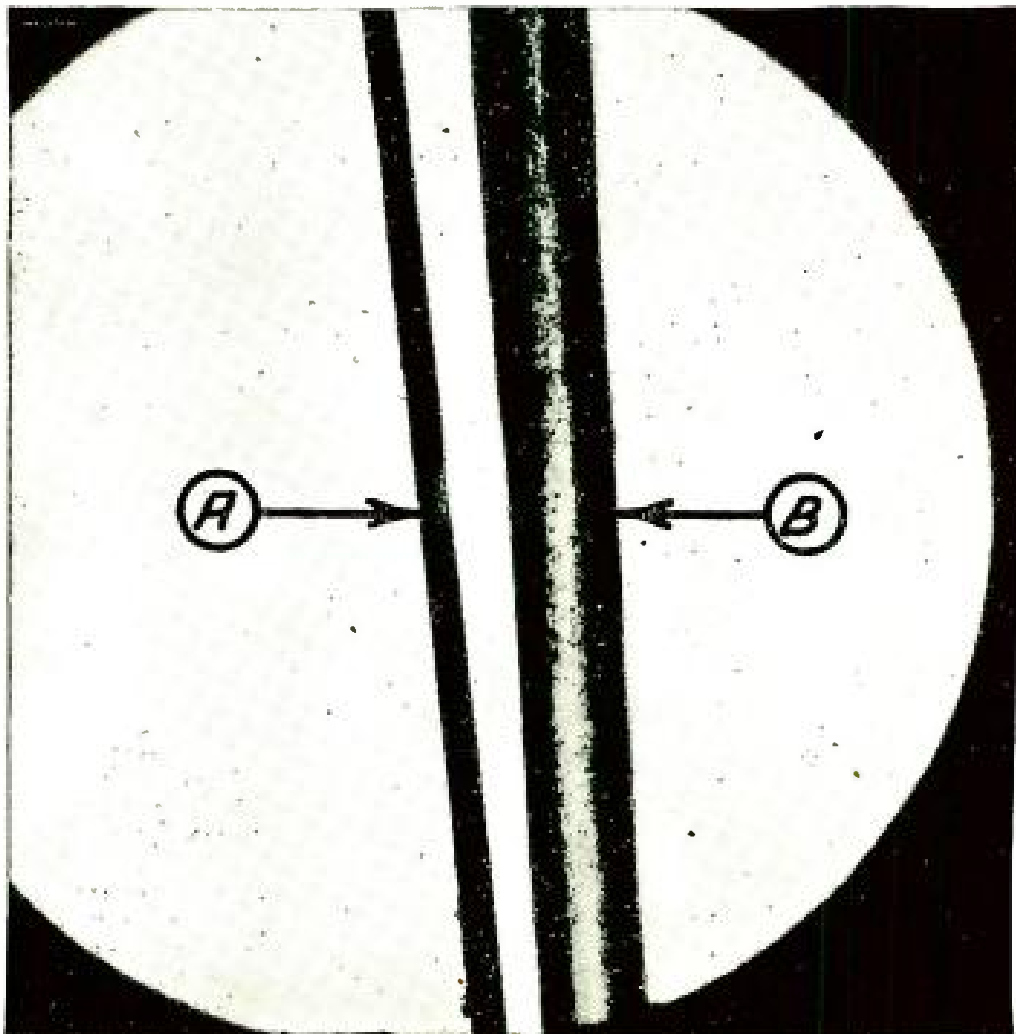

General Electric

HOW THE FILAMENT OF THE NEW TUBE COMPARES WITH A HUMAN HAIR

In this greatly magnified picture A is the filament (made of the new thoriated metal described in the June issue of POPULAR RADIO), and B an ordinary human hair. In spite of its small size, the filament is as strong as the best piano wire.

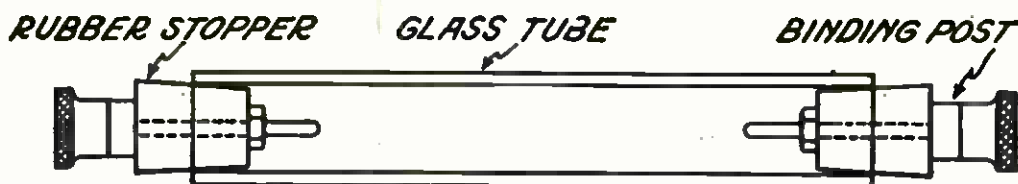

A POLARITY INDICATOR THAT YOU CAN MAKE YOURSELF

FIGURE 1: The container for the liquid. The only parts required are a glass tube, stoppers, binding posts, screws and nuts—which cost about 25 cents.

The Nuisance of a Single-Circuit Regenerative Receiver

EVERYBODY who has listened in on a radio set is familiar with the buzzing, whistling and squawking that so generally interferes with broadcasting reception. This exasperating nuisance was injected into the radio game by the single-circuit regenerative receiver, which was placed on the American market for novices because it was so easy to tune. The annoyance from this source is beginning to arouse serious protest. For example:

The trouble with the single-circuit regenerative receiver lies in the fact that it is almost as good a transmitter as it is a receiver when it is in an oscillating state. When it is used with one bulb, it is hard for the operator to tell when the set is tuned exactly on the wavelength of a station that is being received; it is also difficult to determine when the set is oscillating. It may be set too near the oscillating point; when this is done all the listeners located in the vicinity are disturbed.

Much of the blame which has been thrown at the transmitting amateur for breaking up concerts has been directly traced back to the complainants themselves. It has been found that the latter were using single-circuit receivers, and it is well known that this type of receiver does not tune sharply. Such a set may be tuned to a wavelength of 3,000 to 4,000 meters yet the amateur directly on 200 meters will still interfere. The trouble lies not with the amateur but with this receiver. If a two-circuit receiver is substituted the amateur transmitting is easily tuned out.

In England, the use of American radio apparatus is prohibited for the express purpose of keeping out of the country what is frankly termed "the single-circuit menace." No single-circuit sets are allowed in that country; anyone who uses any type of set that re-radiates is legally liable, and will soon run into trouble with the Post Office authorities.

It seems to me that American manufacturers of radio apparatus should see the handwriting on the wall and eliminate this apparatus which is injuring radio broadcasting so much. I should think that they would be farsighted enough to realize that they would be able to

see that although they make a little more money at first making and selling this cheap and simple apparatus, they are doing themselves harm in the long run by getting people disgusted with radio.

Needless to say that the amateur will not use this type of apparatus; he terms it "junk."

FREDERICK SIEMENS

* * *

How to Make a Polarity Indicator for a Few Cents

THE radio amateur who finds difficulty in determining the positive and the negative poles of a battery that is not marked, will be interested in the following instructions for making a polarity indicator; they come to us from a fan in England:

Get from any drug store small amounts of sodium sulphate and of phenolphthalein. Into a cup half full of warm water put as much of the sodium sulphate as will cover a silver dollar and as much of the phenolphthalein as will cover a dime. Stir until the chemicals are dissolved.

To try this mixture, place your charging wires into it (about $1\frac{1}{2}$ inches apart). The negative wire should turn the surrounding liquid a reddish color. Shake the liquid and the color will disappear at once.

Now put in it two wires from your "A" battery and add a little of each chemical until the mixture is sensitive enough to be discolored by the negative wire as before.

Then you are ready to make the container shown in Figure 1.

Obtain a glass tube about three inches long and two rubber stoppers to fit it. Put the stoppers in each end of the tube and thread screws through them to project $\frac{1}{4}$ inch on the inside. Put a nut on the inside of each screw, and a nut and an extra terminal nut for connections on the outside.

When this has been done, fill the tube with the liquid, leaving a small air space so that it can be shaken to dispel the color.

Paper that indicates polarity can be made by immersing some blotting paper in the liquid. To use this, wet the paper with your finger and place the wires on it about $\frac{1}{2}$ -inch apart. The negative wire will make a red mark.

W. MILLAR

The Fallacy That "Re-radiation" Aids Reception

THE opinion advanced by the Technical Editor on page 231 of the March issue of POPULAR RADIO, to the effect that the remarkable "DX" records established by sets that used only a crystal detector were not due to re-radiation from a vacuum tube set in the neighborhood but were straight cases of reception, has been given almost word-for-word confirmation by Dr. Greenleaf W. Pickard, the noted inventor, in a letter to Mr. Lloyd C. Greene. Dr. Pickard says:

Wave trains from a distant broadcasting station pass the receiving antenna and as a result a varying electrical field exists in its vicinity. This field induces a current in the antenna and the current in turn produces a field around the conductor which is out-of-phase with the signal wave. The resultant field around the antenna, which is a sum of the field in the wave and in the current around

the antenna, is always less than that of the signal wave.

If the impedance of the receiving antenna is lowered by an increase in regeneration, the current in the antenna and consequently the electric field around it will increase, but the resultant field will still further decrease.

If regeneration is increased until the effective resistance of the antenna is zero, the field due to the current in the antenna will exactly equal the wave field and will be 180 degrees out-of-phase from it. The field that results in the immediate neighborhood of the conductor, therefore, will fall to zero and reception will be materially weakened.

If regeneration is increased to such an extent that effective resistance is less than nothing—if it has, in other words, a negative value—oscillations will be produced and the field around the antenna may have greater values than the wave field of the signal. But in that case they represent an unmodulated field and they produce only the all-too-well-known squeal.

In a large measure especially good crystal reception is due simply to a good antenna, a good location, and efficient tuning. It is due also, of course, to the high grade of transmission that sometimes is given, particularly on winter nights.

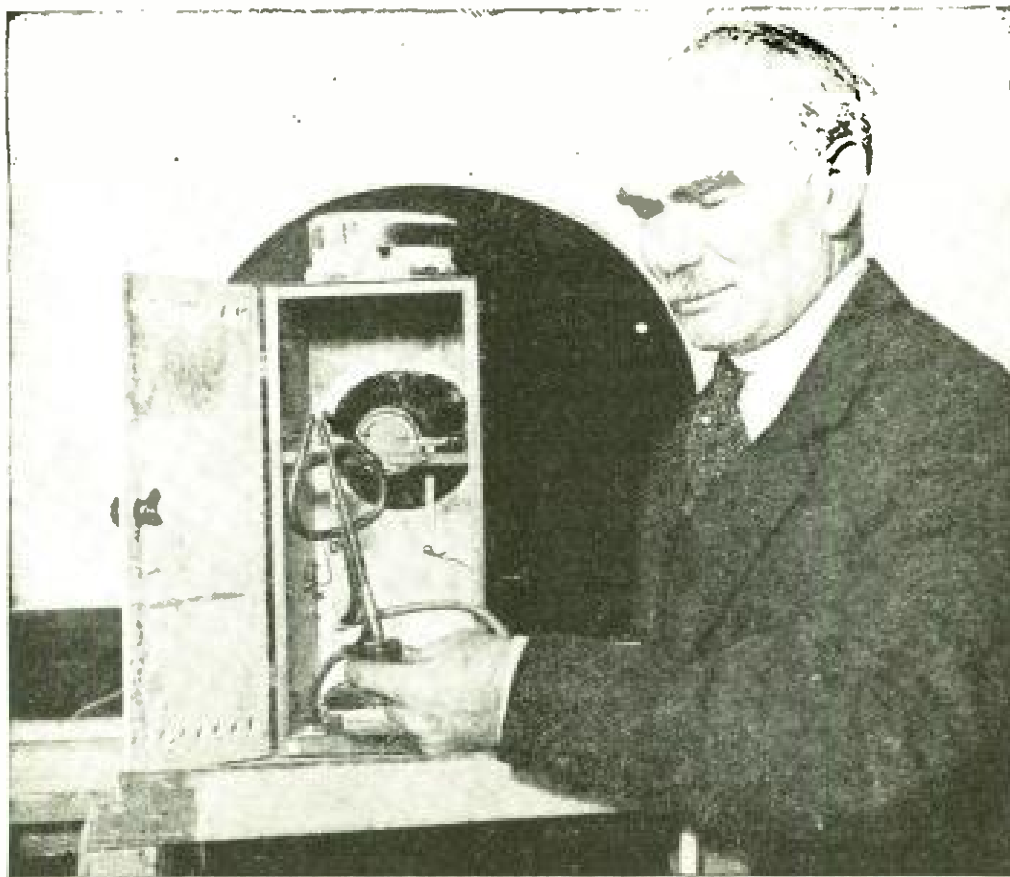

Pacific & Atlantic

THE NEW "FLAME" TRANSMITTER

A microphone device without a metallic diaphragm which, according to its inventor, Dr. Lee De Forest, whose earliest experiments dealt with the sensitivity of a gas flame to sound and to electrical waves, gives almost perfect reproduction.

HINTS FOR

AMATEURS



MANY radio amateurs live in a district where the house-lighting power is direct current. For these the charging of the radio storage batteries presents a troublesome problem, because the ordinary battery charger (which works on alternating current) is useless.

There are two ways to keep the battery charged. One way is to take the battery to a garage and have it charged. But this takes a couple of days, during which time the radio set is out of commission. The other way, which is simple, is to make a charging resistance out of a bank of lamps and connect the battery to the 110-volt *direct current* lines.

A circuit for connecting up your battery to the direct current lines, in series with a bank of six 32-candlepower carbon

filament lamps, is shown in Figure 1. The two leads marked + and - should be connected to the lighting lines of the same polarity by means of a lamp socket and plug. It is *extremely important* that the positive wire of the lighting lines be connected through the lamps to the positive terminal of the storage battery.

To determine the polarity of the lighting line it would be well to procure a polarity indicator from the electrician. This costs but little and it will eliminate any possibility of mistake, and therefore protect your storage battery from harm.

* * *

A VERNIER rheostat when attached to a detector tube of a regenerative receiver will be a great help for tuning in long-

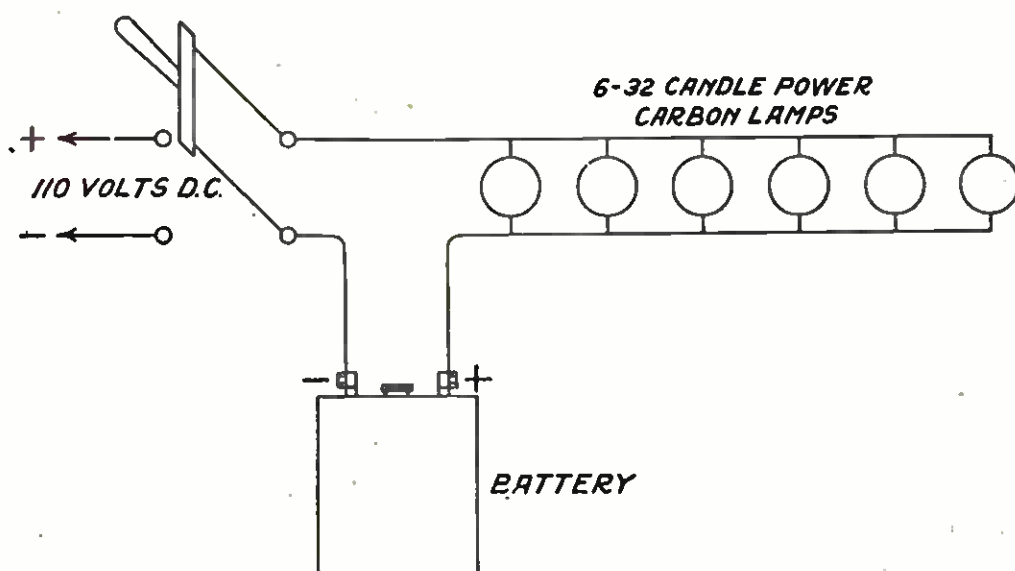

FIGURE 1

How a bank of six carbon lamps should be connected in series with the 110-volt direct current lighting lines to make a storage battery charging resistance.

distance stations. There is no particular advantage in using it on amplifier tubes, as it will not help in the adjustment.

* * *

WHEN building a new radio set of a type that the builder is not familiar with, it is advisable to obtain the necessary instruments and parts and first set them up on a table, and connect them up and learn how to operate the circuit, before going about designing a cabinet for the set. In this way the amateur builder will familiarize himself with the scheme of the set, at least enough to know how to place the

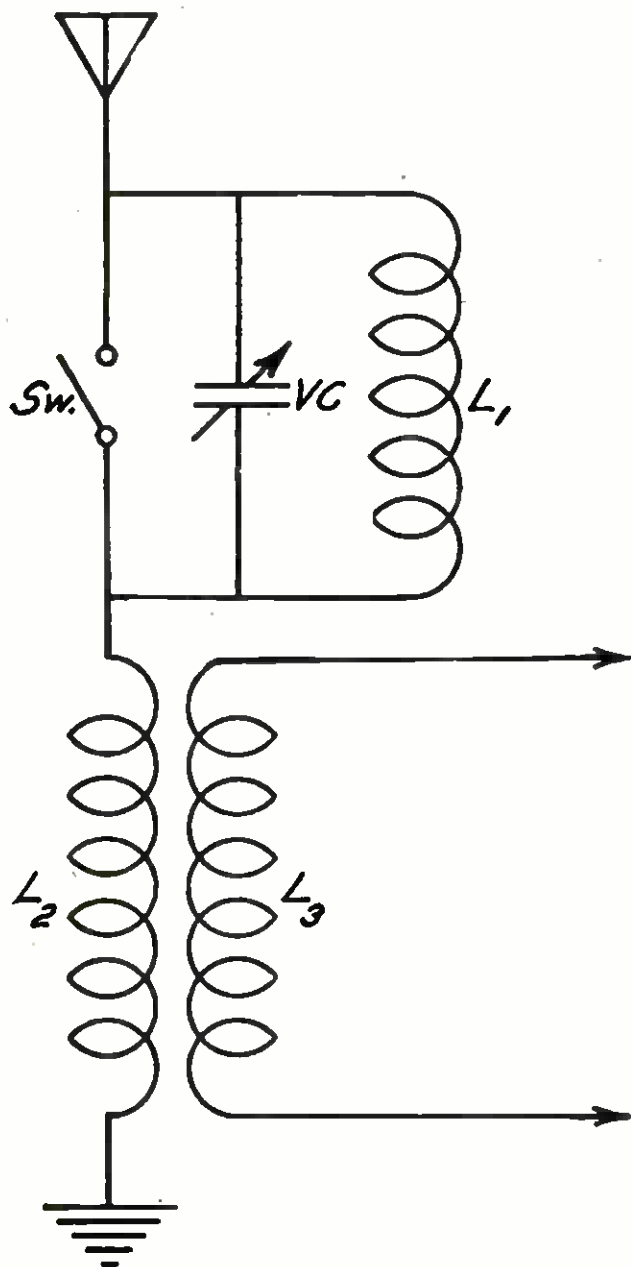

FIGURE 2

A simple wavetrapped antenna circuit, when connected in series with the antenna circuit of your receiving set, will enable you to tune out nearby interfering stations.

different parts so that the set will operate efficiently. Otherwise, serious mistakes may be made in design of the panel or the arrangement of the apparatus that would mean rebuilding the set in order to get the most out of it, and this costs money. This is another case where "An ounce of prevention is worth a pound of cure."

* * *

WHEN disconnecting a radio set take off the connections *at the batteries* first. If the wires are taken off in the set itself, they may touch each other accidentally and ruin the batteries, whereas if the wires are taken off at the batteries there can be no possibility of a short-circuit.

* * *

THE average radio fan can get more thrills and enjoyment out of a small 5-watt C. W. transmitter than from all the receiving sets in the world. Get one or make one and then learn the code and see for yourself.

* * *

RECEIVING sets that are located close to powerful broadcasting stations often cannot tune out the nearby station and tune in stations which are at a greater distance.

For sets in such a location a wavetrapped antenna will be of great assistance in obtaining the sharper tuning which is necessary to accomplish this end. A circuit diagram is shown in Figure 2, which indicates the manner of connecting the wavetrapped antenna in series with the antenna circuit. The trap consists of a 35-turn duolateral coil shunted by a variable condenser of .0005 mfd. capacity. The trap is also shunted by a switch which may be closed when the trap is not needed. The switch should be open when the trap is in use while the local broadcasting station is in operation.

The set is tuned in the usual manner and the variable condenser of the trap is rotated until the point is found at which the interfering station is eliminated.

"STATIONS I HAVE HEARD"



If you are getting good results with your receiving set, tell your fellow-readers of **POPULAR RADIO** how you get them. Give the call letters of the stations you hear, the locations of them, the type of apparatus that you are using and **HOW YOU ARE USING IT.**

A TRANSATLANTIC PASSAGE ON THREE YANKEE TUBES

WITH an American set and three American tubes. Henry Field in Leicestershire, England, hears three American stations. He uses an antenna 100 feet long and 45 feet high. The stations he hears are WJZ of Newark, N. J., WGY of Schenectady, N. Y., and WIP of Philadelphia, Pa. He writes:

"I have received WJZ fairly consistently, but the chief difficulty is that it fades about once every three minutes and the interference over here from the large commercial stations is bad. I have heard parts of concerts, time signals, weather reports and dance music programs." * * *

A 2,100 MILE VOYAGE ON ONE TUBE

ONE dry-cell tube in a single-circuit hook-up covers 2,100 miles for Oren Pollock of Lampasas, Tex.; his record reception is WGY, Schenectady, N. Y. He uses a variocoupler with a spider-web rotor, a 43-plate condenser, and an antenna 90 feet long and 30 feet high.

Other stations on his list are WOC, Davenport, Ia.; WHM, New York City; WLW, Cincinnati, O.; WWJ, Detroit, Mich.; KZN, Salt Lake, Utah; WHAS, Louisville, Ky.; PWX, Havana, Cuba and WMC, Memphis, Tenn. * * *

HE HEARS 81 STATIONS ON A \$11.50 SET

WITH a three-tube set made from parts bought in a 10-cent store, Robert W. Carson hears eighty-one stations at his home in Indianapolis, Ind. By purchasing his tubes and transformers second-hand, he cut the total cost of his set to \$11.50. His "B" battery is home-made. He employs the single-circuit principle with an antenna 80 feet long and 35 feet high.

Within eight minutes he has heard call letters announced from WBZ, Springfield, Mass.; KHJ, Los Angeles, Cal., and CFAC, Calgary, Can.

TO THE PACIFIC ON A REINARTZ CIRCUIT

ONE tube in a Reinartz hook-up frequently spans the continent for Edward J. Benesch of New York City. He has heard KFU, Gridley, Cal., about every other night; KFI, Los Angeles, Cal., three times for a half hour each time, and PWX, Havana, Cuba, twice for periods of 20 minutes. Some of his "old reliables," which he hears every night are WBAP, Fort Worth, Tex.; WDAF, Kansas City, Mo.; WSB, Atlanta, Ga.; WDAP, Chicago, Ill.; WOC, Davenport, Ia.; WLK, Indianapolis, Ind.; WJAX, Cleveland, O., and CFCA, Toronto, Canada.

His antenna is one wire 115 feet long, with a lead-in of 75 feet. He attributes his success to the length of his antenna, a good ground contact, and three weeks of constant experimenting with his tuning instruments. He is constantly finding new stations and he believes that with more careful manipulation of his dials he will continue to better his records. * * *

THE FOUR-CIRCUIT TUNER TAKES HIM TO DENVER THE FIRST WEEK

WITH the four-circuit tuner described in the May issue of **POPULAR RADIO**, it took Russel P. May of New York City just about a week to bring in KDYW, Denver, Colorado, on his loudspeaker.

"It was only a question of learning how to tune the set," he writes; "when I really learn how to tune I expect to move in the best European circles."

May uses a single-wire antenna which is about 85 feet long. It runs from a chimney about 40 feet high to a grape arbor twelve feet high.

Other stations he hears are KYW and WDAP, Chicago; WBAP, Ft. Worth, Texas; WOS, Jefferson City, Missouri; WMC, Memphis, Tennessee, and PWX, Havana, Cuba.

SIXTY STATIONS ON A LOOP

A LOOP antenna with six tubes brings in 60 stations for W. W. Roberts of Norfolk, Va. He hears KHJ of Los Angeles, Calif.; KOP of Detroit, Mich.; WNAC of Boston, Mass.; WKAQ of San Juan, Porto Rico; PWX of Havana, Cuba; CKAC of Montreal, Canada; WOAI of San Antonio, Tex., and practically all of the nearer high-powered stations of the United States.

His loop is of the flat type, with ten turns of No. 18 flexible lamp cord, stranded and insulated, making a total length of 120 feet. Storage battery tubes are used throughout, a detector, three stages of radio frequency amplification and two stages of audio frequency.

* * *

HE RECEIVES THROUGH STEEL WALLS

ALTHOUGH he is on the second floor of a steel and concrete apartment house and is surrounded for several blocks by large steel buildings, W. M. Batts of New York City hears stations as distant as WFAA of Dallas, Tex.; WOC of Davenport, Ia.; WMAQ of Chicago; WSB of Atlanta, Ga.; WNAC of Boston, Mass., and PWX of Havana, Cuba.

A loop antenna composed of five turns of No. 16 copper wire in the form of a four-foot square is used with six tubes, detector, three stages of radio frequency amplification and two stages of audio frequency. A 43-plate condenser across the loop serves as a delicate tuning instrument. The amplifiers use a 67½-volt "B" battery.

* * *

96 STATIONS ON THREE TUBES

USING a De Forest MR-6 receiving set with a C-300 detector, a C-301 tube in the first stage of audio frequency amplification and a W. E. VT-2 in the second, 96 stations have been picked up clearly by Henry K. Jarrett of Boyertown, Pa. He hears practically all of the

large eastern stations and those as far west as the Rockies.

* * *

HE HEARS ALL THE LARGE STATIONS WITH FOUR TUBES

JACK BELL of Detroit, Mich., uses three stages of audio frequency amplification to receive from over 2,000 miles away, and hears all the large stations of North America.

"I use an antenna of one wire, 75 feet long and 35 feet high, and get better results than I did with my old four-strand antenna," he says, and jots down a few of his records, the best of which are KFI and KHJ of Los Angeles, Calif.; WAAB, New Orleans, La.; WDAJ, College Park Ga.; PW Havana, Cuba; WBZ, Springfield, Mass.; WEAJ, New York City; WAOL, San Antonio, Tex., and KDZQ, Denver, Colo.

He uses the Armstrong regenerative hook-up and grounds his set on a steam radiator.

* * *

ONE DRY-CELL TUBE BRINGS IN DX

ONE dry-cell tube covers half the country for Adrian Todd of Philadelphia, Pa. A variometer is placed in the antenna circuit with a variable condenser of 23 plates in series with it. The secret of the hook-up lies in the grid circuit; the terminals of the variometer are connected to the grid and the plate instead of to the grid and the filament. A variable grid leak and a condenser are used between the grid and the variometer. The plate circuit is connected in the usual way.

Todd hears WOC, Davenport, Ia.; WDAP, Chicago; KYW, Chicago; WJAX, Cleveland, O.; WLW, Cincinnati, O.; WWJ, Detroit, Mich.; WHAS, Louisville, Ky.; WNAC, Boston, Mass. and a number of stations in New York and nearby cities.

A diagram of Todd's circuit is shown in Figure 1.

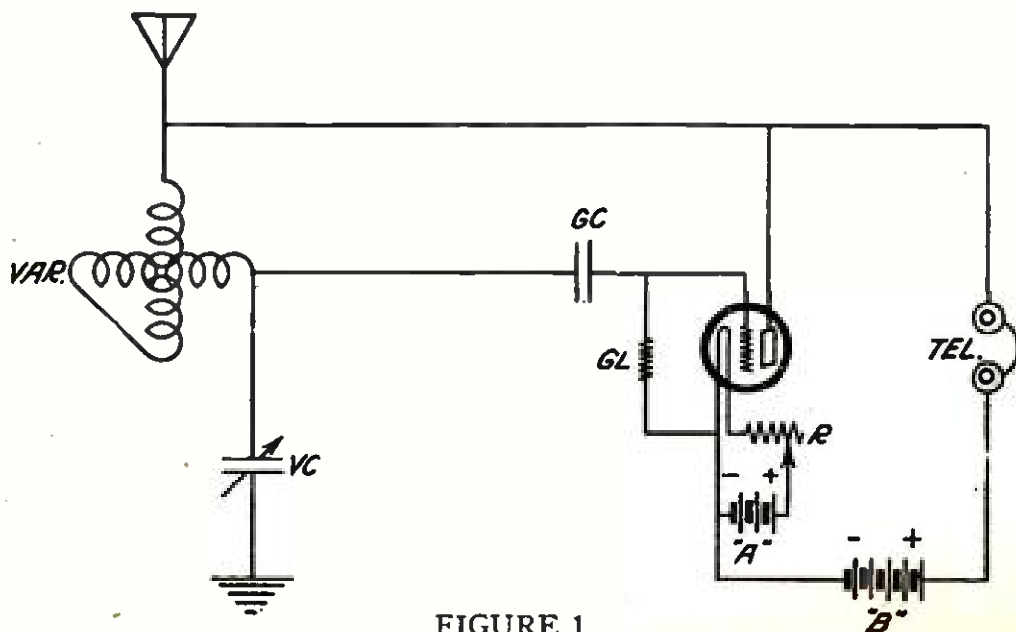

FIGURE 1

A novel hook-up that is a combination of the ordinary single circuit and the old ultra-audion circuit. The two tuning instruments are a variometer and a variable condenser. It has given exceptionally good DX results.

WORKRITE

LATEST RADIO PRODUCTS

WORKRITE RESISTANCE CARTRIDGE

No need to buy a new Rheostat to get the 30 ohms required for the UV199 Tubes or the 15 ohms required for the 201A and 301A Tubes. Just put a WorkRite Resistance Cartridge on the circuit with your old 5 or 6 ohm Rheostat. Price 15 or 25 ohm 40c.



WORKRITE VERNIER RHEOSTAT \$1.00

This instrument is the last word in Rheostats. 50,000 adjustments for \$1.00. The drum is moulded and cannot shrink. No danger of the wires loosening. Pushing the knob way in turns off the filament. Turning the knob gives the finest adjustment. Often a turn of 1/32 inch will clear up a station or separate two stations. The WorkRite Super Vernier Rheostat is made with three different resistances so that there is a WorkRite Rheostat that will work with any Tube now on the market.

- | | |
|--|--------|
| WorkRite Vernier Rheostat 6 ohms..... | \$1.00 |
| WorkRite Vernier Rheostat 15 ohms..... | 1.10 |
| WorkRite Vernier Rheostat 30 ohms..... | 1.25 |



WORKRITE HYDROMETER

Double the life of your battery by giving it proper care. Fill and test it regularly with a WorkRite Hydrometer. Never let it get below 1.150. Full instructions for testing with each "WorkRite." Get one now. Price, 75c.

WORKRITE NON-MICROPHONIC SOCKET

Here is the right socket for your UV199 Tube. It is moulded with a sponge rubber base in one piece which is even better than the soft rubber recommended for use with this tube. Don't look any further. Get one right away. Price 60c.

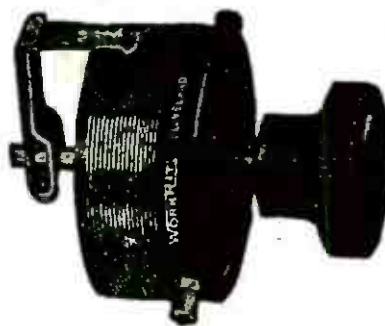

OTHER WORKRITE PRODUCTS

- | | |
|---|---------|
| WorkRite Super Variometer. Made of fine grade mahogany. Wound with green silk. Price..... | \$3.50 |
| WorkRite 180° Super Variocoupler. Made from moulded Bakelite. Green silk wound. 12 taps. Price..... | \$3.50 |
| Guaranteed wave length range of WorkRite Variometers and Variocouplers 150 to 705 meters. | |
| WorkRite E-Z-Tune Dial. Has a knurled flange on outer rim that fits the hand. Price..... | 75c |
| WorkRite Concert Head Set. Just try one with any Headset on the market. Price..... | \$6.00 |
| WorkRite Concertolas. Loud Speakers of Quality. | |
| WorkRite Concertola Jr..... | \$12.00 |
| WorkRite Concertola Sr..... | 24.00 |

WorkRite Radio Parts WorkRite.

THE WORKRITE MANUFACTURING CO.

5519 EUCLID AVE.
CLEVELAND, OHIO

BRANCH OFFICE:
536 LAKE SHORE DR., CHICAGO

BUILD YOUR OWN RADIO OUTFIT

HIGH QUALITY GOODS AT LOW PRICES

FAST SERVICE—THE PRICES QUOTED DELIVER THE GOODS TO YOUR DOOR

BARAWIK SPECIAL PANEL MOUNTING VARIABLE CONDENSERS

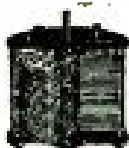

- M812—43 plate .001 Mfd. \$1.73
- M813—21 plate .0005 Mfd. 1.43
- M814—11 plate .00025 Mfd. 1.32
- M815—3 plate Vernier 98c

These are especially high grade condensers and we guarantee them to be mechanically and electrically perfect. Genuine bakelite end plates of high dielectric and great mechanical strength. Sturdy aluminum alloy plates perfectly spaced to insure smooth, even reliable capacity. Our low prices save you money. These condensers are of the very best make and are not to be compared with any inferior cheap condensers offered. We guarantee them to please you or your money back.

COMBINATION VERNIER VARIABLE CONDENSERS

- M824—23 plate .0005 Mfd. Price \$2.89
- M826—43 plate .001 Mfd. Price 3.45



The latest improvement in condensers consists of regular variable condenser controlled by large knob and dial. Separate small knob mounted above dial controls a three-plate vernier condenser. This arrangement permits of very fine tuning. High-grade design and construction. Finely finished. Suitable for panel mounting.

INDUCTANCE "HONEY COMB" COILS



Carefully made — fine looking coils. Highest efficiency. Low distributed capacity effect. low resistance—high self inductance. Very firm enamel impregnation. Range given in meters when varied with .001 variable condenser. Mounted coils have standard plug mountings.

Turns	Meters	Art. No.	Not Mntd.	Art. No.	Price
25	120-	250	M301 \$0.39	M320	\$0.89
35	175-	450	M302 .42	M322	.96
50	240-	720	M303 .49	M323	1.04
75	300-	910	M304 .54	M324	1.08
100	500-	1450	M305 .58	M325	1.13
150	600-	2000	M306 .63	M326	1.17
200	900-	2500	M307 .72	M327	1.26
250	1200-	3500	M308 .78	M328	1.35
300	1500-	4500	M309 .82	M329	1.36
400	2000-	5000	M310 .97	M330	1.57
500	2800-	6100	M311 1.12	M331	1.63
600	4000-	10000	M312 1.27	M332	1.78
750	5000-	12000	M313 1.43	M333	1.93
1000	7900-	15000	M314 1.70	M334	2.28
1250	9750-	19500	M315 1.92	M335	2.49
1500	14500-	26500	M316 2.18	M336	2.65

COIL MOUNTINGS



- M340—Three coil mounting \$3.95
- M341—Two coil mounting 2.95

High grade fine looking mounting. Polished black composition. Center receptacle stationary, two outer ones adjusted by knobs. Takes any standard mounted coil.

GALENA DETECTOR

Easy fine adjustment. Crystal mounted in cup. Moulded base and Knob. Brass parts polished nickel finish. M732—Each \$0.59c



This Guarantee Protects You. Examine the goods we ship you. They must suit you in every respect. If you are not satisfied with your purchase return the goods at once and we will refund the price you paid.



VACUUM TUBES

Standard Brands—Cunningham Radiotron. Every one guaranteed new and perfect. We will ship brand in stock unless you specify otherwise. M105—Detector UV200 or C300 \$4.38

- M112—Amplifier UV201A or C301A. Each \$5.95
- M115—5 Watt Transmitter 7.70
- M107—WD11 1½ volt. 5.95
- M109—WD11 adapter. Each 48c

VACUUM TUBE SOCKETS



Our Special Socket. A wonderful value. Moulded entirely of bakelite. Four binding post connections. Right angled contact springs.

- M140—For Standard Base Tubes. Each 39c
- M108—For WD11 Tubes. Each 49c

PORCELAIN BASE AND TUBE

M144—Crosley for either panel or table mounting for Standard Base. 36c

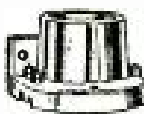

High Grade combination type for panel or table mounting Metal tube. Highly insulated base. For Standard Base Tubes. M146—Each 45c

GRID CONDENSER

- M162—Mounting holes spaced to fit lugs of above leak Cap. .00025 MFD. 14c
- M163—Same as 162 but higher grade. Enclosed in metal case. 35c

VARIABLE GRID LEAK

- Pencil mark type. Resistance may be varied exactly as needed. M100—Each 19c

VARIOMETER

M410—Completely assembled, price \$2.69 Perfect in design and construction. Accurate wood forms. Correct inductive ratios. Solid baked windings, positive contacts. Highest efficiency. M411—Not assembled but all parts complete, except wire, including winding form. \$1.48



VARIO-COUPLER

With this loose coupler and two variometers, together with the necessary other parts, a highly efficient tuning set can be made. Easily mounted on panel. Primary winding on formica tube.

- Inductively coupled for 180 to 600 meters. Multiple taps permit fine tuning. M415—Price, completely assembled. \$2.45
- M416—Not assembled, but all parts complete. Price except wire. 1.18
- M417—Rotor ball only. Each. 29c
- M408—Bakelite Stator tube only. Ea. 35c

RADIO FREQUENCY AMPLIFYING TRANSFORMER

M995—Each \$3.95 This transformer will get the long distance stations loud and clear. Permits of easy sharp tuning. Helps cut out static and interference. Makes your set sensitive enough to use a loop aerial. Enclosed in metal case affording perfect shielding. Suitable for panel or base mounting. Because of its special design can be mounted in any V. T. socket. Works with any make of tube. Wave ranges 150 to 550 meters. Wiring diagrams included.

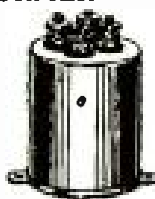

OUR SPECIAL AUDIO FREQUENCY AMPLIFYING TRANSFORMERS



As high as three stages can be used without howling, due to proper impedance ratio, minimum distributed capacity, low core losses and proper insulation. Mounted style has bakelite panel with binding post connections. Unmounted has core and coils assembled with two holes in core for fastening to apparatus. M234—10 to 1 Mounted. Each \$3.48

- M235—10 to 1 Unmounted. Each 2.95
- M236—3 to 1 Mounted. Each 3.40
- M237—3 to 1 Unmounted. Each 2.85

FILAMENT CONTROL RHOESTATS

Crosley—Wound on vulcanized fiber. Adjustable to any panel. Complete with knob. M130—Each 45c



Best grade. High heat resisting base. Diam. 2½ in. cap. 1½ amp. Resistance 6 ohms. 1½ in. Knob with pointer. M132—Each 45c

POTENTIOMETER

Same style as above rheostat. Gives fine "B" battery adjustment. Resistance 140 ohms. M133—Each 98c

VERNIER RHOESTAT

Gives exceedingly fine control of a battery current. A necessity for best receiving results. M135—Each 78c



PLATE CIRCUIT "B" BATTERIES

You can make real savings on these batteries. Don't pay more. We guarantee them to equal any on the market regardless of price. Absolutely uniform. Extra long life.

- M180—Signal Corps type, small size, 15 cells. 22½ volts. Each 95c
- M184—Variable Large Navy size, 5 taps, giving range from 18½ to 22½ volts in 1½ volt steps. Each \$1.80
- M188—Combination Tapped 45 volts, 30 cells. 6¼x4x8 battery. Tapped to give 45, 22½, 21, 19½, 18, and 16½ volts. Handles both detector and amplifier tubes. Ea. \$3.55

DETECTOR CRYSTALS CAREFULLY TESTED

- M736 Galena, Arlington tested, per piece 19c
- M738 Silicon, Arlington tested, per piece 19c
- M735 Tested, Galena, per piece 9c
- M737 Tested, Silicon, per piece 9c

THE BARAWIK CO. 102 S. CANAL STREET CHICAGO, ILL.

USE BARAWIK STANDARD PARTS

YOU SAVE MONEY WHEN YOU BUY FROM US
FAST SERVICE—THE PRICES QUOTED DELIVER THE GOODS TO YOUR DOOR

SOLID BARE COPPER WIRE
 Solid bare copper wire for aeriads, leads or wiring instruments.
 Solid Bare Copper Wire, size 14
 M240—100 ft. coil 49c
 M242—500 ft. coil \$2.35
 Solid Bare Copper Wire, size 12
 M244—100 ft. coil 67c
 M245—500 ft. coil \$3.05

STRANDED ANTENNA WIRE
 Cabled of fine copper strands. Very flexible. High tensile strength. Best for antennas.
 M248—100 ft. coil 72c
 M249—500 ft. coil \$3.20

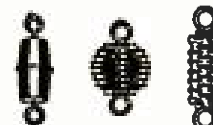
ANTENNA INSULATORS

 M260—Size 1x3 1/4. Two for 17c
 M262—Size 2 1/4 x 3 1/4. Two for 55c
 M264—Size 1 1/2 x 4. Two for 69c
 M266—Size 1 1/2 x 10 1/2. Two for \$1.29

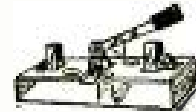
OUTDOOR LIGHTNING ARRESTER
 M980—Price \$1.58
 Protect your instruments with this lightning arrester. You cannot afford not to. Weather-proof porcelain case. Air gap type. Permanent. Durable. The most practical quality arrester obtainable. Underwriters approved.

PORCELAIN BASE SWITCHES

 Fine white porcelain bases. Copper contacts and blades. Can be used as antenna switches.
 M385 Single Pole Single Throw. Each 20c
 M383 Single Pole Double Throw. Each 32c
 M384 Double Pole Double Throw. Each 50c

SWITCH LEVERS
 Moulded composition knob. Exposed metal parts polished, nickel finish. Fitted with panel bushing, spring and two set nuts. A high grade switch.
 M380—1" Radius } Each
 M381—1 1/4" Radius } 19c
 M382—1 1/2" Radius }

SWITCH LEVER STOP
 Brass, polished nickel finish.
 M386—Dozen 18c. Hundred \$1.05.

ONE-PIECE DIAL AND KNOB

 Moulded of highly polished black composition with clean plain engraved scale and numerals in contrasting white enamel. Ribbed knob to fit the hand. An attractive neat pattern.
 M900—2 1/4" Diam. for 3-16" shaft. Ea. 19c
 M901—2 1/4" Diam. for 1/4" shaft. Ea. 19c
 M904—3" Diam. for 3-16" shaft. Ea. 25c
 M905—3" Diam. for 1/4" shaft. Ea. 25c
 M906—3 1/2" Diam. for 3-16" shaft. Ea. 35c
 M907—3 1/2" Diam. for 1/4" shaft. Ea. 35c

GUARANTEED QUALITY GOODS
 at money saving prices. You can build the parts purchased from us into your set and feel confident of the best results. If what you want is not shown here write us for prices—we have every part for your set ready for quick shipment and the prices are right.

RADIO JACKS AND PLUGS
 Finest grade jacks. Improved design. Best materials. Phosphor bronze springs. Silver contact points. Nickel finish. Mount on panels 1/4 to 1/2 in. thick.
 M390—Open circuit. Each 43c
 M391—Closed circuit. Each 49c
 M392—Two circuit. Each 50c
 M393—Single-cir. fil. control. 69c
 M394—Two cir. fil. control. 85c
 M395—Plug. Large space with set screws for attaching cord. Each 49c

COMPETITOR JACK AND PLUG
 Well made, durable, smooth working. Interchangeable with any standard jacks and plugs. Solder connections. Nickel finished metal parts.
 M387—Open Circuit Jack. Each 27c
 M388—Two Circuit Jack. Each 35c
 M389—Standard Plug. Each 35c

BINDING POSTS

 Brass, polished nickel finish. Washer and 6-32" screw extending 1/4".
 M370—Largest size—barrel and knob 3/4" long, dozen 85c
 M372—Smaller size—barrel and knob 9-16" long, dozen 70c
 M376—8
 M374—Large size with composition knob—dozen 50c
 M376—Large size with hole for phone tip or wire, dozen 80c
 M378—Small size with hole for phone tip or wire, dozen 35c

STORAGE BATTERY

 A very high grade battery made especially for radio service. Guaranteed. Properly cared for will give years of service for filament lighting.
 M194—6-v., 40 amp. size. Each \$10.00
 M196—6-v., 80 amp. size. Each 12.50
 Price does not include transportation.

BARAWIK QUALITY HEADSETS
 These headsets have proven on rigid tests to be one of the very best on the market. The tone quality is excellent with an unusual volume. Skilled workmen make them from only the best selected materials. The receiver cases are brass in fine polished nickel finish. Polished black ear pieces. Fabric covered head band comfortably and quickly fitted to the head. Supplied with 5-foot cord. These sets were designed to sell for much higher prices, and at our price are a wonderful bargain. We guarantee that you will be pleased with them and agree that they are the best value by far yet offered. If they don't suit you we will cheerfully return your money.
 M770—2000 ohm. \$3.75

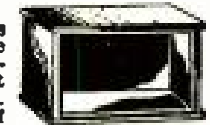
OTHER STANDARD BRAND HEADSETS
 M751—Murdock 56, 2000 ohm. \$4.20
 M752—Murdock 56, 3000 ohm. 4.95
 M764—Frost, 2000 ohm. 4.20
 M766—Frost, 3000 ohm. 4.85
 M756—Red Head, 3000 ohm. 5.78
 M758—Western Electric, 2200 ohm. \$9.50
 M754—Baldwin Type C with universal jack plug. 11.75
 M755—Baldwin Type C unit. 5.50
 M768—Brandes, 2000 ohm. 6.90

CABINETS
 Fine-looking cabinets solidly built. Made of genuine solid mahogany in elegant hand rubbed finish. You will be proud of your set mounted in one of these cabinets. Hinged tops. Front rabbeted to take panels. Panels not included. Prices are transportation paid.

Panel Size	Inside High	Dimensions Wide	Depth	Art. No.	Price Each
6x7"	5 1/2"	6 1/2"	7"	M420	\$2.48
6x10 1/4"	5 1/2"	10"	7"	M422	2.75
6x14"	5 1/2"	13 1/2"	7"	M424	3.30
7x14"	6 1/2"	13 1/2"	7"	M423	3.60
7x18"	6 1/2"	17 1/2"	7"	M426	3.90
7x21"	5 1/2"	20 1/2"	7"	M425	4.20
9x14"	8 1/2"	13 1/2"	10"	M428	3.70
12x14"	11 1/2"	13 1/2"	10"	M430	4.40
12x21"	11 1/2"	20 1/2"	10"	M432	5.25

SOLID GENUINE CONDENSITE CELERON PANELS
 Notice our very low prices in this fine quality grade 10 genuine solid sheet Condensite Celeron (a product with mechanical, chemical and electrical properties like formica and bakelite). Machines well without chipping. Won't warp. Waterproof. Highest mechanical and dielectric strength. Attractive natural polished. Black finish which can be sanded and oiled for extra fine work.
 Panel 1/4" thick 3-16" thick 1/2" thick

Size Inches	Art. No.	Price	Art. No.	Price	Art. No.	Price
6x7"	M450	\$0.50	M460	\$0.75	M470	\$0.98
6x10 1/4"	M451	.75	M461	1.16	M471	1.47
6x14"	M452	1.05	M462	1.55	M472	2.05
7x14"	M456	1.20	M468	2.60	M478	2.40
7x18"	M453	1.55	M463	2.30	M473	3.10
7x21"	M457	1.78	M467	2.65	M477	3.60
9x14"	M454	1.60	M464	2.30	M474	3.10
12x14"	M455	2.10	M465	3.10	M475	4.15
12x21"	M456	3.15	M466	4.65	M476	6.20

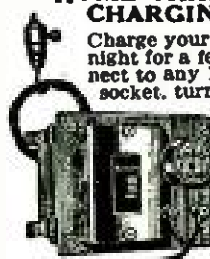
HOME CHARGER BATTERY CHARGING RECTIFIER

 Charge your battery at home over night for a few cents. Simply connect to any 110 volt 60 cycle light socket, turn on current and rectifier does the rest automatically. Will work for years without attention. Simple connections. Gives a tapering charge which batteries should have. You can make it pay a profit charging your friends' auto batteries. Long connecting cords with pair of battery clips. Prices are Transportation Paid.
 M201—For 6 volt battery \$13.95

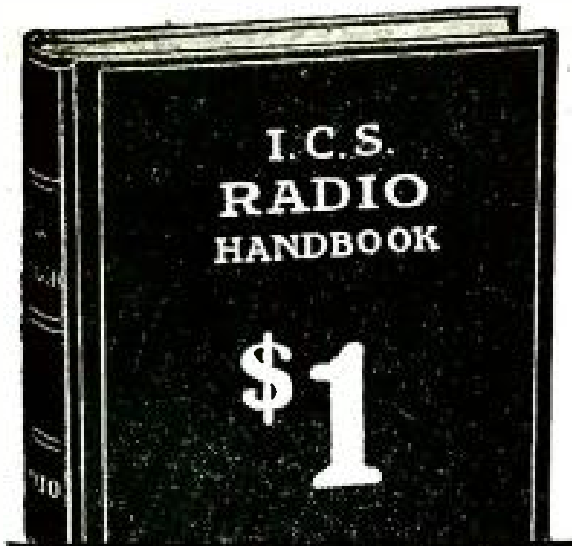
THE BARAWIK CO. 102 S. CANAL STREET CHICAGO, ILL.



Every Radio Fan Should Have This Book

Price Only



562 pages
Pocket Size

Compiled by
HARRY F. DART
B.S. E.E.

Formerly with
the Western
Electric Co.,
and U.S. Army
Instructor of
Radio.

Technically
edited by
F. H. DOANE

LIKE a little radio encyclopedia, this I. C. S. Radio Handbook is packed with concise, sound information useful to everybody from beginner to veteran hard-boiled owl. It starts with simple explanations of radio phenomena and leads you along gently until you can understand the most technical diagram.

You may dip into it at random, or hunt up special information you want, or read it right through. Different types of receiving and sending hook-ups are explained; proposed insurance regulations; lists of broadcasting stations; radio compass stations; interesting experiments; definitions; codes and symbols; technical data and thousands of suggestions for getting more pleasure out of radio.

A pocket course in radio!

Every page tells you something useful, and there are 562 pages; hundreds of illustrations and diagrams. It is the biggest dollar's worth in radio, and will save you from wasting money on things that don't work.

Send \$1 to-day and get this 562-page I. C. S. Radio Handbook before you spend another cent on parts. Money back if not satisfied.

TEAR OUT HERE

INTERNATIONAL CORRESPONDENCE SCHOOLS
Box 8251, Scranton, Penna.

I enclose One Dollar. Please send me—post-paid—the 562-page I. C. S. Radio Handbook. It is understood that if I am not entirely satisfied I may return this book within five days and you will refund my money.

Name.....

Address.....



BURGESS RADIO BATTERIES

- ARE RECOMMENDED by leading manufacturers of radio equipment.
- ARE SPECIFIED by radio engineers.
- ARE DESIGNED and built by radio engineers.
- ARE A GUARANTEE of satisfactory service.
- ASK ANY RADIO ENGINEER.

Burgess Radio Batteries are handled by all progressive jobbers and dealers. Look for the distinctive black and white stripes. If your dealer doesn't handle the Burgess line just address the nearest Burgess office below.



BURGESS No. 6 BATTERIES

are highly recommended for use in "A" or filament circuits where one and one-half volt Vacuum Tubes are used.

BURGESS BATTERY CO.

Engineers—Dry Batteries—Manufacturers
FLASHLIGHT—RADIO—IGNITION—TELEPHONE

General Sales Office: Harris Trust Bldg., Chicago
Laboratories and Works: Madison, Wisconsin

BRANCHES:
NEW YORK BOSTON WASHINGTON
ST. PAUL KANSAS CITY NEW ORLEANS

In Canada:
General Offices and Works: Niagara Falls, Ontario
Branches: Toronto Montreal Winnipeg St. John

"ASK ANY RADIO ENGINEER"

BURGESS RADIO BATTERIES

• Please mention POPULAR RADIO when answering advertisements.



**SOME OF THE PARTS
SPECIFIED BY MR. COCKADAY
IN HIS FOUR CIRCUIT TUNER**

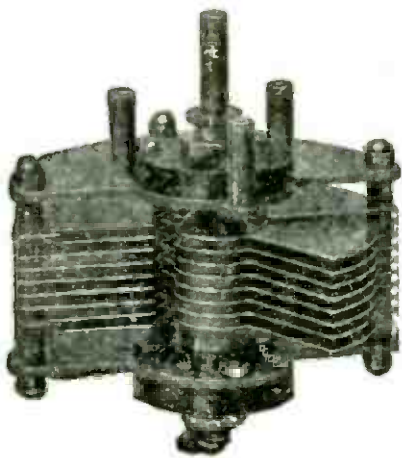

No. 185 VARIABLE CONDENSER . . . \$4.25
CAP. .00035 M. F. 17 PLATES

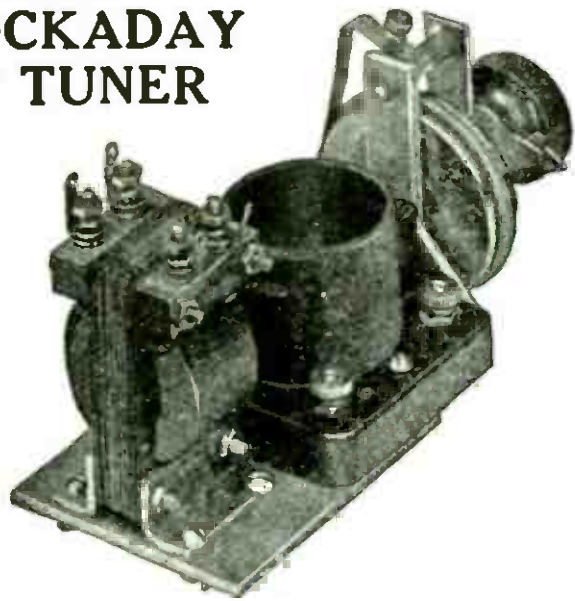

No. 198 AMPLIFYING UNIT \$7.50
ACME TRANS.

No. 211 DETECTOR UNIT \$2.40



No. 164 KNOB AND DIAL \$0.75
MOLDED BAKELITE



No. 193 VERNIER ADJUSTER \$0.35

R. MITCHELL & CO.

255 Atlantic Ave.

Boston, Mass.

*For 47 years Manufacturers of Scientific and other equipment
Look for trade mark on every piece
Jobbers and Dealers write for discounts*

Please mention POPULAR RADIO when answering advertisements.

RADIO

PEARLCO PRODUCTS

THE Pearlco Variocoupler and Variometer illustrated here are moulded in Bake-Lite and are backed by a **FACTORY GUARANTEE** to perform the highest possible service. We are also ready to deliver the new Variometer and Variocoupler with the "pigtail" contact. A Radio Engineer of 18 years' experience supervised the making of these devices. Supreme in range and durability. Write to us—we'll be glad to tell you more about our products.

PEARL RADIO CORPORATION
1033-35 Race Street Philadelphia, Pa.

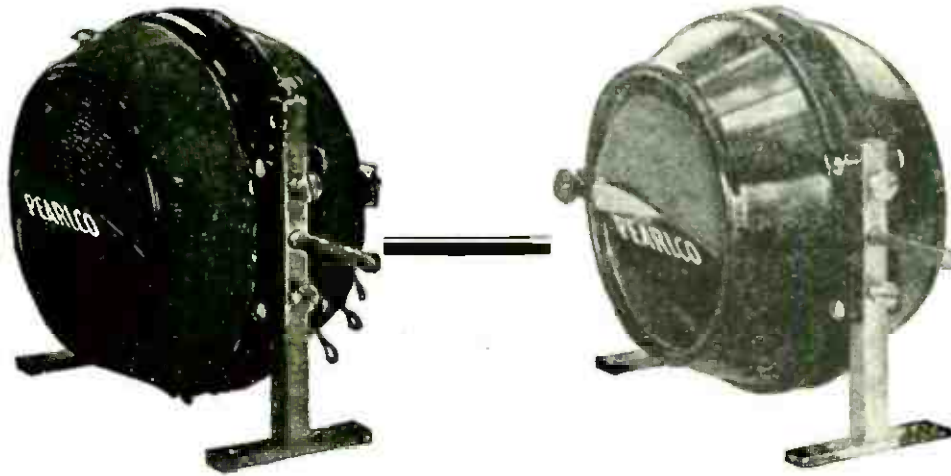

GOOD BYE AERIALS!

Make Your Set Portable



"SHORT CUT ANTENNA"

Replaces aerials, loops, electric light plugs, etc.
 Eliminates lightning dangers.

Reduces *Static* and other interference.

Gives clearer signals and truer tone.

Works on all Standard vacuum tube sets.

Postpaid anywhere for \$5.00.

This has been passed by the Board of Fire Underwriters as eliminating all fire hazard. No inspection necessary.

Short Cut Radio Corp.,
 241 W. 54th St., New York.
 Send me at once one Short Cut Antenna.

- (a) I enclose for \$5.00
- (b) Mail C.O.D.

I have a Set

Name

Street

City State

Dealer's name

Dealer's address

Size
 6 3/4" x 2 1/8"

*Satisfaction guaranteed
 or money refunded*

Short Cut Radio Corporation

241 W. 54th Street
 NEW YORK

DEALERS:
 Write for Our Proposition

Please mention POPULAR RADIO when answering advertisements.

A New Thrill!

Listen-In Tonight with a Kellogg Head Set

Clear reception with plenty of volume is necessary to satisfactorily hear distant stations.

Kellogg head sets should not be classed as ordinary radio receivers. Today Kellogg stands foremost in the manufacture of a high-grade head set that actually surprises listeners in comparative tests.

Maximum volume, unusual clearness, extreme lightness in weight, are a few of the many outstanding advantages. The head band is unusually light, though durably built.

The magnets are of special tested steel and hardened by our own special method which controls the heat and time electrically and mechanically, eliminating any possible variation.

The magnet windings are of great accuracy, the mountings, end plates, wire, insulation, etc. are of the highest grade.

Our twenty-five years experience in building receivers for telephone work has proven invaluable in turning out a real radio receiver of merit.

Listen-in tonight with a pair of Kellogg receivers and get a new thrill from your radio set. With Kellogg radio equipment, USE Is The Test.

Kellogg Switchboard & Supply Company
CHICAGO

COLUMBUS

KANSAS CITY

SAN FRANCISCO

PORTLAND

Kellogg apparatus exclusively is used in building The Symphony Receiver

Can you answer this

What makes a good Variable Condenser?

A STACK OF METAL PLATES may be sold as a condenser but electrical efficiency depends entirely on unseen qualities. To *maintain* these qualities a condenser

Must be rigid—warping continually changes the capacity and spoils original adjustment.

Must have precision spacing. Uneven spacing is equivalent to warping. Bent plates increase the possibility of short circuits.

Must balance in any position. Uneven balance makes for unsatisfactory tuning due to difficulty in maintaining settings.

Must have definite and positive vernier control. Reception of C.W. and Broadcasting demands sharper tuning than can be conveniently accomplished with the old type of condenser. A real Vernier, independently controlled, greatly simplifies operating.

Malone-Lemmon Condensers and other Malone-Lemmon Permanent Parts, meet every requirement of efficiency, and add much to the success, enjoyment and appearance of Radio sets.

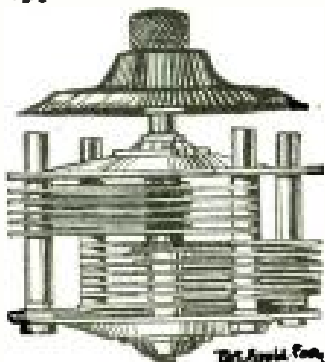

Supplied in following sizes
.00025 MF List \$5.50 .0005 MF List \$6.50 .001 MF List \$7.50
Write for descriptive literature

MALONE-LEMMON LABORATORIES

342 Madison Avenue
New York City

GOOD RECEPTION EASY—

SUMMER OR WINTER

—IF YOU OWN A LEFAX RADIO HANDBOOK

The man who owns a Lefax Radio Handbook gets good results from his set at all seasons of the year. Difficulties disappear readily. He can take instant advantage of every new development to improve his set and perfect reception—because Lefax Radio Handbook keeps pace with the new developments.

The ONE Best Book on Radio

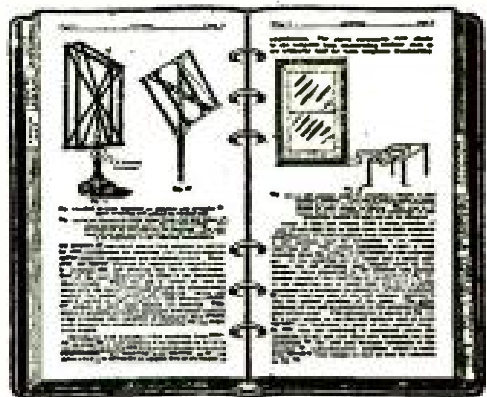

LEFAX NEVER GROWS OLD!

Lefax Radio Handbook is loose-leaf and every month additional pages are sent out covering the new developments. These pages fit the handbook and may be inserted in appropriate places in the handbook thus keeping it *perpetually up-to-date!* Written by the two chiefs of U. S. Bureau of Standards Radio Laboratory (Dr. J. H. Dellinger, and Mr. L. E. Whittemore). Get your copy now. Price, in U. S. A., \$3.50 including one year of the service which keeps it up-to-date.

For sale at all radio dealers and stationers.

LEFAX, INC.

139 S. 9th ST., PHILA., PA.

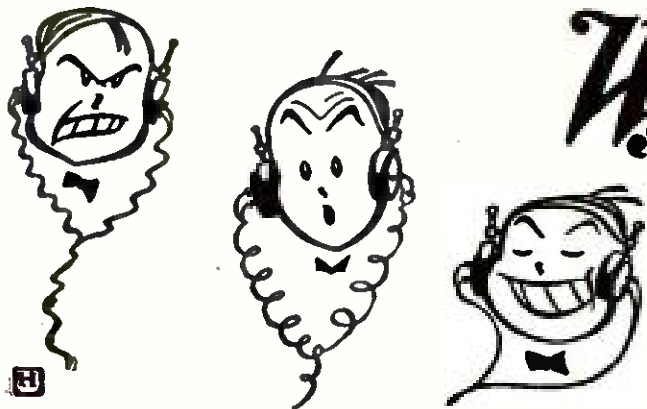

Which is your "Radio Face?"

You can pretty nearly tell by the listener's expression whether he's tuned in on a single circuit or the Paragon three-circuit receiver.

In these days of unlimited broadcasting on overburdened wave bands it's almost a certainty that you'll have jamming and mixed messages just so long as you stick to old style equipment.

But, with a Paragon three-circuit receiver you avoid those ear-splitting, face-twisting interruptions. You can tune in accurately and "hold the line" through an entire program, if you wish, without a break.

Ask some experienced amateur what he knows about

PARAGON

Reg. U. S. Pat. Off.

RADIO PRODUCTS

The amateur will tell you that the Paragon three-circuit receiver, because of its great superior selectivity and sensitivity, can pick and choose between broadcasting stations of about the same signal strength with less than one per cent differential.

This means that with a Paragon receiver you get what you want when you want it—complete messages and clear music from the station you tune in on, without interruption and jamming. Until you have listened in with a Paragon three-circuit receiver, you cannot guess the real pleasure and fascination of radio.

Long before broadcasting popularized radio with the general public, Paragon equipment was the choice of the experienced amateur. He will tell you today that if you want quality and satisfaction, Paragon Radio Products are the best and safest buy on the market.

An illustrated Catalog of Paragon Radio Products Is Yours For the Asking

DEALERS—The Adams-Morgan Company has an interesting proposition to make to reputable radio dealers who believe in quality merchandise. Details on request.

ADAMS-MORGAN COMPANY
20 Alvin Ave., Upper Montclair, N. J.

Also Manufacturers of PARAGON	
Radio Telephone	Amplifier
Transmitters	Transformers
V. T. Control Units	Control Dials
Rheostats	Amplifiers
Potentiometers	Receivers
V. T. Sockets	Switches
Detectors	Variometers

Type RD-5 Regenerative Receiver and Detector—\$75.00
Type A-2 Two-Stage Amplifier—\$50.00
(Licensed under Armstrong Patents.)



Please mention POPULAR RADIO when answering advertisements.

PACIFIC COAST BRANCH
329 Union League Bldg.
Los Angeles



The Superlative Inductance

Four years of careful attention to the details of manufacture of this type of inductance unit has yielded a product of unquestioned superiority. And with increased efficiency in manufacturing methods, moderate prices prevail for all sizes

Ask Your Dealer

Cotoco

"Built First to Last"

COTO-COIL CO. PROVIDENCE

RHAMSTINE[★]

Victophone

*and your phonograph make a
Perfect Loud-Speaker*

This reasonably priced unit makes it possible for you to secure great volume when attached to a horn or the tone-arm of your phonograph.

Critical adjustment of the poles is easily made, giving you the desired fullness and sweetness of the low or high notes.

Compare it with others—even those selling at double the price—and the *Victophone* will be your choice. Order yours now.



Price \$7.50 complete
= with cord

Manufactured by

J. THOS. RHAMSTINE[★]

2162 E. Larned St.

Detroit, Mich.

*Maker of Radio Products



hear
piano
~not
plinkle-
clankle!

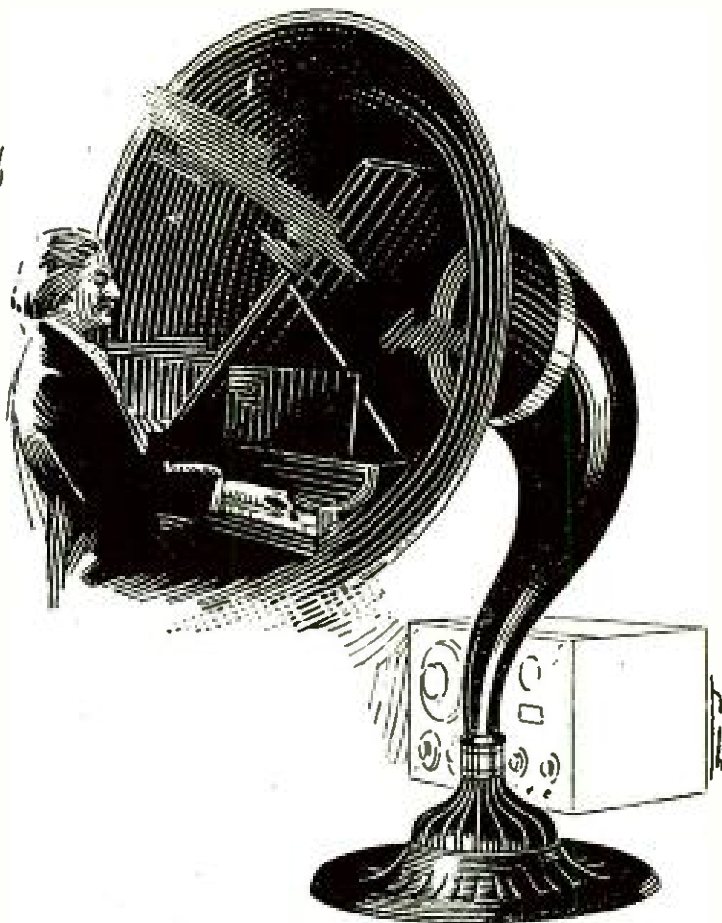
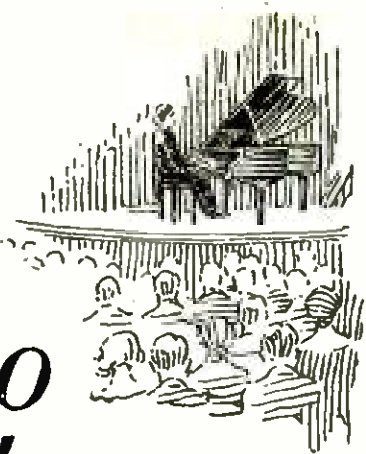

A PIANO *sounds* like a piano through MUSIC MASTER—not like a guitar, old-fashioned music-box or squeaking cart-wheel.

MUSIC MASTER gives you the piano's full, round tones—the sonority of the bass—the brilliance of the treble—the warmth and richness of majestic chords.

It conveys to you the accurate performance of the pianist or other musician at the very moment he plays to his theatre audience—without any twisting of the original tone. A marvel of clearness!

MUSIC MASTER *completes* radio. Tune in . . . Connect MUSIC MASTER . . . Sit back and enjoy radio's perfection. See and hear MUSIC MASTER at your radio dealer's.

Music Master

RADIO AMPLIFIER

14-inch Horn for the Home \$30

21-inch Horn for Concerts \$35

**JOBBERS
DEALERS**

*Write for description
of Geraco Line,
and prices*

GENERAL RADIO CORPORATION

Makers and Distributors of High-Grade Radio Apparatus

CHICAGO

PHILADELPHIA
S. W. Cor. 10th and Cherry Streets

PITTSBURGH

THE BEST HEADSET



At Your
DEALERS
\$5.00

HIGHEST AUDIBILITY
PERFECT MATCHING
GREATEST VOLUME

Why Strain Your Ears?

T. B. H. Headsets reproduce clearly and naturally. No "Fuzz" or "Tinny" tone. Extremely sensitive.

Aluminum cases—6 Foot cord—Weight 12 oz.
Type 6-A 17500 Turns (2200 ohms) Hard Rubber caps \$7.00
Junior 16000 Turns (2000 ohms) Composition caps \$5.00

*If your dealer does not carry them he will order them for you
Dealers and Jobbers write for discounts*

THE T. B. H. CORPORATION

DANVILLE, NEW YORK, U. S. A.

DISTRIBUTORS

The Eastern Specialty Co., Philadelphia, Pa.
(Metropolitan District and South Atlantic States)

Donaldson Radio & Service Station, Kansas City, Mo.
(Southwestern States)

Marie A. Alvarez, Havana, Cuba (Cuba)

ATWATER KENT

RECEIVING SETS AND PARTS



Detector 2-stage Amplifier

ATWATER KENT Sets and Parts are ideal for summer use due to their compact and rugged construction and the fact that they are moisture-proof. They are made mostly of condensite and are thoroughly water-proofed.

Send for an illustrated folder showing all parts and complete sets.

ATWATER KENT MFG. COMPANY
4933 Stenton Ave., Philadelphia

1200 MILES with a Crystal Set Using



**THE WORLD'S GREATEST
RADIO CRYSTAL**

A Needles, California, radio fan writes:

"Using M. P. M. Crystal, I picked up Los Angeles, San Francisco, Salt Lake, Denver and St. Louis. It is far superior to any crystal I have ever used."

Before discarding your Crystal Set for an expensive Tube outfit, give M. P. M. Crystal a trial!

Beware of imitations! The genuine Million Point Mineral is sold only in separate crystals packed by our company in boxes bearing the trade-mark "M. P. M."

Send 25c and name of your Radio Dealer for a sample M. P. M. Crystal—concert-tested and guaranteed. 35c for mounted Crystal.

M. P. M. SALES COMPANY

Department PR

247 So. Central Ave. Los Angeles, Cal.

Please mention POPULAR RADIO when answering advertisements.

MU-RAD RECEIVERS SUPREME



The reception of far distant stations, heralded by owners of ordinary sets as a rare achievement, is the common experience of those who own MU-RAD Receivers. Only a 2-foot loop aerial required. Sensitivity finer than anything you have ever known. Faithful reproduction. Selects with amazing ease and sharpness. Yet these highly perfected sets are very simply operated. Guaranteed to receive 1000 miles, minimum. The maximum record is broken every week. Send for literature.

*The New
Star in
the Radio
World*



MU-RAD LABORATORIES, INC.

809 FIFTH AVE. ASBURY PARK, NEW JERSEY



JEFFERSON

Amplifying Transformers

have gained an enviable reputation for audibility and amplifying power. In tens of thousands of receiving sets they are insuring 100% amplification—increased range, super-sensitivity, and the elimination of howling and distortion.

This positive preference rests on the unmistakable superiorities of design and operation which make Jefferson Amplifiers the choice of discriminating radioists.

FIVE JEFFERSON TYPES

The five Jefferson types meet the demand for an audio-frequency transformer for every requirement. In this assortment you are sure to find the transformer which will make your set super-sensitive, and enable you to tune in distant stations with ease, and freedom from distortion.

Radio Bulletin Sent Free

Jefferson Electric Mfg. Co.
427 S. Green Street Chicago

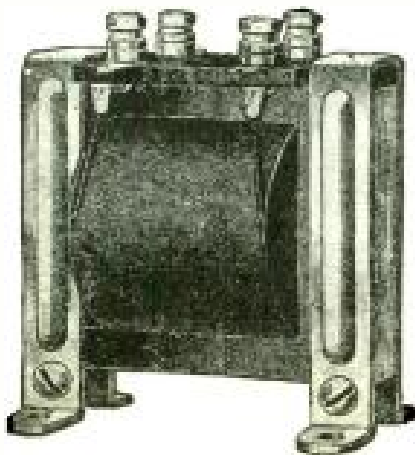

means Radio Insurance

Protection assured!

Every element of risk is eliminated by our money-back guarantee, when you buy AmSCO Products. Every thing we make—from the wonderful Melco-Supreme Radio-Frequency Receiver (150-750 meter wave length) to the smallest binding post, is scientifically correct, mechanically perfect and built for life-long durability.

"PART OF THE AMSCO LINE"



Compensating Condenser



Rheostat
(6, 20 or 50 Ohms)

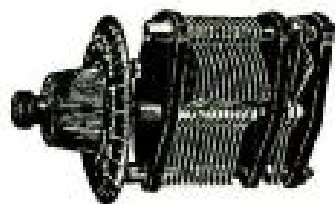

Vernier Air Condenser

AMSCO CONDENSERS are especially adapted for use with the Cockaday Four-Circuit Tuner.

Write for booklets illustrating and describing our entire line of quality apparatus.

AMSCO PRODUCTS, Inc.

Successors to Mortimer Radio Corp. and Advance Metal Stamping Co.

FAIRBANKS BUILDING
Broome & Lafayette Sts., New York City

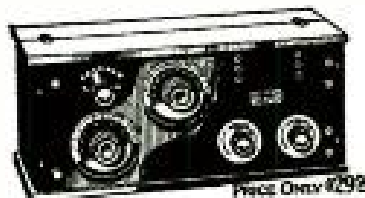

At this low price you get the efficiency of a \$50 set. It is a two tube radio frequency receiver—picks up stations 1500 miles away under good conditions—everywhere—any time. This outfit can be operated with a dry cell or storage battery. Cabinet is of solid mahogany and workmanship the finest throughout. Order direct or send for catalogue.

DEALERS—write for proposition—it's a winner.
AGENTS—wanted everywhere—write for territory
QUICKLY

THE MIDWEST RADIO COMPANY
812 Main Street Cincinnati, Ohio

General Radio Type 247-G Variable Air Condenser:

A quality condenser at a reasonable price. Low dielectric loss. Rigid mechanical assembly. Fitted as shown, with reduction gearing for fine capacity adjustment.

You will notice an immediate improvement in signal strength when a 247 Condenser is connected to tune a low resistance circuit such as a receiving loop or the secondary circuit of your tuner. It is valuable in a wave meter or radio filter and as an experimenter's standard of capacity

Price—

Type 247-G Mounted as shown. With gear. (calibrated in MMF).

\$7.25

Other capacities, with or without gear, from

\$3.25 to \$6.00

Type 231-A Transformer

Gives the maximum amplification possible without distortion. Like all apparatus manufactured by The General Radio Company, the Type 231-A is guaranteed.

Price . . . \$5.00

Type 214 Rheostat

A quality rheostat for the new UV201-A and 199 Tubes. A convenient, practical instrument, equally well adapted for experimental service or permanent installations. You'll never cause unpleasant noises in the phones when you rotate the contact arm of a Type 214 Rheostat.

Prices—

For UV201-A and UV199 Tubes, 20 Ohms. For Tubes such as UV201, 7 Ohms—

\$2.25



If you value your Radio Equipment by the satisfaction it gives rather than by its initial cost, you're a potential customer of General Radio Company.

For more than eight years, in the design and manufacture of Radio and Laboratory Apparatus, we've set a standard of quality rather than of price. The results have justified the policy.

Today, men who know and use Radio Equipment of the better sort—whether Amateurs, Engineers or Scientists—accept the General Radio Company's name on an instrument as a guarantee of satisfaction.

If you're looking for Radio Apparatus—Variable Condensers, Amplifiers, Rheostats, Potentiometers, Sockets, Hot Wire Ammeters, Audibility Meters, Decade and Capacity Bridges, Etc., buy General Radio Company's instruments—apparatus that offers a little greater value per dollar, gives a little more satisfaction, and is designed and made a little better.

Our Bulletin 914U not only describes our Amateur line, but is an educational pamphlet of value. Sent free on request.

GENERAL RADIO CO.

Manufacturers of
Radio and Electrical Laboratory Apparatus
Massachusetts Avenue and Windsor Street
Cambridge, Mass.

5303

Look for this Label



Ask your Dealer

Improve Your Present Set or Make a New One Better by Using

BRANSTON Lateral Wound Honeycomb Inductance Coils

(Licensed under DeForest Patents)

Ask your "Old Timer" Radio friend why sets using Honeycomb Coils are Best.

Send 4c in stamps for Series 1 "Hook-Up" Circular showing five good Honeycomb coil hook-ups and Catalog of famous Branston Radio materials. Write today. Give us name of your Radio Dealer. If he can't supply you, let us know.

Chas. A. Branston, Inc.
811 Main St., Buffalo, N. Y.
In Canada—Chas. A. Branston, Ltd.
Toronto, Ont.



BRANSTON
RADIO

A Plain Statement of Fact

When you say a circle is round or a man is "square" or a job is done you've told the *whole story*.

When we say that
"UNITED"
Radio Condensers
and Transformers
Give Complete
Satisfaction



we leave nothing more to be said. They *satisfy* because both design and construction are right.

United Variable Condensers have a wonderful new patented Vernier Dial Control, which makes possible twice as fine adjustment as any Vernier on the market.

43 plate	\$5.50	5 plate	\$5.00
23 plate	6.00	3 plate	4.75
11 plate	5.50		Postpaid

Vernier alone can be attached to any plate condenser by drilling one hole

"United" Amplifying Transformer Audio Frequency. Instrument is magnetically shielded, a very fine piece of precision workmanship

Show this ad to your Dealer and ask him to supply your needs at the above prices. If he cannot do so remit to us direct, under our money-back guarantee and give us name and address of Dealer you wish to favor.

UNITED MFG. & DISTRIBUTING CO.
536 Lake Shore Drive, Chicago, Ill.

NEW YORK OFFICE: 50 Church St., New York City, N.Y. SAN FRANCISCO OFFICE: 709 Mission St., San Francisco, Cal.

New
Combination
DURHAM
DUBILIER



Get more of the distant stations

Every DX fan knows it all depends upon a quiet tube and sharp tuning. With the DURHAM plunger at your fingertips, the mushy blur changes to a clear, pure tone—DX at its best. DURHAM Variables provide accurate adjustment for every make of tube. Use them with the famous DUBILIER Grid Condensers. Then satisfaction is doubly assured.

DURHAM
Variables



DUBILIER
Micadons

No. 101 to 5 megs.
No. 201A to 10 megs.

.00025 mfd.
.00050 mfd.

There's a combination for your tubes.

DURHAM & CO. 1936 MARKET ST. PHILADELPHIA

Dealers and Jobbers: Read the articles in this issue on Radio vacations and build your stock to suit.

Warren Radio Loop,
cut away to show
construction



For Camping and Vacation Use



WITH a Warren Radio Loop you can easily take your present set with you to camp, shore or mountain, or you can build a very compact portable set. The Warren Loop fits inside a small cabinet and combines aerial and tuning device. All enclosed so that damp, dirt and rough usage cannot harm it. Various types according to your requirements. Write for Bulletin I 102.

A TYPE FOR EVERY SET AT THE BEST DEALERS

Type A-737 (300-700 meters) 6 inches square—non-directional.....	\$10
Type A-7236 (175-1770 meters) 6 inches square—non-directional.....	\$12
Type B-2537 (300-350 meters) 18 inches square—directional.....	\$20
Type SL-2520 (150-15,000 meters) with honeycomb coil, 18 inches square—directional.....	\$25

Send for Bulletin I-102

V-OE-CO RADIO MFG. CO., Dept. F. Asbury Park, N. J.

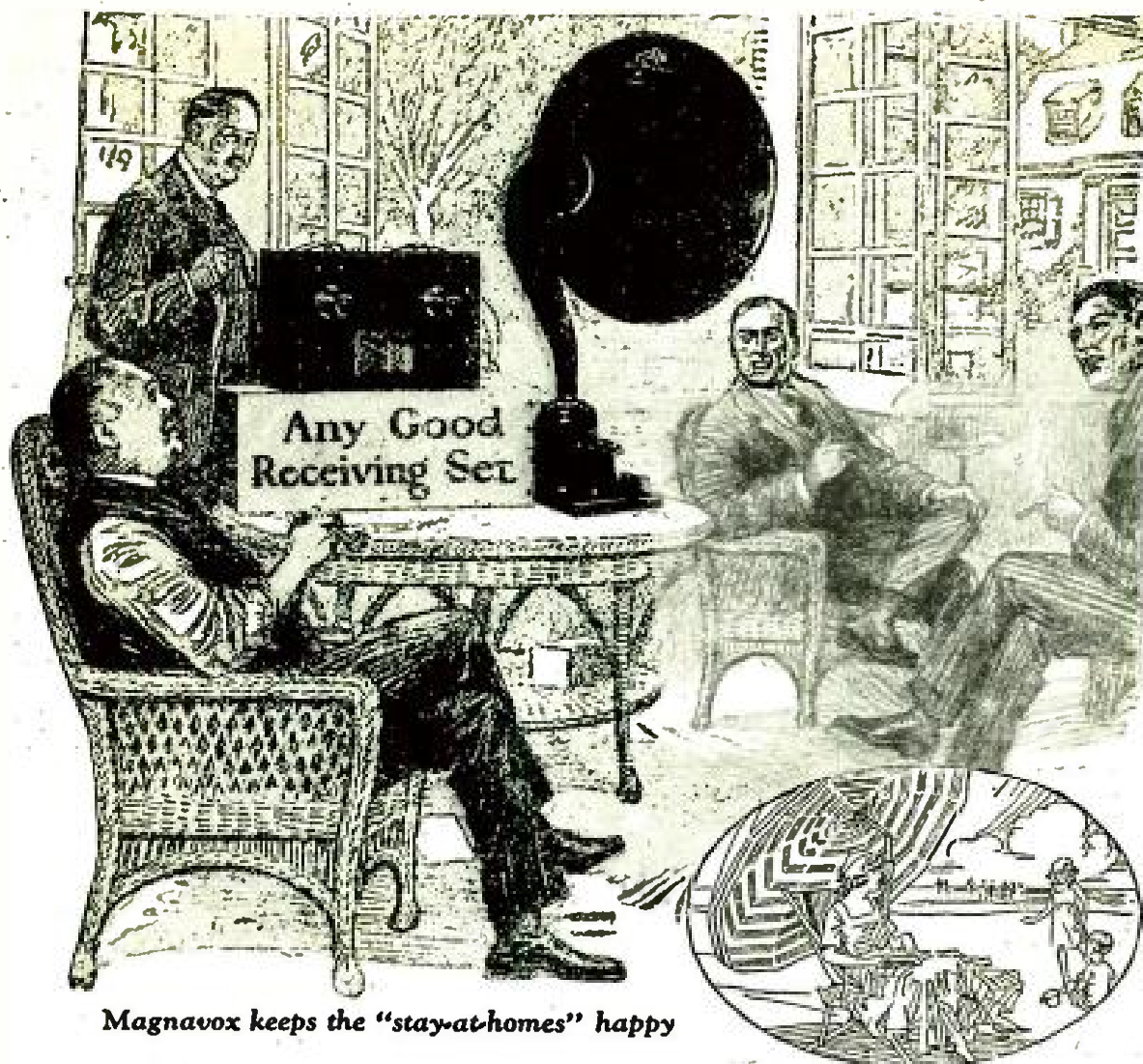

Magnavox keeps the "stay-at-homes" happy

THE "boys" just naturally make their headquarters in proximity to the receiving set whose owner has been wise enough to add a Magnavox Reproducer and Power Amplifier. When "Magnavox invites you," the Radio party is sure to be a success.

Magnavox R2 Reproducer and 2 stage Power Amplifier (as illustrated) \$115.00

R2 Magnavox Reproducer with 18-inch horn: the utmost in amplifying power; requires only .6 of an ampere for the field \$60.00

R3 Magnavox Reproducer with 14-inch curvex horn: ideal for homes, offices, etc. \$35.00

Model C Magnavox Power Amplifier insures getting the largest possible power input for your Magnavox Reproducer
2 stage \$55.00
3 stage 75.00

Magnavox Products can be had from good dealers everywhere. Write for new booklet.

THE MAGNAVOX COMPANY
Oakland, California
New York Office: 370 Seventh Avenue

MAGNAVOX PRODUCTS

No Radio Receiving Set is complete without them

Summer Static Overcome

"Good-bye Aerial"

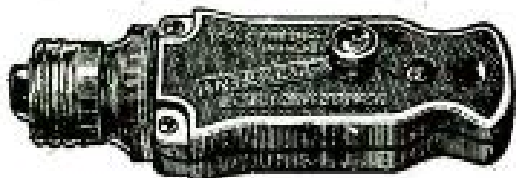

ANTENELLA

No aerial or antenna needed

All outside wiring, aerial, lightning arresters, switches and other inconveniences so inductive to static are eliminated.

Merely plug Antenella in any light socket and you can enjoy all Radio pleasures in any room in your home, apartment or hotel. No current consumed.

New Improved

ANTENELLA
NOW **\$1.25**
ONLY formerly \$2.00

At your dealers—otherwise send purchase price and you will be supplied postpaid.

Chas. Freshman Co. Inc.
Radio Condenser Products
106 SEVENTH AVENUE, NEW YORK

RT-A2

The Audio Frequency Transformer that gives you perfect Tone Quality and High Amplification without distortion.



Moisture-proof—it is ideal for the seashore. Letters received every day state that RT-A2 passes every test and fulfills the most critical requirements of experts and amateurs.

Use RT-A2 transformers at once and enjoy better radio reception.

Price \$6.50 at all good dealers

RASLA SALES CORPORATION

National Distributors

Dept. P, 10 East 43d St., New York City

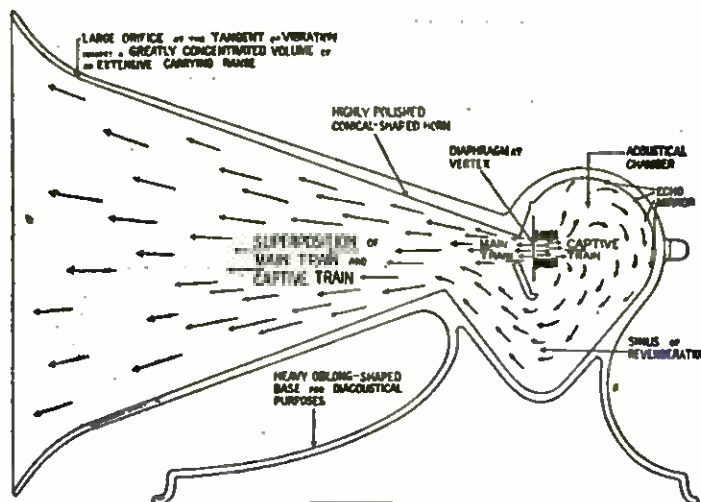

ECHO-JONG

GIVES FINE NEEDLE TONE TO THE RADIO PHONE

A REAL PORTABLE LOUDSPEAKER

Unaffected by Climatic Conditions

NO PART TO BREAK OR JAR OFF

IDEAL FOR

Vacation, Outing or Travel

NO PULP to Crumble

NO WOOD to Warp

NO TIN to Bend

But

CASTED ALUMINUM for DURABILITY

Now Equipped With
A TONE REGULATOR

Retail Price \$35.00

WILLIAMS RADIO COMPANY

Radio Tone Specialists

1438 Washington Blvd., Detroit, Mich.

FREE Radio Catalog

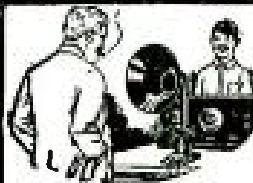

Our big stocks of standard makes of radio sets, parts and supplies enables us to make prompt shipment from stock. Play safe—buy standard equipment from a reliable house. No cut price material.

Send \$1.25 for Univernier for close tuning—mention size of Condenser or Variometer shaft; \$2.00 for 6-phone plug.

JULIUS ANDRAE & SONS CO.

In Business since 1860

127 Michigan Street

Milwaukee, Wis.

Rathbun Variable Condensers

have 4 points of superiority over all others.

- (1) Only 1 hole to drill for mounting.
- (2) Plates die-cast in milled brass tubes.
- (3) Formica ends for plate protection.
- (4) End and side play eliminated through special die-cast Babbitt bearings.

Verrier, 11 plate, 23 plate and 43 plate at your dealers or direct from

Rathbun Mfg. Co., Jamestown, N. Y.

Please mention POPULAR RADIO when answering advertisements.

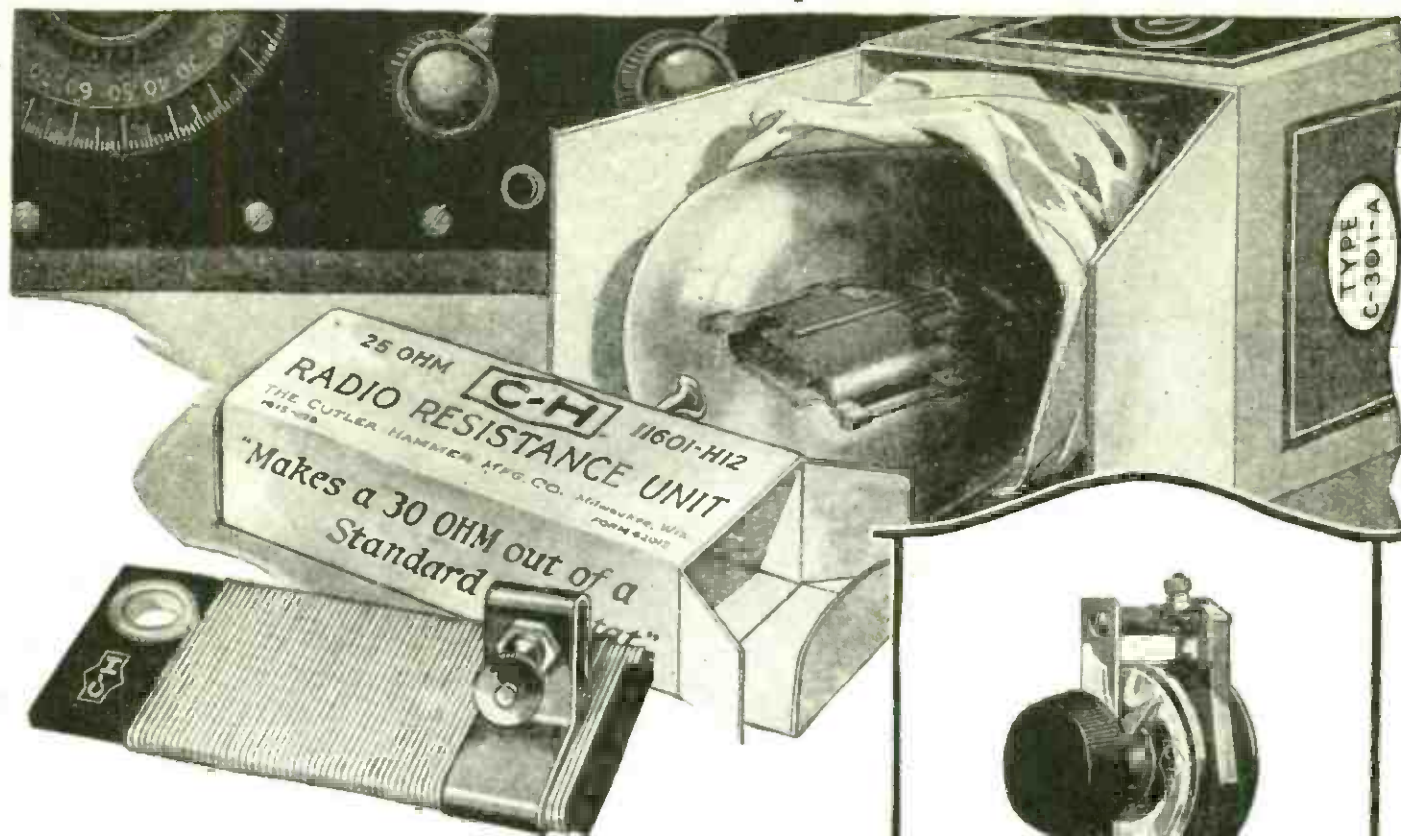

Buy This Unit With Your New Tube!

It Saves the Cost of New Rheostats and the Trouble of Redrilling Your Panel

You can put the new "A" Type (C-301-A or UV201-A) receiving tubes in your set and enjoy better results tonight. The C-H Radio Resistance Unit adds to your present rheostats just the number of ohms required for the regulation of these new $\frac{1}{4}$ -ampere tubes. You do not have to spend several dollars for new rheostats—nor miss a single hour's entertainment while you bother to redrill your panel for them. Just put the eyelet of the C-H Unit over the post of your rheostat, and attach the wire you had to remove to do so to the binding post of the unit. Regulation is obtained from the front of the panel as before—but the unit itself is adjustable to care for changes in battery potential.

Panel Mounting if Desired

The C-H Radio Resistance Unit may be mounted directly on the panel, if desired, attached to a single binding post and wired in series with the rheostat. Its compact, handy size and many possible ways of mounting make it adaptable to every receiving set. Price 25c at all radio dealers and supply houses.

THE CUTLER-HAMMER MFG. CO.

Member Radio Section, Associated Manufacturers of Electrical Supplies
MILWAUKEE · WISCONSIN

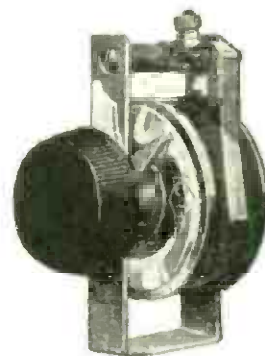

The C-H 30-Ohm Rheostat

The newest of the famous line of C-H Radio Rheostats. Built by the master builders of rheostatic control apparatus and engraved with their guarantee of satisfaction—a trademark you should demand on the vital instruments for your receiving panel.

Designed with a resistance of 30 ohms for the control of the new "A" type receiving tubes (C-301-A and UV201-A). Finished in dull satin nickel and ebony black. Arranged for panel mounting, pointer indicating, and furnished with genuine Thermo-plax knob. The instrument your new receiving set deserves.

Type 11601-H9 \$1.50

*One-half Million
C-H Radio Rheostats
Now in Use*

CUTLER-HAMMER

Please mention POPULAR RADIO when answering advertisements.

DELICATE SOLDERING in RADIO

Both the manufacturers' and amateurs' problem on all fine work is readily solved by the instrument constructed for this particular purpose.

THE POST SOLDERING IRON

Platinum Heating Unit—Interchangeable Tips—Universal Current

(Large and Small)

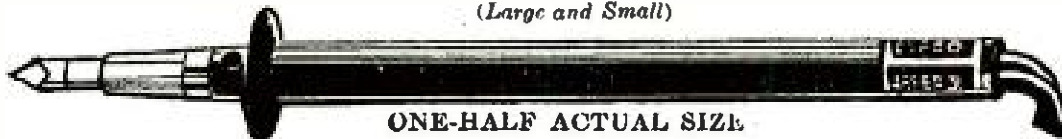

ONE-HALF ACTUAL SIZE

\$6.00

Awarded Certificate of Excellency, N. Y. Evening Mail Radio Institute

From your Dealer, or write

POST ELECTRIC COMPANY (Instruments Division), 30 E. 42nd St., New York

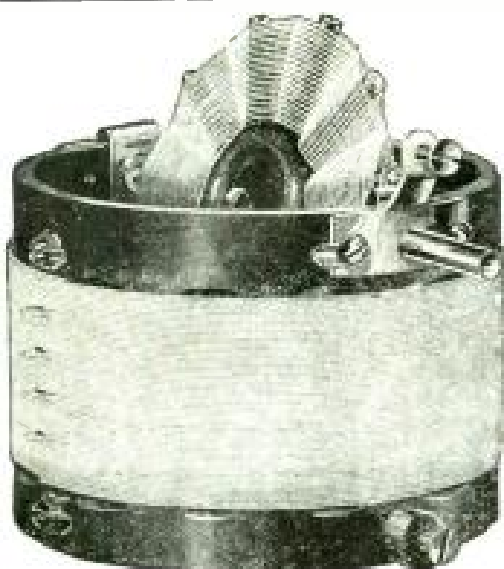

HARTMAN VARIOCOUPLER

WITH
SPIDER WEB ROTOR
PROVIDES

REMARKABLE SELECTIVITY IN TUNING

Designed for us by Alfred A. Crossley

Price \$6.50

Write for bulletins on Hartman Radio Products

THE HARTMAN ELECTRICAL MFG. CO.
MANSFIELD, OHIO



Patent Pending

THE FAVORITE

A perfected radio cabinet, a powerful generator of radio waves. Eliminates static and danger from lightning. No loop, no aerial, no ground or other attachments necessary, has good range, provides for sharp selective tuning, operates any good hook-up with any good vacuum tube.

Carries and conceals all batteries and equipment and is a beautiful piece of household furniture.

Write for descriptive matter and prices.

Manufactured by

G. A. BARTHOLOMEW

409 Guardian Bldg.

Cleveland, Ohio

(Will lease shop rights)

F-F BATTERY CHARGER

All TYPES But "B"
Charge AUTO
Batteries
Overnight
Right in
your CAR

\$15



CHARGES
RADIO & AUTO BATTERIES.

CHARGES RADIO "A" & "B" & AUTO STORAGE BATTERIES at HOME Overnight, for a Few Cents From Any 100 to 130 Volt 60 Cycle A. C. Lamp Socket. F-F AUTOMATIC MAGNETIC TAPER CHARGE DESIGN made BATTERY CHARGING POPULAR. Eventually You Will Buy An F-F CHARGER & The Sooner You Buy One; The More You Save. A-B Charges All 6 Volt & up to 120 Volts Of "B" & Loud Speaker Storage Batteries In Series Inductively At Home Overnight. Disconnecting & Multiple Connections Unnecessary. Charging Circuits Separate. No Chance For Grounds, or Short Circuits. Nothing To Slop Over. Be Filled, Burn Out, Need Attention Or Cause Trouble. Infusible Rectifying Brushes Maintain Constant Efficiency Uninterruptedly. COMPLETE PORTABLE AUTOMATIC. No Skill Required. AMMETER eliminates Guess Work. Nothing Like It Made. Lasts A Lifetime. Screw Plug In Lamp Socket; Snap CLIPS on Battery Terminals; Turn Switch & Battery is Charged In Morning. Charged Batteries Mean Fewer Expensive Replacements. It Costs Less To Buy An F-F CHARGER Than To Be Without One. INSIST ON THE F-F CHARGER. Built By A Master Of The Art In 7 TYPES. Thousands Sold Make Possible These POPULAR PRICES:
Type 6 charges 6 Volt Battery At 6 amperes \$15 Type 12 charges 12 Volt Battery At 5 amperes \$15
Type B charges Radio "B" Batteries Upto 120 Volts \$15 Type A-B is Combination Of 6 & B \$20
Type 166 charges 6 Volt Battery At 12 amperes \$20 Type 161 charges 12 Volt At 7 amps \$20
Type 1626 is a Combination Of Types 166 & 1612 and Charges Both 6 & 12 Volt Batteries \$28
Types B & A-B are RADIO Specials. Types 166, 1612 & 1626 are For Heavy & Rapid Charging.
SHIPPING WEIGHTS Complete with AMMETER & BATTERY CLIPS 11 to 15 lbs.
PURCHASE from DEALER; Mail Check, or WRITE us to Ship TYPE desired C. O. D.
ORDER Now, or WRITE Immediately for FREE Descriptive CHARGER Bulletins 44 & 44A.

FRANCE MFG. CO., Cleveland, Ohio.

Please mention POPULAR RADIO when answering advertisements.

Price, Mounted Only

6 to 1 ratio transformer \$4.50
(With Red Label)

3½ to 1 ratio transformer \$4.00
(With Blue Label)

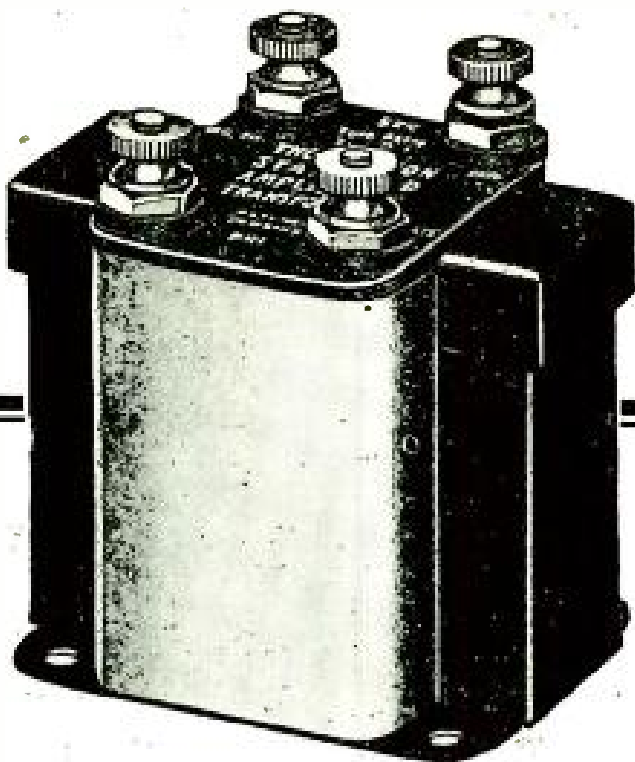

The New THORDARSON Audio Frequency Amplifying Transformer

FOR the past twenty-eight years THORDARSON transformers have been installed in the country's greatest engineering concerns, manufacturing plants and immense central stations. The first 1,000,000 volt transformer in the world was devised and constructed by THORDARSON engineers. The history of the improvement of transformers could be read in the history of THORDARSON development.

The new shell type audio frequency transformer is scientifically and mechanically perfect. A thorough understanding of its construction will convince you that it would be physically impossible for the transformer you are now using to obtain results equal to the THORDARSON in either amplification or tonal perfection.

SPECIFICATIONS

THORDARSON transformers are constructed and assembled entirely in the THORDARSON plant—not merely assembled as is the case of most transformers now on the market. Core is made of .007 mil highest grade silicon steel, No. 36 gauge—the cross section of which measures ¼ inch—twice that of an ordinary amplifying transformer. The coils of No. 40 wire are *square layer wound* to fit the square core—wound by machines designed and developed entirely by THORDARSON. Our new coil is a recent achievement of THORDARSON engineers. Between each layer of wire is the finest grade 1,000 volt condenser paper—the transformer is guaranteed and tested to withstand 600 volts D. C. without breakdown.

These transformers are designed to serve with tubes now on the market. For a one stage set, use the 6 to 1; for two stages, hook up the 6 to 1 type on the first stage, and the 3½ to 1 on the second stage. These transformers which balance the resistance of the plate circuit of one tube with the grid circuit of the following tube has proven to produce the maximum of amplifying efficiency by exhaustive tests and experiments at all audible frequencies.

Your receiving set and the pleasure you derive from it depends upon the transformer you use and it is our firm belief that this new THORDARSON Amplifier is the finest the market affords. For sale at good dealers at our new prices.

THORDARSON

ELECTRIC MANUFACTURING COMPANY

500 HURON STREET, CHICAGO

Radio Advantages of bakelite -dilecto!!



1

(A Laminated Phenolic
Condensation Product)

- (1) Highest Dielectric Strength.
 - (2) Resists Heat.
 - (3) Cannot Warp or Swell.
 - (4) Resists Water.
 - (5) Unharmed by Solvents and Milder Acids.
 - (6) Tough, Durable; Yet Readily Machined.
- (AND MANY OTHERS)



2



3

THE CONTINENTAL FIBRE CO.
Factory: Newark, Delaware

Dealer Service from:
New York, 233 Broadway
Pittsburgh, 301 Fifth Ave.
Chicago, 332 S. Michigan Ave.
San Francisco, 75 Fremont St.
Los Angeles, 411 S. Main St.
Seattle, 95 Connecticut St.



4



5

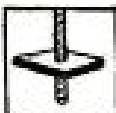

6

X

X

Regal No. 140 Filament Rheostat



Has full exposed resistance wire, giving critical adjustment so necessary to the efficient operation of a vacuum tube. Fine, smooth working control. Handsome knob, heat resistance base and highly nickel-plated parts. 6 ohms resistance—2.2 amperes..... **\$1.00**

30 Ohm Rheostat \$1.25

The Big "Regal" Line

Power Rheostats, Potentiometers, Inductance Switch, Variocoupler, Tube Sockets, Jacks, Condensers, Knobs; Dials, etc. Send for Catalog No. 27.

(If your dealer does not handle Regal Products—write us direct)

"Regal" Inductance Switch

A 15-point switch complete in one unit. Requires but one hole to mount on panel. Smooth wiping contact overheads machined to same height on one piece contacts. Complete soldered assembly attached, or removed from panels by means of one threaded shaft bushing. Gives inductance regulation by dial contact **\$2.00**



The American Specialty Co.

Bridgeport, Conn.

ACKERMAN 11 POINT INDUCTANCE SWITCH

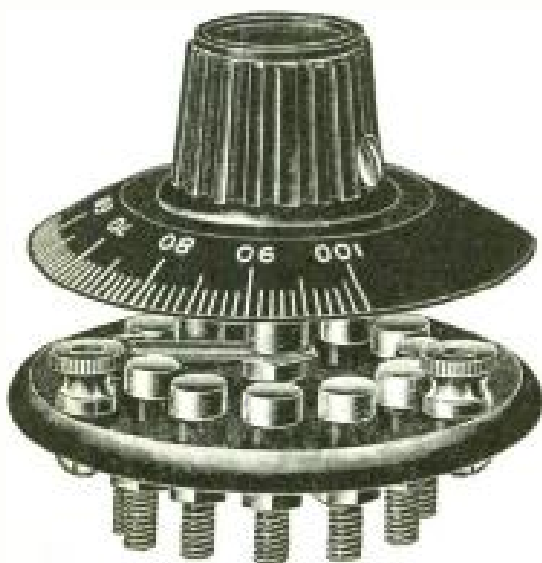

(Actual Size)

With Dial **\$1.25**
Without Dial **1.00**

Sent Prepaid upon Receipt of Cash or Money Order
Liberal Discounts to Jobbers and Dealers

ACKERMAN BROTHERS COMPANY, Inc.
Dept. "PR," 301 W. 4th Street, New York, N. Y.

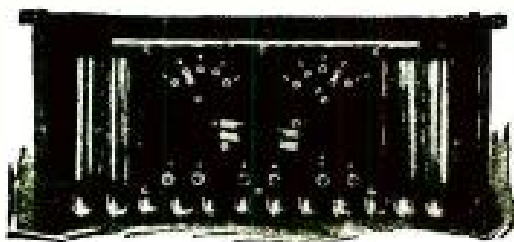

KICO Storage "B" Batteries give long service at low cost

Alkaline type, will not sulphate or buckle. Not harmed by short-circuiting, overcharging, or standing idle. Panel switches afford single cell variations. Easily re-charged from any 110-volt A.C. line by means of small home rectifier. One charge lasts three to six months in detector plate circuit.

Prices without rectifier:	Plain	(With Panels)
16 cell 22 volt.....	\$5.50	
24 cell 32 volt.....	\$7.25	\$11.75
36 cell 48 volt.....	\$9.50	\$14.00
50 cell 68 volt.....	\$12.50	\$17.00
78 cell 100 volt.....	\$17.50	\$22.50
108 cell 145 volt.....	\$23.50	\$28.50
Unmounted rectifier....	\$1.00	
Mounted rectifier.....	\$2.50	

SATISFACTION GUARANTEED

Money is refunded if user is not satisfied after 30-day trial. Write for full information on "A" and "B" Batteries.

KIMLEY ELECTRIC COMPANY, Inc.
2667 MAIN STREET BUFFALO, N. Y.

Please mention POPULAR RADIO when answering advertisements.

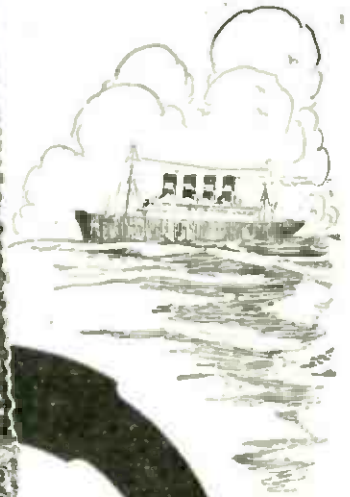
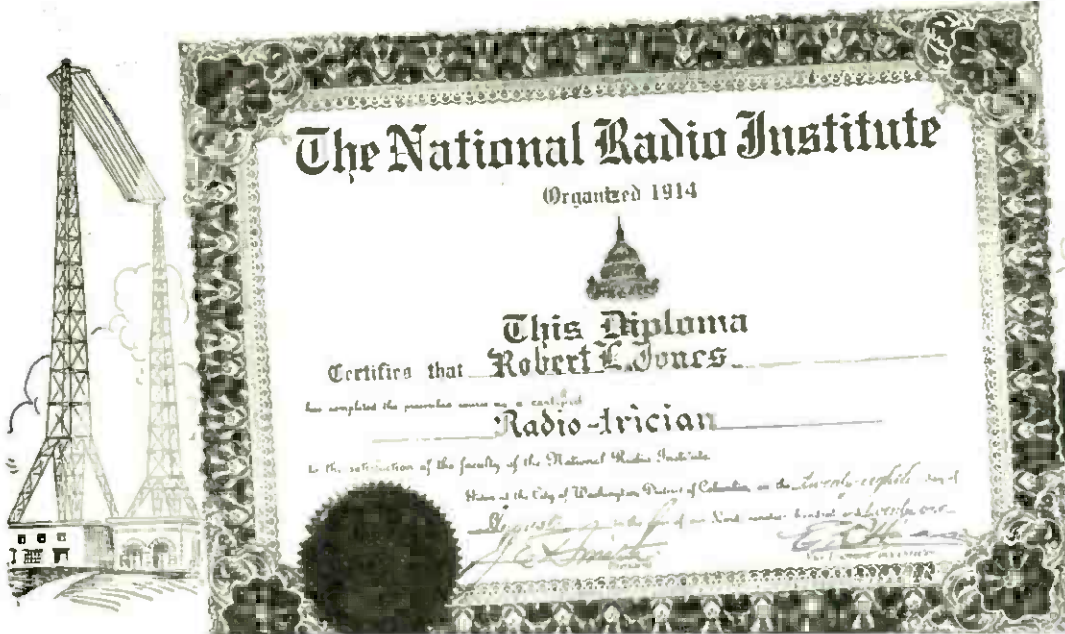

This Certificate Opens the Way to the Best Radio Positions

Get It - You Can Earn Big Money With It

No previous experience in electricity or Radio is necessary. In a few short months, you can easily win this certificate and qualify for one of the splendid, big money positions in Radio.

Edwin L. Powell is an Expert Radio Aide at the Washington Navy Yard and earns Big Money. Leo Goldblatt is earning a Big Salary and all expenses paid as a radio operator. James F. Nicholls is earning \$150 a month and all expenses as a radio instructor at Walter Reed Government Hospital. Harry Ruck has made big money manufacturing radio sets. Hundreds of other men are occupying equally attractive positions after winning our Certified Radio-technician certificate.

Read in the panel of the fine salaries paid in all the wonderful radio positions for which you can qualify once you have this certificate.

Easy Now to Become A Certified Radio-technician

No other work in the world today offers such opportunities, such big money, such rapid advancement, such a promising future as does Radio. And the Expert Radio-technician is the man who is in a position to choose the best of these opportunities—to jump farthest ahead in this newest and fastest growing industry.

Become an Expert Radio-technician. You can—easily and quickly. The National Radio Institute, America's first and largest Radio School, has devised a remarkable method that makes it easy for anyone to qualify right at home during spare time. Prominent radio experts give you personal advice and instruction through the mail. They grade your papers, answer your questions, and in every possible way help you in your work. And you learn the practical, wonderful side of radio by actual practice on patented instruments we send you free. The Certified Radio-technician Certificate awarded

you on the completion of your course is government recognized, counting for 5 to 10 points on all government license examinations.

Pick Out the Job You Want And We Will Help You Get It

This is a brief list of the positions in the Radio field today, and the salaries paid.

- Radio Mechanic, \$1,500 to \$4,000 a year.
- Radio Inspector, \$1,800 to \$4,500 a year.
- Radio Auditor, \$1,200 to \$1,800 a year.
- Radio Salesman, \$2,000 to \$10,000 a year.
- Radio Engineer, \$3,500 a year and up.
- Radio Executive, up to \$15,000 a year.
- Radio Aide, \$6 to \$10 a day.
- Radio Draftsman, \$7 to \$15 a day.
- First Class Ship Operator, \$105 a month, all expenses paid.
- Second Class Ship Operator, \$95 a month, all expenses paid.
- Third Class Operator, \$85 a month, all expenses paid.
- Commercial Land Station Operator, \$160 a month and up.
- Broadcasting Station Operator, \$125 to \$250 a month.

Instruments Loaned to Students

An extraordinary feature of this course is the use of four patented instruments, owned exclusively by us, which give practical training in radio operation, installation, maintenance and repair—all of which you must have to become an Expert Radio-technician.

Among these instruments is the wonderful Natrometer, said by experts to be the perfect device for teaching the Radio Code. All of these instruments are loaned to students.

Send for Radio Book

Thousands of positions are open to Certified Radio-technicians. Find out what your opportunities are in this fascinating profession. Send for interesting book, "Your Opportunity in Radio," which gives complete details on plan by which the National Radio Institute quickly qualifies you at home in spare time as a Certified Radio-technician. Send the coupon or a postcard for free book NOW. NATIONAL RADIO INSTITUTE, Dept. 32-G, Washington, D. C.

NATIONAL RADIO INSTITUTE, Dept. 32-G, Washington, D. C.

Send me your book, "Your Opportunity in Radio," with full particulars about the opportunities in radio, and how you will quickly train me in my spare time at home to win a Certified Radio-technician Certificate. Also about your employment service.

Name..... Age.....
 Street.....
 City..... State.....



Radio Operator



Radio Mechanic



Radio Salesman

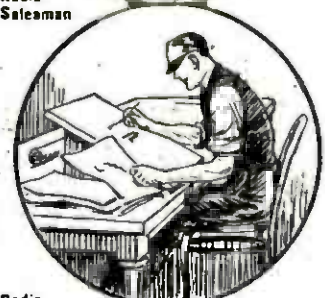

Radio Engineer



Lead Your ACE

**A Better Battery
Makes All the Difference
In the World**

#62 A two cell 1 1/2 volt dry battery

NO more popular battery ever came into existence than the Ace, a fact that is substantiated by the preference shown this battery by thousands of radio users. The Ace has been found to be different from others—its higher voltage immediately impresses one with this individuality. Long life and excellent service bear out the reason for the higher voltage.

ACE RADIO "A" BATTERIES

For vacuum tubes requiring 1 1/2 volts, the Ace is obtainable in several types of various cell power. The design of this battery is expressly for "A" circuit vacuum tube requirements.

ACE WIRELESS "B" BATTERIES

Made in several types from 16 1/2 volts to 108 volts. Testimonials show that this battery is especially helpful in summer for obtaining messages without noisy distortion.

The CARBON PRODUCTS CO.
LANCASTER OHIO

Manufacturers of Dry Batteries, Flashlights and Flashlight Batteries, Carbon Brushes, Projector Carbons and Welding Carbons

#63 A three cell 1 1/2 volt dry battery



AMPLIFYING TRANSFORMERS
(Radio and Audio Frequency)

Give Wonderful Results

When Used In
"Neutrodyne" and "Reflex" Circuits

For best results with the "Neutrodyne" & "Reflex" Circuits, use "All-American" Radio frequency Amplifying Transformers. Type R-10 and Type R-13. Ratio 10 to 1 Audio Frequency Transformers.

Ask your dealer for FREE "All-American" Hand Book of Radio Hookups. If he cannot supply you, write us, sending two cent stamp for postage.



RADIO FREQUENCY
R-10 (150-550 meters) \$4.50



AUDIO FREQUENCY
R-12 (Ratio 3 to 1) \$4.50
R-21 (Ratio 5 to 1) 4.75
R-13 (Ratio 10 to 1) 4.75

RAULAND MFG. CO.
200 No. Jefferson St., Chicago, Ill.

AMPL-TONE PHONES



2200 Ohms—\$6.00

AT LAST, the public may have these EXCELLENT Headsets at a popular price. Positively the equal of the expensive phones, for beauty, comfort, tone and durability. Money back guarantee protects you. "Wonderful value," "Equal to \$12.00 phones" and other testimonials on file.

Write for special prices for a limited period
DEALERS: Get in on our special advertising and extreme discounts. One sample for \$3.00 cash.

C. M. FRENCH MFG. CO.
SEYMOUR, CONN

INSTRUMENT MAKERS

DEPENDABLE  PRODUCTS

SINCE 1909

PRECISION HIGH EFFICIENCY CRYSTAL SETS

Guaranteed to receive local broadcasts with volume and clarity equal to any sets manufactured

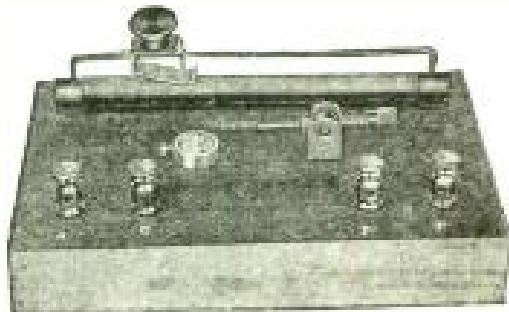

TYPE "A" (Shown in cut) - - \$1.25
TYPE "B" De Luxe - - \$6.00

Type A, Complete with Phones and Aerial... \$6.00
Type B, Complete with Phones and Aerial... \$11.00

Sent prepaid upon receipt of express or postal money orders.

Money refunded if not absolutely satisfactory. Dealers and Jobbers write for discounts.

BOYS: You can make good money selling these sets. Write for terms.

THE EASTERN SPECIALTY CO.
3552 N. Fifth Street, PHILADELPHIA, PA.

Please mention POPULAR RADIO when answering advertisements.

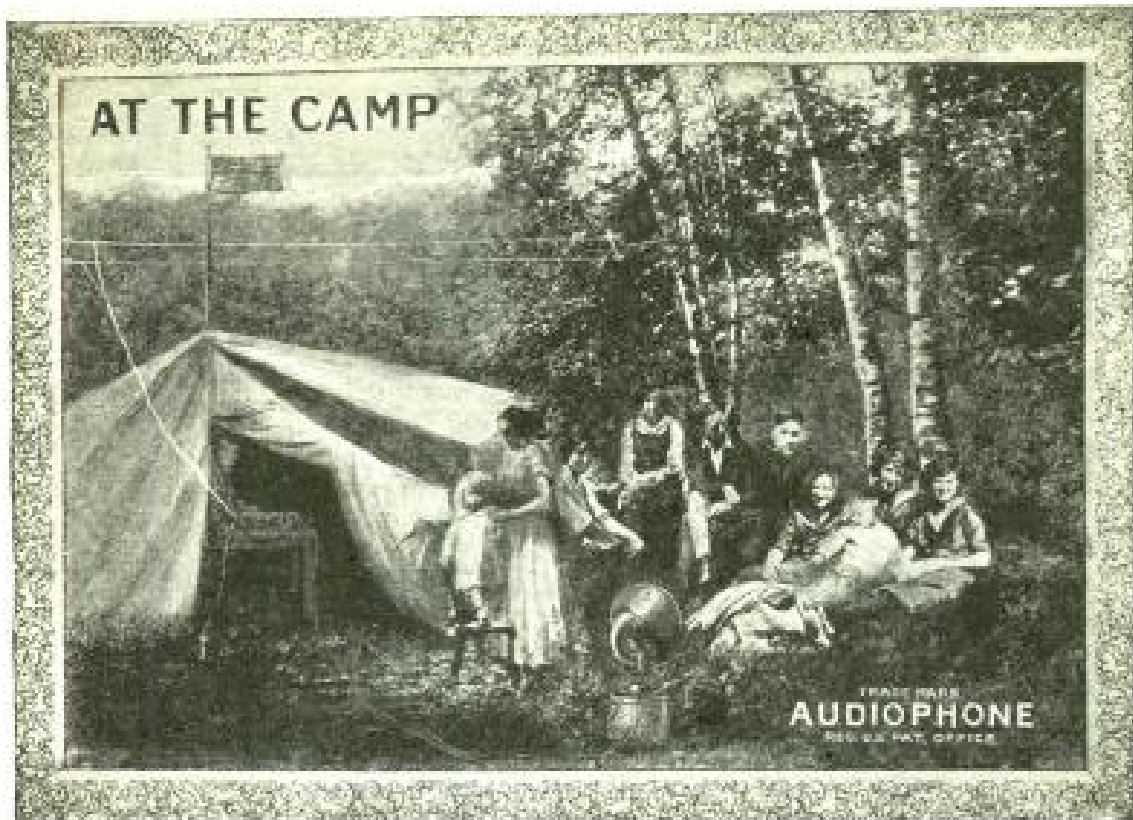

AUDIOPHONE AND CANOE both go to camp

Nobody wants to wear head phones during hot, stuffy weather. A small efficient Loud Speaker ruggedly built will be welcome in any camp outfit. The AUDIOPHONE JR. is just the thing.



Bristol AUDIOPHONE made in two sizes—

Audiophone Sr.
Diameter of horn, 15 inches
Weight, 10 pounds
Price, \$32.50

Audiophone Jr.
Diameter of horn, 11 inches
Weight, 7 pounds
Price, \$22.50

Bulletin 3006-L describes them.

Light in weight and easily assembled or dismantled without tools. Doesn't require any battery. The tone quality is exceptional and will give enough volume to entertain the whole camp party.

See it at your dealers or write direct.

THE BRISTOL COMPANY
Waterbury, Conn.

BOSTON

CHICAGO

NEW YORK

PHILADELPHIA

ST. LOUIS

PITTSBURGH

SAN FRANCISCO

DETROIT

In Any or All Stages of audio frequency amplification

The AMERTRAN



can and should be used. It is made in only one type and one ratio. Its flat-top amplification curve precludes the possibility of distortion on the part of the transformer when used in any or all stages.

It will give the same clear-toned distortionless amplification with all tubes which are approximately alike in A. C. Impedance and Amplification Factor, such as

WD-11,	C-301,
WD-12,	UV-201-A,
UV-199,	C-301-A,
C-299,	UV-201.

Price \$7

Ask your electrical dealer, or sent carriage charges collect. (Wt. 1 lb.)

Its amplification in one stage is 38.6; two stages 1490

American Transformer Company

Designers and builders of radio transformers for over 20 years

175 Emmet St., Newark, N. J.

a Chi-Rad Special!



for W.D. 11 tubes -

Standard, threaded rubber, Willard's, specially adapted for use with W. D. 11 tubes. Supply current at 2 volts to one W.D. 11 tube for 210 hours on a single charge. Rechargeable. Brand new, size 4x5 1/2 x 7 inches—Chi-Rad guaranteed.

2-Volt Willard Charged . . \$7.50
2-Volt Willard Dry 6.50

These same Willards can be adapted to deliver 8 volts for pure D. C. for C. W. Transmitters. Better than a generator because no filter is necessary. Much less expensive.

In lots of 40 (320 volts) \$160.00

(Better prices on larger quantities.)

Specify dry or charged when ordering.

Chicago Radio Apparatus Co.
415 S. Dearborn St., Chicago, Ill.

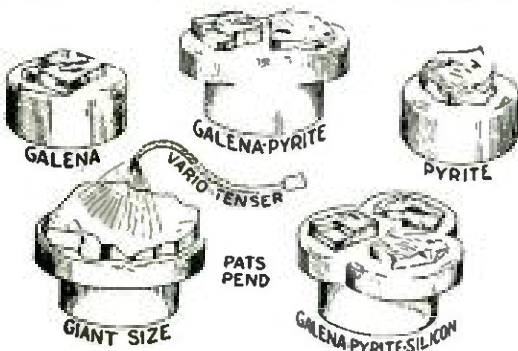

Foote's Triple-Test Crystals

are guaranteed

Loud All Over or a New One

Triplets	\$0.60
Twins50
Single Galena30
Single Pyrite30
Giant Pyrite, 6 times old size75
Giant Galena, 6 times old size75

The "VARIO-TENSER"

A 14 Strand Solid Gold Cat-Whisker. Its brush tip varies and selects the best tension. No spot escapes. Rustless; flexible . . \$0.50

FOOTE MINERAL CO., INC., Mrs.
103 N. 19th St., Philadelphia

Mineral Pioneers for Nearly 50 Years

It's the contact that counts

The Na-ald Special Socket No. 499 is a sturdy little socket with a dependable contact for the G. E. No. 199 dry-cell tube. It has special slot construction, and is moulded of genuine Bakelite. The heat from soldering connections will not affect Na-ald sockets.

Price 50 cents
Na-ald Adapter for No. 199 tube, \$1.00

The dual-wipe contact strips of the Na-ald De Luxe socket avoid the trouble experienced with the socket of conventional design. Because of thorough cure and high dielectric properties Na-ald sockets keep plate to grid losses at a minimum (of particular importance in Flewelling Circuit or in Radio Frequency).

Price 75 cents

Booklet with diagram of Hazeltine's Neutrodyne Circuit and other selected circuits, packed with each Na-ald product or sent in exchange for cover taken from any Na-ald carton.

Alden Manufacturing Co.

Manufacturers of Sockets for Every Tube and Requirement
Dept. C 52 Willow St.
Springfield, Mass.



Na-ald Special Socket No. 499

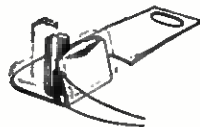

Na-ald De Luxe No. 400



The Symphony



The ability to select your entertainment from the various programs that are being broadcast, and the clarity with which long distance stations can be heard depend entirely on the quality of the receiving set.

The Symphony is an unusually good receiver. By turning a single knob under proper conditions, it is possible to tune in stations, one at a time, to the total exclusion of all others.

This improved circuit, in the vernacular of the technical expert, is an improvement over the simple circuit by means of a variometer, and affords unusually selective reception.

So efficient is the Symphony that its volume, at any stage, surpasses many

sets, and is equal to many other receivers using additional stages of amplification.

Every piece of apparatus that goes into the Symphony is the best that can be produced, and each unit is correctly mounted in proper relation to each other part, factors that play an important part in your satisfaction of radio.

The placing of a Symphony in your home is a permanent investment that will win your instant approval, and occupy a prominent place among your cherished possessions.

The Symphony Receivers are made in two types—detector, and two or three stages of audio frequency amplification.

If your dealer cannot furnish information on the Symphony, wire or write for illustrated catalog, giving us his name.

JONES RADIO COMPANY

Lytton Building, Chicago

The Symphony is manufactured under the U. S. Patent No. 1113149, Armstrong Regenerative Circuit
All parts used in the Symphony are built and guaranteed by the Kellogg Switchboard & Supply Company manufacturers for twenty-five years of complete telephone equipment

TRADE MARK
Wave Trap
 PATENT APPLIED FOR

The Missing Link in RADIO



Stops Interference!

The "WAVE TRAP" will eliminate interfering broadcasting stations and enable you to listen to your favorite station.

It will work on any set, greatly increase its selectivity and clearness, and eliminate code and spark stations.

It is mounted on a Formica panel in a handsome mahogany finished cabinet 6x5x6. It is a high grade instrument throughout and a valuable addition to the operation and appearance of any set. It comes to you complete and there are no extras to buy. It is installed in a minute by changing only one outside connection.

Use the "WAVE TRAP" for real results.

850 **Ferbend Electric Co.**
 21 E. SOUTH WATER ST.
CHICAGO
 Circular on request

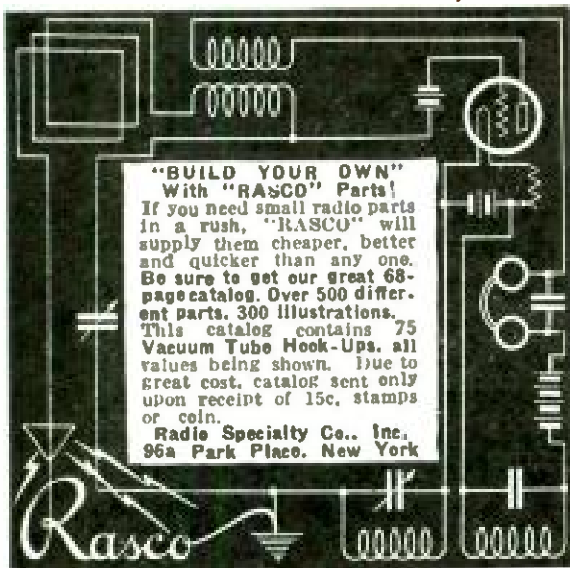

"BUILD YOUR OWN" With "RASCO" Parts!
 If you need small radio parts in a rush, "RASCO" will supply them cheaper, better and quicker than any one. Be sure to get our great 68-page catalog. Over 500 different parts. 300 illustrations. This catalog contains 75 Vacuum Tube Hook-Ups, all values being shown. Due to great cost, catalog sent only upon receipt of 15c, stamps or coin.
 Radio Specialty Co., Inc.,
 96a Park Place, New York

Rasco

Worth Sending For!

Circular describing Rheostat construction is sent free of charge upon request. Explains cut-out switch, constant contact principle, and minute adjustment of UNITY Vernier Rheostat. Write for it now.

THE UNITY MANUFACTURING COMPANY
 224 N. Halsted St., Chicago

RUSONITE

CRYSTAL RECTIFIER

MULTIPOINT

(Patent Pending)

A Synthetic CRYSTAL DETECTOR sensitive over its entire surface
 Eliminates all detector troubles. Extraordinary clearness and volume. Endorsed by radio experts and press. Sold in sealed packages only. Join the ever-increasing Rusonite fans.

Price, mounted..... **50c**

Sensitiveness guaranteed **RUSONITE CATWHISKER**

14-Karat Gold Multiple contact. **25c**

Supersensitive.....

Order from your dealer or direct from us.

Rusonite Products Corp., Dept. "P," 15 Park Row, N. Y.

LEARN RADIO

Here's your opportunity. Radio needs you. Win success in this fascinating field. Trained men in demand at highest salaries. Learn at home, in your spare time.

Be a Radio Expert

I will train you, quickly and easily, to design, construct, install, operate, repair, maintain, and sell all forms of Radio apparatus. My new methods are the most successful in existence. Learn to earn

\$1,800 to \$10,000 a Year

FREE Wonderful, home-constructed, tube receiving set, of latest design.

Write for "Radio Facts" free. Engineer Mohaupt.
 American Electrical Association
 Dept. 67 4513 Ravenswood Ave., Chicago

Cockaday Circuit TUNER COILS

Complete B C D coils as per specifications.

No. 18 Wire Used—D Coil Bankwound. Price, \$2.75

Hook-up, directions and material list furnished free with each set of coils.

MAIL ORDER FILLED

Dealers, Communicate

Eastern Radio Mfg. Co.
 22 Warren Street, New York, N. Y.

DON'T

BUY YOUR RADIO EQUIPMENT UNTIL YOU HAVE SENT FOR OUR PRICE LIST

It Will Pay You To Write

Cut Rate Radio Co.

P. O. Box 472

Newark, N. J.

Please mention POPULAR RADIO when answering advertisements.



Lifelike Re-PRODUCTION

ALMOST as though from the throat of the artist in the distant studio, float the vibrant tones of the song, actually Re-PRODUCED, created anew, faultlessly duplicated through the marvelous musical-radio instrument, the *Atlas Amplitone*. Does not blast or distort.

Adjustable double diaphragm fits the *Amplitone* to your set and the individual receiving conditions.

Made like a fine musical instrument by the joint study and skill of acoustic and radio engineers. In every respect, worthy of your confidence.

Atlas AMPLITONE LOUD SPEAKER

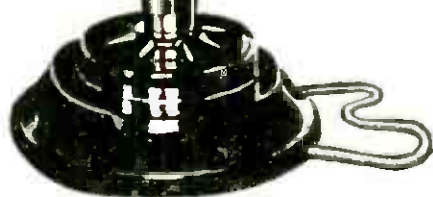

With connecting cord and full instructions **\$25**



Atlas Amplitone Unit

The Atlas Amplitone, minus the horn and base, can be purchased separately for use with your own horn or for attachment to any phonograph (except the Brunswick) with phonograph attachment **\$13.50**

Unit without attachment \$12.50

Insist Upon the Atlas Amplitone

Only the Atlas Amplitone can Re-PRODUCE. If your dealer has none, ask him to order for you.

Write for Atlas Amplitone Book

This fully illustrated book describing this greatly advanced loud speaker and including a list of broadcasting stations, directions for improving reception, and the proper use of a loud speaker, and other valuable information from a widely known expert sent upon request.

Multiple Electric Products Co., Inc.

Radio Division

7 Orange Street

Newark, N. J.

This Offer of Premiums Holds Good Until July 30th!

Get the parts you want for your set—and get them FREE—by taking a few subscriptions for POPULAR RADIO from your friends.

If you've never tried it, you don't know how easy it is to get subscriptions for POPULAR RADIO. Just show this copy to some of your friends. Let the magazine sell itself to them. Then send us their names, with \$2 for each yearly subscription, and take your choice of any of the following radio parts. They'll come to you *free* as a reward for your efforts.

Any One of These for 2 Subscriptions:

Dubilier Ducon

Dubilier Tubular Grid Leak (any standard size) with Grid Condenser .00025 mfd.

DeForest Vacuum Tube Socket with Bingo Rheostat

DeForest Potentiometer

Teleradio Lightning Arrestor with 50 feet of No. 14 r.c. lead-in wire and ground clamp

100 feet of stranded phosphor bronze aerial wire with 2 Electro-se Insulators

Manhattan Combination Volt-Ammeter

Diode Dry Cell Vacuum Tube

Your Choice for Only 5 Subscriptions:

Jefferson Audio Frequency Transformer (new style)

23 Plate Teleradio Variable Condenser, unmounted, with Alden-Napier 3 inch Dial

Set of DeForest Honeycomb Coils (Mounted) No. 35, No. 50 and No. 75

Phono-Phone Fixed Crystal Detector

Bakelite Panel, size 7 x 24 inches

Big Values for 8 Subscriptions each:

Manhattan Genuine Bakelite Variocoupler

Manhattan Genuine Bakelite Variometer

Radiotron U. V. 200 and C. H. Vernier Rheostat

DeForest 3-Coil Honeycomb Mounting

R. C. A. Radio Frequency Transformer

U. V. 201 Vacuum Tube

Post Electric Soldering Iron

Manhattan Headset (3000 ohms)

Free with 10 Subscriptions each:

43 Plate United States Tool Vernier Type Variable Condenser

Brandes Phones

Atwater Kent Detector Unit, Complete with 22½ volt Ever Ready B. Battery

Moon Radio Horn

Atwater Kent Variocoupler

Atwater Kent Variometer

If you want some particular part that isn't listed here, write us and we'll tell you how many subscriptions you'll need to get it free. We'll tell you, also, how you can earn a complete Cockaday 4-Circuit Tuner *free*. Or you can get an Exide Storage Battery, type 3-LXL-9, 80 amp. hr. 6 volt, for only 25 subscriptions! Renewals count just as much as new subscriptions. A two-year subscription for \$4.00 counts the same as *two* one-year subscriptions.

*Start today, and you'll have your required
number of subscriptions in a jiffy!*

POPULAR RADIO

Dept. 73

9 East 40th Street

New York City

Please mention POPULAR RADIO when answering advertisements.

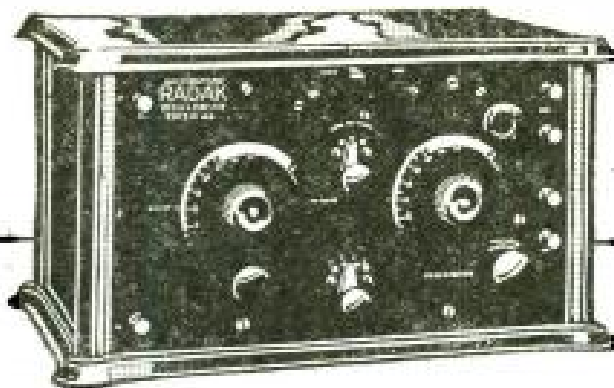

Radak

Is Insulated with Formica

THE Radak radio equipment manufactured by Clapp-Eastham of Cambridge, Mass., and sold everywhere is made with Formica panels and other Formica insulating parts.

This well-known line has genuine prestige in the radio industry. It is sold and known everywhere—and its endorsement of Formica is a matter of moment to every dealer and amateur.

The judgment of Clapp-Eastham Engineers in selecting Formica is supported by practically all the leading independent radio concerns, who likewise use it.

Formica is the best looking, the most uniform, the most efficient laminated phenolic material for radio uses

DEALERS: The Formica Insulation Company supports you with responsive and helpful service and the most aggressive advertising and sales campaign in the industry. Formica dealers can supply you promptly with panels in all standard sizes. They can also supply special sizes when you want them.

THE FORMICA INSULATION COMPANY

4641 Spring Grove Ave., Cincinnati, Ohio

SALES OFFICES

50 Church Street... New York, N. Y.
422 First Avenue... Pittsburgh, Pa.
1042 Granite Bldg., Rochester, N. Y.
415 Ohio Building... Toledo, Ohio

1210 Arch Street... Philadelphia, Pa.
1819 Lyndale Ave., S. Minneapolis, Minn.
Sheldon Building... San Francisco, Cal.
Whitney Central Bldg... New Orleans, La.

414 Finance Bldg... Cleveland, Ohio
9 South Clinton Street, Chicago, Ill.
313 Title Building... Baltimore, Md.
47 King Street... Toronto, Ontario

FORMICA

Made from Anhydrous Redmanol Resins
SHEETS TUBES RODS

Please mention POPULAR RADIO when answering advertisements.

CORYPHONE

"RADIO" HEADSETS
AND
LOUD
SPEAKERS

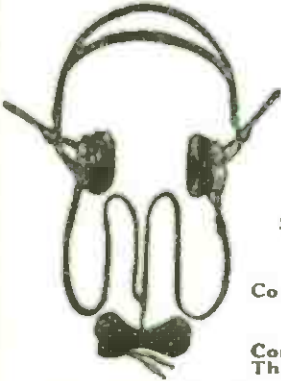

Coryphone "Radio"
Double Receiver
Headsets

3200 OHMS, \$9.50
2000 OHMS, \$8.00

Single Receiver Types
1600 OHMS, \$5.00
1000 OHMS, \$4.25

Coryphone "Loud Speaker"
with Adjustable
Feature, \$40

Coryphone "Master Tone"
The Loud Speaker Jr., \$22

The world's finest reproducers. Coryphones have many exclusive features and are best by comparison. Ask your dealer to demonstrate these remarkable values.

Sold by
ESTABLISHED DEALERS EVERYWHERE
If your local dealer cannot supply you order through him or send order and remittance direct to us

CHAS. CORY & SON, Inc.
183-7 Varick Street, New York
PHILADELPHIA BOSTON SAN FRANCISCO
The Bourse 88 Broad St. 11 Mission St.
Illustrated Literature on Request

\$1.00

RITTER LOOP AERIAL

Packed in Individual Boxes

Including all wood parts, binding posts and green silk covered wire.

Can be assembled in 10 minutes. Wonderful results obtained even with single tube sets. The

Ritter Loop eliminates use of outside aerial and ground, and reduces static and interference. The Ritter Loop is good for home, camp or automobile.

Mail orders filled. Postage: 10c extra.

Size
24 Inches
Square
When
Assembled

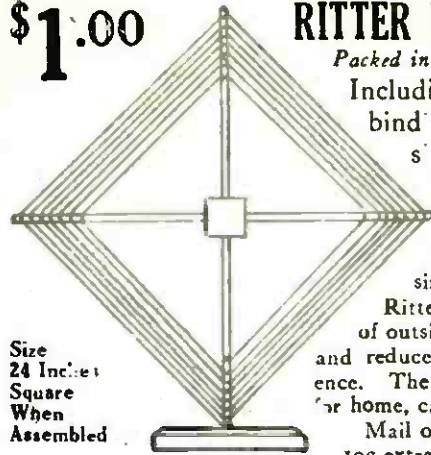

CRYSTAL SET \$3.50

The Ritter Grand Crystal Set will tune up to 600 meters and receive all concerts within 25 to 35 miles. Beautiful mahogany finish, 6 in. high, 3 1/2 in. diameter.

Free circular on how to erect your aerial sent upon request.

Jobbers and dealers who want these two quick selling radio items should communicate with

RITTER RADIO CORPORATION
232 Canal Street, New York City



RADIO PRODUCTS

This trade mark is a symbol of quality in Radio parts.

A. C. ELECTRICAL MFG. CO.
Dayton, Ohio



THE MOON RADIO CORPORATION

*Manufacturers of
Ultra-fine Receiving Sets*

12 Diagonal Street
Long Island City, N. Y.

SPECIAL OFFER

Two new yearly subscriptions \$3.
to POPULAR RADIO for only \$3.

Rope this Special Offer! Any Radio enthusiast can do it. You and a friend of yours may have POPULAR RADIO for a whole year, provided you are both NEW subscribers. You only have to throw a check for \$3 around the double coupon and MAIL IT TO-DAY.

(Coupon good until July 20th, 1923)

POPULAR RADIO, Dept. 72,
9 East 40th Street, New York City
Please send POPULAR RADIO for one year to:

NAME.....
ADDRESS.....
CITY.....STATE.....

And also to this other new subscriber. Here's my cash remittance—(or a check or money order for \$3).

NAME.....
ADDRESS.....
CITY.....STATE.....

(No extra for Canada. Foreign countries 25 cents extra per subscription.)



Please mention POPULAR RADIO when answering advertisements.



VARIOMETER



CONDENSER

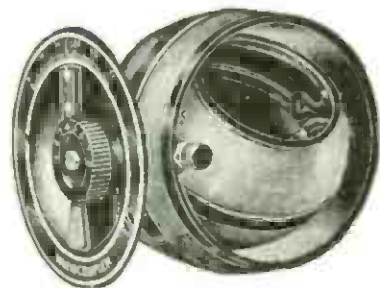

VARIOCOUPLER

THROUGH the use of Eisemann units and panels the assembly of a receiving set entails less than half the labor customarily involved.

The panels illustrated below are completely drilled and ready for use. The units are simply bolted to the panels—the only tool required being a small screw driver. The panels are of aluminum, which acts as a body capacity shield, and have a crystal black finish.

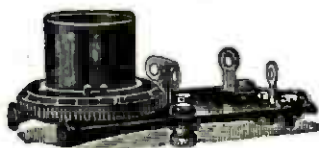

DETECTOR UNIT

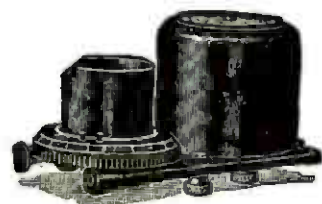

AUDIO AMPLIFIER UNIT

Variometers, variocouplers and condensers, with their matched recessed dials, fit interchangeably into the large circular openings. The rheostat wheels surrounding the sockets on detector and amplifier units extend through the rectangular holes in lower half of panels.



T-1



A-2

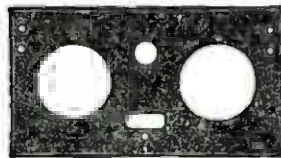

TD-2



TD-3

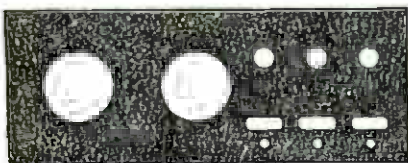

TD-2A

METAL
PANELS

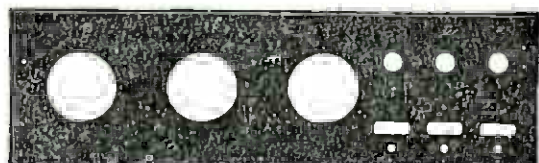

TD-3A

Descriptive literature on request.

EISEMANN MAGNETO CORPORATION

William N. Shaw, President
BROOKLYN, N. Y.

DETROIT

CHICAGO

SAN FRANCISCO

\$1 AMATEUR RADIO CALL BOOK

with  Contains up-to-date list of over 20,000 Amateur, Commercial, Army, Naval, Trans-oceanic High Powered and Broadcasting Stations in the U. S. and Canada. International Morse Code and Convention Signals; also directions for construction of Reinartz Tuner Detector and One Stage Amplifier. \$1.00 at your dealer or by mail. No stamps. Buy the Book with the Blue Cover.

Dealers Write for Proposition
Radio Directory and Pub. Co.
45-J Vesey St., New York

World Radio Batteries SAVE YOU 50%

WRITTEN 2 YR. GUARANTEE

 In buying a WORLD, the highest quality battery built direct from the manufacturer, you gain two profits. First: you get a battery free from extravagant selling expense. Second: you get the profit charged by the middle-man. You take no risk. We ship express C. O. D. subject to your inspection, or will allow five per cent for cash with order. Mail your order today!

COMPARE THESE PRICES

RADIO PRICES:	No other manufacturer offers such a high quality battery at such a low price. Save 50 per cent on your next battery and get better and longer service—buy a World Storage Radio Battery. Write today.
6 Volt. 60 Amps. \$10.00	
6 Volt. 80 Amps. 12.50	
6 Volt. 100 Amps. 14.50	
6 Volt. 120 Amps. 16.00	

World Battery Co., 1219 S. Wabash Ave., Dept. J, Chicago

GIVE YOUR EARS A TREAT!—USE 'RED-HEADS'

3000 Ohms **Now \$6.50**

With Military Head-Band and Cord

At your dealers or direct on receipt of price.

A Triumph in Radio Receiver Design

The Newman-Stern Co. Newman-Stern Building Cleveland, O.

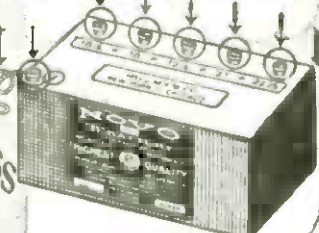

NOVO "B" BATTERIES

NOISELESS  DEPENDABLE

NOTE THE INSULATED BINDING POSTS AND 7/16 IN. WIRE CONNECTOR

NOVO MFG CO.
224 W. 33rd ST. NEW YORK 531 SO. DEARBORN ST. CHICAGO

A NATIONAL RADIO TUBE SERVICE

Send us your burned out or broken Detectors or Amplifiers and receive maximum allowance on the purchase of NEW TUBES. UNLIMITED QUANTITY ALWAYS ON HAND FOR IMMEDIATE SHIPMENT.

We allow you Seventy-five Cents on an old UV200 in the purchase of a new one and One Dollar on WD11 and 12 when buying new Tubes, corresponding allowances on all makes. One allowance on each purchase.

Radio Tubes Repaired in One Week

Customers who purchase new tubes from us are entitled to a special discount on repair work. In other words we sell you new tubes and then keep them in shape for you.

We also usually have on hand a quantity of uncalled-for refilled, licensed tubes at very moderate prices. *all guaranteed.* OUR REPAIRED TUBES SPEAK FOR THEMSELVES. Write to-day for Circular P7 which will explain all the details. SHIPMENTS PROMPTLY MADE C. O. D. TO ALL POINTS IN THE U. S. A.

RADIO TUBE LABORATORIES

Vacuum Tube Specialists

776 Broad Street Newark, N. J., U. S. A.

SPECIAL BARGAIN

WONDERFUL TUBE SET 1000 MILE RANGE . . . **18.00**

Newark Can Get Davenport, Iowa
Free—one pair \$8.00 Everett Phones with each set purchased

Descriptive Circular on Request

VARIABLE CONDENSERS

Bakelite End Plates Standard Construction

3 Plate \$1.25	21 Plate \$1.75
11 " 1.50	43 " 2.25

Enclose Money Order and Goods will be Shipped Immediately by Parcel Post, Postage C.O.D.

AERO MFG. CO., 142 Market St., Newark, N. J.

ELECTRIC SOLDERING IRON

 **\$2.28**

EVERY RADIO FAN has been looking for this iron for both radio and home use. Operates on A. C. or D. C. current.

GUARANTEED one year. Sent anywhere in U.S. or Canada Parcel Post prepaid on receipt of money order for \$2.28.

FANS Send 2c stamp for our list of RADIO BARGAINS

RADIO BARGAINS
17 N. LA SALLE ST.—CHICAGO

CHARGE YOUR BATTERY!

 (RADIO OR AUTO) at HOME for a NICKEL

The **HOMCHARGER**. POPULARLY PRICED—PAYS FOR ITSELF

SEND FOR THE AUTOMATIC ELECTRICAL DEVICES CO. FREE BOOK 132 W. THIRD ST.—CINCINNATI, OHIO.

W.T.501 DETECTOR TUBE

\$2  For tube sets, use our special Adaptor, 75c extra. To convert crystal sets into tube sets, use special socket, 40c extra.

RADIO RESEARCH GUILD
40 Clinton Street, Newark, N. J.



Please mention POPULAR RADIO when answering advertisements.



The SP2 Receiver Has "That Something"—

A Receiver that can be demonstrated with a world of satisfaction and sold with remarkable ease.

The SP2 is everything the radio-receiver purchaser anticipates in the ideal set of his fancy.

It brings in the local stations in all the fullness and clearness of the actual performance of the sender. Stations, broadcasting simultaneously, are tuned in and cut out at pleasure, readily and surely.

Noise and disturbance are practically eliminated. The SP2 is listened to with genuine delight. It gives a **QUALITY** performance; the entertainment as afforded by broadcasting stations **EVERYWHERE**—and at its best.

Long distance stations come in on the SP2 **clearly and distinctly** even to the "faintest" signals that mark the range of a highly efficient receiving set.

The SP2 Receiver has an unlimited range and is nationally known for its compactness of size, elegance of appearance, superiority of quality and scientific perfection.

Retails at \$100

CATALOG 101A—A complete catalog of radio equipment and valuable radio information, will be mailed on receipt of 10c in stamps

Dealers and Jobbers write for our attractive proposition

PITTSBURGH RADIO SUPPLY HOUSE

963 Liberty Avenue

Pittsburgh, Pa.

Distributors For

The SP2 Receiver—
Pathe Loud Speaker—
Amrad—
Cunningham—
Atwater Kent—
Sleeper—
Reflex Speaker—
Callophone—
Homcharger—
Autostat—
Radiall—
Frost—
Baldwin—
Pacent—
Jansen—
Dubilier—
E. M. P.—
A. B. C.—
Keystone—
Hafner—

and other reputable manufacturers.

Please mention POPULAR RADIO when answering advertisements.



Why Not Get a Year's Subscription to POPULAR RADIO—*free?*

HERE'S an opportunity for you to get a full year's subscription to POPULAR RADIO without its costing you a penny!

Three friends of yours will turn the trick for you. Tell them about POPULAR RADIO—show them this copy—get them to subscribe, and we will enter *your* subscription free.

All you have to do is to send us the \$6 you collect from three friends. Give us their names and addresses, so the magazine will reach them without delay. Then we'll put down *your* name as a subscriber, without any charge whatsoever.

Isn't this a mighty easy way of cashing in

on all the good things to be found in POPULAR RADIO during the coming 12 months? Surely a big and long-lasting reward for a few minutes time spent in introducing this live and helpful magazine to your friends who know a good thing when they see it!

No need to write a letter. Just list the names of your three friends on a sheet of paper and mail to us with the coupon below. Your friends' subscriptions can start with this issue or any other issue you specify. And *your* subscription will start with August, unless otherwise requested.

Start today, and you'll have your three necessary subscriptions almost before you know it!

POPULAR RADIO, INC., Dept. 7,
9 East 40th Street New York City

Here are the names of three of my friends who have given me their yearly subscriptions to POPULAR RADIO. Their \$6 is enclosed with their names and addresses. As a reward for sending you these three subscriptions, please enter my subscription to POPULAR RADIO for a year, free of charge.

My Name.....

Street & No.

City..... State.....

(No extra for Canada. Foreign countries 25 cents per year postage extra—\$2.25 in all.)

Please mention POPULAR RADIO when answering advertisements.

Largest
Radio
Store
in
America

Build Your Own Set

According to Our Instructions

RESULTS GUARANTEED

The panel on each set is drilled—ready to mount

Largest
Radio
Store
in
America

Complete Parts for Knocked-Down Receiving Sets \$17.95

CONSISTING OF	Reg. Price	Our Price
2 Variometers.....	\$10.00	\$3.90
1 Variocoupler.....	5.00	1.75
3 Bakelite Dials...	3.00	.75
Bakelite Socket....	1.00	.45
Rheostat.....	1.10	.80
C-300 Detector Tube	5.00	4.45
Mahogany Cabinet.	4.50	2.75
Genuine Formica Panel.....	2.25	1.75
8 Binding Posts....	.80	.40
Switch Lever.....	.50	.25
12 Switch Points...	.40	.20
Grid Leak and Condenser Combined.	1.00	.75
Complete Drawing for Assembly and Wiring.....	1.00	.50
Regular Price.....	\$30.85	
Our Price	\$17.95	

Complete Parts for Reinartz Sets \$11.45

CONSISTING OF	Reg. Price	Our Price
7x18 Formica Panel	\$1.89	\$1.70
Remier Bakelite Socket.....	1.00	.45
Vernier Rheostat....	1.50	1.35
23 Plate Variable Condenser.....	3.30	1.45
11 Plate Cuni Variable.....	3.10	1.35
3 Switch Levers....	1.50	.75
2 Dozen Switch Points.....	.80	.40
1 Schoonhoven Reinartz Coll.....	3.00	1.95
Variable Grid Leak and Condenser Combined.....	1.00	.75
8 Binding Posts....	.80	.40
25 Feet Tinned Wire.	.30	.20
Baseboard for Mounting.....	.50	.25
Blueprint with Complete Instructions for Assembly and Wiring.....	1.00	.50
Regular Price.....	\$21.69	
Our Price	\$11.45	

Complete Parts for 2-Step Amplifier \$12.45

Can be used to amplify Reinartz, Flewelling, Short Wave Receiver, Crystal, Ultra Audion or any Receiving Set so that Loud Speaker or Phonograph can be used in place of head set.

CONSISTING OF	Reg. Price	Our Price
7x10 Formica Panel or Other Suitable Size.....	\$1.05	\$0.80
High Ratio Transformer.....	4.75	3.95
Low Ratio Transformer.....	4.50	2.95
2 Rheostats.....	2.20	2.00
2 Bakelite Sockets..	2.00	.90
3 Double Jacks....	3.00	1.50
13 Binding Posts....	1.30	.65
Baseboard for Mounting.....	.30	.15
Regular Price.....	\$20.00	
Wiring Diagram, with Complete Instructions for Drilling and Assembling Panel		
Our Price	\$12.45	



\$10 VALUE LONG RANGE HEADSET \$3.65

Made in style and design proved by use and experiment to be the best. Coil wound with about 8,500 turns of No. 40 enamel coated copper wire. Direct current resistance approximately 1,600 ohms. Impedance at average music and voice frequency (800 cycles) is 21,000 ohms.

MASTER BALDWIN PHONES

Type C with head band and cord. \$6.95
Type C unit..... 3.95
Brands superior headset..... 5.75
3,000 Ohm Guaranteed Headsets \$8.50 value. 3.65

Complete Parts for Flewelling Circuit \$12.45

CONSISTING OF	Reg. Price	Our Price
6x14 Formica Panel	\$1.26	\$1.10
23 Plate Variable Condenser.....	3.30	1.45
Three .006 Mica Condensers.....	3.00	2.25
CRL Variable Grid Leak.....	1.85	1.35
Grid Leak.....	.40	.25
2 Coil Adjustable Honeycomb Coll Mounting with Knobs.....	4.00	2.65
50 Turn Honeycomb Coll.....	.75	.40
75 Turn Honeycomb Coll.....	.80	.40
2 Coll Mounts with Straps.....	1.20	.80
1 Bakelite Socket....	1.00	.45
Vernier Rheostat....	1.50	1.35
1 Bakelite 3" Dial..	1.00	.25
8 Binding Posts....	.80	.40
1 Baseboard for Mounting.....	.30	.20
1 Blueprint with Complete Instructions for Assembly and Wiring.....	1.00	.50
Regular Price.....	\$22.16	
Our Price	\$12.45	

Complete Parts for Ultra Audion Circuit \$11.90

(Known as the Wonder Circuit)

CONSISTING OF	Reg. Price	Our Price
9x10 1/2 Formica Panel	\$1.42	\$1.20
23-Plate Condenser.	3.30	1.45
Bakelite Socket (Remier).....	1.00	.45
Special Ultra Audion Coll, plain or bank wound with tape..	3.00	1.95
1 Vernier Rheostat..	1.50	1.35
CRL Grid Leak.....	1.50	.95
.0005 Micon Condenser.....	.35	.25
2 Switch Levers....	.70	.50
18 Switch Points....	.50	.30
2 Switch Stops....	.10	.05
8 Binding Posts....	.80	.40
Genuine Solid Mahogany Cabinet, size 9x10 1/2, with hinged top.....	5.00	2.95
25-ft Hookup Wire..	.20	.10
Regular Price.....	\$19.37	
Each order includes complete instructions for drilling, assembling and wiring. These construction plans are not drawn in a schematic form but are drawn so that any one without any technical knowledge can follow with ease.		
Our Price.....	\$11.90	

Complete Parts for Single Tube Reflex Circuit \$32.65

CONSISTING OF	Reg. Price	Our Price
43-Plate Vernier Variable Condenser..	\$7.00	\$3.95
Radion Loop Aerial.	8.50	5.95
Cunningham C301-A Tube.....	9.00	5.95
Grewol Glass Inclosed Detector...	2.00	1.65
Radio Frequency Transformer.....	5.00	3.45
5 to 1 Radio Audio Frequency Transformer.....	4.75	3.95
2—.001 Micon Condensers.....	.70	.50
1—.002 Micon Condenser.....	.45	.35
Potentiometer.....	1.50	1.35
25 Ohm Rheostat....	1.10	1.00
8 Binding Posts....	.80	.40
9x10 1/2 Formica Panel.	1.42	1.20
9x10 1/2 Genuine Solid Mahogany Cabinet with hinged top...	5.00	2.95
Complete instructions for drilling, assembling and wiring furnished so that any one with no technical knowledge can easily follow.		
Regular price, \$45.22.		
Our Price.....	\$32.65	

ELECTRIC SOLDERING IRON \$2.45

Especially adapted to radio work. Simply attach to any light socket 110-120 volts. Complete with six foot cord and attaching plug. Lasts a lifetime for ordinary home or light shop work. A real bargain.

FORMICA PANEL

Black or Brown
cut to size
1/8 in. thick
SQ. IN. 1 1/2c
3/6 IN. 2c

Order Now—Mail Orders Receive Immediate Attention

We Guarantee All Merchandise Purchased of Us

CHICAGO SALVAGE STOCK STORE 509 So. State St. Chicago, Ill.

You Can't Beat This Big Offer!

MONEY saved is money earned. Radio enthusiasts want the most for their money. Here is an opportunity for you to get unusual value for your subscription dollars.

"POPULAR RADIO" and "RADIO" (San Francisco) known the nation over for the wealth of practical information they contain, in addition to a mass of most timely radio news, valuable constructional data for those who "roll their own," feature articles by the leaders of the industry, the latest radio developments and discussions on everything worth-while

talking about, have joined forces in a great money-saving clubbing offer in order to give *you* these leading two radio publications at a cost very little more than the subscription price of either magazine alone. Just imagine—you can subscribe to *both* "POPULAR RADIO" and "RADIO" for a full year for only \$3.00—a saving to you of \$1.50 over what you would pay for them separately.

If you are already a subscriber to either magazine—or both—you can extend your subscription for another year at this unusually low rate.

This is undoubtedly one of the most liberal subscription offers yet made

"POPULAR RADIO" and "RADIO"
—one full year for only \$3.00
—a saving of \$1.50

POPULAR RADIO, Dept. 71,
9 East 40th St., New York City, N. Y.

Send me "POPULAR RADIO" and "RADIO" for one full year. I enclose \$3.00.

Name.....

Address.....

.....

Here's the little coupon that will save you big money if you mail it before July 20th.

Don't turn this page until you have clipped the coupon and started it on the way to "POPULAR RADIO."

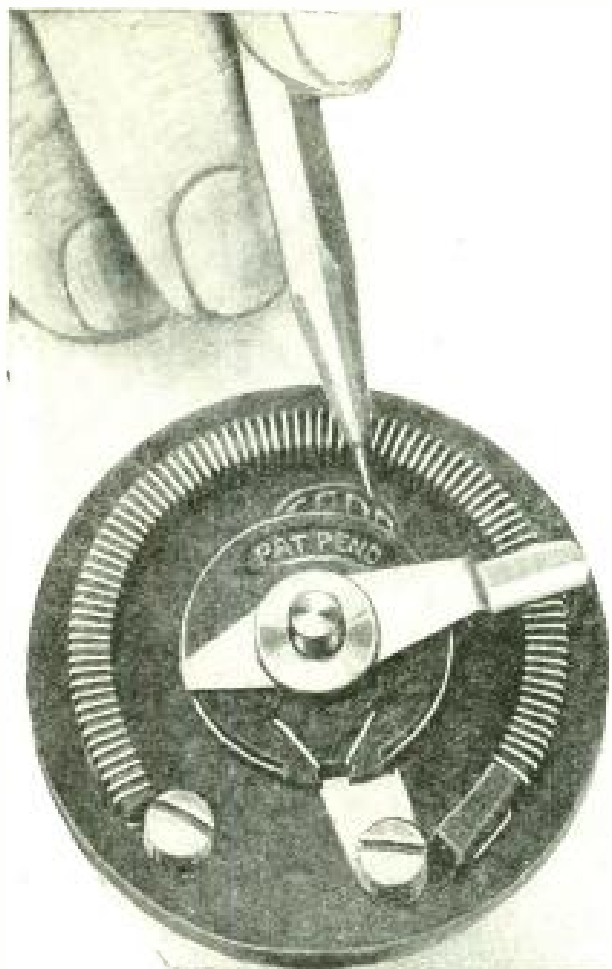

Fada Rheostats and Potentiometers

are favorites with radiophans who construct their own receivers

- | | | |
|-------|--|--------|
| 120-A | 5 ohms plain Rheostat for all 6 volt tubes | \$0.75 |
| 121-A | Power Rheostat for three or four tubes in parallel | 1.20 |
| 150-A | 5 ohm vernier Rheostat for best control of 6 volt detector tubes | 1.25 |
| 151-A | Vernier attachment. Instantly converts almost any 3-16" shaft Rheostat into vernier type | 0.50 |
| 152-A | Potentiometer, 200 ohm, for Kaufman, Flewelling, and many other radio frequency amplifier circuits | 1.00 |
| 153-A | 8 ohm Rheostat — used for low filament current tubes. Can be connected to vernier type by using the 151-A attachment | 1.00 |
| 154-A | 400 ohm Potentiometer. Has many uses in radio frequency amplifier circuits | 1.00 |
| 155-A | 8 ohm vernier Rheostat — same as No. 153-A but with vernier | 1.50 |
| 156-A | 60 ohm Rheostat for dry cell tubes | 1.25 |

Send 10c for the FADA Handbook and Bulletin about the FADA "ONE-SIXTY"

F. A. D. Andrea, Inc.

1581-D Jerome Avenue New York City

Teleradio

(TRADE-MARK)

Another High Grade Instrument Has Been Added to the Popular "TELERADIO" Line of Wireless Equipment

Guaranteed Electrically and Mechanically Perfect

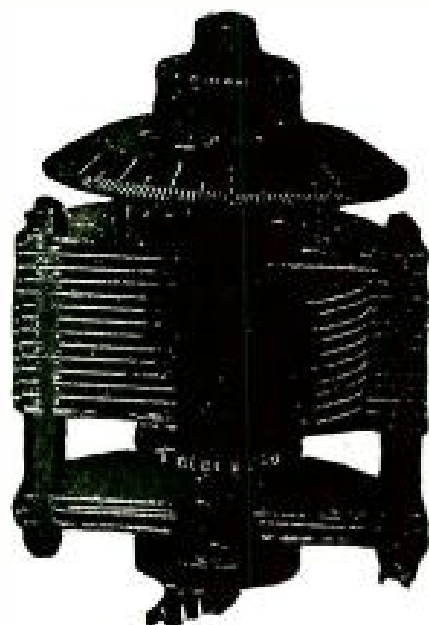

New Improved Vernier Variable Condenser

Makes Fine Tuning a Pleasure
All Metal Parts Nickel Plated

23 Plate \$4.50

43 Plate \$5.50



Supersensitive Headsets

Accurately reproduce the faintest signals on either crystal or tube sets and bring in voice or music with wonderful tonal quality. Equally satisfactory for local or distance work.

2000 Ohms	2200 Ohms	3000 Ohms
\$6.50	\$7.50	\$9.00

Jobbers and Dealers Write for Our Attractive Proposition

Prize winners of "Stay Sold" Contest Announced in March Issue

- 1st—JNO. F. LOVE, Charlotte, N. C.
2nd—VERNON B. DAVIS, Denver, Colo.
3rd—CHARLES DUMMETT, Millville, N. J.

Teleradio Engineering Corp.

484-490 Broome Street, N. Y. C.

Please mention POPULAR RADIO when answering advertisements.

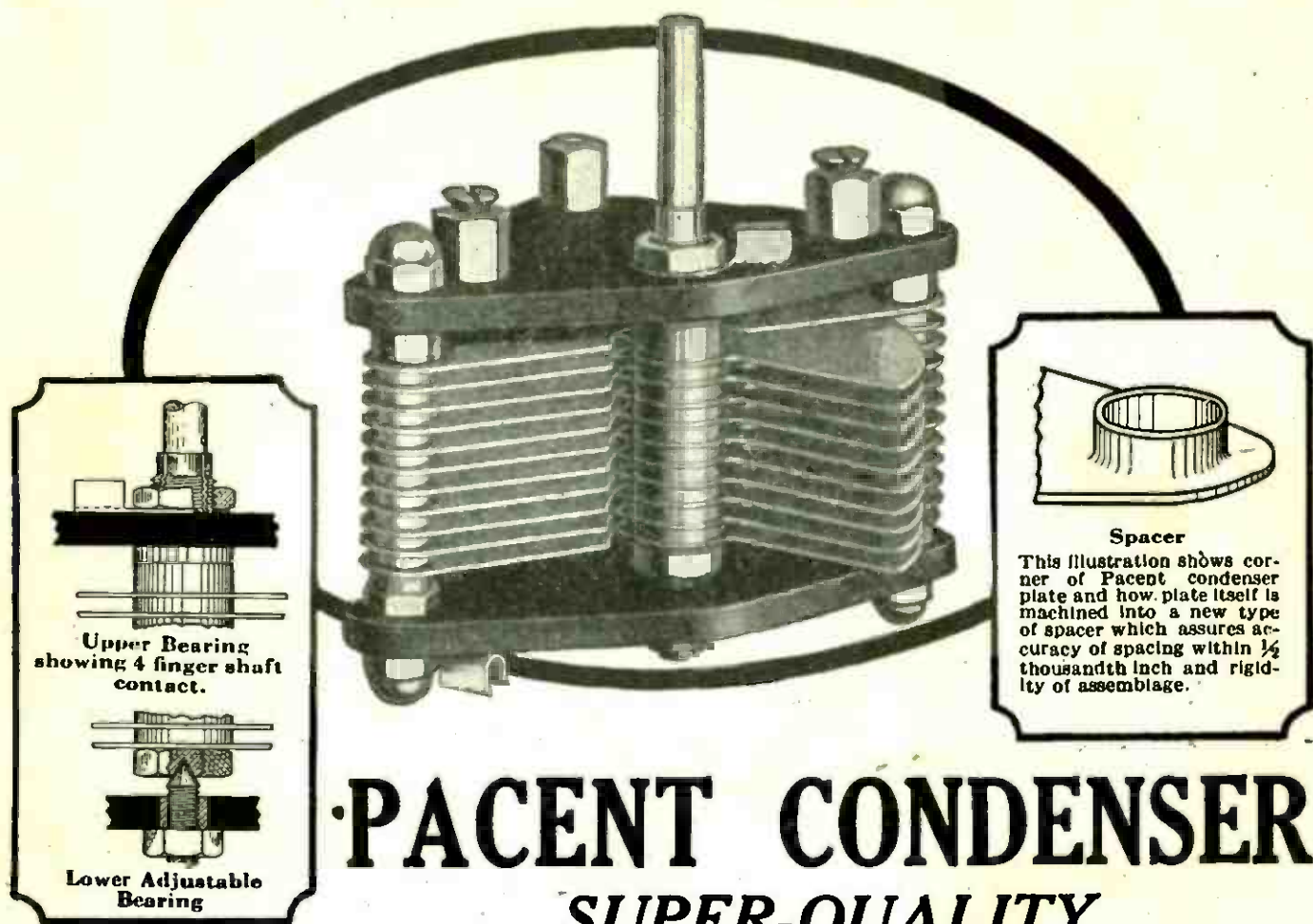

Spacer
This illustration shows corner of Pacent condenser plate and how plate itself is machined into a new type of spacer which assures accuracy of spacing within $\frac{1}{4}$ thousandth inch and rigidity of assemblage.

PACENT CONDENSER

SUPER-QUALITY

NO man ever regretted paying the price for quality. Pacent Condensers are an example of extreme quality at reasonable prices.

Some outstanding points of superiority of the Pacent Condenser are:

1. Elimination of washer separators—plates themselves machined into spacers.
2. Improved bearings—adjustable—including 4 finger contact with shaft.
3. Longer wave length range.

4. Lower resistance—more selectivity.
5. Quality throughout—Genuine bakelite heads, extra heavy aluminum plates, brass parts heavily nicked.
6. Endorsed by leading engineers—Standard with large manufacturers.

The superior service which you will get from a Pacent Condenser is worth twice the price.

No. 200A—	3 plate	.00007	Micro Farad	\$2.75
No. 200B—	5 "	.00012	" "	3.00
No. 200C—	11 "	.00025	" "	3.25
No. 200D—	21 "	.0005	" "	3.75
No. 200E—	43 "	.001	" "	4.50

PACENT ELECTRIC CO., Inc., 22 Park Place, New York

Sales Offices: Chicago, Philadelphia, St. Louis, Washington, D. C., San Francisco, Minneapolis, Jacksonville.

WRITE FOR DESCRIPTIVE BULLETINS P-7

Don't Improvise—"PACENTIZE"

Pacent

RADIO ESSENTIALS

the future of the business of RADIO

from the standpoint of

the user—

depends largely upon the efficiency, dependability and simplicity of the receiver he buys

and the dealer—

upon building a reputation for sterling quality in his equipment and service

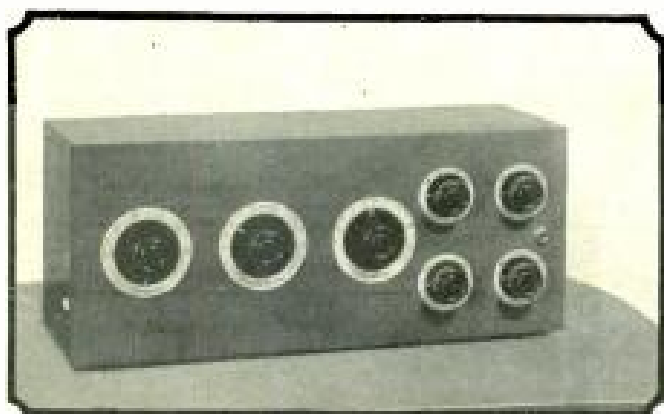

Receiver 11A—Leader of the C & W Line

It is for this reason that we believe Cutting & Washington Receivers to be years ahead in radio.

Designed by Dr. Fulton Cutting and Mr. Bowden Washington, whose apparatus is used by the Ships, Aeroplanes and Shore Stations of the United States Government, built by one of the world's largest manufacturers of automatic electric equipment, C. & W. Receivers bring a new simplicity and sturdiness to radio construction.

If you want dependable operation without annoyance and troublesome service, you want a Cutting & Washington Receiver. Write for literature. See how the Famous Armstrong Regenerative Circuit plus excellent design is incorporated in C. & W. Sets.

The Radio business is changing from a wild craze to the steady buying of a marvelous means of entertainment and recreation. This means better, more sound business ahead for every good dealer in the field.

It also means that you should choose your apparatus and the company that makes it carefully:

1. Cutting & Washington Radio Corporation are America's oldest manufacturers of commercial radio equipment, with practically unlimited resources available.
2. Cutting & Washington apparatus (licensed under Armstrong Patents) combines a simplicity and excellence of workmanship that permits you to *prove it is right*.
3. Dealers are provided with *tested* local advertising, and selling plan to cut sales costs.
4. Complete servicing plan insures satisfactory operation of apparatus.
5. Complete line of instruments and new merchandising plan that covers every phase of a profitable business in radio.



Free Book

"The Future of Radio Retailing" sent to all radio dealers on request. Valuable information. Write for your copy.

Cutting and Washington

America's
Oldest Man-
ufacturers of
Commercial
Radio

Radio Corporation

Minneapolis, Minnesota

Practically
Unlimited
Available
Resources



Just one Reason why ~~CROSLEY~~ RADIO RECEIVERS are so much better

The heart of any receiver is the variable condenser. The superiority of the Crosley book-type variable condenser over the old type interlocking plate air condenser is now generally admitted for the following reasons:

1. Rugged construction that prevents damage.
2. Freedom from short circuits.
3. Permanent metallic contact with plates eliminates sliding contacts.
4. Minimum stray electrostatic field eliminates body effects when tuning.
5. Liberal leakage paths through condenser.
6. Grounded frame provides electrostatic shield.
7. Minimum high frequency resistance or energy loss.
8. Maximum variation in wave length with fixed coil.
9. Maximum mechanical and electrical efficiency.
10. Minimum cost.

We state positively that the substitution of a Crosley condenser for any other type of commercial receiving condenser in any receiving set or circuit will greatly increase the range, volume and simplicity of tuning.



The justly famous Crosley Model VI, a two tube set incorporating one stage of tuned radio frequency amplification and detector, price—\$28.00.

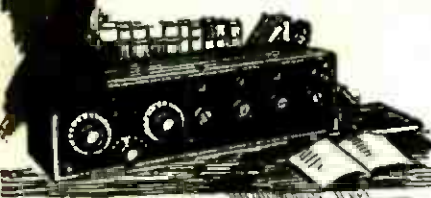

The standard Model X that has made history during the past year, and is now recognized as the most efficient set on the market, will be continued at the same price—\$55.00, notwithstanding the advanced cost of materials.

We announce a new Model X, to be designated as Model X-J, equipped with head phone jacks for detector and one stage of amplification, in addition to loud speaker binding posts.

The instrument has been redesigned internally with new molded sockets, condensers having molded plates, rheostats in molded shells, new dials, price—\$65.00.

Crosley receivers incorporating tuned radio frequency amplification reduce static and other interference to a wonderful degree, which greatly increases summer receiving range.

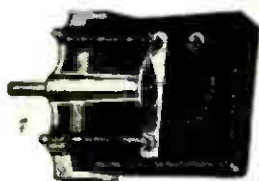

New Crosley type D condenser has molded plates. Price \$2.25.

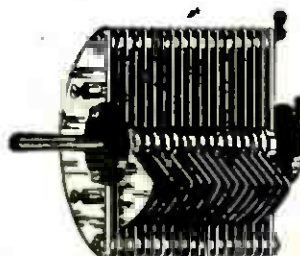

Old-fashioned multiple plate condenser which has been largely replaced by Crosley type D.

New York Office, C. B. COOPER, 1803 Tribune Bldg., 154 Nassau St.
Boston Office, B. H. SMITH, 929 Blue Hill Ave., Dorchester
Chicago Office, 1311 Steger Bldg., 28 E. Jackson Blvd., R. A. STEMM, Mgr.

CROSLEY MANUFACTURING CO.
716 ALFRED STREET CINCINNATI, OHIO