

# POPULAR ELECTRICITY

IN PLAIN ENGLISH

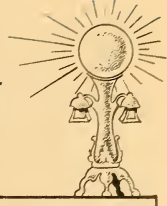

VOL. I

JULY 1908

No. 3

## FOLLOWING A TELEPHONE CALL.

BY STANLEY A. DUVALL.  
PART II.

**A** MATTER will now be explained that has possibly worried you a great deal. In the first place you must understand the telephone industry in this country is one of the most progressive in the history of the world. In Europe they are using to-day the same equipment that they had in service 10 or 15 years ago; in America the modern telephone companies, during that period, have thrown in the junk pile millions and millions of dollars worth of fairly good telephone apparatus, good enough for our English cousins right at this day, but not good enough for the American telephone exchange companies. One of the things that has bothered the telephone users more than anything else, and also has been a source of anxiety and trouble to the exchange managers in the past, has been the "busy signal." A few years ago it was customary for the operator, when she tested and found that the line you wanted was already in use by some other subscriber, to tell you in the following phraseology: "The line is busy," or "The line is busy, please call again." Nine out of 10 users of telephones would immediately inquire "What did you say?" Then the operator would have to repeat it again or some "doubting Thomases" would say "I don't believe it," and this would be repeated sometimes four or five times. Now, you see, this was consuming a lot of unnecessary time and was keeping the operators from giving the proper attention to their real business—that of mak-

ing connections. Every time an argument of this kind was carried on it simply delayed other telephone users from getting the service to which they were entitled. Finally one bright genius in a large city in the East evolved the plan of getting a phonograph and setting it up and connecting it to the main switchboard, then a good stout lineman was brought in and he repeated into the phonograph over and over again in strong and husky language "Line is busy, please call again." Then each operator was equipped with a special key whereby she could turn this torrent of language onto the subscriber's line without doing any talking herself. This worked very nicely for the operators, as it relieved them of all this unnecessary conversation and allowed them to attend to their work, but it did not entirely please the telephone users, for no matter what they said they simply received this constant repetition of this phrase and some of the most impulsive telephone users were made exceedingly angry. Finally the modern up-to-date little buzz-buzz noise was adopted, and outside of the erroneous opinion held by many that this "busy signal" is given falsely now and then, it works in an entirely satisfactory manner.

Now, as a matter of fact, it requires more of an effort on the part of an operator to give you the "busy signal" than it does for her to make a connection for you, and here is a clear explanation why this is true:

After the operator has answered your

call and you have informed her of the number you want (now remember here at this point that the monitor is watching her and has certain signals which tell exactly what she is doing) she picks up the other coupling pin or plug and taps on the coupler that belongs to the line that you want. Now if she gets a certain signal when she taps on this line, which is known as a "busy signal," she must return this plug to its normal position and then turn the "busy signal" on to your line and keep up your plug for a few minutes. But now suppose that when she tapped on this coupler she does not get the "busy signal." She simply pushes the pin or plug into the coupler and almost instantaneously the ringing current is turned on and off of the line you want and she has finished the connection and is ready to take up a call for someone else. Now does it not appear logical that it is easier for her to give you the connection you want than to give you the "busy signal"? After this, don't blame the operator for giving you the "busy signal," but rather blame the party you are calling up for having too much business or not having enough telephone lines connected to his office.

You can, therefore, see the importance of the desirability when calling up another party to limit your conversation to that which only is essential; and you may be losing some business, too, if you are unnecessarily holding your line in communication with some other line upon some trivial matter.

A telephone in a business man's office or store is just like the door to the store. If the door is blocked up by non-buyers, or anyone for that matter, customers cannot get into your office or store to buy your services or purchase your goods.

A telephone exchange is just like a railroad. If the railroad is congested with useless traffic and carrying a large amount of deadheads it is of no real service to anyone, and if a telephone exchange is loaded down with unnecessary messages it cannot do its subscribers justice. It is a traffic proposition in both cases. Not so many years ago Marshall Field & Co. of Chicago had one telephone in their store, then they decided

to get two, then four were added, and now this same establishment has over 1,200 lines in its store, which are connected to an exchange on the top floor, and this exchange has many trunk lines connected to the main exchange.

But how do the operators reach all these different lines that are connected to the switchboard? You say that the plug and cord or connecting link is only six feet long, and in this exchange we were in, the switchboard was over 50 feet long with about 25 operators working at it. They were all seated in what looked like office chairs and none of them ever left their seats to make a connection. You don't understand this. This feature is accomplished by one of the most novel contrivances ever invented by man, and it brought into play the highest type of ingenuity of mechanics. Broadly speaking it is known as the multiple switchboard, and in manual operated exchanges of any size over 500 lines no other system is generally used.

We will now return to the main switchboard. The main switchboard is divided into sections that are called operators' positions, and at each position is placed an operator. Of course you understand an operator has her own telephone, her receiver being different than yours, resembling a watch in design and constantly held on the operator's head by a leather covered head band. This is done to allow the freedom of both the operator's hands. The transmitter is suspended in front of her on a cord which drops from an arm that is fastened on the top of the piano-like switchboard case. Of course it is only in the small exchanges, and very small ones at that, that the operator turns any crank in order to generate the current to ring the bell. This is all done automatically by ringing machines that are in the power room of the telephone exchange. In this room are also located the storage batteries to furnish the power for talking. The storage batteries only furnish direct current, and this is the only current that can be used for talking. This battery also furnishes the current for lighting the signal lamps. Then there is a machine, a motor and dynamo combined, for charging the storage battery, also another little machine to give

us the buzz-buzz or the busy-back signal, and of course there are the big switches and meters for measuring currents, mounted in a convenient manner upon a marble slab and connected in the proper manner to the switchboard and all these different electrical machines and batteries about which we have spoken. Then there is the duplicate set of all this apparatus lying idle and only used now and then to be tested out, but to be used in case of a breakdown of the

We will now use our railroad comparison again. Our two wires come to the first jack which we will say is No. 1 line. No. 1 line will, of course, be on the first position. This line terminates as we have said in this jack, but there is a branch pair of wires that is connected with this jack, or say a very minute railroad track, in the shape of a pair of wires, and these wires run down all along the back of a switchboard past each operator and the track at the end



A VIEW OF THE BACK OF A MODERN TELEPHONE SWITCHBOARD.  
Here are hundreds of miles of wire, tens of thousands of soldered joints.

regular set. Modern telephone engineers never take any chance. Their watchword is always "as good service as is possible to give at all times."

Now we will go back to our operator. We have digressed from our subject in this last explanation, but now we only have to explain this multiple feature. As we stated in the first part of this article, each telephone line always terminates in one signal and a coupling device or jack, but you will notice we make a distinction here, we do not say one jack.

is open. Now a little side track is taken off this line which terminates in a jack in front of each operator on the board. Each one of these jacks are numbered 1, so you see while your line has only one signal and one local jack it may have as high as 20 other jacks which are called multiple jacks, because they all multiply as the board grows longer or as more subscribers or more operators' positions, rather, are added to the switchboard. You see these 20 open jacks are just like so many branch side-

tracks from the main line. Now the question comes up: Suppose two or more operators wanted to get in on your line somewhere along the board and you are already talking to someone else. Here is where the "busy" test of the operator comes in. As we said before, when the operator starts to call the party she wants she picks up her plug and taps on the jack before she pushes the plug in. If she gets a click in her head receiver she knows that your line, No. 1, is in use, and she therefore reports it "busy" to the party who has called for it. This device you also see allows only one operator at a time to get on this branch track of your line, or on any of the multiple jacks, for while there is a connection upon this line any operator testing on it, at any place on the board, will get this click.

#### UNLOADING BANANAS BY ELECTRIC POWER.

This interesting view shows how bananas are unloaded at a large fruit wharf in New Orleans by means of an electrically operated conveyor. The equipment consists of a sort of moving stairway operated by electric motors. It is said that at least two-thirds of the ordinary waste is saved in this way, since the perishable fruit can be hurried to Northern and Eastern points without so much delay, the bananas being unloaded in one-half the time previously required by hand labor.

This unloading plant is built upon a platform upheld by 10 trucks. From the platform booms rise, each in the shape of a hinge which opens and shuts. As the steamship is moved to the wharf, and the hatches are opened, the hinge opens and is lowered into the hold. Then the carrier runs up perpendicularly some 40 feet and across to the wharf.

A lookout tower is stationed on top containing four levers for the entire control of the machine, which may be operated by one man. The levers start or stop the machine by friction gear, move it along the wharf when necessary and hoist the main boom over the deck of the vessel.

It is stated that with one hatch open, and one machine in operation, 40 bunches per minute or 2,400 per hour were un-

loaded. With three hatches open and three machines working together, with better facilities for carrying the fruit to

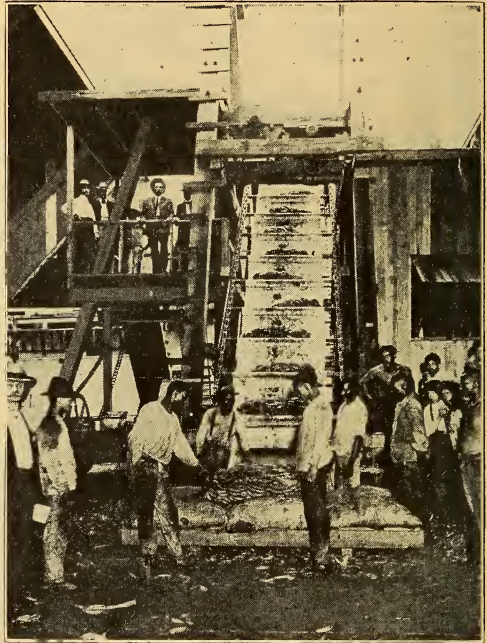

UNLOADING BANANAS BY ELECTRICITY.

the wagons and cars, a rate of 80 per minute on each carrier may be attained, with a total of nearly 15,000 bunches unloaded per hour.

#### ELECTRICITY FOR THE SOUTHERN PACIFIC.

E. H. Harriman is said to have decided that it is feasible to utilize the water power of the Sierra Nevada and Siskiyou mountains to generate electricity to propel his trains. For over a year Mr. Harriman has had men quietly at work securing valuable water rights at four strategic points by means of which he expects to generate electric power for the movement of the trains of the Southern Pacific on certain sections of the road. These rights are located in the mountains of Kern county east of Bakersfield; in Fresno county, east of Fresno; in Eldorado county, on the Rubicon river, and on the Klamath river in Siskiyou county. To develop these sources of power an expenditure of at least \$15,000,000 will be necessary.

**CORNELL X-RAY TUBE.**

Roentgen or X-rays are widely used in the practice of medicine, for their curative properties as well as for the location of foreign objects which may be imbedded in the flesh. In lesions and local manifestations the local effect is best obtained by bringing the tube as close as possible to the part to be treated.

The new Cornell X-ray tube, invented by Dr. A. C. Geysler of Cornell University, is one of the latest developments of

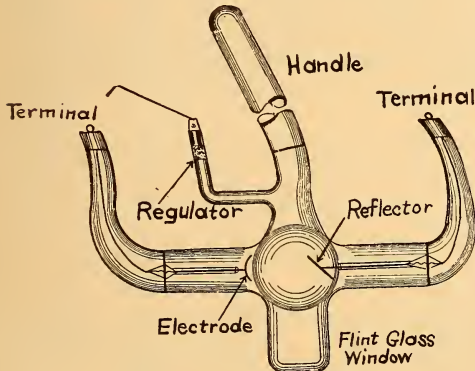

CORNELL X-RAY TUBE.

this interesting apparatus. The Cornell tube, as shown in the diagram herewith, is of peculiar shape. It is made of lead glass which prevents the escape of the rays upon the hands of the operator. The rays can only emerge through a flint glass window which is held directly on the part to be treated. A reflector of platinum directs the rays downward through this window.

The high potential discharge takes place between the electrodes in the interior of the tube, from which the air is nearly all exhausted. The theory of the X-ray is that the discharge of electricity within the tube from electrode to electrode causes the few particles of air left in the tube to bombard each other furiously and to finally become ionized, that is, broken up into particles smaller even than atoms. This action gives off the pale and mysterious rays known as X-rays, which penetrate solids, with the exception of metals.

Dr. Geysler's tube is also provided with a regulator for regulating the degree of vacuum in the tube. The chief advantages of this form of tube are that there is no danger to the operator, owing to the shield provided by the lead glass:

the window from which the rays emerge can be brought in contact with the part to be treated, with no layer of air between, and a convenient handle is afforded by the peculiar form of the tube so that the patient may apply the rays himself under the direction of the physician.

**GERMAN MAGNETIC SEPARATOR.**

A novel and interesting type of magnetic separator of German design and construction is shown in the accompanying cut. It is operated by an electric motor mounted in the base of the machine and driving a countershaft pulley by belt transmission.

The magnets used for separating the

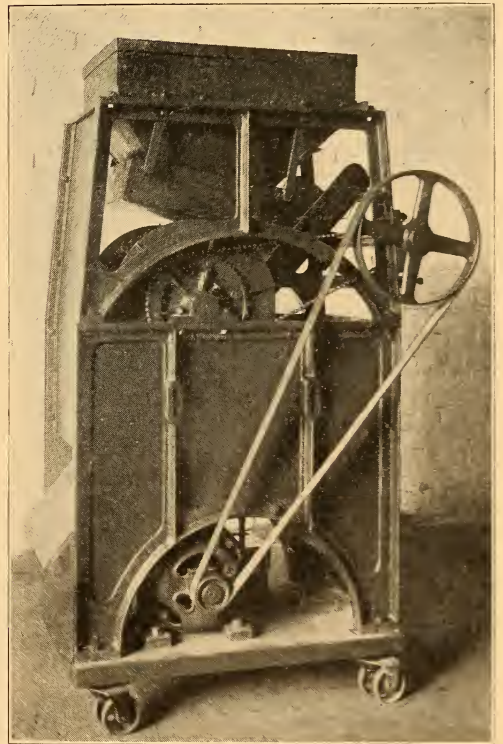

GERMAN MAGNETIC SEPARATOR.

iron from the sand or other foreign material are arranged on cylinders within the machine. These cylinders pick up the iron and deposit it in a tray provided for the purpose. These machines have a capacity of sorting or collecting the iron from 1,200 to 15,000 pounds of material per hour, picking up iron pieces weighing up to 10 or 12 pounds.

# ELEMENTARY ELECTRICITY.

BY EDWIN J. HOUSTON, PH. D. (PRINCETON.)

## CHAPTER III.—MULTIPLE-SERIES AND SERIES-MULTIPLE CIRCUITS.

As we have seen in the preceding chapters, electric circuits can be divided into the two general classes of series-circuits and multiple or parallel circuits. In addition to these, there are a great variety of circuits, many of which at first sight appear to be of an exceedingly complex character. A little study, however, causes this complexity to disappear, and permits them to be divided into the two following classes of circuits, i. e.:

- (1). Multiple-series circuits.
- (2). Series-multiple circuits.

In a multiple-series circuit a number of separate electric sources, or separate electroreceptive devices, or both, are connected in a number of separate groups in series, and these separate groups afterwards connected in multiple. Since a multiple circuit is sometimes called a

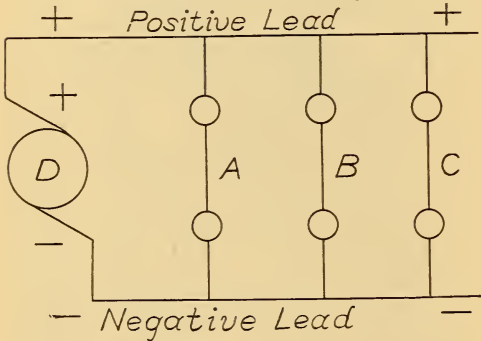

FIG. 18. MULTIPLE-SERIES CIRCUIT OF INCANDESCENT LAMPS.

parallel circuit, a multiple-series circuit is sometimes called a parallel-series circuit.

A multiple-series circuit is represented in Fig. 18. Here, the dynamo (D) has its positive and negative brushes connected with the positive and negative leads. Six incandescent electric lamps are connected in series in three separate groups (A), (B) and (C), of two lamps each, and these groups are then connected in multiple across the positive and negative leads as shown. This circuit is called a multiple-series circuit because it consists of a multiple of series connected circuits.

The separate series connected groups of a multiple-series circuit, may consist of more than the two lamps in each of the groups (A), (B) and (C) of the preceding figure. For example, Fig. 19, (Fig. 129, p. 376, Houston & Kennelly's "Incandescent Lighting"), shows a multiple circuit of 40 incandescent electric lamps connected in four separate groups of 10 series-connected lamps each, that are then connected in multiple across the mains of the dynamo (D). This sys-

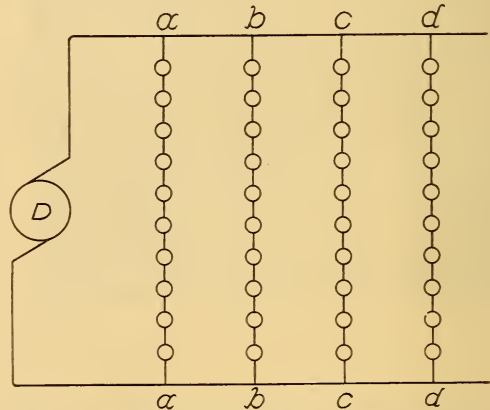

FIG. 19. MULTIPLE-SERIES OR MUNICIPAL SYSTEM.

tem is generally known as the municipal system of series incandescent lighting. It is sometimes employed for the lighting of houses, or other interiors, where some of the lamps in any of the series circuits are apt, occasionally, to be turned off. Unless all the lamps in any of the series groups are turned on or off at the same time, the others would probably be destroyed by the passage of too strong a current.

This difficulty would be even more pronounced if an attempt were made to employ the multiple-series circuit represented in Fig. 18; for here, if one of the lamps in any of the separate groups (A), (B) and (C) is cut out, the other lamp would certainly receive too strong a current. While in point of fact, multiple-series circuits are extensively employed for the lighting of interiors, yet it is a modification of the circuit shown in Fig.

18, that is so employed. This modification is known as the three-wire system.

In order to change the multiple-series circuit, a system shown in Fig. 18, into a three-wire system, it is only necessary to replace the single dynamo (D) by two dynamos, as shown in Fig. 20 (Fig. 56,

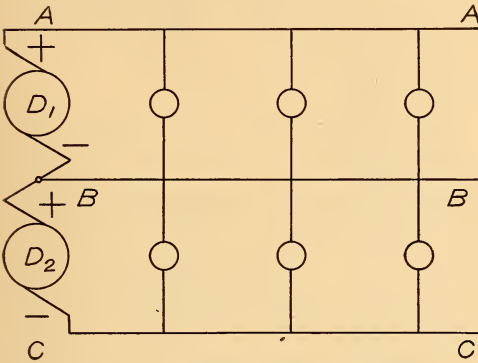

FIG. 20. THREE-WIRE SYSTEM.

p. 221, Houston & Kennelly's "Electric Incandescent Lighting"). These dynamos are connected in series, by joining the negative brush of (D<sub>1</sub>) to the positive brush of (D<sub>2</sub>), the positive brush of (D<sub>1</sub>) to the positive main (AA), and the negative brush of (D<sub>2</sub>) to the negative main (CC). The neutral point where the two dynamos are joined together is

volts between (AA) and (BB), or between (BB) and (CC).

Provided all the lamps are connected with the circuit as shown in the figure, no current will flow through the neutral main (BB), for the system will then be balanced. If, however, one of the series-connected lamps of any group be cut out of the circuit, the remaining lamps will not be injured by the excess of current, since the neutral conductor will then convey a part of the current back to the dynamo.

There are many peculiarities concerning the three-wire systems that we will afterwards explain, especially how the higher pressure employed permits of a great saving in the amount of copper required for the mains.

In a series-multiple circuit a number of separate electric sources, or separate electroreceptive devices, or both, are connected in a number of separate groups in multiple, and these groups afterwards connected in series.

Since a multiple circuit is also called a parallel circuit, a series-multiple circuit is sometimes called a series-parallel circuit.

Fig. 21 (Fig. 10, p. 27, Vol. II, Crocker's "Electric Lighting") represents a series-multiple circuit. Here, 25 incandescent electric lamps are connected in

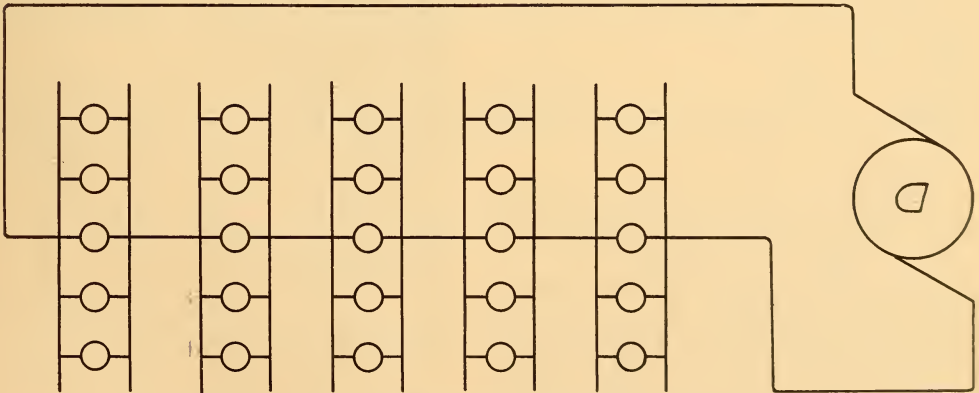

FIG. 21. SERIES-MULTIPLE CIRCUIT.

then connected to the neutral main (BB).

If each of these dynamos is capable of producing a pressure of 115 volts, it is evident that there will be a total pressure of 330 volts between the mains (AA) and (CC), and a pressure of only 115

volts between (AA) and (BB), and these groups are connected in series to the positive and negative terminals of the dynamo (D). This circuit is called a series-multiple circuit because it consists of a series of multiple-connected circuits.

Those beginning the study of electricity frequently experience no little difficulty in distinguishing between a multiple-series circuit and a series-multiple circuit. By remembering, however, that the name, multiple-series circuit means a multiple of series-connected circuits, and a series-multiple circuit means a se-

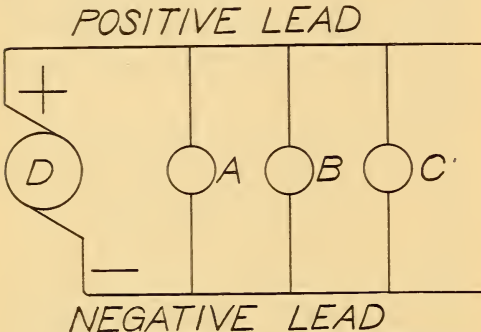

FIG. 22. MULTIPLE CIRCUIT OF THREE INCANDESCENT LAMPS.

ries of multiple-connected circuits, the difficulties will at once disappear.

It is unfortunate that the difficulty should be unnecessarily increased by employing the name parallel for multiple, thus giving rise to the terms parallel-series circuit, employed in the same sense as multiple-series circuits, and series-par-

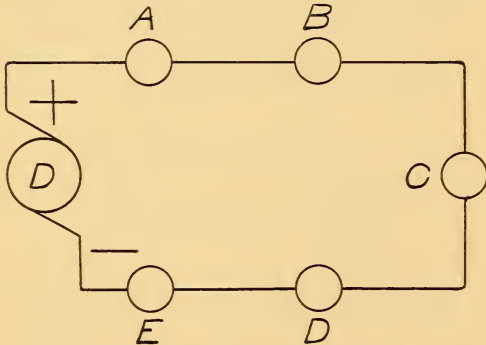

FIG. 23. SERIES CIRCUIT OF FIVE LAMPS.

allel circuit, employed in the same sense as series-multiple circuits. These terms, however, are frequently employed, so that it is necessary that the student memorize them.

A little thought will show that the two general classes of circuits, the multiple-series and the series-multiple circuits, have originated as follows: In any multiple circuit, such, for example, as that shown in Fig. 22, any of the separate

lamps (A), (B) or (C), can be replaced by two or more series-connected lamps, such as shown in Fig. 18. Or each of four separate lamps in any multiple circuit may be replaced by the 10 series-connected lamps, as in the groups (aa), (bb), (cc) and (dd), of Fig. 19. As soon as this is done, the multiple circuit becomes a multiple of series circuits or a multiple-series circuit, since it then consists of separate series groups connected to the mains in multiple.

In a similar manner, the circuit of five series-connected lamps (A), (B), (C), (D) and (E), shown in Fig. 23, may have any of these lamps replaced by any number of multiple-connected lamps as, for example, by five multiple-connected groups of five lamps each, and these groups afterwards connected in series to the dynamo (D), as shown in Fig. 21. This would give rise to a series of mul-

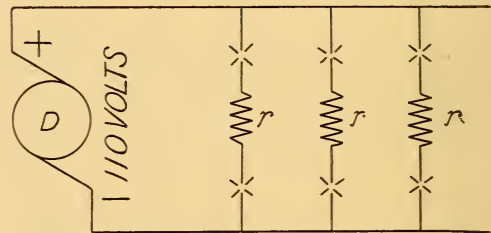

FIG. 24. MULTIPLE-SERIES CIRCUIT OF ENCLOSED ARCS.

multiple-connected lamps, or would be a series-multiple circuit.

It is frequently a matter of considerable advantage to be able to employ enclosed arc lamps on the same multiple circuits that are provided for feeding the incandescent lamps used for the illumination of interiors. Indeed, this ability for being used on the same circuit with incandescent lamps constitutes one of the most important features of enclosed arc lamps. As will be afterwards explained, the enclosed arc lamp possesses two peculiarities that render it especially suited for interior illumination; i. e., its ability to produce a well diffused light, and the fact that its double glass globes, preventing as they do the escape of dangerous sparks, permit it to be safely employed in the neighborhood of inflammable materials, such as are apt to exist in stores or other interiors.

If the mains employed for feeding in-



candescant lamps in multiple, as is frequently the case, are connected with dynamos capable of maintaining a pressure of say 110 volts, and the arc lamps employed require, as is also frequently the case, a pressure of 50 volts only, then

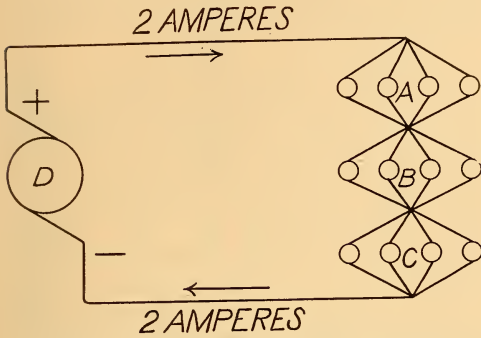

FIG. 25. SERIES-MULTIPLE CIRCUIT.

more than a single lamp must be placed in series across such main. In the case of mains, maintained at a constant pressure of 110 volts, it would be necessary that two such lamps should be placed in series across the main and that, moreover, a small resistance be connected in series with such lamps.

The arrangement above referred to is represented in Fig. 24, (Fig. 27, p. 63, Houston & Kennelly's "Electric Engineering Leaflets, Elementary Grade"). Here a dynamo (D), capable of producing an electromotive force of 110 volts, is connected with the positive and negative leads as shown. Three series-connected groups, each consisting of two enclosed arc lamps and a resistance (r), are placed across the leads. As will be seen from an examination of the figure, a pressure of 50 volts is necessary to force the current through each of the arc lamps and an additional pressure of ten volts to cause it to flow through each of the resistances (r).

This arrangement therefore constitutes a multiple-series circuit and shows one of the practical uses of such a circuit.

In the series-multiple circuit, represented in Fig. 25 (Fig. 28, p. 63, Ibid), a dynamo (D), capable of sustaining a pressure of 330 volts on the positive and negative mains, respectively, is shown as connected with three multiple groups of incandescent lamps (A), (B) and (C). These multiple

groups are connected in series as shown in the illustration, and are then placed across the mains. If each of these incandescent lamps requires a current of say half an ampere, at a pressure of 110 volts, only two amperes will be required to flow along the leads from and to the dynamo. Had all 12 lamps been connected in parallel across the leads of a 110-volt dynamo, the current leaving the dynamo would have been six amperes, so that in order to maintain the same condition, the leads would necessarily have been three times heavier or larger in area of cross-section.

Fig. 26 (Fig. 27, p. 63, Houston & Kennelly's "Electric Engineering Leaflets, Intermediate Grade"), represents a practical application of a multiple-series connection of electroreceptive devices. Here, the receptive devices consist of

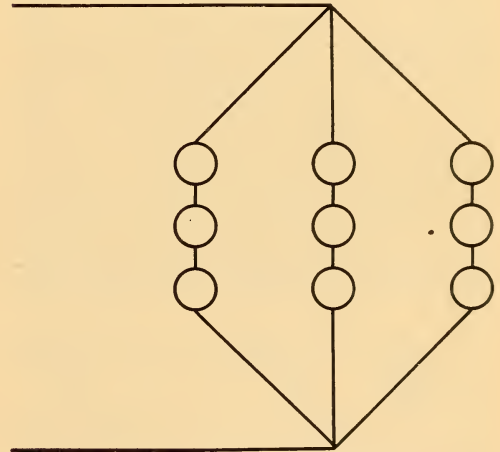

FIG. 26. MULTIPLE-SERIES CONNECTION OF NINE PLATING BATHS.

nine plating baths connected as shown in three separate series groups of three cells each, and these groups afterwards connected in parallel with the mains. An arrangement of this character is limited to cases where it is desired to obtain such relations between the electromotive force and the current strength as may be necessary for the best operation of the electroreceptive devices connected with the circuit.

A well known practical application of a series-multiple circuit, or, as in this case it is more frequently called, a series-parallel circuit, is the car controller that is placed on the platform of the trolley

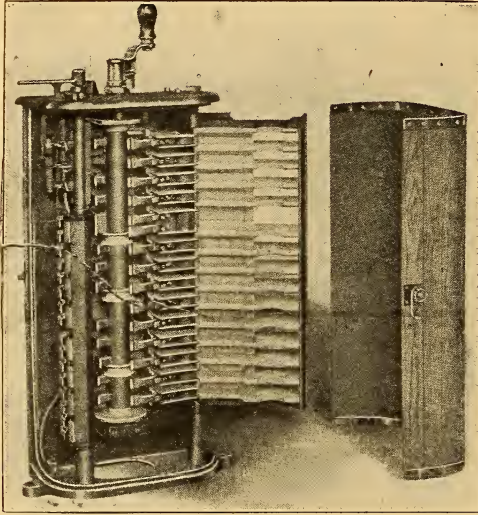

FIG. 27. SERIES-PARALLEL STREET CAR CONTROLLER.

car alongside the motorman, and employed by him for starting or stopping the car, or for varying its speed. The street car provided with this device, which is generally known as the series-parallel controller, is furnished with two or with four motors. As the motorman turns the switch handle, he brings it over a series of notches that correspond with different speeds of the car, gradu-

ances, or some of the motors or the resistances are cut out of the circuit.

A series-parallel street car controller is represented in Fig. 27 (General Electric Company's Bulletin No. 4557), with the front of the upright vertical sheet-iron case within which the apparatus is placed removed, and with the controller thrown open for inspection.

As will be seen, the handle is connected with a vertical cylindrical switch on the surface of which are mounted metallic conducting segments of different lengths and in different positions, so that when the handle is turned to an extent corresponding to the different notches, these segments come in contact at different times with a number of fixed contact springs. It is by this means that the motorman is able to bring about the changes in the connections between the separate motors and resistances that are required to ensure changes in the speed of the car.

It is not our intention to explain here the nature of these changes but simply to point out this very common use of a series-parallel circuit.

Besides the variety of circuits already described, there are two others, known as the metallic circuit and the ground return circuit.

As its name would indicate, a metallic

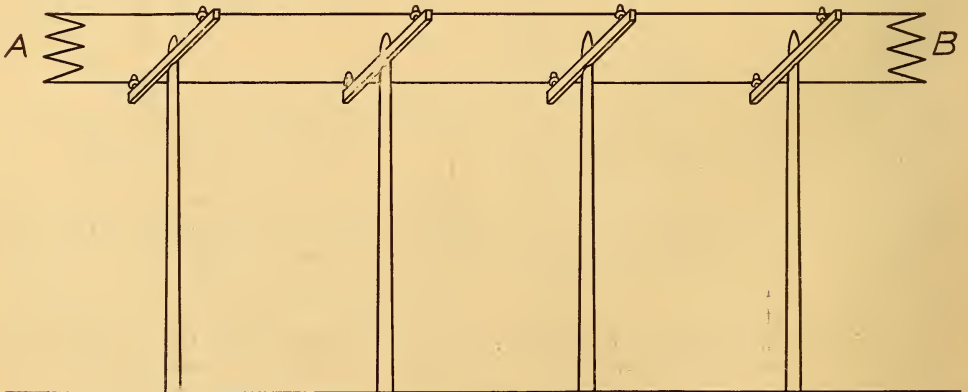

FIG. 28. METALLIC CIRCUIT.

ally increasing from the first notch at starting to the last notch, and decreasing as the handle is turned in the opposite direction. In this way the motors are connected in series or in parallel with each other, or with a number of resist-

circuit is one in which the entire conducting path to and from the electric source consists of a metallic wire, while in the ground return circuit a metallic wire is employed for leading the current to the different electroreceptive devices placed

along the line, and the ground is utilized for the return of the current to the electric source.

A metallic circuit is represented in

telegraphic circuits were metallic circuits until in 1825, when Steinheil endeavored to use the two rails of a railroad track for telegraphic purposes. He discovered

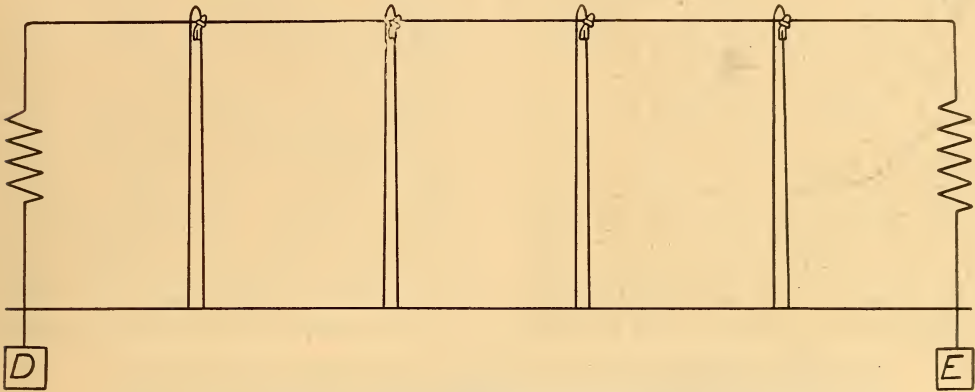

FIG. 29. GROUND RETURN CIRCUIT.

Fig. 28, (p. 34, Houston & Kennelly's "Elementary Leaflets, Elementary Grade").

Here two telegraph stations (A) and (B), situated, say 100 miles apart, are connected by a copper wire of a certain diameter (No. 12, American Wire Gauge). As will be seen, the wire is suspended over poles both from and towards the stations.

Fig. 29 (Fig. 13, p. 34, Ibid), represents a ground return circuit between the same stations as in Fig. 28. Here, only a single copper wire is extended over poles between the stations in order to convey the current from either station to the electroreceptive devices placed on the line. The earth or ground lying between two metallic plates (D) and (E), employed to ensure good connections, is utilized as the return circuit.

The total resistance of metallic telegraphic circuits of this type is higher than that of the ground return circuit; for, if the plates are large and the ground is moist, the resistance of the earth, owing to its great size, is almost negligible.

Metallic circuits are employed for practically all electric light and power circuits, and in all well established telephone circuits. Ground return circuits are generally employed in telegraph lines. In the early days of telephony they were then employed in telephones. At the present time, however, telephone circuits are now almost entirely metallic.

It is interesting to note that the early

that the earth is so excellent a conductor that it could be employed as a return. Since 1825, the earth has been almost invariably so employed.

(To be continued.)

#### EXTRAORDINARY LIGHTNING STROKE.

Prof. A. Herschel, in the Quarterly Journal of the Royal Meteorological Society for October last, describes the extraordinary effects produced by lightning in the midst of an open moor in Northumberland. A hole 4 or 5 feet in diameter was made in the flat, peaty ground, and from this half a dozen furrows extended on all sides. Pieces of turf were thrown in various directions, one 3 feet in diameter and a foot thick having fallen 78 feet from the hole. Investigation showed that in addition to the effects visible on the surface, small holes had been bored in the earth radiating from the large excavation.

Professor Charles P. Steinmetz of Union College, in a lecture to electrical trades students, prophesied that a hundred years or so would see the practical exhaustion of the coal supply, when the world would be dependent on electricity not only for light, power and heat, but for the restoration of fertility to the soil. Days of wonderful economic changes are thus forecast. The children of today's fathers may live practically in a world made over.

## THE WIRELESS TELEPHONE.

MUCH interest has been aroused recently by the development of the radio wireless telephone. The system is the invention of Dr. Lee de Forest, whose achievements in the field of wireless telegraphy have made him noted in this particular field of electrical science. The wireless telephone also takes on an added interest at the present time from the fact that it has been installed on all of the battleships forming the great Pacific squadron, now on its memorable cruise. The accompanying half-tone reproduc-

telephone receiver. This is done because the air vibrations are soon overcome by resistance and hence are limited in scope, while the etheric variations theoretically are unresisted, as the ether permeates every substance and the vibrations transmitted to it travel uninterrupted to infinite distances. Telephony, then, either wireless or otherwise, becomes merely a matter of finding a piece of mechanism capable of the translation from air to ether waves and back to air waves again. Bell caused the translation to be made over an electric current

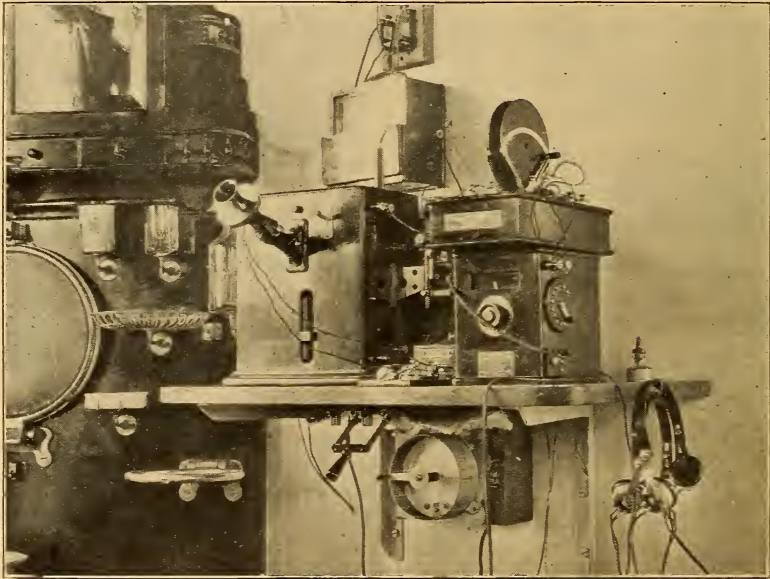

FIG. 1. WIRELESS TELEPHONE ON REAR ADMIRAL'S FLAGSHIP.

tion, Fig. 1, shows the complete wireless telephone station installed in what was "Fighting Bob" Evans' cabin.

In order readily to comprehend the following explanation of the wireless telephone the reader must bear in mind the basic differences between wireless telephony and wireless telegraphy. Speech is but the forming of a very rapid, complex, and ever-varying series of vibrations in the air. In telephoning we translate these vibrations into ether-waves of corresponding fluctuation of intensity, which are again translated back into the original air vibrations by the

traversing a metal wire. De Forest changes the air waves into the vibration of an electrical discharge which oscillates the ether. The principle is much the same, although the apparatus is of necessity quite different. The variation of electrical current is produced by what is technically known as "alternation."

A simple diagram of a wireless telephone transmitting and receiving station is shown in Fig. 2. To obtain the very high frequency alternations desirable for radio transmission, an apparatus similar to the Duddell "singing arc" is used. It comprises an electric arc with one

copper and one carbon electrode, connected to a direct current generator with a capacity of about 250 volts. The upper or carbon electrode is attached to an inductance coil (B) connected in series with a condenser and the copper electrode, forming a shunting or branch circuit around the arc. The result is a current flowing through the coil (B) with exceedingly rapid alternation of direction. The speed of this alternation depends greatly upon the material of the arc electrodes, their temperature, and the atmospheric medium surrounding them. The most practical medium with which to surround the two electrodes of the arc is the vapor from the flame of

creasing the arc current and decreasing the resistance between the electrodes. As the condenser will discharge too much, the reverse process takes place, and thus the condenser is alternately overcharged and undercharged, and the circuit (B), of which the condenser and inductance are parts, sustains an alternating current, whose frequency depends upon the resistance of the arc. The high frequency alternating current is kept from flowing back into the direct current generator by the use of choke coils, as seen in the diagram.

The inductance coil (B) now acts as the primary coil of a transformer, the secondary coil shown on the diagram

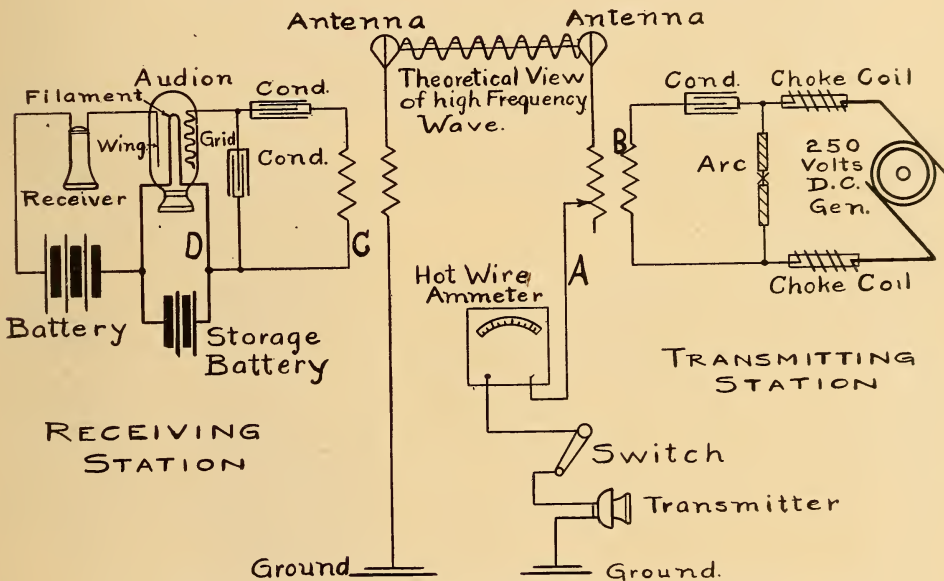

FIG. 2. CONNECTIONS FOR WIRELESS TELEPHONE.

denatured alcohol, which sets up an alternating frequency of over 100,000 variations each second.

The peculiar phenomenon of alternation is accounted for in the following way: The completion of the current around the arc causes a rush of current into the shunt circuit in order to charge the condenser, thus drawing current away from the arc and increasing the resistance between the electrodes of the arc. This causes still more current to seek the condenser, charging it with a voltage higher than the normal capacity of the arc. This causes the condenser to discharge through the arc, in-

being connected to the antenna or aerial wire from which the ether waves are radiated. The principle of a transformer is such that a rapidly alternating current passed through the primary coil will induce in the secondary coil a similar alternating current, although the two coils are not electrically connected with each other.

One terminal of the secondary of the inductance coil is connected to the antenna as already stated. The other terminal is connected through the wire (A), through an ammeter, switch and telephone transmitter to ground.

The above, in brief, constitutes the

transmitting station apparatus. Its operation is as follows: The direct current generator or dynamo pumps current through the arc and causes it to burn. The peculiar properties of this arc cause a very rapid alternating current to flow through the primary coil (B) of the inductance transformer. These fluctuations are taken up by the secondary coil and carried to the antenna where they are radiated out as ether waves.

If a person now talks into the telephone transmitter the sound or air waves of his voice striking upon the transmitter diaphragm effect the resistance of the circuit leading to the antenna. These fluctuations caused by the voice are superimposed upon those set up by the "singing arc" and the ether waves that are radiated by the antenna are modulated in accordance with the modulations of the voice waves. These high frequency electrical waves then pass unseen and unheard through space to the receiving antenna.

The ether disturbances are detected at the receiving station by the Audion, which interesting and valuable apparatus consists of a tantalum filament and platinum wing and grid inside of an exhausted bulb. A current passing through the filament heats it and the little air remaining in the bulb, and forms a gas which is employed as the conducting medium between the wing and the grid, forming the terminals of the secondary (C). The waves intercepted on their way through space by the receiving antenna induce a current in the secondary winding (C) and thus disturb the Audion. The telephone receiver connects with the platinum wing and tantalum filament. The disturbance of the Audion causes the ionized gas to vary in accordance with the oscillation of the effecting waves that come down the antenna wire. As the conductivity of the gas within the Audion depends upon the ionization, the current fluctuates through the telephone receiver and modifies the vibration of its diaphragm exactly as the conductivity of the ionized gas fluctuates; this ionization varies, furthermore exactly as the ether waves sent out by the transmitting station fluctuate. Therefore the ether

waves which are sent out by the transmitting station, and which have there been modified by the human voice, are taken up at the receiving station and changed back into a form to effect the telephone receiver and the speaker's words are plainly heard.

With the means already at hand, including the microphone transmitter, with its restricted variation in resistance, the de Forest instrument is giving satisfactory results from 65 to 150 miles over both land and sea.

#### LIFE BELT WITH ELECTRIC LIGHT.

In order to make life saving apparatus more effective, it is held that if a person can be provided with a light of some kind when using a life saving belt at night, the chances of rescue will be greatly enhanced. The picture shows a cap and electric lamp used with the new



"Insubmersible" life belt designed by Jack Focketyn of Antwerp, Belgium. It is said that the electric lamp attached to the cap can be seen at sea for a distance of about a quarter of a mile.

The belt itself is of special design, such that the neck is preserved from the stroke of the waves. The cushions are so arranged that the head cannot sink beneath the waves even if the unfortunate one is unconscious.

**THE TELEGRAPHONE.**

The telegraphone is a remarkable device invented by Valdemar Poulsen of Copenhagen, Denmark, which records human speech on a wire. This may sound unreasonable, but the feat has been accomplished, and telegraphones have been constructed on this principle.

Briefly described, the telegraphone consists of two drums operated by a spring or small electric motor. A steel piano wire is wound slowly from one drum to the other. Between the two

electromagnet has a peculiar effect on the wire. It seems to rearrange the molecules of the steel and magnetize them to varying degrees, so that a record of the speaker's voice is made on the wire by the variations in the degree of magnetism at the different points along its surface. Therefore, when the wire is run back through the machine these little variations in the magnetism may be made to affect the electromagnet, and if the latter be connected with a telephone receiver, instead of a transmitter, the

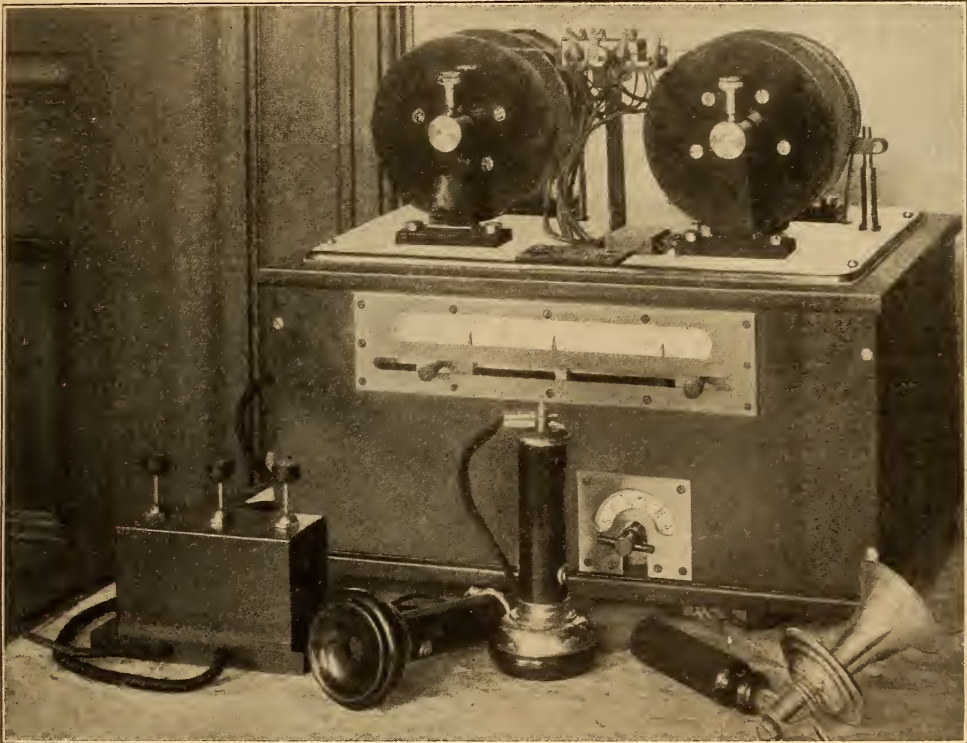

THE TELEGRAPHONE.

drums is mounted an electromagnet, which is very close to the surface of the wire. The electromagnet is connected in circuit with a telephone transmitter, so that a person speaking into the transmitter will, by the vibrations of his voice, set up little fluctuations in the current traveling out from the transmitter and around the electromagnet. What is known as the magnetic field surrounding the electromagnet is consequently varied in intensity according to the fluctuations of the voice waves as in a telephone.

This varying field of force around the

voice of the original speaker may be heard as from a phonograph.

Instead of a wire recorder, a disk of steel like a graphophone disk has been used with success. This is rotated under the electromagnet, and the little variations in magnetism recorded on the surface of the disk. These records may also be reproduced at any time and place by running the disk through a suitable machine. Thus we are confronted with the possibility that letters to our friends in the future will take the form of telegraphone disks sent by mail.

## WIRELESS ELECTRIC TRUCK.

A LITTLE room in the center of one of the big Union Pacific shop buildings at Omaha contains the secret of Dr. Frederick H. Millener's invention for "remote control" of all



kinds of machinery by means of wireless electricity. Dr. Millener calls the invention by which he accomplishes this the "selective device." The reason for the name is apparent because it makes possible the selection of any one of

a number of pieces of machinery and the control of that particular piece alone, leaving all others undisturbed.

A three-ton, 10-horsepower electric truck running on a narrow gauge track in the Union Pacific shop yards is the working apparatus which exemplifies Dr. Millener's invention. On this truck and at a height of about four feet from the ground are the horizontal antennæ, built in cylindrical form of copper wire. The use of antennæ of this kind is especially desirable as it permits of placing them so near to the ground that they do not interfere in going through tunnels or under bridges. Similar antennæ, at-tuned to these, swing from a 65-foot flagstaff over the little room where the sending apparatus is located. Between these antennæ pass the invisible power waves which control the motors of the little truck absolutely, sending it ahead, stopping it and regulating its speed precisely and instantaneously, at the will of the man with his finger on the sending apparatus.

Dr. Millener had another difficulty to overcome, however, before he was able to control machinery on wheels. This difficulty was to get a continuous "ground." The constant passage of the wheels over breaks in the track or over other obstacles broke the "ground" and presented the old difficulty which has been an obstacle to successful communication from moving trains. Dr. Millener

was successful in inventing a "traveling ground." Thus he maintains complete and unbroken control over his selective device located on a moving vehicle. Incidentally he has solved the problem of communicating from a moving train.

The man who has made these successful and important inventions is still quite young. He graduated with honors from Jefferson Medical College, Philadelphia, in 1894, and his early energies were directed toward medicine. His undoubted efficiency as a physician brought him a large practice. But after he had spent the day visiting patients he often spent the night absorbed in his electrical experiments in a private laboratory which he had fitted up. Eventually his true love won out, he abandoned his lucra-

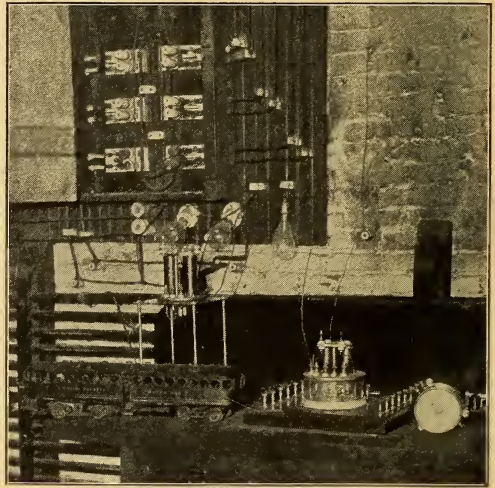

CORNER IN DR. MILLENER'S LABORATORY

tive practice and came several years ago to the Union Pacific shops as electrical engineer. His experiments were conducted at the direction of the higher authorities of the road and with the cooperation of W. R. McKeen, Jr., superintendent of motive power and machinery of the Union Pacific.

Dr. Millener is preparing to equip one of the big mogul locomotives in the shop yards with his selective device for the purpose of demonstrating how a ponderous engine can be controlled by the





THE WIRELESS ELECTRIC TRUCK.

mere touch of a finger even when that finger is miles away. It is not likely that the selective device will be applied to locomotives, practically, at the present stage of railroad development, but it is easy to see how one man in a central sending station could operate a railroad system by means of wireless. A small motor might be placed in the cab of a

steam engine to supply the power to open the throttle or to shut it, the selective device working on the motor.

The system is also admirably adapted for throwing railway block signals, for exploding dynamite in a mine, for steering torpedoes through the water, and other practical things.

#### **ELECTRICITY OPENS A SAFE.**

Recently the huge steel door in the safe of a bank was closed for nearly 100 hours, during which all efforts to open it were unsuccessful, the time lock being deranged. It was a battle of a modern burglar-proof safe against the tools of experts. It was finally decided that the only way to reach the mechanism within was to burn a hole in the safe.

When the decision was reached "to operate," as a surgeon would say, electricity was brought into requisition. The metal of the safe was connected to one side of the railway power circuit. To the other side of the circuit a heavy conductor was attached which terminated in a carbon point. When the carbon point was held against the safe by the operator an arc was formed producing in-

tense heat at the point of application. In this way a hole was rapidly melted entirely through the side of the safe.

#### **TYPESETTING BY WIRELESS.**

A recent newspaper dispatch from London states that a Danish inventor has announced that he has perfected an apparatus by which typesetting machines in New York can be operated from London by means of a wireless telegraph system. The inventor says that he will publicly demonstrate his new wireless typesetting invention within a few weeks, and has already had the first machine constructed, which has proved successful, setting 3,000 words an hour at a distance, just as if the operator were working the machine.

# ELECTRICITY IN MEDICINE.

BY OTTO JUETTNER, M. D., PH. D.

## PART III.

The so-called static machine occupies a very conspicuous place in the electrotherapeutic equipment of the modern physician. It is used for the purpose of furnishing static electricity. It is available for the production of high frequency currents. It is also useful as a generator for the kind of energy which is employed to excite the so-called Roentgen or X-ray tube for the production of Roentgen or X-rays.

The primitive and now obsolete type out of which the modern static machine has been evolved, consisted of a glass cylinder revolving upon a horizontal axis, a cushion of horse-hair to which a long silk flap was attached and an insulated metal cylinder. The latter was called the prime conductor and was mounted in front of the glass cylinder, carrying a row of spikes or needles pointing towards the cylinder. When the glass cylinder began to turn, the glass was charged positively while the horse-hair took up a negative charge. The positive charge, which was carried around on the cylinder, caused an inductive charge to appear in the prime conductor. The charge had a negative character. Thus the electrical equilibrium was sustained by the neutralization of the positive charge in the glass cylinder and the negative charge in the metal cylinder.

In the course of time this simple form of apparatus was modified by substituting one or more plates of glass, mica, rubber or ebonite for the glass cylinder. The horse-hair cushion (one or more) is placed against the plate. The prime conductor is represented by a properly mounted metal rod which carries metal spikes or pins pointing against, but not touching the plate. When the plate revolves, a positive charge appears on the plate and a negative charge in the metal prime conductor. Both the cylinder machine and the plate machine imi-

tate on a more elaborate scale the simple experiment of producing electrical energy by rubbing a glass rod with a piece of silk.

In the year 1865 the German physicist Toepler embodied these principles in a machine consisting of stationary and revolving plates. Friction is produced by tinsel brushes which are held by the prime conductors. When the plates revolve these tinsel brushes rub over brass buttons which are carried by the first and last revolving plates. Positive charges are thus produced which act inductively

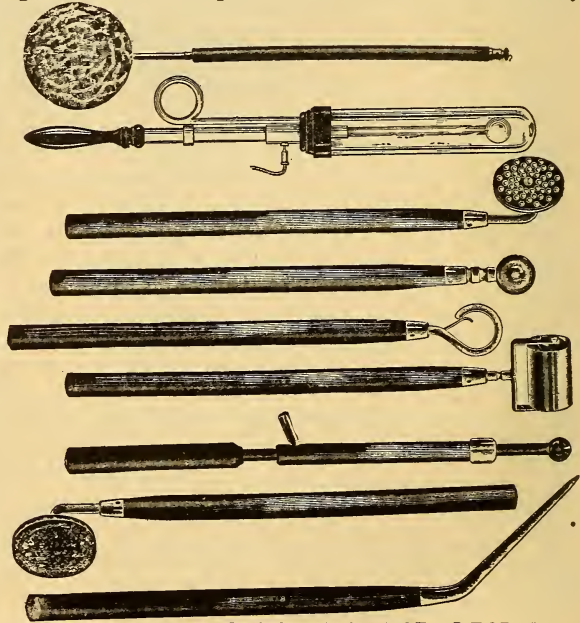

FIG. 8. ELECTRODES FOR BI-POLAR TREATMENT.

upon the prime conductors, causing negative charges to appear in them. Strangely enough, another German physicist, named Holtz, invented an apparatus in 1865 which was almost identically the same as Toepler's machine. The two men worked independently of each other and for this reason their machine, Fig. 9, is now generally known as a Toepler-Holtz machine.

The plates in one of these machines are arranged in sets of four, each set consisting of one revolving, two station-

ary and another revolving plate. There is a space between the different sets. A machine may have, one, two, three, four, five, six or more sets, constituting a four-plate, eight-plate, 12-plate, 16-plate, 20-plate, 24-plate machine or more. The plates are carried by a shaft which passes through circular openings in the center of the stationary plates, without touching the latter. They are held in position by cross bars above and below. The revolving plates are mounted firmly on the shaft so that both shaft and plates turn together. Let us imagine the plates taken away. The remainder of the machine would be a skeleton consisting of the shaft and the other parts that belong to the machine.

Let us study this skeleton picture, Fig. 10, and become familiar with static machine construction as devised by Toepler and Holtz. There are two parallel cross bars at the bottom of the machine. One of these cross bars is No. 2, the other is not numbered. No. 31 shows the support which holds the cross bar. On top we see a cross bar, No. 1. The purpose of these cross bars is to hold the stationary plates in position. We notice the washers on these cross bars. The washers are made of hard rubber and move by accurately fitting into a thread. Each stationary plate is held between two of these washers. No. 3 is the support by means of which the cross bar is attached to the case of the machine. No. 4 is a metal frame which carries the tinsel brushes that rub over the brass buttons on the first and last revolving plates. It is held by a special hub No. 29. No. 9 is one of these brushes. The inside space of this metal frame shows metal combs that collect the electric energy from the plates. One comb fits into the space between two sets of plates. Nos. 6 and 33 are metal brackets which

carry clamps, No. 7, to hold the stationary plates, and tinsel brushes, No. 9. No. 5 is a horizontal frame analogous to the frame No. 4. It carries combs to collect electricity from the plates, and clamps to hold the stationary plates in position. No. 8 is an oil cup for the revolving shaft. No. 12 is an upright hard rubber post which holds the large and small brass balls, Nos. 13 and 14. These balls are in front of the machine. They are

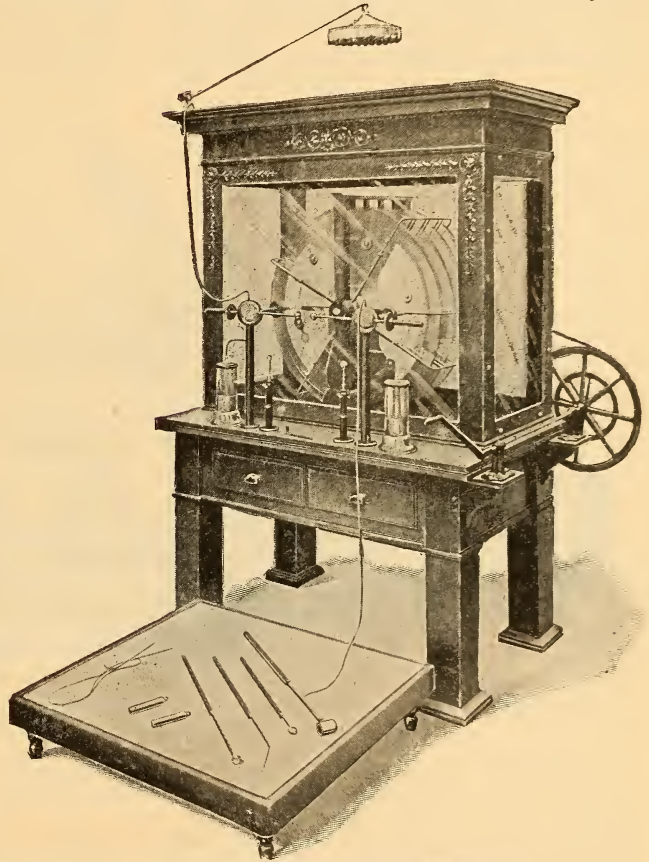

FIG. 9. TOEPLER-HOLTZ MACHINE.

collectors of static electricity. The latter accumulates on even and smooth surfaces. Static machines now-a-days have an X-ray attachment or special posts for the attachment of the wires that go to an X-ray tube. These posts are Nos. 10 and 11. The electric spark which appears in front of the machine, fills up the gap between two small balls (terminals) carried by movable horizontal bars, No. 15. The one on the other side is not numbered. They are sometimes called "sliding rods."

Nos. 16 and 17 are the so-called Leyden jars (pronounce *liden*, not *laden*) which are made of glass. The inside (bottom and lower part of the sides) is covered with tinfoil. This is known as the inner or the internal armature of the jar. The whole jar on the outside rests in a snugly fitting metal cup, No. 24, which is known as the outer or the external armature. The lid of the jar is made of some insulating material. In the center is a metal button which penetrates the entire thickness of the lid. This button holds a chain or wire which is

through the crank shaft, No. 19, the large pulley wheel, No. 20, and the rear axle pulley wheel which is mounted on the revolving shaft. The crank shaft is held in position by an iron bracket, No. 32. In most doctors' offices static machines are not turned by hand but are driven by an electric motor. No. 22 is a device which is found in some machines. It is called a current controller and is frequently the cause of much confusion. It is an unnecessary incumbrance. No. 23 is another attachment of questionable value, a current indicator with a hard-rubber

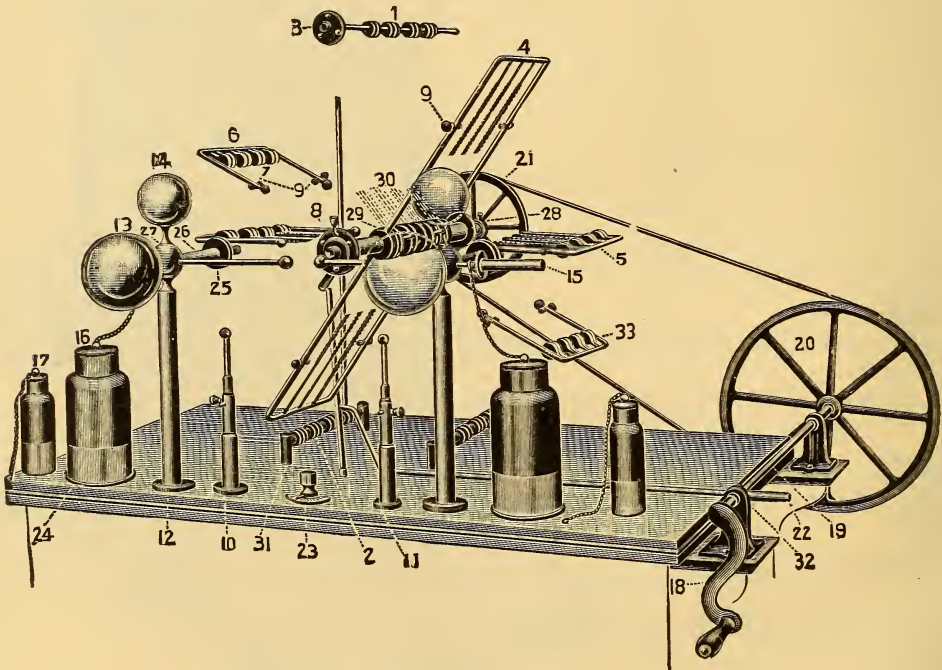

FIG. 10. DETAILS OF TOEPLER-HOLTZ MACHINE.

suspended in the interior of the jar and touches the inner armature. The outer portion of the button is arranged so that the jar can be attached to the static machine by means of some suitable conductor (rod, chain, wire). The Leyden jar is a condenser and offers a beautiful illustration of the principle of induction. When the inner armature is charged, it acts inductively on the outer armature, generating an induced charge. We shall have occasion to refer to this phenomenon again.

No. 18 is the crank handle by means of which the machine is set in motion

switch. Nos. 25 and 26 are a pair of hard rubber washers which fit on the outside and inside of the glass which is a part of the case of the machine. No. 27 is the metal head of the main post, No. 12. No. 28 is an oil cup for the revolving shaft. No. 30 indicates the position of the two kinds of plates (stationary and revolving).

There are certain physical conditions upon which the working quality and capacity of a static machine depends. The machine, especially the plates, must be kept clean. Frequently it is sufficient to use a soft silken rag to keep the plates

clean. Sometimes it is necessary to moisten the rag with alcohol and apply it to the plates by gently moving the rag over them. Care must be taken not to rub too vigorously lest the coating of laquer with which the plates are covered be worn off. In addition to keeping the machine clean it is of great importance to have the air in the case as dry as possible. It is often necessary to dry the air in the machine by means of chloride of calcium which is placed on a tray and put in the case. It is proper to use the fused calcium, in lumps. The machine must run smoothly and easily. The motion of the plates is opposite to the movements of the hands of a watch, i. e., from right to left. Let us remember in this connection that the size of the plates determines the electromotive force of the current produced. The larger the plate, the higher the voltage. The number of the plates determines the strength of the current. The more plates, the greater the amperage.

In using a static machine, the first important point to be remembered is the manner in which the polarity of the current can be recognized. Put the horizontal sliding rods one inch apart and notice the spark. One end of it is bright, the other purple. The bright end of a one-inch spark is the positive side, the purple end is the negative side. Pull the rods away from each other and cause a spark of four, five or more inches to pass. The conditions will be reversed. The bright end is negative and the purple end is positive. Remember that the polarity of a static machine is liable to change. It is proper to test it before using the machine.

The ordinary way in which a static machine is used is by placing the person to be treated on a specially insulated stool or platform and connecting the stool or platform with either the positive or the negative side of the machine by means of a chain or a rod. Which side is to be connected, depends on conditions which we will have occasion to consider later on. The side which is not connected with the stool or platform (and through these with the patient), is either left unconnected or is grounded by attaching a wire to it and connecting the wire with a gas pipe, a water pipe or anything else that will allow the current

to reach the ground. The machine being started, the patient receives a charge from the side of the machine with which he is connected. This kind of an application is the simplest form of a static treatment and is called a static insulation, negative or positive, depending on which ever side is connected. There being but one pole used, the application is known as a "unipolar" or "monopolar" application.

In Fig. 8 are shown a number of electrodes used in giving bi-polar treatments (both poles used).

Each one of these electrodes has a hard-rubber handle which is grasped by the hand of the operator. The electrode is connected with the positive or negative side of the machine, the platform upon which the patient sits or stands being in the circuit of the other side. The character of the electric discharge (spark, brush, spray) will depend upon the kind of electrode used. If the discharging end of the electrode is a round, uniform surface like a ball, there will be a tendency towards accumulation of the electric energy. When a discharge ultimately takes place, it will be in the form of a spark. The discharge will be concentrated, not split up. The larger the discharging surface, the thicker the spark. If the ball is small, a long, slender spark will be the result. If the discharging end of the electrode is uneven or even pointed, the electricity will not be retained but will escape either in the form of multiple small sparks or a spray, especially if the end of the electrode represents many sharp points. If the end of the electrode offers many sharp points for the escape of the current, the result will be the formation of a fine spray and a general electrification of the air in the vicinity of the electrode. The molecules of the air will be violently agitated, giving the patient the sensation of a breeze of wind. This application of static electricity by means of the crown electrode placed over the head of the patient is one of the most effective and popular modes of static treatment. It may be well to add that the voltage of static currents is very high. It requires more than five thousand volts to drive a spark across an air space of 1-10 inch.

If the platform upon which the pa-

tient sits or stands is connected with one side of the machine, the connecting chain being hooked over the horizontal sliding rod of that side and its other end being attached to the platform, and the electrode with which the treatment is being administered is attached to the other horizontal sliding rod by means of a chain, the patient is said to be in the direct circuit of the machine. The treatment is a "direct" application of static electricity. If the electrode is not attached to the machine but to a gas fixture, or, for that matter, to any conductor connected with the earth, the machine having previously been grounded,

Thus he may receive a positive or a negative static insulation.

"Direct positive sparks" are produced by connecting the platform with the negative side and a ball electrode with the positive side. If the platform is connected positively and the ball electrode negatively, the result will be "direct negative sparks." If the platform is connected negatively and the positive side of the machine is grounded, the ball electrode carrying the current from the earth, the result is "indirect positive sparks." Reverse the conditions and you produce "indirect negative sparks." Substitute a sharp pointed or a large or

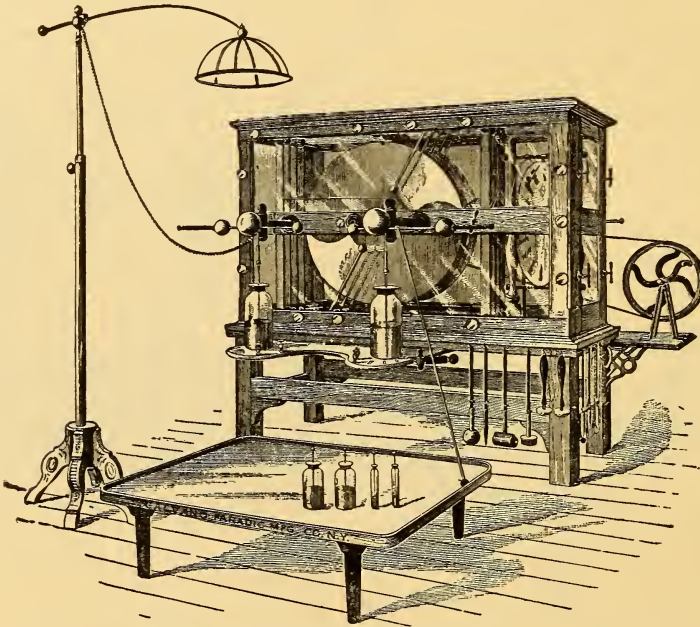

FIG. 11. TOEPLER-HOLTZ MACHINE WITH SMALL PLATES.

the circuit is called a grounded or indirect circuit. The patient receives what is known as an "indirect" application. The circuit is completed through the earth. Grounding the circuit increases the potential of the current.

By way of fixing a few common terms in our minds, let us recapitulate:

A "static insulation" is an application administered by putting the patient on the platform and connecting the latter with one or the other side of the machine. The unengaged side of the machine is grounded. No electrode is used to complete the circuit. The patient only gets the current from one side of the machine.

small crown electrode for the ball electrode, and make the attachments in precisely the same manner. The result will be a "direct positive breeze," a "direct negative breeze," an "indirect positive breeze," or an "indirect negative breeze."

Let us put the horizontal sliding rods close together, leaving no spark gap. Let the wires be attached to the outer armatures of the Leyden jars. We will then get a circuit of a current that is not properly a primary static current. It is a secondary or induced current generated in the outer armatures of the jars, the intensity of the current depending on the character of the primary discharge which

takes place between the sliding rods the moment they are separated. The longer the spark, the more induction in the outer armatures of the jars. This current is generally known as a "static induced current." It is a current of very high voltage. If it is interrupted and applied suddenly, the full charge of the jar emptying itself at once, it is not without danger. It is very painful by violently contracting the muscles. It is capable of completely paralyzing a muscle for the time being. If the muscular tissue thus violently contracted is near the heart, the result might be more or less serious. An exciting but not dangerous experiment can be made in the following manner.

Close the spark-gap between the sliding rods. Short-circuit the outer armatures of the Leyden jars by connecting them (a metal rod or chain will do). Some machines have a special short-circuiting device for this purpose. Attach a wire with a metal handle to the outer armature of one jar. Attach another wire with a metal handle to the outer armature of the other jar. Let any number of people join hands, the persons on the ends holding the metal handles. Now start the machine. Separate the sliding rods slowly and watch for the effect. It will be most startling and amusing.

Fig. 11 shows a machine of the Toepler-Holtz type with a set of smaller plates that serve as a generator to "influence" current-production. This type of machine is very popular in the East. In Europe it is sometimes referred to as the "American" type.

(To be continued.)

#### A FOUR-YEAR-OLD TELEGRAM.

Telegraphing to the stars would be a tedious matter. The transmission of a telegraphic message over a wire to Alpha Centauri would, indeed, tax the patience of all concerned. The key is pressed down, the circuit is complete, the message bounds off on its journey; it wings its way along the wire with a velocity sufficient to carry it 180,000 miles in a single second of time. Even this, the nearest of the stars, is, however, sunk into space to a distance so overwhelming that the message would be four years on the wire before reaching its destination.

#### WHAT TO DO FOR ELECTRIC SHOCK.

Every man engaged around an electric plant should study and practice the means of resuscitation so plainly described in the May number of *Popular Electricity*, until he is able to work at it as automatically as he winds an armature. There is another and later means of saving life jeopardized by high tension currents, with which every electrician professional and amateur should be as familiar as he is with his pliers. This later method seems simpler and has the same basic principle of inducing breathing when respiration has stopped from any cause affecting the nervous system.

The injured man should be placed with his head hanging over a rolled coat, a small armature, or other cylindrical object, exactly as described in the previous article. The jaws should be opened and held apart by a piece of wood of considerable size, as told in the May number. The tongue should be pulled out by the same means described there. The new principle is that the slow, hard, rhythmical stretching and releasing of the tongue is perhaps the most efficient means of starting breathing in these cases.

Grasp the tongue with pliers, or a handkerchief or rag held in the hand; pull it out as far as possible; let it go back until it is loose; pull it out on a hard stretch again; loosen it again; alternately pull it hard taut and release it—do this not faster than once every three seconds. Three seconds is a very long time under such circumstances, and is the time required for an excited man to count from six to ten; it is well to count three during the stretching of the tongue and three while it is being released. Above all things be deliberate—and this applies to the arm and chest method in the May number as well as to this tongue stretching procedure.

The tongue is apt to be injured a little by the amateur practicing this method with a pair of pliers; but a live man with a sore tongue is worth more than a dead man with a perfect tongue. The patient will not feel any pain at the time, and the soreness afterward will soon disappear. So, if you make the tongue bleed a little, simply keep the blood wiped off and go ahead. A sharp hook

of small caliber may be used instead of pliers or the handkerchief to hold the tongue.

Fig. 1 in the May article illustrates the method described above, and in the picture the tongue is being pulled out. Some people will be more effective if they will sit beside the body and pull the tongue out over the chin. It is interesting—and nothing is more valuable—to spend some time at noon practicing means of saving life on one another, for after such practice the method comes as

#### TROLLEY CAR AS A MOVING VAN.

Moving household goods by electric car is the latest innovation by means of which a railway company can serve the community. The Conestoga Traction Company of Lancaster, Pa., has solved this problem successfully. At present most of the moving is done at night. An occasional job is handled in the daytime, the car being loaded between schedules. Moving is not done from one part of the city to another, but from some point in the city to the country or vice versa. The

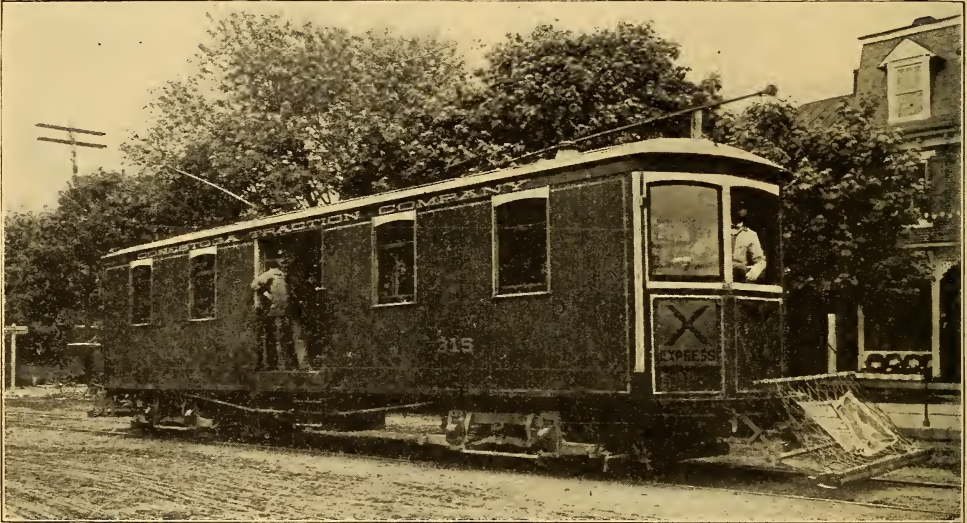

TROLLEY CAR AS A MOVING VAN.

natural as throwing a switch in time of danger. In practicing this tongue stretching method on a conscious subject, only the handkerchief hold should be taken on the tongue to prevent unnecessary pain.

The most important point of all is patience and persistence. Do not stop short of an hour with an apparently dead man. Disregard the undertaker, if he comes quickly, and even a doctor who gives up too soon. Cases are on record from trustworthy sources of men who have been saved by this tongue stretching method an hour after competent physicians agreed with everybody around that the man was stone dead from electric shock. The actual observations are almost past belief. Above all things, don't give up.

G. WALTER BARR, M. D.

accompanying picture is a good view of one of the moving cars.

#### NAVAL ELECTRICIANS IN DEMAND.

A vigorous canvass for electricians for the United States Navy has commenced. The increasing use of electricity in the operation of Uncle Sam's battleships has rendered an increase in the number of technical men in the navy imperative. A man does not have to be an expert when he enlists in the service, but he must have certain qualifications that will fit him to enter a special electrical school that is operated in the Brooklyn Navy Yard for the purpose of training men to manipulate and care for the many types of electrical machines and apparatus, including wireless telegraphy, used for the various purposes on board a modern war vessel.



## NATIONAL ELECTRIC LIGHT CONVENTION.

Each branch of the electrical industry has its typical association. There is the National Light Association for the electric lighting interests, the American Street and Interurban Railway Association for the electric railway interests, the American Electrochemical Society, etc. The great event of the year for electric central station men throughout the country is the National Electric Light Association convention, which is held annually.

the members present. In this way all the knotty problems of the business are threshed out, and the results accomplished by the conventions are of great value to the central station interests, the papers and discussions being printed in book form and sent to all the member companies.

Exhibits by the electrical manufacturing companies assist to a large extent in making these conventions a success. So



CORNER OF EXHIBIT HALL AT N. E. L. A. CONVENTION.

The thirty-first convention of this association was held in the Auditorium Hotel in Chicago May 18 to 22 inclusive, and in many respects it was the best convention in the history of the organization. There were nearly 2,000 delegates and guests registered.

The principal work of these meetings is the reading and discussion of papers bearing upon every phase of the central station industry. These papers are prepared and delivered by men who are recognized authorities in their several lines, and the discussions are entered into by

important has this feature become that of late years the manufacturers have been admitted to an associate membership under a different class from the central station companies. They have their committees who take complete charge of the exhibit features and the elaborate entertainments which are furnished free to the delegates and their friends.

Exhibition Hall, on the ninth floor of the Auditorium presented a scene of beauty and activity. The exhibits showed the latest and most approved electrical apparatus, and the scene was intensely

lighted by tantalum lamps, tungsten lamps, carbon arcs and flaming arcs. The picture herewith shows a small section of the exhibit hall, enough, however, to give an idea of the beauty of the scene.

As showing the importance which is attached to the annual convention, it may be stated that a daily magazine was published during the convention week by the C. W. Lee Company of New York. Each issue contained fifty pages and chronicled the complete doings of the convention.

### ELECTRIC RAIL WELDING.

In order to furnish a continuous path by which current can return to the power house after it has passed from the trolley wire through the motors of a car, it is necessary to make a connection at each

struction of the roadbed of the street railway system in Chicago. The complete outfit consists of four cars which are arranged in the order in which they are used in making a weld.

The first car is called the "sandblast car." A fan driven by an electric motor delivers a stream of compressed air. Sand is introduced into the air and the blast is directed on the rail where the joint is to be made, removing all dirt and leaving the surface clean.

The second and third cars carry all of the apparatus necessary to make the weld and are shown in the illustration. A rotary converter is located in the third car and is used to change the 500 volt direct current from the trolley to alternating current at a pressure of 300 volts. It is necessary to use a potential regulator to



ELECTRIC RAIL WELDING CAR.

rail joint which will let the current through. Sometimes this is done by bonding the joints with copper wires or strips, sometimes by welding the ends of the rails together.

The accompanying illustration from a photograph shows the electric rail welding outfit now being used in the recon-

struction of the roadbed of the street railway system in Chicago. The complete outfit consists of four cars which are arranged in the order in which they are used in making a weld. The first car is called the "sandblast car." A fan driven by an electric motor delivers a stream of compressed air. Sand is introduced into the air and the blast is directed on the rail where the joint is to be made, removing all dirt and leaving the surface clean. The second and third cars carry all of the apparatus necessary to make the weld and are shown in the illustration. A rotary converter is located in the third car and is used to change the 500 volt direct current from the trolley to alternating current at a pressure of 300 volts. It is necessary to use a potential regulator to

seven volts which is the pressure that is used in making the weld.

After the rails have been thoroughly cleaned by the sandblast car, two steel blocks are placed across the joint along the web of the rail, one on each side. The welding jaws shown in the picture are then lowered and secure the blocks in position. The current is now turned on and about 27,000 amperes pass through the rail from jaw to jaw. When the metal has reached the proper temperature for welding, a pressure of about 4,000 pounds per square inch is applied at the jaws by means of a hydraulic pump arrangement, and current is turned

#### PHOTOGRAPHING ELEPHANT BY X-RAYS

In an effort to locate a diamond ring, valued at \$450, which an elephant had swallowed accidentally while being fed peanuts, three expert X-ray operators and four elephant trainers worked a whole day recently in Cincinnati, photographing by the X-ray process the entire interior of the elephant. It is the first time in the history of the science that X-ray photographs have been made of an elephant.

In making the plates the largest X-ray apparatus ever made was used, and the manufacturer himself, Mr. J. R. Kelley,

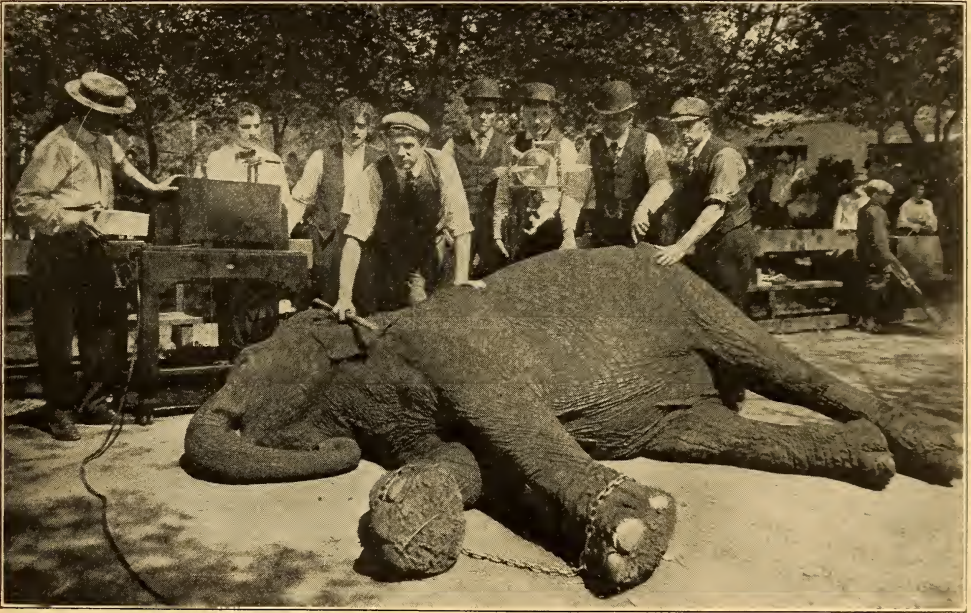

PHOTOGRAPHING ELEPHANT BY X-RAYS.

off. This pressure is applied for about five minutes and is then removed and the jaws are raised.

The jaws are kept cool by a constant stream of cooling water which is forced through them.

Car number four is then moved up and the top of joint is ground off level with the track by an electrically driven emery wheel. This wheel is so mounted that it is impossible to grind below the level of the rail. This completes the weld, the whole operation requiring about fifteen minutes.

of Covington, Ky., superintended the operation. The machine was of the Grasse-Flamme type of X-ray coil, supplying current to an eight-inch Crook's tube, the largest made.

To find the exact spot where the missing ring was located in the elephant, one side of the beast was marked off into sections and numbered. A diagram was also made with corresponding numbers. At first it was necessary to allow the elephant to become accustomed to the crackling of the X-ray coil, an operation which took one hour. Then, when the

Crook's tube was held over the first section of the body and the exposure started, the elephant became frightened at the glare from the tube and half an hour was consumed getting her accustomed to the glare. At last the beast was convinced that the men did not wish to do her harm and she lay comparatively quiet upon the plateholder until the plates, 18 in all, had been exposed. The ring was located in the stomach of the elephant.

### THE SEISMOGRAPH.

Of all the modern aids to science there is none more interesting than the electrically operated instrument whereby earthquake shocks are recorded. This apparatus, known as the seismograph, is so delicate in adjustment and so sensitive to earth tremors that it will accurately record shocks even though the scene be thousands of miles from the location of the instrument. The instrument in possession of the United States Weather Bureau at its headquarters at Washington, and which is here illustrated, not only rendered a graphic record of the San Francisco earthquake 3,000 miles distant but has from time to time conveyed tidings of earthquakes in South America, Japan, etc.

The mechanical principles involved in the construction of the seismograph were first developed and applied to the measurement of earthquakes by James A. Ewing, who was at the time Professor of Mechanical Engineering at the University of Tokio. Like many another invention the seismograph was developed and improved by various experts until the present-day apparatus is, in appearance, widely different from the original. In its present form the seismograph is not only well adapted to measure and record ordinary earthquakes but will even register the feeble, unfelt earthquakes which frequently occur in all parts of the world.

It is essential that so delicate an instrument be sheltered as much as possible from disturbing influences, such as passing wagons, street cars, etc., and accordingly it is secured to thick blocks of stone which are in turn cemented firmly into a concrete foundation. The chief feature of the earthquake recorder is a horizontal pendulum, supported on sharp steel points

and swinging with great freedom of motion. The vibrations to be recorded are reflected in the movement of the delicately poised portions of the apparatus. A prominent part is played by a massive lead weight which is so arranged that it will remain quite at rest during an earthquake, notwithstanding the fact that the earth and its own supports are undergoing severe vibratory displacements.

The magnifying and recording lever which is instrumental in writing down the earthquake's message to science is made of a very thin sheet of aluminum, bent into an inverted trough-shaped form to secure stiffness. The record is traced on a sheet of smoked paper wrapped around a cylinder. In order that there may be the least possible friction at the

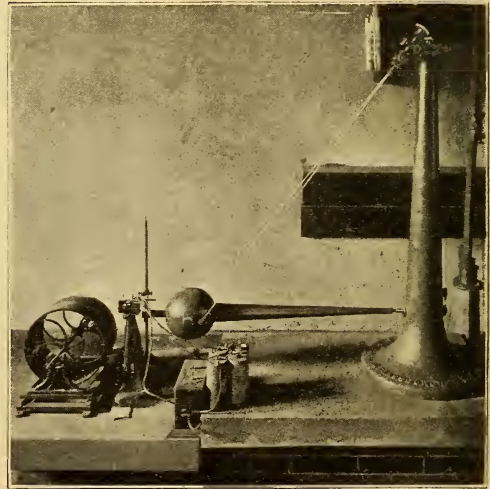

Copyright, 1908, by Waldon Fawcett.  
THE SEISMOGRAPH.

tracing point, the coating of soot is made relatively thin, and paper with a highly glazed surface is used.

The record cylinder bearing the earthquake chronicle makes one revolution per hour and an ingenious mechanical attachment shifts the cylinder endwise as it revolves so that successive portions of the record are clearly separated. Then there is an electric time-marker, the magnet of which is in connection with a circuit closer actuated by a high-grade clock. The circuit is closed momentarily once each minute and causes a finger to mark a stroke each minute on the record.

**OMAHA ELECTRICAL SHOW.**

A marked impetus is given to the electrical industry by the numerous "electrical shows" which have now become an annual event in many of the larger cities of the country. These exhibitions are both interesting and instructive, not only to those connected with the electrical industry but to the layman as well.

In Omaha, Neb., such an exhibition was held, May 4th to 9th, in the Auditorium. The average attendance was 5,000 people daily, and all the visitors

tricity which increase the comfort of the modern home.

In all there were 120 firms exhibiting at the show. Their booths were brilliantly lighted by night, many of them containing moving displays which added to the beauty and animation of the scene.

**ELECTRICITY AS A RESURRECTION FORCE.**

Cases of resuscitation after drowning are some of them so remarkable as to almost indicate that life could be restored



OMAHA ELECTRICAL SHOW.

were enthusiastic over the new applications of electricity for the first time brought to their notice.

The main feature of the show was the Electric Cottage, which is shown in the center of the picture. This was the exhibit of the Omaha Electric Light and Power Company. It contained nine rooms, all fitted with the most up-to-date electrical conveniences, including beautiful lighting fixtures, electric heaters, cooking utensils, laundry equipment and the hundred and one applications of elec-

to a body even after the spirit had once departed. Whether or not a person, actually dead, can be brought to life is a question. Mr. Larmandie, a member of the French Authors' Society, says that this is possible, and that three physicians of his acquaintance who are famous in the scientific world actually succeeded in bringing to life the dead body of a young girl who had been dead three hours. The doctors affirm that she was dead. They worked at the body for three hours, electrified it, kneaded it in tepid water, burnt

it with sulphuric acid, brought it to a semblance of life and made it speak.

It is reported that the girl was able to relate a most wonderful experience. She said that her mind seemed to leave her body which was intensely cold. There seemed to be a connecting force, however, which suddenly broke, like an infinitesimal electric spark. When the girl regained consciousness she was in a state of great excitement. She afterwards died in reality from the effects of morphine given to quiet her.

Feelings described by the patient would seem to be the fancies of a disordered mind. However, it is not beyond the limits of possibility that there was actual restoration of life. There are unseen forces, be they electrical or otherwise, which are beyond the grasp of scientists of the present day. Enough has been observed to indicate that some day these forces will be understood and things which now seem impossible will be explained.

#### A LUXURIOUS STABLE.

Not every horse can spend his hours of leisure in a carpeted stable with gilded stalls lighted by the soft glow of beautiful electric ceiling lights. Such conditions do fall to the lot of some horses, however, and the accompanying picture is intended to show how really



A LUXURIOUS STABLE.

comfortable a stable may be made. A further application of electricity suggests itself as a possible improvement, that is, electric heaters for the stalls, and the horses would also no doubt prefer to have their hot bran mashes prepared in individual electric chafing dishes.

#### THE AUTO-TELEGRAPH CAR.

The United States Government has recently undertaken to utilize automobiles in several novel ways. Probably the most interesting of these is exemplified in the auto-telegraph car constructed for the Signal Corps of the U. S. Army. Not only is this telegraph car the most important war automobile which has been perfected in America, but it is likely to prove of greater practical utility than any military motor employed by any other nation.

In so far as structural details and other technical features are concerned the auto-telegraph car conforms very closely to a standard high power, long distance touring car of the Winton type, with the exception that instead of the ordinary tonneau this car has a specially designed tonneau that is exceptionally roomy and is provided with seats along both sides, the occupants of which face one another. In front, arranged in the approved plan for such machines, are the seats for the driver of the car and his assistant.

The first consideration in designing this car was the provision of ample space for the storage of instruments, wire and other equipment. To this end spacious lockers have been provided under the seats and elsewhere in the body of the machine. Inasmuch as the Signal Corps is now making use in its line work of a wire so light and fine that a reel of it can be carried in a man's pocket, it goes without saying that a considerable quantity of wire can be stowed away in the compartments of the car.

At the sides of the car are racks on which are carried considerable numbers of lances or light poles which may be employed in stringing a temporary overhead telephone or telegraph line when other supports for the wire are not available.

The principal function of the auto-telegraph car is the construction, maintenance and operation of temporary or permanent telephone and telegraph lines for military purposes. Especially is it useful as a moving base of supplies in the erection of a telephone or telegraph line connecting a military post or other headquarters with a force in the field. Heretofore it has been almost impossible to

keep pace in the erection of a communicative line with the march of a rapidly moving field force, especially when troops in the field operate under secret orders, making it impracticable to dispatch a telegraph corps in advance. The auto-telegraph car, however, enables a detachment of the Signal Corps to keep

transmitting instruments and can be brought to a standstill at any point during the erection of a line or where a wire system already exists, and communication may instantly be established with the terminus of the line or any intermediate point. The equipment of the car also includes improved "sounders" which ren-



Copyright, 1908, by Waldon Fawcett.  
THE AUTO-TELEGRAPH CAR.

pace with the most rapidly moving force of infantry or artillery and even hold their own with a "flying squadron" of cavalry.

Equally significant are the possibilities of this new invention as a portable field telegraph and telephone station. The car is fully equipped with receiving and

der possible the receipt and transmission of messages without regard to the roar of artillery or other distractions. The detachment of the Signal Corps in charge of this car embraces eight men, including two telegraph and telephone operators, a driver and assistant and four linemen.

# WIRELESS TELEGRAPHY MADE SIMPLE.

BY V. H. LAUGHTER.

## PART III.

### WIRELESS RECEIVING ENDS.

At the receiving end of a wireless station there are two general types of detecting apparatus employed, those of the metal-filing type, which are used in connection with the automatic tapping device, and those which are self-restoring, used in connection with the telephone receiver. Of the two types the metal filings type has enjoyed a wide popularity and is still in use to a certain extent. The self-restoring coherer, or better known detector, however, is far more sensitive and reliable in its operation. The rate at which messages can be received is also increased to a large extent by the self-restoring kind, due to the fact that the tapping device, which is slow in operation, yet necessary to the metal filing coherer, has been done away with.

The metal filing coherer is still in use by a number of systems, but mainly that of Slaby-Arco manufacture, which employs a vacuum coherer in connection with a polarized relay of high sensibility, the automatic tapping device and Morse register. There are yet other types of coherers used with the relay such as the Lodge-Muirhead revolving coherer, the Castelli electromagnetic and others. However, the metal filing coherer is fully as good and not so difficult in operation as those named above.

Coherers of the self-restoring kind cannot be used in connection with the relay, as the high resistance across the coherer contacts will not allow sufficient current to flow through to actuate the relay. A telephone receiver is used, however, which is far more sensitive.

The best known self-restoring detecting devices are the liquid detector, carborundum detector and silicon detector.

The liquid detector invented by Prof. Fessenden, was the first of the above named to come into actual use, and is now being employed by the leading wireless companies and the Naval service, as well as the carborundum and silicon types. In construction it is very simple and consists of the point of an extremely

fine platinum wire touching a solution of dilute nitric acid, or other electrolyte, with a second contact in the solution.

The simplest form is shown in Fig. 15, which comprises a thin platinum wire soldered in the slit of a thumb screw which works through a metal standard. Under the thumb screw is placed a glass cup containing the electrolyte and with platinum contact soldered in. Connection is made from the aerial wire to the standard bearing the platinum wire in the thumb screw, and from the contact in

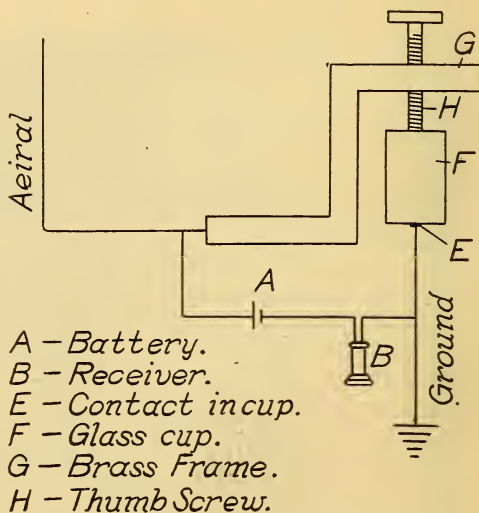

FIG. 15. SIMPLE LIQUID COHERER.

the glass cup to the ground. The telephone receiver and battery are in series across the contacts as shown in the plan, with the positive side of the battery pole leading to the platinum point.

In action the current from the battery flows through the thin platinum point and in doing so sets up polarization around it, which means an accumulation of oxygen gas around the wire, thereby insulating it from the electrolyte and preventing farther flow of the current.

If the key at the transmitting station is now pressed and the circuit closed, which starts the transformer or other high frequency apparatus, waves will be



spread out in all directions, of which a certain portion will enter the elevated aerial wire at the receiving end and flow through the thin platinum wire on the path to the ground, thereby breaking down the insulating medium of oxygen gas surrounding the wire and allowing the current from the local battery to flow through the receiver, giving a hissing sound which is in duration to the incoming wave.

In practice it is found necessary to introduce some form of variable resistance in circuit with the battery and detector in order that enough current may be allowed to flow to the platinum point for the polarization to be set up, yet not strong enough to break down the insula-

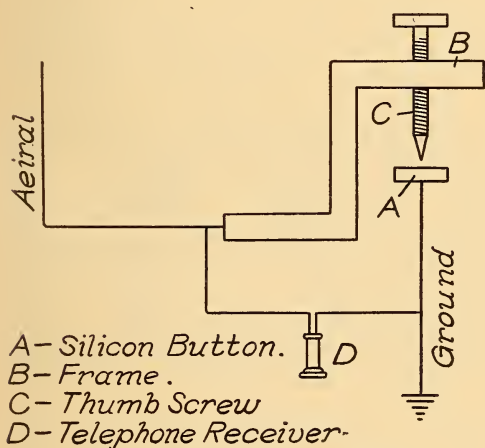

FIG. 16. SILICON DETECTOR.

tion. The best method for finding the exact point is to move the slide wire of the resistance until the hissing noise in the receiver is heard no longer. Thus we have in the detector, as well the coherer and other detecting apparatus a wonderfully sensitive balance which is maintained by a local battery current and overthrown by the incoming wave, which is restored to the first state by its own action or automatic means.

Carborundum and silicon detectors of later manufacture are fully as sensitive as the liquid detector and have gained a wide popularity owing to the simplicity and ease by which they are handled. The carborundum detector consists of a loose mass of carborundum crystals against which rest two contacts with other connections made as for the detector. Either

side of the contacts, however, may lead to the aerial or ground. The crystals used should be in the purest state and for this reason it may be necessary to test out quite a lot of the crystals before getting the kind which give the best results. The frame for this detector may be of any form which will support a quantity of the loose crystals.

The silicon detector, Fig. 16, is quite novel in operation owing to the absence of any local battery, the current being set up by thermal action, a phenomenon which is evident when two dissimilar metals are joined and heated. In this case silicon and brass are used, although other metals can be used in place of the brass. The detector consists of a silicon button against which rests the brass point of a thumb screw with fine micrometer adjustments. The brass point is connected to the aerial wire and the ground to the silicon button. High wound telephone receivers are bridged across the two contacts. The wave current flows through the two dissimilar contacts on the path to the ground and sets up a certain degree of heat, thereby generating the thermo-current which gives the indication in the telephone receivers. This detector also works without the tuning accessories necessary to other receiving sets.

In Part II, the tuning of the sending end was taken up. In the following paragraphs the tuning of the receiving end will be explained, so that both sets will work in sharp resonance with one another. By this we mean that a wave of a certain period and frequency sent out from the transmitting end will produce the maximum results at the receiving end when the regulation of the tuning coil is set at the point of the same wave length.

For tuning at the receiving end we employ a tuning coil, regulating rheostat, telephone receivers and battery in connection with the detecting device, unless a detector is used such as the silicon, where no local battery is used.

A tuning coil as shown in Fig. 17 is used. It consists of a cylindrical frame wound with 115 turns of No. 18 bare tinned copper wire, the turns being 3-32 of an inch apart. Slide wire contacts are

provided which work up the frame and make contact with various portions of the wire. The scale is provided in order that the operator may note the number of turns to use with a station of a certain wave length. In Fig. 18 is shown the complete arrangement, with letters which indicate the special parts.

Before tuning the set the adjustment of the detector should be taken up. The telephone receiver is placed to the ear and the thumb screw run down until the

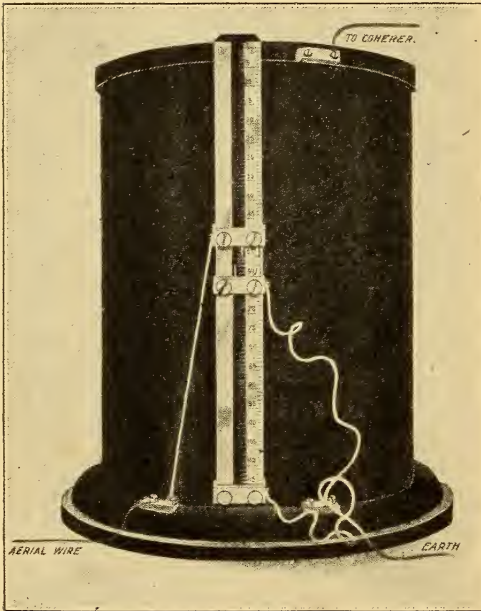

FIG. 17. TUNING COIL.

point touches the electrolyte, a hissing noise will now be heard in the receiver. Next run the slide contact up the resistance frame (E) throwing more resistance in the circuit until the hissing noise ceases.

The tuning can be brought about by a number of different methods. There are also several styles of wave meters on the market which are worked by placing near the tuning arrangement of the sending end, a second coil. The induction of the first tuning coil is picked up by a second coil which terminates in a tube of mercury drawn to a thread. This heats the thread of mercury and raises it in the tube, and a reading is taken from a pre-determined scale from which the wave length is figured. The receiving tuning

coil is now placed to this wave length, when the two will be in resonance, and will respond clearly. A second method is by use of a hot wire ammeter, the ammeter being placed in the circuit with the aerial radiating wire. As is well known, the hot wire ammeter depends on the heating effects of the current flowing through, which distends a wire that works the indicating lever. When placed in the aerial wire the indicating lever will move to a certain degree depending on the heating effect of the emitted current. From the point of the lever is obtained the reading from which the wave length is figured out. All the above named plans cannot be carried out, however, without the use of expensive and accurate apparatus which is not usually in the reach of the every-day investigator, and for this reason a more simple plan, one hardly so reliable, will be given.

Considering that all the instruments have been connected at both sending and receiving end we may begin the tuning. The operator at the sending end sends out a certain letter at certain intervals, of say one minute each, he continues to send and regulate the movable contact over his tuning coil, noting at what points the adjustments are made. At the receiving end the operator moves the slide wire contacts of his tuning coil syn-

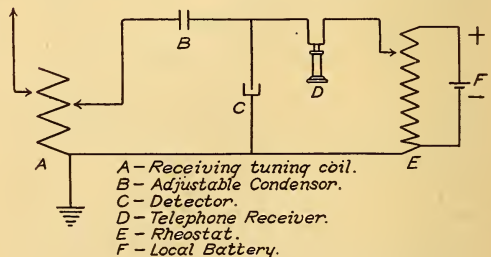

FIG. 18. CONNECTIONS AT RECEIVING END.

chronously with the sending end. When the joint is reached where the clearest indications are heard, note is made of the time and compared with the operator at the sending end. It will be well, however, to go over this operation several times so that the best point will be found.

The condenser (B) which is used in the receiving circuit can be made of three two inch by two inch sheets of tinfoil pasted on thin mica sheets, so that

the capacity can be varied by sliding the two apart.

The majority of wireless systems employ their own special device for receiving as well as for transmitting. Below is given the receiving circuits of the systems, designed to work in conjunction with the sending ends as given in Part II.

The receiving end of the Stone system embodies a number of special features. In Fig. 19 is shown the complete arrangement which is especially designed to work without interference from other sets. As shown in the plan step-up transformers are used which increase the receiving ratio to a certain extent. An inductance coil is inserted in the aerial

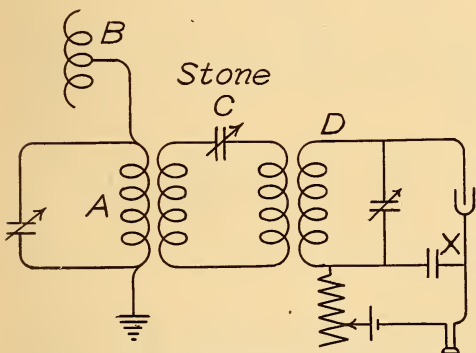

FIG. 19. RECEIVING END OF STONE SYSTEM.

wire which gives a larger range of regulation. The condensers with the arrows across are variable, while the one marked with the cross is fixed.

The Massie circuit is shown in Fig. 20 and much resembles the ordinary tuned circuit with the exception of the condenser, which is fixed. The tuning

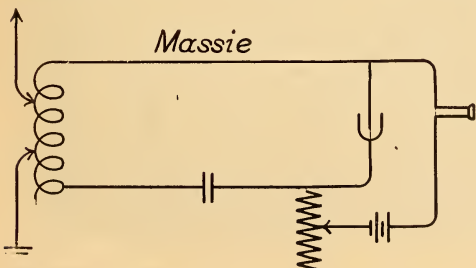

FIG. 20. RECEIVING END, MASSIE SYSTEM.

coil regulation is also some different. This system also employs a very sensi-

tive and simple device known as the oscillaphone for the detection of the incoming wave. The oscillaphone consists of two carbon blocks filed to a knife edge and mounted on a wood base with a light sewing needle laid across the top. The other connections are the same as made for the detector. While this device is

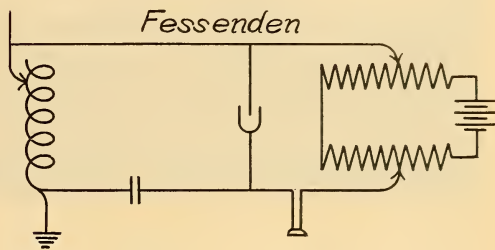

FIG. 21. FESSENDEN DETECTING CIRCUIT.

not as sensitive as the liquid detector, yet it is very popular among experimenters owing to its simplicity.

The Fessenden detecting circuit is shown complete in Fig. 21. Fessenden also employs an interference preventer which gives good results. The range of reception, however, is not so great when this arrangement is used.

(To be continued.)

#### ELECTRIC TRANSPORTER BRIDGES.

Rapidity with which shiploads of coal or ore can be unloaded with an electric traveling bridge transporter is astonishing. A bridge transporter such as shown in the accompanying picture consists of a steel bridge mounted on electrically operated trucks, which travel back and forth over tracks parallel to the ship landing.

One end of the bridge extends out over the water and above the deck of the ship when it is in dock. On top of the bridge a car and derrick are mounted on rails, and can be moved back and forth over the length of the bridge. This car is also driven by electric motors. To the crane is attached what is known as a clam-shell bucket, so called because it is the shape of an enormous clam shell, the jaws of which open and shut on a hinge.

In unloading a ship, the derrick is run out on the bridge above the deck and the clam-shell bucket is lowered, with jaws open, into the hold. As the bucket is hoisted again the jaws shut by their

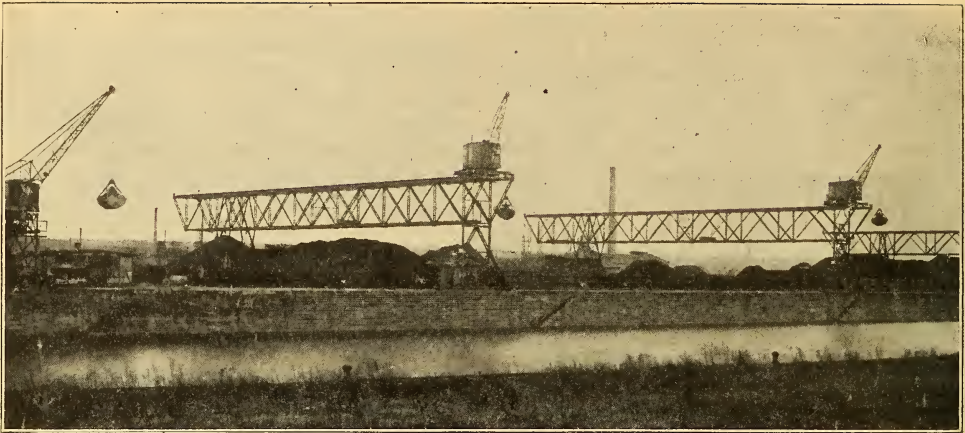

ELECTRIC TRANSPORTER BRIDGES.

own weight and take up huge mouthfuls of the coal or ore. The crane is then moved back over the bridge and the contents of the bucket deposited at any desired point in the yard.

The two bridges shown in the illustration are used in a German coal yard and have a span of 186 feet. The clam-shell buckets have each a capacity of five tons.

## THE MISSION OF POPULAR ELECTRICITY.

BY EDWIN J. HOUSTON, PH. D.  
(PRINCETON).

Electricity has invaded the everyday life of the Twentieth Century to such an extent that it is no longer possible to transact business without a fairly extended knowledge both of its fundamental facts and principles, as well as the phraseology by which such facts and principles are expressed. And when we say business, we do not wish to confine ourselves to business along certain limited, technical lines, but to the common business of everyday life. No matter what one's occupation may be, he must possess a familiarity with both the facts and language of electricity, to be able to conduct his business intelligently. Indeed, without this knowledge he cannot even properly read the daily newspapers, much less current periodical literature. It is, therefore, not a matter of choice, but of necessity, that leads to the publication of a magazine like "Popular Electricity."

The words, terms and phrases that are employed in electricity are so rapidly taking their place in the language of everyday life that they have already become

part of our mother tongue. All will be severely handicapped in their struggle for existence who are not familiar with this language. We have now become so accustomed to electrical language that we feel no greater strangeness in talking about electric generators, trolley cars, electric lamps, telegraphs or telephones, than about sugar, potatoes, cabbages, coal or kindling wood. It seems as natural to discuss the candlepower of our electric lamps, the ignition of our gas lights, the operation of our electric stoves or curling tongs, or of our systems of burglar alarms, messenger or cab calls, as the operation of our coffee mills, egg beaters, lawn mowers, carpet sweepers or griddle greasers.

There is no longer a holy of holies where none but the initiated are permitted to enter. On the contrary, the general public is as ready to criticize the correctness of bills for electric service, as determined by the indications of electric meters, as they are to accuse the butcher, the milkman or the iceman of overcharges. The words ohms, volts,

amperes and watts are no longer venerated as belonging to a class far above the ordinary, but are as familiarly used as the words beefsteaks, scrapple, molasses or vinegar.

A publication like "Popular Electricity" cannot fail to be welcomed by all classes; not only by the members of the bar, the church, the medical fraternity, and teachers generally; not only by the superintendents of our great manufactories and shops; not only by the directors of the great transportation companies, banks and other financial institutions, who labor with their brains, but also by that far greater multitude of artisans, mechanics, laborers, farmers, miners, railroad men, storekeepers and others, who labor with their hands.

The people of any country can be divided into three great classes:

(1) The highly educated, including graduates of colleges, universities and technical institutes.

(2) Those of average education, whose preparation has been limited to the public schools.

(3) The poorly educated, whose sole fitness for work, besides the inheritance

of sound, common sense, has been limited to an elementary instruction in the rudiments of reading, writing and arithmetic.

While it is in the first two of these classes that the world confidently looks for the master minds who shall teach it how to put the mighty force of electricity in its service, yet for too long a time has sight been lost of the third class, a class that contains by far the greater proportion of the world's population. Here, it may again find some of those slumbering giants, those rough diamonds, who need but a little polishing to make them like second Edisons, a man who to-day is unquestionably the world's peerless leader in the practical applications of electricity.

Appealing, as it does, to all these classes, "Popular Electricity" cannot fail to receive a hearty welcome, and, therefore, to prove a splendid success. Its readers are both intelligent and numerous. Its publishers, therefore, offer their magazine to a discriminating public in the belief that they can find in it a publication that will take an important and unique position among magazines.

#### THE HISTORY OF AN ART.

From Edison's first carbon filament electric incandescent lamp to the latest type of tungsten lamp, does not represent a great period of time, but it does

ment is to be found in the collection of electric incandescent lamps laboriously gathered together by William J. Hammer, consulting electrical engineer of New York city. The picture herewith



represent the period of development of one of the greatest utilities of modern times—that of electric lighting. An almost unbroken record of this develop-

is a very good representation of this remarkable collection. Not only is it interesting, but it is also of great value to the engineering profession.

**ELECTRICALLY HEATED GLUE POT.**

Cabinet makers, book binders and workers in other crafts where glue must be used, will be interested in an electrically heated glue pot which is now on the market. A gas heated glue pot is dangerous because of the fire hazard, while steam pipes used for heating are liable to leak and damage valuable materials. In the electric type, however, all that is necessary is to attach the plug to an electric light receptacle and the contents of the pot is soon brought to the desired temperature without flame or steam jets.

The pots themselves are of seamless drawn copper with brass bail and wiper rod. The water bath is made of seam-

ing, the pots are provided with heat regulating switches, by means of which the glue can rapidly be brought to the desired temperature, and then maintained there steadily by a lower current strength.

**ELECTRICITY IN THE CHARGING OF COKE OVENS.**

In the charging and drawing of coke ovens, processes that used to be done laboriously by hand, electricity is now used in most of the larger plants. The coke drawing and charging machines are said to do the work of 20 men with only one-fifth that number for each electrical machine, which will draw the contents of



FIG. 1. ELECTRIC CHARGING OF COKE OVENS.

less copper, and the heating element, which is wrapped around the lower portion, is enclosed in a water-tight tin envelope. The water bath is provided with a patent circulating device, which gives it the maximum heating efficiency. This device consists of a hollow ring, the lower end of which is closed by a diaphragm having a central opening. This confines the heating action to the thin film of water outside of the device, and sets up a rapid circulation in the water, which brings the glue up to the working temperature in a short time.

To further promote economical heat-

from 35 to 50 beehive ovens, screen it and load it ready for shipment in 10 hours.

Among the other advantages may be mentioned the fact that it is not necessary to have an oven open and exposed to the air for longer than half an hour from the time the quenching of the coke begins until the oven is ready to be recharged, while from two to three hours are necessary where the work is done by hand.

A coke oven equipment consists of two parts, an electrically operated charging car which travels on a track on top of

the ovens as shown in Fig. 1, and a drawing machine shown in Fig. 2.

The charging cars are operated by electric railway motors and take current from trolley wires strung along the tops of the ovens. The coal is dumped from

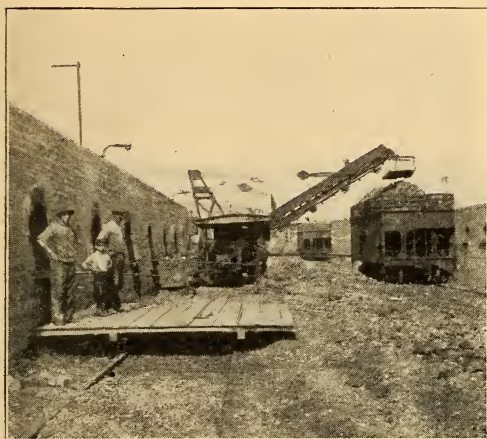

FIG. 2. COKE OVEN DRAWING BY ELECTRICITY.

the bottoms of the cars through holes in the tops of the ovens.

The drawing equipment consists of a motor operated car which travels along in front of the oven doors. The coke is drawn out of the ovens and into a hopper, and from there it is taken by a traveling belt conveyor and dumped into a waiting car. For loosening the coke in the oven a steel ram-bar is provided, which may be seen in Fig. 2. This bar has a chilled steel point and teeth on the side which mesh with a pinion on the drawing machine. This ram-bar may be swung around in any direction to punch and loosen the coke in the oven.

#### ELECTRIC DYEING.

When cloth soaked in aniline sulphate is placed between two metal plates connected with the opposite ends of a dynamo, and an electric current is passed through it, the sulphate is converted into aniline black.

By altering the strength of the solution and of the current, shades varying from green to pure black can be obtained. In the case of indigo, the cloth is impregnated with a paste of indigo

blue and caustic alkali. The electric current converts the insoluble indigo blue, by reduction of oxygen, into indigo white, which is soluble, and on being exposed to the air becomes oxidized once more and turns blue, thus thoroughly dyeing the cloth with that color.

#### UNIQUE TELEPHONE.

Considerable ingenuity as well as an appreciation of the artistic were displayed in the construction of the unique telephone shown herewith. A section of an oak log was hollowed out to receive the wiring which is ordinarily concealed



in the telephone wall set. The receiver and hook, bell, transmitter and ringing crank are all the parts that appear outside the log. This telephone, mounted on an artistic stand, was not only practical but an ornament to the home in which it was used.

#### ELECTRIC SAW FOR BUTCHERS.

The up-to-date butcher shop is now provided with an electric meat saw, and the old handsaw is relegated to the junk pile. In its place is a small bandsaw, driven by an electric motor, which severs all bones in a neat and expeditious manner.

**CAUSING SLEEP BY ELECTRICITY.**

The new discovery of causing sleep by the use of electricity made recently at the School of Medicine at Nantes, France, by Prof. Stephen Leduc, it is believed will be of great importance in surgical operations. The accompanying illustration herewith shows the electrical equipment and method of application used by the French scientist in his experiments with rabbits and dogs. Similar results have been obtained in the case of human

There are two electrodes applied to the skull in a special manner, the points of application being first carefully shaven. In experiments with rabbits the electrodes are from 1.1 to 1.5 inches in diameter and for dogs 1.9 to 2.3 inches in diameter. It is stated that scores of trials have been made on these animals with wonderful success. The application of the currents is not in any way dangerous, and no ill effects have been noted, even

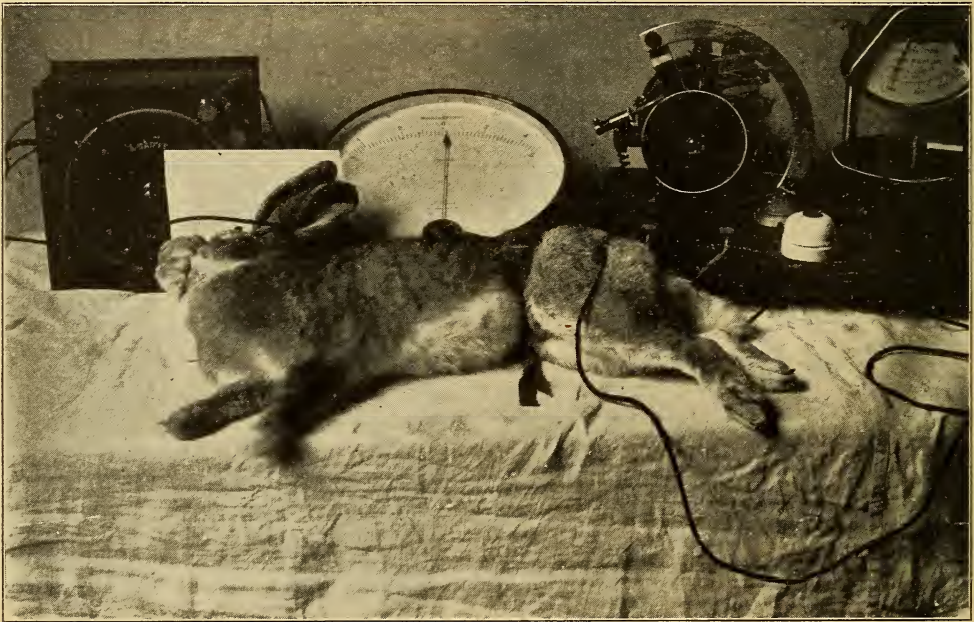

PRODUCING ELECTRICAL SLEEP IN A RABBIT.

beings undergoing operations, successful experiments having been made upon Prof. Leduc himself.

It is stated that the discovery proceeded from study of the effects of intermittent currents and from the knowledge that the skull and brain offer but little resistance to the currents. With periods of only one one-thousandth of a second, the current intensity is applied for one-tenth of the period and turned off nine-tenths of the period, the interruption being timed by a commutator or electric motor driven interrupter. It is stated that for a human being a current of 35 volts and four milli-amperes is applied intermittently for the minutest fraction of a second.

when the experiment has lasted for hours.

It is maintained that electric sleep is better than anæsthesia by chloroform, morphine or ether, which are not only disagreeable but sometimes dangerous or even fatal, while the awakening is usually painful.

It is stated that during electric sleep the patient is perfectly quiet, and as soon as the electrodes are withdrawn the awakening occurs as one arousing from sleep, without pain or discomfort of any kind. It is also held that the sensations are quite agreeable after the operation, the mind working more rapidly and more clearly, while it is also claimed that there is a sense of increased physical vigor.



### PORTABLE ELECTRIC GENERATING PLANT.

The accompanying illustration shows a novel portable dynamo house with direct connected electric generating set, designed for operation with a gasolene, gas, oil or alcohol engine. The outfit is constructed to carry 10, 20 or 30 lights according to the candle power and voltage.

For constant load, with a definite number of lights, no regulator is necessary, the outfit running with practically constant speed, an extra flywheel and a flexible coupling taking up the impulses of the engine very satisfactorily. For a variable load, the portable house is provided on the left hand side with 50 cells of storage battery of eight or 10 ampere hours capacity, this being sufficient to give good regulation and supply a reserve current for night lamps in homes, or for extra current during heavy load.

For boat lighting this set is satisfactory as well as for charging automobile batteries, a double cylinder engine of larger capacity with a larger generator being desirable in the latter case.

The portable house is necessary where



the fire underwriters object to gasolene being used as a fuel in buildings insured, but where gas is employed a plant of this character can readily be employed in a basement of any kind.

### GERMAN TELEPHONES.

In Germany and other foreign countries telephone users have different ideas than people in this country, as to the most convenient form of telephone to use. There are fashions and styles in telephones as well as in clothes. Take, for instance, the two German telephones shown in the accompanying picture. The lower one is a common battery telephone,

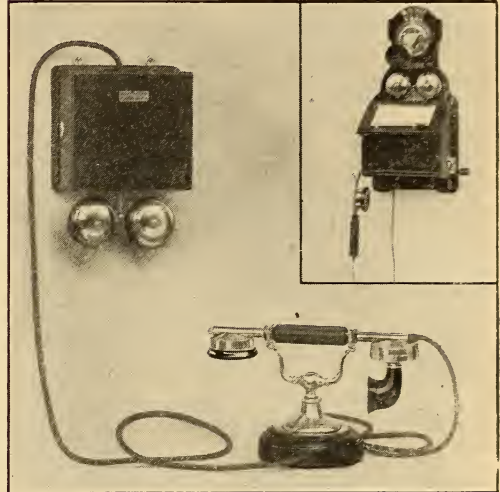

meaning that no crank need be turned to ring up the exchange. In this respect the telephone is the same as most telephones in this country. The shape, however is much different. The transmitter and receiver are connected together by a sort of handle. When they are lifted from the rack and the receiver is held to the ear the transmitter is then in position in front of the mouth, so that it may readily be spoken into. Lifting the handle from the rack closes the circuit to the exchange in the same manner that lifting the receiver from the hook performs the same operation in telephones used in this country.

The telephone in the upper corner of the picture is of the magneto type, that is, a crank must be turned to ring the exchange. In this case the transmitter is fastened to the cabinet in the usual manner, but the receiver is of peculiar shape, being provided with a handle for holding it to the ear. When not in use it hangs from a hook on the cabinet.

## GERMAN SUBMARINE CABLE LAYING.

**I**N THE operation of submarine telephone cables a factor that operates against clear transmission is what is known as the electrostatic capacity of the cable. This phenomenon cannot be

minute current fluctuations which operate the telephone receiver. To overcome this capacity effect, what is known as the Pupin coil is sometimes used. A number of these coils are connected at

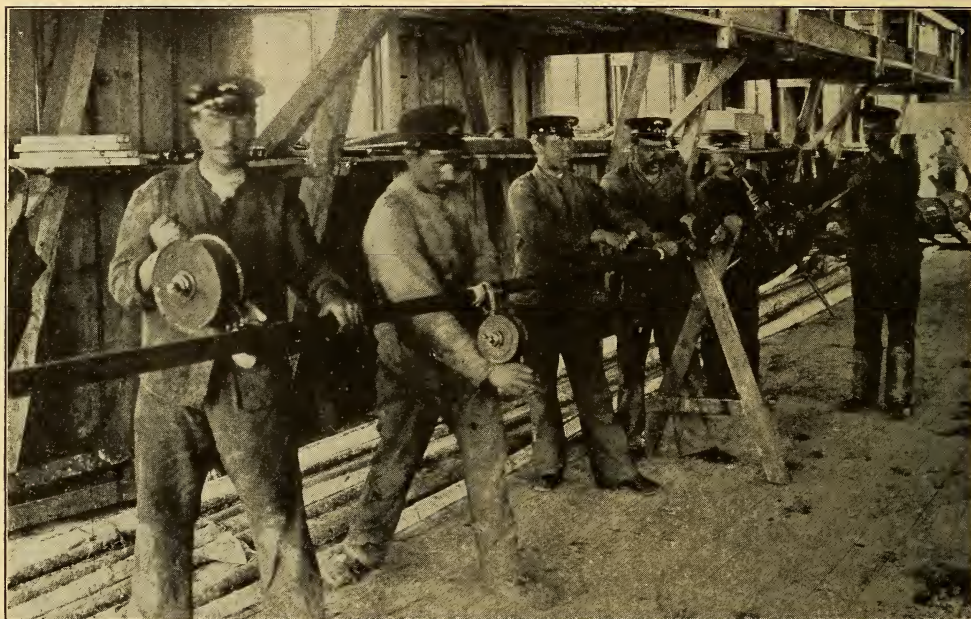

FIG. 1. SPLICING IN PUPIN COILS.

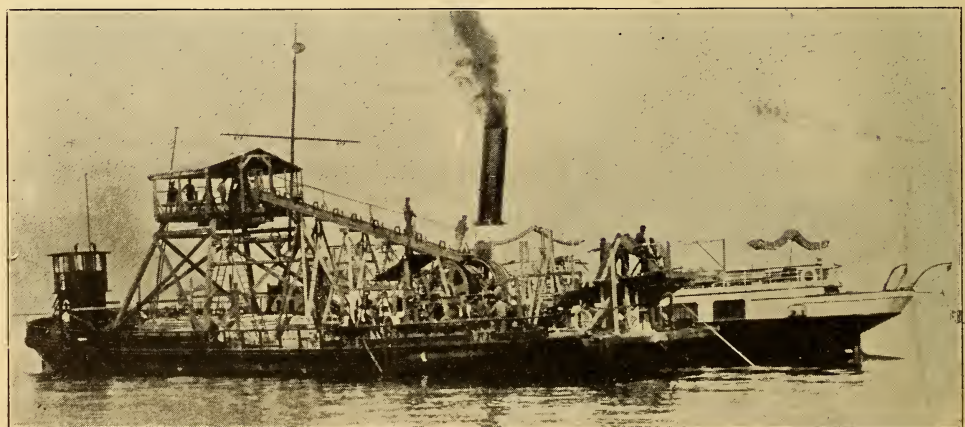

FIG. 2. SPECIAL CABLE LAYING MACHINE.

readily explained without mathematical demonstration, but it will suffice to say that the effect is a retarding of the current and a breaking up of the very

regular intervals throughout the length of the submarine cable. The Pupin coil is simply an inductance coil, and by inductance is meant a phenomenon which

is exactly opposite in its effect to capacity. The Pupin coils therefore tend to neutralize the capacity effect in the cable and permit clear talking.

A little over a year ago a submarine loaded telephone cable was laid with considerable difficulty between Friedrichshaven and Romershorn, Germany, this cable being about seven miles long. The accompanying illustrations show the details of construction and the laying of this cable in Lake Constance.

As the cable could not be brought to

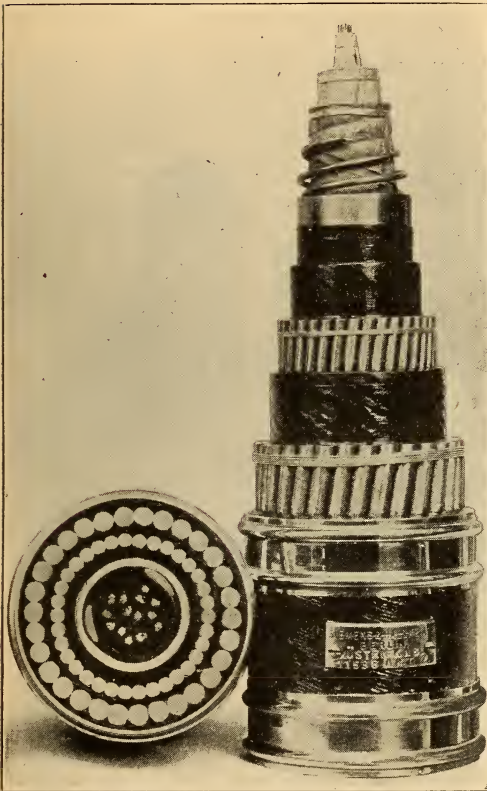

FIG. 3. SECTION OF SUBMARINE CABLE.

Lake Constance for laying by ship without being first transported by rail, the construction and laying of this Pupin loaded telephone cable was no small undertaking. The cable had to be laid at a depth of 138 fathoms, the contour being different on the two sides and gradually falling to a deep channel, traversing the whole length of the lake.

It was necessary that the cable be capable of standing the water pressure of 25 atmospheres at this depth (one at-

mosphere equals about 16 pounds per square inch) and a factor of safety of six was taken, so that the tests were carried out on the cable with a pressure of 150 atmospheres for short periods, the cable tested having seven circuits and being lead covered and armored, as shown in Fig. 3. This illustration shows a portion of the cable used in the middle of the lake, where the pressure is greatest.

Fig. 1 is an interesting view illustrating the method of splicing in the Pupin coils.

The old boat, with which an attempt was first made to lay the cable across Lake Constance, contained only a simple drum for unwinding the cable and proved to be inadequate for the work. Fig. 2 shows the submarine cable laying equipment which was finally successful. As the weight of the cable was considerable when paying out at deepest places, a pull of about 4,000 pounds had to be provided for. The special cable laying machine shown in the foreground in Fig. 4 has an eight-foot drum. The machinery is mounted on a flatboat which is towed by the steamer lying just beyond in the picture. When everything was in readiness only about two hours were required to lay the cable.

#### ELECTRICITY FROM PEAT

Consul-General Robert J. Wynne, of London, reports that before a committee of the British House of Commons interesting details were given of the scheme for establishing in Ireland a new electric supply generated by peat gas, the first of the kind in Great Britain. The Dublin and Central Ireland Electric Power Company is seeking powers to supply electricity to portions of counties Dublin, Kildare, Queens, and Kings, and has arranged to purchase 500 acres of peat bog in the district. Hitherto one of the chief objections to the use of peat for generating power is that it contains 90 per cent of moisture and is too expensive to dry. The promoters propose to use a process, common in Germany, by which it is advantageous to retain 50 per cent of moisture in peat, thereby obtaining by-products, such as sulphate of ammonia, which alone would pay the cost of the peat.

**WIRELESS ON THE GREAT LAKES.**

When the new steamer "City of Cleveland," of the Detroit and Cleveland line went out on her trial trip on April 27th, there were thousands of eager eyes to read the news of her record trip, and the wireless despatches from aboard the vessel were given to the public by the Clark wireless telegraph service.

The wireless station is located forward of the Convention Hall of the steamer and opens directly on the large promenade deck. There is, besides, an entrance from the main cabin to the wireless telegraph office, which is arranged much the

on the Great Lakes. This feature plays an important part in the accuracy and reliability of wireless communication, as with this complete system of tuners, the "City of Cleveland" will be able to get in communication with any other boat or station on the Great Lakes and can also cut in or cut out any other boat or station as desired.

The receiving instrument is arranged with a combination of inductance and capacity so that the operator can adjust to various wave lengths for the different stations. There is an especially designed head telephone for the operator, of

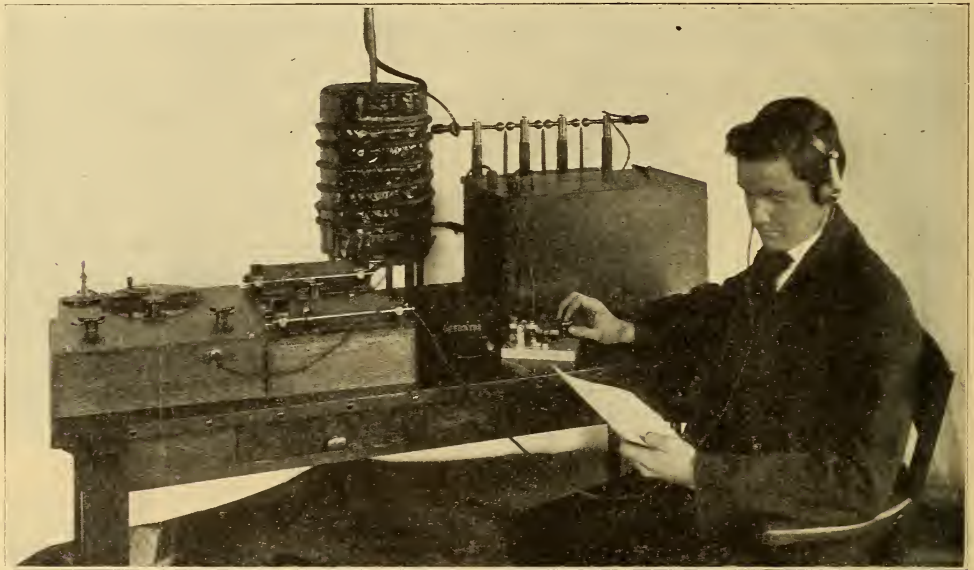

WIRELESS RECEIVING APPARATUS ON THE "CITY OF CLEVELAND."

same as a regular land telegraph office for filing and receiving messages.

A visitor going aboard of this magnificent vessel will find the wireless station one of the most complete to be found afloat. The station is rated as a two K. W. station and the power or current for operating the wireless instruments is taken from the dynamos which furnish current for lighting the steamer.

Arrangement of the station is such that the most perfect, up-to-date receiving and transmitting sets of Clark wireless instruments are installed, an important feature of the equipment being a complete system of tuners, which makes this outfit a distinctive one, as it is not to be found on any other boat equipment

the most sensitive type, to work in connection with the delicate detector on the receiving instrument. There is also a complete system of interference coils to cut out atmospheric electrical disturbances, which marks an important advance in the perfect working of this wireless telegraph set for commercial work.

All the instruments, indicators, regulators and the automatic starter are so arranged that the operator has immediate control at his right hand of the full manipulation of any part of his apparatus and can tell at any moment exactly what results he is obtaining from his instruments and transmitting apparatus.

Mr. Clark has devoted considerable

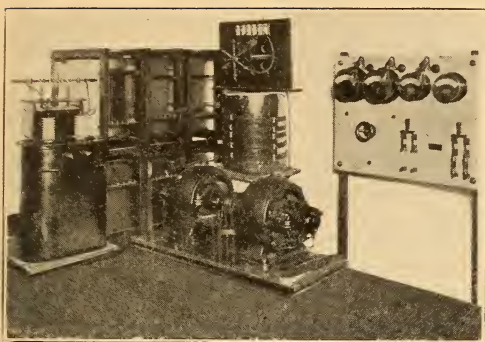

WIRELESS TELEGRAPH PLANT.

time and hard work to designing this special set of instruments for the "City of Cleveland" and considers it one of the best wireless equipments aboard of any boat in the world, and the "City of Cleveland" when afloat will take precedence over all other lake ships in the matter of obtaining and sending communication. She will be in a "wireless" sense the "Queen of the Lakes."

#### LARGEST ELECTRICAL CABLE.

The accompanying picture shows the actual size of cross section of what is

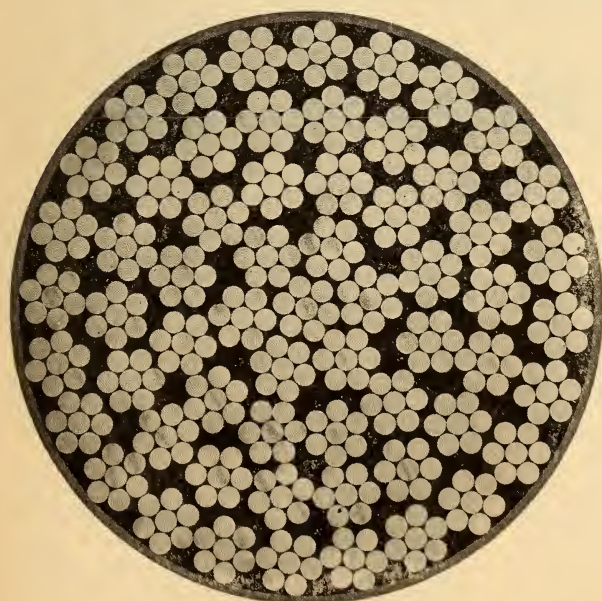

LARGEST ELECTRICAL CABLE.

of Brooklyn by the Standard Underground Cable Company. It is a 5,000,000 circular mil cable. A circular mil is the area of a circle whose diameter is one one-thousandth of an inch, therefore, if this cable were in the form of a single solid wire its cross-section would be almost four square inches. Such a wire would be nearly as stiff as a bar of iron, so to obtain the necessary flexibility it is necessary to make the cable up of a great number of small wires. There are 427 of these wires, arranged in strands of seven wires each. The weight of the complete cable with its insulation is 16.6 pounds per foot. It was furnished in lengths of 440 feet, weighing 7,300 pounds each.

#### ELECTROCUTION VS. HANGING.

Which method of capital punishment is the more humane, electrocution or hanging, is a question hard to determine. Dr. Spitzka, an eminent brain specialist, has made a careful study of the subject, and his conclusions as to electrocution are based on observations at 31 electrocutions in Sing Sing and other prisons.

Dr. Spitzka has observed that seven to

10 amperes of current pass through the body. Consciousness is, without doubt, blotted out instantly. In only two cases was it observed that there was any respiratory effort after the current was turned on.

A post mortem examination of the body reveals many interesting phenomena. There is a rising in the temperature, in one case as high as  $129\frac{1}{2}^{\circ}$  F. The lungs are devoid of blood and weigh six or seven ounces avoirdupois. The blood seems to be under a chemical change and is of a dark brownish hue, sometimes almost black, and it rarely coagulates. On the nervous cells there is no apparent effect, al-

though it is apparent that there is a molecular change of some kind not fully understood.

doubtless the largest electrical conductor ever manufactured. This cable was made for the Transit Development Company

### ILLUMINATIONS A QUARTER OF A CENTURY AGO.

According to a Washington paper, the introduction of electricity into that city had a novel as well as a characteristic beginning. In the fall of 1881 the survivors of the Army of the Cumberland assembled there to dedicate an equestrian statue of their old commander, Gen. Thomas, which now stands in Thomas Circle. The committee having the arrangements in charge determined, as a feature of the event, to have a night parade on Pennsylvania avenue, and have the avenue illuminated by electric lights, which at that time had been used

The plans of the committee came to naught after many hundreds of dollars had been expended for labor and material.

Such an undertaking to-day would involve nothing greatly out of the ordinary. The wires for the illuminations would simply be tapped to the most convenient feeders of the lighting company, and when the time came to light up there would be no failure and the lamps would burn without a perceptible flicker.

### PLOWING BY ELECTRICITY.

The accompanying picture is of interest as showing the possibilities which

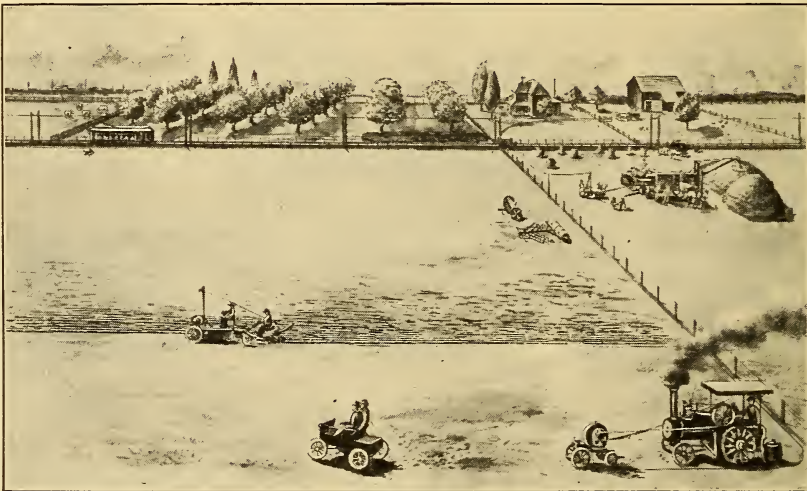

PLOWING BY ELECTRICITY.

for similar purposes in other cities. To carry out this plan, wires were strung across Pennsylvania avenue at stated distances from building to building to support the lamps. A dynamo was installed to furnish current for the lamps in a sawmill on Thirteenth Street, and the engine of the mill utilized for the occasion.

The connections with the lamps were only temporary, and the work was badly done. When all was ready for the illumination and thousands had gathered to see the display, and the military were ready to start the parade, the signal was given for the lighting. There was a sudden flash of light over part of the distance between the Peace Monument and the Treasury, then a few feeble flickerings of the lamps, and then darkness.

the future holds forth for the application of electricity in farm operations. Some years ago Mr. I. Hogeland of Chicago, devised this system and even built an experimental equipment. He was told, however, that he was years ahead of his time, which proved to be the case, but he still has firm belief in the practicality of his idea.

The system consists of an electrically operated locomotive or truck which has sufficient tractive power to draw 10 to 20 plows at once. Power is brought to the truck by a long insulated cable which unwinds and winds up on a drum as the truck moves back and forth across the field. In the picture the electric power is seen to be generated by a small dynamo driven by a portable steam en-

gine. The inventor believes, however, that the time has now arrived when current derived from trolley lines or nearby towns for the performance of the work could be used to advantage.

#### HOW AN ELECTROMAGNET OPERATES.

In reading descriptions of electrical devices and operations one often comes across such expressions as these: "The circuit is closed by an electro-magnet," "an electro-magnetically operated switch," etc. "Now what is an electro-magnet?" This is a question a great many people will ask.

Away back in the early history of electrical development when Faraday discovered the phenomenon of electro-

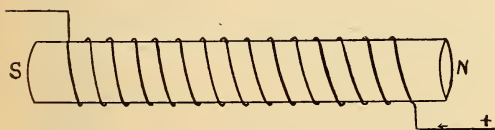

magnetic induction he discovered a principle upon which nearly every electrical machine of the present day is in some way dependent. An electro-magnet is simply a coil of wire wound around an iron core, as shown in the diagram. When a current of electricity from a battery or dynamo is sent through this coil of wire the iron core becomes magnetic, its strength being in proportion to the number of turns of wire, and to the strength of the current flowing. If current is sent through the coil in the direction of the arrows the core has a north or positive pole formed at (N) and a south or negative pole formed at (S). If the current is sent through in the opposite direction the poles are reversed.

The above, in brief, is the nature of an electro-magnet. Upon its application in various ways depends almost everything of consequence that is now done by electricity. A dynamo is dependent upon an electro-magnet to give strength enough to its pole pieces, to permit current to be generated. Without dynamos there would not be much done with electricity. Electro-magnets are the very vitals of a telephone exchange. They are even present in your telephone receiver and transmitter. Circuit-breakers are operated by electro-magnets. If

the currents in the electro-magnet coil of a circuit-breaker becomes too strong the iron core in the coil is pulled down and the switch released, which opens the circuit. Telegraph instruments are operated by electro-magnets, so are nearly all forms of automatic electric control devices.

A form of electro-magnet used for many purposes is the solenoid. This is simply a coil of wire without an iron core. If an iron plunger is started into the hole in the coil it will be sucked farther into the coil or forced out, depending on which way the current is flowing in the coil. This principle is applied in many ways in various automatic devices.

#### TALKING OVER A SUNBEAM.

We are accustomed to think of wireless telephony as a very recent discovery—more recent than wireless telegraphy. As a matter of fact, Prof. A. Graham Bell talked without wires many years ago. His only line was a ray of light.

But the telephone is an electrical instrument. Obviously, to transmit an electrical effect by means of a ray of light, we must use some substance which is affected by light in some electrical manner. A hard bill to fill, it would seem; but fortunately there is such a substance, although it is somewhat rare. It is called selenium.

Selenium is one of those curious chemical elements, like sulphur, that seem only half metal. In fact, in its native state it is often found associated with sulphur, and will not conduct electricity at all. But when it has been subjected to a certain process of heating it becomes metallic, and will then conduct the electric current like other metals.

Everything has electrical resistance, which is a sort of electrical friction, that is, it resists the flow of the current. Most metals have very little resistance; while such substances as glass, rubber, air, etc., have a resistance so high it is almost infinite. But the electrical resistance of selenium is peculiar to itself; for it varies, almost from one extreme to the other. A piece of selenium in the dark has a fairly high resistance, but let a ray of light shine on it, and the resistance instantly decreases. If the light is strong it may allow ten times

as much electricity to pass as it did in the dark.

So it is plain that if we should put a piece of selenium in the focus of a good sized reflector, and should direct a sunbeam into the reflector, every variation and vibration in the sunbeam would cause a corresponding fluctuation in an electric current flowing through the selenium. And if we connected a telephone receiver in circuit with the seleni-

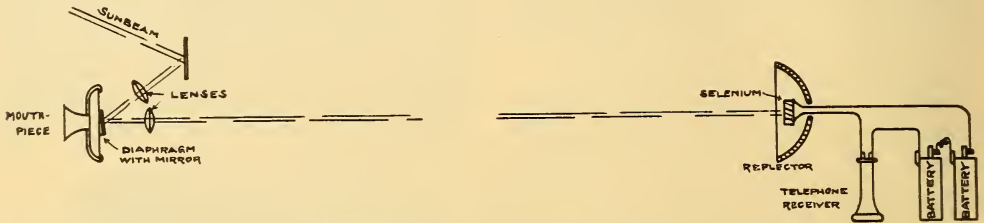

FIG. 1. APPARATUS FOR TALKING OVER A SUNBEAM.

um and the battery, we ought to get some kind of sound out of it.

Of course there will be no vibrations in the sunbeam unless they are put there. If any diaphragm that vibrates when the voice is directed against it has a small mirror fastened to its center so that the mirror moves with the diaphragm, a beam of light reflected from the mirror will vibrate with the voice. This beam goes straight through space until it strikes the selenium and its reflector. The voice moves the diaphragm,

(T), and battery. It is evident that the 50-volt dynamo, being the stronger, would tend to cause current and flow through the small battery and transmitter and spoil them, unless we shut them out in some way. So at (C) we connect in what is called a condenser, which is, briefly, a simple device which an alternating current can work through, but a direct current cannot. All battery currents are direct, but the induction coil changes direct to alternating current. This alternating current can get to the

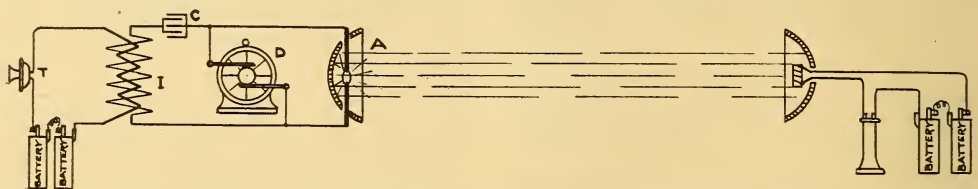

FIG. 2. PRINCIPLE OF THE "SPEAKING ARC."

and the diaphragm moves the sunbeam; the sunbeam moves the molecules of selenium, and the molecules move the electric current; the current moves the telephone receiver and the receiver says exactly, in the same voice, what is being said at the other end of the sunbeam. Fig. 1 is a diagram of the arrangement.

Similar in operation, but of quite recent date, is the "speaking arc." Most of us are familiar with the common electric arc lamp; but it is quite startling to

hear one of them begin to talk, in the voice, perhaps of our best friend. The miracle is brought about in the way shown in Fig. 2. (D) is intended to represent a dynamo or other generator of about 50 volts connected to the two carbons of the arc lamp (A). These same carbons are also connected to the secondary coil of an induction coil (I), the primary of which is connected to an ordinary telephone transmitter



Now let us place a reflector behind the arc, and direct its piercing ray against the bit of selenium with its reflector. Though they be miles apart, the selenium responds instantly, its telephone receiver sounds forth the message and communication is established.

#### A CHINESE TELEPHONE EXCHANGE.

No more enthusiastic users of the telephone can be found than the Chinese, after they have once learned its opera-

quake and fire had a total of 800 subscribers.

Everything in this exchange is Chinese but the switchboard itself. No "hello girls," though you would never guess it from the picture. The operators are men. There is no Chinese word equivalent to our "hello" so the operators save time and breath by calling for the number or name. So many are the dialects in Chinese that it was found that many would not understand or be able to give numbers readily, so it became



CHINESE TELEPHONE EXCHANGE.

tion. To the Celestial the "talkee machine" has an irresistible fascination. In San Francisco, before the fire, there was built in the heart of Chinatown a branch telephone exchange for use of Chinese exclusively. It was a complete central in itself, as far as that famous district was concerned. The illustration shown herewith was made from one of the few photographs extant of this remarkable exchange, which was the first of its kind in the world and at the time of the earth-

necessary to use the names of the subscribers as well as the numbers—a great tax on the memories of the operators. A number in the directory would read something like this: "China 41,144, Ah Fat."

The telephone exchange, moreover, could not be considered complete without a joss altar, so one was erected in a very elaborate room by itself, taking the place of the rest room found in most exchanges



# ELECTRICITY IN THE HOUSEHOLD

## AN ELECTRIC IRONING DAY.

BY ELIZABETH H. CALLAHAN.



I AM sure the housewives who read Popular Electricity will be interested in a conversation I lately overheard between two friends who were very enthusiastic housekeepers.

"Good morning Mrs. Ade! Pardon my calling on such a busy morning as Tuesday, but you remember you promised to show me your electric iron and I thought you would surely be using it this morning. I am an old fashioned housekeeper and have, in the past, shunned these so-called modern improvements that take so much time to set up. I would rather go on in my old way. But this idea of an electric iron seems to be just the thing we all need, and since we moved into our new house all equipped for electricity, I feel as if I must get all the help I can."

"Come right into the kitchen," said Mrs. Ade when her friend finally stopped for breath. "I know it is a warm day, but you will find our kitchen as cool as any room in the house."

"But, where is the iron, and isn't this your ironing day after all?"

"Yes, my friend, but on a warm day like this we iron on the back porch—just attach one end of the cord to the receptacle in the kitchen, which you see is near the window, and attach the other end to the iron which has previously been carried out on the porch with the ironing board. One can iron a whole

morning without coming into the house or away from the fine breeze which is always playing around our back porch on the warmest days."

"Well!" said Mrs. Gate. "If that isn't a house comfort I never saw one. No more tired feet on Tuesday night. I suppose you have tried this iron long enough to know that it does not get out of order easily and keeps a good heat?"

"I have used this same six-pound iron for nearly two years without any repair whatever, and I would not exchange it for any now on the market. You see, the shape is somewhat different from the old-time fire-heated iron—the square corners at the back enable you to give a style to your ruffles and laces that you never could with the old irons. Then, too, the peculiar shape of the front of the iron—like a toe—has made it possible to iron sleeves and corners as easily as any part of the garment."

"The small three-pound iron is another treasure. If you wish to do a little pressing, such as fine handkerchiefs, laces or doilies, the small iron can be ready in a few moments and can be carried to any room in the house. In the sewing room it is invaluable, and every time I go away from home my three-pound iron is one of the first things to go into my trunk. In the summer time when you pack your thin dresses it is almost impossible to avoid crushing them. How annoying it is to arrive at the house of a friend just before dinner and find the dress you intended to wear in a mass of wrinkles. Never mind. Unpack your little three-pound iron, attach it to the

electric light socket, and in three minutes your iron is ready, and surely you can press your dress in fifteen minutes. How delightful to appear at your friend's dinner table in a fresh, crisp dress which looks indeed as if it had just come from the hands of the laundress.

"Yes, my friend, I could talk all day on the advantages of an electric iron—it is a comfort no home should be without. It is a saver of temper, as few can keep calm and tranquil when they have to wait for a fire to come up or must roast their faces over the gas. It does our ironing in half the time it used to take in the old way. It is always hot and clean, no wax is needed, as it is always smooth and never sticks."

"Well, said Mrs. Gate, "may I use your telephone? I won't lose a moment in calling up the electric light company and telling them to send me the two sizes of irons right off, as I shall not iron another piece in the old way. Thank you so much for telling me of your irons. I am so glad I came this morning—I am sure I never will regret it." And she never did.

#### AFTERNOON TEA WITH MRS. VAN SYCKLE.

It was Thursday and Mrs. Van Syckle was receiving in her pretty little parlor. Already six people had called and just as the bell rang to admit the seventh, the little maid opened the doors leading into the dining-room and announced that tea was served. "We have all been looking forward to this day with so much pleasure, Mrs. Van Syckle, we have been so anxious to see your electric devices." "Is this tea really made from water boiled in that fascinating pot with the fire an absent quantity?" These questions were asked by the ladies as they gathered around the dining-room and accepted the pretty cups passed to them, and gazed inquiringly at the tempting little luncheon prepared for them.

"Yes," answered Mrs. Van Syckle, "and this coffee was made in the coffee percolator on purpose for Mrs. Toy as she does not drink tea. You will see that the flavor of the coffee is much finer and the color richer when made in this way." Pretty Mrs. Toy was charmed with the coffee and spoke up in her quick

way: "My husband said he would get some of these devices for me as soon as I learned to be more careful, as I am sorry to say I so often forget, and the water would boil away and then I am told the utensil would be ruined." "Oh, no!" said Mrs. Van Syckle, "that is the beauty of these devices, they are indestructible, they will burn 500 hours or more without injury.

Just then the little maid uncovered the chafing dish and served the delicious creamed lobster with thin bread and butter. "This bread, my friends, was baked in my electric oven, but really this chafing dish is the finest device of all. If you are in a hurry and only want a light luncheon, or an after theatre supper it is invaluable. Some evening I want to have you all come in after the theatre and we will show your husbands how really necessary these devices are."

After a delightful afternoon the ladies went home singing in their hearts, "What is home without electric conveniences?"

#### ELECTRIC HAIR DRYER.

How often some lady has made the remark "I would like a good shampoo at home before going to the theatre, but cannot, because my hair is so abundant that it takes forever to dry." To meet this want the Shelton hair dryer has



been perfected and by its use the exhilarating effects of a good shampoo may be enjoyed in the privacy of the home.

The hair dryer is built of aluminum and weighs  $2\frac{3}{4}$  pounds. It will operate from the ordinary 110 volt alternating current lighting circuit, and is attached by means of a cord and plug.

By simply turning a key the same as

in any lighting socket, one step to the right, you receive a strong breeze of cold air. Turn the key two steps to the right and you receive a powerful breeze of warm air that will dry a heavy head of hair in five to six minutes. A third turn of the key to the right cuts off the current.

These results are obtained from a little electric fan which revolves inside the dryer. To obtain the warm air current a resistance is switched in by turning the key to the second point, and the heat generated by the current flowing through this resistance is carried outward by the breeze.

#### ELECTRIC ROTARY FLOOR POLISHER

A unique labor saving device is shown in the picture herewith, and is used with slight effort on the part of the operator. It not only polishes floors but also is said to be of great value as a sanding

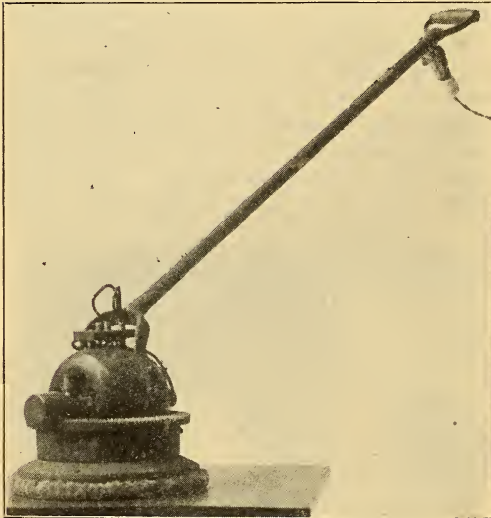

ELECTRIC ROTARY FLOOR POLISHER.

device by applying sandpaper or canborundum cloth.

It is stated that this machine will cut down any burrs or warped edges on any kind of floor with great speed, doing at least 300 square feet per hour and producing a perfectly smooth surface.

It is held that the high speed and rotary motion will not permit the grain of the wood to curl up which, cannot be avoided in hand work. The machine

weighs about 50 pounds and is operated with a direct or alternating current of 2.25 amperes, developing about one sixth of a horse power.

#### AN ELECTRIC SUCTION SWEEPER.

Dust is the greatest vehicle there is for conveying germs, and in using a broom, whatever may be tracked into the house on the shoes is sent up in clouds to settle on pictures, drapery and furniture. Vacuum cleaning outfits prove both convenient and cleanly, although they remove the loose dirt only by suction.

In the electric suction sweeper shown herewith are combined the cleaning effects of the broom, by an electrically op-



ELECTRIC SUCTION SWEEPER.

erated brush, with the dust prevention and absorption of the vacuum process, by an electrical section fan which draws every particle of sand, dust, and dirt into the dirt bag.

The hygienic value of vacuum cleaning, while universally acknowledged, has heretofore been available only where it was possible to install permanent plants or by hauling one of the movable engines to the building. The electric suction sweeper, as the name implies, is a combined sweeper and vacuum cleaner that is as easily handled as an ordinary carpet sweeper.

### VACUUM CLEANING OUTFIT.

A vacuum system for cleaning carpets, rugs, hangings, etc., is ideal, for the reason that no dust is allowed to escape into the room. Many modern homes are now arranged with piping to the various rooms to which the hose for the various cleaning tools is attached. The air pump which produces the vacuum is located in the basement.

In the Palm system the pump is driven by a small electric motor mounted on the pump frame. The motor is clean and

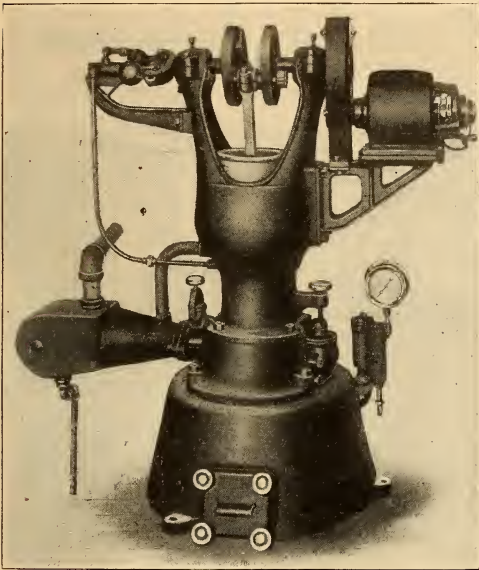

VACUUM CLEANING OUTFIT.

noiseless and requires no attention or special skill in its operation. The dust laden air from the carpets is drawn through the hose into the pipe line and from there is sucked into the pump cylinder. The pump is provided with a loose fitting piston, and a constant flow of water is maintained between the piston and cylinder. The dust on entering the cylinder mingles with the water and is discharged into the sewer.

### ELECTRIC WATER HEATERS NOT DANGEROUS.

The coroner in one city has decided that the many deaths that have occurred in bath tubs, and which have been attributed to heart disease, were in reality caused by the gas water heaters so

often used in bath rooms. Bath rooms are, as a rule, comparatively small and tight. The gas heater consumes the oxygen very rapidly, and it is believed that this is the cause of death which has occurred so often under these conditions.

### WILL ELECTRICITY RETARD OLD AGE?

BY NOBLE M. EBERHART, M. D.

Since the days of Ponce de Leon man has sought in one manner or another for the Fountain of Eternal Youth or for some wonderful elixir of life that would vanquish the ravages of time. For several years the medical press, especially those journals devoted to the healing properties of electricity, have occasionally chronicled the fact that high-frequency electrical currents of the type discovered by D'Arsonval are capable of lowering the pressure of the blood and thus relieving them when subjected to undue strain.

Recently similar articles have appeared in the daily press recounting the effects of these currents in preventing or curing the hardening of the arteries that takes place in old age, and thereby prolonging the life of the individual, particularly in those cases where this change occurs prematurely.

In the first place it will be desirable to tell how the blood vessels become weakened and brittle and why this is dangerous to the life of the individual, and that the saying has arisen that "A man is as old as his arteries."

Medical men consider these changes that take place in the arteries as being essentially the result of an error or failure in nutrition. By nutrition is meant the actual feeding or nourishing of the cells that make up the tissues of the body.

The cause of this nutritional disturbance is usually found to be long-continued muscular strain, gout, rheumatism, excesses, infections, etc.

In the early years of life, repair takes place easily, exceeding the waste and thereby promoting growth. This is followed by a period in which repair and waste are essentially equal and finally by one in which waste exceeds repair and the tissues take on the changes that we call old age. Now if something happens to interfere with the bodily economy, es-

pecially in the nourishment or nutrition of certain parts, these may take on at an early period the changes that usually belong to advanced years.

In the case of the arteries this is manifested by a fibrous thickening of their interlining or by an increased deposit of mineral salts in their walls, making them lose much of their elasticity and tone, so that in this brittle condition they easily give way to any sudden strain put upon them, through increased blood pressure from any cause. If an important artery ruptures, death frequently results, as in the case of apoplexy, which is caused by the bursting of an artery in the brain. In these cases, if death does not follow, paralysis does. The hardening of arteries is called by physicians arterio-sclerosis.

It is obvious to any one that if the walls of the arteries are weakened, then anything that will lower the pressure of the blood will lessen the strain on them and tend to prevent their rupture and the consequences thereof. How are we going to find out whether the arteries are undergoing these changes?

In advanced cases the physician can detect the changes by the touch, and the arteries in the wrists show various degrees of hardness, sometimes feeling like small hard tubes, and in other cases as the finger passes along the artery the sensation is that of passing over a string of beads.

In some cases the degeneration will take place in an important artery that is not accessible for examination. By ascertaining the pressure of the blood in some one of the principal arteries we are able to tell whether it is higher than it normally should be.

For this purpose an instrument called a sphygmomanometer is used which shows by the height of a column of mercury the pressure of the blood. The apparatus need not be described here. Suffice it to say that the normal blood pressure as thus indicated is 100 to 130 millimeters in a woman and 115 to 145 millimeters in a man. A rise above these limits shows the tendency toward arterio-sclerosis and the necessity of reducing this abnormal pressure.

Now for the method.

D'Arsonval discovered that by means of two condensers with a coil of wire

(called a solenoid) interposed, he could, by rapidly charging and discharging these condensers, produce in the solenoid alternating electrical currents of very high frequency, and by connecting the body of an individual with the ends of the coil, these same high-frequency currents could be made to travel rapidly back and forth through the human body.

The effect of these rapid oscillations on the body is to increase nutrition, increase the oxygenation of the blood, lower the arterial pressure and increase the carrying off of urates, phosphates, etc.

An American form of the outfit is shown in the illustration. In this case the current is taken from the electric

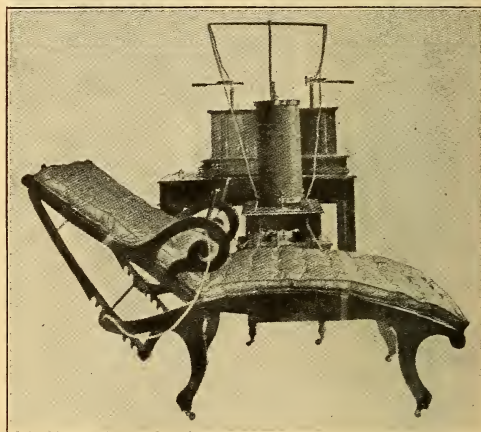

AUTO-CONDENSATION COUCH.

light plug and carried through an induction coil and then into the condensers and solenoid of D'Arsonval, from which it is carried into a couch that the patient is placed on.

This couch has rubber cushions lying on sheets of zinc. The zinc is charged from one side of the machine, and the patient from the other (by holding handles connected therewith): The rubber cushions prevent the current from passing directly between the patient and the plate.

This method is called auto-condensation (self-condensation), because the patient forms one plate of a condenser of which the zinc plate is the other, and the cushion the part (called di-electric) through which the positive and negative charges hold one another, although un-

able to pass through and neutralize. Glass is even better than rubber for this purpose.

By means of a hot-wire meter the current in the patient is accurately measured and the dose is 150 to 500 milliamperes, with 200 as an average amount.

The plate is charged negatively while the patient holds a positive charge. The next instant both have been discharged and recharged with the opposite kind of electricity, thus producing the rapid

wave that passes through the body. These alternations occur a million times per second and the current used is one of millions of volts. After ten to 20 minutes of this treatment the arterial tension will be found, by testing, to be perceptibly lowered, and by keeping up the treatment it may be permanently maintained at the normal pressure, thus robbing the individual of the principal danger of old age, whether timely or premature, namely, the danger of rupturing important blood vessels.

### ELECTRIC RAILWAY ON A 200-YEAR-OLD VIADUCT.

Rio de Janeiro, oldest city of Brazil, once brought up visions of a vast labyrinth of narrow, crooked, unsewered, boulder-cobbled and poorly lighted streets—the haunt of yellow fever breeding mosquitoes. To-day, however, it is

bears, besides its weight of years, one of the lines of the modern and well equipped electric railway system of which the city can now boast. This picture, reproduced through the courtesy of the Electrical World, shows a strange mixture of the ancient and modern. Probably no other electric railway in the



ELECTRIC RAILWAY ON 200-YEAR-OLD VIADUCT.

healthful, well lighted and with a transportation system underway of which any city might be proud.

Splendid examples of ancient architecture have been handed down through the centuries, among them an old viaduct which was built 200 years ago. Still solid and substantial this old structure

world is laid on a road bed such as this.

Leaving aside any feature of advertising, every electric light placed on the buildings in a city street adds to the general illumination, and, by a parity of reasoning, to the cheerfulness and safety of the street.

# ELECTRICAL MEN OF THE TIMES.

## LOUIS A. FERGUSON.

A prominent man in electrical circles today is Mr. Louis A. Ferguson, the newly elected president of the American Institute of Electrical Engineers. Election to this office means, perhaps, the highest mark of approval that it is in the power of the electrical fraternity to bestow upon a fellow worker. Mr. Ferguson is vice president of the Commonwealth Edison Company of Chicago. He and Mr. Bion J. Arnold, a sketch of whose career appeared in the June issue of *Popular Electricity*, are the only two western men to be elected president of the Institute.

Mr. Ferguson was born in Dorchester, Mass., in 1867. Here he received his common school education, later entering Massachusetts Institute of Technology, where he graduated in 1888. Immediately after graduation he accepted a position with the Chicago Edison Company, which was then the name of the Chicago lighting company, and he has remained with the company ever since, filling positions of responsibility in nearly every department of the organization.

Although Mr. Ferguson began his work in the engineering and operating end of the business he handled such commercial work as came within his province so successfully that the attention of the management was attracted to his efforts, leading to his appointment to positions of a managerial nature, leading finally to his election to the office of vice president.

Always active and aggressive, Mr. Ferguson not only drew the attention of the management of his own company to his abilities, but also early became recognized among central station people throughout the country as a man from

whom important things might be expected. He became prominent in the various associations of electrical men, presenting valuable papers before the National Electric Light Association, the Association of Edison Illuminating Companies, the International Electrical Congress, etc. In 1901-2 he was president of the Association of Edison Illuminating Companies, and was re-elected for 1902-3. He was also president of the National Electric Light Association during 1902-3.

Another important contribution was

his work in conjunction with Dr. Louis Bell and James I. Ayer upon the preparation of a suitable specification for a standard incandescent lamp, and the determination of a proper method for the commercial application of this standard. The result of this work was presented in a report entitled "Standard Candle-power of Incandescent Lamps," which was submitted to the National Electric Light Association at Niagara Falls in January, 1897.

While not a club man in the ordinary acceptance of the term, Mr. Ferguson belongs to a large number of clubs, including the Commercial Club of Chicago, the University Club, the Union League, Chicago Athletic, Mid-Day, Evanston Country Club and the Onwentsia and Glenview golf clubs.

Mr. Ferguson is credited with being the first engineer in this country to recommend a central station system generating three phase alternating current, with transmission lines to substations operating rotaries converting from alternating to direct current for general distribution.





## THE THEORIZER'S CORNER.

Many of us have a pet theory that we are aching to give to the world at large. There are others who feel it their duty to run down and "explode" such theories wherever possible. We are, therefore, going to set aside a corner in *Popular Electricity* where the theorizer and the "exploder" may meet on common ground, and we await with interest the "fire works" to follow. The department will be devoted to theories concerning electricity and allied sciences, and the idea was suggested by a "new" theory propounded to us as to the cause of thunder and lightning, which we print below for what it is worth. If any one has any objections to the theory let them be set forth in cold type.—Editor.

---

### CAUSE OF THUNDER AND LIGHTNING.

The earth revolving around the sun moves through space at the enormous speed of 19 odd miles per second. As the earth rotates upon its axis its atmosphere, of course, rotates with it. Since the atmosphere surrounds the earth as a thin envelope, only, at the point, or surface rather, where the atmosphere ends the ether must begin. The ether being stationary, the friction of the rotating atmosphere rubbing against it produces electricity.

As is well known, the atmosphere expands and contracts with the variation of temperature, and may therefore be looked upon as a great ball which is constantly shrinking or expanding. As the atmosphere contracts there is a huge vacuum left between it and the ether. As it expands again it surges back into the vacuum with a loud report, louder than the loudest cannon—a noise called thunder. The sparking of the brush (the ether) and the commutator (the atmosphere) as the ether rubs against the atmosphere is caused by the irregularity of the surfaces and is the phenomenon which we know as lightning. This spark or discharge punctures the vacuum, and, owing to the enormous voltage involved, sometimes punctures clear through to the earth.

R. S.

---

### WORLDS WITHIN WORLDS

Most scientists of the present day believe in the ionic theory of matter; that is, that all matter is made up of positively and negatively charged ions. These ions are supposed to be infinitely smaller than atoms and are also thought to be separated from each other by vast distances—that is, vast in proportion to the size of the ions. These ions are constantly on the move in little paths of

orbits of their own, and the sum of their mutual attractions and repulsions hold them in a state of equilibrium. In the confines of a single drop of water, therefore, we may have a miniature solar system, the ions taking the place of the stars and separated from each other by distances, which, in comparison to the size of the ions, are as great as those between the stars.

This seems hard to understand or imagine, but it is no more difficult of comprehension than the infinitely large. When we look into the heavens on a clear night and try to imagine what is beyond and beyond, we are borne away by our own thoughts. Infinity is incomprehensible, whether the infinitely large or the infinitely small. It is not difficult, therefore, to persuade ourselves that the plan of the universe is but a system, within a system. A drop of water may consist of a system of ions like stars, perhaps inhabited by beings infinitely small. On the other hand, the stars which we see at night may be but the ions of another system, our little earth being but one of them, and all the stars which we see may simply go to make up a drop of water, a grain of sand or whatnot, over which gigantic beings tread and never imagine they are walking on worlds within worlds beneath them.

So it might go on, system within system. The life of a drop of water as compared to that of our solar system is as nothing. The life of our solar system as compared with eternity is, likewise, as nothing. There is time and space in plenty for working out the problem of existence for an infinite number of systems, and it makes no particular difference how large or how small these systems may be.

A. V. D.

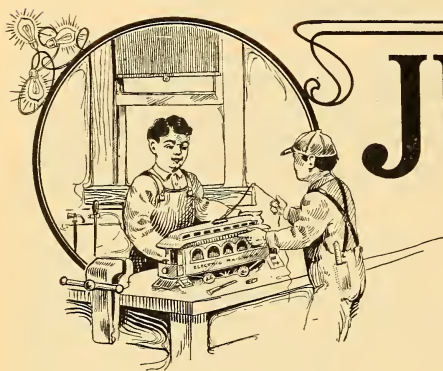

# JUNIOR SECTION

## A SIMPLE ARC LIGHT.

A very simple yet interesting miniature arc light can be made at almost no cost. The first thing needed is a cigar box. Take off the top, and it should now look like (A) in Fig. 1. The next thing necessary is a small block of wood (B), which should be fastened to the bottom of the box, after having a

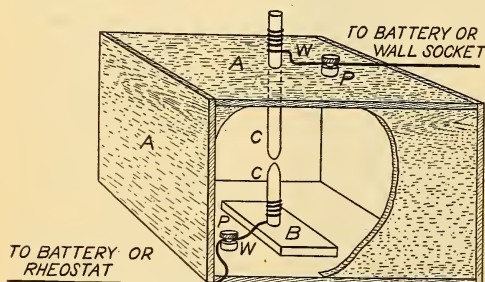

FIG. 1. SIMPLE ARC LIGHT.

hole about 1-16 inch in diameter bored in the middle. This block of wood should be about one inch high.

Next procure two binding posts from an old dry battery and mount them as shown at (PP). The last things needed are two small carbons which are taken from a hard lead pencil. One of these carbons is mounted in the block (B) and the other is run through a hole in the top of the box immediately over the first. This hole should make a close fit for the carbon and the latter may be fed by hand.

To each binding post a piece of No. 22 copper wire (W) is fastened and carried to the carbons, where it is wound around each very tightly. Now connect the wires from the 110-volt house current or 10 dry cells to each binding

post. If the carbons are touched, then slowly drawn apart, you have a bright arc light. The fine copper wires (WW) should be carefully fastened to the carbons, or it will result in the breaking of them.

In case the 110-volt lighting current is used it is best to insert a home made water rheostat in the circuit to cut down the force of the current which would otherwise eat up the carbons too fast.

This water rheostat is shown in Fig. 2. A tin can is partially filled with

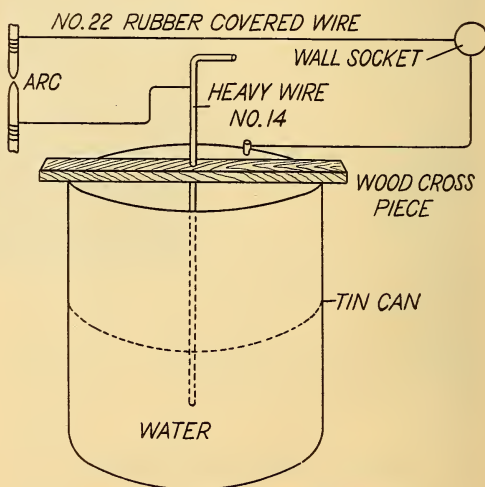

FIG. 2. WATER RHEOSTAT.

water. No. 22 rubber covered wire is run from one connection in the wall socket and soldered to the side of the can. Through a piece of wood across the top of the can a heavy wire is run down into the water as shown. This wire is connected by a rubber covered wire with the lower binding post and from

there to the lower carbon. A wire is then run from the upper carbon to the other connection in the wall socket. By lowering and raising the heavy wire in the water the right amount of current can be obtained. If necessary a little salt may be mixed in the water, which will allow more current to flow.

R. D. HARRIS.

### CONSTRUCTION OF A SMALL SWITCHBOARD.

There are many boys who like to spend their leisure hours in working or experimenting with batteries and other simple electrical apparatus. Such boys, through their reading, soon find out that there are many things which they cannot do with batteries, such, for instance, as heating wires or producing powerful

which are mounted a double pole knife switch (MS) (see diagram), a single pole knife switch (LS), a socket and lamp (S), four small binding posts, ( $P_1$ ), ( $P_2$ ), ( $P_3$ ) and ( $P_4$ ), which hold the fuses (F) and (F'), and two large binding posts, (B) and (B'). The connections between these switches and binding posts should be made with No. 14 rubber-covered copper wire, passed through holes in the base, and pressed snug up against the under side. The courses of these wires are shown by the dotted lines and they come up through holes in the board and fasten to the various contacts.

The board should next be fastened to the wall over the work-table by screws at its four corners, and should be held about three-quarters of an inch from

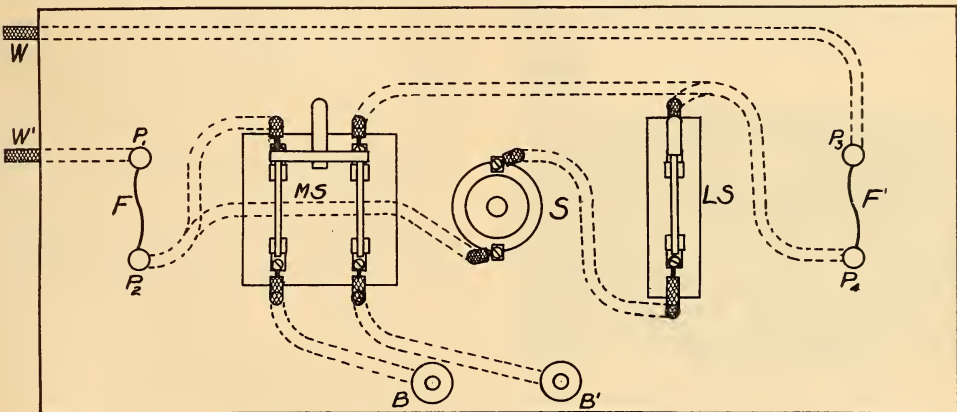

SWITCHBOARD FOR BOYS' LABORATORY.

magnetic forces. But there is a source of current by which these things can be done, and that is the 110-volt current, alternating or direct, which is used for lighting. Because of its strength, however, certain precautions must be taken to prevent it from producing heating effects when they are not desired.

In order to use this 110-volt current safely the youthful experimenter should first provide himself with a simple switchboard, which he may easily construct himself. A switchboard, which any boy may make himself, is described below, and it will enable him to secure current of almost any strength desired.

The first thing that should be constructed is a marble, slate or hardwood base, about 8 inches by 18 inches, upon

the wall by small blocks of wood, so the wires cannot come in contact with the wall. The wires (W), (W') should be run in moulding to a cut-out box or fixture, and there connected to the electric light wires. It is best to have means for quickly turning on or shutting off the current to the apparatus, which is connected, by wires, to the binding posts (B) and (B'). The switch (LS) lights the lamp in the socket (S). This shows whether or not there is current at (B) and (B') when (MS) is on. If a very simple switchboard is desired (LS) and (S), with their connections, may be omitted.

A simple and amusing experiment is the following: Connect a very fine piece of copper wire, No. 30 to No. 36, be-

tween (B) and (B') when (MS) is off. Upon turning (MS) on, the fine wire will explode with quite a report, and a bright flash will accompany the report. This may also be done by short-circuiting a flexible cord with fine wire, but care must be taken not to have it near any combustible material.

LOUIS H. ROLLER.

### A SIMPLE ELECTROSTATIC MACHINE.

Nearly everybody has seen, at one time or another, one of those great electrical machines used for medical, X-ray or experimental purposes, with its rapidly revolving glass or rubber plates, its shining metal, and its flashing, crackling sparks like miniature lightning strokes.

For ordinary purposes of experiment an efficient substitute for one of these machines may be made out of a large

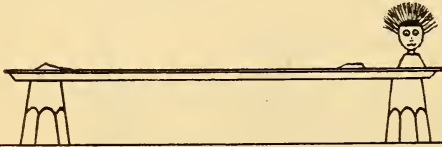

FIG. 1. SIMPLE ELECTROSTATIC MACHINE

metal serving tray, a few common glass tumblers, a sheet of good manila paper, and a woolen cloth. There are no revolving plates about this machine, but the principle is the same.

For good results everything should be dry and warm. The tray is set up on the tumblers, as shown in Fig. 1, and is therefore insulated.

Then the manila paper is spread on the table or floor and rubbed or stroked vigorously with the woolen cloth, after which it is lifted by two corners and dropped onto the insulated tray. Now if the knuckle be quickly approached to the edge of the tray, a sharp little spark will be drawn, possibly a half inch in length.

With this arrangement we may perform many of the experiments described in books on physics. A miniature head of hair placed on one side of the tray will proceed to stand on end through mutual repulsion when the charged paper is in place. (See Fig. 1.)

A short piece of copper wire bent into the shape shown in Fig. 2, with the ends

sharpened, forms the electrical windmill. The center of the wire is flattened and slightly indented with a prick-punch or other sharp instrument, so that the wire may be balanced on the point of a pin.

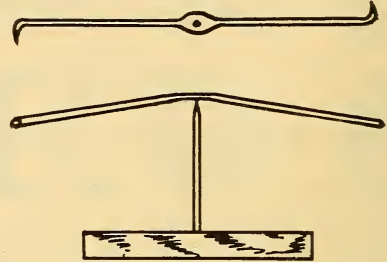

FIG. 2. ELECTRIC WINDMILL.

When the affair is placed on one end of the tray, it revolves furiously while the charge from the electrified paper lasts. The explanation is that the electrified air is repelled from the sharp points so fast that it drives them backward, just as jets of steam would do.

Fig. 3 shows a bell or gong suspended from the edge of the tray on a wire, while a similar one is supported a half inch from it on a metal base. A small metal button, suspended by a silk thread so that it hangs just between the two gongs, will be alternately attracted and

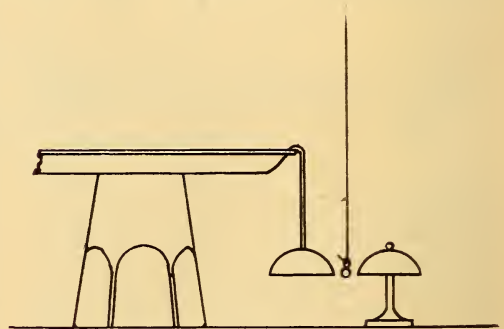

FIG. 3. ELECTRIC GONG.

repelled by the charged gong, and will keep up a lively tattoo while the charge lasts.

Of course we can use this machine to charge Leyden jars, which vastly increases the scope of our experiments. The simplest form of Leyden jar is not a jar at all, but simply a pane of glass with a sheet of tinfoil pasted on each side to within an inch of the edges, as shown in Fig. 4. This must be held so

that the hand touches only the tinfoil on one side. The other side must be presented to the tray several times, when it will be found to be charged with electricity. One can receive quite a smart shock by touching both sides at once, and the spark is much louder and more brilliant than that from the tray alone.

An interesting experiment is to insert a cork in a hole in the side of a tin can (Fig. 4), running a wire through the cork until it almost touches the inside of the can. If the mouth of the can is held over the open gas jet until it contains a mixture of air and gas, the cover

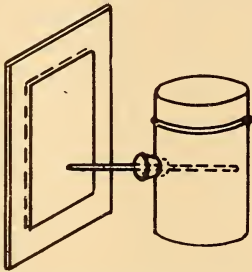

FIG. 4. INTERESTING ELECTRICAL EXPERIMENT.

put on, and the projecting wire touched to one side of the charged Leyden jar or plate, while the other side is touched with the other hand, an explosion will follow that will blow the cover from the can. This illustrates the principle of the electrically ignited gas engine.

A host of other experiments will suggest themselves, but the amateur who has got as far as this will probably decide to build one of the more efficient revolving plate machines.

#### DEPOSITING METAL ON INSECTS.

Those who have a small electroplating equipment will find the following experiment interesting. The insects to be electroplated are first dipped in an albuminous fluid, such as the white of an egg. They are next dipped in a bath consisting of a 20 per cent solution of nitrate of silver (poison) and then exposed to hydrogen sulphide gas, to reduce the silver nitrate to metallic silver. They are then hung in the electroplating bath. As the deposit increases the slightest unevenness of surface is revealed and small hairs and tentacles, before scarcely dis-

cernible to the naked eye, are increased in size and become readily distinguishable so that their curious forms may be studied.

#### THE "ELECTROHEN."

The "electrohen" is a unique and artistic oval glass, electric chicken hatching device to be used for advertising and educational purposes—for advertising purposes at poultry shows, and in store windows; for educational purposes in college and high school laboratories, and in classrooms for nature study. The "electrohen" is readily connected to any electric lighting circuit, either alternating or direct current of 104 or 110 volts, by the usual flexible cord and plug. It is only necessary to turn the button and sufficient heat will be provided in the "electrohen" for hatching and brooding the chicks in the one machine.

Eggs due to hatch within three or four

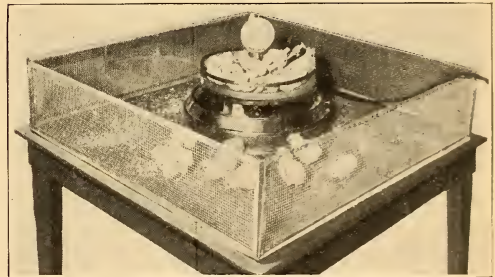

THE "ELECTROHEN."

days can be placed in the "electrohen" to excellent advantage, with the result that spectators can witness, in plain view, the pipping and breaking of the shells, the exclusion and drying off of the chicks or ducklings, while at the same time the chicks or ducklings first to hatch will be running about in the nursery department or feeding in the enclosure surrounding the machine.

It is stated that repeated tests with various electric incubators have demonstrated that the cost of operation is only one-third to one-half more by electricity at the usual rates of current than it is by the use of kerosene oil. This is the cost alone of current consumed as compared with the cost of the oil used, and no account is taken of the labor saved, which

more than counterbalances the difference in cost for heat.

An electrically operated incubator has another advantage over a lamp heated machine. In the electric incubator the heat (or current) is "cut out" as soon as the temperature in the egg chamber reaches 103 degrees and thereupon all expense stops instantly, whereas when the regulator on a lamp machine opens the damper above the lamp flame the consumption of oil continues, the surplus heat being discharged into the apartment in which the machine is located.

#### HOW TO MAKE A POLARIZED RELAY.

The construction of a polarized relay that is highly sensitive and will answer for a number of purposes is not at all difficult. Such a relay will also answer for use in wireless telegraph experiments where the ordinary commercial type fails. The main part needed in the construction is the bell ringer employed in every telephone. These ringers usually come wound in standards of resistance from 80 to 2,000 ohms. The 1,000 ohm size, 500 ohms to each coil, should be used, allowing very sensitive construction and not being so expensive as the higher wound type.

In Fig. 1 is shown the bell ringer, which consists of two oppositely wound magnet coils mounted on a metal base with permanent magnet screwed to the bottom of the metal base and bent over at the top. On the under side of the permanent magnet is a delicately pivoted armature which carries an extended rod with hammer attached on the end that swings against the gongs and gives the indication when the generator current encircles the magnet coils and starts the armature in vibration.

Use of the permanent magnet places the armature in an extreme state of stress. This is due to the fact that both cores of the spools are mounted on one pole of the magnet, which gives each pole the same polarity. The armature balanced between the two like poles is repelled by each to an equal degree. The least bit of current passing through the magnet coils will destroy the balance and cause the armature to swing and hit the gong by means of the extended hammer. This is the action of the bell ringer. By

addition of a few changes we have the polarized relay. By connecting a battery to the terminals of the bell ringer the armature will be attracted in one direction and can be made, by use of suitable contacts, to close a second circuit. The bell ringer, however, in all parts is not adapted for use as a relay and changes must be made.

The permanent magnet which comes with the bell ringer is removed, and one about 3-16 of an inch thick and one inch wide is substituted, being bent in the shape as shown in Fig. 2, with the top (C) clearing the magnet coils  $1\frac{1}{2}$  inches. The permanent magnet can usually be screwed to the same place as the one taken off. This permanent magnet can be easily made by bending to the desired shape a piece of the best hard steel and drilling the holes which will be necessary to mount it to the ringer coils.

The bent rod is now rubbed over the poles of a horseshoe magnet until thoroughly magnetized. In the absence of the horseshoe magnet, wrap several layers

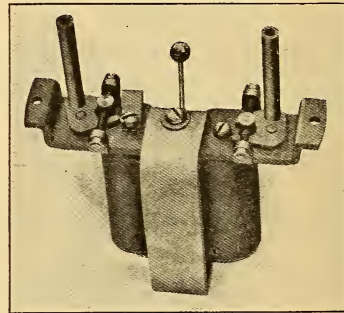

FIG. 1. STANDARD FORM OF BELL RINGER

of thin wire over it from end to end and pass the current from several dry cells through the wire, tapping the magnet occasionally, which causes the magnetism to saturate the rod more freely. The bending and drilling should all be done before the magnetization has taken place, as this operation would destroy the magnetism to a certain extent. In Fig. 2 is shown the plan of screwing the permanent magnet to the ringer coils. The pivot swing which originally supported the armature is now screwed to the under side of the upper end of the magnet, which is shown at (E). The armature is now placed in a vice and the two ex-

tended sides are sawed off so that only the pivot ends and hammer swing remain. Considering that the magnet, ringer coil, etc., have been mounted on a suitable wood base, we place the pivot end in the slot of (E) so that the extended rod will swing down between the two magnet coils as shown clearly in Fig. 3.

Two soft iron pieces shown at (HH), Fig. 3,  $\frac{1}{4}$  by  $\frac{1}{8}$  of an inch in cross section are now screwed to the tops of the cores of the magnet coils. A second soft iron strip (F) is placed on the ham-

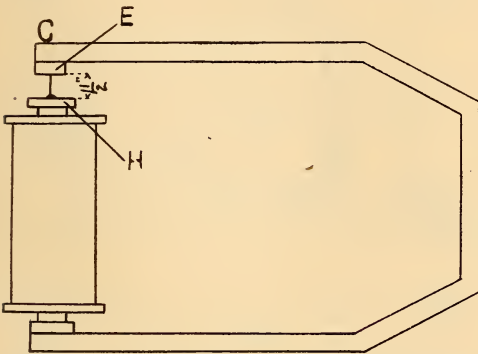

FIG. 2. COILS MOUNTED IN PERMANENT MAGNET.

mer swing, in such a position that it will have  $\frac{1}{8}$  inch play between the two soft iron pieces (HH) mounted on the magnet cores.

The hammer is now cut off from the extended rod and a small platinum contact placed on as shown at (G). The platinum contact may consist of a small platinum wire soldered to the rod. It can be secured by breaking an incandescent lamp bulb and using portions of the lead-in wires which are made of platinum metal.

Two binding posts are now provided as shown at (A) and (B). The binding posts should have regulating screws run through, with lock nut on top. The exact position in which these binding posts are to be placed can best be determined by mounting these parts. Their position, however, should be such that the platinum contact on the extended rod will make good contact with the platinum contact placed on the tip of the regulating screw (A). A very thin bronze wire spring is wound and placed so that its pull will be directed to the post (B). The

bronze spring is shown at (I). Four common binding posts are now mounted on the wood base as shown at (L) and at (M).

The binding posts (L) are for connection to the apparatus (S) to be relayed, which is connected with batteries (X) in circuit. In this secondary circuit current will flow from the batteries (X) and operate the relayed device (S) whenever the contact (G) is against (A), which will be whenever current flows in a certain direction from the source (M) and energizes the coils so as to pull the hammer swing over against the contact (A). Current will then flow through the secondary circuit as follows: From battery (X) through (S) through conductor to the base of the permanent magnet (C), through (C) to the hammer swing, down the swing to contact (A) from there back again through the conductor to the battery from whence it originated.

The extended rod with the platinum contact (G) should be kept at such a tension that it will normally barely clear the contact screw mounted on binding post (A).

In operation it will be found that the battery will not attract the soft iron piece (F) unless the current is flowing in a certain direction. This is due to

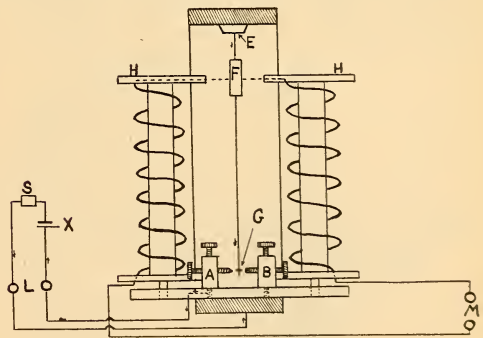

FIG. 3. CONNECTIONS FOR POLARIZED RELAY.

the fact that the pull is exerted towards the post (B), which has no contact. To remedy this it is only necessary to reverse the connections. In actual practice this relay, when built up accurately, will operate with one volt through 10,000 ohms resistance and will find many practical uses.

# NEW ELECTRICAL INVENTIONS.

## TELEPHONING TO TRAINS WHILE IN MOTION.

It is readily recognized that some means by which telephone communication could be held with a train in motion would be of great advantage as an adjunct to the block signal system. Various schemes have been suggested for doing this, one of the latest being a system invented by Joel Ames of Montrose, Ia. The details of this system are clear-

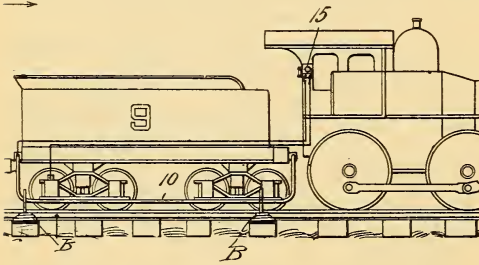

FIG. 1.

ly shown in the accompanying diagrams.

Looking at Fig. 1 it will be noted that there is a horizontal bar or shoe (10) of metal attached to the side of the tender and extending its whole length. This bar may be lowered so as to make electrical connection with little coil-spring metals standards (B) set on the ties beside the track. The distance between these standards is a little less than the

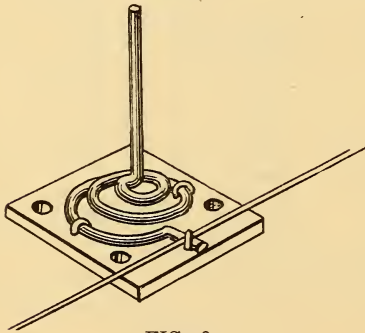

FIG. 2.

length of the bar, so that the latter is always in contact with at least one of them. Fig. 2 shows the arrangement of the standards.

Fig. 3 is a diagram showing the electrical connections of the system. A telephone (15) is mounted in the cab of the locomotive. One side of the telephone is

grounded through the locomotive wheels and the rails of the track. The other side of the telephone is connected to the bar (10) and from there a free path for the current is made through the standards, which are all connected together by a wire (7), to the battery (C) and thence to one side of the telephone (8), which is located at the dispatcher's sta-

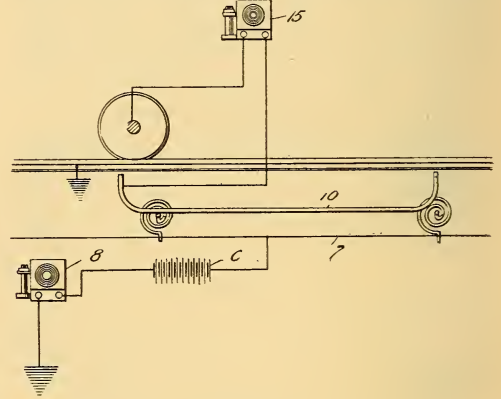

FIG. 3.

tion, block house or other point. The other side of telephone (8) is connected to the ground.

It will be seen, therefore, that communication may be had with the train at all points along the track where the standards are located. These may be located at the beginning and end of blocks or at other points where it would be of advantage to hold communication with the moving train.

## TEMPERATURE REGULATOR FOR INCUBATORS.

The incubation of poultry eggs is divided into two periods, the first period being when the eggs receive heat and the second when they give off heat by virtue of the life contained therein. At the beginning of the second period it is necessary to cool the eggs at the proper time, or the natural heat, plus the artificial heat will raise the temperature to the danger point. It is therefore of advantage to provide some automatic means for the regulation of the temperature, and also to sound an alarm whenever the temperature reaches the critical point. A very ingenious device has been



patented for this purpose by Mr. Georg Mücke of Reisenberg, Austria-Hungary, the action of which is shown clearly in the illustration.

Within the incubator there are two thermometers connected with two separate electrical circuits. Thermometer (15) has a projecting bulb (10) which lies in contact with the eggs. One terminal of an electric circuit is constantly in connection with the mercury of the

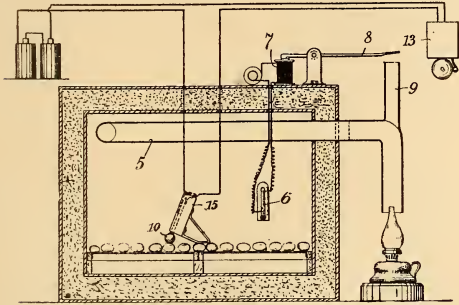

thermometer. The other terminal is inserted in the tube at a point such that when the mercury rises to the predetermined point it will complete the circuit and automatically ring the electric bell (13).

The other thermometer (6) is connected to another electric circuit in the same manner. When the danger point is reached this circuit is also closed, and current passes through the electro-magnet (7). There is a little iron plunger in this electro-magnet working on the well known principle of the solenoid. When the current flows through the coil of the electro-magnet this plunger is sucked into the coil and this action moves the lever (8) so that the damper on the end is lifted from the lamp chimney and the heat passes directly up through the chimney instead of passing through the tube (5) into the interior of the incubator.

A street car fender has recently been invented which possesses the advantage that at an instant's notice it can be dropped to a level with the track and pick up a person or object rather than roll them under the car. The release mechanism is operated electrically, and the motorman has only to press a small lever which is convenient to his hand.

### ELECTROTHERAPEUTIC HEATING DEVICE.

Electricity now plays an important part in the practice of medicine, one of its most useful applications being the concentration of powerful heat and light rays upon affected parts. A new heating device of this nature has been patented by Mr. William E. H. Morse of Algona, Ia., two views of which are shown in the accompanying illustration, which is a side and a top view.

The heater consists of a hemispherical reflector containing an electric incandescent lamp, the edges of the reflector being covered by a soft pad which protects the body from the hot metal shell. The lamp is protected from injury by a wire mesh as shown in the lower part of the illustration.

In the application of the heater the reflector shell is pressed over the part

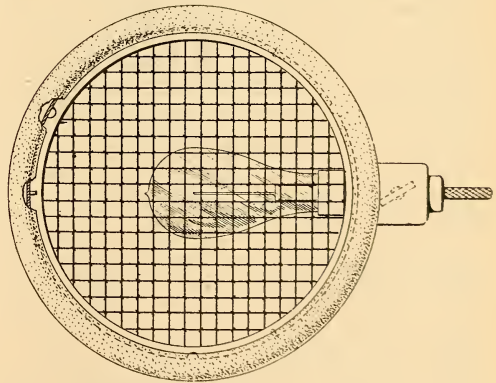
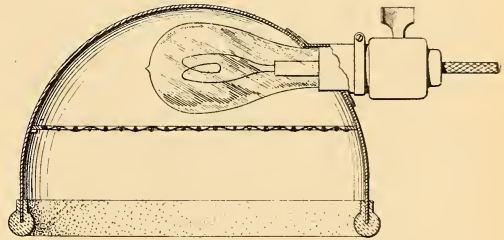

where local application of heat is desired. As no heat can escape, the interior of the reflector soon becomes as hot as can comfortably be borne. The device is always ready for instant application and is far ahead of a hot water bottle, for it never leaks.

## QUESTIONS AND ANSWERS.

Readers of Popular Electricity are invited to make free use of this department. Knowledge on any subject is gained by asking questions, and nearly every one has some question he would like to ask concerning electricity. These questions and answers will be of interest and benefit to many besides the one directly concerned.

### INFORMATION FOR THE PRACTICAL ELECTRICIAN.

QUESTION.—(A) What is the difference in the make-up of a magneto used with a jump spark, and a magneto used on a make-and-break spark?

(B) Can a non-vibrating coil be used in connection with a jump spark?

(C) Please explain what causes the alternating current to continuously change the direction of its flow.

(D) In what way is an alternating current dynamo different from a dynamo producing a direct current.

(E) Can dry-cell batteries be successfully charged, and if so, how?—V. E. H., Cleburne, Kans.

*Answer.*—(A) The difference existing between magneto generators for such purposes is not great. However, there are some points which require consideration for successful operation. One condition in connection with dynamos is that the voltage falls off with an increase in current. This decrease in voltage is mostly due to armature reaction, i. e., the magnetic flux created by the armature current tends to neutralize the flux due to the field coils and thereby decreasing the effective magnetic field. As the armature flux is proportional to the current, it is readily understood that the voltage will fall off at an increased current output. This reaction, which ordinarily is sought to be decreased, is an advantage in the make-and-break spark ignition system, as it is possible to use a high voltage to overcome the poor contact in the engine. It also limits the current and in turn the energy of the spark at high engine speeds, when the open voltage of the dynamo is high. A dynamo to be used in connection with a make-an-break or touch spark system, may be either a constant or variable voltage type and should have a pressure of from 10 to 16 volts.

With reference to the jump spark coil, it is found that a slight change in vibrator adjustment, or slight difference in voltage, produces great difference in the effectiveness of the spark. Therefore the dynamo to be used in this case should

be of the constant potential type. Thus, the armature reaction in this case should be kept low and the speed as constant as possible. Owing to arcing at the vibrator, the voltage of the dynamo should not exceed 10 or 12 volts. From these remarks you may appreciate that a dynamo is not so well suited for use with a vibrating jump-spark coil, as a non-inductive source such as a battery would be.

The constructive details of the make-up of ignition generators, being too extensive to take up in this department, will of course follow the design of standard dynamos of such characteristics as we have shown. Such information you may readily obtain by referring to treatises on dynamo construction.

(B). A non-vibrating coil may be readily used in connection with jump spark ignition, especially for high or variable speed engines, due to the fact that a better contact arrangement is possible with this kind of a coil than with a vibrating jump spark coil. The voltage may be relatively lower, say from five to eight volts, which will leave the current larger. In general this coil may be slightly larger than a vibrating coil, as it is necessary that the single spark of the non-vibrating coil must be stronger than an individual one of the series of sparks, resulting from a vibrating jump spark coil. The timer or current interrupter should be very quick acting, as the number of secondary turns on the coil is proportional to the speed of the break. If a dynamo is used as an energy source, it may be of the same design as a dynamo for a touch spark system, with the exception that the voltage should only be about one-half as high.

(C and D). In any dynamo, alternating or direct current, the armature consists of coils of wire which are rotated between highly magnetized pole pieces. It is supposed that invisible lines of magnetic force pass from the positive to the negative pole and that the wires of the armature have current generated in them

by virtue of the cutting of these lines of force. Figs. 1 and 2, from Mann and Twiss' Physics, show how the armature coils are supposed to generate current, the arrows showing the direction in which current will flow in the armature coils and connecting wires. The diagrams show the pole pieces as ordinary horseshoe magnets, although, as a matter of fact, the shape varies in different forms of dynamos and motors, some having a large number of poles, always alternating, however, a north pole then a south pole, then a north pole, and so on.

All dynamos primarily develop alternating current, because, when the wires of any coil sweep by a north pole, the current is generated in one direction and when they sweep by the next pole, which is a south pole, the lines of force are cut in the opposite direction and the current is reversed. The only difference between an alternating and a direct current dynamo is that in the latter case a device known as the commutator is added, which takes up only the impulses of current which are in one given direction and send them out over the circuit as direct current.

To illustrate: Fig. 1 is the alternator. It has two collector rings on the shaft

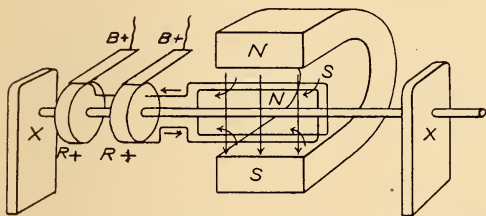

FIG. 1. ALTERNATING CURRENT DYNAMO.

upon which bear the two brushes (B+) and (B-) by which current is taken off for the external circuit. In the diagram the top half of the coil is brushing by the north pole and is generating positive current which flows out of (B+) to the external circuit. The bottom half is generating negative current which flows in the opposite direction. When the top half of the coil gets down and brushes by the south pole, however, it will there generate negative current and (B+) will then become (B-) and (B-) will become (B+). Therefore at each revo-

lution the current in the external circuit will reverse in direction.

Now let us look at Fig. 2; everything is the same except that a commutator, divided into two segments, has been added in place of the collector rings.

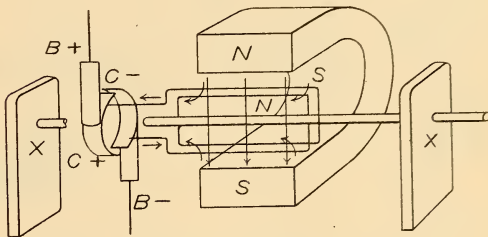

FIG. 2. DIRECT CURRENT DYNAMO.

The negative brush (B-) and the positive brush (B+) remain stationary. In the position shown, the top half of the coil is generating positive current and it is connected to the segment which is passing under the positive brush (B+). The lower half is developing negative current and is connected to the segment passing under the negative brush. Now as the coil turns over the current reverses in it the same as in the alternating current dynamo, but as the reversal takes place the segments of the commutator, which are attached rigidly to the shaft, and to which the top and bottom halves of the coil are connected, swap brushes at the same time. Consequently the positive brush takes positive current all the time and sends it out over the line, the negative brush taking it as it comes back. Thus we have direct or un-directional current in the external circuit.

In practice there are many coils in an armature, consequently there must be an equal number of segments in the commutator. The principle is the same, however.

(E) When dry batteries run down it is often due to polarization of the plates or else drying up of the active material in the cell. Try boring a hole in the bottom of the cell and pouring in about half a teacupful of strong vinegar or salamoniac. It is said that if this is done and the cell is allowed to stand for two hours that it will regain its power, that is, of course, if the zinc plate is not

entirely eaten away. In this case the cell is beyond repair.

#### DESIGN OF A SOLENOID.

**QUESTION.**—I am constructing a machine using solenoids to operate a certain part. I am forced to comply with the following: volts a. c., 110; length of solenoid, 1.5 inches; diameter, 1.5 inches. What size of wire, how many turns, what tube and core should I use? How far should the core project into the tube when no current is flowing? What pull will be exerted upon the core when current is flowing, and how many amperes will be used up?—C. K., West Hoboken, N. J.

**Answer.**—The data you give is rather insufficient to enable us to answer your question intelligently. As the design of alternating current magnets, especially of small dimensions, is more complicated than would be the case if direct current were used, the "cut and try" method would perhaps be most advisable. However, in order to give you an ap-

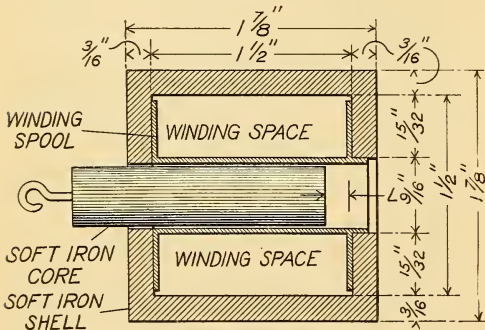

ALTERNATING CURRENT SOLENOID.

proximate idea of what such a coil will do, we will give you some calculated figures.

The magnetic flux depends upon the number of turns, frequency, and voltage of the alternating current. The length of the air gap influences only the current, which is decreased in proportion with the decrease in air gap. Owing to this effect, we find that the pull remains practically constant with different positions of the core from beginning to end of the travel.

A design of an alternating current solenoid is shown in Fig. 1. Its dimensions are in accordance with those given by you. The spool is enclosed by an iron shell in order to increase the magnetic flux. For the same reason the air gap (X) should be as small as possible,

thereby increasing the length of the travel of the plunger (L). If we wind the spool with 5,675 turns of No. 32 single silk covered copper wire, which will have a resistance of 310 ohms, and also assume that the frequency of the alternating current is 60 cycle per second, a current of 0.15 amperes will flow through the coil when the normal position of the plunger is such as to make the distance (L) equal to 3-16 inch. The tractive power of the plunger including its own weight will then be about  $\frac{1}{3}$  pound. If we increase the distance (L) to  $\frac{1}{2}$  inch, the current taken by the coil will be increased to approximately 0.45 amperes, the tractive power remaining almost unchanged.

Changing the frequency of the alternating current to 25 cycles, while keeping the voltage at 110 volts, will cause a current of about 0.9 amperes to flow through the coil, the distance being  $\frac{1}{2}$  inch and the tractive power about the same as before. However, this high current will cause the coil to heat up too much if continued for any length of time.

Owing to the difficulty in estimating the magnetic leakage lines, which greatly affects the operation of the magnets, the values given may only be taken as approximate.

As currents are induced in the iron frame of the magnet, which will cause it to heat up, the iron core and shell generally should be laminated to prevent the flow of these currents. However, with a coil of small dimensions, and assuming that the current will be on for a short time, it is possible to neglect this and use a solid core and shell.

#### TELL OF YOUR EXPERIMENTS.

Popular Electricity wants the assistance of its youthful readers to make the Junior Section a success. There are hundreds of boys who are interested in electricity to such an extent that they have equipped laboratories of their own. We want these boys to write to the Junior Section and give other boys who are working along similar lines the benefit of their experience. A brief description of how you made some piece of electrical apparatus and how it worked will be interesting.

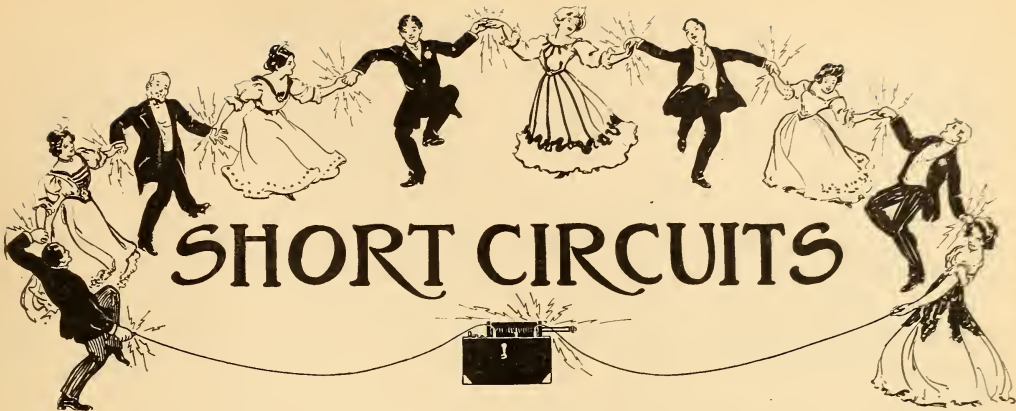

# SHORT CIRCUITS

## AT THE TELEPHONE.

"Are you there?"

"Yes."

"Who are you, please?"

"Watt."

"Who are you, please?"

"Watt's my name."

"Yes, what's your name?"

"I say my name is Watt."

"Oh, well, I am coming to see you."

"All right. Are you Jones?"

"No; I'm Knott."

"Who are you then, please?"

"I'm Knott."

"Will you tell me your name, please?"

"Will Knott."

"Why won't you?"

"I say my name is William Knott."

"Oh, I beg your pardon."

"Then, you will be in if I come round Watt?"

"Certainly, Knott."

Then they were cut off by the exchange, and Knott wants to know if Watt will be in or not.

"John, you are late reading your paper."

"Well, I should say I am. A young lady sitting next to me in the car had washed her hair the night before. About twice a minute she would stroke her hair and say, 'Dear me, I washed my hair last night, and I can't do a thing with it,' each time jamming her elbow through my paper. I finally got up and stepped on her foot as I went out. She said, 'I like your nerve,' and I said, 'I beg pardon, lady, but I washed my feet last night and I can't do a thing with them.'"

The city girl was visiting in the country and had been laughed at many times because of her mistakes concerning country ways. One morning, noticing honey on the table and wishing to show her superior knowledge, she turned to the farmer and remarked:

"Ah! I see that you keep a bee."

An old lady boarded a train in the northern part of New Jersey. She was evidently unused to traveling. Her eye soon caught sight of the bell cord and she asked a boy what it was for. He mischievously told her that the rope was to ring a bell when anyone wanted something to eat. Shortly afterwards, when the train was going at a high speed the old lady gave the cord a vigorous pull. With a terrible lurch and a great groaning of wheels and brakes the train came to a stop. The conductor rushed into the car and shouted:

"Who pulled that rope?"

"I did," calmly replied the old lady.

"What do you want?" said the conductor.

"Well," said the old lady, "you may bring me a fried egg and a cup of tea."

"You say he is a crack shot with the rifle?"

"Best I ever saw. He can hit the glass insulator on a wireless telegraph pole every time."

"Please, ma'am," said the unlaundered hobo at the back door, "would youse give er pore man sumthin' ter eat wot's lookin' fer a job?"

"What kind of a job are you looking for?" asked the lady.

"I'm lookin' fer a job uv chewin' food," explained the soapless traveler.

The lights went out in the Dudley street terminal the other night about 5 o'clock, and everybody evidently kissed his best girl, for the air was full of screams of delight and delicate remonstrances.—Boston Record.

"Henry James," observed the man with the bulging brow, "is like a gas meter. I can read him, but I can't understand him."

Bishop Potter, at an ecclesiastical dinner in New York, read a Cooperstown schoolboy's essay on "Clergymen." The essay, which created much amusement, was as follows:

"There are 3 kinds of clergymen bishups recters and curats, the bishups tells the recters to work and the curats have to do it, a curat is a thin married man but when he is a recter he gets fuller and can preach longer sermons and becoms a good man."—Lux.

Johnnie—"Grandpa, will you make a noise like a frog?"

Grandpa—"What for, my boy?"

Johnnie—"Why, pa says we'll get ten thousand when you croak."

Little Clarence—"Pa, what other prominent social organization is there in New York besides the '400'?"

Mr. Callipers—"The '400 or bust,' my son."

"What's the matter with the candidate?"

"'Sh! He's very ill."

"Isn't it rather sudden?"

"Very. He smoked a cigar from the wrong pocket."

"Do you come to Sunday school voluntarily or because you are coerced?" asked the pretty teacher.

"Voluntarily, I guess," replied little Edgar. "I thought they only had to get coerced if they was Baptists."

Aunty—"Tommy, I put three pies in here yesterday, and now there is only one. How is that?"

Tommy—"Please, it was so dark, aunty, I didn't see that one."—Punch.

"Does your wife talk in her sleep, major?"

"No; I talk in her sleep—it's the only chance I get."

Roommate—"What is this card in your hat?" His Roommate—"Why, that was (hic) the wine-list, but now (hic) it's my table of contents."—Yale Record.

## ELECTRICAL DEFINITIONS.

**Alternating Current.**—That form of electric current the direction of flow of which reverses a given number of times per second.

**Ampere.**—Unit of current. It is the quantity of electricity which will flow through a resistance of one ohm under a potential of one volt.

**Anode.**—The positive terminal in a broken metallic circuit; the terminal connected to the carbon plate of a battery.

**Armature.**—That part of a dynamo or motor which carries the wires that are rotated in the magnetic field.

**Circuit.**—Conducting path for electric current.

**Circuit-breaker.**—Apparatus for automatically opening a circuit.

**Commutator.**—A device for changing the direction of electric currents.

**Condenser.**—Apparatus for storing up electrostatic charges.

**Direct Current.**—Current flowing continuously in one direction.

**Efficiency.**—Relation of work done by a machine to energy absorbed.

**Electrode.**—Terminal of an open electric circuit.

**Electrolysis.**—Separation of a chemical compound into its elements by the action of the electric current.

**Electromagnet.**—A mass of iron which is magnetized by passage of current through a coil of wire wound around the mass but insulated therefrom.

**Field of Force.**—The space in the neighborhood of an attracting or repelling mass or system.

**Fuse.**—A short piece of conducting material of low melting point which is inserted in a circuit and which will melt and open the circuit when the current reaches a certain value.

**Galvanometer.**—Instrument for measuring current strength.

**Inductance.**—The property of an electric circuit by virtue of which lines of force are developed around it.

**Insulator.**—Any substance impervious to the passage of electricity.

**Kilowatt.**—1,000 watts. (See watt.)

**Kilowatt-hour.**—One thousand watt hours.

**Leyden Jar.**—Form of static condenser which will store up static electricity.

**Motor-generator.**—Combined motor and generator for changing alternating to direct current or vice versa.

**Multiple.**—Term expressing the connection of several pieces of electric apparatus in parallel with each other.

**Ohm.**—The unit of resistance. It is arbitrarily taken as the resistance of a column of mercury one square millimeter in cross sectional area and 106 centimeters in length.

**Poles.**—Terminals of an open electric circuit.

**Potential.**—Voltage.

**Relay.**—Instrument for opening or closing a local circuit, which is operated by impulses from the main circuit.

**Resistance.**—The quality of an electrical conductor by virtue of which it opposes the passage of an electric current. The unit of resistance is the ohm.

**Series.**—Arranged in succession, as opposed to parallel or multiple arrangement.

**Shunt.**—A by-path in a circuit which is in parallel with the main circuit.

**Solenoid.**—An electrical conductor wound in a spiral and forming a tube.

**Spark-gap.**—Space between the two ends of an electrical resonator.

**Switch.**—Device for opening and closing an electric circuit.

**Transformer.**—A device for stepping-up or stepping-down alternating current from low to high or high to low voltage, respectively.

**Volt.**—Unit of electromotive force or potential. It is the electromotive force which, if steadily applied to a conductor whose resistance is one ohm, will produce a current of one ampere.

**Voltage.**—Potential difference or electromotive force.

**Watt.**—Unit representing the rate of work of electrical energy. It is the rate of work of one ampere flowing under a potential of one volt. Seven hundred and forty-six watts represent one electrical horse power.

**Watt-hour.**—Electrical unit of work. Represents work done by one watt expended for one hour.



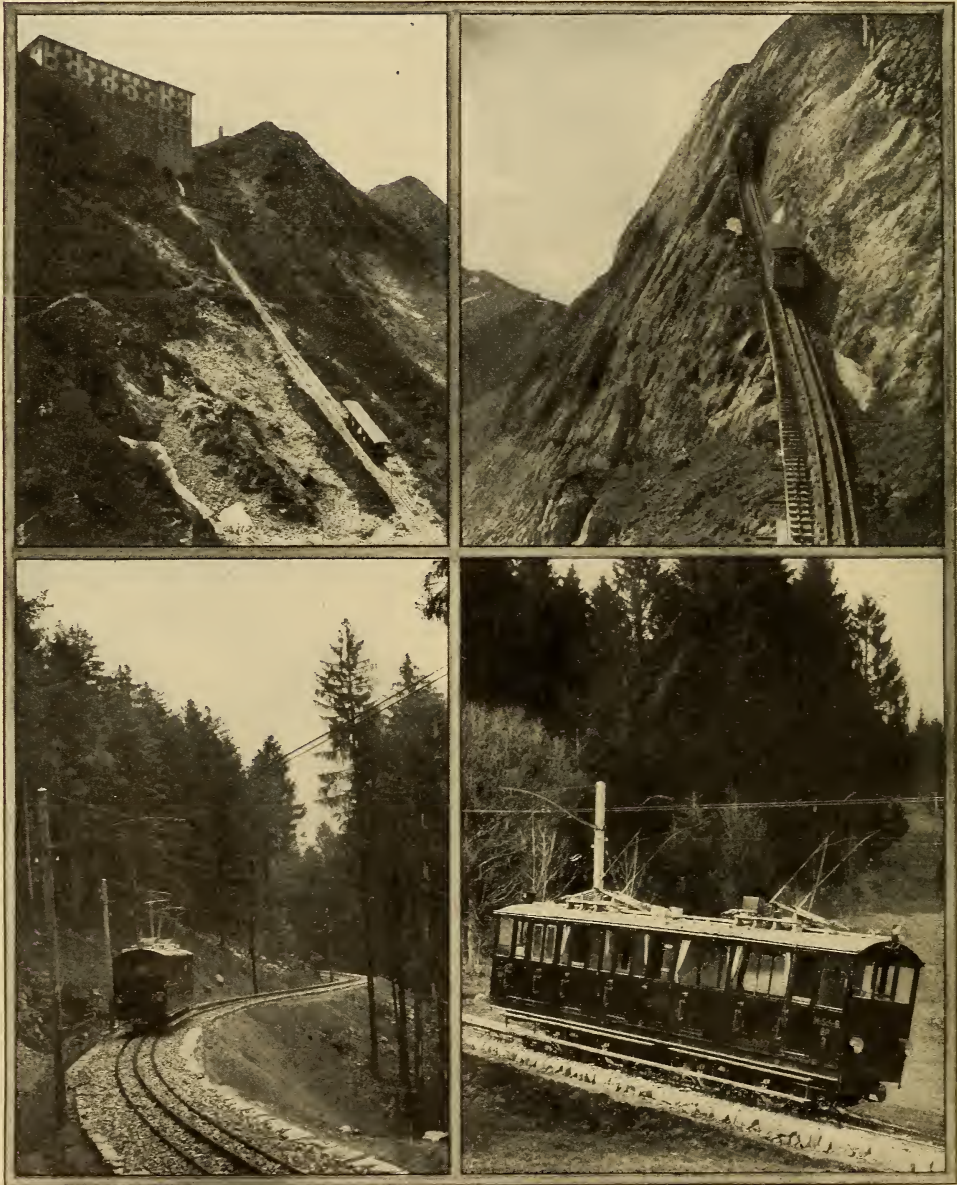

PICTURESQUE SPOTS ON GERMAN MOUNTAIN RAILWAYS.