

Better Designs - Faster

With the Personal Design Solution

The Design Solution Includes: Electronics Workbench Personal Edition + EWB Layout

Electronics
Workbench[®]
Personal Edition

Electronics
Workbench[®] **Layout**
Personal Edition

Full-featured schematic capture and SPICE 3F circuit simulation!

The world's best selling circuit design software. With analog, digital and mixed A/D SPICE simulation, a full suite of analyses and over 4000 devices. Imports netlists. Seamlessly integrated with EWB Layout or exports to other popular PCB programs. Still the standard for power and ease of use. Still the same effective price.

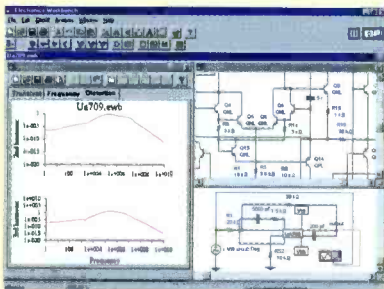

\$299
Version 5

Power-packed PCB layout with autorouting and real-time DRC!

EWB Layout is a powerful board layout package for producing high-quality, multi-layer printed circuit boards. Offering tight integration with our schematic capture program, you can incorporate board layout and design and quickly bring well-designed boards to production.

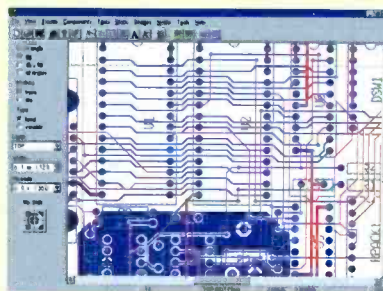

\$299
Version 5

HIGH-END FEATURES

TRUE MIXED ANALOG/DIGITAL	YES
FULLY INTERACTIVE SIMULATION	YES
PRO SCHEMATIC EDITOR	YES
HIERARCHICAL CIRCUITS	YES
VIRTUAL INSTRUMENTS	YES
ON-SCREEN GRAPHS	YES
ANALOG AND DIGITAL MODELS	OVER 4,000
FREE TECHNICAL SUPPORT	YES
DC OPERATING POINT	YES
AC FREQUENCY	YES
TRANSIENT	YES
FOURIER	YES
NOISE	YES
DISTORTION	YES

POWER-PACKED FEATURES

AUTOROUTING	YES
REROUTE WHILE MOVE	YES
LAYERS	32 ROUTING LAYERS
BOARD SIZE	50" X 50"
LIBRARY SHAPES	OVER 3,500
BLIND AND BURIED VIAS	YES
EXTENSIVE OUTPUT	YES
SELECTIVE NET HIGHLIGHTING	YES
USER DEFINED PADS	YES
REAL TIME DESIGN RULE CHECK	YES
DENSITY HISTOGRAMS	YES
FREE TECHNICAL SUPPORT	YES

**30-DAY MONEY-BACK
GUARANTEE**

*Join over 85,000 customers
and find out why more circuit designers
buy Electronics Workbench than
any other circuit design tool.*

**CALL FOR INFORMATION
AND PRICING ON OUR
PROFESSIONAL EDITION.**

ELECTRONICS WORKBENCH Personal Edition \$299.00

EWB LAYOUT Personal Edition \$299.00

**BUY
BOTH
AND
SAVE**

PERSONAL DESIGN SOLUTION ~~\$598.00~~

\$548.00

CALL 800-263-5552

For a free demo, visit our website
at <http://www.interactiv.com>

INTERACTIVE IMAGE TECHNOLOGIES LTD., 908 Niagara Falls Boulevard,
#068, North Tonawanda, New York 14120-2060 / Telephone 416-977-5550.

TRADEMARKS ARE PROPERTY OF THEIR RESPECTIVE HOLDERS. OFFER IS IN U.S. DOLLARS AND VALID ONLY
IN THE UNITED STATES AND CANADA. ALL ORDERS SUBJECT TO \$15 SHIPPING AND HANDLING CHARGE.

Fax: 416-977-1818 E-mail: ewb@interactiv.com
CompuServe: 71333,3435 / BBS:416-977-3540



CIRCLE 14 ON FREE INFORMATION CARD



C O V E R S T O R Y

25 Smart Buses

Melding GPS technologies with dead-reckoning capabilities allows urban mass-transit systems to offer riders a new level of convenience, while enabling both dispatchers and drivers to perform their duties more efficiently—*Bill Siuru*

C O N S T R U C T I O N

31 Build a Power-Line Monitor

If you are concerned about the quality of the electric power delivered to your home by the local utility, perhaps this analyzer will help to ease some of your concerns—*Charles Hansen*

40 Build the BusyBody

This project gives all of the convenience provided by the phone company's automated redialing system, without incurring extra charges on your monthly telephone bill—*Anthony J. Caristi*

P R O D U C T R E V I E W S

17 Gizmo

Panasonic Palmcorder, Actimates' Barney Interactive Toy—TV and PC Pack, plus Gizmo News



Page 25

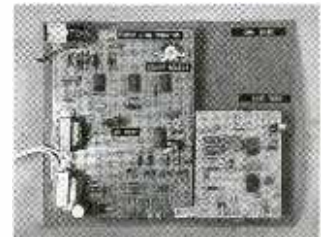

Page 31



Page 40

POPULAR ELECTRONICS (ISSN 1042-170-X) Published monthly by Gernsback Publications, Inc. 500 Bi-County Boulevard, Farmingdale, NY 11735. Periodicals postage paid at Farmingdale, NY and at additional mailing offices. One-year, twelve issues, subscription rate U.S. and possessions \$21.95, Canada \$28.84 (includes G.S.T. Canadian Goods and Services Tax Registration No. R125166280), all other countries \$29.45. Subscription orders payable in U.S. funds only. International Postal Money Order or check drawn on a U.S. bank. U.S. single copy price \$4.50. Copyright 1997 by Gernsback Publications, Inc. All rights reserved. Hands-on Electronics and Gizmo trademarks are registered in U.S. and Canada by Gernsback Publications, Inc. Popular Electronics trademark is registered in U.S. and Canada by Electronics Technology Today, Inc. and is licensed to Gernsback Publications, Inc. Printed in U.S.A.

Postmaster: Please send address changes to Popular Electronics, Subscription Dept., P.O. Box 338, Mount Morris, IL 61054-9932

A stamped self-addressed envelope must accompany all submitted manuscripts and/or artwork or photographs if their return is desired should they be rejected. We disclaim any responsibility for the loss or damage of manuscripts and/or artwork or photographs while in our possession or otherwise.

As a service to readers, Popular Electronics publishes available plans or information relating to newsworthy products, techniques, and scientific and technological developments. Because of possible variances in the quality and condition of materials and workmanship used by readers, Popular Electronics disclaims any responsibility for the safe and proper functioning of reader-built projects based upon or from plans or information published in this magazine.

C O L U M N S

- 8 Multimedia Watch**
Digital Cameras, a Printer, and More!—*Marc Spiwak*
- 12 DX Listening**
Radio Canada International—*Don Jensen*
- 48 Net Watch**
Staying Healthy—*Konstantinos Karagiannis*
- 50 Computer Bits**
Microcontrollers I—*Jeff Holtzman*
- 51 Antique Radio**
Powering Up the NR-5—*Marc Ellis*
- 53 Think Tank**
Back to Basics—*Alex Bie*
- 57 Scanner Scene**
Handheld Test Receiver—*Marc Saxon*
- 58 Ham Radio**
The Delightful, Disdained, Dumb Old Dipole—*Joseph J. Carr*
- 66 Circuit Circus**
CMOS ICs—Decoders and Multiplexers—*Charles D. Rakes*

D E P A R T M E N T S

- 4 Editorial**
- 6 Letters**
- 71 Popular Electronics Market Center**
- 96 Advertising Index**
- 96A Free Information Card**

Larry Steckler, EHF, CET,
editor-in-chief and publisher

EDITORIAL DEPARTMENT

Edward Whitman, managing editor
Julian Martin, editorial advisor
Robert Young, technical editor
Evelyn Rose, assistant editor
Teri Scaduto, assistant editor
Debbie Cybula, editorial assistant
Alex Bie, contributing editor
Joseph J. Carr, K4IPV,
 contributing editor
Marc Ellis, contributing editor
Jeffrey K. Holtzman,
 contributing editor
Don Jensen, contributing editor
Konstantinos Karagiannis,
 contributing editor
Charles D. Rakes, contributing editor
Marc Saxon, contributing editor
Marc Spiwak, contributing editor

PRODUCTION DEPARTMENT

Ruby M. Yee, production director
Ken Coren, desktop production director
Lisa Baynon, desktop production
Melissa Giordano, desktop production
Kathy Campbell, production assistant

ART DEPARTMENT

Andre Duzant, art director
Russell C. Truelson, illustrator

CIRCULATION DEPARTMENT

Theresa Lombardo,
 circulation manager
Gina L. Gallo, circulation assistant

REPRINT DEPARTMENT

Christina M. Estrada, Reprint Bookstore

BUSINESS AND EDITORIAL OFFICES

Gemsback Publications, Inc.
 500 Bi-County Blvd
 Farmingdale, NY 11735
 1-516-293-3000
 FAX: 1-516-293-3115
 President: **Larry Steckler**
 Vice-President: **Adria Coren**
 Vice-President: **Ken Coren**

**SUBSCRIPTION
 CUSTOMER SERVICE/
 ORDER ENTRY**

1-800-827-0383
 7:30 AM-8:30 PM EST

**Advertising Sales Offices
 listed on page 96**

Composition by Mates Graphics
 Cover illustration by David Miller



Since some of the equipment and circuitry described in POPULAR ELECTRONICS may relate to or be covered by U.S. patents, POPULAR ELECTRONICS disclaims any liability for the infringement of such patents by the making, using, or selling of such equipment or circuitry, and suggests that anyone interested in such projects consult a patent attorney.

One scientist's vision revolutionizes the hearing industry, benefiting millions of people...

Crystal Ear® uses sophisticated electronics to provide affordable, cosmetically-pleasing and easy-to-use hearing amplification.

by Harold Sturman

One day a friend asked my wife Jill if I had a hearing aid. "He certainly does," replied Jill, "Me!" After hearing about a remarkable new product, Jill finally got up the nerve to ask me if I'd ever thought about getting a hearing aid. "No way," I said. "It would make me look 20 years older and cost a fortune." "No, no," she replied. "This is entirely different. It's not a hearing aid...it's Crystal Ear!"

No one will know. Jill was right. Crystal Ear is different—not the bulky, old-styled body-worn or over-the-ear aid, but an advanced personal sound system so small it's like contacts for your ears. And Crystal Ear is super-sensitive and powerful, too. You will hear sounds your ears have been missing for years. Crystal Ear will make speech louder, and the sound is pure and natural.

I couldn't believe how tiny it is. It is smaller than the tip of my little finger and it's almost invisible when worn. There are no wires, no behind-the-ear devices. Put it in your ear and its ready-to-wear mold fits comfortably. Since it's not too loud or too tight, you may even forget that you're wearing it! Use it at work or at play. And if your hearing problem is worse in certain situations, use Crystal Ear only when you need it.

A fraction of the price. Hearing loss is the world's number-one health problem, but in

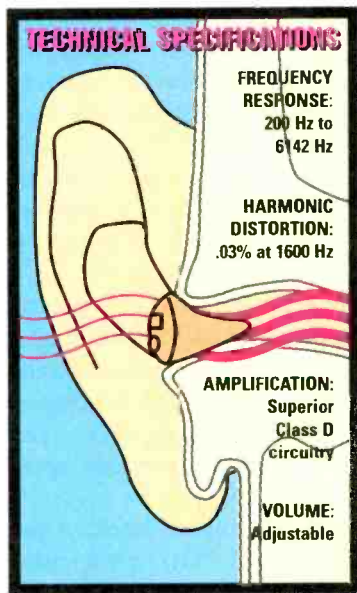

Innovative, breakthrough technology solves common problem...

Hearing loss, which typically begins prior to teenage years, progresses throughout one's lifetime. Nearly 90 percent of people suffering the type of loss Crystal Ear was designed for choose to leave the problem untreated. Crystal Ear is now available to help these people treat their hearing loss with a small and very affordable Class I in-the-canal hearing amplifier.

most cases it goes completely untreated. For many millions of people, hearing devices are way too expensive, and the retail middlemen want to keep it that way. What's more, treating hearing loss the old retail way can involve numerous office visits, expensive testing and adjustments to fit your ear. Thanks to Crystal Ear, the "sound solution" is now affordable and convenient. Almost 90% of people with mild hearing loss, and millions more with just a little hearing dropoff, can be dramatically helped with Crystal Ear. Plus, its superior design is energy-efficient, so batteries can last months, not just weeks.

You'll feel years younger! Wear Crystal Ear indoors, outdoors, at home and at work. Crystal Ear arrives ready to use, complete with batteries, two different fitting sleeves, a cleaning brush and even a carrying case. Crystal Ear is a breakthrough advance in the hearing device field. It is made in the USA, using state-of-the-art micro-manufacturing techniques that cut costs dramatically—savings that we can

pass on to you. The conventional companies, domestic and foreign, don't like that! **Don't be fooled by high prices.** No hearing device, no matter how expensive, can eliminate background noise, despite claims by the manufacturers. Crystal Ear does not promise miracles—just an affordable, sound solution to many common hearing problems.

DON'T TAKE OUR WORD FOR IT...

"My father spent over \$5000 on another brand. I showed him my Crystal Ear, he tried it, and he decided it worked better than his brand, even though it was a small fraction of the cost!"



—A satisfied Crystal Ear user

"Over 32 million Americans experience some loss of hearing. Though most cases go untreated, over 90 percent of these people would be disappointed to learn from their doctor that there is no medical or surgical cure. There is, however, an effective treatment: electronic amplification."

—Dr. Dale Massad, MD

Risk-free. Try Crystal Ear and hear what you've been missing. It comes with a 90-day manufacturer's limited warranty as well as our risk-free home trial. If you're not satisfied, return it within 30 days for a full refund.

Crystal Ear®: Three credit-card payments of \$99.95 \$12 S&H If not purchasing a pair, please specify right or left ear.

Please mention promotional code 3461-12423.

For fastest service, call toll-free 24 hours a day

800-992-2966



comtrad industries

2820 Waterford Lake Dr., Suite 102
Midlothian, Virginia 23113

COMPARE CRYSTAL EAR AND SEE THE DIFFERENCE		
	MOST IN-CANAL BRANDS	CRYSTAL EAR
Require fitting	Yes	No
Require testing	Yes	No
Battery life	160 hours	320 hours
Impact resistance	Average	Excellent
Whistling/feedback	Frequent	Limited
Telephone use	Yes	Excellent
Retail price	\$1,000-2,000	\$299.85

Accredited B.S. Degree in Computers or Electronics

by studying at Home

Grantham College of Engineering
offers 3 distance education programs:

- B.S.E.T. emphasis in Electronics
- B.S.E.T. emphasis in Computers
- B.S. in Computer Science

NEW! Electronics Workbench Professional 5.0
included in our B.S.E.T. curriculums
-Approved by more than 200 Companies,
VA and Dantes, (tuition assistance avail.)

For your free catalog of our programs dial

1-800-955-2527

<http://www.grantham.edu>

GCE

Your first step
to help yourself
better your future!



Grantham College of Engineering
34641 Grantham College Road
Slidell, LA 70460-6815

EDITORIAL

Is Fiction Stranger than Truth?

Since this is the April issue, I thought it would be fun to include a "tongue-in-cheek" article this month and end with a hearty "April Fool!" I looked around at what our previous editors had done. I picked up a copy of "The Collected Works of Mohammed Ulysses Fips," available in our Gernsback Reprint Bookstore. This booklet reprints almost two dozen articles written by Mr. Fips, mostly over the time period 1944-1968, for **Radio-Electronics** magazine (and earlier for **Radio-Craft**), both magazines forerunners to our sister publication, **Electronics Now**. Who was this Mr. Fips? None other than the founder of Gernsback Publishing—Hugo Gernsback.



Gernsback was an inventor, an innovator, and a visionary. Not only was he the founder of this company, but he started the electronics publishing industry. At one time, he was best known as the Father of Science Fiction. To this day, awards for excellence in science-fiction writing are called the "Hugo" (much like the Oscar is presented for motion-picture excellence).

Although his annual April Fool articles would make those in the know laugh, other readers so totally accepted the valid premises he expounded that they actually attempted to construct the devices proposed. Let me share a few of Mr. Fips' "jokes" with you.

In his article entitled the "30-Day LP Record" (April 1961), he developed the world's longest playing record. He stated that in this invention, there is no physical contact between rotating record disc and the pickup—transmission is via magnetic impulses. Interesting, but with the present compact disc, there is no contact between the CD and its pickup; laser technology completes this transmission path. Although I don't believe we will see the day of the 30-day CD, the way we are increasing storage capacities—you can never tell!

Another article (April 1960) described a paper-thin, vest-pocket AM radio, measuring about the size of a standard postcard. Today no one would think twice about an AM radio (with FM) as small as a credit-card. At first glance, Mr. Fips' circuit appears to be a printed circuit board using surface-mounted components. Hmmm...

In our last "fiction" April Fool story (April 1945), Mr. Gernsback, (now using the pen name Grego Bانشuk—which is Hugo Gernsback with all the letters mixed around), developed the "Visi-Talkie." This novel project explained how to develop a portable television handset over which you can talk to as well as see "in full natural colors" persons using similar sets, over considerable distances. Today we don't think twice about closed-circuit TV transmissions, video transmissions using surveillance cameras, even video conferencing with satellite hookups between any points on Earth. Why just a little over 20 years after publishing that "funny article," we were talking with and seeing our astronauts as they roamed over the surface of the moon (or what about the recent transmissions from the Mars Sojourner?).

Just keep these "fictional stories" in mind—the foolish "April Fool" story you read today may turn out to be the seed of a new concept or the spark for a technology of tomorrow.

Ed. Whitman

Ed Whitman, Managing Editor

The professional weather station for people who care about the weather

WIRELESS OPTIONS AVAILABLE

Davis Instruments has a complete line of weather stations affordable enough for home and hobby use. Connect the station to packet radio using shareware program available on Davis' Web Site and BBS.

Features Include:

- Inside & Outside Temps
- Wind Speed & Direction
- Barometer
- Time & Date
- Inside Humidity
- Wind Chill
- Alarms
- Highs & Lows
- Rainfall Option
- Instant Metric Conversion
- Outside Hum. & Dew Point Option
- Optional PC Interface

For more information and a free catalog, call
1-800-678-3669

M-F 7 a.m. to 5:30 p.m. Pacific Time
FAX 1-510-670-0589
M/C and VISA • One-year warranty
30-day money-back guarantee • POE0498

Davis Instruments
3465 Diablo Avenue, Hayward, CA 94545-2778 • www.davisnet.com

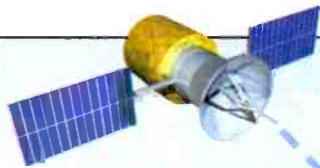

"My TV reception is so clear, you'd think I had a 50-foot antenna on my roof!"

Emerson's ingenious new antennas are hard to spot, easy to install and provide clear, powerful reception of broadcast signals...without rabbit ears.



Replace your unsightly "rabbit ears" today!

home theater systems, televisions continue to work better and better as optical innovations are introduced. Unfortunately, a television's picture is only as good as the broadcast it's receiving, and even the world's best televisions cannot make up for a weak or distorted signal. Antenna technology has not kept pace with television design, and the rabbit ears from the 1950's are not far removed from what's available today. Well, there's finally been a quantum leap in the design of antennas, and it's the result of two patented components developed by scientists. These improvements are the secret behind Emerson's revolutionary new antennas.

Picture imperfect. Cable subscription solves the problem of getting the signal to your television, but storms and other factors can result in cable outages. If you prefer not to pay the rising monthly fees for cable or live in an area where it's not available, your picture is likely to be weak, undefined and distorted.

One way to improve your reception would be to mount a large antenna on your roof.

Unfortunately, most roof antennas are not particularly pleasing to the eye and may even be prohibited in the area where you live. Rabbit ear antennas don't improve your picture to any great degree and make your room look like something from an earlier decade. Most antennas need to be aimed at the source of the broadcast and require turning mechanisms to pick up the signal clearly.

Whether you live miles out in the country or in a concrete building next door to a broadcast tower, bad reception can rob you of the definition and color you were intended to see. The Optima antenna gives you the signal-grabbing

I'm amazed at the way technology has improved television. Developments in electronic circuitry have resulted in TV sets that have sharper pictures, brilliant colors and clearer sound. From the smallest portables to wide-screen

power of a large antenna in an inconspicuous, low-profile size.

Stealth antenna. In the past, creating an antenna with optimal reception meant making it big, with a large amount of surface area. This resulted in products that were large and unsightly or small and ineffective. Either way, the aesthetic look of your room or house suffered. Research and development tended to focus on the television, not on signal reception...until now.



Your neighbors won't know it's there unless you tell them.

Recently, a brilliant scientist in Colorado developed an antenna that would maximize reception without being overly conspicuous. Emerson, a leader in electronic technology, has now made this innovation available to the public.

At a lab in Colorado, they developed two patented design improvements that made the Optima antenna possible. First, they created a flexible circuit board with a serpentine antenna, resulting in a large surface area confined to a small space. Second, they developed a technique that converts the copper shielding on the attached cable to an additional signal receiver that results in an antenna almost 10 feet long. This greatly enhances the antenna's reception power and



Attention mini-dish owners. If you own a mini-dish satellite system, you are aware of the off-air issue and are probably wondering how you can pick up local broadcasts. After all, what good are hundreds of channels if you can't find out who won the local city council race? The Dishmate™ harnesses the same technological innovations as the Optima TV antenna to give you a powerful omnidirectional antenna that is virtually invisible. It is compatible with a variety of systems and is easy to install.

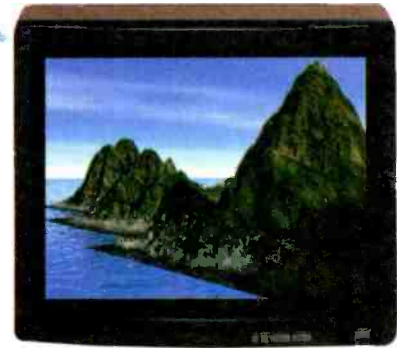

allows you to tune the antenna by simply moving the cable! The handmade assembly is encased in aircraft-grade plastic and high-density foam. The weather-resistant cover is a neutral white and can be painted to match the color of the house or room. Plus, the omnidirectional design allows you to mount the unit anywhere you please. The Optima's universal design makes it adaptable to any component, and installation is a snap. Simply mount the antenna on a wall inside or outside the house, connect the cable and fasten it in place. Then sit back, relax and enjoy the clearest picture you can get from your television.

Get the picture...risk-free. Call now to order the Optima Indoor/Outdoor TV Antenna or the Dishmate™, the small antennas that get big reception. They both come with a 90-day manufacturer's limited warranty and Comtrad's exclusive risk-free home trial. Try them, and if you're not completely satisfied, return them within 90 days for a full "No Questions Asked" refund.

Indoor/Outdoor Antenna \$69.95 \$8 S&H

Dishmate™ UHF/VHF Antenna . \$69.95 \$8 S&H

The Dishmate™ Antenna will work with 18" dishes from RCA, Toshiba, ProScan, GE, Eurosat, Uniden, and Hughes DSS™ Satellite systems.

Please mention promotional code 2832-12424

For fastest service, call toll-free 24 hours day

800-992-2966



To order by mail, send check or money order for the total amount including S&H. To charge it to your credit card, enclose your account number and expiration date.

Virginia residents only—please include 4.5% sales tax.

comtrad industries
2820 Waterford Lake Dr., Suite 102
Midlothian, Virginia 23113

LETTERS

AUTHORS' CORRECTIONS

Regarding my "Electronic Climate Controller" construction article (**Popular Electronics**, January 1998), the diode D1 across relay RY1 should have its polarity reversed in the schematic (Fig. 1, page 31). It is correct in the parts layout in Fig. 2. Also in that schematic, the short between pins 5 and 6 of IC3, angled to the right of R8, should be removed. Fortunately, these errors do not appear on the parts layout.

—Sandeep Bagchi
via e-mail

I am writing in response to the corrections on the construction of my "DTMF Wire Tracer" (**Popular Electronics**, July 1997) submitted by reader M.K. (*Letters*, February 1998). I would like to thank him for pointing out the component labeling errors and several errors due to the "bleeding" together of several pads and nearby circuit traces. But these faults could easily be determined by comparing the PCB artwork to the published schematic diagram, which was drawn correctly. Therefore, I was surprised to learn that M.K. had to make circuit modifications to the PCB pattern in order to get his unit "up and running." Especially since a photocopy of the published artwork was used to etch the PCB in the original working prototype that appeared in the same article.

Perhaps the problems described by M.K. are due to the substitution of a TIL311A LED display unit instead of the specified TIL311. While the TIL311 used in the prototype has two V_{cc} pins, with pin 1 connected to the LED anodes and pin 14 connected to the on-board hexadecimal decoder/driver, it is possible that these two V_{cc} supply pins have been internally connected together at pin 14 in the TIL311A. However, since I do not currently have any data available on the "A" version, I cannot verify this. Readers encountering a non-blanking display might wish to isolate pin 14 of the LED display from +5 volts. If this prevents the display from lighting at all, a jumper can be installed from the collector of transistor Q3 to the now-isolated pin 14 on the LED display unit.

On another note, the SSI-204 DTMF Decoder IC can be purchased from B.G. Micro, P.O. Box 280298, Dallas, TX, 75228; Tel. 800-276-2206; Web: www.bgmicro.com/. The TP5088 DTMF Encoder IC and the MC145436P DTMF Decoder IC, which is a substitute for the SSI-204 IC, can be purchased from JDR Microdevices, 1850 South 10th Street, San Jose, CA, 95112-4108; Tel. 800-538-5000; Web: www.jdr.com.

—Brian Pliiler

The layout of my "Hands-on Approach to Op-Amp Basics" in the February 1998 issue looks great! There are a few minor corrections/additions which would help the reader understand and build these circuits:

1. Page 33, first column, second paragraph: "Norton's Current Law" should read "Kirchoff's Current Law."
2. Page 39, middle column, second paragraph, third sentence should read: "...Using the voltage divider rule, and given that the current drawn by the op-amp inputs can be neglected, the DC voltage at the non-inverting input is $9 \text{ volts} \times [\text{times}] R2/(R1+R2) = 9 \times 51/(51+430) = 0.95 \text{ volts}.$ "
3. Similarly, page 39, third column, second paragraph, second sentence should read: "...Therefore, the op-amp output voltage must be $0.95 \text{ volts} \times [\text{times}] (R4+R7)/R7 = 0.95 \text{ volts} \times (51+15)/15 = 4.2 \text{ volts}.$ "
4. Page 41, first column, second paragraph, second sentence should read: "...During negative half-cycles, current is diverted through D2, allowing C2 [not C3] to discharge through R3 [not R4]." I also suggest adding the sentence, "R4 in parallel with filter capacitor C3 discharges C3 in the absence of RF signal."
5. The following all have to do with the "Electronic Thermometer" project: Page 43, Fig. 12: The S2 switch connections are incorrect in the parts layout. The left-handed terminal (closest to J1) should be the wiper (common) of the switch [not C]. The middle terminal should be the "C" terminal [not F]. The right-hand terminal should be "F" [not common]. Since the overlay was

not published along with the artwork, it's not immediately apparent which control does what. Starting at the end of the board closest to J1/S2, the adjustments are gain (°F), gain (°C), zero (°F), and zero (°C).

As a final note, these two zero adjustments are quite tricky, and would be a lot easier to perform if R14 and R15 are replaced with multi-turn potentiometers. The gain adjustments are much less sensitive, and the specified single-turn pots are entirely adequate.

—Fred Nachbaur
via e-mail

THE "3- \times FILES" SNAFU

After the February 1998 issue of **Popular Electronics** went to press, a strange typographical error was noticed in the "Multimedia Watch" column. In the lead item on page 8, "CD-ROMs and Stuff," the special " \times " or times sign, used to denote CD-ROM speed, appeared as the number "3." This was due to a "quark" in the translation of the original text through the QuarkXPress desktop program. The complete corrected text is available on the Web site. Sorry for any confusion we may have caused the reader.—Editor

ARTICLE SUGGESTIONS

Here are some suggestions for articles I would like to see published in **Popular Electronics**. One good article would be an automatic commercial killer, designed around a software unit that could do voice print identification and drive a SPDT relay. When a commercial was detected, this relay would switch from one audio source to another audio source, such as a CD player, radio station, pink noise, etc.

I am also very interested in obtaining information on a baseband converter to receive commercial-free TV. I was able to pick up two public-TV stations before, but since my carrier changed to digital transmissions to save money and satellite space, I am now unable to receive these broadcasts.

B.S.
via e-mail

I have been a subscriber to **Popular Electronics** for some time now, and I thoroughly enjoy your magazine. My great love is to construct simple broadcast radio AM receivers. I would like to see more articles on the construction of AM radio receivers, if possible. How about a design that starts with a simple loopstick coil and then goes to an NE602N IC and a toroid coil? Or, some easy-to-build radios with standard oscillator/transmit coils available from a variety of mail order firms? To make it even simpler, how about a few articles featuring circuits using a ZN414 IC?

Richard
San Jose, CA

Well Richard, it sounds like you know what types of designs you like. How about putting a project together (just make sure the parts are generally available)? But for a real simple AM receiver, take a look at the first circuit in this month's Think Tank column.—
Editor

ALKALINE BATTERIES mAh RATINGS

I have been a reader and subscriber to **Popular Electronics** for over two decades. This is the first time I am writing to you. The *Product Test Report* on Alkaline Batteries in the January 1998 issue was very timely and appropriate, as we see the *Duracell* and *Eveready* battery battle heating up to unprecedented levels. I have over the last couple of years been on a small mission to find out which brand of battery lasts the longest. To accomplish this, I pursued obtaining the milliamp-hour (mAh) ratings of various commonly available batteries.

My efforts to extract this information from Eveready were met with all kinds of delay. The Duracell battery data is readily available, for the last two years at least, on their Web page: www.duracellusa.com/. Similarly, the RadioShack data can be found, though a little fragmented, through their Web site: http://support.tandy.com/support_electronics/3159.html. You will not find any such data yet at the Eveready Web site: <http://energiser.com>. On their Web site, the Panasonic guys tout that their "Panasonic Plus" batteries last eight times longer than dry cells. However, after repeated e-mail and telephone calls asking the same question on mAh

Size of Alkaline Battery and Capacity in mAh

Manufacturer	D	C	AA	AAA	AA-L	9V
Duracell	15,000	7800	2850	1150	NA	580
Eveready	8900	7200	2450	1100	2600	500(?)
RadioShack	10,000	5000	1700	1000(?)	NA	500

Note: AA-L: Lithium version of AA size; (?): Verbal information—no written communication; NA: Not available/not manufactured.

ratings, I have not been able to obtain the data sheets.

To easily compare the various "capacities" of popular alkaline batteries, the mAh ratings I refer to are summarized in the above table.

As your article pointed out, Duracell comes out on top. For the D cell size, I would even use the RadioShack brand. O.M. MD

West Bloomfield, MI

(Continued on page 11)

PC-BOARD DESIGN made easy



Why have more than 25,000 pc board designers chosen EAGLE as their layout tool?

Mainly because EAGLE is so easy to use that you can start designing your own boards within a few hours. But there are many other good reasons! Check out our Web Site for a free demo and more detailed information.

EAGLE 3.5

Schematic Capture • Board Layout
Autorouter

for Windows® 95/NT

Windows 95 and Windows NT are registered trademarks of Microsoft Corporation.

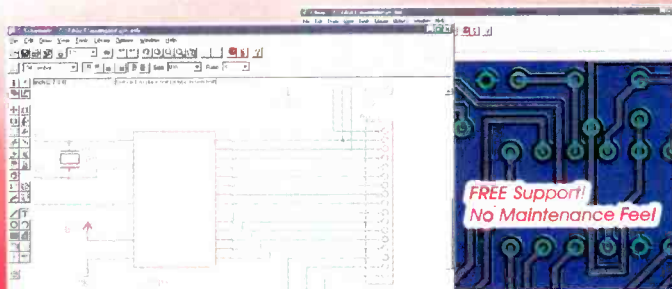

FREE Support!
No Maintenance Fee!

EAGLE Standard

Board Size: 6.3 x 4 inches
4 Signal Layers
99 Sheets per Schematic

398\$

EAGLE Light

Board Size: 4 x 3.2 inches
2 Signal Layers
1 Sheet per Schematic

100\$

EAGLE Professional

Board Size: 64 x 64 inches
16 Signal Layers
99 Sheets per Schematic

798\$

Order a FREE demo today and experience EAGLE first hand. You will be surprised!

800-858-8355

www.cadsoftusa.com

These prices include Schematic Capture and Board Layout. The Autorouter Module is available for 50/199/399\$. Pay the difference for Upgrades.

CadSoft Computer, Inc., 801 S. Federal Highway, Delray Beach, FL 33483
Hotline (561) 274-8355, Fax (561) 274-8218, E-Mail: info@cadsoftusa.com

CIRCLE 13 ON FREE INFORMATION CARD

MULTIMEDIA WATCH

Digital Cameras, a Printer, and More!

MARC SPIWAK
ASSOCIATE TECHNICAL EDITOR
COMPUTER RESELLER NEWS

It's going to be Spring soon, and that means people will be outdoors enjoying themselves. Except for holidays, Spring is also one of the most popular picture-taking times of the year. This season you should consider taking pictures the modern way—with a digital camera. Once you own a digital camera, all of the pictures you take are essentially free, so you never hesitate to snap an image. And sometimes a spontaneous picture can turn out to be a treasure. Inexpensive ink-jet printers do a good job of printing color images, and special paper even makes them shiny. I've even got a special photo printer this month, but more on that later.

DIGITAL CAMERA BASICS

Digital cameras at the low-price end are basically point-and-shoot cameras combined with bells and whistles that would not be possible with traditional film-based photography. However, just like film-based cameras, there are more advanced digital cameras. At the \$30,000 end, you're looking at a traditional high-end SLR camera body with interchangeable lenses mated to an electronic back that replaces the film. Images are stored on tiny Type III PC Card hard drives.

Most digital cameras have built-in flashes, although a flash is not always necessary. Sometimes a dimly-lit picture will look better than one taken with a flash. However, I wouldn't buy a digital camera that doesn't have a flash, simply because there are plenty that do; and sometimes a flash helps. Stay away from gimmicky cameras, because the gimmicks are probably taking away from more important features. Anything that looks flimsy probably is flimsy and will break given enough time and handling.

Optics and resolution are the two most important things when it comes to cameras, but even an inexpensive lens is good enough for a low-resolution digital camera. A zoom lens is always nice. Don't settle for anything less than a 640 × 480 camera—most

low-end cameras are of this resolution. The higher the resolution, the better the image; and there are now cameras with resolutions of around 1300 × 1000 that cost under \$1000. Different compression settings let you have greater image quality but store fewer images, or vice versa. Built-in monitors are used as viewfinders and to review and manipulate stored images—otherwise, they are just expensive accessories. Some digital cameras can store audio clips along with images, and many have a video output for viewing stored images on a TV. Some have a live video output from the camera, which can be recorded with a VCR or video capture card and computer.



ITAC Systems' *Personal Mouse-Trak* features a wrist pad and trackball, along with three mouse buttons.

My biggest gripe with digital cameras is how the images are stored and transferred to a computer. Some cameras have only built-in memory, some use only memory cards, and some have both. Cameras having only built-in memory generally have only a serial interface, which is slow. It can take 30 seconds or more to transfer a single image through a serial port. If you don't have a notebook computer, odds are you don't have access to a PC-Card reader and can't use cameras that store images on tiny solid-state memory cards. The cards fit into Type II PC Card adapters that plug into notebook computers with compatible slots. Some high-end cameras even have built-in SCSI interfaces.

While memory cards are not cheap, you can change the reusable cards like rolls of film; and reading the cards into a notebook computer slot or desktop card reader is fast and simple. A 10-megabyte card can hold hundreds of images, and you can transfer a hundred or so images in seconds! One camera I know of has a built-in PC Card interface that slides right into a notebook computer. Another camera uses common floppy disks to store images. While they're slow, floppy disks are an inexhaustible storage medium that can be read on any PC. I like the idea, but don't know how much longer I want to deal with floppy disks. Other cameras have infrared ports in addition to PC-Card and serial interfaces.

Last but not least, all digital cameras run off batteries; but different cameras use different kinds of batteries. I like cameras that can use regular AA cells, even though these cameras tend to eat the batteries when you use the monitor and flash. But you can carry plenty of "fuel" for the camera on a trip or easily buy more, and you can always use rechargeable batteries. I'd stay away from cameras that use only special rechargeable cells, because sometimes you're not near an AC outlet; and recharging always takes time.

MOUSE-TRAK

If you're looking for a rugged, space-saving pointing device for your computer, then look no further than ITAC Systems' *Personal Mouse-Trak*. This one-piece desktop pointing device has a built-in wrist pad and trackball, along with three mouse buttons. A single press of the middle button can be programmed to execute a double click or a click and drag where you don't have to hold down the button. It can be instantly switched between right- and left-handed operation via a keyboard command. Mouse-Trak also has a built-in speed control for the cursor. You can get yourself a *Personal Mouse-Trak* for only \$89.

MEDIATRIX' AUDIOTRIX

Mediatix Peripherals' new *Audiotrix 3D-XG* is a full-featured, professional quality sound card for electronic musicians. It features 16-bit full-duplex digital audio and Yamaha XG wavetable synthesis with expanded DSP effects, including Yamaha's proprietary 3D YMersion sound. The card has three independent DSP-effects processors, an 18-bit DAC, 676 on-board instruments, 16 parameters per-effect, 21 drum kits with up to 63 sounds per kit, 32-note polyphony, 11 types of reverb, 4 megabyte memory, and a lot more. Audiotrix is compatible with most popular sound standards and operating systems. It comes with a host of software as well. Audiotrix is a serious sound card for serious musicians, who are serious about spending the \$295 it costs to get one!

DESKTOP PHOTO PRINTER

I've recently been making glossy prints of my electronic camera images using a neat new printer from Eiger Labs. The *EigerMedia Photo Lab* is a printer that uses special paper to make prints of electronic images that look just like photographs and fit right into photo albums. The pictures rival the quality of Polaroid photographs, especially if the source image files are chosen wisely. These home-made photos are half the price of Polaroids, or about 50 cents each. Polaroid film tends to cost about a buck a shot, while a 20-sheet cartridge for the *EigerMedia Photo Lab* costs about \$10.

The special photo paper is coated with a polyester resin called Cycolor DI Film, which can reproduce 16.7 million colors at each continuous-color pixel. Each pixel contains thousands of microscopic dye-filled spheres that are "popped" using a modulated-light exposure technique. The disposable photo cartridges produce continuous tone colors and a totally dry, smudge-free final image. It takes 160 seconds to print each 3.5- x 5-inch sheet with a resolution of 640 x 480 in 16 million colors. Software automatically scales images to fit the paper. The printer and its bundled software will work with BMP, PCX, MAC, GIF, TAC, TIFF, and JPEG image-file formats. The printer has a standard parallel interface and is about the size of an external CD-ROM drive. Windows 95 is required.

For years, scanners were the rage because people wanted to get images from their photo albums onto the Internet. Today there is a demand for inexpensive color printing for electronic images pulled off the Internet or taken with digital cameras. The *EigerMedia Photo Lab* is an affordable solution, with a suggested retail price of only \$299. It lets you enjoy printing photos in the privacy of your own home or office, with no messy ink or toner.

THE FIRE INSIDE (MY PC)

The *Fireport 40 Dual* is the latest product in Diamond Multimedia's FirePort line of SCSI adapters. The FirePort 40 Dual is a PCI Ultra/Ultra Wide SCSI host adapter designed for Windows 95 and Windows NT 4.0 desktops, professional graphics and video editing workstations, and entry-level servers. The FirePort 40 Dual supports up to 30 UltraSCSI devices in a single PCI slot, and it also accommodates Fast and Narrow SCSI devices without sacrificing performance.

The dual-channel design allows slower SCSI devices, such as CD-ROM and tape drives, to be connected to one channel; and it allows fast devices, such as Ultra-Wide hard drives, to be connected to the second channel. When you connect a slow SCSI device to an Ultra-Wide chain, the whole chain drops in performance; so it's good to keep the channels separate. Usually you'd use two separate SCSI adapters. The FirePort 40 Dual has a throughput up to 40 megabytes per second. The FirePort 40 Dual kit has an estimated retail price of \$299.95, which includes the adapter, diagnostic utility software, SCSI ribbon cables and drivers for Windows 95, Windows NT, and Novell NetWare.

LOTS OF NEW SOFTWARE

Making your own music CDs and CD-ROM discs has never been easier than with the introduction of Adaptec's new *Easy CD Creator* mastering software. A person who barely knows how to use Windows 95 will have no trouble making and copying discs with this software. *Easy CD Creator* resulted from combining the best of two older products, *Easy-CD Pro* and *CD Creator*, which used to be the two best packages around. So *Easy CD Creator* is now the most powerful and easy-to-use CD recording software available.

VIDEO INVERTER
Create & Restore Inverted Video

R.C. Distributing
Box 552 • South Bend, IN 46624
http://www.south-bend.net/rc



For Free Information Package
on Completed Units and Pricing
Call 219-236-5776

ANTIQUE RADIO CLASSIFIED
Free Sample!

Antique Radio's
Largest Circulation Monthly.
Articles, Ads & Classifieds.



6-Month Trial: \$18.95. 1-Yr: \$38.95 (\$55.95-1st Class).
A.R.C., P.O. Box 802-L18, Carlisle, MA 01741
Phone:(508) 371-0512 VISAMC Fax:(508) 371-7129

Some Say Watching Tropical
Fish Lowers Blood Pressure
& Relieves Stress...



They Could Be On To
Something.



Discover the Caribbean aboard a Tall Ship.
6 & 13 day adventures from \$650.
For more information call your travel agent
or 1-800-327-2601.

Windjammer
Barefoot Cruises.
P.O. Box 190120, Dept. 5568, Miami Beach, FL 33119

CIRCLE 172 ON FREE INFORMATION CARD

WHERE TO GET IT

Adaptec, Inc.

691 South Milpitas Boulevard
Milpitas, California 95035
408-945-8600
www.adaptec.com

**CIRCLE 60 ON FREE
INFORMATION CARD**

Artbeats Software, Inc.

PO Box 709
Myrtle Creek, OR 97457
800-444-9392
www.artbeats.com

**CIRCLE 61 ON FREE
INFORMATION CARD**

Diamond Multimedia Systems, Inc.

2880 Junction Avenue
San Jose, CA 95134
408-325-7000
www.diamondmm.com

**CIRCLE 62 ON FREE
INFORMATION CARD**

Discovery Channel Multimedia

7700 Wisconsin Avenue
Bethesda, MD 20814
800-678-3343
www.planetexplorer.com

**CIRCLE 63 ON FREE
INFORMATION CARD**

Eiger Labs, Inc.

1237 Midas Way
Sunnyvale, CA 94086
800-OK-EIGER
www.eigerlabs.com

**CIRCLE 64 ON FREE
INFORMATION CARD**

Grolier Interactive, Inc.

90 Sherman Turnpike
Danbury, CT 06816
800-217-1495
203-797-3530
www.grolier.com

**CIRCLE 65 ON FREE
INFORMATION CARD**

Hasbro Interactive

50 Dunham Road
Beverly, MA 01915
508-921-3700
www.hasbro.com

**CIRCLE 66 ON FREE
INFORMATION CARD**

ITAC Systems Inc.

3113 Benton St.
Garland, TX 75042
800-533-4822
www.mouse-trak.com

**CIRCLE 67 ON FREE
INFORMATION CARD**

LucasArts Entertainment Company

PO Box 10307
San Rafael, CA 94912
415-472-3400
www.lucasarts.com

**CIRCLE 68 ON FREE
INFORMATION CARD**

Mediatrix Peripherals, Inc.

4229 Garlock Street
Sherbrooke, Quebec
Canada J1L 2C8
819-829-8749
www.mediatrix.com

**CIRCLE 69 ON FREE
INFORMATION CARD**

MGM Interactive

2500 Broadway Street
Santa Monica, CA 90404
310-449-3000
www.mgm.com

**CIRCLE 70 ON FREE
INFORMATION CARD**

Quarterdeck

13160 Mindanao Way
Marina del Rey, CA 90292
800-683-6696
www.quarterdeck.com

**CIRCLE 71 ON FREE
INFORMATION CARD**

Sirius Publishing

7320 East Butherus Drive, Suite 100
Scottsdale, AZ 85260
800-247-0307
www.moviecd.com

**CIRCLE 72 ON FREE
INFORMATION CARD**

Virgin Interactive Entertainment

18061 Fitch Avenue
Irvine, CA 92714
714-833-8710
www.vie.com

**CIRCLE 73 ON FREE
INFORMATION CARD**

CD. Sirius Publishing is using Motion Pixels software compression technology to produce near-VHS quality video that plays back full screen on almost any PC. Movies generally come on two-disc sets and sell for about \$15 each. One new title is *Cabbage Patch Kids the Screen Test*. This is a musical adventure for kids ages 3 to 11, where the Cabbage Patch Kids come to life and attempt to make a movie. All I know is my son has been enjoying this 26-minute movie time and time again since he was about 2-1/2. And I like the fact that I don't have to help him point at anything—the movie runs all by itself, giving me 26 minutes to read the paper.

Another fun title for kids is *Tonka Search & Rescue* (\$29.95) from Hasbro Interactive. Kids get to be in command of their own rescue squad made up of Tonka vehicles including construction trucks, helicopters, fire engines, and rescue boats. Kids will help out at a washed-out bridge, a fire at a lumber yard, and more. A feature of the Search & Rescue program is *The Tonka Print Shop*, which lets kids personalize and print ID badges, license plates, medals, and even Tonka playsets for fun away from the computer. The *Mr. Potato Head Activity Pack* (\$19.95) is filled with activities for preschoolers, including puzzles, dress-up games, connect the dots, printing, and so on. It's just like the plastic Mr. Potato Head—and more—except that kids can't lose the pieces.

New from MGM Interactive this month for children ages 3 to 8 are two new titles, the *Babes In Toyland Interactive Adventure* and the *All Dogs Go To Heaven Activity Center*, both available at a price of (\$29.99). Playing the Babes In Toyland Interactive Adventure, children enter the world of Mother Goose and interact with Humpty Dumpty, the Old Woman in the Shoe, and lots of other familiar characters. Kids can get into all sorts of activities in the All Dogs Go To Heaven Activity Center along with All Dogs characters Charlie, Sasha, Itchy, and Carface. There are games and puzzles to play, and kids can even learn about different types of dogs with this one.

LucasArts' *Jedi Knight Dark Forces II* is now available, where players navigate through more than a dozen mazes and environments facing powerful enemies for the Rebel cause. This game features intense Star Wars action with an all-new story. Players can develop

Easy CD Creator has wizards that guide the user through the CD creation process, and there's even a program that creates custom CD labels and jewel case inserts. Easy CD Creator is the most up-to-date program as far as supported disc formats and CD-R drives are concerned. A full-

featured, fool-proof CD copier utility is also provided. Another utility, CD Spin Doctor, turns scratchy LPs into crystal-clear audio CDs. The software reduces static, hiss, and noise, and converts the analog audio tracks directly to a recordable CD. Easy CD Creator costs \$99.

Last year, I reported on the *Movie-*

Force powers and become a Jedi knight or maybe become a Dark Jedi. They can even discover the secrets of the lost Jedi burial ground, the Valley of the Jedi. Realistic 3-D environments, animated 3-D characters, and a digital soundtrack add to the fun. Join the Jedi Knights here for only \$49.95.

Also *Archives Vol. III* (\$46.95) is a new CD-ROM collection from LucasArts. It features a line-up of best-selling titles that would retail for more than \$100 if purchased separately. The LucasArts Archives Vol. III includes *Dark Forces*, *The Dig*, *Full Throttle*, *Monkey Island Madness*, *Afterlife*, and *The LucasArts Super Sampler-2*. *Dark Forces* is a first-person action game fraught with danger and intrigue. The *Dig* is a deep-space adventure about a team of explorers stranded on an alien planet. *Full Throttle* is about a hard-core biker framed for a murder. *Monkey Island Madness* includes full versions of *The Secret of Monkey Island* and *Monkey Island 2: LeChuck's Revenge* plus a playable demo of *The Curse of Monkey Island*. *Afterlife* lets players build and maintain Heaven and Hell.

There is media available on CD-ROM from Artbeats Software that provides broadcast quality, royalty-free video clips in QuickTime format; and now there are more affordable combo packs. The material is intended for multimedia and game developers. I received a sample *ReelExplosions2/ReelFire 2* two-combo pack. *ReelExplosions-2* contains 34 broadcast-quality pyrotechnic clips created by Hollywood veteran Robbie Knott. Featured are explosions that fill the frame, ground explosions, shockwaves, and more. Nine of the clips are provided at high resolution—the shockwaves are 2916 × 2916 pixels—and can be tilted in any direction for perspective shots. *ReelFire-2* contains 32 broadcast-quality pyrotechnic clips ranging from a tiny match, arcing plasma, a dungeon torch, propane mortars, a burning fuse, giant fireballs, and more. The list price for a single title is \$499, while an \$898 combo pack saves you \$100.

Quarterdeck's *CleanSweep Deluxe* is a complete hard-disk housekeeping package. *CleanSweep Deluxe* clears away digital dirt by safely removing old, unneeded programs. It tracks down duplicate files, redundant DLLs, orphan files, infrequently-used files and more. Automated wizards deter-

mine which files are cluttering up a system, and they are swept away automatically—or you can confirm each action yourself. *CleanSweep Deluxe* can uninstall 16- and 32-bit programs, and it automatically protects against accidental deletion of important files. *CleanSweep Deluxe* costs \$59.95. Also Quarterdeck's *Tuneup* at \$39.95 can help keep your PC running smoothly and clear up harmful viruses. *TuneUp*'s one year subscription to www.tuneup.com provides comprehensive online care. The software profiles your system's hardware and software and generates a list of the latest updates and bug fixes available on the Internet. Then just select the updates you want and *TuneUp* downloads and installs them for you.



Sirius' MovieCDs produce near-VHS quality video that plays back full screen on almost any PC.

Byzantine: The Betrayal (at \$49.95 for the CD-ROM and \$29.95 for the video) is new from Discovery Channel Multimedia. You'll immerse yourself in the mysteries of the Byzantine Empire with this big-budget six-disc game. It takes you on a quest through Istanbul, Turkey, to uncover an international antiquities smuggling ring. Players interact with over 40 live actors in this very involved game filmed entirely in a foreign location. You'll enjoy getting lost in Istanbul and have fun learning your way around as you unlock Istanbul's secrets and solve the case.

The *Grolier Multimedia Encyclopedia 1998 2-CD Deluxe Edition* (\$59.95), from Grolier Interactive, gives everyone good reason to upgrade an old version. The 1998 version is bigger than ever, with more information, expanded multimedia, new features, and online connectivity. The *Online Knowledge Explorer* gives you instant access to online resources and connects to Grolier's online *New Book of Knowledge* and *Encyclopedia Americana*, plus the *Grolier Internet Index* of 21,000 hand-

picked links to the World Wide Web. The multimedia encyclopedia includes the 250,000-word *American Heritage College Dictionary, 3rd Edition*. Multimedia maps feature guided tours, points-of-interest photographs of famous landmarks, and more. (*This encyclopedia was reviewed in-depth, in the Gizmo column of the March 1998 Popular Electronics—Editor*).

Evil has a new address with Virgin Interactive's *Resident Evil*. This game drops you in a remote mansion to investigate a biotechnical experiment gone awry. You're plunged into a death-trap filled with man-eating freaks, swarming crows, and rabid dogs. And you're dead unless you can uncover the secrets hidden among the horror. You're armed with knives and flamethrowers scavenged from dead teammates. *Resident Evil* is completely uncut, with plenty of blood, graphic violence, and gory scenes. Watch out for zombies, snakes, spiders, and other horrors as you investigate the mansion. Also from Virgin Interactive comes *Broken Sword: The Smoking Mirror*. This interactive game pits you against a mad drug kingpin and an ancient Mayan god. Dark mysteries lead you to an ancient horror buried deep in the jungles of Central America. Both games are available in the \$45 price range.

There's a lot of software here—so enjoy! ■

LETTERS

(continued from page 7)

HAVES & NEEDS

I am trying to locate a wiring schematic for a 1956 *Ford* radio (vibrator-type), but to no avail. My radio is manufactured by *Automatic Radio Manufacturing Company*, Model FP 276B, serial number A227426.

Edward Gurren
P.O. Box 681
Borrego Springs, CA 92004

After retiring, I was given an old Toshiba T5100, Model PA8040U laptop computer which had no owner/operator manual. I grew up with vacuum tubes and relays, and this is my first computer. I need all the help I can get; any manuals would be very useful.

John Delany
12963 Mount Olivet Road
Felton, PA 17322

DX LISTENING

Radio Canada International

DON JENSEN

International shortwave broadcasters sometimes seem to be an endangered species. Money is the root of the problem. Each year, it seems, several governments warn that their overseas shortwave services are headed for oblivion because of budgetary difficulties. So far, most of these threatened broadcasters have survived, albeit at a diminished level of activity. Eventually, at the eleventh hour, money has been found to keep them going, at least for the year ahead.

Radio Canada International (RCI) is one such international broadcasting survivor. Although long-range funding plans still are not in place after several years of struggle, this popular shortwave broadcaster has continued on. RCI speaks daily to foreign audiences in seven languages: English, French, Russian, Ukrainian, Chinese, Arabic, and Spanish. It still broadcasts to eastern, central, and western Europe; the Middle East and Asia; Africa; Latin America; the Caribbean; and the United States. Even with Internet competition, RCI says it offers Canada its most important way to reach people around the world, providing a full range of Canadian and international news.

The Canadian shortwave operation's stated role is to "provide a program service designed to attract an international audience with the purpose of further developing international awareness of Canada and the Canadian identity—with programs which reflect the realities and quality of Canadian viewpoints on national and international affairs. RCI also broadcasts programs to the growing number of Canadians abroad in recognition of their need of more Canadian news and information..."

CREDITS—Brian Boulden, CA; Mark Humenyk, ONT; David Krause, OH; Jim Moats, OH; Ed Newbury, NE; Jay Novello, NC; Denis Pasquale, PA; North American SW Association, 45 Wildflower Road, Levittown, PA 19057; World DX Club, c/o Richard D'Angelo, 2216 Burkey Drive, Wyomissing, PA 19610.

A typical RCI program is 30 minutes in length, a ten-minute opening newscast followed by various current features. These include news backgrounds, press reviews, features, and interviews on political, economic, social, and cultural subjects. And primarily for Canadians abroad, information programs from the domestic Canadian Broadcasting Corporation (CBC) networks are rebroadcast on shortwave.

Studios in Montreal are linked by satellite program feeds to the transmitting station at Sackville, New Brunswick on Canada's Atlantic Maritime coast. Sackville is considered a prime site for shortwave broadcasting, because it's surrounded by marshland which acts as an excellent reflector of radio frequency energy. It is also favorably located in regard to RCI's prime overseas target areas, with signals traveling a minimum

number of reflective "hops" between the earth's surface and the ionosphere.

At Sackville, RCI has eight transmitters—three 100-kilowatt and five-250 kilowatt units. There is a sprawling network of computer-controlled curtain antenna arrays—up to 200 different transmission-related functions can be computer programmed on a 24-hour schedule.

RCI's transmitters are automatically programmed to any set of chosen shortwave frequencies between 3,950 to 26,500 kHz. It takes no more than 12 seconds to tune-up the frequency. A complex switching arrangement can match any of the RCI Sackville transmitters to any of the antennas. The curtain antennas, suspended from steel towers, can be switched to transmit in either of two directions, 180 degrees apart. There are antennas beamed to



The transmitting station of Radio Canada International, shown here at Sackville, New Brunswick, is linked by satellite to the broadcasting studios in Montreal.

5 Reasons why NRI Training in PC Servicing puts the emphasis on you

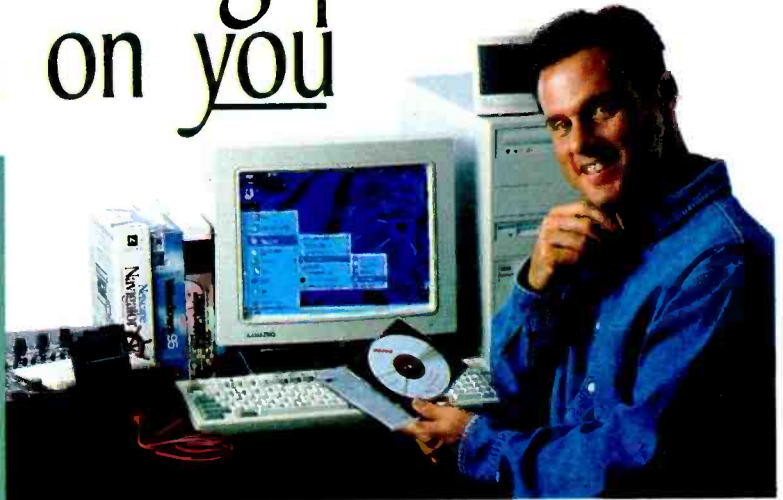

**Real-World Technology...
New Course Features...
Hands-On Experience...
Service...
Convenience**



Real-World Technology

- You get a customized 200 MMX Pentium® computer to train with and keep.
- You use your new computer's 33,600 baud or faster fax/modem in conjunction with Netscape Navigator™ Web browser software.
- You train with a digital multimeter, for quick and easy testing.
- You learn to take advantage of PC communications and the Internet.

New Course Features



- You can move up to an even more feature-packed computer system at special student prices, with NRI's new PC Options Plan.
- You get a free upgrade to Windows 98.
- You receive an exciting multimedia CD-ROM from Norton Interactive
- You gain computer aided electronics troubleshooting experience with diskettes covering four key areas: AC electronics, DC electronics, semiconductors, and electronic circuits.

Hands-On Experience

- You establish a solid foundation with a review of basic electronics.
- You learn how to troubleshoot and maintain today's sophisticated PCs.
- You train with the NRI Discovery Lab to experience circuit design and modification.
- You explore the features you've chosen for your computer, from memory chips to high-speed CD-ROM drive.
- You explore the applications and accessories of Windows 95, then move up to new Windows 98.

Service

- You work one-on-one with an experienced instructor.
- You can call NRI's TeleService hotline, for 24-hour answers to your questions.
- You get immediate feedback with NRI's TeleGrading service, featuring 24-hour exam grading.
- You can continue receiving advice and feedback from your instructor after you graduate.
- You can turn to NRI for letters of recommendation, transcripts, tips on resume writing, and more.

Convenience

- You don't need any experience to get started.
- You study at home, at your own pace.
- Your company may pay for all or part of your tuition.
- You can reach your instructors easily by mail, phone, fax, or online.
- You can tailor your training to meet your immediate interests or professional goals.



CALL 1-800-321-4634 FOR FREE CATALOG!

NRI Schools

4401 Connecticut Avenue,
NW, Washington, DC 20008

Ask for Ext.3003

Check one FREE catalog only

- | | |
|---|--|
| <input type="checkbox"/> PC SERVICING | <input type="checkbox"/> Desktop Publishing with PageMaker |
| <input type="checkbox"/> Game Programming Fundamentals | <input type="checkbox"/> Networking with Windows NT |
| <input type="checkbox"/> Troubleshooting Personal Computers | <input type="checkbox"/> Bookkeeping and Accounting |
| <input type="checkbox"/> Computer Programming | <input type="checkbox"/> Mastering Microsoft Office |
| <input type="checkbox"/> TV/Video/Audio Servicing | <input type="checkbox"/> Multimedia Programming |

Name _____ (please print) Age _____

Address _____

City _____ State _____ Zip _____

A Division of The McGraw-Hill Companies

Accredited Member, Distance Education and Training Council

0018-0498

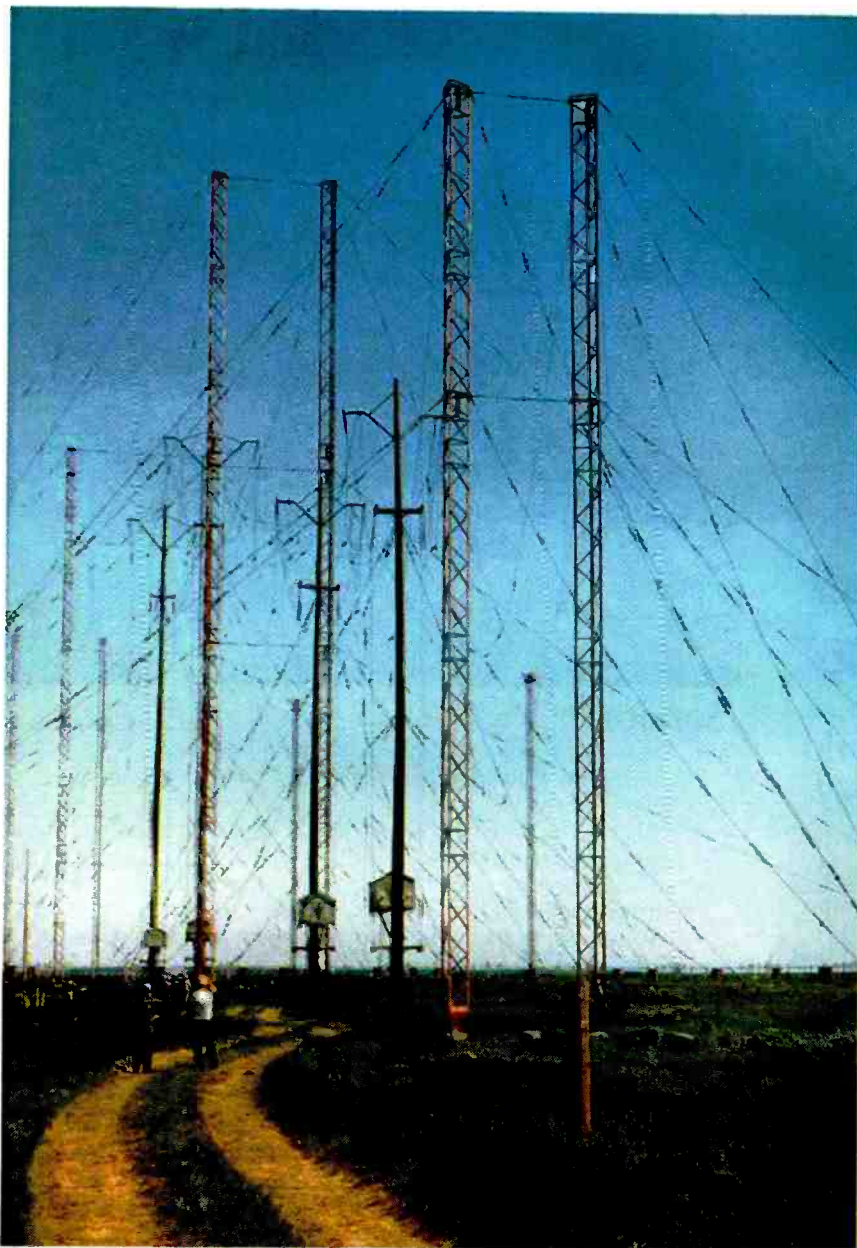

The sprawling curtain antenna arrays, situated over the surrounding marshland, provide the optimum site for transmissions to all corners of the globe.

Africa, Europe, Latin America, the Caribbean, the U.S., and Mexico.

In addition to transmitting from this eastern Canadian site, RCI has arrangements with various foreign SW broadcasters to relay its programs from transmitters in Wertachtal, Germany; Moosbrunn, Austria; Skelton, England; Sines, Portugal; Yamata and Tokyo in Japan; Xian, China; and Kimjae, South Korea.

If you will be traveling in Canada this summer, consider a visit to the Province of New Brunswick and the Sackville transmitter site. To arrange for a tour of RCI's facility there, you can write in advance to the manager at RCI

Shortwave Transmitting Station, P.O. Box 1200, Sackville, New Brunswick, Canada E0A 3C0

DOWN UNDER... BUT NOT OUT

Another long-time listener favorite is Radio Australia, which also has emerged from a funding crunch with reduced shortwave broadcasting capacities. Although the Australian government had spent more than 12 million Australian dollars during the past six years on SW transmitter sites at Darwin and Carnarvon, these have now been shut down.

Radio Australia had modernized its

transmitter site at Shepparton to focus on serving listeners in Papua New Guinea, but now this also must provide service for parts of Asia as well. Now considered beyond reach of consistently reliable Radio Australia signals are Asian listeners in Vietnam, Malaysia, Cambodia, India, and Pakistan.

Radio Australia still broadcasts around the clock, but reception in North America has been weakened; and reception in Europe, the Middle East, and Africa can be difficult indeed. These popular international broadcasts go gamely on, but Radio Australia's own transmission manager calls its position weak because of the government decisions "which have impacted adversely upon its already meager resources."

No longer can we consider any of the major shortwave services of the world to be completely safe. One thing we, as SWLs, can do is write to our favorite shortwave stations and let them know we are listening and enjoying their programs. Letters of support and encouragement can help bolster the arguments of these broadcasters for adequate government financing when the "bean-counters" come calling.

GOODBYE, ARTHUR

One of the grand old men of DXing, a legend in the shortwave-listening hobby, Arthur Cushen has passed away at the age of 73. A New Zealander, Arthur began his listening in 1935. Over the years he became one of the best-known and most admired figures in the DX world. He was cited for his humanitarian efforts during World War II, when he extensively monitored Allied prisoner-of-war messages broadcast by enemy stations for propaganda purposes. Cushen passed this information along to families of the POWs—the messages often being the first word they'd received that their loved ones were alive and had survived capture. In 1970, Queen Elizabeth personally awarded him the M.B.E.—Member of the [Order of the] British Empire.

After a lifetime of deteriorating eyesight, Arthur became blind in 1954. For many years, he served as national vice president of the New Zealand Association of the Blind.

In addition to being a top-flight DXer with an impressive tally of rare station verifications, he also regularly monitored the major world shortwave broad-

(Continued on page 70)

GIZMO®

ZOOM WITH A VIEW

MODEL PV-L857 PALMCORDER WITH LCD. From Panasonic, Matsushita Consumer Electronics Company, One Panasonic Way, Secaucus, NJ 07094; Tel. 201-348-9090. Suggested retail price: \$999.95.

When Sharp introduced the View-Cam in the early 1990s, it revolutionized the way people used camcorders. The addition of a pivoting LCD screen that acted as both viewfinder and playback monitor allowed users to record the action without distancing themselves behind the camera, to shoot from angles not possible with standard viewfinders—and to view their tapes on the spot, without having to connect the camcorder to the TV.

Of course, to get a full-size view of the 8mm tape, you still have to make those audio and video connections between the camcorder and monitor. We wonder how many people, intimidated by (or too lazy to deal with) wires and hookups, contented themselves with the 3- or 4-inch version of their videotaped holidays and birthday parties.

Panasonic's Compact VHS LCD Palmcorders, including the top-of-the-line PV-L857, make it easy to view tapes in two ways—on a 3.2-inch diagonal color LCD or on a TV. That's because VHS-C tapes fit into an adapter, which can be inserted into any VHS VCR, and the tape can be played with no need to connect any wires or dub the tape to another format.

The included PlayPak looks like a VHS cassette—minus the tape. It requires one "AA" battery, which is installed in a compartment on the side. The battery powers the PlayPak's tape



compartment door and tape-tension mechanism. The release button slides to the right to open the door on top of the pack, and the VHS-C tape is inserted into the tape well. With the door snapped shut, the PlayPak can be inserted into a VCR for playback as usual.

But we're getting ahead of ourselves. Before you can view anything, you have to tape it. The PV-L857 has plenty of automatic features to make recoding easy, and plenty of advanced features to make your recordings good. A description of its physical layout will give you some idea of the camcorder's scope of operation.

With its LCD tucked away, the PV-L857 looks like a typical camcorder. The lens and electronic color viewfinder are located on the right side (when holding the camcorder in record position). The lens cap is built in, opening automatically when the unit is switched on to record—the POWER switch is

found next to the lens. Below the lens is a manual focus wheel. To the left of the lens is a powerful light for indoor shooting.

When not in use, the traditional viewfinder folds down flat against the top of the unit and faces forward. The controls for playing back tapes in the viewfinder are found on the viewfinder, along with a VISION ADJUSTMENT switch. Sliding that switch while peering into the viewfinder allows you to customize the camcorder to your eyesight. (It didn't quite compensate for removing our eyeglasses, but it came close. We were able to read the RCA logo on a DSS dish across the yard, without zooming in on it and without wearing glasses. The color viewfinder has approximately 120,000 pixels for fine detail.) On the left side of the viewfinder is a brightness control and the eyepiece removal switch, used for cleaning the viewfinder or for attaching optional filters or lenses.

The electronic zoom controls are found on top of the camcorder just to the left of the viewfinder. (They are blocked by the viewfinder unless you have it folded out to its normal operating position.) The large wide-angle (W) and telephoto (T) buttons are easy to find when holding the camcorder with your hand through the strap found on its right side. So is the RECORD button, located just below the (extended) viewfinder, at the back of the camcorder.

On top of the PV-L857 are found an ON/OFF/AUTO slide switch for the camcorder's light, a built-in microphone, and several buttons that control special features such as backlight, fade, and color digital fade. Three wedge-shaped buttons, set in a circular arrangement, are used to activate the Palmcorder's digital zoom, digital electronic image stabilization, and negative/positive transposer. Rounding out the top panel are a TAPE-EJECT slide switch and a DISPLAY button that serves several purposes, and buttons labeled TITLE, SECURITY MODE, and H.S. (high-speed) SHUTTER.

The battery pack slides onto the rear of the camcorder. To its right are the CLOCK-SET buttons and tape-speed selector. To its left is the switch used to open the LCD and to access the tape compartment, a rotary volume control, and a headphone jack. The LCD screen swings out from the left side—to a maximum 90-degree angle from the body of the camcorder. It also pivots 180-degrees up and 90-degrees down. A POWER SWITCH to its left can be set in off or auto-on mode. The tape compartment is hidden behind a built-in speaker.

We're still not done. Turn the PV-L857 upside down; and you'll find color, tint, and brightness controls, and a tripod-mounting hole. You might want to invest in a tripod, not only for stable, hands-free operation, but because the Palmcorder is a bit hefty.

The specifications list its weight at approximately 2.7 pounds, but that is without the battery and tape installed. The PV-L857 is significantly heavier than the 8mm camcorders we're accus-

tomed to and can cause arm fatigue after extended use.

The PV-L857 is as easy to use—or as complex—as you want it to be. It offers automatic everything, so you can just pop in a tape, set the power switch to CAMERA, flip up the electronic viewfinder or flip open the LCD viewfinder, and press RECORD. Focus, backlight, and shutter speed adjust automatically each time you start recording. The date and time are preset for Eastern Standard Time. (The first time we used the Palmcorder, it greeted us with a friendly: "Happy Thanksgiving." Nine other holiday titles are programmed in at the factory, based on Eastern Standard Time. Resetting the clock for other time zones is easy.) There's no need to do anything more.

Oh, but you'll *want* to do plenty more, unless you're a total technophobe! If that's the case, you'd do better buying a less expensive, less richly featured model (perhaps one of the other three in Panasonic's line of VHS-C LCD Palmcorders).

This is a fun camcorder to play around with. It does, however, require a bit of time and effort to become familiar with all its features—as we found out when watching our Thanksgiving tape, recorded on the fly, without so much as a glance at the manual. (The PV-L857 had arrived late in the afternoon the day before Thanksgiving.)

The first scenes we taped were at Macy's Thanksgiving Day Parade, from a third-floor window. A press of the BACKLIGHT button would have compensated for the bright light streaming in the window and allowed us to better record the faces of the children perched on the window sill. Later, celebrating a birthday after Thanksgiving dinner, we'd have done better to turn on the Palmcorder's lamp as the candles were being blown out. Throughout the recording—but particularly as we zoomed in on the floats and later on the turkey—the Digital Electronic Image Stabilization (DEIS) system would have reduced the shakiness.

Despite our inexperience with the PV-L857, the tape came out at least as good as most of the amateur home videos we've seen, and probably better. The auto backlight feature kept the kids' faces from being thrown completely into shadow, the auto focus

kept our subjects dependably clear, and zooms were smooth transitions.

Subsequent sessions benefited greatly from a thorough reading of the instructions. First, we learned what all the viewfinder indicators meant. Some were obvious—the battery icon, mode, time and date, and tape speed, for instance. The PV-L857 offers warnings when you near the end of the tape, and something called a "10-second reminder," which we particularly liked. An indicator appears for every 10 seconds that you've been recording, reminding you how long you've been shooting that scene. It helps you avoid shooting scenes that are too choppy or those that drag on and on endlessly. Most of the remaining indicators let you know the status of the Palmcorder's many special features.

You have the option of using the Palmcorder's auto focus and auto shutter modes, but during some taping situations, you'd do better to make those adjustments manually. In auto mode, the shutter speed adjusts from 1/60 to 1/350 depending on the brightness. The high-speed shutter, used to capture fast action, can be used only when the light is adequate—generally outdoors or with supplemental indoor lighting. Eight different shutter speeds, ranging from 1/60 to 1/10000, are accessed with repeated pushes of the high-speed shutter button, and the shutter speed is displayed in the viewfinder.

The viewfinder displays "MF" when manual focus is chosen. The auto focus system copes quite well in most situations, but can get confused when your subject is far away and there are other objects up close (it tends to focus on the near objects). For instance, when we tried to tape Santa's float at the end of the parade, it was blurred, but the kids watching it came out clearly. It also focuses on objects in the center of the field of view, so manual focus is required if your subject is off to one side of the picture. The PV-L857 also provides macro focus for extreme closeups.

A lamp icon lets you know that the built-in auto light is turned on. With the light switch moved to the auto position, the lamp automatically comes on when in low-light conditions.

The magnification level appears in the upper right corner of the viewfinder. The PV-L857 features a four-speed power zoom system, whose speed

depends upon pressure. A light touch on the telephoto (T) or wide-angle (W) buttons zooms slowly (16 seconds); a heavy touch zooms all the way in (or out) in just 2.2 seconds. Mastering the proper amount of pressure takes a little practice, but affords great shooting flexibility.

The camcorder's standard zoom provides up to 20× magnification. Its digital zoom feature can be used to increase that to a maximum of 28×. Pressing the digital zoom button while the optical power zoom is at its maximum setting engages the digital zoom feature. Further presses of the T and W buttons control the digital zoom level. You aren't actually zooming in any closer; instead, the image is being digitally enlarged. It's possible for some distortion to creep in, but when you really need that extra magnification, you'll be happy to have it. The biggest problem at such high zoom levels, however, is holding the camcorder steady—another reason that you might want to use a tripod.

The PV-L857's DEIS system compensates for the inadvertent shaking of the camcorder—for instance, when shooting from a moving vehicle or while walking. (Many people could benefit from it while standing still. You can't appreciate how difficult it is to hold your hand perfectly still until you've used a camcorder.) When you press the digital EIS button, the image in the viewfinder appears to jump; it's actually being enlarged just a bit. EIS electronically compensates for motion by moving the "window" in the opposite direction of hand motion. It's using less of the image LCD, so resolution is lower, but usually not noticeably so.

The digital EIS system usually does significantly stabilize the image. It won't work in every situation, however. Extreme movements throw the system off; so do subjects with distinct stripes, intense fluorescent lights, low light, and fast-moving scenes.

The PV-L857 offers several features for doing in-camera "editing" and adding effects. What Panasonic calls its "Intelligent Titler" automatically displays messages on ten holidays that occur on specific days/dates each year: Happy New Year/Cheers!, Valentine's Day/Be My Valentine, Happy Mother's (Father's) Day/We Love You, Memorial Day, Independence Day, Labor Day, Happy Halloween, Happy

Thanksgiving, and Merry Christmas/Ho! Ho! Ho!. Pre-programmed titles for other holidays and occasions (birthdays, anniversaries, Easter, vacation, wedding, and the generic "A Special Day") can be displayed manually, by repeatedly pressing the TITLE button to scroll through the list of available titles. Any message can be recorded with a press of the RECORD/PAUSE button while the title appears in the viewfinder. It is not possible, however, to create any custom titles or messages.

A press of the NEG/POS button inverts the image to its negative. It's not something you'd use very often—not if you want others to watch your videos!—but it could add some spooky effects to your Halloween tape, for instance.

Several fade options are available for smooth, professional-looking scene transitions. You can fade in on the first scene, fade out on the last. In between, you can fade to and from white or black and back again between scenes. Color digital fade provides eight colors and seven fade variations—including soft, sharp, mosaic, stripe, and random—to create a variety of fade effects.

Editing features are among the least popular camcorder extras—a recent poll found that less than a third of camcorder owners had used their editing features within the last year. Perhaps that's why the PV-L857's only "editing" feature is one that provides a smooth scene transition if you begin taping again without viewing what has previously been recorded on a cassette that has been left in the camcorder. The edit stand-by feature works only as long as you begin recording again within 24 hours. Otherwise, it's necessary to rewind the tape a few minutes, monitor it to find the end of the previous recording, and press the STILL button at the precise location where the new recording should begin before hitting REC/PAUSE.

The PV-L857 features a motion sensor, which is activated by pressing the SECURITY MODE button for two seconds. In security mode, the camcorder automatically begins recording about three seconds after it notices movement or detects a sound, and pauses about 30 seconds after the motion has stopped. That feature allows you to videotape yourself, and it also makes the camcorder a good candidate for amateur surveillance work. Display the time

and date, and you'll have a time-stamped record of any action occurring within the range of the camcorder.

Once we got a handle on some of the PV-L857's special features, there was a marked improvement in our videotapes. Gone were the washed-out scenes, shaky movements, and subjects lost in a dark room. It was easy to achieve a professional look with smooth scene transitions, and the 10-second reminder helped keep us in line—no one else wants to see epic footage of our son roller skating, playing with his toys, or opening Christmas presents.

We did continue to experience arm fatigue, even when keeping our taping sessions short. The weight of the PV-L857 caused another problem as well. People with very small hands will have trouble reaching the zoom controls with their right fingers while holding the Palmcorder with their right hand through the strap. Its substantial weight pulls the camcorder away from your hand, and puts those controls just out of reach of short fingers, even with the strap adjusted as tightly as possible.

We liked being able to play back our tapes in a standard VCR. The VHS-C format does have its drawbacks, however, including shorter recording times; it's hard to find VHS-C tapes that will record more than 30 minutes in SP or 90 minutes in EP mode. Of course, that means that your battery pack is likely to last at least as long as your tape does—if you don't go too heavy on the digital features. The LCD monitor (thanks to its backlight), in particular, drains the power much faster than using the electronic viewfinder.

Those problems seemed pretty minor in light of the Palmcorder's many excellent qualities. The LCD monitor allowed us to hold the camcorder above our heads to capture (and see!) the action at a local parade even when taller people blocked our view. It allowed us to feel as if we were part of the action, even while we were taping, since we didn't have a camcorder pressed up against our faces while recording. It also made subjects feel less self-conscious as we were recording. Because we could hold the camcorder at waist level (Kodak twin-lens reflex style) instead of in front of our face, our subjects felt as if they were interacting with us, instead of the camcorder. The color electronic viewfinder 19

offers its own benefits, particularly for folks who often misplace their glasses; its vision adjustment control made it possible for nearsighted videographers to tape without glasses. The auto light was powerful enough to amply light the darkest room, allowing us to capture small faces around a birthday cake or beneath a Christmas tree. Last but not least, after the Christmas-morning gift-opening frenzy was over, we were able to pop the tape into our VCR and relive the fun as we relaxed with our coffee.

All in all, using the PV-L857 was a gratifying experience. It provided ease of use and consistently good results.

BARNEY-MANIA

ACTIMATES INTERACTIVE BARNEY, TV PACK, and PC PACK. From Microsoft Corporation, One Microsoft Way, Redmond, WA 98052-6399; Tel. 425-882-8080; Web: www.microsoft.com/actimates/. Estimated street prices: Barney: \$109.95; TV and PC Packs: \$64.95 each; software titles: \$34.95 each; videotapes: \$14.95 each.

They love him. There's no denying—or understanding—it: Small children are crazy about Barney, that big, purple dinosaur whose saccharine manner and oh-so-jolly voice drives parents crazy.

As with any other popular TV character, Barney has generated tie-ins galore. (In fact, Barney's "owners" earned themselves a high-ranking spot on last year's 10 Best-Paid Performers list.) Now, following in the well-worn path of Barney plush toys, Barney books, Barney videos, Barney games, Barney clothing, and Barney stage shows, comes *Microsoft's ActiMates Barney*, a stuffed, purple dinosaur that interacts with special videotapes and CD-ROM titles—or just with your child.

Barney is a big toy, measuring 16 inches from head to toe. He's also quite heavy, weighing several pounds with his batteries installed. Six "AA" batteries, which are not included, fit in a battery compartment hidden beneath a Dr. Denton-style flap at his seat. (A screwdriver is required to open the compartment, in an effort to keep the batteries



out of small hands.) The batteries contribute a bit to Barney's weight problem (it becomes a problem when a small child refuses to leave Barney home, but then tires of carrying him almost immediately), but most of his heft is due to the amount of electronics and mechanical components packed inside his purple-plush body.

Microsoft's "Realimation" animation technology uses sensors in Barney's eyes, hands, and feet to allow him to respond to a child's actions, and a built-in radio transmitter and receiver to let him interact with ActiMates VCR and PC programs. Motors move his head and arms. A voice synthesizer allows him to talk and sing.

Fortunately, there's no need to immediately run out and buy all three components of the ActiMates Barney system. Even with no added accessories, the doll will play games and sing songs with a child. Theoretically, you don't have to shell out any more money until your child begins to lose interest. And, with Barney's 12 games, 17 songs, and 2000 words, that could take some time.

ActiMates Barney is simple to use. To turn him on, press one of his hands. Barney immediately begins moving his head and arms and talking: "It's so good to see you!" (or "Oh, boy! I'm so happy to see you!"). "Cover my eyes

to play peek-a-boo. Squeeze my hand to play a game." If you do none of the above, after a few seconds Barney continues, saying "Squeeze my middle toe to sing a song." After another pause, he goes on (somewhat imploringly?), "We're going to have fun. Cover my eyes to play peek-a-boo." If there's still no human response, Barney begins to yawn, complains of being sleepy, and shuts himself down.

It's very easy to get Barney started unintentionally. After all, it's human nature to grasp a friend, or a toy, by the hand. Luckily, there's no need to listen to his entire spiel. Squeezing a hand and a foot simultaneously shuts him off immediately. You can also avoid the problem altogether by grabbing his neck instead of his hand (something you've probably been longing to do anyway, if you're the parent of a Barney fan...).

Another command to commit to memory is the two-hand squeeze. That prompts Barney to sing his one song that's as beloved to parents as it is to kids: "Clean-Up." ("Clean up, clean up, everybody everywhere. Clean up, clean up, everybody do your share.") A couple of other songs will be familiar to Barney-watchers: "Hurry, Hurry," "You are Special," and the Barney theme song, "I Love You, You Love Me." The others include nursery rhymes ("Mary

Had a Little Lamb” and “Hickory Dickory Dock”), play songs (“The Wheels on the Bus,” “Head, Shoulders, Knees and Toes,” “If You’re Happy and You Know It”) and learning songs (“The Alphabet Song.”) If your child likes to fall asleep to music or enjoys background music while playing, you can press both of Barney’s feet simultaneously to hear him sing all 17 songs.

Actually, we were able to make Barney sing only a dozen different songs, not the 17 promised in the book and manual, by pressing on his foot. More than 100 presses of his right foot had him singing the same 12 songs, over and over, played in “random mode.” (No, we didn’t have to listen to the whole song time and again. You can press a foot in the middle of a song to hear a different one.) Finally we thought to try the left foot—perhaps that would activate the rest of his play list—but the same songs kept popping up.

If Barney (the TV show) drives you around the bend, be forewarned: Interactive Barney could really push you over the edge. The show only lasts 30 minutes. *This* Barney can go on and on seemingly forever, so perky and sweet it makes your teeth hurt.

The only time we adults had fun with Barney was when we tested his eye sensors by shutting him in a dark closet. He responded with, “Where did you go? Are you still there? It sure is dark.” Then (somewhat peevishly, perhaps?) “Let’s play something different. Please let me see you.” (Okay, so maybe we have a sadistic side!) When there was still no human response, Barney yawned and said, “I’m sleepy. Good night,” and shut himself off.

A press of Barney’s hand puts him into game-playing mode. He responds with “Let’s play!” and suggests a game. For instance, he’ll say, “I know a great imagination game. Think of something that flies in the sky.” After a pause to allow the child to respond, Barney says “What were you thinking of? I was thinking of a helicopter.” Sometimes he’ll be thinking of an eagle, or he’ll ask the child to think of something that is blue, or red, or yellow, or to say what his favorite color is. (Barney’s favorite color is—surprise!—purple.)

Other games include point and find, the question game, the ABCs, exercise,



Barney is so heavy that kids tend to grab him by the neck to get a good grip on him.

and let’s pretend. In point and find, Barney prompts kids to locate various body parts—their own and his. The question game seemed primarily to be Barney asking “Are you having fun?” with other easy questions interspersed (“Is it sunny outside?”). Exercise is sort of cute: Barney tells the child, “Move your head like this”—a pause while he moves his own head back and forth—“back and forth.” He does similar “exercises” with his arms. In let’s pretend, Barney will suggest a make-believe activity, such as having a snack. “Would you like a carrot stick? They’re very crunchy. Let’s drink some milk! Here’s a cupcake for you. It sure is yummy!” Followed by the lesson to be learned: “It’s nice to share.”

Of course, the whole idea behind interactive Barney is that children learn not only through active teaching, but also in the course of playing. Most of ActiMate Barney’s roster of games are designed to help kids learn, and all of them are full of positive encouragements—“Great!” “That was terrific!”—to make children feel good about themselves. In fact, many of the games were close to, or identical to, ones that we play with our two-year-old.

Children also learn better when they learn from a parent or friend. Studies have shown that kids learn best from a “learning partner” who is sensitive and responsive to their actions, who lets them take the initiative, who models

correct performance, and who is perceived as friendly and attractive. Other studies have indicated that children learn through playing when they are actively participating in games.

ActiMates Barney does meet all those criteria. We can’t document the amount of learning going on or predict better school performance down the road. But the two- to five-year-olds to whom we introduced Barney were all completely enchanted by him. They sang songs along with him and shouted out their answers to his games. They all loved covering his eyes, removing their hands, and hearing him say “Peek-a-boo, I see you!”

Our primary tester was 2-½ year-old Christopher, whose interest in television Barney waned about a year ago, and who never exhibits any desire to play with his friends’ stuffed Barney toys. Shy around new people, Chris was happily singing along with ActiMates Barney minutes after meeting him. That evening, he played with him tirelessly for hours, although his longest attention span is rarely longer than 30 minutes when playing with a toy.

Perhaps the key word is toy. When Chris awoke the next morning, the first words out of his mouth were, “It’s not dark anymore. Barney can wake up now.” When asked if he wanted to get his Barney toy, he responded, “Barney not a toy. He a friend.”

Microsoft stresses that the ActiMates system can be used at home and in the classroom, with parental or teacher involvement, and that is particularly true with the PC Pack accessory. Yet, with Barney alone and with the TV Pack, the potential to allow Barney to become a stand-in for a parent looms large. It’s very easy to leave your child playing happily with his new “friend,” while you sit in another room and watch TV (or do the laundry, or balance the budget, or cook a meal). Perhaps it’s healthier to leave a child actively playing with Barney than to plop him in front of the VCR to watch “The Little Mermaid” for the thousandth time. But the fact of the matter is, you’ll *want* to escape to another room to avoid the incessant cheerfulness of Barney’s chatter.

THE TV PACK

Barney reigned supreme in Christopher’s affections for a few days, until he was unseated by a Burger King 21



Cover Barney's eyes to begin a game of "Peek-a-Boo."

give-away toy from *Anastasia* (kids that age are notoriously fickle). At that point, we decided it was time to hook up the *ActiMates TV Pack* to see what other tricks Barney could do.

The TV pack includes a transmitter that connects to a VCR or TV, providing a radio link over which ActiMates Barney can interact with specially encoded videotapes or broadcast TV shows. The required video cable and AC adapter are included, along with one videotape.

The transmitter is a black disc-shaped object, approximately 5-1/2 inches in diameter and 1-1/4 inches thick, with video in, video-out, and AC jacks on its back panel. It must be connected to your TV's or VCR's video-out jack to work properly. If neither component has a video-out jack open, however, it's possible to connect the TV's video-in to the transmitter's video-out (instead of to the VCR) and then the VCR's video-out to the transmitter's video-in jack.

Setup is relatively straightforward—unless you have a TV/VCR like the one in our kitchen, with no video-out jack at all. We'd have preferred to keep Barney out of the living room, but had no choice but to connect the TV Pack receiver to our home-theater VCR. (So much for relaxing with a DVD while Chris and Barney play in the next room ...).

The radio transmitter has a range of up to 15 feet, but that can be affected

by its proximity to metal, and tightly coiled cables can also reduce the range. So it's best not to place the transmitter on top of the TV, but to move it some distance away. If you're not quite within range, Barney's speech might be broken up with words missing, or he might stop speaking in mid-sentence. Because ActiMates Barney uses a radio link, it's subject to RF interference from other radio-operated devices. Those include two staples of households with small children—cordless phones and baby monitors.

A green light on the transmitter lets you know that it's powered up, and it blinks when an ActiMates-compatible video is playing.

When the transmitter is hooked up and a video is playing, Barney responds to a squeeze of his hand with, "Let's watch TV together." If you try to make him sing a song or play a game during the video, you'll be disappointed. ActiMates Barney will direct your attention back to the TV screen. Instead of saying "I can't see you" when you cover his eyes, he'll say "I can't see the TV!" And if you squeeze his foot while the video is playing, he'll say "You're tickling my feet."

The TV Pack comes with one video: *Barney's Stu-u-upendous Puzzle Fun!* Kids are invited to search for ten puzzle pieces shown during the course of the 54-minute tape. Meanwhile, they'll be playing games, singing songs, and listening to stories, with Barney for company.

We found watching TV with Barney to be as annoying as sitting next to a chatterbox in a movie theater—he just never stops talking! (At least there was no plot for him to give away.) He has comments about everything that happens on screen, he sings snatches of every song, and he throws in plenty of "Yup!," "Good job!," "That was fun!," "Oh my!," and giggles. (His vocabulary increases to 4000 words when Barney is in video mode.) It was very distracting—and highlighted the need for a volume control on the Barney doll. The TV volume must be uncomfortably loud to hear the soundtrack over Barney's running commentary.

Christopher also seemed to be distracted by Barney's talking, even though the idea behind it is to "refocus the child and highlight the positive themes on the show." Chris—who at 2-1/2 has already "outgrown" *Barney &*

Friends—showed little interest in the ActiMates-compatible Barney video.

Children who still do like watching Barney, however, seem to enjoy it even more when they can watch it with their new purple friend.

When your child tires of the original videotape, others are available (at \$15 a pop). However, it might not be necessary to go out and buy additional tapes. As of November 1997, certain daily episodes of *Barney & Friends* have carried a specially encoded signal that allows ActiMates Barney to interact with those shows—as long as the local PBS station broadcasts the signal. Living in the New York metropolitan area, we were able to receive the special broadcasts on one of the first 20 PBS stations to carry them—WNET Channel 13. You can even tape the specially encoded Barney & Friends shows to collect a library of interactive programming. During the 1997–1999 television seasons, 68 episodes are expected to be encoded. To find out if your local PBS station is providing the service, contact the Microsoft ActiMates Web site (www.microsoft.com/hardware/actimates) or call the technical support number found in the manual.

Kids love watching Barney sing and dance on TV or video—even more so when they can watch with a "friend." If you have an aversion to the show or the doll, so what? He's harmless, entertaining, and educational. The ActiMates Barney TV Pack requires absolutely no parental guidance or involvement (unless your child is too young to start the VCR). If Barney can keep your child happily glued to the tube for close to an hour, it can be a godsend for busy parents. If your kids have lost interest in Barney's TV show, however, the talking Barney doll is not likely to make them want to start watching it again.

THE PC PACK

Even "interactive" TV, however, is a relatively passive activity. Sure, the kids sing songs and maybe count along with Barney, but, for the most part, they're just sitting and watching TV.

The *ActiMates PC Pack*, on the other hand, provides a truly interactive learning experience, with three levels of difficulty to challenge children of various ages. Like the TV pack, it comes with one piece of software and a disk-shaped transmitter. The includ-

ed CD-ROM is titled *Barney's Fun on Imagination Island*; other titles are available separately.

The royal-blue PC Pack transmitter plugs into the 15-pin MIDI/game port on a PC. If you already have a joystick plugged in, you can use the transmitter cable's "pass-through" port to plug both devices into the computer at the same time. However, not all game devices are compatible with the ActiMates pass-through port. If you connect an incompatible device, the transmitter won't work. No outside power source is required; the transmitter draws its power from the PC. A yellow light indicates that it is powered up.

The PC Pack requires (at the minimum) a 486/66MHz CPU, 8 MB RAM (16 recommended) and Windows 95 or 16 MB RAM and Windows NT 4.0, 20 MB hard disk space, a double-speed CD-ROM drive (quad speed recommended), a 16-bit sound card with external MIDI/game port, a SVGA display card and monitor capable of 800×600 resolution in 256 colors.

The included CD-ROM features a "Parent's Room," which contains information not only about the title itself, but also pointers on how to get more involved and become more effective in your children's learning activities. We'd suggest that you browse through the Parent's Room before getting started with the game. You'll become more familiar with the game itself and discover the learning goals behind each activity. The Parent's Room features on-screen troubleshooting tips (which can also be found in the manual). Click on the Gifts icon (a wrapped present) to see if your child has created any presents for you and turn that special gift into your screen's wallpaper. Click on the globe for an Internet link to the Microsoft ActiMates Web site.

The most useful Parent's Room information is found within the Reading Room. In it, you'll learn the importance of parental involvement, how children learn through playing, and how they develop ideas and vocabulary through talking. You're encouraged to make up stories with your children and to write down their versions in their own words. There's advice on working with kids and computers, and the suggestions are good ones. Show a genuine interest, and you'll help your children develop a sense of adventure, curiosity, and enthusiasm. Make learn-

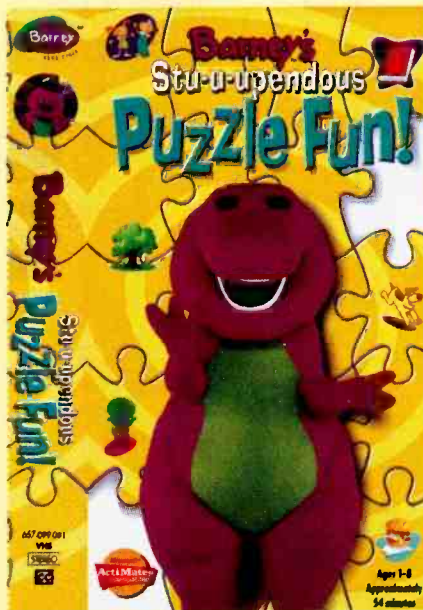

The ActiMates TV Pack comes with one videotape: *Barney's Stu-u-pendous Puzzle Fun!*

ing fun, because the process of learning is as important as the concepts being taught. Keep the sessions short to match the child's attention span. And reinforce the lessons with activities and books.

To that end, the Parent's Room provides recommended reading lists and suggests all sorts of activities that parents and children can share. There are art and language projects, math and science experiments, fun with music, and games to sharpen social and emotional skills—all geared for a preschooler's interests and abilities. The reading list includes books that relate to the lessons taught on the CD-ROM, as well as general activity books. Finally, there are instructions on creating a personalized dictionary of vocabulary words featured in the program, using pictures cut from magazines or drawn by your child, and a "songbook" with the lyrics to all the songs on the CD-ROM.

Barney's Fun on Imagination Island provides six learning adventures—Baby Bop's Buccaneer Bay, BJ's Treasure Cove, Hootin' Annie's Musical Woods, Lucy's Letter Lagoon, Professor Tinkerputt's Treehouse, and Video Volcano. Each offers three different levels of play, as well as an explore mode that lets children create pictures or songs relating to the activities. Those creations can then be sent as "gifts" to the Parent's Room, by click-

ing on the gift icon at the bottom of the screen. There's also a castle icon, which brings you back to the main screen—the overview of Imagination Island—from any of the adventures.

As the child moves through the game, ActiMates Barney plays along, offering encouragement, praising correct responses, and dropping hints if the child runs into trouble. During play, a squeeze of Barney's hand elicits more information about the concepts being taught. In the explore mode, Barney will "take a turn" when you squeeze his hand, yet he follows the child's lead—continuing to draw the same shape, for instance, or to use the same color that the child has been using. Once again, you'll have to keep the computer's volume turned up high for the on-screen characters to be heard over Barney's banter.

Imagination Island held our young tester's attention. We had to help Chris move the mouse, but although he liked being introduced by Barney to each new character and locale on the island, he didn't want his "help" while we played the games. (He still preferred his parent's company to that of a stuffed purple dinosaur.) His personal favorite was Hoot' Annie's Musical Woods, which he had no trouble completing.

We enjoyed using the ActiMates PC Pack with Chris. It was a different parent-child activity, and one that gets him started using a computer. Even if the action is slower than we might like, his responses are wonderful—and there's plenty of time to talk during play. Unfortunately, you can't just shut off Barney and use the CD-ROM alone; he must be in the room and awake as you play. If the program doesn't detect Barney, a pop-up box with instructions for properly positioning the transmitter blocks the screen, remaining until the "problem" is resolved. We resented having Barney intrude on the limited time we have to spend with Chris.

Perhaps older kids can play PC games with Barney with no parental supervision. (At our house, we're still in the paper-clips-in-the-floppy-drive stage!) But we wonder if the ActiMates games, or even Barney himself, will hold much interest for children who are old enough to use a PC on their own.

We have two major complaints (besides the lack of a volume control) about the ActiMates Barney system. First, with the ActiMates TV Pack as



The ActiMate PC Pack provides truly interactive play for kids, parents, and, of course, Barney.

well as the PC Pack, Barney constantly interrupts whoever happens to be speaking at the time. That's something that we try to teach our child not to do. We'd prefer to have Barney's responses come during pauses in the programming.

Second, we wish they'd chosen a character that parents found a bit more tolerable. How, you might ask, can you complain about a companion who is polite, respectful, friendly, optimistic, playful, and always ready to share (even if he does tend to interrupt)? Just try spending a half hour in the company of Barney, and you'll understand. His relentless cheeriness and saccharine sweetness are sure to drive you batty. We wanted to distance ourselves from Barney—which meant being away from our child when he played with Barney or watched TV with him and cutting short computer sessions.

We've never met a parent who could stand Barney, but then we've also never met a toddler who didn't love him. If there are some little Barney lovers in

your home, the ActiMates system could make them very happy indeed.

GIZMO NEWS

Emergency calls given priority

The FCC recently decided that wireless companies must put through all 911 calls placed on wireless phones—even if the call comes from a nonsubscriber's phone. That means that local providers would have to put through emergency calls placed outside the caller's registered area. It would also require cellular providers to handle 911 calls made from phones that have been disconnected due to nonpayment, as well as from those that have never been activated, those whose contacts have expired, and even those that have been reported stolen.

Before the decision, emergency centers could decide whether or not to accept 911 calls from cell phones; they are now required to accept all wireless 911 calls. All cellular compa-

nies are required to put through emergency calls whose signal they pick up. FCC Chairman William Kennard issued a statement saying, "Assuring prompt delivery of emergency 911 calls from whatever source, without delay, best serves the public interest."

The December, 1997 decision revises the June 1996 FCC order mandating that by April 1997 emergency services had to be able to return calls from cellular phones. The FCC also ordered that by October 1, 2001 emergency services should be able to locate the source of wireless emergency calls to within 410 feet (125 meters).

The latest ruling did not take into account situations in which cellular companies are not able to handle calls for technological reasons. At this time, most of the cellular providers across the country offer analog services, but digital systems are becoming available in some areas.

Digital-TV chip set in the works

Motorola Consumer Group is working with Sarnoff Corporation to develop a chip-set architecture for digital-TV (DTV) receivers from which they plan to create a broad-ranging family of chip sets for DTV products including inexpensive set-top decoder boxes and 1080×1960-pixel high-definition televisions. The chip set will demodulate an analog signal to a 19-bit digital bit stream, and it will reproduce all of the 18 valid DTV formats specified by the Grand Alliance.

Those specifications, however, do not include a blueprint for receiver architecture, and that is the challenge faced by Motorola and Sarnoff. "Not everything is there in the standard. And in the end, the standard specifies a delivery format, not a means of decoding," explained Bob Stokes, director of digital TV operations for Motorola.

The architecture will use either PowerPC or ColdFire 32-bit CPUs, which will have to break down the transport layer bit stream into audio and video streams. Those will be directed to MPEG-2 audio and video decoders. User-interface and data-presentation features will be provided by Motorola's proprietary Scorpion on-screen graphics processor.

Digital broadcasts are set to begin in the U.S. in mid-1999. Sample chip sets are expected to be ready before then. ■

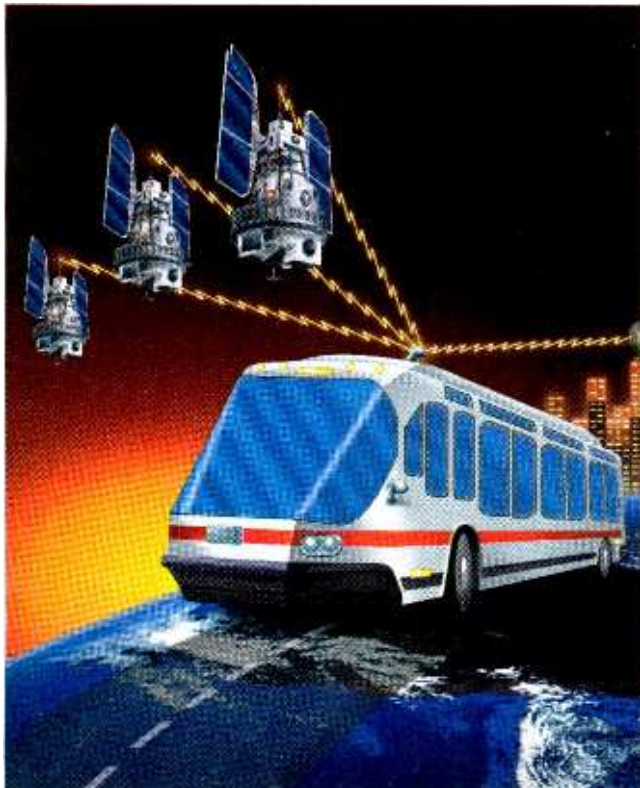

SMART BUSES

Another application for the Global Positioning System. Melding GPS and dead-reckoning capabilities with urban mass-transit systems offers riders a new level of convenience, while allowing both dispatchers and drivers to perform their duties more efficiently.

BILL SIURU

Usually you'd associate the Global Positioning System (GPS) and dead reckoning with navigating in "unknown" territory. Therefore, you might wonder why urban mass-transit buses are being outfitted with navigation systems. After all, city buses don't often stray far from their routes (when they do, the detour is usually only a block or two), and there is little chance they will ever get lost. However, there is a place for advanced navigation technologies in "smart" buses.

Talking Buses. The Americans with Disabilities Act (ADA) requires spoken announcements concerning transfer points, major intersections, and destination points, as well as requiring announcing stops along a bus route for the visually impaired. While announcements can be provided by the bus driver, often the driver—distracted by traffic, collecting fares, and other tasks—fails to call out stops. The added workload has also resulted in union-management disputes in some locales.

Simple announcement strategies that use recorded messages help, but still require initiation and programming by the bus driver. Thus,

transit agencies around the country are becoming increasingly more interested in automated systems that require minimum driver participation. The challenge for automated systems—such as *Talking Bus* voice-announcement technology from *Digital Recorders*—is knowing precisely where the bus is located at all times, so that the right announcement is made at the right moment. (Have you ever ridden on a bus, in which the computer-generated announcement was off by a stop or two? That could result in passengers not familiar with the route getting off at the wrong stop, which

in some locales could be up to a half-mile or so.)

With smart buses, announcements can be triggered automatically by radio-frequency or infrared optical communication beacons located along the route as the bus passes by. Mileage information from an odometer can be used to interpolate distances to pinpoint locations more accurately. While simple in concept, that type of system can be expensive, since many beacons have to be installed and maintained along each bus route. In addition, if a bus route is changed, the beacons will have to be relo-

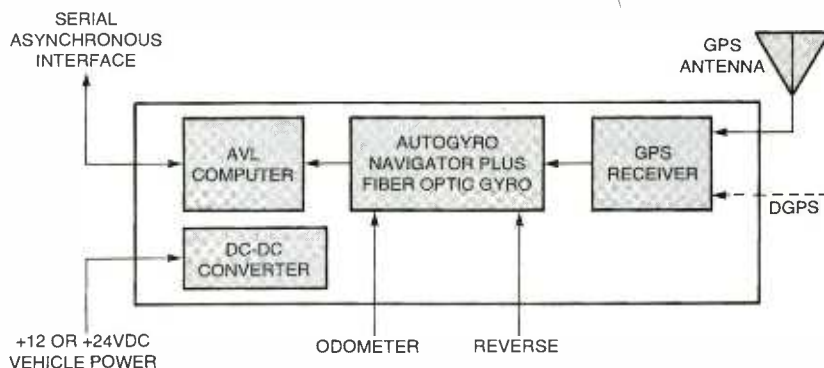

Fig. 1. Block diagram of the Andrew Corporation Continuous Positioning System, which uses GPS data coupled with odometer readings to determine bus location. That information is then fed to a system containing *Talking Bus* technology that communicates the whereabouts of the bus to passengers.

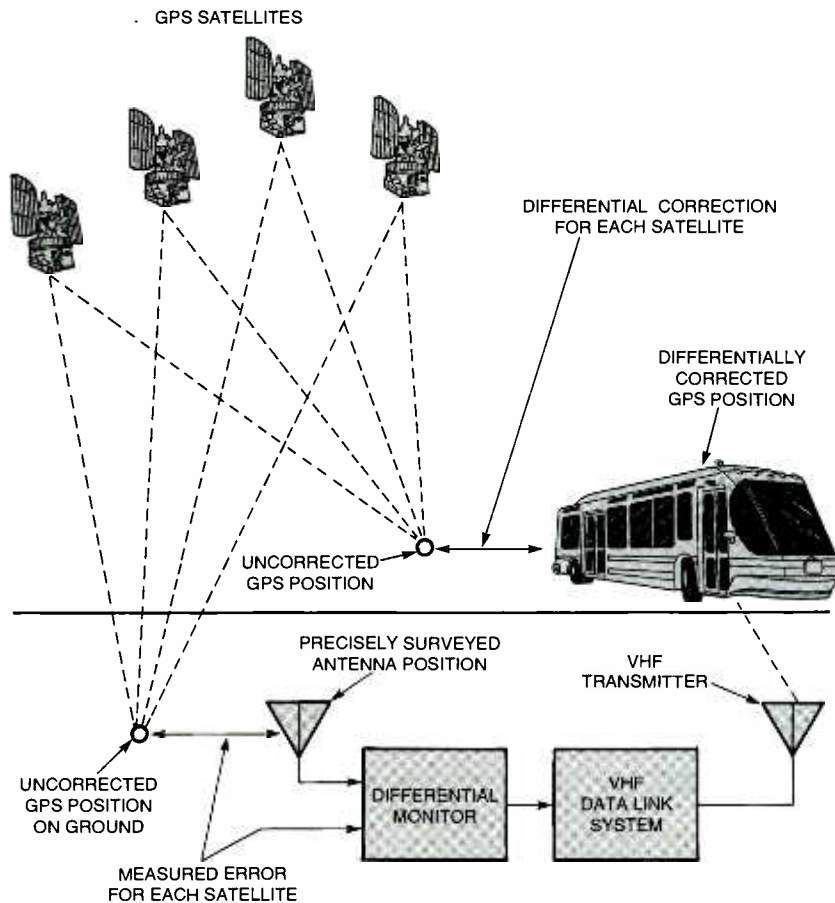

Fig. 2. The much greater accuracy needed for "navigating" buses along urban routes is provided by Differential GPS. Corrections are determined by constantly computing the location difference between signals received from the bus and a fixed location.

ated to reflect those changes.

One solution to the problem is to use an on-board navigation system much like those now found in cars and trucks, which relies on a combination of dead-reckoning and GPS position updates. Dead-reckoning systems navigate by determining the vehicle azimuth and the distance traveled. An economical method of implementing such a system is to use a fiber-optic gyroscope to take inertial measurements of the angular rotation of the vehicle, while using the vehicle's odometer for distance-traveled measurements. An example of such a system—the *Continuous Positioning System* from the *Andrew Corporation*—was recently demonstrated in Washington, DC by the Washington Metropolitan Area Transit Authority (WMATA).

The Continuous Positioning System (see Fig. 1) uses the *AUTOGYRO Navigator Plus*—a fiber-optic gyroscope—that is combined with dead-

reckoning capabilities. In the Continuous Positioning System (CPS), GPS data is used to correct inaccuracies, which accumulate with time. For instance, as tires wear, diameters change; or wheels slip on wet pavement; or the gyro's calibration changes with temperature. However, because basic GPS accuracy—within 100 meters (328 feet) 95% of the time for civilian applications—is insufficient for automated stop announcements,

Differential GPS is used. Differential GPS (DGPS) uses a fixed ground receiver (whose location is precisely known), which receives signals from the same GPS satellites as the receiver on the bus. (See Fig. 2.) Since the ground receiver's location is precisely known, the difference between the actual location and location computed from GPS signals can be determined to accurately establish the actual location of the vehicle. That correction is instantaneously transmitted to the

FOR MORE INFORMATION

**Ann Arbor
Transportation Authority**
2700 South Industrial Highway
Ann Arbor, MI 48104
Tel. 313-677-3901;
Fax: 313-973-6338
Web: liznm@theride.org

Andrew Corporation
10500 W. 153rd Street
Orland Park, IL 60462
Tel. 708-349-5222

Digital Recorders
4900 Prospectus Drive
Durham, NC 27713-4451
Tel. 919-361-2155

Luminator Company
1200 El Plano Parkway
Plano, TX 75074

bus allowing the same correction to be made at the bus site, so that the location of the bus can be pinpointed to within a few feet.

Using both dead reckoning and GPS overcomes the shortcomings associated with GPS alone, especially in urban environments. For example, in such areas GPS signals can be blocked by tall buildings; or the signals can be reflected off buildings, leading to erroneous location determinations. Heavy foliage, bridges, tunnels, and rugged terrain can also cause problems. When such physical impediments are present, dead reckoning provides "smoothing" location information, which can be updated once accurate GPS signals are again available.

In The North-East. The Rochester-Genesee Regional Transportation Authority (R-GRTA) in New York State has also used a similar dead reckoning and GPS system on ten of its buses. In the R-GRTA case, the *Next Stop Information System* from the *Luminator Company* was installed. The Next Stop Information System automatically announces the next stop inside the bus, while a lighted digital display located inside the bus over the windshield gives visual stop announcements. As that's happening, an external speaker announces the bus route to passengers waiting to board the bus when the doors open.

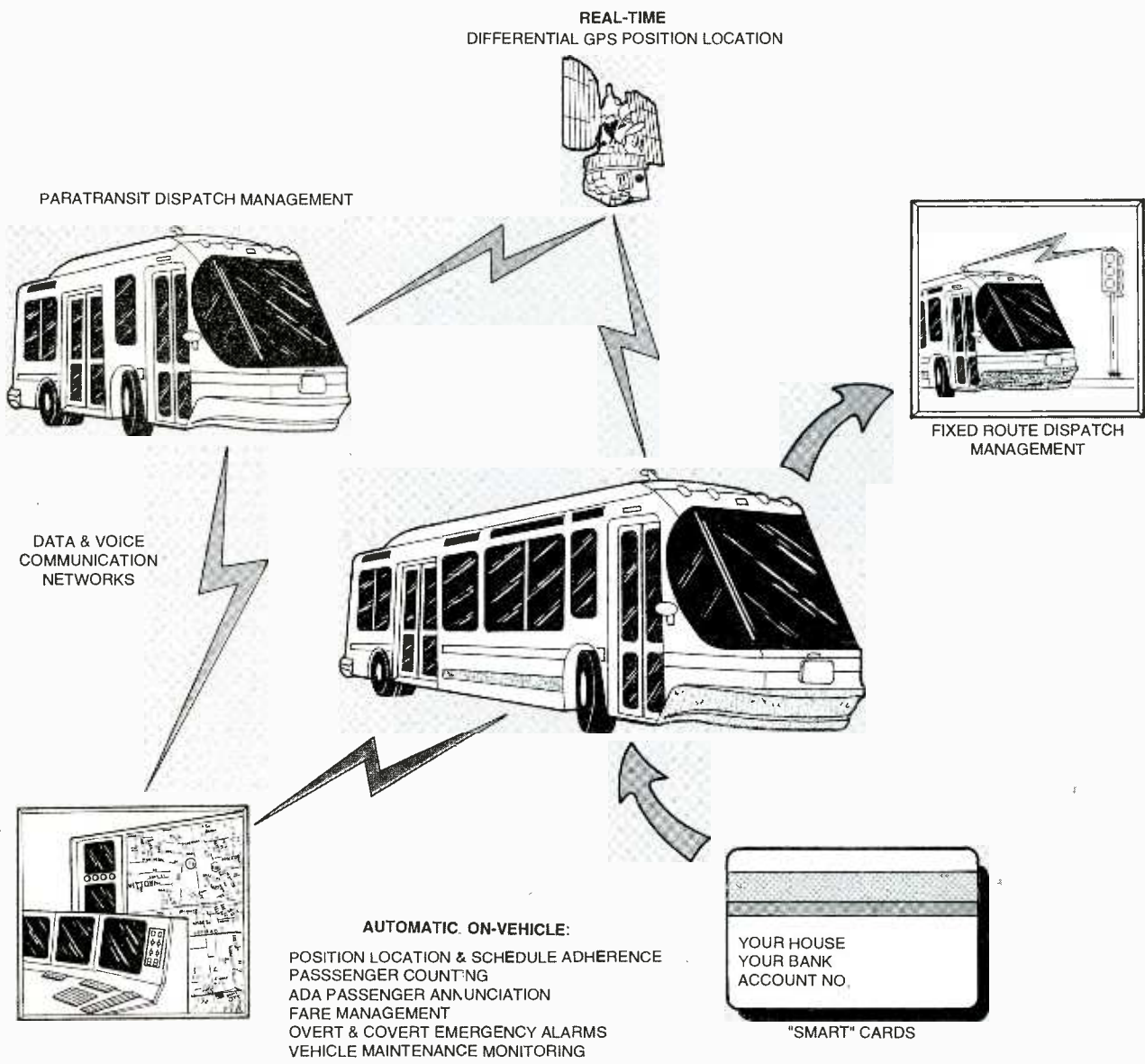

Fig. 3. The Ann Arbor Transportation Authority uses the Rockwell Advanced Public Transit System (APTS), which features Automatic Vehicle Location (AVL), a Mobile Display Terminal (MDT) with "smart key," "Smart Cards," Computer-Aided Dispatching, automated vehicle component monitoring, Computer-Assisted Transfer Management, and more.

Another System. The Ann Arbor (Michigan) Transportation Authority (AATA) recently introduced a new *Advanced Operating System* (AOS) on its buses that goes far beyond just meeting ADA requirements. (See Fig. 3.) It is touted as the first fully-integrated, public-transit communication, operation, and maintenance system in the country. The AOS includes advanced electronic technologies like DGPS, Automatic Vehicle Location (AVL), "Smart" Cards, Computer-Aided Dispatching, and automated vehicle-component monitoring.

Drivers use the Mobile Display

Terminal's (MDT) "low work-load" screen and "smart keys" to operate all the advanced onboard systems—such as the two-way radio—and to read and write messages. AATA buses are equipped with an 800-MHz radio and onboard computers. Voice transmissions are minimized by using data messages that report vehicle status, operating condition, and location. During routine operation, the vehicle sends the information over a data channel. For voice communications between driver and dispatcher, the radio is switched to a voice channel.

DGPS is a key ingredient of the

AOS, so that the Automatic Vehicle Location System can pinpoint bus locations to within three to six feet. Onboard computers store complete route schedules, and DGPS provides accurate time to the vehicles. Scheduled times and locations are compared with actual locations to determine if the buses are on time. If a bus is off schedule, the driver is advised, and if necessary, the onboard computer notifies the Operation Center.

The AVL system provides visual displays and audible announcements both inside and outside the bus. Announcements and displays



A passenger looks on as the bus driver demonstrates the Mobile Display Terminal mounted in one of the vehicles operated by Ann Arbor Transit Authority.

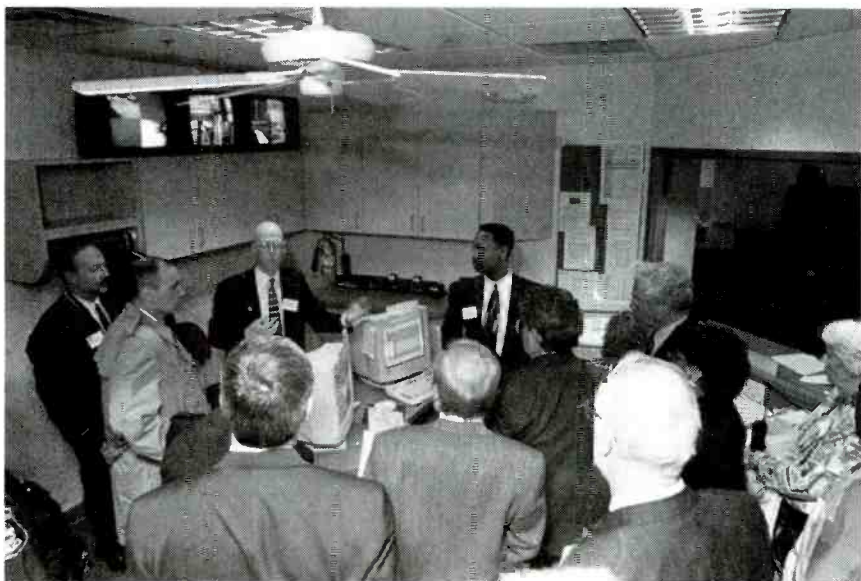

Here at the AATA operation center, the press learns about the array of features offered by the Rockwell APTS.

include next stop information, stop requests, current time, and other messages to keep riders informed. The AVL system also generates en-route information, provides location information for fare collection, and gives the driver pacing information.

The AOS not only benefits drivers and dispatchers, but *Automated Passenger Counters* in the *Rockwell TransitMaster* automatically count passengers as they board and leave AATA buses. AATA management can then use that information for planning routes, assessing ridership patterns, and developing new services. For fleet managers, the

Vehicle Component Monitoring system includes engine sensors that continuously monitor oil pressure, temperature, and so forth. Discrepancies are reported in real-time to the onboard computer, the Operations Center, and the Maintenance Department. The AOS now includes automatic collection of farebox cash payments, and in the future could include cashless fare payment via "smart cards."

Riders transferring from one bus to another during their trips appreciate *Computer-Assisted Transfer Management*. Using the *TransitMaster* software, drivers receive transfer

requests that they will encounter in the next several minutes. The computer at the dispatch center determines whether requested transfers are possible and informs the driver on the *TransitMaster* display. If a transfer is accepted, the dispatch computer sends a message advising the driver to wait for the transferring passenger. Eventually riders will be able to access schedules, as well as other information in real-time through the AATA Web-site kiosks during peak service times, and through public-access cable television.

Computer-Aided Dispatching by *Trapeze Software* also benefits riders by allowing reservations, more flexible scheduling, and integration of special services such as paratransit services for the disabled with fixed routes. Using *Trapeze Software* integrated with the *TransitMaster Software*, AOS allows flexible routing of public transit services—more like an on-demand paratransit—transportation those with disabilities—service.

If a driver encounters a life-threatening emergency, the driver can alert the dispatcher, who can instantly find the location of the bus on the digitized map, while calling the appropriate agency for help. The system can also be used for reporting routine, non-life-threatening situations. For further passenger and driver safety, AATA's New Flyer buses are equipped with a three-camera, video-surveillance system. The system records on videotape for later playback, and one camera also records audio. Other buses are equipped with a two-camera digital system.

Conclusion. Modern buses have provided increased mobility for a great number of persons—the visually and physically challenged, for instance—who up until just a few years ago might otherwise have had no alternative but to depend on others. With the new generation of mass transit vehicles and support systems making possible any number of commuter-friendly services, while offering increased coordination of routing and scheduling, municipal transit systems hope to become the conveyance method of choice for even the most staunch automobile enthusiast. ■

Build a Power-Line Monitor

CHARLES HANSEN

There is nothing inherently wrong with the power normally delivered by your local electric utility. Most power-line disturbances are caused by customers, lightning strikes, accidents involving utility poles, and the switching of non-linear or large industrial loads. In fact, recently released studies show that transients occurred 62 times per month, spikes occurred 51 times, voltage fluctuations occurred 62 times, and outages occurred about once a month. In addition to unintentional disturbances, the utilities sometimes use scheduled brownouts or blackouts to control excessive power demands.

Just a quarter cycle of interrupted power can adversely affect computer data. At higher voltage levels, disturbances can damage electronic equipment, which is why surge protection and power-line monitoring devices have become so popular.

Commercially available power-line monitors can cost upwards of several thousand dollars. But you needn't burst your budget to purchase equipment to keep an eye on your power line. The budget *Power-Line Monitor* described in this article—which is designed to detect power outages, sags, surges, and spikes—can be built at a cost of less than \$50 (plus enclosure). The unit, which was tested with reference to the IEEE/ANSI C6.41 *Guide On Surge Voltages In Low-Voltage AC Circuits*, also detects harmonic distortion, although not with the required 5% or better accuracy of commercial equipment.

Description. The unit plugs into the AC outlet that is to be monitored. It has five levels of detection, listed below. The design prevents false indications for any voltage occur-

tion within the normal utility range of 112 to 123 volts AC.

- **Harmonic Distortion** is line harmonics exceeding 25%.
- **Outage** is less than $100 V_{rms}$ for 50 milliseconds or more.
- **Sag** is less than $105 V_{rms}$ for 0.5 seconds or more.
- **Surge** is greater than $127 V_{rms}$ for 0.5 seconds or more. An inverse time curve is provided such that the higher the surge voltage, the faster the indication occurs.
- **Spike** is greater than $140 V_{rms}$ or 200-volt peak for 50 microseconds or more.

When any of those disturbances occur, the event is stored in a latch that then drives one of the five LED indicators.

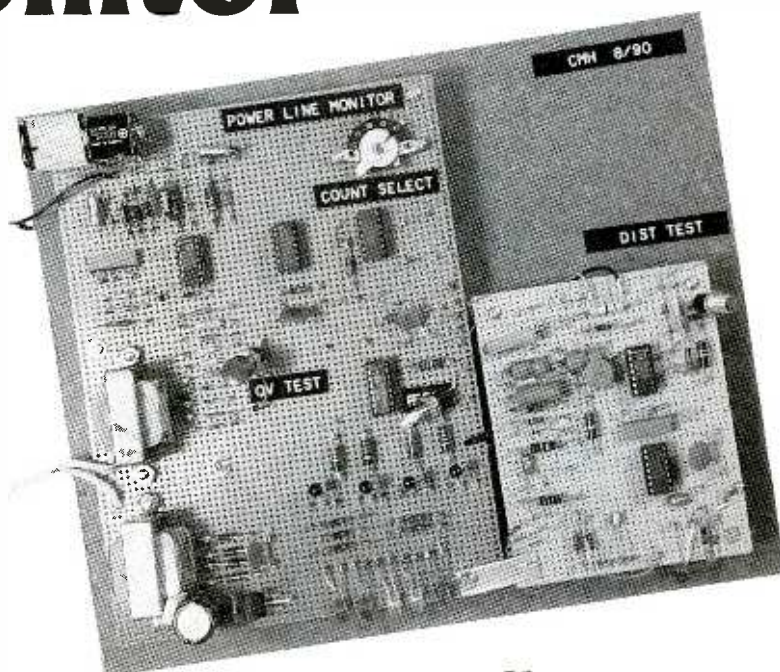

If you are a computer owner, a hi-fi or video enthusiast, or use other sensitive electronic equipment, you are undoubtedly concerned about the quality of the electric power available in your home.

To maintain the latched data in the event of a power outage, the unit has a 9-volt backup battery, which can retain the data for several days if necessary. The Power-Line Monitor is also designed to interface with the *Budget Frequency/Events Counter* described in the May 1990 issue of **Popular Electronics**. That device allows you to count the number of times any one of the above disturbances occurs. The count-output can then be sent to any system that is capable of an alarm-initiated power-down sequence or data logging operation.

The unit has four switches: HARMONIC DISTORTION TEST, OVERVOLTAGE (OV) TEST, RESET, and COUNT OUTPUT. The HARMONIC DISTORTION TEST switch (S1) allows you to test the distortion detector without injecting any harmonics. The OVERVOLTAGE TEST switch (S2) allows you to

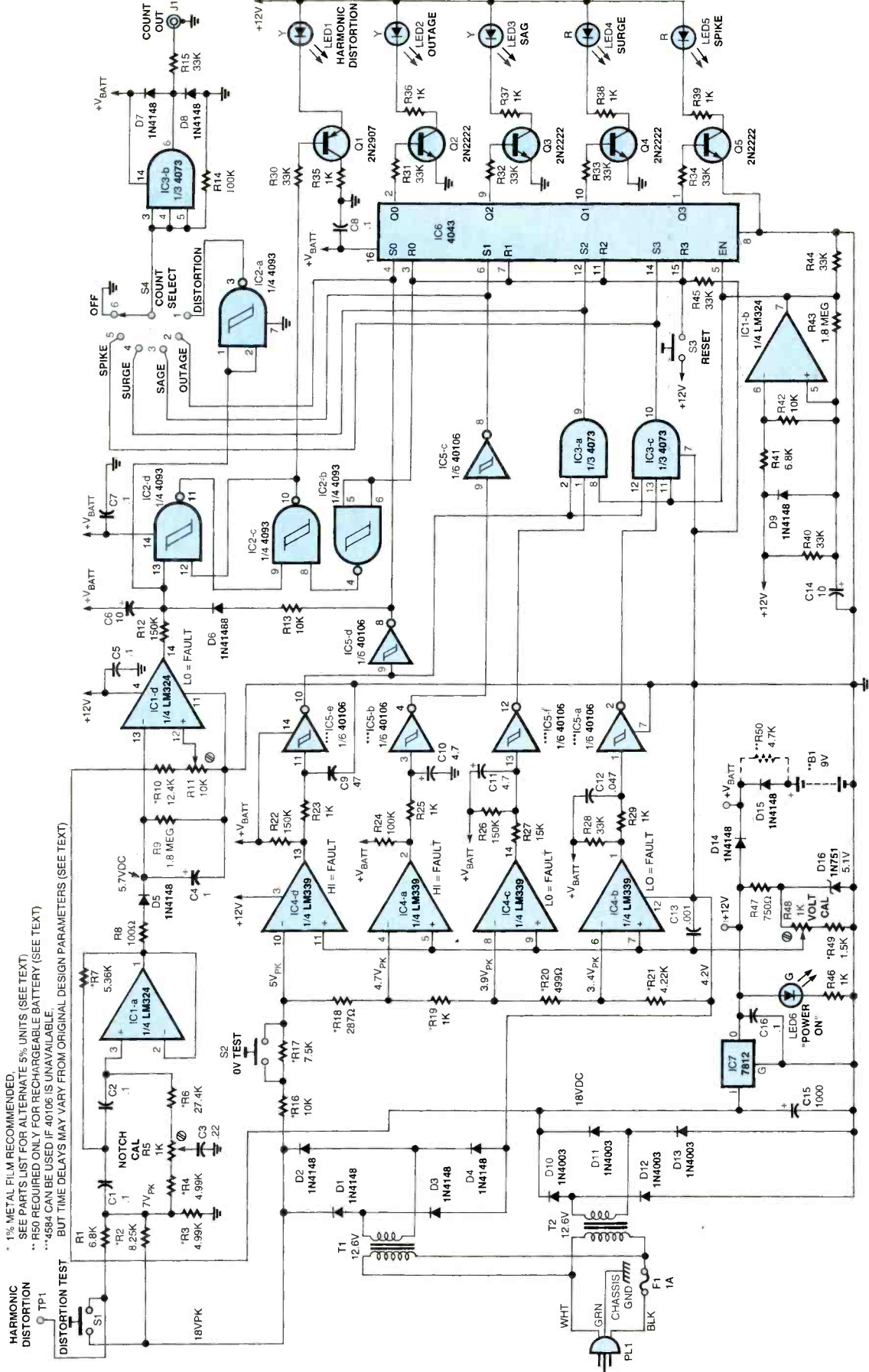

* 1% METAL FILM RECOMMENDED.
 SEE PARTS LIST FOR ALTERNATE 5% UNITS (SEE TEXT).
 ** R50 REQUIRED ONLY FOR RECHARGEABLE BATTERY (SEE TEXT).
 *** 4584 CAN BE USED IF 40106 IS UNAVAILABLE.
 BUT TIME DELAYS MAY VARY FROM ORIGINAL DESIGN PARAMETERS (SEE TEXT).

HARMONIC DISTORTION
 TP1
 DISTORTION TEST

NOTCH CAL
 R1 6.8K
 R2 8.25K
 R3 4.99K
 R4 4.99K
 R5 1K
 R6 27.4K
 C1
 C2
 C3
 C4
 C5
 C6
 C7
 C8
 C9
 C10
 C11
 C12
 C13
 C14
 C15
 C16

DIAGNOSTIC TEST
 S1
 S2
 S3
 S4

Fig. 1. The Power Line Monitor, which is comprised of seven ICs, five transistors, 16 diodes, and several support components, is designed to detect power-line surges, sags, and outages. To monitor the line for those occurrences, the circuit uses a voltage divider network and a quad comparator. Line deviations detected by the comparator are fed to a quad NOR RS latch, which is used to light the appropriate LED via its driver transistor.

check the two overvoltage ranges at normal 117-volt AC power-line voltage. The RESET switch (S3) clears any data latched in the monitor, and the COUNT OUTPUT switch (S4) allows you to select the event to be directed to the counter output.

Theory of Operation. Figure 1 is a schematic diagram of the Power Line Monitor. The unit's operational power is derived from the AC line by way of transformer T2, a 12.6-volt, 300-mA, step-down power transformer. The reduced AC-voltage output by the transformer is applied to a full-wave, bridge-rectifier circuit—comprised of D10–D13—producing a pulsating DC output that is then filtered by C15 (a 1000- μ F, 35-volt, electrolytic capacitor) to provide a relatively ripple-free power source. That filtered voltage is then applied to a 12-volt, 1-amp regulator (IC7) to stabilize the supply voltage. A light-emitting diode (LED6) is the POWER-ON indicator, while capacitor C16 is used to improve regulator response during transients.

During normal operation, the main (operational) power source is fed through D14 and is used to power all circuit elements including those that are connected to V_{BATT} . However, when the main power fails, power from the backup battery (B1) is fed through D15 to the V_{BATT} terminal, and from there it is distributed to the connected circuit components. The backup battery can be either a standard or a rechargeable NiCd battery. If a NiCd is used for B1, R50 should be included in circuit to replenish B1 (at a 7-mA charge rate) during normal operation. **Warning:** If, on the other hand, a non-rechargeable battery is used for B1, R50 should be omitted from the circuit. The charge current could cause hazardous overheating in a standard battery.

To monitor the voltage across the power line, the line voltage is applied to a second transformer, T1 (another 12.6-volt, 300-mA unit). The output of T1 is, as before, full-wave rectified—this time by D1–D4. That configuration allows the circuit to detect disturbances during either half of the AC cycle. Using separate transformers in the power and detection circuits allows the detec-

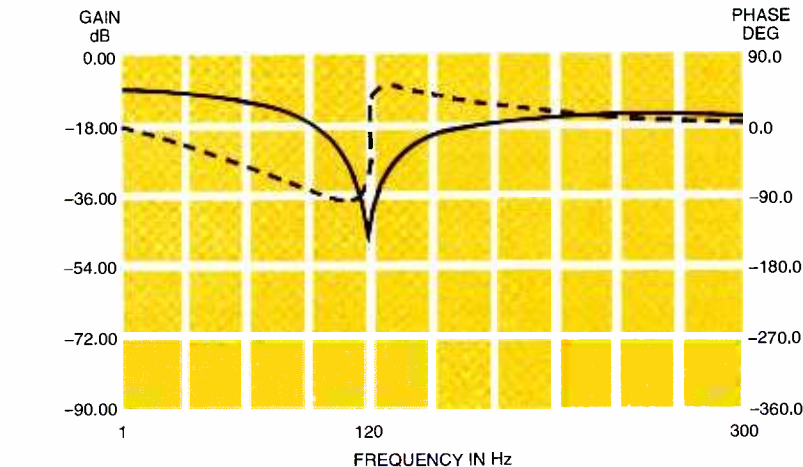

Fig. 2. The circuit also contains a notch filter that's built around IC1-a ($\frac{1}{4}$ of an LM324 quad op-amp). Shown here is a plot of the filter's response.

tion transformer (T1) to be lightly loaded. Because of that, no R-C filters are connected to the output of T1. Doing otherwise would only slow down or prevent the detection of power-line spikes.

Harmonic Distortion Detector. A voltage derived from a voltage-divider network, consisting of R2 and R3, is applied to the harmonic distortion detector (built around IC1-a and IC1-d, $\frac{1}{2}$ of an LM324 quad op-amp). The DISTORTION TEST switch (S1, a normally-open push-button unit), when depressed, connects R1 in parallel with R2, thereby increasing the voltage applied to the non-inverting input of IC1-a. Pressing S1 triggers the distortion fault output for test purposes. To detect harmonic distortion of 5% or less, commercial units use a harmonic distortion detector based on a fourth-order or higher band-reject (notch), high-Q filter that's centered at, and perhaps phase-locked to, the 60-Hz fundamental.

There are a number of limitations on our circuit design that make such precision impractical—not the least of which is cost! Since we are full-wave rectifying the line voltage, the stop-band frequency must be moved to 120 Hz, which is a fundamental of the rectified 60-Hz, AC line voltage. Unfortunately, since diodes are non-linear components, the rectification process itself adds some higher-order harmonics that are not present in the AC wave as received from the power company. The re-

sponse of the iron core in transformer T1 is also non-linear, adding its own share of odd harmonics—mainly the third harmonic—especially at higher voltages when the transformer gets closer to saturation.

With those limitations in mind, and in order to avoid very stable and very tight tolerance parts (expensive 1% capacitors and 0.1% resistors), our design uses a low-Q, second-order, notch filter, which can tolerate some wider parts tolerances in the filter design. The circuit was tested with 10% variations of the capacitors and resistors. While the center frequency varied ± 11 Hz, and the gain varied from -36 to -46 dB, all of those variations still allow a 20% difference in the filter output voltage between the 60-Hz fundamental and the 180-Hz third harmonic. That's sufficient to detect a 25% distortion level.

Integrated circuit IC1-a is used as a notch filter, whose frequency-determining network is comprised of components R4–R7 and C1–C3. Potentiometer R5 allows some adjustment in the Q of the circuit to obtain the best performance. The gain of the filter at the 120-Hz rectified frequency is much less than the gain for lower or higher frequencies. When any harmonics occur on the AC line, the filter's output voltage increases. Figure 2 shows a plot of the filter response (with nominal part values).

The filter is followed by a low-pass, peak-hold circuit, which rolls off the high-frequency response of

the detector. That's necessary to avoid triggering the circuit on spikes, and because the LM324 op-amp is not a very good high-frequency amplifier. The output of the filter is applied to C4 through R8 and D5. Resistor R9 is used to discharge C4 when the distortion falls below the detection limit.

Op-amp IC1-d is used as a comparator. Since the harmonic filter circuit is sensitive to both harmonics and the AC line-voltage amplitude, the comparator is referenced to the filtered, unregulated DC voltage across C15. Thus, when the AC line voltage varies, the reference at pin 12 of IC1-d varies in direct proportion, allowing the detector to be sensitive only to the harmonic content of the waveform. When the voltage across C4 at pin 13 of IC1-d increases above the reference set at pin 12 by potentiometer R11, the output of IC1-d goes low. Resistor R10 prevents the reference voltage from being adjusted above the +12-volt DC supply rail, which could damage the op-amp.

When IC1-d goes low, C6 begins to charge through R12. After about 1.5 seconds, the voltage across C6 reaches the low input threshold of IC2-d (1/4 of a NAND Schmitt trigger), forcing its output high, which in turn causes the output of IC2-c to go low. Gates IC2-d and IC2-c, which are configured as an R-S flip-flop, are powered from the V_{BATT} supply, allowing the flip-flop to retain data indicating that harmonic-distortion has occurred even during a complete power failure. Capacitor C7 is included in the circuit to decouple noise spikes from the power supply in order to prevent false latching when the circuit switches from the normal +12-volt DC source to the V_{BATT} source or during power-up.

Schmitt-trigger gates are used after all the time-delay capacitors in the Power-Line Monitor because of the slowly rising capacitor voltage. A normal CMOS gate requires a minimum rise time of 5 to 15 μ s to prevent its operating in the active region. Long rise or fall times on the inputs to non-Schmitt triggers can cause increased power dissipation, which could exceed the device capability.

Since the output of IC2 (like

PARTS LIST FOR THE POWER-LINE MONITOR

SEMICONDUCTORS

IC1—LM324 quad op-amp, integrated circuit
 IC2—4093 quad NAND Schmitt, integrated circuit
 IC3—4073 triple 3-input AND-gate, integrated circuit
 IC4—LM339 quad comparator, integrated circuit
 IC5—40106 hex, inverting, Schmitt trigger, integrated circuit
 IC6—4043 quad NOR R-S latch, integrated circuit
 IC7—7812 12-volt, 1-amp voltage regulator, integrated circuit
 Q1—2N2907A general-purpose PNP silicon transistor
 Q2—Q5—2N2222A general-purpose NPN silicon transistor
 D1—D9, D14, D15—1N4148 general-purpose silicon diode
 D10—D13—1N4003 1-amp, 200-PIV silicon rectifier diode
 D16—1N751 or 1N4733, 5.1-volt, 1-watt, Zener diode
 LED1—LED3—Yellow T-1-3/4 light-emitting diode
 LED4, LED5—Red T-1-3/4 light-emitting diode
 LED6—Green T-1-3/4 light-emitting diode

RESISTORS

(All resistors are 1/4-watt, 1% metal-film units, unless otherwise noted.)
 R1, R41—6800-ohm, 1/4-watt, 5% carbon
 R2—8250-ohm
 R3, R4—4990-ohm
 R5, R48—1000-ohm, 15-turn trimmer potentiometer
 R6—27,400-ohm
 R7—5360-ohm
 R8—100-ohm, 1/4-watt, 5% carbon
 R9, R43—1.8-megohm, 1/4-watt, 5% carbon
 R10—12,400-ohm
 R11—10,000-ohm, 15-turn trimmer potentiometer
 R12, R22, R26—150,000-ohm, 1/4-watt,

5% carbon
 R13, R42—10,000-ohm, 1/4-watt, 5% carbon
 R14, R24—100,000-ohm, 1/4-watt, 5% carbon
 R15, R28, R30—R34, R40, R44, R45—33,000-ohm, 1/4-watt, 5% carbon
 R16—10,000-ohm
 R17—7500-ohm
 R18—287-ohm
 R19—1000-ohm
 R20—499-ohm
 R21—4220-ohm
 R23, R25, R29, R35—R39, R46—1000-ohm, 1/4-watt, 5% carbon
 R27—15,000-ohm, 1/4-watt, 5% carbon
 R47—750-ohm, 1/4-watt, 5% carbon
 R49—1500-ohm
 R50—4700-ohm, 1/4-watt, 5% carbon
 (see text)

CAPACITORS

C1, C2—0.1- μ F, plastic film
 C3—0.22- μ F, plastic film
 C4—1- μ F, 35-WVDC, tantalum
 C5, C7, C8, C16—0.1- μ F, ceramic disc
 C6, C14—10- μ F, 25-WVDC, tantalum
 C9—0.47- μ F, plastic film
 C10, C11—4.7- μ F, 35-WVDC, tantalum
 C12—0.047- μ F, plastic film
 C13—0.001- μ F, ceramic disc
 C15—1000- μ F, 35-WVDC, aluminum electrolytic

ADDITIONAL PARTS AND MATERIALS

F1—1-amp fuse
 J1—RCA phone jack
 S1—S3—Normally-open momentary-contact, pushbutton switch
 S4—SP6P rotary switch
 T1, T2—12.6-volt, 300-mA, step-down power transformer
 B1—9-volt transistor radio battery
 PL1—3-conductor AC line cord with molded plug
 Printed-circuit materials, battery connector, battery holder, fuse holder, wire solder hardware, etc.

most CMOS ICs) is limited to 1 mA, it cannot directly turn on an LED. Therefore, transistor Q1 is included in the circuit to amplify the low-level output of IC2-c to drive LED1 (the HARMONIC DISTORTION indicator). Resistor R35 limits LED1's current to the optimum value. Gate IC2-a, which is configured as an inverter, is used to invert the low output of IC1-d to provide a logic-high output, which is fed to COUNT SELECT switch S4 (more on that later). There is one additional input to IC2-d pin 13,

which comes from the outage-detector circuit. Since harmonic detector IC1-d is not powered from the + V_{BATT} supply, C6 inadvertently charges during an outage when IC1 loses its power source. To prevent that from happening, the logic-high output of IC5-d during an outage is applied to C6 through R13 and D6 to keep it discharged. (Only the CMOS logic circuits and their various input RC time delays are backed up by V_{BATT} to maximize the battery life.)

Voltage Detection Circuits. A voltage-divider network, consisting of R16 through R21, sets the four voltage detection levels. The ν TEST switch (S2) is connected across R17 to shift the two overvoltage ranges (surge and spike) so that they respond to normal 117-volt AC line voltage. (The undervoltage ranges can be tested by unplugging the Line-Voltage Monitor.) Level-sensing circuitry, comprised of IC4-a through IC4-d (an LM339 quad comparator), compares a calibrated voltage reference—derived from a voltage divider network (R48 and R49), Zener diode D16, and the +12-volt DC supply—to the sensed voltage. Resistor R47 supplies about 10mA of current to D16, ensuring that its voltage remains stable even for low AC-line voltages. Capacitor C13, which is connected between pins 7 and 12 of IC4, is used to decouple high-frequency noise from the reference to prevent false indications.

The outage detection circuitry is built around IC4-d. With normal AC line voltage, the output of IC4-d (pin 13) goes low, providing a discharge path for C9 through R23 every half-cycle. If the AC line drops below 100 volts rms, the peak voltage at IC4-d pin 10 dips below the reference established at pin 11. That dip causes the output of IC4-d to go high, allowing C9 to charge through R22 and R23. When the voltage across C9 reaches the threshold of Schmitt inverter IC5-e (after 50 ms), its output switches low, causing the output of IC5-d to go high. That high is applied to the s_0 input of IC6 (a 4043 quad RS latch) at pin 4. That causes the q_0 (pin 2) output of IC6 to go high. The high output of IC6 at pin 2 is applied to the base of transistor Q2, causing it to turn on. With Q2 turned on, the cathode of LED2 (the OUTAGE indicator) is connected to ground, causing it to turn on. Capacitor C8 is used to decouple noise from the supply input of IC6 to prevent false latching.

The sag detector, built around IC4-a, operates in the same manner as the outage detector. In the sag detector, C10 is prevented from charging as long as the AC line remains above 105 volts rms. If the voltage should drop below that

level, C10 begins charging through R24 and R25. After 0.5 seconds, the charge on C10 is sufficient to cause the output of IC5-b to go low. That low is applied to the input of IC5-c, causing its output to go high. The high output of IC5-c, which is applied to the s_1 input of IC6 at pin 6, causes IC6's q_1 output at pin 9 to go high. That high is delivered to the base of transistor Q3, causing it to turn on, grounding the cathode of LED3 (the SAG indicator), thereby causing it to light.

Next we come to the surge detector, which is built around IC4-c. During normal voltage levels, IC4-c remains off, and C11 is held discharged via R26. Under those conditions, the input to IC5-f is held high by V_{BATT} via R26. If the AC-line voltage rises above 127 volts, IC4-c turns on for part of each AC half-cycle, causing C11 to charge through R27. For the remaining part of the half cycle, when IC4-c is off, C11 discharges through R26. The values of R26 and R27 are chosen to produce an inverse time delay. At the 127-volt AC threshold, IC4-c is turned on only briefly at the peak of each AC half-cycle. The time required to charge C11 is relatively long (about 0.5 seconds). As the line voltage increases, IC4-c turns on for a proportionally greater portion of each half-cycle, causing C11 to charge faster. When the voltage across C11 reaches the low threshold of IC5-f, the output of IC5-f goes high, forcing pin 1 of IC3-a ($1/3$ of a 4073 triple 3-input AND gate) high. Two additional conditions are needed at U3-a. If there is no outage, there will be a high at pin 2 of IC3-a. With the power supply at +12 volts DC, there will be a high at IC3-a pin 8. That causes the output of IC3-a to go high, feeding a high to the s_2 input of latch IC6. That, in turn, causes a high to be applied to the base of transistor Q4, causing it to turn on grounding the cathode of LED4, and thereby lighting the SURGE indicator.

The two additional inputs at IC3-a and IC3-c are required for proper operation during and following a power outage. When AC power is lost, the Zener reference voltage drops before the +12 volts DC power supply reaches zero, since it is not backed up by battery power.

(The 10-mA Zener current would rapidly deplete the 9-volt DC battery.) The low reference voltage at detectors IC4-b and IC4-c could cause the LM339 to turn on during power-down and latch a spike or surge indication into IC6 when none actually exists. For that reason, IC3-a and IC3-c are inhibited by the logic low from IC5-e during the power failure. Schmitt trigger IC5-d performs a similar function to inhibit the harmonic distortion circuit as described earlier.

Conversely, when AC power is first applied, the voltage across the divider network (R16–R21) is detected immediately. However, because the power supply has not yet been established (because C15 must first be charged), the reference derived from IC7 is initially below the required value. That makes the normal AC voltage appear to the circuit as an overvoltage condition. To avoid latching a false (surge or spike) data, one input of both IC3-a and IC3-c is tied to the output of a three-second power-up timer that's built around IC1-b.

To accomplish its task, IC1-b provides a low logic-level inhibit until the 12-volt power supply has stabilized. When power is first applied or restored to the circuit, C14 must first charge through R40 until the voltage at IC1-b pin 5 exceeds that at pin 6. When C14 is sufficiently charged, the output of IC1-b switches high, enabling IC3-a and IC3-c. That allows sufficient time for the Zener reference to stabilize, and for C11 and C12 to discharge if a fault existed previously. Resistor R43 provides positive feedback to IC1-b to ensure a clean logic transition (much like a Schmitt gate) to prevent excess dissipation in IC3-a, IC3-c and IC6. That positive feedback (hysteresis) is necessary since the LM324 is not very fast when used as a comparator. Resistor R44 assures a low logic level when IC1 has no power.

The OUTPUT ENABLE terminal (pin 5) of IC6 is also inhibited when power is lost, turning off the current which would flow from any latched IC6 outputs into the base of driver transistors Q2–Q5. That maximizes battery life during an outage. LED1 and Q1 will not draw any battery

power since they sink current only from the +12 volts DC supply. Diode D9 clamps IC1-b pin 5 to the +12 volts DC bus to rapidly discharge C14 when power is lost.

The spike detector, built around IC4-b, is used to detect line anomalies (disturbance, oscillation or harmonic) that exceed 140 volts rms or 200 volts peak during either half (positive or negative) of the AC cycle. When an abnormality is detected, IC4-b turns on, causing C12 to charge through R29 (in 50 ms). Once a spike is captured, it is kept for the time required to discharge C12 through R28 and R29 (about 1.5 milliseconds), allowing plenty of time for the latch to respond but less than one 60 Hz half-cycle (8.33 ms). That permits the circuit to reset and respond to spikes that occur during every AC

in case external shorts or voltages are inadvertently connected to J1. Resistor R14 keeps the output of IC3-b low when the switch is operated and the input is open between switch wipers. That prevents false counts at J1.

The latched data can be erased by pressing RESET switch S3. Pressing S3 places a high on the four R (reset) inputs to IC6, while at the same time (via IC2-b) placing a low on the reset input (pin 8) of the IC2-c/IC2-d flip-flop.

Part Substitutions. Note that the circuit calls for 1% metal-film resistors for R2—R4, R6, R7, R10, R16—R21, and R49. Low-tolerance resistors assure the most accurate detection of the disturbances. However, it is not always easy to obtain precision resistors in small quantities, so 5%

teresis range, which may shorten the time delays from their design value. If you want to change any of the time delays, do not increase the timing resistor above 220k. At that point, the leakage resistance of the capacitors and the input current of the CMOS gates can conspire to prevent the capacitor from charging.

Note: The unused section of IC1 (IC1-c, not shown) should be terminated as a grounded-input, voltage follower: e.g., the inverting input (at pin 9) connected to the output (pin 8), and the non-inverting input (pin 10) tied to ground. In any circuit design, all inputs of unused IC sections should always be properly terminated to prevent oscillation, which could damage the IC or produce undesirable effects. However, if you want to experiment with the remaining section (IC1-c) to make a fourth-order filter increasing the sensitivity of the harmonic distortion detector, the track from pin 10 to ground can be cut, giving you access to pin 10 and pin 8.

LISTING 1—RESISTOR SUBSTITUTIONS

RESISTOR #	ORIGINAL VALUE	SUBSTITUTE VALUE
R2	8.25K	8.2K
R3, R4	4.99K	5.1K
R6	27.4K	27K
R7	5.36K	5.6K
R10	12.4K	12K
R16	10K	10K
R17	7.5K	7.5K
R18	287-ohm	270-ohm
R19	1K	1K
R20	499-ohm	510-ohm
R21	4.22K	4.3K
R49	1.5K	1.5K

All original resistors are 1/4-watt, 1% metal-film units
All substitute resistors are 1/4-watt, 5% carbon units

cycle. The low at the input to IC5-a causes a high at the S3 input to latch IC6 via IC3-c. That latched signal turns on transistor Q5, thereby lighting the SPIKE indicator (LED5).

Note: Because of the difference in time delays, it's possible to register a brief outage (less than 3 cycles) without a sag indication (which happened while testing the prototype during thunderstorm activity). Similarly, it is possible to detect a spike without a surge indication occurring.

Any one of the five event detectors can be switched by S4 to the count output buffer (IC3-b) and on to connector J1. Components D7, D8, and R15 provide output protection for IC3-c, preventing damage

carbon-film resistors, which perform adequately, can be used. Listing 1 gives the resistor number along with its original 1% values and their 5% substitutes. To use 5% resistors, take the substitute value and, using an ohmmeter, select the 5% resistor that's closest in value to the original 1% resistor. The only problem with using carbon resistors, even selected ones, is that they'll degrade over time, losing up to 15% of their initial value over several years of use. They are also more sensitive to humidity, and higher temperatures affect their value as well. That makes more frequent calibration necessary.

If you cannot find a 40106 hex Schmitt inverter, the 4584 can be used. However, it has a lower hys-

Construction. Although the prototype was built on perfboard, a printed-circuit template is provided in Fig. 3 for those who prefer to go that route. Figure 4 shows the parts-placement and wiring diagram for the AC-Line Monitor's printed-circuit board. Use an enclosure of sufficient size to accommodate the printed-circuit board (or perfboard) and all chassis-mounted components. For safety, use a 3-conductor AC line cord. Connect the black (hot) wire of the line cord to the input side of the fuse holder and the white wire to the board's AC input. Connect the other end of the fuse holder to the board through a short length of insulated AWG-22 wire. If you use a metal chassis, ground the green wire of the line cord to the chassis.

In keeping with good assembly practice, install the least sensitive components first, followed by the more sensitive parts. All six board mounting holes have sufficient clearance for a 6-32 screw with a flat washer; however, be sure metal hardware does not come into contact with any of the board's copper traces. Install the transformers, IC sockets, the AC line cord, switch-

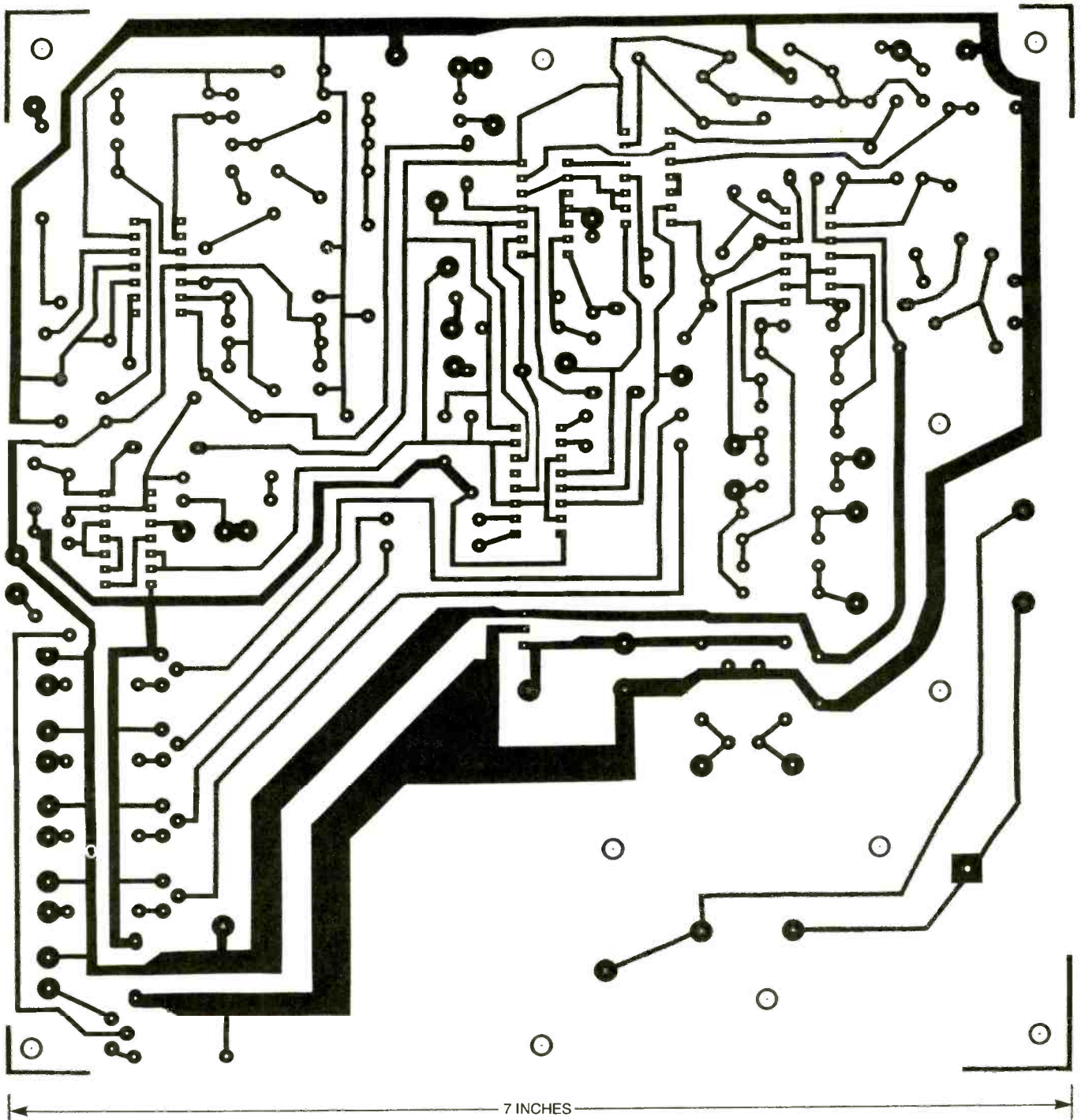

Fig. 3. Although the author's prototype of the Power-Line Monitor was built on perfboard, the author provided a printed-circuit template (shown here) for those who prefer to go that route.

es, and jack first. Next, install the nine on-board jumpers. (If you use the wire-wrap technique to assemble the circuit, use 27 AWG wire for the +12 volt DC, ground, and LED output circuits. For hand wiring, use 24 AWG or larger wire.) Install the passive parts (resistors and capacitors) first. Before installing the variable resistors, preset their wipers to mid-position with an ohmmeter to

make calibration easier later.

Use insulated hookup wire to connect the four switches to the points indicated in the parts placement diagram (or schematic diagram if you are not using the foil pattern provided). Install the three long insulated wire jumpers as indicated in Fig. 4. Be sure to leave room to install the remaining parts later. Finally, install the diodes and

12.6-volt transformers.

Checkout and Calibration. At this point, it is a good idea to test the power supply before installing the transistors and ICs. To test the Power-Line Monitor, first install a 1-amp fuse in the unit's fuse holder, and plug in the unit's line cord. The POWER-ON indicator (LED6) should light. The rectified voltage at both diode bridges

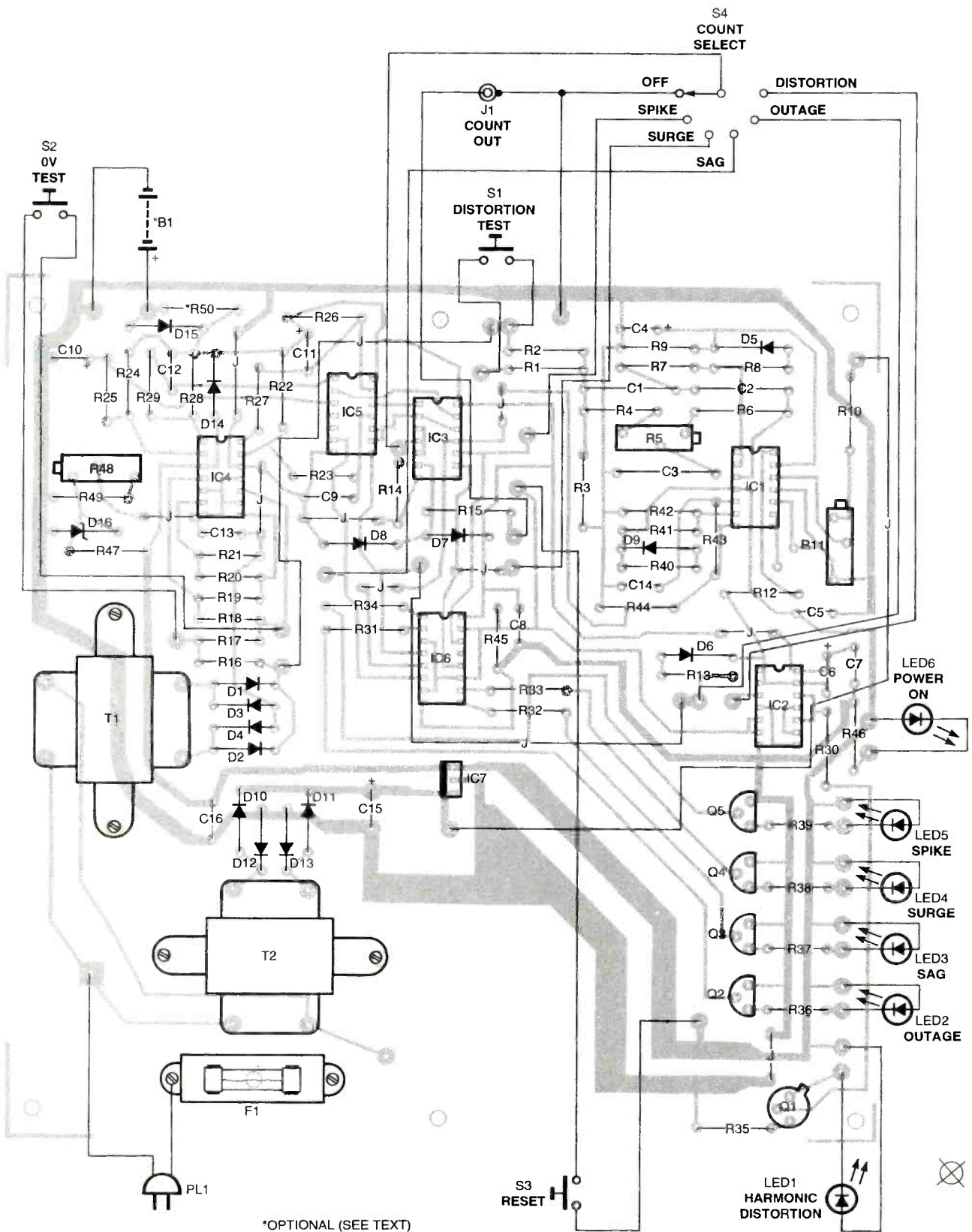

*OPTIONAL (SEE TEXT)

Fig. 4. Here is the parts-placement and wiring diagram for the AC-Line Monitor's printed-circuit board. It is recommended that the ICs be socketed. Note that the printed-circuit layout calls for several jumper connections, some of which follow enigmatic routes.

(D1-D4 and D10-D13) should be about 18 volts DC. The output of IC7 should be +12 volts. Adjust R11 so that the reference voltage applied to pin 12 of IC1-d is 6.1 volts DC.

Then adjust R48 so that the reference applied to IC4 (at pins 5, 7, 9, and 11) is 4.2 volts. Install the battery (B1) and measure the voltage at the V_{BATT} point—it should be 11.5 volts. Check that the voltage at the battery terminals is 9 volts DC to be sure D15 isn't shorted. (If you are using a rechargeable battery, the battery voltage will be higher because of the charge current through R50.) Pull the plug, removing AC power from the circuit, and re-measure the voltage at V_{BATT} . The voltage should now be about 8.5 volts DC. Remove the battery, discharge C15, and install the transistors followed by the ICs.

Follow all proper anti-static precautions when handling the CMOS components. Note that transistors from some vendors may not follow the standard EBC lead arrangement. Be sure to check the data sheet to ensure the leads are properly connected. With the Power-Line Monitor fully assembled, it is time to calibrate and test the unit. Calibrating the harmonic detector requires a clean AC-line waveform. A clean AC-line waveform can easily be obtained on a cool weekend when industry and air-conditioner activity is at a minimum.

With the unit plugged in, press the RESET switch to clear any latched data. Connect a digital voltmeter across C4 and adjust R5 for the lowest voltage across C4. That assures that the filter circuit Q is maximized. Setting potentiometer R11 is accomplished with the aid of an oscilloscope. Hook the scope between IC1-d pin 14 and R12. Adjust R11 so that the output of IC1-d is just beginning to show faint negative-going spikes. If, on the other hand, you do not have access to a scope, there is a second method that can be used to accomplish that task. In the alternative method, simply adjust R11 counterclockwise until LED1 lights. Then adjust R11 clockwise (a quarter-turn at a time) while operating the RESET switch until LED1 stays off. At that point, add another quarter turn clockwise. Press and hold the HAR-

MONIC TEST switch. After a 1.5-second delay, LED1 should light. Press the RESET switch—the indicator should go out.

Calibrating the voltage detectors is most easily accomplished with a 0-150-volt autotransformer (better known as a Variac). However, similar results can also be accomplished using a power rheostat or variable resistor connected in series with the AC line. **Caution:** If you use a series resistor, remember that the metal parts will be conducting AC. Unless great care is taken, under these circumstances, you could receive a dangerous shock.

Adjust the autotransformer or resistor so that the AC voltage at the input to the transformers is exactly 105 volts rms. Next, slowly adjust R48 counterclockwise until the SAG indicator lights. Then slowly adjust R48 in the clockwise direction while pressing the RESET switch until the SAG indicator stays off. Recheck that the sag voltage detection point is at 105 volts AC. Next decrease the autotransformer or resistor until the OUTAGE indicator lights. The voltage should be 100 volts rms. If you are using a autotransformer for calibration, increase the AC voltage to 127 volts, and check the surge detection point. Next increase the voltage to 140 volts AC and check the spike calibration point. **Caution:** Since you are at the upper limit of the transformer's voltage capability, do not leave the high voltage on for any longer than necessary to check the calibration. Keeping the power on could cause damage to the transformers. Finally, go back and recheck the harmonic-distortion setting by varying the autotransformer output over a 100- to 140-volt range to be sure no false output occurs.

All points should be within 1 volt of their nominal values with 1% resistors, but may vary somewhat if 5% resistors were used. The most important point for calibration is the sag point. Press the RESET switch and all of the LEDs should go off. Press and hold the 0V TEST switch. The SPIKE indicator should light, followed by the SURGE indicator after the time delay elapses.

Use. To use the Power-Line Monitor,

simply plug it into the outlet that you want to monitor for power quality. When not in use, disconnect the Power-Line Monitor's battery to prevent it from discharging. Upon removing the unit's line cord from the outlet, the Power-Line Monitor may give a spike indication. That spike is caused by interrupting the primary current, resulting in a collapse of the magnetic flux in the core. That collapse induces a high-voltage transient in the secondary winding. The voltage spike is also a graphic illustration of what happens on a larger scale when a power-line transient occurs. ■

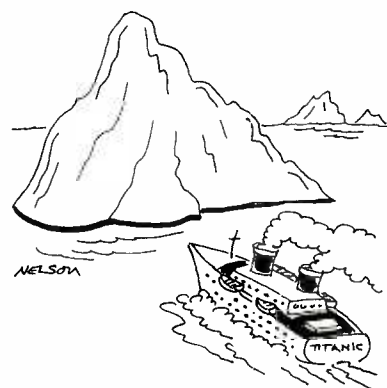

"According to our computer, Captain, we should be able to smash right through that chunk of ice!"

WINDOWS 95 —One Step at a Time

Don't know what to do when confronted with Microsoft's Windows 95 screen? Then you need a copy of **Windows 95—One Step at a Time**. Develop your expertise with the straight-forward presentation of the frequently-used features that make Windows 95 so valuable to the PC user.

To order Book BP399 send \$8.99 plus \$3.00 for shipping in the U.S. and Canada only to **Electronics Technology Today Inc.**, P.O. Box 240, Massapequa Park, NY 11762-0240. Payment in U.S. funds by U.S. bank check or International Money Order. Please allow 6-8 weeks for delivery.



Free Best Seller! Write:
Consumer Information Catalog
Dept. BEST, Pueblo, CO 81009

Build The BusyBody

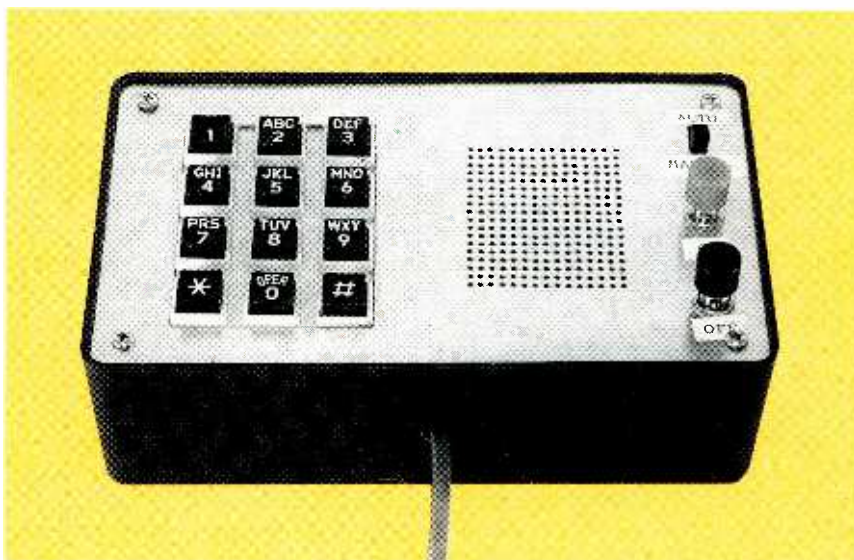

With this easy-to-build circuit get all of the convenience provided by the phone company's automated redialing system without the expense

ANTHONY J. CARISTI

Have you been getting a lot of busy signals lately? It can be very frustrating when you are trying to get through to the same number that everyone else is trying to reach. Of course, you can always pay the telephone company to keep trying the number for you by using their “*66” feature, at about 75 cents a pop. However, you can get the same service with *BusyBody* without incurring extra charges on your telephone bill.

BusyBody contains automatic dialing circuitry that can access the number you are trying to reach, even when dialing outside your local calling area. This easy-to-build circuit derives its operating power from the telephone line, so don't worry about replacing batteries or loss of power during AC power failures. The circuit contains a speaker that allows you to monitor line status.

If after dialing a number, you hear a busy signal in the unit's self-contained speaker, you set the circuit to automatic redial. At that point,

BusyBody takes control, continuing to dial out over and over again at about four times a minute. Then when you hear a ring signal in the speaker, you simply pick up the telephone handset and wait for the party at the other end to answer the phone. What could be simpler?

Because *BusyBody* has no adverse affect on normal telephone operation, it remains connected to the telephone line so that it is always ready for use. When the circuit is not in use, it can be placed in the standby mode (with the press of a switch) until needed. Once it is placed in operation, an LED provides a visual indication that the circuit has made connection to the phone line.

How It Works. A schematic diagram of the *BusyBody* is shown in Fig. 1. The circuit—built around six ICs, four transistors, nine diodes, and an LED—is always connected to the phone line and remains in the standby mode unless activated by the user. Diodes D1 through D4 (four 1N4004 1-amp, 400-PIV, rectifier

diodes) form a full-wave bridge rectifier. That circuit is connected across the telephone line through a pair of isolation resistors, R1 and R2. Using the diode bridge negates the requirement to observe telephone line polarity when connecting the circuit to the line. A varistor (R16) is included in the circuit to protect *BusyBody* from voltage transients that may appear across the telephone line.

In the *BusyBody* circuit, IC1-a and IC1-b (half of a 4001 quad 2-input NOR gate) are configured as a set-reset, bistable multivibrator (RS flip-flop). The two outputs of the flip-flop at pins 3 and 4 are always complementary (opposite) to each other. Pressing S1 (OFF) puts the circuit in the standby mode. Placing *BusyBody* in the standby mode causes pin 3 of IC1-a to go high and pin 4 of IC1-b to go low.

The high output of IC1-a is fed to pin 15 of IC3 (a 4017 decade counter/divider), which has ten decoded outputs, only one of which can be high at a time. The high output of IC1-a puts IC3 in the reset condition, so all of its outputs (except the zero output which is not used in this application) are low.

At the same time, the low output of IC1-b is fed along two paths. In one path, the output of IC1-b at pin 4 is applied to the reset (RS) input of IC2—an LMC555 CMOS oscillator/timer that is configured for astable operation—inhibiting its operation. In the other path, the output of IC1-b is fed to pin 12 of IC4—a 4053 triple, two-channel, analog multiplexer/demultiplexer, which, in this application, functions as three separate SPDT switches.

Since IC3 is in the reset condition, no control signal is sent to IC4, so its pin 4 and pin 14 outputs are open. The open pin 4 output of IC4 keeps Q3 (a BS250 P-channel FET) turned off, thus no operating power is delivered to IC6. Pin 14 of IC4, which connects to the gate of Q2 (a BS107 N-channel FET), is also open, holding Q2 in the cutoff condition. With Q2 cutoff, no gate signal is applied to the base of Q1, keeping Q1 cutoff as well. That causes LED1 to remain dark and prevents operating power from being sent to IC5 (a PCD3310APN DTMF

telephone dialer made by Philips Semiconductors).

When S2 is pressed, the outputs of the bistable multivibrator (IC1-a/IC1-b) are toggled to their complementary logic states; i.e., the low output of IC1-b goes high, and the high output of IC1-a toggles low. The high output of IC1-b at pin 4 is fed to the active-low reset terminal of IC2 at pin 4, allowing it to oscillate. At the same time, the low output of IC1-a is applied to pin 15 of IC3, allowing it to count the pulses produced by IC2. When the count reaches 9, pin

11 of IC3 goes high. That high is applied to pins 9 and 11 of IC4, causing pin 14 to go high and pin 4 to be pulled to ground.

The high output of IC4 at pin 14 causes Q2 to turn on, pulling the base of Q1 to ground potential, which causes it to conduct. With Q1 turned on, a series network (composed of R3, LED 1, and D7) is connected across the telephone line, producing a dial tone.

Turning on Q1 also causes LED1 to light—providing a visual indication that the circuit has successfully

accessed the telephone line—while at the same time causing capacitor C2 to begin charging. The charge on C2 is limited to about 5 volts by Zener diode D7. The C2/D7 combination provides a regulated power source that is used to operate IC5, which contains a 3.579-MHz crystal oscillator that generates the precision DTMF (TouchTone) signals that are required by the telephone network.

At the same time, the high output of IC4 at pin 14 is applied to pin 18 of IC5, thereby enabling the IC.

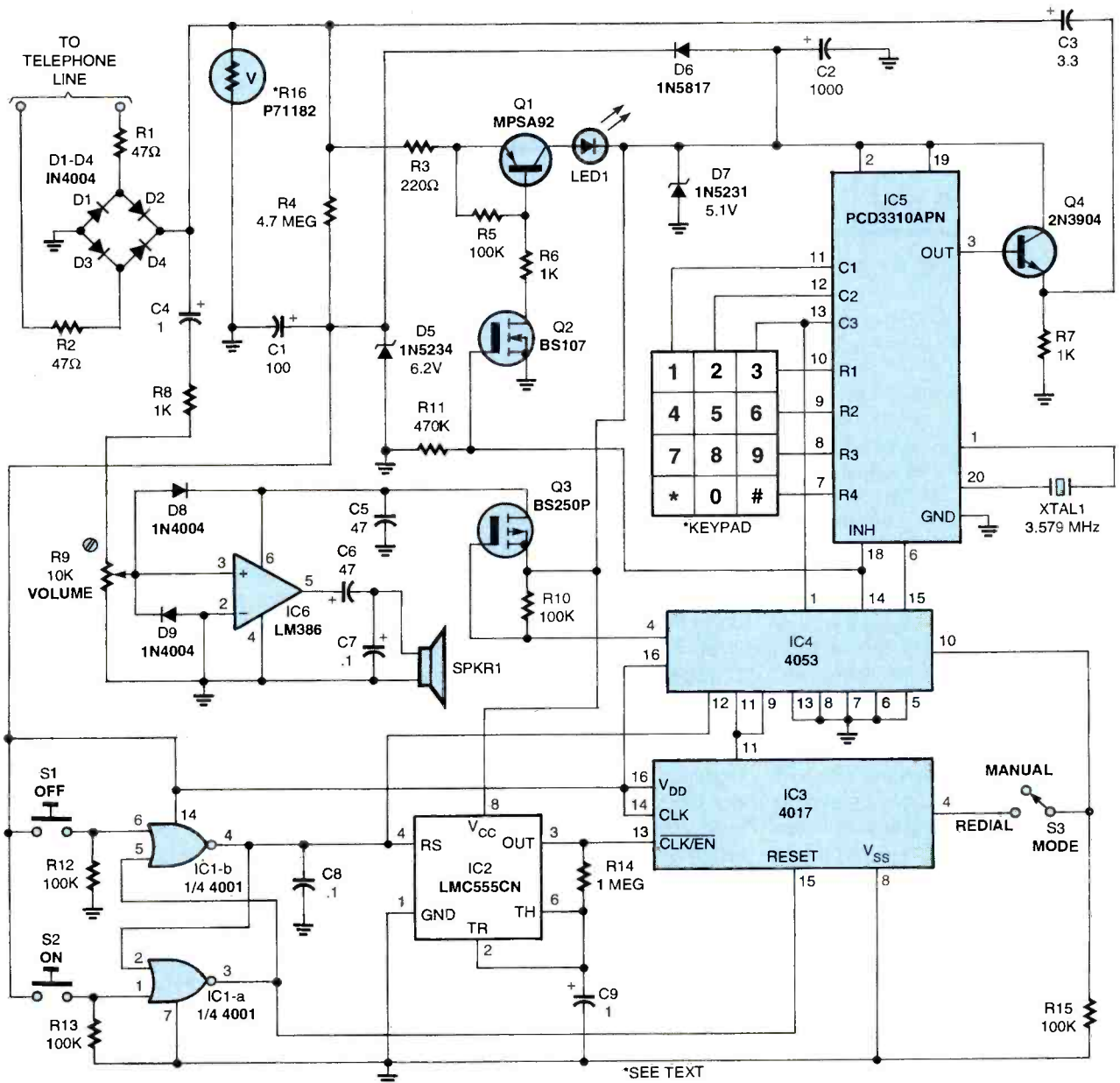

Fig. 1. BusyBody—built around six integrated circuits, four transistors, nine diodes, and an LED—is always connected to the phone line and remains in the standby mode unless activated by the user.

Enabling IC5 allows a telephone number to be entered (dialed) via the connected keypad. Pressing any key of the keypad shorts a column to a row, causing IC5 to produce a signal that is unique to that row/column combination. The signal

to count. When IC3 pin 11 goes low at the zero count, the circuit reconnects to the telephone line as before, obtaining a new dial tone. With the circuit set for automatic redial, when IC3 reaches a count of 2, pin 4 goes high, transmitting a

placed in the circuit backwards will render BusyBody inoperative, and may cause damage to itself or other components. Do not insert the chips into the board until later, when instructed to do so during the checkout procedure.

It is recommended that DIP sockets be used for the integrated circuits. That allows the circuit to be checked out in stages, while permitting you to easily troubleshoot and repair the circuit, if necessary. It is very difficult to remove a multi-conductor component that has been soldered into a board without damage to a printed-circuit board and/or the component itself.

Capacitor C1 should be a low-leakage electrolytic unit, since ordinary types may draw too much current to allow charging through a 4.7-megohm resistor. Capacitors C3 and C4 must be rated for at least 160 volts DC, since those parts are connected directly to the telephone line's bridge circuit.

The printed-circuit board requires four jumper wires to complete the circuit. Connect a jumper from the pad tied to IC1 pin 2 to the pad at IC4 pin 12; connect another jumper from the pad connected to IC3 pin 11 to the pad at IC4 pin 9; connect a third jumper from the pad tied to C1's positive terminal to the pad at the cathode of D5; and the final one connects between pads tied to C3's positive lead and R4. Use stranded insulated wire for the jumper connections; solid wire has a tendency to break.

When the printed-circuit board is completed, examine it very carefully for opens, shorts, and cold solder joints—which appear as dull blobs of solder. Any solder joint that is suspect should be redone by removing the old solder with desoldering braid, cleaning the joint, and carefully applying new solder. It is far easier to correct problems at this stage rather than later on if you discover that your BusyBody does not work.

The circuit can be housed in any enclosure that is large enough to accommodate both the circuit board and off-board components, including the speaker. Any size speaker can be used, but keep in mind that larger speakers generally produce greater volume. Form a

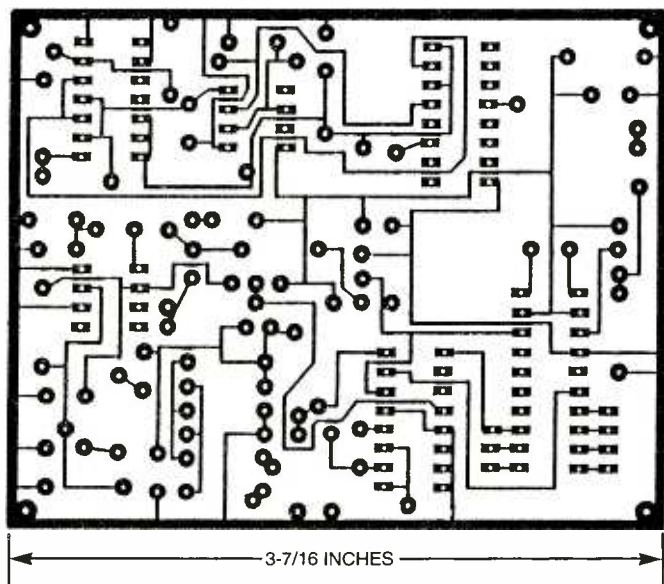

Fig. 2. BusyBody was assembled on a single-sided, printed-circuit board, measuring $3\text{-}\frac{7}{16}$ by $2\text{-}\frac{3}{4}$ inches. A template of that printed-circuit layout is shown here full-size.

generated by pressing a key is converted internally to a unique DTMF signal and is output at pin 3 of IC5. The output of IC5 is applied to the base of transistor Q4 (which is configured as an emitter follower), and then fed through C3 and impressed on the telephone line. The signal is then transmitted to the local telephone switching station (at the central office), where a ring signal is routed to the appropriate trunk and transmitted to its final destination.

While the DTMF chip is doing its thing, the gate of Q3 is grounded via pin 4 of IC4, causing Q3 to turn on. With Q3 turned on, operating power is fed to IC6. Integrated circuit IC6 (an LM386 low-voltage audio-power amplifier) is driven by audio signals appearing across the telephone line. That allows the DTMF, busy, or ringing signals to be heard in the speaker. Potentiometer R9 is used as a volume control. When the user hears a ringing signal, the telephone handset is then picked up to continue the call in the normal way.

If a busy signal is heard, the user places switch S3 in the REDIAL position. During that time, IC3 continues

redial command to IC5 from pin 4 of IC3. That causes the number to be recalled and transmitted to the phone line again and again until a ring signal is detected.

Switch S1 is used to turn the circuit off. When S1 is pressed, the bistable multivibrator is toggled to its opposite state, disconnecting BusyBody from the telephone line. However, a trickle current keeps C1 charged so that the circuit is always ready for operation.

Construction. BusyBody was assembled on a single-sided, printed-circuit board. A full-size template of the author's printed-circuit layout (measuring $3\text{-}\frac{7}{16}$ by $2\text{-}\frac{3}{4}$ inches) is shown in Fig. 2 for those who prefer to etch their own board. If you do not care to etch your own board, one can be purchased from the source given in the Parts List.

Once you've obtained all the parts listed in the Parts List, assemble the board guided by the parts-placement diagram shown in Fig. 3. When installing the polarized components, be sure that they are properly oriented. Just one part

grille by drilling several small holes in the enclosure where the speaker is to be mounted. The speaker can then be secured to the enclosure with RTV silicone rubber or suitable hardware. As for the keypad, it can be any telephone-style, 3 × 4 matrix unit that has three column and four row connections (C1-C3 and R1-R4).

The off-board components—S1-S3, the keypad, LED1, and SPKR1—were connected to the board via the hook-up wire. The circuit connects to the telephone line through a standard four-conductor modular telephone plug and line cord. Prepare the line cord by connecting a modular telephone connector to one end of a length of four-conductor line cord.

Strip back the outer insulation at the free end of the line cord to reveal the four color-coded inner

wires. Then strip a small portion of insulation from each of the inner wires and keep the individual wires separate. Plug the modular connector into a phone receptacle and, using a DC voltmeter, identify the two wires that give a reading of +50 volts DC. Once the appropriate wires have been identified, unplug the line cord from the telephone jack and connect the appropriate wires to the circuit board at the points indicated in the parts-placement diagram.

Checkout. BusyBody can be bench tested using a well-filtered 25- to 50-volt DC power supply and a 1000-ohm, 1-watt resistor connected as shown in Fig. 4. The resistor is used to simulate the telephone line. Use a DVM to check voltages. If available, an oscilloscope can be used to observe the logic and DTMF signals.

The initial check is to verify that C1 charges properly. To do so, insert IC1, IC3, and IC4 into the board with the proper orientation and connect the DVM (set to the 20-volt DC range) across C1. Apply power to the circuit. It is not necessary to observe polarity. Check whether C1 charges slowly in accordance with the R4/C1 time constant. When C1 reaches 3 volts or more, press S2. Note that LED1 lights and C1 immediately charges to about 5 volts. Press S2 to place the circuit in the standby mode. The LED should go out.

If C1 does not charge as described, check the orientation of C1, C2, Q1, Q2, and all of the diodes in the circuit. Also check the orientation of the ICs. Troubleshoot the circuit and correct the faults if necessary before proceeding. Be sure that C1 is a low-leakage capacitor. Try temporarily connecting a 470k

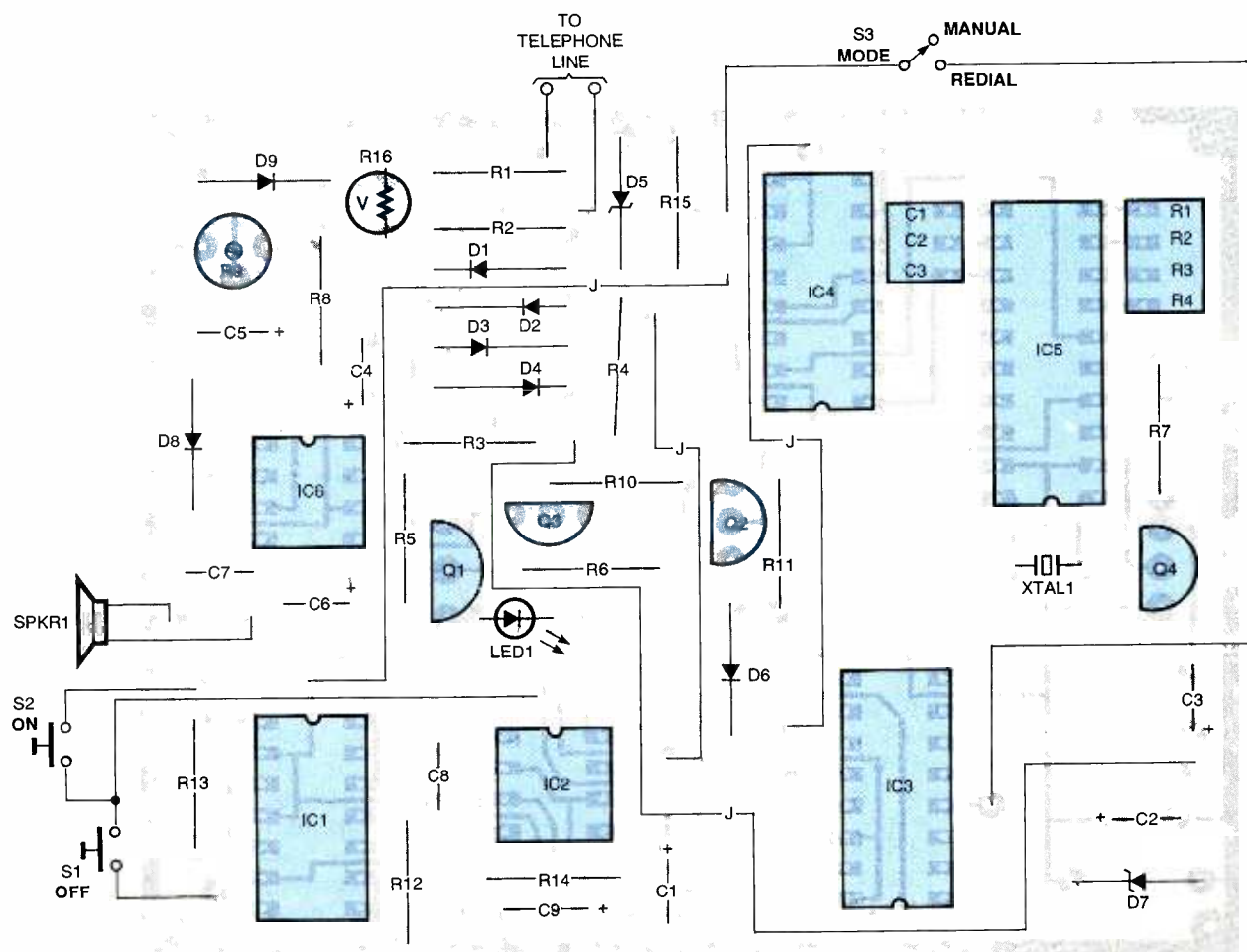

Fig. 3. Once you've obtained all the parts listed in the Parts List, assemble the board guided by this parts-placement diagram. When installing the polarized components, be sure that they are properly oriented as shown.

PARTS LIST FOR THE BUSYBODY

SEMICONDUCTORS

D1—D4 D8, D9—1N4004 1-amp, 400-PIV, silicon, rectifier diode
 D5—1N5234 6.2-volt, $\frac{1}{2}$ -watt Zener diode
 D6—1N5817 (or TCE/SK3311) Schottky diode
 D7—1N5231 5.1-volt, $\frac{1}{2}$ watt Zener diode
 IC1—CD4001BE quad 2-input NOR gate, integrated circuit
 IC2—LMC555CN CMOS oscillator/timer, integrated circuit
 IC3—CD4017BE decade counter/divider, integrated circuit
 IC4—CD4051BE triple 2-channel multiplexer/demultiplexer, integrated circuit
 IC5—PCD3310APN (Philips) DTMF telephone dialer, integrated circuit
 IC6—LM386 low-voltage, audio-power amplifier, integrated circuit
 LED1—General-purpose, light-emitting diode
 Q1—MPSA92 (or equivalent) PNP silicon transistor
 Q2—BS107 N-channel MOSFET
 Q3—BS250P P-channel MOSFET
 Q4—2N3904 (or similar) general-purpose NPN silicon transistor

RESISTORS

(All fixed resistors are $\frac{1}{4}$ -watt, 5% carbon units)
 R1, R2—47-ohm
 R3—220-ohm
 R4—4.7-megohm
 R5, R10, R12, R13, R15—100,000-ohm
 R6—R8—1000-ohm
 R9—10,000-ohm, cermet, PC-mount, trimmer potentiometer
 R11—470,000-ohm

R14—1-megohm
 R16—P7182 140-volt AC, 180-volt DC (or equivalent) varistor (Digi-Key)

CAPACITORS

C1—100- μ F, 10-WVDC, low-leakage electrolytic
 C2—1000- μ F, 10-WVDC, electrolytic
 C3—3.3- μ F, 160-WVDC, electrolytic
 C4—1- μ F, 160-WVDC, electrolytic
 C5, C6—47- μ F, 10-WVDC, electrolytic
 C7, C8—0.1- μ F, ceramic-disc
 C9—1- μ F, 10-WVDC, electrolytic

ADDITIONAL PARTS AND MATERIALS

S1, S2—SPST normally-open, pushbutton switch
 S3—SPST toggle or slide switch
 SPKR1—8- or 16-ohm speaker
 XTAL1—3.579-MHz, colorburst crystal
 Printed-circuit materials, 3 \times 4 matrix keypad (see text), telephone line-cord with modular connector, IC sockets, enclosure, wire solder, hardware, etc.

Note: The following parts are available from A. Caristi, 69 White Pond Road, Waldwick, NJ 07463: An etched and drilled printed-circuit board for \$14.95; IC1, IC2, IC3, or IC4 for \$2.75 each; IC5 for \$13.95; IC6 for \$3.95; and a set of four transistors for \$6.00. Please add \$5.00 postage/handling. New Jersey residents, add 6% sales tax.

Note: The PCD3310APN DTMF telephone dialer (IC5) is available in small lots (18 pieces) from FAI, Tel. 800-964-6117. Contact them directly for details.

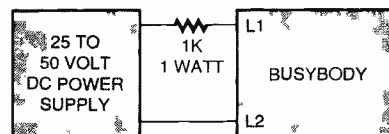

Fig. 4. BusyBody can be bench tested using a well-filtered 25- to 50-volt DC power supply and a 1000-ohm, 1-watt resistor connected as shown here, plus a DVM to check voltages. If available, an oscilloscope can be used to observe the logic levels and DTMF signals.

a scope to verify that the 3.58-MHz oscillator is operating. Check pin 18 of IC5 for a high logic level when the LED is lit. Verify the presence of audio tones at pin 3 of IC5 as the keypad switches are depressed. Also check IC4.

If IC5 is operating properly and the speaker remains silent, verify that +5 volts appears at pin 6 of IC4 when the LED is lit. If the voltage is absent, check Q3. Try a new transistor and/or chip. Check C5, C6, R9, and the speaker wiring.

Test and Operation. The final test is to verify operation of BusyBody using the telephone line. Insert the modular connector into a working telephone receptacle and wait a couple of minutes for C1 to charge.

Set the mode switch to the MANUAL position and press S2. Note that the LED lights, at which time you should hear a dial tone in the speaker. Using the keypad, enter a telephone number that's sure to result in a busy signal such as the same number to which you are connected. An alternative would be to use any three-digit exchange followed by 9970. A busy signal should be heard in the speaker.

Set the MODE switch to REDIAL. After a few seconds, LED1 will go off briefly, and when it comes on a new dial tone will be heard. A couple of seconds later, BusyBody will transmit the telephone number, and the busy signal will be heard again. To disconnect the call, press S1.

In normal use, dial the number using the keypad on BusyBody. If a ringing signal is heard, pick up the telephone handset and turn BusyBody off. If you get a busy signal, set S3 to REDIAL and wait until you hear a ring signal. At that point, the telephone handset may be picked up to complete the call. ■

resistor across R4 to see if additional charging current causes C1 to charge as described. Try new chips if all else fails.

If the circuit, thus far, functions as expected proceed with the test procedure. Remove power and install IC2. Apply power and allow C1 to charge to 3 volts or more as before. Press S2, and note that LED1 lights; after about 12 seconds or so, it should blink off briefly.

If the circuit does not react as described, check that pin 3 of IC2 is outputting a frequency of about 0.7 Hz. Check pin 11 of IC3 to see if it remains at zero volts most of the time and rises to 5 volts for $\frac{3}{4}$ second when the count reaches 9. Check IC2-IC4 and try new chips if necessary. Do not proceed until the fault has been located and corrected.

If all is well, remove power and install IC5 and IC6 into their respective sockets. Set S3 to the MANUAL posi-

tion, set R9 to mid-position, and apply power. Once C1 has charged, press S2 to start circuit operation and enter any telephone number through the keypad switches. You should hear the tones in the speaker as the DTMF signal is produced and transmitted. Throw S3 to the REDIAL position. Wait for the LED to go out and come on again. A couple of seconds later, the circuit should automatically begin dialing the previously entered number. DTMF tones should be heard coming from the speaker, but at a rapid rate.

Allow the circuit to cycle several times. As you listen to the tones emitted from the speaker, adjust R9 for a comfortable volume level without distortion. If the circuit functions as described, that completes the preliminary test.

If no tones are reproduced in the speaker, check the orientation of IC5. Check pins 1 and 20 of IC5 with

It's Not Just Training...

"I needed a refresher in fundamentals and a piece of paper that said I had a degree. CIE gave me both."

Louis P. Briant
Senior Engineer
Sentel Corp.

"CIE allowed me to use my G.I. Bill benefits and independent-study allowed me to continue my studies while deployed."

Charles Hopper
Electronics Senior Chief
U.S. Navy

"The fact that I intended to continue pursuing my Associate Degree with CIE was a key factor in being considered for my current position."

Annamarie Webster
Project Engineer -
Instrumentation
Ketchikan Pulp

"My associates at work recommended CIE... The lessons were structured so they were easy to comprehend."

Vincent R. Buescher
Communications Technician
AT&T

"I enrolled and received my A.A.S. degree from CIE because of the good experiences I had in one of CIE's career courses."

Maurice M. Henthorn, Jr.
Electronic Technician
The Denver Post

Independent study from CIE will give you the skills you need to win your own independence in a successful career.

At CIE, we pride ourselves in keeping pace with the latest developing technologies. In turn, this assures our students that upon graduation they can mesh seamlessly into a variety of exciting and rewarding technology-based careers.

Back in the 1930's, we specialized in teaching radio and television sciences. Today, it's computer technology, programming, robotics, broadcast engineering, information systems management, and the electronics behind it all.

But some things have not changed, like the desire of CIE's faculty and staff to see their graduates succeed.

That is why at CIE we teach not only the hands-on, practical aspects of electronics technology, but also delve into the "why" behind today's technology. Why does it work the way it does?

The insights to be gained from such a broad, rich and comprehensive

education at CIE matches or exceeds those gained through traditional commuter institutes while providing an education schedule to match your commitments and lifestyle.

Our patented learning program is specifically tailored for independent study and backed up by a caring team of professional educators who are at your call whenever you need their help.

At CIE, we'll match our training with your background and career goals and help you decide which of the many career courses that we offer suits you best. We offer an Associate Degree Program and through our affiliation with World College a Bachelor Degree



Computer Programming



Electronics Technician

Program.

If you have the sincerity, the smarts and the desire, CIE can make it happen. CIE is already the institute of choice for many Fortune 1000 companies. Why shouldn't you be next?

...It's an Education.



1776 East 17th Street
Cleveland, OH 44114
(216) 781-9400 • 1-800-243-6446

YES! Please send me more information on:

- CIE's Associate Degree Program
- CIE's Career Courses
- World College's Bachelor Degree Program

Name _____

Address _____

City _____ State _____ Zip _____

Phone: _____

Check for G.I. Bill Active Duty Veteran

AH 114

NET WATCH

Staying Healthy

KONSTANTINOS KARAGIANNIS

Had any bad colds this past winter? Feeling a touch of hay fever right about now? It seems there's always "something going around," and, as a result, the waiting rooms in doctor's offices are just about always full.

The first thing to do when you have a medical question is not always to run

for treatment if you think you're coming down with something.

There's a wealth of information available through these sites, and most of it is from "official" sources, including the U.S. Government. This could be some of the most important information you ever read online.

like this are naturally suited for the Web.

Is the information safe, though? Have no fear and look no further. All physician-credential data has been verified for accuracy and authenticated by accrediting agencies, medical schools, residency training programs, licensing and certifying boards, and other data sources. Remember, this is the AMA's site, not something put together by an organization that has any ulterior motives in your selection of a physician.

There are two main ways to search for a doctor. Say you heard of one that a friend recommended, and you'd like to know more—try searching by name. More often, though, you'll be looking for a doctor that specializes in a field. For this reason, you can select from the following categories: Allergy & Immunology, Anesthesiology, Cardiology, Dermatology, Diabetes & Metabolism, Emergency Medicine, Endocrinology, Family Practice/General Practice, Geriatrics, Internal Medicine, Medical Genetics, Neurological Surgery, Neurology, Obstetrics & Gynecology, Oncology (Cancer), Ophthalmology, Orthopedics, Otolaryngology, Pathology, Pediatrics, Physical Medicine & Rehabilitation, Plastic Surgery, Preventive Medicine, Psychiatry, Radiology, Surgery, and Urology.

For those with a specific ailment, there's no need to weed through the aforementioned list. You can look for a doctor that specializes in asthma, migraines, or HIV/AIDS, via direct search links. There's also detailed information available on each of these three categories—look for it under the Reference Library heading.

CENTERS FOR DISEASE CONTROL AND PREVENTION

This is a resource from an organization with an alarming name—the Centers for Disease Control and Prevention. True, the CDC (for some reason, the word "Prevention" is not included in the acronym) is what would come into play should a plague like

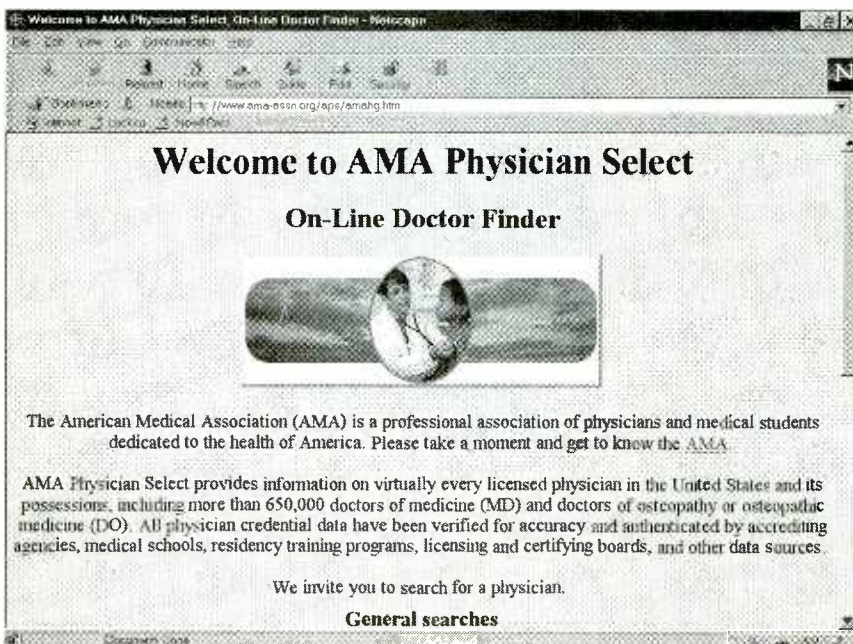

Finding the right doctor can be difficult, so why not let the AMA help you with its Physician Select Web site?

to a doctor. For example, if you have a question about taking two different types of medicine at the same time, you might call a pharmacist. If you think you should be taking some precautions to avoid getting sick in flu season, you might read any number of journals.

It's the latter, general type of health information that we'll be focusing on this month. Join us for a look at some of the more notable sources of medical information on the Net.

In no way are we recommending that you try to diagnose your own health conditions and avoid professional attention. The locations we look at here are just sites on the Web with useful information that might help you to avoid getting ill or to decide where to go

AMA DOCTOR FINDER

The American Medical Association (AMA) is the professional association of physicians and medical students in the United States. Through its various recommendations, the organization aims to protect the health of the nation.

Realizing that people need to find a doctor who suits their personal needs, the AMA has created the OnLine Doctor Finder, or Physician Select. This searchable site provides information on practically every licensed physician in the U.S. and its possessions, including more than 650,000 doctors of medicine (MD) and osteopathy or osteopathic medicine (DO). Try to imagine looking through printed books to sort through this much information! Huge databases

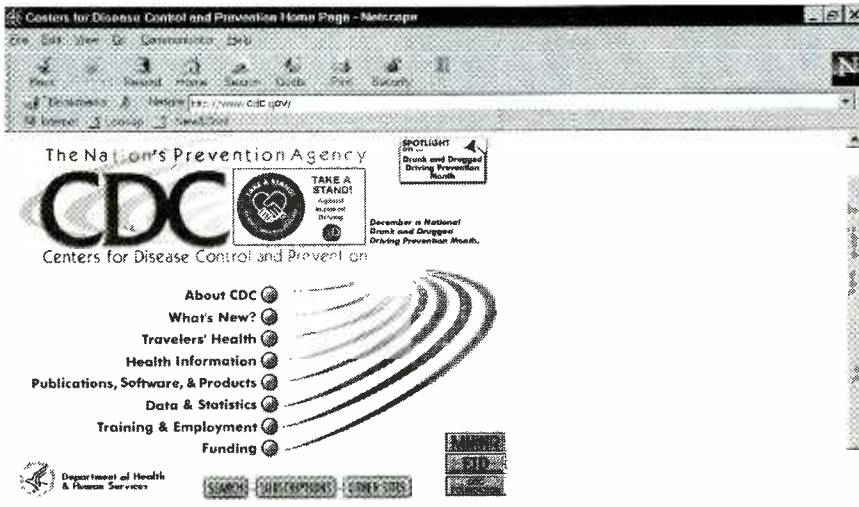

Dr. David Satcher, M.D., Ph.D., Biography

Centers for Disease Control and Prevention (CDC)

[About CDC](#) | [What's New](#) | [Health Information](#)
[Travelers' Health](#) | [Publications & Products](#) | [Data & Statistics](#)

When not battling the plague, Centers for Disease Control and Prevention provide information for keeping people healthy in everyday situations.

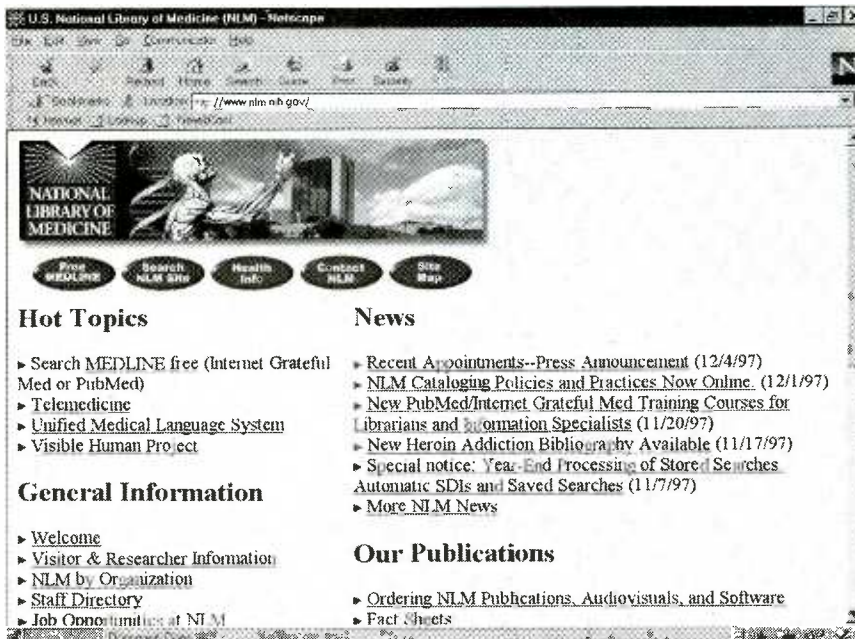

Hot Topics

- ▶ Search MEDLINE free (Internet Grateful Med or PubMed)
- ▶ Telemedicine
- ▶ [Unified Medical Language System](#)
- ▶ [Visible Human Project](#)

General Information

- ▶ [Welcome](#)
- ▶ [Visitor & Researcher Information](#)
- ▶ [NLM by Organization](#)
- ▶ [Staff Directory](#)
- ▶ [Job Opportunities at NLM](#)

News

- ▶ [Recent Appointments--Press Announcement \(12/4/97\)](#)
- ▶ [NLM Cataloging Policies and Practices Now Online. \(12/1/97\)](#)
- ▶ [New PubMed/Internet Grateful Med Training Courses for Librarians and Information Specialists \(11/20/97\)](#)
- ▶ [New Heroin Addiction Bibliography Available \(11/17/97\)](#)
- ▶ [Special notice: Year-End Processing of Stored Searches Automatic SDIs and Saved Searches \(11/7/97\)](#)
- ▶ [More NLM News](#)

Our Publications

- ▶ [Ordering NLM Publications, Audiovisuals, and Software](#)
- ▶ [Fact Sheets](#)

The U.S. National Library of Medicine site has an enormous amount of material in its databases, and it's well worth the time you spend searching through it.

something out of the movie *Outbreak* occur. But for the most part, plague is not something to worry about, and the CDC has some other important functions, too.

If you're just interested in what this organization is really about, check out the What's New? section of its site for news articles and press releases that help dispel some of the unnecessary terror from the CDC acronym.

But, if you're like most people, you'd probably like to stay healthy, and the in-

formation found at the site might help you do this. Under the Health Information section, there are links to articles about Diseases, Injuries, Disabilities, Health Risks, and Prevention Guidelines and Strategies. A search feature makes it even easier to get through all the data to find what you want.

Learn about HIV/AIDS, Sexually-Transmitted Diseases, and Tuberculosis. Find tips for handling Injuries from Violence and dealing with Rehabilitation. If it's life-threatening, the

CDC has information on it.

Find out how to reduce the risk of getting a disease by changing behavior and by avoiding certain environments. There are tips you should try to follow on the job to help reduce the chance of work-related injuries. We were impressed to find that there are even long-term strategies you should follow to lower the risk of illnesses such as cancer.

If you travel a lot, especially internationally, you should consider investigating the section on Travelers' Health. The U.S. State Department contributes information of a non-medical nature including civil unrest, crime, or natural disasters (check out the link there). You can also find out what vaccines are recommended by the CDC and when.

You won't find any holistic or new-age treatments or alternative medicine here, but whatever is listed is coming from a reputable, government source that is prepared for the worst. That's got to count for something.

THRIVE ONLINE DRUG INFORMATION

Thrive Online is a full site covering many aspects of maintaining health and well-being. However, we're only going to briefly focus on one aspect here.

Using the Thrive URL found in our "Hot Sites box," you'll be linked directly to a powerful search engine that is dedicated to prescription and non-prescription drugs, and even dietary supplements. This is great for those who want quick information on just what all the strange multi-syllabic words used by doctors really mean.

If you're considering an over-the-counter product, such as a Zinc supplement to fight colds, you can use this search engine to find out what the experts have to say on its real-world effects. **For finding out about possible dangerous combinations of drugs, definitely call a pharmacist.** But for learning quickly what lots of experts have to say about a particular product, you've found a real jackpot in this site.

U.S. NATIONAL LIBRARY OF MEDICINE

Here's a comprehensive site with an incredible amount of information, though some of it may seem a bit arcane. With a little patience, the words

(Continued on page 70) 49

COMPUTER BITS

Microcontrollers I

JEFF HOLTZMAN

Microcontrollers have certainly evolved since the last time I looked—I don't want to tell you how many years it has been. Not only are there many chip families, there are many development tools, utilities, and accessories—most of which look like lots of fun. But we can't look at everything. We need some selection criteria. The criteria I've come up with are as follows:

1. Chips must be available and reasonably priced.
2. Hardware development tools must be available and reasonably priced.
3. Software development tools must be available and reasonably priced.
4. Ideally, the chip family will have lots of options for on-board gadgets (things like serial I/O, D/A, and A/D).
5. Ideally, the chip will be available in small, low-power packages.
6. Ideally, the chip will have a reasonable architecture.

In addition to chip-level products, there are many cool, relatively low-cost, all-in-one modules, such as the PicStic and the BasicStamp, as well as single-board computers and controllers. Cool though they may be, however, I rejected both classes of devices categorically as being (more) expensive, less of a learning aid, and ultimately a mismatch for the types of applications I have in mind. Of course, working with things at the chip level is harder than simply using preassembled modules. But, personally, I enjoy the challenge and the variety. And in a manufacturing situation, it's usually cheaper to use a \$2 part than a \$34 module or a \$129 board.

AND THE WINNER IS...

It didn't take long to discover that the Peripheral Interface Controller (PIC) family of microcontrollers from *MicroChip Technology* is the market leader. *Motorola* has some interesting devices, but their pricing and availability are less than desirable. There are lots of other companies making lots of other devices, but based on my crite-

ria, they quickly slide off into the nether reaches of the bell curve.

Having said that, however, I want to make sure that my position on this is clear: *I am wide open to suggestion!* If I've overlooked something that clearly meets those criteria, please pass it on—so will I.

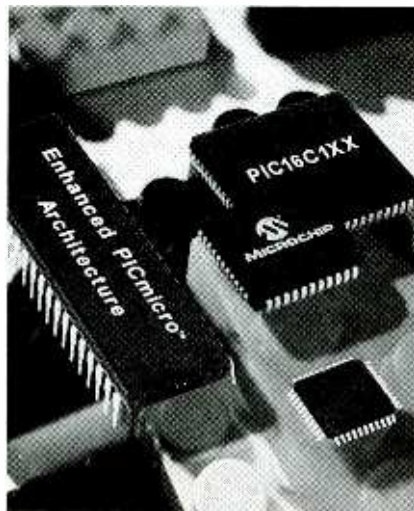

Just released, MicroChip Technology launches enhanced PICmicro architecture for 8-bit RISC microcontrollers.

THE GOOD AND THE BAD

OK. The PIC family meets criteria 1—5, but it fails miserably at criterion 6. That's not going to stop me from using it; nonetheless, I feel compelled to get this off my chest now, before getting started. I'll try not to rant too much about this as we get into it more deeply, but I will certainly be discussing how things might be done with a better architecture.

As I began reading up on the PIC architecture I found lots to like, as we'll see. But I was also shocked at several architectural features; in particular, memory-bank switching and the lack of a true hardware stack. Both "features" will make software more difficult to write and more error-prone because the programmer (that is, you and I) will have to do things that a compiler would normally handle. The lack of a stack probably has much to do with the fact that few

high-level language compilers are available and that most PIC programming is done in assembly language. I hope to find a reasonable macro assembler to implement some crude sort of code reuse. And I hope to find a good C compiler.

BACKGROUND KNOWLEDGE

I don't intend this series to be a basic primer on digital logic, computer architecture, programming, or anything else. I'm going to assume the following:

- You have an Intel-based PC, know how to configure it, and know how to use it.
- You have basic electronics construction skills.
- You know the difference between RAM and ROM and so forth.
- You know what a Program Counter is, as well as a stack, address modes, CPU registers, and so forth.

If you don't have at least basic familiarity with all the above, I'd strongly suggest finding a good book and doing some serious reading. I'm not going to assume any specific familiarity with PICs. If you have a basic background in computers and electronics, but are new to microcontrollers, I can recommend books by Dave Benson of *Square One Electronics*. Both books have a very practical point of view and a down-to-earth writing style.

Easy PIC'n is, as the title says, a beginner's guide to using PICs. It describes the basic architecture of the PIC family, provides a good discussion of the mechanics of writing assembly language code, using an assembler, and burning PICs.

PIC'n up the Pace provides a variety of experiments in which you interface various devices to a PIC. Topics include op-amps, clocked (synchronous) serial I/O, LCD displays, keypad inputs, D/A, A/D, and more. The book has numerous code routines that may be used in your own projects.

(Continued on page 56)

ANTIQUE Radio

Spring Cleaning—Dusting Off the NR-5 and Catching Up

MARC ELLIS

POWERING UP THE FREED-EISEMANN

You'll remember that in the February column, I finally powered up the 3-dial Neutrodyne set (*Freed-Eisemann NR-5*) we'd been working on for some time. It wasn't really ready for a test according to the housekeeping standards I usually apply. In addition to changing out any obviously defective or untrustworthy electrical components, I also like to make sure that a long-disused radio is thoroughly cleaned up before applying power.

I'm not talking about just removing the surface dirt and the mouse nests. The important thing is to clean grime and corrosion from all electrical contact points on tubes, tube sockets, switches, jacks, potentiometers, rheostats, tube shield hardware, etc. I've found that this dramatically increases the chances of a radio working the first time and automatically disposes of strange glitches, clicks, pops, motor-boating, etc., that might otherwise require tedious troubleshooting.

In this case, though, I'd just completed the "A," "B," and "C" power supplies that would replace the batteries originally used to power up the set, and I really wanted to try them out. Not only that, the project had dragged on for an unusually long time—even for one of my restorations—and I figured you readers were probably about ready for some closure. I know I was!

Anyway, I lucked out. As readers of the February column know, the Freed came to life immediately, and I was able to pick up a full complement of local stations even though I had substituted a few feet of wire laid on my office floor for the usual outside antenna and wasn't even using a ground.

AN UNEXPECTED PROBLEM

There had been an unexpected problem, however. Refer to the schematic diagram of the "B" and "C" supplies,



Buttoned up, back in its cabinet, and ready for action, the NR-5 stands by with a "Dictogrand" horn (one of my favorites).

which is reprinted here as it appeared in the December, 1997 column, and you'll see that the B- and C+ connections are made to the same point. This is an inevitable consequence of the fact that the "B" and "C" supplies share the same power transformer.

That placed an obstacle in the way of powering up the Freed, because the design of the set calls for the C+ lead

of the supply (also the B-, remember) to be connected to the A- (negative filament) binding post of the radio. However, as is usual in battery sets, the B- connection from the power supply is to be made to the set's A+ (positive filament) terminal.

Since both filament binding posts are connected to the same circuit point (power supply B-), we have a dead

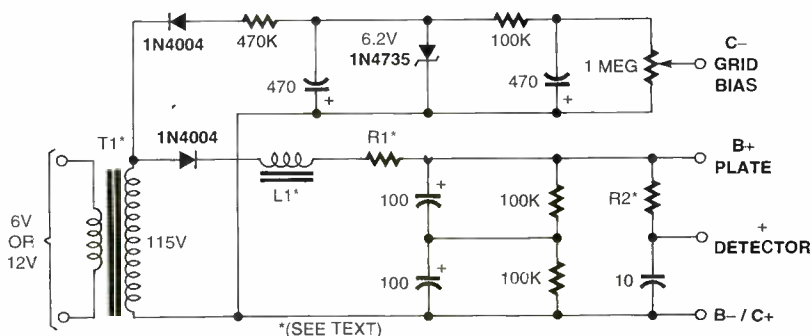

Schematic of our "B" and "C" supply repeated from the December 1977 issue. See text for method of separating the B- and C+ connections.

short across these binding posts after all power supply connections are made. I wasn't smart enough to recognize this when making the original hookup and wound up blowing the fuse of the "A" supply (supply not shown here) as soon as I turned it on! After fixing the fuse and discovering the problem, I had to connect a separate temporary power supply to provide "C" voltage.

A SIMPLE REMEDY

The remedy is inexpensive and simple. Looking at the schematic, you'll see that T1 is a reverse-connected 6- or 12-volt transformer. The 6- or 12-volt secondary is used as the primary, and the 115-volt primary is used as the secondary, supplying input voltage to the rectifier and filter networks of both supplies.

The 6- or 12-volt winding receives its voltage from the (normal) secondary of another (not shown) 6- or 12-volt transformer. The voltage doesn't matter as long as it matches the input voltage of transformer T1. This "back-to-back" hookup is necessary, because transformers with high-voltage secondaries (100 volts or more) are very rare in this day of low-voltage solid-state circuitry. You can't buy one at RadioShack!

To make the "C" supply independent of the "B" supply, with no common connections, a "no-brainer" fix is to provide it with a separate power transformer. For 12-volt systems, purchase the lowest current 12-volt transformer available at RadioShack; at this writing, it is the 300mA, part 273-1385, selling for \$3.99. For 6-volt systems, you'll need a 6-volt transformer from surplus sources or your junkbox.

Connect the primary of the new transformer in parallel with T1's primary, across the secondary of the main power transformer. Then remove the connections from the "C" supply to the secondary of T1, changing them over to the secondary of the new power transformer. The connection formerly made to the B- line of the "B" power supply is now an independent C+ connection and should be provided with a separate binding post.

Those of a more experimental turn of mind might like to try getting along without the extra power transformer. With appropriate changes in the value of the 470-k resistor, it may be possible to feed the "C" supply from the secondary of the main power transformer,

particularly if it is a 12-volt one, instead of from a 115-volt source.

HIGHLY RECOMMENDED

Even though we've devoted a lot of space to new books in the last few months, I still haven't quite caught up with the spate of new volumes that ended up on my desk during the summer. There is still one to talk about, and here it is.

HOW TO BUILD YOUR FIRST VACUUM TUBE REGENERATIVE RECEIVER

by T.J. Lindsay

Published by Lindsay Publications, Inc., P.O. Box 538, Bradley, IL 60915; Softcover; 128 pages; \$9.95 plus \$1.00 S&H. (Illinois residents, add 6.25% sales tax.)

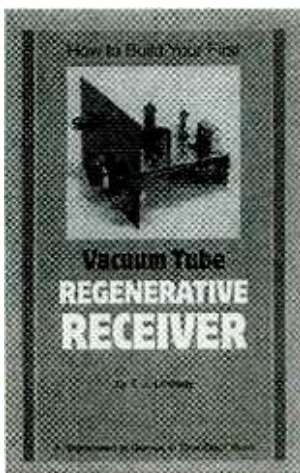

I don't know if T.J. Lindsay, proprietor of Lindsay Publications, has ever published one of his own books before, but I hope he does it more often! For those who don't happen to know, Lindsay specializes in reprints of...to use his own words..."Unusual technical books, past and present, of exceptionally high quality revealing skills and secret processes almost forgotten." As anyone perusing his lively catalogue (write for a free copy or ask him to include one if you order this book) immediately finds out, Lindsay enjoys the books he sells. And, as is certainly clear from this new book, antique electronics is high on his enjoyment list.

The volume's front-cover subtitle, "A 'Bonehead to Genius in One Step' Book," promises that this is a book aimed at beginners and one that is not going to take itself too seriously. And these promises are definitely kept!

Any newcomer to the hobby who becomes interested in reproducing antique vacuum tube circuitry could easily become discouraged. Obtaining authentic vintage components seems to be an impossible task and even the more-modern equivalents are generally available only in surplus stores. Forget shopping at RadioShack for such essentials of vacuum circuitry as high-voltage transformers and caps or higher-wattage resistors, not to mention the tubes (and their sockets) themselves.

However, those who want to experience the romance and excitement of building a regenerative shortwave set will find all of the encouragement and help they need on these pages. Using a very relaxed, often tongue-in-cheek, approach, Lindsay begins by introducing the reader to the delights of flea-market parts scrounging. (A typical tip: "Great sources of radio gear are old tube RF generators... No one wants them. They sell for \$5 to \$10, and they provide almost everything you need to build a radio: coils, capacitor, drive, power-supply tubes, sockets and miscellaneous parts.")

Following chapters discuss typical circuit configurations; provide hints on construction, wiring, and parts substitution; and tell you everything you need to know about putting together an appropriate power supply. Above all, the approach is to take the mystery and "up-tightness" out of building the antique circuits and to foster an open experimental point of view. The book is generously illustrated and includes a lot of interesting graphics of vintage components. Among the very useful items in the Appendix, you'll find a transcription of the original Edwin Armstrong patent for regenerative receiving.

FROM THE MAILBAG

Marcel E. Forest (2731 E. 35 St. Terrace, Kansas City, MO 64128) reminisces about a regenerative receiver kit he built in 1940, just before the start of World War II. Purchased by mail from a dealer on New York's famed (but alas long-gone) Cortlandt Street "Radio Row," it cost all of \$8.95 postpaid and included earphones and plug-in coils!

Housed in a sloping-front black-crackle finish cabinet, the set used two type 76 tubes, with one connected as a diode rectifier. Tube filaments were lit directly from the AC line via a line-cord

(Continued on page 56)

Back to Basics

ALEX BIE

This month's column features new topics, new circuits, and a new columnist. That's right, after seven years of doing this column, John Yacono is passing the *Think Tank* bag of circuits on to me. I have lots of new ideas for this department. Remember *you* are the main contributor to this column—it's *the* place to show off your novel designs. More on this at the end of the column.

I thought we would kick off this column by getting back to basics, and by looking at various electrical components and devices found in every modern circuit. A new series entitled "What Is A...?" by Ian Poole, G3YWX (reprinted with permission from *Practical Wireless*), begins by looking at semiconductors.

WHAT IS A SEMICONDUCTOR?

It is a little over 50 years since the first transistor was invented. Since then, semiconductor technology has grown by enormous degrees, affecting the lives of virtually everyone on the planet. Computers, portable radios, cellular telephones, satellites, electronic watches, and a host of other items in daily use have all been made possible by semiconductor technology. In the field of radio, semiconductors have revolutionized the components and techniques used.

In this series, we hope to uncover the mysteries of how some of the common devices work and what some of the more unusual devices do. We will be looking at Gunn diodes, Gallium Arsenide Field-Effect Transistors (GaAsFETs), as well as devices like High Electron Mobility Transistors (HEMTs) and Pseudomorphic HEMTs (PHEMTs). However, to start, let us begin with the foundation of this revolution—the semiconductor materials themselves.

("What is A...?" series reprinted by permission from *Practical Wireless*, Arrowsmith Court, Station Approach, Broadstone, Dorset BH18 8PW, England.)

Conductors and Non-Conductors

There are two main classes of material as far as electrical theory is concerned: conductors and non-conductors. From their names, it can be gathered that conductors will conduct electricity freely, whereas non-conductors act as insulators preventing the flow of an electric current.

An electric current is made up of the flow of electrons. This means that for a current to flow, the electrons must be able to move freely within the material. In some materials, electrons are moving freely from one atom to the next. And by placing a battery or other source of potential difference across a conductor the electrons can be made to drift in one direction or the other.

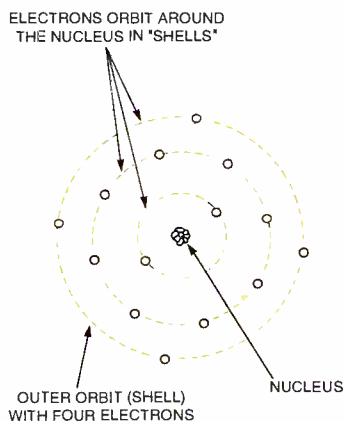

Fig. 1. A silicon atom.

Metals are all conductors of electricity, and a number of other substances also conduct to varying degrees. However, there are many other materials which do not allow electrons to move, and these non-conductors include most plastics, ceramics, and many naturally occurring substances, like wood.

Semiconductors

As the name suggests, a semiconductor is neither a true conductor nor an insulator, but halfway between. A number of materials exhibit this property, including germanium and gallium arsenide, but the most widely used is silicon. Pure silicon is a good insulator, but

when a very small amount of impurity is added, its electrical properties change. To see what happens, it is necessary to look at an atom of silicon. It can be seen from Fig. 1 that the atom consists of a nucleus with three rings or orbits containing electrons, each of which has a negative charge. The nucleus consists of neutrons which are neutral and have no charge and protons which have a positive charge. In the atom, there are the same number of protons and electrons, and so the whole atom has no overall charge. The electrons are arranged in rings with strict numbers of electrons. The first ring can only contain two, and the second has eight. The third and outer ring has four. The electrons in the outer shell are shared with those from adjacent atoms to make up a crystal lattice. When this happens, there are no free electrons in the lattice, making silicon a good insulator.

Germanium has a similar structure. It has two electrons in the innermost orbit, eight in the next, 18 in the third, and four in the outer one. Again, it shares its electrons with those from adjacent atoms to make a crystal lattice without any free electrons.

Properties Dramatically Changed

The properties of silicon and germanium are dramatically changed if very small amounts of an impurity are added. If atoms having five electrons in the outer ring are added to the matrix, they enter the crystal lattice sharing electrons with the silicon. However, as they have one extra electron in the outer ring, one electron becomes free to move around the lattice. This enables the current to flow if a potential difference is applied across the material. As this type of material has a surplus of electrons in the lattice, it is known as an N-type semiconductor. Typical impurities which are often used are phosphorous and arsenic.

It is also possible to place elements with only three electrons in their outer shell into the crystal lattice. When this happens, silicon wants to share its four electrons with another atom with four

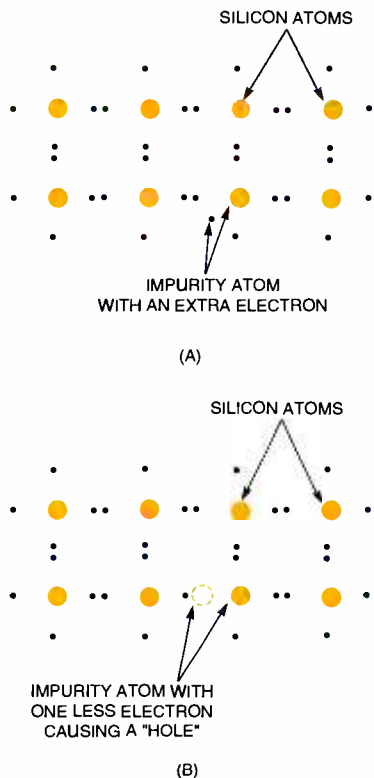
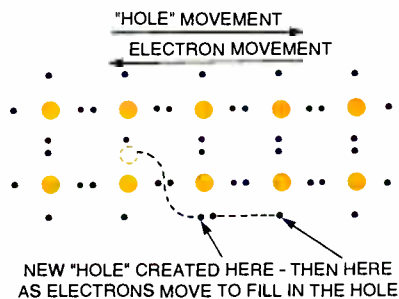

Fig. 2. Crystal structures—Shown in A is the structure of N-type material and B shows a P-type structure.

atoms. However, as the impurity only has three, there is a space or a hole for another electron. As this type of material has electrons missing, it is known as P-type material. Typical impurities used for P-type material are boron and aluminum. Typical crystal structures of these types of materials are shown in Fig. 2.

It is easy to see how electrons can move around the lattice and carry a current. However, it is not quite so obvious for "holes." Movement occurs when an electron from a complete orbit moves to fill a hole, leaving a hole where it came from. Another electron from another orbit can then move in to fill the new hole and so forth, as shown in Fig. 3. The move-



54 Fig. 3. Movement of holes.

ment of the holes in one direction corresponds to a movement of electrons in the other direction. Hence an electric current is produced. The level of doping with impurities governs the number of holes or electrons that are available. In certain applications, high levels of doping are required, and the material is often referred to as a P++ or N++ semiconductor.

Next month, we will continue our "What is a ...?" series with the PN Junction. Now let's get our hands on some physical components by looking at this month's schematics, which feature all sorts of circuits using different types of diodes.

SIMPLE CRYSTAL AM RECEIVER

Want to receive AM radio using two components—look at the circuit in Fig. 4. This simple receiver just needs a signal diode and crystal headphone. The transmitted AM signal is picked up by an antenna and is passed through a germanium diode—which removes the RF portion, leaving behind the audio signal to be heard in the headphone. I used a 1N60 diode, although any equivalent device could be substituted. A piezo speaker can be used instead of a crystal headphone. In areas of high signal strength, the antenna can be just a short whip to ground, or it can be your body. In other areas, the antenna should be mounted on a high mast or tree. A good ground is required—drive a metal stake into the earth and connect this circuit to the ground post. Happy receiving!

—Jawish Hameed, Malé, Republic of Maldives

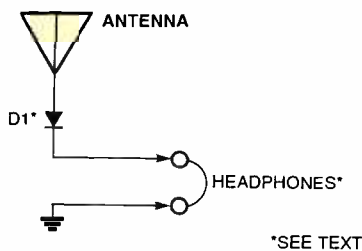
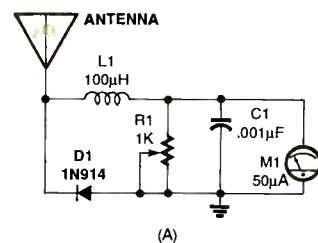
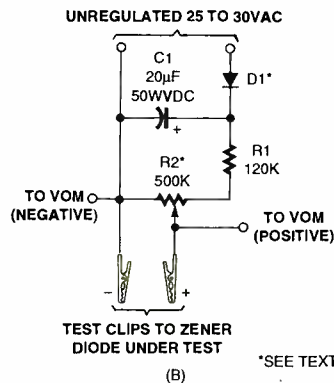

Fig. 4. This crystal receiver is about the most basic of receiver circuits.

This crystal-set receiver is just about the most basic of receiving circuits. Considering your remote location, you must be pretty close to some powerful AM transmitters. I once used a similar circuit, but with an amplifier at the output. The one station I picked up came in as well as with a standard AM radio.



(A)



(B)

Fig. 5. These two simple circuits are additions to your test bench. A field-strength meter that can be used to probe for RF fields is shown in (A), while (B) shows how to determine the voltage value for unknown Zener diodes.

FIELD-STRENGTH METER AND ZENER-DIODE CLASSIFIER

Here's a couple of simple circuits I built which are very useful for your test bench. In the field strength meter of Fig. 5A, the 1N914 signal diode rectifies the incoming RF energy picked up by the probe antenna. This antenna can be any length of solid copper wire one-foot long, or longer. This energy is further filtered and applied to the 50-µA DC meter, where a reading is observed. Use the potentiometer as a sensitivity adjustment. Move the probe antenna around for maximum signal strength.

The circuit of Fig. 5B is used to determine the breakdown voltage of unknown Zener diodes. The input voltage to this circuit is unregulated AC in the 25 to 35 volt range. This AC is rectified by diode D1 (any standard 50 PIV rectifier, such as a 1N4001) and filtered by capacitor C1. Resistor R1 and potentiometer R2 should be rated at 1/2 watt. Place the cathode of the Zener-under-test on the positive clip and the anode on the negative lead. Across these leads is your VOM, which is set to measure DC voltage. The potentiometer should be set to its highest resistance. Slowly run the voltage up (lower the potentiometer resistance) while watching the VOM. When the reading stops,

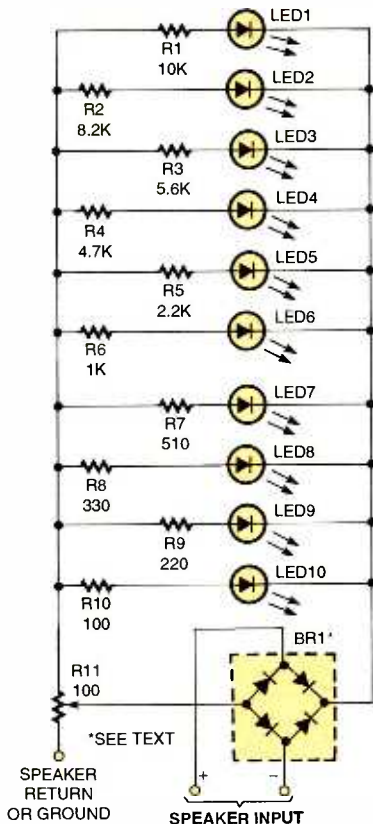

Fig. 6. Here's a handy accessory for your stereo system. The LEDs light (from D10 to D1) in relation to the output volume to the speaker.

you have reached the breakdown voltage of the unknown Zener diode.

—Mike K. Keller, Lancaster, PA

Very nice, Mike! I would recommend that the builders of this Zener circuit take the normal precautions when handling the unregulated AC input voltages.

VISIBLE STEREO V-U METER

I designed the circuit in Fig. 6 as a cheap graphic upgrade for my stereo system V-U meters. The circuit is relatively easy to build and inexpensive. It takes the audio output of any stereo system and converts the signal to polarized DC. This DC is then used to excite the LEDs, depending upon the strength of the signal. As the voltage rises, the LEDs will emit in the order of their arrangement, D10 to D1. I used three colors of LEDs to represent the strength of the stereo's output. Green is from D7 to D10, orange or yellow from D4 to D6, and red for D1 to D3. This arrangement will enable the display to change from green to yellow, and then red. I also added the potentiometer, R11, to use as a compatibility adjustment, since not all stereo levels

are the same.

Build one of these circuits for each channel of your stereo (unless it is a monaural output) and hook it across the output speaker. The full-wave rectifier bridge can be a modular type (such as the RadioShack 276-1146) or four individual 1N4001 diodes. The resistors listed do not have to be the exact value shown, as long as they are installed in this order (most resistance to least resistance from R1 to R10 should work okay). Standard 1/4-watt, 5 percent values are adequate. Also calibrate R11 to meet your system's requirements. Hook the circuit up to your stereo and adjust R11 until it is in a safe operating range. The LEDs should not be as bright as a 100-watt light bulb, but should be emitting a normal glow. To get a relative idea of how bright they should be, connect a 9-volt battery in series with a 1000-ohm resistor and an LED. Make sure you get your polarity correct on your LED, or it will not emit light, may get hot, and possibly burn out.

—Dave Lembke, Enfield, NH

I can see lots of uses for this circuit, Dave. You might consider using some of the dot/bar display driver ICs in conjunction with multi-colored bargraph displays to reduce the quantity of components needed, especially with a multiple-output stereo system. The next circuit illustrates this concept.

VISIBLE AUTO-BATTERY VOLTMETER

The circuit of Fig. 7 shows an interesting design using the National Semiconductor LM3914 dot/bar display driver IC, which senses analog voltage and drives ten LEDs, to provide a linear display of voltage. The LM3914 is designed to be operated in the dot mode, which means there is a small amount of overlap or "fade" between segments. This assures that at no time will all the LEDs be off, and thus any ambiguous display is avoided.

When correctly adjusted, this circuit covers the 2.5-volt–3.6-volt input range, but in this design it is adjusted for the nominal 12-volt range of a car battery. The two 5000-ohm potentiometers are adjusted so that the LEDs will light over the expected lower and upper input voltage range. If the input voltage falls below 10.5 volts, none of the LEDs should light up; if the voltage exceeds 15 volts, all the LEDs should light. To save space, a RadioShack 276-081,

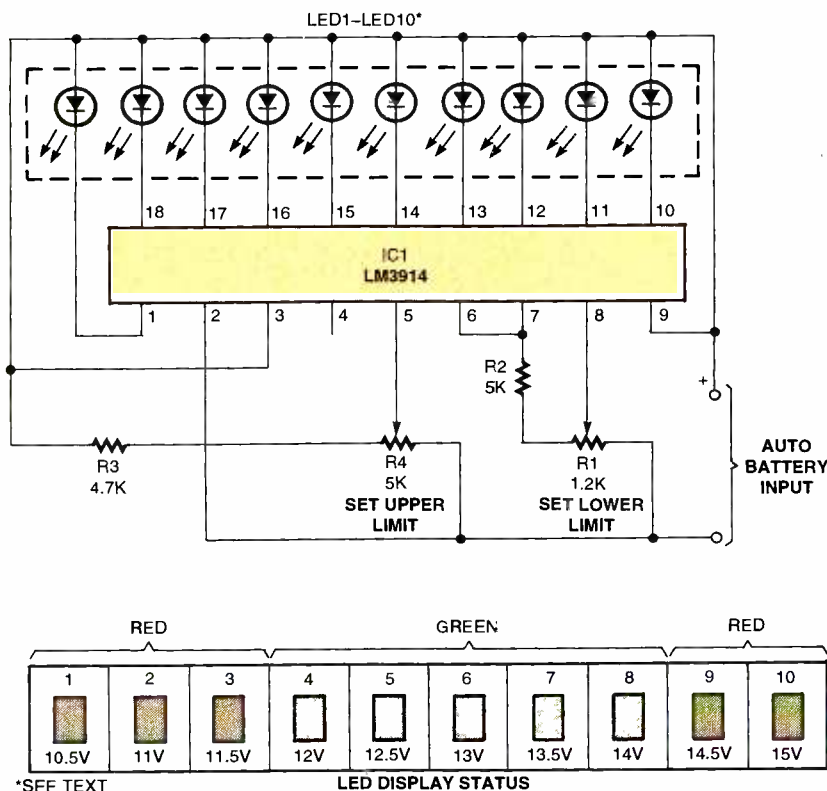

Fig. 7. In this circuit, the LM3914 dot/bar display driver with a ten-segment LED display visibly shows the automobile battery voltage over a 10.5-volt to 15-volt range.

ten-segment red LED bargraph display can be substituted for the ten LEDs.

—Alex Belenky, Brooklyn, NY

Nice going, Alex! How about using this concept with the previous stereo V-U meter circuit. By the way, the NTE1508 is a good substitute for the LM3914 IC. In reviewing the design data for this IC, I see that National recommends hooking up a 2.2- μ F tantalum or 10- μ F aluminum electrolytic capacitor across the 12-volt inputs to this circuit if the leads to the LED supply are six inches or longer.

MAILBAG, ETC.

Here's some corrections to recent *Think Tank* circuits that readers have sent in.

In the January 1998 *Think Tank*, page 67, Fig. 1, besides rotating the full-wave bridge 90° counter clockwise for proper operation, the 160- μ F, 16-volt capacitor should be marked C4, not C5. Also in the February 1998 column, page 64, Fig. 4, are the two transistors, Q2 and Q3 mixed up? The 2N2222 is an NPN-type, but drawn as a PNP.

—John Myers, Cornwall, ON, Canada

*Thanks for noting these errors, John. As far as your last observation, the marking of these two transistors is backwards. The designation of Q2 belongs to the 2N2222, while the device for Q3 should be the 2N2907, PNP transistor. By the way, just as soon as we verify any corrections we will post them on our Web site: www.gernsback.com, under the **Popular Electronics**, Forum link.*

Well, we are about out of circuits for this month's column. When you put together your circuits for *Think Tank*, remember to **keep them simple** (if they are too involved, submit them to the Editor as a full-blown construction project). Make sure that your schematics are neat and legible and that you include a full description of the circuit's operation. If you use any non-standard components, verify that they are still available—list a source or equivalent sources of these items, so that your fellow builders can purchase them. For each of your circuits that appear, you'll receive a book from our library. Send in enough circuits to fill a whole column and you will get a nifty kit or electronics tool to make your construction easier.

Write me—Alex Bie, *Think Tank*, **Popular Electronics**, 500 Bi-County Blvd., Farmingdale, NY 11735. ■

COMPUTER BITS

(continued from page 50)

Next time, we'll start getting our hands dirty. In the meantime, if you have any ideas for PIC projects you'd like to see, be sure to send them in.

READER RESPONSE

Ken Deboy wrote with a complaint about my "Adios ISA" topic in the *Computer Bits* column in the October issue of last year. Ken seemed to assume that I was whole-heartedly blessing Microsoft for the PC98 spec, and he had a major problem with that.

Actually, I am ambivalent about the whole thing. No, I don't want Microsoft to dictate and control yet another aspect of the computer business. But, yes, PC configuration is still a nightmare for most users. I don't mean the people who read this magazine. I mean the non-technical types who don't know an IRQ from an I/O port, and who could care less. It's the type of person who doesn't know about backups, and who one day wakes up to find his or her hard disk trashed because the kids switched the machine off during a disk write. How do those people manage their machines? Companies with technical staff experience the same problems, but in a different way: volume.

FOR MORE INFORMATION

MicroChip Technology
2355 West Chandler Blvd.
Chandler, AZ 85224
Tel. 602-786-7200
Web: www.microchip.com

Square One Electronics
P.O. Box 501
Kelseyville, CA 95451
Tel. 707-279-8881
Web: www.sq-1.com
e-mail: sqone@pacific.net

I strongly believe that the PC industry needs manageability and reliability at least an order of magnitude better than what currently exists. If it takes Microsoft and Intel to ram it down our throats, that should be better than nothing at all—I think. Let's revisit the subject again in a few years. Stay in touch at: jkh@acm.org. ■

BUY BONDS

ANTIQUE RADIO

(continued from page 52)

dropping resistor. Marcel found the set easy to build and, using a 100-foot antenna 40—50 feet high, he spent many happy hours tuning in stations from all over the world.

On entering the armed forces, Mr. Forest gave the radio to a friend and still has fond memories of it. He'd like to correspond with others who want to share memories of the old-time regens.

Frank Charies (Tucson, AZ) was lucky enough to pick up a Knight Star Roamer in like-new condition for \$10 at a thrift store. On the same day, he happened to see the March 1997 issue of **Popular Electronics** on a drug store magazine counter and was surprised to find one of the installments of our Star Roamer restoration series.

Frank has been a short-wave hobbyist since 1936 when he was twelve. One of his favorite sets was the old G.I.-Majestic "morale radio" so common in military orderly rooms during World War II. He'd like to see us do an article on the set. Actually we've already done a series on the similar (but non G.I.-model) metal cabinet Minerva table model. (See the "Antique Radio" columns in **Popular Electronics**, April through July 1995.) Even so, if a Majestic G.I. set crosses my path, I'll try to acquire it and write up the restoration.

Vincent V. Saucedo (924 N. "H" St., San Bernardino, CA 92410) has an Echophone Model A (battery-operated, wood cabinet) manufactured by the H. Earle Wright Co. He'd enjoy hearing from anyone who could provide information on this set.

Finally, thanks to reader Ron Ruple (Schaumburg, IL) for sending in a schematic for a full-featured "A," "B," and "C" battery eliminator for 01-A sets. He was inspired to design it after getting a look at the very rudimentary battery eliminators I had put together for the Freed-Eisemann restoration.

I've discussed the design with Ron, and the more we talked the more it seemed that it would be easy to expand his unit to be a "universal" power supply for any type of battery set from the early regens to the personal portables of the 1940s. We're continuing to kick this idea back and forth, and you may eventually see the result as an "Antique Radio" construction project. ■

SCANNER SCENE

Handheld Test Receiver

MARC SAXON

Leave it to the folks at *Opto-electronics* to think of innovative monitoring devices. This time it's their *R-11 Nearfield FM Test Receiver*. It's capable of sweeping from 30 MHz to 2 GHz in less than one second, instantly locking onto any relatively close FM signal and playing it through its built-in speaker. The R-11 is capable of picking up a 5-watt signal from a distance of 500 feet. Per FCC regulations, the cell-phone bands are blocked on U.S. versions.

Any frequency being monitored can be locked in, or the unit can be instructed to resume its sweeping. In addition, the general frequency transmitting band is shown on the R-11's LED indicator. This test receiver also has the capability to lock out up to 1000 specific unwanted signals. There is an override lockout button as well as a lockout clear function. Squelch and speaker volume are controlled from two knobs located at the top of the unit.

When you want to record the exact frequency being monitored, an *Opto-electronics Scout* can be used in conjunction with the R-11 (via the CI-5 data port). It comes with a detachable (via BNC connector) telescoping whip antenna. Rechargeable batteries are built-in, and the charger is included. A single charge provides five hours of operation.

The R-11 sells for \$399 from Opto-electronics, 5821 N.E. 14th Ave., Ft. Lauderdale, FL 33334; Tel. 800-327-5912; or e-mail them: sales@opto-electronics.com.

SURVEILLANCE BONANZA

A reader in Ohio informed me that many undercover operations, stake-outs, and surveillance operations don't utilize regular police radios/frequencies. (A reliable law-enforcement agency source confirms this.) They use low-powered handheld transceivers operating in simplex mode on itinerant business, or 49-MHz, or Family Radio Service, or similar channels. These devices provide more privacy than police radios, because the transmissions are short range and *people with*



The R-11 Nearfield FM Test Receiver from Opto-electronics is capable of sweeping from 30 MHz to 2 GHz in less than one second, instantly locking onto any relatively close FM signal and playing it through its built-in speaker.

scanners seldom monitor there! I'm advised the practice is employed at times by many agencies, including some of the feds.

These channels cover a wide range of the spectrum, and they include unlicensed radio services as well as those for which the FCC demand station licenses. My own monitoring indicates that relatively few seem to have licenses, from all manner of private to industrial users. The house detectives and security people at a large fancy resort hotel near me operate on 464.50 MHz. They don't seem to have the required FCC license. Nevertheless, the other day I was amused to hear them become hostile with some outsiders who innocently attempted to use the frequency. The hotel people angrily

announced, "Clear this channel immediately! It is an official hotel security channel!" The *interlopers* sheepishly apologized and moved on. Ho boy!

My police source also informs me that even the bad guys use these little two-way radios. They're inexpensive, reliable, convenient, and readily available at communications shops, sporting goods stores, auto-accessory shops, *etc.* Anything goes on these channels! Some channels have gotten so popular that they are often referred to by the general public with an unofficial dot, star, color or other code rather than an actual frequency (*i.e.* 151.625 MHz = Red Dot). In instances where a channel is also known by a code name, it is indicated in parentheses after the frequency.

POPULAR FREQUENCIES

Here are a few of the more popular scanning frequencies:

- Police Radio Service: 39.06 MHz.
This frequency, which most monitors never bother to tune, is covered by low-power handheld radios. The channel is seldom listed in frequency directories.
 - No-License 49 MHz Band: 49.845, 49.86, 49.875, 49.89, 49.93 MHz.
The frequency 49.86 MHz appears especially popular. Remember this band is also used by wireless room monitors.
 - Family Radio Service and GMRS: 462.5625, 462.5875, 462.6125, 462.6375, 462.6625, 462.6875, 462.7125, 467.5625, 467.5875, 467.6125, 467.6375, 467.6625, 467.6875, 467.7125 MHz. Radio-Shack's most inexpensive single-channel unit operates on 462.5625 MHz, so that's a best bet. No licenses are required.
 - VHF Maritime: 156.375 (Channel 67), 156.40 (Channel 8), 156.625 MHz (Channel 72). These are primarily intended for ship-to-ship use. Various unauthorized non-maritime or land uses by means of handheld VHF marine transceivers have long
- (Continued on page 62)

HAM Radio

The Delightful, Disdained, Dumb Old Dipole

JOSEPH J. CARR, K4IPV

There are only a few things that galled me to the point of growling. One of them is people dumping on the dipole antenna. The lowly dipole is often disdained, frequently bad mouthed, and generally held in contempt by those who can afford a large full-size beam antenna with rotator. Fortunately for those of us less well-endowed with \$\$\$, the dipole is a credible antenna that will work wonders. This antenna is well-suited to both amateur radio and shortwave/ scanner listening at frequencies from just above the AM broadcast band to the VHF region. I've used dipoles as high as 144 MHz, and as low as 3.5 MHz. They work well.

WHAT IS A DIPOLE?

One reader once took me to task for calling the antenna I am discussing here a "dipole." Unqualified, a "dipole" is any two-pole (which is what "di" means) antenna. For the purist, the "dipole" meant here is the *half-wavelength, center-fed, horizontal dipole*. I will continue to call it a "dipole" because everyone knows what I mean...especially after reading this disclaimer (sigh). I will also discuss a dipole variant, the inverted-vee dipole.

Figure 1 shows the basic form of a dipole antenna. It consists of two quarter-wavelength radiator elements ("A" in Fig. 1) connected as an overall half wavelength radiator ("B" in Fig. 1) fed in the center. The total length (L in feet) for a half wavelength ($\lambda/2$) antenna operating at a frequency (f in MHz) is found from:

$$L = 492/f$$

Unfortunately, this equation only holds for a perfect, self-supporting antenna in free space, which none of us ever sees. Because of the "End Effect" caused by the dielectric end insulators ("EI" in Fig. 1), and the velocity factor (V) of the wire used for the elements, the actual length is several percent shorter. A first-order approximation

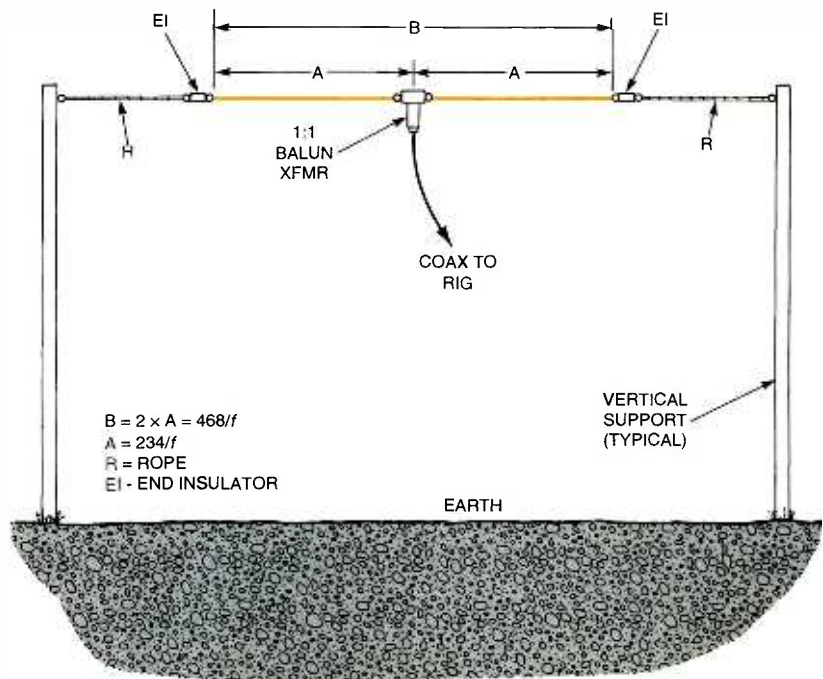

Fig. 1. Illustration showing how simple it is to erect a dipole antenna.

(from which you must tune to the actual length for your particular installation) is:

$$L = 468/f$$

If you use the above equation for, say, 7.2 MHz in the 40-meter band, the numbers are: $L = 468/7.2 = 65$ feet long (each leg is $\lambda/4$ long, or 32.5 feet).

The wire elements are made from 14 gauge or 12 gauge copper wire. Do not use solid copper wire as it will flex in the wind, and then break due to metal fatigue. Always use either Copperweld or hard-drawn copper wire, both of which are stranded. Stranded wire fatigues, like solid wire, but takes a lot more flexing before it breaks. The stranded wire antenna will last several times as long as the solid-wire antenna. Copperweld wire is a special brand of antenna wire. It is a steel wire with a copper coating on the outside surface. It is also called "copper-clad steel" in

some textbooks. I always recommend this type of wire if it is available. Most radio stores that sell ham and SWL stuff carry antenna kits with the correct wire, as well as selling it in 100-foot rolls (usually 14 gauge).

The wire elements are supported from some type of vertical structure (a mast, a tree, or the wall/roof of a building) by a length of rope ("R" in Fig. 1). Don't use just any old rope. I've used standard $3/16$ -inch and $1/4$ -inch cotton clothesline, and it did not last long. I prefer the same size rope in nylon or some other strong synthetic material. Also, the nylon is a better insulator after being wet, because it does not absorb moisture like cotton (and dries out a lot faster).

The antenna is fed with 75-ohm coaxial cable, or is it? The standard literature says that the dipole feedpoint impedance is 73 ohms, so it is a good match to 75-ohm coax (RG-59/U or

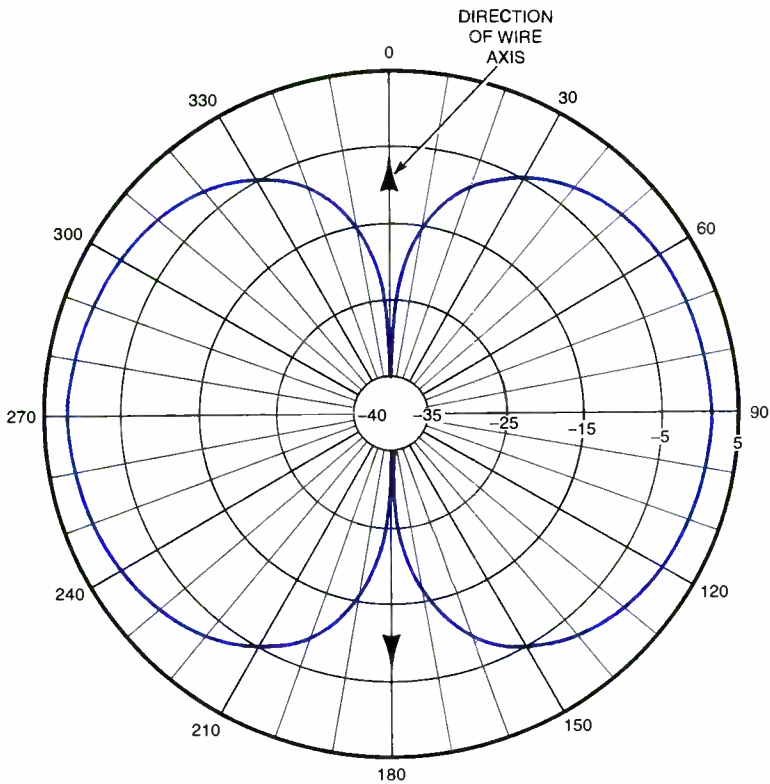

Fig. 2. The ideal half-wavelength dipole antenna pattern in the horizontal plane—a “Figure-8” pattern at resonance.

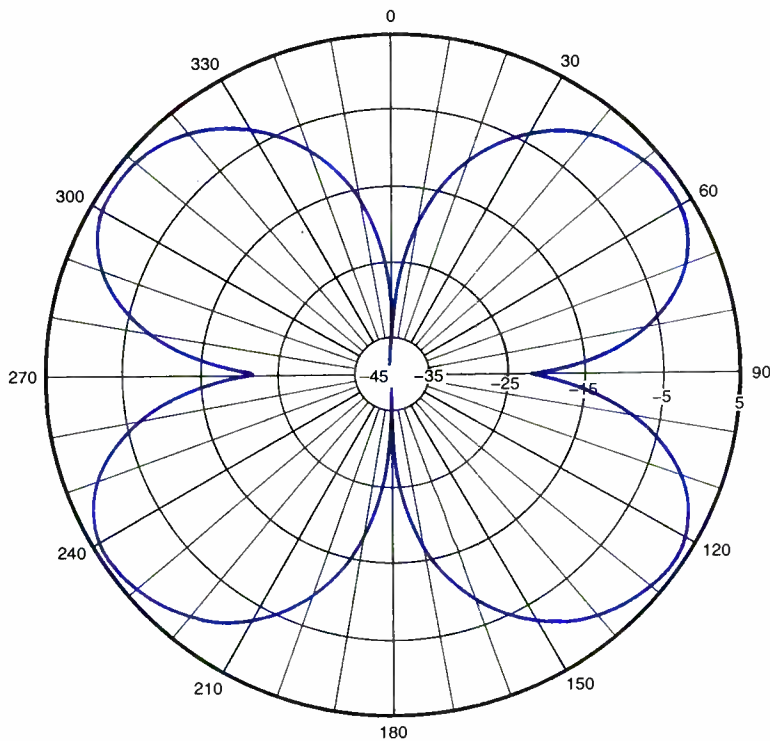

Fig. 3. The dipole antenna pattern at twice the resonant frequency (electrical length is one-wavelength long). Antenna impedance is very high at these even multiples—an antenna tuner is required to reduce VSWR.

RG-11/U). If you are just guessing, then use 75-ohm coax and see what happens. It will probably work well enough to use. The actual impedance will vary from a few ohms to about 120 ohms, so some other form of coaxial cable might be in order. For example, if the impedance is less than about 68 ohms, then it might be a better match to 52-ohm coaxial cable (RG-58/U, RG-8/U, or RG213/U).

Alternatively, if the antenna impedance is close to 120 ohms, then you can use a 52-ohm quarter wavelength matching section. This will transform the 120-ohm feedpoint impedance to about 79 ohms, which is not a shabby match to 75-ohm coaxial cable. The physical length of the matching section is:

$$L = (246 \times V)/f$$

where L is the dipole length in feet and f the operating frequency in MHz, as before. Now we introduce, V , the velocity factor of the coax, which depends on the type of cable used. If you use a standard variety, then the following are good approximations:

- Polyethylene inner insulator: 0.66
- Polyfoam (“foam”) inner insulator: 0.80
- Teflon inner insulator: 0.70

There are other types that are peculiar to specific brands, so look up the velocity factor for the cable you purchase if it is not one of the two standards (polyethylene and polyfoam).

The center point of the dipole antenna is fed with the coaxial cable. The center conductor goes to one element, and the shield to the other. If you are really on a zippo budget, then use an end insulator at the center...but only if you absolutely, positively, cannot afford a proper insulator—a balun (balanced-to-unbalanced) transformer. The weather will eventually mess up the coax with an end-insulator connection installation...so beware. Always use a proper center insulator or balun, if at all possible.

The use of a 1:1 balun transformer (1:1 means the primary and secondary impedances are the same) at the feedpoint in lieu of the center insulator has been controversial for some time. Why, I don't know. Tests have shown conclusively that using the 1:1 balun makes the dipole's radiation pattern more like

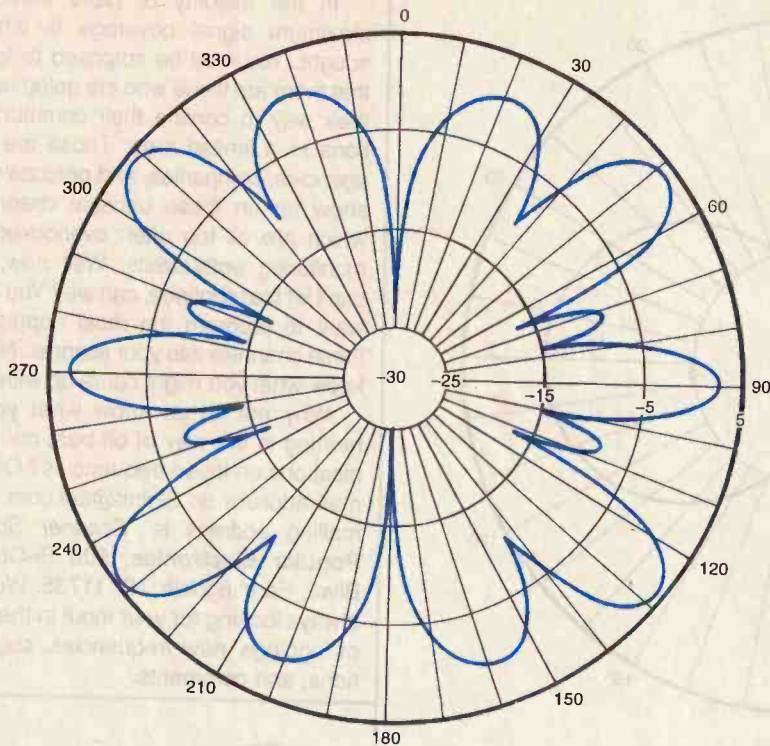

Fig. 6. The dipole antenna pattern at seven times the resonant frequency (electrical length of $3\frac{1}{2}$ -wavelengths long). With the resulting increase in nulls, pattern is almost omnidirectional.

compress the dipole by drooping the ends towards ground to form an inverted-vee dipole (Fig. 7).

The inverted-vee dipole is mounted from a vertical support at the center. Again, a 1:1 balun transformer is highly recommended. The wires are drooped at equal angles down to end insulators and ropes, with the ropes tied off to a support on or near the ground (stakes driven into the ground shown here).

The overall length of the inverted-vee, at least as a first-order approximation, is about 6 percent longer than an ordinary dipole, or:

$$L = 496/f$$

The angle between the wires should be at least 90 degrees, and it may be up to about 140 degrees (of course, if it approaches 180 degrees, then it is a regular dipole—not an inverted-vee!).

The radiation pattern of the inverted-vee, as shown in Fig. 8, is not as sharp as that of the dipole of Fig. 2. The gain is a tad less than the dipole, and the nulls are not as deep. It retains the same Figure-8 pattern, but is less perfect than the dipole antenna. Nonetheless, the ease of installation and smaller "footprint" makes the inverted-vee the antenna of choice for many people.

I recall one fellow who has a wood-frame, three-story house with a high, pitched roof. He placed an inverted-vee such that the feedpoint was at the peak of the roof, and the ends were near the ground. The wire just laid on the roof (I don't recall how the gutter interacted with the antenna, but it had to have some effect).

TUNING A DIPOLE

One of the disadvantages of publishing an equation for antenna length is that readers will actually take it seriously. For example, the dipole's overall length (in feet) is $468/f$, and that looks so darn precise. It isn't; all formulas are approximations only. Differences in location, differences in wire size, and differences in end-insulator characteristics conspire to change the real length required. This effect is greater on the higher bands than on the lower bands. At the higher frequencies, an inch or two is a greater percentage of the total antenna length.

The best way to tune a dipole is to

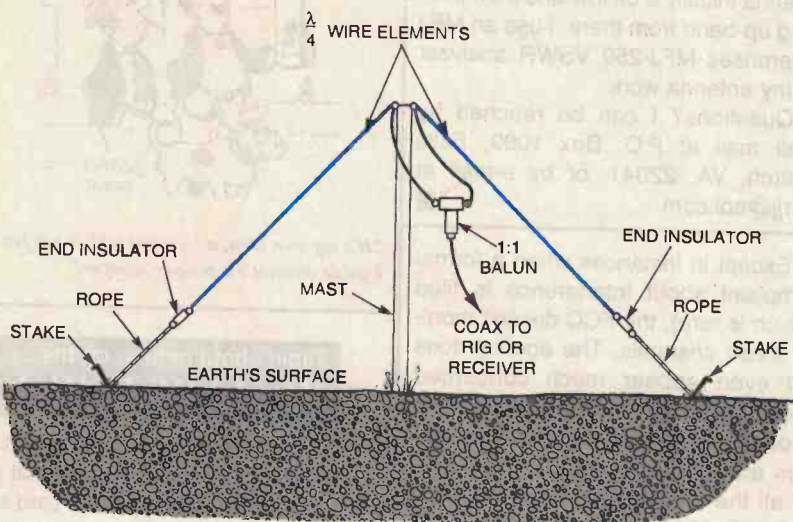

Fig. 7. Illustration showing inverted-vee antenna installation. Actual "footprint" on ground is much less than the half-wavelength dipole.

"n" lobes are found in each hemisphere for an $n \times (\lambda/2)$ long dipole operating at higher harmonic frequencies.

INVERTED-VEE DIPOLES

The one big drawback of the standard horizontal half-wavelength dipole is that it takes up a bit more than half wavelength of space on the ground.

Some of us don't have a running length of a half wavelength at the lowest frequency we want to operate on. At my current home, for example, I can easily accommodate a 31-meter band dipole, but 40-meters comes awfully close to the property line on one side and a power line on the other (**DANGER!!**). Therefore, some people like to

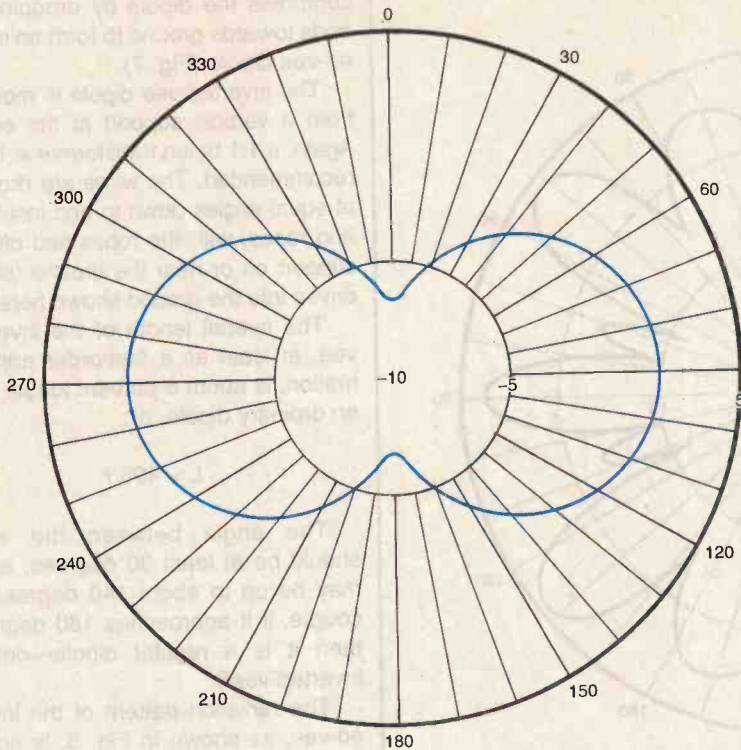

Fig. 8. Typical half-wave inverted-vee antenna pattern at resonance (horizontal plane).

erect it a bit longer than necessary, and then run a VSWR curve (discussed in depth in my February 1998 column). The minimum point is at the resonant frequency. If the resonant point is too low, then shorten the antenna; but if it is too high, you must lengthen the antenna. Because it is easier to shorten than lengthen (cut wires being what

they are!), I recommend cutting the antenna initially a bit low and then trimming up-band from there. I use an MFJ Enterprises MFJ-259 VSWR analyzer for my antenna work.

Questions? I can be reached by snail mail at P.O. Box 1099, Falls Church, VA, 22041, or by e-mail at carrjj@aol.com. ■

SCANNER SCENE

(continued from page 57)

been reported.

- Business and Industrial: 151.505, 151.625 (Red Dot), 151.955 (Purple Dot), 154.57 (Blue Dot), 154.60 (Green Dot), 158.40 (White Dot), 462.625 (Black Dot), 462.675 (Orange Dot), 464.50 (Brown Dot), 464.55 (Yellow Dot), 464.575 (White Dot), 467.7625 (Channel J), 467.8125 (Channel K), 467.85 (Silver Star), 467.875 (Gold Star), 467.90 (Red Star), 467.925 (Blue Star), 469.50, and 469.55 MHz.

The FCC requires that station operations on these frequencies be licensed, but it's doubtful that 90 percent of those you'll hear will have licenses.

Except in instances when a formal complaint about interference is filed (which is rare), the FCC doesn't monitor these channels. The agency does not even appear much concerned about what goes on there. That's another reason why these frequencies attract hordes of offbeat users. Of all the frequencies shown above, 151.625, 154.57, and 154.60 MHz are certainly the most active since they are factory installed in popular VHF handhelds from major manufacturers and importers. In the UHF band, 464.50 and 464.55 MHz are good bets.

Depending upon the band and the radios, two-way communications for the various frequencies range from ¼-mile to as much as seven miles or more. But if you're monitoring from a base station with a good roof antenna, plus a preamplifier, you should be able to get the most from what each fre-

quency has to offer.

In the majority of radio services, maximum signal coverage is what's sought. You may be surprised to learn that there are those who are going out of their way to confine their communications to a limited area. Those are the agencies, companies, and persons who show up on these unusual channels, which are all too often overlooked by monitoring enthusiasts. Well now, we can't let that continue, can we? You may want to program the most popular of these channels into your scanner. Never know what you might come up with!

Why not let us know what you're hearing in the way of off-beat communications on these frequencies? Our E-mail address is: Sigint@aol.com. Our mailing address is: *Scanner Scene, Popular Electronics*, 500 Bi-County Blvd., Farmingdale, NY 11735. We are always looking for your input in the way of loggings, new frequencies, suggestions, and comments. ■



"It's my own idea, a 5/8-wave with a top-hat. Upside down it's a pooper scooper."

Timid about getting on the... World Wide Web?

You've heard about the *Information Superhighway* and all the hype that goes with it! Sort of makes you feel timid about getting on the Web. Put your fears aside! A new book, *The Internet and World Wide Web Explained*, eliminates all the mystery and presents clear, concise information to build your confidence. The jargon used is explained in simple English. Once the tech-talk is understood, and with an hour or two of Web time under your belt, your friends will believe you are an Internet guru!

To order Book #403 send \$6.95 plus \$3.00 for shipping in the U.S. and Canada only to Electronics Technology Today Inc., P.O. Box 240, Massapequa Park, NY 11762-0240. Payment in U.S. funds by U.S. bank check or International Money Order. Please allow 6-8 weeks for delivery.

those found in textbooks. The reason is that the balun converts the unbalanced coax feed to a balanced load, and in the process balances out currents that flow in the outer conductor ("shield"). If those currents are not balanced, they create radiation that changes the pattern of the antenna. As a result, I always recommend the use of a 1:1 balun transformer at the feedpoint of dipole antennas.

RADIATION PATTERNS

Figure 2 shows the standard radiation pattern for a $\lambda/2$ dipole antenna in the horizontal or azimuthal plane. It is a "Figure-8" pattern with the main lobes perpendicular to the run of the wire, and the nulls off the ends of the wire. The dipole is, therefore, bidirectional. Or is it?

One of the lesser known secrets is that you can use a dipole antenna at integer multiples of its design frequency. The odd half-wavelength multiples ($3\times$, $5\times$, $7\times$) are best suited because the feedpoint impedances are within reason. The even half-wavelength multiples ($2\times$, $4\times$, $6\times$) can also be used if some means is provided of matching the high impedances the even multiples present.

Figure 3 shows the pattern that we see when the half-wavelength dipole is operated at twice its resonant frequency (total antenna electrical length is one wavelength at operating frequency). The pattern is a nice four-lobe cloverleaf. The deepest nulls are off the ends of the wire, while lesser nulls are in line with the run of the wire. The main lobes are positioned at angles of 45 degrees or so from the run of the wire.

One of the neat tricks one learns as a Novice on 40-meters (7-MHz band) is that the 40-meter $\lambda/2$ dipole will also work on 15-meters (21-MHz Novice band—the third multiple). It is not for free, however, because the pattern blossoms out to that shown in Fig. 4. Note that besides two main lobes in this pattern, there are also the two minor lobes perpendicular to the run of the wire (a total of six lobes in the plane). As a result, it squirts its signal out in six different directions! It still has deep nulls off the ends of the antenna, but also has nulls at four other angles as well.

If we increase the operating frequency to five times the resonant frequency, we get the splatter pattern of

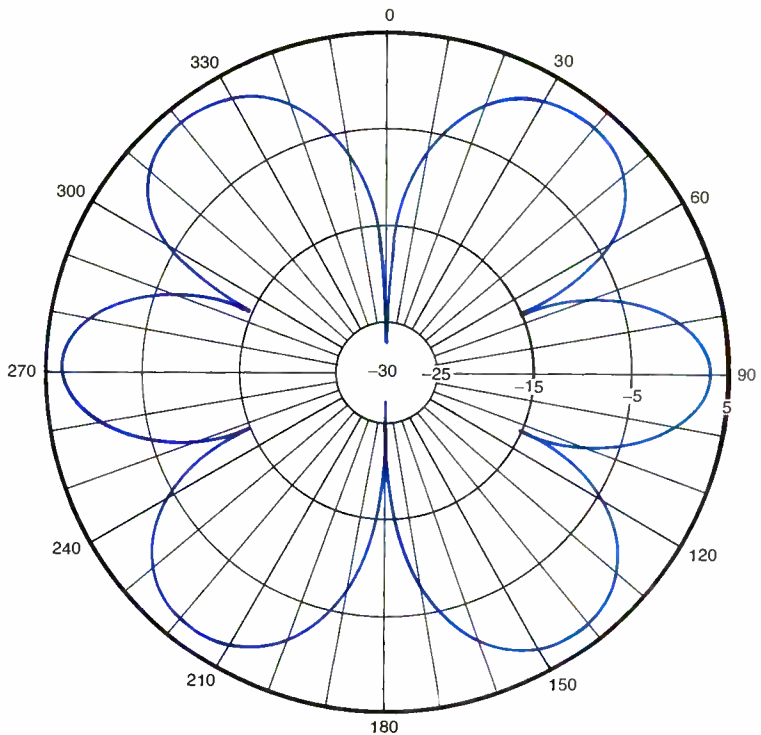

Fig. 4. The dipole antenna pattern at three times the resonant frequency (electrical length of three half wavelengths long).

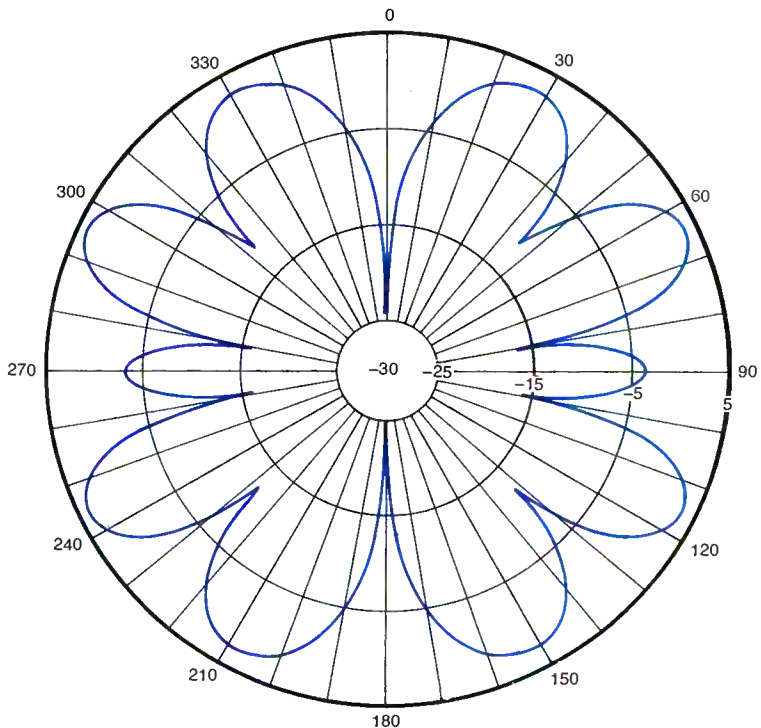

Fig. 5. The dipole antenna pattern at five times the resonant frequency (electrical length of $2\frac{1}{2}$ wavelengths long).

Fig. 5. There are multiple main lobes and a couple of minor lobes, plus a plethora of nulls. This pattern is almost omnidirectional, but not quite. At seven

times the resonant frequency, we get an even more varied pattern (Fig. 6). Note that seven distinct lobes are formed in each hemisphere. In general,

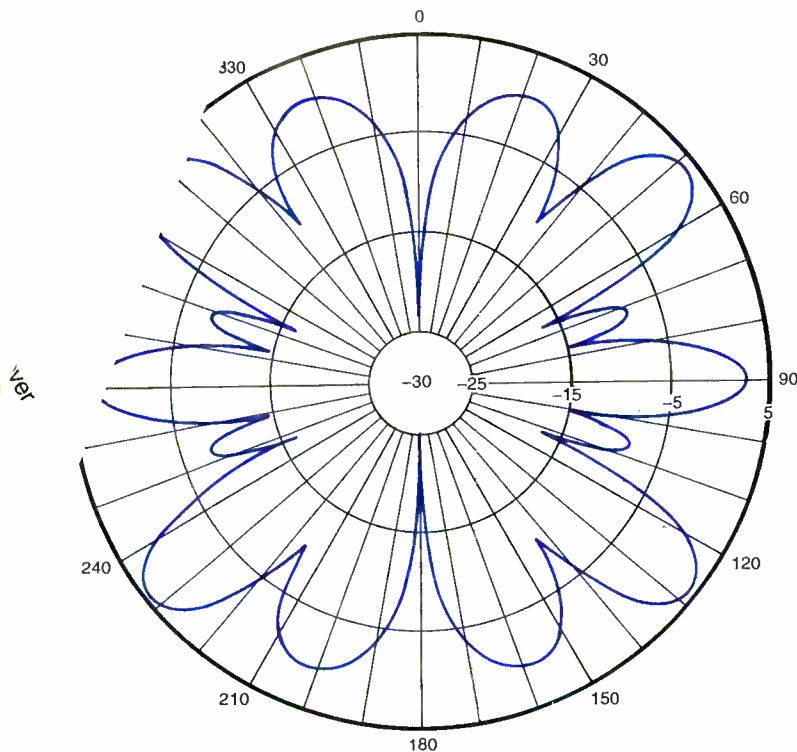

Fig. 6. The dipole antenna pattern at seven times the resonant frequency (electrical length of $3\frac{1}{2}$ wavelengths long). With the resulting increase in nulls, pattern is almost omnidirectional.

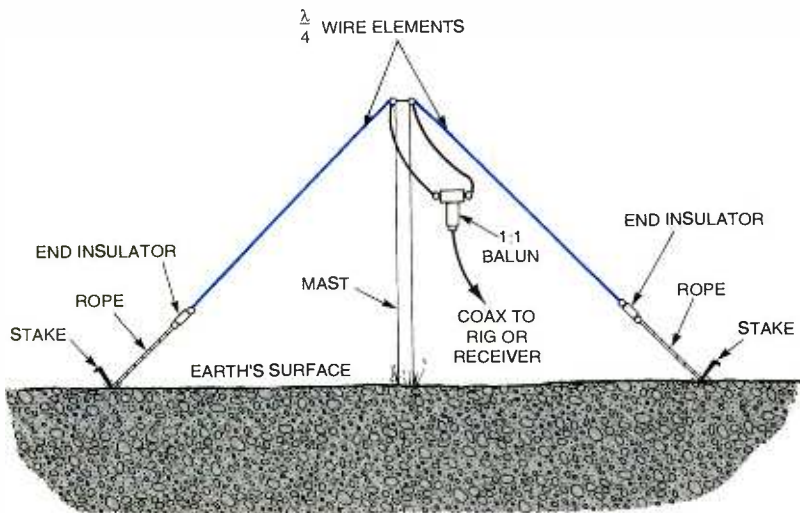

Fig. 7. Illustration showing inverted-vee antenna installation. Actual "footprint" on ground is much less than the half-wavelength dipole.

"n" lobes are found in each hemisphere for an $n \times (\lambda/2)$ long dipole operating at higher harmonic frequencies.

INVERTED-VEE DIPOLES

The one big drawback of the standard horizontal half-wavelength dipole is that it takes up a bit more than half wavelength of space on the ground.

Some of us don't have a running length of a half wavelength at the lowest frequency we want to operate on. At my current home, for example, I can easily accommodate a 31-meter band dipole, but 40-meters comes awfully close to the property line on one side and a power line on the other (**DANGER!!**). Therefore, some people like to

compress the dipole by drooping the ends towards ground to form an inverted-vee dipole (Fig. 7).

The inverted-vee dipole is mounted from a vertical support at the center. Again, a 1:1 balun transformer is highly recommended. The wires are drooped at equal angles down to end insulators and ropes, with the ropes tied off to a support on or near the ground (stakes driven into the ground shown here).

The overall length of the inverted-vee, at least as a first-order approximation, is about 6 percent longer than an ordinary dipole, or:

$$L = 496/f$$

The angle between the wires should be at least 90 degrees, and it may be up to about 140 degrees (of course, if it approaches 180 degrees, then it is a regular dipole—not an inverted-vee!).

The radiation pattern of the inverted-vee, as shown in Fig. 8, is not as sharp as that of the dipole of Fig. 2. The gain is a tad less than the dipole, and the nulls are not as deep. It retains the same Figure-8 pattern, but is less perfect than the dipole antenna. Nonetheless, the ease of installation and smaller "footprint" makes the inverted-vee the antenna of choice for many people.

I recall one fellow who has a wood-frame, three-story house with a high, pitched roof. He placed an inverted-vee such that the feedpoint was at the peak of the roof, and the ends were near the ground. The wire just laid on the roof (I don't recall how the gutter interacted with the antenna, but it had to have some effect).

TUNING A DIPOLE

One of the disadvantages of publishing an equation for antenna length is that readers will actually take it seriously. For example, the dipole's overall length (in feet) is $468/f$, and that looks so darn precise. It isn't; all formulas are approximations only. Differences in location, differences in wire size, and differences in end-insulator characteristics conspire to change the real length required. This effect is greater on the higher bands than on the lower bands. At the higher frequencies, an inch or two is a greater percentage of the total antenna length.

The best way to tune a dipole is to

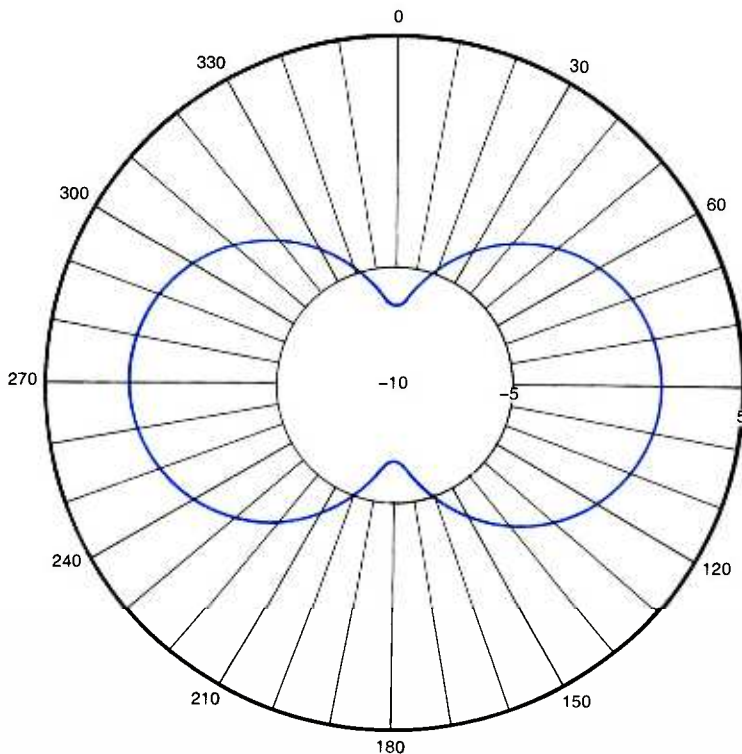

Fig. 8. Typical half-wave inverted-vee antenna pattern at resonance (horizontal plane).

erect it a bit longer than necessary, and then run a VSWR curve (discussed in depth in my February 1998 column). The minimum point is at the resonant frequency. If the resonant point is too low, then shorten the antenna; but if it is too high, you must lengthen the antenna. Because it is easier to shorten than lengthen (cut wires being what

they are!), I recommend cutting the antenna initially a bit low and then trimming up-band from there. I use an MFJ Enterprises MFJ-259 VSWR analyzer for my antenna work.

Questions? I can be reached by snail mail at P.O. Box 1099, Falls Church, VA, 22041, or by e-mail at carrjj@aol.com. ■

SCANNER SCENE

(continued from page 57)

been reported.

- Business and Industrial: 151.505, 151.625 (Red Dot), 151.955 (Purple Dot), 154.57 (Blue Dot), 154.60 (Green Dot), 158.40 (White Dot), 462.625 (Black Dot), 462.675 (Orange Dot), 464.50 (Brown Dot), 464.55 (Yellow Dot), 464.575 (White Dot), 467.7625 (Channel J), 467.8125 (Channel K), 467.85 (Silver Star), 467.875 (Gold Star), 467.90 (Red Star), 467.925 (Blue Star), 469.50, and 469.55 MHz. The FCC requires that station operations on these frequencies be licensed, but it's doubtful that 90 percent of those you'll hear will have licenses.

Except in instances when a formal complaint about interference is filed (which is rare), the FCC doesn't monitor these channels. The agency does not even appear much concerned about what goes on there. That's another reason why these frequencies attract hordes of offbeat users. Of all the frequencies shown above, 151.625, 154.57, and 154.60 MHz are certainly the most active since they are factory installed in popular VHF handhelds from major manufacturers and importers. In the UHF band, 464.50 and 464.55 MHz are good bets.

Depending upon the band and the radios, two-way communications for the various frequencies range from ¼-mile to as much as seven miles or more. But if you're monitoring from a base station with a good roof antenna, plus a preamplifier, you should be able to get the most from what each fre-

quency has to

In the major, maximum signal sought. You may be radio services, that there are those who is what's their way to confine them to a limited area. Out of agencies, companies, and show up on these unusual, which are all too often over monitoring enthusiasts. Well, can't let that continue, can we? You want to program the most popular these channels into your scanner. Now know what you might come up with!

Why not let us know what you're hearing in the way of off-beat communications on these frequencies? Our E-mail address is: Sigint@aol.com. Our mailing address is: **Scanner Scene, Popular Electronics**, 500 Bi-County Blvd., Farmingdale, NY 11735. We are always looking for your input in the way of loggings, new frequencies, suggestions, and comments. ■

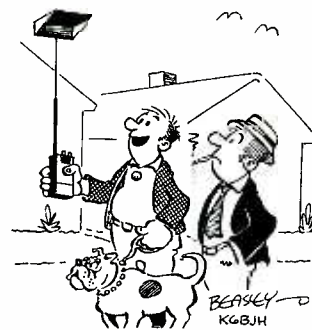

"It's my own idea, a 5/8-wave with a top-hat. Upside down it's a pooper scooper."

Timid about getting on the... World Wide Web?

You've heard about the *Information Superhighway* and all the hype that goes with it! Sort of makes you feel timid about getting on the Web. Put your fears aside! A new book, **The Internet and World Wide Web Explained**, eliminates all the mystery and presents clear, concise information to build your confidence. The jargon used is explained in simple English. Once the tech-talk is understood, and with an hour or two of Web time under your belt, your friends will believe you are an Internet guru!

To order Book #403 send \$6.95 plus \$3.00 for shipping in the U.S. and Canada only to Electronics Technology Today Inc., P.O. Box 240, Massapequa Park, NY 11762-0240. Payment in U.S. funds by U.S. bank check or International Money Order. Please allow 6-8 weeks for delivery.

Take This Giant Circuit Library For Only \$4.95

when you join the
Electronics Engineers' Book Club®

Hundreds of circuit ideas
alphabetically arranged—from
Alarm circuits to Zero
crossing detector circuits!

"...includes schematics for the latest electronics
circuits from industry leaders..."—Popular Electronics

Turn to this comprehensive circuit library for hundreds of project ideas...valuable troubleshooting and repair tips...and concise pinout diagrams and schematics. Each volume contains more than 700 electronic and integrated circuits and covers 100+ circuit categories.

If coupon is missing, write to: Electronics Engineers' Book Club® A Division of The McGraw-Hill Companies P.O. Box 549, Blacklick, OH 43004-0549

As a member of the Electronics Engineers' Book Club...

you'll enjoy receiving Club bulletins every 3-4 weeks containing exciting offers on the latest books in the field at savings of up to 50% off the regular publishers' prices. If you want the Main Selection, do nothing and it will be shipped automatically. If you want another book, or no book at all, simply return the reply form to us by the date specified. You'll have at least 10 days to decide. If you ever receive a book you don't want due to late delivery of the bulletin, you can return it at our expense. Your only obligation is to purchase 2 more books during the next 12 months, after which you may cancel your membership at any time. And you'll be eligible for FREE BOOKS through our Bonus Book Program. Publishers' Prices Shown © 1998 EEBC

ELECTRONICS ENGINEERS' BOOK CLUB®

A Division of The McGraw-Hill Companies, P.O. Box 549, Blacklick, OH 43004-9918

YES! Please send me *The Encyclopedia of Electronic Circuits-Vols. 1-3* (5857863), billing me just \$4.95, plus shipping/handling & tax. Enroll me as a member of the **Electronics Engineers' Book Club** according to the terms outlined in this ad. If not satisfied, I may return the books without obligation and have my membership cancelled.

Name _____

Signature _____

Address/Apt.# _____

City _____ State _____

Zip _____ Phone _____

Valid for new members only, subject to acceptance by EEBC. Canada must remit in U.S. funds drawn on U.S. banks. Applicants outside the U.S. and Canada will receive special ordering instructions. A shipping/handling charge & sales tax will be added to all orders.

PPIF498

The Encyclopedia of Electronic Circuits Volumes 1-3

by Rudolf F. Graf

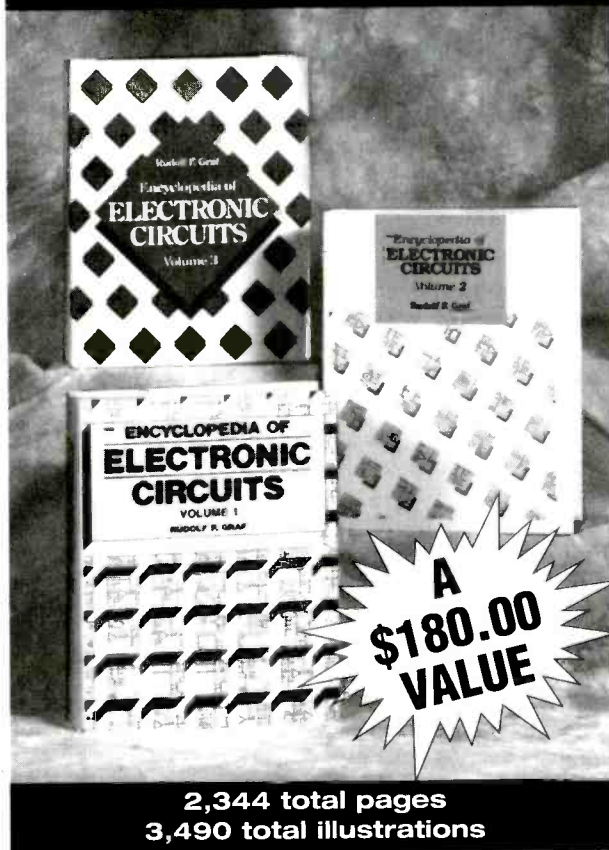

Circuit Circus

CMOS ICs—Decoders and Multiplexers

CHARLES D. RAKES

This month, the Circus is going to spotlight circuits using three very interesting complementary metal oxide silicon (CMOS) ICs. Although all three of these ICs have 24 pins and might look complicated at first, they are all very user-friendly, as we will see in the following circuit applications.

BCD DECODER

Our first centipede IC is a 4514, a CMOS 4-bit latched/4-to-16 line decoder (output a logical "1," or "high" on select), with BCD inputs. With the proper BCD input code, any one of the 16 outputs, can be made high. As we shall see later, the IC can also be used to pass on positive logic data to any one of these outputs.

Now let's take a look at the 4514 circuit shown in Fig. 1 and see how it can work for us. If we monitor IC1's 16 outputs we can tell if the circuit is performing as expected. Connecting an LED to each output makes the job a snap. All of the LED's cathodes are tied together and returned to ground through a single 1000-ohm resistor, R2. Since only one output can be on at a time, a single current-limiting resistor is all that is needed.

The follow (strobe) input, pin 1, is tied to the positive 12-volt supply for normal circuit operation (run). Switch S6 selects the strobe input condition for either a run or store function. In this circuit, the inhibit input, pin 23, is connected to IC2, a 4093 low-frequency oscillator IC, which causes the selected output LED to flash on and off. If this function is not desired, just tie the inhibit input to ground and leave out the 4093 circuitry.

The 4093 is a quad 2-input NAND Schmitt trigger IC, and it is designed to oscillate around 1 Hz (a complete description and applications of this IC were covered in **Popular Electronics**, February 1998). A reminder—as mentioned in previous columns—the inputs to unused gates should always be grounded to avoid pickup, instability,

etc. For IC2, unused pins 8 and 9, 12 and 13 are tied to one another and grounded.

Now we need a simple way to input the BCD codes for each of the decimal numbers 0 through 15. The four single-

pole double-throw switches, S1–S4, are connected to do just that. When any of the switches are in the "1" position, those BCD inputs are tied to the positive supply. If the switches are in the "0" position, the inputs are tied to

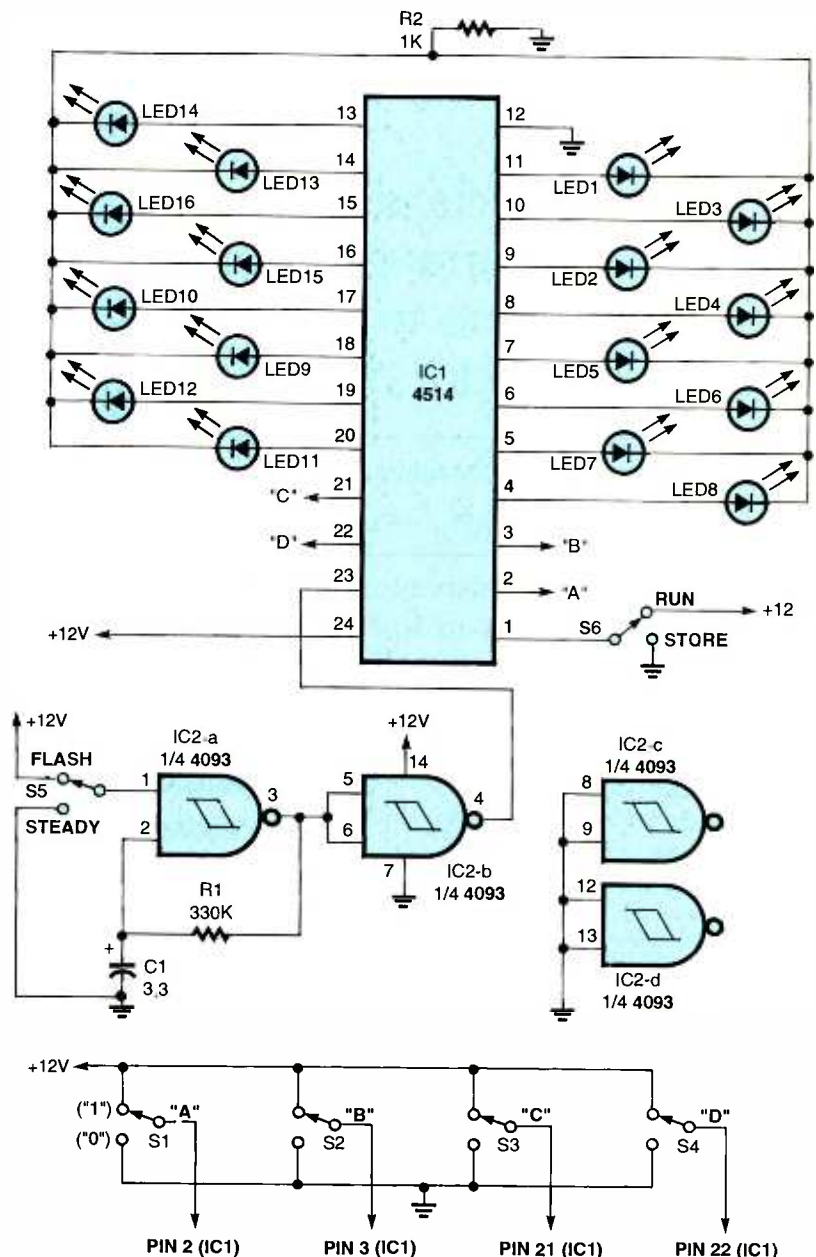

Fig. 1. This decoder circuit converts 4-bit BCD data inputs to one or more decimal outputs. The LEDs represent the output decimal number.

DECIMAL TO BCD CONVERSION																
BCD EQUIV.	DECIMAL NUMBER INPUT															
	0	1	2	3	4	5	6	7	8	9	10	11	12	13	14	15
A	0	1	0	1	0	1	0	1	0	1	0	1	0	1	0	1
B	0	0	1	1	0	0	1	1	0	0	1	1	0	0	1	1
C	0	0	0	0	1	1	1	1	0	0	0	0	1	1	1	1
D	0	0	0	0	0	0	0	0	1	1	1	1	1	1	1	1

PARTS LIST FOR BCD DECODER CIRCUIT (FIG. 1)

- C1—3.3- μ F, 25-WVDC, electrolytic capacitor
- IC1—4514, 4-bit latched/4-to-16 line decoder (high output) IC (NTE4514B, or equivalent)
- IC2—4093, quad 2-input NAND Schmitt trigger IC (NTE4093B, or equivalent)
- LED1-LED16—Any color light emitting diode
- R1—330,000-ohm, 1/4-watt, 5% resistor
- R2—1000-ohm, 1/4-watt, 5% resistor
- S1-S6—SDPT toggle switch

ground. Before going any farther, maybe we should review the BCD to decimal codes for numbers 0 through 15 shown in Table 1. By doing this, we can use the table to jump right in and select a coded input for any desired output number:

Set the four switches, S1-S4, to match whichever number you select, and the corresponding output LED will

light. The IC's four inputs are "A" = 1 (2^0), "B" = 2 (2^1), "C" = 4 (2^2), and D = 8 (2^3).

As an example, let's say we want to turn on the number 9 output LED (referenced to LED10 in the circuit). The input BCD code for number 9 is 1001. Set S1 to position "1," S2 to position "0," S3 to position "0," and S4 to position "1." This sets input "A," pin 2, high; input "B," pin 3, low; input "C," pin 21, low; and input "D," pin 22, high. Now add the inputs—"A" as 1, "B" as 0, "C" as 0, and "D" as 8; and $8 + 1 = 9$. Voilà.

If you want to store a displayed number, switch S6 to ground and that output will remain on as long as S6 is in the store position. While S6 is in the store position and the BCD inputs change to a different value, the output will indicate that new data as soon as S6 is returned to the run position.

The four code switches are only used to show how the inputs are set for a desired output. In some circuit

PARTS LIST FOR CIRCUIT TO CLOCK IN BCD CODES (FIG. 2)

- IC1—4520, 4-bit dual binary counter IC (NTE4520B, or equivalent)

applications, this may be a good way to address the input codes; however, in many circuit applications the BCD input will come from other digital circuitry.

CLOCKING IN THE BCD CODES

A variation of this circuit is shown in Fig. 2. One-half of a dual divide-by-sixteen counter IC, a 4520, is used to supply the BCD codes to the 4514 circuit of Fig. 1. The 4520 CMOS dual binary up-counter contains two divide-by-sixteen counters with a 1, 2, 4, 8 binary output code. The 4520's clock input ties to the output of the 4093 low-frequency oscillator circuit of Fig. 1, and it steps the counter from 0 to 15. The "A," "B," "C," and "D" BCD outputs of the 4520 are connected as shown in Fig. 2 to the 4514 inputs of Fig. 1.

OUTPUT CIRCUITS FOR THE 4514 DRIVER

The next four circuits, all shown in Fig. 3, illustrate how the 4514 positive logic data outputs can control external loads. The circuits shown can be driven with any of the 4514 IC outputs from Fig. 1. The circuit in Fig. 3A allows the IC to control an AC-operated lamp or other low-current load. The MOC3010 optoisolator/coupler can supply a load up to 100 mA at 117-volts AC. The circuit in Fig. 3B uses a IRF511 power MOSFET to drive a 12-volt DC heavy-duty relay. In Fig. 3C, a 2N2222 NPN transistor drives a low-current 12-volt DC lamp. Figure 3D illustrates how to invert any of the 4514's outputs through one section of a 4049 hex-inverting buffer IC.

LOW ON SELECT

If, for some reason, you need the 4514 outputs to go low instead of high, just remove the 4514 and replace it with a 4515 IC. The 4515 presents a logical "0," or low, at the selected output and is a pin-for-pin replacement for the 4514—with only the outputs being reversed. Figure 4 shows how the 16 LEDs may be connected to the 4515 and used for output indication. Refer to Fig. 1 for the other connections.

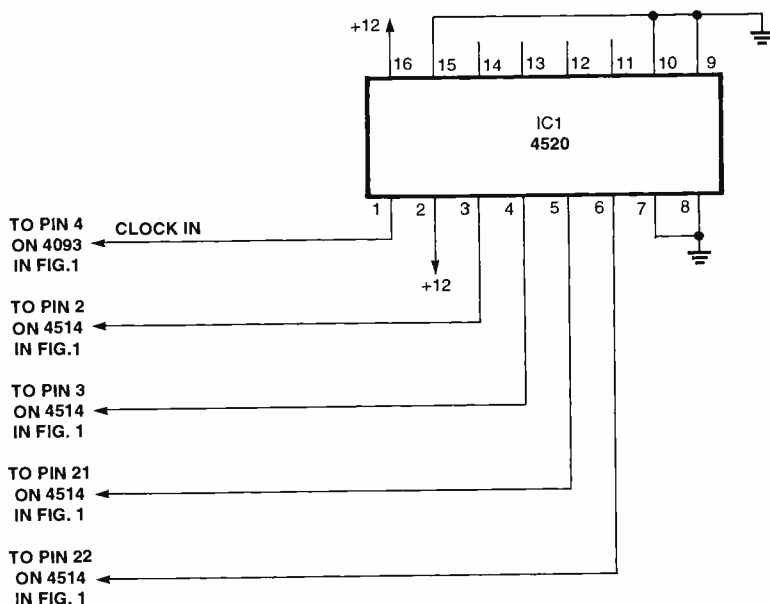

Fig. 2. Here's an addition to the circuit in Fig. 1—an external clock input into the 4520 IC sets the BCD data.

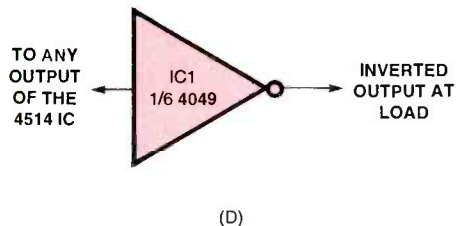
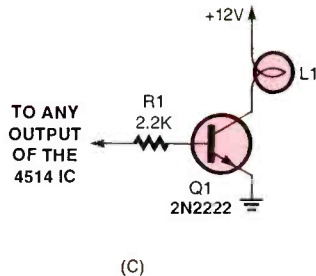
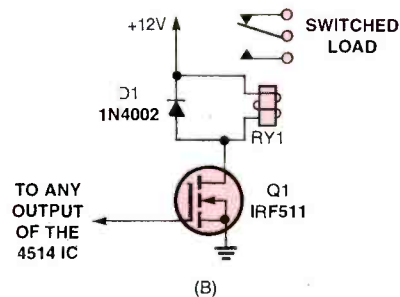
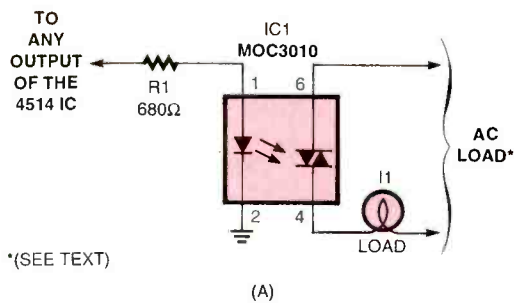

Fig. 3. These four circuits are driven by the 4514 IC in Fig. 1. In (A) the AC load is derived from an optoisolator/coupler. In (B) a MOSFET is used to switch the relay state, which controls the load. A simple transistor in (C) drives a lamp load, and in (D) the circuit shows how an inverting buffer is used to invert the output at the load.

PARTS LIST FOR 4514-DRIVEN OPTOISOLATED OUTPUT (FIG. 3A)

IC1—MOC3010 optoisolator/coupler, triac output IC (NTE3047, or equivalent)
 I1—120-volt low current AC lamp, (see text)
 R1—680-ohm, 1/4-watt, 5% resistor

PARTS LIST FOR 4514-DRIVEN RELAY OUTPUT (FIG. 3B)

D1—1N4002, 1-amp silicon diode
 Q1—IRF511, N-channel MOSFET transistor (NTE66, or equivalent)
 RY1—12-volt DC relay, size to suit need

PARTS LIST FOR 4514-DRIVEN TRANSISTOR OUTPUT (FIG. 3C)

Q1—2N2222 NPN transistor (NTE123A, or equivalent)
 L1—12-volt low current lamp; 200 mA maximum
 R1—2200-ohm, 1/4-watt, 5% resistor

PARTS LIST FOR 4514-DRIVEN INVERTED BUFFERED OUTPUT (FIG. 3D)

IC1—4049, hex-inverting buffer IC (NTE4049, or equivalent)

MULTIPLEXER/DEMULTIPLEXER

The third IC we're looking at is a BCD-controlled 1-of-16 output/input analog switch. The 4067 IC is a very versatile package that can be used as an analog data multiplexer or as a 1-of-16 digital switch. Data can be directed from the in port at pin 1 to any one of the 16 outputs, or conversely, data can be sent from any of the 16 inputs to the out port at pin 1. In the digital mode, the IC operates from a single dc source of 3 to 15-volts, and, in the analog mode, both a positive 5-volt DC and negative 5-volt DC source are required.

The circuit in Fig. 5 shows IC1, the 4067 CMOS 16-channel analog multiplexer/demultiplexer, connected in the digital mode with a single 12-volt DC supply. The 4093 Schmitt trigger, IC2, is connected as a low-frequency oscillator circuit to supply a clock input to IC1 (the same circuit we used in Fig. 1). Switch S5 selects either the oscillator's output or an external digital signal for IC1's in/out port at pin 1. Switches S1–S4 are set up for a BCD-coded input (the same as used in our first circuit) to drive IC1's BCD inputs "A," "B," "C," and "D."

Here's how to transfer data from the

in/out port at pin 1 to one of the 16 input/outputs. First, select one of the 16 input/output positions with a BCD input selected with S1–S4. Second, set switch S5 to either the external data or internal oscillator position and read the same data at the selected output. As an example, we'll place switch S5 in the internal position and set the BCD code for a position "1" output (that's a BCD "1 0 0 0"). The LED connected to the number "1" output (pin 8) will flash off and on at the 1-Hz rate. If the BCD input had been set for position 10 (pin 21), a "0 1 0 1," L1 would flash on and off. Switch S5 to the external position, and data can be sent from the selected output (input) to an external clock circuit. Data can be sent to a single output from any one of the 16 input/outputs.

The circuit can be used in the analog mode by removing the 12-volt supply and connecting a positive 5-volt source to pin 24 and a negative 5-volt source to pins 15 and 12. Now the circuit can pass analog signals, with a maximum peak-to-peak voltage level of about 9 volts, from the in port to any of the 16 output positions, or from any of the 16 output positions to the in port.

Now that we've taken a quick look at

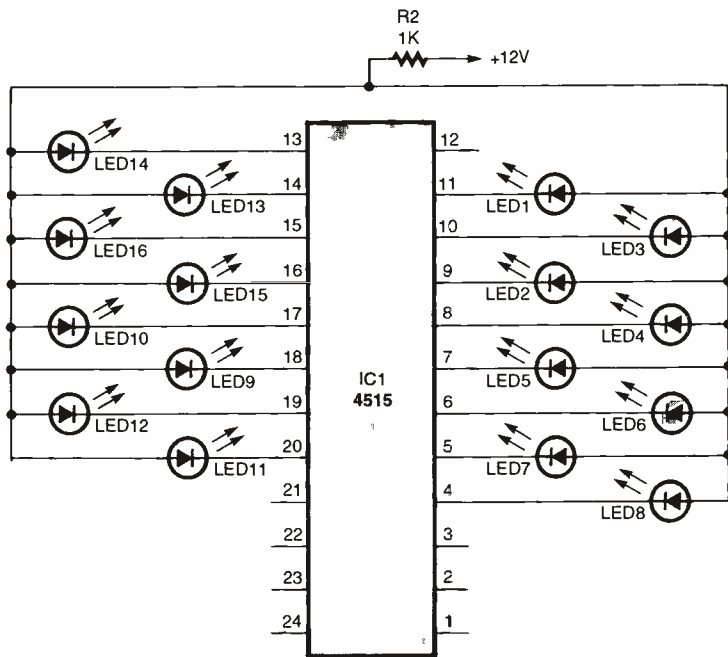

*SEE FIG. 1 FOR CONNECTIONS AT OTHER PINS

Fig. 4. This circuit is a variation of Fig. 1. Here use is made of the 4515 IC—which simply changes the state of the decimal outputs to all low on select.

PARTS LIST FOR BCD DECODER—LOW ON SELECT (FIG. 4)

- IC1—4515, 4-bit latched/4-to-16 line decoder (low output) IC (NTE4515B, or equivalent)
- LED1—LED16—Any color light emitting diode
- R2—1000-ohm, 1/4-watt, 5% resistor (See Parts List of Fig. 1 for other components)

PARTS LIST FOR MULTIPLEXER/ DEMULTIPLEXER (FIG. 5)

- IC1—4067, single 16-channel CMOS analog multiplexer/demultiplexer IC (NTE4067B, or equivalent)
- IC2—4093, quad 2-input NAND Schmitt trigger IC (NTE4093B, or equivalent)
- Q1—2N2222 NPN transistor (NTE123A, or equivalent)
- LED1—Any color light emitting diode
- R1—330,000-ohm, 1/4-watt, 5% resistor
- R2—1000-ohm, 1/4-watt, 5% resistor
- R3—2200-ohm, 1/4-watt, 5% resistor
- C1—3.3- μ F, 25-WVDC, electrolytic capacitor
- S1—S5—SPDT toggle switch
- L1—12-volt lamp, 200-mA or less

these three very interesting CMOS ICs and have some inkling as to their usefulness, it's my hope that at least one of the devices will find its way into your future circuits. Good luck, and may all of your circuits fly true the first try. ■

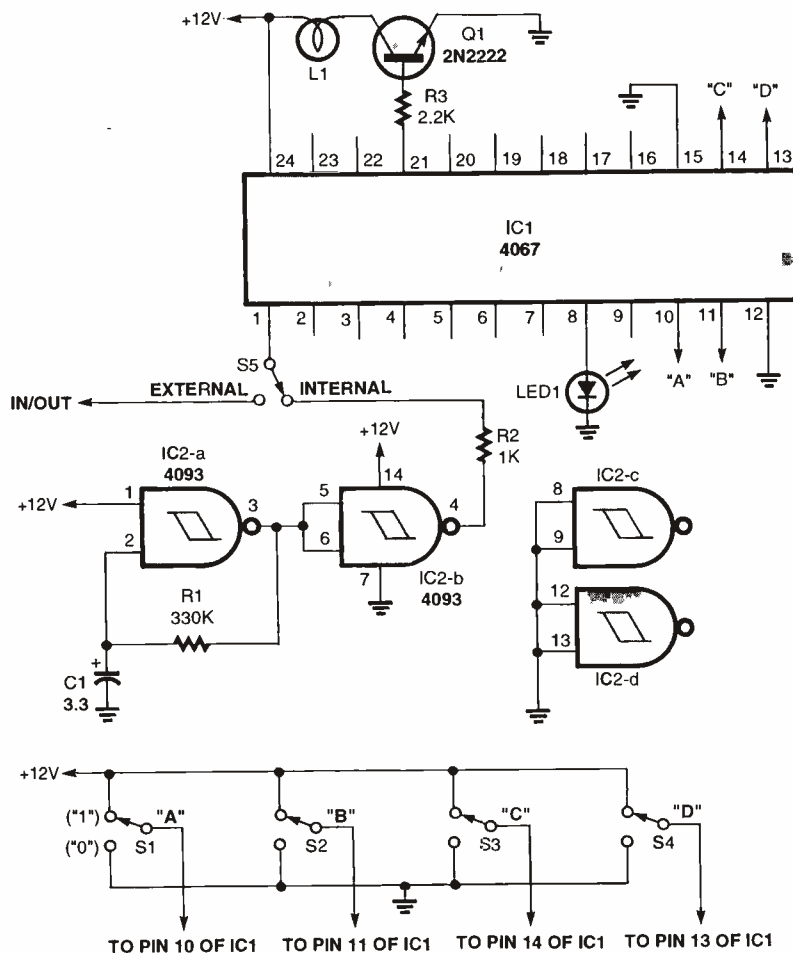

Fig. 5. Here is an illustration of how to transfer data through a multiplexer/demultiplexer. Clocking can be internal or external, and the input BCD data is applied through switches S1-S4.

POPTRONIX
Online Edition
We're on the web **FREE**
<http://www.poptronix.com>

CABLE TV CONVERTERS
Equipment & Accessories
Wholesalers Welcome
Call C&D ELECTRONICS
1-888-615-5757 M-F 10a-6p

DX LISTENING

(continued from page 16)

casters. He edited and produced many programs and publications for shortwave or DX listeners in his home country and around the world. He wrote two books about his SW listening experiences. In recent years, his voice often was heard as part of Radio Netherlands' program, "Media Network."

Well-known Asian DXer, Victor Goonetilleke, one of Arthur's many friends, said: "With him an era has suddenly ended. His life as a DXer, broadcaster, and SWL should inspire anyone who has a love for radio..."

BAGHDAD-Y OF ALL RADIOS

Radio Iraq International is being heard again on shortwave in English after a long silent period. The SW outlet has been noted on a frequency announced as 11,890 kHz; but, in fact, is 11,785 kHz, announcing as: "This is Baghdad, Radio Iraq International." The English language program begins roughly at 2230 UTC, but that start time is as erratic as the announced frequency. Modulation of the signal also leaves a bit to be desired. As a result, programming sometimes is a bit difficult to understand, even when the signal strength is not bad. You can also find Baghdad shortwave programming in Arabic, between 2000 and 2300 UTC, on a frequency which wanders in the 11,290–11,292-kHz range.

DOWN THE DIAL

Here are some shortwave listening targets for you to try. Frequencies are in kilohertz (kHz). Schedules, as always, are listed in Universal Coordinated Time (UTC), using the 24-hour military time system in which 1300 signifies 1 PM, 1400 is 2 PM, etc. To convert UTC to Eastern Standard Time, subtract 5 hours (minus 6 hours for CST, 7 hours for MST, and 8 hours for PST).

BOSNIA—7,102 kHz, Radio Bosnia Herzegovina, broadcasting from Sarajevo, is heard with programming in an unidentified language around 0130 to after 0200 UTC. On the hour, listen for a time signal, four tone pips, and after a pause, a fifth.

CHINA—9,785 kHz, China Radio International, broadcasting in English from a transmitter at Xian, may be heard here at 1500 UTC. It operates in

parallel, but usually is a weaker signal, on 9,750 kHz.

COLOMBIA—4,975 kHz, Ondas del Orteguzza is the name of a well-heard Colombian SW outlet on this frequency. It is noted with its early morning program, "Amanacer Campesino"—Peasant's Dawn—from around 1030–1040 UTC. Programming is all in Spanish, but you may hear promotional announcements for the TODELAR radio network and a newscast called "Noticias Todelar."

ENGLAND—15,575 kHz, British Broadcasting Corp., affectionately known to SWLs as "Auntie Beeb," broadcasts on this frequency from transmitters at Skelton in the United Kingdom. The end of a transmission at 2100 UTC includes a program of news headlines and sports shorts. The same programming can be heard at that time on the parallel frequencies of 9,410 kHz, 11,720 kHz, 11,835 kHz and 12,095 kHz. ■

NET WATCH

(continued from page 49)

you find within the links at the National Library of Medicine's (NLM) site could be of great significance.

Most of the resources of the Library are represented, from medical history to biotechnology. Of particular note is the site's links to two free MEDLINE search engines. MEDLINE is a database of more than 8.8-million references and abstracts of articles published in 3800 biomedical journals. What's great about the design of the database is that the abstracts are succinctly written, which means there's a limited amount of technical medical material to sift through. The short, punchy sentences found in the abstracts should be clearly understandable by anyone concerned about personal health.

As we mentioned, there are two ways to access MEDLINE from the NLM site. Both allow you to type in keywords and search, but the two differ slightly. The first is PubMed, which generates lists of related articles and lets you use both simple keywords and advanced Boolean expressions when searching. There are also links to publishers' sites for full-text versions of the journals (some by subscription only).

The second way of searching through the abstracts is Internet Grateful Med. This Web portal also allows you to access other services like HealthSTAR. When using any of the databases, including MEDLINE, the Internet Grateful Med lets you limit searches by language, publication type, age groups, etc., using pull-down menus.

While at the general NLM site, you can search through its Databases & Electronic Information Sources. These include Images from the History of Medicine, MeSH (Medical Subject Headings), and the catalogs of the vast Library. A Special Information Programs link grants you access to resources about specific diseases, medical technology, and other organizations. Overall, a very content-intensive site that's worth any effort you put into exploring it.

And that's all the time we have this month. I hope you find these sites to be useful—but remember, always consult a doctor, too. If you've got a Net question, feel free to e-mail me at netwatch@comports.com, or send a snail-mail letter to *Net Watch*, **Popular Electronics**, 500 Bi-County Blvd., Farmingdale, NY 11735. ■



HOT SITES

AMA Physician Select

www.ama-assn.org/aps/amahg.htm

Centers for Disease Control

www.cdc.gov/

Thrive Online

www.thriveonline.com/health/liu.drugsearch.html

U.S. National Library of Medicine

www.nlm.nih.gov/

Market Center TM

Weeder Technologies

Add \$4
Ship/Hand
US & Canada

FREE CATALOG!



Pro-Kit

PO Box 2426, Ft. Walton Beach, FL 32549

850-863-5723

Stackable RS-232 Kits

Digital I/O - 12 I/O pins individually configurable for input or output. DIP switch addressable; stack up to 16 modules on same port for 192 I/O points. Turn on/off relays. Sense switch transitions, button presses, 4x4 matrix decoding using auto-debounce and repeat. **\$32.00**

Analog Input - 8 Input pins. 12-bit plus sign self-calibrating ADC. Returns results in 1mV steps from 0 to 4095. Software programmable alarm trip-points for each input. DIP switch addressable; stack up to 16 modules on same port for 128 single-ended or 64 differential inputs. **\$49.00**

Home Automation (X-10) - Connects between a TW523 and your serial port. Receive and transmit all X-10 commands with your home-brewed programs. Full collision detection and auto re-transmission. **\$38.50**

Caller ID - Decodes the caller ID data and sends it to your serial port in a pre-formatted ascii character string. Example: *12/31 08:45 850-863-5723 Weeder, Terry <CR>. Keep a log of all incoming calls. Block out unwanted callers to your BBS or other modem applications. **\$34.50**

Touch-Tone Input - Decodes DTMF tones used to dial telephones and sends them to your serial port. Keep a log of all outgoing calls. Use with the Caller ID kit for a complete in/out logging system. Send commands to the Home Automation or Digital I/O kits using a remote telephone. **\$33.50**

Telephone Call Restrictors

Two modes of operation; either prevent receiving or placing telephone calls (or call prefixes) which have been entered into memory, or prevent those calls (or call prefixes) which have "not" been entered.

Block out selected outgoing calls. Bypass at any time using your password. **\$35.00**

Block out selected incoming calls. Calls identified using Caller ID data. **\$48.00**

Phone Line Transponder

7 individual output pins are controlled with buttons 1-7 on your touch-tone phone. Automatically answers telephone and waits for commands. Monitor room noises with built in mic. "Dial-Out" pin instructs unit to pick up phone and dial user entered number(s). Password protected. **\$49.00**

IR Remote Control Receiver

Learns and records the data patterns emitted by standard infrared remote controls used by TVs, VCRs, Stereos, etc. Lets you control all your electronic projects with your TV remote. 7 individual output pins can be assigned to any button on your remote, and can be configured for either "toggle" or "momentary" action. **\$32.00**

DTMF Decoder/Logger

Keep track of all numbers dialed or entered from any phone on your line. Decodes all touch-tones and displays them on a 18 character LCD. Holds the last 240 digits in a non-volatile memory which can be scrolled through. Connect directly to radio receiver's speaker terminals for off-air decoding of repeater codes, or numbers dialed on a radio program. **\$54.50**

ROBOTIC MACHINING

ROUTE, MILL, DRILL, CARVE, ENGRAVE, PAINT
IN WOOD, PLASTIC, VINYL, PC BOARD, & LIGHT METALS!

STARTING AT
\$695.00

- 4 MOTOR GANTRY MILL CONFIGURATIONS
- PC COMPUTER CONTROLLED CNC/DNC
- IMPORT/EXPORT FILES TO OTHER CADS
- AUTO-BACKLASH COMPENSATION
- PRE-MACHINED HEAVY CASTINGS
- SIMULTANEOUS 3 AXIS MOTION
- FREE 3D CAD/CAM SOFTWARE
- AVAILABLE IN KITS OR ASSEMBLED
- EXPEDITE SERVICE ALSO AVAILABLE
- OPTIONAL ALUMINUM WAY COVERS
- .001" RESOLUTION / AMERICAN MADE



3 AXIS UNITS
FROM 12" X 12" TO
66" X 66" MACH. AREA

<http://www.uscyberlab.com>

U.S. CYBERLAB, INC. 14786 SLATE GAP RD., WEST FORK, AR 72774

CALL NOW FOR INSTANT SPECS 501-839-8293 24 HR. FAX-BACK

ALL ELECTRONICS

C O R P O R A T I O N

QUALITY PARTS

FAST SHIPPING

DISCOUNT PRICING

CALL, WRITE, FAX
or E-MAIL For A
Free 96 Page
CATALOG.
Outside the U.S.A.
send \$3.00 postage.

Equipment Knob

Alcoknob # PKG90B1/4
0.86" dia. X 0.56" black molded phenolic knob with brushed aluminum face. Ribbed body with indicator line. Brass insert with two set screws. Fits 1/4" full round shaft.



CAT# KNB-74

2 for \$1.50

25 for \$16.25
100 for \$50.00

Ferrite Bead

TDK # HF70RH 16X28X9
1.1" x 0.63" od x 0.35" id.



CAT # FB-24 \$1.00 each
10 for \$8.50 - 100 for \$70.00

"HI-8" Video Cassette

SONY Hi-8 Top quality, metal particle 120 minute video cassettes. Used for a short time, then bulk-erased. Each cassette has its own plastic storage box.

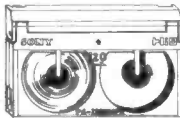

CAT # VCU-8

\$3.00 each

10 for \$28.00
100 for \$250.00

S-VHS Tape (Used)



Super VHS tape users! Save a bundle on name-brand S-VHS, T-120 tapes. These tapes were used for a brief period, then bulk erased.

The record-protect tabs have been broken out, so you will have to cover the notch with a piece of tape, but they work great and cost a fraction of the "new" price. Try some, you'll be back for more.

CAT #S-VHS

\$3.00 each

10 for \$28.00 • 100 for \$250.00

Shielded Woofer

Designed for use in Infinity center channel video sound systems. These well constructed woofers have shielded magnets to prevent interference with picture quality.

5 1/4" 6 OHM

1" voice coil. 8 oz. magnet. 50 watts max power. 3.125" deep.

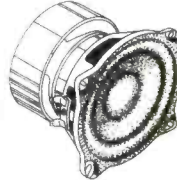

CAT # SK-7346

\$10.00 each

12 for \$96.00

Low Power Audio Amp

Motorola MC34119P

Low power audio amplifier suitable for speaker phones or talking picture frames. The 8 pin DIP package requires only a few additional parts, operates on 2 - 16 volts and drives speakers of 8 ohms or greater. Output power exceeds 250 mW with 32 ohm speaker. Power-down option saves power in battery driven applications. Hook-up sheet.



Large quantity available.

CAT # MC34119P

50¢ each

50 for \$20.00
500 for \$150.00

3 Volt Lithium Coin Cell with PC Leads

Panasonic # BR2330-1GU
3 volt, 255 mAh coin cell. Lithium batteries have a very long shelf life and are great for memory back-up protection. 0.9" diameter x 0.12" thick. 0.7" between positive and negative pc leads.



VERY SPECIAL PRICE
LARGE QUANTITY AVAILABLE

CAT #LBAT-16

2 for \$1.50

20 for \$12.00
100 for \$45.00
1000 for \$300.00

Yellow Ultra-Bright 6,000 mcd LED

Designed for use in outdoor signs, automotive and other lighting. Bright yellow beam looks a lot like light from standard incandescent lamp. Toshiba # TLYH180P (U2) 5 mm, T 1 3/4 yellow LED. Water-clear in off-state.

CAT # LED-44

2 for \$1.20

10 for \$5.00
100 for \$45.00
1000 for \$400.00

High Brightness FLASHER LEDs

T 1 3/4 (5mm) high brightness RED LEDs with built-in flasher unit.

3-5 Vdc operation

CAT # LED-4 2 for 90¢

100 for \$40.00 - 1000 for \$300.00

12 Volt LEDs

T 1 3/4 (5mm) diffused LEDs. Connect directly to 12 Vdc (max. 15 Vdc). No resistor necessary.

RED CAT# LED-100

2 for \$1.00 - 10 for \$4.00

GREEN CAT# LED-200

2 for \$1.00 - 10 for \$4.00

YELLOW CAT# LED-300

2 for \$1.20 - 10 for \$5.00

Miniature Temperature Sensor (THERMISTOR)

Keystone (Similar to #RL0503-17-56K-96-MS) 30K ohms @ 25 degree C. (77 degree F.) Negative temperature coefficient. 0.2" long X 0.09" diameter, epoxy insulated bead. 1.13" long teflon insulated AWG#30 wire leads. Prepped with 0.75" long metal tabs.

CAT# THR-19

2 for \$1.50

box of 264
\$150.48
(57¢ each)

ORDER TOLL FREE

1-800-826-5432

MAIL ORDERS TO:
ALL ELECTRONICS CORP.

P.O. BOX 567
VAN NUYS, CA 91408-0567

FAX (818) 781-2653 • INFO (818) 904-0524
INTERNET <http://www.allcorp.com/>
E-MAIL allcorp@allcorp.com



NO MINIMUM ORDER • All Orders Can Be Charged to Visa, Mastercard, American Express or Discover • Checks and Money Orders Accepted by Mail • Orders Delivered in the State of California must include California State Sales Tax • NO C.O.D. • Shipping and Handling \$5.00 for the 48 Continental United States - ALL OTHERS including Alaska, Hawaii, P.R. and Canada Must Pay Full Shipping • Quantities Limited • Prices Subject to change without notice.

MANUFACTURERS - We Purchase EXCESS INVENTORIES... Call, Write, E-MAIL or Fax YOUR LIST.

Our Complete Catalog is now online  www.cir.com

Circuit Specialists Inc.

SINCE 1971

Check Out What We Have To Offer:

Fantastic DMM Offer!!!

Don't let the price fool you. This meter is a digital multimeter designed for engineers and hobbyists. Equipped with 5 functions and 19 ranges. Each test position is quickly and easily selected with a simple turn of the FUNCTION/RANGE selector rotary switch.

General Rubber Boot Included
 Display: 3-1/2 Digit LCD, 21mm Figure Height with Automatic Polarity
 Overrange Indication: 3 Least Significant Digits Blank
 Temperature for Guaranteed Accuracy: 23°C±5°C RH<75%
 Temperature Ranges:
 Operating: 0°C to 40°C (32°F to 104°F)
 Storage: -10°C to 50°C (14°F to 122°F)
 Power: 9V Alkaline or Carbon-Zinc Battery (NEDA1604)
 Low Battery Indication: BAT on Left of LCD Display
 Dimensions: 188mm long x 87mm wide x 33mm thick
 Net Weight: 400g



Our Best Offer Ever on a

High Quality Full Sized DMM

\$19.00 any qty

DC Voltage (DCV)		DC Current (DCA)		Resistance (Ω)	
Range:	Resolution: Accuracy:	Range:	Resolution: Accuracy:	Range:	Resolution: Accuracy:
200mV	100µV	200µA	1µA	200Ω	100mΩ
2000mV	1mV ±(1%rdg+2dgt)	2000µA	10µA ±(1.2%rdg+2dgt)	2000Ω	1Ω
20V	10mV	20mA	10µA	20KΩ	10Ω ±(1.2%rdg+2dgt)
200V	100mV	200mA	100µA ±(1.2%rdg+2dgt)	200KΩ	100Ω
1000V	1V	10A	10mA	2000KΩ	1KΩ ±(2%rdg+10dgt)
Maximum Allowable Input: 1000V DC or Peak AC.		Overload Protection: mA Input, 2A/250V fuse.		Maximum Open Circuit Voltage: 2.8V	
				Diode Test	
				Measures forward voltage drop of a semiconductor junction in mV test current of 1.5mA Max.	
				ohF Test	
				Measures transistor hFE.	
				Frequency Range: 45Hz-450Hz	
				Maximum Allowable Input: 750V rms	
				Response: Average Responding, Calibrated in rms of a Sine Wave.	
				AC Voltage (ACV)	
				Range: Resolution: Accuracy:	
				200V 100mV ±(1.2%rdg+10dgt)	
				750V 1V	

CAT NO	DESCRIPTION	PRICE
9300G	Rugged High Quality DMM with Rubber Boot	\$19.00

Special Offer! The next generation of Digital Multimeters with 3-3/4 digits, 4000 count, auto-ranging and analog bargraph, 10MHz frequency counter, True RMS mode and RS-232C interface. **LIMITED TIME OFFER!** You MUST enter your order by December 31st, 1997 to receive this special price! Regular C.S.I. price \$169.00. Plus we'll even include the optional temperature adaptor and K-type thermocouple probe! We even include the holster!



CAT NO	DESCRIPTION	PRICE
PROTEK506	Digital Multimeter	\$139.00

Developer This product is used as the developer on our positive photo-resist printed circuit boards. Includes instructions, 50 gram package, mixes with water, makes 1 quart.

CAT NO	DESCRIPTION	1	10	25
POSDEV	Positive Developer	\$.95	\$.80	\$.50

Etching Chemicals/Ferric Chloride
 A dry concentrate that mixes with water to make 1 pint of etchant, enough to etch 400 sq. inches of 1oz board.

CAT NO	DESCRIPTION	1	5
ER-3	Makes 1 pint	\$3.50	\$2.75

Positive Photo Resist Pre-Sensitized Printed Circuit Boards

These pre-sensitized printed circuit boards are ideal for small production runs. They provide high resolution and excellent line width control. High sensitive positive resist coated on 1oz. copper foil allows you to go direct from your computer plot or art work layout. No need to reverse art.

Single-Sided, 1oz. Copper Foil on Paper Phenolic Substrate		PRICE EACH	
CAT NO	DESCRIPTION	1	10 50
PP101	100mm x 150mm/3.91" x 5.91"	\$2.55	\$1.90 \$1.70
PP114	114mm x 165mm/4.6" x 6.6"	2.98	2.45 1.98
PP152	150mm x 250mm/5.91" x 9.84"	5.40	3.98 3.60
PP153	150mm x 300mm/5.91" x 11.81"	6.15	4.48 4.10
PP1212	305mm x 305mm/12" x 12"	12.78	10.65 8.52
Single-Sided, 1oz. Copper Foil on Fiberglass Substrate		PRICE EACH	
CAT NO	DESCRIPTION	1	10 50
GS101	100mm x 150mm/3.91" x 5.91"	\$ 3.90	\$2.98 \$2.60
GS114	114mm x 165mm/4.6" x 6.6"	4.80	3.49 3.20
GS152	150mm x 250mm/5.91" x 9.84"	8.69	5.98 5.78
GS153	150mm x 300mm/5.91" x 11.81"	10.20	7.20 6.80
GS1212	305mm x 305mm/12" x 12"	18.88	15.73 12.59
Double-Sided, 1oz. Copper Foil on Fiberglass Substrate		PRICE EACH	
CAT NO	DESCRIPTION	1	10 50
GD101	100mm x 150mm/3.91" x 5.91"	\$ 5.07	\$3.68 \$3.38
GD114	114mm x 165mm/4.6" x 6.6"	5.95	4.29 3.99
GD152	150mm x 250mm/5.91" x 9.84"	10.47	7.39 6.98
GD153	150mm x 300mm/5.91" x 11.81"	11.95	8.69 8.30
GD1212	305mm x 305mm/12" x 12"	22.09	18.35 14.68

Etching Tank This handy etching system will handle PC boards up to 8" x 9", two at a time. Ideal for etching your PCB's! System includes an air pump for etchant agitation, a thermostatically controlled heater for keeping etchant at optimum temperature and a tank that holds 1.35 gallons of etchant. A tight fitting lid is also supplied to prevent evaporation when system is not being used. Typical etching time is reduced to 4 minutes on 1oz. copper board!

REDUCES ETCHING TIME!

CAT NO	DESCRIPTION	PRICE
12-700	Etch Tank System	\$37.95

1/3" CCD Board Cameras
 Available with PINHOLE LENS with AUDIO; STANDARD LENS with AUDIO; and STANDARD LENS with INFRA-RED. These are the world's smallest commercially available CCD board cameras!

World's Smallest B&W Board Cameras

Specifications

Image Pick-Up Device	1/3" CCD area Sensor	
Picture Elements	EIA=512(H) x 492(V)	
Pixel Pitch	EIA=9.6UM (H) x 7.5UM (V)	
Scanning System	2 : 1 Interlace	
Scanning Frequency	EIA=525 lines, 60 field/sec (II) 15.750 KHz x 60 HK	15.750
Resolution	430 Lines	
Minimum Illumination	0.03 LUX	
S/N Ratio	45DB	
Lens Mounting	4.3mm standard, 5mm pinhole	
Video Output	1.0 VP-P/750OHM composite signal	
Power Requirement	8-12 VDC (9VDC standard)	
Power Consumption	100mA	
Operating Temperature	-20C -- + 70 C RH 95% Max	
Storage Temperature	-40C -- 85 C RH 95% Max	
Audio Pick-Up Sensitivity	-60 DB (0DB = 1B/UBAR, 1KNZ)	
Audio Frequency Range	20 Hz to 20KHz	
Audio S/N Ratio	More than 35DB	
Audio Output Level	1VP-P/600 OHM	
Dimensions		
WDP-2000	30mm (H) x 30mm (W)	
WDS-2005	30mm (H) x 30mm (W)	
WDI-4000	44mm (H) x 30mm (W)	
CAT NO	DESCRIPTION	PRICE EACH
WDP-2000	1/3" B&W Pinhole Lens with Audio	\$89.00 \$77.00
WDS-2005	1/3" B&W Standard Lens with Audio	89.00 77.00
WDI-4000	1/3" B&W Infra-RED (no audio)	89.00 77.00
WDPH-55BW	Plastic Housing Option for B&W Board Cameras	13.00 12.00



CIRCUIT SPECIALISTS, INC. RECEIVE OUR LATEST 132 PAGE CATALOG!

It's chock full of all types of electronic equipment and supplies. We've got I.C.'s, capacitors, resistors, pots, inductors, test equipment, breadboarding supplies, PC supplies, industrial computers, data acquisition products, personal computers and computer parts, plus much, much more. FAX us your name and address or call **800-811-5203, ext. 5**, to leave a message on our catalog request line.

SINCE 1971 **800-811-5203**
602-464-2485
602-464-5824(FAX)

WE ACCEPT:   

FREE 

EARN MORE MONEY!

Be an FCC LICENSED ELECTRONIC TECHNICIAN!



No costly school. No commuting to class. The Original Home-Study course prepares you for the "FCC Commercial Radiotelephone License." This valuable license is your professional "ticket" to thousands of exciting jobs in Communications, Radio-TV, Microwave, Maritime, Radar, Avionics and more...even start your own business! You don't need a college degree to qualify, but you do need an FCC License.

No Need to Quit Your Job or Go To School
This proven course is easy, fast and low cost! **GUARANTEED PASS**—You get your FCC License or money refunded. **Send for FREE facts now. MAIL COUPON TODAY!**

Or, Call 1-800-932-4268 Ext. 240

COMMAND PRODUCTIONS

FCC LICENSE TRAINING, Dept. 240
P.O. Box 2824, San Francisco, CA 94126
Please rush FREE details immediately!

NAME _____
ADDRESS _____
CITY _____ STATE _____ ZIP _____

World Passing You By?

Are you interested in Microprocessors & Embedded Control Systems? If not you should be! Look around, just about everything these days has an embedded microprocessor in it. TVs, cars, radios, traffic lights & even toys have embedded computers controlling their actions. The Primer Trainer is the tool that can not only teach you how these devices operate but give you the opportunity to program these types of systems yourself. Examples & exercises in the Self Instruction manual take you from writing simple programs to controlling motors. Start out in Machine language, then move on to Assembler, & then continue on with optional C, Basic, or Forth Compilers. So don't be left behind: this is information you need to know!

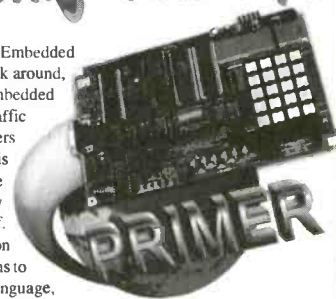

Examples Include:

- Measuring Temperature
- Using a Photocell to Detect Light Levels
- Making a Waveform Generator
- Constructing a Capacitance Meter
- Motor Speed Control Using Back EMF
- Interfacing and Controlling Stepper Motors
- Scanning Keypads and Writing to LCD/LED Displays
- Bus Interfacing an 8255 PPI
- Using the Primer as an EPROM Programmer
- DTMF Autodialer & Remote Controller (New!)

The PRIMER is only \$119.95 in kit form. The PRIMER Assembled & Tested is \$169.95. This trainer can be used stand alone via the keypad and display or connected to a PC with the optional upgrade (\$49.95). The Upgrade includes: an RS232 serial port & cable, 32K of battery backed RAM, & Assembler/Terminal software. Please add \$5.00 for shipping within the U.S. Picture shown with upgrade option and optional heavy-duty keypad (\$29.95) installed. Satisfaction guaranteed.

EMAC, inc.

11 EMAC WAY, CARBONDALE, IL 62901
618-529-4525 Fax 457-0110 BBS 529-5708
World Wide Web: <http://www.emacinc.com>

1985 - 1998

OVER

12

YEARS

OF SERVICE



CABLE TV Converters & Descramblers

Compatible with
**Jerrold, Scientific Atlanta,
Pioneer, Oak, & Hamlin
Equipment**

BRAND NEW!

6-MONTH GUARANTEE

LOWEST PRICES

Volume Control & Parental Lockout Available

Greenleaf Electronics

1-800-742-2567

NO ILLINOIS SALES

It is not the intent of Greenleaf Electronics to defraud any pay television operator and we will not assist any company or individual in doing the same.

MCM ELECTRONICS®

The Source For
All Of Your
Electronics Needs

Prices Effective February 19
through March 31, 1998

To take advantage of special
pricing on the items listed, you
must provide this code: ▼

SOURCE CODE: POP51

For over 20 years, MCM has been the leading supplier to the electronics service industry. Huge inventory, rapid delivery and competitive prices have made MCM the choice for:

Hobbyists Service Technicians
Educators Installers

Discover the MCM difference, call today for your free catalog.



Valor
The Clear Connection

Six
Position

Antenna Coax Switch

Heavy duty six position switch is ideal for all HF and VHF antenna switching applications including Citizens Band. Frequency range 0-250MHz. 1500W P.E.P maximum. Tested insertion loss: < .15dB on the 220MHz band, < .05dB on the 2M band, < .021 dB on the 6M band, < .020 dB on the 10-160M band including CB. All connectors are SO-239 type. Suggested list \$39.95.

Limited quantities.

Order #	(1-4)	(5-up)
58-2820	\$22.50	\$19.95



AC Traveler Inverter

Provides on-the-road AC power from your cigarette lighter. Lightweight, portable power inverter supplies 117VAC, 60Hz, modified sine wave output from 13.8VDC input. Operates devices up to 140W continuous, 200W surge output. Ideal for small electronic devices, work lamps and many other items.

Order # Reg.
72-3090 \$29.95

\$59.95

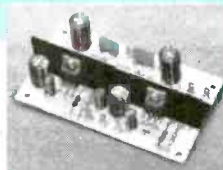

5 Watt x
Two
Channel
Audio
Amplifier

Offers the same features as the #28-4796, with two channel output. Requires 500mA. Board dimensions 90mm x 55mm x 27mm.

Order # (ea.)
28-4800 \$24.95



Poly Cone Woofers

Just a sample of nearly 200 different types of woofers stocked at

MCM. These foam surround, polypropylene cone woofers are excellent for automotive use or repair/upgrade of home speaker systems. Listed models are 8ohm. 4ohm also available. Call for quantity discounts.

Order #	Size	RMS/Peak	Response	Magnet (ea.)
55-1170	6"	45W/60W	40Hz-5KHz	18 oz. \$9.49
55-1195	8"	70W/100W	40Hz-3.5KHz	18 oz. 11.95
55-1250	10"	70W/100W	28Hz-5KHz	20 oz. 18.95
55-1255	12"	75W/100W	25Hz-4KHz	30 oz. 22.95

Five Watt Single Channel Audio Amplifier

Pre-assembled audio amplifier board can be used for many applications

including repair or modification of equipment, projects or prototype work. Accepts line level input, 100mV, 100Kohm. Output impedance 4-8ohm. Operates with supply voltage from 6-16VDC, 250mA. Optimum 12VDC. Includes oversized heat sink. Board dimensions 50mm x 40mm x 20mm.

Order # (ea.)
28-4796 \$13.95

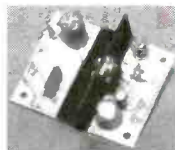

TENMA® DMM with Logic Function

Features 3 1/2 digit LCD display, 10Mohm input impedance, 2.5 per second measuring rate, logic, diode

and transistor hFE test and overload protection. Measures AC/DC voltage to 600V, resistance to 2000Mohm, AC/DC current to 10A, and capacitance to 20mF. Dimensions: 2 1/4" (W) 5 1/2" (H) 1 1/2" (D). Protective holster included.

Order # Reg.
72-4025 \$65.95 **\$39.95**



30 Piece Security Tool Set

This is a complete set of security bits for all of those difficult service applications, such as IBM PS/2 monitors, cable boxes, telephone equipment and many others. Kit contains security hex bits, security torx bits, spanner bits, tri-wings and more. Takes the frustration out of those difficult service situations.

Order # Reg.
22-1475 \$39.99 **\$19.95**



FREE
Catalog!

Call for information on many other types of pre-assembled modules including timers, counters, temperature controls, VOX relays, Programmable LCD displays and power supplies.

1-800-543-4330

www.mcmelectronics.com

Hours: M-F 7 a.m.-9 p.m., Sat. 9 a.m.-6 p.m., EST.

Same Day
Shipping!

In stock orders
received by 5:00 p.m.
(YOUR TIME), are
shipped the same day.



MCM ELECTRONICS®

650 CONGRESS PARK DR.
CENTERVILLE, OH 45459
A PREMIER FARNELL Company

SOURCE CODE: POP51

WORLD'S SMALLEST

Wireless Video Transmitters

Used by hundreds of hobbyists and professionals alike in R/C models, Robots, Surveillance Video, movie Special Effects, and Law Enforcement.

"... previously, I used expensive wireless units from Pelco, MVP, and Supercircuits. Nothing approaches the VidLinks in power, picture quality, size, and value. Thank you." *R. Leslie, CCTV Installer, NY.*
"The best... Incredible color, resolution... very easy to use... cool." *P. Davis, Movie Props, CA.*

Actual Size!!!



Live Remote Video From \$99.00

- Full 100 mW RF Power. Range 500ft. to 1/2mile •
- Crystal Controlled •
- High-Resolution Full Color/ B&W video •
- Fully epoxy encased- no exposed components •
- Fully assembled- only two wires to attach •
- **MONEY BACK GUARANTEE.** •

VidLink 100: 100mW Power- upto 1/4 Mile
\$199.00 New! High-Power!

VidLink 15: 15mW Power- upto 150 Feet
\$99.00 New! Low Price- Same Size!

Covert Camera: 1 1/4" sq. Pinhole Lens
\$169.00 Pro Grade Japanese Quality!

*** Audio Module Now Available. Call. ***
Check/MO, COD +\$5.00, S&H \$5.50

**AEGIS
RESEARCH**

#671-1225 E. Sunset Dr.
Bellingham, WA
98226-3529 USA

1-604-224-0416

Visit our virtual catalog on the INTERNET at:
<http://www.lynx.bc.ca/virtualspy>

Learn MICROCONTROLLERS EMBEDDED SYSTEMS and PROGRAMMING...

...with the AES learning system/
embedded control system.

Extensive manuals guide you
through your development
project. All programming and
hardware details explained.

Complete schematics. Learn to
program the LCD, keypad digital,
analog, and serial I/O. for your applications.

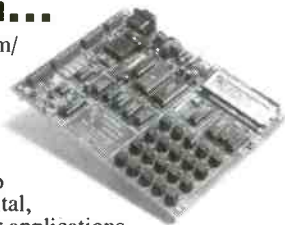

**THREE MODELS AVAILABLE. Choose from an
Intel 8051, Intel 8088, or Motorola 68HC11
based system. All models come with:**

- 32K Byte ROM, 32K Byte RAM • 2 by 16 Liquid Crystal Display • 4 by 5 Keypad • Digital, Analog, and Serial I/O • Interrupts, timers, chip-selects • 26 pin expansion connector • Built-in Logic Probe • Power Supply (can also be battery operated) • Powerful ROM MONITOR to help you program • Connects to your PC for programming or data logging (cable included) • Assembly, BASIC, and C programming (varies with model) • Program disks with Cross Assembler and many, well documented, program examples • User's Manuals: cover all details (over 500 pages) • Completely assembled and ready to use • Source code for all drivers and MONITOR • Optional Text Book

Everything you need. From \$279.
Money Back Guarantee

Call for Free Info Pack, or see
WEB at <http://www.aesmicro.com>
714-550-8094, FAX 714-550-9941

AES
Advanced Educational Systems

Call 1-800-730-3232

AES 575 ANTON BLVD., SUITE 300, COSTA MESA, CA 92626, USA

Digital Oscilloscope 100 MSa/s

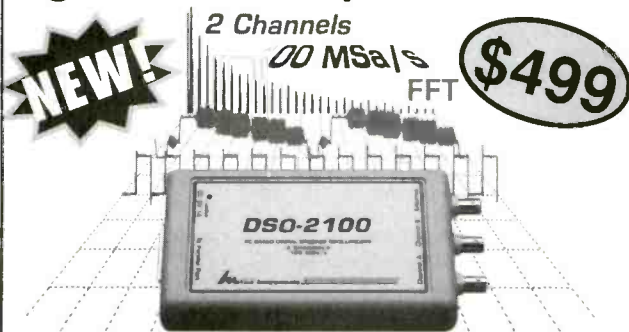

- 2 Ch. Digital Oscilloscope
- 100 MSa/s max single shot rate on both channels
- 32K samples per channel
- Advanced Triggering
- Easy to use Windows and DOS software included
- Small and Lightweight (9 oz and 6.3" x 3.75" x 1.25")
- Parallel Port interface to Laptop or Desktop PC
- Optional FFT Spectrum Analyzer, Advanced Math and TVLine Trigger.

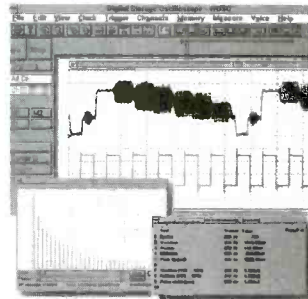

For \$499 you get the model
DSO-2102S Oscilloscope,
Probes, Interface Cable, Power
Adapter, and Windows and DOS
Software.



Link Instruments (973) 808-8990

369 Passaic Ave. • Suite 100 • Fairfield, NJ 07004
www.LinkInstruments.comPE4 • Email: Sales@LinkInstruments.com

PARTS EXPRESS

ELECTRONICS & MORE

FREE 244 PAGE CATALOG



UNBELIEVABLE VALUE!

4 Way Speaker Switch

Control up to 4 pairs of speakers with this compact speaker selector switch. Features circuit protector, heavy duty rocker switches, spring loaded terminals, and silver plated switch connectors. Includes one pair of amplifier inputs. Load to amplifier is minimum 4 ohms (with 8 ohm speakers) or 220 ohms with all speakers switched off. Net weight: 1 lb.

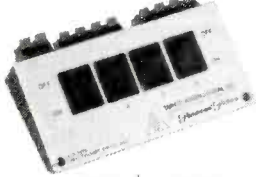

WAS \$22⁵⁰ EACH NOW \$15⁰⁰ EACH

#PO-309-030

"The Sound Bridge" FM Stereo Wireless Transmitter

The Sound Bridge is a mini FM wireless transmitter that can be used to broadcast stereo sound from any audio source like portable CD players, TVs, electronic games, CD-ROM, even computer soundcards, to your home stereo receiver! Adjustable from 89 to 95.5 MHz.



HOT NEW ITEM!

\$14⁹⁵ EACH

#PO-249-220

Weller Professional Irons

Weller



Perfect for a variety of electronic soldering work, this top quality iron features a long life, double coated tip and a quick change, plug-in heater element. Lightweight handle includes a comfortable cushioned grip. Net weight: 1/2 lb.

#PO-372-110 (25 Watt) \$30⁹⁰ (1-3) \$28⁵⁰ (4-UP)
 #PO-372-112 (35 Watt) \$38⁹⁰ (1-3) \$34⁹⁵ (4-UP)

Home Theatre In-Floor Subwoofer

To fully appreciate the potential of movie soundtracks, a dual voice coil subwoofer is a must! Many film special effects are extremely demanding in the low frequency range and require a subwoofer that can duplicate explosions, earthquakes, even the footsteps of Tyrannosaurus Rex! This subwoofer fits the bill by featuring a 10" dual voice coil woofer for true stereo operation and high pass filters for your main speakers. The most unique feature of this subwoofer is the fact that it is designed to be mounted in between the floor joists in new and existing home constructions. Simply mount the in-floor sub to the joists and mount a heat register grill above opening in subwoofer front enclosure. The subwoofer is now totally out of view and ready to rumble! Includes detailed installation manual.

Specifications: 10" dual voice coil treated paper cone woofer with poly foam surround ♦ Frequency response: 30-100 Hz ♦ Nominal impedance: 8 ohms per coil ♦ Power handling: 100 watts RMS channel/140 watts max ♦ SPL: 89 dB 1W/1m ♦ Dimensions: 27" D x 14-5/8" W x 9" H ♦ Net weight: 29 lbs.

#PO-300-445

\$139⁹⁵ EACH



Dayton Loudspeaker Co.®



900 MHz Wireless Speaker System

- ♦ 900 MHz technology sends signal up to 180 ft., through walls, floors and ceilings.
- ♦ Ideal for use as rear surround speakers or for adding wireless sound to every room in the house!
- ♦ Full range, bass reflex design with built-in high power, low distortion amplifier.
- ♦ Weather resistant cabinet for outdoor use.
- ♦ Selectable battery (six C size for each speaker) or AC operation, adaptor included. Built-in recharging circuitry, or ni-cad batteries.
- ♦ System includes: 900 MHz transmitter, wireless speaker pair, AC adaptors, and all cables necessary to hook up system.
- ♦ Limited availability. ♦ Net weight 9 lbs.
- ♦ Frequency response: 20-18KHz.

#PO-319-030

\$169⁹⁵ EACH

Peak Instrument Co.

"The Woofer Tester"

Peak Instrument Co. proudly introduces "The Woofer Tester". Just ask any loudspeaker engineer, and they will tell that the only way to design enclosures of the correct size and tuning is to measure the Thiele-Small parameters for the actual drivers to be used. The reason? Manufacturers published specs can be off by as much as 50%! But until now, measuring the parameters yourself required expensive test equipment and tedious calculations, or super expensive measurement systems (\$1,200 to \$20,000). The Woofer Tester changes all that. Finally, a cost effective, yet extremely accurate way to derive Thiele-Small parameters, in only minutes! The Woofer Tester is a combination hardware and software system that will run on any IBM compatible computer that has EGA or better graphics capability and an RS232 serial port. The Woofer Tester will generate the following parameters: Raw driver data: Fs, Qms, Qes, Qts, Vas, BL, Re, Le, SPL @ 1W/1m, Mmd, Cm, and Rm. Sealed box data: Fsb and system Q. Vented box data: Fsb, ha, alpha, and Q loss. The Woofer Tester system includes hardware, test leads, serial cable, AC wall adaptor, detailed instructions, and software.



QUICK! AND ACCURATE! MEASURES
 Fs, Qms, Qes, Qts, Vas, BL, Re, Le, SPL @ 1W/1m, Mmd, Cm, and Rm
 Vented box data: Fsb, ha, alpha, and Q loss

NO DAY MONEY BACK GUARANTEE

1 YEAR WARRANTY ♦ 6-ME DAY SHIPPING

#PO-390-800

\$249⁰⁰ EACH



♦ 30 day money back guarantee ♦ \$20.00 minimum order
 ♦ We accept MasterCard, Visa, Discover, and company C.O.D. orders ♦ 24 hour shipping ♦ Shipping charge = UPS chart rate + \$1.90 (\$5.00 minimum charge) ♦ Hours 8:00 am - 8:00 pm ET, Monday - Friday ♦ 9:00 am - 5:00 pm Saturday. Mail order customers, please call for shipping estimate on orders exceeding 5 lbs. ♦ Foreign destination customers please send \$5.00 U.S. funds for catalog. ♦ Quantity pricing available.

1-800-338-0531

340 E. First St., Dayton, OH 45402-1257
 Phone: 937-222-0173 ♦ Fax: 937-222-4644
 E-Mail: sales@parts-express.com

CIRCLE 146 ON FREE INFORMATION CARD

New and Pre-Owned Test Equipment

 **Goldstar**

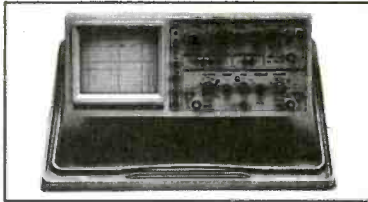

Model OS-9100P → **\$899.00**

Full 100 MHz Bandwidth!

- Dual-Channel, High Sensitivity
- TV Synchronization Trigger
- Calibrated Delayed Sweep
- Includes Two Probes, 2 Year Warranty

FREE SHIPPING!
ON GOLDSTAR EQUIPMENT
ANYWHERE IN THE U.S.
Excluding AK & HI



BK PRECISION
MAXTEC INTERNATIONAL CORP.

Model 4040 \$499.00

20 MHz Sweep/Function Generator

LOWEST PRICES EVER!

NEW FLUKE MULTIMETERS & TEKTRONIX OSCILLOSCOPES

The Industry Standard in Multimeters

Fluke Model 87 \$285.00 !!!

**We Buy Surplus
Test Equipment**

Test Equipment Depot

A FOTRONIC CORPORATION COMPANY

P.O. BOX 708 Medford, MA 02155

(617) 665-1400 • FAX (617) 665-0780

See us on the Web!

www.fotronic.com

1-800-996-3837

email: afoti@fotronic.com



TOLL FREE 1-800-99-METER

AUTOMATIC TELLER MACHINES

ATM crimes, abuses, vulnerabilities and defeats exposed! 100+ methods detailed, includes: Physical, Reg. E, cipher, PIN compromise, card counterfeiting, magnetic stripe, false front, TEMPEST, tapping, spoofing, inside job, vibration, pulse, high voltage - others, con jobs. Histories, law, security checklist, internal photos, figures. *Much more!* \$39.

CELLPHONE PHREAKING GUIDE

How cellphones operate and are modified. Vulnerabilities to hack attack and countermeasures. Details on programming NAMs, ESNs, etc (cloning), control data formats, computing encoded MINs, ESNs, SIDHs, operating systems, PROM programming, forcing ACK, test mode and resets, cable diagrams, scanning, tracking, scanner restorations, freq allocations, roaming. Step-by-steps to keypad-reprogram 100+ popular cellphones. *More!* \$59

PAGER / BEEPER MANUAL

How Pagers work, different types and uses, freqs, advantages over and uses with cellphones, and tips and tricks. How Pagers are hacked/countermeasures. And plans for a Personal Pocket Paging System (xmitter and receiver). *More!* \$29

PHREAKING CALLER ID & ANI

How they work and dozens of ways of defeating Caller ID, ANI, *69, *57, Call Blocking, *67 etc. Describes ESS, SS7, CN/A, CAMA, DNR, Diverters, Centrex - *more!* \$19.

BEYOND VAN ECK PHREAKING

Eavesdropping on TV and computer video signals using an ordinary TV described in detail. Includes security industry reports. Range up to 1 KM. Plans include both the ours and the original Top Secret Van Eck designs! \$29.

HACKING THE INTERNET

The latest tricks and methods being used on the Net to pirate software (warez) and the newest hacking websites. *Updated every two months.* Includes examples, countermeasures, password defeats, UNIX, Sprintnet, brute force methods, lots of tips, and *more!* \$25.

COMPUTER PHREAKING

Describes in detail how computers penetrate each other, and how VIRUSES, TROJAN HORSES, WORMS are implemented. Dozens of computer crime and abuse methods and countermeasures. Includes disk filled with hacker text files and utilities, and the legendary FLUSHOT+ protection system - Internet advice, password defeats, glossary - *much more!* Manual + PC Disk! \$39.

OTHER EXCITING TITLES

Call For Descriptions

- Hacking Fax Machines - \$29
- PBX Hacking - \$19
- Voice Mail Hacking - \$29
- Beyond Phone Color Boxes - \$29
- Hacking Answering Machines - \$19
- By an Order of the Magnitude - \$49
- Ultimate Success Manual - \$15
- Internet Cons & Scams - \$19
- Internet Tracking & Tracing - \$29
- Cookie Terminator - \$19
- Casino Hacking - \$18
- Credit Card Scams - \$29
- Radionics Manual - \$29
- Heal Thyself - \$19
- Stealth Technology - \$24
- High Voltage Devices - \$29
- The Hacker Files - \$39
- Cons & Scams - \$29
- Cryptanalysis Techniques - \$29
- Secret & Survival Radio - \$24
- Secret & Alternate IDs - \$15
- Rocket's Red Glare - \$29
- Mind Control - \$29
- EM Brainblaster - \$29

SPECIAL PROJECTS SERVICES

We will build just about anything. Ask about our application form!

STOPPING POWER METERS



As reported on "60 MINUTES"! All-new 6th Edition!! Over 45 pages jam-packed with how devices can slow down (even stop) watt-hour meters - while loads draw full power! Device plugs into one outlet and normal loads into other outlets. Describes meter creep, overload droop, etc. Plans only! \$29.

THE I.G. MANUAL: External magnetic ways (applied to meter) to slow down and stop power meters while drawing full loads. Plans \$25.

KW-HR METERS: How watt-hour meters work, calibration, error modes (many), ANSI Standards, etc Demand and Polyphase Meters. Experimental results to slow and stop meters by others. \$25.

All 3 (above), Only \$59! (Add \$20 for Video)

NEW S.P.M. THE VIDEO!! \$39



Now its easier to learn about KW-HR Power Meters than ever before! This educational video shows you how they work and their anatomy. Demonstrates SPM device and external magnetic methods used to slow and stop meters! Hosted by a top expert in the field. From the novice to the pro, an excellent source of info on these exciting devices! Great in combo with our SPM related manuals!

Only \$49 for SPM video + SPM manual!!

MAIL \$3 FOR OUR LATEST CATALOG TO: (free w/order)



CONSUMERTRONICS

P.O. Box 23097 ABQ, NM 87192-1097

ORDER TODAY! 505-237-2073

Fax: 505-292-4078 Web Adventure: www.tsc-global.com

Established in 1971. Featured on CBS "60 Minutes," Forbes, New York Times. Add \$5 total S/H (US, Canada). Sold for educational purposes only. Postal M.O. is fastest. VISA, MC OK. COD (\$49-9999), add \$7.

Low Cost CAD Software Now In Windows™95

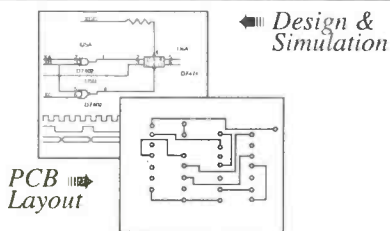

- Easy to use schematic entry program (SuperCAD) for circuit diagrams, only \$149. Includes netlisting, bill of materials, extensive parts libraries.
- Digital simulator (SuperSIM) allows you to check logic circuitry quickly before actually wiring it up. Works directly within SuperCAD and displays results in "logic analyzer" display window. Starting at \$149 this is the lowest cost simulator on the market. Library parts include TTL, and CMOS devices.
- Analog simulator (mentalSPICE) for \$199. Allows AC, DC and transient circuit analysis. Includes models of transistors, discretes, and op amps.
- Circuit board artwork editor and autorouter program (SuperPCB), starting at \$149. Produce high quality artwork directly on dot matrix or laser printers. You can do boards up to 16 layers including surface mount. Includes Gerber and Excellon file output. Autorouter accepts netlists and placement data directly from the SuperCAD schematic editor.
- New!--Complete electronic design package (mentalMAX) including schematic editor, analog and digital circuit simulation, and printed circuit board layout with autorouter for only \$549!

Write or call for free demo disks:
MENTAL AUTOMATION, INC.

5415 - 136th Place S.E.
Bellevue, WA 98006
(425) 641-2141

Internet: <http://www.mental.com>

OSCILLOSCOPES from \$169 !!!

ATC O-Scope uses printer port to turn PC-AT into Digital Storage Oscilloscope, Spectrum Analyzer, Freq. Counter, Logger, DVM. DC-500KHz

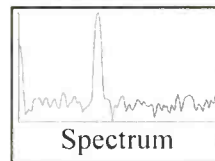
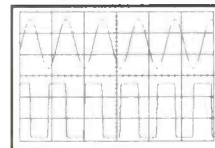

- Print, log to disk, or export data
- Accepts standard scope probes
- Uses standard printer port
- Small and portable
- Works with laptops
- Same day shipping
- Made in U.S.A.
- Single channel units from \$169
- Dual channel units from \$349

Options:

- Probe sets
- Automotive probes
- Battery packs

Order yours today.

800 980 9806

MC/Visa/Amex

Allison Technology Corporation

8343 Carvel, Houston, TX 77036 USA

PH: 713 777 0401, FAX: 713 777 4746, BBS: 713 777 4746

<http://www.atcweb.com>

Xcelite Wheeled Tool Case!!!

- Super tough, black polyethylene rotationally molded for maximum strength.
- 53 individual hand tools, 31 Series 99 interchangeable screwdriver/nutdriver blades and handles, and two specialized screwdriver/nutdriver kits.
- Extra large (3-5/8") roller bearing wheels with wide base for maximum stability and easy transport over rough pavement or stairs.
- Extra wide, comfortable extension handle is molded into case to prevent wear.
- Dimensions: 18" x 15" x 8" deep.
- Extension handle locks into place automatically when extended and retracted. Easy one-handed release.
- Two spring loaded tote handles for convenience.
- "D" ring provided for Bunji cords to carry other cases on top.
- 3-panel hinged tool pallet in lid plus additional pallet in bottom.
- Extra large all new screen mesh literature/utility pocket.
- Extra large storage space for additional equipment.



Xcelite

MODEL TCMB-100/STW

Suggested Price \$1109.80

SUPER SPECIAL \$ 695.00!!!

PRINT™
Products International

8931 Brookville Rd * Silver Spring, MD, 20910 * 800-638-2020 * Fx 800-545-0058

Email: SMPRODINTL@aol.com

CIRCLE 46 ON FREE INFORMATION CARD

www.americanradiohistory.com

CALL TOLL FREE
(800) 292-7711 orders only
Se Habla Español

C&S SALES
EXCELLENCE IN SERVICE

LOOK FOR OTHER
MONTHLY SPECIALS
ON OUR WEBSITE

NEW XK-700 Digital / Analog Trainer
 Elenco's newest advanced designed Digital / Analog Trainer is specially designed for school projects. It is built on a single PC board for maximum reliability. It includes 5 built-in power supplies, a function generator with continuously sine, triangular and square waveforms and a 1560 tie point breadboard area. Tools and meter shown optional. (Mounted in a professional tool case made of reinforced metal).

XK-700
Assembled and Tested
\$189.95

XK-700 - SEMI KIT
w/ Fully Assembled PC Board
\$174.95

XK-700K - Kit
\$159.95

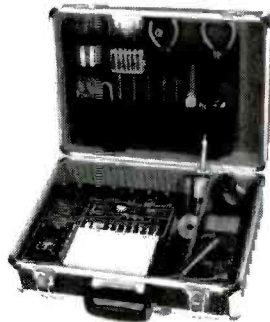

Made In the USA

Volt Alert™ By FLUKE

Volt Alert™ is the new pocket-sized AC line voltage detector from Fluke. Easy to use - just touch the tip to an outlet or cord. When it glows red, you know there's voltage in the line.

Electrician's, maintenance, service, and safety personnel can quickly test for energized circuits and defective grounds on the factory floor, in the shop, or at home.

- Fits in shirt pocket for convenience.
- All outer surfaces are unconductive for safety.
- Detects voltage metallic contact.



#1AC **\$19.50**

DIGITAL LCR METER
Model LCR-1810 **NEW**



\$99.95

- Capacitance 1pF to 20µF
- Inductance 1µH to 20H
- Resistance .01Ω to 2000MΩ
- Temperature -20°C to 75°C
- DC Volts 0 - 20V
- Frequency up to 15MHz
- Diode/Audible Continuity Test
- Signal Output Function
- 3 1/2 Digit Display

20MHz Sweep / Function Generator with Freq Counter

B&K 4040

- 0.2Hz to 20MHz
- AM & FM modulation
- Burst Operation
- External Frequency counter to 30MHz
- Linear and Log sweep

10MHz B&K 4017 \$309
5MHz B&K 4011 \$239



\$399



Model M-6100

The M-6100 is Elenco's most sophisticated meter with almost every possible feature available. The M-6100 even has a computer interface for viewing and storing data on a personal computer. It comes complete with software, RS-232 cable, test leads and manual.

\$125

Model XP-581

4 Fully Regulated DC Power Supplies in One Unit
 4 DC voltages: 3 fixed - +5V @ 3A, +12V @ 1A, -12V @ 1A
 1 Variable - 2.5 - 20V @ 2A

\$89.95



SATELLITE FINDER

Model SF-100A

- Aligns Satellite Dishes
- Range 950-2050MHz
- Audio Tone
- Compact Size
- Self Power Check



\$39.95

Digital Multimeter
Model M-1700

\$39.95

11 functions including freq to 20MHz, cap to 20µF. Meets UL-1244 safety specs.



Technician Tool Kit
TK-1500

28 tools plus a DMM contained in a large flexible tool case with handles ideal for everyone on the go.



\$49.95

Kit Corner
over 100 kits available

AK-700

\$14.95

Phone kit with training course.



RADIO CONTROL CAR KIT

MODEL AK-870

- 7 functions
- Remote control included

\$24.95

No Soldering Required



Model AM/FM-108K Transistor Radio Kit

with training course

\$29.95

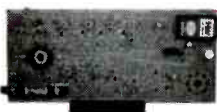

35mm Camera Kit

Learn all about photography

AK-540

\$14.95



No Soldering Required

The New DMM900 Series Handheld Digital Multimeters

For high-performance digital multimeters that are accurate, reliable, and rugged, the DMM900 Series extends the Tektronix line of already affordable DMMs. Twice the accuracy. Up to 10 times the resolution. And a full range of capability that spans voltage, current, digital multimeters features a dual numeric display, 3-year warranty, and autoranging capability. All backed by the reliability of the Tektronix brand.

Features
DMM912, DMM914, DMM916

- 40,000 Count Display
- 0.06% Basic DC Volts Accuracy (DMM916)
- DC Voltage Ranges from 400mV to 1,000V
- AC Voltage Ranges from 4V to 750V (True RMS)
- AC and DC Current Ranges from 10,000µA to 10A
- Resistance Ranges from 400Ω to 40MΩ
- Capacitance Ranges from 4nF to 40µF
- Frequency Ranges from 400Hz to 2MHz
- Temperature Measurements from -50°C to +98°C (DMM916, DMM914)
- 3 Year Warranty
- CE Marking

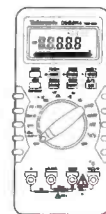

DMM 912
\$189

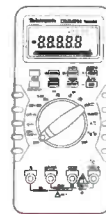

DMM 914
\$235

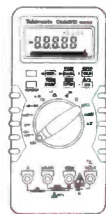

DMM 916
\$275

GUARANTEED LOWEST PRICES ON TEK DMMs

WE WILL NOT BE UNDERSOLD C&S SALES, INC.

150 W. CARPENTER AVENUE
 WHEELING, IL 60090

FAX: (847) 541-9904 (847) 541-0710

http://www.elenco.com/cs_sales/



15 DAY MONEY BACK GUARANTEE

FULL FACTORY WARRANTY

PRICES SUBJECT TO CHANGE WITHOUT NOTICE

**Same Day
Shipping**

C & S SALES
Your one stop source for
all your electronic needs!

CALL OR WRITE FOR OUR
**NEW FREE 64 PAGE
CATALOG!**
(800) 445-3201

Fluke Scopemeters



- 123...NEW.....\$950
- 92B.....\$1445
- 96B.....\$1695
- 99B...NEW....\$2095
- 105B.....\$2495

**ALL FLUKE
PRODUCTS
ON SALE**

**B & K PRECISION
SCOPES**

100MHz THREE-TRACE

Model 2190A

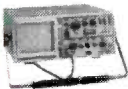

- 1mV/division sensitivity
- Sweeps to 5ns/division
- Dual time base
- Signal delay line
- 15KV accelerating voltage

\$1295.00

60MHz DUAL-TRACE

Model 2160



- 1mV/division sensitivity
- Sweeps to 5ns/division
- Dual time base
- Signal delay line
- V mode displays two signals unrelated in frequency
- Component tester

\$895.00

40MHz DUAL-TRACE

Model 1541C

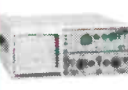

- 1mV/division sensitivity
- Video sync separators
- Z-axis input
- Single Sweep
- V mode displays two signals unrelated in frequency
- Component tester

\$695

60MHz, CURSORS & READOUTS, DUAL TIME BASE

Model 2260



- Cursors and readouts
- 1mV/div sensitivity
- 23 calibrated ranges - main time base
- 19 calibrated ranges - delayed time base
- Signal delay time
- V-mode - displays 2 signals unrelated in frequency
- Component tester
- Z-axis input
- Single sweep

\$1225

20MHz DUAL-TRACE

Model 2120B - 2 Year Warranty

Special \$375

Model 2125A with delayed sweep

\$539.95



- 1mV/division sensitivity
- AUTO-NORM triggered sweep operation
- AC, TVH, TVV and line coupling
- Calibrated 19 step time-base with x10 magnifier
- Compact low-profile design

**Affordable Spectrum
Analyzers by B&K**

500MHz Series

- Model 2615 - \$1595
- Model 2620 w/ tracking generator - \$1895

1.05GHz Series

- Model 2625 - \$2395
- Model 2630 w/ tracking generator - \$2995



Quality Scopes by Elenco

Lowest Prices of the Year!

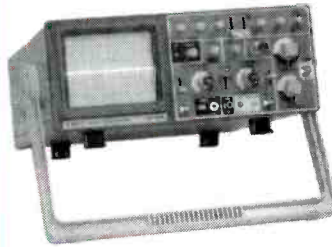

60MHz

DS-603 \$1350

- Analog / Digital Storage
- 20MS/s Sampling Rate

S-1360 \$749

- Analog with Delayed Sweep

100MHz

S-1390 \$995

- Analog

**Includes
Free Dust
Cover and
Probes**

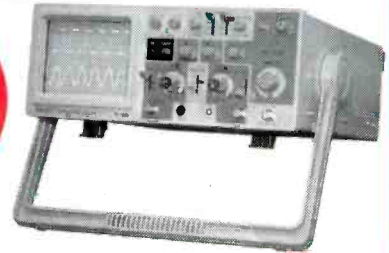

25/30MHz

DS-303 30MHz \$1095

DS-203 20MHz \$725

- Analog / Digital Storage

S-1330 \$439

- 25MHz Analog
- Delayed Sweep

S-1325 \$325

- 25MHz Analog

**2 Year
Warranty**

SIMM MODULE TESTER

B & K 898

\$625

- Tests 72 and 30-pin SIMMs to 36 bits.
- Stand alone and portable. No other equipment required.
- Automatically identifies width, depth and speed of SIMMS.
- 10 built-in tests identify most memory defects. Preheat cycle prior to test.



PORTABLE SEMICONDUCTOR TESTER

B&K 510

- In or out-of-order circuit tests for transistor, FETs, SCRs and darlington.



\$199.00

Fluke Multimeters

Model 70III	\$85	Model 83	\$235
Model 73III	\$115	Model 85	\$269
Model 75III	\$139	Model 87	\$289
Model 77III	\$154	Model 863E	\$475
Model 79III	\$175	Model 867BE	\$650

B&K Precision Multimeters

Model 391	\$143	Model 388A	\$99
Model 390	\$127	Model 2707	\$75
Model 389	\$109	Model 2860A	\$79
Model 5390	\$295	Model 5370	\$219
Model 5380	\$265	Model 5360	\$195

MX-9300

Four Functions in One Instrument

Features:

- One instrument with four test and measuring systems:
 - 1.3GHz Frequency Counter
 - 2MHz Sweep Function Generator
 - Digital Multimeter
 - Digital Triple Power Supply
- 0-30V @ 3A, 15V @ 1A, 5V @ 2A



\$459⁹⁵

GUARANTEED LOWEST PRICES

C&S SALES, INC.

150 W. CARPENTER AVENUE
WHEELING, IL 60090

FAX: (847) 541-9904 (847) 541-0710

http://www.elenco.com/cs_sales/



**15 DAY MONEY BACK
GUARANTEE**

FULL FACTORY WARRANTY

PRICES SUBJECT TO CHANGE WITHOUT NOTICE

UPS SHIPPING: 48 STATES 5%
OTHERS CALL FOR DETAILS
IL Residents add 8.25% Sales Tax

❖ ATTENTION CABLE VIEWERS ❖

CABLE VIEWERS... get back to your BASIC Cable Needs

Call 800-577-8775

For information regarding all of your BASIC cable needs.



**BASIC
ELECTRICAL
SUPPLY &
WAREHOUSING
CORPORATION**

5 GOOD REASONS TO BUY OUR FAR SUPERIOR PRODUCT

- ❖ PRICE
- ❖ EFFICIENT SALES AND SERVICE
- ❖ WE SPECIALIZE IN 5, 10 LOT PRICING
- ❖ ALL FUNCTIONS (COMPATIBLE WITH ALL MAJOR BRANDS)
- ❖ **ANY SIZE ORDER FILLED WITH SAME DAY SHIPPING**

We handle NEW equipment ONLY - Don't trust last year's OBSOLETE and UNSOLD stock!
COMPETITIVE PRICING—DEALERS WELCOME

HOURS: Monday-Saturday 9-5 C.S.T.

It is not the intent of B.E.S.W. to defraud any pay television operator and we will not assist any company or individual in doing the same.
*Refer to sales personnel for specifications.

P.O. Box 8180 ■ Bartlett, IL 60103 ■ 800-577-8775

<http://www.xtronics.com/kits.htm>

Join the exciting and profitable world of factory automation via PLCs. First, buy the *PLC Primer*, a great intro to PLCs & ladder logic programming. It ships with student PLC software and a PLC manual for \$37.94. Next, get our PLC starter kit. It comes with an 8(+2 Pot) in 8 out Toshiba PLC, cable, software (Win95 & 3.1 w/o support) for \$295.00!!

Electronic Kits!
See these and more on our WEB site!



Crystal radio	\$5.75	Glitter-Globe Buckminster Fuller	
Function Gen w/FM	\$28.00	sphere 64 LEDs EN12/92	\$45.00
Function Generator	\$14.95	Deluxe IC Radio	\$11.95
Pulse Generator	\$28.00	World Radio	\$25.95
RF Sig Generator	\$28.00	Train Sound Module	\$3.80
FM Microphone	\$6.95	IR Receiver or Xmitter	\$3.90
Ultrasonic Translator -- Hear ultrasonic-sound	\$18.50	Assembled Metal Detectors from	\$18.50!!



ph 785 841 3089
FAX 785 841 0434

Free catalog

3209 W. 9th Street
Lawrence, KS 66049
Minimum Order \$20.00 +
Shipping - up to 4 lb \$5.00
We ship over seas!

The Pocket Programmer

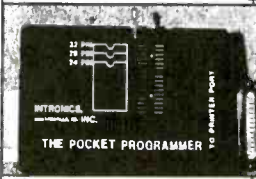

\$129.95

The portable programmer that uses the printer port of your PC instead of an internal card.

Easy to use software that programs E(E)prom, Flash & Dallas Ram. 27(C)/28(C)(F)/29(C)(F)/25 series from 16K to 8 Megabit with a 32 pin socket. Adapters available for MCU's 874X, 875X, Pic, 40-Pin X 16 & Serial Eprom's, PLCC, 5-Gang and Eprom Emulator to 32K X 8.

Same Name, Address & Phone # for 13 Years.... Isn't it Amazing ?

Intronics, Inc.

Box 13723 / 612 Newton St.
Edwardsville, KS 66113 Add \$4.75 COD

Tel. (913) 422-2094 Add \$4.00 Shipping

Fax (913) 441-1623 Visa / Master Charge

SURVEILLANCE

The Latest High Tech Professional Electronic Devices

Our latest catalog offers a HUGE selection of surveillance, counter-surveillance/privacy devices: hidden video equipment, pinhole cameras \$149⁰⁰, telephone recording systems: 12-Hour \$139⁰⁰ 16-Hour \$199⁰⁰ touch tone decoders, scanners, bug/phone tap detectors, voice disguisers, telephone scramblers, locksmithing tools, and more.

Catalog \$5.00

SPY OUTLET

P.O. Box 337, Buffalo, NY 14226
(716) 695-8660/(716) 691-3476

Be a private investigator



Home study. Learn surveillance, interrogation, undercover skills. Solve crimes, earn great pay.
Free literature: 800-223-4542

Name _____ Age _____
Address _____ Phone () _____
City/State _____ Zip _____
School of Private Investigation, Dept. JRE341
6065 Roswell Rd., PCDI, Atlanta, Georgia 30328

Quality Microwave TV Systems
WIRELESS CABLE • ITFS • MMDS
ATV • INTERNATIONAL • S-BAND
Amplifiers • Antennas • Books • Components
Filters • Systems • Video Products

- RF Frequency 1990 - 2700 MHz
- Cable Ready - VHF - UHF Outputs
- SASE For "FREE" Catalog or Send \$1

PHILLIPS-TECH ELECTRONICS
PO Box 8533 • Scottsdale, AZ 85252

ORDER LINE 800-880-MMDS
CATALOG/INFO 602-947-7700
FAX LINE 602-947-7799

CHALLENGER SYSTEM
33-Channel 5208+ Gain
Complete Grid \$265
Five Year Warranty
FREE SHIPPING Visa • M/C • Amx • Disc • COD's • Qty Pricing

Smithy / 3-in-1 Lathe • Mill • Drill
Benchtop machine shop 4 models starting at **\$995**

- Make your own parts and repairs
- Easy to use. free training
- Work metal, wood, or plastic

FREE Info Dept. PE, PO Box 1517
Ann Arbor, MI 48106-1517
Call 1-800-345-6342

"I earned \$1,000 on just 12 VCR repairs in one week"

A true statement by Paul B. of San Pedro, California*

How to cash in on skyrocketing field of VCR repair!

You too can earn up to \$85 an hour, pocket \$200 a day, double your income...in the high-profit field of VCR repair...part-time or full time. There are over 77 million VCR's currently in use in America today - a lot of business out there just waiting for you!

Here is a once-in-a-lifetime opportunity to go into a booming business of your own, make really big money starting right away, be your own boss and enjoy financial freedom and security.

It's easy to learn VCR cleaning, maintenance and repair at home in just a few short weeks through Foley-Belsaw's unique method which emphasizes the mechanics involved in 90% of all repairs, without dwelling on all the unnecessary basic electronics. This exclusive practical hands-on course was developed and proven over a long period of time in an actual VCR repair shop. It combines simple step-by-step lessons with easy-to-follow video cassette guidance. No special experience or electronics background is necessary. Just average mechanical aptitude and the ability to follow simple A-B-C repair procedures that are clearly outlined for you. And when you complete the course you will receive the School's official diploma attesting to your expertise.

Send coupon today for FREE Fact Kit. No obligation.

Don't miss out on this opportunity to give your income a tremendous boost. Send in the coupon NOW. Get all the facts and study them in the privacy of your own home. There's absolutely no obligation and no salesmen will call on you. So don't delay. Mail the coupon today!

"I started 3 months ago, now earn over \$900 a week."
D.K., New York, NY

"Took in over \$3,200 in the past 10 days!"
H.H., Denver, CO

"Doubled my income within 6 weeks."
R.B., Bakersfield, CA

*Last name withheld by request.



MAIL TODAY FOR FREE INFORMATION PACKAGE

**Foley-Belsaw Institute,
6301 Equitable Road
Kansas City, MO 64120-1395**



CHECK ONE BOX ONLY FOR FREE INFORMATION KIT!

YES, without obligation send me information on how I can learn at home to become a VCR technician. 62771

- | | |
|--|--|
| <input type="checkbox"/> Computer Repair 64673 | <input type="checkbox"/> TV/Satellite Dish 31542 |
| <input type="checkbox"/> Computer Programmer 35489 | <input type="checkbox"/> Electrician 95352 |
| <input type="checkbox"/> Networking Specialist 39305 | <input type="checkbox"/> Computer Specialist 38318 |

Name _____

Address _____

City _____ State _____ Zip _____

LEADER

For Professionals Who Know The Difference

- Oscilloscopes
- Video Sync/Test Generators
- Waveform Monitors/Vectorscopes
- EFP/ENG Instruments
- RF Signal Level Meters
- Audio Generators & Meters
- Frequency Counters
- Meters & Bridges
- Power Supplies
- Function Generators
- RF Generators

PRINT™ 
Products International

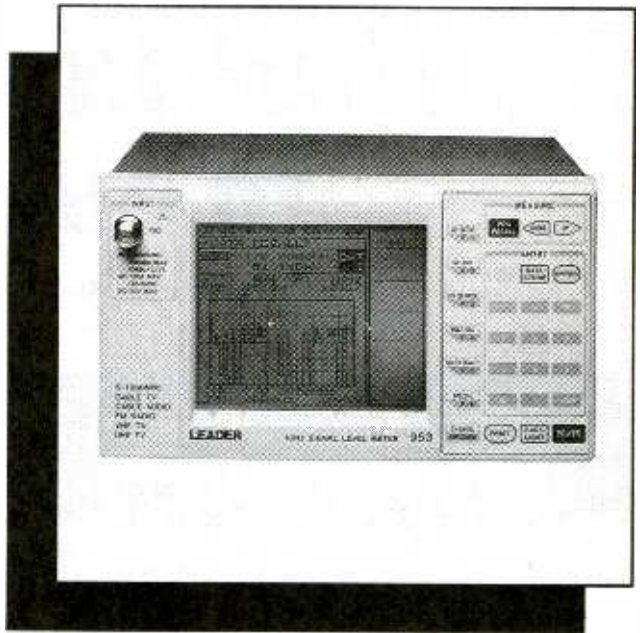

Call, fax or email for your free test and measurement instrument catalog today!
800-638-2020 * Fax 800-545-0058
Email: SMPRODINTL@aol.com

Test Instruments, Equipment, Tools & Supplies For Electronic Production, Maintenance & Service
8931 Brookville Road, Silver Spring, MD, 20910 * 800-638-2020 * Fax 800-545-0058

CIRCLE 47 ON FREE INFORMATION CARD

CABLE TV CHANNELS

EQUIPMENT **Direct!** **GUARANTEED**

SAVE \$1000's
The Nationwide source for cable TV equipment.
"BUY WHERE THE DEALERS BUY."

FREE TV Cable Descramblers, Converters and Magic Box Catalog. Open Every Day!

FREE Your VCR TAPES CAN PLAY AS CLEAR AS DAY!
Eliminates copy protection on any tape
UNJAM NOW WITH Video Decoder!
• Copy any rental/bought tape
• Power Cord and RC Plugs included

CALL NOW! **FREE 30 Day Trial!**

MEGA ELECTRONICS
1-800-676-6342 VISA • MC • COD

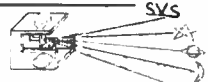
\$139* Laser LightShow 

Draw with a laser beam! Animation, text, music & more! Includes galvos, mirrors, servo amp, demo software disk, analog and digital computer interface. Use an inexpensive pen pointer or high power gas laser.

Computerized Motors \$39* 

Includes: 2 Stepper motors, 2 DC motors, computer interface, training manual, & demo software disk. Expandable! Up to 12 motors, up to 3 amps per phase.

Now with 4 Axis Linear Interpolation

* Add \$6 for shipping. Computer with parallel printer port & cable, assembly, power supply, & laser are required.

FREE FLYER
Voice 510-582-6602 Fax 510-582-6603

SVS 1273 Industrial Pky West Bldg. 460
PO Box 55125 Hayward CA 94545-0125

WHOLESALE PRICES STARTING AS LOW AS \$99.00

CABLE TV DESCRAMBLERS CONVERTERS FILTERS • VIDEO STABILIZERS

1 Year Warranty on All Products. Affordable Extended Warranty. **FREE CATALOG!**

30 Day FREE TRIAL

Call the Cable Professionals 24 Hours A Day!

Orion Electronics

1-800-379-3976
HTTP://WWW.ORION-ELECTRONICS.COM

!!! BROADCAST FARTHER !!!

The model 220 is an 80-110 MHz RF amplifier that connects to mono or stereo FM transmitters and produces a powerful 2-15 watt signal which could broadcast up to 5 miles or more! Requires 50-150 mW drive. Step by step plans complete with part source information and antenna designs... **ONLY \$14 PLUS \$2 S&H NO C.O.D.s**

Progressive Concepts
BOX 586 STREAMWOOD, IL 60107
(630)736-9822 FAX (630)736-0253

Decco is a Kit Builders Paradise
Electronic Kits - Plans - Parts - Computers - Amateur Radio

Call Decco today for your **FREE** copy of
The Electronic Experimenter's Journal

1 800 423 - 4499

Decco Electronics 4025 Edwards Rd. Cincinnati, OH 45209

BUGGED??

EAVESDROPPING is unbelievably widespread! Electronic Devices with amazing capabilities can be monitoring your telephone and room conversations **RIGHT NOW!** Are you sure you're safe? **FREE CATALOG** tells you fast! Includes Free Bonus details on fantastic opportunities now open in Counter-Surveillance field. Exciting, immensely interesting and **EXTREMELY** profitable (up to \$250 hr) full/part-time income. Call Now!

1-800-732-5000

Any waveform you want!



Starting at
\$795
Quantity 1
Money back guarantee

- **Synthesized Signal Generator**
Clean sinewaves DC-20 MHz with .001% accuracy!
.1 Hz steps. DC Offset. RS232 remote control.
- **Arbitrary Waveform Generator**
40 Megasamples/Second. 32,768 points. 12 bit DAC
- **Function Generator**
Ramps, Triangles, Exponentials & more to 2 MHz!
- **Pulse Generator**
Digital waveforms with adjustable duty cycle

Telulex Inc. model SG-100

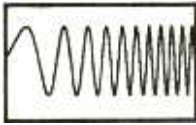

DC to 20 MHz linear and log sweeps

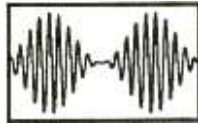

Int/Ext AM, SSB, Dualtone Gen.



Int/Ext FM, PM, BPSK, Burst



Ramps, Triangles, Exponentials



Pulse Generator

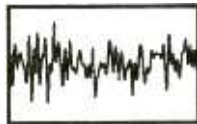

Noise

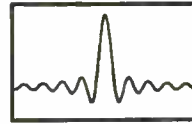

Arbitrary Waveforms

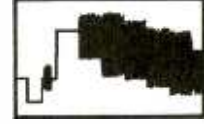

Unlimited Possibilities!



Telulex Inc.

2455 Old Middlefield Way S Tel (415) 938-0240 <http://www.Telulex.com>
Mountain View, CA 94043 Fax (415) 938-0241 Email: sales@Telulex.com

CIRCLE 142 ON FREE INFORMATION CARD

CONTROL MEASURE INPUT

RELAYS • LIGHTS • MOTORS
TEMPERATURE • PRESSURE • LIGHT LEVELS • HUMIDITY
SWITCH POSITIONS • THERMOSTATS • LIQUID LEVELS

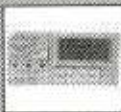
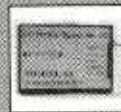
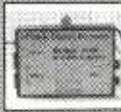
MODEL 30 \$79  <ul style="list-style-type: none"> • PLUGS INTO PC BUS • 24 LINES DIGITAL I/O • 8 CHANNEL • 8 BIT A/D/1K • 12 BIT COUNTER • UP TO 14K BMP/SEC 	MODEL 45 \$189  <ul style="list-style-type: none"> • RS-232 INTERFACE • 8 DIGITAL I/O • 8 ANALOG INPUTS • 2 ANALOG OUTPUTS • 2 COUNTERS-24 BIT
MODEL 100 \$279  <ul style="list-style-type: none"> • 12 BIT 199 KHZ A/D • 4 ANALOG OUTPUTS • 3 TIMER COUNTERS • 24 DIGITAL I/O 	MODEL 150-02 \$179  <ul style="list-style-type: none"> • RS-232 INTERFACE • 10MA, 20 AMP • 12 BIT A/D • OP/IO-ISOLATED • COMPLETE BMM
MODEL 40 \$99  <ul style="list-style-type: none"> • RS-232 INTERFACE • 28 LINES DIGITAL I/O • 8 ANALOG INPUTS • PWM OUTPUT 	MODEL 70 \$239  <ul style="list-style-type: none"> • RS-232 INTERFACE • 18 BIT A/D • 6.5 DIGIT • UP TO 60 BMP/SEC

Prairie Digital, Inc.

PHONE 608-643-8599 • FAX 608-643-6754
846 SEVENTEENTH STREET • PRAIRIE DU SAC, WISCONSIN 53578

CIRCLE 45 ON FREE INFORMATION CARD

Electronic Training Videos



Learn electronics quickly and easily with UCANDO's computer-animated training videos. Students can learn at their own pace and professionals will find the UCANDO videos to be a valuable source of reference material. If these videos aren't the best learning tools you've ever seen, return them within 30 days for a complete refund. These videos are being used by Tech-Schools, CET's, Military Branches, Ham Operators, Industries, and more, across the United States and around the world. Order today and see how UCANDO is ...

"Changing The Way The World Learns Electronics."

VCR Maintenance & Repair ... \$29.95 All others ... \$44.95 each
 * Intro to VCR Repair * Direct Current * Alternating Current * Semiconductors * Power Supplies * Amplifiers * Oscillators * Digital 1 * Digital 2 * Digital 3 * Digital 4 * Digital 5 * Digital 6 * AM Radio * FM Radio Part 1 * FM Radio Part 2 * TV Part 1 * Intro to TV * TV Part 2 * The Front End * TV Part 3 * Audio * Fiber Optics * Laser Technology *

SAVE!!! 6 videos for only \$240 or 12 videos for only \$450



1-800-678-6113

or mail check or money order to:

UCANDO Videos

P.O. Box 928

Greenville, OH 45331



FREE Shipping ... FREE Catalog

CIRCLE 136 ON FREE INFORMATION CARD

TURN YOUR PC INTO A DIGITAL STORAGE OSCILLOSCOPE!

The all new PC-MultiScope 2

10Mhz analog bandwidth!

At right: Actual scope screen as seen on your PC monitor.

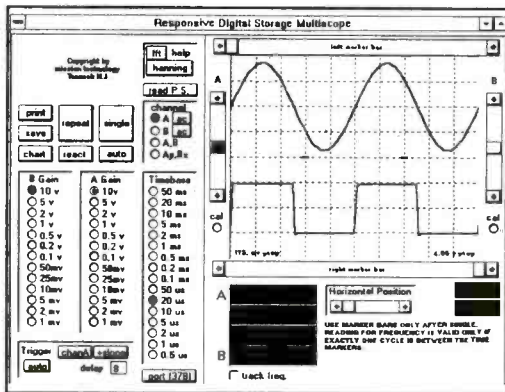

FEATURES:

1. Dual channel; external triggered
2. Digital storage; Windows based
3. Connects to PC parallel port
4. 20Megasamples/sec sampling; 10Mhz max. analog bandwidth
5. 8 bit resolution/ 8K RAM buffer
6. Prog. gain: 10v/div to 1m/div
7. Spectrum analyzer (fft) function
8. Strip chart recorder function
9. TTL output for control app's
10. Visual Basic source code avail.



For industrial, educational, hobbyist, auto, and audio test & measurement

\$399 + S/H. Visa/MC/Check OK
Add \$99 for source code option

The top choice of corporations, universities and scientists worldwide!

AMAZE ELECTRONICS CORPORATION
amaze@hooked.net www.hooked.net/users/amaze
Phone: 800-996-2008 Fax: 408-374-1737

Carpet Rover Robot Kit \$115.00

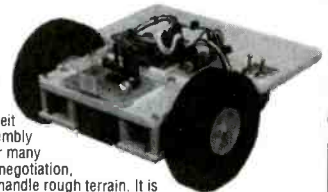

Build your own functional Carpet Rover Robot

The kit comes complete with all hardware, structural components, 2 Hitec servos, Counterfeit Basic Stamp kit, software and an illustrated assembly manual. This robot is an excellent foundation for many experiments such as; obstacle avoidance, maze negotiation, computer art and line tracking. Large 3" wheels handle rough terrain. It is a lot of fun to build and even more fun to operate. Check out our web site for more information and other robot kits.

• Line Tracker Option \$20.00 • Infrared Proximity Det \$30.00 • Mobile Robots Book \$48.00

Quantity discounts available. \$7.50 Shipping & Handling for USA, call for international and quantity shipping charges. IL residents add 6.25% sales tax to total.

Many more robot kits, ask for our free catalog!

Technical Service & Solutions
104 Partridge Road
Pekin, IL 61554-1403 USA

Tel: 309-382-1816

Fax: 309-382-1254

www.lynxmotion.com

jfrye@lynxmotion.com

KEEP YOUR C-BAND SYSTEM RUNNING STRONG!

Free Buyer's Guide

BEST VALUES ON...

- Receivers, including 4DTV
- Dish Movers & LNBs, all kinds
- Tune-up Kits, Tools & Parts
- Skypac® Programming
- Toll Free Technical Help



Fax: 218-739-4879 1010 Frontier Dr.
Int'l: 218-739-5231 Fergus Falls, MN 56537

800-543-3025
www.skyvision.com



CABLE CONVERTER DIAGNOSTIC TEST CHIP

NEAR FULL-LENGTH LINE OF CABLE CONVERTER

WE STOCK A COMPLETE LINE OF CHIPS, TOOLS, WIRELESS QUICK INSTALL TEST BOARDS AND DIAGNOSTIC CUBES FOR ALL CONVERTERS!

- ***ANYONE IMPLYING ILLEGAL USE WILL BE DENIED SALE. WE SELL PRODUCTS ONLY!! TO TECHNICIANS OR CABLE REPAIR FACILITIES!!
- #1 IN CUSTOMER SERVICE & TECH. SUPPORT!
- *ALL ORDERS SHIP WITHIN 24HRS. UPS/ FED-X.
- *PRIORITY NEXT DAY SHIPPING AVAILABLE!
- *SALE= BUY 5 TEST BOARDS AND GET 1 FREE.
- *MON-FRI - 8AM-7PM - SAT 10AM-2PM EST.
- *WEB PAGE HTTP://WWW.800-GOCABLE.COM

VISA **VISUAL COMMUNICATIONS INC.**
ORDERS/CATALOG 1-800-GO-CABLE
TOLL FREE TECH. DEPT. 1-888-519-TECH EST. 1976

SURVEILLANCE TRANSMITTER SCHEMATICS!

FM band-2 telephone and 3 room transmitters constructed using Radio Shack parts with their numbers given. One telephone and two room transmitters are tunable from 65 to 305 MHz, and constructed with listed supply house parts. PC board patterns presented.

PRICE: \$25.00 + S&H \$2.00. For immediate shipment, pay with money order.

SHEFFIELD ELECTRONICS CO.
P.O. Box 377940-B
Chicago, IL 60637-7940
Tel: (773) 324-2196

Cable TV Converters

Save \$100 Dealers Welcome

30 Day Money Back

Call Us Last!

We will beat any advertised price

2 Pc. Combo \$95.00

Minimum 10 Lot

1-800-842-9670

T.C.V.

PROGRAMMERS OVER 50 MODELS

ADVANTECH EETOOLS NEEDHAMS DATA VO ICE TECHNOLOGY HILO SYSTEM GENERAL CHROMA MODULAR CIRCUIT TECHNOLOGY XELTEK



PROMAX EMP-20 MEGAMAX MEGAMAX4 SIMM/SP TESTER EMUPA

- | | |
|-------------------------|------------------------|
| CALL ADVANTECH LABTOOL | 599 EETOOLS SIMMAX |
| 629 ICE TECH MICROLV | 795 CHROMA SIMM/SP |
| 650 EETOOLS ALLMAX + | 359 MOD-MCT-EMUPA/R |
| 409 EETOOLS MEGAMAX | 279 MOD-MCT-EMUP/R |
| 509 EETOOLS MEGAMAX4 | 49 EPROM 1G TO 512K |
| 369 XELTEK SUPERPRO II | 69 EPROM 1G TO 1MEG |
| 409 XELTEK SUPERPRO I P | 99 EPROM 4G TO 1MEG |
| 249 XELTEK SUPERPRO L | 199 EPROM 16G TO 1 MEG |
| 165 XELTEK ROMMASTER II | 89 EPROM 1G TO 8MEG |
| 479 MOD-MCT-EMUPA | 129 EPROM 4G TO 8MEG |
| 739 STAG ORBIT-32 | 250 EPROM 8G TO 8MEG |



LABTOOL48 MICROMASTER SUPERPRO ALLMAX PLUS ROMMASTER2

General Device Instruments

Sales 916-393-1655 Fax 916-393-4949 BBS 983-1234

Web www.generaldevice.com E-Mail icdevice@best.com

LEARN ELECTRONICS!

Home study. Make excellent money. Repair and install camcorders, TVs, VCRs, stereos, sound and lighting, alarm systems, and more!

FREE LITERATURE: 800-223-4542

Name _____ Age _____
Address _____ Phone (____) _____
City/State _____ Zip _____

School of Electronics, Dept. ELE341 PCDI, 6065 Roswell Rd., Atlanta, GA 30328

SURVEILLANCE HIDDEN CAMERAS DIRECT FROM MANUFACTURER - BEST PRICE IN THE MARKET

Ultra miniature hidden camera. In dorm, smoke or motion detector w/ r/c. B/W or Color. Wide view angle. Low light sensitivity + super sharp images, plus video and audio output. From \$150.00. Also 1/2" B/W board cameras w/ r/c. only \$90.00 USD. Wireless hidden camera, start at only \$249.00 USD. Plus \$5.95 for S/H. Wholesale/Retail Welcome. C.O.D. Check, Money Order or Visa/MC.

BOLIDE INTERNATIONAL CORPORATION
PH (800) 355-0895 or (618) 575-8178
9660 Ryan Drive #318, El Monte, CA 91731
http://www.bolideinternational.com

**OVER
30,000
ITEMS
IN STOCK**

Dalbani®

The Ultimate Saving Source

**LARGE VARIETY
SAME DAY SHIPPING**

Over 6,000 new items

SHIP UP TO
5lbs
FOR ONLY **\$3.95**

 **2nd Day Air** 

Plus handling & C.O.D. charge if it applies

- Audio/Video Service Parts**
- Audio/Video Accessories**
- Professional Audio**
- Security Products**
- Connectors**
- Technician Aids**
- Chemicals**
- Test Equipments**
- Soldering Equipment**
- Automotive Products**
- Automotive Installation Kits**

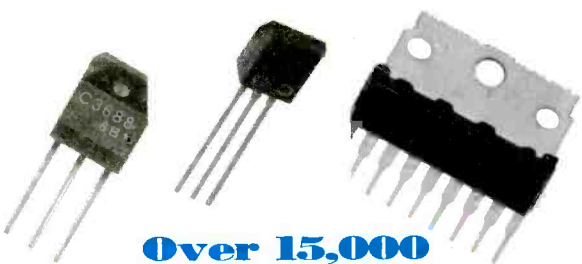

**Over 15,000
Original SEMI in stock.**

Dalbani®
4225 NW 72ND AVE. MIAMI, FLORIDA 33166
TEL : (305) 716-1016 ----- FAX : (305) 594-6588

TO ORDER A CATALOG CALL "258"
1-800-325-2264

CIRCLE 155 ON FREE INFORMATION CARD

April 1998, Popular Electronics

NEW! ELECTRONICS CD-ROM

The most effective way of learning electronics

Two Courses on one CD-ROM!
Only \$49⁰⁰

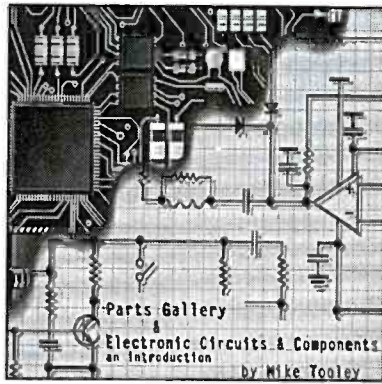

Electronic Circuits and Components

Discover the standards and application of common types of electronic components and how they are used to form complete circuits in **Electronic Circuits & Components**. Sections on the disc include: Fundamental Electronic Theory, Active Components, Passive Components, Analog Circuits, and Digital Circuits. The CD-ROM includes:

- Interactive laboratories • Supervisor notes
- Full audio commentary • Editable worksheets
- About 20 links to pre-designed Electronics Workbench circuits

The Parts Gallery

Many students have a good understanding of electronic theory but still have difficulty in recognizing the vast number of different types and makes of electronic components. **The Parts Gallery** has been designed to help overcome this problem; it will help students recognize common electronic components and their corresponding symbols in circuit diagrams. This CD ROM incorporates a quiz so that students can check their knowledge of electronic components and symbols. The CD-ROM includes:

- Over 150 component and circuit photographs • Supervisor notes
- Self-test component and symbol quizzes • Hundreds of electronic symbols

To Be Released Soon!

A series of interactive CD-ROMs provides a comprehensive and up-to-date introduction to the world of electronics. The series provides a sound understanding of the principles and behavior of electronic components and the circuits to which they are connected. Two new CD ROM discs are to be released in the very near future. They are **Analog Electronics** and **Digital Electronics**. As soon as they are released, information on their contents and availability will be published.

Claggk Inc., PO Box 4099
Farmingdale NY 11735-0792
e-mail: claggk@poptronix.com



Name _____ Phone _____
Address _____
City _____ State _____ Zip _____

Enclosed is \$49 for each Student version (single user) of **The Parts Gallery** and **Electronic Circuits & Components** on a single CD-ROM, shipping included inside the U.S.

I am ordering (....) copies at \$49 each. NY State residents must include sales tax.

I have enclosed my check for \$ _____
 Please charge my credit card for \$ _____
 Visa MasterCard Discover Expiration Date: ___/___/___
 Card Number _____ Signature _____

(Name on order and signature must be same as on Credit Card.)

7 SECOND IC REMOVER

Remove 100's of good IC's per hour
Won't damage IC's or circuit boards

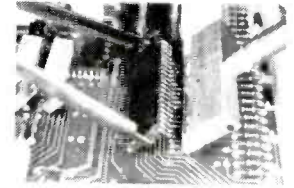

8 Desoldering Tools
(Remove 6 thru 40 pin IC's) \$ 89.95
 10 Desoldering Tools
(Remove 6 thru 64 pin IC's) \$114.95

FRANKS ELECTRONICS

P. O. BOX 357 — GLEN, MISS. 38846
Orders By Mail Only. No COD's.

ADAPT-11 68HC11 Modules for Solderless Breadboards

- miniature 2.0" by 2.8" module
 - plugs vertically into solderless breadboard for easy development
 - BOOT/RUN switch for easy programming via PC serial port
 - all I/O lines on dual row connector
- Complete modular prototyping system!
Expansion accessories available!

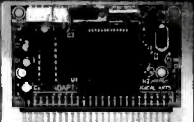

For just US\$74.95, our Starter Package (AD1ISP) provides everything you need to get going fast! Now you can harness the power of the popular 68HC11 in your projects! Includes ADAPT-11 with 68HC11E2, providing 2K EEPROM (re-programmable), 8 channel 8-bit Analog-to-Digital Converter (ADC), hardware timers, counters, interrupts, Serial Peripheral Interface (SPI), Serial Communications Interface (SCI), & more! On-board RS-232 interface (cable included), 5-volt regulator, 8MHz crystal, reset circuit, and convenient program/run switch. Comes with non-commercial versions of 11C11 Assembler, BASIC, & C, as well as handy utilities & example code. Includes Motorola 68HC11 Pocket Programming Reference Guide and manual with schematic. All you need is a PC to write & program your software, a DC power supply, and a solderless breadboard (or protoboard) to build your application circuits on (or use our modular accessories!).

Visa • MasterCard • AmericanExpress • Discover

TECHNOLOGICAL ARTS

309 Aragona Blvd., Suite 102, Box 418, Va. Beach, VA 23462
1644 Bayview Avenue Box 1704, Toronto, ON M4G 3C2
voice/fax:(416) 963-8996 www.interlog.com/~techart

Slot Machines \$ 449.00



Free Shipping
Slot Machine Demo
Video \$ 5.99
40 - Minutes
33" High 20" Wide 14" Deep
Brochure \$ 1.00
Magic Box
Test Chips
Filter Kits
Beep - Boop
Buzz - Buzz
Notch Filters

Video Media www.nutnet.com

P.O. Box 93/6025
Margate, Fl. 33093
(954)-752-9202



AMAZING PRODUCTS!



ELECTRONIC & SCIENTIFIC DEVICES



LASER WINDOW BOUNCE SCIENCE PROJECTS

USES SCATTERED AND DIRECT REFLECTIONS

Remarkable concept allows user to hear sounds within a premise over a beam of laser light reflected from a window or similar surface. Experimental device provides hours of interesting and educational use. Utilizes a visible red laser that simplifies alignment and discourages illegal use. Usable range will vary—expect about 20 to 50 meters. Optional lens will increase range 200 to 400 meters! Further range requires expensive optics. Requires a sturdy video tripod (not incl.) Caution—check local law in your state if planning to use for accessing oral communication. **REQUIRES OPTICAL ALIGNMENT!**



- LWB5 Plans.....\$20.00 LWB5K KIT/PLANS.....\$149.50
- LWB50 Ready to Use With Selected Laser Pointer.....\$199.50
- LWB70 Above With High Performance Laser Gun Sight, Long Range
Extender Lens and Cushioned Headsets.....\$299.50

WIRELESS LAB KITS

ALL PARTS TO BUILD 6 EXCITING TRANSMITTER PROJECTS

- 1 Super Sensitive Ultra Clear 1 Mile+ Voice Transmitter
- 2 1 Mile+ Telephone Transmitter
- 3 Beeper Alert for Above Telephone Transmitter
- 4 Tracking/Homing Beacon "Beeper Transmitter"
- 5 Transmitter Rebroadcasts Video or Audio Outputs
- 6 Short Range TV/FM Disrupter NEAT PRANK!!! Discretion Advised

All 6 Above Kits Plus FREE Info Data Pack on "HELPFUL HINTS" Building and Tuning Wireless Devices

COMBOX Kits and Plans.....\$59.50

ULTRA BRIGHT LASERS

4 to 7x brighter 650-630 nm Radiation

ALL METAL CONSTRUCTION
1 YEAR WARRANTY



- LAPN65 15mw equiv 2000 ft.....\$29.95
- LAPN63 30mw equiv 3000 ft.....\$69.95

FOCUSABLE LASER POINTER

LAPN65F Focusable Above LAPN65...\$39.95

TRANSISTORIZED TESLA COIL

URNS A LIGHT BULB INTO A SPECTACULAR PLASMA DISPLAY

Transmits Wireless Energy
Noiseless Operation
Pyrotechnic Effect
12 VDC/5 Amps or Battery
115 VAC Optional Converter
Adjustable Frequency
Control For Effect

- TCL5 Plans.....\$8.00
- TCL5K Kit/Plans.....\$59.50
- TCL50 Ready to Use.....\$99.50
- TCL2C/7 12VDC@7Amps.....\$39.50

JACOBS LADDER

Observe a pyrotechnical display of "traveling" fiery plasma. Starts off as 1/2" arc and expands to over 3" before evaporating into space. This is an excellent attention getting display as well as a winning science project!! With arc control.

- JACK1 Plans.....\$8.00
- JACK1K Kit Minus Case.....\$129.50
- JACK10 Ready to Use.....\$249.50
- 12KVGEN20 Pwr Supply Only.....\$99.50
- 12KVGEN2K Kit of Pwr Supply.....\$79.50

250KV TESLA COIL

10'-14" of Explosive Bolts of Lightning

Transmit Wireless Energy
Strange and Bizarre pyrotechnical effects.
Ion Motors Anti-Gravity
Size 20" H x 8" Sq
Weight - 25 Pounds
115 Volts/2 Amps AC
Labeled "Use Caution"

- BTC3 Plans.....\$15.00
- BTC3K Kit/Plans.....\$349.50
- BTC30 Ready to Use.....\$449.50
- BTC4 Plans, 500kv Unit.....\$20.00

BURNING LASER RAY GUN

UTILIZES LOSSLESS ENERGY CHARGING

All Parts Available

LAGUN2 Plans.....\$20.00

BURNING CO2 BENCH LASER

HOTTER THAN MOST TORCHES!

All Parts Available

LC7 Plans.....\$20.00

KINETIC ELECTRIC GUN

PIONEER A FUTURISTIC WEAPON!

500 Joules Energy Storage
Constant Current Charging
Triggered Spark Switch
Ballistic Velocities
Handheld Battery Operated
Labeled A Dangers product

EGUN1 Plans with Parts List.....\$20.00

All Parts are Individually Available

3MI FM BC TRANSMITTER

Safely Product Allows Listening to Children or Invalids in Hazardous Areas, Pools, Ponds etc. Great Security Intrusion Alert! Uses FM Table Top Radio.

FMV1K Kit/Plans.....\$39.50

ION RAY GUN PROJECTS ENERGY!

Star Wars Technology Demonstrates Weapons Potential!

IOG7K Kit/Plans.....\$99.50

GRAVITY GENERATOR

Demonstrates a unique phenomena of electrical reactions that produce the effect of "anti-gravity". You build and levitate a small mock space ship from simple materials. Excellent scientific demonstration of a fascinating method of levitation. **Levitate an Object!**

- GRA1 Plans and Book.....\$20.00
- GRA1K Pwr Sup Kit/Plans.....\$99.50
- GRA10 Assbled Pwr Sup.....\$149.50

ELECTRONIC HYPNOSIS AND MIND CONTROL

Generates Highly Effective Audible and Visual Stimuli With Bio-Feedback That Can Induce Hypnotic as Well as ALPHA Relaxed States of the Mind. Place Subjects "Under" Your Control. Enhances Hidden PSYCHIC Ability in Many People!

- MIND Plans.....\$15.00
- MIND2K Kit and Plans.....\$49.50
- MIND20 Assembled.....\$79.50

TELEPHONE TAPING SYSTEM

EXTENDED X4 PLAY. Tapes Phone Conversation 20 Mins Input 21 Check Laws!

- TA P30X Ready to Use.....\$84.50
- BEEP10 Beeper Alert.....\$29.95

SHOCK FORCE FIELD/VEHICLE OBJECT ELECTRIFIER

Hand Shock Balls, Wands, Elasticity Objects. Great Payback for Those Wiseguy!!

SHK1K Kit of Pwr Module.....\$19.50

NEW CYBERNETIC EAR!

Use For Courtesy Lowering of TV Volume Control etc. Defeat Rattles and Other Mechanical Abnormalities, Leaking Gases, Air, or Corona. Great Safety Aid for Shop or Office!

Enhances Most Hearing 3 to 4 Times! Adjustable Volume Control. Fits Easily Into Either Ear. Heavy Duty Used!

CYBEREAR Ready to use...\$19.95

3 MI TELEPHONE TRANSMITTER

Tunable On FM Broadcast. Excellent Telephone Project. Only Transmits When Phone is Used

VWPM7 Plans Only.....\$7.00

ELECTRIC CHARGE GUN

WITH 15 FOOT RANGE!!

Stuns and Immobilizes Attackers From a Distance. More Knockdown Power than a Handgun!! Check Your State Legality

FREE!! 100KV Stun Gun

ECG10 With STUN100.....\$249.50

STUNGUNS SOLD SEPERATELY

STUN200 200KV StunGun.....\$49.50

STUN300 300KV StunGun.....\$69.50

HIGH CRIME AREA SECURITY!

INFINITY+ TRANSMITTER

ROOM MONITOR/ LINE GRABBER/CONTROLLER

- MONITOR YOUR PREMISES
Avoid ambushes and track the
- ACCESS ON GOING CALLS
Long-Distance Intercepts!!
- CONTROL 8 APPLIANCES
Remote control your home!!
- EXTRA ADDED FEATURE!!!
Detects THOSE "CON JUNGLES"
Toll Calls Made From Pay Phones!!

- TELCON3 Plans.....\$10.00
- TELCON3K Kit/Plans.....\$99.50
- TELCON30 Ready to Use.....\$149.50

Programmed With built in BEEPER ALERT

PHASOR BLAST WAVE PISTOL

130 db of Directional Sonic Shock Waves Energy Handheld and Battery Operated

- PPP1 Plans.....\$8.00
- PPP1K Kit/Plans.....\$49.50
- PPP10 Ready to Use.....\$79.50

ATTENTION! HIGH VOLTAGE EXPERIMENTERS

Battery Powered Mini Sized Modules for research in: HOVERCRAFT, ION GUNS, FORCE FIELDS, SHOCKERS etc

MINIMAX4 4KV@10ma.....\$19.50

INFORMATION

UNLIMITED DEPT PE 1097
BOX 716 AMHERST, N.H. 03031

24 Hr Toll FREE "Orders Only" Line 1-800-221-1705

Fax Your Order to 1-603-672-5406

9 to 5 pm EST Information Line 1-603-673-4730

See Our Web Site at <http://www.amazing1.com>

ATTENTION!! RAILGUN EXPERIMENTERS

HIGH ENERGY PULSER

EXPERIMENTORS AND RESEARCHERS

RAIL GUN, COIL GUN, EXPLODING WATER, ANTIGRAVITY, MASS WARPING, LEVITATION, PLASMA PROPULSION, LATTICE SNAPPING, EMP etc

- Lossless Energy Charging
- Programmable Voltage to 2 KV and Energy Control to 3 KJ
- Triggered Spark Switch [1KJ]
- Universal 12 VDC or 115 VAC
- 7.5 X 7.5 X 7" Light weight

HOTSHOT

HEP3 Plans High Energy Pulser/Ignitor.....\$15.00

HEP3K Kit/Plans (Minus Energy Storage).....\$199.50

HEP30 Assembled (Minus Energy Storage).....\$299.50

HEPCAP 800 Joules Energy Storage.....\$199.50

WE ACCEPT MC, VISA, CASH, MO, CHECKS. PLEASE ADD \$5.00 SHIPPING. COD ORDERS ADD ADDITIONAL \$4.75. REQUEST A FREE CATALOG!!

Introducing Eagan Technical Services, Inc.

Surface Mount Rework System

The Eagan Technical Services SMT Rework System and Procedures were developed to meet the needs of several high volume computer repair facilities and provide an efficient and economical method for removal and installation of Surface Mount devices. The system includes all tools, supplies, and materials required to perform nondestructive removal and installation of most package/types of surface mount components.

Just \$249.95!

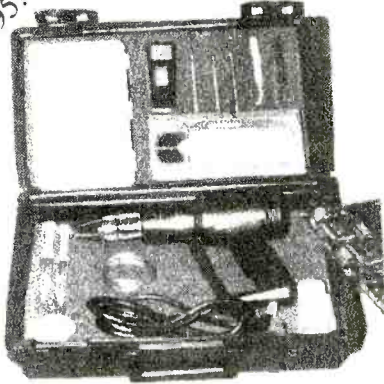

- SMT Reflow Gun
- Reduction Nozzle
- Set of 3 Probes
- Set of 2 Tweezers
- Cleaning Sponge
- Illuminated Magnifier
- Water-Soluble Flux
- Organic Core Solder
- Flux Applicator
- Tool/Parts Box
- Instructional Video
- Practice PC Board
- Instruction Booklet



Eagan Technical Services, Inc.
1408 Northland Drive, Suite #304
Mendota Heights, MN 55120
Phone: 612.688.0098 Fax: 612.688.7829
Toll Free: 800.285.1873 Internet Address: www.eagantech.com

ATTENTION DEALERS: WHOLESALE ONLY!



Formerly JES, Inc.

BEST PRICES!
FAST SERVICE
SAME DAY SHIPPING

EXCLUSIVE:



NEW!
Wavemaster 99 Channel
• Sleep Timer • Std./HRC Switch • Parental Control

10+	20+	50+
\$57	52	45

	5+	10+	20+
Panasonic 145	\$72	65	60
Refurb. Panasonic 145	57	55	52
Panasonic 100	52	49	--
Panasonic 175	---	CALL!	---
Starcomm DQN (99 ch; Refurb.)	49	45	39

TOLL FREE:
800-322-9690



FAX:
516-246-5634

MONDO • TRONICS

ROBOT STORE

* KITS *

Your

* BOOKS *

Mailorder

* PARTS *

Source

* VIDEOS *

For

* MODELS *

Robots!

* MORE! *

(REQUEST OUR FREE CATALOG)

www.robotstore.com

800-374-5764

Or write to us:

4286 Redwood Hwy #226-137
San Rafael CA 94903
Phone 415-491-4600 • Fax 415-491-4696
Email info@mondo.com

ALFA ELECTRONICS, INC.

HIGH QUALITY TEST EQUIPMENT PROVIDER

1-800-526-2532 (526-ALFA)

15 Days Money Back Guarantee!

	<p>DMM</p> <p>DMM-10 (\$19.95): 3 1/2 digit, DC/AC V, Ω, hFE, diode, signal output(+3V, -0.5Vsq., 50% duty)</p> <p>DMM-17B (\$39.95): 3 1/2 digit, DC/ACV, contin., DC/ACA, Ω, Capacitance, hFE, diode, Freq</p> <p>DMM-20 (\$74.95): AC/DC (V, A), Freq, cont., Capac, Induct, Ω, hFE, diode, duty cycle</p> <p>DMM-22 (\$89.95): 4000 counts, bar graph, Freq, AC/DC (V, A), Ω, Capacitance, diode, contin.</p> <p>DMM-23T (\$99.95): 4 1/2 digit, high resol. (10uV, 10nA, 10mΩ), hFE, diode, contin., true rms</p> <p>DMM-89S (\$179.00): true rms, AC/DC (V, A), Ω, bar graph, freq, capac., dBm, logic, diode</p>		<p>LCR METER</p> <p>CAP-15 (\$49.95): 3 1/2 digit, 0.1pF-20mF, 9 Ranges, 0.1pF resolution zero adjustment.</p> <p>LCR-19S (\$89.95): 1uH-200H (induct.), 0.1pF-200uF (Capac.), 0.01Ω-20M Ω (resistance)</p> <p>LCR-814 (\$189.95): 0.1uH-200H, 0.1pF-20mF, 0.1Ω-20MΩ, Q Factor, dissipation, zero adjust</p> <p>LCR-131D (\$229.95): autorange, 0.1uH-10kH, 0.1pF-10mF, 1mΩ-10MΩ, Q Factor, serial/parallel, 120Hz/1kHz testing mode</p>	<p>FREQ. COUNTER</p> <p>FC-1200 (\$129.95): 1.25GHz Handheld, 8 digits display, 10ppm accuracy, sensitivity 5mV (130-350MHz), 30mV (440MHz), 22m (800MHz), batteries or 9V adapter.</p> <p>FC-2500 (\$179.95): 2.5GHz Handheld, 8 digits display, 4ppm accuracy, sensitivity <50mV, batteries or 9V adapter.</p> <p>FC-5278A (\$149.95): 1.2 GHz bench type, 8 digit, 10 ppm, 35mV sensitivity, 10Vp-p max input, power by 9V adapter.</p> <p>FC-5700 (\$329.95): 1.3GHz bench type, 8 digit, 1 ppm accuracy, 20mV sensitivity, period 0.1us to 100ms. Ideal for test & repair of audio instrument.</p>																		
	<p>DMM-113 (\$24.95): Pocket Size, DC/ACV, Ω, diode, Continuity beeper</p> <p>DMM-120 (\$24.95): economy type, DCV, ACV, DCA, Ω, hFE, diode</p> <p>DMM-122 (\$59.95): DC/AC(V, A), Ω, hFE, diode, capacitance, freq, logic, continuity</p> <p>DMM-123 (\$44.95): DMM + capacitance, DC/AC(V, A), Ω, hFE, diode, continuity</p> <p>DMM-124 (\$69.95): Electrical + Temp, DC/ACV, , capacitance, freq, 3 phase, diode, contin.</p> <p>DMM-125C (\$54.95): Autorange + bar graph, DC/ACV, Cap, Ω, diode, continuity beeper</p>		<p>FLUKE DMM</p> <table border="1"> <tr> <th>HandHeld</th> <th>Scope Meter</th> </tr> <tr> <td>12 \$ 84.95</td> <td>92B \$1,399</td> </tr> <tr> <td>70-II \$ 75.95</td> <td>96B \$1,699</td> </tr> <tr> <td>73-II \$ 97.95</td> <td>99B \$1,999</td> </tr> <tr> <td>75-II \$129.00</td> <td>105B \$2,499</td> </tr> <tr> <td>76-II \$175.00</td> <td>863E \$469</td> </tr> <tr> <td>77-II \$155.00</td> <td>867E \$659</td> </tr> <tr> <td>79/29-II \$175.00</td> <td></td> </tr> <tr> <td>87 \$287.00</td> <td></td> </tr> </table>	HandHeld	Scope Meter	12 \$ 84.95	92B \$1,399	70-II \$ 75.95	96B \$1,699	73-II \$ 97.95	99B \$1,999	75-II \$129.00	105B \$2,499	76-II \$175.00	863E \$469	77-II \$155.00	867E \$659	79/29-II \$175.00		87 \$287.00		<p>SPECIALTY</p> <ul style="list-style-type: none"> • Sound meter \$169.95 • EMF Tester \$69.95 • Conductivity \$169.95 • Thermometer \$69.95-\$89.95 • Humid./Temp meter \$169.95 • Press. meter \$299.95 • Electr. scale \$89.95 • Watt Meter \$129.95 • High Voltage Probe \$59.95 • pH Meter \$79.95 • Light Meter \$80-\$90 • Light Adapter \$49.95 • Anemometer \$179.95 • Anemometer adapter (And More) \$89.95
HandHeld	Scope Meter																					
12 \$ 84.95	92B \$1,399																					
70-II \$ 75.95	96B \$1,699																					
73-II \$ 97.95	99B \$1,999																					
75-II \$129.00	105B \$2,499																					
76-II \$175.00	863E \$469																					
77-II \$155.00	867E \$659																					
79/29-II \$175.00																						
87 \$287.00																						

OSCILLOSCOPE

Dual Trace, Component Test, 6" CRT, X-Y Operation, TV Sync, CH2 Output, Graticule Illum, 2 Probes(x1;x10)

- PS-200 20 MHz Dual Trace \$339.95
- PS-205 20 MHz Dual w/ Delay Sweep \$429.95
- PS-400 40 MHz Dual Trace \$494.95
- PS-405 40 MHz Dual w/ Delay Sweep \$569.95
- PS-605 60 MHz Dual w/ Delay Sweep \$769.95
- PS-1000 100MHz Dual Trace \$999.95

Digital Scope:

- DS-303 30MHz Digital, 20 Samples/sec \$849.95
- DS-303P RS-232 interface, 30Mhz \$1,049.95

Scope Probe:

- HP-9060 (60MHz) \$15, HP-9150 (150MHz) \$22, HP-9250 (250MHz) \$29, HP-9258 (250MHz, 100:1) \$39

AUDIO/RF/FUNCT. GENERATOR

RF Generator

- SG-4160 (\$124.95) 100kHz-150MHz sinewaves in 8 ranges, 100mV at 35MHz
- SG-4162 (\$229.95): Generate same signal as SG-4160, but with int. counter (150MHz)

Audio Generator





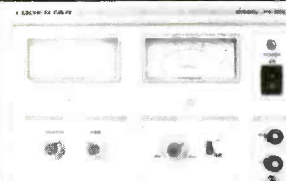

- AG-2601 (\$124.95) 10Hz-1MHz, 0-8Vpp sine, 0-10Vpp squarewave
- AG-2603 (\$229.95): Same as AG-2601, but with additional counter and digital display.

Function Generator

- FG-2100A (\$169.95): 2Hz-2MHz, 5mV-20Vpp
- FG-2102AD (\$229.95) same as FG-2100A, but with int. counter and TTL, CMOS output
- FG-2103 (\$329.95) Sweep 0.5Hz-5MHz, linear/log, VCG, GCV, and int. counter

POWER SUPPLIES	Single Output DC Power Supplies	Dual Tracking	Triple Output
 <ul style="list-style-type: none"> • Short Circuit and overload protected • Constant current, constant voltage mode • 0.02%+2mV line regulation; 0.02%+2mV load regulate <p>Analog Meters Display</p> <ul style="list-style-type: none"> PS-303 (\$159.00) 30V/3A PS-305 (\$219.95) 30V/5A PS-8110 (\$289.95) 60V/5A PS-8112 (\$399.95) 60V/5A PS-1610 (\$289.00) 16V/10A PS-8107 (\$399.95) 30V/10A <p>Digital Voltage, Analog Current</p> <ul style="list-style-type: none"> PS-8200 (\$179.95) 30V/3A PS-8201 (\$239.95) 30V/5A <p>Digital Volt & Current Display</p> <ul style="list-style-type: none"> PS-8300 (\$199.95) 30V/3A PS-8301 (\$259.95) 30V/5A 	<ul style="list-style-type: none"> • Short Circuit & overload protected • Constant current & constant mode • Independent or Tracking <p>Dual Tracking (Analog V & I Displays)</p> <ul style="list-style-type: none"> PS-303D (\$314.95) 30V/3A/30V/3A PS-305D (\$399.95) 30V/5A/30V/5A PS-8108 (\$549.95) 60V/3A/60V/3A PS-8109 (\$699.95) 60V/5A/60V/5A 	<ul style="list-style-type: none"> • One fixed 5VDC, 3 Amp output • Parallel to double current output (PS-8102 & PS-8103 only) <p>Triple Output (Analog displays)</p> <ul style="list-style-type: none"> PS-8102 (\$399.95) 30V/3A/30V/3A PS-8103 (\$489.95) 30V/5A/30V/5A <p>Digital Displays</p> <ul style="list-style-type: none"> PS-8202 (\$499.95) 30V/3A/30V/3A PS-8203 (\$549.95) 30V/5A/30V/5A 	

INSTEK® Test & Measuring Instrument ISO 9002 Cert. #934163 (2 Years Warranty)

OSCILLOSCOPE	DC POWER SUPPLIES	FUNCTION GENERATOR	BENCHTOP DMM
<p>OS-653 \$699.95 50MHz Trigger Ring</p> <p>OS-622B \$399.95 20 MHz Oscilloscope</p>   <ul style="list-style-type: none"> • Dual CH / Delay sweep • ALT trigger, trigger lock • 1mV/div sen., delay line • Zaxis input, CH1 output • Hold off, TV syn. • 2 probes (x1, x10) <p>OS-305 (\$209.95) - 5 MHz One Channel OS-310 (\$324.95) - 10 MHz One channel</p>	<p>Triple Output</p> <p>Single Output</p> <p>Programmable</p>    <ul style="list-style-type: none"> • 2 variable out 0-30V, 0-3A • One fixed 5V, 3A output • Auto track, serial, parallel • Const. volt, current mode • 4 analog or 2 digital display <p>PC-3030 (\$499.95) PC-3030D (\$549.95)</p> <p>Analog Meters Display</p> <ul style="list-style-type: none"> PS-1830 (\$209.95) 18V/3A PS-1850 (\$219.95) 18V/5A <p>PS-3030 (\$224.95) 30V/3A PS-6010 (\$209.95) 60V/10A</p> <p>PR-3060 (\$314.95) 30V/6A PR-6030 (\$314.95) 60V/3A</p> <p>Digital Meters Display</p> <ul style="list-style-type: none"> PS-1830D (\$219.95) 18V/3A PS-1850D (\$244.95) 18V/5A PS-3030D (\$254.95) 30V/3A PR-6030D (\$399.95) 60V/3A 	<p>FG-8015G (\$189.95) Sweep 0.02Hz-2MHz, no/counter • Sine/Sqr/Trn/pulse/Ramp</p> <p>FG-8016G (\$239.95) 0.02Hz-2MHz w/ counter • Pulse, function generator</p> <p>FG-8017G (\$249.95) Sweep • Sine/Trn/Sqr/TTL/CMOS 0.02Hz-2MHz, FM mod.</p> <p>FG-8019 (\$399.95) Sweep 0.02Hz-2MHz w/counter • INT/EXT AM/FM mod</p> <p>FG-8019 (\$209.95) 0.02Hz-2MHz w/counter</p> <p>FG-8050 (\$499.95) Sweep 0.05Hz-5MHz w/counter • INT/EXT AM/FM mod</p> <p>FG-830 (\$1,499.95) 30MHz Synthesized Function Gen. • Output: sine, tri., square, sync out, arb. waveform</p>	<p>DM-8034 (\$179.95) 3 1/2 digit • AC/DV(V, A), C, Ω, diode • 1000V, 20A, 0.5% accu.</p> <p>DM-8040 (\$339.95) 3 1/2 digit • ACV to 50kHz, true rms</p> <p>DM-8055 (\$649.95) 5 1/2 digit • 0.006% basic accuracy • 1uV, 1mΩ, 1nA resolution • dBm, auto, REL., min/max</p> <p>DM-8055G (\$889.95) GPIB • Same funct. as DM-8055</p> <p>Frequency Counters</p> <ul style="list-style-type: none"> FC-8131 (\$469.95) 1.3GHz FC-8270 (\$629.95) 7GHz UC-2010G (\$249.95) 

Programmable Electronic Load (PEL-300) (Patent Nos. 81011 & 81324)

- Operating Rating: voltage 3-60V, current 6mA-60A, power 300W, temp 0-40C (operate)/-10-70C (store)
- Over voltage, over current, over power protection
- Operation mode: constant voltage, current, resistance
- Transient Gen. Frequency 1Hz-1kHz, duty 10-90%
- High Resolution: 20mV, 0.2mA, 0.3mΩ
- Self-Test and Software Calibration
- Meet UL CSA IEC Safety regulation

*** NEW * \$1409.95**

ALFA ELECTRONICS P.O. BOX 8089 PRINCETON, NJ 08543

TEL: (800) 526-ALFA (2532) / (609) 897-1135 FAX: 609-897-0206 Email: alfa0168@aol.com

Call/Write/Fax/Email for FREE CATALOG Visa, MC, AMEX, COD, PO Accepted. OEM Welcome. 1 Year Warranty (2 Years for Instek)

April 1998, Popular Electronics

CABLE T.V. EQUIPMENT

Friendly, Knowledgeable Service



ORDERS CALL:
1-800-361-4586



- All Equipment New
- Convertors & Descramblers
- 30 Day Money Back Guarantee
 - 6 Month Warranty
- Visa, MC, C.O.D. Welcome

KDE ELECTRONICS, INC.

P.O. Box 1494
Addison, IL 60101

Info. 630-889-0281 HRS: Mon-Fri, 9-6 CST
Fax 630-889-0283 Sat, 10-2 CST



Are you overpaying . . .
. . . your cable company?

You are if . . . 
. . . you are leasing their
equipment.

- Forest Electronics, Inc. offers a complete line of New Cable Decoders and Converters that are fully Compatible with your cable system.
- All systems come with: Remote Control, & Parental Guidance Feature. Volume Control is also available.
- All Equipment is fully guaranteed & comes with a 30 day money back option.

For More Information Call Us 24 Hours a Day At:

800-332-1996

FAX: 813-376-7801

ELECTRONIC COMPONENTS



Visit our web site!
www.mouser.com

FREE catalog is available on the internet, CD-ROM, or in paper!

- 70,000+ Products
- 145 Manufacturers
- Same Day Shipping
- No Minimum Order

800-992-9943

817-483-6828 Fax: 817-483-0931
www.mouser.com catalog@mouser.com

958 North Main St., Mansfield, TX 76063



BASIC ELECTRICAL SUPPLY & WAREHOUSING CORPORATION

ATTENTION CABLE VIEWERS
Own Your Own Unit Today
Cable TV Converters &
Descramblers
All Makes / All Models

Call 1-800-577-8775

Technical Info: 847-584-2099

BUY BONDS

Call for FREE Catalog!

CABLE TV BONANZA



LOW PRICES!
GREAT SERVICE!

FULL VIEW CABLE BOXES
WHOLESALE PRICES!
30 Day Free Trial!
1 Year Guarantee!

- VIDEO STABILIZERS—Removes video tape copy protection
- TEST CHIPS, DEVICES, FILTERS AND ACCESSORIES

FREE BULLET BUSTER

with cable box purchase (REG.\$9.95)

Anyone implying theft of service will be denied assistance

N.S. INTERNATIONAL

OPEN DAILY
9am - 11pm (EST)

1-800-449-9189

C.O.D. or
Credit Cards

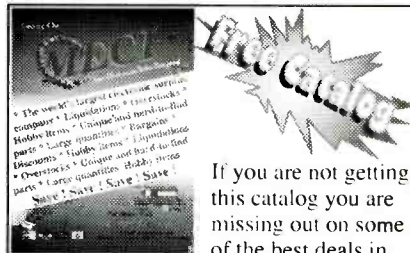

If you are not getting this catalog you are missing out on some of the best deals in electronics today! We have thousands of items ranging from unique, hard-to-find parts to standard production components. Call, write, or fax today to start your free subscription to the most unique catalog in the industry, filled with super values on surplus electronic and hobbyist type items. If you have a friend who would like to receive our catalog, send us their name and address and we will gladly forward them a complimentary 100 page catalog.

Why pay more? Call today.



340 East First Street Fax Order Line
Dayton, Ohio 45402 1-800-344-6324

Order Toll-Free
1-800-344-4465

CIRCLE 151 ON FREE INFORMATION CARD

EPROM+ *The Professionals Choice!*

A DEVICE PROGRAMMER FOR BENCH AND FIELD

Uses parallel printer port!

Excellent software!

Supports all standard parts!



- FIRST GENERATION EPROMS** 2708, TMS2716*, 25XX
SECOND GENERATION EPROMS (24, 28, 32 PIN) 2716 - 27C080 (8 MEG) *ADAPTER REQUIRED (DIAGRAMS INCLUDED)
16 BIT EPROMS (40, 42 PIN) 27C1024 - 27C160 (16 MEG)
FLASH EPROMS (28, 32 PIN) 28F, 29C, 29EE, 29F FAMILIES PLUS BOOT BLOCK DEVICES
EEPROMS/NVRAMS (24, 28, 32 PIN) 28C04 - 28C010, X2210/12, ER5901, PLUS DALLAS 12XX
SERIAL EPROMS* (8, 14 PIN) 17XX, 24XX, 25XX, 35XXX, 59XX, 85XX, 93XX, 95XX+ER1400
BIPOLAR PROMS* (16 - 24 PIN) 74SXXX AND 82SXXX FAMILIES
MICROCONTROLLERS* (ALL FAMILIES) 874X, 875X, 87C5XX, 87C75X, 89C5X, 89C05T, 68705, 68711, PIC12XXX - 16CXXX, 17C4X PLUS FLASH AND 14000
 * READ, PROGRAM, COPY, COMPARE FILE LOAD/SAVE (PLUS MUCH MORE!)
 * FULL SCREEN EDITOR W/25 CMDs + BYTE/WORD MODES
 * RUNS UNDER DOS, WINS.1/95 ON ANY SPEED MACHINE
 * SUPPORTS INTEL HEX, S-RECORD AND BINARY FILES
 * MADE IN USA + 30 DAY MONEY BACK GUARANTEE

\$289

SYSTEM INCLUDES: PROGRAMMING UNIT, PRINTER \$5.00 SHIPPING + \$5.00 C.O.D.

PORT CABLE, POWER PACK, SOFTWARE & MANUAL VISA *MASTERCARD* AMEX

ANDROMEDA RESEARCH, P.O. BOX 222, MILFORD, OH 45150
 (513) 831-9708 FAX (513) 831-7562

The World's Largest Source for Home Automation

- The Best & Most Comprehensive Home Automation Catalog in the Industry.
- Best Customer Service & Technical Support

Thousands of hard-to-find automation, X-10 and wireless control products. Computer interfaces, software, development tools, lighting control, telephone systems, security systems, surveillance cameras, infrared audio/video control, home theater, touchscreen control, HVAC, pet care automation, wiring supplies, books and videos and much more!

FREE
128 page full color catalog!

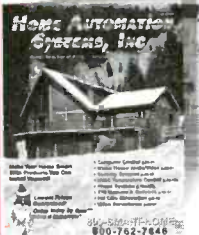

World's Largest Selection!

Lowest Prices Guaranteed!

HOME AUTOMATION SYSTEMS, Inc.
 Questions: 714-708-0610 Fax: 714-708-0614
 e-mail: catalog@smarthome.com
 www.smarthome.com

Call for a **FREE** Catalog! 800-762-7846

800-SMART-HOME

Dealers/Resellers ask about our HASPRO Dealer Program 800-949-6255

CABLE TV CONVERTERS

Equipment & Accessories
 Wholesalers Welcome

Call C&D ELECTRONICS
 1-888-615-5757 M-F 10a-6p

STRANGE BOOKS! for Mad Scientists!

Unusual, detailed how-to books, manuals, references, old & new, for experimenters and

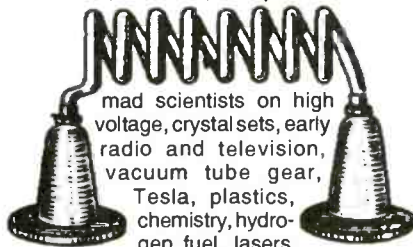

mad scientists on high voltage, crystal sets, early radio and television, vacuum tube gear, Tesla, plastics, chemistry, hydrogen fuel, lasers, whiskey, solar cells, embalming, telegraphy, more! Highest quality! Guaranteed! Write (or send Igor) for big illustrated catalog! <http://www.keynet.net/~lindsay> fax:815/935-5477
Lindsay's Technical Books
 PO Box 538-WJ4, Bradley IL 60915

Cable TV Outlet



Get the Clearest Coverage of Sports, Movies, News, Main Events and Adult!

- Unbeatable Wholesale Pricing-
- Converters/Descramblers-
- Filters and Accessories-
- Premium Channel Coverage-
- Full Satisfaction Guaranteed-

QB VIDEO

Open M-F 9a to 5p (CT)

1-800-249-3025

Visa, MC & C.O.D.'s Welcome

COPY RENTAL TAPES WITH OUR VIDEO STABILIZERS

BEFORE

AFTER



FREE CABLE TV CATALOG!

The clearest picture possible playing back movies. **GUARANTEED** to eliminate copy protection.

- No Rolls/Jitters/Flickers/Fading
- Works on all TV's, VCR's Beta & Cable
- Gold Video Connectors & Cables Included
- 1 Year Warranty
- Money Back Guarantee



VISION ELECTRONICS
1-800-562-2252

2609 S. 156TH CIRCLE • OMAHA, NE 68130
<http://www.modernelectronics.com>

REMEMBER, ONLY YOU CAN PREVENT FOREST FIRES.

A Public Service of the USDA Forest Service and Your State Forester.



TV cable CONVERTERS & EQUIPMENT

Interactive catalog: www.tekview.com



- * 30 days money back guarantee
- * 1 yr warranty
- * Quantity Discounts
- * Dealers Welcome!

VISA MC AMEX C.O.D.

TekView Electronics

(800)739-2253

BEST DEALER PRICING!
CABLE DIRECT
 CONVERTERS • FILTERS
 DESCRAMBLERS

IMPROVE YOUR IMAGE WITH
VIDEO STABILIZERS

FREE CABLE TV CATALOG! **100% MONEY BACK GUARANTEE!**

Now you can tune-in your favorite cable TV programming and **SAVE \$100'S - EVEN \$1000'S** on premium CABLE TV EQUIPMENT.

30 DAY FREE TRIAL!

VISA MasterCard

MODERN ELECTRONICS
1-800-906-6664
 2609 S. 156TH CIRCLE • OMAHA, NE 68130
<http://www.modernelectronics.com>

Radiotelephone - Radiotelegraph
FCC Commercial License

Why Take Chances?
 Discover how easy it is to pass the exams. Study with the most current materials available. Our **Homestudy Guides**, Audio, Video or PC "Q&A" pools make it so fast, easy and inexpensive. No college or experience needed. The new commercial FCC exams have been revised, covering updated Aviation, Marine, Radar, Microwave, New Rules & Regs, Digital Circuitry & more. We feature the Popular "Complete Electronic Career Guide" 1000's of satisfied customers **Guarantee** to pass or money back. Send for **FREE DETAILS** or call **1-800-800-7555**
 WPT Publications
 4701 N.E. 47th Street
 Vancouver, WA 98661

Name _____
 Address _____
 City _____ St. _____ Zip _____
1-800-800-7555

CLASSIFIED

CABLE TV

CABLE TV descramblers. One piece units. Pioneer 6310's, Scientific Atlanta 8580's, DPV7's and others. Lowest prices. Money back guarantee. Precision Electronics, Houston, TX (888) 691-4610.

CONFUSED? Descramblers. Will explain all your options, all makes and models. Wholesale and retail. Open 6 days wk 9AM - 8 PM Est. Best tech support and friendly service. Toll free 1 (888) 238-0967 **ROYAL ENGINEERING INC.**

CABLE descramblers and converters. 10 lot decoders \$38.00 ea. 10 lot converters \$57.00 ea. Visa and Mastercard accepted. (304) 337-8027.

Wholesale Cable Warehouse decoders for all systems **Best Prices Guaranteed** Helpful, friendly service and support ready to help. 30 Day money back guarantee and full 1 year warranty. Call now 1-800-387-0349 **Dealers Welcome Call for free price quote.**

CABLE TV, DESCRAMBLERS, CONVERTERS QUANTITY DISCOUNTS, LOW LOW PRICES 30 DAY-MONEY BACK GUARANTEED. CALL NOW 888-898-3284 SKYLAB SALES INC.

CABLE DESCRAMBLERS AND CONVERTERS SHOP NO MORE, BEST PRICES AND TECH SUPPORT. EXTREME ELECTRONICS 1-888-609-4910

Free Cable Descrambler Plans, For Details Write: Sierra Publishing, 909 E. Yorba Linda Blvd., Suite H-181, Dept PEP, Placentia, CA 92870

Signal Eliminator can block severe TV interference or unwanted channels! Order by channel number - 0 thru 36 available. Only \$30.00 each plus \$4.00 S/H. Quantity discounts. Money Back Guarantee. Prepay, Visa or Mastercard. COD \$5.00 additional. Visit us on the web today at <http://starcircuits.com/tvfilter>. Star Circuits, PO Box 94917, Las Vegas, NV 89193. 1-800-433-6319

CABLE Descrambling, New secret manual. Build your own Descramblers for Cable and Subscription TV. Instructions, schematics for SSAVI, Gated Sync, Sinewave, some free methods \$12.95, \$2.00 postage. **CABLETRONICS**, Box 30502PE, Bethesda, MD 20824.

CABLE TV EQUIPMENT & ACCESSORIES. Wholesalers Welcome! 30 Day Moneyback Guarantee! Free Catalog! **PERFORMANCE ELECTRONICS, INC. 1-800-815-1512.**

BIG SALE! BEST PRICES!! Notch filters \$18.00 EZ install test activation chips/boards from \$5.00. Bullet/ID Stoppers \$9.95. **Name brand descramblers from \$98.00.** External activators from \$65.00. **DEALERS WELCOME, LET US BEAT YOUR BEST PRICE. 1-800-449-9189 ANYTIME. SE HABLA ESPANOL.**

CABLE BULLET "TERMINATOR/I.D. BUSTER." Electronically shields yourself and your box. **LIFETIME GUARANTEE. Wholesale prices. 1-800-820-9024.**

CABLE DESCRAMBLER!! ANYONE CAN BUILD IN SEVEN STEPS WITH RADIO SHACK PARTS. PLANS/KIT from \$5.00 PLUS FREE BONUS!! 1-800-818-9103

MISCELLANEOUS ELECTRONICS FOR SALE

Electronic sales of security systems for home, apartment or business, stop burglaries now, call 812-295-4240

Call for a **Free Electronics Catalog** or visit our web site at www.bgmicro.com/. **B.G. Micro** PO Box 280298 Dallas, TX 75228. Order line **800-276-2206**

PLANS-KITS-SCHEMATICS

ELECTRONIC Project Kits. www.qkits.com. 1 (888) GO-4-KITS, 292 Queen St., Kingston, ON, K7K 1B8. **QUALITY KITS.**

UNDERGROUND ELECTRONIC DEVICES AND MORE. FREE CATALOG INFORMATION CENTER, P.O. BOX 876PE, HURST, TEXAS 76053. WWW.THEINFORMATIONCENTER.COM

DATA acquisition and sensors. Plans, hard to find kits, software - www.total.net/~simonf/kits

SATELLITE EQUIPMENT

VIDEOCYPHER II descrambling manual. Schematics, video and audio. Explains DES, EPROM, CloneMaster, Pay-per-view \$16.95, \$2.00 postage. Schematics for Videocypher Plus, \$20.00. Schematics for Videocypher 032, \$15.00. Collection of software to copy and alter EPROM codes, \$25.00. VCII Plus EPROM, binary and source code, \$30.00. **CABLETRONICS**, Box 30502PE, Bethesda, MD 20824.

DSS Hacking: How to construct and program smart cards, w/pic16C84, software. Complete DSS system schematics. \$16.95. **CABLETRONICS**, Box 30502R Bethesda, MD 20824.

FREE DSS Test Card information package. Works on new system and turns on all channels including PPV, adult and sports channels. Write: **SIGNAL SOLUTIONS**, 2711 Buford Rd., Suite 180, Richmond, VA 23235.

SKYVISION! Your Satellite Home Entertainment Source. **Best values:** DBS and C/Ku-band equipment, including 4DTV. Most complete selection: Parts-Tools-Upgrades-Accessories! **Free Discount Buyer's Guide.** Call 800-543-3025. International 218-739-5231. www.skyvision.com.

OBTAINING SOUND for your VCII and VCII Plus is easy. No codes Needed. Also **DSS TEST CARD** information. Details **1-800-211-5635.**

BUSINESS OPPORTUNITIES

\$\$\$ Millions in Scrap Gold from old electronics, computers, circuit boards, jewelry, 24 hours: (603) 645-4767.

ELECTRONIC ENTERPRISES, Home Based, Part/Full time. 250pg. Comprehensive Guidebook, Insider information, 24hr recording (800)326-4560 x145.

Inventions/new products. ISC, America's leading invention firm, helps submit to companies. Patent Services. 1-800-288-IDEA.

EASY WORK! EXCEKENT PAY! Assemble Products At Home. Call Toll Free 1-800-467-5566 EXT. 5730

CB-SCANNERS

CB Radio Modifications! Frequencies, kits, high-performance accessories, books, plans, repairs, amps, 10-Meter conversions. The best since 1976! Catalog \$3.00. CBCI, Box 31500PE, Phoenix, AZ 85046

COMPUTER SOFTWARE

Brainteasing Great Fun. Easy set-up program installs 10 shareware working game icons to your **Windows or Win95** Program Manager. Only \$17.95 to: Alisha, POB 377, Dept. 3, Old Bethpage, NY 11804

EDUCATION

BE A COMPUTER PROGRAMMER. Train at home for an exciting new career with ICS-Accredited Member of the Distance Education and Training Council. Call today for free information with absolutely no obligation: 1-800-595-5505, ext. 1739.

BE A PC REPAIR TECHNICIAN. Train at home for an exciting new career with ICS-Accredited Member of the Distance Education and Training Council. Call today for free information with absolutely no obligation: 1-800-595-5505, ext.1741.

FIBER OPTIC EDUCATIONAL EXPERIMENTS KIT, Includes: tutorial w/experiments, 40ft. fiber assortment, +cutting tool. \$19.95+S/H 800-373-7078

FREE CASH GRANTS

FREE CASH GRANTS! College. Scholarships. Business. Medical bills. Never Repay. Toll Free 1-800-218-9000 Ext. G-14087

SEIZED CARS:

SEIZED CARS FROM \$175. Porsches, Cadillacs, Chevys, BMW's, Corvettes. Also Jeeps, 4WD's your area. Toll free 1-800-218-9000 Ext. A-14087 for current listings.

FORECLOSE:

GOV'T FORCLOSED homes from pennies on \$1.00. Delinquent Tax, Repo's. REO's. Your area. Toll free (1)800-218-9000 Ext. H-14087 for current listings

AUDIO-VIDEO-LASERS

VIDEO Stabilizer. Works with all videotapes. \$45.95 + \$6.00 S&H. Free brochure. 30 day moneyback. **STAR DEVELOPMENT**, Box 92457, Milwaukee, WI 53202. (414) 860-1471.

POPTRONIX®
 Awaiting your call! **Online Edition**
<http://www.poptronix.com>

Call Today And SAVE! **Unbeatable PRICES!**

CABLE TV

**DESCRAMBLERS
 CONVERTERS · FILTERS
 VIDEO STABILIZERS**

FREE ➤ 30 Day Trial
FREE ➤ Product Catalog
FREE ➤ 1 Year Warranty

100% MONEY BACK GUARANTEE



Let us point you in the right direction ...

Arrow Technologies
 Omaha, Nebraska

**TOLL FREE
 888-554-ARROW**

888-554-2776

Turn Your Multimedia PC into a Powerful Real-Time Audio Spectrum Analyzer

Features

- 20 kHz real-time bandwidth
- Fast 32 bit executable
- Dual channel analysis
- High Resolution FFT
- Octave Analysis
- THD, THD+N, SNR measurements
- Signal Generation
- Digital Filtering
- Triggering, Decimation
- Transfer Functions, Coherence
- Dynamic Data Exchange (DDE)
- Time Series, Spectrum Phase, Spectrogram and 3-D Surface plots
- Real-Time Recording and Post-Processing modes

Applications

- Distortion Analysis
- Frequency Response Testing
- Vibration Measurements
- Acoustic Research

System Requirements

- 486 CPU or greater
- 8 MB RAM minimum
- Win. 95, NT, or Win. 3.1 + Win.32s
- Mouse and Math coprocessor
- 16 bit sound card

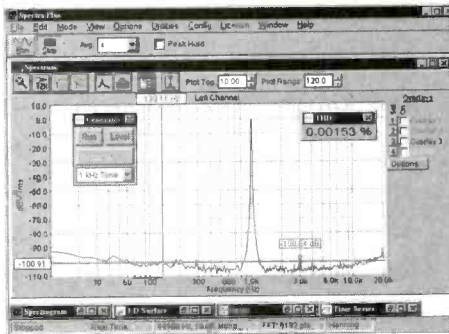

Priced from \$299

(U.S. sales only – not for export/resale)

Professional Quality Sound Cards Available...Call

DOWNLOAD FREE 30 DAY TRIAL!

www.telebyte.com/pioneer

PHS Pioneer Hill Software
 24460 Mason Rd. N.W.
 Poulsbo, WA 98370

Spectra Plus 4.0
 Affordable Signal Processing Software

Sales: (360) 697-3472

Fax: (360) 697-7717

e-mail: pioneer@telebyte.com

Super Savings!!! Super Savings!!!

10 Watt Multimedia Speakers
 Amplified speaker system features 10 watt max. power output, 80Hz-20KHz frequency response, 0.5% THD, 40dB signal-to-noise, 2" x 4" full range speaker. Separate controls for volume and power. Includes cables and wall transformer. Size: 3-7/8" (D) x 3-1/2" (W) x 5-1/2" (H).
 Retail Price: \$34.95
 No. 220-0201.....\$9.95 (per pair)

50 Watt Multimedia Speakers
 Amplified speaker system features 50 watt max. power output, 80Hz-20KHz frequency response, 3" magnetically shielded full range speaker. Separate controls for power, volume and tone. Includes LED power indicator and front headphone jack. Includes cables and wall transformer. Size: 5-1/8" (D) x 4-1/2" (W) x 7" (H).
 Retail Price: \$79.95
 No. 220-0203.....\$29.95 (per pair)

20 Watt Multimedia Speakers
 Amplified speaker system features 20 watt max. power output, 80Hz-20KHz frequency response, 0.3% THD, 45dB signal-to-noise, 3" full range speaker. Separate controls for volume, power and tone. LED power ON indicator. Includes cables and wall transformer. Size: 5-1/2" (D) x 3-3/4" (W) x 7-1/8" (H).
 Retail Price: \$59.95
 No. 220-0202.....\$19.95 (per pair)

Super CHARGER™
 Alkaline and Ni-Cd Charger for AAA, AA, C and D Cell batteries. Incredible space-age technology automatically and safely recharges regular alkaline (1.5V) and nickel cadmium (1.2V) batteries. Mfg: Buddy L Model #8000.
 Repackaged
 No. 140-0140.....\$7.95 (ea)



340 E. 1st St.
 Dayton, Ohio
 45402

Call for a free catalog

**Order Toll-Free
 1-800-344-4465
 Fax Order Line
 1-800-344-6324**

CIRCLE 150 ON FREE INFORMATION CARD

ADVERTISING INDEX

Electronics Now does not assume any responsibility for errors that may appear in the index below.

Free Information Number	Page	Free Information Number	Page
— Aegis Research, Canada	76	— Lynxmotion	86
— AES	76	138 MCM Electronics	75
26 Alfa Electronics	91	— Mega Electronics	84
28 All Electronics	72	151 Mendelson's	92
— Allison Technology	79	150 Mendelson's	95
— Amaze Electronics	86	— Mental Automation	79
— Andromeda Research	93	16 MicroCode Engineering	CV4
— Arrow Electronics	95	— Modern Electronics	94
— Basic Electrical Supply	82	— Mondo-tronics Inc.	90
127 C&S Sales, Inc.	80	152 Mouser Electronics	92
13 Cadsoft	7	— NRI Schools	15
— CD Electronics	86	— NS International	92
— Circuit Specialists	73	— Orion Electronics	84
— Cleveland Inst. of Electronics	47	156 Parallax	CV3
— Command Productions	74	146 Parts Express Inc.	77
— Comtrad Industries	3, 5	— Pioneer Hill Software	95
— Consumertronics	78	45 Prairie Digital	85
155 Dalbani Electronics	87	47 Print	84
162 Davis Instruments	4	46 Print	79
— DC Electronics	88	— QB Video	93
— Eagan Technical Services	90	— RC Distributing Co.	9
— EDE - Spy Outlet	82	— Sheffield Electronics	86
— EMAC	74	— Silicon Valley Surplus	84
— Foley-Belsaw	83	— Skyvision	86
— Forest Electronics	92	— Tab Books	27, 65
— Fotronic Corporation	78	— Technological Arts	88
— Franks Electronics	88	— Tek View	93
— General Device Instruments	86	142 Telulex	85
— Grantham Col. of Engineering	4	— Transtronics	82
— Greenleaf Electronics Inc.	74	136 UCANDO Videos	85
— Home Automation Systems	93	— U.S. Cyberlab	71
— Information Unlimited	89	— Video Media	88
14 Interactive Image Technologies	CV2	— Vision Electronics	93
— Intronics, Inc.	82	— Visual Communications	86
— James Electronic Systems	90	— Weeder Technologies	71
— KDE Electronics	92	172 Windjammer Barefoot Cruises	9
— Lindsay Publications	93	— WPT Publications	94
— Link Instruments	76		

ADVERTISING SALES OFFICES

Gernsback Publications, Inc.
 500 Bi-County Blvd.
 Farmingdale, NY 11735-3931
 1-(516) 293-3000
 Fax 1-(516) 293-3115

Larry Steckler
 publisher (ext. 201)
 e-mail advertising@gernsback.com

Adria Coren
 vice-president (ext. 208)

Ken Coren
 vice-president (ext. 267)

Christina Estrada
 assistant to the publisher (ext. 209)

Arline Fishman
 advertising director (ext. 206)

Marie Falcon
 advertising assistant (ext. 211)

Adria Coren
 credit manager (ext. 208)

For Advertising ONLY

EAST/SOUTHEAST

Stanley Levitan
 Eastern Advertising
 1 Overlook Ave.
 Great Neck, NY 11021-3750
 1-516-487-9357
 Fax 1-516-487-8402
 slevitan26@aol.com

MIDWEST/Texas/Arkansas/Okla.

Ralph Bergen
 Midwest Advertising
 One Northfield Plaza, Suite 300
 Northfield, IL 60093-1214
 1-847-559-0555
 Fax 1-847-559-0562
 bergenrj@aol.com

PACIFIC COAST

Janice Woods
 Pacific Advertising
 Hutch Looney & Associates, Inc.
 6310 San Vicente Blvd., Suite 360
 Los Angeles, CA 90048-5426
 1-213-931-3444 (ext. 228)
 Fax 1-213-931-7309
 woodyowl@aol.com

Electronic Shopper

Joe Shere
 National Representative
 P.O. Box 169
 Idyllwild, CA 92549-0169
 1-909-659-9743
 Fax 1-909-659-2469
 Jshere@gernsback.com

Megan Mitchell

National Representative
 9072 Lawton Pine Avenue
 Las Vegas, NV 89129
 Phone/Fax 702-838-6924
 Lorri88@aol.com

Customer Service

1-800-999-7139
 7:00 AM - 6:00 PM M-F MST

PARALLAX

888.512.1024 (toll free)

916.624.8333

916.624.8003 fax

Monday-Friday 7 am to 5 pm PST

Tiny computers run PBASIC programs

to pin 11

BASIC Stamps are small computers programmed in Parallax BASIC (PBASIC), a simple programming language with powerful I/O instructions. The Parallax web site (<http://www.parallaxinc.com>) provides free software, manuals, and application notes.

BASIC STAMP® MODULES

BS1-IC Module (#BS1-IC) \$34

8 I/O lines; 80 PBASIC instr max; 2000 instr/sec; 2400 baud serial I/O; 14-pin SIP module. PBASIC language with I/O instructions including BLTTON, HIGH, INPUT, LOW, OUTPUT, PGT, PULSIN, PULSOUT, PWM, REVERSE, SERIN, SEROUT, SOUND, and TOGGLE.

BS2-IC Module (#BS2-IC) \$49

16 I/O lines; 500 PBASIC instr max; 4000 instr/sec; 50k baud serial I/O; 24-pin DIP module. Similar language as BS1-IC, plus DTMF FRE-OUT, SHIFTIN and SHIFTOUT, XOUT (X-10 powerline control), etc. I/O function have a higher resolution on the BS2-IC, due to its faster clock speed.

STARTER KITS

BASIC Stamp I Starter Kit

(#27205) \$99

BASIC Stamp II Starter Kit

(#27203) \$149

Starter Kits include BS1-IC or BS2-IC module, carrier board w/prototype area & 9V battery clip, manual, application notes, software, and free tech support.

NEW! BASIC Stamp Activity Board (#27905) \$79

is used to learn and experiment with BS1-IC and BS2-IC modules. All components and current limit resistors are prewired to BASIC Stamp I/O pins. Board doubles as a "carrier board" with strip header access to I/O pins. Features include LEDs, pushbuttons, piezo-speaker, an RC network for changing PWM into a smooth analog output, and an X-10 interface via RJ-11. Sample source code and power supply included!

2-line x 16 character Serial LCD Display (#27910) \$54

4-line x 20 character Serial LCD Display

(not shown #27919) \$109

Use the BASIC Stamp's SEROUT instruction (requires one I/O line, ground and power) to communicate with the Serial LCD display.

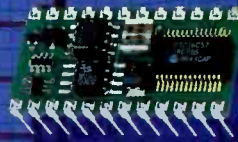

Using the PBASIC HIGH command and a 470 ohm resistor, BASIC Stamps can electrify BLUE LEDs! A stamper necessity! (#27355) \$8

BASIC Stamp Bug (#27922) \$129

(pictured above near Parallax Inc logo) The BASIC Stamp Bug is a walking robot with 6 legs that is controlled by the BASIC Stamp I interpreter chip. Antennas under the LED eyes attach to switches which detect obstacles and inform the robot to maneuver around them.

Kevin Kelm is an arthropomorphic enthusiast in Denver, CO. "Sir Karl" is a full size knight costume that uses a BASIC Stamp module to control ear, eye, and facial movements. See Sir Karl's construction and PBASIC code at <http://www.vvt.com/users/kevink/furry/build.html>

Milford Instruments of the UK uses 3 networked BS2-IC modules in their Laser Velocity and Imaging equipment, which measures the speed of projectiles travelling at up to 10km/sec. One BS2-IC looks after the user interface, another manages the steering logic, and the third gives additional I/O capabilities.



•Australia +61 57 722 777, +61 39 338 3306 •Austria +49 5232 8171 •Belgium +32 4 377 5151 •Bulgaria +359 2-72 77 50 •Brazil +55 11 453 5588, +55 11 801 3045 •Canada (514) 336-9426 •Czech Republic +42 49 5813 252 •Finland +358 51 266 1285 •France +33 328 550 328 •Germany +49 5232 8171 •Greece +36 1 982 0115 •Hungary +36 1270 7680 •India +91 422 232 561 •Ireland +44 1 977 683 665, +35 31 621 5060 •Israel +972 3 498 543 •Italy +39 0542 55400 •Japan +81 3 3251 1775 •Netherlands +31 10 450 4949 •New Zealand +64 947 82323 •Poland +48 34 648 882 •Slovak Republic +42 7 580 2574 •South Africa +27 11 493 6242 •Sweden +46 131 11 00 88 •Switzerland +49 241 918 900 •Taiwan +886 2 647 1978 •Thailand +66 2 739 118 •United Kingdom +44 1 977 683 665 •United States 818 882-7621, 800 344-4539 (Digi-Key), 800 831-4242 (Jameco), 800 538-5000 (JDR), 800 652-6733 (Marlin P. Jones) 415 491-4600 (Mondo-Tronics), 800 843-7422 (Radio Shack Unlimited) 363 512-2060 (TechAmerica)

the Parallax Inc logo and BASIC Stamp are registered trademarks of Parallax, Inc

CIRCLE 155 ON FREE INFORMATION CARD

www.americanradiohistory.com

Professional Power at a hobbyist price.

That has been our philosophy at MicroCode Engineering since 1987. So it's no surprise that **CircuitMaker** and **TraxMaker** are the leading software tools for affordable, easy-to-use circuit design, simulation and PCB layout.

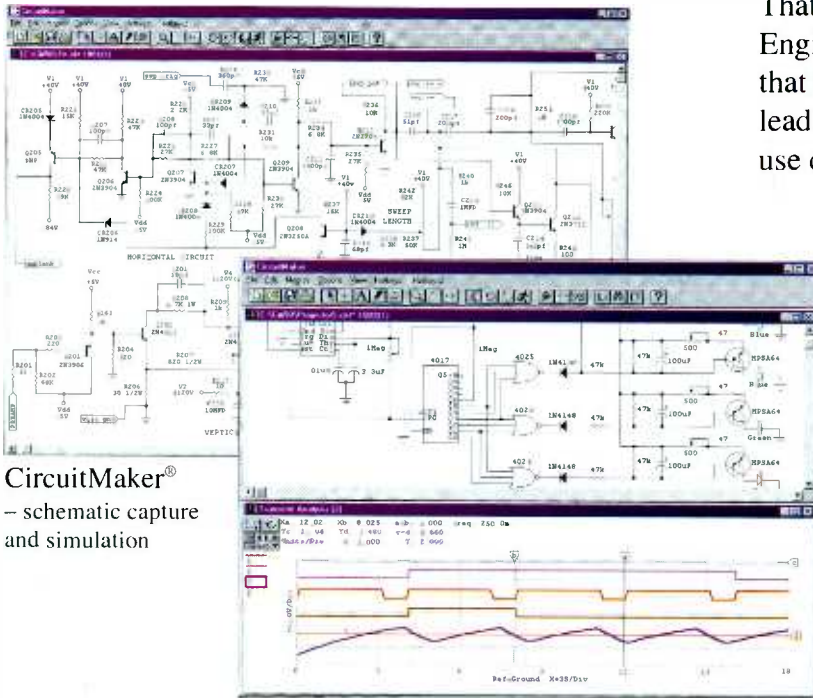

CircuitMaker®
– schematic capture
and simulation

QUICKLY DESIGN analog, digital or mixed analog/digital circuits with CircuitMaker's advanced schematic features. You fully control the wiring, device placement, annotation and colors. And the Symbol Editor and macro features let you create unlimited custom devices and symbols.

SIMULATE and ANALYZE what you create – try all the "what if" scenarios with:

- Fast, proven 32-bit SPICE 3f5/XSpice simulator
- True mixed analog/digital simulation
- Fully interactive digital logic simulation
- 4,000-device library
- AC Frequency Analysis
- DC Operating Point Analysis
- DC Transfer Function
- Transient Analysis
- Step Function – step component values and sources over a user-definable range

TraxMaker® – PCB layout and autorouting

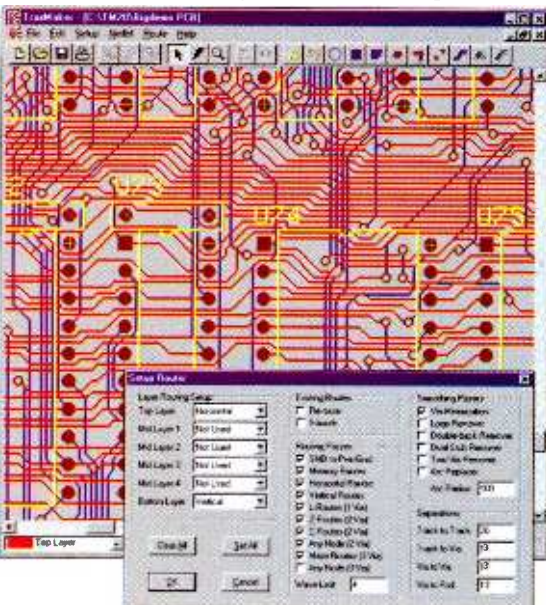

TAKE MEASUREMENTS at any point in the circuit with a click of the Probe tool. Results appear immediately on virtual instruments like the Digital Oscilloscope, Curve Tracer, Digital Multimeter and Bode Plotter. No other simulator lets you take measurements as quickly and easily as CircuitMaker.

COMPLETE the design process with TraxMaker, a professional printed circuit board layout program with built-in autorouter. Import netlists from CircuitMaker and other schematic programs, or design boards from scratch.

- Includes autorouter, auto component placement and Design Rules Check
- Supports up to 8 copper layers, board sizes up to 32 x 32 inches
- Surface mount and through-hole components from a customizable library
- Outputs your PCB as a Gerber file, Excellon N/C drill file, and prints to any Windows-selectable printer or plotter

RELY ON free technical support from qualified engineers. And every MicroCode product is backed by our **30-day Money-Back Guarantee** if it does not live up to your expectations.

**Call 800-419-4242 for more
information and free demos**

(or download from www.microcode.com)

CIRCLE 171 ON FREE INFORMATION CARD

CircuitMaker Version 5	\$299
TraxMaker Version 2	\$299
CircuitMaker Design Suite™	\$549
<small>(CircuitMaker and TraxMaker)</small>	