

THE PROFESSIONAL MAGAZINE FOR ELECTRONICS AND COMPUTER SERVICING

# ELECTRONic<sup>TM</sup>

Servicing & Technology

November 1993/\$3.00

Horizontal output transistor problems

Gremlins in the power lines

## Soldering devices

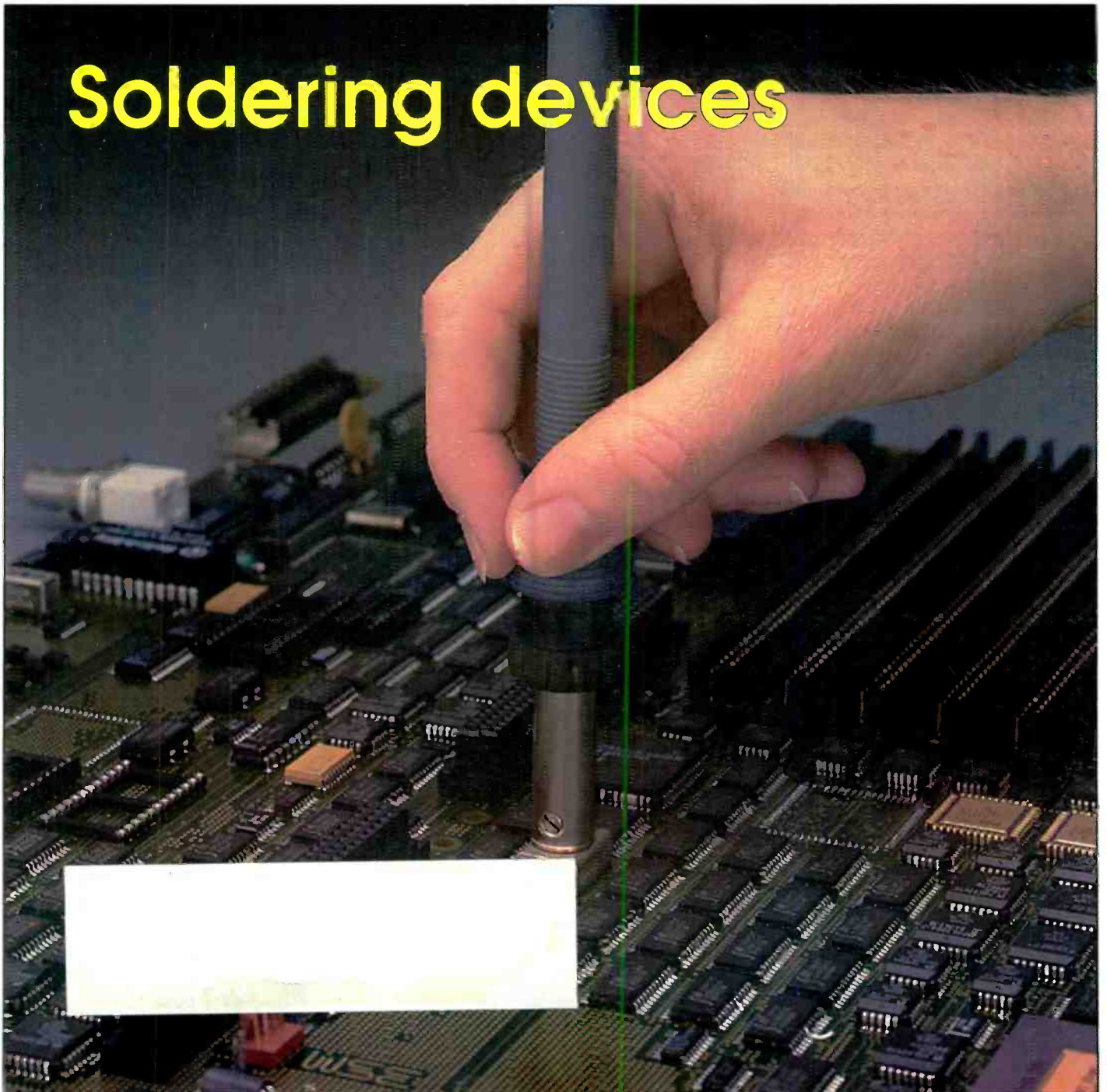

# What's Up?

## VCRs, TVs, And Profits!

### VCRs Remain The Number One Product To Service Among Top Electronic Service Centers!

Field seminar trainers are reporting that in excess of 98% of service centers are now maintaining a high volume of VCR and/or camcorder service activity. Also, recent EIA statistics show that VCR/camcorder sales are continuing to show high sales and thus high service potential.

However, many technicians still report that they are having difficulty with isolating head defects, separating servo electrical and mechanical problems, and troubleshooting color and luminance circuits. This is in part due to the fact that most defects are mechanical and the technician isn't familiar with the electronics.

One company has designed a test instrument to help the VCR technician better make a profit on all VCR repairs. In fact, it's the only VCR analyzer on the market, and it's only from Sencore.

### Improved TV Circuits Prompt Better Analyzing Techniques To Be Used By Service Centers!

Most TV manufacturers are now using switch mode power supplies, microprocessors, digital tuning, and other video processing circuits to produce a clear crisp picture. These newer circuits are providing new features and components that make the job of the technician even more challenging.

Couple the new features with the prices offered by many retailers, and the servicer must now find a way to determine if the TV is profitable for him to service. Successful servicers are welcoming the changes to video by meeting these chal-

### One Test Instrument Company Remains The Technician's Choice For Innovation And Time Saving/Profit Adding Tests!

Again this year Sencore has proven to be the technician's choice for test instruments. From NESDA surveys of test equipment preference to technical support of the service industry, Sencore remains on top.

Sencore is number one because of the dedication of the entire factory toward their customer's success. This is evident in Sencore's new product innovations and toll-free access to the entire company. Sencore is the leader in American made instruments, and can be reached at **1-800-SENCORE (736-2673)** anytime you have test instrument or industry related questions.



*Sencore's New "Tech Choice System" Instruments Have Proven Themselves As The Leading Instruments For The Service Industry. You Should Try Them For Yourself!*

lenges with new estimating techniques and new ways to pinpoint the defects.

Recently introduced test instruments are now allowing service centers to isolate TV defects, troubleshoot start-up/shutdown problems and test expensive components. And some of the tests are even being done with the TV turned off.

Again, only one company is standing strong with the servicer, and has introduced solutions to modern TV servicing challenges - Sencore.

Circle (32) on Reply Card

**Call  
1-800-SENCORE  
For Free Technical  
Servicing Information  
And To See How  
Sencore Instruments  
Can Be Put To Work  
On Your Bench!**

**SENCORE**

3200 Sencore Drive, Sioux Falls, SD 57107  
Phone (605) 339-0100 FAX (605) 339-0317

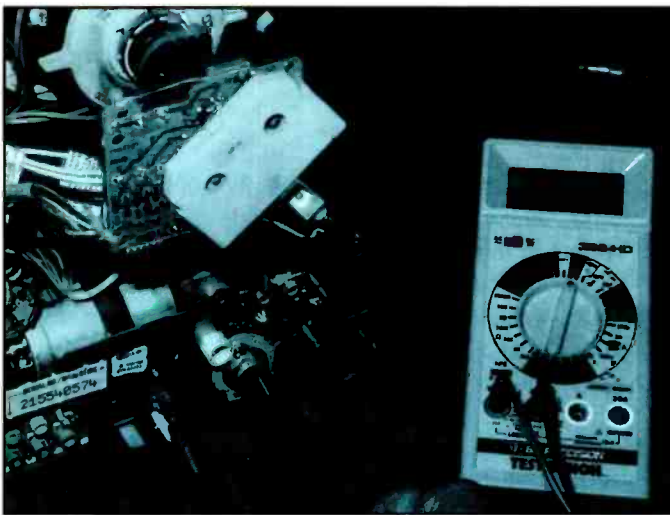

page 16

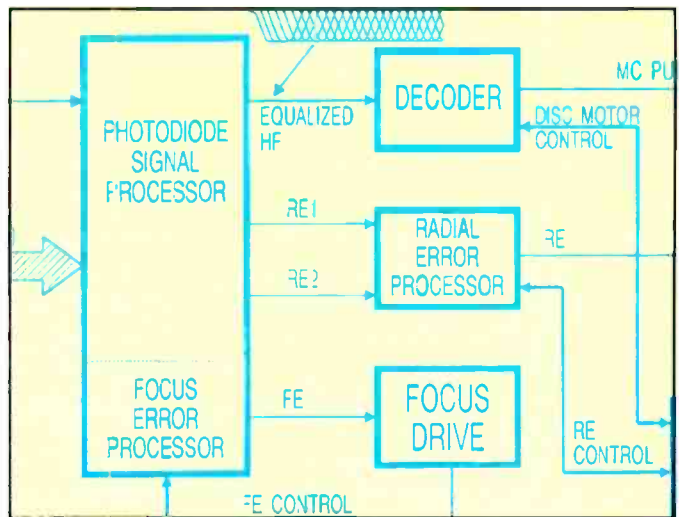

page 24

## FEATURES

### 6 Soldering devices

By Sheldon Fingerman

In a market filled with a huge variety of soldering devices, choosing one can be a real dilemma. This article will help you decide which to choose.

### 12 Gremlins in the power lines

By Bob Polk

You've been banging your head against the wall trying to solve a customer's problem. When all else fails, look for other causes. Could it be a power problem?

### 16 Horizontal output transistor problems

By Homer L. Davidson

Although there are fewer breakdowns in TV sets today because of improved chassis reliability, more problems still occur in the horizontal and high-voltage circuits than in any other area.

### 24 Understanding compact disc troubleshooting concepts—Part 2

By Marcel R. Rialland

As considered in Part 1 of this series, it is important to under-

stand how a product works before attempting any troubleshooting. Here, the single-beam servo system will be examined and common troubleshooting techniques will be applied.

### 29 Test equipment probes—Part 2

By Vaughn Martin

This installment of ES&T's series of articles on test equipment probes looks at how the type and design of a probe can affect the measurements.

### 49 What is CMOS RAM?

By David Presnell

This article looks at CMOS RAM as a low-powered consumption chip and at how it works.

### 54 Audio Corner

More musical instrument amps and other MI equipment

### 59 Test Your Electronics Knowledge

### 60 Video Corner

Servicing the Hitachi VM Series camcorder

### 63 What Do You Know About Electronics?

Graphical Solutions—Continued

### 66 Computer Corner

CMOS battery failure—Part 2

### 69 Products

### 71 Readers' Exchange

### 72 Advertisers' Index

## DEPARTMENTS

2 Editorial

4 News

5 Literature

33 Profax

53 Business Corner

Will Total Quality Management work for you?—Part 4

## ON THE COVER

Electronic components and ICs, as well as PC circuit traces, have become smaller and more delicate. The number of pins on ICs and their close spacing make them a real challenge to solder and desolder. New soldering/desoldering tools and techniques help the technician overcome the challenges presented by these changes. (Photograph courtesy of Pace, Inc.)

# More about electronics words and concepts

Some time ago I wrote an editorial in which I speculated on the origin and meaning of certain words, abbreviations and concepts that we frequently run across, that have to do with electronics. For example, I wondered in print what might be the meaning of the terms "aquadag" and "raster." In a later issue, I disclosed what one reader had written in about the origin of the term "aquadag," (it means "deflocculated Acheson graphite"), and I speculated about the term "raster" (I believe it comes from the Greek word "rastere," meaning rake).

Another term that I mentioned was the name of that ubiquitous connector, the BNC connector. Is there an oscilloscope anywhere that doesn't use that style of connector? I thought that someone's suggestion that it simply meant Bayonet Connector made a lot of sense.

I also thought that the possibility of it meaning "Bayonet Neill-Concelman," as someone suggested, was a little far fetched. I have egg on my face. According to a pamphlet on use of the oscilloscope published by none other than Tektronix, BNC does in fact stand for bayonet Neill-Concelman, named after the two engineers who designed it.

## How about "eye pattern"

Here's another term whose origin is obscure: "eye pattern." In a number of articles that have appeared in this magazine, authors have instructed readers who are servicing compact disc players how to observe and adjust the eye pattern. Recently it has occurred to me to wonder why it's called that. So far, no one has been able to explain where it comes from. Anybody out there know where the term "eye pattern" comes from? If you do, please let us know. And let us know where you got the information from.

## BCD

A recent installment of "Test Your Electronics Knowledge" has raised a few eyebrows, and, according to Sam Wilson,

has broken all records for mail about subjects that have appeared in that department. Sam addresses the subject in this month's installment of "What Do You Know About Electronics," but I wanted to use this space to reinforce his explanation, and to express it in a slightly different way.

The question was "Convert the following BCD number to a decimal number: 10010111." The answer Sam gave was 97. That's correct. But a lot of readers disagreed with him, convinced that the correct answer is 151.

The problem here seems to be in the definition of BCD. Let's start with that. BCD is the abbreviation for "binary-coded decimal." BCD is different from any other system of numbers that we work with in the mathematics of electronics: it is a completely artificial number system.

The best way to approach an understanding of BCD is to start with decimal numbers. Take for example the decimal number 53. If we were to convert decimal 53 to binary, we would simply divide successively by 2 to arrive at the binary equivalent: 110101.

But that's not what we do to convert decimal 53 to BCD. To convert decimal 53 to BCD, we separate the number into its component digits, 5 and 3, and represent *each digit* by its binary equivalent. Thus the binary equivalent for 5 is 1001, and the binary equivalent for 3 is 0011: so the BCD equivalent for 53 is 10010011, not 110101.

In BCD, four binary digits are used to represent each decimal digit because the largest digit in decimal, 9, requires four binary digits. A binary number of three digits can only represent up to decimal 7. A binary number of four digits can represent up to decimal 15, but in BCD we just ignore anything greater than 1001 (decimal 9).

Taking the conversion in the reverse direction, as in the original article by Sam, first you take the BCD (not binary) number 10010111 and divide it into two

groups of four digits: 1001 and 0111. The binary number 1001 represents decimal nine, ( an eight, no fours, no twos and a one). The binary number 0111 (no eights, one four, one two and one one) is seven. Thus BCD 10010111 is 97 in decimal.

## BCD is only for interface

The use of BCD is limited. Humans have no use for BCD in performing calculations. Computers also have no use for BCD; they use binary. But once a computer has performed whatever tasks it has been programmed to do and is ready to output it to a display, whether LCD, a number on a screen, a printer or some other device, the number must be converted to decimal for the human operator.

This conversion is a two-step process. First the computer converts the binary number to a BCD number. In doing so it has converted the number into a series of digits that, ultimately, will be converted to a number that a human is comfortable with. The final step performed by the computer is to process each digit of the BCD through a BCD-to-decimal converter which then outputs the decimal number to the display device.

## A proliferation of concepts

As consumer electronics continues to advance, and as more and more products, especially sophisticated digital products come under the consumer electronics category, all of us connected with consumer electronics have to learn new, and sometimes difficult, concepts—such as the idea of BCD. It's challenging, but always interesting to wrestle with new ideas.

We enjoy discussing new ideas in this magazine. If any readers have any terms that puzzle them, or concepts that seem obscure, please write in and let us know. We'll find out what we can and share it with all readers.

*Nile Conrad Penner*

# ELECTRONIC

Servicing & Technology

**Electronic Servicing & Technology** is edited for servicing professionals who service consumer electronics equipment. This includes service technicians, field service personnel and avid servicing enthusiasts who repair and maintain audio, video, computer and other consumer electronics equipment.

## EDITORIAL

Nils Conrad Persson, *Editor*  
Linda Romanello, *Assistant Editor*

## CONSULTING EDITORS

Homer L. Davidson, *TV Servicing Consultant*  
Victor Meeldijk, *Components Consultant*  
John E. Shepler, *Audio Consultant*  
Sam Wilson, *Electronics Theory Consultant*

## PRODUCTION

Elizabeth Ryan, *Art Director*  
Barbara Terzo, *Assistant Art Director*  
Susan Reale, *Artist*  
Edmond Pesonen, *Electronic Composition Mgr.*  
Dorothy Kehrwieler, *Production Manager*  
Emily Kreutz, *Production*  
Pat Le Blanc, *Phototypographer*

## BUSINESS

Richard A. Ross, *Publisher*  
Dorothy Kehrwieler, *General Manager*  
Frank V. Fuzia, *Controller*  
Catherine Ross, *Circulation Director*  
Melissa Kehrwieler, *Data Processing Manager*  
Carol Licata, *Data Processing*  
Denise Pyne, *Customer Service*

## SALES OFFICE

Electronic Servicing & Technology  
76 N. Broadway, Hicksville, NY 11801  
516-681-2922; FAX 516-681-2926

Diane G. Klusner, *Director of Advertising*  
Emily Kreutz, *Sales Assistant*

## EDITORIAL CORRESPONDENCE



Member, Electronic Servicing Dealers Association



P.O. Box 12487  
Overland Park, KS 66212  
913-492-4857

Electronic Servicing & Technology (ISSN 0278-9922) is published 13 times a year by CQ Communications, Inc. 76 N. Broadway, Hicksville, NY 11801. Telephone (516) 681-2922. Second class postage paid at Hicksville, NY and additional offices. Subscription prices (payable in US dollars only): Domestic—one year \$24, two years \$40. Foreign countries—one year \$30, two years \$52. Entire contents copyright 1993 by CQ Communications, Inc. Electronic Servicing & Technology or CQ Communications, Inc. assumes no responsibility for unsolicited manuscripts. Allow six weeks for delivery of first issue and for change of address. Printed in the United States of America.

Postmaster: Please send change of address notice to Electronic Servicing & Technology, 76 N. Broadway, Hicksville, NY 11801.

CQ Communications, Inc. is publisher of CQ The Radio Amateur's Journal, Popular Communications, ComputerCraft, CQ Radio Amateur (Spanish CQ), CQ Amateur Radio Equipment Buyer's Guide, CQ Amateur Radio Antenna Buyer's Guide, Popular Communications Communications Guides, and Electronic Servicing & Technology.

# The Meter to Pick When You Have Things to Fix

## No Other DMM Makes So Many Measurements So Many Ways!

	True RMS AC on DC	True RMS AC	Average Responding AC	DC	Resistance to 0.01 Ω	Diode Test, Continuity	Capacitance to 2000 μF	Frequency to 2 MHz	Duty Cycle	50 ns Pulse Detector	True RMS AC on DC	True RMS AC	Average Responding AC	DC
	VOLTAGE					CURRENT								
<b>Digital Readout</b> Backlit 4-digit display with big numerals (17mm, 5.8").	✓	✓	✓	✓	✓	✓	✓	✓	✓	✓	✓	✓	✓	✓
<b>Analog Bar Graph</b> Simulates an analog meter to indicate trends and changes.	✓	✓	✓	✓	✓						✓	✓	✓	✓
<b>Probe Hold™</b> Store your last stable reading for later; allows safer meter operation because you can keep your eyes on your work.	✓	✓	✓	✓	✓						✓	✓	✓	✓
<b>Peak Hold™</b> Measure and store peaks as short as 1ms. Detect transients, measure inrush currents, and determine crest factors.	✓	✓	✓	✓							✓	✓	✓	✓
<b>Auto Min Max™ with Averaging</b> Record the minimum, the maximum and the average reading, unattended. Fully autoranging for maximum resolution.	✓	✓						✓						
<b>Auto Rel™ Relative Mode</b> Read the difference between the present and previously stored values. Fully autoranging for maximum resolution.	✓	✓	✓	✓	✓	✓	✓	✓	✓	✓	✓	✓	✓	✓
<b>Intermittent Detector</b> Locate intermittents, broken wires, loose connections quickly and easily. Once you've used Wavetek's exclusive Fault Finder™, you'll never want to be without it.	✓	✓	✓	✓	✓						✓	✓	✓	✓

The Wavetek Model 2030 DMM is packed with powerful tools for tough troubleshooting jobs. The exclusive Fault Finder pinpoints intermittents faster than any other multimeter. Memory modes can store readings while your hands and eyes are busy. True rms, as well as peak readings, help hunt down damaging power harmonics.

And there's a big, 10,000-count backlit display, and an easy-to-use MENU system that lets you jump between all these capabilities without having to drag out the manual.

The Wavetek 2030. It's the one meter you'll choose when it's time to fix something.



Wavetek Corporation  
9145 Balboa Avenue  
San Diego, CA 92125  
**(800) 854-2708**  
(619) 279-2200

©1993 Wavetek Corporation



Circle (19) on Reply Card

## **Bloomington Indiana dealer/ technician conference set for December third and fourth**

The Greencastle, Indiana office of ETA has announced the dates for the fall Technical and Business Management Schools as December third and fourth, a Friday and Saturday. This two-day, 16-hour college-credit course will follow by two weeks a similar event taking place October 21-22 at Central Community College in Grand Island Nebraska. Both events are sponsored by ETA and are open to any dealer or technician involved in consumer electronics sales and/or servicing.

The Bloomington event takes place at the Comfort Inn, 1722 N. Walnut St. It is easily accessed from Indiana Highway 37 by taking Highway 46 East to Walnut Street.

Three types of technician testing are planned, in addition to two days of varied technical and business training: Certified Electronics Technician (CET) and CSI (Certified Satellite Installer) exams; Indiana State TV-Radio-Antenna-Satellite-MATV exams will be given by the Indiana TV Radio License Examiners Board; and the first General Radiotelephone Operator License exams to be given in the state since FCC exams were privatized will be offered by ETA.

The two days of schooling is not a prerequisite for any of the exams. Anyone wishing to sit for one or more can register with ETA by December 1 by calling 317-653-4301.

In addition to one full day of electronics technology and troubleshooting classes, and one full day of business management training/profit school for business owner and managers, the antenna, satellite, and Master Antenna school will feature the first full day of basics for technicians and installers or other consumer electronics workers who have had little or no previous schooling. A more advanced school will be presented in the spring of 1994 that will take attendees through a headend design and building session necessary to learn the ins and outs of the private cable business. Industry people who want to be brought up to speed on antenna theory and installation, satellites and Master Antennas should consider attending both this December class and the spring follow-up, also to be held in Indiana. Gary Cope, CET, of Ohio Valley Microcablevision, who has represented Pico-M/Acom at previous training ses-

sions, will head up the instructor staff for this day of the Antenna School.

Members of the Indiana Electronic Service Association and the Indiana Satellite Dealers Association will staff the Electronics Technology classes taking place on Saturday. TV-VCR and other consumer electronics servicing classes will help prepare working technicians for overcoming today's difficulties in performing profitable electronic service. The school will focus also on briefing sessions for those technicians wishing to take the required Indiana License Exams.

The antenna school second day will feature six hours of questions and answers aimed at helping technicians pass the antenna, satellite or MATV state license exams, or to be able to pass the CSI certification test. Students can bring up any topic related to the exams and have experts explain the theory and the types of questions one can expect on the actual tests. License Board members will be available to answer questions regarding the requirements of the Indiana law. Six months reduction in apprenticeship time is allowed for those who participate in this two-day school.

In conjunction with the schools and the state and ETA certification exams, the FCC Commercial License Exams will be available at 3 p.m. on December 4th. ETA was chosen by the FCC to administer FCC exams, beginning on September 1, 1993. At the Bloomington conference, the Marine Operator Permit, and the General Radiotelephone Operators License exams will be offered. At this time the General Radiotelegraph, Ship Radar, GMDSS and other license exams are not available. They will become available by Spring of 1994 and ETA will make announcements when that happens.

For more information, call the Indiana Electronic Service Association at 219-293-9664 or to register for any of the events in advance, call 317-653-4301.

## **EIA survey forecasts rapid growth in vehicle security**

U.S. sales of vehicle security systems are predicted to grow 15 percent during 1993, and average 9 percent gains each year over the next five years, according to a forecast survey by the Electronic Industries Association (EIA). The EIA survey of U.S. vehicle security manufacturers shows a shift to more flexible "high-

er-tech" security systems, including vehicle location recovery systems.

"Although a relatively small industry of small firms, U.S. vehicle security manufacturers are the world leaders and are rapidly pursuing the technology frontiers of electronics," says Gary J. Shapiro, group vice president of EIA's Consumer Electronics Group (EIA/CEG). "The consumers will benefit greatly in the future because prices are forecasted to drop as the sophistication of products grows and the market expands."

Private vehicle theft reportedly costs U.S. drivers \$8 billion a year in loss and damage. Once considered a "big city" phenomenon, rural and especially suburban areas are no longer immune. Foreign demand for U.S. systems, particularly in Europe, is growing as well.

Results of the vehicle security forecast survey show U.S. sales at \$473 million in 1992 and increasing 15 percent during 1993 to \$542 million. The five-year outlook predicts sales gaining 53 percent by 1997 to \$724 million.

The Mobile Electronics Association recently merged with EIA/CEG to create a Mobile Electronics Division. "The merger with EIA/CEG brings together the right mix of experience and resources to provide a wide range of services to benefit this dynamic, fast-growing industry," says Shapiro.

## **1993 Electronics Technician of the Year announced**

The Greencastle headquarters of the Electronics Technicians Association has announced that the winner of the 1993 Norris R. Browne Memorial, Technician of the Year award, is Fred deFerbrache III of Elkhart, IN.

The 15th presentation of this award plaque was made at the 1993 annual ETA convention and trade show, held at the Holidome Convention Center, Moline, IL. DeFerbrache was in attendance, as were his two sons and other family members.

Dick Glass, President of ETA, made the presentation, noting that some of the reasons for his selecting deFerbrache to receive ETA's highest award include the fact that deFerbrache is a working technician, selling and servicing consumer electronics products, he was recently elected President of the Indiana Electronic Service Association, he initiated a computer communications network, using the

GENie system, which has resulted in upwards of 100 dealers and technicians learning how to communicate through their computers, thus far. Also, he was elected as a 1993 divisional officer of the Electronics Technicians Association and has established an association talk show on Spacenet 3 satellite, weekly, which utilizes the technology that TVRO dealers and technicians are providing to the public. The ProShow, which he hosts each Sunday evening, is yet another modern means of expanding communications in the industry he is a part of.

DeFerbrache was also nominated for the satellite industry's highest award, the "Friend of the Satellite Dealer" Pat Porter Memorial award for 1993.

### **Color TV sales see best July ever, laserdisc players rise fourth time in last six months**

Sales of color televisions and laserdisc players were strong in July 1993, with the former posting its best July sales performance ever, and the latter rising for the fourth time in the last six months, according to statistics released by the Electronic Industries Association's Consumer Electronics Group (EIA/CEG).

Overall, video sales gained seven percent in July over the same period last year, despite declines in monthly shipments of projection TVs, camcorders and VCR decks during the same period. Unit sales of video products were up 10 percent through the first seven months of this year.

Conditions in the United States retail market were also mixed. According to a story in the *Washington Post* on August 6, the Johnson Redbook service reported that, although large to medium retail chains registered good results in July, specialty stores generally performed poorly.

The article also noted that other analysts discounted July completely, saying the month is traditionally a poor indicator of the health of the retail market. Brown Brothers Harriman & Company said that July is often a month of heavy discounting as retailers unload merchandise from earlier in the year in anticipation of Christmas stocks arriving in warehouses. Retail analysts with Barnard's Retailing Marketing Report note that they see no reversal of the trend of strong results for retailers selling home-oriented durable goods.

*(Continued on page 68)*

### **Expanded relays and accessories product line**

Philips ECG announces another expansion to their relay and accessories line to include a broader base of new types and accessories.

The line now totals more than 600 products, including five new series with 31 types, 39 additions to already established series, and over 48,000 cross references for 191 brands. New series includes Slim Line Relays, High Power Cube Timers and Thermal Circuit Breakers.

New additions are described in *ECG Relays and Accessories Catalog—Volume 2*. This companion to Volume 1 has a consolidated pictorial/tabular selector guide which includes established relay products from Volume 1, as well as new products cataloged in Volume 2. New products are highlighted and all products are indexed by page and volume numbers.

Volume 2 also contains detailed electrical and mechanical data for 70 new products. A two-part replacement directory crosses over 9,200 additional relay manufacturer's part numbers to ECG replacements. In the first section, part numbers are sorted alphanumerically. In the second section, numbers are grouped by brand name.

Circle (70) on Reply Card

### **Parts catalog**

The 1993 catalog from Parts Express International, Inc. lists parts for TV/VCR repair and for home and car audio. They carry a wide range of products that include video heads, flybacks, belts, idler tires, RF modulators, computer accessories, raw speaker drivers, in-wall speakers, car amplification products, connectors, service literature, instructional videotapes, and loudspeaker design software.

Circle (71) on Reply Card

### **Interconnection products catalog**

L-Com announces the release of a 128-page catalog listing a variety of interconnection component products for the computer, research and OEM markets.

This catalog is divided into six product classifications which include: IEEE-488, coaxial, modular, datacom products, and service aids. Altogether, more than 4,500 components are listed.

Circle (72) on Reply Card

### **SMT assembly/rework catalog**

A comprehensive product catalog with specific focus on low volume SMT as-

sembly and rework equipment is now available from OK Industries. The catalog provides process and application information for a variety of assembly tasks including: solder paste deposition—printers and dispensers, component placement—pick and place systems and hand tools, reflow—ovens and hand tools, and rework—forced convection and contact heating tools. The catalog targets low volume production, prototyping and rework applications. It includes complete product specification and accessories information.

Circle (73) on Reply Card

### **Electronic components catalog**

Mouser Electronics announces the publication of their latest industrial electronic components catalog. The comprehensive 240-page catalog is easy to use with a Quick Index on the front cover and a comprehensive index of both manufacturers and product categories. The company is sensitive to time constraints and provides same day shipping on all orders.

This catalog contains over 42,000 in-stock, factory-authorized product selections from more than 90 manufacturers and features new product listings from Cornell Dubilier, 3M, Tripp Lite, LMB, AMP, Carol Cable, Amphenol, Rohm, Spectrol, SGS Thomson, Augat, Keystone, Switchcraft, and DGS Pro Audio. Select from semiconductors, passive components, electromechanical devices, resistors, capacitors, switches, transformers, inductors, wire and cable, connectors, publications, equipment, and supplies.

Circle (74) on Reply Card

### **Fall 1993 catalog features test equipment, tools, and supplies**

A 48-page catalog from Contact East comes packed with hundreds of new test instruments and tools for engineers, managers, technicians, and hobbyists. Featured are quality products from brand-name manufacturers for testing, repairing, and assembling electronic equipment. Product highlights include new DMMs, oscilloscopes, soldering tools, EPROM programmers, power supplies, clamp probes, two-way radios, reference books, datacom tools and testers, adhesives, cables, precision hand tools, tool kits and portable digital scopes. Also included are DMMs, soldering/desoldering systems, static protection products, ozone safe cleaners, magnifiers, inspection equipment, workbenches, cases and more.

Circle (75) on Reply Card

# Soldering devices

By Sheldon Fingerman

With a huge variety of soldering devices on the market, choosing one can be a real dilemma. With everything available from solder strips that wrap around wire and melt with a match, to high-tech high priced soldering stations, what's a technician to choose?

## The soldering gun

Back in the good old days you just pulled out a soldering gun. You know, the ones that are about the same size and weight as a 44 magnum. But in today's world of transistors, ICs, and surface mount devices (SMDs) that old soldering gun could do a lot more harm than good.

Actually, the soldering gun still has many uses. It really does look like a gun, and pulling the "trigger" produces almost instant heat. The tip will cool rapidly when the trigger is released, making the soldering gun one of the safer soldering devices on the market.

Its high heat makes the gun suitable for quick desoldering when the traces on the circuit board are large enough to take it, and it's great for soldering chassis grounds and RF shields.

Unfortunately, the soldering gun is a bit too much for today's microelectronics. The tips are just too large to maneuver around today's circuit boards, and most guns weigh a lot. If not used with great caution they can lift or burn through circuit board traces quite easily.

If your only choice is a soldering gun, try filing the tip to a small chisel or point. Since many have two trigger positions—very hot, and extremely hot—use the lower of the two on most circuit boards.

Actually, one of the biggest drawbacks to the soldering gun is that your hands are just too far away from your work. I think most technicians like to get a little more "intimate" with their solder joints, which is why pencil-type irons are so popular.

## Advantages of pencil-type soldering irons

It's easy to see where the pencil-type



Figure 1. Back in the days of vacuum tubes and hand-wired chassis choice of a soldering tool was easy: a 100-watt soldering gun. It heated up quickly and cooled quickly.

soldering iron got its name: you hold it like a pencil. It's small, inexpensive, and certainly convenient.

There are many variations of the pencil-type soldering iron; the simplest being the ones that just plug straight into any ac outlet. Several models offer a variety of tips and heat ranges, and on some, changing the tip, or the complete heating element, offers the user a wide range at bargain prices.

However, since most of the inexpen-

sive models offer only one heat range, the purchaser has some decisions to make. My theory on soldering is to get the job done quickly. I feel that high heat fast is better than lower temperatures for longer periods, and does less damage.

Some would disagree. If you are only going to have one soldering device, you have to compromise. Just take into account the type of soldering you do the most, and don't be afraid to ask the manufacturer for advice.

One drawback to inexpensive soldering irons is that you can't leave them plugged in all day. They lack the stamina of irons with regulated power supplies, and the tips don't last very long. The grips also get quite hot, many times forcing you to unplug the thing just so it can cool down enough to hold it again.

## Regulated pencil-type irons

By far, the most popular choice of service technicians are pencil type irons with regulated power supplies. These models can get pretty exotic, with adjustable temperature ranges, digital readouts, and enough options to solder everything from the most delicate SMDs to the heaviest chassis work.

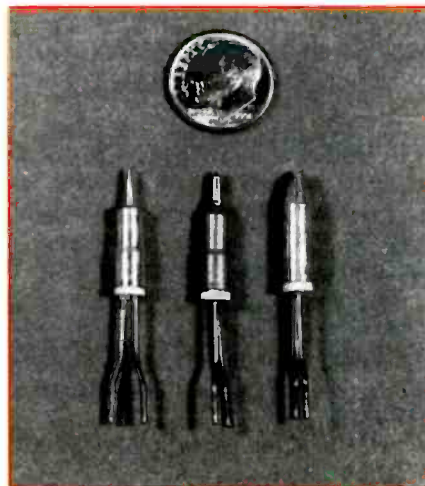

Figure 2. Many of today's soldering irons have a selection of tips to choose from depending on the job to be done.

Fingerman is an electronics and computer consultant and servicing technician.



# **Sodr-Pen™**

## **More than a slim advantage...**

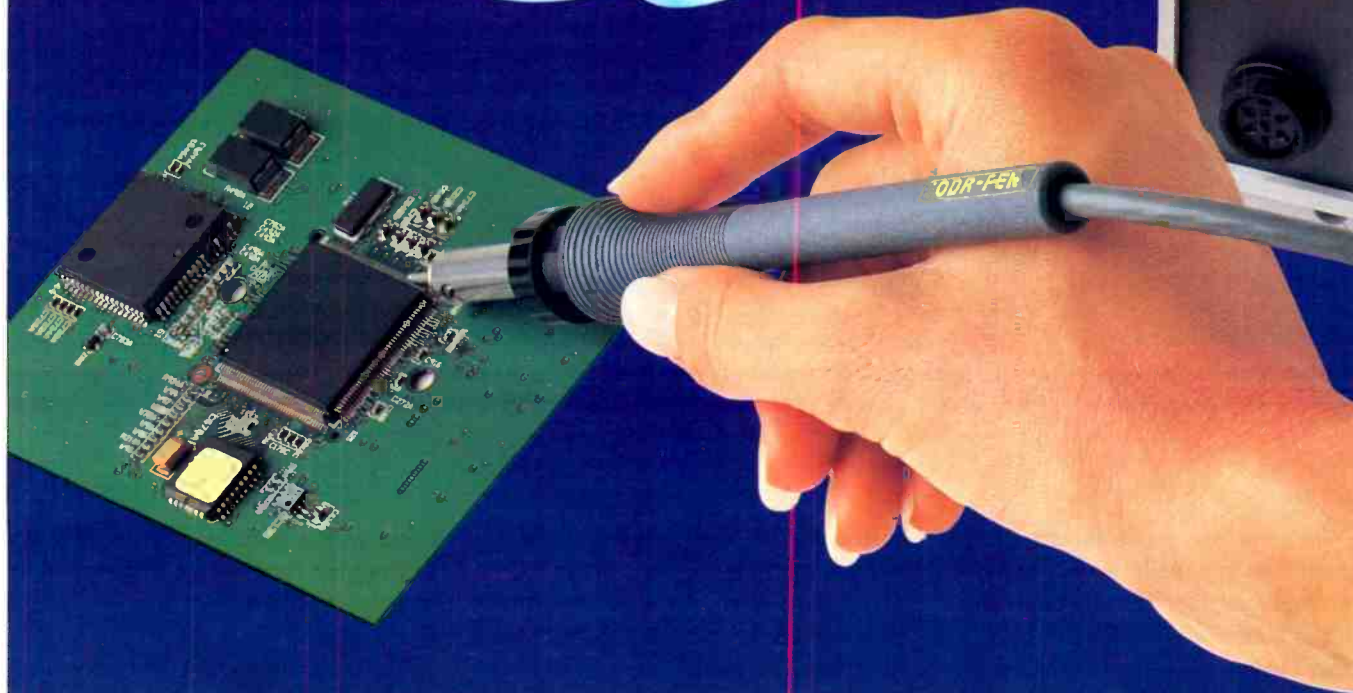

***For low temperature, high capacity SMT and Thru-Hole soldering.***

***Along with the balance and control of a fine writing instrument, the Sodr-Pen delivers high capacity heating for all Surface Mount and Thru-Hole production soldering at safe low temperatures—as low as 525°F!***

***With SensaTemp® control for accurate, honest tip temperatures between 200°F and 900°F, over 60 Surface Mount and Thru-Hole tip choices and five-second hot tip changeover, your productivity will soar!***

***All this, at a price you can afford...Sodr-Pen from PACE.***

**PAGE®**  
**INCORPORATED**

**PACE, Inc. • 9893 Brewers Court • Laurel, Maryland 20723-1990 • Tel: (301) 490-9860 • Fax: 301 498 3252**

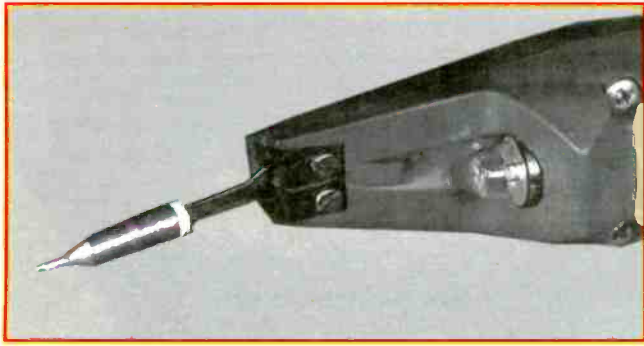

**Figure 3.** Cordless soldering irons are convenient because they don't have a cord to contend with. Some even come with a light to illuminate the joint you're soldering.

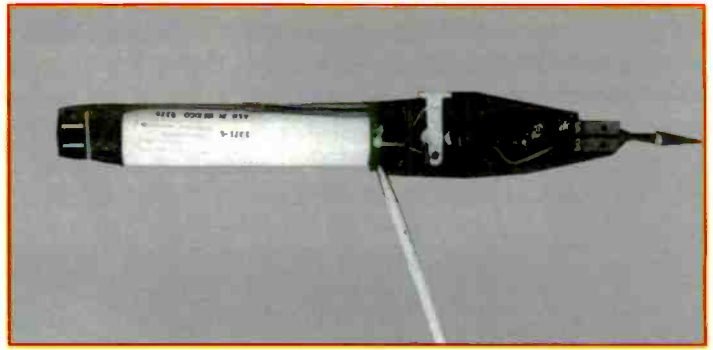

**Figure 4.** NiCd batteries in cordless irons can be charged and discharged only a finite number of times. Replacing the battery not difficult, but remember, you'll need another soldering iron to do this job.

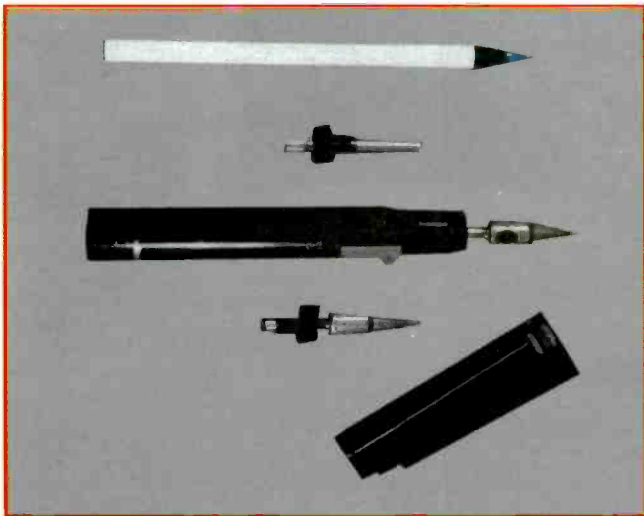

**Figure 5.** Butane powered soldering irons are handy for soldering outside of the service center.



**Figure 6.** The temperature of the tip of a butane soldering iron can be controlled over a narrow range by adjusting a valve in the end of the handle.

When you use one of these tools you are tethered to a small power supply, but you gain constant temperatures and a built-in holder. I have yet to see one that doesn't have a place for a sponge to keep the tip clean and a light to tell you it's on.

Because of their available temperature ranges and tip selection, you can easily solder and unsolder some of those new surface-mount ICs—the ones that seem to have about a thousand tiny little legs. Those legs don't just look delicate, they *are* delicate.

If done correctly, and with the right equipment, not only can most SMDs be removed quickly, but they can be reattached with the odds of them still working. The trick is to heat all of the legs at once and quickly remove the IC. You can heat all the legs of an IC at once with a tip that resembles a hollow block. This tip

surrounds the IC and melts the solder without touching the body of the IC.

Although tips like this are usually available on the more expensive irons, I have seen inexpensive ones; some are sold as a complete iron, and some are sold as a tool direct from the manufacturer.

#### Advantages of rechargeables

The biggest drawback to an ac-powered soldering iron is the cord. The absence of a cord makes the rechargeable iron a favorite of mine.

Although it must be recharged, it frees you from a cord and offers the least amount of heat exposure to surrounding areas. One brand even offers a small drill that can be attached in place of the soldering tip—perfect for cleaning out excess solder from circuit board holes.

These irons are lightweight, and many

come with a built-in prefocused lamp. Recharging time varies from model to model—anywhere from only one hour to sixteen hours.

The better ones come with a recharging stand that switches to a trickle-charge after the iron has been fully charged. This is important for maximum battery life.

Most rechargeable soldering irons are turned on with a momentary switch that can be locked in the off position, allowing you to keep an iron in your tool kit without burning up your van.

Like their ac counterparts, rechargeable irons offer a variety of tips. One brand has fifteen. Temperature is adjusted by using different tips—the largest being hottest. It can also be reduced by carefully feathering the power button.

A drawback of rechargeable irons is that they can only be used for a limited

time without recharging. They are usually rated at how many joints can be soldered on one charge. To be safe, assume you won't get even close to that number. Just remember, even though they work quite well, "up to 125 joints" may in reality wind up being only 50.

Since NiCd batteries discharge on their own in about a month, the occasional user may find that every time he wants to solder something the iron needs to be recharged. These products also exhibit all the characteristics of most products that use NiCd batteries. They have that "memory" problem—if you don't discharge and recharge them completely, you may not get full service life.

Another problem that plagues NiCd batteries is that they can only be recharged a finite number of times. The batteries that recharge in an hour can't be recharged as many times as their slower counterparts. The better manufacturers offer replacement batteries, which is a lot cheaper than buying a new iron.

Though replacing a set of batteries is not an easy job, the average technician shouldn't have too difficult a time. Just

remember, you'll need another soldering device to do the job.

### Gas-heated soldering irons

The newest irons on the market are the butane types. These also free you from a cord, and again offer a wide variety of tips, ranging from fine to a small blowtorch. These irons are easily and quickly refilled using standard lighter refills, and their temperatures can be adjusted over a small range by simply twisting the bottom of the unit.

Unlike rechargeable soldering irons, gas heated units can sit around for long periods without a thought. They are easily fired up by a sparkwheel in the cap, and most models have a window to let you see how much fuel is left (an important feature to look for).

Some drawbacks are that they generate excessive heat around the heating element. Caution must be used in tight places, and there never seems to be a good place to "park" them. Otherwise, they work extremely well and are an excellent choice for service calls. Since they are filled with butane, I would give them the

same respect you would give a disposable lighter when it comes to storage.

### High-tech soldering

The last model we'll mention, and the last word in soldering, is the high-tech soldering/desoldering station. These have all the advantages of a soldering station, with the added luxury of being able to desolder at the touch of a button. Light years ahead of solder suckers and desoldering braid, these wonderful gadgets take the chore out of removing components from circuit boards.

For a high volume shop, one of these soldering/desoldering stations can definitely speed up productivity. We all hate the idea of having to remove components for testing, but with one of these models it's a breeze, especially when working on multilayered circuit boards.

Considering what these devices can do, it's hard to find any drawbacks. Price would be the first that comes to mind. The second would be the fact that you are dealing with not only a cord, but hoses on some models as well. They aren't huge, but they aren't very portable either.

**Come Out of the Dark.**

If you're searching for the perfect way to illuminate your business, make the switch to the NESDA Form, a universal billing form for COD or warranty work accepted by all major manufacturers. It's only *one* of many "enlightening" benefits offered to members of NESDA. For more information about NESDA, and a sample of the NESDA Form, just mail the following to NESDA:

Name \_\_\_\_\_  
 Address \_\_\_\_\_  
 City \_\_\_\_\_ State \_\_\_\_\_  
 Zip \_\_\_\_\_  
 Phone \_\_\_\_\_

**National Electronics Service**  
**NESDA**  
 Dealers Association, Inc.

2708 W. Berry St.  
 Ft. Worth TX 76109  
 (817) 921-9061

## The SC-7000 Compact Desoldering Tool

*The only Desoldering Tool with the Motor and Pump built into the handle.*

No Bulky Base Station ✓ No Factory Air ✓ No Hoses ✓



**Features:**

- ESD SAFE
- Meets MIL-SPECS
- Portable
- Temp. Range 300C-450C
- Long Life Tips
- Quick Change Filter
- High Vacuum Efficiency
- Hot Air Reflow Mode
- SMD Removal Kit
- Weight 1lb

**Also Available:**

- SS-8000 Microprocessor Controlled Soldering System
- SS-8100 Compact Soldering Station 24V
- SS-8200 Pencil Soldering Iron with Variable Temp
- KC-1 Soldering Iron Analyzer (Mil-Spec)

**DEN-ON INSTRUMENTS (USA), INC.**  
 2580 Corporate Place, F-103  
 Monterey Park, CA 91754  
 Phone: 800-397-5960 Fax: 213-266-5963  
 In Canada Call: New World Enterprises  
 at 604-276-8277

## The choice is yours

Which model you decide on depends on your type of work and your personal preferences. If you do a lot of soldering you may choose to have more than one type at your disposal.

My preference is to have a couple of one-hour rechargeable irons on my bench. I don't have to contend with any cords, and one is always in the charging stand when the one I'm using runs out of juice.

The light is a nice touch as well. I don't have to constantly grab a lamp to see what I'm doing, and the light dimming coincides with the batteries weakening.

If you decide to use rechargeables, never try to work with an iron that is running down. Placing it back in its charging stand for only a few minutes will always get you a few more good solder joints.

Although the tips can be locked into place with screws. I have them set up so I can change tips quickly by just pulling them out. The large chisel is good for heavier duty applications, such as desoldering. The fine tip is excellent for general PC board work, and the micro tip is perfect around ICs and surface mount components.

For bench use I've disabled the lock on the power switch. It was a pain having to make sure the button was rotated into the unlocked position all the time. Speaking of the power switch, you must remember to keep it on until the tip has been removed completely from the solder joint.

These rechargeable irons have worked extremely well for me. I can put it down anywhere on my bench, and as soon as I put it down I know it's off. I do use a standard soldering gun for desoldering RF shields, ground leads, and audio output transistors that are on large pads with lots of solder. When I'm sure I won't put either the circuit board or the component in jeopardy it works well. It's definitely fast, but it usually sits on a shelf with the cord wrapped around it. I have enough cords and wires on my bench now.

## Outside service calls

For service calls and working outside, I find it hard to beat a butane soldering iron. They are lightweight, cordless, and can even be clipped in your pocket like a pen. Being able to adjust the temperature

is great, allowing you to switch from desoldering a chassis ground lead to delicate IC work. Refilling is quick, and tips can be changed easily without tools.

The biggest problem is where to put it down. You can try perching it precariously on end, but a small bump will tip it over quickly. You have to be careful not to burn a hole in someone's carpet or in their furniture.

While we're on the subject, be careful where you put any soldering device down, not only for the obvious reasons. If you throw a bunch of papers on top of any cordless soldering device you have no cord to lead you to it. And never put a hot iron, or an iron that's cooling down on top of any thermal fax pages. I learned this one the hard way.

Soldering is a skill that we use constantly. As with any profession, or hobby, using the right tools can make the job much easier. As a servicing professional I've learned to adapt and work with what I've got now. But I have to admit, whenever I get a new catalog I tend to linger over the pages with high-tech soldering stations on them. One of these days. ■

## DESOLDERING TIPS WHY SPEND MORE IF WE COST LESS!

PRECISION ENGINEERED  
INTERCHANGEABLE  
GUARANTEED

ONCE YOU HAVE  
A COPY OF THE A.P.E.  
"CERTIFIED SPARES"  
REPLACEMENT PARTS GUIDE,  
YOU'LL FIND OUT EXACTLY  
HOW MUCH YOU'VE BEEN  
OVERPAYING FOR FACTORY  
REPLACEMENT PARTS.

A.P.E. "Certified Spares" are genuine, industry-tested replacement parts for solder extractors, circuit repair kits, pumps, handpieces and more!

For example, A.P.E. deluxe desoldering tips, are engineered from a special high-conductive copper alloy and a corrosive-resistant plating, assuring longer life and instant heat recovery. Our tips are precision-engineered replacements for tips by PACE, Venter, AirVac, Plato or Ungar.

And don't be fooled. The Magnuson-Moss Warranty Act states that any manufacturer claiming that the failure to use their replacement part will void a warranty, must provide those replacement parts free of charge or be in violation of the law!

Call today for free sample tips  
and the A.P.E. "Certified Spares"  
Replacement Parts Guide  
to our full-line of replacement parts  
for your PACE equipment.  
WE WON'T TELL, IF YOU DON'T!

**A.P.E.**  
Automated Production Equipment Corp.

142 Peconic Avenue, Medford, New York • 516-654-1197 • fax 516-289-4735

## Improve Your Form.

**3-Part** A continuous feed form used for customer c.o.d. service or parts/accessory sales receipts (N3CS-X). Not for warranty billing.

**5-Part** A continuous feed form for warranty billing.

**7-Part** A universal snapout form (N7SN) designed for both customer service c.o.d. and manufacturer warranty billing. Complies fully with the requirements of state and local ordinances, including California.

**Discounts** Carbonless NESDA Forms are available to NESDA members at additional savings. For pricing information and samples, or information regarding other NESDA membership benefits, contact the NESDA office.

## The NESDA Form

2708 West Berry St.  
Fort Worth, TX 76109  
(817) 921-9061; Fax (817) 921-3741

## Introducing a New Era In Technical Training.

World College, an affiliate of the Cleveland Institute of Electronics, was created to provide a four year, independent study, technical degree program to individuals seeking a higher education. The Bachelor of Electronics Engineering Technology Degree, offered by World College, prepares students for high-paying careers in electronics, telecommunications, electrical power, computer and control systems. World College's curriculum is taught in an effective, time-proven, independent study environment. With World College's flexible study schedule, students have the opportunity to work or spend time with their family without having to worry about rigid scheduling residential colleges offer.

### A Quality Education with a Flexible Schedule.

In a world heavily dependent on electronic equipment, people who understand electronics will have no problem putting their knowledge to work... in high-paying careers. The staff and faculty of World College have invested over ten years developing, what we believe to be, the finest independent-study, baccalaureate degree program available. World College's mission is to instill in each student the knowledge, *education*, and *training* that employers are seeking for the many technical positions available today. It's a program created to provide the best education and training possible with a flexible schedule to match your busy lifestyle.



World College is currently seeking approval to confer the Bachelor Degree from the Virginia Council of Higher Education.

# Earn A Bachelor of Electronic Engineering Technology Degree from



**WORLD  
COLLEGE**  
*Bringing Technology Home!*

Lake Shores Plaza  
5193 Shore Drive, Suite 113  
Virginia Beach, VA 23455-2500

### Send For Your Free Course Catalog.

Take the first step towards a new start in life. Send for World College's Free Independent Course Catalog today and discover how easy and affordable it is to get started on your Bachelor Degree.

World College is affiliated with



## Complete the Entire Degree Program Under One Roof. Yours!

Only World College offers an independent study, four year technical degree which can be completed through one school. All lab equipment\*, parts, and software are included in your tuition and the program's 300-plus laboratory experiments can be completed in your own home.

### You Pay Only For Time Actually Used.

World College not only provides a means to earn a Bachelor Degree while fulfilling current obligations, but there are no restrictions on how fast you can complete the program. At World College, you pay tuition only for the actual upper-level semesters it takes to graduate. The quicker you complete the program, the less you pay in tuition. It's an effective way to keep you motivated in order to complete the course and move on to a better paying position as quickly as possible.

Currently not available in Ohio.

\* Student must have access to a personal computer system.

**YES!** Please send me World College's Free Course Catalog detailing the full curriculum.

Name: \_\_\_\_\_

Address: \_\_\_\_\_

Apt: \_\_\_\_\_

City: \_\_\_\_\_

State: \_\_\_\_\_ Zip: \_\_\_\_\_

Phone: (\_\_\_\_) \_\_\_\_\_

Age: \_\_\_\_\_

Return to: WAS003

World College  
Lake Shores Plaza  
5193 Shore Drive, Suite 113  
Virginia Beach, VA 23455-2500

# Gremlins in the power lines

By Bob Polk

You've been banging your head against the wall trying to solve a customer's problems. You replace some boards, and a few days later the same problem (or worse) arises again. Back you go with your kit of replacement parts. This happens over and over again and the customer is rapidly losing faith in your ability to fix the problem. Your boss is blowing his stack at losing money on the service contract.

## Stand back and consider

Stop a minute and start looking around for other causes for the equipment failure. Could it be a power problem? What else is on the same circuit as the problem equipment? Is there a good ground? (Get yourself a ground tester). Do the lights flicker? Are there errors in data transmission? Do unexplained system lockups occur? Have there been hard drive crashes? All of these occurrences are symptomatic of power gremlins at work.

Power disturbances can do strange things to electronics. The effects of some power problems are immediate, others just continue to degrade components until they finally fail. In the case of computers, data may be being lost or corrupted.

Power disturbances are the most prevalent cause of computer system malfunction and failure. All electrical and electronic components are sensitive to power disturbances; some more than others. Understanding power quality helps users and technicians to better use and service today's advanced electronics.

## What is a power disturbance?

Power disturbances are often called "electrical noise," "transients" or "power surges." The disturbances are anomalies on the ac power line that are of sufficient magnitude, frequency and duration to cause equipment to malfunction.

Each type of equipment is affected differently by power disturbances. AC power is used to supply most of today's sensitive equipment. The alternating current delivered by the power systems in most

Disturbances	Causes	Effects
SPIKES	Lightning, arcing switches, or motors, relays, transformers, etc.	Operating errors, memory loss, program damage and/or destruction of electronic components.
SURGES	Open neutral connections, sudden load reductions, improper wiring.	Lights flicker, degradation of electrical contacts. Excessive surges can cause equipment damage.
SAGS	Large inductive loads, like photocopiers turning on.	Common cause of computer system failures. Hardware damage unlikely.
POWER OUTAGE	Utility faults, alternative power source failure, circuit breaker trip or loose wiring.	Loss of computer/ controller memory, equipment failure or hardware damage.
HIGH FREQUENCY NOISE	Electronic equipment feeding internal noise back onto the power line or logic induced noise from switching power supplies. Also from broadcast signals.	Can cause internal component degradation, system lockups, resets and data transfer errors will increase.
NORMAL MODE NOISE	Voltage induced on the neutral line by other equipment. Loose neutral wiring, loose grounding wires, excessive ground current and faults to ground.	Data alterations may occur and equipment errors. Increased audible noise.
WAVEFORM DISTORTION	Caused by overloaded wiring, loose or corroded wires.	Results in low efficiency and reduced life of electrical equipment such as motors.

Figure 1. Intermittent problems or erratic operation of computers or computer-based equipment may be caused by problems with the power line.

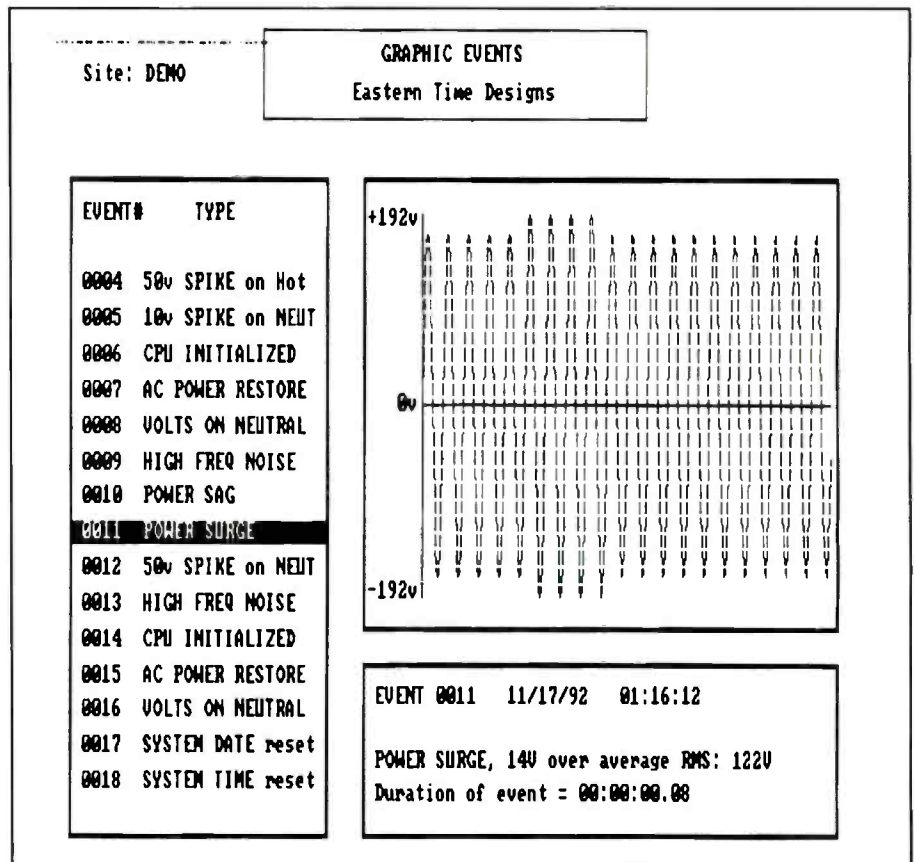

Figure 2. Excessive line voltage, or a power surge, as captured here by a line monitor, may be the cause of computer-related problems.

Polk is a sales engineer with the PowerTronics Division of Eastern Time Designs. His background includes systems engineering and management information systems activities.

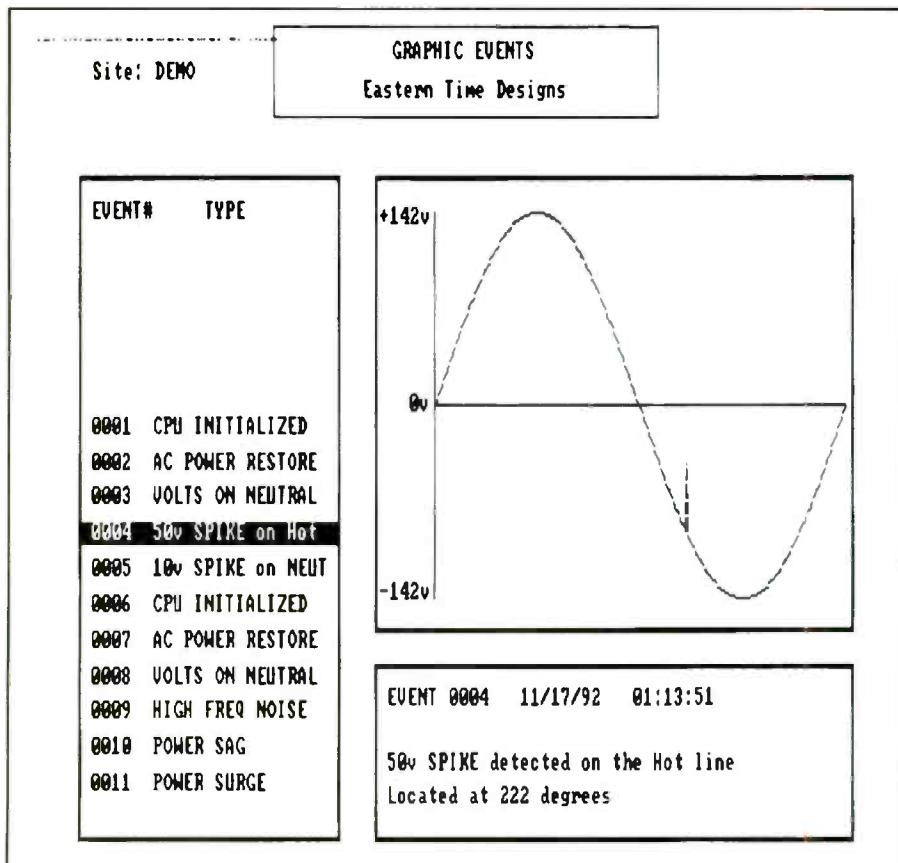

Figure 3. A voltage spike on the power-line voltage waveform, as captured here by a line monitor, is another possible cause of computer-related problems.

parts of this country is a sinusoidal waveform that alternates between -170V and +170V. This alternating voltage produces a steady state, or "heating" value (rms), that is equivalent to what a dc voltage of 120V would provide.

Common disturbances that occur on the power line are voltage sags (also called dips, brownouts); voltages surges (also called swells); power failures (also called blackouts); dropouts; high frequency noise; impulses on the hot, neutral, and even ground lines, sometimes called spikes or surges; and phase shifts.

There are two types of "noise" discussed in literature for power protection devices. Normal mode noise consists of disturbances that occur between the hot line and neutral wiring. These can be impulses or high frequency noise. Common mode noise consists of disturbances on the neutral and ground lines. These are referred to as neutral line impulses or spikes on ground.

#### What can happen?

Modern computer systems are particularly vulnerable to power disturbances because they utilize the high energy of the

ac power to generate the supply voltages for low energy digital integrated circuits (ICs). Problems caused by power disturbances include:

- Hardware damage to power supplies, hard drives, floppy drives, IC board components, add-on boards, peripherals.
- Program lockups: disruption of the normal operation, or slowing down of programs for error checking.
- Loss of data or data alteration, substitution of other characters or gremlins.
- Parity errors and transmission failures in networked systems.
- Premature degradation and replacement of computer systems and components.

#### What causes disturbances?

Up to 90% of power quality problems or transients are generated *within the building*, and are not generally the result of electric utility faults. Most transients can be traced to specific conditions in the placement of equipment or faulty wiring practices inside the facility. Internally generated transients result from switching within the facility such as the simple act of turning a motor or light on or off

## ULTRA-LOW COST LINEAR PROGRAMMABLE POWER SUPPLIES

2 Year  
Warranty



User-friendly with LCD readouts  
at analog prices

- Output Voltage/Current Programming and Readback via LCD Panel
- Data Entry with Front-Panel Keypad
- Power-off Memory
- Microprocessor Controlled
- Voltage and Current Step-up/Step-down Function
- Superior Line/Load Regulation
- Output Enable/Disable
- Intelligent Forced-Air Fan Operation
- Optional RS-232 Interface for Remote Operation (standard on LPS-305)

American Reliance, Inc.

11801 Goldring Road, Arcadia, CA 91006  
(800) 654-9838 • Fax: (818) 358-3838

Circle (2) on Reply Card

# FREE CATALOG

CALL TOLL FREE  
**1-800-338-0531**



The free catalog is sent via bulk mail to U.S. addresses. For express delivery, please send \$2.50 to cover 1st class postage. Foreign destination customers, please send \$5.00 to cover postage.

Parts Express is a full-line distributor of electronic parts and accessories, geared toward the consumer electronics industry and the technical hobbyist. We stock an extensive line of replacement parts for TV and VCR repair. Call for your FREE 172 page catalog today.

340 E. First St., Dayton, Ohio 45402

Circle (8) on Reply Card

can result in a transient such as an impulse or sag in line voltage.

In the office environment coffee pots, laser printers, copy machines, elevators, heating and air conditioning, janitorial equipment, even computer power supplies are often responsible for many types of transients. In the industrial area look for solid-state equipment, like rectifiers, adjustable speed drives, industrial processors and induction furnaces, elevators controlled by static inverters, welders, furnaces, compressors, microwave/radio frequency sealers, etc.

### Shared load placement

Sensitive equipment sharing the same circuit is an obvious, but overlooked problem. Sensitive electronic equipment should not be plugged into a branch cir-

cuit that also supplies products that generate electrical noise. It should be powered by an individual branch circuit. This will minimize the effects of adjacent equipment cycling on and off.

### Building wiring

Improper, missing or poor quality electrical connections exist in many receptacles or panels. Many problems of this type are caused by non-adherence to the National Electrical Code (NEC):

- Improper neutral to ground ties can cause ground loops, split currents between neutral and ground, safety concerns.
- Undersized neutrals create safety concerns because they may result in overheated neutral conductors from harmonics created by switching power supplies or unbalanced three-phase systems.

• Open neutral or open ground lines in receptacles cause safety concerns and equipment malfunction.

• Data cable between two systems referencing different grounds can create voltage differences. Current from faults or static will travel between the two systems using the data cable. (Up to 15% of commercial receptacles are miswired: all outlets should be tested).

### The individual branch circuit

A phrase often found in computer installation specifications is the term "dedicated circuit." This should read "individual branch circuit," defined as "a branch circuit that supplies only one utilization equipment." Often a so-called "dedicated circuit" is little more than an outlet with one system plugged into it. This outlet may or may not be part of a branch circuit with several other receptacles powering other equipment.

### What to do

In combatting power disturbances, a power line disturbance monitor may provide some help. These devices can be put in a customer site for a week and record all the transients that may be causing equipment problems.

The more sophisticated monitors will date and time stamp the disturbances and record their type and magnitude. The data is stored in memory and can be viewed or uploaded to a computer and a complete power audit report can be assembled.

### How to fix it

There are a wide variety of power protection devices and systems on the market today. But for general power problems a line conditioner will often provide the solution to voltage control sags and surges. Many line conditioners also have built in protection for various types of transients. An entire article could be (and many have been) written on the various types of power protection equipment.

A good line conditioner will correct most problems generated by disturbances on the power line. Use care in choosing a line conditioner, though. Many surge suppressors bought at the corner consumer electronics store are not really properly designed to correct line problems. These devices provide little more than a false sense of security and can often cause problems themselves. ■

## To Order Back Issues

Send \$3.50 Per Issue (Check, Money Order, Mastercard, VISA, Discover and AMEX.)

Send All Correspondence To:

**CQ Communications**  
**76 North Broadway**  
**Hicksville, NY 11801**  
**Or Call**  
**516-681-2922**  
**FAX 516-681-2926**

## TANDY DISTRIBUTOR SALES

### COUNTER SALES TO IMPROVE YOUR PROFITS?

**Tandy Distributor Sales** offers a line of product displays. These displays may enhance your retail sales to walk-in customers. Some of the product lines available are: Cordless telephone antennas and batteries, belts, calculator ink rollers and educational VCR tapes covering many electronic and repair subjects. Here are some of the displays:

**DANTONA CORDLESS TELEPHONE ANTENNAS:** A product display with complete cross-reference information so your customer (or you) can locate the replacement antenna (or rubber equivalent). Additional products are available. Antennas are available either packaged for retail sales/ bulk.

**DANTONA CORDLESS TELEPHONE BATTERIES:** A product display and cross-reference information to find the battery needed for repair.

**PORELON REPLACEMENT CALCULATOR INK-ROLLERS:** Product displays are available for replacement ink-rollers for many name-brand calculators. A complete cross-reference guide is available to locate the exact replacement needed. **Tandy Distributor Sales** will be glad to recommend a product mix, or you may select your own. Call today for information on these and other displays available through **Tandy**

**Distributor Sales. CALL TOLL FREE 800-322-3690 Ext. 378**

Circle (18) on Reply Card



# New From **CQ** . . . Radio T-Shirts!!

High-Quality T-Shirts, made in U.S.A., pre-shrunk 100% cotton.

Special Introductory Offer  
\$2 off each shirt!

\$15.95 per shirt plus shipping & handling regularly \$17.95



**Yes! Rush my CQ T-Shirt(s) to me right away! Here's my order below**

Name \_\_\_\_\_ Callsign \_\_\_\_\_  
 Address \_\_\_\_\_  
 City \_\_\_\_\_ State \_\_\_\_\_ Zip \_\_\_\_\_

Qty	Item #	Size	Price	S & H	Total
Grand Total					

Please allow 4-8 weeks delivery  
 Available sizes: L, XL, XXL (add \$2) Please add \$2 shipping and handling per item ordered. Order 4 or more and receive free shipping.  
 Make your check or money order payable to: CQ Communications, Inc., 76 North Broadway, Hicksville, New York 11801  
 Please charge my: MC/VISA/AMEX/Discover # \_\_\_\_\_ Expires \_\_\_\_\_ Signature \_\_\_\_\_



**To Order Toll Free Call (800) 853-9797 or FAX (516) 681-2926**

# Horizontal output transistor problems

By Homer L. Davidson

**H**orizontal output transistors (HOTs) and surrounding components have probably made more money for TV technicians than any other components. The horizontal circuits were the major cause of failure back in the days of tube chassis. When the solid-state chassis was introduced, replacement of the horizontal output transistor was an everyday occurrence in most service centers. Today there are fewer breakdowns, because of improved TV chassis reliability, but more problems still occur in the horizontal and high-voltage circuits than in any other area of the TV set.

## Some typical HOT problems

A leaky horizontal output transistor may blow the fuse and cause chassis shut-down (Figure 1). A leaky damper diode may cause the same symptoms. An intermittent output transistor or surrounding components may produce that TV tough dog symptom. An open output transistor

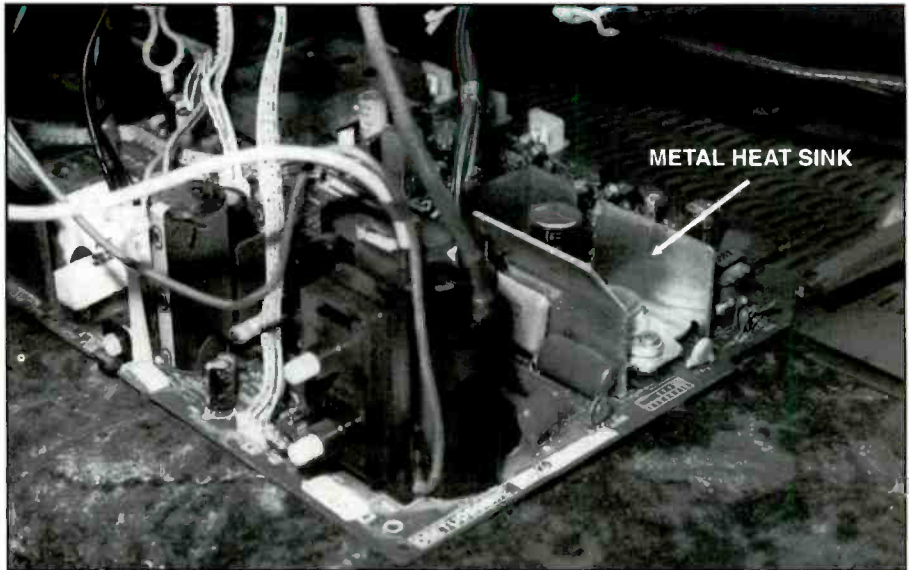

Figure 1. The horizontal output transistor is usually located on a metal heat sink.

or circuits may produce a dead chassis.

A frequent cause of failure in early fly-backs or horizontal output transformers was arcing over and firing between windings. Repeated damage to the HOT might be caused by a leaky, arcing flyback and overloaded secondary circuits.

## Innovations in horizontal circuits

More recent sets feature an integrated high-voltage transformer (IHVT) with internal HV diodes. These diodes may arc over, destroying the transformer and horizontal output transistor.

Other recent innovations are the many

Davidson is a TV servicing consultant for ES&T.

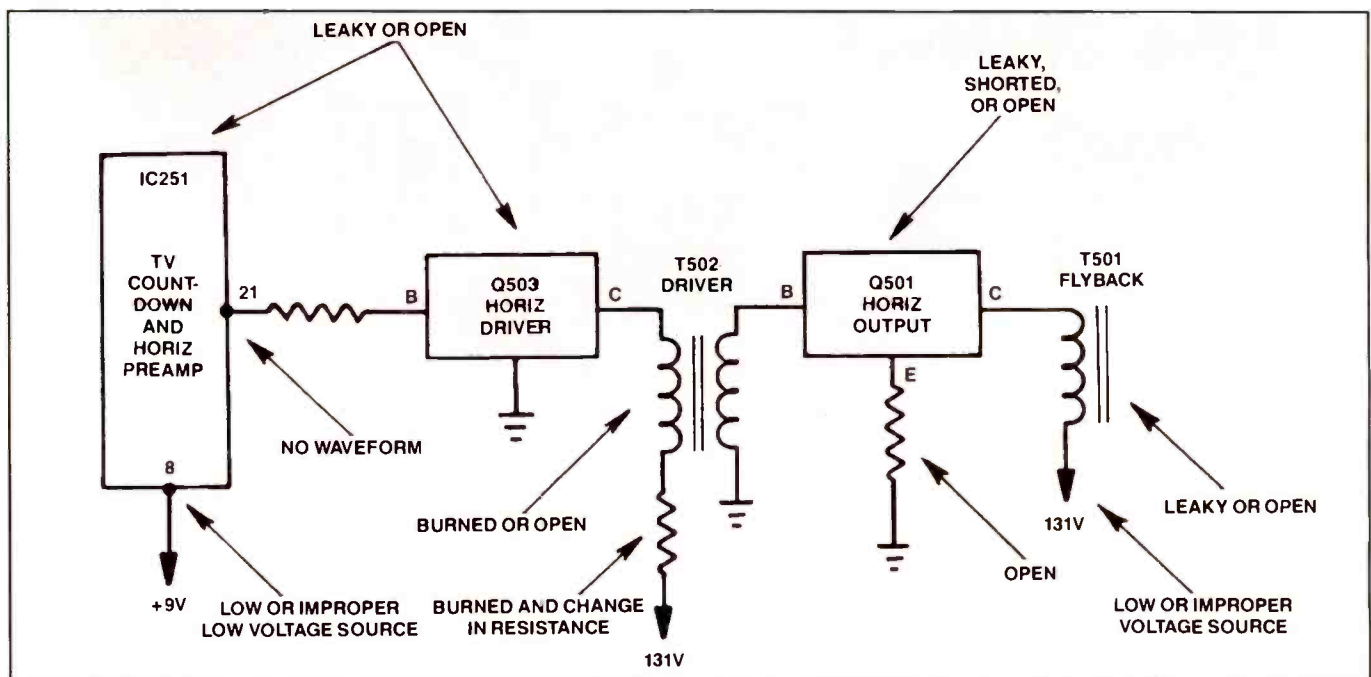

Figure 2. A basic horizontal output circuit with possible defective components.

# ES&T Postcards An Easy Way to Get Immediate Action.

If Jensen's Postcard is Missing  
Circle (5) on Reply Card  
For More Information

**Order Today!  
and  
Save 75%**

Just complete and  
mail this card,  
or call  
**1-800-428-7267**  
**1-317-298-5566**  
for immediate service

If Sam's Postcard is Missing  
Circle (16) on Reply Card  
For More Information

**PACE**  
INCORPORATED

- Video and Live Training
- Soldering/Desoldering Systems
- SMT Component Installation and Removal
- Circuit Board Repair and Modification
- Fume Extraction Systems

**9893 Brewers Court  
Laurel, MD 20723-1990  
Tel: (301) 490-9860  
FAX: (301) 498-3252**

If Pace's Postcard is Missing  
Circle (6) on Reply Card

## Free Catalog! To Meet All Your Electronic Service Needs

- Instrument Repair Kits
- Troubleshooting Aids
- Test Equipment
- Wire/Cable & Connectors
- Soldering/Desoldering
- Computer Accessories
- Metric Tools
- Shipping Containers
- YES! Send me my free catalog  
(fill in reverse & mail, or call 602-968-6231)

**JENSEN**® 7815 S. 46th Street  
Phoenix, AZ 85044-5399



YES, I want to save over \$1100.00 (that's more than a 75% discount) annually by subscribing to Howard W. Sams & Company's **PHOTOFACT®-OF-THE-MONTH** subscription program. I understand my subscription will be forwarded to my nearest authorized Sams "Stocking Core" Distributor. I agree to pay \$46.95 per month upon receipt of my first shipment. Please start my subscription on the following month:

- Jan  Feb  Mar  Apr  May  Jun  
 Jul  Aug  Sep  Oct  Nov  Dec

Customer Name \_\_\_\_\_  
Address \_\_\_\_\_  
City \_\_\_\_\_  
State \_\_\_\_\_ Zip \_\_\_\_\_  
Signature \_\_\_\_\_  
Telephone Number \_\_\_\_\_  
Local Sams Distributor \_\_\_\_\_

## Check into PACE® SMT Training for the 90's!



PACE, Inc. provides the most comprehensive "hands-on" training in **SMT Assembly and Repair**. Safe, effective component removal and replacement techniques are taught using a variety of manual and benchtop systems. We also offer custom and on-site training upon request.



- IMPROVE PRODUCTIVITY
- REDUCE SCRAP
- RETAIN SKILLED EMPLOYEES
- HIGH RETURN ON INVESTMENT

For a free listing of available courses reply today.  
Tel: (301) 490-9860 Fax: 301 498 3252

Name \_\_\_\_\_ Title \_\_\_\_\_  
Company \_\_\_\_\_ Telephone \_\_\_\_\_  
Address \_\_\_\_\_  
City \_\_\_\_\_ State \_\_\_\_\_ Zip \_\_\_\_\_

PACE, Inc. 9893 Brewers Court Laurel, MD 20723-1990

YES! Send me my Free Catalog.

Name (Please Print or Type) \_\_\_\_\_  
 Title / Mail Stop \_\_\_\_\_  
 Company \_\_\_\_\_  
 Address \_\_\_\_\_  
 City \_\_\_\_\_ State \_\_\_\_\_  
 Zip \_\_\_\_\_ Phone \_\_\_\_\_

- Job Function (Check only one):**
- 01 Corporate/Gen. Mgr./Owner
  - 02 Purchasing
  - 03 Field Service
  - 04 Depot/In-house Service
  - 05 Plant Maintenance
  - 06 Manufacturing/Production
  - 07 Data Processing/MIS
  - 08 Network Mgr./Tech.
  - 09 Electrician
  - 10 Installer
  - 11 Engineer/Technician
  - 12 R & D
  - 13 Educator
  - 14 Student/Hobbyist
  - 15 Other

Place Stamp Here

**JENSEN TOOLS INC.**  
 DEPT 82  
 7815 S 46th STREET  
 PHOENIX AZ 85044-5399

**Use  
 ES&T  
 Postcards  
 For  
 Quick  
 Response.**



NO POSTAGE  
NECESSARY  
IF MAILED  
IN THE  
UNITED STATES



Howard W. Sams & Company  
 2647 Waterfront Parkway, East Drive  
 Indianapolis, IN 46209-1418

ATT'N: Customer Service Department



NO POSTAGE  
NECESSARY  
IF MAILED  
IN THE  
UNITED STATES

**BUSINESS REPLY MAIL**  
 FIRST CLASS MAIL PERMIT No. 4395 LAUREL, MD

POSTAGE WILL BE PAID BY ADDRESSEE

**PAGE**  
**INCORPORATED**

*Systems for Development, Production and Repair of Electronic Assemblies*

9893 BREWERS COURT  
 LAUREL MD 20723-9982



**ES&T  
 Postcards  
 An Easy  
 Way to Get  
 Immediate  
 Action.**

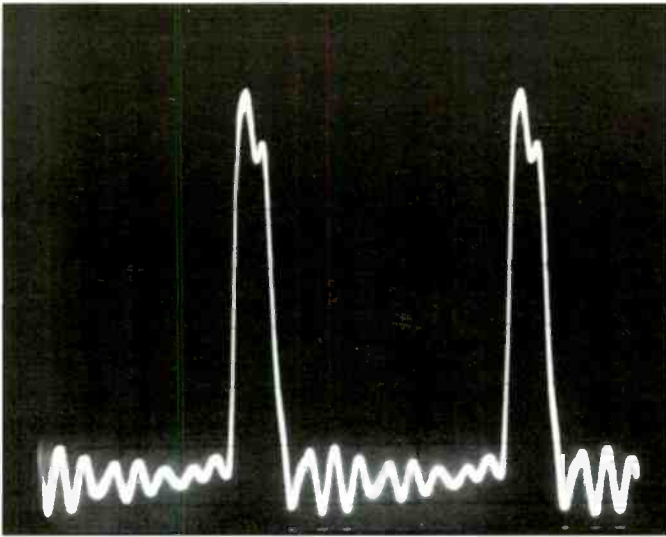

**Figure 3.** The waveform observed when the oscilloscope probe is placed near the flyback.

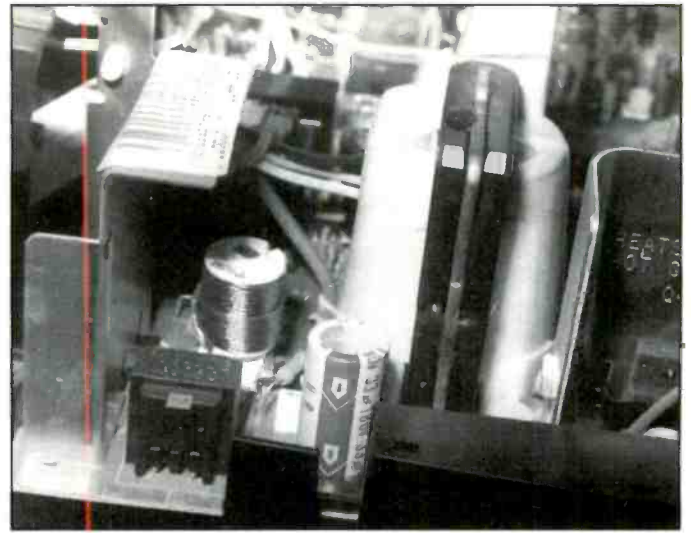

**Figure 4.** The horizontal output transistor (Q4401) is mounted on a separate "hot" heat sink in this 1993 RCA chassis.

circuits that derive their supply voltages from additional windings on the secondary of the flyback. These scan-derived voltage sources produce supply voltages for other circuits in the TV chassis.

In TV sets that feature scan-derived sources, after the transformer starts up, the derived voltage is fed to the horizontal oscillator or countdown circuits.

Although the introduction of scan-derived voltage supplies solved many problems for manufacturers (for example, elimination of the power transformer) it introduces additional complexity for service centers. To cope with this complexity, different service techniques were tried and mastered to repair the present-day horizontal output circuits.

Defective safety capacitors are another cause of failure in the horizontal transistor output circuits: they may cause excessive high voltage arcover and HV shutdown. A shorted or leaky safety or hold-down capacitor may blow the B+ and ac line fuses (Figure 2). An arcing deflection yoke or internal shorted windings may inhibit horizontal sweep.

### Checking horizontal circuits

The horizontal output circuits can be quickly checked using scope waveforms, and voltage, diode, resistance and signal injection tests. A quick waveform test, performed by placing the scope probe next to the flyback, will indicate if horizontal sweep is present (Figure 3). A check of the voltage on the B+ fuse or isolation resistor to the primary winding of the horizontal output transformer will

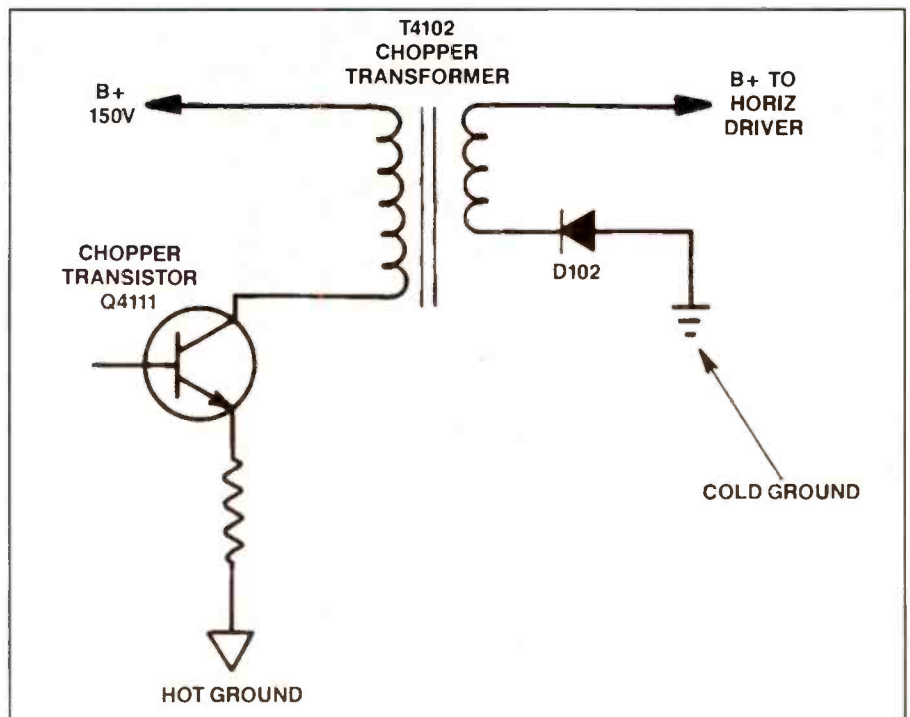

**Figure 5.** The primary of transformer T4012 contains the hot ground in a low voltage chopper circuit, while the secondary winding is tied to cold ground.

determine if the collector supply voltage is correct.

Voltage and diode tests upon the collector (body) of the horizontal output transistor may indicate a leaky, open, or overloaded transistor. Of course, some of these statements may be a little fuzzy at this point. I will explain it later in this article.

A semiconductor junction test from the collector terminal to chassis ground may indicate a leaky transistor or damper diode. A low resistance measurement, with reversed test leads, may indicate a leaky transistor or diode. In some cases,

the output transistor may be open and you are only measuring the resistance of the damper diode.

An open horizontal output transistor can cause the technician fits and produce a few gray hairs, since it's usually located behind a metal heat sink or chassis. Then too, the secondary winding of the driver transformer returns the base terminal to chassis ground, producing test problems.

### Horizontal waveform tests

Oscilloscope tests are the most accu-

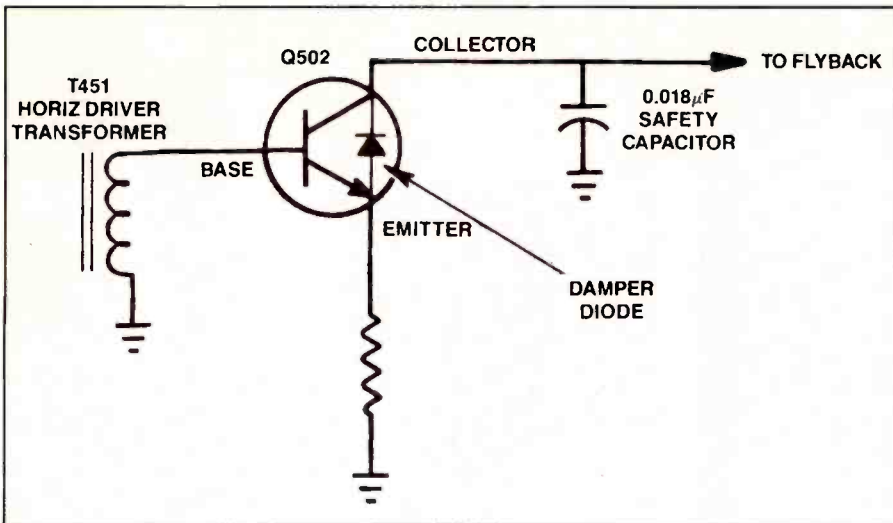

**Figure 6.** Look for the damper diode inside the case along with the HOT in the latest TV chassis.

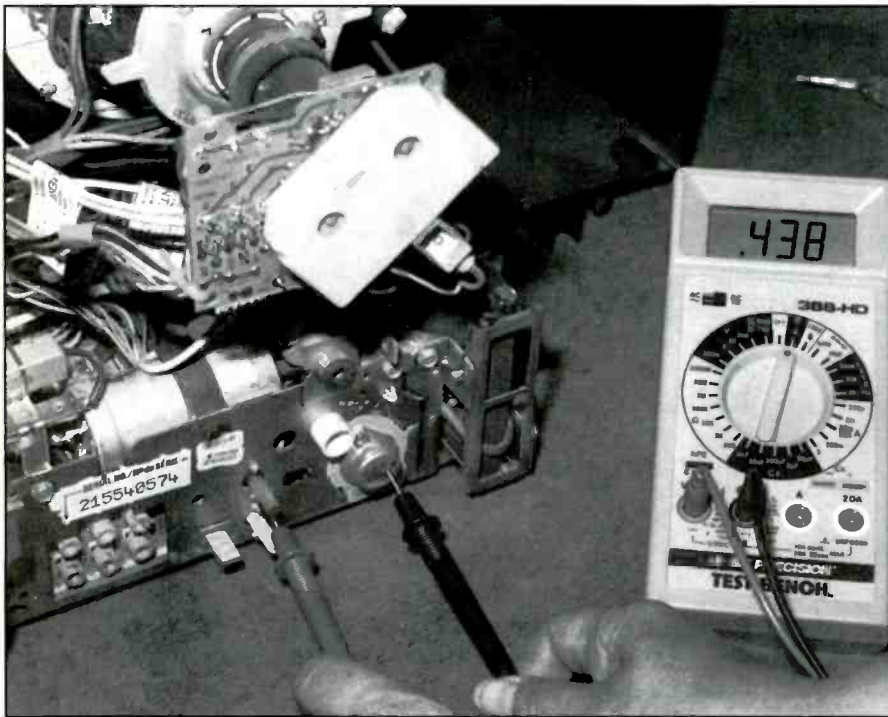

**Figure 7.** Check the resistance of the output transistor and damper diode for leakage to chassis ground.

rate and least damaging to your test instruments. A quick waveform check made by placing the scope probe next to the flyback may indicate a correct or improper horizontal sweep. Low waveform amplitude, or absence of a waveform may be caused by a defective flyback, insufficient drive voltage, a leaky output transistor, or an abnormal low-voltage supply source.

Next, a horizontal sweep test at the horizontal oscillator or countdown IC circuit, drive transistor, and the base of the horizontal output transistor, may turn up a

defective component. Measure the voltage at the collector terminal of the HOT only if you observe no sweep waveform at the flyback. I will explain later.

#### Signal injection tests

If the set is totally inoperative, determine if the chassis is shut down because of a defective horizontal component, or if shutdown was due to excessive high voltage. High voltage shutdown can be determined with a variable isolation ac transformer. Connect the set to the transformer and gradually increase the ac voltage. If

the set operates at reduced voltage, but then fails as you increase the ac voltage toward 120Vac, most likely the problem is high-voltage shutdown.

If this test confirms chassis shutdown, inject a signal from a waveform generator at the base of the horizontal output transistor. If this injected signal results in horizontal sweep, check voltages and waveform at the driver transistor, oscillator or countdown IC. Voltage measurements within the drive circuits may uncover the defective component.

If injection of a signal at the base of the HOT doesn't produce horizontal sweep, suspect improper voltages, a defective output transistor, or a defective flyback. Overloaded circuits in the secondary derived output transformer windings may prevent horizontal sweep. If the yoke assembly is defective, it may be loading down the output circuits. In order to determine if this is the case, disconnect the red yoke lead and see if sweep occurs. If so, the yoke assembly is the problem.

#### Hot chassis—cold chassis

Many of the new TV sets have separate "hot" chassis and "cold" chassis. The "hot" chassis is necessary in sets that employ a full-wave bridge rectifier. The common point of the bridge output cannot be connected to ground, or some components would be shorted out and destroyed. The hot chassis may include the horizontal output transistor (Figure 4).

In some sets, the output of the bridge rectifier is applied to, or part of, a switched mode power supply (SMPS) or a variable interval pulse regulator (VIPUR) power supply. The heat sink of the horizontal output transistor, chopper, SMPS and VIPUR transistors may operate upon a hot heat sink, away from the regular PCB chassis. The regular PCB or metal chassis may be referred to as the cold chassis.

If you take a voltage measurement from a horizontal output transistor mounted on a hot chassis with respect to chassis ground, it will not be accurate or the same voltage on the schematic. All voltage measurements made on components mounted on the hot chassis should use the heat sink as the negative or ground terminal. The hot ground symbol is a standard ground outline. All components on the hot chassis are returned to it (Figure 5). Use the hot heat sink as the common

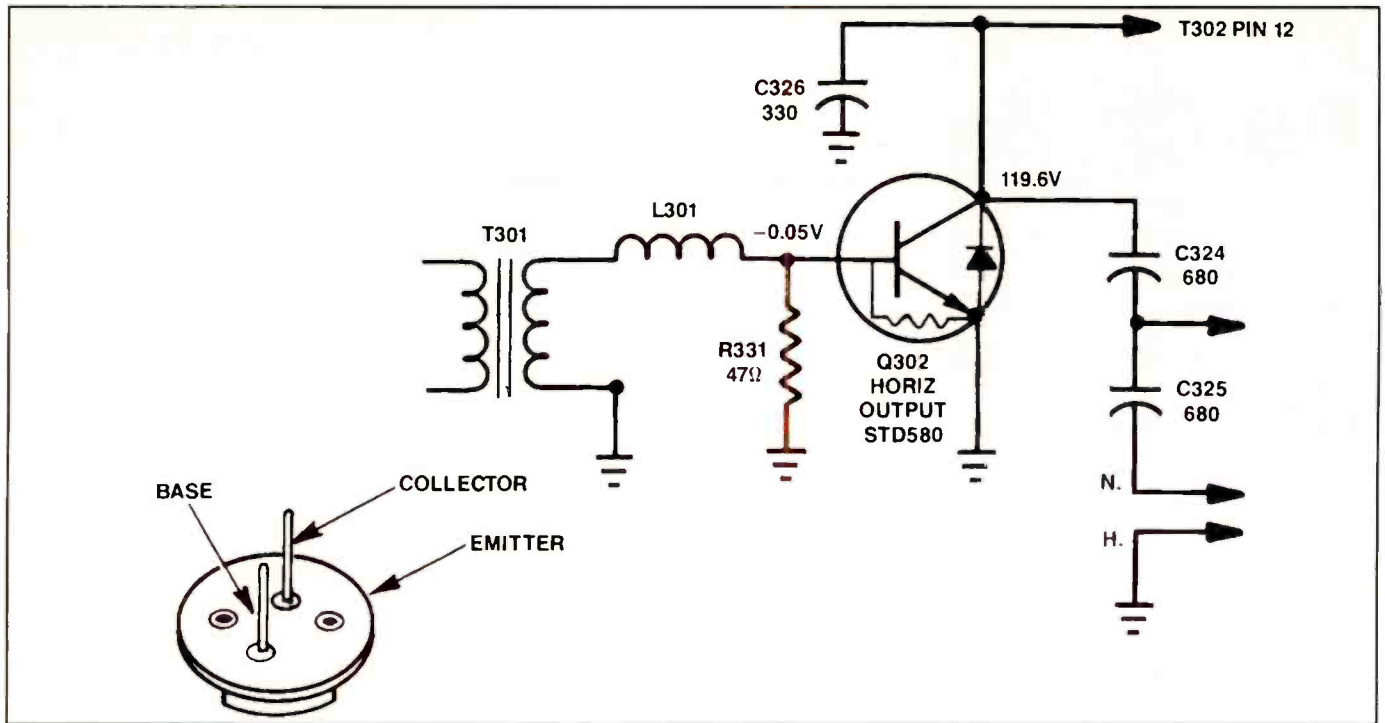

Figure 8. The STD580 output transistor found in the horizontal circuits of a Sanyo 91C550A portable with correct base connections.

hot ground when taking voltage and resistance measurements.

#### Different horizontal output transistors

In the earliest solid-state TV sets, the damper diode was connected to the collector terminal of the HOT, next to the safety capacitor. Later, the damper diode was mounted within the same case with output transistor.

If you suspect a leaky horizontal output transistor, take diode and resistance tests at its terminals. Examine the schematic diagram to determine if the damper diode is inside the output transistor case, before making tests or replacing the HOT. Simply check the transistor number within the semiconductor replacement manual to determine if the damper diode is inside (Figure 6). In some TV chassis, you may see a flat plastic horizontal output transistor mounted upon the large heat sink.

#### STD580 horizontal output transistor

In several of my books and magazine articles, I have stated that you should connect the meter probe to the case (metal body) of the horizontal output transistor to check for a short or leaky transistor to chassis ground.

A fellow technician from Maryland wrote that this statement was misleading;

that the HOT case is not always connected internally to the HOT collector. He referred to several Sears and Sanyo TV chassis that he had serviced, in which the metal case of the horizontal output transistor was the emitter terminal instead of the collector terminal.

This was news to me. I have never seen a HOT connected in that manner in all my years of servicing TV sets, so I checked with local and Sears TV service techs. They had never seen one either. Most had not heard of such a thing. The collector terminal was always insulated from the heat sink and the metal body was definitely the collector terminal. Since I was born in Missouri, he had to show me, and after several years, he did.

Michael B. Danish of Mike's Repair Service of Aberdeen Proving Grounds, MD, tried to get information on the STD580 output transistor. He contacted Sears, Sanyo and Sanken without any results. As you know, Sanyo manufactures several TV chassis for Sears. The STD580 transistor was manufactured by Sanken. Of course, this output transistor is not listed in any semiconductor replacement manuals.

After about four years of trying to get the required information on the STD580 transistor, he hit paydirt courtesy of Sams Photofact. He received a photocopy of a Sanyo model 91C55UA schematic with

pinout information. Q302, a STD580 horizontal output transistor shows the emitter terminal as the metal body and the two terminal pins are collector and base terminals (Figure 8).

I tip my hat to Michael Danish for his persistence and determination in the matter of the metal emitter terminal. From now on, I shall write that the resistance test from the collector terminal of the horizontal output transistor to chassis ground will indicate a leaky transistor or damper diode. I will no longer assume that the metal case is the collector terminal.

#### Voltage test of the horizontal output transistor

Most TV manufacturers and Sams Photofacts warn against measuring the voltage on the collector terminal of the horizontal output transistor. The high signal voltages can quickly damage almost any meter.

In fact, we had a DMM that was damaged when accidentally touched to the collector terminal or any place near the flyback and yoke circuits. The fuse would blow and parts within the tester were destroyed. This turned out to be costly each time it was sent in for repair. That meter is now collecting dust upon a shelf.

In the past year, I have heard from several beginning technicians, and even a few more experienced technicians, who

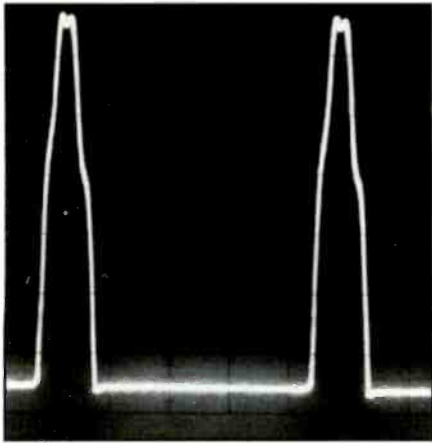

**Figure 9.** Use the oscilloscope to observe the horizontal output waveform at the collector terminal of the HOT.

service articles and books, I have used the Beckman Tech 310 DMM and safely measured the horizontal output transistor collector terminal. That meter is still working fine. But not every DMM will take this measurement without damage. Play it safe; take a scope waveform.

If observations using an oscilloscope show that there is no waveform on the horizontal output transistor, measure the collector voltage with a DMM. A low voltage measurement may indicate a leaky output transistor or damper, improper drive voltage, or overloaded horizontal circuits. Higher than normal voltage may indicate an open output transistor, or emitter resistor, if there is an emitter resistor in the circuit. In the horizontal output circuits in some imported sets, a small resistor is found in the emitter circuit.

And never use a meter to measure the high voltage at the anode terminal of the picture tube either. You will receive a nasty shock, and the meter will be damaged beyond repair. Always use a high voltage probe meter to measure the picture tube anode voltage, preferably one that measures up to 40KVdc. A high voltage probe connected to a VTVM does a

fine job. Be sure to connect the meter ground cable to the TV chassis.

### Quasar TP2020DW portable TV horizontal tests

A Quasar TV set was brought into the shop. The symptoms were no raster, no picture, no sound. Both the line fuses (F001) and B+ fuse (F002) were open. Since both fuses were blown, I suspected a defective low-voltage regulator circuit or horizontal output transistor. A quick leakage test from collector terminal to common ground ( $0.13\Omega$ ) indicated a leaky horizontal output transistor or damper diode (Figure 10).

I removed the output transistor and tested it out of circuit. This test confirmed that it was leaky. This transistor was a flat plastic three-leg part mounted on a heat sink ahead of the flyback. I replaced the leaky output transistor with an ECG2302 replacement.

I connected the DMM as monitor at TP91 (the same point electrically as pin 14 of the low-voltage regulator source). This 131V source supplies collector voltage for the horizontal output transistor (Q551) and driver transistor (Q501).

have experienced meter damage by taking voltage measurements upon the metal body of the horizontal output transistor.

Do not take any voltage measurements upon the collector output terminal if the output circuits are functioning. Instead, use an oscilloscope to observe waveforms at this terminal (Figure 9).

In preparing material for many of my

## ORGANIZE AND PROTECT YOUR COPIES OF **ES&T**

Now there's an easy way to organized and keep copies of your favorite magazine readily available for future reference.

These custom-made titled cases and binders are ideal to protect your valuable copies from damage.

They're designed to hold a year's issues (may vary with issue sizes), constructed with reinforced board and covered with durable leather like material in red, title is hot-stamped in gold, cases are V-notched for easy access, binders have special spring mechanism to hold individual rods which easily snap in.

**Electronic Servicing & Technology**  
Jesse Jones Industries, Dept. EST  
499 East Erie Avenue, Philadelphia, PA 19134

Enclosed is \$ \_\_\_\_\_ for \_\_\_\_\_ Cases;  
\_\_\_\_\_ Binders. Add \$1 per case/binder for postage & handling.  
Outside USA \$2.50 per case/binder (US funds only).

PA Residents add 7% sales tax.

Print Name \_\_\_\_\_  
Address \_\_\_\_\_ No P.O. Box Numbers Please  
City/State/Zip \_\_\_\_\_

CHARGE ORDERS: (Minimum \$15): AMEX, VISA, MC, DC accepted.  
Send card name, #, Exp. date.

**Call TOLL FREE 7 days, 24 hours 1-800-825-6690**

## Portable Computer Monitor Tester



Checker I (photo)- Color patterns for CGA, EGA, & VGA monitors. Battery or AC operation.....\$229.95  
Checker II- 720X350 graphics pattern (cross hatch) for mono monitors, battery operated.....\$99.95

**Special, Both Checker I & II.....\$299.95**

NEW!..Checker VI- Stand alone color pattern generator for up to SIX VGA monitors, 604X480 mode. It displays 64 color boxes(8x8), that shift every 3 minutes to reduce the chance of pattern burn.....\$349.95

For additional information Call: 1(800)466-4411  
Computer & Monitor Maint. Inc.

Circle (3) on Reply Card



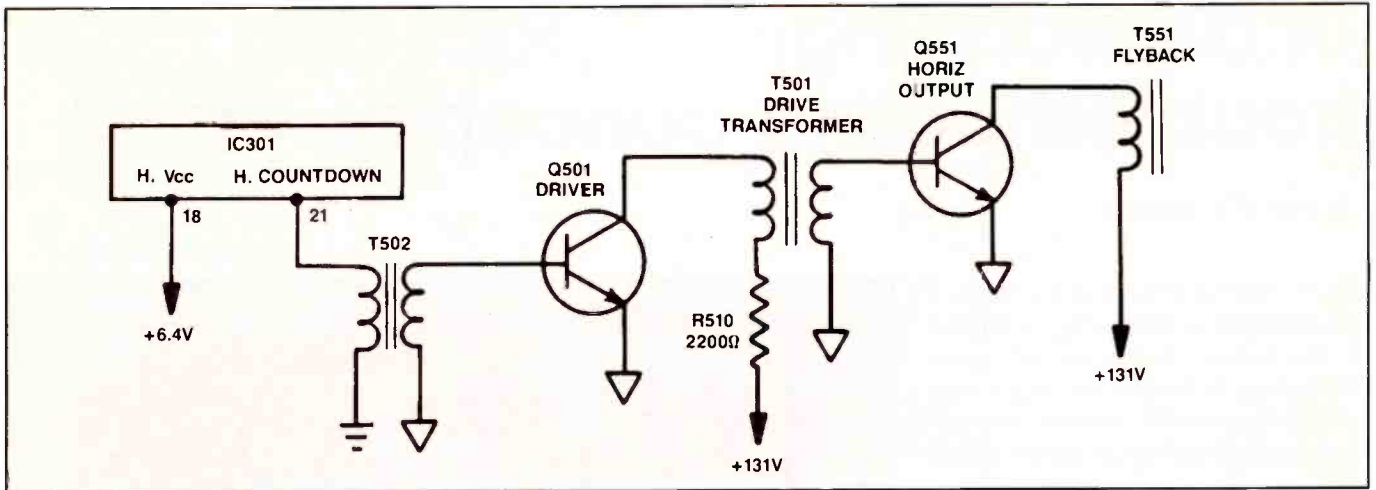

Figure 10. Horizontal circuits of the Quasar TP2020DW TV chassis.

### Some further tests

After replacing Q551 and both fuses, I slowly raised the variable isolation transformer voltage to about 65Vac. The voltage at the regulator was extremely low, and the horizontal output transistor was getting warm. I connected the oscilloscope probe to the collector terminal of the driver transistor and pin 21 of countdown IC, IC301. There was no signal at that point. I turned off the set and disconnected the ac plug then turned to the TV schematic diagram for further study.

At first I suspected that IC301 was open or leaky. But other possible causes of this symptom occurred to me. The voltage applied to IC301 might not be correct. Or a component connected to the countdown IC terminals might be defective, loading it down.

Examination of the schematic indicated that the voltage source for IC301 (terminal 18) was supplied by a dc source

originating from a transformer other than the flyback. I was in luck. If this voltage was supplied from the flyback, troubleshooting would have required more time.

### Checking the supply voltage

To prevent damage to the new output transistor during further troubleshooting, I removed fuse F002, supplying voltage to regulator IC801 and Q551. I could have removed horizontal output Q551, but this was a lot easier and faster. Slowly I raised the line voltage and checked IC301 supply source at pin 18. The voltage remained at zero, even when the line voltage reached 100Vac. Either IC301 was leaky or the supply voltage, specified at 6.4Vdc, was incorrect.

I decided to check the supply voltage circuits. Using Sams Photofacts grid trace location guide I located the vicinity of regulator diode D507. After pulling back a few wires I saw that the 6V regulator

showed signs of having been overheated. Replacing the overheated R503 and the leaky D507 restored the 6.4V source (Figure 11).

I replaced the fuse and slowly increased the output voltage of the isolation transformer. Sound and raster returned. I was lucky that the low-voltage regulator had not been damaged as well.

If I had jumped to the conclusion that IC301 was defective when I was evaluating the possible causes of the symptoms, I would have done a lot of desoldering and soldering on IC301 for nothing.

### Servicing means proper procedures and constant learning

With this article I have tried to show how to make quick and correct tests in servicing the horizontal output circuits. I also wanted to point out that we can learn from other technicians. Constant learning can help keep one on the right track. ■

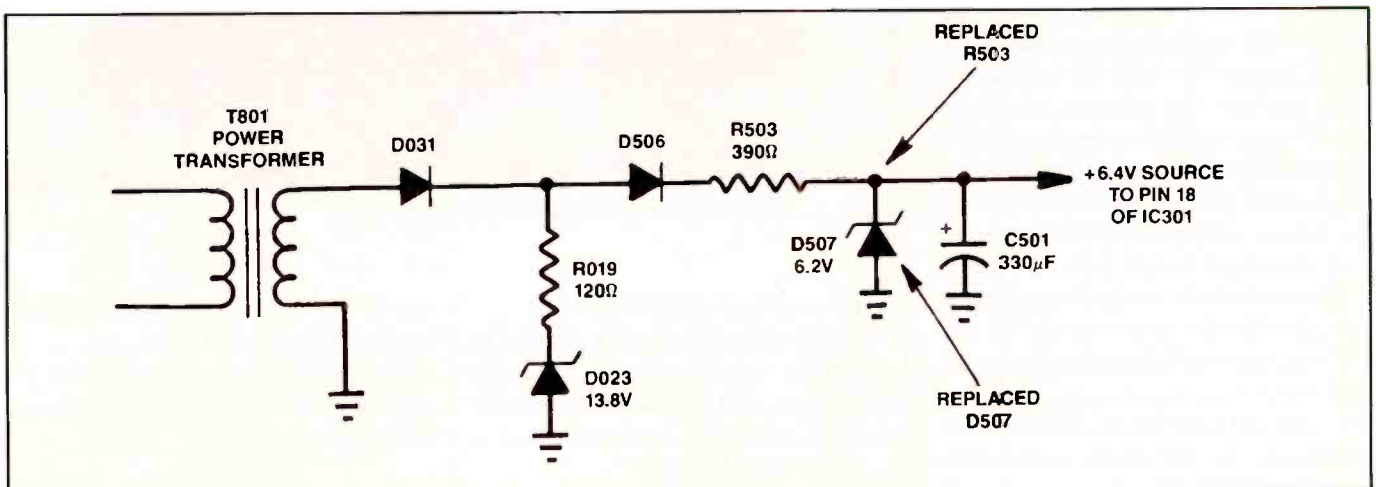

Figure 11. D507 was leaky and R503 was burned in this power supply. Consequent absence of dc source voltage (6.4V) to IC301 caused the no raster-no sound symptom.

# Understanding compact disc troubleshooting concepts—Part 2

By Marcel R. Rialland

As considered in Part 1 of this series, it is important to understand how a product works before attempting any troubleshooting. In this part, the single-beam servo system will be examined and common troubleshooting techniques will be applied to both the single-beam and three-beam systems.

In many respects the single-beam and three-beam systems are quite similar. But there are some important differences which should be considered. The major difference is in each mechanism's tracking system. The difference is discernible in looking at the CD mechanism itself.

Actually, the single-beam system's CD Mechanism (Figure 1) is simpler. Rather than using a sled assembly to track the disc, the single-beam system uses a radial swing arm, which pivots on a single axis to radially follow the spiral tracks.

## The single-beam servo system

In order to understand the single-beam servo system we need to examine the optical pick-up unit more closely (Figure 2). Just as with the three-beam system, a single laser diode is used to emit a laser beam. The single laser beam is directed to the disc by the half mirror and the collimator lens and is focused via the objective lens.

This single beam must be controlled to read, focus, and track the disc's spiral tracks. The spinning disc modulates the single beam as it is reflected back into the objective lens. The reflected, modulated beam is directed back to the photodiodes. In order to detect focus and radial errors the beam is split to strike two areas of the photodiode array as illustrated in the photodiode array physical layout of Figure 3.

The photodiode array contains up to five photodiodes as illustrated. The output from each photodiode is totaled as the HF signal ( $I_{HF}=I_{D1}+I_{D2}+I_{D3}+I_{D4}+I_G$ ). Tracking and focus errors are detected by calculating the differences in the photo-

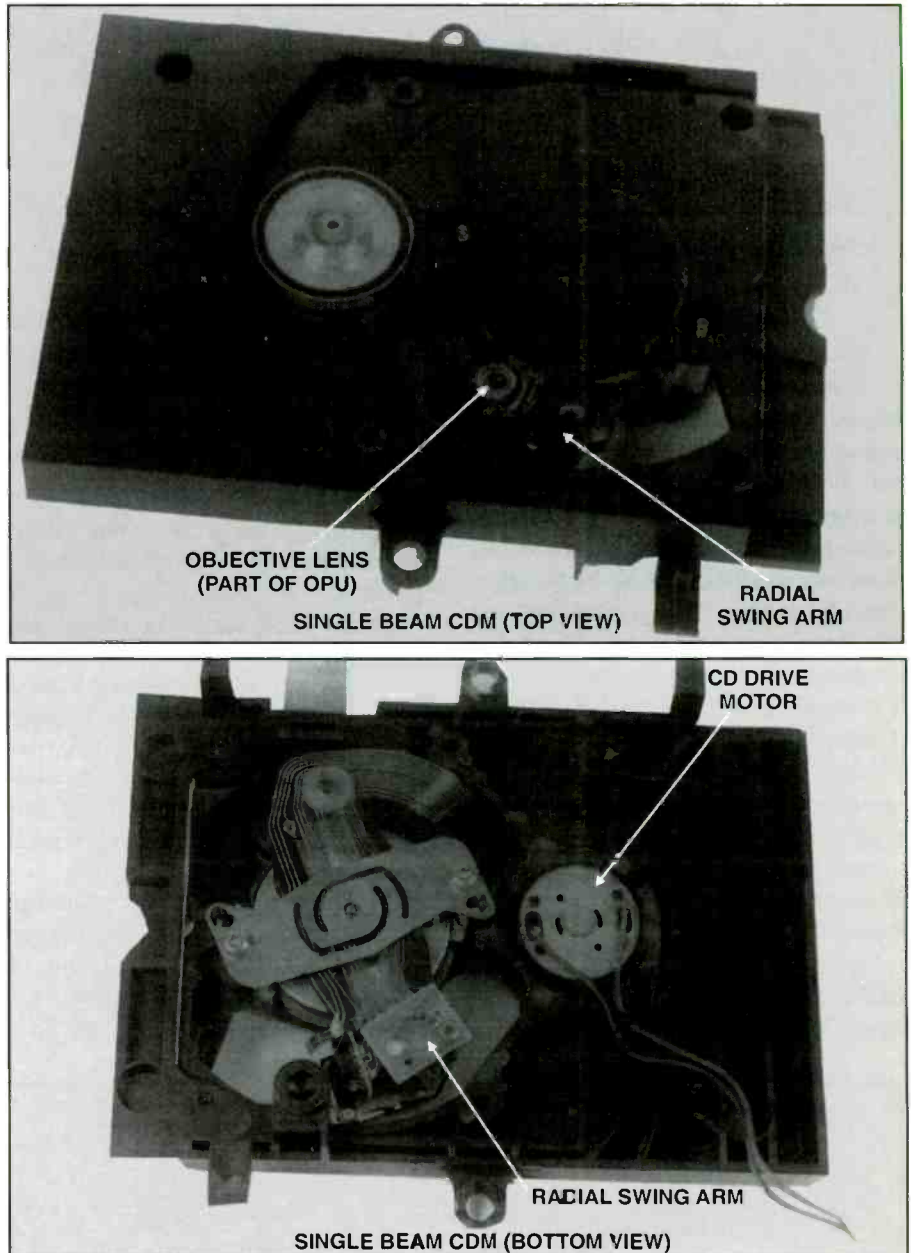

Figure 1. View of single-beam CDM (top and bottom views).

diode low frequency (LF) currents.

Radial (tracking) errors are detected by calculating the difference between the total current of  $D_1+D_2$  with the total current of  $D_3+D_4$ , which can be expressed as  $I_{RE}=(I_{D1}+I_{D2})-(I_{D3}+I_{D4})$ .

Focus errors are detected by calculating the difference between the total cur-

rent of  $D_1+D_4$  with the total current of  $D_2+D_3$ , or  $I_{FE}=(I_{D1}+I_{D4})-(I_{D2}+I_{D3})$ .

These signals are processed by the servo circuits to provide control of the CD mechanism.

## Start-up

In most players, each time a CD is

Rialland is a Senior Training Specialist with Toshiba America.

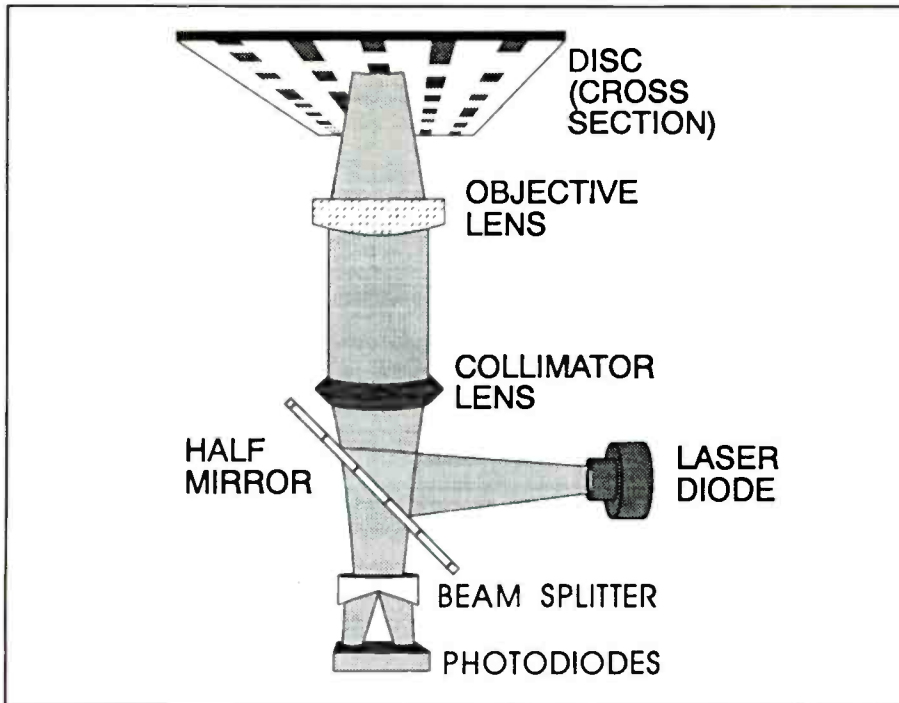

Figure 2. Single-beam OPU.

Certain player conditions must be met before start-up can be initiated by the decoder microcomputer. When a CD mechanism is removed from the cabinet to allow troubleshooting, these conditions are at times difficult to accommodate. For example, some players have tray switches to signal the microcomputer that the tray is closed. This switch must be closed before you attempt start-up troubleshooting.

In the stop condition, SI/RD (IC6501, pin 6) is low. Start-up is initiated when the photodiode signal processor (IC6501) receives a start initiate signal (high) from the decoder microcomputer (IC6530) via pin 6. The start capacitor (C2513) begins to charge as indicated by the start-up signals. At that time pin 17 (low) supplies about 3V to the laser driver circuit to turn the laser diode on.

The focus search is initiated by swinging the FE voltage between +1.2V and -1.2V. This causes the objective lens to move up and down to attempt focus servo lock. The focus search pattern occurs twice in this model. If focus is not found after the second focus attempt, the system assumes there is no disc present.

### Start-up problems

In troubleshooting start-up problems, the start-up signals can be checked during the start-up initiation. Using an oscilloscope, with the input set to dc, allows the start-up initiation voltages to be observed.

For example, if the objective lens does

placed in the player, a start-up sequence is initiated to read the table of contents from the CD. In this way, the player detects not only the presence of a CD, but it also determines the type of disc present and decodes information pertaining to that disc. Some of that information is decoded and displayed on the CD player's display.

Some of the data is also used by the microprocessor to control access to the tracks on the disc. The information allows

the user to program the tracks to be played. When the play key is pressed, the start-up sequence must again be initiated.

Figure 4 shows a typical single beam laser/focus start-up circuit. Although this is the start-up circuit for a single-beam system, the principles can be applied to the three-beam system. Also there are variations in the start-up circuits between different single-beam models. Check the service manual for the model being serviced when checking the start-up circuit.

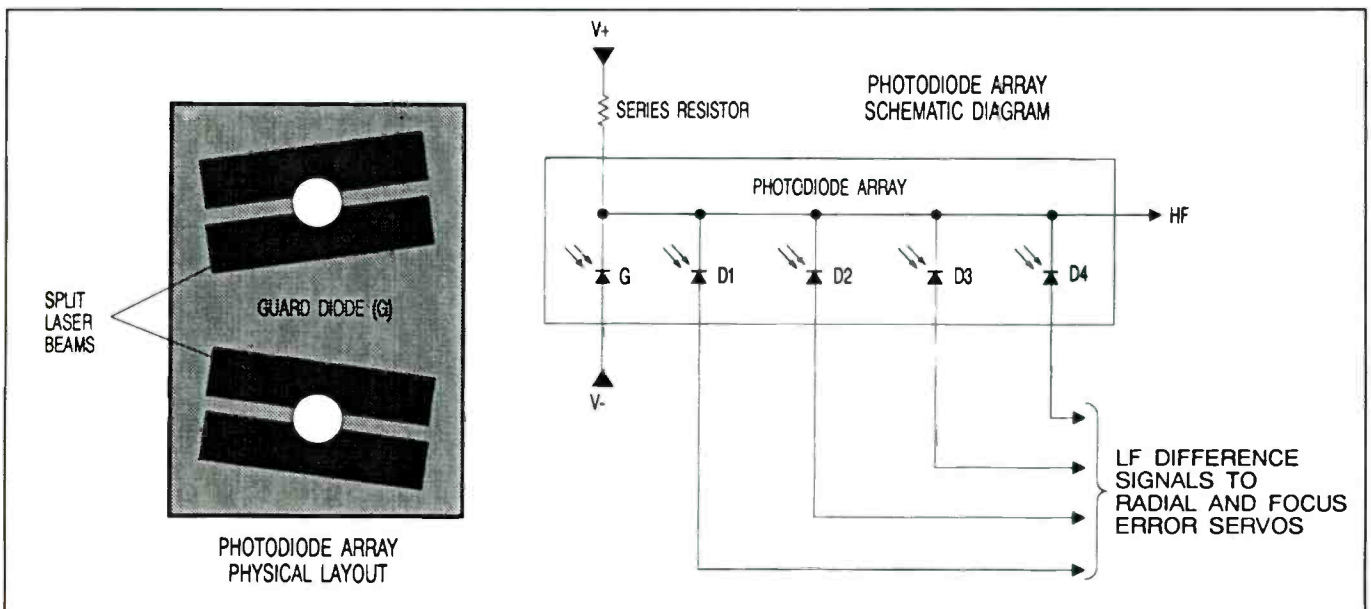

Figure 3. Photodiode array.

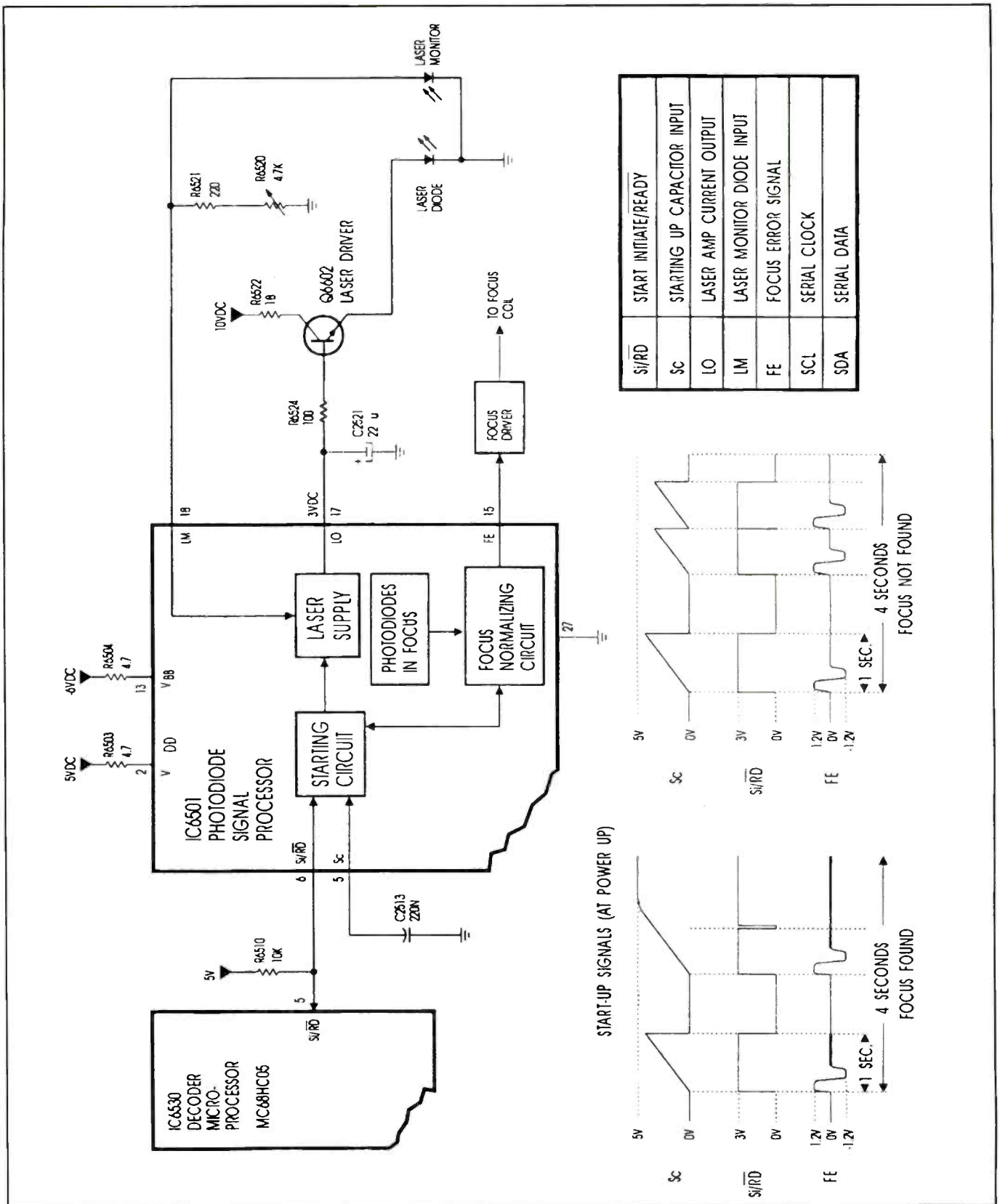

Figure 4. Focus/laser start-up circuit.

not move up and down during start-up, check the FE signal at pin 15. If the signal is present, check the output from the focus driver. If the signal is present at the output of the focus driver, check the flex

cable connection from the circuit board to the CD mechanism. If all the connections are good (don't forget to check the ground return), the optical pick-up unit is most likely defective.

### Single-beam servo

The single-beam servo system block diagram is shown in Figure 5. The decoder microprocessor controls the functions of the servo system, including start-

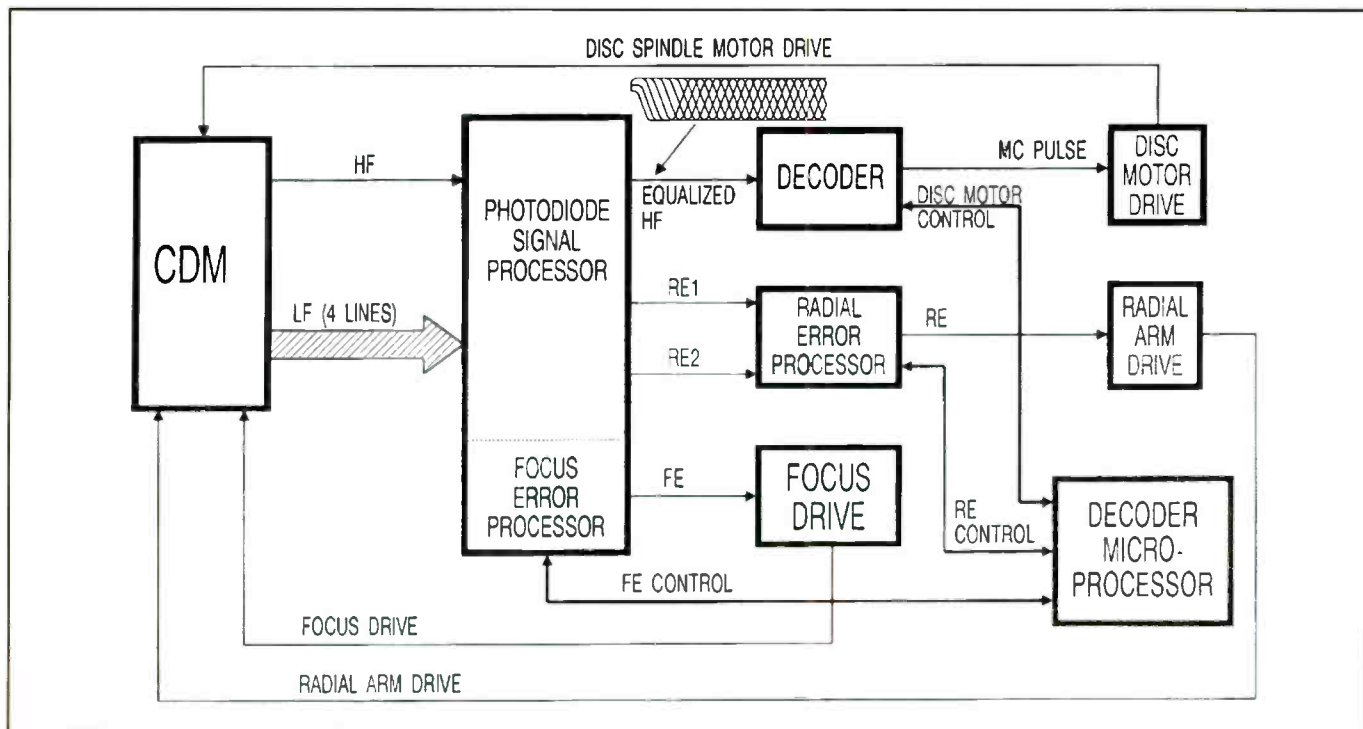

Figure 5. Single-beam servo block diagram.

up. As is the case in the three-beam system, the decoder microprocessor must also control tracking during some operations, such as during track loss and search forward and reverse.

There are three main servo loops in the single beam system: (1) the focus error (FE) servo, (2) the disc motor control (MC) servo, and (3) the radial error (RE) servo. Each of the servo circuits must lock in during the start-up procedure in order for a disc to play.

First the laser diode must come on. Next, the laser beam must be focused onto the CD, which also indicates the presence of a disc. Then the disc motor spins the disc and the radial arm pivots to locate the lead-in track in order to read the CD's table of contents (TOC). The TOC contains information about the disc: the type of disc (CD-DA, CD-ROM, or CDI), total number of tracks, total time, and the CD's catalog number.

After the TOC is read, most CD audio players display the user information, such as the total tracks and total time, on the front display. Therefore, the display is a good place to start looking for clues when troubleshooting.

For example, if disc information is never displayed, there may be a problem in the start-up. If there is a disc error during start-up, monitor the equalized HF signal (eye pattern) output from the pho-

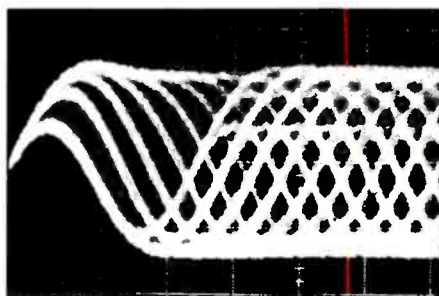

Figure 6. Equalized HF (eye pattern).

todiod signal processor during the start-up procedure. The clarity of the eye pattern can give a clue as to where the problem may be located.

Of course, if the HF signal is never present, the problem may be in the start-up initiation. For example, the laser may not even be coming on. The service mode can reveal if this is the case. Moreover, a laser power meter can show if the laser diode is indeed coming on.

#### Focus error servo

Although the objective lens and the focus drive circuit of each system (single-beam and three-beam) are similar, the focus servo of the single beam is quite different from the focus servo of the three-beam system. The four low-frequency signals from the CDM are processed by the photodiode signal processor to develop the focus error signal.

Internally, the LF signals are applied to adders and comparators to find the focus error (FE is actually a focus error correction signal to keep the laser focused). Generally, there is a focus drive circuit that applies the focus correction drive signal to the focus coils on the optical pick-up unit.

Most CD players require some adjustments (such as focus offset and laser current) in the focus servo loop for optimum performance. If the focus offset adjustment is too far off, the disc may have trouble tracking and may even stop playing due to error occurrences during the decoding process. Observing the eye pattern of the HF signal can help in determining if there is a problem in the optical pick-up system. The eye pattern should be fairly clear as shown in Figure 6.

#### Disc motor control loop

The method of controlling the disc rotational speed is similar to the three-beam system's method. The disc motor control servo loop controls the rotational speed of the disc motor. As shown by the block diagram, the HF is amplified and equalized by the photodiode signal processor. This equalized HF signal, which is observable as the eye pattern at the output of the photodiode signal processor, is applied to the decoder block.

The decoder is usually an LSI IC which

performs several functions for decoding the incoming data (e.g., data slicer, demodulator, EFM decoder, interleaver corrector and descrambler, and interpolator). In the decoding process, the bit clock of 4.3218Mb/sec must be regenerated.

At the same time the incoming data flow must be regulated so that the data does not come in too fast or too slow. The regulation is provided by means of the pulse width modulated motor control (MC) pulse, which is used to control the rotational speed of the disc spindle motor via the disc motor drive block (integrator circuit).

Starting and stopping the disc motor is controlled by the decoder microprocessor via the SSM line. If the decoder does not receive the control information from the decoder microprocessor, the disc spindle motor may not start; or, the opposite may occur. The spindle may start but not stop when a stop is initiated.

### Radial servo loop

Just as in the three-beam servo system, a radial servo loop is necessary to provide proper tracking of the disc in the single-beam system. As shown by the block diagram (Figure 5), the radial error correction signal is primarily developed in the radial error processor.

The radial error (RE) correction signal is developed from RE<sub>1</sub> and RE<sub>2</sub>. RE<sub>1</sub> and RE<sub>2</sub> are derived from the LF signals, which are processed in the photodiode signal processor. RE<sub>1</sub> is the sum of the currents from D<sub>1</sub> and D<sub>2</sub>, and RE<sub>2</sub> is the sum of the currents from D<sub>3</sub> and D<sub>4</sub>.

In addition to these signals, there is also a wobble signal of about 650Hz which is injected into the radial servo loop of the single beam system. This wobble signal is generally produced by an oscillator in the radial error processor. If this signal is not present the disc will not track properly (poor playability).

The wobble signal is introduced into the service loop to compensate for laser spot asymmetry errors (D-Factor) and to compensate for the tracking angle variations as the radial arm moves from the inner tracks to the outer tracks of the disc (K-factor).

(you may want to use the service mode to verify the condition of the servo system):

1. Does the laser diode come on? If not, check the laser current source.
2. Is the focus search initiated (the objective lens moves up and down)? If not, check the start-up initiation drive signals with an oscilloscope.
3. Is focus achieved?
4. Does the OPU move to search for the lead-in track?
5. Is the lead-in track found (table of contents track)?

If all these processes are working while in the service mode, the CD player's servos should all be locked. The eye pattern (HF signal) should be available to the decoder circuits. Verify this. There may be a problem in the decoder section.

If, for example, the decoder's subcode processor was not functional, the display may show an error and the disc would go into the stop mode, which may appear to be a no start-up condition. But the problem may be due to a decoder fault.

### Diagnosing poor playability symptom

First, let's define poor playability. Poor playability can be poor tracking, poor tracking on only some discs, difficulty in start-up, easy loss of track due to jarring.

What can cause poor playability? Don't overlook the obvious: a dirty objective lens reduces the optical system's efficiency and can even prevent start-up. A little alcohol on the end of a cotton swab can be used to clean the objective lens. However, do not apply too much pressure in cleaning the lens.

If the lens is clean, make sure there is nothing obstructing the mechanical tracking mechanism (both in the three-beam sled system and the single beam radial swing arm). If it is a single beam system, make sure the wobble signal is present.

Do not overlook the possibility that there may be more than one symptom. For example, I came across a CD player (single beam) which displayed two symptoms: the radial arm swung all the way to the outer perimeter and the objective lens was pulled to its lower extremity. I traced the problem to an open resistor from the power supply to a quad op-amp, which was common to both the focus drive circuit and the radial drive circuit.

Part 3 will deal with the decoder part of a CD system.

### Troubleshooting summation

As with any consumer electronics product, it's a matter of isolating the symptom to a particular circuit. Then, with a few more checks, the problem can be traced to a few components. These components can then be checked or substituted to verify which component is indeed defective.

Knowing the operating requirements of the CD player is essential to diagnose a symptom properly. It's a matter of determining the path to follow. For example, if power is applied to the CD player and the display doesn't illuminate and no other activity is observed, the power supply is the most likely place to start.

If, however, the display does illuminate and other activity is observed, the power supply can most likely be ruled out. But even in this case, a problem may still be traced back to the power supply.

Let's apply this troubleshooting technique to both the three-beam and single-beam servo systems. The symptom is: "the disc will not play."

First, look for the start-up condition

**W** Wholesale Electronics, Inc.  
 ORIGINAL PARTS:  
 HITACHI PIONEER  
 GE RCA ZENITH

MasterCard VISA

FAX: 605-996-4300 ORDER: 800-351-2233

Circle (22) on Reply Card

**ISCET**  
**VCR**  
**Cross Reference**  
 VCR Model Number Cross Reference  
 and VCR Parts Cross Reference

**4th Edition.**  
 Contains both model- and parts-number cross-references for more than 1300 additional parts, and more than 50 brand names. **\$36.00**  
 shipping 3.00

**One 3 1/2" disc, or**  
 **Two 5 1/4" 360K discs.**  
 Version 5.0, for IBM PC AT/XT or compatibles. Requires hard drive and DOS 2.1 or greater. **\$69.95**  
 shipping 3.00

**Special Combo Offer.**  
 Your choice of discs, plus 4th Edition VCR Cross Reference. **\$95.00**  
 shipping 3.00

Allow 4-6 weeks delivery when using personal checks. VISA, MasterCard, money orders and cashiers checks processed immediately.

Amount \_\_\_\_\_  Visa  MasterCard  
 Card No. \_\_\_\_\_ Exp. \_\_\_\_\_  
 Name \_\_\_\_\_  
 Business \_\_\_\_\_  
 Address \_\_\_\_\_  
 City \_\_\_\_\_ State \_\_\_\_\_ Zip \_\_\_\_\_  
 Phone \_\_\_\_\_ Member:  NESDA  ISCET

Texas residents multiply dollar amount by 7-3/4% for taxes.  
 Foreign shipments please add international postage.  
 Send to: ISCET, 2708 West Berry St., Ft. Worth TX 76109

# Test equipment probes—Part 2

By Vaughn Martin

The first installment of this series of articles on test equipment probes began with an elaborate justification of why use a probe by asking “why not just use a regular unshielded wire?” Now let’s see how the type and design of a probe can affect the measurements.

## How probe design affects your measurements

Probes are available in a large variety of sizes, shapes and functions, but they do share several main features: a probe head, coaxial cable and either a compensation box or a termination.

The probe head contains the signal-sensing circuitry. This circuitry may be passive (such as a  $9M\Omega$  resistor shunted by an 11pF capacitor in a passive voltage probe or a 125-turn transformer secondary in a current probe); or active (such as a source follower or Hall generator) in a current probe or active voltage probe.

The coaxial cable couples the probe head output to the termination. Cable

types vary with probe types. The termination has two functions:

- To terminate the cable in its characteristic impedance.
- To match the input impedance of the scope to which it is connected.

The termination may be passive or active circuitry. For easy connection to various test points, many probes feature interchangeable tips and ground leads.

## The types of probes available

What is the most meaningful way to classify the wide variety of probes? The first and simplest way is by purpose: is a particular probe’s purpose to sense voltage or current? Figure 1 is a list of probe types. Figure 2 provides a breakdown of a probe’s integral parts.

## Voltage-sensing probes

The two main types of voltage-sensing probes, active and passive, differ in their internal circuitry and mode of operation. Passive voltage-sensing probes are built with passive circuit components: resistors, capacitors and inductors.

Their main advantages are:

- Ruggedness
- Relatively low cost
- Wide dynamic range (therefore less liable to electrical damage)
- Simplicity (which makes them easy to use and calibrate)
- Fast risetime

The main limitation of passive voltage-sensing probes is that they present lower input impedance as the input signal frequency increases. Adding attenuation to the probe increases the impedance, but it reduces the displayed signal level. Passive voltage-sensing probes may be further classified by their attenuation:

- 1X (no attenuation)
- 10X (10 to 1) probe-input-to-probe-output attenuation working with the resistance of the scope
- 100X (100 to 1 attenuation)
- 1000X (1000 to 1 attenuation)

Attenuation is neither good nor bad in itself. For example, high attenuation probes are very useful for measuring

Martin is Chief Engineer in the Automatic Test system Division at Kelly Air Force Base.

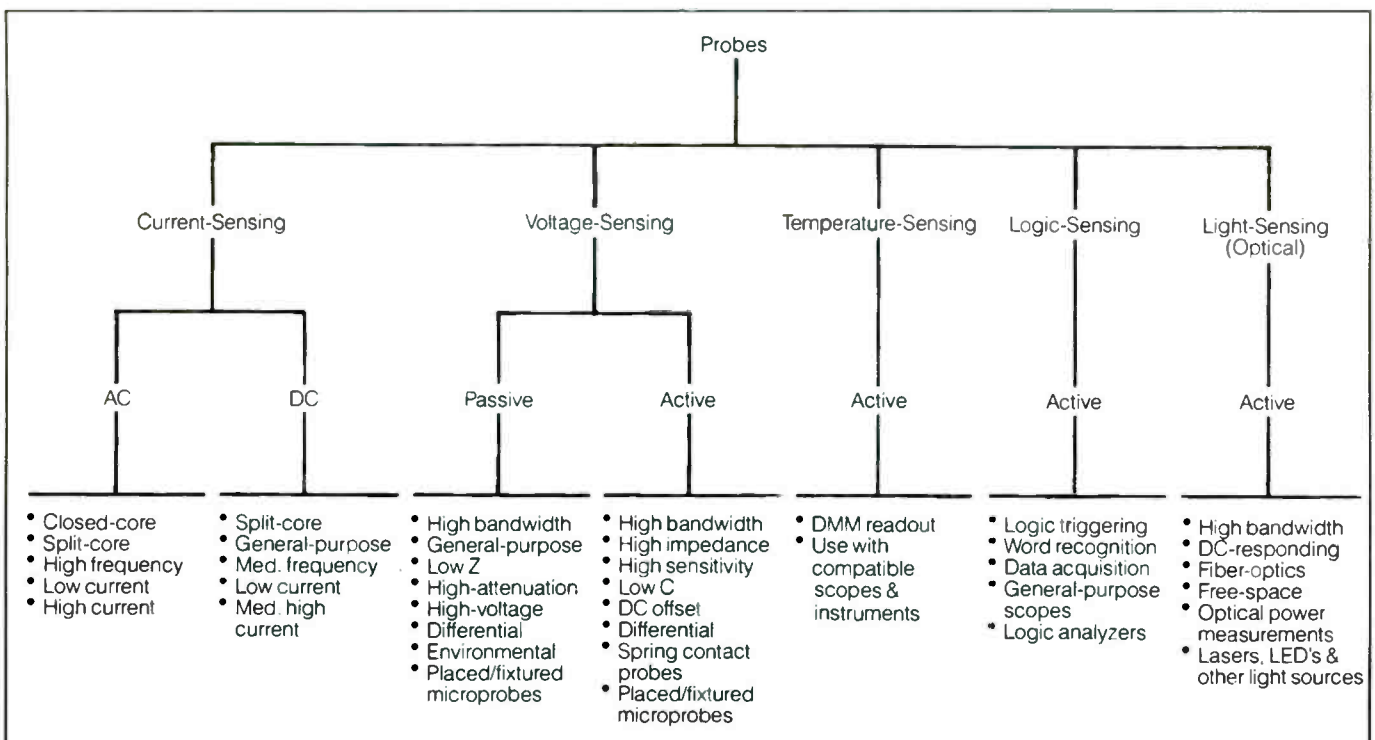
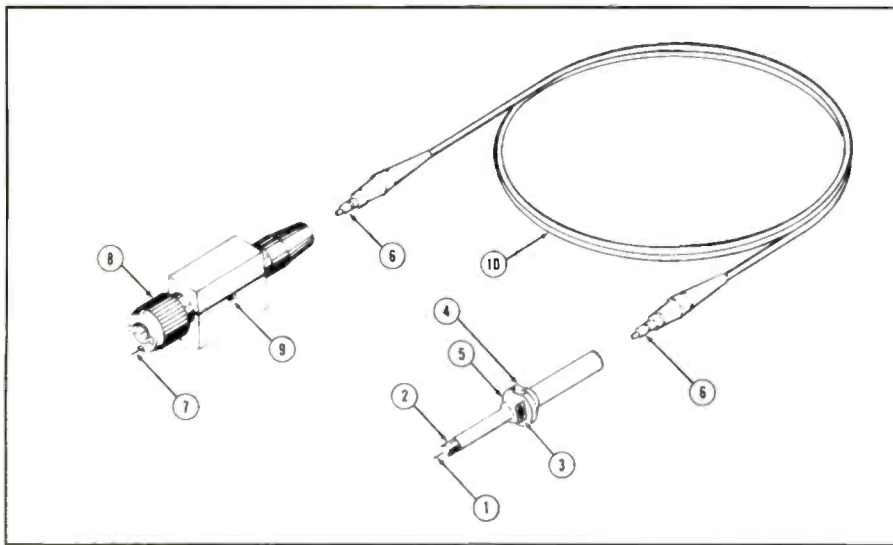

Figure 1. Manufacturers offer a dazzling array of test probe types for every imaginable application.



**Figure 2.** Anatomy of a typical probe: 1. A low-inductance tip to reduce ringing, 2. the grounding ring, 3. a covered ground lead connection point, 4. A ground reference button, found on some probes, 5. The finger guard to keep fingers away from the DUT, 6. An interconnection system part, 7. The coding for either a 1X or 10X probe, used with scopes that have either a vertical scale factor readout or knob-skirt readout, 8. The BNC housing, 9. the compensating box, 10. the cable itself, designed for low capacitance.

high-voltage signals while protecting your scope's input circuits. However, a high attenuation probe may attenuate a low voltage signal so much that you can't measure it (Figure 3).

Low Z passive probes are specially designed for measuring very high frequency signals. The benefits of Low Z probes (also called "low capacitance" probes) include: consistent and predictable loading through a wide range of frequencies.

Probe impedance is matched to the 50Ω input of high-bandwidth scopes, thus enabling probe designers to use a transmission-line approach in the design of the probe termination and cable. This design cancels the effects of cable capacitance and allows you to use longer cables at bandwidths up to 3.5GHz.

### Probes for making differential measurements

Signals which are not referenced to ground, such as the voltage drop across a collector load resistor or the gate drive signal in a three-phase switching power supply, require differential measurement techniques to extract the signal in the presence of unwanted information. Refer to Figures 4 and 5 for an illustrated explanation of passive and active differential probes. Figure 5a is an FET differential active probe.

This unwanted information may be the power supply voltage (elevated signal) or

line frequency signals associated with switching power supplies. Differential amplifiers measure only the difference signals between two points and reject the unwanted common mode signal (a signal or dc voltage common to both test points).

In order to preserve the high common mode rejection ratio (CMRR) of scope differential amplifiers, it is necessary to use one of the following methods: direct connections, specially designed differential probe pairs or differential probes (probes that provide differential processing in the probe itself).

Direct connections load the DUT, so probes used in pairs, are matched in length (for equal transit-time), loading and attenuation. (Attenuation is adjustable over about a  $\pm 1\%$  range to ensure maximum CMRR). A differential probe (one probe with two inputs) provides maximum CMRR at high frequencies.

In general, differential measurements should be made without using the probe ground leads on signal connections (probe pairs). The ground leads should be clipped to each other or removed altogether to avoid accidental contact with elevated circuitry.

### Specialty probes

A special category of passive voltage-sensing probes are high-voltage probes, which handle signals up to 40kV. Another type of passive voltage-sensing probe is the environmental probe, which operates

over a very wide temperature range. Logic probes sense logic states. Temperature probes are used to measure the temperature of components such as solid-state devices and other heat-generating items.

### Surface mount device interconnects

A rapidly growing area in electronic circuit boards (ECB) is the incorporation of surface mount technology (SMT). Increased circuit density, increased product reliability, and lower assembly costs are among the many benefits of this new technological trend. Troubleshooting and device interconnection, however, have become more difficult due to decreased device size, tighter lead spacing, and increased ECB densities.

Specially designed interconnects will complement and enhance the usefulness of your probe and enable you to access signals in high-density areas.

For example, the SMT grabber clip is an interface device for attachment of logic and analog probes to today's SMDs, DIPs, and discrete components with maximum lead diameters of 0.095" and stackable on lead centers 0.050" (50 mils). Dual sided 0.025" lead contacts allow this grabber to be used in multiple signal insertion/acquisition.

Figure 5b illustrates a handy probe for getting at small closely spaced IC pins on a computer board. This probe has an inline row of DIP rocker switches, allowing the "hard" wiring of a logic low or high while it is grabbing the pins of the IC. This can serve as a trigger qualifier for use with a logic analyzer, a test instrument which may be thought of as a scope with many channels.

Active voltage measuring probes employ active elements in the probe body and termination box to acquire and process signals from the circuit under test. They may be hand-held or used with circuit-board-to-probe-tip adapters for best waveform fidelity, or they may be specially fixtured.

Spring contact probes are designed for bed-of-nails mounting and high-speed testing of boards at the component level. These are true active probes, and represent state-of-the-art in miniaturization and performance. Smaller versions allow mounting on 50 mil (1.27mm) centers.

Figures 5c through 5e show various





ZES 7235

\$215 ea.

**3M Field Service Vac.**

**A clean sweep for field engineers.**

◁ This powerful, durable, highly-reliable vac sweeps out copier toner and has countless other cleaning applications, including printers and floors. It's completely self-contained and static safe. Includes a heavy-duty case, self-storing vacuum hose, crevice and tubular nozzles, replaceable filter and dusting brush/adaptor.



**FREE  
overnight delivery**



ZES 7704

\$109 ea.

**Heavy-Duty Luggage Cart. A lightweight Δ contender for heavy-duty jobs.**

At only 14 pounds, the 770 can easily transport samples, tool kits, test equipment, office equipment or any other heavy or bulky items...up to 300 pounds! Its chrome-plated steel construction, heavy-duty wheels and double-width, telescoping aluminum extruded handles also make it one of the most durable carts around. Assembled.



ZES 7075

\$215 ea.

**Deluxe Modular Plug Kit. Helping you Δ make all the right connections.**

The perfect shop or field kit for repairing or installing RJ-type modular plugs. The set features an AMP termination tool for cutting, stripping and crimping. Includes a four-, six- and eight-position die set (RJ11), an eight-position (RJ-45) die set and 25 each of four-, six- and eight-position genuine AMP plugs.

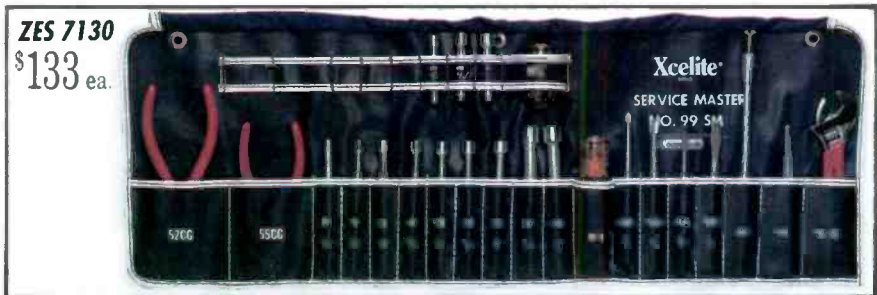

ZES 7130

\$133 ea.

**The Service Master Kit. Δ**

**Twenty-four pieces. One great buy.**

For some basic service functions, a complete tool kit's just not practical or economical. That's when our Service Master tool set makes so much sense. It includes regular and stubby handles, nine regular and three stubby nut-drivers (1/16"-1/2"), two slotted and two phillips screw-drivers, a reamer, an extension, a long-nose plier, a diagonal cutter and 6" adjustable wrench in a canvas case.

**The DXB-65 Dual Function Cable Tester.**

**It passes the test for versatility.**

◁ This is one of our most requested testers. Or should we say "two". While it checks and evaluates the condition of the 10BASE-T UTP cable, it can also independently test any BNC-terminated coaxial cable. Shorted or miswired cable pairs show in red; if okay, in green. Includes two RJ45K jacks (1-2-3-6 pairs) and two BNC female connectors.



ZES 7492

\$79 ea.

# ORDER FORM

Company \_\_\_\_\_

Buyer \_\_\_\_\_ Phone (    ) \_\_\_\_\_

Street Address \_\_\_\_\_

City \_\_\_\_\_ State \_\_\_\_\_ Zip \_\_\_\_\_

QUANTITY	STOCK NO.	DESCRIPTION	PRICE EA.	TOTAL

**ALL ORDERS  
REQUIRE  
TELEPHONE NUMBERS!**

Shipping Charges	\$00.00
(TX: 8.25%, CA: 7.75%, VA: 4.5%) Sales Tax	
<b>Total</b>	

**Call toll free 1-800-866-5353**

**METHOD OF PAYMENT:**

**CREDIT CARD**

- VISA
- MASTERCARD

**OTHER:**

- CASH IN ADVANCE
- COMPANY P.O. (PLEASE FAX OR ATTACH)

CARD NUMBER

-

EXPIRATION DATE

\_\_\_\_\_ AUTHORIZED SIGNATURE \_\_\_\_\_ DATE

**PRODUCT GUARANTEE**

At Specialized Products Company, we stand behind everything we sell. If, for any reason, you are not completely happy with your purchase, simply return it to us within 30 days and we will exchange it or refund your money--no exceptions!

**24 hour fax 1-800-234-8286**

ZES 1230 \$199 ea.  
Complete Tool Kit

ZES 2034 \$36 ea.  
Tool Case Only



△ "Mini" Workstation Repair Kit. Proof that great things come in small packages.

Who said big has to be better? In our Mini 1230 Kit, you'll find all the tools you need to perform basic repair at the workstation level: Screwdrivers, nutdrivers, hex tools, Torx® drivers, soldering iron, knife, tie wraps, pliers/cutters, wire stripper, pocket flashlight and jeweler's screwdriver. Beyond the basics,

we've made provisions for two RS-232 gender changers, a key cap puller and screen prep pads for cleaning. Our tough Cordura® case has exterior pockets for extra storage. The Mini 1230. Our smallest kit ever. Includes pen-type digital multimeter! (Case also sold without tools.)

**Our Kit for Voice & Data Site Managers.**

**The perfect solution to network interference.**

◁ The ultimate installation and repair kit for twisted-pair applications! Every tool you'll need to install wiring, connectorize cable and perform basic troubleshooting is right here... in one neat package... on two removable pallets.

You'll find essentials like screwdrivers, nutdrivers, pliers/cutters, soldering/desoldering equipment, cable cutters, an adjustable wrench, Torx® drivers, wire strappers, ball hex drivers and a receptacle analyzer. We complete the set with a wide variety of specialty tools like "RS-Type" adapters, gender changers, a punch-down tool, a tone tracer, inductive amplifier, DB to RJ connectors, test cables, universal cables, a crimper/stripper and more.

Best of all, we pack them in an attractive Roto-Classic textured case for strength and durability. (Case also sold without tools.)

© 1993 SPECIALIZED PRODUCTS COMPANY

**Comprehensive LAN Kits.**

**Network installation or repair, all the tools for your trade.**

A total installation and repair solution for network supervisors or LAN managers. We offer two versions to accommodate both twisted pair and coax (Ethernet) environments. Both kits start with the 2069 double-sided Cordura® zipper case. One side features two pallets for tools and adapters. The other side has a full briefcase filing insert and a modular pallet for topology-specific tools.

Into this extraordinary case, we've packed a full complement of tools—everything you need to install premise wiring, connectorize cables, repair boards and perform basic troubleshooting. You'll find screwdrivers, pliers/cutters, a soldering iron, adjustable wrench, wire stripper, wire cutter, wiring scissors, Torx® drivers, toner/tracer, modular jack tester, conductive wrist strap and a huge selection of adapters. Each kit also offers additional specialty tools. The Ethernet (coax) version also has a crimp tool, an ethernet die set, special strippers and an assortment of R658 and R659 connectors. The Twisted-Pair version adds in a crimp/strip tool, cable stripper, punch-down tool and an assortment of modular plugs. ▽

ZES 1410 \$675 ea.

Complete Tool Kit  
(Twisted-Pair Version)

ZES 1405 \$699 ea.

Complete Tool Kit  
(Ethernet (Coax) Version)

by Fax 1-800-234-8286

ZES 2069 \$139 ea.  
Tool Case Only



# Tomorrow, your tools are delivered. And we'll cover the shipping.

ZES 5168 \$1995 ea.  
Spectris 68

ZES 5165 \$1479 ea.  
Spectris 65



△  
**Spectris LAN Cable and  
Activity Testers.  
No two units are better  
qualified to qualify cable.**

The 65 and 68 are high-quality, hand-held instruments designed to test, certify and report cabling conditions—ensuring cost-effective, reliable LAN installation and operation.

They both feature RJ45 and BNC network connectors. NEXT and attenuation capabilities. TDR functions (1% accuracy to 2000'), wire mapping, noise measurements and LAN monitoring. Spectris 65 provides full qualification on UTP and coax cables, measures to 10 MHz and stores up to 50 cable test results. Spectris 68 also certifies coax, UTP and STP cables, measures to 20 MHz and stores up to 500 test results.

Perfect for installing, expanding or troubleshooting, the testers include a full complement of accessories and come in convenient carrying cases.

**CALL TOLL FREE**

**1-800-866-5353**

**BY FAX 1-800-234-8286**

**The new Spectris 110 10BASE-T  
Wiring Fault Tester. One-button,  
one-person fault-finding.**

The Spectris 110 is an effective, easy-to-use instrument for testing and identifying faulty wiring in 10BASE-T cabling. The unit first runs all necessary tests automatically. Green LEDs indicate correctly-wired pairs. If faults are found, red LEDs display the pairs at fault and a single-digit LED identifies the type of fault: open, shorted, crossed, reversed or split pair. The 110 can also verify or identify up to 8 individual cables using numbered remote units. (#1 Remote Indicator is supplied with the unit; Nos. 2-8 are additional.)

▽  
**Additional Remote Indicators,  
#2-#4 (Set/3) \$115/set  
#2-#8 (Set/7) \$275/set**



ZES 5110 \$379 ea.  
Spectris 110



ZES 5163 \$549 ea.  
Spectris 63

**The Spectris 63 TDR, Cable Fault Locator.  
It does its best work when it's at fault.**

△ The Spectris 63 is a low-cost, hand-held unit that tests a variety of cables from coaxial and twisted pair to paired metallic cables like CATV, Telco and LAN. Depending on the cable type, the maximum testable length is 1,999 feet. It's perfect for measuring cable on a spool to prevent unnecessary splicing and wasted man hours.

With the Spectris 63, one button accesses a powerhouse of information. The distance to the fault or to the end of the cable is instantly displayed on a large LED panel. OPEN and SHORT indicators identify the fault type. A unique Sensitivity Control locates smaller faults normally invisible to fixed-sensitive TDRs. And a powered Cable Warning illuminates if there is power on the cable being tested.

Greater testing accuracy is available through a VOP input switch that actually matches the cable under test to the instrument.

**SPECIALIZED PRODUCTS COMPANY**



ZES 1475 \$555 ea.

Complete Tool Kit

ZES 2062 \$99 ea.

Tool Case Only

△ **The 1475 Special Service Kit. At last, a kit just for the datacom engineer.**

△ A tool kit designed to meet the specific needs of the data communications specialist, our 1475 consists of a durable double-sided Cordura® case filled with over 50 datacom

tools and accessories. You get all the basic adjusting and servicing tools, like screwdrivers, pliers/cutters, wire strippers, soldering/desoldering equipment, hex wrenches and nutdrivers.

We've also added wirewrap/unwrap tools, Torx® drivers, gender changers, a double connector RS-232 ribbon cable, a micro-patch adapter and a conductive wrist strap with a special ac plug-in ground that doubles as a receptacle analyzer. And of course, we've included a 66-type punch-down tool, a modular adapter plus a PEI tone tracer and line aid.

(The two-sided case, which features a full-size document pouch, is also sold without tools.)



**Place your order today. As dusk turns to night, your order takes flight.**



ZES 1570 \$725 ea.

Complete Tool Kit

ZES 2002 \$175 ea.

Tool Case Only

**FREE overnight delivery**



ZES 2085 \$119 ea.

Tool Case Only



**Call toll free 1-800-866-5353**

**ESD Computer Repair Kit. If you're concerned about total "ESD" protection.**

△ For completely safe ESD computer repairs, you need to make the 1225 your kit. Why? In addition to the nearly 40 essential tools (screwdrivers, nutdrivers, ignition-type wrenches, pliers, cutters and soldering tools), it also features special static-control equipment including an ESD wrist strap, work mat, ground cord and ESD ground receptacle adapter.

Our 2085 Cordura® case's two-sided design boasts a unique pair of interior compartments. One side holds the tools while the other features a special conductive accordion folio for safely carrying PCBs and other repair items. \*Fluke 77DNM is optional-add \$165.

ZES 1225 \$365\* ea.

Complete Tool Kit

# ORDER TODAY & YOUR TOOLS FLY FREE

ZES 1210 \$265 ea.  
Complete Tool Kit

ZES 2048 \$99 ea.  
Tool Case Only

FREE  
OVERNIGHT SHIPPING!

ZES 1500 \$420 ea.  
Complete Tool Kit

ZES 2015 \$125 ea.  
Tool Case Only



△  
**PC/Electronic Repair Kit.  
The CSR field kit with a split personality.**

We'd like to present our case for customer service reps who want to carry everything they need on-site in one kit. Two durable zippers create a unique configuration that allows tools to be stored on one side, documents, cards, clipboard, pens and calculator on the other. Features 45 tools and accessories, including screwdrivers, nutdrivers, hex keys, wrenches, pliers, cutters, soldering tools and more... all packed in a durable black Cordura® case. Additional paper work or tools can be stored in three roomy exterior pockets. (Zipper case also sold without tools.)

△  
**The 1500 Electronics Repair Tool Kit.  
A strong case for quality.**

Tough jobs require equally tough tool cases. Like our 1500. A heavy-duty kit, fit for the complete service or installation of sophisticated electronic equipment. Two removable pallets are filled to capacity with all the tools you'll need for computer field service, office or medical equipment repair and automated process maintenance. Screwdrivers, nutdrivers, pliers/cutters, hex tools, a crimp tool, wire strippers, soldering iron and ring pliers are only part of the selection we've included. You also get a complete socket set, knives, adjustable wrenches and alignment tools. And the durable polyethylene case is built to withstand even the most adverse conditions. (The case is also sold without tools.)

**SPECIALIZED**  
PRODUCTS  
COMPANY

Call toll free 1-800-866-5353 • by Fax 1-800-234-8286

## WHY COMPENSATE YOUR PROBE?

Compensation (or low-frequency compensation, or lf comp) is done to ensure flat frequency response of the probe (& accurate time response).

Here's why:

### MODEL OF 10X HIGH-Z PASSIVE PROBE

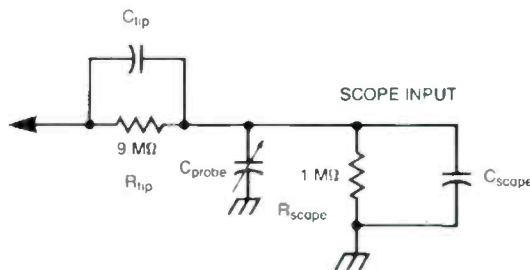

This is a frequency-compensated voltage divider when:

$$R_{tip} \times C_{tip} = R_{scope} \times (C_{scope} + C_{probe})$$

**Figure 3.** Test probes are compensated to ensure accurate signal reproduction at all frequencies of interest.

spring clip probes with different terminations. Note the long pin which slips over a 25 thousandths square post for a grounding point and on the inline connector the spacing is again a tight 50 thousandths to accommodate the newer small outline DIP packages in newer ICs.

Probe card types (microprobes) can be used for probing micro-electronic devices, hybrid circuits, surface-mounted packages, and integrated circuits at the wafer level.

Differential active probes are used for probing computer back planes and for accessing small signals in the presence of high-frequency common mode voltages. They provide a greater than 10:1 improvement in high-frequency common mode rejection compared to the best passive differential probe-pair systems.

The first active probes employed vacuum tubes as the active element, and were generally known as cathode follower (CF) probes. This type has long since been replaced by probes employing semiconductors and are used as source followers in active bipolar probes. Mostly, field effect transistors, or FETs, are used.

Active probes require a source of power for their operation which is either obtained from an external power supply, or from the scope itself.

### How to interpret probe specifications

This list of key parameters, and comments, will help you evaluate specs published by the probe manufacturer.

Some of the parameters discussed here may not show up on manufacturers' probe charts due to lack of space, but the information should be available and be part of the overall probe specifications. The following is a detailed glossary and further explanation of various terms associated with probes:

**Aberrations.** An aberration is a deviation from a theoretically correct response to an input signal. In practice, aberrations usually occur on the leading edge of a step function. Aberrations are measured as a  $\pm$  percentage deviation from the final level (flat top). Aberration specs sometimes specify time as well. Example "aberration specifications are +3% and 5% p-p within the first 30 nano-

seconds." Before assuming that aberrations are caused by a probe, consider scope aberrations, the probe grounding techniques used and the signal source (Figure 6).

**Amp-second product.** For current probes, this spec is a measure of the current transformer core's energy-handling capability. If the peak current times the pulse width exceeds the amp-second product rating, the core saturates and clips portions of the displayed signal.

**Attenuation.** A high-attenuation probe allows you to safely view large signals and minimize probe tip capacitance. However, a disadvantage of a high attenuation probe is that it may prevent you from measuring small signals.

**Bandwidth.** Most passive voltage probes are designed to provide a specified scope bandwidth at the probe tip. These probes will not degrade the upper 3dB bandwidth spec of the scope with which they are compatible. The risetime formula (square root of the sum of the squares) that usually applies to active probes does not apply to these passive voltage probes.

**Accuracy.** For voltage-sensing probes, accuracy generally refers to the scope's attenuation of a dc signal. The calculations and measurements of probe accuracy generally include the scope input resistance. An example specification is: 10X within 3% (scope input 1M $\Omega$  within 2%).

For current-sensing probes, this spec is actually the accuracy of the current-to-voltage conversion. The accuracy of the conversion depends on the current transformer turns-ratio and the value and accuracy of the terminating resistance.

Current probes that work with dedicated amplifiers read directly in amperes/division, and specify attenuator accuracy as a percentage of the current/division setting. This specification is similar to scope attenuator specs.

To make probe selection a little easier, simply choose a probe that has a bandwidth spec equal to or higher than the scope's bandwidth spec.

You can use a higher bandwidth probe on a lower bandwidth scope if the probe is otherwise compatible. Beyond bandwidth figures, the assumption is that the

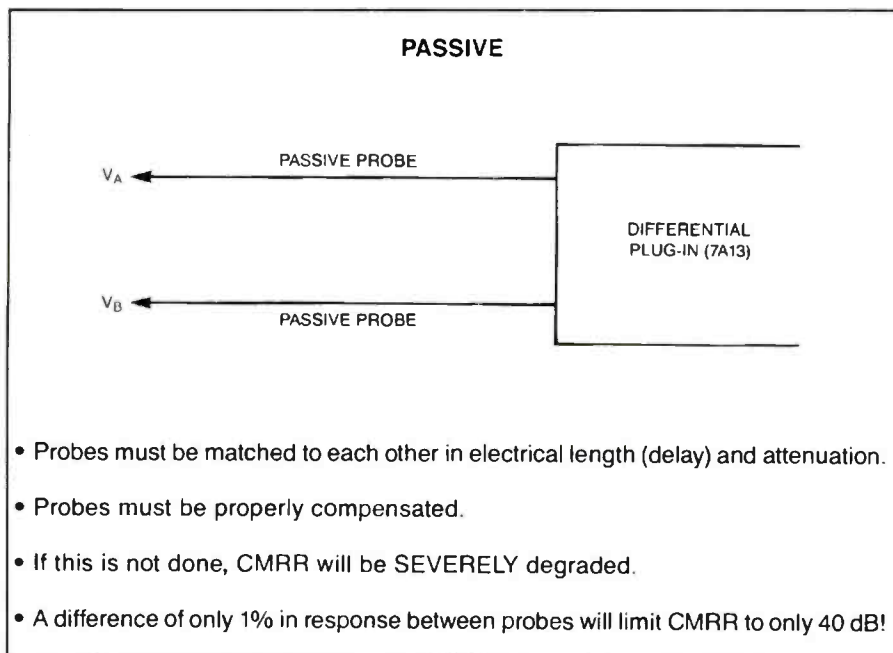

Figure 4. A passive differential probe.

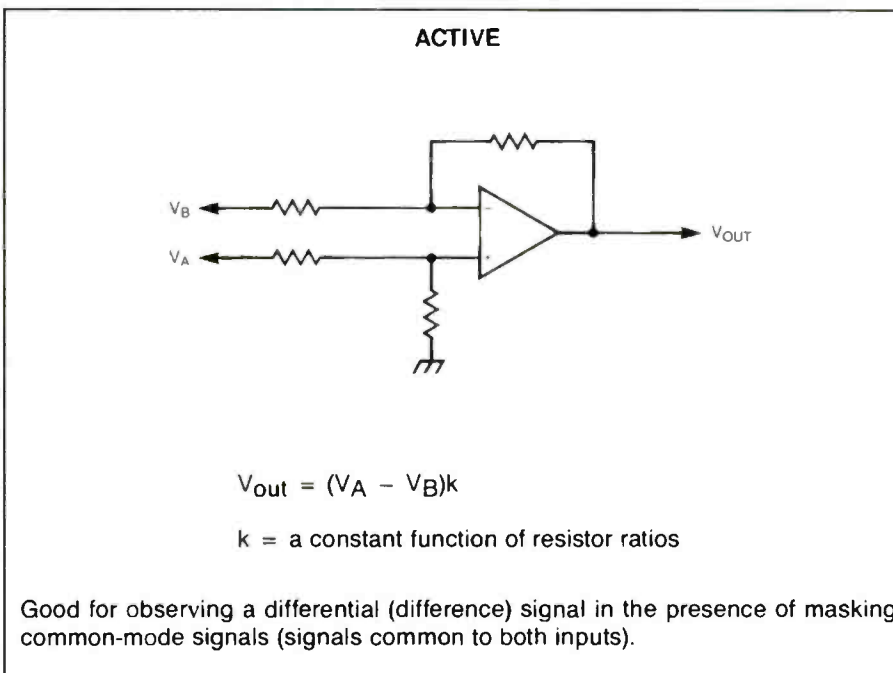

Figure 5. Block diagram of an active differential probe.

probe performs within all advertised specs, including maximum aberrations. Manufacturers not coupling bandwidth specs to realistic aberration specs may claim enhanced bandwidth without delivering total performance.

Do not use a lower bandwidth probe on a higher bandwidth scope unless the signals you are measuring are within the probe's frequency range. The lower of the two bandwidth specs determines the probe-system's upper frequency limit.

Passive 1X probes have an upper frequency limit between 4MHz and 34MHz, depending on their type and cable length. These limits control the probe-scope system's upper 3 dB point. Either 1X or 1X/10X switchable probes may be used with wide bandwidth scopes.

**Capacitive loading.** For voltage probes, probe capacitance is important because lower capacitance minimizes risetime errors. Probe capacitance affects

pulse amplitude measurements if pulse duration is less than five times longer than the probe RC time constant.

**CW frequency current derating.** Current probe specs include amplitude versus frequency derating curves that relate core saturation to increasing frequency. If the average direct current is zero amps, the waveform peaks progressively clip as the frequency rises or the amplitude increases.

**Decay time constant.** For current probes, the decay time constant indicates a probe's pulse-supporting capability. This time constant is the secondary inductance divided by the terminating resistance. The decay time constant is sometimes called the probe L/R ratio.

**Direct current.** For current probes, dc decreases permeability which in turn decreases the effective secondary inductance and L/R time constant. The high-frequency response usually doesn't change. As dc current flows through the probe, the operating point frequency rises and low frequencies are lost. Some current probes have current-bucking options that null the effects of dc.

**Insertion impedance.** For current probes, insertion impedance is the impedance reflected from the current transformer's secondary circuit. Typically, a current probe's reflected impedance has an insignificant effect on circuits that have more than 25Ω impedance. Typical insertion loss values are 0.03Ω and 0μH to 5μH.

**Input resistance.** A probe's input resistance is the resistance that the probe offers to signals from the DUT at dc.

**Input capacitance (probe).** The probe capacitance measured at the tip.

**Maximum input current rating.** Maximum input current is the total current (dc plus peak ac) that the probe will accept and still perform as specified. In ac current measurements, peak-to-peak values must be derated versus frequency to calculate the maximum total current.

**Maximum input voltage.** Maximum continuous input voltage at dc.



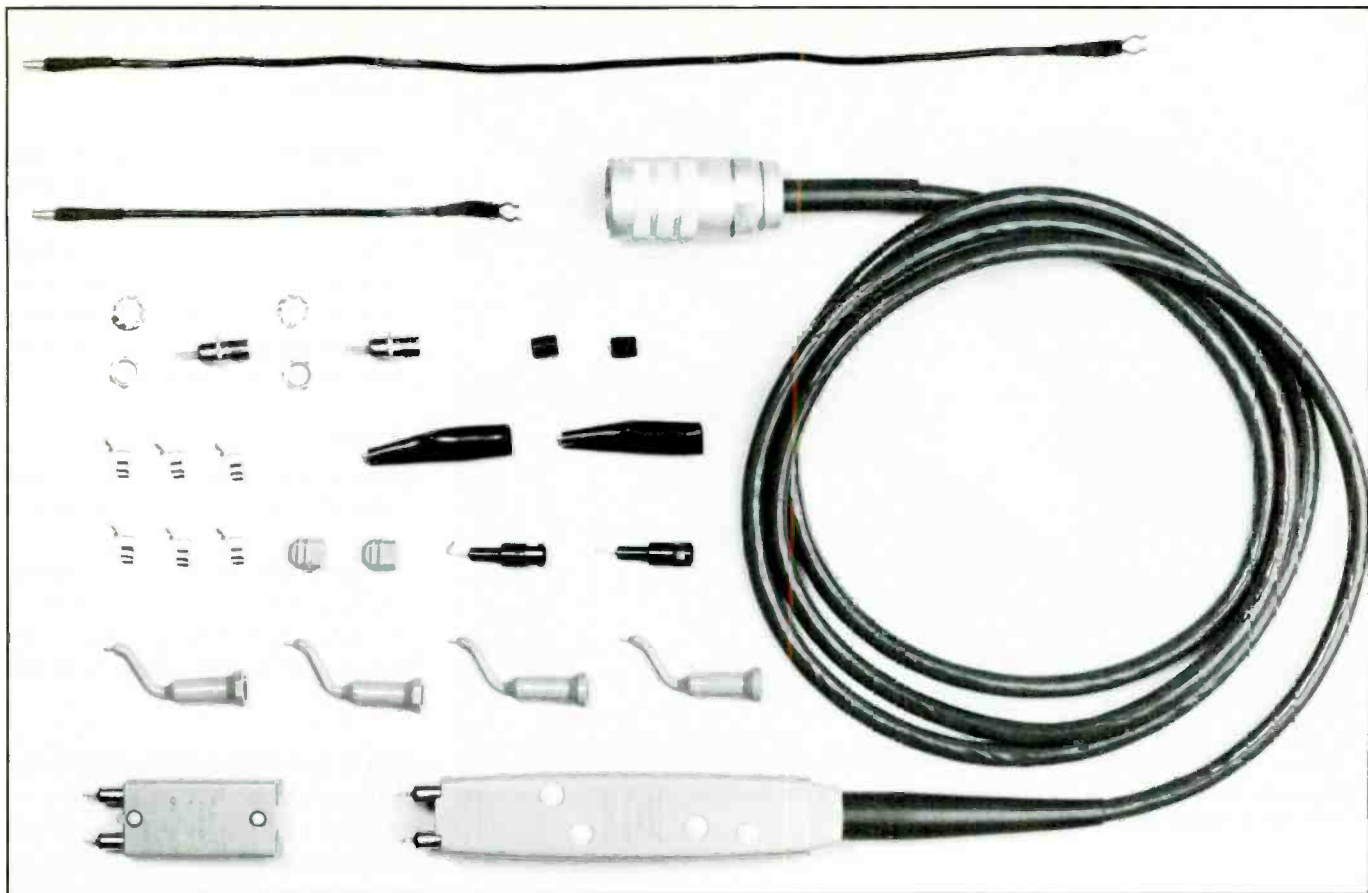

Figure 5a. An active differential probe.

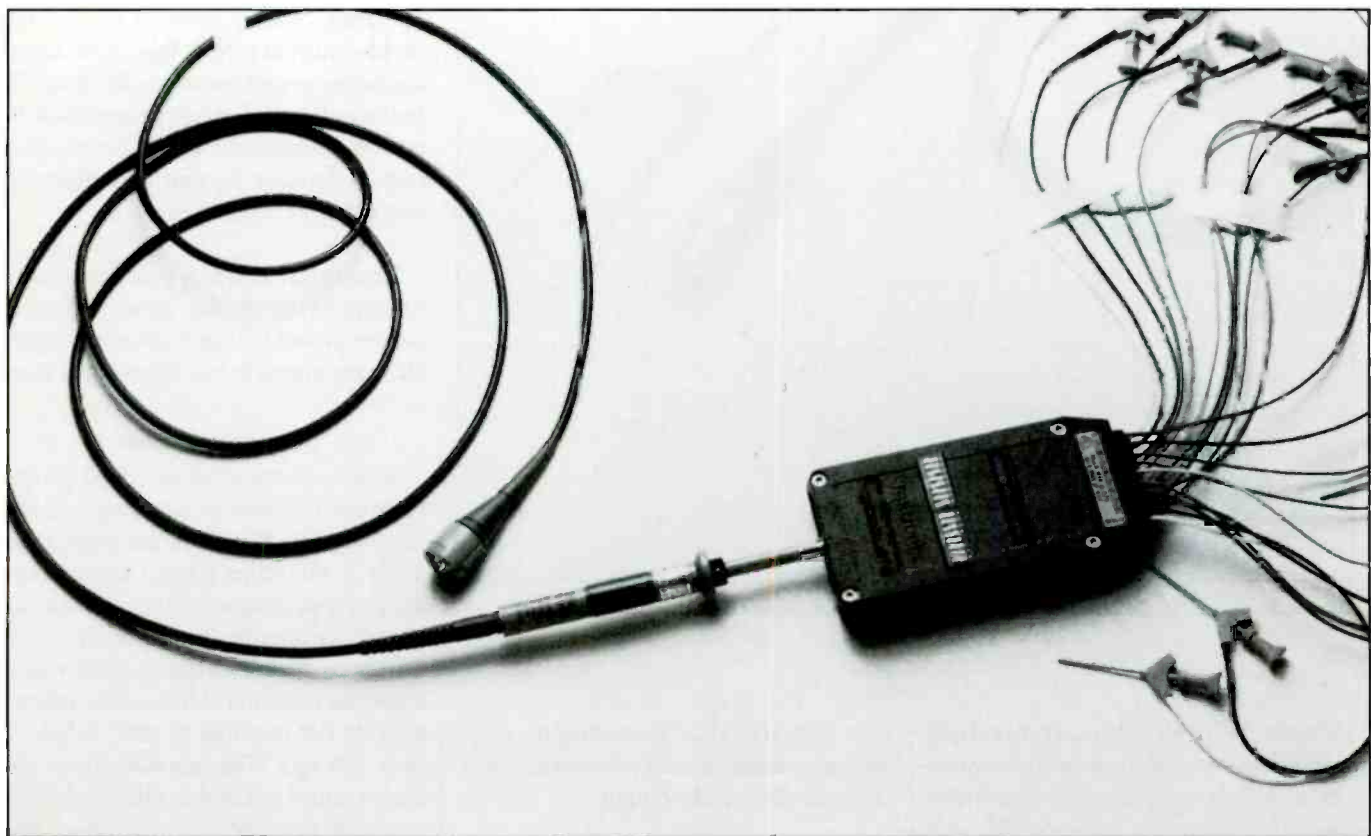

Figure 5b. A word recognizing/trigging probe.

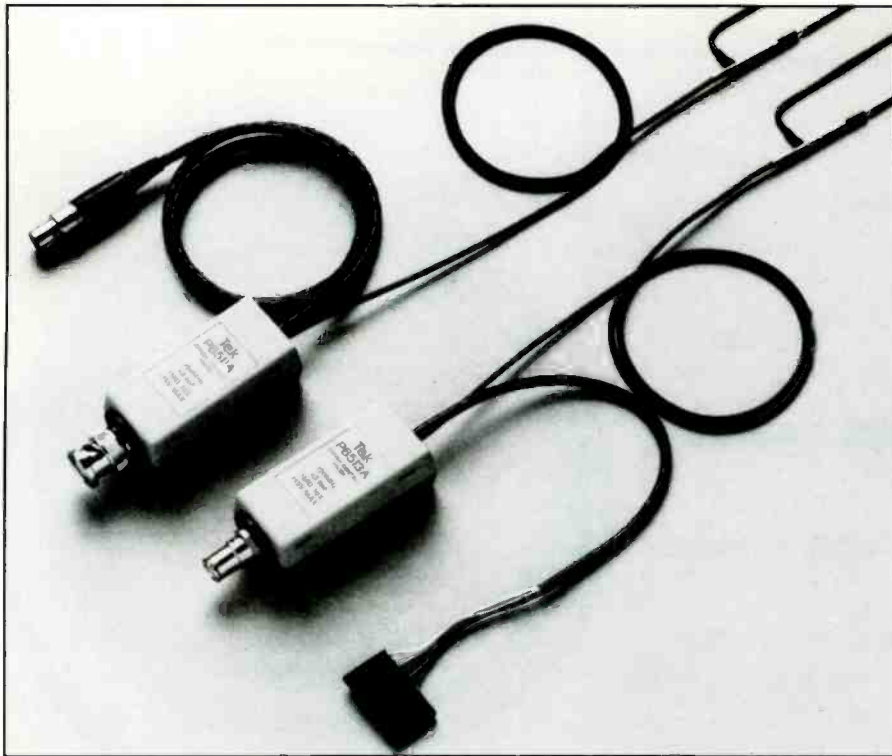

Figure 5c. Spring clip probes with grounding pins and a circular 5-pin and a SIP (single-in-line 0.05-inch spacing) connectors.

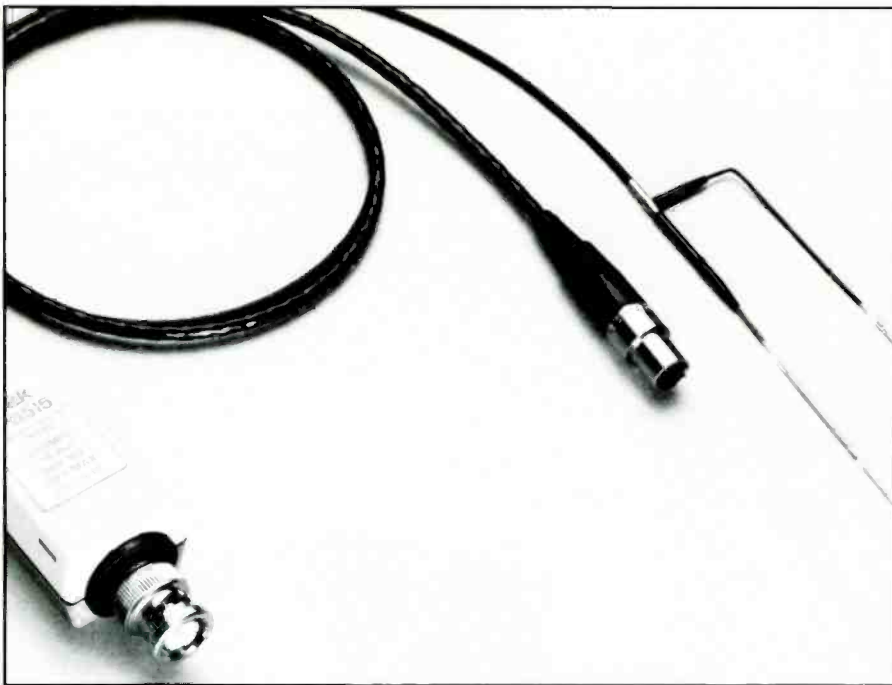

Figure 5d. A spring clip probe with grounding pins and a circular 5-pin.

**Maximum peak pulse current rating.** This rating takes into account core saturation and development of potentially damaging secondary voltages and must not be exceeded. The maximum peak pulse current is usually specified with an

amp-second product. Exceeding the amp-second product saturates the transformer core and distorts the output.

**Maximum voltage rating.** A voltage probe's maximum voltage rating is deter-

mined by the breakdown voltage rating of the probe body or the probe components at the measuring point.

**Propagation delay.** Every probe introduces some time delay or phase shift with frequency. A 42-inch probe has a 5ns signal delay. At 1MHz, a 5ns delay should only be of concern when measuring time differences of two or more waveforms, or when making power measurements with current and voltage probes.

**Risetime.** A probe's 10% to 90% response to a step function is approximately related to bandwidth by the factor 0.35.

**Ringings.** Damped oscillation response usually caused by inductive effects of poor probe grounding techniques (long leads, no ground leads, non-use of probe tip adapters).

**RMS (root mean square) current.** A parameter describing the equivalent heating effect of CW waveforms in relation to steady-state dc. For sinewaves, the conversion is Peak Value X 0.707 = RMS.

**Temperature range (rating).** For current probes the temperature is the probe operating temperature. Like voltage probes, current probes have a maximum amplitude versus frequency derating. The heating effects of energy induced into the current transformer magnetic shielding require derating. Increasing temperature causes increasing losses.

**Tangential noise.** A practical method of specifying probe generated noise (active probes). Tangential noise figures are approximately two times RMS noise.

### Selecting probes

When selecting oscilloscope probes, there are a number of factors to consider. A good place to start is the scope itself. What is the scope's input capacitance? Scope input capacitance is normalized at the factory to a certain value such as 20pF. This normalization ensures proper attenuator stacking (the ability of the scope to provide flat response at each volts/division setting). The normalization also allows you to use probes previously compensated (nevertheless, it is wise to check probe compensation whenever you reconnect a probe).

What are the scope's capabilities and limits? Consider these features when you look for probes. What is the scope's bandwidth? Select a probe with equal or greater bandwidth specs. What is the scope's input capacitance? Select a probe with a compensation range covering the scope's nominal input capacitance.

Does the scope have CRT or knob-skirt read-out coding capability? Select a probe that provides automatic coding for scale factor equipped scopes.

Does the scope have a 50Ω/1MΩ input provision (switchable or fixed)? Consider a 50Ω passive probe or an active (FET) probe for the 50Ω inputs, in addition to standard passive probes for the 1MΩ inputs. Does the scope have side mounted input connectors? Select probes with right-angle connectors for compact routing of probe cables.

Does the scope have full differential input capability? Select a differential probe or matched differential probe pair for maximum CMRR.

What are the trade-offs? Generally, high frequency (specialty) probes also perform satisfactorily in low frequency applications, if they are compatible with the scope input capacitance.

Drawbacks to using the high-frequency probes for low-frequency applications are their higher price, compared to low-frequency probes offering the same performance at lower frequencies. Low-frequency (general purpose) probes may be perfect for many applications, even on high-frequency scopes, but they do put a ceiling on scope performance.

### Consider the application

You may be able to select a probe that serves many similar measurement needs. For three broad areas of interest, the tables below list typical measurement requirements and suggest probe parameters and probe choices that fill the requirements. If your needs fit those listed for one of these areas, you may pick a probe simply by choosing one that has:

- Wide enough bandwidth
- Ability to compensate to the scope input capacitance.
- Ability to operate CRT or knob-skirt read-out, if needed.
- Required attenuation
- Mechanical requirements (such as length and available accessories).

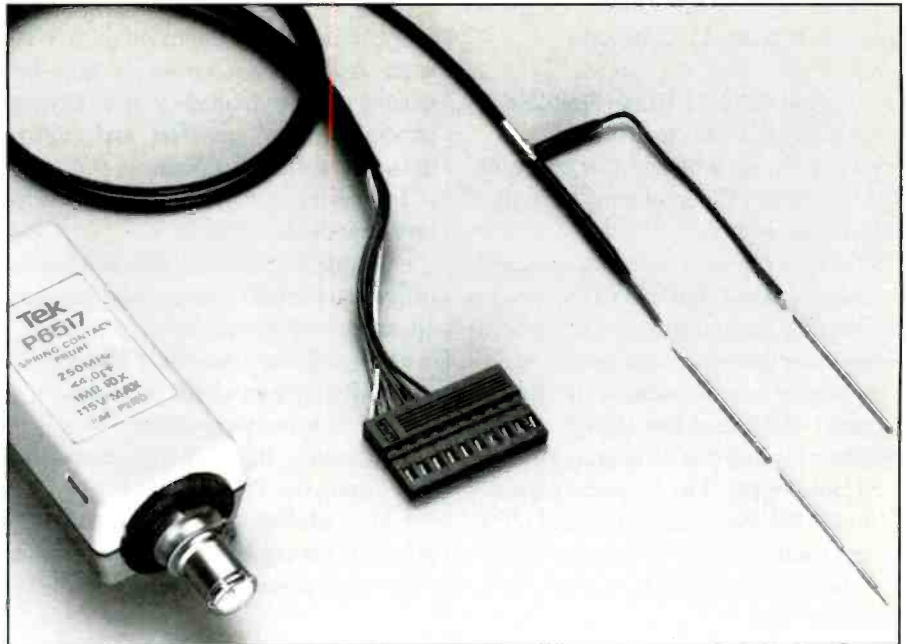
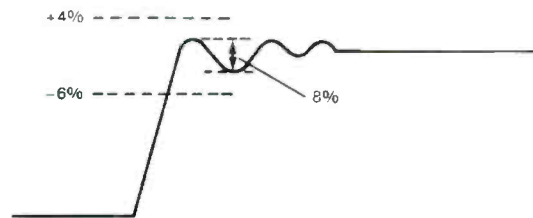

Figure 5e. A spring clip probe with grounding pins and a 0.05-inch SIP connector.

Consider a probe with an aberration spec of +4%, -6%, 8% peak-peak.



This diagram illustrates what the spec means:

The spec states that the probe's step response will not exceed:

- +4% of final value
- OR -6% of final value
- OR 8% peak to peak total aberrations

**WHEN USED ON A SCOPE OF SPECIFIED BANDWIDTH!**

Figure 5. Aberrations explained.

### Engineering and design application

A typical engineering and design application will present these kinds of measurement challenges:

- High-frequency, specialty, absolute measurement applications
- Typical measurement requirements
- Circuit design and circuit operation performance evaluation

- High speed, fast risetime, low load.
- Measurements of pulse risetime, duration of the pulse, propagation delay and time coincidence
- Small size
- Direct access to IC pins
- Direct access to circuit board
- Test points accessible via probe to etched circuit board adapters.

For this type of application, the probe parameters needed will be these:

- Bandwidth: 200MHz to 300MHz
- Risetime: 1.75ns to 1.16ns
- Low tip capacitance (for example, 8pF to 10 pF) for minimum loading at high frequencies
- Compatible with scope input impedance of 1M $\Omega$  and 20pF (50M $\Omega$  scopes are suitable for general engineering applications under certain conditions; for example, where low capacitive loading is required and where low (500 $\Omega$  to 5k $\Omega$ ) resistive loading can be tolerated)
- Cable length: 1 to 2 meters; typically 1 meter for the maximum bandwidth, fastest risetime and lowest tip capacitance
- Short ground leads to reduce ringing to a minimum
- Probe-tip-to-ECB adapter (for minimum ringing and maximum performance)

#### A typical service application

The requirements for an oscilloscope and probes that will be used in servicing

are different from those required of a scope to be used in engineering. Service work involves a mixture of high-frequency and low-frequency, specialty and general purpose, absolute and relative measurement applications.

Typical measurement requirements for service include:

- On-site troubleshooting: computers; office equipment; plant installations, electrical and electronic.
- Ruggedness, portability, low cost.
- Verification of signal presence.
- Verification of waveform shape.
- Measuring signal amplitude and timing. Strong tips for reliability.
- Availability of medium and long ground leads to provide freedom of movement while probing several test locations.

Probe parameters needed:

- 100MHz to 300MHz, but typically 100MHz
- Risetime of 3.5ns to 1.16ns (3.5ns at 300MHz)
- Medium capacitance: 11pF to 14pF

• 10X, 1X or 10X/1X switchable attenuation (1X limits bandwidth to a frequency range of about 20MHz)

- Cable length: 2 or 3 meters
- Strong tips
- Strong cables
- Medium to long ground leads: 130mm to 30mm

#### Consider your electrical requirements

What is your specific test or measurement need? Are you making tests or measurements? Are you measuring amplitude (sinewave or pulse), pulse risetime, frequency or duty cycle? Are you making differential measurements?

A test produces a yes/no, go/no-go, pass/fail answer. For example: 3.25Vp-p risetime, 5.8nsec; pulse width, 1msec. For simplicity's sake, we will generally use "measurement" to cover both.

This concludes part II. In the next installment we will look at loading, active FET probes, phase shift effects, attenuation and other factors that affect your measurements. ■



Surges, sags, spikes, brownouts, blackouts, lightning, and other damaging electrical power disturbances can render a personal computer system and its data useless in a few milliseconds—unless you're prepared!

Written in easy-to-understand, non-technical language for any personal computer user, **Surges, Sags and Spikes** takes a comprehensive look at approaches to solving computer power problems. Helpful diagrams and photographs are included to document computer power needs and solutions.

Subjects include:

- Large and small computers—the differences and similarities
- Basic electricity—an elementary lesson on electrical power and the laws that govern it
- Power problems—definitions and troubleshooting tips
- Quality power—the differences between what your computer needs and what the power company provides
- Lightning—how to protect your computer from this deadly phenomenon
- Static and noise—the effects and solutions for your computer
- Grounding and surge suppression devices—practical ways to ensure protection
- Power line conditioners—how to get clean power for the best performance
- Standby power systems—the way to keep current flowing to your computer
- Full glossary and index

To order, call your nearest PROMPT® Publications distributor or talk to a customer service representative at our TOLL-FREE number.

Mark Waller's **Surges, Sags and Spikes**  
ISBN: 0-7906-1019-1  
\$19.95 U.S./\$24.95 Canadian  
Paper/240 pp./7-3/8 x 9-1/4/Illustrated

**Howard W. Sams & Company**  
2647 Waterfront Parkway, East Drive  
Indianapolis, Indiana 46214-2041

**Phone TOLL FREE 800-428-7267 • FAX 800-552-3910**

Circle (30) on Reply Card

# What is CMOS RAM?

By David Presnell

As modern integrated circuits become smaller and more sophisticated, the demand for lower-power-consumption chips (and less heat generation) remains a goal for chip designers. Computer motherboards of today are often one-fourth the size of boards produced only a few years ago. Microprocessors now use thousands of transistors (or gates) on a single chip.

Consequently, memory chips must continually hold more data, move it faster, and produce less heat, at the lowest price possible. Battery powered computers are becoming more and more popular, thus chips must use less power.

Currently, these demands are being satisfied largely by the application of CMOS (pronounced see-moss) chips. Sooner or later CMOS chips will be improved upon. But, for now, CMOS chips are providing the memory for the latest laptop computers, low power RAM memories, single-board computers, and some very powerful microprocessors.

This article will take a look at CMOS RAM; what it is and how it works.

## A definition of CMOS RAM

CMOS RAM stands for complementary metal-oxide semiconductor random access memory. In IBM compatible computers, the term CMOS RAM refers to a battery backed up memory chip (or segment of memory) that is used to store system configuration information.

This user modifiable information is available to the BIOS (basic input/output system) and operating system at startup to provide setup information such as hard disk type, floppy disk type, monitor type, date, time, and other information required by the system to operate efficiently. Because CMOS RAM uses little power, a small battery is sufficient to maintain the setup information during periods when the power is off.

CMOS RAM is also being used as primary memories in many laptop and palm

BINARY TO HEX CONVERSION TABLE		
	BINARY	HEX
	0000	0
	0001	1
	0010	2
	0011	3
	0100	4
BINARY	0101	5
NUMBER	0110	6
1001 1101	0111	7
TO HEX	1000	8
	1001	9
	1010	A
	1011	B
	1100	C
	1101	D
	1110	E
	1111	F

Conversion of Binary 10011101 to the HEX number 9D.

Figure 1. HEX is a code that uses the numbers 1 through 9 and the letters A through F to represent 4-bit binary numbers 0000 through 1111, and decimal numbers 1 through 15.

top computers because of its low power consumption.

## The necessary math

A computer's microprocessor operates on a fixed length binary word that may be

8, 16, 32, or 64 bits long. A byte is composed of eight bits. A bit is represented as either a one or zero at the human level. On the circuit board itself a one bit is generally represented as +5V and a zero bit is represented as 0V. (A logic probe will generally record a high as anything above 2.5V, and as low as anything below 0.8V).

As you may recall, an eight bit binary word, or byte, is one such as 10011101. These individual bits of this byte, or "binary word," would travel over eight separate bus lines at the same time, side by side. The one bit bus lines would be carrying +5V and the zero bit bus lines would be carrying 0V.

This binary word could have been typed in at the keyboard, or could have come from many other input/output operations. Any input such as a key press at the keyboard would be translated into a numerical code, and further decoded into a binary word that the CPU can handle. The above binary number translated into decimal would be 157.

## Hexadecimal numbers

Binary numbers are large and their value is hard to grasp at a glance, so a numerical code was devised (to make it easier for humans to understand and use) called HEX (hexadecimal) code. You

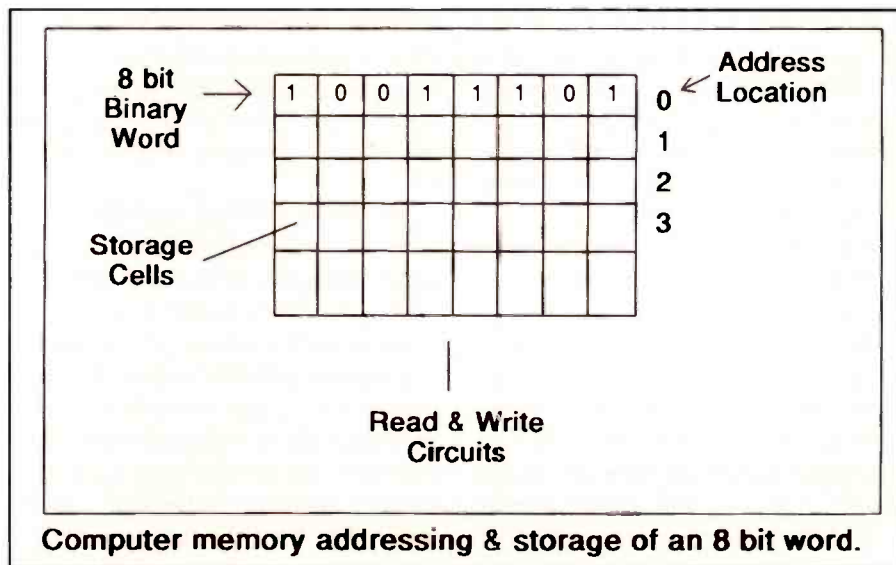
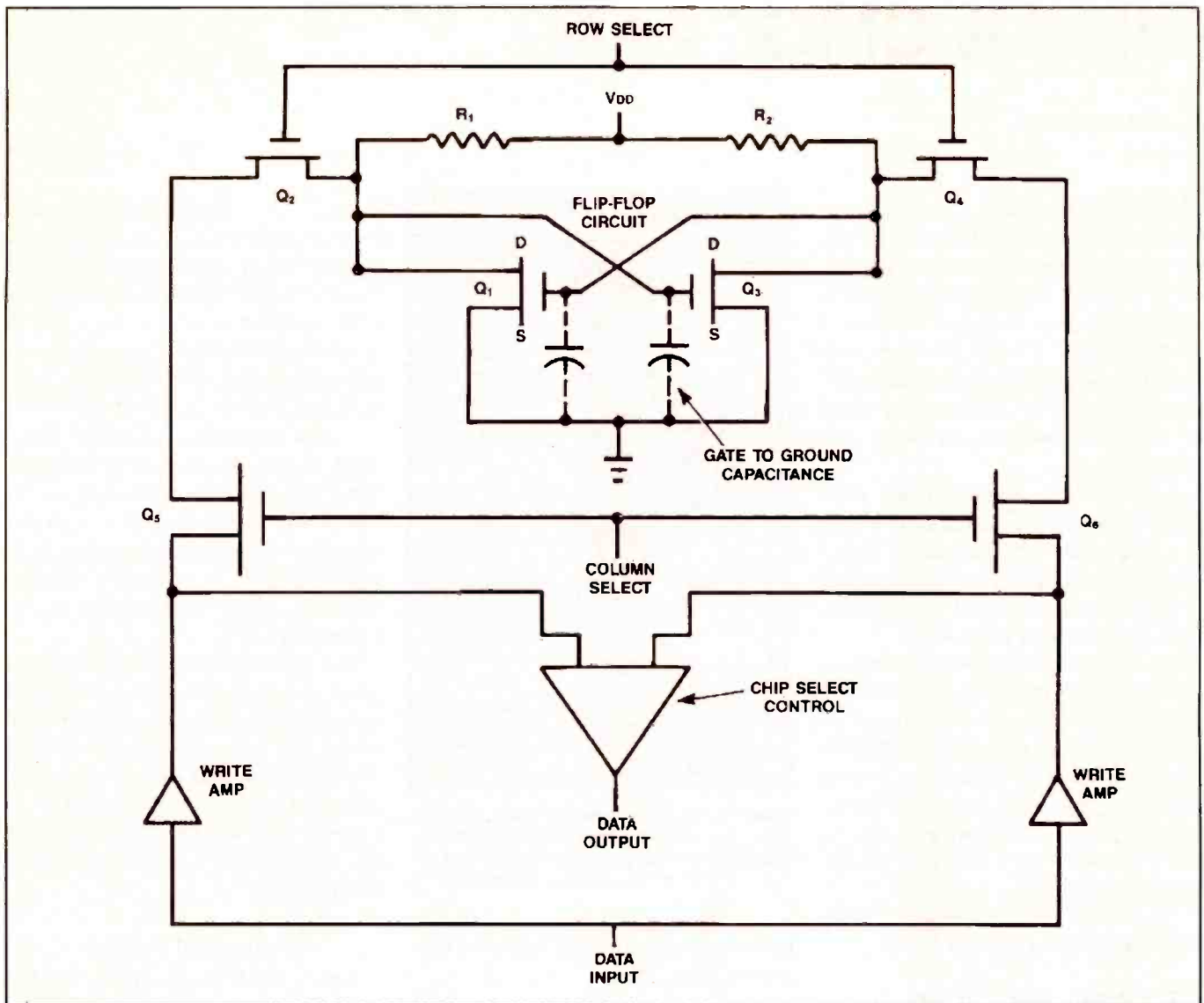

Figure 2. When power to the computer is disconnected, all information stored in RAM is lost.

Presnell is owner of an independent computer servicing business and a freelance technical writer.



**Figure 3.** Here is a schematic diagram of a typical CMOS static RAM cell. The block composed of Q1 and Q3 make up the basic flip-flop circuit using complementary MOSFETS. Resistors R1 and R2 will act like pull-up resistors in this circuit.

may recall that the binary system is based on the power of two, while the decimal system is based on the power of ten. HEX is a code using the numbers one through nine and the letters A through F to represent four bit binary numbers 0000 through 1111, and decimal numbers one through 15. (See Figure 1).

It would be a tough task for programmers to deal with long strings of ones and zeroes when they write programs, so computers, with the help of programs, recognize HEX and internally convert HEX code to ones and zeroes; (true machine language). In HEX, the binary number system is represented as sets of four binary digits, so the binary number 10011101 would be written as 1001 1101.

Looking at diagram 1, you should notice that 1001 represents HEX 9 and 1101

represents HEX D, so this binary number would be written as HEX 9D or simply 9D. Programmers use HEX code in combination with Assembly language programming to write powerful programs that make the computer a useful machine.

#### Computer memory arrangement

The computer's RAM memory is made up of rows and columns of transistor (or gate) storage cells, each row holding one binary word. Each row is provided a location number called an address. Each one word row is stacked on top of another in consecutive order. Read and write circuits can store and retrieve data from these memory addresses as the CPU and the built in ROM BIOS program directs.

At power down, any bits stored in these memory cells will be lost (See Figure 2).

The binary bits in ROM (read-only memory) are permanently stored when the chip is manufactured and does not require the presence of voltage to maintain a one or zero (high or low). ROM memory does not allow the CPU to write bits to it, thus its name, read only memory.

CMOS RAM cells are manufactured with a type of metal oxide semiconductor field effect transistors (MOSFETs) called "enhancement-mode" MOSFETs. (Some are manufactured using silicon oxide material but are still referred to as CMOS). These MOSFETs are arranged in complementary n-channel and p-channel pairs. The complementary pairs use p-channel MOSFETs for pull-ups and n-channel MOSFETs for pulldowns.

As you may recall, FET's or field effect transistors are unipolar devices that oper-

ate using either holes or electrons but not both. A MOSFET uses a thin piece of metal oxidized on one side for both the gate and the insulator. The metal portion will conduct electricity and the oxidized side will act as an insulator.

Using this MOSFET pair scheme, there are no dc paths between  $V_{CC}$  and ground. There is no current flow from the channel to the gate or gate to the channel. Thus, one switch or gate within the pair is always on, and the other is off at all times. This condition will remain, using little power, until a forced change in the switch state is required.

Large current flow occurs only when these circuits change states from a one to zero or zero to one. This allows for CMOS chips to dissipate very little dc power. Normal TTL chips require +5V at  $V_{CC}$ ; however, CMOS chips are being produced that require much less voltage to operate. Most of these CMOS chips can be turned on at around 1.5V with full operation occurring at around 2V.

### Static storage

Bit storage within the computer is referred to as either static or dynamic. The names SRAM for static RAM storage, and DRAM for dynamic RAM storage are used to represent these two types of storage. Static storage generally requires TTL chips and is performed using transistor flip-flops. A flip-flop can store a one bit

(+5V) or zero bit provided power is maintained to the circuit, and will not change until a high (+5V) is introduced to flip or flop the circuit thus changing its state.

CMOS RAM is capable of using static storage (flip-flops) and dynamic storage as well, using much less than 5V to produce a logic high. Modern CMOS RAM chips primarily use a form of dynamic storage, however, so CMOS RAM cannot be firmly classified as either static or dynamic; thus it's called CMOS RAM—in a class by itself. It would seem that CMOS technology uses a form of both flip-flop switching and capacitor storage to accomplish its goals.

### Dynamic storage

Dynamic RAM (DRAM) bit storage is accomplished by the use of a tiny capacitor integrated on the chip. These capacitors can be charged and discharged, allowing them to hold a one or zero bit. CMOS DRAM storage can also be accomplished using the source-to-gate capacitance on a MOSFET as the holder of a one or zero bit (high or low). CMOS RAM using capacitance as its storage element utilizes this MOSFET source-to-gate capacitance.

As you know, capacitors will lose their charge and must be recharged every few milliseconds to maintain the proper bit high or low. Part of the computer circuitry is used exclusively to "refresh" or re-

charge these dynamic memory capacitors. The CPU activates a memory address where 1's and 0's are stored (in RAM) in a top to bottom fashion by the control of the ROM BIOS program.

Once a memory address is accessed, the CPU may send a read or write signal over its control line to either read the contents of that RAM memory address, or write a new series of 1's and 0's to that address. If the CPU reads from that address, it will generally act based upon the data stored within that address. Certain gates will be opened or closed (turned on or off) as dictated by the highs and lows in RAM.

Unless told to jump to another address, the CPU will continue to read from that point consecutively. This illustrates how a computer has a memory. You will hear statements such as: "A computer is nothing more than thousands of switches allowing current to flow (a high), or not flow (a low), to other switches". This is basically a true statement. When we think of computers, we often think of complex circuitry. So, it would now be fitting to jump into the structure of the complex.

### What is a CMOS RAM cell?

As I mentioned above, CMOS RAM can be either static or dynamic in nature, possibly using a little of both. First, let's look at a CMOS static RAM cell. A typical CMOS static RAM cell is shown in Figure 3. The block composed of Q1 and

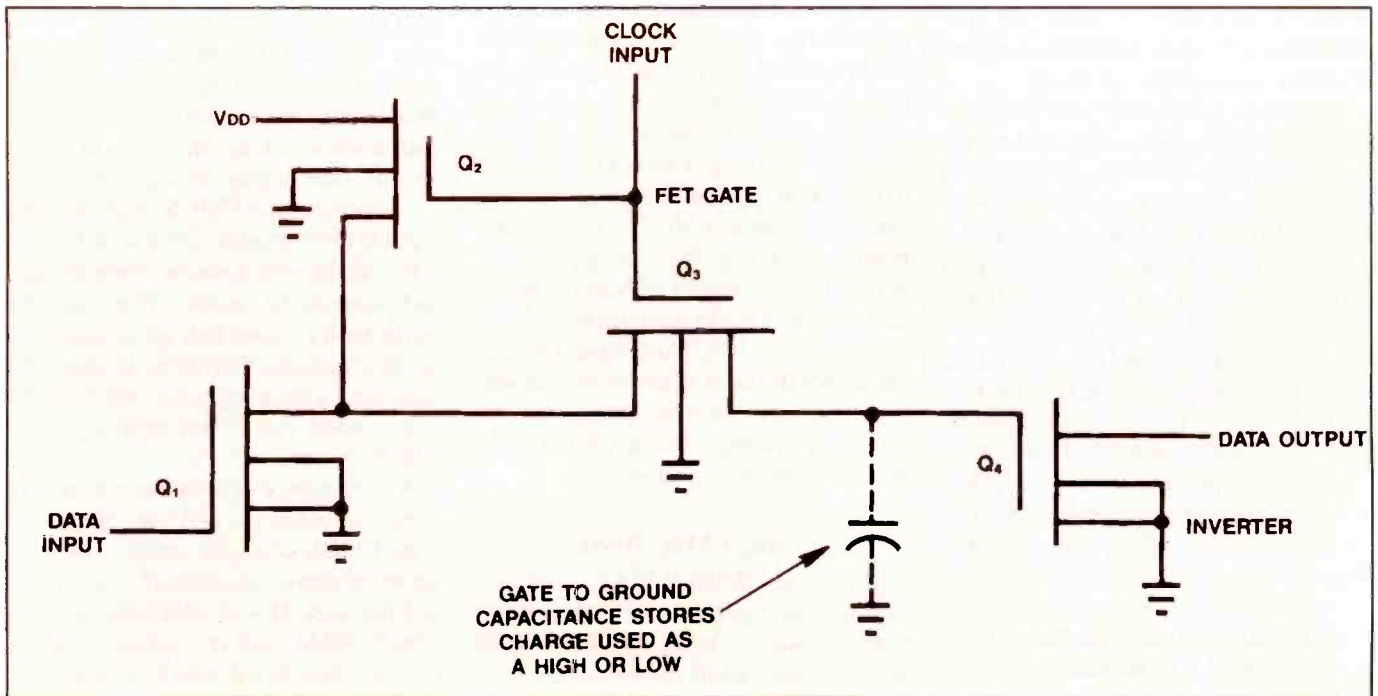

Figure 4. This schematic shows the construction of a typical CMOS dynamic RAM.  $V_{DD}$  supply feeds Q2. A clock input feeds Q3. Data is input to Q1.

Q3 make up the basic flip-flop circuit using complementary MOSFETS. Resistors R1 and R2 will act like pull-up resistors in this circuit.

A MOSFET will cut off when the voltage between the gate and source is less than about 1.5V. A higher voltage will cause the MOSFET to conduct and will produce a low resistance between the source and drain. A small capacitance will appear between the gate and source.

A static RAM circuit does not normally use capacitance for storage. However, in the case of a CMOS static RAM circuit, this small capacitance between the gate and source will help maintain storage of a bit of data. The circuit in Figure 3 acts as a flip-flop due to the fact that when Q1 is conducting, Q3 is cut off; and when Q3 is conducting, Q1 is cut off. The gate to source capacitance of Q1 charges through R2 to the supply voltage  $V_{\text{sub-DD}}$ .  $V_{\text{sub-DD}}$  supply voltage is higher than the cut off or threshold voltage of 1.5V; therefore, Q1 will be held on, and will conduct and produce a very low voltage between the source and drain. Q3, at this time, will be cut off because the supply voltage is below the 1.5V threshold.

#### Addressing the memory cells

First, the cell is selected by making both the row and column select lines a binary 1 or high. This switches Q2, Q4, Q5, and Q6 on. With these MOSFETs now conducting (acting as short circuits), the write amps are connected to Q1 and Q3. Data is sent through the data input line, and depending on the state of the flip-flop, this bit will travel to either Q1 or Q3.

As this 1 or 0 passes Q5 and Q2 or Q6 and Q4, the drain of Q1 or Q3 will be driven low and cause the other MOSFET to be cut off. A high output of either write amp will match the high output at the drain of Q1 or Q3. The high drain signal will force either Q1 or Q3 to remain on, while the other MOSFET is cut off.

A read is accomplished by selecting the cell. A high is applied to the row and column select lines. This will turn on MOSFETs Q2, Q4, Q5, and Q6, allowing the flip-flop output to pass through these lines to a chip select control, that depending on the state of the flip-flop, will produce a binary 1 or 0 output.

#### The function of capacitance in CMOS memory

Notice the capacitors shown at Q1 and Q2. These are not part of the circuit, but

are shown to indicate the capacitance produced between the source and the drain. This capacitance, though small, helps to maintain the storage of a 1 or 0 within the flip-flop.

Remember that in a CMOS Static RAM the flip-flop itself is made up of complementary MOSFETs, both p-channel and n-channel.

It's apparent that capacitance plays an important role in the holding of a binary 1 or 0 within a digital circuit. A true dynamic RAM or DRAM chip is made up of tiny capacitors; however, a CMOS dynamic RAM chip uses the capacitance between the source and drain of complementary MOSFETs to accomplish this storage task.

A typical CMOS dynamic RAM is shown in Figure 4.  $V_{\text{DD}}$  supply feeds Q2. A clock input feeds Q3. Data is input to Q1. If a 0 or 1 bit is input to Q1, as the clock goes low or high, Q2 and Q3 turn on if 0, or off if 1 is input. The output of Q1 is inverted. This inverted bit is sent to Q4 where it is inverted again, back to its original input state.

There is a capacitance to ground gate between Q3 and Q4, which charges due to the very high resistance of Q4, or discharges due to a low resistance of Q4, and this charge or discharge will be stored as a binary 1 or 0. Thus, the circuit stores a high or low in the gate capacitance. This capacitance charges or discharges during the clock phase and must be refreshed to maintain this storage state.

As you can see, there are major differences in how static and dynamic CMOS RAM operates, but both are dependent on the use of capacitance: dynamic to the greater extent, and static to the lesser extent.

Dynamic storage does not make use of a flip-flop as does static storage, but both use complementary MOSFETs to accomplish their storage task. In applications where a small amount of battery operated, high speed RAM is required, the higher cost static CMOS RAM is used most often. In applications where large amounts of low power RAM is required, at the lowest price possible, dynamic CMOS RAM would be the chip of choice.

#### Using CMOS RAM

The name CMOS RAM is used as a common term to represent a small RAM segment required by ROM BIOS to hold the computer setup information. However, CMOS chips may include most or all of the RAM within the computer, the

microprocessor, and many support chips, especially in laptop computers.

In the IBM AT compatible 386 and 486 clone computers, CMOS RAM is usually located in the real-time clock chip, typically a 146818 or equivalent IC. This is a CMOS IC of the complementary MOSFET static (flip-flop) variety discussed above, and may contain up to 64K of RAM storage. This is the IC that the battery maintains even when power is off.

It is within this chip that the computer configuration information (such as hard disk type) is stored, as well as time and date information. If a computer regularly shows a CMOS checksum error at power on, it could indicate that this chip is faulty.

CMOS RAM is also available in 64K, 256K, and 1MB configurations for computer applications. The 54C200 IC is a 256 X 1 RAM chip. As you may know, the "C" within the part number identifies the chip as CMOS. A microprocessor identified with the number 80C88 is a CMOS version of the 8088 XT microprocessor. The 80C88 was developed for use in laptops and single board computers where low power consumption was of major concern.

#### Other CMOS devices

Support chips other than RAM and microprocessors are also usually available as CMOS devices. The 74373 TTL IC is also available as a 74C373 or 74HC373 IC as a three state latch.

It is important to note that a chip is a CMOS device when replacing it. If you see a "C" within the part number, be cautioned that this may be a CMOS device. You should always handle CMOS devices with caution, using measures to guard against static damage to the chip.

The reason that CMOS chips are susceptible to electrostatic discharge damage is the thin insulator used between the gate and substrate of circuits. This insulator can be easily burned through if it receives an electrostatic discharge (ESD). So, wear your grounding strap, and work on a grounded pad when working with CMOS devices.

As technology develops, there are sure to be improvements in IC design; but for now, CMOS chips are serving the need for lower power requirements, fast speed, and low cost. If you would like to see a CMOS RAM chip in operation, take a look at your digital watch. Chances are you're wearing a CMOS RAM chip on your arm everyday. ■



# Will Total Quality Management work for you?—Part 4

By John A. Ross

For the past three months, Business Corner has been looking at the management theory called Total Quality Management. In this installment, we'll talk about point 4 of the TQM concept propounded by W. Edwards Deming.

## **TQM Point 4**

*End the practice of awarding business on the basis of price tag. Instead, minimize total cost. Move toward a single supplier for any one item, on a long-term relationship of loyalty and trust.*

When profit margins become a priority, we often look for sources for cheaper parts. However, temperature, frequency, and other factors can cause the breakdown of components that do not meet certain specifications. Many times, only OEM (Original Equipment Manufacturer) parts meet the tolerance specifications of electronic equipment. All of us have experienced the uncomfortable situation of returning to a customer's house and replacing a previously replaced component. Even if we do not directly pay the cost of the replacement component, we pay a price in customer relations.

## **Establishing standards for components**

With his fourth point, Deming advises that we should move away from components that do not meet high standards. In addition, his point shows that setting a specific standard for parts that you use during the repair process also becomes a matter of establishing long-term vendor-buyer relationships. In the service business, this is a sometimes difficult-to-fulfill proposition. Some manufacturers and vendors have either gone out of business or have downsized. Warehouses often drop product lines that have poor sales records.

Like all relationships, the success of a

vendor-buyer relationship depends on the cooperation of two parties. From the vendor perspective, establishing good vendor-buyer relationships requires prompt payment of accounts and an adherence to the rules set by the vendor. Have you noticed that those rules have become stricter? Some manufacturers allow only fifteen days for the return of in-warranty parts. A tighter economy is one reason that the rules have changed. In many cases, though, buyer abuses of the vendor-buyer relationship have hurt.

As an example of those rules, most vendors have guidelines covering the return of merchandise. When you order merchandise, the order affects the inventory controls applied by the vendor. If you realize that you have ordered the wrong parts or find that a part was defective "out-of-the-box," ask for approval to return the part and obtain a return authorization number as soon as possible. Always return the part in its original container and include any information—invoice numbers, reason for return, and purchase date—that the vendor may find useful.

In addition, do not abuse the warranty procedures set by manufacturers. I'm sure that all of us have received form letters sent by manufacturers advising that a number of returned in-warranty parts have no defects. Admittedly, the pressures of satisfying a customer can cause a mis-diagnosis of a problem. Certainly, returning a customer's good part as an "in-warranty defective unit" is a way to avoid the payment of restocking charges or the total cost of the part. Yet, as honest businessmen attempting to maintain a good vendor-buyer relationship, we cannot abuse the warranty privilege.

## **Vendor/buyer relationships**

Now that we have looked at things from the vendor perspective, let's balance the approach to a good vendor-buyer relationship. From our perspective as buyer

and customer, we have seen a change in vendor loyalties throughout the years. At one time, a manufacturer or vendor would begin a relationship by establishing exclusive sales territories. Now, we can walk into well-known discount houses and see the same products that we sell advertised at a lower-than-not-cost price.

Or, because of market pressures, we can see vendors establishing many "exclusive" dealerships in a limited geographic area. Re-establishing good vendor-buyer relationships may mean that the vendor should abandon the "bottom-line" approach and re-focus on loyalty to the customer.

Earlier in this article, we briefly touched on the issue of vendor rules. From the perspective of the buyer, re-establishing good vendor-buyer relationships may mean that the vendor should take another look at some rules regarding returned merchandise. In addition, vendors also should look at both the warranty rates that they offer and the annual fees charged to a service center. After accepting the responsibility of becoming a warranty repair station, many of us have found that the given labor and mileage rates simply do not cover today's operating costs. Others have found that warranty payments are either delayed or never arrive at all.

Deming tells us that the use of quality parts and the establishment of a good vendor-buyer relationship will out our total operating costs. Maintaining a stock of parts and supplies requires a careful study of when and how parts and supplies are used. All of us should remember that a cheap substitution may cost more in the long-term.

Establishing a good vendor-buyer relationship requires the recognition that two different perspectives affect the relationship. Therefore, long-term trust and loyalty can only result from a cooperative effort made by both the vendor and the buyer. ■

---

Ross is a technical writer and microcomputer consultant for Ft. Hays State University, Hays, KS.

# More musical instrument amps and other MI equipment

By Ron C. Johnson

Those of you who have been around the service business for a while are probably not surprised that tubes are still used extensively in guitar amps. And you've probably seen your share of tube circuits from the "old days" of television. On the other hand, some of you younger guys may find the idea pretty archaic. But, really, we're still using vacuum tubes as CRT's in televisions and monitors, so we're not all that far removed from the days of vacuum tubes.

## Servicing vacuum-tube amplifiers

As I mentioned in a previous article, many guitar amps still use tube circuits because musicians like the sound they get out of them. Solid state amps just seem to be too clean. Not enough texture, some would say. Whatever the reason, if you find yourself repairing musical instrument electronics you're going to run into tube amps.

Normally, the first thing I would say about tube amps is to be careful. Four hundred volt power supplies require some care and attention to avoid a shock. But anyone who works on televisions on a regular basis should already be aware of the danger of high voltage. Just the same, don't let your guard down just because you're working on an amplifier instead of a TV. The results of an electrical shock can run from mild discomfort all the way to electrocution and the dangers of secondary injuries can be just as serious.

## A typical tube amp

The circuit shown in Figure 1 is a typical low power bass guitar amp made by Fender. This one only uses four tubes: two 7025's (dual triodes) and two 6V6GTA's (pentodes). Both of these are very common (or at least used to be when tubes were in general use). The 7025 is used as a signal amplifier and the 6V6's are power outputs. For those of you unfamiliar with

tube circuits, a few quick points follow.

Vacuum tubes work on the basis that, if you apply a potential between two metal electrodes in a vacuum, and then provide a source of free electrons (by the heating one of the electrodes), electrons will flow through the vacuum from the negative (heated) electrode to the positive.

The positive electrode is called the anode (or plate) and the negative electrode is called the cathode. The heater, or filament, is under or inside the cathode. It heats the cathode, releasing electrons which are attracted to the plate.

## The vacuum-tube diode

A tube with two electrodes constitutes a diode. If the plate is positive and cathode negative, and there is a closed circuit between the two, external to the tube, current will flow. Within the tube, this current will be from positive to negative if you use conventional current flow, or vice versa if you use electron flow.

I personally use conventional current flow although some still prefer the other. If the voltage is applied in the opposite polarity no current flows. Because the current flows if the voltage is applied in one direction, but doesn't flow when the voltage is in the opposite direction, the vacuum-tube diode is a rectifier.

For amplification, vacuum tubes add at least one more electrode, (called a grid), between the anode and cathode. By applying a voltage to the grid, the current flow from anode to cathode can be controlled. If you're familiar with FET's you can easily catch on to tubes. A voltage on the gate (grid) controls the current flow (transconductance) of the device from drain (anode) to source (cathode).

## The triode as amplifier

The circuit in Figure 1 shows the input signal applied to the grid of V1A, the first half of the first 7025 tube. We won't get into how to determine gain of the amp but the schematic conveniently tells us that with 3.5mV of signal in, there should be

195mV on the plate of the tube. The signal is inverted because, as the plate current is modulated, the voltage drop across the 100K plate resistor varies.

The output is capacitively coupled, with a relatively simple treble/mid/bass filter section and volume control before the next gain stage. Again, typical signal voltages are shown on this schematic. Notice that the grids of both stages are switched to ground through the input jack when nothing is plugged into the amp. This keeps noise from being amplified.

The output signal of the second stage is capacitively coupled to a difference amp made up of the two halves of V2. Although it may not look like it at first, this amp is very similar to the difference amp shown in a previous amplifier article. The signal is fed to the grid of V2A while the feedback signal is fed to the grid of V2B. Both cathodes are tied together and their common current flows (eventually) to ground.

## The effect of negative feedback

If the cathode current of one side increases, the voltage of the other cathode increases as well. This decreases the potential from anode to cathode which reduces the current through that half of the tube. Decreased current means decreased voltage. It amounts to negative feedback. That's how the feedback voltage from the output can reduce the overall gain of the circuit.

Negative feedback also minimizes distortion and noise in the output stage. Assuming the input signal to the stage is clean, any distortion (or noise) which is added by the output stage is fed back to the input, out of phase. Since the distortion part of the signal is only found in the feedback, it is amplified (out of phase with the distortion added in the stage) and this subtracts out, leaving a clean output.

## Push-pull output

The output stage is a push-pull configuration: one side drives the output on the

---

Johnson is a journeyman electronics servicing technician and an instructor of technology at the Northern Alberta Institute of Technology in Edmonton, Alberta, Canada.

**Save  
50%  
off the  
68 Minute  
MECHANICAL  
DIAGNOSIS  
training tape**

**\$12.<sup>50</sup>**

**WITH COUPON**

EXPIRES DEC. 15, 1993

If Tentel's Postcard is Missing  
Circle (30) on Reply Card  
For More Information

**Get Serious about VCR REPAIR:  
Without test equipment it's JUST a Hobby!!!  
1-800-336-VCRS (8277)**

TENDEL offers the ONLY UNIVERSAL test instruments for performing the mechanical tests and measurements shown in all VCR service manuals; If you aren't using TENDEL gauges you're only guessing for:

- Tape Holdback Tension 23 to 35 grams
- Take-up Torque 80 to 200 gm-cm.
- Restoring torque 90 to 190 gm-cm
- FF / REW over 350 gm-cm
- Reel table heights 2 mm ± .2 mm
- Carriage latching / Tape guide Heights
- Video Head Wear 45 to 10 microns
- Drum eccentricity < 5 microns
- AND MORE!

Lease the FULL PACKAGE of Test Instruments for about \$65 per month  
- Your business will do BETTER with these UNIVERSAL test gauges!

**CALL MCM  
ELECTRONICS  
FOR ALL  
YOUR  
ELECTRONIC  
PARTS NEEDS**

**1-800-543-4330  
FAX 1-513-434-6959**



**MCM ELECTRONICS**  
A PREMIER Company

If MCM's Postcard is Missing  
Circle (31) on Reply Card  
For More Information

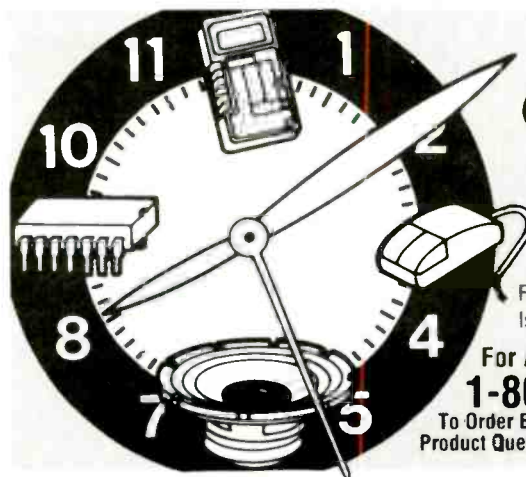

**TIME TO BUY,  
CALL MCM**

When it's time to buy electronic parts or components, MCM has over 20,000 top-quality items in stock and ready to ship within 24 hours. You'll also get timely advice from our Toll-Free Technical Assistance Line. Isn't it time you tried MCM?

For A FREE Catalog Call:

**1-800-543-4330**

To Order By FAX: 1-513-434-6959 For  
Product Questions: 1-800-824-TECH(8324)

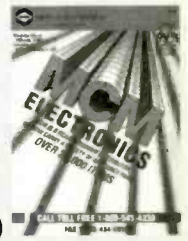

Business Name \_\_\_\_\_ City \_\_\_\_\_  
Your Name \_\_\_\_\_ State \_\_\_\_\_ Zip \_\_\_\_\_  
Address \_\_\_\_\_ Phone (\_\_\_\_) \_\_\_\_\_ ESTC-12

**ES&T  
Postcards  
An Easy  
Way to Get  
Immediate  
Action.**

**Turn faulty VCRs into Profits**

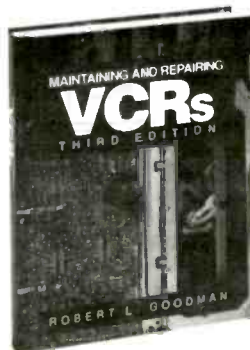

#4204H, \$39.95

You've got the know-how—now get the repair tips you need to successfully repair any VCR malfunction in **MAINTAINING AND REPAIRING VCRS—3rd Ed.** by Robert A. Goodman. This new edition takes an illustrated, problem-solving approach to fixing every VHS, 8mm and camcorder in the business—from diagnosing the problem to servicing any potential problem. This "insiders" guide to the latest VCR technology, service data, and troubleshooting tips will help you boost your earning power. 400 pp., 400 illus.

**Easily fix:**

- jammed video cassettes
- programming controls
- mechanical noises
- power supplies
- roller guides
- sound/video circuits
- and more.

**CALL TOLL FREE**  
**1-800-822-8158**  
or FAX: 717-794-2080

**SATISFACTION GUARANTEED**

Name \_\_\_\_\_ (Please print)

Address \_\_\_\_\_

City \_\_\_\_\_

State/Zip \_\_\_\_\_

Orders are subject to credit approval and acceptance by McGraw Hill.

After 15 days honor our invoice for \$39.95 plus postage, handling, and state and local sales tax or return the book and owe nothing.

**X**

Sign Here: invalid without signature.

COMPANY: \_\_\_\_\_  
STREET: \_\_\_\_\_  
CITY: \_\_\_\_\_ STATE: \_\_\_\_\_ ZIP: \_\_\_\_\_  
NAME: \_\_\_\_\_  
PHONE: ( \_\_\_\_\_ ) \_\_\_\_\_  
TENTEL TOLL FREE 1 800 336 8277

19¢ STAMP  
OR CALL  
TOLL  
FREE

SEND TO:  
TENTEL CORP.  
4475 GOLDEN FOOTHILL PKWY.  
EL DORADO HILLS, CA 95762

TENTEL CORP.  
UNIVERSAL  
TEST  
INSTRUMENTS  
FOR FASTER,  
BETTER  
VCR REPAIR  
CALL  
1-800-336-VCRS

ES&T 1/93



NO POSTAGE  
REQUIRED IF  
MAILED IN  
THE UNITED  
STATES

**BUSINESS REPLY MAIL**  
FIRST CLASS MAIL PERMIT NO 4182 DAYTON OH

POSTAGE WILL BE PAID BY ADDRESSEE

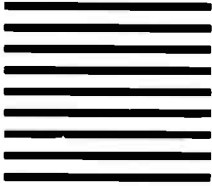

MCM ELECTRONICS  
650 CONGRESS PARK DR  
DAYTON OH 45459-9954



ES&T 1/93



NO POSTAGE  
NECESSARY  
IF MAILED  
IN THE  
UNITED STATES

**BUSINESS REPLY MAIL**  
FIRST CLASS MAIL PERMIT NO. 9 BLUE RIDGE SUMMIT, PA

POSTAGE WILL BE PAID BY ADDRESSEE

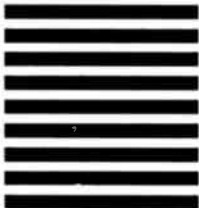

TAB/McGraw-Hill, Inc.  
Blue Ridge Summit, PA 17214-9979

ES&T  
Postcards  
An Easy  
Way to Get  
Immediate  
Action.



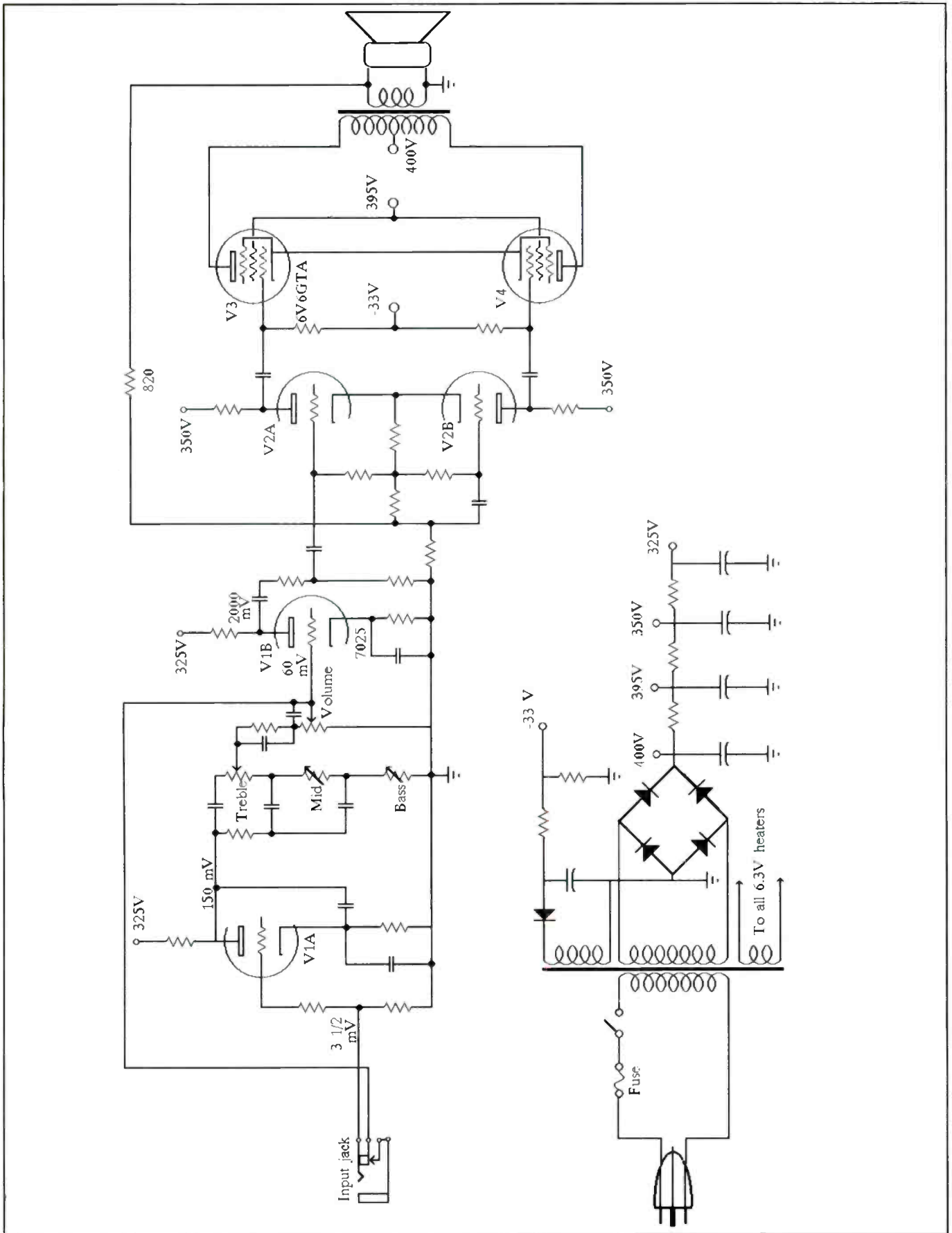

**Figure 1.** This is a schematic diagram of the circuit of a typical low power bass guitar amp made by Fender. This one only uses four tubes: two 7025's (dual triodes) and two 6V6GTA's (pentodes).

positive excursion of the signal while the other side takes care of the negative excursion. Notice the additional -33V power supply which sets a bias on the grids of each output tube.

The 6V6 pentode is a power tube. Its extra internal grids give it better drive capacity without the capacitive and grid limitations of the smaller tubes. In this case the 400V power supply is connected to the center tap of the output transformer. On each signal excursion current flows in alternate directions through the input windings inducing a current in the output windings which are connected to the speaker.

The transformer not only allows this bias arrangement but it matches the high impedance tube output circuit to the low impedance speaker load. The feedback signal is obtained from the output side of the transformer and sent back to the input of the difference amp to control the gain.

### Servicing

Tube circuits are actually pretty easy to troubleshoot. There are two dc power supplies here: the 400V main supply and the -33V bias supply. The 400V supply uses a full wave bridge while the negative supply uses a single diode for half-wave rectification. Each has its own transformer winding.

Watch for bad power supply caps which will cause large levels of ripple on the supply rails. Also, make sure the tube filament voltage is present. This 6.3Vac is provided by a separate output winding on the power supply transformer and is connected to each tube.

Tubes, of course, can fail. They tend to be somewhat fragile, especially in an amp that is hauled around to gigs. Sometimes the internals come loose and the tube goes "microphonic". Even though it amplifies, the slightest vibration will be amplified as well. In extreme cases the vibrations from the speaker itself will feed back causing the amp to howl.

The positive aspect of tubes is that they are easily replaced and can be tested if you have a tester available. I wouldn't trust a tube tester too far though.

### Signal tracing

Signal tracing through a circuit like this is fairly easy as well. You need to know which pin is which on the tubes. I have an old GE tube manual which lists most

of the common tubes, their specs and pinouts. Schematics like this one give typical signal levels which is helpful. Watch out for open capacitors, shorted or open rectifiers in the power supply, and dirty, intermittent potentiometers in the volume and tone control circuits. Also look for signs of abuse. It's fairly common to find dried residue of beer and soft drinks inside the chassis.

The newer tube amplifiers have tube sockets mounted on printed circuit boards. The older ones still have point to point wiring between sockets. These can be a nightmare to troubleshoot and worse when you're soldering or desoldering components. Usually, the easiest way to remove a component is to cut it out and then remove the solder and the ends of the component leads.

Well, that's a pretty sketchy overview of a typical tube amp but hopefully it will help somebody to feel more comfortable tackling one for the first time.

### Mixing boards and effects

Sound mixing boards are another kind of musical instrument equipment that you'll see quite often probably because they receive a fair amount of use and abuse. They run from small four channel microphone mixers to large road consoles with 32 or more input channels, monitor and effects mixes, and several submixes.

The features on these are limitless. Some have built in "phantom power" (a technique of simplexing dc power out to condenser microphones), clipping indicators, LED bargraphs, solo and cue switching, and so on. Ultimately, they all do basically the same thing. They take audio signals and route them to various outputs while controlling their levels.

One of the common problems with mixers is dirty or damaged potentiometers. Each channel has a volume "fader" or linear potentiometer which adjusts the main output level of that channel. Each channel will have several other rotary potentiometers which adjust equalization (tone) in several ranges, signal level to monitor and effects busses, input signal trim controls (to avoid overdriving the input circuitry), and other controls depending on the complexity of the board.

### Cleaning noisy controls

Inevitably you'll have to clean up noisy potentiometers using spray cleaners. I

recommend you find the best kind available and use it liberally. Unfortunately, these pots wear out and eventually cleaning them won't help. You'll have to replace them. Also I've only had limited success trying to clean linear faders. These have to operate smoothly and can't create any noise.

Usually trying to clean faders results in a quiet but sticky action which the customer won't accept. Keep a good stock of replacement faders for the brand of mixer you repair. They are expensive but necessary to do the job right. You'll also find that, often, these faders can only be obtained from the manufacturer of the equipment as they have been specifically manufactured for that product.

### Locating noisy components

Another common problem with mixers is noise generated somewhere on the board. This can be caused by bad filter caps in the power supply, leaky signal caps or leaky transistors or op amps. The frustrating part of troubleshooting these problems is in trying to find the source of the problem.

A heat gun and some freeze spray can be handy here as some noise problems are caused by thermal defects in components. Warm up the suspected area (not too hot) and then spray individual components. Sometimes this will show up a bad one. Dirty connections and cracked circuit boards are common sources of problems here as well. Just moving the equipment around, or flexing the printed circuit board, will show up some problems.

Although the newer (and more expensive) mixers are being engineered for easier servicing, you'll find half the job on some repairs is just getting the thing open. Besides removing lots of screws you often have to remove all the knobs and nuts from the potentiometers before you can get to the solder side of the printed circuit board. For one particular brand and model I used to have a special, homemade "puller" just to get the knobs off without damaging the mixer.

Finally, don't always believe what the customer tells you about a mixer. Mixers are complex pieces of equipment and sometimes the problems are caused by the operators themselves. So insist that the customer gives a detailed explanation of the problem and then check it carefully yourself before tearing the board apart to start testing. ■

# Test your electronics knowledge

## Electronics potpourri

By J.A. Sam Wilson

1. Is the following statement correct? You cannot use the equation  $\text{dB} = 10 \text{ LOG } P_{\text{out}}/P_{\text{in}}$  unless the input and output impedances are equal.

- A. Correct
- B. Incorrect

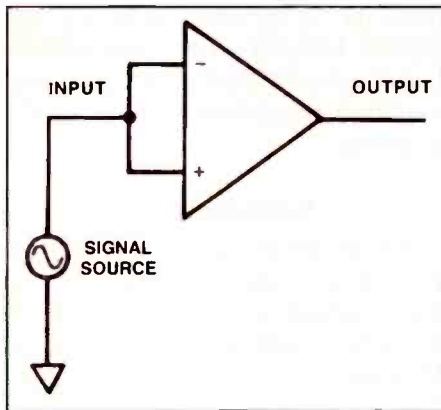

Figure 1.

2. What is the name for the input to the op amp in Figure 1?

- A. Common mode input
- B. Tied input

3. Which of the following is best described as a feedback control?

- A. Logarithmic control
- B. Servo control

4. Which of the following is an example of an active transducer?

- A. Thermistor
- B. Thermocouple

5. A variable resistor that is used to control current is called a \_\_\_\_\_.

6. The initials used for a certain component are LASCR. What do the initials stand for?

7. In the relay circuit of Figure 2 when

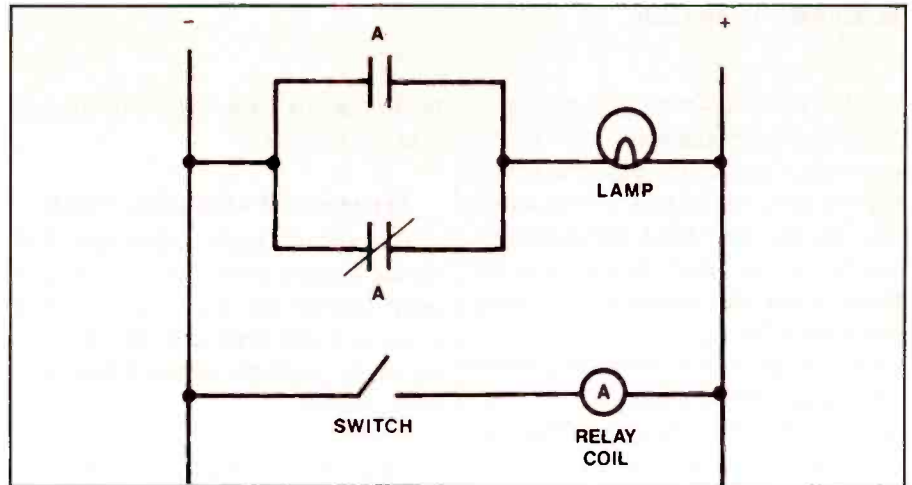

Figure 2.

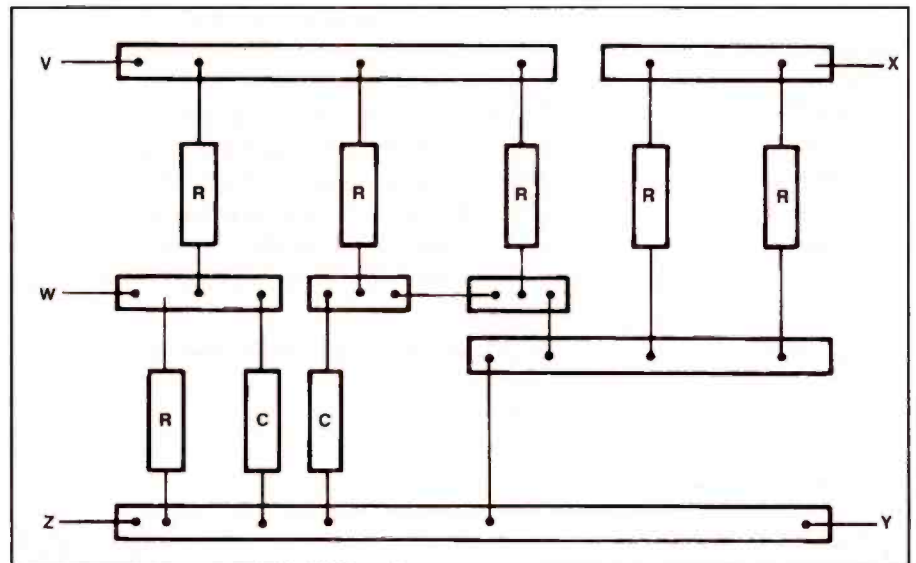

Figure 3.

SW is operated (opened or closed) the lamp is

- A. never on.
- B. always on.

8. Refer to the circuit in Figure 3. If each resistor is 47K, what is the resistance between points X and Y?

9. The power triangle shows phase angle, true power, apparent power and

10. Signal generators are sometimes designed for portable operation because

- A. the circuit has less shot noise.
- B. it is a cheaper design.
- C. (Neither choice is correct.)

### BONUS QUESTION

A certain amplifier has a dB gain of 4.8. The output power is unknown, but, the input power is 0.75W. Calculate the output power.

(Answers on page 68)

Wilson is the electronics theory consultant for ES&T.

## Servicing the Hitachi VM Series camcorder

By Timothy W. Durhan

VHS camcorders from all manufacturers have a lot in common. They have to have a lot of similarities in order to record and play back on the same VHS tape cassette. On the other hand, manufacturers also have a great deal of freedom in the details of how they design and construct their camcorders.

This article will describe procedures for servicing Hitachi models VM 3000 through VM 5000 camcorders. Many of the problem symptoms and actions to correct the problems will also apply to other brands and models of camcorder.

Hitachi manufactured thousands of camcorders in the late 80's as models VM 3000 to VM 5000. Radio Shack, RCA and Sears sold these units too, using their own names and model numbers. All feature the same tape mechanism. The capstan,

mode cam and tape wind functions are actuated by belts.

### Symptoms of worn rubber parts

You probably know rubber parts deteriorate in time, even if they're not used often. Chances are, a five or six year old camcorder will need new rubber. Some common symptoms of worn belt problems include:

- Tape starts to load, then camcorder shuts off.
- Tape runs, then after a while, shuts off.
- Camcorder eats tapes.
- Tapes won't play or record.

If you have serviced VCRs with similar problems, you know it's not too difficult to replace worn rubber parts.

Many VCR technicians are reluctant to service camcorders, even though they wouldn't think twice about opening up

and repairing a hand held remote control. If you can repair a remote control unit without destroying the case or losing any of the buttons, performing a mechanical repair on a camcorder shouldn't be too difficult. Lost screws, pinched wires and broken pc boards can be avoided by using a systematic disassembly and reassembly procedure.

### Getting started

Start by powering up the camcorder using the customer's ac adapter, since a defective battery may also be the cause of any of the symptoms mentioned earlier. Moreover, there is nothing more frustrating than running out of power in the middle of a repair. If your customer didn't include the adapter along with their camcorder, put this repair on hold until they do.

Slide the power switch to on, and press eject. If the mode belt is in good shape, the cassette lid should pop up. If it doesn't

Durhan is an independent consumer electronics servicing technician and a freelance technical writer.

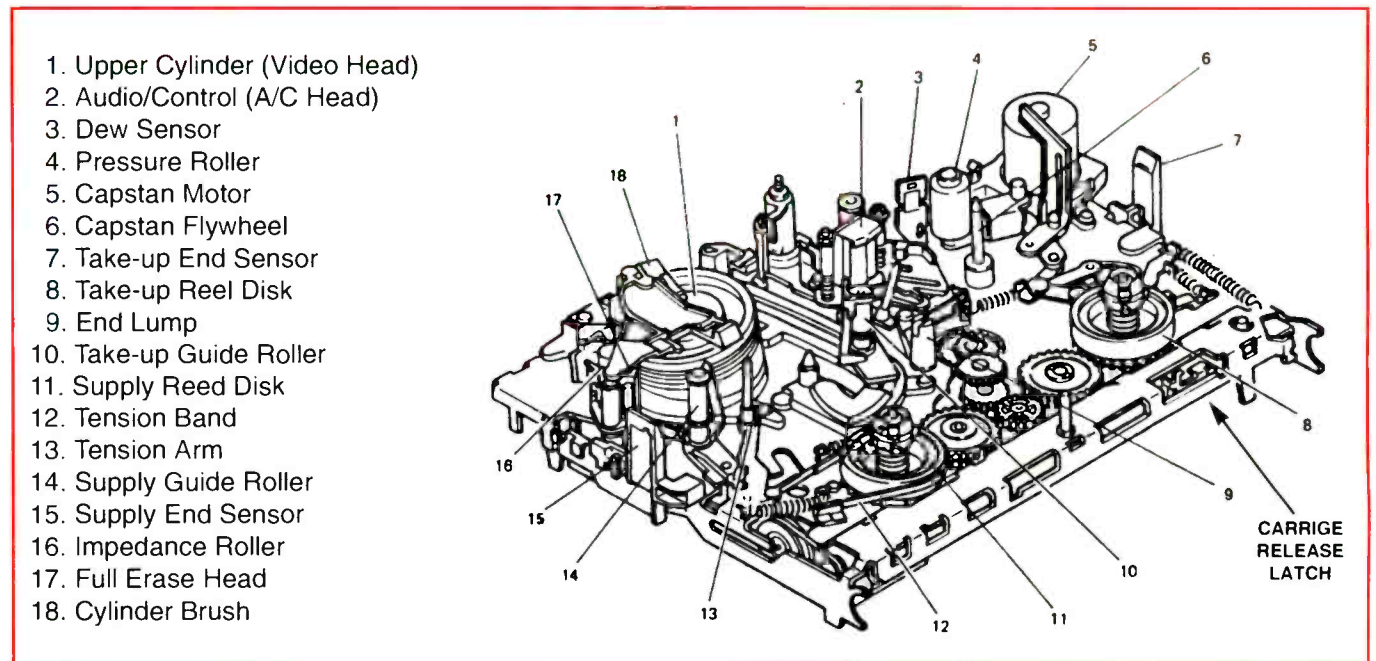

Figure 1. Tape transport mechanism-Top View.



open, you'll have to trigger the carriage latch manually.

To open this latch manually, unplug the ac adapter and remove the two screws that hold the cassette lid on. Carefully slide off the lid, and set it out of your way. On the right side at the top edge of the chassis is a tiny latch (Figure 1). Gently move the latch to one side with a small screwdriver or pick. The housing should pop up, and you can remove the video tape, if one is stuck inside.

### Performing the diagnosis

Once the cassette lid is off, power-up the camcorder again. Cover up the sense LED in the center of the transport with black tape or other suitable light shield, and press play. Again, if the mode belt is in good shape, the guide posts should move to their stoppers, and the drum will start to spin.

To determine whether the tape-wind belt is doing its job, use a torque gauge on the take-up spindle. Hitachi recommends 80gm-cm to 110gm-cm. If you lack such a handy tool, you can try to stop the spindle with your fingers. Obviously, if the spindle doesn't turn, or stops very easily, the tape-wind belt is defective. Is the pinchroller turning?

If the take-up spindle and pinchroller aren't moving, the capstan belt is defective, or there may be an electronic fault. Listen closely for the sound of the capstan motor spinning. You will have to press the play button continually in this

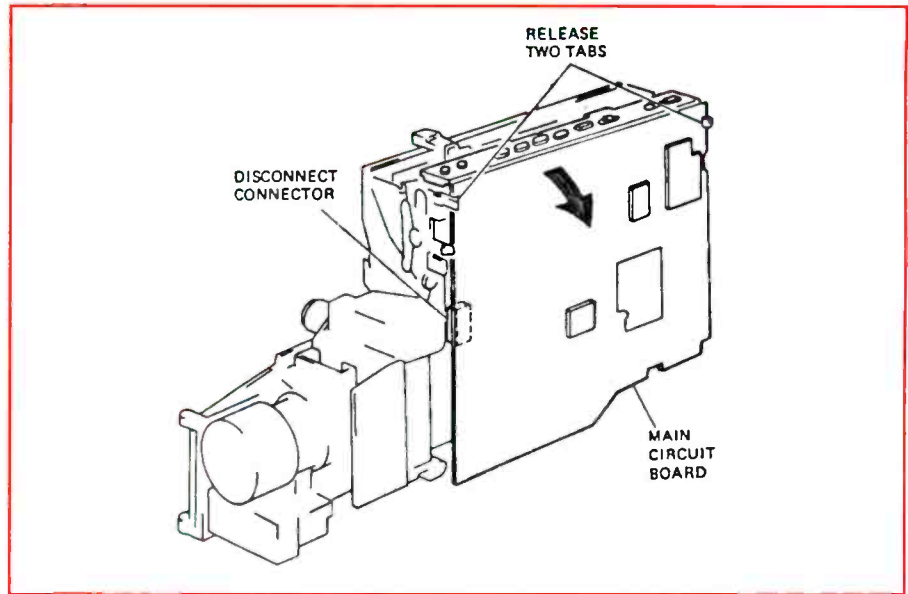

Figure 2. Jack circuit board removal.

condition, because the lack of pulses from the capstan and take-up sensors will alert the system control microprocessor to enter the protection mode, and the camcorder will shut off.

If you have checked all of these functions, and have determined that a belt may need to be replaced; replace them all.

There are only three belts on the mechanism, and since they were all manufactured at the same time, if one is worn, the other two can't be far behind.

Belt part numbers 6356445, 6356472 and 6358012 should be available from any Hitachi part distributor. Use numbers 174757, 174758 and 174759 if you want

to order your parts from RCA instead of ordering from Hitachi.

### Getting to the belts

To begin, remove the covering from the sense LED you put on earlier. Close the cassette holder, (if you can). Unplug the adapter cable to give yourself more room. Unplug and remove the viewfinder.

Lay the camcorder on its side, with the cassette housing facing down, and the lens assembly pointing to your left. Remove the screws that hold the case shells together. Next, carefully pull the shell that's facing you off and set it aside.

Release the main pc board from the two

## To Order Back Issues

**Send \$3.50 Per Issue**

(Check, Money Order, Mastercard, VISA, Discover and AMEX).

Send All Correspondence To:

**Electronic Servicing  
& Technology**

76 North Broadway  
Hicksville, NY 11801

**Order Toll Free  
1-800-853-9797**



**ORDER YOUR BACK ISSUES TODAY!**

EST

Name: \_\_\_\_\_  
 Address: \_\_\_\_\_  
 City: \_\_\_\_\_ State: \_\_\_\_\_ Zip: \_\_\_\_\_  
 Issue(s) Orders: \_\_\_\_\_  
 Payment Enclosed  Money Order  
 MasterCard  VISA  AMEX  Discover  
 Card # \_\_\_\_\_ Exp. Date \_\_\_\_\_  
 Signature: \_\_\_\_\_

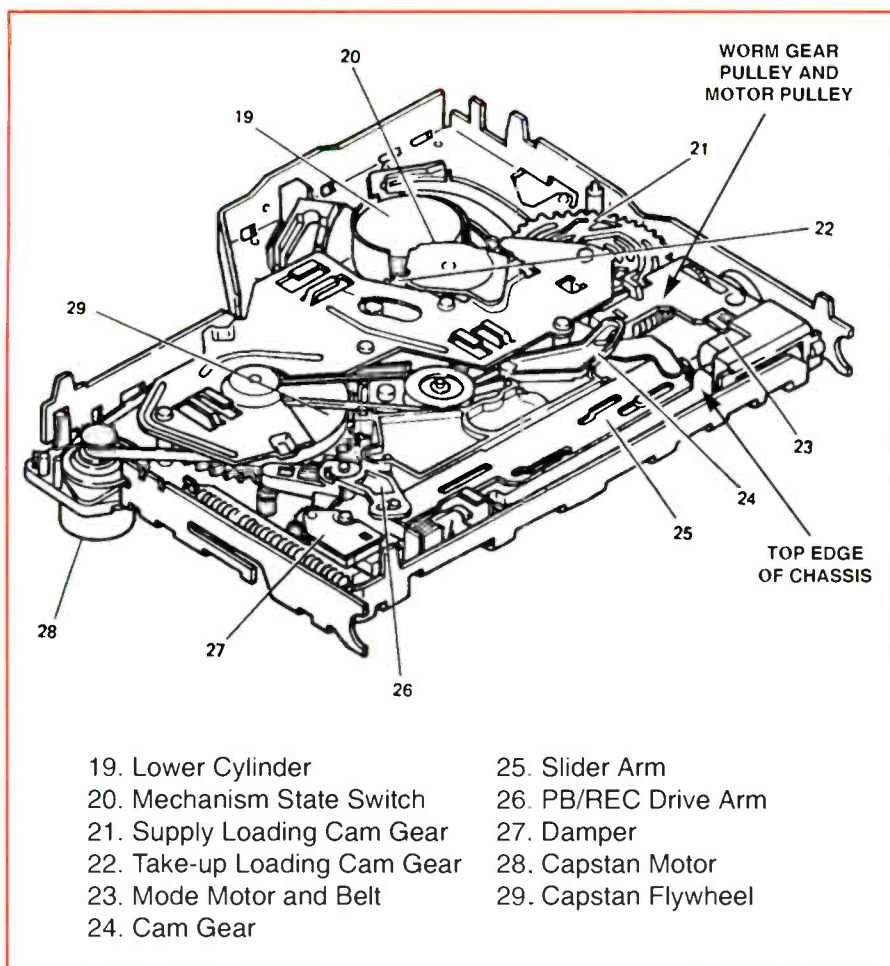

Figure 3. Tape transport mechanism- Bottom view.

white clips on both sides (Figure 2) and slide the control pc board (buttons and all) slowly toward you. Unplug the small connector from the bottom of the main pc board, and remove the large wiring harness from its holder. This should allow you to tilt the board for free access to the tape mechanism.

Next, remove the plastic sheet covering the capstan pulley. Locate and remove the screws and cover holding the flywheel in place, and lift off the cover. Remove the old belts and clean the gum deposits off the pulleys with a solvent, such as alcohol or acetone.

### Replacing the belts

Replace the capstan belt, then the tape-wind belt. Rotate the flywheel by hand to insure that there are no twists in the belts, and remove any grease that may have found its way onto the new belts.

Reinstall the flywheel cover and screws. Reinstall the plastic sheet and

inspect the area for wiring that may interfere with any movement of the mechanism. It's a tight squeeze, but you can take off the mode belt from the motor pulley and worm gear pulley without removing either one.

Located in the top left corner (Figure 3), these pulleys should be cleaned too. Again, make sure there are no twists or excess grease on the new belt.

While you have the case off, it's a good idea to use a small soft brush to clean out the dirt and dust that has found its way inside. Reinstall the connector to the main pc board, tuck the large wiring harness back into its holder and slide the control pc board into the slots on the top case. Then snap the main pc board back into the clips that hold it in place.

### The finishing touches

Next, turn the camcorder over and remove the other side shell. Clean the video heads, lower cylinder lip, guides, guide

rollers, pinchroller, ACE heads, impedance roller and capstan shaft with isopropyl alcohol (or other suitable chemical).

Always be extremely careful when cleaning the video heads. Follow the manufacturer's directions carefully, and use only specially made plastic foam or chamois leather swabs.

Remove any excess grease and dirt with Q-tips or a soft brush. Reinstall the side shells and viewfinder.

Before powering up the camcorder, clean the lens and viewfinder window with a lens cleaning solution and lens tissue (available at any retail camera store). Then connect the camcorder and TV (or monitor) to the ac adapter and plug it in.

Slide the power switch to on, press eject and put in a tape to test play quality. If everything is in order, you should have a clear picture on the screen and in the viewfinder. Make sure that the audio is playing back at the proper level and that it is not distorted.

### Perform a thorough operational test

Stop and eject your play test tape and insert a tape you can record on. Remove the lens cover and put the camcorder into the record mode. While recording, use the zoom, focus and other features on the camcorder to verify that everything is working properly, and that no connectors are loose. Playback your recording and check the video and sound for accurate and natural qualities.

Because you didn't disturb any electrical circuitry or tape path geometry, you won't need expensive jigs, charts or other test equipment for a repair job such as this. Replacement of pc boards, power supply components or the CCD and associated parts would require a more involved repair and adjustment procedure.

If, after a few belt and cleaning jobs, you like the challenge that a camcorder provides, there are books available from Ryder Press, Howard Sams and others that deal with camcorder theory and operation in full detail. Also, Philips of North America, and others, have classroom education on camcorder repair.

Camcorders manufactured in the 90's require more elaborate test jigs and contain exotic concepts never thought of in the 80's. But isn't the same true in other areas of electronics? ■

# What Do You Know About Electronics?

## Graphical Solutions—Continued

By J. A. Sam Wilson

This is a continuation of excerpts from my upcoming book on mathematics of electronics. The book is based upon the idea that graphical solutions are valid, interesting, easy to understand, and give a better insight to the math solutions.

I said I was going to do a calculus problem in this issue, but I've decided to put that off until another time. Pay close attention. You may be able to get one of my highly coveted certificates with my genuine logo.

I have written many times about the strange number epsilon ( $\epsilon$ ). For some reason that number shows up in every study about growth. For example, the growth of a child, the growth of a bean stalk and the growth of an exploding star can all be plotted on a graph and the

Wilson is the electronics theory consultant for ES&T.

curves superimposed—one over the other—to show that the curves all have the same general shape (Figure 1).

The increase of voltage across a charging capacitor follows the same curve defined by the following general equation:

$$y = 1 - 1/\epsilon^x.$$

$$\text{It is often written as } y = 1 - \epsilon^{-x}$$

The size of a balloon as you let the air out and the voltage across a discharging capacitor are among the many things that are also related to epsilon. In that case the general equation is:

$$y = 1/\epsilon^x, \text{ or, } \epsilon^{-x}$$

If your scientific calculator doesn't have an epsilon key you can call it up by punching INVerse ln1. Once you have it

displayed use the  $V^x$  key and you can punch in any number for  $-1/RC$ . Try numbers from -1.0 to 5.0 for  $-1/RC$ .

You're not going to do it, are you?

Anyway, the graphs of the equations will give you curves that you can easily recognize as universal time constant curves shown in Figure 1.

When applied to the circuit of Figure 2 the general equations are modified to include the circuit parameters. The starting condition is with an uncharged capacitor. When the switch is turned to position 'C' the equation for the voltage ( $V_c$ ) across the charging capacitor at any time ( $t$ ) from the instant the switch is closed is given by the equation:

$$V_c = V[1 - \epsilon^{(-t/RC)}]$$

Assume the capacitor has charged to

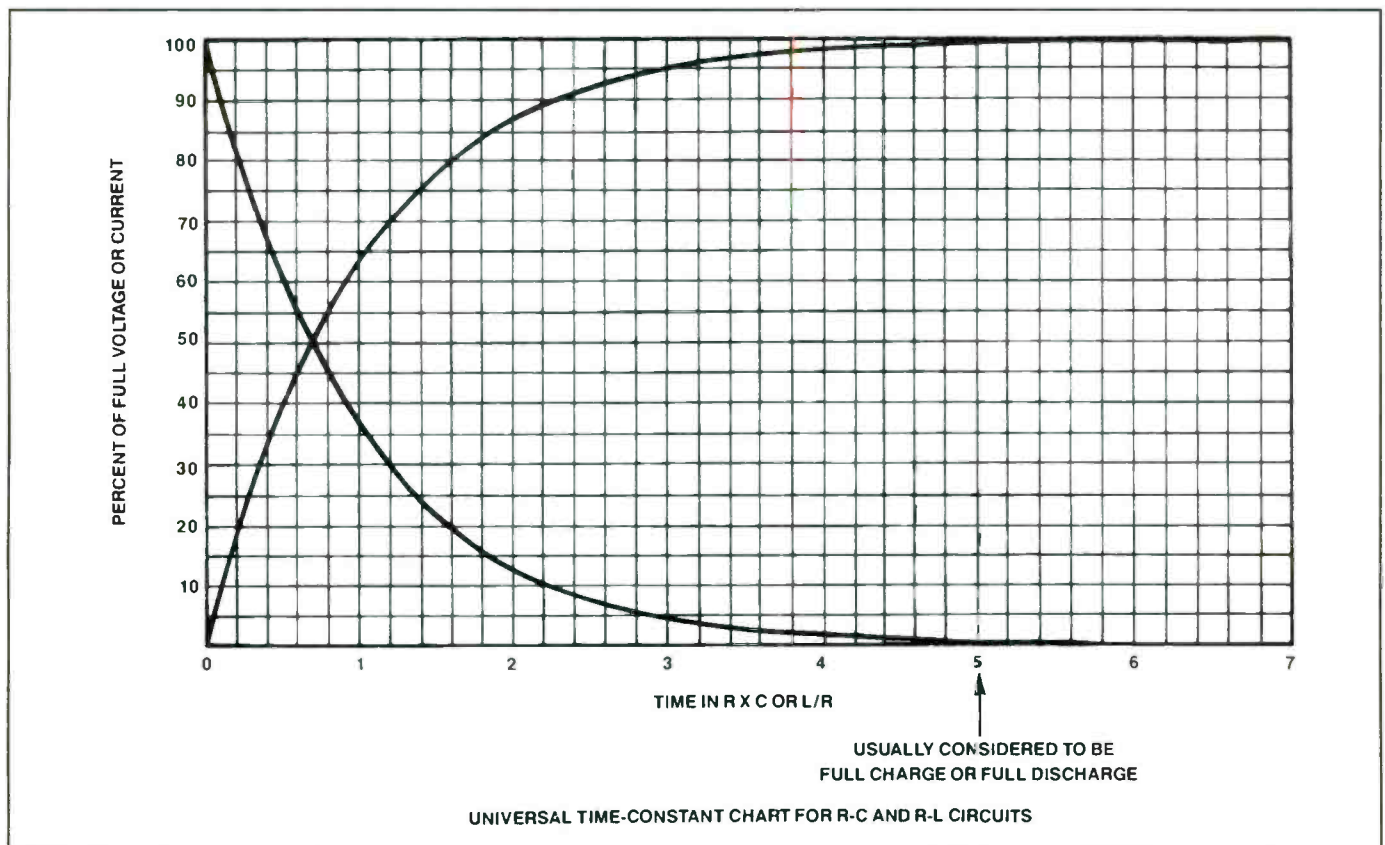
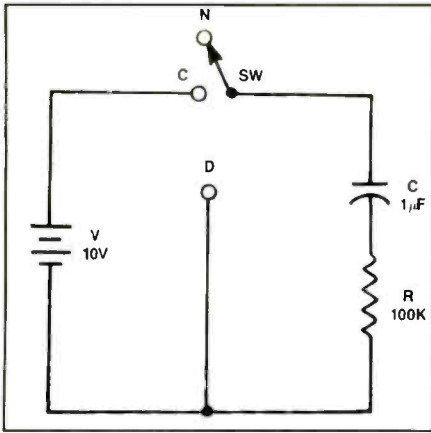

Figure 1. A number of phenomena in nature; the growth of a bean stalk, the expansion of an exploding star, or the charging of a capacitor; have this same general shape when plotted mathematically.



**Figure 2.** In this circuit, the capacitor is uncharged and the switch is in position N. What will be the voltage across the capacitor 0.05 seconds after the switch is turned to position C?

voltage  $V$ . When the switch is turned to position D the capacitor discharges through R. The voltage across the capacitor at any instant of time after the switch is turned to position D is given by the modified general equation:

$$V_c = V [e^{-(t/RC)}]$$

Consider again the voltage across the charging capacitor. When  $t = RC$  the

exponent of  $e$  equals  $-1$ . Solving the equation with an exponent of  $-1$  gives a value for  $V_c$  of about 0.63V. That is why the time constant (T) of the RC circuit is given as:

$$T = RC$$

where T is the time it takes for the capacitor to charge through R to a voltage equal to 63% of the applied voltage.

For the discharging capacitor, letting  $t = RC$  again makes the exponent of  $e$  equal to  $-1$ . Solving for  $V_c$  in that case gives a voltage across the capacitor of about 0.37V.

So when the capacitor is discharging the voltage across it will drop to 37% of the full-charge voltage in a period of one time constant (T). Again,

$$T = RC$$

The equations for  $V_c$  are useful for solving to get the voltage across the capacitor at any time (t). Here is an easy example:

*Sample Problem*—In the circuit of Figure 2 the capacitor is uncharged and the switch is in position N. What is the voltage across the capacitor 0.05 seconds

from the time the switch is turned to position C?

*Solution*—Use the equation for the increasing voltage. Determine that  $-t/RC = -0.5$ . Therefore,

$$\begin{aligned} V_c &= 10(1 - e^{-0.5}) \\ &= 10(1 - 0.606) = 3.93V \end{aligned}$$

You can solve the same problem graphically using the universal time constant curve. Don't tell me it takes too long to find the curve. Keep it in your freezer. That's where I keep mine. Besides, how long does it take you to find your calculator and then find the equation to do it mathematically?

The bottoms of the curves in Figures 1 and 3 are marked in time constants.

In our problem, the time constant is equal to 0.1, and, the time for full charge is  $5 \times 0.1 = 0.5$  seconds. That means each division on the time constant line is equal to 0.1 second.

Move along the time constant line to the 0.05 point (one-half of 0.1) as shown in Figure 3. Then, go up to the curve and to the left to the decimal part of the full voltage (10). If you are careful you will get an answer of 3.9 volts.

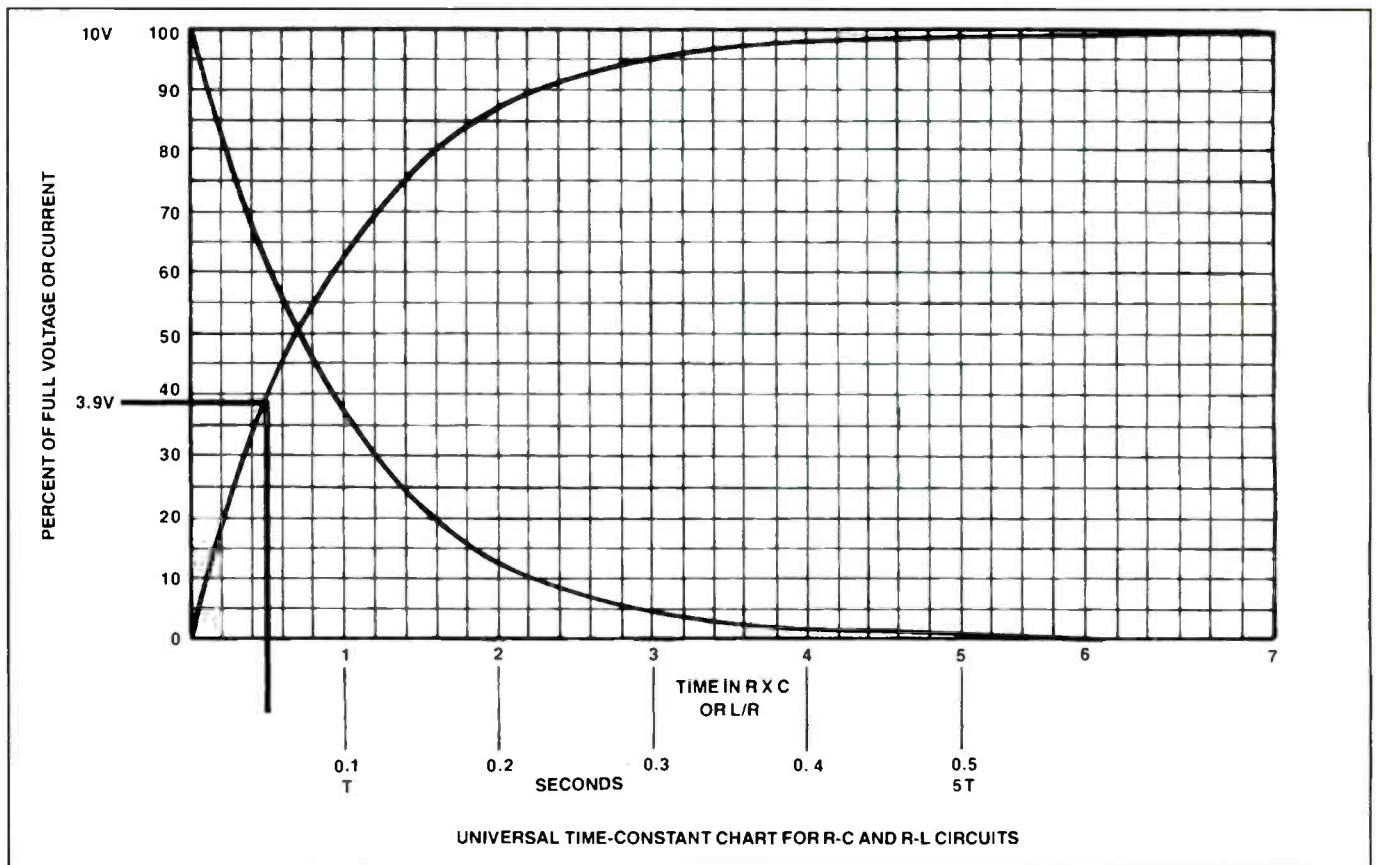

**Figure 3.** You can find the solution to problems concerning the exponential charging of a capacitor, such as this one, using the universal time constant curve of Figure 1.

Now, use the math solution (only) to solve this one:

*Second Problem*—How long does it take the voltage across the capacitor in the circuit of Figure 2 to reach 5.5 volts?

Send me your solution to that one. Ken Muncey and Ron Weinstein will be the judges. If they say your solution is right I'll send you a genuine certificate saying that you solved one of the problems given in Sam Wilson's WDYKAE? If you don't think that is rare see if you can find someone who has one.

In the next issue I'll give the math and graphic solutions for the problem. I think you will agree that the graphical solution is much easier and faster.

### Check those resistors

Brad Thompson is a contributing editor for a magazine called *Test and Measurement World*. In an article titled "Carbon-comp Resistors Revisited" he tells about his experience when he tested some older  $51\Omega$ ,  $1/4W$  resistors. It turns out that the carbon-composition types were badly out of tolerance.

After he wrote about the experience in an article he got mail from others who had the same experience. He got a letter from Victor Meeldijk of Oakland NJ that referred to an article in ES&T magazine titled "Effects of Storage and Dormancy on Components." That article appeared in the December 1990 issue.

The bottom line is that carbon composition resistors undergo a change in resistance over a period of time. The cause is absorption of moisture from the air. In some of the cases cited the resistors were so badly out of tolerance that they could cause serious problems in equipment. There did not seem to be any similar problem with carbon-film resistors.

One letter reported that there was also an increase in noise with the resistors that were out of tolerance.

It would be a good idea to check the resistance of carbon-composition resistors before you install them in a circuit.

### Give up our gills? No way!

You may want to sip on a few gills of beer or Coca Cola—whichever you prefer—while you ponder this next idea.

Imagine you are the CEO of a large company located in Europe. (If you can imagine you are rich you shouldn't have any trouble imagining you are the chief

executive officer of a large company.) You need to make a purchase of machines that will be part of many installations. This will be a very large order, so, you can't afford to make a costly mistake.

Only two companies make the machines in the quantity you require. One company is in Germany and the other is in the United States. The cost of the machines is the same for both companies. Both are equally reliable. However, you are having a problem with this decision.

When you make the installations you must supply maintenance for the equipment. If you buy the German model you can specify the metric tools you already have at each site. If you buy the machines from the company in the United States you will have to supply a complete set of tools for each installation. The reason is that the product from the United States requires tools based on the British system. That will cost you an additional half million dollars for the initial installations plus an additional hundred thousand for replacement tools.

This is not an easy decision. If you buy the USA tools you might get a chance for a free trip to Disney Land. That means you can take Mugwomp Fetchmore—your wife's 30-year-old son from a previous marriage. You might even be able to lose him there.

Make an intelligent decision in only four seconds!

Of course! You buy the German-made machines! You realize you can send Mugwomp to the USA for a lot less than

\$600,000 and you will get an additional savings by getting a one-way ticket.

People who are raising strong objections to the metric system in the USA just may be overlooking the cost to the USA in world trade.

### BCD is BCD is BCD

A few months ago I put a problem in "Test Your Electronics Knowledge" that has broken records for mail! Here it is.

Convert the following BCD number to a decimal number:

10010111

Answer: 97

I got many, many letters saying the answer is wrong. In most cases the letter writer proceeded to convert the number as if it were a straight binary number. However, binary numbers are not the same as binary coded decimal numbers. The solution to binary coded decimal numbers is very simple. Here's how it is done:

1. Separate the numbers into groups of four binary digits:

1001 0111

2. Write the binary number for each four-bit group.

1001 = 9, and, 0111 = 7

3. Write the answer as 97.

I'll have to put some more of those in TYEK. Many thanks to those who took the time to write. I suppose that I should sign off with.

00110000. ■

## ES&T READER SURVEY



Bound into this issue is the ES&T Reader Survey card. It's located on page 31.

It's a mini survey about *you*. We would like to hear about the problems you face, the opportunities you see and the equipment you use during the course of your work day.

The postage is paid. All you have to do is fill it out and mail it.

*What could be easier?*

**Please fill yours out  
and mail it today.**

## CMOS battery failure—Part 2

By David Presnell

Computer Corner in the October 1993 issue discussed CMOS RAM, and the battery used to maintain the information that is entered into this RAM to tell the BIOS how the computer is configured. This installment is a case history of my experience with a failing CMOS battery. It describes how to replace the battery and get the system back up and running.

### A case history

A customer brought in a Tandon AT (286) computer for repair. The complaint was that, "the hard drive is not working." One of the owner's computer enthusiast friends had suggested that the hard drive was bad and would most certainly require replacement. Upon questioning the customer, I determined that the computer had been purchased several years ago and had never been serviced. My first reaction was to suspect the CMOS battery; it was pretty old, and the primary symptom of a dead CMOS battery is a non-responding hard drive.

I placed the computer on the service bench, removed the cover and powered it up. It went directly to the BIOS setup screen. Upon looking over the standard CMOS setup screen, I noticed the current date was in the early 80's, probably when the chip was manufactured. The setup screen showed no hard drive present. I proceeded to boot the computer with MS-DOS 5.0 from floppy drive A and everything worked well except the hard drive.

I powered down the computer and (using static precautions) removed the CMOS battery. It was a round, flat, 3.6V, 3-pin plug-in Tadiran Lithium, No. TL-5135, about the size of a fifty cent piece. I checked it for voltage and it was basically dead. It had served its purpose well. Upon receiving a new replacement, I plugged it in and proceeded to power up the computer. The work began.

### Setting up the computer

When the computer came up, the setup screen still showed no hard drive. This

setup information must be entered by the user or by a program designed to set up the CMOS for you. My hard disk database (Diskbase from Landmark Research Corp.) provided extensive information about the hard drive. (Cyl, Head, WPCOM, LZON, Sec, Size). What I needed, however, was a number from 1 to 46 (the hard disk type as identified by the ROM BIOS manufacturer), to enter in the setup.

Most modern setup programs allow you to view the Cyl, Head, and other data relating to each type number as you scroll through the types. If you don't find a type to match your hard drive, you can often select type 47, a user definable type, and enter the drive information directly. This setup program (as is the case with most older setup programs) would not allow me these options. It simply wanted a number from 1-46.

The problem faced here is twofold. If you enter the wrong hard disk type, the drive may be recognized, but you will not be able to use or recognize the customer's data and programs contained on the hard disk. When faced with a situation in which you have to set up a computer configuration after replacing a battery, do NOT format or partition the hard disk. If you do you will possibly lose years of your customer's data that probably has never been backed up. The hard disk data is there; you just have to get the BIOS to recognize it. You must match the setup to the original setup the system had before the backup battery went dead.

At this point, had I known the hard disk type I would have entered it in the setup; however, I was not that fortunate. I could possibly have obtained the type of information from the manufacturer of either the hard disk or the computer, (in this case both were Tandon), but that's a time consuming process. My next and only logical choice was to run a floppy drive program that would try to automatically recognize hardware installed and proceed to setup the BIOS. I chose this option.

### Using disk management software

I proceeded to boot MS DOS 5.0 from

floppy drive A. Once at the A prompt I started Disk Manager (from Ontrack Computer Systems) which is an excellent program for setting up new hard drives. I used the program's BIOS setup option from the main menu. The program informed me that it didn't recognize some of the hardware, but asked me if I wanted it to attempt BIOS setup anyway. I proceeded, and the program set up the hard disk very nicely.

I closed the program and rebooted the computer (you always have to reboot the computer after you have made changes in the CMOS RAM). The BIOS setup now revealed a type 46 hard disk installed as 30MB. I proceeded to the A: prompt. I then typed C:\ and the computer responded with "Incorrect DOS Version".

I obtained the original Tandon MS-DOS 3.2 disk from the customer (Which I should have obtained to begin with), booted it from floppy drive A, typed C:\ and came up with the C:\ prompt. I proceeded to type DIR: there were all my customer's original programs and data files in good order. I ran a few of the programs to be sure all was well, and it was. This job was almost over.

### Checking the condition of the disk

At this point, I usually would have completed the service invoice and contacted the customer. However, this customer was prepared to spend \$400 on a new hard disk because a friend had informed them that the hard disk was bad. In this customer's mind this was the only solution.

From past experience I have learned that once a customer's mind is made up it can be very hard to change. This was an old hard disk, and I knew that if I told the customer that the hard disk was just fine, it would probably suffer a terminal crash within two weeks (Murphy's Law). If the hard drive failed shortly after I worked on the system, I'm sure that the customer's reaction would have been: "he didn't fix it to start with; my friend said the hard drive was bad and it was."

In my eyes that's bad business. To help avoid such a situation, I felt it necessary

---

Presnell is owner of an independent computer servicing business and a freelance technical writer.

# What's Your Best Servicing Value?

## The magazine that makes money for you — *Electronic Servicing & Technology!*

to test the hard disk extensively. If it showed a large percentage of failures, then it might be a good time to upgrade it while the computer was still on my bench, but not without first discussing the original problem (dead battery) with the customer. It's only good business practice.

So, in this case, complete repair included testing the hard drive. I loaded DOSUTILS from Ontrack Computer Systems. I ran the DNA (Diagnose -N- Analyze) program. The DNA program allows exhaustive testing of drives attached to the computer and also includes a CMOS set-up and type utility. Although these are excellent programs, use care when running them; you can destroy data on the hard disk very fast.

I set the program so that it would not allow writes to the hard disk, thus data could not be written over. Then I ran the Sequential Read-Only Test. This test reads every track on the hard disk. I ran it through twice. It took about 10 minutes, and to my surprise not even one bad sector was found. I proceeded to run controller test and seek test, and all showed no errors. In my opinion, this drive was in excellent condition for its age and did not need to be replaced.

### Communicating with the customer

I wrote up a charge of \$14.95 for the battery plus my bench fee and contacted the customer. I had to explain carefully why the hard disk did not need replacing. She was very happy. "You have saved me a lot of money," she exclaimed. This computer and hard disk combination will serve her needs for some time, considering the simple programs she uses.

It would be well for me to mention the practice of good business ethics at this point. It is tempting in a case such as this one, to give the customer what they want, (a new hard disk), and also what they need, (a \$14.95 battery).

That kind of service will gain you nothing in the long term. Sooner or later customers will become aware of it. This is when you lose. This customer has sent me business that has brought me far more profit than I would have made selling her a new hard disk she didn't need. It's our duty, and our future, to keep the service industry honest.

Next time I will show you some of the symptoms that may arise from CMOS battery failure.

Each month, *ES&T* brings you how-to service articles on TVs...VCRs...computers...CD players...microwave ovens... audio products and more. It's just the information you need to do your job everyday.

Regular columns and special features from experts will make you more efficient — and more

profitable — in no time. Plus, our monthly PROFAX, a FREE 8-page pull-out of popular TV, VCR and computer schematics, makes *ES&T* an even greater value.

Subscribe today to the only magazine devoted to *you*, the electronic servicing professional. You'll also receive the all-new **PROFAX SCHEMATICS SPECIAL** with over 50 pages of the hottest schematics — absolutely FREE!



Simply answer the following questions and you've earned this qualified rate!

### 1 Type of business

- 21  Consumer Electronic Equip. Independent or Franchised Service Business
- 22  Retailer with Consumer Electronics Equipment Service Department
- 23  Electronics Equipment Field Service Organization
- 24  Service, Installation or Operation of Electronics Equipment in Industrial or Commercial Facility
- 33  Engineering of Electronics Equipment in Industrial or Commercial Facility
- 35  Wholesaler, Jobber, Distributor
- 37  Electronics Equipment or Components Manufacturer
- 38  Government and Military, Federal, State, Municipal
- 09  Education:  (a) College, Library, School, including Instructors  (b) Student
- 30  Other \_\_\_\_\_

(please specify)

### 2 Position

- EE  **Company Management** Such as General Manager, Owner, Partner, President, Vice President, Director and other Corporate Personnel
- FF  **Operations Management** Such as Service Manager, Operations Manager, Production Manager, Customer Service Manager, Marketing/Sales Manager, Purchasing Manager, Credit/Accounts Manager and other Operations/ Administrative Personnel
- GG  **Engineering/Technical & other Personnel** Such as Engineer, Technician Field Service Engineer, Specialist, Engineering Associate and other Engineering and Technical Support Personnel
- KK  Other \_\_\_\_\_

(please specify)

Enter my subscription to *Electronic Servicing & Technology* for (check one)

- 2 Years (24 issues) \$45  1 Year (12 issues) \$24.75
- 2 Years Foreign \$57  1 Year Foreign \$30.75
- Check/Money order enclosed
- Bill to:  MasterCard  VISA  AMEX Expires \_\_\_/\_\_\_

Name \_\_\_\_\_ Title \_\_\_\_\_

Company \_\_\_\_\_ Phone # \_\_\_\_\_

Address \_\_\_\_\_

City \_\_\_\_\_ State \_\_\_\_\_ Zip \_\_\_\_\_

Signature \_\_\_\_\_ Date \_\_\_\_\_

Mail your subscription to: *Electronic Servicing & Technology*  
76 North Broadway, Hicksville, New York 11801  
Order Toll Free 1-800-853-9797 or FAX: 516-681-2926

# Test your electronics knowledge

Answers to the quiz  
(from page 59)

1. B. The impedances are taken into consideration when the input and output powers are calculated or measured.
2. A. This connection is used during operational amplifier qualification tests. There should be no output signal.
3. B. Servos utilize feedback control in their operation.
4. B. An active transducer generates a voltage that is related to the thing being sensed. The output of a thermocouple is a voltage related to heat.
5. Rheostat—by definition.
6. Light Activated SCR.
7. B. Always on regardless of the position of SW. It is a useless circuit.
8. 47K (All other circuits are shorted out.)
9. VARS (Volt Amperes, Reactive). It is the power that would be dissipated if the equivalent reactive component was a resistance.
10. C. The battery supply has absolutely no ripple, so, it cannot affect the output signal. This is true for low-frequency signal generators.

## SOLUTION TO BONUS QUESTION

$$\begin{aligned} \text{dB} &= 10 \log P_{\text{out}}/P_{\text{in}} \\ 4.8 &= 10 \log P_{\text{out}}/0.75 \\ 0.48 &= \log P_{\text{out}}/0.75 \\ \text{antilog}^{-1} 0.48 &= \text{antilog}^{-1} \\ &= (\log P_{\text{out}}/0.75) \\ 3 &= P_{\text{out}}/0.75 \\ 2.26 \text{ W} &= P_{\text{out}} \text{ (ANSWER)} \end{aligned}$$

# News

Sales of color televisions in July were the best ever for that month, rising 14 percent over the same period last year. Shipments jumped 76 percent during the last week of the month. Sales during that week were at their highest level for any week since the last week of September in 1990.

Joseph P. Clayton, executive vice president, Marketing and Sales-Americas, Thomson Consumer Electronics, says that "If unit sales of color TVs continue at this record pace, we can look forward to even more dramatic growth in the second half of this year, when the industry traditionally has its best sales results."

## Independent appliance servicers unite

A group of independent appliance service dealers have banded together to help their industry to grow, and to become more prosperous for practicing professionals. A new association, the National Independent Appliance Servicers (NIAS) was formed at an organizational meeting on August 3, 1993 in Louisville, KY.

The meeting was held at Louisville's Galt House-East Hotel in conjunction with the 1993 National Professional Electronics convention (NPEC) and Trade Show. This is a follow-up to actions taken at a fact-finding meeting held at the 1993 Major Appliance Servicers Convention in Denver last February.

The new group immediately affiliated themselves with NESDA, the National Electronics Service Dealers Association. This provided them with instant access to the myriad programs and benefits of NESDA and allows them to operate under the NESDA organizational and corporate umbrella. These benefits include association and industry publications, group insurance programs, bankcard discount programs, business and technical aids and supplies, public relations and advertising materials, the annual convention and trade show, forms purchasing discounts, functioning task forces, and more.

Ken Kroeber, CAT of Kroeber's Repair Service in Santaquin UT, was named as chairman of this appliance division of NESDA. Mr Kroeber said that the appliance service industry is deserving of the same caliber of representation that electronics groups now enjoy through NESDA. The mission of the new organization was affirmed as being, "To provide programs to assist all independent appliance service dealers to prosper in a professional manner."

The next meeting of the NIAS Board

of Directors will be held in Las Vegas in early January. This will be in conjunction with the Winter Consumer Electronics Show and the NESDA/ISCET Board meetings. Following that, NIAS officers will again attend the Appliance Tech Talk! Major Appliance Servicers Convention in Orlando in April 1994.

For more information about NIAS, contact Ken Kroeber CAT at 190 W. Main St., Santaquin UT 84655 or phone 801-754-5341; or contact Clyde Nabors, Executive Director of NESDA and NIAS, at the address below.

## Military Education Offices eligible to administer FCC commercial license examinations

The Greencastle office of the Electronics Technicians Association, Int'l., (ETA), has announced that DANTES test sites in the U.S. Military, are eligible to administer the FCC commercial license examinations. Testing under the new privatized procedures began on September 1 after more than a half century of testing by the FCC regional offices only.

ETA is one of nine entities that have been granted authority to administer the commercial license exams. Purpose of the privatization action was to provide for increased opportunities to sit for examinations, and to involve outside technical associations in the modernization of the exams themselves.

DANTES test control officers at military installations around the world have participated in ETA's CET, (Certified Electronics Technician), program for over 10 years. Dick Glass, CET, ETA president, indicated that the procedures for administering the FCC licenses will remain much the same as that used for the exams. TCOs can order examination packets utilizing standard procurement forms beginning September 1, 1993.

As of September 1, only elements 1 and 3 are ready to be used for testing. These apply to the General Radiotelephone and Marine Radio Operator Permit exams. Within the next few months, additional test question pools will be available for testing in all nine categories of commercial examinations. To order exams or for further details about FCC exams from ETA, TCOs may use the following: ETA, 602 N. Jackson, Greencastle, IN 46135. The phone number is 317-653-8262, and you can Fax at 317-653-8262. Alternate voice numbers are: 317-653-4301 and 317-653-5541. ■





### Multi-outlet surge protector

The Model 299 industrial-grade, multi-outlet surge protector from *MCG* guards computers, printers, disk drives, VCR's, TV's and sensitive equipment from transients caused by lightning, switching surges, the operation of heavy machinery, etc. This compact unit is a solid state, plug-in protector which clamps incoming noise to safe, non-damaging levels. The UL/CSA listed protector plugs into a local 120Vac, 15A outlet and incorporates six ac line outlets, a circuit breaker, and a protection present indicator.

Clamp voltage on the ac power line is 200V peak (initial) to 335V peak (maximum). The unit uses brute force MOV technology and is rated for 70 joules of energy handling capability. The company's sine wave tracking filter enables superior transient attenuation at the lower frequencies.

The unit provides critical load protection from high energy impulses by an exceptionally low "let-through" voltage. In less than one nanosecond, destructive transient currents are intercepted and safely diverted to ground. After a transient event has occurred, the device automatically resets. A green LED gives verification that the unit is operational and full protection is present.

Circle (55) on Reply Card

### Repair and manufacturing center

*Automated Production Equipment Corp.* (A.P.E.) introduces the Model SMD-250 for a variety of surface mount and PTH applications in one system.

The product accommodates interchangeable sensor driven handpieces for a number of system applications. Thermal quad-pak tweezer provides an ergo-

nomically designed handpiece for solder reflow and removal of PLCC surface mount devices. Temperature control high-thermal mass heaters target the heat to the leads without causing damage to the adjacent component or board. A variety of interchangeable tips are available with a low viscosity wall for dense packaged devices.

Static dissipative solder extractor provides quick response to changes in temperature for multi-layer boards and ZVS switching ensures no voltage spikes at the tip during continuous desoldering.

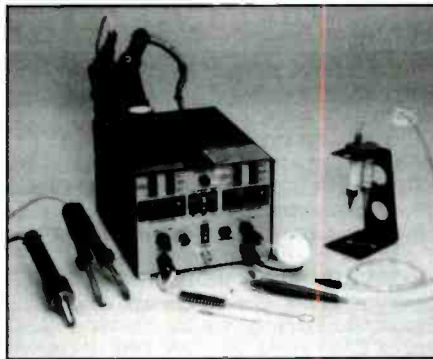

High-efficiency lightweight soldering iron is useful for both thru-hole and surface mount applications. Temperature-controlled iron accommodates a variety of tips for SMD integrated circuits, chips, SOT's, and SOIC's.

Automatic epoxy/solder paste dispenser applies consistent deposits of paste. Output air pressure up to 30 psi to match viscosity, from micro dots to/or large deposits for control pad applications. Standard timing range is 0.01-1.0 seconds. Solid-state timer with +/-0.1% tolerance. Complete range of interchangeable tips.

SMD vacuum handling tool kit handles all types of SMD devices with variable vacuum that produces 15 inch Hg. Interchangeable vacuum cups to facilitate handling and placement of PLCC's, chips, SOT's, SOIC's, and flat packs.

Hot Thermal Jet-Flow for solder/desolder of SMD surface components. Hand tool attaches to airflow regulation control and electronic circuits thermocouple control for precise temperature solder reflow applications.

Circle (56) on Reply Card

### Low temperature component desoldering system

*MTS Electronics* announces the availability of their Chip Quik surface mounted device (SMD) removal kit. The kit consists of a solder removal alloy which is sufficient to remove 8 to 10 SMDs, a special removal flux to be used with the alloy, a special low-temperature desoldering braid and flux to be used for clean-up of remaining solder after the chip has been removed, and detailed instructions for first time users. To use this product, the technician melts the special alloy (which looks like solder wire) with a heat gun or soldering iron (temperature need not be more than 200F), covering all pins of the chip to be removed uniformly with the alloy, and keep the alloy at melting temperature for at least one minute to give it time to react with the solder. Once the alloy has reacted with the solder, the solder remains molten so the technician may use a chip puller to remove the chip. The technician then cleans up the remaining solder/alloy with heat gun, brush and cleaning solvent or desoldering braid.

Circle (93) on Reply Card

### Anti-static soap

A new anti-static, soft hand soap has been specifically designed for the electronics industry by *Tech Spray, Inc.*

The new soap, called Zero Charge Hand Soap (product #1745), gently dissolves oils, flux residues and other common hand soils, and leaves hands clean without contaminant residues, like silicones or lanolin.

The soap, designed to be used with Zero Charge Hand Lotion to keep skin moist and reduce static build-up, is available in a concentrated form packaged in eight-ounce finger pump bottles and one-gallon plastic containers. Bulk dispenser gallon hand pumps and gallon wall-mounted dispensers are also available.

Because the soap and hand lotion leave no contaminant residues, they are suited for PCB manufacturing, assembly operations, computer operators, soldering and rework stations, field service and general hand care.

Circle (58) on Reply Card

Classified advertising is available by the word or per column inch.

**By-the word.** \$1.65 per word, per insertion, pre-paid Minimum charge is \$35 per insertion. Initials and abbreviations count as full words. Indicate free category heading (For Sale, Business Opportunities, Miscellaneous, Wanted). Blind ads (replies sent to ES&T for forwarding) are \$40 additional. No agency discounts are allowed for classified advertising by the word. Contact Emily Kreutz at 516-681-2922 to place your classified ad (by-the-word). Mastercard, VISA, American Express and Discover are accepted for FAX or mail orders.

**Per column Inch** (classified Display): \$235 per column inch, per insertion, with frequency discounts available, 1" minimum, billed at 1/4" increments after that 10" maximum per ad. Blind ads are \$40 additional. Reader Service Number \$25 additional to cover processing and handling costs. (Free to 4-inch or larger ads.) For more information regarding classified display advertising please call 516-681-2922. Optional color (determined by magazine) \$150 additional per insertion.

Send your order, materials and payments to:

**Electronic Servicing & Technology**  
76 North Broadway  
Hicksville, New York 11801  
Attn: Emily Kreutz  
Phone: 516-681-2922 FAX: 516-681-2926



## FOR SALE

**FREE REPAIR TIPS!** If you order our demo program for \$10.00 we will send you 20% of our tips. That's 10% of our tips FREE. The Dog Catcher 2.2 is a computer based repair tips program. We have been told by our customers that we have the best tips on newer models. Our tips come from our customers. Call to get a free brochure, order the demo for \$10.00 or order The Dog Catcher with all the tips for \$99.95. Call our toll free number now at 1-800-967-5924.

**VHS-VCR Repair Solution Sets I, II, III IV, V, VI, VII, VIII.** Each contains 150 symptoms and cures, updated cross reference chart, free assistance, \$11.95 each, all eight \$79.95. Schematics available. Visa/MC. Eagle Electronics, 52053 Locks Lane, Granger, IN 46530.

## FOR SALE

**HELLO! Doctors Do It! Airlines Do It! Lawyers Do It! TV TECHNICIANS SHOULD DO IT! No Matter What Industry - SERVICE HISTORY PAYS!** From the Original World Wide TECH-TIP Program comes 2.5 Million Dollars worth of solid repairs. 1987 through August 1993. Whether you are computerized or not, our Tech-Tip program provides the most current comprehensive published paper format there is today. You may also wish to choose our Tech-Tip computer program, licensed World Wide under (PARADOX) by The Boreland International Co. We're not fooling around and you shouldn't either. Remember it's not the quantity of tips but the constant update quality of solutions that makes the difference. Our initial 10,000 TECH-TIPS cover VCR-VCP-TV/VCR combo CD/LD-FAX-Camcorder-VHS/SVH/C/8MM-Stereo-Monitors-Amps Projection Front and Rear-Microwave-Satellite. Category is easily cross referenced first by Model, Chassis or FCC ID Number and printed out or simply scanned by Make and Category. Unlike other programs, we provide OEM Part numbers and substitutes. Our on-going program is actual day-to-day repairs written on the Bench by technicians for technicians. No need for you to spend time updating your data base or paper binders. We send you a complete revised program at each update of your choice (Computer or Paper Format). Outside technicians and students love the portability and say it is a must in the field where time is very critical. As an added Extra, we provide an FCC ID Cross Reference list which saves the expense of purchasing Service Manuals you may already have and just don't know it. This program was produced by Ed Erickson technician and owner of TV-Man Sales & Service, Inc., and President of The Professional Electronics Association of South Florida. The PHONE CALL is "FREE" and so is the Disk or Paper Sample Demonstration. **CALL (800) 474-3588 or Write TECH-TIPS, 8614 State Road 84, Ft. Lauderdale, FL 33324.**

**Tech ReSource**, a computerized directory of over 650 total listings of consumer electronic part distributors in over 90 manufacturer and other categories. IBM compatible 3-1/2" or 5-1/4". Mastercard/Visa 1-800-580-4562 **\$34.95.** Brochure available. M.C. Humphrey & Co. P.O. Box 1414, Noblesville, IN 46060.

## FOR SALE

**\*\*\*\* The TIP COMPUTER PROGRAM \*\*\*\***  
**One of the LARGEST tip databases in the COUNTRY — over 12,000 tips!!! HIGH QUALITY, PROFESSIONAL SOLUTIONS with up to 8 LINES of problem solving information** (not just 1 line like in other programs). Special **DATA EXCHANGE** feature **INCLUDED with every program**, allows Service Centers with the TIP Program to exchange tips via diskettes. **PRINT** any tip. **EASY** to operate — **ANYONE** can use the TIP Program. This is the **BEST** technical tip database program on the market today. If you want to use only one tip program — **this is the TIP Program to buy.** Used by National Association Members & Officers. **CALL NOW!!! (516) 643-7740 HIGHER INTELLIGENCE SOFTWARE, 60 Farmington Lane, Melville, NY 11747**

**AVAILABLE TO YOU FOR THE FIRST TIME!**  
**TechFix™** has over 5500 tips. TVs, VCRs, Camcorders. Updates available by mail or modem. Add you own tips. Share your tips with other users. QuickLookup, Symptom codes, Wildcard Models, and Word searches. EIA code compliant. Used by Circuit City technicians. \$295 gets you the best! Only tech tip program supplier with an online database service. Call 404-968-3715 or write to TIPS Box 1681, Forest Park, GA 30051-1681.

**TECHNICIANS, FINALLY A BREAKTHROUGH IN SMD REMOVAL! CHIP QUIK™ SMD REMOVAL KIT.** • NO DAMAGE TO CHIP OR BOARD • LOW OPERATING TEMPERATURE • EASY TO USE • INEXPENSIVE. \$12.00 per kit + \$2.00 S&H. 24 hr Fax for credit card orders (508) 879-7727. Info available, call **MTS ELECTRONICS (508) 879-3131**

**Zenith TV Module Cures YOU Can Do.** 60 page binder—110 profit-boosting repairs for modules 9-152 thru 9-1119. These are **actual** no-nonsense repairs that work. Updates available quarterly. \$10/sample or \$100 complete to: **ZMEX, 807 Queen Palm Lane, Sarasota, FL 34243.**

**TEST EQUIPMENT BOUGHT & SOLD: OSCILLOSCOPES, ETC. 1-408-738-4206. FAX 1-408-736-6946.**

**TV/VCR REPAIR SOLUTIONS:** 1,000 VCR printed \$83. 5 1/4" IBM disk \$72. 5,400 TV prints \$135. Disks \$113. 1,000 latest TV \$54. Electronic Solutions, 407 W. Ave. "N", San Angelo, TX 76903.

**\*\*\*\*\* INTRODUCING SERVICE TIPS \*\*\*\*\***  
The **BEST** Technical Tips Computer Program available today containing over **15,000 CURRENT TIPS** including TV's - VCR's CAMCORDERS - MONITORS - AUDIO EQUIPMENT & Other Electronic Equipment **ONLY \$199.95** Demo Disk & Quarterly Updates Available - Call or Write **Electronic Software Developers Inc. 826 S. Main Street South Farmindale NY 11735 Phone (516) 221-6403**

**FOR SALE.** Sencore VC-93 analyzer, SC3080 Scope, PR57 Power Supply \$4,500.00 or take over payments of \$150.00 per month. Call 814-838-6897

**RCA 176342/176343 TUNER CURE!** Repair easily to component level. For complete instructions send \$20.00: **TEK Enterprises 212 Marabou Dr. Newark, DE 19702.**

**MONITOR REPAIR SOFTWARE.** Designed for the bench technician, fast easy to use, eliminates costly testers. Write or call for details. Fessenden Technologies, 116 North Third Street, Ozark, MO 65721 (417) 485-2501.

## FOR SALE

**REDUCED 85%.** Diehl Mark III \$69, Diehl Mark V Horizontal circuit tester \$179. New. Conductive coating for remote control keypads \$9.99 ppd. WEEC, 2805 University Ave., Madison, WI 53705. 608-238-4629, 608-233-9741.

**TV-VCR SHOPS:** A program of over 2800 fixes on disk. Only \$99.95. TECH-DAT, 212 Earth Row, Waynesville, MO 65583. Call 1-800-280-2100. VISA & M/C.

**SENCORE** SC61 \$1150; CR168 CRT Tester \$295; Sadelco 719C Signal Level Meter \$295; Tek 442 35 MHz Scope w/TV Trigger \$295; Tek 2215 60 MHz Scope w/TV Trigger \$450. More equipment available, call **TEST EQUIPMENT SALES (603) 434-2544**, 8 am - 8 pm EST.

## BUSINESS OPPORTUNITIES

**FOR SALE:** Electronics Sales & Service Business in the beautiful mountains of North Central Idaho. 208-983-0429

**MOVE TO THE LARGEST REPAIR PROFIT MARKET IN THE COUNTRY — SUNNY SOUTH FLORIDA** Think about it, our clients bring their REPAIRS & MONEY from all parts of the world. Annual Gross 375,000k, take home 80 - 95,000k. Owner retiring, Fully staffed & operated in the largest growth area of Ft. Lauderdale. Established 12 years. No competition. Authorized 15 major brands. Totally computerized. Simple to operate Business. Price is 125,000k, Owner financing available. \$5,000 deposit holds price and availability for 30 days. (305) 474-2677

**VIDEO REPAIR & VIDEO TRANSFER LAB.** Established 8 years, Modesto, CA. Fully equipped bench & lab. Good customer base and reputation. Call 209-576-1094.

**ESTABLISHED 15 YEARS** authorized service center: good location, great potential. authorized 17 major brands, 100% computerized, well equipped with tools and schematics. Call 212-447-7562

**CALL 516-681-2922  
TO PLACE YOUR  
CLASSIFIED AD TODAY!**



The  
**Professional  
Electronics  
Technicians  
Association**

## Join Us

## on the ETA-SDA Pro Show

**Satellite S3, ch. 21, 5.8 mHz**  
Sunday evening tech show: 9-11 p.m. EST

*On the ETA-SDA RBBS*  
through the GENie Network  
**1-800-638-8369**  
to sign up on GENie

For TechniTips - job openings - Association Journal - Tech Training monographs - regional tech & business seminars (with college credit) - Certification - local chapters - a voice in your profession - 1993 national convention and satellite trade show in Moline - August 1993.

**For Information Call:**  
**317-653-8262**  
602 North Jackson  
Greencastle, IN 46135

Circle (116) on Reply Card

## Readers' Exchange

Readers' Exchange has been reinstated as a free service.

The following restrictions apply to Readers' Exchange:

- Only individual readers may use Readers' Exchange, and items must be restricted to those that are ordinarily associated with consumer electronics as a business or hobby. If you're in business to sell the item(s) you want to offer for sale, the appropriate place for your message is in a paid advertisement, not Readers' Exchange.

- Readers' Exchange items must be restricted to no more than three items each for wanted and for sale, and may be no more than approximately four magazine column lines in length (about 20 words).

- All submissions must be typed or printed clearly!

Send your Readers' Exchange submissions to:

**Readers' Exchange  
Electronic Servicing &  
Technology  
76 N. Broadway  
Hicksville, NY 11801**

### WANTED

VCR idler assembly for Cannon model VR-20A. Phil, 970 Lost Dutchman, Tucson, AZ 85737.

Color IC #VEFSC001, 619502004 or GE EW84X244 for Curtis Mathes portable VHS recorder model #JV733. Tom, P.O. Box 971, Baytown, TX 77522. 713-424-2744, Fax 713-424-3346.

Equipment manual/schematic, calibration tables, etc. for a Jackson model 658A tube tester and a Laupklin Laboratories model LM-105. Will purchase or copy. Joe Waters, POB 1171, Eugene, OR 97440.

Fisher VCR service manuals; adaptor socket #GR-42 for B&K 470 CRT checker. Ed Herbert, 410 N. Third St., Minersville, PA 17954.

Front Panel assembly for RCA VCR model VMT400 (Part #180083). Doug Hoff, 140 Loraine Ct., Vacaville, CA 95688. 707-448-3917.

Isolated variable ac power supply 0 to 150VAC, B&K model 1653 or equivalent. Magnavox flyback #361846-3 or junk 25C 202-BB chassis with good flyback. Mike Reynolds, P.O. Box 936, Rock Springs, WY 82902. 307-875-6745.

### FOR SALE

Leader dual-trace 10MHz oscilloscope, \$300.00, B&K 1077 TV analyst, \$400.00, B&K 415 Sweep-Marker generator, \$500.00. Original box in excellent condition. John 201-432-7635.

Three 25 inch by 13 inch size boxes packed full of service manuals, schematics, and Photofacts for \$150.00 or best offer. 216-923-4989, Charlene.

Sencore SC3080, less than 25 hours. of use, 1-year-old, excellent condition. All manuals and leads. Asking \$2000.00. Must Sell. Phillip, 912-283-4309 after 6:00 p.m.

Sencore equipment, SC61-\$1500.00, VA62-\$1500.00, CR70-\$650.00, VC63-\$100.00, NT64-\$100.00, LC53-\$300.00, PR57-\$300.00, R667-\$400.00, EX231-\$75.00. Will sell as package at firm price for \$4900.00 or as individual items at stated prices. All excellent condition, original cartons. 216-923-4989, Charlene.

# Resolve Monitor Repair DataBase

1305 repairs  
109 Models  
Component Sources  
Cross Reference  
4 Updates per year  
Starting at \$159  
Call for FREE Demo  
1-800-999-0304



Circle (1) on Reply Card

**Tech's Guide To Pricing**  
**NEW**  
**"Sperry Tech's Pricing Guide"**  
Updated new 6th edition...a framework for setting rates that apply to Hi-Tech products...a formula that guarantees SUCCESS!  
Call Toll Free for details  
1-800-228-4338

Circle (17) on Reply Card

## I.C.'S! TRANSISTORS!

Largest selection of original RADIO, T.V. & VCR semiconductors. Call or write for free catalog.

PRELCO ELECTRONICS DISTRIBUTOR  
805 CHESTNUT STREET • UNION, N.J. 07083  
TEL: 1-908-851-8600 • FAX: 1-908-886-4858

Circle (9) on Reply Card

## TUBES • TUBES • TUBES

World's Largest Range  
Over 2,000 Types, Domestic & Foreign  
**UP TO 85% OFF** Ask for price list  
International Components Corporation  
Toll Free 800-645-9154 • N.Y. State 516-293-1500  
105 Maxess Road, Melville, New York 11747

Circle (4) on Reply Card

## THE SOURCE . . . for quality Electronic Parts & Accessories.

"We'll get your parts to you as fast as you need them!"

Call today and ask about our **PREMIUM DELIVERY** and for your **FREE** copy of our catalog . . .

**1-800-558-9572**

or for 24 hour ordering call **FAX 414-473-4727**

"First in Quality, Service and Delivery"



P.O. Box 28 • Whitewater, Wisconsin 53190

Circle (14) on Reply Card

# Advertiser's Index

Company	Page Number	Reader Service Number	Advertiser Hotline
American Reliance .....	13	2 .....	800/654-9838
Anatek Corporation .....	72	1 .....	800/999-0304
Automated Production Equipment....	10	21 .....	516/654-1197
Cleveland Institute .....	11	.....	.....
Computer Monitor Maintenance .....	22	3 .....	800/466-4411
Den-On Instruments .....	9	20 .....	800/397-5960
Electronic Technician Association ....	71	116 .....	317/653-8262
Fluke Corporation.....	BC	57 .....	800/87FLUKE
International Components Corp. ....	72	4 .....	800/645-9154
Iscet.....	28	.....	817/921-9101
Jensen Tools .....	17	5 .....	602-968-6231
Jesse Jones Industries.....	23	.....	800/825-6690
MCM Electronics .....	55	31 .....	800/543-4330
NESDA .....	9,10	.....	817/921-9061
PACE Communcations.....	7,17	7,6 .....	301/490-9860
Parts Express.....	13	8 .....	800/338-0531
Philips E.C.G. Company.....	IBC	10,11 .....	800/526-9354
		12,13	
Prelco Electronics.....	72	9 .....	908-851-8600
Premium Parts + .....	72	14 .....	800/558-9572
Sams, Howard & Company .....	17,48	16,30 .....	800/429-7267
Sencore .....	IFC	32.....	800/SENCORE
Specialized Products Company ..Insert		.....	800/866-5353
Sperry Tech .....	72	17 .....	800/228-4338
Tab Books.....	55	.....	800/822-8158
Tandy Distributor Sales .....	14	18 .....	800/322-3690
Tentel.....	55	104 .....	800/538-6894
Wavetek Corporation.....	3	19 .....	800/854-2708
Wholesale Electronics .....	28	22 .....	800/351-2233

We'd like to see your company listed here too. Call Diane Klusner at 516/681-2922 to work out an advertising program tailored to suit your needs.

## SALES OFFICE

**PHONE (516) 681-2922**

**FAX (516) 681-2926**

## ECG® antenna rotator: high torque plus long service life!

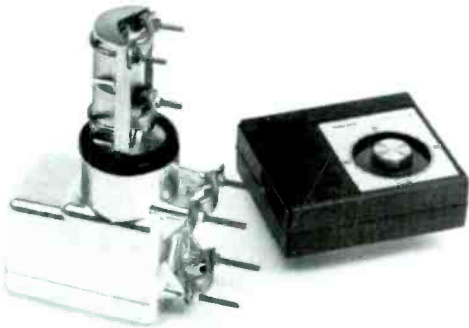

High-torque ECG® U-105 Rotator turns even largest TV/FM antenna array. Manufactured and tested exclusively to our specifications. Precision cut, hardened steel drive train, rugged cast aluminum housing and reinforced mast support for long service life.

At 900 Philips ECG distributor locations or call 1-800-526-9354.

**The Smart Choice** 

Philips ECG



**PHILIPS**

Circle (10) on Reply Card

## 72 new ECG® semis, 8,100 new crosses in guide supplement.

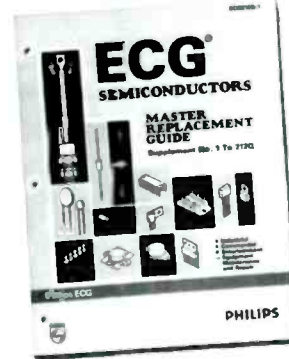

Supplement to ECG Master Guide details newest replacement modules, ICs and discretes for use in entertainment and industrial equipment, adds 8,100 more part-number cross references to the industry's most complete semiconductor line.

At 900 Philips ECG distributor locations or call 1-800-526-9354.

**The Smart Choice** 

Philips ECG



**PHILIPS**

Circle (11) on Reply Card

## All nine most-used measurements, by one multimeter: DM-38!



Ideal for field, lab and shop. Measures capacitance, frequency, logic, transistor hFE, AC/DC voltage and current, resistance, semi junctions and continuity. 3-3/4 digit with peak hold, 0.5% accuracy.

At 900 Philips ECG distributor locations or call 1-800-526-9354.

**The Smart Choice** 

Philips ECG



**PHILIPS**

Circle (12) on Reply Card

## New ECG® parts, tools bring A/V line to over 350.

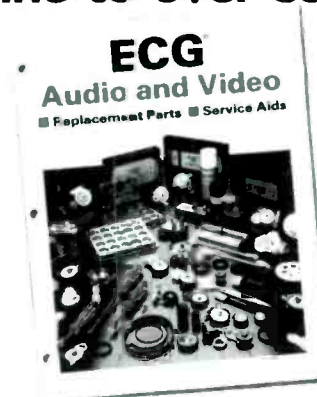

Replacement parts that meet or exceed OEM specs for 31 popular VCR brands, VHS and Beta. Catalog: over 3,500 crosses; industry's best source for replacement parts and tools. Ask for a copy.

At 900 Philips ECG distributor locations or call 1-800-526-9354.

**The Smart Choice** 

Philips ECG



**PHILIPS**

Circle (13) on Reply Card

# Top Choices.

Fluke meters are your top choice for accuracy, reliability, and performance. They offer more combinations of features and functions than any other meters on the

Fluke 97  
ScopeMeter®

market. Features like true-rms measurements, high resolution, Smoothing™ and Peak Hold. Or simultaneous scope and meter

functions in one portable package. Whichever Fluke meter

you choose you can count

on benchtop accuracy,

test lab versatility, and

handheld convenience.

Plus, Fluke keeps you

covered with a full line of quality

accessories, strong customer support,

and product warranties that measure up

to any in the industry. When it's up to you to get the job done, look to

Fluke for the choices you need to get it done right. See your

Fluke distributor, or call 1-800-87-FLUKE

8060A

for a catalog and the name of the

distributor nearest you.



Fluke 87

Fluke 79



## FLUKE 79 FLUKE 87 8060A FLUKE 97

The Fluke meters listed above feature diode test, auto and manual range, continuity, and frequency measurements.

Lo-Ohms measurements	True-rms	True-rms	True-rms ac, or dc & ac
Capacitance measurements	Capacitance measurements	Resistance measurements to 300 MΩ	Scope, Meter or simultaneous meter and scope display
Smoothing™	Duty Cycle measurements	High-impedance DC voltage function	Dual Trace 50 MHz bandwidth
4000 count display	20,000 count high resolution display	20,000 count display	40 nanosecond glitch capture
Basic accuracy 0.3%	Offset/Relative reference 1 millisecond Peak Hold	Offset/Relative reference dB measurements	Store waveforms and setups dBm, dBV, dB Relative and Audio Watt calculations
	Basic accuracy 0.1%	Basic accuracy 0.04%	Basic accuracy 0.5%

John Fluke Mfg. Co., Inc.  
P. O. Box 9090, Everett, WA 98206  
For more information call:  
(416) 890-7600 from Canada  
(206) 356-5500 from other countries

© Copyright 1992 John Fluke Mfg. Co. Inc. All rights reserved.  
Ad No. 00282

# FLUKE®

Circle (57) on Reply Card

