

ELECTRONIC

Servicing & Technology

August 1990/\$3.00

Continuing education for technicians

Using symptom analysis to troubleshoot a VCR



Replacement Parts Showcase

Pinpoint AM Stereo-FM Stereo Receiver Troubles Right From The Antenna With The Fully Integrated SG80 AM Stereo - FM Stereo Analyzer™

NEW!

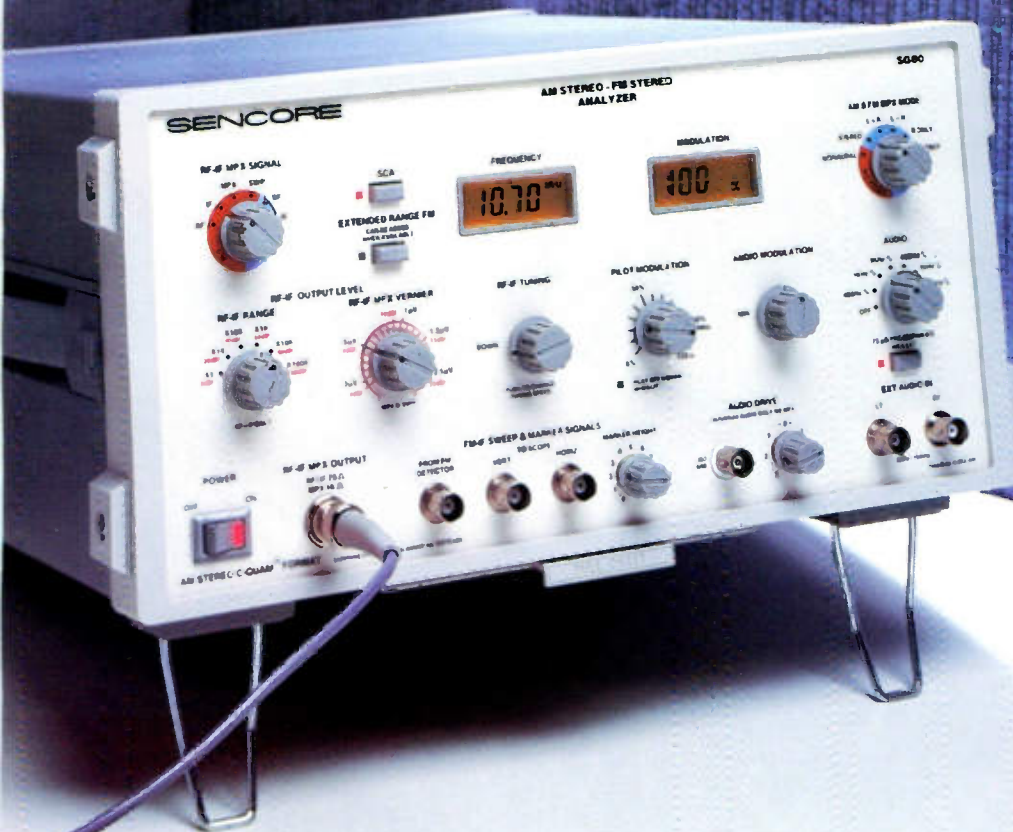

"Try the SG80 AM Stereo-FM Stereo Analyzer on your bench for 10 days. If the SG80 meets your testing needs, we'll arrange for you to keep it. If you're not completely satisfied, send it back and we'll take care of the freight both ways"

Patented
\$3,995
U.S. Funds

Analyze modern receivers with the accuracy and efficiency needed for profitable servicing:

- Every signal you need to troubleshoot and performance test any AM Stereo or FM Stereo
- Rock solid digital tuning gives you fast, accurate, channel-by-channel control
- Microprocessor calibrated attenuator provides accurate signal levels for all your testing and troubleshooting needs

- Patented analyzing signals let you use the same troubleshooting techniques for both AM Stereo and FM Stereo receivers
- Exclusive tuneable IF sweep system allows you to dynamically analyze the latest FM IF stages
- Isolated audio drive signal lets you troubleshoot from the stereo decoder to the audio amplifier
- High quality signals give you confidence the receiver is operating at peak performance
- Automate your testing with optional IEEE 488 or RS-232 computer interface accessories

C-QUAM is a registered trademark of Motorola, Inc.

SENCORE

3200 Sencore Drive, Sioux Falls, South Dakota 57107
Circle (43) on Reply Card

Call 1-800-SENCORE

(736-2673)

In U.S. And Canada

Ask About

A 10 Day

Video Preview



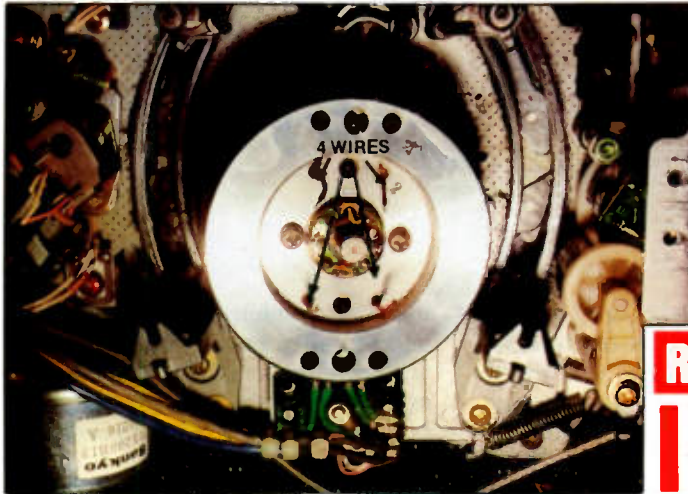

page 8

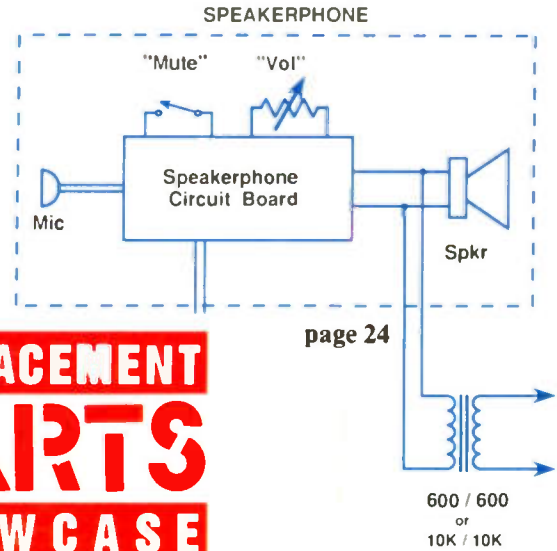

REPLACEMENT PARTS SHOWCASE

page 41

SPECIAL ADVERTISING SUPPLEMENT

Replacement Parts Showcase

41 **Choosing your replacement parts supplier**
 In these days, with the number and kind of consumer electronic products growing rapidly, the sophistication of those products constantly increasing, and the number of replacement parts increasing exponentially, it gets harder and harder to identify the correct replacement part and obtain one in order to get that TV or VCR back in operation. Does your replacement parts supplier make it easy for you to identify and order the correct part? Does he have it in stock? If he sends you the wrong part what is his policy on returns? Here are some questions you might want to ask when you're trying to decide on who to order your parts from. Then turn to the profiles of the companies published in this section to see what their answers are.

FEATURES

- 8** **Using symptom analysis to troubleshoot a VCR**
By Victor Meeldijk
 Analysis of the symptoms points toward the problem location, and examination of the schematic diagram helps pinpoint the area of the circuit that's causing the problem in this account of the solution of a VCR sound problem.
- 14** **Continuing education for technicians**
By Conrad Persson
 Being an electronics servicing technician has never been easy. Today it's impossible unless you constantly work to stay abreast of all of the new products and circuits the manufacturers are churning out. Here are some suggestions on finding the training resources you need to keep your head above water.

- 18** **What Do You Know About Electronics?**
 Equivalent series resistance in capacitors
- 22** **Video Corner**
 Isolating video head problems
- 23** **Technology**
- 24** **Audio Corner**
 Interfacing the telephone with an audio system
- 27** **Profax**
- 37** **Computer Corner**
 Understanding floppy disks
- 38** **Products**
- 39** **Feedback**
- 40** **Test Your Electronics Knowledge/Photofacts**
- 59** **Reader's Exchange**
- 60** **Advertiser's Index**

DEPARTMENTS

- 2** **Editorial**
 Help us help you
- 4** **News**
- 5** **Literature**
- 17** **Business Corner**
 Keys to servicing success: education, participation, innovation

ON THE COVER

Consumer electronics products, which have always been complex, have in recent years become almost impossibly complex. In many cases the operation of these products, especially those that are computer controlled, can no longer be understood by simply studying the schematic diagram. More and more it is becoming necessary to get literature, in order to understand and service consumer electronics products. (Photo courtesy Sencore).

Help us help you

As you'd expect with a magazine with a circulation approaching 40,000, we receive quite a bit of mail from readers. It's not overwhelming, but we do get quite a bit. And we love to get mail. Sometimes it's a compliment, like a letter we once received telling us that a reader really liked a particular article and it saved him more than the price of the subscription on a servicing job. We especially like those.

Sometimes it's a complaint that we've made a typo or a technical error. Believe it or not, while we don't like to make errors, when we have made one, it's nice to have someone point it out to us. It tells us that at least some readers are reading the magazine carefully, which means we're doing something right. And it helps keep us on our toes, and when the error is something significant it gives us the chance to correct the error.

Sometimes it's a letter asking us to cover a specific subject that we haven't given much coverage to. Letters like that are very helpful. Although we try very hard to keep in touch with readers and learn what kinds of information and articles they need, in this fast moving technical world it's sometimes hard to know everything that consumer electronics servicing technicians are becoming involved with.

Another kind of letter we get from time to time is one asking for specific information. For example, it's not unusual to receive a letter asking us to identify the manufacturer of an obscure brand of TV or VCR, or looking for a source of replacement parts for a less well known manufacturer's product. When time permits, we do supply that kind of information if it's available. Many times it's simply a matter of having a look in the Consumer Electronics Replacement Parts Source Book, or the Consumer Electronics Show Guide.

We also provide what most readers agree is an excellent service: Readers' Exchange. Many readers avail themselves of it and are able to buy at an attractive price a product that another reader no longer has use for, or to sell a product that has served its purpose and is now merely gathering dust on a shelf.

Most readers are great about these things; typing or printing correspondence so that it's legible, spelling out abbreviations, including a self-addressed stamped envelope (SASE) whenever they need a personal reply, and understanding that there's a considerable lead time between the time we receive something for publication and the date of publication. The following guidelines are published here just for general information, and to try to help streamline things.

- All editorial correspondence: article submissions, troubleshooting tips, symcures, letters to the editor, and other such correspondence should be sent to me at the Overland Park, KS address.
- All other correspondence: Readers' exchange, questions about your subscription, etc. should be directed to the Hicksville, NY address.
- All correspondence, but especially submissions for articles or departments, should be typed, or printed on 8 1/2 by 11 paper.
- If you're requesting an individual reply, or if you're submitting an article and would like to have it returned if it's not accepted, please state that, and include a self-addressed stamped envelope of the appropriate size and with the appropriate amount of postage. We occasionally receive a request for a copy of the magazine with a self addressed, 10 inch envelope with a 25 cent stamp on it.

We do try to treat all correspondence with the care and respect it deserves, especially articles and other

materials submitted for publication, and we will always try to reply to letters from readers. We cannot, however, assume any responsibility for material submitted to us or guarantee its return.

Further, because we have a limited staff and ever-present deadline pressure, we will never be able to answer all letters from readers. If yours is one of those that doesn't receive a reply, we apologize. It's not that we didn't deem it important, it's just that time didn't permit. If it's really urgent, try writing again.

Finally, please try to understand the lead time that a monthly magazine works with. As I write this, June 27, almost everything that will appear in the August issue is now in production. If a reader has sent in a Readers' Exchange item since about June 15, it will not be published until the September issue at the earliest. And as we have stated before, we make no guarantees that any item will be published in Readers' Exchange ever, and can't accept any responsibility for consequences if an item is not published. If an item absolutely must be published, the place for it is in the Classified Advertising section.

Letters and other correspondence from readers is the lifeblood of this magazine. We need to know what you're thinking and the kinds of information you need. We do, however, operate under some stringent constraints of money, personnel and time, and therefore unfortunately we can't respond personally to them all. We do, however, read, and find valuable, every single letter.

Nile Conrad Pearson



LEADER STACKS UP A SELECTION FIT FOR A KING

If you've been stalking the city in search of an oscilloscope to suit your needs, you know that the market can seem like a jungle. But with Leader as your guide, you'll be rescued by a product line approaching gargantuan proportions. With more than 20 scopes to choose from, we'll help you eliminate those safari from one small manufacturer to the next.

Leader's large selection also ensures you'll find a scope with the latest technology—at an appropriate price—or the size of the task confronting you. Look to Leader for analog or digital scopes; for CRT readouts and cursors; for up to 8 trace capability; for a range of bandwidths; and for battery-operated or benchtop scopes and portables weighing as little as 2.1 lbs.

If you want to be king of the hill, let Leader's extensive line of oscilloscopes help you make the climb. For help in selecting the right scope or for our full-line catalog, in the Empire State call 516 231-6300. Or call toll free: 1 800 645-5104.

1 800 645-5104

LEADER

FOR PROFESSIONALS WHO KNOW THE DIFFERENCE

Leader Instruments Corporation,
380 Oser Avenue, Hauppauge, New York 11788
Regional Offices: Chicago, Dallas, Los Angeles, Boston, Atlanta.
In Canada call Omnitronix Ltd., 416 628-6221.

Circle (15) on Reply Card
For Demonstration Circle (18) on Reply Card

New warranty parts program

Thomas Consumer Electronics (TCE) has recently introduced two new parts-related programs designed (1) to help optimize in-and out-of-warranty service for the purchases of its RCA-and GE-brand consumer electronics products and (2) to simplify warranty claim procedures for its nationwide network of Authorized Service centers.

Thomson on April 2 implemented for its RCA and GE brands warranty parts program with the following service-oriented benefits. TCE authorized service centers now may purchase warranty replacement parts from any TCE Parts Distributor they choose. (Previously, they had to pur-

chase warranty parts from a Parts Distributor designated by TCE.)

The number of TCE Parts Distributor locations from which Service centers may obtain warranty parts has been increased from less than fifty to more than 350 nationwide.

Service centers now submit their warranty eligible part claims directly to TCE and receive reimbursement directly from TCE. (Previously, Service centers were reimbursed for warranty parts with a credit to their account at an assigned TCE Parts Distributor.)

Service centers no longer need to return defective warranty-eligible parts to a TCE Parts Distributor. Instead, service centers merely keep the

defective parts until they receive reimbursement for them from TCE, at which time they discard the parts.

These and other Service center-oriented benefits of the new parts program are described in a comprehensive warranty policies and procedures manual that has been mailed to all TCE authorized service centers immediately before the start of the program.

New parts distributor program

Complimenting TCE's new warranty parts program is a new TCE parts distributor program, called "Premier", that enhances Service center parts support and helps ensure that TCE replacement parts are conveniently available whenever and wherever they are needed nationwide.

Position for technical trainer for consumer electronic group

A position has become available for a technical trainer who will report to the staff Vice President of Product Services. The individual will be responsible for the operation of the EIA/CEG resident training facility including developing, implementing and conducting new and ongoing training programs at the resident site as well as field locations. Specific duties include: working with Service Education subcommittee members in developing new training programs, coordinating revisions, rewrites, and updates of existing programs with EIA/CEG educational consultants; development of laboratory manuals, lesson plans, outlines and other required written material for courses; conduct training classes at EIA/CEG resident facility and field locations; assist equipment procurement, and contest implementation for the National United States Skills Olympics; assist with training and preparation of the U.S. competitor to the International Youth Skills Olympics. Must be capable of developing and presenting service training for consumer electronic products. Travel required. For more information contact the Personnel Office, Ext 8785.

Watch and Learn.

Learn Car Stereo Repair from the Expert . . . Sony



The easiest way to learn is to watch an expert at work. And, now you can with Sony's new videotape on the repair of Car Stereo Mechanisms. Covering four distinct mechanisms, you will learn to trouble-shoot and repair 40 different Sony models manufactured from 1986 through 1991. See all the details with disassembly and reassembly demonstrations. Learn to isolate the problem—mechanical or electrical. Available in either Beta or VHS, this hour-long tape will help you work more confidently go right to the problem and fix it fast.

Not intended for consumer use.
© 1990 Sony Corporation of America
Sony is a trademark of Sony

SONY
Service Company

- YES**, please send me a copy of the Car Stereo Mechanisms videotape. I've enclosed a check in the amount of \$30.00* which includes shipping and handling.
- Please send me more information about Sony's videotape library.

When ordering, return this form with check payable to:

Sony Service Co.
National Parts Div.
8281 NW 107th Ter.
Kansas City, MO 64153
Attn: Publications Dept.

NAME _____
COMPANY _____
ADDRESS _____
CITY _____
STATE _____ ZIP _____

Format: BETA [T-CSM-1] VHS [T-CSM-9]

*INCLUDE APPLICABLE SALES TAX OR A COMPLETED RESALE CERTIFICATE.

Circle (44) on Reply Card

Electronic Servicing & Technology is edited for servicing professionals who service consumer electronics equipment. This includes service technicians, field service personnel and avid servicing enthusiasts who repair and maintain audio, video, computer and other consumer electronics equipment.

EDITORIAL

Nils Conrad Persson, *Editor*
Jeffrey Uschok, *Assistant Editor*

CONSULTING EDITORS

Carl Babcoke, *Consumer Servicing Consultant*
Homer L. Davidson, *TV Servicing Consultant*
Christopher H. Fenton, *Circuit Fabrication Consultant*
William J. Lynott, *Business Consultant*
Victor Meeldijk, *Components Consultant*
Kirk G. Vistain, *Audio Consultant*
Sam Wilson, *Electronics Theory Consultant*

PRODUCTION

Elizabeth Ryan, *Art Director*
Barbara Terzo, *Artist*
Dorothy Kehrwieler, *Production Manager*
Emily Kreutz, *Production*
Pat Le Blanc, *Phototypographer*
Florence V. Martin, *Phototypographer*

BUSINESS

Richard A. Ross, *Publisher*
Dorothy Kehrwieler, *General Manager*
Frank V. Fuzia, *Controller*
Catherine Ross, *Circulation Director*
Melissa Kehrwieler, *Data Processor*
Kathleen Bell, *Customer Service*

SALES OFFICE

Electronic Servicing & Technology
76 N. Broadway, Hicksville, NY 11801
516-681-2922; Fax, 516-681-2926

Jonathan Kummer, *Advertising Manager*
Emily Kreutz, *Sales Assistant*



Member, Audit Bureau
of Circulation



Member, Electronic
Servicing Dealers
Association

EDITORIAL CORRESPONDENCE

P.O. Box 12487
Overland Park, KS 66212
913-492-4857

Electronic Servicing & Technology (ISSN 0278-9922) is published monthly by CQ Communications, Inc., 76 N. Broadway, Hicksville, NY 11801. Telephone (516) 681-2922. Second class postage paid at Hicksville, NY and additional offices. Subscription prices (payable in US dollars only): Domestic—one year \$24, two years \$36. Foreign countries—one year \$30, two years \$42. Entire contents copyright 1990 by CQ Communications, Inc. Electronic Servicing & Technology or CQ Communications, Inc. assumes no responsibility for unsolicited manuscripts. Allow six weeks for delivery of first issue and for change of address. Printed in the United States of America.

Postmaster: Please send change of address notice to Electronic Servicing & Technology, 76 N. Broadway, Hicksville, NY 11801.

CQ Communications, Inc. is publisher of CQ The Radio Amateur's Journal, Popular Communications, Modern Electronics, CQ Radio Amateur (Spanish CQ), CQ Amateur Radio Equipment Buyer's Guide, CQ Amateur Radio Antenna Buyer's Guide, and Electronic Servicing & Technology.

New soldering tips literature

New from *Metcall* is the company's latest quarterly four-page publication designed to share new ideas in soldering technology. The feature article in the summer 1990 issue known as Hot Tips, details the introduction of Metcal's newest product—the STSS-055-TEMP Solder/Desolder System and the STSS-044 Desoldering System into one unit powered by a standard Metcal power supply. It is the electronics industry's first combination solder/desolder system to incorporate products based on self-regulating skin effect heating technology.

Circle (57) on Reply Card

Distributor products catalog

The new 1990 distributor products catalog featuring analog/digital multimeters, digital thermometers and multifunction counters manufactured by *John Fluke Mfg. Co.*, is now available from authorized Fluke distributors, worldwide. The 20-page catalog, which includes an expanded selection of new leads, probes and clips for a variety of applications is available free of charge. Featured this year is the rugged and versatile Fluke 80 Series handheld multimeters. The 80 Series offers a combination of functions and special features for a broad range of markets including automotive, electrical, and electronic test and troubleshooting applications.

Circle (58) on Reply Card

Digital multimeter booklet

Fluke Mfg. Co. offers along with its other various booklets and literature a short course on the operation, capabilities and selection of a digital multimeter (DMM). The 16-page, 4-color booklet is available free of charge from authorized Fluke distributors. The "ABC's of DMM's" features sections on the common use

of a DMM, ac and dc voltage measurements, resistance, continuity and diode tests, dc and ac current measurements, multimeter safety and multimeter accessories. Each section of the booklet is clearly illustrated and includes a glossary of electronic and multimeter related terms.

Circle (59) on Reply Card

Soldering irons accessories catalog

A new catalog featuring a complete line of miniature and standard size soldering irons, a wide selection of tips, and accessories for electronics assembly, field service and general use is being offered by *M.M. Newman Corporation*. The Antex soldering irons catalog describes a complete line of precision miniature soldering irons, standard size irons, a heavy-duty 60 watt soldering iron, temperature control stations, a universal power supply unit, a portable 12 volt soldering iron, and a wide selection of slide-on tips and soldering iron stands.

Circle (60) on Reply Card

ESD catalog

The *Desco* 1990-91 catalog lists all of the products the company offers for the control of electrostatic discharge (ESD). Electrostatic control products for the electronics workbench listed in the catalog include wrist straps, ground cords, testers, table/floor mats, ionization equipment, tools, foot grounders, binders, labels and signs. In addition to the product listings, the catalog provides a brief description of the nature of the problem, and defines some of the terms. A one page listing provides other information on static discharge, including names and addresses of companies that offer literature and training tapes on ESD, ESD association procedures and standards, and a list of Desco's own literature on the subject of ESD.

Circle (61) on Reply Card



We think it's about time troubleshooting guides stopped giving you hopelessly confusing directions.

Which is why our manuals and videos are simply-written and to the point. Whether they're for VCRs, CD players,

© 1990 Mitsubishi Electric Sales America, Inc.

fax machines, projection or direct view TVs. And because of our on-screen video indexing, the answers you need are a lot easier to find. But for all the invaluable help our guides have to offer,



Our technical manuals are just as easy to follow.

they are surprisingly inexpensive, ranging from \$40 to \$100. For example, there is our step-by-step VCR troubleshooting guide (part number TT-109) selling for \$95.00.

If you'd like to place an order, or for a free brochure, just

(1) Pick up your telephone, (2) Dial 1-800-553-7278, and (3) Speak. (See? We said our directions are easy to follow.)

 **MITSUBISHI**
TECHNICALLY, ANYTHING IS POSSIBLE™

Circle (5) on Reply Card

Using symptom analysis to troubleshoot a VCR

By Victor Meeldijk

This repair case history illustrates how the cause of a problem in a VCR was isolated by analyzing the symptoms and reviewing the schematic diagram before any major disassembly was done. Also included is a follow up to the repair one year later.

The VCR, a Fisher FVH-515, when first seen a year ago was 7 years old and had never been serviced. The owner complained about garbled sound during playback of tapes and when questioned further also mentioned rewind problems.

Removing the top cover to examine tape loading revealed that the machine was clogged with dirt and pet

hair; see Figure 1. It was later confirmed that the owner had the VCR on a low shelf of a TV/VCR table where the dog always passed by.

Checking the symptoms

After cleaning the machine I loaded an expendable pre-recorded tape and performed checks to confirm the problem and isolate the failure cause. When I connected an antenna to the VCR I discovered that most of the channels were not tuned properly. Once I adjusted the thumbwheels properly the picture and sound were fine. This meant that the RF converter was functioning properly.

I again played the known good tape and checked the RF output. This time the sound was garbled. I then checked the sound from the audio output jacks; it was also garbled.

This confirmed that the VCR/TV relay was functioning normally.

To determine whether record and playback was affected, I put a blank tape into the machine and made a recording. Playback of this also had garbled sound. Another recording was made with sound going into the external audio jack, the playback results were the same. I put the tape that I had recorded on the faulty VCR into a known good machine. The sound on the recorded sections was fine. This meant that most of the circuits in the unit were functional and just the parts in the audio playback function were suspect.

The schematic provided some clues

The schematic diagram (Figure 2) showed that the playback circuit consists of IC 401 and IC 402, with their associated circuitry, along with relay RE401 and the audio head itself. (Note: Early Fisher VCR's had a Service Manual, that contained only parts lists and schematic diagrams. All the detailed maintenance, alignment and troubleshooting instructions are contained in a "Basic Manual". Some of the regional service centers seem to be unaware of this. I finally obtained a Basic Manual after contacting the Sanyo-Fisher Service Corporation, Customer Care Clinic, 11343 Moorpark St., Studio City, CA 91602, 818-508-0947 unfortunately it is no longer available in a paper copy only the fiche copy is available and at this late date even this is very hard to get).

Isolating the problem

Suspecting a fault in the electronics, since the garbled sound was like something caused by a leaky capacitor, I put the VCR on its side and removed the bottom cover. Using a

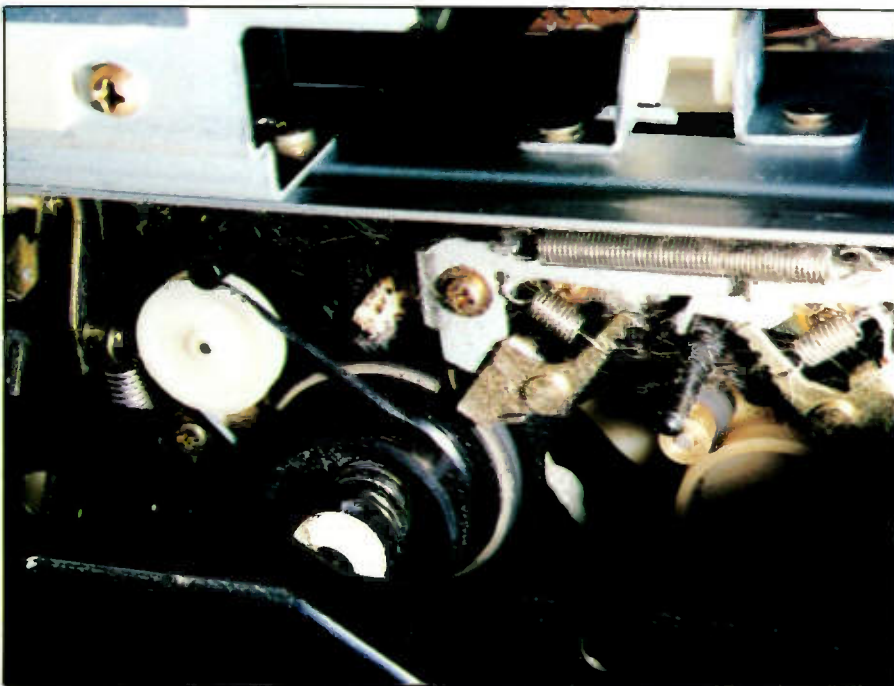

Figure 1. This 7 year old VCR was clogged with dirt and pet hair.

small transistorized audio amplifier, I checked pin 16 of IC 401 (Fisher P/N IMAN262 an AN262 device) while a known good tape was played in the VCR. The sound was garbled, and this reduced the suspect devices to C406 (1 μ f 50V 20% tolerance), RE401 (relay Fisher P/N 4-2324-00010 or 00011) the PV401 (Fisher P/N 4-2364-00030 a 3P Plug con-

nection or the head itself. The output of RE401 was then checked. As the test probe applied pressure to the relay pin the sound suddenly cleared. Very lightly touching the pin caused the sound to again become garbled. None of the solder connections to the relay looked bad, so I tapped the relay with the eraser of a pencil. The relay was sensitive to the tapping, with

the sound sometime being garbled and then clearing as it was tapped (see Figure 3).

These symptoms seemed to indicate that the relay contacts were dirty, and consequently in play mode the record section was not being grounded out. I removed the relay cover and sprayed the contacts with a freon cleaner (making sure that this

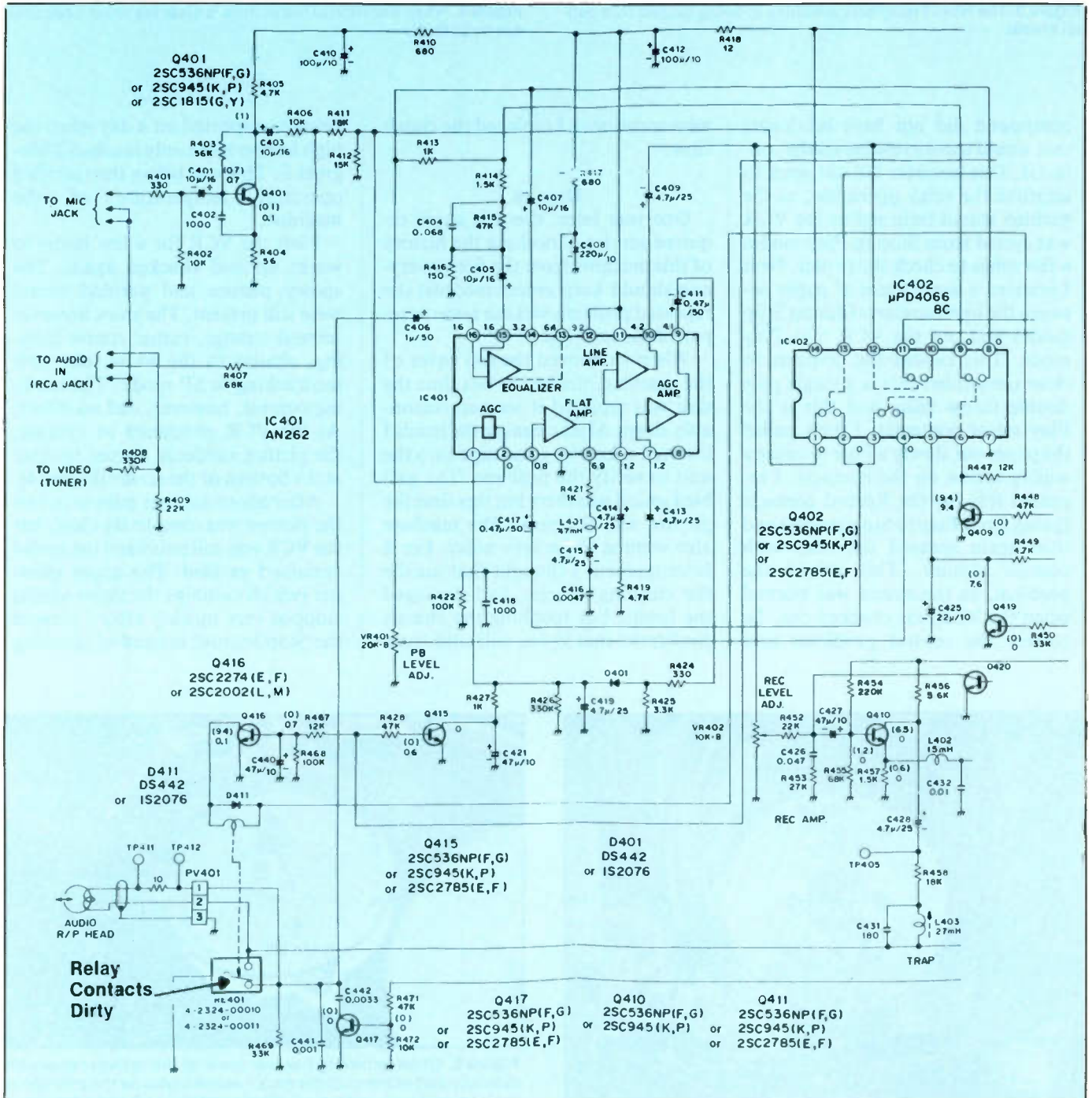

Figure 2. The Record/Playback circuitry of the FVH-515.



Figure 3. The RE401 relay was sensitive to being tapped by a pencil eraser.



Figure 4. When a portion of the picture is clear the video heads can not be at fault.

compound did not have lubricants that would leave a residue on the contacts). This however did not seem to improve the relay operation, as the garbled sound returned as the VCR was cycled from Stop to Play modes a few times to check the repair. Next I inserted a small piece of paper between the open contacts (during Stop mode) and put the VCR into Play mode. This caused the contacts to close (remember this is a single pole double throw relay and this is the Play set of contacts). I then pulled the paper out slowly a little to cause a wiping action on the contacts. I repeated this for the Record contacts (going from Play to Stop modes) and then again sprayed the relay with contact cleaner. This solved the problem, as the sound was normal when the VCR was checked out. To correct the rewind problems that

were mentioned I replaced the clutch tires.

Deja vu

One year later, the unit again required service. Checking the history of this machine from the files (everyone should keep repair records) the reported problem was the same as repaired the last time.

When I removed the top cover of the machine, unlike the last time the unit was repaired it seemed reasonably clean. After cleaning the heads I inserted a known good tape into the unit to verify the problem. The garbled sound was there but this time the picture was all snow. The machine also seemed to be very noisy. For a brief moment I thought that maybe the cleaning process had damaged the heads, but touching the chassis confirmed that it was still cold from

being transported on a day when the high temperature only reached 20 degrees F. This was below the specified operating temperature of the machine.

I left the VCR for a few hours to warm up and checked again. The snowy picture and garbled sound were still present. The snow however seemed strange, rather coarse looking, similar to the snow seen with mistracking in SP mode. The tracking control, however, had no effect. As the VCR continued to operate, the picture suddenly started to clear at the bottom of the screen (Figure 4).

After about another minute or two the picture was completely clear, but the VCR was still noisy and the sound remained garbled. The upper cylinder (which contains the video heads) stopped very quickly after I pressed the Stop button, instead of spinning

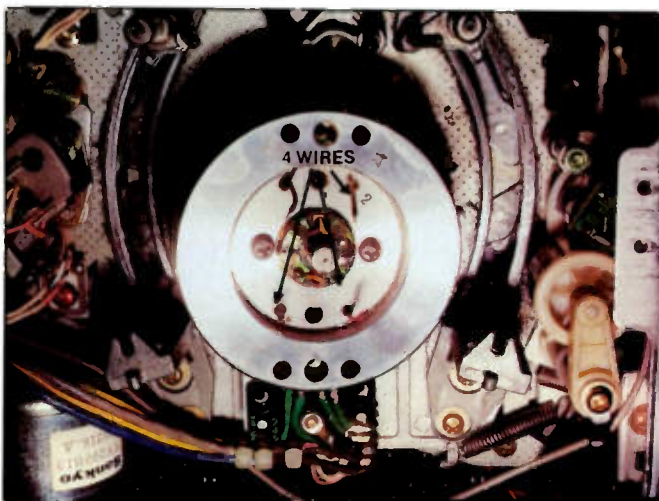

Figure 5. Unsolder the four wires at the top of the upper cylinder.

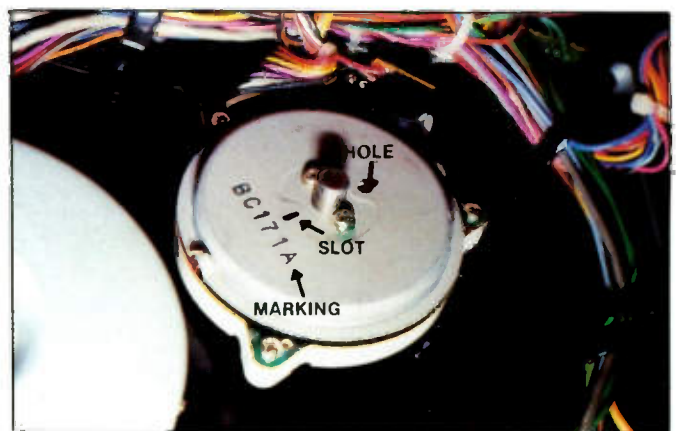
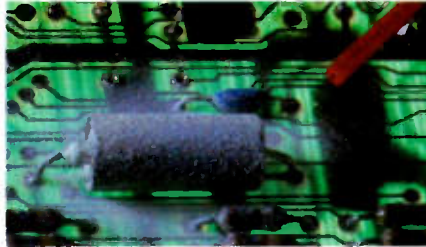

Figure 6. When removing the rear cover of the cylinder assembly (actually part of the cylinder motor assembly) note the position of the part markings and the small hole and slot so it can be replaced in the correct position.

Chemswab™
IPA Saturated
Foam Swab



Freez-It® -96° F
Tracks Intermittents
CFC Free



Ultrajet® Dusters
Precision Filtered
CFC Free

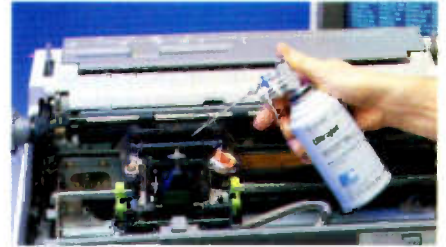

Flux-Off® Plus
Improved Cleaning
CFC Free



Konform®
UL Listed
CFC Free



Gold Guard®
Preserves Contacts
CFC Free



Chempad™
IPA Saturated
Cleaning Pad



Chem-Wik® Lite
Desolders
50% Faster



Twillwipes™
Textured Cotton
Lint Free



Performance you can count on.

The electronic service industry's most popular chemicals and cleaning products for over 30 years.
Call or write today for a free catalog, samples or technical assistance.



Chemtronics

Chemtronics Inc. 8125 Cobb Centre Drive, Kennesaw, GA 30144 800-645-5244 In GA 404-424-4888

Circle (27) on Reply Card

Table 1

1. With the top cover of the VCR already removed, remove the shield plate and chassis beam which are held in place by two screws (items 13 and 14 shown on page 7 of the service manual).

2. Remove the two screws securing the contact finger assembly (called the earth plate assembly in the Fisher service manual P/N 143-0-4704-02800) and remove the contact finger.

3. Unsolder the 4 wires located on top of the cylinder (reference Figure 5), make a note of where each wire goes to avoid problems during reassembly.

4. Remove the two screws that secure the upper cylinder assembly. Pull up and remove the upper cylinder. When doing this be careful not to put your fingers on the video heads. With the upper cylinder removed the rotating transformer is now visible. (The upper cylinder is Fisher P/N 143-0-4704-06000. If this part ever needs replacement clean the bottom of the new upper cylinder and the mounting surface of the sub-cylinder, sometimes called the service cylinder assembly by Fisher (P/N 143-0-9934-00800), with alcohol).

5. Turn the VCR over and remove

the six screws securing the bottom cover and remove the cover.

6. Remove the 8 screws that secure the printed circuit card assembly, they are the ones denoted by arrows.

7. Since the circuit card pivots at the rear, lift it from the front and prop it up, a screwdriver can be used to do this.

8. The underside of the cylinder assembly, which is the cylinder motor (Fisher P/N 4-5254-00280) is now visible and the rear cover containing the motor magnet can be removed (two screws). Remember how the cover was facing by noting the position of the part markings and the small round hole and slot (Figure 6). If this cover is put on the wrong way you will get a snowy picture in playback mode.

9. Once the cover is removed you will see a collar (Figure 7) held in place by set screws. Use an Allen (Hex) key to loosen these set screws and remove the collar. At this point if the shaft was well lubricated the upper portion of the rotating transformer, which is secured on the other side of the shaft would probably pull the shaft down as this was the collar holding it in place. In this case where

lubrication was needed nothing happened.

10. Under the collar is a bronze washer which acts like a spring (Figure 8). Remove this part. Lower the printed circuit card and secure it in place with one or two screws at the front of the card. Turn the VCR over again.

11. The top portion of the rotating transformer and the cylinder assembly shaft can now be pulled up and lifted out of the VCR (Figure 9).

12. Use a little oil to lubricate the shaft and reassemble the cylinder assembly (Follow the above disassembly steps in the reverse order).

13. Once the cylinder has been completely reassembled clean the upper cylinder and heads to remove fingerprint oils.

Note: If there is a small dropout moving at the bottom of the picture, or if the picture breaks up or gets noisy if the VCR is turned on its side while in play mode, there is too much play in the way the cylinder assembly was reassembled. on a properly reassembled unit the VCR playback picture will not break up or be noisy even if the VCR is played upside down.

gradually to a stop. Most service manuals do not discuss periodic lubrication of the cylinder assembly, they only mention it when replacing the heads, if at all. But this was clearly one time when lubrication of this

component was called for. Table 1 lists the steps involved in disassembly of the cylinder.

With the head rotation problem solved, it was time to tackle the garbled sound. I performed the same

checks as before and again confirmed that the relay was the problem. Looking at it more closely this time I noted that the contacts seemed blackened, when they are supposed to be gold clad, see Figure 10 (From

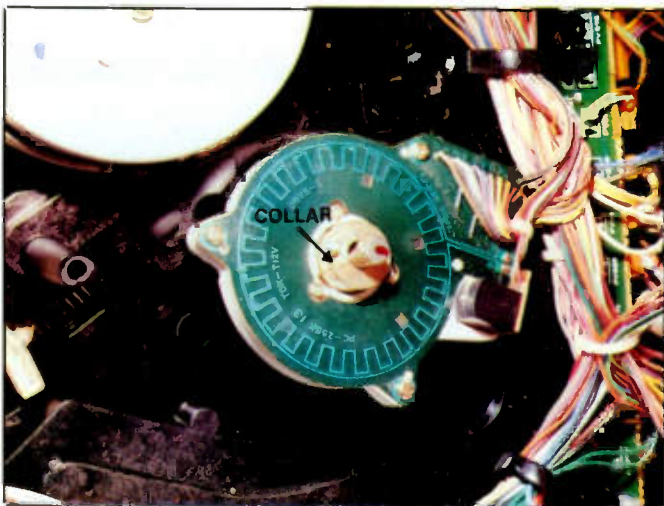

Figure 7. Remove the collar using an Allen (Hex) key.

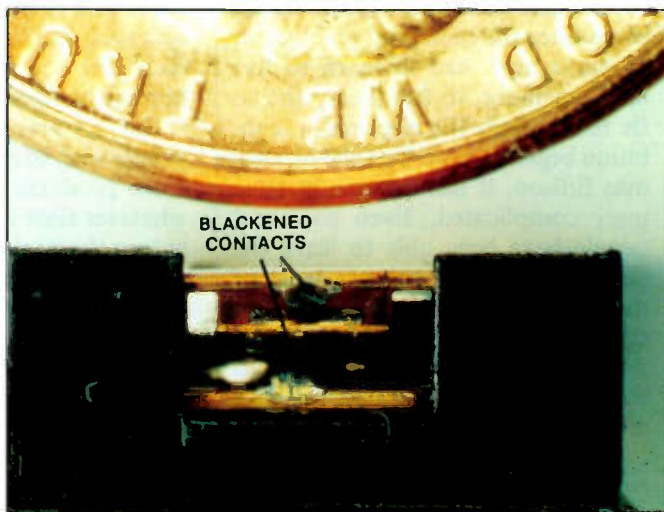

Figure 8. Remove the bronze washer (spring).



Figure 9. Pull up on the upper part of the rotating transformer to remove it and the cylinder shaft from the VCR.

Figure 10. The RE401 blackened relay contacts (note how small they are as compared to the penny).



the photograph you can also see just how small these contacts are). I replaced the relay as I probably should have done a year ago.

While this relay is Fisher part number 4-2324-00010 (or 00011) it was manufactured by Fujitsu, their model FBR211SB D009-M, this is an ultra-miniature SPDT relay with a 9 volt coil with silver contacts that have a gold overlay. It was designed to be suitable for immersion cleaning in freon and aqueous systems and has flux-contamination immunity. (To locate a distributor in your area contact Fujitsu Component of America, 3330 Scott Blvd, Santa Clara, CA 95054-3197, (408) 562-1000).

If a Fujitsu relay is not readily available various other manufacturers make equivalent relays, such as ITT Components Takamisawa relays (ITT Components, A Unit of ITT Corporation, 5 Jenner St., Irvine CA 92718 (714) 727-3100 or ITT Components, A Division of ITT Industries of Canada Ltd., 300 N. Rivermeade Road, Concord, Ontario L4K 2Z4, (416) 736-1048) part number MZ-9HG-C. This substitute is equivalent to the Fujitsu relay except that it has 5 pins. It is missing one of the two end pins which are electrically connected together. The printed circuit card of the VCR however also has both these pins shorted together and therefore it does not matter that it is missing).

In Table 1 we can see the disassembly of the cylinder assembly. Caution: To prevent any chance of electric shock disconnect the VCR power cord from the power source.

To prevent any possible damage to components from static discharge, follow ESD control procedures (i.e., grounded soldering iron, ESD controlled work area, use of a wrist strap.

LEARN VCR

CLEANING/MAINTENANCE/REPAIR

EARN UP TO \$1000 A WEEK, WORKING PART TIME FROM YOUR OWN HOME!



Secrets Revealed!

NO Special Tools or Equipment Needed.

EARN UP TO \$60 AN HOUR AND MORE!

THE MONEYMAKING OPPORTUNITY OF THE 1990's

IF you are able to work with common small hand tools, and are familiar with basic electronics (i.e. able to use voltmeter, understand DC electronics)...

IF you possess average mechanical ability, and have a VCR on which to practice and learn...then we can teach **YOU** VCR maintenance and repair!

FACT: up to 90% of ALL VCR malfunctions are due to simple MECHANICAL or ELECTRO-MECHANICAL breakdowns!

FACT: over 77 million VCRs in use today nationwide! Average VCR needs service or repair every 12 to 18 months!

Viejo's 400 PAGE TRAINING MANUAL (over 500 photos and illustrations) and AWARD-WINNING VIDEO TRAINING TAPE reveals the SECRETS of VCR maintenance and repair - "real-world" information that is NOT available elsewhere!

Also includes all the Info you'll need regarding the BUSINESS-SIDE of running a successful service operation!

FREE INFORMATION

CALL TOLL-FREE 1-800-537-0589
Or write to Viejo Publications, Inc.
3540 Wilshire Bl., STE 310
Los Angeles, CA 90010, Dept. EST

Circle (49) on Reply Card

CONSOLIDATED

ELECTRONICS



VOLUME I - TEST EQUIPMENT

CONSUMER & INDUSTRIAL ELECTRONICS 18TH EDITION \$5.00

"Volume I-Test Equipment"

112 pages packed with specifications on the most popular test equipment like B&K, Beckman, ARI, Simpson, Mercer, Soar, Goldstar and Vector/Viz. Choose from hundreds of multimeters, oscilloscopes, frequency counters, function generators, power supplies & more. Send \$5.00 check or money order, or call 1-800-543-3568 today & use your Mastercard or Visa. Consolidated Electronics, Incorporated 705 Watervliet Avenue., Dayton, Ohio 45420-2599

NAME _____

ADDRESS _____

CITY _____ STATE _____ ZIP _____

Circle (28) on Reply Card

Continuing education for technicians

By Conrad Persson

The world has been a complicated place since the industrial revolution. Humans have had to learn to live with machines, to use them, and to fix them. Since the electronics revolution began around the time of Thomas Edison, it has become increasingly complicated. Even so, most people have been able to learn the skills necessary to operate most of the electronics products that have come on the market.

The computer revolution has changed all that. Many people have an aversion to computers, and many

Persson is editor of ES&T.

even seem to fear or hate them. In addition, computers have made it possible to add so many features to products such as TVs, VCRs, stereos, fax machines and more, that they have become increasingly complex.

But it's pretty obvious that most people wish to enjoy the benefits that these products bring, so they take whatever time is necessary to obtain at least the minimum of use out of the products. It's a standing joke that there are millions of VCRs out there that are still blinking 12:00, because the owner never learned to set the clock. A lot of people I know don't know how to program a VCR to record a program in the future, but they do know how to pop a prere-

corded tape in the VCR and watch a movie at home.

Another problem in this complex world is that there are so many products with so many features that if you don't use the features very often, you have to relearn before you take advantage of them. I know that from personal experience. I have a radio in my car that has three FM "bands" and an AM "band." When a band has been selected, each of the six pushbuttons can be set for a different station than it was set for in one of the other bands. It's even possible with the push of a single button to automatically program one band with the six strongest stations that it receives.

Trade associations

Electronic Industries Association/
Consumer Electronics Group
Pennsylvania Avenue, N.W.
Washington, DC 20006-1813
202-457-4919

Electronics Representatives Association
20 E. Huron
Chicago, IL 60611
312-649-1333

Electronic Technicians Association
604 North Jackson St.
Greencastle, IN 46135
317-653-3849

Musical Instrument Technicians
Association, International
8216 Audrain Drive
St. Louis, MO 63121-4504
314-389-3290

National Association of Business and
Educational Radio (NABER)
1501 Duke St, Suite 200
Alexandria, VA 22314
703-739-0300

NARDA (National Association of Retail
Dealers of America)
NASD (National Association of Service
Dealers)
10 East 22nd Street
Lombard, IL 60148
312-953-8950

National Association of Service Managers
650 W. Algonquin Road, Suite 204
Des Plaines, IL 60016
708-640-8133

National Electronic Distributors
Association
35 East Wacker Drive
Suite 3202
Chicago, IL 60601
312-558-9114

National Electronic Servicing Dealers
Association
2708 W. Berry Street
Ft. Worth, TX 76109
817-921-9062

Technical book publishers

Hayden Book Company
Rochelle Park, NJ 07662

McGraw-Hill Book Company
1221 Avenue of the Americas
New York, NY 10020

Prentice-Hall, Inc.
Rte. 9W
Englewood Cliffs, NJ 07632
201-592-2455

Tab Books
PO Box 40
Blue Ridge Summit, PA 17214
717-794-2191

Van Nostrand Reinhold Company
135 W. 50th St.
New York, NY 10020

Home study

Cleveland Institute of Electronics
1776 E. 17th St.
Cleveland, OH 44114

Cook's Institute of Electronics
Engineering
Desk 15
PO Box 20345
Jackson, MS 39209

Electronic Institute of Brooklyn
4823 Avenue N
Brooklyn, NY 11234

Grantham College of Engineering
2500 S. La Cienega Blvd.
Los Angeles, CA 90034

Heath/Zenith
PO Box 167
Hilltop Rd.
St. Joseph, MI 49085

National Institute of Technology
1701 W. Euleuss Blvd.
Euleuss, TX 76039

National Technical Schools
456 W. Santa Barbara Ave
Los Angeles, CA 90037

NRI Training for Professionals
McGraw-Hill Continuing Education
Center
4401 Connecticut Avenue, NW
Washington, DC 20008

Private trade schools

National Association of Trade and
Technical Schools
2251 Wisconsin Ave. N.W.
Washington, DC 20007

The radio also has seek, scan, and much more. It can even be set to be illuminated in either amber or green when it's turned on. Unfortunately, although I spent quite a bit of time when I first had it, I have forgotten how to take advantage of some of its features. Things have become complicated indeed.

Service is more complicated as well

If the operation of consumer electronics products has become more complex, requiring more training on the part of users to learn to operate them, far more training is now required on the part of servicing technicians. In addition, the need for training is ongoing.

Back in the good old days of vacuum tube TVs and radios, all of the products were based on a handful of tubes and pretty much standardized designs. While the types of problems that afflicted these products might vary and occasionally cause a technician to mutter under his breath, a good general knowledge of the principles of radio and TV was all it really took to service a consumer electronics product.

Those days are gone forever. The advent of integrated circuits and digital techniques has not only caused the number and type of consumer electronic products to increase dramatically, but the number of ways to design any one of that increasing number of products has increased to become almost uncountable. Every manufacturer has his own pet designs, and usually proprietary ICs to carry out the design. A technician needs to become reeducated every time he begins to work on a new set.

Training, literature and books can help

Fortunately, today a lot of people and agencies know that it's in their best interests if there are technicians around who know how to fix today's complex electronic products. Manufacturers of today's consumer electronics products want to have competent technicians on hand to fix their products when they break. Private and public schools want to attract students. Book publishers can sell a lot of books if they are able to publish good, helpful texts that will help technicians learn to understand and fix consumer electronics products.

There has been a great deal of effort in these areas. Manufacturers

and their organizations are churning out training materials and scheduling classes. Schools are increasing the availability of servicing courses. Book publishers are cranking out quantities of technical books.

Doing it

Most consumer electronics servicing technicians are aware that they need to upgrade their skills. The problem is complex, but there are usually two questions that the technician needs to get answered: "What do I need to learn?" and "How do I go about learning it?"

It's important to analyze these questions thoroughly to determine beforehand exactly what it is you need to study. It's not enough to just say "I need to learn more about camcorders and then to charge off to find a book, a home study course or a local school that might offer a course on camcorders. Do you just want an overview on camcorder technology for starters? Or do you really have a pretty good idea of how camcorders work and what you really need is a course in servos?"

Once you set the specific goals, the question becomes how to achieve them. One simple but effective method might be to contact other technicians in your area. If you have a skill that they lack and vice versa, you might be able to arrange for a session in which you educate each other.

Self study

Another simple, although less effective method is to buy a book on the subject and study it yourself. Depending on a number of factors, including complexity of the subject, the quality of the book, and your own self discipline, this experience might bring anything from complete understanding of the material to fruitlessness. Home-study courses offer a major improvement over studying from books. The material is broken down into study units, someone tells you what is expected of you, and you get feedback through regular tests.

Schools and seminars

If time and money permit, a more effective way to learn is through structured class and lab courses. Here again, there are many avenues. Public and private technical schools throughout the country offer a selection of courses from the most ele-

It's no fluke.



Made in the U.S.A.

Building the best DMM for the money is no accident. The new RMS225 was carefully designed to give you what you wanted at a price you could afford. Visit your local distributor today and you'll agree the choice is obvious.

Fluke Model 77	Beckman Industrial RMS225
3-1/2 Digits	4 Digits
3,200 Counts	10,000 Counts
0.3% Accuracy	0.25% Accuracy
Touch Hold®	Probe Hold™
31 Segment Analog Bar Graph	41 Segment Analog Bar Graph
2,000 Hour Battery Life	1,000 Hour Battery Life
10A Range (Fused)	10A Range (Unfused)
Protective Holster	Protective Holster
3 Yr. Warranty	3 Yr. Warranty
—	True RMS
—	Auto Min Max™
—	Relative Mode
—	Self-Resetting Fuse (40mA Input)
\$159*	\$149

® Touch Hold is a registered trademark of the John Fluke Mfg. Co., Inc. *1990 Fluke and Philips Catalog

Beckman Industrial™
An Affiliate of Emerson Electric Co.

Instrumentation Products Division
3883 Ruffin Road, San Diego, CA 92123-1898
(619) 495-3200 • FAX (619) 268-0172 • TLX 249031
Outside California 1-800-854-2708 Within California 1-800-227-9781
© 1990 Beckman Industrial Corporation. Specifications subject to change without notice. Fluke is a registered trademark of John Fluke Mfg. Co., Inc.

Circle (26) on Reply Card

mentary introductory courses to detailed theory and design. If you have the time and the budget to travel, manufacturers of home electronic equipment offer seminars on the operation and servicing of specific items to servicing technicians.

In addition, manufacturers of test equipment and tools such as multi-meters, oscilloscopes, soldering tools, etc. offer instruction in using their products. Some have books and pamphlets that help you understand the kinds of things you can do with their products, and others offer formal courses of study, some to do at home, others offer courses and seminars that travel to different areas of the country so you can take a formal course taught by the experts near home.

Identifying the available resources

A local school may have just the course you need listed in its catalog. One of the book publishers might have just the book or series of books to fill in the gaps in your knowledge. One of the associations related to home electronics equipment manufacturing sales or service may have just the item of information you need

or be able to point you in the right direction.

Included in this article are several lists of companies and other organizations that offer some kind of training, but space doesn't permit a comprehensive list. There are a number of lists available that will provide someone who is serious about training many avenues to explore. For starters, take a look at the ES&T March Buyers' guide. That issue contains a large list of companies with addresses and phone numbers.

Especially, look into both the manufacturers of the consumer electronics equipment that you want to provide service for and the manufacturers of test equipment. Many companies who belong to both of these groups offer fine training courses that will help any technician improve his skills. One of the helpful aspects of this kind of training is that it is frequently offered in a number of ways: some courses are available at the company's site, some travel to many of the large cities and offer seminars, in other cases, you can order a videotape along with a workbook and take the course in the comfort of your own home, but with a

skilled instructor teaching you on videotape.

Try experimentation

Many of today's consumer electronics products are electromechanical, and it's frequently the mechanical portion of these products that cause problems. In understanding a mechanical system, it's frequently very useful just to open the unit up and watch how things work; even to introduce some problems to see what happens. I wouldn't suggest this approach to learning with a \$600.00 hi-fi VCR, but some of the low-end units cost in the neighborhood of \$200.00. If you take a look at the cost of books these days, or the cost of seminars, or even just the cost of lodging at a hotel or motel while attending a seminar, \$200 is pretty cheap for a unit to take apart, observe, check with DMM and oscilloscope, and you might get a pretty good education from it.

Table 1 lists a number of correspondence schools, book publishers and associations whom you might want to contact for further information on what educational opportunities they have to offer. ■

Presenting an affordable Light Box System.

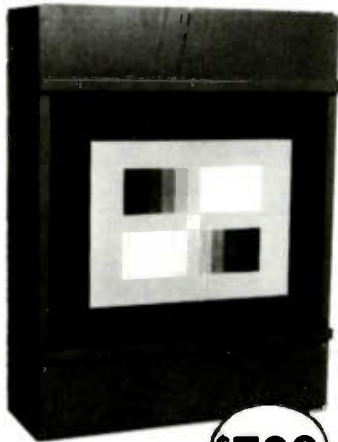

Model TR100 CB
Camera Light Box
with (2) transparencies

- (2) 3200° Kelvin Lamps (meets mfr. spec.)
- 1-year conditional guarantee
- Transparencies mounted in acrylic with optical scratch-resistant surface
- 11-step gray scale transparency
- 7-Bar color transparency
- All orders are shipped within 72 hours, U.P.S.

\$799

The method most manufacturers recommend

NUTRONIX (313) 726-1278

P.O. Box 77103 • Sterling Hts., MI 48077

Circle (36) on Reply Card



63 Styles of rugged Vaco professional screwdrivers fill your exact needs

- Standard and special purpose
- Exceed U.S. Standards

VACO screwdrivers give you exceptional quality...tough tempered blades to withstand high torque...nickel chrome plated with precision-ground tips...Comfordome® handles. See your VACO distributor.

Send for
FREE CATALOG

VACO®

7200 McCormick Blvd.
Chicago, IL 60645

Circle (48) on Reply Card

By William J. Lynott

Servicing electronics today is a lot more demanding than it was a decade or two ago.

Not only because of the dizzying escalation of technology, though that certainly is a major part of the reason. While new technology has been drastically raising the level of technical skills required of servicers, it has also been indirectly setting new standards for management skills.

Though many of my older associates don't like to hear it, running a profitable electronics service business was a snap 25 or 30 years ago. All you had to do was rent a little space, put an ad in the Yellow Pages, and provide reasonably competent service. A lot of successful service businesses were built in those times by men who blithely broke nearly every management rule in existence.

Television was still relatively new then, customers were tolerant, and sets of those days broke down with comfortable (for service dealers) regularity. Inventory management was utterly simple, with a few dozen standardized vacuum tubes, capacitors, and resistors to keep on hand. Technical schools were jammed with students anxious to get into the new field of TV service.

In those days, I knew several so-called technicians who really weren't technicians at all. When they came across a set they really couldn't fix, they farmed it out to a real technician, added their own mark-up to his charges, and delivered it back to the customer.

But things are quite different today. New technology has greatly increased reliability, expensive modular construction has made skillful parts management a necessity, and customers are as sophisticated as the circuitry in their equipment. Couple that with skyrocketing wages and other costs and you have a situation

far different from that of the early stages of the industry.

As a result, many of the less competent business managers are falling by the wayside. Others are struggling along in businesses that are barely earning a living for them.

Does all this mean that electronics service is not a good business to be in? Certainly not. It means that electronics service is now a business that demands top-level managerial and marketing skills. Simply being a good technician is no longer enough.

For those who have the qualifications and who are willing to put out the necessary effort, however, the rewards can be as great as they ever where.

There are countless successful service dealers around the country who learned how to capitalize on the industry's particular set of peculiarities, rather than agonize over them. Two who come to mind are Gerry McCann and Frank Grabeic.

Gerry McCann, of McCann Electronics in Metairie, LA, is an innovator and a skilled marketer who understands the need for managing his business and not just repairing things. Like most successful service executives I meet, Gerry is constantly on the lookout for new ideas. Not only is he an active participant in at least two different trade associations, he is also unstinting in his willingness to share his methods with others. Gerry has presided over many seminars and workshops for fellow members of his associations.

Despite his own level of skill and experience, Gerry is a regular at seminars conducted by others. Whenever I am invited to speak at a service workshop, Gerry McCann's face is one I can usually count on seeing in the audience. Typical of his breed, Gerry simply doesn't want to miss a single good idea that someone else may be using successfully.

Industry veteran Frank Grabeic is another good example of a service executive who is tuned in to the times. Frank, owner of Dyna-Tronics, in

Phoenix, AZ has seen both ends of the equation I described in the opening paragraphs of this column. In his 35 years in the business, Frank has seen changes and he has adapted to it. Today, his business employs seven full-time technicians, his son-in-law, a full-time office manager, and himself.

Most recently, I read in NARDA News of Frank's involvement in what he calls recycling of consumer electronics. He says he was forced to seek alternative sources of income when his basic business of 35 years began to feel the same revenue reductions that were plaguing other service companies. His answer was the rebuilding for resale of TV's, VCR's and other consumer electronics products. today, the selling of "recycled" products accounts for 20 to 30 percent of Dyna-Tronics total revenues.

This solution to a problem didn't just happen. Frank and his son-in-law, Mike Armbruster, tried several alternatives that didn't work out in their search for ways to shore up falling revenues. Among the things they tried were opening two small branch stores and repairing of electronic games. What got Frank into the recycling business was a book called *The Blue Book* that he picked up at a consumer electronics show (*The Orion Blue Book*, audio edition, Orion Research Corp.). The book lists what customers consider fair prices for home electronics items in top condition.

As you can see, Frank, like Gerry McCann, believes in, and participates in, industry functions that bring him into contact with people with whom he can share ideas.

Gerry and Frank are just two examples of countless electronics servicers who have decided not to roll over and play dead because things have gotten tougher in their industry.

Chances are the best ideas for improving results in today's electronics servicing industry are yet to be born. Perhaps you'll be coming up with one of them. ■

Lynott is President of W.J. Lynott, Associates, a management consulting firm specializing in profitable service management and customer satisfaction research.

What do you know about electronics?

ESR—Equivalent series resistance

By Sam Wilson

Some time ago a friend of mine who lives in Arizona made an astonishing remark. It went something like this: "Leakage resistance is no longer important in electrolytic capacitors. The important thing today is their series resistance."

They haven't made any great changes in the way they make those capacitors. So, why should the problem of leakage suddenly disappear?

The answer is that it didn't disappear. It is still with us. What has happened is that a better way of evaluating capacitors has been made available to technicians. It is called the ESR measurement and it is available as part of very sophisticated capacitance meters. It is also available in a single piece of relatively inexpensive test equipment.

I wrote about this in a previous issue, but I am still seeing and hearing about it as if it is the series resistance of the capacitor. Let me review, again, some simple network theory.

Two very useful concepts in ac circuit analysis are the equivalent series and equivalent parallel circuit concepts. Let me explain it by giving a dc concept that gives the same idea.

Figure 1 shows a series circuit with two resistors across a battery. Suppose you are asked to convert it to a parallel circuit with the following requirements:

- The battery current must not be changed.
- The ratio of the currents in the parallel circuit must be the same as the ratio of the voltages in the series circuit.

Another way of stating that last requirement is that the ratio of the resistances in the series circuit must be the same as the ratio of the resistances in the parallel circuit.

If you have a good algebra hammer in your toolbox you can pound out that problem with very little ef-

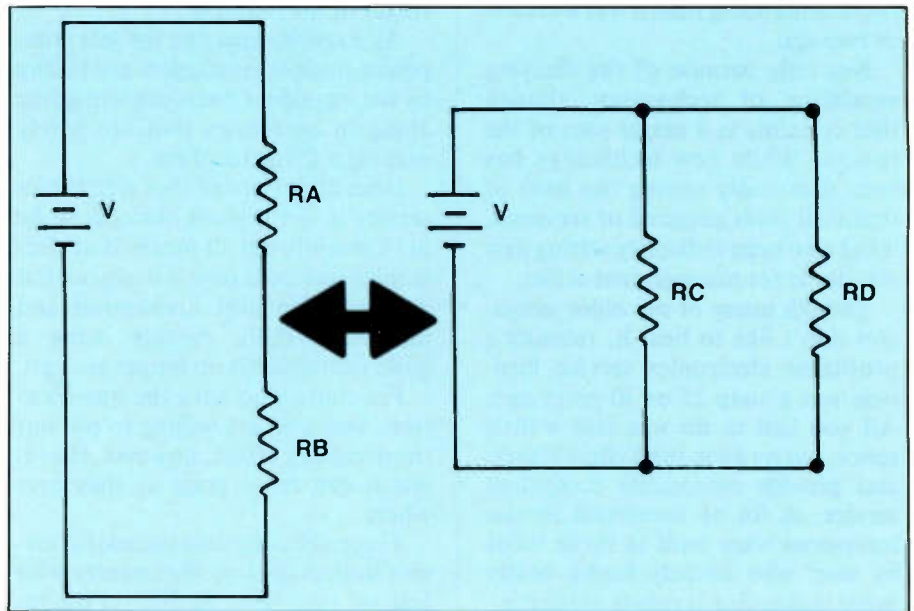

Figure 1.

fort. If your algebra hammer is badly rusted—read on.

Figure 2 illustrates a version of that problem with ac as the source. Now it is necessary to talk about im-

pedances instead of resistances. However, the exact same conversion can be made. Again, you need to get all of the rust cleaned off your math hammer.

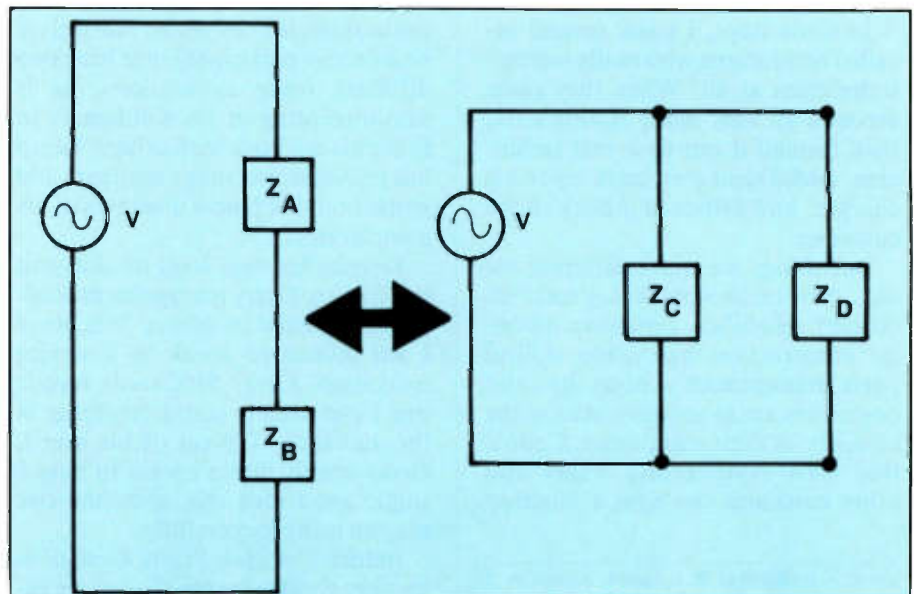

Figure 2.

Wilson is the electronics theory consultant for ES&T

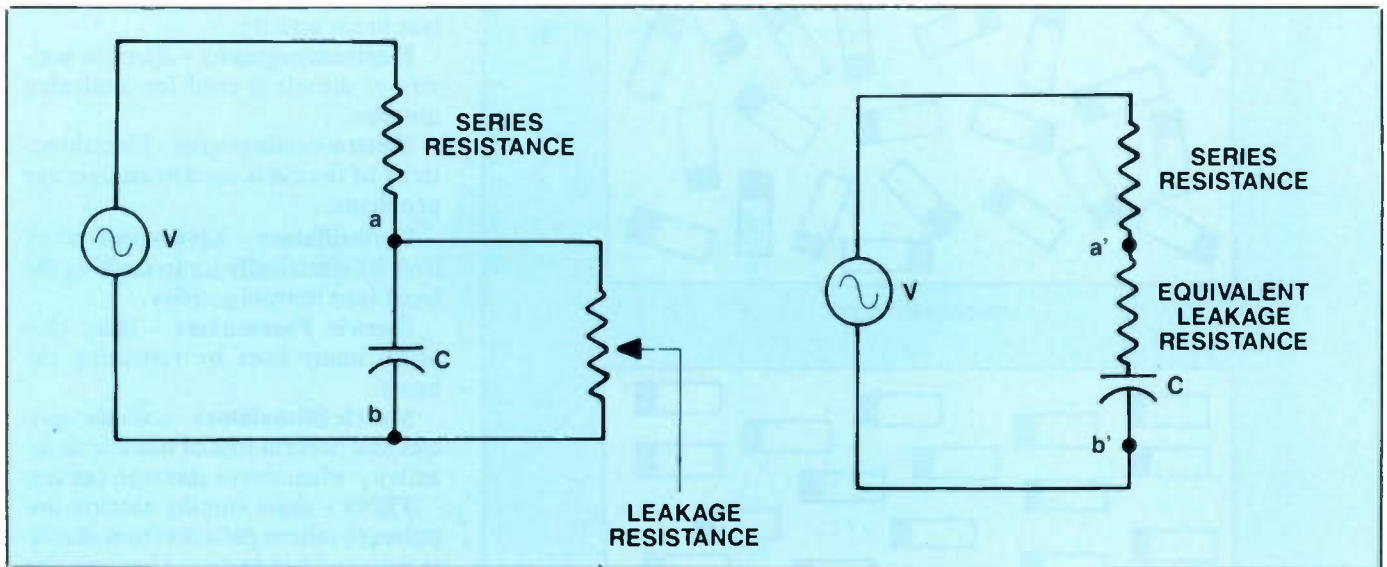

Figure 3.

So far, we have discussed going from a series circuit to an equivalent parallel circuit. However, you can easily go the opposite direction. An example, of that case is shown in Figure 3.

Using the concept shown, you can convert the parallel leakage resistance of the capacitor to a series resistance!

Going a step further, that series resistance can be combined with the series resistance that is already present. The result is called the equivalent series resistance of the capacitor! see figure 4.

So, the equivalent series resistance is not the same as the series resistance! Don't just jump over the word equivalent.

I wrote the complete mathematical proof of what I have presented here in the way of theory. If you like your theory laced with a jigger of math, send me a stamp (not an envelope) and I'll send you an in-depth mathematical proof of what I have said. (Address your mail to me in care of ES&T.)

Measuring the equivalent series resistance of a capacitor is easier and a better indication of its condition than measuring its leakage resistance.

Vocabulary department

I learned these terms when I ran across them on the way to looking up some other terms:

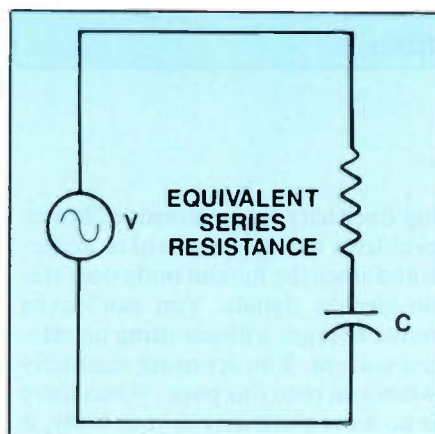

Figure 4.

Raleigh Fading - This is a rapid variation in signal strength of a signal being received from a mobile 2-way radio unit. It is a form of multipath distortion caused by varying lengths of signal paths as the signal bounces off various objects. A good example is when the mobile units is on the move in downtown areas.

NIT - A unit of light recommended by the International Commission on Illumination. It is a unit of luminance and it is equal to one candela per square meter. The candela is similar (but not exactly equal to) candle power.

Some guesses that worked

The first person to propose the existence of an atom was, according to

some historians, a philosopher names Leucippus. His idea of the atom was proposed in 500 B.C.

Most historians give credit for conceiving the idea of atoms to Democritus. He developed the full theory of the atom—very close to today's concept—about 465 B.C.

Despite the fact that his ideas turned out to be accurate, they were simply a result of guessing. He had no evidence.

If you have studied electronics in a technical school, you likely were taught the Weber-Ewing theory of magnetism. This theory proposes that magnetic materials are made of tiny magnets. They are illustrated in Figure 5.

In the unmagnetized state, the magnets point in random directions. When the material is magnetized, the fields of all the little magnets combine.

This turned out to be a very accurate guess. Today, the tiny magnets are called domains. The Weber-Ewing theory still makes a good model for explaining magnetism.

And one that didn't

Everyone knows that a wave is a form of energy that moves through a material. Sound waves, for example, move through air or water. However, sound cannot travel through a vacuum. It must have a material (medium) to travel through.

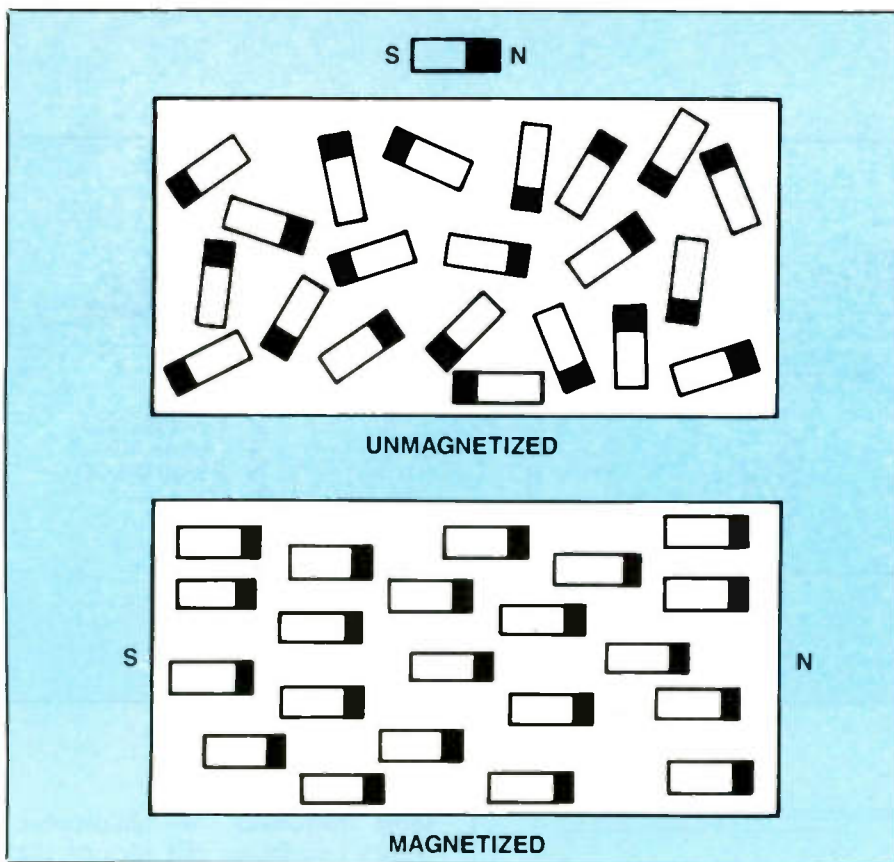

Figure 5.

So, how do light waves travel through a vacuum? For example, how do the light waves get from the sun to the earth?

A long time ago some great minds put their heads together and guessed there must be a medium that hadn't been discovered. They called it ether, or aether.

With nothing more than that guess, they started out to find it, to measure it and—if possible—to harness it for some useful application.

Many great scientists spent years trying to find ether. Of course, there was no hope of finding it, but two guys (Michelson and Morely) performed a very sophisticated experiment trying to locate it.

They thought their experiment failed because they couldn't find it. Einstein properly interpreted the results of the experiment: ether does not exist.

Electricity is not voodoo!

Mention electricity and treating the human body in the same sentence and some people get very stiff around the neck. Words like fraud and voodoo start floating around the room.

You wouldn't think the idea of us-

ing electricity for treatment of health problems would be so hard to understand since the human body operates on electric signals. You can't even move a finger without using an electric current. You are using electricity when you read this page. When there is no more electricity in your body, it is Big Casino!

Of course, there have been some real wackos that have used electricity to milk people out of money.

Let's look at some of the proven uses of electricity in medical electricity and electronics.

Bone Healing - By using electric currents through a bone break or fracture, the healing time has been greatly reduced. In some cases, older patients whose break or fracture could not heal by itself have been completely cured by the use of current healing.

Kidney Stimulation - This has been a great help for older patients.

Shock Treatment - This method of treating mental disorders got off to a very bad start. It is no longer the scary procedure you see on old movies. It is now being used very successfully.

Electrocardiograms - Electric sig-

nals generated by the patient are used to analyze heart problems.

Electroencephalography - Electric signals of the brain are used to analyze brain activity.

Electromyography - Electric activity of muscle is used for analyzing muscles.

Electro-oculography - Electric activity of the eye is used to analyze eye problems.

Defibrillators - have saved many lives by electrically jump starting the heart into normal activity.

Electric Pacemakers - have also saved many lives by restarting the heart.

Muscle Stimulators - activate muscles and prevent loss of use due to inactivity when nerve damage occurs.

TENS - units employ electric impulses to relieve patients from chronic pain and headaches. They are also used to relieve minor temporary pain.

Diathermy machines - employ r-f energy for deep tissue heating.

This is just a small sample of the beneficial uses of electricity in treating health problems.

Of course, it is more interesting to read (and write) about the frauds that have been thrust upon hapless patients. But, it is more productive to learn about the benefits of electrotherapy.

If you write to me

I enjoy getting letters from readers. If there are just nasty letters, I enjoy throwing them into the trash where they belong. If they are professionally written, I make every effort to answer them. I don't care if they are hand written (if I can read them) or done on an expensive word processor. Don't worry about spelling and sentence structure.

There is one problem. Sometimes it takes months to get an answer to you. That doesn't mean I don't care. I really do. But, no one every accused me of being well organized.

So, if you don't get a letter right back, it has probably merged to level 2 or level 3. After about 6 months it has obviously sunk to level 4 - the black hole. Please write again!

Please don't write to me in West Palm Beach, Miami, Akron, Ohio or anyplace in Colorado. Send your letter to me in care of ES&T. Once in a while they send me a check, so I'm not about to get out of touch with them!

Come Out of the Dark.

If you're groping for a better method of running your business, let NESDA light your way with Professional Electronics magazine, only one of many "enlightening" benefits available to members of NESDA, the association of electronics sales and service dealers. For information about NESDA, and a sample issue of the magazine, just mail the following to NESDA:

Name _____

Address _____

City _____ State _____

Zip _____

Phone _____



2708 W. Berry St.
Ft. Worth TX 76109
(817) 921-9061

*One of a series.

OFF AIR INTERFERENCE *Getting It? - Causing It?*

101 Fast Solutions

Call our on-line experts to find **your solution today!** (or to request our FREE tutorial catalogs)

Filters For:

- Off Air Interference
- Mobile Radio/Paging
- Cable/Video Systems
- Broadband LAN
- TVRO Interference
- Microwave Systems
- MMDS/ITFS Systems
- TV/FM Broadcast Stations

"We Make Filters In A Hurry For Customers In Trouble!"

Microwave Filter Company, Inc.

6743 Kinne Street • East Syracuse, NY 13057

Toll Free(US/Canada): 1-800-448-1666 • Collect(NY/AK/HI): 315-437-3953

FAX: 315-463-1467 • Telex: 249-613



Collocation
Interference
Eliminator

Ask For Catalog C/87



Low Cost Traps
35-300 MHz

Ask For Catalog C/87



Tunable Traps
22-900 MHz

Ask For Fastrap
Bulletin #8

Circle (35) on Reply Card

THE RIGHT CHOICE FOR QUALITY TOOLS, TOOL KITS & TEST EQUIPMENT!



Techni-Tool's 248 page, **Catalog #39**, is filled with more than 18,000 items from over 850 manufacturers. You can find anything you need from, electro-mechanical and assembly devices to electronic, telecommunication and



field service tool kits.

We also carry a full-line of items for aerospace production, computer maintenance and the fast growing field of surface mount technology. Techni-Tool offers a complete line of ESD, static control and clean room items.



FREE 1990 CATALOG!

This new 248-page catalog of quality products. It's Free! Call or write today.



TECHNI-TOOL®

5 APOLLO ROAD, BOX 368
PLYMOUTH MEETING, PA 19462
PHONE: (215) 825-4990
SALES: (215) 941-2400
FAX: (215) 828-5623

Circle (46) on Reply Card

Isolating VCR video head problems

By the ES&T Staff

The video heads in a VCR are the points where the magnetic and electronic domains meet. In playback, as the video heads plow through the oxide material on the tape they convert the magnetic signal that had been previously recorded into an electrical signal. Because of their strategic position in the recording/playback chain, their proper operation is critical. They are also one of the first components suspected when the playback picture is bad. Unfortunately, in a modern VCR, defects in other circuits can cause problems that mimic video head problems.

In fact, the biggest problem in working with possible video head problems is that defects in as many as 16 different circuits produce symptoms that look like problems caused by a bad head. These are all the circuits from the video heads to the output of the head switcher. When symptoms appear that seem to be caused by bad video heads, one way to determine whether the problem is in fact the head, or the video circuitry is to inject a video signal directly into the video circuitry. If the problem disappears, this points to a video head problem. If the problem is still, there the problem is obviously somewhere in one of the circuits.

Don't rush to judgment

Before you try any signal substitution, confirm that the symptoms point to problems directly related to the heads and input circuits. There are only two symptoms that can be caused by the video heads. Use the following methods for confirmation when you encounter one of these symptoms.

The first symptom is a complete loss of video. This could be caused by

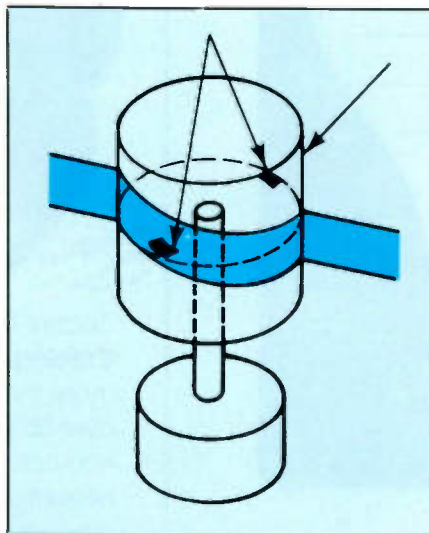

Figure 1. The video heads are always used in pairs.

a failure of both video heads simultaneously, or a defect in any stage downstream from the video heads.

The second symptom appears when only one of the two heads fails. The VCR produces a picture on a TV connected to its output, but the picture will contain noise. Here's the es-

sentential part of interpreting this symptom: the heads are the problem only if the noise covers every part of the picture. If any section of the picture is clear, even if it's only a few inches somewhere on the screen, you do not have a defective head. Here's the reason why this is the case.

The video heads are always used in pairs. A VCR with two or three video heads uses the same pair for all tape speeds, while a VCR with four or five video heads uses one pair for the fastest tape speed (VHS-SP or Beta I) and the other pair for the other two speeds. If the deck has an odd number of heads (three or five) the extra head is there to provide a clear picture during special effects, such as stop-action or scanning. The "special effects" or "trick" head is not used when playing a tape at normal speed.

As the tape plays, each video head picks up half of the horizontal lines in the picture. The first head produces the 262.5 horizontal lines that form the first field, and the second

(Continued on page 58)

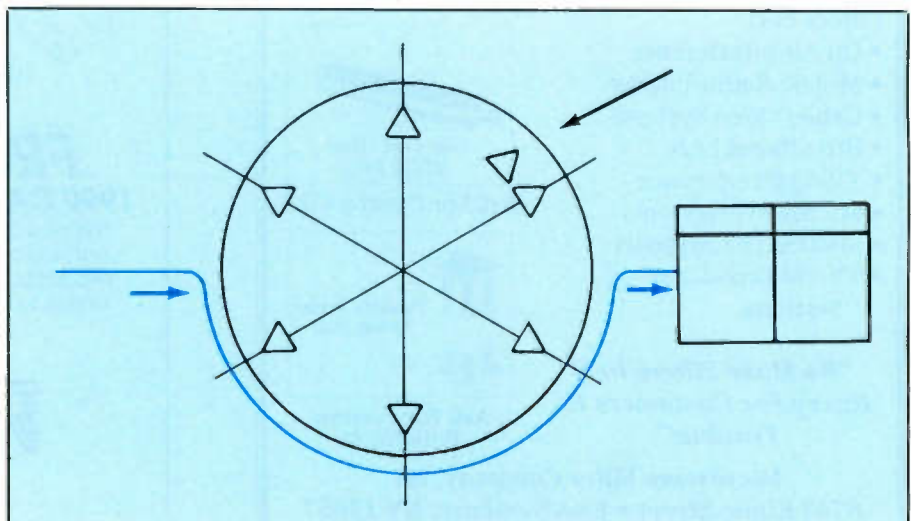

Figure 2. A multi-head machine still uses the video heads two at a time, based on the tape speed being used.

Adapted with permission from Tech Tip -107. Published by Sencore, Inc. Sioux Falls, SD.

IBM researcher reports self-induced repair of electronic-circuit wiring

An IBM researcher has invented a process in which a defect in wiring between integrated-circuit chips can induce its own repair. The process can repair manufacturing defects in interconnection wiring known as constrictions, or near "opens." With an additional step, the process allows complete open circuits to be repaired and even new interconnections to be customized.

The process is aimed at decreasing the cost and increasing the reliability of the components used in computers. Such considerations are becoming more and more important as the components are getting even more complex.

Until now, it has been very time consuming and expensive to correct such defects. In fact, near-open defects are often difficult to locate. One existing technique uses pulses of very high current to transform constrictions into open circuits. Then after a particular defect is located, solder is used to repair it. This new method of

defect repair is expected to make important contributions to the reduction of those manufacturing costs.

The new self-induced repair process, recently patented by C. Julian Chen of the IBM T.J. Watson Research Center, involves a novel variation of electroplating. When a sufficiently high current is passed through a wire with a constriction, more heat is generated at that location than elsewhere on the wire, because the thinner the wire, the greater its electrical resistance and the slower the heat dissipation. As a result of the temperature rise that occurs, a deposition process is induced and the constriction becomes plated with metal such as copper that is transferred from cooler parts of the wire through the plating solution, or electrolyte. So little material is needed to fill up a constriction that there is no appreciable effect on the rest of the wire.

The process is also self-terminating—when an incipient open or constriction becomes sufficiently plated,

its resistance drops, no further excess heat is generated at the defect location, and deposition ends.

The two-step process for the self-induced repair of open circuits might even be simplified. In related work, Robert J. von Gutfeld, another Chen colleague at IBM, suggests that the step involving the laser decomposition of organometallic film can be eliminated in certain circumstances. Von Gutfeld, with IBM co-author Donald R. Vigliotti, described the alternative technique in that same June 18 issue of the journal *Applied Physics Letters*. Here, self-induced repair proceeds after a high-frequency electrochemical process encourages crystal growth of an initial interconnection.

Chen believes that the self-induced repair process could even be applied to the repair of defects in interconnection wiring between components on integrated-circuit chips themselves in addition to the wiring between them. ■

If You're In VCR Repair . . .

Like any profession, "The Difference Between an Expert and an Amateur Are His Tools & His Training".

When your "LUCK", "HOPE" & "FEEL" VCR repair tactics start to run out, remember that TENTELE has the right tools for professional diagnosis mechanical VCR problems.

- TENTELOMETER® Tape Tension Gauge
- Dial Torque Gauge
- Spindle Height / 6-Function Reference Plane Gauge
- Head Protrusion / Eccentricity Gauge

You can't afford to guess when your customers and your future depends on professional service, done right the first time. Let TENTELE increase your efficiency!



NOW AVAILABLE - Video Training Tape "VCR Mechanical Problem Diagnosis" - \$24.95 Includes Shipping In Cont. U.S.

TENTELE® 4475 Golden Foothill Parkway
El Dorado Hills, CA 95630

Call For A FREE CATALOG
(800) 538-6894 / (916) 939-4005

Telephones for sound systems

By John Shepler

A telephone can sometimes become an important part of your sound system.

Say you have been asked to supply the audio for a public event. It will be held in the center of a shopping mall, with loudspeakers throughout the facilities. Some of the participants cannot attend, but would like to be heard anyway. How can they do this?

One good solution is to provide a telephone link so that the master of ceremonies can chat with these people over the phone. Both sides of the conversation need to be clearly understood through the PA speakers.

Traditional phone recording techniques involved tapping the phone line using a type QKT coupler rented

Shepler is an electronics engineering manager and broadcast consultant. He has more than 20 years of experience in all phases of electronics.

from the phone company. This works, but the local mouthpiece audio sounds terrible and is much louder than the caller's voice.

A better solution uses a hands-free telephone, also called a speakerphone. You can purchase one of these in any discount store for \$50 to \$100. They are manufactured by big names such as GE, Panasonic, GTE, Bell and others.

The tricky part is connecting the phone to your audio mixer or PA amplifier. Figure 1 shows an easy solution. A small isolation transformer connects across the phone's loudspeaker leads. The purpose of the transformer is to completely isolate the sound system from the telephone line voltages.

Just about any matching transformer will work. Telephone audio has a very limited frequency response

and noticeable distortion. The speaker level is about normal audio line level, so a 1:1 matching transformer provides enough output. A standard 600/600 ohm matching transformer does a nice job with most line inputs. A 10K/10K works well with high impedance mixer inputs. This is a bridging voltage tap, so there is very little power involved. You may even want to mount a miniature audio transformer inside the telephone case.

In a pinch, you can get by without even a transformer. Simply place another PA microphone close to the telephone speaker. Now, let's see how this system will work in actual operation. The phone is located on the podium or master of ceremony's table. The mic built into the speakerphone must pick up the MC and anyone else speaking. The MC and guests also speak into their normal PA wireless or stand microphones at the same time. No need to tamper with the volume settings. When you want to put the phone through the system, simply turn up the phone channel input to a normal level.

The speakerphone is based on a voice-operated switch or Vox, that switches the phone automatically between "talk" and "listen." When you speak through the phone's mic, the circuit shuts off the speaker and sends your voice to the caller. Otherwise, the caller's voice is switched to the speaker. Voice quality through the PA will be excellent because the MC is heard via the PA mic and the caller is picked up via the telephone speaker.

One caution: pick a phone with a mute button that shuts off the phone mic. If the location is noisy, you can push the mute button so the caller will not be interrupted by room noises. ■

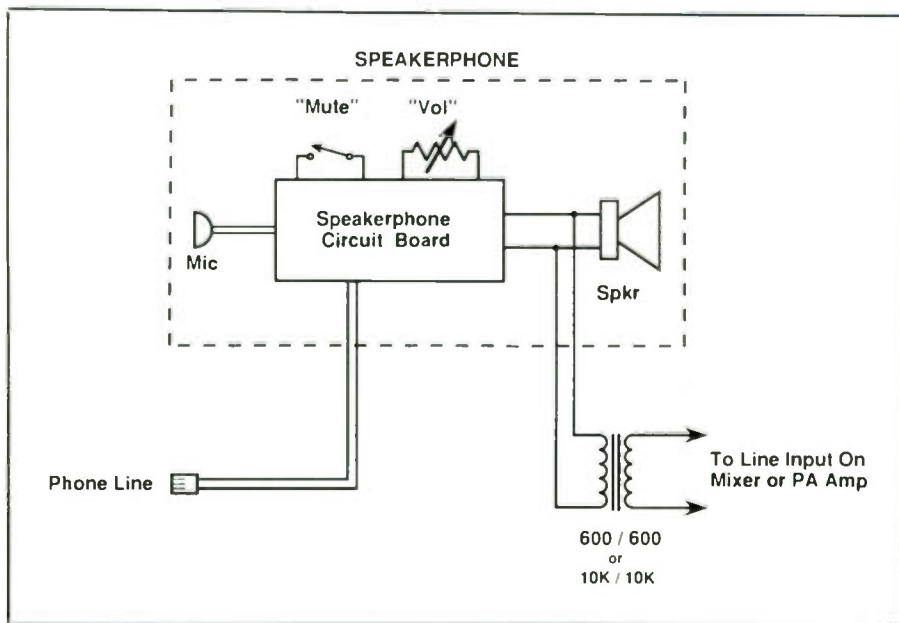

Figure 1. Speakerphone connection

TUNER (MTP-M-2006)

Product safety should be considered when component replacement is made in any area of an electronics product. A star next to a component symbol number designates components in which safety is of special significance. It is recommended that only exact cataloged parts be used for replacement of these components.

Use of substitute replacement parts that do not have the same safety characteristics as recommended in factory service information may create shock, fire, excessive x-radiation or other hazards.

TUNER (MTP-M-2006)

This schematic is for the use of qualified technicians only. This instrument contains no user-serviceable parts.

The other portions of this schematic may be found on other Profax pages.

All integrated circuits and many other semiconductors are electrostatically sensitive and require special handling techniques.

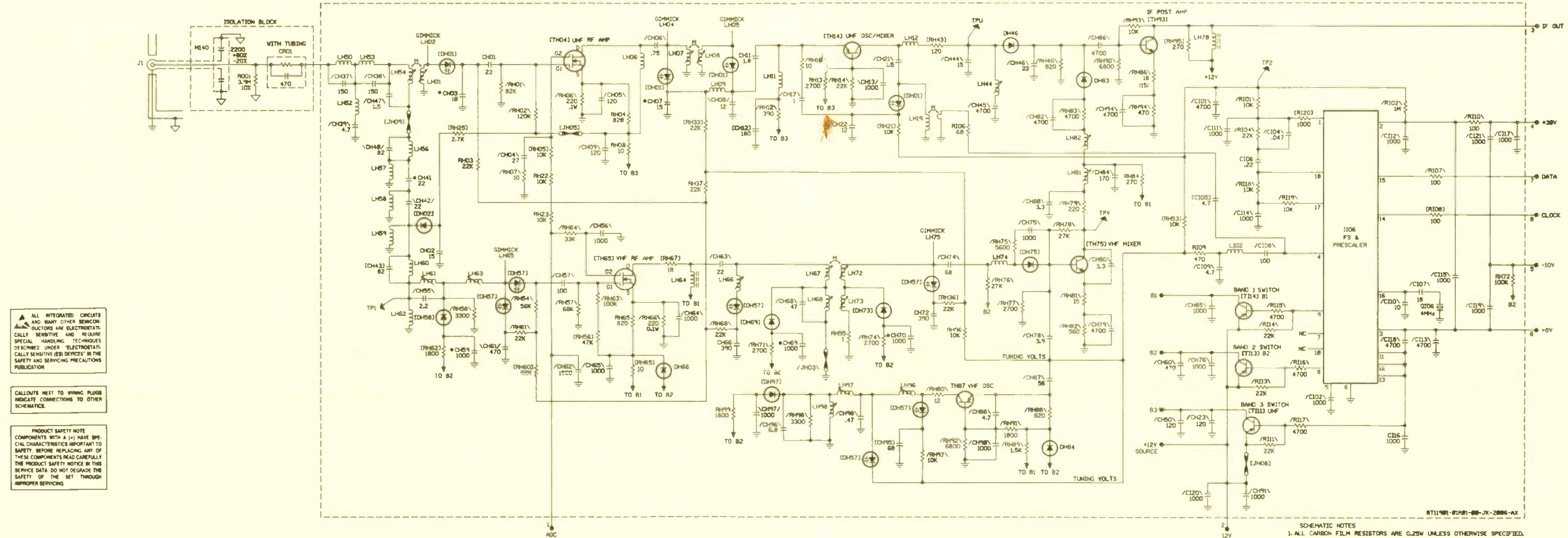

▲ ALL INTEGRATED CIRCUITS AND MANY OTHER SEMICONDUCTORS ARE ELECTROSTATICALLY SENSITIVE AND REQUIRE SPECIAL HANDLING TECHNIQUES DESIGNATED UNDER ELECTROSTATICALLY SENSITIVE (ES) DEVICES IN THE SAFETY AND SERVICE PRECAUTIONS PUBLICATION.

○ CALLOUTS NEXT TO WING PLUMBS INDICATE CONNECTIONS TO OTHER SCHEMATICS.

PRODUCT SAFETY NOTE
COMPONENTS WITH A (*) HAVE SPECIAL CHARACTERISTICS IMPORTANT TO SAFETY. BEFORE REPLACING ANY OF THESE COMPONENTS READ CAREFULLY THE PRODUCT SAFETY NOTICE IN THIS SERVICE DATA. DO NOT DEGRADE THE SAFETY OF THE SET THROUGH IMPROPER SERVICING.

- SCHEMATIC NOTES
- 1. ALL CARBON FILM RESISTORS ARE 0.25W UNLESS OTHERWISE SPECIFIED.
 - 2. RESISTANCE VALUES IN OHMS 0=10000% TOLERANCE.
 - 3. CAPACITANCE VALUES ARE IN PF EXCEPT AS INDICATED.
 - 4. UNLESS OTHERWISE SPECIFIED ALL CAPACITORS ARE 50V.
 - 5. TP INDICATES SERVICE TEST POINT (TP).
 - INDICATES A FLAT SURFACE MOUNTED COMPONENT. RESISTORS ARE 0.25W 1206 SIZE CHIP.
 - INDICATES A 0005 MINI CHIP COMPONENT. RESISTORS ARE 0.0625W EXCEPT AS INDICATED.
 - △ INDICATES A TUBULAR-SHAPED CHIP COMPONENT.
 - ▽ INDICATES A TUBULAR-SHAPED MINI-CHIP COMPONENT. RESISTORS ARE 0.0625W EXCEPT AS INDICATED.
 - 6. A ⊕ DENOTES CHASSIS HOT GROUND.
 - 6. A ⊖ DENOTES CHASSIS COLD GROUND.

DC-DC CONVERTER SCHEMATIC

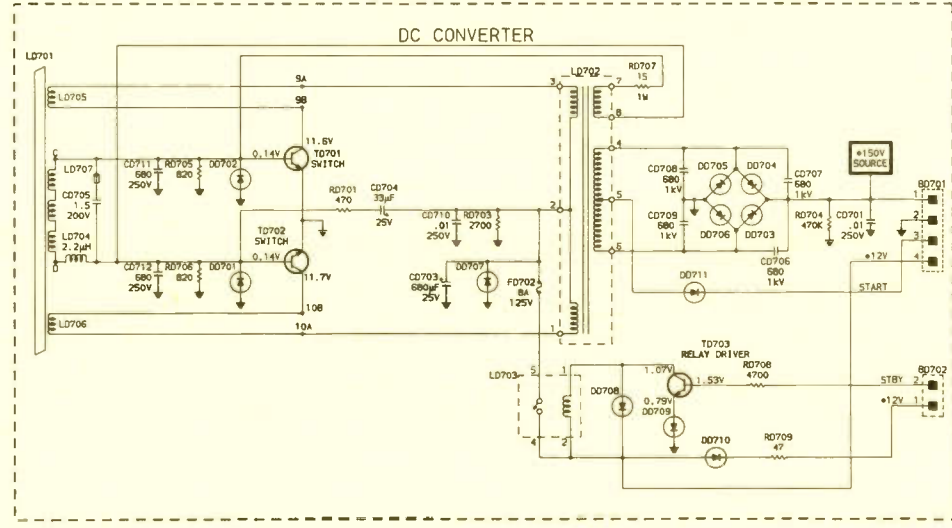

- SCHEMATIC NOTES
- 1. ALL CAPACITORS ARE 50V, EXCEPT WHERE INDICATED.
 - 2. ALL RESISTORS ARE 1/4W 5%, EXCEPT WHERE INDICATED.
 - 3. CAPACITANCE VALUES 1.0 AND ABOVE ARE IN µF. CAPACITANCE VALUES BELOW 1.0 ARE IN nF, EXCEPT WHERE INDICATED.
 - 4. RESISTANCE VALUES ARE IN OHMS, EXCEPT WHERE NOTED.
 - 5. ⊕ DENOTES CHASSIS GROUND.
 - 6. VOLTAGES MEASURED WITH SIGNAL APPLIED AND SHOULD HOLD WITHIN 10%.
 - 7. WAVEFORMS TAKEN WITH KEYS RAISED WITH SIGNAL APPLIED, EXCEPT WHERE NOTED.

REMOTE TRANSMITTER (CRK52/S) SCHEMATIC

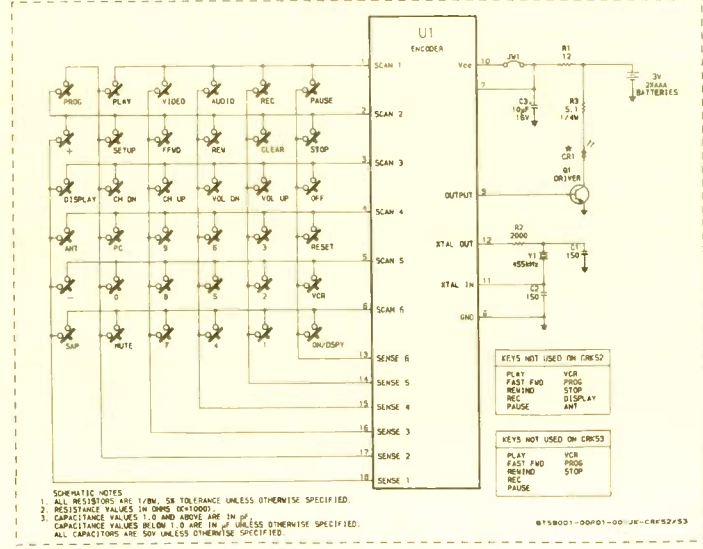

- SCHEMATIC NOTES
- 1. ALL RESISTORS ARE 1/8W, 5% TOLERANCE UNLESS OTHERWISE SPECIFIED.
 - 2. RESISTANCE VALUES IN OHMS 10=10000.
 - 3. CAPACITANCE VALUES 1.0 AND ABOVE ARE IN µF. CAPACITANCE VALUES BELOW 1.0 ARE IN nF, UNLESS OTHERWISE SPECIFIED.
 - 4. ALL CAPACITORS ARE 50V UNLESS OTHERWISE SPECIFIED.

August 1990

Profax Number

RCA/GE TX81 Color TV3067

Product safety should be considered when component replacement is made in any area of an electronics product. A star next to a component symbol number designates components in which safety is of special significance. It is recommended that only exact cataloged parts be used for replacement of these components.

Use of substitute replacement parts that do not have the same safety characteristics as recommended in factory service information may create shock, fire, excessive x-radiation or other hazards.

This schematic is for the use of qualified technicians only. This instrument contains no user-serviceable parts.

The other portions of this schematic may be found on other Profax pages.

DEFLECTION SCHEMATIC

Product safety should be considered when component replacement is made in any area of an electronics product. A star next to a component symbol number designates components in which safety is of special significance. It is recommended that only exact cataloged parts be used for replacement of these components.

Use of substitute replacement parts that do not have the same safety characteristics as recommended in factory service information may create shock, fire, excessive x-radiation or other hazards.

This schematic is for the use of qualified technicians only. This instrument contains no user-serviceable parts.

The other portions of this schematic may be found on other Profax pages.

All integrated circuits and many other semiconductors are electrostatically sensitive and require special handling techniques.

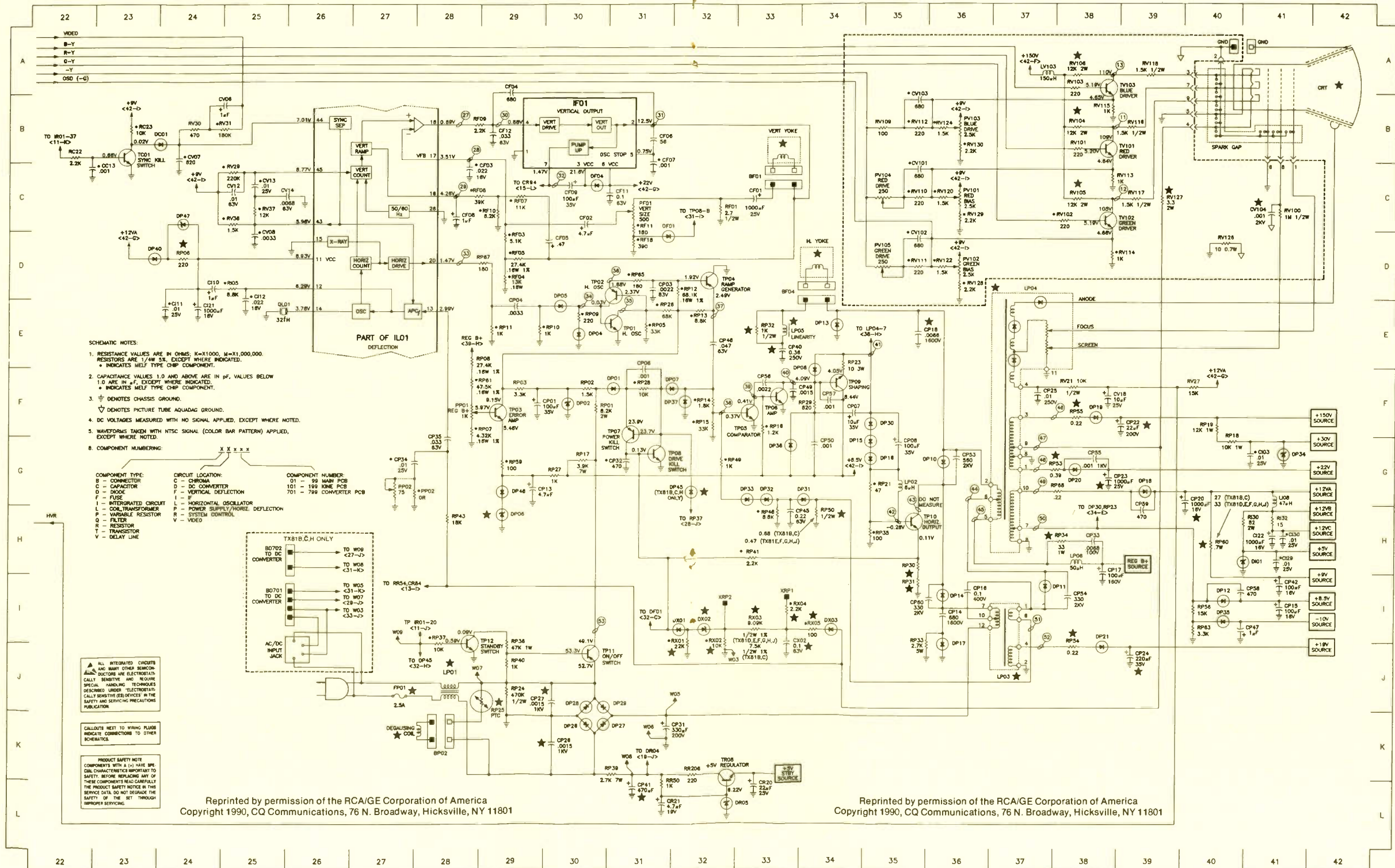

Reprinted by permission of the RCA/GE Corporation of America
Copyright 1990, CQ Communications, 76 N. Broadway, Hicksville, NY 11801

Reprinted by permission of the RCA/GE Corporation of America
Copyright 1990, CQ Communications, 76 N. Broadway, Hicksville, NY 11801

CHASSIS BLOCK DIAGRAM

Product safety should be considered when component replacement is made in any area of an electronics product. A star next to a component symbol number designates components in which safety is of special significance. It is recommended that only exact cataloged parts be used for replacement of these components.

Use of substitute replacement parts that do not have the same safety characteristics as recommended in factory service information may create shock, fire, excessive x-radiation or other hazards.

This schematic is for the use of qualified technicians only. This instrument contains no user-serviceable parts.

The other portions of this schematic may be found on other Profax pages.

All integrated circuits and many other semiconductors are electrostatically sensitive and require special handling techniques.

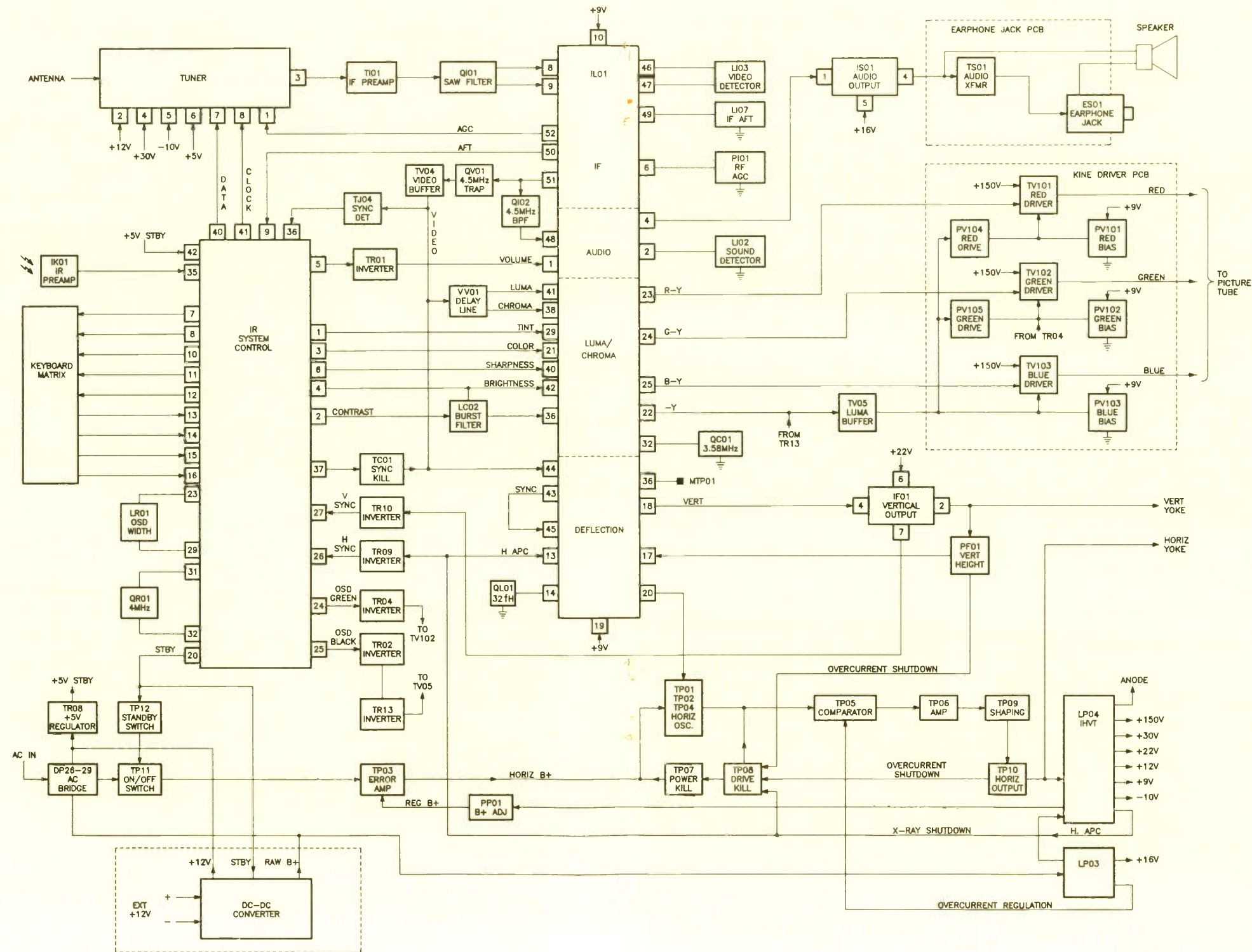

CHASSIS BLOCK DIAGRAM

Product safety should be considered when component replacement is made in any area of an electronics product. A star next to a component symbol number designates components in which safety is of special significance. It is recommended that only exact cataloged parts be used for replacement of these components.

Use of substitute replacement parts that do not have the same safety characteristics as recommended in factory service information may create shock, fire, excessive x-radiation or other hazards.

This schematic is for the use of qualified technicians only. This instrument contains no user-serviceable parts.

The other portions of this schematic may be found on other Profax pages.

All integrated circuits and many other semiconductors are electrostatically sensitive and require special handling techniques.

SIGNAL SCHEMATIC

Product safety should be considered when component replacement is made in any area of an electronics product. A star next to a component symbol number designates components in which safety is of special significance. It is recommended that only exact cataloged parts be used for replacement of these components.

Use of substitute replacement parts that do not have the same safety characteristics as recommended in factory service information may create shock, fire, excessive x-radiation or other hazards.

This schematic is for the use of qualified technicians only. This instrument contains no user-serviceable parts.

The other portions of this schematic may be found on other Profax pages.

All integrated circuits and many other semiconductors are electrostatically sensitive and require special handling techniques.

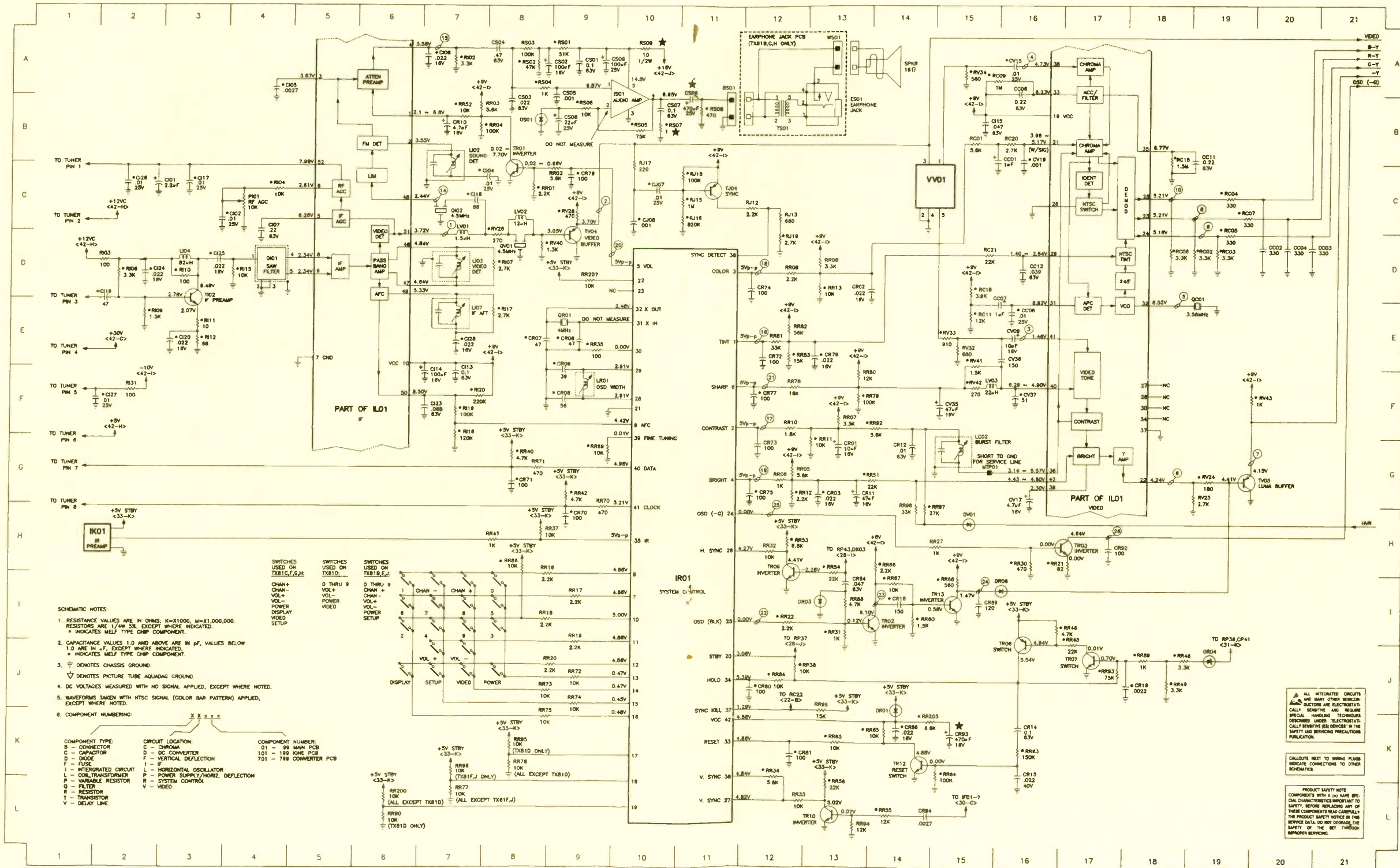

SIGNAL SCHEMATIC

Product safety should be considered when component replacement is made in any area of an electronics product. A star next to a component symbol number designates components in which safety is of special significance. It is recommended that only exact cataloged parts be used for replacement of these components.

Use of substitute replacement parts that do not have the same safety characteristics as recommended in factory service information may create shock, fire, excessive x-radiation or other hazards.

This schematic is for the use of qualified technicians only. This instrument contains no user-serviceable parts.

The other portions of this schematic may be found on other Profax pages.

All integrated circuits and many other semiconductors are electrostatically sensitive and require special handling techniques.

All about floppy disks

By Glenn R. Patsch

Did you ever put a high density 1.2 megabyte (MB) 5.25 inch floppy disk in a low density 360 kilobyte (KB) drive and get the all too familiar "General failure error reading drive B Abort, Retry, Fail?" error message. This is the same message you get if you place a blank unformatted disk in the drive. This is very easy to do if you have a high density 1.2 MB drive as A: and a low density 360K B: drive. It is also easy to mistake this as a problem with the floppy drive and think there is something wrong with the drive. Always suspect that the disk is bad, has the wrong format or that the drive door is open before considering that the drive is defective. Use a disk you know to be good for testing the drive. IBM puts a small asterisk (*) on the drive to indicate a low density 360 KB drive.

In figure 1 we see a list of floppy disks used by the IBM PC, XT, AT and PS/2 computers (all disks are soft sector).

To identify a floppy disk, look carefully at the label: A 3M 5.25 inch 360 KB disk label looks like: DS,DD, 48 TPI, RH. A 3M 3.5 inch 1.44 MB disk is labeled: 3.5, DS, HD, 2.0 MB. #M also has preformatted disks that are labeled: Formatted, 3.5" DS, HD, IBM PS/2 1.44 MB. The high density 1.44 imprinted on the blue disk eject button. To format 3.5 inch 720 KB disk in a 1.44 MB drive use the DOS format command as follows:

FORMAT a: /N:9 /T:80. T speci-

Patsch is a consultant specializing in the selection, and evaluation and installation of IBM personal computer and compatible hardware and software.

Size	Sides	Density	Capacity	Formatted	TPI
5.25"	SS	DD	160KB	160KB	40
	SS	DD	180KB	180KB	48
	DS	DD	320KB	320KB	40
	DS	DD	360KB	360KB	48
	DS	HD	1.2MB	1.2MB	96
3.5"	DS	HD	1.0MB	720KB	135
	DS	HD	2.0MB	1.44MB	135
		HD			

Notes: SS = single sided; DD = double density; DS = double sided; HD = high density; TPI = Tracks per inch; RH = reinforced hub ring.

Figure 1.

fies the number of tracks and N specifies the number of sectors per track. Refer to the table for the correct value for each disk type. I find it handy to have a FORM720 batch file, FORM720.bat, that stores this format command. Then I enter FORM720 as a DOS command to format a 720 KB disk in my 1.44 MB A: drive. Form720.bat, REM formatting a 3.5" 720K disk in a 1.44M drive FORMAT a: /N:9 /T:80.

In figure 2 we see the tracks and sectors used by floppy disks:

Be careful that you ALWAYS enter a drive letter when using the DOS

Format command to avoid accidentally formatting the hard disk. Newer versions of DOS will return a "Drive letter must be specified" error message if you try to use the format command without specifying a drive letter.

Knowing how to identify and format floppy disks can save you a lot of time. Understanding floppy disks and drives can save you from attempting to fix what to be a defective floppy drive that is actually the wrong type of floppy disk for that drive. Knowing floppy disks helps you specify the correct type of disk for a particular drive. ■

Size	Sides	Density	Capacity	Tracks	Sectors/Track
5.25"	SS	DD	160KB	40	8
	SS	DD	180KB	40	9
	DS	DD	320KB	40	8
	DS	DD	360KB	40	9
	DS	HD	1.2MB	80	15
3.5"	DS	HD	720KB	80	9
	DS	HD	1.44MB	80	18
		HD			

Figure 2.

New function generator

New from *Beckman Industrial Corp.* is a portable field test instrument. The FG2A is a high-performance product in a small, inexpensive



package. The combination of flexible controls and powerful functional capabilities make the FG2A a real test workhorse. It performs over seven frequency ranges covering 0.2Hz through 2MHz, and a very large array of signal outputs, including both TTL pulse outputs and adjustable low-distortion sine, square or triangle wave signals. Product applications include testing vibration, servo systems, audio systems and ultrasonic devices. The FG2A is housed in a durable case which features a cushion-grip handle/tilt stand and is available for immediate delivery.

Circle (69) on Reply Card

Instant freeze chiller

New from *Tech Spray* is the minus 96 Instant Chiller in a 100 percent CFC-free Ozone-friendly formulation. This trouble shooting freeze spray is used to track down thermal intermittents, detect cracks in printed circuit boards, and prevent cold solder joints. Minus 96 Instant chiller



shrink-chills inside parts to permit insertion or removal and speeds solidification of solder joints to stop movement during molten state. It also protects heat sensitive components, and cools components during mounting to prevent heat damage. The reformulation has not altered its effectiveness, safety and odor.

Circle (70) on Reply Card

Regulated d.c. power supplies

Recently added to its series of regulated Power supplies from *Brunelle*, is a new line of power supplies designed for laboratories, production and test bench applications. Among



the features we find, short-circuit protection, over voltage protection, constant current and voltage output, very low ripple, coarse and fine controls on voltage. 12 models are available in 4 voltage ranges from 0-18 volts to 0-150 volts. Current as high as 10 amperes is available. These units are contained in a rugged meal case with a carrying handle to make transportation easy.

Circle (71) on Reply Card

3¾ digit display

Versatile and accurate the new 4,000 count SOAR model 4041A digital multimeter delivers a variety of functions usually found only in higher cost models. *Carlo Gavazzi* multimeters delivers a variety of functions usually found only in higher cost models. The high speed amplifying rate updates the digital indication 2.3 times/sec. and the analog bargraph 23 times/sec. With auto or manual range selection, the 4041A performs

DC V measurements from 400uA to 1000V (5 ranges) at 0.3% basic accuracy.

Circle (70) on Reply Card

Test bench jr. multi tester

A new pocket sized instrument with the capabilities of five separate instruments has been unveiled by *B&K-Precision*. The Test Bench Jr., model 377 is a smaller tester in addition to the best selling testers by B&K-Precision. It is a voltmeter, ammeter, ohmmeter, frequency counter, capacitance tester, logic tester, diode tester, continuity tester. All of these capabilities are now contained in a case the size of a compact digital multimeter.

Circle (71) on Reply Card

Multi purpose VCR belt

Project-Recorder Belt now offers a total of 5 different VCR multi purpose maintenance kits. Each kit comes in a sturdy, reusable clear utility case. Each compartment is labeled for quick reference and comes stocked with 5 belts of each size indi-



cated. These handy kits are easy to restock with belts purchase at lower bulk rate prices. This new, innovative packaging allows you to easily show and test belts without opening a sealed package.

Circle (73) on Reply Card

Service technicians kit

Jensen Tools Inc. has introduced a new service kit for maintenance and repair of sound and video equipment. The JTK-99 Service technician's kit contains over 80 basic tools for servicing radio, TV, VCR, two-way communication systems, and similar electronics. The tool selection includes hex drivers, nutdrivers, slotted and Phillips screwdrivers, cutters, pliers, wrenches, punch files, measuring tools, wire strippers, saw,



hammer, tweezers, knife soldering equipment and more. The tools are conveniently positioned in two removable pallets, one lower and one upper double-swing, leaving ample room in the bottom of the case for spare parts and optional test equipment.

Circle (74) on Reply Card

Air leveling tape

New from *Electro Insulation Corp.* is a hot polyethylene paper laminate specifically designed to protect a circuit boards gold contact fingers during solder reflow and hot air leveling of printed wiring boards. The N700 is easy to apply, no heat required and very comfortable. There is no solder leakage or wicking under

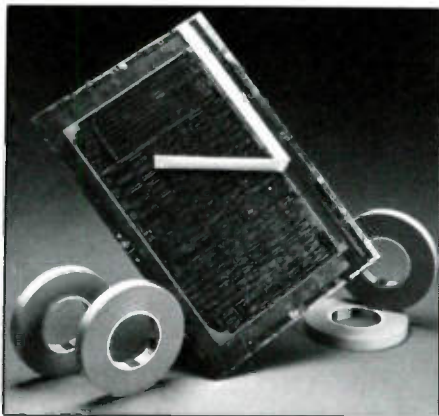

the tape. The superior air-pressure adhesion means the N700 will not be blown off during hot air leveling. N700 is easily removed with no residue or tape silvering.

Circle (75) on Reply Card

Soldering systems

A new series of mid-priced soldering systems is now available from *Ungar*. With many features these soldering systems are not available in

competitively priced stations. Called the "Concept 200", the new product line offers high capacity soldering capability, excellent temperature stability, MIL-SPEC compliance and ESD safety. Its features include a 24-volt, micro-sized handpiece that is cool and comfortable to operate, and can handle everything from delicate precision work to the most demand-



ing, high capacity soldering applications. The maintenance is simplified with external calibration and fuse access. The ceramic heater, which typically lasts one to two years, may be replaced at the work station with no tools needed.

Circle (76) on Reply Card

Adapter kits for coaxial combinations

To provide a quick way for lab users, field service/installation technicians and designers to adapt almost any coaxial end termination style to another, including banana plugs, a specially assembled kit is now available from *Pomona Electronics*. The



model 5698 universal adapter kit allows users to make their own adapter combinations, such as SMA to BNC, or BNNC to double banana plugs for connecting coax to instruments. All of the adapters in the kit are of the highest quality design and manufacture, with gold plated center pins and silver plated bodies.

Circle (77) on Reply Card

Have a question, a comment, a gripe, a suggestion? Found a better way of servicing an electronics product discussed in an article? Or maybe you would like to see an article about a subject you haven't seen covered yet. We want to hear your ideas.

Feedback
Electronic Servicing & Technology
 P.O. Box 12487
 Overland Park, KS 66212

Solving software problems

In reference to the "Computer Corner" article in your May 1990 issue, you discussed solving computer software problems by first checking the autoexec.bat file. As this is an excellent technique, which I have successfully used on many occasions, you made a suggestion which could be dangerous for the new or inexperienced operator. You suggested renaming the autoexec.bat file autoexec.bak. While renaming the autoexec file is a wise safeguard against disaster, renaming it autoexec.bak is not wise since the DOS edlin editor automatically renames any file edited by its filename.bak. Being in the computer service industry for many years, a general policy of our company is indeed to rename the autoexec.bat as well as the config.sys file whenever a change is to be made by copying the autoexec.old or autoexec. (technicians initials) and the config.sys in a similar manner. While the method you use to edit these files may not automatically rename them.bak, many machines already have it installed. I have enjoyed many of the fine articles in your magazine, keep up the good work.

In regards to Mr. Sam Wilson-All your articles are always interesting and informative, and your quizzes are needed for our mental health. If I may be allowed to correct what looks like a printers error in the May 1990 issue on page 37 in the article "More About Nepers": $1\text{np} = 8.686\text{ db}$ and $1\text{db} = 0.1151\text{ np}$. Looking forward to more of your articles.

Renato Annati
Tamarac Fla.

Editors note- thank you Mr. Annati for pointing this out. This error was introduced by the editor and not Mr. Wilson.

JVC

2753-1 AV-2779S

MITSUBISHI

2750-1 CS-207OR

PANASONIC

2749-2. CTL-103OR, CTL-1031R,
CTL-1032R, PC-11T3OR,
PC-11T31R, (CH. AGP159,
YAGP159)

2752-1 CTL-1942R/R-1
(CH. ADP179/GL7H2,
ADP195/GL7H2)

2749-2. CTL-103OR, CTL-1031R,
CTL-1032R, PC-11T3OR,
PC-11T31R, (CH. AGP159,
YAGP159)

QUASAR

2747-1 TT6236CW,
(CHALDC165/GL7H)

2751-1. TT6237CE (CH. AEDC165)

RCA

2748-1 JPR985PR (CTC131M)

2749-1 F2O5O7WNAO2/3/4,
F2O5O7WNNNO3/4,
F2O5O8BHNO3, F2O5O9AKNO3/4,
F2O514WNAO1/2/3/4,
F2O514WNNNO1/3/4,

F2O515EGNO1/2, F2O516BHAO3,
F2O516BHNO3, F2O517WNAO2/3,
F2O51WNNNO2/3/4, F2O519AKAO3,
F2O519AKNO3, F2O526AKAO1,
F2O527CPAO1, F2O527CPNO1,
F220533BMAO1/2/4,
F2O533BMNO3,

F2O53DWAO1/2/4, F2O53DWNNO3,
F2O536EHAO1/2/4,
F2O536EHNO1/2,
F2O536EHAO1/2/4,
F2O537CPNO1/3,
F2O537CPAO1/3/4,
F2O538DGNO1/2/3,
X2O131EBAO1/3,
X2O133WNNNO1/3

RCA

X2O161EBAO1/2/4,
X2O161EBNO1/2/3/4,
X2O163WNAO1/2/3/4,
X2O163WNNNO1/3/4
(CH. CTC146B/C/D/E/G/H)

SEARS

2747-2 564.42072950/1,
564.42093950/1

2748-2 580.40357950

2750-2 564.48014950

2751-2 564.42905950

ZENITH

2752-2 SD27O5G/G3,
SD2707N/N3, SD27O9P/P3,
SD2713H, SD2715A, SD2717N,
SD2719P, SD2721H, SD2767H,
SD2769W, SD2783P, SD2787H,
SD2789W/Y, SD2799S, SD5721H,
SD5729W, SD5749Y, SD5759Y,
SD5779H

Test your electronics knowledge

By Sam Wilson, CET

Are you keeping up with the technology? These questions are about microprocessors. This is a very difficult quiz. Any grade over 60% puts you in the super technician level.

1. When a program is interrupted, it may be temporarily stored in a high-speed memory called a/an _____.
2. Two or more devices may be used to perform the same function in order to increase reliability. This is called _____.
3. When decimal numbers are represented by groups of four binary num-

bers it is called _____ (initials only).

4. A circuit that performs addition without a carry is called a/an _____ (two words).

5. Whole numbers—such as those used to indicate a sequence, are called _____.

6. Any system operation or signal that may be due to mere chance is called _____.

7. An outlet that permits information to be taken from or delivered to a computer is called a/an _____.

8. A type of read-only memory that can be erased with ultraviolet light and reprogrammed is called a/an _____ (initials only).

9. A type of I/O system that permits data to be sent to (or retrieved from) memory without going through the microprocessor is called _____ (initials only).

10. With this type of interrupt, each peripheral device has its own address. The way the microprocessor handles the interrupt request is determined by software. This is called a/an _____ interrupt.

(Answers on page 58.)

Wilson is the electronics theory consultant for ES&T

Choosing a replacement parts supplier

By Conrad Persson

Locating replacement parts to bring a TV or VCR back to life has never been more difficult than it is today, and it just continues to get harder. There are more and more no-name products being sold, with nary a clue as to who made the unit or where to go for parts and information. More and more of the circuitry is highly sophisticated, with esoteric parts for which no one but the manufacturer has the replacement. What's a technician to do when he's faced with a problem like this?

Right. The answer is talk to your replacement parts distributor. That is if it's the right kind of distributor: the kind who's responsive to the needs of the servicing technician.

The nature of the problem

Today's crop of consumer electronics products is more sophisticated than most people realize. Much of it is so technologically advanced that even the technicians who work on it every day can't really appreciate the complexity of it. In many cases these days a consumer electronic product isn't really a product, it's an intricate system. Take a VCR, for example. There's the electromechanical portion of the system, which loads the tape and records or plays it. There's the electronic portion that manipulates the video signal. There's the control section, which makes sure that all the other sections work properly together, and just for good measure senses conditions like the presence of moisture or end of tape and shuts down the system if there's danger of damage.

Because there are so many components with so many specific characteristics, designers of today's sophisticated consumer electronics products have an incredibly broad number of ways in which to realize the circuits they want to build. And if they want to achieve a function and don't

like the components available with which to get the job done, they can go to an integrated circuit manufacturer, or the IC division of their own company, and have a new, proprietary IC designed and fabricated.

All of this leads to a huge variety of components that the technician will run across any time he opens up a product for repair. The problem is made more difficult by the fact that each manufacturer has his own part numbering system. In a lot of cases, when a technician has identified a particular component as the cause of the problem, he can find a cross reference that will allow him to determine if he has an equivalent in stock.

Unfortunately, in as many cases, there is no cross reference, and even if a technician has a needed part on hand, he doesn't know it.

What to do

There are many things that can be done to alleviate the situation. The most obvious is to obtain copies of every cross reference that exists and become familiar with them so that when a part is needed it can be identified. Some of the cross references are available free from manufacturers through distributors, and some cost a pretty good chunk of change. If a technician adds up all the long distance calls, and all the time spent on the phone, to say nothing of the toll charges for those long distance calls, any cost for cross references might be found to be money well spent.

Talk to a good distributor

Whether you've identified the replacement component needed to effect a repair by doing your own research, or if you've come up with a blank, obtaining a part from the distributor is your next step. Just as with any supplier, distributors are not all equal in their commitment or ability to solve your problem. The advertisers who are represented in this special advertising supplement have taken this opportunity to tell you a little

more about themselves than they can in just an ad. They want technicians to be aware of what kind of facilities they have, what kinds of people work for the company, the efforts they are making to keep the satisfaction of their customers as high as possible, and how to contact them when you need a replacement component.

Here are some of the questions we asked the manufacturers and distributors to address in their articles:

- How many locations do they have?
- How often are they able to fill orders from stock?
- What payment options do they offer—open order account, credit card?
- How soon after receipt of an order to they ship?
- Do they add a shipping surcharge?
- Do they have a toll free number?
- What ordering options do they offer?
- What is their return policy?
- Do they offer a warranty?
- Is there a minimum order amount?
- What shipping options do they offer?
- What special services do they offer?
- Do they have a research department to help technicians find a specific part?

When you're searching for a replacement part supplier you can count on for convenience and service, keep some of those questions in mind. After all, just finding someone who carries the part isn't the only consideration. If you have to wait until you fill a large minimum order amount before you order, or if you have to wait weeks for the part to arrive, you're stuck with a defective TV and probably an irate customer. The impulse to order from the first name in the book might be high, but take the time to ask some question. It could save time, money and aggravation. The following section will give you a head start in answering some of those questions. ■

DELIVERY IS THE MOST IMPORTANT FUNCTION OF A PARTS DISTRIBUTOR. BUT IT'S NOT ENOUGH.

AVAILABILITY
DELIVERY
RELIABILITY
SUPPORT
NETWORKING
QUALITY

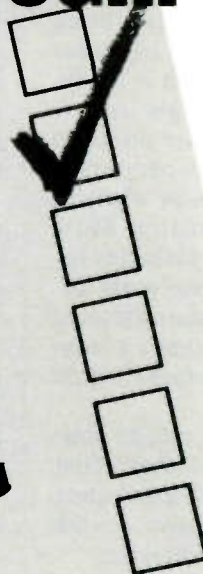

MATSUSHITA AUTHORIZED PARTS-LINK™ DISTRIBUTORS. BECAUSE IT PAYS TO BE SURE.

Some distributors are quick to promise fast delivery of replacement electronic parts. But they may not always be the right parts. That's never a problem when you put your trust in a Matsushita Authorized PARTS-LINK™ Distributor — your best source for Panasonic, Technics and Quasar original replacement parts. For basic stocking, each distributor maintains over 1,000 of the most demanded part numbers for off-the-shelf delivery. Even if the part you need isn't so common, your Matsushita distributor is tied into our exclusive PARTS-LINK™ network, tracking over 385,000 part numbers, so that we can locate the part you need, lock in the order, and deliver it — if overnight delivery is requested to your doorstep within 24 hours. They can even cross-reference these original

replacement parts to other Matsushita built products so that you can retain the high quality and reliability of Matsushita's design.

THE DIFFERENCE BETWEEN A PROMISE KEPT, AND A PROMISE BROKEN.

Your Matsushita Authorized PARTS-LINK™ Distributor isn't authorized by accident; each has met (and continues to meet) stringent requirements to ensure fast, courteous and responsive service backed by Matsushita's replacement parts warranty.

The right part at the right time from the right source. For the name and location of your Matsushita Authorized PARTS-LINK™ Distributor — see our listings at right.
YOUR SOURCE OF CONFIDENCE.



MATSUSHITA SERVICES COMPANY

50 Meadowland Parkway, Secaucus, NJ 07094

Panasonic® • Technics™ • Quasar®

MATSUSHITA

AUTHORIZED REPLACEMENT PARTS DISTRIBUTORS

Panasonic® • Technics™ • Quasar®

ARIZONA

ARIZONA WHOLESALE SUPPLY CO. (C/M) • 2020 E. University Dr., Phoenix 85062 • 602-258-7901
ELECTRONIC PARTS CO. (C/V/M) • 4021 N. 31st. Ave., Phoenix 85017 • 602-277-7281

CALIFORNIA

ANDREWS ELECTRONICS (C/V/M) • 25158 Avenue Stanford, Valencia 91355 • 805-257-7700
AUDIO VIDEO PARTS, INC. (C/V/M/A) • 1071 South La Brea Ave., Los Angeles 90019 • 213-933-8141
CASS ELECTRONICS (C/V/M/A) • 801 Seventh Ave., Oakland 94606 • 415-839-2277
CMUCK HURLEY ELECTRONICS (C/M/A) • 2557 Albatross Way, Sacramento 95815 • 916-927-5891
E AND K PARTS, INC. (C/V/M/A) • 2115 Westwood Blvd., Los Angeles 90025 • 213-475-6848
HURLEY ELECTRONICS (C/M) • 10712 Inglewood Ave., Inglewood 90304 • 800-356-8734
HL RLEY ELECTRONICS (C/M) • 730 W. Spruce, San Bernardino 92410 • 714-885-0721
HL RLEY ELECTRONICS (C/V/M) • 318 16th St., San Diego 92101 • 619-235-6245
HL RLEY ELECTRONICS (C/M) • 2101 N. Fairview, Santa Ana 92706 • 714-971-2992
PACIFIC COAST PARTS (C/V/M/A) • 15024 Staff Court, Gardena 92048 • 213-515-0207
WHOLESALE VACUUM (V) • 5811 Rmse Ave., Long Beach 90813 • 213-428-6411

COLORADO

DENVER WALKER WINTRONICS (C/M) • 1001 W. Arizona Ave., Denver, 80223 • 303-744-9505

CONNECTICUT

SIGNAL ELECTRONICS SUPPLY, INC. (C/M/A) • 589 New Park Ave., West Hartford 06110 • 203-233-8551

FLORIDA

HERMAN ELECTRONICS (C/V/M/A) • 1365 N.W. 23rd St., Miami 33142 • 305-634-6591
LAYCO, INC. (C/V/M) • 501 South Main St., Crestview 32536 • 904-682-0321
VANCE BALDWIN (C/A/M) • 2207 S. Andrews Ave., Fort Lauderdale 33316 • 305-523-3461
VANCE BALDWIN (C/M/A) • 1801 NE 2nd Ave., Miami 33132 • 305-379-4794
VANCE BALDWIN (C/V/M/A) • 1007 N. Himes Ave., Tampa 33607 • 813-870-2606
VANCE BALDWIN (C/V/M) • 500 Clematis St., West Palm Beach 33401 • 407-832-5671

GEORGIA

BUCKEY VACUUM CLEANER (V) • 2870 Plant Atkinson Rd., Smyrna 30080 • 404-351-7300
WHOLESALE INDUSTRIAL (C/M/A) • 5925 Peachtree Corners East, Norcross 30071 • 404-447-8436

HAWAII

PANASONIC HAWAII, INC. (C/V/M) • 99859 Iwalwa St., PO Box 774, AIEA, HI 96701 • 808-488-1996

ILLINOIS

B-B & W, INC. (C/V/M) • 2137 S. Euclid Ave., Berwyn 60402 • 708-749-1710
HESCO, INC. (V) • 6633 North Milwaukee Ave., Niles 60648 • 708-647-6700
JOSEPH ELECTRONICS, INC. (C/M/A) • 8830 N. Milwaukee Ave., Niles 60648 • 708-297-4200
UNION ELECTRONIC DIST. (C/V/M/A) • 16012 S. Cottage Grove, South Holland 60473 • 708-333-4100

INDIANA

ELECTRONIC SERVICE PARTS (C/V/M) • 2901 E. Washington St., Indianapolis 46201 • 317-269-1527

IOWA

JONES DISTRIBUTING CO. (C/V/M/A) • 2650 Bridgeport Dr., Sioux City 51111 • 712-277-8600

KANSAS

G & A DISTRIBUTORS, INC. (C/V/M/A) • 635 N. Hydraulic St., Wichita 67201 • 316-262-3707

KENTUCKY

MAJOR DISTRIBUTING COMPANY (C/M) • 449 S. 16th St., Paducah 42003 • 502-443-5345
SERVICE ELECTRONICS SUPPLY (C/V) • 1046A New Circle Rd., NE, Lexington 40505 • 606-254-5786

MARYLAND

FAIRWAY ELECTRONICS (C/V/M) • 3040 Waterview Drive, Baltimore 21230 • 301-576-8555
FAIRWAY ELECTRONICS (C/V/M/A) • 4210 Howard Ave., Kensington 20895 • 301-564-1440
TRITRONICS, INC. (C/V/M/A) • 1306 Continental Dr., Abingdon 21009-2334 • 301-676-7300

MASSACHUSETTS

MIL ELECTRONICS (C/V/M/A) • 1500 Main St., Waltham 02154 • 617-891-6730
SIGNAL ELECTRONICS SUPPLY, INC. (C) • 484 Worthington St., Springfield 01105 • 413-739-3893
TEE VEE SUPPLY CO. (C/V/M/A) • 407 R. Mystic Avenue, P.O. Box 649, Medford, MA 02155 • 617-395-9440

MICHIGAN

G.M. POPKEY CO. (C/V/M/A) • 4477 East Paris Ave. S.E., Grand Rapids 49512 • 616-698-2390
REMCOR ELECTRONICS (C/M/A) • 10670 Nine Mile Rd., Oak Park 48237 • 313-541-5666

MINNESOTA

NESS ELECTRONICS, INC. (C/V/M/A) • 441 Stinson Blvd. NE, Minneapolis 55413 • 612-623-9505
MID AMERICA VACUUM CLEANER SUPPLY CO. (V) • 666 University Ave., St. Paul 55104 • 612-222-0763

MISSISSIPPI

TRI-STATE ELECTRONICS (C/V/M) • 605 W. Fortification St., Jackson 39203 • 601-355-3431

MISSOURI

CITITRONIX, INC. (C/V/M/A) • 1641 Dielman Rd., St. Louis 63132 • 314-427-3420
MANHATTAN ELECTRONICS, INC. (C/V/M) • 1101C E. 76th Terrace, Kansas City 64131 • 816-361-9440
TACONY CORP. (V) • 1760 Gilsinn Lane, Fenton 63036 • 314-349-3000

NEW HAMPSHIRE

TEE-VEE SUPPLY CO. (C/V/M/A) • 51 Kinsley St., Nashua 03060 • 603-889-4171

NEW JERSEY

NIDISCO ELECTRONICS (C/V/M/A) • 181 Route 46 W. Lodi 07644 • 201-773-1771

NEW YORK

DALE ELECTRONICS (C/V/M/A) • 7 E. 20th St., New York City 10003 • 212-475-1124
GREEN TELE-RADIO DIST. (C/M/A) • 84-00 73rd Avenue, Glendale 11385 • 718-821-1114
GMB SALES (C/V/M/A) • 140 Terminal Rd., Setauket 11733 • 516-689-3400
MILL ELECTRONIC SUPPLY (C/V/M/A) • 2026 McDonald Ave., Brooklyn 11223 • 718-336-4575
PAGO APPLIANCE PARTS (C/M/A) • 700 Broadway, Buffalo 14212 • 716-856-8133
PANSON ELECTRONICS (C/V/M/A) • 268 Norman Avenue, Greenpoint 11222 • 718-383-3400
RADIO EQUIPMENT CORP. (C/A) • 196 Vulcan St., Buffalo 14207 • 716-874-2690
STAR FOR PARTS (V) • 250 Rabro Drive East, Hauppauge 11788-0255 • 800-525-6046
UNITED TELETRONIC PARTS (C/M) • 3860 10th Ave., New York 10034 • 212-569-2330

NORTH DAKOTA

WESTECH DISTRIBUTING (C/V) • 1345 Main Ave., Fargo 58103 • 701-237-4885

OHIO

FOX INTERNATIONAL, INC. (C/V/M/A) • 23600 Aurora Rd., Bedford Heights 44146 • 216-439-8500

OREGON

DIVERSIFIED PARTS (C/V/M/A) • 2104 S.E. 9th Ave., Portland 97214 • 503-236-6140
THE MOORE CO. (C/V/M) • 333 SE 2nd, Portland 97214 • 503-234-5000

PENNSYLVANIA

CRS ELECTRONICS (C/M) • 818 Brownsville Rd., Pittsburgh 15210 • 412-431-7700
LINWOOD WHOLESALE, INC. (C/M) • 1139 Sumner Ave., Whitehall 18052 • 215-820-0357
S.E.I. ELECTRONICS INC. (C/V/M/A) • 2520 N. Broad St., Philadelphia 19132 • 215-223-9400

RHODE ISLAND

JABBOUR ELECTRONICS (C/V/M/A) • 1744 Cranston SL, Cranston 02920 • 401-944-2570

SOUTH CAROLINA

WHOLESALE INDUSTRIAL (C/V/M) • 515 E. Bay St., Charleston 29403 • 803-722-2634

TENNESSEE

CURREY'S, INC. (C/V/M) • 1027 8th Ave. S., Nashville 37203 • 615-242-4221
MILLS MORRIS CO. (C/V/M/A) • 677 Phelan Ave., Memphis 38101 • 901-774-9810
SHIELDS ELECTRONICS SUPPLY, INC. (C/V/M/A) • 4722 Middlebrook Pike, Knoxville 37921 • 615-588-2421

TEXAS

ELECTRONIC COMPONENT (C/V/M/A) • 2401 Bissonnet, Houston 77005 • 713-528-1543
FOX INTERNATIONAL (C/V/M) • 752 So. Sherman, Richardson 75081 • 214-231-1826
M-TRONICS (C/V/M/A) • 3201 West Ave., San Antonio 78213 • 512-340-4069
PORTER BURGESS CO. (C/V/M) • 1233 Levee St., Dallas 75207 • 214-741-5161
SHERMAN ELECTRONICS (C/V/M) • 702 San Pedro Ave., San Antonio 78212 • 512-224-1001
SHERMAN ELECTRONICS (C/V/M) • 1701 Morgan Ave., Corpus Christi 78404 • 512-888-9454
SOUTHWEST MANUFACTURERS, INC. (V) • 3243 S. Jones St., Fort Worth, TX 76110-4397 • 817-926-8281
VCP INTERNATIONAL INC. (V) • 2285 Merritt Dr., Garland 75040 • 214-271-7474

VIRGINIA

AVEC ELECTRONICS CORP. (C/M) • 711 Granby St., Norfolk 23510 • 804-627-3502
AVEC ELECTRONICS CORP. (C/M) • 2002 Staples Mill Rd., Richmond 23230 • 804-359-6071
AVEC ELECTRONICS CORP. (C/M) • 2009 Williamson Rd., Roanoke 24012 • 703-344-6288
FAIRWAY ELECTRONICS, INC. (C/V/M) • 2304 Chamberlayne Ave., Richmond 23222 • 804-321-7255

WISCONSIN

DEALER OFFICE EQUIPMENT INC. (A) • 19300 W. Janacek Court, Waukesha 53186 • 414-784-7850
DYKRO, INC. (C/V/M) • N90 W14401 Commerce Dr., Menomonee Falls 53051 • 414-255-1900
G.M. POPKEY COMPANY (C/V/M/A) • 2035 Larsen Rd., Green Bay 54307-2237 • 414-497-0400

CODING:

(C) . . . Consumer Electronic Parts
(V) . . . Vacuum Parts
(M) . . . Major Appliance Parts
(A) . . . Accessories

(as of 7-1-90)

Matsushita Services Company, 50 Meadowland Parkway, Secaucus, NJ 07094

Circle (34) on Reply Card

Matsushita Services Company

50 Meadowland Parkway
Secaucus, NJ 07094
201-348-7589; FAX: 201-348-7527



From headquarters in Secaucus, NJ, Matsushita Services Company (MSC) coordinates a U.S. network of factory servicenters, independent servicenters, self-servicing dealers, parts and accessory stocks and training sessions.

Matsushita Electric Industrial Company (MEI) manufacturer of Panasonic, Technics and Quasar products, is the world's largest manufacturer of consumer electronic products. MEI sales worldwide have passed the \$39 billion mark. At the heart of this success is a tradition of service.

The life blood of Matsushita is a

blend of state-of-the-art products, accurate anticipation of market demands, effective manufacture and distribution, and a compelling program of sales promotion and marketing. But the heart of its business is the quality of service it renders to each customer.

That's why Matsushita Services Company (MSC) was established to

meet the service and parts needs of customers. These customers include Matsushita authorized servicenters, authorized replacement parts distributors, the nationwide network of Panasonic, Technics and Quasar dealers, and the many millions of Americans who purchase Matsushita products each year.

The total commitment to service quality at MSC is evident everywhere. It is the philosophy that guides every person in the organization. Even if an employee doesn't deal directly with one of the customer groups, the goal of everyone is to provide excellent service so that customers receive maximum satisfaction of their service needs. The MSC service organization is Matsushita's way of saying to customers, "Thanks for your business and we hope you will select a Panasonic, Technics or Quasar product again."

To meet its service commitment in North America, MSC has a support operation second to none in the consumer electronics industry. A staff of 900 trained men and women provide a wide range of services to customers. Twenty-four MSC factory servicenters (FSCs) are strategically located throughout the country. Technicians in each FSC are well-trained in diagnosing and correcting malfunctions in sophisticated electronic products. Independent authorized servicenters and self-servicing dealers, backed by a factory training and a comprehensive stock of original equipment replacement parts, complete the network that makes service easily available to owners of Panasonic, Quasar and Technics. ■

REPLACEMENT PARTS SHOWCASE

Twenty-four MSC factory servicenters (FSCs) are strategically located throughout the country.

Distributors of:

Panasonic

Technics

Quasar



Factory servicenters at convenient locations throughout the United States provide repair services and replacement parts.



Owners of Panasonic, Quasar and Technic products are never far from factory-trained service technicians.



Trained parts and service personnel provide a telephone link to customers seeking product and service information.



The MSC Parts-Link computer system quickly locates the nearest source of original equipment parts needed to service products.



Highly trained technicians use sophisticated instrumentation to speed and improve the quality of customer service.



In thousands of service departments, service procedures developed by MSC speed product repair.

REPLACEMENT PARTS SHOWCASE

NTE Electronics

44 Farrand Street
Bloomfield, NJ 07003
(Outside NJ) 1-800-631-1250
(NJ only) 1-800-624-2624
FAX:201-748-6224

In the electronics servicing industry, NTE's program of "replacitivity" is irreplaceable. The company has recently printed and distributed its 5th edition of NTE's Technical Guide & Cross Reference, which cross references 240,000 industry parts num-

bers to just 3,500 replacement components, including obsolete and hard-to-find types. This bi-annual catalog has practically become the bible of the replacement parts industry.

NTE's product offerings are con-

stantly reviewed and updated. Current product lines include Replacement Semiconductors; Flameproof resistors from 1/8 watt to 25 watts; Capacitors that include Electrolytic, Non-polar, Tantalum, and 50v and 1Kv ceramic discs; and wiring accessories.

Available only through NTE's network of worldwide distributors, all NTE replacement parts are double-checked on state-of-the-art equipment to ensure that they meet or exceed the specifications of the original parts, and each comes with an exclusive two-year warranty.

Headquartered in Bloomfield, NJ, NTE has grown in just 11 short years from a small-town supplier to one of the top replacement semiconductor sources in the dealer, service, MRO, and industrial markets. And the company's market scope has expanded to include Canada, Latin America, the Caribbean, Europe, and even the Middle East. This monumental growth is the result of NTE's keeping all of its operations in one location to facilitate inter-department communication and deliveries. Warehousing & Distribution, Sales & Customer Support, Engineering & Product Development, Technical Assistance to End-Users, Data Processing, and the Administrative Departments are all under one roof.

This department consolidation and the nationwide "800" number let NTE offer same day service to distributors on their out of stock items. In most cases, NTE distributors carry sufficient inventory for off-the-shelf delivery.

For a copy of the NTE Technical Guide and Cross Reference contact your local NTE distributor or NTE Electronics, Inc. in Bloomfield. ■

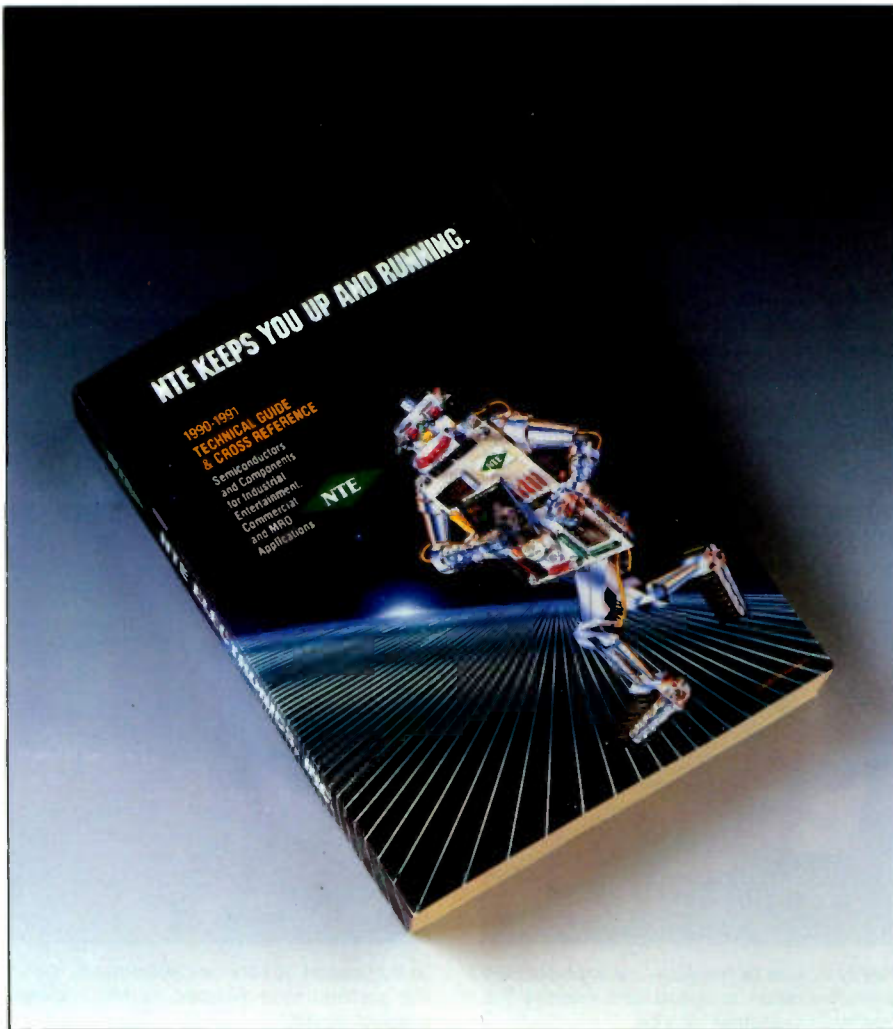

NTE KEEPS YOU UP AND RUNNING.

NTE specializes in "replacitivity," the science of getting things up and running again-fast! After all, downtime is costly, so no one can wait weeks on end for an OEM part to come in. With NTE, no one has to! One call gives you access to 3,550 top of the line universal replacement semiconductors that are cross-referenced to more than 238,000 original devices! Included in the NTE line are: bipolar transistors, integrated circuits, rectifiers, diodes, thyristors, optoelectronic devices, varistors, resistors, capacitors, and much, much more. All are backed by NTE's exclusive two-year warranty.

For your copy of the NTE Technical Guide contact your local NTE distributor, or simply fill in the coupon below and send it to us today with a check or money order for \$3.25 each.



NTE ELECTRONICS, INC.

A WORLDWIDE REPUTATION FOR QUALITY, SERVICE AND VALUE

Please rush me _____ copies of the NTE Technical Guide and Cross Reference manual at \$3.25 each. I have enclosed my check or money order for a total of \$ _____

Name _____

Company _____

Address _____

City _____

State _____ Zip _____

Mail to: NTE, 44 Farrand St., Bloomfield, NJ 07003



FOR THE NAME OF YOUR NEAREST NTE DISTRIBUTOR, CALL NTE TOLL FREE: OUTSIDE NJ 1-800-631-1250 • INSIDE NJ 1-800-624-2624

Circle (8) on Reply Card

REPLACEMENT PARTS SHOWCASE

International ©

International Components Corporation

105 Maxess Road
Melville, NY 11747
800-645-9154 (IN NYS) 516-293-1500

When the Grossman family entered the tube business in 1928, it never imagined the changes the world of electronics would go through in the ensuing 62 years. At that time, not being able to predict the future, they thought that tubes would last forever as an important element in the marketing of electronic products. Today, in this era of miniaturization, we know this is not true. But, strangely enough, what is true is that after all this time the tube business still lives.

A fourth generation of Grossmans in the tube business believes there is no end in sight. And, while they are not surprised that the main products of ICG's business today—passive components, speakers and buzzers—are thriving, the Grossmans are pleasantly surprised that the tube

business still provides a constant source of revenue. But there appears to be good reason.

The fact is, there are and will continue to be many kinds of equipment still operating faithfully in industry and homes that utilize tubes. This is true both domestically as well as around the world.

In fact, new equipment such as musical amplifiers and specialized commercial equipment are using tubes and depending on them. Surely, the tube market isn't growing, but consider the fact that over twenty years ago the Grossmans thought it would be all over by now. It certainly isn't. And they really don't foresee its demise, particularly for a specialized company. The Grossmans have carved a niche in the tube business that resulted from a commitment they

made when it all began and they have remained true to ever since.

Today, for example, International Components Corporation still maintains an inventory of over 2,000 tube types, both domestic and foreign, including the most commonly used to the rarest antiques. Distributors who have major lines know that the available types they are being supplied dwindles every year. But they also know that what is no longer available from a major manufacturer is still available from ICC.

The company—which is referred to by RCA, G.E. and Sylvania for buyers seeking tubes—forms a perfect complement to distributors who still sell major tube lines. That's why the Grossmans are confident that when the last tube is sold sometime next century—it'll probably come from ICC.

SPECIAL ADVERTISING SUPPLEMENT

OVER 2,000 TUBE TYPES—UP TO 85% OFF

Domestic & Foreign

Ask for price list.

International ©

International Components Corporation

105 Maxess Road, Melville, NY 11747 • Toll Free 800-645-9154 • In NY State 516-293-1500 • TELEX 221576 • FAX 516-293-4983



REPLACEMENT PARTS SHOWCASE

MCM Electronics

650 Congress Park Drive
Centerville, OH 45459-4072

800-545-4330

Fax: 513-434-6959

MCM Electronics is a company of dedicated people committed to offering only the best electronic parts, components and service to the customer.

Because needs in the electronic industry are constantly changing, MCM Electronics continually and thoroughly researches the market and reacts to the market's changing demands. MCM is constantly in touch with national and international manufacturers to bring both commonly used and the hard-to-find products to its customers. In fact, three full-sized catalogs are mailed each year, and the last issue introduced more than 700 new items. And, MCM is an authorized distributor for more than 3,000 RCA/GE replacement parts.

Sale flyers are mailed regularly which feature specially priced products. These flyers keep the customers continually informed of new items that are being added.

The Sales/Customer Service department has been thoroughly trained to answer all calls on the toll-free lines promptly and efficiently. These representatives are professionals who can provide immediate information on stock availability and pricing. They are available Monday through Friday, 7 a.m. to 8 p.m. EST, and Saturday 9 a.m. to 5 p.m. EST. Orders can also be placed after hours with a national toll-free number, ensuring service 24 hours a day, seven days a week. Technical questions about a particular product can be answered by MCM's highly trained electronics technicians; who are available to provide the answers customers need.

The company's distribution center houses an enormous inventory of parts and components. Every order is pulled and double-checked to strive for timely and error-free shipment. Because more than 15,000 of the items in the catalog are stocked and ready for shipment, orders are shipped within 24 hours.

Even though most orders are shipped by UPS, MCM offers a broad range of shipping options. Customers can establish Net 30 accounts or have their orders shipped COD, charged to MasterCard or Visa, prepaid or picked up at the Distribution Center's will call area. There is a \$20 minimum order for COD, checks and open accounts, and a \$25 minimum for mastercard and Visa orders.

For more information and a free catalog subscription, call 1-800-543-4330. In Canada, call 1-800-824-9491; in Dayton, OH, call 434-0031. ■

MCM ELECTRONICS

The Best Of All Worlds!



Place just one order from our new 196-page catalog of over 15,000 in-stock products and discover why thousands of satisfied customers have chosen MCM as their #1 supplier of parts and components. Choose from an extensive selection of high-quality products from some of the most respected names in the industry like RCA/GE, Switchcraft, Weller, PIC, Xcelite, Pyle, Cambridge, Mueller, B&K, Littelfuse, Chemtronics, Cramolin, AMS, Tyton, Rawn, Panasonic and many more. Enjoy TOLL-FREE or FAX ordering, convenient hours, fast delivery, a variety of payment options and superior customer service support, too. Make MCM your #1 choice and start enjoying the best of all worlds today!

Get Your **FREE, ONE-YEAR SUBSCRIPTION** to the MCM Electronics Catalogs, Call **TOLL-FREE, 1-800-543-4330.**



MCM ELECTRONICS

650 CONGRESS PARK DR.
CENTERVILLE, OH 45459-4072

A PREMIER Company

SOURCE NO. ES-54

SPECIAL ADVERTISING SUPPLEMENT

Circle (32) on Reply Card

REPLACEMENT PARTS SHOWCASE

MAT Electronics

975 Jaymore Road
Southampton, PA 18966
800-628-1118; FAX:215-364-8554

MAT Electronics is a full-line parts distributor that gears its inventory to the TV, VCR and stereo repair industry. The company's parts are used by technicians, engineers, trade schools, hobbyists and manufacturers.

MAT Electronics stocks an extensive line of replacement accessories as well as one of the largest selections of semiconductors in the nation.

The company publishes an easy-to-use, 32-page catalog with thousands of items, all inventoried in the company's computer, enabling customers to check availability within seconds.

With its huge overseas imports, as well as domestic sources for components, the company is always current with the industry, always emphasizing what is new in electronics components-for VCR's, TVs and stereos.

MAT Electronics takes great pride in its exceptional conscientious abil-

ity to accommodate the varied needs of all of its customers. The company normally ships within 24 hours of your order; however, they offer UPS red and blue labels to ensure even faster delivery service if it is needed.

The company has friendly and knowledgeable telephone operators waiting to take your phone call and courteously deal with any questions you may have about any electronic part, even if you don't see it in the catalog, ask for it!

At MAT Electronics, they know that there are certain risks involved in mail-ordering certain components and that is why the company guarantees 100 percent of all products for 90 days from purchase date. Volume discounts are always available. The company's toll-free lines are open now and waiting for your phone call. Just call 800-628-1118. ■

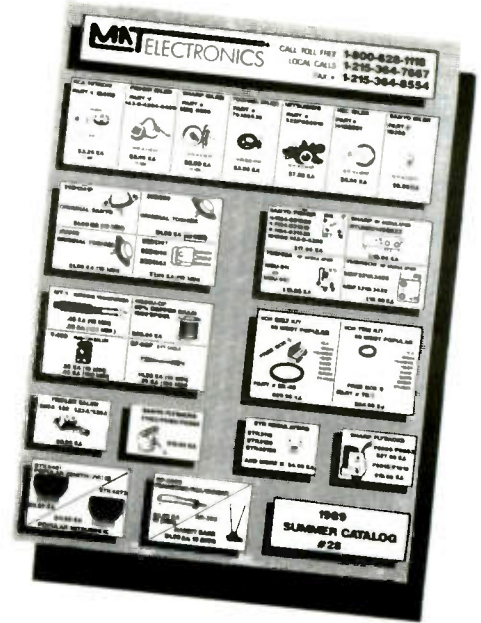

SPECIAL ADVERTISING SUPPLEMENT

VCR PARTS

SANYO FISHER RF Modulators 4-1164-031600	\$17.95 Ea.
TOSHIBA RF Modulator MSU-911/MSU-951	17.95 Ea.
SHARP Idler Replacement NIDL0006	2.99 Ea.
FISHER Idler Replacement 143-0-4204-00400	3.99 Ea.
RCA Idler Original 164113	3.25 Ea.
RCA Loading Belts 157061 or 157062	10/For 8.50
FISHER Loading Belt 143-2-7504-01000	10/For 8.50
RCA End Sensor 161757	10/For 8.50
GOLDSTAR Samsung Photo Interrupter	1.99 Ea.
Chamois Cleaning Swabs (10 per pack) 144589	2.50 Ea.
FISHER Loading Motor 4-5254-00331	11.95 Ea.
FISHER Motor Pulleys FMP-1	10/For 7.50



POPULAR REPLACEMENT FLYBACKS

Sharp Flyback	F0009G	\$19.95 Ea.
Sharp Flyback	F0003G	19.95 Ea.
Sharp Flyback	F0014	19.95 Ea.
Sharp Flyback	F0015	19.95 Ea.
Sharp Flyback	F0016	19.95 Ea.
Samsung Flyback	FCC1415AL	19.95 Ea.
Samsung Flyback	FCC2015AL	19.95 Ea.
Emerson Flyback	3214003	24.50 Ea.
Emerson Flyback	3214008	24.50 Ea.
Panasonic Flyback	TLF14530F	29.95 Ea.
Goldstar Flyback	154-040A	19.95 Ea.
Goldstar Flyback	154-074E	19.95 Ea.



POPULAR CAPACITORS

4.7MFD/250 Volts	Radial	20 For \$11.00
10MFD/350 Volts	Radial	10 For 7.50
100MFD/63 Volts	Radial	20 For 10.00
100MFD/100 Volts	Radial	10 For 10.00
100MFD/200 Volts	Radial	10 For 10.00
470 MFD/200 Volts	Snap-In	5 For 9.95
560 MFD/200 Volts	Snap-In	5 For 12.00
680MFD/200 Volts	Snap-In	5 For 12.50
820MFD/200 Volts	Snap-In	5 For 12.50
1000MFD/200 Volts	Snap-In	5 For 12.50



POPULAR SEMICONDUCTORS

2SC1341P	Original Sanyo	10 For \$19.90
2SD869	Original Toshiba	10 For 19.90
2SD1398	Original Sanyo	10 For 19.90
2SD1453	Original Hitachi	10 For 19.90
2SD1427	Original Sanyo	10 For 25.00
STK0080	Original Sanken	16.95 Ea.
STK4273	Original Sanken (10 min)	9.95 Ea.
STK5482	Original Sanken	9.95 Ea.
STK563F	Original Sanken	10.50 Ea.
STR3115	Original Sanken	4.95 Ea.



CALL TOLL FREE: 1-800-628-1118
in U.S. and Canada

FAX #1-215-364-8554
Call for our Free Catalog!!

MAT ELECTRONICS

975 Jaymor Rd.
Southampton, PA 18966

Circle (33) on Reply Card

Parts Express

340 East First Street
Dayton, Ohio 45402
513-222-0173; FAX:513-222-4644

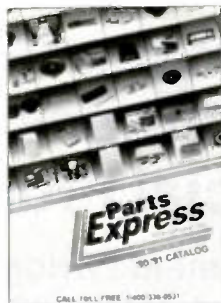

**REPLACEMENT
PARTS
SHOWCASE**

Parts Express, a full-line distributor of electronic parts and accessories, is geared toward the consumer electronics repair industry, manufacturing design and engineering, and the technical hobbyist. The company stocks an extensive line of speaker drivers and accessories for replacement, plus one of the largest selections of semiconductors in the country. In addition, they stock commonly needed items including resistors, capacitors, switches connectors, cable, wire, chemicals, tools, technical books and schematics, alarm equipment and computer accessories. They offer a free 148 page catalog, listing more than 5,000 popular items, and it's extensive computer inventory-control system allows monitoring of each item to ensure

that it is in stock when you need it.

With overseas and domestic sources for parts, and an aggressive new product research team, Parts Express keeps in touch with the needs of the industry. The company can supply replacement parts for the newest TVs, VCRs, and stereos as those products are introduced to the market, and it can special order non-stocked items for volume users. Parts Express prides itself on being flexible, and it makes every effort to accommodate special requests. The company normally ships within 24 hours with delivery by UPS ground or any requested method. Unlike some companies, Parts Express service doesn't stop there. They understand that you aren't always sure what you're getting when you order from a

catalog, so they have taken the risk factor out of mail-order. If you are not satisfied with any item you've purchased (for any reason), you can return it within 15 days for a refund. No questions asked, no restocking fee.

Parts Express can offer a money-back guarantee because they don't think you'll have to use it. On-staff, quality control technicians extensively test and evaluate products before adding them to stock. The company won't sell any item that its technicians wouldn't use themselves.

Call Parts Express at 1-800-338-0531 for your copy of the 1990/1991 catalog. It is available free of charge within the U.S. and its territories. Foreign customers should remit US \$5.00 for postage in order to receive the catalog. ■

SPECIAL ADVERTISING SUPPLEMENT



**YOUR #1 WITH US
1-800-338-0531**

DISTRIBUTION...



SALES...



WAREHOUSE...

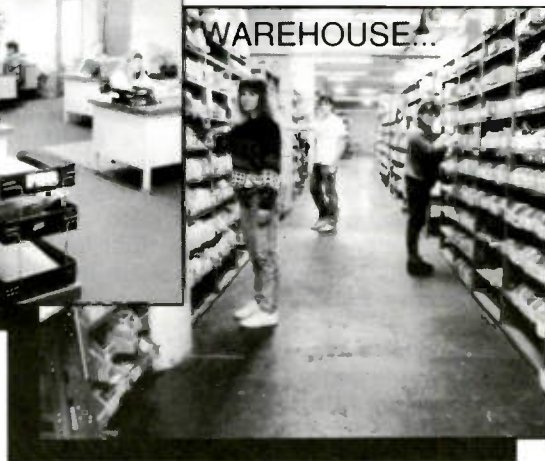

FREE CATALOG AVAILABLE

SALES... Our friendly and knowledgeable sales staff is ready to take your order and answer any questions you may have about our products.

DISTRIBUTION... Our computerized inventory allows us to process your order quickly and efficiently. We offer 24 hour shipping and most orders placed before 1:00 pm are shipped the same day.

WAREHOUSE... With over 5,000 line items in stock you can be sure that we'll have the part you need on hand to fill your order. And all of our parts are backed by an unconditional 15 day, money back guarantee.

Parts Express Int'l. Inc. 340 E First St. Dayton OH 45402 Fax: 513-222-4644 Local: 513-222-0173

Circle (37) on Reply Card

REPLACEMENT PARTS SHOWCASE

Thomson Consumer Electronics Distributor and Special Products

200 Clements Bridge Road
Deptford, NJ 08096-2000
800-257-7946; FAX: 201-348-7527

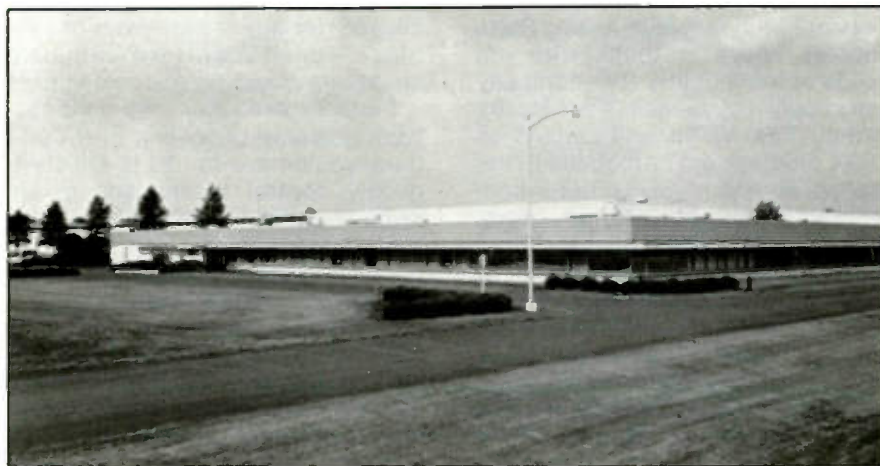

Two of the most recognizable trademarks in the consumer electronics business are RCA and GE. Both represent a long and proud tradition of customer satisfaction and leading edge technology. That tradition is carried on today at Thomson Consumer Electronics Distributor and Special Products operation in Deptford, NJ. Offering exact replacement parts for RCA and GE consumer electronics products is a major part of the business. Distributor and Special products provides parts support to more than 7,000 authorized RCA and GE Servicenters plus thousands of after warranty servicers located throughout the United States through its extensive distributor network.

These authorized distributors stock and maintain inventory levels based on Thomson's IMP program identifies the most commonly used parts and recommends an adequate stocking level to meet demand. Orders for all items can be placed via toll-free telephone, fax or by using the "Instant Access" system. Distributors with "Instant Access" computer software provided by Thomson can place orders directly into the system and check stock, pricing and delivery status. Distributors can request a Blue Ribbon or Emergency order and have their orders shipped overnight.

Also, Distributor and Special Products offers a line of replacement semiconductors. SK semiconductors replace more than 217,000 original devices, and the recently published SK Cross Reference Guide contains a 329 page cross reference section to make finding the replacement part easy. SK devices cover a variety of discrete devices and integrated circuits for consumer and industrial applications. Included in the SK line are thyristors, transistors, rectifiers and optoelectronics microprocessors. The new guide also contains expanded specifications in the discrete devices charts.

In addition to replacement semiconductors, Distributor and Special Products offers rapid delivery of small quantities of semiconductors and discrete devices produced by major manufacturers. This JEDEC/Generic line includes products from Harris, Fagor, International Rectifier and Powerex.

Another important reference book produced by Distributor and Special Products is the new VCR Key items Cross Reference. This comprehensive, 120 page guide provides the servicer with a quick reference source of key wear items, such as belts, motors, pressure rollers and headwheels for nine different VCR brands: GE, RCA, Hitachi, Magnavox, Panasonic, Philco, Philips, Qua-

sar and Sylvania. Listing more than 900 models the guide contains references to more than 90 percent of a servicer's parts needs for these brands. The VCR Key items Cross-Reference provides the servicer with the Thomson stock number, as well as a reference number corresponding to the number shown on the service data parts list and on the exploded view diagram of the VCR model listed.

Another publication that Distributor and Special Products offers servicers is the 1990 edition of the RCA and GE Remote Controls Catalog. This catalog contains all available direct replacement remote control hand units for RCA and GE televisions, video recorders, video disc players, camcorders and audio components. The catalog is divided into three sections: One section contains more than 220 photos to aid in identifying the correct remote. The two other sections contain cross-reference material in model number sequence and in remote type number sequence.

Thomson Consumers Electronics Distributor and Special Products operation provides service from a 358,000-square foot facility with all aspects of the business located there—customer service, sales and marketing, quality assurance, product analysis, administrative departments, and warehousing. Some parts are also stocked in a satellite warehouse in EL Paso, TX. Technical support is available, as in identification for distributors who cannot locate this information in the company's technical literature.

Other product lines at Distributor and Special Products include RCA and GE videotape and GE audiotape. Picture tubes, surge suppressors, anti-static kits and service aids are also marketed from this operation. The business is managed by Dennis D. Edson, general manager. Thomson Consumer Electronics Corporate headquarters is in Indianapolis, where several TV manufacturing facilities are located. ■

RCA



Cut through the Confusion

When you are repairing any electronic equipment and need a reputable and dependable source for high quality, original Japanese Semiconductors see your authorized Thomson Consumer Electronics distributor

FOR MORE INFORMATION AND A COPY OF THE LATEST PRODUCT/PRICE LIST COMPLETE THE COUPON BELOW AND MAIL TO:
JAPANESE SEMICONDUCTOR MERCHANDISING
THOMSON CONSUMER ELECTRONICS
2000 CLEMENTS BRIDGE ROAD
DEPTFORD, NJ 08096-2088



Please send me a copy of your Japanese Jedec Product/Price List and a list of authorized distributors:

Name _____
Company _____
Address _____
City _____
State, Zip _____
Telephone _____

REPLACEMENT PARTS SHOWCASE

Prime Electronics

P.O. Box 28
Whitewater, Wisconsin 53190
800-558-9572; FAX: 414-473-4727

Prime Electronics is a leading distributor of electronic parts, supplies and information for the electronic industry. Our company is dedicated to providing quality electronic parts, components and service to the customer.

Prime offers a free 100 plus page catalog listing over 10,000 popular items. Our catalog is also the resource for the complete PRB Replacement Belt System. It contains all the information you need to order just the right replacement belt for most electronic equipment. Prime also can provide you with a complete Electronics Technician's Reference Library. This package of reference materials includes the PRB Cross Reference Belt Guide, NTE Semi-

conductor Cross Reference Guide, and the PRB Measure-A-Belt plus the latest Prime catalog and data sheets. This \$15.00 value library of materials is yours free when requested with orders of \$150.00 or more.

Service is what Prime is all about. We pride ourself on being flexible and providing customers the best and fastest service possible. "We'll get it to you as fast as you need it!" Prime guarantees same day shipment on all orders received before 2:00 p.m. CST, and all orders are shipped within 24 hours. Our excellent staff and exceptional computer inventory controlled system guarantees our dependable service.

You have a 100 percent guarantee on any item purchased from Prime. If

you are not completely satisfied with any item you've purchased you can return it, in saleable condition, for an account credit. Prime's "hassle free" service is backed-up by an exceptional staff of professionals who function in all departments with a 99.25 percent rate of order accuracy.

It all adds up to just what we claim when we say Prime Electronics Co. is first in quality and service-you can depend on it! For your FREE copy of our new 1990-91 Catalog call us Toll Free at 800-558-9572. ■



SPECIAL ADVERTISING SUPPLEMENT

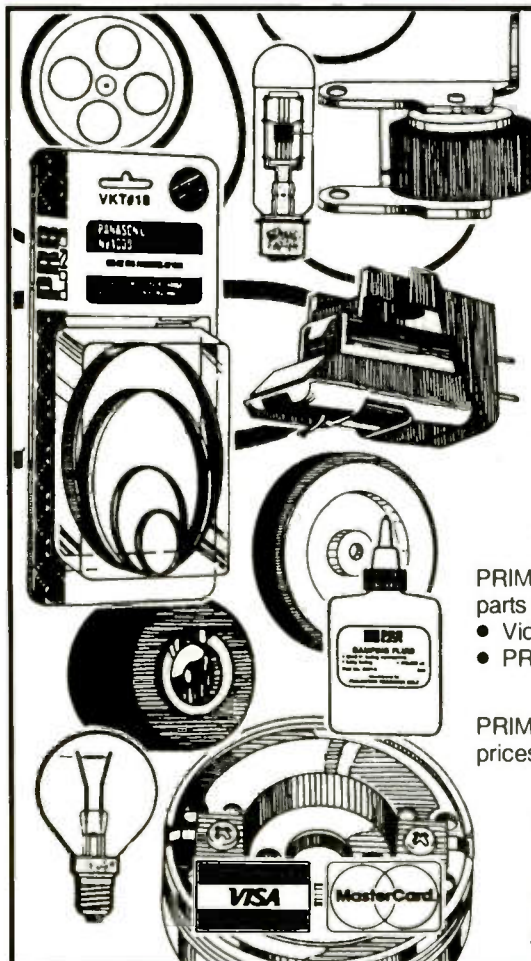

PRIME ELECTRONICS CO.™

For all your electronic parts & accessories

WE'RE THE ONE . . .

- With Over 10,000 Electronic Parts
- With Everyday **LOW** Prices & Volume Discounts
- With Excellent Service . . . "We'll get it to you as fast as you need it!" PRIME guarantees same day shipment on all orders received before 2:00 PM CST . . . and all orders are shipped within 24 hours.
- With 100% Guarantee On All Products

PRIME ELECTRONICS is the number one source for a complete selection of electronic parts and accessories. We offer you high quality . . .

- Video Heads
- Audio/Visual Lamps
- VCR Idler Assemblies
- PRB Line of Belts & Tires
- Needles
- Specialty Chemicals
- Plus . . . A Whole Lot More!

PRIME urges you to shop and compare. We're confident you'll like our low, competitive prices, excellent service, and quality products.

For your **FREE COPY** of our All New Catalog Call Toll Free . . .
1-800-558-9572 or for 24 hour ordering call . . . FAX: 1-414-473-4727



"First in Quality & Service"

P. O. Box 28 • Whitewater, Wisconsin 53190

Circle (42) on Reply Card

Herman Electronics

1365 N.W. 23rd St.

Miami, FL 33142

800-327-8378

Fax: 305-634-6247

Herman Electronics is a diverse, full-line distributor of everything in electronics. Over the past 40 years, the company has acquired many major lines in order to provide better service to all phases of the electronics industry.

Herman Electronic's product base varies from transistors to satellite antenna systems, including all types of batteries; audio, video and telephone accessories; cable; connectors; capacitors; semiconductors; test equipment; speakers; tools; transformers; line conditioners; relays; antennas; chemicals; audiotape and videotape.

The parts department, at the heart of the business, has several sales representatives to serve your needs from 6:30 a.m. to 5:30 p.m. (EST) Monday through Friday and from 6:30 a.m. to 12:30 p.m. (EST) Saturday. Whether your request is for pricing, stock availability or research, the company's toll-free lines and 24 hour fax lines are readily available to fulfill all of your requests. Herman Electronics uses state-of-the-art parts distribution computer system, enabling the sales repre-

sentatives to provide efficient, effective and professional service and to assure that the part is in stock when you need it.

Herman Electronics is a factory authorized, original replacement parts distributor for Sony, General Electric, Quasar, Samsung, Panasonic, Technics and RCA, catering to the consumer and industrial parts clientele. Stocking one of the largest and most comprehensive inventories, the company fills approximately 80% of its orders out of its 12,000 stocking items. All in-stock orders placed before 1 p.m. are shipped the same day-guaranteed.

The company has always prided itself on being flexible and accommodating to its customers requests. "We realize that there are many good distributors throughout the country", says Jeffrey A. Wolf, national sales manager and son of one of the company's founders. "It is our job to be better by taking that extra step in giving our customers professional, personalized service. Our industry has clearly become predominately service-oriented; therefore, we are committed and dedicat-

ed to maintaining a standard of excellence in servicing our clientele."

The company provides several key fringe benefits that makes its service and customer satisfaction one of the best in the business. Herman ships all out-of-state orders UPS second-day at no extra charge to the customer. Individual computerized monthly backorder reports are provided upon request, and the company makes its toll-free lines available for research requests. Herman basically does whatever it takes to achieve customer satisfaction.

Herman Electronics also offers several shipping alternatives, including overnight service and drop shipments. The company offers customers many payment options, including a Net 30 open account (based on credit approval) MasterCard, Visa, American Express of C.O.D. The company has a \$15 minimum order.

Call Herman Electronics toll-free at 800-327-8378 (in Florida, 800-432-4357) and see how the company is constantly working harder to serve you better. ■

**REPLACEMENT
PARTS
SHOWCASE**

SPECIAL ADVERTISING SUPPLEMENT

HERMAN
ELECTRONICS

Now, more than ever, the service industry is turning to Herman Electronics to fulfill
All their electronics needs.

Why? **SERVICE!**

Your factory authorized original replacement parts source for:



SONY
RCA

GENERAL  ELECTRIC

 **SAMSUNG**

- Stocking one of the largest and most comprehensive consumer and industrial parts and accessory inventories in the nation
- All in-stock orders shipped same day if placed before 1:00 PM EST. Guaranteed!
- Two-day service at NO additional cost to you
- Technical assistance at your fingertips
- Personal, efficient and experienced sales representatives standing by to serve you every need

All of this is one Toll-Free call away **800-327-8378**. Florida only: **800-432-4357**. Fax: **305-634-6247**.

Call now and see that at Herman Electronics, your complete satisfaction is Priority 1!

1365 N.W. 23rd Street • Miami, FL 33142

Circle (51) on Reply Card

REPLACEMENT PARTS SHOWCASE

Philips ECG

1025 Westminster Drive
Williamsport, PA 17701
Tel: 800-526-9354

In the electronics servicing industry today, particularly everyone recognizes the ECG trademark. It represents the broadest available line of replacement semiconductors and a company that has been meeting the needs of service dealers for 66 years. Today's Philips ECG organization had its roots in the old Sylvania Products Company, which began making receiving tubes for the fledging radio industry in 1924. Through the years, the Sylvania brand became synonymous with quality, and the company grew to become one of the "big three" in the receiving tubes business. During this period, original equipment manufacturers were the principal customers. With the advent of semiconductors, however, fewer and fewer tubes were used in radio and TV sets, and the replacement markets took on added importance. Soon, it became apparent that electronics servicers would also need a variety of transistors, integrated circuits, rectifiers, diodes and other components to repair the newer equipment using these devices.

Sylvania was one of the first suppliers to identify this need and respond to it. The ECG semiconductor replacement line was introduced in 1967 and quickly became a mainstay product. The first ECG semiconductor replacement guide, published in late 1967, cross-referenced 23 ECG types to approximately 2,700 industry part numbers. The current 14th Edition ECG Master Replacement Guide and its recently published second supplement cross some 4,100 ECG types to over the years to ensure that the ECG line kept pace with the industry's needs.

In 1981, GTE Corporation, Sylvania's parent company, sold the Consumer Electronics Group to North American Philips Corporation and this operation's name was changed to Philips ECG. Little else was changed, however as Philips ECG

continued to serve the electronics servicing and industrial/MRO markets through a long-established national network of independent distributors. Philips ECG, together with Amperex, Mepco/Centralab, is currently a part of Philips Components, a North American Philips Company. That's our background. Now, let's talk a little about how Philips ECG operates.

All Philips ECG products are sold only through authorized distributors. These distributors maintain sufficient inventories to provide off-the-shelf delivery in most cases. In the rare instances where a product is not in stock, distributors can access the Philips ECG Distribution Center via toll-free telephone and telefax lines. When the customer specifies "Hot Line" service, the products can be shipped within 24 hours.

The Distribution Center, located in Williamsport, PA, serves as the focal point for the company's activities. The modern 105,000-square-foot facility includes warehousing, customer service, finishing, quality, engineering, and product marketing, data processing and administrative departments. It is fully equipped and staffed to provide Philips ECG distributors with prompt, efficient service. The engineering department also offers direct assistance to distribu-

tors' customers who require technical information not otherwise available.

In addition to the ECG Semiconductors, current Philips ECG product lines include digital multimeters and analog multimeters, logic and oscilloscope probes, electromechanical and solid-state relays, I/O modules, cube timers, surge suppression devices, audio-video parts and accessories, flameproof resistors, TV converters, remote controls, circuit designers, aerosol chemicals for electrical and electronic applications, solder wire, desoldering braid and antenna rotators. These lines are continuously monitored and updated to ensure that Philips ECG customers receive the latest in state-of-the-art technology.

Philips ECG is under the direction of Donald R. Kronenwetter, vice-president and general manager. All ECG products are managed by L. Randall Brophy, general manager, electronic components and products.

After 66 years of service to the electronics industry, Philips ECG looks forward to continuing this tradition for many more. Sincere thanks to the loyal customers who have supported us and continue to do so through their purchases of ECG products. ■

The Smart Choice



ECG® Replacement Parts And Tools Fit 31 VCR Brands.



New catalog covers RF modulators, VHS and Beta heads, idler wheel assemblies, pinch rollers, belts, opto-sensing devices and more. All meet or exceed OEM specs. Lists over 2400 crosses. Service aids include test cassettes, jigs, tools, cleaning materials.

Ask for a copy at 900 Philips ECG distributor locations or call 1-800-526-9354.



Philips ECG



PHILIPS

Circle (38) on Reply Card

Latest ECG® Guide Supplement: 76 New Semis, 5,000 New Crosses.



New 2nd supplement to ECG Master Guide shows electrical/mechanical data for new linear ICs for TV, VCR, CD and PCs; IC protectors, transistors, rectifiers, and opto devices. Comprehensive cross-reference to industry part numbers. Ask for your copy at 900 Philips ECG distributor locations or call 1-800-526-9354.



Philips ECG



PHILIPS

Circle (39) on Reply Card

3 Surge Suppressors Are Philips ECG's Newest: TV, Phone, Data Line.



EMF-TV3 protects TV signal and AC power in TVs, VCRs, cable converters, video/audio receivers. **EMF-325** protects phone and AC line in telecom equipment. **EMF-232C** is for computers and RS-232-port peripherals—a must for modems. All at 900 Philips ECG distributor locations or call 1-800-526-9354.



Philips ECG



PHILIPS

Circle (40) on Reply Card

Digital Multimeters Have Heavyweight Features, Lightweight Prices.



ECG® DM-26 and DM-27 Pocket DMMs offer the best value available. Rotary Switch with usual ranges and "OFF", 20 Megohm Full Scale and 10 Amps DC. Tilt stand. DM-26 \$34.95 Sug. Ret., DM-27 (w/beeper) \$39.95 Sug. Ret. At 900 Philips ECG distributor locations or call 1-800-526-9354.



Philips ECG



PHILIPS

Circle (41) on Reply Card

Test your electronics knowledge

Answers to the quiz

(Questions on page 40.)

1. Scratchpad. After the interrupt is serviced, the microprocessor retrieves the program from the memory and continues from where it left off.
2. Redundancy. The idea is that if one fails, the other(s) can carry on the task.
3. BCD. An example of a Binary Coded Decimal number is 0101 0111. It represents decimal number 57.
4. A half adder. This arithmetic operation can be performed by an Exclusive or gate.

5. Integers. Mixed numbers and fractions are not integers.
6. Stochastic. As an example, stochastic noise is random noise. It does not follow any set pattern.
7. Port. Ports are used for input/output (I/O) data lines.
8. EPROM. The letters stand for Erasable Programmable Read Only Memory.
9. DMA. The letters stand for Direct Memory Access.
10. Vectored. With this type of interrupt the programmer can determine how each interrupt is handled.

Video Corner

(from page 22)

head picks up the remaining 262.5 lines (there are two fields in each complete frame of 525 lines). If one head is good and the other bad, the TV shows a noisy picture because it gets the lines needed to fill one trace from top to bottom, mixed with 262.5 lines of noise.

Both heads must produce an output if any part of the picture is clear. For example, a common symptom in some 4-head or 5-head VCRs is a picture that's noisy for three-quarters of the screen, and clear for the remaining quarter. In this case, the heads and head amplifiers are working correctly. The problem is in the relay that selects the correct pair of heads for each tape speed. Injecting an FM carrier modulated with a video pattern at the input and output of the head selecting relay quickly isolates the problem. Test equipment is available that generates such a signal.

If any section of the picture is clear, even if it's only a few inches somewhere on the screen, you do not have a defective head. ■



IS CET
VCR
Cross Reference
VCR Model Number Cross Reference
and VCR Parts Cross Reference

UPDATED - Feb. 1990. 272-page reference guide. \$35 plus \$3 shipping.

DISC - IBM-compatible disc with expandable data base. \$99 plus \$1 shipping.

COMBO OFFER: Book and disc for only \$125 plus \$3 shipping.

MORE INFO? Contact IS CET, 2708 West Berry St. Fort Worth TX 76109 (817) 921-9101

Allow 4-6 weeks delivery when using personal checks or VISA and MasterCard. Money orders and cashiers checks processed immediately.

Amount _____ VISA MasterCard
 Card No. _____ Exp. _____
 Name _____
 Business _____
 Address _____
 City _____ State _____ Zip _____
 Phone _____ Member: IS CET; NESDA
 Texas residents multiply dollar value x 7 1/2% for taxes.
 Foreign shipments please add international postage.
 Send to: IS CET, 2708 W. Berry St., Ft. Worth TX 76109

Improve Your Form.

3-Part

A continuous feed form used for customer c.o.d. service or parts/accessory sales receipts (N3CN). Not for warranty billing. Computer generated software to be available soon.

5-Part

Available in snapout (N5SN) or continuous feed (N5CN). Matching fields with N3SN, except for customer estimate and receipts. For warranty billing.

7-Part

A universal snapout form (N7SN) designed for both customer service c.o.d. and manufacturer warranty billing. Complies fully with the requirements of state and local ordinances, including California.

Discounts

Carbonless NESDA Forms are available to NESDA members at additional savings. For pricing information and samples, or information regarding other NESDA membership benefits, write to NESDA, 2708 W. Berry St., Ft. Worth, TX 76109; or call (817) 921-9061.

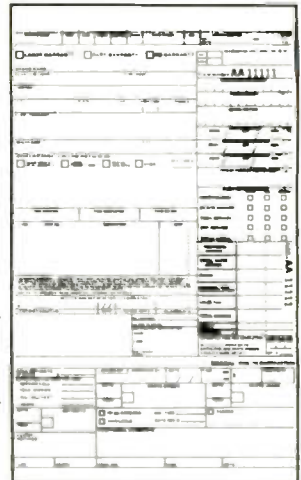

The NESDA Form

NESDA, 2708 W. Berry St.
Fort Worth TX 76109
Phone: (817) 921-9061

Classified advertising is available by-the-word or per column inch. **By-the-word: \$1.65 per word, per insertion.** Initials and abbreviations count as full words. Blind ads (replies sent to ES&T for forwarding) are \$40 additional. Minimum charge: \$35 per insertion.

Per Column Inch (Classified Display): \$235 per column inch, per insertion, with frequency discounts available. 1" minimum, billed at 1/4" increments after that. 10" maximum per ad. Blind ads are \$40 additional. Reader Service Number \$25 additional to cover processing and handling costs. (Free to 4-inch or larger ads.)

Optional color (determined by magazine) \$150 additional per insertion. No agency discounts are allowed for classified advertising.

Contact Jeff Uschok, 516-681-2922, for information on frequency and pre-payment discounts, or to place your classified ad. Or send your order and materials to Jeff Uschok, Electronic Servicing & Technology, 76 North Broadway, Hicksville, NY 11801.

BUSINESS OPPORTUNITIES

LARGE AUDIO/VIDEO SERVICE BUSINESS - In sunny S.W. city. Established 20 yrs. Well equipped. Price and terms negotiable. (602) 298-8827 evs. 8-89-tfn

BEAUTIFUL ASPEN, COLORADO VIDEO AUDIO/SALES SERVICE - New test equipment, stock, parts, established 20+ years, downtown. Semi-retiring partnership, purchaser. Aspen Electronics Center, 333 East Main Street, Box 12 Aspen Colorado 81612. 8-90-1t

TV/VCR REPAIR SHOP - One man carry in. Sencore equipment, numerous Sams and MFG manuals. 70K gross. Adjoining 2 bedroom, Florida home on large lot with ample parking. Privacy, fence, pool and deck. \$125,000. 813-545-3061. 8-90-1t

FOR SALE

TELEVISION AND MONITOR TROUBLESHOOTING BOOKS: 336 Problems/Solutions, \$12.00, 35 Steps to Easier Television Repairs, \$15.00 Add \$1.50 shipping. Refunds if not satisfied. Fred Jones, 407 Morningbird, Niceville, FL 32578. 12-89-tfn

REDUCED 85%, Diehl Mark 111 scanner \$89. Diehl Mark V scanner \$219. New. Restore remote control keypads with our conductive coating \$8.99 ppd. WEEC, 2805 University Ave., Madison, WI 53705. 608-238-4629. 608-233-9741. 6-90-tfn

TV TOUGH DOGS: 300 symptoms and cures. Send \$9.95 to DAVIS TV, 11772 Old Fashion Way, Garden Grove, CA 92640. 10-87-tfn

VHS-VCR Repair Solutions Sets I,II,III,IV,V. Each contains 150 symptoms and cures, cross reference chart, free assistance, \$11.95 each all five \$49.95. Eagle Electronics, 52053 Locks Lane, Granger, IN 46530. 12-89-tfn

COMPUTER AIDED TV/VCR REPAIR: 3,500 solutions. 37 manufacturers. Printout or IBM compatible hard drive, 5 1/4 disk, time saver. Quick scan by model, chassis, and stage. Send \$90 to Electronic Solutions, 407 West Avenue "N", San Angelo, Texas 76903. 7-90-tfn

CASE HISTORIES: Over 700 TV symptoms and cures. Professionally prepared, satisfaction assured, \$18. Mike's Repair Service P.O. Box 217, Aberdeen Proving Ground, MD 21005. 7-90-3t

PHOTOFACTS: Folders under \$1400, \$4.00. Above \$1400, \$6.00, sent same day first-class postpaid. Allen Loeb, 414 Chestnut Lane, East Meadow, NY 11554. 8-90-3t

TV PROBLEM SOLUTIONS: 450 solutions by area and component. Symptom Remedy make model sams ref. Save time, you'll love it. Send \$24.50 to Phase Control, ENG Box 520 Chahassen, MN 55317. 8-90-1t

TV SYMPTOMS AND CURES: all current: Nothing old listed all makes of sets send \$29.95 to Joe Massaro, 1041 Revere Ave, Trenton, N.J. 08629. 8-90-1t

EQUIPMENT WANTED

TUBES WANTED: We buy receiving and transmitting tubes. Send your list for bid. New tubes in original boxes only. Also need radio. I.F. XFMRs. Antique Electronic Supply, 688 West First St., Tempe, AZ 85281. Phone 602-894-9503, Fax 602-894-0124. 8-90-1t

WANTED

OLD ANTIQUE RADIOS AND TV's - Pre 1950. Any condition. Will repair same. Old tubes for sale. Thrifty TV, 11 E. Marie, Hicksville, NY 11801. 516-822-4501. 8-90-2t

Readers' Exchange

Readers' Exchange has been reinstated as a free service, effective with the February issue.

The following restrictions apply to Readers' Exchange:

- Only individual readers may use Readers' Exchange, and items must be restricted to those that are ordinarily associated with consumer electronics as a business or hobby. If you're in business to sell the item(s) you want to offer for sale, the appropriate place for your message is in a paid advertisement, not Readers' Exchange.
- Readers' Exchange items must be restricted to no more than three items each for wanted and for sale, and may be no more than approximately four magazine column lines in length (about 20 words).

Send your Readers' Exchange submissions to:

**Readers' Exchange
Electronic Servicing & Technology
76 N. Broadway
Hicksville, NY 11801**

FOR SALE

Components: Resistors, capacitors, IC's etc. etc. All new never used. Will send very healthy sample for \$10.00 + 2.50 for shipping or sell whole lot. Inquiries welcome. *Brad Doody, Rt. 2 Box 199, Chester, Vermont 05143; 802-875-3779*

H.H. Scott Stereomaster 387 amplifier/receiver, w/schematic; believed to be 100W/channel; \$75 plus shipping. *Cyril Brennan, 205-272-0692.*

Sencore FET tester: FT155; \$65, Sams Photo-fact: 1-1200 (total 343); \$4 each, tubes old and new. *Eddie Bryant, 9809 Hilgert Drive, Cleveland, OH 44104, 216-721-9435.*

Sencore VA62 with VC63 and NT64 gen., in box, used two hours, \$2840, I will ship UPS. *Steve Bonar, Box 240, Kekaha, HI 96752, 808-337-1197.*

Standard brand new tubes in manufacturers cartons. 90 percent off list prices. Radio and TV parts, text books, service manuals, magazines. Send large S.A.S.E. *Max Seligsohn 1455-55th Street, Brooklyn, NY 11219.*

H.P. 712B Power Supply-\$50.00, B&K 707 tube testers \$65.00 each, B&K 177 VTHM \$45.00, B&K 1045 telephone product tester \$375.00 mint. B&K 1076 T.V. analyst \$75.00, B&K 1077B T.V. analyst 250.00 mint. Shipping extra, call anytime. *David Lehman P.H. 1-417-924-3350.*

Oscilloscopes, Tektronix RM502, bandpass 450 KHz, \$165, and Hewlett Packard 130C, bandpass 500 KHz, \$195. Frequency counters, Hewlett Packard 5512A and 5214L, 300KHz, \$120 each. Integrating digital voltmeter and frequency counter H.P. 2401B, \$250. *Fred Jones, 407 Morningbird Court, Niceville, FL 32578.*

WANTED

Flyback tester. *Glover Electronics, Rt. 3 Box 46, Hwy 70 East, Durant, OK 74701, 405-924-4962 (10 AM to 1 PM).*

Operation manual, schematic and parts list for Seco VT grid circuit tester, Model No. GCT-5. *Larry Cook, 608-647-4678.*

Would like to purchase owner's manual for Realistic Comp 100 Scanner, Model No. 20-110. *Keith Tonn, PO Box 103, Coleman, WI 54112.*

Schematic diagram or service manual for Sears VCR: HD 38835, Quasar VCR: VH 5162, Sears color TV: 564-41692804, Magnavox color TV: RX4240 WAD1. *E. Cardona, Apenninos 633, Puerto Nuevo, PR 00920.*

RCA service notes and service data (bound red volumes) from the 1930's and 1940's. Also want radio retailing magazines. *Doug Heinstead, 1349 Hillcrest Dr., Fridley, MN 55432, 612-571-1387.*

Hallicrafter Comm. Receiver. SX-62A or SX42-working or not. A.C. Weiss, 11658 Harvard Dr., Norwalk, CA 90650; 213-865-7842.

Lafayette HB-525A CB, First IF Coil, includes mechanical filter. Part number 1332-24. Will buy part or old board, to restore mine. *Gary Baldis 5115 Somerset Dr., Las Vegas, NV 89120.*

3-Volume Set 1990 IC MASTER



Vol 1 - Functional guide to 80,000 standard ICs including 14,000 NEW devices.

Vol 2 - 1,000+ manufacturers tech data pages.

Vol 3 - Systems level guide to Custom / Semi-custom ICs and Design Automation tools.

ALL NEW!

List Price \$145.00

(Taxable in NY, MA, IL, CA)

10 Day Money Back Guarantee

Send Check with P.O. To:
ICM / Hearst Business Communications,
645 Stewart Ave., Garden City, NY 11530,
Attn: Marie Botta
(516) 227-1300 • FAX (516) 227-1901

VISA and MC welcome

Circle (30) on Reply Card

“Sperry Tech's Pricing Guide”
Updated new 6th edition...a framework for setting rates that apply to Hi-Tech products...a formula that guarantees SUCCESS!
Call Toll Free for details 1-800-228-4338

Circle (45) on Reply Card

LEARN TO CLEAN/MAINTAIN/REPAIR FAX MACHINES

HUGE NEW UNTAPPED MARKET!



Over 8 million Fax machines in homes/offices - predictions are for over 25 million by 1992!

- Work from your home/van
- Home study program gets you started servicing fax machines in 2 weeks!
- No special tools/equipment needed
- Earn additional profits selling fax supplies!
- Fax machines are not cheap - therefore, you can get good \$\$ for the repair
- Average Fax machine requires professional service every 18 months.
- Home study training program includes full Instructions on EVERY ASPECT of Fax maintenance/repair FULL COVERAGE of how to set up your home-based service business

FREE DETAILS
CALL 1-800-537-0589
Or write to: Viejo Publications, Inc.
3540 Wilshire BL #310
Dept EST Los Angeles, CA 90010

Circle (50) on Reply Card

Advertisers' Index

Company	Page Number	Reader Service Number	Advertiser Hotline
Beckman Industrial Corp.	15	26	619/495-3200
Chemtronics	11	27	800/645-5244
Consolidated Electronics	13	28	800/543-3568
Dandy Mfg. Co.	60	29	800/331-9658
Fluke Manufacturing Co., John	IBC	4	800/227-3800
Herman Electronics	55	51	800/327-8378
IC Master	60	30	516/227-1314
ISCET	58		817/921-9101
International Components Corporation	48	31	800/645-9154
Leader Instruments Corp.	3	15,16	800/645-5104
MCM Electronics	49	32	800/543-4330
MAT Electronics	50	33	800/628-1118
Matsushita Services Co.	42,43	34	201/348-7589
Microwave Filter Company	21	35	800/448-1666
Mitsubishi	6,7	5	800/553-7278
NESDA	21,58		817/921-9061
NTE Electronics	47	8	800/631-1250
Nutronix Inc.	16	36	313/939-4710
Parts Express Int'l Inc.	51	37	513/222-0173
Philips ECG	57	38,39	800/526-9354
		40,41	
Prime Electronics	54	42	800/558-9572
Sencore, Inc.	IFC	43	800/SEN-CORE
Sony Service Company	4	44	
Sperry Tech, Inc.	60	45	800/228-4338
Techni-Tool, Inc.	21	46	215/825-4990
Tentel	23	47	800/538-6894
Thomson Consumer Elec.	53		609/853-2417
Vaco Products	16	48	708/677-9500
Viejo Publications	13,60	49,50	800/537-0589
Zenith	BC		

We'd like to see your company listed here too. Contact Jonathan C. Kummer, to work out an advertising program tailored to suit your needs.

TV TECHNICIANS

TEST/CLEAN/RESTORE with a UNIVERSAL CRT ADAPTER that fits all CRT testers and quickly hooks-up to all CRT's on the market (now or in the future). Guarantees profit & total CRT servicing. Used by TV Repair, US Govt., Airlines, Computer Serv., Dept. of Defense. Patented Adaptor-Sockets-CRT Reference/Setup book—Only \$59.95 plus \$2.50 postage & handling. Our 6th year. Over 15,000 sold. Chargecards/Checks/COD. Money Back Guarantee.
FREE CALL 1-800-331-9658
DANDY MFG. CO./RANDALL ELECTRONICS
(918) 682-4286, 2323 Gibson St., Muskogee, OK 74403

Circle (29) on Reply Card

SALES OFFICE

76 North Broadway
Hicksville, NY 11801
(516) 681-2922
FAX: (516)681-2926

Jonathan Kummer
Advertising Manager

Emily Kreutz
Sales Assistant

FLUKE



PHILIPS



Great Choice.

More professionals in more industries make Fluke their first choice in multimeters.

Fluke DMMs. Reliable. Accurate. Powerful. Tough. Versatile. Easy to use and simple to operate. Backed by the longest, most comprehensive warranty in the business. Made in the U.S.A. In short, Fluke makes meters you can bet your reputation on.

More choice. No matter what the job, there's a Fluke to handle it.

There's the new 80 Series—the most powerful, most complete test and measurement system available in a handheld package.

The popular 70 Series—simply put, the most requested DMM in the world, with nearly 2 million units in service since 1984. And the Fluke 21 and 23—70 Series simplicity in high-visibility yellow.

The Fluke 25 and 27—the most rugged meters ever built, totally sealed against water, dust and other contaminants.

And the precise 8060 Series—with the versatility of a test lab, the accuracy of a bench instrument, and the convenience of a handheld.

Smart choice. Compare Fluke DMMs with any other handheld. No one else gives you as much meter for your money. And no other meter costs less to own.

Your choice. For the name of your nearest Fluke distributor, call toll-free **1-800-44-FLUKE, ext. 33.** And make a great choice.

John Fluke Mfg. Co., Inc. P.O. Box C9090 M/S 250C Everett, WA 98206 U.S. (206) 356-5400. Canada: (416) 890 7600. Other Countries: (206) 356 5500. © 1989 John Fluke Mfg. Co., Inc. All rights reserved. Ad No. 0491-F70

FROM THE WORLD LEADER
IN DIGITAL MULTIMETERS

FLUKE

A collection of Zenith chemical products is arranged on a light-colored surface. The products include several spray cans: 'Zenith Electronic Cleaner/Lubricant', 'Zenith T.E. Solvent', 'Zenith VCR/VTR Cleaner', 'Zenith Super Freeze II', 'Zenith Electronic Cleaner/Degreaser', 'Zenith Flux Remover II', and 'Zenith Duster II'. There is also a package of 'Zenith Cotton Swabs' and several individual swabs scattered around. The Zenith logo is visible on all products.

THE PROFESSIONAL CHOICE!

Zenith chemicals are designed to meet the ever increasing demands of your service department.

Backed by a name you can trust, Zenith chemicals can keep you operating at peak performance... and they're the choice of today's leading professionals.

Call your Zenith distributor today and put Zenith chemicals to work for you!

ZENITH CHEMICALS

THE QUALITY GOES IN BEFORE THE NAME GOES ON®