

THE MAGAZINE FOR CONSUMER ELECTRONICS SERVICING PROFESSIONALS

ELECTRONICTM

Servicing & Technology

MAY 1989/S2 50

The benefits of a tool program • VHS camcorder servicing

Servicing the RCA CTC107 color TV

Designing
a working
service kit



Dynamically Analyze Stereo Audio Power Amplifiers In Less Than 1/2 The Time You Now Take, With Superior Accuracy And Reduced Measurement Errors, To A Full 500 Watts (250 Watts/Channel) And To IHF/EIA* Specifications.

New!



With The Completely Integrated PA81 Stereo Power Amplifier Analyzer

Introductory Price \$1995!

Now Test To A Full 5,000 Watts With Optional Accessory!
Call For Details

Presenting the missing link in audio service. The ALL NEW PA81 is designed to pinpoint hard to find problems in stereo and monaural audio power amplifiers, in a fraction of the time you now take.

- Twin Autoranged Wattmeters Make The Job A Snap.
- Built-In IHF/EIA testing components at your fingertips to make your job easy and your work accurate.
- Monitor sound quality at all times to prevent backtracking.
- RMS and dB audio signal tracing ability lets you tie down troubles in any driver stage.
- Prevent amplifier damage, plus monitor intermittents.
- "Audio Line" tests ensure that the component signals to the amplifier are "OK".
- Stereo separation tests to 126 dB to speed AM, FM and Stereo TV work.

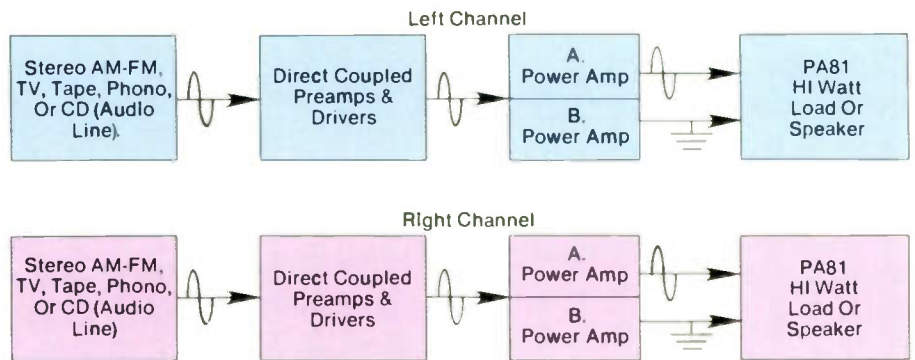

Walk troubles out of any power amplifier stage, step by step, with the PA81.

* IHF - Institute of High Fidelity
EIA - Electronics Industry Association

Call or Write For A 10 Day Videotape Preview



Circle (1) on Reply Card

SENCORE
3200 Sencore Drive Sioux Falls, South Dakota 57107

Call 1-800-843-3338

In Canada Call 1-800-851-8866

There is no smarter choice than Philips ECG.

Keep equipment in top shape with Philips ECG's top of the line Audio/Video products.



The best performance from any piece of equipment. The line-up that delivers it looks like this:

- To measure and adjust frequency response of audio tape decks, the AR20 frequency response cassette
- To accurately adjust audio tape running speed and record/playback head alignment, the AR30 speed and adjustment cassette
- To observe tape travel path in the VCR, the Video tape path view cassette
- To measure torque in play or fast forward/rewind modes, the Video torque meter cassettes

Contact your Philips ECG distributor or call 1-800-225-8326. It just might be the smartest call you make all week.

Circle (3) on Reply Card

The Smart Choice.
Philips ECG

A North American Philips Company

Philips ECG's PR60 & PR200: The smart answer to your scope probe needs.



Whether you're an engineer, technician or a hobbyist, we've got the popular scope probes you're looking for. Each features X1 and X10 attenuation, a switchable ground reference, and 360° rotatable ground clip.

- The PR60 has a 60 MHz bandwidth; the PR200 has a 200 MHz bandwidth and both are compatible with most popular oscilloscopes
- Both models are supplied with a retractable hook. The PR200 also comes with an IC tip, BNC adapter and insulating tip

Contact your local Philips ECG distributor or call 1-800-225-8326. It just might be the smartest call you make all week.

Circle (6) on Reply Card

The Smart Choice.
Philips ECG

A North American Philips Company

Philips ECG's Cable Converter brings in the signal loud and clear!



The TV 2000 adapts any TV set to cable ready
 Remote control adjusts volume, turns TV on/off, has direct channel selection and channel stepping

- Receives up to 139 VHF, UHF and cable channels
- Separate video and audio outputs for direct connection to VCR and stereo systems
- Stores up to 12 user-selected channels for quick selection

Contact your Philips ECG distributor or call 1-800-225-8326. It just might be the smartest call you make all week.

Circle (4) on Reply Card

The Smart Choice.
Philips ECG

A North American Philips Company

ECG® DM-76 Auto-Ranging Digital Multimeter: The smart choice for value!

ECG DM-76 Multimeter is accurate, priced right and packed full of features. Here's what you get:

- Auto or manual range selection
- 0.5% basic accuracy
- 3½ digit LCD with range indicator
- Data hold
- 20 megohm full scale
- Transistor h_{FE}
- Diode V_F
- Audible continuity test

Accuracy! Value! All the features you need! Contact your ECG products distributor or call 1-800-225-8326. It just might be the smartest call you make all week.

Circle (7) on Reply Card

The Smart Choice.
Philips ECG

A North American Philips Company

Philips ECG's Master Guide gives you all the replacement semiconductor information you'll ever need.



For speed, accuracy and ease-of-use, nothing beats the Philips ECG® Master Guide!

- Contains technical data for 4000 Philips ECG semiconductors that replace over 240,000 industry part numbers
- Contains the most accurate cross-references available.
- New edition has 13,000 additional cross-references

and 230 new devices

All this, all in one book. Contact your Philips ECG distributor or call 1-800-225-8326. It just might be the smartest call you make all week.

Circle (5) on Reply Card

The Smart Choice.
Philips ECG

A North American Philips Company

Ensure pinpoint accuracy with the ECG® DM-410 Multimeter.

The ECG DM-410 4½ digit multimeter ensures a level of accuracy that's hard to beat! And it's loaded with features:

- 0.05% basic DC accuracy
- 7 functions, 26 ranges
- Data hold
- 10 amps AC/DC
- Audible and visual continuity tests
- Measures down to 0.01 ohms
- RF shielded
- Diode test

Contact your ECG products distributor or call 1-800-225-8326. It just might be the smartest call you make all week.

Circle (8) on Reply Card

The Smart Choice.
Philips ECG

A North American Philips Company

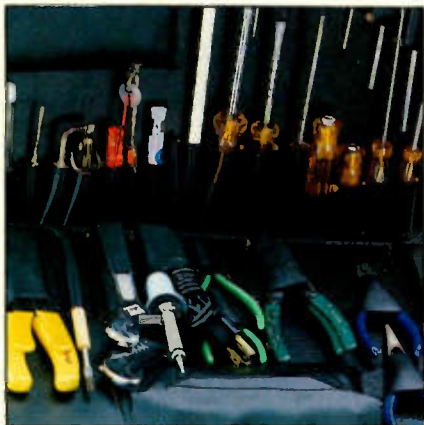

Page 12



Page 18

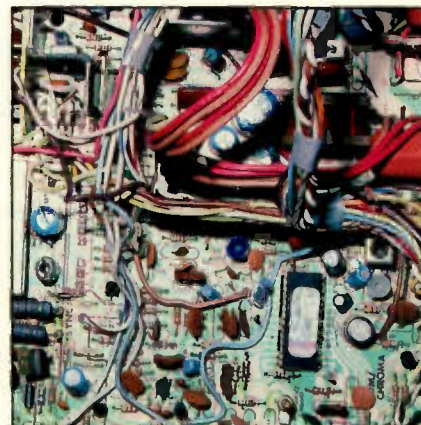

Page 38

FEATURES

10 Designing a Working Service Kit

By Edward S. Graham

It makes sense that if electronics are getting more complex, the tools you use to service them must require a little more thought than in the past. Whether you need a job-specific kit with special tools, a heavy-duty kit for field service or a static protective kit, an experienced manufacturer can help you stock the right kit with the right tools.

12 The Benefits of a Tool Kit Program

By Jeff Richardson

If you work in a shop with more than one tech, you probably are used to inheriting the last tech's tools, stocking your own case or just borrowing the tools you don't have. However, there are several reasons why making do might not be the best way to keep your company in tools.

18 Reforging the Weakest Link

By Dennis Behling

If you think of your computer system as a chain and each peripheral — from the power source to the disk drive, monitor, computer and printer — as one link in the chain, you might not think to

include the connections *between* the peripherals in your tally. However, a failure in the wire and cable is often the link that breaks your flow of information.

22 VHS Camcorder Servicing

A camcorder is very similar to a VCR — a light-weight, miniaturized, portable VCR, of course. Still, there are some differences that take some getting used to. This article introduces some of the details to watch for by describing how you would service one particular model of VCR.

38 Servicing RCA CTC107 Video/color Circuits

By Homer L. Davidson

The RCA CTC107 13-inch TV can be difficult to service because of the crowded video and chroma circuits and the limited number of tests that can be made. However, this chassis has some nice features that should make a busy electronics servicer breathe a sigh of relief.

DEPARTMENTS

4 Editorial

Stocking the Tool Box

6 News

8 Business Corner

Using the Computer in the Shop

16 Technology

An Intelligent TV System

20 Troubleshooting Tips

29 Profax

37 Literature

45 Books

46 Test Your Electronics Knowledge

48 What Do You Know About Electronics?

The Differentiating Circuit

50 Products

54 Symcure

Sears TVs

56 Audio Corner

Servicing the Compact Disc Player — Part VIII

58 Video Corner

Rebuilding VCRs

60 Computer Corner

Diagnosing Phantom Floppy-disk-drive Problems

61 Readers' Exchange

64 Advertisers' Index

ON THE COVER

Choosing a tool kit requires electronics servicers to decide on which specialized tools and what type of case would work best for the type of work they do. The right tools in the right type of kit can make the toughest job seem faster and easier. (Photo courtesy of HMC.)

LEADER

CARVER DENON harman/kardon  HITACHI
NEC ONKYO  PIONEER  SANSUI
SHARP SONY  TEAC YAMAHA

These leaders specify Leader.

When servicing electronics, depend on Leader for your test equipment needs.

Leader meets the standards of so many, because we set such high standards in design.

Equip your bench with our standard test equipment as required by manufacturers. Leader continually consults manufacturers and their service facilities to determine what products and features you'll need. The unique features on Leader equipment help you work smarter and increase efficiency.

You'll find hard-to-beat capabilities and value throughout the Leader line.

See all there is to Leader's leadership, and benefit from our more than 34 years of experience. Phone now to discuss your equipment requirements, for a copy of our catalog, and for the name of your nearest "Select" Leader Distributor. All Leader equipment is backed by a TWO-YEAR WARRANTY, and factory service on both coasts.

Call toll-free
1 800 645-5104
In NY State
516 231-6900

Leader Instruments Corporation
380 Oser Avenue, Hauppauge, New York 11788
Regional Offices:
Chicago, Dallas, Los Angeles, Boston, Atlanta
In Canada call Omnitronix Ltd. 416 828-6621

LEADER
FOR PROFESSIONALS WHO KNOW
THE DIFFERENCE

SEE LEADER INSTRUMENTS AT ELECTRO '89, BOOTHS 1663-1667

1. LCG-400S NTSC Pattern Generator
2. LVS-5850B NTSC Vectorscope
3. LDC-823S 250-MHz Frequency Counter
4. LMS-238 TV Stereo Generator
5. 3216 AM FM Stereo Generator
6. LHM-80B High Voltage Meter

7. LSW-333 TV Sweep Generator
8. LAG-126S Audio Generator
9. LMV-185A AC Millivoltmeter
10. LFM-39A Wow & Flutter Meter

11. LDM-171 Distortion Meter
12. LTC-906 Transistor Checker
13. LDM-853A Digital Multimeter
14. LPS-152 DC Power Supply
15. LPM-8000 Laser Power Meter
16. L3O-2060 CRT Readout Oscilloscope

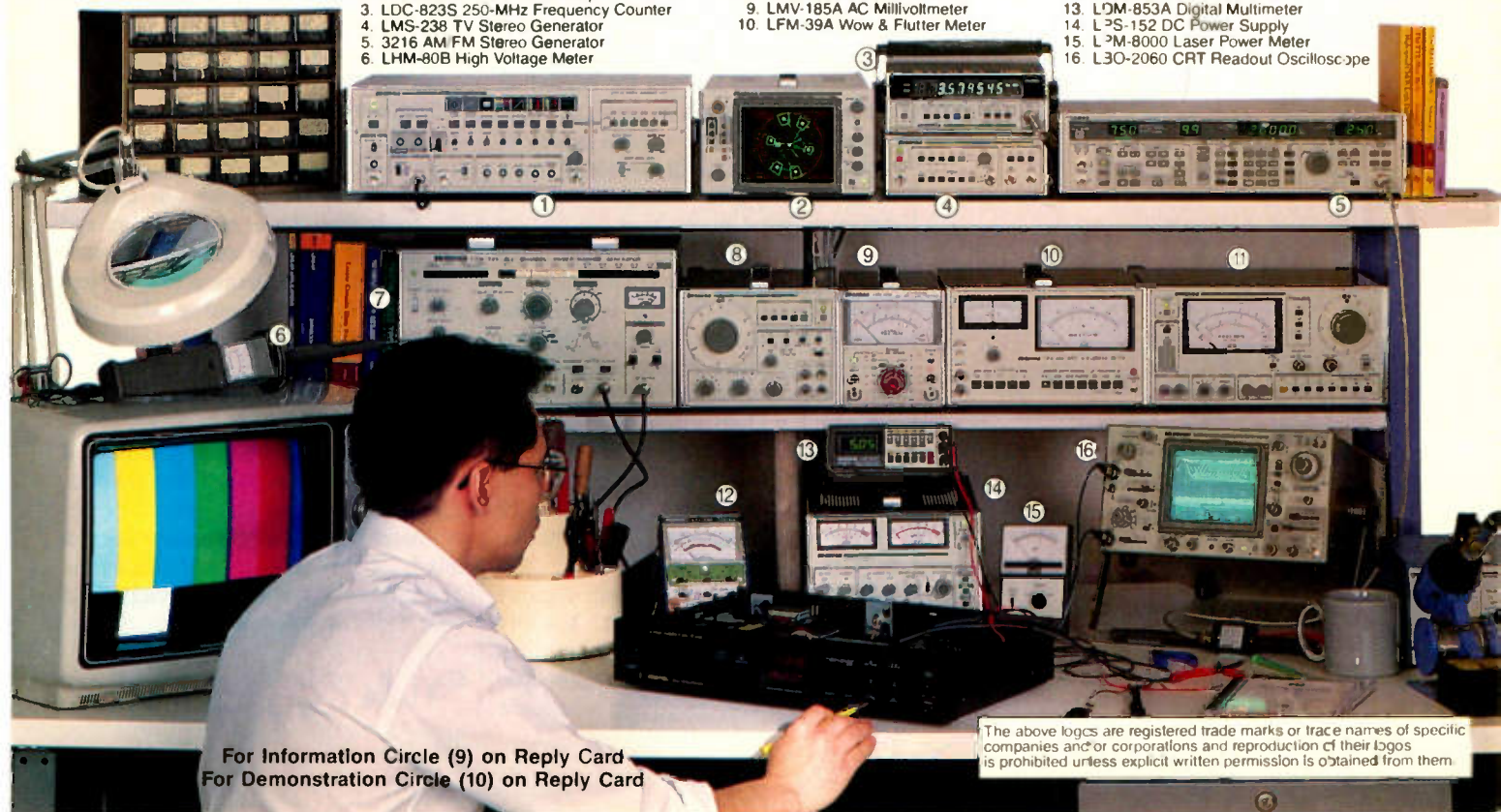

For Information Circle (9) on Reply Card
For Demonstration Circle (10) on Reply Card

The above logos are registered trade marks or trade names of specific companies and/or corporations and reproduction of their logos is prohibited unless explicit written permission is obtained from them.

Stocking the tool box

The progress of humankind is marked by the materials out of which humans made tools: the stone age, the bronze age, the iron age. Each represented a significant step forward in sophistication and the ability to cope with the environment.

In spite of our considerable progress, we are still limited in our ability to complete certain tasks by the tools available to us. For example, have you ever tried to remove the insulation from the end of a wire without tools? It's rough on the fingernails. Rough on the teeth, too. Even more important, it's rough on the wire, and if you caused damage to the wire while you were stripping it, it might come back to haunt you as a failure in the future.

OK, so no one's foolish enough to try to remove insulation from a wire without tools. But how many of us try to do it with the wrong tool: a jackknife, a pair of cutting pliers or the like? Any of these tools is the wrong tool and can make a nick in the wire that will eventually lead to failure of the product it's used in.

I still remember when I was building a TV kit. I initially bought an inexpensive insulation stripper with sharp jaws that were adjusted with a screw assembly. It worked, but it was almost impossible to set it so the jaws would cut deep enough to sever the insulation but not deep enough to nick the wire. I suspect that I have several pieces of nicked hookup wire in that set. I really should throw away that pair of wire strippers, but I never have.

Soldering irons are another area where nothing but the right tool will do, especially in today's era of hair-fine circuit-board traces, tight lead spacing and heat-sensitive components. If you use a soldering tool that's right for the job, you'll end up with a solid connection and no damage to the traces or the component. Use the wrong tool and the result could be disaster: lifted traces or a brand-new, expensive component that is ruined.

Tools are one of those things you buy once and forget about, right? You buy a kit or a few tools at a time and then never think about them again unless you lose one or break one. Then, sometime

when it's convenient, you go buy one from the distributor or order one from the mail-order catalog. Until then, you get by with some makeshift device, or you borrow whatever you're missing.

That's a pretty standard approach to technician's tools, but one that tends to be inefficient. The problem is that tools are one of those things you often forget about. As time goes on — and it flies by quicker than most of us realize — the cutting edges on the dikes gets duller, the joints on the long-nosed pliers get worn, the tip of the soldering iron gets oxidized and doesn't heat up the way it once did. Compounding the problem is that these things happen gradually, a little at a time over a period of months and years, so we take the poor condition of our tools for granted, forgetting how nice they were to use when they were new. It's only when we're forced to get a new one and use it for the first time that we realize how worn the old one had become.

But that's only part of the situation. With technology advancing as rapidly as it does these days, new types of tools are frequently needed. However, unless a technician keeps up with the field, one day he'll try to replace that new type of connector or surface-mount device, and it won't budge until he learns what tool is needed and finds out where to get one.

Technology not only affects the tools needed to do the job, it also affects the tools themselves. Tool manufacturers are constantly seeking ways to improve the tools they have to offer. Refined ergonomics make the tools easier, more comfortable and less tiring to use. New materials make the cutting edges and joints last longer. New technology improves the performance of tools, making wire nicks less likely and solder joints more reliable.

Tools are the technician's lifeblood and should not be taken for granted. They're something that should be re-evaluated periodically. Three articles in this issue discuss tools and tool cases. You might think about the condition of your tools as you read them.

Mike Conrad Pearson

FLUKE



PHILIPS

Find trouble when you're not there... with the new Fluke 80 Series.

The 80 Series' unique recording functions make it easy to find intermittent faults. Hook it up, walk away, and let the meter do the work.

- MIN MAX AVERAGE recording stores the highest, lowest and true average of all readings.
- Selectable response times let you record such changes as turn-on surges or voltage drift.
- 1 ms PEAK MIN MAX hold on the Fluke 87 lets you capture elusive transients or half-sine surges to 400 Hz.
- Audible MIN MAX Alert™ on all three models signals you for readings above or below previous limits.

The new Fluke 80 Series—with 12 different measurement functions, it's the first multimeter that's truly multi. For a free brochure, or the name of your local distributor, call toll-free 1-800-44-FLUKE, ext. 33.

FROM THE WORLD LEADER IN DIGITAL MULTIMETERS.



FLUKE 83	FLUKE 85	FLUKE 87
Volts, ohms, amps, diode test, audible continuity, frequency and duty cycle, capacitance, Touch Hold™, relative, protective holster with Flex-Stand™.	Volts, ohms, amps, diode test, audible continuity, frequency and duty cycle, capacitance, Touch Hold™, relative, protective holster with Flex-Stand™.	Volts, ohms, amps, diode test, audible continuity, frequency and duty cycle, capacitance, Touch Hold™, relative, protective holster with Flex-Stand™.
\$189*	\$219*	\$259*
0.3% basic dc accuracy	0.1% basic dc accuracy	0.1% basic dc accuracy
5 kHz acV	20 kHz acV	20 kHz acV
Analog bargraph & zoom	Analog bargraph & zoom	High resolution analog pointer
Three year warranty	Three year warranty	True rms ac
		1 ms PEAK MIN MAX
		4½ digit mode
		Back lit display
		Three year warranty

*Suggested U.S. list price

FLUKE

General Instrument expands VideoCipher program

General Instrument's VideoCipher Division and Channel Master have announced that the VideoCipher Module Service Dealer (VMSD) program has been expanded to include field repairs of satellite equipment containing Channel Master-manufactured VideoCipher II descrambler modules. The original program only included repairs to General Instrument modules. Under the agreement, each company will exchange modules for their own modules. Warranty and charges for both will be identical.

The VMSD program is intended to assist the satellite TV industry with quick turnaround repairs on VideoCipher II-equipped satellite TV systems. Dealers enrolled in the program can provide module replacement services for most integrated receiver/descramblers and stand-alone descramblers for consumer satellite TV systems.

To apply for participation in the VMSD program, satellite TV dealers may call 800-344-6754 for an application. Once approved, dealers can purchase up to seven VideoCipher II descrambler modules.

Zenith seeks HDTV R&D funding

Zenith has submitted two co-funding proposals to the U.S. Defense Advanced Research Projects Agency (DARPA). In the first proposal, Zenith and AT&T are each seeking \$13 million in co-funding from DARPA. The companies will use the funding for a research and development program to develop an HDTV processor/receiver, integrated circuitry and prototype hardware for evaluation and demonstration of Zenith's "spectrum compatible" HDTV transmission system. AT&T Microelectronics will design and produce the integrated circuits, and AT&T Bell Laboratories will apply its system-design technology to certain elements.

Zenith has also announced a \$21.5-million research and development

program to develop large-screen versions of the company's "flat tension mask" high-resolution color picture tubes. Zenith is seeking \$10 million in co-funding from DARPA. The research is intended to produce flat tension mask color picture tubes at a lower price than other high-resolution display technology, in a range of sizes from 14-inch to 35-inch diagonal.

NPEC features seminars

The 1989 National Professional Electronics Convention (NPEC) — which will be held August 7-12 at the Loews Ventana Canyon Resort in Tucson, AZ — will offer several business management seminars. The seminars include sessions on the changing demographics of the industry and which decision-making processes are now necessary; a session on the "Better Idea" contest; a session on basic management skills; informal meetings with the National Service Managers of most consumer electronics manufacturers; and a hands-on competition for technicians.

Technical sessions will feature a digital-microprocessor school, an oscilloscope school and seminars on Super VHS VCRs and LaserVision videodisk technology.

For more information, write NPEC '89, 2708 W. Berry St., Fort Worth, TX 76109, or call 817-921-9061.

SDC plans satellite trade show

The Satellite Dealers Coalition and Morning Star Productions will be holding the second annual Satellite Trade Show. The show, which will be held June 23-25 at the Stouffer Concourse Hotel in St. Louis, will feature major industry suppliers, a dish farm, seminars and workshops, and special activities for family members. Registration fees are \$35 for attendees, \$10 for spouses. For more information, call 314-394-1145. To register by credit card, call 800-727-STAR. For Stouffer hotel reservations, call 800-HOTELS-1.

ES&T

The magazine for consumer electronics servicing professionals

ELECTRONIC

Servicing & Technology

Electronic Servicing & Technology is the "how-to" magazine for technicians who service consumer electronics equipment. This includes service technicians, field service personnel and avid servicing enthusiasts who repair and maintain audio, video, computer and other consumer electronics equipment.

EDITORIAL

Nils Conrad Persson, *Editor*
 Carl Babcoke, *Consumer Servicing Consultant*
 Tom Cook, *Senior Managing Editor*
 Alisa Carter, *Associate Editor*
 Pamela S. Fleener, *Editorial Assistant*

CONSULTING EDITORS

Homer L. Davidson, *TV Servicing Consultant*
 Christopher H. Fenton, *Circuit Fabrication Consultant*
 Victor Meeldijk, *Components Consultant*
 Kirk G. Vistain, *Audio Consultant*
 Sam Wilson, *Electronics Theory Consultant*

ART

Kevin Callahan, *Creative Director*
 Barbara Miles, *Graphic Designer*

BUSINESS

Cameron Blishop, *Group Vice President*
 Eric Jacobson, *Group Publisher*
 Greg Garrison, *Sales Manager*
 Marcia Durrett, *Marketing Director*
 Evelyn Hornaday, *Promotions Manager*
 Kelly Hawthorne, *Promotions Coordinator*
 Dee Unger, *Advertising Business Manager*
 Catherine Grawe, *Advertising Coordinator*

ADVERTISING

Regional advertising sales offices are listed in classified pages.

ADMINISTRATION

R.J. Hancock, *President*
 Chuck Rash, *Corporate Circulation Director*
 Jane J. Powell, *Circulation Director*
 Jo Ann DeSmet, *Fulfillment Manager*
 Barbara Clare, *Reader Correspondent*



Member, Audit Bureau of Circulation



Member, American Business Press



Member, Electronic Servicing Dealers Association

CORRESPONDENCE

Editorial, advertising and circulation correspondence should be addressed to: P.O. Box 12901, Overland Park, KS 66212-9981 (a suburb of Kansas City, MO); 913-888-4664. Home office fax: 913-541-6697. Home office telex: 42-4156 INTERTEC OLPK

SUBSCRIPTION PRICES: one year, \$19.49; two years, \$32.98 in the USA and its possessions. Foreign countries: one year, \$23.49; two years, \$36.98. Single copy price: \$2.50; back copies, \$3.00. Adjustment necessitated by subscription termination to single copy rate. Allow 6 to 8 weeks for new subscriptions.

PHOTOCOPY RIGHTS: Permission to photocopy for internal or personal use is granted by Intertec Publishing Corp. for libraries and others registered with Copyright Clearance Center (CCC), provided the base fee of \$2 per copy of article is paid directly to CCC, 21 Congress St., Salem, MA 01970. Special requests should be addressed to Eric Jacobson, publisher. ISSN 0278-9922 \$2.00 + 0.00

Electronic Servicing & Technology (ISSN 0278-9922) is published monthly for \$19.49 per year by Intertec Publishing Corp., 9221 Quivira Road, Overland Park, KS 66215. Second-class postage paid at Shawnee Mission, KS and additional mailing offices. POSTMASTER: Send address changes to ELECTRONIC SERVICING & TECHNOLOGY, P.O. Box 12960, Overland Park, KS 66212.

©1989 All rights reserved.



Hand Tools With Horsepower!

That's the name of the game

Pick up a Paladin tool and you've got hand tool horsepower to get the job done... *whatever* game you're in.

Your hand will fit Paladin's ergonomically-designed grip like a glove. You always get comfortable, precise tool control everytime you wrap your hand around a Paladin tool! Because Paladin tools feel better in your hand, your hand gets a better feel for the job.

Professionals prefer the variety, versatility and lasting value of Paladin tools... cable preparation tools, strippers, crimpers and cutters, slitters, notchers, screwdrivers; and accessories like connectors, telecom hardware and other valuable service and production aids. Whatever your industry, whatever your need, Paladin has your tool.



If you expect quality, reliability, performance and productivity from your hand tools, demand Paladin. Serving the electronic, electrical, telecommunications and various other industries for more than 10 years, we understand your specialized requirements, and have precision-engineered and patented sol-

utions for almost every application.

The Only Game In Town

Feel the hand-held horsepower for yourself with Paladin tools. Check us out for comfort, quality, versatility, and pure spirit of performance. You'll discover... when you put Paladin energy in your hand, every job becomes a little easier.

It's your move... contact us for the authorized distributor near you. Remember, Paladin is the only game in town!



At work with professionals every day

PALADIN CORPORATION

3543 Old Conejo Road, Suite 102

Newbury Park, CA 91320

(805) 499-0318 - FAX (805) 499-4006

A member of the Weidmüller group of companies

Circle (35) on Reply Card

Using the computer in the shop

By William J. Lynott

If you're like many electronics servicers I know, you're still on the fence when it comes to servicing computers. Whether you want to get into computer servicing is a management decision that depends on a number of variables only you can judge. However, no matter which way that decision goes, I sincerely hope you won't let it stand in the way of your use of a computer to help you manage your business.

A few years back, when desktop PCs were still relatively new, I was advising servicers to hold off computerization until their annual gross revenue rose above \$500,000 or so. As prices for hardware began to drop and good software designed for service businesses became available, I dropped my benchmark to \$250,000. Today, there is plenty of evidence to indicate that a PC is a good investment for all but the tiniest one- or two-person operations. In fact, as I write this, I can even think of several one-man operations that are putting a desktop computer to profitable use.

Today, for an investment of \$2,000 to \$3,000, you can purchase computer hardware with capabilities and speed that would have cost perhaps ten times that much a half-dozen years ago.

Equally important, software (the programs that tell the computer how to do the jobs you want done) has been going through a revolution of its own. Crude programs that disappointed many buyers have been gradually weeded out of the market while the better ones have been improved with slicker, easier-to-use features.

As a result of all this, desktop computing is showing up in the shops of all but the most diehard holdouts. Much of the mail in my office and many of the questions I get as I visit small service dealers around the country have to do with desktop computing — what tasks it is best suited for and how to do them.

Lynott is president of W.J. Lynott, Associates, a management consulting firm, and publisher of the Service Dealer's Newsletter.

I'll use this month's and next month's columns to answer a few of the more common questions.

What should I buy? Unless I know you and your specific business, this question can only be answered in general terms. But here are a few guidelines: IBM is the prestige image in desktop computing. However, its equipment tends to be more expensive than competing makes, and there are even people around who feel strongly that competitors such as Compaq make better-quality machines. Actually, a number of small manufacturers who started out making IBM clones have made names for themselves by producing quality

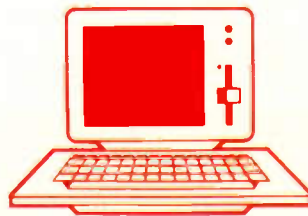

equipment at low prices. In addition to Compaq, I like Leading Edge, Proteus, PC-Brand and Wyse. There are many others.

What do I need to know in order to buy the right system? Even if you are not inclined to get involved with the technical aspects of computing, there are a couple of considerations that you should keep in mind. The speed and power of a computer is basically dependent on an internal device called the *microprocessor*. The original 8086 and 8088 microprocessors are now seriously out of date. Some of the better software won't even run on machines that use them. If you're buying a new computer, regardless of the brand, make sure it has at least the 80286 microprocessor. That's the minimum for practical speed and power. Even better is the 80386. An 80386 computer will cost you a bit more, but it should protect you from obsolescence for years.

No matter how small your business is, don't buy a computer that doesn't have a *hard disk*. Without a hard disk, you must save all your data on floppy disks. They're OK for simple household applications, but floppy disk storage is simply not adequate for serious business purposes.

The storage capacity of hard disks is measured in *megabytes* (Mbyte). One megabyte is roughly equivalent to one million characters of information. The smallest hard disk you should consider is 40Mbyte. That will easily take care of all the data storage requirements for a small service company (say, up to \$500,000 or so in annual gross).

What about printers? In addition to the computer, you will also need a printer. Of the two most popular types of printers, the latest and most expensive is the laser printer. Laser printers represent state-of-the-art technology for printing with desktop computers. The Hewlett Packard LaserJet II, which you can buy for about \$1,700 if you shop around, is the leader. As with computers, though, there are other makes that are competitive in both price and features.

Laser printers are nice. However, the dot matrix printer is a better choice for a small service dealer. It sells for far less money and you can buy an excellent one for \$400 to \$500. We use both dot matrix and laser printers in our office, and we find the dot matrix is fine for everything except preparing camera-ready copy for commercial printers. When I'm finished with this column, it will be printed on an Okidata model 293 dot matrix printer for mailing to ES&T.

Those are a few of the basics for buying a first-time computer setup or upgrading an outdated system. Next month we'll look at the various tasks that can be handled by your computer system, and I'll review some of the commercial software that can help you automate a number of your routine business tasks.

ES&T
magazine

HIGH PLACES



TIGHT SPACES



No matter where you go, Tek's new 222 is a perfect fit.

Introducing Tek's new 222 Digital Oscilloscope. Weighing in at under 4.5 pounds, the new Tek 222 is an ultra-portable, 10-MHz digital storage scope that's perfect for service applications. So tough, rugged, and totally self-contained, it can go just about anywhere. And it's incredibly easy to use—even in extreme conditions.

Extraordinary capability and reliability at a great price. The 222 is a dual-channel scope that can measure a wide variety of electronic instrumentation and circuitry. It has rechargeable on-board batteries with a floating ground to 400 volts, and meets tough environmental standards.

Plus, the 222 lets you pre-define front-panel setups, and call them up with a single button in the field. You can also save waveforms in the scope's memory, then transfer them to a PC for analysis and hard-copy output when you get back to the shop.

Best of all, the 222 is yours for only \$2350. And that includes Tek's remarkable three-year warranty on parts, labor, and CRT.

Get one to go! Pack a handful of power with you wherever you go. To order your 222, or for a free brochure, contact your local Tek representative or authorized distributor.

In a hurry? Call
1-800-426-2200.



Circle (12) on Reply Card

Tektronix
COMMITTED TO EXCELLENCE



Designing a working service kit

By Edward S. Graham

Was there ever a time when you could grab a department store tool box, toss in a couple of tools and confidently face that Goliath of a console TV on its own turf? Probably not in the past, and certainly not now. The increasing complexity of consumer-electronics products means servicing technicians are now dealing with increasingly varied systems and components, so choosing the right tools for your applications takes a little more thought. To control costs and

Graham is a product manager for HUB Material Company (HMC), a national stocking tool kit/test equipment supplier based in Canton, MA.

select appropriate tools for the job, you should always consider whether to purchase a basic in-stock kit or build a custom kit to meet special needs. A standard kit is a good choice if it provides the tools necessary to make required repairs and if the case is appropriate for the technician's work. The chances are good that a pre-assembled, general-purpose kit can be found if you will be servicing common electronics such as TVs, VCRs and computers.

You can also find special, off-the-shelf kits used for servicing ATMs, datacom and telecom networks, broadcast and microwave equipment,

biomedical apparatus, robotics, fiber optics and other technologies. The tool kit buyer can often get away with adding, deleting or substituting a few tools of a standard kit to meet specific requirements. If you service specialized repair applications or if you require a large quantity of kits, a completely customized kit may be warranted.

Tool options and configurations

You need to evaluate a great variety of tool options and case configurations if you are to create a kit that can be effectively used to repair the assortment of equipment your organization services. Tools common to most kits include screwdrivers and nutdrivers for fastening; pliers for cutting, bending and stripping wire; and a soldering tool to repair damaged electrical connections.

Other useful tools are sometimes included in general-purpose kits: desoldering pumps, scribes, punches and drills, inspection mirrors, flashlights and leakproof plastic oilers. Hammers, saws, socket sets, IC extractors, alignment tools, vises, knives, scissors and rules are all nice to have but may not be included as part of the kit because of cost, space or weight constraints.

Today, kits contain a great number of specialty tools and instruments because of the sophistication of the equipment now integrated into the day-to-day activities of consumers and businesses. Your tool kit might include some specialized equipment: telephone test sets, breakout boxes, circuit board pullers, torque wrenches and screwdrivers, metric wrenches and sockets.

Tool cases

The case is the backbone of the tool kit. Its style and construction play a major role in assuring the long-term functionality of a tool kit. When you choose your case, consider whether it will hold items other than tools, such as test instruments, electronic components, disc packs, catalogs, circuit boards and so on. You should also consider whether your tool case will be riding in a car or



in the back of a pick-up truck.

If the case is properly selected, tools and test equipment will be organized for easy access and safe transport to and from the job site. You'll spend less time looking for the right tool, and you'll be able to spot missing tools at a glance.

When you're shopping for a tool case, be aware of the durability of the outer material as well as its look. Cases that cannot withstand the rigors of the working environment eventually show signs of wear. Some servicers still prefer the original wood/vinyl attache-style tool case. Its leather-like exterior has an executive look, but it's heavier than aluminum or high-impact plastic. The wood case is the oldest style available, and some manufacturers aren't producing them anymore because of lack of demand.

Sleek, lightweight aluminum cases enhance the professional, high-tech image of a service organization. They are also the most expensive type of case you can select. Aluminum cases have high-strength, lightweight and wrinkle-free surfaces. They also are dust and weather-resistant. Unfortunately, it doesn't take long for aluminum cases to be dented, nicked and scraped.

If cost is a major concern, consider a case made of ABS thermoplastic, injection-molded polypropylene or vacuum-formed polyethylene. These cases are considerably less expensive than other types of attache-style tool cases. Polypropylene is just about as strong and resistant to chemicals as polyethylene, and it usually costs 10% to 15% less.

Keep in mind that ABS thermoplastic cases are not quite as durable, but they feature a scuff-resistant pebble-grain finish. As a general rule, ABS and polypropylene are substantially lighter in weight than polyethylene and are appropriate for applications requiring maximum protection while being hand-carried. Cases made of rugged polyethylene, the same material used in airline containers, are the strongest of the three plastic-made cases and are typically used for shipping purposes.

A transit-style case is the answer for those who require maximum durability. It is used primarily for heavy-duty servicing, carrying or shipping. The case is typically constructed with panels of high-density polyethylene sheeting that is shaped by bending as opposed to vacuum-forming. In vacuum-forming, the plastic is heated and shaped with aluminum molds, and it loses some of its strength. Because the polyethylene is bent, the initial strength is maintained throughout the case. An anodized aluminum frame is riveted around the entire shell, inside and out, to provide unique exterior protection. The top is secured to the back of the case with a heavy-duty continuous piano hinge. The biggest objection to the transit-style case is its weight. At approximately 18 pounds, it weighs about eight pounds more than most other comparable-sized cases.

Consider the interior, too

Attache-style case interiors usually contain a top and bottom pallet with elastic or sewn pockets that have been stitched or riveted in place for extra strength. The pocket configuration is precisely designed to accommodate a wide variety of tools for easy access while holding them snugly in place for transport or storage. Tough, leather-like pockets retain their shape and withstand extreme temperature changes and rough treatment.

Other interior possibilities include the use of Velcro, custom die-cut molded partitions, polyurethane foam cushioning, divider boards, material pouches and manual or literature pockets. Three-piece foam inserts are ideal for a tight, make-your-own fit. The middle insert consists of pre-cut cubes that make it easy to design your own configuration for specialized tools, instruments or repair parts. The bottom layer of protective foam ensures excellent impact resistance. The top foam is convoluted or egg-crate shaped to help cushion and hold any object firmly in place.

Although the larger, rigid-styled cases contain enough tools to handle every

situation and can provide added security with optional combination locks, a small zipper case with fewer tools is adequate for less complex repairs. But don't let the size of these soft-sided cases fool you — they are more versatile than they look.

There's a wide selection of zipper cases that are lightweight, compact and available in vinyl, leather or Cordura-type fabric. Heavy-duty grain vinyl gives the appearance of high-quality leather but is less expensive. Its complete padding and sturdy stitched seams provide added tool protection. A long-wearing, water and stain-resistant Cordura case looks like soft-side designer luggage but functions as a tool case. It can have as many as three expandable pockets on the outside for meters, service manuals, parts and catalogs. Optional features for zipper tool cases include custom-designed interior pocket configurations; web-strap, sturdy leather-wrapped, or steel-reinforced retractable handles; and detachable shoulder straps.

Static protective kits

Portable, static-protective field service kits are as important as screwdrivers when you're dealing with electronic equipment that contains static-sensitive circuitry. A portable static-protective field service kit consists of a grounded wrist strap for the technician to wear and a static-dissipative mat that is used as a static-free work surface. The mat is thin enough to fold and fit easily into a tool kit, and it includes pockets to hold the wrist strap, ground cords and other accessories. With the mat, you can lay powered-up PC boards on a surface without the danger of shorting out the electronics. The mat also features a flame-retardant material, printability and cold-weather flexibility.

A reputable and experienced tool kit manufacturer can research and inform you about new state-of-the-art tools to complement either a standard or custom kit. You can be sure to get the right tools for your service application, and at a reasonable cost.

ES&T



The benefits of a tool kit program

By Jeff Richardson

The procurement and control of hand tools is often given little real management consideration. Very often new personnel are given a former employee's tools — incomplete as these may be — or they are given a loose list of tools to pick up from the local distributor. To these tools the service person will add others "as needed."

Although this method takes very little management time, the price actual-

ly paid to acquire those tools can easily be triple the purchase cost. For example, it takes more time for individual service people to drive to different stores to buy individual tools. The tools chosen may not be the best available for your service tasks, and neither the individual nor the many vendors involved are held accountable for lost or defective tools.

Advantages of a tool kit program

Once your tool kit program has been set up, you'll see benefits immediately. By working with a company that specializes in tool kits and test equip-

ment, the initial time required to set up the program can be minimized and overall service costs reduced because of the following savings:

- You will have lower direct tool costs through centralized negotiation with one vendor for standardized tools and test equipment.
- You won't purchase unnecessary tools.
- You can lower acquisition costs — all the tools necessary for a new hire can be ordered with one part number from one vendor.
- Service efficiency will be improved. Standard tool kits tend to reinforce stan-

Richardson is product manager at Contact East, a national distributor of testing, repair and assembly electronics based in North Andover, MA.



- standard service and installation procedures.
- Individuals will be accountable for lost tools. Well-designed tool kits make it easy to spot missing tools before you leave the job site.
 - Defective tools will require only a simple warranty replacement.

Selecting your tools

Begin by defining the type of work performed by service personnel. Does the same person handle both bench work and service calls? What tools are required for each task? Does each person repair all types of equipment? Does it make sense to have a separate kit to carry on-site for servicing certain equip-

ment (VCRs, for example), even if there is some duplication of tools?

Companies that specialize in assembling best kits can also help you select tools best suited to your tasks. Some tool kit companies offer standard, off-the-shelf kits for specific servicing tasks in different industries. Reputable tool kit companies make every effort to ensure that kits contain high-quality, brand-name tools at the lowest possible price. As a practical matter, it is generally easier to start with one of these kits and add any additional tools or test equipment unique to your application. However, when volume purchases are involved, you can save money by work-



ing with a tool kit specialist to design a custom tool kit.

Selecting a tool case

The case that will carry your tools is just as important as the tools you select. Tool cases store and protect your investment and they can help your service people be more organized. They also can have a positive effect on how customers perceive your company's professionalism. The two most common styles of cases used today are hard-sided

MCM ELECTRONICS...

...Where You Can Always Count On The Best Of Everything—Every Time!

THE BEST SERVICE, including TOLL-FREE and FAX ordering, knowledgeable telephone representatives, fast order turnaround, and extremely flexible payment terms.

THE BEST PRODUCT SELECTION, with over 11,000 different items, including...semiconductors, connectors, audio and VCR parts and accessories, hardware, television parts, test equipment, chemicals, tools, and lots more!

THE BEST ORDERING GUIDE, MCM's FREE 176-page "powerhouse" catalog. It's organized for easy reference; and each edition includes hundreds of new products to make your work easier.

For your FREE subscription to MCM's Catalog, call today!

TOLL-FREE 1-800-543-4330

Only the best is good enough for MCM Customers like you!



MCM ELECTRONICS
650 CONGRESS PARK DR.
CENTERVILLE, OH 45459-4072
A PREMIER Company

ES-45

Circle (13) on Reply Card

Quality Tool Kits



FREE CATALOG

The HMC Catalog displays products with large clear photos and describes their features with concise copy and easy-to-understand comparison tables. Now there's a quick and easy way of ordering service kits, hand tools and test equipment. Take advantage and request your **FREE** HMC Catalog!

HMC 33 Springdale Avenue, Canton, MA 02021

Circle (14) on Reply Card

attache-style and sewn zipper cases.

Attache tool cases have been in use for more than 25 years and were developed not only to create a professional image, but also to solve problems inherent with the use of tool boxes. These problems include wasted time spent searching to find a particular tool, and the difficulty of quickly detecting missing tools before you leave the job site. Attache's solve these problems by using removable pallets designed to store tools in individual pouches. By simply scanning pallet pouches, the servicer can quickly locate tools or identify which are missing.

The best tool pallets do more than simply help keep track of tools. A well-designed pallet is arranged so that the most frequently used tools are in the most accessible pallet locations. Delicate tools should be protected, and the weight of the tools should be distributed evenly. Professional-quality tool pallets will have pouches made from a special reinforced vinyl material sized to hold specific kinds of tools snugly in place during transit. Companies that specialize in providing tool kits are adept at selecting the right combination of pallets to meet your needs.

Table 1 provides an overview of the many types of tool cases designed to be used with tool pallets. Cases come in different sizes and are designed to hold two or more tool pallets. They also have extra room for storage of documents and spare parts behind and underneath the pallets.

case construction	strength	ability to withstand abuse	relative cost
polyethylene	excellent	excellent	excellent
aluminum	excellent	excellent (might bend)	high
vinyl/wood walls reinforced with steel	excellent	excellent	high
vulcanized fiber reinforced with steel	excellent	very good	low
injection-molded polypropylene	good	moderately	moderate
molded ABS	good	poor	moderate
padded vinyl with wood frame	good	poor	moderate
vinyl zipper case	good	poor	poor
Cordura zipper case	excellent	excellent	low

Of the cases described in Table 1, the polyethylene, attache-style cases are by far the most popular today. These professional-looking, rugged cases can easily hold more than 40 pounds of tools and take the abuse of being thrown in and out of service vehicles daily, and they can still look presentable years later. Polyethylene cases typically have

full-length, heavy-duty piano hinges and thickly padded, steel-core handles. They may even include a built-in combination lock.

The other case style in use today is the sewn zipper case. These cases are extremely lightweight and durable, and they are becoming increasingly popular for board-swap service calls. The outer



shell of these cases consists of either a leather-like vinyl or Cordura nylon — a special Dupont fiber that is ten times more abrasion-resistant than leather. Cases have self-healing zippers that open to allow access to built-in tool pallets usually designed to hold from 30 to 90 tools. Some zipper cases also feature built-in document holders or additional external pockets for holding test meters and bulky accessories.

Selecting a tool kit vendor

People often make the mistake of assuming that if a supplier carries tools, it automatically qualifies as a tool kit expert. Yet a kit that has missing tools because of assembly errors or back orders does you little good. Cost-effective and timely shipment of complete kits requires inventory control of many individual products, careful assembly and inspection, and tested shipping methods.

Other factors to consider as you select a vendor include:

- *Same-day shipment.* Response time can be critical when a service person is in the field without equipment.

Factors to help you select a tool kit vendor

- Same-day shipment
- Product quality
- Product guarantees
- Technical assistance
- One-stop buying
- The vendor's track record

- *Product quality.* Does the vendor carry a wide selection of brand-name, quality merchandise? Does the company carefully and accurately describe these products?

- *Product guarantees.* You should be able to return products when they don't satisfy you. A hassle-free return policy helps keep your costs of doing business low.

- *Technical assistance.* Does the vendor have technical product specialists (not order takers) who can answer your questions?

- *One-stop buying.* Can you order your tool kits, tool accessories and test equipment from the same vendor? Can you order around the clock? Can you order by phone? By Fax?

- *The vendor's track record.* A vendor with a demonstrated record of good service to others will most likely also serve you well.

A good tool kit program will reduce your overall tool procurement costs and improve your servicers' efficiency. It will, at the same time, enhance your company's professionalism.

ES&T

Come Out of the Dark.

If you're groping for a better method of running your business, let NESDA light your way with Service Control System II, a business management software system designed to help you run a more efficient business (NESDA members also receive a 20% discount). For more information about NESDA and Service Control System II, just send the following information:

Name _____

Address _____

City _____ State _____

Zip _____

Phone _____

National Electronics Sales & Service Dealers Association

NESDA

Service Dealers Association

2708 W. Berry St.
Ft. Worth TX 76109
(817) 921-9061

*One of a series.

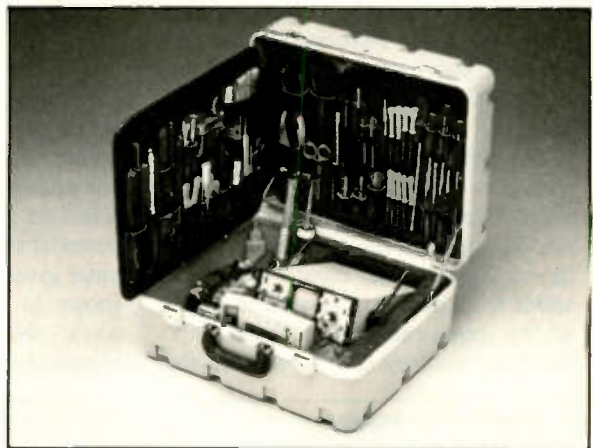

Custom kit, or off-the-shelf, isn't it time you owned a JENSEN®?

Each year Jensen Tools custom-designs and builds tool kits for use in electronics, telecommunications, robotics, process controls, all types of industries.

Our experience and knowledge of tools and tool manufacturers enables us to supply you with practically any type of specialized tools or tool cases you need. Why waste valuable time ordering individual tools and hand assembling kits yourself? Let Jensen do the work for you and save you money doing it too!

For custom kit help, or for a free catalog illustrating more than 60 Jensen standard kits, call or write today.



JENSEN® TOOLS INC.

7815 South 46th St., Phoenix, AZ 85044-5399
Phone: 602-968-6241 TWX: 910-950-0115

Circle (15) on Reply Card

An intelligent TV system



The SmarTV system, stored in a black box the size of a TV stand, contains two VHS VCRs, a personal computer with a modem, and a robot tape changer with a 32-cassette capacity.

A VCR that knows your taste in TV viewing and automatically records anything it thinks you might like? Sounds like science fiction, but Metaview, a San Francisco-based corporation, has combined PC, VCR and artificial intelligence into one "genius" VCR.

The SmarTV monitors all the TV channels and automatically records every show the viewer might want to see. To see what the system has saved, the viewer uses the remote control to select from an on-screen menu listing all the shows recorded in the system's 186-hour memory. The viewer can also

scan past uninteresting program material at 30 times the regular speed (which is about one commercial a second).

How it works

The system is connected to the home phone line. Once a week, it dials an 800 number and links to a central computer containing both the coming week's TV schedule and a profile of the viewer's personal tastes in TV. The central computer gives the SmarTV a list of all the shows to record during the coming week. New programs are usually recorded over shows that have already

been watched. However, the viewer can mark shows to be saved permanently.

Metaview uses a telephone interview with the new customer to establish a profile of the viewer's TV tastes. The customer can call the company's customer service representatives to adjust the profile.

The company is offering an initial model that has a capacity to store at least 32 video cassettes-worth of programming and two VCRs, so it can function as an automatic tape duplicator. Prices start at \$6,000. The company expects to have consumer versions priced under \$1,000 in two or three years. **ES&T**

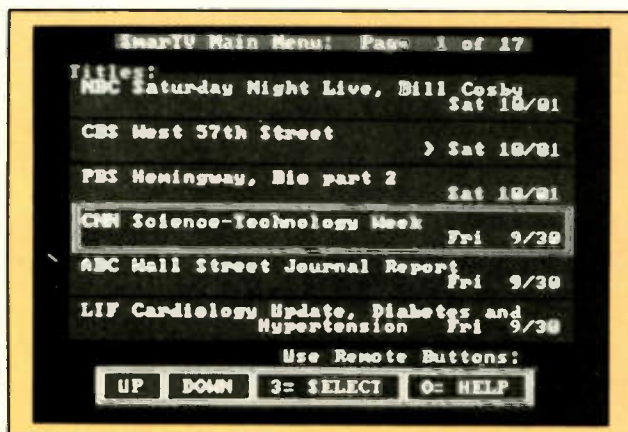

The system's on-screen menu lists all the shows stored in its 186-hour TV memory.

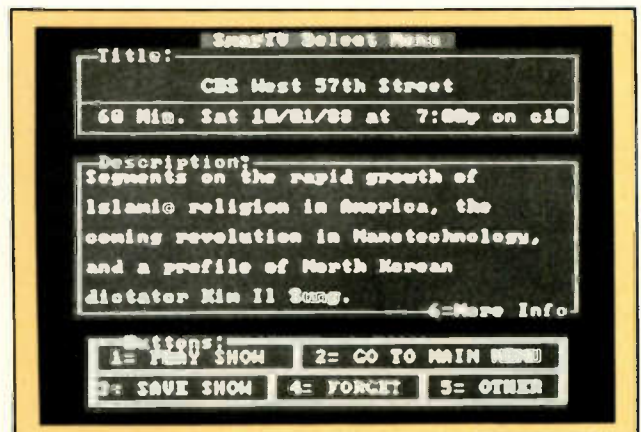

When the viewer selects a show, a description of the show is shown on-screen. Pressing keys on the remote control tells the system what to do next: play the show, return to the main menu or forget the show.

New Smart Scope makes troubleshooting trouble-free.

When you're looking for trouble, the new 100 MHz Tek 2247A will help you find it—fast.

With its integrated counter/timer, Auto Setup, unique Smart-Cursors™ and voltmeter, the 2247A makes short work of the measurements you need most.

The built-in counter/timer/voltmeter automatically calculates and displays more than 11 different voltage and time measurements.



Time-saving automation and ease of use are

built into every measurement routine. The 2247A gives you one-button setup, storage and recall of up to 20 setups, time and voltage cursors, plus on-screen readouts. It also measures rise/fall time and propagation delay automatically, with counter accuracy to 0.001%.

Best of all is the price: only \$2795! This is the most extensive set of capabilities ever

assembled in a low-cost scope. And it's backed by Tek's standard 3-year warranty on parts and labor—including the CRT.

Bandwidth	100 MHz
No. of channels	4
Vertical/Horizontal Accuracy	2%
Integrated Counter/Timer/Voltmeter	Yes
TV Line and TV Field Triggering	Yes
Auto Setup	Yes
Store/Recall	20 front-panel setups
SmartCursors™	Yes
Warranty	3 years, incl. CRT

LISTED

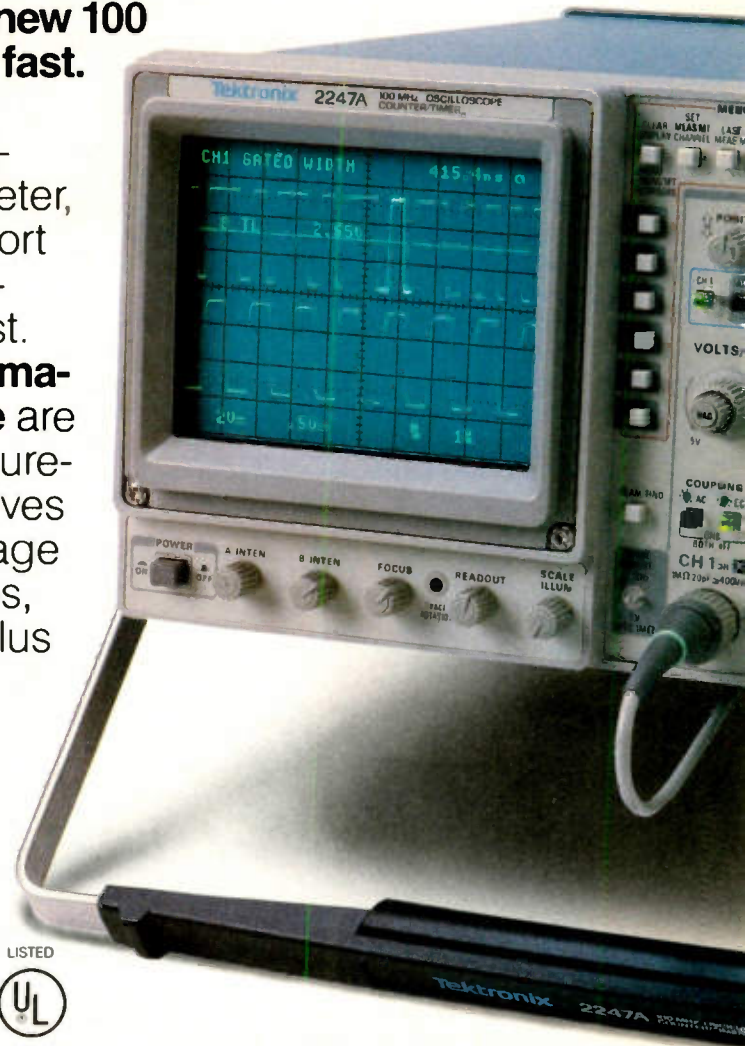

Getting one is easy, too.

For rapid ordering or a free videotape demonstration, call Tek today.

1-800-426-2200



Tektronix®
COMMITTED TO EXCELLENCE

Reforging the weakest link

By Dennis Behling

If a computer system is a chain of interlocking, interdependent functions, the wire and cable connections are often the weak link that fails, bringing the entire system crashing down.

Electronics servicers know the importance of quality equipment. From the actual hardware to the wires and cables needed in each application, superior products offer longer life cycles and require less servicing than their less reliable counterparts. Yet hardware is just one factor contributing to a well-functioning system. To rephrase an old

proverb, a system is only as good as its weakest connection. Electrical connection, that is. Although electronics servicers have long insisted on quality hardware, more and more people in the service industry are also recognizing the importance of quality stripping and termination tools to eliminate the hazards of bad connections in computer applications.

Communication problems between the CPU and the printer frequently in-

dicade a faulty connection. Warning signs may appear as open data lines on a parallel printer. Invisible to an unaided eye, the faulty pin connection must be identified and replaced with the help of a meter. In this application, an 8-position silver satin line cord must be stripped and, depending on the hardware, a DB-25 or an RJ-45 connector must be installed.

However, numerous factors can ruin the connection in this simple operation.

Behling is senior products manager at Paladin Corporation, Newbury Park, CA.



Quality tools eliminate CPU and printer communication problems that result from faulty connections. A modular termination tool guarantees perfect crimps every time.



In this application, an 8-position silver satin line cord must be stripped and, depending on the hardware, a DB-25 or RJ-45 connector must be installed.



The hazards of non-professional tools are nicked, broken and partially stripped wires that slow down the job.



Featuring a full-cycle ratchet, the most efficient tools remain locked until the crimp is precise or the release mechanism is activated.

For example, when stripping with a pocketknife and pliers, even the careful technician can easily nick, break or only partially strip an internal wire when attempting to remove the outer insulation jacket. To rectify the situation, the technician has to cut back and restrip the cable, with no guarantees that the scenario will not repeat itself.

Once the technician makes a proper strip, a DB-25 must be installed. Overcrimping or undercrimping the plug will also result in a faulty connection and will eventually cause the crimp to fail. If the servicer notices the problem during the crimping operation, it can be repaired immediately. If it is not detected at that time, it may fail in the future and force the technician to search through the entire system with an ohmmeter for the culprit.

Proper tools can forestall all of these complications. The manufacturers of today's state-of-the-art wire strippers guarantee a perfect strip without breaking, nicking or partially stripping the internal wires. Precision-crafted tools make it impossible to damage the wires by over- or understripping — the strip is right the first time, and the technician doesn't waste time repeating the operation. The spring action strips the wire and expels the jacket with a squeeze of the handle — no more muscling the coating from the internal wires.

Precision tools are also available today to guarantee a proper crimp on DB-25 and RJ-45 connectors. With a full-cycle ratchet, the most efficient tools remain locked until the crimp is completed or the release mechanism is activated (a safety feature for the technician who changes his mind). This feature makes it impossible to over- or undercrimp. A one-way loading feature eliminates the chance that the connector will be inserted incorrectly. Proper

Stripping applications in cable TV

Cable TV is one of the more resilient electronic applications, often receiving fairly clear reception with a bad or even missing connection. Many cable users strip the cable and bend the center conductor of coax around the screws for the antenna. When a VCR is added, however, the right connection becomes as important to clean visuals for viewing and taping as quality equipment and tapes.

The once standard method of installa-

tion with a pliers and a pocketknife or X-acto knife is quickly being replaced by precision-crafted stripping tools similar to the ones making inroads to computer applications. Stripping to any configuration, these tools consistently produce a strip that can be relied upon. Precision-crafted crimping tools for the F-connector ensure that the connection will be secure enough to withstand the vibrations from moving the TV or cable.

stripping and crimping ensure the quality of the connection, saving the user costly downtime and the maintenance person the aggravation of redoing the job.

Connection problems in networking

As users increasingly discover the benefits of networking, the troubleshooter is confronted more often with the problem of bad coax connections. Similar to the telltale signs the servicer will find with faulty DB-25 and RJ-45 connections, faulty BNC connections surface when the terminal fails to send and receive information from the printer or when the screen is littered with indistinguishable letters and symbols.

Although an exposed inner-grade of the coax cable may alert the technician to the faulty connection, visual inspection may not always be reliable. The main connection is done with the center conductor, and failures there often are not immediately apparent. An undetected faulty connection can cause havoc within the network. Although the cables are often wire-clipped or run through raceways, a cable concealed behind a desk may be routinely bumped or shaken when file drawers are opened or closed. This is often enough move-

ment to shake a loose connection free and interrupt the communication network. Many in the service industry prefer a tool that ensures a precise connection to checking each termination with a meter.

The remedy to a faulty coax connection is similar to the solution with faulty silver satin connections — restriping the wire and replacing the connector. State-of-the-art tools designed especially for coax applications guarantee that each strip will be free of nicks and incomplete strips, regardless of the configuration chosen. Precisely adjusted crimp tools guarantee that each crimp will be fully terminated to industry specifications.

Servicers today find that the service life of today's reliable tools outweighs the initial cost. The outdated pocketknife and pliers methods of repair, as well as the use of primitive wire strippers, impose a far greater cost when faulty connections go undetected and the job must be repeated to solve a later problem. Today's technician no longer has to wonder whether a connection is right, because reliable tools are readily available.

ES&T_{inc.}

Troubleshooting Tips

Symptom: Tape-function switches have no effect; clock and LEDs are on.
Set ID: Sears (Sanyo) VCR model 564.53100150, top-loading.

When a tape was inserted into this Sears 564.53100150 VCR, none of the tape-function switches had any effect. The clock operated and LEDs for channel, off/on switch and TV/VCR switch were on.

The tape-function switches are inputs

to the system-control circuitry. The main processor is IC3001, so it is a good starting point. VDD (pin 41) was correct. Frequency and amplitude of the crystal oscillator circuit (pin 1) is not given in the servicing manual. A scope check indicated a frequency of 398kHz and 3.9Vpp, which seemed correct when compared with other machines. A reset pulse (pin 7) was present at turn-on. I didn't suspect the inputs at pins 37, 38 and 39 as causing the dead VCR symp-

tom because they serve as tape-end and reel sensors. A problem in this circuit would most likely cause the machine to load and then eject the tape.

All pins on the right-hand side of IC3001 are outputs and would probably not cause this problem. Pins 2 through 5 are scan pulse outputs. A quick scope check indicated that all were active. These pulses are fed into IC3002, which is a 16-to-4 decoder. A scope check at IC3002's output pins (23, 24, 25 and 26)

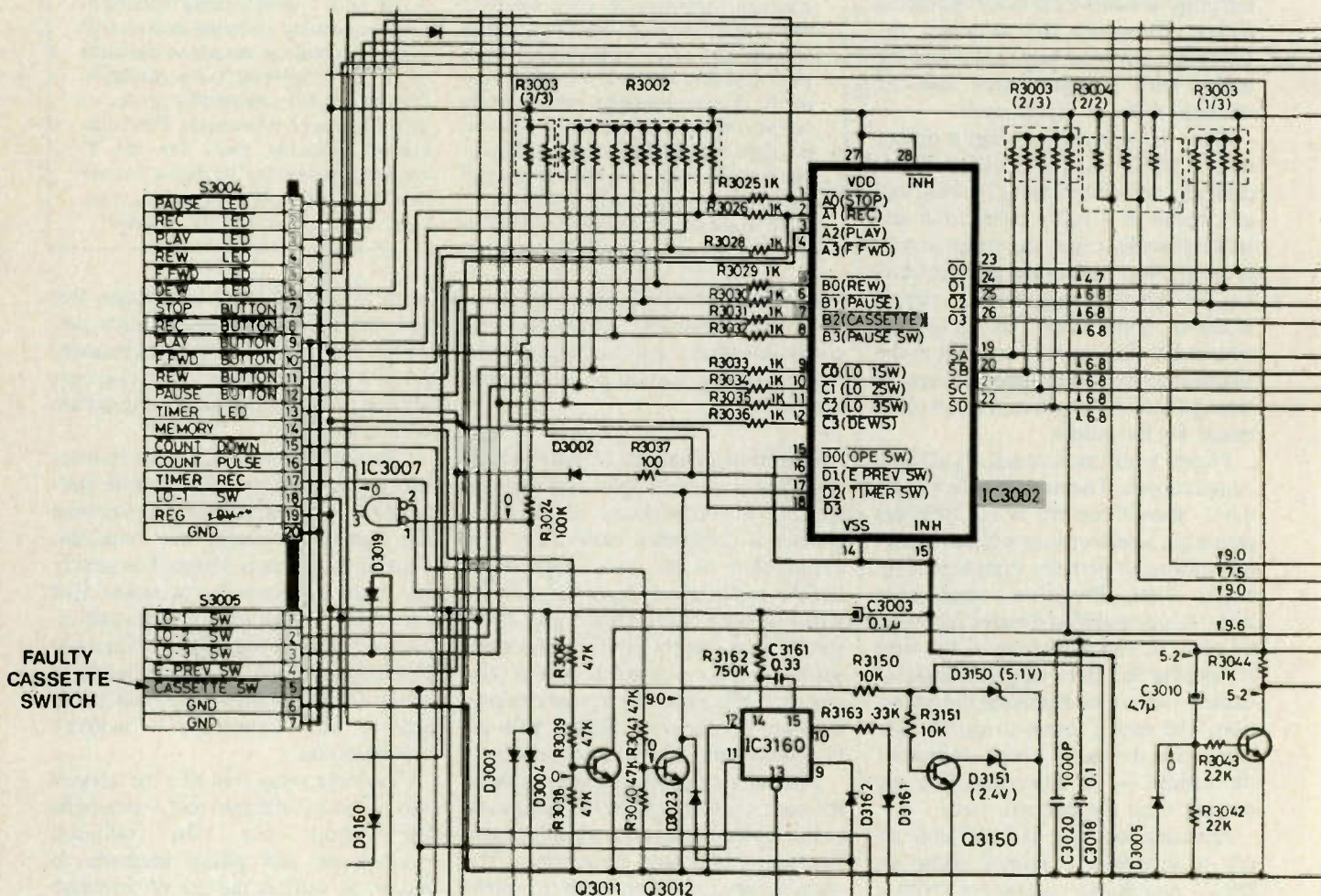

Figure 1. With a cassette in the VCR, pin 7 of IC3002 should be at a logic LOW. A faulty cassette switch in connector S3005 caused a logic HIGH.

indicated that each of the four outputs would have some activity when any of the front-panel function switches was pressed. Undoubtedly, the cause of this problem had to be a defective sensor. Looking down the row of inputs (left side of IC3002), the first sensor is the cassette switch (pin 7). With the cassette in the VCR, this pin should be at a logic LOW, as indicated by the bar above the word cassette. This pin measured logic HIGH.

Pin 7 is connected directly to the cassette-down switch via pin 5 of connector S3005. An ohmmeter check to chassis at pin 5 measured 10kΩ with the cassette in or out, indicating that the switch contacts never closed properly,

even though visually the switch was fine.

Burnishing the contacts brought this 7-year-old VCR back to life.

Wayne Smith, CET
Arden, NC

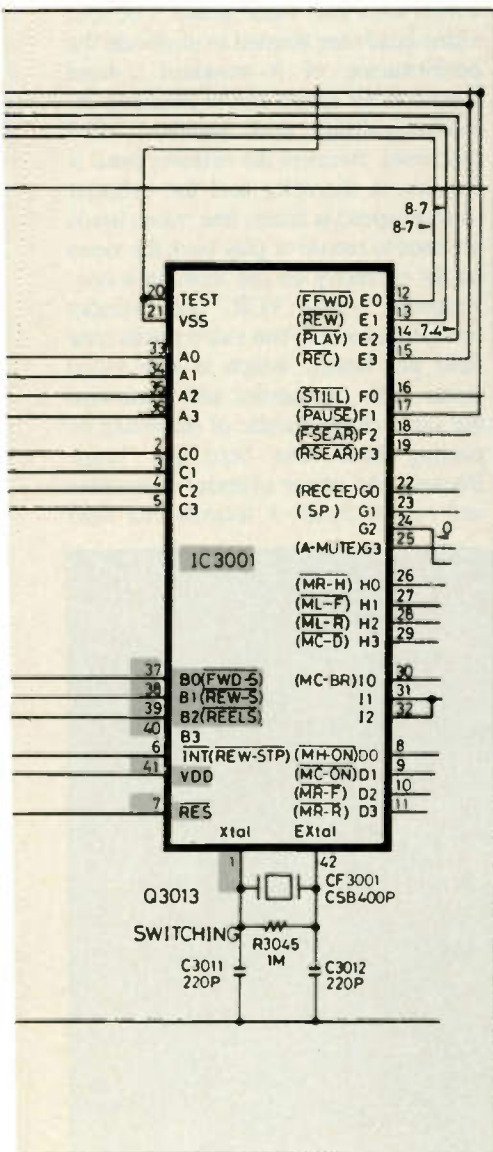

THE NEW OLD FAITHFUL.



Generations of engineers and technicians have come to depend on the reliability, accuracy and versatility of the Simpson 260 VOM.

Now Simpson introduces the new 260-8, with even more features than its predecessors. Like increased voltage measurement resolution. A mirrored scale on all units for parallax reduction. Or continuity tone for hands-free operation.

Try the Simpson 260-8. The tradition of yesterday. The features of today.

simpson

853 Dundee Ave., Elgin, IL 60120 312/697-2260 FAX: 312/697-2272

Circle (17) on Reply Card

VHS camcorder servicing

Servicing a modern, light-weight camcorder is similar in many ways to servicing a VCR. At the same time, there are many differences because a camcorder has to be portable. This article will use the RCA CLR200 ProWonder camcorder to discuss some of the similarities and differences that you will note when you open one of these units.

The tape transport mechanism

The tape transport mechanism portion of a VHS camcorder contains very similar mechanics to those of other VHS VCRs. The mechanism uses the standard-sized VHS cassette tape, so the dimensions for the cassette compartment remain the same as for other VCRs. Also, to maintain compatibility between tapes recorded with a VHS camcorder and a VHS VCR, the tape path must be the same as in a conventional VCR. Therefore, the mechanical components (the guide posts, angle posts, full-erase head, etc.) are located in about the same areas when compared to conventional VCRs.

Adapted from the RCA training manual "CLR200 ProWonder Camcorder Service Education Program" with permission of Thomson Consumer Electronics, Inc.

In order to reduce the size of the tape transport, the diameter of the headwheel cylinder assembly had to be reduced. However, to maintain compatibility with conventional VCRs, additional variations are present within the transport to compensate for the reduction of the diameter of the cylinder. In a conventional VHS VCR, the videotape is wrapped approximately half-way around the cylinder (180°). In the VHS camcorder, the videotape wrap is approximately three-quarters of the way around the upper cylinder assembly (270°). (See Figure 1.)

As mentioned previously, the greatest difference between the mechanism in the VHS camcorder and in conventional VHS recorders is the diameter of the upper cylinder assembly. To maintain compatibility with the standard VHS systems, the headwheel cylinder diameter has been reduced to two-thirds; thus the conventional upper cylinder assembly has a diameter of 62mm, whereas the camcorder upper head assembly has a diameter of 41.33mm. Because the diameter of the upper cylinder assembly is much smaller, more tape wrap must be

achieved to get the same length of tape around the surface of this smaller upper cylinder. By having the same length of tape wrapped around the cylinder, the same tape-track length is recorded on the videotape. Because the cylinder is smaller in diameter in the VHS camcorder, the rotation speed is increased from the standard 1,800rpm to 2,700rpm to maintain relative head-to-tape speed compatibility.

Another difference is that the camcorder uses four video heads. The four video heads are needed to duplicate the performance of a standard 2-head system at SP speed and to maintain interchangeability with standard VHS machines. Because the cylinder head is smaller in diameter and the cylinder rotation speed is faster, four video heads are used to record or play back the video tracks correctly on the tape. In a conventional 2-head VCR, one cylinder revolution records two video tracks (one field per head), which is one video frame. The camcorder still maintains the same characteristic of recording or playing back one field per head. Because the upper cylinder is smaller and rotates faster, it records one field

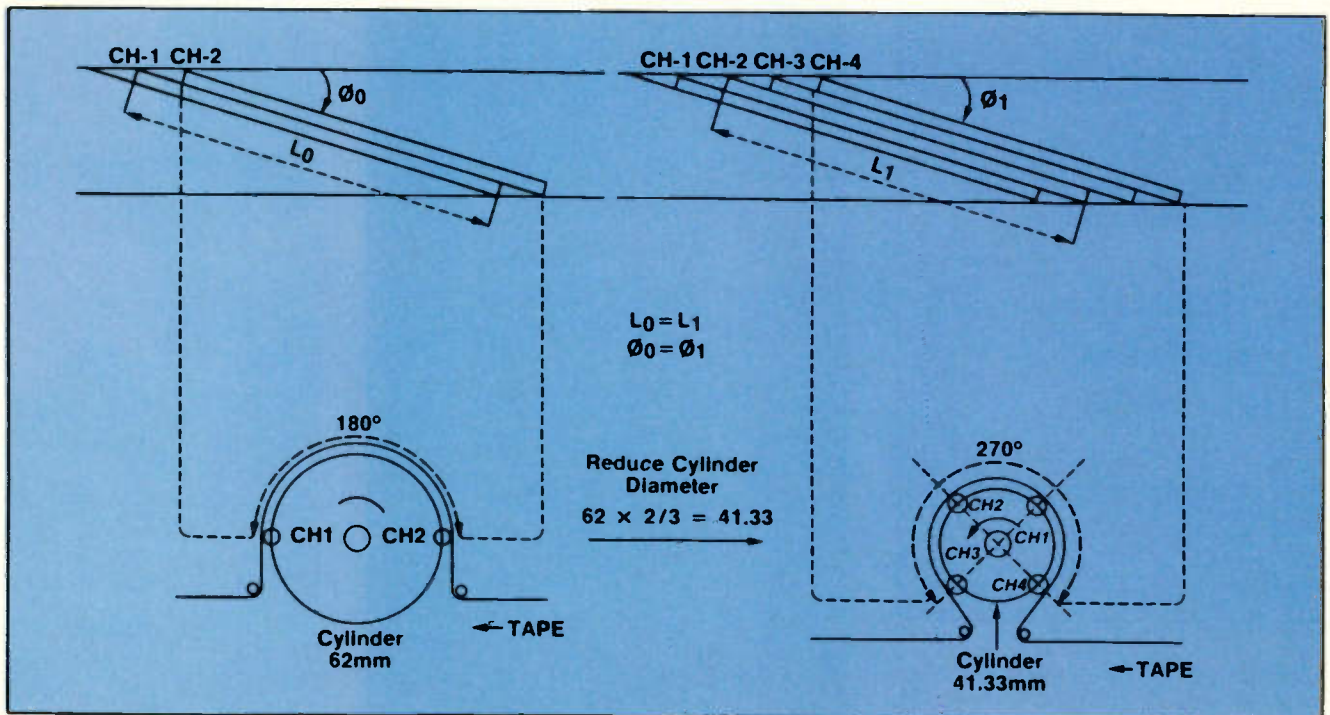

Figure 1. The head cylinder in a VHS camcorder is smaller in diameter than its counterpart in a VCR, it rotates faster, and it contains more heads. In spite of these differences, tapes recorded on a VHS camcorder are compatible with a VHS VCR and vice versa.

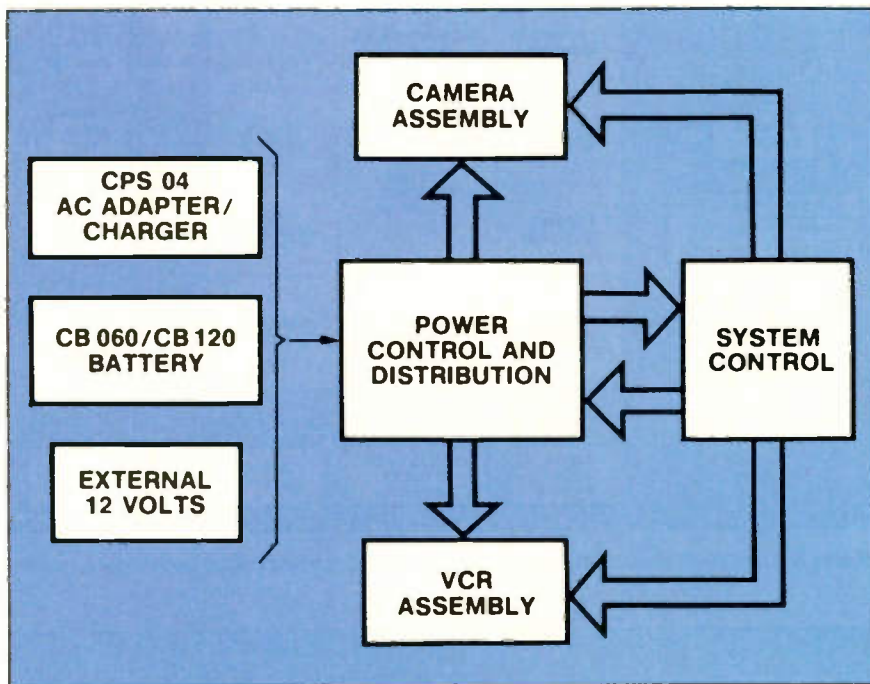

Figure 2. The VHS camcorder can be powered from one of three sources: an ac adapter/charger, its own battery or an external 12V source.

in three-quarters of a revolution or one frame (two fields) per one and a half revolutions. The resulting tracks duplicate the same path left by a standard 2-head VHS VCR during an SP recording. To prevent adjacent track pickup during playback, each video head is only turned on when it is scanning its specific field. A sophisticated headswitching scheme is used.

Remember, even though the cylinder is smaller in diameter, rotates at a faster speed and contains more video heads, the signal recorded on the tape is totally compatible with standard VHS video recorders.

The electrical systems

The electronic control of the camcorder is performed by a system-control microcomputer similar in concept to those in other VCRs. The system-control circuitry in the camcorder controls the camera assembly, the power supply and the power distribution circuitry. Operating power for the unit can be obtained from one of three sources: the ac adapter/charger, a NiCd battery or an external 12V supply. (See Figure 2.) The external 12V can be obtained from an

optional automotive dc power cord or, during servicing, from an external power supply via a servicing cable.

During servicing, if the outside case is removed from the camcorder, there is no provision to mount the ac adapter/charger. The way to get around this problem is to use a special external dc input adapter cable in conjunction with an adjustable dc power supply.

This camcorder uses three LEDs as a battery voltage-level indication system. These LEDs and associated circuitry can be checked for normal operation using the adjustable power supply at different voltage settings as specified in the servicing manual.

System control

System control for the camcorder uses a 64-pin flatpack integrated circuit, IC901, located on the bottom of the main circuit board. The system-control microcomputer controls all functions of the camcorder, including the camera and VCR operation. (See Figure 3.) Referring to the block diagram, various portions of the microcomputer control circuit areas of the camcorder's VCR and camera assemblies. The similarity

One case for all your needs . . .
files and paper, tools and parts
. . . samples and briefcase

THE 2X1

CASE SERIES FITS ALL YOUR NEEDS



With and without parts boxes, this is the fast-selling, great utility, CORDURA® CARRYING CASE SERIES. Innovative, new, designed especially for professional executives and technicians. So many features: soft handle for easy carrying, dcable/lockable zippers and pockets inside and outside; sturdy; attractive; with unique options.

Two models to purchase; one includes compartmented parts box for components, fuses, parts, etc.

Get the facts on THE 2X1 CASE SERIES from your manufacturers' sales representative or, communicate with us for informative, colorful, sales literature.



Chicago Case Co.

4446 S. Ashland Avenue, Chicago, IL 60609
(312) 927-1600 FAX: (312) 927-2820

Circle (18) on Reply Card

in the control functions of the system-control area as compared to conventional VCRs should be apparent. For example, the loading-motor control area drives the loading-motor circuitry, which mechanically engages various levers and gears to control the mechanism mode of operation. Also associated with the loading-motor system is the mode-sense switch, which is engaged by the moving mechanism. The mode-sense switch tells the system-control microcomputer the mechanism's position. As in all VCRs, there is a trouble-sensor area that monitors for a variety of troubles. If a trouble sensor is activated during VCR operation, the system control places the VCR in stop mode.

Power on/off operation

The first objective of system-control microcomputer IC901 is to control the on/off operation of the VCR/camera sections of the camcorder. B+ is applied through connector PG909-2 (see Figure

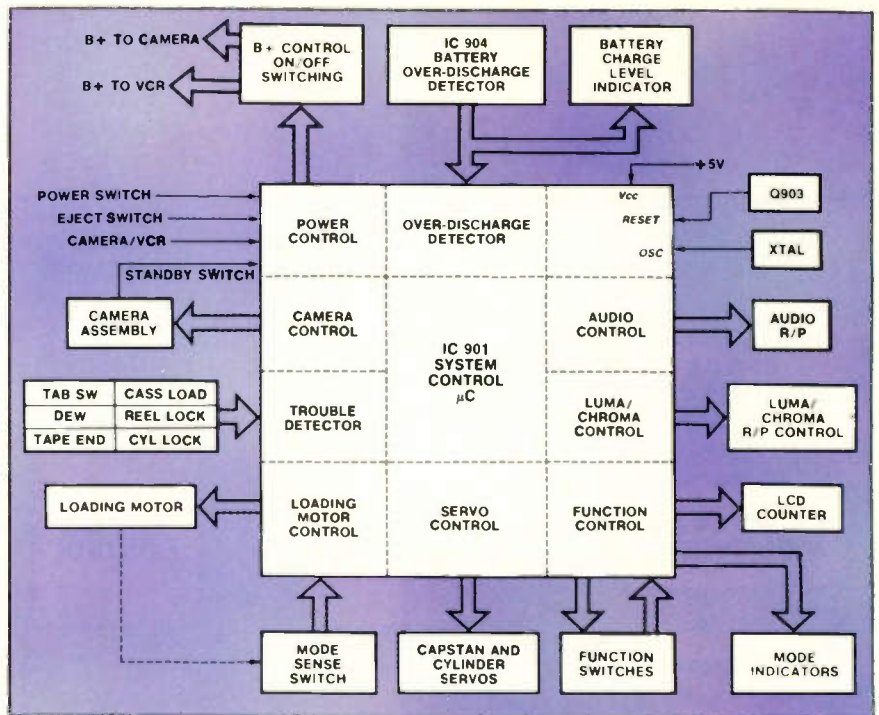

Figure 3. The system-control microcomputer controls every aspect of the camcorder's modes.

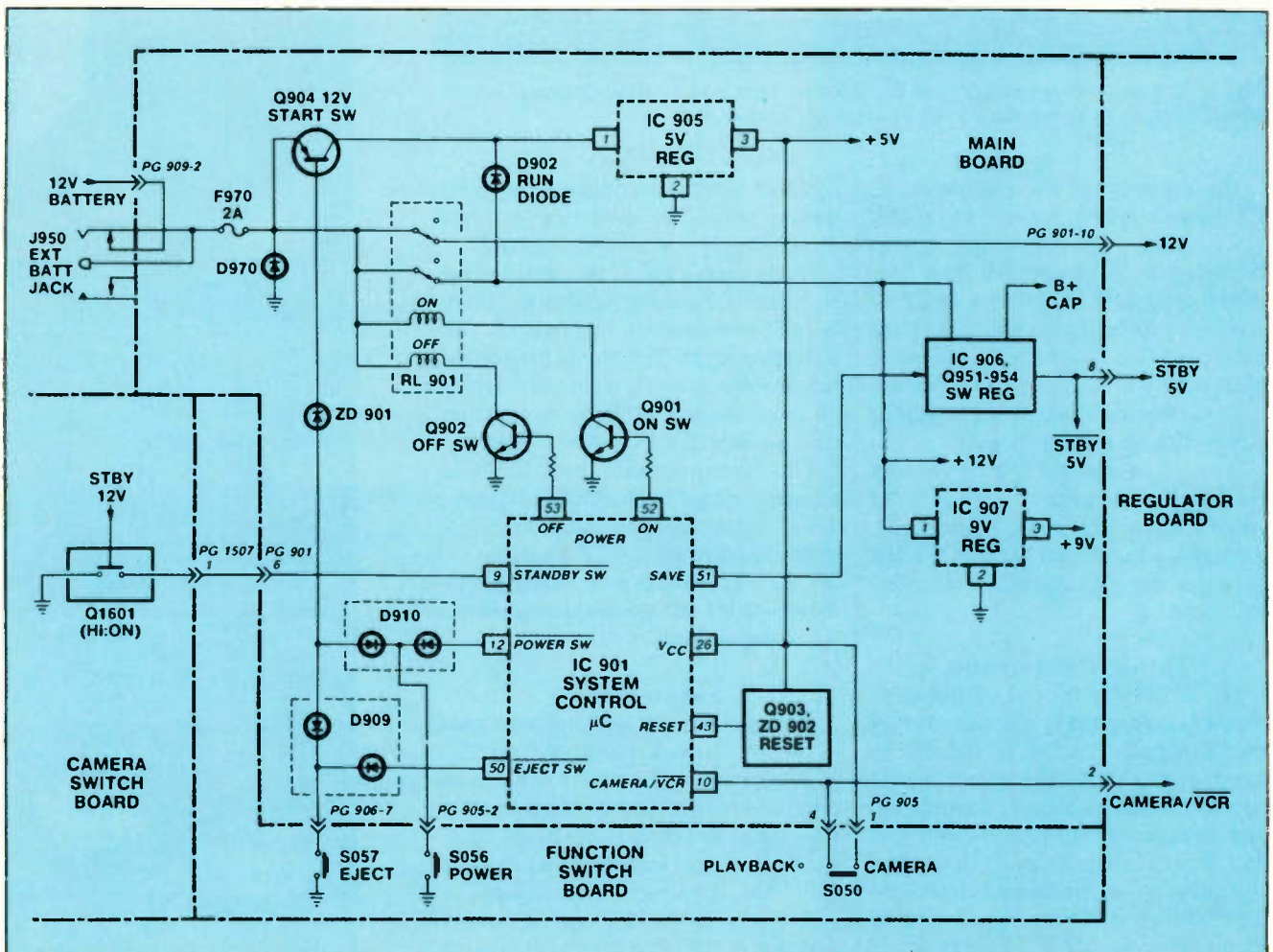

Figure 4. On/off operation on the VHS camcorder is controlled through a combination of user controls, the power source used and the system-control status.

4), from the battery contacts on the rear of the camcorder, through a switch on the external battery jack, J950, to fuse F970. The +12V is then applied to the emitter of switching transistor Q904 and latching relay RL901. Transistor Q904 is a start-up switching transistor used only when the camcorder is initially turned on. Relay RL901 contains two sets of switches along with two coils. One coil is powered momentarily to latch the contacts in the ON state, and the other coil is used to unlatch the contacts to the OFF state. A small pulse of energy is required in the appropriate ON or OFF winding to toggle the contacts open or closed for the mode desired. Using a latching relay conserves battery power during operation of the camcorder.

Pressing the front-panel power button (switch SO56) grounds the cathode of a diode within dual-diode D910. This forward-biases diode D910 and grounds the base of switching transistor Q904 through ZD901. Transistor Q904 turns on, applying 12V to the input of IC905, a 5V regulator. The 5V output of IC905, pin 3 is passed to the B+ input of IC901, pin 26 and to the reset circuitry consisting of Q903 and ZD902. With B+ and reset applied, microcomputer IC901 turns on and monitors its input pins for a mode instruction. The previously described initial start-up mode occurs fast enough that IC901 senses the logic LOW at input pin 12 caused by holding the power button in. At that time, the microcomputer realizes that power-on is requested and applies a pulse from pin 52, which turns on Q901. Transistor Q901 applies a LOW to the turn-on coil of RL901. The power-on pulse at pin 52 occurs for approximately 100 μ s, which is enough time to energize the ON winding of RL901, allowing it to latch the contacts in the ON position.

At that time, 12V supplied by RL901 to IC905 bypasses Q94 with diode D902. Also, 12V from RL901 is supplied to IC906, which is part of a switching regulator system that supplies a standby 5V to the camcorder circuitry and B+ to the capstan motor system. The 12V is also passed to IC907, a 9V regulator, which is used to power a variety of circuits in the unit.

After the power-on function is completed (unit not in record standby), the power supply provides four voltage sources: -12V, 9V, 5V and the standby 5V.

Associated with the switching

regulator is a power-save control line from IC901, pin 1. The standby/normal switch located on the side of the unit is connected to the base of transistor Q1601. When the switch is in the standby position, a logic HIGH is applied to the base of Q1601, turning on the transistor, which applies a logic LOW to IC901, pin 9. A logic LOW at IC901 pin 9 informs IC901 to save battery power in the record mode. As a result, pin 51 of IC901 goes logic HIGH, turning off the switching regulator. The VCR works normally in the playback mode (viewer/inoperable) if the camera/standby switch is in the standby position. The standby 5V line and the B+ to the capstan motor drops to zero. During the power-save mode, the +12, +9 and +5V sources are still present in the system.

Also associated with the power-on/off system is the eject system. The eject switch is wired through dual-diode D909 to also turn on transistor Q904. If the camcorder is in the OFF state and the eject button is pressed, Q904 is turned on to apply start-up B+ to 5V regulator IC905, which turns on the system-control microcomputer. At that time, IC901 senses that the eject button is held in and applies a power-on pulse to Q901, turning on the relay, applying power to the VCR system. IC901 activates the loading motor to eject the cassette. After the eject operation is completed, IC901 turns off the camcorder by applying a momentary pulse to Q902.

Associated with the input system of IC901 is playback/camera switch S050, located on the function switch board. In the camera mode, S050 applies 5V to pin 10, informing the system-control microcomputer that the camera mode is requested. IC901 then places the VCR into the record-pause mode. In the playback position, a logic LOW is applied to pin 10 of IC901, allowing for manual operation of the VCR. In the playback mode, the VCR is operated as a conventional VCR with the viewfinder as a monitor. An optional external monitor can be used via the included audio/video output cable, or a conventional TV receiver can be used via the optional RF adapter (modulator) CRF010.

Service procedures

To service a camcorder that does not turn on, substitute a known-good battery or ac adapter/charger. Next, check

ATTENTION VCR TECHNICIANS



VCR REPAIR PARTS KIT

Now you can do most of your VCR repair jobs the **same day**. Parts Express VCR Parts Kit makes this possible. It contains over 45 of the most commonly used parts to repair RCA, Hitachi, Fisher, Sanyo, Lloyds, Panasonic, Sony, Sharp, JVC, Samsung, TMK, GE, Magnavox, and more. Idler assemblies, pinch roller, sensing transistors, switches, and lamps are included in this comprehensive kit. You also save over \$20.00.

Kit contains replacements for: Sharp (2) NIDL0005, (2) NIDL0006, (1) NPLY-V0051, Panasonic (2) VXP0329, (2) VXP0401, (2) VXP0344, (2) VXP0521, RCA (1) 150614, (1) 164113, (1) 150650, Hitachi (1) 641311, Fisher/Sanyo, (1) 143-0-4204-00300, (2) 143-0-4804-00100, (1) 143-0-4904-00900, (1) 143-0-741T-20002, RCA/Hitachi (2) up/down switch, (5) 161757 sensing transistors, Panasonic lamps (2) XAMQ27P150W, (5) XAMV0019, (5) XAM125, (1) Molybdenum grease. Normal dealer cost of over \$110.00 (All parts are available individually for reorders.)

Order #
400-950

\$8995

Plus shipping



VCR IDLER TIRE KIT

This popular kit contains 150 of the most popular idler tires (10 each of 15 different sizes). With this kit in your stock room, you can do over 90% of VCR repair jobs the same day, saving time and money! Also included is our comprehensive cross reference listing over 80 manufacturers' assembly numbers and over 200 model numbers. A \$400.00 retail value. (All tires are available individually for reorders.)

Order #
400-900

\$5500

Plus shipping

**FREE
CATALOG**



**Parts
Express**
International Inc.

CALL TOLL FREE

1-800-338-0531

340 E. First St., Dayton OH 45402
Local—1-513-222-0173

Circle (19) on Reply Card

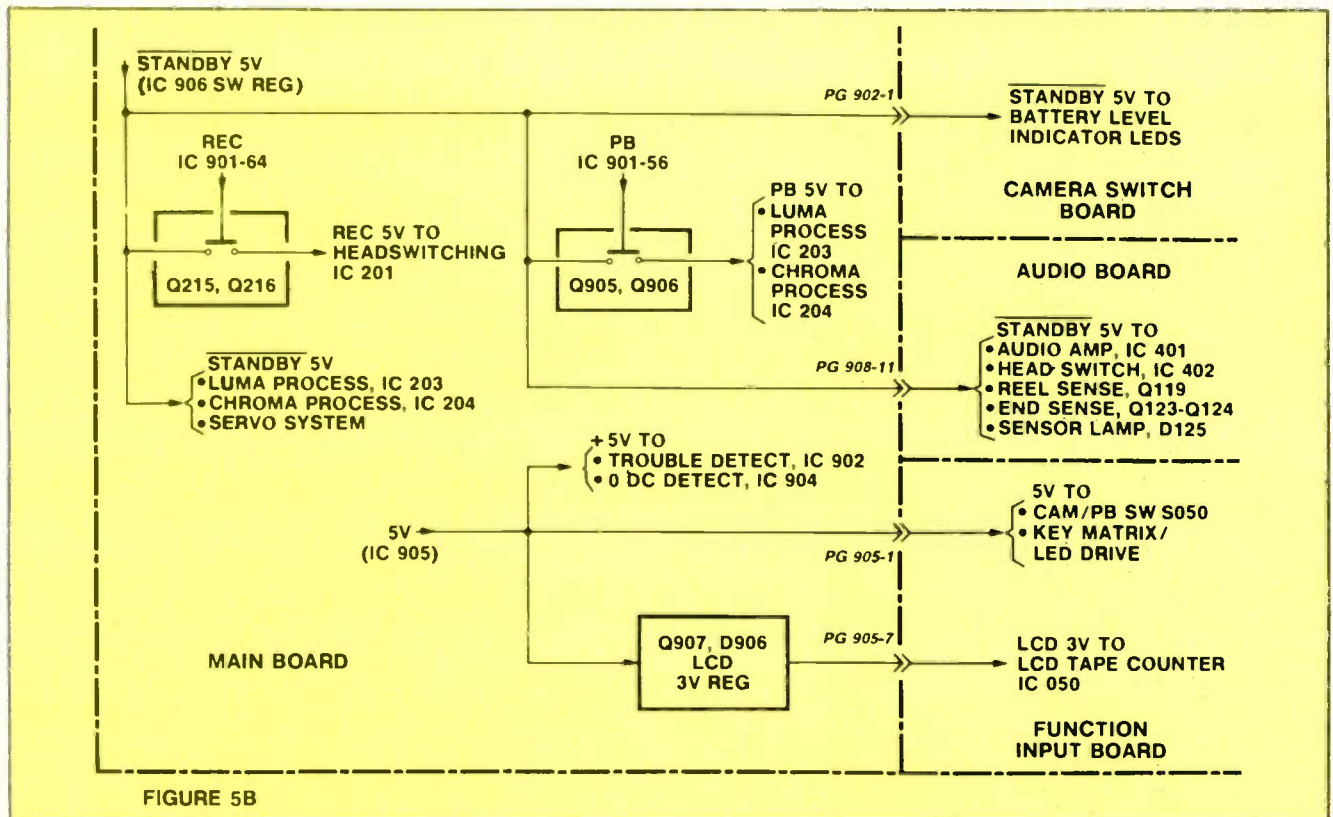
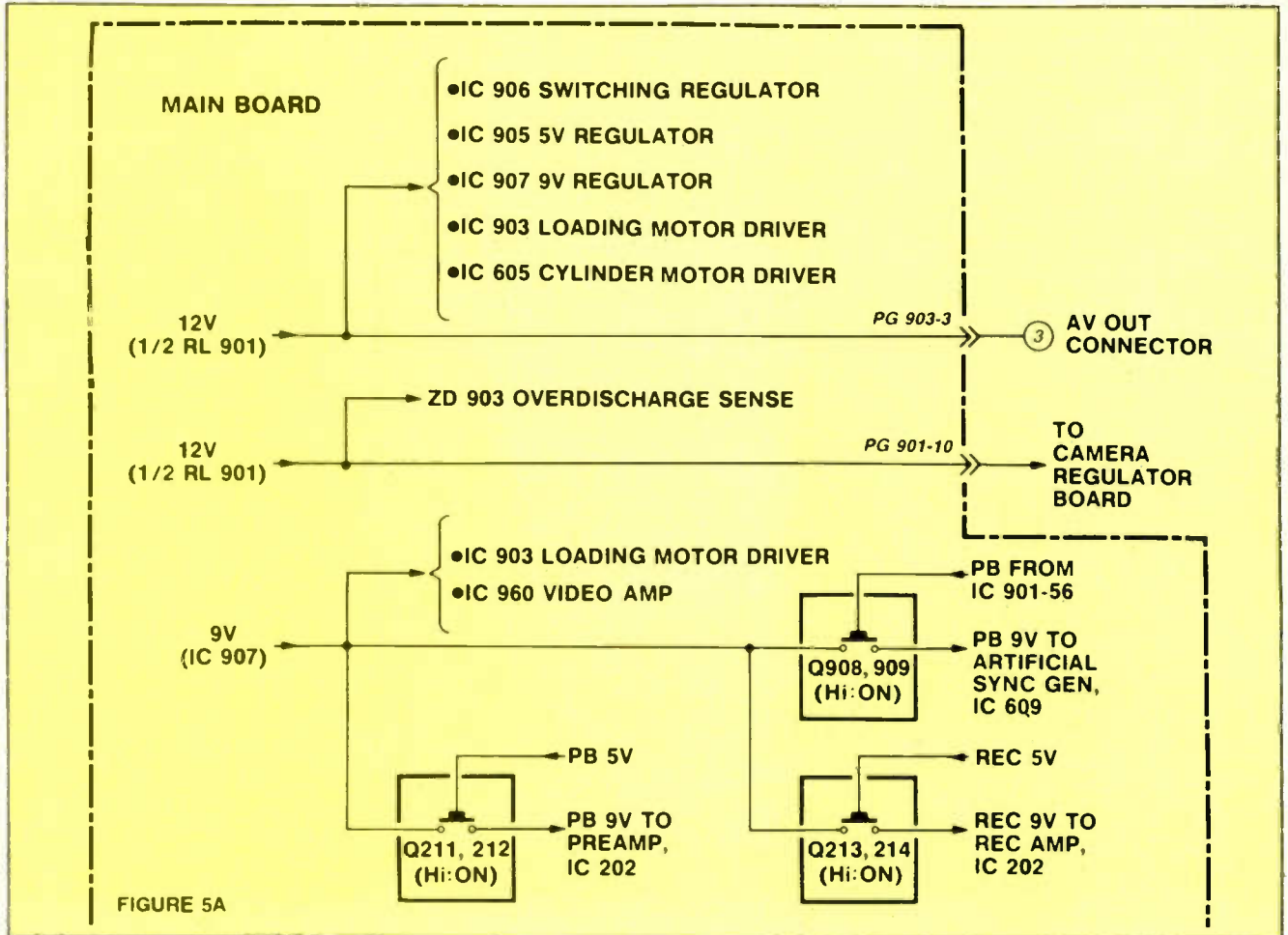

Figure 5. The power distribution diagram for the VHS camcorder.

fuse F970. If it is open, suspect D970, IC905, IC906, IC907 or the motor-drive integrated circuits.

If power is present on both sides of the fuse, confirm the B+ input at IC905, pin 1 when the power button is held in. If the B+ is missing, suspect the power switch, D910, ZD901 or transistor Q904. If B+ is present, check for +5V at pin 3 of IC905. If the 5V is missing, suspect IC905. If it's present, monitor for the generation of a turn-on pulse at the base of Q901. If you don't find this turn-on pulse, suspect a defective reset system associated with Q903 or ZD902, or suspect IC901. If this pulse is present, confirm the operation of Q901 to turn on RL901. If 12V is not present at the anode of D902, suspect a defective Q901 or RL901, or a leaky Q902.

If B+ is present at the anode of D902, confirm the presence of the standby 5V at pin 8 of connector PG901. If this voltage is missing, suspect switching regulator IC906 and/or associated transistors. Also confirm that the output at pin 51 of IC901 is a logic LOW. If this logic level is HIGH, suspect incorrect

position of the standby/normal switch or a defective Q1601 or IC901. Check for +9V at IC907 pin 3. If that voltage is missing, suspect IC907. Also check the battery over-discharge circuitry. Figure 5 is a power-distribution drawing indicating the routing of the +12V, 9V, +5V and the standby +5V to different areas of the camcorder. These four power-supply voltages are passed through a variety of B+ switch transistors to power different circuit areas under different modes of operation. These drawings are for reference only. Always refer to the manufacturer's service data for exact information on circuit areas.

Function switch input operation

The VCR portion of the camcorder uses a keyboard input matrix system that is applied to matrix input pins 18, 19 and 20 of system-control microcomputer IC901. (See Figure 6.) Clock output pulses, phase 0 and phase 1 from pins 35 and 36 are applied through diodes D050 and D051 to the keyboard input matrix circuit. This matrix system operates when the clock pulses are ac-

tive LOW. The VCR control system also monitors various inputs from the camera-mode switches, such as the stop/start switch, S1604, which is applied to pin 48 of IC901. An external record remote switch also can be used when connected through connector J101

Because of the extremely small size of these units, you will encounter components so small that they can barely be seen.

to pin 48. A LOW signal input to pin 48 of IC901 from either the stop/start switch on the side of the camcorder or from the external stop/start switch toggles the camcorder from record-pause to record mode or vice versa.

There is another input from the front-panel review button, S1603 to pin 49 of

MSC Spring Training Sale!

Training Publications and Videotapes for Video Cameras and Camcorders

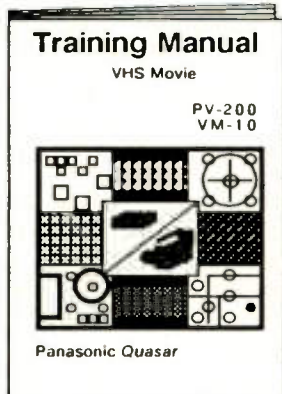

Matsushita Services Company

... Service is our middle name!

Matsushita Services Company TAS/Publications 2B-6
50 Meadowland Parkway Secaucus, N.J. 07094

Panasonic Technics Quasar

Division of Matsushita Electric Corporation of America

- TRAINING PUBLICATIONS**
- VC-01 Video Cameras Theory and Servicing .. \$19.95
 - TM-52 PV-200 Camcorder Training Manual .. \$19.95

- TRAINING VIDEOTAPES**
- TT-V39 What is a Color Camera? \$39.95
 - TT-V42 What is a VHS Movie? \$39.95
 - TT-V43 What is a CCD VHS Movie? \$39.95

- Please send me all five at the special price of **\$119.75**, a savings of \$40.00 over the regular price of \$159.75.
- Please send my free copy of your latest Training Materials Catalog.

SHIPPING CHARGES: Total Amount _____

Under \$40.00...\$3.00 Tax (if applicable) _____

\$40.01 ~ \$80.00...\$6.00 Shipping & Handling _____

\$80.01 & Up...\$9.00 Total Enclosed _____
(Check or Money Order Only)

Name _____ Company _____

Address _____

City _____ State _____ Zip _____

New Jersey residents please add 6% N.J. state sales tax.
Sale ends June 30, 1989

Circle (20) on Reply Card

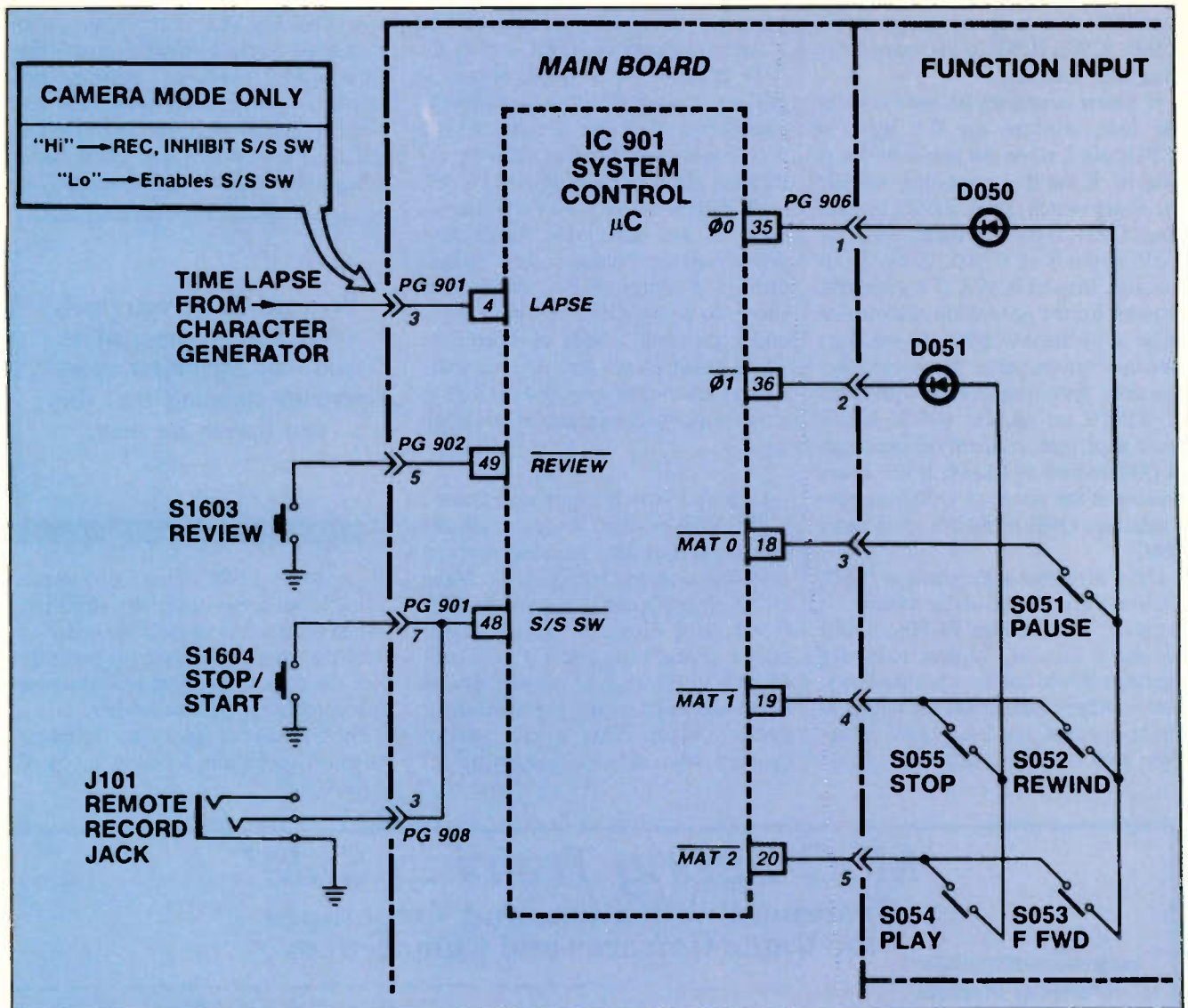

Figure 6. In a scheme similar to that used in VHS VCRs, the camcorder function switches are matrixed to provide more input functions than there are input pins on the system-control microcomputer.

IC901. When the review button is pressed, the system-control microcomputer places the VCR into reverse-playback for 4 seconds, forward-playback for 4 seconds, and then returns back to the record-pause mode. An additional input to the system-control microcomputer is from an optional character generator (CCG020), which controls the record period of the camcorder via the lapse input at IC901, pin 4.

In the camera mode, if a LOW is passed into pin 4 of microcomputer IC901, the VCR operates normally via the start/stop switch. If time-lapse control is performed via the external character generator, the VCR goes to record upon receiving a logic HIGH from the character generator. When the logic HIGH is applied to IC901, the stop/start input at IC901, pin 48 is in-

hibited. After the preprogrammed record period ends, the character generator pulls pin 4 logic LOW. Pin 4 is held logic LOW during the wait period of the recording. At this time the stop/start switch function is enabled if needed.

Service procedures

If a malfunction exists with the function-input mode operation, first confirm the presence of the clock signals at pins 35 and 36 of IC901. (See Figure 6.) If they are present, check for the operation of each of the function switches of the VCR key input matrix system by monitoring for the presence of the phase pulses at input pins 18, 19 or 20 when the appropriate function button is pressed.

Confirm the operation of the camera-

mode buttons, the remote stop/start button, the attached start/stop button, the review switch and, if available, the input port for the character generator input, which is applied to pin 4 of IC901 via PG901-3.

Approaching camcorder servicing

The many similarities between VCRs and camcorders should lend a degree of familiarity to VCR servicers who wish to branch out into camcorders. There are a number of considerable differences, though, so it's important to study the manufacturer's service data for the particular unit you plan to work on. You also should be aware that, because of the extremely small size of these units, you will encounter components so small that they can barely be seen. Patience and a steady hand are a necessity. **ES&T**

GENERAL ELECTRIC CTC136 DEFLECTION AND POWER SUPPLY SCHEMATIC

Product safety should be considered when component replacement is made in any area of an electronics product. A star next to a component symbol number designates components in which safety is of special significance. It is recommended that only ex-

act cataloged parts be used for replacement of these components. Use of substitute replacement parts that do not have the same safety characteristics as recommended in factory service information may create shock, fire, excessive x-radiation or other hazards.

This schematic is for the use of qualified technicians only. This instrument contains no user-serviceable parts.

The other portions of this schematic may be found on other Profax pages.

- SCHEMATIC NOTES:
1. ALL CAPACITORS ARE 50V, EXCEPT WHERE INDICATED.
 2. ALL RESISTORS ARE 1/4W 5%, EXCEPT WHERE INDICATED.
 3. CAPACITANCE VALUES 1.0 AND ABOVE ARE IN μF , CAPACITANCE VALUES BELOW 1.0 ARE IN pF , EXCEPT WHERE INDICATED.
 4. RESISTANCE VALUES ARE IN OHMS, K = X 1000.
 5. \perp DENOTES CHASSIS GROUND.
 6. VOLTAGES MEASURED WITH SIGNAL APPLIED, AND SHOULD HOLD WITHIN 10%.
 7. WAVEFORMS TAKEN WITH KEYS RAINBOW SIGNAL APPLIED, EXCEPT WHERE NOTED.

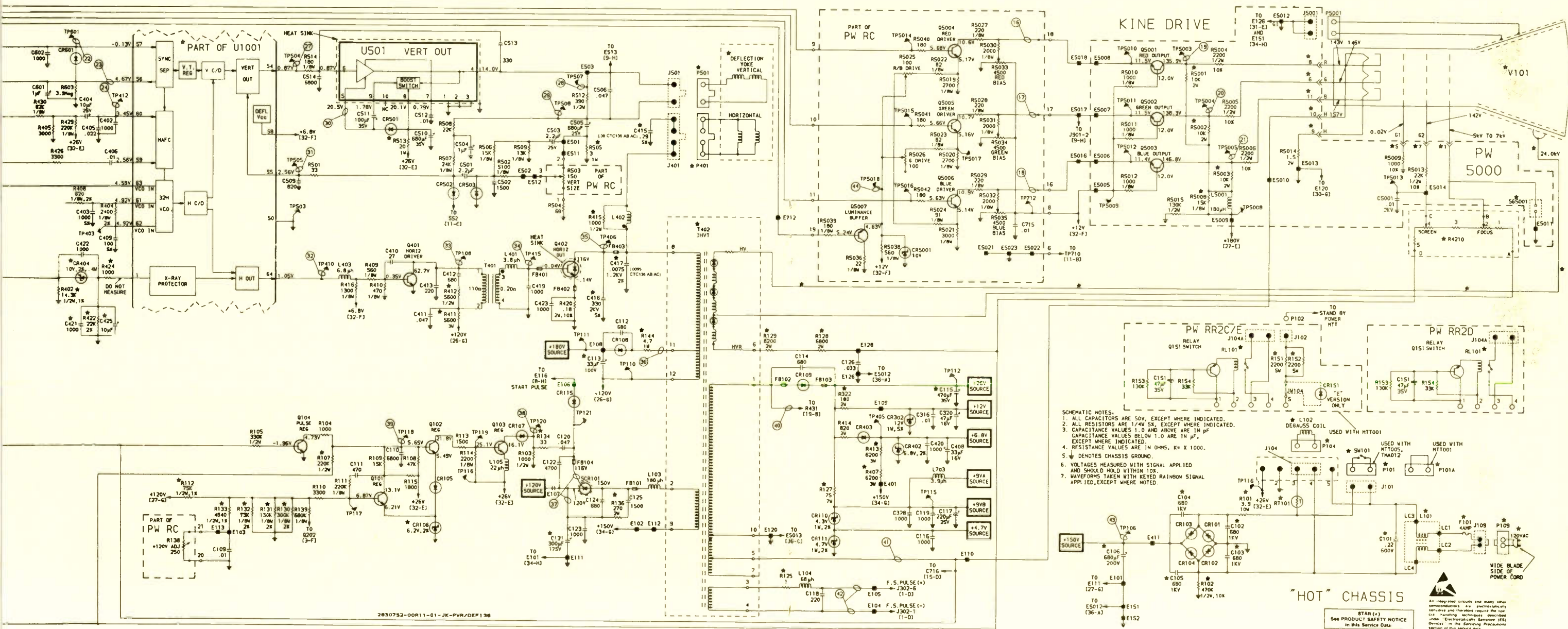

2830752-00R11-01-JK-PWR/DEF138

"HOT" CHASSIS
STAR (*)
See PRODUCT SAFETY NOTICE
in this Service Data

All integrated circuits and many other semiconductor components are polarity-sensitive and therefore require the correct handling techniques described under "Electrostatic Sensitivity (ES) Devices" in the Servicing Procedures section of this service data.

GENERAL ELECTRIC CTC136 SIGNAL CIRCUIT SCHEMATIC

Product safety should be considered when component replacement is made in any area of an electronics product. A star next to a component symbol number designates components in which safety is of special significance. It is recommended that only exact cataloged parts be used for replacement of these components. Use of substitute replacement parts that do not have the same safety characteristics as recommended in fac-

tory service information may create shock, fire, excessive x-radiation or other hazards.

This schematic is for the use of qualified technicians only. This instrument contains no user-serviceable parts.

The other portions of this schematic may be found on other Profax pages.

Product safety should be considered when component replacement is made in any area of an electronics product. A star next to a component symbol number designates components in which safety is of special significance. It is recommended that only exact cataloged parts be used for replacement of these components. Use of substitute replacement parts that do not have the same safety characteristics as recommended in fac-

tory service information may create shock, fire, excessive x-radiation or other hazards.

This schematic is for the use of qualified technicians only. This instrument contains no user-serviceable parts.

The other portions of this schematic may be found on other Profax pages.

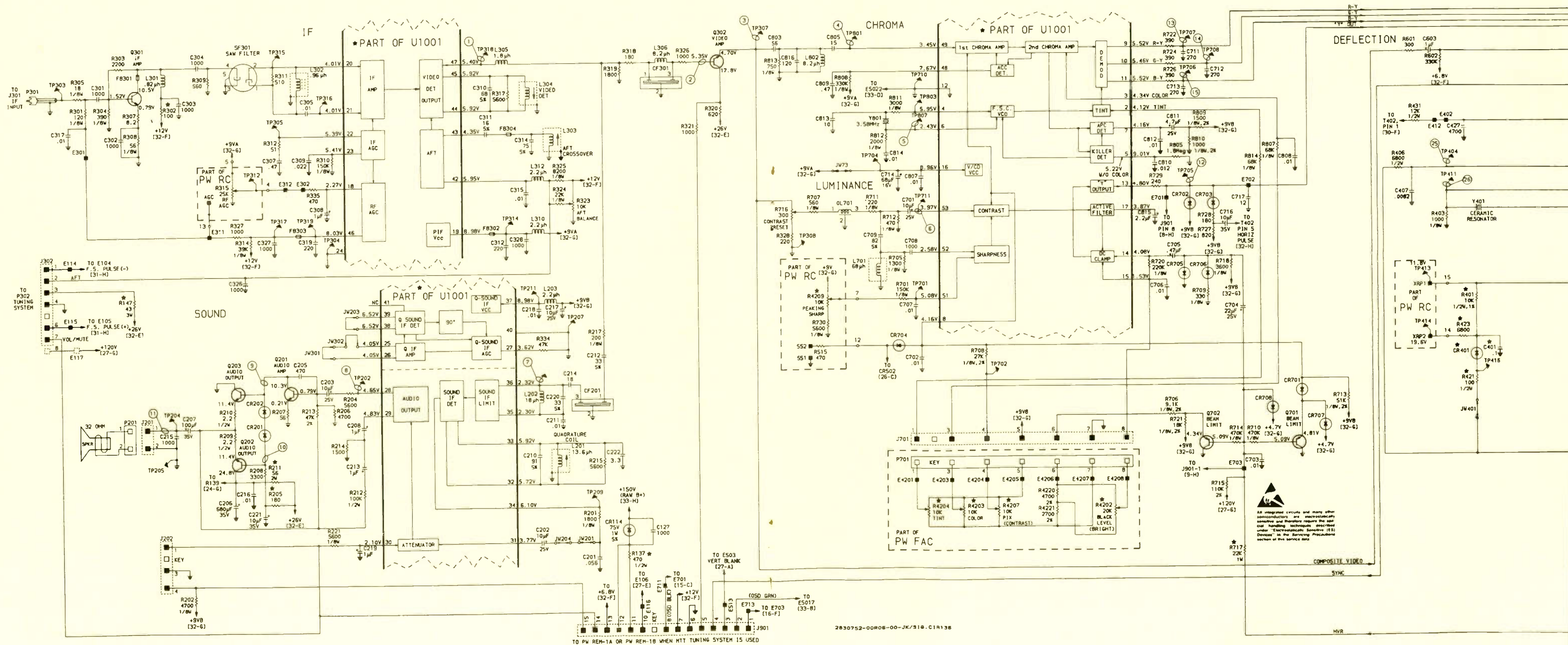

ZENITH CM-140/B-3(1) BASIC CIRCUIT DIAGRAM

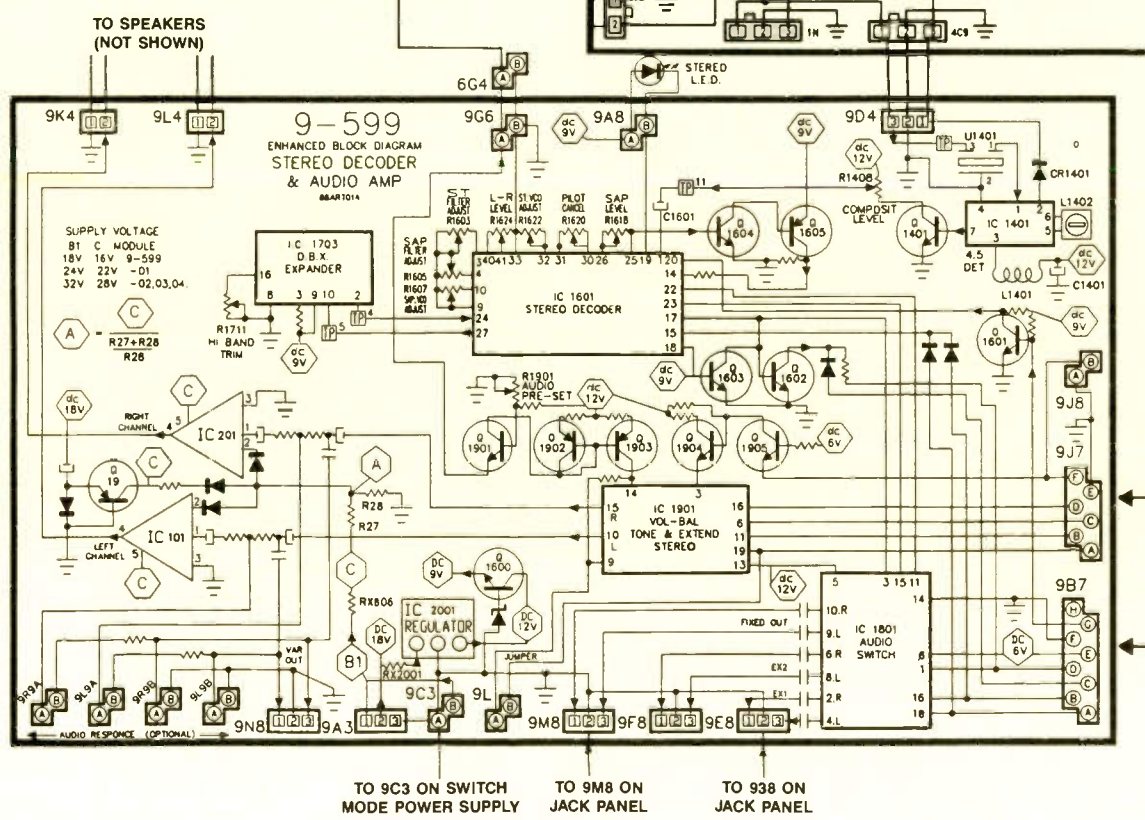
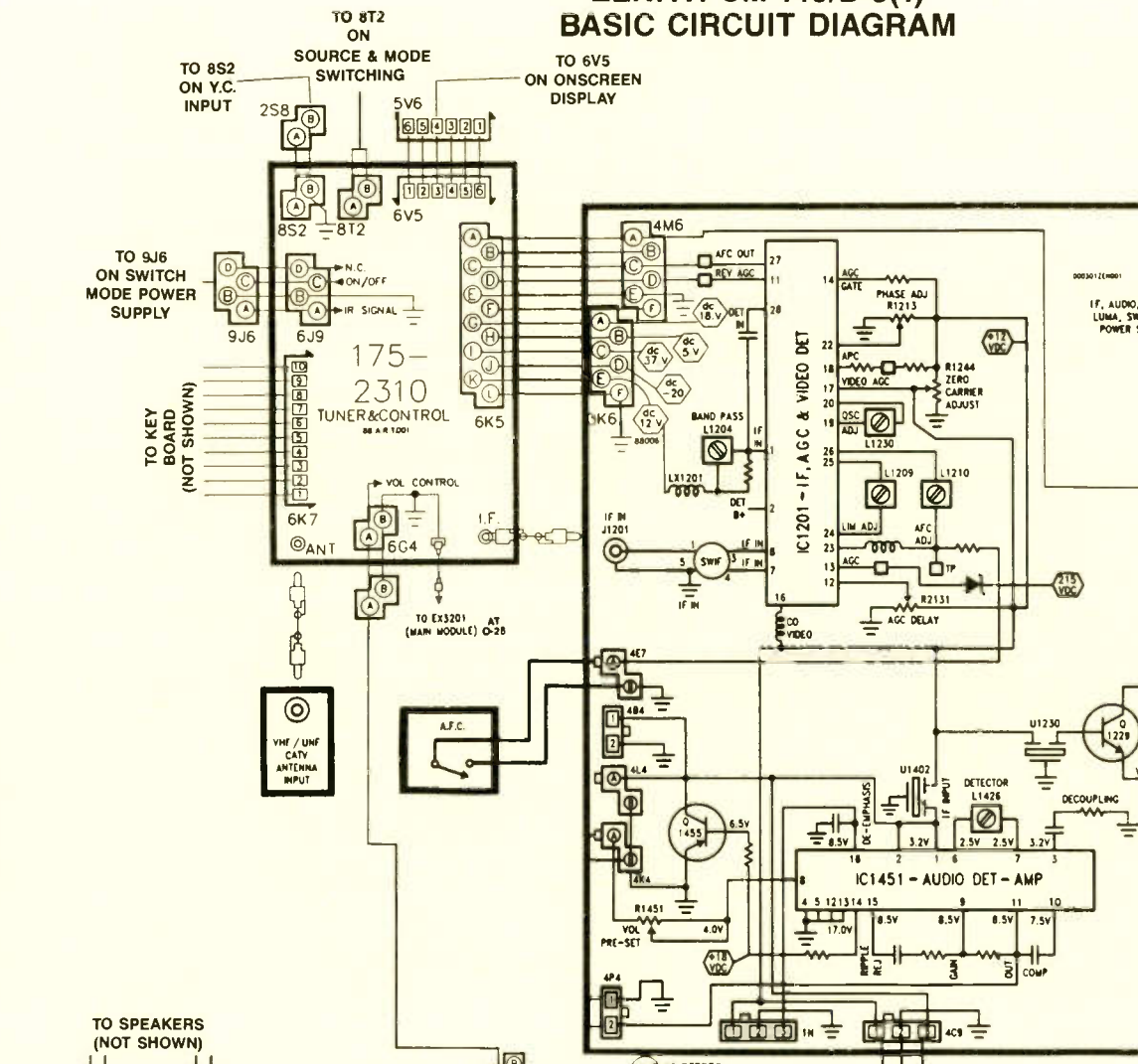

ZENITH CM-140/B-3(1) BASIC CIRCUIT DIAGRAM

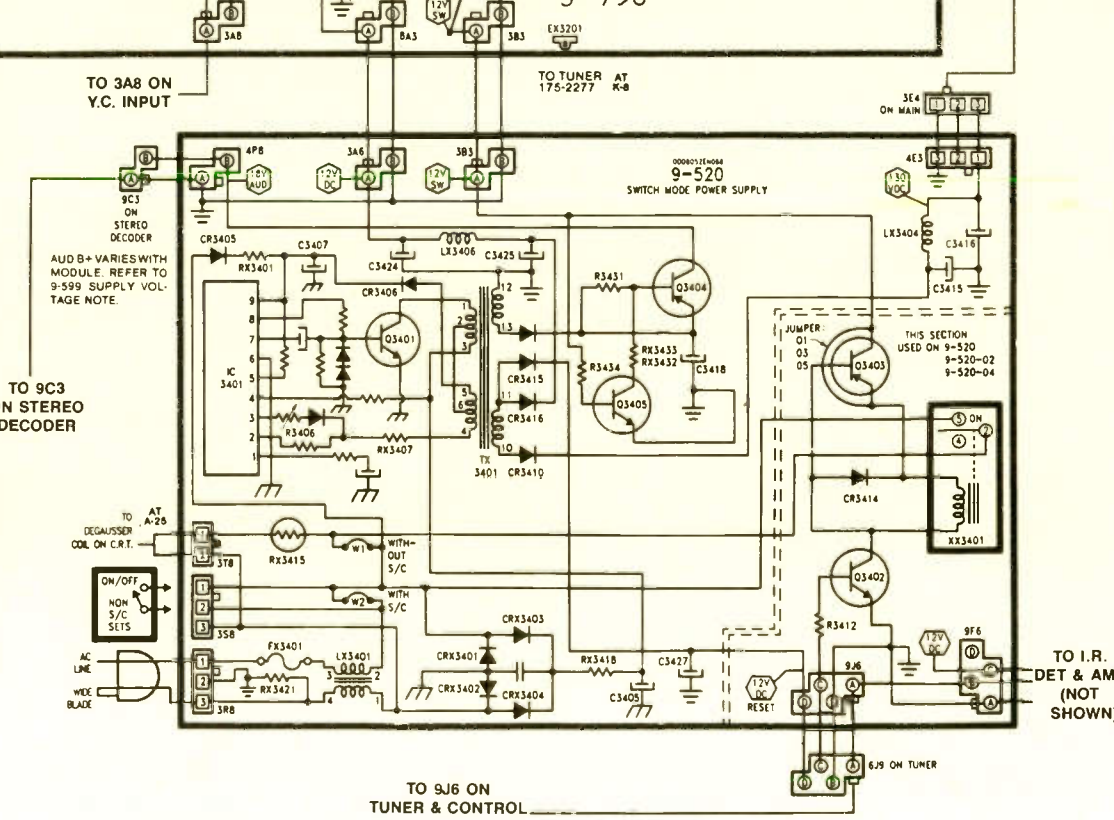
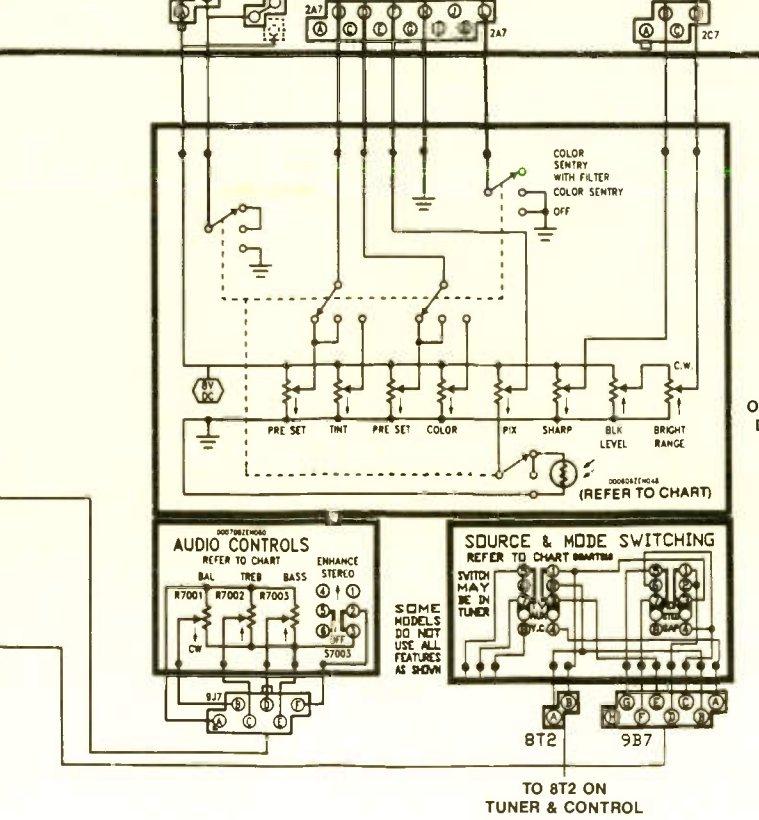
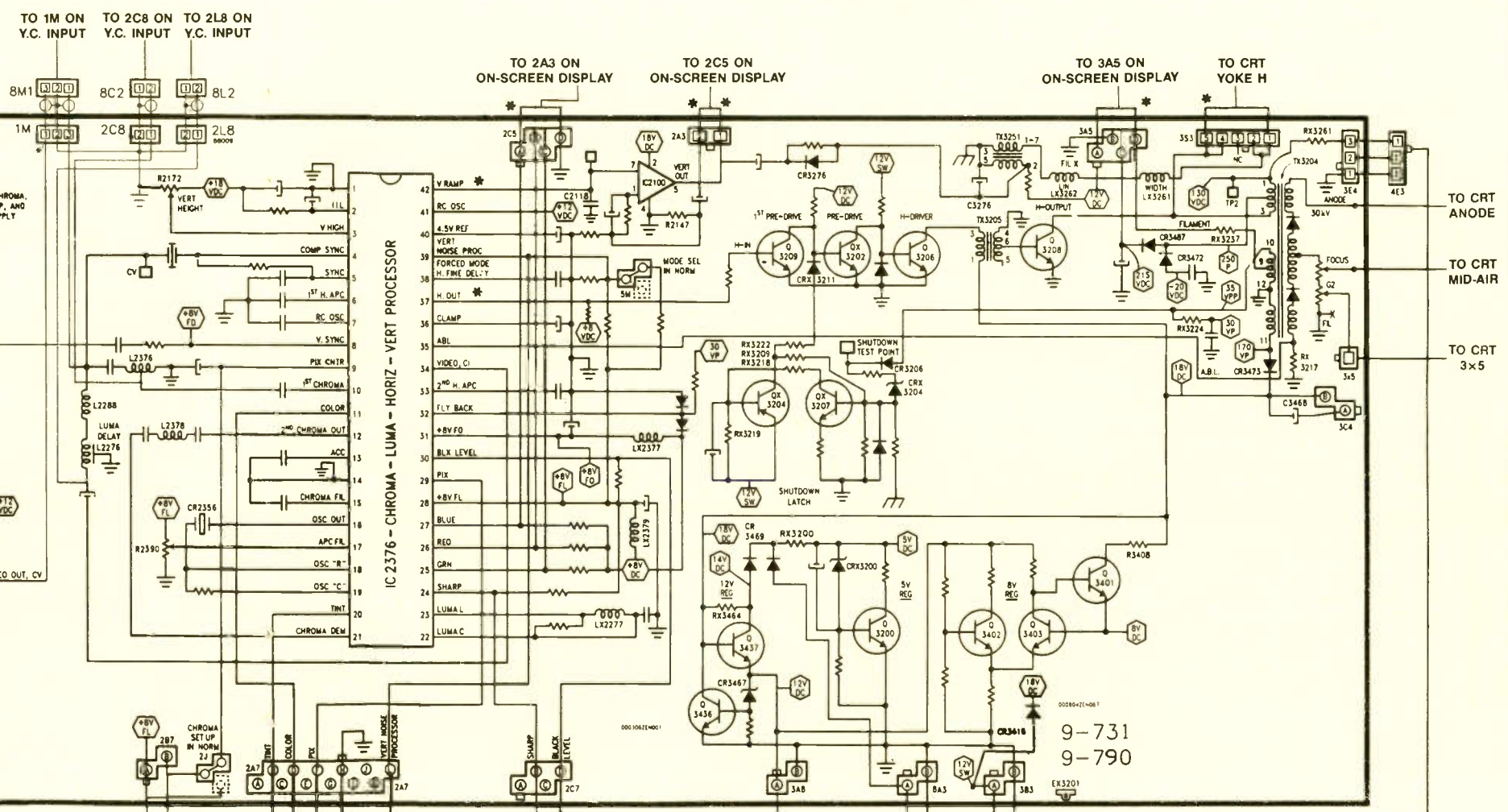

ZENITH CM-140/B-3(1) Y.C. INPUT/COMB FILTER/VIDEO SWITCHING CIRCUIT DIAGRAM

Product safety should be considered when component replacement is made in any area of a receiver. An exclamation point on the schematic diagram designates the components in which safety is of special significance. It is recommended that only exact cataloged parts be used for replacement of these components.

Use of substitute parts that do not have the same safety characteristics as recommended in factory service information may create shock, fire, excessive x-radiation or other hazards.

The lightning flash with arrowhead symbol is intended to alert the service personnel to the

presence of uninsulated "dangerous voltage" that may be of sufficient magnitude to constitute a risk of electric shock.

This schematic is for the use of qualified technicians only. This instrument contains no user-serviceable parts.

ZENITH CM-140/B-3(1) VIDEO OUTPUT/ON-SCREEN DISPLAY CIRCUIT DIAGRAM

Product safety should be considered when component replacement is made in any area of a receiver. An exclamation point on the schematic diagram designates the components in which safety is of special significance. It is recommended that only exact cataloged parts be used for replacement of these components.

Use of substitute parts that do not have the same safety characteristics as recommended in factory service information may create shock, fire, excessive x-radiation or other hazards.

The lightning flash with arrowhead symbol is intended to alert the service personnel to the

presence of uninsulated "dangerous voltage" that may be of sufficient magnitude to constitute a risk of electric shock.

This schematic is for the use of qualified technicians only. This instrument contains no user-serviceable parts.

SYSTEM DIAGRAM

A system diagram is a hybrid troubleshooting aid consisting of a functional block diagram and simplified module schematics. It provides an overview for tracing major circuits and includes these features: key voltages, the make-up of individual cables, all connections between modules and assemblies, major components and the main lines of interaction related to these components.

The intention of the system diagram is to provide sufficient information to analyze the TV as a system for determining which major component is faulty. For complete module and assembly schematics, refer to the appropriate service manual.

*WAVE FORMS (AT PIN-OUT ADDRESS)

- AC GROUND
- DC GROUND
- TO DC VOLTAGES
- DC VOLTAGE SOURCE

FD = FILTERED DIGITAL
FL = FILTERED LINEAR

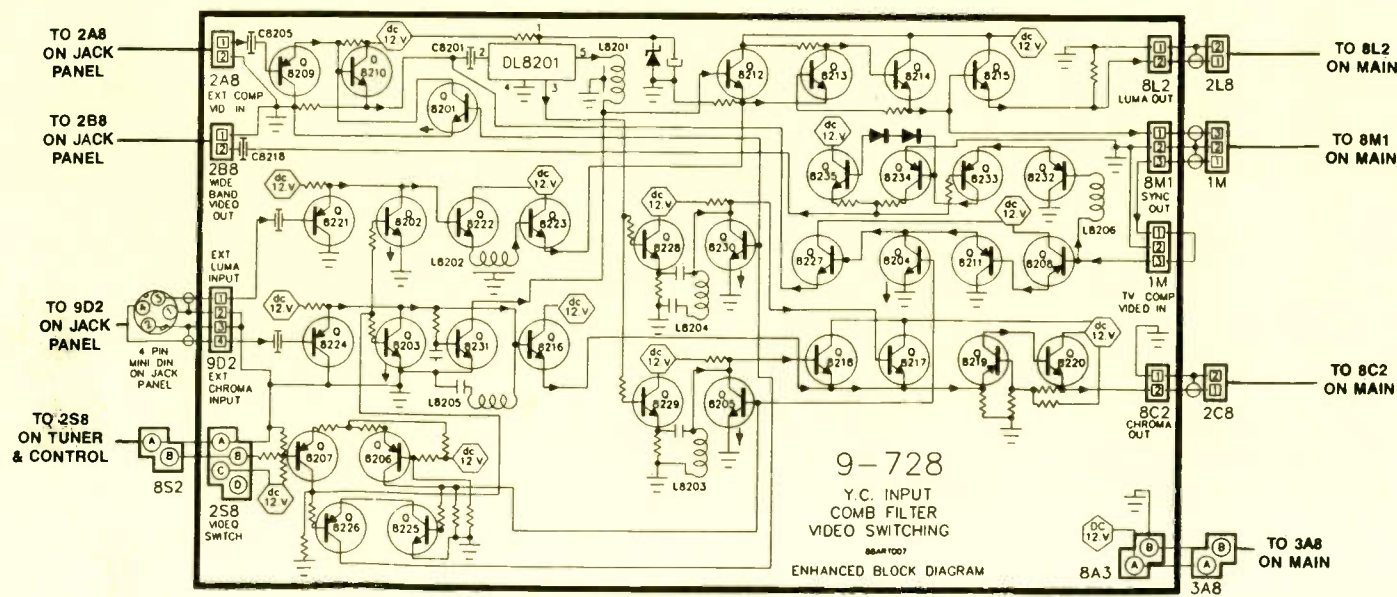
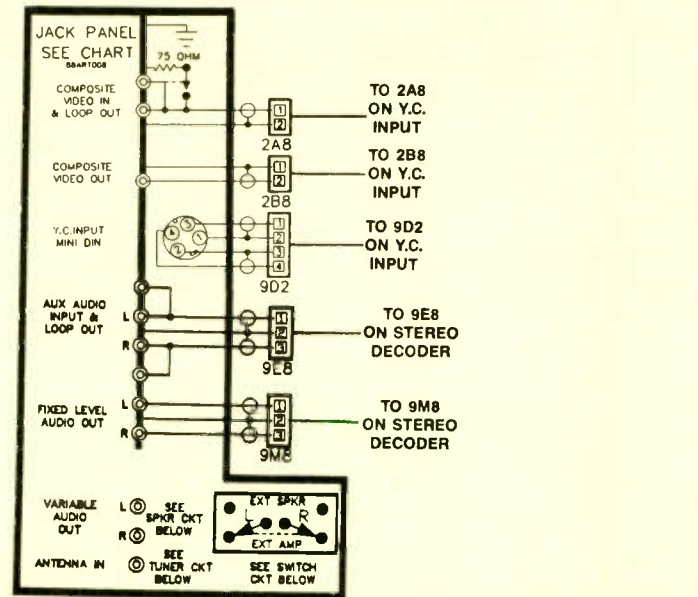

The other portions of this schematic may be found on other Profax pages.

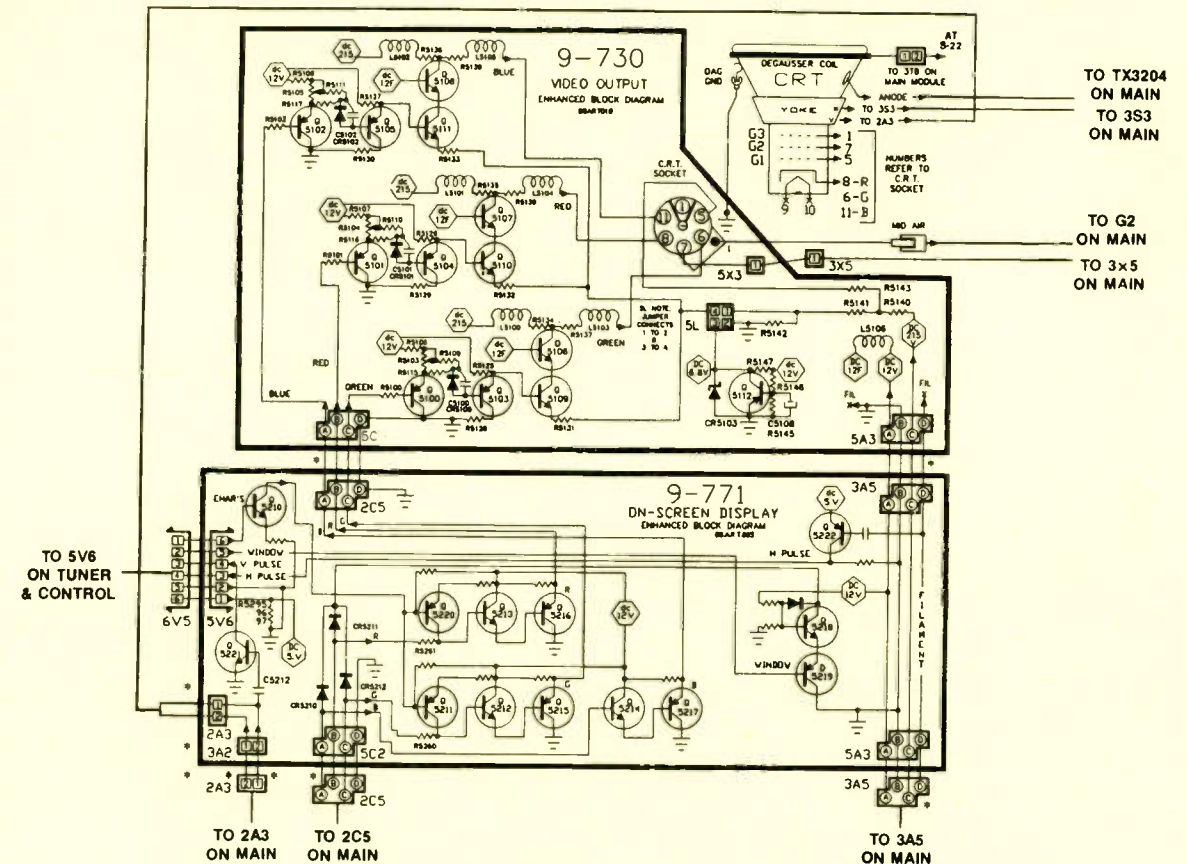

The other portions of this schematic may be found on other Profax pages.

Electronic workbench catalog

A 32-page catalog of electronic workbench products is now available from *Desco Industries*. The catalog includes hand tools, continuity testers and static control products.

Circle (130) on Reply Card

Product catalog

Vector Electronic's full-line catalog is now available. The 102-page catalog is organized to match the selection process of prototyping products, and is complete with all necessary specifications and a selector guide. Parts that are designed for use with each other are referenced throughout the catalog to follow cross-indexing.

Circle (131) on Reply Card

Fiber optics article

Intelco is offering a copy of a technical article titled "Fiber Optics Test: Tools of the Trade." The article summarizes the current state of the fiber-optic test industry and anticipates developments on the immediate horizon. The article is designed to teach readers the advantages and disadvantages of currently available equipment.

Circle (132) on Reply Card

Tool catalog supplement

Tools, tool kits and test equipment are detailed in a 96-page catalog supplement offered by *Jensen Tools*. The catalog introduces new diagnostic software and other field service systems, plus the latest additions to Jensen's tool kits. Other categories cover tools and equipment for fiber optics and wire cable systems, precision instruments for SMT and other technologies, soldering supplies, static control, cleaning products, lighting and optical aids, work-holding devices, a selection of cases and shipping containers and more.

Circle (133) on Reply Card

Test and instrumentation catalog

U.S. Instrument Rentals has published its 1989/1990 product guide, a hard-bound guide that covers 5,000 models from more than 170 manufacturers. Included in the catalog are analyzers, CAE/CAD equipment, generators, meters, recorders, scopes, signal modifiers, microcomputers and general telecommunications test equipment.

Circle (134) on Reply Card

Adhesive selector guide

Master Bond is offering an application selector guide on surface-mount adhesives. The guide describes 1- and 2-component systems and lists viscosity, specific gravity, lap shear strength, volume resistivity, service operating temperature range, cure speed and shelf life for each adhesive.

Circle (135) on Reply Card

Field service catalog

Huntron has published its "1989 Field Service Solutions" catalog, featuring the company's Tracker 5100DS. The catalog also includes information on the Tracker family of power-off troubleshooting equipment based on analog signature analysis technology.

Circle (136) on Reply Card

ES&T

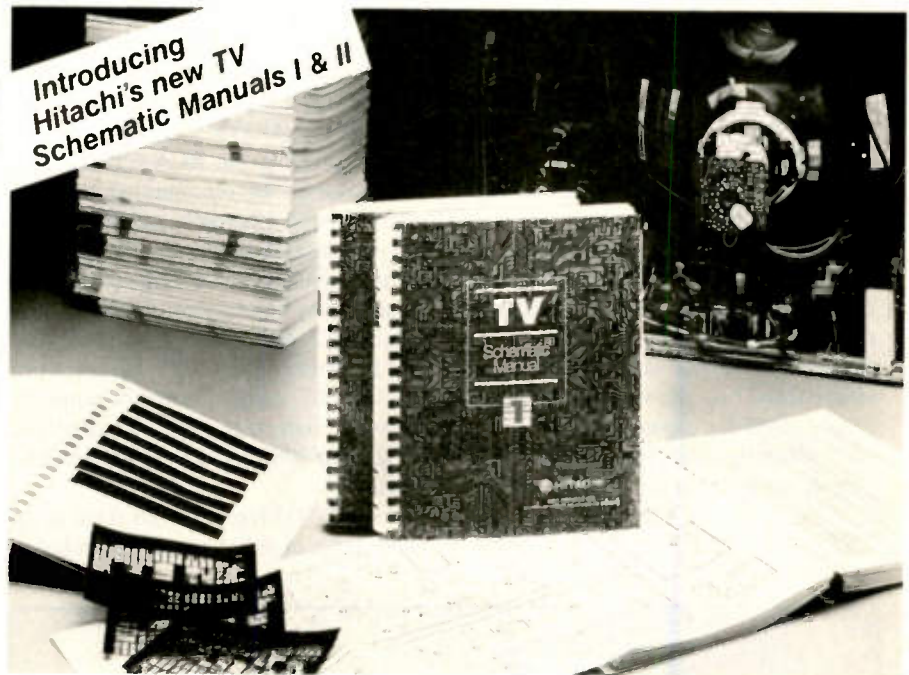

All the technical data of 83 Hitachi TV Manuals—in just two volumes



Our new Hitachi TV Schematic Manuals give you the best of both worlds—

With the compact storage of 32X microfiche and full-view hard copies of the items you use the most. Organized by year and model number in both formats, these volumes give you everything you need—83 models from 1975–1981. They're neatly packaged, easy to use, and economically priced.

You'll get hard copies of:

- Schematic Diagrams • Block Diagrams
- Printed-Circuits Board Layouts • Part Lists • Mechanical Part Exploded Views

And get the works on microfiche:

- Service Manuals with Technical Data and Information • Troubleshooting Tips • Revised or Supplemental Manuals • Instruction

Manuals • Parts and Service Bulletins

Volume I covers: 54 models from 1975–1978.

Volume II covers: 29 models from 1979–1981.

That's a lot of service data for a low **\$54.95** per volume! About what you would expect to pay for information on only two models. Or save even more by getting both volumes for just **\$104.00**. Take advantage of these savings now. It's a simple, cost-effective way to increase proficiency and increase profit. Also available are our VCR Volumes I, II and III.

Call toll-free 1-800-447-2882 for your nearest Authorized Hitachi Distributor

HSC Service Company

division of Hitachi Sales Corporation of America

Circle (21) on Reply Card

May 1989 *Electronic Servicing & Technology* 37

Servicing RCA CTC107 video/color circuits – Part I

By Homer L. Davidson

Troubleshooting the RCA CTC107 13-inch color receiver is complicated by the crowded video and chroma circuits. Also, one 28-pin integrated circuit, U701, performs many of the video and chroma functions that formerly were powered by separate transistors. This alteration reduces the number of tests that can be made.

On the positive side, however, the test points located at strategic places help immensely when you are troubleshooting. Several case histories and the explanations about schematics in the article show how the various test points can be used for signal tracing.

Incidentally, the chassis can be removed easily from the cabinet without

disconnecting any cables or interfering with normal operation of the set. The ability to move the chassis gives you access to many areas for testing or repairs. These helpful features should more than balance any reluctance you might have about servicing the RCA CTC107.

Of course, we recommend that you obtain a good schematic and other service information before you begin work on any small receiver. The cost will be repaid many times over in testing time saved. RCA has complete service data, and Photofact offers three variations of the CTC107 under Photofact numbers 1969-2, covering 1981 production, 2032-2 for 1982 and 2104-1 for the 1983 circuits.

For CTC107 repairs, your most often used items of test equipment probably

are the basics: an accurate digital multimeter (DMM) and a good quality, stable oscilloscope. If the DMM has an excellent diode test function, a transistor tester becomes optional. The DMM is generally expected to measure dc and ac voltages, resistances and diode or transistor junctions. The scope is unexcelled for displaying waveforms on a calibrated screen where the waveforms can be checked against specifications. In this article, the signal source for tests is a strong signal from a TV station (if available) or, even better, the output of a color-bar generator connected to the receiver's antenna terminals and tuned in as a station.

Troubleshooting always is easier for a technician who is familiar with the model, especially if he has had previous experience testing several. If you are not that fortunate, this article will provide the kind of information usually needed for the CTC107.

Introduction to the CTC107

The RCA CTC107 is a 13-inch table-model color TV receiver of the one-circuit-board design. In addition to the largest board, there are other boards including the CRT socket board, which also includes the CRT drive circuits, a tuner module (shielded board), and a tuner-control module (shielded board). Several different tuners were used by the factory during the many months the model was in production. Most models have a remote control with CHANNEL-UP/CHANNEL-DOWN, VOLUME-UP/VOLUME-DOWN, MUTE and POWER functions. Some models have the same functions available for the receiver's front panel.

Tracing sound and video

Most experienced technicians looking at a schematic of the CTC107 would say that if the set exhibited normal sound without picture, they would nevertheless expect to find both sound and video

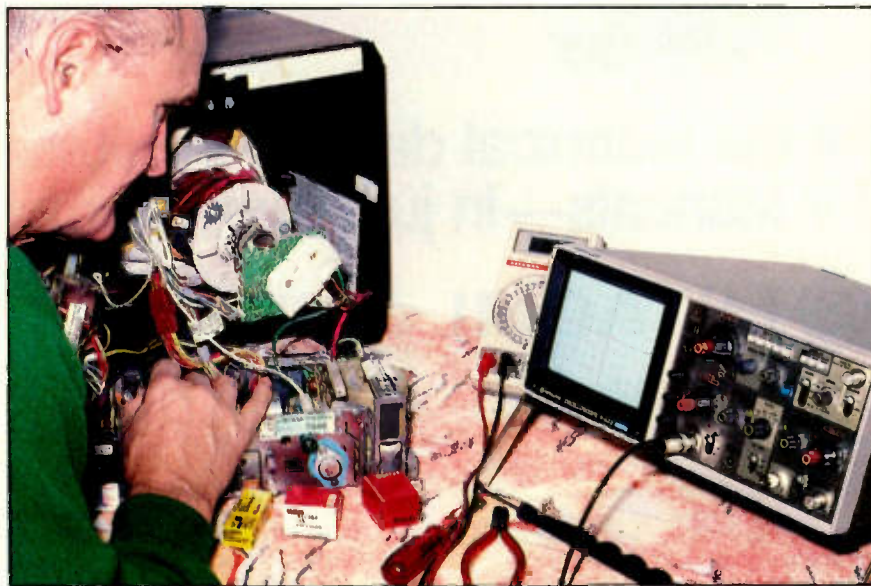

Before the chassis can be moved backward, the cabinet back must be removed. Six hex-head screws hold the back, so remove these and slide off the back with care. To remove the chassis, unscrew the two screws fastening the chassis at the rear, grasp the corners of the circuit board and gently pull backward. As the chassis moves, loosen wire ties as needed and slide the chassis to the rear until the desired position is reached. After tests or repairs are completed, unplug the power and push the chassis forward. Remember, the circuit board's front area is held in position by sliding the board edges forward into a slotted guide at each extreme side of the cabinet. Make certain the board has entered both slots before pressing too hard against the board, then slide the chassis forward to the stop. Replace any wire ties previously removed. Test the total television performance and reinstall the cabinet.

Davidson is the TV servicing consultant for ES&T.

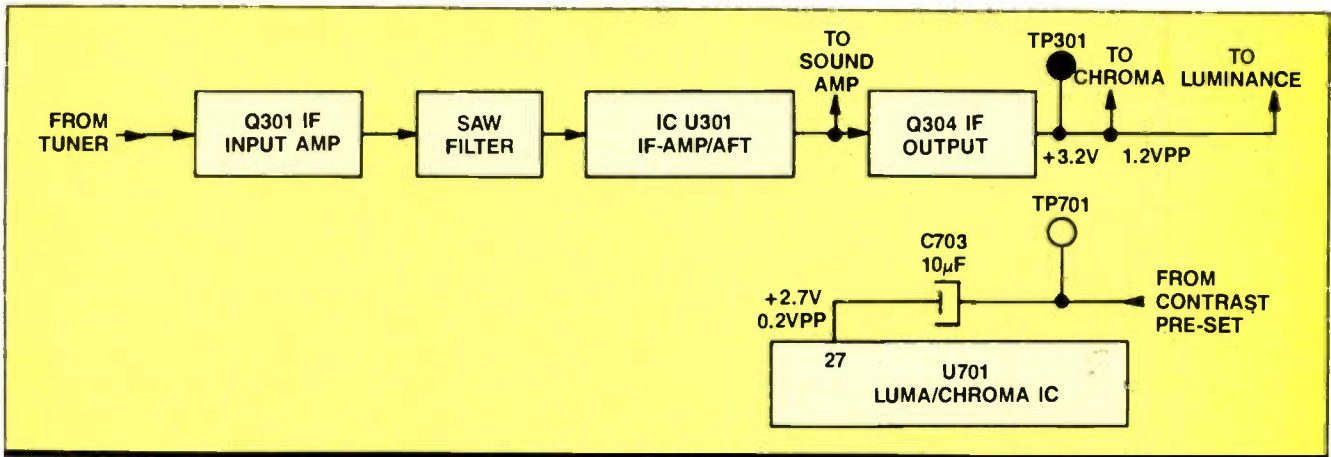

Figure 1. These two test points are very important because they help us isolate a video problem quickly. If the video waveform is present at TP301 but not at TP701, the defect is in the signal path between these points.

signals at test point TP301 (see Figure 1), and that perhaps the video is blocked later in the video circuits. This convenient theory is true for most sets. However, in this set, the 4.5MHz sound carrier does not appear at TP301 (the emitter of Q₃₀₄); instead it is removed just before the 4.5MHz trap at Q₃₀₄'s base eliminates the sound carrier. The sound carrier does not reach the Q₃₀₄ base, so it certainly cannot appear at the emitter and TP301.

Symptoms of normal sound without picture usually indicate that the composite video signal is defective somewhere after the 4.5MHz take-off point.

Loss of video

When the symptom is a complete lack of video in the picture, scope TP301, the first test point. If the scope finds improper or insufficient video at TP301, replace tuner module MST005. If a new tuner doesn't result in a change of symptoms, the tuner is not at fault. Next, check the SAW filter (SF₃₀₁). Scope pin 12 (video output) terminal of U₃₀₁ IC expecting to see normal composite video. The waveform there should be compared to those at test point TP301 to determine if there's any distortion or loss of signal amplitude between the two points.

Accurately measure the dc voltages at U₃₀₁ pin 11 (+11.24V) and pin 12 (+4.1V with video). If the +11.24V supply voltage at pin 11 is low, suspect Q₃₀₂, CR₁₁₁ and R₃₂₅. Replace all components that are visibly damaged or measure out of tolerance. A leaky U₃₀₁ also can reduce the +11.24V source voltage. Test for this possibility by disconnecting pin 11 from the circuit board. If this results in an increase of the +11.24V source to

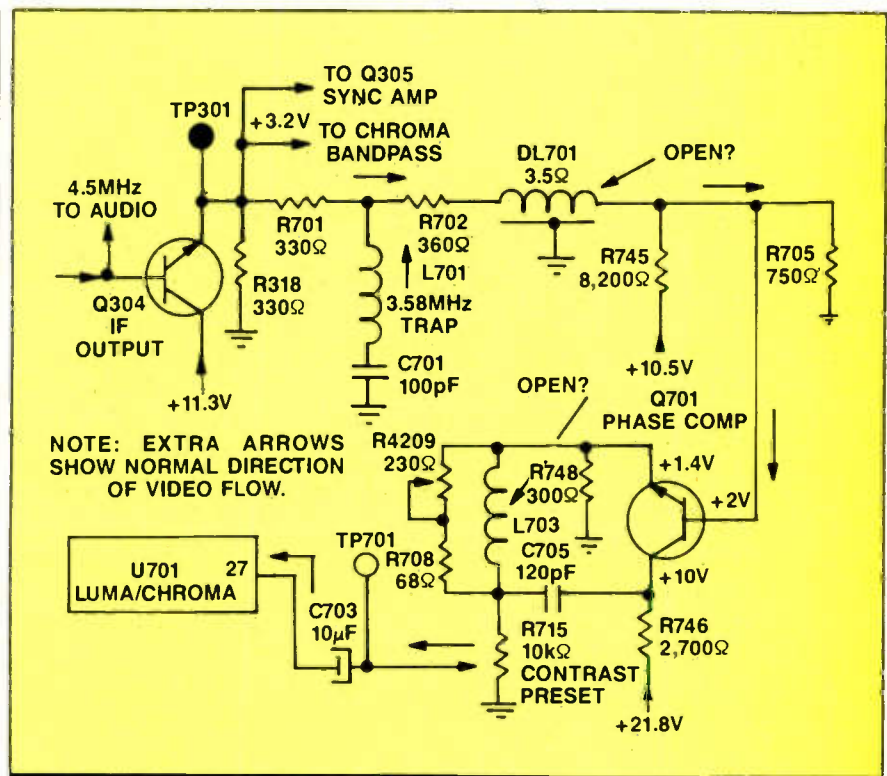

Figure 2. At TP301, video and chroma signals separate, with the video traveling through the DL701 delay line, through Q701 phase-compensation emitter-follower (with coil L703 as the emitter resistor), and on to the contrast-preset control and TP701. From TP701, the video passes through only one capacitor to U701 pin 27. An open 3.58MHz coil does not eliminate the video, but an open DL701 delay line or L703 compensation coil removes all video. When either is intermittent, the video is intermittent. When the symptom is loss of video, check the resistance of DL701 and L703.

a value closer to its specified value, U₃₀₁ is probably leaky, and it is drawing excessive current. If the +11.24 source voltage stays low even after you disconnect pin 11, the problem probably lies elsewhere.

After video waveforms have been identified at TP301, go on and scope TP701. (See Figure 2.) If the video there is normal, go to U₇₀₁ pin 27 for the last external appearance of any video before

it exits as part of the red, blue and green drive waveforms from U₇₀₁ pins 20, 21 and 22. These various test points should show where the video disappears or becomes distorted. (Notice that only 10µF C₇₀₃ separates TP701 from U₇₀₁ pin 27. An open C₇₀₃ or one with high equivalent series resistance or ESR can reduce the contrast greatly.)

Remember, when you reach a test point that shows a weak or distorted

waveform, the problem is located between this point and the upstream test point where the waveform last showed normal.

The following is one example in which audio from a CTC107 was normal, but the CRT showed no picture. The oscilloscope waveform of the signal at test point TP301 showed the normal

video. When I connected the scope to TP701, looking for a video waveform, I found none. One thing that could have caused this situation is if the R_{715} contrast pre-set control had been turned down accidentally. Unfortunately, rotating the R_{715} control while scoping TP701 failed to show any video. Next, I tested phase-comp transistor Q_{701} for

shorts, leakages and opens. Then I remembered that an open DL_{701} delay line or an open L_{703} peaking coil eliminates the video waveform before it reaches TP701.

I measured the resistances of the DL_{701} delay line (normally 3.5Ω) and L_{703} phasing coil (normally 4.7Ω). In this case, the DL_{701} delay line was open, stopping all video. (Oddly, when the delay line is open from coil to ground, the video amplitude is not decreased greatly, but reflections, such as multiple ghosts, are visible in the picture.) Replacement of the delay line produced a good picture.

Did you notice that the method of bracketing video problems between two test points worked nicely in this example? TP701 had no video, but TP301's video was normal. Therefore, the defect should have been (and was) between the two test points.

Incidentally, U_{701} should be suspected and replaced when pin 27 has video but no video is emitted from the three video drive pins at 20, 21 and 22. (Caution: Before you replace U_{701} because it has no signals at any of the three video drive output pins, make certain that input pin 27 has normal video and pin 23 has normal +10.5V from the B+ supply.)

Weak video

Weak video (low contrast) might be caused by a defective SF_{301} SAW filter. Sometimes this weak video has a beat-frequency pattern. If the video amplitude at TP301 is lower than normal, SAW filter SF_{301} should be the first suspect. Visually inspect the four connections of SF_{301} , using a magnifier to make small cracks visible. Resolder each SF_{301} joint with enough heat to perform good soldering quickly, and then rapidly withdraw the iron tip. I believe that excessive heat applied too long might damage the internal piezoelectric crystals in SAW filters.

For weak video, check Q_{304} and Q_{701} for leakages or opens. Replace all defective video transistors with the exact RCA part numbers. Suspect U_{301} IC if the picture is snowy and/or grainy. Measure all dc voltages. Test the +11.25V supply voltage for U_{301} at pin 11 and determine (by methods given previously) if the IC has internal leakage. Replace U_{301} if any two tests agree that it is the problem. Until the defective component is found, rotate R_{715} for maximum contrast. Re-adjust it carefully after everything else is operating correctly.

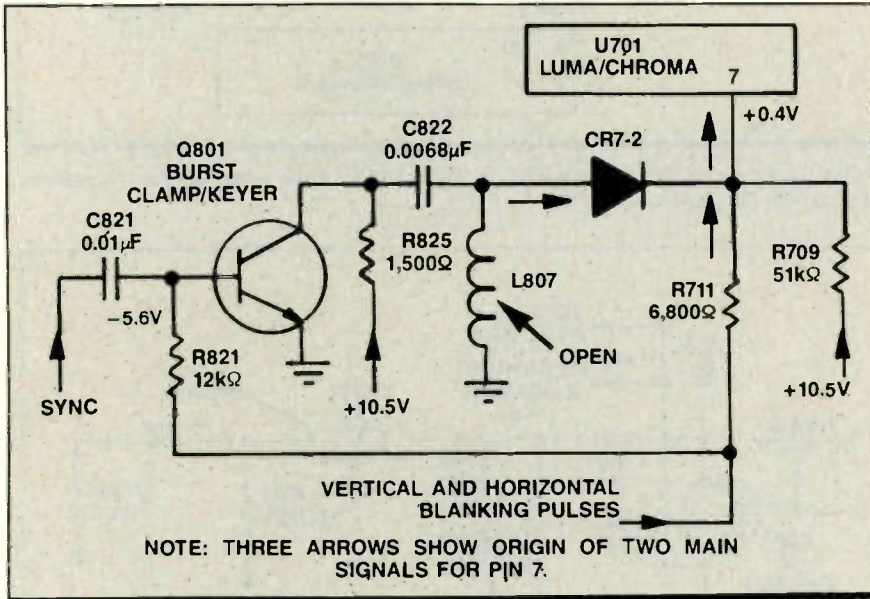

Figure 3. Very low brightness without video is a typical CRT-screen symptom when the U_{701} pin 7 sandcastle waveform becomes distorted and/or weak. Q_{801} amplifies the TV sync. The amplified sync pulses appear at the collector of Q_{801} where they ring series-tuned circuit C_{822}/L_{807} . This moves the maximum first sine peak to the right (corresponding to the position of burst in composite video); therefore CR_{701} rectifies only the first (highest-amplitude) pulse and passes it to the mixture of vertical blanking and horizontal blanking before all three signals arrive as one signal at U_{701} pin 7. Inside U_{701} the sandcastle is decoded into burst-clamp and burst-keyer actions. In this example, coil L_{807} was open, stopping the tuned ringing and almost eliminating the most important part of the terminal-7 signal.

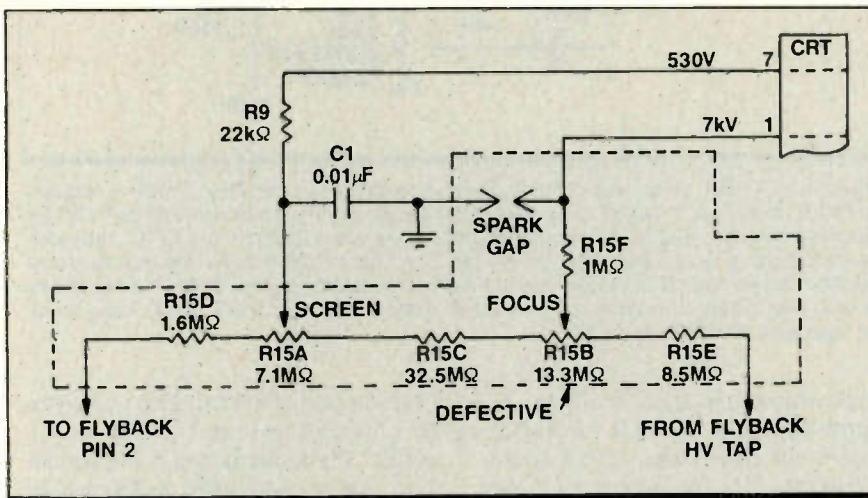

Figure 4. Low CRT screen voltage causes dark pictures; unusually high CRT screen voltages produce excessive picture brightness. In one RCA CTC107A, the CRT's other dc voltages measured within tolerance, but the screen voltage at CRT pin 1 was too high. Increased resistance in R_{15D} (likely), or a carbonized short across R_{15C} (possible) can increase the CRT screen voltage. However, individual resistors and potentiometers in the focus/screen-control component are not replaceable; all are sealed inside a common covering. Installation of a new focus/screen-control part required proper adjustment of the two controls. Afterward the TV performance was normal, including the CRT brightness.

In a few cases of weak video on CTC107s, replacement of U₇₀₁ cured the problem of weak contrast and low brightness.

Video problems

DL₇₀₁ delay line was proved to be the cause of intermittent video in several cases. If you have a dual-trace scope, connect one probe to the input of DL₇₀₁ and the other probe to the output of the same DL₇₀₁ delay line. When the intermittent occurs, a glance at the scope screen will show if one, both or neither of the signals has disappeared. The delay line connections simulate test points, and the test should reveal if the delay line is the source of the intermittent or not. When both scope patterns disappear simultaneously, the delay line is not defective.

If the previous scoping test did not definitely prove the delay line's guilt or innocence (sometimes intermittents fail to perform when test equipment is connected!), resolder all delay line connections. Measure the delay line's resistance, expecting 3.5Ω. Occasionally, a questionable U₃₀₁ will cause the

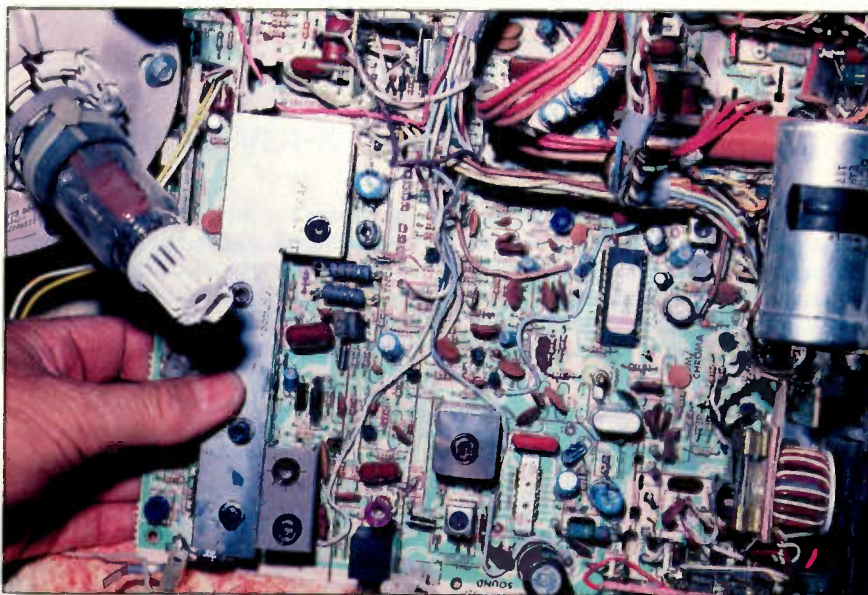

In the RCA CTC107 chassis, the IF, video and chroma circuits are crowded together closely. It is almost imperative to use service data that includes photographs or detailed drawings that show the identification and location of all circuit-board components.

picture to disappear after the receiver becomes very warm. If there is doubt, try a heat test of the U₃₀₁ area, or replace U₃₀₁. One of these tests should identify the defective component.

Sometimes we technicians look in the

wrong places for causes of very low brightness coupled with only a hint of video on the screen. In one such case, after several hours of frustration from looking in non-defective circuits, I found an open in keyer circuit coil L₈₀₇.

Tools & Tool Kits, Test Equipment, for Every Need in the Industry!

Techni-Tool's latest **FREE CATALOG** includes the biggest and best selection of top-quality items to be found anywhere! The catalog presents more than 18,000 items from over 850 fine manufacturers. You will find tools and accessories for electro-mechanical assembly and maintenance, electronics, telecommunications, field service, and computer maintenance, plus ESD products, clean room supplies and tools for SMT applications.

Send for your
copy of our
Free Catalog!

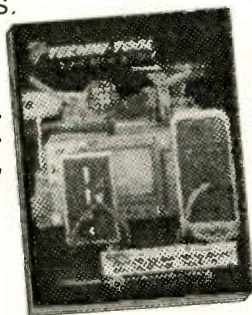

TECHNI-TOOL *INC.*

5 Apollo Road, Box 368 Plymouth Meeting, PA 19462 U.S.A.
Sales (215) 941-2400 • (215) 825-4990 • FAX (215) 828-5623

The CTC107 x-ray protection system

To help your understanding of this shut-down operation, the schematic has been carefully arranged by showing the components in related groups. The three basic circuits are an overvoltage sensor, an overcurrent sensor and a latch (electronic switch).

Let's talk about the overvoltage sensor first. Horizontal pulses from flyback pin 10 pass through R445 to CR409, the rectifier, which, with filter capacitor C421, supplies dc voltage to testpoint XT1. This XT1 positive voltage varies in step with the amplitude of the flyback pulses, and approximately in step with the high voltage. From XT1, a precision resistor R434 brings voltage to testpoint XT2. Remember that the XT2 voltage triggers the latch, producing shut-down. (The other sensor also feeds XT2 and the latch.) Normal pulse rectification by CR409 produces about +44V, which, because of the limiting from R434, does not increase the XT2's +32.1V. However, pulses of higher amplitude will increase the XT2 voltage enough to initiate shut-down triggering.

In the second basic circuit, the overcurrent sensor continually monitors the pin-2 dc voltage at the cold end of the flyback's HV winding — a point that becomes more negative as increased current is drawn through the CRT. This negative dc voltage is joined with a slightly higher positive voltage from R449. After some voltage drop in base resistor R450, the Q415 base voltage should measure at normal brightness about +0.63V, which is saturation bias, produc-

ing in turn a collector voltage of about +0.1V through load resistor R436 from the XT2 supply. In effect, this grounds R436. The R436 load causes the XT2's voltage of +32.1V. Excessively high CRT brightness increases the negative voltage at flyback pin 2, forcing the Q415 base to almost zero volts (cut-off bias) and causing the Q415 collector current to stop. Therefore, the current coming through R436 also stops, allowing the XT2 supply voltage to rise and trigger shut-down.

Notice these important power-supply details: +33.8V is the zener-regulated major B+ source. Most power for the +32.1V supply comes through diode CR408 from the +33.8V supply. CR408 provides some regulation but allows enough voltage change for the XT2 voltage to increase and trigger the latch for shut-down.

The latch is simple. The base of each transistor connects to the collector of the other. Some similar circuits oscillate strongly. However, this one is stable because Q413 is a PNP transistor, while Q414 is an NPN transistor.

To trip the latch, the base of Q413 should become negative relative to its own emitter, or the emitter (and X2) must be driven more positive than its base, as is the case here. Q413 then conducts, passing positive voltage out the collector to the Q414 base. Q414 then conducts, and its collector voltage reduces the Q413 base voltage, making the base more negative than its emitter (forward bias). This keeps the latch locked after the in-

itial triggering pulse is gone. The latch remains in shut-down until the 120Vac power is stopped for a time, and then the power is turned back on. If defects have been repaired, the set should operate normally.

If repairs have been made in the x-ray protection circuit, or if there is doubt about its protection, test the circuit operation by starting with a correctly functioning television chassis. While the TV is playing, short testpoint XT1 to testpoint XT2. Shut-down should occur instantaneously. To restore operation, turn the power off and then on again. If shut-down occurs as expected, the overvoltage and latch circuits are operating properly. If shut-down did not occur, the protection circuits must be repaired. There are no adjustments or controls for this protection system.

If the color receiver has no picture and DMM tests show a loss of horizontal sweep, the receiver might be in shut-down because of excessive high voltage. With ac power off, disconnect one end of diode CR409 (in the x-ray protection circuit) and notice if the picture returns. If it did not, excessive HV is not the problem. If the picture returns, the HV probably is too high, so immediately measure the high voltage. If the HV reading is normal, more testing of the protection circuit is needed. However, an excessively high HV reading calls for shutting off the receiver quickly and then searching for the cause of the high HV. After repairs have been made, reconnect rectifier CR409 and apply power to the receiver. Assuming that shut-down did not occur, short testpoint XT1 to testpoint XT2. This should throw the receiver into instant shut-down. If it doesn't, the x-ray protection circuit needs additional repairs, and repairs should be continued until shorting together the testpoints results in shut-down.

The 2-transistor latch stops all functions except the +166V source when it is closed. The emitter of Q414 is wired directly to the base of horizontal driver Q411. When the latch closes, a pulse of positive voltage is sent from the Q414 emitter to the Q411 base, and this high positive voltage saturates Q411, stopping all amplification and the drive for the output transistor. Without base drive for the output transistor, the HV stops, along with all the lower voltages powered by the flyback. Shut-down is then completed and the TV is dead.

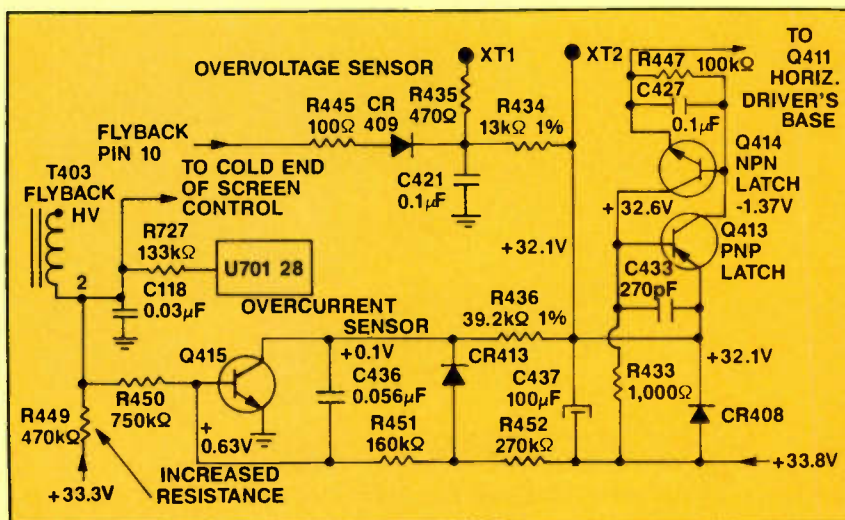

Figure 5. This x-ray protection system is a shut-down circuit with two sensors.

In the collector circuit of burst clamp/keyer Q₈₀₁ is 0.0068μF C₈₂₂ and coil L₈₀₇, which form a series resonant circuit (Figure 3). CR₇₀₂ passes on only the higher amplitude parts of the waveshape through R₇₄₄ to U₇₀₁ pin 7. When L₈₀₇ is open, the resonant circuit does not function, so the signal at CR₇₀₂'s anode is distorted and has little amplitude.

If CR₇₀₂ is not shorted and the test probe polarities are correct, the 21.1Ω resistance of L₈₀₇ can be measured in-circuit. If the coil measures open when you test it in-circuit, remove it from the chassis and test the resistance again. If it still tests open, install a new coil.

The correct waveform at U₇₀₁ pin 7 often is called a sandcastle because the waveshape vaguely resembles a child's castle made of sand. Severe reduction of brightness, as described, is typical of the consequences of loss or major distortion of the pin 7 waveform. Remember, the U₇₀₁ pin 7 waveform (sandcastle) is indispensable. Do not overlook it.

Excessive brightness

Most problems with higher than normal brightness are caused by defective components in the video circuits. If the excessive brightness is erratic, check the service/normal switch for corroded contacts or broken soldered connections. Wiggle the switch and notice if that triggers the brightness problem. Clean the contacts or resolder the connections as needed.

A defective luminance/chrominance IC, U₇₀₁, can cause excessive brightness. If U₇₀₁ or the picture tube is leaky, the resulting high brightness can cause shut-down.

Also, test for insufficient boost voltage or excessive CRT-screen voltage. An open 4.7Ω R₁₂₅ reduces the +193V boost voltage to near zero, which causes the CRT cathodes to become less positive, thus decreasing the CRT's grid/cathode bias and increasing the brightness.

Next, measure the CRT screen voltage, which should not exceed +600V at maximum adjustment of the screen control. If the screen voltage is higher, the screen/focus-control component (see Figure 4) undoubtedly is defective and should be replaced. In one CTC107A case history, the receiver showed those symptoms, and the installation of a new screen/focus-control component solved the television's prob-

lem with excessive brightness.

Retrace lines

Retrace lines in the picture can be caused by incorrect adjustments of screen color and tracking, which involve the screen control, the bias controls and the drive controls for each of the three colors. A complete readjustment is easy when you use the method shown on page 51 of Photofact 1969-2 for the CTC107A.

High brightness with retrace lines followed quickly by shut-down might be symptoms of a shorted picture tube. Excessive brightness with retrace lines but without any change when the brightness control is rotated might be caused by a defective U₇₀₁, the luminance/chrominance IC. Sometimes leakage in U₇₀₁ produces retrace lines in the picture followed by shut-down.

High brightness with retrace also can be caused by a leaky flyback. Check for

Sony Servicers: You Don't Have to Follow the Book.

Introducing the on-line information system.

Now, Sony makes it easier and faster than ever to access critical information.

The Service Information System (SIS) from Sony Service Company makes it possible.

Simply put, SIS offers you on-line access to a central database that delivers this and more:

- Repair Data that lists the most frequent repairs and solutions
- Parts, including price and availability
- Service bulletins on current and discontinued products
- Field Problem Reports that provide detailed repair tips

SIS is easy to use. All you need is a personal computer and modem — and password, of course. Best of all, it gets you the exact information you need without waiting, so you can quickly get products back where they belong — to your customers.

If you service Sony products, this may be the most important tool in your shop. For further information, complete the coupon or call today: 1-201-930-6883.

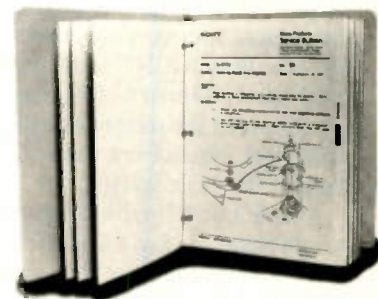

Please send details on Sony's new Service Information System (SIS).

Name _____

Title _____

Company _____

Address _____

City _____

State _____ Zip _____

Mail to:
Sony Service Company
Sony Corporation of America
1 Sony Drive, M-4, Park Ridge, NJ 07656

Sony Service Company
Sony Corporation of America
1 Sony Drive, M-4
Park Ridge, NJ 07656

SONY®

Copyright 1989 Sony Corporation of America. Sony is a trademark of Sony Corporation.

Circle (23) on Reply Card

May 1989 *Electronic Servicing & Technology* 43

a leaky CRT filament winding at flyback T₄₀₂.

When the white retrace lines are at the top of the picture, check the Q₅₀₃ vertical error and the Q₅₀₄ vertical pre-amp transistors. Sometimes the regular transistor tests do not indicate Q₅₀₃ and Q₅₀₄ as defective. Therefore, accurately test resistors R₅₁₆, R₅₁₄, R₅₂₉ and R₅₁₈. If they are all normal, replace Q₅₀₃ and R₅₀₄.

Blooming

When the problem is blooming of the picture at high brightness, first recheck the screen control and the bias adjustments for the three colors; a serious misadjustment of these controls can produce higher than normal brightness with raster blooming.

In one RCA CTC107, I noticed that the picture would bloom when the brightness was increased. Further observations showed that the entire picture was becoming larger as the brightness was turned toward higher brightness, although the picture did not become brighter. HV tests made at the CRT anode showed that the high voltage decreased as the picture size increased. Evidently, the problem was poor regulation of the high voltage.

I made several preliminary tests, such as checking the focus control action (it was normal) and feeling around for areas of excessive heat on the flyback

transformer (after the acV was turned off). No gross defects were found, so I went on to the more complicated circuits.

Although the x-ray/protection circuit is complex, it is a good place to begin in the case of these unusual symptoms. As shown in the Figure 5 schematic, the protection circuit has three sections: the part with CR₄₀₉, which rectifies horizontal pulses to produce a positive dc voltage that varies with the HV-pulse amplitude; the overcurrent section with Q₄₁₅ that monitors the HV current via the low end of the flyback winding; and the 2-transistor latch that, when activated, stops all operation of Q₄₁₁ horizontal-driver transistor and thus the entire receiver.

Now, back to the blooming. Careful and accurate resistance tests on these three protection circuits finally located R₄₄₉ in the over-current circuit, which had increased from 470kΩ to more than 1MΩ. The unvarying positive voltage through R₄₄₉ normally just slightly exceeds (at Q₄₁₅'s base) the varying negative voltage from the T₄₀₅ flyback terminal, the cold end of the HV winding. That same point connects to the cold end of the screen control and through a resistor to U₇₀₁ pin 28, where it normally controls the brightness limiting. Automatic tracking of the screen voltage is lost by the open R₄₄₉. More important is that the brightness-

limiting action is stopped or seriously reduced by voltages from the nearly open R₄₄₉. This cannot be described in detail because the vital circuitry is inside U₇₀₁, but it appears certain that the loss of brightness-limiting was responsible for the blooming.

Replacement of R₄₄₉ restored normal television operation.

Unusual brightness problem

A slightly out of focus picture appeared on the CRT screen of an RCA CTC107A 13-inch color receiver, then the raster quickly would become very bright, resulting in shut-down. I thought the symptoms were those of a shorted picture tube. When I removed the picture tube's socket, the sound and HV were normal. When the socket was returned to the CRT base, the screen again would become bright and then the set would shut down. All signs indicated a defective CRT. However, the CRT tested normal.

A visual recheck of the CRT socket showed that dust had collected at the top of the spark-gap assembly. After I blew the dust from the CRT socket, the unusual brightness problem was gone and the receiver operated correctly.

Important chroma waveforms

A defective chroma stage often can be found quickly by signal-tracing methods that analyze scope waveforms at the various test points. Remember to scope these important signals:

- Check the 0.12V_{PP} chroma peak-level signal at TP801 or pin 3 of U₇₀₁. (See Figure 6.)
- Test for the 3.58MHz crystal-oscillator 1.6V_{PP} signal at U₇₀₁ pin 13.
- Scope for the 10V_{PP} sandcastle waveform made up of horizontal sync, horizontal blanking and vertical blanking pulses at U₇₀₁ pin 7.
- Scope the demodulated chroma signals at U₇₀₁, looking for approximately 3V_{PP} at pin 20 for green, 3.8V_{PP} for red at pin 21 and 4.2V_{PP} at pin 22 for blue.

An analysis of these waveforms should indicate the location of the chroma problem. Incidentally, many chroma problems are caused by or related to the luminance/chrominance processor, U₇₀₁.

Next month, we'll look at some specific problems that can be caused by a defective U₇₀₁, the luminance/chrominance IC.

ES&T

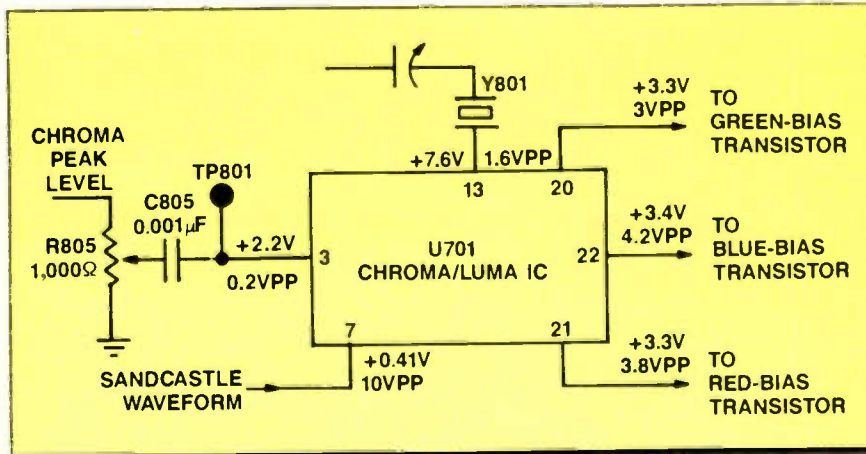

Figure 6. When a color-bar generator is connected and operated correctly, these chroma test points on U701 usually can show the location of chroma problems, in addition to allowing the servicer to make visual analysis by scoping the waveforms. Scoping pin 3 (TP801) should show the color-bar pattern (minus the luminance portion) with an amplitude of about 0.2V_{PP}. Pin 13 shows 3.58MHz sine waves (if you sync the scope for them) with at least 1.6V_{PP} of amplitude. Pin 7 is the sandcastle waveform, which appears, at first glance, to consist of positive-going horizontal pulses and each with a tall, narrow pulse slightly beyond the center. Amplitude of the waveform measures between 7.5V_{PP} and 10V_{PP} according to the height of the narrow pulses on top. Pins 20, 21 and 22 each have wide blanking bars and demodulated color bars for the three primary colors. Measured dcV and ac PP voltages can vary from those shown because of individual differences without affecting the overall color performance.

Books/Photofact

IBM PC Advanced Troubleshooting & Repair, by Robert Brenner; Howard W. Sams; 300 pages; \$24.95.

This guidebook uses step-by-step troubleshooting methods and detailed circuit description to explain how PCs operate and how to use test equipment. This book includes troubleshooting programs to help locate failures and oscilloscope screen photos and drawings to help identify problems. Subjects covered include a system overview; detailed system operation; troubleshooting techniques; preliminary service checks; and detailed circuit troubleshooting and analysis.

Howard W. Sams & Company, 4300 W. 62nd St., Indianapolis, IN 46268; 317-298-5722.

IBM PC Peripheral Troubleshooting & Repair Guide, by Charles J. Brooks; Howard W. Sams; \$21.95.

PC owners, service technicians, students and hobbyists can learn to service and repair computer peripherals with this step-by-step procedures manual. This book presents the basic theory of operation, hardware descriptions, preventive maintenance, and troubleshooting and repair techniques for all major IBM compatible peripherals. Some of the topics covered include disk drives, monitors, input devices, printers and modems.

Howard W. Sams & Company, 4300 W. 62nd St., Indianapolis, IN 46268; 317-298-5722.

Introduction to Electronics Design, by F.H. Mitchell, Jr. and F.H. Mitchell, Sr.; Prentice-Hall.

This book provides a broad, systems-oriented introduction to electronics design through analysis of semiconductor devices and computer-aided design. The text emphasizes the importance of manufacturing and economic constraints to the design process, as well as modeling and model-building as a key element of computer-aided design. More than 440 examples and exercises are provided in the text and more than 450 in the Solution Manual, which is also available. Fifty computer applications and 30 experimental applications are integrated into the text.

Prentice-Hall, Prentice-Hall Building, Englewood Cliffs, NJ 07632.

Microcomputer Troubleshooting &

Repair, by John G. Stephenson and Bob Cahill; Howard W. Sams; 272 pages; \$21.95.

This text, as an introduction to microcomputer servicing, includes basic information for repairs and complete step-by-step troubleshooting charts. Some of the topics covered include servicing today's equipment; reducing environmental problems; disk drives; printers; and advanced troubleshooting. Appendices discuss the resistor color codes, IC numbering systems and ASCII/hexadecimal conversion.

Howard W. Sams & Company, 4300 W. 62nd St., Indianapolis, IN 46268; 317-298-5722.

Newnes Computer Engineer's Pocket Book, by Michael Tooley; CRC Press; 203 pages; \$19.95.

This helpful book contains facts, figures, circuits and data pertaining to computer and microcomputer systems. The edition offers information at a practical level for designers, students, and service engineers alike, and is presented succinctly to accommodate quick access. The contents are arranged in a sequence of hardware, software and interfacing, from power supplies to support devices.

CRC Press, 2000 Corporate Blvd., NW, Boca Raton, FL 33431; 800-272-7737.

Television Symptom Diagnosis, 3rd edition, by Gregory R. Capelo; Howard W. Sams; 300+ pages; \$19.95.

This introductory text is for the beginning-to-intermediate TV repair technician. The latest in high-tech televisions, with expanded theory and troubleshooting coverage, is included. The book explains how to identify failures in advanced circuits. Sections on test equipment, troubleshooting techniques for repair of component defects, and fold-out circuit diagrams are provided.

Howard W. Sams & Company, 4300 W. 62nd St., Indianapolis, IN 46268; 317-298-5722.

Power Electronics: Circuits, Devices, and Applications, by Muhammad Harunur Rashid; Prentice-Hall.

This book explains the fundamentals of conversion techniques, then presents the characteristics of power semiconductors in reference to their applications

to power circuit designs. The book covers dc and ac drives, power supplies and important design formulae. Magnetic circuits, 3-phase circuits, spectrum multiplication techniques, Fourier series, dc transient analysis and computer programs lists are reviewed. A disk that contains 51 programs appropriate for the book is included.

Prentice-Hall, Prentice-Hall Building, Englewood Cliffs, NJ 07632.

PHOTOFACT

EMERSON

2649-1 M1975R
2650-1 MS2700RD (SUFFIX
A/B/C/D). MS2700RDA
(SUFFIX A/B/C/D)

GE

2654-1 8-2500A (CH. X130)

JCPENNEY

2649-2 685-2306-00 (855-0154)
2650-2 685-2157-00 (855-9825)
2651-1 685-2155-00 (855-9817)
2652-1 685-2147-00 (855-0378)
2655-1 685-4223M-00
(CH. CTC133B-JCP)

MAGNAVOX

2654-2 CG4600PE01,
CG4712AK01, CG4716PE01
(CH. 25C801-00AA/BB/CC,
25C804-00AA/BB/CC/DD,
25C811-00AA/BB/CC/DD,
25C812-00AA/BB/CC/DD/EE,
25C813-00AA/BB/CC,
25C814-00AA/BB/CC/DD,
25C815-00AA/BB/CC,
26C804-00AA/BB,
26C806-00AA/BB)

PANASONIC

2652-2 CTJ-1350R/51R/52R/59R,
PC-14P51R (CH. ADP153,
YADP153)
2653-1 CTJ-2551R-1/57R-1
(CH. LDPI30/GL6S)
2655-2 CTJ-2561R-1/67R-1
(CH. EDPI30/GL6S)

RCA

2651-2 JMR950W/955W/960HR/
NR/WR/YR/962WR/968ER/
MR/WR/YR (CH. CTC120C)

SEARS

2653-2 564.42872850

ES&T

Test your electronics knowledge

By Sam Wilson, CET

1. What is the frequency of the waveform in Figure A?

2. Refer to Figure B. If R3 is open, the emitter voltage will be
A. more positive than it was before R3 opened.
B. less positive than it was before R3 opened.
C. 0V.

3. Figure C shows the Thevenin equivalent of a more complicated circuit. The silicon diode has a maximum rating of 50mA at 4V. How much current will flow through R when the diode is connected?

4. When switch SW is closed in the circuit in Figure D, the LED will
A. glow.
B. not glow.

5. Which of the following materials is known for its piezoelectric properties?

- A. P-type material
- B. Barium titanate
- C. Niobium-tin
- D. Gallium arsenide

6. The input impedance of a bipolar transistor can be increased by using a

- A. Q strap.
- B. bootstrap configuration.
- C. low-pass filter circuit.
- D. bead ledge.

7. Which of the following is a possible use for a phase-locked loop?

- A. A frequency synthesizer
- B. An FM demodulator
- C. A motor speed control
- D. All of these choices are correct.

8. Gain-bandwidth product is

- A. a frequency value.
- B. an amplitude value.
- C. a power gain measured in watts.
- D. measured in somes.

9. The symbol at the left in Figure E represents a constant-current generator, sometimes called a Norton generator. Its output is always 0.4A regardless of the amount of resistance across it. How much current (I_L) flows through R_L in the circuit in Figure E?

10. Which of the following devices is unilateral?

- A. thermistor
- B. 3-layer diode
- C. 4-layer diode
- D. None of these choices is correct.

Answers are on page 55.

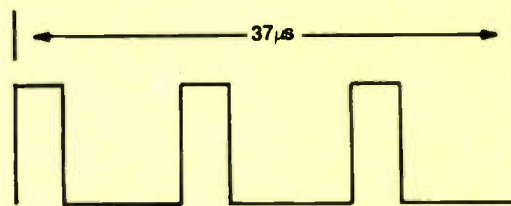

FIGURE A

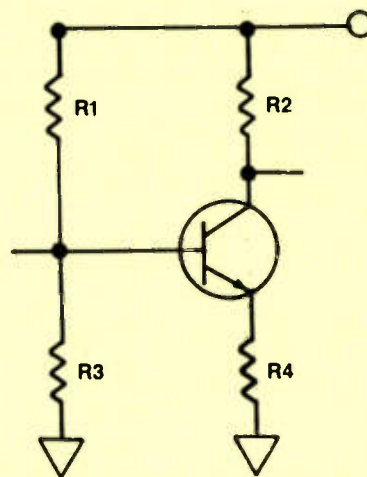

FIGURE B

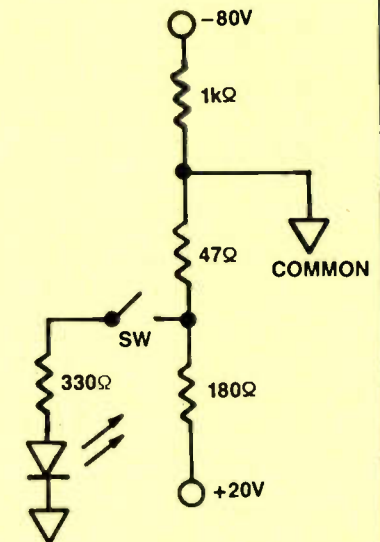

FIGURE D

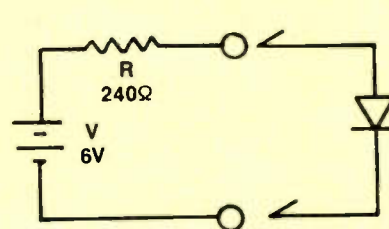

FIGURE C

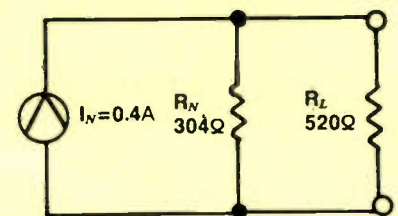

FIGURE E

Wilson is the electronics theory consultant for ES&T.

TRADE SECRETS AT SUMMER CES

LOOK INTO THE FUTURE AT THE VIDEO WORKSHOPS.

Get a sneak preview of what's ahead in video at the Summer CES Workshops. You can also find out the latest trends in:

- **Audio**
- **Home Office**
- **Retailing**—including the **Retail Management Seminar!**

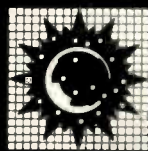

The 1989 International Summer Consumer Electronics Show®

June 3-6, 1989,
McCormick Place
Chicago, Illinois



SATURDAY, JUNE 3

8:45 a.m. Room M-1
■ **Industry Overview**—*John Roach*, Tandy Corporation, *Frank Myers*, EIA/CEG Industry Vice President

1:00 p.m. Room M-4
■ **Tomorrow's Video Store** (panel)—*Doug Kirschner*, Video Insider

RETAIL MANAGEMENT SEMINAR

4:00 p.m. Room M-1
■ **Planning For Growth And Survival**—*John Sherris*, NARDA

5:00 p.m.
■ **What Your Financial Statements Can Tell You**—*Jules Steinberg*, Steinberg & Assoc.

SUNDAY, JUNE 4

RETAIL MANAGEMENT SEMINAR

8:00 a.m. Room M-1
■ **Interviewing Job Applicants—The Right Way**
Sandra MacMillan Cloud, NARDA

9:00 a.m.
■ **How And Where To Invest Your Promotion Dollar**—*Jules Steinberg*, Steinberg & Assoc.

10:00 a.m. Room M-2
■ **The Future of Toys And Games: Interactive Television** (panel)—*Greg Fagan*, Video Review

11:00 a.m. Room M-1
■ **Video Overview**—*Bud O'Shea*, MGM/UA

2:00 p.m. Room M-1
■ **HDTV: Who's Doing What?** (panel)—*Peter F. McCloskey*, Electronic Industries Association

3:00 p.m. Room M-1
■ **HDTV: What Will It Look Like?** (panel)—*Richard E. Wiley*, Wiley, Rein & Fielding and FCC/HDTV Committee Chairman

4:00 p.m. Room M-1
■ **HDTV: What Is Congress Doing?** (panel)—*Gary Shapiro*, Electronic Industries Association

MONDAY, JUNE 5

RETAIL MANAGEMENT SEMINAR

8:00 a.m. Room M-1
■ **Motivating Employees To Do Their Best**—*Jules Steinberg*, Steinberg & Associates

9:00 a.m.
■ **Coping With The Stress Of Being In Business For Yourself**—*Huger Pates*, Programs In Communications

10:30 a.m. Room M-2
■ **Sell-Through's Here To Stay** (panel)—*Al Stewart*, Billboard

1:00 p.m. Room M-4
■ **Tomorrow's Digital Video** (panel)—*David Lacherebuch*, TV Digest

2:30 p.m. Room M-1
■ **The Home As Theater** (panel)—*Scott Schuman*, Marketing Consultant

This schedule is subject to change. Please consult your CES Official Directory for the final program.

What do you know about electronics?

The differentiating circuit

By Sam Wilson, CET

Readers occasionally want to pursue a particular concept to greater depths. I frequently get letters asking for more details or a more extensive discussion of a subject.

In one recent issue, I answered a query from Thomas G. Vlazny, CET, of Milwaukee, WI. He wanted to discuss my answer to a Test Your Electronic Knowledge question in the December 1988 issue. Referring to Figure A, the question was:

- Figure A shows
- a differentiating circuit.
 - an FM de-emphasis circuit.
 - Both choices are correct.
 - Neither choice is correct.

The answer given was A. What made Mr. Vlazny's response interesting was his contention that the question couldn't be answered because the input signal waveform wasn't known. In the examples he gave, he made it clear that he was concerned with the waveform of the input signal. My answer is in the December 1988 issue, page 46.

I stressed the point that the input signal does not determine whether or not it is a differentiating circuit, and I gave three examples of waveforms that could be differentiated. I went on to point out that the circuit *must* operate within a chosen time period. Because the parameters are resistance and

Wilson is the electronics theory consultant for ES&T.

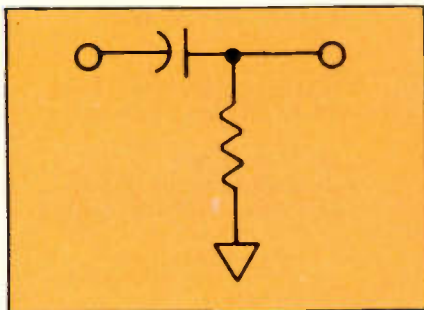

Figure A. A quiz question in the December issue asked whether this circuit was a differentiating circuit or an FM de-emphasis circuit.

capacitance, it should be clear that the time period is dependent on the time constant.

Had Mr. Vlazny objected to the fact that the time constant wasn't known, I would have answered that it was supposed to be a question about the configuration and that is why A was given as the choice.

A number of readers objected to my reply to Mr. Vlazny because I didn't go deeper into the influence of the R and C values. However, his query was directed toward the input signal and its wave shape. That was the query I answered.

Because of the interest that has been generated by Mr. Vlazny's letter and my reply, I have decided to devote some more space to that interesting circuit (the differentiating circuit) and to its counterpart — the integrating circuit.

The differentiator

The circuit in Figure A is used for a coupling network, differentiator, peaker and other applications. Let's look at its operation as a differentiator first.

We are dealing with a different kind of mathematics if we want to analyze this circuit by equations and math. That doesn't mean that the math is more difficult, it is just different, so a few rules will have to be discussed.

The reason the math has to be different is that we are dealing with changing conditions. If you change the input voltage from 0V to a fixed positive value (using the circuit shown in Figure B) several important things will happen:

- the capacitor charges.
- the charging current flows through R.

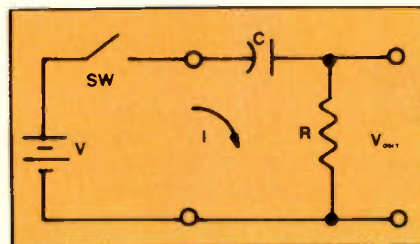

Figure B. When switch SW is closed, a step voltage is applied to the differentiator.

- the charging current flows and is continuously changing until the capacitor is charged.

The equation that shows how the voltages are related to the charging current is:

$$(1/C)i + R(di/dt) = dv/dt$$

That is, the rate of change of the input voltage with respect to time (dv/dt) is equal to the sum of the rates of change of the voltages across the capacitor and the resistor.

We are interested in the part of this equation that deals with the voltage across the resistor: $R(di/dt)$. This voltage, according to the equation, depends upon the amount of resistance (R) and the rate of change of the charging current (di/dt). The output voltage (across R) is dependent upon the rate at which the capacitor is charging.

What is differentiating?

Differentiating is the process of finding how rapidly one quantity is changing with respect to another. Therefore, Figure B is a differentiating circuit because the output voltage depends on how fast the current is changing — that is, how fast the current is changing with respect to time.

The rate of change of charging current is directly related to how fast the input voltage is changing. The easiest case to understand occurs when the input voltage changes almost instantaneously as shown with the step function in Figure C.

If the input voltage changes rapidly, you would expect a high output voltage while it is changing. See the waveform in Figure C.

Note that after the changing period of the input voltage is over, the input is a dc (unchanging) voltage, so the rate of change of the input is zero. The output voltage shows this because it is 0V.

We have to slightly modify what has been said to make it useful in the real world. In the first place, the input step function cannot actually change instant-

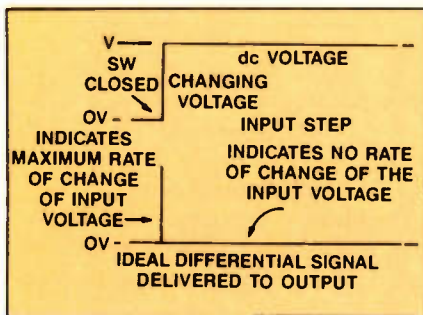

Figure C. When the input voltage changes almost instantaneously, such as when a step voltage is applied, there would be a high output voltage while it is changing. After the changing period of the input voltage is over, the input is a dc (unchanging) voltage, so the rate of change of the input is zero.

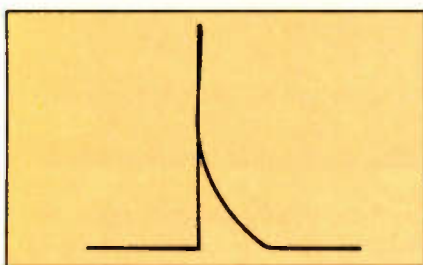

Figure D. If you look at the spike in Figure C using a sweep expander, the output pulse looks like this.

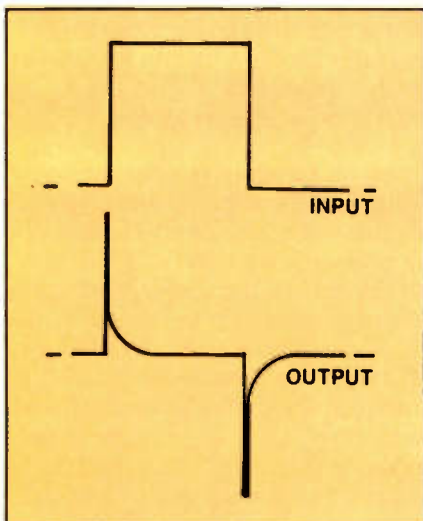

Figure E. If a pulse is applied to the circuit, an output will be produced whenever the input is changing. The output is 0V when the input is not changing.

ly. It takes a very short moment to go from zero to maximum. If the change was instantaneous, the output amplitude would be infinitely high.

In the second place, it takes a certain amount of time for the capacitor to charge through the resistor. There is an output voltage during this charging period, so the output pulse has width. In practice, it is shaped like the output pulse shown in Figure D.

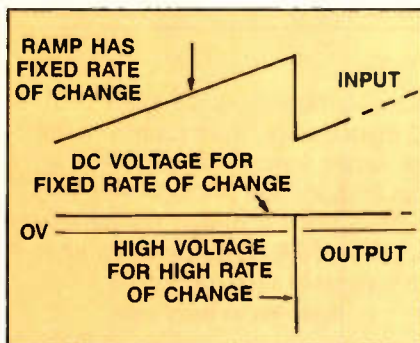

Figure F. If a sawtooth is applied to the input terminals of a differentiator, there will be an unchanging dc output voltage during the ramp portion because the input voltage has a fixed rate of change. When the sawtooth goes from its maximum value to 0V, however, the rate of change is rapid, so the output voltage is high.

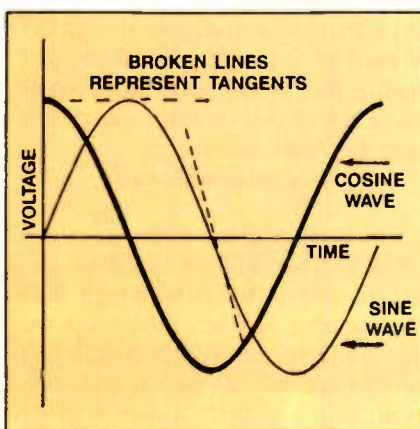

Figure G. To see how a differentiator responds to a sine wave, draw tangents to see how fast the voltage is changing. The greater the angle that the tangent makes with the time axis, the greater the voltage's rate of change. At the peak, the tangent is parallel to the time axis, so the rate of change is zero. The tangent line makes a maximum angle as the sine wave goes through zero, so the rate of change is maximum.

The shorter the time it takes for the capacitor to charge, the more nearly the output voltage is related to the rate of change of input. That relationship simply boils down to this: The shorter the time constant, the better the circuit works as a differentiator.

Applying a pulse

Instead of a single step function, a pulse can be applied to the circuit. The pulse will produce an output whenever the input is changing. The output is 0V when the input is not changing. This result is shown in Figure E.

Consider what happens when you apply a sawtooth waveform to the input

terminals of the differentiator. This situation is shown in Figure F. The ramp of the sawtooth is a period during which the voltage changes from zero to maximum at a constant rate of change. You would expect a dc output voltage that is directly related to the rate at which the ramp voltage changes.

When the sawtooth goes from its maximum value to 0V, the rate of change is rapid, so the output voltage is high. Study these waveforms on the basis of the rate of change of input voltage.

How does a differentiator respond to a sine wave? To answer that, let's look at a differentiated sine wave without the circuit. To differentiate the sine wave we ask, "What is the rate of change of a sine wave voltage with respect to time?"

At the instant the sine wave reaches its peak value, it is not changing. You can see this lack of change in Figure G. Note that at the instant of peak voltage, the value projected onto the voltage line is neither increasing nor decreasing.

The maximum rate of change of the sine wave voltage occurs at the instant the sine wave passes through zero.

You can get an idea of the voltage's rate of change by drawing a tangent to the curve. The greater the angle that the tangent makes with the time axis, the greater the voltage's rate of change. Note that, at the peak, the tangent is parallel to the time axis, so the rate of change is zero. Note also that the tangent line makes a maximum angle as the sine wave goes through zero, so the rate of change is maximum there.

If the differentiating circuit is working properly, the output will be zero at the instant the input sine wave reaches the peak value. Also, the output waveform will be maximum when the input waveform goes through zero.

In other words, the output waveform must be a cosine wave. That's another way of saying that the output must be 90° out of phase with the input wave.

So far, we have explained what a differentiator is supposed to do: produce an output that is related to the rate of change of the input. Also, we have considered the output for the following inputs: step function, pulse, sawtooth, and sine wave.

In the next issue, I'll explain how that 90° phase shift is accomplished by the differentiator to get the required cosine waveform. Then we'll look at some practical circuit applications of the differentiator.

Products

Surge suppressor

Perma Power has introduced its model RW-500 remote surge suppressor. The unit has five outlets, a master and four auxiliaries. A special circuit monitors the power flow through the master outlet, so switching on equipment connected to the master automatically switches the other four outlets at the same time. The RW-500 offers a clamping threshold of 225V peak and is rated for maximum transient voltage greater than 6,000V.

Circle (77) on Reply Card

Analog/digital storage oscilloscopes

Three analog/digital storage oscilloscopes have been introduced by *John Fluke Mfg.* The Philips PM 3335, 1 M 3350 and PM 3365 feature analog bandwidths from 50MHz to 100MHz; sampling rates from 20MS/s to 100MS/s for each channel; and up to 8K memory. The scopes include cursor facilities for on-screen measurements, an LCD panel, and GPIB/IEEE-488 and RS-232 interface options.

Circle (78) on Reply Card

Waveform processing/storage tool

The 2402 TekMate software and hardware product from *Tektronix* provides waveform processing, storage and communication capabilities. When linked to a Tektronix 2400 series digital oscilloscope, the 2402 allows users to perform complex waveform analyses



and will store more than 500 waveforms with date/time markers. Users can make immediate waveform comparisons, establish pass/fail wave-shape tests or view derived functions, such as FFT, on the scope screen. Tekmate includes GPIB, parallel and serial ports.

Circle (79) on Reply Card

Digital soldering station

M.M. Newman has introduced a com-

pact soldering station, the Antex TCSU-D2 digital temperature-control station. The station features dial-selectable settings from ambient to 450°C with $\pm 5^\circ\text{C}$ accuracy and 1°C display resolution. It includes a 50W soldering iron with interchangeable slide-on tips.

Circle (80) on Reply Card

Telephone service kit

The *Paladin* PA 1556 telephone service kit contains all the tools needed to install and service RJ-11, handset and RJ-45 modular plug connectors for data or telephone installers. The kit includes PA 1502 and PA 1505 modular plug termination tools; a PA 1525 professional RJ-45 crimp tool; a PA 1101 wire stripper; a PA 1820 round cable splitter; and 20 each of 2-, 4-, 6- and 8-position modular plug connectors. The kit comes in a case with custom foam cutouts and room for other accessories.

Circle (81) on Reply Card

Insulating pads

NTE's Thermo-Pads provide low heat-transfer resistance with high electrical isolation between assembly parts. The insulators can conform to rough services and reduce contact resistance, resulting in a securely mounted power semiconductor with minimum resistance to the heat transfer.

Circle (82) on Reply Card

VCR

Ten-Lab has introduced the Multiplay TL-1000, a VCR that plays PAL, NTSC and SECAM tapes. The Multiplay features HQ circuitry, wireless remote control, a 14-day/4-events timer, electronic-tracking, an index search system and a 110-channel, frequency synthesized tuner. The unit connects to a regular NTSC TV or monitor.

Circle (83) on Reply Card

Industrial multimeter

Amprobe Instrument has introduced its model AM-14 liquid crystal industrial multimeter. The AM-14 features voltage ranges of up to 750Vac, 1,000Vdc and 200mV ac/dc. Current ranges are up to 2,000mA ac/dc in addition to 0-10A ac/dc. Resistance ranges offer up to 200k Ω and 20M Ω . Direct temperature reading capability is -40 to $+300^\circ\text{F}$. Features include over-range, low-battery and reversed-polarity indication; auto

zeros on all ranges; and diode test range.

Circle (84) on Reply Card

Bench multimeter

The *Fluke 45* bench multimeter from *John Fluke Mfg.* features a multifunction, vacuum-fluorescent dual display.



The 5-digit, 100,000-count meter also offers selectable resolutions of 30,000 and 3,000 counts. Other features include a comparison function for in-tolerance testing, a frequency counter function to 1MHz, a dB function with 21 reference impedances, audio power, diode test and continuity check. A built-in RS-232 interface is included.

Circle (85) on Reply Card

Conductive pen

Planned Products has introduced a pen that writes in a highly conductive, silver-bearing ink. With a 250°F, 15 to 20 minute cure, the Circuit Works pen can make solderable terminations and traces as narrow as 1/16-inch. Although hand soldering is not recommended, it is possible at 350°F for more than 5 seconds. The 2200 HV thermoplastic acrylic polymer ink dries in 3 to 5 minutes and is many times more conductive than solder.

Circle (86) on Reply Card

Oscilloscopes

Beckman Industrial has added two oscilloscopes to its line of test instruments. The 20MHz model 9202 and 40MHz model 9204 feature on-screen readouts of cursor positions and scale settings. The reference and delta cursors measure amplitude, time, frequency, duty cycle and phase shift, and each cursor can be moved individually or dually in eight different directions. Both models provide "A" and "B" sweeps with delayed sweep and segment

magnification; TV sync coupling; camera-mount CRT bezel, variable scale illumination and single sweep operation for waveform photography; Z-axis input; and variable hold-off control.

Circle (87) on Reply Card

Portable vacuum

The Mini-turbo, available from *Jensen Tools*, is a 5-pound portable vacuum that moves 100 cubic feet of air per minute. It is constructed of high-impact plastic with a sealed ball-bearing motor and is powered by rechargeable Ni-Cd batteries, which are included. The vacuum features a permanent,

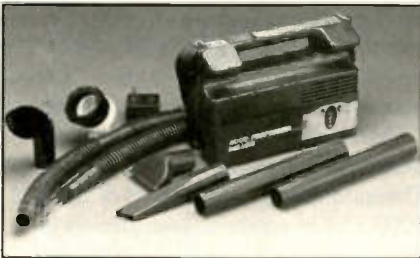

washable filter bag and six cleaning attachments: flexible hoses, an extension wand, a crevice tool, a needle-nose nozzle and brushes.

Circle (88) on Reply Card

Disk drive tester

The *Lynx* model 470, available from *HMC*, is a floppy disk drive tester designed to perform on-site realignment to a 100% accuracy level. The model is compatible with every make of 3½-, 5¼- and 8-inch disk drive and provides all standard alignment testing and exercising functions. All ranges required for amplitude, radial, index, track 0, head load and sector are incorporated, and power for the tester is supplied through the disk drive.

Circle (89) on Reply Card

Multimeters

The 200 Series of 3½-digit, professional-grade DMMs is available from *Beckman Industrial*. The autoranging meters feature a self-

resetting fuse on current ranges and an analog-to-digital converter for fast-range selection. Current ranges are 20mA, 200mA and 10A with 10µA resolution; ac voltage ranges are 200mV, 2V, 20V, 200V and 750V with resolution of 100µV. Both models have a 2.0% accuracy in the 45Hz to 1kHz band. The model 223 has audible readout that can detect intermittents, TTL and CMOS logic pulses to 50ns, and shorted or open capacitors.

Circle (90) on Reply Card

Digital storage oscilloscope

The Gould 400 digital storage oscilloscope from *Gould* features high-speed transient or repetitive signal capture. A sampling rate of 100MS/s is available on both input channels for single-shot capture with 8-bit analog, 10ns time resolution. The unit features trigger delays of up to 5,000 seconds with 20ns resolution; a pre-trigger facility with a range of 0-100%; an auto-setup function; on-screen cursors; post-

HOLD IT ANYWHERE YOU WANT IT!

PanaVise electronic work holding systems allow you to position, tilt and rotate your projects without removing them from their holding devices! With over 30 years experience and made-in-USA quality, PanaVise ensures reliable, long-lasting service.



MULTI-PURPOSE WORK CENTER: Self-Centering Extra Wide Opening Head (opens to 9"), famous "split ball" Standard Base (moves in three planes), and convenient Tray Base Mount (with parts wells) handle difficult to hold items with ease! Model #350.



STANDARD PANAVISE: Our most popular vise, the Standard PanaVise is an extremely versatile, useful workbench tool. Jaws open a full 2.25", and the patented "split ball" base tilts, turns and rotates through three planes. One convenient control knob locks work into any position! This durable, all-purpose mini-vise stands about 6" tall and will deliver years of rugged service. Model #301.



ELECTRONIC WORK CENTER: A complete combination to make work areas more efficient and manageable! Circuit Board Holder gently, but firmly, holds PCB's up to 12" wide. Add our Standard Base (moves in three planes), Tray Base Mount (with parts wells), and Solder Station (self-centers wire and holds iron at perfect angle) for a great combo! Model #324.

PANAVISE

See your local electronics supplier or contact PanaVise for the source nearest you:
PanaVise Products, Inc. 2850 E. 29th Street,
Long Beach, CA 90806. (213) 595-7621

Circle (24) on Reply Card

storage magnification; and storage and archiving capabilities. The oscilloscope is powered by ac, external dc or batteries.

Circle (91) on Reply Card

Computer screws

Curtis Computer Speed Screws, available from *Curtis Manufacturing*, are designed to replace conventional, slotted or Phillips metal screws used on PC chassis covers and internal add-on boards. The screws are available in two sizes: 8/32"×3/8", which are compatible to chassis covers on IBMs and PC clones, and 6/32"×3/8", which are compatible with internal add-on boards in all CPUs and Compaq chassis covers. They are packaged 20 to a bag, 10 of each size.

Circle (92) on Reply Card

Wrist strap tester

Desco has introduced a wrist strap tester that can be attached to a standard 10mm static mat snap, thus eliminating

the need for additional mat grounding cords. It can also be mounted on benches, bench legs or vertical uprights. Two

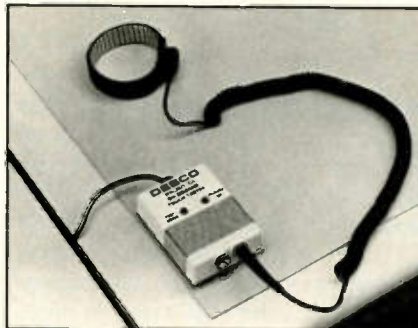

banana jacks are provided for proper grounding. The tester is a touch-type and will verify the proper connection each time it is lightly touched by a wrist strap wearer, even if the strap is not directly plugged into the unit.

Circle (93) on Reply Card

Surge protection system

The TeleSpiker series surge sup-

pressors/power line filters, available from *Kalglo Electronics*, provide integral protection for RJ-45/RJ-11 modular telephone jacks. They are designed to protect facsimile machines, modems and electronic telephones. The Mini-T is a compact, 2-outlet, plug-in system with Premium Protection circuitry. The unit has a less than 1ns response and is rated at 140V clamping, with a total of 436J energy absorption.

Circle (94) on Reply Card

Programmable counter/timer

The *Tektronix* DC 5004 programmable 100MHz counter/timer measures signals with dc frequencies to 100MHz, averages events with up to 1,000 counts, and totals up to 99,999,999 events for signals up to 10MHz. It also makes period measurements on signals up to 2.5MHz and makes width measurements on pulses as narrow as 200ns. The autoranging unit is part of the TM 5000 line of modular instruments and, when integrated into a TM 5000 main-

MOVING?

TAKE US WITH YOU.

Just peel off your subscription mailing label and attach it to the address change card inside this issue. Please allow 6-8 weeks to process your address change.



frame, can be used on the lab bench, as a portable test package, or rack-mounted for system/package application solutions.

Circle (95) on Reply Card

Disposable wrist strap

The 2209 disposable ground wrist strap from HMC provides the protection of a durable, multiuse strap for those who don't require the standard, reusable wrist strap. The 2209 features hypo-allergenic adhesive; self-sticking copper foil that adheres to any electrical ground to drain static; a $1M\Omega$ resistor; and a 4-foot, flexible working length.

Circle (96) on Reply Card

Static control kit

A static control companion kit for field service has been introduced by Jensen Tools to fit behind the upper pallet of tool cases or inside briefcases. The kit opens up to a 18"×24" static-dissipative work surface and includes a 5-foot grounding cord for the mat and an adjustable elastic wrist strap with a 4-foot ground cord for the user.

Circle (97) on Reply Card

Power amplifier analyzer

The PA81 stereo power amplifier

analyzer from Sencore finds problems in stereo and monaural audio power amplifiers. The unit features the required bandpass IHF/EIA audio filters; twin autoranged meters that measure wattage directly to 500W or up to 5,000W with the optional dummy load accessory; built-in, high-accuracy 2Ω , 4Ω , 8Ω , 16Ω and 32Ω , zero reactance loads; two internal speakers with volume control; an external input rms voltmeter and a dB meter; and a dc balance tester. A dB measuring function tests separation up to 126dB.

Circle (98) on Reply Card

Cleaning kit

Jensen Tools has introduced its lightweight, compact Circuit Board Contact Cleaning Kit. The kit includes a 4oz. bottle of Contact Cleaning Solution; a 4oz. bottle of Nyetact 518; 20 plastic foam-tip swabs; and 50 low-lint cotton wipes. An optional 30X illuminated microscope is also available.

Circle (99) on Reply Card

ES&T

KISS YOUR AIR COMPRESSOR GOOD-BYE!



Circle (25) on Reply Card

DUST-OFF™ PRO SYSTEM—THE ONE OF A KIND SYSTEM THAT DELIVERS THOUSANDS OF BLASTS AND TAKES TO THE ROAD!

- Blows away dust, dirt and other contaminants of the electronics world with safe, dry, triple-filtered blasting power you can control—from a gentle puff to a full blast!
- Unique, sure-shot dusting gun at the end of the Pro System's flexible 8 foot hose permits easy, single-handed operation at any angle—even inverted!
- Pro Dust-Off's industrial-size, replaceable 32 oz. canister travels easily from its wall-mounted or countertop bracket in the shop to any service location!

Welcome the Dust-Off Pro System into your shop and kiss your compressed air good-bye! Available through Jensen Tool or contact the Falcon Sales Department.

FALCON THE SAFE, DRY, CLEANING SYSTEM

Falcon Safety Products, Inc.
25 Chubb Way, P.O. Box 1299
Somerville, NJ 08876-1299
(201) 707-4900 • FAX (201) 707-8855

Sears 564.41692800
Photofact 1852-3

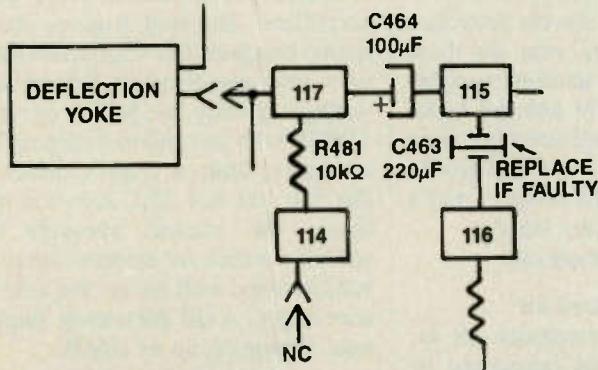

Symptom: Non-linear vertical foldover.
Cure: Check non-polar capacitor C463.

Sears 564.41730500-501-502
Photofact 1604-1

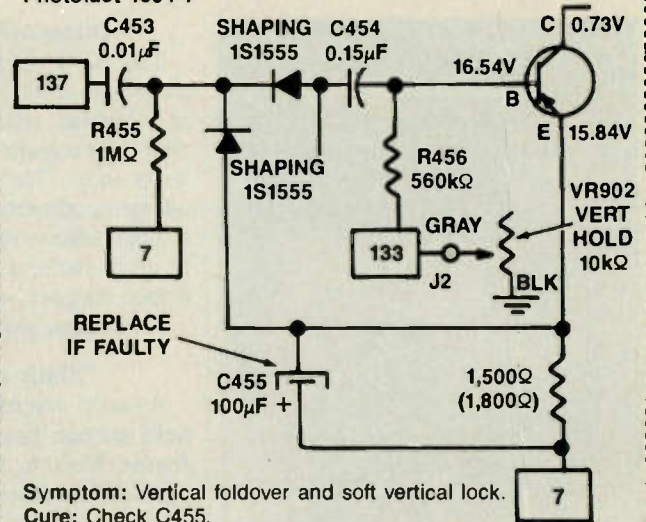

Symptom: Vertical foldover and soft vertical lock.
Cure: Check C455.

Sears 564.41692800
Photofact 1852-3

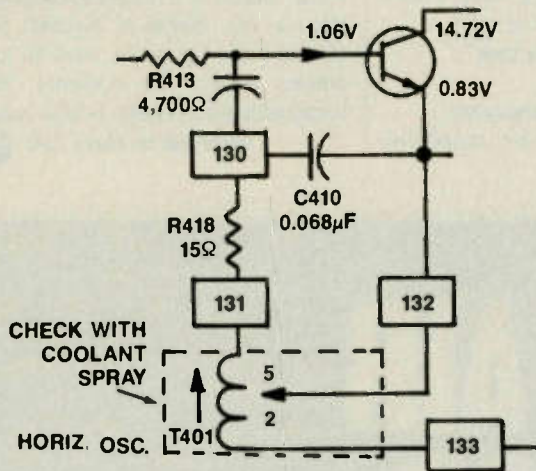

Symptom: Runs OK until it is warm, then loses horizontal sync.
Cure: Transformer T401 aging problem. Test with coolant spray.

Sears 564.41730500-501-502
Photofact 1604-1

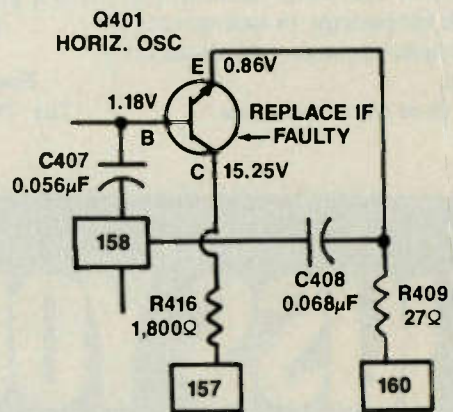

Symptom: Runs properly until it warms up, then stops.
Cure: Check Q401 with coolant spray.

Sears 564.41701502-503
Photofact 1604-1

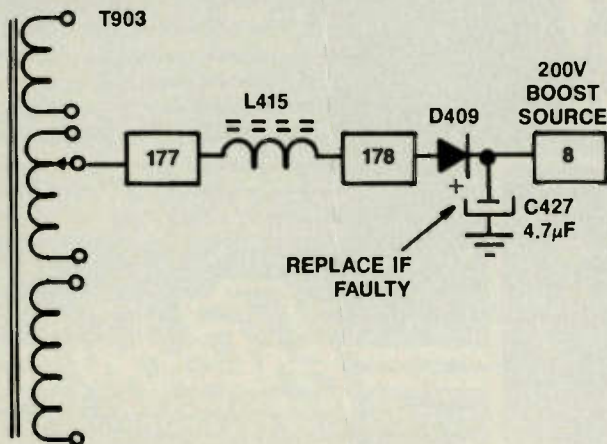

Symptom: Picture is OK, but it has retrace lines.
Cure: Check C427.

Sears 564.42160700
Photofact 1763-2

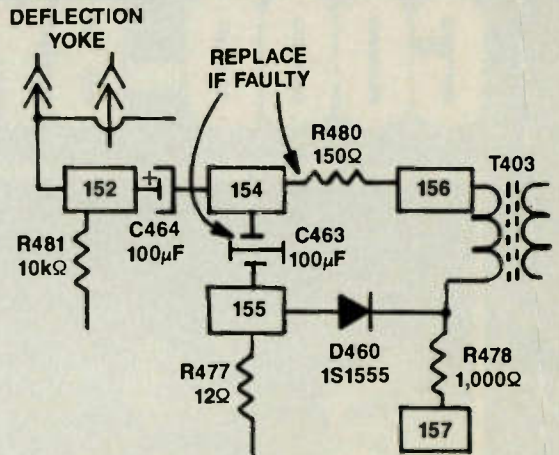

Symptom: No vertical sweep.
Cure: Check C463 and R480.

Answers to the quiz

Questions are on page 46.

1. 81+kHz. The formula is $f = 1/T$ (where T = time for one cycle = $37\mu\text{s}/3 = 12.3\mu\text{s}$):
 $f = 1/12.3 = 81\text{+kHz}$

2. A — When R3 is open, the base voltage becomes more positive. The emitter-collector current increases, so the emitter voltage becomes more positive.

3. About 17mA — A piecewise characteristic curve is shown in Figure F. The loadline, drawn between the open-circuit voltage and the short-circuit current of the Thevenin generator, crosses the piecewise curve to show a current of approximately 17mA. The voltage across the diode will be approximately 1.9V.

As with all graphical solutions, your answer might be slightly different. The accuracy of the drawing is the key to getting an accurate answer.

4. A — it will glow. The $1\text{k}\Omega$ resistor and the -80V supply do not have anything to do with solving this problem. The LED is connected between the 47Ω and 180Ω resistors. They form the voltage divider between the $+20\text{V}$ supply and common.

The key to determining whether or not the LED is on is that it must be connected to a voltage greater than

1.5V. That is the breakover voltage for an LED. In this case the voltage at the junction of the resistors is $47\Omega/(47\Omega+180\Omega) \times 20\text{V} = 4.14\text{V}$

so the LED is forward-biased and it glows.

5. B — Barium titanate. Niobium-tin is known for its low resistance at cryogenic temperatures; gallium arsenide is a material used in LEDs and other semiconductor devices.

6. B — a bootstrap configuration. A Q strap is used between stacked antennas to provide impedance matching to the transmission line. A bead ledge is used in tire molds designed to put white sidewalls on tire.

7. D — All of the choices. This is not the limit of uses for phase-locked loops.

8. A — a frequency value. Gain has no units of measurement, so when it is multiplied by bandwidth, which is measured in frequency, the result is a frequency.

9. About 0.148A — Constant-current generators are also called Norton generators. They produce the same amount of current regardless of the amount of resistive load. The current can be calculated by the reciprocal method as follows:

$$304\Omega/(304\Omega+520\Omega) \times 0.4\text{A} = 0.1475\text{A}$$

Another way to solve the problem is to note that the parallel resistance is 191.8Ω , so the voltage across the parallel resistance is $191.8\Omega \times 0.4\text{A} = 76.7\text{V}$. That voltage divided by 520Ω gives a current of 0.1475A.

10. C — A unilateral device conducts current in one direction only. Of course, any device will conduct if a sufficient amount of voltage is placed across it. A better definition of unilateral is that it is a device in which current flows more easily in one direction.

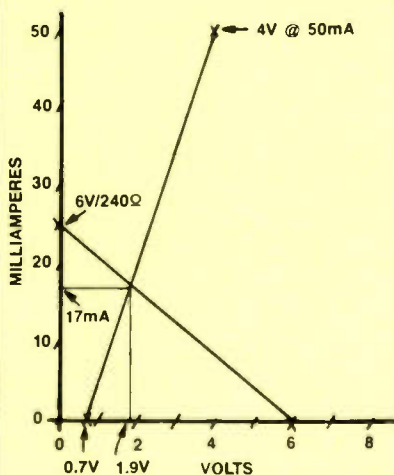

PRIME ELECTRONICS CO.

For All Your Electronic Parts & Accessories

WE'RE THE ONE . . .

- With over 10,000 Electronic Products
- With Everyday LOW Prices and Volume Discounts
- With 100% Guarantee On All Products
- With the PRB LINE of Replacement Belts and Tires

For Your Free Copy of Our New Catalog Call Toll-Free
1-800-558-9572

In Wisconsin 1-800-242-9553
 or for 24 Hour Ordering Call . . .
 FAX: 414-473-4727

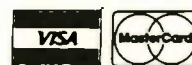

"First in Quality And Service"

PRIME ELECTRONICS CO.

P. O. Box 28
 Whitewater, Wisconsin 53190

Circle (26) on Reply Card



Your Ticket To

SUCCESS

Over 25,000 technicians have gained admittance worldwide as certified professionals. Let your ticket start opening doors for you.

IS CET offers Journeyman certification in Consumer Electronics, Industrial, Medical, Communications, MATV, Radar, Computer, and Video. For more information, contact the International Society of Certified Electronics Technicians, 2708 West Berry St., Fort Worth, TX 76109 • (817) 921-9101.

Name _____
 Address _____
 City _____
 State _____ Zip _____

Send material about IS CET and becoming certified.

Send one "Study Guide for the Associate Level CET Test." Enclosed is \$5 (+ \$1 postage).

Servicing the compact disc player – Part VIII

By Martin Clifford

This is the eighth part in a series on servicing compact disc players, based on *The Complete Compact Disc Player* by Martin Clifford (published by Prentice-Hall). This month we will continue our discussion of audio problems in CD players.

Ordering replacement parts

Replacement parts needed by service technicians can be ordered from the manufacturer's repair depots, but the fastest response is obtained if the parts are clearly and specifically identified. This information can be obtained from the manufacturer's servicing manuals or are supplied by companies furnishing detailed servicing along with schematics of the player.

Parts are identified by a reference number and a part code, followed by a description. In addition, you will need to supply the player's model number.

Inhospitable environment problems

As far as the CD player is concerned, a car or other vehicle can only be regarded as a hostile environment. Portable CDs experience the same problems. The most desirable location for the player is a secure, non-movable position in the home.

For the CD player to have an optimum opportunity to work well, it should not be exposed to direct sun and heat, high humidity, excessive dust or vibration.

CD players for cars sometimes have a built-in self-protection circuit. When the ambient temperature is over 120°F (50°C), the self-protection circuit functions and disables the player. This feature may cause anxious moments for the owner not familiar with this feature, and you might receive a request for servicing.

The car CD player may have a built-in shock absorber, but if you are doing an installation, you may want to add

your own in the form of rubber grommets or a small section of rubber sheet. Position these shock absorbers between the support brackets and the CD player. Extremely severe driving conditions could possibly interfere with playback. The operator should be advised about this problem and encouraged to turn the CD player off under such conditions.

Sound compression

The CD player may have a built-in sound compressor, which makes it possible to listen to CDs at a lower volume without losing quiet passages. Also, it is possible to make cassettes of CDs for car stereos and personal portables. (It should be understood that these cassettes are for personal use and not for resale.)

It may seem strange to have a compressor in a CD player, but in a noisy environment such as a car, pianissimo passages must compete with wind noise, car operating noises and passengers' conversation. This combination of sounds can often reach levels as high as 70dB. Without compression, if you set the volume of a CD so that you could hear these passages, the loudest passages would be deafening. Compressor circuitry helps keep the music being played in a range that is more practical for a car. It also makes it unnecessary to ride the gain on the volume control.

The best arrangement is to have a sound compressor that can be controlled by a switch positioned on the front panel, giving the user an option.

Accidental skipping

If part of a selection is skipped accidentally because of car vibration, play will return at once to the point where the skip began. If the fault is only the result of car vibration and the disc is in good condition, it will then be possible to listen to the entire disc.

If, on the other hand, the disc is the source of the trouble, the sound will

continuously skip and repeat. If that is the case, use the front-panel controls to move ahead to the next selection. When the opportunity presents itself, clean the disc and then try it again. If cleaning does not remove the problem, it is possible to continue using the disc, either by pressing the skip control when that selection is reached or by programming playing to skip the defective band automatically.

Checking de-emphasis

Definite values of de-emphasis are built into CD players. Using Sony's test disc, YEDS 2, the de-emphasis should be -0.37dB at 1kHz, -4.53dB at 5kHz and -9.04dB at 10kHz.

Line noise

Electrical noise in the form of voltage spikes (see Figure 1) can ride in on the power-line voltage. Although the line voltage is nominally 117V, the spikes can be in the order of several kilovolts peak-to-peak and are capable of causing considerable damage. The voltage spikes can be produced by lightning or can be generated by equipment connected to the line.

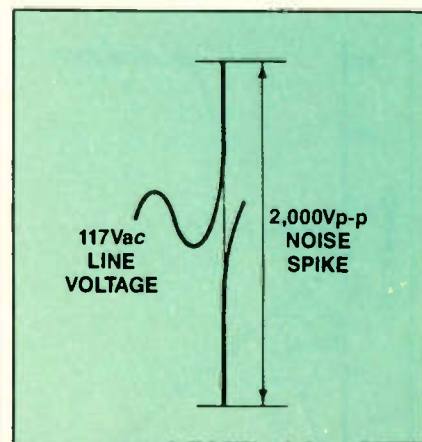

Figure 1. High-voltage electrical noise spikes can ride in on the power-line voltage. (Not drawn to scale.) Although the line voltage is nominally 117V, the spikes can be in the order of several kilovolts peak-to-peak and are capable of causing considerable damage.

Clifford, a freelance writer, has published more than 75 books on electronics.

Although the line frequency is 50Hz or 60Hz, voltage spikes can be any frequency and are usually much higher than that of the line. Protective filters are commercially available and can be inserted between the line cord of the CD player and the power line outlet (Figure 2).

The line filter is an L-C network and may include a one-to-one power transformer equipped with an electrostatic shield connected to ground. In the L-C circuit, the capacitors act to bypass the higher-frequency voltage pulses while the inductors have a high reactance to their passage. The values of capacitance and inductance are selected so they have little effect on the much lower frequency of the line voltage.

Dither

The music supplied by a phono record carries along with it the noise of the

prior tape-recording process. This noise is caused by the random distribution of the magnetized particles on the tape, which generates low-level signals, more familiarly known as tape hiss. As a result, when listening to a phono record

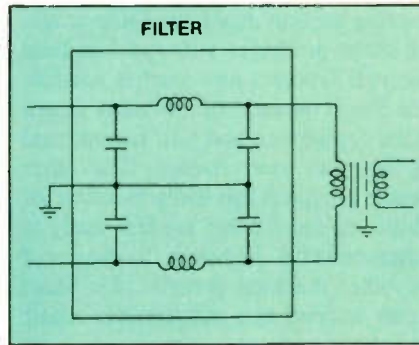



Figure 2. Although the line frequency is 50Hz or 60Hz, voltage spikes can be any frequency and are usually much higher than that of the line. Line noise filters can be inserted between the line cord of the CD player and the power line outlet.

we hear what could be referred to as a noise floor, most evident when the stylus tracks the unmodulated grooves of the record. During playing of the record, we may not be as conscious of the noise because of the *masking effect*, a condition in which noise seems to become inaudible when in the presence of a much louder sound.

Although we can hear a noise floor when listening to LPs, such noise is not present when we listen to compact disc playback. Some people who have installed CD players find this disturbing, so digital audio engineers have added random noise to CD masters, a technique known as *dither*.

Not all manufacturers engage in dithering, a technique that seems to work at cross purposes with the achievement of the compact disc. The sound supplied by the compact disc is practically identical with the original sound, an advantage negated by dithering. **ES&T**





Plug in!

To the NESDA system.

YOUR BUSINESS is in the world's fastest changing industry. If you're not careful, you could find your business in the dark.

But, you don't have to stay there.

Through a system of local, state, and regional groups, the National Electronics Sales & Service Dealers Assn. (NESDA) keeps members up-to-date with the fast pace of advancing technology while offering:

- ◆ Managerial and technical training.
- ◆ Business contacts.
- ◆ Technical and management certification.
- ◆ Information on new products.
- ◆ Legislative activities that affect the industry.

Don't be left in the dark. Let the NESDA system work FOR YOU!

For more information and an application, write to:
NESDA, 2708 W. Berry St., Ft. Worth, TX 76109; Ph (817) 921-9061

Name _____

Bus. Name _____

Address _____

State _____ Zip _____ Phone _____

Member of State Local Assn. _____

CUSTOM TOOL KITS FROM TOOL KIT SPECIALISTS



TKS customizing makes us special.

- Highest quality tools, cases and test equipment.
- Custom design at no extra charge.
- Kits for field service, technicians, assemblers, or hobbyists.
- TKS expertise and service.

Call for catalog
(800) 621-0854 Ext. 202

Inside California
call (408) 745-6020



TOOL KIT SPECIALISTS INC.
1366 Borregas Avenue
Sunnyvale, CA 94089

Circle (27) on Reply Card

Rebuilding VCRs

By Stephen J. Miller

Should we be repairing or rebuilding VCRs? That question is widely debated among technicians. Repairing involves merely replacing the already defective parts. Rebuilding replaces not only the presently defective parts but also those with failure rates that indicate they are soon likely to fail.

Many technicians are afraid that rebuilding units will deny them future repairs when these additional parts fail. An alternative argument is that customers will complain about the higher initial repair costs to rebuild their

The most important factor to the customer is the longevity of the repair. Turnaround time is the second most important, and repair costs are a distant third.

VCR. Although these are legitimate viewpoints, I have a different perspective. I believe that good repairs that last will result in numerous referrals generated by your satisfied customers, with an attendant increase in business and, thus, revenue.

What's important to the customer?

In my experience, the single most important factor to the customer is not price. The most important factor is the longevity of the repair. Turnaround time is the second most important, and repair costs are a distant third.

For example, consider two groups of my customers: owners of Sharp VC-481Us and owners of another VCR. Both groups of VCRs use the same drive idler assembly. All VCRs from both groups receive new idlers when I service them. The Sharp machines will, on average, run for 2.5 years before

needing another new idler. On average, the other machines will run less than one year before a new idler is needed. The Sharp owners will probably return to me for service and will recommend my shop to their friends. The other owners are much less likely to return for additional service and are less likely to recommend me. Although the owners of the other machine perceive this short repair interval as a substandard repair job, the actual reason has to do with shortcomings in the design of the VCR.

The customer doesn't care about design flaws, however, or the fact that the present problem is unrelated to a previous repair. All that matters to the customer is that the machine is again in for service. In general, my customers will regard my repair work as poor if the unit requires any additional work within a year. If the unit does not require additional service for at least two years, I find that most customers will regard the work as excellent.

Assembling a rebuild kit

Rebuilding a unit with a repair history that justifies it, rather than just repairing it, helps ensure better repair longevity and a better level of customer satisfaction. Parts to be included in a rebuilding job are simply those parts that routinely fail in that particular model. These parts normally are inexpensive mechanical parts such as idlers and belts. Any part with a history of intermittent failure should be included in rebuilding a unit. For example, many RCA and Fisher VCRs develop problems with either the drive idler or the loading belt. I make it a practice never to replace just the idler or the loading belt. I always replace both at the same time. Should one of these machines need new video heads or other major part, I always automatically change the idler and loading belt as well. I try to maintain a service log on the various models that I service. From these records, I track high failure-rate parts and develop my *rebuild kits*. Rebuild

kits or procedures need not be extensive to be effective. Include only those items that your case histories have shown to have a high failure rate.

Specific rebuild kits

Sometimes a simple circuit modification is required. A good example is a problem with the Sharp VCR models VC-582U, VC-583U/UB and VC-585U. These machines develop "no audio record" problems because of an intermittent connection between the full-erase head and its plug. Under the right conditions, this loose connector can cause Q601, Q602, R602 and T601 to be damaged.

To prevent repeat failures of these parts, Sharp recommends that the full-erase head plug be removed and the wires soldered directly to the head. I remove this plug on all units of these models, regardless of the reason service was requested. The modification takes only a moment and saves the customer from future problems with the record oscillator circuit. Two later model years of Sharp machines, listed in Table 1, also have problems with this full-erase head connector. In these machines, the complaint is, again, "won't record audio." In these units, though, no parts are damaged when the connector is intermittent in these models. Even so, I routinely remove the connector and hand solder the connections in these units also.

Circuit adjustment or realignment should be performed on those units with repair histories to indicate it. Many VCRs suffer from drifting FM envelope alignment because of loose loading posts. In some older models, such as the RCA VJT275, servo realignment is necessary as the unit ages.

In addition to intermittent safety-tab switch problems (which we will discuss in more detail next month), both the 1985 and 1986 Matsushita models have had problems with noisy mode switches. In the 1985 line, a noisy mode switch will cause the unit to act erratically, fail

Miller is a senior bench technician for a Lancaster, PA, repair company.

to load the tape, and often enter an operational mode the user didn't request. Noisy mode switches in the 1986 line may confuse the system-control microprocessor, IC6001, with bad data. The microprocessor will then erroneously turn on the carriage motor, causing the motor to overheat and melt the side of the carriage assembly. In units where the carriage assembly is already damaged, Matsushita recommends replacing the melted carriage side, the carriage motor, the motor drive IC, the system-control microprocessor and the mode switch. In units that have not yet failed, I routinely replace the old mode switch with the new redesigned version. To date, I have not had any of

Table 1
Sharp model numbers

VC-7842U	VC-2200U
VC-7843U	VC-A102U
VC-7844U	VC-A103U
VC-7846U	VC-A201U
VC-785U	VC-A500U
VC-7855U	VC-A600U
VC-7864U	VC-A601U
VC-787U	XA-101
VC-797U	XA-200
VC-7977U	XA-205
VC-7995U	

these rebuilt units return with the melted carriage problem. Replacing the drive idler, safety tab switch and mode switch will rebuild many of these Matsushita models.

One final way to ensure that your repairs hold up is to use only quality replacement parts. You sometimes will have to insist that the parts be from the OEM or original equipment manufacturer. Many good after-market parts exist. However, many poor after-market parts do also. It's very easy to get cheated with inferior after-market parts, such as belts and idlers. These parts cost you much more in repeat service calls than they save you on the initial wholesale price, so shop wisely. **ES&T**

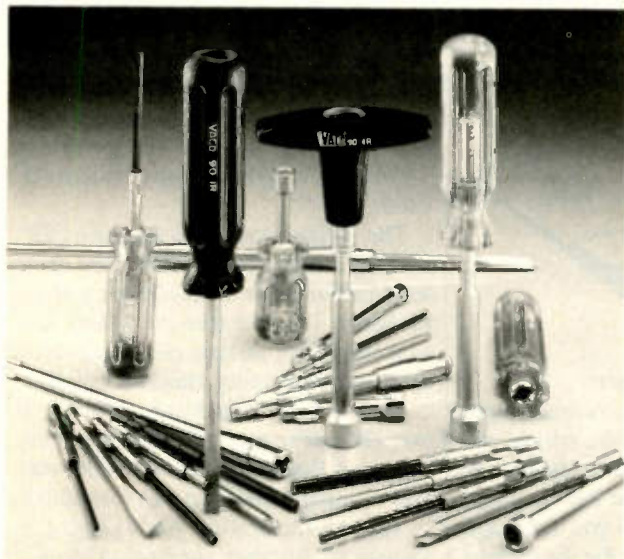

76 Vaco Vacombo® convenient, compact handles and blades fill most of your tool needs

Individual blades and handles...and multi-tool pouch kits:

- Screwdrivers • Nut drivers • Hex keys

Quickly exchange and combine handles, extensions, and blades in the field. Tight, precision fit. Durable vinyl pouches. Tools built for a lifetime. See your VACO distributor.

Send for
FREE CATALOG

VACO®

7200 McCormick Blvd.
Chicago, IL 60645

Circle (28) on Reply Card

**Presenting
an affordable
Light Box System.**

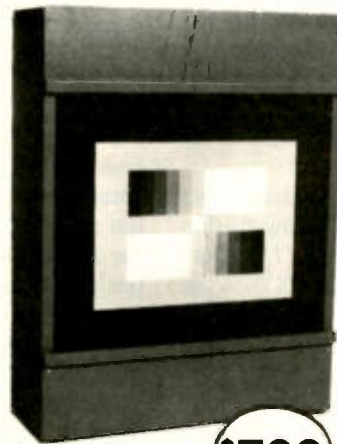

\$799

The method most
manufacturers recommend

Model TR100 CB
Camera Light Box
with (2) transparencies

- (2) 3200° Kelvin Lamps (meets mfr. spec.)
- 1-year conditional guarantee
- Transparencies mounted in acrylic with optical scratch-resistant surface
- 11-step gray scale transparency
- 7-Bar color transparency
- All orders are shipped within 72 hours, U.P.S.

KUTRONIX (313) 939-2740



P.O. Box 77103 • Sterling Hts., MI 48077



Circle (29) on Reply Card

Diagnosing phantom floppy-disk-drive problems

By Conrad Persson

The other day, I formatted a floppy disk at 1.2Mbytes. When I finished I got the message:

Format complete

1213952 bytes total disk space
107520 bytes in bad sectors
1106432 bytes available on disk

It seemed to me that because nearly 10% of the total disk space was in bad sectors, there must be a problem with the disk. In the past such a message hadn't caused me any concern, but I was sensitive to the quality of our disks after another member of the editorial staff had had at least two of a box of ten disks fail to format at all. I thought we had another bad batch.

My first step was to call the computer support specialist — the individual in the company in charge of contracting for computer maintenance, as well as buying and inventorying disks — to suggest that he might want to find another disk source. He suggested that the problem might be the disk drive heads in my machine and that I might want to try cleaning the heads.

That seemed like a reasonable possibility, so instead of taking further action to condemn the disks, I checked the same disk on two other XTs in the office. The results were interesting. In both cases, the message that appeared on the screen after the format was complete said that some of the bytes on the disk were in bad sectors, but in both cases the number of bytes in bad sectors were fewer than had been the case when I formatted the disk on my machine.

Being curious and wanting to have a complete scientific look at the situation,

I formatted the disk again on my drive and again I got a message that nearly ten percent of the bytes were in bad sectors.

The next step, of course, was to try cleaning the heads. Here in the office we have a head-cleaning system that uses a mildly abrasive disk. To use it, you place the disk in the floppy disk drive and start the computer up, or if the computer is already running, you do a warm boot. After I cleaned the heads, I tried again to format the disk. The results were disappointing: no improvement. In fact, the number of bytes in bad

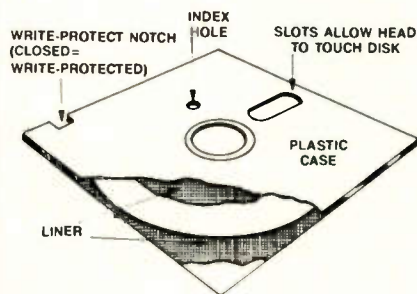

sectors was a little higher.

I have a disk-cleaning system of my own that uses a fiber disk, which you spray with a solvent. Putting the disk in the drive and closing the handle starts the drive, and it runs until you disengage the handle. I ran the disk for the recommended 30 seconds, waited a minute or two to make sure any solvent had evaporated, and did a format once more.

Disappointment again. The number of bytes in bad sectors was in the same range as it had been to start with.

That evening I brought the disk home and did a format on my own system. The message that appeared on the screen this time was:

1213952 bytes total disk space
1213952 bytes available on disk.

Naturally, my conclusion was that something was wrong with the disk drive on the computer in my office, so I again called our computer support specialist and described the results of my investigation. He called out our computer maintenance company.

A few days later the computer maintenance man came to check out the problem. He tried formatting a disk and got the same results as I had. His comments surprised me, though. I had been under the impression that our standard, double-sided, double-density disks are of a high enough grade to be formatted to the 1.2Mbytes that our disk drives are capable of. That turns out not to be the case. The 2S/2D disks we use format perfectly (when the disks are not faulty) at 320kbytes, but to format at 1.2Mbytes, a high-density disk must be used.

The maintenance man then tried formatting a high-density disk. The drive formatted the disk at 1.2Mbytes with no problem. To make sure everything was as it should be, he then ran a diagnostic disk and everything checked out fine.

The moral of this lesson is clear: If you encounter a problem with formatting on a floppy disk drive, make sure you're using a disk that was formulated to support the density you're trying to format at. Another conclusion here is that different floppy disk drives will give you different results during formatting, even though they're all within specification. Knowing this may keep you from chasing a phantom problem that doesn't exist at all.

One thing still troubles me, though, and I'll do some more research into it and report on it here. If my own disk drive formatted the disk, on which it's almost certain there are some bad sectors, will I eventually lose some data?

ES&T

Persson is editor of ES&T.

Readers' Exchange

Editor's Note: Readers' Exchange items are published in the order they are received. We are happy to offer this service at no charge to you, our readers, but we ask that:

- Items are typed (or legibly written).
- You include your name and address on the same page as your ad (envelopes and contents are often separated). Please also include your telephone number (specify if you don't want it published). Using your peel-off label or a return label is a good idea.
- You limit any ad to no more than three items. If space demands, ads will be edited to roughly four lines in the magazine.
- Mail to: Readers' Exchange, Electronic Servicing & Technology, P.O. Box 12901, Overland Park, KS 66212.

Please remember that ES&T is in production six weeks to two months ahead of publication date. To get your ad in the May issue, for example, you should get your ad in by the last week in March.

WANTED

Any Flying-Spot test equipment such as a B&K 1000, 1076, others; TEK NTSC signal generator #146; Teletex decoder for TV. All reasonable. *D. Test, P.O. Box 9064, Newark, NJ 07104.*

Schematics and parts list for Midland VCR model 15-928 and 15-930. Send price. *Jim Mourick, Mourick TV, Rt. 3, Box 337, Mountain View, MO 65548; 417-934-2940.*

Schematic for B&K model 1474 oscilloscope. Will pay all costs. *George Meserve, Capital Comm Inc., 2721 Raintree Circle, Tallahassee, FL 32308; 904-576-7113 days, 904-386-7036 after 5 p.m. EST.*

Flyback transformer for RCA model FD500W, part no. 145800. Quote price. *Sam Marvosh, 514 Dunbar Drive, Henderson, NV 89014.*

Schematic and service information for Pioneer KPA200 car stereo, must include part numbers (photocopy will do); NRI or ICS servicing courses (especially VCR). *Jeffrey Brady, 35 Herrs Ridge Road, Gettysburg, PA 17325; 717-846-9827.*

Source for the high-voltage coil/transformer in Ram electronic igniter. *Mike McLay, 925 W. Brentwood Lane, Glendale, WI 53217; 414-352-5739.*

Electronics student needs a good, used single- or dual-trace oscilloscope. Will pay up to \$100. *Thomas Schloeder, 2515 W. Pecos Ave., Mesa, AZ 85202.*

VHF 150-174MHz mobile transceivers, solid-state, under-dash only, ANY condition. Quote price and

condition. *Jerry's Radio Service, 409 S. Oklahoma St., Shamrock, TX 79079; 806-256-3405.*

Sencore model CB42 CB analyzer. *Louis S. Parkansky, 315 Main St., Marinette, WI 54143; 715-732-2052.*

RCA model WC-528B and RCA model WT-524A test equipment in A-1 condition. Send prices. *Paul Capito, 637 W. 21st St., Erie, PA 16502.*

Oscilloscope display CRT for Marantz 18 stereo receiver. *Robert Carlough, 22310 Sands Point Drive, Boca Raton, FL 33433; 407-488-3467.*

Copy of the original system disk for Toshiba model T-250 computer. Must contain all original files, including assembly language. CP/M version 2.20. Will supply disk and a fee for copying if required. *Paul J. Fanelli, 4305 Furman Ave. #5D, Bronx, NY 10466; 212-325-8003.*

Schematic and IC chip 141099 for a GTR Organtron 4A organ; schematic and selector switch for a Keystone 100 8mm projector. *L.E. McHenry, 6225 N. 20th Lane, Phoenix, AZ 85015; 602-249-2325.*

For old Zenith — 20X1 12-inch set vert opt. 79B24-1 — sub with Stancor A-8112 — Merit
Continued on page 62.

LEARN VCR CLEANING/MAINTENANCE/REPAIR

EARN UP TO \$1000 A WEEK, WORKING PART TIME FROM YOUR OWN HOME!



EARN UP TO \$60 AN HOUR AND MORE!

THE MONEYMAKING OPPORTUNITY OF THE 1990's

IF you are able to work with common small hand tools, and are familiar with basic electronics (i.e. able to use voltmeter, understand DC electronics)...

IF you possess average mechanical ability, and have a VCR on which to practice and learn...then we can teach YOU VCR maintenance and repair!

FACT: up to 90% of ALL VCR malfunctions are due to simple MECHANICAL or ELECTRO-MECHANICAL breakdowns!

FACT: over 77 million VCRs in use today nationwide! Average VCR needs service or repair every 12 to 18 months!

Viejo's 400 PAGE TRAINING MANUAL (over 500 photos and illustrations) and AWARD-WINNING VIDEO TRAINING TAPE reveals the SECRETS of VCR maintenance and repair - "real-world" information that is NOT available elsewhere!

Also includes all the info you'll need regarding the BUSINESS-SIDE of running a successful service operation!

FREE INFORMATION

CALL TOLL-FREE 1-800-537-0589
Or write to: Viejo Publications,
3540 Wilshire Bl., STE 310
Los Angeles, CA 90010, Dept. EST

Circle (30) on Reply Card

ATTENTION TECHNICIANS

- ★ JOB OPENINGS
- ★ MONTHLY TECHNICAL TRAINING PROGRAM
- ★ BUSINESS MANAGEMENT TRAINING
- ★ SDC SATELLITE NEWS
- ★ CERTIFICATION
- ★ TECHNICAL SEMINARS

All of this in a nonprofit international association for technicians

FIND OUT MORE:



604 N. Jackson St.
Greencastle, IN 46135
1-800-359-6706

CONSOLIDATED ELECTRONICS

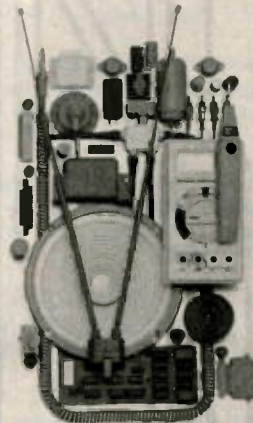

CONSUMER & INDUSTRIAL ELECTRONICS CATALOG • 17TH EDITION

THE ULTIMATE ELECTRONICS CATALOG.

Order your 260 page catalogue packed with over 10,000 money saving electronic parts and equipment. Send \$3.00 check or money order, or call 1-800-543-3568 today and use your Mastercard or Visa.
Consolidated Electronics, Incorporated
705 Watervliet Ave., Dayton, Ohio 45420-2599

NAME _____
ADDRESS _____
CITY _____
STATE _____ ZIP _____

Circle (31) on Reply Card

Readers' Exchange

A3036 — Chicago TS05. *M.E. Andrews Jr.*, 89 Ten Rod Road, P.O. Box 491, Exeter, RI 02822.

Schematic or service information for Senator AM/FM stereo, manufactured by Space-Tone in 1962. Need rectifier tube number. Will pay copying, postage, etc. *Joseph F. Barcsansky*, 7 Savoy St., Hamden, CT 06514.

Any info, schematic, specs, hook-up data, etc., for RGB color monitor model CMC-122, TCP P/N 25913-016, mfg. by Daewoo Electronics (Korea). *Robert Miller*, Rt. 1, Box 223, Anadarko, OK 73005; 405-247-6553.

1950 Admiral combo unit 32x35A (TV CH. 20Z1) fine tuning knob, picture knob, Sams set #100, Telematic #CR-59 plug-in retrace eraser. *J. De Lasse*, 17 Seldin Ave., Richmond, NY 10314; 718-981-1218/761-6559.

Xerox copy or original schematic for Capehart console stereo model 7005AT8 (number must be exact). I'm only interested in the audio amplifier section. I am willing to pay \$7. *Augustine's TV*, 530 N. Ninth St., Reading, PA 19604; 215-372-5438.

Transistor test data sheet for Precision model 660 apparatus tube and transistor tester. *Ross Mensik, Jr.*, 7505 Hemlock St., Crystal Lake, IL 60014; 815-455-4092.

Owner's manual and schematics for Motorola test set P-8501-A; literature pertaining to U.S. Army "A.C. portable generating set, M-5," engine is Hercules model ZXB, generator made by Hobart Mfg. Co., no model number. Copies OK. Will pay any reasonable fees. *Darrell Stafford*, FBN Electronics, 363 E. Teton, Shelby, MT 59474; 406-434-5768.

Information or parts for an FM-stereo MPX adapter for a Blaupunkt type 11153 ser. no. E243640 console radio. *Dennis Hoey*, 634 Walnut St., Lansdale, PA 19446; 215-855-7726.

Symcure Vol. II and III; Knight 83YX137 AF generator; Tekfax #100 through #105. *Charles T. Huith*, 229 Melmore St., Tiffin, OH 44883; 419-448-0007.

Recent TV servicing course by NRI, CIE, etc.; two flybacks: Sony #1-439-254-II and Panasonic TLF 14712F. *Ed Herbert*, 410 N. Third St., Minersville, PA 17954.

B&K oscilloscope, 15+20MHz. *A.A. Salim*, 2088 Anthony Ave., Bronx, NY 10457; 212-364-3917 or 295-8296.

Catalin radios — Multicolored tube-type radios from the late 1930s and 1940s made with Catalin (colored Bakelite plastic) cabinets. Will pay up to \$500 each depending on style and condition. (Tony from Alberta, Canada — please call me again regarding Sparton mirrored radio.) *Doug Heimstead*, 1349 Hillcrest Drive, Fridley, MN 55432; 612-571-1387.

Mills jukebox service manual for Mills Constellation or model 951 jukebox. Will copy and return or purchase outright. *Mike Zuccaro*, Voice & Video, 5038 Ruffier St., San Diego, CA 92111; 619-271-8294 evenings and weekends.

Sams Scanner manual #SD-5. Will pay reasonable fee. *B.G. Staples*, 275 Colwick Road, Rochester, NY 14624; 716-247-6509.

Sams Photofacts above #1900. Send your list and price. *Jennings Hanson*, 735 Clematis Road, Venice, FL 34293; 813-497-0108.

An out-of-print service manual for a Technics SL1400 MK2 single-play turntable. *Kerry Keel*, P.O. Box 686, Fort Mill, SC 29715.

Flyback transformer, part number RTRNF-1214CEZZ for Sharp 19-inch color TV, model 19F72. *John Brouzakis*, 247 Valley Circle, Charleroi, PA 15022; 412-483-3072.

Servicing diagrams for Diehl Mark III, IV and VII-e. *Eric P. Smith*, 1812 33rd St., Zion, IL 60099; 312-872-5753.

Flyback transformer (T402), P/N 50-3015344-2, for 19-inch Philco model C2909MW color TV (Sams 2028-3); Heathkit IMA-100-10 high-voltage probe. Send prices. *Scott Cohen*, 4640 N. Britain Pl., Tucson, AZ 85705; 602-887-6387.

FOR SALE

Heath 10-4510 15MHz dual-trace scope, 45MHz bandpass and Heath IG 4505 calibrator, with probes and manuals, like new, both for \$325; Viz WR 515B color generator, hardly used. \$200; B&K model 465 CRT tester/analyzer with Dandy Dapter, \$200; B&K 1077B TV Analyst, complete, \$175. Add UPS. *B.F. Church*, 1157 White Ave., Grand Junction, CO 81501; 303-245-7693.

Sams Photofact sets #69 through #496. \$1 each or all 275 sets for \$100 plus shipping. *John Brouzakis*, 247 Valley Circle, Charleroi, PA 15022; 412-483-3072.

Antique radios; more than 200 new and used tubes; Rider service manuals; test equipment; old Photofacts; parts — a small pickup truck load — all for \$250 or trade for ham SSB rig. *Jerry Allnoch*, 311 Gentilly Road, Statesboro, GA 30458; 912-764-5794 (evenings).

Sencore VC63 VCR test accessory with manuals, like new, never used. \$350. *Clarence G. McKee*, 9516 Zion Road, Rives Jct., MI 49277; 517-569-3139.

Oscilloscope; Tektronix C-12 instant camera w/hood; microfiche reader. Realist Co. 13" x 19" screen for table-top, like new, \$90 delivered within 50 miles; pocket tube tester, \$7 each, postage paid. *D. Test*, P.O. Box 9064, Newark, NJ 07104.

Chicago Case Indestruco model attache-type tool case for electronic field service technicians, black, 8-inch depth, excellent condition, includes two tool pallets (tools not included!), \$60 firm. I pay shipping. Money order only. *James Cicatello*, Major Magic, 35 Saber Lane, Amherst, NY 14221.

Philco dial belt kit, consists of 80 assorted woven fabric belts in steel cabinet (replacements for dial belts used in pre-WWII radios — replacement index included), excellent condition, \$20 plus UPS costs. *William A. Thoma*, 762 Silverleaf Drive,

Dayton, OH 45431; 513-253-9706.

New RCA receiving tubes, 75% discount from list. Send SASE for list. *James Vandemark*, Box 3472, Santa Rosa, CA 95402.

Sams Photofacts #1000 to #2295, many unopened, plus duplicates, \$3.50 each; test equipment: Sencore, Hickok, RCA, Leader, H.P., etc.; RCA CRT tester for vintage tubes, \$40; Philco Invicta, \$300. Add shipping. *Walter J. Froehlich*, P.O. Box 271, Westfield, NJ 07091; 201-232-3867.

Sencore SC60 oscilloscope, will read to 100MHz, includes all probes and manuals, brand new, still in box, \$750; B&K model 415 sweep marker generator with all cables and manuals, like new, \$85; Fluke 77 DVM, still in box, \$85 new; RCA WR-50B RF generator, like new, \$50; Micronta FET analog meter, \$40 new; Eico model 324 RF generator, works good, \$25. All items in excellent condition. Add shipping. *Gordon E. Lane*, 239 Jacksonian Drive, Hermitage, TN 37076; 615-889-6195 (no collect calls, please).

Hitachi model V355 35MHz dual-trace scope, like new, in box, \$475; Diehl Super Tech Mark V, excellent working condition, best offer. *Tom Malco*, P.O. Box 971, Baytown, TX 77522; 713-424-2744 evenings.

Sony ¼ U-Matic VCRs; model VO-2630 PAL/SECAM recorder; model VO-1600 NTSC recorder. *Robert Carlough*, 22310 Sands Point Drive, Boca Raton, FL 33433; 407-488-3467.

Thousands of new resistors, capacitors, diodes, ICs; used equipment. Send SASE for list. Best offer — swap — trade. You make the deal. Don't delay — I need the space. *Len Powell*, 985 Ridge Road, Finksburg, MD 21048.

Eastern New Mexico TV/VCR/audio business closing, nice building and showroom available for lease; test equipment: Tektronix, Leader, Sencore, B&K, RCA, etc.; service manuals: 25 years TV/VCR/audio OEM manuals for RCA, Quasar, Zenith, Sony; Sams #900-#1500; all office equipment and furniture, plus up-to-date extensive parts inventories with on-line data base. Send SASE for list. *Miller TV*, P.O. Box 364, Portales, NM 88130; answering machine: 505-356-4207 (open Saturday a.m. only).

Sencore TF46 Super Cricket portable transistor and FET tester, \$325; Sencore LC75 portable Z Meter II capacitor/inductor analyzer, \$675; Sencore NT64 NTSC pattern generator for VA62, \$275. All like new with manuals. UPS COD cash only. *Rob's Video*, 3100 S. Georgia, Amarillo, TX 79109; 806-352-6699.

Browning Golden Eagle Mark IV AM/SSB citizen's band receiver, superb performance — tube-type double conversion, low noise, two tunable bands or crystal-controlled. Use on CB, retune for 10 meters or use as tunable IF for 2-meter, satellite or microwave receiver. Missing top cover, but otherwise complete and working, includes schematic, \$100. *Peter Ferrand*, 65 Ather-ton Ave., Nashua, NH 03060; 603-889-1067.

Sencore equipment: VA48 video analyzer, TR219 drive isolation transformer, LC52 Z Meter,

SCR224 SCR/TRIAC test accessory, FC221 field calibrator; B&K 467 CRT analyzer, Dandy Picture Tube Adapter; Telematic SG785 Ferret tuner subber; VCR alignment tools; assorted Sams. Make offer. *John Dews, 4608 Churtres Lane, Montgomery, AL 36116; 205-288-8479.*

Sencore VA62, including VC63 and TP212 10kV probe, excellent condition, in original box, with manuals, \$2,800; B&K model 1035 wow-flutter meter, almost new condition, with manuals, \$450; B&K model 470 CRT tester-rejuvenator with adapters and manuals, very good condition, \$175. *Eric Kehew, 2907-B Cedar Creek Road, Greenville, NC 27834; 919-752-7245.*

Service manuals — large shop has 18-year collection of duplicates, all original manufacturer, all new. Audio, \$2; video, \$5. Send SASE for list. *Tape Recorder Clinic, 4850 E. Speedway, Tucson, AZ 85712.*

RCA TV service manuals for 1980, 1984, 1985 (purchased for \$156.65); RCA VCR service manuals for 1982, 1983, 1984 (purchased for \$227.55). Never used. Best offer will be accepted. *KASC, 145 70th Ave. S., St. Cloud, MN 56301; 612-255-1180.*

Fluke model 21, new, used only once, \$90 plus shipping. *Stanley Todorow, G8468 Belle Bluff Drive, Grand Blanc, MI 48439; 313-695-0271.*

B&K 1481 oscilloscope, \$140; B&K dual-trace scope, \$150; Hickok Chroma-ligner, \$79; Simpson 498A field-strength meter, \$90 — all working condition (add \$15 for shipping on each); old radio-TV tubes, must send needs and SASE; 10J106B RCA test jig and many adapters, \$175. *Maurer TV, 29 S. Fourth St., Lebanon, PA 17042; 717-272-2481.*

Owner relocating — service manuals (Sams, Quasar, NAP); test equipment; tubes; parts inventory; merchandise inventory; office equipment; many miscellaneous items; van; building and property. Great hunting and fishing area. Building adaptable to many uses. *R.N. Yasko, Fremont TV, 407 E. Main St., Fremont, WI 54940; 414-446-2239.*

Out of business — complete set of Sams, VCR Sams, MHF and Computerfacts, with file cabinets, all to March 1989; complete line of ECG semis. Secore and B&K equipment, priced to sell. *Douglas Darrow, State of the Art TV, 15053 E. Mississippi, Aurora, CO 80012; 303-690-8480 evenings.*

Sencore VA62, VC63, NT64 and EX231, 1-year old, take over payments, like new; Sams with file cabinets, #961-#2207, make offer; microfiche and paper for GE/RCA, '87-'88-'89 years VCR and TV. *Mike Kayala, 812 Front, Brainerd, MN 56401; 218-829-0124.*

Sencore SC61 in original shipping box, with manual and cables, \$2,100; Sencore CG25 in original box, \$90. Both in excellent condition. Add shipping. *C. Johnson, 2384 Shadow Hill, Riverside, CA 92506; 714-684-5583.*

TV Photofacts, VCRfacts and MHF, TSM, AR, TR manuals. Thousands available, priced from \$1 each and up. Will sell individually or all in one lot. Send \$2 for numbers list, refundable with a purchase. *H.L. Morrison, P.O. Box 199, Stony Point, NC 28678.*

New B&K 467 rejuvenators; yoke/flyback tester with high-voltage probe (never used); Beckman Tech 300 DMM, 100's stk; audio IC chips and transistors, etc. Best offer. *A.A. Salim, 2088 Anthony Ave., Bronx, NY 10457; 212-364-3917 or 295-8296.*

Sams TV Photofacts from #250 to #600, \$125 for all; Sams TV Photofacts — 86 misc. #1300 through #1828, \$2.50 each or all for \$175 (send SASE for list). Add shipping. *Jennings Hanson, 735 Clematis Road, Venice, FL 34293; 813-497-0108.*

NRI TV and advanced video servicing texts, 27 lessons, \$130 Canadian funds. *J. Hillrich, 732 Queen St., Regina, Saskatchewan, Canada S4T 4A3; 306-757-5458.*

ES&T

Classified

Advertising rates in the Classified Section are \$1.65 per word, per insertion, and must be accompanied by payment to insure publication.

Each initial or abbreviation counts as a full word.

Minimum classified charge \$35.00.

For ads on which replies are sent to us for forwarding (blind ads), there is an additional charge of \$40.00 per insertion to cover department number, processing of replies, and mailing costs.

Classified columns are not open to advertising of any products regularly produced by manufacturers unless used and no longer owned by the manufacturer or distributor.

FOR SALE

VHS-VCR Repair Solutions Volumes I, II, III, IV. Each contains 150 symptoms and cures, cross reference chart, free assistance. Each \$11.95, any two \$19.95, any three \$29.95, all \$39.95. *Eagle Electronics, 52053 Locks Lane, Granger, IN 46530. 01-89-TFN*

TV/VCR TUFF TIPS listed by mfg. & model. Over 400 tips. \$21.95. TV Tips only \$11.95, VCR Tips only \$13.95. **VCR CROSS-REFERENCE** listing for electronically similar manufacturers, RCA, GE, Sylvania, Panasonic, Quasar, Magnavox, Philco, & J.C. Penney, \$19.95. **TV/VCR FAILURE HISTORIES.** Multiple cures for most problem areas. Send \$7.95 with mfg. and model number. Money will be refunded with free sample if model is not on database. Add \$1.50 postage and handling. **TECH CURES,** 4825 Fredericksburg Road, San Antonio, Texas 78229. 12-88-TFN

PHOTOFACTS: Folders under #1400, \$4.00. Above #1400, \$6.00. Sent same day first-class postpaid. *Loeb, 414 Chestnut Lane, East Meadow, NY 11554. 3-89-3t*

TV TOUGH DOGS: 300 symptoms and cures. Send \$8.95 to **DAVIS TV,** 11772 Old Fashion Way, Garden Grove, CA 92640. 10-87-tfn

REDUCED 75%, Diehl Mark V scanner \$249, Diehl Mark III scanner \$99. New. 2805 University Ave., Madison, Wis. 53705, 608-238-4629, 608-233-9741. 3-89-tfn

SONY-TRINITRON Rebuilt Picture Tubes are now available. All tubes shipped U.P.S. No Charge. We buy all Sony duds. *Rochester Kinescope, 716-235-0750. 3-89-tfn*

SENCORE EQUIPMENT FOR SALE: SC-61 oscilloscope \$2,200; SG-165 Stereo Analyzer \$900; PR57 Variable Isolation Transformer \$350; DVM37 Ohm-Volt-Amp Meter \$250. Call 402-352-5317. 4-89-2t

TV TROUBLESHOOTING: 300 PROBLEMS/SOLUTIONS. 3 VOLUME SET. NOTHING OLD LISTED. \$12.00 PER SET OR \$5.00 PER VOLUME. **JONES, BOX 702, NICEVILLE, FLORIDA 32578 01-89-TFN**

FOR SALE: Photofacts #100 thru #2416 incl. met. file cabinets. \$2000.00. *C.O.D. Angelo Massetti, 106 South Park Drive, Madera, CA 93637. (209) 674-4968. 5-89-11*

COMPUTER PROGRAMS—Estimates by computer for T.V.-VCR-Stereo-Computer. P.C. compatibles. Working sample disk \$9.95. *Eastside Electronics Inc., 1214 Sequel Ave., Santa Cruz, Calif. 95062, (408) 423-6515. 5-89-11*

T.V., STEREO, TEST EQUIPMENT, parts and service literature, from retired serviceman. Call 303-641-3002 for details. 5-89-11

FOR SALE: Contents of Radio & TV service shop—tubes, testing equipment, parts, manual, etc. *George Roney, 2900 Pine St. Rd., Oxford, PA 19363. (215) 932-4298. 5-89-11*

FOR SALE: 1987 Sencore SC61 scope waveform analyzer. Like new. 2500.00 or best offer. Call evenings, ph. 1-406-665-1516. 5-89-11

SENCORE: VA62, VC63, ST65, SG165, HP2000, B&K 1251 NTSC generator, 1655 AC supply, 1601 DC power supply, 1822 150 MHz counter. *Tektronix 2235 O'scope and cart. 419-999-1549. 5-89-11*

HELP WANTED

CENTRAL FLORIDA REPAIR SHOP needs an experienced video/audio visual service technician. Send resume to Blumberg Communications, Inc., 7101 Presidents Drive, Orlando, Florida 32809, attn: Service Dept. 5-89-2t

SERVICES

SPEAKER REPAIR. 4"-18" Speakers reconed. Cross-over parts. *Orban Audio, 119 7th St. NW, North Canton, Ohio 44720, (216) 497-9932 6pm-9pm EST. 4-89-tfn*

BUSINESS OPPORTUNITIES

KALISPELL, MONTANA—Electronic & TV repair, in beautiful Northwest Montana. Near Glacier Park, Big Mountain Ski Area, Flathead Lake, Business, building, inventory, fixtures, service library, test equipment, only \$90,000, or without building \$35,000. Books open to qualified buyers. Much expansion possible. Contact *Ellingson Agency, 406-752-7500. #PJ 372. 5-89-11*

LARGE AUDIO/VIDEO SERVICE BUSINESS. In sunny S.W. city. Established 20 yrs. Well-equipped. Price & terms negotiable. *Tape Recorder Clinic, 4850 E. Speedway, Tucson, AZ 85712, (602) 298-8627 eves. 5-89-11*

A SMALL TOWN—BUSY SHOP, equipment & inventory, owner retiring, price negotiable. *Box 488, Salmon, Id. 83467, 208-756-2916. 5-89-11*

FIX VCR's

3 out of 4 VCR breakdowns are due to mechanical problems.

Do you have the tools to find these problems?



TENTEL® Does!

Call Toll Free
(800)538-6894
In Calif -(408) 379-1881



Circle (32) on Reply Card

"Tech's Guide To Pricing"
updated new 5th edition... a framework for setting rates that apply to Hi-Tech products... a formula that guarantees SUCCESS!
Call Toll Free for details
1-800-228-4338 8/5 CST

Circle (34) on Reply Card

WHY PAY SENCORE S1295?

TEST/CLEAN/RESTORE with a UNIVERSAL CRT ADAPTER that fits all CRT testers and quickly hooks-up to all CRT's on the market (now or in the future). Guarantees profit & total CRT servicing. Used by TV Repair, US Govt., Airlines, Computer Serv., Dept. of Defense. Patented Adaptor-Sockets-CRT Reference/Setup book—Only \$59.95 plus \$2.50 postage & handling. Our 6th year. Over 15,000 sold. Chargecards/Checks/COD. Money Back Guarantee.

FREE CALL 1-800-331-9658
DANDY MFG. CO./RANDALL ELECTRONICS
(918) 682-4286, 2323 Gibson St., Muskogee, OK 74403

Circle (33) on Reply Card

REPRINTS

Interested in ordering article reprints out of this or another issue? * Reprints can be excellent learning tools for your technical staff and great marketing tools for your sales staff. Call or write Kelly Hawthorne at Intertec Publishing Corp., P.O. Box 12901, Overland Park, KS 66212; (913) 888-4664.

* Minimum order 500 copies.

Ad Index/Hotline

Company	Page Number	Reader Service Number	Advertiser Hotline
Beckman Industrial Corp.	IBC	2	619/495-3200
Chicago Case Co.	23	18	312/927-1600
Consolidated Electronics Inc.	61	31	800/543-3568
Consumer Electronics Show	47		202/457-8700
Dandy Mfg. Co.	64	33	800/331-9658
ETA	61		
Falcon Safety Products, Inc.	53	25	201/707-4900
Fluke, John Mfg. Co., Inc.	5	11	800/227-3800
Hitachi Sales Corp. of America	37	21	516/921-7200
HMC-Hub Materials Company	13	14	
Iscet	55		
Jensen Tools Inc.	15	15	602/968-6241
Leader Instrument Corp.	3	9-10	800/645-5104
Matsushita Services Co.	27	20	
MCM Electronics	13	13	800/543-4330
Nesda	15,57		
Paladin Corporation	7	35	
Panavise Products, Inc.	51	24	213/595-7621
Parts Express Int'l., Inc.	25	19	513/222-0173
Philips ECG	1	3-8	800/225-8326
Prime Electronics	55	26	414/473-4727
Sencore, Inc.	IBC	1	800/843-3338
Simpson Electric Co.	21	17	312/697-2260
Sony Service Company (Software Div.)	43	23	201/930-6883
Sperry Tech, Inc.	64	34	800/228-4338
Techni-Tool	41	22	215/825-4990
Tektronix, Inc.	9,8A-8B	12	800/835-9433
Tektronix, Inc.	17,16A-16B	16	800/835-9433
Tentel	64	32	800/538-6894
Tool Kit Specialists, Inc.	57	27	800/621-0854
Tronix, Inc.	59	29	313/939-4710
Vaco Products	59	28	
Viejo Publications	61	30	800/537-0589
Zenith	BAC		

ADVERTISING SALES OFFICES

ELECTRONIC

Servicing & Technology

KANSAS CITY, MISSOURI
Greg Garrison, Sales Manager
P.O. Box 12901
Overland Park, KS 66212
Phone: (913) 888-4664
Fax: (913) 541-6697
Telex: 42-4156 INTERTEC OLPK

OXFORD, ENGLAND
Nicholas McGeachin
Roseleigh House, New Street
Deddington, Oxford OX5 4SP
Phone: (0869) 38794
Telefax: (0869) 38040
Telex: 837469 BES G

TOKYO, JAPAN
Mashy Yoshikawa
Orient Echo, Inc.
1101 Grand Maison
Shimomiyabi-Cho, 2-18
Shinjuku-ku, Tokyo 162, Japan
Tel: 03-235-5961
Telex: J-33376 MYORIENT

FREWVILLE, SOUTH AUSTRALIA
John Williamson
Hastwell, Williamson, Rep. Pty. Ltd.
109 Conyngham Street
Frewville 5063
South Australia
Phone: (08) 79 9522
Fax: 08 79 9735
Telex: AA87113 HANDM

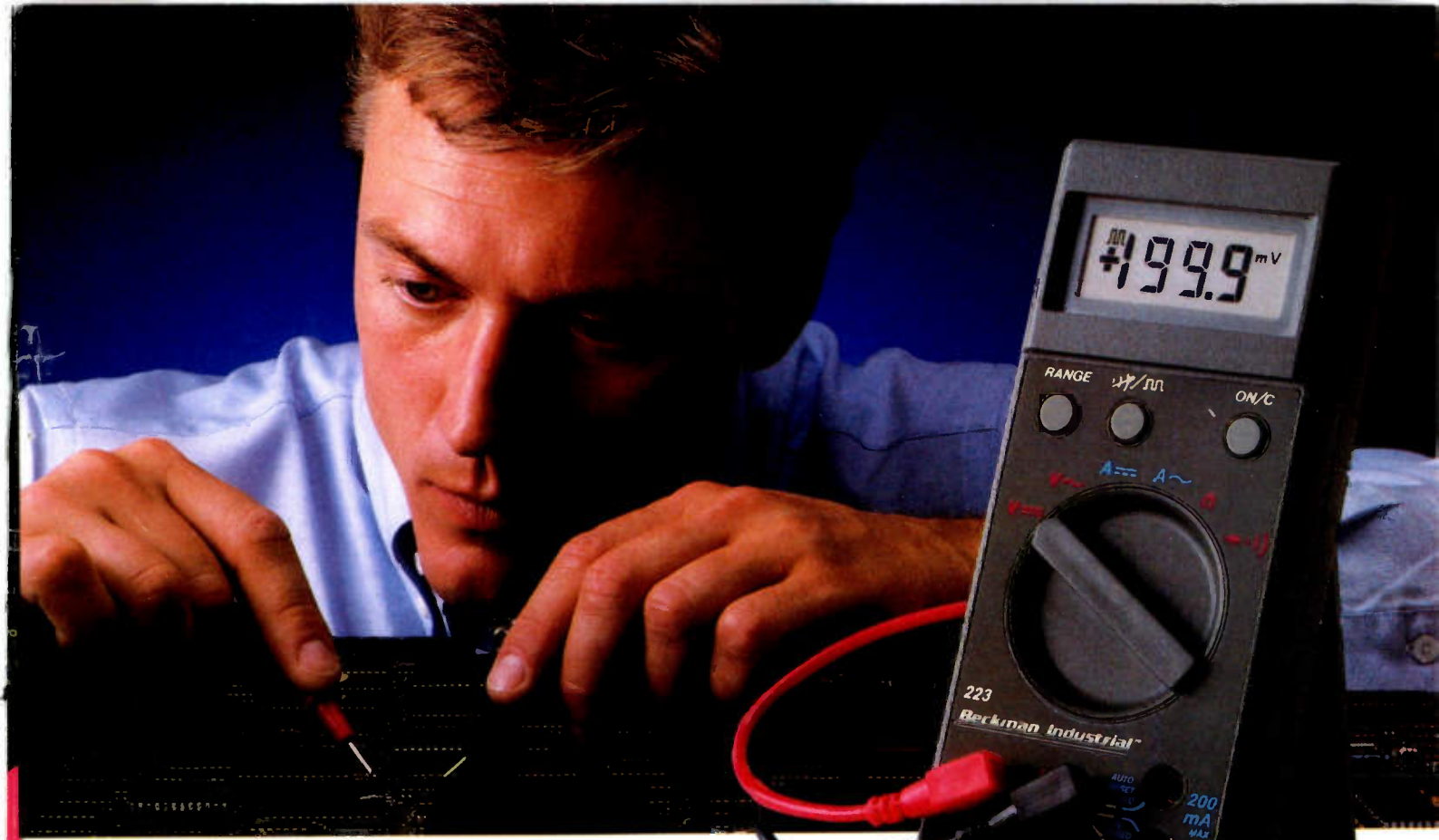

Now Testing Is Seven Times Easier.

1. End Blown Fuses.

The new 200 Series multimeter is protected from excess voltage or surges with a self-resetting fuse.

2. Keep Your Eyes On Your Work.

Quickly probe a circuit board listening for audible tone changes that pinpoint the problem without glancing at the LCD.

3. Detect Intermittents.

Hear a distinctive crackling sound when an intermittent occurs.

4. Find Dead Capacitors.

Capacitor voltage build-up or

bleed-off is heard loud and clear with the 200 Series' Audible Readout.

5. Find Logic Stuck-Ats.

Using standard leads, a fast Logic Pulse Detector lets you easily detect pulses down to 50ns.

6. Adjust Voltage Levels.

When adjusting audio or video response, an audible tone that changes pitch as measured signals increase or decrease permits faster and easier adjustments.

7. Stop Third Hand Problem.

Tilt stand and Skyhook,[™] auto-ranging,

and Audible Readout allow you to spend less time fiddling with your meter.

FEATURES	222	223
Audible Readout		•
Logic Pulse Detector		•
Fast Auto-Ranging	•	•
Self-Resetting Fuse	•	•
Auto-off Battery Saver	•	•
DC Voltage Accuracy	0.5%	0.25%
Warranty	2 years	2 years
Price	\$129.00	\$149.00

The 200 Series. Multimeters that take the work out of work. Call or write for complete information. 1-800-227-9781 Inside California. 1-800-854-2708 Outside California.

Circle (2) on Reply Card

Beckman Industrial

3883 Ruffin Road, San Diego, CA 92123-1898

Beckman Industrial Corporation Instrumentation Products Division A Subsidiary of Emerson Electric Company
© 1989 Beckman Industrial Corporation Specifications Subject To Change Without Notice.

**30 DAY
MONEY BACK
GUARANTEE**

**For your own reputation
and in your customers' best interest
always insist on**

Genuine Zenith
Remanufactured Replacement Parts
Reconditioned and Serviced for Reliability
by Zenith People
as Knowledgeable and Dedicated as
Those Who Made the Originals!

One of the easiest, fastest, and surest ways for you to preserve the pedigree and maintain the quality of the Zenith products you service is with genuine Zenith replacement parts.

And at no time is this more critical than when you replace the more sophisticated components like modules, tuners, channel selectors and sub-assemblies.

Your participating Zenith parts distributor will supply you with a replacement remanufactured, reconditioned and serviced for reliability by Zenith people as dedicated and knowledgeable as those who made the original.

Equally important, the replacement module or sub-assembly you receive in exchange from your Zenith parts distributor

will most likely incorporate any Zenith factory-made modifications in effect at the time of remanufacture.

And nowhere else but in a participating Zenith parts distributor's Exchange Program can you get assurance that a replacement incorporates Zenith factory up-dates!

To learn the location of the Zenith R&R Exchange Counter in your area, write on your company letterhead and we will help you locate one that's nearby.

Risking an exchange for a Zenith replacement anywhere else doesn't make sense. Not when factory-fresh replacement modules and sub-assemblies are so readily available thru a Zenith parts distributor's Exchange Program! Write now!



The quality goes in before the name goes on.®