

The how-to magazine of electronics...

ELECTRONICTM

Servicing & Technology

JANUARY 1987/\$2.25

MTS: TV sound in stereo, Part 1 • Digital circuits...enhance viewing

You have to buy test equipment. Or do you?

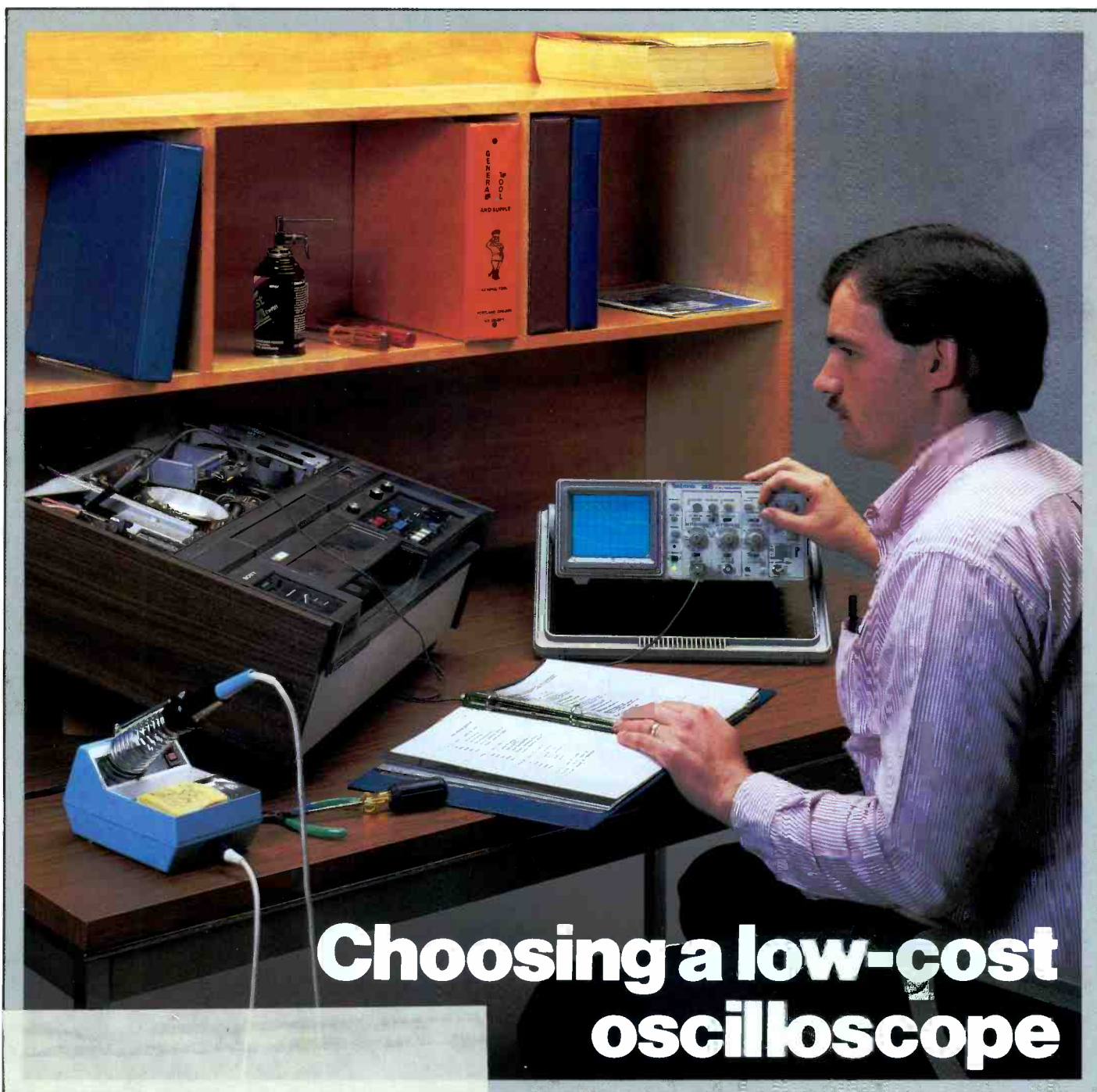

**Choosing a low-cost
oscilloscope**

More Functions. Smaller Budget.

Beckman Industrial Circuitmate™ DMMs put hFE, Logic, Capacitance, Frequency and True RMS In Your Hand. For Less.

Get more, for less. It's a simple definition of value. For DMMs, value means finding the combination of capabilities that meets your needs at the right price. Without losing sight of accuracy and reliability. If you want more functions at a low price, Beckman Industrial's Circuitmate™ Digital Multimeters are the best value around.

From the pocket-sized DM20L to the DM850, with true RMS capability and accuracy to 0.05% ± 1 digit, Circuitmate DMMs give you the functions you need.

For instance, the DM20L puts both a Logic Probe, a transistor gain function (hFE), and a full range of DMM functions in the palm of your hand. For only \$69.95.

Then there's the DM25L. Where else does \$89.95 buy you a Logic Probe, capacitance measurement, transistor gain function (hFE), and 24 DMM ranges including resistance to 2000 megohms? Nowhere else.

When high accuracy counts, there's the DM800 with a 4 1/2 digit display. The DM800

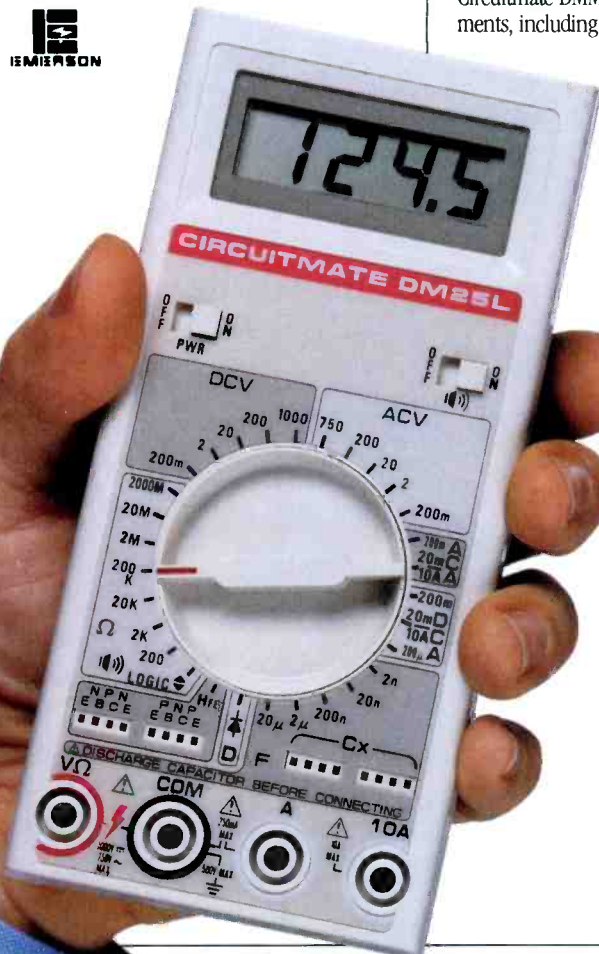

DM20L Pocket-Size w/Logic \$69.95*

TTL Logic Probe: 20MHz
Hi/lo/off indications
Detects 25nS pulse widths

hFE (NPN or PNP):
1 range (1000)

DMM: Input Impedance—
10 Megohms
DCA/ACA-5 ranges
(200µA to 2A)

Ohms-8 ranges (200 ohms
to 2000 Megohms)

Continuity beeper



also gives you frequency counting. A full-function DMM, and more, doesn't have to cost over \$169.95. If it's a Circuitmate DM800.

Or, for a few dollars more, get true RMS (AC coupled) to let you accurately measure non-sinusoidal AC waveforms, and all the capability of the DM800, in the DM850.

Of course, there's a whole range of Circuitmate DMMs and service test instruments, including the DM78 autoranger that

DM25L Capacitance, Logic, hFE \$89.95*

TTL Logic Probe: 20MHz
Hi/lo/off indications
Detects 25nS pulse widths

Capacitance: 5 ranges
(2nF to 20µF)

hFE (NPN or PNP):
1 range (1000)

Continuity beeper

Built-in bail

Anti-skid pads

DM850 True RMS

4 1/2 digits. DCV accuracy is .05% + 3 digits

True RMS

Frequency counter to 200KHz

Data Hold display capability

Continuity beeper

Built-in bail

Anti-skid pads

Price: DM850 (True RMS) . . . \$219.95*
DM800 (Average) . . . \$169.95*



fits in a shirt pocket, yet gives you a full size 3 1/2 digit, 3/8" readout. Not to mention a complete line of accessories like test leads, current clamps, even probes that can extend your DMMs range and sensitivity. All designed to work flawlessly with your Beckman Industrial Circuitmate DMM.

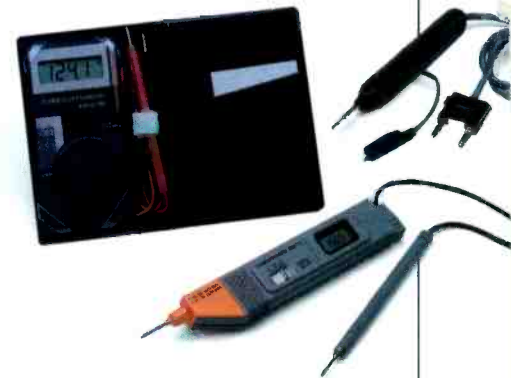

See your Beckman Industrial distributor and discover more DMM performance. For less.

*Suggested list price (\$US) with battery, test leads and manual.

In Service Instruments, We're The One.

Beckman Industrial™

Beckman Industrial Corporation, Instrumentation Products Division
A subsidiary of Emerson Electric Company
630 Puente Street, Brea, CA 92621
(714) 671-4800 • FAX: (714) 671-4874 • TLX: 188790
©1986 Beckman Industrial Corporation

Circle (1) on Reply Card

14

Test your electronic knowledge

By Sam Wilson

You may make an unnecessary calculation. This month's quiz isn't as difficult as some, however.

16

Digital circuits, squared corners enhance viewing on this TV

Improved picture quality, a simultaneous display from two video inputs and three inserted still pictures are features of interest.

18

Choosing a low-cost oscilloscope

By Dave Herrington

To avoid overspending, measure actual testing requirements in terms of an oscilloscope's fundamental specifications. Today's scopes have a higher performance/price ratio than earlier, more expensive models.

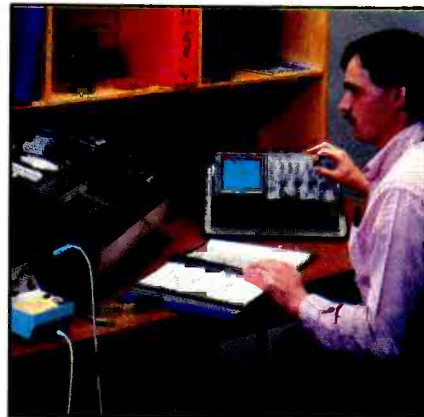

Page 18

Beyond mere adequacy, today's oscilloscopes have a high performance-to-price ratio. (Photo courtesy Tektronix)

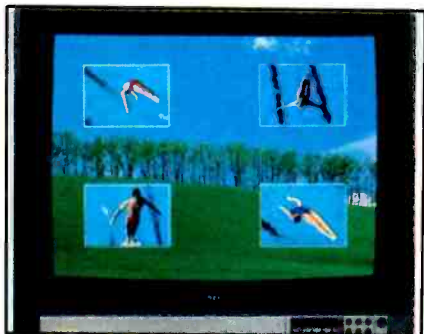

Page 17

The square-design picture tube and digital signal processing combine for viewing flexibility. (Photo courtesy NEC)

Departments:

- 4 Editorial
- 6 News
- 7 Feedback
- 9 Technology
- 31 Profax
- 43 Books
- 51 Literature
- 57 Products
- 58 Audio Corner
- 60 Video Corner
- 62 Computer Corner
- 64 Reader's Exchange
- 64 Photofact

25

You have to buy test equipment. Or do you?

By Jack Cunningham

Invest in basic equipment, but weigh the advantages of renting seldom-used items.

44

MTS: TV sound in stereo, Part 1

By Bert Huneault

Principles of FM multiplex stereo now have been applied to television stereophonic sound.

50

What do you know about electronics? – Circuits in digital audio (CD) circuitry

By Sam Wilson

Here's state-of-the-art electronics based on well-known theory and circuitry.

60

Video corner

By Conrad Persson

Brand-new this month!

Will (electronic) wonders never cease?

Back in October last year, I had to rent a car to take a business trip. I wound up renting a van that had a computer on board. This was my first exposure to such sophisticated electronics in a car.

I had read about such units, of course, but that hadn't prepared me for this experience. As I was checking out the car before I got underway, I found above the windshield several buttons and a small screen. The agent at the rental agency just pointed out the computer controls but declined to explain how they worked. His attitude notwithstanding, I proceeded to experiment with the computer.

When I pressed the FUEL button, a number appeared that was obviously the number of gallons in the tank. No amount of pressing of the RESET button would change that number to zero as it did with most of the other numbers displayed. That made sense. There was another button marked DTE. That readout remained steady at about 380 even though I pressed the RESET button. It took a while before I figured out what that one was for.

Some of the other readouts were immediately self explanatory. One was marked AV FUEL ECONOMY or something like that, and displayed the overall fuel economy since the last time that value had been reset. MILES and MPH were simply repeats of the speedometer and trip odometer readings on the dashboard instruments. The AV MPH was one of my favorites. It showed my average speed from the start of the trip to the current instant.

There was one more button, and for me it was the most fascinating. It was marked INST FUEL ECON, or something similar. It told me what my fuel economy was at that instant in time. If I was laboring uphill, this readout showed me that my fuel economy had plummeted down to the low teens. If I was coasting downhill and had just taken my foot from the accelerator, my instantaneous fuel economy soared to around 50 miles per gallon. During most of the trip, I had the computer display this value.

The effect of knowing my fuel economy at any moment was uncanny. Even though this was a rented van and my company was paying for the gas, not me, I found myself striving to keep the fuel economy number high.

This experience drove home for me the incredible potential yet to be realized by the computer, and with only a small investment in effort and technology. If a driver can constantly be aware of the state of the car he's driving, why can't this information be made available about other electrical and mechanical equipment.

Take the home for example. Every home has a watt-hour meter and it's simplicity itself to read it periodically and so to keep track of the amount of power consumed. Still, when air-conditioning season comes to the warm parts of the country, people consume power to cool their homes and don't check the watt-hour meter. They have no idea what it's costing them until they're shocked by the bill. The same is true with the gas meter.

With sensors costing practically nothing these days, it really wouldn't be too hard for the utilities to make this information available to a central home computer where a computer exists. Programmed with the appropriate information, it should be no problem to keep the homeowner apprised of the number of kilowatt hours of electricity and the number of cubic feet of gas consumed, as well as the approximate cost in dollars and cents for a period of an hour, a day, a month or a year.

With the appropriate sensors and relays, it should be simple to use the computer as a load regulator so that if your home is beginning to use too much electricity, some preselected loads can be shed automatically.

We recently have witnessed a revolution in electronics as a result of the introduction of the computer and all manner of other solid-state electronic devices. A little thought about what has been achieved suggests that present achievements will pale by comparison to what is yet to come. Not very far in the future, if someone doesn't know about computers, he will not know about electronics.

Oh, in case you're still wondering, the DTE display was for Distance to Empty. It was comforting to have that knowledge when making a long trip, on unfamiliar roads in an unfamiliar car. As it turned out, when I completed my trip I still had 70 miles to go before the tank was dry.

Nils Conrad Persson

Not all RCA modules are re-created equal.

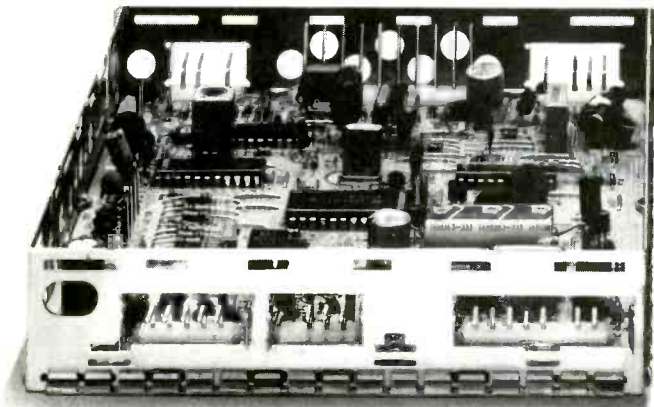

Competitor's rebuilt RCA module

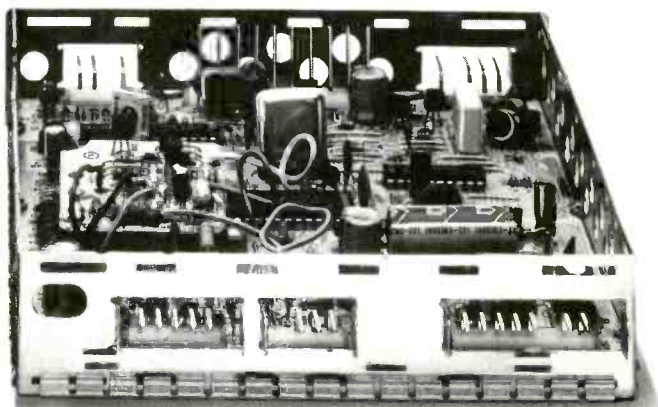

RCA rebuilt RCA module

Only modules rebuilt by RCA guarantee RCA quality.

Recently, one of our competitors slashed prices on their rebuilt RCA modules by up to 40%. Sounds good, until you review their products' performance. Then you'll wonder why they didn't do it sooner.

To demonstrate, we selected a random cross-section of their "bargain" boards for inspection. Using the same stringent testing methods RCA applies to its remanufactured boards, more than an incredible 70% of their rebuilt modules were rated unacceptable.

Some simply didn't work. Others lacked design updates, or had a wrong or missing component. The rest suffered from problems in

workmanship, such as the use of wire to bridge broken circuit board etchings, which could affect both reliability and performance.

Which all goes to show, RCA modules remanufactured by RCA remain your best bet. Ours are re-created to perform as well as, if not better than, the RCA original. Each contains the latest design updates. And all are thoroughly tested, inspected, and covered by warranty.

Their rebuilt modules may cost less, but the quality just isn't equal.

So do it right the first time. Insist on RCA. Because the quality and performance are built in.



RCA Distributor and
Special Products Division

HRRC to continue fighting VCR circuitry legislation

In the closing days of the 99th Congress, the motion picture industry sought legislative support for an anti-videotaping chip. The Motion Picture Association of America (MPAA) announced its intention to ask Congress to pass legislation that would modify VCR circuitry to prevent prerecorded cassette duplication.

At a Senate Judiciary Committee hearing, MPAA President Jack Valenti argued that the chip is necessary to prevent back-to-back copying of 70 million tapes each year. Charles Ferris, representing the Home Recording Rights Coalition (HRRC), opposed the anti-taping chip proposal, calling it a "ticking time bomb" that could be used by software manufacturers to take away the consumer's right to timeshift programs from commercial and cable television.

The Home Recording Rights Coalition, of which EIA is a major member, will continue its fight against any tampering with re-

coding hardware or taxing of recorders when the MPAA asks the 100th Congress for legislation.

President Reagan vetoes TV efficiency standards bill

On October 15th, the Congress passed H.R. 5465. "The National Appliance Energy Conservation Act of 1986." The legislation would preclude any state or federal efficiency standard for television sets until 1992. President Reagan pocket-vetoes the legislation, however, thus preventing its enactment this year.

Present law requires the Department of Energy (DOE) to set an energy efficiency standard for TV sets and 12 other products. The bill would have mandated efficiency standards for most of these products, but would have left a TV set standard to the discretion of DOE after 1992.

Las Vegas gearing for CES

The Winter Consumer Electronics Show, Jan. 8 through Jan. 11, is expected to attract more than 100,000 trade attendees and approximately 1,400 exhibitors at the Las Vegas Convention Center, and Hilton, Riviera and Sahara Hotels. Like the summer counterpart in Chicago, the Winter CES is sponsored by the Electronics Industries Association (EIA) Con-

sumer Electronics Group. Members of EIA include manufacturers of audio, video, home information and telephone products for the consumer.

CD Player sales to record high

When all the 1986 sales figures for compact disc players are tabulated, they should indicate a record sales year, according to a study by Venture Development Corporation (VDC), Natick, MA. If VDC's projection is accurate, compact disc player sales will have topped 1.5 million units during this past year, exceeding the projected sales of the more traditional, component turntables.

When introduced less than three years ago, CD players were considered an expensive novelty and, initially, less than 40,000 units a year were shipped, notes VDC. Also, CD players cost approximately \$800 apiece when they were new on the market; they now sell for about \$200. The study credits declining prices, effective promotion and the absence of competing formats with fueling market growth. Two additional factors are cited as important keys to the CD player's success: its demonstrable sound quality and its small size.

VDC further predicts that the availability of compact discs will continue to be a problem. **ES&T**

ELECTRONIC

Servicing & Technology

Editorial, advertising and circulation correspondence should be addressed to: P.O. Box 12901, Overland Park, KS 66212-9981 (a suburb of Kansas City, MO); (913) 888-4664.

EDITORIAL

Nils Conrad Persson, *Editor*
Cari Babcoke, *Consumer Servicing Consultant*
Dan Torchia, *Group Managing Editor*
Marjorie Riggin, *Associate Editor*
Joy Culver, *Editorial Assistant*
Darryll Fortune, *Editorial Assistant*
Alisa Carter, *Editorial Assistant*

CONSULTING EDITORS

Homer L. Davidson, *TV Servicing Consultant*
Christopher H. Fenton, *Circuit Fabrication Consultant*
Bud Izen, *Computer Servicing Consultant*
Victor Meeldijk, *Components Consultant*
Kirk G. Vistain, *Audio Consultant*
Sam Wilson, *Electronics Theory Consultant*

ART

Kevin Callahan, *Art Director*
Tim Lynch, *Graphic Designer*

BUSINESS

Cameron Bishop, *Group Vice President*
Eric Jacobson, *Publisher*
Greg Garrison, *Sales Manager*
Stephanie Fagan, *Promotions Manager*
Kelly Hawthorne, *Promotions Coordinator*
Dee Unger, *Advertising Supervisor*
Julie Chilson, *Advertising Coordinator*

Regional advertising sales offices are listed in classified pages.

ADMINISTRATION

R. J. Hancock, *President*
John C. Arnst, *Circulation Director*
Jo Ann DeSmet, *Circulation Manager*
Dee Manies, *Reader Correspondent*



Member, Audit Bureau of Circulation



Member, American Business Press



Member, Electronic Servicing Dealers Association

ELECTRONIC SERVICING & TECHNOLOGY is the "how-to" magazine for technicians who service consumer electronics equipment. This includes service technicians, field service personnel and avid servicing enthusiasts, who repair and maintain audio, video, computer and other consumer electronics equipment.

SUBSCRIPTION PRICES: one year \$18, two years \$30, three years \$38 in the USA and its possessions. Foreign countries: one year \$22, two years \$34, three years \$44. Single copy price \$2.25; back copies \$3.00. Adjustment necessitated by subscription termination to single copy rate. Allow 6 to 8 weeks delivery for change of address. Allow 6 to 8 weeks for new subscriptions.

PHOTOCOPY RIGHTS: Permission to photocopy for internal or personal use is granted by Intertec Publishing Corp. for libraries and others registered with Copyright Clearance Center (CCC), provided the base fee of \$2 per copy of article is paid directly to CCC, 21 Congress St., Salem, MA 01970. Special requests should be addressed to Eric Jacobson, publisher. ISSN 0278-9922 \$2.00 + 0.00

INTERTEC
PUBLISHING CORPORATION

©1987 All rights reserved.

Feedback

Letter to Sam Wilson

Addressing the subject of gamma once again...

I remain unconvinced that h-parameters cannot be useful in follower circuits (determining input impedance, for example) but because we normally consider I_c to be equal to I_e when we calculate beta, we are actually approximating gamma anyway. Also, $h_{ic} = h_{ie}$, $h_{oc} = h_{oe}$ and, h_{rc} is almost equal to unity, so common collector h-parameters in addition to common emitter parameters would be redundant and would appear to serve no useful purpose.

I do believe, however, that the third set of transistor h-parameters serves a useful function as an educational aid and that its inclusion in textbooks is justified. In the study of electronics, it is often necessary to consider an impractical circuit to better illustrate the advantages and disadvantages of electrical phenomenon. A demonstration of impracticality is often the shortest road to understanding. How better to illustrate the advantages of feedback than to consider the circuit without feedback?

In the special case of reducing a transistor to a hybrid model and understanding the four parameters (h_i , h_r , h_f and h_o), we are severely limited in demonstrating their dynamic nature with respect to basing because there are only three possible transistor configurations. To disregard the common collector configuration would suggest a false either/or relationship, making an understanding of the total concept more difficult.

I have often been at odds with the manner in which some electronic concept has been presented only to later find myself in total agreement. An example that comes readily to mind is the concept of hole movement in semiconductors. It took a few years for me to come to terms with it but today it seems an essential concept when considering transistor operation. Still, I know good technicians who are much more knowledgeable than I and have been in the field for many, many years but still refuse to subscribe to the concept. Perhaps the concept of gamma has that same kind of effect.

Roy F. Graves C-29382
Soledad, CA

Yours was the first letter that mentioned the use of common-collector h parameters as an educational aid. I specifically like your statement: "The demonstration of impracticality is often the shortest road to understanding."

So, I am in agreement with you that those h parameters (or gamma) do not appear to be valuable in terms of amplifier design. They do, however, round out the 3-terminal possibilities and complete the h parameter set.

I know what you are saying about holes. The biggest problem was converting experienced technicians from dedicated electron flow to hole flow. I used all types of analogies like parking spaces and missing cue balls, but never found the universal magic words....

Sam Wilson

ES&T



Our catalog will make your work easier!

Catalog #13 from MCM has all the things you're looking for in a great electronic parts catalog.

Our wide selection will save you time! An unbeatable line-up of parts and products will make us your one and only source. You'll always find the things you need when you need them!

Save money, too! Great, low prices help you get more value for the money you spend.

Enjoy the fast, dependable service that has become our trademark. Your order will always be correct and delivered on time — that's guaranteed.

Convenient ordering — our toll-free numbers put us just a phone call away!

Call TODAY for the latest edition of the MCM catalog. Discover how this great book will make your work easier!

Catalog #13 Now Available
Call TOLL-FREE
1-800-543-4330

(In Ohio call 1-800-762-4315) (In Alaska or Hawaii 1-800-858-1849)



MCM ELECTRONICS
A PREMIER Company

Source No. ES&T-17

Circle (4) on Reply Card

PROFIT FROM THE MILLION-DOLLAR VCR SERVICE & REPAIR INDUSTRY

VCRfacts™

TECHNICAL SERVICE DOCUMENTATION



VCR Coverage Includes

FISHER	PV1310	VCR75	VFT193	VCR67
FVH-530	PV1370	VCR70	VFT250	VCR70
(SN 10,001)	PV1470	VCR68	VFT450	VCR68
THRU 70,000)	PV1500	VCR19	VFT456	VCR68
FVH-520	PV1600	VCR36	VFT650	VCR72
FVH-615	PV1650	VCR53	VFT654	VCR72
FVH-730	PV1750	VCR60	VG7200	VCR74
FVH-530	PV1770	VCR72	VG7203	VCR74
(SN 70,001	PV1780	PF 2340*	VG7205	VCR76
& LATER)	PHILCO		VG7207	VCR76
FVH-510	VI011	VCR67	VG7225	VCR75
FVH-515	VI012	VCR74	VG7650	PF 2375*
FVH-525	VI300	VCR39	SANYO	
FVH-715	VI001QBK01	VCR76	VR3900	PF 2396 (1)*
FVH-720	VI333QH01	VCR75	VCR3900-11	PF 2396 (1)*
FVH-720R	VI441	VCR70	VCR4000	PF 2396 (1)*
FVH-721	VI500	VCR45	VCR4000-2	PF 2396 (1)*
FVH-722	VI550	PF 2312*	VCR4300	PF 2284
FVH-725	VI551	VCR68	VCR5000	VCR40
GE	QUASAR		VTC9100A	VCR50
1VCR1010W	VH5000	VCR8	SEARS	
HITACHI	VH5010	VCR20	564.53030700	VCR13
VT-5000 A	VH5011TW	VCR67	564.53040700	VCR13
JC PENNEY	VH5021	VCR74	564.53050800	VCR15
685-5006-00	VH5022UW	VCR76	564.53060900	VCR37
685-5007-00	VH5030SW	VCR65	564.53180150/151	PF 2284*
685-5018-00	VH5040SW		564.53110250	PF 2396 (1)*
686-5010-00	(Early Production)	VCR61*	SHARP	
686-5012-00	VH5040SW	VCR56*	VC6800	VCR52
686-5013-00	VH5100QW	VCR22	SONY	
686-5020-00	VH5125UW	VCR75	SL2500	VCR73
686-5021-00	VH5155RW	VCR46	SL5000	VCR69
JVC	VH5210TW	VCR70	SL5400	VCR27
HR3300U	VH5310TW	VCR68	SL5600	VCR33
HR3600AU	VH5610TW	VCR72	SL5800	VCR64
HR6700U	VH5623UW	PF 2340*	SL7200.A	VCR1
MAGNAVOX	RCA		SL8200	VCR7
VH8000	PEP600	VCR71	SL8600	VCR10
VH8200BR01	SFT100W	VP2	SYLVANIA	
VJ8225BR01	TFP1500	VCR71	VC2210	VCR67
VJ8225BR01	TFP1504	VCR71	VC2212	VCR74
VK8222BR01	VBT200		VC2700	VCR30
VK8227BR01	(Early Production)	VCR2	VC2910	VCR70
VK8229BR01	VBT200 (From Serial		VC2215BK01	VCR76
VR8306BK01	8033FM001)	VCR9	VC2950BK01	VCR75
VR8315BK01	VCT200	VCR9	VC3000	VCR38
VR8316BK01	VCT201	VCR16	VC3100	PF 2312*
VR8318BK01	VCT300	VCR16	VC3110	VCR68
VR8318BK01	VCT310	VCR16	VC3610	VCR72
VR8325BK01	VCT400	VCR11	VC3620BK01	PF 2354*
VR8330BK01	VDT201	VCR25	TOSHIBA	
VR8330BK02	VDT350	VCR23	V5310C	VCR32
VR8335BK01	VDT501	VCR28	V5310T	VCR32
VR8345BK01	VDT555	VCR31	V5420C.T.U	VCR59
VR8346BK01	VDT600	VCR34	ZENITH	
PANASONIC	VDT625	VCR43	JR9000P.W	VCR3
PV1000	VET180	VCR55	KR9000W	VCR12
PV1100	VET250	VCR57	VR8900W	VCR69
PV1200	VET253	VCR57	VR9000W	VCR29
PV1265	VET450	VCR48	VR9700J	VCR42
PV1270	VET650	VCR54	VR9750J	VCR66
PV1275	VFP170	VCR71	VR9775PT	VCR73
	VFP174	VCR71		
	VFT190	VCR67		

*PHOTOFACT™ Format

**VCRfact Format
Manual Format-Specialized Series Manuals

VCR-76 last VCR "Manual" published - VCR's now covered in PHOTOFACT.

*VCR-61 has 2 system control boards.

**VCR-36 has 1 system control board (1) March Release.

Make Money--Save Time-- Make Repairs Easier

Increase productivity. Accelerate turnaround. Profit with quality, dependable, service documentation from the people who have provided repair data to technicians for over 40 years... Sams.

At \$21.95 each, VCRfacts will more than pay for themselves with a single repair. Less time spent on repairs will increase turnaround time that creates customer loyalty, repeat business, and referrals. VCRfacts can be even more affordable through Sams "Bonus-Buy Plan" for volume discounts.

VCRfacts technical service documentation is available from local electronics distributors, or from Sams. For information about where you can get VCRfacts, call toll-free **800-428-SAMS**.



HOWARD W. SAMS & COMPANY

4300 West 62nd Street
Indianapolis, Indiana 46268 USA

Circle (5) on Reply Card

Automatic Focusing system uses video signal

Piezofocus, the new automatic focusing system by Matsushita that is based on the human eye, uses its video signal to focus on the sharpness of an object image. The focal state is changed cyclically to adjust the sharpness of an object image on an image sensor. To do this, Piezofocus uses the change in high frequency components that correspond to the sharpness level used to adjust the focus lens.

This approach to focusing a video camera has won a *Research & Development* magazine I-R 100 Award for excellence in industrial R&D for Matsushita Electric Industrial Company of Osaka, Japan, and its Central Research Laboratories.

To date, conventional focusing systems adjust to the focus by measuring with infrared rays the distance between the camera and the object being videotaped. Infrared measuring accuracy can be im-

paired because of variations in degrees of light reflection, light may be reflected in the wrong direction, or objects may be beyond reflection. The size and location of the object as well as the position of the zoom lens also may contribute to errors in focusing.

Infrared systems consisting of an emitter and receiver tend to be bulky, and consume extra power, adding to the camera's cost and size. Piezofocus occupies only one-third the size, uses one-half the power, and costs about two-thirds as much as other automatic focusing systems.

Piezofocus operation

The master lens in the Piezofocus system is oscillated along the optical axis by a built-in piezoelectric element. This produces high frequency components in the video signals that contain a focus error signal. The error signal

Our guaranteed savings plan.



Fluke 70 Series Analog/Digital multimeters are like money in the bank. Buy one, and you're guaranteed to save both time and money.

Money, because you get longer battery life and longer warranty coverage — 3 years vs. 1 year or less on others.

And time, because 70 Series meters are easier to operate and have more automatic measurement features.

So before buying any meter, look beyond the sticker price. And take a closer look at the new low-priced \$79 Fluke 73, the \$99 Fluke 75, and the deluxe \$139 Fluke 77. In the long run, they'll cost less, and give higher performance, too.

And that, you can bank on.

For a free brochure, and your nearest distributor, call toll-free 1-800-227-3800, ext. 229.

FROM THE WORLD LEADER
IN DIGITAL MULTIMETERS.

FLUKE[®]

© 1985 Fluke

Circle (6) on Reply Card

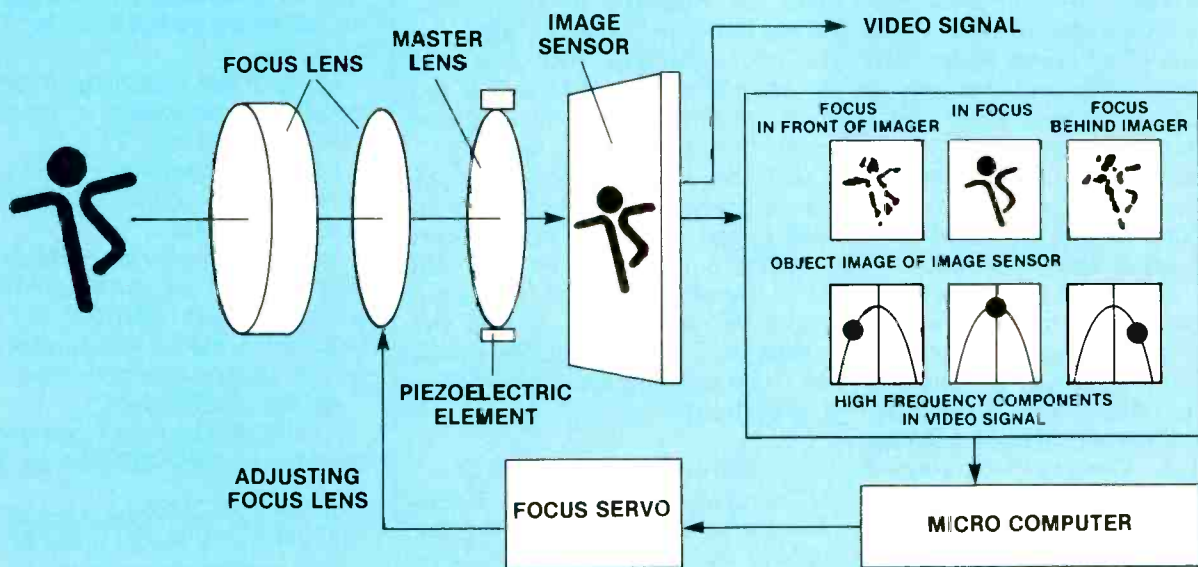

represents the amount and direction of the focus deviation from the optimum in amplitude and sign. The Piezofocus video signal is used in controlling the focal lens servo system so the camera maintains optimum focus at all times.

To operate the system, two new ICs and a microcomputer chip are used. The microcomputer always adjusts the condition of the system so that under any circumstances the video camera is brought into

focus quickly. The system also has a focus zone function, called a *Magic Window*. This window, displayed on the viewfinder, allows the user to select three different focal zones to set the autofocus: Zone one can be used for close ups; zone two for medium shots; and zone three for distance.

Matsushita has installed Piezofocus systems in more than 100,000 of its NV-M3, F2, WV-3250 camera models.

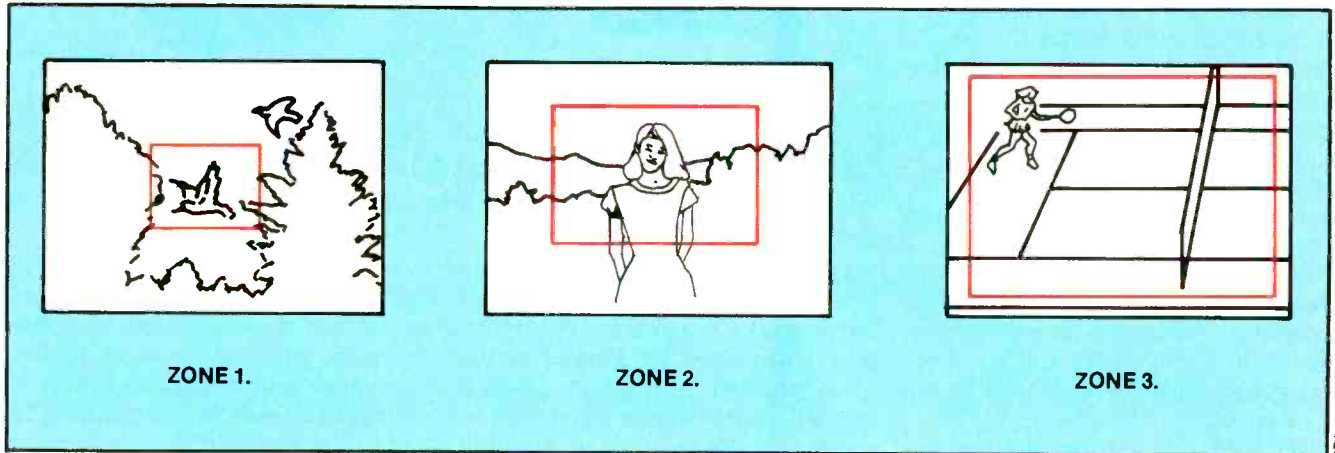

(Diagram courtesy of Matsushita)

150 MHz

- Advanced technology from Kenwood...**
- ▶ 4-Channel, 8-Trace
 - ▶ Dual Sweep and Delayed Sweep
 - ▶ Light weight (16.3 lbs.)
 - ▶ Bright, Sharp, 6-in. Rectangular CRT
 - ▶ 20-kv 2nd Anode Potential
 - ▶ Wide Range of Waveform Display Functions
 - ▶ Pushbutton Vertical, Horizontal, and Trigger Modes
 - ▶ and more!
- See the full-line of 5-MHz to 150-MHz oscilloscopes at your Kenwood distributor today!

KENWOOD

KENWOOD U.S.A. CORPORATION
 Test & Measuring Instruments
 1111 West Walnut Street
 Compton, California 90220
 Phone: (213) 639-9000
Circle (7) on Reply Card



Specifications and prices are subject to change without notice or obligation.

Fiber-optics system now can handle 1990's telecommunication capacity

Until this latest optical communications development by Toshiba, the high-capacity transmission of data forecast for the next decade would have been impossible to handle, even by today's fiber-optics systems wherein a single optical fiber has a communications capacity 1,000 times greater than non-optical means. With most such systems today, however, only light beams of a single wavelength can be conveyed in each single fiber, and a wavelength separation of 1,000 Å is required.

Toshiba's new, integrated, next-generation demultiplexer can separate as many as *five* signals of differing wavelengths transmitted simultaneously from a single optical cable, with a wavelength separation of 50 Å - 1/20 of the current limitation. Each wavelength can be received accurately with little interference from adjacent waves.

This demultiplexer has most of its key components integrated on a single crystal silicon substrate

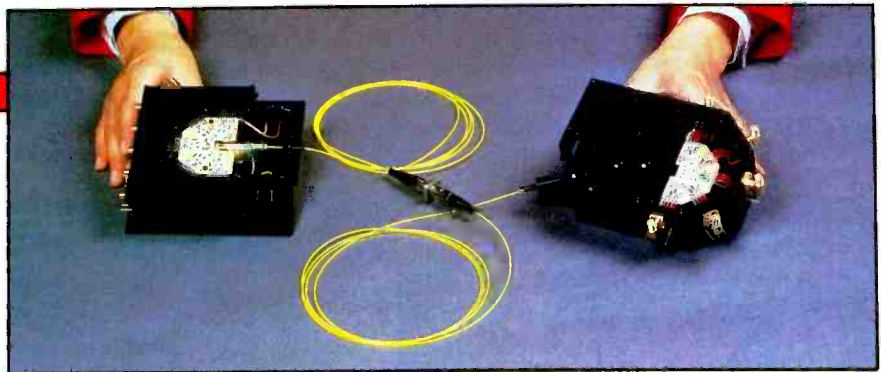

(Photo courtesy of Toshiba Corporation)

In this photo, the optical transmitter (multiplexer) is on the left, and the optical receiver (demultiplexer), on the right.

atop which a thin glass layer acts as a guide for lightwaves transmitted from the fiber cable. The multiple, multiplexed lightwaves strike a corrugated diffraction grating (etched on the silicon substrate) at a specific angle, and as a single signal.

Working like a prism, the grating separates the multiplexed signal back into the five different signals originally transmitted. This grating, with its minute grooves (0.7 μm wide and 0.3 μm deep) is etched on the substrate at 1.5 μm intervals—an achievement made possible only by sophisticated microlithography.

Besides developing this new receiver, Toshiba has improved the

wavelength accuracy of the transmitter. Both have been incorporated into a system that has been operated at a data rate of 32 Mb/s per beam to demonstrate the feasibility of full optical integration. An extended transmission capacity is planned.

The present research effort is part of a major research and development project on optical measurement and control systems, conducted under a program set up by the Ministry of International Trade and Industry's Agency of Industrial Science and Technology.

Figure 1. Key components, integrated on a single silicon substrate. Note the light waveguide.

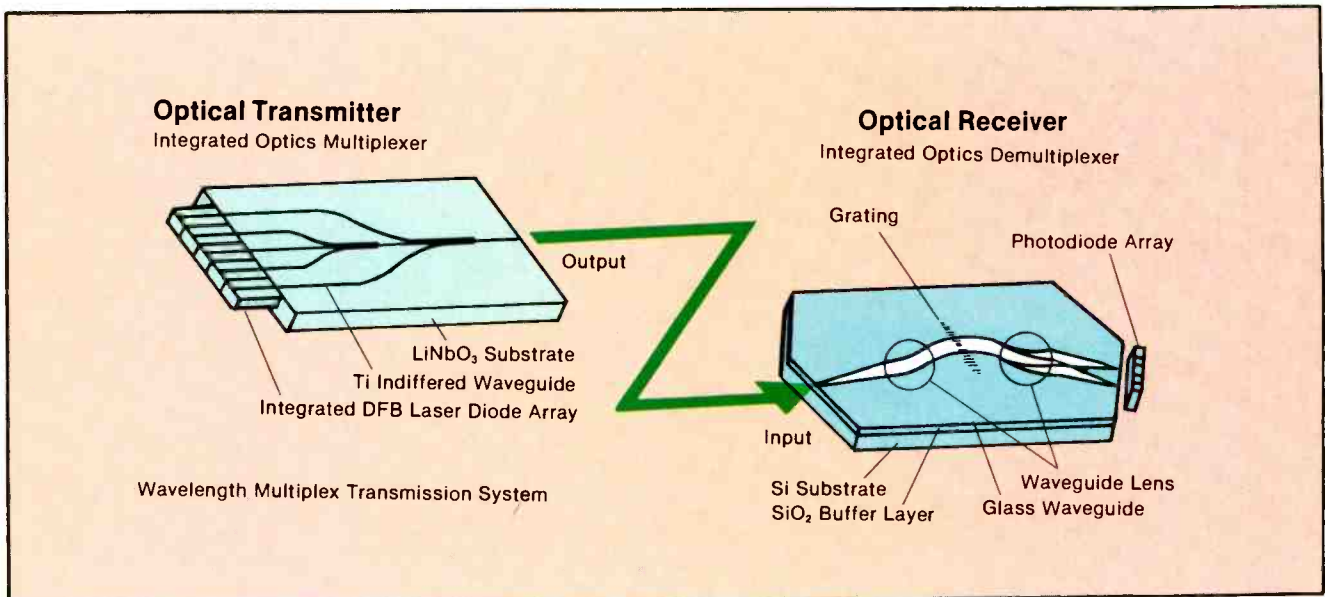

(Diagram courtesy of Toshiba Corporation.)

★ **RESEARCH**

★ **DEVELOPMENT**

★ **PROTOTYPING**

★ **PRODUCTION**

Diehl Industries of Amarillo, Texas proudly announces the opening of a new and unique research, development, and prototyping division, for use by the nation's electronic industry.

WHAT MAKES IT SO UNIQUE

Traditionally, when a company or an individual has a new idea, mass confusion sets in, - - - and promptly takes control of the project.

The "electronics" for the original idea goes one direction (to R & D), while another "team" scrambles to develop the mechanicals for the case that will house the final product.

From "R & D" the artwork for PC boards must be generated, then sent to a PC board manufacturer, the mechanicals for the case must then be sent to a plastics manufacturer, once they are finished, the PC boards must then be sent to a "board stuffing" company, someone must then find the best price on component parts and hardware, someone else must coordinate the receiving of same, while yet another team s frantically trying to develop an operations manual for the final product (which must then be sent to a printer, who will ultimately have to send it out to a bindery to be bound, and turned into an actual book).

You guessed it! By the time all of the above comes back to home base, - - - nothing fits ★! ↘ \$* (just ask anyone who has tried it).

Diehl's new division has a unique advantage over tradition, in that all of the above is done under one roof.

Diehl's R&D Department can take a preliminary schematic (or just an idea without the schematic), design it, or refine it, bread board it,

test it, turn it into working artwork for printed circuit production, then, using their own proto typing system, produce the original "trial" PC boards. Our R&D staff has immediate access to four, totally separate individual, full time, "in house" CAD systems (computer assisted design). In a "total design" project all four will become necessary.

"Auto CAD 86" will be used to generate shop drawings which will then be used by Diehl's Plastic Division.

Winteks "Hi-wire" will be used to generate the necessary schematics for use by Diehl's own in-house printing and bindery department along with the necessary text for same, which will be provided by Diehl's in-house technical writing staff.

Winteks "smart-work" will be used to generate artwork to produce PC boards. This same artwork is then given to Diehl's in-house camera and stripping dept. where it will be photographically reduced, and turned into working transparent positives, which will then be given to Diehl's in-house PC manufacturing division (once the R&D proto type boards have been approved).

Meanwhile, Winteks "drill" CAD System is used to generate the necessary "drilling" information for our Excellon "Mark III", four spindle, computerized drill which is just part of Diehls in-house PC board manufacturing division. Once our Excellon drill (which is based on an 8,000 lb. granite slab for accuracy) has completed the drilling operation (at 10,000 holes per hour × 12 boards at a time), the boards will go through our own in-house chemistry, then into one or more of

our fourteen in-house electro platers for copper, tin-lead, nickel, or gold.

After being properly sized, the PC boards will then go to our in-house "board stuffing" department (which employs 20 full time stuffers). There it will be "stuffed", wave soldered, inspected, tested, then given to quality control for final inspection.

Meanwhile: Our purchasing dept. has been on the phone with every major supplier in the country fighting for the best possible price on the highest quality components. Our in-house printing and bindery division has produced the operation manuals from artwork that was provided by our own technical staff. Our in-house plastics division (which does some of the most sophisticated vacuum forming in the nation) has produced the cases into which the final product will be assembled. Our own in-house silk screening department has produced all necessary escutcheon plates and panels.

All of the necessary components are now ready for mass production by our own final assembly division. Because everything was done under one roof, and monitored by one project supervisor, - - - everything fits!

In addition to the above, we also have our own in-house advertising agency and international marketing facilities.

The next time you have a "project" think about us, - - - **we can make it happen!**

DIEHL INDUSTRIES
6661 Canyon Dr.
Amarillo Texas 79110
Phone (806) 359-0329

Test your electronic knowledge

by Sam Wilson

1. A pure sine wave voltage is applied to the input terminal of the differentiating op-amp circuit in Figure 1. The output *waveshape* should be

- A.) a sine wave.
- B.) a triangular wave.
- C.) short pulses.
- D.) a square wave.

2. Figure 2 shows the distribution of signals in a television channel. Which of the following is correct?

- A.) X is the I signal and Y is the Q signal.
- B.) X is the Q signal and Y is the I signal.

3. A certain 12V power supply has an output voltage of 8V when it is delivering its full load current. As far as regulation is concerned, could this supply be replaced with a 12V supply having a percent regulation of 20%?

- A.) Yes B.) No

4. Which of the following statements is correct?

- A.) The VITS signal is located on the horizontal blanking pedestal.
- B.) The VIRS signal is located on the horizontal blanking pedestal.
- C.) Neither statement is correct.
- D.) Both statements are correct.

5. At the alpha cutoff frequency, the emitter-to-collector current of a transistor

- A.) is maximum for a common emitter amplifier.
- B.) is zero for a common base amplifier.
- C.) is 70.7% of maximum for a common emitter amplifier.
- D.) None of these choices is correct.

6. Which of the waveforms in Figure 3 is best for a sawtooth qualitative test?

- A.) The one shown in (a).
- B.) The one shown in (b).
- C.) The one shown in (c).
- D.) The one shown in (d).

7. The track on a compact disc is about

- A.) 800 feet long.
- B.) 1,280 yards long.
- C.) 2½ miles long.
- D.) None of these choices is correct.

8. What is the name of the block marked 'x' in the phase-locked loop in Figure 4?

- 9. Which of the following is a reason for using ECL logic in a bit-slice system?
- A.) Low cost
- B.) High speed
- C.) TTL compatible
- D.) Does not require interfacing

10. You are going to secure an antenna with guy wire. One of the guy wires will be attached to a point on the pole 40 feet above the base; and a point 30 feet out from the base. (See Figure 5.) Disregarding extra length for tying, what length should the guy wire be cut?

- A.) 45'
- B.) 50'
- C.) 55'
- D.) 60'

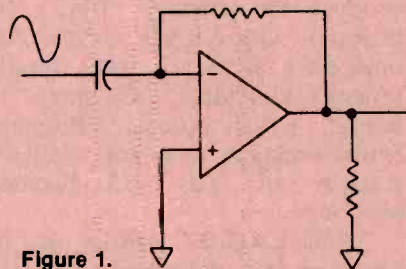

Figure 1.

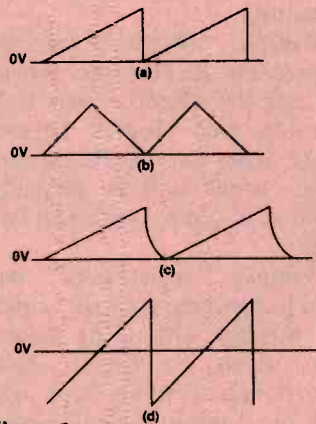

Figure 3.

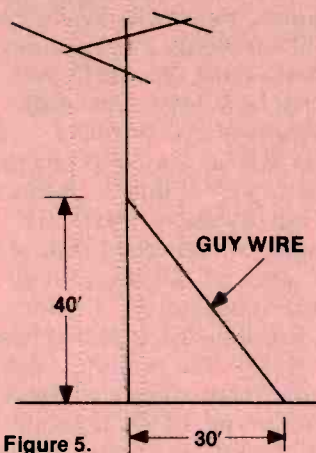

Figure 5.

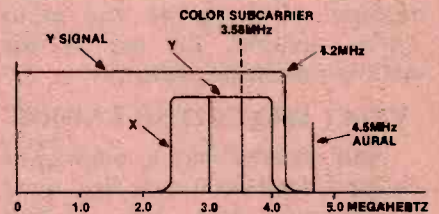

Figure 2.

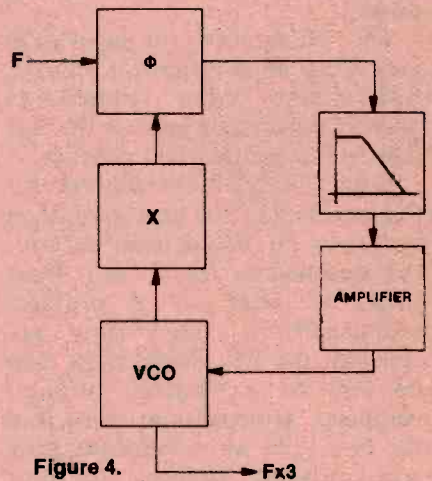

Figure 4.

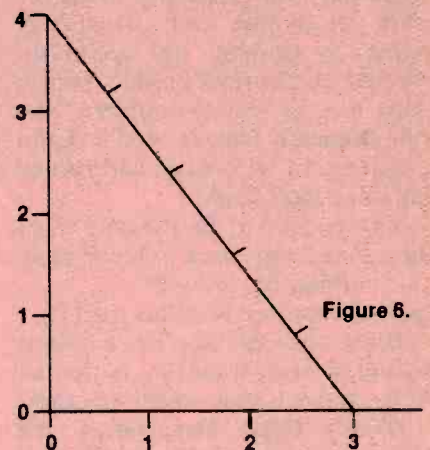

Figure 6.

Answers are on page 51

WANTED

TV TECHNICIANS

Diehl Industries is looking for about thirty competent, well seasoned, TV technicians who are good at repairing TV sets but somewhat tired of the everyday "Rat Race" that goes with it.

Specifically, we are looking for some thirty salaried (plus commission) area sales reps to call on TV service shops, schools, colleges, major industries, and military installations, to sell test equipment and other services.

These positions require five day a week travel with anticipated annual earnings of about \$70,000⁰⁰ for anyone who is willing to work at it.

After a thirty day trial period company vehicles are available as is a weekend "fly home" expense account.

A pleasing, outgoing personality, a good working knowledge of the TV service industry, and a strong technical background will get the job done, --- our products sell themselves!

In Case You Don't Believe It

Anyone who fits the above description is well aware of the fact that late model start up and shut down circuits are making it all but impossible for most shop owners to earn a living. If not, they are certainly "absorbing" most of his time, and much of his normal profits.

One of our products is a diagnostic computer called the Mark VII-E Eliminator. The Mark VII-E will (at the push of just one single button), identify the exact, specific, defective component that has caused any type of "dead set" or start up / shut down symptom, i.e. in the power supply, the LV regulator, horiz output, damper diode, safety capacitor, yoke, pin cushion transformer, discharge (return) capacitor, centering diode, horiz osc/driver, any type of start up or shut down circuit, the flyback,

HV multiplier, any scan derived B+ source (the specific leg), or any short in any circuit that is connected to any scan B+ source.

In addition, the Mark VII-E will instantly tell you whether the defective component is open or shorted, as well as tell you exactly how the defective component has affected the performance of the overall LV/HV circuit. (i.e. Did it cause the horiz osc/driver to go into shut down, cause LV regulator shut down, kill the start up pulse, create an inductive short in the flyback circuit, etc.).

Whats more, the Mark VII-E will also automatically give you a "landmark" test point to measure so that you can verify that its findings are 100% accurate. (i.e. It might tell you to measure the collector of any R-B-G output transistor for a minimum of +150 volts. If that voltage is not present, the computer's decision is 100% accurate).

As far as locating the exact, specific "leg" of the circuit that has failed, the Mark VII-E never misses. In cases where several components on that same "leg" could cause the same condition (i.e. an open or a short), the Mark VII-E will automatically calculate the "odds of probability" then give you the most likely to fail component first. If that component checks ok, the next time you push the test button it will automatically give you the next most likely suspect.

For the sake of example: Let's say the Mark VII-E has determined that the scan B+ leg for the horiz osc/driver is open. The Mark VII-E sees the open, but may not know why it is open.

Further, lets say that this "leg" has two series resistors in it (R1 and R2). The Mark VII-E will calculate the odds for both resistors then light the one that's most probable to fail (R-1). If that resistor is ok, the next

time you push the test button it will light R-2. If R-2 is ok, the next time you push the test button, the Mark VII-E will tell you that an open solder joint exists between R-1 and R-2.

The Mark VII-E may not know why that particular leg is open, but it knows for **absolute certain** that it is. Once that is established, it then knows how to isolate the exact, specific, component that has failed.

Add to the above, the fact that the Mark VII-E can isolate intermittants while the technician is out picking up parts, and it doesn't take a "mental giant" to figure out why we are looking for thirty salesmen.

For years the TV service industry has been looking for a magic wand, --- we have exactly that. The problem is, the Mark VII-E is so incredibly fast, accurate, and effortless (a freshman electronics student can operate it), most shop owners just can't believe it until they have seen it. Then, when you tell them that it does all of the above in just one/one hundredth of one second, at the push of just one button, and that it requires no "hunt and peck" probe to work, and no computer experience whatever, --- they **really** can't believe it!!

The fact is: it doesn't matter whether or not they want a Mark VII-E, once they see one in operation, --- they will have to have one!!

The Mark VII-E is just one of our products. Everything we do is innovative.

If you think you have what it takes to be a sales rep., we'd like to talk to you.

DIEHL INDUSTRIES
6661 Canyon Dr.
Amarillo, Texas 79110
Phone (806) 359-0329

Digital circuits, squared corners enhance viewing on this TV

The DT-2680A digital television by NEC uses digital technology to enhance picture quality as well as to add features. Specifically, digital signal processing achieves horizontal resolution of 500 lines, through video inputs. Digital processing also enables the company to build in such features as picture-in-picture (PIP) and memory for three still pictures.

Picture quality

The DT-2680A uses a newly developed LSI for digital signal processing of video, chroma (with comb filter) and deflection control. Combined with precise in-line electron guns and a fine-pitch 26-inch screen, digital processing results in 500 lines of horizontal resolution (via video inputs).

This is the second receiver/mon-

itor to use NEC's Square 90 26-inch picture tube. In comparison to conventional, spherical tubes, the Square 90 design reveals more picture information in the corners, reduces geometric distortion, and cuts down ambient light reflection. To reduce reflection further and assure deep, rich contrast, the screen uses a special dark glass.

Picture-in-picture

The DT-2680A can simultaneously display the station tuned in, plus moving pictures from any of three video inputs or color computer graphics from the set's RGB input. Initially, the TV picture occupies the entire 26-inch screen, while the external picture is displayed in an 8½-inch diagonal area in the lower right. The consumer can use the remote control to switch these pictures around, placing the external picture on the entire screen and the TV picture in

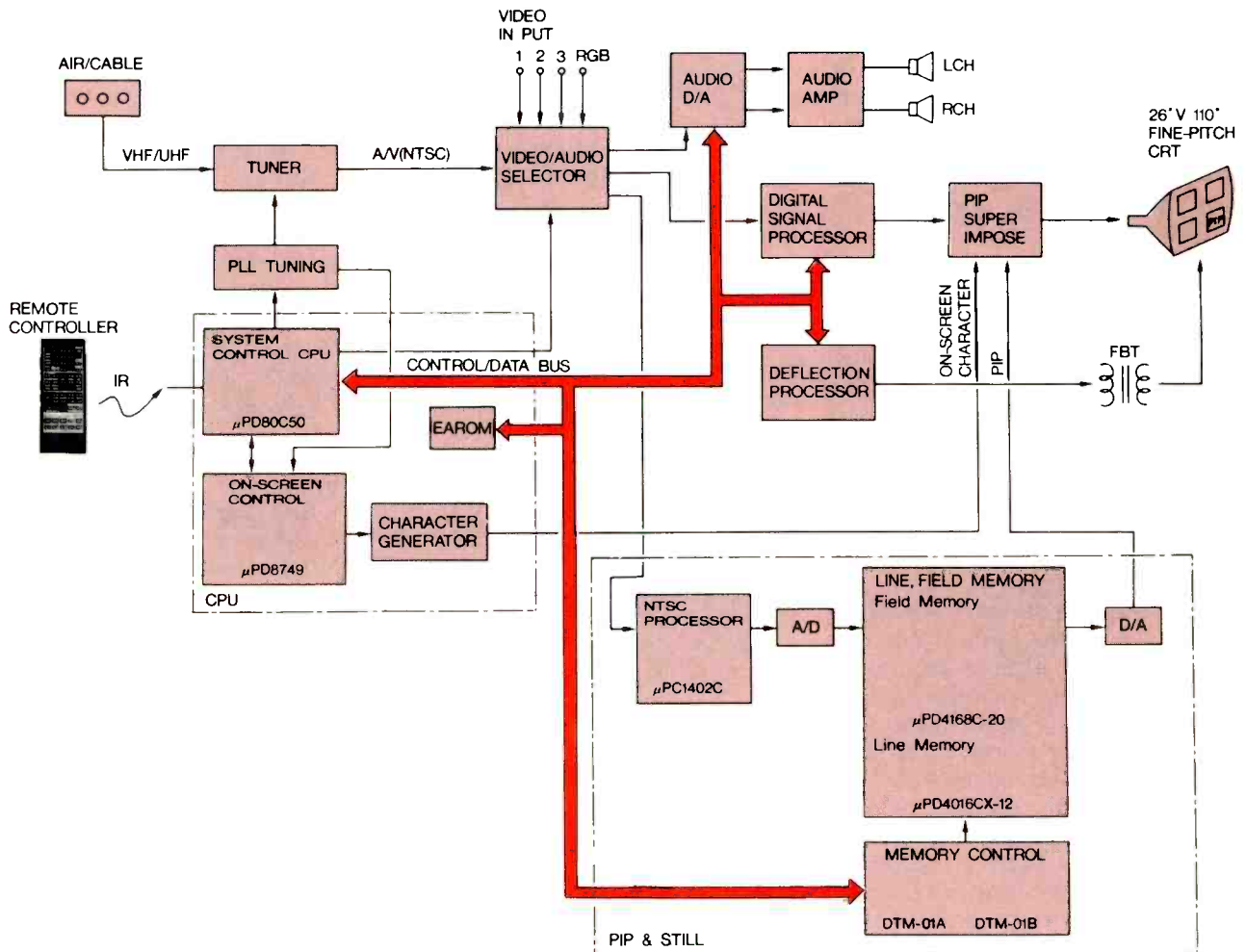

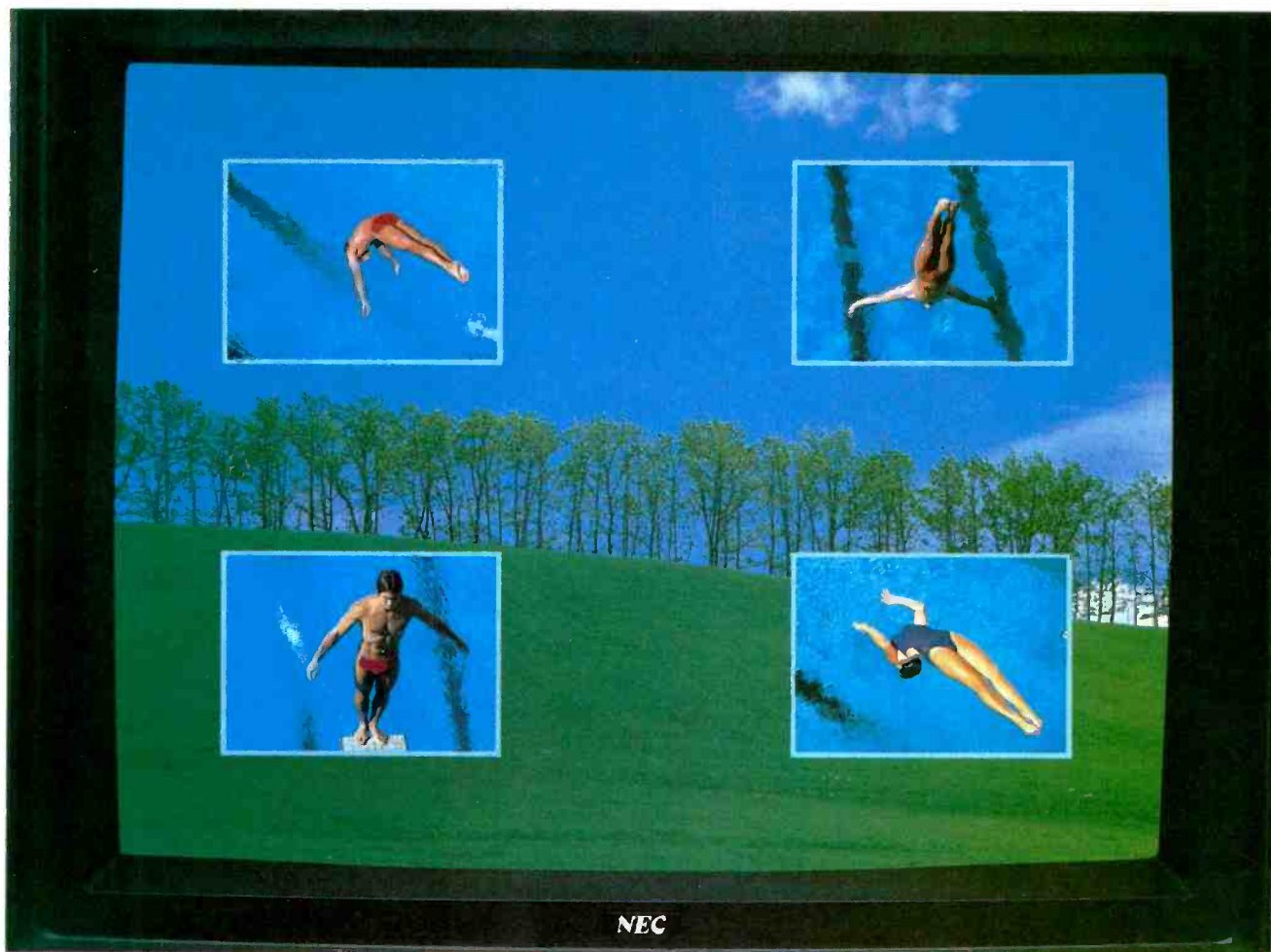

Simulated TV picture

the lower right.

This means computer owners can follow their stocks, VCR owners can check out a tape or tune in a second channel, all without interrupting their TV viewing.

Memory for three still pictures

The DT-2680A has the memory to store up to three different still pictures at a time. Pictures for memory are selected by remote control and displayed as 8½-inch diagonal inserts: No. 1 in the upper-right, No. 2 in the upper-left, and No. 3 in the lower-left quadrant of the screen.

Connection and reception

The set has frequency synthesis tuning of 142 channels, including non-scrambled cable channels. Built-in MTS decoder, stereo amplifier and stereo speakers provide reception of TV stereo and second audio program (SAP). A special RF output and auxiliary antenna input permit connection of a pay-TV decoder box.

Three sets of line video inputs accept connections for VCRs, videodisc players, color cameras and home computers. An 8-pin RGB input enables the DT-2680A to display high-resolution computer graphics from IBM and NEC personal computers. Outputs include a monitor output that carries whatever is on-screen, a TV output that carries whatever channel the DT-2680A has tuned, external speaker outputs, fixed audio line outputs for recording, and variable audio-line outputs for volume-controlled connection to a high fidelity system.

Remote control feature

The set offers comprehensive remote control of functions including channel tuning, sleep timer, and a myriad of picture and sound adjustments. A variety of on-screen displays identify the channel and operating mode, and help the user make adjustments. Picture reset and sound reset functions return the controls to factory preset positions.

ES&T_{INC.}

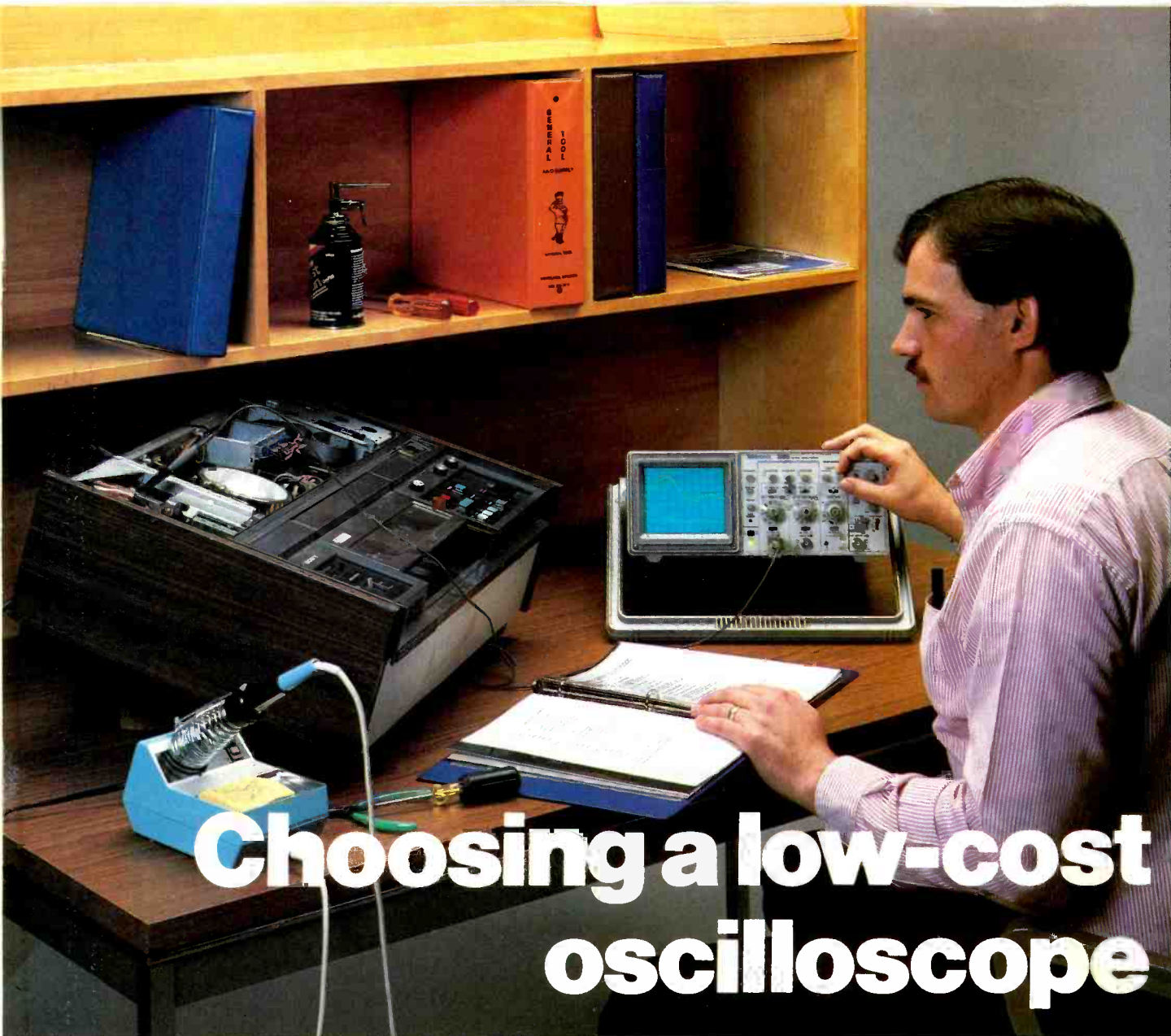

Choosing a low-cost oscilloscope

By Dave Herrington

There's an old axiom, "You get what you pay for."

The nice thing about electronics technology is that today you get far more for your dollar than was possible even a year ago. This is especially true of oscilloscopes. Choosing a low-cost scope today, doesn't have to mean giving up features to save money. The performance/price ratio has never been higher, particularly for scopes under \$1,000.

For example, the new Tektronix 2225 scope starts with basic 50MHz, dual-channel capability. To this, add 500 μ V/div input sensitivity instead of the usual 2mV or even 5mV maximum sensitivity. This scope also provides high-fre-

quency/low-frequency trigger reject along with normal, peak-to-peak automatic, single-sweep, and TV field/line triggering. There's even X5, X10 and X50 horizontal alternate magnification for simplifying measurements normally done with a dual-time-base oscilloscope.

A number of technologies have come together to make such features possible in low-cost scopes. In particular, engineering investment is much more effective with computer-aided design. Modern analog ICs have reduced part counts for quicker manufacturing (and higher reliability) while providing more features in a smaller package. And modular design features (Figure 1) have speeded assembly.

Advanced technology has built more scope for less money. But the question still remains: Will these new scopes do the job for you? How do they perform?

Table 1 lists some applications and related scope requirements. This is but a brief summary, however. Making a final scope selection still requires understanding the scope specifications and how far they can be pushed for any application. The alternative—if money is no object—is to buy the fastest scope on the market.

Bandwidth, rise time and sensitivity

In considering any scope for a given application, first look at its bandwidth, rise time and sensitivity characteristics. These are the

Herrington is product support specialist. Portable Test Instruments division, Tektronix, Beaverton, OR.

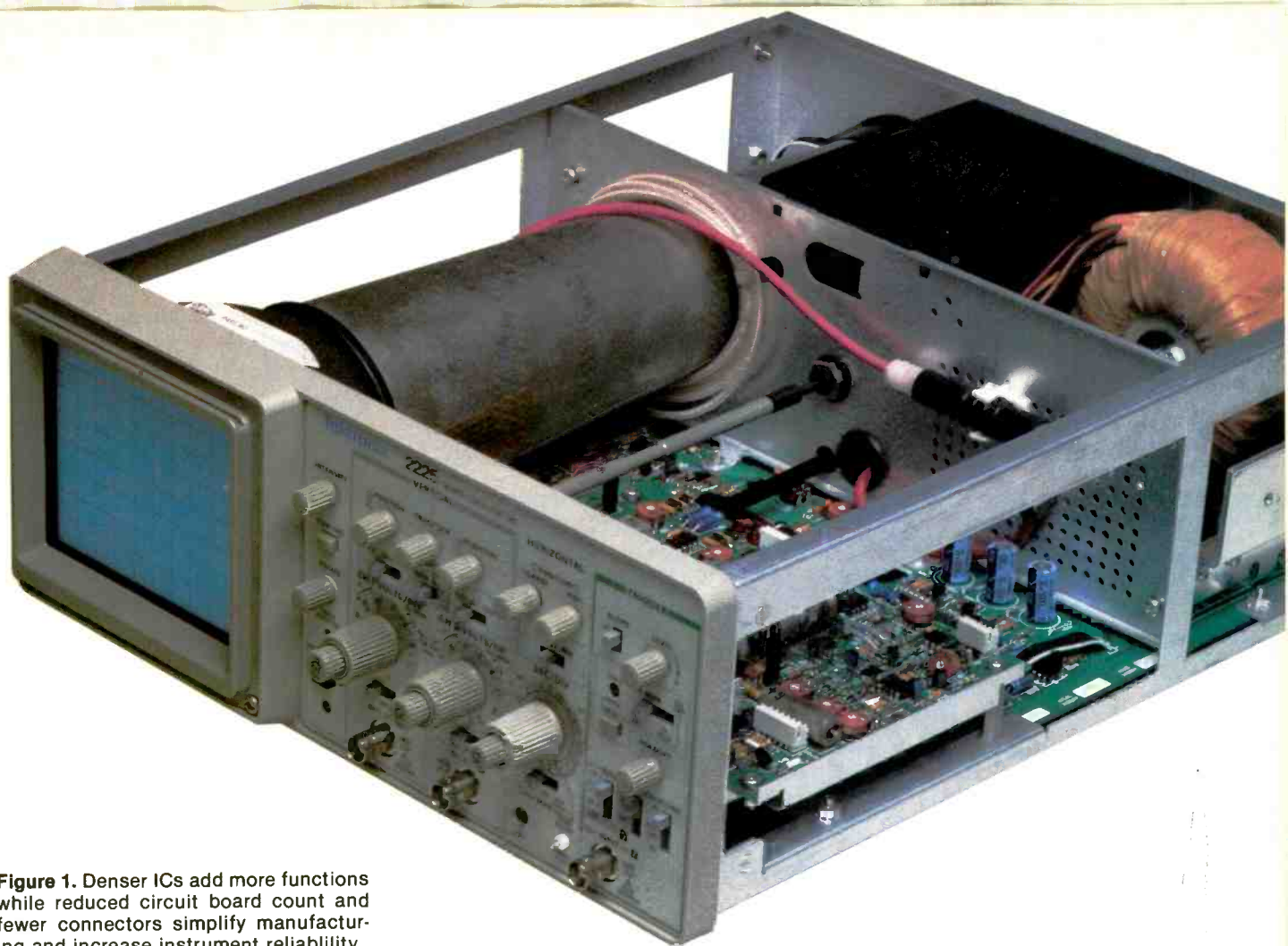

Figure 1. Denser ICs add more functions while reduced circuit board count and fewer connectors simplify manufacturing and increase instrument reliability.

Oscilloscope Applications Summary

	Bandwidth	Rise Time	Other Key Features
1. TV/Video	12.5MHz	28ns	TV Frame and Line Triggering
2. Digital	50MHz	7ns	Dual Channels, Alternate Horiz. Mag.
3. Audio	175kHz	---	500 μ V Sensitivity
4. Electro-mechanical	5-10MHz	35ns	Single Sweep, HF/LF Reject Trigger
5. Robotics	5-10MHz	35ns	Single Sweep, HF/LF Reject Trigger, 500 μ V Sensitivity
6. Power Supplies	175kHz	--	500 μ V Sensitivity

Notes:

1. Based on 0.14 μ S sync pulse rise time requirements. At least 50MHz needed for IF sections.
2. Covers most consumer digital systems (e.g. personal computers).
3. Does not cover digital recording; 500 μ V sensitivity for microphone, tape head measurements.
4. Based on rise time/switching requirements.
5. Same as 4; high sensitivity for low amplitude sensor waveforms.
6. Bandwidth determined by supply switching rates; 500 μ V sensitivity for low-level ripple measurements.

Measurement capabilities such as rise time and bandwidth and special features that you need to have in an oscilloscope depend on what you intend to measure with it. This table indicates some possible applications, but technicians' needs vary.

may be easier to deal with in the single-shot mode. In this mode, a single display sweep is triggered when the signal occurs. The scope trigger is then manually rearmed for the next signal. Typically, low-speed single-shot signals, such as a relay or switch closure, can be viewed directly on screen. Faster transients usually must be captured with single-shot CRT photography or more expensive digital storage technology.

TV frame and line triggering modes (Figure 3) are less commonly found on low-cost scopes. As their name implies, these modes allow synchronous triggering on TV display frames or scan lines. Naturally, this is an important feature for TV servicing, but it is becoming increasingly important for general use because more and more products are using raster scan displays: video terminals, video games and personal computers are a few common examples.

In cases where signals are low level, any of the above modes can have trouble locking in on the signal for a stable display. This is usually because of noise, which is a common problem in most low-level measurements. Power supply ripple, 60Hz from lighting and general random noise are the usual culprits. Their presence disrupts trigger stability by obscuring the desired trigger point.

In the past, many low-level measurements had to be made in shielded rooms or with some kind of shield cage constructed on the bench. Now, however, low-frequency and high-frequency reject modes are extending standard scope triggering to much lower level signals (Figure 4). These modes reject unwanted bands of noise from the triggering pick off of the signal being measured.

When 60-cycle or other low-frequency interference is the problem, use low-frequency reject to obtain stable triggering. For other trigger jitter problems, high-frequency reject is usually the solution.

But not all low-cost scopes provide all of these triggering modes. Although a scope may meet basic bandwidth and sensitivity requirements, lack of a convenient

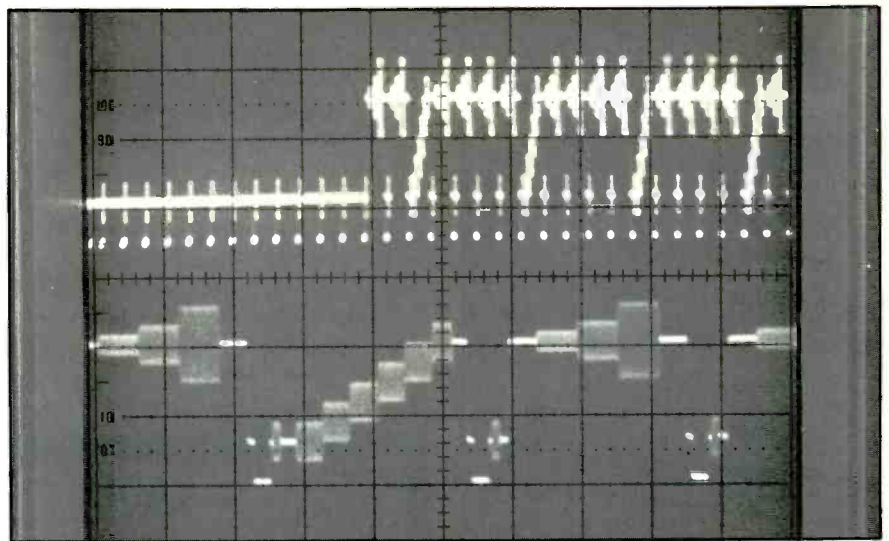

Figure 3. The ability to synchronously trigger on a TV frame or a scan line is an important scope feature in a world that is becoming increasingly video oriented.

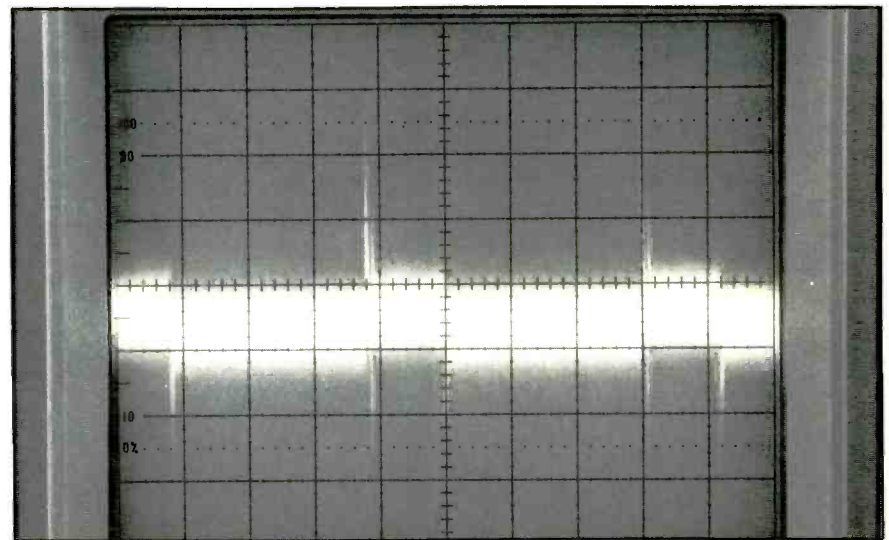

Figure 4. High sensitivity input ($500\mu\text{V}/\text{div}$) and high-frequency reject triggering provide large, stable displays of low-level signals.

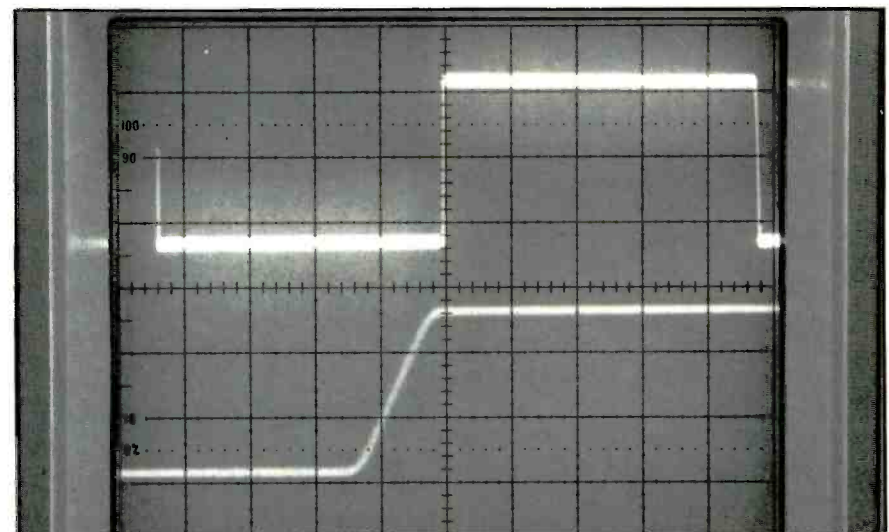

Figure 5. Alternate horizontal magnification allows zooming in on transition details without the complexity or expense of dual time base or delaying time base features.

triggering system can make the measurement process unnecessarily difficult. In short, a wide range of triggering features can multiply the scope's value several fold simply by the convenience and time savings they provide.

Horizontal alternate magnification

After bandwidth, rise time, sensitivity and triggering considerations are resolved, the next considerations are the number and types of additional features included in the scope's price. For example, number of input channels can be an important additional feature.

In reality, most measurements can be made with a single-channel oscilloscope. However, dual input channels expand capability and convenience. One channel can be used to observe the input to a signal stage, and the other used to observe the output simultaneously. This makes comparisons and level adjustments much easier because both signals are displayed. Also a single probe does not have to be switched back and forth between circuit input and output.

If two channels are good, might not three or four channels be even better?

Certainly—if you really need to look at three or four signals simultaneously. But how often does that need arise in day-to-day measurements? How often could the job be just as easily done with two channels? And is the extra price of additional channels really worth it? In walking through advanced engineering areas, it is surprising how often you see just one or two probes attached to an expensive 4-channel scope.

Dual time bases or delaying time bases are more likely additional features of usefulness. Although they are useful for high resolution time measurements, dual or delaying time bases do add to scope cost. They are also typically advanced features that are not always easy to understand or use.

Alternate horizontal magnification, on the other hand, is a simpler and easier-to-use feature. It is also a feature that can make the most of measurements associ-

ated with dual-time base or delayed sweep features, and without the additional cost.

Using this feature is basically a matter of pressing a button for the amount of expansion desired. One or two expansion factors such as X5 or X10 are typical for most scopes. However, on the Tektronix 2225, three factors are provided: X5, X10 and X50 expansion.

With all of the different low-cost scopes on the market today and

the variety of features available, there is certainly plenty to think about before spending your money. The nice thing about the newer models, though, is they usually provide all of the features, plus some you may not expect. Moreover, thanks to modern engineering and manufacturing technology, they are able to do it at about the same price as older, less capable scope models.

Circle (135) on Reply Card **ES&T**



Because Your Customers Deserve the Best



Hitachi Original Replacement Parts

Quality, reliability, service...they're the touchstones of the Hitachi tradition, as recognizable as our trademark. And now those same standards that have earned us our reputation as a technological leader in consumer products, back up our new line of **Hitachi Original Replacement Parts**.

We know that for the service professional, time wasted is profit lost. Which is why Hitachi makes it easy for you. With our complete line of parts, we provide you with a single source for all your repair needs—and a profitable addition to your business. From VCR kits, IC chips and

diodes—to battery packs, video, audio accessories and technical publications.

What's more, our nationwide network of distribution centers means that you can get the parts and accessories you need, when you need them. And, of course, **Hitachi Original Replacement Parts** are included in our total service support program...because your customers deserve the best.

For more information, call toll-free
1-800-447-2882.

HSC SERVICE COMPANY
division of Hitachi Sales Corporation of America

401 W. Artesia Blvd.
Compton, CA 90220
(213) 537-8383

Circle (14) on Reply Card

When you rent test equipment from us you don't get just the equipment. You get the company. U.S. Instrument Rentals. The leading company. That means broader and deeper inventory. The latest equipment. The best quality equipment. Delivered on time. Better value. Better support. It also means the most flexible terms in the business. Rent. Buy. Lease.

Get the company.

U.S. Instrument Rentals.

The 1987/88 U.S. Instrument Rentals
Product Guide. Phone for yours today.
CAE Workstations, PROM Programmers,
Microprocessor Development Systems.

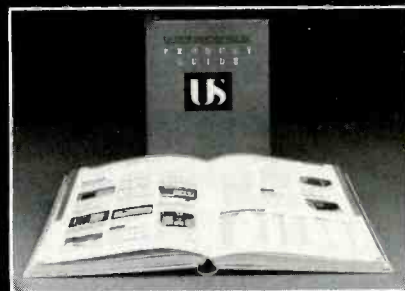

COMPANY FOR RENT.

(800)-824-2873

on sale.

United States Instrument Rentals, Inc.

US

A U.S. Leasing Company
2988 Campus Dr., San Mateo, CA 94403
(415) 572-6600

Circle (15) on Reply Card

You have to buy test equipment OR DO YOU?

A decision to acquire test equipment is not always a choice between buying and not buying. This is particularly true when budgets are stretched. It's also true when the need is immediate or short-term. But it's especially true when you're not sure as to just what instrument will be the right tool for the job. At those times, it might be better to rent.

People who buy, build, install or repair electronic equipment do not have unlimited budgets and instrumentation is expensive. Few businesses can afford to purchase all of the instruments they would like to have. Additionally, the rapid progress of technology increases the risk of obsolescence. Even if you had an unlimited capital budget, you might have a difficult time keeping pace with the regular introduction of new and better products.

When choosing the right instrument, you must weigh many variables. For instance, how much does the equipment cost? How soon is it needed and for how long? How many functions can it perform? And will a new, better model be available before the current model receives its first scratch.

As all of these questions are important in deciding whether to acquire a given instrument, they are equally important in trying to decide how to acquire that instrument, particularly when the variety of test equipment available—in relation to the number of test functions required—can be enormous.

For such users, access to rental equipment also makes it possible to avoid premature commitments to undefined requirements. You can minimize these risks by making a thorough evaluation of the alternatives. Some important benefits of choosing the rental option are discussed in this article.

The benefits of renting

Virtually all types of test equipment are available from rental companies. For example, the current U.S. Instrument Rentals catalog lists everything from digital multimeters, analyzers and oscilloscopes to data communications,

By Jack Cunningham

microwave test sets and logic analyzers. Also in inventory is a variety of power supplies, meters and generators. A single phone call provides immediate access to a wide range of test equipment.

Try before you buy

Given the high price tags of most test equipment, it is critical that the instrumentation is right for the job. Rental permits you to try, risk free and at a low cost, individual instruments before opting for purchase. Renting also enables users to do hands-on testing of comparable equipment. That's something that can't be obtained through spec sheets and catalogs. The chance of acquiring the wrong equipment for the job is virtually eliminated.

Cost allocation and tax savings

With rental, specific equipment costs can be isolated and assigned directly to individual projects. In this way, special equipment costs can be directly borne by the group or individual that specifically benefits from its use. And, because rental payments are currently considered operating expenses, the full value of those payments can be deducted from income for tax purposes. Purchased equipment must be capitalized over a number of years as a charge against future earnings.

Making it work

Rental companies maintain permanent stocks of all kinds of instruments in their inventory centers. In most cases, these locations are combined warehouses and metrology labs. These facilities not only store, they also provide personnel to calibrate, maintain, and if necessary, rebuild equipment to meet manufacturers' specifica-

tions. Warehouse and calibration activities are integrated to provide immediate availability of ready-to-use equipment.

Test instruments can be rented for terms as short as one week or as long as several years. Typically, instruments are rented for three to eight months. During this time the rental user need not worry about problems related to maintenance or service. Most rental companies will replace a malfunctioning piece of equipment with an identical one—at no cost to the customer.

At the end of the rental term, equipment can be returned, renewed, upgraded or purchased outright. Many rental companies offer equity build-up plans. These plans allow a customer to accrue equity in an instrument while it is being rented. This accrued equity then can be applied to the equipment purchase, if the customer decides to buy it. Or a predetermined portion of the equity can be swapped and used to buy or lease a completely different instrument.

Rental companies are also in a position to offer excellent opportunities to purchase test equipment outright. Both new and used instruments can be purchased directly from a rental company's inventory, with warranty protection and immediate delivery. In this sense, even those who prefer to purchase can benefit from the rental alternative in the test equipment marketplace.

Prospective buyers should ask themselves these few questions before deciding to purchase an instrument. Do I have an immediate need for this instrument? Is the instrument still in a dynamic phase of its development or in danger of becoming obsolete? Could my capital funds be more productively

Cunningham is senior vice president and general manager of U.S. Instrument Rentals, San Mateo, CA.

How much? How long?

OK! But what will it cost, and what's the minimum rental period?

The following figures are very rough, just to get you into the ballpark of what it might cost to rent a piece of test equipment. Depending on what you rent and for how long, actual cost could be very different from this.

The average rental period for a piece of test equipment rented by U.S. Instrument Rentals is three to eight months. Some equipment may, however, be rented for as little as a few weeks. The monthly rental cost is ordinarily in the range of 8% to 10% of the purchase price of the unit. There also will be shipping costs and any applicable taxes.

spent on something else at this time? Is there reason to believe this product will not be needed full time or long term? If the answer to any or all of these questions is yes, prospective buyers should seriously consider the merits of rental as a means of meeting instrumentation needs.



U.S. Instrument Rentals, Inc.
A U.S. Leasing Company

ALTERNATIVE PURCHASE PLAN

RENTAL AGREEMENT NO. _____
SALESMAN NUMBER _____

BILL TO:
(CUSTOMER)
STREET _____
CITY _____
ATTN. _____
TELEPHONE _____

STATE _____ COUNTY _____
ZIP _____ EXT. _____

SHIP TO (EQUIPMENT LOCATION):
COMPANY NAME _____
STREET _____
CITY _____
ATTN. _____
TELEPHONE _____

STATE _____ COUNTY _____
ZIP _____ EXT. _____

ITEM	MFR.	MODEL #	DESCRIPTION	SERIAL OR ASSET NO.	MONTHLY SERVICE FEE	MONTHLY RENTAL FEE	ORIGINAL VALUE

START RENT DATE _____ RENTAL TERM _____ MONTHS _____ CUSTOMER P.O. NO. _____
SHIP VIA _____ FRT. \$ _____ IF TAX EXEMPT - EXEMPTION CERTIF. NO. _____ CUSTOMER NO. _____

TOTAL AMOUNT _____

PURCHASE OPTIONS

1. AT RENTAL TERM EXPIRATION, for _____ % of original value
 2. AT MIDTERM OR AFTER _____ MONTHS } for original value less _____ % rent credit
 OR AFTER _____ MONTHS } (credit not to exceed _____ % of original value)

CANCELLATION PRIVILEGE (check one):

AT MIDTERM OR AFTER _____ MONTHS
 NONE
 OTHER: AFTER _____ MONTHS

EQUITY TRANSFER (SWAP OPTION)

YES: _____ % of accrued equity transferable to new purchase or rental
 NO At midterm or thereafter or After _____ months

SERVICE OPTION (check one):

FULL
 ON-SITE
 SELF-SERVICE

USIR rents to Customer and Customer rents from USIR the Equipment listed above or, if separately scheduled, in the schedule attached hereto, upon the terms and conditions on this **AND THE REVERSE SIDE HEREOF**. This lease shall not be binding upon USIR unless signed at USIR's office by an authorized employee.

UNITED STATES INSTRUMENT RENTALS, INC. (U.S.I.R.)

BY _____ AUTHORIZED SIGNATURE _____
 NAME _____ TITLE _____ DATE _____

CUSTOMER

BY _____ AUTHORIZED SIGNATURE _____
 NAME _____ TITLE _____ DATE _____
 (FULL LEGAL NAME OF _____)

Books

Troubleshooting and Repair of Microprocessor-Based Equipment, by John D. Lenk; Howard W. Sams, 250 pages, \$21.95, softbound.

In this manual, Howard W. Sams & Company, a division of Macmillan, provides a simplified, practical system for diagnosing, isolating and locating faults in microprocessor circuits. Although the book concentrates on the basic approach to troubleshooting, numerous, effective shortcuts (tricks?) are included. The following subjects are covered: microprocessor test equipment; problems in troubleshooting microprocessors; troubleshooting the gate and IC; stimulus-response testing; Vcc and ground shorts from unexpected causes; flip-flop troubleshooting; register troubleshooting; current flow analysis; wired-AND and wired-OR troubleshooting; using the logic analyzer; step-by-step procedure for troubleshooting the VCR.

Published by Howard W. Sams & Company, 4300 W. 62nd St., Indianapolis, IN 46268; 317-298-5409.

Books for electronic communication available from Microwave Filter Company; prices and content are varied.

More than 60 books and videotapes are available for purchase from a bookstore of electronic communications organized by MFC, a producer of filters for the communications industry. Selections offer theoretical and hands-on problem solving information in six electronic communications markets that include satellite and cable television, mobile and general communications, local area networks and amateur radio. Among publications are the "Avoidance and Suppression of Terrestrial Interference" (ASTI) handbook, and its video counterpart, "The ASTI Guide to TI," both written and produced by this company.

Contact Microwave Filter Company, 6743 Kinne St., East Syracuse, NY 13057; 800-448-1666, or NY, HI, AK, Canada residents call collect, 315-437-3953.

Exclusive, triple patented dynamic cap and coil analyzing . . . guaranteed to pinpoint your problem every time or your money back



**with the all new LC75 "Z METER 2"
Capacitor Inductor Analyzer
Patented \$995**

The "Z METER" is the only LC tester that enables you to test all capacitors and coils dynamically — plus, it's now faster, more accurate, and checks Equivalent Series Resistance (ESR) plus small wire high resistance coils.

Eliminate expensive part substitution and time-consuming shotgunning with patented tests that give you results you can trust every time. Test capacitor value, leakage, dielectric absorption, and ESR dynamically; with up to 600 volts applied for guaranteed 100% reliable results — it's exclusive — it's triple patented.

Save time and money with the only 100% reliable, in- or out-of-circuit inductor tester available. Dynamically test inductors for value, shorts, and opens, automatically under "dynamic" circuit conditions.

Reduce costly parts inventory with patented tests you can trust. No more need to stock a large inventory of caps, coils, flybacks, and IHVTs. The "Z METER" eliminates time-consuming and expensive parts substituting with 100% reliable LC analyzing.

Turn chaos into cash by quickly locating transmission line distance to opens and shorts to within feet, in any transmission line.

Test troublesome SCRs & TRIACs easily and automatically without investing in an expensive second tester. The patented "Z METER 2" even tests SCRs, TRIACs, and High-Voltage Diodes dynamically with up to 600 volts applied by adding the new SCR250 SCR and TRIAC Test Accessory for only \$148 or FREE OF CHARGE on Kick Off promotion.

To try the world's only Dynamic LC Tester for yourself, CALL TODAY, WATS FREE, 1-800-843-3338, for a FREE 15 day Self Demo.



Call Today Wats Free 1-800-843-3338

SENCORE
3200 Sencore Drive
Sioux Falls, SD 57107
605-339-0100 In SD Only

*innovatively designed
with your time in mind.*

Circle (16) on Reply Card

PART 1

MTS

TV sound in stereo

By Bert Huneault

A new dimension came to North American television in 1984: stereophonic sound. Do you know how it works yet? Although many technicians probably studied the principles of FM multiplex stereo a long time ago (it's been around for 25 years), how many still remember those fundamentals?

This article is designed to familiarize readers with the basics of the new *multichannel television sound* (MTS), the TV stereo sound system that really has gotten off the ground in the last year or so.

To set the stage for MTS, we should first review the basics of FM stereo. This stroll down memory lane should benefit oldtimers as well as newcomers to the field, because the new TV stereo sound is based on, and is really an extension of, the standard stereo system used in FM broadcasting.

FM multiplex stereo

To broadcast in stereo, an FM station must transmit left-channel and right-channel audio information simultaneously, in such a way as to allow the two channels to be

ultimately separated in receivers. This calls for *multiplexing* techniques. Multiplexing (MPX) means interleaving or simultaneously transmitting two or more messages on a single channel; MPX is thus a modulation method that combines two or more signals into a single wave from which the signals (left and right audio) can be individually recovered in a receiver.

Two carriers are involved in FM MPX broadcasting: the station's main RF carrier (VHF), and a much lower frequency subcarrier. One of the two channels of audio intelligence *frequency-modulates* the station's main carrier directly. The other audio signal *amplitude-modulates* the subcarrier, resulting in AM sidebands; these sidebands are then used to frequency-modulate the station's main carrier. Sound confusing? What follows will clear it up.

Now, you would think that the two channels of audio intelligence that actually modulate the carrier and subcarrier consist only of the left and right audio signals, wouldn't you? Not so; that would

be too logical. But there is a reason why it can't be accomplished so simply: compatibility with monophonic FM receivers.

L + R and L - R audio

When the Federal Communications Commission (FCC) authorized standards for multiplex stereo broadcasting back in 1961, it decreed, in its wisdom, that FM stereo broadcasts should be compatible with existing monophonic receivers. That put a bit of a fly in the ointment, but as it turned out, it was no big deal. Broadcast equipment designers solved the compatibility problem by simply combining the left and right audio signals in a matrix circuit that produces two different outputs: a left plus right (L + R) signal and a left minus right (L - R) signal. L + R audio is sometimes referred to as the *monophonic signal* because it satisfies the requirements of mono receivers. L - R audio is often called the *stereo signal* because, when added to L + R in a stereo receiver, it makes possible the recovery of separate left and right audio signals, thus reproducing the stereo effect.

What's in that bag of tricks called the *matrix*? Essentially, it consists of a combiner circuit that contains a couple of adders and a phase inverter. (See Figure 1.)

The signal voltage from the left microphone is added to that from the right microphone in an L + R adder, resulting in the monophonic (L + R) audio signal. Also, the signal from the right microphone is phase-inverted into a - R signal and then combined with the L signal in an L - R adder, resulting in the stereo (L - R) signal. Note that both L + R and L - R are still *audio* signals as they exit from the matrix. These are the two signals that actually modulate the station's carrier and subcarrier. Filtering (not shown in Figure 1) limits these audio signals to a frequency range of 50Hz to 15,000Hz.

Stereo transmitter

Next, let's get down to brass tacks and see how modulation is achieved, and discuss the role the subcarrier plays in this scheme. (See Figure 2.)

Note that the L + R signal from the matrix goes directly to the RF

transmitter, where it frequency-modulates the station's carrier. But the L-R audio signal doesn't take such a direct route. Instead, it amplitude-modulates a 38kHz subcarrier in a balanced modulator, and the resulting L-R AM sidebands are then fed to the transmitter where they also frequency-modulate the RF carrier. The 38kHz subcarrier is a continuous wave generated by a 19kHz oscillator and a frequency doubler.

Now, a word about those AM sidebands. Because the modulator circuit is of the *balanced* type, the 38kHz subcarrier gets suppressed, and the only signals emerging from the modulator are AM double sidebands ranging up to 15kHz on both sides of the suppressed 38kHz frequency, occupying the spectrum between 23kHz and 53kHz. This is referred to as AM double sideband suppressed-carrier (DSBSC) modulation. It is essential to recognize that no 38kHz subcarrier accompanies these L-R sidebands into the FM transmitter; the missing subcarrier will have to be reckoned with

Take another look at Figure 2. Note the 19kHz pilot signal that also feeds the FM transmitter; this is a sample of the unmodulated (continuous wave) signal generated by the 19kHz oscillator. As we'll see later, this pilot signal plays a vital role

So, we have several distinct signals applied to the transmitter, and each of them frequency-modulates the station's VHF carrier at its own specific rate. Obviously, this keeps the FM carrier quite busy, deviating all over the place! Let's take a specific example: Suppose a 2,000Hz musical note is played into the L and R microphones. This results in a 2kHz L+R audio signal and the following pair of L-R side frequencies: 36kHz and 40kHz ($38-2=36$; $38+2=40$). These signals, as well as the 19kHz pilot, cause the station's FM carrier to deviate at four different rates; the amount of carrier deviation is determined by the amplitudes of these modulating signals (maximum deviation allowed: ± 75 kHz).

Thus the L+R audio signal forces the station carrier to deviate 2,000 times per second; the pilot signal makes it deviate 19,000

Analyze defective waveforms faster, more accurately, and more confidently — every time or your money back



with the SC61 Waveform Analyzer
Patented \$2,995

If you value your precious time, you will really want to check out what the exclusively patented SC61 Waveform Analyzer can do for you. 10 times faster, 10 times more accurate, with zero chance of error.

End frustrating fiddling with confusing controls. Exclusive ultra solid ECL balanced noise cancelling sync amplifiers, simplified controls, and bright blue dual trace CRT help you measure signals to 100 MHz easier than ever.

Accurately and confidently measure waveforms from a tiny 5 mV all the way to a whopping 3,000 V without hesitation with patented 3,000 VPP input protection — eliminates expensive "front end" repairs and costly equipment downtime.

Make only one circuit connection and push one button for each circuit parameter test: You can instantly read out DC volts, peak-to-peak volts and frequency 100% automatically with digital speed and accuracy. It's a real troubleshooting confidence builder.

Confidently analyze complex waveforms fast and easily. Exclusive Delta measurements let you intensify any waveform portion. Analyze glitches, interference signals, rise or fall times or voltage equivalents between levels; direct in frequency or microseconds.

Speed your digital logic circuit testing. Analyzing troublesome divide and multiply stages is quicker and error free — no time-consuming graticule counting or calculations. Simply connect one test lead to any test point, push a button, for test of your choice, for ERROR FREE results.

To see what the SC61 can do for your troubleshooting personal productivity and analyzing confidence, CALL TODAY, WATS FREE, 1-800-843-3338, for a FREE 15 day Self Demo.



Call Today Wats Free 1-800-843-3338

SENCORE

3200 Sencore Drive
Sioux Falls, SD 57107
605-339-0100 In SD Only

*innovatively designed
with your time in mind.*

Circle (17) on Reply Card

January 1987 *Electronic Servicing & Technology* 45

times per second; the L-R lower sideband causes it to deviate 36,000 times per second; and the L-R upper sideband creates 40,000 deviations per second, all going on simultaneously.

Loudspeaker analogy

If you have any difficulty visualizing an RF carrier that simultaneously swings in frequency 2,000, 19,000, 36,000 and 40,000 times per second, the following analogy might help. Think of a loudspeaker with an audio input signal consisting of two musical tones: a 100Hz bass note and a 5,000Hz treble note. These two ac currents cause the voice coil to vibrate at two different rates simultaneously: while the speaker cone wobbles back and forth at a relatively slow rate of 100 swings per second, it also wobbles at a much faster rate of 5,000 vibrations per second, reproducing both tones simultaneously.

The RF carrier of our FM stereo station follows the same scenario: while its frequency wobbles back and forth at a relatively slow rate of 2,000 swings per second due to the L+R signal, it also deviates at a much faster rate of 19,000 swings per second due to the pilot signal; and at 36,000 and 40,000 deviations per second due to the L-R sidebands. Therefore, at any given moment, the instantaneous carrier frequency is actually the net result (resultant vector) of all those different modulation rates acting upon it. The FM carrier thus undergoes complex deviations, just as a loudspeaker cone experiences complex vibrations while reproducing music or speech.

The end product is an FM signal that contains modulation representing the total *composite stereo signal*, whose baseband frequency spectrum is illustrated in Figure 3.

SCA signal

As shown in Figure 3, the composite stereo baseband also includes an optional subchannel with a subcarrier frequency of 67kHz. This subsidiary communication authorization (SCA) subcarrier is *frequency-modulated* (typical deviation: ± 6 kHz) and may be used by some FM stations to transmit privileged information, control signals, or background

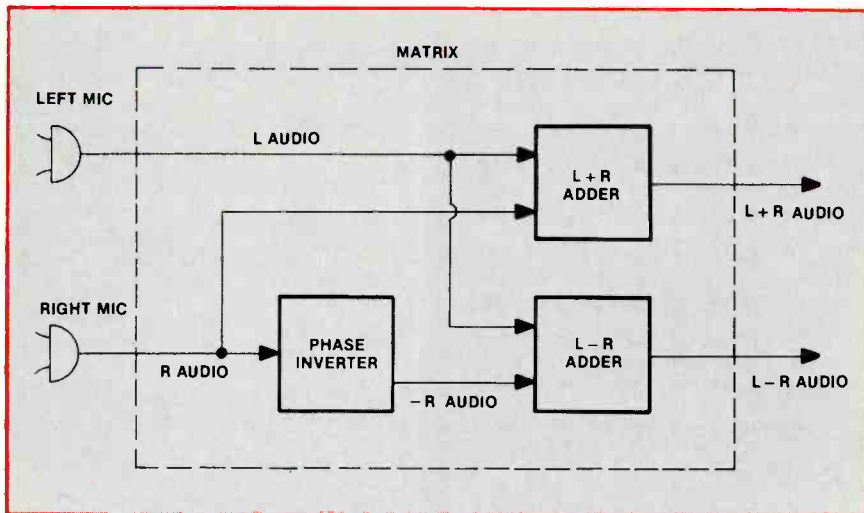

Figure 1. The matrix outputs L + R and L - R audio signals.

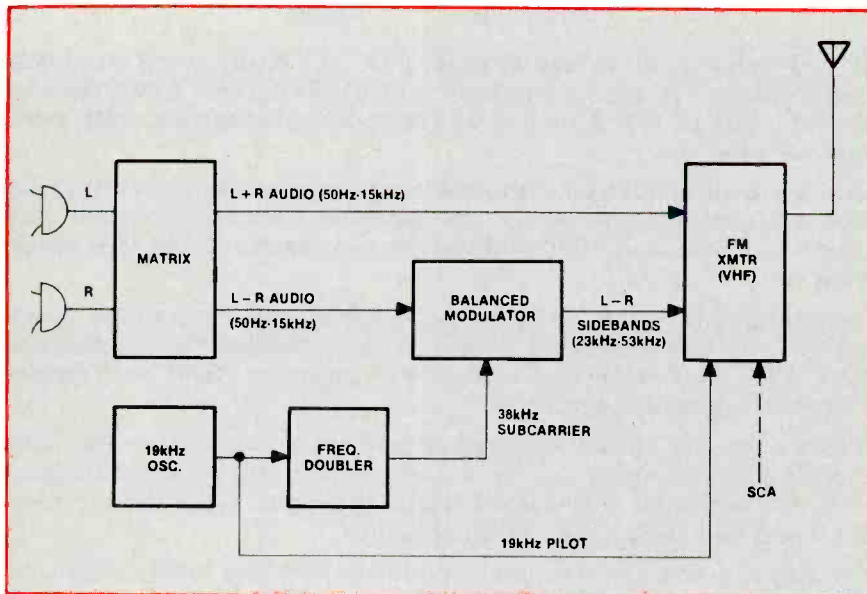

Figure 2. Simplified block diagram of FM stereo transmitter.

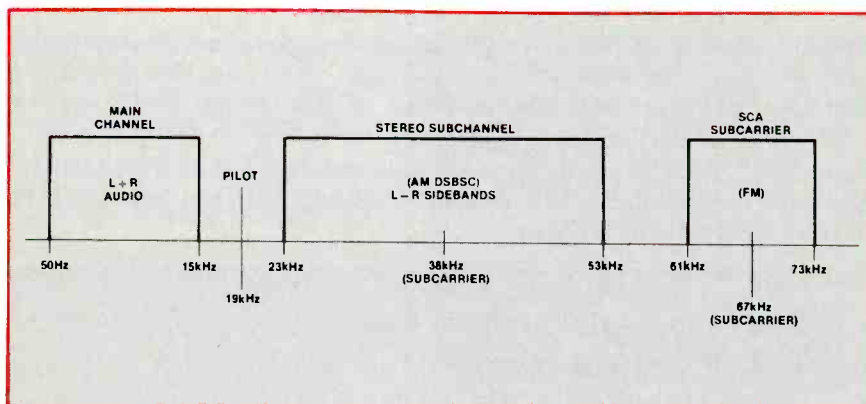

Figure 3. Composite stereo signal baseband.

music (storecasting). Ordinary FM stereo receivers reject this signal.

Pre-emphasis

A final word about the L+R audio signal at the FM transmitter: the higher audio frequencies are pre-emphasized in order to obtain a better signal-to-noise ratio in transmission; the treble boost is achieved by means of a high-pass filter with a time constant of $75\mu\text{s}$. This doctoring up of the audio signal will have to be offset in FM receivers in order to restore the natural balance of bass and treble tones.

An interesting comparison

Until now, while you were reading the article, did you by any chance get a sense of *deja vu* even if you had never studied FM MPX stereo before? Did you perhaps get the feeling that all this jazz about subcarrier modulation is already familiar in connection with color TV? If so, you're right. Before we leave the subject of composite stereo signal generation and transmission, let's make a quick comparison between the block diagram of an FM stereo transmitter (Figure 2) and that of a color TV picture transmitter (Figure 4).

Note the striking similarity between the two systems. In the color TV transmitter diagram, the camera feeds three video signals (red, green and blue) to the matrix; this is analogous to the L and R audio signals from the two microphones in Figure 2. In Figure 4, the matrix mixes the three color signals in various proportions and outputs three different video signals. The luminance (Y) signal, which contains brightness (B&W) information, goes directly to the RF transmitter where it amplitude-modulates the picture carrier; this is like the L+R audio signal that directly modulates the FM transmitter in Figure 2. The I and Q color video signals produced by the matrix are applied to the balanced modulator, where they amplitude-modulate a 3.58MHz subcarrier, producing chroma sidebands on either side of the suppressed 3.58MHz subcarrier frequency (this is a *two-phase* AM DSBSC modulation system because there are two modulating signals, I and Q). These AM sidebands then modulate the RF

Now test and restore every CRT on the market . . . without ever buying another adaptor socket or coming up embarrassingly short in front of your customer . . . or your money back



with the new improved CR70 "BEAM BUILDER"™
Universal CRT Tester and Restorer
Patented \$995

Have you ever?

Thrown away a good TV CRT, data display CRT, or scope CRT that could have been used for another two or three years because you had no way to test or restore it?

Lost valuable customers because you advised them that they needed a new CRT when another technician came along and restored the CRT for them?

Lost the profitable extra \$35 or more that you could have gotten for restoring a CRT while on the job and locked in the profitable CRT sale later?

Avoided handling profitable trade-ins or rentals because you were afraid you'd have to replace the picture tube when you could have restored it?

Had a real need to test a CRT on the job, but didn't have the right adaptor socket or setup information in your setup book?

If any of these things have happened to you, **CALL TODAY, WATS FREE, 1-800-843-3338**, for a FREE 15 day Self Demo.

"BEAM BUILDER" is a trademark of Sencore, Inc.



Call Today Wats Free 1-800-843-3338

SENCORE

3200 Sencore Drive
Sioux Falls, SD 57107
605-339-0100 In SD Only

*innovatively designed
with your time in mind.*

Circle (18) on Reply Card

transmitter, just like the L-R sidebands did in Figure 2. And, finally, a sample of a 3.58MHz c.w. (continuous wave) signal (color burst) is fed to the transmitter where it also modulates the picture carrier, just like the 19kHz pilot signal in Figure 2.

The similarities between the two systems are remarkable. As a matter of fact, it looks like the engineers who designed the FM MPX stereo system stole a page right out of the NTSC color TV handbook.

FM MPX stereo receiver

Now that we understand the make-up of the composite stereo signal, let's shift our attention to the stereo receiver and see how the various ingredients (L+R audio, 19kHz pilot and L-R sidebands) fit together. Figure 5 is a highly simplified block diagram of such a receiver.

As expected, the composite stereo signal is recovered after demodulation of the IF signal by the FM detector. The signal is then applied to a *stereo decoder* circuit, which may consist of a single IC or distinct circuits with discrete components. Separate L and R audio signals emerge from this decoder. After de-emphasis by 75µs time constant low-pass filters (in order to compensate for pre-emphasis at the transmitter), the two signals are amplified and fed to separate L and R loudspeakers, thus reproducing the stereo effect.

What's in that black box labeled *stereo decoder*? Various circuit

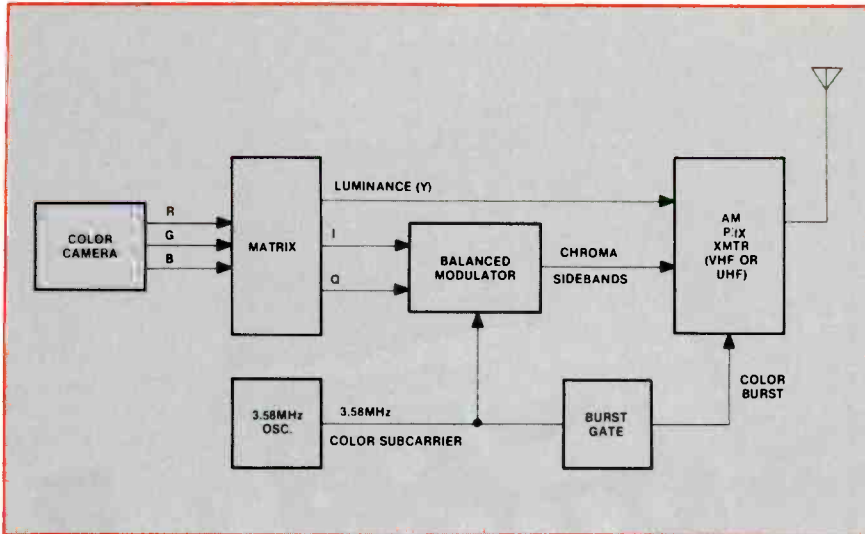

Figure 4. Simplified block diagram of color TV transmitter.

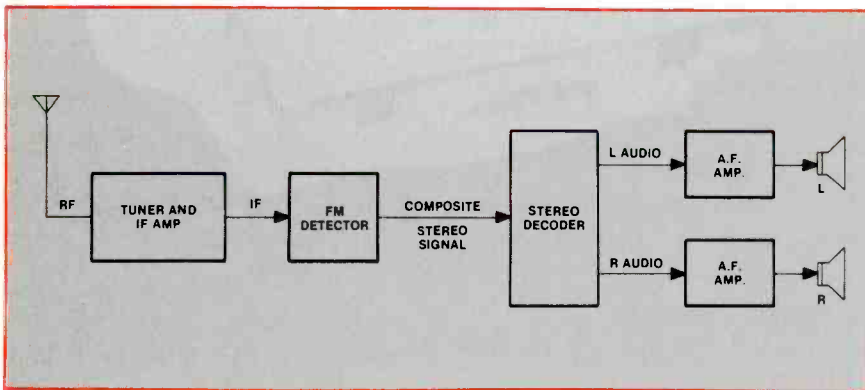

Figure 5. Simplified block diagram of stereo receiver.

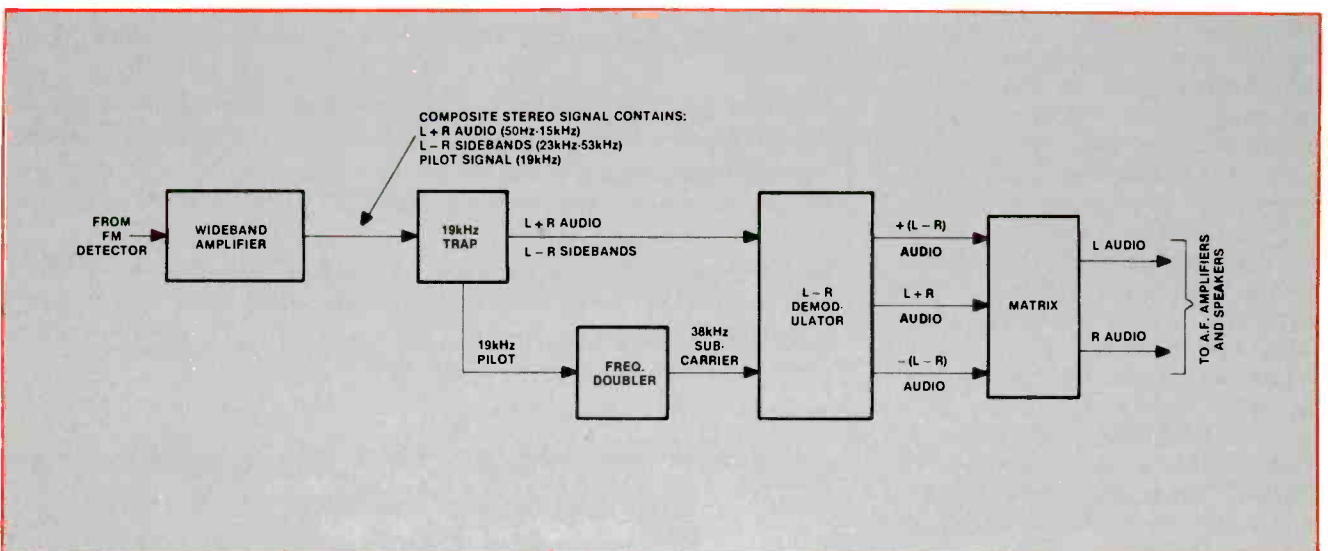

Figure 6. Block diagram of one type of stereo doubler.

designs are possible, including PLLs (phase-locked loops), but the decoder block diagram shown in Figure 6 illustrates one widely-used method of reconstituting left and right audio from the composite stereo signal.

After passing through a wide-band amplifier with a notched response at 67kHz (to reject SCA signals), the composite stereo signal runs into a trap. This 19kHz tuned circuit allows the 50Hz-to-15kHz L+R audio and the 23kHz-to-53kHz L-R double sidebands to pass through, on their way to the demodulator, but the 19kHz pilot signal is extracted and sidetracked to a frequency doubler, resulting in a subcarrier with the same frequency and phase as the 38kHz subcarrier back at the transmitter. This is essential for proper demodulation of the L-R sidebands. Recall that the subcarrier was suppressed by the balanced modulator in the stereo transmitter, thus the missing subcarrier has to be regenerated in the decoder.

The L-R sidebands can now heterodyne with the reinserted 38kHz subcarrier in the L-R demodulator, thus recovering the L-R audio signal. Because the demodulator actually contains two opposite-polarity detectors, a pair of L-R signals emerge from the demodulator circuitry: positive (L-R) audio, and negative (L-R) audio. As for the L+R signal, it doesn't need to be demodulated because it already is an audio signal; it simply passes right through the demodulator and is applied, along with the (L-R) audio signals to a matrix circuit that adds them together. (L+R) added to +(L-R) produces 2L (left channel signal only) and (L+R) added to -(L-R) yields 2R (right channel signal only). So we've gone full circle, with the original left and right audio signals having been individually recovered in the receiver. They are then fed to separate audio amplifiers and loudspeakers, to reproduce sound in full stereo.

The conclusion of this article next month will provide a detailed discussion of Multichannel Television Sound (MTS), the new electronic baby of the mid-eighties. You'll be pleasantly surprised at the similarities between TV stereo sound and conventional FM broadcast stereo.

ES&T

Walk "tough dog" troubles out of any TV & VCR in half the time . . . or your money back

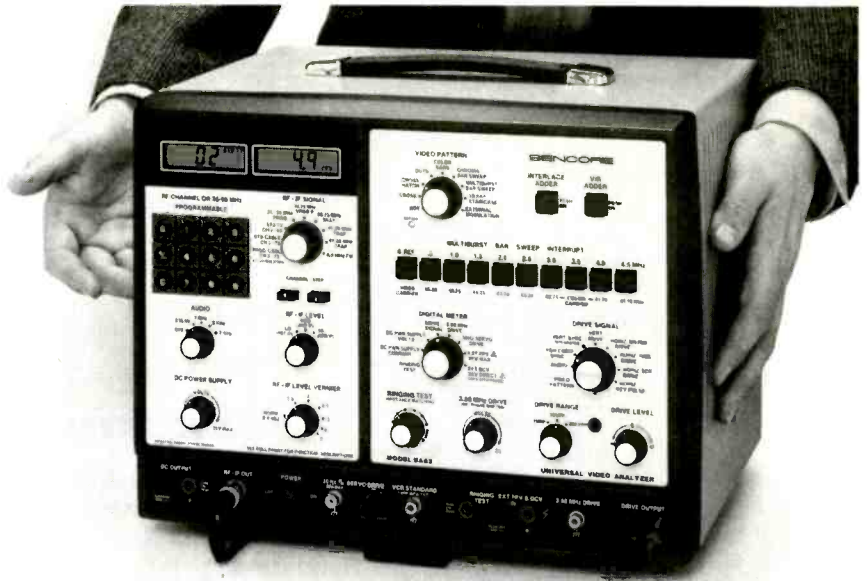

with the exclusive, patented,
VA62 Universal Video Analyzer . . . \$3,295

Would you like to?

Reduce analyzing time: Isolate any problem to one stage in any TV or VCR in minutes, without breaking a circuit connection, using the tried and proven signal substitution method of troubleshooting?

Cut costly callbacks and increase customer referrals by completely performance testing TVs & VCRs before they leave your shop? Own the only analyzer that equips you to check all standard and cable channels with digital accuracy? Check complete, RF, IF, video and chroma response of any chassis in minutes without taking the back off the receiver or removing chassis plus set traps dynamically right on CRT too? Simplify alignment with exclusive multiburst pattern?

Reduce costly inventory from stocking yokes, flybacks, and other coils and transformers, for substitution only, with the patented Ringing Test. Run dynamic proof positive test on any yoke, flyback, and integrated high voltage transformer . . . in- or out-of-circuit?

Protect your future by servicing VCRs for your customers before they go to your competition? Walk out "tough dog" troubles in any VCR chrominance or luminance circuit — stage-by-stage — to isolate problems in minutes? Have proof positive test of the video record/play heads before you replace the entire mechanism?

Increase your business by meeting all TV and VCR manufacturers' requirements for profitable warranty service work with this one universally recommended analyzer?

To prove it to yourself, CALL TODAY, WATS FREE, 1-800-843-3338, for a FREE Self Demo . . . or learn how the VA62 works first by calling for your free simplified operation and application instruction guide, worth \$10.00.



Call Today Wats Free 1-800-843-3338

SENCORE

3200 Sencore Drive
Sioux Falls, SD 57107
605-339-0100 In SD Only

*innovatively designed
with your time in mind.*

Circle (19) on Reply Card

January 1987 *Electronic Servicing & Technology* 49

What do you know about electronics?

Digitizing sound

One way to learn about components is to study them in various circuit applications. In the previous issue I gave several applications of the Hall Effect through the courtesy of F. W. Bell Inc., Columbus, Ohio.

Figure 1 shows another of Bell's interesting applications. In this case the Hall device is used in a multiplier circuit. There are two input currents. One of them (Ia) establishes flux in the soft iron circuit. The second (Ib) is the current that flows normally through the Hall device.

The output voltage (Vo) is directly proportional to the product of Ia and Ib. This circuit is called an *analog multiplier*.

From time to time, I will show other applications of Hall devices.

Although the compact disc represents state-of-the-art electronics, there is practically no new circuitry or theory involved. The concept of pulse code modulation (PCM) was known in the communications field years before it was applied to audio discs. Memories are not new. The diode laser has been with us for many years.

In fact, the compact disc is an advance in technology that was

made by taking already-existing circuitry and putting it to work. The exception is the disc. Video discs have used the same basic concept for years. However, putting an hour or more of music on a disc that is only about 4¾ inches in diameter required a considerable amount of innovation.

This is not to detract from the technological advance of the CD system. It is one thing to have all of the circuits and components available, and quite another thing to get them put together into a workable system. That is probably the greatest accomplishment of compact disc technology.

This article will discuss some of the circuits in compact disc systems. As mentioned before, they are not new, but it may have been some years since these concepts have come to your attention. This will be a good way to review state-of-the-art electronics. The circuits are used in just about every field of electronics. So if you're not that much interested in compact discs, don't go away; these circuits apply to your field too.

The concept

Music consists of sound of continuously variable frequencies and amplitudes. Until the compact disc was introduced, analog methods were used for recording music, so there was a direct relationship between the sound being recorded and the shape of the grooves in the disc or the magnetic fields on the tape. The compact disc consists of digital numbers that represent the recorded sound.

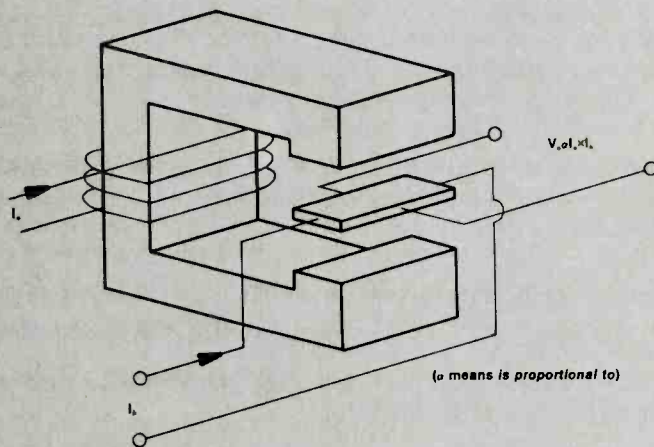

Figure 1.

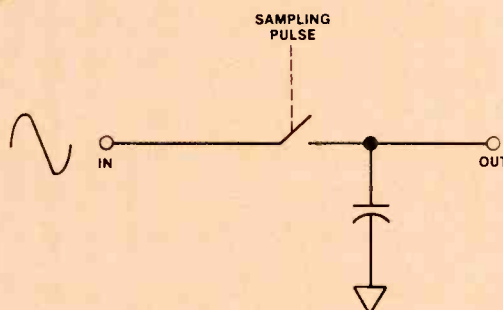

Figure 2.

Answers to the Quiz

By Sam Wilson Questions are on page 14

1. A. The output of a differentiating circuit is proportional to the rate of change of the input signal. The output is a cosine wave. It has the same *waveshape* as a sine wave.

2. A. It is important to understand the TV signal in order to understand how a TV receiver works.

3. A. Yes. The substitute supply also must be able to deliver the required current. Other factors also may be important in the selection of a power supply.

$$\% \text{ Regulation} = \frac{V_{NL} - V_{FL}}{V_{FL}} \times 100$$

V_{NL} = no load V V_{FL} = full load V

The *lower* the percent regulation, the better the supply regulation. Use this equation and you will see that the substitute supply has a lower (better) percent regulation.

4. C. The VIRS and VITS signals are both located on the *vertical* blanking pedestal. They are useful testing signals.

5. D. The alpha cutoff *frequency* cannot be a *current* value. The alpha cutoff frequency is that *frequency* at which alpha drops to 70.7% of the value at 1kHz. Remember that alpha is a common-

base gain; beta is a common-emitter gain.

6. D. The test signal should have both positive and negative peaks so that clipping (if present) can be observed.

7. D. Putting that much track on a 4¾-inch disc is, by itself, a great technical achievement. Making a laser follow the track is another great achievement. Neither of these technical aspects of the compact disc represents a very recent achievement.

8. The block is a divide-by-three circuit. It must divide the 3 x f output by 3 so the signal will match the f input at the phase comparator.

9. B. The advantage of a bit slice over a microprocessor system is speed. To obtain the best possible speed, the ECL family is a logical choice.

10. B. There is no calculation required. This problem involves the 3-4-5 triangle. Any time two sides of a right triangle are in a 3 to 4 ratio, the hypotenuse is in a 5 relationship. Examples: 3-4-5, (Figure 6), 30-40-50, 300-400-500, etc.

Literature

The 56-page full color product catalog includes descriptions of Pace's "CRAFT-100A" removal-and-replacement system for surface mount components, rework-and-repair systems, desoldering systems, function accessories, work materials, tools and aids.

The new catalog has information on motion picture/video training courses, "Basic Soldering" (now available in 11 languages) and "Rework and Repair for Electronics."

This company also provides a repair support program, including documented solutions to specific repair problems with customized repair instructions and instructor courses.

Circle (125) on Reply Card

The 1987 **Hand Tool Industries** catalog is the first issue to combine with the hand tool product line the electronic tool kits of **Hi-Tech Tool Supply**.

The catalog features a new line of 15 electronic tool kits, in 80 different case models. In addition, the new catalog pictures and describes hundreds of hand tools, ranging from simple probes and alignment tools to complete sets of Xcelite screwdrivers, Easco wrenches and Klein pliers in vinyl and Cordura pouches. Test equipment of well-known manufacturers is included.

Circle (126) on Reply Card

Services for diagnosing terrestrial interference (TI) at a proposed or operating TVRO site are described in a new catalog, "InfoTek/86," from **Microwave Filter Company**.

The services help pinpoint the interference type affecting the site and assist in determining whether the problem can be solved with natural or artificial shielding, or by inserting filters in the system.

Described are area maps of 4GHz towers by state, reports providing frequency, polarization of carriers transmitted along paths and potentially affected TVRO channels, area maps of 4GHz networks near a specific TVRO site

and a computerized satellite tracking program that prints the longitude, azimuth and elevation for every satellite within a viewing arc when exact latitude and longitude are inserted in the program.

Other services covered include a one day TI seminar that will train installers and operators to diagnose a wide variety of interference symptoms and provide solutions; Field Service, a team of experts that will arrive onsite to analyze and solve interference problems and The Fast Filter Rescue.

Circle (127) on Reply Card

International Data Sciences announces its "Data Communications Products" catalog. This 24-page catalog describes IDS' complete line of hand-held test sets, data traps and data comm testers, test sets and printers, modems, data switches, modular switching devices, and the recently introduced 5000 Series Network of test equipment. The variety of data communications products could be useful in the formation and maintenance of large and small networks.

Circle (128) on Reply Card



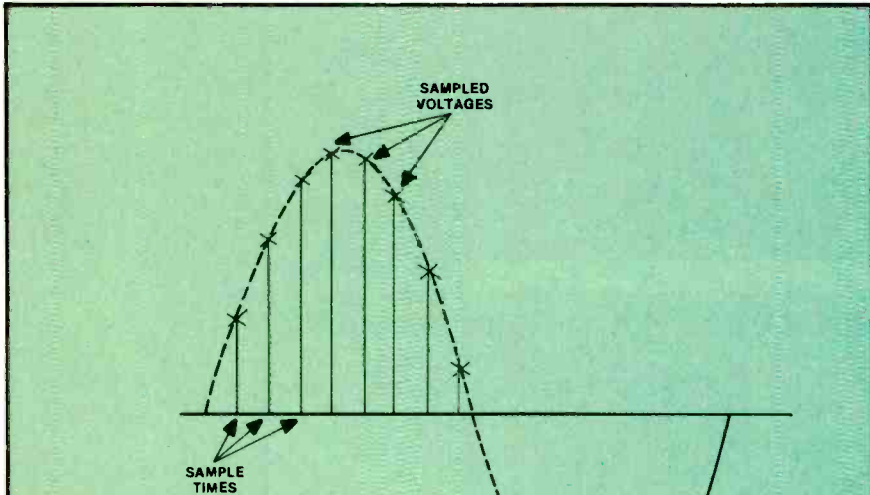

Figure 3.

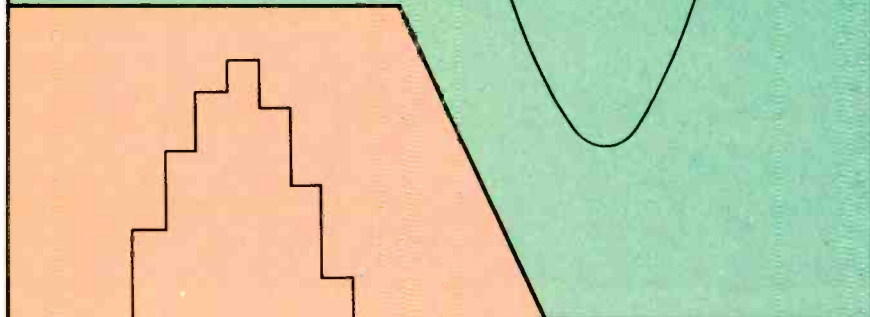

Figure 4.

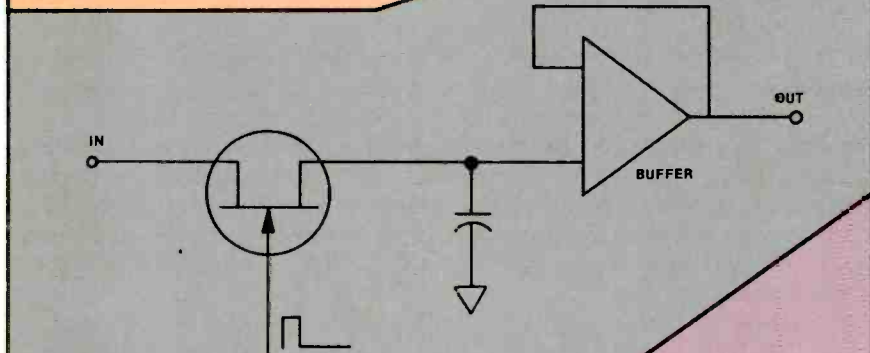

Figure 5.

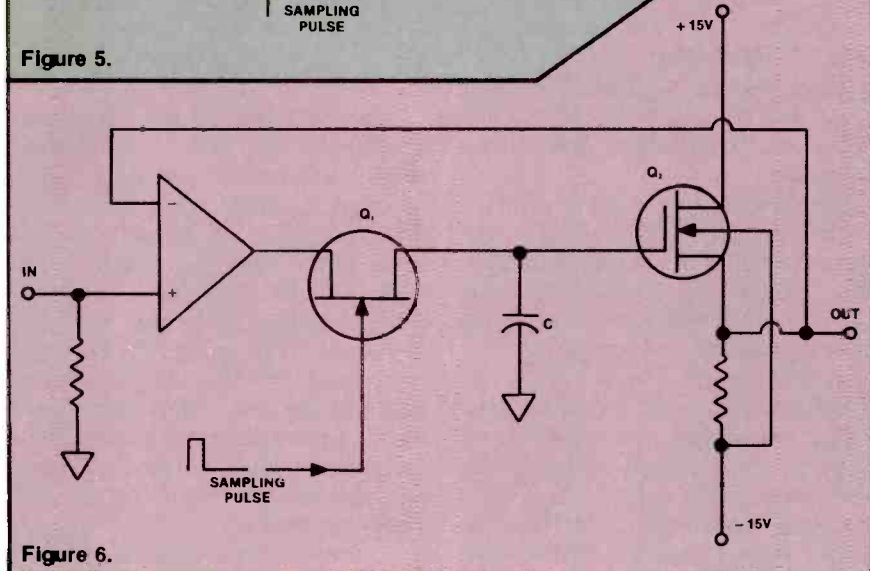

Figure 6.

Digitizing

Continued from page 50

How do you go from an audio signal to a bunch of numbers that represent the signal? That is a good place to start this discussion.

The sample-and-hold circuit

The sample-and-hold circuit is an important part of the analog-to-digital conversion of the audio signal. It is shown in simplified form in Figure 2. In this case, an input sine wave is to be sampled. The sampling pulse turns the switch *on* and *off* very rapidly in even time segments called *sampling times*.

Because the voltage across the capacitor at any instant will be equal to the input voltage, it follows that the output will be a point-to-point representation of the sine wave. This is illustrated in Figure 3.

The capacitor holds the output voltage until the next sampling pulse arrives, so the actual output waveform for the circuit looks like the one shown in Figure 4.

As you can see, this waveform has the general shape of the sine wave half-cycle. A basic problem with the sample and hold in Figure 2 (in addition to the fact that it is impossible to operate a switch quickly enough to get logical samples) is in the fact that the capacitor may discharge a small amount between the sampling pulses. That is undesirable because it means the output is no longer a faithful representation of the input amplitude for a particular instant of time.

A greatly improved sample-and-hold circuit is shown in Figure 5. Here, the sampling pulse saturates the JFET at the instant the input signal is to be sampled, charging the capacitor to the instantaneous value. At the end of the sampling pulse, the JFET becomes a high impedance. Also, the operational amplifier input will be a high impedance if it has an FET input circuit. So the capacitor is isolated and the output of the buffer amplifier is directly proportional to the capacitor voltage.

Figure 6 shows another example of a sample-and-hold circuit. In

this case the input signal is to an operational amplifier that is stabilized by feedback from the output of the circuit. Q1 is a JFET that delivers the sampled signal to the capacitor, and, Q2, a MOSFET, acts as a buffer between the capacitor and the outside world.

There are many other versions of sample-and-hold circuits, all of them having the same purpose: to sample an analog input signal and deliver an output voltage that is proportional to the amplitude of the input signal at some particular instant of time.

Sampling errors—It should be obvious that the outputs of the sample-and-hold circuit must be a good representation of the input signal and also that a large number of samples are required over a period of time so that no part of the input signal is lost. Take for example the condition in Figure 7.

The sampling points are shown, but note at the point where the arrow is, there is a period where the signal goes through a change but is not sampled.

At first, you might think that an infinite number of samples would have to be taken to get a fair representation of an analog signal representing music. Actually, some mathematical geniuses named Shannon and Nyquist spent some time mulling over this problem, and they proved without doubt that you could exactly reproduce the analog signal, provided that your sampling rate is at least twice as high as the highest frequency component of the analog signal. So if the highest frequency you are going to record is 20,000Hz, the sampling rate must be at least 40,000Hz.

In practice, the sampling rate in the compact disc system is about 41,000 samples per second.

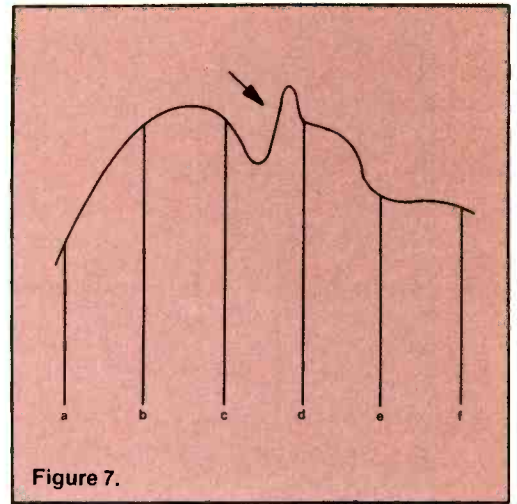
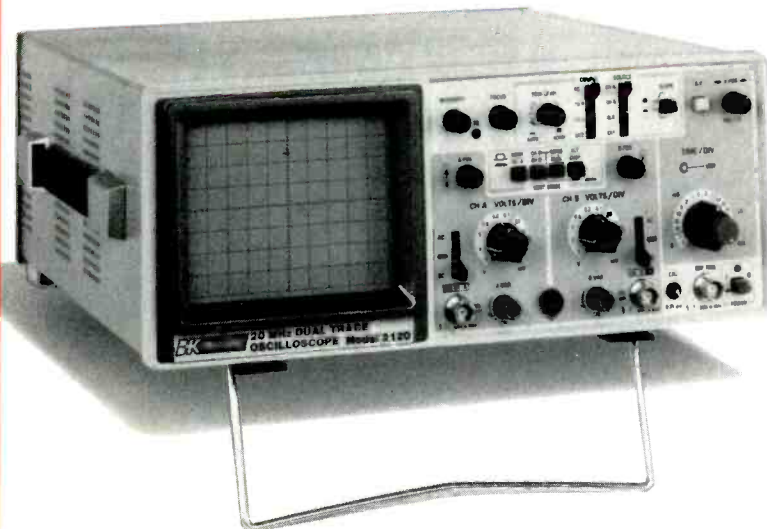

Figure 7.

SCOPE PRICE BREAKTHROUGH!

New B&K-PRECISION Dual-Trace 20MHz Scope... \$440!!



Now you can own a professional quality 20MHz, dual-trace scope for under \$450. Best of all, it's a full featured instrument, from B&K-PRECISION—famous for quality, dependable products.

Compare these outstanding features, then compare price!

- Dual or single trace operation • 1mV/div sensitivity
- 20MHz response at a true -3dB • AUTO/NORM triggered sweep operation with AC, TVH, TVV and Line coupling
- Calibrated 18 step timebase with x10 magnifier • X-Y operation
- Bright, sharp rectangular CRT with P31 phosphor
- Front-panel trace rotation control • Tilt stand and soft handle
- Selectable +/- slope • Built-in calibration source
- Compact low-profile design.

For immediate delivery, contact your local B&K-PRECISION distributor or call B&K-PRECISION today.

BK PRECISION DYNASCAN CORPORATION

6460 West Cortland Street • Chicago, Illinois 60635 • 312/889-9087
International Sales, 6460W Cortland St. Chicago, Illinois 60635 • Canadian Sales, Atlas Electronics, Ontario
South and Central American Sales, Empire Exporters, Plainview, NY 11803

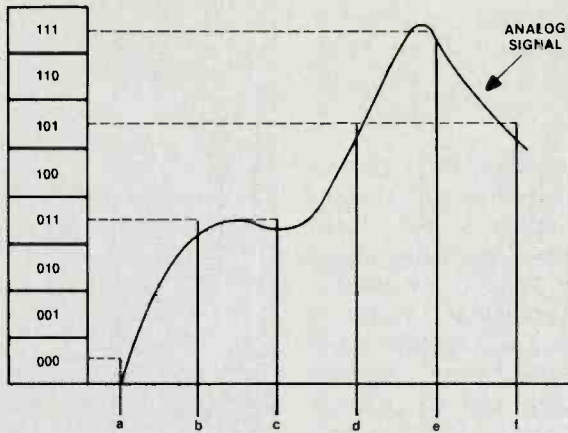

Figure 8.

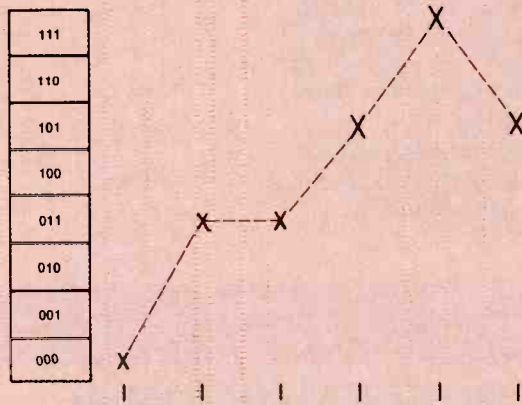

Figure 9.

Converting a signal to a number

The output of a sample-and-hold circuit represents the instantaneous voltage at the time the sample was taken. The next step is to convert these voltage values into binary numbers. I am going to use a limited binary count so that we don't get bogged down with large numbers when we are trying to understand basic digitizing. In practice, the amplitude of the analog wave is resolved into a great many more values requiring much larger binary numbers.

Consider the analog signal in Figure 8. Samples are taken of this signal at points *a* through *f*. In other words these represent the sample-and-hold voltages. The amplitudes may be represented by one of eight binary values. At sample point *a*, the nearest binary number is 000. At *b* and *c*, the same binary number (011) represents the two voltages for the samples taken. At points *d* and *f*, the binary representation is 101. Finally, at *e*, the highest point, the binary representation is 111.

If you would take these signals in order, the analog signal can now be represented by the binary numbers as shown in Table 1.

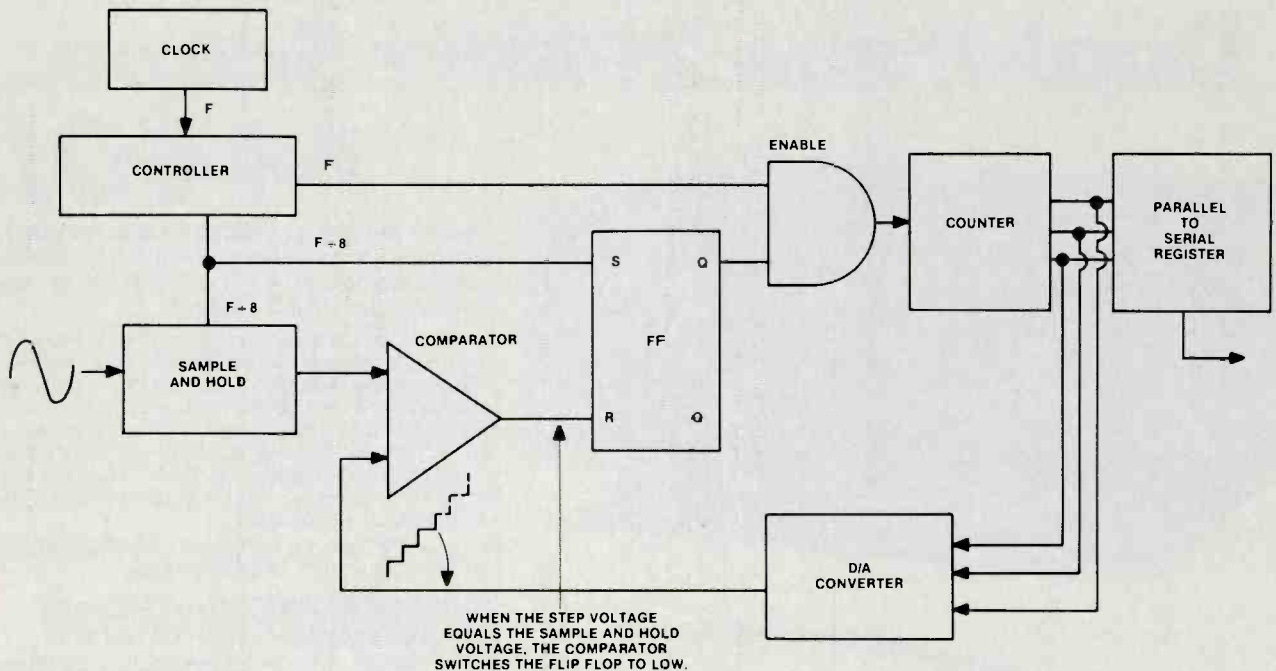

Figure 10.

Table 1.

Binary Number	000	011	011	101	111	101
Sample Point	a	b	c	d	e	f

It is important to note that the sample voltage is always represented by the *nearest* binary number. In Figure 9, the points are connected together with a broken line to show that the numbers taken at the related sampling points give a fair representation of the original wave. If a greater number of digital values had been available, the stored numbers would more closely represent the exact waveform.

Figure 10 represents a method of converting the sample-and-hold output to a binary number. This is a simplified diagram but it shows the essential steps.

To start with, a clock with an output frequency of f delivers a signal to a controller. That signal also is delivered out of the controller to one input of an ENABLE.

You will remember that an ENABLE is an AND circuit connected so that it either will pass a signal or reject it. Here, the clock pulse is the signal to be passed.

When the output (Q) of the flip flop is at a logic 1, the clock signal will pass to the counter; when the output of Q is at logic 0, the signal is disabled and the counter can no longer count pulses.

The pulses that are delivered to the counter cause it to increment one step for each pulse. The counter has only three outputs so the maximum binary number is 111 representing decimal number 7. Because zeros also count, there are a total of eight counts. Therefore, a maximum of eight pulses could pass through the ENABLE for one sampling time.

At the end of that sampling time, the divide-by-8 out of the controller delivers a sampling pulse to the sample-and-hold cir-

cuit and a new voltage is delivered to the comparator.

The output of the counter goes to a digital/analog converter that produces a step voltage. Each step represents one binary count. So there will be a maximum of eight steps when the counter goes from 000 to 111.

In the comparator, the output of the sample-and-hold circuit is matched with the steps. *The first step that exceeds the output of the sample-and-hold circuit* results in an output from the comparator that switches the flip flop to a low condition. That, in turn, causes the ENABLE to stop the flow of the clock pulses and the counter stops.

Note that the counter stops at a count that represents the point where the step voltage equals the sample-and-hold voltage. So the counter output will be a binary number somewhere between 000 and 111 that represents the output of the sample and hold.

The output of the counter, in addition to going to the D/A converter, also goes to a parallel-to-serial register. It produces a series of output pulses that represent the binary number. At the end of eight counts the flip flop is always switched high and the ENABLE again begins to deliver pulses to the counter.

We will talk about this parallel-to-serial register later. It must have a clock input pulse (not shown) in order to step the binary counts to the outside world.

This simple analog-to-digital converter is used to represent the relatively simple method of converting the sample-and-hold output voltage to a binary number.

I will continue with circuits in compact disc systems in the next article.



DISCOVER PROFITS WITH THE PRB BELT SYSTEM



PROJECTOR RECORDER BELT offers you the world's most complete inventory of replacement belts for all types of electronic equipment including . . .

- Video Recorders
- Turntables
- Cassette Recorders
- Projectors
- 8-Tracks
- 102 Video Belt Kits

PRB has the replacement belt you need in just the right shape, size and material. PLUS . . . our system helps you find that "perfect" replacement belt easily and fast. DISCOVER . . . The PRB Belt System for maximum convenience that assures profitable returns.

PRB . . . THE SOURCE FOR OVER 10,000 ELECTRONIC COMPONENTS

We stock virtually every electronic component. These are all high quality electronic components at everyday low prices backed by personalized service you can depend on. PRB will even pay the freight on your 1st pound of the UPS charge (ground only).

For details on our profitable belt system and a FREE copy of our 98 page 30th Anniversary Catalog, just write or call toll free . . .

NATIONAL 1-800-558-9572 **IN WISCONSIN** 1-800-242-9553

BUSINESS NUMBER
1-414-473-2151

In Canada call collect: 1-613-225-5003
TLX 4994411 PRB USA



PROJECTOR RECORDER BELT
200 Clay Street, Whitewater, WI 53190

Circle (21) on Reply Card

**WE MAKE
START UP / SHUT DOWN**

“DEAD SET”

PROBLEMS

THE FASTEST, EASIEST

MOST PROFITABLE

JOBS THAT EVER REACH YOUR BENCH

- - - So, why are **YOU** still struggling for hours and hours when you repair them?

Our **Mark V** will take you to specific defective “circuit” level in minutes, at the push of a button, for only \$795⁰⁰. In just 30 days, the Mark V can make you enough extra profit to purchase a Mark VII-E!

Our Mark VII-E will take you all the way to the specific defective “component,” tell you whether the defective component is open or shorted, tell you how the defective component has affected the operation of the overall circuit, and give you a single “landmark” test point to measure that will prove its finding to be 100% accurate. The Mark VII-E does all of the above in just one/one hundredth of one second, at the push of one button, for only \$3,495⁰⁰.

The Mark VII-E will also isolate “intermittants” while you play golf!



**VISA / MASTERCARD
WELCOME**



DIEHL INDUSTRIES

6661 Canyon Dr. “D” • Amarillo, TX • 79110

Phone (806) 359-0329

Products

Digital storage scope

Kikusui International (KIK) announces a price-competitive, 4-channel, dual-time base, digital storage oscilloscope. The COM 7101 features a 50ms/sec sampling rate, digitizing of 100MHz repetitive signals, 20MHz transient capture, full CRT readout, and familiar front panel control. Included as

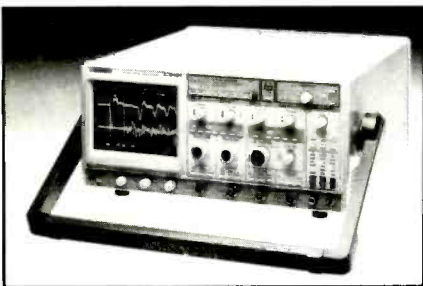

standard equipment, the 7101's built-in, bi-directional GPIB interface bus provides full front panel control and I/O of all CRT data.

Circle (75) on Reply Card

Wire and cable stripper

The Eraser Company announces the availability of a new precision die blade automatic hand-held wire and cable stripper, the model B.

The model B is a lightweight, automatic hand tool for stripping insulation from stranded, solid, coaxial and multicore wires and cables of sizes between 8 AWG and 18 AWG. Most insulation types

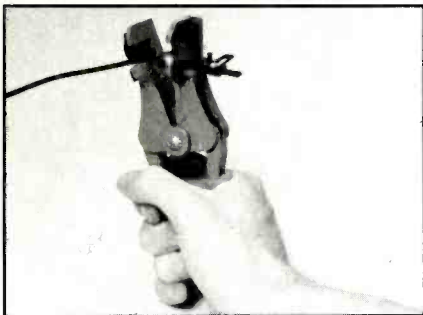

can be stripped, including PVC, polyethylene, nylon, and some PTFE and Teflon type insulations. Wires are cleanly stripped, with no risk of nicking, cutting or deforming the conductors.

Hardened steel, precision ground die blades are activated by a single squeeze of the tool handles. The blades cut the insula-

tion cleanly, and the slug is automatically removed. The die blades and clamps for slug removal cycle in such a manner that the stripped end of the wire is not crushed or damaged on the return cycle of the tool.

Circle (76) on Reply Card

Super-compact digital multimeter

The model 2030 shirt-pocket-sized digital multimeter from Triplet Corporation, a Penril Company, provides four functions and 19 microprocessor-controlled ranges for workshop or in-field consumer power testing of electrical/electronic devices. It is designed for use by the home workshop do-it-yourselfer and electronics hobbyist, as well as the technician.



The 3.5 digit LCD display includes automatic polarity indication. Autoranging, low battery indication and overload protection are also provided.

Circle (77) on Reply Card

Static dissipative bench mat

The 8000 series soft bench mats from Desco Industries feature a computer grey color that is designed to reduce eye strain and fatigue. The mats are made from CompoStat material with a volume resistivity of $10^8 \Omega/\text{cm}$. This material will provide a static decay time of less than .10 second. All Desco mats come individually packaged with illustrated instructions for proper grounding. Each mat includes a Desco 9860 screw-on mat ground snap. Mats also are available with a 10 foot grounding cord. Samples of the mat material are available.

Circle (78) on Reply Card

ELENCO PRODUCTS AT DISCOUNT PRICES!

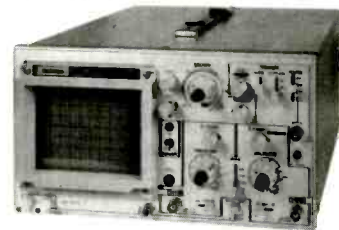

20 MHz Dual Trace Oscilloscope
\$349.95 MO-1251

Two 1x, 10x 100 MHz probes, diagrams and manual included. Write for specs.
35 MHz \$499.95 MO-1252

GF-8016 Function Generator with freq. counter



\$219.95

Sine, Square, Triangle
Pulse, Ramp, .2 to 2 MHz
Frequency .1 thru 10 MHz

GF-8015 without freq. meter \$169

Triple Power Supply XP-660

0-20V @ 1A
0-20V @ 1A
5V @ 5A



\$149.95

Fully regulated, short circuit protected with 2 limit cont. 3 separate supplies

3 Amp Power Supply XP-650

0-40V @ 1.5A
0-20V @ 3A



\$119.95

Fully regulated, short circuit protected current limit control

Color Convergence Generator



SG-200
\$69.95

Finest in the industry
10 rock steady patterns

Multimeter with Capacitance and Transistor Tester

Model CM-1500

\$64.95

Reads volts, ohms, current, capacitors, transistors, diodes



Digital LCR Meter \$148.95



Model LC-1800
Measures: Inductors
Capacitors, Resistors
Inductors .1uH to 200H
Capacitor .1Pf to 200uF
Resistor .01 Ohms to 20M Ohms
Ranges 6 Ind, 7 cap, 7 res

C&S Sales, 8744 W North Ter.
Niles, IL 60648 800-292-7711
312-459-9040 ASK FOR CATALOG
Add 5% P&H (\$10 Max per item)
IL Res., add 7% sales tax



Circle (23) on Reply Card

Multichannel TV sound (MTS)

It's taken a while, but multichannel TV sound (MTS) is a reality, at least in a few parts of the country. Once again, an audio development is intimately connected with video, but this time, the technology comes from the former. While CD, 8mm PCM, and VCR hi-fi were developed from video applications, MTS adapted its technology from FM stereo and tape noise-reduction systems.

MTS carves four information channels out of the 120kHz audio baseband of a TV channel, hence the term *multichannel*, instead of merely *stereo*. Here's the layout.

- **Main (L + R)**—Good old mono information, with a couple of kilohertz sliced off the top end to make room for the MTS pilot, at 15.734kHz (the horizontal scan rate). Deviation is ± 25 kHz, with a pre-emphasis of 75 μ s.
- **Stereo (L - R)**—Double sideband, suppressed carrier AM, just like FM MPX. The audio bandwidth restricted to about 13kHz. The suppressed carrier's frequency is 31.47kHz, twice the horizontal scanning rate (Fh), which also happens to be the stereo pilot in this system. To reduce noise, DBX compansion is used.
- **SAP**—This channel may contain the soundtrack in a second language, or whatever the broadcaster wishes. It's FM, with an audio passband of 50Hz to 10kHz, centered on a carrier of 78.67kHz (5Fh). It uses the same type of noise reduction as the L - R information.
- **Professional**—Used for voice, data, control or other subsidiary services, this channel has a bandwidth of 3kHz for voice, 1.5kHz for data. The good news is that the stereo effect greatly

enhances enjoyment of TV programs that make use of it, notwithstanding the bad news—a frequency response shamed by cassette decks of the mid '70s. In order to cram SAP and the professional channel into the spectrum, designers parked the stereo pilot too low in the band to allow the complete top octave of audio to be transmitted. Of course, it's understandable that the pilot must be a multiple of the horizontal frequency to minimize the possibility of beats, but the audiophile might wish they had chosen a pilot of 2Fh, and retained the original bandwidth of the mono channel.

Noise reduction

As we all have learned in technical training, the broader the bandwidth of a signal, the more noise that is present. Since MTS stereo uses triple the space of a mono signal, it follows that its unprocessed S/N ratio will be inferior to mono. This is true also of FM stereo, but is exaggerated in MTS, due to the narrower deviation of a modulated TV audio signal. To overcome this problem, noise reduction is used, in the L - R and SAP channels.

If you've serviced many tape decks, you're probably familiar with a system of compression/expansion (compansion) developed by a company called dbx. It's a double-ended system that requires reduction of dynamic range (compression) on the transmitter end, and reconstruction of it (expansion) at the receiver. In the process, the signal is essentially transmitted above the noise floor. When received, the low amplitude signals, which had been boosted, are reduced to proper levels. In the process, the noise gets reduced as well. This is called *wideband*

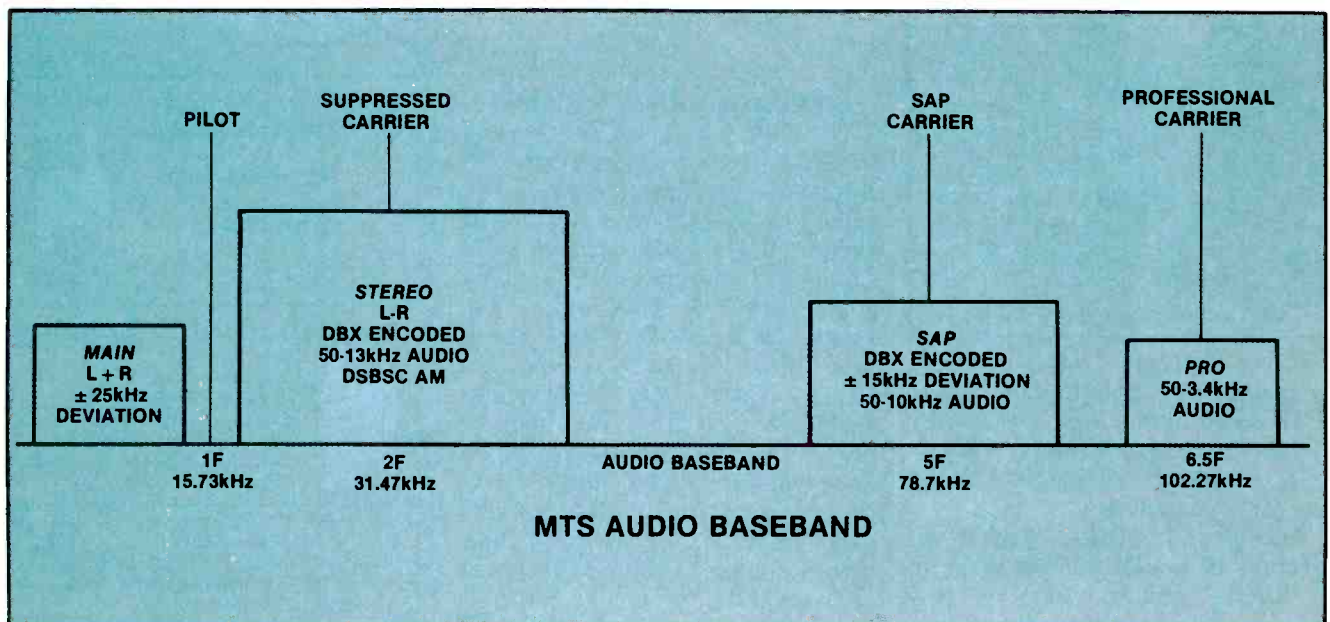

compansion. To further improve performance, a second process, *spectral companding*, is used. Basically, it varies the pre-emphasis of high frequencies, depending on the amount of signal that is present in that band. If the signal is rich in high end material, it will tend to mask the noise, so less pre/de-emphasis is needed. When treble material is lacking, pre/de-emphasis is boosted to improve S/N ratio.

To summarize, dbx MTS noise reduction improves S/N ratio in two ways. First, it uses wideband compansion to keep the overall signal level high, and above the noise floor. Second, it varies pre/de-emphasis to keep high frequency noise in line.

Test equipment

We all love the new technology, but what kind of test gear will we need to service it? Well, in this case, we have to commit some of our capital to an MTS generator. At least two companies are meeting the need: B&K, with its model 2009, rumored to sell for about \$400, and RE Instruments, whose RE540 is scheduled for release this November. As soon as I've had a chance to mess with one or both of these

units, I'll report back to you with the results.

Quirks

MTS is where FM MPX was 20 years ago. During such a transition period, "bugs" are inevitable, and MTS has its share. First of all, only a few stations are transmitting it. The ones that don't sometimes cause the stereo indicator on sets to flicker. Remember that in the "old days," the mono channel extended up to 15kHz, which is within 5% of the new MTS pilot, so a program rich in high frequencies tends to trigger the stereo light falsely, usually resulting in a customer complaint.

Some complain of relatively poor separation between left and right channels. I don't believe this is a fault of the system. It arises from two factors. First, some of the program material, even on stereo stations, is monophonic. Second, the FCC has recently ruled that broadcasters may leave the stereo pilot *on* at all times. I can tell you that most stereo broadcasts produce a respectable looking X-Y display on a scope, so separation is quite good. When MTS generators are in wider use, the truth will out.

ES&T_{inc.}



Plug in!

To the NESDA system.

YOUR BUSINESS is in the world's fastest changing industry. If you're not careful, you could find your business in the dark.

But, you don't have to stay there.

Through a system of local, state, and regional groups, the **National Electronics Sales & Service Dealers Assn.** (NESDA) keeps members up-to-date with the fast pace of advancing technology while offering:

- ◆ Managerial and technical training.
- ◆ Business contacts.
- ◆ Technical and management certification.
- ◆ Information on new products.
- ◆ Legislative activities that affect the industry.

Don't be left in the dark. Let the NESDA system work **FOR YOU!**

For more information and an application, write to:
NESDA, 2708 W. Berry St., Ft. Worth, TX 76109; Ph (817) 921-9061

Name _____
 Bus. Name _____
 Address _____
 State _____ Zip _____ Phone _____

Member of State Local Assn.



9600 N.W. 12 St. Miami, Florida 33172

<p>FLYBACK TRANSFORMERS Replacement for: SANYO F-0260.....\$11.00 F-1119.....\$15.50 F-1108.....\$11.00 4-2751-48500...\$ 7.50 4-2751-60108...\$ 7.50</p> <p>Replacement for: SHARP/SAMPO 8FT-043-B.....\$ 7.50 8FT-046.....\$ 7.50</p> <p>POPULAR FOCUS BLOCK Replacement for: SANYO/SEARS Z20063UAA.....\$ 9.50 Z20064UAA.....\$ 9.50 Z20065UAA.....\$ 9.50</p> <p>SEMICONDUCTORS (Min 5 Pcs) AN-214...\$0.75 CX-097...\$4.95 CX-885...\$8.70 IN-4007...\$0.018 IN-4148...\$0.018 SG-613...\$6.50 STK-043...\$9.46 STK-439...\$4.63 TA-7617...\$2.15 (Min 10 Pcs) 2SC-454...\$0.09 2SC-930...\$0.08 2SC-1162...\$0.25</p>	<p>COMBO CHAIN NOSE PLIER N-20261.....\$1.20</p> <p>THREE WAY SPIKE PROTECTOR P-511.....\$2.50</p> <p>HONOA TYPE CAR ANTENNA NP-2097.....\$1.00 (Min. 3 Pcs)</p> <p>MULTIPURPOSE ADAPTOR (Min 3 Pcs) DV-5467 (500 ML Amp) \$2.50</p> <p>ECONOMY VIDEO DUBBING KIT VOK-1G.....\$2.25 VOK-2G.....\$3.95</p> <p>COLORED MICROPHONE CABLE MC-1 (300 Ft Spools) Yellow/Blue/Red.....\$18.00</p> <p>OMNIDIRECTIONAL MICROPHONE FOR CASSETTE TAPE RECORDERS OM-24.....\$1.39</p> <p>ELECTRIC FEEDING SOLDERING IRON EF-6.....\$10.00</p> <p>MIMI TYPE MULTITESTER Model 23-200.....\$2.95 Ideal for Home, Shop, Auto etc.</p> <p>STEREO HEADS (Replaces most Stereo Tape Heads with Standard Mounting) FV-1622.....\$0.80</p> <p>GOVERNOR MOTORS (Adjustable Speed) 6-9-12 Volts.....\$2.98</p> <p>WET TYPE VIDEO HEAD CLEANING CARTRIDGES N-8780 (VHS).....\$2.25 N-8782 (BETA).....\$2.25</p> <p>HEAVY DUTY HOT LINE FILTER (8 Amp) Blocks Ignition Noise HD-0019.....\$1.60</p>
--	--

CALL OR WRITE TODAY
WELCOME 1-800-327-7522 MIN.
C.O.D. (305)-592-2616 592-2618 \$25.00

Circle (24) on Reply Card →

Just a tape recorder?

The home VCR burst onto the consumer electronics scene along with a flurry of other new products: laser video discs, audio compact discs, personal computers, personally-owned phones, and more. Little wonder, that the technical marvelousness of the consumer VCR has been obscured within a cloud of hype, hoopla and information about all these electronics technology luminaries.

The modern consumer VCR is truly a marvel; it is a system, rather than simply a product, with several complex interacting subsystems, controlled by an intricate computer-based control system. If VCRs seem to be complex to service, they are.

Let's take a look at the overall block diagram of a VCR (Figure 1). There's a whole lot going on in there. There are signal processing circuits, tuning, manipulating and recording the TV signal. There are the drive circuits transporting the tape and controlling the motion of the video head cylinder. There's the tape loading mechanism. All these subsystems are intricately interrelated and controlled by the system control circuits, which consist of one or more microcomputers.

And you thought this was just a tape recorder!

That's the reason for this column, which will be a regular monthly feature of *ES&T*. In it, we will be bringing you articles that describe the operation of some of these complex circuits and their interrelationships, maintenance guides, cleaning and lubrication, tips on troubleshooting and remedying faults.

This installment contains the overall block diagram of a modern consumer VCR and a top-level troubleshooting chart, which provides the first steps in logical VCR troubleshooting. Over the next three months, we will be concentrating on the control circuits, based on material provided by GE. In February, we'll feature an *Introduction to system and servo control*; March will concentrate on *System control diagnosis* and April will feature *Servo control circuits*.

Proper servicing of VCRs, as with servicing any other product, begins with becoming thoroughly familiar with the subsystems and components, and thoroughly understanding the features and normal operation of the unit. This familiarity will enhance troubleshooting ability. For example, grasp of the circuits that connect to the signal input/output jacks, as shown in Figure 1, will suggest that in

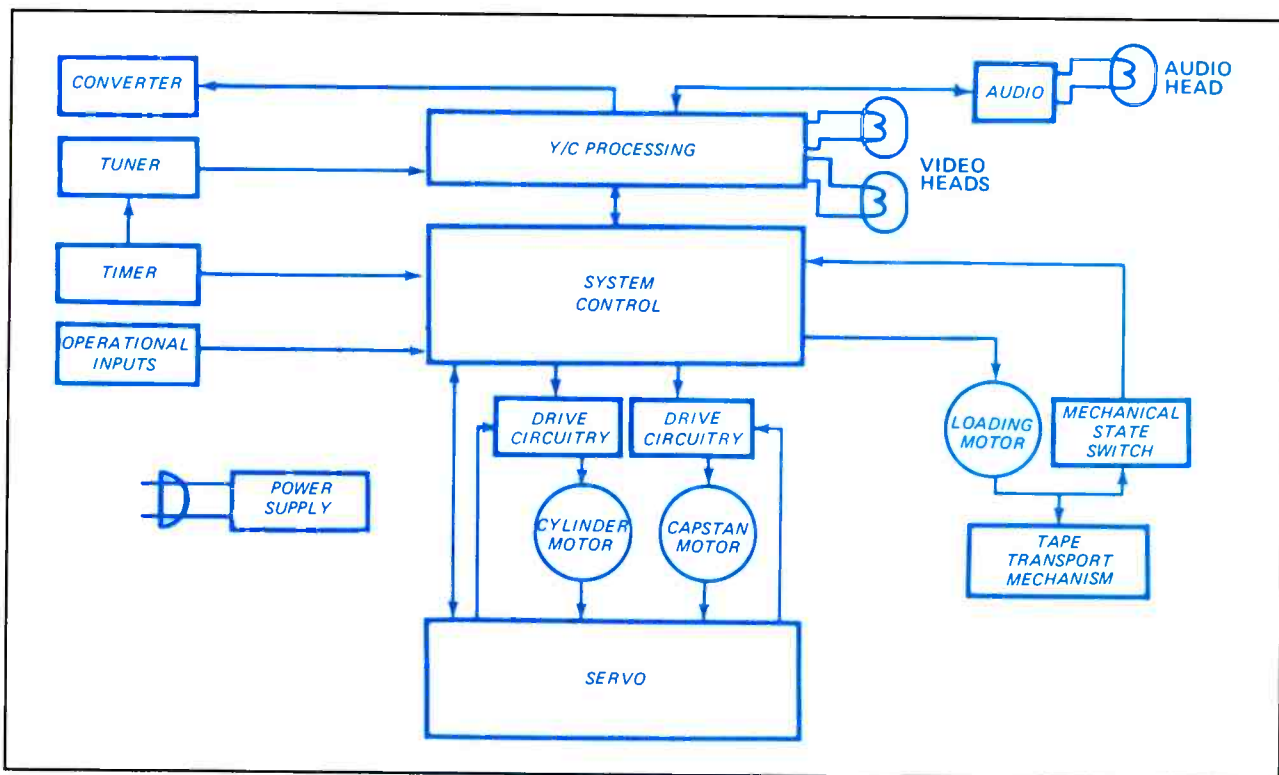

Figure 1. As the overall block diagram shows, a consumer VCR is not a simple product, but a system consisting of several complex subsystems all controlled by a system-control section. If you plan to service one of these units, you should have a pretty good idea of what's going on inside.

most VCRs, using these jacks will allow you to bypass the tuner, IF and RF converter stages, and thus confirm or absolve them as causes of the problem.

This understanding of VCR operation will enable you to interpret symptoms so you can zero in on specific areas before you begin troubleshooting. For example, in the servo system, malfunctions in the cylinder servo system will affect only the picture, while the capstan servo stages (which pull the tape through the transport path) will cause changes in both picture and sound. But watch out, life's never quite that simple. Video tapes with high-fidelity audio have the audio track recorded along with the video on the helical track as well as on the standard audio track. You have to be sure you know which track you're listening to. Another fly in the ointment is that, as remote a coincidence as it may be, both servo systems *could* fail or lose a common reference input at the same time.

No one ever said that electronics servicing was going to be easy. And the relatively innocuous appearance of the average VCR really doesn't prepare a technician for the complexities that lurk inside. But a logical approach to troubleshooting and the right kind of information can help simplify the complexities and bring VCR troubleshooting within the capabilities of mere humans. With this column we plan to help make this happen.

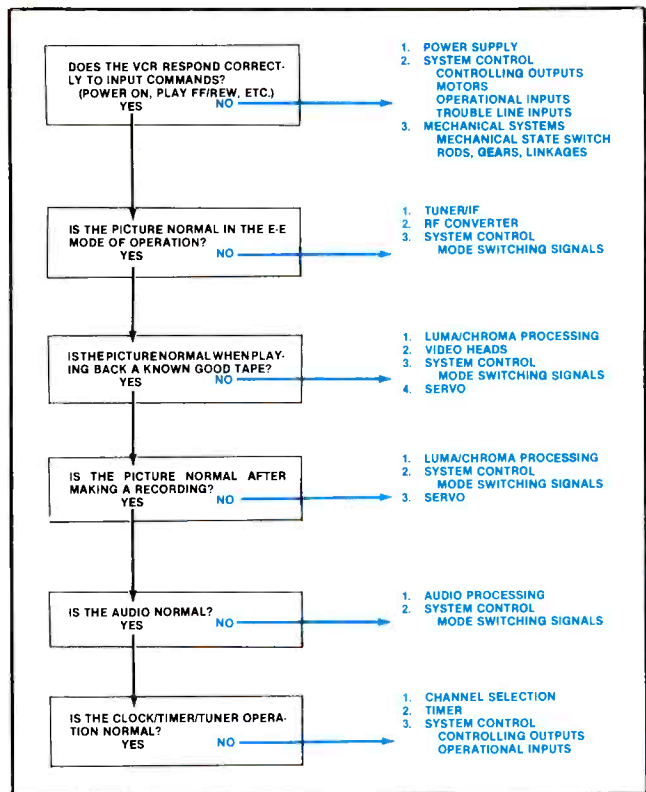

Figure 2. A logical troubleshooting approach will help isolate a problem to a specific area of the VCR. **ES&T**

Technicians,
Get Serious
About Your
Profession



Being a certified electronics technician lets people know that you are a professional in your field. It tells them that you are serious about your work and can perform up to CET standards.

Now you can order the "Study Guide for the Associate-Level CET Test" from the International Society of Certified Electronics Technicians. It includes material covering the most often missed questions on the Associate CET Exam. 8 1/2" x 11", paperback, 60 pages.

For More Information Contact:
IS CET 2708 W. Berry, Ft. Worth, TX 76109. (817) 921 - 9101

NAME _____
ADDRESS _____
CITY _____ STATE _____
ZIP _____

_____ copies @ \$5 (+ \$1 postage.)
_____ send material about IS CET and becoming certified.

SAVINGS
UP TO

70%

CALL TOLL-FREE
1-800-524-0747

NEW and CUSTOM-RECONDITIONED Test Equipment



CALL OR WRITE FOR
OUR LATEST CATALOG

- Digital Plotters & Printers
- Strip Chart Records
- Counters, Timers & DVM'S
- Pulse & Function Generators
- Oscilloscopes
- Logic & Spectrum Analyzers
- IC & Component Testers
- Audio, Video, & RF
- Power Supplies
- Line Conditioners & Regulators
- Prom Programmers

ACCUTEST INSTRUMENTS, INC.

P.O. Box 130 / Route 526, Clarksburg, NJ 08510 / In N.J.: (609) 259-0460

Circle (25) on Reply Card

When is a computer not a computer?



Hardware and software available from a number of vendors, such as this system from Virtual CAT, can turn a personal computer into a piece of test equipment.

The earliest electronic computer was just that: a computer. It was designed to compute trajectories of artillery shells to aid the war effort.

This wondrous machine has evolved to such a degree that even its own mother (if it had a mother) wouldn't recognize it. And yet, unfortunately (I think), we still call it a computer. We label as computers today's descendants of that first computer even though they process information, process words, play games, compose songs, in short process just about any kind of information that can be converted into digital form, in just about any way that anyone can think of to process it in. They don't just compute.

One example of the versatility of today's com-

puters is personal computer-based test equipment. By connecting the appropriate electronic module or adding in the appropriate printed-circuit board and loading the appropriate software, a home computer can be turned into a multimeter, a function generator, a timer/counter or an oscilloscope.

There are a number of manufacturers of such systems: Rapid Systems, Hewlett-Packard, Summation, Virtual Instrument and Vistar, to name a few.

The Virtual CAT (Computer Aided Testing) by Virtual Instrument Corporation is one example of this generation of personal computer-based test equipment. It will turn an IBM PC, AT, XT or compatible into a full function 4½ digit digital multimeter, a 10MHz timer/counter, and a 100MHz function generator. The front panels of these instruments are displayed simultaneously on the personal computer's CRT. Front panel controls are activated by keyboard command or mouse. Measured values appear as they would on a standard instrument display.

According to the manufacturer, these instruments are comparable in performance to many popular bench top stand-alones.

The instruments may be used individually or in combination to perform tests. No programming is necessary. Because of its instrument-to-instrument interaction, the Virtual CAT can conduct tests, store, recall and print out results. Several options are available and near-future plans call for the introduction of additional instruments and accessories.

Specifications

These specifications show the capabilities of the IBM PC as a piece of test equipment with the Virtual CAT installed.

FUNCTION GENERATOR

Waveforms:	Sine, Triangle, Square	Operational Modes:	
Modes:	Continuous, Sweep, N-burst	Burst Modes:	N-burst frequency range — 8MHz max. Sends out "N" number of bursts. Single burst mode — 2 to 65,535 full cycle increments.
Outputs:		Continuous Mode:	Limited to .01 to 10MHz. Amplitude and dc offset limited to ± 10V.
Waveforms:	± 10V into 50 Ω	Linear Sweep Mode:	User sets start/stop frequencies on panel thumbwheels. Rate limited by start/stop frequencies.
Dc offset:	± 10V into 50 Ω	Logarithmic Sweep Mode:	A continuous logarithmic sweep defined in the same manner as the linear mode.
Sweep Range:	.1 to 1,000 sweeps/sec		
Waveform Characteristics:			
Frequency Range:	.01 to 10MHz		
Frequency Resolution:	.01Hz lowest scale to 10kHz on highest		
Frequency Accuracy:	<±4%		
Sine Distortion:	<1% .01Hz to 1MHz, <3% 1MHz to 10MHz		
Triangle Linearity:	Better than 97% linear.		

Table 1. (continues on adjacent page)

UNIVERSAL COUNTER/TIMER

Frequency		Time Intervals:	
Overall	10Hz to 100MHz	A-->B:	250ns to 10s
Channel A Direct:	10MHz	Resolution:	100ns
With Prescaler	100MHz		
Sensitivity:		Ratio:	
Channel A/B:	50mV rms, ac coupling 75mV rms	Channel A:	10Hz to 10MHz
		Channel B:	10Hz to 2.5MHz
Period:		Event Count:	
Range:	100ns to 10s where N = 1	Maximum Total:	100MHz
Resolution:	100ns		
Pulse Width:		General:	
Periods Averaged:	1, 10, 100 or 1,000	Display Digits:	8
Sensitivity:	25mV rms	Clock:	10MHz
		Sample Rates:	250ms/reading

DIGITAL MULTIMETER

Voltage:		dB:	
Range:	200mV to 200V full scale in 4 ranges	True RMS, Autoranging:	- 30 to 48dBm
Resolution:	0.01mV to 10mV	General:	
Accuracy:	dc, + 0.1% reading, ac (30-1kHz) + 1% of reading. Both ± 1 digit	Display:	4½ Digits
		Maximum Meas. Rate:	2.5 readings/sec
		Input Impedance:	10M ohms all ranges
Current:		Normal Mode	
Range:	2mA to 2A in 4 ranges	Rejection Ratio:	> 50dB at 50/60Hz
Resolution:	0.0001mA to 0.1mA	Common Mode	
		Rejection Ratio:	> 50dB from DC to 60Hz
Resistance:		Isolation Voltage	
Range:	200 Ω to 20M Ω in 6 ranges	Rating:	> 600V peak between input and ground.
Resolution:	0.01 Ω to 1k Ω		
Accuracy:	200 Ω to 200M Ω at 1% of reading ± 1 digit		

Table 1. is continued from page 62.

ESM



Moving?

Take us with you.

Just peel off the subscription mailing label and attach it to the address change card located at the front of this issue. Please allow 6-8 weeks to process your address change.

ELECTRONIC
Servicing & Technology

ATTENTION TECHNICIANS

- ★ JOB OPENINGS
- ★ MONTHLY TECHNICAL TRAINING PROGRAM
- ★ BUSINESS MANAGEMENT TRAINING
- ★ LOW COST INSURANCE
- ★ CERTIFICATION
- ★ TECHNICAL SEMINARS

All of this in a nonprofit international association for technicians

FIND OUT MORE:



604 N. Jackson St.
Greencastle, IN 46135



ESR METER

**CHECKS ELECTROLYTICS
IN-CIRCUIT
WITH 99% RELIABILITY**

A great time-saver that's been tested by 3 magazines and thousands of satisfied customers since 1978.

Ideal for preventive maintenance: measures electrolyte dryness & shows up intermittent opens.

60-day Satisfaction Guarantee

Send check or M.O. or call
(313) 435-8916 for COD

Or write for free brochure to:

Creative Electronics

ESR Brochure **\$130.00**
1417 N. Selfridge postpaid
Clawson, Mich. 48017 USA & CAN

Circle (26) on Reply Card

Readers' Exchange

Needed: Schematic for Motorola auto radio FM210A. Will buy or copy and return. *C.T. Cooper, R.D. 4, Box 482A, Dover, DE 19901; 302-674-1636.*

Needed: Complete service information for Uniden model Ex6000B cordless telephone. Will buy or copy and return. *Fred MacKenzie, 519 SW 6th Ave., Hallandale, FL 33009; 305-458-3824.*

Wanted: Sencore VA48 or VA62 video analyzer; course material for NRI VCR training course. Send postcard with phone number and price. *Jerry Polasek, 1511 Elmscott Drive, Sugar Land, TX 77478; 713-757-3406, days: 713-494-1291 after 6 p.m., or weekends.*

For Sale: New receiving and transmitting tubes in original cartons, 80% off list price. S.a.s.e. with wanted list. Shipping cost is 25¢ per tube. Heathkit model 1G-57A post marker/sweep generator with manual and all cables, perfect condition, \$99. *Walter G. Dowdy, 1243 Marlin Place, Tracy, CA 95376.*

For Sale: Hewlett-Packard 1712 oscilloscope, 200MHz, 2-channel, delayed sweep, main, delayed or mixed time base, new H.P. probes, excellent condition, asking \$600. *Denny's TV, 2725 Eden Lane, Rapid City, SD 57701; 605-342-8852.*

For Sale: B&K 1077B TV analyst, \$200; B&K 466 CRT tester/rejuvenator, \$150; Heathkit IM-18 VTVM, \$30. All in good condition, manuals included. All prices plus shipping. *Dwayne Talley, Route 4, Box 221, Arab, AL 35016; 205-586-8502 after 5:00 p.m.*

Wanted: Heathkit EF-2, "How to Understand and Use Your Oscilloscope"—theory and application of oscilloscope, including experimental chassis with parts and text. Will pay for entire course, plus postage. *Sidney R. Creacey, 1358 Turquoise Ave., Mentone, CA 92359.*

For Sale: EICO resistor-capacitor bridge analyzer, model 950B, good working condition, \$40; Sams Photofact folders Nos. 69 through 496, \$1 each, or all 275 sets for \$175, s.a.s.e. for complete list; Sams record changer service manuals, CM-2 through CM-9, RC-11, RC-12, \$2.50 each, or all 10 manuals for \$20; Philco wideband oscilloscope amplifier, model 8300, \$10. All prices plus shipping. *John Brouzakis, 247 Davidson Drive, Charleroi, PA 15022; 412-483-3072.*

Wanted: Tripler for Panasonic color TV, model CT-915, chassis No. NMXP3B. Number on tripler is ECX-B 1070B. State price. *M.X. Romando, P.O. Box 895, Floral Park, NY 11002.*

Needed: Service manual/schematic for Simpson model 85, 6-band, ship-to-shore, 2-way radio, manufactured by Pearce-Simpson, Miami. Company out of business. **Wanted:** Vintage radio station transcription turntable, preferably RCA type 70-D or 70-C with 78/33 1/2 speeds only. Built during the 1930s/40s. I will appreciate any information leading to the purchase of this equipment. *Kenneth L. Mizon, 401 E. San Pedro Ave., Perry, FL 32347; 904-584-2116.*

Needed: Rider's schematic for Victor RCA table model 125, cathedral; power transformer for this same model. I will buy the single or section of this schematic. Also need #80 tube in A-1 condition. *Jos. A. Gontarz, JAG's Radio & TV, 14 Rudolph Road, Forestville, CT. 203-583-7532.*

Wanted: Manual, or copies of pages relating to Starkit tube and transistor tester, model 12-22A. State price (if copies, will pay extra above copying cost). The tester was made in Canada, but may be same as Hickok tester. *Donald W. Marshall, P.O. Box 70, Chester, Nova Scotia, Canada BOJ 1J0.*

Wanted: Diagram for ECA TV, model No. E1800 (12" B&W). *Jiranek TV, Farrington, IA 52626.*

Wanted: Schematic or service manual for FM signal generator, model 100W, New London Instrument Corporation, New London, CT. State price. *Joseph M. Mockus, 12683 W. Hawaii Ave, Lakewood, CO 80228.*

Needed: Knight RF generator and signal tracer with manuals. **Wanted:** Supremes manuals—TV1, 2, 11 and R1; Sams TR-82. *C.T. Huth, 229 Melmore St. Tiffin, OH 44883.*

For Sale: B&K equipment—1077B, \$250; 283 bench DVM, \$50; 801 capacitor-analyst, \$50; 707 and 667 tube testers and extensions, all \$100. Keithley 4.5 digit bench DVM, \$125; 0-140Vac Variac, \$50; Sencore VA48, \$750; Tektronix 503 scope and chart, \$275. Many other items; offers considered. *E. Garay, 2436 Pocatello, Rowland Heights, CA 91748; 818-918-1590.*

Wanted: Weller solder station, WTCPL; dual-trace scope, working or non-working. *Ron King, 551 E. North Ave., Flora, IL 62839; 618-662-2531.*

For Sale: Bell & Howell ABR-917 dual lens microfiche reader, \$150. *Charles R. Woodward, Woody's TV Service, 3133 8th St., Meridian, MS 39301; 601-482-3995.*

Wanted: Schematic or service manual for Allied radio stereophonic receiver, model 498. Will buy or will copy and return. *John Takish, 3415-173rd Place, Lansing, IL 60438; 312-895-3118.*

For Sale: Sencore CR161 picture tube tester and restorer with 11 sockets (other sockets available from Sencore), complete with manual and set-up chart, \$85; B&K sweep-marker/generator, model 415, complete with manual, \$125. *M.B. Danish, P.O. Box 217, Aberdeen Proving Ground, MD 21005; 301-272-4984, evenings.*

For Sale: Flybacks and yokes for older televisions. If interested, write for listing. *Glennon E. Swoboda, 402 East Brook, O'Fallon, MO 63366.*

Photofact

These Photofact folders for TV receivers have been released by Howard W. Sams since ES&T's last report.

HITACHI	
CT2020B, CT2020W	2453-1
HITACHI	
CT19C5, CT1966	2456-1
MAGNAVOX	
Chassis 25C601/02/04/05/06/07/08, 26C601/04/05/06/07/08/09/10	2459-1
RADIO SHACK	
16-237	2454-1
RADIO SHACK	
16-250	2458-1

SEARS	
564.48701550	2455-2
SHARP	
19J93	2458-2
SHARP	
FF19634, 19KP35	2459-2
SONY	
Chassis SCC-648H-A, SCC-6480-A	2454-2
TOSHIBA	
CX435, CX1435	2453-2
TOSHIBA	
CX2044, CX2044C	2455-1
TOSHIBA	
Chassis TAC8533	2456-2
TOSHIBA	
Chassis TAC8541	2457-1
ZENITH	
SB2727P3/29N3/29P3/31G3/37Y3/41X3/71R3/ 75G3/75G6/77P3/77P6/95PA/97YA	2457-2

PLEASE NOTE

SYMCURES and T.TIPS

Beginning in January, ES&T will pay the following rates for reader-submitted items accepted for publication:

SYMCURE per page - \$60

**TROUBLESHOOTING
TIPS** - \$25 each

If you have solved one or more difficult servicing problems, share these unusual experiences with other ES&T subscribers.

Write for guidelines.
**ELECTRONIC SERVICING &
TECHNOLOGY**
P.O. Box 12901,
Overland Park, KS 66212

Classified

Advertising rates in the Classified Section are 85 cents per word, each insertion, and must be accompanied by payment to insure publications.

Each initial or abbreviation counts a full word.

Minimum classified charge is \$20.00.

For ads on which replies are sent to us for forwarding (blind ads), there is an additional charge of \$30.00 per insertion to cover department number, processing of replies, and mailing costs.

Classified columns are not open to advertising of any products regularly produced by manufacturers unless used and no longer owned by the manufacturer or distributor.

FOR SALE

AUTOMOBILE RADIO and tape replacement parts. Delco, Chrysler, Philco-Ford, Motorola, Panasonic and many others. Large inventory. Laran Electronics, Inc., 3768 Boston Road, Bronx, NY 10469. (212) 881-9600. National (800) 223-8314, NY State (800) 446-4430.

1-85-tfn

CABLE TV CONVERTERS & EQUIPMENT. Plans and parts. Build or buy. Send S.A.S.E. C&D Electronics, P.O. Box 1402, Dept. ES&T, Hope, Arkansas 71801.

1-86-tfn

VCR REPAIR FAST AND EASY - Comprehensive guide on theory and operation + proven Tech Tips on all brands - Send \$8.95 to: J.C.O., P.O. Box 567, Bradenton, Fl. 33506.

1-87-1t

Technicians

**Our world of Home Electronics...
your new home for growth.**

If you're looking for a growth opportunity with a company that has expanded from 12 employees to over 400 in just five years, NEC Home Electronics (U.S.A.) Inc. may be just for you.

Due to our tremendous expansion, we are seeking Technicians to work in various locations throughout the nation. If you have a 2 year technical degree or equivalent experience and are well versed in any of the following areas, we'd like to talk with you.

- Audio Products
- Projection TVs
- VCRs
- Camcorders
- PC Products & Peripherals

We offer competitive salaries, an excellent benefits package including educational assistance and the outstanding opportunity to advance rapidly.

For immediate consideration, please call 1-800-323-1728, weekdays during business hours, or send resume, including salary history, to: Personnel Dept. EST, NEC Home Electronics (U.S.A.) Inc., 1255 Michael Drive, Wood Dale, IL 60191-1094. We are an Equal Opportunity Employer.

**where our performance
matches our promise**

NEC

NEC Home Electronics (U.S.A.) Inc.

SONY-TRINITRON REBUILTS are now available. Call for price & delivery, 1-716-621-5250. 7-86-tfn

INDIVIDUAL PHOTOFACT FOLDERS (not sets) #1 to #1400, \$3.00 first-class postpaid. Loeb, 414 Chestnut Lane, East Meadow, NY 11554. 8-86-6t

3000 COLOR TV REPAIR TIPS, 31 Brands 116 Page Manual. Send \$21.00 to A. Fernandez, Box 546110, Surfside, Florida 33154. 10-86-3t

FOR SALE: Descramble the latest video cassette copy protection scheme. Our simple LINE ZAPPER circuit takes the jitter out of your picture. Complete plans and theory only \$9.95 plus \$1.50 postage and handling. Printed circuit board or complete kit also available. Elephant Electronics Inc., Box 41865-E, Phoenix, AZ 85080 (602) 581-1973. 10-86-tfn

FORSALE: Jerrold gated pulse theory. Twelve information packed pages covering DI & DIC converter operation. Includes introduction to trimode system. \$6.95 plus \$1.50 postage and handling. Elephant Electronics Inc., Box 41865-E, Phoenix, AZ 85080 (602) 581-1973. 10-86-tfn

SERVICE MANUALS. Large Shop has 18 yr. collection of duplicates. All original manufacturer. All new. Audio \$2.00, video \$5.00. Send SASE for list. Tape Recorder Clinic; 4850 E. Speedway; Tucson, Arizona 85712. 11-86-tfn

TV TROUBLESHOOTING: Over 120 schematic ILLUSTRATED problems-solutions of difficult repairs. 25 pages of valuable tech data. \$12.00. Jones, Box 702, Niceville, Fla. 32578. 12-85-3t

VCR REPAIR SOLUTIONS for VHS models. Over 150 symptoms and cures. The hard ones. Send \$11.95 to Eagle Electronics, 2534 Miracle Lane, Mishawaka, IN 46545. 12-86-6t

TV TOUGH DOGS 200 symptoms and cures. Send \$6.95 to DAVIS TV, 11772 Old Fashion Way, Garden Grove, CA 92640. 1-87-1t

ATTENTION: Sylvania remote control motor for hospital televisions no. 23-99-383 for sale. With exchange \$39.00, without exchange \$47.00. Kinirral Electronics, 68-26 64th Place, Glendale, N.Y. 11385. Tel. (718) 366-3859. 1-86-4t

HELP WANTED

CAMERA-VIDEO Technicians needed. Top pay and benefits for well trained and experienced technicians who are expert with consumer and/or industrial cameras and VCR's. Training by manufacturers such as Sony, Hitachi, Panasonic, etc., are necessary for job experience. Come to sunny Florida and enjoy your work & leisure time. Write or call ATLANTIC ELECTRONICS INC., 1881 NE 26 St., Ft. Lauderdale, FL 33305. (305) 564-8274 10 AM to 6:30 PM. Ask for Dave or Joe. 8-85-tfn

VIDEO/AUDIO technician needed. Top pay and benefits for well trained and experienced technicians who are expert with consumer TV and audio equipment. Training by manufacturers such as: Sony, Hitachi, RCA, Panasonic, etc. are necessary for job experience. Write or call: Atlantic Electronics, Inc., 1881 NE 26th St., Ft. Lauderdale, FL 33305, 305-564-8274 (10 AM 6:30 PM). Ask for Dave or Joe. 06-86-tfn

BUSINESS OPPORTUNITIES

T.V. SALES & SERVICE. Well established business located northern Virginia. Owner retiring and will help with financing. Call 703-972-7027 after 7:00 p.m. EST. 8/85-tfn

ALABAMA OPPORTUNITY. One acre fenced, with 2400 sq. ft. bldg. Electronic shop and music store building. Excellent opportunity, in warm friendly south. Will take \$39,500. Call Mrs. Small (205) 295-8020. 1-87-1t

T.V. SALES & SERVICE. Top quality shop. Fully equipped in Miramar, Fla. Unlimited potential for right party. (305) 961-1011. 1-87-1t

3 HOURS FROM SAN FRANCISCO. Electronic repair shop in Pine Forested foothills. Vision problem forces sale. 7 rm residence, lg beautiful gdn all shop equip included, \$155k min 50% dwn req (916) 872-1962. 10-86-tfn

RADIO-TV REPAIR SHOP! USA Virgin Islands! Established 15 years - reasonably priced - 809-773-7867. 10-86-4t

EXCELLENT ZENITH RCA SALES SERVICE, North Idaho. Commercial building and adjoint lot. 90,000.00. Owner retiring, will help financing. (208) 773-9522 or 773-3255 evenings. 12-86-2t

POSITION WANTED

LET ME HELP YOU promote your equipment in the deep South. Interference run in broadcasting, 2-way radio, microwave, satellite & test equipment. 35 years background in above equipment. Travel expense plus commission. Put my experience to work for you! P.O. Box 65, Armuchee, GA 30105. 1-87-11

SERVICES

TELEVISION TUNER REBUILDING, all makes & models. 24-hour turnaround, one year limited warranty. Competitive pricing. Contact: ElectroDYN, 917 South Rogers St., Bloomington, In. 47401. Telephone: 812-334-1023. 12-86-2t

TVRO EQUIPMENT REPAIR, satellite receivers, antenna actuators and down converters. 72-hour turnaround, 90-day limited warranty. Contact: ElectroDYN, 917 South Rogers St., Bloomington, In. 47401. Telephone: 812-334-1023. 12-86-2t

REPAIR OF ZENITH circuit board 9-160-all; with dud exchange \$33.00. One year guarantee. Kinirral Electronics, 68-26 64th Place, Glendale, N.Y. 11385. (718) 366-3859. 1-86-3t

ATTENTION ELECTRONIC TECHNICIANS



Highly Effective Home Study BSEE Degree Program for Experienced Electronic Technicians
Our New Advanced Placement Program grants Credit for previous Schooling & Professional Experience. Advance Rapidly! Our 40th Year
FREE DESCRIPTIVE LITERATURE!
Cook's Institute of Electronics Engineering
P.O. BOX 20345, JACKSON, MS 39209

Circle (27) on Reply Card

NEW 20-PAGE CATALOG FREE

7 MILLION TUBES

Includes all current, obsolete, antique, hard-to-find receiving, transmitting, industrial, radio/TV types. **LOWEST PRICES.** Major brands in stock.
Unity Electronics Dept. E
P.O. Box 213, Elizabeth, N.J. 07206



Circle (28) on Reply Card

"Tech's Guide To Pricing"

updated new 5th edition...a framework for setting rates that apply to Hi-Tech products...a formula that guarantees SUCCESS!
Call Toll Free for details
1-800-228-4338 8/5 CST



Circle (29) on Reply Card

A MUST FOR THE TV TECHNICIAN

UNIVERSAL CRT ADAPTER- Don't buy another socket for your CRT Tester! Join 10,000 satisfied buyers & WIN the Socket War! GUARANTEED to fit your tester. Test/clean/restore ALL Color, BW, Projection. \$59.99ppd w/SetUp book, Visa, MC, COD.
1-800-331-9658
DANDY MFG. CO.
2323 Gibson, Muskogee, Oklahoma 74403



Circle (30) on Reply Card

ADVANCED TEST EQUIPMENT RENTALS

Rent — Sell — Service — Buy
Electronic Equipment
ADVANCED TEST EQUIPMENT SALES
SAN DIEGO, CA
CALL (619) 483-2832

Circle (31) on Reply Card

ELECTRONIC SERVICING & TECHNOLOGY (Volume 7 No. 1) (USPS 462-050) is published monthly by Intertec Publishing Corp., 9221 Quivira Road, P.O. Box 12901, Overland Park, KS 66212. Second Class Postage paid at Shawnee Mission, KS, and additional mailing offices. POSTMASTER: Send address changes to ELECTRONIC SERVICING & TECHNOLOGY, P.O. Box 12952, Overland Park, KS 66121-9981.

Advertisers' Index

	Page Number	Reader Service Number	Advertiser Hotline
Accutest Instruments, Inc.	61	25	609/259-0460
Advanced Test Equipment Rental	66	31	
Automated Production Equipment Corp.	39,40		516/654-1197
B&K Precision Dynascan Corp.	53	20	312/889-9087
Beckman Industrial Corp.	IFC	1	714/671-4800
C & S Sales	57	23	800/292-7711
Chemtronics, Inc.	27,28		800/645-5244
Cleveland Institute of Electronics	39,40		800/321-2155
Cooks Inst. Elec. Engrg.	66	27	601/371-1351
Creative Electronics	63	26	313/435-8916
Dandy Mfg. Co.	66	30	800/331-9658
Diehl Enterprises	13,15,56	8,9,22	806/359-0329
E.S.I., Inc.	21	13	800/645-4720
E-Z-Hook	20	10	818/446-6175
Electronic Specialists, Inc.	29,30		800/225-4876
ETA	63		
Fluke, John Mfg. Co., Inc.	9	6	800/227-3800
Hitachi Sales Corp. of America	23	14	516/921-7200
ISCET	61		
Kenwood Test & Measuring Instruments	11	7	213/639-9000
MCM Electronics	7	4	800/543-4330
National Technical Schools	29,30		800/BBE-TTER
NESDA	59		
Nippon American Inc.	59	24	800/327-7522
NRI Schools-Electronics Division	27,28		202/244-1600
Philips Test & Measuring Instruments	39,40		
Projector Recorder Belt Corp.	55	21	800/558-9572
RCA Distributor and Special Products	5	3	800/227-3800
Sams, Howard W. & Co., Inc.	8	5	800/428-SAMS
Sencore, Inc.	43,45	16,17	800/843-3338
Sencore, Inc.	47,49	18,19	800/843-3338
Sperry Tech, Inc.	66	29	800/228-4338
Tektronix, Inc.	IBC,29,30	2	800/433-2323
Tentel	27,28		800/538-6894
U.S. Instrument Rentals	24	15	800/824-2873
Unity Electronics	66	28	201/351-4200
Zenith	BC		

ELECTRONIC

Servicing & Technology

KANSAS CITY, MISSOURI
Greg Garrison, Sales Manager
P.O. Box 12901
Overland Park, KS 66212
Phone: 1-913-888-4664

NORWOOD, AUSTRALIA
Hastwell, Williamson, Rouse PTY. LTD.
P.O. Box 419
Phone: 332-3322
Telex AA 87113

LONDON, ENGLAND

Nicholas McGeachin
Suite 460, Southbank House
Black Prince Road, London SE1 7SJ
Telex: 295555 LSPG
Telephones: Central Line 01 582-7522
Direct Line 01 587-1578

TOKYO, JAPAN

EMS, Inc.
Sagami Bldg., 4-2-21,
Shinjuku, Shinjuku-ku,
Tokyo 160, Japan
(03) 350-5666
Telex: 2322520 EMSINCJ
Cable: EMSINCPERIOD

WANT FREE, QUICK INFORMATION? USE THESE READER SERVICE CARDS...

- 1** Attach your peel-off label from the cover to address box on card, or print your name, title, company, address, Zip Code and phone number.
- 2** Sign and date the card.

- 3** Circle the number (or numbers) on the card corresponding to the number at the bottom of each advertisement or editorial item for which you want more information.

- 4** Use card to start or renew your subscription to ES&T.
- 5** Affix postage stamp and mail right away.

ELECTRONIC
Servicing & Technology

READER SERVICE INFORMATION AND SUBSCRIPTION SERVICE CARD
For issue of January 1987
Void after May 1, 1987

FOR FASTER ACTION!

I have an immediate interest in the items I've indicated here. Please have a salesperson call me.

RJ7

For more information on products or services mentioned in this issue, simply circle the appropriate numbers below.

- | | | | | | | | | | | | | | | | | | | | |
|-----|-----|-----|-----|-----|-----|-----|-----|-----|-----|-----|-----|-----|-----|-----|-----|-----|-----|-----|-----|
| 1 | 2 | 3 | 4 | 5 | 6 | 7 | 8 | 9 | 10 | 11 | 12 | 13 | 14 | 15 | 16 | 17 | 18 | 19 | 20 |
| 21 | 22 | 23 | 24 | 25 | 26 | 27 | 28 | 29 | 30 | 31 | 32 | 33 | 34 | 35 | 36 | 37 | 38 | 39 | 40 |
| 41 | 42 | 43 | 44 | 45 | 46 | 47 | 48 | 49 | 50 | 51 | 52 | 53 | 54 | 55 | 56 | 57 | 58 | 59 | 60 |
| 61 | 62 | 63 | 64 | 65 | 66 | 67 | 68 | 69 | 70 | 71 | 72 | 73 | 74 | 75 | 76 | 77 | 78 | 79 | 80 |
| 81 | 82 | 83 | 84 | 85 | 86 | 87 | 88 | 89 | 90 | 91 | 92 | 93 | 94 | 95 | 96 | 97 | 98 | 99 | 100 |
| 101 | 102 | 103 | 104 | 105 | 106 | 107 | 108 | 109 | 110 | 111 | 112 | 113 | 114 | 115 | 116 | 117 | 118 | 119 | 120 |
| 121 | 122 | 123 | 124 | 125 | 126 | 127 | 128 | 129 | 130 | 131 | 132 | 133 | 134 | 135 | 136 | 137 | 138 | 139 | 140 |
| 141 | 142 | 143 | 144 | 145 | 146 | 147 | 148 | 149 | 150 | 151 | 152 | 153 | 154 | 155 | 156 | 157 | 158 | 159 | 160 |
| 161 | 162 | 163 | 164 | 165 | 166 | 167 | 168 | 169 | 170 | 171 | 172 | 173 | 174 | 175 | 176 | 177 | 178 | 179 | 180 |
| 181 | 182 | 183 | 184 | 185 | 186 | 187 | 188 | 189 | 190 | 191 | 192 | 193 | 194 | 195 | 196 | 197 | 198 | 199 | 200 |

Please print
Name _____ Title _____
Company Name _____
Address _____
City _____ State _____ Zip _____

BUSINESS TELEPHONE: AREA CODE () NUMBER _____
Signature _____ Date _____

Please check one box under each () to expedite your request for information.

- () Type of Business**
- 21 Consumer Electronics Equipment Independent or Franchised Service Business
 - 22 Retailer With Consumer Electronics Equipment Service Department
 - 23 Electronics Equipment Field Service Organization
 - 24 Service, Installation or Operation of Electronics Equipment In Industrial Or Commercial Facility
 - 33 Engineering Of Electronics Equipment In Industrial Or Commercial Facility
 - 35 Wholesaler, Jobber, Distributor
 - 37 Electronics Equipment Or Components Manufacturer
 - 38 Government and Military: Federal, State, Municipal
 - 09 Education
 - (a) College, Library, School, Including Instructors
 - (b) Student
 - 30 Other **KK** Other
- () Position**
- EE** **Company Management**
Such as General Manager, Owner, Partner, President, Vice President, Director And Other Corporate Personnel
 - FF** **Operations Management**
Such as Service Manager, Operations Manager, Production Manager, Customer Service Manager, Marketing/Sales Manager, Purchasing Manager, Credit/Accounts Manager and Other Operations/Administrative Personnel
 - GG** **Engineering/Technical & Other Personnel**
Such as Engineer, Technician, Field Service Engineer, Specialist, Engineering Associate and Other Engineering And Technical Support Personnel
- () Check the number of Service Technicians employed at your facility.**
- A 1-5
 - B 6-10
 - C 11-25
 - D 26-50
 - E Over 50
 - F Not applicable
- () Check the statement that best describes your role in the purchase of major electronics servicing equipment and servicing components, accessories and services.**
- 1 Make final decision to buy a specific make or model.
 - 2 Recommend make or model to be purchased.
 - 3 Have no part in specifying or buying.

SUBSCRIBE NOW!

- 1 Year - 12 issues **ONLY \$18.00**
 - 2 Years - 24 issues **ONLY \$30.00**
 - 3 Years - 36 issues **ONLY \$38.00**
- Year Biggest Savings!* Please check preferred order (Allow 6-8 weeks for delivery of first issue)

Note: Outside U.S.A. rates are: 1 Year \$22 2 Years \$34 3 Years \$44

CHARGE TO MY: (Please check one)

MASTERCARD **VISA**

ACCOUNT NUMBER _____
INTERBANK NUMBER _____
MASTER CHARGE ONLY (4 digits above your name) _____

CARD EXPIRES _____ MO. YR.

Signature required _____ Date _____

ELECTRONIC
Servicing & Technology

READER SERVICE INFORMATION AND SUBSCRIPTION SERVICE CARD
For issue of January 1987
Void after May 1, 1987

FOR FASTER ACTION!

I have an immediate interest in the items I've indicated here. Please have a salesperson call me.

RJ7

For more information on products or services mentioned in this issue, simply circle the appropriate numbers below.

- | | | | | | | | | | | | | | | | | | | | |
|-----|-----|-----|-----|-----|-----|-----|-----|-----|-----|-----|-----|-----|-----|-----|-----|-----|-----|-----|-----|
| 1 | 2 | 3 | 4 | 5 | 6 | 7 | 8 | 9 | 10 | 11 | 12 | 13 | 14 | 15 | 16 | 17 | 18 | 19 | 20 |
| 21 | 22 | 23 | 24 | 25 | 26 | 27 | 28 | 29 | 30 | 31 | 32 | 33 | 34 | 35 | 36 | 37 | 38 | 39 | 40 |
| 41 | 42 | 43 | 44 | 45 | 46 | 47 | 48 | 49 | 50 | 51 | 52 | 53 | 54 | 55 | 56 | 57 | 58 | 59 | 60 |
| 61 | 62 | 63 | 64 | 65 | 66 | 67 | 68 | 69 | 70 | 71 | 72 | 73 | 74 | 75 | 76 | 77 | 78 | 79 | 80 |
| 81 | 82 | 83 | 84 | 85 | 86 | 87 | 88 | 89 | 90 | 91 | 92 | 93 | 94 | 95 | 96 | 97 | 98 | 99 | 100 |
| 101 | 102 | 103 | 104 | 105 | 106 | 107 | 108 | 109 | 110 | 111 | 112 | 113 | 114 | 115 | 116 | 117 | 118 | 119 | 120 |
| 121 | 122 | 123 | 124 | 125 | 126 | 127 | 128 | 129 | 130 | 131 | 132 | 133 | 134 | 135 | 136 | 137 | 138 | 139 | 140 |
| 141 | 142 | 143 | 144 | 145 | 146 | 147 | 148 | 149 | 150 | 151 | 152 | 153 | 154 | 155 | 156 | 157 | 158 | 159 | 160 |
| 161 | 162 | 163 | 164 | 165 | 166 | 167 | 168 | 169 | 170 | 171 | 172 | 173 | 174 | 175 | 176 | 177 | 178 | 179 | 180 |
| 181 | 182 | 183 | 184 | 185 | 186 | 187 | 188 | 189 | 190 | 191 | 192 | 193 | 194 | 195 | 196 | 197 | 198 | 199 | 200 |

Please print
Name _____ Title _____
Company Name _____
Address _____
City _____ State _____ Zip _____

BUSINESS TELEPHONE: AREA CODE () NUMBER _____
Signature _____ Date _____

Please check one box under each () to expedite your request for information.

- () Type of Business**
- 21 Consumer Electronics Equipment Independent or Franchised Service Business
 - 22 Retailer With Consumer Electronics Equipment Service Department
 - 23 Electronics Equipment Field Service Organization
 - 24 Service, Installation or Operation of Electronics Equipment In Industrial Or Commercial Facility
 - 33 Engineering Of Electronics Equipment In Industrial Or Commercial Facility
 - 35 Wholesaler, Jobber, Distributor
 - 37 Electronics Equipment Or Components Manufacturer
 - 38 Government and Military: Federal, State, Municipal
 - 09 Education
 - (a) College, Library, School, Including Instructors
 - (b) Student
 - 30 Other **KK** Other
- () Position**
- EE** **Company Management**
Such as General Manager, Owner, Partner, President, Vice President, Director And Other Corporate Personnel
 - FF** **Operations Management**
Such as Service Manager, Operations Manager, Production Manager, Customer Service Manager, Marketing/Sales Manager, Purchasing Manager, Credit/Accounts Manager and Other Operations/Administrative Personnel
 - GG** **Engineering/Technical & Other Personnel**
Such as Engineer, Technician, Field Service Engineer, Specialist, Engineering Associate and Other Engineering And Technical Support Personnel
- () Check the number of Service Technicians employed at your facility.**
- A 1-5
 - B 6-10
 - C 11-25
 - D 26-50
 - E Over 50
 - F Not applicable
- () Check the statement that best describes your role in the purchase of major electronics servicing equipment and servicing components, accessories and services.**
- 1 Make final decision to buy a specific make or model.
 - 2 Recommend make or model to be purchased.
 - 3 Have no part in specifying or buying.

SUBSCRIBE NOW!

- 1 Year - 12 issues **ONLY \$18.00**
 - 2 Years - 24 issues **ONLY \$30.00**
 - 3 Years - 36 issues **ONLY \$38.00**
- Year Biggest Savings!* Please check preferred order (Allow 6-8 weeks for delivery of first issue)

Note: Outside U.S.A. rates are: 1 Year \$22 2 Years \$34 3 Years \$44

CHARGE TO MY: (Please check one)

MASTERCARD **VISA**

ACCOUNT NUMBER _____
INTERBANK NUMBER _____
MASTER CHARGE ONLY (4 digits above your name) _____

CARD EXPIRES _____ MO. YR.

Signature required _____ Date _____

The how-to
magazine
of
electronics...

...brings
you current
information
on:

- Personal/
Home Computers
- VCRs
- TVs
- Audio Equipment
- Video Games
- Satellite Dishes
- Microwaves

*New Technology
and service
data in every
issue...
Plus how-to
articles with
charts,
graphs, pictures
and schematics.*

**SUBSCRIBE
NOW!**

Tell us what you think about this issue?

What was the most interesting article in this issue?

List the subjects you want to read about most?

Which one advertisement in this issue was of most
interest to you?

Advertiser's name _____

Circle No. _____



PLACE
FIRST CLASS
POSTAGE
HERE

ELECTRONIC
Servicing & Technology

Product Information
P.O. Box 12951
Overland Park, KS 66212-0951



Tell us what you think about this issue?

What was the most interesting article in this issue?

List the subjects you want to read about most?

Which one advertisement in this issue was of most
interest to you?

Advertiser's name _____

Circle No. _____

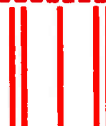

PLACE
FIRST CLASS
POSTAGE
HERE

ELECTRONIC
Servicing & Technology

Product Information
P.O. Box 12951
Overland Park, KS 66212-0951



NOW GET SCOPE, COUNTER AND DMM INPUT ALL AT ONCE THROUGH ONE PROBE!

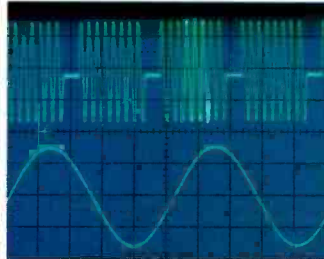

Gated frequency measurement. B sweep triggering during the intensified portion of the A sweep. Intensified portion frequency is measured with the counter/timer/DMM.

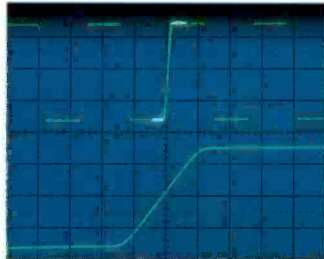

Delay time measurement. Delay time from the start of A sweep to the start of the B sweep is measured with crystal accuracy.

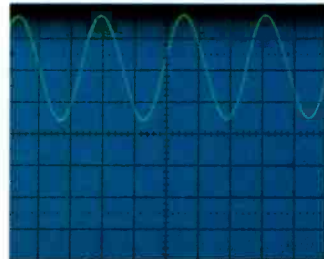

Channel 1 dc volts measurement. The average dc component of a waveform is measured directly through channel 1 with direct digital fluorescent readout.

The Tek 2236 combines 100 MHz, dual timebase scope capability with counter/timer/DMM functions integrated into its vertical, horizontal and trigger systems. For the same effort it takes to display a waveform you can obtain digital readout of frequency, period, width, totalized events, delay time and Δ -time to accuracies of 0.001%.

The same probe is used to provide input for the CRT display and the digital measurement system, resulting in easy set-up, greater measurement confidence and reduced circuit loading. Probe tip volts can also be measured through the Ch 1 input.

Precision measurements at the touch of a button.

Auto-ranging frequency, period, width and gated measurements are push-button-simple. And the 2236 offers an independent floating 5000 count, auto-ranging multimeter with side inputs for DC voltage mea-



Bandwidth	100 MHz
No of Channels	2 + Trig. View
Max. Sweep Speed	5 ns/div
Digital Readout Features	Direct Ch 1 Voltage Meas. 0.5% DC; 2.0% AC RMS Resistance: .01 Ω to 200 Meg Ω Continuity/Temp: Audible/C $^{\circ}$ or F $^{\circ}$ Totalizing Counter: — 1 counts to 8,000,000 Direct Freq. Meas: 100 MHz to 0.001% acc. Period, Width Meas: 10 ns with 10 ps max. resolution
Timing Meas. Accuracy	.001% (delay and Δ -time with readout)
Trigger Modes	P-P Auto, Norm, TV Field, TV Line, Single Sweep
Weight	7.3 kg (16.2 lb)
Price	\$2650
Warranty	3-year including CRT (plus optional service plans to 5 years)

surements to 0.1%.

A built-in, auto-ranging ohmmeter provides resistance measurements from 0.01 Ω to 2G Ω —as well as audible continuity. Automatic diode/junction detection and operator prompts serve to simplify set-up and enhance confidence in your measurements.

The 2236: scope, counter, timer, DMM plus a 3-year warranty —all for just \$2,650.

Contact your nearest distributor or call Tek toll-free. Technical personnel on our direct-line will answer your questions and expedite delivery. Orders include probes, 30-day free trial and service worldwide.

Call Tek direct:

1-800-433-2323 for video tape or literature,

1-800-426-2200 for application assistance or ordering information.

In Oregon, call collect:
1-627-2200

Tektronix
COMMITTED TO EXCELLENCE

Start the New Year right by selling Zenith Video/Audio Accessories to the same people whose electronic products you now service.

Like all Zenith products, Zenith Audio/Video Accessories are made to the same uncompromising quality and performance standards that have earned Zenith a reputation unsurpassed in consumer electronics.

And it goes without saying that the better known and the more respected a product's name the easier, faster, and the more profitably you can sell it across the counter ...or while you're out of the shop on a service call.

To learn how it's done, how other service techs just like you are cashing in on the selling power of the Zenith name, call your Zenith distributor's Accessory Sales Manager now.

Everything you need is there at your Zenith distributor's place – the help and encouragement of an

experienced Zenith Accessory Sales Manager...the selling power of the Zenith name on video and audio accessories...and the overall support of your Zenith distributor's dedicated personnel.

With easy access to this wealth of know-how, you should have no trouble turning some 6, 7 or 8 feet of your floor space into a very respectable profit center. With Zenith Electronic Accessories, of course.

Call your Zenith distributor's Accessory Sales Manager now or write direct for the name of the Zenith distributor serving your area.

Call or write now, today!



The quality goes in before the name goes on.®

Zenith Service, Parts & Accessories • Department 30 • 11000 Seymour Avenue, Franklin Park, Illinois 60131 • A Division of Zenith Electronics Corporation

DEALER  **INQUIRIES INVITED**

