

ELECTRONICTM

Servicing & Technology

APRIL 1983/\$2.25

How to test audio amplifiers

Taking the charge out of static electricity

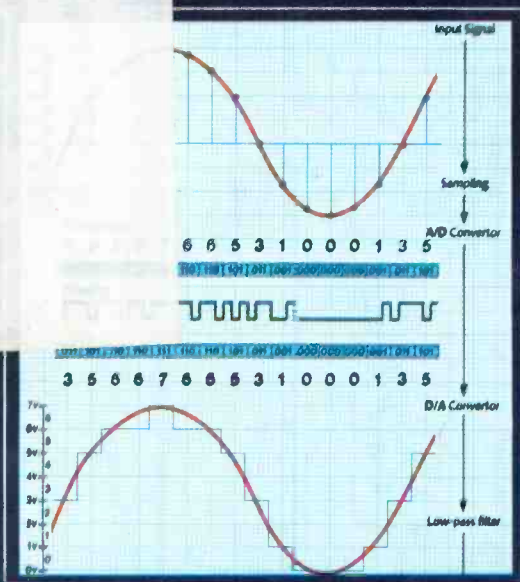

Digital audio emerges



PTS CORPORATION
No. 5 in a Series
RCA MAH001A, MAH007A

Module Update

PTS automatic updates make these RCA horizontal oscillator modules so stable the L1 coil can be eliminated.

The challenge presented by these horizontal oscillator modules was to make the entire circuit more stable and to bring it within tighter tolerances. PTS technicians began by improving various components and changing some of the resistance values. The result: automatic updates that improve stability and performance to new standards with our reliance on the L1 coil.

Changing these parts automatically update the MAH001A to 1B and the MAH007A to 1B. And that is the kind of quality and service you can expect *automatically* from the world's largest independent electronics rebuilder.

You'll find PTS quality rebuilt modules with automatic updates at over 1,500 locations nationwide. For the name of the location nearest you and your free copy of the PTS Price and Technical Information Guide, use the reader response card or write: PTS Corporation, P.O. Box 272, Bloomington, IN 47402.

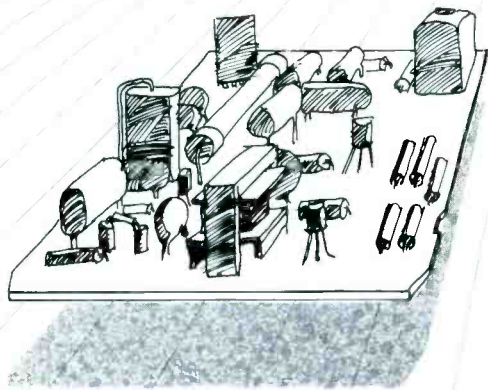

PTS CORPORATION

Circle (1) on Reply Card

"No one else gives you as many functions in a handheld DMM.

Now you can move up to Fluke."

We've got great news for people who've been holding out for a high quality, high performance DMM at a moderate price: Fluke's new nine-function model D 804 is now available at select electronics supply stores.

With a suggested U.S. price of only \$249 and features you won't find in any other handheld DMM, the D 804 is an exceptional value. Here's why.

Logic level and continuity testing: A real time-saver for troubleshooting passive circuits in pcb's, cables, relay panels and the like. The D804 has a switch-selectable audible tone and visual symbols to indicate continuity or logic levels.

Direct temperature readings in °C: Used with any K-type

thermocouple, the D 804 delivers fully-compensated readings in °C from -20°C to +1265°C, for checking heating and refrigeration systems.

Peak hold feature captures transients: A short-term memory in the D 804 captures and holds the peak reading of a motor starting current.

And more: 0.1% basic dc accuracy, conductance, 26 measurement ranges, battery, safety-designed test leads and a one year parts and labor warranty. A full line of accessories is also available to extend the measurement capabilities of your DMM.

Ask your dealer about the powerful, versatile D 804 and the rest of Fluke's new Series D line of low-cost digital multimeters



From the world leader in DMM's. Now we've designed one for you.



*Suggested U.S. list price

Circle (5) on Reply Card

If your dealer doesn't carry Series D Multimeters yet, call this number. We'll be happy to tell you who does. 1-800-426-0361

FLUKE[®]

ELECTRONIC

April 1983
Volume 3, No. 4



The Philips Compact Disc Digital Audio player uses pulse code modulation to convert analog signals to digital. The analog waveform is sampled (measured at short intervals), then in the A/D convertor, the measured values are quantized into a binary number and encoded into a pulse train. The pulse train is then fed into the transmission system (for example record or tape). At the other end of the transmission system, the pulse train is detected and regenerated in its original form.

10 Audio: alive and well

By Conrad Persson, editor

This year brings the introduction of two new developments in audio technology to the public. The compact audio disc will be available by the end of 1983, and AM stereo may be incorporated by many radio stations.

16 What makes your cartridge tick

By George Alexandrovich, Stanton Magnetics

With an area of contact between the stylus tip and the groove wall on the order of 0.0000002 of a square inch, the phono cartridge is a precise instrument that requires special care.

48 Audio servicing myths

By Kirk Vistain

The troubleshooting method endorsed by the manufacturer or other technicians may not always be the best one. The master tech must learn to see through these common myths.

52 How to test audio amplifiers

By Mannie Horowitz

Manufacturers' specification sheets don't always have all the information needed for testing amplifiers. This article gives suggestions on how to deal with problems in achieving specifications.

60 Taking the charge out of static electricity

By Jack H. Gaines, Ungar

The static electric potential that occurs under ordinary circumstances can reach hundreds of thousands of volts, but it takes less than 100V to damage the substrate of a microcircuit.

Departments

- 4 Editorial
- 6 Symcure
- 7 Letters
- 7 Books
- 8 Technology
- 29 Profax
- 43 News
- 44 Readers' Exchange
- 46 Photofacts
- 47 Quickfacts
- 62 Products
- 63 Literature

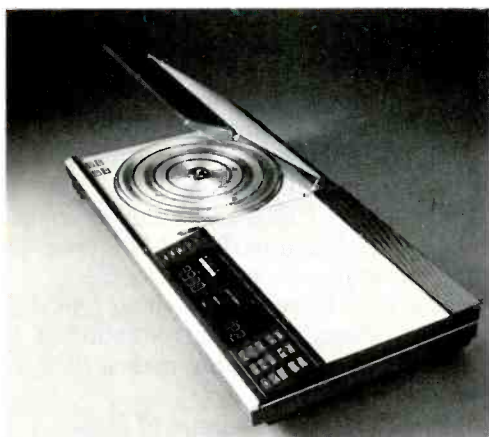

Page 10

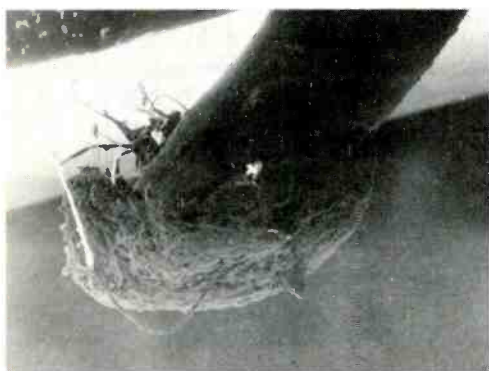

Page 16



Page 60

Next month...

An ounce of prevention. Many VCR problems can be prevented by proper cleaning and other routine maintenance. This article describes procedures for both Beta and VHS types.



Digital audio, AM stereo: landmarks emerge

Two landmark audio developments are discussed in this issue: the compact digital audio disc and AM stereo. One of them, the disc, is here. It will be available in the United States, depending upon which source you listen to, sometime this summer or fall. The other development, AM stereo, is still in doubt, although some AM stations are currently broadcasting in stereo. Whether or not it is deemed to be of sufficient significance by broadcasters and listeners alike to warrant the required investment in a system when there are four separate and incompatible AM stereo broadcasting schemes available, is far from certain. The introduction of the universal AM stereo decoder by Sansui, described in this issue, may be a deciding factor.

That being the case, let's forget about AM stereo for the moment and look at the laser compact disc.

For one thing, anyone who wants one of these new players will have to be willing to part with something in the order of \$600, and it sounds as though each compact disc will cost the better part of a \$20 bill. And while record companies are rushing to put out records in this new format, the early selection of music on compact discs will be limited to some degree. And certainly no one with any size of collection of 33 $\frac{1}{3}$ rpm analog discs will be rushing out to replace them with compact discs. Which means, for the foreseeable future at least, the compact disc player will be a companion to the existing turntable, not a replacement for it.

For this investment, however, an audiophile gets a system that gives him considerably greater dynamic range (difference between softest and loudest passages), freedom from surface noises (the clicks and pops from scratches and static

electricity), and discs that don't have to be handled with utmost care and that can be stored in a smaller space than conventional discs.

Additionally, because the music from both sides of a conventional album can fit on one side of a compact disc, you don't have to turn it over.

Another important consideration about compact digital discs is uniformity. A fairly large number of manufacturers will be offering players. And most, if not all, of the recording companies will be publishing recordings in this new format. *They will all be compatible with one another.* In videotape, VHS and Beta formats exist. In videodisc there is the optically encoded disc, the capacitive electronic disc (CED) and a third format by JVC. And as we have said earlier, AM stereo offers four different approaches. Perhaps the digital audio disc people learned something from the difficulties encountered in the introduction of these other technologies. It certainly makes things much easier for the consumer.

An article in the January 1983 issue of *High Fidelity* magazine described the reactions of a panel of critics to a listening test between high-quality analog recordings and the same music on digital discs. The reactions were mixed, but the general conclusion seemed to be that the sound of the digital discs represents an improvement in sound over that of conventional audiophile-quality discs, but not an earth-shattering improvement. One of the critics stated that to him, the absence of surface noise, the convenience of the player and the absence of wear of the disc were more important features of the new format, to him, than the slight improvement in sound.

Nils Conrad Persson

ELECTRONIC Servicing & Technology

Editorial, advertising and circulation correspondence should be addressed to: P.O. Box 12901, Overland Park, KS 66212-9981 (a suburb of Kansas City, MO); (913) 888-4664.

EDITORIAL

Bill Rhodes, *Editorial Director*
Nils Conrad Persson, *Editor*
Carl Babcoke, *Consumer Servicing Consultant*
Rhonda Wickham, *Managing Editor*
Tina Thorpe, *Associate Editor*

ART

Kevin Callahan, *Art Director*
Kim Nettie, *Graphic Designer*

CIRCULATION

John C. Arnst, *Director*
Evelyn Rogers, *Manager*
Dee Manies, *Reader Correspondent*

ADMINISTRATION

R. J. Hancock, *President*
Cameron Bishop, *Publisher*
Eric Jacobson, *Associate Publisher*

ADVERTISING

Greg Garrison, *National Sales Manager*
Jean Jones, *Production Manager*
Mark Raduziner, *Marketing Coordinator*



Member, Audit Bureau
of Circulation



Member, American
Business Press

ELECTRONIC SERVICING & TECHNOLOGY (USPS 462-050) (with which is combined Electronic Technician/Dealer) is published monthly by Intertec Publishing Corp., 9221 Quivira Road, P.O. Box 12901, Overland Park, KS 66212-9981. Second Class Postage paid at Shawnee Mission, KS 66201. Send Form 3579 to P.O. Box 12952, Overland Park, KS 66212-9981.

ELECTRONIC SERVICING & TECHNOLOGY is the "how-to" magazine of electronics. It is edited for electronic professionals and enthusiasts who are interested in buying, building, installing and repairing home-entertainment electronic equipment (audio, video, microcomputers, electronic games, etc.).

SUBSCRIPTION PRICES: one year \$15, two years \$26, three years \$34 in the USA and its possessions. Foreign countries: one year \$20, two years \$30, three years \$40. Single copy price \$2.25, back copies \$3.00. Adjustment necessitated by subscription termination to single copy rate. Allow 6 to 8 weeks delivery for change of address. Allow 6 to 8 weeks for new subscriptions.

PHOTOCOPY RIGHTS: Permission to photocopy for internal or personal use is granted by Intertec Publishing Corp. for libraries and others registered with Copyright Clearance Center (CCC), provided the base fee of \$2 per copy of article is paid directly to CCC, 21 Congress St., Salem, MA 01970. Special requests should be addressed to Cameron Bishop, publisher.
ISSN 0278-9922



INTERTEC PUBLISHING CORP.

©1982 All rights reserved.

CEI Consolidated Electronics, Inc.

Your Complete Electronic Parts Source

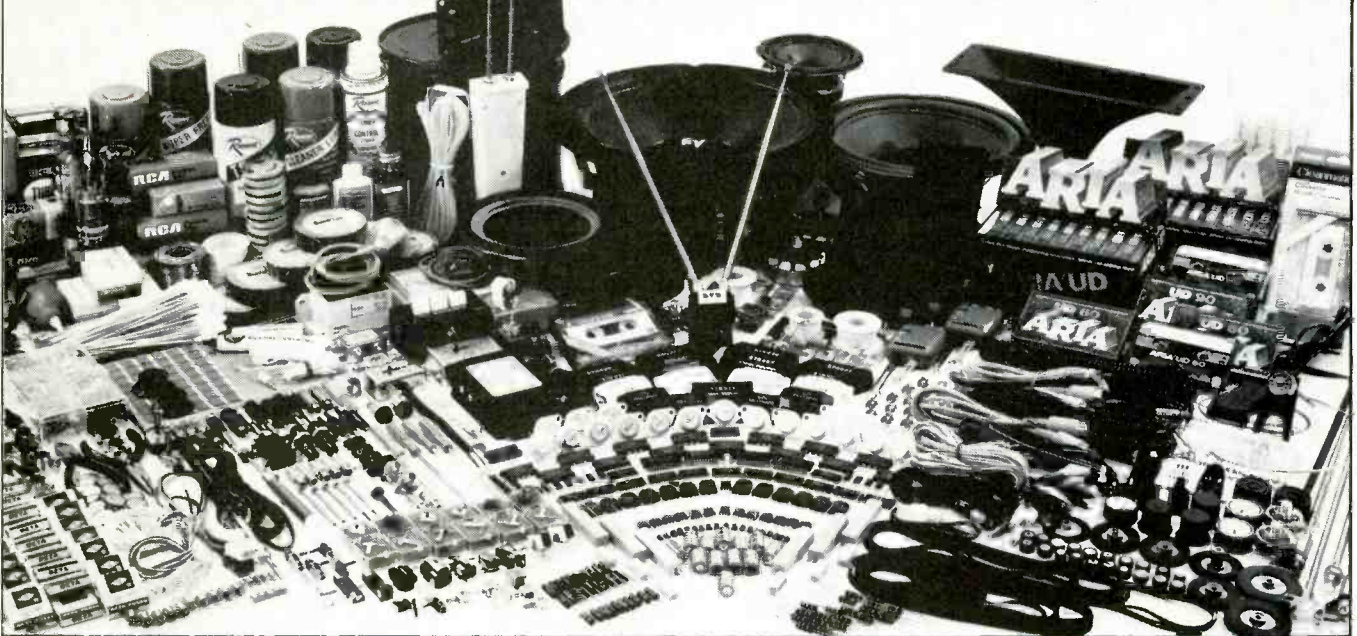

Most Orders Shipped Within 24 Hours • Compare Our Low Prices and SAVE!

WE STOCK A COMPREHENSIVE LINE OF SEMICONDUCTORS AND BELTS AT LOW, MONEY SAVING PRICES.

SUPER SPECIAL

2SC1413A

Horizontal Output Transistor
Equivalent to ECG® 238

ALSO REPLACES

- ECG 165
- C1172B
- C1174
- C1295
- C1308K
- C1309
- C1358
- C1454
- C1875
- C1893
- C1922
- C1942



ALSO REPLACES

- C1894
- D200
- D201
- D348
- D350
- D368
- D627
- D649
- D380
- D663
- D869
- D870

\$2.09 (10-99) **\$1.69** (100 & Up)

Cassette Belt Kit

Contains one each: SS 2.6, SS 3.4, SM 4.2, SS 4.6, SS 5.1, SM 6.1, SS 6.2, SM 7.5, SM 8.0, SM 8.5, SS 8.8, SS 8.9, SS 9.1, SM 9.9, SS 10.0, SS 10.5, SS 11.0, SS 11.4, SM 12.1, SM 12.4, SS 13.3, SS 13.6, RS 1.2, RS 3.7, RS 5.0, RS 5.8, RS 5.9, RS 6.1, RS 7.0, RS 7.7, RS 9.3, RS 10.1, RS 10.8, RS 11.7, RS 11.9.
35 Pieces Total

PART NO

BK-2

\$19.95 ea.
2 for **\$34.50**

Free Belt Cross Reference Guide with purchase of BK-2

SAVE!



MINIMUM \$10 ORDER
NO MIXED QUANTITIES



Consolidated Electronics
Incorporated

1-800-543-3568

NATIONAL WATS

1-800-762-3412

OHIO WATS

705 WATERVLIET AVE., DAYTON, OHIO 45420

IN DAYTON (513) 252-5662

Circle (6) on Reply Card

Chassis — Hitachi model CT-911
PHOTOFACT — 1444-2

1

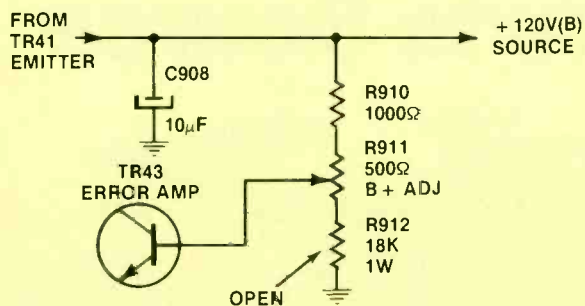

Symptom — Vertical cannot be locked and vertical-hold adjustments vary the height erratically
Cure — Check resistor R912 and replace it if open or value increased

Chassis — Hitachi model CT-911
PHOTOFACT — 1444-2

2

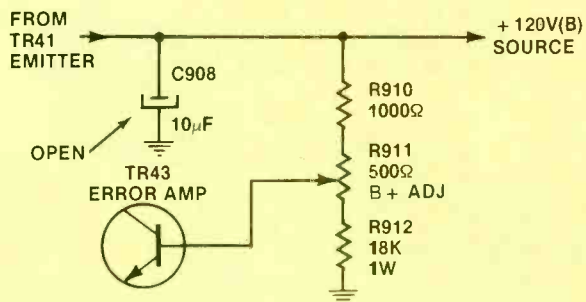

Symptom — Horizontal lines (resembling ignition noise) in picture
Cure — Check capacitor C908 and replace it if open

Chassis — Hitachi model CT-911
PHOTOFACT — 1444-2

3

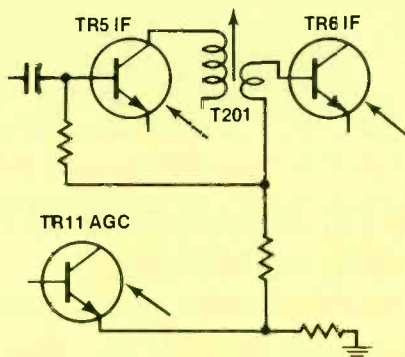

Symptom — Sound and picture fade out after several hours
Cure — Check TR-5, TR-6 and TR-11 transistors and replace them if they are sensitive to heat

Chassis — Hitachi model CT-913
PHOTOFACT — 1516-1

4

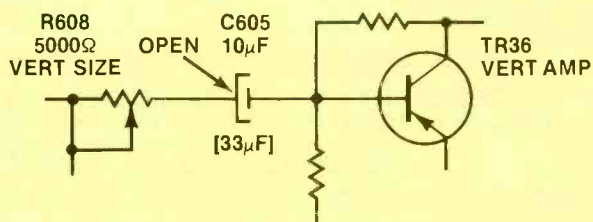

Symptom — Insufficient height
Cure — Check capacitor C605 and replace it if open

Chassis — Hitachi model CT-913
PHOTOFACT — 1516-1

5

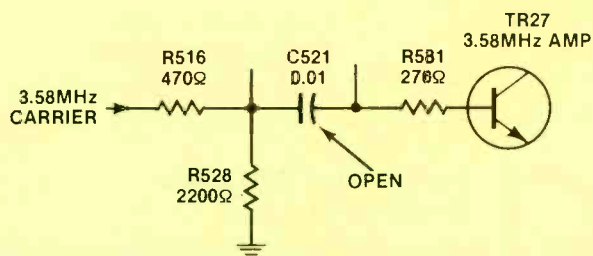

Symptom — No color; b&w is normal
Cure — Check capacitor C521 and replace it if open

Chassis — Hitachi model CU-100
PHOTOFACT — 1337-1

6

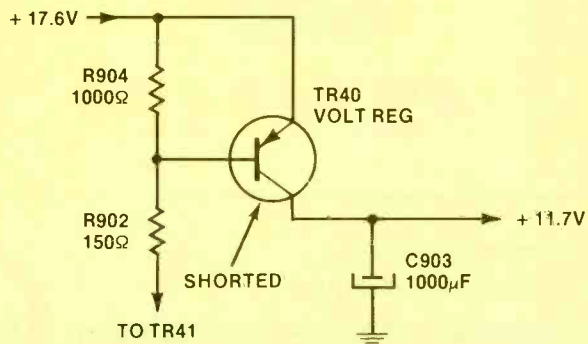

Symptom — Hum bars in picture
Cure — Check regulator transistor TR40 and replace if shorted

Books

Magnetic Tape Recording for the Eighties; U.S. Government Printing Office; \$6.50.

This new book from NASA examines the practical and theoretical aspects of state-of-the-art magnetic tape recording technology. It covers tape and head wear; wear testing; magnetic tape certification; care, handling and management of magnetic tape; cleaning, packing and winding of magnetic tape; tape reels, bands and packaging; coding techniques for high-density digital recording; and tradeoffs of coding techniques. Its contributors are among the foremost experts in this country. Users and would-be users of magnetic tape recording will find this book helpful, and in many cases, essential.

Published by U.S. Government Printing Office. Stock number 033-000-00855-4 may be ordered from Department 36-J, Superintendent of Documents, Washington, DC 20402.

Complete TV Servicing Handbook, by Walter H. Buchsbaum; Prentice-Hall; 251 pages; \$19.50

The computer terminal is essentially a TV set, and when it needs repair or adjustment, anyone who knows TV servicing can fix it. The Complete TV Servicing Handbook

shows the reader how to service any and every kind of device that has a TV screen, including computer CRT terminals. It is written by an electronics expert for readers who understand the basics of electronics.

The book starts out with a quick, reliable way to diagnose most TV defects by using only the TV screen and the readily accessible controls. Then, without getting into complicated mathematics or theoretical physics, the following "how-to-do-it" chapters cover topics such as how TV receivers and monitors work; how color TV works; color TV picture tubes; TV tuners and IF circuits; sync, deflection and high-voltage circuits; color circuits; and audio and power supply circuits.

Published by Prentice-Hall, Business and Professional Books Division, Englewood Cliffs, NJ 07632.

How to Read and Interpret Schematic Diagrams, by J. Richard Johnson; Hayden; 196 pages; \$9.95.

This book explains schematic diagrams in a systematic, rather than random manner, so the principle can be more easily understood. The meaning and purpose of schematic diagrams are explained in the first chapters. The next two chapters explain schematic symbols and basic building blocks and synthesis into diagrams. The other six chapters offer diagrams and explanations of power supply and audio system diagrams; radio receiver, transmitter and transceiver diagrams; and TV diagrams. In addition, a section on how to read and interpret

computer-type diagrams is included in the book.

The book is of interest to students, hobbyists and technicians. It complements the study of electronic principles and enables the reader to use schematics in testing, repair and design.

Published by Hayden Book Company, 50 Essex St., Rochelle Park, NJ 07662.

Third Book of Electronic Projects, by John E. Traister; Tab Books; 80 pages \$4.95.

Anyone looking for a collection of electronic projects that can be built from inexpensive or salvaged parts and components will find the answers in this handbook.

Here are all the step-by-step instructions needed to put together everything from power supplies (a basic dc unit, a dc supply that uses a zener diode, a device with electronic regulation, or a 9V, highly regulated supply) to an audible turn signal, a crystal radio, a transistor ignition system or a "do nothing" box.

This handbook has important hints and tips for working with electronic circuitry, shows how to make electronic calculations the easy way (using a standard electronic calculator) and supplies valuable information on how to find and use inexpensive salvage and obsolete parts.

For those just getting started in electronics, there's an appendix that explains fundamentals like Ohm's law, the resistor color code, common conversions and basic electronic symbols.

Published by Tab Books, Blue Ridge Summit, PA 17214.

ES&T_{inc}

Feedback

Readers' Exchange

I wish to thank you for the running of my listing of excess test equipment that I had in the *Readers' Exchange* section of your magazine. For your information, I wish to advise you that I received my December copy of **Electronic**

Servicing & Technology on Nov. 27 and on Monday, Nov. 29, about 8 a.m., I received a long-distance call from L&B Electronics in Eldon, MO, wanting to know if the B&K model 1077-B TV Analyst was sold. I advised them that it was not. They advised to hold it for them, as they would leave at once and drive into Warrenton, MO, and pick it up. (Also they would pay cash for it). They arrived about 3 p.m.

For your information, I had long-distance calls and letters from California, Texas, Kansas, New York, Canada, Tennessee

and Florida. If I had 10 more Analysts I could have sold them. Three of the letters I received had certified cashier's checks in them, which I promptly returned.

Again, I want to thank you for your help and want to assure you that when my present subscription expires, it will be promptly renewed. You have, in my estimation, the perfect magazine for people in service and repair of all types of electronic equipment.

**James Sattgast
Warrenton, MO**

ES&T_{inc}



Chamber eliminates electronic pollution

Car manufacturers can now overcome the problem of electronic pollution by testing their radios in an electronically clean environment. The RF-shielded, anechoic chamber, built by Keene Corporation's Ray-Proof Shielding Division, pinpoints interference sources so radio designers and test engineers can build interference-free radios.

The chamber protects the radio testing from two sources of electronic pollution. Externally, there is a massive buildup of

electromagnetic waves in the atmosphere. Internally, waves bounce around inside the chamber—from the radio itself, from test equipment or from other electronic systems in the car. To absorb internal waves, which would cause erroneous test readings, huge cones of anechoic material line the chamber walls. To block atmospheric electronic waves from entering, a continuous conductive metal skin surrounds the chamber. These two shields create an electronically *clean* test environment.

On earlier car radio models, Keene tested in an RF-shielded

chamber. This kept out atmospheric RF waves, but did not stop the waves ricocheting inside. Test results were still inconclusive. Designers had to make radio evaluations based on subjective ratings of a panel of engineers. They rated, on a one-to-10 scale, how much the radio's static, fading or popping bothered them.

Precision testing

The 32' x 33' x 16' chamber is lined with long, RF-absorbing cones on the ceiling, floor and walls, which absorb waves inside the chamber. RF-shielding blocks any atmospheric RF from entering, from 14KHz to 1GHz.

Pinpointing interference sources and their effects on a radio has posed problems for designers as atmospheric electronic pollution proliferated and cars became increasingly electronic. Test engineers couldn't tell if interference came from an outside or inside source, such as the radio itself or a car's electrical/electronic system. Power lines, CB radios, police transmitters, and the car's ignition and electronic control systems have created the main interference problems, but the new chamber eliminates these sources of confusion.

Details of testing

How does the testing proceed? With a signal generator located in an RF-shielded control room attached to the chamber, engineers force signals over a wide spectrum of frequencies into the room. Then they test how the radio reacts, identifying the trouble-causing frequencies with a spectrum analyzer. Readings are fed into a computer, which reveals patterns that develop. Then the appropriate suppression components—braided groundstraps, filters, capacitors and the like—can be selected.

Effect of electrical changes

The engineers can also measure the effect of modifying the car's electronic or electrical design. For example, re-routing wiring near the alternator might cause interference. Now testing in this chamber will tell where the wiring can safely run. **ES&T**

Information and photo courtesy of Keene Corporation, Ray-Proof Shielding.

Now! A 60 MHz Tektronix scope built for your bench.

Wide-range vertical sensitivity: Scale factors from 100 V/div (10X probe) to 2 mV/div (1X probe). Accurate to $\pm 3\%$. Ac or dc coupling.

Two high-sensitivity channels: dc to 60 MHz bandwidth from 10 V/div to 20 mV/div; extended sensitivity of 2 mV/div at > 50 MHz.

Sweep speeds: from 0.5 s to 50 ns. To 5 ns/div with X10 magnification.

Delayed sweep measurements: Accurate to $\pm 3\%$ with single time-base 2213; to $\pm 1.5\%$ with dual time-base 2215.

Complete trigger system. Includes TV field, normal, vertical mode, and automatic; internal, external and line sources; variable holdoff.

Probes included. High-performance, positive attachment 10-14 pF and 6C MHz at the probe tip.

In 30 years of Tektronix oscilloscope leadership, no other scopes have recorded the immediate popular appeal of the Tek 2200 Series. The Tek 2213 and 2215 are unapproachable for the performance and reliability they offer at a surprisingly affordable price.

There's no compromise with Tektronix quality: The low cost is the result of a new design concept that cut mechanical parts by 65%. Cut cabling by 90%. Virtually eliminated board electrical connectors. And eliminated the need for a cooling fan.

Yet performance is written all over the front panels. There's the bandwidth for digital and analog circuits. The sensitivity for low signal measurements. The sweep speeds for fast logic families. And delayed sweep for fast, accurate timing measurements.

The cost: \$1200* for the 2213. \$1450* for the dual time base 2215.

You can order, or obtain more information, through the Tektronix National Marketing Center, where technical personnel can answer your questions and expedite delivery. Your direct order includes

probes, operating manuals, 15-day return policy and full Tektronix warranty.

For quantity purchases, please contact your local Tektronix sales representative.

**Order toll free:
1-800-426-2200
Extension 82**

In Oregon call collect:
(503) 627-9000 Ext. 82

*Price F.O.B. Beaverton, OR. Price subject to change.

Audio: alive & well

quality recordings in a room with good acoustics, an audiophile can practically recreate the sonic splendor of listening to the greatest philharmonic orchestra in the world's finest concert halls.

All of this breadth and depth and precision and beauty of sound is recreated based on Edison's principle: A stylus riding in a groove recreates the sounds that were used to make the groove.

A new technology

If all goes according to schedule, 1983 will be the first time that a totally new technology for playing back sound will be available to the general public in the United States. Called the digital audio compact disc, this system hits the world marketplace after 10 intensive years and hundreds of millions of dollars in research and development by PolyGram Records, N.V. Phillips and the Sony Corporation. According to information provided by Polygram, the compact disc, 4.7 inches in diameter, is a digitally encoded, metalized record with a protective plastic coating with the signal embedded under the surface. It has a capability of playing up to 60 minutes of studio-quality sound on one side by a non-contact solid-state laser "readout" system. Some eight billion microscopic pits on one side of a compact disc have the straight-away track length of 2½ miles (if the disc were enlarged to the size of the Roman Colosseum, these pits would be no bigger than matchtips). The compact disc takes up approximately one-sixth of the storage space now required for LP records.

Advantages

Among the many compact-disc advantages are that dust and dirt on the outside of the disc are "out of focus" and do not interfere with sound reproduction, wear-out risk is minimum because there is no stylus contact with the record, the digital reproduction of sound is of studio quality, and there is a capability for display of video text, to be utilized in the near future.

Software

More than 250 varied musical titles, produced by the PolyGram Group (a subsidiary of Philips) will be initially available in Europe and Japan and subsequently in the

The top-loading CD 100 will be one of four compact disc players introduced by Magnavox during the second half of 1983.

Edison's original phonograph operated on a wonderfully simple principle: Recordings were made by converting sounds into mechanical motion, which was in turn transformed into wiggly grooves on a waxed cylinder. The recordings were played back by placing a stylus (needle) in this wiggly groove and rotating the cylinder at the same speed at which it was rotated during the recording process. The resulting motions of the stylus were amplified by means of a diaphragm and horn assembly to an audible level.

The limitations of this system were, of course, many and severe. The range of frequencies that could be reproduced was narrow, the variations in sound level between the softest and loudest passages (dynamic range) were barely noticeable, it was expensive, and styli and cylinders wore

rapidly. But for the first time, voices, music and sounds of all kinds could be recorded.

The developments in recording and playback from that day to this have been improvements on that basic technology pioneered by Edison. At various times, and not necessarily in their correct order, these advances took place: the wax cylinder was replaced by a shellac disc, which was in turn replaced by a vinyl disc; electronic amplification was included; various techniques were incorporated to extend the frequency response and expand the dynamic range; stereophonic sound was introduced; and a number of noise-reduction schemes were developed.

These developments and countless others have transformed that early miracle into what today can only be described as a true wonder. Given the best available playback equipment and highest

By Conrad Persson, editor

United States. PolyGram will then release 30 titles monthly, producing them alongside albums and cassettes. By the end of this year, there will be 500 to 600 PolyGram titles available with CD production volume at three million. Among the classical titles and talents now available from London, Deutsche Grammophon and Philips, are Vladimir Ashkenazy, Leonard Bernstein, Alfred Brendel, Jose Carreras, Placido Domingo, Luciano Pavarotti, Bernard Haitink, Itzhak Perlman, Sir George Solti, Joan Sutherland, Herbert Von Karajan, John Williams and the Boston Pops and many others. Popular artists whose work will be initially available include The Moody Blues, Rush, Kool & The Gang, The Statler Brothers, The Bee Gees, John Cougar and others. Film soundtrack albums initially include *Saturday Night Fever*, *Fame*, *Grease* and others.

Sound reproduction

The compact disc possesses ultimate sound reproduction because it offers full audio frequency range, extended dynamic range, greatly improved signal-to-noise ratio, almost no wow and flutter, negligible distortion and complete channel separation. It is not susceptible to shock, vibration and feedback; does not deteriorate with use, storage or age; has no pops, clicks, surface noise or other disturbing sounds; completes the digital audio chain from the recording studio to the living room; and provides almost perfect reproduction of the original master tape in the home.

Convenience of operation

The compact disc is insensitive to dust, dirt, scratches or accidental damage during handling, offers no wear on disc or pick-up no matter how often it is played, is completely compatible for integration with the amplifier and speaker portions of existing hi-fi systems, plays up to 60 minutes uninterrupted on one side (or twice one side of an LP), offers precise pre-selection of tracks to be played with many other programmable features possible and provides simple handling. The player equipment has few moving parts, thereby requiring little maintenance, and, because of its

pocket-size, is perfectly suited for portable operations.

World standardization

The compact-disc players and discs, avoiding recording errors of the past, are totally standardized throughout the world. It has an immediate large selection and wide range of software available for store debut sales, with more than 38 equipment manufacturers licensed to join Philips and Sony to produce compact disc digital audio system players (these include Akai, Hitachi, Matsushita, Nakamichi, Pioneer and Sanyo). Presently more than a dozen record labels have joined the PolyGram family to produce compact discs with many more now in negotiations. Philips introduced the first compact discs in the spring of 1979 and was subsequently joined in its further development by Sony.

How it works

In the digital audio system, the sound wave is sampled at very high speed, and the value of each sample is converted to a digital number. These numbers can then be stored, processed and reproduced in a way impervious to the kinds of noise and distortion that affect even the best analog systems. A digital system also allows automatic error corrections, which compensate for any flaws that occur in the system components.

The player

The standardized compact-disc player is now licensed by 40 hardware manufacturers. Philips and Sony players, to sell initially at no less than \$600, are completed, ready-for-sale units that are only awaiting marketing debut dates. Sony is now selling compact-disc players and discs in Japan to excellent initial response. Philips will introduce its players and PolyGram discs in March in Europe. Both players will be in U.S. stores later this year with the other 38 name-brand hardware units to follow shortly thereafter. Operating any of the players only requires popping in the compact disc and closing the lid. The Philips' player is half the size of a regular turntable. Remote control of playback will also be possible

with the player, as is now available with some TV sets.

More about digital advantages

In digital recording, the original sound wave is sampled thousands of times per second and converted into binary computer language. At about one-sixth the size, the compact disc offers many advantages over the conventional analog LP record. It provides wider frequency response (20 to 20,000Hz) and less high-frequency distortion (0.05%). The system provides a signal-to-noise ratio and dynamic range of more than 90dB for each. There is no contact between the laser pickup and disc, resulting in an extremely long record life.

The right and left sound channels are encoded as separate bits of information that cannot be mixed in the record. Channel separation is greater than in conventional LPs for a stereo effect that significantly increases realism in playback.

How it developed

The compact disc system, with its miniaturized ICs, was developed from an intensive 10-year program of research and development by Philips, later joined by Sony.

The packaging

Each compact disc fits on a black plastic tray, housed in a clear plastic, hinged box. A booklet containing liner notes is held in the cover of the box. Cover graphics of the album are visible through the top of the box. An inlay card, visible through the bottom of the box, gives details of contents, artists and other information. Also titles and artists are printed on both ends (spines) of the box. The boxes, capable of holding up to four compact discs, have also been developed for use in 2-, 3- and 4-record sets.

Quality control

Compact discs are presently manufactured under "clean room" conditions at two existing factories, one in Germany and the other in Japan. Additional factories by some other compatible suppliers are expected to be added soon. Strict quality control procedures are observed at every stage of the production.

A remote-controlled stereo system



The Beocenter 7700-S music system by Bang & Olufsen of Denmark brings a choice of music sources into every room by remote control.

Most people have an assortment of equipment in their homes to listen to music and radio programs—a radio on the kitchen counter, clock radio in the bedroom, compact stereo in a youngster's room and a full stereo system in the living room.

Bang & Olufsen decided that it would be great if one were able to replace all of this equip-

ment with one centralized stereo system that brings a choice of music sources into every room by remote control. Their new, computerized and programmable music system, which will be available in the United States this year, accomplishes all this and more.

The key to this state-of-the-art ensemble, the Beocenter 7700-S, is Bang & Olufsen's proprietary Master Link System. It enables the user to tap into the Beocenter for music from radio, phonograph records and cassettes into any or all rooms of a home or apartment by merely installing an auxiliary 2-unit Master Link and a pair of speakers in each of the selected rooms. A button pressed on the Master Link (actually an infrared transmitting and receiving device) conveys a message to the Beocenter to direct music from whatever program source is in operation in the main listening room to the room where music is desired.

An extra measure of flexibility and control is provided by a remote control unit, the Beocenter Terminal, that comes with the system. This slim, hand-held cordless module incorporates a set of primary control buttons duplicating those on the music center. A different remote control module, the 7700 Master Control Panel, is available as an option. This unit incorporates digital readouts as well as primary control buttons. Either of the remote control modules can be employed to direct the Beocenter 7700 from any point in the same room.

A remote control module may also be used in any of the rooms connected to the Beocenter 7700 via the Master Links and loudspeakers for complete operation of the system and remote controlled selection of any music source. It can turn the system on, or even change whatever program source is in operation to a different one. For example, while the user is in the



Buttons controlling the primary functions are mounted flush to the front panel, while secondary controls are placed under an aluminum panel that lifts when the programming bar is touched.



The optional remote control unit is an infrared transmitting/receiving device that incorporates a set of primary control buttons and digital readouts.

When it comes to choosing the right DMM, you really only have four choices...

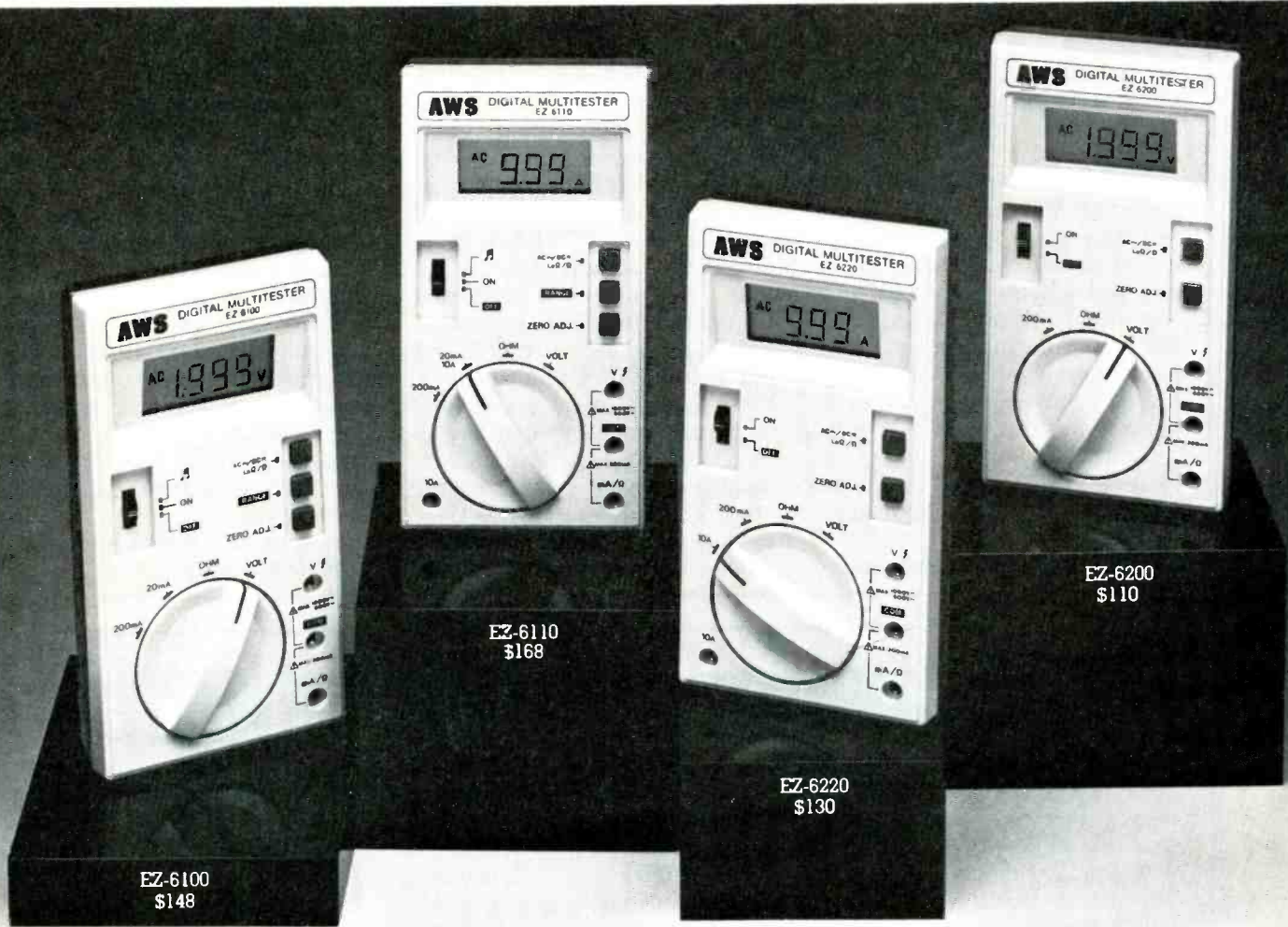

The AWS Easy-Meter™ Series with an exclusive Five-Year Warranty.

- Autoranging on Volts and Ohms
- 10 Amp AC/DC Range (EZ-6110 & 6220)
- Range hold button for manual operation override (EZ-6100 & 6110)
- Large, easy-to-read 3½ digit display
- Autopolarity
- Low battery drain, 300 hours continuous operation
- Continuity buzzer (EZ-6100 & 6110)
- Low Power and Normal Ohm ranges
- CMOS-LSI advanced circuitry
- Automatic indication of units and signs
- Low battery warning sign
- Zero adjust feather-touch button
- Economically powered with two "AA" 1.5V batteries
- Safety fused
- Compact and lightweight (weighs only 8.8 ounces)
- Rugged, shock resistant ABS housing

EZ-6100 & 6110		EZ-6200 & 6220	
DCV 0-1000	5-Autoranges	DCV 0-1000	5-Autoranges
ACV 0-600	4-Autoranges	ACV 0-600	4-Autoranges
AC/DCA 0-10	1-Range (EZ-6110)	AC/DCA 0-10	1-Range (EZ-6220)
AC/DCMA 0-200	2-Ranges	AC/DCMA 0-200	1-Range
Ω 0-2000K Ω	5-Autoranges	Ω 0-2000K Ω	5-Autoranges
Low Power Ω : 0-2000K Ω	4-Autoranges	Low Power Ω : 0-2000K Ω	4-Autoranges
Continuity Buzzer			

For more information on the Easy-Meter™ Series or any of the other fine AWS test instruments call your local A.W. Sperry distributor today or contact A.W. Sperry Instruments Inc., 245 Marcus Blvd., Hauppauge, N.Y. 11788, 800-645-5398 Toll-Free (N.Y., Hawaii, Alaska call collect 516-231-7050).

A.W. SPERRY INSTRUMENTS INC. The Measurable Advantage.

Circle (25) on Reply Card

www.americanradiohistory.com

bedroom and touches a button marked *phono* on a remote-control unit, an electronic signal is sent to the Master Link. It, in turn, directs the master unit located in another room to start playing a record previously placed on the system's turntable, and in a moment the disc's sound is emanating from the speakers installed in the bedroom.

A touch of one of a series of buttons marked *FM* on a remote-control module instantly brings music, news or whatever radio fare is preferred, into a particular room. A touch of the *tape* button directs the music center in the living room to play a prerecorded tape placed in the unit. Within seconds, the sound from a favorite prerecorded cassette will emanate from the speakers in the room.

Essentially the Beocenter

7700-S, with its Master Links, offers the benefits of multi-system ownership from a single space-saving stereo system, with a minimum of auxiliary equipment.

A pair of loudspeakers (Model S-45), designed to coordinate with the Beocenter, is supplied with the new music system. The Beocenter 7700, itself, combines the components of a complete stereo system in a single, centralized unit that fits easily into a limited space. The elegantly styled, low-profile unit incorporates a 40W-per-channel (into 4 Ω) FM stereo receiver, radial arm turntable and cassette player/recorder. A built-in visual display indicates which music program source is in use at a given time and its operating mode (play, record, etc.). The optional Master Control Panel remote control module provides similar pro-

gram source and operating information.

The Beocenter 7700 allows the user to listen to any one of six preselected FM stations at a mere touch of a button—either on the set's control panel or on a remote control module. Another touch, and the turntable directs one music source to be switched off when another source is selected.

Two timers, each with a 24-hour memory, allow users to direct the system to make unattended radio broadcast recordings and/or play any music source at specific times. Typically, the system could be programmed to activate the turntable or cassette deck to start the day off with a disc or tape of favorite music and to shut off the entire system at bedtime after playing a record, tape or radio music program intended to induce sleep.

AM stereo developments

AM stereo radio took several steps closer to realization this year. A number of manufacturers exhibiting at the Winter Consumer Electronics Show (CES) displayed equipment that confirmed this. There were several demonstrations of off-the-air AM stereo reception.

Sansui Electronics announced development of an AM stereo tuner that automatically receives *all* approved AM stereo systems (there are four). A prototype of a car AM stereo tuner was demonstrated by Sansui at CES.

The following statement by Tom Ioda, Sansui vice president of sales and marketing, explains their reasons for investing Sansui's resources in such a development.

"The purpose of this demonstration was to indicate that universal reception is possible and that at least one hardware manufacturer has the capability of providing equipment for reception of AM stereo regard-

less of which system the market ultimately chooses.

"As of this time, Sansui is investigating the incorporation of this circuit in a chip, and based on the price of that chip, will announce when and if they will be manufacturing equipment for reception of AM stereo. Present planning is for this decision to be made soon with initial product to be shown and demonstrated at the 1983 Summer CES."

According to *Broadcast Engineering* magazine, Marvin Collins, chief engineer, KFI/KOST, Los Angeles, is one of the engineers who saw the Sansui system in operation following the CES convention. "I believe they (Sansui) have what may be the answer to our current AM stereo dilemma," he said. "The Sansui engineers drove to the KFI studios in a car equipped with a very interesting AM Stereo receiver: a universal AM-stereo decoder that decodes all four stereo systems

automatically without any manual switching. I enjoyed listening to KFI in Harris stereo and then tuning the dial in KHJ in Kahn stereo. The engineers told me that the receiver *does not* favor one system over another, but works equally well on each system. The receiver can be built for only a slight additional cost over a single-system receiver.

"If all the receiver manufacturers will produce universal stereo receivers," Collins continued, "our present chicken-or-egg dilemma will be solved. A universal receiver means the broadcasters are free to choose any AM stereo system they like, knowing that all receivers will receive all systems. This will surely encourage widespread AM stereo broadcasting soon. Congratulations to the Japanese and Sansui for leading the way. Now I hope the American manufacturers will do their part."

ES&T

Our innovation.



Their imitation.

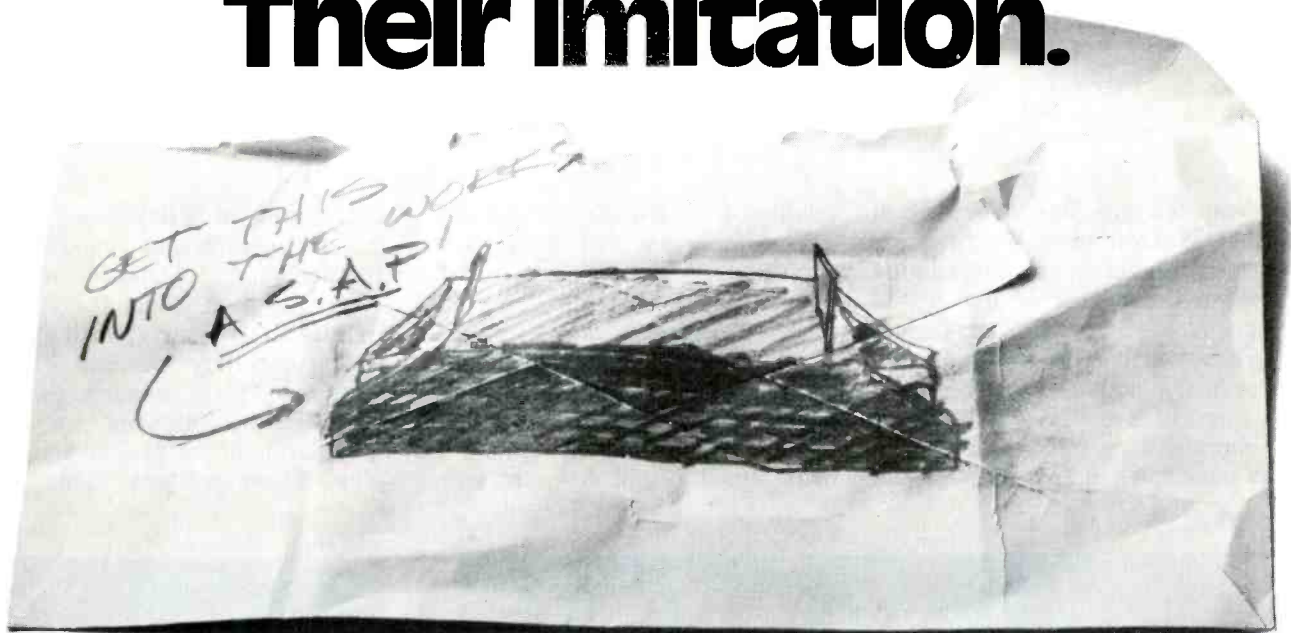

If you need any one of nine microwave oven rectifiers now, only Philips ECG is ready to deliver today.

You can tell where your new markets are by checking out what's new from Philips ECG. Whether you're looking for a semiconductor, resistor, or thermal cut-off, you should look to Philips ECG first. We're introducing about 300 new parts each year to our current line of 3,000 ECG types that replace over 200,000 industry numbers. And you find them faster in our Master Guide.

While our competition looks to us first for new ideas, the parts they come up with never quite equal either our performance specs or our Master Guide's cross reference accuracy.

Pull the ECG® Master Guide first to save yourself searching time and repair time.

For the name and number of your nearest distributor, call 1-800-225-8326 toll free (In Massachusetts, dial 1-617-890-6107). Or just send \$3.25 for your Master Guide to Philips ECG, Inc., Dept. EST, 70 Empire Drive, West Seneca, NY 14224.



Philips ECG

A North American Philips Company

If it's ECG®, it fits. And it works.

What makes your cartridge tick



By George Alexandrovich, vice-president of field engineering and professional products manager, Stanton Magnetics

From the day Alexander G. Bell called Watson over his first experimental telephone line, sound became the center of our attention. A new era began when spoken words were transmitted over long distances by wire. Slowly, engineers mastered the basics of simple means of communication and have worked on improving the

quality of this transmitted signal.

The importance of sound is indisputable. What most of us take for granted, audiophiles are struggling to perfect. Just ask anyone of them about audio and what it means (be it AM, FM or even TV sound) and you will probably get a lecture about what it takes to bring good sound to your home

entertainment system.

Let's imagine that you are about to turn on the turntable of your stereo system. The tonearm is resting on its armrest with the cartridge carefully cleaned and adjusted to play modern records, which are notorious for high modulation of the groove and complex music content. This is a

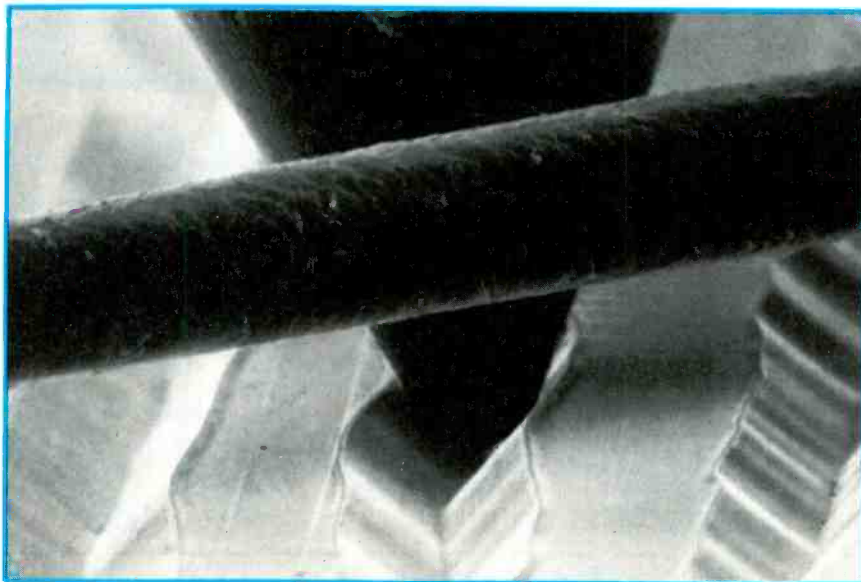

A stylus in a stereo disc groove. A human hair, approximately 0.002in in diameter, shows comparative sizes (magnified 800X).



A spherical stylus sits in a phono disc groove. Note the space between the tip and the bottom of the groove. The radius of the stylus is 0.7mil (magnified 2500X).

Photos courtesy of Stanton Magnetics, Plainview, NY.

The trouble with most delayed-sweep scopes is the delay—not the electronic kind, but the delivery delay. B&K-PRECISION has solved that problem, so now you can have the delayed-sweep scope you need, when you need it.

The new model 1530 delayed-sweep scope from B&K-PRECISION is not only available at local distributors now, but it has all of the most frequently needed features. Thirty MHz response, 2mV division sensitivity and rectangular CRT assure that the 1530 will handle the requirements of most engineers involved in digital and microprocessor circuit development. High-triggering sensitivity and very-flat frequency response also allow the 1530 to be useful well beyond its rated bandwidth.

Five ranges of time-base delay from 1nS to 100mS highlight this new instrument. The delayed-sweep capability of the 1530 is a major advantage in the evaluation of digital pulse trains and other complex

waveforms. Complex signals can be expanded by as much as 1000 times for examination of signal components and troublesome "glitches." The absolute minimum magnification is 5 times at frequencies to 30MHz. The delayed-sweep feature is also useful in the measurement of rise and fall times of pulse signals.

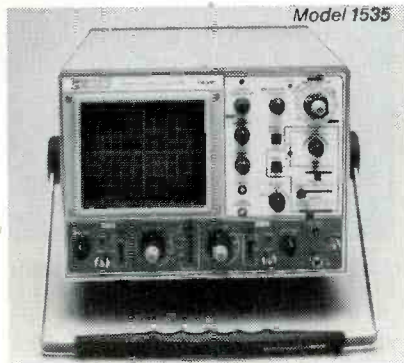

For highest display accuracy, the 1530 offers a variable hold-off function. This ensures triggering at the first pulse of a multi-pulse signal, preventing improper waveform display. The 1530 can also display two signals that are unrelated in frequency by alternately triggering on both the channel A and B signals.

Other convenient features include a FIX mode to eliminate trigger level adjustments, differential input capability, single sweep operation, selectable triggering filters and a built-in video sync separator.

If you're looking for the kind of features and performance found in the 1530, but without delayed-sweep capability, B&K-PRECISION offers the 35MHz model 1535. The 1535 is a high-performance instrument that doesn't sacrifice performance.

For immediate delivery, contact your local B&K-PRECISION distributor or call toll-free 1-800-621-4627.

B&K PRECISION DYNASCAN CORPORATION

6460 W. Cortland Street • Chicago, IL 60635 • 312/889-9087

International Sales, 6460 W. Cortland Street, Chicago, IL 60635 USA: TELEX 25-3475

Canadian Sales, Atlas Electronics, Ontario

Delayed sweep without delay.



Direct factory consumer rebate!
\$50.00 on Model 1530 • \$75.00 on Model 1535.

Purchase a 1530 or 1535 from your local B&K-PRECISION distributor, between March 1, 1983 and June 30, 1983. Submit special rebate certificate available at your distributor, along with warranty card, serial number and distributor's dated invoice to B&K-PRECISION Scope Rebate, P.O. Box 35440, Chicago, IL 60635.*

*Please allow 6-8 weeks to receive your check from B&K-PRECISION. Sales receipts cannot be returned. Void where prohibited, taxed or otherwise restricted.

Circle (9) on Reply Card

www.americanradiohistory.com

challenge in itself. But will the cartridge cope with this challenge? Will it stay in the groove and track, or will it jump the groove? What makes the cartridge tick, and what can we do to help it accomplish its assignments?

Tough working conditions

Actually the phonograph cartridge, (or pickup, as many still call it even today) is the most complicated and demanding transducer we know. The term *transducer* means a device that converts one form of energy into another. A phonograph cartridge converts mechanical motion of the stylus into electrical impulses, which are almost a perfect replica of the mechanical modulation of the groove in amplitude, crosstalk between channels and signal form. This true reproduction of all signals on the record has to take place at all frequencies, from subsonic to ultrasonic regions of the audio spectrum.

A phonograph cartridge is sensitive to magnetic fields, vibration, shock, temperature and strong acoustic fields. But at the same time, when properly installed and used, it can supply us with signals having a dynamic range of more than 80db and the same magnitude of signal-to-noise. The vital prerequisite here is *when properly installed*. This means proper selection of cartridge for the job, using a specific tonearm designed to perform certain functions, then align-



A Stereohedron stylus rests in a disc groove (magnified 2000X).

ment and mounting of the tonearm assembly and application of adequate tracking force and corrective bias or antiskating force. Other requirements are *proper use* and *maintenance*. This includes care in handling of the tonearm and of records in preparation and during the playback, as well as record and stylus care.

Regardless of the fact that many phono cartridges are extremely reliable today, a few points of trivia about the cartridge point out the importance of proper care and maintenance. For instance the area of contact between the stylus tip and the groove wall is on the order of 2 ten-millionths of a square inch and one gram of vertical force produces tons of pressure per square inch on the record

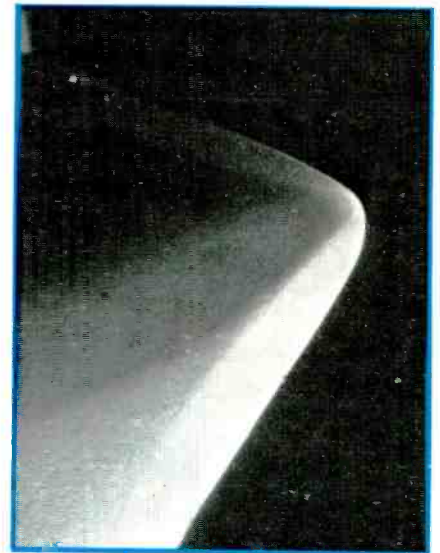

A Stanton Stereohedron stylus tip providing a large contact area (magnified 1200X).



A disc with high groove modulation, as found in many modern recordings. Such modulation would be almost impossible to trace properly (magnified 2000X).

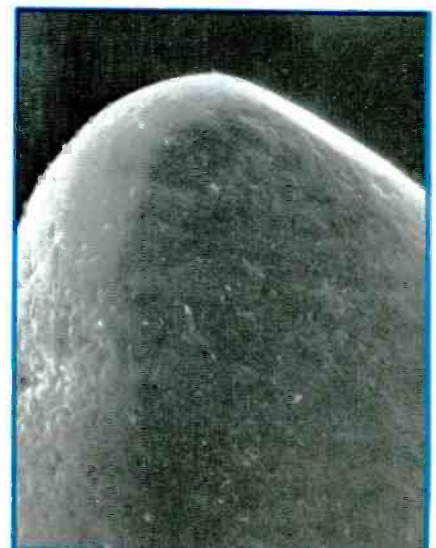

An elliptical stylus beginning to wear at approximately 100 hours of use (magnified 3000X).

Now television technicians can get into VCR Servicing quickly and easily

Learn professional VCR servicing at home or in your shop with exclusive videotaped demonstrations

Today, there are more than 5 million VCRs in use, with people standing in line to have them serviced. You can bring this profitable business into your shop with NRI professional training in VCR servicing. It's top-level training that supports the industry's claim that the best technicians today are those who service VCRs.

Integrated Three-Way Self-Teaching Program

In one integrated program, NRI gives you a study guide, 9 instructional units, 2 hours of video training tapes accompanied by a 32-page workbook that pulls it all together. At home or in your shop, you'll cover all the basic concepts of video recording, mechanical and electronic systems analyses, and the latest troubleshooting techniques. Your workbook and instructional units also contain an abundance of diagrams, data, and supplementary material that makes them valuable additions to your servicing library.

The "How-To" Videotape

Your NRI Action Videocassette uses every modern communications technique to make learning fast and easy. You'll enjoy expert lectures and see animation and video graphics that make every point crystal-clear. You'll follow the camera eye into the heart of the VCR as step-by-step servicing techniques are shown. Both electronic and mechanical troubleshooting are covered . . . including everything from unjamming cassettes to complete replacement of the recording head.

Plus Training On All The New Video Systems

Although your course concentrates on VCRs covering Beta, VHS, and 3/4" U-Matic commercial VCRs, NRI also brings you up to speed in other key areas. You'll get training in capacitance and optical video disc players, projection TV, and video cameras. All are included to make you the complete video technician. There's even an optional final examination for NRI's VCR Professional Certificate.

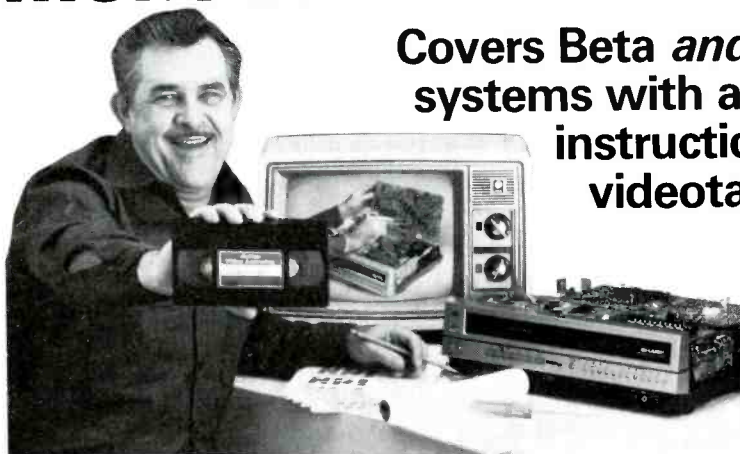

Covers Beta and VHS systems with actual instruction on videotape.

The Best Professional Training

This exclusive self-study course has been developed by the professionals at NRI. NRI has trained more television technicians than any other electronics school! In fact, NRI has consistently led the way in developing troubleshooting techniques for servicing virtually every piece of home entertainment equipment as it appears in the marketplace.

Satisfaction Guaranteed . . . 15-Day No-Risk Examination

Send today for the new NRI Self-Study Course in VCR Servicing for

Professionals. Examine it for 15 full days, look over the lessons, sample the videotape. If you're not fully satisfied that this is the kind of training you and your people need to get into the profitable VCR servicing business, return it for a prompt and full refund, including postage. Act now, and start adding new business to your business.

Special Introductory Offer

This complete VCR training course with two hour videotape is being offered for a limited time only, on orders received from this ad, for a low introductory price of \$179.95. Save \$20 by acting now!

NRI Training For Professionals
McGraw-Hill Continuing Education Center
3939 Wisconsin Avenue, Washington, DC 20016

YES! Get me started in profitable VCR servicing. Rush me my NRI self-study course in VCR Servicing for Professionals. I understand I may return it for a full refund within 15 days if not completely satisfied.

PLEASE SPECIFY TAPE FORMAT DESIRED VHS BETA

Name (please print) _____

Company _____

Street _____

City/State/Zip _____

Enclosed is my check money order for \$179.95 (D.C. residents add 6% tax) Make check payable to NRI

Charge to VISA MasterCard _____

Interbank Number _____

Card Number _____ Expiration Date _____

Signature _____

(required for credit card sales)



NRI Training For Professionals
McGraw-Hill Continuing
Education Center
3939 Wisconsin Avenue
Washington, DC 20016

2630-043

groove wall. Also, the instantaneous temperature of the contact area during the playing of the record is about 480°F—the melting temperature of vinyl. Do you realize that the stylus tip can easily change its direction of travel more than 40,000 times a second, with an acceleration/deceleration of more than 1600Gs? Astronauts experience an acceleration of about 10Gs; a bullet accelerates along a rifle bore at less than 1600Gs.

The same stylus capable of all this simultaneously supports the tonearm and carries it across the record. A cantilever, which interconnects the stylus tip and the generating element inside the cartridge (usually magnetic), is made of aluminum tubing, which has a wall thickness of one or two thousandths of an inch. Human hair is about two thousandths of an inch thick.

Selecting a cartridge

It is no news that several things influence the decision of selecting and buying a cartridge. Unfortunately part of this decision-making process depends largely on economic factors. But there are many good cartridges available today at affordable prices that can do an excellent job.

Certain facts will help make an intelligent choice of cartridge model. First of all, buy products from a reputable and established supplier of professional transducers, because you will be looking for availability of the replacement styli, speed of service and cost. There are too many cartridge models on the market today that will not be here tomorrow, and there will be no styli for them.

Never get a cartridge without being able to replace the stylus. The best diamonds under the most favorable conditions will wear out after 1000 hours of use when working with 1g of tracking force. Higher tracking forces and dirty records will make it necessary to replace the stylus every 200 to 300 hours. Check the diamond stylus at least that often for wear. When you shop for the cartridge, pay attention to the construction of the stylus tube or cantilever. Flimsy and long, exposed styli will bring you troubles, especially with careless use. Select the models



Tracking at 1.5g, an elliptical stylus leaves definite evidence of record wear after 200 hours of use (magnified 3000X).

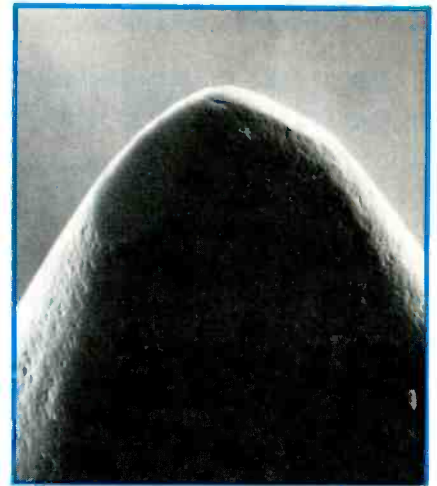

An elliptical tip shows increased wear after 500 hours of playing time. Note the smooth polish of the contact areas (magnified 2000X).

designed to retract their styli into the cartridge body when there is an excessive downward pressure or sidethrust. One of the most destructive tests professional cartridges have to withstand is when the tonearm is dropped onto the records and then under pressure slid across the record.

Another factor affecting the behavior of a cartridge is the polish of the diamond. Generally speaking, good polish will reduce the abrasion of the groove wall. However, don't forget that the best polish of the diamond is achieved in playing records. We are so conditioned to think in terms of everything being new and perfect that we forget that the stylus is new only for a few days. After that, the stylus shape determines how fast the stylus will wear and what shape it will take. The fastest stylus wear will take place during the first few hours of playing time, when the contact areas of the tip are curved and the pressure is the highest. Actually, I consider the stylus at its peak performance after it has been broken in for a few hours. The stylus will last longest if the position of the cartridge with respect to the record surface remains the same for the life of the stylus. Plug-in styli help achieve this. If you use plug-in headshells, they should not be used in a variety of tonearms with different alignments.

Years ago 45rpm discs were pressed using vinyl, like their 12-inch LP brothers. But today, for economy reasons, almost all

45s are made of polystyrene, a material that is bad news as far as long life of the record is concerned. In a few playings, the outer layer of the record surface starts peeling off at the area of contact—like old house paint. When the stylus starts touching the inner portion of the record material, which is very grainy, there is an increase in noise. Some records can be ruined in only a few plays. By using a super-polished (or used) stylus you can delay the destruction of the outer skin of a record surface, but you can not avert it. By reducing the tracking force, you can achieve the same effect, but then you are exposed to the increased possibility of tracking light.

Tracking force

This brings up another important aspect about the cartridge operation—tracking force. We know that record and stylus wear are directly proportional to the tracking force, yet most audiophiles tend to ignore this fact and apply the maximum tracking force a cartridge can withstand, with good reason. There is nothing worse than to lose the contact with the groove or have a cartridge get stuck in one spot. There is always the danger of your tonearm skidding across the record surface.

This use of heavy tracking force is also a leftover from the days of the 78rpm transcription discs. The stylus tip was then spherical with a 2.7mil tip radius and the tonearm looked more like a railroad cross-

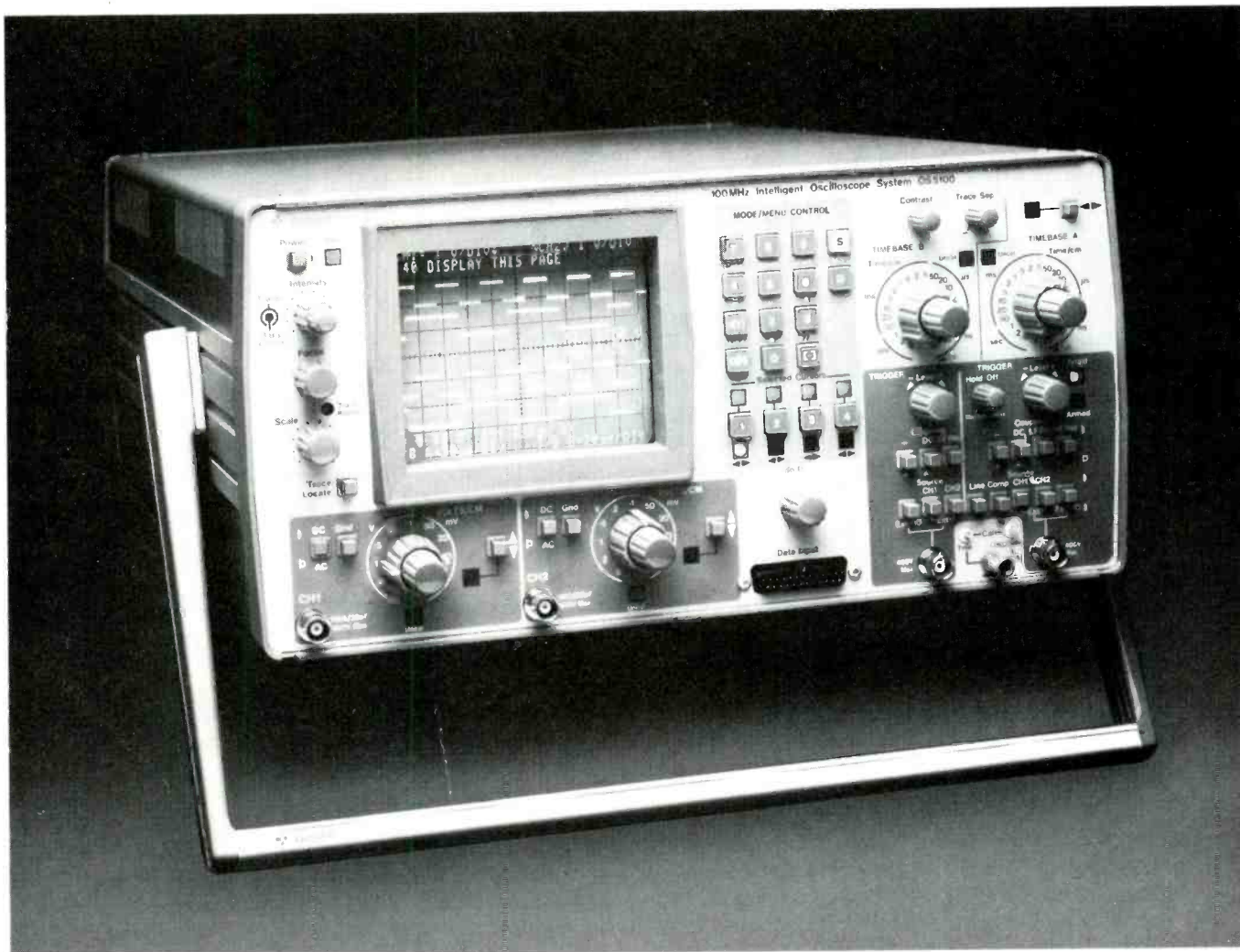

TIME SAVER

Gould 100 MHz OS5100 Intelligent Oscilloscope System. In servicing and maintenance of electronic components, circuits and equipment, our OS5100 pin-points problems quickly, accurately and inexpensively.

The result: minimized downtime and increased productivity.

The Gould OS5100 is a highly sophisticated measuring system. Yet it's easy to use. And it's portable. That unique combination puts more on-site measuring power at the fingertips of field service technicians than ever before. They can compare expected results — either a waveform or a measurement — with the actual. And come up with an accurate diagnosis in far less time than normally required for initial trouble-shooting.

The OS5100 features an analog bandwidth of 100 MHz, waveform storage to 100 MHz, and two 1K x 8-bit stores. Plus front-panel keyboard

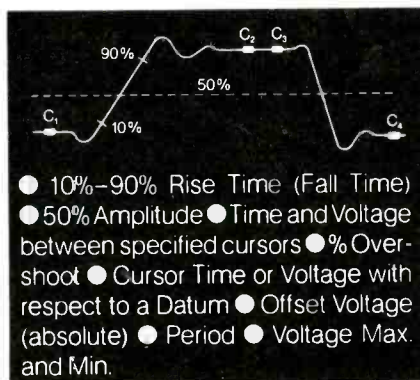

- 10%–90% Rise Time (Fall Time)
- 50% Amplitude
- Time and Voltage between specified cursors
- % Overshoot
- Cursor Time or Voltage with respect to a Datum
- Offset Voltage (absolute)
- Period
- Voltage Max. and Min.

Typical automatic calculations available operation through a menu-control system. Combined alphanumeric and waveform display capabilities. Auto-measurement capabilities. And analog and digital interfaces

that allow it to function as the heart of a complete measurement and analysis system.

Extensive trigger facilities include delay-by-time (up to 344 seconds) and delay-by-event (count selectable to 999,999,999) modes. Or you can trigger on a specific logic word if the OS5100 is used with an optional logic analyzer word-recognition pod.

Now is the time to learn how the Gould OS5100 Intelligent Oscilloscope System will speed your service and maintenance operations. Contact Gould Inc., Instruments Division, 35129 Curtis Boulevard, Eastlake, OH 44094; phone 800/321-3035.

 **GOULD**
Electronics & Electrical Products

Circle (24) on Reply Card

April 1983 *Electronic Servicing & Technology* 21

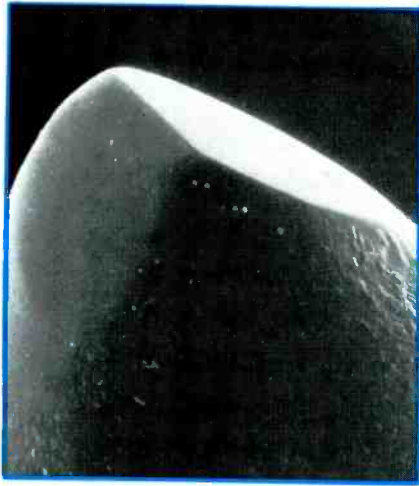

A tip that should have been discarded shows the equivalent of 2000 hours of use (magnified 2000X).

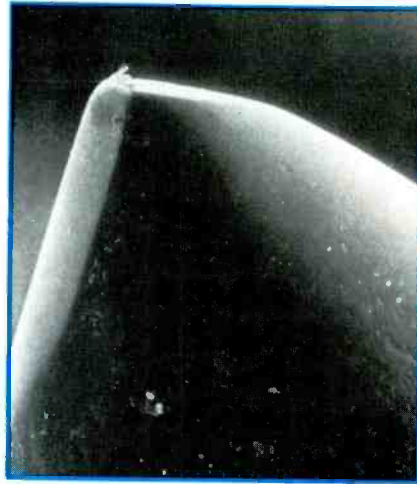

The tonearm that carried this stylus was not compensated for skating force. Note the uneven wear (magnified 2000X).

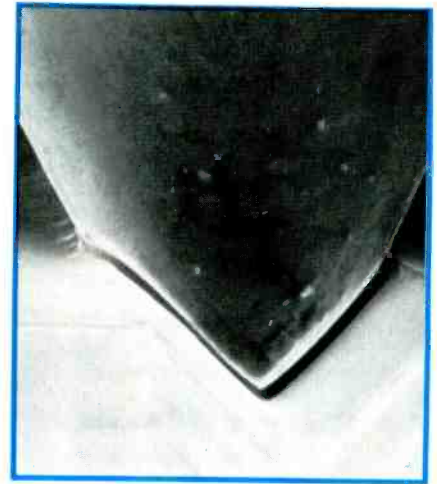

A badly worn stylus in a disc groove. Its continued use will soon destroy the groove modulation (magnified 2000X).

ing gate. Today, to track the groove, we can get by comfortably with two grams of tracking force.

Maintenance

Just as tape heads require cleaning, a cartridge stylus needs cleaning too. Tapeheads wear; so do styli. Azimuth alignment is being constantly checked; cartridge mounting and stylus positioning do not get the same share of attention but should. Tapes are stored, then rewound periodically; discs need to be cleaned and checked for possible warpage.

The maintenance of the turntable starts with cleaning the mat. If the mat is made of felt, it should be vacuumed frequently. The electrostatic charges carried by the record can be transferred onto the mat, which attracts and traps dust. If the mat is made of rubber or a similar substance that can be washed or wiped using damp cloth or sponge, do it frequently. Records can be cleaned with dry brushes and special cleaning liquids. Some of them make records electrostatically inert.

To preserve the cleanliness of the stylus, never play records moist or wet. Moist records may sound fine the first time you play them, but as you play them, part of the surface may dry. Particles of dust that were trapped in the liquid will cake up into small balls and settle to the bottom of the groove. The record will never sound the same again, especially if you decide to play it dry again. The small dirt globules will be pushed

into the vinyl material and embedded into the groove wall permanently. To dissolve and remove this dirt is almost impossible. Meanwhile, your signal-to-noise gets worse.

The cartridge is the last link in the chain of equipment before the mechanical motion of the stylus is converted into electrical signals. In order to achieve this type of energy conversion without distorting the signal, the stylus has to

be clean. Special cleaning brushes for diamond tips are almost indispensable. Follow instructions judiciously—clean the stylus by brushing carefully only in the direction of record motion—away from the tonearm pivot point. NEVER brush sideways or inward. The brush can be used dry or moistened with a special stylus cleaning liquid or water-alcohol mixture (a safe substitute for exotic formulas). Avoid applying the

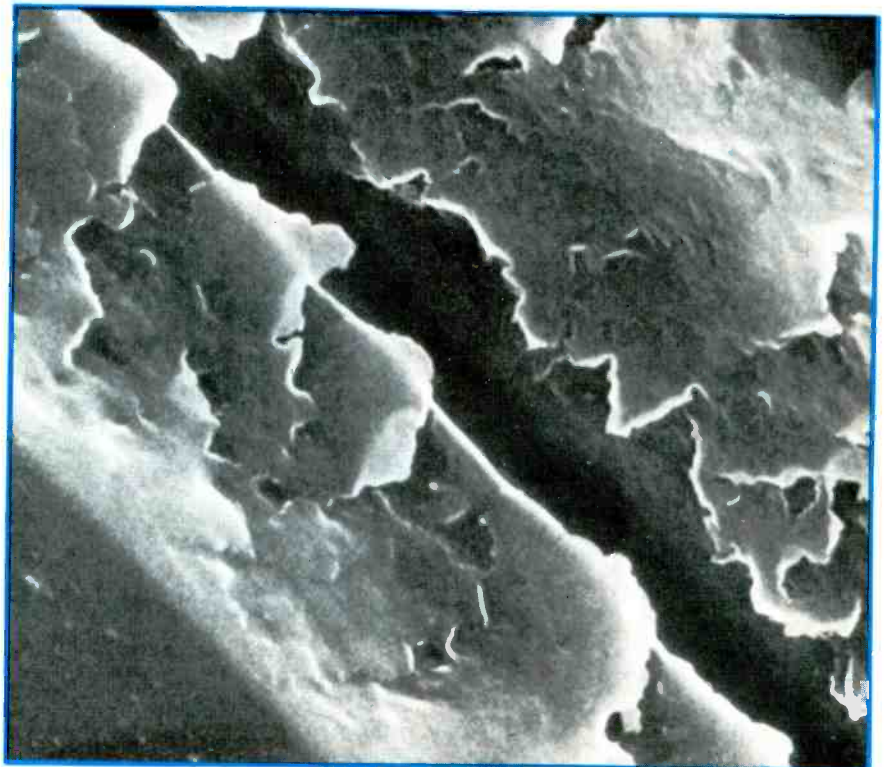

A 45rpm disc shows peeling of the outer shell of polystyrene material after back-cueing 10 times with a spherical tip (magnified 10,000X).

THE REPLACEMENT LINE THAT'S TURNING THE PARTS INDUSTRY UPSIDE DOWN.



When TCG first set out to make a complete line of replacement semiconductors of outstanding quality and value, the big guys tended to look down at us. Now, four successful years later, they're suddenly seeing us from a whole different perspective. In fact TCG now offers more replacement numbers than either G.E. or RCA.

We've grown so fast because we give you more of what you were buying the other manufacturer's parts for. We test our parts extensively on state-of-the-art equipment during every phase of production. That means you get top quality, backed by our full, two-year replacement warranty. And while we already offer one of the industry's most extensive parts lines, we're continuing to add more each year. That's why technicians in the know are turning to TCG's Replacement Master Guide, cross referencing over 210,000 different parts numbers.

Our special, computer-controlled inventory system means that when you decide to replace or design with TCG, you'll always find the part you need on your distributor's shelf. So, look for TCG replacement parts in either polybags or carton packs with device type, rating limits, package diagrams and competitive replacements right on the package.

While it's been a tough year for almost everyone else, thanks to all of you smart technicians it's been the best year ever for TCG.



G.E. is a registered trademark of the General Electric Company.

NEW-TONE ELECTRONICS
TECHNICIAN COMPONENTS GROUP
44 FARRAND STREET
BLOOMFIELD, NJ 07003

**FIND TCG REPLACEMENT PARTS AND THE TCG REPLACEMENT MASTER GUIDE
AT YOUR NEARBY DISTRIBUTOR.**

liquid to other parts of the stylus assembly, especially the elastomer-damper, which is a seal, a pivot and a damper at the same time. Only the stylus tip has to be cleaned. Use a small amount of cleaning liquid by depositing only one drop of it on the top of the stylus cleaning brush. If the liquid gets between the damper and the stylus assembly support surface, the compliance of the stylus may be affected.

What is compliance?

Compliance is a measure of stylus deflection for a given force applied to the tip. We distinguish two forms of compliance: static and dynamic. Static compliance can be determined by observing, through a microscope, deflection of the tip when various amounts of tracking force are applied to the tonearm. The dynamic compliance of the stylus assembly is a measure of stylus deflection when alternating force is applied to the tip. Dynamic compliance can be measured at different frequencies and it will have different values.

The reason we are concerned with compliance is because it is closely related to the tracking ability of the cartridge. The higher the compliance of the cantilever, the easier it is to track low frequency modulation of the groove. But with higher compliance, we also encounter problems of tonearm instability, which is aggravated by warped records. Compliance can be compared to spring action. If you attach a weight or mass to the spring, it will have its own resonance. Vibration of the spring/mass combination is a function of the spring constant (compliance of the stylus) and mass

(tonearm-cartridge assembly).

Selection of the cartridge for a certain tonearm involves matching the compliance of the cartridges so that the resonance of the ready-to-play tonearm will be between 8 and 12Hz. For this we have to know the effective mass of the tonearm.

The reason we want the tonearm to resonate between 8 and 12Hz is because this range of frequencies happens to be just above the region of frequencies produced by record warps and just below the lower end of the audio range. A higher resonant frequency will affect lowest musical notes and may emphasize turntable rumble. Lower frequency resonance will produce tonearm instability when playing warped records.

Electrical properties of the cartridge

Electric current is generated by moving magnetic lines of force through the coil or a single conductor. The electrical parts of the cartridge we are dealing with are realistic components having dc resistance, inductance and capacitance. Coils used in the cartridge have fairly large inductances and dc resistance with interwinding capacitance, as well as capacitance to ground. The current that flows through these coils

is small and the method by which we use this current affects the quality of reproduced sound. The termination of the cartridge is important and the effects of loading begin with the wires attached to the terminal pins of the cartridge. The wire has some inductance, some dc resistance and some interwire capacitance. Inductance and resistance are so small that usually, with the cartridge having 500mH inductance, they can be completely ignored. However, capacitance of the wire may be in the order of 100pF or more, depending on the length and type of the wire. This capacitance across the inductance of the coil and in series with the resistive component of the coil can affect the frequency response of the output signal. If you add all the capacitances of the cartridge terminals (see Figure 1), which includes capacitances, tonearm wiring, interconnecting cables and of the preamp input circuit, including all connectors and switches (switches have capacitance also), you will accumulate a total capacitance of several hundred pF. To be aware of possible problems caused by the excessive capacitive loading, look at the curves taken with a few popular cartridges under different load conditions (Figures 2 and 3), and you will ap-

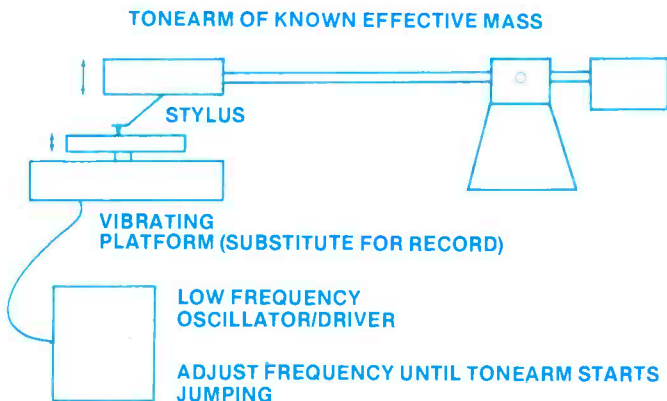

Figure 1. Measuring the compliance of a cartridge.

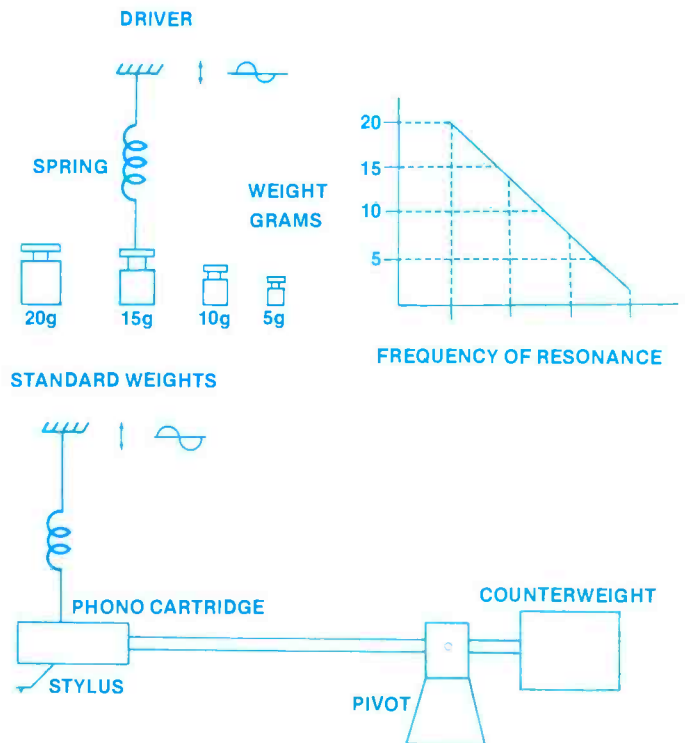
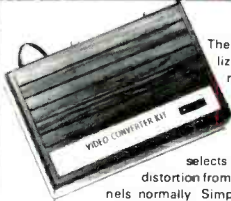

Figure 2. Measuring the effective mass of a tonearm.

SWD-1 VIDEO CONVERTER

FOR CABLE TV



The SWD-1 Video Converter is utilized on cable TV systems to remove the KHz's signal from a distorted video (channel 3 in/out) and also pass thru the normal undistorted/detected audio signal. Rocker switch selects operating mode to remove KHz's distortion from the video or pass all other channels normally. Simple to assemble—less than 30 minutes. Pre-tuned. Input/output Channel 3. Impedance 75 ohms. 117VAC.

SWD-1 Video Converter Kit \$69.95

VTR ACCESSORIES

SIMPLE SIMON VIDEO STABILIZER



Simple Simon Video Stabilizer, Model VS-125, eliminates the vertical roll and jitter from "copy guard" video tapes when playing through large screen projectors or on another VTR. Simple to use, just adjust the lock control for a stable picture. Once the control is set, the tape will play all the way through without further adjustments. Includes 12V power supply.

VS-125 Video Stabilizer, wired Reg. 54.95... **\$39.95**

NEW VCR Quality

MODULATOR



Not a Game Type Modulator

The MPS-1 Kit converts Video/Audio signals to a crystal controlled RF output for TV Channels 3 and 4. The MPS-1 Modulator inputs are designed to match all TV Cameras and VCR's and features a voltage regulated power supply, power switch and LED indicator. No Tuning Required. Operates on 117VAC.

Assembly Time Approximately 5 Minutes

MPS-1 Kit \$39.95

UHF ANTENNAS and ACCESSORIES

MDS-AMATEUR-ETV 32 ELEMENT YAGI ANTENNA



● Not A Kit ● 1.9-2.5 GHz ● 38 1/2" Long
● 23dB Average Gain ● Commercial Grade
● Die Cast Waterproof Housing with 4 1/2" x 2 1/2" Area for Electronics
● Includes P.C. Probe, F-61 Connector and Mounting Hardware

MAE-2 32 Element YAGI Antenna \$23.95

Kato Sons' Down Converter Kit ★ 1.9 - 2.5GHz ★

Designed for Simple Simon by former Japanese CQ Amateur Magazine's UHF Editor/Engineer. Unit utilizes new ingenious Printed Circuit Probe for maximum gain. Circuit board fits inside MAE-2 antenna housing. Requires 1 hour assembly. IC and capacitors pre-soldered.

Model KSDC-KIT 1.9 - 2.5GHz Down Converter Kit \$34.95

Kato Sons' Regulated Variable DC Power Supply

For use with KSDC-KIT 1.9 - 2.5GHz Down Converter. Completely assembled with Attractive Cabinet, TV/Converter Mode Switch, Frequency Control and LED Indicator.

Model KSPS-1A Assembled Power Supply \$23.95

ORDER ALL THREE ITEMS

MAE-2, KSDC-KIT and KSPS-1A for Only. **\$74.95**

Regular price if ordered separately \$82.95

— CO-AX CABLES ARE NOT INCLUDED —

ZYZZX VHF-UHF Wideband Antenna Amplifier

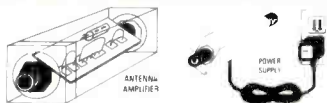

Revolutionary New HYBRID IC Broadband Amplifiers

50 MHz - 900 MHz
Model ALL-1 12dB Gain
Model ALL-2 35dB Gain

These units are not available anywhere else in the world. Each unit will serve many purposes and is available in Kit or Assembled form. Ideal for outdoor or indoor use. I/D impedance is 75 ohms. Amplifiers include separate co-ax feed power supply. Easily assembled in 25 minutes. No coils, capacitors to tune or adjust.

ALL-1 Complete kit w/power supply \$24.95 ALL-1 Wired/Tested w/pwr supply \$34.95

ALL-2 Complete kit w/power supply 34.95 ALL-2 Wired/Tested w/pwr supply 44.95

Our New STVA 14.5dB GAIN, 14 ELEMENT CORNER REFLECTOR YAGI ANTENNA



STVA-3 Yagi Antenna, 14.5dB Gain, Selectable 75 or 300 ohm Channel 60-80 \$19.95

STVA-4 Yagi Antenna, 14.5dB Gain, Selectable 75 or 300 ohm Channel 44-52 \$19.95

RG-59/U 75 ohm Low Loss Coax Cable \$1.2p/ft. F-59 Coax Connector \$.39 ea.

MT-1 Special UHF 75-300 ohm Matching Transformer \$1.45 ea.

Switch to Bambi!™

Electronically

Bambi Electronic Video Switch ... makes switching of your VCR/VTR, Pay TV Decoders, Cable TV, Video Discs, Video Games, Closed Circuit TV, Antennae and Microcomputer as easy as pushing buttons.

The Bambi Electronic Video Switch is an electronic switching network which can accept up to six different sources of video signals and provide the flexibility of directing the inputs to any or all of the three outputs.

Now you can eliminate ... the drudgery of disconnecting and reconnecting your video equipment each time you use it ... the tangled mess of cables which are impossible to trace out ... not being able to use more than one function at a time.

Bambi lets you enjoy using your video equipment the way it should be ... electronically and on line at the push of a button.

Model BEVS-1 Completely Wired and Assembled. Includes comprehensive Instruction/Operation Manual and Decal Set for customizing your Video Switch installation.

\$129.95

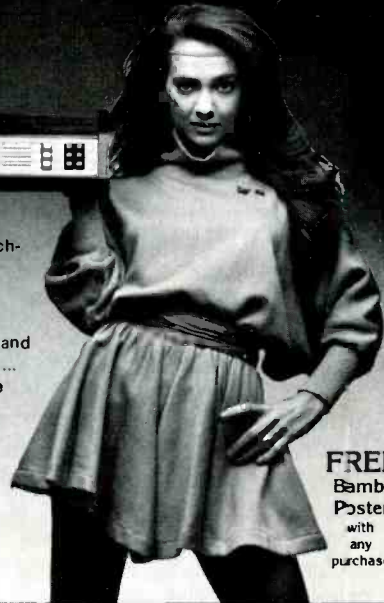

FREE Bambi Poster with any purchase



Bambi's front panel was designed with the user in mind. Computer styled construction, with soft-touch keyboard (rated for over 10 million operations), arranged in matrix form allows easy input/output selection without referring to charts. Functions selected through the keyboard are immediately displayed on the 18 LED status indicators.

Check the quality of Bambi against that of much higher priced competition. All solid state electronic switching provides low attenuation (3dB), wide frequency response (40-890 MHz), and excellent isolation between signal sources (each I/O section individually shielded for 65dB min. isolation).

Bambi's Specifications:

● Input/Output Impedance	75 ohm
● Signal Loss	3dB ±1dB
● Noise	4dB ±1dB
● Input Return Loss	12dB min.
● Isolation	65dB min.
● Power Req.	117VAC 60 Hz, 2W
● Dimensions	10 1/2" W x 6 1/2" D x 3 1/4" H
● Weight	4 1/2 lbs

7+11 PWD PARTS KITS

INTRODUCING OUR 7+11 PWD PARTS KITS



KIT No	PART No	DESCRIPTION	PRICE
1	1VT1-PWD	Varactor UHF Tuner	\$24.95
2	2CB1-PWD	Printed Circuit Board, Pre-drilled	18.95
3	3TP11-PWD	PCB Potentiometers 4-20K, 1-5K, 2-10K, 2-5M, 1-1K, and 1-50k. (11 pieces)	8.95
4	4FR-31-PWD	Resistor Kit, 1/4W, 5% 29-pcs, 1/2 W 2-pcs	4.95
5	5PT1-PWD	Power Transformer, PRI-117VAC, SEC-24VAC at 500ma	9.95
6	6PP2-PWD	Panel Mount Potentiometers and Knobs, 1-1KBT and 1-5KAT with switch	5.95
7	7SS17-PWD	IC's 7-pcs, Diodes 4-pcs, Regulators 2-pcs Transistors 2-pcs, Heat Sinks 2-pcs	29.95
8	8CE14-PWD	Electrolytic Capacitor Kit, 14-pieces	6.95
9	9CC20-PWD	Ceramic Disk Capacitor Kit, 50 WV, 20-pcs	7.95
10	10CTS-PWD	Variable Ceramic Trimmer Capacitor, 5-65pfd, 5-pieces	4.95
11	11L5-PWD	Coil Kit, 18mhs 3-pcs, 22µhs 1-piece (powrround inductors) and 2 T37-12 Ferrite Toroid cores with 6 ft. #26 wire	8.00
12	12ICS-PWD	IC Sockets, Tin inlay, 8 pin 4-pcs, 14 pin 1-pc and 16 pin 2-pcs	2.95
13	13SR-PWD	Enclosure with PM Speaker and Pre-drilled Backpanel for mounting PCB and Ant. Terms	14.95
14	14MISC-PWD	Misc. Parts Kit, Includes Hardware, (6/32, 8/32 Nuts & Bolts), Hookup Wire, Solder, Ant. Terms DPDT Ant. Switch, Fuse, Fuseholder, etc	9.95
15	15MC16-PWD	Mylar Capacitors, 14-pcs and Silver Mica Capacitors 2-pieces	7.95
When Ordering All Items, (1-15), Total Price			159.95



CUSTOMER NOTICE: BUY WITH CONFIDENCE... BEWARE OF LOW QUALITY IMITATORS. All of our kits consist of New, 1st Class, RF Quality, Parts Engineered for Optimum Operation, not factory seconds or stock close-outs. We service your completed kits that you've purchased and built. You will never get stuck with a BAG OF PARTS when ordering from Simple Simon.

SIMPLE SIMON ELECTRONIC KITS,™ Inc.

3871 S. Valley View, Suite 12, Dept. E, Las Vegas, NV 89103

NEED 6 OR MORE OF AN ITEM? WRITE FOR QUANTITY DISCOUNTS
In Nevada Call: **702-871-2892**
1-800-782-3716

Outside Nevada Call:

Available by Mail Order Only
Send Check* or Money Order. Minimum Order: \$16.95. Add 10% Shipping and Handling on orders under \$40.00. For orders over \$40.00, add 5%. Minimum Shipping and Handling \$2.00. Cat. \$1.00 — VISA and Mastercard Acceptable — *Check orders will be held 30 days before shipping.

preciate more the need for proper capacitive loading. A word of advice: Find out the input capacitance of your phono preamp and add the value to the capacitance of cables.

Manufacturers of cartridges usually state what capacitive load the cartridge should be terminated with. The only cartridges that are insensitive to the capacitance loading in the range we are talking about are moving-coil cartridges or low-impedance moving-magnet types. The MC cartridges or MM low-impedance cartridges have very low source impedance, which means small inductance and dc resistance. These cartridges also require additional preamplification because their output voltages are low. Even more important is the selection of proper wires and cables when using low impedance transducers. Because source impedance of the cartridge is low, cable inductance and dc resistance are very much part of the cartridge electrical circuit.

Today for economic reasons, many commercial and consumer cables are manufactured with a so-called wrap-around shield, where thin wire is inductively wound over



A cross-sectional view of an old 78rpm record (magnified 1000X).

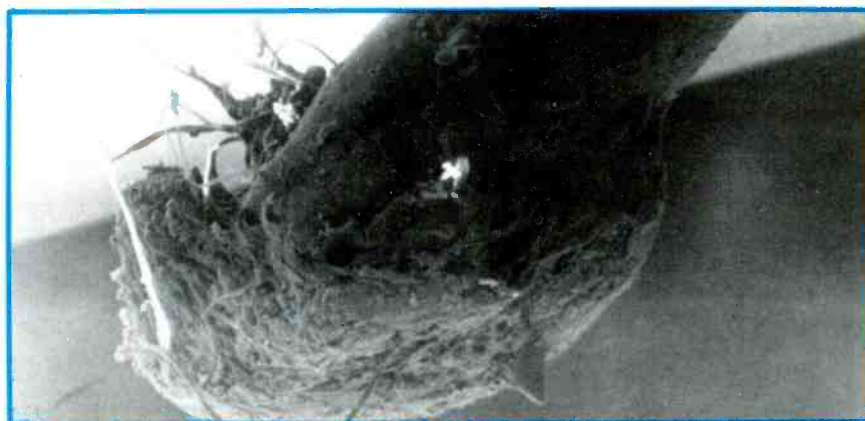

The most probable cause of mistracking of disc groove modulation is dirt (magnified 300X).

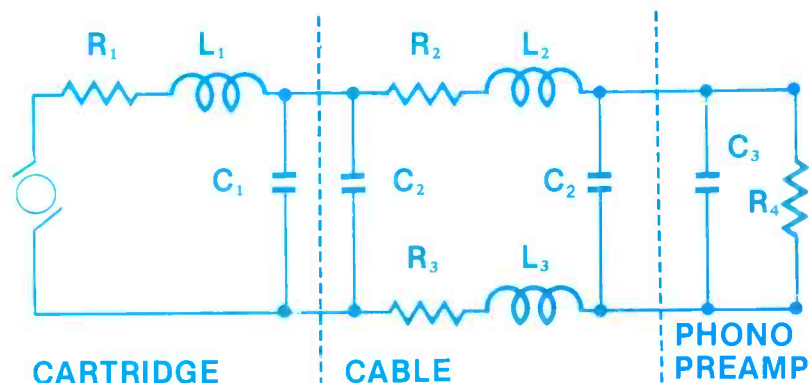

CARTRIDGE
IN MAGNETIC CARTRIDGES
(MOVING MAGNET – HIGH OUTPUT)

$$R_4 > R_1 > (R_2 + R_3)$$

$$C_{LOAD} = C_2 + C_3$$

$$R_1 \cong 1000\Omega$$

$$R_3 + R_2 = 0.1\Omega$$

$$R_4 = 47,000\Omega$$

$$C_1 \cong 50\text{pF}$$

$$C_2 + C_3 \cong 150\text{pF}$$

$$C_3 \cong 50\text{pF}$$

CABLE
MOVING COIL

$$R_1 \cong R_2 + R_3$$

$$L_1 \cong L_2 + L_3$$

$$R_1 = 3\Omega$$

$$R_3 + R_2 = 0.1\Omega$$

$$R_4 = 100\Omega$$

PHONO PREAMP
 $C_1 = \text{NOT IMPORTANT}$

the inner strand insulation. It presents a problem. First of all, such shields are usually only 60%-80% effective. In strong RF fields, they work very well as an antenna coil. Stay away from such cable, and use only woven or foil shields.

Instead of using additional preamplification for MC or MM low Z cartridges, many have elected to use step-up transformers. There is nothing wrong with it, unless we forget that the more you step up this minute voltage, the more sensitive the secondary of the transformer becomes to resistive and capacitive loading. It is better to get a high output ordinary cartridge that does not require additional amplification.

A lot has been said, and much more is left to be discussed. Disc recording has been most forgiving to us. If we would treat the disc the same way we care for tape, video, telephones and transmitters, there would be no talk about disc obsolescence.

ES&T

Figure 3. Distribution of the reactive elements in a phonograph system.

Three New Simpson 3½ Digit DMMs! FOR THE MAN ON THE JOB...

Professional-grade instruments have: continuity beeper, diode test, transient protection and double fusing. UL Recognized test leads and a full line of optional accessories.

The 470™ is our new low-cost, full-function, hand-held DMM with 25 ranges, 1.5% basic accuracy, thumbwheel knobs, and a 2-way fold-out stand. The 467E hand-portable DMM has peak hold, true RMS and 26 ranges. The 360 Series 3 digital VOM (with world famous 260® styling) has 28 ranges, bright LED display, rechargeable batteries.

These 3 new DMMs will join the family of 29 other UL Listed Simpson Instruments... available at leading electrical/electronics distributors worldwide.

Multichannel TV sound report published by EIA

The Electronic Industries Association (EIA) Multichannel Sound Subcommittee has announced the publication of its report.

This comprehensive technical report is considered necessary in reaching a decision regarding transmission standards for multichannel television sound. The Electronic Industries Association of Japan (EIAJ), Telesonics Systems and Zenith Radio Corporation have demonstrated viable systems capable of transmitting stereo, a separate audio program and an auxiliary service multiplexed on the aural carrier.

The 2-volume report represents more than three years' effort. Volume 1 contains the basic information, and Volume 2 contains the test data, studies and background information. Complimentary copies of Volume 1 are available to interested parties with instructions for obtaining Volume 2. Requests for Volume 1 should be addressed to Eb Tingley, Staff Vice President/Engineering, Consumer Electronics Group, 2001 Eye St. N.W., Washington, DC 20006.

Personal datacom outstrips personal computer growth

Modems and software for personal computers now represent the fastest-growing segment of the personal computer market, according to a new report from International Resource Development, a Norwalk, CT, market-research firm. The 112-page report, based upon recent telephone surveys of microcomputer users and vendors, predicts continued, rapid growth, with year-to-year sales increases jumping more than 60% for each of the next five years.

ES&T

Simpson
INSTRUMENTS THAT STAY ACCURATE

SIMPSON ELECTRIC COMPANY
A Katy Industries Subsidiary
853 Dundee Avenue, Elgin, IL 60120
(312) 697-2260
Telex 72-2416
Cable SIMELCO

470
147.0
POWER OFF ON
V mA kΩ
1000^{OHM} 2000 20MΩ
750^{OHM} 200 200
200 20 20
20 10A 20
2 2 J 2
200mV 200Ω
DCV
ACV
DC
AC
kΩ
10A mA 100mA COM

360 Series 3
-1563
SIMPSON 260-3
ALL TERMINALS 100V P.P.P.
MANUFACTURED ALL IN U.S.A.
\$275

467E
Simpson model 467E
-1999
TRUE RMS DIGITAL MULTIMETER
200V 2V 20V 200V 500V
100Ω 1kΩ 10kΩ 100kΩ 1MΩ
\$225

470™
\$139

Free, free, free...



Hurry, hurry, step right up! It's RCA's Carnival of Awards. And what a lineup of acts. First, the headliners: RCA receiving tubes, very popular with TV technicians for their top performance and dependability.

Plus, a stupendous carnival of valuable awards. Shown here are just a few of the 21 great gifts waiting for you. To earn them, just purchase RCA receiving tubes in required quantities from your participating RCA distributor. Each purchase helps qualify you for the award of your choice. See your participating RCA distributor for details. And come one, come all to RCA's Carnival of Awards!

Readers' Exchange

Needed: Horizontal output transformer for MGA 14in color portable, #TP 140. *D. Cooper, 2678 Haring St., Brooklyn, NY 11235; 1-212-648-1264.*

Needed: Horizontal output transformer in good condition for RCA color television, CTC 31A 906224-501-RCA or TM# Fly312. *Jiraneck TV, Farmington, IA 52626.*

Needed: Schematic, parts list and alignment instructions for TV field strength meter, model A-460, made by Approved Electronic Instrument Company. *George W. Davenport, Box 204, Trenton, NC 28585; 1-919-448-4561.*

Needed: EICO grid DIP meter, model 710, in excellent condition. *Lenwood Williams, P.O. Box 326, Brunswick, NC 28424.*

Needed: Schematic for a Sears television, model #528.44751406 (about eight years old). *Jack W.*

Spitler, 558 Bucyrus Nevada Road, Bucyrus, OH 44820.

Needed: Manual and charts for Boes-Dayton model 214 tube tester and manual for Boes-Dayton model 416 signal generator. *D.P. Urban, 36 Spring St., Port Henry, NY 12974.*

Needed: Schematics for Panasonic AM/FM tape unit, model #RS-281-S and Kenwood AM/FM tuner amp, model Eleven II. *R. W. Ferus, 11311 Irvington, Warren, WI 48093.*

Needed: Schematic or other servicing information for Lindsay JET-1 CATV converter. Also need information on compensating for the Channel 5 and 6 frequency offsets used in the HRC system. *Jeff Phillipson, 33640 Ave. C, Yucaipa, CA 92399.*

Needed: Sencore VA48 TV analyzer. Will pay up to \$700 plus shipping for fully operational and complete tester. *Briggs Electronics 724 E. Las Palmas Drive, Fullerton, CA 92635; 1-714-526-3129.*

Needed: Audio transformer, Stancor part #A-3849 or Merit part #A-2930; filter choke, Stancor #C-2325 or Merit #C-2994; and yoke for SAMPO model 69112BW b&w chassis #MR-12B. *August Aubert, Sunset TV, Box 700, Connell, WA 99326.*

Needed: Service manual and operating manual for

with your purchase of **RCA Receiving Tubes!**



CG7170
RAY-O-VAC "Magnum"
5-Function Light
Value: \$27.45



CG7178
Waring
Ice Cream Parlor
Value: \$44.99

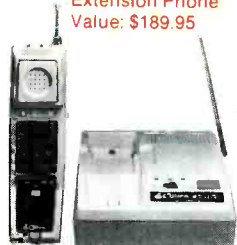

CG7163
Cobra Cordless
Extension Phone
Value: \$189.95

CG7164
Wittnauer "Saturn"
Man's Quartz Watch
Value: \$175.00



CG7169
Skil Cordless
Screwdriver
Value: \$39.99



CG7162
Canon Palm-sized
Printing Calculator
Value: \$64.95



CG7168
Skil Double Insulated
7 1/4" Power Saw
Value: \$65.99

CG7167
American Tourister
13 Inch Attache Case
Value: \$56.00



CG7180
London Fog
Man's Raincoat
Value: \$150.00

RCA Receiving Tubes

RCA Distributor and Special Products Division, Deptford, NJ 08096

Grundig tape recorder, model TK23A. *J. E. Humphrey, 1006 E. 28th St., Los Angeles, CA 90011.*

For sale: B&K model 1077 TV analyst, \$225. *John Gjerdevig, 507 10th Ave. East, West Fargo, ND 58078.*

For sale: Philco VHF-to-VHF signal generator-adaptor, \$15; Du Kane Recordermaster, model 14A 225, \$20, plus postage. *Kenneth Miller, 10027 Calvin St., Pittsburgh, PA 15235.*

For sale: About 25 old Sams Photofacts from the early 1950s, and a mint Hammarlund RJ274C (SP600) all-brand SW receiver, \$150. *Chris Hood, P.O. Box 44110, Crafton, PA 15205; 1-412-921-4357.*

For sale: REM cathode recovery unit, \$90; model TF-26 Sencore Cricket with manual and parts list, \$95; and model 1076 B&K TV analyst, \$50, plus shipping UPS. *Clarence McGinnis, P.O. Box 601, Morristown, TN 37814.*

For sale: New remote-control transmitter for use with Sharp television, model 19A83, never used. *J. M. Thurston, 5738 U.S. 33, North, Fort Wayne, IN 46818.*

For sale: B&K TV analyst, model 107, excellent, complete with manual, \$220. *G. Barzily, 84-39 120 St., Jamaica, NY 11415.*

For sale: Tektronix 547 50MHz, dual-trace scope, \$595; HP330B distortion analyzer, \$195; miscellaneous lab-quality test equipment. Send SASE for list. *Gerald Shirley, 133 Sagamore Road, Tuckahoe, NY 10707.*

For sale: Approximately 375 various radio and TV tubes, new and used, all operable. Send SASE for listing. *D. F. Roberts, 2138 Salamanga Drive, Port Richey, FL 33548.*

For sale: Sencore CB49 portable analog CB analyzer, never used, box with book, \$400; Sencore CB42 digital CB analyzer, just overhauled at factory, complete with cables, \$600; deluxe mutual conductance tube tester by Seco, \$65. *A&B Electric, Joseph Silver, 1883 E. Main St., Rochester, NY 14609.*

For sale: Sencore model TR139 transistor tester, \$35; 2-meter, 40W amplifier, \$40; Heathkit IM4190 bidirectional inline RF wattmeter, \$85. *Steve Halvorson, 100 W. 96th St., Apt. 2G, Bloomington, MN 55421; 1-612-884-5538 (home) or 1-612-445-2969 (work).*

For sale: Will sell for \$150 or trade for B&K test equipment one Wilcox-Gay model #A-911 upright record maker and player with AM radio plus crystal microphone and approximately 300 new needles. Write or phone for more information. *Frank E.*

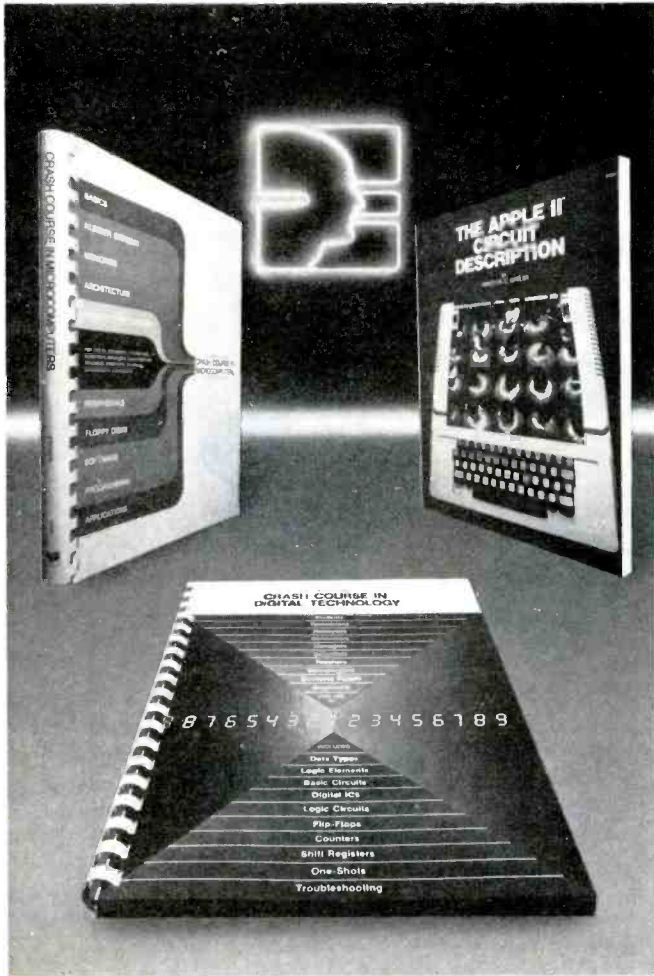

SAMS COMPUTER UPDATE

Here's news for computer technicians. Sams' library of computer books can help you keep up-to-date on the latest in computer servicing and technology. Some recent examples are:

THE APPLE II® CIRCUIT DESCRIPTION which provides a detailed circuit description of the Apple II motherboard. No. 21959, \$22.95. (tentative)

HOWARD W. SAMS CRASH COURSE IN DIGITAL TECHNOLOGY is the most up-to-date digital book on the market today. It covers all the necessary fundamentals, components, ICs and techniques of digital technology. No. 21845, \$20.95. (tentative)

HOWARD W. SAMS CRASH COURSE IN MICROCOMPUTERS covers software, programming, peripherals and other important microcomputer fundamentals to help you learn the complete microcomputer system. No. 21634, \$19.95.

To order these Sams Books, contact your local electronics distributor. Or call 800-428-3696 toll-free, or 317-298-5566 and reference AD295.

HOWARD W. SAMS & CO., INC.
4300 West 62nd Street, P.O. Box 7092
Indianapolis, IN 46206

Apple II is a registered trademark of Apple Computers, Inc. Offer good in USA only and expires 7/31/83. Prices subject to change without notice. In Canada, contact Lenbrook Industries, Ltd., Scarborough, Ontario.

Circle (11) on Reply Card

Myers, 227 N. William, York, PA 17404;
1-717-792-0002.

For sale: B&K model 415 sweep and marker generator, complete with cables and instruction book; like new; sacrifice at \$160. *Emil Di Giulio, P.O. Box 481, Sonoma, CA 95476.*

For sale: Conar 682 pattern generator, like new; Radio Shack dual tracking/independent power supply, 0-20V, 1A; Conar 255 triggered scope, good for parts. Make offer; all must go. *Ron's TV & Stereo, Box 365, Highland, KS 66035; 1-913-442-5580.*

For sale: Dentron model MLA-2500 linear amplifier, \$700; RCA master color bar generator, type 515A, \$100; Mercury model 1000 dynamic transconductance tube tester, \$50. *William Shevtchuk, 1 Lois Ave., Clifton, NJ 07014; 1-201-471-3798.*

For sale: B&K 415 sweep generator with cables and book, \$175; RCA W091B 5in scope, \$75 or trade for CRT checker; Sams 1000 and up. *Joe's Repair, 60835 N. Hwy. 50, Montrose, CA 81401.*

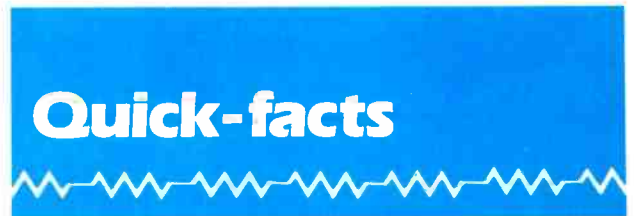

These Quickfacts volumes for TV receivers have been released by Howard W. Sams & Company.

GENERAL ELECTRIC
Chassis AA through YM Vol. 1, Sept. 1982

MAGNAVOX
Chassis T809 through T998, 13C1,
1302 Vol. 1, May 1982

RCA
Chassis CTC68 through CTC91 Vol. 1, July 1982
Chassis CTC92 through CTC108 Vol. 2, July 1982

SEARS
Models:
363.50000400 through 363.50070400
528.40590300 through 528.51330114
562.40320800 through 562.42280801
564.40360800 through 564.54300051 . . Vol. 1, Nov. 1982

SONY
Models:
KP-4000 through KP-7220
KV-1200U through KV-9000U Vol. 1, Feb. 1983

SYLVANIA
Chassis D14 through E32 Vol. 1, Dec. 1982

ZENITH
Chassis 9FB1X through 25JC55Z Vol. 1, April 1982

Photofacts

These Photofacts for TV receivers have been released by Howard W. Sams & Company since the last report in ES&T.

EMERSON

EC-130 2141-1
ECE-200 2147-1

JC PENNEY

685-2008G,-20/053G,-10 2140-1
685-1034G,-30 2143-1
685-2039-00 2145-1
685-2043-00 2148-1
685-1518,-00 2149-1
685-4015,-00,-10/16,-00,-10 2150-1
685-2034,-00,-10 2151-1

KMC

KMB-1221G 2144-1
1921G 2146-1

PHILCO

Chassis E32-A 2142-1

RCA

Chassis CTC115A 2149-2

SANYO

Chassis A4S-40000 2138-1
Chassis A2V-62000 2139-1
Chassis A4A-30N00/0000 2142-2
Chassis A2V-53000 2145-2
Chassis A2M-51000/52000 2148-2
Chassis A4S-47000 2151-2

SHARP

19G79 2150-2

SONY

Chassis SCC-406D-A 2147-2

TOSHIBA

TAC8101/150 2140-2

WARDS

GGV-12924A,B,C,D/934A,B,C/954A,B 2138-2
GEN-11212A/222A/232A 2149-3

ZENITH

Y1310A,PT/318W/322W/382W 2139-2
SY1927W 2141-2
S1904C, Y1908W/918W/926W/990W1 2143-2
Y2500W,W2/504E,E2/506M,M2/508P,P2/410PN,
PN2/512E,E2/514PN,PN2/516E,E2/518E,E2/584P,
P2 2144-2
SY2501W,W2/513E,E2/515PN,PN2/517E,E2/519E,
E2 2146-2

**DESOLDER-IT,
CLEAN-IT, COAT-IT,
FREEZ-IT...SEND FOR IT!**

Our new electronic problem solving catalog
and Free Chem-Wik[®] samplers!



Chemtronics
681 Old Willets Path
Hauppauge, NY 11788
800-645-3244
In NY 516-922-3322
Telex 964567

Circle (13) on Reply Card

MOVING?

If you're planning a move in the near future, don't risk missing an issue of Electronic Servicing & Technology. Please give us 6-8 weeks notice if you're planning on changing your address. Just write in your new address below and mail this coupon, WITH YOUR SUBSCRIPTION MAILING LABEL, to:

ELECTRONIC
Servicing & Technology

P.O. Box 12901, Overland Park, KS 66212

For address change you MUST affix label from cover here. Print new address below.

Name _____

Address _____

City _____

State _____ Zip _____

A technician's ability to produce depends upon his flexibility. It also depends, to a certain degree, upon his ability to empirically find the best and quickest method of repair for the unit being serviced. This may not be the one endorsed by the manufacturer, time or common technical opinion. In fact, the master tech must be an iconoclast, a "myth breaker."

The dictionary defines *myth* as "any fictitious story, or unscientific account, theory, belief, etc." In our business, these myths arise from several sources. One is the misapplication of theory. Another is some of the service information provided by equipment manufacturers, whose mindset is more attuned to the needs of mass production than to the repair of an individual unit. Many service procedures are written for the factory technician who works repetitively on the same make of unit, unlike the independent who may service scores of different brands and types of devices.

For most of the myths in this article, I'm sure there's another side to the story. But if this article prompts you to review some of your service procedures and streamline them a bit, it will have been worth the effort.

My point of view will be that of utility. The desired result of a service operation is to produce a properly operating unit in the minimum length of time. Theoretical considerations, while interesting, must take a back seat to practicality. This is not to say that a theoretical background is not necessary. It is. But you need not examine the foundation of a building every time you change a storm window. An intuitive feel for how equipment behaves in the field is frequently more useful than a knowledge of ideal models. Rules of thumb often give us better service on a day-to-day basis than textbook theory.

The myths that follow have been derived from my own 10 years of experience on the audio service bench, from talking to other technicians, and from being obliged to repair previously mis-serviced units.

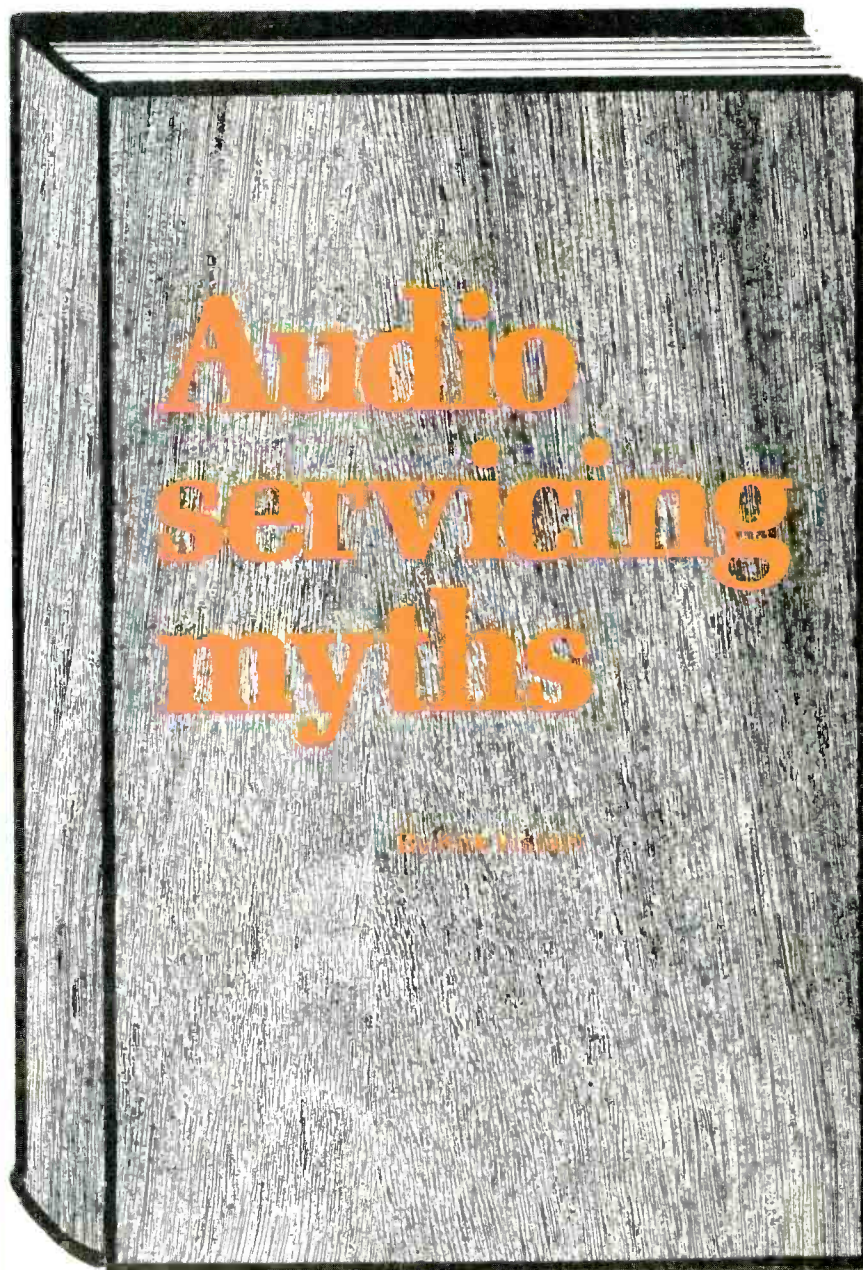

Myth

Never run an amp to full power on the bench. If you run an amp or receiver to full power for more than a few seconds, damage will result.

This myth goes back to the old days of audio, before the FTC Power Rule of 1974. At that time, a war was being waged on

specification sheets. Many marginal designs with germanium output transistors rated at 500mW boasted 120W P-P power ratings. Heat sinking was inadequate in many designs.

Customer and industry complaints brought the government into the fray. The FTC, after a period of open debate, promul-

gated a rule that specified how the manufacturers could advertise power, and what test methods were to be employed. Basically, the rule calls for a preconditioning period of one hour, during which the amp is driven to one-third rated power with a 1kHz sinewave.

Then the power output at rated distortion is measured at representative frequencies within the rated power band. The rule also requires that each unit be run full power for five minutes, at the frequency of interest, before the THD measurement can be taken. After an understandable period of grumbling, manufacturers beefed up designs and made power specifications more reasonable.

Most manufacturers specify performance in a 20Hz to 20kHz range; this means that the output subsection of an amp or receiver must be able to deliver full power for at least five minutes, at 20kHz. This is a grueling test for a device, because as frequency increases, the output transistors have less time to "rest" between peaks. If an amp can take this, a full power

1kHz test after repair is a breeze. I feel that if you don't test an amp at full power, you really can't be sure whether your repair has been successful.

Myth 2

Audio repair requires you to use a special reactive load to simulate a speaker during tests.

The standard load specified by the FTC rule and used by most audio servicers is an 8Ω, noninductive resistor, such as a Dale RH 250. The idea that some sort of reactance must be placed across the load resistor to simulate a speaker is interesting, but not common practice. Different model and manufacture speakers will probably depart as much from some idealized "dummy speaker" as they will from a resistive load.

The Institute of High Fidelity's "Standard Methods of Measurement for Audio Amplifiers," IHF A202, 1978, states in section 2.5.1 on standard test conditions, "Each channel of a power amplifier shall be terminated with a resistive load as specified by the manufacturer. The resistor shall have not more

than 10% reactive component at any frequency up to five times the highest test frequency..."

The IHF does specify a reactive load for one specific power test, but it is not one in common use in R&D, not to mention in servicing.

Myth 3

You must have a distortion analyzer to do competent audio servicing.

Although handy, on occasion, a distortion analyzer's most important function is in helping a shop get warranty station certification. Ask anyone who has worked on audio equipment for more than a few years, and he will tell you that the types of failure that occur usually result in gross distortions that can easily be seen on an oscilloscope. Crossover distortion, resulting from trouble or misadjustment in the bias circuit, is about the only amp problem that results in small deviations from spec. It can be observed on a scope by feeding a 10kHz sinewave to the amp, adjusting for an output power of 250mW, and increasing the vertical gain control on the

JAPANESE SEMICONDUCTORS

SANYO
STK-435

\$4.10



SANYO
STK-437

\$6.50



ZENER DIODE KIT
ZDK-23

Most popular zener diodes in kit of 23

Plastic Cabinet

\$11.95



SANYO



2SC1308K

\$1.99

TOSHIBA



2SC1172B

\$1.99

TRANSISTORS	A808 3 18	6697 3 23	C789 1 20	C1212A 5R	C1959 30	D470A 2 51	HA1138 1 36	STK0029 3 88	TA7222AP 1 87	UPC1185H 3 11
	A840 1 44	2SC352A 2 73	C799 1 50	C1213 18	C1973 61	D471 25	HA1151 1 62	STK0050 5 87	TA7227PK 4 04	UPC1186H 1 56
	A908 10 47	C371 32	C829 14	C1215 28	C2028 58	D525 90	HA1156W 1 26	STK0080 10 60	TA7310P 1 02	UPC2002 1 43
	A839 1 54	25922 25	C380A 14	C1235 40	C2039 153	D526 81	HA1196 1 36	STK013 7 70	TC4081P 5 8	UPC14305 1 74
	A90 81	B75 28	C381 28	C839 2 71	C1238 1 50	D1279 40	HA1197 1 28	STK015 3 20	TC5080P 5 42	UPD857 6 50
	A495 16	B173 32	C382 40	C840 1 62	C1306 97	D266A 1 10	HA1199 1 43	STK032 7 65	TC5081P 2 19	UPD858 6 50
	A496 45	B202 0 04	C383 46	C867A 2 80	C1307 1 72	D272 65	HA1201 7 6	STK040 7 42	TC5082P 2 19	UPD861C 5 87
	A509 36	B220 1 00	C387A 34	C895 5 09	C1308K 1 99	D92 1 66	HA1202 9 4	STK043 8 80	UHI001 4 07	
	A545 41	B257 32	C388A 52	C900 20	C1316 3 40	D93 1 72	HA1306W 2 08	STK078 7 75	UHI003 4 07	
	A806 1 99	B303 32	C394 18	C941 25	C1318 18	D187 2 51	HA1309 1 62	STK080 7 85	UHI004 4 07	DIODES
	A607 1 58	B324 36	C458 14	C945 11	C1320 53	D823 84	HA1339A 1 84	STK430 5 50	UHI005 4 07	GD3F 89
	A626 3 66	B367 1 85	C466 1 09	C959 1 17	C1345 16	D187 2 51	HA1342A 1 84	STK435 4 10	UPC157A 2 19	SID3015 1 39
	A627 2 03	B407 1 22	C495 52	C960 1 10	C1346 43	D201 2 49	HA1366W 1 89	STK439 6 80	UPC554C 2 15	IN60 14/100
	A634 64	B426 1 22	C496 45	C1012 1 36	C1354 29	D226A 1 43	HA1366W 1 89	STK439 6 80	UPC555H 4 5	IN6001 10/100
	A661 36	B449 1 72	C497 1 56	C1025 90	C1383 27	D237A 82	HA1366WVR 1 89	STK463 9 65	UPC571C 2 44	IN6004 12/100
	A662 50	B474 1 12	C509 32	C1034 5 80	C1384 29	D238 2 97	HA1366WVR 1 89	STK503 7 50	UPC572C 2 44	IN6005 15/100
	A664 32	B507 60	C517 4 40	C1040 1 10	C1403A 3 21	D238 2 97	HA1377 2 93	STK502 7 50	UPC575C 1 10	IN6006 18/100
	A699A 64	B509 2 15	C537 1 6	C1050 1 71	C1413A 4 97	D313 45	HA1398 4 22	TA7055P 1 99	UPC577H 72	SILICONE
	A705 58	B511 64	C563 63	C1051 56	C1419 56	D315 1 02	HA1398 4 22	TA7055P 1 99	UPC577H 72	2.5 Amp-1000 Volts
	A706 1 28	B528 66	C627 1 28	C1096 40	C1448 1 20	D325 82	HA1398 4 22	TA7055P 1 99	UPC577H 72	SL 100 10/100
	A719 20	B529 66	C642A 3 86	C1114 3 45	C1567A 56	D325 82	HA1398 4 22	TA7055P 1 99	UPC577H 72	
	A722 20	B536 90	C696 1 36	C1115 4 06	C1664A 2 00	D357 61	HA1398 4 22	TA7055P 1 99	UPC577H 72	
	A738 43	B537 90	C706 1 51	C1168A 4 13	C1188A 4 13	D358 66	HA1398 4 22	TA7055P 1 99	UPC577H 72	
	A740 2 35	B541 2 77	C710 1 6	C1124 99	C1676 1 05	D381 76	HA1398 4 22	TA7055P 1 99	UPC577H 72	
	A745A 6 64	B555 3 09	C732 14	C1127 90	C1728 81	D386A 79	HA1398 4 22	TA7055P 1 99	UPC577H 72	
	A747 7 62	B556 3 35	C733 14	C1181 1 95	C1760 82	D424 3 03	HA1398 4 22	TA7055P 1 99	UPC577H 72	
	A747A 7 50	B557 2 93	C735 28	C1166 50	C1815 11	D425 3 03	HA1398 4 22	TA7055P 1 99	UPC577H 72	
	A748 92	B561 1 8	C756A 1 40	C1169 5 69	C1815 2 26	D426 2 89	HA1398 4 22	TA7055P 1 99	UPC577H 72	
	A750 14	B595 1 24	C781 1 99	C1204 3 6	C1904 36	D436 34	HA1398 4 22	TA7055P 1 99	UPC577H 72	
	A762 4 15	B617A 1 36	C784 28	C1173 52	C1904 36	D467 16	HA1398 4 22	TA7055P 1 99	UPC577H 72	
	A771 2 08	B656A 3 84	C785 28	C1209 28	C1951 1 44	D468 16	HA1398 4 22	TA7055P 1 99	UPC577H 72	

OMNITRON

ELECTRONICS
770 Amsterdam Ave., New York, NY 10025

► Also ask for Free 100 Page Catalog ◀

Send Purchase Order, Check or Money Order
or Call Toll Free **800-223-0826**
in NY STATE (212) 865-5580
ALL ORDERS SHIPPED UPS/COD F.O.B., N.Y.C.

MASTER CARD • VISA

Circle (14) on Reply Card

scope to the point where the zero crossing point of the output waveform can be observed. A relatively clean (less than 1% THD) sinewave generator is adequate for most applications.

Myth 4

Head adjustment is required whenever you service an audiotape deck.

It seems that every time a tape recorder coughs, some neophyte jumps in with a screwdriver and tweaks the heads. To make matters worse, many customers will give as a complaint, "It doesn't sound right. I think the head or something needs adjustment."

About the only time you really need to adjust the heads on reel-to-reel machines is if a beginner gets to it before you, or if heads are replaced. Just look at the adjustment screws and see if the lock paint has been broken. If not, and assuming the machine has given satisfactory service up until now, the heads were properly adjusted at the factory. On reel-to-reel machines of any consequence, head adjustments do not drift with time.

Check to see that the wear pattern is rectangular. If it is trapezoidal or varies much from head to head, you can assume they have been misadjusted. You might want to leave well enough alone, especially if the owner's complaint is unrelated, because the real cure for this problem is complete head replacement, which is expensive and time consuming. Readjusting improperly worn heads usually results in tape travel and skewing problems.

As a rule, cassette recorders do not require regular head readjustment either. In a few cases, rough use will misalign the heads, but this is quite rare. Most of the heads I've realigned had been "adjusted" by the owner or a previous technician. If sound quality and frequency response are satisfactory, leave the heads alone.

Myth 5

Save the customer some money by only replacing the defective transistor in an output pair.

This myth arises from the understandable desire to replace only the defective part, coupled with the need to repair a unit as

quickly and cheaply as possible. In practice, however, the result is often a mismatch in the output subsection, which can lead to performance degradation, spurious oscillation and other trouble. The worst example of this is the substitution of one transistor with a universal replacement. Most high-fidelity equipment is Oriental, and JIS standard semiconductors do not mix well with the universals. The right way to go is to replace both devices in the pair, preferably with paired OEM devices. Many suppliers now offer Japanese transistors at attractive prices, so the use of universals seems pointless.

Another factor to consider is that a C-E short in one output device (a common trouble) could cause the absolute maximum (ABSMAX) ratings of the other to be exceeded. Although this usually causes total failure of the transistor, occasionally the device will check good but its ABSMAX performance will have been lowered. Unreliability is the result.

It also helps to learn how to read and understand transistor spec sheets, because substitution manuals from both sides of the Pacific tend to be unreliable for audio use.

The adjustments on solid-state receivers do not drift with time. Only in rare cases will alignment improve reception significantly.

Myth 6

The best fix for FM trouble is alignment.

I see plenty of units that had been "aligned" when the only defect in the IF strip was a bad IC

or transistor. It amazes me how often this happens. The best advice for FM servicing is, *Don't mess with the alignment until you've fixed the unit.* The adjustments on solid-state radio receivers do not drift with time. Only in rare cases will an alignment improve performance significantly, such as when the unit comes misaligned from the factory.

A receiver rated at $2\mu\text{V}$ sensitivity, which comes in at 3 or 4 in a test, may be improved by a touch-up alignment, although the customer is unlikely to notice the difference. But if you're seeing $25\mu\text{V}$ or $50\mu\text{V}$ sensitivity or worse, a part is defective. (Assuming, of course, somebody hasn't messed things up previously.)

Myth 7

Dial scale alignment on FM stereo receivers should be done electrically, using the local oscillator (LO) trim capacitor and coil.

It would be amusing, if time were cheap, to watch a new tech, fresh out of vocational school, trying to get the dial scale to read the correct frequency from one end to the other by twiddling the LO adjustments. The textbooks, as well as the manufacturers' service info, will often tell you to follow this procedure, but from my experience, it is usually bad advice.

Nine out of 10 units that come in with a complaint of inaccurate tuning have a linear error. This means that the tuning is off by the same amount from one end of the scale to the other. If this is the case, the oscillator adjustments are correct. The cure is to adjust the pointer, which takes about two minutes. This can be done either by moving the pointer along the dial string or by loosening and adjusting the pulley on the tuning capacitor.

Your best calibration is the signal from local radio stations. Try to find one each near 90, 98 and 106MHz. You must keep in mind, however, that most stations advertise a rounded-off frequency, so FM98 might actually be broadcasting at 97.9MHz. Call the engineering staff if you need the exact allocation.

If you're sure of the calibration of your FM generator, you can use that, but I've seen plenty of them come back from the calibrator with

2MHz errors. A broadcast station is more stable and reliable.

Myth 8

Once you've replaced the defective components in an audio power amp, you're finished.

Replacement is the first stage of the repair process. It is now necessary to assure that idle bias and offset are properly adjusted. Carl Babcoke covered this subject well in the April 1982 issue of **ES&T** (page 13-14). I would only add two suggestions. The offset adjustment should be made with standard 8Ω dummy loads connected across the speaker terminals. Secondly, if you encounter an older amp, with capacitor or transformer coupling, you have to adjust balance instead of offset. I prefer to do this dynamically, by running the amp just to clipping at 1kHz, while adjusting for best symmetry. Static methods, in which balance is adjusted to obtain equal voltage drops across each output device of a pair, are generally inadequate under dynamic, i.e., normal, conditions.

Myth 9

Clear silicone grease is a good heat sink compound.

Even some manufacturers fall prey to this one. Clear silicone grease is best suited to light-duty lubrication of sliding surfaces or rubber parts, or the protection of battery terminals. The better heat sink compounds have some sort of metal oxide in them to boost heat transfer. GC's Z-9 product, which is composed of zinc oxide in a silicone grease base, will help keep down the operating temperature of heat-sinked transistors, thus enhancing reliability.

Myth 10

Logical troubleshooting procedures will always lead you to the cause of trouble.

I don't know how many of you will admit it, but while we all wish this were true, it isn't. Logic, like a computer, is simply a tool. If your "facts" are inaccurate, or inadequate, your logical conclusions will also be. There are some repairs for which you simply can't get all the facts to make a logical decision.

You must rely on your experience and intuition. Don't feel guilty about it. An intuitive approach, coupled with a solid theoretical and experiential background, often yields the highest production. Of course, rigid adherence to any one troubleshooting system is also counterproductive.

Myth 11

A unit should always be returned to the customer minus a few screws.

This one is seldom discussed, but almost universally followed. All I have to say is that modern technological revolutions in the processing of plastic have made cheap containers, such as boxes and bags, within easy reach of any service department's budget. Why not use them to hold the hardware during repair? A customer who notices missing fasteners (and don't think he won't) probably wonders what else you forgot!

I hope you've enjoyed this treatment of audio servicing myths; some of you have other ones to contribute. If so, write me in care of **ES&T**.

ES&T

OPTIMA ELECTRONICS

TO ORDER CALL TOLL FREE 1-800-327-0224

G.E., SYLVANIA, ZENITH, RCA, 75% OFF LIST NEW-BOXED

<input type="checkbox"/> 3A3	5 FOR \$15.75	<input type="checkbox"/> 6LF6	5 FOR \$34.44
<input type="checkbox"/> 6MJ6	5 FOR \$34.88	<input type="checkbox"/> 6LB6	5 FOR \$31.50
<input type="checkbox"/> 6JE6	5 FOR \$32.75	<input type="checkbox"/> 6CJ3	5 FOR \$14.69
<input type="checkbox"/> 3DJ3	5 FOR \$17.44	<input type="checkbox"/> 6JS6	5 FOR \$29.00
<input type="checkbox"/> 6GH8	5 FOR \$12.44	<input type="checkbox"/> 6BL8	5 FOR \$12.25

All Tubes Not Advertised, Write in at 75% Off List.
Sleeves Only. Singles 72% Off List

HORIZONTAL OUTPUT TRANSISTORS ECG REPLACEMENT TRIPLERS

<input type="checkbox"/> RKS1172B	<input type="checkbox"/> RKS238	<input type="checkbox"/> 500A .. \$11.50	<input type="checkbox"/> 526A .. \$14.95
<input type="checkbox"/> RKS1308K	<input type="checkbox"/> RKS165	<input type="checkbox"/> 523 .. \$13.50	<input type="checkbox"/> 529 .. \$15.50

TRANSISTORS & I.C.'s...MIN. 10, CAN MIX

T.V. #'s	Pop. I.C. #'s	STEREO #'s
<input type="checkbox"/> 2SC1114 .. \$3.75	<input type="checkbox"/> 712 .. \$1.40	<input type="checkbox"/> DM133 .. \$5.95
<input type="checkbox"/> MN8303 .. \$3.95	<input type="checkbox"/> 713 .. \$1.40	<input type="checkbox"/> DA101 .. \$5.75
<input type="checkbox"/> 2SC1034 .. \$5.95	<input type="checkbox"/> 714 .. \$1.50	<input type="checkbox"/> HA1377A .. \$3.25
<input type="checkbox"/> 2SC867A .. \$3.50	<input type="checkbox"/> 731 .. \$1.50	<input type="checkbox"/> HA1388 .. \$5.25
<input type="checkbox"/> 2SD870 .. \$4.75	<input type="checkbox"/> 790 .. \$1.50	<input type="checkbox"/> HA1396 .. \$5.50
<input type="checkbox"/> 2SD871 .. \$5.50	<input type="checkbox"/> 791 .. \$1.95	<input type="checkbox"/> HA1398 .. \$4.95
<input type="checkbox"/> AN5210 .. \$6.50	<input type="checkbox"/> 792 .. \$1.95	<input type="checkbox"/> UPC1181 .. \$1.75
<input type="checkbox"/> AN5310 .. \$3.95	<input type="checkbox"/> 793 .. \$2.25	<input type="checkbox"/> UPC1182 .. \$1.75
<input type="checkbox"/> AN5320 .. \$3.25	<input type="checkbox"/> 819 .. \$1.50	<input type="checkbox"/> UPC1185H .. \$2.95
<input type="checkbox"/> AN5435 .. \$2.95	<input type="checkbox"/> 820 .. \$2.10	<input type="checkbox"/> 2SA1105 .. \$2.95
<input type="checkbox"/> 2N3055 .. \$.95	<input type="checkbox"/> 821 .. \$2.25	<input type="checkbox"/> 2SC2580 .. \$2.95

GENERAL

<input type="checkbox"/> 2.5 Amp. 1000 PIV Rect.	100 for \$ 8.75
<input type="checkbox"/> Pop. HI DIV-3...focus block divider	10 for \$35.00
<input type="checkbox"/> 6 ft. Cheater Cords SPT2	10 for \$ 7.95
(Heavy Duty - UL App. 7 Amp. 125V. P & NP)	
<input type="checkbox"/> 800-860 Zenith Safety Cap	\$ 3.95
<input type="checkbox"/> Pop. Mag. Safety Caps 250663-11-17-19-20	\$ 3.95
<input type="checkbox"/> Pop. GE Caps 25x60-75-78-79	\$ 3.95
ATARI GAME CHIPS:	
<input type="checkbox"/> Voltage Regulator	\$ 1.00
<input type="checkbox"/> CPU	\$ 5.50
<input type="checkbox"/> RAM/IO	\$ 7.50

Quantity Prices Available

Letters of credit and all checks placed on deposit with Bank of Hallandale, FL. VISA & Master Charge accepted. Min. order \$75. FOB Dania, FL. Catalog \$3, refundable upon order.

SEND CHECK OR MONEY ORDER TO: OPTIMA ELECTRONICS

2022 Tigertail Blvd., Dania, FL 33004

Phone (305) 920-3550 TOLL FREE: 1-800-327-0224

Circle (15) on Reply Card

FINALLY. COMPUTERS AS A NEW TOOL FOR T.V. REPAIR.



Primefax puts computer-assisted repair capability in your shop today.

Primefax drastically reduces the number of sets requiring extensive trouble-shooting procedures.

Through the use of today's technology, Primefax maintains—in a central computer—a database of problem-solving solutions for television set malfunctions.

Primefax is a compilation of the most current, applicable technical information acquired from hundreds of valuable sources ... and updated daily.

With a Primefax Computer Terminal installed in your shop, you can do your job more quickly and more

accurately. You have more satisfied customers, and your profits are increased substantially.

Reduced call backs • faster turn-around • reduced chance of repeated failure • more thorough service and complete repair at reasonable cost.

The more Primetax is used, the more profit you realize.

CALL US OR WRITE. No matter how you compute it, Primefax means profit for you. It's worth looking into.

In Texas, call (512) 344-5999 • Out of Texas, call 800-531-5953

Primefax

4825 Fredericksburg Road • San Antonio, Texas 78229

Circle (16) on Reply Card

How to test audio amplifiers

By Mannie Horowitz

A technician's only guide to the performance expected from an audio amplifier is the manufacturer's specification sheet. Some important specifications include: *power output, distortion, frequency response, signal-to-noise ratio, sensitivity, input impedance and output impedance.* When the specs are available and the technician has the essential test equipment, it would appear that the task of verifying compliance with these specifications should be easy and routine. Unfortunately, any of several possible problems can interfere.

Some important specs might be omitted entirely, or some figures might have been exaggerated in an attempt to make the amplifier appear better than it actually is. Also, the standards for some tests have been changed over the years, creating questions about which standard should be used.

Technicians are forced to call upon their individual experiences, therefore, about when to stop replacing components and making adjustments in a futile effort to achieve specifications that may be inflated or incorrect. For example, the voltage applied to the output transistors, the type of transistor and the size of the heat sink can provide an experienced audio technician with an estimate of the maximum output wattage.

Other problems can be produced by the connections between various items of audio equipment. Excessive 60Hz hum and high-frequency attenuation can be

caused by the connecting cables between a preamplifier and its power amplifier, or between other auxiliary equipment, such as a tape deck or phonograph.

Ground loops

Some stereo hi-fi systems have the amplifying circuitry divided into a preamplifier unit and a power-amplifier unit. The preamp has selector switches, controls and active circuitry for amplifying signals from a phonograph cartridge, a radio tuner and a tape deck. Also, most preamps include tone controls, a noise or scratch filter, a rumble filter, a balance control, loudness switch (for Fletcher-Munson correction) and a frequency-compensated preamp for magnetic phonograph cartridges.

Better quality units have low-impedance output circuits that feed the power-amplifier channels. Low impedance and shielded cables almost totally eliminate

noise, hum and radio interference coming from outside. Ideally, all connecting cables should be short and have low-capacitance shielding. A combination of high-impedance, long cables and high-capacitance shielding can produce excessive high-frequency attenuation.

The second unit contains the power amplifiers that provide a very large current (or power) amplification while giving some voltage amplification. For example, each channel might require a 1V RMS input signal at 50k Ω or higher (insignificant power) while producing an output of 12V RMS to an 8 Ω LOAD (18W). The voltage gain is only 12, but the power gain is enormous. Several voltage-amplifier and driver stages precede the large power-output transistors that must develop sufficient power to properly drive the speakers. These power amplifiers seldom have tone controls, and few have a level or gain control.

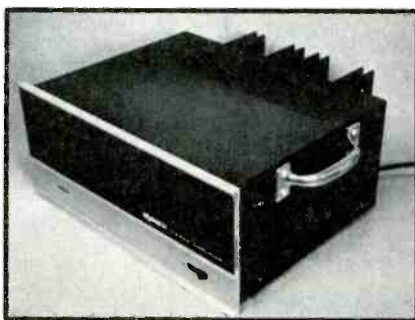

This Dynaco amplifier can be considered typical of the medium-power types manufactured several years ago. No level or tone controls are supplied. Notice the large cooling fins on the rear panel.

Preamp output jacks feed signals through shielded leads to the power-amplifier input jacks. The wiring is simple and appears to be virtually foolproof. However, the cable shielding (whose main function is to eliminate capacitance pickup of hum from power lines and other noises) can cause excessive 60Hz hum of another type to be heard in the speakers. *Ground loops* and *common grounds* are separate conditions that produce hum of different types.

With amplifier common grounds, a 60Hz or 120Hz hum can be produced in an amplifier circuit when a path through a metal chassis or a length of ground wire is common to both signal currents and ac currents (60Hz heater current) or 120Hz pulsating dc currents of a power supply. For example, the emitter resistor of a transistor might connect to the common (or negative) lug of a filter capacitor, and then a single wire connect the capacitor ground lug to a chassis ground some distance away. The filter-capacitor charging current develops a voltage drop across this grounded wire, and the voltage might be as high as several millivolts, which can add a significant hum level to the tiny signal voltage in transistor circuits.

Few good-quality stereo system components will have hum from common-ground problems (which usually originate in production engineering, not design engineering). However, technicians should be aware of the potential problem when replacing components. A replacement filter capacitor should be connected to the same ground to which the original was connected. Not all grounds are ap-

propriate.

With ground loops, a hum of 60Hz frequency can be added to a *stereo* hi-fi system by the same cable shields that are included to prevent capacitive pickup of hum. Shields of both cables are connected to a common ground inside the preamp. At the other end, both shields are connected to another common ground inside the power amplifier. Notice that the shields form a narrow but continuous loop that is the equivalent of a 1-turn winding around the core of any nearby power transformer, solenoid or ac relay. Any hum signal picked up inductively is added to the desired audio signal, as though connected in series with the signal.

The cure for ground-loop hum is simple: Break the ground at one end. If there are two shielded signal cables, disconnect the shield at *one* of the phono plugs so that the loop is broken.

Hum from ground loops must be suspected during frequency-response, sensitivity and distortion tests of any preamp or amplifier. Check the temporary wiring and eliminate any possibility of ground loops. Remember that extra filtering in the circuitry *cannot* remove this inductive hum.

Integrated units that have both preamp and power amplifier on one chassis usually do not have either common-ground or ground-loop hum, unless it is introduced by cables to an external phonograph, tape deck or other accessory. Listen for the hum as you unplug all shielded cables one at a time. Any major reduction of hum identifies the problem cables.

Output-power specification

Before 1975, several methods were used to determine power output ratings. For all methods, the Figure 1 wiring of amplifier and equipment was used.

An adjustable-amplitude, 1000Hz sinewave signal from an audio generator is supplied to the amplifier input, and a resistor of proper specifications is connected to the amplifier output. This resistor should be made of non-inductive wire-wound power resistors, providing the correct resistance and having a total wattage higher than the amplifier's rated power. All the wattage is

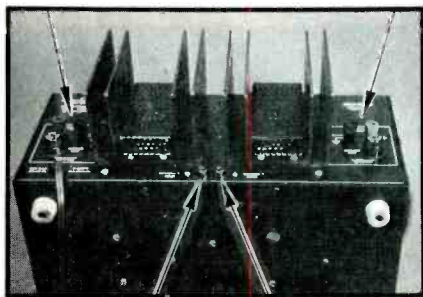

Two arrows at the top show the output banana jacks for the two channels, while the two phono-jack inputs are identified by the two lower arrows.

PAT. #4,259,705

DON'T BLAME THE SOFTWARE!

ISO-3

Power Line Spikes and Hash often cause memory loss or erratic operation. Often floppies, printer & processor interact!

OUR patented ISOLATORS eliminate equipment interaction AND curb damaging Power Line Spikes, Surges and Hash.

Filtered 3-prong sockets and integral Spike Suppression. 125 VAC, 15 Amp, 1875 W Total - 1 KW per socket.

ISO-1 ISOLATOR. 3 Filtered Sockets; 1000 Amp 8/20 usec Spike Suppressor \$76.95

ISO-4 ISOLATOR. 6 Filtered Sockets; 1000 Amp 8/20 usec Spike Suppressor \$128.95

ISO-3 SUPER-ISOLATOR. 3 DUAL filtered Sockets; 2000 Amp 8/20 usec Spike Suppressor \$115.95

ISO-7 SUPER-ISOLATOR. 5 DUAL filtered Sockets; 2000 Amp 8/20 usec Spike Suppressor \$186.95

Master-Charge, Visa, American Express
TOLL FREE ORDER DESK 1-800-225-4876
(except AK, HI, MA, PR & Canada)

Electronic Specialists, Inc.
171 South Main Street, Natick, MA 01760
Technical & Non-800: 1-617-655-1532

Circle (17) on Reply Card

Q* MULTIMETERS

NOT JUST A FLUKE!

Compare new Philmetric Multimeters for performance, accuracy and price. Discover the quality that's no accident, yet costs far less. You get Pushbutton and Rotary dial Models; 0.5% accuracy; 3½ digit readout; AC/DC; 26 Ranges; 2 year warranty.

And there's more! A free \$5.00 factory-direct cash bonus when you buy our Model 150 Pushbutton — to prove that Philmetric measures up as the "best buy" ... "Quality-Assured for Performance and Price."

Send for Free Catalog & Details.

"We Measure Up ..."

Philmetric Philmetric,
(a Div. of Philmore Mfg. Co.)
40 Inip Drive, Inwood, NY 11696 Tel: 516-239-6161

Circle (18) on Reply Card

converted to heat, so these load resistors will become hot. Usually, the resistance is 4Ω , 8Ω or 16Ω , but if no specifications are known, use 8Ω . Total harmonic distortion (THD) is measured by a distortion meter connected across the load resistor. It is helpful to connect a scope across the same load also, because it reveals gross distortion, hum or ultrasonic oscillation much more rapidly than a distortion meter can.

When a stereo unit is tested, only one channel is driven and measured at a time. The output power is increased by raising the input level until a certain distortion appears in the output, then the power is calculated from that output voltage.

When a wide-bandwidth RMS meter is used, the power should be calculated by squaring the sinewave RMS voltage and dividing by the load resistance. Accuracy of the wattage calculation is limited by meter and load-resistance accuracies.

If the output voltage is measured by a scope, remember its calibrations are in peak-to-peak values, which must be multiplied by 0.353 to produce the RMS equivalent. Again, the power is calculated by squaring the RMS voltage and dividing the result by the load resistance.

This power-output test method is adequate. However, technician frustration can result from vagueness about what distortion figure is used to determine the output-power rating. Some manufacturers use 0.5% total harmonic distortion (THD) as the point giving rated power. Others measure output power at distortions between 1% and 5%. Even more confusing, many amplifier

These are examples of different distortion percentages. The top waveform in each picture is the generator's 1000Hz sinewave of 0.1% distortion, for reference. (1) Distortion of only 1% is not discernable. (2) Second and other even harmonics of 15% distortion produced smaller rounded negative peaks. (3) When the maximum power is exceeded, clipped peaks result. For balanced output devices, the clipping should be the same on positive and negative peaks, as shown. (4) A weak output device, and an attempt to obtain more power than the amplifier could produce, caused this highly distorted waveform. (Waveforms supplied by Carl Babcoke.)

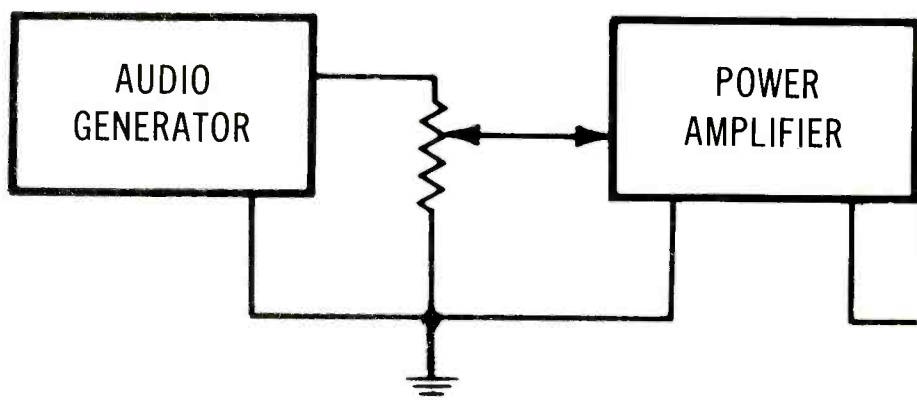

Figure 1. When testing amplifier power, connect the amplifier and test equipment as shown during power-output, frequency-response, distortion and sensitivity tests. The variable control usually is part of the audio generator.

specs do not list the distortion at claimed power. Others measure power when the scope waveform first begins to flatten at the sinewave tips.

If you are testing an amplifier having a power rating, but no distortion specified, use 5% distortion as your standard, or you might be wasting time trying to improve a hopeless case.

Power vs. load resistance

If the amplifier undergoing testing is ideal (and none is), the output voltage should not vary as the load resistance is changed. For example, if 8V RMS is across a 16Ω load resistor, the power is 8 squared, divided by 16, or 4W. Changing the load resistor to 8Ω gives an output of 8W. A 4Ω load resistor increases the power to 16W. In practice, however, the change of wattage is not quite that

much, although the precise amount is determined by the individual model.

To make the advertised wattage as high as possible, the manufacturer might have listed the 4Ω output-power rating without specifying the load resistance used, and then recommended that speakers of lower than 8Ω impedance *not* be used.

If the specifications of an amplifier you are servicing are similarly vague, assume the manufacturer is listing the 4Ω rating, but do *not* test at 4Ω , because the amplifier might be damaged if operated with a 4Ω load at full power. Instead, test for distortion of 5% with a 8Ω load resistor, and then multiply the calculated wattage by 1.75. The answer should be very near the specified power, but without the danger of operating with 4Ω load.

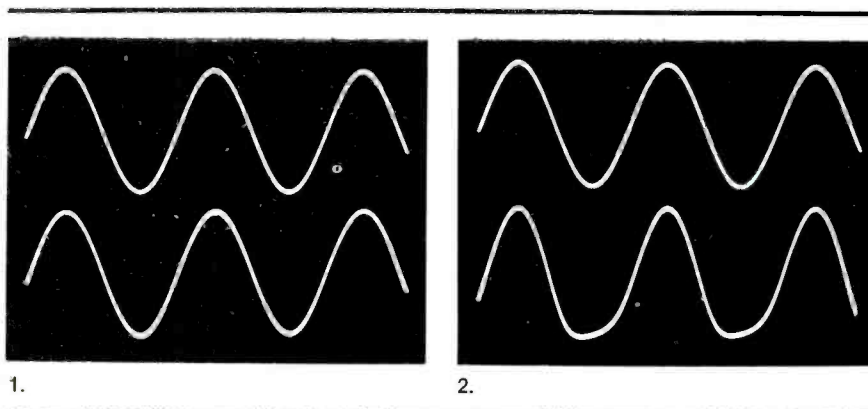

**HIGH-WATTAGE
NON-INDUCTIVE
RESISTOR**

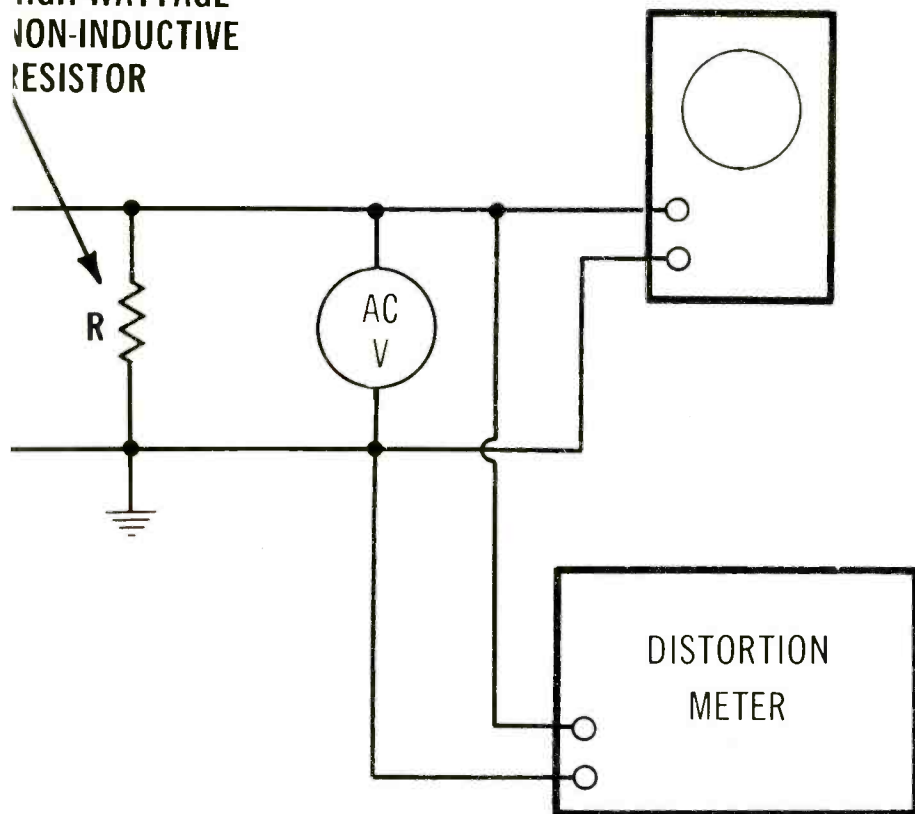

Other power ratings

After the RMS sinewave rating had been standard for some years, the peak-power rating was introduced. This method assumed that the sinewave peaks were present for more than twice per cycle. The signal was viewed as being at peak amplitude over the complete cycle. In other words, the sinewave is treated as if it is a square wave of the same maximum amplitude. When measured this way, the wattage was doubled. Therefore, to obtain peak power, measure and calculate the RMS sinewave power as described previously and then double the figure.

A more rational method of measuring peak power directly involves using a square wave signal to drive the amplifier. Increase the input amplitude until the output amplitude at the load resistor fails to increase in step, and then measure the amplitude of one peak using a scope. A square wave can be considered as equal to a dc voltage having a value of one peak of the square wave. To measure and calculate the peak power of square waves, measure the peak-to-peak voltage, divide it by two, square the result, and then divide that figure by the load resistance. Because the amplifier's dc power-supply voltage falls more in this

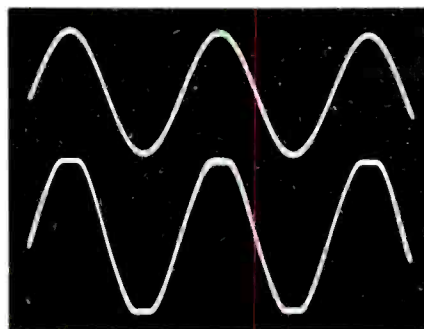

3.

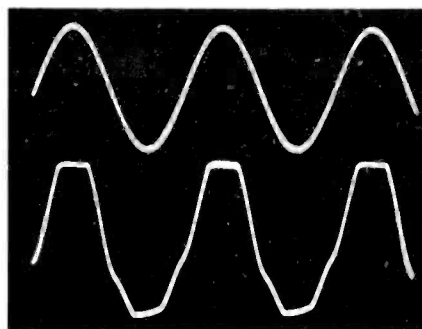

4.

ESR METER

checks electrolytics
IN-CIRCUIT and is TV shop
FIELD-TESTED:

The most fantastic instrument I've ever bought—Billings, Mt. Used it 3 months; it only missed once—Marinette, Wis. (Typical). Squeal & no sync: 3 bad caps in B+ & AGC; Many Thanks—Taos, N.M. Please ship another; very satisfied—Glen Rock, Pa. It's fantastic—St. Joseph, Mo. Please rush; heard good reports—Hicksville, N.Y. One tremendous meter—Alexandria, Minn. Send your Super meter; heard about it—N. Olmstead, Ohio. Love that ESR Meter—Acton, Mass. Used it intensively for 30 days; it's been 100% effective—Pittsburgh, Pa.

Ideal for preventive maintenance: measures electrolyte dryness & shows up intermittent opens.

60-day Satisfaction Guarantee.

Send check or M.O. or call
(313) 435-8916 for COD

Or write for free brochure to:

Creative Electronics

ESR Brochure \$ 99.00
1417 N. Selfridge postpaid
Clawson, Mich. 48017 USA & CAN.

Circle (19) on Reply Card

ATTENTION TECHNICIANS

- ★ JOB OPENINGS
- ★ MONTHLY TECHNICAL TRAINING PROGRAM
- ★ BUSINESS MANAGEMENT TRAINING
- ★ LOW COST INSURANCE
- ★ CERTIFICATION
- ★ TECHNICAL SEMINARS

All of this in a nonprofit international association for technicians

FIND OUT MORE:



R.R. 3 Box 564
Greencastle, IN 46135

test than when sinewaves are used, the peak power is somewhat less than when obtained by doubling the sinewave power.

Next, the Institute of High Fidelity (IHF) developed a music-power rating that assumed the peak amplitudes of music and speech were so rapid that power-supply voltages would not decrease. Therefore, amplifiers were tested with sinewaves (which reduce the power-supply voltages), but the supply voltages were restored to the idling level during the tests. The music power is calculated at the artificially maintained normal supply voltage.

Do not operate any solid-state amplifier for very long under the conditions of full power output and full supply voltages. Damage to the amplifier is very likely. Instead, make the measurements rapidly and then turn off the amplifier. Also, if the supply voltage has been maintained by increasing the line voltage during the tests, be sure to decrease it to the normal 120Vac before removing the sinewave input signal.

About 1974, the FTC insisted on a more stringent procedure for specifying amplifier power. One shortcoming of previous tests was that only one channel of a stereo amplifier was tested at a time. These are the major FTC conditions for testing amplifier power output:

- The test signal must be 1000Hz sinewaves.
- All channels must apply rated RMS power to their resistive loads simultaneously.
- Each load resistor must have the resistance for which the amplifier was designed.
- Before the power measurements, all channels must be operated at one-third rated power for one hour.

In addition, the published specifications must state the frequency bandwidth were *rated* power can be delivered.

The IHF approves of the FTC specifications for RMS power, and this simplifies the testing of amplifiers manufactured during the last few years.

Dynamic headroom

IHF also has instituted a *dynamic headroom* specification that replaces the older music-

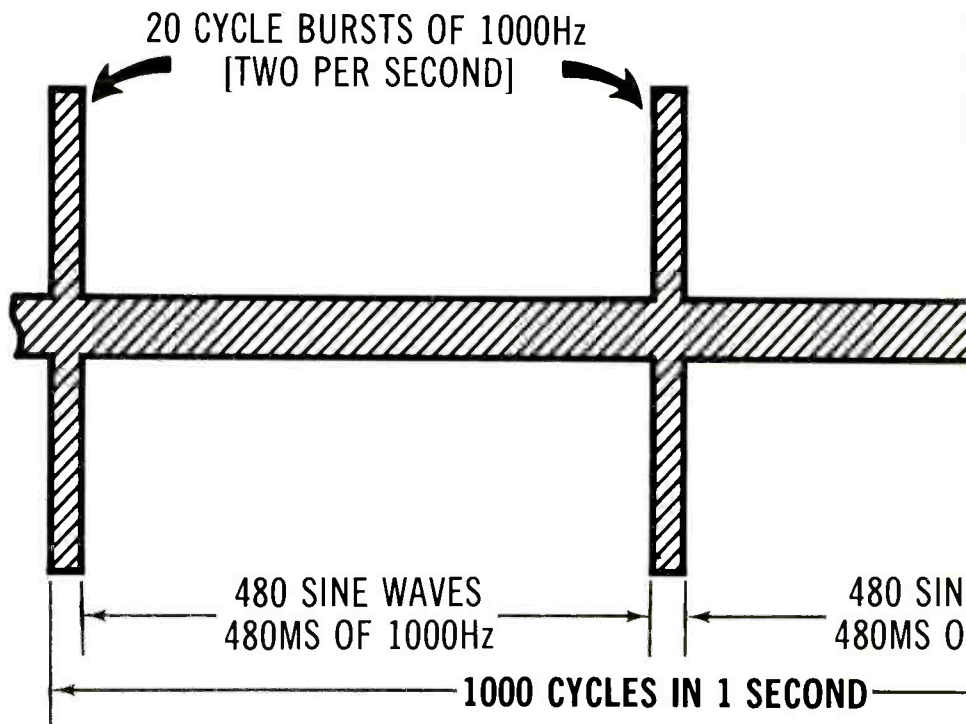

Figure 2. This waveform from a special generator is required for the dynamic-headroom measurement.

power rating. The special waveform of Figure 2 is required.

First, a continuous 1000Hz sinewave signal is applied to the amplifier, and the RMS power is measured according to the FTC method given previously. This RMS power is used later to calculate headroom.

The special waveform in Figure 2 is composed of 1000Hz sinewaves, but the amplitude is changed recurrently. During each half second, 20 cycles of the 1000Hz signal are supplied at a high level, followed by 480 cycles at 1/10 the amplitude. This sequence is repeated without breaks. The IHF says the combination waveform is a good approximation for the transient peaks that are present in music (and to a lesser degree in human speech).

A scope is connected to the amplifier load resistor, and the amplitude of the Figure 2 waveform is increased until higher amplitude sections barely begin to distort. The peak-to-peak voltage of the higher amplitude sinewaves is measured by the scope. Power of the 20-cycle high-amplitude sinewaves is calculated as if they had this high amplitude constantly. Square the PP voltage and divide by eight times the load

resistance to obtain the power.

Next, the dynamic headroom is calculated by inserting the peak power and RMS power into the following equation:

$$DH = 10 \log \frac{P_p}{P_{rms}}$$

Higher dynamic headroom numbers are desirable.

This is an excellent test, but unfortunately few technicians have access to the special generator that produces the keyed waveform. Without the DH generator, you are limited to the RMS power measurements when testing amplifier specifications.

Sensitivity

Sensitivity is a measure of the level of sinusoidal input signal voltage (usually 1000Hz) that is required for an amplifier to produce a power of 1W. The power-measuring circuit in Figure 1 can be used for sensitivity measurements, also. Of course, Ohm's Law can be employed to determine the RMS voltage for 1W across the known load resistance. However, there is a shortcut formula: *The voltage producing 1W equals the square root of*

specifications to find which method is listed.

Low gain often is caused by improper bias (either too high or too low) of a transistor, a reduced-value feedback resistor, or an open emitter bypass capacitor.

Frequency response

During frequency-response measurements (wiring of Figure 1), the frequency of the audio generator is varied across the bandwidth and slightly beyond while the output level is monitored by a decibel meter. The test results can be listed on a simple chart or plotted on a log graph. Factories and other facilities who do response measurements regularly often have automated equipment that provides a machine-run inked graph.

Years ago the amplifier level controls were adjusted to maximum (with the tone controls, if any, adjusted for flat response) and the generator amplitude of the 1000Hz input signal was varied to produce an output of 1W across the load resistor. Then the fre-

quency was varied and output recorded over the entire bandwidth.

However, the evaluation of the response curve had a shortcoming. For example, if the curve was flat except for a 2dB droop at both extremes, the specs would show $\pm 1\text{dB}$, which is very good. Such moderate departure from perfect flatness is not important, but consider a case where the curve was flat except for -6dB at both high and low ends of the band. This would be $\pm 3\text{dB}$ by the previous standard, and the non-flatness could be confused with a $+3\text{dB}$ peak somewhere on the curve and a -3dB rolloff at the extremes. The combined plus and minus figures can be misleading or can contribute to imprecision.

A recommendation by the IHF separates the maximum positive and negative figures. For example, the $\pm 1\text{dB}$ from -2dB rolloffs at the extremes becomes $+0\text{dB}$, -2dB . And the $\pm 3\text{dB}$ spec becomes $+0\text{dB}$ and -6dB . Accuracy has been improved.

Another IHF change is to apply

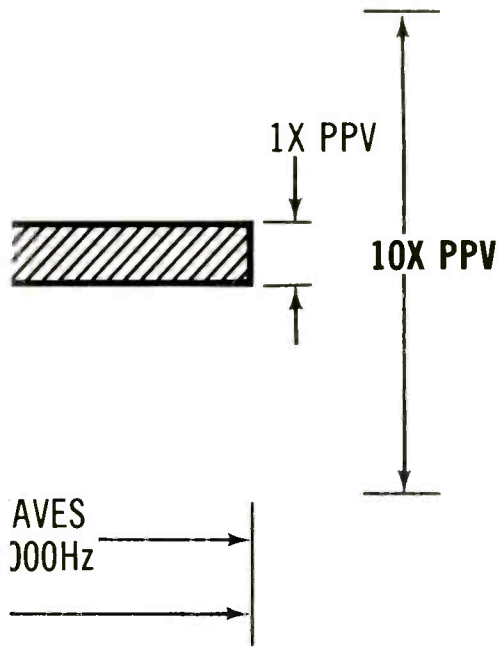

the load resistor in ohms.

Incidentally, the old method of judging sensitivity was to list the input voltage required to produce rated power output. Check the

ECG • REN • GE • SK
REPLACEMENT TYPES

Why pay their high prices??

CHECK THIS!
IDENTICAL REPLACEMENT FOR ECG®
(Min. 5 pcs. each)

ECG® Type No.	YOUR PRICE	ECG® Type No.	YOUR PRICE
123A.....	.28	500A.....	8.95
152.....	.60	523.....	10.75
153.....	.65	526A.....	10.95
165.....	2.25	HIDIV-1®.....	3.75
238.....	2.25	HIDIV-3®.....	3.75

3 YEARS WARRANTY ON EXR PARTS

SPECIAL (Min. 5 pcs. each)

2SC867A.....	2.95	AN214Q.....	1.50
2SC1034.....	5.95	STK439.....	7.25
2SC1114.....	3.45	UPC1181H...	1.95
2SC1308K...	2.25	UPC1182H...	1.95

Call Toll-Free 800-526-4928
COD ORDERS WELCOME (Min. order \$25)

CALL OR WRITE FOR OUR 1982 PRICE LIST

DIGITRON ELECTRONIC
110 Hillside Avenue, Springfield, N.J. 07081
201-379-9016 201-379-9019

ECG IS A TRADE MARK OF PHILIPS ECG.
DIGITRON IS NOT ASSOCIATED IN ANY WAY WITH PHILIPS ECG.

Circle (22) on Reply Card

**COMPACT
ECONOMICAL
DESOLDERING**

It's so Dependable, there's a Two-Year Warranty on the Pump. The EX-525 may be A.P.E.'s lowest-cost portable solder extractor, but it's full of features: • easily desolders components from multi-layer PC boards • pump is vibration-isolated for quiet operation • Model 550 for use with shop air • EX-1000 handpiece is non-clogging and temperature-regulated by panel controls.

You need the A.P.E. EX-525 in your shop. Call or write today for all the details. **Automated Production Equipment Corp.**, 142 Peconic Ave., Medford, N.Y. 11763 • 516-654-1197, TWX: 510-228-2120

DEPEND ON A.P.E.

Circle (23) on Reply Card

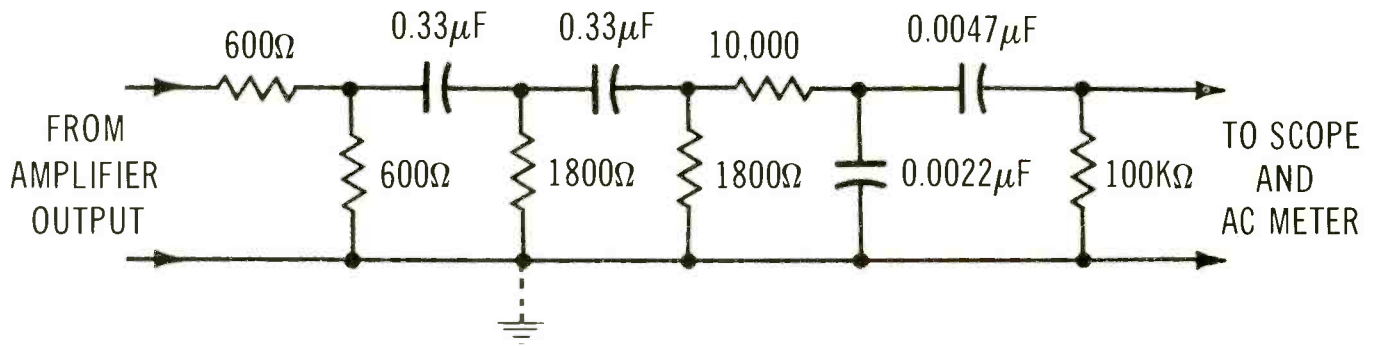

Figure 3. For signal-to-noise ratio tests, this resistor/capacitor filter is connected between the power amplifier load resistor and the measuring instruments. The frequency response has decreased bass and treble to simulate human hearing. Therefore, readings through the filter are more in line with the unpleasantness of the noise when it is heard.

0.5V RMS to the amplifier's input, and then adjust the amplifier level control to produce 1W at the load resistor. This shows any degradation occurring from the exact rotation of the level control. One condition that can cause a loss of high frequencies is excessive shielding capacitance on the wire from the level control's wiper. A low-pass filter is formed, and it can cause a large loss of treble response in some cases.

When frequency response measurements are to be made, determine which of these standards apply to that amplifier.

Decreased low-frequency (bass) response can be caused by electrolytic coupling capacitors that have begun to lose appreciable capacitance. Poor high-frequency response can be produced by increased-value collector resistors, open emitter bypasses or replacement transistors with limited bandwidth.

Signal-to-noise ratio

In the past, the signal-to-noise (S/N) ratio was measured by turning up the amplifier's level control to produce rated output wattage, shorting the input jack, and then measuring the noise voltage across the output load resistor.

With an alternate method, a 1000Hz input signal of higher amplitude than necessary to obtain rated output power was supplied to the amplifier. The amplifier's output power was adjusted (by the level control) to the rated wattage. Then the generator cable was disconnected, the amplifier input jack was shorted, and the noise measured across the output load resistor.

The noise level in decibels can be

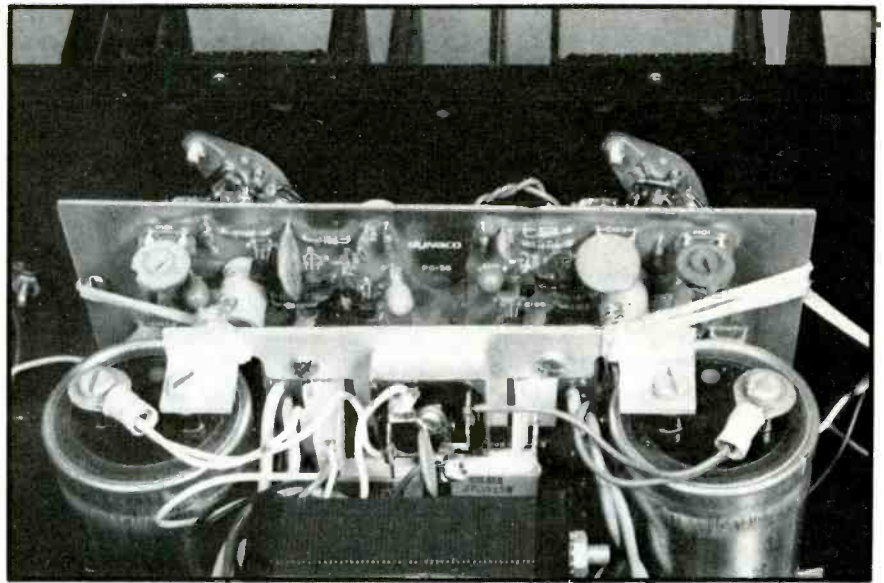

An inside view of the Dynaco amplifier shows heat-sink-mounted power transistors, one circuit board, and a power supply with huge filters and power transformer.

found by using this equation:

$$\text{dB} = 20 \log \frac{V_{\text{noise}}}{V_{\text{signal}}}$$

Again, the newer IHF method is slightly different. Input signal to the amplifier is adjusted to 0.5V RMS and the amplifier level control is adjusted for 1W at the output load resistor. However, the scope and decibel meter are disconnected from the load resistor, and the S/N filter of Figure 3 is connected between the amplifier and the measuring instruments. This filter compensates for the human ear's relative response to different audio frequencies. Therefore, the S/N ratio obtained with the filter will correspond to the *audible* judgement of human ears about the apparent amount of noise.

With the filter in place and the amplifier producing 1W at the load resistor, measure the voltage level at the filter's output. Remove the amplifier's input signal, connect a 1000Ω resistor across the amplifier's input jack, and measure the noise voltage at the filter's output. Calculate the decibel S/N ratio, as given before in the formula.

Excessive hissing noises can be

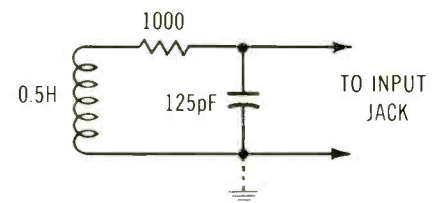

Figure 4. This filter is substituted for the generator signal when testing the moving-magnet phonograph input for S/N ratio.

Table 1

Frequency (Hz)	Old standard (dB)	New standard (dB)
15,000	- 17.2	- 17.2
10,000	- 13.8	- 13.8
5000	- 8.2	- 8.2
3000	- 4.8	- 4.8
2000	- 2.6	- 2.6
1000*	0.0*	0.0*
700	+ 1.2	+ 1.2
400	+ 3.8	+ 3.8
100	+ 13.1	+ 12.9
50	+ 17.0	+ 16.3
30	+ 18.6	+ 17.0
20	**	+ 16.3
8	**	+ 11.2
2	**	+ 0.2

* 0dB for reference

**Not stated in old standard

Use this table when measuring the frequency response of moving-magnet and moving-coil phonograph inputs. Notice the new standard has a rolloff below 30Hz that should minimize rumble.

caused by defective transistors (especially input transistors), noisy resistors or cold solder joints. Erratic opens in any component or wiring can produce popping noises, sometimes at random times.

Carbon-deposited and carbon-film resistors are less noisy than are carbon-composition types, while metal-film and wire-wound resistors have the least noise. Noisy transistors and resistors often can be identified by alternately heating and cooling them, while listening for a large change of noise.

Another mysterious source of noise is soldering flux between connections or copper wires on a circuit board. Remove the flux with cleaners designed for that purpose.

Testing preamplifiers

For testing preamps, the same general tests and methods should be employed, with a few differences. (All the signals used in the following procedures are 1000Hz sinewaves.) Apply 5mV to the input for moving-magnet phonograph cartridge, and apply 0.5mV to the moving-coil input. For all other inputs when they are tested, apply 0.5V RMS. Connect

the Figure 3 filter between the preamp output and the measuring instruments (no load resistor is required). The filter has an impedance of about 1200Ω; therefore, it should not be used with high-impedance circuits. Adjust the level control (all tone controls to neutral position) for 0.5V at the filter's input. Measure the voltage at the filter's output; this is the signal voltage for the formula.

Remove the input signal. If the moving-magnet input is being tested, parallel the Figure 4 dummy load across the input jack. When the moving-coil input is tested for noise, parallel a 100Ω resistor across the jack. Other inputs should have a 1000Ω resistor paralleled across the input jack. Now measure the noise voltage at the output of the filter. Probably a high-sensitivity meter will be required, because of the low levels. Use the S/N equation to produce the S/N ratio in decibels.

Measuring preamplifier frequency response uses the same input levels that were given previously. However, the preamp should have a 1nF capacitor and a 10KΩ resistor in parallel across the output jack instead of the noise filter. Adjust the level control for 0.5V RMS across the temporary load,

vary the generator frequency, and record the decibel readings.

Remember that only the auxiliary inputs should have flat response. These include tuner input, tape deck input, crystal or ceramic phono input and so on. Magnetic moving-coil and moving-magnet inputs should follow the RIAA curve (see Figure 5). Notice the differences between old and new standards. Your frequency-response measurements of the magnetic phono inputs should be within ±2dB of those shown in the table.

Testing integrated amplifiers

Previous suggestions and standards for separate amplifiers and preamps should be adequate for measuring integrated amplifiers that have both functions on one chassis. However, the preamp output usually is not accessible for separate tests, but these can be combined with the power amplifier tests that are measured at the output load resistor.

Troubleshooting some defects might require separate tests of preamp and power-amplifier sections. Check the schematic to locate the equivalent point.

Comments

This article has been aimed principally toward measuring amplifier performances and comparing them against the published specifications. Often there are no published specifications, particularly for the amplifiers in stereo systems by certain manufacturers.

Remember that each stereo system has two separate channels in the audio section. It can be extremely helpful to compare the measurements of one channel against those of the other. For example, after one power amplifier is repaired, and a listening test indicates it might be normal, check the sensitivity, frequency response and power output of the two channels, and compare the readings. If these characteristics are within about 10% tolerance between channels, there is a high probability that the repaired channel now is normal.

The only exceptions to this practical hint occur when the defect is a common power supply.



Taking the charge out of static electricity

By Jack H. Gaines, engineering manager,
Ungar Division, Eldon Industries



This modular soldering iron is electrically ground from tip to plug connection. A third wire drains static electricity to ground before it can build up to harmful levels. (Ungar photo).

Static electricity occurs in every environment. Wherever there is friction (even from air blowing over a surface) or two dissimilar materials making and breaking contact, there is a buildup of a positive charge on one side and a negative charge on the other. When the charged object touches or comes near a conductor of electricity, there is a rapid flow of electrons to neutralize the charge.

The static electric potential that occurs under ordinary circumstances can reach hundreds of thousands of volts. It takes less than 100V to damage the substrate of a microcircuit such as a MOS IC, or to cause erratic behavior.

Some combinations of materials generate considerably more static electricity than others. Synthetic fabrics generate higher static electric potentials than cotton. Low humidity is conducive to static electricity build-up. Anyone walking across a nylon carpet has, at some time, been "shocked" upon touching a doorknob.

Even normal movements of a person seated at a workbench can generate thousands of volts. The human body will become charged to a static electric potential of 30,000 to 40,000V without even feeling it.

Microcircuit manufacturers were the first to feel the economic impact of the static electricity problem and to take steps to solve

it. It is said that the armed forces became actively involved in static electricity control when technicians unrolling a plastic sheet from a missile generated enough static electricity to set off the ignitor, sending the missile through a wall and injuring people. As a result, precise military specifications were written.

From this industrial and military research, anti-static advice for the electronic technician can be gleaned. Because soldering and circuit board repairs are a potential source of static damage to microcircuits in the shop or field, this article will concentrate on preventing damage during those operations. The same techniques



An electronic circuit board assembler at Litton Industries' Guidance and Control Systems Division, Woodland Hills, CA, wears a grounded plastic wrist strap, cotton smock and has a conductive plastic pad under the work. (Photo courtesy of Litton Industries.)

are applicable to other operations involving circuit boards or assemblies containing microcircuits.

Combining the following two general approaches will go a long way toward eliminating damage caused by static electricity. (1) Eliminate devices or materials that generate high static voltages; (2) drain static electricity to an earth ground before it can build up to harmful levels.

Conductive plastic parts and components trays, as well as conductive handling and shipping containers will help drain away static electricity before a high potential builds up. Because the friction of synthetic clothing materials generates high voltages, assemblers and technicians in electronic plants using microcircuits generally wear smocks made of cotton or fabric impregnated with conductive material.

Two universal safeguards will lessen the danger of static electric damage for anyone working on a circuit board or assembly incorporating microcircuits. First, cover the workbench with a grounded conductive material, such as copper or conductive plastic, and second, wear a conductive wrist strap to drain static electricity to ground.

Conductive wrist straps come in many forms. Conductive plastic and bead chains are most popular because they are comfortable. There is a danger of the conductive strap accidentally touching an open electric line. Because the wrist straps are grounded, the

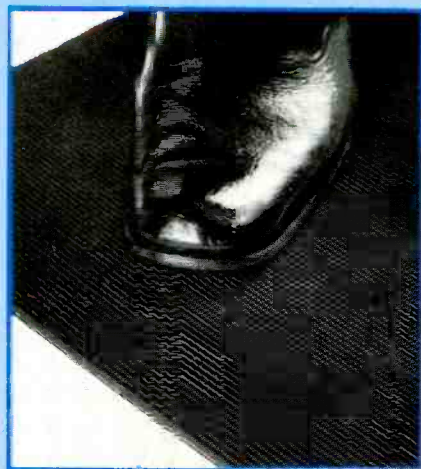

Conductive floor mats are used in both shops and offices to drain static electricity caused by walking. (Photo courtesy of Wescorp.)



Specially designed carriers of conductive plastic help prevent static electricity damage to DIP components for shipping. Note the conductive foam pad on the workbench. (Photo courtesy of Rockwell International.)

static electricity buildup generated by the technician, but it cannot drain static electricity generated by the soldering iron itself. New irons have a third wire for that purpose. It drains static electricity from the tip of the iron to the grounded electrical outlet.

Special care also should be taken when handling sensitive microcircuits. When they are shipped from the manufacturer, all leads are in contact with a conductive material, equalizing the potential across all leads. Conductive DIP tubes also provide this protection. Often the leads are pushed into conductive foam, which additionally protects them against mechanical damage in shipment. Conductive shunt bars can be attached to all leads to equalize the potential when the microcircuits are removed from their containers.

Technicians should understand that under certain conditions they can generate sufficient levels of static electricity to damage microcircuit boards when they are merely handling or operating

equipment and not working on the circuits. Users of newest microprocessor-based equipment suffer failures and faults even though they do not come into direct contact with a PCB and the system is built to equalize or shunt static electricity charges. Devices such as word processors, computers or terminals often are used in office environments with heavy carpets, air conditioning and heavy foot traffic. Under such conditions, normal precautions are not enough.

For this reason, conductive floor mats and carpets are used more frequently in office environments. The technician operating, handling or testing equipment should therefore wear a wrist strap, even when the equipment is fully assembled.

More and more products now incorporate static-sensitive microcircuits. Fortunately, these few simple procedures can enable the technician to work on circuit boards containing these devices without adding static damage to his problems.

ES&T_{inc}

electric shock can be severe.

Commercially available wrist straps have built-in resistors that reduce the voltage that will be experienced by the wearer. Because the function of the strap is to drain low-level static electricity before it can build up, the effectiveness of the strap is not reduced by the resistors. Straight wire grounding straps are not recommended.

The wrist strap drains away

August 1-6

1983 NESC

Make your plans now to attend the 1983 National Electronics Service Convention at the Olympia Resort & Spa in Oconomowoc, Wisconsin. The convention will include a program of the most relevant business and technical training for the serious professional in electronics sales and service. Other features include the "Electronics-Fest" Trade Show, the extended 4-day instructors' conference, management seminars, annual awards presentations, and the prestigious Electronics Hall of Fame Banquet.

Early Bird Registrations must be mailed by midnight April 30, 1983, to receive a \$30 discount per person. For more information, write to the National Electronics Sales & Service Dealers Assn. (NESDA), 2708 West Berry St., Fort Worth, TX 76109, or call (817) 921-9061.

Full Convention Registration includes all meal functions and banquet, golf tournament, door prize drawings, Instructor's Conference and admission to all meetings and workshops (except Business Management Seminar).

	First registered (fully paid) Adult:	Each additional fully paid adult from same family or business:
If registered prior to April 30	\$ 90	\$ 70
if registered prior to June 30	105	85
If registered after June 30 and at the Door	120	100

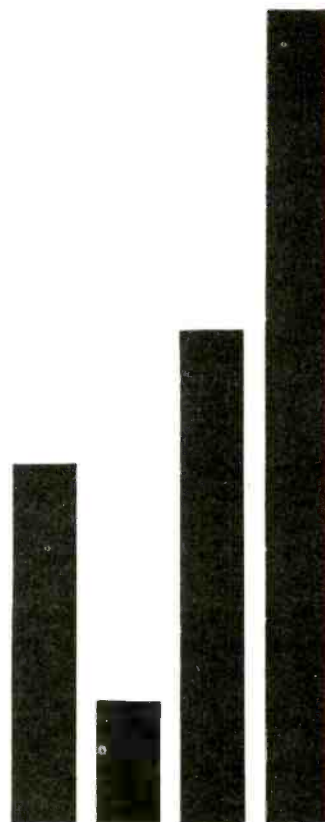

FREE THE GREAT ELECTRONIC THINGS & IDEAS BOOK!

HUNDREDS OF UNUSUAL PARTS, GADGETS & IDEA ITEMS, UNAVAILABLE IN STORES OR CATALOGS ANYWHERE! Bargain prices on everything! New items in every issue! Rush postcard for your copy!

ETCO ELECTRONICS
Dept. 311
Plattsburgh, N.Y. 12901

Circle (20) on Reply Card

It's no puzzle to order Oelrich Service Forms



For TV-radio and two-way radio service - legal forms for Calif., Florida and Utah. Now at parts jobbers or write for cat. B64.

OELRICH PUBLICATIONS
4040 N. Nashville Ave., Chicago, IL 60634
Now call toll-free! 800-621-0105

Circle (21) on Reply Card

Marketplace

Put Professional Knowledge and a **COLLEGE DEGREE** in your Electronics Career through

HOME STUDY

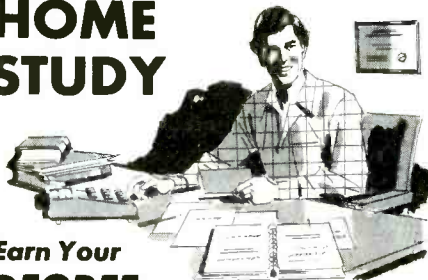

Earn Your **DEGREE**

No commuting to class. Study at your own pace, while continuing your present job. Learn from easy-to-understand lessons, with help from your home-study instructors whenever you need it.

In the Grantham electronics program, you first earn your A.S.E.T. degree, and then your B.S.E.T. These degrees are accredited by the Accrediting Commission of the National Home Study Council.

Our free bulletin gives full details of the home-study program, the degrees awarded, and the requirements for each degree. Write for *Bulletin in T-83*.

Grantham College of Engineering
2500 So. LaCienega Blvd.
Los Angeles, California 90034

Use ES&T classified ads

Products

Desoldering tools

The Pro and Handy, from *Con-sell*, are used for fast, efficient desoldering of components leads, terminal strips and PC boards. The technician melts the solder, applies the solder vacuum at a slight angle, and fires by pressing the trigger button. A precision-machined barrel and low-mass plunger with a compression

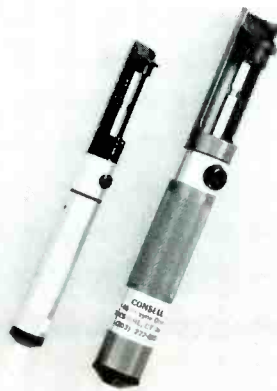

spring, assure rapid onset of vacuum with negligible recoil. The tip cleans itself on each loading.

Circle (75) on Reply Card

Power desoldering system

Pace's model SX-301 is a self-contained, spike-free power desoldering/soldering system. The system contains two variably controlled, polarized outputs for temperature level control, zero power switching for safe ESD operation, a fast-rise vacuum pump with fixed vacuum outlet, a variable pressure outlet for

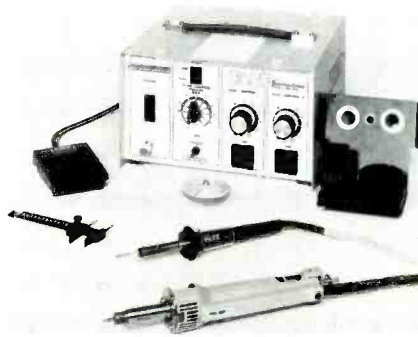

pressure/hot-air jet operations and a foot-pedal control switch.

Circle (77) on Reply Card

Solderless alligator clip

A new solderless alligator clip from *AMP Special Industries* has an expanded mouth design that reduces hook-up time.

These clips, which accept wire sizes 22-16 AWG, feature nickel-

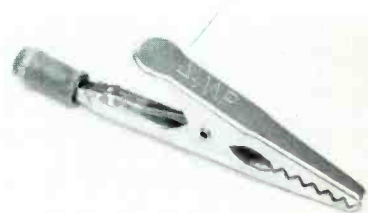

plated copper-steel construction and serrated jaws. They eliminate the need for screw-type mechanical connectors and their funnel entry helps minimize frayed wires.

Circle (76) on Reply Card

Extreme isolation transformers

PMC Industries has just introduced its new line of UL-listed and CSA-approved extreme isolation transformers for protecting computers, microprocessor-based instruments, laboratory equipment, medical electronics, and telephone and cash register systems from the damaging effects of ac line surges, transients

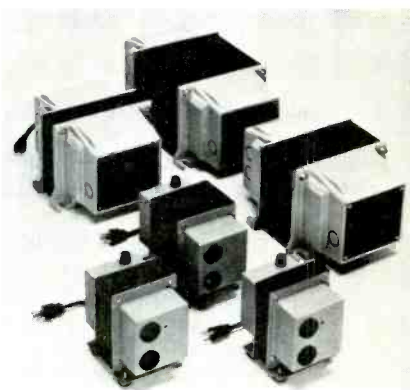

and noise from lightning strikes, switching power supplies and heavy equipment.

The line includes models from 250VA to 5kVA with either input line cords or barrier strips and output duplex receptacles or barrier strips. They are for 115Vac or 230Vac operation.

Circle (78) on Reply Card

ES&T

Literature

A 20-page, brochure describing **Weston Instruments'** new line of distributor-stocked series 7000 DMMs is now available. Hand-held models with 3½-digit resolution, 4½-digit bench instruments, 5½-digit ATE units and a full line of accessories are presented with complete specifications.

Circle (101) on Reply Card

An expanded *ECG Semiconductor Master Replacement Guide* lists approximately 3100 individual ECG solid-state replacement devices, used as substitutes for domestic and foreign types in entertainment, commercial and industrial equipment, plus industrial maintenance, repair and operations (MRO). The publication has been announced by the Distributor

& Special Markets Division of Philips ECG.

Circle (102) on Reply Card

A new "how-to" guidebook from **GC Electronics** shows video system owners how to make professional-quality, in-house TV/VCR installations at do-it-yourself savings.

The authors of this handbook have succeeded in replacing complex video circuit drawings and technical electronic terms with simple component codes keyed to picture diagrams. The result is an easy-to-follow guidebook that takes the confusion out of video system hook-ups so that laymen can easily select the exact components they need to make professional installations.

Information on how to obtain copies of this new Do-It-Yourself Guidebook (Cat. No. 32-3300; price \$2.95) is available from GC Electronics upon request.

Circle (100) on Reply Card



SINCE 1950

- LEADING SPOKESMAN
- TRADE INFORMATION DISPENSER
- WATCHDOG
- NATESA SCOPE
- STANDARDS YARDSTICK
- CONSUMER RELATIONS
- PROBLEM SOLVER
- CONCISE PRACTICAL BUSINESS OPERATIONS MANUAL
- SERVICE CONTRACT MANUAL
- CUSTOMER PLEASING PROFIT PRODUCING ORDER FORMS
- PARTS PROCUREMENT EXPEDITOR
- SERVICE BUSINESS
- DIVERSIFICATION PLANS
- TECHNICIAN DEVELOPER

5930 So. Pulaski Rd. • Chicago, Illinois 60629

Classified

Advertising rates in the Classified Section are 50 cents per word, each insertion, and must be accompanied by payment to insure publication.

Each initial or abbreviation counts a full word.

Minimum classified charge \$10.00.

For ads on which replies are sent to us for forwarding (blind ads), there is an additional charge of \$3.00 per insertion to cover department number, processing of replies, and mailing costs.

Classified columns are not open to advertising of any products regularly produced by manufacturers unless used and no longer owned by the manufacturer or distributor.

For Sale

AUTOMOBILE RADIO and tape replacement parts: Delco, Chrysler, Philco-Ford, Motorola, Panasonic and many others. Large inventory. Laran Electronics, Inc. 3768 Boston Road, Bronx, NY 10469. (212) 881-9600, out of New York State (800) 223-8314. 5-79-1f

ELECTRONIC SURPLUS; CLOSEOUTS, LIQUIDATIONS! Parts, equipment stereo, industrial, educational. Amazing values! Fascinating items unavailable in stores or catalogs anywhere. Unusual FREE catalog ETCO-011, Box 762, Plattsburgh, N.Y. 12901. 6-78-1f

SCRAMBLED TELEVISION, encoding/decoding. New book. Theory/circuits. \$9.95 plus \$1 shipping. Workshop, Box 393ES, Dept. E, Bethpage, N.Y. 11714. 7-80-1f

PRINTED CIRCUIT boards from your sketch or artwork. Affordable prices. Also fun kit projects. Free details. DANOCINTHS INC Dept. ES, Box 261, Westland, MI 48185 5-81-1fn

25C1172B's, 50 LOTS—\$1.69; 25C1308K's, original Sanyos, 50 lots—\$1.99; Cheater cords, 25 lots—35¢; pol- and nonpolarized, 1,000 ft. reels of RG 59 U. Coax Cable—\$39/roll. Minimum order \$75. Redcoat Electronics, 104-20 68th Drive, Forest Hills, NY 11375, 212-459-5088. 10-82-1fn

SPRING SPECIALS on Popular Electrolytics—40/450V—75¢; 80/450V—85¢; 100/450V—95¢; 200/300V—\$1.05. Quantity 20 lot only. Minimum order of \$50. SUPER SPECIALS. Bulk Zenith safety capacitors 800-860, 12 lot only \$2.50 each. REDCOAT ELECTRONICS, 104-20 68th Drive, Forest Hills, NY 11375, 212-459-5088. 10-82-1fn

REPLACEMENT COLOR YOKES-DEALERS ONLY. Zenith 95-2501-2532-2887 etc. \$22.95. Magnavox 361380-1 etc. \$24.95. Sylvania \$24.95. American-made fuses in bulk—example 3AG 2 regular price .23 each our price .12 each. Factory packaged GE transistors at discounts. Example GE-20 regular price \$1.10 our price .65. Request circular on your letterhead. David Sims Enterprises, Inc., 665 East Jericho Tpke., Huntington Sta., NY 11746. 800-645-5030, NY State (516) 549-3925-1592. 10-82-1fn

TUBES—Receiving, Industrial and Semi-conductors, factory boxed. Free price list. Low, low prices. **TRANSLETERONIC INC.**, 1365-39th Street, Brooklyn, N.Y. 11218E, 800-221-5802, 212-633-2800. 5-82-1f

TV TROUBLE ANALYSIS TIPS. Over 300 symptoms/remedies by circuit area; tough ones over the years. Save time and money. Send \$12.50 to CHAN TV, 8151 Grandview Rd., Chanhassen, Mn. 55317. 5-82-1fn

CB SERVICERS: Hygain 9 replacement mike assemblies with cord and plug, for all model 2679. (23 or 40 channel). \$39.95 each plus \$4.00 shipping and handling. Write for free list. Send inquiry for hard to get CB parts—old Sams Manuals. W-H Electronics, P.O. Box 14703, Omaha, NE 68124. 4-83-1f

SONY-PANASONIC-RCA-ZENITH-EXACT REPLACEMENT PARTS-LARGE INVENTORIES-SEND PART OR MODEL NUMBERS-WILL UPS OR COD-GREEN TELE RADIO DISTRIBUTORS, 172 SUNRISE HIGHWAY, ROCKVILLE CENTRE, N.Y. 11570. 5-82-1f

TUBES FOR TV AND RADIO—35¢ ea. Washington TV Service, 1330 E. Florence Ave., Los Angeles, CA 90001. 1-83-12f

USED RADIO-TELEVISION TUBES. All types. Working condition. 30 for \$13.00 postpaid. Loeb, 414 Chestnut Lane, East Meadow, NY 11554. 3-83-3f

TEKTRONIX 212 ultra mini portable oscilloscope 500khz bandwidth dual trace. AC or Nicad Battery operated with ac & dc probes, going out of business, must sell, bought for \$1750 will sell \$1100.00. Major Gresham, 195 Fairburn Rd. #C4, Atlanta, GA 30311. 4-83-1f

TV SALES & SERVICE in sunny southern California. Small established shop with high potential in Ventura County. Authorized Sylvania, Zenith, Tatung Dealer, call Frank, (805) 646-5818 or (805) 649-1566. 4-83-1f

FOR SALE: Variety of parts and manuals for older Sony video equipment. CVI 1006 Industry Dr. Seattle, WA 98188. 4-83-1f

T.V. SHOP CLOSE OUT: SET OF SAMS from 200 up. Tubes and ass't equipment. N.P. Teleservice, Box 723, Walden, Colorado 80480 303-723-8326 or 303-723-8459 (home). 4-83-1f

SAMS FOTOFACTS to 1650—AR—TSM—Manuals, B&K color dot generator—\$89.00—Precision oscilloscope \$69.00. Maurer TV, 29 South 4th St., Lebanon, GA 17042. 4-83-1f

NEW PHILCO color TV modules. \$9.95 plus \$1.50 postage, 3 or more \$7.95 each. Maurer TV, 29 South 4th St., Lebanon, GA 17042. 4-83-1f

SATELLITE TELEVISION SYSTEMS. Starting at \$1,750. 100°K LNA's \$389. FREE Wholesale Catalog. Call or write. 313-361-5146. SIGNALS Box 8836, Detroit, MI 48224. 4-83-3f

For Sale (Cont.)

COMPUTER! Heath H-89 w/single 5 1/4" floppy, H-14 Printer, Cassette player-recorder, Cassette interface, software, manuals & more. **BEST OFFER.** HAMS! Heathkit SB-300 & SB-401 complete w/manuals **BEST OFFER.** Unemployed, must sell. (319) 354-9726. 4-83-11

TEST EQUIPMENT! New Heathkit unassembled IO-1045 DC-5 Mhz Oscilloscope. SAMS manuals CB-1 through CB-125. Tube tester. Unemployed, must sell. **BEST OFFER** (319) 354-9726. 4-83-11

SENCORE POWER SUPPLIES UPS164, Stereo Analyzers SG165 B/K E2000, 1471B, E310B and more. Many in cartons. Half price. List available Apex Magnavox 1606 NE 205 Terrace Miami FL 33179. 4-83-11

SUBSCRIPTION T.V. MANUAL, covers both Sinewave and Gated Sync system, only \$12.95. Complete coverage including theory, circuits, waveforms and trouble shooting hints. D & S Enterprises, Box 09292A, Cleveland, Ohio 44109. 4-83-11

Wanted

WANTED FOR CASH: 50, 53, 6AF6, 6HU8, 304TL, 4CX1000A, 4-1000A, all transmitting, special purpose tubes of Eimac/Varian. DCO, Inc., 10 Schuyler Avenue, North Arlington, New Jersey 07032. Toll Free (800) 526-1270. 5-82-tfn

MECHANICALLY INCLINED INDIVIDUALS: Assemble electronic devices in your home. Knowledge or experience not necessary. Get started in spare time. Turn your spare or full time into cash. NO investment. Write for free details. **ELECTRONICS DEVELOPMENT LAB,** Box 1560ES, Pinellas Park, FL 33565. 5-82-tfn

ELECTRONIC

Servicing & Technology

Advertising Sales Offices

NATIONAL SALES MANAGER

Greg Garrison
P.O. Box 12901
Overland Park, KS 66212
Phone: (913) 888-4664

LONDON, ENGLAND

*John Ashcraft & Co.,
John Ashcraft*
12 Bear Street, Leicester Square
London WC2H 7AS, England
Phone: 930-0525 Telex: 895-2387

AMSTERDAM, HOLLAND

*John Ashcraft & Co.
John J. Lucassen*
Akerdijk 150A
1171 PV-Badhoevedorp, Holland
Phone: 0-2968-6226 Telex: 18406 HARKE NL

TOKYO, JAPAN

*International Media
Representatives, Ltd.
Sumio Oka*
2-29, Toranomon 1-chome
Minato-ku, Tokyo 105, Japan
Phone: 502-0656

NORWOOD, AUSTRALIA

Hastwell, Williamson, Rouse PTY. LTD.
P.O. Box 419
Norwood, S.A. 5067
Phone: 332-3322
Telex AA 87113

TAIPEI, TAIWAN, R.O.C.

Antony Liu
Long Life Advertising Agency Co.
P.O. Box 17-134
Taipei, Taiwan, R.O.C.
Telephone: (02) 561-6629
Cable: Photop Taipei

BUSINESS OPPORTUNITIES

DEALERS EARN EXTRA PROFIT selling cable TV converters, Video accessories and other great items in our brand new dealer catalog. Request a **FREE** copy on your letterhead. ETCO, Wholesale Division, Dept. 535, Box 840, Champlain, N.Y. 12919. 9-82-12t

TV TECHNICIAN! Increase your income up to \$60,000 yearly. Rent-lease-sell TVs new-used, even from comfort of your home. Basic Preliminaries \$10.00. PERRY'S TV SYSTEMS, P.O. BOX 2120-2014 TRIPLETT ST., OWENSBORO, KY 42302. 12-81-tf

NORWALK, CALIFORNIA ESTABLISHED TV AND STEREO SERVICE AND SALES very busy money maker, excellent location, low rent, very good lease, 2300 square feet, 10 minutes to beaches and Los Angeles. \$40,000 includes inventory, large enough for living quarters, owner retiring, phone 213-863-1919. 11-82-tfn

TEXAS SUNBELT - Thriving TV & Video Sales & Service. RCA, Zenith, Litton. In booming east Texas area. Total package includes modern custom building, 3000 sq. ft., display, sales and warehouse with complete inventory, tools, fixtures. On 1/2 acre. 300 ft. frontage on major highway. Large trade area. Contact Glen Drennan, Agent, 214-675-8856. 11-82-tfn

COLORADO'S WESTERN SLOPE BECKONS: Established T.V. Repair and Sales business. Good lease, good terms. Old Homestead Realty, John McDermott, Agent, 737 Horizon Drive, Grand Junction, Colo. 81501 or call (303) 243-5100. 4-83-11

RAMPART SECURITY SYSTEMS DEALERS' sales are booming. The Rampart Franchise Program offers **ENORMOUS PROFIT POTENTIAL PLUS EXCITING RESIDUAL INCOME.** Our success and reputation are a result of a total business format approach for the EXPLoding alarm market. Product, marketing and management training with complete backup has made success a reality for over 70 dealers. No experience necessary just a strong desire to succeed. Investment only \$15,000 backed by inventory. Call Bob Pollack (800) 523-8002 or write RAMPART INDUSTRIES, INC., 1 Oxford Valley, Suite 317, Langhorne, PA 19047. 4-83-3t

OREGON COAST ESTABLISHED TV REPAIR SERVICE - high volume. Everything for \$44,500. Clarice at Century 21, Coos Realty Inc., 503-269-9346, #591. 3-83-2t

Help Wanted

SENCORE

APPLICATION ENGINEER

Electronic Test Instrument Co.

Due to growth, Sencore has immediate openings for 2 Application Engineers in our Sioux Falls, SD facility. Key responsibilities will include: writing application articles for our monthly 24 page technical publication with national circulation of 200,000, working closely with our design team in new product development and testing, as well as creating effective seminar material including reference material and video tape productions.

Successful candidates will have a minimum 2 year formal electronics education, or equivalent, with 4 years desired. Knowledge of digital circuits is a must. Past technical writing is a prerequisite. Good communications skills necessary. This position requires a strong background in test instrumentation and video, communications and general maintenance. At least 4 years practical hands-on experience necessary.

Sencore offers a competitive salary, full benefit program, profit sharing, and potential for growth. Located in Sioux Falls, SD, one of America's Top Ten Small Cities.

If this sounds like your kind of opportunity, send resume' to: Doug Bowden, Sencore, Inc., 3200 Sencore Drive, Sioux Falls, South Dakota 57107

EXPERIENCED BENCH TECHNICIAN. Minimum five years. VCR and color television, mostly Sony. Full or part time. TOP dollar paid for right man. 312-935-2150 Chicago. 4-83-1t

TV TECHNICIAN. Immediate opening for top quality benchman experienced in major brands, some audio experience desired. 14K-20K depending on qualifications. Paid benefits and bonus plan. Excellent opportunity for self motivator. Two stores with one service dept. Located near Smith Mtn. Lake. Send resume and references to J&L Electronics and Appl. Rt. 2, Box 30, Moneta, VA 24121, 703-297-5384. 4-83-1t

Advertisers' Index

Reader Service Number

Page Number

23 Automated Production Equipment	57
9 B & K Precision	17
13 Chemtronics, Inc.	47
Cleveland Institute of Electronics	37-38
6 Consolidated Electronics	5
19 Creative Electronics	55
D.A.T.A. Books	37-38
22 Digitron Electronics Corp.	57
ETA	55
20 ETCO	62
17 Electronics Specialists, Inc.	53
5 John Fluke Mfg. Co., Inc.	1
Global Specialties Corp.	25-26
24 Gould Instruments	21
Grantham College of Engineering	62
Jensen Tools	27-28
Leader Instruments	27-28
NRI Schools/Electronics Division	19, 25-26
NESDA	61
15 Optima	51
21 Oelrich Publications	62
14 Omnitron Electronics	49
1 PTS	IFC
Pace, Inc.	25-26
Philips ECG	15
18 Philmetric	53
16 Primefax	51
Primefax	27-28
RCA Distributor & Special Products	37-38, 44-45
RNJ Electronics	39-40
11 Howard W. Sams & Co.	46
2,3 Sencore	BC
Sencore	39-40
10 Simple Simon Electronic Kits, Inc.	41
8 Simpson Electric	43
25 A. W. Sperry Instruments, Inc.	13
TCG/New-Tone	23
Tektronix, Inc.	9
13 Temtron Electronics	39-40
Zenith	IBC



New from Zenith!

Two-way protection from high voltage surges for the appliances and electronics you sell or service!

A brief, high voltage surge – or spike – can occur in any electrical system and, at amplitudes lower than 600V, cause little or no damage.

But at greater amplitudes, a spike can do real damage. And the greater the high voltage surge – resulting from nearby lightning, for example – the greater the risk of harm, especially to solid-state devices.

That's why Zenith now introduces the Spike Suppressor to protect the susceptible TV receivers and household appliances you sell or service from damaging high voltage surges!

And the Zenith Spike Suppres-

sor protects not one, but two ways.

First, the new Zenith Spike Suppressor absorbs most line voltage spikes so only a safe voltage level reaches the protected equipment.

Second, heavy or prolonged voltage surges cause the Zenith Spike Suppressor to cut off power completely for added protection and to signal the need for a replacement.

That's double-duty protection against spikes and reason enough for you to stock and sell the Zenith Spike Suppressor. Your bottom line's another. So call your Zenith distributor now!

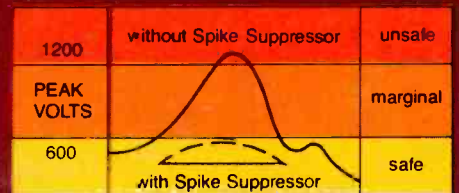

In this graph, the solid curve represents the excess voltage or "spike" imposed on an electric system and, represented by the dotted line, the protection provided household appliances as the Zenith Spike Suppressor absorbs the excess voltage and prevents it from surging thru the system.

ZENITH
The quality goes in before the name goes on.

Double Your Troubleshooting and Testing Productivity . . . Or Your Money Back!

Six-digit readout: Automatically tracks every CRT test. We call it digital autotracking. It's patent pending.

Bright 60 MHz dual-trace: 60 MHz CRT (3 dB); usable to 100 MHz (12 dB)

Delta PPV, Time, Freq: Measure any part of a waveform for PPV, time or frequency using Delta measurements. Just dial in waveform section you want to measure and push.

Simplify Freq ratio tests: Automatically compare input/output ratio of multiply/divide stages from 1:1 to 1:999,999 with the push of a button.

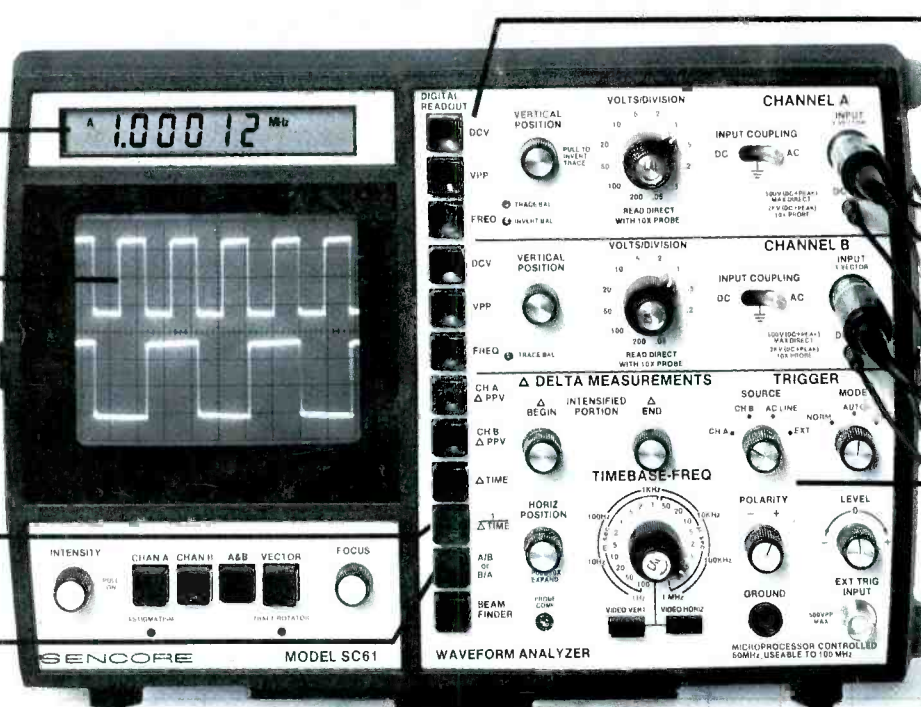

Autotracking DCV, PPV, Freq: Measure DCV to .5%; PPV to 2%; freq. to .001%. Just push a button for either Channel A or B.

One probe input: One probe input per channel for all measurements—digital and scope—with 5 mV to 2000 V measuring range. (2 lo-cap probes provided.)

Super sync: ECL provides rock-solid sync trigger circuits with only 4 controls; includes TV sync separators for video work.

\$3275

U.S. Patent Pending
Financing Available

The first scope with push button digital readout. If you use general purpose oscilloscopes for troubleshooting or testing, we can double your present productivity with the SC61 Waveform Analyzer, the first scope with push button digital readout.

It's ten times faster — ten times more accurate. The SC61 is the first and only instrument to integrate the speed and accuracy of a digital readout with the viewing capability of a high performance 60 MHz scope. Connect only one probe and you can view any waveform to 60 MHz. Then, just push a button to read DCV, PPV, frequency and time.

There are no graticules to count or calculations to make so every measurement is 10 to 100 times faster than before.

The digital readout is 10 to 10,000 times more accurate than conventional scopes as well, for measurements you can trust in today's high precision circuits.

Plus having everything you want to know about a test point, at the push of a button, eliminates guesswork and backtracking.

A special Delta function even lets you intensify any part of a waveform and digitally measure the PPV, time or frequency for just that waveform section.

And it's neat. No more tangled leads, piles of probes or dangling cords. The SC61 is an entire test station in one unit.

Double your productivity. When we say the SC61 will double your productivity, we're being conservative. We've seen cases of three, four, even ten time increases in

productivity with this first-of-its-kind, automated oscilloscope. Every situation is different, however, so try the SC61 and judge for yourself. Here's our offer.

Money back guarantee. If the SC61 does not at least double your productivity during the first thirty days, you may return it for a full refund, including freight both ways.

Call today. Get the entire SC61 Waveform Analyzer story. Call toll-free today, and ask for our eight page color brochure. It could be the most productive call you make this year!

**Phone Toll-Free
1-800-843-3338**

Alaska, Hawaii, Canada, and South Dakota call collect (605) 339-0100

SENCORE

3200 Sencore Drive, Sioux Falls, SD 57107

For Information Circle (2) on Reply Card
For Demonstration Circle (3) on Reply Card