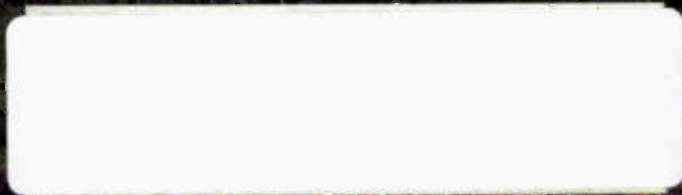


For industrial maintenance and consumer servicing professionals

June 1981 □ \$2.25

# Electronic Servicing



**TV antenna source guide**  
*Locating MRO parts*

**PHILIPS KNOWS  
HOW TO SUCCEED  
IN BUSINESS.  
THEY JUST BOUGHT  
SYLVANIA ECG.**

SYLVANIA RECEIVING TUBES                      SYLVANIA PICTURE TUBES  
SYLVANIA ECG® SEMICONDUCTORS           SYLVANIA SPECIAL PRODUCTS  
SYLVANIA DATA DISPLAY TUBES

**Philips ECG, Inc.**

A NORTH AMERICAN PHILIPS COMPANY

Circle (1) on Reply Card

## Electronic Servicing

Editorial, advertising and circulation correspondence should be addressed to: P.O. Box 12901, Overland Park, KS 66212 (a suburb of Kansas City, MO); (913) 888-4664.

### EDITORIAL

Bill Rhodes, *Editorial Director*  
Carl Babcoke, *Consumer Servicing Consultant*

Rhonda Wickham, *Managing Editor*  
Lynn Chamberlain, *Associate Editor*  
Marjorie Riggan, *Editorial Assistant*

### ART

Dudley Rose, *Art Director*  
Linda M. Pocsik, *Graphic Designer*

### CIRCULATION

John C. Arnst, *Director*  
Evelyn Rogers, *Manager*  
Dee Manies, *Reader Correspondent*

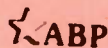
### ADMINISTRATION

R. J. Hancock, *President*  
George Laughead, *Publisher*

### ADVERTISING

Greg Garrison, *National Sales Manager*  
Mary Birnbaum, *Production Manager*

Regional advertising sales offices listed near Advertisers' Index.



Member, American Business Press



Member, Audit Bureau of Circulation

**ELECTRONIC SERVICING** (USPS 462-050) (with which is combined PF Reporter) is published monthly by Intertec Publishing Corp., P.O. Box 12901, 9221 Quivira Road, Overland Park, KS 66212. Second Class Postage paid at Shawnee Mission, KS 66201. Send Form 3579 to P.O. Box 12901, Overland Park, KS 66212.

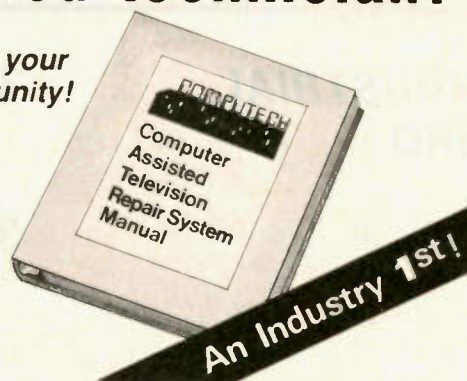
**ELECTRONIC SERVICING** is edited for technicians who repair home-entertainment electronic equipment (such as TV, radio, tape, stereo and record players) and for industrial technicians who repair defective production-line merchandise, test equipment, or industrial controls in factories.

Subscription prices to qualified subscribers: one year \$12, two years \$19, three year \$24 in the USA and its possessions. Foreign countries: one year \$17, two years \$27, three years \$35. Subscription prices to all others: one year \$25, two years \$50 in the USA and its possessions. Foreign countries: one year \$36, two years \$72. Single copy price \$2.25; back copies \$3.00. Adjustment necessitated by subscription termination to single copy rate. Allow 6 to 8 weeks delivery for change of address. Allow 6 to 8 weeks for new subscriptions.

**INTERTEC PUBLISHING CORP.**  
©1981 All rights reserved.

# Would you pay \$20 a month for a highly skilled technician?

Here's your opportunity!



Our exclusive COMPUTECH manual is an organized, easily accessible source of solutions to those frustrating "tough-dog" service problems. Most importantly, this manual is expanded and updated each month to keep you in step with the rapidly changing television industry.

COMPUTECH can save hours of frustrating and unprofitable diagnostic time!

- approximately 6500 symptoms and solutions to "tough-dog" problems.
- indexed numerically by SAMS number.
- symptoms listed alphabetically for faster access.
- monthly updating provided.
- contains step-by-step procedures to locate the most difficult problems.
- standardizes your trouble shooting techniques.
- excellent training aid.
- saves YOU time and guesswork.

Over the past two years "COMPUTECH" has combined hundreds of hours of experience by professional technicians with the unique advantage of a computer to produce an attractive, easy to read, 8½"x11" binder that contains the type of information needed to make TV servicing faster, easier, and more profitable.

**COMPUTECH — AT TODAY'S PRICES... YOU CAN'T AFFORD NOT TO!**

COPYRIGHT © 1980

Call us direct (801) 277-2655 or mail this coupon today.

<b>COMPUTECH</b>	ES-2
4685 Holladay Blvd. Salt Lake City, Utah 84117 Phone (801) 277-2655	
Please send my COMPUTECH manual on the following basis:	
<input type="checkbox"/> A trial issue for \$24.95 plus postage and C.O.D. charges.	
<input type="checkbox"/> My yearly subscription updated monthly on the basis of \$20.00 per month plus postage and C.O.D. charges.	
<input type="checkbox"/> Or, my yearly subscription for \$240.00 which includes all monthly updating and postage.	
Name	_____
Service Company	_____
Phone	_____
Address	_____
City	_____ State _____ Zip _____



4685 Holladay Blvd.  
Salt Lake City,  
Utah 84117  
Phone (801) 277-2655

Circle (3) on Reply Card

# Electronic Servicing

June 1981 □ Volume 31, No. 6

---

## INDUSTRIAL MRO

### 30 A computerized service operation

*By Carl Babcoke, CET*

The Computech system, designed to handle the electronic servicing business, is described.

### 38 Service center provides technical background

The success of the Ohaus Scale Corporation's factory service program is based on specialized training, a self-teaching service manual and free access to the company's service department for expert advice.

---

## CONSUMER SERVICING & INDUSTRIAL MRO

### 23 Locating MRO parts

A chart from General Electric shows how to locate parts the easy way.

### 26 Antenna roundup

*By the Electronic Servicing staff*

The latest in antennas and how to choose the one you need.

### 40 Reports from the test lab

*By Carl Babcoke, CET*

The Sperry model EZ-6100 digital multimeter is discussed.

---

## CONSUMER SERVICING

### 6 Servicing RCA CTC74

*By Homer L. Davidson*

Service problems and their solutions are analyzed for RCA CTC-74 chassis color receivers.

### 16 Zenith chroma servicing

*By Carl Babcoke, CET*

Troubleshooting the Zenith model SM1973P.

---

## Departments

4 Scanner

37 People

15 Symcure

42 Photofacts

24 Test equipment

43 Reader's exchange

32 Product report

---

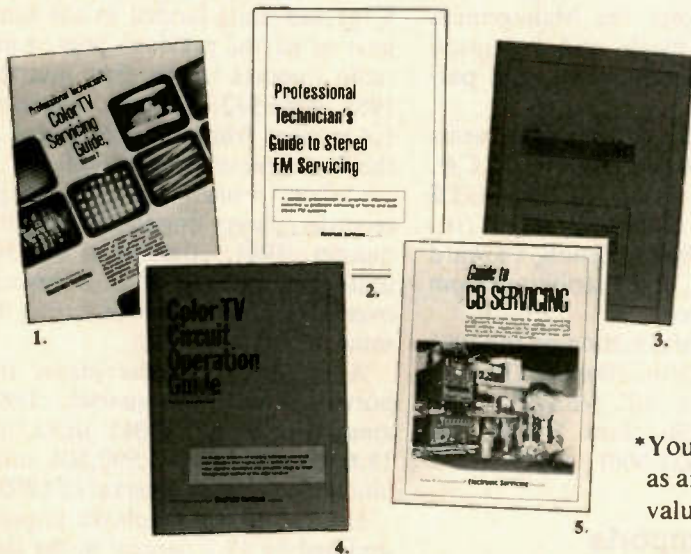
## About the cover

*A possible home receiving dish in a remote setting is featured, courtesy Jim Kluge of the Winegard Company. For information on current antennas, see the Antenna Roundup on page 26.*

# Special Inventory Clearance Offer...

Get all 5\* great books for

**\$10.00**  
(a \$25.00 value)



**Electronic Servicing** brings you 5 of its most popular reference guides for a fraction of their original value...

- Color TV Servicing
- Better Management
- Stereo FM Servicing
- Color TV Circuit Operation

plus:

\*You get "Guide to CB Servicing" FREE as an extra bonus for ordering this valuable set of reference manuals.

*For a limited time* **Electronic Servicing** is offering this complete package of 5 reference guides for one low price

**1. COLOR TV SERVICING GUIDE Volume 2**

Fourteen chapters explain many repairs of color TVs from the tuner to the deflection yoke. Included are photos of trouble symptoms from the screen of the picture tube, transistor tests, case histories of typical repairs, explanations of scan rectification, and descriptions of essential tools and techniques.

**3. BETTER MANAGEMENT GUIDES**

Practical information about bookkeeping and accounting procedures, service labor pricing, technician incentive programs, methods for increasing shop productivity, and how to get the most from your insurance dollars, plus a checklist for evaluating your own business management techniques.

**2. PROFESSIONAL TECHNICIAN'S GUIDE TO STEREO FM SERVICING**

A concise presentation of practical information essential to proficient servicing of home and auto stereo FM systems.

**4. COLOR TV CIRCUIT OPERATION GUIDE**

An in-depth analysis of existing tube and solid-state color circuitry that begins with a review of how the color signal is developed and proceeds stage by stage through each section of the color receiver.

*Order your set today for only \$10.00 by sending in this coupon:*

**Electronic Servicing**

P.O. BOX 12901, DEPT. GG, OVERLAND PARK, KS 66212

Please send me Electronic Servicing's 5 reference guides at the price of only \$10.00 for the complete set.

Name \_\_\_\_\_

Company \_\_\_\_\_

Address \_\_\_\_\_

City \_\_\_\_\_ State \_\_\_\_\_ Zip \_\_\_\_\_

Signature \_\_\_\_\_

Charge to my  VISA or  MasterCard # \_\_\_\_\_  
or  I have enclosed my check for \$10.00

Make checks payable to: Electronic Servicing

**5. Your FREE bonus:**

**"Guide to CB Servicing"**



The information most needed for efficient servicing of Citizen's Band transceiver radios; including circuit analysis, suggestions for test equipment and advice about CB business.

## IEC publishes hearing aid agreement

The year 1981 not only marks the 75th anniversary of the International Electrotechnical Commission but also the International Year for Disabled Persons. Just published by the IEC in this vein is a new international agreement concerned with the magnetic field strength in audio-frequency induction loops for hearing aid purposes.

IEC Publication 118-4 gives recommendations to audio-frequency loop systems producing an alternating magnetic field and intended to provide an input signal for hearing aids operating with an induction pick-up coil. For further information, write the Information Officer, Central Office of the IEC, 1 Rue de Varembe, 1211 Geneva 20, Switzerland.

## If you want to be a 10

Dr. Robert E. Lindberg, author of the NESDA training tape "Success is Self Propelled," will lead a training seminar, "You, too, can be a 10," for the Management School at the 1981 National Electronics Service Convention to be held August 3-8 at the Innisbrook resort, Tarpon Springs, FL. His seminar on personal relationships at work and with the family will include an analysis of self-image and how it is used to set personal goals. Dr. Lindberg is an associate professor of Educational Psychology at the University of Texas at San Antonio. He is also the author of several educational publications, including a book on coping with psychological stress.

Registration for the Management School seminar with Dr. Lindberg is \$20.00 for a single, \$30.00 for two people from the same company, and \$50.00 each for non-members, in addition to regular convention registration.

Convention registration is \$100.00 for one and \$80.00 for each additional adult. Add \$10.00 per person after June 30. The registration fee includes all schools and

seminars (except the Management School), all meals and banquets, golf, tennis tournaments, and parties.

Sponsors for convention events include Tronics 2000, RCA, Panasonic, Sony, PTS, GTE Sylvania, General Electric, Magnavox, Sharp, Zenith, Howard W. Sams Co., and distributors from the Florida area.

For more information on the 1981 National Electronic Service Convention write or call NESDA, 2708 West Berry St., Fort Worth, TX 76109, (817) 921-9061.

## Exports, imports show increase

According to the marketing services department of the Electronic Industries Association's consumer electronics group, exports of color television receivers increased to 162,610 units in the first quarter of 1981, a gain of 29.8 percent above the 125,249 reported in the first three months a year ago. Monochrome TV exports advanced to 59,618 units in the first quarter, 1981, up 110.4 percent over 28,338 units shipped out of the country in the same period a year ago. Color television imports in the first quarter of 1981 increased to 413,511 units, up 98.6 percent over 208,245 units landed in the same period a year ago. Monochrome TV imports were 1,405,339 in the first three months of 1981, a rise of 2.1 percent above 1,376,044 units brought into the U.S. in the first quarter of 1980.

Auto radio exports in the first quarter, 1981, amounted to 185,199 units, an increase of 83.6 percent over 100,852 units exported in the first quarter of the previous year. Entertainment band radio exports in the first quarter, 1981, totaled 150,527 units, up 34.3 percent above 112,079 units shipped out in the first quarter of 1980. Phonograph and tape equipment exports also advanced in the first three months of 1981.

Home radio imports amounted to 6,700,000 units in the first quarter, 1981, a gain of 16.3 percent over

5,761,223 units landed in the same interval of the previous year. Auto radio imports in the first quarter, 1981, were 912,426 units, a gain of 1.4 percent from 900,155 landed in the first three months of 1980.

Color video (VCR) tape recorder/player imports in the first quarter, 1981, climbed to 385,303 units, an increase of 86.0 percent over 207,197 units landed during the same period a year ago.

Audio tape recorder/player imports in the first quarter, 1981, amounted to 4,733,041 units, up 18.6 percent over 3,990,504 units landed in the same interval of 1980.

Home audio tape player imports declined by 19.3 percent in the first quarter of 1981, while auto audio tape players gained by six percent.

Customs value of U.S. imports increased for all consumer electronics products, except phono-combinations, in the first quarter, 1981, with color television customs value up 101.4 percent over the same period of 1980 and color video (VCR) tape recorder import customs value up 95.4 percent.

Dollar value of total U.S. exports increased in the first quarter, 1981, for television, auto radios, phonographs and tape equipment, with entertainment band radios registering a decline.

## EDS '81 draws 2,300 customer personnel

More than 2,300 distributors and sound contractors attended the 1981 Electronic Distribution Show, according to preliminary attendance figures, exceeding the show management's attendance predictions for EDS' first visit to Atlanta. With 2,300 customer personnel attending, EDS '81 attendance was on par with the 1980 Las Vegas show. Although different in geographic and product interest mix, this show offered participating manufacturers the opportunity to meet with Eastern customers who have not travelled to Las Vegas.

The opportunity to meet a new



## RCA Receiving Tubes - for one-trip servicing.

Most callbacks aren't caused by bad servicing. Components are the reason.

That's why you need receiving tubes you can trust, dependable receiving tubes from RCA. We offer over 1,000 types - all produced to exacting specifications.

For miniatures, Novars, Compactrons, Nuvistors, Glass Tubes, Metal Tubes and more, count on your RCA Distributor. He's got the tubes that help you finish the job in just one trip.

### Increase your profits with RCA service aids and sales promotion aids.

See your local RCA Tube Distributor for RCA's technical guides, service tools and tube caddies. They all make your service work faster and easier while RCA's in-store signs and eye-catching displays promote your business professionally.

**RCA** Receiving Tubes



RCA Distributor & Special Products Division,  
Deptford, N.J. 08096

audience also attracted more exhibitions to the show, to the point where manufacturers had to be turned away because the show was sold out. Total EDS '81 attendance, including manufacturers and sales representatives, is estimated at 7,500.

### D&B subsidiary surveys mergers, acquisitions

Each company which acquired other companies during the past two years completed an average of 2.6 transactions after considering an average of 82 possibilities, according to recent surveys released by Mergex Inc., a new subsidiary of Dun & Bradstreet. Of the candidate companies considered by the 273 acquirers that responded, 77 percent were privately owned and 23 percent were publicly held companies.

Mergex, which became operational in 1980, maintains detailed information for prospective acquisitions on approximately 425,000 companies through a nationwide system of reporting, research, com-

puter and analytical resources. Of these, 413,000 are privately owned.

### Light industry a priority in China

The light industrial sector of the Chinese economy is being brought into a higher priority as a result of economic restructuring that is taking place within the country this year. Consequently, there is considerably less emphasis being placed on large capital investment projects, bringing them into balance with light industry.

Stephen A. Sind recently returned from China where he met with officials of Chinese organizations, the U.S. Embassy and Consulate and Wang Wen-Lin, Vice President of the China Council for the Promotion of International Trade (CCPIT.) Wang emphasized that Chinese purchasing authorities have not stopped buying, but have been shifting their priorities into projects that require less foreign exchange over a shorter period of time and that will enable China to continue

both domestic and export growth.

CEG's Sind also emphasized that the Chinese 4th Ministry of Machine Building (which is responsible for electronics production, processing and component manufacturers) stressed that the 3000 factories under their jurisdiction are undergoing intense development and modernization plans in order to keep pace with a growing domestic demand for electronic components and high quality electronic products, as well as to increase export capabilities.

The Cahners Exposition Group will hold two international exhibitions in 1982, both in the light industry sector: Electronics Production/semiconductor Expo in Beijing, April 15-24; and the Food Processing and Packaging Expo, in Guangzhou, July 7-14.

Trade promotion activities in China, such as the expositions being planned by CEG, are supported by the U.S. Embassy and Consulate, and continue to provide exporters with a good vehicle for market penetration in China.

# Servicing RCA CTC74

By Homer L. Davidson, Davidson Radio & TV, Fort Dodge, Iowa

*Typical service problems and their solutions are presented for RCA CTC-74 chassis color receivers.*

Problems in RCA CTC74 Color-Trak color TV receivers often are concentrated in the low-voltage, horizontal-sweep and high-voltage sections, as is true of many other brands and models. These typical trouble symptoms and methods of locating the defective components should help technicians troubleshoot more efficiently.

The CTC74 vertical chassis (Figure 1) becomes accessible when two screws holding brace rods at the top and one screw in the swiveling mechanism are removed so the

chassis can be tilted backward.

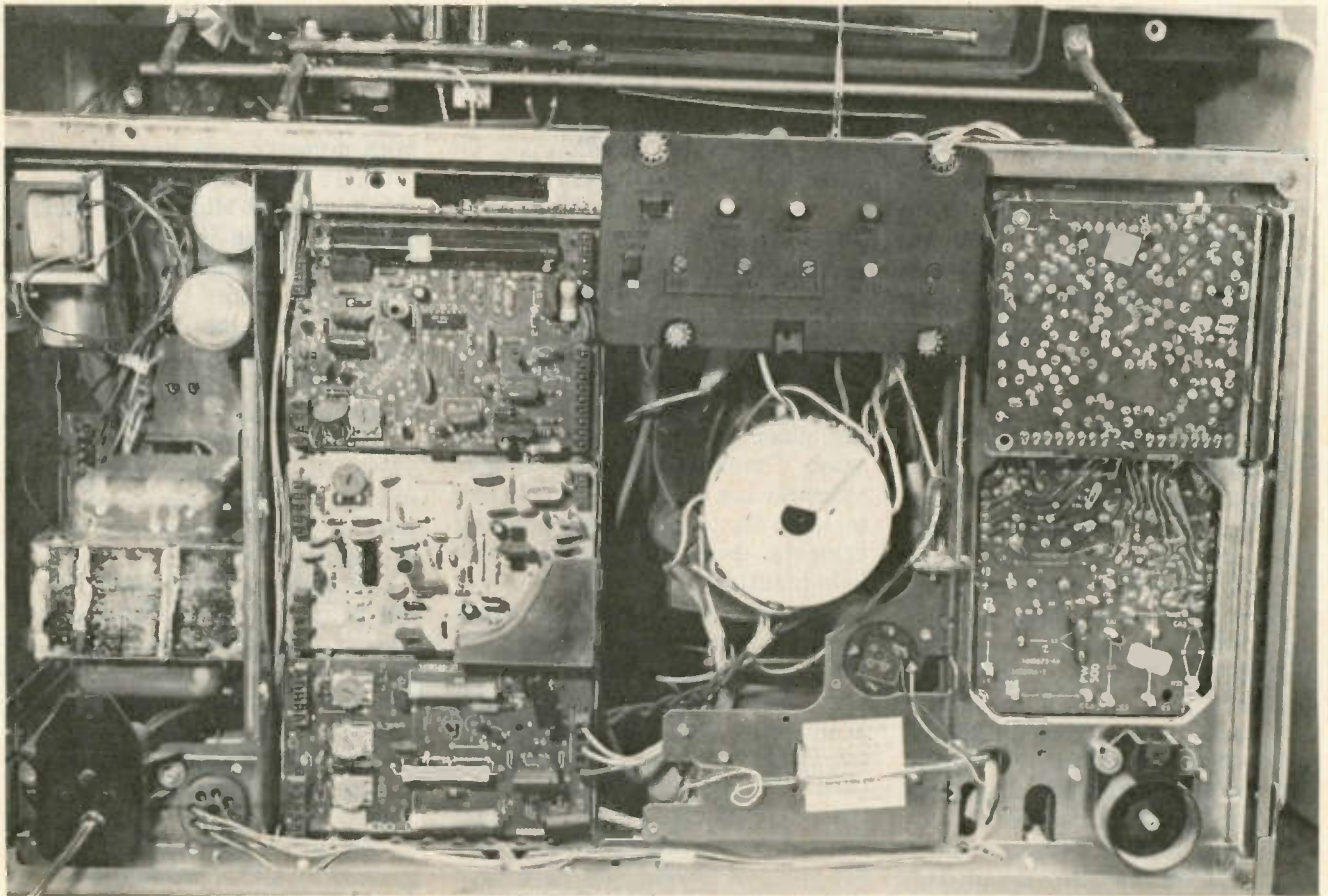
## Intermittent operation

Many types of no operation or intermittent operation are caused by failure of the power relay (K201 in Figure 2).

K201 relay has two sets of normally-open contacts (they are open when the relay coil does not have power applied). When receiver power first is switched on, both sets of contacts are open. Therefore, magnetizing current of T201 power transformer and rectified Vdc

charging current flow through thermistor RT202. This limits the maximum current peak, protecting the components and reducing the blinking of house lights.

The +171V (A) source voltage rises rapidly at turn on, because the other set of contacts also is open, disconnecting the heavy load of the horizontal-sweep circuit. When voltage of the +171V (A) source reaches about +140V, the relay coil has sufficient power from voltage divider R203/R213 to close both sets of contacts. (The voltage con-



**Figure 1** This rear view of an RCA CTC74-chassis color receiver shows: power-supply components in the left one-quarter; video module, chroma module and matrixing module (from top to bottom); and at the right the horizontal/vertical module above and the horizontal and high-voltage sections below.



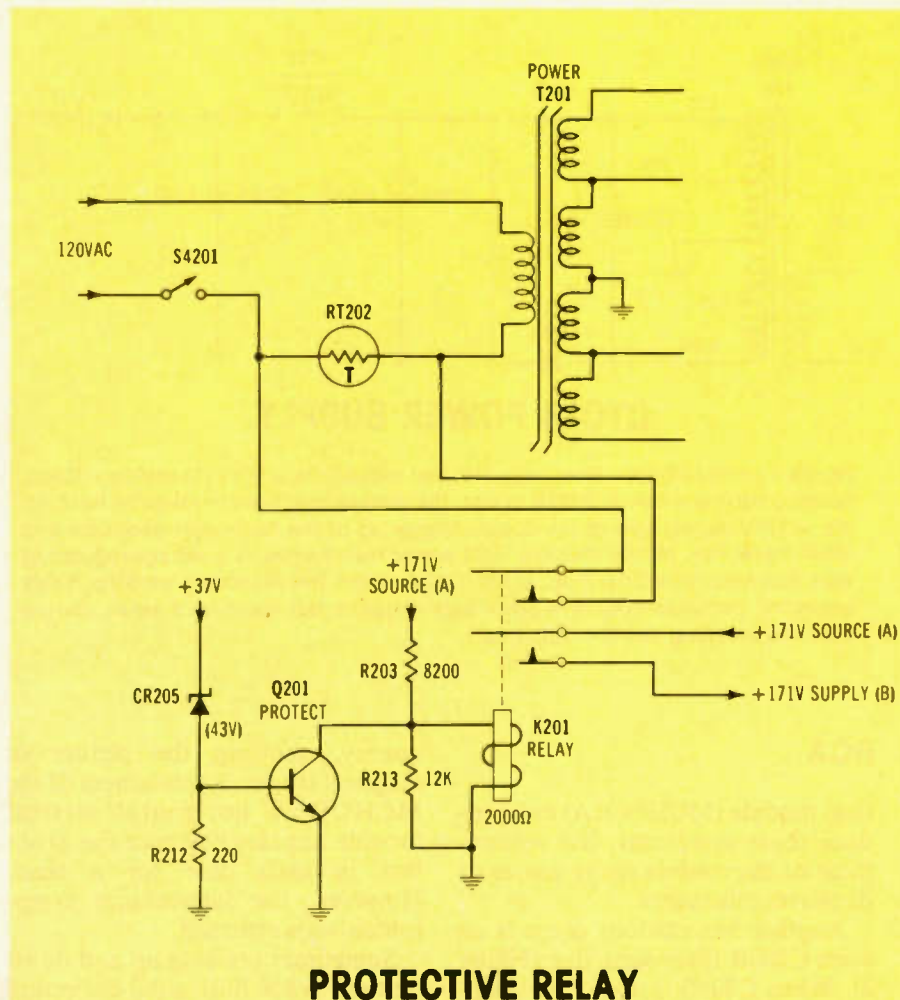
tinued to rise until it reaches the required +171V.) One set of contacts shorts across thermistor RT202, increasing the ac voltage at the power-transformer primary. The other set of contacts connects the +171V (A) supply to the +171V (B) supply that powers the SCR horizontal-deflection system. The horizontal oscillator is operated from the +171V (A) source, so it begins operation before the SCRs, thus preventing starting transients and possible damage. The SCR sweep circuit is sensitive to off-frequency operation and incorrectly phased pulses from the horizontal oscillator.

Protective transistor Q201 does nothing unless the +37V supply rises above +43V, which causes zener diode CR205 to conduct positive voltage to the Q201 base. Sufficient forward bias at the Q201 base forces Q201 to short across the K201 relay coil. Without coil voltage, the relay releases and removes all supply voltage from the horizontal-sweep circuit. This eliminates sound, picture and raster (along with the high voltage).

An open circuit in the relay contacts that short across the RT202 negative-temperature-coefficient thermistor fails to remove RT202 from the line-current path. Therefore, the RT202 resistance continues to decrease as the current continues to heat the thermistor. Eventually, the resistance will stabilize at a low value so it should not interfere with receiver operation. However, the thermistor is not designed for constant operation with such a large load, and it might fail. If it becomes open, the receiver will have no power; not even a dial lamp will light. If it becomes a near short, the receiver operates normally, but without the surge suppression that minimizes component failures.

After RT202 has been overheated, it should be cooled for several minutes to restore the normal  $15\Omega$  cold resistance.

If the contacts that connect +171V (A) to +171V (B) become open, all B+ is removed from the SCR deflection circuit, thus eliminating the raster and HV. If



## PROTECTIVE RELAY

Figure 2 Erratic contacts of the K201 relay can produce many symptoms.

these contacts become erratic, the picture and sound also will be intermittent.

Open K201 contacts are the first suspects when the pilot lamp is lighted, but the receiver is dead or has erratic width.

In a normal CTC74 receiver, a click from the relay should be heard distinctly each time the power switch is operated on or off. If the click is soft or occurs later than the switch operation, the relay might require replacement.

Incidentally, it is not practical to attempt repairs on the K201 relay contacts, because the relay is fully enclosed. Check the voltage at filter capacitor C206B. If the voltage is higher than +171V, but at pin 4 of the yoke socket the voltage is lower, fluctuating or zero, the relay con-

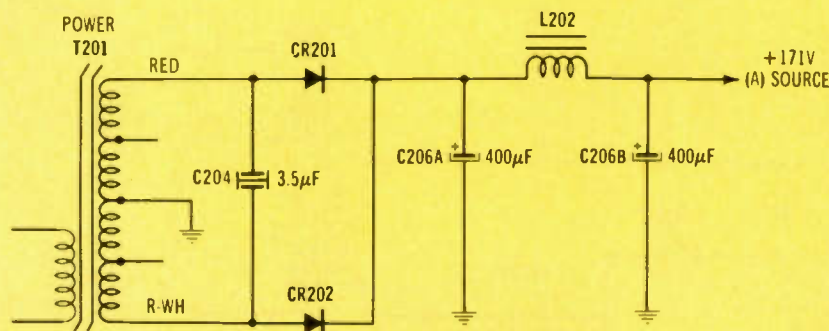
tacts undoubtedly are defective.

Buzzing of relay K201 is rare because the coil is operated from a Vdc supply. However, it can buzz or chatter if the supply voltage changes rapidly or when the power supply has excessive hum. The picture symptoms can become very complicated when the relay buzz opens the relay contacts and causes further variation of the B+. Test by connecting jumpers across both sets of relay contacts.

### Flashing and incorrect sweep frequency

These symptoms appear to describe two separate defects. It seems unlikely for a narrow picture with erratic flashes to have any connection with an out-of-lock picture.

Defects in the horizontal and ver-



### CTC74 POWER SUPPLY

**Figure 3** An open C206A filter capacitor can reduce the + 171V (A) source voltage, causing narrow width. If C206B opens, the unbypassed horizontal-pulse hash on the + 171V supply can cause double triggering of the horizontal oscillator and other instability. Notice that the T201 power transformer is a voltage-regulating type that requires a 3.5µF capacitor (C204) across the secondary winding. If this capacitor becomes open the secondary voltages fall, causing a small picture from the resulting low B+ voltages.

## RCA

tical module (MCHOO1A) can produce those symptoms, but replacement of the module easily proves or disproves this source.

Another less obvious cause is an open C206B filter capacitor (Figure 3). When C206B is open, the symptoms probably include a narrow picture with flashing white lines from erratic triggering of the SCR-sweep circuit. Often the picture is out of lock because the horizontal oscillator also is affected.

A fast and dependable test is to scope the filter capacitors, especially C206B. There should be no more than a few volts of sawtooth ripple and a little horizontal hash at the capacitor. If there is more, turn off the power, parallel the filter with another 400µF, turn on the power and repeat the scope-and-picture analysis. Normal performance proves the original capacitor is defective. It is recommended that the entire unit be replaced, rather than merely paralleling the old section. Two fuses and the lugs of C206 are pointed out in Figure 4.

### Intermittent frequency

Over the years, several CTC74 chassis have developed intermittent or erratic drifting of horizontal fre-

quency, showing the picture in diagonal stripes. Replacement of the MCHOO1A horizontal/vertical module appeared to cure the problem in each case for a time. However, the intermittent symptoms always returned.

Sometimes pressing up and down on the PW500 horizontal-deflection board (Figure 5) started or stopped the out-of-lock stripes. Resoldering all joints along the right edge of the PW500 board solved the problem.

Symptoms of a slow horizontal-frequency drift that appears after several minutes of operation often can be cured by installation of a thermistor in series with the horizontal-hold control (Figure 6). This added thermistor (RCA stock number 142552) is installed physically between stake "HH" and one lug of the horizontal-hold control. Shorten the thermistor leads and dress it away from all other components.

### Sound but no raster

When there is no raster, one of the first tests should be measuring the high voltage. Loss of HV often is caused by defects in or around the two intrinsic-rectifier (ITR) devices that each contain one SCR and one diode of the correct polarity. Average voltage is about +160V at

the case of ITR402, the retrace SCR in Figure 7. This voltage comes from the +171V supply through a winding of T402.

ITR401 terminal-3 dc voltage usually measures about +70V. Notice that there is no resistive path bringing this voltage from any Vdc supply. The voltage comes through coupling capacitors C1A and C1B from the ITR402 supply voltage. The +70V actually is produced by charging currents of C1A and C1B. All negative peaks at the trace ITR are clipped by conduction through the internal diode of ITR401. Part of the positive voltage produced by capacitor-changing current creates the dc voltage reading. The ITR401 SCR is gated into conduction, and grounds the remainder of the positive voltage.

ITR devices can be tested for shorts by using an ohmmeter. But leakage tests are not accurate, because the devices operate with high ac voltages that cannot be used during tests. If either of the ITRs are suspected, it is advisable to replace both.

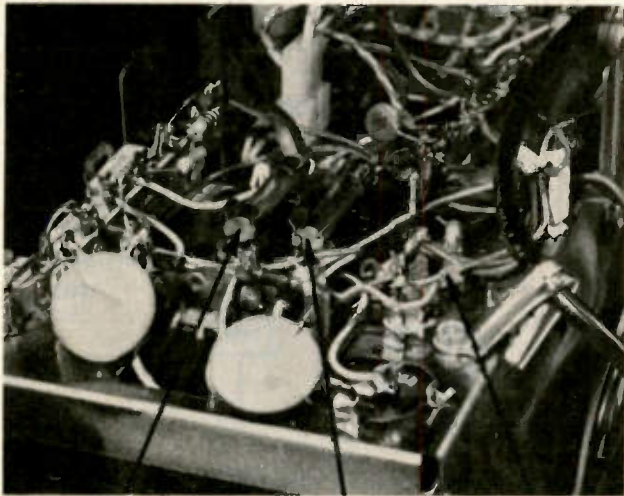
Other circuits and components connected to the T401 flyback transformer also can become defective, loading the flyback and killing the high voltage. For example, when C516 (Figure 8) shorts, diode CR504 also is destroyed, and the resulting flyback overload eliminates the high voltage while reducing the ITR401 voltage to about +15V.

### Horizontal foldover and narrow width

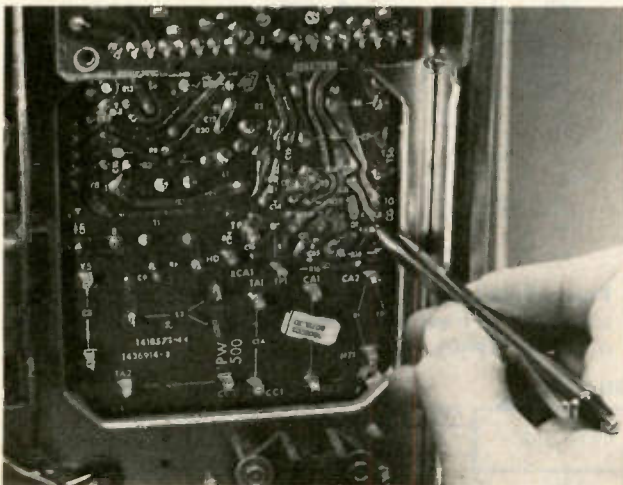
Most cases of narrow picture combined with severe foldover are produced by an open C7 or L3 (Figure 9). C7/R7 is a high-pass filter and L3/R6 is a low-pass filter. These filters together change the T402 waveshape into a different waveshape that is needed to drive the ITR401 gate.

An open C7 or L3 greatly reduces the drive signal, although some signal passes by stray capacitance. This incorrect signal has improper waveshape and phase, so ITR401 gates-on at the wrong time, causing foldover.

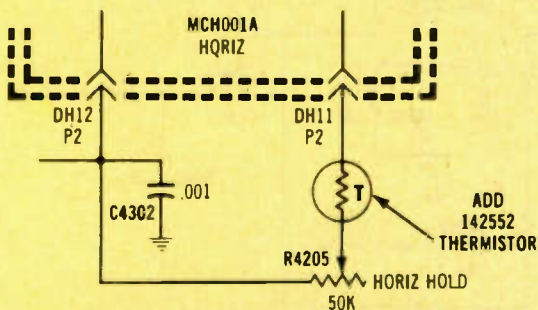
Other intermittent width and high-voltage problems can be caus-



**Figure 4** The arrow at left points to F202, a 3A fuse for the picture-tube heaters. At center is F203, a 3A fuse protecting the +37V supply, while the arrow at the right points to the lugs of filter-capacitor C206.



**Figure 5** When the cause of horizontal instability is obscure, carefully resolder all joints along the right edge of the PW500 circuit board (above and below the pen tip).



### CURE HORIZ DRIFT

**Figure 6** To cure a slow drift of horizontal frequency that causes locking problems, add a thermistor as shown.

# Lots of smart companies have high blood pressure control programs.



MASSACHUSETTS MUTUAL LIFE INSURANCE COMPANY

*Campbell Soup Company*



AT&T



bloomingdale's

## What about yours?

Uncontrolled high blood pressure is a major health problem. About 26 million workdays and billions of dollars are lost each year because of high blood pressure.

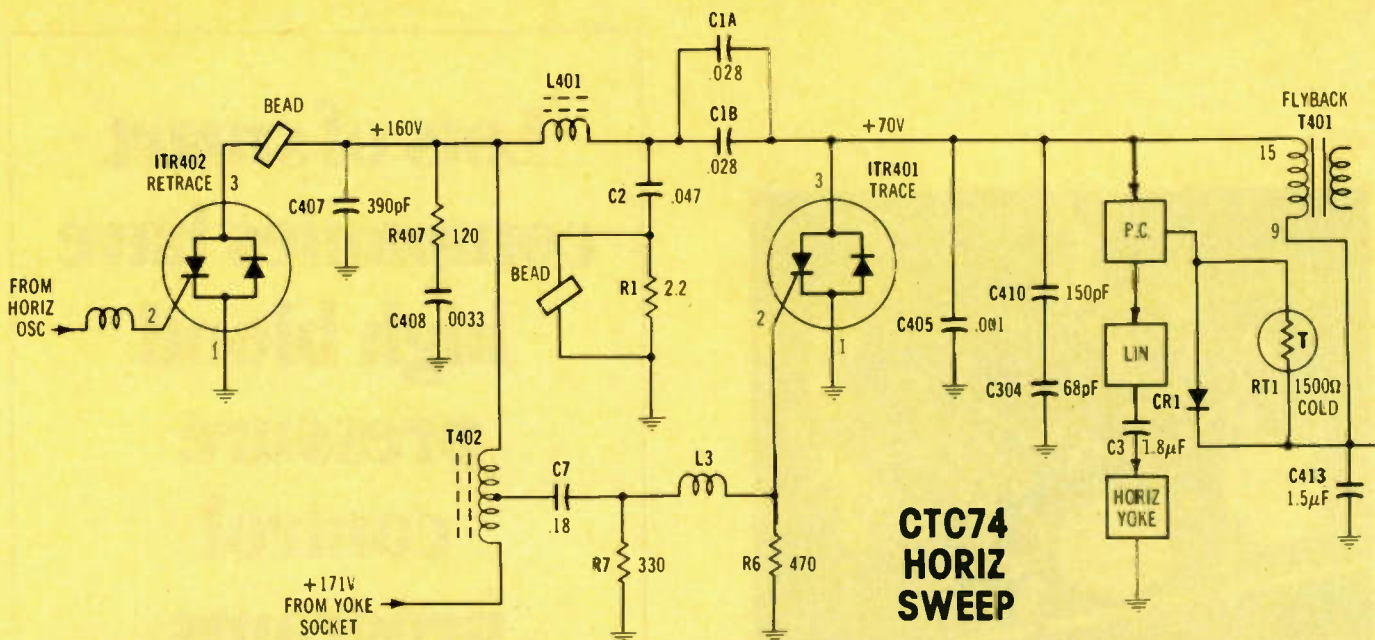
But high blood pressure can be easily detected and controlled. Proper treatment, every day, can prevent heart failure, kidney disease, stroke and premature death caused by high blood pressure.

Many companies, large and small, have successful on-the-job high blood pressure programs for their employees and management. Look into it. You can save time and money. And protect your employees' health. To find out the whole story write:

Ms. Judie LaRosa  
Worksetting Programs Coordinator  
National High Blood Pressure Education  
Program  
Bethesda, MD 20205

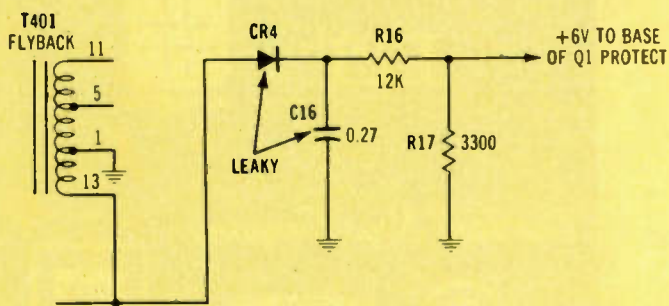
## High blood pressure. Treat it and live.

National High Blood Pressure Education Program,  
National Heart, Lung, and Blood Institute,  
U.S. Department of Health and Human Services



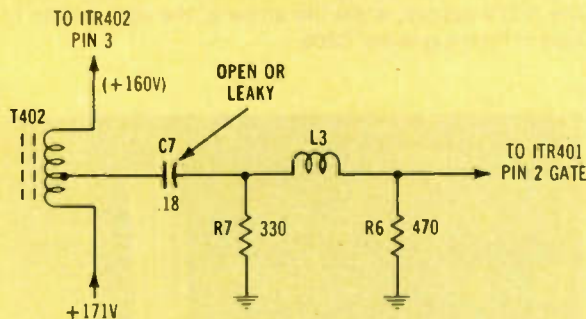
### CTC74 HORIZ SWEEP

**Figure 7** Most important horizontal-deflection components are shown here. The circuit and the yoke can be operated with the flyback disconnected, if necessary, to isolate flyback overloads. These are the critical components: T401; L401; L3; C7; C1A; and C1B. The capacitors must be intended for high-current pulse operation, otherwise they will overheat and fall rapidly.



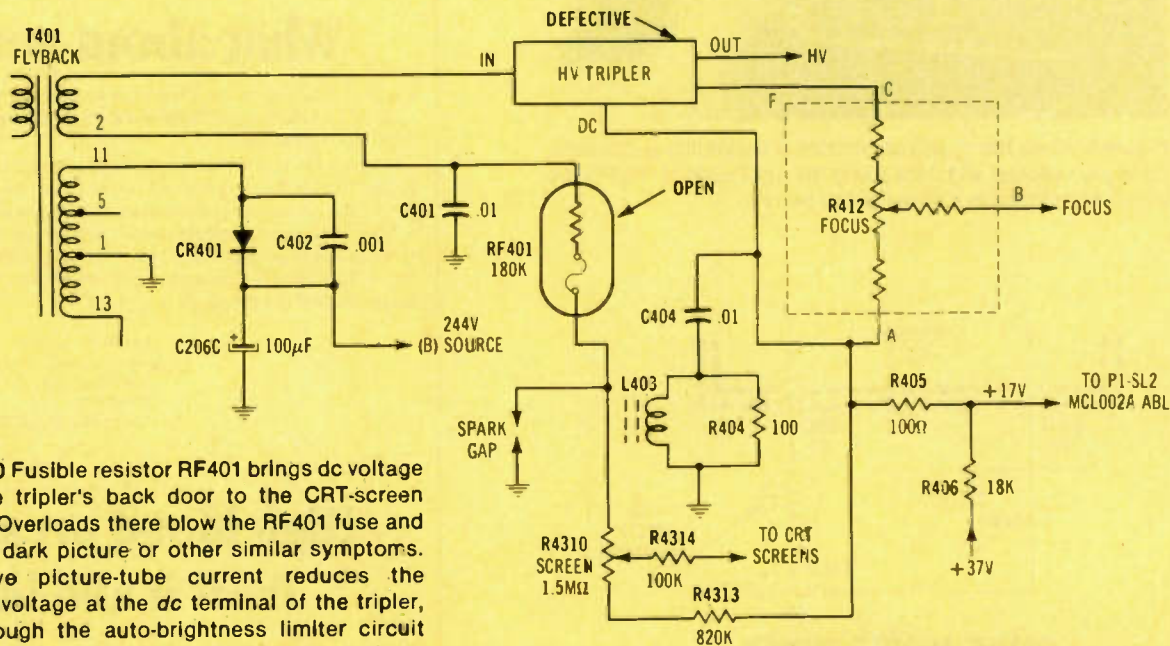
### FLYBACK OVERLOAD

**Figure 8** When C16 shorts, usually CR4 also shorts and the overload eliminates the high voltage.



### HORIZ FOLDOVER

**Figure 9** An open C7 or L3 usually gives symptoms of narrow width with extreme foldover and low dc voltage at terminal 3 of ITR401.



**Figure 10** Fusible resistor RF401 brings dc voltage from the tripler's back door to the CRT-screen control. Overloads there blow the RF401 fuse and cause a dark picture or other similar symptoms. Excessive picture-tube current reduces the positive voltage at the dc terminal of the tripler, and through the auto-brightness limiter circuit tends to reduce the picture brightness. Defects here can cause a dark picture or one that is too light.

### ABL AND CRT SCREEN CONNECTIONS

## RCA

ed by defective soldered joints where the MCHOO1A module plugs into the deflection board. If a new module fails to solve the problem, remove the module and carefully check the soldering around each metal stake that plugs into the module.

When these need resoldering, remove the rubber stops from all metal stakes and solder the stakes directly to the circuit board. Replace the MCHOO1A module and time test the receiver.

### Low HV and no raster

Only +28V was present at ITR401 pin 3 and the high voltage measured 2kV. Voltages at ITR402 were about normal. The pin-2 gate terminal of ITR401 trace SCR had the proper drive signal. These readings and symptoms indicated that something was loading down

the flyback.

CR401 (Figure 10) and CR504 with their nearby components tested as normal. To remove any overload coming from the tripler or the picture-tube current, the wire on the *in* terminal of the HV tripler was disconnected. Even though no picture or high voltage is possible after the tripler is disconnected, the dc voltage at terminal 3 of the ITR401 trace thyristor will return to the usual +70V, proving the overload was in the tripler or caused by excessive current through the picture tube. A neon lamp now would light when held near the flyback.

It was noticed that the tripler was warm. Installation of a new tripler restored normal performance, including a good picture.

Some defective triplers have burn marks on the case from arcs to the chassis. Others have internal arcs that can be heard.

Because these triplers are con-

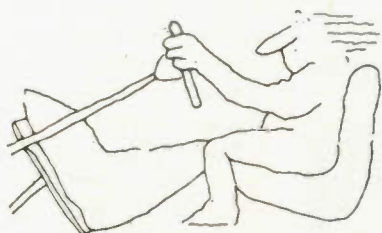
structed with many diodes, an ohmmeter test is not practical. Replacement is the best test.

### Many symptoms

A variety of symptoms can occur when fusible resistor RF401 (Figure 10) becomes defective. Because RF401 supplies B+ to the picture-tube screen control (R4310), an open or increased value produces a dark picture, and usually eliminates the horizontal line when the service/normal switch is changed to the *service* position. A reduced value increases the picture brightness, reducing contrast.

RF401 is a resistor in series with a fuse. It therefore protects against overloads in the screen circuit. Until the source of the RF401 failure is found, it is wise to temporarily replace the fusible resistor with a 180K $\Omega$  or 220K $\Omega$  1W type. After all problems have been repaired, install the correct RF401 (Figure 11).

# NOT SO FAST



You'll get about 20 more miles from every tank of gas if you slow down from 70 to 55 mph on the highway. For a free booklet with more easy ways to save energy and money, write "Energy," Box 62, Oak Ridge, TN 37830.

**ENERGY.**  
**We can't afford to waste it.**

U.S. Department of Energy

## Find Defective Receiver Signals At Any Stage Anywhere



With the Mark 5B, professional TV service technicians can quickly analyze which signal stage in the receiver is defective. The Mark 5B performs field strength measurement, and tests antennas, UHF tuners, VHF tuners, video IF amplifiers, video, video sound IF amplifiers, audio and AGC systems. All at a very affordable price.

- For tube, solid state, modular IC or hybrids
- Substitutes signals at 40 MHz IF video, 4.5 MHz sound IF audio, color or black and white
- Portable, lightweight, and durable
- Includes batteries, AC adapter and many accessories

**\$299.95**

For all the specs and a test of the Mark 5B, see your nearest PTS Service Center or authorized stocking distributor.



PTS ELECTRONICS, INC.

General Headquarters: P.O. Box 272  
Bloomington, IN 47402

Circle (4) on Reply Card

## RCA

### Loss of vertical deflection

Always substitute a new MCH001A vertical/horizontal module as the first step when a vertical-sweep problem is encountered. Secondly, test thoroughly (or replace) both vertical-output transistors, which

are mounted on a separate heat sink. If the original-type replacements are not available, use SK3856 and SK3855 or ECG310 and ECG308. Always apply silicone heat-conducting grease to both sides of the mica insulators.

A defective CR3 (sometimes marked CR503) can cause vertical problems. The 33V zener is located

off the vertical module, but it connects to terminal P3-DH20 of MCH001A module.

Also, inspect the stake terminals between the MCH001A module and the power-output transistors. Resolder the stakes, if there is doubt about intermittent opens.

### Intermittent height

When the complaint is erratic height, go directly to sockets of the vertical-output transistors. Push the base and emitter pins and socket pins in various directions while watching the height on the screen. Sometimes the transistor pins might be corroded or discolored. Clean the pins, but if the problem persists, either replace the offending socket or solder the transistor pins to the socket. If these steps fail to clear the intermittent, replace both Q401 and Q402 power transistors.

Many intermittent height problems can be identified by pushing the vertical module in different directions. Check the soldered joints in any area where this movement starts or stops the problem.

Some early-production receivers had problems with connections between J504 and P504. To correct the intermittent, first resolder all five connections. If that does not solve the problem, solder short lengths of insulated wire between similar numbers of the plug and jack.

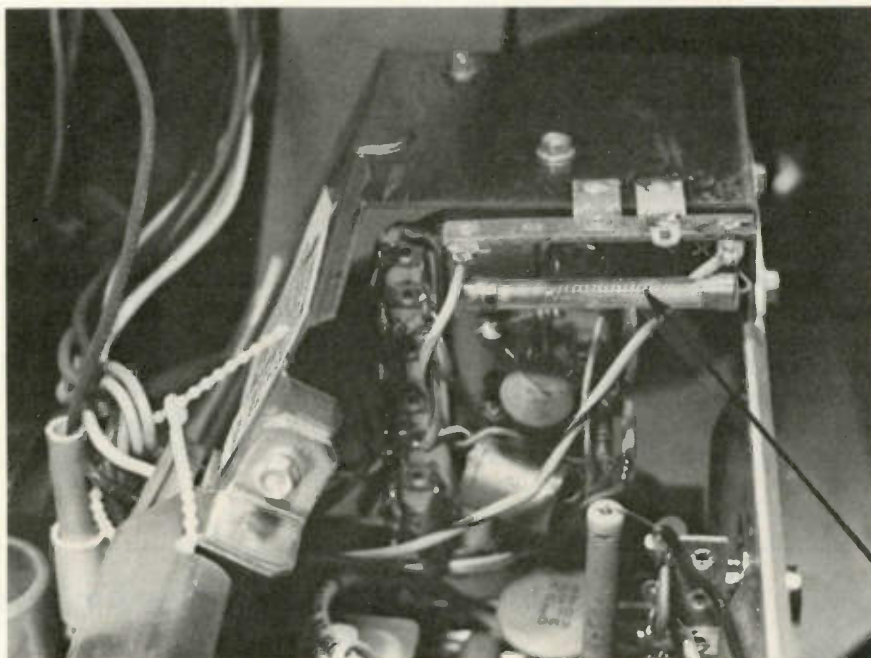
For other cases of intermittent vertical functions, check the connections at pins 2 and 7 of the yoke plug and socket. Also, resolder all pins of pincushion transformer T501 and phase-coil L501.

Vertical jitter might be produced by C409, the 4700 $\mu$ F coupling capacitor between the output transistors and the yoke.

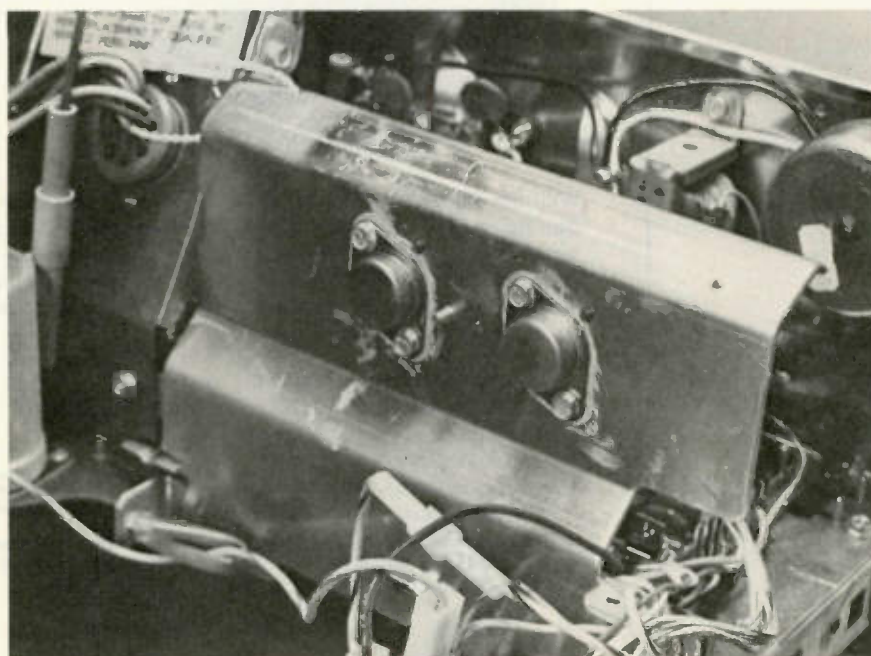
### Other problems

Most sound problems can be cured by replacing the MCS001A sound module. Some early-production receivers had above-average replacement of the sound IC because of excessive distortion.

If repeated failures of the sound module are encountered, make certain the CRT mountings, tuner and metal chassis are bonded securely together. This minimizes minor arcs that can destroy ICs or transistors. □

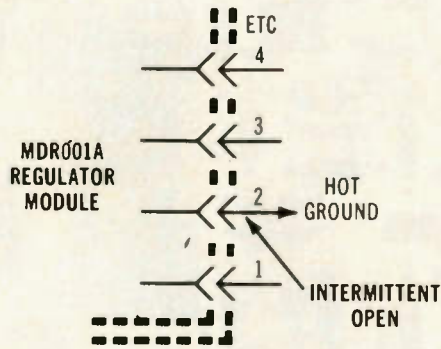


**Figure 11** An arrow points to fusible resistor RF401. It has a series-connected 180K $\Omega$  resistor and a fuse inside.



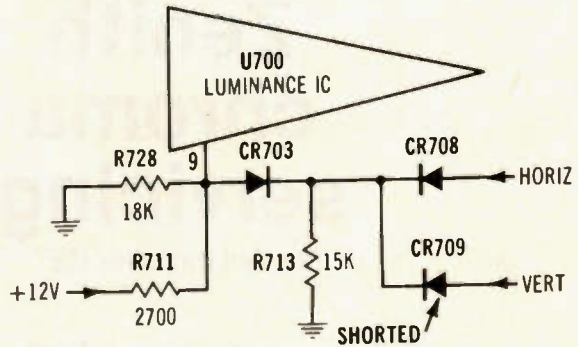
**Figure 12** The two TO-3 power transistors are Q402 (left) and Q401 of the vertical-output circuit. These socket connections often cause intermittent height problems.

Chassis — RCA CTC92  
PHOTOFACT — 1788-2



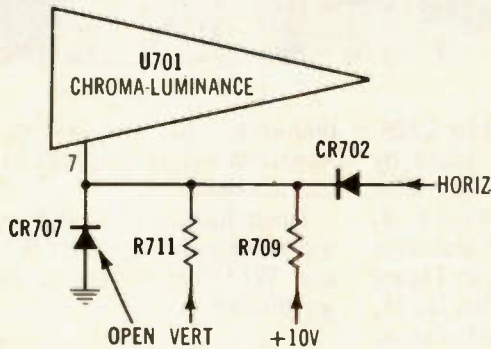
**Symptom** — Shutdown occurs intermittently  
**Cure** — Check for a bad ground connection at pin 2 of the MDR001A regulator module

Chassis — RCA CTC99  
PHOTOFACT — 1895-1



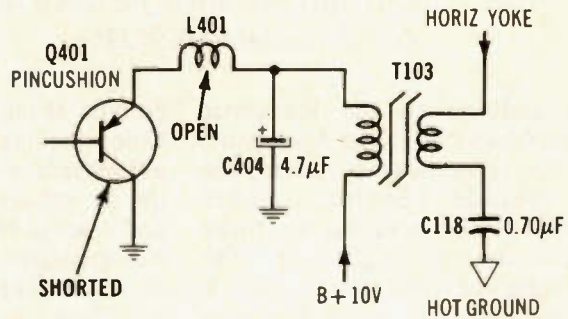
**Symptom** — Darker at top of picture; no control of brightness  
**Cure** — Check or replace diode CR709 in vertical-blanking circuit

Chassis — RCA CTC109  
PHOTOFACT — 1952-1



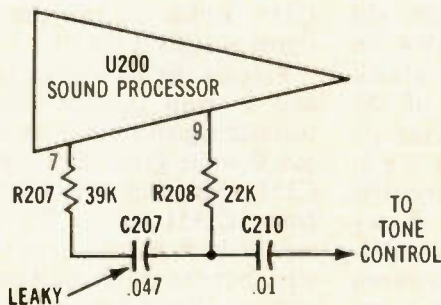
**Symptom** — Vertical bars in picture  
**Cure** — Replace diode CR707 at pin 7 of luminance-chroma IC

Chassis — RCA CTC101  
PHOTOFACT — 1896-2



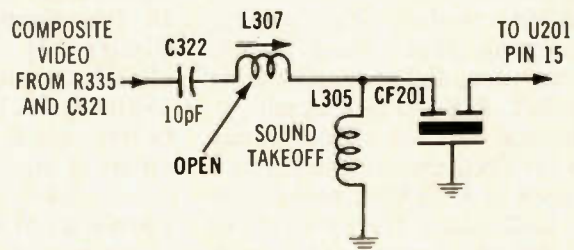
**Symptom** — Narrow width  
**Cure** — Replace transistor Q401, and check for open in L401

Chassis — RCA CTC101  
PHOTOFACT — 1896-2



**Symptom** — Sound is distorted  
**Cure** — Check capacitor C207, and replace it if leaky

Chassis — RCA CTC108  
PHOTOFACT — 1937-3



**Symptom** — Buzz in sound  
**Cure** — Check coil L307, and replace it if open

# Zenith chroma servicing

By Carl Babcoke, CET

*New chroma circuits perform more automatic functions while requiring fewer components because of sophisticated integrated circuits. Efficient troubleshooting of these IC circuits requires a knowledge of testpoints, dc voltages, and signal waveforms and amplitudes. This information is featured for Zenith model SM1973P.*

In addition to the luminance system (described in the April issue) and the vertical-sweep system, the M2 module (Zenith number 9-152-01B) also contains the entire chroma system (Figure 1). The matrixing of luminance and -Y chroma signals is accomplished in the M5 module that includes the picture-tube socket.

Figure 2 shows locations of major luminance and chrominance components on the upper 2/3 of the M2 module.

## Chroma IC

One integrated circuit (IC2351 in Figure 3) performs chroma-IF amplification, 3.58MHz oscillation, 3.58MHz carrier amplification, burst keying, color locking, chroma demodulation, and preamplification of the B-Y, R-Y and G-Y signals.

Chroma with some video comes from the Q402 emitter (see Figure 3 on page 8 in April *Electronic Servicing*). L327 and C332 removes the video and tilts the chroma response, while crosstalk-control R303 adjusts the "Q" of this take-off tuned circuit.

A tap on L327 supplies burst and picture chroma to pin 7 of IC2351. After internal amplification, the

chroma at pin 12 is tuned by L326. Color locking is accomplished by adjustment of R327, which varies the dc voltage at pin 2. Pins 1, 3, and 4 act as the 3.58MHz oscillator (see expanded waveforms in Figure 4), while components at pins 16, 18, and 22 change the 3.58MHz-carrier phase (Figure 4) as needed for proper demodulation.

Color intensity is adjusted by the color-level control which changes the dc voltage at pin 11. Similarly, the tint control varies the dc voltage at pin 23, and this changes the phases of the demodulation continuous carriers.

Vertical and horizontal sweep signals from IC226 and IC2351 pin 14 (waveforms W3 and W4 in Figure 3) evidently blank something, although none of the available chroma-IF signals (waveforms W5, W6, W7 or W8 in Figure 3) show blanking of the first color bar. Figure 5 shows waveforms W3 and W4 at vertical-sweep rate. A comparison between the Figure 3 and Figure 5 waveforms show strong vertical-rate pulses in W4V but none in W3V. Also, it is likely the horizontal-rate pulses in W3 and W4 are accidental, because the pulse widths are too narrow for

blanking. In any event, these waveforms should appear in a normal television.

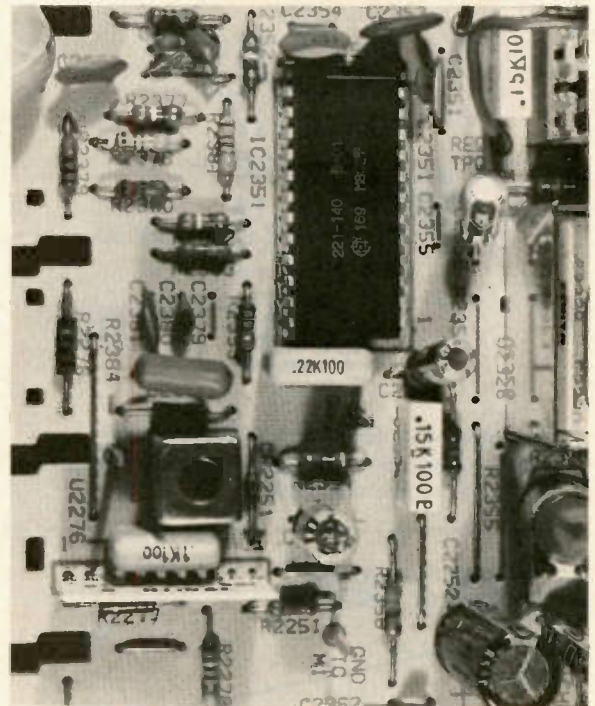
Demodulated R-Y, B-Y and G-Y waveforms are shown by W11, W12 and W13 respectively in Figure 3 waveforms.

## Adjusting color locking

The 2J plug and double socket (near top center of Figure 3 schematic) are used to adjust the color AFPC or locking. For normal operation, the 2J plug (with two wires attached) is placed in the pin 1 and pin 2 position of the 2J plug. This grounds one end of C326 and connects IC2351 pin 9 to capacitor C351, which couples the color-IF signal to IC2351 pin 10.

Placing the 2J plug in the pins 3 and 4 setup position couples the color-IF signal from C326 to IC2351 pin 9 while grounding one end of C351, thus removing all IF signal from IC2351 pin 10. The color intensity is reduced during the next step, but the color can be seen well enough. Watch the screen while the R327 APC control is rotated slowly until diagonal color stripes are eliminated. Each color bar should have the same *tint* from top to bottom, although it is permissible for

Figure 1 The M2 Zenith module.





the bars to have incorrect hues or slowly drifting hues.

After the color-locking adjustment, insert the 2J plug in the normal pins of the 2J socket to restore normal operation. Check the color locking on weak signals to verify correct and stable locking.

APC control R327 can be reached (with moderate difficulty) through holes in the metal frame while the M2 module remains undisturbed in the grooves. It is not necessary to remove the module during color-locking adjustments.

### Matrixing luminance and chrominance

Most solid-state color television receivers matrix the luminance (Y) signal with the three -Y demodulated-chroma signals inside three power transistors. Each transistor has the proper B-Y, R-Y or G-Y signal applied to its base, while the chroma-free luminance signal is connected to all three emitters. (The same luminance signal, differing only in amplitude, is fed to all three emitters.) The emitter signal is subtracted from the base signal to form the true input signal that is amplified and appears at the collector. Matrixing occurs inside these color output transistors. Each collector has a pure color signal that drives the appropriate cathode of the picture tube.

This system is called **pre-CRT matrixing**, contrasting to the older method of applying chroma -Y signals to the three picture tube grids and connecting Y luminance to all three CRT cathodes. Matrixing occurred inside the picture tube with this system.

The Zenith SM1973P (and all other new Zenith color receivers) incorporates pre-CRT matrixing. The M5 module that includes the CRT socket has all three power transistors with heat sinks, the driver transistor and several variable controls (Figure 6).

Figure 7 shows the waveforms (from a Hickok model 240 video generator) and the measured dc voltages of the sample Zenith receiver, along with a complete schematic of the luminance driver

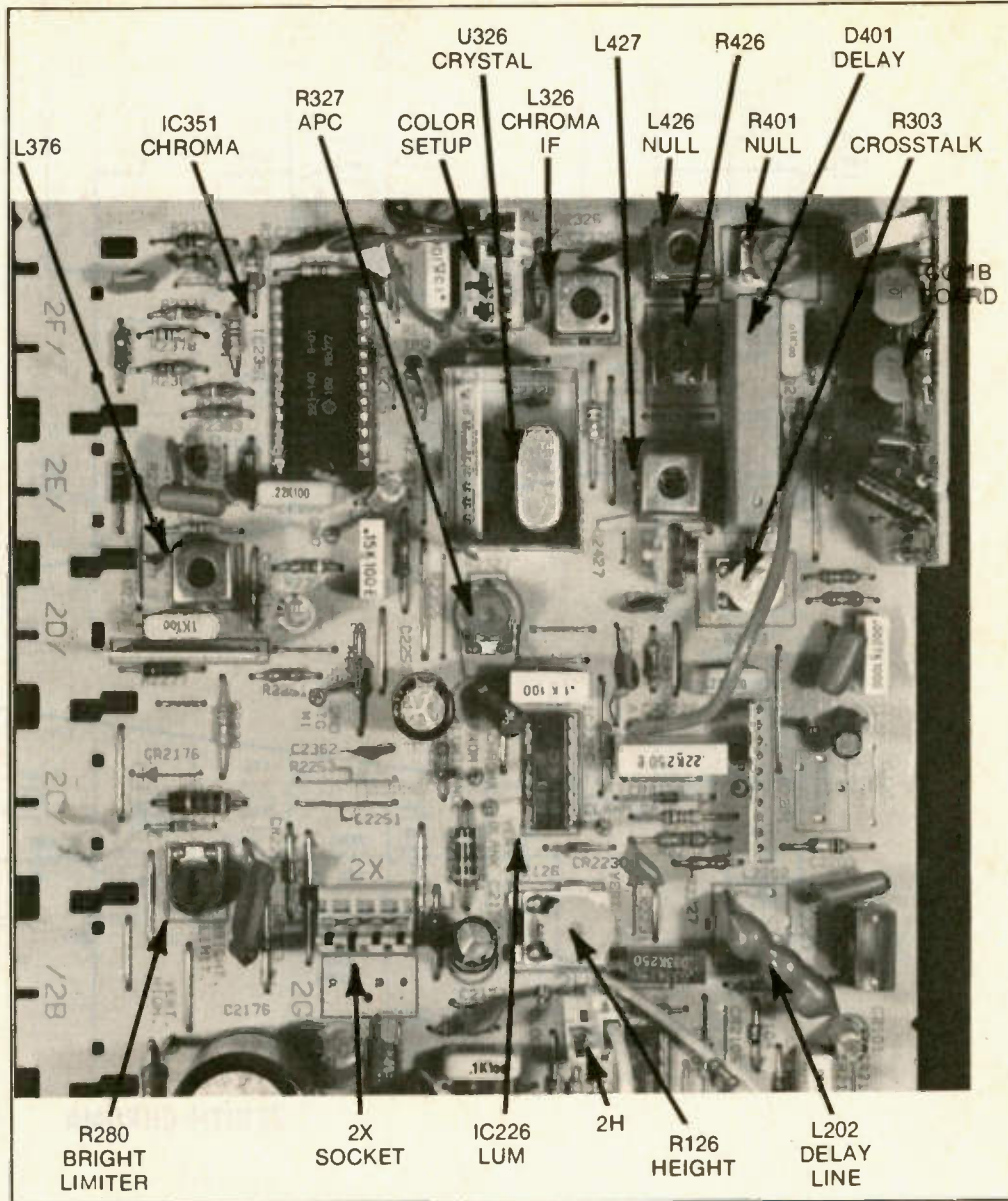


Figure 2 Arrows point to the many important components of the luminance and chrominance systems on the M2 module.

and *one* matrixing/color-amplifier power transistor stage. These color amplifier stages are identical (except for two resistor values in each). Of course, the signal levels and dc voltages are different in each of the three color amplifiers, so all dc and peak-to-peak voltages are shown in the same sequence (red at top, blue lower, and green at bottom).

### Matrixing operation

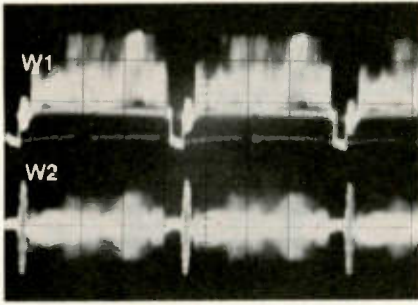
Luminance video for matrixing arrives at 5A pin 3 and travels through 820Ω R151 before reaching the Q151 base. The horizontal sweep pulses in the Figure 7 W1 waveform were added to the luminance in the M2 module. However, the waveshape and excessive amplitude of these pulses make them unsuitable for horizon-

tal blanking. The pulses are clipped by using a PNP-polarity transistor for Q151. Therefore, most of the positive-peak amplitude is reversed bias to Q151, and that part of the amplitude does not appear in the emitter-to-ground waveform (W2 in Figure 7).

This clipping of the excessive amplitude is explained by the dc waveform in Figure 8, which shows the zero-voltage line.

Please note: the original Zenith schematic for the M5 module showed Q151 as NPN. But NPN luminance-driver transistors have positive-supply voltage entering at the collector and leaving the emitter through a resistor to ground. This did not agree with the M5 actual wiring which connected a positive voltage (from the color-amplifier





Waveforms W1 and W2 in Figure 3 are repeated here with a TV station signal. Top trace is the composite video with augmented chroma level. The lower trace shows the chroma input at IC2351 pin 7 after filtering to remove luminance.

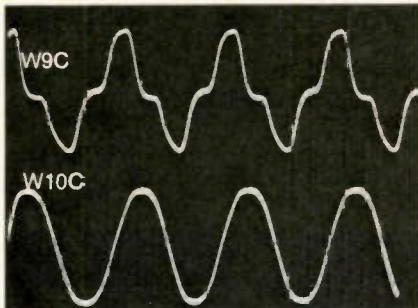


Figure 4A Decreasing the scope sweep to  $0.1\mu\text{S}/\text{div}$  widened the W9 waveform of Figure 3, showing a combination sine and square wavelike shape (top trace) at IC2351 pin 1. The lower trace shows near-sines at pin 3.

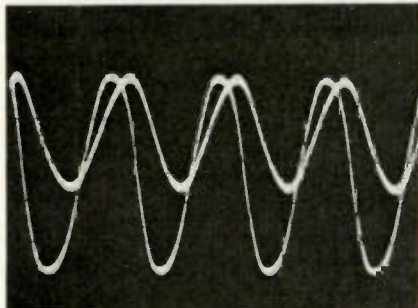


Figure 4B The same  $0.1\mu\text{S}/\text{div}$  sweep shows the phase differences between pin 3 sinewaves (large trace) and pin 4 sinewaves (smaller amplitude). This phase shift is about  $80^\circ$ .

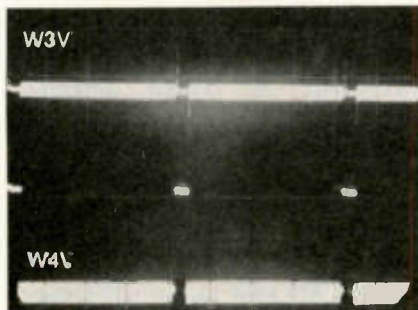


Figure 5 When the scope sweep was changed to vertical rate, the Figure 3 W3 showed no vertical pulses (upper trace); but W4 (lower trace) revealed 2VFP vertical pulses.

## Chroma servicing

emitters) to the Q151 emitter, while the collector returned to ground through a low-value resistor. These discrepancies indicated a mistake in the schematic. A diode-polarity check of the Q151 junctions proved the transistor was a PNP (as shown correctly in Photofact 1966-2 for a similar model).

Output of the Q151 luminance driver is taken from the emitter. The emitter luminance signal is sent through three fixed resistors to the color-output emitters. Values of  $130\Omega$ ,  $150\Omega$  and  $110\Omega$  are specified to provide the proper luminance drive without requiring variable controls. Incidentally, all other resistors (except U105E, U105K and U105C bias resistors) have the same value in all three color amplifiers.

Therefore, the luminance (or black-and-white) signal enters each

color-output transistor at its emitter, while the appropriate -Y demodulated signal is applied to the base. Of course, the actual input signal is a vectorial subtraction of the emitter signal from the base signal. Since there is little similarity between the base and emitter signals (at least, before matrixing crossmixing), the collector signal is made up of an inverted-and-amplified base waveform plus an amplified but not-inverted emitter signal. Matrixing occurs inside the transistor. The true color signal (both luminance and chrominance) appears at the collector. Each collector drives a picture-tube cathode. No other video or chroma signals reach the picture tube.

### Side-effects of matrixing

This type of pre-CRT matrixing has excellent performance. However, two factors cause confusion by blending the waveforms. (1)

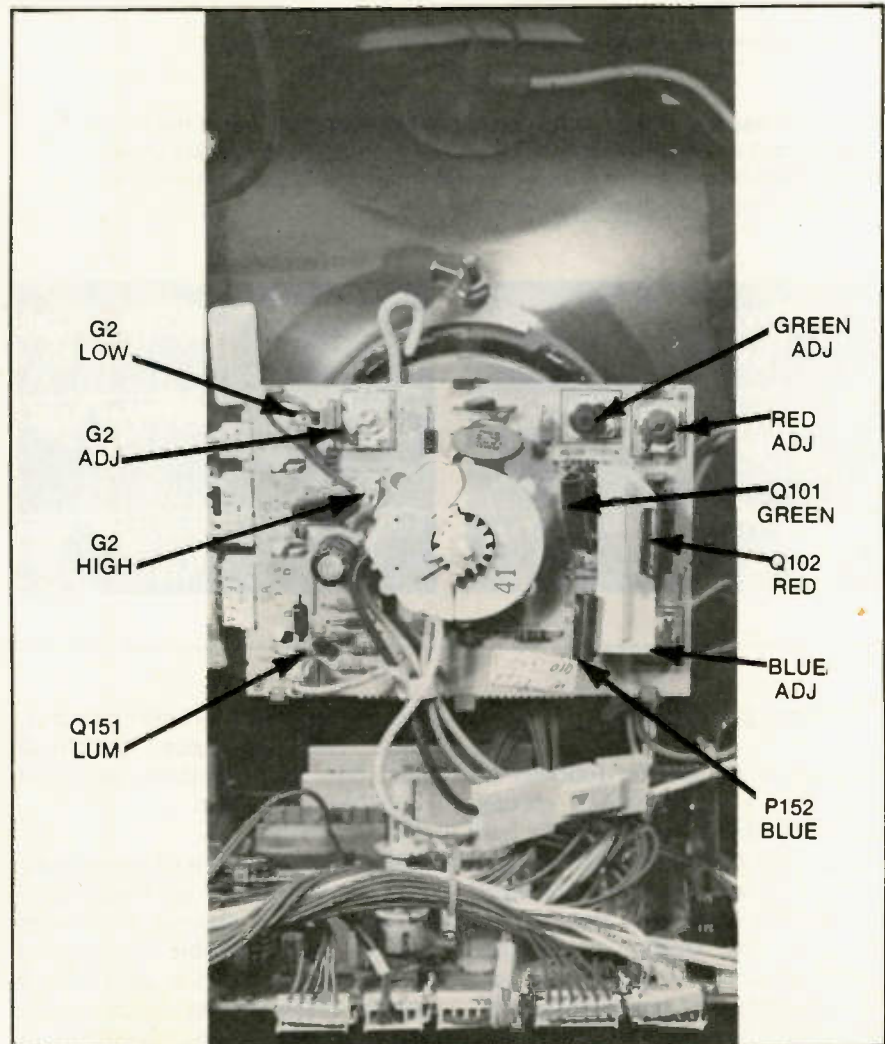
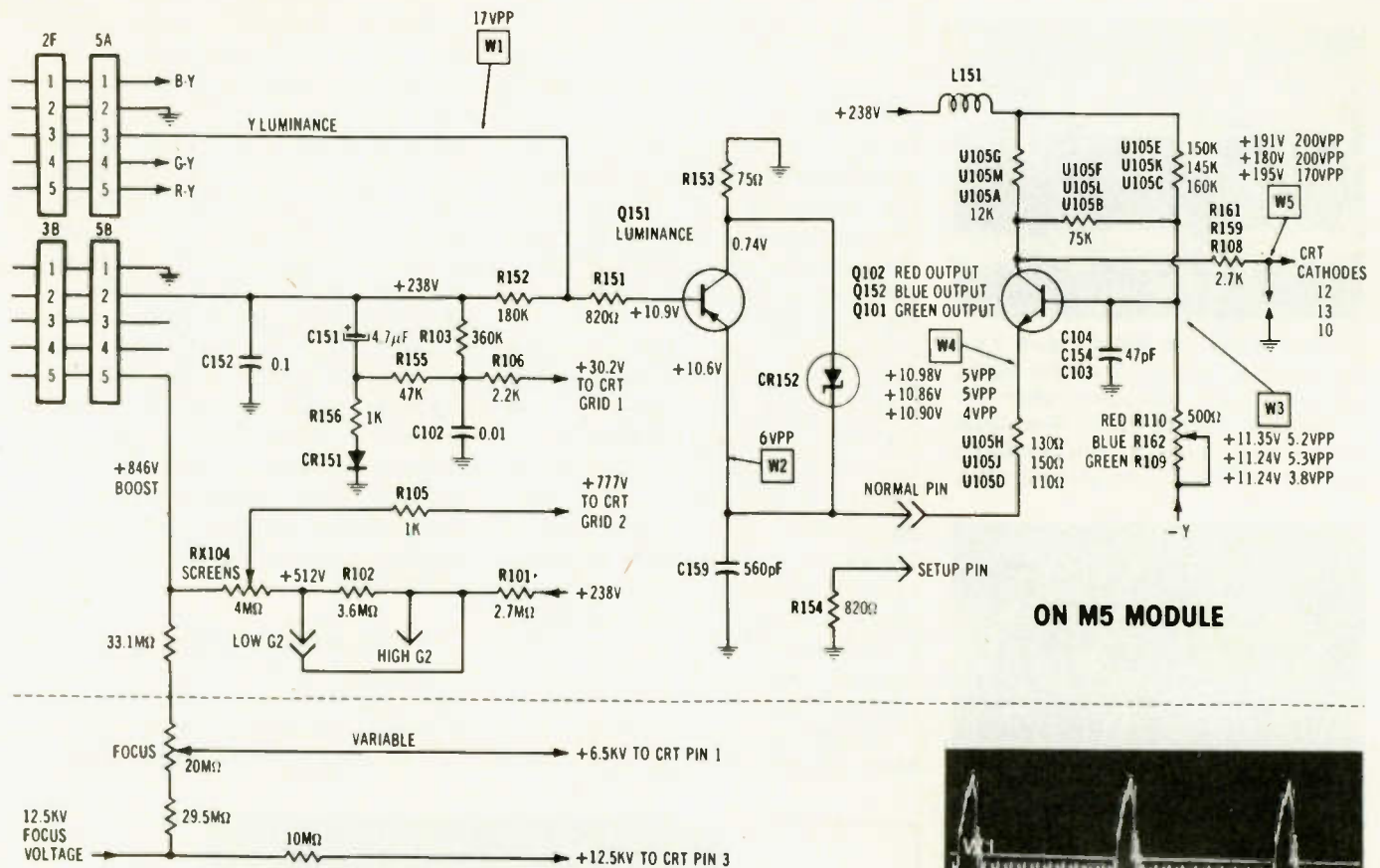
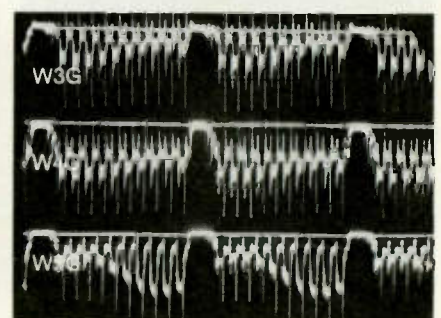
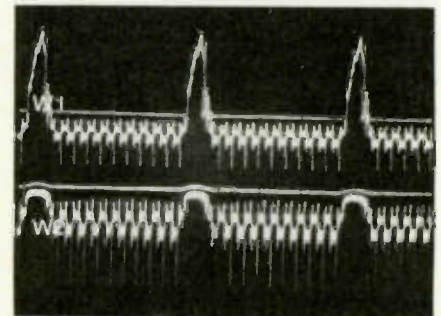
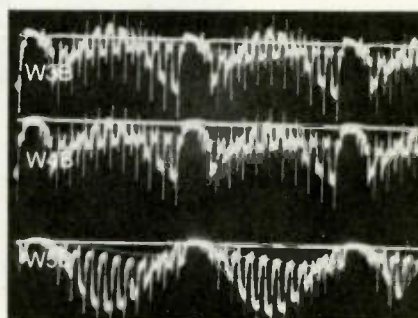
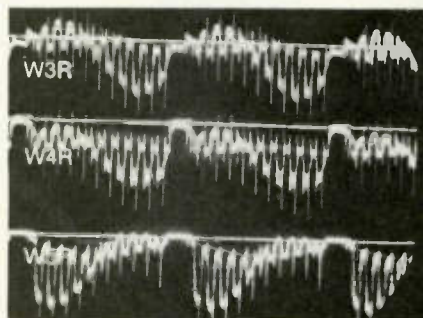


Figure 6 Arrows point to transistors and controls on the M5 module (that includes the picture-tube base socket). Collectors of the three power transistors are connected to their heatsinks, thus allowing easy dc-voltage tests.



**Figure 7** These matrixing circuits on module M5 show only one of the three power-output amplifier transistors. Dc and peak-to-peak voltages are shown for the three color-amplifiers. These waveforms and voltages were recorded from one sample Zenith color receiver.



## Chroma servicing

Because of the emitter-follower effect, the -Y demodulated chroma waveform that is applied to the base also appears (with almost the same amplitude) at the unbypassed emitter. (2) The luminance signal is applied to the emitter, but some amplitude is transferred to the base by the substantial base/emitter current that flows at all times (see Figure 9). Demodulated-chroma color bars trace a sinewave pattern by the tips of the bar pulses

(sometimes called a *rocker pattern*), while the luminance waveform black-bars and overshoot pulses all have the same height.

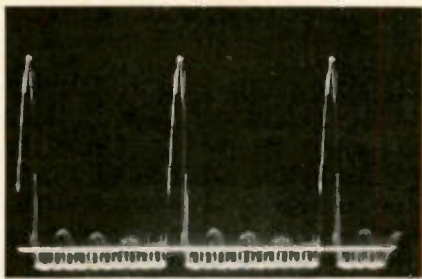
### Waveforms change with generators

Other sources of confusion during servicing are chroma waveforms that do not resemble the printed waveforms in service data. Even normal receivers can appear to be defective when video waveform of the color-bar generator *used for servicing* is radically different from the one used for the service-data

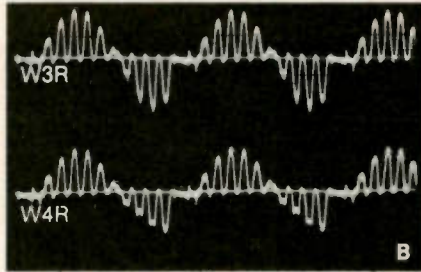
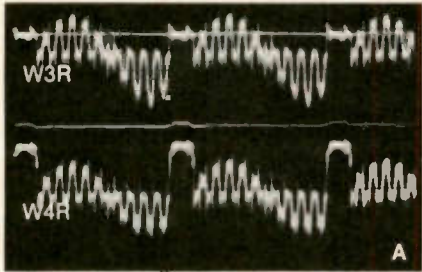
waveforms.

Figure 10 compares the Zenith waveforms of video detector, chroma IF, luminance and matrixed-chroma that were obtained from an old RCA model WR64B generator and a new Hickok model 240 video generator as signal sources.

There are two major differences between waveforms from these RCA and Hickok generators. Luminance in the RCA composite video has narrow pulses that mark the 10 color bars, but there are no



**Figure 8** Most of the pulse amplitude at the Q151 base is ignored by the transistor (because it is reversed bias). This waveform was made by connecting the scope input *between Q151 base and emitter*. The zero line (near the bottom of the pulses) was added by dual-trace operation and dc coupling. Because Q151 is a PNP-polarity type, all parts of the waveform *above* the zero line are positive, so they are reversed-bias and produce no transistor current. Only the waveform below the line is amplified.



**Figure 9** These waveforms show the cross-mixing of luminance and chrominance signals that occurs at the three color-output transistors. (A) Top trace is the Q102 base signal (a repeat of W3R in Figure 7, except an RCA color-bar generator was used) during normal operation. Lower trace is the Q102 emitter signal (a repeat of W4R). (B) After the wire was changed from *normal* to *setup*, the luminance signal was eliminated, and the same chroma-only waveform was found at *both* base (top trace) and emitter (lower). Notice in the A waveforms, that some emitter luminance is transferred to the base, and some base chroma signal is formed at the emitter by the emitter-follower effect.

pedestal bars. The Hickok provides nine black bars located between ten color bars. These bars have a large luminance amplitude. Therefore, the Hickok luminance signal has higher amplitude than the RCA does.

Also, the pre-shoot and post-shoot edge pulses in the Hickok waveform have much higher amplitude than those in the RCA waveform.

These two sets of waveforms are typical. Most other generator waveforms will resemble one or the other.

In addition, individual adjustments of the receiver color level, brightness and contrast can change the shape of these matrixed waveforms somewhat. It is recommended that each technician adjust these controls carefully for a normal picture before any waveforms are scoped.

These facts about generators and waveforms were presented to help technicians accurately analyze luminance and chrominance waveforms regardless of minor variations in the generator waveforms.

#### Chroma test instruments

A digital multimeter and a stable wide-band triggered scope are two

essential instruments for diagnosing chroma problems. Fortunately, all normal chroma waveforms can be viewed with sufficient trace height. Waveshapes are vitally important in luminance and chrominance circuits.

#### Chroma test methods

The first step of efficient servicing is to collect all available information by use of the five human senses. For chroma troubleshooting, this step should include a visual analysis of the picture as the television is tuned to different channels and during adjustment of the front panel controls.

It should be possible to make a preliminary general diagnosis after the visual analysis. Most chroma problems include these: no color; weak color; color cannot be controlled (either up or down); diagonal stripes of color (color out of lock); wrong tints; or tint cannot be adjusted. In addition to these actual chroma problems, there are pseudo-color defects such as wrong black-and-white screen color (poor gray-scale tracking).

The following incomplete listing of chroma testing methods is tailored specifically for the System-Three Zeniths:

- *Hues are incorrect.* Check first for proper change of dc voltage at

IC2351 pin 23 as the tint control is rotated. Insufficient variation or no change indicates a defect in the tint-control circuit including the plugs and wiring. Of course, an internal short in IC2351 can remove the voltage. When sufficient variation of dc voltage occurs at pin 23, the defect is not in the tint-control circuitry, but it is likely to involve the components or voltage around IC2351 pins 16, 18 and 22.

- *Hues are incorrect but -Y waveforms are normal.* Correct demodulated phase is indicated by the maximum and zero-level color bars in the -Y waveforms. For example, the R-Y waveform should have the third bar at maximum amplitude, while the sixth bar is at zero. B-Y maximum should be at the sixth bar with zero at bars three and nine, while G-Y has zero at the sixth bar (maximum occurs during horizontal retrace). The tint control should vary these at least one bar to the left and to the right. When all three bar crossovers are correct, any wrong hues in the visible picture probably are caused by a tinted gray-scale screen color. Turn down the color and examine the black-and-white screen at all brightness and contrast levels. Go through the gray-scale sequence if the screen color is other than gray through white. Of course, the picture tube and the matrixing circuits on the M5 module are prime suspects for any sudden and serious changes of screen color. Check the collector dc voltages at all three power transistor heatsinks on the M5 module. These voltages should be within about 15V of each other, or else a problem is indicated.

- *Erratic color locking.* At IC2351 pin 21, scope for 3VPP positive-going horizontal pulses. These are necessary for burst separation. Scope the signals at IC2351 pins 9, 10 and 12, comparing them with W5, W7 and W8 in Figure 3. Test for loose connections or wrong position of 2J setup/normal plug.

- *No color.* Remember, both chroma-IF sidebands and a

## Chroma servicing

3.58MHz reference carrier are needed for demodulation. Use color bars and follow the chroma signal at pin 7 (input to the IC) and pin 12 (output). If these signals are normal, test for demodulated-color signals at pins 15 (B-Y at 2F-5), IC2351 pin 17 (R-Y at 2F-1) and pin 19 (G-Y at 2F-2). Loss of only one indicates a bad IC2351. Although loss of all three -Y signals might indicate a bad IC, it usually points to a 3.58MHz problem. Scope for 3.58MHz carriers at pins 1, 3, 4, 16, 18 and 22. Loss of all carriers might be caused by a defective CR326 crystal. There is little possibility of losing all colors in the M5-module matrixing.

- *Intermittent color and weak color.* Weak or erratic color should be checked by the same method given for *no color*.

### Power-on tests

Most of the tests previously described must be made with full power. One of the few practical tests for bad ICs is to scope all incoming signals and measure all dc voltages. If these measurements are within tolerance, but the IC has no output, it is almost certain the IC is defective.

These power-on tests demand utmost care to prevent accidental shorts that can destroy ICs, transistors, diodes and other susceptible components. Use spring-clip type adapters that allow access to IC pins safely. If a probe must be placed against an IC pin, it should be a needle-tipped probe to minimize slippage. Remember, one split-second short can zap many components.

If very many measurements are necessary on the M2 module, the module should be removed and reconnected external to the chassis, as shown in Figure 11. Remember to insulate the wiring side of the module to prevent shorts.

Alternately, a new module can be connected externally by this method to verify that a defect is present in the old module. Much time can be saved by this shortcut, since the old module is not removed unless it is bad.

### Next month

Vertical countdown and vertical sweep are the subjects of the next Zenith article. □

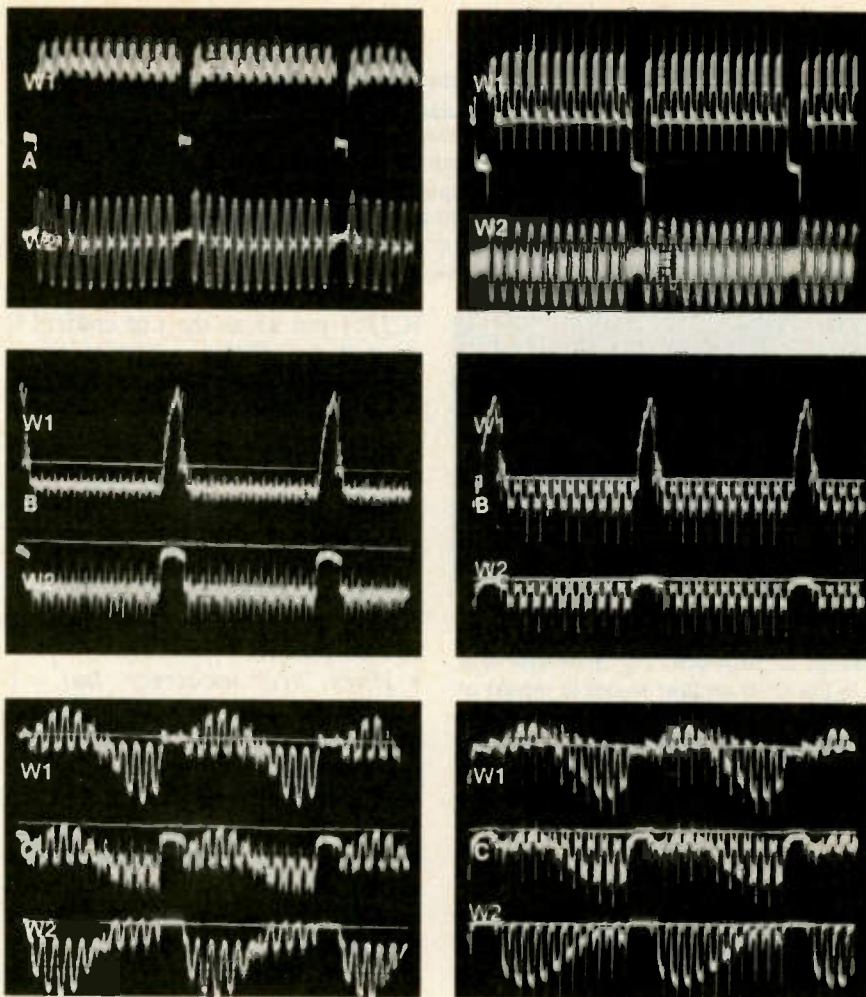


Figure 10 Waveforms originating in RCA (left waveforms) and Hickok (waveforms at right) are compared. (A) Both top traces correspond to Figure 3 W1 (composite video), and the lower traces correspond to Figure 3 W2 (separated chroma). (B) Top traces are Figure 7 W1 (chroma-free luminance with blanking at base of Q151), and lower traces are Figure 7 W2 (Q151 emitter). (C) Top traces are Figure 7 W3R (base of Q102); center traces are Figure 7 W4R (emitter of Q102); and bottom traces are Figure 7 W5R (collector of Q102). Notice the 10 pulses in the Hickok waveforms (at right) that represent black bars between the color bars. Most color-bar generator waveforms will resemble one of these examples.

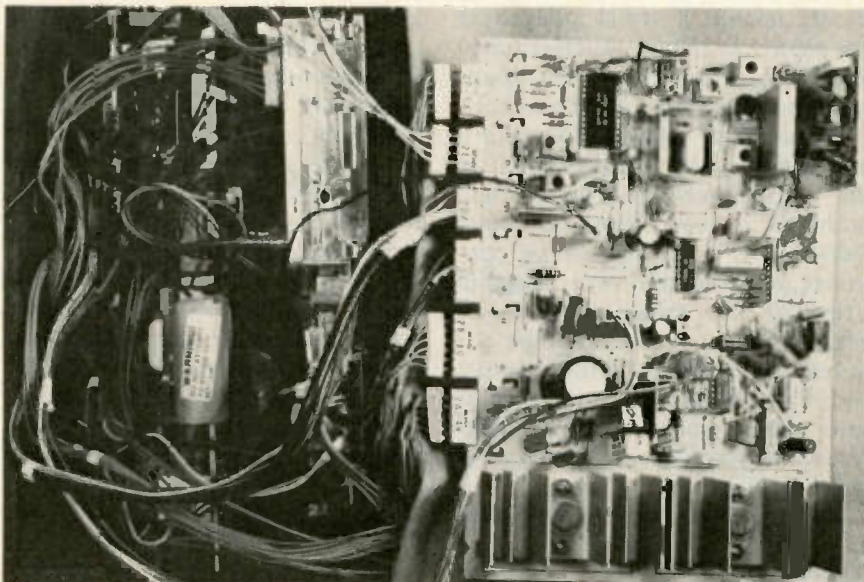
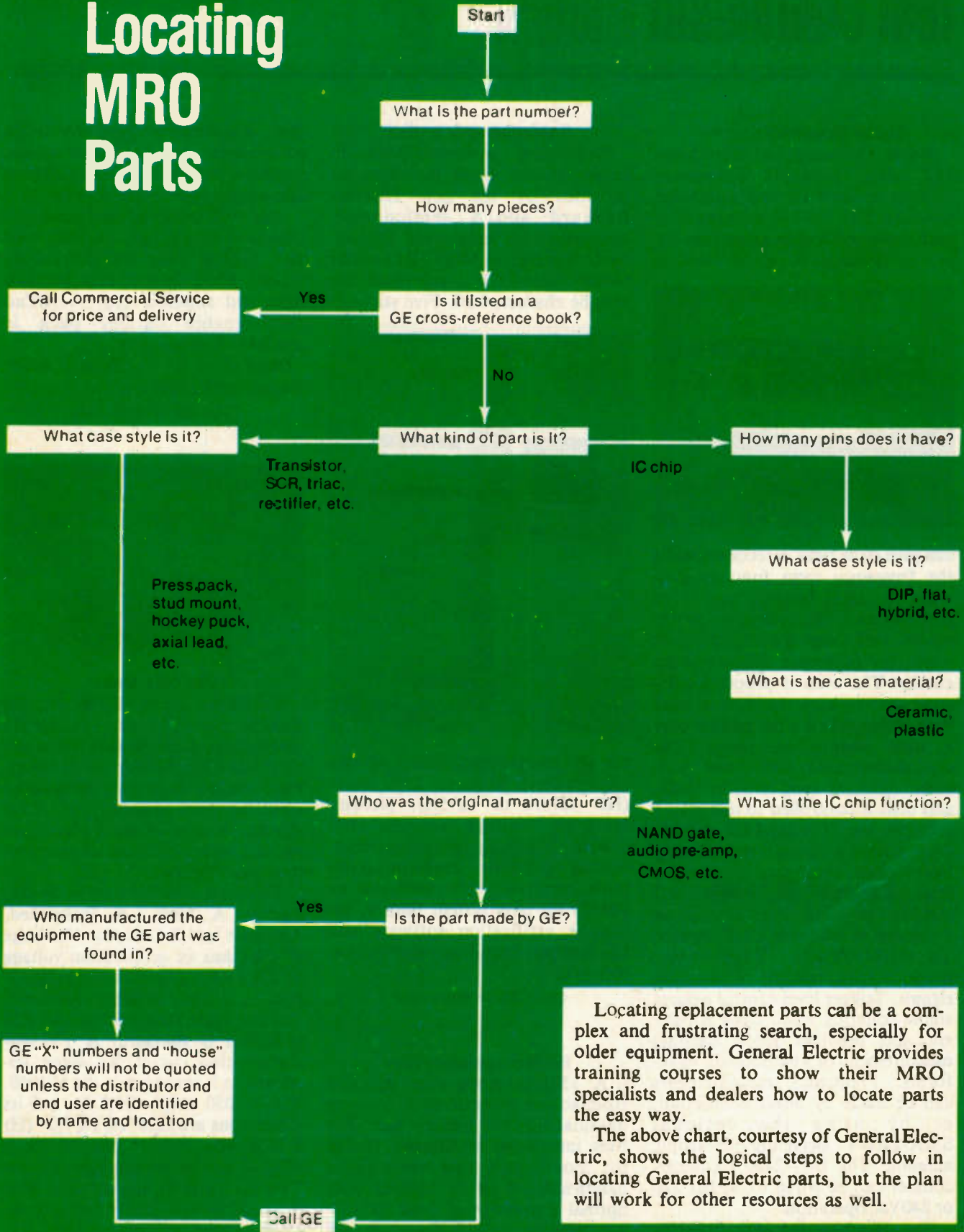


Figure 11 During tests and measurements, remove module M2 and reconnect the cables as shown. Most components are then easily accessible. Insulate the wiring side of the module to prevent shorts.

# Locating MRO Parts



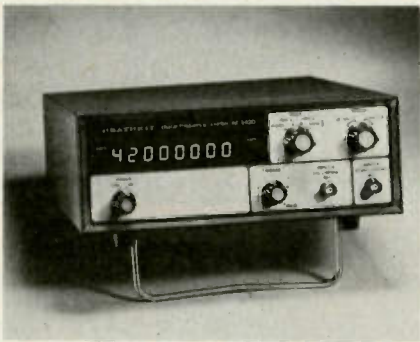
Locating replacement parts can be a complex and frustrating search, especially for older equipment. General Electric provides training courses to show their MRO specialists and dealers how to locate parts the easy way.

The above chart, courtesy of General Electric, shows the logical steps to follow in locating General Electric parts, but the plan will work for other resources as well.

# test equipment report

## Digital frequency counter

**Heath Company** has introduced 512 MHz portable frequency counter in both kit and assembled versions. The IM-240 features four gate times and 8-digit resolution for precise readings. A period function



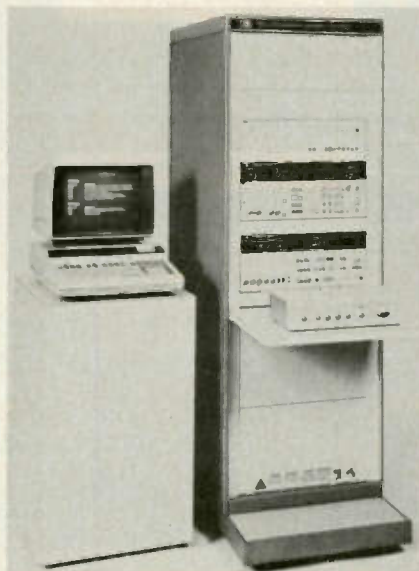
can give cycle time in seconds, while the frequency ratio function provides the ratio between two input frequencies. The standby power switch can keep the crystal oven warm for maximum frequency accuracy. The oven is proportionally controlled to keep the internal time base within 0.1 part per million over a wide temperature range. The crystal-controlled time base provides excellent long-term stability, and drift is controlled to less than 1 ppm per year. The IM-2420 also has provisions for using external time base signals. Four gate times and a large, 0.43-inch-high, 8-digit LED display provide the resolution necessary to measure UHF signals. The IM-2420's 4-15 mV typical sensitivity allows counting of low level signals. Trigger level control assures stable counting when noise is present and provides more accurate measurement of complicated waveforms. Frequency measurements can be made by direct connection, or by using the optional SMA-2400-1 swiveling telescopic antenna. The IM-2420 frequency counter can be wired for either 120 or 240Vac operation.

The Heathkit IM-2420 512MHz frequency counter is mail order priced at \$239.95. Assembled, \$299.95.

Circle (21) on Reply Card

## Semiconductor testing

Real-time process data in semiconductor wafer processes are provided by the new **Hewlett-Packard 4061A** semiconductor/component test system. Packaged devices such as MOS FETs can be tested; basic LCR components can also be characterized. Five state-of-



the-art components make up the system: multi-frequency LCR meter (HP 4274A or 4275A); picoammeter/dc voltage sources (HP 4140B); switching subsystem; combining cabinet; desktop computer/controller (HP 9835A/B or 9845B/T), plus system library, including verification software and substantial turn-key application software.

Circle (22) on Reply Card

## Battery operated scope

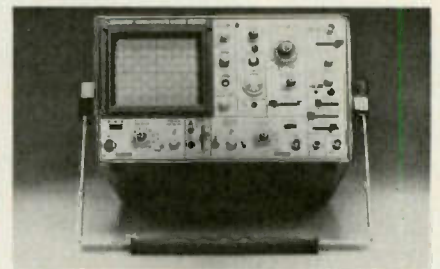
A 15MHz scope that operates from ac line, external dc or from an optional internal battery pack has been introduced by **Kikusui**. Called the model 3010, this scope has a bandwidth of dc to 15MHz with normal sensitivity of 5mV to 10V per division in 11 steps. A 5X magnification can increase this sensitivity to 1mV to 2V per division. Model 3010, contained in a com-

compact, aluminum housing that helps to minimize external signal noises, measures 244mm x 112mm x 330mm and weighs approximately 6 kg.

The 3010 is completely modular. Standard accessories include two 10:1 probes, plug for external dc power, hood to minimize ambient light and shoulder bag. A NiCad rechargeable battery pack is available as an option.

Base price for the 3010 is \$895. Battery pack: \$100.

Circle (23) on Reply Card



## 100MHz scope

Priced at under \$2400.00, the V-1050 quad trace, 100MHz oscilloscope from **Hitachi** features a sensitivity of 500 $\Omega$ /div (5MHz). Four channel capability permits the simultaneous display of four signals. A total of eight traces can be seen with operation of alternate time base feature.

There are four horizontal display modes: A Only, A Intensified, Alternate and B Delayed. The large 6" CRT has an acceleration voltage of 20kV with a useful screen area of 8cm x 10cm. Internal graticule, variable scale illumination and P31 phosphor is standard. A TV synchronization circuit for video applications is standard in the V-1050. The V-1050 weighs 20.5 lbs and its dimensions are 12.4" (W) x 7.2" (H) x 16.4" (D). Power consumption is 50W or less at normal line voltage. Two X10 probes are supplied with the oscilloscope. Other features include variable trigger hold-off, beam finder, single sweep capability and front panel X-Y operation.

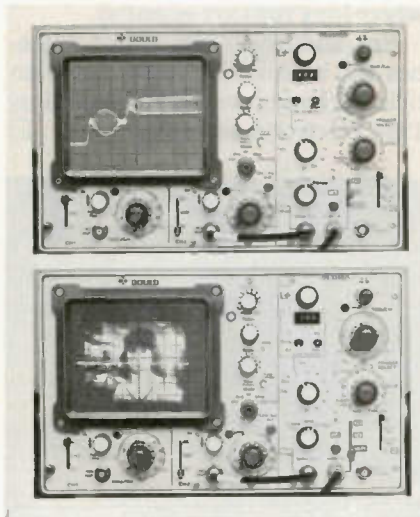
Circle (24) on Reply Card



### Dual display DMM

In the differential peak mode, the recently released **Simpson** model 467 hand-portable DMM makes percent modulation and signal tracing measurements. In the pulse detection mode, it gives visual and/or audible indication of pulse presence and logic states. Other standard features include 26 ac/dc voltage, current and resistance ranges, true RMS AC voltage and current measurements, 0.1% basic Vdc accuracy, continuity detection with both visual and audible indications, high-energy double fusing protection, high-voltage transient protection and overload capabilities.

Circle (25) on Reply Card



### Combination scope

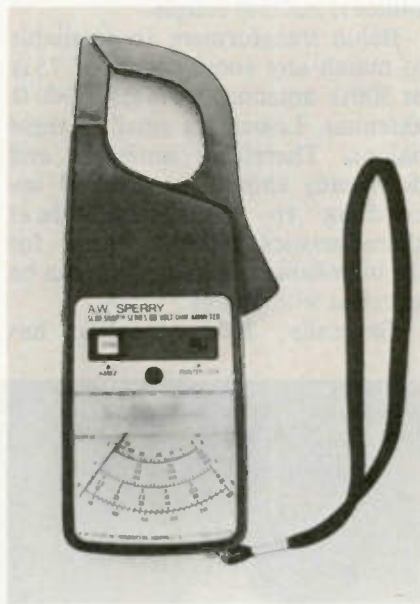
**Gould's** TV monitor oscilloscope, the OS3350/5, combines performance of an NTSC 525-line waveform and picture monitor with that of a general purpose 40 MHz dual trace scope in a single package.

A timebase generator in the OS3350/5 allows it to be used for line-by-line examination of 525-line waveforms or to display complete pictures. The OS3350/5 accepts standard level composite video signals with or without sound-in-sync signals and provides five dif-

ferent triggering modes.

A multiturn vernier control provides triggering delays up to 90  $\mu$ s, allowing parts of a line to be examined in detail. The displayed video signal can be clamped or not. When the unit is used to display a TV picture, the triggering point selected may be displayed as a bright-up line on the picture, enabling a direct relationship to be established between waveform and picture.

Circle (26) on Reply Card



### Has 600 VAC fuse

The Slim-Snap Series 60, pocket size model TD-6 features a 600 VAC rated fast acting, high interrupting capacity fuse in its Ohmprobe. Also of interest is the low mass meter movement intended to provide protection against damage from shock.

Introduced by **A. W. Sperry Instruments**, Slim-Snap is designed with teardrop-shaped Easy-Probe jaws for one-hand operation in tight places, pointer lock for dimly lit locations, range selector switch with color-coded window display, twist and lock safety test leads, safety swivel wrist strap, and shock-resistant ABS plastic housing.

Circle (27) on Reply Card

## ESR METER

checks electrolytics  
IN-CIRCUIT and is TV shop  
FIELD-TESTED:

The most fantastic instrument I've ever bought—Billings, Mt. Used it 3 months; it only missed once—Marinette, Wis. (Typical). Squeal & no sync: 3 bad caps in B+ & AGC; Many Thanks—Taos, N.M. Please ship another; very satisfied—Glen Rock, Pa. It's fantastic—St. Joseph, Mo. Please rush; heard good reports—Hicksville, N.Y. One tremendous meter—Alexandria, Minn. Send your Super meter; heard about it—N. Olmstead, Ohio. Love that ESR Meter—Acton, Mass. Used it intensively for 30 days; it's been 100% effective—Pittsburgh, Pa.

Ideal for preventive maintenance: measures electrolyte dryness & shows up intermittent opens.

60-day Satisfaction Guarantee.

Send check or M.O. or call  
(313) 435-8916 for COD

Or write for free brochure to:

*Creative Electronics*

ESR Brochure \$ 99.00  
1417 N. Selfridge postpaid  
Clawson, Mich. 48017 USA & CAN.

Circle (5) on Reply Card

### NATESA

5930 S.

Pulaski Rd

Chicago

IL 60629



### ARE YOU A PRO?

...the not for profit association championing independents' right to compete, and delivering valuable benefits continuously since 1950.

- LEADING SPOKESMAN
- TRADE INFORMATION DISPENSER
- WATCHDOG
- LOBBYIST
- YARDSTICK OF STANDARDS
- CONSUMER RELATIONS
- COUNSELOR
- PROBLEM SOLVER

We are not freeloaders. So our check for \$60.00 dues is attached. As our special premium, please ship the indicated \$15.00 Manual.

- Practical Business Manual  
- OR -  
 Service Contract Manual

# Antenna roundup

Antenna manufacturers are constantly making antenna improvements. New metal finishes extend antenna life by resisting corrosion, while the electrical improvements provide wider bandwidth, higher gain and better front-to-back ratio.

## Choosing TV antennas

Snow-free TV reception requires  $1000\mu\text{V}$  of signal at the  $300\Omega$  receiver antenna terminals for the weakest station carrier. The signal level at the antenna must be stronger than  $1000\mu\text{V}$  by losses in the downlead and any matching transformers. In other words, a downlead loss of 10dB at the channel frequency must be offset by an antenna with additional gain of 10dB for the weakest carrier.

If the most sensitive antenna cannot intercept sufficient signal in the customer's location, a preamplifier can be installed between the antenna and its downlead. But remember that a preamplifier at best can only retain the antenna's signal-to-noise ratio (SNR). It cannot improve the SNR. Do not install a preamplifier between the downlead and the receiver; the preamp noise will then be added to the other noise.

A truism among antenna engineers is that more metal in the air produces increased signal. That pertains to skin area of the active and parasitic elements, and not masts or crossarms. Therefore, an antenna with additional element rods usually provides higher gain (but don't count UHF elements when VHF gain is the most important).

The number of elements gives a hint about the directivity. Usually, additional elements sharpen the

front lobe. In any event, if ghosts are a problem in the antenna neighborhood, check the polar-plot chart available from many manufacturers for unwanted side lobes, a narrow front lobe and a high front-to-back ratio.

## Impedance and downlead

Antennas are designed either for  $300\Omega$  or  $75\Omega$  impedance. Downleads are available in shielded or unshielded  $300\Omega$  twinlead or  $75\Omega$  coaxial cable. This would appear to eliminate any need for a decision; just use  $75\Omega$  cable with a  $75\Omega$  antenna, or  $300\Omega$  twinlead with a  $300\Omega$  antenna. However, the choice is not that simple.

Balun transformers are available to match any combination of  $75\Omega$  or  $300\Omega$  antennas to  $75\Omega$  or  $300\Omega$  antennas. Losses are small in these baluns. Therefore, antennas and downleads should be selected according to their individual characteristics without regard for the impedances, because they can be matched with baluns.

Generally,  $300\Omega$  twinlead has

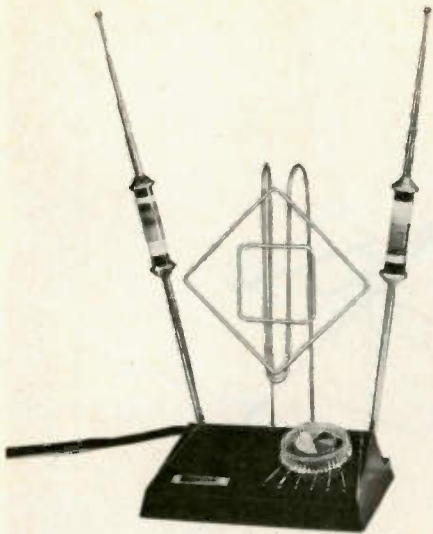
lower loss. But there are serious drawbacks: Loops or coils of twinlead develop extra impedance, perhaps causing ghosts; it can pick up signals that might be out of phase with the antenna signal, also producing ghosts (twisting the twinlead minimizes this effect); twinlead never should be run inside metal, such as conduit, or near metal; and twinlead deteriorates faster than coaxial cable when outdoors.

Coaxial cable performance does not change from metal near it or from mechanical movement (such as blowing in a breeze), but it does require care during installation. Do not make sharp bends or deform the cable with staples that are too tight. Coaxial cable has higher loss at high VHF and UHF channels than twinlead does, but the frequency-dependent losses can be compensated by tilted-response amplifiers, where long runs are essential.

For additional tips about antennas and installations, refer to the article beginning on page 8 of the July 1980 *Electronic Servicing*. □

**The HD-73 control unit features 2-speed rotation with one 5-position switch. This presents a speed of one revolution per minute for rotating over an extended arc, and a slower speed for adjustment of several degrees for fine adjustments for the best signal on receiving and transmitting. Courtesy of the Alliance Manufacturing Company.**



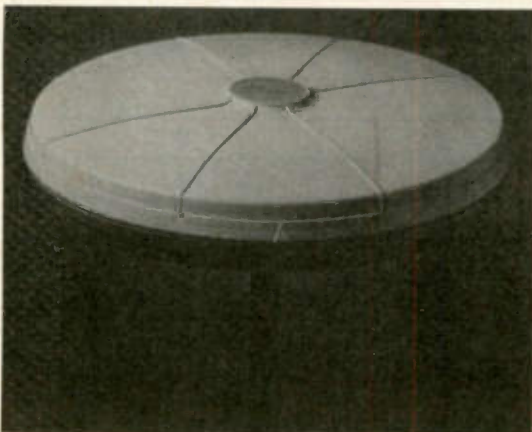


The Apollo model, catalog number 32-332, has a 6-position tuning switch for maximum picture clarity. A 4-section telescoping VHF element extends 38 inches. Decorator-accented grips on the VHF element eliminates static during adjustment. Other models available from the company include the Galaxy, which is the top of the line model, and the Saturn and Venus. *Courtesy GC Electronics.*



This small electronic amplifier installs with any 12V negative ground system. The unit picks up weak and fading FM signals and leaves AM stations unaffected. *Courtesy Antennacraft Company.*

The ac-dc Mini-State model 5MS550 UHF-VHF TV antenna system is weather-resistant, lightweight and compact. A rotating unidirectional antenna inside a polyethylene radome allows the best TV reception for each channel up to 35 miles from the station. *Courtesy RCA.*



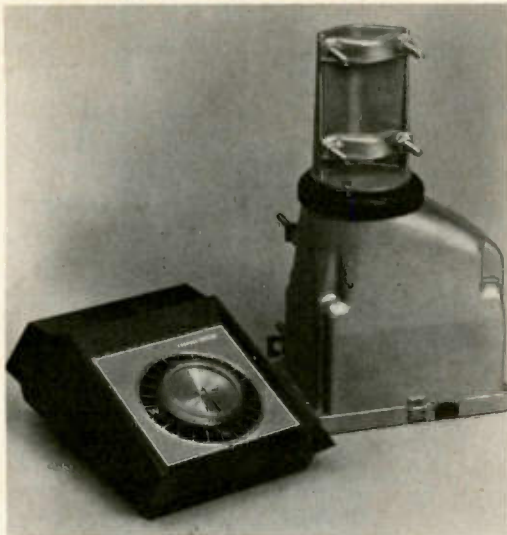
The ASP-710 low-band base station antenna features a coaxially centered radiating element encapsulated in a fiberglass radome. The antenna has a rated wind velocity of 150 mph with a 1.65 safety factor (RS-329). *Courtesy The Antenna Specialists Company.*

Fixed-station antennas from Sinclair Radio Laboratories include ground plane, coaxial, cardioid, yagi, external dipole, corner reflector, open-grid parabolic, and, pictured here, omni/collinear. The antennas are 25-960MHz. *Courtesy Sinclair Radio Laboratories.*

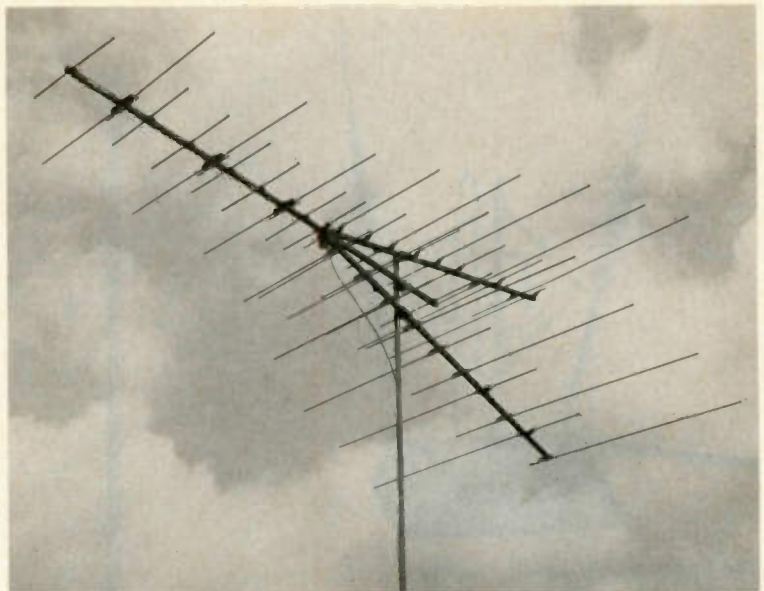


The model G-959 UHF-VHF broad-band pre-amplifier has a frequency range of 54 to 216MHz (channels 2 through 13), 470 to 890MHz (channels 14 through 83), separate UHF and VHF 300  $\Omega$  inputs, and 75  $\Omega$  download. The unit comes complete with a 75  $\Omega$  power supply. *Courtesy The Finney Company.*

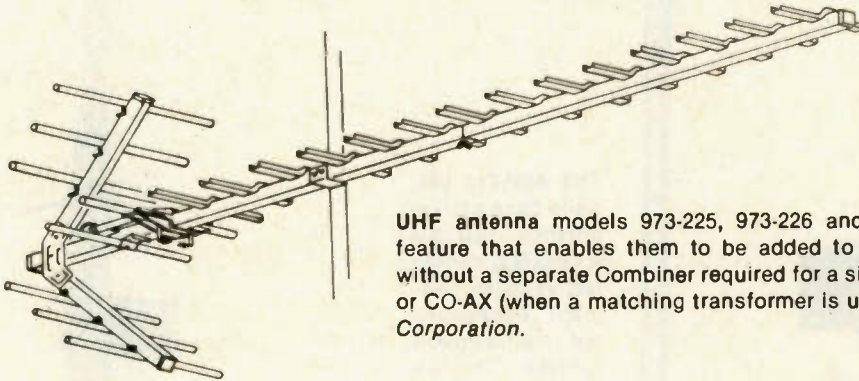
## Antenna roundup



The model 9512A automatic TV antenna rotator is offered by Channel Master. The company also has available the Monitenna 4-band antenna, and UHF, VHF and FM suburban, fringe, near-fringe, deep fringe and deepest fringe antennas. *Courtesy Channel Master.*



The Chromster model CH-5100 combines the Electro-Lens director system with cross-phased, end-fire driven elements. The VHF antenna has low-Q/16-Inch-diameter elements and dual directors to give increased capture area and to allow finer tuning. *Courtesy Winegard Company.*



UHF antenna models 973-225, 973-226 and 973-227 have a diplexing feature that enables them to be added to any existing VHF antenna without a separate Combiner required for a single download, either 300  $\Omega$  or CO-AX (when a matching transformer is used). *Courtesy Zenith Radio Corporation.*

## ANTENNA MANUFACTURERS

	TV OUTDOOR	TV INDOOR	CB RADIO	BUSINESS RADIO	ROTATORS	MATV	HARDWARE	TOWERS
Alliance Mfg. (80)					X			
Antenna, Inc. (81)			X	X				
Antenna Craft (82)	X							
Antenna Specialists (83)			X	X				
Channel Master (84)	X	X	X		X	X	X	
Finney Co. (85)	X	X				X	X	
GC Electronics (86)	X	X	X				X	
RCA Distributor (87)	X	X			X*	X	X	
Shakespeare (88)			X				X	
Sinclair Radio (89)			X	X				
Telex/Hy-Gain (90)			X	X	X		X	X
Winegard (91)	X	X			X*	X		
Zenith (92)	X	X			X	X	X	

\*These rotators are part of an indoor/outdoor system

TO RECEIVE MANUFACTURER'S INFORMATION, CIRCLE NUMBERS ON THE REPLY CARD

With the approval of DBS (Direct Broadcast Service) by the FCC, a new market of supplying direct TV reception to homes and businesses is on the verge of blossoming. The cover this month, courtesy of Jim Kluge of the Winegard Company, illustrates a possible home receiving dish in a remote setting.

The table shows a number of manufacturers and some of their earth station antennas. These dishes are chiefly for the commercial and broadcast markets, too expensive for the general consumer. But as DBS becomes more realistic and as transponder frequencies and power go up, less expensive systems will become available to the public.

Company	Model	Transmit/ Receive	Receive Only	Antenna Size (meters)	Frequency (GHz)	
					Uplink	Downlink
Andrew Corp. <i>Notes 1, 2</i>	ESA10-46B	X	...	10	6	4
	ESA10-46HP	X	...	10	6	4
	ESA10-46CP	X	...	10	6	4
	ESA12-46	X	...	12	6	4
	ESA12-46HP	X	...	12	6	4
	ESA12-46CP	X	...	12	6	4
Anixter-Mark	ES-40200SD	...	X	5	...	4
California Microwave <i>Note 3</i>	SAT4	...	X	1.2	...	4
	SAT6	...	X	1.8	...	4
	SAT10	...	X	3	...	4
	SAT15	...	X	4.6	...	4
	C6040	X	...	10,11,12	6	4
Compact Video <i>Note 4</i>	Compact 42	X	...	5	6	4
COMSAT <i>Note 5</i>	Multibeam Torus	X	...	5-10	6, 14	4, 12
Fairchild	SDX	X	...	5.9	6	4
	...	...	X	2,2.5,3	...	4
Gardiner Communications	5.6	...	X	5.6	...	4
Harris Broadcast	5242	...	X	6.1	6	4
	5251	X	...	8.8	6	4
	5260	X	...	11	6	4
Holzberg	NEC-790	...	X	1.2	...	12
Hughes	SVRT	...	X	4.5,5,6	...	4
Microdyne	PR23	...	X	7	...	4,12
Scientific Atlanta	8006	...	X	3.0	...	4
	8005	X	...	4.6	6	4
	8008	X	...	5.0	6	4
	8010	X	...	7.0	6	4
	8002	X	...	10	6	4
	8007	X	...	11	6	4
	8101-5.5	X	...	5.5	14	12
	8101-7.7	X	...	7.7	14	12
US Tower	USTC 3.3	...	X	3.3	...	4
	4 MLF	...	X	4.0	...	4
	5 MDF	...	X	5.0	...	4
	6 MDF	...	X	6.1	...	4

*Note 1: HP configurations exceed US and CCIR pattern recommendations for greater frequency coordination in frequency-congested areas.*

*Note 2: CP configurations are specifically designed for use with Intelsat satellites.*

*Note 3: All systems designed to handle program audio material; in addition, SAT6, 10, and 15 designed to handle data transmission; the C6040 handles program, data and TV transmissions.*

*Note 4: Mobile uplink/downlink system uses Scientific Atlanta 5m parabolic antenna.*

*Note 5: COMSAT: The Multi-Beam Torus Antenna (MBTA) was developed to transmit/receive from as many as seven satellites simultaneously.*

# A computerized service operation

*Computers are gradually coming to the aid of almost all businesses. This article describes the Computech system specifically designed to handle the electronic servicing business—set diagnosis, repair estimates, billings and accounting.*



The complete Computech system includes a 32K computer terminal with full keyboard and a small CRT readout, a dual-drive floppy disc, a hard-copy printer and a notebook having about 6500 items of TV parts failures indexed by Photofact numbers. A typical circuit is displayed on the TV screen. H. Lyle McCallister, Computech president, is shown.

---

By Carl Babcoke, CET

---

Computers are necessities for large businesses. Also, a surprising number of smaller companies now use computers to reduce operating expenses and reduce many mistakes. For many years, electronic technicians have dreamed about a computer that could be fed all available symptoms of a malfunctioning TV receiver, and the computer display then would identify (by the schematic callout number) the most likely defective component.

Previously, no computer system was capable of handling both finan-

cial and technical information. The Computech system might be the first. Therefore, the following description of the Computech capability is intended to benefit the readers; it is not an endorsement by **Electronic Servicing** or an advertisement.

### Computech manual

Two packages are offered by Computech. One is a manual. The other is a complete computer system with both technical and business capability.

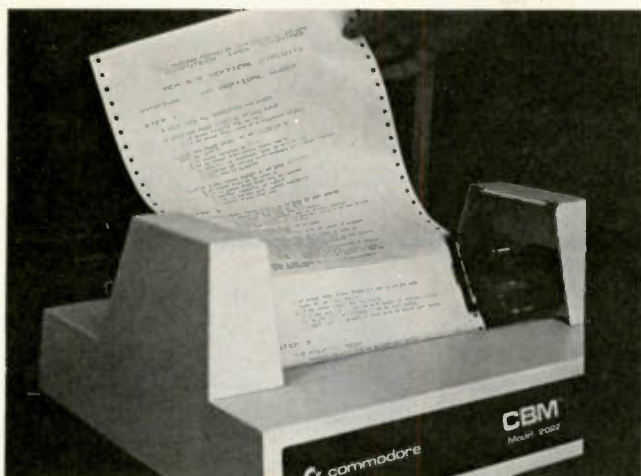
The manual is a three-ring computer-printed notebook with 8½-inch by 11-inch pages containing approximately 6500 symptoms

and suggested remedies. These manuals can be purchased by the month, or outright by the year, with monthly updates.

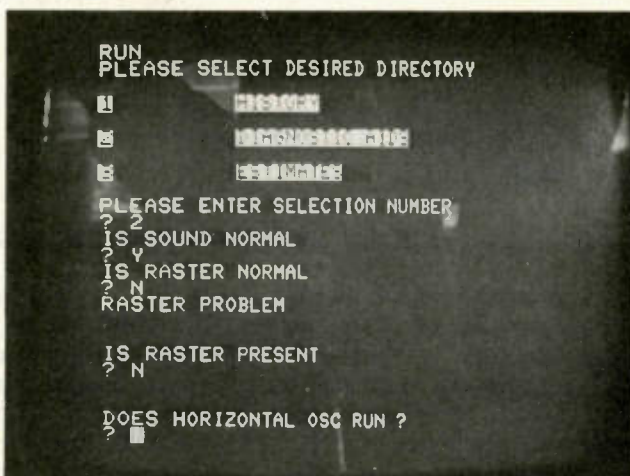
These symptoms are indexed numerically by Howard W. Sams Photofact numbers. Step-by-step procedures and troubleshooting techniques for locating difficult problems are included in addition to the short tips about defective parts.

### Computer capabilities

Computech offers a computer system consisting of a Commodore 32K-memory keyboard-operated computer with a small CRT screen, a dual-drive floppy disc and a hard-copy printer. A 19-inch or larger



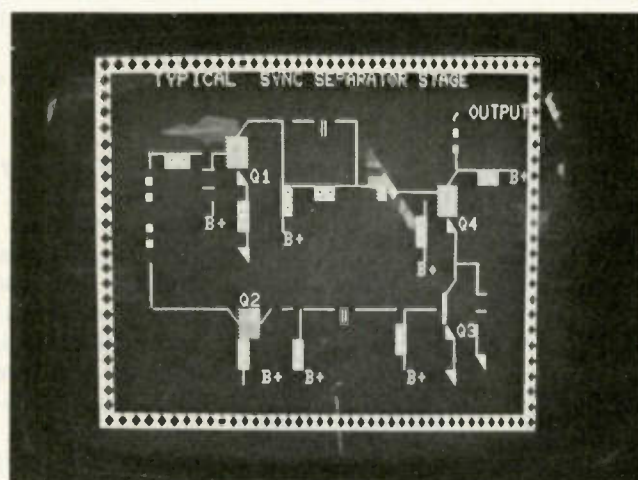
The printer can produce a page of information when it is needed, with step-by-step servicing instructions.



When questions from the computer are answered, the screen shows the diagnosis.



The repair estimate in minutes, labor and parts costs, and the total cost are displayed on the monitor receiver after the proper routine is followed.



Simple schematics can be drawn by the computer of the Computech system. Elements that are suspected of having failed are flashed to pinpoint faults.

color television receiver should be connected by a video-to-RF converter to this system for the main readout.

The Computech system functions in these four major categories: accounting, customer records, production of manual pages and service assistance.

**Accounting**—The computer handles general ledger entries, accounts receivable, accounts payable, inventory, large-job costs, and payroll and mailing lists. The computer files are random-access types, which allow easy correction of any errors that might occur.

At the end of an accounting period, the computer provides

statements and master records for review.

**Service programming**—These four basic service functions are provided: identifying the bad circuit; selecting the best troubleshooting procedure; estimating repair costs; and selling the customer.

First, the technician responds yes or no to the computer's questions about the symptoms. From these entries, the computer determines the circuit needing testing, and it prints a troubleshooting procedure for that type of circuit. Next, the computer draws a schematic, indicating by blinking symbols the most common failures. This animation is particularly impressive to the customers

because the whole sequence is displayed on the television-receiver monitor.

After the schematic is displayed, the computer can display and print an estimate of the repair costs. The estimate is broken into labor and parts costs, along with a brief description of the labor procedure.

The entire service program can be run in less than 10 minutes, and an estimate charge should be made if the customer does not want the set repaired.

#### More information

For more product information from Computech, circle (99) on the Reader Service Card. □

# product report

## Amp-Clamps UL listed

Simpson Electric Company has announced that its line of Amp-Clamp clamp-on electrical testers and adapters have been listed by Underwriters Laboratory. The Amp-Clamp testers include: the model 296 series-2 volt-ohm-ammeter (\$96.00), which measures 0-30 to 0-600 volts ac in four ranges, 0-500 ohms, and 0-6 to 0-300 amperes ac rms in five ranges; and the model 294 series-2 ammeter (\$73.00), which measures 0-6 to 0-300 amperes ac in five ranges.



Also UL-listed are the model 150 series-2 Amp-Clamp adapter (\$46.00), for Simpson analog volt-ohm milliammeters, and the models 153 series-2 and 154 series-2 Amp-Clamp adapters (\$46.00), for Simpson digital multimeters.

Circle (30) on Reply Card

## Portable desoldering

Micro Electronic Systems introduces another concept in portable vacuum desoldering with Super Vac III. The unit operates about 3000 times from a Freon can or from shop air at 5-7 kg/cm<sup>2</sup>. Super Vac III is available from stock at \$59.95 each. The freon cans are \$4.50 each.

Circle (31) on Reply Card

## Canvas carrier

Klein Tools announces addition of a line of open-top canvas tool/general purpose carriers made of heavily stitched, riveted white canvas with black nylon strap handles extending completely around the bottoms. Sizes from 17 inches to 31 inches in length and widths from 9 inches to 12 inches. Depth of these handy carrying bags ranges from 10 inches to 15 inches, depending on the specific catalog number.

Circle (32) on Reply Card

## Four-way screwdriver

Klein Tools also announces a new reversible four-way screwdriver, a tool that drives slotted and Phillips screws with a single handle. The reversible shaft holds screwdriver bits in both ends and the bits are also reversible. Bits are for 3/16-inch and 1/4-inch slotted screws as well as No. 1 and No. 2 Phillips screws. The shaft locks securely into its large, comfortable-size handle.

Circle (33) on Reply Card

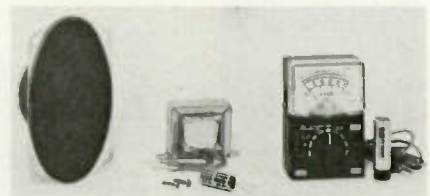
## Six second stripping

Corex, a six second, coax-wire stripper is available from Electronic Tool Company. The Corex has precise cutting blades to remove dielectric, braid and outside insulation simultaneously, or in any combination the user desires.

The Corex coax-wire stripper employs a cassette system. With different color-coded cassettes accurate stripping lengths from 4mm to 12mm can be made.

Two models are available: a two-bladed tool for 480 "B" DIM and 260 "B" DIM that makes a two-level strip; for three-level strips, a three-bladed tool for the MS309012 type crimp connectors. The Corex coax-wire stripper comes complete with the Corex tool, one cassette, three V-block, one hex, and keys. A selection of cassettes is available for different strip length requirements.

Circle (34) on Reply Card



## Miniature multi-tester

Speco announces the addition of a miniature pocket-size economy multi-tester with 1000 ohms volt sensitivity. The molded plastic 3 1/2" (H) 2 1/2" (W) and 1 1/4" (D) unit comes complete with battery, instructions and test leads and is blister packaged for display.

Circle (35) on Reply Card

## Dc crowbar

Model LVC-1H from MCG is one-fifth to one-third the size of conventional crowbars. The unit has a trip voltage from 5.0 to 35 Vdc (higher voltages on request) at a current level of 55 amperes dc (continuous). The LVC-1H crowbar has been designed to operate over a very wide temperature range and is useful in applications where high dc transients may destroy boards of ICs, microprocessors and microprocessor power supplies. By shorting the dc bus in the event of power supply failure, the crowbar can prevent wholesale damage to electronic components. Recovery is automatic when power is removed temporarily. Price: \$48 in 100-piece quantities.

Circle (36) on Reply Card

## Interconnection protection

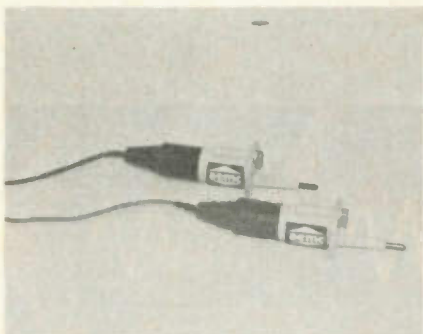
Shielded RS-232C interface cable assemblies, for interconnecting data terminal equipment and data communications equipment, protect transmitted signals from EMI/RFI in electrically noisy environments. Developed by Belden/ISO, the assemblies feature a Duofoil foil-film shield and shielded male or female subminiature D connectors. Available in 10 standard constructions in lengths from five to 70 feet.

Circle (37) on Reply Card



### Multimeter accessory

A multimeter accessory has been developed by AEMC Corporation to reduce user danger in the event of multimeter misuse or high capacity systems. The probes will be particularly useful for power utilities and industrial plants where high capacity systems are common. Each probe includes a high interrupting fuse: 100,000A at 600Vac, and 100,000A at 250Vdc with  $L \div R = 25mS$ . One black probe and one red probe are included in each set.



Circle (38) on Reply Card

### Mounting ear kit

Philips ECG has introduced a universal mounting ear kit which facilitates installation of replacement picture tubes in color television sets.



Designated type EK1, the kit provides a fast method of placing mounting ears on color picture tubes not equipped with such devices. It consists of a 74-inch metal band, clamp and four ears. The metal band accommodates popular domestic and imported picture tubes up to 25-inches in size. Each kit is furnished with a tube interchangeability chart and illustrated directions.

Circle (39) on Reply Card

### Heavy duty DMM

The HD-100 from Beckman Instruments is made waterproof and dustproof to resist the elements. Reportedly, it can withstand the physical impact of accidental drops and boasts a built-in input protection.

Voltage inputs are protected to 1500Vdc or 1000Vrms. Current ranges are protected to 2A/250V while resistance ranges are protected to 500Vdc.

The O-ring sealed ABS plastic case is fire retardant with double-thick, ribbed side walls. In bright "NATO" yellow the case is highly visible—easy to spot in a tool box or on a ledge before leaving a job.

Inside, the electronics, including the "large area" LCD and battery, are shock-mounted. A common 9V alkaline battery provides up to 2000 hours of continuous operation and up to two years of life under typical conditions.



A visual continuity test function, called Insta-Ohms, enables you to check electrical continuity. In any resistance range, an ohms symbol ( $\Omega$ ) appears instantly in the LCD when continuity is detected.

A complete line of accessories include a clip-on vinyl case, 2 ac current clamps, deluxe test lead kit, RF probe and a high voltage probe.

U.S. list price: \$169.

Circle (40) on Reply Card

# APPLIANCE REPAIR BOOKS



Thirteen Handbooks written in easy-to-understand language by experts in the service field with illustrations and diagrams! Acclaimed by instructors and professionals alike! How to diagnose and repair air conditioners, refrigerators, washers, dryers, ranges, microwave ovens, dishwashers, vacuum cleaners, electrostatic air cleaners, RV gas appliances, hair dryers, motors, water heaters, coffeemakers, can openers, floor polishers, steam irons, food mixers, lawn care appliances, electric knives, electric and digital clocks and many others. Also fundamentals of solid state, setting up a shop, using test instruments and more. Only \$2.65 to \$4.90 ea.

SEND FOR FREE PRICE LIST

Gamit, Dept. ES  
110 W. St. Charles Road,  
Lombard, Illinois 60148

Circle (6) on Reply Card

## NATIONAL ELECTRONICS SERVICE DEALERS

Are you standing idly by while ideas that can be money in your pocket fly away? Membership in NESDA is one of those ideas.



### WHAT DO YOU GET FROM NESDA?

1. Insurance
2. Special Bancard Rates
3. ServiceShop Magazine
4. Electronic Service Industry Yearbook
5. Service Industry Information
6. Legislative Programs with State and National Government
7. Advocate for Better Warranty Practices
8. Business Information



Don't let your bucks get lost in the shuffle.

Send in your check today.

On the bottom line it will mean extra \$\$\$ in your pocket.

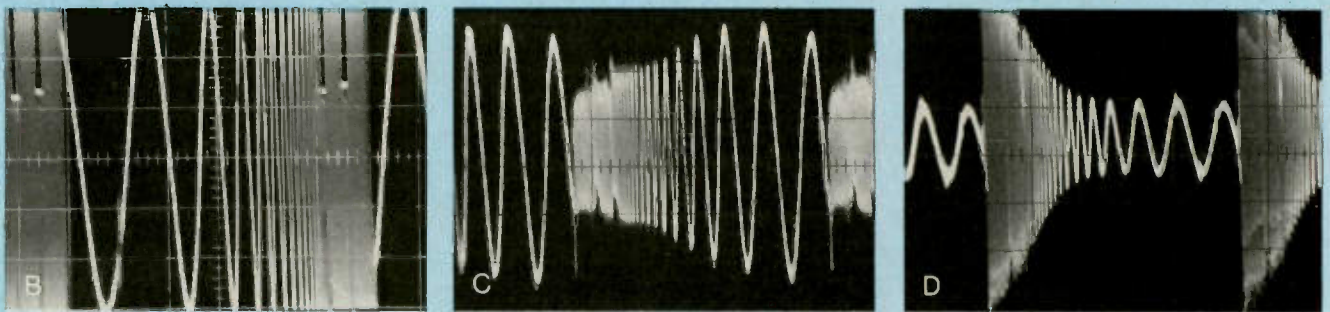
JOIN NESDA  
And Your State Association  
Send for more information:  
NESDA, 2708 W. Berry St.  
Fort Worth, TX 76109



## Correction —

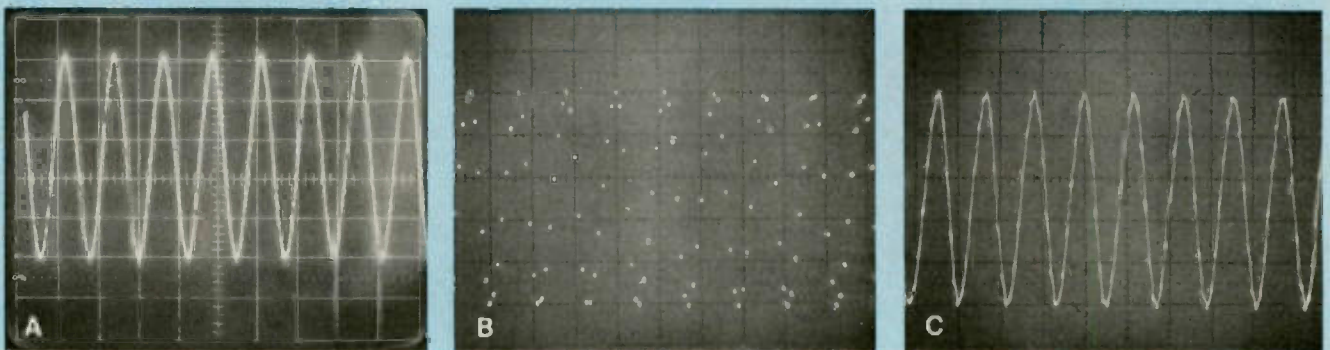
In the May 1981 issue of **Electronic Servicing**, the photos on pages 16 and 28 were transposed. Photos B, C and D shown on page 28 belonged on page 16 with the "Applications of digital scopes" article. Photos A, B and C on page 16 belonged on page 28 with the "Typical auto audiocassette repairs" article. The photos are placed correctly, below. Our apologies to the authors and to our readers.

### Audiocassette



**Figure 4** Stereo tape recordings can be tested for frequency response and the effects of recording supersonic bias by connecting as shown in the (A) block diagram. Recording the ramp signal on one channel provides stable locking of the scope. The amplitude of supersonic bias affects the audio distortion and high-frequency response of the recorded signal on the tape. (B) This is the swept-audio signal from the generator, which covers the 500Hz to 25kHz range. (C) Excessive supersonic bias reduces the amplitude of the high frequencies. (D) Insufficient supersonic bias produces excessive high-frequency response while increasing the distortion.

### Digital scopes



**Figure 2** Challenging the process: In A, an 80kHz sine wave is displayed in real time as it would appear on a conventional scope. In B, this signal has been transformed into dots by a digital scope, and in C, the dots are joined by straight-line constructions. At this high frequency, the scope's sampling rate of 1MHz means only 12 dots are available to plot each wave repetition ( $1,000,000/80,000 = 12$ ). Because the instant of digital sampling does not occur at exactly the same point wave-to-wave, some slight variation appears between identical waveform. Thus, some peak values may be minutely clipped as shown here, or if a superimposed megahertz transient occurred between two adjacent dots, it might be missed entirely. If such sampling errors are critical, a much higher sampling-rate instrument would be required.

# people in the news

**Thomas D. Mock** has affiliated with the Electronic Industries Association's consumer electronics group as staff engineer. He will have responsibilities in the area of the recently formed CEG personal electronics division, audio standards, reports of the Teletext subcommittee of the EIA Broadcast Television Systems (BTS) committee and special assignments. Mock was most recently senior project engineer with the Raytheon Service Company.

**William J. Anderson II** has joined TRW semiconductors as manager, marketing programs. In his new post, Anderson manages distributor and export sales of the division's RF and power groups.

He had been marketing manager of fiber optics for the Deutsch Company in Los Angeles. For 14 years, until 1977, he was in business for himself as a manufacturers' representative and a marketing and engineering consultant.

**Raymond Gerr** has been appointed director, research & development, for Dumont oscilloscope laboratories. Gerr formerly worked at Bendix Corporation, flight systems division, and was chief engineer at Ballantine Laboratories. His appointment is announced as part of a continuing program to develop a new line of oscilloscopes.

**Jim Auer** has joined the magnetic tape division of Fuji Photo Film USA as assistant to the advertising manager.

Auer will assist in the development of sales promotions materials, product literature, and will coordinate the activities of the division's advertising agency.

Prior to joining Fuji, he was an assistant account executive at Foote, Cone and Belding Advertising where he was involved with the Lorillard, Western Electric and the Bermuda Department of Tourism accounts.



**Lewis Kornfeld**, vice chairman of Tandy Corporation and a 33 year Radio Shack veteran, was honored by Boston University at its 108th commencement with the conferral of an honorary Doctor of Humane Letters (LHD) degree.

Kornfeld was honored in March with the Distinguished Professional Achievement Award from the University of Denver.

When Kornfeld joined Radio Shack in 1948, it was a 30-man store in Boston. He plans to retire next month, remaining as a Tandy director.

GCA Corporation has formed a separate IC systems service division, under its IC systems group, to provide customer service and training for all semiconductor production equipment manufactured by GCA. **Peter J. Simone** was appointed general manager of the new division.

Prior to being named general manager of the new service division, Simone was west coast operations manager for the GCA/IC systems group. He has been with GCA for six years, and earlier, was a certified public accountant for Arthur Young and Co.

**Kenneth R. Pynn** has been appointed director of field service for the new division. Pynn has been

with the GCA/Burlington division for 20 years, most recently as manager of field service. In his new position, he will manage the domestic field service operations in both the Burlington division and for GCA California operations.

**Robert Stearns**, who was the field service manager for GCA California operations, was promoted to director of technical services in the new division. Stearns has been with GCA for approximately two years, and earlier, was technical support manager at National Semiconductor.

Also appointed was **John J. Iannini** as product marketing manager. Iannini has been with GCA for six years, most recently as a product line manager.

*It's no  
puzzle  
to order*

**Oelrich Service Forms**

For TV-radio and two-way radio service—  
legal forms for Calif., Florida and Utah.  
Now at parts jobbers or write for cat. B64.

OELRICH PUBLICATIONS  
4040 N. Nashville Ave., Chicago, IL 60634  
Now call toll-free! 800-621-0105

Circle (7) on Reply Card



**FREE CATALOG**

**HARD-TO-FIND PRECISION TOOLS**

Lists more than 2000 items: pliers, tweezers,  
wire strippers, vacuum systems, relay tools, op-  
tical equipment, tool kits and cases. Send for  
your free copy today!

**JENSEN TOOLS INC.**

1230 SOUTH PRIEST DRIVE · TEMPE, ARIZONA 85281

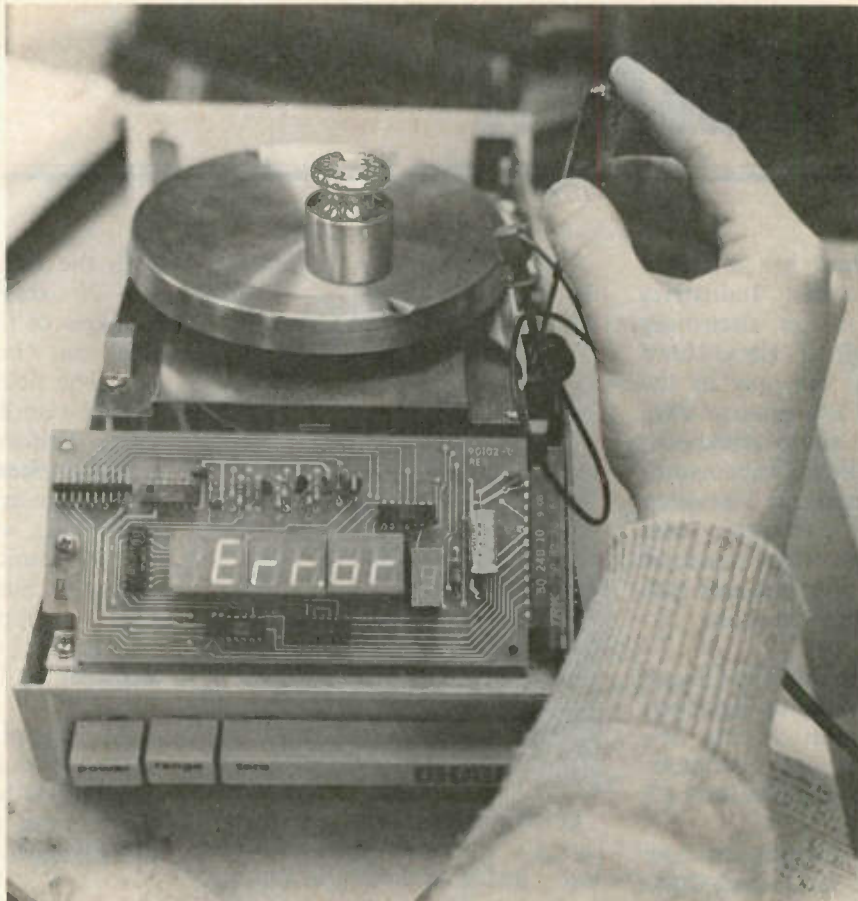
Circle (8) on Reply Card



**American  
Heart  
Association**

WE'RE FIGHTING FOR YOUR LIFE

Technicians at Ohaus adjusting some of the trimmers in the disassembled balance, and using an oscilloscope to check the functioning of some of the circuits. Just as in TV servicing, the technicians use and rely on the extensive service data to help them keep the electronic balances in good working order.



## Service center provides technical backup

As a major part of its product servicing program, the Ohaus Scale Corporation has a factory service program for its electronic balances that is on a two-day turnaround schedule. This helps assure that a field service technician gets prompt and effective backup when required.

Because Ohaus management sees the company's "first line of service" as the trained field technician, the chief role of the central service department is to provide technical backup. As well as repairing electronic balances, the department also coordinates field activities, supplies replacement components and is a troubleshooting consultant for the more than 100 technicians in 50 service centers throughout the United States.

Service is also provided for

Central and South America and part of the Far East from the company's headquarters in Florham Park, NJ. A corresponding center in England serves Europe and Asia.

Three factors have made major contributions to the acknowledged success of the service program. All are based on the philosophy of decentralizing service activity by relying on the dealer field technicians being as skilled, up to date and self-sufficient as possible. The three factors are: thorough specialized training, a self-teaching format service manual and free access to the Ohaus service department for expert advice on unusual problems.

At the start of the program, Ohaus service personnel conducted field training programs for all technicians. This was done through class instruction and a supportive

videotape on electronic balance servicing. Nevertheless, Ohaus sees its chief training tool to be the service manual.

The service manual functions in two ways: It provides the information necessary to provide maintenance and service on the Ohaus electronic balances. It also details the operation and construction of the balance. Then, by component and by malfunction it specifies which can and cannot be serviced in the field. In the course of working with the manual, the technician is involved in a course of self-instruction because the construction and operation of the balance are explained through both instructions and diagrams.

Sometimes the technician's experience and the service manual are not enough. Then he or she can call

# MRO solid state problems?

1,400 RCA SK Series  
+3,500 JEDEC\* Devices

4,900 MRO Solutions

To fill your solid state replacement needs — for MRO/industrial and consumer applications — see your RCA Distributor for copies of the 1981 RCA MRO Replacement Manual (1K6804) and the 1981 RCA SK Replacement Guide (SPG-202Z).

For a list of RCA Distributors, write to Sales Promotion Services, RCA Distributor and Special Products Division, 2000 Clements Bridge Road, Deptford, N.J. 08096.



For MRO/  
industrial applications  
Make replacements from your  
RCA Distributor's shelf with 3,500 RCA  
JEDEC and RCA commercial types.

For MRO/industrial and  
consumer applications  
1,400 SK replacements for more than  
170,000 domestic and foreign types.



\*Joint Electron Device Engineering Council

**RCA** SK Replacement  
Solid State

the service department for troubleshooting advice. Ohaus maintains a toll-free line to assure maximum access in solving repair problems. As appropriate, pre-tested and "burned-in" replacement circuit boards or other components are supplied by the service department

to the field technicians.

The 100 technicians are in the 50 field service centers associated with major Ohaus dealers. The technicians there also service other products sold by the dealer.

"In fact, some technicians may never see one of our electronic

balances, but if they do, we want them to be ready. That is one of the main reasons for our emphasis on the service manual; it can stay on the shelf until it is needed," said Earl Myers III, Ohaus product service manager. □



# Reports from the test lab

Each report about an item of electronic test equipment is based on examination and operation of the device in the **Electronic Servicing** laboratory. Personal observations about the performance and details of new and useful features are spotlighted, along with tips about using the equipment for best results.

By Carl Babcoke, CET

## A. W. Sperry digital multimeter

Sperry model EZ-6100 is a 3½-digit LCD-display digital multimeter having autoranging and several unusual features, including an audio tone to indicate continuity and overrange. The small plastic cabinet (approximately 3¼ x 6 x 1½ inches) has black and non-glare-gray colors (Figure 1).

Eleven functions (in addition to the digital numbers) are displayed automatically by the LCD readout. These symbols plus the autoranging allow simple operation. Figure 2 shows *AUTO*, *V* (voltage) and *-* (minus) legends.

Four positions of a large knob selects volts, ohms and current. The current function has two ranges without autoranging. Usually, voltage and ohms ranges are selected by the meter's autoranging. How-

ever, there are two methods of obtaining a desired range either by range-hold action or by a stepping action involving the *RANGE* button, one of three push-buttons at the right below the LCD display, as shown in Figure 3. These features allow simple but accurate operation.

Three test-lead jacks are used. One is for Vac and Vdc measurements. The center jack is common for all functions, and the third jack handles current and resistance readings.

The on/off switch has three positions: OFF, ON, and audio tone (marked by a twin sixteenth-note musical symbol).

## Dc voltage measurements

Five dc-voltage ranges cover 200mV full scale to 1000V maximum with autoranging. Input resistance of the 200mV range is 100mΩ, while all others are rated at 10mΩ.

Accuracy of all dc-voltage ranges is ±0.2% of full scale ±0.5% of reading. For dc voltage, the display shows an *mV* or a *V* at right of the digits in addition to a minus sign before any readings of negative voltage. Absence of the minus sign indicates positive voltage. Also, the word *AUTO* appears in the lower left corner when autoranging is in operation. The word is missing when range-hold or manual range selection is employed.

Overrange of the LCD display is indicated by a blinking number 1 followed by three unblinking zeros. When the audio tone indication is selected by the on/off switch, a beep-beep, pause, beep-beep, pause, etc. sound is heard during any overrange.

## Ac voltage measurements

Four RMS-calibrated Vac ranges cover 2V full scale to 600V (maximum recommended voltage). Input resistance is about 10MΩ for all ranges.

Accuracy of the 2V range is specified as ±0.4% of full scale ±0.1% of reading, while the other three ranges are rated at ±0.25% of full scale ±1% of reading. These specifications apply between 40Hz and 500Hz.

A frequency-response chart was made of the 2V and 20V ranges, to determine the suitability for audio

measurements. On the 2V range, -1dB was found at 4kHz with -6dB at 13.5kHz. The 20V range measured -1dB at 30kHz with -6dB at 117kHz. One decibel is about 11%; therefore, accurate measurements of audio ac voltages should not be attempted unless a correction chart is made of all ac ranges. The frequency response of model EZ-6100 is typical of DMMs with ac input impedances of 10MΩ.

To select ac readings, the power must be turned on, the function switch rotated to *VOLTS*, and the ac/dc button (top of the three) pressed firmly one time. This produces auto-ranging ac readings, with the *AC* and *AUTO* symbols visible in the readout. When *RANGE* hold or search is activated by the center push-button, the *AUTO* symbol is eliminated.

## Current measurements

Two ranges (20mA and 200mA full scale) are provided for both ac and dc currents. These ranges are not autoranged, but must be selected manually. Ac current requires a push on the *AC/DC* button, as is needed for ac voltage.

Accuracy of the dc-current ranges is ±0.2% of full scale ±1% of reading. Ac-current ranges are rated at ±0.25% of full scale ±1.3% of reading.

## Resistance measurements

Five high-power resistance ranges are provided; 200Ω, 2KΩ, 20KΩ, 200KΩ and 2000KΩ. Open test-lead voltage was +1.54V on the 200Ω range. All other high-power ranges had +0.65V (red probe was positive, relative to the black probe). At 10% above overrange, test-lead voltages of the four highest ranges were +0.33V. A typical silicon-type diode gave an overrange indication (open circuit) on all but the 2MΩ range, but the reading was about 500KΩ and thus not useful.

Open-circuit voltages of the four low-power ranges (the 200Ω range is not operative on low power) were +0.325V. At about 10% above overrange, the voltages were about +0.155V. This low voltage should not cause any conduction in solid-state junctions, even germanium types.

Accuracy of the high-power ranges is specified as ±0.2% of full

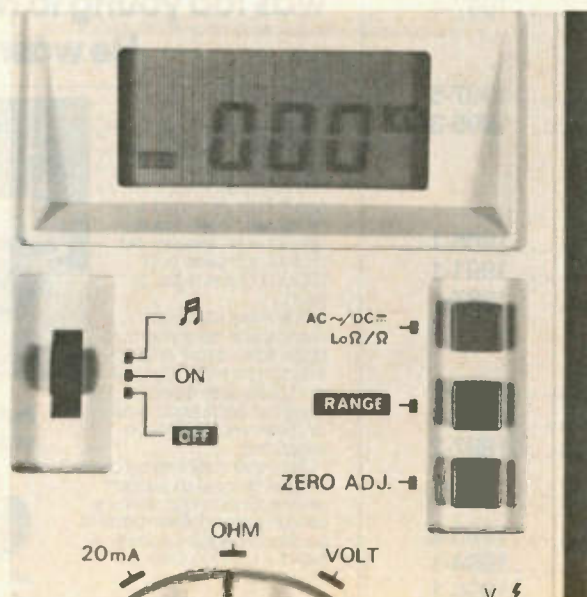


Figure 1 Sperry model EZ-6100 is a small digital multimeter having several unusual features, including additional symbols in the readout, autoranging, and two AA batteries.

Figure 2 Additional legends and signs in the readout include: mV; V; - (minus);  $\Omega$ ; K $\Omega$ ; AUTO; BATT; LO; and AC. These are activated by the switches and push-buttons. The 1.588V readout of the flashlight battery has a minus sign before the numbers because the test leads were reversed. Below the minus sign is the AUTO symbol that shows autoranging operation. A small V for voltage follows the readout numbers. During resistance tests, an omega (ohm) symbol appears above the V along with a preceding K when the reading is in K $\Omega$ . MA appears at the bottom during current tests.



Figure 3 This closeup photograph shows the 3-position on/off/audio switch at the left, the three non-latching push-buttons at the right, and the display above.



scale  $\pm 0.5\%$  of reading, except for the 2000K $\Omega$  range, which has a  $\pm 0.25\%$  of full scale  $\pm 1.8\%$  of reading rating.

All low-power resistance ranges (except 2000K $\Omega$ ) have an accuracy rating of  $\pm 0.5\%$  of full scale  $\pm 1\%$  of reading, while the 2000K $\Omega$  range is rated at  $\pm 0.5\%$  of full scale  $\pm 2\%$  of reading.

### Comments

Sperry model EZ-6100 is powered by two AA batteries for up to 300 hours of constant operation. Meter protection includes a fuse mounted next to the AA batteries for voltage and resistance ranges, and a twin diode added to the resistance ranges for extra protection.

An audible tone (appears to be around 2kHz) begins about a second after continuity is established during resistance measurements. The tone persists for perhaps a half second after the continuity is broken. Over-ranges of ac and dc voltage and current also produce audio tones. The tone source is on the back where it can be obstructed when the meter is lying on its back. The tone volume is not loud; therefore, do not cover the audio transducer if maximum volume is needed to overcome ambient noise.

A ZERO ADJ is provided to null-out test-lead resistance when the 200  $\Omega$  range is used. No provision is made for tilting the instrument during operation.

The three push-buttons do not remain down when they are pushed (non-latching types). But the resulting change of measurement condition is revealed by symbols around the digital numbers of the readout. It is strongly recommended that the meter user carefully read the instruction manual and review it periodically to prevent mistakes. The manual methods are accurate, and no errors should result if they are followed.

Accuracy of dc and ac measurements was good when compared simultaneously with a 0.05%-accuracy 4½-digit multimeter. Operation is easy, rapid and accurate after the operator learns to watch the readout symbols rather than noting the position of knobs and buttons.

Sperry model EZ-6100 is recommended for all portable operations. □

<b>CURTIS MATHES</b> Chassis CMC81-1/2/3/4 .....	1997-1	<b>SOUNDESIGN</b> 3802A .....	1985-3
<b>EMERSON</b> RED5660A, B .....	1986-3	<b>SYLVANIA</b> Chassis E48-11/12 .....	1996-2
RTS-5910 .....	1991-3	MW0156W .....	1997-3
<b>GENERAL ELECTRIC</b> Chassis EC-P .....	1989-1	Chassis E53-1/-2/-7/-8 .....	1988-3
<b>GOLD STAR</b> Chassis NF9X .....	1993-1	<b>TATUNG</b> 13CTBR .....	1985-2
<b>HITACHI</b> CT1903, CT1904 .....	1984-1	19CTA1, 19CTF .....	1987-3
<b>LLOYD'S</b> J290 (Series 738A) .....	1989-3	<b>TOSHIBA</b> Chassis TAC970/975/980/985 .....	1990-2
<b>PANASONIC</b> Chassis 9B01-A .....	1988-1	<b>TRUETONE</b> SCJ4008A-08 (24-4008-9) .....	1989-2
RC-76 .....	1984-3	<b>WARDS</b> GGV-16235A, B/16360A, B/17560A, B/17570A, B .....	1992-1
<b>JC PENNEY</b> 685-4009E, -00 (855-1939), 685-4010E, -00 (855-1917) .....	1995-1	<b>ZENITH</b> M19600P, W, X, M1970P, M1992W .....	1986-2
<b>PHILCO</b> Chassis A12-30/-32 .....	1988-2	M2510W/22E/24M/26DE/26P/28P/ 30E/32PN/40X/42E/44M/48E/88P/ 90M/92P, M3930E, M4528P .....	1991-2
<b>QUASAR</b> Chassis ADTS-/ASDTS-/DTS-/ GTS-/SGTS-976 .....	1984-2	M2502W/504E/506M/508DE, P/582E/ 584E, M4510P .....	1992-2
Chassis GTS-975 .....	1984-4	Chassis 9JB5X/6X .....	1993-3
Chassis AGTS-/EGTS-/GTS-970 .....	1985-1	SM1741W, SS1921W9 .....	1994-2
Chassis ASDTS-970 .....	1996-3	SM1321E, W .....	1995-2
LTS-973, MTS-973, WT5931RW/950RW .....	1997-4		
<b>RCA</b> Chassis CTC92K .....	1997-5		
EER330S .....	1995-3		
<b>SANYO</b> Chassis PM-39A00/01, PM-40A00/01 .....	1986-1		
Chassis A2T-72N00 .....	1991-1		
91T52 .....	1987-1		
<b>SEARS</b> 564.44100050/51 .....	1987-2		
564.42072050/2230050 .....	1990-1		
564.42110900/01 .....	1997-2		
<b>SHARP</b> 19E91 .....	1993-2		
13E35, 13E39 .....	1994-1		
19E85 .....	1996-1		

## Richard Brown thought he was too young to have a stroke. He wasn't.

Because having a family, a good job and a bright future doesn't protect anyone from a stroke. In fact, nearly one million Americans — many with those assets — die of heart disease and stroke each year. And 200,000 of them die "too young."

The American Heart Association is fighting to reduce early death and disability from heart disease and stroke with research, professional and public education, and community service programs.

But more needs to be done. You can help us support research and education by sending your dollars today to your local Heart Association, listed in your telephone directory.



Put your money where your Heart is.





# reader's exchange

---

**Needed:** Instruction manual and diagram for Hallicrafter radio model SX101. Will buy or copy and return. *Cecil P. Ibarra, Box 60412, Sunnyvale, CA 94086.*

**Needed:** Power transformer for Symphonette Slumber-center radio with light on top. Model No. LCR500. This radio is not listed in Sams catalog. *George O'Bailey, 709 Madison Rd., Williamsburg, VA 23185.*

**Needed:** VHF and UHF channel selector knobs to fit Sylvania model CB 34W and/or CB 30 GY TV receiver. *Duncan H. Eadie, 3884 Ewings Rd., Lockport, NY 14094.*

**Needed:** 110V ac four pole motor used in Bradford stereo tape recorder model No. WGT 60178, serial No. 72027. Motor used to operate, by belt, the capstan drive; and, by mechanical linkage, the take-up and rewind reels. *Angelo Ippolito, 37 Berkeley Place, Bloomfield, NJ 07003.*

**Needed:** AM oscillator coil (L2) for Allied Knight kit, AM-FM tuner No. 820018, made by Allied Radio Corporation in 1957. Has companion amplifier No. 820022; both units have chrome face-plates with black trim, and are mounted in gray metal cabinets. *William M. Suhy, 456 Burritt Ave., Stratford, CT 06497.*

**Needed:** B and K 747B tube tester in good condition. Offering B and K 415 sweep analyzer, mint condition, in exchange. *K. Miller, 10027 Calvin St., Pittsburgh, PA 15235.*

**Needed:** Power transformer part No. PT-22 for Holiday stereo model No. 16-099. *Syverson's, Inc., Box 98, Wanamingo, MN 55983.*

**Needed:** Would appreciate hearing from anyone using R.W.S. Television Trainer model CL-35 for technical training. *Fred Happy, Acheron College, Box 190, Kingston, Ontario., Canada K7L4V9.*

**Needed:** Circuit diagram or service manual for Schoper console organ, vacuum-tube type. The 12 tone generators carry No. 1111A and use four 12A x 7 tubes per panel. Will copy and return or purchase. *Bill's Radio and TV, Box 183, Clarkdale, AZ 86324.*

**Needed:** Sams Photofacts No. 1000 and up. *Ray's TV Shop, 6742 W. Coal Mine Road, Littleton, CO 80123.*

**Needed:** Record-A-Phone model 100, service data and schematics, manufactured by Robosonics. *Stan Kern, 3 Cinnamon Circle, Apt. 3C, Randallstown, MD 21133.*

**Needed:** Sams tape recorder manual TR19. *James Humphrey, Room 212, 1006 E. 28th St., Los Angeles, CA 90011.*

**Needed:** A front cabinet for Zenith TV model D3721/E3721. Part No. S93092 or S98721. This part is no longer available from Zenith. May be new or used. *Karl Rybak, 29641 Marshall, Southfield, MI 48076.*

**Needed:** Power transformer for Precision scope model ES-550. *C. E. Ouellette, 87 Sidney St., Fall River, MA 02720.*

**Needed:** High voltage transformer for Tektronix 545 scope. *Lynn Finch, NYSEG Corporation, 4500 Vestal Parkway East, Binghamton, NY 13902.*

**Needed:** Tube set up data, Hickok, model 600A tube tester. *Charles R. Wells, 2085 Barcelona Dr., Florissant, MO 63033.*

**Needed:** Schematic and alignment instruction for RCA Victor, model 362P three band portable and radio receiver, purchased about 1954, 1955. *Jess Bailey, Rt. 2, Box 1023, Oviedo, FL 32765.*

**Needed:** Telefunken No. D5-100W (miniature) picture tube and schematic for Sinclair micro TV model MTV 1A. *A. Stellerman, 24 Kyle Court, Staten Island, NY 10312.*

**Needed:** Sams book No. 21410, *Study Guide for Journeyman CET Examinations*, out of print. *Shannon O. Sellers, Rt. 11, Box 160, Bessemer, AL 35023.*

**Needed:** Sams photofacts TR-82 and TR-85. Also, servicing manual for IPC model 8TP-716/726 stereo unit. *Charles T. Huth, 146 Schonhardt St., Tiffin, OH 44883.*

# the marketplace

Advertising rates in the Classified Section are 35 cents per word, each insertion, and must be accompanied by cash to insure publication.

Each initial or abbreviation counts a full word.

Minimum classified charge \$3.00.

For ads on which replies are sent to us for forwarding (blind ads), there is an additional charge of \$3.00 per insertion to cover department number, processing of replies, and mailing costs.

Classified columns are not open to advertising of any products regularly produced by manufacturers unless used and no longer owned by the manufacturer or distributor.

## Help Wanted

**TECHNICIANS WANTED:** Television-Audio-Communications, excellent fringe benefits, salary depends on experience. Miller's Electronics, Hwy. 24, Rt. 1, Box 120, Goodland, Kansas 67735, 912-899-2386 6-81-11

**T.V. Benchman** looking for experienced, hard working partner to open up a "service only" T.V. shop in N.J. area. Please reply, P.O. Box 1747, Union, N.J. 07083 6-81-11

## For Sale

**PICTURE TUBE REBUILDING EQUIPMENT** capable of producing four high quality tubes per day (WILL TRAIN TO OPERATE). Call or Write Atoil Television, 6425 Irving Park, Chicago, Illinois 60634, ph. 312-545-6667. 4-81-61

**AUTOMOBILE RADIO** and tape replacement parts: Delco, Chrysler, Philco-Ford, Motorola, Panasonic and many others. Large inventory. Laran Electronics, Inc., 3768 Boston Road, Bronx, NY 10469, (212) 881-9600, out of New York State, (808) 223-8314. 5-79-1f

**TV & RADIO TUBES**, 36 cents EA! Free color catalog. Cornell, 4221 University, San Diego, California 92104. 8-76-1f

**ELECTRONIC SURPLUS: CLOSEOUTS, LIQUIDATIONS!** Parts, equipment stereo, industrial, educational. Amazing values! Fascinating items unavailable in stores or catalogs anywhere. Unusual FREE catalog. ETCO-011, Box 762, Plattsburgh, N.Y. 12901. 6-78-1f

**SCRAMBLED TELEVISION**, encoding/decoding. New book. Theory/circuits, \$9.95 plus \$1 shipping. Workshop, Box 393ES, Dept. E, Bethpage, N.Y. 11714. 7-80-1f

**CRT REBUILDING EQUIPMENT. Great Profits.** (815) 459-0873 after 7 PM. George, 1909 Louise, Crystal Lake, IL 60014. 2-81-8f

**FOR SALE:** Well established RCA Sales and Service shop near beautiful Minnesota River, attached to country store and spacious 3 bedroom home. For details call owner, 507-925-4448. 5-81-2f

**PRINTED CIRCUIT** boards from your sketch or artwork. Affordable prices. Also fun kit projects. Free details DANOCINTHS INC. Dept. ES, Box 261, Westland, MI 48185. 5-81-1fn

**TUBES FOR TV AND RADIO**—35¢ ea. Washington TV Service, 1330 E. Florence Ave., Los Angeles, CA 90001. 3-81-9f

## For Sale (Cont.)

**FREE**

**THE GREAT ELECTRONIC THINGS & IDEAS BOOK!**

HUNDREDS OF UNUSUAL PARTS, GADGETS & IDEA ITEMS, UNAVAILABLE IN STORES OR CATALOGS ANYWHERE! Bargain prices on everything! New items in every issue! Rush postcard for your copy!



ELECTRONICS  
Dept. 311  
Plattsburgh, N.Y. 12901.

Circle (9) on Reply Card

**B&K TV Analyst, Model 1077B, B&K Solid state sweep marker generator, model 415, like new, \$250.00 each, Martin, 4 Andusson Ave., Pensacola FL., 32507 (904) 456-9091. 6-81-1f**

**1—B&K 415 Sweepmarker Generator—\$250; 1—Tektronix 524AD Scope—\$250; 2—Precision UTUM EV-10 both—\$100.00; 1—RCA WO-91B Scope—\$200.00. TELE-Sonic, 164 Halstead Ave., Harrison NY 10528, 914-835-0111 5-81-2f**

**SAMS PHOTOFACTS.** 1 through 1309 and 1445 through 1528. All but first 100 in metal filing cabinets. \$900 or best offer plus shipping. Robert Knapp, Box 145, Lyndhurst, VA 22952. 6-81-2f

**LOCKING NEEDLENOSE PLIERS.** (Last time at this price.) Hospital Quality forceps, 1001 uses! Heat sink; holds transistors while soldering; reaches hard-to-get-at parts. Gap for varied uses. Instructions included. Finger holes insure safe, non-slip usage. \$10.95 for three! \$1.00 shipping-handling. Oklahomans add 39¢ tax each set. Electronic Entertainment (t1), P.O. Box 416, Nicoma Park, OK 73066. 6-81-11

**FOR SALE: VTR SERVICE EQUIPMENT: TEKTRONIX 465 (opt5,7), 1470, TM-501, TM-506, FG-502, DC-504, DM-502, 200C, P6401, LAMBDA LMF-12, HICKOK 220, PARTS, JIGS, MANUALS, TEST TAPES. Tom O'Brien, 2194 Coker Ave., Charleston, S.C. 29412 (803) 762-0824. 6-81-11**

**ELECTRONIC SERVICING MAGAZINES,** April 1968 to date. James L. Bolich, 460 Doris Circle, Aberdeen, Maryland, 21001. 6-81-11

**"SAMS PHOTOFAC T FOLDER SETS #20-1000 \$2.50 per set includes postage, Quidnick Radio & T.V., 175 MacArthur Blvd., Coventry, R.I. 02816" 6-81-1f**

**USED B&K-1250 NTSC (used 2 mos.) \$500, B&K-1801 Counter \$60, Sound Technology FM Generator-1000A \$1200, Ferrograph RTS-1A Recorder Test Set \$800, HP330B Distortion Analyzer \$100, Sony CVM-194 B&W Video Monitor \$175, or best offer. Call (201) 526-4693. 6-81-11**

## Wanted

**MIRROR IN THE LID,** and other PRE-1946 Television sets wanted for substantial cash. Also interested in 12AP4, MW-31-3 Pre-War picture tubes, parts, literature on Pre-War Television, Arnold Chase, 9 Rushleigh Road, West Hartford, Conn. 06117 (203) 521-5280 2-81-7f

**DESPERATELY NEED:** Information on "Tellcon" projection TVs from 1947, RCA "Test Lamp" for 1940's projection TVs. Arnold Chase, 9 Rushleigh Road, West Hartford, Conn. 06117 (203) 521-5280. 2-81-7f

## Business Opportunity

**TV TECHNICIAN!** Increase your income up to \$60,000 yearly. Rent-lease-sell TVs new-used, even from comfort of your home. Basic Preliminaries \$4.00. Perrys TV Systems, Hwy. 181, Box 142, R1, Bremen, KY 42325 12-80-1f

**ESTABLISHED TV-STEREO REPAIR SHOP** in beautiful Black Hills of South Dakota, main street location. Good steady business, excellent library equipment and inventory, priced right, terms available. Call 605-347-4243. 6-81-3f

# advertisers' index

Cleveland Institute of Electronics .....	35
Creative Electronics .....	25
Dictaphone Corp. of America .....	35
ETCO .....	44
Gamit Enterprises .....	33
Jensen Tools Inc. ....	37
North American Philips ....	IFC
Natesda .....	25
Nesda .....	33
Oehlrich Publications .....	37
PTS Electronics Inc. ....	13
RCA Distributor & Special Products .....	5, 39
Zenith Radio Corp. ....	BC

## Electronic Servicing

### Advertising Sales offices

**NATIONAL SALES MANAGER**  
*Greg Garrison*  
P.O. Box 12901,  
Overland Park, KS 66212  
Phone: (913) 888-4664

**LONDON, ENGLAND**  
*John Ashcraft & Co.,  
John Ashcraft*  
12 Bear St., Leicester Square  
London, WC2H 7AS, England  
Phone: 930-0525 Telex: 895-2387

**AMSTERDAM, HOLLAND**  
*John Ashcraft & Co.,  
John J. Lucassen*  
Akerdijk 150A  
1171 PV-Badhoevedorp, Holland  
Phone: 0-2968-6226

**TOKYO, JAPAN**  
*International Media  
Representatives, Ltd.*  
2-29, Toranomom 1-chome,  
Minato-ku, Tokyo 105, Japan  
Phone: 502-0656

**NORWOOD, AUSTRALIA**  
*Williamson & Associates,  
John Williamson*  
No. 2 Edmund St.  
Norwood, S.A. 5067, Australia  
Phone: 42-7074



For the man that would rather fix it himself –

# Technical Publications has service manuals designed for you!

SES-13 Small (Air Cooled) Engines Service Manual. \$9.95 (336 pages). You can service your own engines on lawnmowers, tractor sprayers and other power equipment. Special section on fundamentals, troubleshooting, preventive maintenance. Step-by-step instructions.

WLMS-1 Walking Lawnmower Service Manual \$7.95 (128 pages). The **complete** guide to the care and repair of your walk-behind, push-type lawnmower. Exploded views and diagrams.

CSS-6 Chain Saw Service Manual. \$8.95 (over 300 pages). Here's everything you need to know to tear down, repair, reassemble and adjust most popular chain saws. A truly **complete** chain saw manual.

GSM-1 Small AC Generator Service Manual \$7.95. A brand new manual that contains maintenance, service and troubleshooting procedures, as well as wiring schematics for most generator models. Covers electrical powerplants under 8kW that generate alternating current and are driven by air cooled engines.

OS1-8 Outboard Motor Service Manual Volume 1 \$8.95 (236 pages). Covers motors below 30 hp.

OS2-8 Outboard Motor Service Manual Volume 2 \$8.95 (232 pages). Covers motors with 30 hp and above. Both Volumes 1 and 2 provide detailed fundamentals on periodic servicing.

**Put these books to work on your own equipment...(Or service outside equipment for profit!)**

- Small (Air Cooled) Engines Service Manual
- Walking Lawnmower Service Manual
- Chain Saw Service Manual
- Small AC Generator Service Manual
- Outboard Motor Service Manual (Vol. 1)
- Outboard Motor Service Manual (Vol. 2)

Remittance must accompany orders of less than \$25.00. Postage paid when payment accompanies order. Allow four weeks for delivery.

How to send money: The best way to send money is your own personal check, post office money order, express money order or by bank draft or check. **DO NOT SEND CURRENCY OR STAMPS.**

- Check Money Order Enclosed
- Ship C.O.D. (No C.O.D.s outside of U.S.)

Missouri and Kansas Residents add 4% sales tax. Tennessee Residents add 6% sales tax.

Write for a free catalog covering our entire line of service manuals and wheel-type tractor service manuals.

VISA     MASTERCHARGE  
 Credit Card Number \_\_\_\_\_  
 Expiration Date \_\_\_\_\_

Please Print:

Name \_\_\_\_\_

Street \_\_\_\_\_

City \_\_\_\_\_

State \_\_\_\_\_ Zip \_\_\_\_\_

Signature \_\_\_\_\_



Division  
 Intertec Publishing Corp.  
 P.O. Box 12901, Dept. ES  
 Overland Park, KS 66212  
 (913) 888-4664

# Special limited-time introductory offer on ZIP!

## Zenith Instant Parts Program.

Inventory control – that's the name of the game today! And Zenith's Instant Parts Program (ZIP) is the way to play it safe, sure...and money-wise. Because with ZIP, you've got Zenith's most frequently needed exact replacement parts where you want them when you want them.

Also with ZIP, slow-moving stock numbers are periodically replaced with new, more popular parts thru periodic checks by your Zenith distributor salesman. As a result, your original investment is protected and your inventory of Zenith exact replacement parts is current.

And best of all, today you can add a little ZIP or a lot of ZIP to your inventory control of Zenith parts.

For a little ZIP, you'll want ZIP-50 – the top 50 Zenith parts available with or without System 3 components. If you want more ZIP, get ZIP-100 – the most active 100 Zenith parts now available with or without System 3 components.

Call your Zenith distributor now for the ZIP program that best suits your need. Four to choose from!

ZIP – it's the easiest, least expensive, most versatile inventory control system ever devised by Zenith for TV service technicians! Call your Zenith distributor now!

**Call your Zenith distributor now for a  
special limited-time-only introductory offer  
on ZIP — Zenith's Instant Parts Program!**

*For your own reputation and in your customers' best interest,  
always service with Zenith exact replacement parts.*

**ZENITH**  
The quality goes in before the name goes on®

Zenith Radio Corporation/Service, Parts & Accessories Division/11000 Seymour Avenue/Franklin Park, Illinois 60131  
Circle (2) on Reply Card