

Electronic Servicing

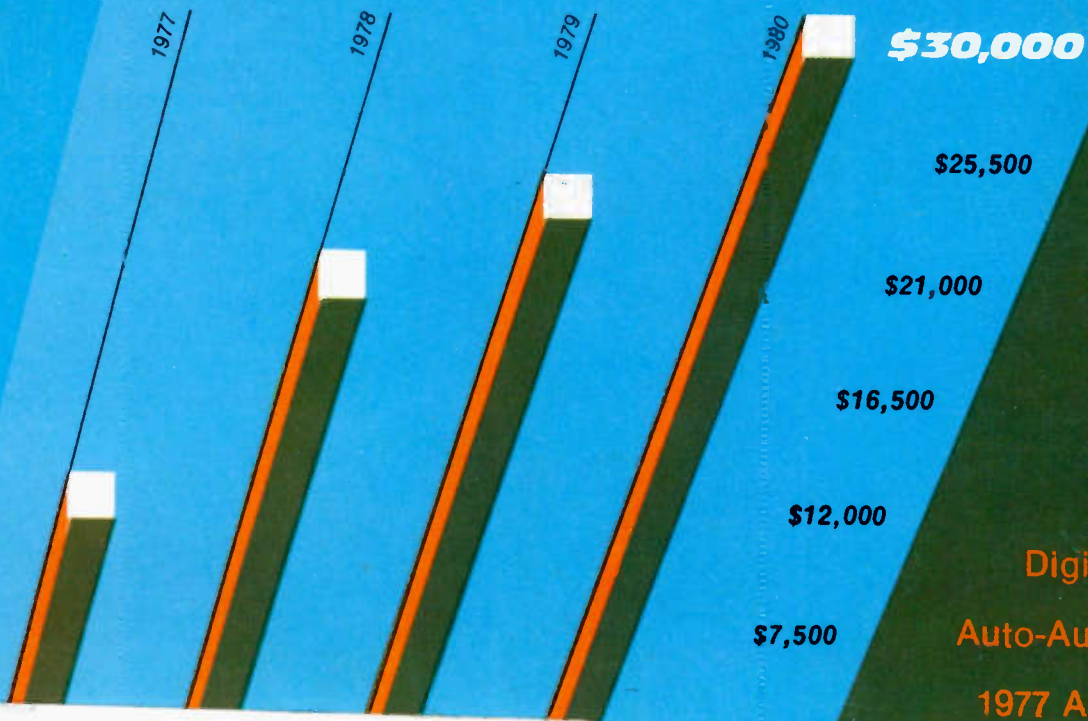

A HOWARD W. SAMS PUBLICATION

Service Management Seminars BY DICK GLASS

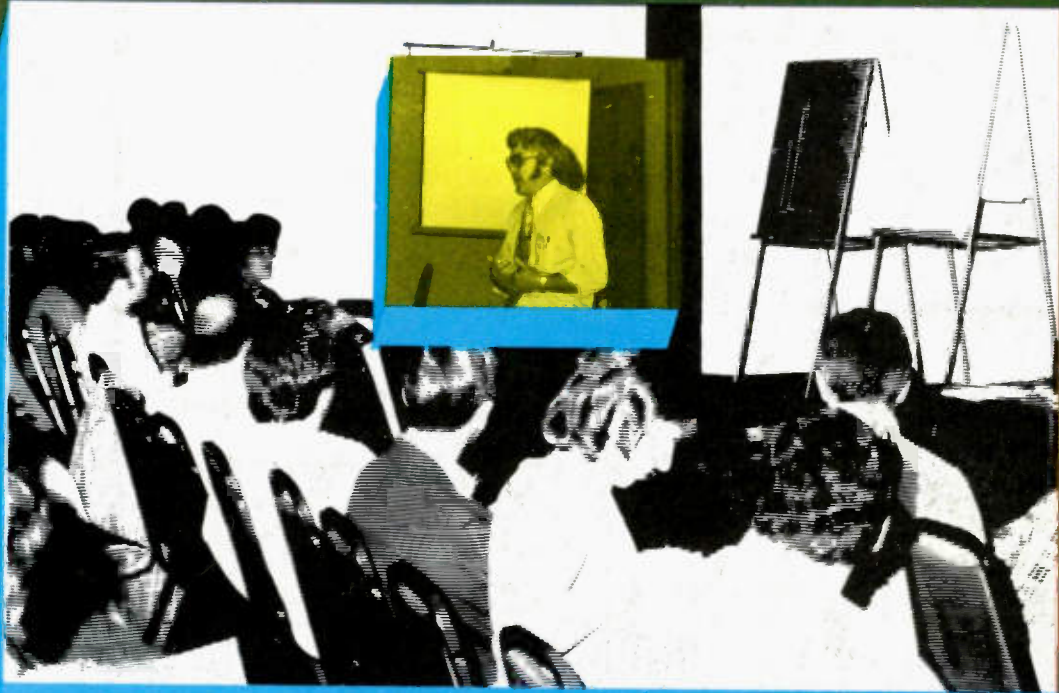

An up front discussion on tuner repair and module rebuilding.

TV service technician dealers are in business to earn a profit, providing customers with timely, professional work. To maximize profits and still provide quality work, it makes sense to take advantage of outside independent help. Our tuner repair and module rebuilding services can add new dimension to your shop's profits. Consider the advantages PTS offers.

1. One stop shopping. Our tuner repair service includes

all makes and models including foreign—color, black and white, tube, transistor or varactor. We repair them all. Our module rebuilding services include all leading brands.

2. Repair . . . our first business and our major business. Our service business isn't an after thought to manufacturing. We stay on top of the latest design developments in all brands—not just one or two.

3. Same day service. Your reputation is as much time as it is quality. Same day service isn't a gimmick with us, it's a promise we strive to keep.

4. Module Exchange. Not only do we rebuild modules. We also exchange and buy duds.* You can turn dud modules into needed cash.

5. One year warranty. We're so confident of the professional quality of our work, we provide a one year limited warranty to back it up.

6. Protective packages. Tuners and modules are shipped to you in protective packaging, eliminating risk of damage.

7. Replacement parts. All tuner and module services utilize original or superior parts. Parts are constantly updated to improve module and tuner performance and reliability.

8. Servicenters. There are PTS company owned servicenters in every metropolitan area of the U.S. Each is fully equipped and professionally staffed to serve you.

* Acceptable brands are Admiral, GE, Magnovox, Montgomery Ward, Philco, Quosor, RCA, Sylvania, Sears/Warwick, Wells-Gardner and Zenith. PTS reserves the right to reject any or all modules presented for dud value including ceramic encapsulated, broken or cannibalized modules.

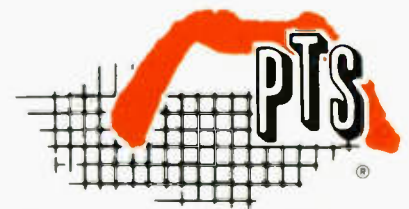

PTS ELECTRONICS, INC.

A COMPLETE LIST OF PTS SERVICENTERS
APPEARS AT THE RIGHT.

For More Details Circle (1) on Reply Card

Electronic Servicing®

PTS SERVICENTER GUIDE

MIDWEST

Home Office
BLOOMINGTON, IN 47401
 5233 S. Hwy. 37, P.O. 272
 812-824-9331
CLEVELAND, OH 44134
 5682 State Road
 216-845-4480
KANSAS CITY, KS 64104
 3119A Merriam Lane, P.O. 6149
 913-831-1222
MINNEAPOLIS, MN 55408
 815-W. Lake St., P.O. 8458
 612-824-2333
ST. LOUIS, MO 63130
 8456 Page Blvd., P.O. 24256
 314-428-1299
DETROIT, MI 48235
 13707 W. 8-Mile Rd.
 313-862-1783
GRAND RAPIDS, MI 49501
 1134 Walker Northwest
 P.O. 1435
 616-454-2754
CINCINNATI, OH 45216
 8172 Vine St.
 513-821-2298
MILWAUKEE, WI 53218
 7211 Fond du Lac
 414-464-0789
COLUMBUS, OH 43227
 4005A E. Livingston
 614-237-3820
INDIANAPOLIS, IN 46202
 28 E. 14th St.
 317-631-1551
DAVENPORT, IA 52805
 2024 E. River Dr., P.O. 187
 319-323-3975
OMAHA, NE 68132
 5008 Dodge Street
 402-552-1800
CHICAGO, IL 60645
 5744 N. Western Ave.
 312-728-1800

NORTHEAST

SPRINGFIELD, MA 01103
 191 Chestnut, P.O. 3189
 413-734-2737
PHILADELPHIA
 Upper Darby, PA 19082
 1742-44 State Rd., P.O. 207
 215-352-6609
PITTSBURGH, PA 15202
 257 Riverview Ave. W, P.O. 4130
 412-761-7648
E. PATERSON, NJ 07407
 158 Market St., P.O. 421
 201-791-6380
BUFFALO, NY 14212
 993 Sycamore St., P.O. 1241
 716-891-4935
BOSTON
 Arlington, MA 02174
 1167 Massachusetts Ave., P.O. 371
 617-648-7110
SYRACUSE, NY 13204
 418 Solar St., P.O. 207, Solina Sta.
 315-475-2330
BALTIMORE, MD 21215
 5505 Reisterstown Rd.
 301-358-1186

PACIFIC

SACRAMENTO, CA 95841
 4351D Auburn Blvd., P.O. 41354
 916-482-6220
SAN DIEGO, CA 92105
 5111 University Ave., P.O. 5794
 714-280-7070
LOS ANGELES, CA 90023
 4184 Pacific Way
 213-266-3728
PORTLAND, OR 97213
 5220 N.E. Sandy Blvd.
 P.O. 13096
 503-282-9636
SEATTLE, WA 98109
 432 Yale Ave. N., P.O. 9225
 206-623-2320
SAN JOSE, CA 95112
 466 Reynolds Circle
 408-289-1117

SOUTH

ATLANTA, GA 30311
 2180 Campbellton Road
 P.O. 42558
 404-753-0007
JACKSONVILLE, FL 32210
 1918 Blanding Blvd., P.O. 7923
 904-389-9952
WASHINGTON, DC
 Silver Spring, MD 20910
 8880 Brookville Rd.
 301-565-0025
CHARLOTTE, NC 28225
 726 Seigle Ave., P.O. 5512
 704-332-8007
BIRMINGHAM, AL 35201
 210 N. 9th St., P.O. 1801
 205-323-2657
MEMPHIS, TN 38118
 3614 Lamar Ave., P.O. 18053
 901-365-1916
NORFOLK, VA 23504
 3118 E. Princess Anne Rd.
 804-625-2030
NEW ORLEANS
 Metairie, LA 70004
 3920A Airline Hwy., P.O. 303
 504-837-7569
TAMPA, FL 33690
 2703 S. Macdill, P.O. 14301
 813-839-5521
NASHVILLE, TN 37214
 2426 A Lebanon Rd.
 615-885-0688

MOUNTAIN

DENVER
 Arvada, CO 80001
 4958 Allison St., P.O. 672
 303-423-7080
SALT LAKE CITY, UT 84106
 1233 Wilmington Ave.
 P.O. 6218
 801-484-1451
PHOENIX, AZ 85009
 2916 West McDowell Rd.
 602-278-1218

SOUTHWEST

LONGVIEW, TX 75601
 110 Mapac Rd., P.O. 7332
 214-753-4334
OKLAHOMA CITY, OK 73104
 3007 N. May, P.O. 60566
 405-947-2013
HOUSTON, TX 77207
 4326 Telephone Rd., P.O. 26616
 713-644-6793

CONTENTS

- 14 **Service Management Seminar, Part 1**—Dick Glass, former executive secretary of NESDA, lists the steps of a plan that can boost your yearly income to \$30,000—*Dick Glass, CET.*
- 17 **Semiconductor Crossword Puzzle**—Another type of crossword puzzle for your entertainment—*Frank R. Egner.*
- 18 **Servicing Magnavox Modular Color TV, Part 8**—The final Magnavox T995 coverage completes the Touch-Tune circuit operation, and makes suggestions for troubleshooting—*Gill Grieshaber, CET.*
- 28 **Auto-Audio Update**—A review of older solid-state audio stages in car radios and stereos is followed by descriptions of the new 1978 circuits—*Joseph J. Carr, CET.*
- 36 **The Basics Of Industrial Electronics, Part 7**—Digital information will be presented for the next several months. Logic probes, truth tables, three kinds of gates, and troubleshooting questions about gates are the first subjects—*J. A. "Sam" Wilson, CET.*
- 46 **Index Of 1977 Articles**—All 1977 *Electronic Servicing* articles are listed alphabetically and according to subject matter. Troubleshooting Tips and Symcures are listed by brand and chassis number—*Electronic Servicing Staff.*



Page 18



Page 36

About the cover—One of the NESDA duties Dick Glass performed was to conduct Professional Service Management Schools all over the United States. Original picture was by Carl Babcoke, with graphic design by Mary Christoph.

DEPARTMENTS

- 4 Electronic Scanner
- 8 Symcure
- 11 Reader's Exchange
- 12 Troubleshooting Tips
- 25 Book Review
- 35 Photofact Bulletin
- 49 Test Equipment
- 50 New Products
- 51 Antenna Systems
- 52 The Marketplace
- 52 Advertisers' Index

Second class postage paid at Shawnee Mission, Kansas and additional mailing offices. Published monthly at 9221 Quivira Road, Overland Park, Kansas 66212 by Intertec Publishing Corp., 9221 Quivira Road, Overland Park, Kansas 66212. Send Form 3579 to 9221 Quivira Road, P.O. Box 12901, Overland Park, Kansas 66212.

©Copyright, 1978, Howard W. Sams & Co., Inc. All rights reserved. Material may not be reproduced or photocopied in any form without written permission of publisher.



PTS ELECTRONICS, INC.

For More Details Circle (4) on Reply Card

INTERMITTENT PROBLEM?

FREEZ-IT AND FIND IT



Thermal intermittent? Freez-It and find it. PC board crack? Freez-It and find it. Even if Chemtronics Freez-It did only these two things, it would be a winner. By cutting hours from your troubleshooting chores. But it does even more!

Freez-It is a fail-safe heat sink for soldering delicate components. It cools down overheated parts to save them from damage. Prevents cold solder joints. Helps you put tight-fitting metal parts together. Even aids in removing adhesives.

Freez-It is 100% pure Freon* 12, the instant-evaporating chilling agent with no liquid residue or noxious odors. Chills parts instantly down to -65°F. And comes complete with pinpoint extender tube, for work on densely-packed circuits.

Ask for Freez-It by name from your Chemtronics distributor.



CHEMTRONICS
INCORPORATED

45 Hoffman Avenue, Hauppauge, N.Y. 11787
(516) 582-3322 (212) 895-1930
In Canada: Paco Electronics, Ltd. Montreal, Quebec H4N 2E1

Meets all applicable Federal and Military Specifications
*Reg Dupont Trademark

For More Details Circle (5) on Reply Card

We want to put our eggs in one basket...



Electron Tubes International supplies millions of tubes world wide to equipment and tube manufacturers, distributors and service dealers.

The industry knows us well as a full service tube source with a multi-million tube inventory of over 1000 types available for immediate delivery at the most competitive prices.

Get to know us. We can help you with just about any replacement receiving or industrial tube you're looking for. Contact your Electron Tubes International El-Menco tube representative call us toll-free at (800) 645-9512.

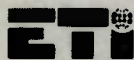

ELECTRONICS
ELECTRON TUBES INTERNATIONAL, INC.

380 SMITH STREET • FARMINGDALE, NEW YORK 11735 • TEL. 516-694-7700
CABLE: LECTROTEL, FDLE • TLX 14-4620

For More Details Circle (6) on Reply Card

Electronic Servicing

Editorial, advertising and circulation correspondence should be addressed to: 9221 Quivira Road, P.O. Box 12901, Overland Park, Kansas 66212 (a suburb of Kansas City, Missouri). (913) 888-4664.

EDITORIAL

RONALD N. MERRELL, Director
CARL H. BABCOKE, Editor
MICHAEL SCHEIBACH, Managing Editor
DUDLEY ROSE, Art Director
CINDY NELSON, Editorial Assistant
MARY CHRISTOPH, Graphic Designer

EDITORIAL ADVISORY BOARD

LES NELSON, Chairman
Howard W. Sams & Co., Indianapolis
JOE A. GROVES, Technical Consultant
Howard W. Sams & Co., Indianapolis

CIRCULATION

GREG GARRISON, Director
EVELYN ROGERS, Manager



Member, American Business Press
Member, Audit Bureau of Circulations

ADMINISTRATION

GEORGE H. SEFEROVICH, President
MIKE KREITER, Publisher

ADVERTISING SALES

Overland Park, Kansas 66212
(a suburb of Kansas City, Missouri)
Phone: (913) 888-4664

MARILYN CARROLL, Production
Regional and Advertising Sales Offices
with Advertising Index

ELECTRONIC SERVICING (with which is combined PF Reporter) is published monthly by Intertec Publishing Corp., 9221 Quivira Road, Overland Park, KS 66212.

ELECTRONIC SERVICING is edited for technicians who repair home-entertainment electronic equipment (such as TV, radio, tape, stereo, and record player) and for industrial technicians who repair defective production-line merchandise, test equipment, or industrial controls in factories.

Subscription prices to qualified subscribers: 1 year—\$8.00, 2 years—\$13.00, in the USA and its possessions. All other foreign countries: 1 year—\$11.00, 2 years—\$19.00. Subscription prices to all others: 1 year—\$25.00, 2 years—\$50.00, in the USA and its possessions. All other foreign countries: 1 year—\$34.00, 2 years—\$68.00. Single copy price \$2.25; back copies \$3.00. Adjustment necessitated by subscription termination to single copy rate. Allow 6-8 weeks delivery for change of address. Allow 6-8 weeks for new subscriptions.



INTERTEC PUBLISHING CORP.
Subsidiary of HOWARD W. SAMS & CO., INC.

ELECTRONIC SERVICING



Graham Holmes

Sound Engineer, Aerosmith Winter Tour '77,
Tasco Sound, Newburgh, NY;
London, England; Los Angeles, CA.

**“I can't afford foul-ups on the road.
After all, 11,000 people bought
tickets to see Aerosmith.
So, I demand GE components.”**

Your reputation is our reputation

Tube Products Department • Owensboro, Kentucky 42301

GENERAL  ELECTRIC

electronicsscanner

news of the industry

General Electric and Hitachi of Japan have formed General Television of America, Incorporated, a jointly-owned company for the engineering, manufacturing and marketing of television products. Under the proposed agreement, the new company will combine GE and Hitachi technologies, and will utilize the facilities and personnel of GE's current television business, which employs approximately 4,000 employees in the U.S. General Electric and Hitachi each own 50% of the new company shares. GE, Hitachi, and private-label TVs will be manufactured. Both GE and Hitachi brand names will be retained, as will the present separate distribution and servicing branches.

Charles L. Porter, CET, of Norfolk, Virginia, has been named executive vice president for the National Electronic Service Dealers Association (NESDA), replacing Dick Glass who recently resigned. Porter brings to NESDA more than 20 years in the electronics service industry. He is a member of NESDA, the International Society of Certified Electronics Technicians (ISCET), and the Virginia Electronics Association (VEA). Since 1976, Porter has been president of VEA, as well as chairman of the advisory board of the electronics department of the Norfolk Technical Vocational Center. Before his appointment as executive vice president, Porter was NESDA Region III vice president.

Matsushita Electric has designed a videodisc player system capable of one-hour or two-hour color playback with stereo sound. The Visc system uses a polyvinylchloride disc similar to an audio record. The unit will sell for about \$600 in Japan; no American price has been set. According to Matsushita, videodisc prices will be 20% to 50% higher than conventional audio records, but significantly lower than videotapes.

Employers now may hire up to six full-time students at 85% of the normal minimum wage without obtaining prior authorization from the Department of Labor. The change was made possible by the recent 1977 amendments to the Fair Labor Standards Act. Prior to November 1, 1977, employers could hire only up to four full-time students at the subminimum wage. The provision applies to retail, service, and agricultural employers. Employers merely need to certify to the Department of Labor that this employment will not reduce full-time job opportunities for their other workers.

Magnavox is recalling some MX brand component tuner-amplifiers manufactured since May 1974. The company said a possible malfunction in the power amplifier circuitry could cause the speaker cone to ignite in speaker units other than "MX" brand speakers. Model numbers subject to the recall are 1580, 1581, 1620, and 1630. Consumers using these tuner-amplifiers with other than "MX" brand speakers are requested to unplug the tuner-amplifier and to contact the Magnavox consumer affairs department.

continued on page 6



How to Hire an Expert For \$18.00 a Month

Make your tough repairs easy and your easy jobs a breeze! Save time and right now—save money. Join up with Photofact® through P.O.M. — Sams Photofact-of-the-Month Club.

With Photofact you have an expert advisor in your shop. The most reliable source for service data available anywhere. Loaded with detailed circuit information covering TV, radio, stereo and more. As a P.O.M. member you'll build your own Photofact library quickly and economically.

Join P.O.M. and save \$162 annually over regular Photofact prices. It's like getting 3 Photofact sets FREE every month. And each Photofact contains a multitude of product information in handy file folders. All yours for only \$18.00 a month.

Enroll in P.O.M. by sending us the coupon below. **SEND NO MONEY.** Your P.O.M. distributor will deliver your package of 7 Photofact sets to you each month. Each package contains data on about 100 models of equipment. Plus P.O.M. "Members Only" extras that help you build profits and stay abreast of technology changes. Hire an expert. Join P.O.M. today!

Send No Money — Send Coupon Only

Mail to: Howard W. Sams & Co., Inc.
4300 West 62nd Street
Indianapolis, IN 46206

Please enroll me as a new member of the P.O.M. Club. I agree to pay \$18.00 per month for my membership and understand my subscription will begin with the 7 current Photofact sets, plus the Photofact Index, which will be delivered by my Sams distributor.

NAME _____

BUSINESS NAME _____

ADDRESS _____

CITY _____ STATE _____ ZIP _____

My Sams Distributor is _____

I don't know my Sams distributor. Please send a list of Sams Distributors.

YOUR SIGNATURE _____

Howard W. Sams & Co., Inc. 4300 West 62nd Street/Indianapolis, IN 46206 TC937



Howard W. Sams & Co., Inc.

4300 West 62nd Street/Indianapolis, Indiana 46206

continued from page 4

A new approach in teaching young people electronics servicing as a possible career is being offered by Ricks College, a privately-owned junior college in Rexburg, Idaho. During the 20-month course, students learn to service television sets, as well as audio, CB, and other electronic equipment. In addition, students take business and mathematics courses, to better prepare them to own and operate their own business. The program also includes about five weeks of work in an electronic repair shop as on-the-job training. The school helps the students find immediate placement after completion of the course.

Total television receiver sales to dealers for the first 47 weeks of 1977 were 13.1 million, an increase of 15% over the same period in 1976, according to the Electronic Industries Association's marketing services department. Sales to dealers of color television receivers, for the first 11 months of 1977, were 8.1 million units, up 19% over the 6.8 million units sold in the same interval of 1976. Total B&W television receiver sales to dealers for the first 11 months of 1977 were 5 million, a gain of 9.1% over the 4.6 million units sold for the same period of 1976.

A series of four week-long technical seminars devoted to servicing of the new Magnavox videocassette recorders was conducted last month as Magnavox's Fort Wayne, Indiana headquarters. Under the direction of Ray Guichard, technical-services manager, the seminars involved "hands-on" training of Magnavox field-service personnel. Training of dealer and independent servicemen will begin this month in selected locations throughout the U.S. Below, Howard Shoudy, service-training specialist, points out VCR circuitry to Jim Fritsche, dealer-service manager from Cleveland (at left), and Bill Nurge, dealer-service manager of Dallas.

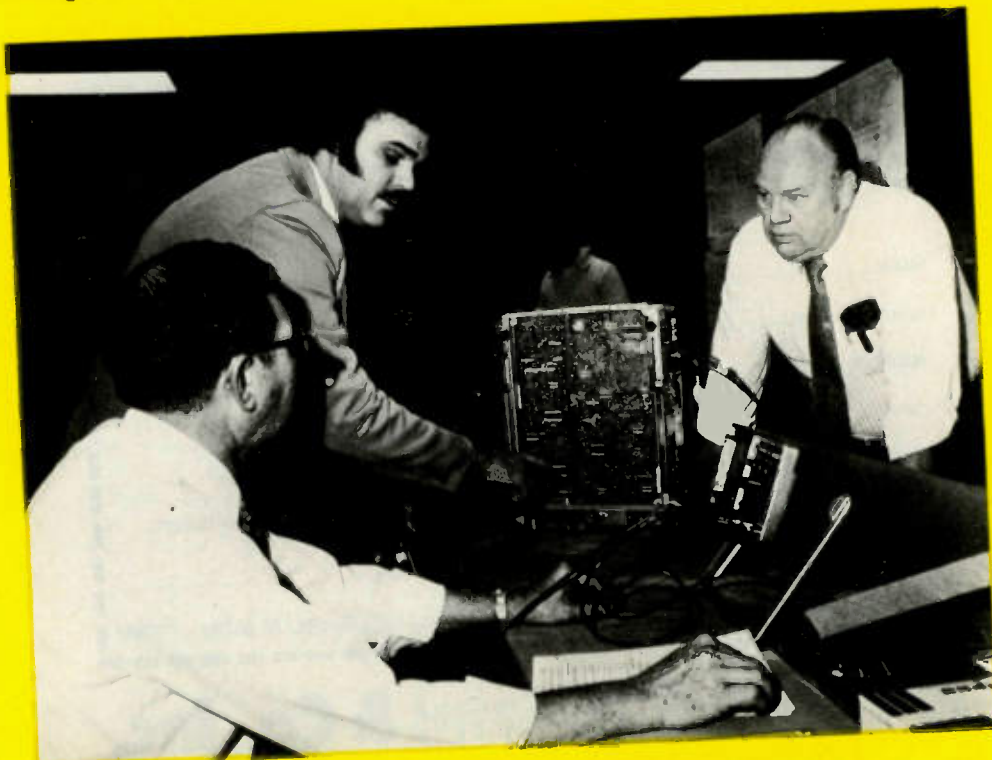

BUSS ELECTRONIC FUSES.

Nearly every type of fuse and fuse holder you need to protect electronic circuits and devices you can get from us, easy. For example, Buss® Semiconductor Fuses; 700 volts, with extremely low I^2t and I_p let-thru values. TRON® Rectifier Fuses, ½ to 1,000 amps, up to 600 volts. Fusetron® dual-element time-delay fuses. Buss quick-acting glass tube fuses. Buss signal-indicating, alarm-activating fuses. TRON sub-miniature pigtail fuses. Buss sub-miniature GMW fuses. Buss telecommunications fuses. Buss military fuses. And Buss fuse holders and fuse blocks. Get your hands on exactly what you want. Write us now. Ask for Buss Bulletin SFB.

SUPPLIED THE ECONOMICAL WAY
THRU DISTRIBUTORS
BUSS FUSES
THE QUALITY LINE

BUSSMANN MANUFACTURING
a McGraw-Edison Company Division
Earth City, Missouri 63045



**WE MAKE IT EASY
TO GET YOUR HANDS
ON WHAT YOU WANT.**

Chassis—RCA CTC72
PHOTOFACT—1439-2

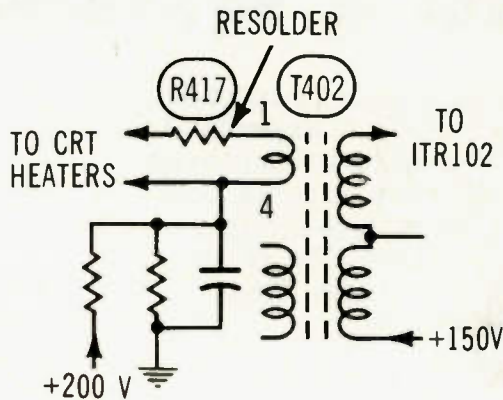

Symptom—Intermittent CRT heater and raster
Cure—Resolder all T402 connections

Chassis—RCA CTC81 (with remote)
PHOTOFACT—1615-2

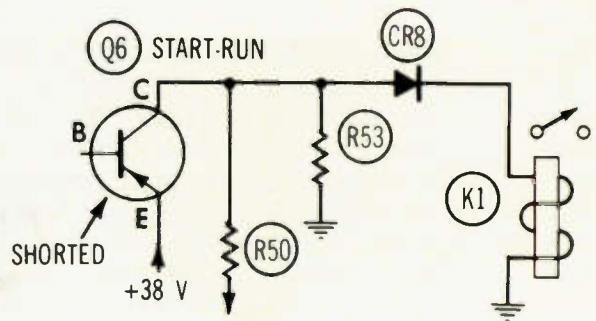

Symptom—Channel motor runs constantly
Cure—Check Q6 on PW4000E, and replace it if shorted

Chassis—RCA CTC81
PHOTOFACT—1615-2

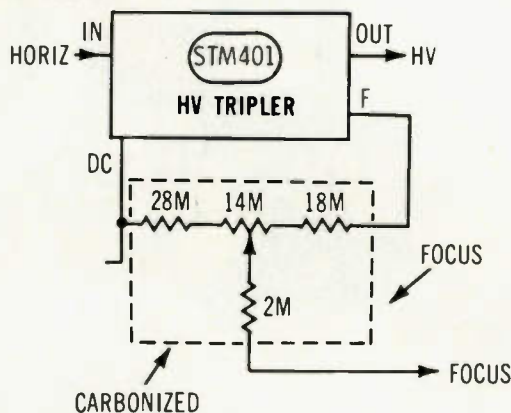

Symptom—Poor focus, dim raster
Cure—Check focus-control housing, and replace it if carbonized

Chassis—RCA CTC71
PHOTOFACT—1435-3

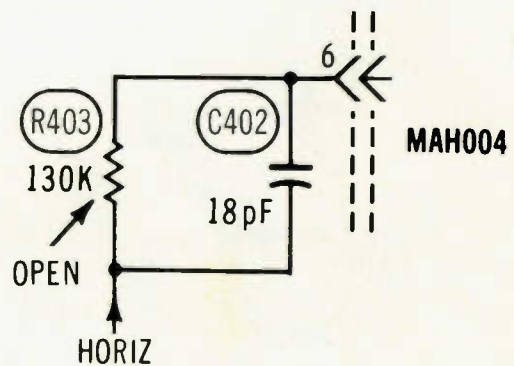

Symptom—Blanking bar at right side of picture
Cure—Check R403, and replace it if open

Chassis—RCA CTC74
PHOTOFACT—1588-1

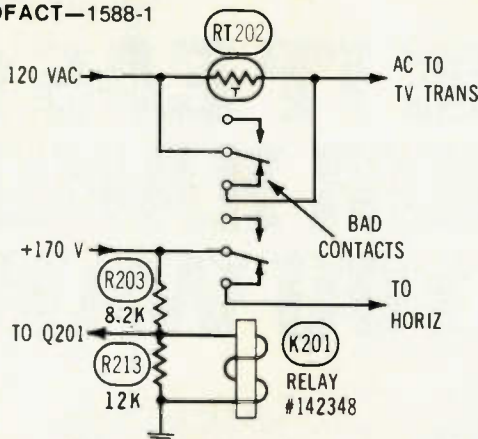

Symptom—Narrow picture, perhaps intermittent
Cure—Short across K201 contacts, if wider, replace the relay

Chassis—RCA CTC85
PHOTOFACT—None

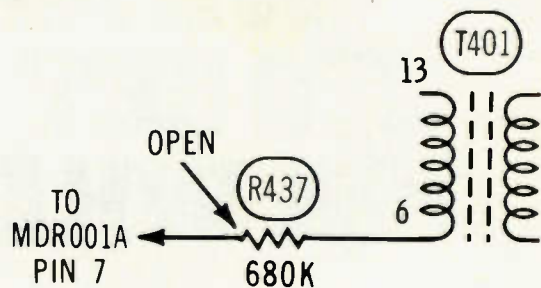

Symptom—No video, no audio (loss of +27 volts)
Cure—Check R437, and replace it if open

reader's exchange

Needed: Setup book or chart for a Weston tube tester, model 978. Also, a schematic for a Weston multimeter, model 976. Will buy, or copy and return. Scott Brown, 9 Millstone Road, Randallstown, Maryland 21133.

For Sale: 6000 used radio and television tubes from trade-ins and abandoned sets. Will accept best offer. Allen J. Loeb, 414 Chestnut Lane, East Meadow, New York 11554.

Needed: A service and instruction manual for a Solar Exameter capacitor analyzer, model CF. Will buy, or copy and return. H. Thomson, 25844 Normandy, Roseville, Michigan 48066.

For Sale: Heath ID-101 scope switch, \$25; Heath IG57A post-marker/sweep-generator, \$125; Heath IG62 sine/square-wave generator, \$20; Eico 460 scope, factory wired, with low-cap and demod probes, \$125; Eico 565 multimeter, \$25; Eico HUP2 high-voltage probe, \$5; Calectro H3-367 FET multimeter, \$35; and Elenco SG100 dot/crosshatch generator, \$30. William J. Glass, 3256 Hampshire Road, Janesville, Wisconsin 53545.

Needed: Delco custom-fit original AM/FM-stereo car radio for a Chevelle model 307. Paul Capito, 637 West 21, Erie, Pennsylvania 16502.

For Sale: Heathkit curve tracer (\$99.95), \$50; Heathkit color bar/pattern generator (\$89.95), \$40; Heathkit sweep/marker generator (\$169.95), \$90; Heathkit dual-trace adapter (\$42.95), \$25; RCA WO-535A triggered scope (\$360), \$230; extra probe (\$15), \$5; RCA Vector probe and overlay (\$15), \$5. Would like to sell as a package for \$395, plus shipping. Gerald L. McKouen, 534 Pacific, Lansing, Michigan 48910.

Needed: Back issues of Electronic Servicing for March, April, May, and June 1975. Also, Sams TR-55 for Panasonic RQ-2325 tape player (no longer available from Sams). Steven J. Wilhelm, Box 217, Ladora, Iowa 52251.

For Sale: Hickok 288X generator; RCA WR-59C sweep generator; RCA WR-89A marker generator; Precision E-200C marker generator; Precision model 98 VTVM; Heath IG-57 post-marker sweep; Precision G-140 adapter for tube tester; and Heath IG-18 square-wave generator. All have manuals. Offer any or all. Reiney's Radio & TV, 4733 Lewis Drive, Port Arthur, Texas 77640.

Needed: Schematic for Fisher multiplex chassis MPX-200. Also, T932-115 power transformer. Xerox copy is okay. Misiaszeh's TV, 160 Sachem, Norwich, Connecticut 06360.

For Sale: Eico 460 scope with probes, \$120; Heath electronic switch ID101, \$50; RCA VTVM, WV98C, \$75; Eico tube tester 667, \$130; Eico VTVM 23ZW with HV probe, \$40; and Eico sine/square generator 377, \$35. All equipment like new with manuals and probes. Frank Centola, 79-11 255th Street, Floral Park, New York 11004.

Needed: Meter for Knight K6-600B tube tester part 654207 (1 milliamper movement—4½-inch). State price and condition. Fenton's TV Service, Box 106, Manilla, Indiana 46150.

Needed: An owner/service manual for a model ES-550 Precision scope. Will borrow and return, buy, or copy and return. T. W. Wilson, 490 East Anchor, Eugene, Oregon 97404.

Needed: WWII-vintage shortwave receiver, commonly called ACR-5 Command Sets, covering 3-6 MHz or 6-9 MHz. Please submit condition and price. Ernie Neumann, 7800 De Barr Road, Sp. #47, Anchorage, Alaska 99504.

For Sale: Complete Cleveland Institute of Electronics' master course in electronics and radio communications for \$100, plus COD and shipping charges; and one complete Capitol Radio Engineering Institute advanced electronics and radio communication course for \$100, plus COD and shipping charges. City Radio & TV, 205 North Donley, Tulia, Texas 79088.

For Sale: Complete set of radio, television, and electronics test instruments. All are like new; most are recent models. Write, stating your needs. Thomas F. Burns, #9 Allegheny Terrace, Pittsburgh, Pennsylvania 15207.

For Sale: B&K-Precision tube tester model 600, latest tube chart and all adapters, \$45; Sencore field-effect meter model FE-14, \$35; Heath digital multimeter model IMD-202-2, \$65; RCA 3-inch scope with Quicktracer, \$75; and Electrotech Vectorscope and color-bar generator model V7, \$85. Kenneth Miller, 10027 Calvin, Pittsburgh, Pennsylvania 15235.

Needed: Transformer A3141682 for a Philips radio, type BX626A. Also, need a schematic of the radio. Martin Augustine, Star Route #2, Box 26, Downsville, New York 13755.

Needed: Source for an IC dual regulator, part number SG3501T by Silicon General, or a cross-reference to another major brand. Micky J. Harrison, Harrison's TV and Appliance Service, 652-C Kenwere Loop, Tampa, Florida 33621.

Needed: Service and alignment manual for Precision signal generator, model E200C. Will buy, or copy and return. Carlos Jayne, 21 Knollcrest, Chatham, Illinois 62629.

Needed: Information about a Bruno ribbon microphone, purchased from Allied Radio about 1940. Elmer L. Mosley, 720 Poplar, Kenova, West Virginia 25530.

Needed: Schematic for Lumina series Westinghouse solid-state clock radio. Enever Naggar, 152 Bliss Road, Longmeadow, Massachusetts 01106.

Needed: Schematic and service manual for Telequipment model S-54 scope. Will buy, or copy and return. Charles A. Bulovas, 45 Boston Street, Methuen, Massachusetts 01844. □

Weak color; color too red Sony KV1710 (Photofact 1325-1)

The customer complained that color programs would get too red, sometimes too green, and even a normal but weak color.

I also noticed that the color control VR905 would not completely eliminate color at minimum setting.

First, I checked the resistances and voltages of the chroma circuit before the color control; this included the first chroma bandpass (Q302) and the ACC transistor Q303. I found all within tolerance, except the base of Q303. The reading should have been 28K, but it was only 6K.

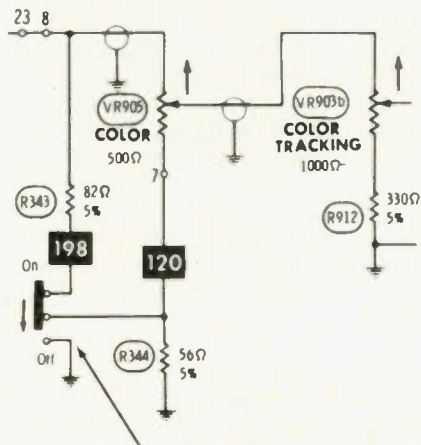

After examining this circuit, I concluded that the 6K reading was correct. Q303 is an NPN, and so a 6K reading is about right from the base through the emitter to ground.

While having a cup of coffee, I studied the schematic closely and noticed that the AFT switch (SW301) was connected to several sections of the chroma circuits. Remembering articles I had read in *Electronic Servicing* that said this type of slide switch is famous for creating oddball problems, I started probing it.

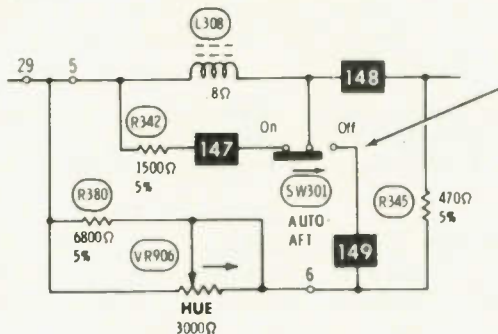

Sure enough, by doing this I could create the problems that the customer had complained about, as well as the one I noticed of no color elimination at the minimum color control setting. I found two defects: a cable coming from the AFT switch (which is mounted on a small PC board) was shorting intermittently, apparently damaged in production; and later, a dirty switch, which I thoroughly cleaned with tuner spray.

Also, checking the color control settings, I found that it was erratic at mid-range. After I changed it, the set was restored to normal operation.

Dominick Balducci
Astoria, New York

No color Zenith 20YIC48 chassis (Photofact 981-2)

This set had floating color bars, which meant that the 3.58-MHz oscillator was operating. I checked the burst amp, phase detector, and color amplifier tubes, and all were good. Then I checked the voltages around these tubes, but none were wrong. The next step was to scope the color signals.

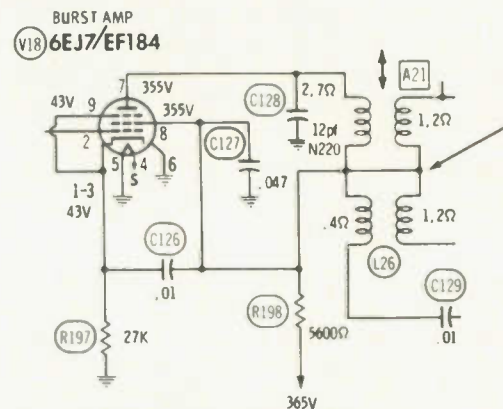

The signal at the 6EJ7 burst-amplifier plate had proper amplitude. However, when I checked at the secondary of the burst amplifier transformer, there was none. My first inclination was to think that the transformer had an open winding. It checked good in-circuit.

I disconnected the capacitors from the secondary of the transformer, and still had no signal. At this point, I removed the transformer for a closer examination. While doing another resistance check, I found that one side of the secondary was shorted. Replacement of the transformer (Zenith part S-77202) and touching up the transformer adjustment restored the set to normal operation.

Ron Schmitz
Miamisburg, Ohio

Circuit breaker trips Motorola 23TS-918A chassis (Photofact 880-2)

Sound could be heard when the set first was turned on, but within 25 seconds the circuit breaker would trip, killing B+ and stopping the sound. Routine tube replacement in the home did not correct the problem.

All voltages at 6JS6 (V11, horiz. output) checked okay, except at pin 5 (grid). From the lack of grid drive, I concluded that the 6JS6 current was excessive

and had tripped the circuit breaker.

I removed the chassis to the shop, where the scope revealed a normal horizontal output-tube grid-drive waveform at the cathode of pulse-gate diode, X14. But, no waveform was the anode.

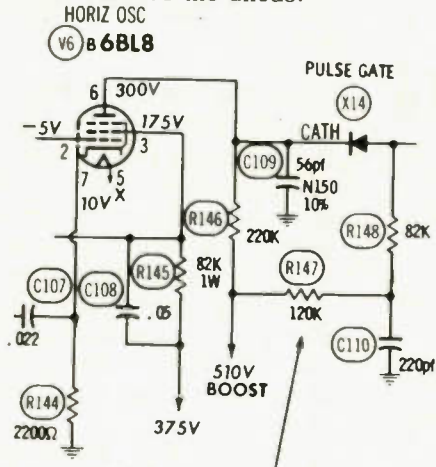

The diode checked okay, so the logical conclusion was that X14 was reverse biased.

The problem seemed to be at the voltage divider network for X14, consisting of R146, R147, and R148. R146 and R148 checked within tolerance, but R147 measured 10 megohms instead of 120K.

I replaced R147 with a 2-watt 120K resistor, and the set operated normally.

Bill DeRita
Providence, Rhode Island

No sound, breaker trips Motorola CL337 BM (Photofact 868-2)

When I started working on this set, it had no picture and no sound. After pushing the reset button, however, I obtained a good color picture. But it still had no sound. After a few minutes, I noticed a burning smell.

After placing the chassis on my bench, I found several burned resistors under the audio-output tube. I assumed the tube had shorted, so I replaced both the tube and the resistors. Then, while checking resistances, I measured an open at pin 8; the volume control also was burned out.

I hooked up the chassis to a test rig, but the sound was weak and distorted. Next, I checked the voltages, and found none out of tolerance at any of the sound tubes. An audio generator was connected to locate a bad stage, and it seemed that the audio-output tube had no gain. Wondering at this point if the audio output transformer could have been damaged, I sniffed it, finding a burning smell. Replacing the transformer restored perfect sound.

Robert Snow, Jr.
Clearwater, Florida

Send in your helpful tips—we pay!

NEW & DAZZLING!!!

MS-15 Miniscope—the Ultra
Oscilloscope for \$289.00 from NLS



Features Include:

- Bandwidth: 15 MHz.
- External & internal trigger.
- Automatic & line sync modes.
- Input sensitivity: vertical - 10 mV; horizontal - 1V.
- Vertical gain: .01 to 50V/div - 12 settings.
- Time base: .1 μSec to .5 Sec/div - 21 settings.
- 3% accuracy on all functions.
- Power consumption: <15 W.
- Battery or line operation with batteries and charger unit included.
- Weighs only 3 lbs & dimensions are 2.7" H x 6.4" W x 7.5" D.
- Options include a 10 to 1, 10 megohm probe and leather carrying case.



Non-Linear Systems, Inc.

Originator of the digital voltmeter.

Box N, Del Mar, California 92014 Telephone (714) 755-1134

For More Details Circle (7) on Reply Card

**GET ALL THE FACTS ON THE NEW
GTS-10 GENERAL TELEVISION SERVICER
- the concept that is changing the course
of TV servicing!
SEND FOR A FREE GTS-10 TWO-VOLUME
OWNER'S MANUAL!**

Advanced yet sensibly priced at \$349.00 the GTS-10 is the ultimate instrument on the TV service equipment market.

In addition to free two-volume set of the GTS-10 owner's manuals you will receive a comprehensive 6 page full color brochure - describing its profit making potential and its many unique patterns as well as information on our 30 day shop trial offer of the GTS-10 General Television Servicer.

**MODEL GTS-10
OWNER'S MANUAL
VOLUME 1**

**MODEL GTS-10
OWNER'S MANUAL
VOLUME 2**

**MODEL GTS-10
OWNER'S MANUAL
VOLUME 3**

**FOR IMMEDIATE REPLY
TO THIS OFFER
SEND COUPON OR
WRITE DIRECT
TO**

Telephone orders of the GTS-10 General Television Servicer on VISA and MASTER CHARGE accepted for same day shipment. Call 303 275-8991.

ATC

AMERICAN TECHNOLOGY CORP.
225 Main Street, Dept. A
Canon City, Colorado 81212

Send \$1.00 if First Class delivery is desired.

Name _____ Phone _____
Company _____ 1A/ES1
Address _____
City _____ State _____ Zip _____

For Color Brochure Only Circle (8) On Reply Card



Service Management Seminar,

By Dick Glass, CET **Part I**

In this first part of the Service Management Seminar series, Dick Glass has these two goals: He will reveal the plan that can make you prosperous, and inspire you to start the "\$30,000-Per-Year SUCCESS PLAN"; then he'll tell you the various subjects to be covered in future months, as the success plan unfolds.

You Can Earn \$30,000 Per Year!

Do you know that *some* electronic technicians are making more than \$25,000 annually? That's true, and not all of them are shop owners who profit from parts sales and their employees. Several barely squeaked through high school, so a college degree is not the reason for their successes.

On the other hand, most service technicians earn far less than \$15,000 per year. Why do they earn

less than men in other trades that require little skill or knowledge?

After working personally with electronic service dealers in all areas of the country, I believe that low profits for dealers and low wages for technicians are two wrongs which POSITIVELY can be corrected!

If you're a competent technician, or a shop owner who employs efficient technicians, *you CAN make an above-average wage or income.* In fact, you can become RICH!

There are few other businesses today where competition is so limited, and the opportunities for profit are so certain. Some of your fellow service dealers already have accumulated personal wealth in the hundreds of thousands, and several are millionaires.

Perhaps you feel that such good fortune could not possibly happen to you, especially if you've just written checks for the skyrocketing costs that plague your business. When you are faced with excessive re-calls (where you are trapped into giving away both parts and labor

costs), and your techs are stymied completely by several impossible-to-locate repair problems, large profits seem like an impossible dream.

But, if that accurately describes your business today, *don't give up.* The majority of your fellow servicers' businesses can be described the same way. These problems are universal.

Starting The SUCCESS PLAN

Your "\$30,000-A-Year SUCCESS PLAN" might require more than a year to complete. After all, we can't give you all the secrets in this first article, and each step does require time. So, it's possible you might fall a bit short of the goal the first year. The Plan makes such allowances, and it's far better (as we shall see) to accomplish part of the goal, than to do nothing.

Suppose you set a goal of \$30,000. "Impossible," you say? No, the following simple mathematics proves it to be possible.

First, if you are to be paid \$30,000 for one year's work as an employed service technician, you *should* be entitled to a larger-than-usual percentage of the total labor income you produce. That's because you will be bringing in "more-efficient" dollars. The shop's fixed expenses (mostly overhead) are the same whether you bring in \$10 an hour or \$50 per hour. So, if you generate more than the average gross income, you should be entitled to about 50% of the labor income (probably the industry average is 40% at this time). For example, if you average \$30 per-hour in billed labor charges, you could be paid at a \$15 per hour rate.

Can you produce that much?

If you were to work for a 50% commission, you would need to bill \$60,000 of labor in a year's time (perhaps next year?). *Is that possible?* Here is the mathematics:

- \$60,000 divided by 52 weeks equals \$1,154 per week.
- \$1,154 divided by 40 hours equals \$28.75 per hour for a 40-hour week.
- \$1,154 divided by 48 hours equals \$24 per hour for a 48-hour week.

Now, that's a lot of repair work!

Dick Glass is well known to electronic technicians because of his many years as executive vice president for NEA and NESDA. He helped develop (and often instructed in) the Profitable Service Management seminars, and has written several books for Howard W. Sams, including "Service Shop Management Guide." Dick now has his own management consulting firm and invites calls from servicers who have specific problems. (Dick Glass & Associates, 7046 Doris Drive, Indianapolis, Indiana 46224; phone 317-241-7783.)

Actually, most techs today don't produce even \$30,000 worth of labor in a year. Nevertheless, it *IS* possible. For the past nine years, I rarely ever saw the inside of a TV receiver, yet during a test period I produced the equivalent of more than \$30,000 of labor per year.

Tailor your goal

Suppose this year you don't quite make your goal. If you are certain you can't make the goal, then set it lower than \$30,000.

On the other hand, if you are a shop owner with several employees, you might want to set the goal higher, perhaps at \$32,000 or more.

Total Commitment

Whether or not you reach your goal depends on how much you *want* to do it. *Nothing less than total commitment will do.*

Therefore, make your decision. Do you only want to make a little more money? Or, do you want to increase your income greatly, and even eventually become rich? If the latter, you must carefully follow these steps:

Step #1 You want to be wealthy, and are willing to work hard at it.

Step #2 Set a realistic dollar goal.

If you now are making \$12,000 per year (\$230 per week), perhaps \$30,000 is too high for this first year. Set it at a realistic point, such as \$18,000. Write it in your personal file, "1978 goal is \$18,000" and date it. Also, carry this goal in your billfold or notebook at all times, where you will be reminded

of your singleness of purpose toward the goal.

Don't let the fear of failure stop you. Because people fear failure, lovely paintings are not begun, wild ducks are not hunted, useful hooked rugs never are started, beautiful mountains are not seen, and fortunes are not earned. You'll never know how many botched pictures were thrown out by a beginning photographer before he could make the artistic ones shown in displays or published in magazines. So, don't be afraid to set your personal goal this year. Look at it this way: If you set your goal for \$25,000 annually, and actually increased your previous \$15,000 to "only" \$21,000, you have gained \$6,000 by having a goal. That's not bad.

Step #3 What price will you pay?

You must decide what you are willing to "pay" for a higher income. Would you rather take long breaks, visit with your friends, dazzle the customers with long discourses about technical developments, and take every opportunity to skip your work? If so, you won't reach your goal.

If you want more income and are willing to work hard for it, you'll

begin coming in early to the store, and even work late some evenings. These are a few of the things you should do to make progress toward your goal, and you will find the work won't be drudgery any longer; it will be a pleasure because you have a goal that you can reach.

But, you must vow to give it a 100% effort; nothing less will do.

Step #4 Keep the faith.

Lack of confidence is responsible for servicers having the low income and poor working conditions that they have endured for years. Think about your knowledge compared to that needed for other trades. As a service technician, your abilities rank near the very pinnacle of human talents and intelligence. It's very difficult to learn everything about electronic technology. The job of servicing home-entertainment electronic products requires unusual dexterity, strength, and knowledge. You have an extensive mental list of unique methods and "fixes," plus valuable shortcuts for effective troubleshooting. Few craftsmen in other industries possess even a small percentage of the wide-ranging experience, training, and knowledge that you take for grant-

continued on page 16



**SERIOUS ABOUT
YOUR FUTURE IN HOME
ELECTRONIC SERVICE?**



The Sign of
Professional
Service

...a not for profit association championing independents' right to compete, and delivering valuable benefits continuously since 1950.

NATESA offers low cost group insurance, discounts on everything from eyeglasses to motor vehicles, individual consultation on particular problems, representation to government and industry at all levels and a place to unite to protect each individual member with the strength of all.

Membership. \$60.00 enclosed.

Send this ad with your card or letterhead to:

NATESA, Dept. ES
5908 S. Troy St.
Chicago, Il. 60629

As our member premium, please send free . . .

Practical Business Manual

- OR -

Service Contract Manual

**Want to cut out
a career as a
two-way radio
technician?**

MTI offers the only training for professional FM two-way radio available. Qualified technicians are employed in government, industry, and public service. But training is your key.

You could cut out a career as a two-way radio technician by cutting out this coupon. We'll send you information on how you can learn more about this specialized field, at home.

Name _____

Address _____

City _____

State/Zip _____

N 88



formerly

**MOTOROLA TRAINING
INSTITUTE**

Summerville, Pennsylvania 17093

For More Details Circle (9) on Reply Card

Service Management

continued from page 15

ed in electronics. You regularly solve electronic mysteries that would baffle Sherlock Holmes, and you diagnose conditions that are as complex as those faced by medical doctors. Of course, sometimes you don't locate the bad part or condition immediately. Nevertheless, you often accomplish the impossible. Compare your abilities and your income against those of others.

You are a technical genius, so *keep the faith.*

Step #5 Be persistent.

You must persist, and not work erratically at your **SUCCESS PLAN**, for only complete commitment will be effective. Obstacles will arise, and other people probably will try to slow you or change your direction. Therefore, you should be firm and resolute, and even stubborn or obstinate.

Keep your goal in mind, but realize that the first efforts and changes will seem almost futile. It's only after you have been persistent and have overcome the obstacles one at a time, that the results will begin.

In many projects, including this one, *persistence* is of more value than genius, intelligence, knowledge, or talent.

Start The Plan NOW

Don't delay the start of your **SUCCESS PLAN** any longer; today is the only time you ever will do it. Write \$30,000 on a piece of paper, and think about it for a few hours. Later in the day, after mentally arguing with yourself, *write on that paper your goal for the next year.*

After you have established the goal, read this entire article again. Remember, you are the only one who will have the guts and persistence to see this project through to completion. If you become confused or have questions, call or write me (phone number and address listed elsewhere in the article). Meanwhile, we'll present more management information each month.

Future Months

Next month, we'll show you how to measure your productivity, and how to figure the productivity of

your technicians. This is vital to your **SUCCESS PLAN**, yet few servicers know how to do it.

Later, we will take the mystery out of Balance Sheets, and make easy work of reading and understanding your Profit-And-Loss Statement. Also, we'll help you determine whether or not you can afford certain types of test equipment, tools, and other service aids.

In order to properly make wise decisions, you need to know much about your competitors, and whether they are a real threat to you, or are of no importance. We will ask and answer the extent of the service work that's available.

Good "customer relations" and "employee relations" are vital to the financial health of any business, particularly in our industry where direct contact is essential. I'll try to help you understand the problems that are common to all servicers, and tell you how the successful managers overcome them.

A valid pricing system is imperative to convince your customers that your prices are fair and honest, so we'll explain and compare various systems.

Other subjects should include: Breakeven Calculation; Bookkeeping Procedures; Return On Investment; Technician Training; Service Data; Generating More Repair Business, and Solving Parts Problems.

This general principle will be behind every subject: You desperately need to identify each problem, and then solve it, before going on to the next one. Unless you can see the problems, or have a way of identifying them, you will fail in your business. But, if you follow the **SUCCESS PLAN**, we expect you to succeed and become prosperous.

Steps Of The SUCCESS PLAN

You must hunger for success.

You must set a goal in dollars.

**Are you willing to
pay the price?**

**Recognize your valuable
abilities.**

**Work constantly toward
the GOAL.**

*This one may
require some
head-scratching
unless you
remember your
basics.*

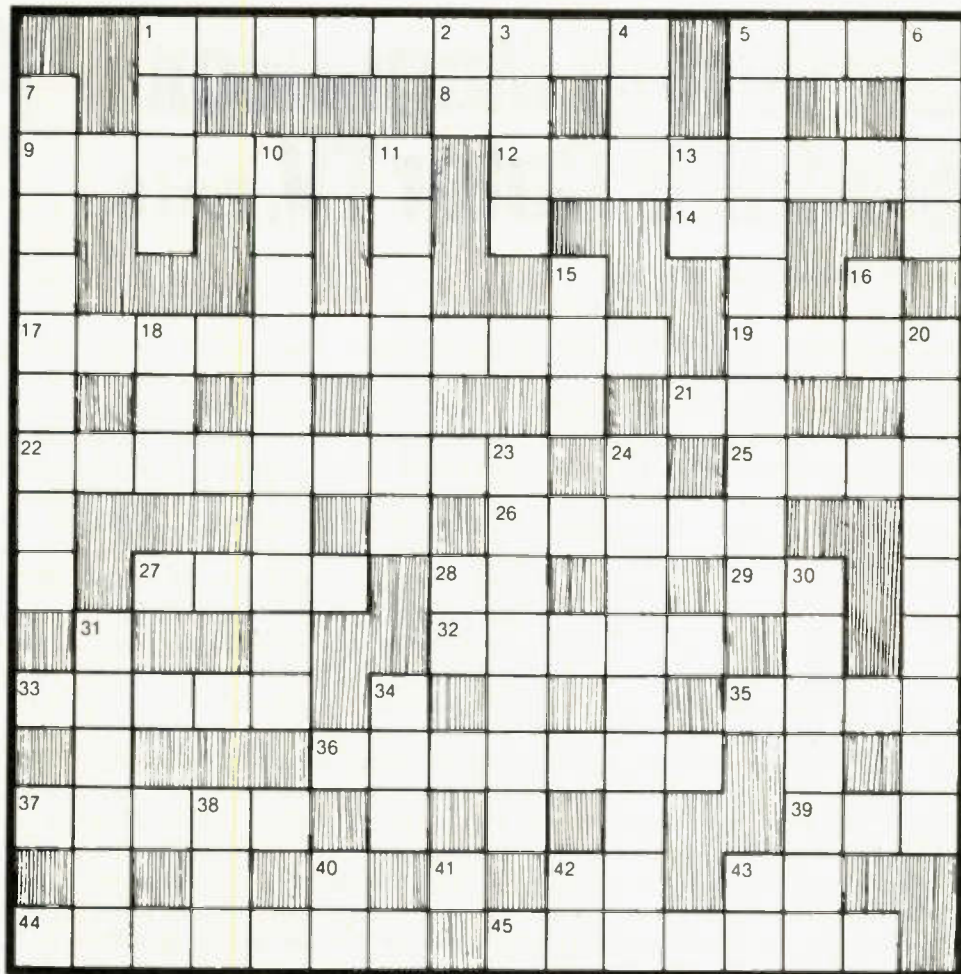

Semiconductor Crossword

by Frank R. Egner

ACROSS

- 1 Semiconductor material
- 5 Transistor leakage
- 8 Output capacitance
- 9 Transistor terminal
- 12 Reverse bias
- 14 Emitter current
- 17 Type of MOSFET
- 19 CB transceivers (slang)
- 21 Power amplifier
- 22 Pure crystal material
- 25 Junction check
- 26 Diode terminal
- 27 SCR terminal
- 28 Total current
- 29 Unit of power gain
- 32 Atom electron ring
- 33 Current amplifier
- 35 Collector Identification

- 36 To pass current
- 37 Current control device
- 39 Light emitting diode
- 41 Transistor designation
- 42 Output resistance
- 43 Public address function
- 44 ICBO indication
- 45 "On" bias

DOWN

- 1 Amplification
- 2 Normally closed
- 3 Unbalanced atoms
- 4 Maximum amplifier gain
- 5 Packaged circuit
- 6 Diode defect
- 7 Type of MOSFET
- 10 NPN or PNP
- 11 "Off" bias

- 13 Current gain
- 15 Transistor type
- 16 SCR gate voltage
- 18 Thermal runaway condition
- 20 Maximum current condition
- 23 Diode terminal
- 24 Transistor terminal
- 28 Source current (FET)
- 30 Two pole device
- 31 FET terminal
- 34 Inverted OR gate
- 38 SCR terminals
- 40 Gate voltage (FET)
- 41 Symbol for transistors
- 42 Output resistance
- 43 Power amplifier

Solution on page 25

Servicing Magnavox Modular Color TV, Part 8

By Gill Grieshaber, CET



This concluding installment of the Magnavox coverage describes the combining of the tuning voltage and the AFC, the transistor/diode band-switching circuits, the operation and circuits of the sound-control channel, and some suggestions for servicing the Touch-Tune system.

Digital Signals Are Pulses Of DC

In previous articles, we showed how digital pulses could produce a DC voltage. This is possible because digital pulses are actually slices of DC voltage. (Remember that these explanations do not apply to AC pulses that go through capacitors or transformers, which remove the DC component.)

Pulses and square waves for digital operation could be obtained by feeding DC voltage through the contacts of a high-speed relay. Admittedly, this is not practical, but it illustrates the point. Such pulses and square waves of DC can be measured on a DC meter (which averages the slices of DC voltage). Or, the DC pulses can be filtered until only pure DC remains; and **the voltage reading will be identical to that obtained by measuring the pulses with a DC meter.** This is the method used in the T995 Magnavox Touch-Tune system to develop the DC tuning voltage for the VVC tuners.

If either the top or the bottom of a digital waveform is at zero volts, the measured DC voltage will be the same as the peak-to-peak reading times the duty cycle expressed in percentage. For example, a 20 VPP pulse waveform with zero volts at the bottom, and a duty cycle of 25%, will read +5 volts DC on a DC meter. (For a duty cycle of 25%, the pulse would be followed by a base line that's three times as wide as each pulse.)

These facts have been verified

experimentally. The voltages around Q106 were measured by a VOM, a VTVM, a digital meter, and a DC scope, and all the readings were identical (after allowing for the individual inaccuracies). The +0.590 voltage read +0.6 on the 2.5 VDC scale of the VOM. I must admit I was surprised to find a VOM could be used in such digital circuits without any sign (on a scope) of any amplitude of waveform change from the loading.

One more bit of knowledge is needed before we can reconcile the theoretical with the measured voltages from DC digital pulses. That knowledge can be obtained by use of the DC-coupled vertical channel of your scope: **you must prove whether or not the pulses actually are clamped to zero voltage at top or bottom.** If zero voltage is not precisely at the top or the bottom of the pulses, you must make an allowance for the difference. Otherwise, you will believe the formula given two paragraphs back is incorrect. An example is given next in the analysis of the Q106 stage.

Developing The Tuning Voltage

Generation of the variable-duty pulses in IC104, and the buffering and shaping in IC105 were described last month. Also, the circuits of Q106 were given a brief explanation. However, the operation of the Q106 stage is so important to our understanding of digital circuits in general, that I'm repeating the schematic and increasing the explanation. Also, a couple of errors were in Figure 9, and they are corrected here.

Voltages and waveforms of Q106

Q106 C/E path functions as an on/off switch that controls the pulses of DC voltage there. When the base signal of Q106 is sufficiently positive (from the incoming pulses), the C/E path through Q106 is nearly a dead short (the collector

voltage then is less than 0.1 volt). During the times the base signal is nearly zero volts, the C/E path is an open circuit. That's the general operation of Q106, in the circuit of Figure 1.

Negative-going pulses from IC105 go through R121 to the base of Q106. The peak-to-peak and DC readings don't seem to follow the rule about the DC reading being equal to the PP reading times the duty cycle in percent. At the input of R121, a scope measured 0.8 VPP, and a DMM read +0.801 VDC, when the channel 4 pulse waveform had about a 68% duty cycle. According to the rule, the DC reading should have been +0.544, rather than the measured +0.801 VDC. But the waveform of Figure 1A shows 0.24 volt between the zero-voltage line and the bottom of the pulses; and +0.544 added to +0.240 is +0.784 volt. This is quite close to the actual +0.801 reading, considering the difficulties of determining the duty cycle, and of reading the scope as accurately as possible.

The waveform of Figure 1B has the same 0.240 volt gap between the line and the pulses. Again the measured and calculated voltages are nearly identical. 0.5 VPP times 68% is 0.340 plus 0.24 equals 0.580, compared to the DMM reading of +0.586 volt.

Collector readings

The zero-voltage line is not shown in Figure 1C, because it would have obscured the base line of the waveform, but it is less than 0.1 volt above the bottom of the pulses. Therefore the formula can be used without any changes or additions. So, 8 VPP time 32% (the duty cycle was reversed along with the polarity) is +2.56 volts for the calculated voltage from the collector pulses, while the DMM reading was +2.58 VDC. That's very good

continued on page 20

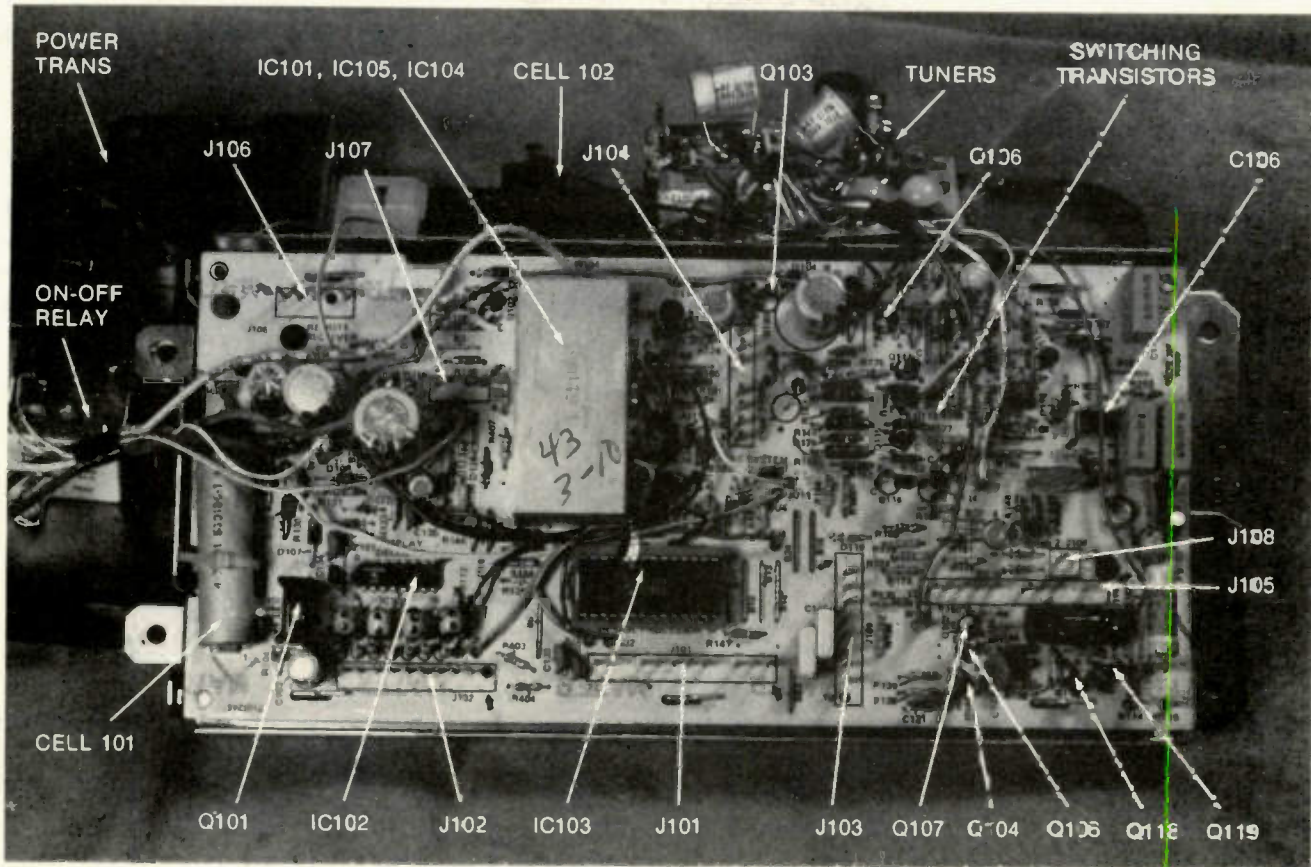

Many components are pointed out by arrows, on the tuner-control chassis of the Magnavox Touch-Tune system in chassis T995.

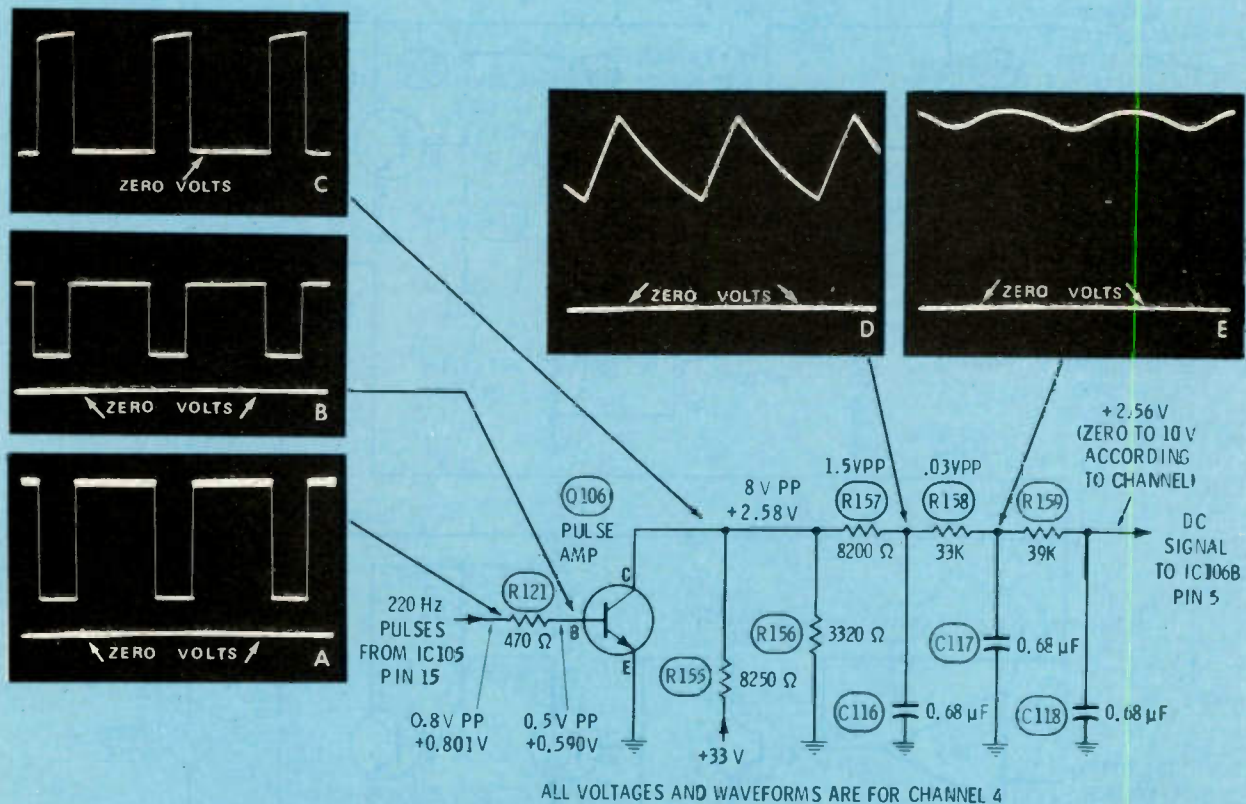

Figure 1 The variable duty-cycle pulses from IC105 are amplified by Q106, and the output waveform is integrated by three low-pass filters. From the output at R159/C118, the DC voltage (which is different for

each channel) goes to IC106B for mixing with the AFT before it is amplified and becomes the varactor diode-tuning voltage.

Servicing Magnavox

continued from page 18

accuracy, despite the difficulties of making precise measurements.

Actually, since the waveform has only positive peaks, the collector amplitude *should* be expressed as 8 volts *peak*. True PP readings are from the positive peak to the

negative peak, and a peak reading can be made of only a portion of a waveform. The scope calibration and deflection are exactly the same in both cases.

Because the R155/R156 voltage divider limits the maximum Q106 collector voltage when the conduction is cut off, the output pulses never can exceed 9 VDC (or 9 volts

peak). This conforms fairly well to the measured 8 volts peak.

Filtered waveforms

Square waves after integration by an appropriate low-pass filter become triangular waveforms; and narrow pulses integrated by a low-pass filter become ramps (or sawteeth). The collector waveform from

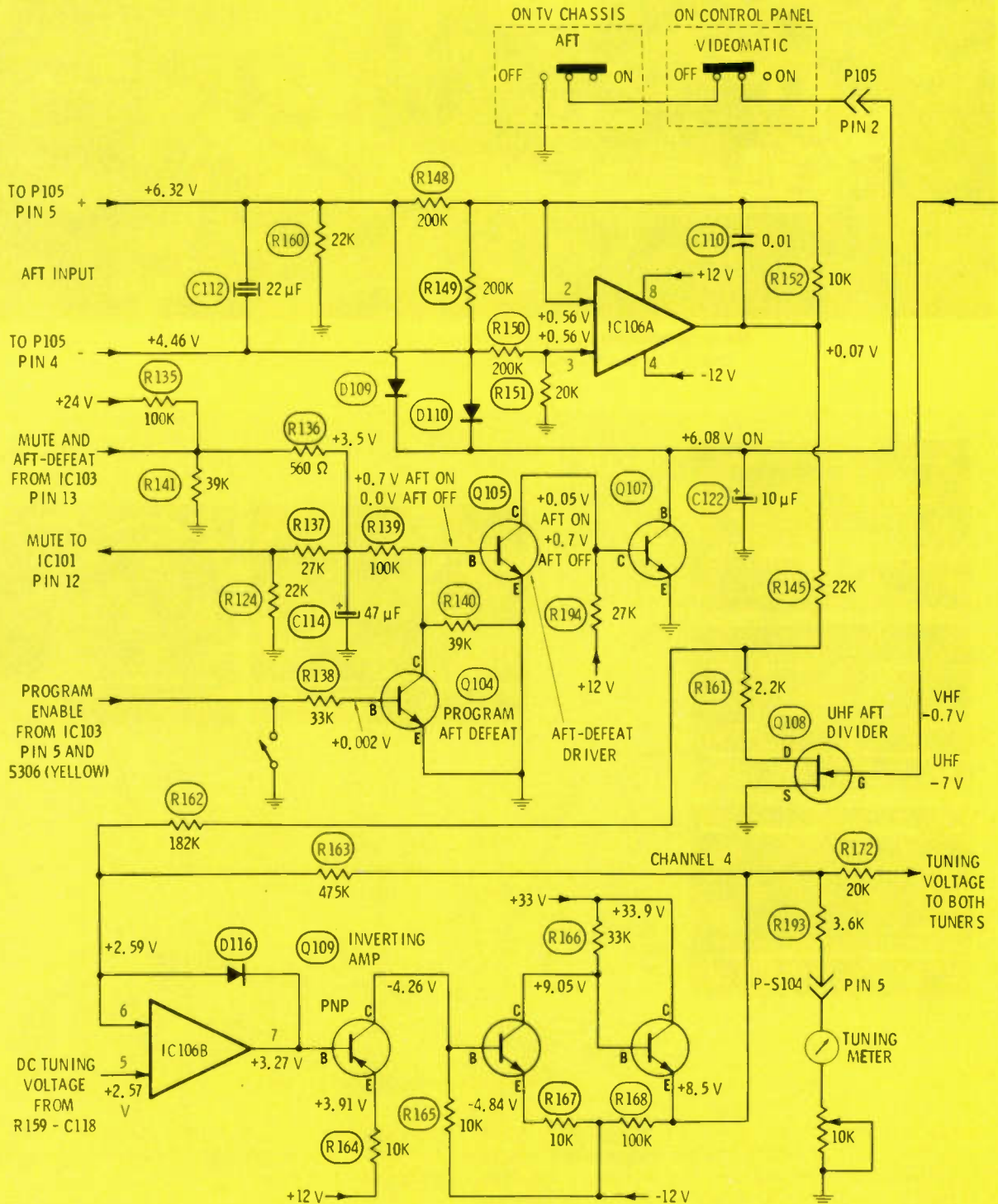

Q106 appears as fairly broad pulses; therefore, after passing through the R157/C116 filter, the waveform has a shape that is between a sawtooth and a triangle.

But, regardless of the amplitude reduction from the filtering, the measured DC voltage remains the same as at the collector. The zero-voltage line at the bottom of Figure

1D proves the near-sawtooth is riding on top of the DC component.

Following the next filter section (R158/C117), the almost-sawtooth has been smoothed to a tiny near-sine waveform (Figure 1E). This is the only waveform that is not perfectly true. The ripple amplitude was so low that the actual waveforms would seem to be two

straight lines. Therefore, I cheated by raising the scope gain enough to show the ripple.

No waveform is shown at the output of the three-section filter (R159/C118) because my sensitive scope produced only a line; the amplitude was unmeasurable by the scope.

Good filtering of the tuning
continued on page 22

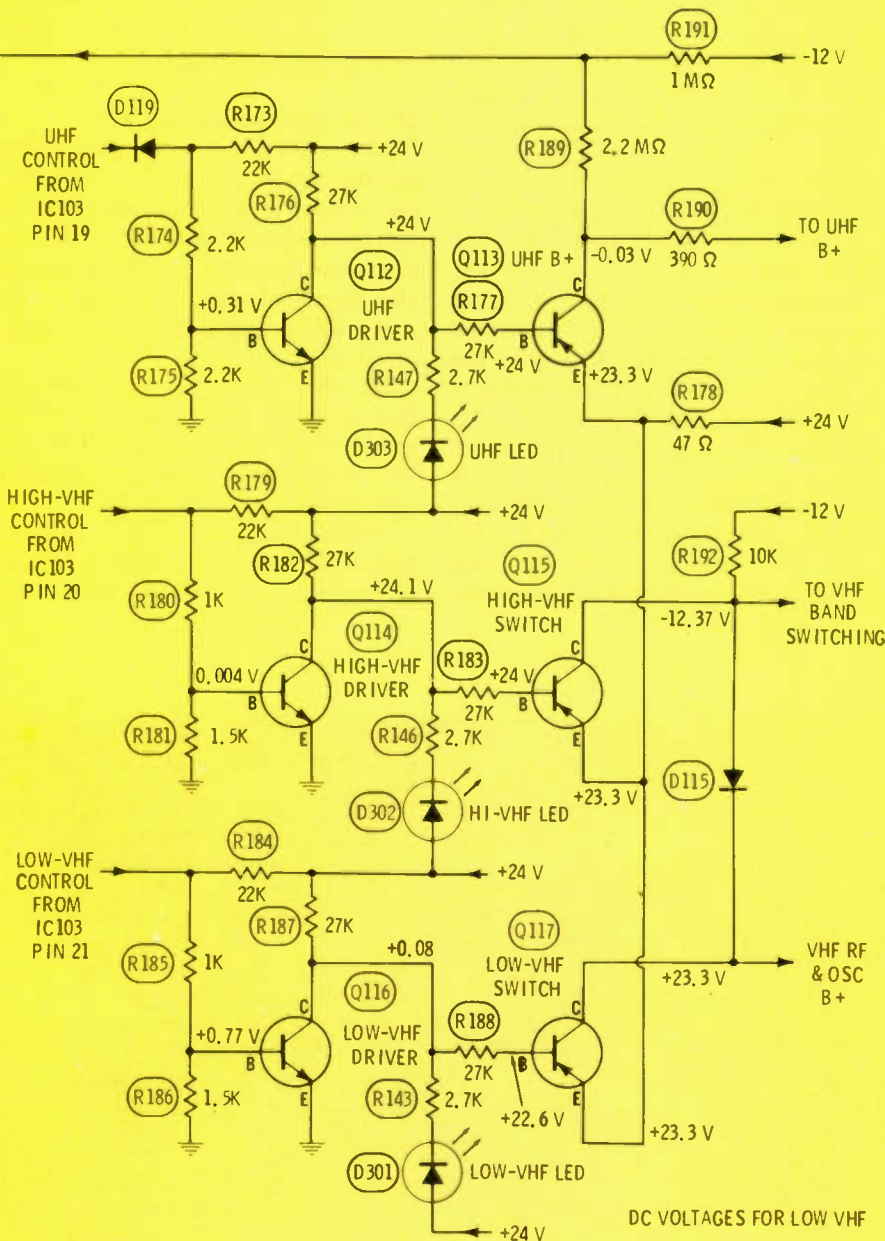

Figure 2 Many of these stages are interconnected, so follow the circuit operation given in the text.

Servicing Magnavox

continued from page 21

voltage is required, otherwise any 220-Hz ripple would cause dark horizontal bars to move rapidly down through the picture. An open in C116, C117, or C118 could cause that symptom.

Adding the AFT

VVC tuners don't need an added varicap diode (that's controlled by the AFT) to shift the oscillator frequency slightly, because the oscillator tuning *already* is done by a varicap (varactor) diode. Therefore, the AFT voltage slightly varies the tuning DC voltage.

Figure 2 shows that the DC tuning voltage from R159/C118 is applied to pin 5 of IC106B, an op-amp. The other input to IC106B at pin 6 is fed the amplified DC AFT voltage from IC106A. Both inputs together determine the output at pin 7 of IC106B; this DC signal is amplified by Q109 and reduced in impedance by Q110 and Q111. **The output of Q111 is the DC tuning voltage that's applied to both tuners.** But, this simplified explanation omitted several previous important circuit actions.

AFT and AFT defeat

Two AFT DC voltages come from the AFT circuit in the TV chassis. When a tuning correction is needed, one voltage should increase above +6 volts, and the other decreases below +6 volts. Both voltages are

filtered by C112, and are reduced by series resistors before the remaining +0.6 volt is applied to each input (pins 2 and 3) of IC106A, another op-amp. The output of IC106A is fed to one input of IC106B at pin 6.

Another function, AFT defeat, is necessary for: manual control of the AFT; disabling the AFT for a split second during station selection; and for stopping the AFT during the initial programming of channels.

AFT defeat circuits

AFT defeat is done in three different ways. The anodes of D109 and D110 diodes are connected to the AFT voltages that come from the TV chassis. When the common cathodes are grounded, the AFT voltages of +0.56 volt at IC106A pins 2 and 3 are reduced to about +0.05 volt each. During manual turnoff of the AFT, these common cathodes are grounded through the Videomatic switch (on the control panel) and the AFT switch on the back of the main TV chassis.

During the split second after a new channel is selected by the pushbuttons, and before the tuning voltage stabilizes, the AFT must be disabled to prevent locking to the wrong channel. So, IC103 produces a LOW at pin 13, which goes through R136 to the Q105 base, measuring +0.009 volt there. This is cutoff bias, and the collector voltage tries to climb to +12 volts. But the base of Q107 is tied directly to the collector; therefore,

the base current stops the voltage at +0.71 volt, which is saturation bias for Q107. Consequently, the Q107 C/E path grounds both D109 and D110 cathodes, greatly reducing the TV AFT voltages, and disabling the AFT.

After the tuning has stabilized, pin 13 of IC103 measures about +3.6 volts, and through R139 it supplies the base of Q105 with +0.628 volt (in this individual chassis) of forward bias. The bias is sufficient to cause saturation in Q105, reducing the collector voltage (and the base voltage of Q107) to only +0.057 volts. Q107 is cut off, and its collector rises to +6.08 volts. This voltage reverse-biases both D110 and D109, they become open circuits, and the AFT voltage is allowed to pass on to pins 2 and 3 of IC106A. The AFT operates normally now.

Muting and programming AFT

When pin 13 of IC103 goes LOW during station selection, +0.001 volt comes through the R137/R124 voltage divider to pin 12 of IC101, the sound-control IC. This mutes the sound channel to silence any noise happening during the change of channels.

At other times, the +3.51 volts at the junction of R136 and R137 supplies +0.744 volts to IC101 pin 12, and the sound has normal operation.

During programming, "yellow" switch S306 opens to allow a HIGH to reach pin 5 of IC103, where the

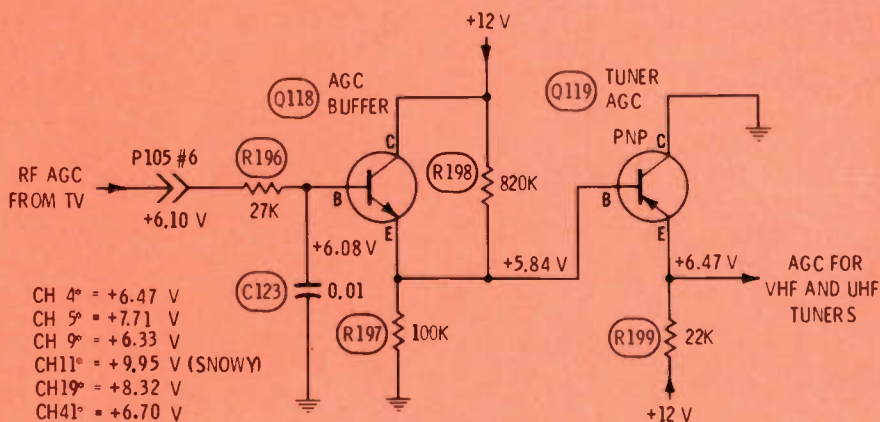

Figure 3 Although the TV chassis provides AGC for other types of tuners, the Touch-Tune system processes this voltage with two emitter followers. R197 and R198 prevent the base voltage of Q119 from dropping below +2 volts. During tests, the AGC voltage ranged between about +4 volts for a very strong carrier to +9.95 for no signal.

DC VOLTAGES WITH STRONG VHF SIGNAL

Servicing Magnavox

continued from page 23

that select the low-VHF, high-VHF, or UHF band. In addition, pin 19 receives a small "keep alive" voltage from battery cell 101. This is necessary to prevent loss of the UHF bandswitching memory, and D119 is included to stop any battery current from flowing into the circuits when the power is off.

The voltages shown in Figure 2 for Q112, Q113, Q114, Q115, Q116, and Q117 were recorded during operation of the low-VHF band.

IC103 pin 19 (UHF switching) measured +0.005 volt for both of the VHF bands, and +1.37 volts for UHF. Pin 20, for the high-VHF band, measured +0.006 volt for low-VHF and UHF, and +1.75 for high VHF. Similarly, pin 21, for the

low-VHF band, measured +0.005 volt for UHF and high-VHF bands, or +1.75 volts for low-VHF operation. In other words, each pin had a HIGH for its own band, and a LOW for the other two.

Those voltages should enable you to follow the switching of all three bands.

UHF switching

When either of the VHF bands is selected, both Q112 and Q113 are cut off. Lack of Q112 conduction prevents D303 (LED) from lighting, and removes the forward bias from Q113. Conversely, a HIGH at D119 provides saturation bias for both transistors. The collector current of Q112 lights the UHF LED (D303), and the collector voltage coming from Q113 is the B+ supply for the UHF tuner (a zener on the UHF tuner regulates it to +15 volts).

Because Q112 is a NPN type, and Q113 has PNP polarity, both are cut off at the same time (or saturated at the same time). This also applies to Q114/Q115 and Q116/Q117 in the other switching circuits.

Low-VHF switching

For low-VHF operation, a HIGH is applied to the base of Q116, lighting the D301 LED by the collector current, and strongly biasing-on Q117 (HIGH). The collector power from Q117 supplies the B+ power for the RF and oscillator stages of the VHF tuner.

At the same time, the high-VHF switching transistors are without forward bias, so no DC voltage is supplied to the VHF tuner band-switching diodes. Diode D115, at the collector of Q115 prevents the RF/osc supply from feeding the

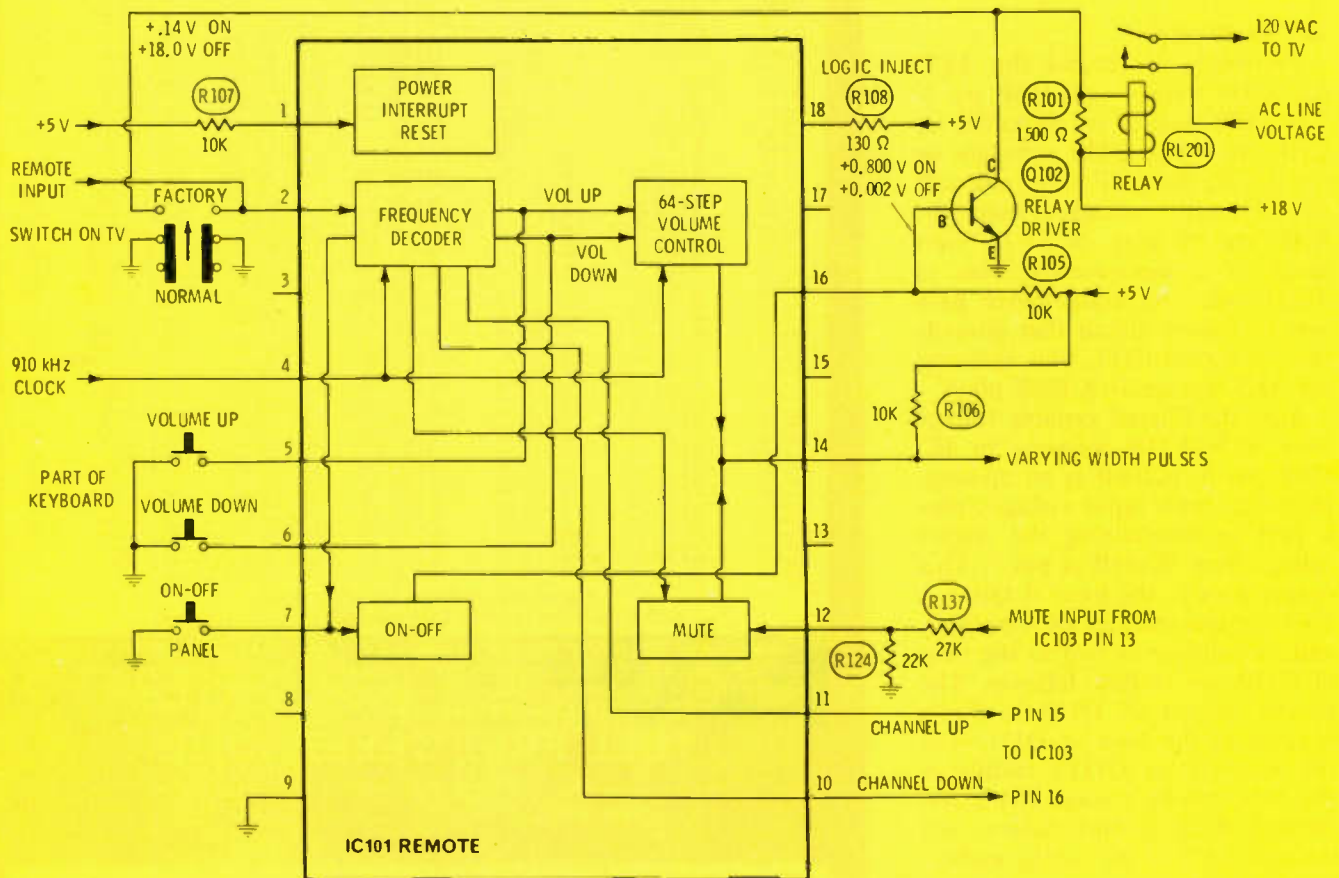

Figure 4 Pinouts for IC101 are numbered from above the IC, and the internal functions are shown by blocks. In addition to decoding the signal from a remote receiver (when used), IC101 also provides 64 steps of effective

pulse width to control the audio volume, includes on/off logic and drive for the relay, and mutes the audio during station changes.

VHF bandswitching circuit.

Of course, when high-VHF or UHF bands are selected, the two transistors are cut off, preventing the LED from lighting and removing the RF/osc B+ voltage of the VHF tuner.

High-VHF switching

For high-VHF operation, the HIGH from IC103 pin 20 becomes saturation bias for Q114's base, LED D302 is lighted by the collector current, and the reduced collector voltage is saturation bias for Q115. Positive voltage from the collector of Q115 goes to the band-switching diodes in the VHF tuner. Also, the positive voltage goes through D115 and becomes the supply voltage for the VHF RF/oscillator stages. Thus those stages have B+ for both high and low VHF, but not for UHF.

R192 is between the collector of Q115 and the -12-volt supply, and it supplies the -12 volts needed to reverse-bias the switching diodes in the VHF tuner during low-VHF operation.

HIGHs and LOWs

Incidentally, a **HIGH** for a NPN transistor must be positive, while negative voltage is a **HIGH** for the base of a PNP transistor. Thus, for UHF bandswitching, both Q112 and Q113 have HIGHs at their bases, although Q112 has positive bias and Q113 has negative-voltage bias.

Tuner AGC

All Magnavox T995 chassis develop AGC for the tuner, but models without Touch-Tune or STAR systems do not have an RF stage in the UHF tuner; therefore, the AGC supplies only the VHF tuner.

The Touch-Tune control chassis includes two emitter followers that provide increased power and other advantages to the AGC for the VVC tuners (see Figure 3).

In the VHF tuner, a MOSFET is the RF amplifier. It requires cut off bias for gain reduction. This is supplied by *reducing* the positive AGC voltage for stronger signals.

A PNP bipolar transistor (requiring saturation biasing) is the RF amplifier in the UHF tuner. Again, the requirement is met by

reducing the positive AGC voltage for stronger signals. Therefore, both tuners can share the same RF AGC voltage.

Q118 is wired as an emitter-follower that controls the bias of Q119, another emitter follower. The voltage divider R198/R197 prevents the Q119 base from dropping below +2 volts, as it might if the TV AGC dropped below +2 volts.

If you want to analyze the operation of the two AGC transistors the hard way, this is the sequence: Decreased positive voltage of the RF AGC is less forward bias for Q118, which reduces the C/E current and the emitter-to-ground voltage; the Q118 emitter is tied to the base of Q119, so the reduction of Q118 emitter voltage is increased forward bias for PNP Q119, and the C/E current of Q119 is increased. Therefore, less positive voltage reaches the emitter of Q119 through R199, and the emitter positive voltage is decreased.

It's much easier to say that a negative-going TV AGC voltage at the base of Q118 produces a negative-going voltage at the base of Q119. In turn, the emitter DC voltage of Q119 is negative-going.

Note: references to positive-going (meaning more-positive or less-negative) and negative-going (meaning more negative or less-positive) greatly simplify the explanation of many circuits, because the PNP or NPN polarity does not change this fundamental relationship.

The varying positive voltage from the Q119 emitter is the RF AGC voltage that controls both tuners.

DC voltages in the Figure 3 schematic were measured while a strong signal was being received. To give you an idea of the *range* of RF AGC voltages, the readings for six stations received in Kansas City also are included.

Control Of Sound Levels

A method having many similarities to that used for developing a DC tuning voltage from variable-width pulses is employed in the T995 to control the audio volume. Remember that, in the TV chassis, a DC voltage applied to the sound IC varies the audible volume. Therefore, a varying DC voltage is required from the Touch-Tune control system to control the volume.

continued on page 26



WE'RE GROWING!

to better represent

YOU

the successful service business operator.

*Over 2500 firms belong

*39 State Affiliates

*167 Local Associations

YOU CAN JOIN!

and learn how to make money and work less hours.

Write today for a membership application and more information.

1715 Expo Lane
Indianapolis, Indiana 46224
Phone (317) 241-8172

Solution to Semiconductor Crossword

ACROSS

1 Germanium	28 IT
5 ICBO	29 dB
8 CO	32 Shell
9 Emitter	33 Power
12 Negative	35 Spot
14 IE	36 Conduct
17 Enhancement	37 Trlac
19 Rlgs	39 LED
21 PA	41 Q
22 Intrinsic	42 RO
25 Test	43 PA
26 Anode	44 Leakage
27 Gate	45 Forward

DOWN

1 Gain	20 Saturated
2 NC	23 Cathode
3 Ions	24 Collector
4 MAG	28 IS
5 Integrated	30 Bipolar
6 Open	31 Source
7 Depletion	34 NOR
10 Transistor	38 AGK
11 Reverse	40 VG
13 AI	41 Q
15 PNP	42 RO
16 VG	43 PA
18 Hot	

Servicing Magnavox

continued from page 25

IC101

The remote decoder, IC101, controls the up or down scanning of channels during remote operation (our sample TV did not have remote equipment), controls the on/off relay, develops the pulses that eventually produce a DC voltage to control the audio volume, and mutes the sound during the short time of channel selection. Figure 4 shows the external wiring, and has blocks for the internal functions.

Notice that the normal/factory switch, in the factory position, grounds one end of the relay coil (to keep the power on) and grounds the input signal from the remote receiver (prevents remote operation). This switch is used during programming of the remote system.

Also, the AC power can be operated manually by pressure on the on/off switch that's mounted on the Touch-Tune control panel. On push of the button turns on the power, the next push turns off the power, while the next turns it on again, etc.

The on/off button connects to pin 7 of IC101, and the internal circuitry alternately shorts or becomes open at pin 16, which is supplied with power through R105 from the +5-volt source, and it also

connects to the base of Q102, the relay-driver transistor. When pin 16 is open, about +0.80 volt is applied to the base of Q102. This is saturation forward bias, and the C/E path grounds the collector end of the relay coil, turning on the AC power to the TV chassis.

Changing effective duty cycle

The volume changes slowly, so you must keep pressure on the volume-up or volume-down button. IC101 pin 5 is grounded for volume-up, and pin 6 is grounded for volume-down operation. To the ear, the volume changes without steps, in a normal continuous way. But, there are 64 steps of volume, produced by 64 variations of the number of pulses, their spacing, and their duty cycles. Magnavox calls this a variable "effective" duty cycle.

The 64-step pulse generator operates from the 910-KHz clock signal, and the effective duty cycle is varied by adding or subtracting positive pulses from the output at IC101 pin 14. It's fascinating to watch the pulses change, for the pulses are not necessarily added evenly. Instead, a pulse will be added here or there, and a change to the next step varies the pattern of pulses and spaces. Also, the amplitude does change (contrary to a statement in the Magnavox

manual). In the sample TV, the pulses at the collector of Q103 measured 8 VPP at loud volume and only a bit over 3 VPP at soft volume.

It's difficult to lock the waveform, even when using a triggered scope, because it's not certain where one cycle of pulses begins or ends. Of course, you should not have to look at the pulse waveforms very often. Just operate the buttons from very soft to maximum volume and notice the change of DC voltage at the collector of Q103. For example, at minimum volume the base had +0.711 volt and the collector measured +0.020 volt; and at maximum volume the base checked +0.005 volts, and the collector had +8.65 volts (the maximum permitted by the voltage divider R110/R111).

In addition, the pulses stop at step 1 and step 64 of the 64-step pulse generator. At minimum volume a DC voltage of slightly more than +0.7 volt was applied to the base, and at maximum volume, the DC voltage was virtually zero.

Q103 amplifies and inverts the volume-control pulses (Figure 5), and then following R109, C109 filters the DC pulses. The filtered DC voltage from R109/C109 is sent to the TV chassis where it varies an IC voltage; and in turn, this changes the sound volume. Only

Figure 5 Although a small amplitude change occurs during times the volume is varied, the pulses applied to the base of Q103 change duty cycle by adding pulses or combining adjacent pulses, as the 64-step clock operates. It's not possible to describe in words all of the variation patterns. The dual-trace waveform shows one "step" of pulses at base and collector of Q103. The bottom of each trace is at zero volts. Because these are DC pulses, an integrating low-pass filter produces a DC voltage that changes in step with the varying effective duty cycle.

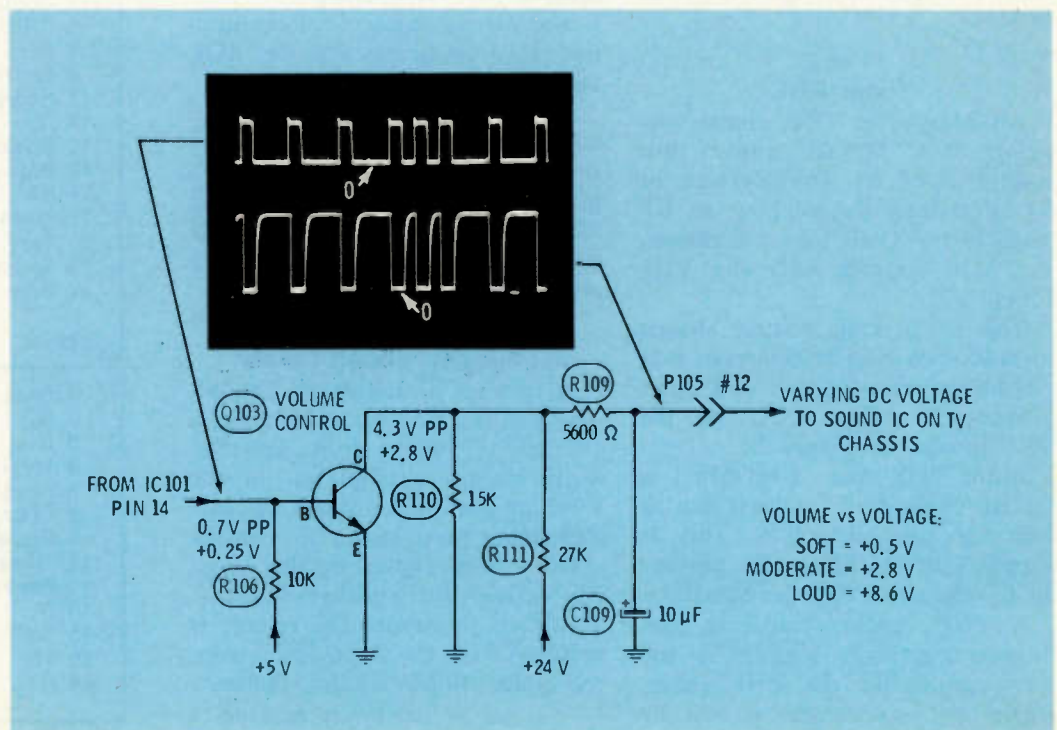

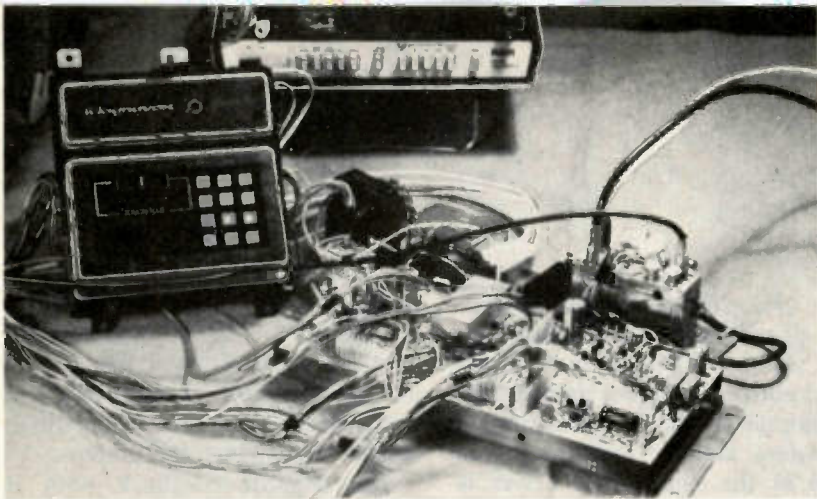

Remember that only two extension cables (available from Magnavox) are needed to permit normal operation of the Touch-Tune system with the control panel and control chassis removed.

one filter stage is used because the repetition rate is much higher than that for the tuning voltage, and a small amount of ripple doesn't affect the operation.

Servicing The Touch-Tune System

Although servicing the Touch-Tune system usually is done in the shop, several basic preliminary tests should be made in the cabinet, before you remove any components.

First check all active channels, and write down any significant problems. If only one channel has digits that flash on and off, this indicates the programming was not done, or the programming has been lost. Once during these tests, I lost the programming of one VHF channel (I don't know what happened, but the digits started flashing and the tuning voltage was zero). However, I just went through the usual programming procedure for that channel exactly as if it never had been programmed. The channel programmed perfectly, and has given no further trouble.

First, you must determine if the tuners, the control-panel switches or pushbuttons, or the control-chassis circuitry is at fault. Watch the tuning meter and the band LEDs as you push the buttons for each channel. If all the channel voltages are low, probably the defect is in the IC and transistors that amplify and filter the pulses into the DC tuning voltage. Verify this by changing the tuning voltage of one channel.

Next measure the B+, tuning voltage, handswitching DC voltages,

and AGC voltages. If these are wrong, the suspected area will be apparent. If they are all correct (considering that the loss of signal will cause a high positive AGC), one or both tuners must be bad. Try a tuner substituter to verify the diagnosis (but test those voltages first!).

At the shop

Try to localize the defect to one of these functions or areas:

- channel pushbuttons;
- operation of the digital channel-number display;
- programming by the four switches;
- the DC tuning voltage, including the pulses, DC amplifiers, and filters;
- AGC, tuners, and supply voltages; and
- other functions, such as muting or AFT defeat, volume control, on/off, and remote operation.

ICs should be tested by verifying all of the supply voltages and input signals. Then, if the output signal (or signals, including HIGHS and LOWs) is missing, the IC is defective.

Magnavox publication ST1020-977 lists several detailed procedures for testing the Touch-Tune system.

Comments

Although digital circuits are new to many of us who service home-electronic equipment, the facts presented about the Magnavox Touch-Tune system in these three articles should enable you to troubleshoot and repair most problems without undue difficulty.

APPLIANCE REPAIR BOOKS



Thirteen Handbooks written in easy-to-understand language by experts in the service field with illustrations and diagrams! Acclaimed by instructors and professionals alike! How to diagnose and repair air conditioners, refrigerators, washers, dryers, ranges, microwave ovens, dishwashers, vacuum cleaners, electrostatic air cleaners, RV gas appliances, hair dryers, motors, water heaters, coffeemakers, can openers, floor polishers, steam irons, food mixers, lawn care appliances, electric knives, electric and digital clocks and many others. Also fundamentals of solid state, setting up a shop, using test instruments and more. Only \$2.65 to \$4.90 ea.

SEND FOR FREE PRICE LIST

Gamit, Dept. ES

5841 W. Montrose Avenue
Chicago, Illinois 60634

For More Details Circle (11) on Reply Card

PUT YOUR FINGER ON THE TRUTH

It's the one and only flat-rate increment system that gives you the great feeling of pricing every job right. A system that treats both customer and shop owner fairly. Fast finger-tabs in both editions: 6x9 Hard Cover, steel ring-bound - \$19.95 ea. post pd.

Or The Satellite Edition for pocket sized convenience - \$16.95 ea post pd.

New Computerized Parts Pricing manual lists over 3,500 most-used parts - \$75 initial set-up plus \$10 per copy.



tv & radio
tech's guide
to pricing

P.O. Box 5234
Lincoln, NE 68505

Nebr. residents
add sales tax

sperry tech inc. (No. editions)

My check enclosed
 BankAmericard Exp. _____
 Master Charge Exp. _____
 Name _____
 Co. _____
 Address _____
 City _____
 State _____ Zip _____

For More Details Circle (12) on Reply Card

Auto-Audio Update

By Joseph J. Carr, CET



Here is a review of the older solid-state audio stages in car radios and stereos, along with an update of the latest 1978 features.

Early Solid-State Radios

A few transistors appeared in the 1958 car radios. At first, tubes were used for all stages, except for the power-output transistor. These hybrids allowed operation direct from the car battery, without those troublesome vibrator power supplies. Most of the pioneering transistor outputs had transformer coupling at both the input and the output, because tubes never have worked well when direct-coupled to low transistor input impedances.

In 1962, Delco introduced the first all-solid-state car radios. Figure 1 shows a typical class-A single-ended auto radio power amplifier of a Motorola. All three direct-coupled transistors amplify and invert the phase of the signal. The driver is direct-coupled (through matching resistor, R9) to base of the Q3 output PNP transistor, and the speaker is matched to the collector by a tapped audio choke, or autoformer.

Silicon transistors usually exhibit zener characteristics between reverse-biased base and emitters, so D6 actually is a transistor (with an open collector) that regulates the B+ to the preamplifier transistor, Q1.

Two feedback paths are marked on the schematic. R2, C3, and R3 supply the base bias for Q1 from the collector of Q3, the output transistor. Therefore, this is feedback for DC stabilization, to prevent serious shifts of DC voltages from variations of ambient heat.

The negative feedback path (R4 and C4) connects the same two points of the circuit, and also gives a small amount of bass boost.

Next, ICs

A circuit similar to the one in Figure 1 uses one IC and a PNP power transistor (see Figure 2). We can view the IC as a "black box" (yes, it *is* black!) with the preamplifier and driver transistors inside of the MFC4050 integrated circuit. Notice that the pinouts have been reduced to the four essentials.

Potted Modules

Both Delco and Philco-Ford have used packaged electronic-component modules to house the driver and preamplifier stages, as shown in Figure 3.

Notice that these devices are *not* integrated circuits, but consist of either discrete components, or a combination of discrete components plus hybrid transistor chips. However, other Delco radio modules are conventional ICs.

Delco began using packaged

modules in the late 1960s with the original DM-8 audio module, and now are up to DM-48 (see Figure 3). The principle change, over the years, has been to make them smaller and reduce the pinouts.

The negative feedback path is between the collector of Q1 and pin 3 of the IC, and a DS-189 zener is wired as a limiting diode between base and collector of Q1.

In this stage, the output transistor is the venerable and time-tested Delco DS-503 (which along with the larger DS-501) has been the workhorse for Delco's auto output stages for almost two decades. In a few models, smaller transistors were used in complementary stages, but the single-ended ones continue to be used.

Incidentally, be a bit cautious about using other than Delco replacements for the DS-501 and DS-503, else you might have an early callback. Check the spec sheet of the proposed replacement for maximum ratings that match or exceed those of the Delco transistors.

Plastic Power Transistors

"Plastic" power output transistors are used in the radios of Figure 4 and Figure 5.

Philco

The Philco circuit of Figure 4 uses a packaged electronic-component module that contains the preamplifier and driver stages. This output transistor can be replaced by the industry 2N5249 (or the replacement-line equivalents of the original part number).

However, I recommend that you obtain callback insurance by installing a NPN "similar to TO-66"-type replacement.

Bendix

Some Bendix models use three direct-coupled stages with a NPN plastic transistor in the output stage (Figure 5). Several feedback loops are included. R8 and R9 supply DC-only feedback between

continued on page 30

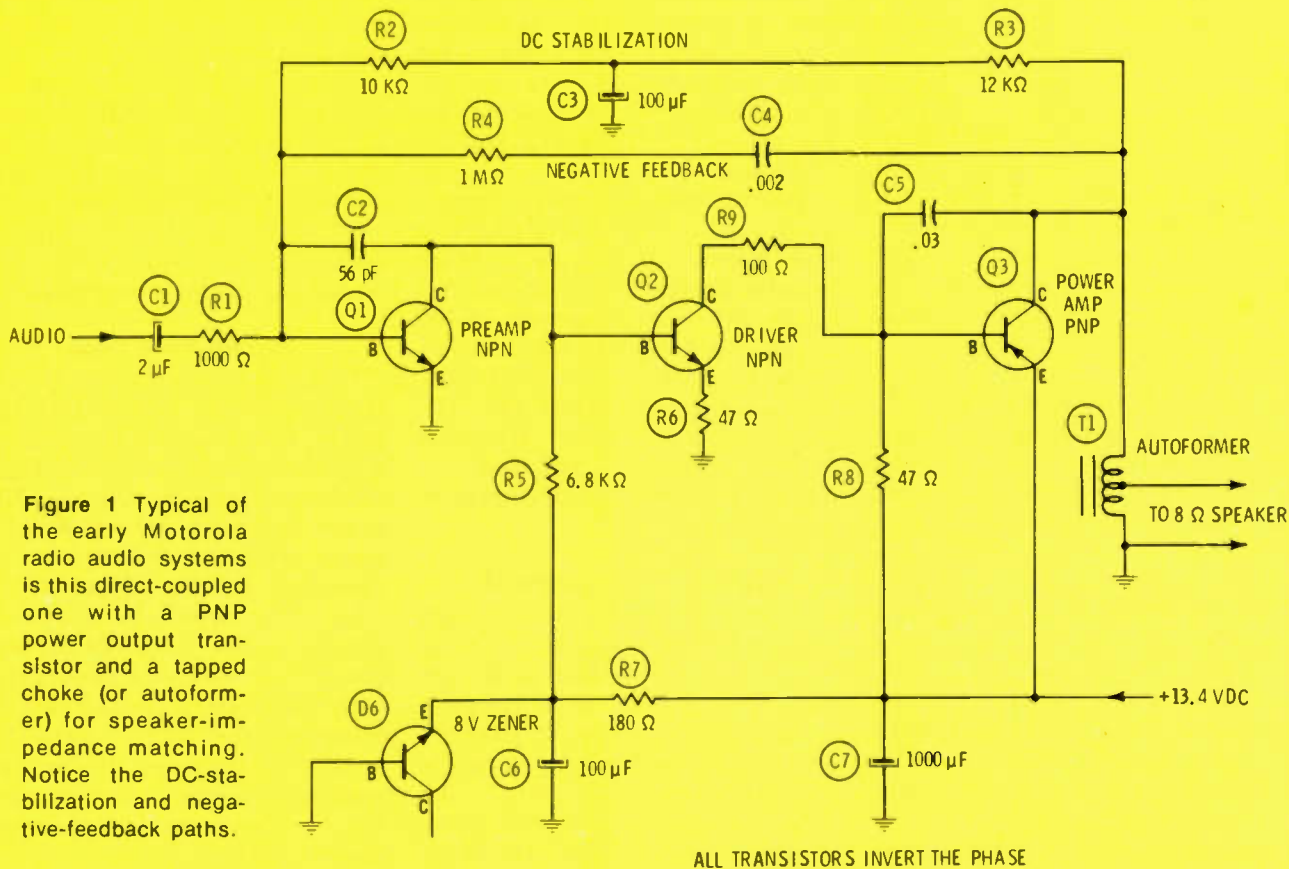

Figure 1 Typical of the early Motorola radio audio systems is this direct-coupled one with a PNP power output transistor and a tapped choke (or autoformer) for speaker-impedance matching. Notice the DC-stabilization and negative-feedback paths.

ALL TRANSISTORS INVERT THE PHASE

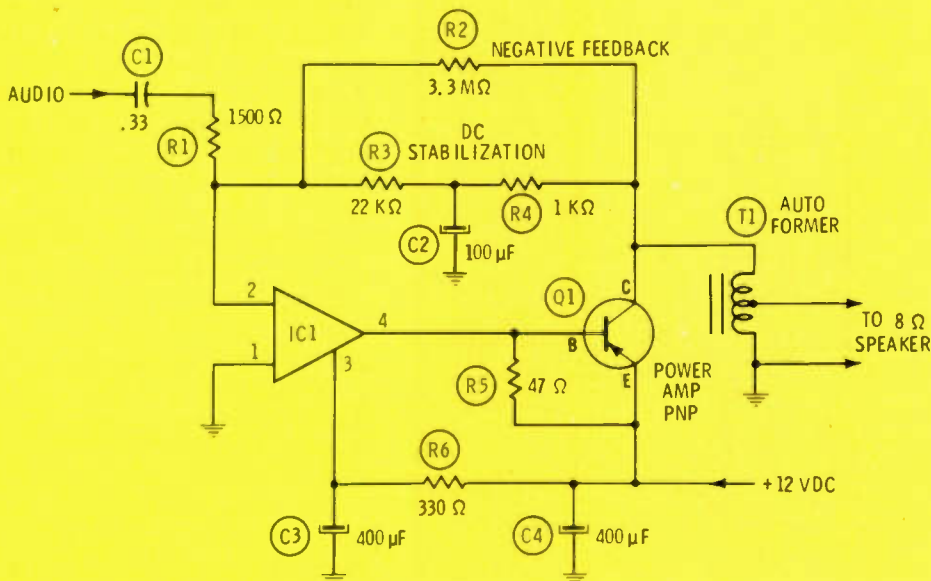

Figure 2 In later designs, the preamp and driver stages were contained in a simple IC having only four pins.

Auto-Audio

continued from page 28

the emitters of Q3 and Q1, because C5 removes the AC signal. This provides some compensation for thermal drift, and Bendix added thermistor R3 to minimize drift of the Q1 base voltage.

Resistor R7 provides negative feedback for the AC signal, between the same points as R8 and R9 (for the DC feedback). Both the emitter and collector paths of Q3 go through the T1 output transformer. One circuit drives the speaker, and the other provides negative feedback within the Q3 stage; however, I'm not sure which one does each function. Probably the winding with the most turns is the one that drives the speaker.

Output Transistor Failures

Most PNP germanium car-radio power transistors that fail do so by developing a collector-to-emitter short that promptly blows the fuse resistor.

On the other hand, the plastic NPN transistors fail in another way: an open base-emitter junction. The symptoms are a very low current drain reading on the bench-mounted ammeter, and a base voltage that's almost as high as the collector voltage. This failure occurs frequently.

Replacement of a plastic transistor with one having *identical*

ratings often results in an unusual amount of callbacks. The answer is to substitute a TO-3 or TO-66 power transistor.

Fortunately, most Bendix and Philco radios, which use the plastic types, already have holes in the case escutcheon for the larger types of transistor.

Radios that have been drilled or cast to accept TO-3 transistors (usually Bendix radios made for Ford, Chrysler, and VW) can use the 2N3055 type (or replacement-line equivalent) of power transistor (NPN silicon).

The C5 1000-microfarad capacitor in Figure 5 has had a relatively high failure rate. It is a black cylindrical capacitor, mounted vertically on the audio portion of the circuit board, and in some models it also houses a 50-microfarad AGC bypass capacitor. When the 100-microfarad section opens, the audio gain is drastically reduced, requiring a full-volume adjustment to be heard at all.

Class-A Versus Class-B

All of the previous output stages operated the transistor in class "A", which means that plate current flows during each complete cycle of audio. Far more power is drawn from the B+ supply than is delivered to the speaker. The difference between those two powers is dissipated as heat. Therefore, these class "A" output transistors

tend to run at very hot temperatures.

Push-pull amplifiers can be operated in class "B", with each transistor contributing either a positive or a negative peak. Not only does the current in each transistor flow for just half of the time, but the average current drain varies with the volume. Loud music requires maximum current, and soft sounds call for a small current.

The higher efficiency of the class "B" operation permits the designers to specify smaller, lower-cost transistors, for the same maximum audio power that single-ended class "A" amplifiers attain, thus reducing the heat, and often eliminating any need for heat sinks.

Totem-Pole Type

One popular circuit used in many imported auto radios and tape players is the totem-pole connection of push-pull transistors (see Figure 6). Two identical PNP or NPN power transistors are connected in series, with the collector of one connected to the emitter of the other. The driver transformer is phased so one transistor is being biased for increased conduction, while the other secondary winding biases-off the second transistor. Another advantage of the split secondary is that each transistor can be biased separately, for improved stability.

Both burned-up driver transformers and shorted power transistors often are found after a malfunction. I don't know which fails first, but check the driver transformer with an ohmmeter before you apply power to the new transistors, else they might short, too. Notice especially any secondary-to-ground leakages or carbonized paths.

Complementary-Symmetry Circuit

Complementary-symmetry circuits (Figure 7) are very popular. The two power transistors are said to be a "complementary pair," because they are electrically identical, except that one is a PNP and the other is an NPN polarity.

Two power supplies, one positive and one negative, can power the appropriate transistors (thus eliminating the output-coupling capaci-

continued on page 32

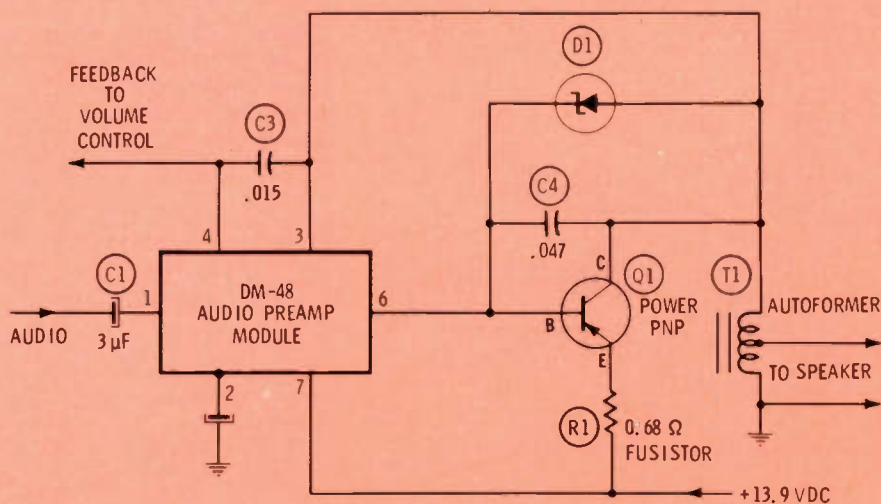

Figure 3 Packaged electronic-component modules used in Delco and Philco-Ford had discrete components that were potted inside the module.

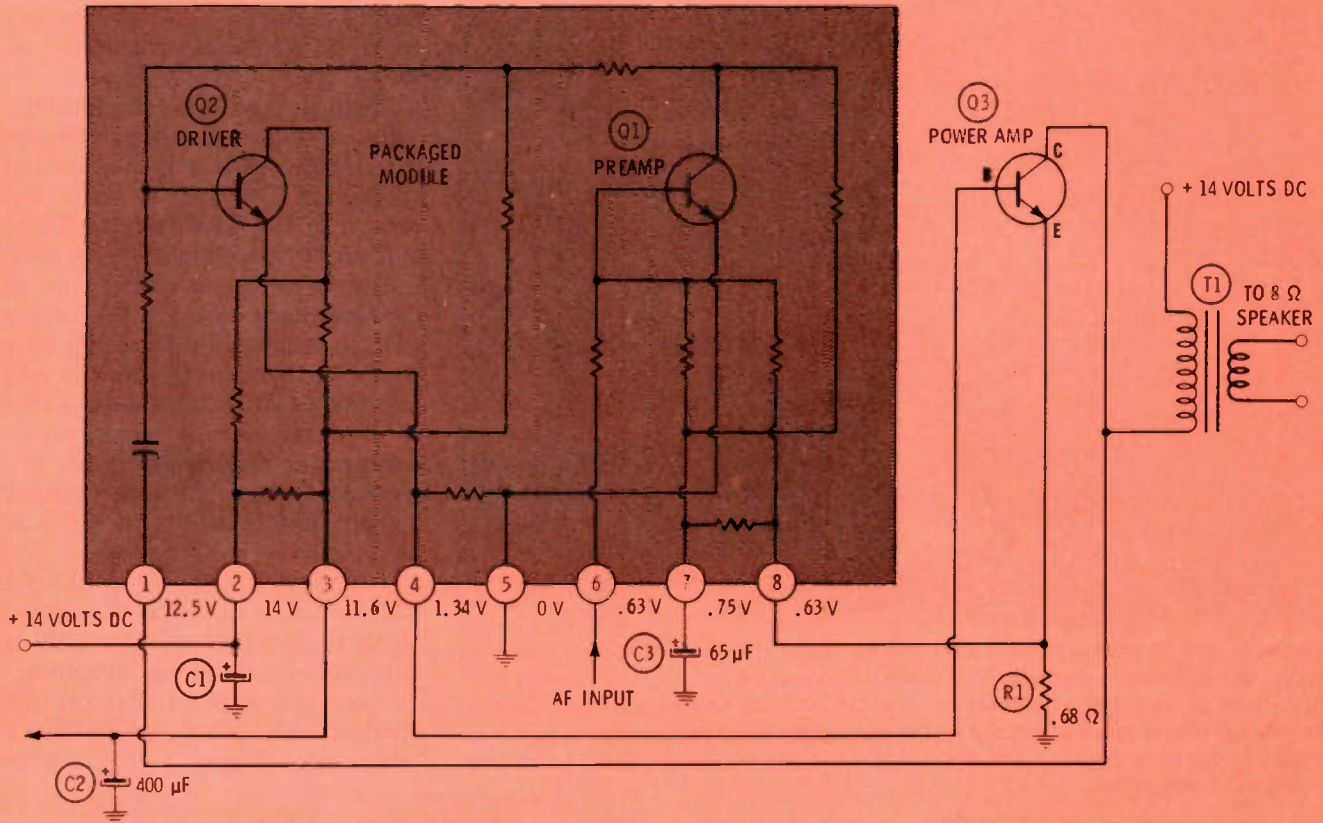

Figure 4 A "plastic" NPN power transistor and a packaged module are used in this Philco circuit.

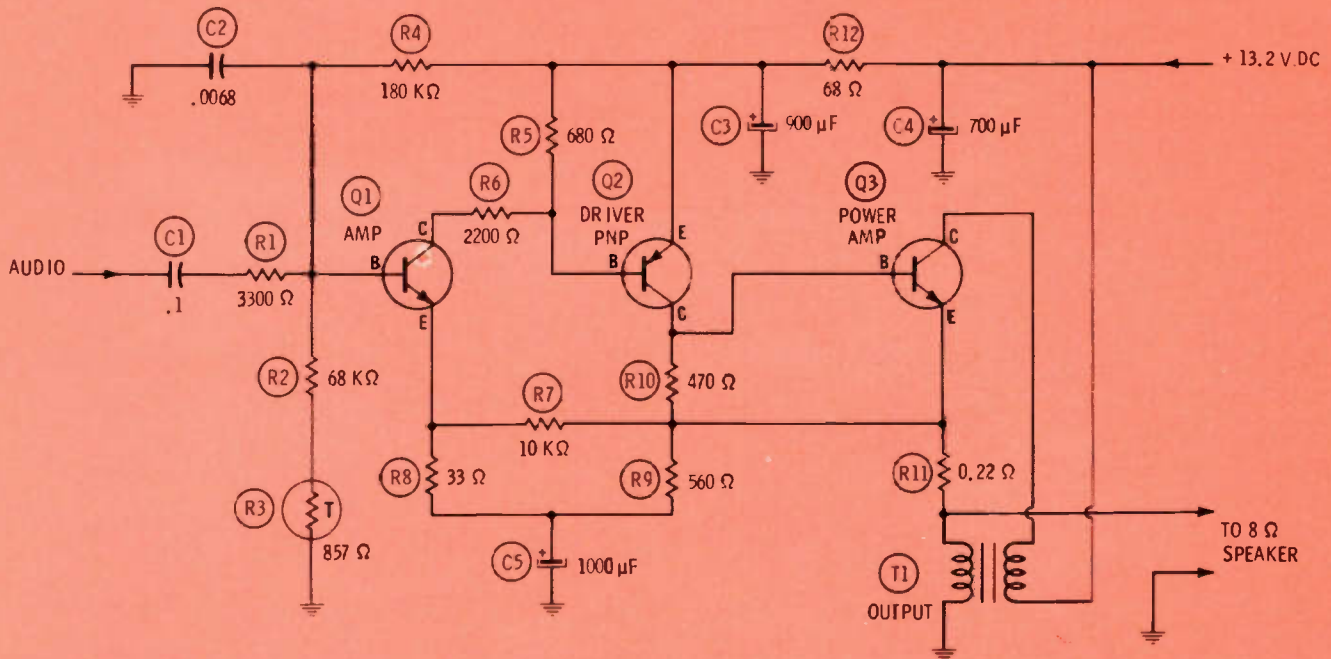

Figure 5 Some Bendix radios have a plastic NPN output transistor in a 3-stage direct-coupled configuration. Signals at the unbypassed emitter of a transistor have the same phase as the input at the base; therefore, R7 supplies

negative feedback to the emitter of Q1 from the equivalent of the Q2 collector (which is connected to the base of Q3, and produces the same phase at the Q3 emitter.)

Auto-Audio

continued from page 30

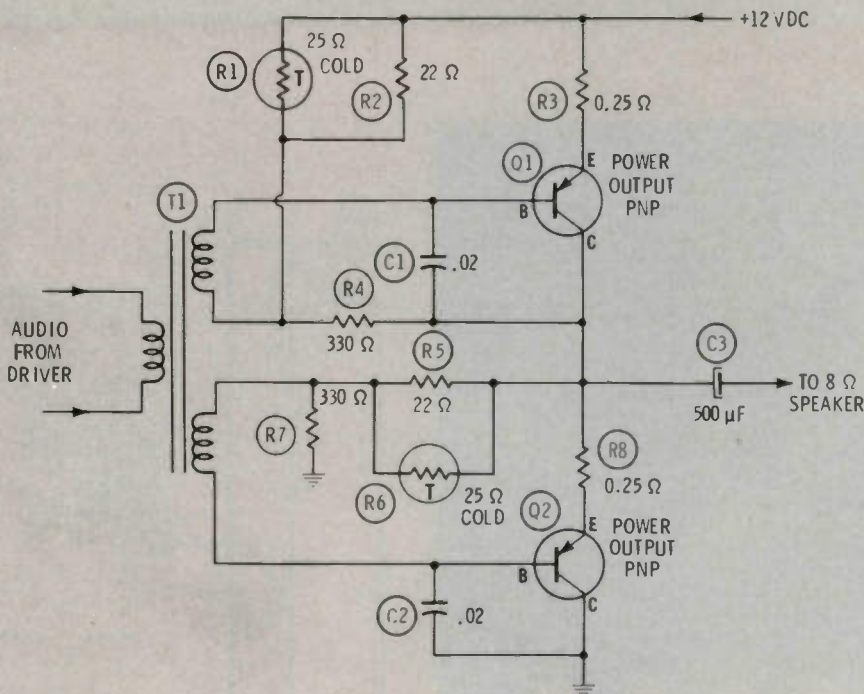

Figure 6 At first glance, this circuit seems to be the old transformer coupled class "B" schematic, because the bases are supplied by a driver transformer. But, there is no output transformer. The Q1 and Q2 transistors are "stacked" between B+ and ground. Phases of the secondary windings are arranged so the signal at the base of Q1 is positive-going when the Q2 base signal is negative-going, and vice versa.

tor), or both can be wired in series across a single power supply, as shown.

When the emitters are connected together, a more-positive drive signal at both bases will *increase* the current of Q3 and *decrease* the current of Q4. Therefore, no push-pull driver transformer is required.

There's only one catch. One of the bases must have a small voltage difference; otherwise there will be a small time between the positive and negative peaks of the audio waveform when *neither* transistor is conducting. This produces an unpleasant-sounding distortion (called "notch" distortion) that is worse at low volume levels.

Components CR1, R9, R10, and R11 are added to supply the voltage offset to the base of Q4. R10 is adjustable for minimum distortion.

When the output transistors are operated without a signal, or have a symmetrical signal such as sine

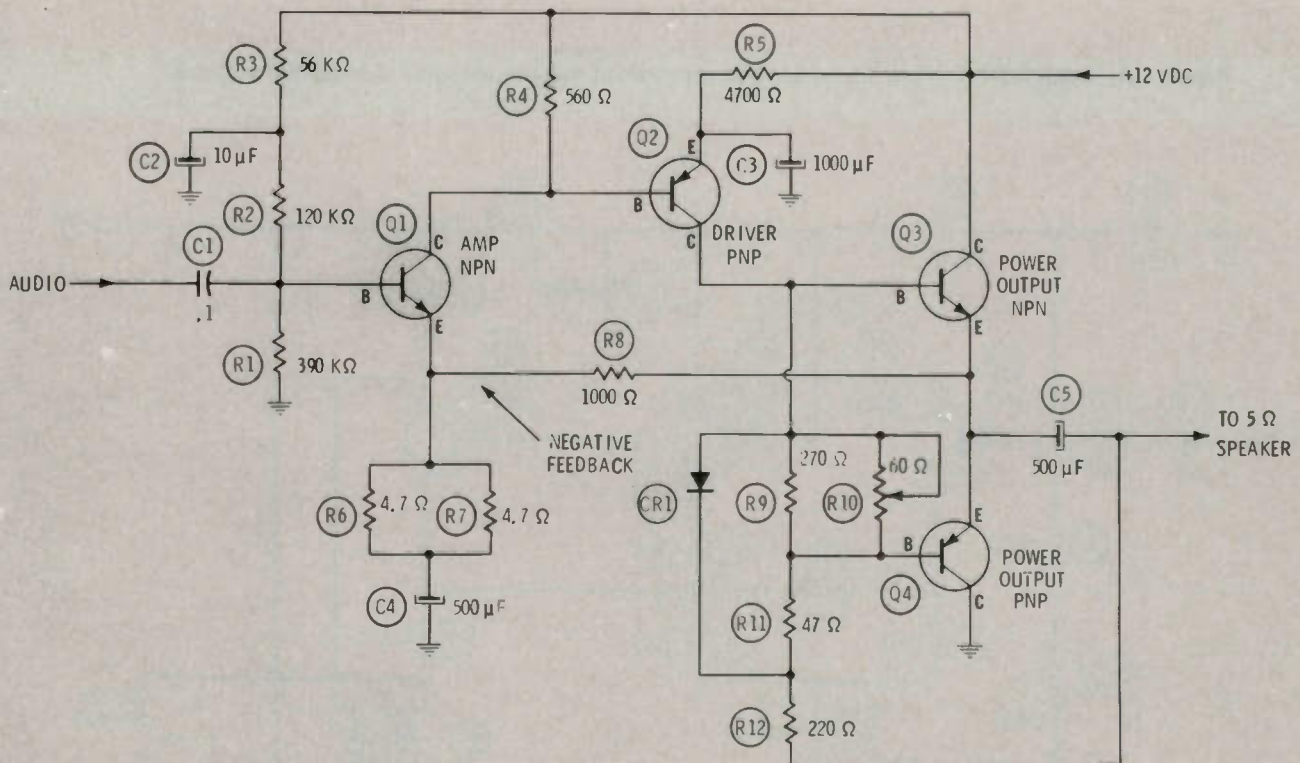

Figure 7 This is the popular "complementary-symmetry" circuit, where the output transistors are identical except for the polarity (notice that Q3 is a NPN and Q4 is a PNP polarity). The bases are tied together by CR1, R9, and R10, which make the base of Q4 a bit less positive than is the

base of Q3. The slight bias offset is necessary to minimize "crossover" or "notch" distortion caused by the times when neither transistor has any forward bias. R8 supplies negative feedback from the output emitter (the same signal as at the collector of Q2) to the emitter of Q1.

waves, proper balance of the two transistors produces nearly-equal voltage drops across the C/E paths. This can be a valuable clue during troubleshooting, because the common-emitter point should measure approximately half of the supply voltage. Any major deviation from the half-voltage reading indicates a serious imbalance that can cause excessive distortion or cause the overloaded transistor to fail early. Consequently, you should check *first* for the half voltage.

Hybrids And Power ICs

Hybrid modules and integrated circuits of the power type have been used as the complete auto-radio audio section, especially in imports.

An IC power amplifier is a monolithic device in a multipinned case that is about the size of a TO-3 transistor, and is capable of several watts of audio power.

Hybrid modules are different, since they are similar in concept to the packaged electronic-component modules discussed before. Even the power transistors are located inside the potted case. What's more, the transistors are in chip form (no individual cases), which permits a smaller component. For non-auto applications, the hybrids are operated at higher supply voltages, and so are rated in powers up to about 60 watts.

Neither IC nor hybrid modules are repairable, and replacement is the solution when one is defective. Fortunately, these usually are available from the replacement-semiconductor manufacturers.

A New Approach

Figure 8 shows a simplified schematic of a very-recent Delco audio section. IC2 and IC3 are Delco's new IC bridge audio (ICBA) chips, which are used in several 1977 and 1978 models.

Another new innovation is DM-47 (IC1). It's an integrated-circuit volume/tone (ICVT) chip that controls volume, tone, and balance by variations of DC voltages from external controls. No signal AC voltages are applied to these controls (R1, R2, and R3).

Before this DC-controlled chip was introduced, standard potentiometers were used, and the AC signals to and from them often

continued on page 34

ZENITH

....Presents A New Concept



An opportunity to obtain a complete up-to-date library of chassis schematics on all Zenith color television models.

Each volume puts vital information at your fingertips when you need it, resulting in more efficient and profitable repairs.

Contact the Zenith Distributor in your area.

**Zenith Radio Corporation / Parts & Accessories Division
11000 Seymour Avenue / Franklin Park, Illinois 60131**

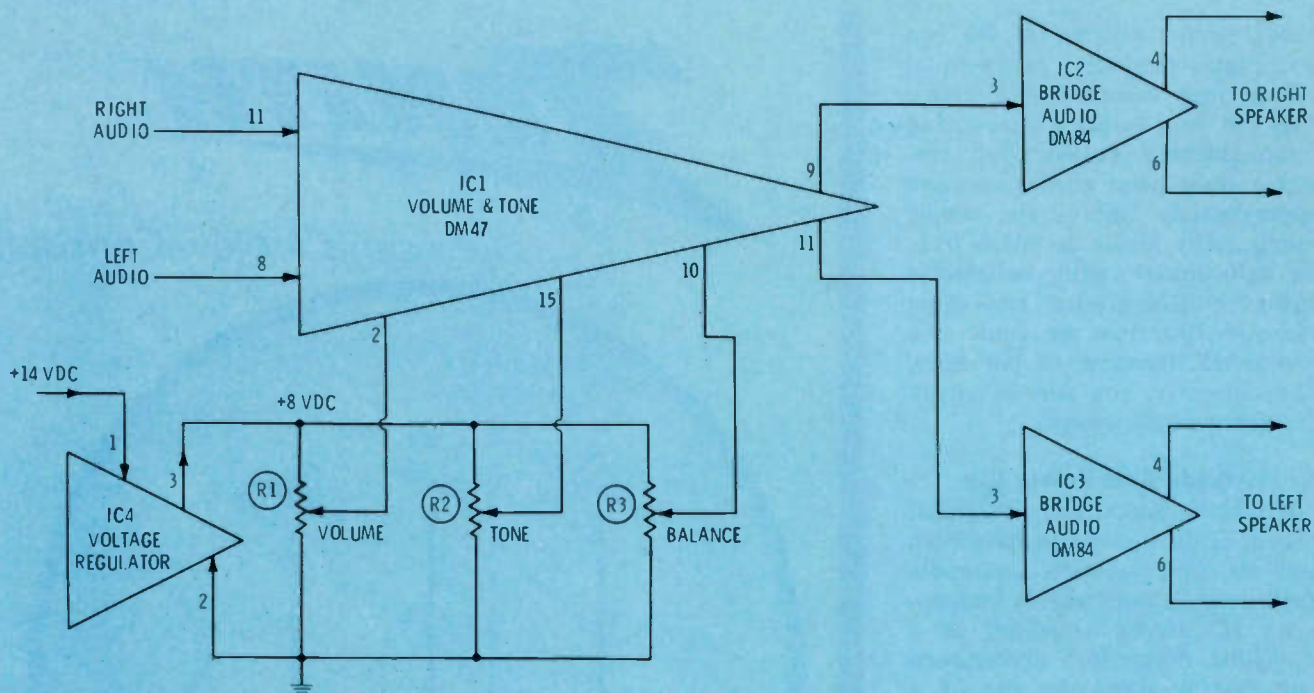

Figure 8 Two new features of Delco auto radios are illustrated here. IC1 contains the preamps for both stereo channels. But, the unique characteristic is that a DC voltage from one control adjusts the volume of both

channels. In the same way, one control adjusts the tone of both, and another determines the balance. IC2 and IC3 are hybrid-type bridge-audio stages inside one kind of module. Notice that the cold speaker wire is NOT grounded.

Auto-Audio

continued from page 33

were routed through unshielded wires that were dressed near various noise sources inside the radio. One type of repair involved relocating the audio wires to minimize noise pickup.

The Delco DM-47 allows the use of short leads that carry the signals to the IC. And the wires to the controls carry only DC, so noises from stray circuit capacitances are minimized.

Also, one set of volume, tone, and balance controls can be used for both stereo channels of audio.

WARNING!

With those radios that use the DM-84 audio-bridge IC (ICBA), **NEVER GROUND THE COLD END OF THE SPEAKER TO CIRCUIT GROUND OF THE RADIO!** In fact, don't let either lead accidentally touch ground, even for a split second. If you do, the audio module will be destroyed. (In some shops, one lead of each speaker is connected permanently to the negative side of the bench power supply. You must change this before you connect one of these Delco radios.)

Wiring of the new-model Delco connector is shown in Figure 9. From this, you can find the correct (and safe) points to connect your test speakers. Repeating: don't connect either speaker wire to ground or to power-supply common.

Comments

The giant strides taken in modern solid-state radio technology are "brought home" to us by a remark made once by an old-timer in car-radio repairs: "Well, only two-tenths of a volt can't make much difference—can it?" □

Figure 9 Circuits of the Delco power connector are labelled so you can attach external test speakers without damaging the bridge audio packaged modules.

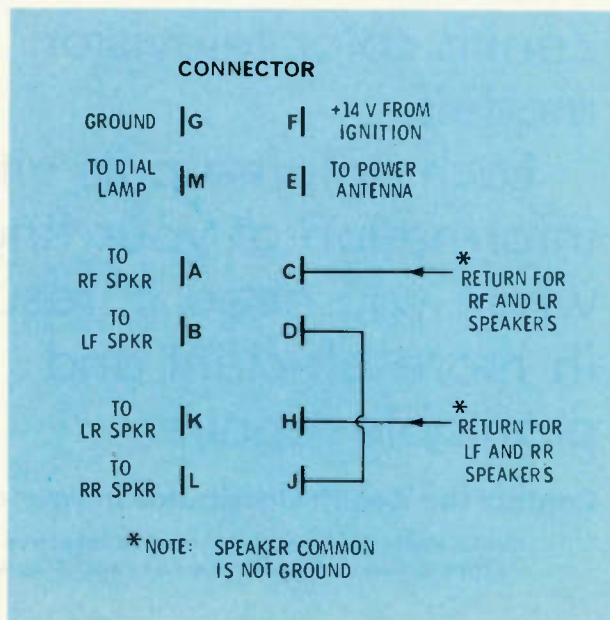

Color-TV Servicing Guide, Third Edition

Author: Robert G. Middleton

Publisher: Howard W. Sams & Co., Inc., 4300 W. 62nd St., Indianapolis, Indiana 46268

Size: 112 pages

Price: \$6.95 paperback

The third edition concentrates on the newer solid-state circuits and the techniques for servicing them. Recent tube-type circuits also are included, as well as troubleshooting techniques for receiver sections utilizing integrated circuits and modular construction. Convergence troubles and setup procedures are covered for the recent in-line color picture tubes and for conventional picture tubes with a delta gun assembly. Color photographs of television screens aid in identifying and analyzing symptoms. Discussions of troubleshooting procedures are used to locate the defect producing the symptoms shown. The book should serve as complete reference guide for servicing modern color television receivers.

Learn Electronics through Troubleshooting (Second Edition)

Author: Wayne Lemons

Publisher: Howard W. Sams & Co., Inc., 4300 West 62nd, Indianapolis, Indiana 46268.

Size: 608 pages, 5½" x 8½"

Price: \$10.95 paperback

The basic principles of electronics are presented through practical troubleshooting situations faced daily by the technician. Learned in this manner, the concepts should prove valuable to the student entering servicing or any other branch of electronics. The illustrated text includes two appendices containing frequently-needed information for ready reference. Questions are located at the end of each chapter, with answers at the back of the book. The 15 chapters cover: electronics mathematics; basic electronic equipment and tools; DC circuits and laws; alternating current and AC circuits; vacuum tubes; transistors; and troubleshooting and repair techniques.

Color TV Training Manual (Fourth Edition)

Author: Howard W. Sams Editorial Staff

Publisher: Howard W. Sams & Co., 4300 West 62nd, Indianapolis, Indiana 46268.

Size: 8½" x 11", 232 pages

Price: \$9.95 paperback

The most recent developments in color-TV circuitry are covered in this widely-used text. Section I deals with the principles of color-TV systems, including: colorimetry composite color-signal requirements, and makeup of the color picture signal. Section II discusses the fundamentals of each type of circuit used in color receivers (tube-type and solid-state). Section III covers servicing techniques with information for troubleshooting and adjusting color receivers, as well as setup-procedure outlines for currently used color picture tubes. A glossary and index are included. Invaluable to the new TV service technician, the text also is a useful reference for the experienced technician.

Understanding & Using Electronic Servicing Test Equipment

Author: Charles M. Gilmore

Publisher: Tab Books, Blue Ridge Summit, Pennsylvania 17214

Size: 251 pages

Price: \$5.95 paperback

Low-cost, basic test instruments, including analog and digital VOMs, digital frequency counters, scopes, curve tracers, and test leads with probes are discussed. Each chapter is divided into four sections: a brief systems-level review of the fundamentals of a particular instrument; detailed definitions and comparisons of specifications; features and characteristics; and applications of the instrument and possible measurement errors.

photofactTMbulletin

ADMIRAL

Chassis 9M50ET3RA 1711-1
Chassis 9M45-1A/-1B/-1D/-1D1/
-2A/-2B/-2D/-2D1 1714-1

MGA

CS-1390, CS-1590 1713-1
Remote Control 939P00503 939P01201 1713-1-A
CS-1791, CS-1994 1712-1

MAGNAVOX

Chassis T997-01-ZA thru -04-ZA 1716-1

PANASONIC

Chassis T125Q-A 1710-1

JC PENNEY

685-4908/-4909, 4908, 4909 1709-1
685-2010 (855-0444) 1711-2
685-2005 (855-0394) 1714-2

QUASAR

Chassis D17TS-953, F19TS-953 1715-1

RCA

Chassis CTC90B/C/D/F/H 1710-2
Chassis CRK24A, CTP23A 1710-2A
Chassis KCS203A/D 1713-2

SONY

TV-116, TV-780, TV-970 1715-2

SYLVANIA

Chassis A19-6 1709-2

TOSHIBA

Chassis TAC640, TAC650 1716-2
Remote Control CR-312, CT-312 1716-2-A

The Basics of Industrial Electronics, Part 7

By J. A. "Sam" Wilson, CET

Many industrial electronic devices have digital circuits. Therefore, the next few articles will present practical digital information.



Linear Versus Digital

Electronic circuits can be divided into the two broad categories of linear or digital.

Linear operation

Linear circuits operate with many different levels of input amplitude and output amplitude. The output amplitude varies in step with changes of the input amplitude. (For example, even small changes of input level cause changes of the output amplitude.) Of course, the output signal can be either in-phase or out-of-phase with the input; and the gain either can be more or less than one. In most cases, each linear stage has a *voltage* gain or a *power* gain.

Input and output signals can have any desired waveshape or amplitude. **Linear operation often is called analog.**

Digital operation

Digital circuits have fixed amplitude levels of input and input signal voltages. In fact, they can't operate at any other levels.

Most popular is the binary digital-logic circuit. Each device has an output level that's either **HIGH** or **LOW** (with nothing between). **HIGH** also is called **ON** or **1**, and **LOW** often is referred to as **OFF** or **0** (zero).

We will use **HIGH** and **LOW** for the text, and **1** and **0** for tables and mathematics.

Remember that the numbers **1** and **0** do *not* refer to voltage, or to a voltage value, but merely to different levels of signal.

Digital stages usually have square or pulse waveforms, and the input and output levels are equal (in other words, the gain is 1).

The repetition rate or duty cycle of the waveform might change during operation, but the amplitude levels remain constant.

Either the top or bottom of each digital waveform is at zero voltage; therefore, the signals can be thought of as pulses of DC voltage. By comparison, capacitor-coupled and transformer-coupled *analog* pulses have the zero-voltage line near the center, with the exact location determined by the duty cycle. A square wave has half of its amplitude above the line (positive) and the other half below the zero line (negative).

continued on page 38

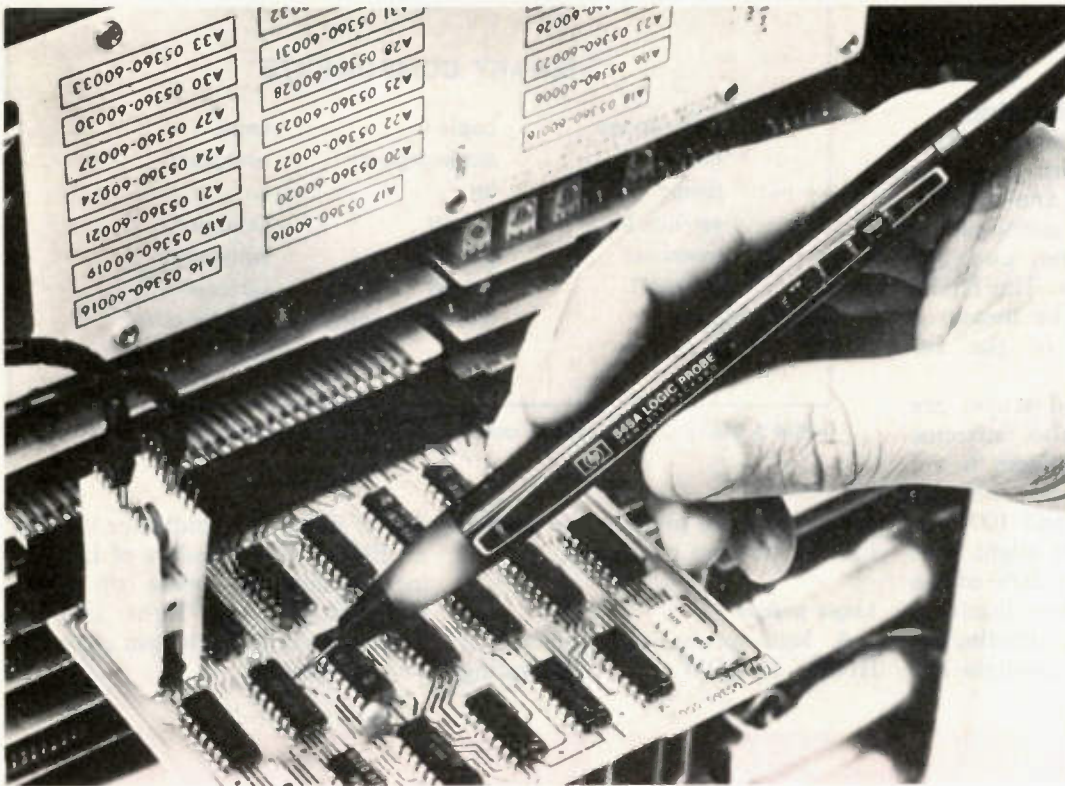

Figure 1 The Hewlett-Packard model 545A Logic Probe has a switch for selecting TTL or CMOS families of digital signals, plus a latch circuit that can be switched In to hold the indication, An LED (mounted near the tip) lights for logic 1 (HIGH) states.

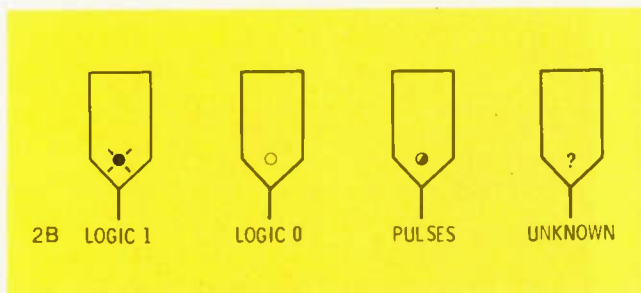
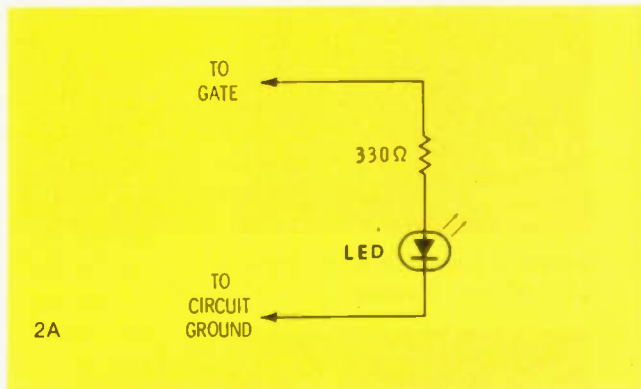

Figure 2 Most logic probes light to indicate a HIGH (logic 1). The most simple probe is shown at (A). It does load the circuit somewhat. Next month we'll describe a better one. (B) These are the probe symbols used in the next few articles. Logic 1 (HIGH) produces a bright light; the LED or lamp is dark for a logic 0 (LOW); pulses are shown symbolically by the half-dark, half-light circle (however, with real probes, pulses produce either a dim light, or a regular flashing on and off, depending on the type of probe); and during the troubleshooting questions, unknown states are indicated by a question mark.

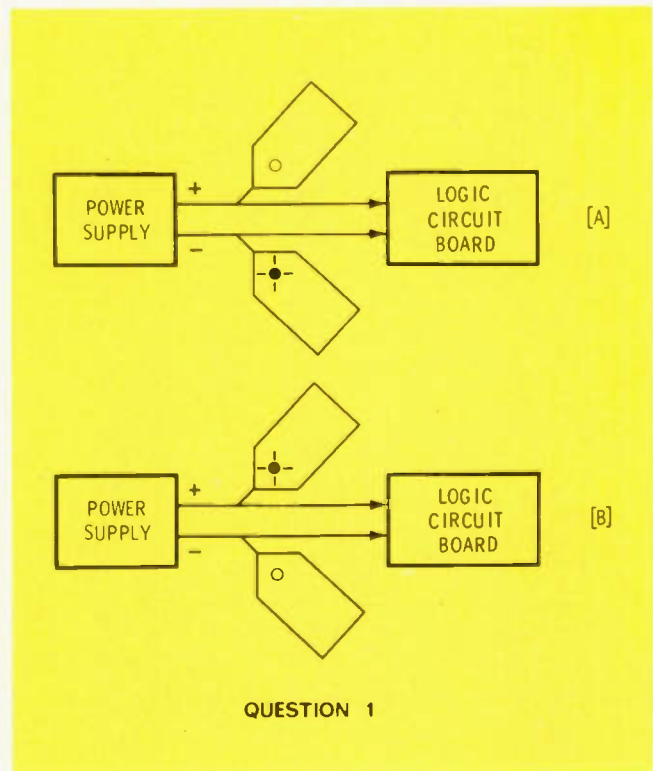

Figure 3 Troubleshooting Question #1: Which diagram shows the correct logic probe indications?

continued from page 36

Digital Troubleshooting

In some digital equipment, manual switches or sensors determine the various HIGHs and LOWs. Therefore, the desired states can be selected, and then not changed during the testing time. The HIGH and LOW states can be measured by a DC voltmeter or the DC function of a scope.

However, meters and scopes are slow in operation. Also, extreme accuracy of the DC voltages is not required (a HIGH can be any voltage between 80% and 100% of the supply, and a LOW might have any voltage from 0% to 20% of the supply voltage). Another disadvantage of meters is that continuous pulses read as an intermediate DC

voltage. A *logic probe* is the answer to most of these problems.

Logic probes

A logic probe can indicate a HIGH, a LOW, or a pulsating

digital signal. The indicator (usually a LED, or several colors of LED) is located near the probe tip where you can see the light without looking away from the pin of the IC you are testing.

BINARY COMPONENTS

Component	Logic 0	Logic 1
relay	not energized	energized
lamp	off	on
vacuum tube	cut off	saturated
transistor	cut off	saturated
MOSFET	cut off	saturated
diode	reverse biased	forward biased
switch	off	on

Table 1 Many commonplace components can be used in binary systems.

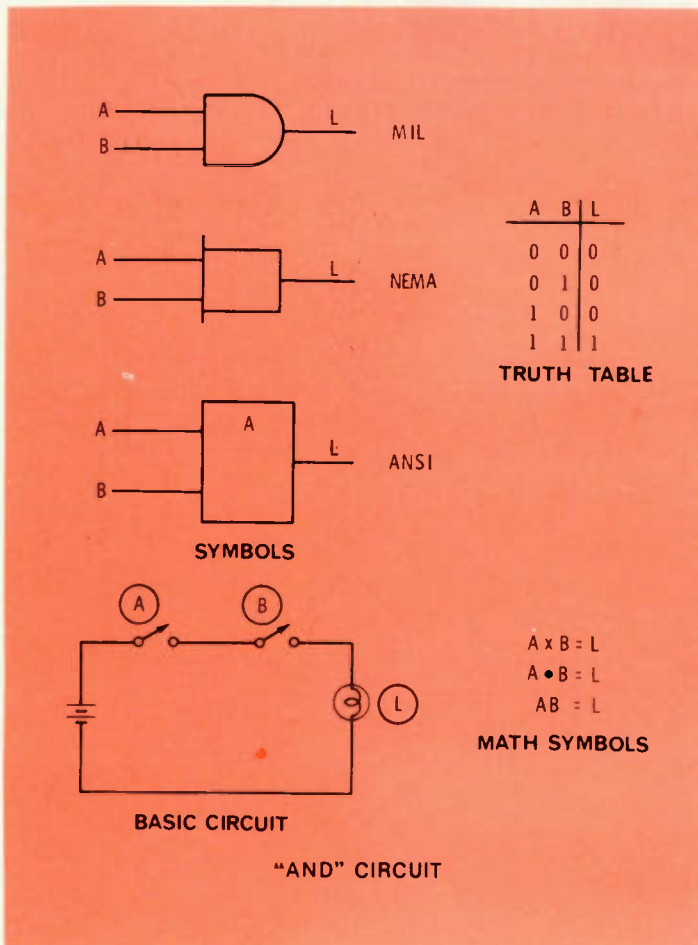

Figure 4 An AND gate produces a HIGH output only when both inputs are HIGH. The math formula is read as: A AND B equal L.

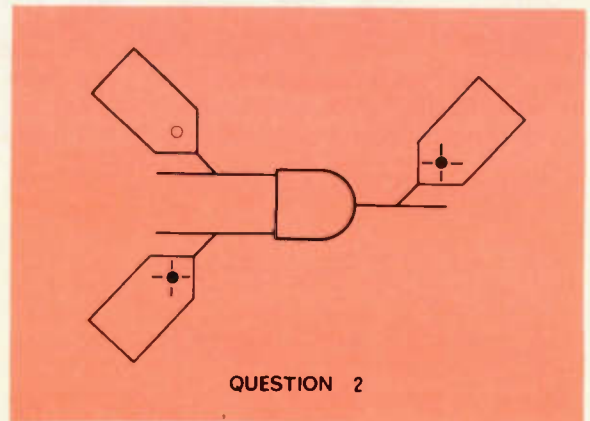

Figure 5 Troubleshooting Question #2: Is the AND gate working properly?

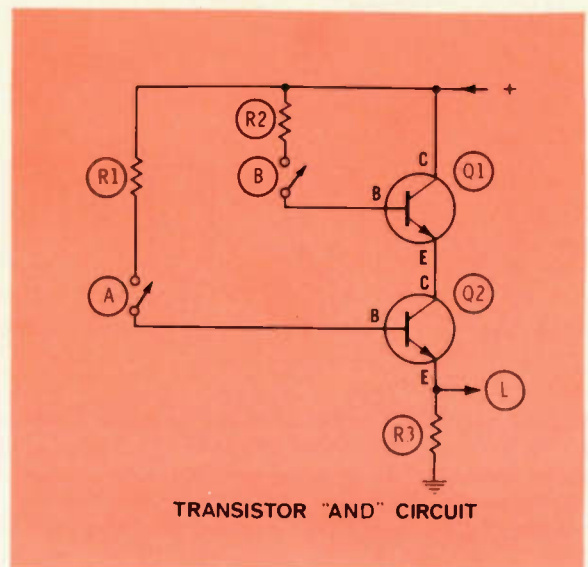

Figure 6 Two transistors can make up an AND circuit. Both switches must be on (HIGH) so both transistors can conduct the supply voltage (HIGH) to the output load, R3.

One commercial probe is shown in Figure 1. You can build your own simple probe (Figure 2A). Of course, it only identifies HIGHS, LOWs and pulses, while some of the manufactured models can be adjusted for the *family* of devices you want, and they have sophisticated circuits (such as pulse stretchers) that permit more accurate additional tests.

Digital signals that have a constant stream of pulses should be viewed with a scope; a logic probe will indicate the pulses are there, but can't measure the duty cycle, the repetition rate, any distortion of the waveform, or the presence of noise.

Tests with a probe can be made very rapidly; therefore, such probe tests usually are done first. If they can't find the source of the defect, a scope should be used next.

Troubleshooting questions

Troubleshooting questions with schematics will be inserted at appropriate points in this series. Logic probes will be shown making the measurements. We assume a ground connection (plus the supply voltage, where one is required for the probe); therefore, only one connection to the tip of the probe will be indicated.

Figure 2B lists the probe symbols we are using to indicate the HIGHS, LOWs, and pulses.

Supply voltage—HIGH or LOW?

In many logic circuits, the supply voltage is marked V_{CC} for collector voltage, if bipolar transistors are used. Or, it's marked V_{DD} , if it is the drain voltage of MOSFETs. As a general rule, the positive power-supply voltage is considered to be logic 1 (HIGH), and the common (ground) connection is logic 0 (LOW).

(Answers for the troubleshooting questions are listed at the end of this article.)

Binary Operation

Binary digital circuits are used extensively in logic systems, especially with industrial devices. Many components can operate *only* at two levels. Others can be forced to operate at two levels only.

The components of Table 1 are used in the basic logic building-block circuits called GATES.

There are seven basic GATES, and you should memorize their characteristics if you want to become proficient in servicing logic systems. These GATES are: AND; INCLUSIVE OR; NOT; NAND; NOR; EXCLUSIVE OR; and LOGIC COMPARATOR. The first three are covered in this article.

Four characteristics of these basic gates will be described in detail: the schematic symbols, the math formula symbol, the truth table, and a typical circuit showing the operation.

Unfortunately, three different types of circuit symbols are used in

continued on page 40

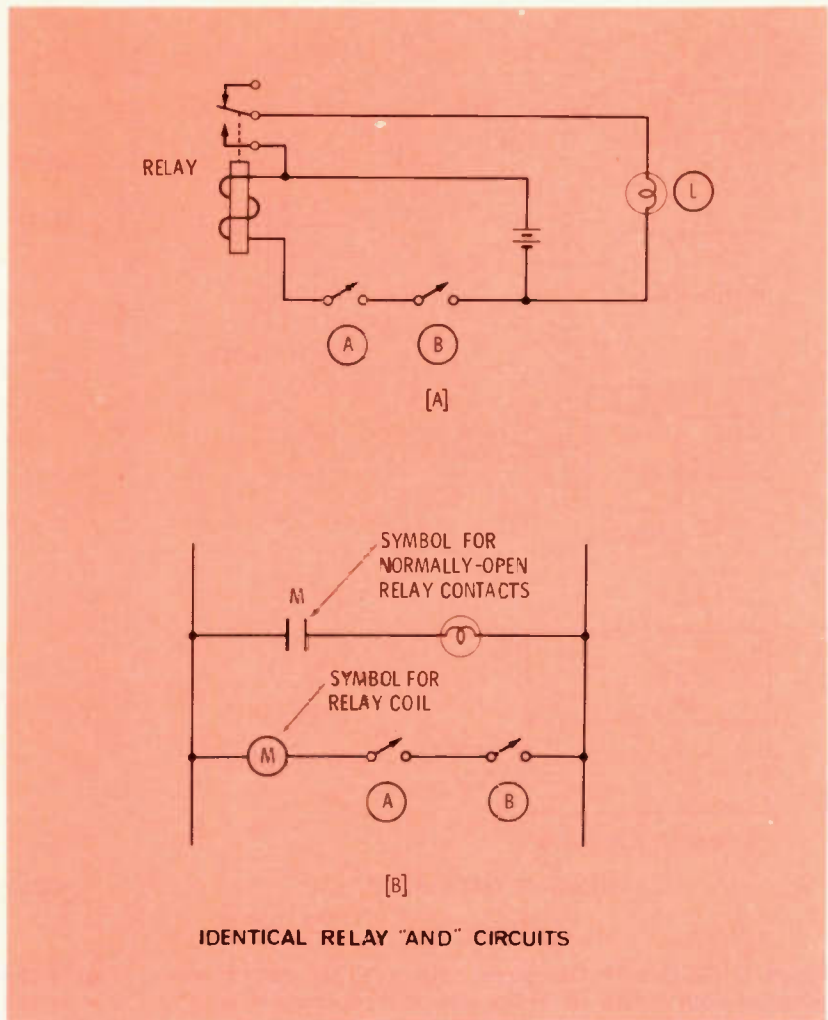

Figure 7 (A) This is an AND gate using switches and relay, with the conventional electronic symbols. (B) The "ladder" diagram is exactly the same as (A), but industrial symbols are used.

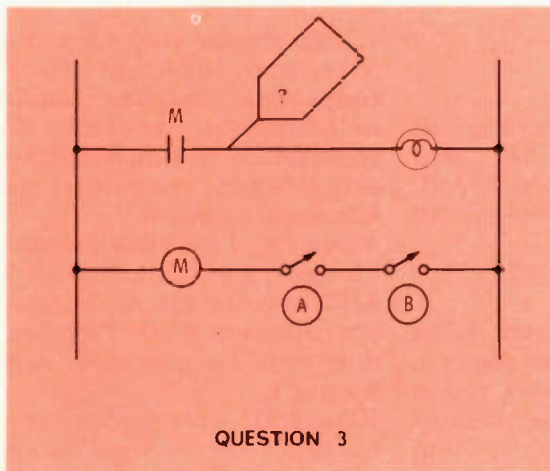

Figure 8 Troubleshooting Question #3: When switches A and B are closed, what should the logic probe indicate?

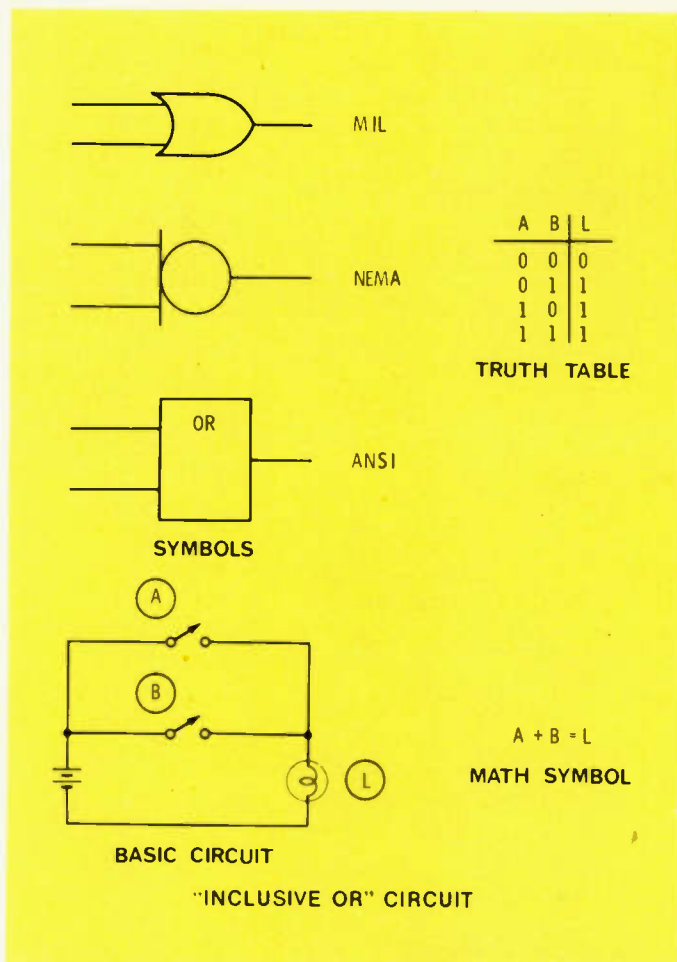

Figure 9 INCLUSIVE OR gates have a HIGH output when either or both inputs are HIGH. The math formula means: A OR B equals L.

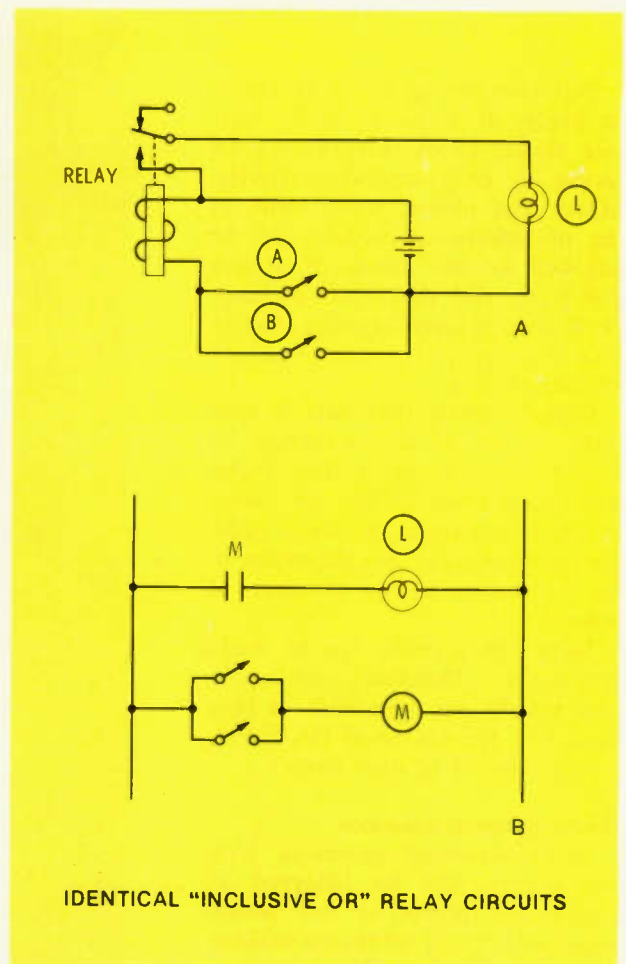

Figure 10 (A) Here an INCLUSIVE OR gate is wired with a relay and switches, using electronic symbols. (B) The same circuit is drawn this way when industrial symbols are used.

Industrial

continued from page 39

industrial electronics. Therefore, all three will be shown. You most likely will be working with MIL symbols, but you should learn all three kinds.

AND Gate

The AND gate of Figure 4 has inputs A and B, plus the output L (for load). This is a binary system having only two possible levels of input and output signals. **Both inputs must be HIGH to obtain a High output.**

Truth tables provide maximum information in a minimum space. All combinations of input HIGHS and LOWs are listed at the left, and at the right is shown the output state that results from those inputs. Of the four possible combinations, notice that only one gives an output.

AND circuits can be constructed from many different kinds of components, including transistors or tubes. But, the basic circuit operation can be demonstrated with only a battery, two switches and a light bulb, as shown.

Don't read the math formulas as "A times B equals L." With logic AND circuits, the multiplication sign represents AND. Therefore, all three math examples read "A AND B equal L."

An AND gate made with two transistors can be wired as shown in Figure 6. Because they are NPN transistors, a positive voltage (HIGH) is required at both bases to saturate the collector current (HIGH). When both transistors are saturated, the B+ goes through them to the output load, R3. A zero voltage (LOW) at either or both bases stops the current flow in either or both transistors, giving a zero-voltage output (LOW).

Use your analog skills to trace the circuit operation, and prove to yourself that it conforms to the specs for AND gates.

AND industrial symbols

Figure 7 contrasts an AND gate drawn with conventional electronic symbols (A) to the same circuit (B) with industrial symbols. Input A and input B both must be HIGH (logic 1) to produce a HIGH at the lamp.

Ladder diagrams (similar to Figure 7B) are easier to read when the circuit is complex, and it can be drawn smaller than the usual symbols can. All of the contacts of the relay are marked with the same letter as the relay coil symbol.

INCLUSIVE OR GATE

The four characteristics of INCLUSIVE OR gates are given in Figure 9. A HIGH at either or both

continued on page 42

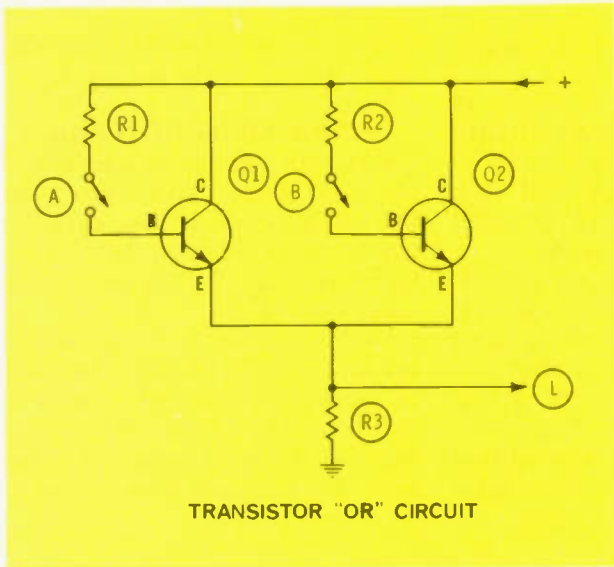

Figure 11 Paralleled transistors can function as an INCLUSIVE OR circuit. Conduction of either or both transistors brings the supply voltage to the output R3.

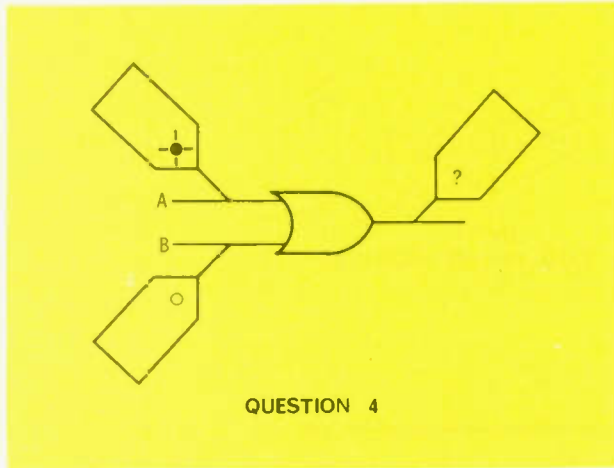

Figure 12 Troubleshooting Question #4: Assuming that the OR logic gate is working correctly, what indication should the probe show?

MIL

NEMA

ANSI

A	L
1	0
0	1

TRUTH TABLE

BASIC CIRCUIT

NOT GATE

$\bar{A} = L$
MATH SYMBOL

Figure 13 These are the important characteristics of NOT gates (or inverters). The output state always is opposite to the input state.

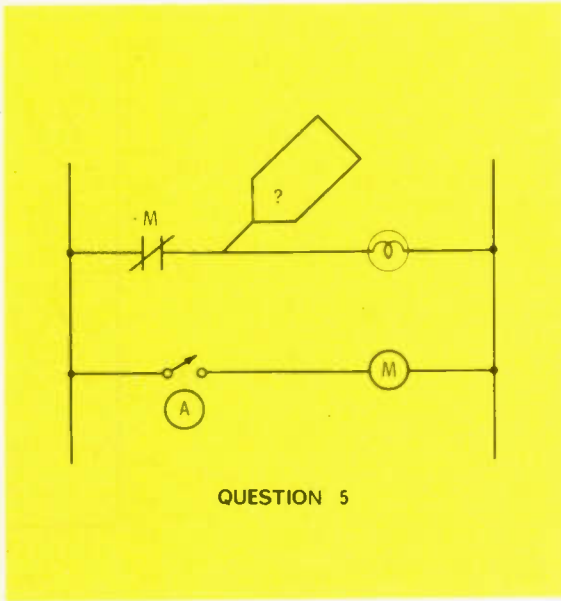
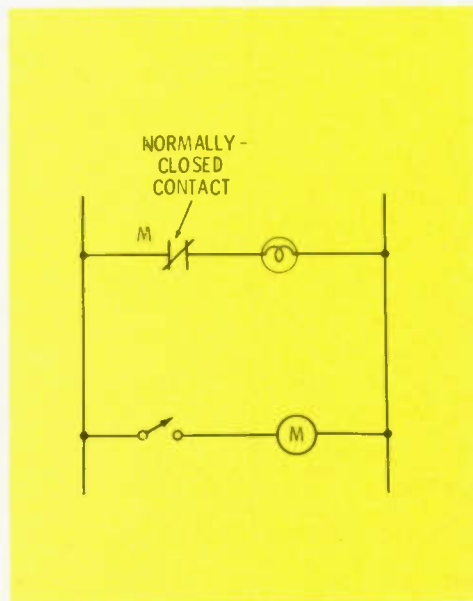

Figure 14 (at left) When industrial symbols are used, the schematic of Figure 13 appears this way.

Figure 15 (at right) Troubleshooting Question #5: What should the logic probe indicate?

Industrial

continued from page 40

A and B inputs produces a HIGH at the output of an INCLUSIVE OR gate.

Our normal language does not make clear the differences between an "inclusive or" and an "exclusive or." For example, if someone says, "John or Mary can go to the store," and the intent is to say that *either or both* can go, this is the inclusive form. But, if the person intended to say that *one or the other* can go (but not both), the exclusive form

was needed. Both forms are used in logic circuitry.

When either or both switches in the basic circuit are closed (HIGH), the bulb lights (HIGH).

The math formula $A + B = L$ means A or B equals L (it never should be read as A plus B).

Figure 10 shows both the conventional schematic of an INCLUSIVE OR gate with a relay, and the same circuit using industrial symbols.

Transistors can operate as an INCLUSIVE OR gate (Figure 11). When a switch brings forward bias to either or both bases, the satura-

tion current applies nearly full supply voltage to the output, R3.

INVERTER (or NOT) Gate

Figure 13 gives the characteristics of NOT gates, also known as INVERTERS, which have only one input and one output. The output logic level always is opposite to the input level.

In the relay basic circuit, closing switch A (HIGH) energizes the relay coil, and it opens the NC contact to open the lamp circuit (LOW). The ladder diagram in Figure 14 is the same, but with industrial symbols.

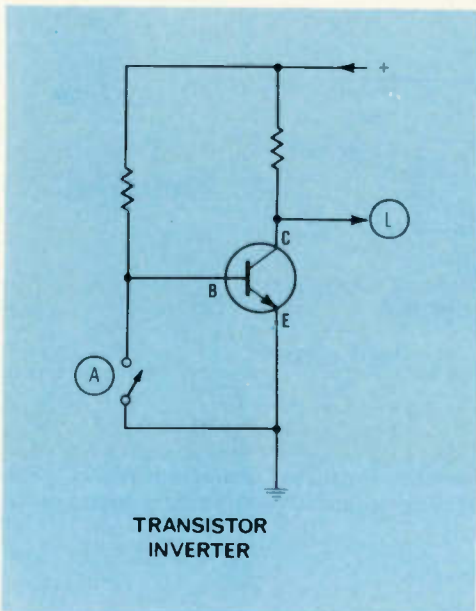
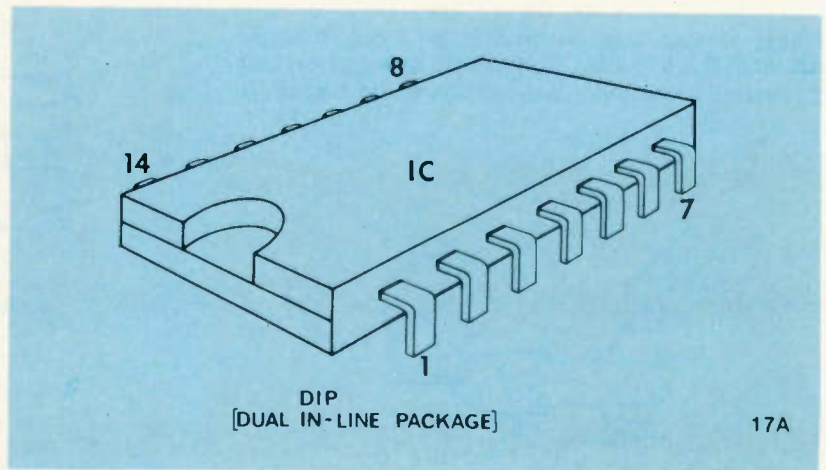
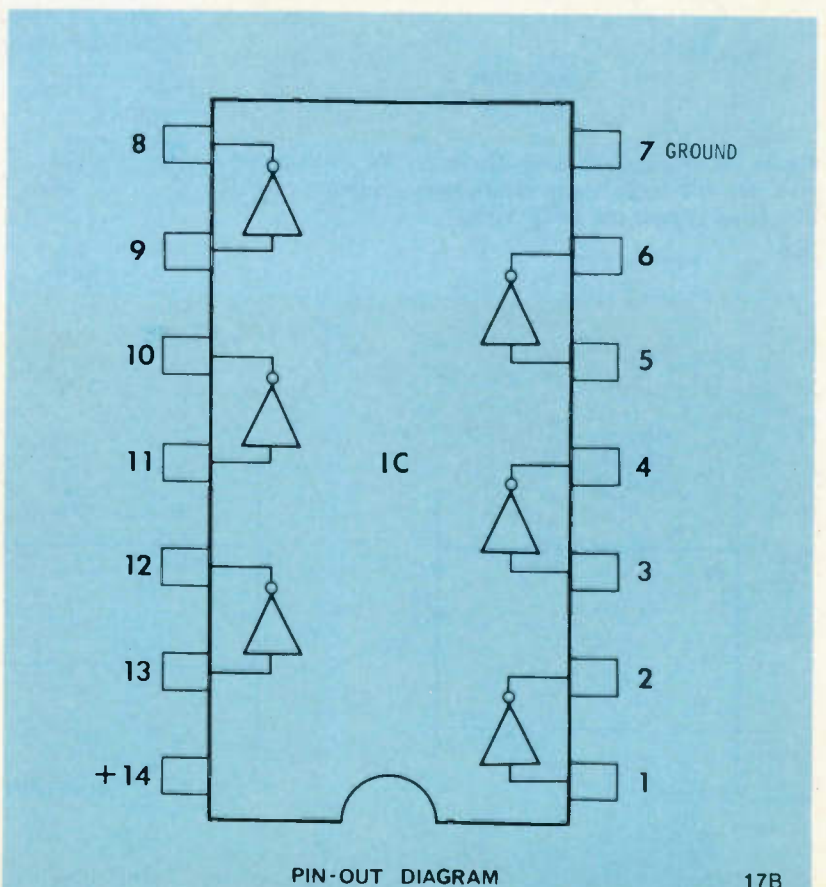

Figure 16 A common-emitter transistor can function as a NOT gate.



17A

Figure 17 (at right) (A) Dual-In-Line Package (DIP) ICs have rows of pins down each side. Pin-out numbering from the top is counter-clockwise from the marked end. (B) Hex NOT gates contain six separate gates, which can be operated (below saturation) as amplifiers.



17B

An overbar, as shown in the math symbol, always indicates that the letter (or letters) below it are negated. For example, the expression \bar{A} is read "NOT A." A double overbar indicates a double inversion, to be read "NOT NOT A," and is identical to A.

A NOT gate can be constructed by using the inversion of a transistor (Figure 16). Closing switch A removes the forward bias (LOW), and cuts off the collector current. Therefore, the collector voltage at L rises to the supply voltage (HIGH).

The circuit of Figure 16 also illustrates an important point about other uses for inverters. Although they are intended for operation either saturated or cut off, most can be used (below saturation) as amplifiers. Hobbyists enjoy operating them in trick circuits.

Hex inverters, in DIP form, contain six separate inverter amplifiers (see Figure 17). Correct pin-out numbering also is shown in the same illustrations. Most troubleshooting of ICs is done above the board; therefore, you should locate the identified end of the IC, and start counting at 1 and upward in a counter-clockwise rotation. Usually, pin 7 is grounded, and the B+ enters at pin 14 of 14-pin ICs,

although many schematics omit the ground and B+ connections.

Lab Projects

As this digital-logic series progresses, we will show you several experiments that can be performed easily at home. Plug-in circuit boards (such as the two shown in Figure 18) are very convenient for performing these experiments.

The following companies manufacture experiment boards:

AP Products, Incorporated
Box 110, 72 Corwin Drive
Painesville, Ohio 44077

Continental Specialties
44 Kendall Street, Box 1942
New Haven, Connecticut 06509

You could write for a catalog describing the boards and other items useful in logic work. Many local electronic distributors stock them, and several kit companies incorporate them into complete systems.

The first experiment will be described at the beginning of the February article.

Answers To Troubleshooting Questions

#1—The probe indications of

Figure 3B are correct. Usually the negative terminal of a power supply is common, or ground (LOW); therefore, the positive supply line is HIGH.

#2—In Figure 5, the AND gate is not working properly. The input probes show one HIGH (logic 1) and one LOW (logic 0), so the AND gate should have a LOW (logic 0) output.

#3—The probe LED should be lit, indicating a HIGH (logic 1) output. The circuit of Figure 8 is a relay AND gate; therefore, both input switches turned on (HIGHS) should produce closed relay contacts, and a lighted lamp (HIGH output).

#4—The probe should indicate a logic 1 (HIGH), because the gate of Figure 12 is an OR. The inputs are 1 and 0 (HIGH and LOW), and either or both inputs HIGH should produce a HIGH output.

#5—When switch A is open (LOW), the probe should indicate a logic 1 (HIGH) at the lamp output of the relay NOT gate (inverter). With NOT gates, the output state always is opposite to that of the input. Therefore a LOW input produces a HIGH output. □

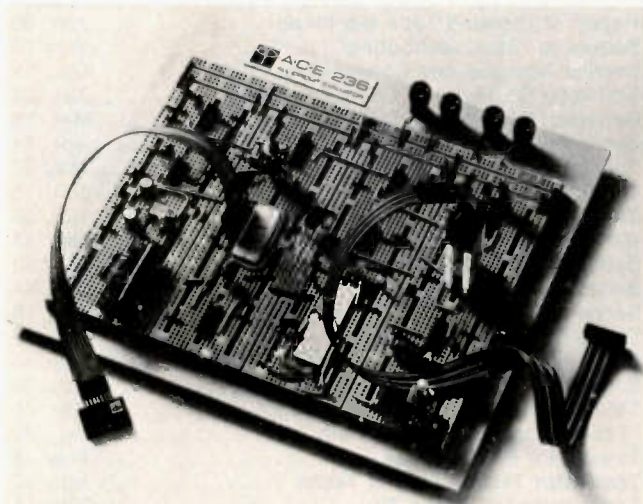

Figure 18A (above) Logic systems can be breadboarded easily by using plug-in circuit boards such as this one from AP Products. (Courtesy of AP Products)

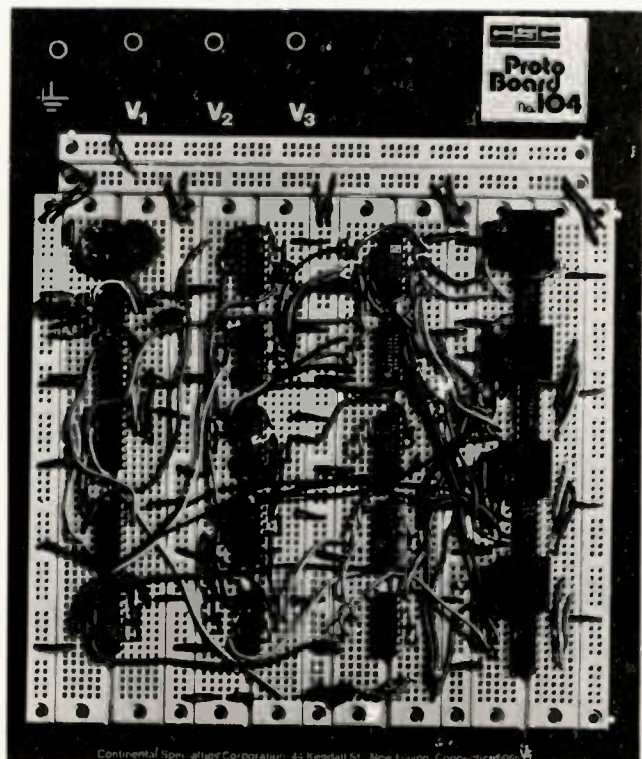

Figure 18B (at right) Another plug-in board for experiments is offered by Continental Specialties. (Courtesy of Continental Specialties Corp.)

INDEX OF 1977 ARTICLES

TITLES OF ARTICLES

Blood-Pressure Measurements	Dec. 19	Picture-Tube Voltages	Nov. 28
CB Radio Sound	May 36	Profitable Repairs of CB Mikes, Part 1	Jan. 31
Check-Cashing Tips	Oct. 34	Profitable Repairs of CB Mikes, Part 2	Feb. 26
Convergence Trouble Symptoms	Mar. 29	Repair of Stereo-8 Tape Machines	Jan. 36
Customer Relations	Jun. 31	Sequel to "Troubleshooting"	May 58
Customer Talk	May 33	Service Associations Conventions	Oct. 18
Eliminating Radio Noise	Dec. 40	Servicing GE Modular Color TV, Part 6	Jan. 24
Emerson-to-RCA Parts	Jul. 44	Servicing GE Modular Color TV, Part 7	Mar. 18
Emerson-to-Thordarson Parts	Sep. 62	Servicing GE Modular Color TV, Part 8	Apr. 24
4-Channel Auto Tape Players, Part 1	Aug. 57	Servicing GE Modular Color TV, Part 9	May 24
4-Channel Auto Tape Players, Part 2	Sep. 37	Servicing Magnavox Color TV, Part 1	Jun. 18
Factory Technicians	Jul. 26	Servicing Magnavox Color TV, Part 2	Jul. 30
Five Steps to TV Repair	Nov. 26	Servicing Magnavox Color TV, Part 3	Aug. 42
Goodbye, TV Snow!	May 14	Servicing Magnavox Color TV, Part 4	Sep. 48
Index of 1976 Articles	Jan. 49	Servicing Magnavox Color TV, Part 5	Oct. 24
Industrial Electronics, Part 1	Jul. 20	Servicing Magnavox Color TV, Part 6	Nov. 18
Industrial Electronics, Part 2	Aug. 52	Servicing Magnavox Color TV, Part 7	Dec. 26
Industrial Electronics, Part 3	Sep. 42	Servicing Zenith Remote Control	Jun. 34
Industrial Electronics, Part 4	Oct. 38	Streamlined Tests for Transistors	Aug. 34
Industrial Electronics, Part 5	Nov. 36	TV Tube Stock	Mar. 41
Industrial Electronics, Part 6	Dec. 48	"Tough Dog" Vertical Problem	Sep. 22
Installing CB Base Antennas	Jan. 16	Towers for Fringe Areas	May 48
Interpreting Alignment Curves	Feb. 16	Transistor Techniques for Techs	Apr. 42
Job Interview Pointers	Sep. 26	Translators for Fringe TV	Apr. 16
Over the Coffee Cups	Dec. 38	Trouble with Troubleshooting	Feb. 33
PLL for CB Radios	Mar. 42	Troubleshooting Tips for Admiral Vertical	May 40
		Typical Day at the CB Bench, Part 1	Jun. 42
		Typical Day at the CB Bench, Part 2	Jul. 38
		Vertical-Circuit Picture Symptoms	Apr. 33
		Video Games Operation	Aug. 20

Weird TV Repairs Feb. 36

ANTENNA, MATV, CATV

Installing CB Base Antennas Jan. 16
Towers for Fringe Areas May 48
Translators for Fringe TV Apr. 16

AUDIO

Eliminating Radio Noise Dec. 40
4-Channel Tape Players, Part 1 Aug. 57
4-Channel Tape Players, Part 2 Sep. 37
Repair of Stereo-8 Tape Machines Jan. 36

BUSINESS

Check Cashing Tips Oct. 34
Customer Relations Jun. 31
Customer Talk May 33
Job Interview Pointers Sep. 26

CB AND COMMUNICATIONS

CB Radio Sound May 36
Installing CB Base Antennas Jan. 16
PLL for CB Radios Mar. 42
Profitable Repairs of CB Mikes, Part 1 Jan. 31
Profitable Repairs of CB Mikes, Part 2 Feb. 26
Typical Day at the CB Bench, Part 1 Jun. 42
Typical Day at the CB Bench, Part 2 Jul. 38

COLOR TV & VIDEO

Convergence Trouble Symptoms Mar. 29
Emerson-to-RCA Parts Jul. 44
Emerson-to-Thordarson Parts Sep. 62
Goodbye, TV Snow! May 14
Interpreting Alignment Curves Feb. 16
Picture-Tube Voltages Nov. 28
Servicing GE Modular Color TV, Part 6 Jan. 24
Servicing GE Modular Color TV, Part 7 Mar. 18
Servicing GE Modular Color TV, Part 8 Apr. 24
Servicing GE Modular Color TV, Part 9 May 24
Servicing Magnavox Color TV, Part 1 Jun. 18
Servicing Magnavox Color TV, Part 2 Jul. 30
Servicing Magnavox Color TV, Part 3 Aug. 42
Servicing Magnavox Color TV, Part 4 Sep. 48
Servicing Magnavox Color TV, Part 5 Oct. 24
Servicing Magnavox Color TV, Part 6 Nov. 18
Servicing Magnavox Color TV, Part 7 Dec. 26
Servicing Zenith Remote Control Jun. 34
TV Tube Stock Mar. 41
"Tough Dog" Vertical Problem Sep. 22
Troubleshooting Tips for Admiral Vertical May 40
Vertical-Circuit Picture Symptoms Apr. 33
Video Games Operation Aug. 20
Weird TV Repairs Feb. 36

HORIZONTAL & HV

Servicing Magnavox Color TV, Part 3 Aug. 42
Weird TV Repairs Feb. 36

INDUSTRIAL ELECTRONICS

Factory Technicians Jul. 26
Industrial Electronics, Part 1 Jul. 20
Industrial Electronics, Part 2 Aug. 52
Industrial Electronics, Part 3 Sep. 42
Industrial Electronics, Part 4 Oct. 38

Industrial Electronics, Part 5 Nov. 36
Industrial Electronics, Part 6 Dec. 48

MEDICAL ELECTRONICS

Blood-Pressure Measurements Dec. 19

MISCELLANEOUS

Five Steps to TV Repair Nov. 26
Index of 1976 Articles Jan. 49
Over the Coffee Cups Dec. 38
Sequel to "Troubleshooting" May 58
Service Associations Conventions Oct. 18
Trouble with Troubleshooting Feb. 33

PUZZLES

A Short-Circuit Puzzle! Jun. 30
All Around Ohm! Nov. 25
Electronic Roundup! Dec. 16
For Live Wires Only! Feb. 43
Late Fuse Flash! Aug. 56
Look Watts Up! Apr. 40
Shocking! Sept. 25
Wire You Waiting? May 32

REPORTS FROM THE TEST LAB

B&K-Precision model 530 semiconductor tester Sep. 68
B&K-Precision model 1827 frequency counter Apr. 48
Cricket transistor-and-FET-tester Dec. 57
Danameter II digital multimeter Aug. 40
Hewlett-Packard model 3435A DMM Jul. 50
Hickok CB Test Instruments Jan. 43
Jerrold model TRC-82 TV remote control Nov. 46
Leader models LAV-190 audio tester,
LDM-170 distortion meter Jun. 46
LogiMetrics model 980 CB generator Feb. 44
Sencore model FC45 digital frequency counter Oct. 46
TeleMatic "Ferret" tuner-substitutor/
convergence generator Apr. 36
VIZ models WD-750A digital voltohmmyst,
WA-504B/44D audio generator Mar. 53

SOLID STATE

Streamlined Tests for Transistors Aug. 34
Transistor Techniques for Techs Apr. 42

VERTICAL SWEEP

A "Tough Dog" Vertical Problem Sep. 22
Servicing Magnavox Color TV, Part 2 Jul. 30
Troubleshooting Tips for Admiral Vertical May 20
Vertical Circuit Picture Symptoms Apr. 33

SYMCURE

PHILCO

E06/E20/E21 no raster, R22 burned or hot Jan. 8
E06/E21 green tint Jan. 8
E06/E21 intermittent vertical, horiz locking Jan. 8
E06/E21 picture shifted to left Jan. 8
E06/E21 soft hum Jan. 8
E20/D21 no color or weak color Jan. 8

continued on page 48

Index of 1977 Articles

continued from page 47

RCA

CTC39 smeared video and horiz pulling	Jul. 16
CTC58 crooked vertical lines at edges	Nov. 11
CTC62 no high voltage	Jul. 16
CTC68 compressed vertical at right side	Nov. 11
CTC68 narrow picture with center foldover	Jul. 16
CTC68 no HV regulation, no horiz lock	Apr. 10
CTC68 wrong channel, or erratic readout	Apr. 10
CTC71 intermittent or no horiz lock	Apr. 10
CTC72 no HV, picture-tube heater not lit	Apr. 10
CTC74 intermittent height or roll	Jul. 16
CTC74 intermittent height, or sweep loss	Nov. 11
CTC74 low brightness and smeared video	Jul. 16
CTC74 remote cannot change channels	Apr. 10
CTC76 narrow raster	Apr. 10
CTC81 no horiz lock and squeals	Nov. 11
CTC81 no vertical sweep	Nov. 11
CTC81 no video, excessive brightness	Nov. 11
CTC81 (varactor tuning) no low-band VHF	Jul. 16

SHARP

C-6010 loss of AGC after warmup	Nov. 12
---------------------------------	---------

SYLVANIA

D05 erratic height, or bottom foldover	Mar. 12
D06 vertical bars at left of picture	Mar. 12
E02 excessive height	Mar. 12
E03/E04/E05 no vertical deflection	Oct. 11
E04 raster compressed at bottom	Oct. 11
E06 series, HV arcing or excessive HV	Mar. 12
E08 excessive brightness	Oct. 11
E08 intermittent snow	Oct. 11
E08 no sound, no picture, no raster	Sep. 12
E08 no vertical deflection	Oct. 11
E08 no vertical sweep	Mar. 12
E08 no vertical sweep	Sep. 12
E08 repeated operation of "shut-off"	Sep. 12
E08 video smeared	Oct. 11
E10 hum bar in picture	Mar. 12
E21 dark picture	Jun. 12
E21 insufficient +112-volt supply	Jun. 12
E21 little control of brightness	Jun. 12
E21 R/B bottom lines not converged	Jun. 12
E21 snivets on low channels	Sep. 12
E21 snow, AGC voltage not changing	Jun. 12
E21 too bright, no control	Sep. 12
E21 no vertical lock	Sep. 12
E40 AGC overload	Jun. 12

ZENITH

12FB12X (B&W) incorrect horiz frequency	Dec. 9
12GB1 (B&W) low contrast, retrace lines	Aug. 8
13GC10 black raster with vertical bars	May 10
13GC10 excessive pincushioning	Dec. 9
13GC10 retrace lines, negative video	Dec. 9
19EC45 series, buzz in speaker, no HV	Feb. 8
19EC45 series, double stationary bend	Feb. 8
19EC45 series, intermittent height	Feb. 8
19EC45 series, low brightness	Feb. 8
19EC45 series, no HV, no overload	Feb. 8
19EC45 series, speaker buzzes, breaker trips	Feb. 8
23GC45 intermittent raster	Aug. 8
23GC45 little or no brightness	Aug. 8
23GC45 no HV, no raster	Aug. 8

23GC45 picture intermittently goes dark	Aug. 8
23HC45 no high voltage	Nov. 9
23HC45 foldover near center of raster	Dec. 9
25DC56 intermittent narrow width	May 10
25DC56 no brightness control	May 10
25DC56 no high voltage or 240-volt supply	May 10
25EC58 raster half dark, with retrace lines	Aug. 8
25GC50 insufficient brightness	May 10
25GC50 insufficient height	May 10
25HC50 zoom light stays on	Dec. 9

TROUBLESHOOTING TIPS

ANY BRAND

Poor auto degaussing	Sep. 13
----------------------	---------

ADMIRAL

TG2-1 (B&W) horiz bending	Nov. 12
T15K10-1A no color	Aug. 11
4M10C blown fuses and burned parts	Oct. 12
4M10C small picture	May 8
9P210 (B&W) TV won't turn off	Feb. 9

CRAIG

3135 tape unraveling from cartridge	Nov. 12
-------------------------------------	---------

FLEETWOOD

C01 small picture	Jan. 9
-------------------	--------

GENERAL ELECTRIC

YA/YM blown fuses	Jul. 14
-------------------	---------

MOTOROLA

23TS921 no picture	Nov. 12
--------------------	---------

PHILCO

22QT79 intermittent sound and video	Nov. 12
5BL23 "souped-up" chassis	Jun. 16
5CY82 consecutive multiple troubles	Oct. 12

RCA

CTC35 narrow raster	Dec. 10
CTC36M poor locking	Jul. 14
CTC38XT no raster	Sep. 13
CTC51E hum in picture	Apr. 8
CTC53/CTC55 no control of brightness	Apr. 8
CTC53XP hum bar and slow height change	Dec. 10
CTC55AXP intermittent locking	May 8
CTC70AD narrow, blurred picture	Aug. 11

SYLVANIA

A19-2 no raster, no audio	Aug. 11
D16 excessive 6LR6 failures	Jan. 9
E11-3 intermittent blue lines	Dec. 10
12A12C52 no raster, no HV	Mar. 12
14B38Z (B&W) low contrast	Oct. 12
16N24 blooming	Jun. 16
16Z8C50 insufficient height	Jul. 14
17GC45 buzz in sound	Jun. 16
19HC50 intermittent raster	Dec. 10
25EC58 dark picture	Sep. 13



test equipment report

Color Pattern Generator

Model LCG-396, an advanced state-of-the-art color/bar generator from Leader Instruments, provides the signals needed to test, adjust, and evaluate the alignment or performance of TV color receivers. Also, the adjustments of VTR, MATV, and CATV equipment can be made accurately with the TV-broadcasting patterns.

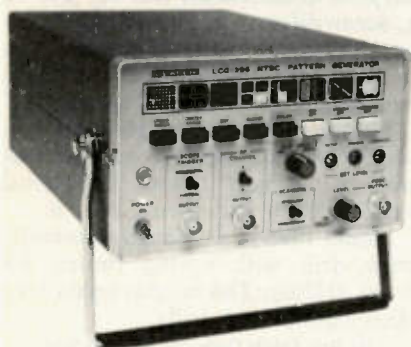

Red, blue, green, and white rasters are provided for purity and gray-scale-tracking adjustments, while the various crosshatch and dot patterns facilitate center convergence and dynamic convergence. Both fixed and variable video levels are available, and NTSC color bars are generated. Either the chroma or the luminance signals can be switched off.

Scanning either can be interlaced or progressive, and vertical or horizontal scope-trigger pluses can be selected. Another switch selects either channel 3 or channel 4. Separate RF and video outputs are provided.

With all cables, the Leader model LCG-396 generator sells for less than \$900.

For More Details Circle (20) on Reply Card

Remote Control Tester

Zenith Radio has introduced a remote-control transmitter tester



(model 852-240) to check TV remote-control signals from a hand-held remote transmitter.

The unit can test all Zenith "Space Command" remote control transmitters, mechanical as well as electronic hand-held, and any other brand of transmitters producing a continuous sinewave up to 50,000 Hz.

With tester switch turned on and the customer's transmitter held about six inches away from the grated end of the tester, the transmission functions then are activated. If the red LED indicator glows, the function is producing sufficient output to operate the remote receiver in the television receiver.

A BCN output jack allows connection to a frequency counter, when necessary to verify the output frequency of an electronic transmitter.

For More Details Circle (21) on Reply Card

AC/DC Multi-Tester

Sperry Instruments has introduced the SP-170 portable electrical AC/DC multi-tester. It features a 21-position selector switch with an



"off" position, full view window, 2-color scale, fuse protection on all ranges except 10 amps DC, safety-designed front panel, and a simplified polarity selector switch. Sensitivity is 20 kilohms/VDC and 5 kilohms/VAC. Accuracy is $\pm 3\%$ FS DC and $\pm 4\%$ FS AC.

Ranges are: AC volts 2.5/10/50/250/500/1000; DC volts .25/1/2.5/10/50/250/500/1000; DC MA. 0.5/1/10/100/500; DC amps 10; 2k/200k/20 megohms; and -20 +56 dB.

For More Details Circle (22) on Reply Card

Frequency Counter

B&K-Precision's model 1850 frequency counter features an LSI integrated circuit. Guaranteed frequency measurement extends from 5 Hz to 520 MHz. Period-measurement capability permits accurate high-resolution measurements from 5 Hz to 1 MHz.



The 1850 is fully autoranging in either auto or prescale modes, with automatic decimal point position and MHz/KHz readout. The 1850 features a 6-digit, 0.43-inch LED display, with leading-zero blanking. A TCXO (temperature-compensated crystal oscillator) time base is a standard feature, for 1 PPM stability over a 0° to 50°C range.

Model 1850 is priced at \$450 and includes a 44-page instruction manual, AC and DC power cords, and input clip-lead cable.

For More Details Circle (23) on Reply Card

Snoop Loop for Frequency Counters

Sencore offers a closed loop for signal pickup and frequency measurements, without any direct connection to the circuit. The "Snoop Loop" connects to the Sencore FC-45 frequency counter, the PR-47 UHF Prescaler, or any other 50-ohm-input frequency counter.

It enables the user to "hold back" from high-power circuits, thus protecting the frequency counter and the operator. The unit can be used to "snoop back" along the signal path to low-level circuits, and to be placed directly over oscillator coils, for example, without upsetting the operating frequency of the oscillator.

For More Details Circle (24) on Reply Card

Features of these products were supplied by the manufacturers, and are listed at no charge to them. If you want factory bulletins, circle the corresponding number on the Reply Card, affix a stamp, list the required information, and mail the card.

Tuner Cleaner/Degreaser

Chemtronics' "Electro-Wash" is a heavy-duty aerosol cleaner/degreaser for electronic, electrical, and mechanical applications. The concentrated blend of Freon® solvents penetrates, dissolves, and washes away accumulated gunk,



grease, dirt, and oxidation from delicate assemblies without damage to plastics. Propelled by EPA-approved CO₂, Electro-Wash has 97% of active ingredient.

When teamed with the reusable "Vibra-Jet" pulsating attachment (\$1.98), Electro-Wash dislodges contaminant encrustations. The rigid 12-inch extension tube permits spraying in any direction with the can remaining upright. A 24-ounce can of Electro-Wash retails for \$3.80.

For More Details Circle (25) on Reply Card

Automobile Fuse

Bussman's new Buss ATC closed fuse for automobiles features angled edges on both terminal corners for easier installation. (A totally enclosed fuse is necessary in case explosive gasoline fumes are present.)

When the ATC fuse opens, the arc is completely enclosed. Automatic OEM feeding into fuse blocks is facilitated because snag points have been eliminated by the design.

For More Details Circle (26) on Reply Card

IT'S NO PUZZLE

TO ORDER

OELRICH SERVICE FORMS

FOR TV-RADIO & 2 WAY RADIO SERVICE LEGAL FORMS FOR CALIF. FLA. UTAH NOW AT YOUR PARTS JOBBER OR WRITE FOR CATALOG B64

OELRICH PUBLICATIONS

4040 N. NASHVILLE AVE. CHICAGO, ILLINOIS 60634

For More Details Circle (14) on Reply Card

Ratchet Set

Klein Tools has introduced a compact, ratcheting screwdriver/drill combination (number 64025).

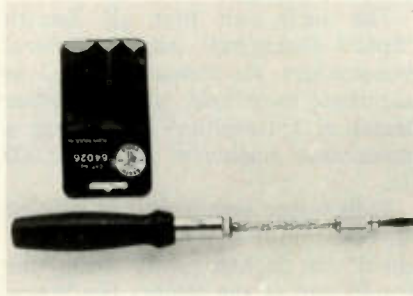

The tool is designed for use in confined spaces, and has a forward and reverse ratchet drive plus a manual setting. It comes with a five-piece driver-bit and drill-bit set in a plastic pouch.

For More Details Circle (27) on Reply Card

Remote CB Transceivers

Two new 40-channel remote CB transceivers (which can be mounted virtually anywhere) now are available from **Sparkomatic**.

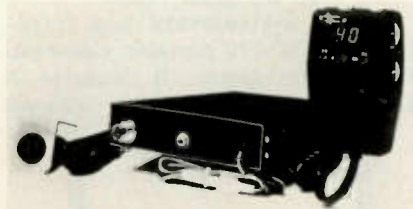

Model CB-4000 is a PLL 40-channel remote transceiver with all controls (including an LED channel indicator, variable squelch, rotary channel selector, and transmit light) located on the unit's detachable microphone.

Controls on the model CB-4100, also located on the detachable microphone, include two-speed electronic up-down channel selector buttons with LED channel indicator, 40-channel auto scan, RF gain, variable squelch, and transmit and receive lights.

Both models have RF power output of 4 watts and digital PLL frequency synthesizers.

For More Details Circle (28) on Reply Card

Test-Equipment Catalog

Leader Instrument's 1977-78 catalog features color-bar/pattern generators, scopes, multimeters, millivolt meters, signal/sweep-marker generators, mounting racks, and accessories.

Also offered is a complete line of

test equipment for CB, ham, marine, land, mobile, and other communications uses.

All items are illustrated and specifications are given. The catalog which costs \$1, includes an index.

For More Details Circle (29) on Reply Card

Screwdrivers/Drills

General Hardware has introduced a line of spiral-ratchet screwdrivers and automatic push drills.

Model 1500 is a 10-inch multi-purpose combination tool for use as a screwdriver, and as a drill for wood, plastics, and soft metals. The transparent plastic handle holds two blades and two drill points.

Model 1505 is a 10-inch reversible-spiral ratchet screwdriver with a 1/4-inch blade, lacquered wood handle, and spring return.

Model 1525 is a 12-inch automatic push drill with spring return for rapid drilling. The handle holds four alloy steel-plated drills.

For More Details Circle (30) on Reply Card

Carts and Trucks

Bay Products' stock carts and service trucks are available in a variety of shapes, sizes, and weight-carrying capacities to satisfy the requirements of most users.

Carts and trucks are equipped with a formed-tubular push handle and are assembled with vibration-



proof lock bolts and lock nuts. All have baked-on enamel bonderized over a phosphatized undercoat.

For More Details Circle (31) on Reply Card

Features of these products were supplied by the manufacturers, and are listed at no charge to them. If you want factory bulletins, circle the corresponding number on the Reply Card, affix a stamp, list the required information, and mail the card.

antenna systems report

Mobile Antenna Mount

A new 3/4-inch-hole mobile antenna mount interchangeable with standard 3/8-inch snap-in mounts, and a new fender cowl mount, have been introduced by **Antenna Incorporated**.

While the coaxial cable is prepared in the same way for the 3/4-inch-hole mount as it is for the snap-in mount, the new mount "toggles" in to simplify installation.

The cowl mount, which also toggles in, uses a 7/8-inch hole and will accommodate all base-loaded antennas. A 35-degree swivel adjustment is incorporated in the mount to ensure proper vertical position for the antenna.

For More Details Circle (32) on Reply Card

Antenna Preamplifiers

Winegard has added five preamps to its Gold-Star line: GA-3800 (VHF only), GA-4800 (UHF only), GA-8800 (VHF-UHF), and GA-6300 and GA-6700 (FM only).

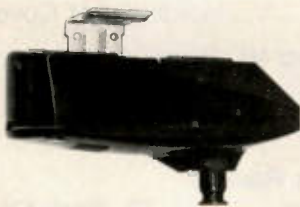

Each preamp features a lightning-protection circuit that reduces the possibility of transistor burnout. Antenna and download terminals are internal, protected from corrosion. A tough, weather-proof housing protects the circuitry. A fixed FM trap in the VHF circuitry prevents overload from strong FM stations.

The noise figure runs from 3.4 dB for VHF to 4.2 dB for UHF. Gain is 26 dB for VHF, and 18 dB for UHF. The FM-only models have a gain of 15 dB, and a noise figure of 3.5 dB.

Gold-Star preamps can be mounted on any antenna mast or boom. Each preamp includes a power supply in a metal housing with mounting bracket and F-59 connectors.

For More Details Circle (33) on Reply Card

Marine CB Antenna

The "Target" BS-190 marine CB antenna by **S&A Electronics** features a two-piece fiberglass radiator element. The antenna is a 1/2 wavelength type (96-inch), or can be

used with a loading coil to reduce the height to 56 inches.

The corrosion-resistant unit is constructed of fiberglass with chrome-plated brass ferrules. The radiating element is made of copper.

Impedance is matched at 50-52 ohms. Either tip gives VSWR of 1.5:1 or better. A swing-down mounting bracket has been designed for this model. The standard 3/8-24 thread fits many universal mounts.

For More Details Circle (34) on Reply Card

CB Antenna Disconnect

GC Electronics' Quick Disconnect (18-1073) removes whip antennas without damaging the threads.

To install, thread the antenna into the top portion of the disconnect. Then, remove the base section and thread it into the antenna mount. Insert the antenna into the base section, and give it a push and twist. To remove the antenna, push down and turn clockwise.

The weatherproof disconnect is constructed of chrome-plated brass.

For More Details Circle (35) on Reply Card

Indoor FM Antenna

British Industries has designed an indoor FM antenna, "The Beam Box," that provides a choice of four directivity patterns, two bandwidths, and variable tuning. There



are no moving parts (except the knobs and switches). The circuit is passive; therefore, no transistors are used, and no power is required.

This tuned antenna is said to provide improved rejection of images, and to reduce interference from unwanted signals.

Suggested list price is \$89.95.

For More Details Circle (36) on Reply Card

CB Antenna Hardware

The CB antenna hardware mer-

chandising program 49-817 by **GC Electronics** is a collection of antenna-installation hardware as well as essential accessories for antenna maintenance.



The products are 40-channel approved and are displayed on a 4-foot by 4-foot self-service display. Ten types of hatchback, trunk, mirror, and bumper mounts are featured. Four varieties of co-phase harnesses with GC mixer-balun circuitry are included.

For More Details Circle (37) on Reply Card

Antenna Mount

Genex Tool and Die has manufactured an all-aluminum CB antenna mount which permits flipping the antenna (as well as the mount and wires) completely out of sight, leaving no tell-tale signs that attract thieves to the CB radio equipment.

The "No-See-B" adapts to many standard antennas, including gutter and magnetic-mount types. It installs in the trunk or under the hood of cars, on the rear door of vans, and under the hood of trucks.

The mount employs a series of connecting hinges, and it stores the antenna by spring tension up against the inside trunk lid, inside a van roof, or inside the hood.

For More Details Circle (38) on Reply Card

Features of these products were supplied by the manufacturers, and are listed at no charge to them. If you want factory bulletins, circle the corresponding number on the Reply Card, affix a stamp, list the required information, and mail the card.

Advertising rates in the Classified Section are 35 cents per word, each insertion, and must be accompanied by cash to insure publication.

Each initial or abbreviation counts a full word.

Minimum classified charge \$3.00.

For ads on which replies are sent to us for forwarding (blind ads), there is an additional charge of \$3.00 per insertion to cover department number, processing of replies, and mailing costs.

Classified columns are not open to advertising of any products regularly produced by manufacturers unless used and no longer owned by the manufacturer or a distributor.

For Sale

REPLACEMENT COLOR YOKES-DEALERS ONLY. Zenith 95-2501-2532-2638-2667-S-89633 etc. 16.95, Magnavox 361380-1 18.95, Sylvania, GE etc. 14.95 to 19.95. Request for price list on your letterhead. David Sims Enterprises, Inc., 665 Jericho Turnpike, Huntington Station, N.Y. 11746. 12-78-tf

TV SALES AND SERVICE BUSINESS in Florida. Same location 17 years. Zenith franchise, excellent test equipment, customer list, and all supplies, \$7000.00 cash. Bill Ellis, 7900 46th Ave. No., St. Petersburg, Fla. 33709. 1-78 1t

TV TUBE REBUILDING EQUIPMENT. Makes 4 every 3 hours, \$5,000 including tube parts. Phone 314-772-6241, 2333 South Compton, St. Louis, Mo. 63104. 1-78 2t

PHOTOFACTS 420 thru 1605 with cabinets. \$600.00. Ted's TV, 2 Brookhill Pl., Cedar Grove, N.J. 07009. 1-78 1t

SAMS OLDER PHOTOFACT folders, \$3.25 each. Beltman, Box 46, Highland Park, Illinois 60035. 1-78 1t

OSCILLOSCOPES Dual Trace 22 MHZ Triggered Scopes Calibrated guaranteed \$350. Send for catalog. A-OK ELECTRONICS, 1445 N.W. 9th Street, Homestead, Fla. 33030 (305) 247-6349. 1-78 2t

Help!

Anytime you have a question about your subscription to Electronic Servicing, please include a mailing label to insure prompt service on your inquiry.

Change of Address

If you're about to move, please let us know approximately four weeks before the move comes about. Simply affix your present label here, and carefully print the updated information below.

Please Help Us to Serve You Better

Name _____
(Please Print)
Employer _____
Address _____
City _____ State _____ Zip _____

Electronic Servicing
P.O. Box 12901
Overland Park, Kansas 66212

AFFIX LABEL HERE

For Sale (Cont.)

TUNER SUB ONLY \$19.95, wired, tested, complete with batteries and ready to use on tube or transistor sets. This unit is without knobs or cabinet but very compact with no wires or controls dangling. Easy to use, simply hook set's coax to sub and view picture (instructions provided). Only \$19.95, we pay the shipping. This is not a gimmick. If not completely satisfied, return within 10 days for full refund. TEXAS TUNER SERVICE, 4210 N.E. 28th Street, Fort Worth, Texas 76117. Phone (817) 834-8201. 1-78 3t

TV & RADIO TUBES 36c EA! Free color catalog. Cornell, 4221 University, San Diego, California 92105. 8-76-tf

Services

ELECTRONIC MANUFACTURERS; electronic and printed circuits requiring hand finish assembly or modification work wanted. Via drop ship method. Gilbert Whitley, R.R.2, Metamora, Ill. 61548. 11-77-3t

Business Opportunity

SAVE HUNDREDS OF DOLLARS on high quality, dependable, American Made, MATV Head-Ends, V/V, U/V Converters, Camera Modulators, at factory-direct prices. Send \$5.00 (or your MATV Installers Letterhead). "Information", Box 809, Boynton Beach, Fla. 33435. 1-78 5t

Education-Instruction

REPAIR TV TUNERS—High Earnings; Complete Course Details, 12 Repair Tricks, Many Plans, Two Lessons, all for \$2. Refundable. Frank Bocek, Box 3236 Enterprise, Redding, Calif. 96001. 8-76-tf

Wanted

START ELECTRONIC FACTORY IN YOUR HOME. GET STARTED IN YOUR SPARE TIME. ONE MAN OPERATION. EXPECT BIG PROFITS. EXPERIENCE NOT NECESSARY. PRACTICALLY NO INVESTMENT. WRITE FOR FREE LITERATURE TELLING HOW. ELECTRONIC DEVELOPMENT LAB, DEPT. A, BOX 1535, PINELLAS PARK, FL 33565. 8-77-tf

TELEVISION SALES SERVICE established twenty years major brands mid Ohio growing community. Modern store, central location, gross exceeds \$100,000. Owner retiring. Principals Only. Electronic Servicing, Dept. 515, P.O. Box 12901, Overland Park, Kansas 66212. 12-77-2t

INCREASE YOUR INCOME! Rent, Lease or Sell TV's New or Used; Anyone can! Easy to start and operate, part or full time; even from your home. Basic preliminaries \$4.00. Perry's TV Leasing, 308 N. McClelland, Santa Maria, Calif. 93454. 12-77-2t

advertisers' index

American Technology Corp	13
B&K Precision, Dynascan Corp	Inside Back Cover
Bussman Mfg. Div. McGraw-Edison Co	7
Chemtronics Inc	2
Dynascan Corp., B&K Precision ..	Inside Back Cover
Electron Tubes Int'l., Inc	2
Fuji-Svea Enterprise	23
Gamit Enterprise	27
General Electric Co., Tube Div	3
MTI Inc	16
NATESA	16
NESDA	25
Non-Linear Systems, Inc	13
Oelrich Publications	50
PTS Electronics, Inc	Inside Front Cover-1
Howard W. Sams & Inc	5
Sperry Tech, Inc	27
Zenith Radio Corp	33, Back Cover

Regional Advertising Sales Offices

INDIANAPOLIS, INDIANA 46280
Roy Henry 2469 E. 98th St.; Phone: (317) 846-7026

GREENLAWN, NEW YORK 11740
Chuck Horner, P.O. Box 175; Phone: (516) 757-7863

MOUNTAIN VIEW, CALIFORNIA 94043
Dennis Triola, 2680 Bayshore Frontage Road, Room 102; Phone: (415) 961-0378

LONDON, W.C. 2, ENGLAND
John Ashcraft & Co., 12 Bear Street, Leicester Square; Phone: 930-0525

BADHOVEDORP, HOLLAND
John Ashcraft & Co., John J. Lucassen, Mgr., Slotweg 303; Phone: 2968-6226

TOKYO 105, JAPAN
International Media Representatives, Ltd., 2-29, Toranomon 1-chome, Minato-ku; Phone: 502-0656

Now you can save money and get the counter you want— immediately

A frequency counter should deliver all the performance you expected when you placed the order. If the counter is a B&K-PRECISION you'll be getting that plus some equally important benefits—a price that you can easily afford and off-the-shelf delivery.

B&K-PRECISION has engineered a line of full-feature frequency counters to suit most

applications. All have been conceived as cost-effective answers to frequency measurement needs in communications, lab, field and plant applications. Every B&K-PRECISION counter features: autoranging, liberal input overload protection, a minimum of 1Hz resolution, conservative specifications, and easy-to-read LED displays.

MODEL 1850

- 520MHz guaranteed; 600MHz typical
- Period measurement capability



MODEL 1801

- 40MHz guaranteed; 60MHz typical
- Reliable discrete TTL logic



MODEL 1827

- 30MHz guaranteed; 50MHz typical
- Compact size; portable
- 8 digit accuracy with 6 digit readout

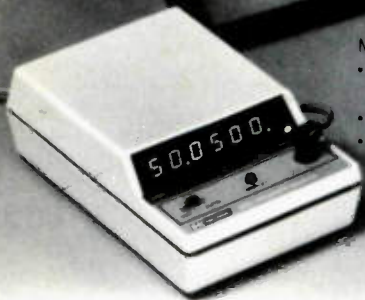

MODEL 1820

- 80MHz guaranteed; 100MHz typical
- Period, event and time measurements



At the top end of our line is the new Model 1850, very conservatively rated at 520MHz. Features include: TCXO time base...Period measurements from 5Hz to 1MHz...Leading zero suppression...Bright .43" LED display... Gate times from 10 ms to 10 seconds... \$450.

The 1820 Universal Counter is one of the most versatile counters available at any price. Frequency measurement typically extends beyond 100MHz...Period measurements from 5Hz to 1MHz... Period average, auto and manual positions... Elapsed time measurements to 9999.99 seconds (plus overflow)... Totalizes event counts to 999999 (plus overflow)... \$260.

At only \$120, the 1827 portable frequency counter is slightly larger than a pocket calculator. 30MHz guaranteed; 50MHz typical... Battery saver for all-day field use... Full range of optional accessories available.

The 1801 is a rugged frequency counter designed for production line and maintenance applications. Readings to 40MHz guaranteed; 60MHz typical... Easy to use and read...Wide range input eliminates the need for level adjustments... \$200.

Isn't it time you stopped sacrificing features and performance for price? See your local distributor for immediate delivery.

BK PRECISION **DYNASCAN CORPORATION**

6460 W. Corlind Avenue, Chicago, IL 60635 312/889-9087

In Canada: Atlas Electronics, Ontario

International Sales: Empire Exporters, Inc., 270 Newtown Road, Plainview, L.I., NY 11803

Chances are you can improve color viewing
no matter what make TV your customers now have.

ZENITH

CHROMACOLOR[®]

Replacement Picture Tubes

Before Chromacolor, every large screen color TV picture was made up of thousands of tiny red, green and blue dots on a gray background.

But Zenith found a way to make the dots smaller, surround them with jet black and, for the first time, fully illuminate every dot not only for greater brilliance, but also for dramatic contrast.

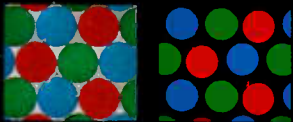

The result was the famous Chromacolor picture tube – widely recognized at its introduction as one of the most important breakthroughs in color picture tube technology since the coming of color television.

Today, Chromacolor still represents a significant forward step in the state of picture tube technology... in brightness, contrast, and true-to-life color.

And for reliability, there's no compari-

son between a Chromacolor picture tube from your Zenith distributor and that you may attempt to re-build yourself. When you get down to it, you simply can't invest man hours in a re-built that will seldom, if ever, measure up to the reliability, the consistency, the integrity of a factory-supplied Chromacolor.

As a result of this reliability, Chroma-

color can do a lot for older color TV's...and many-not-so-old sets as well. Even those of other makes.

That's why you should check with your Zenith distributor now and stock up with Zenith's 17", 19", 23", and 25" diagonal sizes.

Besides brightening your customers' picture viewing, Chromacolor will brighten your profit picture too! Reliably!

Call your Zenith distributor now.

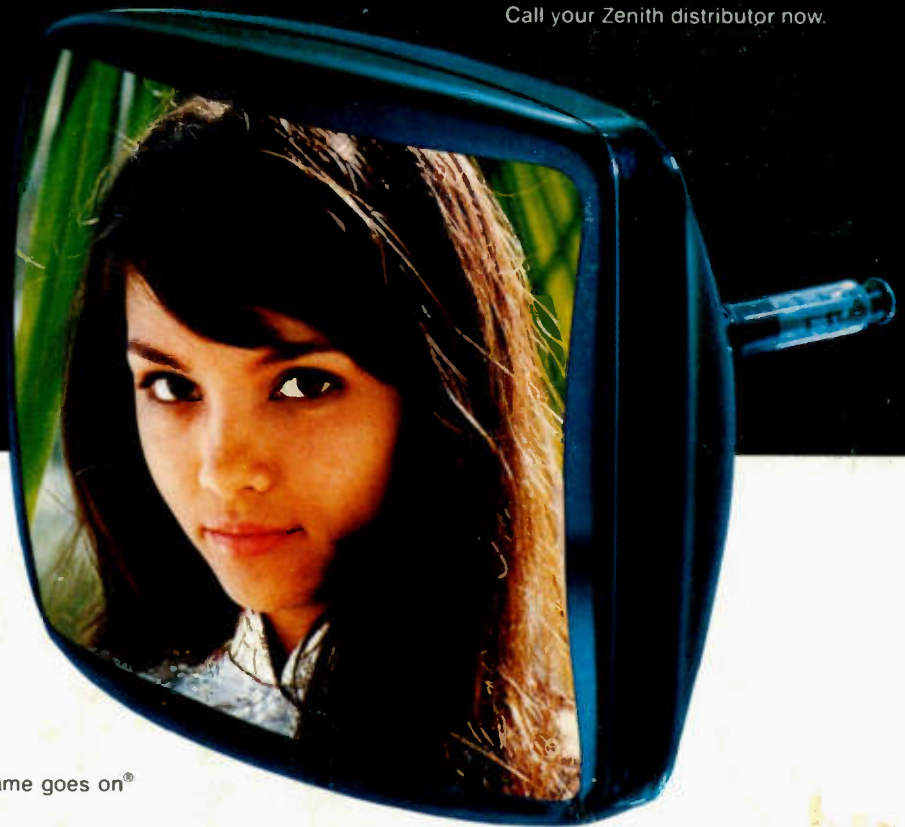

For your own reputation and in your customers' best interest, always specify Zenith exact replacement parts and accessories.

ZENITH

The quality goes in before the name goes on[®]

Zenith Radio Corporation/Service, Parts & Accessories Division/11000 Seymour Avenue/Franklin Park, Illinois 60131

For More Details Circle (3) on Reply Card