

# PF Reporter

PHOTOFACT

*the magazine of electronic servicing*

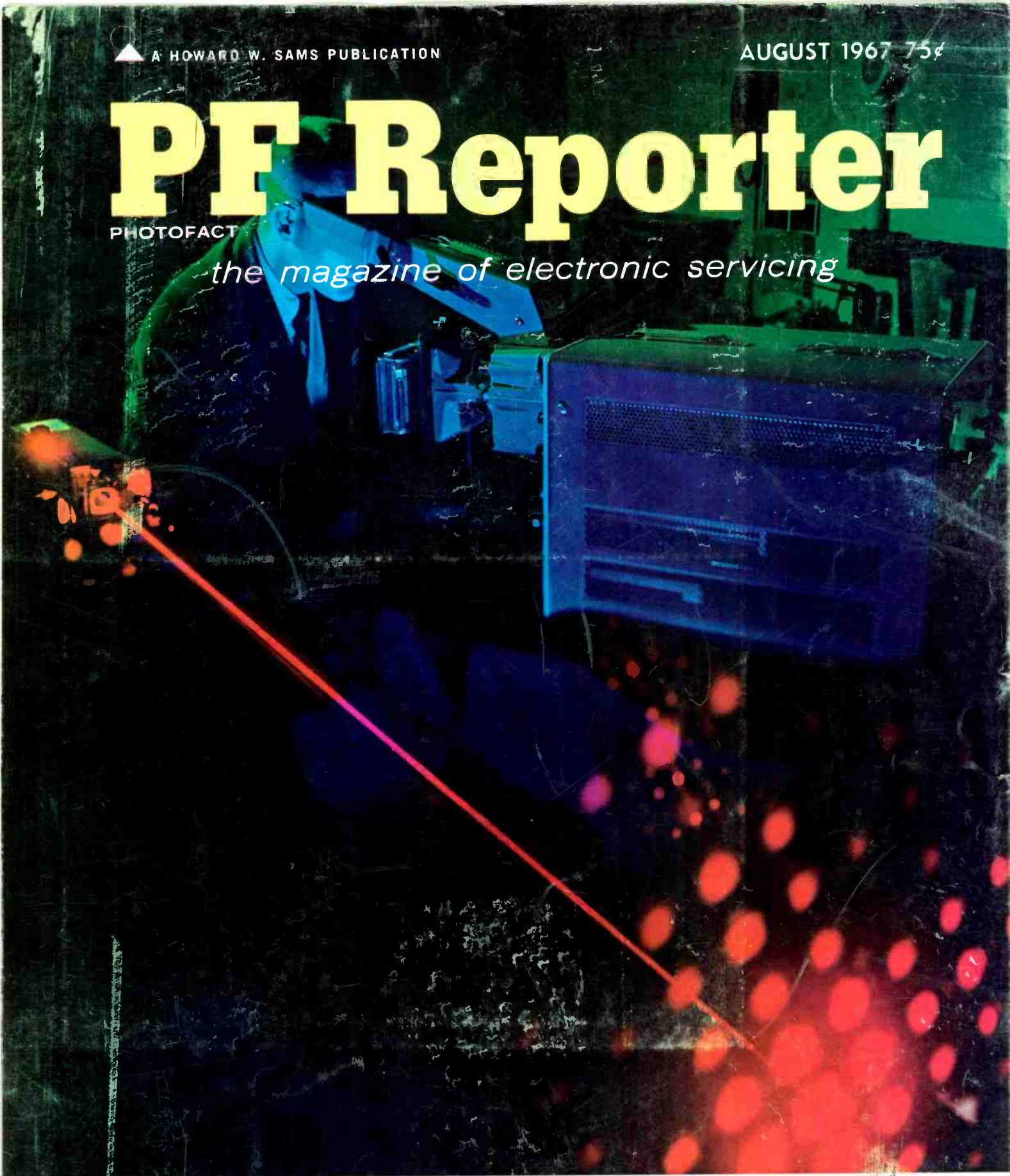

IN. CL. 4279 1859  
 WM. W. DAVIS  
 RADIO & TV SERVICE  
 118 RIVERSIDE AVE.  
 CANON CITY, COLORADO 81202

- Solid-State Deflection Circuits—Part I
- Color TV Service Training—Part I
- Measuring the Results of Advertising
- Solid-State Color TV is Here
- Servicing High-Quality Audio

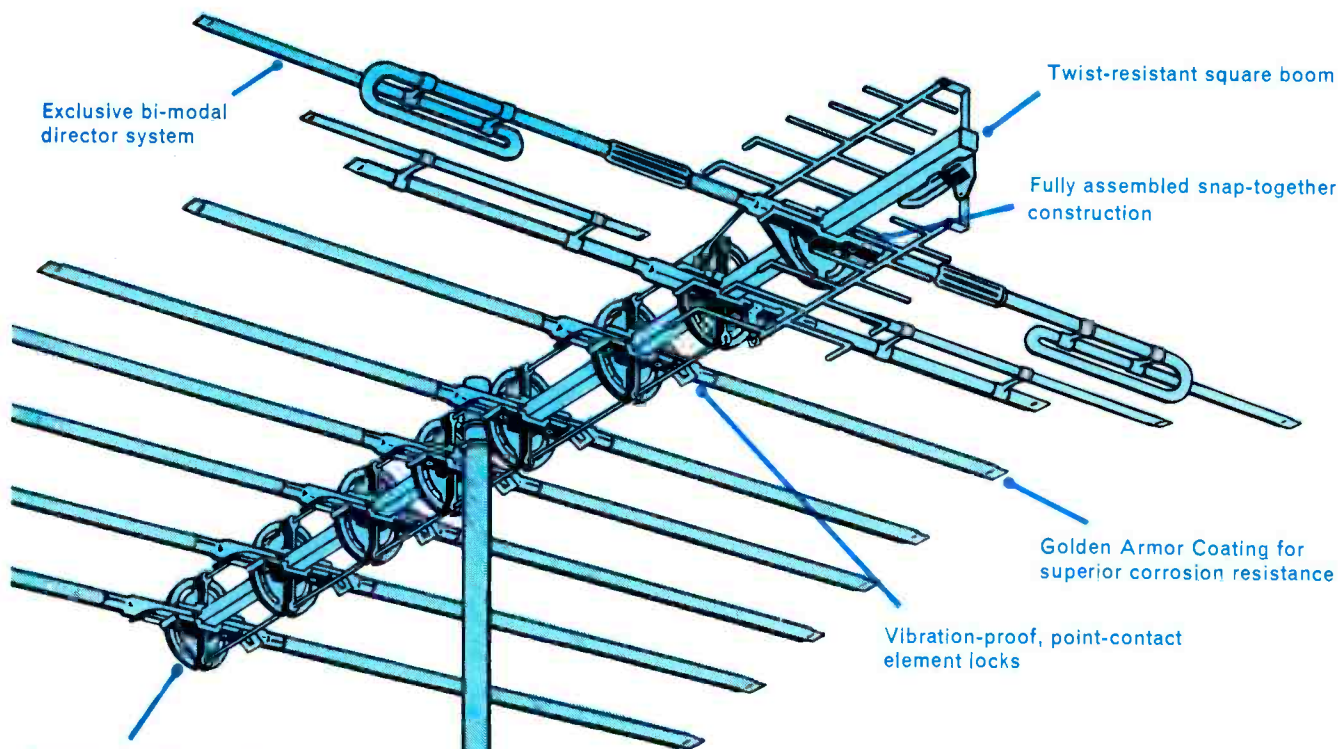

Exclusive bi-modal director system

Twist-resistant square boom

Fully assembled snap-together construction

Golden Armor Coating for superior corrosion resistance

Vibration-proof, point-contact element locks

Rugged Cyclocac insulators add strength

# 82-channel signal grabber

The Jerrold VUfinder® Antenna. The first 300-ohm UHF-VHF-FM antenna designed—from the ground up—for uncompromising color and black-and-white excellence across the entire TV spectrum. Models available for metropolitan to deepest fringe areas.

- Sharp directivity eliminates color ghosts
- Flat response ( $\pm 1$  db per channel) for optimum color fidelity
- Exclusive bi-modal director system for extra gain

VUfinders are easy to put together, can't possibly fall apart. The quality that's built in stays in. Quickly convertible to 75-ohm Color-axial performance. VUfinders come in 5 models. Each is supplied with a UHF/VHF frequency splitter. And the list prices range from \$17.95 to \$79.95. There's no better performance per dollar than this—anywhere.

For the most efficient 300-ohm signal grabber in Jerrold's Spectrum '67, see your Jerrold Distributor *today* about the Jerrold VUfinder antenna.

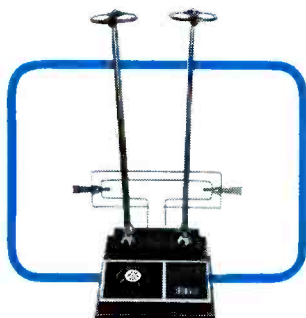

Indoor antennas



Home pre-amplifiers

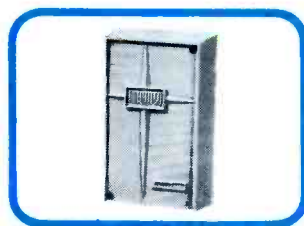

Distribution equipment



*Focusing on one thing...  
better reception*

Circle 1 on literature card

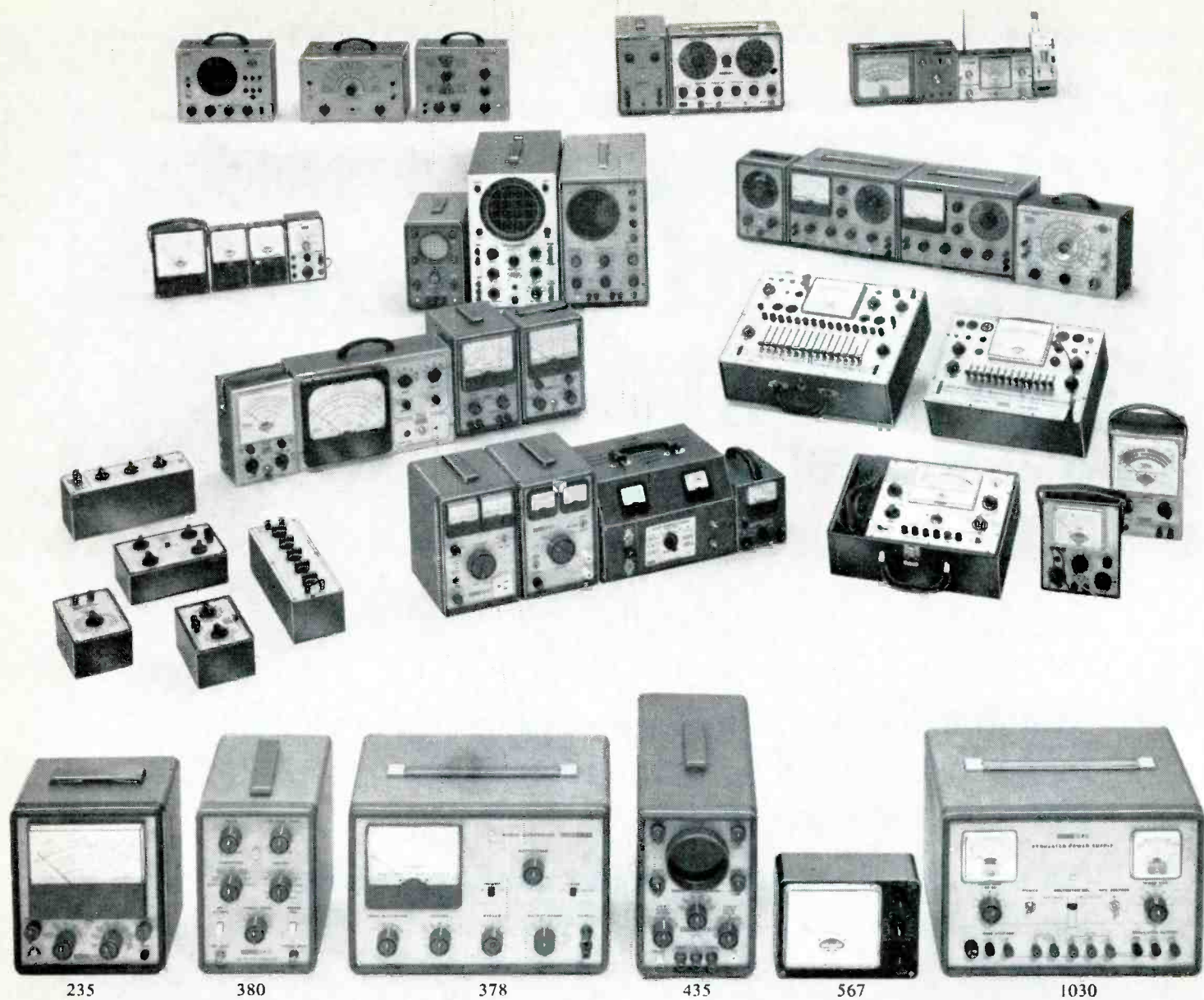

235

380

378

435

567

1030

# Be choosy.

You can afford to with EICO

The reason EICO's line is the industry's most comprehensive (100 to choose from!) is because each instrument serves a specific group of professional needs. You name the requirement—from a resistance box to a VTVM, from a signal tracer to a scope, from a tube tester to a color TV generator, etc., you can depend on EICO to give you the best professional value. Compare these latest (foreground) professional instruments at your neighborhood electronics distributor. You judge who knows your needs best — and serves your needs with the best values!



21 years of service to the Professional Serviceman.  
Laboratory precision at lowest cost.

## 1967 Guidebook to Professional Test Equipment AVAILABLE FREE TO PROFESSIONAL SERVICE TECHNICIANS

EICO Electronic Instrument Co., Inc. 131-01 39th Avenue, Flushing, N. Y. 11352

Please send further data on New EICO instruments below:

- =235 Professional VTVM. Measures to 0.01V for transistor servicing. Large 6" meter. 8DC ranges 0.5V to 1500V. 7 AC P-P ranges to 4200V. 7 AC RMS ranges to 1500V. 7 ohms ranges to 100MΩ. Response 30Hz to 3MHz ± 1 db. **Kit \$49.95 Wired \$64.95**
- =380 Solid-State NTSC Color Generator. The first serviceman-priced. True NTSC Generator. Extremely compact weighs only 4 lbs. **\$169.00 Wired Only.**
- =1030 Regulated Power Supply. 0-150V @ 2ma, 0-400V up to 150ma, all to 1/2 of 1% Ripple 3mV. 6.3V & 12.6V. @ 3A. **Kit \$59.95 Wired \$99.95**
- =435 Direct-Coupled DC-4. 5MHz Scope. Outperforms 5" scopes 3 times its size. **Kit \$99.95 Wired \$149.95**
- =567 Professional V-O-M. Measures to 0.005VDC. 7DC ranges to 5KV (20,000Ω/V). 5 DC ranges to 10A. 5db ranges. 3R ranges to 20 Meg. **Kit \$34.95 Wired \$44.95**
- =378 Near-Distortionless Audio Generator. 0.1% 20-20,000Hz Switch selection of frequencies from 1Hz to 110KHz. **Kit \$49.94 Wired \$69.95** PF-8

NAME \_\_\_\_\_

ADDRESS \_\_\_\_\_

CITY \_\_\_\_\_ STATE \_\_\_\_\_ ZIP \_\_\_\_\_

Circle 2 on literature card

August, 1967/PF REPORTER 5

# Are you up-to-date on solid state?

(Let Motorola help you)

**Motorola has one of the largest programs in the industry to help independent servicemen keep pace with solid state technology.**

**No other manufacturer is better qualified to help you than Motorola—the TV industry's largest producer of solid state devices.**

Every day, you see more and more home entertainment products with advanced solid state circuitry. This means great opportunities for service organizations that stay abreast . . . and problems for those that don't.

That's why Motorola has developed a complete program designed to help you and your technicians stay on top of solid state. Many Motorola Distributors conduct regular training meetings. Often, the Motorola Regional Service Managers take part in the meetings to provide detailed information about design and service features.

In some cases, your Motorola Distributor can enroll your servicemen in Motorola's "Professional Technician Program."

These "P.T.P." training sessions are conducted right in your place of business, with your technicians working on a man-to-man, face-to-face basis with one of our factory technicians.

Each member of our large (and greatly expanded) staff of technical representatives has had extensive, practical experience. They know your business—from your side of the counter. It's their job to teach you all that's new in solid state.

Stay up-to-date on fast-changing solid state technology—contact the service manager from your Motorola Distributor. He's the man who can help you with almost any type of training activity.



Circle 3 on literature card



provides the time constant of the oscillator; namely, C21 and R79. The discharge of C21 through R79 produces a basic exponential waveform, which is linearized into a good sawtooth by negative feedback via R81. Circuit tolerances make manual control of linearity necessary, and this is provided by R6B, which operates as a waveshaper in combination with C77. The driving waveform to the base of Q15 can accordingly be made convex or concave—between these two extremes of curvature, linearity is realized.

It is also necessary to control the amplitude of base drive to Q15 in order to adjust vertical deflection. This control is provided by R6A. Negative feedback is also provided for Q15 via R89; in other words, the waveform from the vertical-deflection coils returns to ground through the emitter resistor for Q15. The necessity for negative feedback (linearity correction) is seen in Fig. 2. Collector current is not directly proportional to base voltage. However, the characteristics shown in Fig. 2 become more nearly linear when negative feedback is applied via R89.

### Output Stage

The vertical-output stage employs a power type of transistor. Because of the comparatively wide tolerances on replacement transistors, a bias control (R6) is provided for maintenance adjustment of the emitter-base bias on Q16. In a power-out-

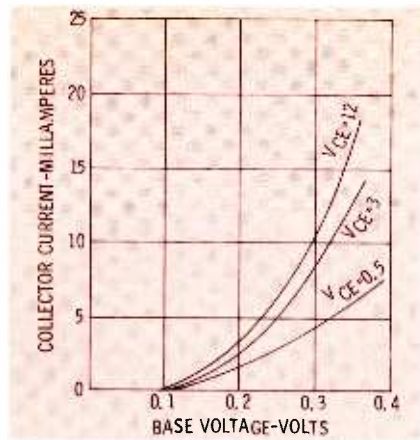

Fig. 2. Collector current is not directly proportional to base voltage.

put stage, the transistor is operated near its maximum rated output. Since the collector current flow is heavy, the transistor heats up. In turn, the resistance of the transistor decreases and its beta (current amplification) increases. Unless a compensating circuit is utilized, the transistor is very likely to be destroyed by thermal runaway. Hence, R86 is connected in the base circuit. R86 is a nonlinear resistor (thermistor) that has lower resistance when the base draws more current. R86 thus provides a lower resistance between emitter and base of Q16 when the current increases, thereby reducing the forward bias on Q16.

Note that the collector waveform for Q16 is a peaked-sawtooth wave. The negative spike is produced by inductive kickback from T3 and the vertical-deflection coils. Although there is only 8.6 volts DC between the collector and emitter of Q16, this inductive kickback generates a

total peak-to-peak voltage of 50 volts for the output waveform. The peaking pulse is tapped off for vertical-retrace blanking of the picture tube. R90 not only provides emitter bias for Q16, but it also develops some negative feedback inasmuch as the resistor is not bypassed. This negative feedback helps to improve the linearity of the vertical-output stage and also tends to stabilize the operating characteristics as the transistor ages.

### Two-Stage System

Some transistor television receivers use a two-stage vertical sweep system, as shown in Fig. 3. The oscillator also operates as a driver for the output stage. Note in Fig. 3 that the driving waveform is taken from the collector of Q17, whereas in Fig. 1, the driving waveform was taken from the emitter of Q14. Height control R11 in Fig. 3 varies the emitter bias as well as the amount of negative feedback for Q17. Capacitors C24, C25, and C26 are charged during the conduction interval of Q17. Then, these capacitors proceed to discharge through the associated resistors, and a sawtooth wave is formed.

To linearize the basically exponential discharge, negative feedback is utilized. This feedback is taken from T3 via R7. Since R7 is adjustable, vertical linearity can be controlled manually. Note also the negative-feedback coupling path provided from base to emitter of Q18, which helps to linearize the

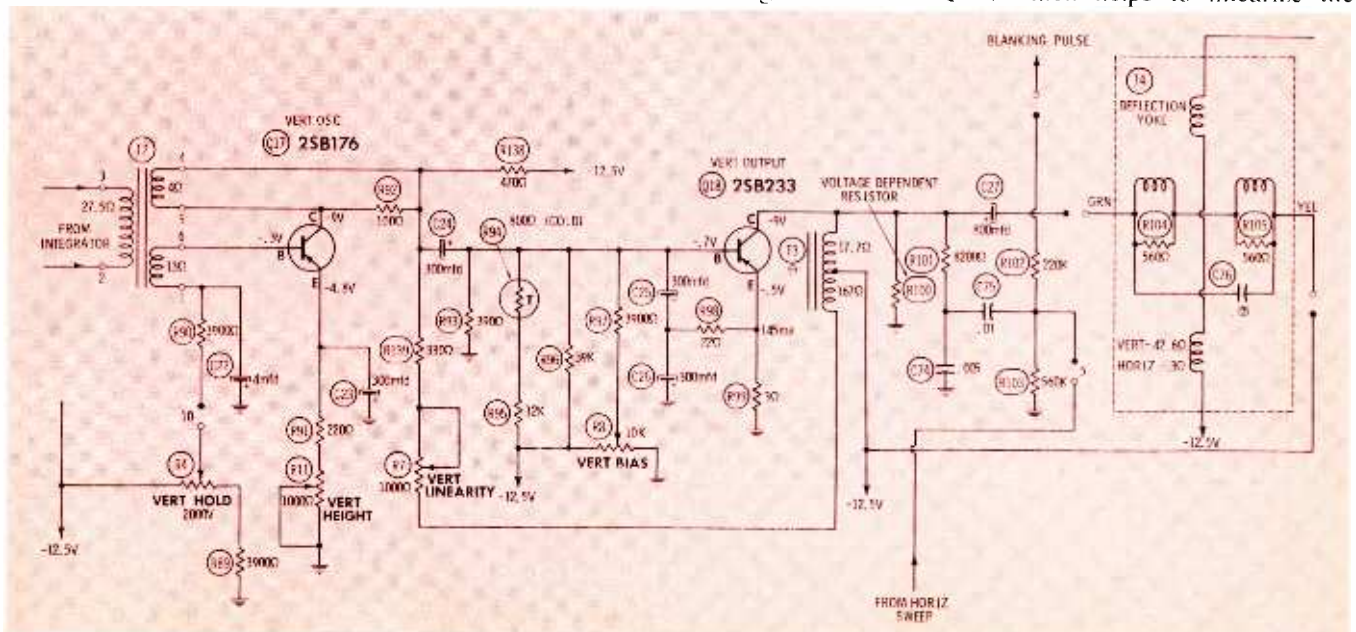

Fig. 3. A two-stage transistor vertical sweep system.

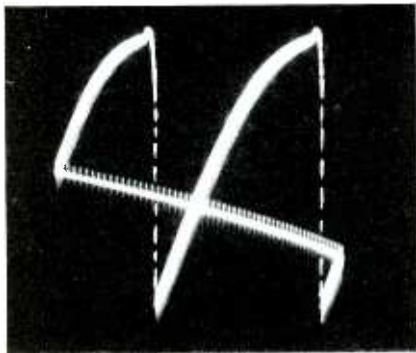

Fig. 4. Horizontal pulses present in nonlinear vertical sawtooth.

sawtooth waveform, and also to stabilize the output stage against drift and aging transistor characteristics. Thermistor R94 protects output transistor Q18 from burnout due to thermal runaway. As the transistor heats up, collector-current flow increases, and current amplification increases. However, increased current flow through R94 causes its resistance to decrease; in turn, the base-emitter bias drop is decreased, and thermal runaway is prevented.

Of course 100% control cannot be realized—the collector current in Q18 does increase somewhat at higher temperatures. To keep the vertical deflection at a constant level, R100 is connected in parallel with the collector of Q18. As the amplitude of the output waveform increases, the resistance of R100 falls, thereby keeping the drive to the vertical-deflection coils essentially constant.

### Common Troubles

Trouble within the vertical sweep section can often be localized by the picture symptom, although scope waveform checks and DC voltage measurements, sometimes supplemented by resistance measurements, are generally required to pinpoint the defective component.

The first step in analyzing the picture symptom is to observe the action of the vertical controls. If one of the controls must be set to an extreme end of its range to minimize the symptom, it is probable that the defect will be found in the associated circuit. While this is not a hard-and-fast rule, it is the most helpful preliminary test. Scope waveform checks are extremely useful. For example, Fig. 4 illustrates a nonlinear sawtooth wave with

spurious horizontal pulses present. When a vertical oscillator produces this type of waveform, it indicates that a circuit defect is present which not only distorts the waveform, but also permits the entry of horizontal pulses that cause loss of interlace.

### Loss of Vertical Sweep

Loss of vertical sweep can be caused by a number of defects in the vertical-sweep system. Capacitors are the most common troublemakers. An open capacitor is pinpointed best by scope waveform checks.

An open coupling capacitor obviously interrupts the circuit for deflection waveforms. However, a shorted coupling capacitor may also “kill” the vertical sweep. For example, if C24 in Fig. 3 shorts, the collector voltage on Q17 will be decreased, and the base bias on Q18 will be increased. The oscillator will stop. Moreover, Q18 will be burned out. A shorted capacitor such as C25 in Fig. 3 will practically “kill” the drive to Q18, and the deflection waveform will be stopped in this stage. The same symptom occurs when C76 in Fig. 3 is shorted. An open height or hold control can open the base circuit for DC (R4 in Fig. 3), or open the circuit for AC waveforms (R6 in Fig. 1).

If a semiconductor diode (such as X8 in Fig. 1) shorts, the feedback coil will also be shorted, and the vertical oscillator will stop. Solder splashes between printed-circuit conductors can cause the same type of trouble. A power-output transistor can still be burned out by thermal runaway even though there is no defective component causing excessive current in the transistor. This is commonly caused by inefficient contact with the heat sink. However, when replacing a power transistor, making sure that it is in good contact with the heat sink, it is advisable to check the protective thermistor before the receiver is turned on. For example, R94 in Fig. 3 could be defective and could measure an incorrect cold resistance. Even if its cold resistance is approximately correct, remember that its control action might be defective. Hence, monitor the base-emitter bias on Q18 as the receiver warms up. If the bias voltage in-

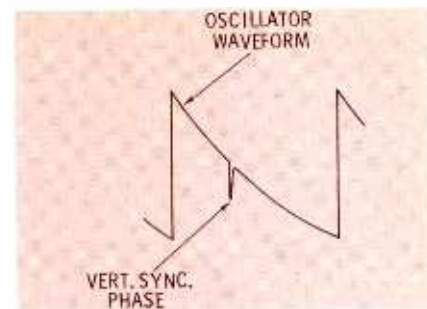

Fig. 5. Vertical sync pulse seen when picture is slowly rolled.

creases appreciably, replace the thermistor.

### Insufficient Vertical Deflection

Insufficient vertical deflection corresponds to attenuation of waveforms in the vertical-deflection system. Accordingly, scope waveform checks are very helpful in localizing the defective stage. Then, DC voltage and resistance measurements will assist in pinpointing the defective component.

When the base-emitter bias is adjusted too close to cutoff in a vertical-output stage, the output waveform is attenuated, and the size control can no longer bring the pattern to normal height. Therefore DC voltage measurements should be made in the output stage and compared with values specified in the receiver service data before assuming that a defective component is present. When the vertical-bias control is adjusted correctly, it may be found that normal pattern height is obtained. However, if full height is still lacking, the drive waveform to the output stage should be checked next. In case the drive waveform has subnormal amplitude, check the pertinent capacitors for leakage, and then proceed to check the height control, if necessary.

On the other hand, suppose that the drive waveform has sufficient amplitude, and full height still cannot be obtained; this situation throws suspicion on the vertical-output transistor. Check the DC bias voltage carefully—it might be observed for example, that although the base-to-emitter voltage is correct, the emitter voltage is high with respect to ground. This DC voltage distribution points to excessive collector-to-base leakage, and the transistor should be replaced. Again, when the drive waveform has sufficient amplitude and no DC voltage discrepancies are found, the

most likely culprit is the collector load impedance. For example, partial breakdown of T3 in Fig. 3 will cause reduced vertical deflection. Remember that capacitor leakage (such as C76 in Fig. 3) is a more likely trouble source than inductor defects.

Resistors are infrequent troublemakers; however, this possibility must not be overlooked when other components have been cleared. For example, R100 in Fig. 3 would be checked as a matter of routine in tracking down an obscure cause of insufficient vertical deflection. In general, voltage-dependent resistors are more likely to change value with age than are conventional fixed resistors. The same observation applies to semiconductor diodes; if the output from the vertical oscillator has subnormal amplitude, it is more likely that X8 in Fig. 1 is deteriorated than that a fixed resistor has changed in value.

#### **Vertical Nonlinearity**

We find that component defects which cause nonlinear vertical deflection are often accompanied by insufficient height. For example, if the gain in the vertical-output stage is subnormal, the height control must be advanced considerably to fill the screen. However, because there is interaction between the height control and the vertical-linearity control, it may be impossible to obtain satisfactory linearity. In such case, check the emitter-base bias on the output transistor first—perhaps adjustment of the vertical-bias control is all that is required to restore normal vertical deflection. If you must dig deeper, check the amplitudes of the vertical-deflection waveforms with a scope. In most cases, waveform distortion will indicate the defective stage.

A leaky coupling capacitor disturbs the DC voltage distribution in its associated circuit. Therefore, DC voltage measurements are made next to pinpoint the defective component. On the other hand, loss of capacitance cannot be determined by DC voltage measurements. Scope waveform analysis is the most useful approach. A suspected capacitor can be disconnected at one end for test on a capacitor bridge, or a substitution test can be made. Be

on the alert also for worn and noisy vertical-linearity controls. It may be found that lack of sufficient range is due to inability to obtain a correct resistance setting. Finally, if the vertical-output transistor is defective, this fact shows up in incorrect DC voltages at the electrodes, which cannot be brought to normal values by adjustment of the vertical-bias control. It is possible for an oscillator or driver transistor to become defective, although this is less likely because these transistors are not driven as hard as the vertical-output transistor. Note that the emitter current flow for Q18 in Fig. 3 is 145 ma. This is a very heavy current in comparison with the current in the preceding stages.

#### **Loss of Vertical Sync**

Loss of vertical sync can be caused by attenuated and/or distorted output from the vertical integrator. For this reason, a preliminary check of the vertical-sync signal should be made with a scope. If the integrator output is normal, the trouble will be found in the vertical sweep system. The vertical oscillator is probably operating off-frequency and cannot be brought on-frequency by adjustment of the vertical-hold control. In such a case the symptom is minimized when the vertical-hold control is set to one extreme end of its range.

When a bypass capacitor, such as C22 in Fig. 3 or C19 in Fig. 1, is leaky, the vertical-hold control is partially grounded and lacks normal range. Of course, the same difficulty can be caused by a worn resistance element in the vertical-hold control—in some cases, one or more open circuits are found in a badly worn resistance element. Oscillator transformers occasionally become defective, due to absorption of moisture or to charring by careless handling of soldering guns in cramped locations. If a vertical-oscillator transistor is defective, the trouble nearly always shows up in DC voltage measurements.

#### **Critical Vertical Sync**

Critical vertical sync can be caused by attenuated output from the integrator, and this possibility should be checked first with a scope. To make the vertical sync pulse

clearly visible at the base of the oscillator transistor, roll the picture down slowly, while observing the waveform. This will result in a display of the vertical-oscillator waveform with the sync pulse “riding” on the main pattern. Thereby, it is easy to observe the amplitude of the sync pulse (Fig. 5). On the other hand, if the picture is locked vertically, the pulse remains at the extreme end of the oscillator waveform, and it is much more difficult to determine the pulse amplitude.

When the vertical sync pulse has normal amplitude at the base of the oscillator transistor, critical vertical sync can be caused by oscillator instability that causes the blocking-oscillator frequency to fluctuate excessively. This can be compared with an intermittent condition, except that the fluctuation is marginal and not extreme. In general, the same type of component defects that cause intermittent operation are also responsible for critical vertical sync arising in the vertical sweep system.

To confirm a suspicion that the blocking-oscillator frequency is fluctuating excessively, set the vertical-hold control to roll the picture down slowly. If the speed of rolling then varies greatly, or if the picture comes to a standstill and then starts to roll, the suspicion of oscillator instability is confirmed. This is not a clear-cut trouble situation, because the defect is marginal and can occur in almost any component of the oscillator circuit. However, experience proves that capacitors are the prime suspects, and these should be checked first. Vertical-hold controls that have seen long service are also logical suspects. Do not overlook the possibility of an erratic semiconductor diode, such as X8 in Fig. 1.

#### **Poor Interlace**

As previously noted, poor interlace is commonly caused by integrator defects. On the other hand, if the integrator supplies a clean vertical sync pulse essentially free from horizontal pulses, we know that spurious horizontal pulses are entering the base or emitter of the oscillator transistor along some other path. Scope checks are very helpful in this situation, and they



are made to best advantage with no signal input to the receiver. The spurious horizontal pulses are generated by the horizontal sweep system, and waveform checks will show which branch of the vertical-oscillator circuit is contaminated with horizontal pulses.

Useful clues are obtained by observing whether loss of interlace (line pairing) is steady or "jumpy." A steady display of line pairing indicates a leakage path that permits a constant flow of horizontal pulses into the vertical-oscillator circuit. However, an erratic or "jumpy" condition of line pairing is more likely to be caused by pickup of horizontal radiation (often accompanied by streaks in the picture) which is due to small high-voltage arcs. Unstable vertical controls, or small defects in a vertical transformer also tend to cause "jumpy" symptoms. Scope patterns will also indicate whether the symptoms are steady or "jumpy."

#### Keystoning

This trouble is almost always caused by a breakdown in one of the vertical-deflection coils. It is possible for a damping resistor across a coil to decrease substantially in value, but this is far less likely than short circuits between turns of the deflection coil. Rough treatment of yokes at the bench can cause mechanical damage that results in keystoning. Breakdowns occur in normal service because of marginal insulation that deteriorates.

#### Horizontal AFC and Oscillator

A typical solid-state horizontal-AFC, oscillator, and driver configuration is shown in Fig. 6. This is a balanced type of AFC circuit that is driven by push-pull horizontal pulses from a sync phase inverter. Comparison pulses from the collector of the driver transistor are fed through L17 and C39 to the center of the balanced-diode circuit. When there is no signal present, the base bias of Q20 depends chiefly on the settings of R6, R5, and the net value of the comparison pulses rectified by X14 and X15. X15 conducts only on positive-going pulses; the bottom of R122 becomes less negative than the top of R121. Incoming sync pulses from the sync phase inverter are applied to the opposite electrodes of the AFC diodes; diode conduction depends on the combined peak voltages of the sync pulses and the comparison pulse. These resultant peak voltages change when the phase of the comparison pulse shifts away from the phase of the sync pulses.

In turn, the rectified output from the AFC diodes changes from the average value. This positive or negative voltage change at the base of Q20 keeps the horizontal oscillator on frequency and in phase via R124, L16, and T5. Note that C96, C38, R123, R124, C97, and C98 constitute a combination filter and anti-hunt network. Filter action converts the rectified pulses into a smooth DC control voltage. The

anti-hunt network is an RC phase-shifting circuit which provides out-of-phase feedback, thereby preventing motorboating (hunting). L16 and C99 function as a waveshaping arrangement to provide an optimum oscillator drive waveform to the base of Q20.

Positive feedback from the collector to the base of Q20 occurs through blocking-oscillator transformer T5 and thus permits oscillation. Note diode X16; this diode short-circuits the overshoot pulse at the trailing edge of the collector waveform and thereby operates both as a waveshaper and as a protective device for the transistor. Q20 appears to be reverse-biased on the basis of DC voltage measurements, but the scope waveforms show that the transistor is forward-biased during pulses of collector current. The resistive network, which includes thermistor R128, stabilizes collector current against temperature changes to prevent oscillator frequency drift.

#### DC Voltage Distribution

Voltages in transistor AFC and oscillator circuits are quite different from those in tube-type configurations. For example, Fig. 7 notes electrode voltages for a tube and a transistor used in typical horizontal-oscillator circuits. The tube electrode voltages are 265, 0, and -75 volts, whereas the transistor electrode voltages are -7.3, -1.5, and -0.36 volt. The DC voltage at the top of R118 (Fig. 6) has a range

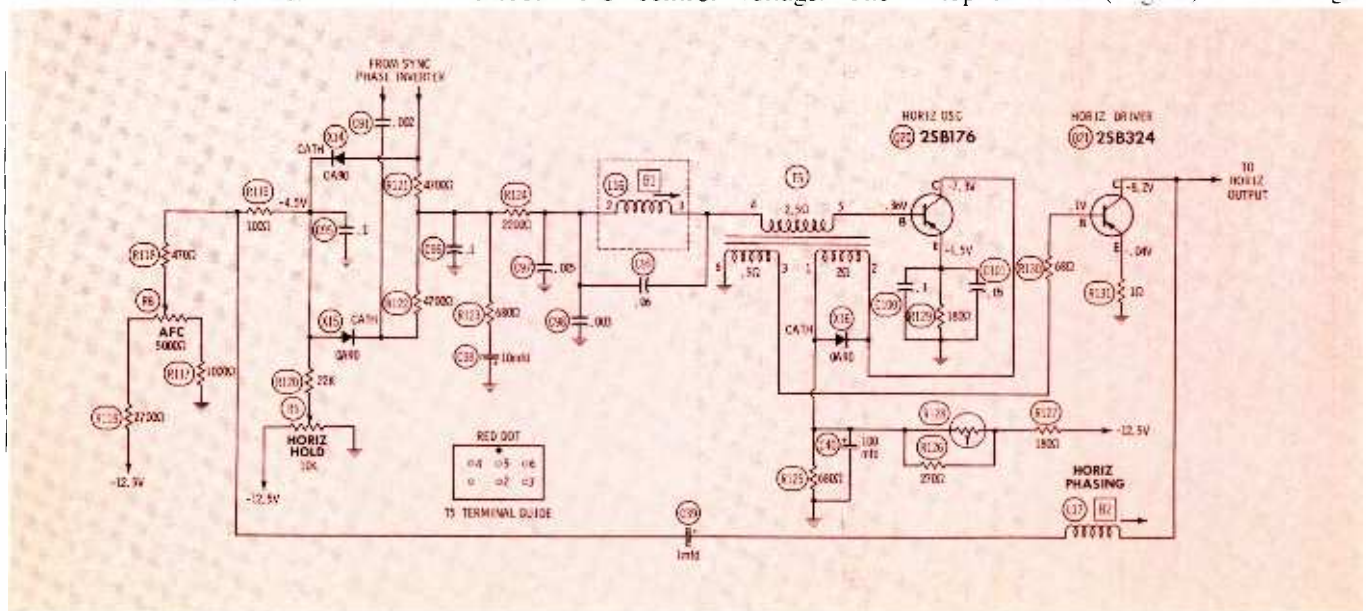

Fig. 6. A typical solid-state horizontal AFC, Oscillator, and driver.

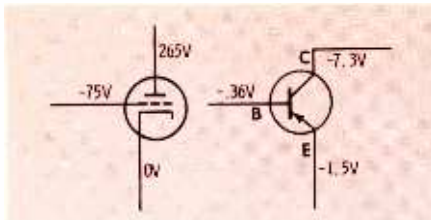

Fig. 7. Comparison of DC voltages in transistor and tube oscillators.

of  $-1$  to  $-7.5$  volts, depending on the setting of R6. A range variation of about 2 volts DC is provided by the setting of R5. Presence or absence of signal has little effect on the DC voltage value, although the no-signal DC voltage is about 0.1 volt higher in normal operation.

The DC voltage at the top of R121 has a range of from  $-1$  to  $-6$  volts, depending on the setting of R6. In normal operation, when R6 is set to mid-range, adjustment of R5 causes the DC voltage to vary through a range of from  $-3.8$  to  $-4.8$  volts. When signal is present, the DC voltage normally increases about 0.3 volt. Next, at the lower end of R122, the DC voltage goes through zero and changes to a positive voltage as the setting of R6 is reduced to minimum. At the base of Q20, adjustment of R5 varies the DC base voltage through a range of from  $-0.2$  to  $-0.7$  volt. Adjustment of R6 to minimum causes the DC base voltage to go through zero and swing to a value of about 0.2 volt positive.

The DC voltage at the emitter of Q20 goes through a range (in normal operation) of from  $-1.3$  to  $-1.8$  volts as R5 is turned through its range. However, the collector voltage changes very little. Adjustment of L16 has little effect on DC

voltages, but changes the waveshape at the base of Q20. As in tube-type receivers, L16 is adjusted to bring the peak of the pulse and the peak of the sine wave to the same level—oscillator operation is then at maximum stability. L17 also has little effect on DC voltages; it is a phasing coil for the comparison pulse.

#### Other AFC Circuits

You will find another basic type of AFC circuit in various transistor television receivers, as shown in Fig. 8. This is a common-emitter configuration, and it is analogous to the common-cathode type of AFC circuit used in many tube-type receivers. Horizontal sync pulses are fed to the base of Q21, and a flyback comparison pulse is fed to the collector. The emitter waveform is a combination of the sync and comparison pulses, since both affect emitter current. When the phase of the flyback pulse changes with respect to the sync pulse, the peak voltage of the combination waveform also changes, which increases or decreases emitter current. In turn, the DC control voltage to the base of Q22 changes to correct the frequency and phase of oscillation.

Although the foregoing arrangements are the most common, you will also find configurations that employ a DC amplifier in the AFC section, as shown in Fig. 9. Transistor Q19 amplifies the DC correction voltage from the AFC diodes, thereby providing tighter control of frequency and phase for Q20. Note that the dual-diode circuit in Fig. 9 is different from that shown in Fig. 6. We call the configuration in Fig. 6 a balanced AFC circuit—the

diodes are driven by push-pull sync pulses. On the other hand, the arrangement in Fig. 9 is termed an unbalanced AFC circuit—sync pulses are injected from a single-ended source. A balanced system has a theoretical advantage of somewhat greater noise immunity.

Different waveforms are present at the terminals of X14 and at the terminals of X15 in Fig. 9. Accordingly, the current in the diodes changes from one instant to the next and depends on the instantaneous voltages of the two waveforms. However, over one complete cycle of operation there is an average value of current in each diode. The difference between these two average values determines the amount of DC voltage applied to the base of Q19. In case the horizontal oscillator drifts off-frequency, the relative phases of the two waveforms across the terminals of an AFC diode change. In turn, the average value of rectified voltage also changes. One diode now conducts more than the other diode, and the DC control voltage becomes higher or lower, depending on whether the phase error is leading or lagging.

#### Common Troubles

The following analysis of troubles deals with those which are most common. You will note that these symptoms are much the same as those displayed by tube receivers.

#### Loss of Raster

Loss of raster can be caused, as we know, from a defect in the horizontal sweep system. Therefore a preliminary localization test is necessary. If a scope check shows that normal drive is being applied to the horizontal-output stage, we will not waste time looking for a defect in the horizontal-oscillator and AFC section. On the other hand, a weak, absent, or distorted drive waveform directs our attention to the horizontal oscillator.

When a shunt capacitor is shorted, such as C104 in Fig. 9, the DC voltage on the base of Q20 falls to zero. A very heavy current flows from emitter to base, which burns out the transistor and stops the horizontal oscillator. Comparison pulses are not present, but sync pulses are displayed in the AFC section. The

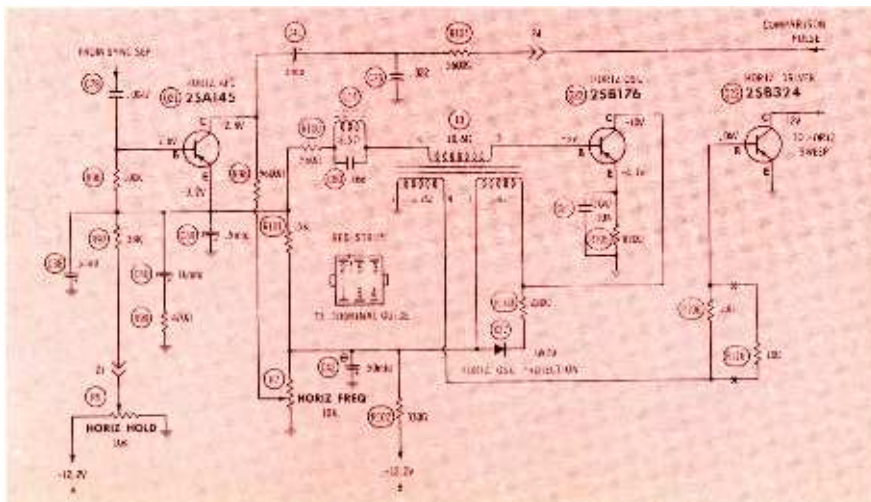

Fig. 8. AFC circuit using a transistor in place of diodes.

suspicion of a shorted capacitor can be confirmed by an ohmmeter test. Suppose that X16 in Fig. 6 is shorted. In this case, there is no feedback from collector to base for Q20, and the horizontal oscillator stops. The shorted diode is more difficult to pinpoint than a shorted capacitor, because the diode is shunted by a low-resistance coil winding. However, DC voltage measurements provide a useful clue. Since the electrode voltages on Q20 are unchanged, failure of the stage to oscillate points to a defect in the feedback circuit.

When a receiver has seen considerable service, the potentiometer controls become likely suspects. If R6 in Fig. 6 is open, the bias on the base of Q20 will drop to less than half of its normal voltage and have incorrect polarity; the oscillator will operate at an excessively low frequency. The picture-tube screen will be dark unless the horizontal hold control is turned toward the end of its range. Then, a dim raster with a split picture will appear when the hold control is very carefully adjusted. At this point the oscillator is operating at 7875 Hertz. A scope check will show that the sync section is normal and that the trouble is in the AFC or horizontal-oscillator stage. Voltage measurements direct attention to the AFC stage, because of positive bias on the base of Q20 and subnormal DC voltages through the AFC circuit. The same symptom can be caused either by a break in the printed-circuit wiring or a cold solder joint to R116 or R118. Resistor failure is also a possibility, but R6 should be checked first.

A dark screen also occurs if there is a short in C40 (Fig. 6). The collector voltage is removed from Q20, and the circuit does not oscillate. Substantial leakage in C40 also results in a dark screen; in this case the collector voltage is reduced to a fraction of its normal value. On the other hand, if components in the oscillator circuit are cleared, failure to oscillate points to a defective transistor. If Q20 in Fig. 6 develops excessive collector-to-base leakage, the DC voltage at the base becomes positive and the stage fails to oscillate. The emitter voltage remains negative but measures only a fraction of its normal value.

#### Loss of Horizontal Sync

Loss of horizontal sync can result from defects in the signal channel or sync section, as well as in the horizontal-AFC and oscillator section. Hence, a preliminary localization test is necessary. If you find normal pulse output with a scope check at the output of the sync section, it can be concluded that the trouble will be found in the horizontal-AFC or oscillator section.

When the AFC feedback capacitor in Fig. 6 is open, the comparison pulse is missing from the AFC waveforms. This is the most helpful preliminary clue. Voltage measurements are not very informative, because the absence of the comparison pulse produces slight changes in DC voltage values. Scope checks will show that the comparison pulse is present at the right-hand terminal of C39 in Fig. 6, thereby pinpointing the defect. Note that the picture can be framed by critical adjustment

of the horizontal-hold control. However, a phasing error is present and the picture is considerably decentered to the left.

If the stabilizing capacitor is open, the stabilizer coil rings at too high a frequency, and adjustment of the core has little effect on the picture display. The picture can be framed by critical adjustment of the horizontal-hold control, but three overlapping images are displayed. Voltage measurements afford one clue in that the emitter voltage on Q20 reads about 0.4 volt too high. However, the most direct indication that the stabilizing capacitor is open arises from the observation that slug adjustment in the stabilizer coil produces little response.

Defective AFC diodes are the most common cause for loss of horizontal sync, aside from capacitor defects. Marginal failure results in touchy horizontal hold. Waveform checks in the AFC section will show incorrect proportions. Voltage measurements are not very informative unless one of the diodes is completely open or completely shorted. A poor front-to-back ratio shows up clearly on an ohmmeter check. However, a diode must be disconnected at one end for testing, because of the comparatively low value of circuit resistance. Do not confuse diode defects with capacitor defects. For example, if C91 in Fig. 6 is open, negative-going sync pulses are absent, and it might be falsely concluded that X15 is shorted. However, an ohmmeter test will clear the diode.

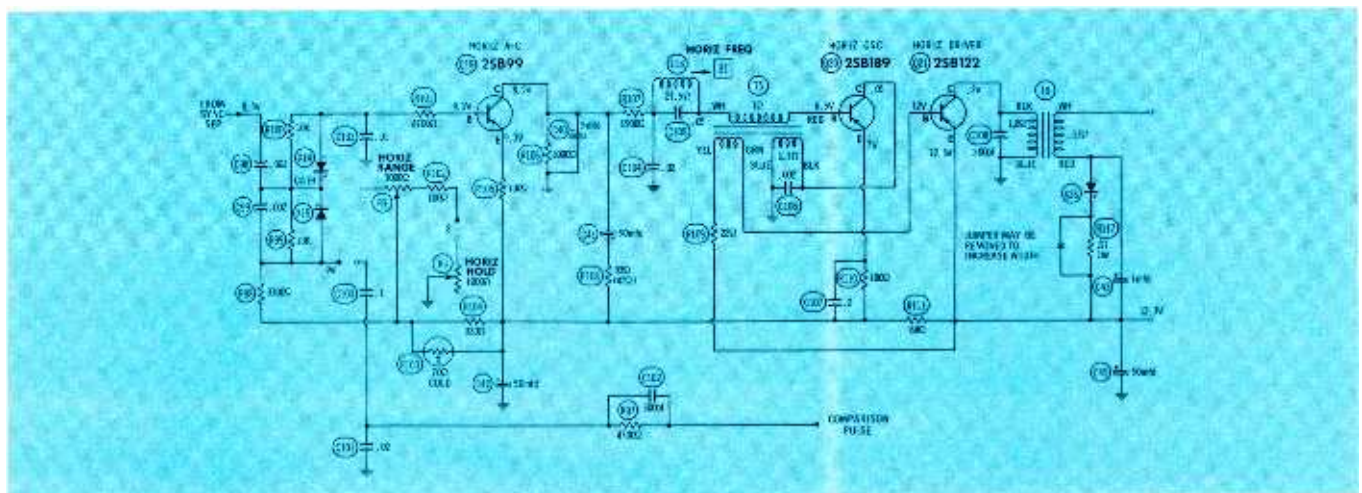

Fig. 9. Unbalanced AFC configuration using amplifier.

### Incorrect Horizontal Phasing

Incorrect horizontal phasing is commonly associated with critical horizontal hold. The reason for this symptom is that component defects which cause triggering of the horizontal oscillator at a delayed time also result in distorted AFC waveforms that fail to provide a normal range of control voltage.

An open capacitor, such as C39 in Fig. 6, is easily pinpointed by scope waveform analysis—the comparison pulse is missing from the AFC waveforms, but the pulse is present at the right-hand terminal of C39. A leaky coupling capacitor shows up as an abnormal DC voltage distribution in the associated circuit. In a circuit such as the configuration of Fig. 9, it could be difficult to decide whether the abnormal DC distribution is caused by a defective capacitor or a defective transistor. Analysis of DC voltage values is complicated by inability to determine what the normal setting of the horizontal-hold control may be. Therefore we proceed to check out the capacitors first, because they are the most common troublemakers.

If a capacitor appears to be open on the basis of scope tests, it is generally true that the capacitor has actually opened. However, it is good practice to check for breaks in printed-circuit wiring and cold solder joints before replacing the suspected capacitor. Similarly, when

a capacitor appears to be leaky on the basis of DC voltage measurements, it is good foresight to inspect the printed-circuit wiring for evidence of leakage paths between conductors. These simple precautions can occasionally save time otherwise lost in replacing a capacitor that is actually in good condition.

Horizontal pulling is often associated with critical horizontal synchronization. In such cases, refer to the discussion under Symptoms 2 and 3. When the picture pulls at the top, the first step is to check the waveform at the base of the horizontal-oscillator transistor. If the waveform is distorted, determine whether it can be restored to normal by adjustment of the slug in the horizontal-stabilizer coil. However, if this adjustment is ineffective, we know that there is a defective component in the AFC circuit.

It is generally found that only one defect is present. Nevertheless, it is possible for two marginal defects to occur simultaneously. For example, if there is collector-to-base leakage in a transistor such as Q19 in Fig. 9, this defect will aggravate picture pulling caused by a defective AFC diode. Transistor leakage reduces the normal gain of the amplifier and impairs the range of the already abnormal control voltage. When a semiconductor diode becomes defective, we usually find that the forward resistance has in-

creased, and the back resistance has decreased.

### Insufficient Width

Insufficient width, when caused by a defect in the horizontal-oscillator stage, is due to subnormal amplitude of the output waveform (Fig. 10). In most transistor television receivers, the driver output waveform has a normal amplitude of about 6 volts p-p. However, there are exceptions, and the service data should be consulted for the particular receiver.

Scope waveform checks are very helpful in preliminary localization tests. If the drive waveform to the base of Q21 in Fig. 10 is normal, we know that the trouble occurs after the horizontal-oscillator stage. An attenuated drive waveform at the base of Q22 in Fig. 10 is most likely to be caused by collector-to-base leakage in Q21. This suspicion can be confirmed by DC voltage measurements. Collector leakage is indicated by a reduced value of collector voltage. However, if the transistor is not defective, transformer T4 in Fig. 10 becomes the logical suspect. It is difficult to detect marginal defects, such as a few shorted turns, on the basis of ohmmeter measurements. Therefore, a substitution test is advisable.

*Part 2 of this two-part article will cover the horizontal-output and high voltage sections employed in transistor TV receivers.* ▲

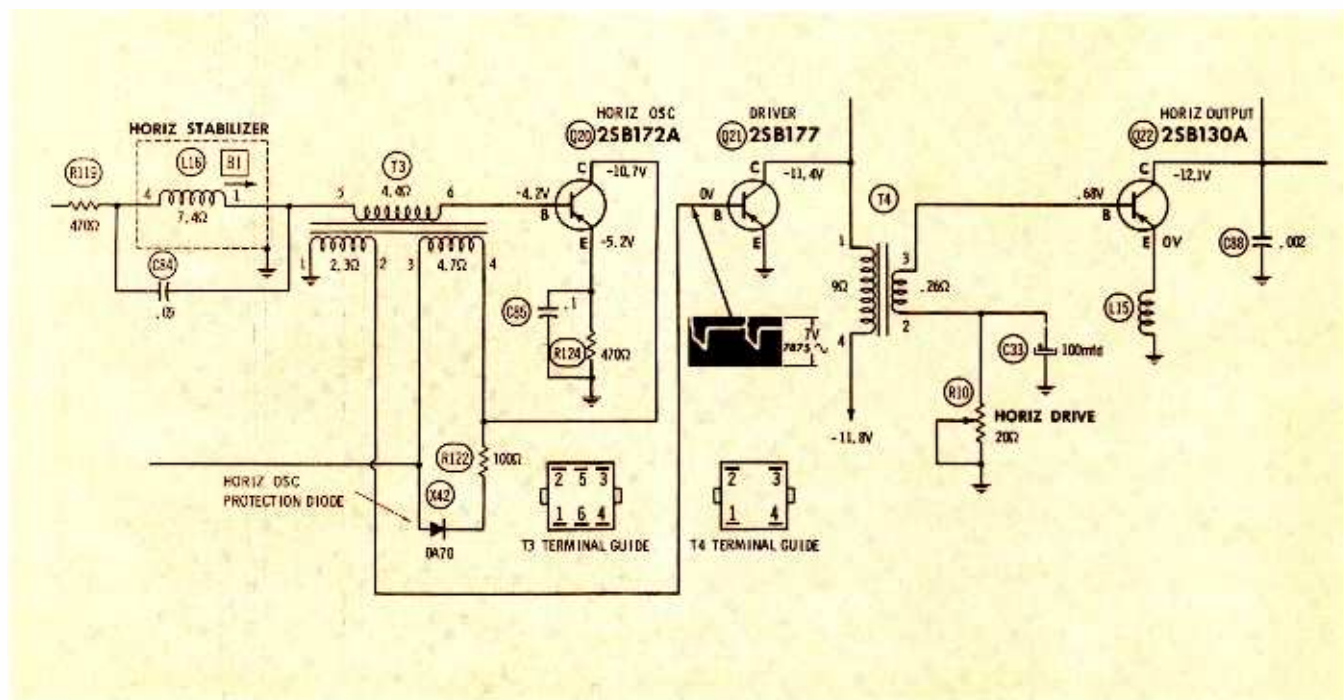

Fig. 10. To obtain full picture width, driver waveform must have normal amplitude.



# \$975

EFFECTIVE 8/1/67

## GUARANTEED

Nine-seventy-five buys you a complete tuner overhaul—including parts (except tubes or transistors)—and absolutely no hidden charges. All makes, color or black and white. UV combos only \$15.

Guaranteed means a full 12-month warranty against defective workmanship and parts failure due to normal usage. That's 9 months to a year better than others. And it's backed up by the only tuner repair service authorized and supervised by the world's largest tuner manufacturer—Sarkes Tarzian, Inc.

Four conveniently located service centers assure speedy in-and-out service. All tuners thoroughly cleaned, inside and out . . . needed repairs made . . . all channels aligned to factory specs, then rushed back to you. They look—and perform—like new.

Prefer a replacement? Sarkes Tarzian universal replacements are only \$10.45, customized replacements \$18.25. Shipped same day order received. Order custom tuners by TV make, chassis, and model number. Order universal replacement by part number:

Part #	Intermediate Frequency	AF Amp Tube	Osc. Mixer Tube	Heater
MFT-1	41.25 mc Sound 45.75 mc Video	6GK5	6LJ8	Parallel 6.3V
MFT-2	41.25 mc Sound 45.75 mc Video	3GK5	5LJ8	Series 450 MA
MFT-3	41.25 mc Sound 45.75 mc Video	2GK5	5CG8	Series 600 MA

Genuine Sarkes Tarzian universal replacement tuners with Memory Fine Tuning—UHF Plug in for 82-channel sets—Pre-set fine tuning—13-position detent—Hi gain—Lo noise—Universal mounting

FOR FASTEST SERVICE, SEND FAULTY TUNER WITH TV MAKE, CHASSIS, AND MODEL NUMBER, TO TUNER SERVICE CENTER NEAREST YOU



**TUNER SERVICE CORPORATION** FACTORY-SUPERVISED TUNER SERVICE

MIDWEST . . . . . 817 N. PENNSYLVANIA ST., Indianapolis, Indiana . . . . . TEL: 317-632-3493

EAST . . . . . 547-49 TONNELE AVE., Jersey City, New Jersey . . . . . TEL: 201-792-3730

SOUTH-EAST . . . . . 938 GORDON ST., S. W., Atlanta, Georgia . . . . . TEL: 404-758-2232

WEST . . . . . SARKES TARZIAN, Inc. TUNER SERVICE DIVISION  
10654 MAGNOLIA BLVD., North Hollywood, California . . . . . TEL: 213-769-2720

Circle 4 on literature card



SYLVANIA

SYLVANIA  
RADIO  
TV  
SERVICE

BRIGHT  
GUY

# Are you eligible for the Bright Guy Awards?

It's easy to get them—and to get all the business they'll bring you. New customers. More sales. More money.

The Bright Guy Awards is the big program Sylvania's running this year to boost your sales.

Your Sylvania distributor can put your name and address in TV Guide in your own area. These Sylvania ads will call you "the brightest serviceman in town"—and tell people in your town why they should call you.



You'll get into the Yellow Pages, too, under the heading "TV Service and Repairs."

Once again this year you'll be eligible for over



one hundred valuable, interesting SMB-Bright Guy gifts, just for buying the Sylvania TV replacement parts you normally buy anyway.

And you'll get window displays proclaiming you "the brightest"—the TV serviceman everyone's reading about.

You're eligible for the Bright Guy Awards just by buying Sylvania's famous *color bright 85*<sup>®</sup> color picture tube. And our other picture tubes, and our receiving tubes. So see your Sylvania distributor.

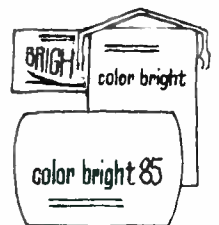

Sylvania Electronic Tube Division, Electronic Components Group, Seneca Falls, New York 13148.

**SYLVANIA**  
SUBSIDIARY OF  
GENERAL TELEPHONE & ELECTRONICS **GTE**

Circle 5 on literature card

[www.americanradiohistory.com](http://www.americanradiohistory.com)

# Channel Master smashes the 82 Channel size barrier!

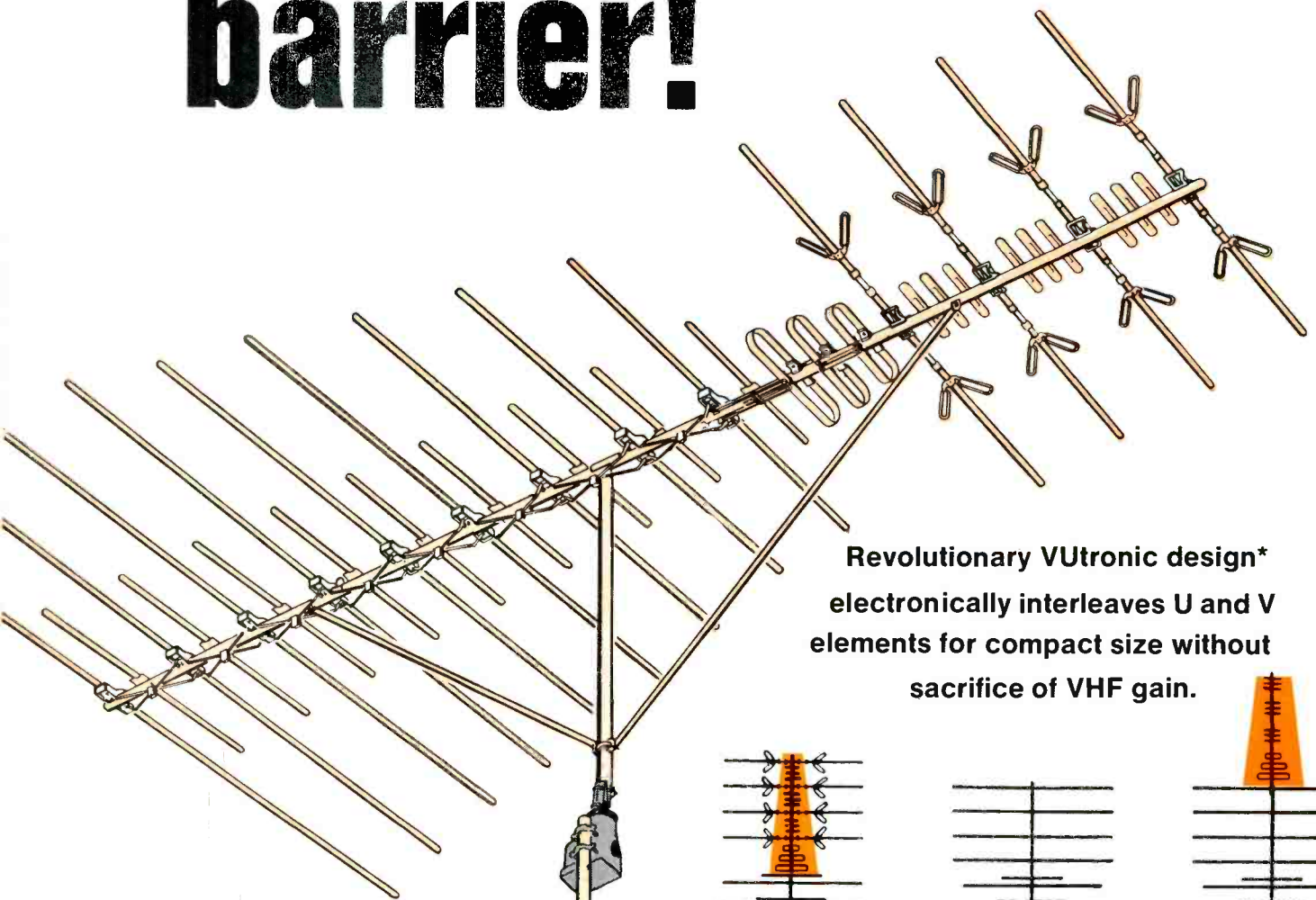

Revolutionary VUtronic design\*  
electronically interleaves U and V  
elements for compact size without  
sacrifice of VHF gain.

Deep Fringe  
**Model 3661-G**  
Same VHF gain as  
Color Crossfire  
Model 3610-G

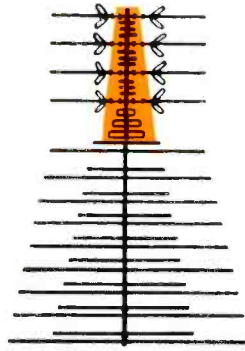

Fringe area Model 3661G has all UHF elements contained within the over-all length of the VHF section

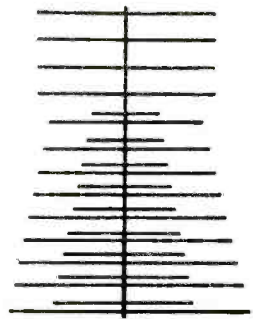

A VHF only antenna with exactly the same VHF gain as the 82-channel Model 3661G is also practically the same size.

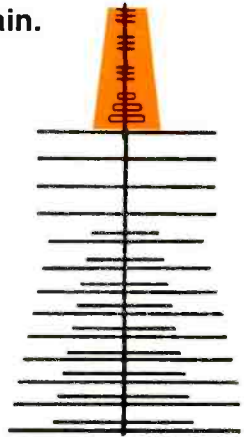

Usual design 82-channel antenna would have to be 34% longer to provide the same UHF and VHF gain as Model 3661G Color Crossfire 82.

\*Patent Applied For



# New Color Crossfire 82

## UHF/VHF Antennas plus FM/FM Stereo

Totally new concepts in UHF/VHF design are joined with Channel Master's proven Crossfire principle to produce the first 82-channel antennas that meet UHF reception needs yet also provide unsurpassed VHF gain...and with no appreciable increase in over-all size.

Here is another example of a major development from Channel Master Laboratories where, as always, leadership begins with research.

Until now, antenna manufacturers have created combination UHF/VHF antennas by coupling a UHF section to the front of a VHF antenna. To avoid costly, unwieldy, and unsightly construction, this has always meant sacrificing VHF gain. Now Channel Master fills the 82-channel gain gap with Color Crossfire 82 antennas designed for metropolitan to fringe areas where maximum VHF gain is as important as UHF reception power.

In addition to the famous Channel Master Crossfire VHF Proportional Energy Absorption Principle, these new antennas employ unique series-fed folded UHF dipoles with carefully engineered dimensions so that they literally "disappear" and operate as a perfect 300 ohm line at VHF frequencies...no "lossy" couplers required as is the case with the usual parallel-fed UHF elements.

And, of course, every Color Crossfire 82 antenna features Channel Master's famous E.P.C. golden coating and rugged preassembled construction.

**HERE'S THE SECRET**

UHF Director Low end UHF  $\frac{1}{2}$  UHF Director High end UHF  $\frac{1}{2}$  2 UHF Wave-Lengths overall

VHF Director UHF Phase Controller Center Insulator VHF Director

VUtronic design employs unique dual-function co-linear directors (on all but three metropolitan models) serving both UHF and VHF sections. This permits space-saving inclusion of the UHF elements **into** the physical structure of the full-power VHF array. The exclusive UHF phase controller "whiskers" boost UHF gain by making each full-wave director the equivalent of two full wave lengths.

**Now the first and only complete line of full VHF Power 82-channel antennas.**

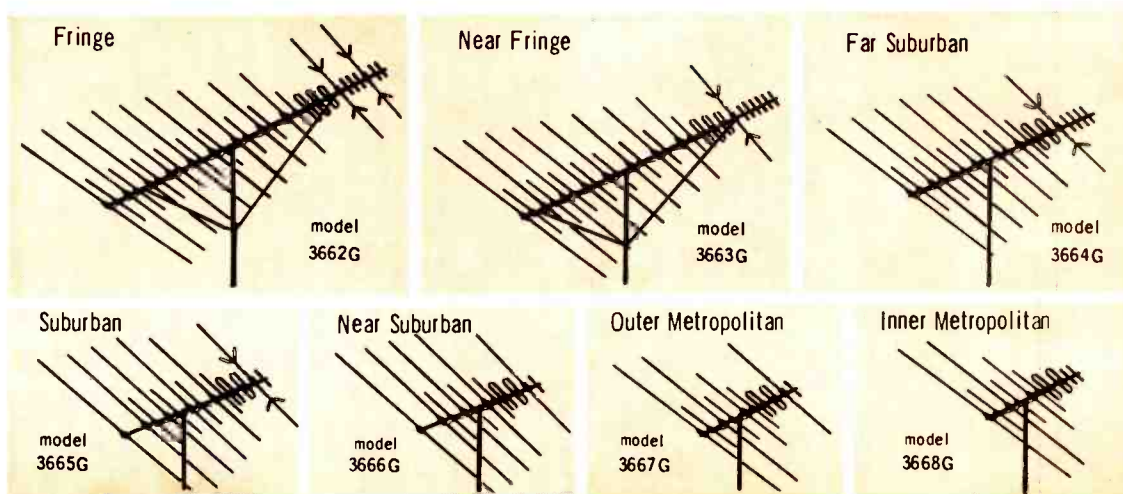

**More Channel Master Crossfire Series Antennas have been sold and are being sold...than any other antenna in the history of television.**

**CHANNEL MASTER**  
Ellenville, N.Y.

Circle 6 on literature card

# PF Reporter

PHOTOFACT

*the magazine of electronic servicing*

VOLUME 17, NO. 8

AUGUST, 1967

PUBLISHER  
HOWARD W. SAMS

GENERAL MANAGER  
DONALD W. BRADLEY

EDITOR  
WILLIAM E. BURKE

MANAGING EDITOR  
JAMES M. MOORE

ASSOCIATE EDITORS CONSULTING EDITORS

Thomas T. Jones Joe A. Groves  
J. W. Phipps C. P. Oliphant  
Carl F. Moeller George B. Mann

PRODUCTION MANAGER RESEARCH LIBRARIAN  
Esther M. Rainey Mrs. Bonny Howland

CIRCULATION MANAGER  
Pat Osborne

ART DIRECTORS  
Louis J. Bos, Jr. & Robert W. Reed

PHOTOGRAPHY  
Paul Cornelius, Jr.

ADVERTISING  
SALES MANAGER  
HUGH WALLACE

ADVERTISING SALES OFFICES

*central and midwestern*

ROY HENRY

Howard W. Sams & Co., Inc., 4300 W. 62nd St.  
Indianapolis, Ind., 46206 • 317-291-3100

*eastern*

ALFRED A. MENEGUS

Howard W. Sams & Co., Inc., 3 W. 57th St.  
New York, New York, 10019 • 212-688-6350

*southwestern*

MARTIN TAYLOR

P. O. Box 22025, Houston, Texas 77027  
713-621-0000

*western/Los Angeles*

G. R. (JERRY) HOLTZ

The Maurice A. Kimball Co., Inc.  
2008 W. Carson St., Suites 203-204  
Torrance, Calif., 90501 • 213-320-2204

*western/San Francisco*

The Maurice A. Kimball Co., Inc.

580 Market St., Room 400  
San Francisco, Calif., • 415-392-3365

Address all correspondence to PF REPORTER  
4300 W. 62nd Street, Indianapolis, Indiana 46206



Copyright © 1967 by Howard W. Sams & Co., Inc. PF REPORTER is a trademark of Howard W. Sams & Co., Inc. No part of PF REPORTER may be reproduced without written permission. No patent liability is assumed with respect to use of information herein. Acceptance of advertising does not in any manner signify the products, policies and services so advertised have been approved, endorsed or recommended by this magazine.

Subscription Prices: 1 year—\$5.00, 2 years—\$8.00, 3 years—\$10.00, in the U. S. A., its possessions and Canada. All other foreign countries: 1 year—\$6.00, 2 years—\$10.00, 3 years—\$13.00. Single copy 75¢; back copies \$1.

Indexed in Lectrodex. Printed by the Waldemar Press Div. of Howard W. Sams & Co., Inc.

## CONTENTS

Tube Substitution Supplement	1
<b>Solid-State Deflection Circuits—Part I</b> Robert G. Middleton	7
8-page book section analyzing the operation and troubleshooting of transistor sweep systems.	
<b>Color TV Service Training</b>	22
First installment in a training series covering color from basic fundamentals to advanced servicing.	
<b>The Electronic Scanner</b>	29
<b>Servicing High-Quality Audio</b> Carl F. Moeller	32
Component and system analysis, plus a review of performance tests.	
<b>Solid-State Color is Here</b> T. T. Jones	40
A look at Motorola's new transistor color TV.	
<b>Measuring the Results of Advertising</b> Elizabeth M. Sorbet	44
Getting the most from advertising involves planning and evaluation—hit and miss techniques will probably miss.	
<b>Notes on Test Equipment</b>	52
Lab report on Hickok Model 860 Injecto-Tracer and Sencore Model CR 143 CRT Tester.	
<b>The Troubleshooter</b>	54
<b>Letters to the Editor</b>	56
<b>PHOTOFACT BULLETIN</b>	61
<b>Product Report</b>	
<b>Book Review</b>	72
<b>Puzzler</b>	73
<b>Free Catalog and Literature Service</b>	76
<b>Monthly Index on Free Literature Card</b>	

## ABOUT THE COVER

Nearly all advances in electronic technology have been spectacular in the sense that they represent a completely new concept or improvement in the state of the art. However, few developments have created such spectacular visual evidence of their uniqueness as the laser and its intense beam of light. Our cover photo, taken at the Crystal Products Research and Development Laboratory of Union Carbide Corporation, illustrates this point quite well. The technician in the photo is using an oscilloscope to determine the intensity and duration of the laser impulse.





PART  
1

**COLOR TV**

**service training**



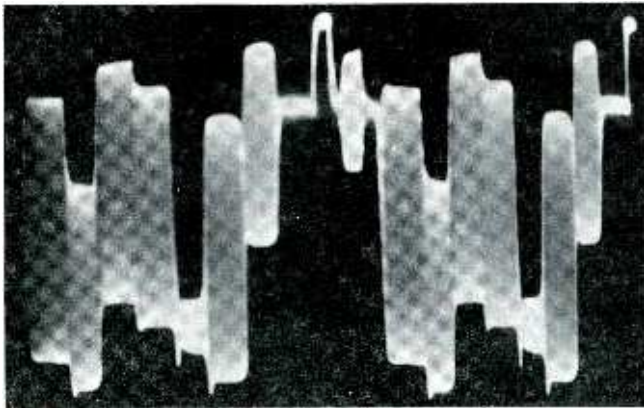

# developing the color signal

Color TV is now the success that was predicted many years ago. It is an exact science that demands a certain degree of knowledge on the part of the technician before he can successfully troubleshoot and repair a color receiver. Too many technicians are still using the hit-and-miss servicing techniques that have allowed them to "get by" in monochrome servicing. We are presenting this series in an attempt to educate all technicians to the level required for successful color TV servicing.

—The Editor

The video signal from a color-TV transmitter actually consists of two separate signals. These are the luminance and chrominance signals. To properly understand the color-TV transmission system, we must study the make-up of these signals at the transmitter.

The scene to be televised is viewed by a tricolor camera which receives white light from the scene and produces three signals representative of the red, green, and blue components of that white light. Fig. 1 shows the basic components of the tricolor camera.

The white light from the scene is focused by the optical system and is directed onto the dichroic mirror at A. This type of mirror is designed and manufactured to pass all light frequencies of the spectrum except those of one particular primary color. Thus the mirror at A reflects blue light and passes all the other light. The beam of blue light is directed onto a front-surface mirror at B and thence onto the photo-surface of the blue camera tube.

The light passing through the

mirror at A strikes another dichroic mirror at C, which is designed to reflect red light. The red beam is directed to a front-surface mirror at D and thence to the red camera tube. The light beam passing through mirror C is devoid of blue and red and contains only green light; thus it goes directly to the green camera tube. We can see that the light from the scene being televised has been broken up into the three primary colors.

The three camera tubes and their associated amplifiers develop three voltages which are representative of the three colors. These voltages we will designate as  $E_R$  for red,  $E_G$  for green, and  $E_B$  for blue. We will go on to see how the luminance and chrominance signals are formed from these three voltages.

## The Luminance Signal

In order for the color signal to be compatible with black-and-white receivers, one portion of the signal must represent the televised scene in terms of brightness only and must be very similar to the video signal specified for monochrome transmission. This signal is called the luminance signal.

When the specifications for this

luminance signal were being drawn up, the response of the human eye to light of different frequencies was considered. The human eye does not see all colors with equal brightness. We can best illustrate this with three projectors for red, green, and blue beams. If these projectors are adjusted so that their outputs are equal, as measured by photoelectric instruments, white light will be produced when the three beams are superimposed upon each other. When viewed separately, the green light will appear to the average person to be almost twice as bright as the red light and from five to six times as bright as the blue light. We can see that the human eye is most sensitive to green, less sensitive to red, and least sensitive to blue.

This varying sensitivity of the eye was considered when the luminance signal was designed. The color signals from the camera are combined in definite proportions to form the luminance signal: 59 per cent of the total green signal, 30 per cent of the total red signal, and 11 per cent of the total blue signal.

We frequently call the luminance signal by the term, Y signal, and express its signal voltage as  $E_Y$ . The equation for expressing the content of  $E_Y$  can be derived from the percentages given previously and is written as:

$$E_Y = .59 E_G + .30 E_R + .11 E_B \quad (1)$$

where,

$E_G$  = the voltage of the green signal,

$E_R$  = the voltage of the red signal, and

$E_B$  = the voltage of the blue signal.

The actual formation of a luminance signal can be understood by

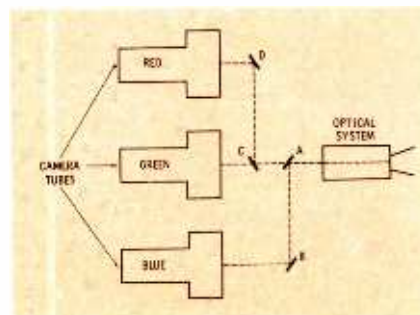

Fig. 1. Arrangement of basic components of a tricolor camera.

considering Fig. 2. Assume the scene to be televised consists of a card having four vertical bars. These are, from left to right: white, red, green, and blue. We adjust the camera so that each of the color signals from the camera is one volt when the camera is focused on the white bar. As equation 1 states, the luminance, or Y signal, will also be one volt at this time. A monochrome receiver tuned to this signal would produce a bright white bar on its screen.

When the camera is shifted to scan the red bar, the red signal remains at one volt and the blue and green signals drop to zero. If  $E_B$  and  $E_G$  in equation 1 are zero,  $E_Y$  must equal .30 volts. A monochrome receiver will produce a gray bar with this signal.

Scanning of the green bar will produce a green signal of one volt and zero for the red and blue signals. The luminance or Y signal will have a value of .59 volts and will produce a very light gray bar on the monochrome receiver. Scanning of the blue bar will cause the blue signal to be one volt and the red and green signals to be zero. The Y signal will be .11 volts and the monochrome receiver will produce a dark gray bar.

### The Chrominance Signal

In addition to the luminance signal which conveys the black-and-white information, we must transmit

a signal conveying the color information. This is called the chrominance signal and, since it conveys only color information, we must remove the black-and-white or luminance information from it. We can do this by subtracting the luminance voltage,  $E_Y$ , from each of the three color signals produced by the color camera. Fig. 2 shows how this is done. The polarity of the luminance signal is inverted and combined with each of the three camera signals. The result is three signals representing red minus luminance, blue minus luminance, and green minus luminance. These are the important *color-difference signals* and are designated as:  $E_R - E_Y$ ,  $E_B - E_Y$ , and  $E_G - E_Y$ . These are often shortened to R-Y, B-Y, and G-Y; but it should be remembered that these represent voltages and not colors.

The term  $E_Y$  in each of the color-difference signals has the value given in equation 1. If we substitute this value, we obtain three equations for the color-difference signals in terms of the three primary colors.

$$\begin{aligned} E_R - E_Y &= E_R - (.30 E_R + .59 E_G + .11 E_B) \\ E_R - E_Y &= E_R - .30 E_R - .59 E_G - .11 E_B \\ E_R - E_Y &= .70 E_R - .59 E_G - .11 E_B \end{aligned} \quad (2)$$

Similarly

$$\begin{aligned} E_G - E_Y &= .41 E_G - .30 E_R - .11 E_B \end{aligned} \quad (3)$$

$$\begin{aligned} E_B - E_Y &= .89 E_B - .59 E_G - .30 E_R \end{aligned} \quad (4)$$

A further understanding of these color-difference signal equations can be derived from Fig. 2. If the red bar is being scanned, the R-Y matrix receives one volt of red signal. The luminance signal is .30 volt at this time (from equation 1). The polarity inverter changes this value to  $-.30$  volt which is also applied to the R-Y matrix. The two voltages applied to the R-Y matrix form the R-Y signal: 1.0 volt minus .30 volt or .70 volt. Note that this agrees with the coefficient of  $E_R$  in equation 2.

The luminance signal is .59 volt when the green bar is being scanned and the red signal is at zero. The R-Y signal becomes  $-.59$  volt. This agrees with the coefficient of  $E_G$  in equation 2. During the scanning of the blue bar, the signals to the R-Y matrix are zero and  $-.11$  volt; the resultant R-Y signal becomes  $-.11$  volt. This is the coefficient of  $E_B$  in equation 2. The voltages of the color signals in equations 3 and 4 can be derived in a similar manner.

The voltages of the color-difference signals all become zero when the white bar is scanned and no chrominance signal is developed. This is as it should be, because only a luminance signal is needed for black-and-white information. This is also true for any shade of gray.

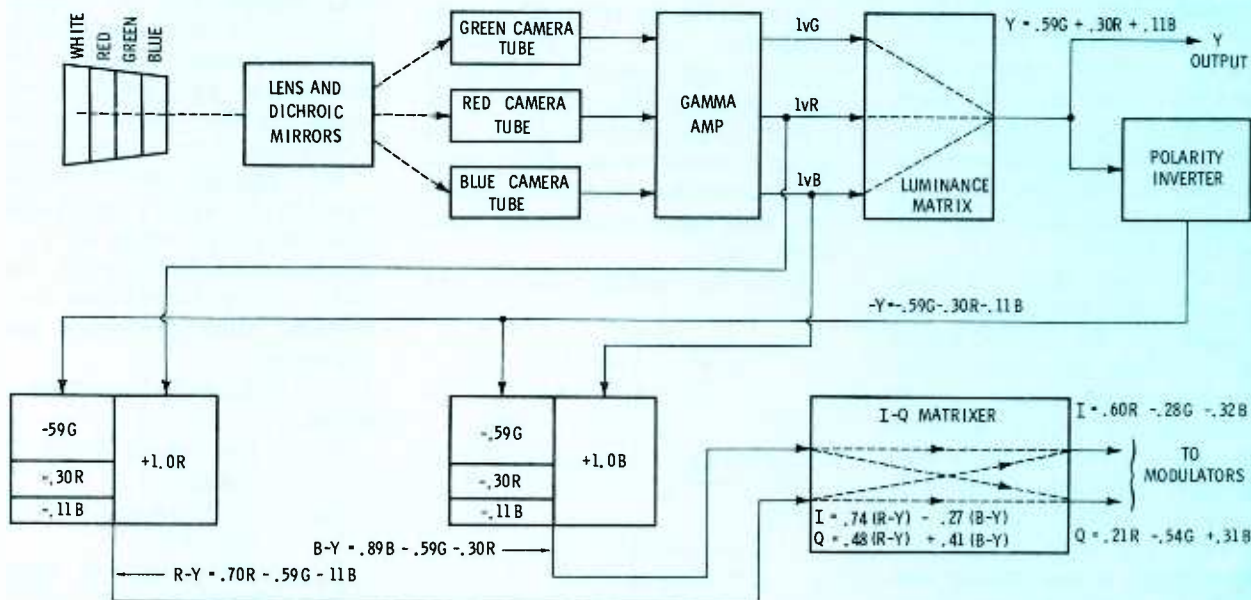

Fig. 2. Developing the luminance and color-difference signals in the transmitter.

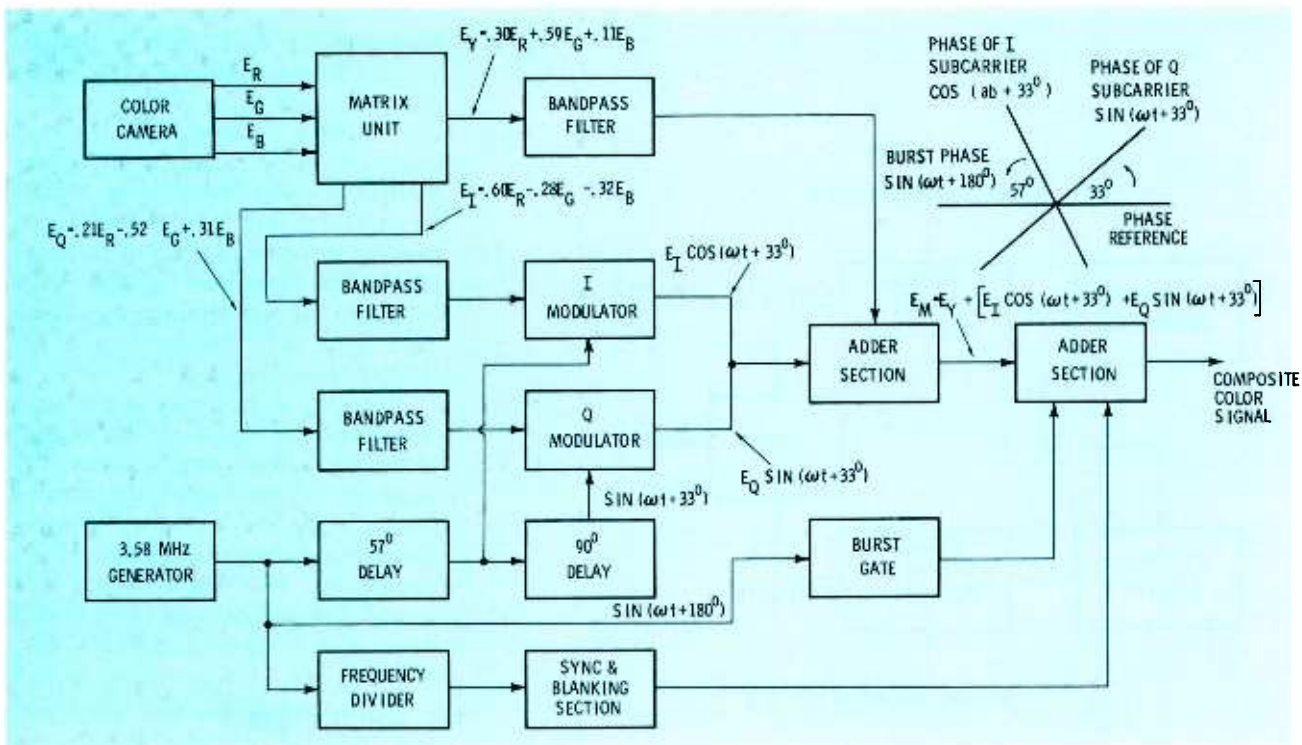

Fig. 3. Matrix unit in transmitter mixes three camera signals to form luminance, I, and Q signals.

Assume that the brightness of the white bar has been reduced to 50 per cent. This means that the camera tube output signals would be reduced to .50 volt. If each coefficient in equation 1 is reduced by 50 per cent, the luminance signal voltage would equal .15 + .295 + .055 or .50 volt; and the color-difference voltages would still be zero. The only signal would be the luminance signal representing the bar but its amplitude would be only 50 per cent. The monochrome receiver would reproduce a gray bar half-way between white and black.

For the sake of economy, the designers of our color-TV system decided that only two signals could be used to transmit the three color-difference signals. It was found that a signal representative of  $E_G - E_Y$  could be formed in a receiver by combining suitable proportions of  $E_R - E_Y$  and  $E_B - E_Y$ ; therefore there was no need to transmit  $E_G - E_Y$ . The proportions of  $-.51 (E_R - E_Y)$  and  $-.19 (E_B - E_Y)$  will produce a signal equivalent to  $E_G - E_Y$ .

In the actual transmission of color, two signals are used to convey color information. These are the I and Q signals and they are formed by combining specific proportions of  $E_R - E_Y$  and  $E_B - E_Y$ , as shown in

Fig. 2. It was found that better reproduction of color could be obtained with this system.

By combining  $.74 (E_R - E_Y)$  and  $-.27 (E_B - E_Y)$ , the I signal is formed. The Q signal is composed of  $.48 (E_R - E_Y)$  and  $.41 (E_B - E_Y)$ . If we subtract the value of  $E_Y$  (equation 1), we obtain  $E_I$  and  $E_Q$  in terms of the three color camera signals.

$$E_I = .60 E_R - .28 E_G - .32 E_B \quad (5)$$

$$E_Q = .21 E_R - .52 E_G + .31 E_B \quad (6)$$

The matrix unit in the transmitter forms the luminance, I, and Q signals by mixing the three camera signals as can be seen in Fig. 3. The luminance signal passes through a bandpass filter and is fed into the adder section. The I and Q signals also pass through bandpass filters but then are fed to the modulators. The I signal modulates a subcarrier with a phase of  $\cos(\omega t + 33^\circ)$ ; the Q signal modulates a subcarrier with a phase of  $\sin(\omega t + 33^\circ)$ . The phase reference  $\omega t$  is the phase of the color burst plus  $180^\circ$ . The phase angles between the two subcarriers and between them and the color burst are also shown in Fig. 3. The I subcarrier is leading the Q subcarrier by  $90^\circ$  and lags the color burst by  $57^\circ$ .

A very close tolerance is required for these phase differences. This is

accomplished by using a common source at 3.58 MHz for all signals including the synchronization.

The chrominance signal is formed by the outputs of the I and Q modulators, and is then merged with the luminance, sync, and blanking signals to form the composite color signal ready for transmission.

### The Composite Color Signal

The original 4.25-MHz bandwidth of the monochrome (luminance) signal had to be retained in the color TV system in order to meet the requirements of compatibility. The chrominance signal also had to be included within the allotted 6-MHz channel. Meeting these requirements posed quite a problem to the system designers but was accomplished by placing the chrominance signal at the proper place within the band of video frequencies and by limitation of its bandwidth.

An interleaving process makes possible the inclusion of both the chrominance and luminance signals within a 4.25-MHz video band. The energy of the luminance signal, as with any signal, concentrates at definite intervals in the frequency spectrum. Consider an amplitude modulated signal of 10 MHz. The sidebands of the signal would exist relatively close on either side of 10

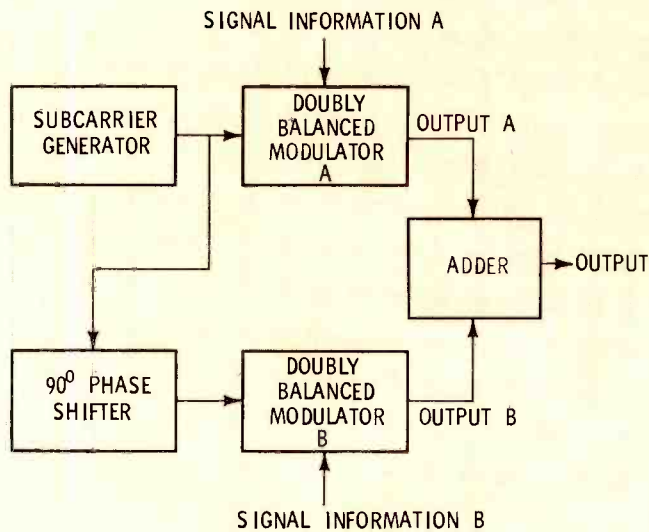

Fig. 4. Divided-carrier system modulates subcarrier with I and Q signals.

MHz. There would be no energy existing between the upper sideband and the edge of the lower sideband of the second harmonic at 20 MHz. It is in these blank areas that the chrominance signal energy is concentrated. There is no objectionable interference between the luminance and chrominance signals.

The luminance signal is transmitted by conventional amplitude modulation of the video carrier. The chrominance is transmitted by means of a subcarrier, the frequency of which was chosen to interleave

properly with the luminance signal. This subcarrier frequency (3.579545 MHz) is high in the video band so that its sidebands, when they are limited in bandwidth, do not interfere with monochrome reproduction of the luminance signal.

The subcarrier is modulated by a process known as divided-carrier modulation since two different signals (I and Q) must be placed on the same subcarrier. Fig. 4 illustrates the basic principle of the system. A generator supplies the subcarrier

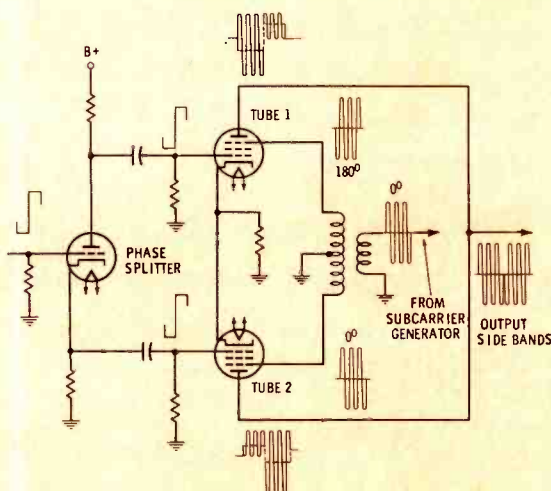

Fig. 5. Doubly balanced modulator circuit used in divided-carrier system.

frequency of 3.58 MHz which is applied to modulator A. The same signal is shifted in phase by 90° and applied to modulator B. The schematic in Fig. 5 represents either modulator. The modulating signal (I or Q) is split in phase and applied to the control grids of the two tubes. The subcarrier is also split in phase by the transformer and applied to the suppressor grids of the two tubes.

Tube No. 1 increases in conduction when the signal at its control grid goes positive and a subcarrier signal of increased amplitude is produced. Tube No. 2 receives a negative signal at the same time and its conduction and output signal decrease. On the next half cycle of the input signal, these conditions are reversed.

The plates of the two tubes are tied together so the waveforms shown at the plates cannot exist separately but are actually combined. The signals at the plates can be seen to be 180° out of phase, and the actual output sidebands will consist of a combination of the two plate signals. Because they are out of phase, a cancellation takes place, and the output amplitude becomes the difference in the amplitudes of the two signals. Additionally, the phase of the output is the phase of the largest signal.

A change in the amplitude of the input signal causes amplitude change of the output signal. If the phase of the input signal changes, the phase of the output signal will change 180°. The output signal therefore represents the input signal but in terms of the phase and amplitude of the subcarrier frequency.

Modulator B in Fig. 4 operates in an identical manner except that the subcarrier input is delayed by 90°. Thus, the output of modulator B is 90° from that of A. This can be either a lead or lag depending upon the polarities of the modulating signals.

The output signals from the modulators are combined in the adder stage. Fig. 4, and become a single waveform varying in amplitude and phase in accordance with the amplitudes and phases of the I and Q signals. Two signals have been placed upon a single subcarrier and can be recovered by reversing the modulation process in the receiver.



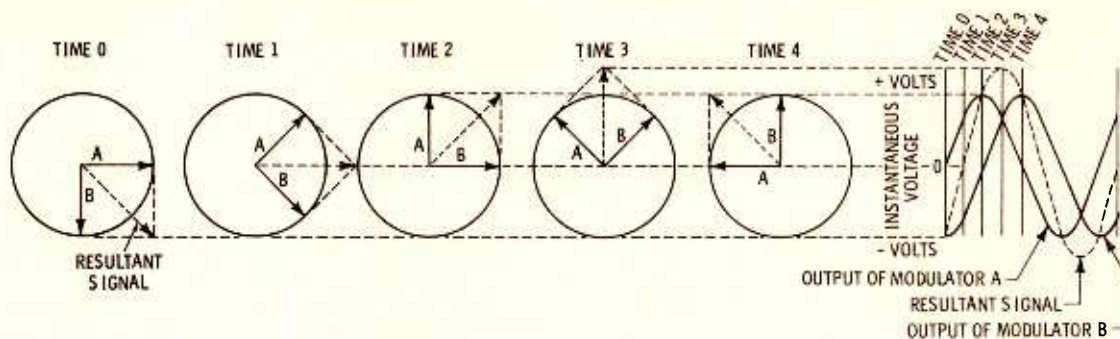

Fig. 6. Deriving a resultant waveform by use of vectors.

So far, we have considered only simple, unchanging waveforms applied to the modulators. In actual practice, the waveforms are quite complex because the picture may be composed of many different hues and may be constantly changing as well. Consequently, it is necessary to consider the modulation characteristics in terms of vectors rather than in terms of sine waves. Referring to Fig. 6, we have two vectors which are displaced from each other by  $90^\circ$  just as the I and Q axes are separated by this amount in a color transmitter. The first pair of vectors are shown at zero time. The vector which represents the instantaneous value of A leads vector B by  $90^\circ$ . (Vector motion is arbitrarily in the counterclockwise direction.) At this point in time, the value of A is zero while B is maximum negative. The resultant, or vector, sum of the two voltages is equal to the value of B.

If we cause the vectors to rotate  $45^\circ$ , the magnitudes of A and B will be equal in value (70.7% of maximum) but opposite in polarity. In the sine wave diagram, the resultant is shown to be zero. At time 2, A is maximum positive while B has decreased to zero and the resultant is equal to A. We see that at time 3 the resultant has reached its positive maximum and both A and B are 70.7% of their maxima. At time 4, the value of the resultant is the same as it was at time 2, but the amplitudes of A and B have been interchanged. It is possible to show the value of A and B by simply performing the calculations for every degree of rotation of the two vectors. However, the above illustration should prove adequate for our purposes.

The voltages from modulators A and B of Fig. 4 are combined in the adder to form a single waveform which varies in phase and amplitude in accordance with the amplitudes and phases of the two signals (I and Q axes) which produced it. Thus, the two modulating signals are able to modulate a single carrier in such a manner that both signals may be recovered separately in the receiver. As we shall see later on, it is not even necessary that the demodulation be accomplished on the same axes as the ones on which the modulation was impressed. In fact, receivers in use today demodulate on I and Q, X and Z, R-Y and B-Y axes, and even on three axes (R-Y, B-Y, and G-Y).

### Video Spectrum

The discoveries of Pierre Metz and Frank Gray were the key to the problem of inserting the color information into what seems to be the already-crowded 6-MHz TV channel. Their studies of the scanning process used in telephotography and television proved that the energy in the video spectrum is concentrated at certain discrete points in the bandwidth. These points are situated at frequencies which are whole multiples of the scanning rate or frequency. The actual proof which they developed is far too complicated for inclusion in this series, but the following illustration should help to understand the principles involved.

It can be proven mathematically that any video signal is the combination of a number of pure sine waves which are multiples or harmonics of a fundamental frequency. Thus, a video waveform consists of a series of sine waves all of which

are multiples of the horizontal scanning frequency. There is a second series of frequencies to be considered, the vertical scanning frequency and its harmonics. This energy is concentrated in "sidebands" of each multiple of the horizontal scanning frequency.

From the foregoing, it is apparent that there is actually a considerable portion of the video spectrum of the TV channel which is not used in passing the monochrome information. Further analysis shows that these "holes" in the spectrum occur at the odd harmonics of one-half the horizontal scanning frequency. The color subcarrier frequency was carefully chosen to occupy one of these "holes."

In radio transmission and in monochrome TV, the modulation is recovered by a simple detection process. In color TV, however, the color subcarrier sidebands are made a part of the video modulation and must be processed further after video detection in order to recover the chroma information. Since the sidebands of the chroma subcarrier are a portion of the composite video signal, the frequency of the chroma subcarrier has to be chosen not only for minimum degradation of the existing monochrome information but also so that it will not add undue interference to the picture. In addition, it must be chosen so that the chroma information which is modulated on it will not be outside the receiver bandpass.

By keeping the chroma subcarrier frequency as high as possible, the interference will be held to a minimum. In this manner, the reduced response near the upper limit of the video passband of most monochrome receivers will reduce the

amplitude of the interference which reaches the picture tube, and the relatively fine "grain" produced by a high frequency is less objectionable. On the other hand, the subcarrier frequency must be low enough so that the upper sideband of the chroma information will pass through a color receiver.

Experimentation proves that it is not necessary for the pure chroma information to have frequency components which extend as high as the components of the monochrome signal. Stated another way, the R, B, and G signals do not require rise times which are as steep as the rise time of the Y signal. While luminance information must have frequency components above 3MHz to produce a pleasing picture, there will be no noticeable decrease in quality of a color picture if the upper limit of the chroma information is only 600kHz. Thus, the chroma subcarrier frequency should be approximately 3.6MHz if we consider that the practical video bandwidth for color transmitters and receivers is approximately 4.2MHz.

It has been shown that the signal energy which is produced by scanning an image is concentrated around the harmonics of the scanning frequencies. By the same reasoning, we find that the energy contained in the chroma subcarrier sidebands appears at frequencies which are the sum and difference of the subcarrier and the line and frame frequencies. Therefore, a frequency which is an odd multiple of one-half the horizontal frequency must be used for the chroma subcarrier so that the "interleaving" characteristic may be utilized. This subcarrier may be tentatively established by the following formula:

$$f_s = \frac{15,750 \times 455}{2} = 3,583,125 \text{ Hz}$$

This frequency was not adopted because of an objectionable feature which became apparent. Monochrome receivers which employ an intercarrier sound system develop a 4.5-MHz signal at the output of the video detector. When this 4.5-MHz signal beats with the color subcarrier, a difference frequency of approximately 900kHz results and this produces an objectionable pattern on the screen. When the beat frequency is an odd multiple of one-half of the horizontal scanning fre-

quency, it is least objectionable.

Since it would have been impractical to change the 4.5-MHz intercarrier frequency, another method had to be found. This was done by changing very slightly the horizontal scanning frequency for color. This new scanning frequency was computed as follows:

$$f = \frac{4.5 \times 10^6}{286} = 15,734,264 \text{ Hz}$$

Thus, the 286th harmonic of the new line frequency equals the 4.5-MHz intercarrier frequency.

Since each frame must consist of 525 lines, the color field frequency has been changed to 59.94 Hz. Finally, the color subcarrier frequency becomes 3.579545 MHz.

The new scanning frequencies are slightly below those which were chosen for black-and-white transmission; however, the changes amount to less than 1%. These are within the tolerances that are allowed and do not affect the operation of black-and-white receivers when receiving a color signal. For the purpose of maintaining close synchronization of color receivers, the tolerance for the subcarrier frequency is held to  $\pm 0.0003\%$ , or about  $\pm 10$ Hz; and the rate of change may not exceed 1/10Hz per second. The same percentage of tolerance also applies to the line and frame frequencies, and it is standard practice to develop all these frequencies from a common source.

Now let's see how all this theory works out on a real, live TV set. Since the chroma signal falls within the bandpass of the video amplifier, a dot pattern is actually produced on the screen of a receiver which is tuned to a colorcast. However, the interference is not visible because of a phenomenon known as "cancellation effect." This cancellation effect is actually nothing more than a way of taking advantage of a characteristic of the eye which has been known for a long time. The eye has the ability to actually integrate a series of visual signals and, consequently, it can detect a signal of very low intensity if it recurs at corresponding points in each of a group of adjacent traces on a scope. This was discovered in radar technology where it was found that an observer could detect a target whose amplitude was actually less than

the amplitude of the receiver background noise or "grass."

Since it has been established that all of the sine wave components of the luminance signal are harmonics of the line and field frequencies, these components may be considered to be in phase during successive lines or frames. Thus the signals on adjacent lines are additive and tend to reinforce each other. The eye tends to integrate these successive signals and consequently it "sees" not individual lines and frames, but a composite of a number of them.

Conversely, the interference signal, which is the result of the 3.579545-MHz subcarrier, is applied to the picture tube in opposite polarity on adjacent scanning lines. The eye tends to reject this signal because it averages the light produced by the spots, and, of course, the average of the alternate dark and light spots is zero.

### Summary

In this first lesson, we have discussed the fundamental operation of the color camera and the method by which the three color signals from it are used to develop the luminance and chrominance signals. These have to be transmitted separately so that a black-and-white receiver can receive a color signal. The chrominance signals from the color camera are ultimately impressed on a subcarrier in such a manner that they may be recovered by the color receiver.

The chroma subcarrier sidebands can be transmitted in the same spectrum along with the luminance or Y information because the luminance signal energy is not evenly distributed in the spectrum, and so the two signals may be "interleaved" without interference.

To achieve compatibility, slight modifications had to be made in the horizontal and vertical scanning frequencies, but these are so slight that the normal tolerances of receivers will accept either scanning rates.

The second in this series of lessons will appear in the September issue of PF REPORTER. In that lesson, we will discuss the RF and IF circuits, audio channel, luminance channel, and AGC circuits of present-day color receivers. ▲

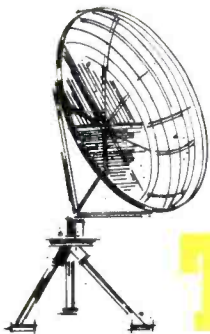

# THE ELECTRONIC SCANNER

*news of the servicing industry*

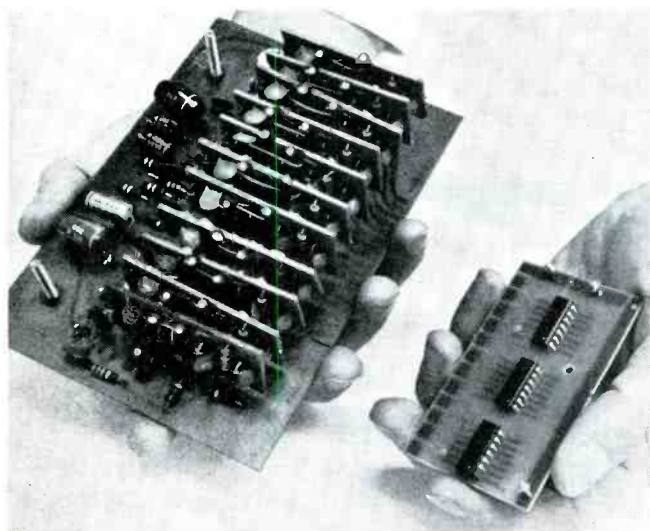

### MOS IC's

Simplicity of integrated circuitry vs discrete component design for an electronic organ divider section is shown here. Both boards perform the same function. **Motorola's** new MC1124P MOS frequency divider contains four toggle flip-flops; two cascaded internally and two externally. The MC1124P and the MC1120P MOS dual keyer gate are the industry's first MOS IC's to be developed specifically for consumer products.

### Dual Insulated-Gate MOS Transistors

The industry's first line of "consumer-type" dual insulated-gate, metal-oxide-semiconductor (MOS) transistors was announced at the 1967 Chicago Spring Conference by **RCA Electronic Components and Devices**.

"These new devices open the way for substantial improvements in performance of solid-state television and AM and FM receiver entertainment products," according to F. B. Smith, Manager, Market Planning.

# COMPLETE TUNER OVERHAUL

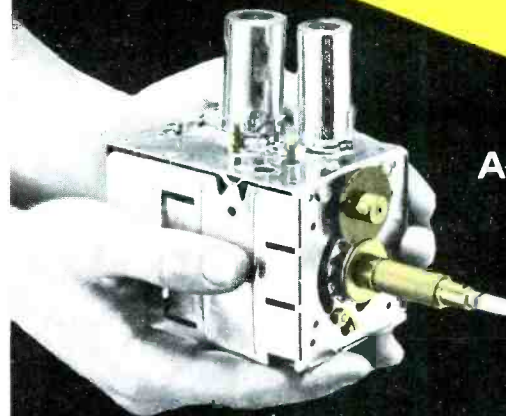

ALL MAKES — ONE PRICE

# 995

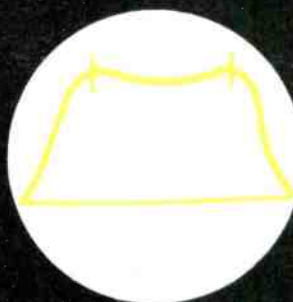

3.58

ALL LABOR AND PARTS (EXCEPT TUBES & TRANSISTORS)\*

## COLOR TUNERS

GUARANTEED ALIGNMENT — NO ADDITIONAL CHARGE



VHF



UHF



COLOR



U-V



TRANS STOR

Simply send us the defective tuner complete; include tubes, shield cover and any damaged parts with model number and complaint. Your tuner will be expertly overhauled and returned promptly, performance restored, aligned to original standards and warranted for 90 days.

UV combination tuner must be single chassis type; dismantle tandem UHF and VHF tuners and send in the defective unit only.

Exact Replacements are available for tuners unfit for overhaul. As low as \$12.95 exchange. (Replacements are new or rebuilt.)

And remember—for over a decade Castle has been the leader in this specialized field . . . your assurance of the best in TV tuner overhauling.

Pioneers of TV



Tuner Overhauling

# CASTLE TV TUNER SERVICE, INC.

MAIN PLANT: 5701 N. Western Ave., Chicago 45, Illinois  
EAST: 41-90 Vernon Blvd., Long Island City 1, N.Y.  
CANADA: 136 Main Street, Toronto 13, Ontario  
\*Major Parts are additional in Canada

Circle 8 on literature card

Get Trouble-Free Fuse Protection  
in Wet Locations with a

# TRON

IN-THE-LINE  
WATERPROOF  
Fuseholder

FOR PROTECTION OF CIRCUITS  
OF 600 VOLTS OR LESS

**FOR USE ON:**

- Electronic Components at Missile Sites
- Marine Equipment
- Mobile Power Supply Units
- Yard Lights
- Military Field Applications
- Communications Equipment
- Any circuit operating in exposed locations.

Watertight construction; resistance to damage by weather, water, salt spray or corrosive fumes permit use of TRON fuseholders in exposed locations where safety and long life are of vital importance.

TRON fuseholders are available to take two sizes of fuses,  $1\frac{1}{2}$ " x  $1\frac{1}{2}$ " and  $1\frac{3}{32}$ " x  $1\frac{1}{8}$ "; and take many sizes of solid or stranded wire.

Write for BUSS Bulletin SFH-11

**INSIST ON**

## BUSS QUALITY

BUSSMANN MFG. DIVISION, McGraw-Edison Co., ST. LOUIS, MO. 63107

picture tubes during the first quarter of 1967, up 53% from sales of 1.1 million during this period in 1966, the Electronic Industries Association's Marketing Services Department reported.

While color TV picture tube sales were up 70% during January 1967 to reach 592,833 units, the rate of increase by month in comparison to the same month of 1966 has gradually declined.

Sales of color TV picture tubes during March 1967 amounted to 553,542 units, rising 31% from sales of 442,681 units during this month a year ago.

### Mergers and Expansions

Avnet, Inc., and Channel Master Corporation announced that they have reached an agreement in principle to combine Channel Master Corporation and its affiliated companies with Avnet, Inc. No change in the management or the business of Channel Master is contemplated. The agreement is subject to the execution of definitive contracts and the approval of the Boards of Directors and Stockholders of both corporations.

Dynascan Corporation announced a major expansion of its citizens band communications product line through the acquisition of the assets of Vibratrol.

President Carl Korn said the acquisition was for cash, but the purchase price was not disclosed. He said the Vibratrol accessory units will be added to Dynascan's B & K Cobra CB line of equipment.

Vibratrol products include transistorized compressor

## BUSS: The Complete Line of Fuses and . . . . .

"The five new MOS devices, which operate much like a vacuum tube, offer significant performance advantages over bipolar transistors—particularly in the critical front-end circuits of solid-state AM, FM and TV receivers," Mr. Smith said. "They are also well suited for other critical applications in color television receivers such as burst amplifiers, color demodulators, IF amplifiers, product detectors and quadrature detectors," he added.

They offer improvements in cross-modulation performance, reduce oscillator radiation through the antenna, and feature as much as 60 dB of AGC control utilizing the second gate of a single RF stage. The cross-modulation performance actually improves as AGC causes the device to approach cutoff—with essentially no power being consumed for AGC control by the second gate.

These versatile solid-state devices are N-channel, depletion-type, silicon dual insulated-gate, MOS field-effect transistors. They feature extremely low gate leakage currents, typical feedback capacitances in the order of 0.02 pf, high transadmittance (typically 10,000 micromhos at a drain current of 7 milliamperes) and a square-law transfer characteristic. These features make them substantially superior to conventional bipolar transistors or single-gate field-effect transistors from the standpoint of cross-modulation performance.

### Color TV Picture Tube Sales Climb

U. S. manufacturers sold 1.7 million color television

**BUSS**



Write for BUSS Bulletin SFB.

## QUICK-ACTING FUSES

"Quick-Acting" fuses for protection of sensitive instruments or delicate apparatus;—or normal acting fuses for protection where circuit is not subject to current transients or surges.

**INSIST ON**

## BUSS QUALITY

BUSSMANN MFG. DIVISION, McGraw-Edison Co., St. Louis, Mo. 63107

Circle 9 on literature card

# FUSEHOLDERS for BUSS FUSES

Panel mounted, in-the-line, lamp indicating, signal activating, visual indicating—with solder terminals or quick-connect terminals—for fuses from 1/4 x 3/8 inches and larger.

The most complete line of fuseholders to meet Commercial and Military specifications.



Write for BUSS Bulletin SFB.

INSIST ON

## BUSS QUALITY

BUSSMANN MFG. DIVISION, McGraw-Edison Co., St. Louis, Mo. 63107

expected to be increased to a major facility of more than 100,000-square-feet with employment totaling over 2000 and a production capacity of 2 million TV tuners per year. Operations are scheduled to begin in the third quarter of 1967.

The new company, to be known as OEN-Korea, is being established as a controlled operating division of O/E/N, but a minority interest will be held by the Hyun Dai Construction Co., an internationally known Korean firm.

OEN-Korea will be the third Far Eastern production operation established by Oak Electro/Netics Corp. within the past five years. An 84,000-square-foot facility in Hong Kong also produces television tuners, and a Japanese facility produces component assemblies for Japanese electronics companies.

Construction work has started on a multi-million-dollar plant in Belgium for the production of color television picture tubes for **General Telephone & Electronics International Incorporated.**

William F. Bennett, President of GT&E International, said the 100,000-square-foot plant, about 30 miles east of Brussels, is scheduled for completion late this year, and production is expected to begin early in 1968. GT&E International is a subsidiary of General Telephone & Electronics Corporation.



## .. Fuseholders of Unquestioned High Quality

amplifiers, power and standing wave ratio meters. CB radio testers, transistorized vibrators, and silicon rectifier replacements for vacuum tubes.

As part of a continuing expansion program, the E. F. Johnson Company has begun construction of another addition to its headquarters plant. The manufacturer of two-way radios and electronic components moved into a new research and development addition earlier this year.

The latest addition, scheduled for completion by the end of 1967, will provide needed expansion of Johnson's manufacturing facilities. The new 46,000 square feet, plus the 27,000-foot R & D facility just completed, will bring total plant area to 186,000 square feet.

**JFD Electronics Company** announced the acquisition of the equipment and inventory of Brach Manufacturing Corp., a division of General Bronze Corporation.

JFD management announced that it will undertake to expand production and distribution of the auto aerials, portable TV antennas, top-of-the-set indoor antennas, lightning arresters, testers, and other accessories manufactured by Brach. All design and production facilities of Brach will be centered in JFD plants.

**Oak Electro/Netics Corp.** announced plans for the construction of a television tuner assembly plant near Seoul, South Korea.

Initially, the facility will total 25,000-square-feet and employ 500 workers.

Within the first two years of operation, the plant is

## SUB-MINIATURE FUSEHOLDER COMBINATION

For space-tight applications. Fuse has window for inspection of element. Fuse may be used with or without holder.

Fuse held tight in holder by beryllium copper contacts assuring low resistance.

Holder can be used with or without knob. Knob makes holder water-proof from front of panel.

Military type fuse FM01 meets all requirements of MIL-F-23419. Military type holder FHN42W meets all military requirements of MIL-F-19207B.

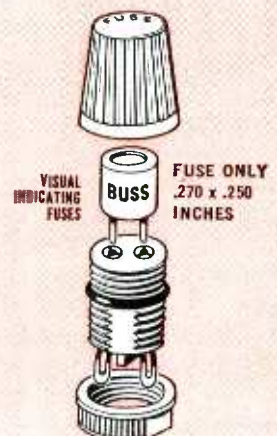

VISUAL INDICATING FUSES FUSE ONLY .270 x .250 INCHES

GMW FUSE and HWA FUSEHOLDER

Write for BUSS Bulletin SFB

INSIST ON  
**BUSS QUALITY**

BUSSMANN MFG. DIVISION, McGraw-Edison Co., ST. LOUIS, MO. 63107

Circle 9 on literature card

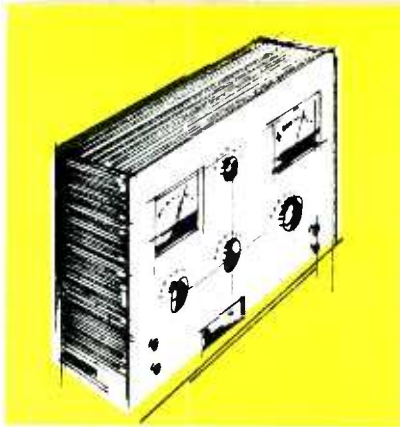

# SERVICING HIGH-QUALITY AUDIO

by Carl F. Moeller

It's a fine Saturday afternoon, the sky is clear and the temperature is just right for the picnic you promised the wife and kids. Besides, you've finally cleaned up most of the work and, even more satisfying, finally solved the problem with that 6-year old color set that's been bugging you. Robin, your boy-wonder partner, can handle things for the rest of the day, providing no more urgent outside calls come up. It'll be the first Saturday afternoon you've had off in . . . well, it's been so long you can't remember.

Then you get a call from Mrs. John Doe III, out in upper suburbia. While she is identifying herself, you come to the conclusion that she lives in a nice neighborhood and is in either the lower half of the upper middle class or perhaps in the bottom half of the middle upper class. In either event, she will pay the bill.

Finally, she gets around to the reason for her untimely call. It seems that a couple of years ago she and Mr. Doe bought a beautiful French Provincial Brand "X" color-TV-Radio-Stereo-AM/FM console and now they are having trouble.

"So what's the problem," you're asking yourself. "Didn't I just finish the factory authorized color TV training course, and didn't I just blow this summer's vacation on some pretty expensive color test equipment?"

Then Mrs. Doe III interrupts your thoughts and informs you that the problem is not the color TV, it's the radio. Oh yes, it still works, but she just bought an album of Rimski-Korsakov, and they played the same album on the local stereo FM station this afternoon, and the station didn't sound as good as her album,

and she just tried the album, and it did too sound better, and please come over quick and have a look at the stereo. And that, my friend, is what we mean by servicing high-quality audio equipment.

After calling your wife to tell her the picnic must wait (she muttered something about feeling like a widow), you depart for the Doe residence. Since the high-rent district is some distance away, the trip gives you time to mull over your knowledge of high-quality audio equipment (which gets your mind off the loss of the free afternoon and your wife's comments concerning the sudden change in plans).

## What To Expect

Paradoxically, some of the most difficult faults to isolate occur in the type of high-quality audio equipment which is the least apt to cause trouble. If this sounds a little confusing, consider the relative difficulty of finding the trouble with a record player that is just plain "dead" and one that, to quote a common complaint, "Just doesn't sound right anymore." In the first instance, it is usually not difficult to poke around inside the amplifier, using any of a number of accepted techniques, until the component that "loused up" everything is located. You whip out your trusty soldering gun and in a few more minutes you are writing up the invoice. "You never had it so good."

Of course, these high-quality sets also "just plain quit" on occasion, but this probably doesn't happen nearly as often as it does with the \$38.88 special, which was built to a price and not much of anything else. After all, a good piece of sound

equipment is built to perform well for a long time and just isn't prone to a lot of the faults of the "cheapie" that is built for the competitive market. On the other hand, since the owner of a really good sound system spends upwards of \$500.00 for the set, he often expects it to sound as good as a live performance.

## Components of the Quality System

Although the actual components of a high-quality set may vary somewhat, depending on manufacturer and price range, it will probably have at least these major parts:

1. An AM/FM tuner having good sensitivity and equipped with an AFC circuit for the FM local oscillator. The sensitivity of the AM receiver will be somewhere in the neighborhood of 50 to 150 microvolts to produce a 30-dB signal-to-noise ratio. The FM sensitivity may be rated in a couple of ways. One of these is expressed as the number of microvolts required to produce 30 dB of quieting in the receiver. A typical value is around 10 microvolts. This figure may change considerably, depending on whether the measurement is made while receiving a monaural or stereo signal. Usually, monaural sensitivity will be somewhat better. The other sensitivity measurement is called the "least usable sensitivity" method and is accomplished by determining the input signal level required to produce an output which has no more than 3% of harmonic distortion. (This is approximately a 30-dB signal-to-noise ratio.)
2. A multiplex decoder (converter)

which decodes the FM stereo composite signal. We will review the operation of the decoder later.

3. A turntable (probably a four-speed changer) with stereo cartridge.
4. An audio amplifier with gain, balance, treble, and bass controls. The most important amplifier specifications are frequency response, power output, and distortion level. The frequency response indicates the range of frequencies that are amplified within 3 dB of the maximum gain, and it is usually expressed in terms of the frequencies at the half-power points (3 dB) on a gain-versus-frequency curve. These frequency limits are typically in the vicinity of 30Hz and 15kHz. Power output and distortion are closely interrelated since the distortion level increases as the output level is increased. A good audio amplifier will produce about 40 watts of power in each channel, with no more than 3% of harmonic and noise content.

5. The speakers and their enclosure. This is perhaps the area of greatest variety in audio systems on the market today. We have found that the prospective customer is interested primarily in how many speakers a certain set has — and nothing else. Needless to say, the quality of speakers varies so widely that a set with two speakers per channel may easily have better tonal quality than another set having twice that number. To complicate things, the quality of a speaker is hard to determine by simple methods. Also, the enclosure has a great effect on the performance of the speakers.

### System Analysis

The AM/FM tuner is so familiar to the average technician that its operation requires little review here. It may be either a tube type or transistorized, but in either case, its operation is essentially the same. Its function is to amplify the signal from the antenna and demodulate it for further amplification and, in the case of stereo, decoding. It will probably have an AFC circuit to prevent drift of the local FM oscillator. The most frequent tuner troubles that affect the quality of reproduction are poor sensitivity, high

noise (essentially the same thing), and improper alignment.

The multiplex decoder, or converter, receives the audio output from the discriminator in the tuner and converts it to left and right channel audio signals. Two general types of decoders are used, matrixing and switching types. Although both perform exactly the same function, their methods are different.

The composite stereo signal from the discriminator consists of three basic signals. One of these is the L + R signal, which consists of the sum of the audio for the left and right channels. If the station is broadcasting a monaural program, this is the only signal present at the output of the discriminator. Also, if a monaural FM receiver is tuned to a stereo broadcast, this is the only part of the signal which it recovers. However, if a stereo receiver is tuned to a stereo broadcast, this signal must be processed to remove the right (R) signal so that only L is applied to the left channel of the audio amplifier.

The second element of the composite signal obtained from the discriminator is the L - R signal, which consists of the difference between the left and right channel information. Using two detectors, the decoder divides the L - R signal into two outputs, (L - R) and -(L - R). This is just a complicated way of stating that one output is positive and the other negative.

Unlike the L + R signal, the L - R signal taken from the discriminator is not audible. To prevent it from mixing with the L + R signal, it is modulated onto a 38-kHz carrier at the transmitter, and then the carrier is removed so that only the two sidebands are contained in the composite output of the discriminator.

The third element of the composite signal is a 19-kHz pilot subcarrier. This subcarrier is generated at the transmitter by dividing the 38-kHz carrier which was originally modulated by the L - R signal.

An alternate method is to generate a 19-kHz signal and use its second harmonic for the L - R carrier. The important consideration is that the 19-kHz subcarrier has the phase of the subharmonic of the 38-kHz carrier. Since this 19-kHz pilot subcarrier has an amplitude of

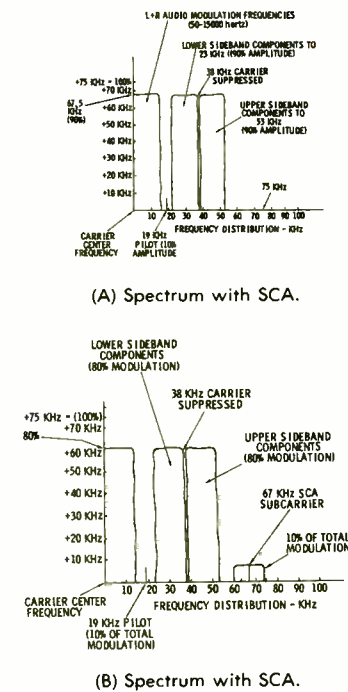

Fig. 1. FM stereo spectrum without SCA.

only 10% of the normal carrier, the decoder must amplify it, double its frequency, and reinsert it between the two sidebands before they can be demodulated.

If you are wondering why they went to all the trouble of generating a subcarrier instead of transmitting the 38-kHz carrier, a look at the spectrum of a standard stereo FM signal will answer the question (Fig. 1A). The L + R signal must be in the audible range so that monaural receivers can operate on a stereo signal; therefore, the spectrum from 50Hz to 15 kHz is used for the purpose. Another 15kHz of the available spectrum is required for the R information contained in the L - R signal. This is the upper sideband of the 38-kHz suppressed carrier and uses the spectrum from 38kHz to 53kHz. The L information of this signal is the lower sideband of the same suppressed carrier and fills the spectrum from 23kHz to 38kHz. The gap between 15kHz and 23kHz is necessary to prevent crosstalk, and the 19-kHz pilot subcarrier is in the exact center of this portion of the spectrum. The spectrum from 53kHz to 75kHz may be used for SCA (subscriber background music), as well as to provide "guard bands" to prevent interference and crosstalk. (See Fig. 1B).

The circuitry of the decoder is surprisingly similar to the chroma

circuit of a TV set. The 19-kHz pilot subcarrier can be compared to the color burst since both are used to control the phase of a reference oscillator. The similarity extends to the L-R demodulator, which can be compared to the chroma demodulator. In both cases, the demodulator has two inputs (reference and intelligence) and produces outputs which are dependent on the amplitude of the intelligence input as well as the phase relation it has to the reference oscillator. The 19-kHz pilot subcarrier is amplified and then used to control the phase of a 38-kHz oscillator. As an alternate method, the 19-kHz signal may be simply doubled without the use of an oscillator. In either case, the resultant 38-kHz signal is amplified to a level approximately three times as great as the sidebands, and is then applied to the demodulator.

The L-R sideband signal is applied to the demodulator and two outputs are obtained. These are the L-R output and the  $-(L-R)$  signal. This  $-(L-R)$  may also be expressed as the  $-L+R$  signal. Of course, we also have available the L+R signal which was broadcast in the clear. Using a few resistors and filters, these signals are combined as follows:

1.  $L+R + (L-R) = 2L.$
2.  $L+R - (L-R) =$   
 $L+R - L+R = 2R.$

There are several things in the decoder that can upset the stereo. If the relative amplitudes of the L+R, L-R, and  $-L+R$  signals should change, it is obvious that pure L and R signals will no longer be present at the output. (This may be done intentionally to either enhance or de-emphasize the stereo effect.) Much the same thing will result if the phase of the reconstituted 38-kHz subcarrier differs from the one generated at the transmitter. For example, if the phase relationship differs by more than about 12 to 15%, the theoretical separation of the two channels will decrease to around 18 dB. This means that the R component present in the L channel will be 18 dB below the R component in the R channel, or vice versa. Minimum separation at the transmitter is at least 30 dB. Of course, there are many other decoder defects that can cause distor-

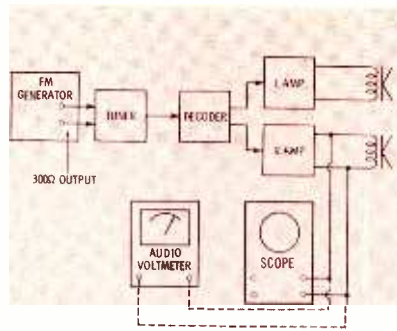

Fig. 2. Setup to check sensitivity.

tion in either channel, but most defects will decrease the separation of the channels. Thus, channel separation is perhaps the most important characteristic of the decoder.

The audio amplifier is essentially two high-fidelity amplifiers built on one chassis. While it is possible to have faults in the amplifiers that can affect separation, usually a fault in this part of the receiver will be confined to only one channel. The two most important characteristics of the audio amplifier are frequency response and distortion.

Problems originating in the speaker system are usually confined to actual damage of the speaker cones or voice coils, and occasional failure of a crossover network. Quite often the crossover networks are nothing more than fairly large capacitors in series with the high-frequency speakers (tweeters and mid-range speakers) to block the lower octaves. Occasionally, a low-pass filter is placed in series with the low-range speakers (woofers) to eliminate the higher octaves.

Problems originating in the turntable usually fall into two categories, cartridge deterioration and speed variations. Cartridge faults may cause reduced output from one or both channels, distortion in one or both channels, or stylus wear that degrades the audio output and also damages the records. Mechanical problems produce speed variations, low speed, and rumble which is the result of excessive vibration.

### At the Scene

From the symptoms which Mrs. Doe III described on the telephone, it appears that the trouble must be located in either the tuner or the decoder. Remember, her own record sounded OK; so you can rule out the turntable, audio amplifiers,

and the speakers. Armed with all this information and the certain knowledge that Rimski-Korsakov was just one man, you are ready to do battle with her receiver.

When you arrive, you find that a stereo broadcast is being received but it sounds a bit "fuzzy." After you listen for a few minutes, you note that the separation between channels is almost nil. Well, separation takes place in the decoder, so you have a look. It could be a lot of things, but you "luck out" and find a very weak tube in the pilot subcarrier amplifier circuit. A new "bottle" clears up the problem. Simple, eh?

After accepting Mrs. Doe's check, you express your appreciation for her business and wish her happy listening for the remainder of the week-end. She replies that you are very welcome, but she and her husband are just preparing to leave for two weeks in Bermuda and won't get a chance to listen to the stereo until they return.

You exercise self-control, suppress the thoughts that her last remark has kindled, and leave before you lose the good will you have previously created.

Back at the shop, you call your wife to ask if it's too late for the outing. She says it is and that you should go ahead and stay till closing time because it might feel strange having you at home so early in the day (its only 5:00 PM).

As you gently replace the phone in its cradle, Boy Wonder inquires about Mrs. Doe's problem. You again exercise restraint at the mention of Mrs. Doe and calmly explain Mrs. Doe's problem to Boy Wonder.

After hearing how quickly you found and cured the problem, Boy Wonder exclaims, "Holy Stereo," comments on how easy you make it sound, and asks if would you let him in on the secret of your quick servicing techniques.

Because you know he is sincere and because there isn't any work that can be started and finished before closing time, you decide to pass a little servicing info his way.

### The Lecture

Unfortunately, not all the audio problems will be so easy as Mrs. Doe's, and there will be times when



# Join "THE TROUBLESHOOTERS"

who get paid top salaries for keeping today's electronic world running

Suddenly the whole world is going electronic! And behind the microwave towers, push-button phones, computers, mobile radio, television equipment, guided missiles, etc., stand THE TROUBLESHOOTERS—the men urgently needed to inspect, install, and service these modern miracles. They enjoy their work, and get well paid for it. Here's how you can join their privileged ranks—without having to quit your job or go to college to get the necessary training.

JUST THINK how much in demand you would be if you could prevent a TV station from going off the air by repairing a transmitter... keep a whole assembly line moving by fixing automated production controls... prevent a bank, an airline, or your government from making serious mistakes by servicing a computer.

Today, whole industries depend on electronics. When breakdowns or emergencies occur, someone has got to move in, take over, and keep things running. That calls for one of a new breed of technicians—The Troubleshooters.

Because they prevent expensive mistakes or delays, they get top pay—and a title to match. At Xerox and Philco, they're called Technical Representatives. At IBM they're Customer Engineers. In radio or TV, they're the Broadcast Engineers.

What do you need to break into the ranks of The Troubleshooters? You might think you need a college degree, but you don't. What you need is know-how—the kind a good TV service technician has—only lots more.

### Think With Your Head, Not Your Hands

As one of The Troubleshooters, you'll have to be ready to tackle a wide variety of electronic problems. You may not be able to dismantle what you're working on—you must be able to take it apart "in your head." You'll have to know enough electronics to understand the engineering specs, read the wiring diagrams, and calculate how the circuits should test at any given point.

Learning all this can be much simpler than you think. In fact, you can master it without setting foot in a classroom... and without giving up your job!

For over 30 years, the Cleveland Institute of Electronics has specialized in teaching electronics at home. We've developed special techniques that make learning easy, even if you've had trouble studying before. Our AUTO-PROGRAMMED™ lessons build your knowledge as easily and solidly as you'd build a brick wall—one brick at a time. And our instruction is personal. Your teacher not only grades your work, he analyzes it to make sure you are thinking correctly. And

he returns it the same day received, while everything is fresh in your mind.

### Always Up-To-Date

To keep up with the latest developments, our courses are constantly being revised. This year CIE students are getting new lessons in Laser Theory and Application, Microminiaturization, Single Sideband Techniques, Pulse Theory and Application, and Boolean Algebra.

In addition, there is complete material on the latest troubleshooting techniques including Tandem System, Localizing through Bracketing, Equal Likelihood and Half-Split Division, and In-circuit Transistor Checking. There are special lessons on servicing two-way mobile radio equipment, a lucrative field in which many of our students have set up their own businesses.

### Your FCC License—or Your Money Back!

Two-way mobile work and many other types of troubleshooting call for a Government FCC License, and our training is designed to get it for you. But even if your work doesn't require a license, it's a good idea to get one. Your FCC License will be accepted anywhere as proof of good electronics training.

And no wonder. The licensing exam is so tough that two out of three non-CIE men who take it fail. But our training is so effective that 9 out of 10 CIE graduates pass. That's why we can offer this famous warranty with confidence: If you complete a license preparation course, you get your FCC License—or your money back.

### Mail Coupon for 2 Free Books

Want to know more? Send for our 40-page catalog describing our courses and the latest opportunities in electronics. We'll also send a special book on how to get a Government FCC License. Both are free—just mail coupon below.

### ENROLL UNDER NEW G.I. BILL

All CIE courses are available under the new G.I. Bill. If you served on active duty since January 31, 1955, or are in service now, check box in coupon for G.I. Bill information.

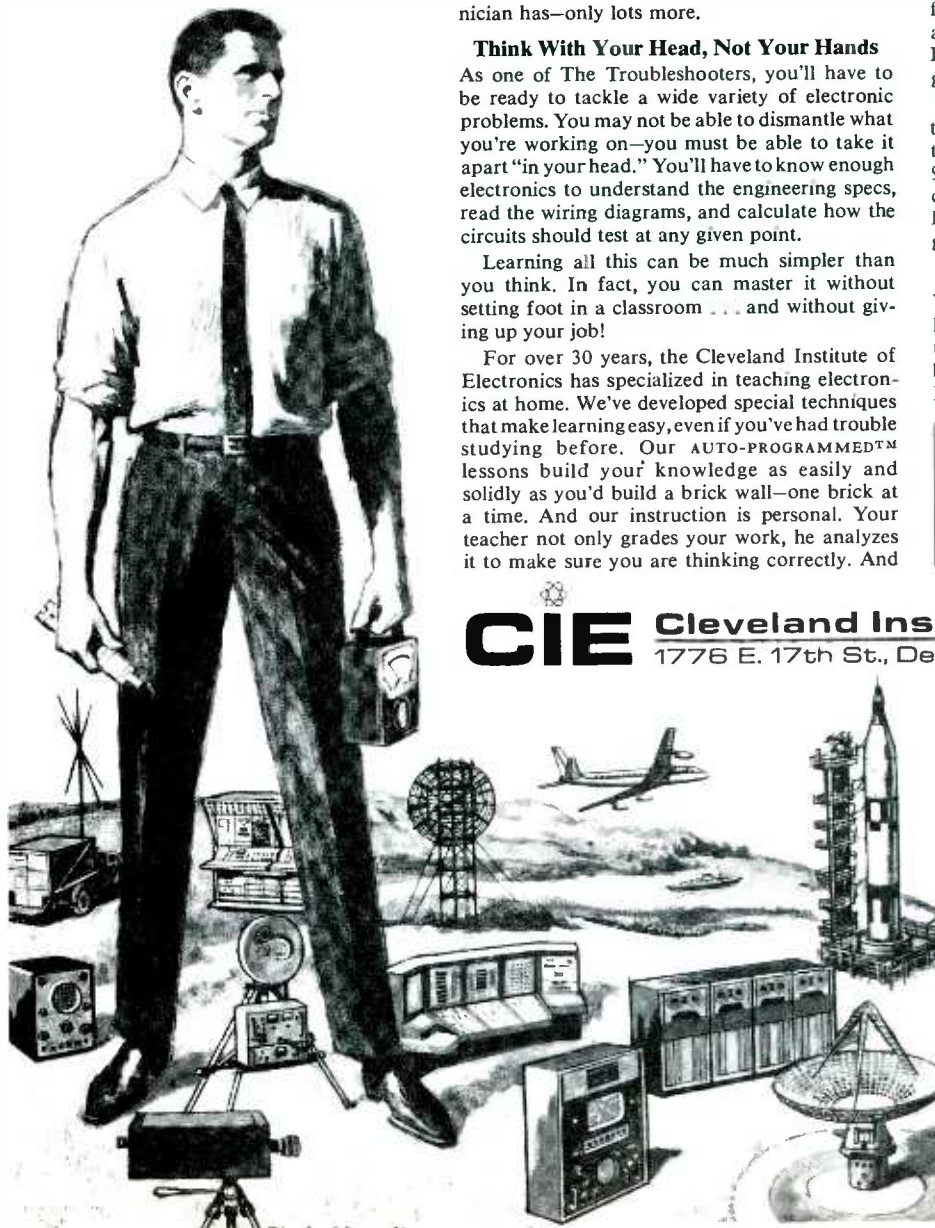

Circle 10 on literature card

**CIE** Cleveland Institute of Electronics  
1776 E. 17th St., Dept. PF-37 Cleveland, Ohio 44114

### Cleveland Institute of Electronics

1776 E. 17th St., Cleveland, Ohio 44114

Please send me without cost or obligation:

1. Your 40-page book "How To Succeed In Electronics" describing the job opportunities in electronics today, and how your courses can prepare me for them.
2. Your book on "How To Get A Commercial FCC License."

Name \_\_\_\_\_  
(Please Print)

Address \_\_\_\_\_

City \_\_\_\_\_

State \_\_\_\_\_ Zip \_\_\_\_\_

Occupation \_\_\_\_\_ Age \_\_\_\_\_

Check here for G.I. Bill information

Accredited Member National Home Study Council  
PF-37

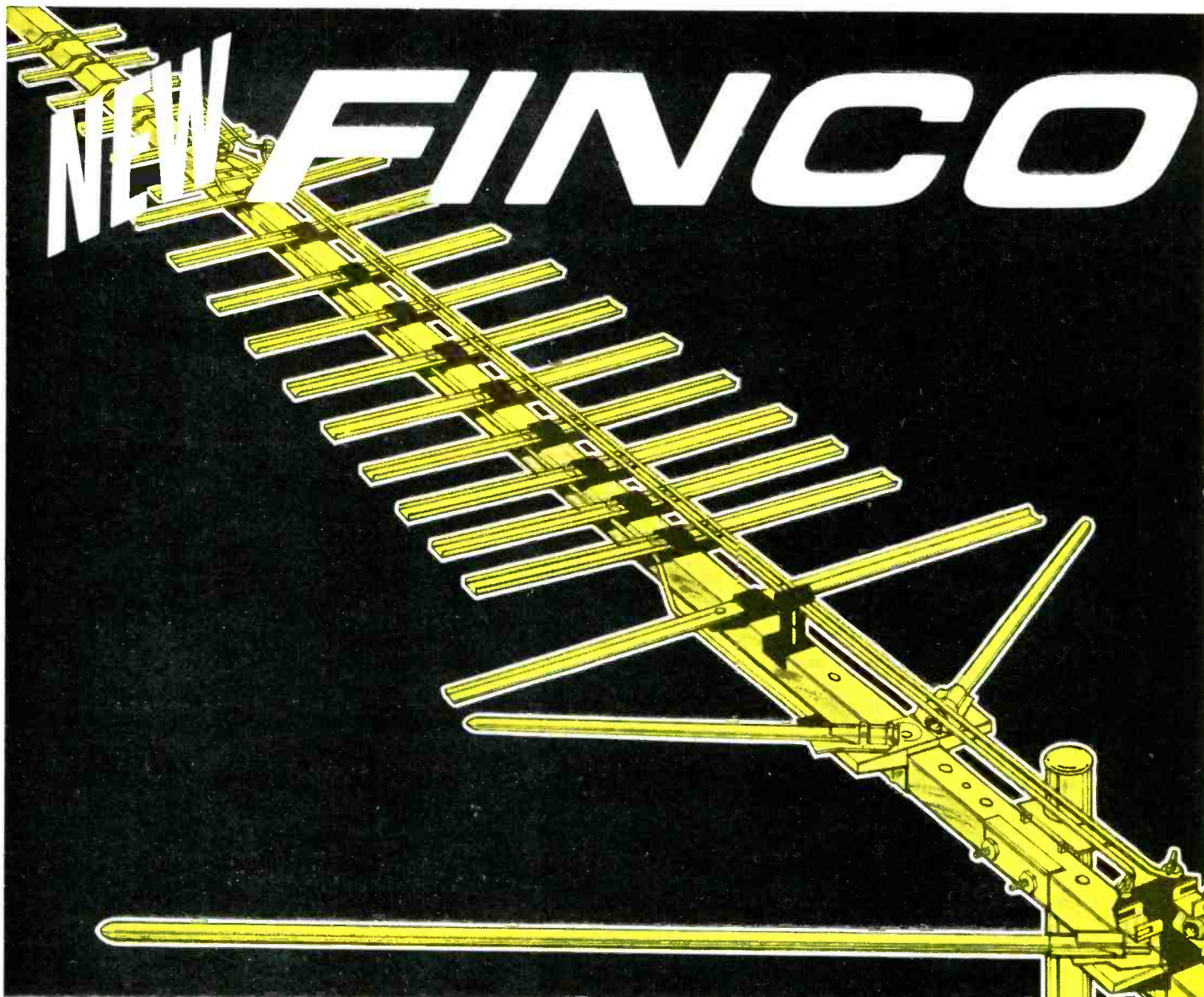

*“the ANTENNA that captures the RAINBOW”*

No two reception areas are alike in the number of stations, UHF and VHF, station channel frequencies, and signal strengths.

FINCO has developed the Color Spectrum Series of antennas — “Signal Customized” — to exactly fit the requirements of any given area. There is a model scientifically designed and engineered for every area, even the most troublesome, and for all combinations of signal conditions.

Engineering studies show that a receiving antenna should have more gain as channel frequency is increased — that is, channel 6 more than channel 2, channel 13 more than channel 7, and UHF from channel 14 on up...

- 1 — to compensate for signal strength loss
- 2 — to compensate for down-lead loss
- 3 — to meet receiver requirements for more signal to operate properly

FINCO Color Spectrum Antennas obtain this frequency dependent characteristic through a newly developed principle of spacing between elements. Gain increases as frequency increases. This new FINCO engineering break-through, combined with superior flat response patterns and unusually high front-to-back ratios, assure the finest COLOR and B & W reception possible... everywhere.



Write for full information on “Signal Customized” Antennas:











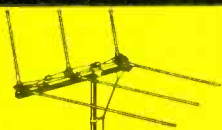

**THE FINNEY COMPANY**

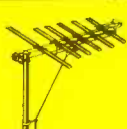
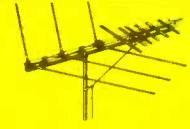
34 West Interstate Street • Dept. 310 • Bedford, Ohio 44146

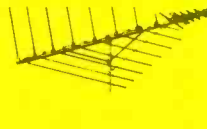
# COLOR SPECTRUM ANTENNAS

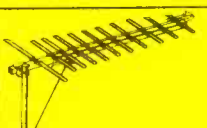
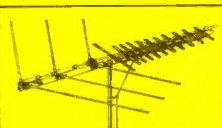
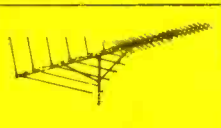
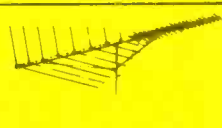
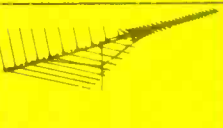
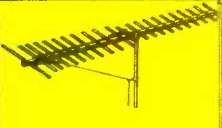
## are "signal customized" for better reception.

Check this chart for the FINCO "SIGNAL CUSTOMIZED" Antenna best suited for your area

STRENGTH OF UHF SIGNAL AT RECEIVING ANTENNA LOCATION	Strength of VHF Signal at Receiving Antenna Location				
	NO VHF	VHF SIGNAL STRONG	VHF SIGNAL MODERATE	VHF SIGNAL WEAK	VHF SIGNAL VERY WEAK
NO UHF →		 CS-V3 \$10.95	 CS-V5 \$17.50   CS-V7 \$24.95	 CS-V10 \$35.95	 CS-V15 \$48.50   CS-V18 \$56.50
UHF SIGNAL STRONG →	 CS-U1 \$9.95	 CS-A1 \$18.95	 CS-B1 \$29.95	 CS-C1 \$43.95	 CS-C1 \$43.95
UHF SIGNAL WEAK →	 CS-U2 \$14.95	 CS-A2 \$22.95	 CS-B3 \$49.95	 CS-C3 \$59.95	 CS-D3 \$69.95
UHF SIGNAL VERY WEAK →	 CS-U3 \$21.95	 CS-A3 \$30.95	 CS-B3 \$49.95	 CS-C3 \$59.95	 CS-D3 \$69.95

NOTE: In addition to the regular 300 ohm models (above), each model is available in a 75 ohm coaxial cable downlead where this type of installation is preferable. These models, designated "XCS", each come complete with a compact behind-the-set 75 ohm to 300 ohm balun-splitter to match the antenna system to the proper set terminals.

Circle 11 on literature card

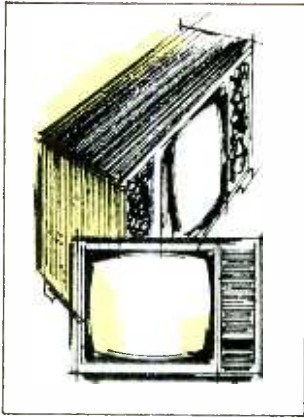

# solid state COLOR TV is here

By T. T. Jones

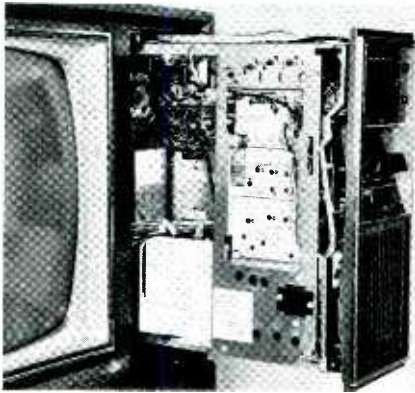

Fig. 1. The TS-915 chassis rolled out for servicing.

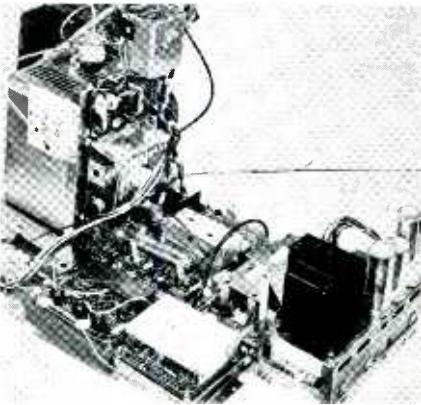

Fig. 2. The TS-919 chassis with rear panel lowered.

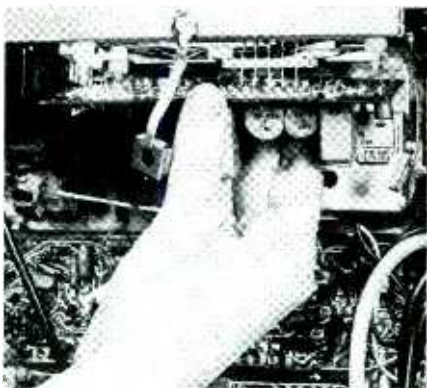

Fig. 3. Removing the audio panel board.

As was mentioned in *MERCHANDISING WEEK*, Motorola has indeed performed a "coup d'etat." Their "big gun" in their 1968 color line is not only solid-state but features modular construction as well.

These modules, however, are not to be confused with modular, or "plug-in," construction such as we have seen heretofore. Instead, they are of conventional printed circuit board construction. The complete PCB is replaceable. Not as a "throw away" to be sure, but through a program whereby the PCB panel is exchanged under warranty until June 1968, and at a nominal charge after that date.

Each board contains from 4 to 10 stages. In most instances they are grouped in families so that the repairman can make quick tests to determine which PCB is at fault. To aid in this troubleshooting procedure, Motorola has elected to pack a troubleshooting guide and a schematic inside each set. The guide shows logical steps which are taken in sequence to determine which area is at fault.

Perhaps at this point we should give some details on the mechanical construction of the new models before proceeding to the electrical circuits, which are in many instances also unique.

The new solid-state color set is offered in two basic chassis: the TS-915 and the TS-919. The 915 (Fig. 1) is the deluxe model. It features a pull-out-from-the-front chassis. All service controls are readily accessible after rolling this chassis out. It is necessary to remove 3 screws at the rear of the cabinet and then you're ready to troubleshoot the set.

The 919 (Fig. 2), though electrically identical, has a more conventional configuration, and it is necessary to remove the back from

the set to gain access to the chassis. In either case, it is not necessary to remove the chassis from the cabinet for servicing. We'll qualify that, since there are some parts, such as the audio output transistor, which are mounted on the main frame. However, for the usual problems which you are likely to encounter, servicing is a 10-minute job.

Fig. 3 illustrates the technician removing the audio circuit panel. As can be seen, there are two grounding clips and a shielded wire which have to be pulled loose. Then the technician just pulls, and the board snaps out—no screws, no solder joints.

Electrically, the TS-915/919 is well designed. It has 62 transistors, 28 diodes, 1 IC, a high voltage rectifier tube, and a picture tube.

It should be mentioned that all those transistors and diodes are "off the shelf" parts. There are no FET's, no exotic diodes or transistors for which replacements may be difficult to obtain. This concept has been closely adhered to all through the design. Most of the transistors are epoxy silicons, but a few, such as the horizontal outputs, are housed in TO-3 power-transistor cases.

Sixty-two transistors may seem like a lot of parts, and it is. However, after a close look, it appears that the set has been pared to the bone. All those active components are necessary to perform two functions: to produce a color picture as good or better than tube sets, and to present no special service problems to the technician.

An example of a protective circuit is the arc-gate, shown in Fig. 4. This circuit senses an arc anywhere in the secondary circuit of the fly-back. It conducts heavily under arc conditions, causing the horizontal driver to conduct, shutting off the horizontal output transistors. With-



# new miniature electronic pliers

HOLD, BEND, CUT  
ALL FINE WIRES  
WITH EASE

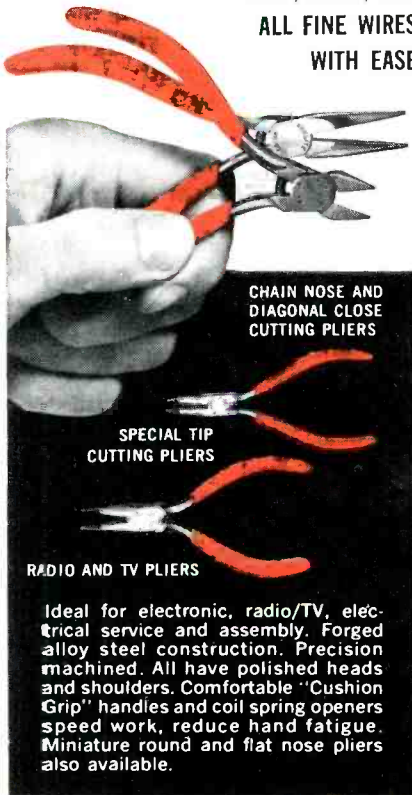

## a complete line of regular pliers and snips, too

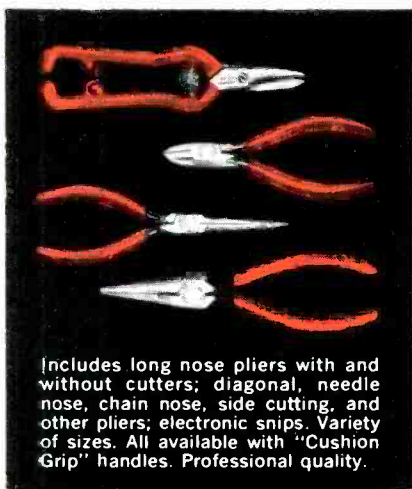

# XCELITE

XCELITE, INC., 18 Bank St., Orchard Park, N.Y. 14127  
In Canada contact Charles W. Pointon, Ltd.

Circle 13 on literature card

out this circuit, the output transistors would almost certainly fail if the high voltage shorted.

Incidentally, the horizontal output transistors are exactly the same as those used in Motorola's new black-and-white sets. Like all other transistors in the TS-915/919, they're standard off-the-shelf parts and cost \$6.50 each. Motorola's engineers have used several little tricks to enable them to use a standard part in this critical area. The arc gate is one; the pulse limiter diode (Fig. 4) is another.

The color circuits (Fig. 5) have some interesting variations. The color killer control is eliminated. Instead, the killer circuit consists of Q5 and Q6 in a one-shot multivibrator configuration which biases off the second color IF amp unless burst is received. Since the color oscillator is of the "ringing crystal" type, several cycles of burst frequency are needed to activate the killer circuit. Thus it is virtually impossible to receive confetti, yet the color circuits are turned on with any usable color signal.

The hue control splits the output of Q11, the color oscillator phase splitter. Though the vectors are a little hard to understand, the circuit action is fairly simple. The signal at Q11's emitter is 180° out of phase with the signal at the collector. The hue control can be thought of as a voltage divider. (In this case it's a phase rather than voltage divider.)

A glance at the circuit will bring arguments, we know. However, those of you familiar with vectors and phases can follow the signal through. The end result is that the 3.58-MHz reference applied to the base of Q12 may be rotated through 140° by the hue control.

The color demodulators are dual-diode phase comparers. However, the luminance or "Y" information is restored in the secondary of the second IF transformer, and the circuits directly demodulate red, blue, and green video signals. After suitable amplification, these signals are applied to the cathodes of the CRT. The cathodes are biased at 150 volts; the grids, which have no signal applied, are biased at 35 volts. The screens are set at about 440 volts. A big advantage of this method of demodulation is better gray-

*If it moves,*  
**The Antenna Specialists**  
*have a great new CB antenna*  
*to help it communicate!*

*on land...*



New "Grip-Stick" magnetic mount sticks to its business at all legal speeds! VSWR less than 1.5/1.0, capacity-matched. 16' cable. Less than 27" long. No-mar vinyl underside. Model M-168.

*on water...*



New "Sea-Hook" half-wave-length marine antenna has exceptionally low radiation angle. No ground plate required! Spring-loaded fold-down feature. White cyclac base, chrome-plated brass parts. VSWR less than 1.5/1.0. Model ASM-23.



*in the air...*

New "Sky-Hook" fiberglass airborne CB antenna—low-profile design, wind-rated over 250 mph. Temp. range: minus 50°F/plus 200°F. VSWR 1.5/1.0 or better. Only 24" long—reduces static, gives ample ground clearance. Model M-149.

 **the antenna  
specialists co.**  
Div. of Anzac Industries, Inc.  
12435 Euclid Ave., Cleveland, Ohio 44106

Whatever your need, you can  
trust the "Stripes of Quality"!

Export: 64-14 Woodside Ave.  
Woodside, N.Y., 11377

Circle 14 on literature card

scale tracking as compared to the usual method of matrixing in the CRT. As a side benefit of course, the boost voltage requirements are much lower.

There are many other circuits worthy of mention in the TS-915/919. Among these are: automatic brightness limiting to limit CRT conduction; a fine-tuning indicator circuit which lights a red lamp on the front panel if the 45.75-MHz carrier is lost; and an integrated-circuit in the sound IF, detector, and first audio amplifier circuits.

The whole set is interesting, from the volume control (a vertical strip with sliding contact) to the interlock (near the front on the 915 chassis). The biggest impact though is the very existence of a solid-state color set. It's obvious that time is running out for those technicians who have ignored their solid-state training.

Further evidence of the solid-state trend is the recent announcements by Thorn Electrical Industries (Great Britain) and Sony that they will manufacture solid-state color TV receivers.

Thorn's set is big-screen and employs 90 transistors. It is designed for serviceability, with PC cards similar to those used in computers.

Sony's entry in the solid-state color market is typically Japanese—a 7-inch "tiny-vision" set. It will use a variation of the chromatron tube (switching-grid rather than shadow-mask). It is claimed that the stability problems of the large-screen chromatrons are easily solved in the 7" version. The set is expected to hit the American market early in 1968.

RCA's recently-released new CTC-31 chassis features several transistors in the color circuits. Their remote control circuits feature integrated circuits this year.

Of course we're all aware that Philco has had solid-state RF, IF, and AGC stages. Zenith has used transistors in several of their color chassis. GE's diode demodulator is well-known.

The trend is evident, and Motorola's move will force the other manufacturers to quicken the pace of their engineers. We should expect nearly every set maker to have solid-state in his color line next year.

We have been asked time and again, "what will the solid-state trend mean to the serviceman? Will I be out of a job?" The answer is no! A good comparison would be Hi-Fi instruments. A few years back, the market was long established, yet really not accepted by the public. Then transistorized Hi-Fi's were introduced to the market and sales boomed. Actually, the Hi-Fi market was growing before the transistorized set was introduced, but the transistor gave the market

a big push. The public accepted the slogan "solid-state reliability."

Now the color TV market is in much the same position. It has struggled for years, experienced a spurt, and now shows signs of leveling off its growth pattern. Transistors should give the market a big push. This means more sales for dealers and more customers for service men. You may not work on the same set as often, but there will be a lot more sets. ▲



## Perk it up with Perma-Power COLOR-BRITE

Perma-Power does for color TV sets what we've done for millions of black and white CRT's: adds an extra year of useful picture tube life.

When a color tube begins to fade, COLOR-BRITE *instantly* brings back the lost sharpness and detail. It provides increased filament voltage to boost the electron emission and return full contrast and color quality to the 3 gun color picture tube.

COLOR-BRITE is automatic... no switching or wiring. Just plug it in. Your delighted customers will brighten up as fast as their color sets!

Model C-501, for round color tubes.

List Price \$9.75

Model C-511, for rectangular color tubes.

List Price \$9.75



COLOR-BRITE is a Hue-Brite product from Perma-Power, famous in TV service for b & w Vu-Brites and Tu-Brites.

**Perma-Power** COMPANY  
5740 N. TRIPP AVE., CHICAGO, ILLINOIS 60646  
PHONE (312) 539-7171

Circle 15 on literature card

August, 1967/PF REPORTER 43



*Making the public aware of your services and/or products is essential to the success and continued growth of your business. The information presented here will help you plan your advertising, and equally as important, determine its effectiveness.*

# measuring the results of advertising!

By ELIZABETH M. SORBETT



**I**F YOU are new to the retail or service business, you may still be learning about advertising through trial and error. Perhaps you watch your competitors and run ads when they do. Or you run an ad only when you can offer a bargain.

Whether you are a newcomer or a veteran advertiser, you should always keep one question foremost in your thinking: How much good is my advertising doing?

In a small firm, neither time nor money is sufficient to engage in complicated ad-measurement methods. But even so, you can use certain rule-of-thumb devices to get a better idea than you may now have about the results of your advertising.

### WHAT RESULTS DO YOU EXPECT?

Essentially, measuring results means comparing sales with advertising. In order to do it you have to start early in the process—before you even make up the advertisement. The question to answer is: What do you expect the advertising to do for your store?

In thinking about the kinds of results to expect, it is helpful to divide advertising into two basic kinds: immediate response advertising and attitude advertising.

*Immediate response advertising* is designed to cause the potential customer to buy a particular product from you within a short time—decision-triggering ads is one that pro- today, tomorrow, the weekend, or next week. An example of such denotes regular-price merchandise with immediate appeal. Other examples are ads which use price appeals in combination with clearance sales, special purchases, seasonal items (for example, white sales, Easter sales, etc.), and “family of items” purchases.

Such advertising should be checked for results daily or at the end of 1 week from appearance. Because all advertising has some carry-over effect, it is a good idea to check also at the end of 2 weeks from appearances, 3 weeks from appearances, and so on to insure that no opportunity for using profit-

making messages is lost.

*Attitude advertising* is the type you use to keep your store’s name and merchandise before the public. Some people think of this type as “image-building” advertising. With it, you remind people week after week about your regular merchandise or services or tell them about new or special services or policies. Such advertising should create in the minds of your customers the attitude you want them to have about your store, its merchandise, its services, and its policies.

It is your reputation builder. To some degree, all advertising should be attitude advertising.

Attitude (or image-building) advertising is harder to measure than immediate response advertising because you cannot always attribute a specific sale to it. Its sales are usually created long after the ad has appeared and are triggered by the customer some time after having seen the ad. However, you should keep in mind that there is a lead time relationship in such advertising. For example, an ad or a series of ads that announces you have the exclusive franchise for a particular brand probably starts to pay off when you begin to get customers who want that brand only and ask no questions about competing brands.

In short, attitude advertising messages linger in the minds of those who have some contact with the ad. These messages sooner or later are used by people when they decide that they will make a certain purchase.

Because the purpose of attitude advertising is spread out over an extended period of time, the measurement of results can be more leisurely. Some attitude advertising—such as a series of ads about the brands which the store carries—can be measured at the end of 1 month from the appearance of the ads or at the end of a campaign.

### PLANNING FOR RESULTS

Whether you are trying to measure immediate response or attitude advertising, your success will depend on how well the ads have been planned. The trick is to work out points against which you can check

after customers have seen or heard the advertisement.

Certain things are basic to planning advertisements whose results can be measured. First of all, *advertise products or services that have merit in themselves*. Unless a product or service is good, few customers will make repeat purchases no matter how much advertising the store does.

Many people will not make an initial purchase of a shoddy item because of doubt or unfavorable word-of-mouth publicity. The ad that successfully sells inferior merchandise usually loses customers in the long run.

Small marketers, as a rule, *should treat their messages seriously*. Humor is risky as well as difficult to write. Be on the safe side and tell people the facts about your merchandise and services.

Another basic element in planning advertisements is to know *exactly what you wish a particular ad to accomplish*. In an immediate response ad, you want customers to come in and buy a certain item or items in the next several days. In attitude advertising, you decide what attitude you are trying to create and plan each individual ad to that end. In a small operation, the ads usually feature merchandise rather than store policies.

*Plan the ad around only one idea*. Each ad should have a single message. If the message needs reinforcing with other ideas, keep them in the background. If you have several important things to say, use a different ad for each one and run the ads on succeeding days.

The pointers which follow are designed to help you plan ads so they will make your store stand out consistently when people read or hear about it.

*Identify your store fully and clearly*. Logo-types or signatures in printed ads should be clean-lined, uncluttered, and prominently displayed. Give your address and telephone number. Radio and television announcements to identify your sponsorship should be full and as frequent as possible without interfering with the message.

*Pick illustrations which are all similar in character*. Graphics—that is, drawings, photos, borders, and

†Associate Professor Marketing,  
University of Southern Mississippi,  
Hattiesburg, Mississippi

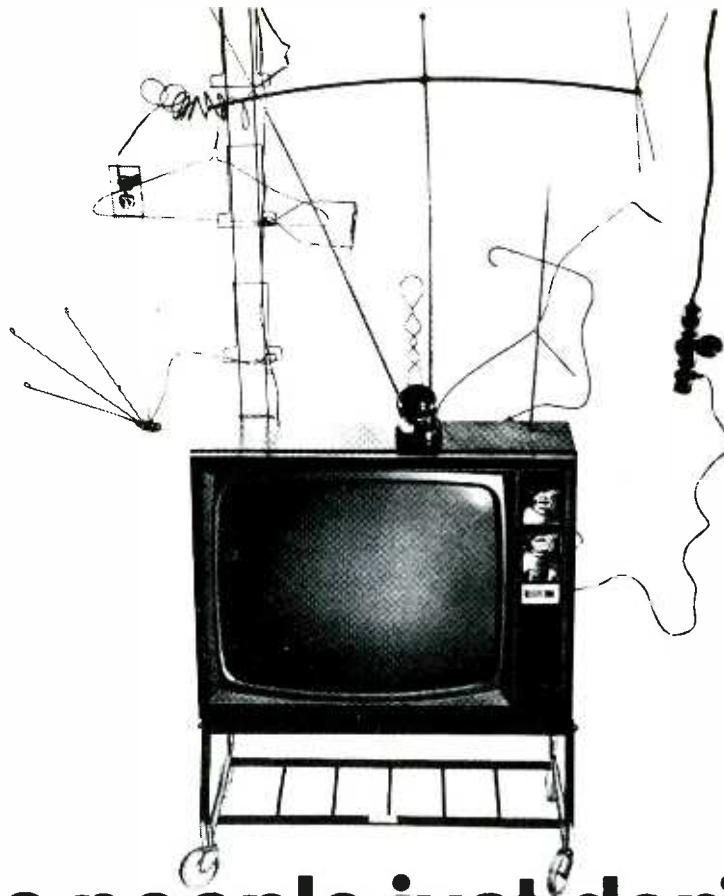

# Some people just don't like to admit they need a service man.

They know they're going to have to pay bills for something they don't really understand. They feel a little uneasy, a little helpless.



That's why millions of Philco owners automatically choose their local Philco Qualified Service Center when they need something fixed. They feel safer with the specialist.

There's a lot of new business waiting for you when you hang out the Philco sign.

Your service technicians can get all the training they need right there in your area. And when they're through, our Tech Data Service keeps them in the picture with all the new developments and service short cuts.

When your shop appears in our Yellow Pages listings you become the headquarters for Philco Service in your area. You can get new business you'd probably never have uncovered. And you get the fastest parts delivery in the industry.

That's briefly how it works — how it'll mean more business for you. Your local Philco-Ford Distributor will give you all the details. Call his Service Manager.

Philco-Ford Corporation  
Philadelphia, Pa. 19134



Circle 17 on literature card

layout—that are similar in character help people to recognize your advertising immediately.

*Pick a printing type face and stick to it.* Using the same type face or the same audio format on radio or television helps people to recognize your ads. Also using the same sort of type and illustrations in all ads allows you to concentrate on the message when examining changes in response to ads.

*Make copy easy to read.* The printed message should be broken up with white space to allow the reader to see the lines quickly.

*Use coupons for direct mail advertising response as often as possible.* Coupons give an immediate sales check. Key the coupon in some manner so that you can measure the response easily.

*Get the audience's attention in the first 5 seconds of the radio and TV commercial.* Also, get your main message in the first sentence if possible.

#### TESTS FOR IMMEDIATE RESPONSE ADS

In weighing the results of your immediate response advertisements the following devices should be helpful:

*Coupons brought in.* Usually these coupons represent sales of the product. When the coupons represent requests for additional information or contact with a salesman, were enough leads obtained to pay for the ad? If the coupon is dated, you can determine the number of returns for the first, second, and third weeks.

*Requests by phone or letter referring to the ad.* A "hidden offer" can cause people to call or write. Include—for example, in the middle of a paragraph—a statement that on request the product or additional information will be supplied. Results should be checked over a 1-week through 6-month or 12-month period because this type ad may have considerable carry-over effect.

*Split runs by newspapers.* Prepare two ads (different in some way you would like to test) and run them on the same day. Identify the ads—in the message or with

a coded coupon—so you can tell them apart. Ask customers to bring in the ad or coupon. When you place the ad, ask the newspaper to give you a split run—that is: to print "ad A" in part of its press run and "ad B" in the rest of the run. Count the responses to each.

*Sales made of particular item.* If the ad is on a bargain or limited-time offer, you can consider that sales at the end of 1 week, 2 weeks, 3 weeks, and 4 weeks come from

the ad. You may need to make a judgment as to how many sales came from display and personal selling versus advertising.

*Check store traffic.* An important function of advertising is to build store traffic which results in purchases of items that are not advertised. Pilot studies show, for example, that many customers who are brought to the store by an ad for one item also bought a second item during the same visit.



### USERS CAN'T BE WRONG!

Technicians everywhere rely on famous Sencore Mighty Mites. Here's why.

- Grid Leakage Test with ultra-high sensitivity of 100 megohms
- Emission Test at full rated cathode current
- Shorts Test picks out interelement shorts of 180K ohms or less
- Mighty Mite accurately checks over 3,000 tubes, including foreign.



## NEW MIGHTY MITE V

TC142

Now, Sencore's new Mighty Mite V gives you the same reliability and accuracy, plus new features that make the "V" the most up-to-date tester of all.

- NEW—Magnoval socket so you check many more tubes.
- NEW—Horizontal in-line switch layout saves setup time.
- NEW—Rugged vinyl-clad steel case stays new longer.
- NEW—Brushed chrome panel; detachable cover.

The new TC142 is truly Sencore's mightiest Mighty Mite and it's still only

**\$74.50**

IN STOCK AT YOUR DISTRIBUTOR NOW.



**SENCORE**

NO. 1 MANUFACTURER OF ELECTRONIC MAINTENANCE EQUIPMENT

426 SOUTH WESTGATE DRIVE, ADDISON, ILLINOIS 60101

Circle 18 on literature card

August, 1967/PF REPORTER 47



## Using silicon rectifiers in horizontal AFC circuits

FIG. 1. 6AL5 AFC CIRCUITS

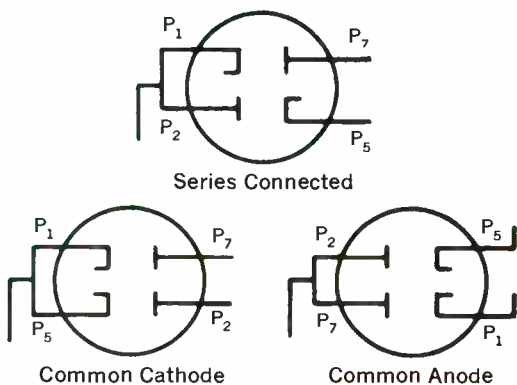

Many of the older TV sets you'll run into have a 6AL5 dual rectifier tube in the horizontal automatic frequency control circuit. Its function is to insure a stable horizontal frequency, by comparing the input signal from the sync separator with a feedback signal from the horizontal output. Three different circuits were used for this job, as shown in Figure 1.

In some later sets, selenium rectifiers took over the 6AL5 job for AFC. These were connected as shown in Figure 2.

FIG. 2. SELENIUM RECTIFIER AFC CIRCUITS

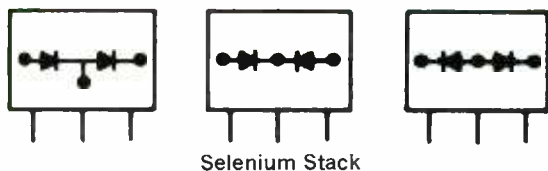

When you run into one of these AFC circuits that needs fixing, you can do your customer a favor by switching to Mallory silicon rectifiers. You'll give him a repair job that will shape up this part of the set for all time, at no extra cost. You won't have to chase around finding a selenium stack with exactly the rating you need. And you're sure you won't ever have a call-back on the job.

You can go either of two ways with Mallory silicon replacements. Simplest is to use a Mallory packaged rectifier circuit—a pair of factory-connected rectifiers in a single compact plastic case. Cost is slightly less than two separate rectifiers, and installed reliability is better because you have fewer solder connections to make. The VB doubler is ideal for the series-connected AFC circuit; just get a Mallory VB100 and hook it to the tube socket. For the common cathode AFC circuit, use a Mallory CTP100 (full wave, center tap positive). And for the common anode circuit, use a Mallory CTN100 (full wave center tap negative).

FIG. 3. MALLORY SILICON RECTIFIER REPLACEMENTS

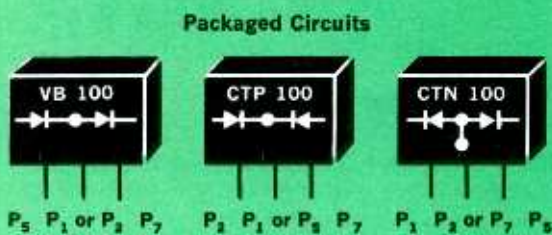

Or if you prefer to work with separate rectifiers, get yourself a pair of Mallory Type A's. The A100 will work fine. Either way, just make your connections as shown in Figure 3.

Type A Rectifiers

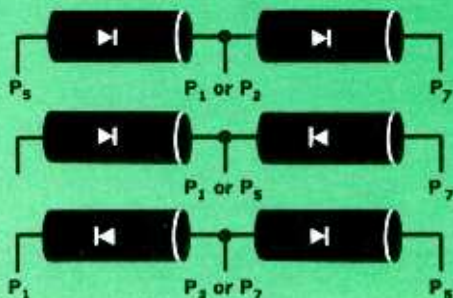

For this service, 100 volt ratings are ample to give you full protection against transient "spikes" and assure long life. For other applications in TV sets, stereo, radios and industrial equipment, take a look at the complete line of Mallory power rectifiers, zener diodes and other semi-conductors stocked by your Mallory Distributor. He's a good guy to know for everything you need for service, prototype building or experimental work. Mallory Distributor Products Company, a division of P. R. Mallory & Co. Inc., Indianapolis, Indiana 46206.

DON'T FORGET TO ASK 'EM—*What else needs fixing?*

Circle 19 on literature card

You may be able to use a local college or high school distributive education class to check store traffic. Class members could interview customers as they leave the store to determine: (1) which advertised items they bought, (2) what other items they bought, and (3) what they shopped for but did not buy.

#### TESTING ATTITUDE ADVERTISING

When advertising is spread out over a selling season or several seasons, part of the measurement job is keeping records. Your aim is comparing records of ads and sales for an extended time.

An easy way to set up a file is by marking the date of appearance on tear sheets of newspaper ads, log reports of radio and television ads, and copies of direct mail ads. The file may be broken down into monthly, quarterly, or semi-annual blocks. By recording the sales of the advertised items on each ad or log, you can make comparisons.

*In attitude (or image-building) advertising*, the individual ads are building blocks, so to speak, which make up your advertising over a selling season. The problem is trying to measure each ad and the effects of all the ads combined.

One approach is making your comparisons on a weekly basis. If you run an ad, for example, each week, at the end of the first week after the ad appears, compare that week's sales with the sales for the same week a year ago. At the end of the *second* week, compare your sales with those of the end of the first week as well as year-ago figures.

At the end of the *third* week, 1 month, 3 months, 6 months, and 12 months from the appearance of the ad, repeat the process even though additional ads may have appeared in the meantime. For each of these ads, you will also make the same type of comparisons. You will, of course, be measuring the "momentum" of all of your ads as well as the results of a single ad.

After a time, you probably will be able to estimate how much of the results are due to the individual ad and how much to the momentum of all of your advertising. You may then make changes in specific details of the ad to increase customer response.

When comparing sales increases over some preceding period, allowances must be made for situations that are not normal. For example, your experience may be that rain on the day an ad appears cuts its pulling power by 50 percent. Similarly, advertising response will be affected by the fact that your customers work in a factory that is out on strike.

Some of the techniques which you can use for keeping on top of and improving attitude advertising follow:

#### REPEAT

*Repeat an ad.* If response to an ad is good, run it—without change—two or three times and check the responses of each appearance against previous appearances.

Keep repeating the process. Much advertising loses effectiveness because the advertiser doesn't keep reminding people. Repetition helps increase knowledge of, and interest in, the product. You can soon estimate how often you should repeat each ad.

*Analyze all ads in relation to response.* Divide ads into at least two classes: high-response ads and low-

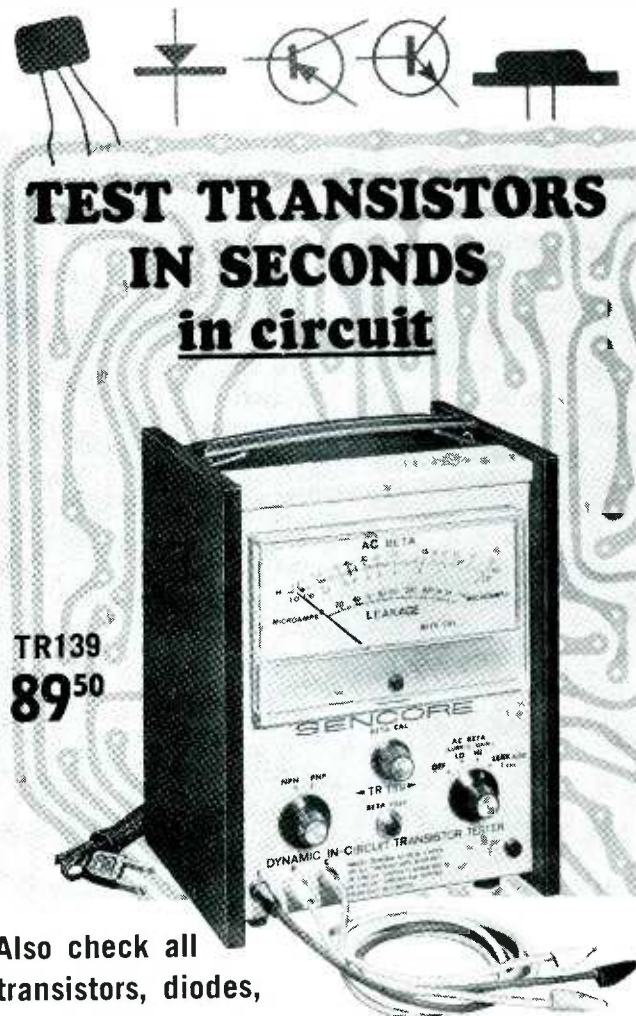

Also check all transistors, diodes, and rectifiers out of circuit for true AC beta and  $I_{cbo}$  leakage.

#### Your best answer for solid state servicing, production line testing, quality control and design.

Sencore has developed a new, dynamic in-circuit transistor tester that really works—the TR139—that lets you check any transistor or diode in-circuit without disconnecting a single lead. Nothing could be simpler, quicker or more accurate. Also checks all transistors, diodes and rectifiers out of circuit.

**BETA MEASUREMENTS**—Beta is the all-important gain factor of a transistor; compares to the gm of a tube. The Sencore TR139 actually measures the ratio of signal on the base to that on the collector. This ratio of signal in to signal out is true AC beta.

**ICBO MEASUREMENTS**—The TR139 also gives you the leakage current ( $I_{cbo}$ ) of any transistor in microamps directly on the meter.

**DIODE TESTS**—Checks both rectifiers and diodes either in or out of the circuit. Measures the actual front to back conduction in micro-amps.

**COMPLETE PROTECTION**—A special circuit protects even the most delicate transistors and diodes, even if the leads are accidentally hooked up to the wrong terminals.

**NO SET-UP BOOK**—Just hook up any unknown transistor to the TR139 and it will read true AC beta and  $I_{cbo}$  leakage. Determines PNP or NPN types at the flick of a switch.

Compare to laboratory testers costing much more. . . . **\$89.50**

See America's Most Complete Line of Professional Test Instruments — At Your Distributor Now.



NO. 1 MANUFACTURER OF ELECTRONIC MAINTENANCE EQUIPMENT

**SENCORE**

426 SOUTH WESTGATE DRIVE, ADDISON, ILLINOIS 60101

Circle 20 on literature card

August, 1967 / PF REPORTER 49

response ads. Then look for differences between the two classes.

The time the ad was run may be responsible for a particular response level. Other factors, however, may be just as much or more influential than time. Consider the feature subject used in the illustration, persons shown, activities shown, types of merchandise, settings or backgrounds, different colors used. Also consider the message and how well it was expressed. Did the copy stick to the theme? Or did it wander? If slogans were used, did they help make the point?

Graphic elements may be important. Check to see which response category is associated with the presence of coupons, borders, display lines, small or incidental illustrations. Check response in relation to any variation in the way each appears. Compare any difference in type size and design or the boldness of the type.

Emphasis on brand names should

also be checked. Price figures should be analyzed. If price lines are involved either in the ad or in the merchandise line of which the advertised product is a part, you should consider them also.

Check the size of the ad. It usually has a bearing on response. As a general rule, the larger the ad, the greater the response.

*Try to see a pattern of dominance.* Your analysis of high-and-low response ads may show that certain details—such as certain picture subjects—make the difference between a high or low response. Try to find the combinations which work best for your firm.

*Note changes occurring over time.* A small retailer should never take a winning combination for granted. There is no single formula that will insure high response ads every time. Advertising changes. Therefore, you should watch the ads of others to see what changes are occurring. Continue to analyze

your own ads, make small changes occasionally, and note any variations in response.

*Listen to what people say about your ads.* In doing so, try to discover the mental framework within which any comment about your ad was made. Then try to find points which reinforce believability and a feeling that your product fulfills some wish or need.

However, you should not be misled by what people say. An ad can cause a great deal of comment and bring in practically no sales. An ad may be so beautiful or clever that as far as the customer is concerned the sales message is lost.

#### WHEN YOU USE SEVERAL MEDIA

When your ads appear simultaneously in different media—such as the newspaper, on radio and television, in direct mail pieces, and as handbills—you should try to evaluate the relative effectiveness of

# Why not sell the best

## Now...get genuine Zenith parts three ways faster—with ZIP!

Your Zenith Distributor has a revolutionary new system to speed your replacement parts ordering. Called "ZIP" (Zenith Instant Parts), it gives you much improved service.

1. *Looking up parts numbers is 100% quicker than before.* Because parts lists and schematics for the past ten years are now microfilmed on compact, easily-handled filmcards.

2. *"Out-of-stocks" are cut down.* The new ZIP program helps your Zenith distributor keep tighter inventory controls and maintain a more complete stock.

3. *Factory special orders are shipped faster.* Under the new ZIP program, the Zenith factory is geared to ship orders without delay.

Order from your Zenith Distributor for "Zenith Instant Parts" service on all genuine Zenith replacement parts and accessories.

**ZENITH®**  
The quality goes in before the name goes on

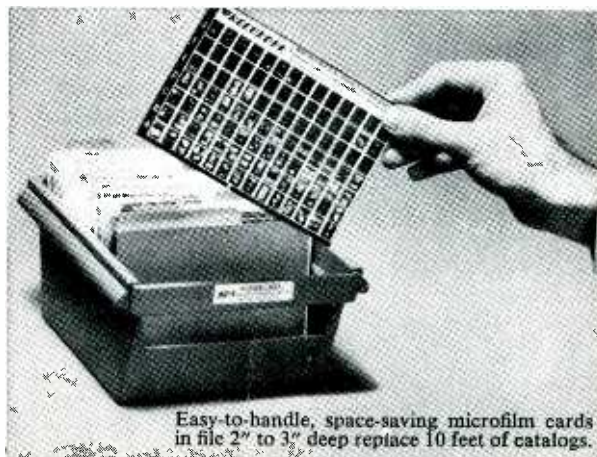

Easy-to-handle, space-saving microfilm cards in file 2" to 3" deep replace 10 feet of catalogs.

Circle 21 on literature card

each. You can check one printed medium against the other by using companion (the same or almost identical) ads in the newspaper, direct mail, and handbills.

You can make the job of analyzing and comparing results from among the media easier by varying your copy—the message. Your ad copy thus becomes the means of identifying your ad response.

You can check broadcast media—radio and TV—by slanting your message. Suppose, for example, that you advertise an item at 20 percent reduction. Your radio or TV ad might say something like this. "Come in and tell us you want this product at 20 percent off."

You can compare these responses with results from your "20 percent off" newspaper ad. Require the customer to bring in the newspaper ad—or a coupon from it.

Some of the ways to vary the copy are: a combination of the brand name with a word or some words indicating the product type; picture variations; size variations; and color variations. You might use the last three to check your printed ads against each other as well as against radio and TV ads.

Be careful that the copy variation is not so great that a different impression is received from each medium.

#### FOR FURTHER INFORMATION

Readers interested in exploring further the subject of measuring advertising may wish to consult the references indicated below. This list is necessarily brief and selective. However, no slight is intended toward authors whose works are not mentioned.

*Measuring Advertising Effectiveness* by Darrell Blaine Lucas and Stewart Henderson Britt. 1963. \$9.95. McGraw-Hill Book Company, 330 W. 42nd St., New York, N. Y. 10036.

*Advertising Management* by Nugent Wedding and Richard S. Lesser. 1962. \$8.50. The Ronald Press Company, 15 E. 26th St., New York, N. Y. 10010.

*Advertising: Mass Communica-*

*tion in Marketing* by C. A. Kirkpatrick. 2d ed. 1964. \$11.50. Houghton Mifflin Company, 2 Park St., Boston, Mass. 02107.

*Printers Ink.* 50 cents, single copy. \$7 per year. Decker Communications, Inc., 501 Madison Avenue, New York, N. Y. 10022.

*The Journal of Marketing.* \$3 single copy. \$10 per year. The American Marketing Association, 230 North Michigan Ave., Chicago, Ill. 60601.

*A Guide for Retail Advertising and Selling.* 1963. \$12.50. Association of Better Business Bureaus, Chrysler Building, New York, N. Y. 10017.

This article was reproduced from Small Marketers Aid No. 121, Small Business Administration, Washington, D. C. Copies of this Aid are available free from field offices and Washington headquarters of the Small Business Administration.

## NO MORE GUESSWORK!

**AMERICA'S MOST RELIABLE TUBE ANALYZER**

You don't need three guesses to tell if a tube is bad—or why. With the new Sencore MU140 Continental, you **know**. Right now. And you simply can't go wrong. Because it's a complete tube analyzer for 4-way testing—true mutual conductance (using exclusive 5000 hertz square wave), full cathode emission, 100 megohm grid leakage, and internal shorts. Tests all tubes, including foreign—over 3000 in all. Obsolete-proof, too—with "new socket" panel, and controls so standard the switch numbers correspond to the pin numbers in any tube manual.

If it's reliability you want—for years to come—you need the Continental. It's the best way to be sure—

See America's most complete line of professional test instruments—at your Distributor now.

for only  
**\$179<sup>50</sup>**

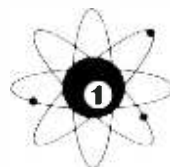

**SENCORE**

NO. 1 MANUFACTURER OF ELECTRONIC MAINTENANCE EQUIPMENT

426 SOUTH WESTGATE DRIVE, ADDISON, ILLINOIS 60101

Circle 22 on literature card

# NOTES ON TEST EQUIPMENT

*analysis of test instruments  
...operation...applications*

by T. T. Jones

## Injecto-Tracer

Hickok's new Model 860 Injecto-Tracer should be a big help to any shop which services AM radios. (And who doesn't?)

Transistor portables just naturally fall into the "dog" category, because they take too long to service. Now, however, the whole job can be done with two instruments; the Injecto-Tracer, and any good VTVM. If you can spare about one square foot on your instrument shelf, you can start servicing transistor portables at a profit.

The Model 860 provides a regulated power supply, 0-15 volts at up to 15 ma. That solves the power supply problems for nearly all portable radios. The supply is metered for both voltage and current. The Model 860 provides RF and IF outputs from 240 kHz to 1750 kHz, modulated up to 50% AM, or unmodulated. It also has a 1000-Hz audio output, and a 10.7-MHz fixed frequency FM output. These outputs should meet all requirements for testing by signal injection, and also serve quite well for alignment purposes. The dials are set up in two overlapping bands so that you merely change bands and slightly readjust the dial while aligning an AM set. No cranking from one end to the other of the dial.

But the most useful portion of the Model 860 is the signal tracer. It covers the same range as the signal generator (no FM tracer though), and is one of the most sensitive we've ever used. It has an input of over 2 megohms to minimize loading, and has sensitivity controls at both input and output. The sensitivity con-

trol is quite necessary, because at maximum the Injecto-Tracer can detect signals with the probe two inches away from the IF stages of an average set.

The Model 860 also functions as an audio signal tracer. In this mode the sensitivity is not as great, but still more than adequate.

The technique of troubleshooting with a tracer is familiar to most of us. It's the same as using a scope through the video stages of a TV set. For those of us a little rusty on the techniques, Hickok has included 8 pages of solid, concise information in the operator's manual. They even include servicing hints on soldering PC boards, use of heat sinks, etc.

After a few preliminary checks, we tried the Injecto-Tracer "on the job." Our own little pocket transistor hadn't played at all since the last time the kids borrowed it. Moving from base to base through the stages with the tracer, it took 3 minutes to find a cracked foil on the board. Another 3 minutes with the generator for alignment, and the set played fine.

*For further information circle 50  
on literature card*

## New CRT Tester

With all the CRT testers on the market, the buyer certainly can shop around. Most brands are about the same. Certainly, if one manufacturer comes up with a new feature, the others follow suit. So the shopper's choice is essentially reduced to brands. If he likes "Brand X," he'll buy it.

Sencore's new CR 143 however, has several new features—not just new and different, but also quite desirable. Foremost among these is separate screen



Fig. 1. Hickok's new Model 860 Injecto-Tracer.

### Hickok Model 860 Injecto-Tracer Specifications

#### Outputs:

Audio; 1000 Hz, 0-1V P-P, 3.2 ohms impedance. RF; 240-1750 kHz unmodulated or AM, 10.7 MHz FM. Low impedance.

#### Inputs for Signal Tracing:

RF; 240-1750 kHz. 2 megohms + 15 picofarads input impedance.  
Audio; entire audio spectrum,

same impedance as RF input.

#### Power Supply:

0-15 volts, 0-50 ma, regulated.

#### Size (HWD):

8" × 11" × 5½".

#### Weight:

8 pounds, 12 ounces.

#### Power Requirements:

105-125 VAC, 3 watts.

#### Price:

\$149.50.





Fig. 2. Sencore's new CR 143 CRT tester.

controls for each gun in a color tube. With this feature, it is only necessary to flip the gun switch to compare the beam currents on each gun. A considerable time saver at the least, and it should also help reduce errors that often creep in when we use the pencil-and-paper method.

Another feature of the CR 143 is the high-sensitivity interelement shorts test. Even though the indicators are neon bulbs, the shorts tester can detect leakage or gas up to 20 megohms.

The cathode emission tester is supplied by a DC power source. Since DC rather than AC is employed, the set-up chart lists a G1 cutoff voltage. The use of DC insures a test which can be referenced to tube manuals. The tester can actually be used without a setup book.

The CR 153 has all the other features most desirable in a CRT tester —“rejuvenate” and “remove shorts” functions, lightweight socket leads, etc.

We tried the CR 143 on an old set which obviously had a “sick” picture tube. When we tried to read emission, the needle wouldn’t budge. It appeared as if the tube had an open cathode. Rejuvenating on the first position didn’t help much. The needle just barely moved upscale, but enough to show the tube wasn’t dead. Punching the button on the “Rejuvenate 2” position brought the tube into the green, and it even passed life test. The picture was bright and sharp. We later found out the set had not been turned on for about 2 years, and evidently the cathode of the CRT had oxidized. Regardless of the reasons for the CRT originally checking dead, we were impressed with the CR 143’s performance. ▲

For further information circle 51 on literature card

### SENCORE CR 143 Specifications

**CRT's Tested:**

All presently manufactured types—both color and black-and-white.

**Tests Performed:**

Interelectrode shorts, emission, cutoff voltage, life test.

**Corrective Functions:**

Three levels of cathode rejuvenation, removes shorts, welds open cathodes.

Size (HWD):

9" × 10" × 3½".

**Weight:**

10 pounds 2 ounces.

**Power Requirements:**

117 VAC 60 Hz.

**Price:**

\$99.50.

# stability!



In one word, STABILITY is why you need a new Sencore CG141 Color King. With its exclusive thermostatically controlled heating element and its patent pending timer circuitry, the Color King maintains absolute stability from 20° below zero to 140° in the shade. Gives you the most reliable and rock solid patterns ever designed into a standard color bar generator.

**Now-generates seven patterns in all:** Standard RCA color bars, cross-hatch, individual vertical and horizontal lines, adjustable size dots plus two new patterns — single dot and cross that can be moved to any spot on the screen to speed up dynamic convergence. New snap tuning, channel 2 through 6; interlace control to form a perfectly round dot; and increased chroma and sync signals make the color king a complete color analyzer too.

Get yours now — the KING OF VALUE at **\$149<sup>95</sup>**

See America's most complete line of professional test instruments — at your Distributor now.

## SENCORE

NO. 1 MANUFACTURER OF ELECTRONIC MAINTENANCE EQUIPMENT

426 SOUTH WESTGATE DRIVE, ADDISON, ILLINOIS 60101

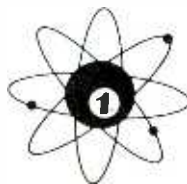

Circle 23 on literature card

# THE TROUBLE-SHOOTER

## Post Video Twist

I have a Trav-ler Chassis 740-78 (PHOTOFACT Folder 414-3) that is plagued with post video twist. When I inject a signal from a TV Analyst at the grid of the horizontal output tube, the picture is clear with no twist. However, when C45 is disconnected from the sync amplifier and a signal injected through it to the horizontal AFC circuit, waveform W11 is nearly identical to W14, while W10 is near normal with an amplitude of 27 volts p-p. With the picture in sync, W11 measures 33 volts p-p (should be 7.5 volts p-p). W12 and W13 are distorted and are normal only with the oscillator far off frequency. The waveform at the output of the low voltage power supply wiggles and changes amplitude when the picture is in sync. With the picture out of sync, the wiggle is more pronounced. The vertical waveforms are normal, as are all waveforms, with the exception of W10 and W11.

All components in the power supply have been replaced, as well as most of the components in the horizontal AFC

answers your servicing problems

and oscillator circuits. I have also replaced M3. Could the trouble be coming from the flyback through R70?

JAMES H. ANDING

Chicago, Ill.

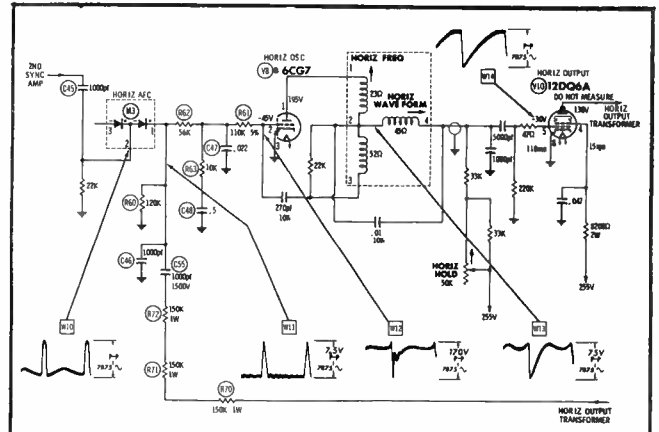

Your description of the waveforms indicates that the trouble is in the grid circuit of the horizontal oscillator, specifically in the feedback circuit from the horizontal output transformer. Since the waveform at W11 appears to be seriously integrated, something has caused the RC time constant of the grid to change. R60 is probably open. If this is not the source of trouble, check R61, R62, R63, R70, R71, R72, C46, C47, C48, and C55.

An open decoupling capacitor in one of the low voltage lines could be causing the discrepancy in the waveform at the power supply output. Since the ripple and vertical frequencies slightly differ when the set is out of vertical sync, the "wiggle" you described may be normal.

## Lost Color Sync

A Curtis Mathes CMC15 chassis (PHOTOFACT Folder 799-2) would lose color sync when the program switched to a commercial. The color would sync when the tint control was rotated to one end and would remain in sync when the control was rotated back to the position that produced proper hues. However, as soon as a commercial came on, the color would lose sync again. Changing all tubes in the chroma circuits had no effect on the trouble. While waiting for another commercial, I barely touched the horizontal hold control and the color lost sync. I changed the horizontal oscillator tube and the set has worked for 2 months without a recurrence of the color sync problem. Since horizontal sync was not affected when the color lost sync, I had not suspected the horizontal oscillator tube as a possible cause. I imagine the trouble had something to do with the color burst being keyed with a horizontal pulse, but I would appreciate an explanation.

J. L. BLACK

Grandfalls, Texas

## A MACHINE THAT REBUILDS TV PICTURE TUBES!

BLACK & WHITE and COLOR

Black and White for Less Than \$5.00

Color for Less Than \$12.00!



Exclusive

STATE DISTRIBUTORSHIPS

It's real — factual and phenomenal. Proven successful since 1964 — a machine that actually rebuilds television picture tubes. Black and white for less than \$5.00 and color for less than \$12.00 in one hour. 30% brighter and guaranteed better than new. No competition. Yes, unbelievable but true. Make me prove it. No franchise fee required. Small investment for equipment only.

WRITE MR. JESSE RAMSEY, PRESIDENT

NATIONAL ELECTRONIC  
ENTERPRISES

2014 Peachtree Center Bldg.  
230 Peachtree St., N.W.,  
Atlanta, Ga. 30303

Circle 25 on literature card

The condition which you describe is typical of a number of sets. This is the result of the horizontal oscillator circuit having a wider range of tolerance than the color killer circuit. As a result, even though the picture remains in horizontal sync, the gate pulse from the horizontal output transformer does not arrive at the color killer at the correct time to allow it to pass the burst signal.

Weak tubes in the color killer, chroma oscillator, and color killer detector circuits may aggravate the condition, but I have also seen many new sets exhibit the symptoms which you describe.

### Loss of Focus

I have an Admiral Chassis 1G1155-1 (PHOTOFACT Folder 825-1) that loses focus when the antenna is disconnected. The same symptom is also displayed when the brightness control is positioned in the range from  $\frac{3}{4}$  to maximum brightness. Loss of focus and blooming are normal for some sets; however, the degree displayed by this particular chassis is excessive.

I have replaced the high voltage rectifier and regulator diode, focus rectifier, and horizontal output and oscillator tubes. Replacement of the regulator diode helped a little; however, the loss of focus and blooming are still excessive.

TOM BURTON

Synder, Texas

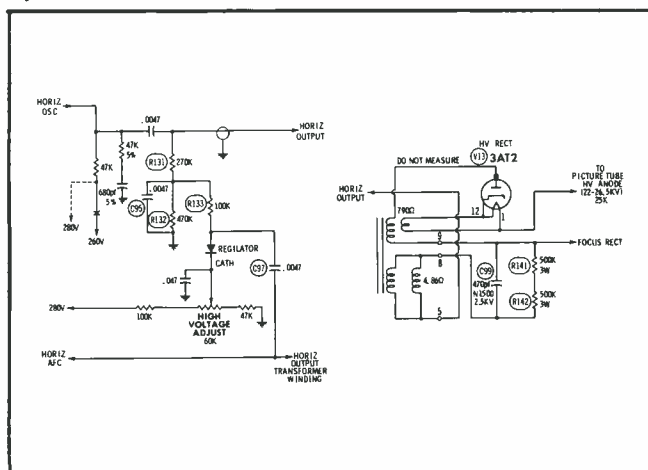

The symptoms you describe could be caused by either improper high voltage regulation or poor focus tracking. Perform the horizontal sweep circuit adjustments described in the PHOTOFACT Folder. If the trouble persists, check the focus tracking resistors, R141 and R142. If C99 is leaking, it would have the same effect as R141 or R142 being below tolerance. Improper regulation could be caused by failure of a component in the feedback circuit—C97, C95, R131, R132, or R133.

### MOVING?

Don't lose touch . . .

RECEIVE PFR AS USUAL  
(INCLUDE OLD AND NEW ADDRESS)

PF REPORTER  
CIRCULATION DEPT.  
4300 W. 62nd St.,  
Indianapolis, Ind. 46206

## the instrument with endless uses ... the all new improved completely solid state

### SENCORE FS134 FIELD STRENGTH METER



only  
**199.50**  
lowest price going

HERE ARE JUST A FEW OF THE MANY USES ...



**INSTALLING AND CHECKING OUT DISTRIBUTION SYSTEMS**  
Qualify for this multi-million dollar business in hotel, motel, and hospital installations.



**COLOR INSURANCE**  
Be sure the signal is adequate on each channel for proper color TV operation.

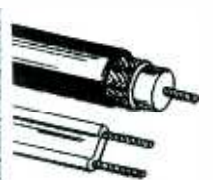

**CHECK TRANSMISSION LINES**  
For the first time read actual db loss in either 75 or 300 ohm transmission lines.

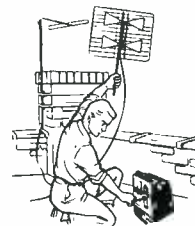

**INSTALLING UHF, VHF, AND FM ANTENNAS**  
Cut down installation time and pay for the FS134 in a short time on critical UHF as well as VHF and FM antennas.

**COMPARE ANTENNAS**  
For actual db gain; see which is best for each location, both VHF and UHF. Also excellent for orienting "dishpans" for translator use at the high end of UHF band.

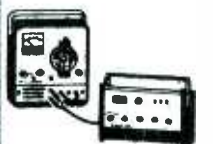

**CHECK ANY GENERATOR OUTPUT**  
For correct frequency and output all the way up to a tenth of a volt RMS. What a time saver when you want to know if your generator is putting out.

### PLUS: LOCALIZE NOISE AND INTERFERENCE

Fine noise source fast; pick quiet locations for antenna installations or orient antenna away from noise when possible.

These are only a few uses of this UHF-FM-VHF accurately microvolt calibrated field strength meter. You can start paying for the FS134 tomorrow in the time saved today—if you see your Sencore distributor now. Why not pick up the phone and ask him to show you the new FS134?

SEE AMERICA'S MOST COMPLETE LINE OF PROFESSIONAL TEST INSTRUMENTS—AT YOUR DISTRIBUTOR'S NOW.



**SENCORE**

NO. 1 MANUFACTURER OF ELECTRONIC MAINTENANCE EQUIPMENT

426 SOUTH WESTGATE DRIVE, ADDISON, ILLINOIS 60101

Circle 26 on literature card

August, 1967/PF REPORTER 55

# FAST

## COMPLETE OVERHAUL ON ALL MAKES OF TV TUNERS

Maximum Time In Shop 24 Hrs.

(WE SHIP C.O.D.)

# \$9.50



Black &  
White  
or Color

VHF or  
UHF

UV Combo's \$15.00

Price includes all labor and parts except Tubes, Diodes & Transistors. If combo tuner needs only one unit repaired, disassemble and ship only defective unit. Otherwise there will be a charge for a combo tuner. Ship tuners to us complete with Tubes, Tube Shields, Tuner Cover and all parts (including) any broken parts. State chassis, model number and complaint.

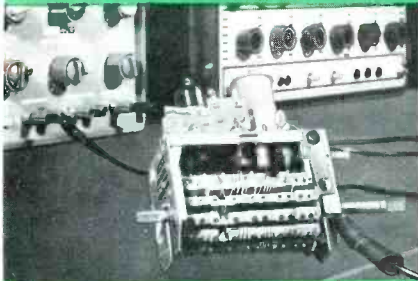

All tuners are serviced by **FACTORY TRAINED TECHNICIANS** with years of experience in this specialized field. All tuners are **ALIGNED TO MANUFACTURERS SPECIFICATION** on crystal controlled equipment and air checked on monitor before shipping to assure that tuner is operating properly.

## GEM CITY TUNER REPAIR SERVICE

Box 6 B Dabel Station  
2631 Mardon Drive  
Dayton, Ohio 45420

Circle 28 on literature card

56 PF REPORTER/ August, 1967

## LETTERS TO the EDITOR

Dear Editor:

In certain relatively inexpensive Japanese made AM/FM tube type table radios the 19A3 tube is frequently used as a rectifier.

There is no American made equivalent for this tube and in many areas the 19A3 is difficult and even impossible to obtain.

Experience has shown however, that a 35W4 will, in nearly all instances, operate satisfactorily in the circuit.

I would appreciate your passing this information on to any service men who write to you for your assistance.

ROBERT E. GERSON  
ELECTRONIC DIVISION  
JAPAN LIGHT MACHINERY  
INFORMATION CENTER  
New York, N. Y.

*The 19A3 and 35W4 differ only in the filament voltages required. While the substitution of the 35W4 for the 19A3 probably will work satisfactorily in many receivers, there could be some marginally designed sets in which it will not work. The lowered filament voltage on the other tubes in the string and the lowered B+ voltage could cause the oscillator to stop working. A substitution of the 19A3 for the 35W4 is also possible but is dangerous because of the increased voltage and current on all tubes in the filament string.—Ed.*

Dear Editor:

Re: April, 1967 issue—Letters to the Editor.

Apply heat lamp eight inches away for 10 to 15 minutes. Slug will be free.

E. FOSTER

Chicago, Ill.

# NEW



## GENERAL PURPOSE

VINYL PLASTIC

## ELECTRICAL TAPE

### BUY IT at your local GE Electronic Components Distributor

Insulating Materials Dept.

GENERAL  ELECTRIC

846-03

Circle 27 on literature card

Dear Editor:

I've just received my copy of April PF REPORTER and noticed where one of our service friends is having some trouble with cores being stuck in coils. Well I'm glad to pass along my little bit of help.

I have found only one brand of contact cleaner that will do this job for me, and that is Channelmaster Contact Shield with silicon base.

I have been getting mighty good results from it for the past few years. The trick that I found is: spray close to the place you think is stuck and let it soak for ten or fifteen minutes before you try to break the part loose. I have found this good also for frozen yokes, control shafts, controls, door locks, and most any small parts that need to be freed.

Now I don't say that other brands of contact cleaner won't do as good, but this brand works well. I hope it works as well for Mr. A. DuBusley.

I get a lot of help from reading my PF REPORTER and look forward to seeing my new copy every time.

W. McNEILL

Seagrove, N.C.

*I'm glad to see that the fraternity of servicemen still help each other in a very competitive business.—Ed.*

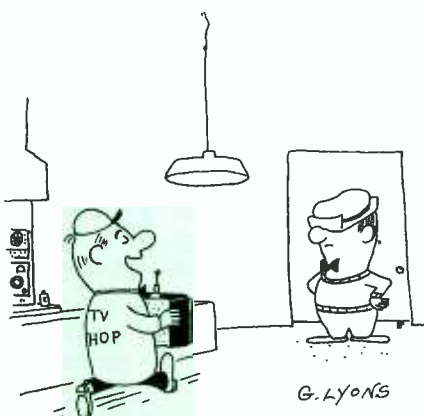

"You should check with the Internal Revenue Service to see if you can claim this as a dependent!"

**"I was TROUBLE-SHOOTING  
in the DARK 'til Sencore's Scope  
Showed Me What Color Waveforms  
Really Look Like."**



PS 127 5" WIDE BAND  
OSCILLOSCOPE

**Technicians everywhere are talking about the PS127 5" Wide Band Oscilloscope. Try one and you, too, will send us comments like these—**

"So easy to use! With my Sencore scope I can read high or low frequency signals without band switching. As easy to use as a voltmeter."—R. L., Portland, Ore.

"I've only had my PS127 a couple of months, but it's more than paid for itself already with the extra jobs I've been able to handle."—S. O., New Orleans, La.

"With the direct peak-to-peak readout I can compare voltage readings to those on the schematic without wasting valuable time setting up my scope with comparison voltages."—J. M. F., Plymouth, Michigan.

"Those Sencore exclusives really sold me, like the extra 500KC Horizontal Sweep range and the free high voltage probe."—D. N., Brooklyn, N.Y.

You'd expect a wide band scope of this quality to cost at least double."—W. L., Chicago, Ill.

"With the PS127, I find I can trouble-shoot those tough ones twice as fast as before—especially color TV."—F. C., Burlingame, Calif.

"Once I compared the specs, I knew Sencore had the best buy in scopes. We now have three PS127's in our shop."—J. S., Ft. Lauderdale, Fla.

#### SPECIFICATIONS

Vert. Freq. Resp. 10 CPS to 4.5 MC  $\pm$  1 db, — 3 db @ 6.2 MC • Rise Time .055 Microseconds • Vert. Sens. .017 Volts RMS/inch • Horiz. Freq. Resp. 10 CPS to 650 KC • Horiz. Sens. .6 Volts RMS/inch • Horiz. Sweep Ranges (10% overlap) 5 to 50 CPS, 50 to 500 CPS, 500 CPS to 5 KC, 5 to 50 KC, 50 to 500 KC • Input Impedance 2.7 megohms shunted by 99 MMF, 27 megohms shunted by 9 MMF thru low-cap. jack • High Voltage Probe 5000 Volts Max. • Dimensions 12"x9"x15 1/2", Wt. 25 lbs. • Price Complete \$199.50

NO. 1 MANUFACTURER OF ELECTRONIC MAINTENANCE EQUIPMENT



**SENCORE**

426 SOUTH WESTGATE DRIVE, ADDISON, ILLINOIS 60101

Circle 29 on literature card

August, 1967/PF REPORTER 57

## High Quality Audio

(Continued from page 38)

put impedance of the distortion meter is relatively low and it cannot be used to measure voltages at high-impedance points.

If you are looking for some more uses for that "hot" new scope that's sitting on the bench, you can use it as a fairly accurate distortion meter. It has high input impedance and a calibrated vertical attenuator to measure voltage. Just train your eyeballs to reject the input signal, and everything that is left is distortion. Fig. 3 is a drawing of a typical signal with distortion. The amplitude of the signal is measured as usual. Then you change the vertical position and decrease the attenuation (Fig. 3B) to measure the distortion—not extremely accurate, but it's fast.

While measuring the distortion in the audio amplifiers, you will find that it will increase as the output of the amplifiers increases. You will also find that, although the distortion is about the same in both channels of the decoder (even with a malfunction), this is not necessarily the case in the audio amplifiers. In fact, there are very few problems that will cause increased distortion in both channels. This can be helpful in troubleshooting if you don't know the distortion specifications of the set. If one channel has more distortion than the other, it is a definite indication that something is wrong.

### Separation Measurement

The degree of channel separation in the stereo receiver is usually determined by the decoder, although it is possible that the audio amplifiers or the tuner could be causing the crosstalk. To measure the separation, inject an RF signal (100% modulated by a composite stereo signal) at the antenna terminals. Adjust the gain and balance controls so that the outputs of the left and right channels are equal. A scope is convenient for this measurement. Now remove the L signal from the input and determine how much R signal is "slopping over" into the L-channel output. The ratio of this voltage to the original level is expressed in dB's of separation. To complete the test, repeat the process, except measure the residual L

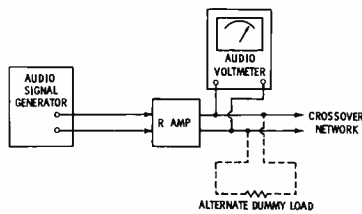

Fig. 4. Setup to measure response.

signal in the R channel. If your equipment will not allow you to inject an "R-only" signal, it is possible to get a fair approximation of the separation by scope observation, provided the L and R signals are of different frequencies. Simply observe the amount of unwanted frequency riding on top of the signal in the channel under test. This is not extremely accurate, but after you try it a few times, it is not quite as difficult as it sounds.

### Frequency Response Measurement

Normally, the only part of the set that requires a frequency response test is the audio amplifier section. The test setup is shown in Fig. 4. Of course, each of the two stereo amplifiers is measured separately. There are two methods that can be employed to measure frequency response: constant input and constant output. Since the results are approximately the same using either method, we will deal with only one, the constant input method.

The output of the audio generator must be perfectly flat across the audio spectrum, or else it must be monitored throughout the test and adjusted as needed to maintain the test signal at a constant amplitude. It is also important that the measuring device (meter or scope) has a flat response. A third consideration to remember is that the apparent response of the amplifier under test can be drastically altered by the load (speakers). For this reason, it is desirable to make the measurements with a resistive load substituted for the speakers. (Be sure that the impedance is correct.) You may want to measure response both with and without the speakers, just to see what happens. This can give you some clues about oddball problems such as speaker malfunctions and speaker loading effects.

Apply a 1000-Hz signal to the input of the amplifier and adjust the generator level so that the amplifier output is about one-half the rated maximum with the amplifier gain or level control at mid-scale. Naturally, any tone or compensation controls should be at the center or neutral position. The output impedance of the signal generator should be approximately equal to the input impedance of the amplifier. If it is not, a resistive impedance matching pad should be employed. A matching transformer may be used, but it must be high quality or its frequency response characteristics will affect the results.

Adjust the level controls slightly so that a convenient level of voltage is indicated at the output. If your meter reads in dB, a setting to produce a reading near mid-scale is desirable. Change the input frequency to 400Hz while maintaining a constant input level and record the output in dB above or below what it was at 1000Hz. Repeat this process at all the desired frequencies. Normally, if you check at 30, 100, and 400Hz and at 2, 5, 7.5, 10, 15, and 20kHz, in addition to the reference frequency of 1000Hz, you will have adequate information to determine if the amplifier's response meets specifications.

Many technicians prefer to get some "ball park" figures before checking each of the specific frequencies listed previously. This can be done by sweeping the frequency from one end of the audio spectrum to the other with the frequency control knob of the generator while simply observing the output meter. If any peaks or dips are observed in the output, check more thoroughly. Sharp excursions from the normal response are usually the result of resonance effects in the speakers, output transformers, or feedback networks.

If both amplifiers display about the same response characteristics, it is probably safe to assume that both of them are working properly. If they do not have the same response, the trouble in the faulty amplifier may be isolated by injecting the signal alternately to each amplifier and checking the level at corresponding points in the two amplifiers.

**There's a heckuva lot of VTVM units around.  
Only the 177 "Professional"  
has battery eliminator, mirrored scale,  
half volt scale for transistor circuits  
and—your name.**

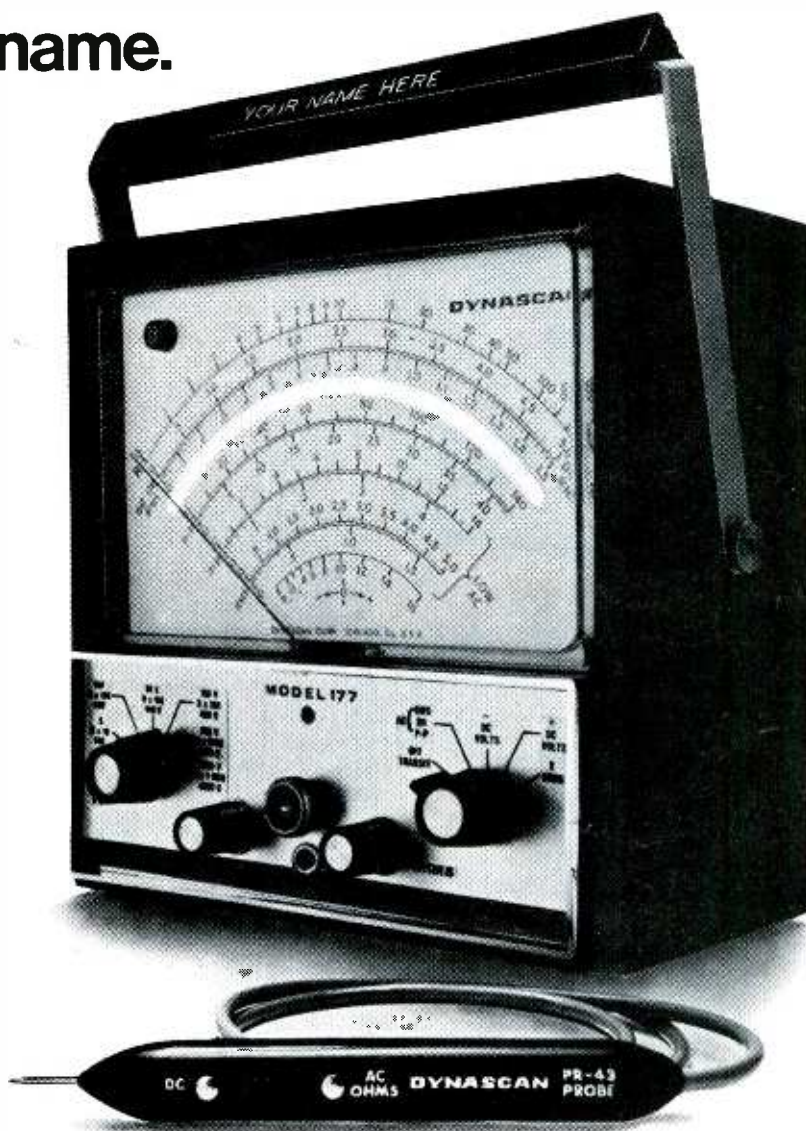

If you're one of the skeptics who think one VTVM is pretty much like another, the B&K 177 "Professional" will change your mind. This one stands out from the crowd.

A gigantic 7" mirrored scale reads faster, more accurately. An extra-sensitive 0.5 VDC range will check transistor circuits.

A zener diode regulated power supply insures reliable ohmmeter performance. No batteries required. A single probe ends cable fumbling. Transit switch position protects the meter on the road. The vinyl covered steel case is good-looking and tough. Its appearance symbolizes your professional status and, above all, it has B&K quality.

Any way you look at it, the 177 "Professional" is really different and it's all yours—the handle is personalized with your name. Cost? Just \$79.95.

B&K Division of Dynascan Corporation  
1801 W. Belle Plaine • Chicago, Illinois 60613



Where Electronic Innovation Is A Way Of Life

Circle 30 on literature card

August, 1967 / PF REPORTER 59

# NEW

## GOOD

## BAD

# Transistor Testing... in or out-of-circuit!

- No guesswork or confusion
- No numerical readings to interpret.



## NEW LECTROTECH **TT-250** TRANSISTOR ANALYZER

*One Year Warranty*

**IN-CIRCUIT TESTS.** Positive Good/Bad in-circuit and out-of-circuit testing. No numerical readings to interpret. In-circuit testing is a measurement of dynamic AC gain. No transistor leads to unsolder or disconnect.

**OUT-OF-CIRCUIT-TESTS (BETA OR GAIN).** Measures transistor Beta or Gain on 2 scales: 0 to 250 and 0 to 500. Automatic biasing . . . no calibration required.

**LEAKAGE.** Measures transistor leakage. ( $I_{cbo}$ ) directly in micro-amperes.

**DIODES AND RECTIFIERS.** Measures reverse leakage and forward conduction directly to determine front-to-back ratio.

**POWER TRANSISTORS.** Simple Good/Bad test instantly determines condition of power transistors. Power Transistor Socket on panel for ease of testing.

**ELECTROLYTIC CAPACITORS.** Measures leakage current of transistor electrolytics at a test voltage of 6 volts.

**PNP OR NPN** determined immediately . . . no set-up book needed for testing.

**NON-DESTRUCTIVE TESTING.** Regardless of misconnections, you cannot damage transistors or components tested.

### SPECIFICATIONS

- Large easy to read 6" meter • 3 color-coded test leads with self-storing feature • Power and Milliwatt Sockets on panel for ease of out-of-circuit testing • Zener Diode Regulated Power Supply • All steel case • Size: 10½" x 7" x 4" • Wt. 5½ lbs. • 115 volts, 60 cycles.

NET **87<sup>50</sup>**



See your distributor or write . . . DEPT. PF-8

**LECTROTECH, INC.**

1221 W. Devon Ave., Chicago, Illinois 60626

Circle 31 on literature card

A rough check of the relative response characteristics of the right and left speakers may be made by placing a test microphone, coupled to a sensitive indicator, along the axis which bisects the console. With all controls of the stereo amplifiers set the same, alternately connect the audio generator to each channel and measure the output of the test mike to see which channel has the best response at each frequency. This test will help spot bad speakers, as well as faulty crossover networks. Remember, you are not making very precise measurements with this method, so don't get carried away over a dB or two. Even with elaborate sound level meters and test setups, there are a lot of variables such as room size, configuration, and reverberation characteristics that will affect results.

### Turntable Tests

Turntable rumble can usually be detected simply by listening to a record. Notice particularly any sounds which are produced during the quiet intervals between selections on the record. (Any vibration of the turntable will be more audible while the stylus is tracking an unrecorded groove.) You may encounter a situation where acoustic coupling between the turntable and the speakers causes very objectionable noises on loud passages at certain frequencies (usually in the lower registers). This can normally be remedied by removing the remainder of the shipping braces under the turntable. If it is a component system, placing a sponge-rubber pad under the turntable or moving it to another location should solve the problem.

Check the speed of the turntable with a strobe disc and a small neon light. If the turntable is running slowly but at a steady speed, the drive motor bearings probably need lubrication. Be sure that the lubricant you use will not become gummy after a period of time. The type of penetrating oil which is packaged in the familiar spray can is probably the most convenient lubricant and seems to work very well.

If the turntable runs "steady by jerks," the problem may well be oil or grease on the drive wheels. This may be removed with a greaseless solvent such as alcohol. If this does not solve the problem, replace the drive wheels. There are some other things which can cause either of the last two problems: turntable bearings, motor bearings, a part rubbing the turntable, etc.

### Conclusion

Repairing high-quality audio equipment is actually less difficult than servicing an ordinary color set, and the profits are at least as great. The only drawback is that your ears are just not as well "calibrated" as your eyes and so it requires some quantitative measurements to uncover the "poor performance" problems that occur in audio. Most anyone can distinguish between green faces and "people color" faces, but it's a rare set of ears that can spot 3 dB of loss in response. In either case, it is the head that those eyes and ears are mounted on that makes the difference. Use it (and a little good equipment) and maybe you can still afford that vacation trip this summer. ▲



# PHOTOFACT<sup>TM</sup> BULLETIN

PHOTOFACT BULLETIN lists new PHOTOFACT coverage issued during the last month for new TV Chassis. This is another way PF REPORTER brings you the very latest facts you need to keep fully informed between regular issues of PHOTOFACT Index Supplements issued in May and September.

<b>Admiral</b>	Chassis H1-1A, H2-1A, 1H1-1A, 1H2-1A .....	894-1
<b>Airline</b>	GHJ-W-5310B, GHJ-7347A/B/ 57A/B/-74-7A/B/57A/B/77A/ B/-7527A/B/C/37A/B/C/47A/ B/C/57A/B/C/7927A/77A/ -8647A/57A/-8827A/47/57A .....	895-1
<b>AMC</b>	CLR-76B, CLR-82A, CLR-202A, CLR-296A .....	899-1
	CLR-382, CLR-386 .....	894-2
<b>Automatic</b>	CTV-6600 .....	898-1
<b>Magnavox</b>	Chassis T922-01-AA .....	896-1
<b>Packard Bell</b>	MSM-202, MSM-204 .....	895-2
<b>Philco</b>	Q1054BK .....	896-2
	Q2712WH, Q2714WA (Ch. 17H22) .....	895-3
	Chassis 17C21, 17C21A/V .....	897-1
	Chassis 17NT82, 17QT85A .....	899-2
<b>Pilot</b>	C309 .....	898-2
<b>RCA Victor</b>	Chassis KCS152D (1968 Prod.) .....	898-3
	Chassis KCS163A (1968 Prod.), KCS163N .....	899-3
	Chassis KCS164D/E .....	897-2
<b>Sears</b>	7102, 8104 (Ch. 564.10030) .....	896-3
<b>Truetone</b>	HFP1685A-66/5B-66/5C-66/ 7A-66/7B-66/7C-66, HFP1765A- 76/5B-76/5C-76/7A-76/7B-76/ 7C-76 .....	897-3
<b>Westinghouse</b>	BP09A68 (Ch. V-2652-2) .....	894-3
The following TV sets are given schematic coverage in the Extra Contents.		
<b>Admiral</b>	Chassis H3-1A, H4-1A, 1H4-2A .....	898-10-S
<b>RCA Victor</b>	AJ061E/M (Ch. KCS152D-1968 Prod.) .....	894-9-S
	AJ083E/M, AJ089GH, AJ093MR/WR, AJ135HK/NK/WK, AJ137WK/YK (Ch. KCS160C/E/F/P/N) .....	895-9-S
	AJ115W (Ch. KCS159H) .....	895-9-S
<b>Sears</b>	8109 (Ch. 562.10380) .....	894-9-S
<b>Sony</b>	TV-120U/UD .....	898-10-S

**only picture tube analyzer  
that tests all color tubes  
as they should be tested!**

(THE WAY TUBE MANUFACTURERS DO)



**NEW LECTROTECH CRT-100  
PICTURE TUBE ANALYZER**  
FOR COLOR AND BLACK AND WHITE

Does everything . . . you would need **all three units** of the leading competitive brands to equal the performance of the Lectrotech CRT-100. No other brand has all the features . . .

- Line voltage adjustment (to insure all tube voltages are correct regardless of line voltage).
- Critical Grid-to-Cathode Leakage is read on sensitive meter for greatest accuracy.
- Leakages in all other elements are indicated on neon lamp.
- Tests **all** black and white and **all** color tubes for leakage, shorts and emissions.
- Tests each color gun separately.
- Tests each color gun to a standard set of test conditions. With variable G-2 voltage, each grid is normalized to a reference cut-off voltage. This method is used by tube manufacturers and simulates tube performance in color receiver.
- Rejuvenates and removes shorts on both color and black and white tubes for increased brightness.
- Life expectancy test, predicts remaining useful life of both color and black and white picture tubes.
- Continuously variable G-2 voltage for all tubes, present and future, including new 15 inch color tubes.
- Complete plug-in cables for easy replacement.
- Complete self-contained black and white socket assembly. No adapters to lose or cables to break.
- Including Pilot Light.

Only **89<sup>50</sup>** net

ONE YEAR WARRANTY

See your distributor or write DEPT. PF-8



**LECTROTECH, INC.**

1221 Devon Ave., Chicago, Illinois 60626

Circle 32 on literature card

August, 1967 / PF REPORTER 61

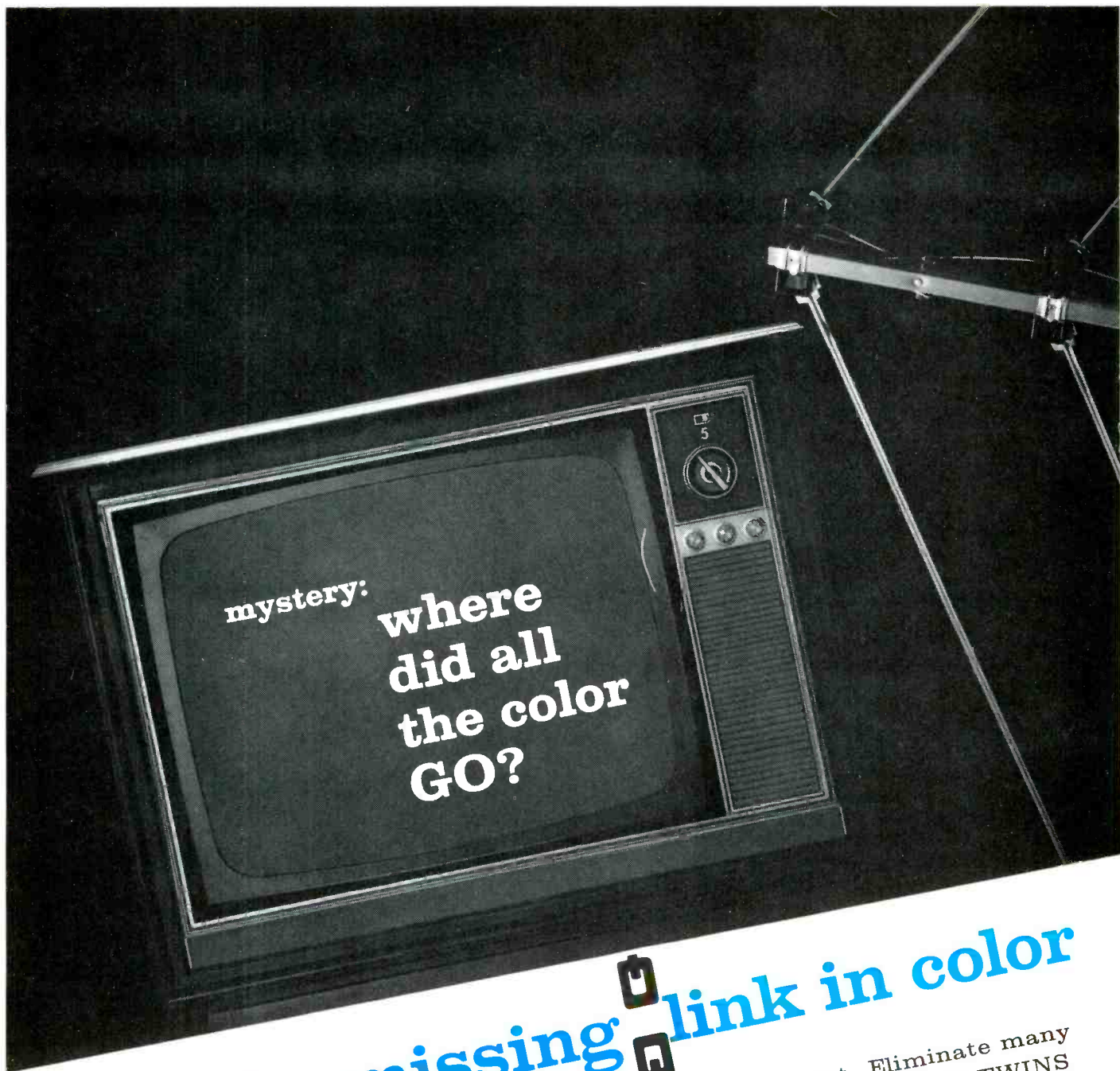

## here's the missing link in color

Belden's Color Twins deliver full color power all the way to the set. Eliminate many causes of lead-in signal loss. Deliver a ghost-free picture. ■ Belden's COLOR TWINS are: 8290<sup>†</sup> Shielded Permohm with Beldfoil\* for congested or high interference areas; and 8285<sup>†</sup> Unshielded Permohm for rural, low-signal-strength areas. ■ 8290 with patented Beldfoil shielding prevents line pick up of interference signals that produce ghosts and electrical interference. 8285 Permohm's conductors are encapsulated in low-loss cellular polyethylene to maintain a strong signal in all weather conditions, especially in fringe reception areas. ■ 8290 Shielded Permohm is designed so that you can install it without expensive transformers, connectors, and "stand offs." You can even tape it to a mast or run it through a rain gutter. ■ With Permohm UHF or VHF, too.) Now owners can get the full color power of the signal (full power for bought a color set for. You get the laurels.

**BELDEN CORPORATION**  
P.O. Box 5070-A • Chicago, Illinois 60680

reception!

8285<sup>†</sup>

Belden  
Unshielded Permohm  
for rural areas.

Call your Belden distributor about the  
Color Twins—



**Belden**

PERMOHM

8285

8290<sup>††</sup>

Belden  
Shielded Permohm  
with Beldfoil  
for congested areas.

ALL CHANNEL TV

\*Belden Trademark Reg. U.S. Patent Office †Belden Patent No. 2,782,251 ††Belden Patent No. 2,782,251 and Pat. Pending

Circle 33 on literature card

# new Sams books



## Audio Amplifier Design

by *Farl J. Waters*. Written for the audio enthusiast interested in designing his own amplifiers, either single-stage or for a complete multistage stereo system. Explains the theory of each stage; then illustrates design methods through an example showing how component values may be determined; finally, an actual design problem is undertaken and solved. Those readers who have an aversion to mathematics will welcome the generous use of nomographs throughout the book. Through their use, problems can be solved easily by simply placing a straightedge across appropriate values.

160 pages; 5 1/2 x 8 1/2". Order **20560, only**. \$425



## Lasers and Masers

by *Charles A. Pike* (under the direction of *Training and Retraining, Inc.*). This programmed text describes the basic operating principles of the laser and maser, and details the characteristics of representative types. As new types make their appearance, the same basic principles will continue to apply. Physics is introduced only to the extent required to understand the subject.

Includes the early history and development of the atomic structure upon which laser and maser devices are based. Questions and answers for study and review purposes are included at the close of each topic. 176 pages; 5 1/2 x 8 1/2". Order **20559, only**. \$495



## Hi-Fi Stereo Handbook, Revised

by *William F. Boyce*. You'll find all the information you want on hi-fi and stereo in this completely updated third edition of the classic book on high-fidelity. Includes new material on stereo needles, headphones, adapter circuits, tape-cartridge players, and multiplex operation. Covers a number of new transistor circuits, including preamps, amplifiers, and stereo control circuits; includes new information on recording techniques, compact hi-fi systems, and multipath-checking equipment. The ideal reference guide for everyone interested in high-fidelity sound. 288 pages; 5 1/2 x 8 1/2". Order **20565, only**. \$495

**101 Ways to Use Your Ham Test Equipment, 2nd Ed.**  
by *Robert G. Middleton*. This practical handbook encourages the ham to explore the total possibilities of his test equipment. Describes how to save time using basic ham test instruments and how to avoid trial-and-error experimentation. Covers the use of dip meters, antenna impedance meters, vom's and vtvm's, scopes, reflected-power and swr meters, and bridges. Describes proper test setups, procedures, and how to evaluate test results. Fully illustrated. 160 pages; 5 1/2 x 8 1/2". Order **20566, only**. \$295

## Handbook of the Elements

by *Samuel Ruben*. An invaluable reference about the chemical elements for students and engineers. The 25 physical and chemical constants referred to most frequently are given for each element. Nine of these are summarized at the top of the page devoted to each element. The atomic structures of the 104 elements are sufficiently detailed to serve as a reference for advanced research. Equivalent names are given in Spanish, French, German, Russian, Hebrew, Japanese, and Chinese. 128 pages; 5 1/2 x 8 1/2". \$325 comb-bound. Order **20563, only**.

These and over 300 other SAMS Books are available from your local Electronics Parts Distributor . . .

**HOWARD W. SAMS & CO., INC.**  
4300 WEST 62nd ST. - INDIANAPOLIS, INDIANA 46268

Circle 48 on literature card

# PRODUCT REPORT

for further information on any of the following items, circle the associated number on the Catalog & Literature Card.

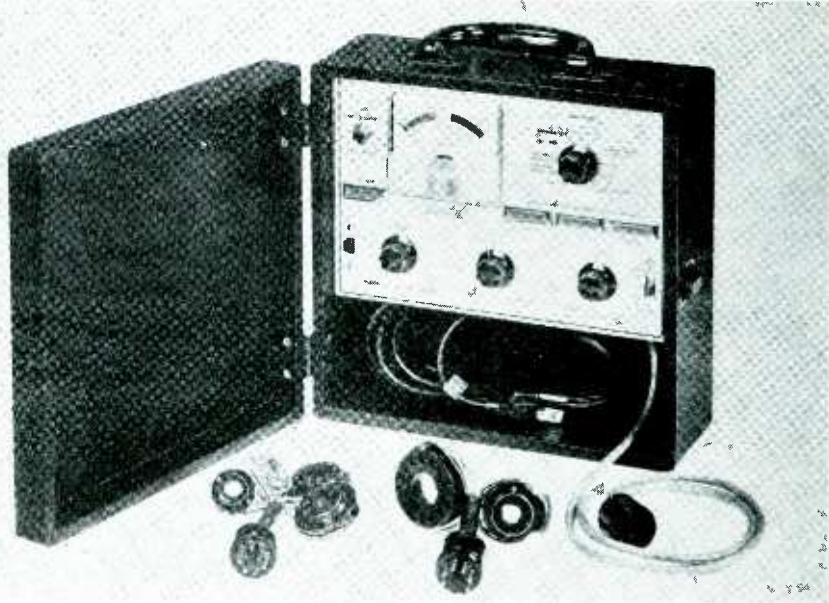

## Color Bar Generator

55

A new color bar generator that provides dot, crosshatch, and color bar patterns with both video and RF outputs has been announced by **The Hickok Electrical Instrument Company**. Gun-killer controls are supplied for fast purity checks and a 4.5-MHz crystal-controlled sound carrier output permits accurate setting of fine

tuning by the operator during TV servicing.

Stability over wide temperature ranges results from the use of solid-state, "short-count", frequency dividers in the timer section of the Model GC660. The unit is lightweight, small in size, and mounted in a carrying case for field service use. Price is \$159.50.

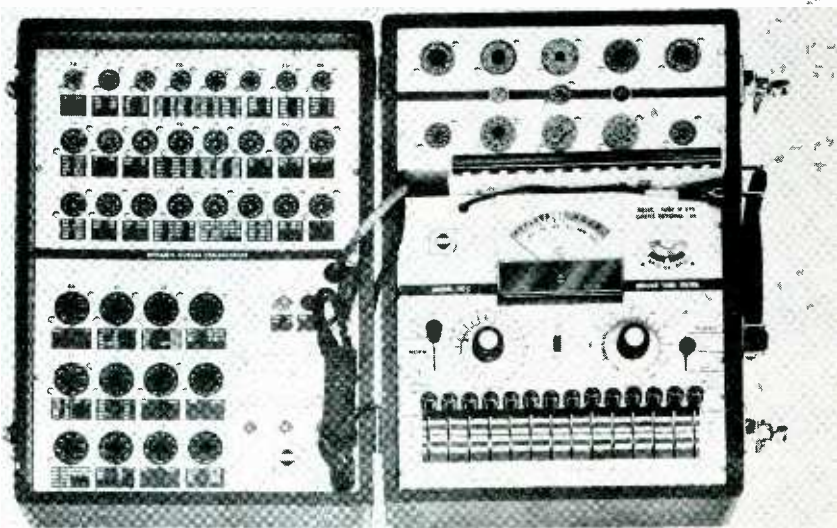

## Portable Tube Tester

56

A compact, portable tube tester with a number of unique features is

now available from **Seco Electronics Corp.** Designated Model 107-C, the

# The hottest thing in electronics hardly gets hot at all



(RCA's solid integrated circuit, that is)

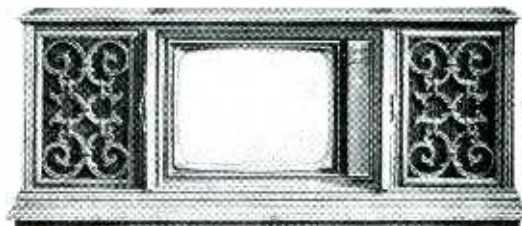

With the tiny chip there are few heat problems and low power consumption. And because integrated circuits run cooler, parts can be placed closer together to enhance design convenience. One day you may see stereo cabinets with more real storage space, and color TV sets the size of a transistor radio. At RCA Victor we've taken a

step into tomorrow by using integrated circuits now in new color and black and white TV and in stereo phonographs. They're not only the most advanced products of their kind, they are more reliable than ever before.



The Most Trusted Name in Electronics

™(s)®



## CAN A SPEAKER HAVE TALENT?

If you have the talent it takes to get a professional sound out of an electric musical instrument . . . you need a speaker that's as good as you are. You need an Oxford speaker . . . the one professionals depend upon.

Deep bass notes at high volume? A "talented" Oxford Professional Musical Instrument series speaker gets the sound out without distortion. High notes you thought you needed a tweeter to get? The response of an Oxford speaker gets it every time.

Whether you're replacing an existing speaker . . . or designing for O.E.M. applications, remember that a talented musician needs a "talented" speaker: Oxford.

Write for full information.

  
**OXFORD TRANSDUCER**  
 COMPANY      A Division of  
                          Oxford Electric Corporation  
 3911 S. Michigan Ave.  
 Chicago, Ill. 60653

tester incorporates a 6AF6G "eye" tube in a patented "Magic-Eye" circuit which effectively spots momentary shorts missed by normal meter "lag." The same indicator is used on the grid emission check, and to indicate filament or heater continuity. Another important feature of the Model 107-C is a constant-voltage transformer, which provides greater stability and accuracy by delivering proper filament and test voltages. In addition, the constant-voltage transformer eliminates the need for a "line-adjust," and because of the transformer's special design, also eliminates the need for a fuse.

The unit is furnished complete with speed-indexed, setup data and mounted in a vinyl-covered carrying case measuring 13" x 9" x 7". Weight is 12 lbs. The tester is priced at \$198.50.



### Cordless Sound System 57

Shown here is a new cordless portable sound system designed for speech or music amplification. Self-contained and offering complete mobility, this **Audiowave Inc.** unit is 7" high and weighs only 76 ounces. Suggested applications of the Mark 7 series include use as a secondary public address system, lectures and guided tours, and conversion to a hailer-type system for up to a half-mile extended coverage.

Features of the unit include solid-state printed circuitry, a highly sensitive dynamic microphone, and an on-off/volume control which eliminates all battery power consumption in the off position. Two standard 9-volt batteries permit over 100 hours of intermittent operation (one to two years of average use). Frequency response is 70 to 15,000 Hertz with residual noise less than 70 dB.

**Join the  
P.O.M. Club!**  
 (Photofact-of-the-  
Month Club)

**ONLY \$10 PER MONTH  
brings you 20% MORE  
PHOTOFACT® coverage!**



As a P.O.M. member, you get 6 new PHOTOFACT Sets every month to keep you ahead earning more—and you SAVE OVER \$60 PER YEAR! (Individually purchased Sets now sell for \$2.50 each.) Your 6 Sets come in sturdy file folders sealed in factory carton to insure perfect condition and completeness—easier-than-ever to file and use. To stay ahead, to save money—join the P.O.M. Club today!

**SEE YOUR SAMS DISTRIBUTOR  
OR SEND ORDER FORM BELOW**

**HOWARD W. SAMS & CO., INC. Dept. PFF-8  
4300 W. 62nd St., Indianapolis, Ind. 46268**

Enroll me in the Photofact-of-the-Month Club. I agree to pay \$10 per month, and understand I will receive 6 current Photofact sets monthly to be delivered by my Sams Distributor (named below).

Name \_\_\_\_\_

Shop Name \_\_\_\_\_

Address \_\_\_\_\_

City \_\_\_\_\_ State \_\_\_\_\_ Zip \_\_\_\_\_

My Sams Distributor is: \_\_\_\_\_

Signed: \_\_\_\_\_

Circle 49 on literature card

Options offered include rechargeable batteries, battery charger with overcharge protection, and a miniature dynamic 2-ounce microphone. The unit is priced at \$129.50, complete with batteries and carrying strap.

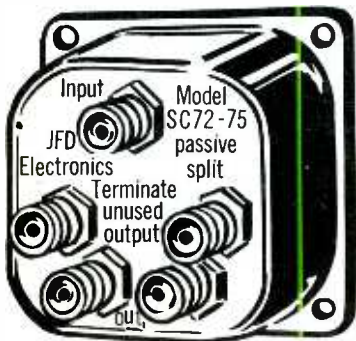
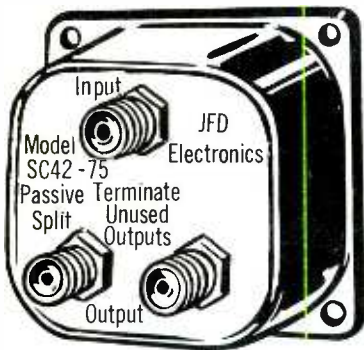

### 75-Ohm Splitters

58

A new 75-ohm, 2-way splitter and a new 75-ohm, 4-way splitter have been announced by **JFD Electronics Co.** Both are designed for VHF, UHF, and FM transmission. Low insertion loss, good inter-set isolation, and low VSWR recommend these units for use with color sets as well as monochrome. Wideband response is essentially flat.

Model SC42-75, the 2-way splitter, splits one 75-ohm VHF/UHF/FM line into two 75-ohm outputs. Insertion loss is 3.2 dB, isolation 15 dB, frequency response  $\pm 0.5$  dB, and VSWR 1.2:1. Three "F" connectors are supplied with the splitter.

Model SC72-75, the 4-way splitter, splits one 75-ohm VHF/UHF/FM line into four 75-ohm outputs. Insertion loss is 6.4 dB, isolation 12 dB, frequency response  $\pm 0.5$  dB, and VSWR 1.3:1. Five "F" connectors are supplied with this splitter.

Both units can be converted to 300-ohm impedance by using JFD matching transformers. Models MT54, MT56, or MT58. Both splitters may be combined to provide any number of lines. Measurements of both are 2" x 2" x 3/4". Model SC42-75 is priced at \$7.95 and Model SC72-75 sells for \$10.95.

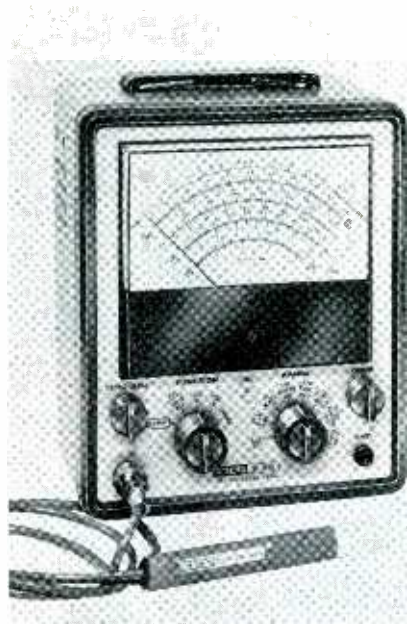

### VTVM 59

Accurate measurement down to 0.01 volts—especially useful in transistor servicing—highlights the many capabilities of Eico's new model 235 Professional VTVM, designed for servicing today's FM, AM, b-w and color TV, and precision equipment.

Operation of the instrument is made easier and more efficient by unique

### Save Time on PC Board Repairs!



MODEL 100A

Melted solder disappears up hollow tip into tube

### The ENDECO Desoldering Iron Removes Soldered Components in seconds... without damage!

Endeco melts solder, then removes it by vacuum • Leaves terminals and mounting holes clean • Resolders too • One-hand operation • Temperature controlled for continuous use • Ideal for use with shrinkable tubing • 4 tip sizes • Quickly pays for itself in time saved • Only \$18.75 net.

SMALLER SIZE AVAILABLE. SEE YOUR DISTRIBUTOR OR WRITE:



ENTERPRISE  
DEVELOPMENT  
CORPORATION

5151 E 65TH • INDIANAPOLIS, IND. 46220

Circle 35 on literature card

## BUZIT TRANSISTORIZED SIGNAL TRACER

FOR ONLY \$9.57 DEALER NET  
WITH BATTERIES

NO CLIPS  
NO WIRES



MADE IN  
U.S.A.

### USED FOR TROUBLE SHOOTING

- A.F. CIRCUITS • I.F. CIRCUITS
- R.F. CIRCUITS • CONTINUITY CHECKS • SPEAKERS, ETC.

EXCELLENT FOR TRANSISTOR  
RADIOS BECAUSE BUZIT USES  
ONLY A 3 VOLT POWER SUPPLY

ASK YOUR ELECTRONIC  
PARTS DISTRIBUTOR FOR

W MODEL NO. **BZ-1**

MANUFACTURED BY  
**WORKMAN** Electronic  
SARASOTA FLORIDA PRODUCTS INC

Circle 36 on literature card

### ELECTRONICS DATA GUIDE

## FREE Electronics Data Guide

Want help in working out those tricky electronics calculations? Send for our FREE Electronics Data Guide. This heavy-duty plastic guide fits right in your shirt pocket—gives you instant reference to over 40 indispensable electronics formulas...plus conversion factors, color codes and decibel table as well. Saves you time and the trouble of memorizing or "looking it up." A "must" for every man interested in electronics—provided as a service by CIE. Why not get your FREE Data Guide today? Just fill in your name and address below, then cut out this ad and mail it to:

**Cleveland Institute of Electronics**  
1776 E. 17th St., Cleveland, Ohio 44114

Name \_\_\_\_\_ (Please Print)

Address \_\_\_\_\_

City \_\_\_\_\_

State \_\_\_\_\_ Zip \_\_\_\_\_

Accredited Member National Home Study Council. 902

Circle 34 on literature card

August, 1967/PF REPORTER 67

2-color coding of the function and range switches with the scales of the 6" meter, and by the dual-purpose AC/DC "Uni-Probe." Both p-p and rms voltages are read on separate scales in 7 over-lapping ranges, up to 1500 volts for rms scales and 4200 volts for p-p. Frequency response is 30Hz to 3MHz (to 250 MHz with optional probe). Its 11-megohm input provides negligible loading for precision DC measurements.

The Model 235 can be purchased in kit form for 44.95, or completely wired and ready to use for \$64.95.

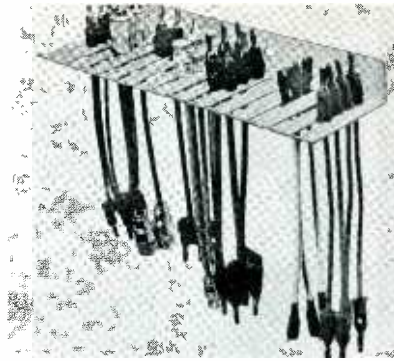

**Tube Test Adapters**

60

Two new, tall, test socket adapters,

## Major Breakthrough in TV Accessories... NEW from Mosley!

In response to your requests, Mosley introduces a completely NEW 'profit building' line of TV accessories for use with shielded and other types of twin lead cables on the market!

These solderless receptacles, line splicers, 2 and 4 set couplers, clamp the line securely so it can't pull out! Assure peak performance, especially for color. Eliminate call backs. Help simplify the cable lead-in job . . . for a compact, time saving installation.

Stock up now and watch your sales climb! Send for complete details.

Write: Dept. 145

**Mosley Electronics Inc.**

4610 N. Lindbergh Blvd., Bridgeton, Mo. 63042

Circle 37 on literature card

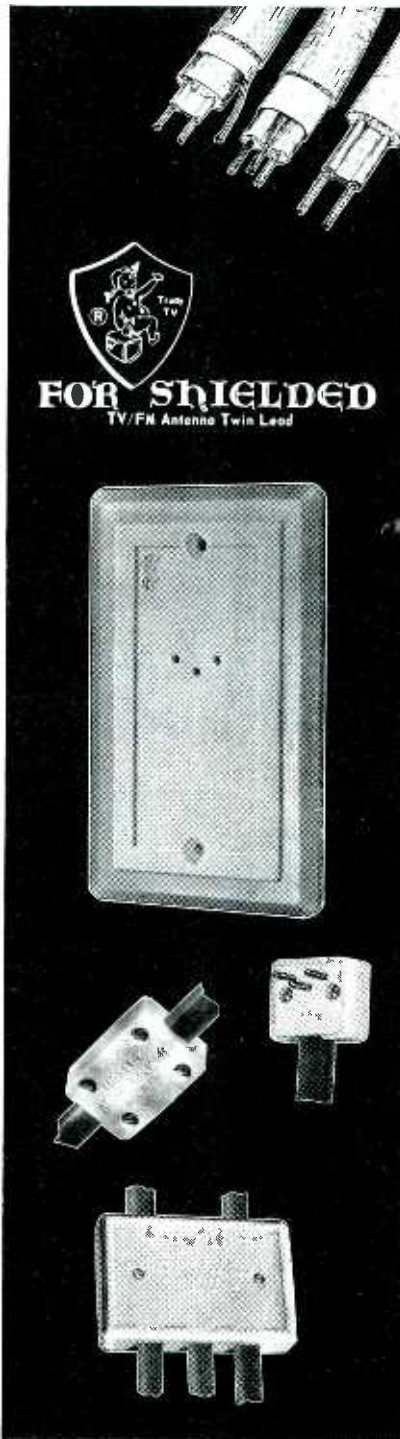

a 9-pin novar and a 12-pin compactron version, have been added to the line of radio and television service accessories offered by **Pomona Electronics Co.** The units are designed to facilitate taking test measurements from tube sockets equipped with captive or telescoping tube shields. Adapters are tall enough to rise above the top of tube shields, bringing test tabs out in the open.

The series includes four additional models to fit 7-pin, 9-pin, and 10-pin miniature tube bases. Model 2749 (9-pin novar) is priced at \$3.25 and Model 2742 (12-pin compactron) at \$3.55.



**CRT Test Adapter**

61

Existing CRT test equipment can be converted to test the picture tubes used in small screen personal portable television sets through the use of a new tube socket test adapter introduced by **Pomona Electronics, Inc.** CRT's such as 9YP4, 11RP4, 12-BEP4, 16BXP4, etc., fit the adapter.

The Model 2713 adapter socket accepts tubes using 7GR basing (E7-91 base), and plugs into the standard 12L Duo-Decal socket found on current tube testers. The unit features a clearance hole in the 7GR socket which accepts the CRT evacuation stem and prevents accidental breakage. Price is \$1.95.

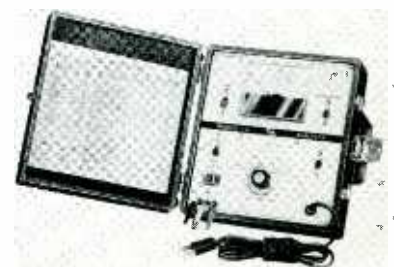

**Portable Transistor Analyzer**

62

A compact, solid-state transistor analyzer, designated Model 260, is announced by **Seco Electronics**. Designed to provide accurate analysis of both power and signal transistors with-



out setup, the Model 260 is fast, easy to operate, and completely safe. Without removing the transistor from its original circuit, and utilizing the unit's test leads, the Model 260 electrically inserts the transistor under test into a self-contained oscillator circuit for a fast "go-no-go" check. The dynamic test also lets you immediately identify NPN and PNP transistor types, as well as lead connections. DC analysis is made "out-of-circuit" by inserting the transistor under test into a panel-mounted, universal socket. The Beta Test position provides a direct meter reading of the DC gain, while the I<sub>ceo</sub> and I<sub>cbo</sub> Test positions read both the collector-to-emitter and the collector-to-base leakage. The completely self-contained unit is mounted in a vinyl-covered carrying case and measures 8 3/4" high by 7 3/8" wide by 4 1/4" deep. The analyzer weighs 5 lbs. and is priced at \$69.50.

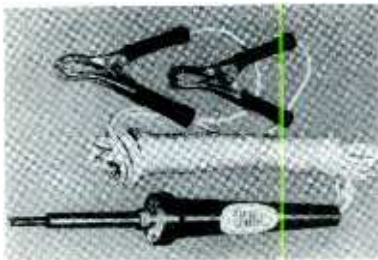

### Soldering Iron (63)

This new 12-volt soldering iron, designated as model TCP-12, is designed for field servicing of communications, marine, automotive, aircraft, and telephone equipment, as well as for hobby models. The tool operates from any 12-volt battery, or 12-14-volt AC/DC power supply.

The light-weight, pencil-type unit includes a 12' power cord with battery clips. It also incorporates Weller's "temperature control" system, which affords minimal battery source power drain, long tool and tip life, and rapid recovery. The tool comes with a 700° F., 3/16" screwdriver tip. Other tip configurations and temperature ranges are also available. A similar tool is available for 24-28-volt operation. Model TCP-12 is priced at \$10.95.

### Nutdriver Screwdriver Roll Kit (64)

A new 14-piece, multipurpose tool kit that takes up little space in a tool caddy and is light and compact enough to be carried easily in a hip pocket has just been introduced by Xcelite Incorporated. Identified as Model No. 99PR, the roll kit contains a Regular Series 99 Service Master handle, nine interchangeable nutdriver



has  
everything  
in

# alignment tools

Whether it be channel selectors or tuning wands, aligning wrenches or screw drivers, all-purpose or specialty tools, GC meets those needs perfectly.

All GC tools and kits, designed and manufactured to strict quality standards from the finest materials available, reflect the GC dedication to quality and performance that makes jobs easier, faster, more profitable. Small wonder GC tools are preferred . . . everywhere.

*Insist on GC . . . and you'll get the best!*

Write for your Giant FREE GC Catalog today . . . over 12,000 items including TV Hardware, Phono Drives, Chemicals, Alignment Tools, Audio, Hi-Fi, Stereo & Tape Recorder Accessories, Nuts & Bolts, Plugs & Jacks, Service Aids, and Resistive Devices.

*only GC gives you  
everything in electronics.  
..... for almost 40 years!*

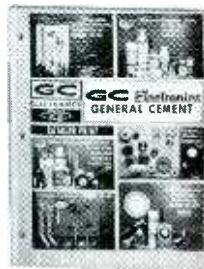

Universal Coax TV Alignment Tool Kit  
Cat. No. 8-54



TV Plastic Long Slim Screw Driver . . . Cat. No. 8987



All-Purpose 12 Tool Alignment Kit  
Cat. No. 5040



Zenith-Admira-DeLrin Hex Wrenches  
Cat. No. 8506-5"  
Cat. No. 8506-L-11"



TEL-A-TURN TOOLS  
J.F. Aligner . . .  
Cat. No. 8867  
Alignment Screwdriver . . . Cat. No. 8868  
Hex Aligner . . .  
Cat. No. 8869



## GC ELECTRONICS COMPANY

400 South Wyman Street  
Rockford, Illinois 61101  
A DIVISION OF HYDROMETALS, INC.

Circle 38 on literature card

# New **B&K** Dynamic Transistor Analyst

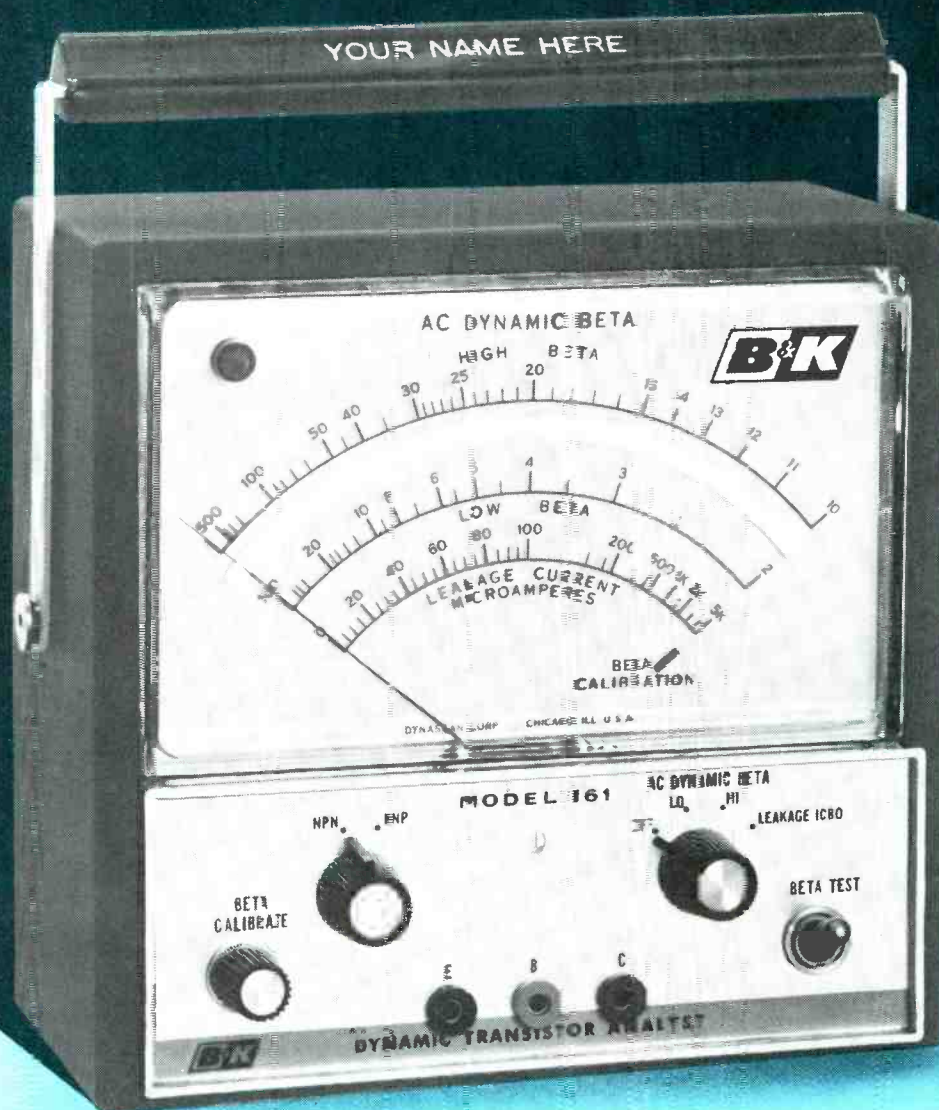

## Simple to operate... fast... safe to use. In-Circuit Transistor Tester. Personalized for professional pride.

B&K ends the mystery, fears and misunderstanding surrounding transistor servicing, application and theory. With every Model 161 Transistor Analyst, you get *two free reference manuals*: the new edition of Howard W. Sams' Transistor Specification Handbook, plus the all-new, years-ahead B&K Basic Course on Transistors — everything you need to know to test and service unfamiliar solid-state sets. You get ahead of your competition and stay ahead of the market.

The new B&K 161 means fast, accurate, *in-circuit* testing of transistors for AC Beta. With the same simple procedures, the 161 makes out-of-circuit tests, too, including  $I_{cbo}$  (current leakage) and front-to-back conduction of diodes and rectifiers. There's no chance of damaging transistors or components; special circuitry protects all parts, even if leads are connected incorrectly. The huge 7" mirrored meter insures accurate readings on three separate scales. Two ranges check AC Beta: 2 to 100; 10 to 500. For leakage tests,  $I_{cbo}$

range is 0 to 5000 microamps on an expanded scale for better readability. A flick of the switch checks polarity. It's so simple, you don't need any set-up book.

To stay ahead of the game, get the B&K Model 161 with a scuff-proof case and the two exclusive B&K Transistor reference manuals. A complete transistor service package with all leads included and your personalized name plate — for only **\$89.95**.

B&K Division of Dynascan Corporation  
1801 W. Belle Plaine • Chicago, Illinois 60613

Circle 39 on literature card



Where Electronic Innovation Is A Way Of Life

# 349 PHONO CARTRIDGES!



# 459 PHONO NEEDLES!



## NEW! PHONO AND TAPE RECORDER WHEELS, DRIVES, BELTS!

**(E-V)** That's how many models are listed in the current Electro-Voice phono needle and cartridge catalogs. With more being added as you need them.

No other single source offers such variety—all built to the highest industry standards. All are exact replacements that install quickly, to give your customers "like new" performance—or better!

Electro-Voice models are listed in your Photofact files, or ask your E-V distributor for free copies of the E-V catalogs. It's your guarantee of complete customer satisfaction!

**ELECTRO-VOICE, INC.**, Dept. 877 R  
632 Cecil Street, Buchanan, Michigan 49107



Circle 41 on literature card

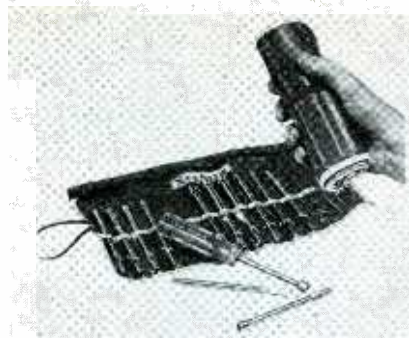

blades with hex openings from 3/16" through 1/2", No. 1 and No. 2 Phillips single-end screwdriver blades, and two single-end blades for slotted screws with tip widths of 3/16" and 1/4".

The amber plastic handle is shock-proof and breakproof. A spring device holds the blades firmly, yet permits easy insertion and removal. Any of the interchangeable screwdriver, nut-driver, and other blades in the Series 99 line will fit this handle.

All screwdriver blades are made of high carbon steel. The hex-head nut-driver sockets are precision formed, cold drawn, case hardened steel. All have a polished nickel chrome finish. They will fit Series 99 Junior size and Tee handles and can be used with 4" and 7" extensions to add extra reach. The roll-up, plastic-coated canvas case has eyelets which permit wall hanging. An elastic loop secures the roll, eliminating the need for tying. The kit is priced at \$15.70.



### Transistor Analyst (65)

In-circuit checks for AC Beta without removing transistors are performed by this new dynamic transistor analyst introduced by **B & K**. Each unit is personalized, with the owner's name inlaid in the handle. Other features of Model 161 include a 7" mirrored meter movement, and special circuitry to protect transistors and diodes from damage due to incorrect connections. Price is \$89.95.



? ? ? ? ? ? ? ? ? ?

**SAVE MONEY BY  
SPENDING MORE?**

? ? ? ? ? ? ? ? ? ?

Yes, you see we have competitors whose equipment costs less.

Buy it if you must. But please remember that for our equipment your money will buy better training; it will buy better equipment and it will buy the knowledge of people who have been in the glass and vacuum business for over 50 years.

So save money initially by buying our competitor's TV tube rebuilding equipment **BUT** please don't come to us like many others have, asking for the experience, service and superior equipment that is included in the initial purchase price.

*Please write for our free booklet:*

**Windsor Electronics**  
999 North Main St.  
Glen Ellyn, Ill. 60137  
phone: 312-469-4920

*Representatives*

**Bill Childs**  
Post Office Box 135  
Pocatello, Idaho  
phone: 208-232-8329

**Bob Linde**  
2324 N.W. 30th Ct.  
Fort Lauderdale, Fla.  
phone: 305-583-2240

Circle 40 on literature card

August, 1967/PF REPORTER 71

## NEW COLOR ELECTROLYTIC CAPACITOR REPLACEMENT GUIDE AVAILABLE

Including Every Color Set Manufacturer



A new 32 page cross reference from Cornell-Dubilier Electronics has been compiled to include all electrolytic capacitors used in color chassis from 32 set manufacturers. The new listing has been designed to help the technician service all current color chassis with high quality electrolytic capacitors, immediately available from stock, due to the wide range electrolytic concept pioneered by Cornell-Dubilier. The booklet indicates the recommended Color-Lytic® replacement by cross reference to the OEM number, and also by direct reference to rating capacity/voltage for single, dual, triple and quadruple section units.

**Write today!**

for more information contact

**CORNELL-DUBILIER ELECTRONICS**  
Division of Federal Pacific  
Electronic Company

50 Paris Street Newark, N.J. 07101 624-7500

Name \_\_\_\_\_

Address \_\_\_\_\_

City \_\_\_\_\_

State \_\_\_\_\_

Zip \_\_\_\_\_

Circle 43 on literature card

**WORLD'S FINEST  
5-CORE  
SOLDER**

**ERSIN  
MULTICORE**

**NEW EASY  
DISPENSER**

**ONLY 69¢**

**BUY IT AT RADIO-TV PARTS STORES**  
Multicore Sales Corp. Westbury, N.Y. 11591  
Circle 51 on literature card

# BOOK REVIEW

**Transistor Basics: A short course;** Hayden Book Co., Inc., New York, N. Y., 1967; 102 pages, 5 $\frac{3}{8}$ " x 8 $\frac{1}{4}$ ", soft cover, \$2.75.

Transistor terminology is the subject covered in Chapter 1 of this volume. Detailed explanations are provided for such terms as hole, doping, majority carrier, minority carrier, stored minority carriers, lifetime, and junction.

Chapter 2 begins with a comparison of conventional current (method adopted in this book) and electron flow. Next, the PN diode junction is examined briefly. An introduction to the effects of heat on semiconductor diodes closes Chapter 2. The discussion of the effects of heat is applied to transistors in Chapter 3. Leakage current, stabilization, and biasing are the specific areas covered in this chapter.

The amplifying action of transistors is presented in Chapter 4. Graphic analysis and detailed word descriptions explain the transistor characteristic curve, the construction of a load line, and plotting of the operating point.

Chapters 5 and 6 deal with the various techniques employed in transistor circuit analysis. The H parameter equivalent circuit technique is presented first, and this is followed by a simplified or rule-of-thumb method of computing circuit performance. Chapter 7 examines the effects of feedback.

The breakdown diode, step recovery diode, PIN diode, hot-carrier diode, and tunnel diode are presented in Chapter 8. Special semiconductor devices, including the silicon controlled rectifier (SCR), unijunction transistor (UJT), and field-effect transistor (FET), are discussed in Chapter 9. Chapters 10 and 11 are devoted to transistor handling and troubleshooting techniques. ▲

## Now an Atlas Sound speaker that can do more than any one speaker could do before...

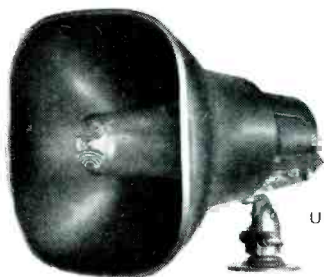

SERIES AP-30

U.S. Design Patent #205,663  
Other Patents Pending.

... and all you need is a screwdriver to mount, connect and adjust it.

New Series AP-30 install easier, faster and better with built-in transformers, screw-to-line terminals and watts/impedance switch. Very high efficiency is thrifty with amplifier power for low level reinforcement. The speakers are 30 watts rugged for penetration over distance and noise.

From solderless installation to quality performance on the job, four weather-sealed AP-30 models cover your requirements for most single and multiple installations.

From 24.30 net.

For the complete Professional Series AP-30 story, ask for catalog PFH-18



**ATLAS SOUND**, Division of  
American Trading and Production Corporation  
10 Pomeroy Road, Parsippany, N.J. 07054  
Canada: Atlas Radio Corporation, Toronto  
THIRTY YEARS OF LEADERSHIP IN COMMERCIAL SOUND



Circle 42 on literature card

# PFR PUZZLER

If you can go around in circles without getting dizzy, you'll have fun solving this puzzle based on electronics. The last letter of each word is the first letter of the next word. It's that easy! Ready? Then, Go!

1. Units of electrostatic capacity.
2. Extent of radiomagnetic radiation.
3. Prefix meaning one-thousandth.
4. Apparent opposition to the flow of current in a circuit.
5. A science dealing with stationary charges of electricity.
6. Nonmetallic element used in various photoelectric devices.
7. Attractive body.
8. One skilled in the finer details of a trade or profession.
9. Disturbance or undesired sound in audio system.
10. Increase in dynamic range.
11. A fastener.
12. Small pincher-like implement.
13. A type of electrical circuit.
14. Sign or letter used to designate something else.
15. Authority granted by controlling body.
16. Capacity for performing work.
17. Type of antenna named after Japanese electrical engineer.
18. Passage of electricity prevented by nonconductor.
19. Vacuum tubes with cold anode and heated cathode.
20. Light caused by sudden discharge.
21. Prefix denoting 1000.
22. Part of multimeter.
23. Variety of electronic systems for locating, direction finding, etc.
24. AC changed to DC.
25. Decreasing the amplitude of oscillations, waves, etc.
26. One departed.
27. Vacuum tube with an anode, a cathode, and a control grid.
28. Elementary charge of negative electricity.
29. Indicator or stylus.

(See page 74 for solution) ▲

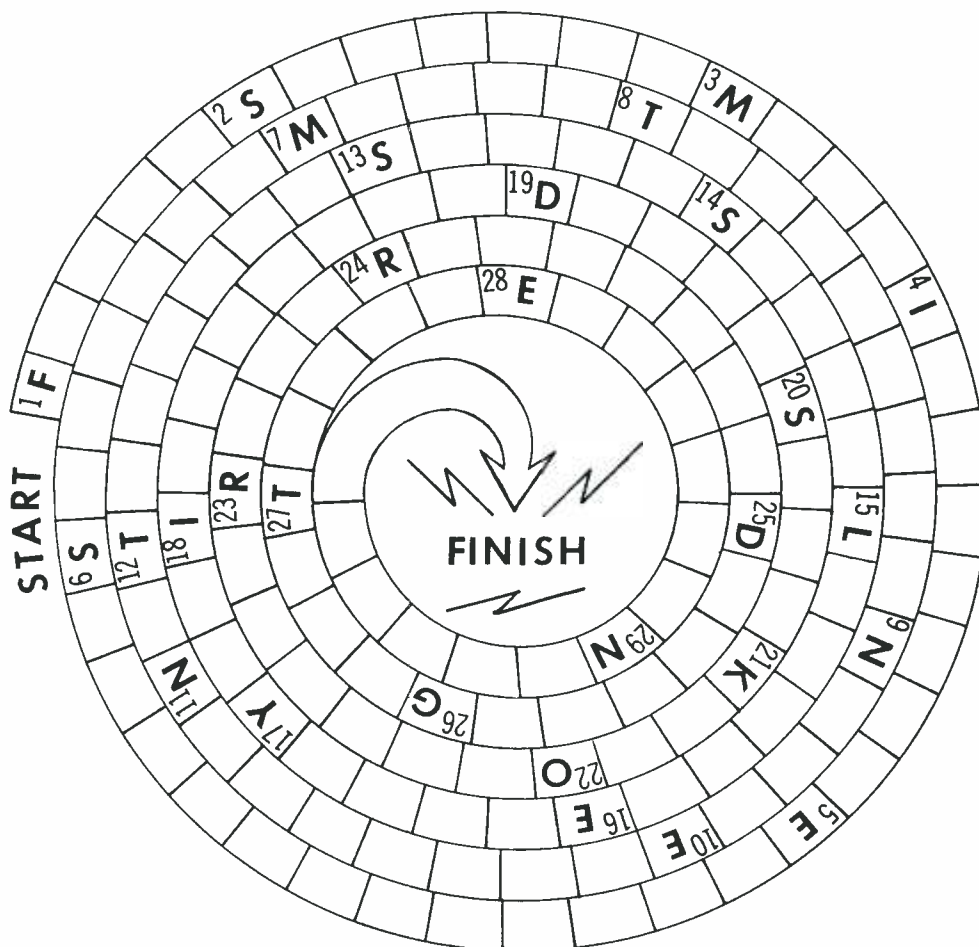

**NEW!** from **SECO**

**"IN-CIRCUIT"  
CURRENT CHECKER**

Eliminates most common cause of "callbacks" (unstable focus, shrinking pictures, etc.)! Should pay for itself on next months' calls alone!



Nothing else like the HC-8 available! Tune horizontal drive and linearity for "dip"—and in seconds—you've got best possible focus, width and stability at minimum cathode current. Makes convergence adjustments faster, easier—longer lasting!

Especially useful on color TV where a slight misadjustment of horizontal linearity or efficiency coils drives cathode currents sky high! 5 pre-wired sockets for all popular horizontal output tubes lets you plug into circuit fast—no clipping or unsoldering of leads!

Model HC-8  
**\$34.50**  
Net

**ASK YOUR DISTRIBUTOR**  
or write for full details.

**SECO**  
**SECO ELECTRONICS CORP.**

1001 Second St. So. • Hopkins, Minn. 55343  
Circle 45 on literature card

74 PF REPORTER/August, 1967

**Solution to Puzzle  
on Page 73**

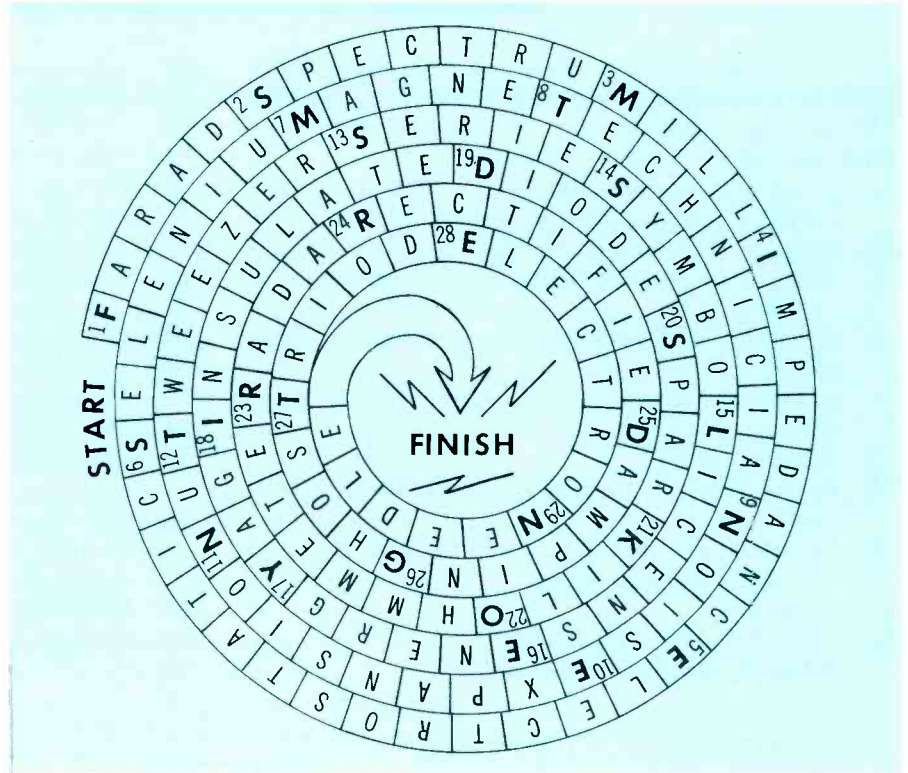

**We offer You  
nothing but  
finer, faster,  
Precision  
Tuner  
Service!...**



**(Period)**

VHF-UHF  
**\$7.95**

+parts & shpg.

**Why pay for parts you don't need?**  
Mail coupon now for free information!  
**PRECISION TUNER SERVICE**

...one of the OLDEST and LARGEST TV tuner repair firms in the world!  
Box 272 P Bloomington Indiana 47401

-----  
Firm \_\_\_\_\_  
Name \_\_\_\_\_  
Title \_\_\_\_\_  
Address \_\_\_\_\_  
City \_\_\_\_\_ St. \_\_\_\_\_ Zip \_\_\_\_\_  
-----

Circle 50 on literature card

**Make an extra "fin" or more  
on service calls with new**



**WIRELESS  
REMOTE**

**Teleswitch™**

It's so easy to sell Teleswitch on service calls! Just hook one up after servicing the set and demonstrate it. Turns set ON OFF by remote control. List **22.95**  
"SOUND-OFF." "Commercial killer."  
Mutes TV audio by remote control.  
List Price ..... **22.95**

See your distributor today.

**Euphonic** MARKETING Dept. PF-8  
173 W. Madison St., Chicago, Illinois 60602  
Circle 44 on literature card

# INDEX TO ADVERTISERS

August, 1967

The Antenna Specialists Co., Div. of Anzac Industries, Inc. ....	42
Atlas Sound .....	72
Belden Mfg. Co. ....	62, 63
B & K Mfg. Co., Div. of Dynascan Corp. ....	59, 70
Bussmann Mfg. ....	30, 31
Castle TV Tuner Service .....	29
Channel Master Corp. ....	18, 19
Cleveland Institute of Electronics .....	35, 67
Columbia Wire Products Co. ....	75
Cornell Dubilier .....	72
Duotone Co. ....	54
Eico .....	5
Electro-Voice, Inc. ....	71
Enterprise Development Corp. ....	67
Euphonics Marketing .....	74
The Finney Co. ....	36, 37
G. C. Electronics .....	69
Gem City Tuner Repair Service .....	56
General Electric, Industrial Sales Div. ....	56
Jerrold Electronics Corp. ....	cover 2
Lectrotech, Inc. ....	60, 61
Littelfuse, Inc. ....	cover 4
Mallory, P. R. & Co., Inc. ....	48
Mosley Electronics, Inc. ....	68
Motorola Consumer Products, Inc. ....	6
Multicore Sales Corp. ....	72
National Electronic Enterprises .....	54
Oxford Transducer Co. ....	66
Perma-Power Co. ....	43
Philco-Ford Co. ....	46
Precision Tuner Service .....	74
RCA Components and Devices (Entertainment Tubes) ....	cover 3
RCA Sales Corp. ....	65
Sams, Howard W. & Co., Inc. ....	64, 66
Sarkes Tarzian, Inc. ....	15
Seco Electronics Corp. ....	74
SENCORE, Inc. ....	47, 49, 51, 53, 55, 57
Sprague Products Co. ....	21
Sylvania Electric Products Corp. ....	16, 17
Triplett Electrical Instrument Co. ....	39
Windsor Electronics, Inc. ....	71
Workman Electronic Products, Inc. ....	67
Xcelite, Inc. ....	42
Zenith Sales Corp.— Parts and Accessories .....	50



## SEE THE ANTIQUE!



Columbia Wire Products Company's new shielded ultra-low loss Permafoam transmission cable has made standoff insulators a thing of the past. Hookup to the antenna (with terminals already fitted to the cable for your convenience), then run the cable to the set by the easiest route. **Easily terminated at TV set.** You can tape new shielded Permafoam cable to the antenna mast . . . run it down gutters . . . **anywhere!** Yet, there is no pickup interference. It gets the job done faster . . . to make you more of a good, old-fashioned profit.

You can get full specifications on new shielded Permafoam from your distributor.



*Columbia*   
**WIRE PRODUCTS COMPANY**  
2850 Irving Park Rd., Chicago, Ill. 60618

Available in 50', 75' and 100' coils - 500' spools and 1000' reels.

Circle 46 on literature card

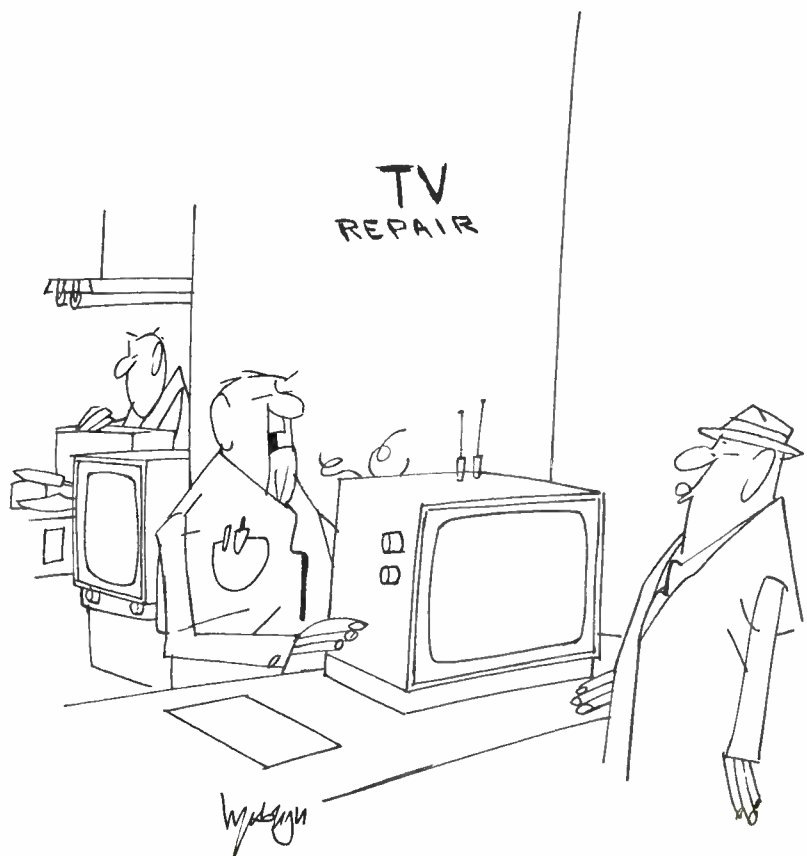

"... The short welded everything together, . . . you might call it 'solid state'."



# \$ FREE \$

## CATALOG AND LITERATURE SERVICES

\*CHECK "INDEX TO ADVERTISERS" FOR FURTHER INFORMATION FROM THESE COMPANIES

### ANTENNAS

90. **ALLIANCE** — Colorful 4-page brochure describing in detail all the features of Tenna-Rotors.
91. **ANTENNA-CRAFT** — 12-page catalog listing complete Antennacraft line of UHF, VHF & FM antennas for all types of installations.
92. **BLONDER-TONGUE** — Compact brochure detailing a line of all-channel products expressly designed to improve reception in the home and small MATV systems.
93. **COLORMAGIC**—Form FR-28-C describes a complete line of antennas and accessories.
94. **CORNELL-DUBILIER** — New 4-page brochure with instructions for installation of AK10B Skyline Series rotor.\*
95. **DELHI**—Twelve-page catalog introducing a complete new line of home TV towers, ham towers, citizen's band towers, masts and telescoping masts.
96. **FINNEY** — 6-page color brochure (form 20-413) lists new color spectrum antennas for VHF-UHF-FM, VHF-FM, and UHF.\*
97. **JERROLD** — New 4-page full-color catalog describes the new Paralog Plus antennas.\*
98. **JFD** — Color Laser and LPV antenna brochures. New 1967 dealer catalog covering complete line of log-periodic out-door antennas, rotators, and accessories.
99. **MOSLEY** — Information on new Mosley MATV system for up to 8 TV/FM sets. Includes TV antenna, distribution system and outlets.\*

### AUDIO

100. **ATLAS SOUND**—Catalog 567 illustrates complete line of speakers, horns, microphone stands and booms, transformers, patio speakers, and accessories.\*
101. **DUOTONE** — Catalog of accessory and maintenance items for the audiophile.\*
102. **GIBBS**—Information on complete line of reverberation units for use in automobiles.
103. **JENSEN**—New catalog 1090-B lists complete line of replacement speakers.
104. **NATIONAL TEL-TRONICS** — 2-color spec sheet lists phonograph plugs and jacks, terminal strips, speakers, and microphone connectors.
105. **OXFORD TRANSDUCER** — Bulletin A-109 features speaker installation in automobiles, hospitals, and recreation rooms.\*
106. **RACON** — Full-line catalog lists horns, drivers, sound columns, microphone stands, and accessories.
107. **SONOTONE**—8-page catalog, SAH-115, lists microphones, stands, and parts and accessories.
108. **SWITCHCRAFT**—Bulletin 172 describes Model 307TR, a new, battery-operated mixer for studio, home, or remote use.

### COMMUNICATIONS

109. **AMPHENOL** — 2-color spec sheets on new Model 650 CB transceivers and Model C-75 hand-held transceiver.
110. **MOTOROLA** — New brochure tells how to reach people on-the-move through use of personal two-way radio.\*
111. **PEARCE-SIMPSON**—16-page color brochure includes illustrations and specs on complete line of CB, business, and industrial radios.

### COMPONENTS

112. **BUSSMANN** — Bulletin on BUSS Fusat Box Cover Units offers simple, low-cost way to protect work bench tools against damage and burnout. Units fit standard outlet or switch box, have fuse-

holder plus a plug-in receptacle, pilot light, switch, etc.\*

113. **BIRNBACH** — New, 2-color, 64-page complete catalog includes specs and illustrations of wire, cable, tubing, electronic accessories and hardware, switches, and components.
114. **CENTRAL-AB** — 24-page replacement parts catalog No. 33GL.
115. **CHICAGO MINIATURE LAMP WORKS** — Specifications of miniature lamps and barretters are included in catalog CML-1. Catalog CMT-2 lists specs of subminiature lamps.
116. **LITTELFUSE** — Pocket-sized TV circuit breaker cross-reference gives the following information at a glance. Manufacturer's part number, corresponding Littelfuse part number, price, color or b/w designation. A second glance gives trip ratings and acquaints you with a line of caddies. Ask for C'BCRP.\*
117. **ONEIDA** — 32-page catalog lists complete line of hardware, wire, sockets, plugs, jacks, clips, switches, resistors, capacitors, and other replacement items.
118. **SOUNDOLIER** — Flyer AC-2 includes specs on audio attenuators, T-pads, L-pads, potentiometers, and autotransformers.
119. **SPRAGUE** Co17, a complete catalog of the Sprague line.\*
120. **TRIAD**—Replacement catalog and TV guide, TV-67/68.
121. **WALSCO** — Phono drive wall chart, FR-250-W, and supplement, FR-250-WS, give latest replacement data.
122. **WORKMAN**—New coil catalog lists general and exact replacements for radio and TV schematic drawings and illustrations of all coils.\*

### SERVICE AIDS

123. **CASTLE TUNER** — How to get fast overhaul service on all makes and models of television tuners is described in leaflet. Shipping instructions, labels, and tags are also included.\*
124. **ELECTRONIC CHEMICAL** — Catalog sheets on aerosol sprays for servicemen.
125. **G.C.** — FR-67G flyer on color harnesses. FR-67A complete Audio-tex catalog.\*
126. **ILLINOIS BRONZE** — Brochure lists aerosol chemicals, lubricants and finishes.
127. **INJECTOR-ALL** — New 1967 catalog of chemicals and alignment tools.
128. **MIDSTATE TUNER** — 24-hour service on any make tuner is described in a colorful brochure.
129. **PERMA-POWER** — Chart shows correct brightener for every TV set in the field.\*
130. **PRECISION TUNER** Mailing kit and replacement tuner list for same-day service.
131. **QUALITY TUNER SERVICE** — Introductory letter describing costs and service on all makes of TV tuners. Repair tags and shipping labels included.
132. **RAVN** — Bulletins on repair ideas using Plas-T-Pair knob and plastic repair kits. Also, bulletins on tuner cleaners and circuit coolers. Includes price sheets.
133. **SPRAYWAY** — Brochure on C-60 solvent cleaner and degreaser.
134. **WESTERN TUNERS REBUILDERS** — Overhaul service on TV tuners.

### SPECIAL EQUIPMENT

135. **FACCO** Catalog No. T-210 describes new quick-connect terminals and insulators.
136. **HINEGARD** — FactFinder No. 250 gives detailed information on 7 new booster/coupler amplifiers in 82-channel and VHF models. New 40-page MATV catalog features Ultra-Plex amplifier system.

### TECHNICAL PUBLICATIONS

137. **CLEVELAND INSTITUTE OF ELECTRONICS**—Free illustrated brochure describing electronics slide rule and four lesson instruction course and grading service.\*
138. **3 M COMPANY** — "Taping Tips for Electronic Servicing," a 32-page booklet for professionals and hobbyists.
139. **PHILCO**—Information about Tech Data & Business Management service. Also, free parts catalog.\*
140. **RCA INSTITUTES** — New 1967 career book describes home study programs and courses in television (monochrome and color), communications, transistors, industrial, and automation electronics.\*
141. **SAVIS, HOWARD H.**—Literature describing popular and informative publications on radio and TV servicing, communications, audio, hi-fi, and industrial electronics, including special new 1967 catalog of technical books on every phase of electronics.\*
142. **SIMPSON**—88-page booklet "1001 uses for the 260 VOM."

### TEST EQUIPMENT

143. **B & K**—New 1967 catalog featuring test equipment for color TV, auto radio, and transistor radio servicing, including tube testers designed for testing latest receiving tube types.\*
144. **EICO** — New spec sheet describes model 100X4 multimeter with DC sensitivity of 100K ohms per volt.\*
145. **HICKOK** — Quick reference catalog No. 67D gives brief descriptions and prices for complete test equipment line.
146. **JACKSON** — New catalog lists complete line of "service engineered" test equipment.
147. **ELECTROTECH** — Two-color catalog sheet on new Model V6-B color bar generator, the latest improved model of the V6. Gives all specs and is fully illustrated.\*
148. **MERCURY** — All-new low price color dot bar generator and Model 2000 conductance tube checker all for under \$100.
149. **PRECISION APPARATUS**—Illustrated catalog describing signal generators, oscilloscopes, and meters.
150. **SFCO**—Operating manual for the HC8 in-circuit current checker.\*
151. **SEMITECHNICS** Brochure on the new Model 1000 transistor tester.
152. **SENCORE** 8-page full color catalog plus a new 4-page supplement catalog.\*
153. **SIMPSON** — 16-page catalog No. 2076, features 15 VOM's with specifications plus other types of test equipment.
154. **TRIPLETT**—Literature sheet on the new model 600 transistorized VOM.\*

### TOOLS

155. **ARROW**—Catalog sheet showing 3 staple gun tackers designed for fastening wires and cables up to 1/2" diameter.
156. **DIAMOND**—16-page booklet, W-68, lists wrenches, pliers, snips, and electronic tools.
157. **ENTERPRISE DEVELOPMENT** — Time-saving techniques in brochure from Endeco demonstrate improved desoldering and resoldering methods for speeding and simplifying operations on PC boards.
158. **PORTABLE TOOLS, INC.**—Form 1614 describes "Shopmate" electric screw driver model 1895.
159. **FACO** — Catalog SD-06X describes 5 tools available with imprinting for promotional use.
160. **XCELITE** Bulletin N567 lists two sets of nut drivers with color coded handles and plastic cases.\*

### TUBES AND TRANSISTORS

161. **GENERAL SEMICONDUCTOR** — 26-page reference list covering 3000 zener and reference diodes.
162. **IR**—Transistor cross reference guide—22 pages of detailed specifications on universal silicon and germanium transistors and a complete listing of more than 5000 devices which they replace.
163. **SYLVANIA** — 42-page book lists 750 types of picture tubes with interchangeability, basing diagrams, and key characteristics.\*
164. **RADIO CORP. OF AMERICA** PIN 300, a 12-page product guide on RCA picture tubes covering both color and black-and-white. Includes characteristics chart, terminal diagrams, industry replacement, and interchangeability.\*





Fig. 1 - Rear Chassis View - CTC-16.

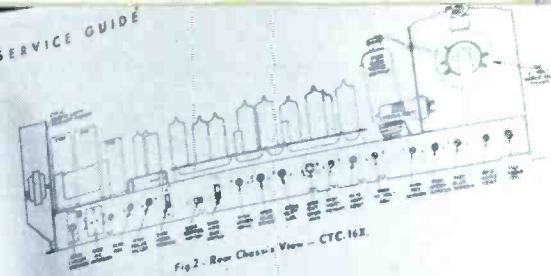

Fig. 2 - Rear Chassis View - CTC-16X.

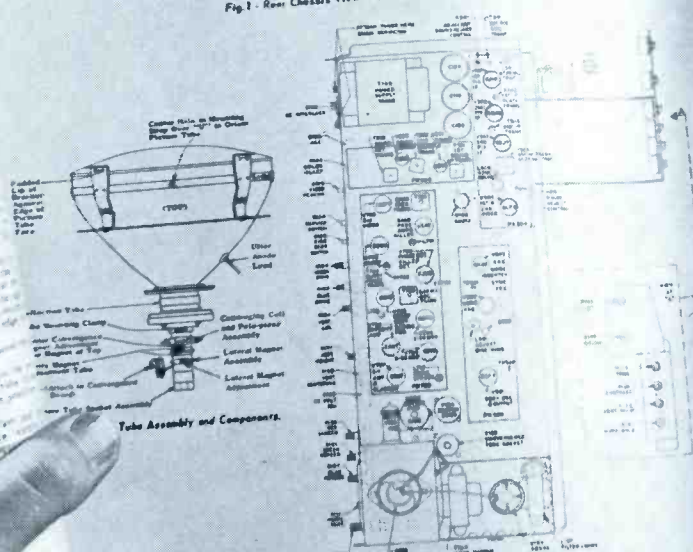

Fig. 4 - Top Chassis View - CTC-16.

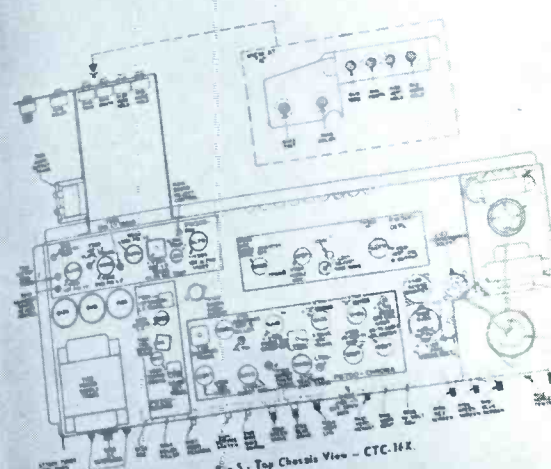

Fig. 5 - Top Chassis View - CTC-16X.

# You need this guide for RCA Color Home Service Calls!

RCA'S NEW FIELD SERVICE GUIDE, ERT-200 helps you make all adjustments on all RCA color sets from 1955 to 1966 that can be performed in the home ... including step-by-step procedure for replacing a color picture tube.

Three part index lets you look up the set you are working on by model number, name or chassis number. You'll find the ERT-200 Field Service Guide indispensable. There's nothing like it on house calls for RCA color sets.

**WHAT THIS GUIDE CONTAINS:**

- Schematics on all RCA color sets from 1955 to 1966
- Field service adjustments (AGC, linearity, centering, etc.)
- Convergence, purity and black and white setup adjustments
- Parts lists
- Wave forms keyed to test points for majority of chassis
- Top and rear chassis views
- Photos of typical receivers
- Index of models from CTC2 through CTC20
- Separate section on tuner schematics
- Separate section on remote tuner schematics

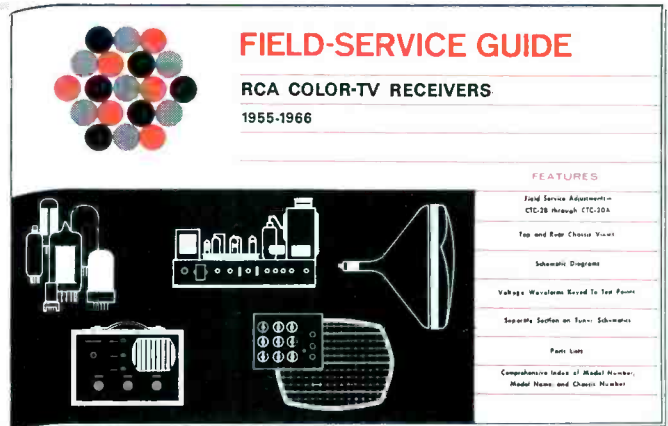

See your RCA Tube Distributor today and arrange to get your copy.

RCA Electronic Components and Devices, Harrison, N.J. 07029



The Most Trusted Name in Electronics

# Give yourself a break you can depend on!



actual size  
1 3/4" x 1 3/8" x 1/2"



#094077

#### CIRCUIT BREAKER CADDY

10 ratings, one each 2-1/4, 2-1/2, 2-3/4, 3, 3-1/4, 4, 4-1/2, 5, 6 and 7 amps.

#### SERVICE CADDY Breakers and Fuses

One service call is all —8 breakers—one rating each 2-1/4, 2-3/4, 3, 3-1/4, 4, 4-1/2, 5 and 7 amps and 30 fuses—five each type C3/10, C1/2, C3-1/2, N3/10, N7/10 and N1.



#094076

Designed for the protection of television receiver circuits, the Littelfuse Manual Reset Circuit Breaker is also ideally suited as a current overload protector for all types of electronic and electrical control wiring such as model railroads and power operated toy transformers, hair dryers, small household appliances, home workshop power tools, office machines and small fractional horsepower motors.

Available individually packaged one breaker per display card; or 5 breakers of same rating per unit pack or as complete, versatile assortments for shop use or replacements in the field.



Included with each assortment:

Pocket size cross reference on color and black/white TV circuit breaker applications.  
Form No. CBCRP-1266H

# LITTELFUSE

DES PLAINES, ILLINOIS

Circle 49 on literature card