



PF Reporter™

PHOTOFACT

the magazine of electronic servicing



1966

**HIGHLIGHTS
OF THE NEW
TV RECEIVERS**

IA 3F 122 567
R. A. FRAMPTON
FRAMPTON RADIO SERV.
BOX 144
ELDRED, PA.

PLUS THESE SERVICING FEATURES:

- Making Money With Tinyvision Receivers
- Understanding Pads and Attenuators
- Latest Circuits for FM Stereo
- Sales Tips for New and Used TV
- And other regular departments



Be super-critical.

Whether you're looking for the fun and economy of building quality kits or you want ready-to-use factory-wired equipment — before you buy, examine carefully. Compare

EICO with anybody else — feature for feature, chassis for chassis, part for part. The more critical you are, the more you'll see for yourself that your best buy is EICO.

EICO

Over 3,000,000 EICO instruments now in use! Preferred by engineers, scientists, technicians and students. EICO equipment is available nation-wide through 2500 EICO dealers.



New Model 435 — DC Wideband Scope. Top-quality DC 4.5mc scope with 3" flat-face CRT. Zener calibrator: Outperforms 5" scopes three times its size, facilitates on-location color TV and other servicing. \$99.95 kit, \$149.95 wired.



New Model 342 — FM Multiplex Signal Generator. Design lab quality. Both composite audio and FM RF outputs. Inputs for stereo audio source for store demonstrations, critical A/B listening tests. \$149.95 wired.



New Model 965 — FaradOhm Bridge/Analyzer. 9-range, low-voltage capacitance-resistance bridge safely measures even 1-volt electrolytics. Metered bridge balance, leakage test voltage (6 DC VTVM ranges 1.5-500V), leakage current (11 DC VTVM ranges 0.15ua-15ma). DC VTVM & VTAM externally usable. \$129.95 wired.



New Model 1030 — Regulated Power Supply. Speeds troubleshooting, design work, production line testing, electronics teaching. Variable bias and plate sources regulated to 1/3 of 1%: 0-150V @ 2ma; 0-400V @ up to 150ma. Ripple less than 3mv rms. Unregulated fil. volts of 6.3V & 12.6V, @ 3A. Switchable, monitoring milliammeter and voltmeter. \$59.95 kit, \$99.95 wired.



New Model 378 Audio Generator. Near-distortionless sine wave generator (<0.1% 20-20,000c) providing fast, convenient, switch-selection of frequencies from 1c to 1,000c (1c steps 10c-100c, 10c steps 100c-1kc, 100c steps 1kc-10kc, 1kc steps 10kc-100kc). 8-pos. 10db/step output attenuator & fine attenuator. Output meter (4 1/2" 200ua) with 8 voltage ranges & db scale. \$49.95 kit, \$69.95 wired.



New Model 440 Scope. Lowest-priced quality oscilloscope available. Excellent for electronics teaching and home workshop. Flat 2c-500kc. 3" flat-face new CRT. Compact, light, rugged. \$49.95 kit, \$69.95 wired.

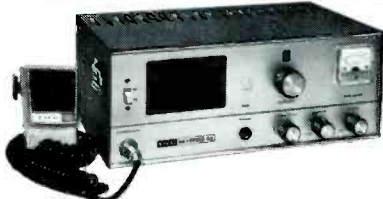

New Model 779 — Sentinel 23 CB Transceiver. 23-channel frequency synthesizer provides crystal-controlled transmit and receive on all 23 channels. No additional crystals to buy ever! Features include dual conversion, illuminated S/R/F meter, adjustable squelch and noise limiter, TVI filter, 117VAC and 12VDC transistorized dual power supply. Also serves as 3.5 watt P.A. system. \$169.95 wired.



New Model 712 — Sentinel 12 Dual Conversion 5-watt CB Transceiver. Permits 12-channel crystal-controlled transmit and receive, plus 23-channel tunable receive. Incorporates adjustable squelch & noise limiter, & switches for 3.5 watt P.A. use, spotting, & Part 15 operation. Transistorized 12VDC & 117VAC dual power supply. \$99.95 wired only.



New Model 753 — The one and only SSB/AM/CW Tri-Band Transceiver Kit. 200 watts PEP on 80, 40 and 20 meters. Receiver offset tuning, built-in VOX, high level dynamic ALC. Unequaled performance, features and appearance. Sensationally priced at \$179.95 kit, \$299.95 wired.



New Model 3566 — All Solid-State Automatic FM MPX Stereo Tuner/Amplifier. No tubes, not even nuvistors. Delivers 112 watts IHF total to 4 ohms, 75 watts to 8 ohms. Completely pre-wired and pre-aligned RF, IF and MPX circuitry, plus plug-in transistor sockets. \$219.95 kit (optional walnut cabinet \$14.95), \$325.00 wired including walnut cabinet. UL approved.



Model ST70 70-Watt Integrated Stereo Amplifier. Best buy of highest ranked stereo amplifiers according to independent testing. \$99.95 kit, \$149.95 wired. ST40 40-Watt Integrated Stereo Amplifier, \$79.95 kit, \$129.95 wired. ST97 Matching FM MPX Stereo Tuner, \$89.95 kit, \$139.95 wired.

EICO Electronic Instrument Co., Inc.
131-01 39th Ave., Flushing, N. Y. 11352

Send for FREE catalog describing the full EICO line of 200 best buys and name of nearest dealer. I'm interested in:

- test equipment
- hi-fi
- ham radio
- CB

Name _____

Address _____

City _____

State _____ Zip _____

1945-1965: TWENTY YEARS OF LEADERSHIP IN CREATIVE ELECTRONICS

Circle 1 on literature card

The trend to small-screen personal portables, both transistorized and tube-type, is quite evident in most manufacturers' new lines. American companies are strongly challenging the imported transistor sets by developing lines of their own. Emphasis on large-screen receivers is presently diminishing; most are offered primarily as consoles or in combinations. The once-popular 21" picture tube is scarcely used in the new models.

Color receivers are being offered by virtually all American manufacturers, and are available in a number of CRT sizes ranging from 12" to 25". Look for more news of developments in color receivers and circuits in next month's (November) PF REPORTER.

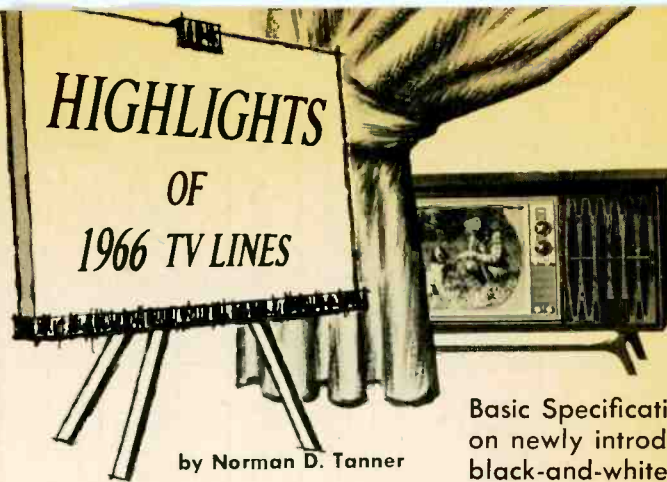

Basic Specifications on newly introduced black-and-white chassis.

ADMIRAL

Admiral's '66 line of black-and-white receivers makes available a variety of picture-tube sizes. An 11" portable is the smallest, and the largest is a 25" console, while 13", 15", 17", 19", 21", and 23" models fill out the selection. The biggest news is the 15" and 17" receivers which incorporate square-cornered, flat-faced picture tubes. A 110° steelbond 15JP4 picture tube provides 103 square inches of viewing area. The implosion-proof CRT eliminates reflection problems and makes cleaning the tube much simpler as there is no safety glass to remove.

The *Terrace*, a 17" portable, uses

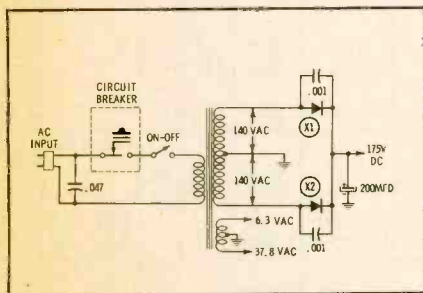

Admiral's G3 chassis and the CRT is a 114° steelbond 17ELP4. Another new portable, the 21" *Fireside*, is also a recent addition to the company's line.

Highlighting the big-screen black-and-white line is the transformer-powered G7 chassis used in the 23" and 25" models. This horizontal-mounted chassis has a three-stage high-gain IF strip — a 6U9 compactron functions in the first and second stages. Other compactrons used in this chassis are the 6U9 video output/sound IF amplifier, 6BF11 sound detector/output, 6JZ8 vertical multivibrator/output, and 38HK7 horizontal output/damper.

The low-voltage power supply (its schematic is shown here) uses two silicon diodes in a full-wave rectifier circuit. Notice this is not a full-wave doubler, but merely a simple full-wave rectifier with an output of 175 volts DC. The filament winding on the transformer is tapped; one section supplies 6.3 volts AC to all the tubes except

the horizontal output. Its filament power is supplied by the 37.8 volt AC winding.

The C21-B12 and C12 chassis used in the 11" and 13" portables employ a series filament string and incorporate some interesting tube types. A 12AL11 serves as sound detector/output; the vertical multivibrator/output stage uses a 17JZ8, and a 33GY7 functions as horizontal output/damper; all these are compactrons. These same tubes are also used in the 21D20 and the G3 chassis.

The G4 chassis is another transformerless type with an interesting array of tubes. A 8BM11 (a compactron consisting of two pentodes) serves as the first and second video-IF amplifiers. These are followed by a 10LW8 which serves as video output/sound-IF amplifier. The sound detector/output is a 17BF11. Vertical sweep is obtained with a 17JZ8. The functions of horizontal output and damper are combined in one envelope — a 38HE7; the high-voltage rectifier is a 1AY2.

AIRLINE

This company's 1966 line includes four basic tube-type receivers, along with 6" and 9" transistor sets. The tube sets are available with 12", 16", 19", or 21" picture tubes. The 23" models have a completely new transformer-powered chassis. Sweep-output tubes are types designed to operate from a low B+ source voltage; thus, only one silicon rectifier is used in the power supply.

Three individual printed-circuit boards are used: one contains the video IF, sync, and AGC circuits; a second houses the audio section; and the third incorporates the vertical multivibrator and horizontal oscillator stages. The horizontal output, vertical output, and damper stages are located on the main chassis. Conventional tubes are used throughout. However, the 6BJ8 is worth mentioning; its triode section is part of the vertical multivibrator and the dual-diode section is used for horizontal AFC.

The 9" transistor receiver, Model GEN1966A, uses a 90° 230DP4 picture tube and has a total of 27 transistors, including the UHF oscillator and the

three in the VHF tuner. Three 1DK29 high-voltage rectifiers are the only tubes used. This set may be operated from 117 volts AC or with a 12-volt rechargeable battery. When the set is AC operated, a bridge rectifier circuit supplies the negative 12 volts DC. Two fuses are used; a .5-amp in series with one side of the AC line provides protection when operating the receiver on AC and a 2-amp is used in the B+ line when the set is battery powered.

At press time, only limited information was available on the 6" transistor set, Model GEN-1686A, which also uses 27 transistors and three tubes. Here a 90° 150HB4 picture tube is used. This 6" set may be operated on AC or DC, and uses a rechargeable battery.

ARVIN

The 12" and 16" portables Model 65K28 and 65K38, respectively, are being offered again this year; these are imported carryovers from the '65 line. (Interesting features of these two receivers were given in PF REPORTER "Highlights" October 1964.) New this year are Models 66K48, a 19" portable, and 66K18, a 9" transistorized receiver.

The new 19" set uses a 114° A47-21W picture tube and has a transistorized UHF tuner. Three high-gain frame-grid tubes occupy the video-IF strip. A number of unfamiliar tube types (5GS7, 6LN8, 10DX8, 10GV8, 11BM8, 20AQ3, and 21KW6) are employed throughout the chassis.

Sweep-circuit adjustments include a tapped width coil and a horizontal linearity coil. The transformerless power supply uses two silicon diodes as a half-wave voltage doubler. A 4.7-ohm fusible resistor in the doubler supply is employed as a protective device.

A 9" transistor receiver Model 66K18 with a 90° A23-10W picture tube is being offered for 1966. This small-screen receiver has a total of 26 transistors, 13 signal diodes, 4 silicon diodes (as a fullwave bridge rectifier in the low-voltage power supply), and 3 tubes used in the high-voltage rectifier cir-

CHASSIS NO.	CRT TYPES	DEG DFL	UHF TUNER	PWR XFM	B+ RECT	IF AMP	DC CPL	AGC	NL	HOR AFC	WIDTH CTRL	FOCUS	SOUND DET	PROTECTED CIRCUITS			
														LINE	B+	FIL	
ADMIRAL																	
C21B12	11GP4	110	TR		one sil	2		P-N		CC		jumper	quad	FR 5.5			
C21C12	13AP4	110	TR		one sil	2		P-N		CC		jumper	quad	FR 5.5			
G21D20	15JP4	110	TR		one sil	2		P-N		CC		jumper	quad	FR 5.5			
G3	17ELP4, 19FBP4	114	TR		one sil	2		P-N		CC		jumper	quad	FR 5.5			
G4	19ENP4, 19EGP4, 21FUP4, 23FRP4	114	TR		one sil	2		P-N		CC		jumper	quad	FR 5.5			
G7	19EGP4, 21FUP4 23FRP4, 25HP4	114	TR	✓	*	3H		M-C	M	CC	coil	jumper	quad	ckt brkr			
AIRLINE																	
GEN-1166A, 1266A	12BFP4	114	2DV4		one sil	2H		S-N		CC	coil	jumper	quad	fuse 1.6A			
GEN-1866A	16AUP4-J	114	2DZ4		HW dbl	3		*		T	pot	jumper	quad	ratio	fuse 2A		
GHJ-1066A, 1366A	19ENP4	114	TR		one sil	2H		T-N		CC	sleeve	jumper	quad	ckt brkr			
GHJ-4836A, 46A,B; 56A,B; 76A,B; 96A,B; 14815A	23FMP4, 23GBP4	110	TR	✓	one sil	3		M-N		D		jumper	quad	ckt brkr			
ARVIN																	
65K28	A31-12W	114	TR		one sil	2H		S		T	coil	NA	quad	fuse 1.6A			
65K38	AW40-12	114	TR		HW dbl	2H		M-C	M	CC	jumper	NA	ratio	fuse 1.5A			
66K48	A47-21W	114	TR		HW dbl	3H		T-C		CC	coil	NA	ratio	FR 4.7			
CATALINA																	
122-632	19DQP4, 19FDP4	114	TR		HW dbl	3		†		CC	sleeve	jumper	quad	ckt brkr			
122-640, 646, 648	23FMP4, 23GBP4	110	TR		HW dbl	3		†		CC	sleeve	jumper	quad	ckt brkr			
122-642, 644	23FCP4, 23FDP4	110	TR		one sil	2H		†		CC	sleeve		quad	ckt brkr			
122-652, 654, 656	23FCP4, 23FDP4	110	TR		one sil	2H		†		CC	sleeve		quad	ckt brkr			
CHANNEL MASTER																	
6573	12AYP4	114	TR		one sil	2H		T-C		D		jumper	quad	fuse 2A			
CORONADO																	
TV2-9368A	12BGP4	110	TR		one sil	2H		S-N		CC	sleeve		quad	FR 4.7			
TV2-9369A, 70A, 71A	12BGP4	110	TR		one sil	2		†		CC	sleeve	NA	quad	FR 4.7			
TV2-9372A, 73A	19EAP4, 19ENP4	114	TR		one sil	2H		†		CC	sleeve		quad	ckt brkr			
TV2-9374A	19DQP4, 19FDP4	114	TR		HW dbl	3		†		CC	sleeve	jumper	quad	ckt brkr			
TV2-9506A	23FCP4, 23FDP4	110	TR		one sil	2H		†		CC	sleeve		quad	ckt brkr			
TV2-9508A, 09A	23FMP4, 23GBP4	110	TR	✓	FW	2H		†		CC	sleeve	jumper	quad	ckt brkr			
TV2-9547A, 48A, 49A	23FMP4, 23GBP4	110	TR		HW dbl	3		†		CC	sleeve	jumper	quad	ckt brkr			
CURTIS MATHES																	
TV-16	23FHP4	110	NA		HW dbl	2H	✓	P-N		CC	NA	pot	quad	ckt brkr			
TV-17	19EGP4	114	NA		HW dbl	3H	✓	P-N		CC	NA	pot	quad	ckt brkr			
	23FHP4	110															
TV-19	19EGP4	114	NA	✓	FW dbl	3H	✓	P-N		CC	NA	pot	quad	ckt brkr			link
DUMONT																	
120780-A	16CEP4	114	TR		one sil	2H		T-C		CC			quad	fuse 1.2A			
120783-A, 810-A	19FJP4	114	TR		one sil	2H		T-C		CC			quad	fuse 1.2A			
120804-A, 805-A	19DRP4, 19EDP4	114	TR	✓	5U4GB	3H		T-C	T	CC	coil	jumper	quad		fuse .45A	link	
120806-A	23GFP4	110	TR	✓	5U4GB	3H		T-C	T	CC	coil	jumper	quad		fuse .45A	link	
ELECTROHOME																	
13T4E	19BSP4, 23ARP4	110	NA	✓	*	*		P-C		S		jumper	quad	ckt brkr			link
	19AVP4, 19EUP4	114															
14T4P	19BSP4, 23ARP4	110	TR	✓	*	*		P-C		D		jumper	quad	ckt brkr			link
15T4P	19BSP4, 23GXP4	110	TR	✓	*	*		P-C	M	S		jumper	quad	ckt brkr			link
16T4E	19BSP4, 23GQP4	110	NA	✓	*	*		P-C	M	D		jumper	quad	ckt brkr			link
16T4P	23GQP4, 23GXP4	110	TR	✓	*	*		P-C	M	D		jumper	quad	ckt brkr			link
EMERSON																	
12P50	310JB4	NA	TR		one sil	3H		T-N		CC	jumper	jumper	ratio	fuse 2.3A			
120779, 780	16CEP4	114	TR		one sil	2H		T-C		CC			quad	fuse 1.2A			
120781, 782, 810, 811, 813	19FJP4	114	TR		one sil	2H		T-C		CC			quad	fuse 1.2A			
120804-A, 805-A	19DRP4, 19EDP4	114	TR	✓	5U4GB	3H		T-C	T	CC	coil	jumper	quad		fuse .45A	link	
120806-A, 807-A	23GFP4	110	TR	✓	5U4GB	3H		T-C	T	CC	coil	jumper	quad		fuse .45A	link	
GENERAL ELECTRIC																	
AB	23DYP4, 23FVP4	114	TR	✓	FW dbl	3H		T-C		D	coil	jumper	quad	fuse 2A			#26 link
DB	19ECP4	114	TR		one sil	2H		T-N		D	coil		quad	fuse 1.5A			
SB	12BMP4, 16CFP4		TR		one sil	2H		T-N		D			quad	fuse 1.5A			
MAGNAVOX																	
T914	23HGP4, 23HQP4	110	TR		one sil	3		P-N		CC		jumper	quad				
MOTOROLA																	
TS-454	12BGP4, 12BKP4	110	TR		one sil	2		T-N		CC	capacitors	jumper	quad	FR 5			
TS-586	19DSP4, 19EFP4	114	TR		one sil	3		P-N	T	CC	capacitors	jumper	quad	ckt brkr			FR 5
TS-588	23FSP4, 23GSP4, 23HLP4, 23GXP4	110	TR		HW dbl	3	✓	T-N	T	CC	capacitors	jumper	quad	ckt brkr			
TS-589	19EBP4, 21FVP4, 21FZP4	114	TR	✓	FW dbl	3	✓	T-N	T	CC	coil	jumper	quad	ckt brkr			
	23FSP4, 23GSP4, 23HLP4, 23GXP4	110															

CHASSIS NO.	CRT TYPES	DEG DFL	UHF TUNER	PWR XFM	B+ RECT	IF AMP	DC CPL	AGC	NL	HOR AFC	CTRL WIDTH	FOCUS	SOUND DET	PROTECTED CIRCUITS		
														LINE	B+	FIL
MOTOROLA (Conf.) TS-596	19EGP4 19AEP4, 19ENP4	114 110	TR		one sil	3		P-N	T	CC	capacitors	jumper	quad	ckt brkr	FR 5	
MUNTZ AS-5002 AS-5003	19ENP4, 19ETP4 23GP4		TR TR	✓ ✓	FW FW	2 2		S-N S-N		D D			quad quad	fuse 2A ckt brkr		link link
OLYMPIC NCP	23EZP4		TR		one sil	2H		T-C		CC		jumper	quad	ckt brkr	FR 5.5	
PACKARD BELL 88-16, 16C 88-18C 88-19	23EKP4, 23FLP4 19DQP4, 19FCP4A, 19FDP4 19DQP4, 19FCP4A	92 114 114	TR TR TR	✓ ✓ ✓	FW dbl HW dbl HW dbl	3 3 3		P-C P-C P-C	T T T	CC CC CC	coil coil coil	pot pot pot	ratio ratio ratio	ckt brkr ckt brkr ckt brkr	FR 5.6 FR 5.6 FR 5.6	
PHILCO 16J26, J26A 16J27 16N35	19DUP4 19DUP4 23GWP4	114 114	TR TR TR		one sil one sil one sil	* 2H 2H		* T-N T-N	T T T	CC CC CC	pot pot pot	jumper jumper jumper	quad quad quad	ckt brkr ckt brkr ckt brkr	FR 1.5 FR 1.5	
RCA KCS136M KCS142XA KCS144 KCS148 KCS149 KCS152 KCS154 KCS155	23BKP4, 23BLP4 19DQP4 19DQP4 19DQP4 19DQP4 16AYP4, 16BGP4 21FVP4 19DQP4	114 114 114 114 114 114 114 114	TR TR TR TR TR TR TR TR	✓ ✓ ✓ ✓ ✓ ✓ ✓ ✓	FW dbl HW dbl HW dbl FW dbl FW dbl one sil HW dbl one sil	3 2H 3 2H 3 2H 3H 2H	✓ ✓ ✓ ✓ ✓ ✓ ✓ ✓	P-N P-C P-C P-C P-C T-N P-C T-N		CC CC CC CC CC CC CC CC	coil coil coil coil coil pot coil capacitors	pot jumper	quad quad quad quad quad quad quad quad	FR 5 FR 5 FR .35 FR 5	ckt brkr ckt brkr fuse .4A ckt brkr fuse ckt brkr ckt brkr	link link link
SEARS/SILVERTONE 528.61620, 21 528.61680, 81 528.61720, 21 528.70000, 01 528.70120, 21 562.10090, 91, 92, 93, 94, 95 562.10110, 11	19ENP4 23HFP4 23HFP4 19DQP4, 19DWP4 19DQP4, 19DWP4 16BFP4 280GB4	NA NA NA 114 114 NA NA	TR TR TR TR TR 3DZ4 TR		one sil one sil HW dbl one sil one sil HW dbl one sil	2H 2 2H 2 2 3 3		T-N S-N T-N S-N S-N T-C S-C	* *	CC CC CC CC CC T CC	sleeve sleeve sleeve sleeve coil	pot pot pot jumper jumper jumper	ratio ratio ratio ratio ratio ratio	ckt brkr ckt brkr ckt brkr ckt brkr ckt brkr fuse 2.2A	fuse 1.9A	
SPARTON OF CANADA 19P1 23P1, P2, P9 23P3, P4	19XP4 23FUP4 23FUP4	114 110 110	TR TR TR	✓	HW dbl FW HW dbl	3 3 3	✓	P-N P-N P-N	NA NA NA	S S S		NA NA NA	ratio ratio ratio	ckt brkr	FR 9 FR 9	
SYLVANIA B04 B05 B06	23BGP4 19CVP4 19CVP4	110 114 114	NA NA NA	✓	5BC3 HW dbl HW dbl	2H 2H 2H	✓ ✓ ✓	T-C T-C T-C	* * *	CC CC CC	pot pot pot	jumper jumper jumper	quad quad quad	ckt brkr ckt brkr ckt brkr	#28 link	
WELLS GARDNER T03, T04, T12, T21 T05 T06, T07, T10, T13 T14, T22	19EAP4, 19ENP4, 23FCP4, 23FDP4 12BGP4 19DQP4, 19FDP4, 23FMP4, 23GBP4 23GBP4, 23FMP4	114 110 110 114 110 110	TR TR TR TR		one sil one sil HW dbl *	2H 2 3 2H		* * *		CC CC CC	sleeve sleeve sleeve	NA jumper	quad quad quad	ckt brkr FR 4.7 ckt brkr	ckt brkr	
WESTINGHOUSE V-2486 V-2487 V-2490	19FEP4 23HRP4 19CMP4, 19FEP4 23HRP4, 23HSP4 12BLP4	114 110 114 110 110	TR TR TR TR		one sil HW dbl one sil	2H 2H 2H		* P-C *		CC CC CC	jumper pot	NA	quad quad quad	fuse 1.75A fuse 2A fuse 1.75A		
ZENITH 14N26 14N29 14N31 14N32 14N34	21FXP4 19EZP4 19EZP4 19EZP4 19EZP4	114 114 114 114 114	TR TR TR TR TR	✓ ✓ ✓ ✓ ✓	FW dbl HW dbl HW dbl FW dbl FW dbl	3 3 3 3 3		M-C M-C M-C M-C M-C	M M M M M	CC CC CC CC CC	pot pot pot pot pot	pot jumper jumper jumper pot	quad quad quad quad quad	ckt brkr ckt brkr ckt brkr ckt brkr ckt brkr	#24 link #26 link #24 link	

ABBREVIATIONS AND SYMBOLS—In any column, CHECK MARK indicate chassis has feature named; ASTERISK means "see text"; NA means data not available at press time. For individual columns—UHF TUNER: tube type given, if known; TR, transistorized. B+ RECT: one sil, one silicon rectifier; HW dbl, half-wave voltage doubler using two silicon rectifiers; FW dbl, full wave silicon doubler. IF AMP: Figure indicates number of stages; "H" indicates use of two or more tubes having substantially higher gain than the 6CB6. DC CPL means set has DC path or DC restoration in video drive circuit of CRT. AGC; First letter—M, multipurpose tube ('HS8, 'BU8, or similar); P, pentode keyer; T, triode keyer; S, simple (no tube). Second letter—C, has AGC potentiometer; N, no AGC adjustment. NL (noise limiter): M, part of multipurpose tube ('HS8, BU8, etc.); T, triode noise inverter; †see text for Wells Gardner. HOR AFC: CC, common-cathode dual selenium diode; CT, common-cathode dual diode plus triode section of tube (controlling sinewave or "Synchroguide" oscillator); S, two selenium diodes in series; D, dual diode sections of tube; T, triode used. SOUND DET: quad, quadrature circuit; ratio, ratio detector circuit. FOCUS: jumper, set has wire from CRT to select voltage; pot, has focus potentiometer; CRT base, focus jumper located on base of picture tube. PROTECTED CIRCUITS: figure following "fuse" is rating in amps; FR indicates fusible resistor and is followed by rating in ohms; "link" means short wire, of gauge indicated.

cuit. Two fuses—a .4-amp in the AC line and a 2-amp in the DC power path—are located in the power supply. Three transistors are used in the 40-mc video-IF strip. Separate amplifiers are used for RF and IF AGC voltages. This receiver may be operated from a 117-volt AC source or by ten dry-cell batteries. Along with the built-in antenna is provision for connecting an external 300-ohm antenna.

CHANNEL MASTER

Latest introduction by this company is a 12" tube-type receiver, the Model 6573. This personal portable comes equipped with a built-in monopole antenna for VHF, a built-in UHF loop antenna, and an earphone jack. Only twelve tubes, including the two in the VHF tuner and the 12AYP4 picture tube are used. Two and three functions are combined within one tube envelope, by using compactrons. Among these compactrons are the 17BF11 audio detector/output, 17JZ8 vertical multivibrator/output, 8B10 AGC keyer/sync separator/horizontal AFC, and 33GY7 horizontal output/damper. The power supply is transformerless and uses a single silicon rectifier for the B+ supply; protection is provided by a 2-amp fuse in the 117-volt AC line.

CURTIS MATHES

Two CRT sizes used in three separate chassis make up this year's line. A 19" receiver is available with either the transformer powered TV-19 chassis or the series-filament TV-17 chassis. The transformer-powered chassis is only slightly changed from those used in previous years.

Chassis TV-16 and TV-17 are similar in that both are transformerless and use a 23FHP4 picture tube. However, TV-16 has only two video IF stages—a 4JD6 and a 4JC6 are used as the first and second video-IF amplifiers. TV-17 has three video-IF stages—it uses a 4BZ6, 5GM6, and 4JC6, in that order. Other tube differences are in the audio-output stage: a 12FX5 is used in TV-16, while a 6AQ5 serves the same purpose in TV-17. Both chassis use a 22JC6 as the horizontal output and a 17AY3 as the damper.

Some models using the TV-17 chassis are equipped with an "instant-on" circuit which supplies a reduced voltage to the tube filaments while the on-off switch is in the OFF position. The ac-

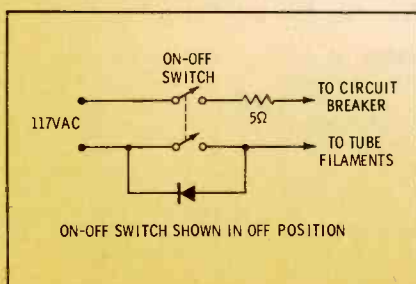

companying schematic shows how this circuit is arranged.

ELECTROHOME

A number of features highlight these five Canadian chassis used with 19" and 23" picture tubes. All are equipped with a swing-down vertical chassis which permits extensive troubleshooting without removing the chassis. Also, the majority of components can be substituted with the chassis in the lowered position. Other features include a full-wave bridge-rectifier circuit in the low-voltage power supply—all sets have a power transformer and use four silicones in the

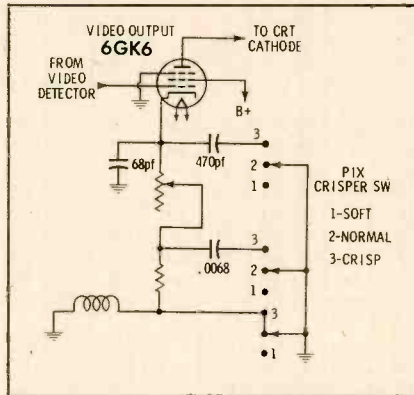

bridge rectifier circuit. Low-voltage protection is provided by a circuit breaker in series with the AC input. This breaker is preceded by a thermistor (17-ohm cold, 1.7 ohms hot) for added protection.

A four-stage solid-state video-IF strip is used throughout the entire line. PNP transistors in all four stages operate with a positive DC supply since the collectors are near DC ground potential. B+ dropping resistors are used to lower the 250-volt DC source to approximately 10 volts for the first three IF amplifiers and to 20 volts for the fourth IF stage.

Four controls are used in the vertical sweep circuit. Along with the HOLD and HEIGHT are linearity controls for shaping both the top and bottom of the picture.

A "spot-killer" switch is wired between B+ and one side of the brightness control. The switch opens when the receiver is turned off, removing DC voltage from the cathode of the picture tube and eliminating any lingering spot from the screen. Deluxe chassis 164TP has a "pix crisper" switch in the cathode circuit of the video-output tube. In the circuit diagram shown here the switch is in NORMAL position.

At present, all chassis are hand-wired; however, there is a good possibility that this manufacturer will switch to printed-circuit boards throughout the entire line before the end of 1966.

EMERSON

This year's line consists of 11", 12", 16", 19", and 21" receivers, using both tube- and transistor-type chassis. The

biggest news is Model 11PO4A (shown here), a transistorized 11" portable. The only tubes found in this set are the 11JP4 picture tube and the 1X2B high-voltage rectifier. There are eighteen transistors on the main chassis board, three in the VHF tuner, and one in the UHF tuner.

The transistors function in the circuit in much the same manner as tubes do in tube-type receivers. Diodes are used as the damper, sound discriminator, horizontal AFC, and low-voltage power supply rectifiers. This power supply uses four diodes (two connected in each full-wave rectifier circuit) to develop four source voltages—three negative and one positive. A 1.2-amp fuse in series with the AC line provides protection in case of overload.

The AGC circuit employs an NPN transistor as AGC amplifier. Input signal to the base is varied by the AGC control. A LOCAL-DISTANT control is located on the antenna terminal board, but it functions independently of the AGC circuit. When the switch is in the local position, a 330-ohm resistor

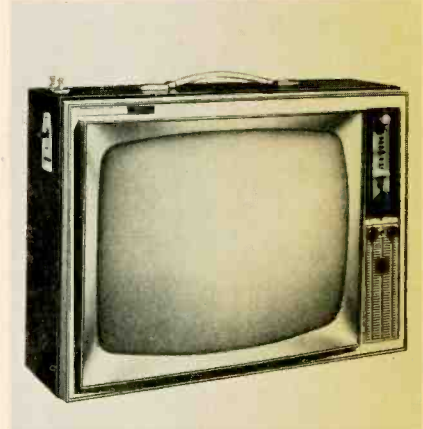

is placed in series with each side of the balanced 300-ohm line at the input to the tuner.

Model 12P50 is another portable, but this 12" set uses tubes. This receiver is electrically similar to other transformerless receivers. Several tube types in this one deserve comment. For example, a 17JZ8 serves as the vertical multivibrator/output, a 21GY5 is used as horizontal output, and a 17BR3 functions as the damper.

The remainder of the chassis shown in the large chart incorporate only minor modifications from those offered a year ago. A few new tube types are used, such as the 6LN8 sound IF amplifier/sync separator, 6LX8 AGC keyer/horizontal oscillator, 21KA6 horizontal output, and 20AQ3 damper.

GENERAL ELECTRIC

Three new chassis and four CRT sizes (12", 16", 19" and 23") are available for the coming year. 23" table models and consoles use the deluxe transformer-powered AB chassis. Compactrons are certainly in evidence throughout the entire '66 line. The AB

chassis has a single 6AR11 operating as the first and second video-IF amplifiers; a 6AF11 serves as video output/sound IF amplifier/sync separator. Audio detector/output functions are accomplished with a 6T10; and a 6B10 is the horizontal phase detector/multivibrator.

All 19" models use the DB chassis in which compactrons are even more numerous than in the AB. Seven tubes operate fifteen different stages. A 9BJ11 functions as first and second video-IF amplifiers; video amplifier/AGC keyer/sound IF amplifier operations are performed by a 14BL11; a 17BF11 is audio detector/output. For the sync-separator/vertical - multivibrator/vertical - output a 2329 is employed; an 8LT8 performs as horizontal phase detector/oscillator, and a 38HE7 serves as horizontal output/damper. The only single-purpose tube is the 1K3 high-voltage rectifier.

Receivers with 16" and 12" (pictured here) picture tubes use chassis SB which is quite similar to DB but uses several different tube types. For example, in the first and second video-IF stages an 11BQ11 is used; a 33GY7 functions as hori-

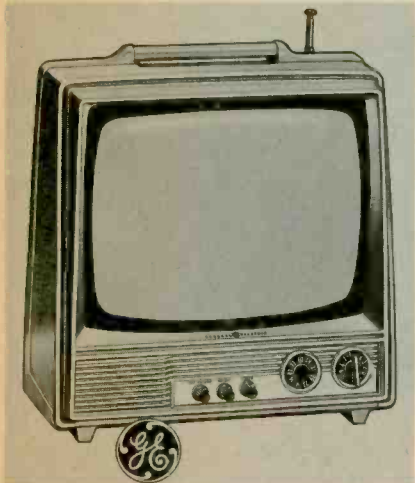

zontal output/damper, and the high-voltage rectifier is a 1BC2.

All chassis use printed circuitry with practically all the small components mounted on the printed board. Chassis AB has two boards—the smaller board houses the sweep section, while the larger one consists of the video, sound, sync, and AGC circuits. DB and SB chassis use only one printed-circuit board.

MAGNAVOX

A 23" tube-type set and a 24" and 27" transistor console lead the field for Magnavox in 1966. Other models are available but contain only minor modifications of those introduced a year ago.

The tube-type receiver (T914 chassis) has a series filament string for its 16 tubes which include the VHF tuner and picture tube. 140 volts B+ is developed by a single silicon rectifier which is preceded by a 4.7-ohm, 5-watt wire-wound resistor (the only protective device in the power supply).

Some models using the T914 chassis

incorporate the *Magnalux* circuit. This circuit varies brightness and contrast as room light changes. An LDR (light dependent resistor) which changes resistance according to variations in surrounding light controls DC voltage on the video-amplifier screen and on the picture-tube grid.

Magnavox is the first company to introduce a large-screen transistor receiver—chassis 1908. This chassis is used in the 24" and 27" models; the 27" picture tube is a 27ZP4, the 24" in a 24AHP4. With the exception of the CRT, the only tube used is the 1K3 high-voltage rectifier which supplies 18 kv to the anode of the CRT.

The total of 22 transistors includes three in the VHF tuner and UHF oscillator. In the main television chassis 18 transistors function in the following manner; three are used as video-IF amplifiers; and are followed by a video driver and the video output stages.

The sound section has a 4.5-mc IF amplifier, audio detector and driver, and single-ended audio output. AGC system consists of an AGC keyer (keyed in the

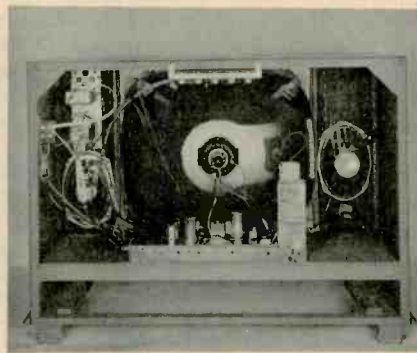

normal manner by a pulse from the horizontal output transformer) and AGC driver stages. AGC output is a positive DC voltage applied to the base of the second video-IF stage. Two transistors are used in the sync stages—one as a separator and the other as a splitter. Vertical sweep is obtained

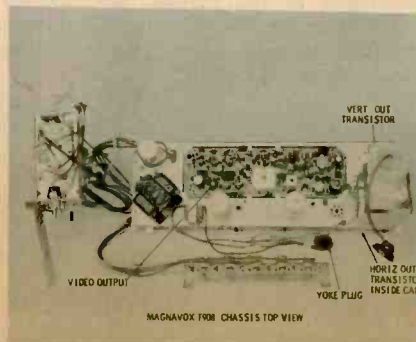

from a blocking oscillator circuit followed by the driver and output stages. The horizontal blocking oscillator frequency is controlled by a pair of series-connected AFC diodes. The remainder of the horizontal circuit consists of the driver and output stages; a diode damper is used.

Input to the low-voltage power supply is 117 volts AC (the receiver cannot be operated by batteries). The power supply uses a power transformer and has a number of positive DC output voltages: 140, 110, 68, 14.5, and 12 volts. A circuit breaker between one side of the AC line and the primary winding of the power transformer provides protection. A separate 6.3-volt winding powers the picture-tube filament and pilot light.

MOTOROLA

This company has broadened its assortment of screen sizes, and now offers four different picture tube sizes in its 1966 line. The smallest of these is a 12" portable using the TS-454 chassis; other sizes use 19", 21", or 23" picture tubes. Only two chassis are new this year—TS-454 and TS-596. Other chassis are essentially modifications of previous models.

The TS-454 employs two horizontally mounted chassis boards and has eleven tubes (including the two used in the VHF tuner). Two of the tubes used are compactrons, a 17BF11 as sound detector/output and a 33GY7 as horizontal output/damper. The large printed-circuit board on the lower chassis contains the majority of small components. The upper chassis contains the filter capacitors, chokes, transformers, etc.

Chassis TS-596 is employed in 19" portables. This is a horizontally-mounted, hand-wired chassis containing 15 tubes; none are compactrons. There are some interesting tube types, however, such as the 21JV6 horizontal-output stage, 17BE3 damper, and 1S2 high-voltage rectifier. Five diodes are put to use in this chassis. One serves as the B+ rectifier (only one is necessary because the sweep-output tubes operate from a lowered B+ voltage). A germanium diode is used as the video detector; another diode is part of the vertical blanking network, and two others form the horizontal AFC circuit.

All this year's sets are equipped with a transistorized tuner, and pushbutton UHF tuning is provided on many models.

MUNTZ

Both new chassis have a power transformer and use a pair of silicon rectifiers connected in a fullwave rectifier arrangement. Chassis AS-5002 comes in the 19" portables, and AS-5003 is used in 23" consoles. These portables are available with a transistorized remote-

control unit and have a built-in monopole antenna.

Physically and electrically these chassis are quite similar; both have two vertically-mounted printed-circuit boards and the horizontal hand-wired portion of the chassis houses the low- and high-voltage power supplies and the horizontal-output section.

Chassis AS-5003 may use either a single tube (12HE7) as horizontal output and damper or use individual tubes for each function (2 6GT5 in the output stage and a 6AY3 as damper). Both chassis use a link for filament protection; a 2-amp fuse provides line protection for the AS-5002, while the AS-5003 uses a circuit breaker.

OLYMPIC

Three 23" consoles and a 23" TV-radio-phonograph combination using the NCP chassis are this company's latest introductions. All the other receivers have been introduced earlier as this company's "Models of the Month."

Physically, the new NCP chassis is virtually the same as those used previously. However some new tube types are being employed. The video output/sound-IF amplifier is a 15BD11 followed by a 17BF11 sound detector/output. A 17JZ8 functions as vertical multivibrator/output, and a 21JZ6 is used in the horizontal output stage. The damper is a novar 17BE3. For the AGC keyer, a 4AV6 triode is used, and the AGC control is part of its cathode circuit.

Resistor-capacitor packaged circuits are quite popular throughout the chassis. One is used in the sync-separator grid circuit; another serves as the vertical integrator; a third functions as the horizontal-AFC network; and the remaining two are used in the horizontal oscillator and output grid circuits.

B+ is derived from a single silicon rectifier. Power-supply protective devices include a circuit breaker and 5.5-ohm fusible resistor. The circuit breaker is in series with one side of the AC line and protects the series filament string. A 5.5-ohm resistor precedes the silicon diode and protects the B+ line.

PACKARD BELL

Four different chassis are being used in the new receivers. The 88-16 is being carried over from the 1965 models and the new chassis 88-16C differs only slightly from the 88-16. In the C version, differences are: use of a different tuner, absence of a picture-fidelity control, substitution of an illuminated dial for a computer dial, and absence of remote control adaptability. The 16 and 16C chassis are used with 23" picture tubes.

19" portables use either the transformer-powered 88-19 chassis or the series-filament 88-18C. Some models using the 88-19 chassis have the computer-type dial; some are equipped with

remote control; and still others have a timer, which allows the customer to set times (up to three hours) for the receiver to turn off or on. The 88-19 is a vertically mounted hand-wired chassis and uses the same tube lineup as does the 88-16.

Chassis 88-18C is also vertically mounted but uses both hand wiring and printed-circuit boards. Two printed boards are used; one contains the video-IF and output stages, while the other consists of the sound-IF and output circuits. To our knowledge, this is the first time this company has used printed boards in its TV receivers. The circuitry in this transformerless receiver is much the same as that found in sets using a power transformer. However, with a series-filament string, different tube types are necessary. In most cases, these tubes differ only in the filament-voltage requirements; one exception is the 12AL11 (compactron) used as the AGC keyer/audio output.

PHILCO

Three new Philco chassis have been introduced this year. Two of these are simply modifications of the ones used a year ago. Circuitry and tube complement is basically the same. The warmed-over 16J27 chassis is used in 19" compact models, and the other, the 16N35, is found in 23" table models and consoles. Both these chassis have the same tube lineup used in last year's 15J20 and 15J27 chassis.

An entirely new chassis, the 16J26 (A), is used in Philco's line of 19" portables. This chassis could be classified as a hybrid—it uses both tubes and transistors. Five transistors are employed, three of them in the video-IF stages.

Two transistors make up the AGC circuit (one as the AGC gate and the other as the AGC amplifier). This transistorized AGC circuit operates in much the same manner as an AGC keyer found in tube-type receivers. A video signal from the plate of the video output tube is applied to the base of the AGC gate, and a low-level keying pulse from the flyback is applied to the emitter of the same transistor. Conduction of the gate transistor is determined by the amplitude of the video signal. When the gate conducts, a positive voltage is developed at the emitter and applied to the base of the AGC amplifier, controlling the gain of the RF and first video-IF amplifiers.

Aside from the usage of these transistors, the circuits in this chassis are quite conventional. Some different tube types, however, are used; for example, a 17BZ3 operates as the damper, a 10BQ5 as audio output, and a 21J26 serves as the horizontal output.

RCA

Many of the chassis used last year are

continued in this year's models with only minor modifications. Also three completely new chassis have been added. Two are tube-type (KCS154 and KCS155) and one is transistorized (KCS153). All chassis except the KCS152 use new VHF tuners in which a 13-position wafer switch is used for the antenna, RF, and mixer sections—while the oscillator uses a turret (rotating-drum) system with individual coils for each channel.

Many new tube types are used in both the old and new chassis. The KCS152 and KCS155 chassis use an 11LQ8 as video output/AGC amplifier; a 15KY8 serves as vertical multivibrator/output; a 17BS3 functions as the damper; and the horizontal-output stage has a 22JU6. A 22JF6 performs as horizontal output in Chassis KCS154.

The KCS155 chassis has a power transformer but employs a series-filament



string. AC voltage is applied to a tap on the autotransformer. One side of the transformer is connected to ground and the other side ties to the circuit breaker in series with the single silicon rectifier. The filament circuit is connected directly to one side of the AC line.

The chassis photo of the all-new 12" transistor portable using Chassis KCS153 compares its size to that of a tube-type receiver. A total of 27 transistors are employed including the four used in the UHF and VHF tuners. Although transistors are used throughout (except for the 2BJ2 high-voltage rectifier), the circuits operate in much the same way as in tube receivers. The video IF section uses three transistors as IF amplifiers; single transistors are used in the video amplifier and output stages. The sound section has two IF amplifiers followed by a ratio detector, driver and single-ended output. Single-stage circuits are used for the AGC, noise canceller, and sync separator. The vertical sweep circuit has four transistors functioning as: oscillator, buffer, driver, and output. A phase splitter, oscillator, driver, and output are used in the horizontal

section. The horizontal-output transistor is protected against excessive current by another transistor in a current-limiting circuit. Rounding out the transistor complement are the power-supply regulating units which supply nearly ripple-free DC voltage.

SEARS/SILVERTONE

Eight different chassis are used in the new line; five of these are assembled in this country and three (chassis with a 562 prefix) are imported. Three different American-made chassis are used in 19" receivers and two are used in the 23" models. Of the imported sets, two are tube-type and one uses transistors.

Chassis 528.61620 has some rather interesting circuit features. In the sound section a 12BA6 is used as the IF amplifier. The triode section of a 12AV6 is the audio amplifier, the diode section functions as half of the ratio detector, and a germanium diode is the other half of the ratio detector. A 50C5 is used in the audio-output stage. These three tubes, along with another 12AV6 used as the sync separator, are connected in an individual series filament string—all have a filament current rating of 150 ma. The remainder of the tubes receive filament voltage from a series 450-ma string.

Also, this .61620 chassis uses an NPN transistor as a noise gate. Video from the video detector is applied to the base of the transistor; the emitter is grounded and the collector is tied to the cathode of the sync separator. Thus, the sync separator is cut off by the noise gate whenever noise pulses are present in the video signal.

Chassis 528.61680, 528.70000, and 528.70120 are similar to the one just described except that they don't have a noise gate nor do they use a tube in the AGC circuit. 528.61720 is basically the same as .61620 but uses a 23" picture tube and has two silicon rectifiers in the power supply.

Chassis 562.10120 is completely transistorized except for the three 1D-K29 tubes used in the high-voltage rectifier circuit. This receiver will operate on either an AC or DC power source. The power-supply uses a bridge rectifier to develop the DC voltage when the set is operated from 117 volts AC. Circuitry is quite similar to that found in other imported transistor receivers.

SPARTON OF CANADA

The hand-wired 19P1 chassis is used in 19" portables. These sets are equipped with a built-in dipole antenna and ear-phone jack. The chassis uses 16 tubes including the VHF tuner and picture tube. A dual-selenium diode is used for horizontal AFC and two silicon rectifiers develop the B+ voltage.

The deluxe models (one is shown here) use the horizontally mounted 23P2 hand-wired chassis, equipped with a power transformer and circuit breaker. Silicon

diodes are used as B+ rectifiers.

A transformerless chassis 23P3 is also available in some 23" sets. The circuitry in this chassis is similar to that in the 23P3 except for the low-voltage power supply.

SYLVANIA

Two 19" tube-type, one 23" tube-type, plus one 19", and one 12" transistor chassis are found in this company's new line.

Both 19" tube-type receivers use a bonded picture tube and have a series-filament string. The horizontally mounted chassis has one large printed-circuit board with practically all the components, except the high- and low-voltage power supplies, mounted on the board.

The deluxe transformer-powered B04 chassis is used with 23" picture tubes. Some models are equipped with "Halo-Lite," a feature not unfamiliar in this company's earlier receivers. This chassis used a 5BC3 as the low-voltage rectifier, and to our knowledge in the only 1966 chassis using a tube in the low-voltage power supply. Again this year, a transistor noise gate is used in the cathode circuit of the sync separator tube in all three chassis.

The 19" transistor receiver uses the AO1 chassis and has 23 transistors, and 2 tubes—the 1K3 high-voltage rectifier and 19CAVP4 picture tube. These receivers operate from 117 volts AC and use three silicon rectifiers in the power supply; two of the rectifiers supply positive 38 volts, and the third is used for the positive 135-volt supply. Two circuit breakers—one in series with one side of the AC line and the other in series with the positive 38-volt source—are used for protection against overload.

The 12" transistor, chassis AO2, operates from either AC or DC. It has 20 transistors and 2 tubes (a 1X2B high-voltage rectifier and 12BGP4 picture tube).

WELLS-GARDNER

Four general categories, including eleven different chassis with 12", 19", and 23" picture tubes, complete this private-label manufacturer's new line.

A power transformer is used in deluxe chassis T14 and T22. Two silicon rectifiers, connected as a fullwave rectifier, supply B+. A circuit breaker is incorporated at the secondary winding of the transformer, from center tap to ground.

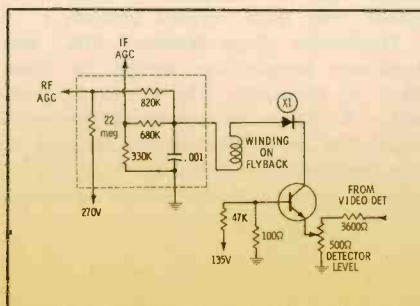

The T14 chassis has a "Quick-on" feature; the filaments receive reduced power when the receiver is turned off. Filament power can be disabled entirely, by turning the VACATION switch to the off position. These receivers are built with a horizontal chassis using two printed-circuit boards. The two-stage video-IF strip uses high-gain frame-grid tubes. A 6JD6 first video-IF amplifier is followed by a 6JC6 for the second stage.

A new AGC circuit using a transistor is found in the 19" and 23" models. This circuit is shown in the accompanying diagram. The detector level (AGC) control determines the amount of video signal applied to the emitter of the NPN transistor. Operation of this circuit is similar to keyed AGC circuits used in tube-type receivers.

The 12" personal portable using the T05 chassis is a transformerless receiver. It develops B+ with a single silicon rectifier. Overload protection is provided by a 4.7-ohm fusible resistor. Noteworthy tubes include the 17CU5 audio output, 17JZ8 vertical multivibrator/output. The horizontal output and damper are contained in the envelope of a 33GY7.

WESTINGHOUSE

New tube types, along with some other features, are found in this manufacturer's new line of receivers. However, the big news in an entirely new receiver called the *Jet Set*. Overall front and rear views and a rear shot of the printed board are shown in the accompanying photos. This 19" portable is transistorized, except for the 1K3 high-voltage rectifier, and has a changed appearance. The 114° 19CM-P4A picture tube is covered by a no-glare safety shield.

Chassis V-2486 is used in both 19" and 23" models—the 19" uses a bonded 19FEP4A picture tube and the 23" uses another bonded tube, a 23HRP4. Some models are equipped with the "Instant-on" feature and have a black-glass safety shield. The new tube types in this chassis are a 10LZ8 used as video amplifier/sync separator and the 21JZ6 horizontal output.

Both 19" and 23" models using the V-2487 chassis are available with bonded CRT's or safety glasses. These sets also



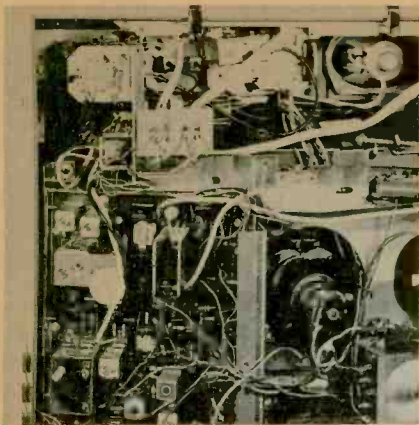

incorporate the Instant-on feature. The vertical output stage has a new tube—type 6HR5; this chassis also uses the 21J26 in the horizontal output stage.

The 12" portable uses the transformerless V-2490 chassis, which incorporates several noteworthy tube types. For example: the audio stage has a 17CU5; the video amplifier/sync separator is a 10LZ8; and the damper and horizontal output are in the same envelope—a

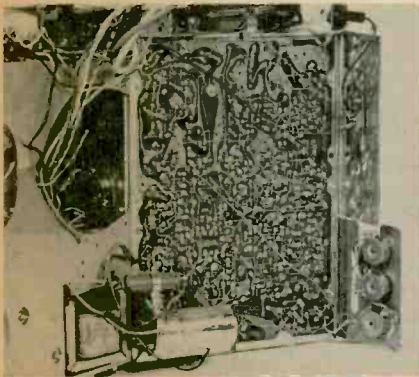

33GY7. Width is adjusted by grounding or ungrounding the lead emerging from the left-hand side of the high-voltage enclosure. (Maximum width is obtained with the lead grounded.)

A carryover from previous years in the V-2486 and V-2490 chassis is the manner in which the AGC is adjusted: a trimmer capacitor controls the keying pulse amplitude to the AGC tube.

Chassis V-2483 employs 27 transistors including three in the VHF- and one in the UHF-tuner circuits. Three are used as video-IF amplifiers; three more as video amplifier/output; the sound section has two IF amplifiers, a driver, and an output; individual transistors are used for AGC and noise canceller functions; the vertical circuit employs three transistors as oscillator, driver, and output; in the horizontal circuits there is an AFC amplifier, an oscillator, a driver, and an output; the remaining three are located in the regulated DC power supply. There are 23 diodes used throughout the receiver.

The regulated power supply develops the three B+ source voltages—240 volts, 60 volts, and 12 volts. There are two fuses in the power supply: a 1¼-amp slo-blo in the AC line; and a 1-amp in the 60-volt DC circuit. This receiver

has a built-in dipole antenna and a VHF-UHF matching network. Provision is also made for connecting an external VHF or UHF antenna.

ZENITH

Six new chassis are being offered for the coming year, but major attention is focused on only one of these—the hand-wired 12" transistor model. The five new tube-type receivers include four 19" portables and one 21" portable.

The 21" version (Chassis 14N26) and two of the 19" (Chassis 14N32 and 14N34) are equipped with a power transformer; also, a factory-installed remote control unit is available with the N26 and N34 chassis. Two transformerless 19" receivers (Chassis 14N29 and 14N31) are physically similar to the ones with a power transformer, but the tubes used are less conventional.

The 12" solid-state receiver, *Royal 1290* (shown here), can be operated on either 117 volts AC or from any suitable 12-volt DC source. The CRT used in the IM30T20 chassis is a 12BRP4 with 92° deflection. Thirty transistors are used in this completely solid-state receiver—the only vacuum tube is the CRT. A number of diodes are found throughout the receiver; this includes one as a high-voltage rectifier to develop 12 kv for the CRT anode.

The 40-mc video-IF strip consists of four individual stages. Output from the video detector is applied to a video driver, then coupled to the video output stage. At the collector of the video output transistor, the signal is divided and applied to the sound IF, AGC, and sync sections, and to the cathode of the CRT.

Output of the single-stage sound-IF section is applied to the ratio detector. Audio signal from the ratio detector is coupled to the base of a common-emitter audio amplifier which is followed by a paraphase amplifier. The outputs are coupled through 10-mfd electrolytics to the base of the push-pull output transistors.

The vertical sweep circuit uses three transistors—one as a vertical blocking oscillator, another as driver, and the last as output. Along with the controls normally used in the vertical circuit, this receiver also has a vertical bias control. (It shouldn't require adjustment unless the output transistor is replaced. If it is necessary, adjust it for .6 volt on the emitter of the vertical output transistor; this setting must also be consistent with good vertical linearity.)

Horizontal phase detector, AFC, and oscillator circuits are similar to those used in tube sets. The oscillator transistor functions as a normal sine-wave oscillator; the oscillator coil is used as the horizontal hold. Oscillator output is applied to a horizontal driver; its output is transformer-coupled to the base of the output stage.

The negative 12-volt output of the power supply is derived from a bridge

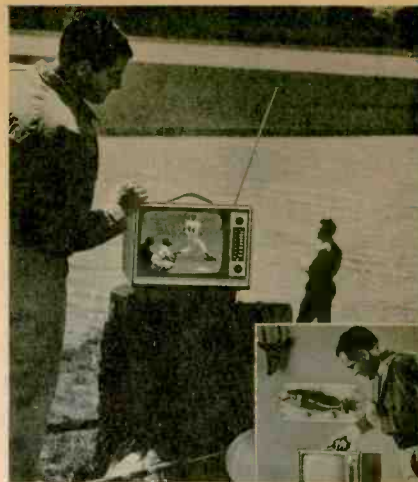

rectifier circuit and kept constant by a three-transistor series regulator network. Protective networks include a circuit breaker in the AC line and a 2-amp fuse in the DC output. DC input from the battery is also fused by another 2-amp fuse.

The optional battery pack (B129) consists of two Z600 rechargeable batteries—each is a 6-volt unit. The batteries are charged automatically when the receiver is connected to the AC line and the on-off switch is in the OFF position.

OTHER U. S. BRANDS

Editor's Note: Complete information from these companies hadn't been received by press time. Here's what we know about them.

Andrea will maintain part of last year's chassis and offer them again this year; they will have a rectangular 25" color receiver, too.

Hoffman will build a line of '66 receivers to be marketed under their own brand name.

Setchell Carlson will continue to market its '65 line of black-and-white receivers for the coming year.

Sonora will feature a line of 19" portables and a few 23" consoles.

FROM JAPAN

Aiwa is offering an 11" tube-type portable which is carried over from their 1965 line.

Delmonico has a rather complete line for this year; it consists of a 4" transistor, 9" transistor, 12" tube-type, 19" tube-type, and a number of 23" combinations.

Hitachi's '66 line will consist of a 16" tube-operated receiver, a 12" transistor, and a 5" transistor.

Panasonic by Matsushita additions include 9" transistor, 12" transistor, 19" transistor, and a 19" tube-type.

Sharp has three personal portables in its new line. The two tube-type receivers have 12" and 16" picture tubes; the transistorized set is a 6" model which uses 27 transistors and 3 tubes; it operates from either an AC or DC power source.

Sony's new line consists of three transistorized receivers. Along with their 5" set is a 9" and a 4".

TUNER REPAIRS

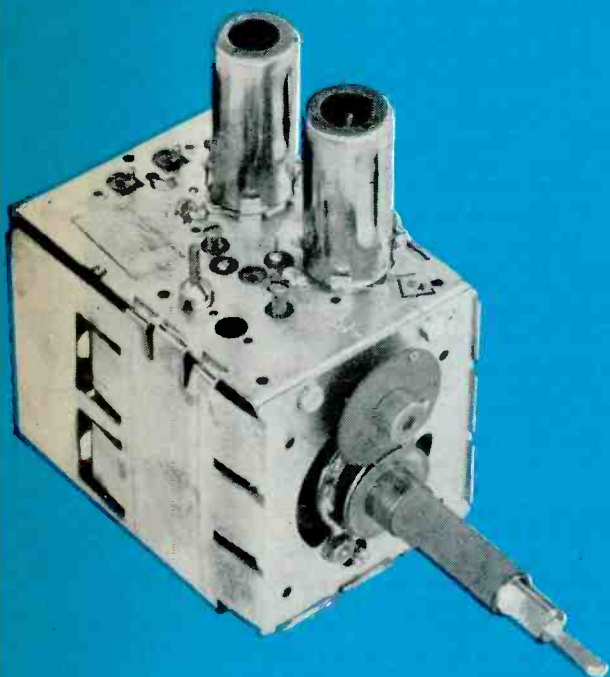

\$9.50

FOR COMPLETE OVERHAUL

**Includes ALL parts (except tubes)
ALL labor on ALL makes**

**24-HOUR SERVICE with
FULL YEAR WARRANTY**

Sarkes Tarzian, Inc., largest manufacturer of TV and FM tuners, maintains two completely-equipped Service Centers to serve YOU. Both centers are staffed by well-trained technicians in this specialized field and are assisted by engineering personnel to assure you of FAST, DEPENDABLE service.

Ⓢ Tarzian-made tuners—identified by this stamping—received one day will be repaired and shipped out the next. A little more time may be required on other makes. Every channel is checked and re-aligned per manufacturer's specifications, not just the channels which might exist in any given area.

You get a 12-month guarantee against defective workmanship and parts failure due to normal usage. Cost to you is only \$9.50 and \$15 for UV combinations, including all labor and parts except tubes. No additional costs. No hidden charges. All tuners repaired on approved open accounts. You pay shipping. Replacements on tuners beyond practical repair are available at low cost.

When inquiring about service on other than Tarzian-made tuners, always send TV make, chassis and Model number. Check with your local distributor for Sarkes Tarzian replacement tuners, parts, or repair service. Or, use the address nearest you for fast factory repair service.



SARKES TARZIAN, INC.
TUNER SERVICE DIVISION

See your distributor, or use the address nearest you

537 South Walnut St.,
Bloomington, Indiana
Tel: 332-6055

10654 Magnolia Blvd.,
North Hollywood, Calif.
Tel: 769-2720

Manufacturers of Tuners . . . Semiconductors . . . Air Trimmers . . . FM Radios . . . AM-FM Radios . . . Audio Tape . . . Broadcast Equipment



A HOWARD W. SAMS PUBLICATION

PF Reporter™

PHOTOFACT

the magazine of electronic servicing

VOLUME 15, No. 10

OCTOBER, 1965

CONTENTS

Highlights of 1966 TV Lines	Norman D. Tanner	1
<small>Basic specifications on new black-and-white chassis—tube type or transistorized.</small>		
Letters to the Editor		13
The Electronic Scanner		15
Making Money With Tinyvision Receivers	Edward F. Rice	28
<small>Quicker Servicing—Circuit analysis and troubleshooting procedures for small-screen sets.</small>		
Square-Wave Tests for Three-Terminal Networks	Robert G. Middleton	30
<small>Advanced Service Techniques—Modules needn't be a mystery; here's a way to analyze what's inside.</small>		
Understanding Pads and Attenuators	Harry J. Abramson	32
<small>A valuable lesson on selecting the proper type.</small>		
Keep AM-FM Portables Working	Thomas R. Haskett	34
<small>There's money in servicing these two-band radios—this article tells you how to get your share.</small>		
The Sly Old Vox (Recorder)	Robert M. Glover	36
<small>He isn't deceptive when you know how to uncover his secrets.</small>		
Latest Circuits for FM Stereo	E. F. Rice and William Krueger	38
<small>A detailed explanation of the stages that handle the multiplex signal.</small>		
Sales Tips for New and Used TV	Wayne Lemons	49
<small>Dollar and Sense Servicing—The customer's first impression of you and of the set is very important.</small>		
Watch A Schematic in the Making		52
<small>Picture Story—Follow a PHOTOFACT diagram from beginning to end.</small>		
Notes on Test Equipment	Arnold E. Cly	54
<small>Lab reports on the EICO Model 965 Farad-Ohm bridge, Mercury Model 202E Tube Tester, and RCA Model WO-91B Oscilloscope.</small>		
Symfact: Power Supply (Transistor Regulated)		67
<small>See what happens to voltages and waveforms when troubles occur.</small>		
Unlocking Secrets of TV Alignment	Carl Babcoke	72
<small>Some factors to consider when adjusting the coils in the RF and IF stages.</small>		
Meet the . . . istor Family	Rufus P. Turner	76
<small>How many of these 18 semiconductors are familiar to you?</small>		
Book Review		90
PFR Bench Report		96
The Troubleshooter		103
Product Report		107
Free Catalog and Literature Service		112
Monthly Index	on free literature card	

publisher

Howard W. Sams

editor

Forest H. Belt

managing editor

James M. Moore

asst't to the editor

Norman D. Tanner

associate editors

Arnold E. Cly

David I. King

consulting editors

William E. Burke

Joe A. Groves

C. P. Cliphant

research librarian

Bonny Howland

production manager

Esther M. Rainey

circulation manager

Pat Tidd

Katharine Krise, Ass't.

Cora La Von Willard, Ass't.

art directors

Louis J. Bos, Jr.

Robert W. Reed

advertising & editorial assistants

Hazel Boyer

Rebecca Clingerman

photography

Paul Cornelius, Jr.

advertising sales offices

Hugh Wallace, advertising sales manager

midwestern

Paul N. Houston

PF REPORTER, 4300 West 62nd Street,

Indianapolis, Ind., AXminster 1 3100

eastern

Gregory C. Masefeld

Howard W. Sams & Co., Inc. 3 West 57th Street,

New York, N. Y., MUrray Hill 8-6350

southwestern

C. H. (Jake) Stackwell

C. H. Stackwell Co., 4916 West 64th St,

Mission, Kansas, RAndolph 2-4417

western

G R. Holtz

The Maurice A. Kimball Co., Inc.

Los Angeles area: 2008 West Carson Street,

Suites 203-204, Torrance, Calif. 90501,

320-2204; and 580 Market Street,

Room 400, San Francisco 4, Calif. EXbrock 2-3365

Address all correspondence to

PF REPORTER, 4300 W. 62nd Street

Indianapolis, Indiana 46206



Copyright© 1965 by Howard W. Sams & Co., Inc. PF REPORTER is a trademark of Howard W. Sams & Co., Inc. No part of PF REPORTER may be reproduced without written permission. No patent liability is assumed with respect to use of information herein. Acceptance of advertising does not in any manner signify the products, policies and services so advertised have been approved, endorsed or recommended by this magazine.

Subscription Prices: 1 year—\$5.00, 2 years—\$8.00, 3 years—\$10.00, in the U. S. A., its possessions and Canada. All other foreign countries: 1 year—\$6.00, 2 years—\$10.00, 3 years—\$13.00. Single copy 50¢; back copies 65¢.

Indexed in Letradex. Printed by the Waldemar Press, Div. of Howard W. Sams & Co., Inc.

ABOUT THE COVER

Our cover this month portrays only five of the many receivers being offered for the coming year. For an inside tour of these and the entire 1966 line of black-and-white TV sets, turn to our 8-page book section beginning on page 1.



Have you tried **KWIKETTE**[★] connectors?

Not just another wire spring connector!
The 3-in-1 KWIKETTE is brand new and different...
Copperweld wire inner core, a layer of flux, and
an outer jacket of solder... all you need is heat!
Makes one-handed soldering possible!

Once again, Sprague helps the TV-radio service industry by solving two increasingly serious problems... parts replacement in those "inaccessible" chassis nooks, such as crowded tube sockets, as well as soldering onto the delicate circuitry of printed wiring boards.

Mechanically sturdy and electrically reliable, the revolutionary KWIKETTE provides fast, expertly-soldered connections as easy as A-B-C!



Ten times
actual size

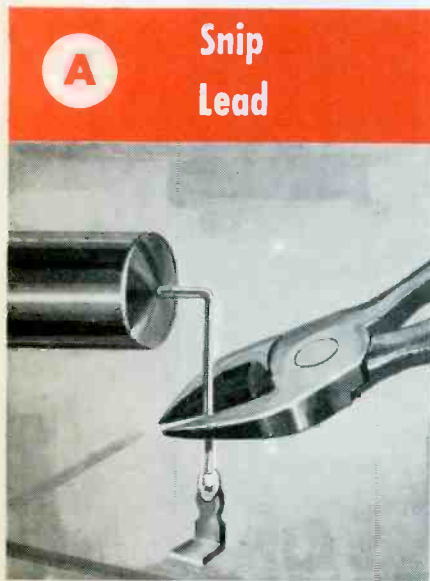

**NOBODY ELSE HAS KWIKETTE CONNECTORS...
YOU GET 'EM ONLY FROM SPRAGUE PRODUCTS!**

KWIKETTES are now being packed with Sprague Atom[®] Capacitors *at no extra cost to you!* Whenever you need tubular electrolytics, insist on pre-packaged Sprague Atoms from your parts distributor and you'll automatically get your KWIKETTE component connectors... the biggest boon to the service technician since the soldering gun!

★TRADEMARK

WORLD'S LARGEST MANUFACTURER OF CAPACITORS

Circle 3 on literature card



The cover gives you the whole story.



The United Delco box tells you for sure you're getting a replacement radio part of the same high quality as the original.

And it tells you who authored it, too. Namely, Delco Radio.

So, if you'd like to hang on to your reputation and customer goodwill, just ask yourself this next time you order transistors:

Do they come individually packed in a distinctive box? (Bushel buying is for potatoes, not transistors.)

Do they carry an easy-to-read, can't-make-a-gooof number?

Are the numbers—and the transistors—grouped in such a way that you can service more car radios with fewer parts?

Is there a good chance that the parts are original equipment on nearly half of the car radios on the road?

Delco Radio transistors are all of these, and you can get them from your United Delco supplier. He handles the most widely advertised, merchandised and recognized

name in the parts business—United Delco.

That's how your customers know a good part when they see it.



DELCO RADIO, Div. of General Motors, Kokomo, Ind.

Circle 4 on literature card



Letters to the Editor

Dear Editor:

I would like to applaud the series of articles on square-wave testing. On the strength of the material presented, I have upgraded myself to a high-quality square-wave generator; used with a Hickok 770 scope, it shows most of the effects described in the "Advanced Service Techniques" articles. Unfortunately, a 30-mc scope is a bit beyond my budget (and needs) at the moment, but the day is coming when it will be an essential part of the equipment in any good shop.

If you'll pardon my reminiscing, it sounds very much like the days of 1935, when we were debating whether it would be wise to take the plunge and buy a scope (I did). Or about 1939, when a signal tracer became the last word in test equipment; I went for that one, too, and was never sorry.

In each case, I found that I had taken a great step forward. I feel the methods described in your new series (methods which have been used for ten years in certain fields) will be the next major step forward in rapid servicing methods.

FRANCIS C. WOLVEN

Saugerties, N.Y.

In initiating this series, Francis, we indulged in a bit of reminiscing, too. There was a period, up to as recently as three or four years ago, when it was difficult to convince many service technicians that they needed a scope of any kind. Finally, after years of teaching and dozens of articles, PF REPORTER got the message across, and our mail now indicates that competent service shops include a good scope in their lineup of test equipment. Our SYMFACT feature, introduced in September 1962, helped clinch the need for a scope; SYMFACT has proved once and for all that some symptoms simply do not cause any noticeable change in DC voltages. In these days of tough competition, it is business suicide to try to repair television sets without a scope; you can't afford the time for cut-and-try methods.

"Advanced Service Techniques" is a bit ahead of its time, we admit, but this is our way of helping serious technicians meet the changing technology that is so rapidly catching up with them.—Ed.

Dear Editor:

After reading Steve P. Dow's article "Keep It Clean" in the August 1965 issue, I thought I'd better send you some good safety advice. Mr. Dow mentions carbon tetrachloride ten times in clean-

ing phono and tape-recorder parts, and only once did he suggest that the technician "avoid breathing" this dangerous killer. You should pass along to your readers the contents of the National Safety Council booklet "Strange Killer."

MELVIN T. HYATT

Prairie Village, Kans.

You are so right, Melvin. The booklet points out that: "Carbon tet is one of the most toxic household substances known . . . It can be absorbed directly through the skin . . . Its most vicious hazard is its vapor, which a person can innocently inhale, a vapor more poisonous than chloroform . . . Only three thimblefuls of carbon tet will saturate the air to the danger point in a room 10' x 10' x 10' . . . Safety and medical authorities say no one should ever use carbon tet in the home (or in the shop—Ed.) . . . Carbon tet in a glass bottle, if the bottle broke, could turn a room into a lethal gas chamber . . . Opening a couple of windows isn't "adequate" ventilation . . . The only safe place to use carbon tet is outdoors, with a stiff breeze blowing away the vapor. . . ." If you want the booklet, it is Stock No. 580.01 at the National Safety Council, Chicago 60611.

Seems like enough said. There are other less toxic substitutes on the market: perchlorethylene, trichlorethylene, methyl chloroform, and trichlorethane; all have cleaning powers similar to carbon tet. After all the years we've avoided carbon tetrachloride—cleaning hundreds of phono and tape-recorder mechanisms with safe, simple isopropyl (rubbing) alcohol—we'd strongly recommend that all our readers do the same.—Ed.

Dear Editor:

I took two years of your magazine, ending in 1960, and since then tried another well-known American publication. Looking back over my old copies of PF REPORTER, I'm completely convinced on one thing: in the TV service field, your magazine is easily the most informative and helpful to be found anywhere in the world. I would like to restart my subscription immediately.

GEORGE PETERSEN

Ayr, Australia

Music to our ears, George. The science of electronics troubleshooting apparent-



Little Devil® Composition Resistors

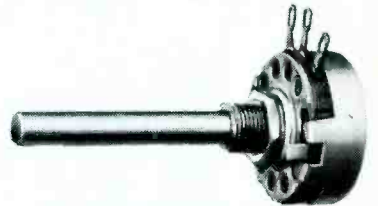

Type AB 2-Watt Molded Pots

five ways to stop customer "static"



Gold-Bonded Germanium Diodes



Brown Devil® Wire-Wound Resistors



Series 99 Wire-Wound Resistors

Customer "static" is hard on the ears . . . hard on profit. But you're always safe with Ohmite quality replacements in your repair jobs. Order Little Devils in handy cabinet assortments or on Tally-Tape; all popular sizes and values. Select AB Pots from 50 ohms to 5 megohms in several shaft lengths. Choose from ninety 1N types of diodes. Get Brown Devils from 3 to 20 watts in 0.5-ohm to 100K-ohm values. Order Series 99 resistors in 1½, 2¼, 3¼, 5, 11 watt sizes from 1 to 51,000 ohms. Ask your distributor for the latest edition of Ohmite's Stock Catalog 30.

Be right with



Circle 5 on literature card

October, 1965/PF REPORTER 13

This tool solders faster, better, at lower cost

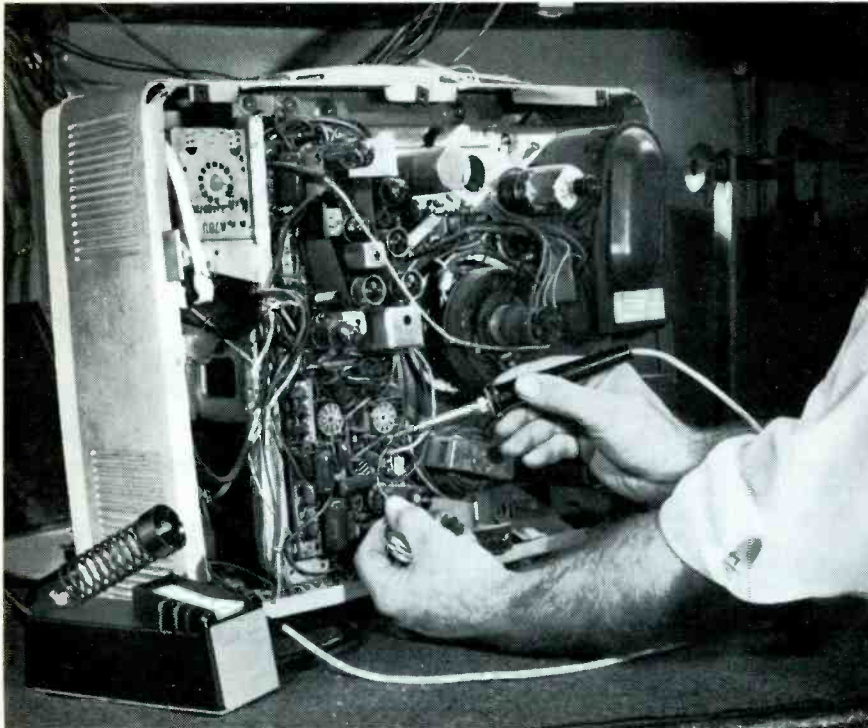

Weller®

temperature-controlled low voltage soldering pencil does the work of several irons

Extremely versatile. Use it for all your bench soldering, including heavy-duty chassis work.

Improves quality of soldered connections. Tip temperature remains constant. No peaks or lows to cause component damage or cold soldered joints.

Lightweight, highly efficient. Weighs only 2½ ounces, cord included. Yet it does the work of irons that weigh much more and have much higher wattage. Reduces fatigue and downtime.

Faster soldering. You make more soldered connections a minute. Tool has tremendous capacity, rapid recovery. Handle remains cool.

Does the work of several irons. Temperature control is in the tip. Interchangeable tips are available in 500°F, 600°F, 700°F and 800°F controlled temperatures, and in 1/32", 1/16", 3/32", 1/8" and 3/16" screwdriver types. Merely interchange tips to change the controlled temperature of the iron.

Low cost operation. 24-volt operation provides more efficient heat transfer, and long life inherent in low voltage elements. Tips are alloy plated, low in cost, last long, won't freeze.

Saves working space. Compact transformer has soldering pencil holder and tip cleaning sponge attached. Transformer is rated at 60 watts, 120 volts or 220 volts, 50/60 cycles.

Special trade-in offer. See your Electronic Parts Distributor now about the soldering tool trade-in deal on the Weller Temperature-Controlled Low Voltage Soldering Pencil-Model W-TCP.

WELLER ELECTRIC CORP., EASTON, PA.

In Canada: Kingston, Ontario. In England: Horsham, Sussex
WORLD LEADER IN SOLDERING TECHNOLOGY
Circle 6 on literature card

ly knows no national boundaries, for we've been getting letters like this from several other countries.—Ed.

Dear Editor:

I have been reading your wonderful publication for many years, and let me say here and now that no other publication on this green earth could hope to equal it. You have been pounding electronics into our heads these many years in such a simple, down-to-earth way that even an idiot can understand it . . . I know one who can. Your staff really knows their stuff and they know how to write for the technician.

BUT, for some, even this great writing and simplification doesn't hit home. When "servicemen" have to resort to changing parts without knowing whether they are faulty or not—they simply don't know what they are doing. If a set owner knew his set was in that sort of hands, he would run seven miles if need be to rescue it; and who could blame him!

I'm no expert, but I believe in using my head in servicing. I'm enclosing a pair of problems I'll bet half your readers can't find the solutions to. Want to let them try?

NAME WITHHELD

City, Too.

This is our month for bouquets. My friend you're on! Here, readers, are the problems:

(1) There are 46 components in an RC amplifier. If there are 12 more resistors than there are capacitors, what is the number of capacitors?

(2) A technician can wire a stereo amplifier in 3 hours. His helper can wire it in 4 hours. How long will it take them to wire it, working together?

Readers, is he right? You can solve them, can't you? The solutions are on page 102—Ed. ▲



"Remind me to notify" "PF REPORTER" of my address change."



The Electronic Scanner

news of the servicing industry

Study Shows Service Profits Up

Net income from appliance-radio-TV service operations jumped 54% in 1964 as compared with the previous year, according to a survey conducted by the **National Appliance & Radio-TV Dealers Association** among its members. Total net profit before taxes in 1964 was 5.89% of sales, while in 1963 this same profit figure was 3.81%. The improved profit apparently

1964 OPERATING COST AND PROFIT RATIOS

Line No.	Item	Ratios(%)
1	Gross Sales	100.00
2	Returns, Adjustments, Allowances	0.00
3	Net Sales (Line 1 minus Line 2) (Includes: Parts, Labor, and Merchandise)	100.00
4	Cost of Parts and Labor Sold	57.67
5	Gross Margin (Line 3 minus Line 4)	42.33
6	Total Operating Costs (1 thru 15, below)	39.42
	(1) Proprietors/Partners/Executive Salaries	11.68
	(2) Other Payroll (Office Salaries, Wages, Commissions, Bonuses)	5.10
	(3) All Payroll Taxes	2.10
	(4) Other Taxes (except income) and Licenses	0.43
	(5) Occupancy Expense (Rent, Utilities & Heat, Maintenance)	3.31
	(6) Advertising, Promotion, Publicity	1.67
	(7) Truck and Auto Expense (excluding depreciation)	4.63
	(8) All Depreciation (including Vehicle Depreciation)	2.96
	(9) Office Supplies, Stores, Postage	1.27
	(10) Telephone and Telegraph	1.20
	(11) Accounting and Legal	0.55
	(12) Travel and Entertainment	0.26
	(13) Dues, Donations, Collection Expense, Miscellaneous	0.98
	(14) Insurance (Employees and general)	1.80
	(15) Other Shop and Service Expense	1.48
7	Net Operating Profit (Line 5 minus Line 6)	2.91
8	Other Income (Bad Debt Recoveries, Interest Income, Other)	4.78
9	Total Income (Line 7 plus Line 8)	7.69
10	Other Expense (Bad Debt Loss or Provision, Interest Paid, Other)	1.80
11	Total Net Profit Before Income Taxes (Line 9 minus Line 10)	5.89
12	Federal and State Income Taxes	1.26
13	Net Income after Income Taxes (Line 11 minus Line 12)	4.63

stems from the fact that gross margins are up, because operating costs are also up. In 1964, the gross margin was 42.33% compared to 37.35% in 1963. However, operating costs took a big bite out of this increase; the 1963 figure was 36.07%, but in 1964 it rose to 39.42%. A rather interesting picture of the service business is reflected by these figures: The cost of parts and labor, measured as a per cent of total volume, is down; inasmuch as actual dollar costs of both parts and labor have been going up rather than down, the apparent conclusion is that service shops have been pricing their work more realistically than in the past. The chart shows tabulations of cost and profit ratios among NARDA members surveyed.

International Expansion

A major international expansion move by **BSR Limited** includes the construction of a greatly expanded facility in the United States. The new home is now under construction on an 18-acre site in Blauvelt, Rockland County, New York. Execu-

COMPLETE TUNER OVERHAUL

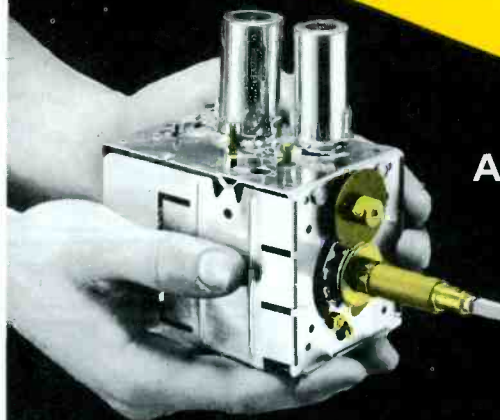

ALL MAKES —
ONE PRICE

995

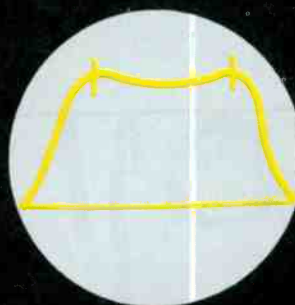

3.58

ALL LABOR
AND PARTS
(EXCEPT TUBES
& TRANSISTORS)*

COLOR TUNERS

GUARANTEED
ALIGNMENT — NO
ADDITIONAL CHARGE



VHF



UHF

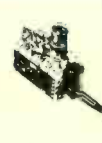

COLOP



U-V



TRANSISTOR

Simply send us the defective tuner complete; include tubes, shield cover and any damaged parts with model number and complaint. Your tuner will be expertly overhauled and returned promptly, performance restored, aligned to original standards and warranted for 90 days.

UV combination tuner must be single chassis type; dismantle tandem UHF and VHF tuners and send in the defective unit only.

Exact Replacements are available for tuners unfit for overhaul. As low as \$12.95 exchange. (Replacements are new or rebuilt.)

And remember—for over a decade Castle has been the leader in this specialized field . . . your assurance of the best in TV tuner overhauling.

Pioneers of TV



Tuner Overhauling

CASTLE TV TUNER SERVICE, INC.

MAIN PLANT: 5701 N. Western Ave., Chicago 45, Illinois

EAST: 41-90 Vernon Blvd., Long Island City 1, N.Y.

CANADA: 136 Main Street, Toronto 13, Ontario

*Major Parts are additional in Canada

Circle 7 on literature card

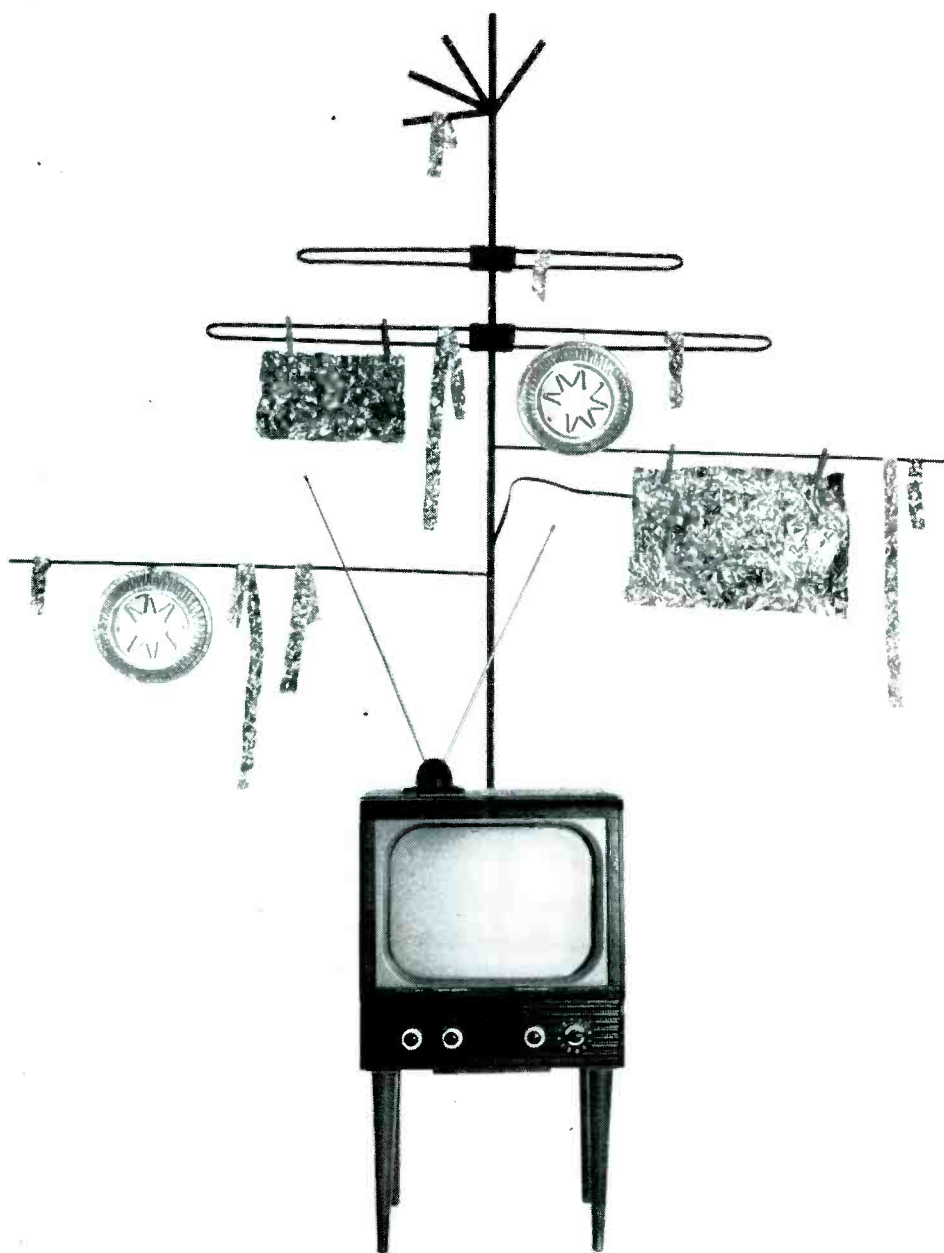

aerial view: do-it-yourself style

He's going to need a real antenna. So he'll be looking in the Yellow Pages. The chances are 9 in 10 he'll then take action. Will he see your ad?

When his wife sees his creation, this man will be joining the 21 million people who turn to the radio, television, and high fidelity headings of the Yellow Pages every year. (That's 33% of the entire market!)

When he does look in the Yellow Pages, chances are 9 in 10 he'll either call, write, or visit. (Every 100 references to the radio, television, and

high fidelity headings of the Yellow Pages bring 93 calls, letters, or visits!)

That's action! With Yellow Pages ads you can expect that kind of action . . . a recent extensive national usage study — consisting of over 19,000 interviews—proved it.

Call your Yellow Pages man. He'll show you what the study learned

about your business. And he'll be glad to help you plan your own Yellow Pages program. You'll find him in the Yellow Pages under "Advertising—Directory & Guide."

Advertise for action...



Circle 8 on literature card

Congress DIDN'T GO FAR ENOUGH!

PUBLIC LAW 87-529; 76 STAT. 150

[H. R. 8031]

An Act to amend the Communications Act of 1934 in order to give the Federal Communications Commission certain regulatory authority over television receiving apparatus.

Be it enacted by the Senate and House of Representatives of the United States of America in Congress assembled, That:

Section 303 of the Communications Act of 1934 (47 U.S.C. 303)³⁴ is amended by inserting at the end thereof the following:

“(8) Having authority to require that apparatus designed to receive television pictures broadcast simultaneously with sound be capable of adequately receiving all frequencies allocated by the Commission to television broadcasting when such apparatus is shipped in interstate commerce, or is imported from any foreign country into the United States, for sale or resale to the public.”

Sec. 2. Part I of title III of the Communications Act of 1934 is amended by inserting at the end thereof a new section as follows:

THEY SHOULD HAVE ALSO REQUIRED...

“—that all 82-channel television receivers* must use an 82-channel television antenna.”

Of course, you can't take the law into your own hands—but you *can* take advantage of today's ready-made opportunities to sell an 82-channel antenna with each 82-channel TV set.

Our Antenna Research Laboratories in Champaign, Illinois knew what they were doing when they teamed the acclaimed Log Periodic concept of the University of Illinois Antenna Research Laboratories with our new antenna design advance—the capacitor-coupled electronic dipole. Proof is the fact that the JFD LPV-VU is America's No. 1 82-channel TV/FM antenna!

Who says you can't have everything

you want in a TV antenna—VHF?... UHF?... FM Stereo?—with a *single* down-lead to boot!

MOST EFFICIENT PERFORMANCE EVER ON VHF, UHF, FM/STEREO FROM ONE ANTENNA USING ONE DOWN-LEAD!

- *Cap-electronic* dipole design makes more elements resonate on channels 7 to 13 with a corresponding increase in gain.
- *Higher mode* operation in UHF band achieves higher gain on channels 14 to 83—and FM stereo.
- *Narrower beamwidths* . . . higher front-to-back ratios step up ghost rejection . . . intensify color.
- *Patented frequency independent* design maintains peak perform-

ance characteristics regardless of channel or band tuned.

- Includes 3-way splitter so single down-lead can be tied into individual VHF, UHF and FM system inputs.

REMEMBER — AN 82-CHANNEL TV SET IS NOT AN 82-CHANNEL TV RECEIVER UNLESS IT HAS AN 82-CHANNEL TV ANTENNA!

*Lest we forget—every *color* set is also an *82-channel* set requiring a color-perfect antenna. In fact, many color TV shows are broadcast on UHF channels.

JFD

SEE YOUR DISTRIBUTOR OR WRITE FOR BROCHURE 806

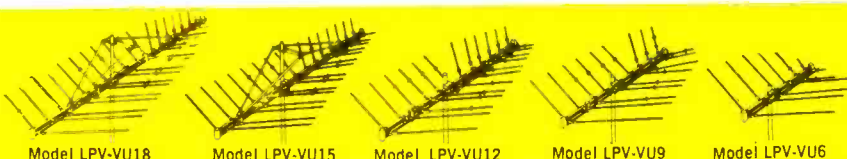

JFD LPV-VU LOG PERIODICS for channels 2 to 83 and FM/Stereo.

Licensed Under One or More of U.S. Patents 2,958,081; 2,985,879; 3,011,168; 3,108,280; 3,150,376 and Additional Patents Pending in U.S.A. and Canada. Produced by JFD Electronics Corporation under exclusive license from the University of Illinois Foundation.

Circle 9 on literature card

JFD ELECTRONICS CORPORATION

15th Ave. at 62nd Street, Brooklyn, N.Y. 11219
 JFD Electronics-Southern Inc.
 Oxford, North Carolina
 JFD International
 64-14 Woodside Ave., Woodside 77, N.Y.
 JFD Canada, Ltd.,
 51 McCormack Street, Toronto, Ontario, Canada

TRON SUB-MINIATURE PIGTAIL FUSES

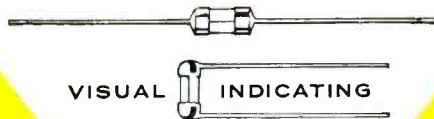

VISUAL INDICATING

BODY SIZE ONLY
.145 x .300
INCHES

For use on miniaturized devices, or on gigantic space tight multi-circuit electronic devices.

Glass tube construction permits visual inspection of element.

Smallest fuses available with wide ampere range. Twenty-three ampere sizes from 1/100 thru 15 amps.

Hermetically sealed for potting without danger of sealing material affecting operation. Extremely high resistance to shock or vibration. Operate without exterior venting.

**Insist On
BUSS
QUALITY
Fuses**

Write for
BUSS
Bulletin SFB

BUSSMANN MFG. DIVISION, McGraw-Edison Co., St. Louis, Mo. 63107

Brighter, Smaller Picture Tubes

Improved phosphors, including a Europium red "rare earth" phosphor, are now being used in all **Radio Corporation of America** color-television picture tubes to provide brighter and more vivid pictures. The company has completed the conversion of facilities at plants in Lancaster, Pa., and Marion, Ind., for manufacturing all 25", 21", and 19" color tubes with the improved phosphors.

The new tubes, known as "Hi-Lite" tubes, utilize improved green and blue sulfide phosphors and a red "rare-earth" Europium phosphor. These phosphors are applied by an advanced slurry screening process, developed by the company.

Sample commercial quantities of a 90°, rectangular 19" color-television picture tube are now being made available to the nation's set manufacturers. This tube is currently in pilot production at the company's plant in Lancaster, Pa. The short length of the tube will permit reduced cabinet sizes as well as new innovations in styling. The tube has the following approximate dimensions: minimum screen area is 180 square inches, minimum screen size is 12.2" x 15.6", and tube length is 18"—about 7.2" shorter than the 70° round 21", color tube.

The 19" tube utilizes the three-gun, shadow-mask principle and is designed to use the same basic components (deflecting yoke, purifying device, radial-converging device, and lateral converging device) that were developed for RCA's 90° rectangular 25", color tube.

Establishes Consumer and Distributor Products Division

A Consumer and Distributor Products Division has been established by **International Resistance Company** to market other manufacturers, products as well as its own through consumer and electronic distributor outlets. The new division will concentrate on marketing high-quality products of other manufacturers under the manufacturer's label, a joint label, the IRC label, or a private label.

BUSS: The Complete Line of Fuses and



tive and general sales offices will occupy a 10,000-square-foot wing of the new building. The remainder of the 125,000-square-foot structure will be used for warehousing and a large parts depot, and to house an expanded technical, research, and development laboratory geared to the special requirements of American manufacturers. Based in Great Britain, BSR Limited is a major producer of automatic record changers, tape decks, cartridges, and tape heads.

New Color CRT Manufacturer

Pilot production of color television picture tubes has begun at **General Electric**. Although technical details of the tube have not been disclosed, it is described as "an improved version of the shadow-mask type, which is standard in the industry." It is the "three-gun" type and incorporates the brighter rare-earth phosphors now being introduced in the industry. Since tube production will be limited in 1965, the company has no plans to sell its tubes externally and will continue purchasing tubes from outside sources for the next few years to serve its color-TV business.

For 1½ x 1½ inch fuses. Series HPC

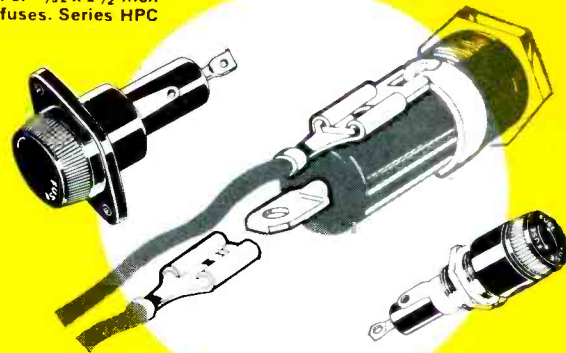

For ¼ x 1¼ inch fuses Series HJ, HK and HLD

SAVE ASSEMBLY TIME with QUICK CONNECT TERMINALS ON BUSS FUSEHOLDERS

Eliminates soldering. Permits use of pre-assembled harness. Reduces assembly time.

**Insist On
BUSS
QUALITY
Fuseholders**

Write for
BUSS
Bulletin SFB

BUSSMANN MFG. DIVISION, McGraw-Edison Co., St. Louis, Mo. 63107
Circle 10 on literature card

BUSS SHIELDED FUSEHOLDERS



**PREVENT
RADIO
FREQUENCY
INTERFERENCE**

For use where fuse and fuseholder could pick up radio frequency radiation which interferes with circuit containing fuseholder —or other nearby circuits.

Fuseholder accomplishes both shielding and grounding.

Available to take two sizes of fuses— $\frac{1}{4} \times 1\frac{1}{4}$ " and $\frac{1}{4} \times 1$ " fuses.

Meet all requirements of both MIL-I-6181D and MIL-F-19207A.

**Insist On
BUSS
QUALITY
Fuseholders**

*For complete information
write for
BUSS Bulletin SFH-12*

BUSSMANN MFG. DIVISION, McGraw-Edison Co., St. Louis, Mo. 63107

Speaker Phasing Standards

A definite method to insure proper phasing of loudspeakers is set forth in EIA Standard RS-233-A. In summary, speakers conforming to this standard will have a + mark, a green dot, or both on the right-hand terminal when the speaker is viewed from the back and the terminals are on the bottom. Should the terminals be spaced so it is not clear which is the left or the right terminal, the coded terminal shall be the positive terminal. The application of a positive DC voltage to the + terminal will cause the speaker diaphragm to move forward, away from the speaker housing. For a 3.2-ohm voice coil, 1.5 volts DC is recommended. Higher-impedance speakers should have a voltage applied which will provide approximately the same amount of voice-coil movement. If the speaker cone is so stiff that sufficient motion is not possible with a reasonable voltage, a DC millivoltmeter or microammeter with the meter positive terminal connected to the speaker + terminal will indicate an upscale movement at the instant the speaker diaphragm is moved away from its housing.

If the speaker terminals are on the enclosure, the terminal that causes the cone of the lowest-frequency speaker to move forward will be coded to correspond with that on the speaker. Speaker systems with cables, plugs, or other connections to the speaker will be suitably marked by the manufacturer.

Consolidated Operation

The eastern manufacturing, warehousing, and office facilities of Alpha Wire have been consolidated into a new 140,000-square-foot plant complex at 711 Lidgerwood Avenue in Elizabeth, New Jersey. The company has set up new wire-extruding lines, improved cabling equipment, installed modern quality-control apparatus, and greatly increased its coaxial-cable manufacturing capacity. ▲

.. Fuseholders of Unquestioned High Quality

Caribbean TV Subsidiary

Production of the first television sets to be manufactured in an independent Caribbean nation began recently in Trinidad and Tobago. The TV sets are being manufactured by **General Telephone & Electronics Export Corporation**, a GT&E International subsidiary, and will be sold under the brand name of Sylvania Electric Products, Inc. Both Sylvania and GT&E International are subsidiaries of General Telephone & Electronics Corporation.

The manufacturing facility is located about 20 miles from the center of Port of Spain, the capital of Trinidad and Tobago. The plant initially will produce table models with 19" and 23" picture tubes and consoles with a 23" tube.

Test Equipment Company Bought

All the outstanding stock of Jackson Electrical Instrument Company of Dayton, Ohio, has been acquired by **Mercury Electronics Corporation**, Mineola, N. Y.

Jackson has designed and built electronic test equipment for the radio and television servicemen for over 30 years. The combined new activity will give both companies broader base and scope. The combined research capabilities of the two companies will be utilized in the development of components and peripheral items to give the electronic technician a broad range of products.

U. S. TV Stations

A recent release by TELEVISION DIGEST reports that 678 TV stations (541 VHF, 137 UHF) are now operating in the U. S. Commercial stations now total 575 (482 VHF, 93 UHF) while noncommercial (educational) stations make up the other 103 stations, of which 59 are VHF and 44 are UHF. There are 30 VHF and 73 UHF commercial stations, plus 7 VHF and 23 UHF noncommercial stations which have been granted construction permits but are not yet on the air.

BUSS QUALITY

small
dimension
fuses



For protection of all types of electronic and electric devices

The complete line of BUSS and "TRON Family" fuses includes quick-acting, slow-blowing, signal or visual indicating fuses in sizes from 1/500 amperes up.

All standard items are easily obtained through your BUSS distributor, but if you don't find what you want get in touch with us.

**Insist On
BUSS
QUALITY
Fuses**

*Write for
BUSS
Bulletin SFB*

BUSSMANN MFG. DIVISION, McGraw-Edison Co., St. Louis, Mo. 63107

Circle 10 on literature card

October, 1965/PF REPORTER 19

MATV

Market Arrives... Tremendous Volume

The demand for Master Antenna TV installations has entered a totally new phase . . . one which goes far beyond the already big market for commercial applications and reaches to millions of newly created multiple set homes.

Color TV . . . as well as increasing FM multiplex popularity is the big reason why. Every homeowner who buys a color set instantly becomes a prospect for a residential MATV installation to operate two, three, or more receivers with maximum quality reception from one antenna.

The Home MATV Market is Here Now!

This potential...

plus the vast Commercial MATV Market...

**enables Channel Master to
reduce prices drastically.**

New Channel Master mass production techniques on the same precision-quality, commercial-grade MATV components designed for big building applications have resulted in equipment price reductions that average 25% *and more* per installation. For MATV installing companies this means more volume and profit from highly competitive commercial jobs. For radio-TV service dealers it means an opportunity to get started in a totally new, high-income business meeting the booming demand for residential master antenna system.

Contact your nearest Channel Master Distributor.

CHANNEL MASTER Ellenville, N.Y.

Compare Color Generators

look at the rest... and you'll buy the best, new B&K model 1245

The all solid-state B&K Model 1245 Color Generator duplicates the waveforms transmitted by a color TV station.

Adherence to these waveforms makes it easy to converge the color tube, check sync and make other raster adjustments... and the color generator with station quality signal will be able to sync next year's sets. Generators with compromise waveforms do not give you this obsolescence protection.

Here are oscilloscope photographs from the outputs of two typical competitive color generators, one transistorized and one tube type, and the B&K Model 1245. The detailed analysis with each photograph shows a few of the reasons why you'll save time and effort with B&K.

COLOR

CROSSHATCH

STANDARD STATION SIGNAL

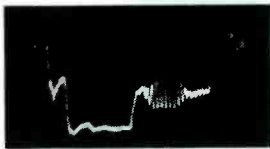

One horizontal sync pulse with its color burst.



Two lines showing horizontal sync pulse with black and white tv signal.

TRANSISTORIZED B&K MODEL 1245

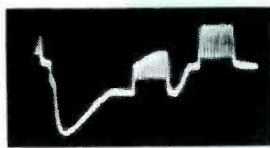

Good duplication of station signal including back porch. If the set won't sync, the set is defective.

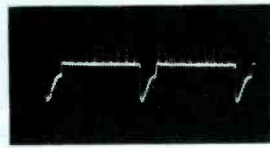

Well defined back porch on horizontal sync pulse permits accurately setting color killer and almost eliminates need to adjust brightness and contrast.

TRANSISTORIZED GENERATOR A

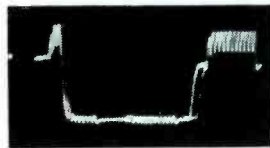

No back porch causes unstable color sync. Burst amplitude compression may permit sync on wrong color bar.

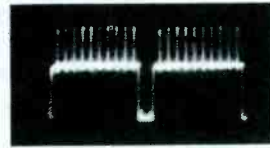

Square wave horizontal sync pulse with no back porch and poor dc coupling forces adjustments of brightness, contrast & fine tuning to obtain usable pattern.

GENERATOR B

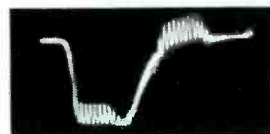

No back porch; color information on top of sync-pulse makes sync difficult on some sets.

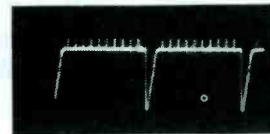

Complete absence of any back porch necessitates readjustment of brightness, contrast and line tuning to obtain a usable pattern.

See your B&K Distributor for a demonstration or write for Catalog AP22.

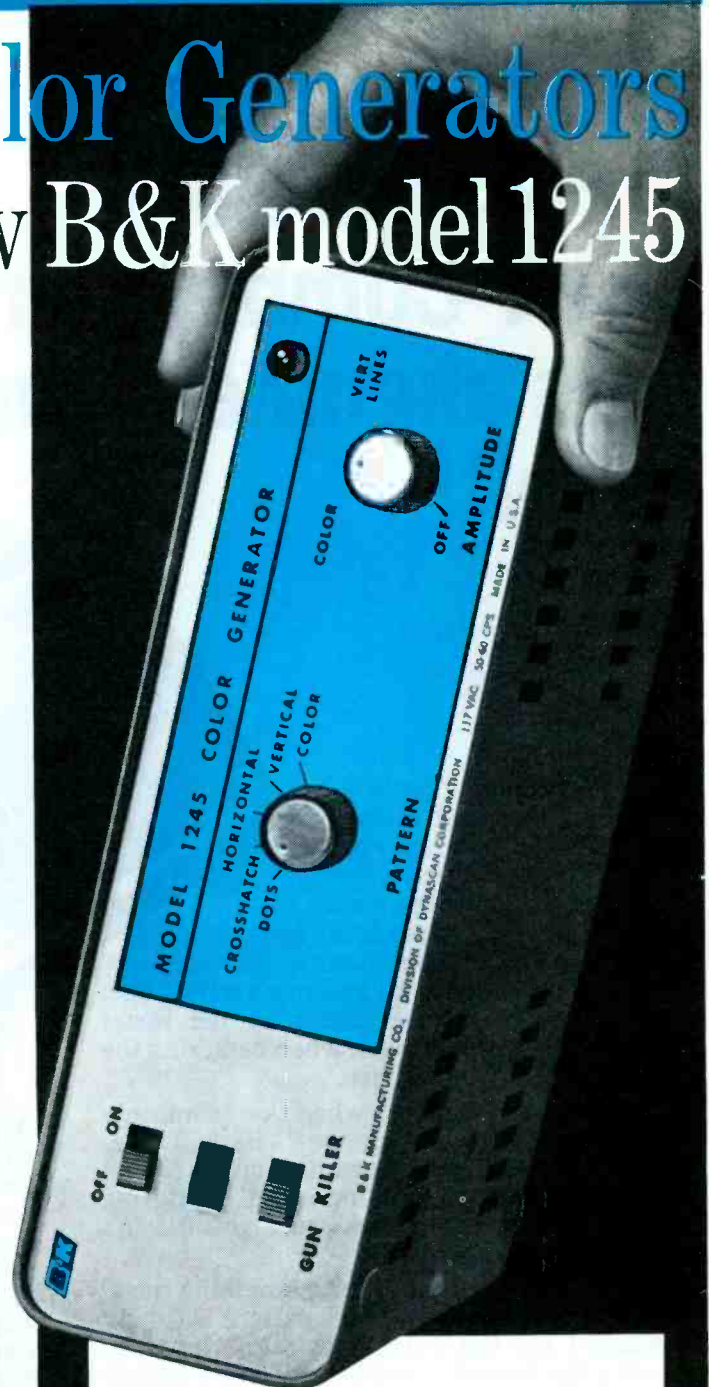

For the first time, with the no-compromise waveforms from the B&K Model 1245, it is possible to accurately set the color killer threshold control with a color generator.

The miniature size and convenience of the Model 1245 match its performance. It provides crystal-controlled keyed rainbow color bar display, and dot, crosshatch, horizontal line and vertical line patterns as well as gun killer controls that will work with any picture tube. Size only 2 7/8 x 8 1/2 x 8 7/8". Net \$134.95.

B & K MANUFACTURING CO.

DIVISION OF DYNASCAN CORPORATION
1801 W. BELLE PLAINE AVE. • CHICAGO, ILL. 60613

Canada: Atlas Radio Corp., 50 Wingold, Toronto 19, Ont.
Export: Empire Exporters, 123 Grand St., New York 13, U.S.A.

The new Amphenol 860 Color Commander cuts alignment time in half!

Ever finish a convergence job to find the raster off center. Lose convergence when you re-centered? Can't happen with the Amphenol Color Commander, battery-powered, solid-state color generator. A special, single-crossbar pattern consists of one horizontal and one vertical line, crossing just where the center of the raster should be. No need to guess when centering the raster with this new pattern.

See dots before your eyes when you want only one to start static convergence? The 860 gives you that single dot, right at center screen. You'll be switching back to this important dot during dynamic adjustment to make sure you haven't gone off the track.

Even the old patterns offer something new. Line spacing in the cross-hatch pattern is rigidly maintained for the 4:3 aspect ratio. You can rely on it for linearity, height, and width adjustments. The pattern gives you finely etched line width at normal brightness levels. What good is perfect convergence at reduced brightness if you lose it when the set's readjusted for normal viewing? This special crosshatch also eliminates receiver fine-tuning error. Among the 860's nine (most generators have only 5 or 6) are: multiple-dot, single vertical line, single horizontal line, vertical lines only, and horizontal lines only.

Finally, the Color Commander's unique color bar pattern (just three bars: R-Y, B-Y and -R-Y) simplify color adjustments. You can get a rapid, overall check of color circuits. Then adjust color demodulator phase or pre-set the hue control and check its operating range. In each step, you know precisely how the color bars should look and how they should change during adjustment.



A new timing circuit eliminates instability and loss-of-sync problems. Silicon transistors maintain built-in precision and stability indefinitely. RF output is on channel 3 or 4, switch selected. An attenuator simulates weak-signal conditions. It has gun killer circuit. Uses 9 penlight cells. Weighs 3½ lbs. in compact leatherette carrying case. \$149.95. Optional AC power supply, \$19.95.

AMPHENOL CRT COMMANDER, MODEL 855. Solid-state. Checks all black-and-white or color CRT's with the same techniques used by tube manufacturers. Rejuvenates where others fail. Versatile 5-socket cable accommodates 7 different sockets. With CRT chart, \$89.95.

See the new Color Commander test instruments at your Amphenol distributor.

Amphenol
DISTRIBUTOR DIVISION
amphenol corporation
2875 S. 25th Ave., Broadview, Ill. 60155



Circle 13 on literature card



The quality goes in before the name goes on

FOR THE FINEST COLOR AND UHF RECEPTION INSTALL ZENITH QUALITY ANTENNAS

... to assure finer performance in difficult reception areas!
More color TV sets and new UHF stations mean new antenna installation jobs for you. Proper installation with antennas of Zenith quality is *most* important because of the sensitivity of color and UHF signals.

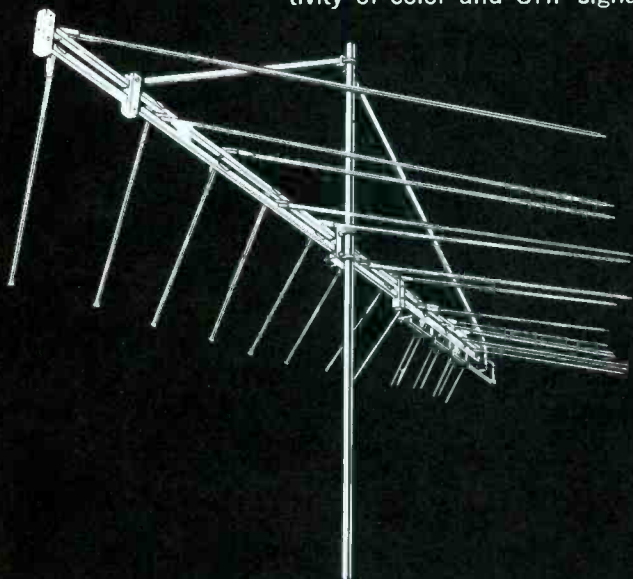

ZENITH ALL-CHANNEL VHF/UHF/FM AND FM-STEREO LOG-PERIODIC ANTENNAS

The unusually broad bandwidth of the new Zenith VHF/UHF/FM and FM-Stereo log-periodic resonant V-dipole arrays pulls in all frequencies from 50 to 900 mc—television channels 2 to 83 plus FM radio. The multi-mode operation provides high gain and good rejection of ghosts.

These frequency independent antennas, developed by the research laboratories at the University of Illinois, are designed according to a geometrically derived logarithmic-periodic formula used in satellite telemetry

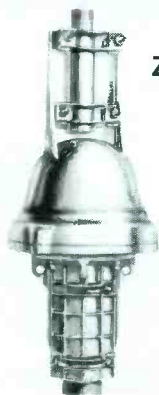

ZENITH QUALITY HEAVY-DUTY ANTENNA ROTORS

Zenith quality antenna rotors are heavy-duty throughout—with rugged motor and die-cast aluminum housing. Turns a 150-lb. antenna 360 degrees in 45 seconds. The weather-proof bell casting protects the unit from the elements. Each rotor mounts easily to either a mast or tower without an adapter.



ZENITH QUALITY WIRE AND CABLE

Zenith features a full line of quality packaged wire and cable. Also especially designed UHF transmission wires, sold only by Zenith. Zenith wire and cable is engineered for greater reception and longer life, and is available in various lengths to suit every serviceman's needs.

Check the Yellow Pages for the Zenith Distributor nearest you.
Or write to Zenith Sales Corporation, Parts and Accessories Division,
5801 West Dickens Avenue, Chicago, Illinois 60639,
for Distributor name plus complete catalogue and technical
information on Zenith Quality antenna installations.

Specifications subject to change without notice.

Circle 74 on literature card

The move's on to



JERROLD

Coloraxial™

**best for color . . . best for black-&-white
. . . best for FM . . . best for business**

The days of twinlead are numbered. Spurred by Jerrold's introduction of Coloraxial, both the TV trade and the public are moving unmistakably towards this revolutionary shielded coaxial antenna system—not only for great color TV, but for black-&-white and FM stereo too.

And, starting this Fall, a big national advertising program in TV Guide will have your customers asking even more for the perfection in reception that only Coloraxial offers.

So important is 75-ohm Coloraxial in your future that Jerrold now offers a wider line than ever of Coloraxial products to meet every reception need from metropolitan to deepest fringe areas. On these pages are described a

complete range of Coloraxial antennas with 75-ohm output; matching transformers for converting existing 300-ohm antennas to Coloraxial operation; Coloraxial Powermate preamplifiers; and 50- and 75-foot lengths of Coloraxial cable complete with screw-on fittings. One of the easiest—and most profitable—jobs you can do is install a Coloraxial reception system.

There's a pocket-size Jerrold Blue Book waiting for you at your distributor's. It's yours to use in figuring installed Coloraxial prices for your customers. The Jerrold Blue Book is just one part of a big five-part program your distributor has ready to help you sell Coloraxial installations this Fall. Talk to him now.



COLORAXIAL MATCHING TRANSFORMERS AND KITS Model T0-374A mast-mounting transformer converts any existing 300-ohm outdoor antenna to 75-ohm Coloraxial operation. Model T378 mounts on set to match it to 75-ohm coax. Available separately or as a set in Kit Model CAT-2.



COLORAXIAL SHIELDED CABLE Here's the heart of every Coloraxial installation—the reason for it all. Coloraxial is the highest-quality shielded RG-59/U cable, factory sweep-tested and complete with screw fittings and a weatherboot for the outdoor connection. Models CAB-50 and CAB-75 contain 50 and 75 feet of cable respectively. Model K-CAB-50 contains 50 feet of cable and one each of Model T0-374A and T378 matching transformers.



COLORAXIAL POWERMATES The coaxial versions of the transistor antenna amplifier that set an industry standard, made "fringe area" a thing of the past. Model SPC-103 has two transistors, Model SPC-132 "De-Snow" has five transistors in two-stage preamp-postamp. Both Powermates are pre-matched to antenna and receiver, making separate matching transformers unnecessary.

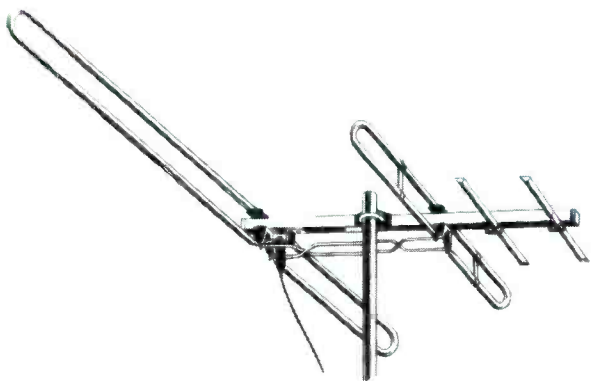

COLORAXIAL COLORGUARD ANTENNAS AND ANTENNA KITS Like all the antennas shown here, Coloraxial Colorguards are already equipped with 75-ohm output to coaxial downlead. Three models (CAX-16, 17, and 18) for metropolitan and suburban reception areas. Model CAX-16 is also available in kit form with 5-foot mast and trimount, CAB-50 cable with fittings and weatherboot, and set-mounting T378 matching transformer—everything you need for a complete Coloraxial installation.

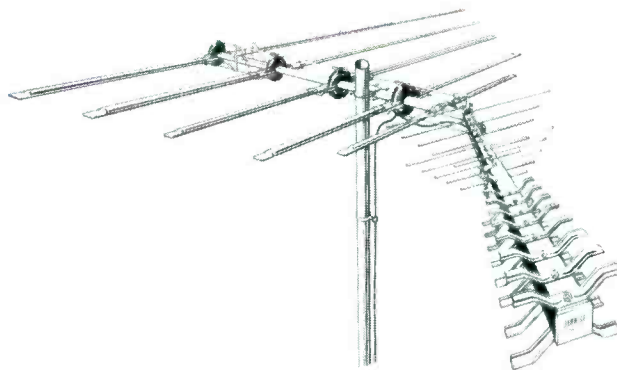

COLORAXIAL PATHFINDER VHF/UHF/FM ANTENNAS The first all-channel antennas with 75-ohm output and individual orientation of VHF and UHF sections in one hinged unit. All the flexibility of separate antennas without splitter losses. You have a choice of five PATHFINDER models, PXB-30, 45, 50, 70, 90.

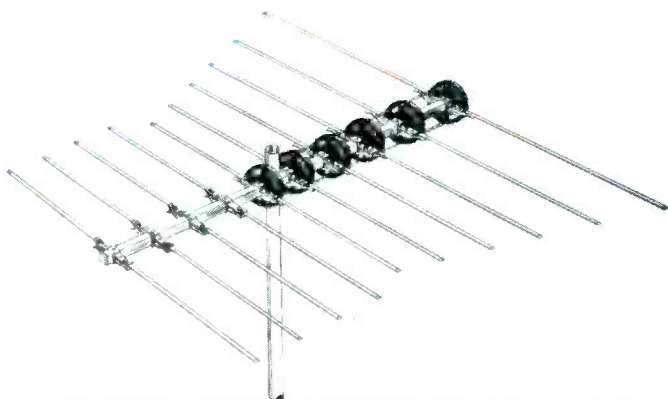

COLORAXIAL PARALOG FM ANTENNAS FM stereo needs Coloraxial too! So the outstanding Paralog FM antenna line is now offered also with Coloraxial 75-ohm output. Three models, FMPX-8, 10, and 16.



COLORAXIAL Stratophonic FM YAGI AND KIT This fine five-element yagi antenna, pre-matched to 75-ohm Coloraxial operation, keeps stereo signals in, keeps interference out. Model FAX-5, available also in kit form with mast, trimount, 50 feet of cable with fittings and weatherboot, and set-mounting matching transformer—everything you need for a complete Coloraxial stereo installation.

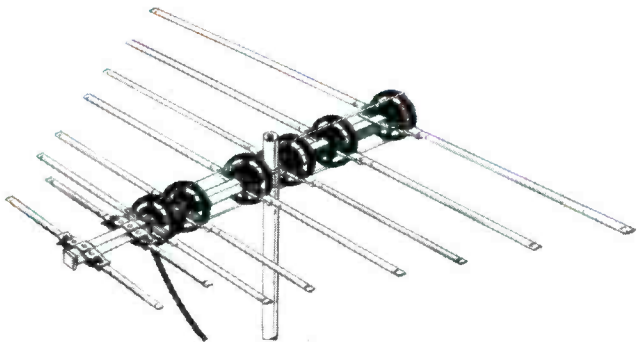

COLORAXIAL PARALOG TV ANTENNAS The full line of seven renowned high-gain Paralog log-periodic VHF antennas is now available pre-matched to 75-ohm Coloraxial cable. In the wide range of Paralogs (Models PAX-40, 60, 100, 130, 160, 190, and 220) you can choose the perfect antenna for metropolitan to deepest fringe reception.

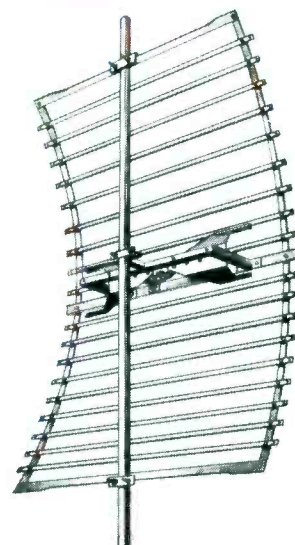

COLORAXIAL PARACYL UHF ANTENNAS These five famous all-band UHF antennas, now available with 75-ohm Coloraxial output, feature an extended-resonance driver which assures effective operation over the entire UHF band (Ch. 14 to 83). Models JUX-1, 2, 3, 4, 5.

JERROLD ELECTRONICS CORPORATION

Distributor Sales Division ■ 15th & Lehigh Ave., Philadelphia, Pa. 19132

JERROLD

Circle 14 on literature card

Don't install half a tv system!

The all-channel and color TV era is here. Most sections of the country will have both UHF and VHF channels. Only all-channel TV sets are now being sold. All three TV networks are increasing their color TV programming — so, if you're installing a TV system, it makes sense to put in a color approved all-channel system. Here are the Blonder-Tongue all-channel, color approved products that will do the job most effectively, at a down-to-earth price. **All-Channel UHF/VHF Amplifiers** The world's first channel 2 to 83 amplifiers provide superior color or black and white TV reception on all channels when used with any all-channel TV receiver, or with sets equipped with UHF converters.

UHF/VHF Amplifier. Mounts near antenna to achieve optimum signal-to-noise ratio. Unique 2-transistor circuit provides power to turn fuzzy pictures into sharp clear ones and handle strong local TV signals without overloading. Built-in FM filter reduces overload caused by local FM stations. Remote AC power supply can be installed anywhere indoors. Rugged, weatherproof, cast aluminum amplifier housing.

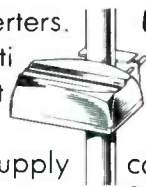

U/Vamp-2 mast-mounted Separate antenna inputs (300-ohm) for UHF and VHF. Built-in, low-loss UHF/VHF splitter, no additional unit is required to separate the signals at the TV set or UHF converter antenna terminals. \$49.95 list.

V/U-All-2 indoor UHF/VHF Amplifier. Installs easily anywhere in the home. unique two-transistor circuit provides excellent gain and low noise figure for one or two TV sets. For two-set operation, it provides an excellent impedance match, necessary isolation between sets plus an increase in antenna signal power. Single 300-ohm input accepts signals from both UHF and VHF antennas. A two-transistor circuit and a built-in filter minimize overloading caused by strong local stations. Patented 300-ohm stainless steel stripless terminals. \$42.50 list.



All-Channel Couplers—Color-approved, channel 2 to 83 delivering full-power signals to all-channel sets, only VHF Excellent inter-set isolation, low-loss, patented 300-ohm stainless steel stripless terminals. Model A-102 U/V two-set coupler. \$3.75 list. Model A-104 U/V four-set all-channel coupler. \$5.85 list. Model A-107, UHF-VHF antenna coupler combines UHF and VHF antennas or provides separate VHF and UHF outputs from a common line or a single antenna.

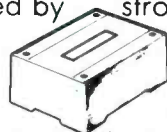

Model MT-283 UHF/VHF indoor/outdoor matching transformer. High quality color-approved unit matches 300-ohm antennas to 75-ohm coax down-lead (or 75-ohm terminals at set). Superior rejection of interference. Minimum insertion loss. "Jiffy Mount" provided for quick mast mounting. Connectors: Patented stainless steel stripless terminals (300-ohm); BTF connector (75-ohm). Solderless male connector supplied. \$6.75 list.

Cablematch U/V—All-channel, indoor matching transformer covers channels 2 to 83. Matches 75-ohm to 300 ohm impedance or reverse. Ideal for matching TV set inputs to a 75-ohm distribution system. Low insertion loss. Connectors: two spade lugs (300-ohm) and patented, solderless Autoplug supplied for RG-59/U cable (75-ohm). \$4.50 list.

TF-331 U/V All-Channel, 300-ohm Outlet Plate. Fits standard AC receptacle boxes. Designed to allow 300-ohm distribution systems to terminate at wall outlets for easy connect, disconnect. Patented 300-ohm stainless steel stripless terminals. \$3.35 list.

In addition to all-channel TV products, Blonder-Tongue provides a complete line of VHF (300-300Ω twinlead, & 75-Ω coax) and UHF system products. Blonder-Tongue, and only Blonder-Tongue, makes them all. Don't install half a system. Insist upon a system to meet all your customer's requirements, now and in the future. Insist on the top-rated line from the leader in all-channel products. Write for free booklet "How To Plan A Color Approved Home TV System".

BLONDER-TONGUE
9 Alling Street, Newark, New Jersey 07102
home TV accessories • closed circuit TV • community TV • UHF converters • master TV

Circle 15 on literature card



FREE!

From now through December 15, 1965

Get a Color-TV TEST Picture Tube with every RCA WR-64B Color Bar/Dot/Crosshatch Generator you buy

Yes! You read right!

From now through December 15, 1965—with every purchase of an RCA WR-64B Color Bar Generator—you get a FREE color-TV TEST picture tube for use in your color-TV test jig. This is a 21-inch 70° round color-TV TEST picture tube, electrically guaranteed six months from first installation date. These tubes will have minor mechanical (not electrical) defects... they're not quite good enough to go into a new TV set but perfectly adequate for testing purposes.

How to get your FREE Color Test Tube

Simply buy an RCA WR-64B Color Bar Generator—THE essential color-TV test instrument—between now and December 15, 1965. Fill out your warranty registration card and attach the red identification label on the WR-64B carton. Send them to RCA, Test Equip-

ment Headquarters, Bldg. 17-2, Harrison, N.J. We send you the tube (either from Lancaster, Pa. or Marion, Ind.) freight charges collect. To allow for postal delay, we will honor cards received up until December 31st.

Don't miss out on this never-before offer. You've got to have a color-bar generator anyway—so be sure you buy it now—at the regular price—while you can get a FREE color test tube.

\$189.50*

Optional distributor resale price; subject to change without notice. Price may be higher in Alaska, Hawaii and the West.



RCA WR-64B Color Bar/Dot/Crosshatch Generator

RCA ELECTRONIC COMPONENTS AND DEVICES, HARRISON, NEW JERSEY



The Most Trusted Name in Electronics

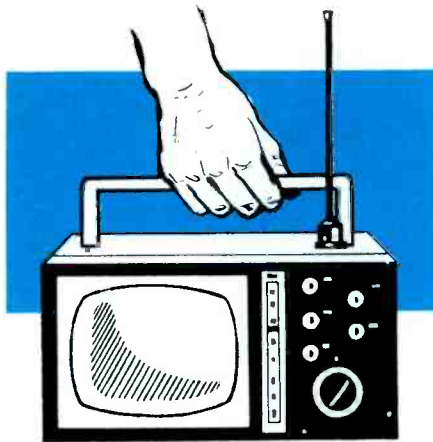

making money with **TINYVISION RECEIVERS**

**It can be done if you know how
to repair them quickly.**

by Edward F. Rice

Let's face it, transistorized TV is here to stay and the number of different models is increasing. If you have not already encountered one of these chassis on your service bench, chances are you will soon. Because of the physical nature of the chassis, troubleshooting must be based upon theory rather than the *cut and try* technique (aside from repairing intermittent circuit boards). In this sense, your experience with transistor radios will aid greatly, but the new circuitry must be studied and some new servicing routines must be worked out.

Waveforms provide the most reliable analysis. Voltage analysis is difficult because very small voltages

must be measured at inaccessible places, and some voltages depend on signal conditions. As in transistor radios, ohmmeter readings are often unreliable because of multiple low-impedance paths throughout the circuitry and the presence of semiconductor junctions which may be activated by the ohmmeter battery.

Because these sets are portable and the transistors usually are soldered in, only limited repairs and adjustments are done in the home. Parts are often guaranteed, or of such small cost that they do not contribute greatly to the profit from repair of these receivers. So, successful servicing of these receivers will require special bench techniques

which allow the technician to complete the job in a minimum of time. A few reliable tests are needed that: apply generally to all models; can be made quickly without butchering the chassis; do not depend on absolute accuracy of the instruments; or do not require familiarity with the variations due to signal conditions. Some of these tests will be presented in this article along with brief descriptions of some unique circuitry and a check list of general rules for service bench.

Sweep Circuit

Techniques for maintenance of the RF and IF circuits of transistor TV are basically the same as those

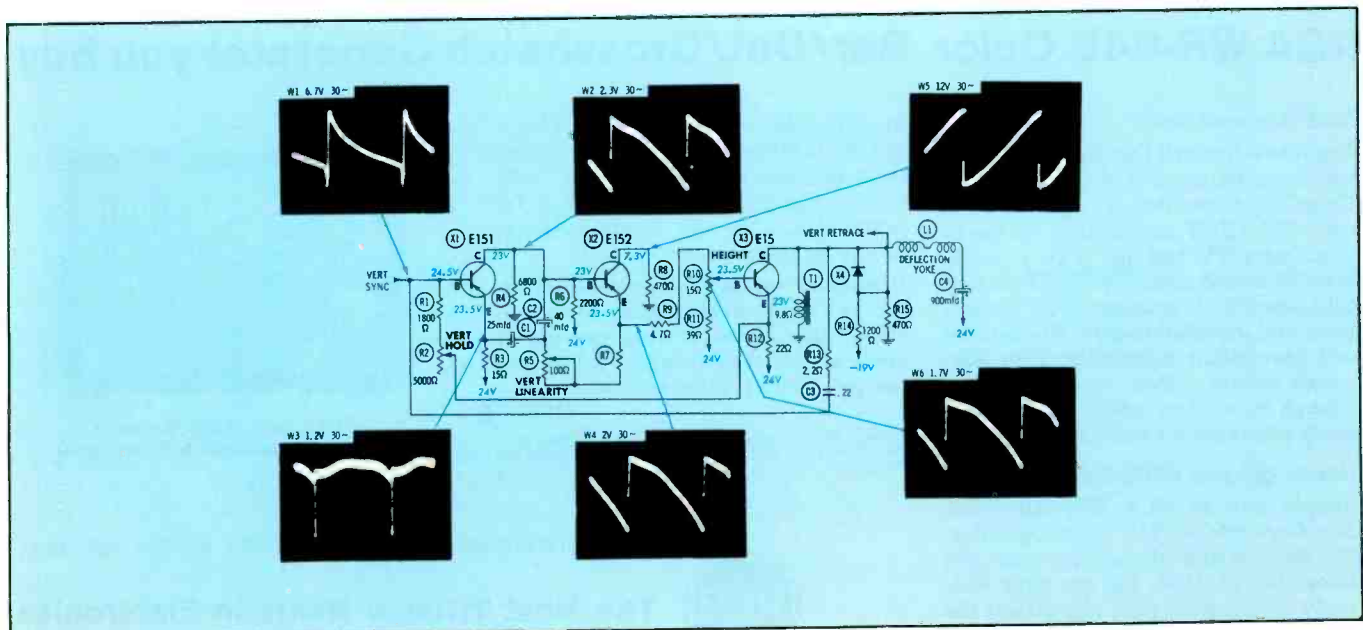

Fig. 1. Schematic diagram shows typical three-stage vertical sweep circuit used in transistor television receiver.

for transistor AM and FM radio circuits although alignment is more complex. Transistorized sweep circuits are more complicated; often, it will take more than a rapid glance to determine how the circuit works. Also, although vacuum-tube circuits have become standardized, there is still much diversity in circuit design for transistorized sweep systems.

Vertical Sweep

The appearance of a thin line on the screen will localize the fault to the vertical section. But there are often several transistor stages in this section and it is necessary to identify the faulty stage before unsoldering anything. Fig. 1 is the vertical section of Emerson chassis 120771. As an example, let's see how it works and how you could track down failures.

The base of X1 (Fig. 1) is reverse-biased through R1, R2, and R12; the negative vertical-sync pulse from the sync amplifier drives X1 into conduction, which discharges C1 and C2, thus cutting off driver X2. With no current flow through X2, the base bias of X3 rises to 24 volts (the source voltage) and current flow ceases from ground through T1, X3, and R12.

Vertical damper X4 conducts as T1's magnetic field collapses, which prevents damage to X3 and keeps the negative spike from exceeding -5 volts. Simultaneously, C4 is charging rapidly and the resulting current flow causes the sawtooth to retrace. C3 charges from its -5 volts clamp potential to 24 volts, thus X1 is driven into cutoff at the end of the retrace pulse from T1. As C2 charges, conduction increases via X2, R7, and R5. The waveform fed to X2's base is a linear, not an exponential sawtooth. As X3 conducts, C4 discharges through the yoke and X3, providing a linear sweep.

Features of this circuit immediately suggest importance to the troubleshooter. Knowing what you do about the horizontal damper used in tube-type circuits should lead you to check this diode first when there is no vertical deflection in a transistorized TV. An ohmmeter should reveal a 100:1 ratio of reverse to forward resistance. Or, one lead can be clipped from the circuit board; then by bending little hooks on the ends of the leads of a new

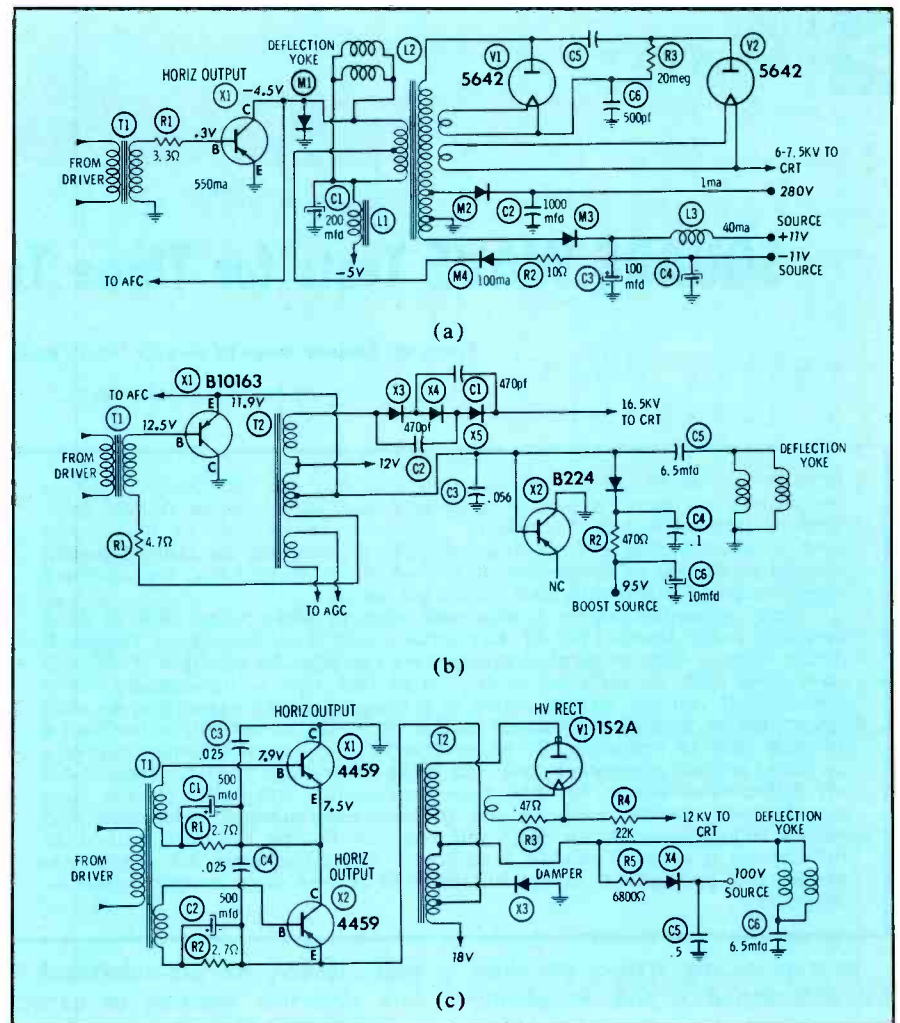

Fig. 2. Transistor horizontal-output stages similar to vacuum-tube types.

unit, you can substitute it temporarily. If the diode is open you are also likely to find a damaged output transistor.

If the damper is okay and there is no vertical deflection, the faulty stage must be located by signal tracing with an oscilloscope. Start by viewing the 60-cps sawtooth at the base of X1 and (if there is a sawtooth there) move through each stage toward the yoke until the signal disappears. The old method of substituting a 60-cps signal at various points and watching for deflection on the screen is not convenient in transistorized sets as it is in the tube-type because you must control the amplitude of the test signal very carefully to avoid damaging transistors; furthermore, you may not be able to hook up the CRT very easily after the chassis is removed from the cabinet (or the cabinet from the chassis as the case may be).

Shorted turns in the choke (T1) could cause linearity problems, and this part must be checked in addi-

tion to the regular suspects in the feedback circuit which are found defective in so many cases of poor linearity in tube-type sets.

Another cause of poor linearity that would not occur with tubes is transistor leakage. This causes a change in the operating point and produces clipping and saturation which can distort the sweep waveform. Leakage will also change the cut-off characteristics of a transistor, and this affects the vertical size and sometimes the sync.

Horizontal Sweep

Different kinds of horizontal output circuits are shown in Fig. 2 and 3. The one in Fig. 2A uses a voltage doubler to supply the high-voltage to the anode of the CRT—a circuit that brings back memories to some of us who have been around the servicing business for a decade or more.

Basic operation of this circuit (from the Philco 10AT10 chassis) is similar to that of standard vac-

• Please turn to page 86



SQUARE WAVE Tests for Three Terminal Networks

More on modern ways to service future equipment.

by Robert G. Middleton

Fifth in a series of articles on square-wave testing, this installment continues the analysis of three-terminal RC networks that started in the August issue. That "Advanced Service Techniques" feature described tests in RC circuits used as differentiating and coupling networks. In this one, the same principles are applied to tests of integrating circuits which are so packaged that ordinary capacitance-bridge and ohmmeter checks are useless.

These techniques require a wideband triggered-sweep scope such as those described in the March 1965 PF REPORTER article "Learning About Triggered-Sweep Scopes." Measurement of square-wave rise time, for example, is virtually impossible with an ordinary service scope that uses a free-running sweep generator. If you can arrange access to a triggered-sweep scope from an electronics lab or television broadcast station, it would be helpful to familiarize yourself with its operation. By experimenting with substitution-box networks or actual printed components, you can make theory and practical applications of square-wave testing become more meaningful. Integrated circuits have already been demonstrated for use in home-entertainment equipment, and testing techniques such as these will one day be the practical method of determining if a circuit module is defective. Articles to come will describe to the practical principles of testing RC networks of even more complex nature.—
The Editor.

In a preceding article, we studied differentiating and integrating circuits and the waveforms they normally produce when excited by a square wave. We are now prepared to make more detailed evaluation of what happens to a square wave when there are defective components in these RC circuits. Inasmuch as certain defects occur commonly, *their* effect is what we'll first consider. Resistors usually either open or increase in value, and capacitors usually become leaky or open.

When capacitors and resistors are assembled as partial or complete circuits, especially in printed or integrated combinations, it is difficult if not impossible to disconnect components for individual

tests. Hence, we are interested in how defective resistors or capacitors affect the square wave response of the entire network. These networks have an input end and an output end. In a TV receiver, for example, the input signal is applied to one end and the output signal is taken from the other. However, we will find that square wave tests are often greatly facilitated if we pass the square wave signal backward through the network.

Testing Resistors

Forward-backward tests are often very helpful in localizing defective resistors. For example, Fig. 1 shows a standard printed-circuit integrator. We can check this unit either as shown in A or B. Let's apply a 6-volt peak-to-peak 5-kc square wave as in A; this is normal operation. The output waveform is illustrated in Fig. 2. If the 10K resistor is of the correct value, the output amplitude is reduced to 5.4 volts peak-to-peak. But suppose the 10K resistor has doubled in value. In such a case, the output amplitude is related inversely to the change in resistance value.

It is helpful to review briefly the

action of an integrating circuit, to see why the 6-volt peak-to-peak square wave is reduced to 5.4 volts. In Fig. 1B the 10K resistor and the .0047-mfd capacitor shunting it form an integrating circuit. The 22K resistor, the .0047-mfd capacitor, and the high impedance of the 10w-C probe form a coupling circuit with a very long time constant; therefore they have no noticeable effect on waveshape or amplitude—output waveshape and amplitude are determined by the integrating circuit time constant ($RC = 10,000 \times .0047 \times 10^{-6} = 47 \text{ usec}$).

Fig. 3 shows that after five time constants the voltage across the shunt capacitor will equal input voltage. The time constant in Fig. 1A is 47 usec, so it takes 5×47 or 235 usec for the output voltage to rise to the value of the input voltage. This much time is not permitted by a 5-kc square wave; one cycle lasts only 200 usec, and a half-cycle lasts only 100 usec. In other words, the output voltage can rise and fall in Fig. 3 for only approximately 2.1 time constants. We see from the curve that the output voltage must be about 88% of the input voltage. The universal time-constant chart in Fig. 3 can be used to determine how much output voltage to expect at an integrator output at any chosen square-

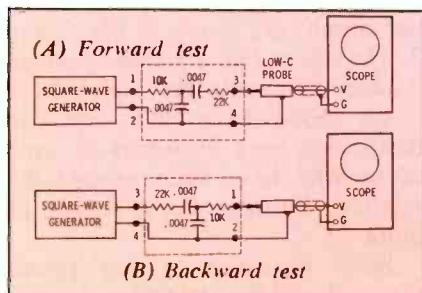

Fig. 1. Square wave passed in the opposite directions checks resistors.

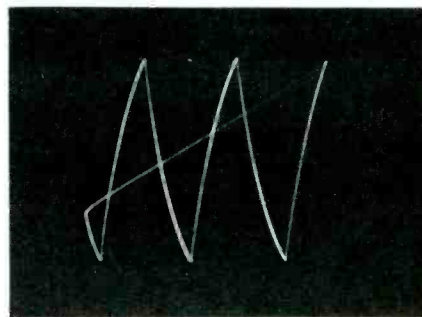

Fig. 2. Integrated 5-kc square wave from 3-terminal network of Fig. 1.

wave frequency.

Now, consider the 22K resistor in Fig. 1A. If this resistor doubles value, there will be practically no change in the reproduced square wave because the 22K resistor feeds into a low-C probe. The probe has an input resistance of 10 megohms and an input capacitance of 9 pf. This is a very high impedance, and even large variations in the value of the 22K resistor have little effect; the output waveform remains virtually unchanged.

Therefore, a "backward" test is made to check the 22K resistor, as shown in Fig. 1B. Now, the 22K resistor feeds into a substantial capacitance, and if the resistor is off-value, the result can be seen as an abnormal output amplitude. As before, a 5-kc square wave at 6 volts peak-to-peak is applied. The time constant of this circuit is determined by both capacitors; since the charge path is from the square wave generator, through the 22K resistor and the two series capacitors back to the generator. Total capacitance is .0024 mfd (.0047 mfd/2), and the time constant is: $RC = 22,000 \times .0024 \times 10^{-6} = 52 \text{ usec}$. Voltage is divided equally across each capacitor as loading by the scope is negligible. Using a 5-kc square wave will allow the capacitors to charge for approximately two time constants, and the output voltage will equal $1/2 \times 85\% \times 6 \text{ volts} = 2.55 \text{ volts}$. If the 22K resistor doubles in value, the output of this circuit would drop to 1.8 volts.

This is a quick and easy way to find out whether the 22K resistor is defective or not because its value cannot be measured with an ohmmeter. But, with this square wave test, the output amplitude is inversely related to the change in resistance value. You can rely on

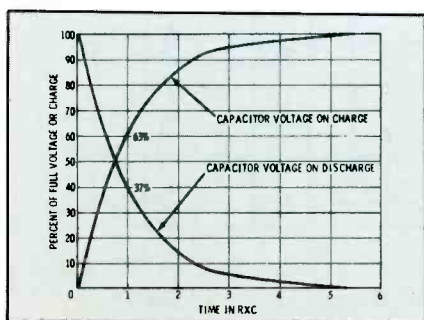

Fig. 3. Graph shows charge and discharge percentage vs time constant.

output amplitude for a definite test. It is much easier to note the amount of vertical deflection than to look for comparatively small changes in waveform curvature.

Capacitor Analysis

Next, let's consider what happens when the series .0047-mfd capacitor in Fig. 1 becomes leaky. A leakage test can be made at any square-wave frequency; 5 kc will be satisfactory, as before. Simply switch the scope from AC to DC operation. If the capacitor is not leaky, the pattern stays put on the screen. On the other hand, if the capacitor has appreciable leakage, the pattern will shift vertically on the screen. The shift is caused by the DC component in the square-wave signal. There are other methods of checking for leakage, but it is instructive to analyze the pattern-shift method.

Of course, not all square wave generators have a DC component; if the generator is of the type which has a large capacitor in series with the output, the DC component is blocked. In such a case, a DC component must be provided. One method is shown in Fig. 4. Connect a semiconductor diode in parallel with the generator output; Then, if a 6-volt peak-to-peak square wave is applied, there will also be a 3-volt DC component. A slight amount of leakage in the .0047-mfd series capacitor in Fig. 1 will produce a substantial vertical shift in the pattern when the scope is switched to DC response.

On the other hand, suppose the .0047-mfd capacitor is open. In such a case, there will be no pattern on the screen; only the horizontal base line will appear. Of course, the same "no output" symptom could be caused by an open 22K or 10K resistor. A "no output" symptom can also be caused by a

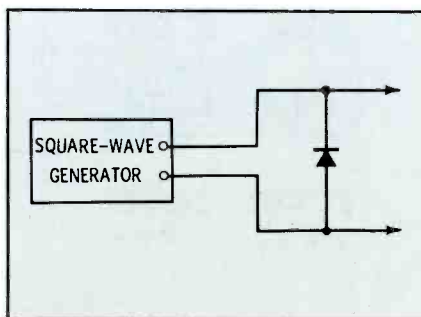

Fig. 4. Diode produces DC component from generator with output capacitor.

shorted .0047-mfd shunt capacitor in Fig. 1. In any of these cases, the printed integrator unit does not pass the square wave test and must be rejected.

Of course, complete shorts are less common than leakage. Hence, let's see what effect leakage or an open in the shunt capacitor has on the output square wave. Serious leakage in the shunt capacitor attenuates the output; this defect will result in rejection of the unit through earlier tests. A 6-volt peak-to-peak input will not produce a 2.55-volt output, but only 1 volt, .5 volt, or even zero volts for a complete short.

Then suppose the shunt capacitor in Fig. 1 is open. In such a case, a 5-kc square-wave test does not give the waveform shown in Fig. 2; instead, the square wave feeds through at full amplitude.

We find that a few square-wave tests evaluate very thoroughly the resistances and capacitances in Fig. 1, without disconnecting a single component. This is a great convenience in ordinary printed circuits and is essential for testing integrated circuits which cannot be "divided up" without destroying them. In factories today, square-wave tests at incoming inspection save excessive lost time in production. Techniques such as this will become more important to maintenance of electronic equipment as miniaturization continues. In the future, an entire television circuit may have only input, output, and power-supply terminals; square wave analysis and similar tests may be the only way to determine if the circuit is functioning.

Another Practical Test

Fig 5 shows another standard printed-circuit integrator. This is a

• Please turn to page 91

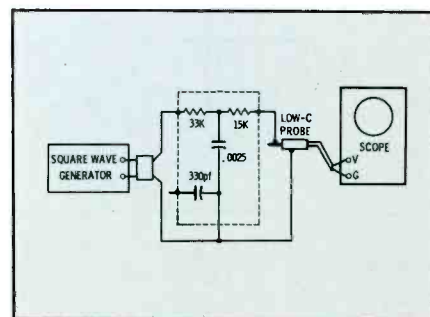
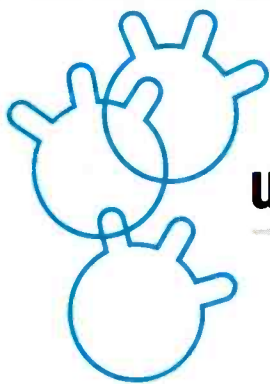

Fig. 5. Capacitor value can be determined by rise time of square wave.



understanding Pads & Attenuators

You can even make your own, in an emergency.

by Harry J. Abramson

An attenuator is a resistive network used to control signal level while maintaining a particular impedance at its input, its output, or both. It always produces a loss; in other words, it attenuates the source voltage to some lower value. They are used very commonly in audio circuits and sometimes in RF circuits.

Attenuators may be fixed or variable. The fixed resistor types are commonly called *pads*; the variable potentiometer types, *attenuators*.

The most familiar attenuator is the volume control. This type reduces output without any attempt at matching the impedance of the input or output circuits. In low impedance circuits, however, it is necessary to reduce the outputs and keep the circuits reasonably match-

ed to avoid unnecessary power losses and distortion.

Variable Attenuators

Two common attenuators which do attempt to match circuit impedance are the "L" and "T" pads. They derive their names from the shape of their circuit configuration—Fig. 1. Other less well known attenuators are the "H," "O," "U," and "P" types.

The variable "L" pad consists of two controls, generally wirewound, on a common shaft with the contact arms tied together externally. As one unit increases in resistance, the other decreases, thereby maintaining a constant impedance in one direction—usually the source. The "T" pad has three control sections and works much in the same manner, but it maintains

impedance in both directions.

For most audio systems, the "L" pad will suffice because, with it, the amplifier sees a constant load regardless of speaker volume setting.

Attenuator Characteristics

The two most important considerations for selecting attenuators for audio circuits are: (1) *impedance*—the resistance of the control should match the output impedance of the amplifier and (2) *power rating*—especially important since any power not used in the speaker must be dissipated in the control; the power rating of the control must therefore equal the output of the amplifier. If the speaker rating is unknown, the attenuator should have at least a 15-watt audio rating.

Other attenuator characteristics

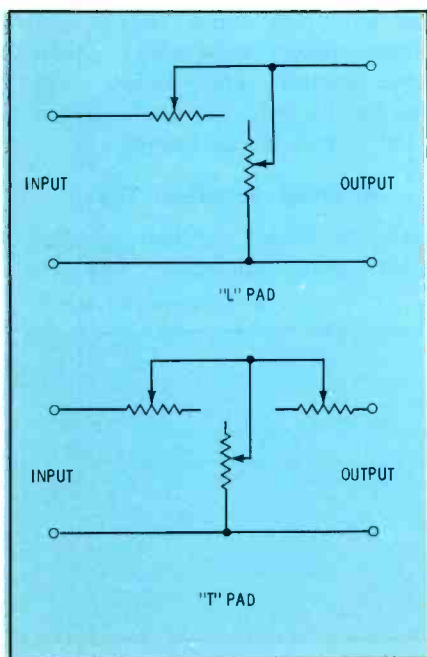

Fig. 1. Simplest forms of resistive pad.

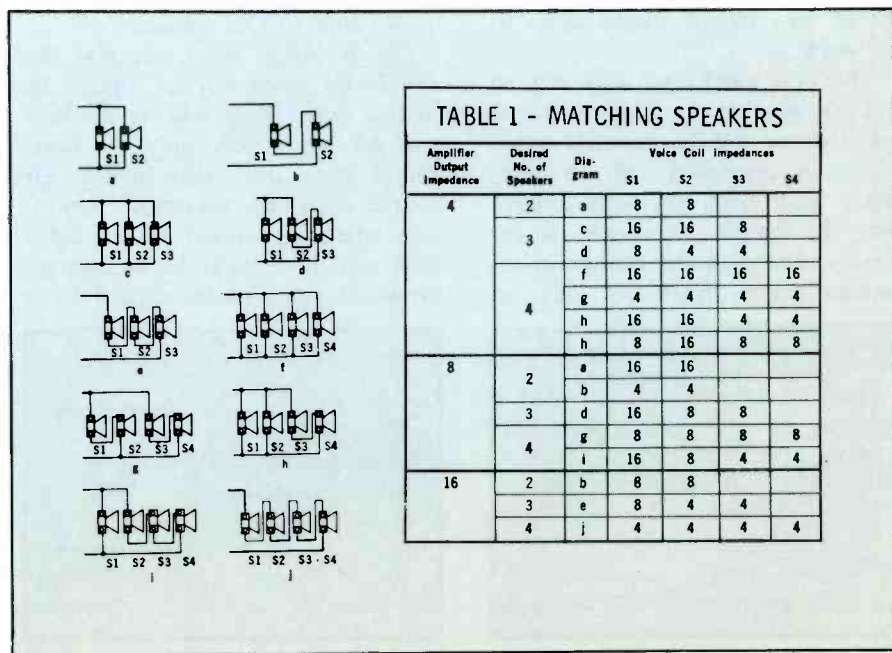

Fig. 2. A number of connection combinations for proper speaker impedance match.

to consider are:

1. **Insertion Loss**—When the control is set for minimum attenuation, little loss should be introduced into the circuit. This is especially important in low-level circuits, where insertion loss should not exceed .5 db.
2. **Constant Impedance**—The attenuator should be within +20% of its nominal impedance value at any level setting.
3. **Frequency Response**—An audio attenuator must have a frequency response flat from 20 cps to at least 20 kc to prevent frequency distortion.
4. **Noise**—Where attenuators are in low-level circuits, such as with microphones and preamps, their inherent noise must be less than -150 db; otherwise, objectionable scratching sounds occur whenever the control is rotated. Noise is of little significance in speaker circuits where the control is generally left at one setting.

Attenuator Applications

"L" and "T" pads let the listener enjoy the convenience of remote speaker operation without a loss of audio quality. The volume level of a speaker in a group can be changed without affecting the volume level of others. To distribute the output of a music system to various points, it is first necessary to determine how the speakers must be connected to obtain maximum output and fidelity. This can be done by selecting speakers with voice coil impedances that combine to provide the required total impedance for the amplifier.

An attempt should be made to use speakers of the same impedance, so you will have equal power distribution. For example, a 16-ohm speaker will have to dissipate twice the power as an 8-ohm speaker on the same line. Also, series connections should be avoided if possible since an open circuit in any one speaker will cause those in series with it to become inoperative.

Fig. 2 shows various ways of connecting speakers in series, parallel, or series-parallel, and Table 1 gives the required voice coil impedance of each speaker to obtain

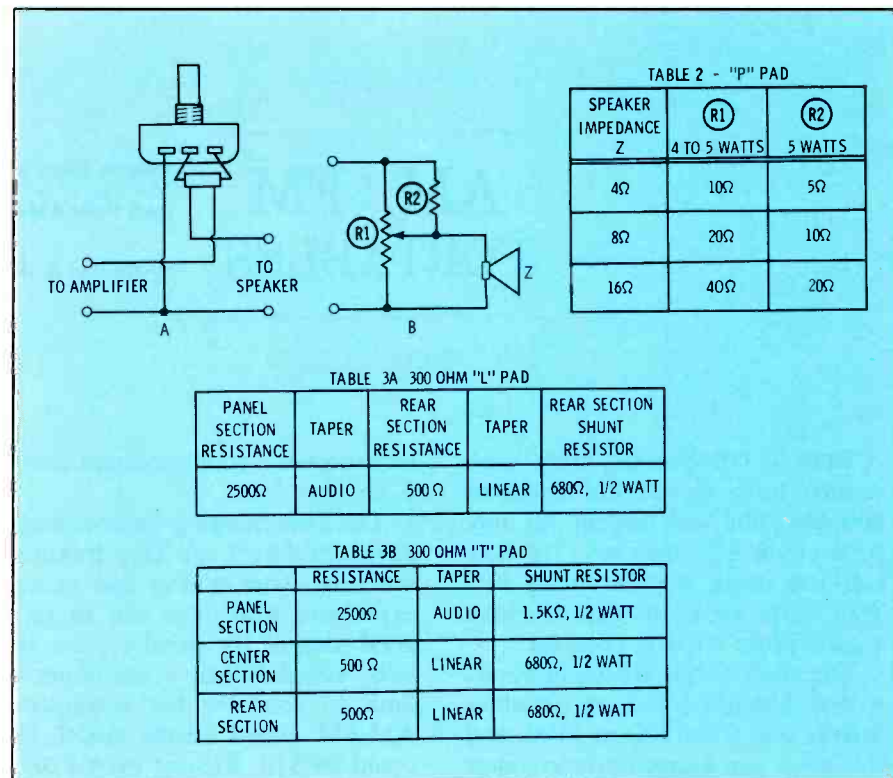

Fig. 3. A simple attenuator that you can make from available components.

any particular impedance match.

Matching of impedance cannot be overstressed. For example, an upward mismatch of four times the proper load produces a power loss of 50%; a downward mismatch will not only introduce excessive power loss but will also affect low-frequency response.

The "P" pad speaker control is an inexpensive form of attenuator which can be assembled from spare parts in an emergency situation. It consists of a single wirewound potentiometer, shunted by a 5-watt resistor, with characteristics comparable to its more sophisticated dual-pot counterpart—the "L" pad.

Fig. 3 shows the pictorial and schematic diagrams, and Table 2 lists the component values for common speaker impedances.

RF Attenuators

"L" and "T" pads have other applications besides as audio attenuators. They can be used as TV-signal attenuators to (1) reduce overloading in strong signal areas, (2) diminish crosstalk interference caused by nearby or powerful stations, (3) minimize buzz due to high-level signal, (4) prevent mismatch of antenna to set, and (5) simulate fringe-area signals for service work.

The 300-ohm "L" and "T" pads can be assembled easily and inex-

pensively by ganging 1/2-watt carbon-composition control sections. Ganged controls are available in several manufacturers' lines of replacement controls.

Fig. 4A shows the parts and wiring necessary for "L" pad; Fig. 4B, the "T" pad. Their schematic drawings are shown in Fig. 5.

These controls have fairly constant impedance characteristics and linear attenuation from 0 to 70 db. Their maximum power dissipation is 1/4 watt.

A simple and even less expensive

• Please turn to page 94

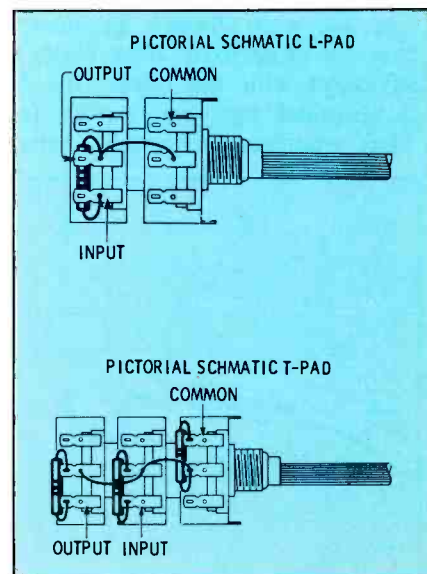

Fig. 4. Pads for 300-ohm balanced line.

keep

AM/FM PORTABLES

working

They're more profitable
than their AM-only brothers.

by Thomas R. Haskett

Since its introduction, many servicemen have viewed the transistor portable radio with disdain. "It only costs about \$9," they say, "so how can you make a profit fixing it?" Well, there are shops that do make a good profit on such cheapies.

The point of this article, however, is that AM-FM transistor portables usually cost from \$20 to \$100, and this gives you a much greater range for profit. The presence of the FM band makes the owner less likely to think of the radio as a toy, and he is more inclined to get it fixed rather than throw it away and buy another. This is true of multiband sets, also, which often cover longwave or shortwave bands in addition to AM and FM broadcast.

Merchandising Your Services

Some shops find it good business to establish a minimum or estimate charge on these radios. It works this way: A customer brings his set to you for an estimate. You try new batteries for free, but if this doesn't fix it, you tell him an estimate will cost \$5, even though he doesn't have the radio fixed. If he elects to go ahead with the repair, the \$5 is absorbed by your service fee. Thus, whatever the trouble (batter-

ies excepted), your minimum charge is \$5.

The *limit charge* is another useful device to attract and keep transistor business. After you've had enough experience with these sets to get a good idea of the usual repairs and bills, you establish a maximum or limit to your fee for a transistor AM-FM. Based on the model, this could be \$10, \$15, or even \$20.

You might also find it wise to set up a flat rate for all such sets. Customers are impressed by such a policy, for it convinces them you are being fair and not overcharging them.

Factory-warranty service can also be a profitable venture, and you would do well to investigate the chances of taking on such business. Here the factory pays you a flat rate plus all parts (either on an exchange, direct-replacement, or reimbursement basis.)

General Transistor Procedures

It makes good sense to have one

department in your shop that does nothing but transistor service. This could be one man or six; but when they do this day in and day out they become expert at it, fix the sets faster, and raise the profit rate for the shop. It requires some break-in for a "tube man" to get used to transistors, and the break-in is faster if he does nothing but transistor work.

Of course, you know the major differences in transistor and tube radios: smaller voltages; less or no heat; no rectifiers, batteries instead; smaller in size; and more rugged than tube sets. Transistors are often thought to be heat sensitive, but aren't as bad as some think—it depends on the transistor. (One manufacturer made a surprising demonstration: A transistor radio was turned on and tuned in to a station; a technician applied the flame from a cigarette lighter to a transistor. The radio went dead, then the flame was removed. After a few minutes'

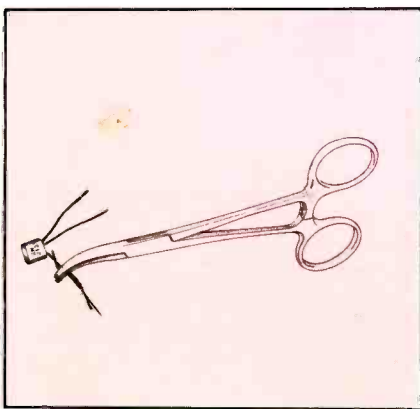

Fig. 1. Heat sink for transistor work.

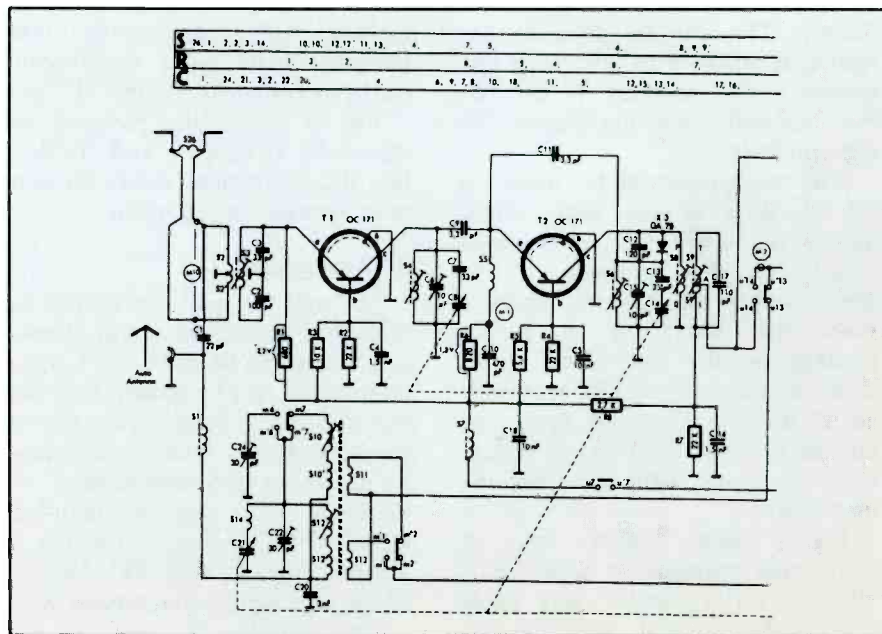

Fig. 2. Schematic as you see it with some imported AM-FM portable radios.

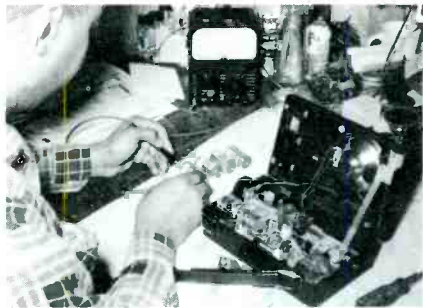

Fig. 3. Testing batteries is first step. (cooling, the radio played again.)

What is required for transistor service? Well, a few special tools, to begin with: Hand tools must be small; solder pencils are better than big guns or irons; a magnifying lamp is useful for examining printed boards for cracks; hemostats (Fig. 1) are useful for a heat-sink when soldering transistors, diodes, and quarter-watt resistors; bulb-type solder removers and desoldering tips are valuable for removing defective components from circuit boards; and even headphone jacks require special wrenches.

Some of the test instruments used for tube servicing can be used with transistors, but others are built especially for transistors. Examples: Transistor tester, bench power supply, the special analyzer, and a low-range, low-current VOM or VTVM. Then, too, the parts stock for transistor radios is bound to be different—quarter-watt resistors, low-voltage electrolytics, tiny speakers and headphone jacks, transistors, diodes, and thermistors.

Servicing Methods

It goes without saying that you must know something about transistor circuits before you can specialize. Fig. 2 shows a partial schematic of a typical AM-FM transistor portable. The symbols are a bit unusual if you haven't seen them before (remember, many of these sets will be imports). Notice the resistor symbol—a box with the value in ohms printed inside. The ground symbol is different, too—a single bar across the end of a perpendicular line (the ordinary ground symbol with the two bottom lines removed). The strip across the top of the schematic gives the location of every coil (marked S), resistor (R), and capacitor (C) in the circuit. Test points are circles with M-numbers inside them.

Now let's examine a logical servicing sequence which can be used on nearly all sets. The most common difficulty is batteries — they're in backwards, they're weak, or the holder contacts are corroded. The receiver may be completely dead, the local oscillator might be all that's dead, the set can sometimes play on FM but not on AM, and sometimes you will hear motorboating. Your first test should be to either substitute fresh batteries or (as in Fig. 3) check voltage of the old — they should be anywhere from rated voltage to no more than 20% below.

The next step is to hook up a bench power supply and an analyzer to the receiver, as in Fig. 4. Some radios use a tapped power supply, with the tap going to the speaker, and your power supply should have such an arrangement available. Monitor the set's current with the power-supply meter, or with the current range of a VOM. The amount of current varies widely, depending on the model of receiver, but you can assume when the switch is on, the set should draw current. If the current is high (more than 20 or 30 ma), this suggests a short; no current indicates an open circuit. Turn up the volume control and tune the dial; if the current shown by the meter increases, the set is probably working up through the output stage, and the trouble could be a faulty earphone jack, open voice coil, broken speaker lead, or bad speaker.

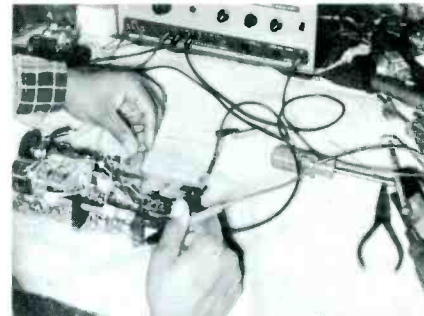

Fig. 4. Connecting set to bench supply.

At this point, if the trouble lies farther back in the set, it's best to resort to either signal injection or signal tracing, or a combination of the two. You must isolate the defective stage.

You can inject a 400-cps signal at the volume control to test the audio stages, which are always common to both AM and FM. Some sets have common transistors in the IF strip, while others have separate IF modules for AM and for FM; you will have to inject either 10.7 mc or 455 kc to check these stages.

It's also possible to use a signal tracer with a high-gain audio amplifier and a detector probe. While this technique works fine in audio, detector, and IF stages, it is practically useless at the converter and RF stages because the RF signal is very low-level. This is one point, however, where a high-gain scope is helpful — with a low-capacitance probe you can view the RF; use a modulated signal from a generator and adjust the scope horizontal fre-

• Please turn to page 97

VOLTAGE CHECKS FOR DIFFICULTIES FOUND IN TRANSISTOR CIRCUITS

DEFECT	N-P-N			P-N-P		
	COLLECTOR	EMITTER	BASE	COLLECTOR	EMITTER	BASE
Open base IF transformer	High	Low	Low	Low	High	*
Open collector coil	Low	Low	OK	High	High	OK
Open emitter resistor	High	High**	OK	Low	Low**	OK
Open base (internal)	High	Low	OK	Low	High	OK
Emitter-collector leak	Low	High	OK	High	Low	OK

Notes:

* Reading depends on resistance of meter.

**Small change only. Emitter assumes voltage on base.

Use 20,000-ohm-per-volt meter.

All indications will be opposite to those listed if a positive ground is used.

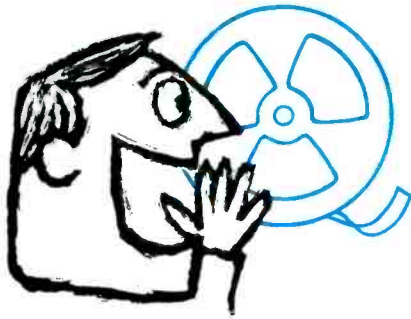

The Sly Old Vox

TAPE RECORDERS

He can't hide his trouble from you if
you know what you're looking for.

by Robert M. Glover

VOX is Latin for "voice," a term used for years by amateurs to describe voice-controlled transmitters. The operator speaks into the mike, and the rig is automatically switched to TRANSMIT by his voice. When he stops speaking, the transmitter is cut off and the receiver is actuated.

More recently, the same operational concept is being applied to tape recorders. When the voice starts, so does the tape machine. A recorder so equipped is especially handy for someone who wishes to record comments, but needs both hands for something else. One example is a surgeon during an operation. Physically handicapped persons also find VOX machines helpful for carrying on business, preparing school assignments, or corresponding by mail. Executives utilize the VOX method to record ideas as they occur and to handle

paper work at the same time.

An impressive number of VOX tape recorders are sold to private investigation agencies. Many are purchased also by personnel departments for recording interviews with job applicants. Ways to use VOX tape recorders are numerous and more are being found daily. You can easily conclude, then, that VOX tape recorders are fast becoming a profitable service item.

Is the VOX really sly? Let's track him down and find out! For the most part, the VOX recorder is the same as any other; the big difference is in the addition of the VOX section. Since solid-state construction is used predominantly in VOX recorders, we will concern ourselves with transistor circuits.

Simple Amplified VOX

A typical VOX section (Fig. 1) consist of a two-stage amplifier

and a relay-control (or trigger) stage. In the schematic, we've traced through the switches for you, drawing them in RECORD position. Most recorder schematics are drawn with the switches in PLAYBACK instead of RECORD position. When you get a machine on the bench, get out your pencil and redraw the switches like this to avoid becoming confused.

In Fig. 1, when the operator speaks, audio is taken from the secondary winding of the recorder's output transformer and fed to the primary winding of T1. Variable resistor R1 across the secondary winding of T1 forms part of the biasing circuit for transistor X1. R1 acts as a sensitivity control, because it works with R2 and R3 to set base bias for X1. This reverse bias must be overcome by negative peaks of the audio signal to forward-bias the transistor into conduction. The value of C1 is such that it bypasses the bias-oscillator signal from the recorder amplifier so that only audio is available at the base of X1 across R3. The value of bypass capacitor C2 is sufficient to insure that the output of this emitter-follower stage is well filtered and contains little audio.

When X1 is conducting, negative voltage across R4 increases and is applied directly to the base of X2, a common-collector DC amplifier (the same as an emitter-follower).

The output of X2, also negative-going, provides forward bias for relay-trigger transistor X3. Conduction in X3 causes relay K1 to energize, closing a set of contacts and starting the tape drive motor. When the voice stops, audio no

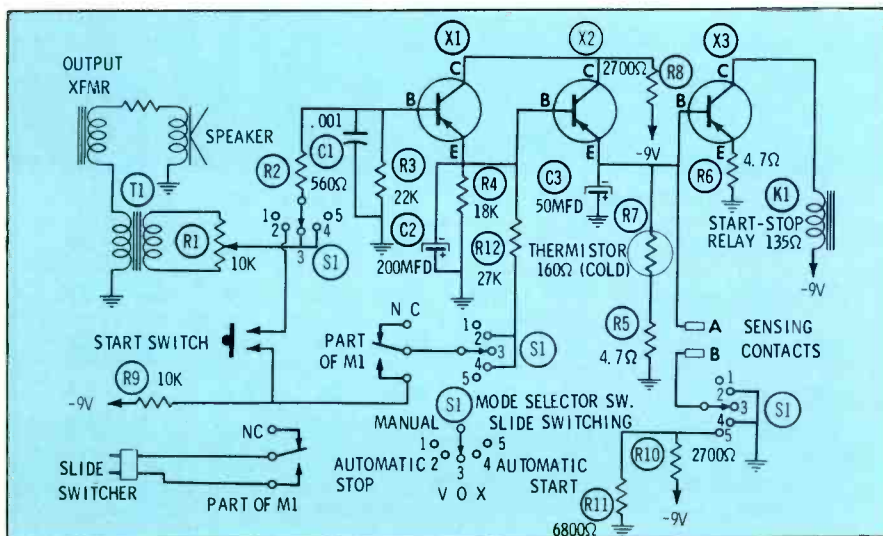

Fig. 1. Both saturation and filtering actions change audio to DC to operate relay.

longer reaches T1 and the entire chain returns to the normal state. K1 de-energizes and the drive motor stops.

Interesting use is made of a thermistor in the output (emitter) circuit of DC amplifier X2. This thermistor prevents the bias voltage for trigger transistor X3 from becoming great enough at any time to damage the junction. This could happen during any large increase in emitter current flow through X2. For example, if the mode selector switch is set for AUTOMATIC STOP (position 2), X2 emitter current does increase when the START switch is closed, and for an instant both X1 and X2 are driven to high conduction. Usual forward biasing of transistor X2 is furthered during this instant by the voltage supplied through R9 and R12 when the relay contacts close. The thermistor's resistance lowers during this high current condition and prevents forward bias on X3 from becoming high enough to damage the transistor. When the start switch opens, sufficient forward bias remains on X2 and R9 and R12 to keep K1 energized. Moving S1 to MANUAL position removes the biasing voltage on X2 and allows K1 to de-energize

and remove power from the drive motor.

One form of automatic stop can be provided by a strip of metallic sensing tape on the dull side of regular recording tape. When the mode switch is in position 2 or 4, the metal strip grounds the base of X3 whenever it comes to rest across sensing contacts A and B. This places the base of X3 at the same voltage level as its emitter and K1 will de-energize as X3 no longer conducts. Thus, one way to operate this machine is by starting the drive motor with the START switch and stopping it with the sensing tape.

Another mode of operation (position 4) uses audio to start the drive motor. In this mode, the machine continues to operate until S1 is moved to MANUAL position or a piece of sensing tape contacts with A and B. (You can see that a little piece of sensing tape in the wrong place could cause abnormal operation!)

Sensing tape is used in yet another mode (position 5) to trigger K1 for operating a projector's slide-changing mechanism. In this position, S1 deactivates the audio portion of the VOX circuit and connects voltage divider R10 and R11

to sensing contact B. When a piece of sensing tape passes over A and B, trigger transistor X3 is biased into conduction and K1 is energized. This closes the appropriate contacts and the projector mechanism is actuated.

Rectified-Type VOX

A look at the circuit in Fig. 2 could be somewhat deceiving because it looks simple enough to be found in a portable. This VOX circuit is used, however, in one of the more sophisticated transistor machines; in fact, the only time this large model is likely to leave its owner's home is when repair is needed! VOX can be included in machines of various prices, as there is no need for elaborate circuits. The main function of VOX is to act as a start-stop device, no matter how complex the recorder.

Basically, the VOX unit in Fig. 2 consists of a two-stage amplifier, a rectifier and delay network, and a relay-trigger stage. The first stage is a common-emitter amplifier that receives audio from the output of either amplifier channel, depending upon the position of a selector

• Please turn to page 99

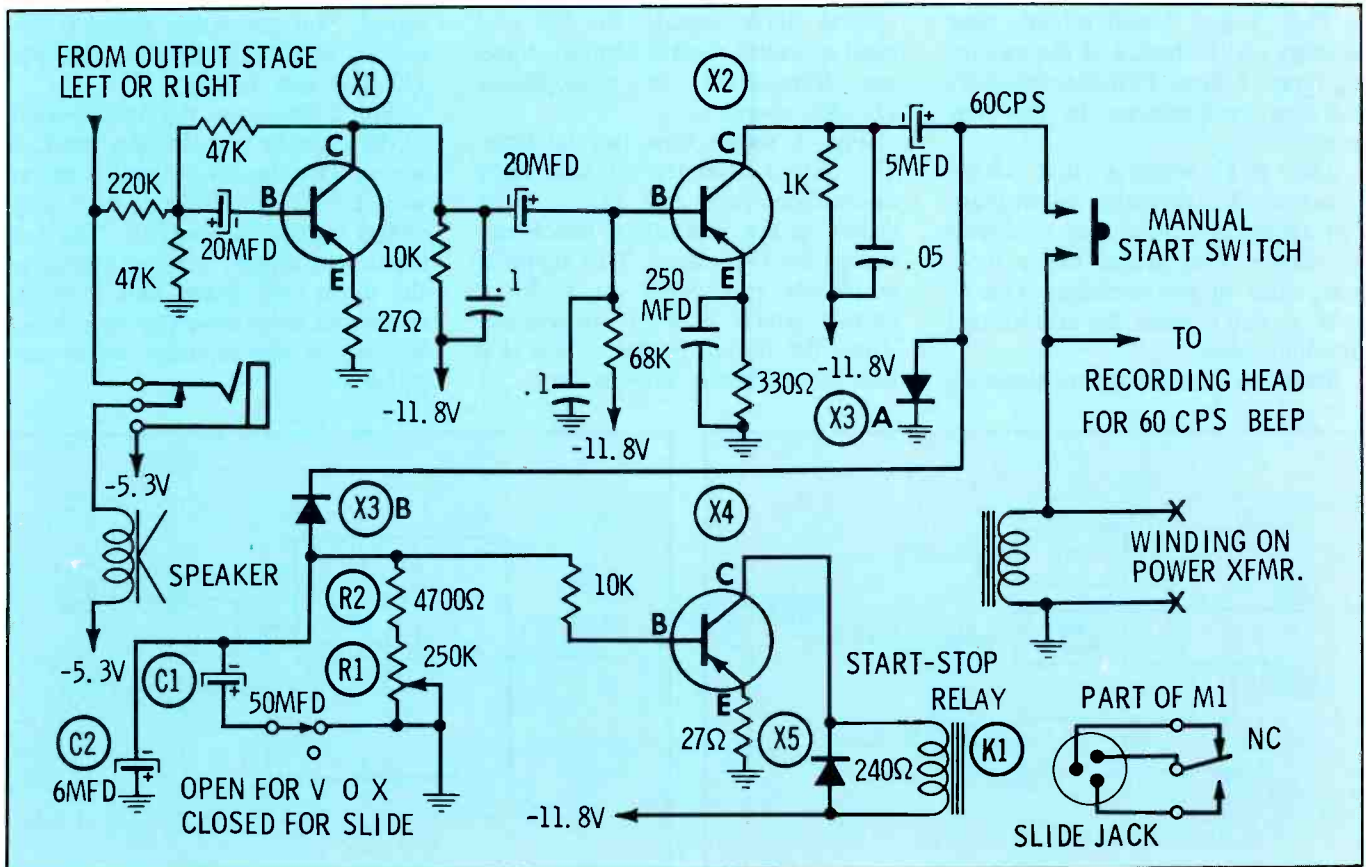

Fig. 2. In this unit, two-stage audio amplifier feeds rectifiers, and their DC output actuates the trigger transistor.

A double-barreled dose of up-to-date servicing information.

LATEST CIRCUITS for FM STEREO

by E. F. Rice and
William Kreuger

In this article we will review the highlights of the newest circuits found in FM stereo. Multiplex theory and alignment have been well covered in past issues, so a glance at Figs. 1 and 2 will refresh your memory on the basics of the switching-type of Time-Division detectors that are predominant in the new models.

The FCC requires that stereo broadcasts be receivable on ordinary FM receivers—those not equipped for stereo. This means music from both sides of the orchestra (the L + R signals) must be transmitted simultaneously.

Stereo is created by transmitting

a special signal capable of being processed by multiplex equipment only, in which the left and right channels are separated. When the receiver is not equipped to use the special stereo signals, the left and right channels remain combined and are transmitted as monophonic (L+R) sound.

Fig. 1 shows how this is done. The output from the left and right microphone are fed to a 38-kc switch in the transmitter which develops the L-R signal. This signal is amplitude modulated on a 38-kc carrier which is then suppressed. Thus, the output of the switch is a pair of sidebands ranging from 23

kc to 38 kc and 38 kc to 53 kc.

The monophonic signal (L+R) and a 19-kc pilot signal are combined with the L-R sidebands to produce the composite FM stereo signal. This composite signal is frequency modulated on the main FM (88-108 mc) carrier.

Fig. 2 illustrates the 38-kc switch in the receiver that decodes the L-R signal. This decoded signal is mixed with L+R and results in two individual signals (L and R). The two separate outputs, corresponding to the upper and lower halves of the composite wave-envelope, are shown leading to the separate audio amplifiers.

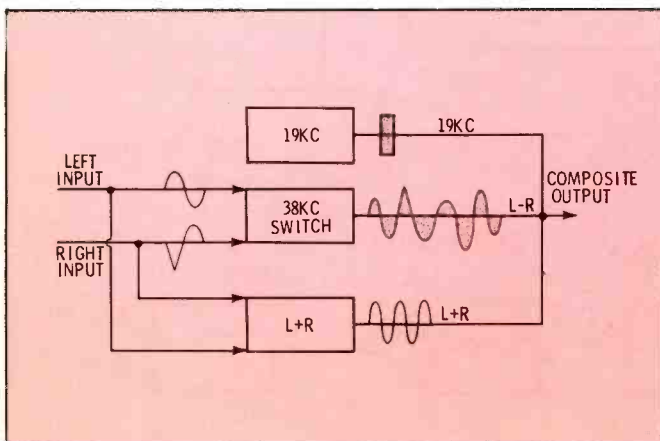

Fig. 1. Waveforms show how FM stereo signal is generated.

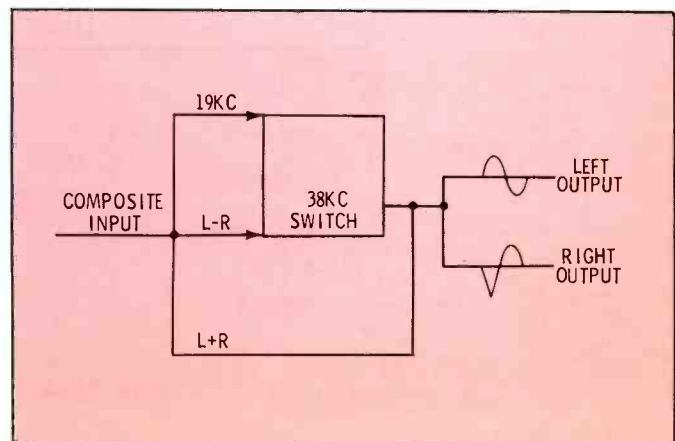

Fig. 2. Extracting both the left- and right-channel information.

The switch in Fig. 2 is actually the 38-kc oscillator that serves to reinsert the 38-kc carrier that was suppressed at the transmitter. A special sync pulse, in the form of a 19-kc sine wave pilot signal is always transmitted during stereo broadcasts to keep this switch synchronized with the one at the transmitter.

In recent models, new designs are appearing in the circuits handling the 19-kc pilot signal and developing the 38-kc carrier. Let's have a look at some of these circuits.

Double-Amplifiers

Many new models use a pair of diodes connected as a full-wave rectifier for converting the 19-kc pilot signal into positive 38-kc pulses. These pulses are fed to an amplifier whose output is a 38-kc sine wave. This sine wave is produced by a tank circuit in the amplifier. Since a free-running oscillator isn't used, the 38-kc sine wave doesn't appear at the detector diodes unless a stereo signal, containing a 19-kc pilot, is being received. This is a good point to remember when checking the oscillator output from a circuit of this type.

A typical circuit of this kind is shown in Fig. 3. Both sides of transformer L11 are tuned to extract the 19-kc pilot from the composite output of the first amplifier. When the top of the secondary is positive and the bottom is negative, diode M9 conducts, drawing electrons upward through R55, thus producing a positive pulse that is coupled through C53 to the grid of V8B. On the positive half-cycle,

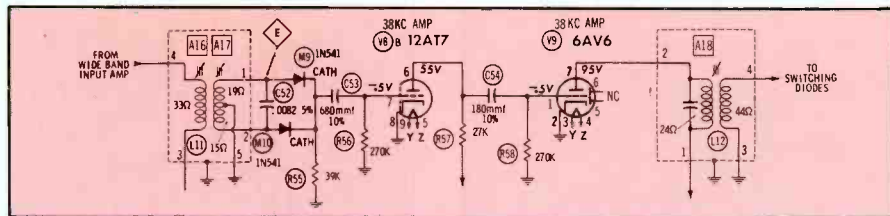

Fig. 3. Some receivers use two doubler diodes to redevelop the 38-kc signal

M10 conducts through the same path, producing another positive pulse at the grid of V8B. Therefore, this grid receives two positive pulses for each cycle of 19-kc pilot signal.

Transformer L12 is tuned to 38 kc and the sine wave produced across its secondary is used to switch the synchronous detector diodes on and off.

In contrast to this method of obtaining the 38-kc carrier are the circuits that use an oscillator, such as those in Fig. 4.

X1 is a self-sustaining 38-kc oscillator, with C4 providing collector-to-emitter feedback. This type of oscillator circuit generates a 38-kc signal even when a monophonic station is tuned in. Thus, the 38-kc signal converts supersonic noise into audible noise. This results in background hiss being heard when using a multiplex tuner on a monophonic transmissions. The circuit in Fig. 4 uses a special automatic converter switch that turns off the 38-kc oscillator when the incoming signal is monophonic. Let's see how this is done. The tuned output of the second 19-kc amplifier is coupled to the base of X2 by C1. When a stereo signal is received, positive alternations of the 19-kc pilot cause X2 to conduct. This conduction

lights the stereo-indicator lamp and causes X5 to rectify the 19-kc signal and charge C3. The result is a positive voltage on the base of X3, causing it to conduct. Since the oscillator draws its base current through the collector-to-emitter resistance of X3, the oscillator runs when X3 conducts; when it doesn't conduct, the oscillator is disabled. The switch in the emitter of X3 provides for manual control of the oscillator.

The oscillator is synchronized by the 19-kc pilot coupled through C5, and is adjusted by phase control R7. Switch S1 is included in this circuit to allow the oscillator to run freely for easier adjustment during alignment.

Squelch or Muting Circuits

There are two kinds of squelch circuits in use. One functions only when the receiver's multiplex section is operating; thus, the multiplex receiver is kept silent between stations or when tuning across monophonic signals. The other type circuit operates continuously but silences the multiplex receiver only between stations.

The first type is illustrated by the circuit shown in Fig. 5. When the set is receiving stereo, switch S1 is open, causing both sections of the

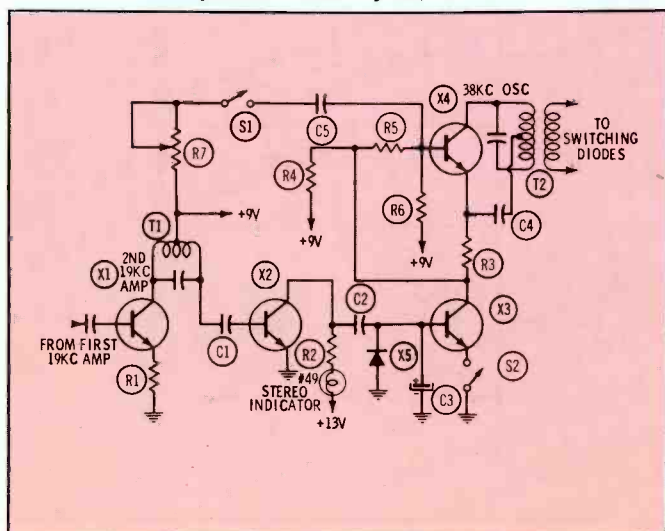

Fig. 4. 38-kc killer circuit prevents mono background hiss.

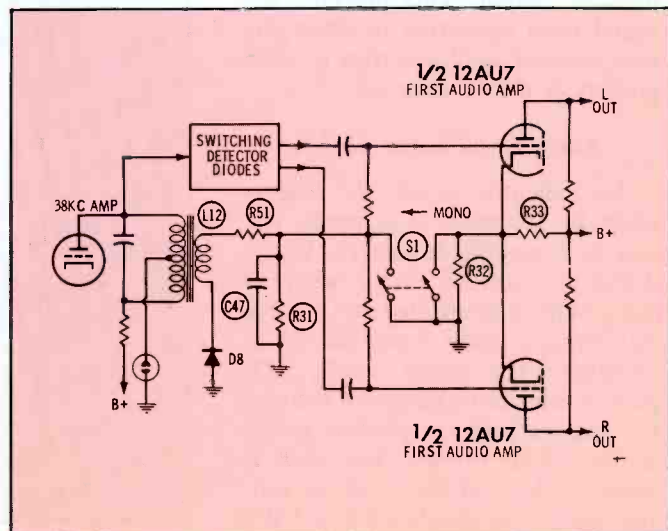

Fig. 5. Circuit allows only stereo output signals to appear.

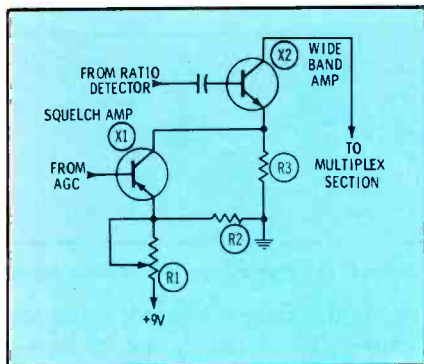

Fig. 6. Between-station muting circuit.

12AU7 to be cut off by the high positive cathode voltage produced by voltage divider R12-R33. When a stereo station is tuned in, the 38-kc amplifier operates and a portion of its output is rectified by D8. The result is a positive charge on C47 which is applied to the grids of the 12AU7 causing them to conduct. During monophonic reception, the switch disables the squelch by connecting the cathodes directly to ground and shorting C47.

The squelch arrangement in Fig. 6 is typical of the second type of muting circuit. AGC voltage is fed to the base of squelch amplifier X1. The IF transistors are PNP's so the AGC is positive when the receiver is tuned to a station and is negative between stations. This positive voltage causes X1 to conduct between stations when no carrier is present. Because the collector current for X1 is drawn through R3, the emitter of X2 becomes positive when X1 conducts. Notice, however, X2 is an NPN unit, and positive voltage on the emitter of an NPN cuts it off. X2 is the first amplifier following the ratio detector and when it is cut off the signal path is broken at the detector output. This prevents any signal from appearing in the multiplex receiver until a carrier is again present in the IF channel.

Stereo Indicator Lights

An indicator to tell the listener when he is tuned to a stereo station is a popular accessory. Fig. 7 shows a common circuit where a neon bulb is controlled by a rectified voltage taken from the 38-kc amplifier. The upper diode, M1, permits current to be drawn through R1 and the bulb on positive halves of the 38-kc carrier. The bulb is biased with a variable positive voltage taken from bleeders R2 and R3. M2 prevent the positive alternations

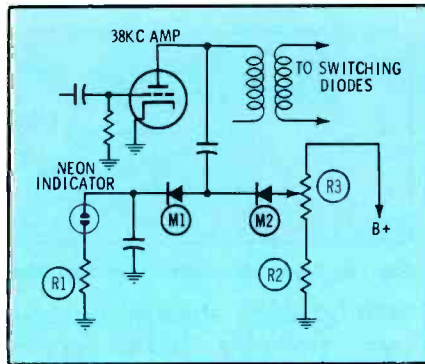

Fig. 7. Rectified 38-kc fires neon bulb.

of the signal from reaching the bleeder resistors.

The indicator circuit shown in Fig. 8 is a bit more detailed. The indicator voltage is taken from the doubler circuit. The 19-kc signal from the secondary of L19 is used to forward-bias NPN transistor X12 on positive halves of the 19-kc pilot signal. The resulting collector current of X12 supplies base current for X13, which is a PNP. The collector current of X13 is drawn through the #49 bulb causing it to glow when a stereo broadcast is tuned in. The collector of X12 and the emitter of X13 both require a positive voltage; a special winding on the power transformer is used to provide this voltage.

Demodulator Circuits

Nearly every recent stereo receiver uses the switching type (so-called "time division") synchronous detector. With this method the composite stereo signal, which looks like

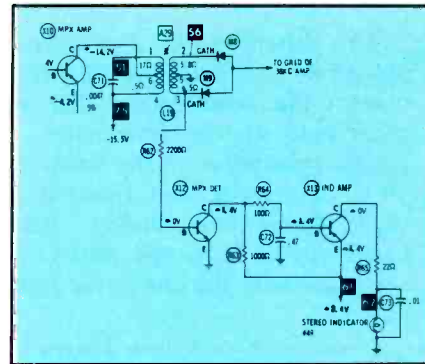

Fig. 8. L19 signal controls indicator.

Fig. 2 and contains the sidebands of the 38-kc suppressed carrier, is combined with the 38-kc oscillator signal at the input to the switching diodes. No attempt is made to separate the components of the composite signal and send them to separate amplifiers. Regardless of whether the circuit uses two diodes, four, or even six in a modified bridge, the operation always relies on the fact that L-R information is carried on one half of the 38-kc wave envelope and - (L-R) information is carried on the other half.

An entirely different approach to synchronous detection (The Biphase Detector) is used by at least one manufacturer. This system uses only one special transistor and gives the advantage of equal volume on both stereo and monophonic stations.

Fig. 9 depicts this unusual circuit in simplified form. The composite signal fed to the base contains mono-

• Please turn to page 102

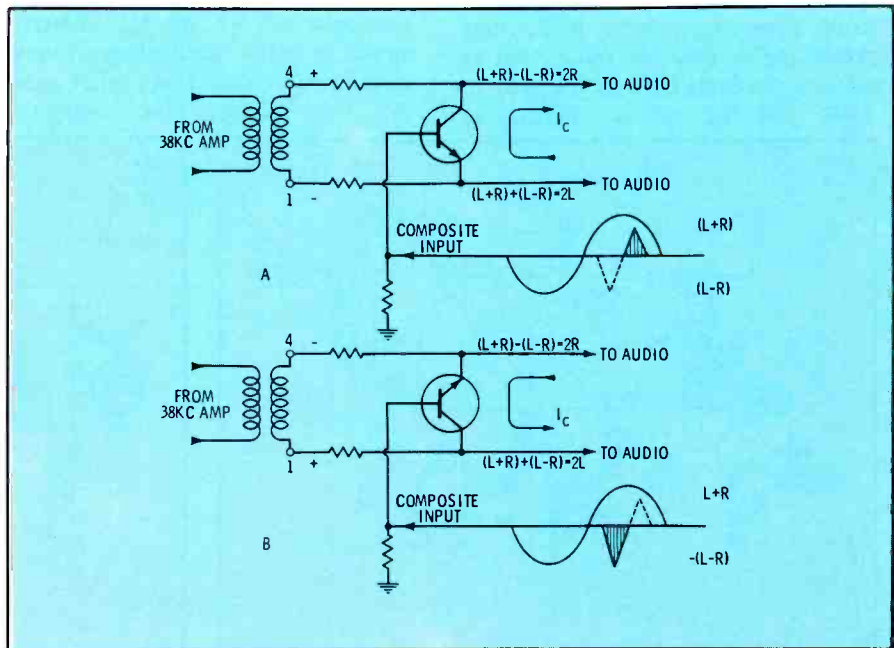

Fig. 9. This simplified schematic shows detailed operation of Biphase detector.

SALES TIPS

for **NEW** and **USED** TV

Dollars are to be had if you prepare. Here's how.

by Wayne Lemons

How do you sell new or used TV sets? Or do you?

No one has more opportunity to sell TV sets than TV technicians themselves, and possibly no group loses more sales every day. Why? I dare say that the first and greatest reason is simply lack of confidence in your own ability to sell. How often have you said to yourself or to someone else, "I'm no salesman!" The sad fact is that the fellow who says this probably isn't, but — and here the odds are 100 to 1 — he *can* be if he really *wants* to be.

I've watched good TV technicians, who can chatter entertainingly and sensibly on a service call, become literally word-bound when faced with a sales prospect. I've seen them deeply embarrassed by their shy, bumbling, anemic, and inept sales presentations. What's the underlying cause? In most cases, it is a lack of information about the product you're selling or, maybe more to the point, a lack of the right kind of information.

Sales Points—What the Customer Wants

The technician, perhaps because he is trained to sniff out trouble, is more aware of what the set looks like underneath, what tubes it uses, how easy it is to work on or make technical adjustments to, than he is of what the customer wants to see.

The average customer, on the

other hand, couldn't care less whether the set has quadrature sound detection or a stacked IF system. He is looking for a good picture and adequate sound. His wife may want a cabinet that goes well with the rest of her furnishings and a set that doesn't require an engineer for its operation. Both want a set that will be reasonably trouble-free.

You can set your customer's mind at ease on this last point by having a sensible guarantee. Nothing is a stronger sales clincher than a good warranty; unless you're a fly-by-night, you're going to stand behind any set you sell anyway, so capitalize on your guarantee — use it to overcome this one reluctance of your potential TV buyer.

You will note that up to now there has been no mention of price. Strange as this may seem to some technicians, price is usually no object. This doesn't mean the customer is not interested in obtaining the best price possible for what he is getting; he is. But it is the salesman's job to get the selling done before the price tag is mentioned. Furthermore, in these days of installment buying, price-per-month may be a more important selling point than total price anyway, so don't be stampeded into talking price only. Customers quickly become suspicious of low prices and easily get the idea that something must be wrong with the set.

It is often the policy of larger merchandisers to "sell up" — that

is, advertise a price leader to get the customer into the store, then—after this spider-and-fly buildup—pressure the sale of a higher-priced set.

I've found that "selling down" is a much more effective and honest approach for the technician. Here's what I mean. Show the prospect a better set than you believe he will buy and at more money than you think he may wish to pay. If you do a good job, don't be surprised when he buys the set. When you use this approach, don't be too quick to sell down. Also, never take for granted by the way a customer is dressed just how good a set he might purchase. A farmer in overalls may be able to buy and sell your store ten times over; so start with the best — you can always come down if you have to.

With a sincere sales approach, you can establish a price level that will start the customer thinking more of product quality than of price. You can instill quickly the reason why every set doesn't sell for \$69.95. Once you have established this "quality" idea, you are well on your way to making the sale you want to make. The sell-down technique takes practice but it can be mastered.

The Showroom

Selling sets, whether new or used, cannot generally be done most effectively in a disorderly atmosphere. Perhaps it has been done, but the



Fig. 1. Haphazard care of sets is likely to discourage those prospective buyers.



Fig. 2. Neat appearances of the sales-room makes a difference in set sales.



Fig. 3. Rug and flowers will add greatly to attractiveness of any showfloor.

salesman's personality and orderliness of mind was the compensating factor.

If you have your used or new sets piled in helter-skelter fashion (Fig. 1), one on top of the other with little protection in between, this clearly implies to the customer what small regard you have for the sets you're selling. If you want a prospective buyer to believe your pitch about the sets, don't treat those sets with contempt. Arrange them in orderly fashion (Figs. 2 and 3), pamper them, dust them, display a bouquet of flowers on them, and make sure they're not cluttered up with old dust rags or a three-week-old newspaper (Fig. 4). Treat the sets with respect, and the customer will in turn respect your opinion of them.

Create Self-Assurance

Another important factor in selling a set, and one that will build your self-confidence, is to be sure in your own mind that the set is a good one — at least as good as you claim it to be! And be sure you know how to turn it on and adjust it. The best salesman can have little

•Please turn to page 65



Fig. 4. Sloppy housekeeping creates an atmosphere in which selling is difficult.



...IT'S THE FINEST

Color Keyed

Model 825 Picture Tube Tester/Booster



the most versatile and accurate of all CRT testers...for all

BLACK/WHITE and COLOR PICTURE TUBES...

look
at all the valuable and profitable functions

Tests for continuity, leakage, emission, picture tube cut-off and life-expectancy • Removes shorts • Welds cathode • Boosts picture tube back to life

look
at these brilliantly engineered Jackson features

12 separate heater voltages including color • Line indicator control for accurate voltages • Grid guard limits peak current for protection of picture tube • Checks each color gun separately • Plug-in socket cable for easy replacement or repair • Separate variable voltages applied to G1-G2 of picture tube

look
at all these convenient operational features

Color keyed—push buttons for ease and speed in testing • FM tuning eye...no separate lights to interpolate • Angled view roll chart on panel...tube set-up information at your fingertips • Easy to keep up-dated
Size: 14¾" Wx13½" Dx5¾" H.
Wt.: 13 lbs. 3 oz. Dealer Net **\$11995**

See your Jackson distributor, or write for catalog

JACKSON ELECTRICAL INSTRUMENT COMPANY

124 McDonough Street, Dayton 2, Ohio

In Canada: William Cohen Corp. 8900 Park Ave., Montreal Export: Morhan Exporting Corporation 458 Broadway, New York 13, N.Y.

Circle 17 on literature card

Fall lineup of STANDARD KOLLSMAN Television Stars

Featuring the fastest rising star in the TV tuner industry.
Now available for replacement profits.

NEW STANDARD KOLLSMAN COLOR and black and white VHF ARBOR TUNER WITH PRE-SET FINE TUNING

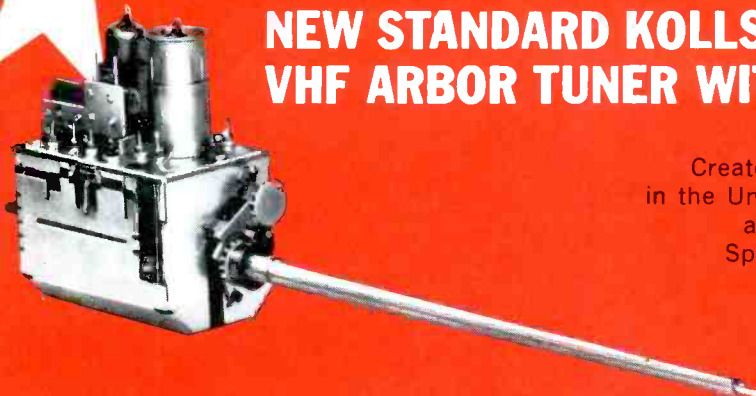

Guaranteed positive adjustment to eliminate service callbacks.
Created to replace TV tuners in practically every set manufactured in the United States since 1956. A simple adjustment of the knob automatically adjusts the oscillators for easy, perfect tuning. Specially designed brackets permit simple installations in any position—guaranteed to eliminate all previous mechanical problems of replacement installations.

Three new models to sell.
New SKi Arbor Tuner installed with the SKi UCT-051 UHF Tuner converts any set into a modern 82 channel TV.

Sell the custom look STANDARD KOLLSMAN BUILT-IN Transistorized UHF Converter



UCT-051

Easily installed in about 45 minutes

- Best performance—low noise
- Fits all consoles, table models and most portables
- Compact size: 5½" x 1½" x 3¼"; weight 1¼ lbs.
- Easy to read dial calibrated to read at any angle regardless of installation position
- Easy tuning high-ratio ball bearing drive
- Reliable service-free tuning element
- All UHF channels—14 through 83
- Built-in safeguards against interference with other TV sets in vicinity
- Excellent for replacement of defective tuners
- Quick and easy way to make TV trade-ins saleable

IF STANDARD KOLLSMAN MADE IT, STANDARD KOLLSMAN WILL FIX IT

- Only brand new parts used
- 48 hour service on all SK tuners
- Latest testing techniques to assure proper alignment
- No hidden costs—\$11.50 plus parts . . . \$13.50 maximum cost
- \$3.00 Trade-in allowance on new tuner.
- 6 month guarantee
- Special shipping cartons to avoid damage in transit

INTRODUCING WORLD'S MOST BEAUTIFUL BEST PERFORMING TRANSISTOR UHF CONVERTER



Model TA

- Earns more profit because it's easier to sell
- More picture power with latest nuvistor amplifier circuits
- Easy tuning
- Exceeds minimum F.C.C. requirements for spurious radiation specifications
- Very low drift
- Easy hook up
- All channels 14 through 83
- U.L. listed
- Full year warranty on all parts and workmanship.

NEW UHF TRANSLATOR MULTI PURPOSE TEST EQUIPMENT AND DEMONSTRATOR

- Translates VHF to UHF even when no UHF signals are on air
- Saves Time Servicing all Channel TV Sets
- Easier to Sell
- All Channel TV sets



VUT-1

FOR MORE PROFIT FOR THE SERVICE DEALER • GREATER CUSTOMER SATISFACTION

**GUARANTEED BY THE WORLD'S LARGEST
MANUFACTURER OF TELEVISION TUNERS**



**Standard Kollman
INDUSTRIES INC.**
2085 NORTH HAWTHORNE AVE., MELROSE PARK, ILLINOIS

Circle 18 on literature card

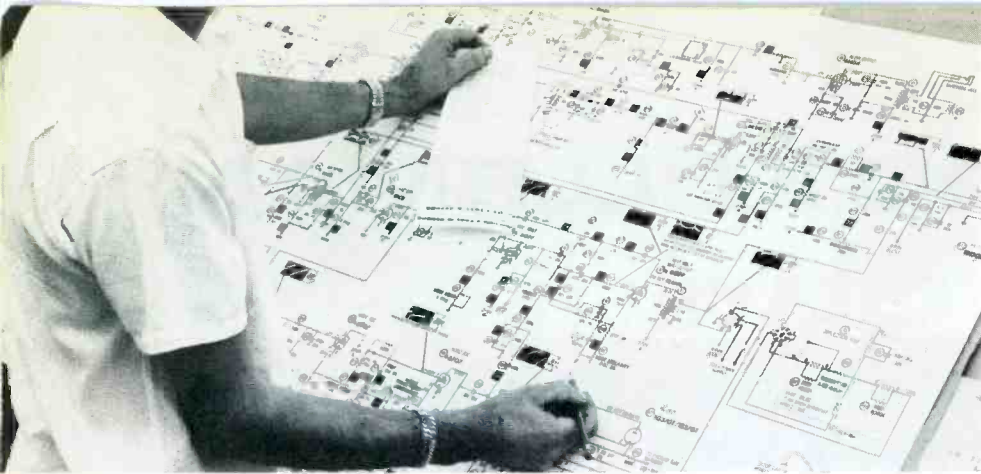

7. Finally the schematic is complete. Now the job is the final checkout. This includes verifying once more all component callouts, all voltages, points of identification (such as alignment and test points) at their proper position, CircuitTrace numbers at correct locations if the chassis uses printed boards, and all other data that was collected in the Analysis Department.

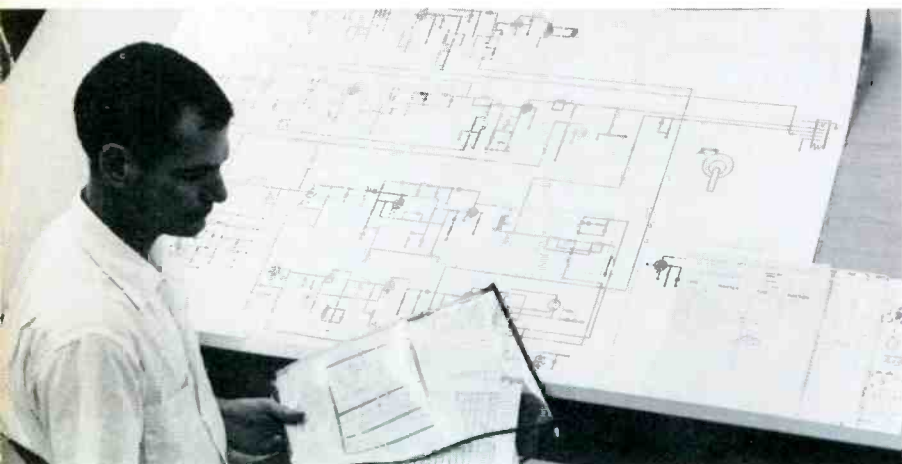

5. During the time the sketch was being prepared with Art-type, the TV chassis has been processed in the Analysis Department. One purpose of this analysis is to verify the accuracy of all components values indicated on the sketch; further, the analysis includes voltage measurements, resistance checks of coils and transformers, etc. Here the collected analysis material is being reviewed and arranged so it can be applied in proper order.

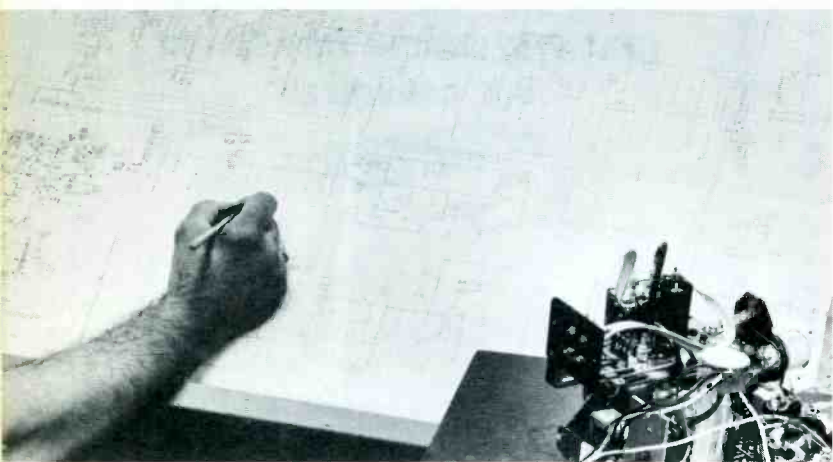

3. When the draftsman has thoroughly checked the TV chassis, and made appropriate notes, the sketching of the PHOTOFACT Standard Notation Schematic® begins. Circuit changes that constitute an alternate circuit are drawn. Components and wiring found in the actual chassis form the main diagram sketch; any circuit that was different on the manufacturer's schematic is drawn separately and shown as an alternate circuit.

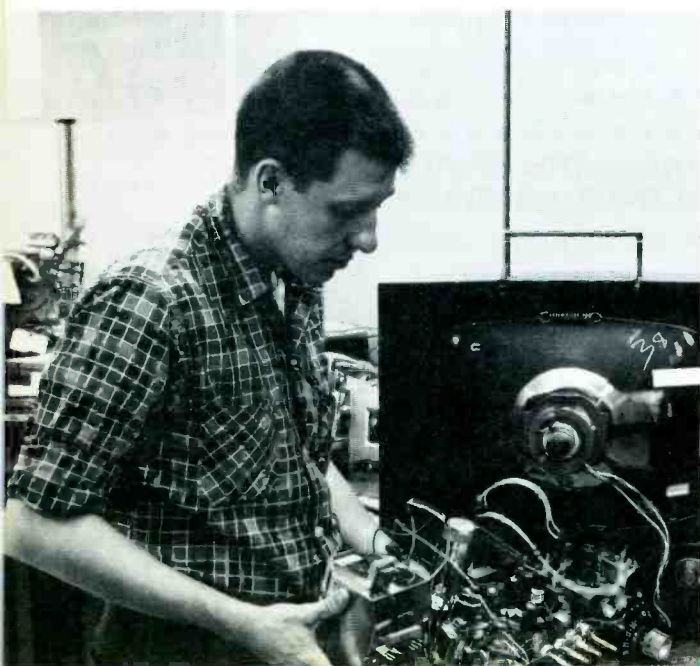

Watch **SCHEM** Gr

Many different steps and procedures enter into a completed is removed from the cabinet. These photos follow the PHOTOFACT

1. The first step is to disassemble the chassis and remove all shields. This permits the schematic draftsman to verify which components are inside shields, consequently, they can be so indicated in the preliminary sketch.

8. This final photo is of the first step in preparing the completed schematic for final printing. A photo is taken to reduce the schematic to the size you see in your PHOTOFACT Folder. From the reduced photostat, negatives are made and then zinc press-plates. On the press, the schematic is combined with the other data related to the set. The finished product is a folded and trimmed PHOTOFACT Folder.

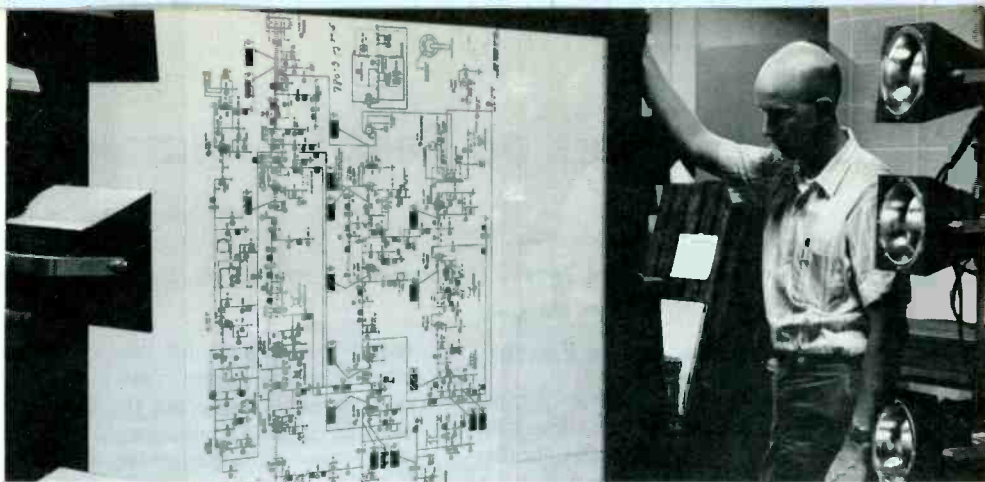

6. All component parts are assigned identification numbers (known as callouts), such as (R1), (C1), (L1), (T1), etc. The original sketch is used as a reference guide in the process of placing this information on the schematic, again in Art-type. A watchful, experienced eye is alert here for any possible errors and any that are found are corrected in this step.

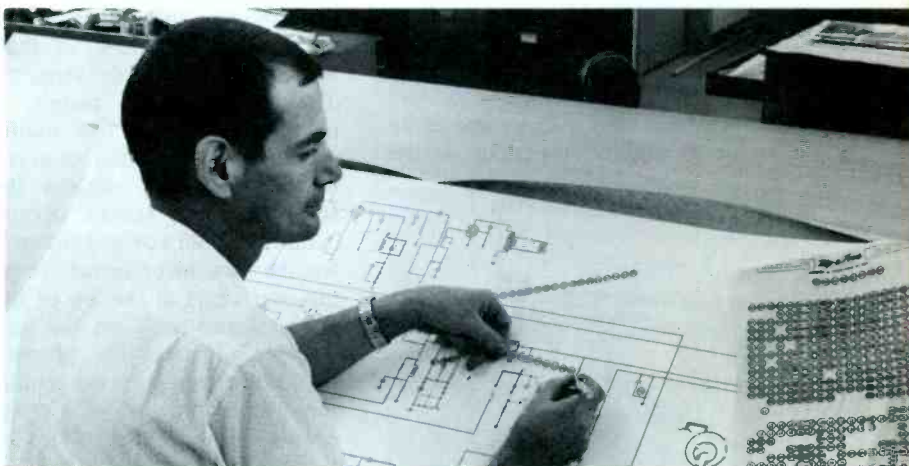

4. The hand-drawn sketch is then sent to the Schematic-Layout Department. With the master sketch as a guide, the diagram is rendered in Art-type on a grid board (lightweight cardboard with $\frac{1}{4}$ " grids similar to graph paper). The Art-type is preprinted on sheets of clear acetate paper with wax on the back; it adheres easily to the grid board. The Art-type consists of lines, cross-overs, resistors, capacitors, coils, transformer, switches of all types, and other configurations that make up a standard PHOTOFACT schematic.

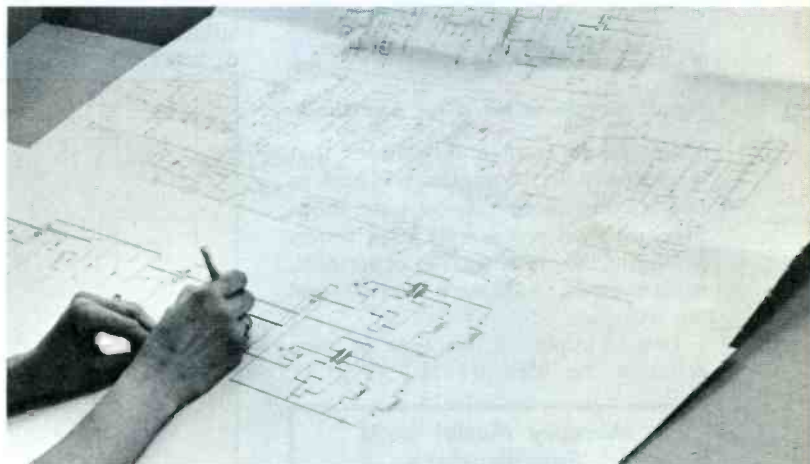

How ATICS OW

PHOTOFACT schematic. The process begins as soon as the chassis schematic from birth, through its growth to the completed product.

2. The chassis is then passed along to the draftsman. He checks the manufacturer's schematic of the unit against the actual TV chassis; every circuit is traced in its entirety. Any differences are noted on the manufacturer's schematic.

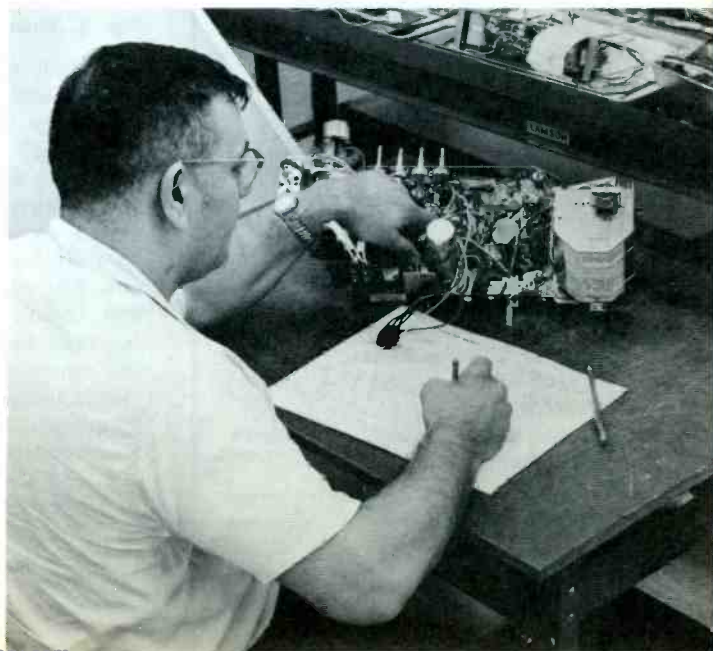



Notes on Test Equipment

analysis of test instruments . . . operation . . . applications

by Arnold E. Cly

Self-Service Tube Tester

For many years, a number of radio-TV service shops have given free tube-check service, but it is often bothersome and costly for a technician to stop in the middle of a repair job to check 10 tubes someone has just brought in. Also, the common do-it-yourselfer is usually on the defensive when he walks into a shop, and quite often he is slightly suspicious of the



Fig. 1. Simple to setup for fast check.

results taken from a tube tester that is probably too complex for him to operate. For these reasons, some shops have installed *self-service* tube testers similar to the types used in drugstores, supermarkets, hardware stores, and the like.

One example of this type of tube tester is the Mercury 202 (Fig. 1),

Mercury Model 202E Specifications

Tube-Socket Complement:

9-pin novar, 12-pin compactron, 9- and 10-pin miniature, 8-pin loctal, 8-pin octal, and 5-pin nuvistor.

Tests Performed:

Interelement leakage, shorts, gas, emission. Checks vibrators, fuses, light bulbs.

Interelectrode Leakage Test:

Neon bulb.

Grid-Current (Gas) Test:

Neon bulb.

Power Requirements:

105-125 volts, 60 cps, 18 watts

(HWD) Size:

61" x 20" x 19½"

Weight:

20 lb

Price:

\$129.95

which is designed for simple operation. With this tester, more than 1200 tube types — including the latest nuvistors, novars, compactrons, and 10-pin types — along with vibrators, fuses, and light bulbs can be tested.

Simplicity and safety of operation are the major features of this instrument. There are only three switches: The ON-OFF toggle switch, the filament-voltage SELECTOR multiposition switch, and the TUBE QUALITY pushbutton. The user obtains the tube-socket number, METER SETTING indication, and SELECTOR SWITCH position for the tube to be tested from a large flip-over chart at the top of the tester. A numbered scale on the large 7" x 7" face indicates the proper setting for the METER SETTING control with the pushbutton in the normal (up) position. Calibrating voltage is fed to the meter, and the METER SETTING control determines the meter shunt resistance. As the block diagram in Fig. 6 shows, the SHORT and GAS tests are

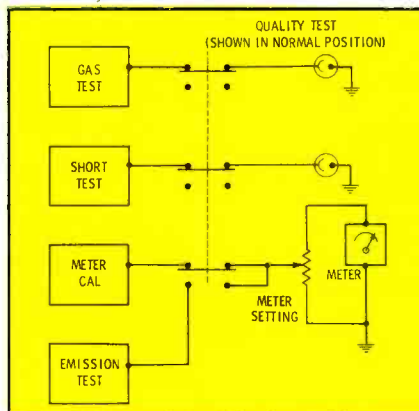

Fig. 2. Pushbutton in the up position.

also made with the pushbutton in the up position. The possibility of tube or tube-tester damage resulting from a shorted or misplaced tube is greatly decreased with this arrangement.

Two silvered contacts for fuse tests and a bayonet socket for pilot-light tests are wired into the short-test circuit for continuity checks. Also, 6- and 12-volt three- or four-pin vibrators can be checked. Type 44 lamps are connected to each vibrator contact; a burned contact can be detected by unequal lighting of the bulbs, while a completely inoperative vibrator will not light either lamp. Above the fuse and pilot-light tester are 7- and 9-pin straighteners.

The tube tester is solidly built; the

etched aluminum panel is neat and attractive. All 63 sockets have phosphor-bronze beryllium contacts to insure positive contact and long socket life. Although this tube tester will not give as much information about the status of a tube as a mutual-conductance instrument, it will show the most common defects. A Model 202 has been used in our lab for some time and has proven reliable in determining whether tubes were good, weak, or bad. Because of its simple fail-safe operation, this tester should give trouble-free operation and prove to be profitable for self-service tube sales.

FaradOhm Bridge/Analyzer

In the last few years, better-quality home-entertainment equipment has gone into more households. Usually these instruments have sophisticated circuits that are not found in the lower-priced units, and they may contain several components of close tolerance rating. When trouble appears in these

EICO Model 965 Specifications

Capacitance Range:

5 pf to 5000 mfd in 4 steps.

Power Factor:

0-80% at line frequency, on two highest capacitance ranges only.

Resistance Ranges:

0 to 500 megohms in 4 steps; resistances up to 100,000 megohms can be measured with the metered variable DC supply.

Resistance-Capacitance-Inductance

Comparator Range:

Capacitance — standard divided by .025-50; Resistance, Inductance — standard multiplied by .025-50.

Bridge Supply Voltage:

.45 volt AC at line frequency, except 10 volts AC on lowest capacitance and highest resistance ranges.

Variable DC Supply Voltage Range:

0-500 volts DC in 6 steps.

DC VTVM Range:

0-500 volts in 6 steps; input impedance 10 megohms.

DC VTAM Range:

0-15 ma in 11 steps.

Accuracy:

±5% throughout, except on power factor below 30%.

Power Requirements:

32 to 45 watts, 117 volts AC.

Size (HWD):

8½" x 12½" x 9".

Weight:

15 lb

Price:

\$129.95 (wired only).

WHY... SERVICE COLOR TV ?

**WHY WAIT?
YOU CAN MAKE
MONEY NOW!**

**...IF YOU'RE EQUIPPED - AND
A WIDE BAND SCOPE IS A MUST**



1,300,000 SETS SOLD IN '64

70% OF NBC PROGRAMMING
NOW IN COLOR

OVER 3,000,000 NOW IN USE

*PRIME TIME

This Hickok-quality, full 5", wide-band scope - factory assembled, wired and calibrated can put you in color TV service... for less than \$200.00.

- Rise time—less than 0.08 μ sec.
- AC response—5 cycles to 4.5 MC within 3 db
- Vertical sensitivity—40 MV RMS/inch
- 5 times horizontal sweep expansion
- Sharp, bright (1600 volts anode potential) trace with full astigmatic correction and, of course, it's...



THE COMPLETE COLOR LINE

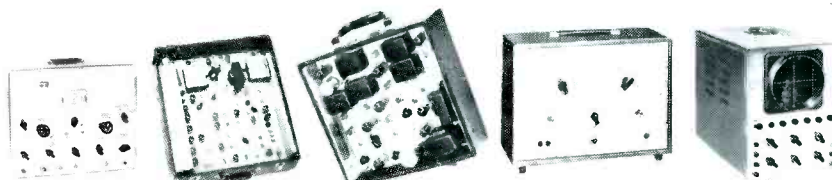

MODEL 615

MODEL 656XC

MODEL 660

MODEL 661

MODEL 675A

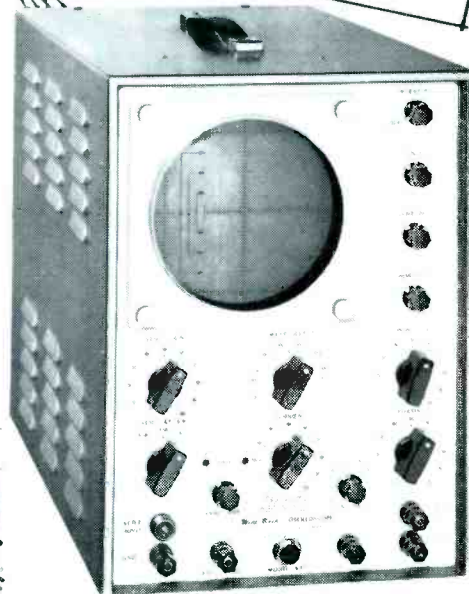

THE **Hickok**

ELECTRICAL INSTRUMENT CO.

10566 Dupont Avenue

Cleveland, Ohio 44108

Represented in Canada by Stark Electronics, Ajax, Ontario
Internationally by Hughes International, Culver City, California

Circle 19 on literature card



Fig. 3. This unit has a low range of .15 ua when in the DC VTAM Position.

circuits, an instrument capable of making precision measurements is required. The EICO Model 965 Farad-ohm Bridge/Analyzer (Fig. 3) is capable of doing this job. It provides facilities for making precision measurements of resistance and capacitance; checking diode reverse and transistor quiescent current; testing insulation; and comparing resistances, capacitances, or inductances with external standards.

A DC VTVM with 6 ranges and a DC VTAM (vacuum-tube ammeter) with 11 ranges are employed in this instrument and may be used for external purposes. The voltage drop across the DC VTAM terminals is

only 75 mv, and the lowest current range is an almost incomprehensible .15 ma (150 nanoamps). The meter is electronically protected in all ranges and cannot be overloaded more than 200%.

The Model 965 can be used to check the lowest-voltage capacitors found in transistorized equipment without danger of damage to the component. This is due to the low bridge-supply voltage of .45 volts AC at line frequency. When the bridge is to be used for measurements that require a different frequency and/or voltage than the instrument provides, an external supply can be used. A 1/32-amp fast-action fuse is used to protect the BRIDGE BALANCE potentiometer if excessive current is present when an external generator is applied.

Another feature of the bridge circuit is the AGC action to control the bridge detector-amplifier tube when an out-of-balance condition exists. The AGC tends to keep the meter reading on scale; however, when the null point is reached, the AGC action diminishes to afford a sharp null reading.

A 0-500 volt DC supply variable in six steps is used in measuring capacitor leakage and resistance and diode reverse or transistor quiescent current.

A capacitor to be tested for leakage is placed between the proper terminal posts, and the variable-voltage supply is adjusted until the meter indicates the rated voltage of the component. The proper switch is then positioned to place the DC VTAM in the circuit, and the current drawn by the component is read from the meter. By using Ohm's law ($R = \frac{E}{I}$), the leak-

age resistance is determined. If desired, resistors may be measured in this manner instead of with the bridge; however, the applied voltage is chosen so the current drawn will be a convenient divisor, such as 1 ua. Then the true value is known from a simple application of Ohm's law. A plug-in shield is supplied with the instrument; when in place it encloses the component being tested to eliminate the effects of a stray field when a very low capacitance or a very high resistance is being measured.

Another feature of the Model 965 is the COMPARATOR position of the BRIDGE RANGE switch. This is especially useful when making an inductance comparison. Since the bridge supply voltage is low—.45 volts AC—magnetic-cored inductances rarely will be saturated.

great profits



that's about the size of it

Microminiaturization has come to cartridge design in the new Sonotone Micro-Ceramic[®] Cartridge—a king-sized profit-maker in a tiny case. This remarkable new cartridge updates to 1965 performance almost any phonograph using a ceramic cartridge produced within the past 20 years.

The Sonotone Micro-Ceramic Cartridge embodies all the advantages of miniaturization and light weight. Designed for low mass, lightweight tonearms—it weighs less than 1 gram (without bracket). Superb stereo performance is assured by—high compliance; ability to track at the low forces required by today's modern record changers; excel-

lent separation and a smooth, clean response over the full audio range. To top it off, all Micro-Ceramic cartridges are equipped with the virtually indestructible Sono-Flex[®] stylus. For ease of installation, three different standard mounts are available.

Four Micro-Ceramic cartridges cover all of your replacement needs; the "27T," a high capacitance model for transistorized phonographs; the high compliance "25T" for deluxe stereo units; the "26T" and "28T" for replacement in a wide range of popularly priced phonographs.

For comprehensive Cartridge Replacement Guide, write:



Sonotone Corp., Electronic Applications Div., Elmsford, N. Y.

Circle 20 on literature card

FINCO

COLOR-VE-LOG ANTENNAS

FOR UHF, VHF, FM RECEPTION

ALL-BAND UHF-VHF-FM ANTENNA

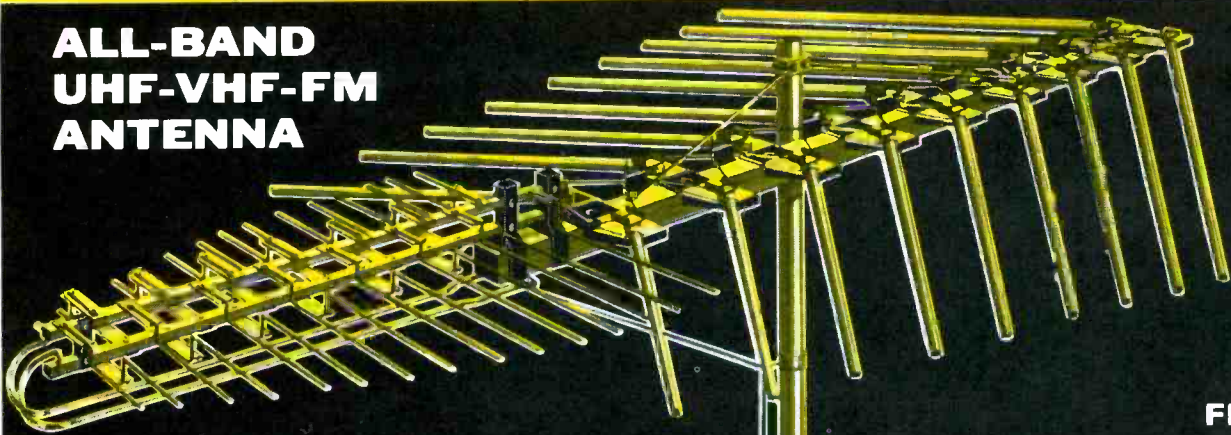

FINCO
Model UVF-24
\$59.95 list

The one antenna that does the work of 3! Gives startlingly clear black and white pictures and beautiful color on both UHF and VHF television channels — plus the finest in stereophonic and monophonic sound reproduction.

FINCO Model UVF-18 — \$42.50 list
FINCO Model UVF-16 — \$30.50 list
FINCO Model UVF-10 — \$18.50 list

SWEPT-ELEMENT VHF-FM ANTENNA

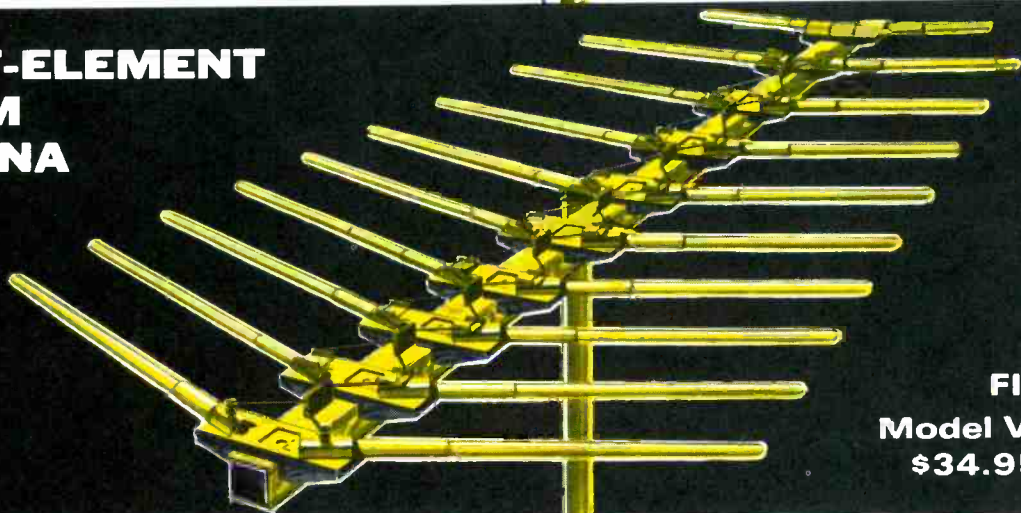

FINCO
Model VL-10
\$34.95 list

FINCO's Color-Ve-Log challenges all competition! Its swept-element design assures the finest in brilliant color and sharply defined black and white television reception — as well as superb FM monaural and stereo quality.

FINCO Model VL-18 — \$54.50 list
FINCO Model VL-15 — \$46.95 list
FINCO Model VL-7 — \$23.95 list
FINCO Model VL-5 — \$16.95 list

Featuring FINCO's exclusive Gold Corodizing

FINCO COLOR-VE-LOG

Prices and specifications subject to change without notice

THE FINNEY COMPANY • 34 W. Interstate Street • Bedford, Ohio

Write for beautiful color brochures Number 20-322, and 20-307, Dept. 310

Circle 21 on literature card

October, 1965/PF REPORTER 57

3 Reasons Why It Pays to Use General Electric Renewal Parts

INCREASED CUSTOMER SATISFACTION

The best customer is a satisfied one—satisfied with your service and with the quality of the parts you use. Satisfy your customers with G-E quality.



REDUCED INVENTORY AND SERVICE COST

With G.E.'s continuing parts standardization program you can stock fewer parts. Save time and money in everyday service operations.



FAST PARTS SERVICE

Need a part? Count on General Electric for quick service—your distributor will ship your order promptly.



BUILD PROFITS WITH THESE FAST MOVING TV AND PHONOGRAPH PARTS



Transistor EA15X25



Spindle EA97X174



Knob ET43X299



Polarized Extension Cord
ET90X32

These are four samples of G-E renewal parts, parts that are factory engineered, precision-fitted, and designed for long-lasting performance. Call your nearby General Electric distributor and ask him for Genuine G-E Renewal Parts.

830-38

GENERAL ELECTRIC

Circle 22 on literature card

Several components were tested with the Faradohm Bridge/Analyzer in our lab with excellent results. One protective feature that stood out was the illumination of the meter dial when excessive current was drawn. Insulation leakage or breakdown of a capacitor under test would cause this condition. Two incandescent lamps (in series) are in the circuit and mounted behind the meter panel. As the current increases to a high amount, the lamps glow.

A small lamp is mounted above the TEST terminal posts. When the instrument is set up so that a voltage is across these terminals, the lamp "blinks" continually as long as the voltage is present. This warns the operator that voltage is present and greatly reduces a potential shock hazard. There is also a DISCHARGE position on the FUNCTION switch to remove the charge from a capacitor when its test is completed.

A polarized jack is provided on the front panel. It is used in supplying an external polarized DC voltage to the instrument when a component being tested requires this type of voltage. Also on the front panel is a zero push-button. By depressing this button and adjusting the ZERO ADJUST control, the operator can reset the meter to zero during any part of any test.

The operating manual supplied with the Model 965 is self-explanatory. Careful reading of the manual will familiarize the user with the unit, and after a few tests are accomplished he will become aware of the versatility and usefulness of the instrument.

Circle 141 on literature card
on literature card

Versatile Oscilloscope

The Model WO-91B RCA oscilloscope (Fig. 4) is similar in many ways to the



Fig. 4. Scope has provision for coupling RF signal direct to Vertical Plates.

Steve Lovitch is too busy to wait a week for any part to arrive.

Steve Lovitch keeps on the go. He gets a lot of business because he is running a Philco Qualified Service Center. And the attention he gets from his Philco Parts Distributor helps to keep things moving.

99 out of 100 times that Steve needs a part, he finds that his Philco Distributor has it right on hand. That hundredth time, Philco's Lifeline Emergency Service swings into action, and Steve's part is on its way to him — by air — in 24 hours or less.

That's not all Steve likes about being teamed up with Philco. He's his own boss, but he still gets all the training, attention and benefits he could want.

Philco Tech Data Service helps him keep posted on how to service new Philco products. Steve knows that he gets the facts faster, fuller and at lower cost through Philco. And Steve's other Philco benefits include a complete accident insurance program for himself and his men and valuable advice on how to make his business more profitable.

Steve Lovitch has a good deal. And he knows it. Shouldn't you find out what Philco can do for you? Talk to your Philco Parts Distributor, or contact Parts & Service Department, Philco Corporation, Tioga & "C" Streets, Philadelphia, Pa. 19134.

PARTS & SERVICE DEPARTMENT

PHILCO

A SUBSIDIARY OF *Ford Motor Company*

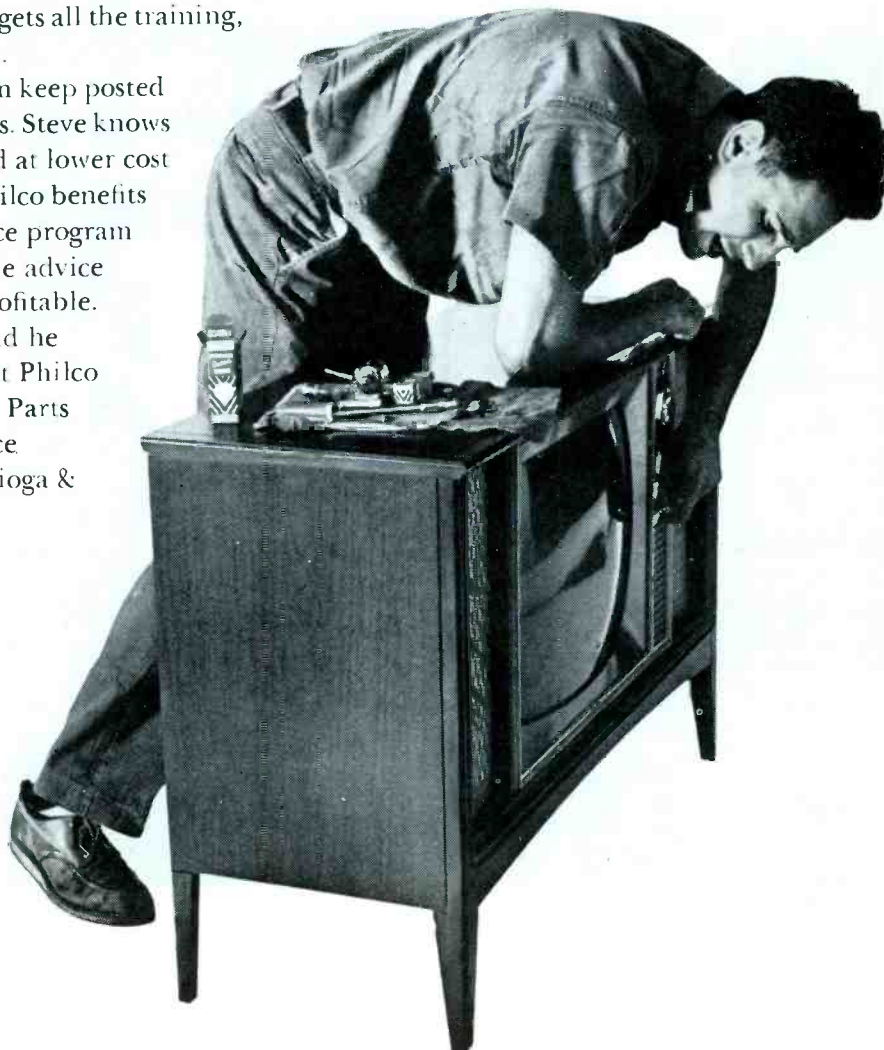

Circle 23 on literature card

earlier versions—WO-91 and WO-91A. It has many features that are essential in the service shop and for industrial uses. In case you're not familiar with the earlier WO-91's, here's a rundown on this newest model.

The instrument has a three-position (4.5 MC, CAL, and 1.5 MC) bandwidth selector switch (Fig. 5A). With the switch in the 4.5-mc (wideband) position, the bandpass of the vertical-amplifier stage has a frequency response within ± 1 db from 3 cps to 4.5 mc. With the switch set to 1.5 mc (high sensitivity), the frequency response is within ± 6 db from 3 cps to 1.5 mc. With the switch resting in CAL position, the input circuits and at-

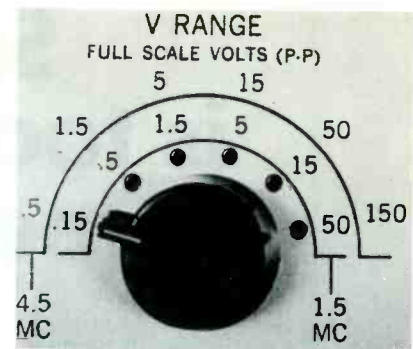
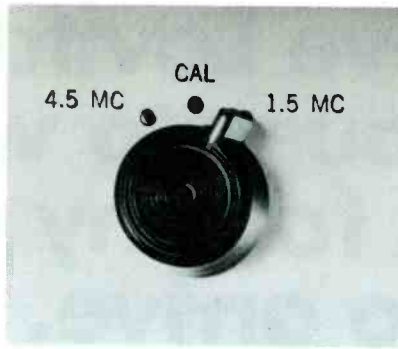



Fig. 5. Selector marks aid in calibrating instrument bandwidth and amplitude.

NOT JUST HORNS NOT JUST CONES OXFORD HAS THE FULL LINE

**Model
OP-6**



**to Supply Commercial
Sound Needs...**

**Model
OH-10**



**Model
DVC-8J4**



From the OP-6 & OP-8 paging and talkback horns and the OH-10 outdoor high fidelity system, which changed the outdoor speaker market in 1964, to the startling new DVC-8H4 and DVC-8J4 units with two separate voice coil winding, providing immediate access to the speaker, Oxford is the one source best qualified to supply all your speaker needs.

Our line also includes intercom speakers, public address speakers, all-weather cones, shallow ceramic magnet units, and the "Specialist Series." The Specialists (which includes models DVC-8H4 and DVC-8J4) are a series of popular 8-inch speakers that have been prepared for "instant use" by the commercial sound installer, with factory installed transformers and bulk packaging.

It makes good sense to use the line that is orientated toward the commercial sound installer by both design and marketing. For more information on the OXFORD line, write for complete catalog.

**OXFORD
TRANSDUCER
COMPANY**



A Division of Oxford Electric Corporation

3911 South Michigan Avenue • Chicago, Illinois 60653

Circle 24 on literature card

RCA Model WO-91B

Specifications

Vertical Channel:

Response— ± 1 db from 3 cps to 4.5 mc (wideband) with maximum sensitivity of .05 rms volt per inch; -6 db from 3 cps to 1.5 mc (high sensitivity) with maximum sensitivity of .018 rms volt per inch. Rise time .1 usec in 4.5-mc position; .5 usec in 1.5-mc position. Vertical input load 1 megohm shunted by 40 pf (1 megohm shunted by 75 pf with direct probe; 10 megohm shunted by 11 pf with low-capacitance probe). Maximum input voltage, 600 volts p-p (in presence of not more than 400 volts DC).

Horizontal Channel:

Response— -6 db from 3 cps to 500 kc. Sensitivity .18 rms volt per inch. Input load 2.2 megohms shunted by 30 pf. Phase control range 0° to 160° .

Z-Axis Input:

Response—3 cps to 500 kc. 12 volts rms required for trace blanking.

Internal Sweep:

Range—10 cps to 100 kc in four steps, continuously variable; two preset positions, 30 cps (TV vertical) and 7875 cps (TV horizontal).

Features:

Calibrated graticule with divisions for peak-to-peak voltage measurements. Input terminals for coupling RF directly to vertical plates of CRT (approximately 40 volts p-p per inch deflection). Combination direct/low-capacitance probe. Strong synchronization of 30-cps and 7875-cps waveforms.

Power Requirement:

105-125 volts, 50-60 cps, 75 watts

Size (HWD):

13½" x 9" x 16¾"
13¾" x 9" x 16½"

Weight:

30 lb

Price:

\$249.50

There's BIG MONEY in SMALL master-antenna SYSTEMS

...and JERROLD makes the work easy

DON'T pass up the profits waiting in the small motels, apartment houses, schools, and TV dealers' showrooms in your area. They all need a low-cost, efficient master-antenna system. And you're the logical one to install these systems . . . quickly, easily, profitably.

Jerrold gives you a honey of a package for these installations. You can vary it a hundred ways according to your needs.

GIBRALTAR Amplifier, Model 3440



Heart of the system is the new solid-state GIBRALTAR amplifier. Low noise figure (less than 6 db) means GIBRALTAR works well even in weak-signal areas. High output capability (more than 150,000 microvolts) lets it work in very-strong-signal areas without overload. High gain (25 db avg. hi band; 23 db avg. lo band and FM), consistent performance and maintenance-free reliability make GIBRALTAR the ideal amplifier for every small VHF system you install.

VARIABLE-TAP Room Outlets, Model VT-300

These attractive, low-priced wall outlets give you a choice of three isolation values simply by the turn of a screw. Model VT-300 is matched to 300-ohm twinlead. Also available as Model VT-75, with coaxial outlet to receiver. Ivory-colored cover plate mounts flush to wall; decorative without painting, but accepts paint readily. VARIABLE-TAPS are the newest member of the Jerrold line aimed at making your small systems installations easy and profitable.



JERROLD

THE NATION'S FOREMOST
MANUFACTURER OF ANTENNA
SYSTEMS EQUIPMENT

TYPICAL SYSTEM COST FOR 20 OUTLETS

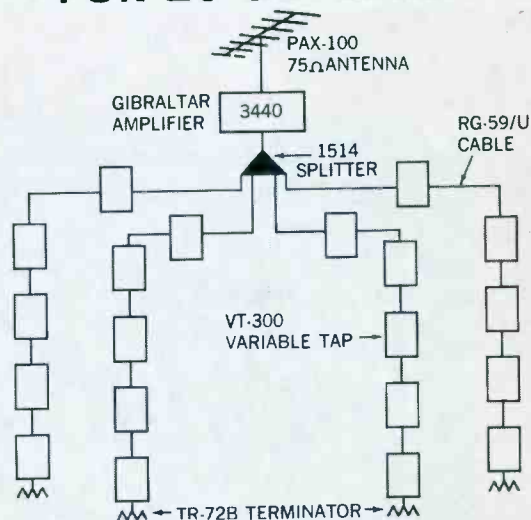

	Dealer Price
Model PAX-100 75-ohm antenna	\$ 25.77
Model 3440 Gibraltar amplifier	53.70
Model 1514 4-way splitter	9.14
20 Model VT-300 Variable-Tap outlets @ \$2.15	43.00
Miscellaneous (mast, mount, hardware, fittings, etc.)	20.00
Cable (500 ft. of RG-59/U)	20.00
Total Materials	\$171.61
Labor (16 hours @ \$5 per hour)	80.00
	\$251.61
Suggested installed price to customer	350.00

YOUR PROFIT \$98³⁹

Above is shown a typical system layout, along with a bill of materials and your average profit on installation of a 20-tap system in a motel, school, or dealer showroom in your area. Start now to earn BIG profits on small systems like this—send the coupon for complete information.

JERROLD ELECTRONICS CORPORATION

Distributor Sales Division
15th & Lehigh Ave., Phila., Pa. 19132

I'm interested in cashing in on the small antenna-systems business.

- Send me complete information.
 Have your technical rep call on me.

Name _____

Company _____

Address _____

City _____ State _____ Zip _____

tenuators are disconnected from the vertical amplifier, and a calibrating voltage is applied to the grid of the first vertical amplifier.

Peak-to-peak voltages may be measured by using the calibrated graticule (Fig. 6) along with the frequency-compensated vertical-input attenuator and the variable internal calibrating voltage source. The vertical-input attenuator selector (Fig. 5B) is a six-position switch with two ranges, one for each bandwidth setting.

To measure the peak-to-peak value of a waveform: (1) Set the bandwidth switch to the CAL position; a 60-cps wave-

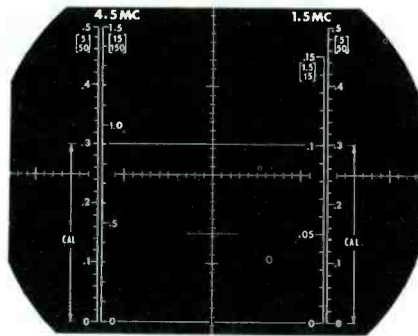

Fig. 6. P-P volts are directly on graticule.

form will appear on the screen. (2) Adjust the V CAL control until the trace is contained exactly between the lines identified by the CAL arrows on both sides of the graticule. (3) Set the bandwidth switch to whichever position is appropriate for the waveform you're measuring. (4) Adjust the V RANGE switch to display a pattern of convenient height—within the graticule. (5) Set the V CENTERING control so that the bottom of the waveform rests on the baseline of the graticule (marked 0). (6) Read the peak-to-peak voltage on the calibrated graticule, using the 1.5-mc or 4.5-mc scale, depending on the position of the bandwidth switch.

Convenient in the WO-91B is the automatic sweep synchronization for 60-cps and 15,750-cps waveforms. In the TV V position, the scope sync is fed through an integrator network to the sync amplifier; for TV H position, a differentiator network handles the scope sync. This special handling of the sync makes the scope presentation exceptionally stable for composite television waveforms. The SWEEP range switch also provides sweep frequencies from 10 cps to 100 kc in four steps; inside the limits of each step, frequency is variable with the SWEEP VERNIER control.

The SYNC/H SEL switch (Fig. 7) has four steps for choosing sync: EXT—permits an external synchronizing voltage, applied to the SYNC terminal on the front panel, to control the sweep oscillator; LINE SYNC—couples 60-cps energy from the power transformer to lock the sweep oscillator at the power-line frequency; INT- and INT+—chooses whether the positive-going or negative-going excursion of the input waveform will synchronize the sweep oscillator.

The SYNC/H SEL switch also has two steps for selecting a horizontal input other than the scope's own sweep. One position is labeled LINE; in this position, a 60-cps signal from the power supply is coupled to the horizontal amplifier, which provides a sinusoidal horizontal sweep at the power-line frequency. A PHASE control varies the phase of this sweep voltage. When the SYNC/H SEL switch is set to the INPUT position, an external signal voltage—such as the deflection signal of an RF sweep generator—may be applied to the scope through the H input terminal.

The Z AXIS terminal on the front panel provides for intensity modulation of the

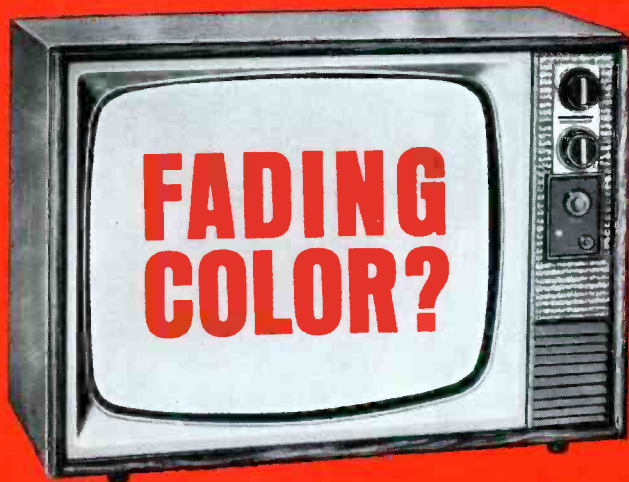

Perk it up with Perma-Power COLOR-BRITE

Perma-Power does for color TV sets what we've done for millions of black and white CRT's: adds an extra year of useful picture tube life.

When a color tube begins to fade, COLOR-BRITE instantly brings back the lost sharpness and detail. It provides increased filament voltage to boost the electron emission and return full contrast and color quality to the 3 gun color picture tube.

COLOR-BRITE is automatic... no switching or wiring. Just plug it in. Your delighted customers will brighten up as fast as their color sets!

Model C-501, for round color tubes.

List Price \$9.75

Model C-511, for rectangular color tubes.

List Price \$9.75



COLOR-BRITE is a Hue-Brite Product from Perma-Power, famous in TV service for b & w Vu-Brites and Tu-Brites.

Perma-Power COMPANY

5740 N. TRIPP AVE., CHICAGO, ILLINOIS 60646

PHONE (312) 539-7171

Circle 26 on literature card

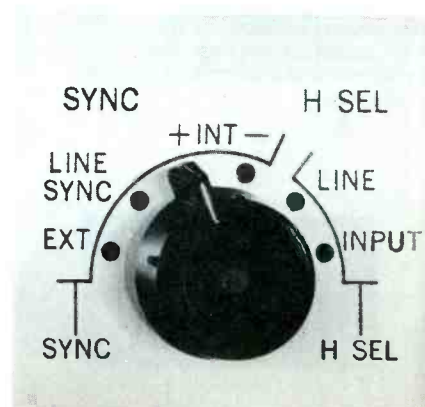

Fig. 7. Single selector chooses among horizontal inputs and the types of sync.

NOW! OVER 2700 REPLACEMENTS

with only 13 RCA Top-of-the-Line transistors

With RCA's "Top-of-the-Line" SK Replacement Series, you need only 13 transistors, including two matched pairs for ready replacement of more than 2700 types. In addition, RCA's two new SK-Series rectifiers—the SK3016 and SK3017—enable you to replace virtually any selenium or silicon rectifiers having comparable ratings.

Stock the complete SK-Series—13 transistors and 2 rectifiers. They will provide the answer to many of the replacement problems you face servicing auto radios, battery-operated portable radios, tape recorders, hi-fi equipment, phonographs, black-and-white and color TV, and other entertainment-type equipment using solid-state devices.

Accurate, comprehensive replacement information is given in the new 16-page RCA "Top-of-the-Line" Semiconductor Replacement Guide SPG-202. With it you have at your fingertips information on more than 2700 transistor types, including many of foreign manufacture—which the 13 RCA "Top-of-the-Line" types replace.

See your RCA Distributor about the RCA SK-Series, and be sure to ask for your copy of the RCA Semiconductor Replacement Guide.

RCA ELECTRONIC COMPONENTS AND DEVICES, HARRISON, N.J.



The Most Trusted Name in Electronics

"Top-of-the-Line Replacement Transistors"

SK-3003 pnp type, AF Driver and Output Stages (9 V Supply)
 SK-3004 pnp type, AF Driver and Output Stages (15 V Supply)
 SK-3005 pnp type, RF, IF, and Converter Stages of Broadcast Receivers
 SK-3006 pnp type, RF, IF, and Converter Stages of FM and AM/FM Receivers
 SK-3007 pnp type, RF, IF, and Converter Stages of All-Wave Receivers
 SK-3008 pnp type, RF, IF, and Converter Stages of Auto Radios
 SK-3009 pnp type, Audio Output Stages of Auto Radios

SK-3010 npn type, AF Driver and Output Stages of Broadcast Receivers
 SK-3011 npn type, RF, IF, and Converter Stages of Broadcast Receivers
 SK-3012 pnp type, Audio Output Stages of Auto Radios
 SK-3013 Matched pair of SK-3009
 SK-3014 Drift Field type for Output and Driver Stages of Hi-Fi equipment
 SK-3015 Matched pair of SK-3014
 SK-3016 Silicon Rectifier for color, B/W TV, Radios, Phonographs
 SK-3017 Silicon Rectifier for color, B/W TV, Radios, Phonographs



Circle 27 on literature card

scope trace on the scope face with an external signal; an amplitude of 12 volts is required to blank the trace. The panel terminal is connected through a .01-mfd capacitor to pin 2 (first grid) of the cathode-ray tube.

A feature that was not incorporated in previous WO-91 models is provision for coupling an RF signal directly to the vertical deflection plates by way of two terminals at the back of the unit. Coupling is through two .01-mfd capacitors.

This feature is useful for interpreting modulation quality of any transmitted AM signal. Trapezoidal and wave-envelope patterns, shown in Fig. 8, are the basic waveforms that are developed to show modulation characteristics.

To produce a trapezoidal waveform on the scope, the RF signal—taken from a pickup loop in the transmitter output tank—is coupled, through a shielded cable to avoid distortion, to the terminals at the back of the scope. The switch directly above these terminals is moved to DIRECT. The audio signal that is modulating the transmitter is connected to the H IN scope terminal, again with shielded cable, and the SYNC/H SEL switch is set to its INPUT position. Fig. 8—left—shows the various patterns displayed on the scope screen and what each means in terms of modulation percentage.

To obtain a wave-envelope pattern the RF signal is coupled to the deflection plates in the same manner as for a

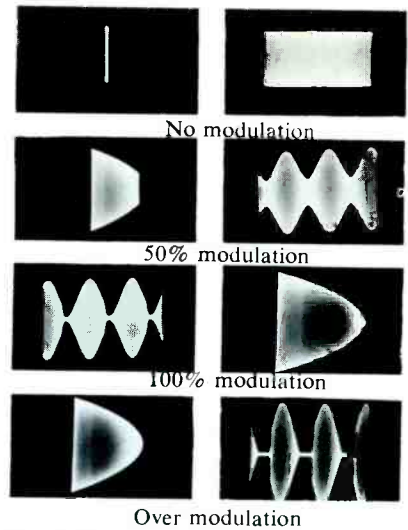

Fig. 8. Trapezoidal and wave-envelope patterns for analyzing modulation.

trapezoidal waveform. The SYNC/H SEL switch is set for INT and the SWEEP switch and SWEEP VERNIER control are adjusted at approximately the audio modulation frequency. The resulting patterns are at the right in Fig. 8. The wave-envelope system is useful mostly for tests with sine-wave modulation, but the trapezoidal system can be used with any kind of complex modulation—even voice.

The WG-300B direct/low-capacitance probe that is supplied with the WB-91B incorporates a high-impedance circuit, connected across a slide switch that allows the user to easily choose either a direct or low-capacitance probe function. This eliminates groping for separate cables when changing from a direct probe to a low-capacitance type.

While working with the scope in our lab, we noticed that whenever the probe touched to DC-carrying circuit the trace would bounce—at times it would leave the screen completely, and require several seconds to return. This condition was most noticeable when the probe was used in its low-capacitance position. This phenomenon is caused by the charging of the large-value input capacitor within the probe. The time required for this capacitor to charge is further affected by the series resistance of the vertical-input attenuators. The time can be reduced considerably by momentarily turning the V RANGE switch to its highest position; the capacitor charges more quickly and the trace returns more rapidly.

The WG-302A probe for tracing RF or IF signals, is an accessory that may be purchased for the WO-91B. It snaps over the tip of the WG-300B probe. Signal tracing with this probe is quite convenient in troubleshooting VHF tuners and video-IF stages.

The comprehensive manual supplied with the WO-91B contains complete instructions on setup procedures for its many applications. There is even a section devoted to the maintenance of the unit, which describes—among other things—astigmatism adjustment; alignment of vertical attenuators; and sweep-oscillator adjustments.

For further information, circle 142 on literature card

Business/Industrial 2-Way Radio is hot!

Johnson has the Product,
Experience & Marketing
Know-How for YOU to "cash
in" on this Market.

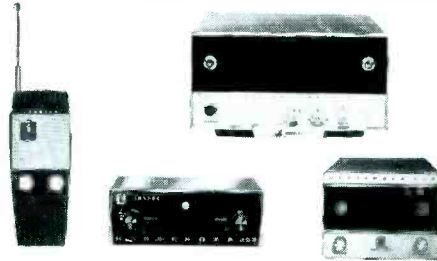

You can sell Citizens Band equipment for many Business/Industrial applications—and we recommend it! However, our 25 to 50 Mc. AM BUSINESS INDUSTRIAL 2-WAY LINE opens *new* profit potential for you!

Johnson has the equipment, experience and marketing support to enable you to get your share of this expanding, profitable market. Because Johnson AM equipment costs less to buy, less to service—you'll find doors open to you that are closed to other Business/Industrial radio equipment dealers and distributors!

Shouldn't you be selling Johnson
Business/Industrial Two-Way Radio?

E. F. JOHNSON COMPANY

7687 Tenth Ave. S. W. • Waseca, Minn.



GET THE FACTS! Send today for informative booklet with AM and FM marketing facts!

Sales Tips

(Continued from page 50)

sales success with a set that won't come on without a jiggle here or there, or on which the salesman fumbles to find which knob turns it on or adjusts the picture.

Be sure all wires (such as the antenna) are connected *before* you turn the set on. Don't turn on a set and wait several minutes only to find the power cord hasn't been plugged in! Even if this doesn't upset the customer, it nearly always causes the salesman to blurt out some covering conversation that implies the particular set probably can't be trusted to work every time. Moral: Be sure about what you are selling. Don't just turn it on and hope; check out each set before the prospect arrives.

Be enthusiastic. If you can't believe in the set you are selling, you're not likely to sell it. Every set, new or used, has some good points, something that gives it an advantage over other sets. Get those good points fixed in your mind. Does the set have a good picture? A large speaker and good sound? A tone control? A nice cabinet? A remote control? Preset fine tuning? Keyed AGC? Filter-glass front? Simple control setup? Controls clearly marked? Hidden controls? Is it newly overhauled? Easy to service?

Some salesmen jot down the sales features and tape them to the back of the set or list them in a book they carry. Others tie a card to the front of the set with all the sales features listed; then they take the sales card and, with pen or pencil, point out each feature to the prospect and elaborate wherever it is helpful. This kind of presentation can't help but impress the customer and it also helps the salesman who is hard-put to remember sales points on all the various sets in the store. The few minutes it takes to make out such a card are nothing, considering the increased sales you can make using this technique.

Closing the Sale

Finally, you should know how to close a sale. Ask the buyer: What kind of terms do you prefer? How much down payment do you wish to make? How many months to

pay? Fill out the forms your firm requires of the customer for establishing credit. About the trade-in: tell how much you can allow on it.

If you can't get answers to those questions, you may as well have saved your breath on the rest of your sales pitch. Make sure you know how to wind up a sale and get the prospect's name on the dotted line. In most instances, small shops find it best to have a professional financing source. These finance companies will furnish rate cards and

other necessary forms for you to use with installment customers.

In summary, if you want to be a salesman, know your product, expect your customer to buy, point out the sales features, and be ready to close the deal when you ask the customer to buy. And, as a final word: Don't let a lost sale give you an inferiority complex. Analyze your sales pitch to see if there were any flaws. If there weren't, forget it, and smile . . . there's another prospect coming in the door! ▲

AGC PROBLEMS?

SENCORE BE113 ALIGN-O-PAK DUAL TV BIAS SUPPLY

... a *MUST* for AGC trouble shooting; Quickly isolates the problem by direct substitution of TV AGC voltage with a variable bias supply. A *MUST* in B&W TV alignment, and *NOW*, a *MUST* for Chroma Bandpass amplifier alignment in color TV sets. The BE113 ALIGN-O-PAK provides all the voltages recommended by TV manufacturers with two non-interacting bias supplies of 0 to 20 volts DC at less than 1/10th of 1% ripple with calibration accuracy better than standard battery tolerances. Eliminate those messy time consuming batteries and get your BE113 from your distributor today.



\$12.75

SENCORE 426 South Westgate Drive • Addison, Illinois 60101
Circle 31 on literature card

NOW! Solve Electronics Problems fast with New Patented Slide Rule.



That's right! This amazing new Electronics Slide Rule will save you time the very first day you use it. It's a patented, all-metal 10" rule that features special scales for solving reactance, resonance, inductance and circuitry problems . . . an exclusive "fast-finder" decimal point locator . . . widely-used formulas and conversion factors for instant reference. And there's all the standard scales you need to do multiplication, division, square roots, logs, etc.

Best of all, the CIE Electronics Slide Rule comes complete with an Instruction Course

of four *AUTO-PROGRAMMED* lessons. You'll quickly learn how to whip through tough problems in a jiffy while others plod along the old-fashioned "pad and pencil" way.

Electronics Slide Rule, Instruction Course, and handsome, top-grain leather carrying case . . . a \$50 value for less than \$20. Send coupon for *FREE* illustrated booklet describing this Electronics Slide Rule and Instruction Course and *FREE* Pocket Electronics Data Guide. Cleveland Institute of Electronics, 1776 E. 17th St., Dept. PF-105 Cleveland, Ohio 44114.

*TRADEMARK

GET BOTH FREE!

ELECTRONICS
SLIDE RULE

Send
coupon
today →

**Cleveland Institute
of Electronics**

1776 E. 17th St., Dept. PF-105, Cleveland, Ohio 44114

Send *FREE* Electronics Slide Rule Booklet. Special Bonus: Mail promptly and get *FREE* Pocket Electronics Data Guide too!

NAME _____ (Please Print)
ADDRESS _____ COUNTY _____
CITY _____ STATE _____ ZIP _____

A leader in Electronics Training... since 1934

Circle 30 on literature card



In a
printed circuit
TV set it can take
20 MINUTES to
unsolder and resolder
a transistor

It takes only
3 SECONDS to change
one of the plug-in transistors
in Zenith's new Handcrafted
transistorized portable TV



ZENITH
HANDCRAFTED TV



IS BUILT WITH THE SERVICEMAN IN MIND!



Shielded Permohm*

Shown Actual Size

**new
8290**

Shielded Permohm*
Shown Actual Size



82 Channel TV lead-in for the strongest, cleanest picture signal and best color... ever!

- Provides 82 channel color reception
- Less installation time and cost
- Eliminates transmission line pick-up of noise and ghost signals
- No expensive matching transformers required
- Can be installed anywhere

Photos courtesy of WGN-TV.

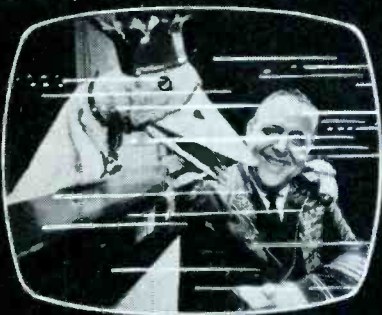

Unshielded twin-lead
Severe picture disturbance
due to ignition noise.



Coaxial Cable
Ignition noise minimized—
but not eliminated.



*** Shielded Permohm**
Eliminates automobile
ignition noise.

■ New 8290 Shielded Permohm TV Lead-in combines the strong signal strength of twin-lead with the clean signal protection of shielded cable. Because it is a balanced line for 300 Ohm TV antennas and receivers, *costly matching transformers and connectors are eliminated.*

8290 is specifically designed for superior color reception on all 82 channels. The twin-lead is encapsulated in low-loss cellular polyethylene insulation, Beldfoil** shielded against all outside disturbances, and protected with a weatherproof

*Belden Trademark—Reg. U.S. Pat. Off.

jacket. A drain wire is provided for grounding the shield to the chassis. The need for stand-offs, twisting or routing of lead-in is eliminated. 8290 can be taped directly to a mast or tower, routed through metal pipe, buried underground, or even installed in rain filled gutters to reduce installation time and cost.

Ask your distributor about 8290 Shielded Permohm TV Lead-in cable, today! Or, write P. O. Box 5070-A for complete information.

*Belden U.S. Patent 2,782,251

**Belden U.S. Patent 3,032,604

8-9-5

BELDEN MANUFACTURING COMPANY

Belden

P. O. Box 5070-A • Chicago, Illinois 60680

Circle 33 on literature card

October, 1965/PF REPORTER 71

Unlocking Secrets of TV Alignment

by Carl Babcoke

Alignment equipment is often the most neglected and dusty of shop instruments. All too many technicians buy expensive sweep and marker generators and try enthusiastically to align a few sets; and then disillusionment sets in. Some sets worked better before his realignment and others didn't respond "the way the book said." Before he has time to develop any skill at alignment, that maze of cables and the awkwardness of the equipment—added to normal difficulties—have caused him to shove all those shiny new panels to the rear of the bench, there to gather dust in disuse.

Has this been your experience? Don't let it get you down! Drag that expensive gear back out of those dark corners and let it help you make money more quickly. Some of the following tips will help you either with the equipment or with the actual alignment. In either case, you'll find your investment isn't a loss, after all.

Equipment Accessibility

Test equipment must be ready for use without much preparation if it is really to save time (money). All of the major units should be kept in one place, with AC power and signal cables connected, ready for instant use.

One solution to this problem of equipment availability is shown in Fig. 1. Dimensions of this alignment rack are not necessary, since you may have other models of different sizes. If you build such a rack, measure your own equipment carefully and allow room for internal shelves, bracing, and AC wiring. You can build the rack in a permanent position, then put TV sets on rollabout tables and bring them close for alignment. Or, you can make the rack portable with large wheels, and move it into position at whatever bench it is needed.

Some of the convenience features of this particular rack are:

1. Sloping panel for visibility.
2. Generators and accessories arranged for shortest interconnecting leads.
3. VTVM can be removed for use elsewhere; AC plug is inside the well.
4. All other equipment plugged into outlet strips inside rack. Sweep and scope line plugs should be phased to



Fig. 1. Alignment equipment rack simplifies connections, and saves time.

produce alignment curve with high-frequency end to the right.

5. One AC cable and master switch controls all units.
6. Small light plugged into outlet at top provides soft illumination and shows when rack is "on."
7. Hooks on the side keep cables out of way when not in use.
8. Large drawer-type handles for easy moving.
9. Small shelf (beneath) holds soldering iron, attenuating pads, extra leads, and miscellaneous parts.
10. Extra AC plugs on front for receiver power, soldering iron, other equipment, or portable lights.
11. Storage space below; door adds to appearance.
12. Large rubber-tired (wagon) wheels for mobility.

Alignment Tips

The next step, after the "haywire look" is removed from your equipment, is to develop alignment techniques to permit accurate and speedy adjustment. Each model of TV receiver is a different problem, but some of the techniques are universal. Check the schematic for RF traps, determine which stages are stagger-tuned or overcoupled, and then pay close attention to the tips we'll give you in the following paragraphs.

Equipment requirements:

Sweep generator for IF and RF frequencies; (should develop sweep 10 mc wide over channel wanted).

Marker generator at IF and RF, (with internal crystal for calibration).

Oscilloscope with good low-frequency response—no tilt on 20-cps square wave.

Bias supplies should have two or more variable voltages, with good regulation.

Marker-adder is convenient but not necessary.

Assortment of pads, loads, coupling capacitors, and test leads (Fig. 2).

An overall sweep curve from antenna to detector is quick to obtain and may be all that is necessary if the alignment is normal or needs only slight touchup. This overall response curve will often reveal the source of some pretty obscure troubles. To set up this curve, hook up the chassis and alignment equipment as it is shown in Fig. 3.

If more is necessary than a slight adjustment of one

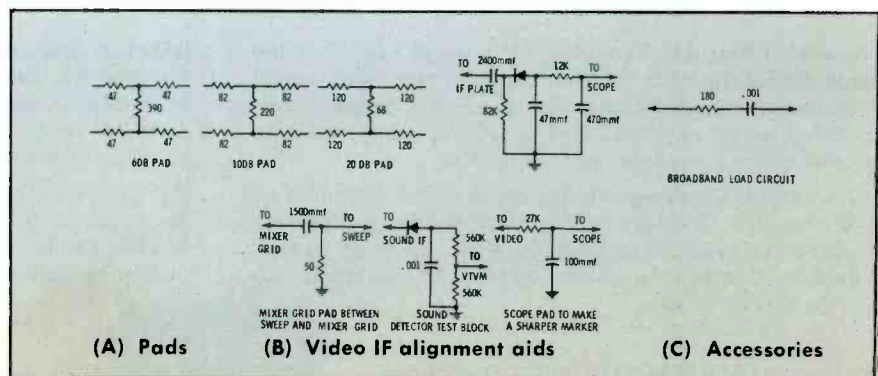

Fig. 2. Alignment is much easier with pads and detector circuit test blocks.

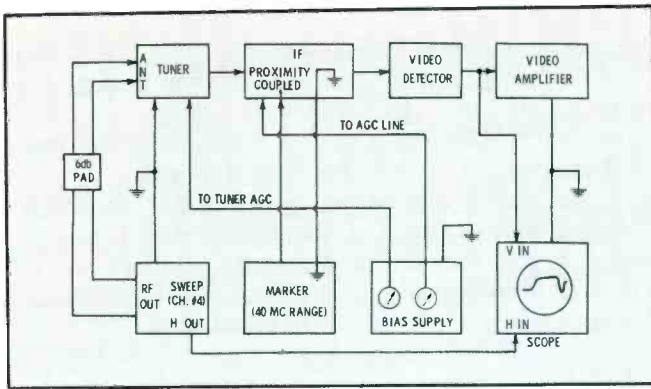

Fig. 3. The overall curve is rapidly measured with this setup.

or two slugs, a complete alignment should be undertaken. These general tips should help you align any set.

Initial Setup

Check your equipment for proper operation. The sweep-generator output cables should have resistor pads at the end of the cables. This is important. If in doubt, just add an 82-ohm carbon resistor between the two wires at the end.

Use the fixed AGC bias specified by the manufacturer, if it is known. Otherwise, just measure the AGC on the strongest channel and set the IF bias for this voltage. The tuner can be set at -2 volts in most cases.

Use the pads and loads that are specified by the set manufacturer for connecting the equipment to the set, if you know what they are. If not, ignore them for now.

Preliminary

Look at the overall curve, *but do not adjust anything until you have:* (1) Moved the tubes in their sockets and noted any variation in the scope trace; (2) checked tube shields for the same effect; (3) moved the chassis and printed boards and noted any variations. A normal chassis will show only temporary and very minor changes in amplitude or shape of the sweep curve. If you see more than this, clean tube sockets, resolder grounds, or take whatever steps will eliminate the instability. *Only* when the curve is stable should you actually align the set.

Aligning

Turn the sweep-generator output as high as possible without flattening the scope pattern; then reduce the output until the pattern on the scope is about half that height. Do this step without any marker at all.

Next, use as much marker as possible without distorting the sweep pattern. Distortion will vary according to the marker position on the curve, so this should be checked often and reduced if necessary. Normally, the marker should be inserted in such a way that the height or shape of the curve is not changed; this is easier if the sweep and marker are not attached to the same point. One excellent attachment method is with the marker-cable ground on the receiver chassis and the "hot" lead to the shield of the first IF tube. Some experimenting will find the best method for each receiver.

Where the shape of the curve is not important and a strong marker is needed, such as while adjusting traps, you may inject the marker at an unbypassed cathode in the IF strip or at an IF grid through an isolation resistor.

only picture tube analyzer that tests all color tubes as they should be tested!

(THE WAY TUBE MANUFACTURERS DO)



NEW LECTROTECH CRT-100 PICTURE TUBE ANALYZER

FOR COLOR AND BLACK AND WHITE

Does everything . . . you would need **all three units** of the leading competitive brands to equal the performance of the Lectrotech CRT-100. No other brand has all the features . . .

- Line voltage adjustment (to insure all tube voltages are correct regardless of line voltage).
- Critical Grid-to-Cathode Leakage is read on sensitive meter for greatest accuracy.
- Leakages in all other elements are indicated on neon lamp.
- Tests **all** black and white and **all** color tubes for leakage, shorts and emissions.
- Tests each color gun separately.
- Tests each color gun to a standard set of heat conditions. With variable G-2 voltage, each grid is normalized to a reference cut-off voltage. This method is used by tube manufacturers and simulates tube performance in color receiver.
- Rejuvenates and removes shorts on both color and black and white tubes for increased brightness.
- Life expectancy test, predicts remaining useful life of both color and black and white picture tubes.
- Continuously variable G-2 voltage for all tubes, present and future, including new 15 inch color tubes.
- Complete plug-in cables for easy replacement.
- Complete self-contained black and white socket assembly. No adapters to lose or cables to break.
- Including Pilot Light.

Only **89⁵⁰** net



See your distributor or write DEPT. PF-10

LECTROTECH, INC.

1737 Devon Ave., Chicago, Illinois 60626

Circle 34 on literature card

October, 1965/PF REPORTER 73

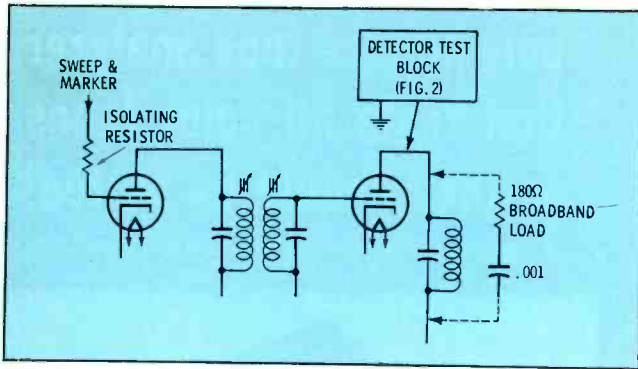

Fig. 4. Load shunts coils to allow individual adjustment.

The single-tuned (stagger-tuned) coils should be pre-set for their approximate frequency, even though they may be changed later in the alignment procedure. One easy method of presetting is to set the marker for each desired frequency and adjust the slug for maximum height of the marker, while viewing the overall sweep. For this step, disregard any change in the shape of the curve, but tune the marker as far above the base line as possible. A finger placed under the marker pip on the scope face can help find this maximum point.

Overcoupled stages should be aligned one at a time, as shown in Fig. 4. A broadbanding load circuit (Fig. 2B) is connected across all overcoupled coils except the one to be adjusted, to load them down so they won't affect the adjustment. A detector test block (Fig. 2B, also) is used for connecting the scope, since

the set's own video detector can't be used. These steps are taken for each IF transformer, until all have been aligned. In many sets, both the tuner IF transformer and the first IF transformer are overcoupled. In others, only the last IF transformer is overcoupled.

Traps, also, can be set by the same technique—aligning only the stage containing the trap. This avoids false results because of overloads or problems with multiple traps. Simply disable those not being adjusted.

Only after traps and overcoupled stages have been done should the stagger-tuned stages be tackled. Do them while watching overall sweep pattern. *Do not reset* the overcoupled stages or the traps when you do this final alignment.

A radically different curve on each channel indicates need for alignment of the antenna, RF, and mixer stages in the tuner. Black-and-white sets are usually considered normal if the curve does not tilt more than 20% from one channel to another.

Conclusion

This, obviously, isn't a step-by-step alignment procedure for any particular set. The manufacturer's instructions or the PHOTOFACT Folder will give you comprehensive and specific data on each model. This group of hints and tips, however, should give you enough general insight into alignment to allow you to dust off those sweep instruments and start using them to upgrade the quality of service you offer. ▲

new!

All-Transistor Color Bar Generator

Rugged, solid-state Seco 900 puts you on top of the booming Color-TV Service Market... with the finest unit in the field!

Setting new standards in both engineering and design, Seco's new Model 900 will outperform every other color bar generator on the market!* A true precision instrument that offers brightest dots and purest color quality, the 900 takes the "guess" out of color TV-servicing, makes possible big new profits in the booming color service field!

Only the Seco 900 offers all of these features:

- Single Burst Dots are bright—"rock" solid... will not move
- Purest Color Quality—10 completely different color bars... positive graduation from color to color
- Single Trace Horizontal Lines—are bright, sharp... begin and end during horizontal retrace
- No Blinking On Cross Hatch—at any intensity level
- All Transistor Circuit—for highest reliability and instant operation with no warm-up
- Outstanding Stability—Zener regulated power supply... crystal controlled oscillators!



SECO ELECTRONICS CORP., 1207-B So. Clover Dr., Minneapolis, Minn. 55420

\$12995

Dealer Net



Circle 35 on literature card

ALL ANTENNAS ARE NOT THE SAME

Consider the Channel Spanner TV antenna series by Antennacraft. Antennas as new and different as any can be. Built to receive all TV channels, UHF and VHF plus the full spectrum of FM stations. Modern TV sets, with color picture tubes and built-in UHF tuners need antennas designed for color and UHF. Antennacraft's Channel-Spanners fill this need.

Built-in electronic integrity assures a strong, ghost-free signal reaching the TV set terminals. Mechanical masters have structurally designed these antennas to last for years. All elements fold and lock into position with a minimum of time and effort. Antennas are gold vinyl coated for lasting beauty and performance.

If fast installation and no "call-backs" means more money to you, then consider the Channel Spanner series of TV antennas by Antennacraft. Because it is true, all antennas are not the same.



For UHF-VHF and FM
**ANTENNACRAFT
CHANNEL-SPANNER**

MODEL 604

Other Models Available.

ONLY \$24.95 LIST PRICE



BETTER BUILT FOR BETTER PERFORMANCE

ANTENNACRAFT

Automatic Channel Selector

TV ANTENNAS

BURLINGTON, IOWA

Circle 36 on literature card



This modern group
deserves your acquaintance.

by Rufus P. Turner

Words coined to name electronic devices often use certain suffixes (or sometimes, root-endings) which eventually come to designate whole families of devices—thus . . . *tron* and . . . *ode* for tubes and tube-like devices (magnetron, thyratron, cyclotron, diode, triode, pentode), . . . *ac* for computers (Eniac, Geniac, Seac) and . . . *syn* for synchronous devices (autosyn, selsyn, microsyn). And there are many more.

The most glamorous of these word endings at present is . . . *istor*. This is simply a derivative of the word *resistor* and designates a device that behaves in some way like a resistor. Best known for its most famous member, the transistor, the . . . *istor* family contains

many semiconductor devices; but the family also boasts cousins which are not semiconductors, even though they behave somewhat like a transistor.

The ending . . . *istor* was first used in the late 1940's to name a newly developed heat-sensitive resistor, the *thermistor*. That was the start of the present . . . *istor* clan. Next came the transistor (a *transfer resistor* or resistor having transconductance), and since then the family has grown so fast and so large that several new members may appear before the ink has dried on this page. How many . . . *istors* do you know? Meet here 18 important members of this numerous family.

Ferristor™

This device is not a semiconductor but it's a miniature, high-frequency magnetic-amplifier-type component. Its name derives from the term *ferromagnetic*, which describes the nature of this device, and from the fact that it is transistor-like in many of its applications (thus, *ferristor* = "iron transistor").

The core of the ferristor usually is made from a high-permeability metal such as *Permalloy*, and on it are wound control and load coils as in any other magnetic amplifier. The load winding is tuned to resonance at the power supply frequency (generally 100 kc) by means of a series capacitor. The ferristor displays negative AC resistance and consequently is easily adaptable to simple flip-flop operation. This relatively simple component finds application in counters and computers for relatively slow speeds.

Fieldistor

The *fieldistor* is a transistor in which the input (control) electrode is capacitive, to provide high input impedance comparable to that of a tube. Control of the current carriers within the semiconductor wafer of the device is therefore accomplished by action of the electrostatic field set up by the input signal. What was attempted in the laboratory model of the fieldistor now is accomplished on a commercial basis in the field-effect transistor (June 1964 PF REPORTER).

Hallistor

Fig. 1 is a simplified diagram of the *hallistor* (Hall-effect generator). In this device, electrical contact is made to the four edges of a thin wafer of indium antimonide or indium arsenide. A DC bias voltage, E_i , is applied between two opposite edges, A and B; and output terminals are connected to the other two edges, C and D. If a magnetic field then is caused to penetrate the wafer in the direction shown, a DC voltage (E_o) will appear at the output terminals, with the polarity shown, and will be proportional to the strength of the magnetic field. This action is termed the *Hall effect*.

The *hallistor* output voltage may be used in measuring magnetic field strength (as in a fluxmeter in which the *hallistor* is mounted in the end of the test probe). It also may be used for electronic control operations involving a magnetic field, since it requires no switch contacts.

The *hallistor* finds use in analog computers in which

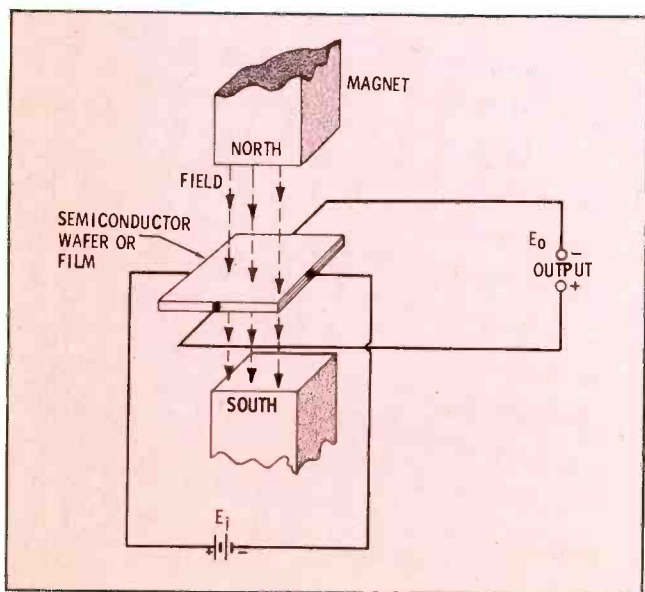

Fig. 1. Structure of the hall-effect transistor (hallistor).

GC Electronics doesn't have the reputation for leading the industry in Antenna Design...so

This should surprise you!



GOLD GUARD FINISH

this is an illustration of the **TRUEST ALL-CHANNEL ANTENNA EVER DESIGNED...**

for CLEAR, SPARKLING COLOR BLACK and WHITE

COLORMAGIC
EXP*

introducing...

**ALL-CHANNEL ANTENNAS
SUPERB UHF·VHF·FM&FM-STEREO**

*
EXPONENTIAL...an Antenna Design based on a natural mathematical Formula...an All-Channel Antenna that almost perfectly matches all the signals transmitted over the entire UHF, VHF and FM bands. In other words, to define the Perfect All-Channel Antenna would be to describe EXP. Compact, Low Cost, 5 brand new models for every televising area. You have to see it to believe it.

**4 ANTENNAS in 1
WITHOUT COMPROMISING
ANY PORTION OF THE UHF,
VHF or FM FREQUENCIES!**

GOT A MINUTE? WRITE US!

A textron COMPANY



GC ELECTRONICS
400 South Wyman Street Rockford, Illinois 61101

Circle 37 on literature card

the magnetic field may be used to represent one variable, the DC bias a second variable, and the output voltage their product. This latter application suggests another use of the hallistor—in a wattmeter in which the magnetic field is proportional to a current component, bias voltage to the voltage component, and output voltage thus represents the power in watts.

Lumistor

The *lumistor* (see Fig. 2) is a sandwich consisting of an electro-

luminescent (light-emitting) layer and a photoconductive layer facing each other. The arrangement is similar to mounting a flat lamp on a flat photocell.

In operation of the lumistor, the DC voltage E1 biases the electro-luminescent layer to the point that its phosphor coating emits light. The input signal, introduced through transformer T1, modulates the current from E1, causing the electro-luminescent layer to emit cycles of light proportional to the frequency and intensity of the signal. These

luminous cycles cause the resistance of the photosensitive layer to change in the same way, and thus modulate the current flowing from battery E2 through the lumistor and load resistor R1. If E2 is much larger than the signal voltage, the AC signal voltage across R1 will be proportionately greater than the input signal voltage. Thus, the lumistor can amplify.

Magneto resistor

This device is somewhat similar to the hallistor, except that the *magneto resistor* has only two terminals. The magneto resistor is a resistor made of indium antimonide or indium arsenide, the resistance of which may be varied by means of an external magnetic field (the field traverse the magneto resistor as it does the hallistor in Fig. 1).

A magneto resistor may be connected in series with a bias voltage (AC or DC) and a meter, amplifier, or conventional load resistor. The current flowing through the magneto resistor is proportional to the strength (and frequency, if the field is alternating or fluctuating) of the magnetic field. This action has been made the basis of flux meters, tubeless and transistorless amplifiers, and specialized analog computers.

Magnistor™

Like the ferristor, the *magnistor* is not a semiconductor device, but behaves as some semiconductor devices (such as switching transistors) do. It consists essentially of a flat plate of suitable ferrite or ceramic which has several apertures through which coils are wound for input and output signals. The response of the plate to pulsations shows a pronounced hysteresis loop (like that of a magnetic amplifier), and this provides two-state response which may be used in switching and memory application in computers.

Memistor

Here is an electrolytic device. Essentially, it is a refined, subminiature electroplating cell. Current passing through the cell removes metal from the anode and then

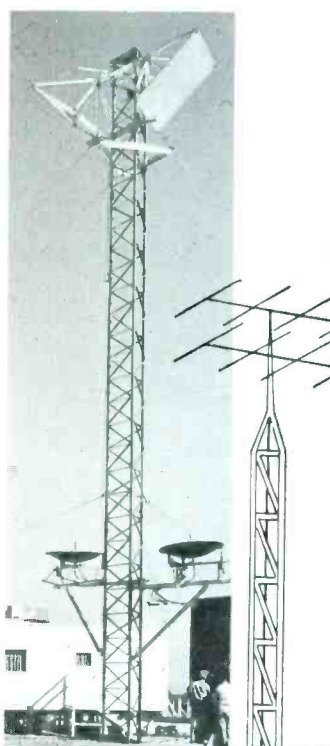

The most Famous Name in
TOWERS of ALL KINDS!

Here are the advantages you get
when you insist on **ROHN TOWERS**

LARGEST FULL RANGE OF TOWERS—you can get anything from home TV and amateur radio towers to heavy-duty communication and micro-wave towers. Included are 500 foot self-supporting towers, 1,000 foot guyed towers, "fold-over" and crank-up towers. Regardless of your needs, ROHN can supply it.

UNQUESTIONED LEADERSHIP IN DESIGN AND MANUFACTURE—you get the latest in advanced tower engineering. All communication towers are engineered to EIA specifications, and are proved by thousands of installations. No other manufacturer can surpass the quality and fine reputation of ROHN.

QUALITY MATERIALS AND WORKMANSHIP—Only highest quality steel is used which fully meets the specifications for the job. ROHN towers are hot-dipped galvanized **after fabrication**—a feature ROHN pioneered!

SERVICE WHEREVER YOU WANT IT—ROHN representatives are world-wide. Complete erection service for communication systems, broadcasting, micro-wave, and other needs is available; also competent engineering service to help you.

Settle for the BEST in TOWERS—ROHN—today the world's largest, exclusive manufacturer of towers of all kinds!

Also available: Rohn Lighting Kits, Microwave Passive Reflectors, Tower Installation Service and Engineering Assistance. Representatives World-Wide to Serve You.

For your needs, contact your local ROHN salesman, distributor or dealer; or write direct for information.

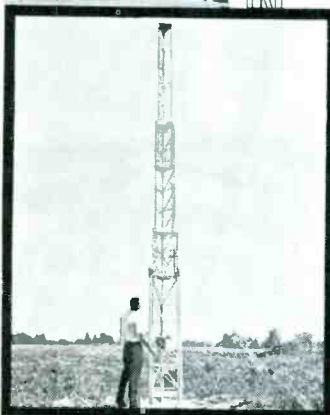

SEND THE HANDY COUPON INDICATING YOUR NEEDS

ROHN
Manufacturing Co.
BOX 2000
PEORIA, ILLINOIS

Send me complete literature on the following ROHN Products:

- | | |
|---|--|
| <input type="checkbox"/> Home TV Towers | <input type="checkbox"/> Amateur Towers |
| <input type="checkbox"/> Communication Towers | <input type="checkbox"/> AM-FM Broadcasting Towers |
| <input type="checkbox"/> Micro-Wave Towers | <input type="checkbox"/> Government |

Name _____

Firm _____

Address _____

City _____ State _____

"World's Largest EXCLUSIVE Manufacturer of Towers; designers, engineers, and installers of complete communication tower systems."

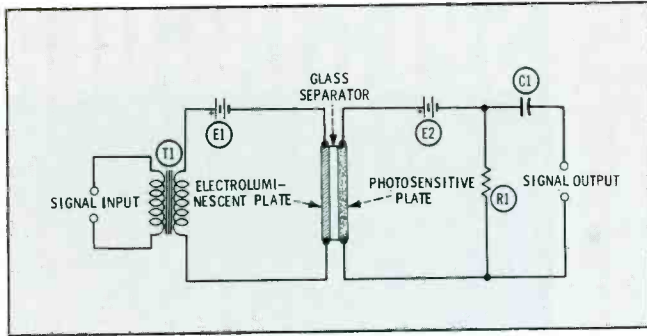

Fig. 2. The lumistor utilizes light to produce amplification.

plates it on the cathode. Elapsed time then may be determined by testing the cell to determine the extent of the metal deposition on the cathode. In its action, the memistor is a time-variable resistor (*memistor* = "resistor with memory").

Negistor

Semiconductor devices such as the tunnel diode have made available to the designer and experimenter simple two-terminal negative resistors. These are resistors whose volt-ampere response curve shows a negative slope over some part of its range (at which an increase in current produces a decrease in voltage drop). The negistor is such a component, which provides higher power-handling capability than conventional tunnel diodes.

Although the negistor is a two-terminal device, its internal structure is complex: It often consists of two suitably processed transistors (one NPN, one PNP) direct-coupled to each other and provided with heavy positive feedback. Direct current is passed in at one lead of the negistor, flows through the transistors in "series-aiding," and out through the other lead. A part of the volt-ampere characteristic exhibits the desired negative slope.

The negistor makes possible simple, two-terminal oscillators, amplifiers, Q-multipliers, and loss compensators.

Photoresistor

A photoconductive cell, of whatever type, is a light-sensitive resistor. Adjustable-intensity light may be used to vary its resistance and thus control either AC or DC. Such cells are available in the following types: cadmium sulfide, copper oxide, germanium, lead sulfide, selenium, and silicon. They are obtainable in a wide range of operating voltage, power capability, and light sensitivity.

Raysistor[®]

This device is a combination of lamp and photocell in a light-tight housing. It may be used for control, switching, and amplification in the same manner as the lumistor (Fig. 2), which it resembles in operating principle. *Raysistors* are available in a wide range of operating values and in types that use either a neon lamp or filament-type lamp.

Sensistor[™]

A simple, two-terminal component, the *sensistor* is

**"TAKING THE
COUNTRY BY
STORM!"**

**THE
ALL NEW
IMPROVED
SENCORE
TC136 MIGHTY MITE IV**



Now checks them all including Compactrons, Novars, Sylvania 10 pin, Nuvistor, plus the new 10 pin tubes by Amperex and Mullard (now being used in many of the new color TV receivers) such as . . .

5U9, 5V9, 5X9, 6U9, 6V9, 6W9, 6X9, 6Y9, 8U9,
9V9, 11Y9, 16Y9, ECF200, ECF201, and EF1200

Plus . . . over 1200 foreign tubes, not checked by other checkers, giving you a total of more than **3,000** tubes in all. In a nutshell, the Mighty Mite is so popular because it checks . . .

- **GRID LEAKAGE** — at sensitivities of over 100 megohms or less than one half microamp of grid current. Picks out the ones other checkers miss.
- **EMISSION** — puts each tube under its full rated load, just like it's used in the TV receiver, to give you a true and accurate check on the quality of the tube.
- **SHORTS** — picks out true shorts using the Sencore "stethoscope" approach, testing each tube element individually.

With These New Exclusive Mechanical Features . . .

- New third hand plastic set-up booklet holder. Keeps the set-up booklet open to the right page for easier and speedier set-up and testing.
- New hinged cover to speed servicing; cover easily removable if desired.
- New taut band meter: gives you a burn out proof, stick proof, durable meter movement. If every check is made backwards, Sencore guarantees you can't damage the meter, Tube, or tester even with a shorted tube.

Why don't you see your Sencore distributor today for your Mighty Mite, and join the more than 30,000 Mighty Mite users that make this America's Number One portable tube checker. All these features are yours, and the Mighty Mite still sells for only . . . **\$74.50**

SENCORE

426 SOUTH WESTGATE DRIVE • ADDISON, ILLINOIS

Circle 39 on literature card

WINEGARD'S FALL COLOR SPECTACULAR

SPECTACULAR

Know how many color TV sets will be sold before the end of the year? Close to 2 million! There's no telling how many more will be sold during 1966. But the figure will be way up in the millions—and we'd like every single one of those sets to be hooked-up to a new Winegard made-for-color antenna. Impossible? Maybe. But we're sure going to try. And here's how we plan to do it. We're going to tell more people than ever before (and more often than ever before) that they do need a special antenna for color TV reception. Then we're going to tell them how very special Winegard made-for-color antennas are . . .

- * They effectively reduce snow, ghosts and distortion in all reception areas—metropolitan, suburban and deep fringe!
- * They make color TV brighter, sharper and more brilliantly alive!
- * They make all-channel black & white reception better than ever!
- * And they make expensive new color sets (black & white sets, too) worth every penny!

We're going to tell them on television, in magazines and via in-store merchandising aids. And the nice thing about advertising is, if you have an outstanding product, a truthful story and sensible prices—and if you tell people often enough, they'll buy. We call it our Fall Color Spectacular. Winegard dealers will call it the best thing that ever happened to antenna and accessory sales. Better call your Winegard distributor or write for complete information about Winegard's Fall Color Spectacular. It's here now!

Spectacular WINEGARD Made-For-Color TV Commercials . . . thousands of them!

Winegard has actually scheduled more than 2,000 minute and 30-second commercials to run before the end of the year. They'll be seen from coast to coast and in color as well as black & white. And here's the best part. They're more than commercials. They're station testimonials! That's right. Station engineers throughout the country have tested Winegard made-for-color antennas and found them to be everything we say they are and more. Wait 'til color TV prospects (and owners) hear these commercials. And they'll start hearing them in October!

Spectacular WINEGARD Made-For-Color Ads in * LIFE * PARADE * SUNSET

They're the powerful, hard-selling publications that are read, believed and used as a buyers' guide by families (more than 6 million of them) now in the market for color television sets. They're your prospects and they'll soon read about Winegard made-for-color antennas . . . believe in them . . . and buy!

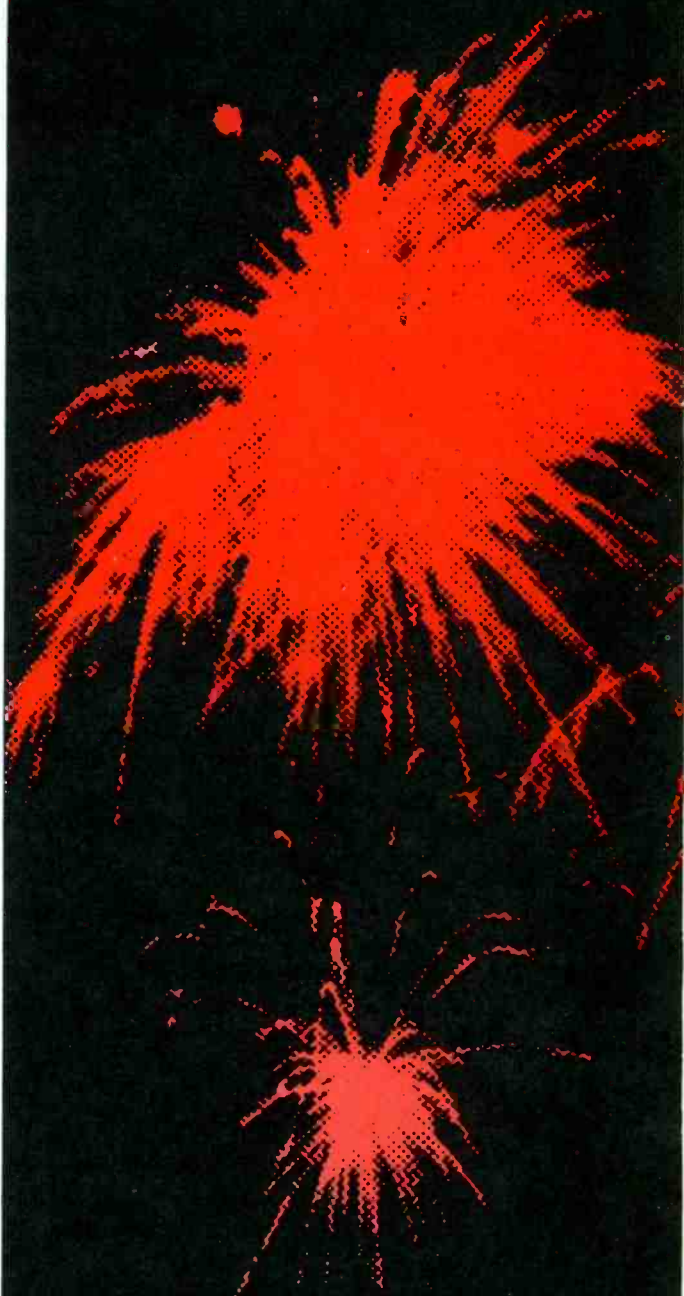

WINEGARD CO.

MADE-FOR-COLOR ANTENNAS

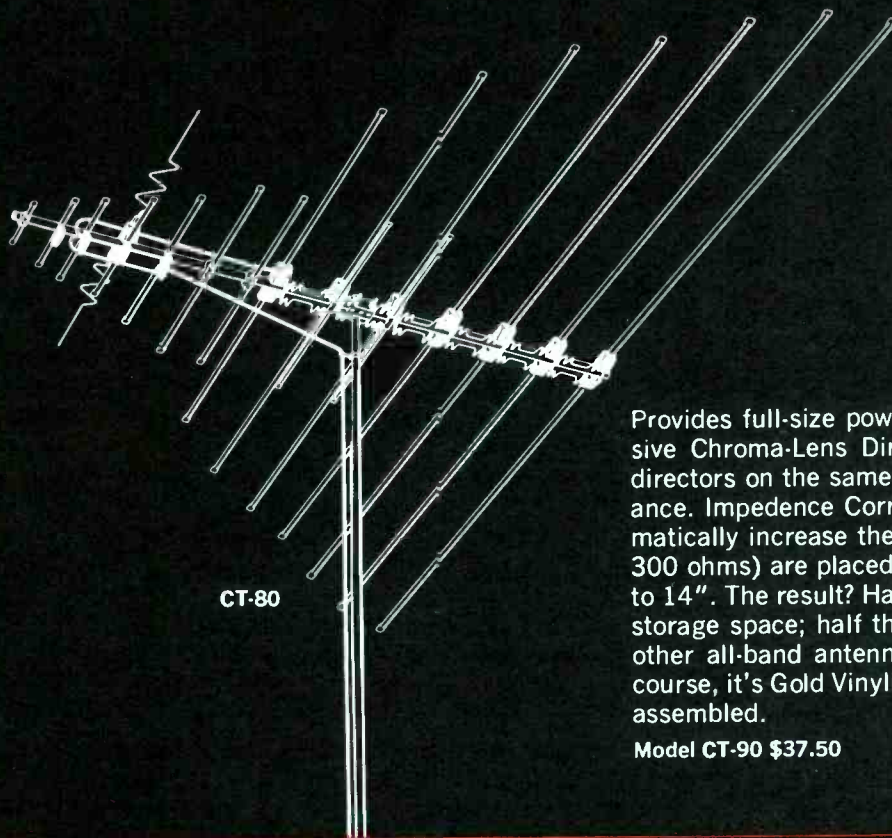

CT-80

WINEGARD CHROMA-TEL

... for the best all-band reception (UHF, VHF & FM color and black & white)

Provides full-size power in a half-size all-band antenna. Exclusive Chroma-Lens Director System intermixes VHF and UHF directors on the same linear plane without sacrificing performance. Impedance Correlators (special phasing wires that automatically increase the impedance of Chroma-Tel's elements to 300 ohms) are placed only 5 3/4" apart instead of the usual 10" to 14". The result? Half the bulk; half the wind loading; half the storage space; half the truck space; and half the weight of all other all-band antennas—and at a much lower price. And, of course, it's Gold Vinylized to triple antenna life, and factory pre-assembled.

Model CT-90 \$37.50

Model CT-80 \$27.50

Model CT-40 \$17.50

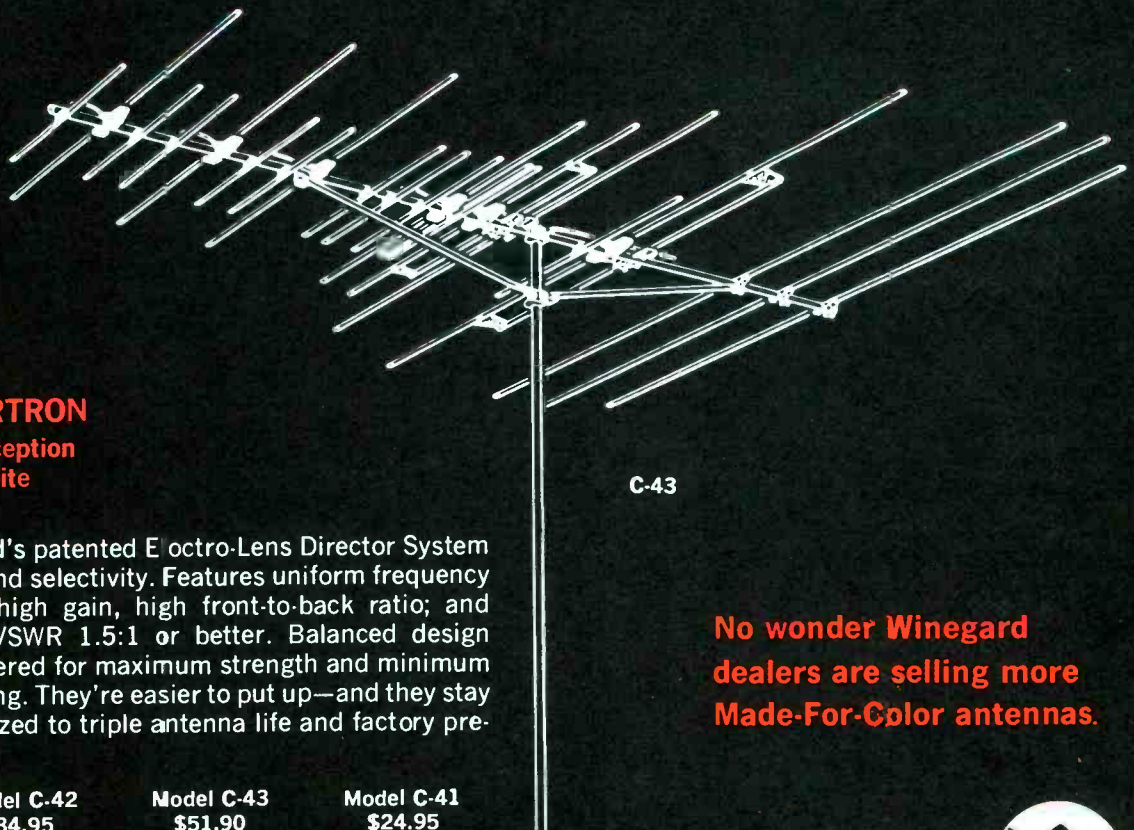

C-43

WINEGARD COLORTRON

... for the best VHF reception in color and black & white

Incorporates Winegard's patented Electro-Lens Director System for maximum power and selectivity. Features uniform frequency response; extremely high gain, high front-to-back ratio; and pinpoint directivity. VSWR 1.5:1 or better. Balanced design Colortrons are engineered for maximum strength and minimum weight and wind loading. They're easier to put up—and they stay up longer. Gold Anodized to triple antenna life and factory pre-assembled.

No wonder Winegard dealers are selling more Made-For-Color antennas.

Model C-44
\$64.95

Model C-42
\$34.95

Model C-43
\$51.90

Model C-41
\$24.95

ANTENNA SYSTEMS 3000 KIRKWOOD, BURLINGTON, IOWA

Circle 40 on literature card



a temperature-sensitive resistor made from specially processed silicon. It has a positive temperature coefficient of resistance and may be used in temperature measurement and control, time delay, compensation of transistor bias circuits, and measurement of wind velocity.

Silistor

Another name for the sensistor.

Stabistor

This is a specially processed silicon diode (or assembly of diodes in series) which is used to stabilize the current in transistor circuits and similar systems. In this application, the stabistor is made to conduct forward current. This compensating device also corrects for ambient temperature variations.

Thermistor

As the name indicates, this is a temperature-sensitive resistor. Thermistors are available in rod, disc, wafer, washer, and bead shapes and in an extensive range of current, voltage, power, nominal resistance, and temperature ratings. They are also available with either positive or negative temperature coefficient of resistance.

Thermistors are used in a great many ways—temperature measurement and control, circuit stabilization, time delay instrumentation, and low-frequency

switching are only a few.

Thyristor

This is a special, switching-type transistor whose operation is similar to that of a thyratron tube. With the thyristor connected as a common-emitter transistor with DC collector-to-emitter voltage, the collector current is extremely low (ideally, zero). This is the OFF state. At a critical value of collector voltage, a positive base-input trigger signal will switch the collector current to a stable high value (this is the ON state), and this high current will continue to flow, even though the trigger pulse is removed, until either a negative base-input trigger signal is applied or the collector current is momentarily interrupted.

The thyristor enables the user to achieve switching action with a single-transistor circuit.

Transistor

This component now needs no identification. Transistors presently are available with maximum-collector-voltage ratings from 12 to better than 100, frequency ratings from audio to UHF, and power dissipation from 1 mw to several tens of watts. Transistors may soon be separated into two basic categories: conventional and field-effect (see Fieldistor).

Trigistor®

The *trigistor* is a low-powered switching device consisting of a silicor bar in which four layers are pro-



TYPE IL . . . why use old fashioned wax end-filled cardboard capacitors in radio repairs? Avoid call-backs with Planet type IL dual section tubular electrolytics . . . hermetically sealed in aluminum tubes with wax impregnated insulating jacket. Planet IL's are also available in 450 volts for TV servicing. Ask for them by type number at your distributor.

PLANET SALES CORP.

225 Belleville Ave.
Bloomfield, New Jersey

Circle 42 on literature card

82 PF REPORTER/October, 1965

**Now an
Atlas Sound
speaker that
can do more
than any one speaker
could do before**



SERIES AP-30
PATENTS PENDING



**and all you need is a
screwdriver to mount,
connect and adjust it**

New Series AP-30 install easier, faster and better with built-in transformers, screw-to-line terminals and watts/impedance switch. Very high efficiency is thrifty with amplifier power for low level reinforcement. The speakers are 30 watts rugged for penetration over distance and noise.

From solderless installation to quality performance on the job, four weather-sealed AP-30 models cover your requirements for most single and multiple installations.

From \$23.10 net.

For the complete Professional Series AP-30 story, ask for catalog PFJ-110



ATLAS SOUND, Division of
American Trading and Production Corporation
1419-51 39th Street, Brooklyn, New York 11218
Canada: Atlas Radio Corporation, Toronto

THIRTY YEARS OF LEADERSHIP IN COMMERCIAL SOUND

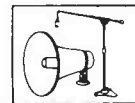

Circle 41 on literature card



new 260[®]SERIES 5 VOM

We're at it again... making the 260[®] a better buy than ever. This latest improvement is built-in meter protection... standard on regular* 260 volt-ohm milliammeters—Series 5 and 5M.

It prevents mechanical damage to the moving element in the movement from instantaneous overloads up to 1,000,000%, or steady state overloads up to 500,000%. It also stops overheating or burnout of the armature coil, damage to hair springs, and calibration change due to high overloads. Otherwise the famous 260 remains unchanged.

If you now have a Series 1, 2, 3, or 4, 260 VOM, you can install your own meter protection. Ask your electronics distributor for a Simpson meter "safe/guard[®]." It takes only minutes to install.

260-5 with new meter protection..... **\$4995**

260-5M (mirror scale) with meter protection..... **\$5195**

*Model 260-5P has both meter and circuit protection except on the 1000V and 5000V DC and AC ranges, and the 10-amp DC range. Price **\$78.95**

RANGES

DC VOLTS: 0-0.25; 0-2.5; 0-10; 0-50; 0-250; 0-1000; 0-5000

AC VOLTS: 0-2.5; 0-10; 0-50; 0-250; 0-1000; 0-5000

DC MICROAMPERES: 0-50 (250 MV Drop)

DC MILLIAMPERES: 0-1; 0-10; 0-100; 0-500

DC AMPERES: 0-10 (250 MV Drop)

RESISTANCE RANGES: RX1 0-2000 ohms (12 ohms center) RX100 0-200K ohms (1200 ohms center) RX10K 0-20 megohms (120K ohms center)

ACCURACY: DC, $\pm 2\%$ F.S.; AC, $\pm 3\%$ F.S.

Write for Bulletin 2070 showing the entire line of Simpson VOM's



SIMPSON ELECTRIC COMPANY

5209 W. Kinzie Street, Chicago, Ill. 60644 • Phone: (312) ESTebrook 9-1121
Representatives in Principal Cities... See Telephone Yellow Pages

Export Dept: 400 W. Madison St., Chicago, Ill. 60606 Cable, Amgarcio
In Canada: Bach-Simpson Ltd., London, Ontario

In India: Ruttonsha-Simpson Private Ltd., Vikhroli, Bombay

WORLD'S LARGEST MANUFACTURER OF ELECTRONIC TEST EQUIPMENT

Circle 43 on literature card

look to Xcelite for the best in pliers & snips, too

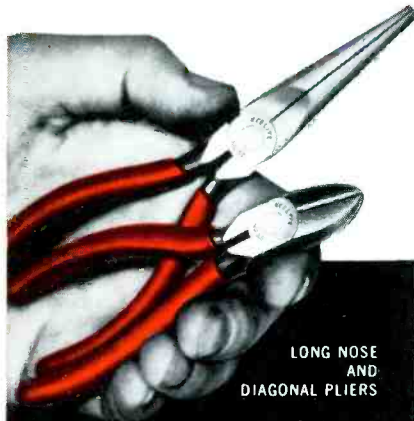

LONG NOSE
AND
DIAGONAL PLIERS

CHAIN NOSE
ELECTRICIAN'S PLIERS

COMBINATION
SLIP JOINT PLIERS

NEEDLE NOSE PLIERS

RADIO AND TV PLIERS

SIDE CUTTING PLIERS

TRANSVERSE CUTTING PLIERS

UTILITY PLIERS

ELECTRONIC SNIPS

Same professional quality as famous Xcelite screwdrivers and nutdrivers. Forged alloy steel construction. Precision machined. Scientifically proportioned. Variety of sizes. All available with permanent, plastic coated Cushion Grip handles for extra working comfort (except slip joint models).

WRITE FOR CATALOG SHEET N664

XCELITE

XCELITE, INC., 18 BANK ST., ORCHARD PARK, N. Y.
Canada: Charles W. Pointon, Ltd., Toronto, Ontario

Circle 44 on literature card

84 PF REPORTER/October, 1965

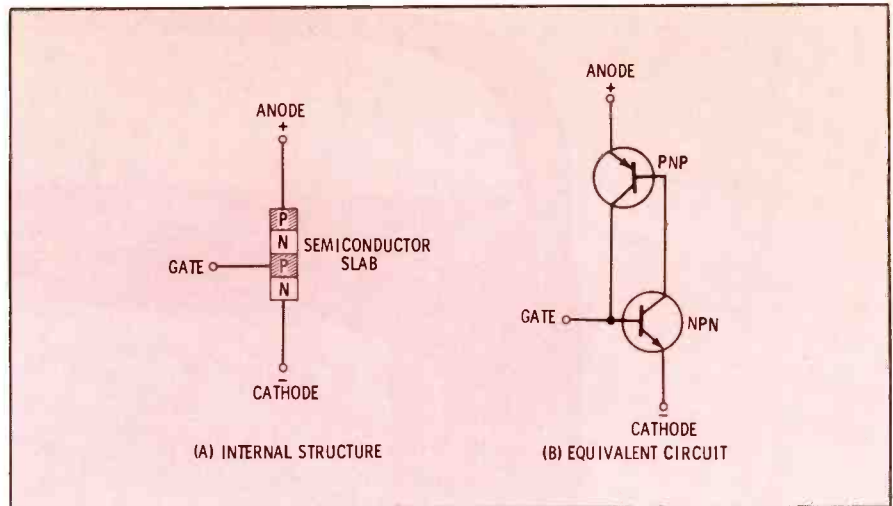

Fig. 3. Solid-state trigistor operates in virtually the same way as a thyatron.

cessed to give a PNPN structure (see Fig. 3A). Leads are attached to the top P-layer, bottom N-layer, and the lowermost P-layer. This structure gives the effect of two transistors, one PNP and one NPN, direct-coupled to each other automatically and providing positive feedback between themselves (Fig. 3B).

At a certain critical value of applied DC voltage, the device passes very little current (ideally, zero current). This is its OFF state. If then a positive trigger voltage is applied to the gate electrode (cathode negative), the current will switch to a high value (the ON state) and will continue to flow, even though the pulse is applied or the anode voltage is momentarily removed. This action, like that of the thyristor, resembles thyatron behavior.

Varistor

Whereas the resistance of many semiconductor devices varies with applied voltage, the varistor is de-

signed specifically to exploit this "nonohmic" peculiarity. The silicon carbide resistor is an example. The current through a varistor increases nonlinearly with applied voltage thus, in some units when the voltage is doubled the current increases eight times.

This action may be used in many ways. Some applications of varistors include harmonic generation, voltage level detection, curve changing, selective control of circuits, volume compression, surge protection, and voltage regulation. Varistors are obtainable in a very wide range of current, voltage, and power ratings; and, like thermistors, are available in many shapes and sizes.

Conclusion

New members of the family . . . istors are being born in research labs regularly. This introduction should help you to recognize them in almost any form, in any surroundings. You'll be seeing a lot of them in months and years ahead. ▲

NEW...POSITIVELY NEW

Positively—

- CONTAINS NO CARBON TETRACHLORIDE
- HARMLESS TO ANY PLASTICS KNOWN TO KRYLON
- CLEANS AS IT LUBRICATES
- NON-FLAMMABLE
- NON-CORROSIVE . . . NON-TOXIC

Contact your local jobber for Tuner Cleaner and other everyday Krylon aerosol products—Crystal Clear, Let-Go (oil penetrant), Red Insulating Varnish, Silicone Lubricant, Cleaner and Degreaser

If you prize it... KRYLON-ize it!®



Circle 45 on literature card



B&K MODEL 970 RADIO ANALYST

SERVICE AM & FM AUTO AND TRANSISTOR RADIOS AT A PROFIT!

NEW!

Jobs that used to be unprofitable now go so quickly that you can make good money handling them! There are millions of auto radios and transistor radios in the field—portables, auto and table models, plus hi-fi and communications equipment. Instead of turning them away, you can turn them into money-makers with the B&K Model 970 Radio Analyst.

The 970 is effective because it's *accurate* and *complete*. Using the famous B&K signal injection technique, this all-in-one instrument provides the required dc power, lets you test power and signal transistors in and out of circuit; generates RF and audio signals, and includes a rugged, accurate VOM. Four functions in one compact package—with solid state reliability, B&K professional quality.

LOW INVESTMENT—QUICK RETURN

See your B&K Distributor or write for Catalog AP22-R

Net \$199.95



B & K MANUFACTURING CO.
DIVISION OF **DYNASCAN CORPORATION**
1801 W. BELLE PLAINE AVE. • CHICAGO, ILL. 60613
Canada: Atlas Radio Corp., 50 Wingold, Toronto 19, Ont.
Export: Empire Exporters, 123 Grand St., New York 13, U.S.A.

Circle 46 on literature card

FEATURES:

BUILT-IN POWER SUPPLY

Auto Radios—High current, low-ripple, for transistor, hybrid, and vibrator types.

Transistor Portables—1½ to 12 volts for battery substitution—plus separately variable voltage tap for bias.

QUICK AND ACCURATE TESTING OF POWER AND SIGNAL TRANSISTORS

In-Circuit—stage by stage DC signal injection and sensitive metering of power supply current.

Out-of-Circuit—Direct Beta and Leakage meter scale readings. Easy balancing or matching.

VERSATILE SIGNAL GENERATORS

RF Generators—provide broadcast and IF frequencies for both AM and FM bands.

Audio Generator—for AM or FM modulation of the RF signals, and for troubleshooting audio circuits.

RUGGED VOM

Volt-OHM-Milliammeter—with rugged, taut band meter—provides correct ranges for easy, fast servicing of all home and auto radios, as well as transistor portables.

Tinyvision

(Continued from page 29)

uum-tube horizontal-output circuits. Note that the yoke is connected in series with the supply voltage and the output transistor; also note that the flyback primary shunts the yoke.

In the circuit of Fig. 2B (General Electric TA Chassis) the yoke is shunt-fed—connected through C5 across X1—to prevent DC shift from affecting the centering. During retrace time C5 is charged from ground through the yoke by the power-supply and the flyback pulse. During trace time C5 discharges through the deflection yoke and X1, producing the sweep. T2 is tapped to feed a pulse back through R1 to sharpen the edges of the retrace pulse. Although the load (T2) is connected in series with X1's emitter, signal is applied between the emitter and base, and X1 is connected as a common-emitter class-C amplifier. The solid-state high voltage rectifier uses C1 and C2 to bypass RF hash.

Operation of the output circuit of the Motorola TS-432 (Fig. 2C) is basically the same as the circuit in

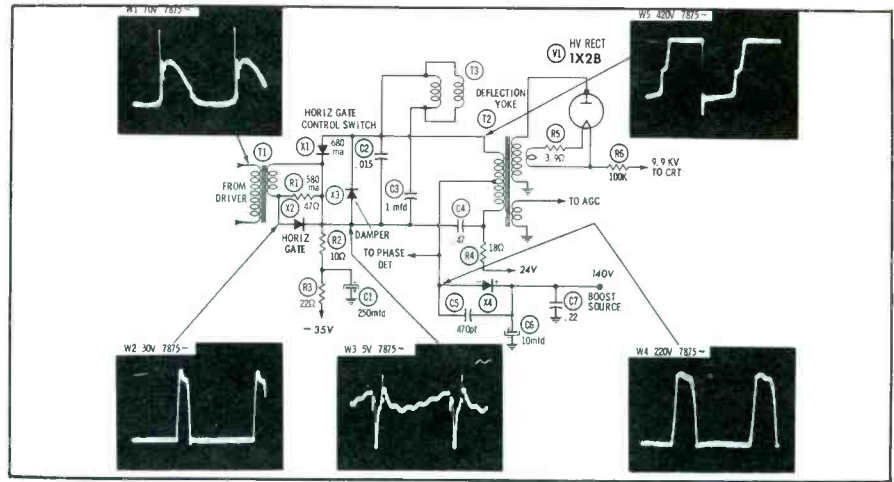

Fig. 3. GCS replaces vacuum tube or transistor in horizontal-output stage.

Fig. 2B. The two transistors are not connected in push-pull, but in series to reduce the breakdown voltage requirements. If one transistor shorts they should both be changed without bothering to check further! T2 has an adjustable core which permits control of the width and high voltage.

The *gate-controlled switch* replaces the output transistor, in Fig. 3. Unlike in the SCR, anode current can be shut off by a negative pulse on the gate. Operation is then comparable to a class-C amplifier.

All of these circuits use transformer coupling into the horizontal output stage and this eliminates a favorite test used by many technicians when approaching high voltage or horizontal sweep problems in tube-type receivers: measurement of the DC "drive voltage" at the horizontal output grid. In the transistor sets this test will no longer be reliable. A scope at the input to the horizontal output stage is the best way to tell if the transistor oscillator is driving the output stage properly; but remember, a good wave-

form here does not prove that the emitter-base circuit of the output stage is working correctly.

Another point to remember in connection with oscillator operation is: operating the receiver with an intermittent horizontal oscillator, or one that is off-frequency, is likely to result in damage to the output transistor. This means that when testing or adjusting the horizontal oscillator an isolating probe (one which does not detune the circuit) must be used with the scope or voltmeter. Be careful not to short between terminals accidentally. When troubleshooting in the horizontal section, a 130-volt, 10-watt zener diode should be temporarily connected across the horizontal output transistor with the cathode of the zener on the positive element of the transistor (on the emitter in the case of a PNP unit). Also, avoid checking the high voltage by sparking the anode to ground, as this also will damage the output transistor.

Leakage in Transistors

The failure of associated compon-

CHEK-IT CIRCUIT TESTER

FOR ONLY **\$1.49** DEALER NET
LESS BATTERIES

**BATTERY OPERATED
TESTS WITH POWER OFF**

MADE IN
U.S.A.

- CONTINUITY • FUSES • SWITCHES
- CHIMES • APPLIANCES • MOTORS
- BUZZERS • PUSH BUTTONS
- AUTO IGNITION and VOLTAGE REGULATORS, ETC.

ASK YOUR ELECTRONIC
PARTS DISTRIBUTOR FOR

W MODEL NO. BZ5

MANUFACTURED BY
WORKMAN Electronic PRODUCTS INC.
SARASOTA FLORIDA

Circle 48 on literature card

9⁵⁰

ALL PARTS
(except tubes)
Plus Shipping Charge

QUALITY TV TUNER SERVICE

24 hrs.

**Service
Most Makes**

UHF - VHF - COLOR - (COMBOS. - 14.50)

15 YEARS OF TUNER EXPERIENCE

- 1 Year Warranty
- Tuners completely cleaned and checked
- Open Account on approved credit
- Dist. write for price structure

- Pack Tuner Carefully
- Insure Package —
- Include all parts (Broken or not)

QUALITY TUNER SERV.
5142 W. 25th St.
CHICAGO, ILL. 60650

Circle 47 on literature card

**NOW YOU CAN HAVE THE BEST ...
FOR ONLY PEANUTS PER MONTH**

**See Your Distributor About
The New Hickok Credit Plan**

- ONLY 10% DOWN
- UP TO 3 YEARS TO PAY
- INTEREST RATE ONLY 2/3% A MONTH
- SIMPLE, EASY AND FAST

You can own

any of this

test equipment

for as little

as \$15

a month

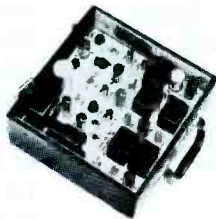

Model 660
White Dot
Color Display
Television Generator

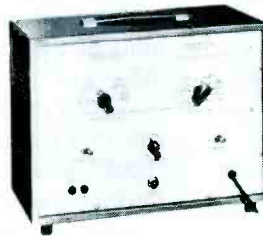

Model 661
Chrom-aligner
NTSC Standard
Color Bar and
White Dot Generator

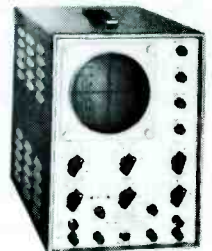

Model 677
Wide Band Service
Technician's
Oscilloscope

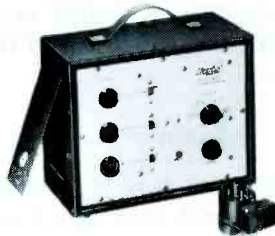

Model 662
Installer's Color
TV Generator



Model 656XC
Color Space Bar,
White Dot
TV Generator



Model 6000A
Service Technician's
High Speed
Deluxe Portable
Tube Tester

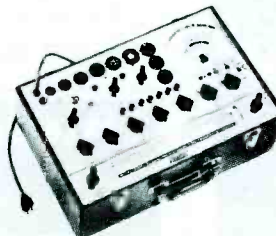

Model 800A
Portable Tube Tester,
Transistor and
Diode Checker

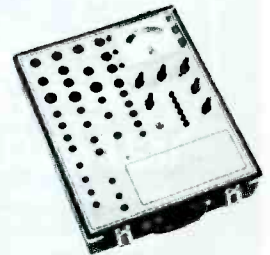

Model 799
Multi-socket
Tube Tester

HICKOK

THE HICKOK ELECTRICAL INSTRUMENT CO.

10566 Dupont Avenue

Cleveland, Ohio 44108

Represented in Canada by Stark Electronics, Ajax, Ontario • Internationally by Hughes International, Culver City, California

Circle 49 on literature card

October, 1965/PF REPORTER 87

ents is usually more common than failure of transistors. When a transistor fails, the most common symptom is leakage. Leakage is directly related to the junction temperature and so tests for leakage must be made under operating conditions. High leakage in a transistor is characterized by:

1. Excessive heating of the outer case.
2. Low collector-to-emitter voltage. (The difference between the collector and emitter potentials can be determined by subtraction or by direct measurement between the two elements).
3. Large voltage drop across the emitter resistor.

One way to check the general condition of a transistor without removing it from the chassis is to short the base to the emitter while noting the collector or emitter voltage (whichever is greater with respect to ground). The voltage should increase to practically the full power-supply potential because shorting the base to the emitter will cause a normal transistor to be cut off. In a

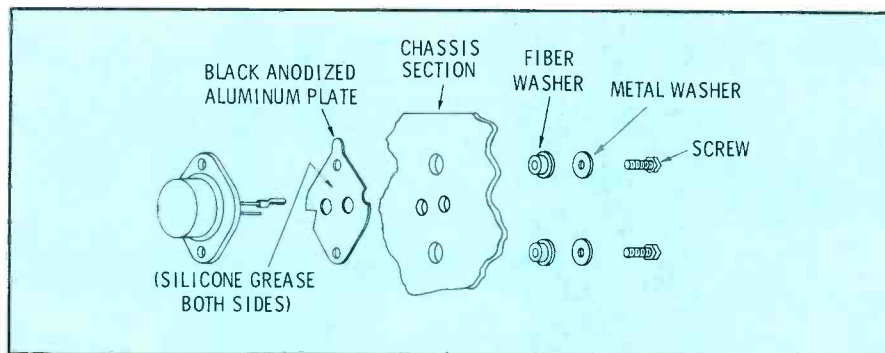

Fig. 4. Typical method of mounting replacement transistor to heat sink.

defective transistor, however, leakage current continues to flow and the resulting voltage drop across the series resistance in the collector or emitter circuits gives a clue to the defect.

In TV servicing, you must be more careful about using "substitution-type" transistors than in radios, because the amount of leakage current varies between different units of the same type and makes a difference in circuits where wave-shapes or cutoff voltages are important. In TV's, replacement transistors should be of the type specified by the manufacturer.

Also, be sure to replace mica or fiber washers, silicon grease, and other accessories which have been used to improve the efficiency of the heat sink. Fig. 4 illustrates a typical mounting; note that in this case the transistor is insulated from the chassis.

Summary

To summarize, here is a checklist of ideas to speed your bench work on transistorized receivers:

1. Always have complete service information available before starting the job.
2. Use the scope to identify the defective stage, followed by the

VTVM or VOM to pinpoint the faulty part.

3. Use the ohmmeter with caution; in-circuit readings are unreliable.
4. Use only specifically recommended transistors for replacement. And reinstall all heat-sink parts and silicon grease.
5. Check high voltage at the anode with a high-voltage probe, or use a neon bulb near the flyback transformer; don't arc the anode lead.
6. Connect a 130-volt, 10-watt zener from collector to emitter of the horizontal output transistor when servicing the oscillator. Better still, when possible disconnect the output stage and use the scope to observe oscillator operation.
7. Look for defective damper diodes in any sweep circuit which is not working (vertical and horizontal; oscillator and output).
8. Check emitter voltage and case temperature first when you suspect a transistor is defective.
9. Use only a capacitor checker (especially an in-circuit checker) specifically designed for transistorized equipment.
10. Never try to use a booster on the CRT filament voltage because the supply voltage is often DC.

INJECTORALL

THE NEEDLE DOES THE JOB!

No. 899
NEW!
WAX FREE LUBRICANT ADD

INJECTORALL
REG. U.S. PAT. OFF.

TUNER CLEANER

CLEANS AND REMOVES
NOISE FROM VOLUME
CONTROLS AND TUNERS

• CAN'T SPILL
• CAN'T EVAPORATE

...TIGER of a CLEANER!

Injectorall's Tuner Cleaner—No. 899WN... is the best cleaner on the market today. It cleans **better, faster** than all other cleaners and **...leaves a wax-free coating** that protects and lubricates contacts. Equipped with the **Injectorall 6 inch steel needle** it reaches hard-to-get-at places in tuners. Ask for... INJECTORALL TUNER CLEANER in the blister-pack.

INJECTORALL ELECTRONICS CORPORATION... Great Neck, N. Y. 11024

NO. 899WN
6 oz... \$1.95 net

Circle 50 on literature card

PRECISION TUNER SERVICE

P. O. BOX 272 1210 S. WALNUT ST.
BLOOMINGTON, IND. EDISON 99653

7.95
V or U
COMBO PLUS
9.95 POSTAGE

6 MONTH WARRANTY

All Types T.V. Tuners Cleaned, Repaired and Aligned to Factory Specifications. Same day in shop service on most Tuners. Price Includes Minor Parts, Major Parts at Cost Price. We use Original Parts if possible. State Make Model and Enclose all Parts and Tubes. Pack Well and Insure.

ALSO HAVE LARGE STOCK OF EXCHANGE TUNERS, WRITE FOR TYPES AND PRICES.

Circle 51 on literature card

locate defective capacitors in-circuit

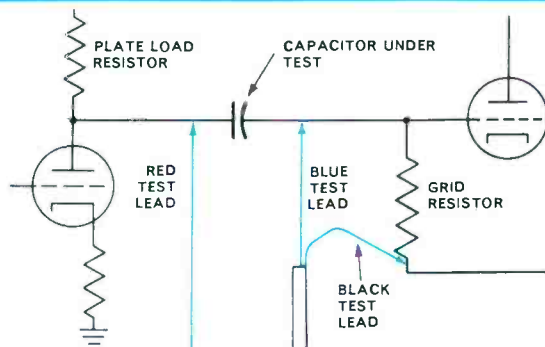

3-LEAD LEAKAGE TEST: One test lead is connected to the plate side of the capacitor and the ground lead to the grid leak return on the other side of the capacitor, and the meter is zeroed. The third test lead is then connected to the grid side of the capacitor and the meter scale shows the leakage directly in megohms.

The B & K model 801 capacitor analyst really works without unsoldering or altering circuitry

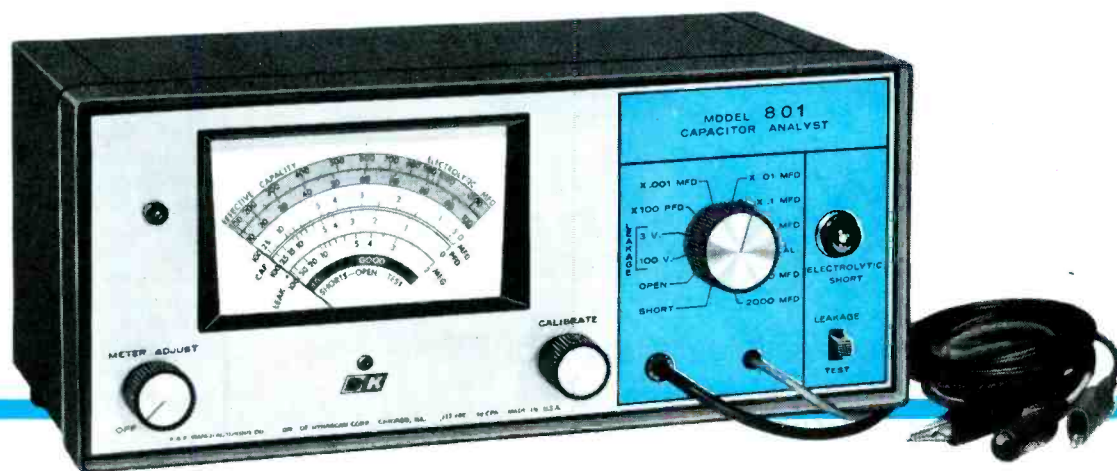

Both in-circuit and out-of-circuit capacitor testing can be done quickly and accurately with the new B & K Model 801 Capacitor Analyst. Foil, mica, general purpose and temperature compensating ceramic, and electrolytic capacitors can be accurately tested for leakage, capacitance, opens, and shorts.

Leakage can be determined in-circuit. The unique B & K 3-lead method permits a degree of accuracy not possible with any 2-lead tester. For normal circuits defective capacitors can be located immediately.

Open capacitors with values as low as 25 pF are easily located with the sensitive high-frequency-signal and resonant- $\frac{1}{4}$ -wave-transmission-line method.

Electrolytic capacitors are tested with a circuit that accurately measures their effective capacitance. Their inherent characteristics of variable equivalent series resistance and internal parallel resistance are automatically accounted for. Only one capacitor lead need be disconnected. The capacitor is charged and then discharged under load. High peak load currents up to 2 amperes ensure testing to in-circuit conditions. Unlike with other testers, capacitor can not be deformed by a reverse polarity voltage. The actual power transferred to a load is measured and the capacitance is read directly from the meter scale for immediate replacement decisions.

All these tests and short tests too are performed with the one set of test leads which is included with the instrument.

Here's the capacitor analyst that really works: B&K Model 801 quickly pays for itself with reduced shop time. Net \$109⁹⁵

See your B & K distributor or write for catalog AP-22.



B & K MANUFACTURING CO.
DIVISION OF DYNASCAN CORPORATION
1801 W. BELLE PLAINE AVE. • CHICAGO, ILL. 60613
Canada: Atlas Radio Corp., 50 Wingold, Toronto 19, Ont.
Export: Empire Exporters, 123 Grand St., New York 13, U.S.A.

HOT OFF THE PRESS!

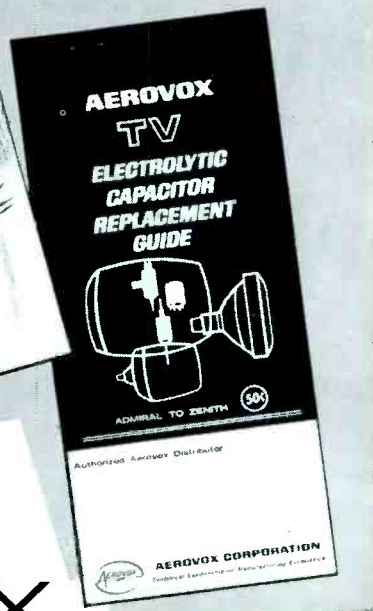

NEW AEROVOX

- servicemen's catalog (SE565)
- TV electrolytic capacitor replacement guide (AFG465)

Up-to-the-minute—and loaded with the kind of information you want and need.

The New Aerovox Servicemen's catalog has complete information on all types of capacitors, filters, decade boxes, and money-saving capacitor kits.

The Replacement Guide lists every TV manufacturer from A to Z—their part number, and the **exact Aerovox Electrolytic replacement**. Remember, Aerovox has the largest in stock line of electrolytics in the business, and can therefore offer fast, efficient service on high quality, twist prong electrolytics.

Available only from your authorized AEROVOX Distributor—see him for your copy.



AEROVOX CORPORATION

DISTRIBUTOR DIVISION, NEW BEDFORD, MASS. 02741

Technical Leadership—Manufacturing Excellence
Circle 53 on literature card

BOOK REVIEW



Planning and Installing Master Antenna TV Systems: Lon Cantor; John F. Rider Publisher, Inc., New York, New York; 136 pages, 6" x 9", soft-bound; \$3.95.

MATV installations are becoming more common in hotels, motels, and apartment buildings. This book describes ways a radio-TV technician or sound-system installer can enter this lucrative field.

The first two chapters describe the economics of MATV installation, list methods of obtaining contracts, and supply a typical specification sheet for an installation contract. Chapter three describes small systems and their applications in homes, TV shops and showrooms, and schools.

Requirements for the head-end system are covered in the fourth chapter. Block diagrams instead of schematics are used, and many other illustrations support the text material — graphically explaining characteristics of antennas, baluns, mixers, and preamplifiers. Methods of eliminating ghosts, co-channel, adjacent-channel, and man-made interference are also described. Distribution components (cable, tapoffs, matching transformers, terminations) and their applications are covered in the fifth chapter.

Methods of actually laying out an MATV distribution system are listed in Chapter six. A thorough explanation of the use of the **db** and **dbmV** is given to aid in calculations of the signal voltage available at any part of the distribution system. Gain, output capability, noise figure, and VSWR for head-end and distribution equipment are explained in Chapter seven. Overall requirements for the head-end and entire distribution system are summarized by Chapter eight.

Methods of adding background music or CCTV to MATV systems are brought out in the ninth chapter. The tenth chapter supplies information on CATV and translator operation. Chapter 11, the final one, brings the reader methods of installation, initial system checkout, plus maintenance and troubleshooting procedures. The appendix contains a db conversion chart and nomograph, plus other charts and tables useful for MATV system designers and installers. ▲

Square Waves

(Continued from page 31)

four-terminal network. However for a square wave check, the unit is treated as a three-terminal network. Since there is a DC path through the resistors, it is best to check for defective resistors with an ohmmeter. If the resistance from input to output does not read within 20% of 48K, the unit is rejected. Again, since both terminals of the 330-pf capacitor are externally available, we can check it on a capacitor bridge.

On the other hand, a square wave test is the only feasible method of checking the value of the .0025-mfd capacitor; the test setup shown in Fig. 5 is used. It follows from previous discussion that the 15K resistor can be neglected. Accordingly, this is a test of a simple integrating circuit in which a 33K resistor feeds into a .0025-mfd capacitor. The value of this capacitor can be measured quickly by determining the rise time of the output wave-form. The time constant of the integrating circuit is: $RC = 33,000 \times .0025 \times 10^{-6} = 82.5 \text{ usec}$. If the time constant of an integrating circuit is T_c , the rise time of the output waveform is equal to $2.2 T_c$.

This is perhaps a novel fact, but it is easily demonstrated. Fig. 3 shows the universal time-constant curves. Curve A rises from 10% to 90% of its final value in 2.2 time constants. This is the basis of the capacitance-measurement test. The time constant of the integrating circuit in Fig. 6 was found to be 82.5 usec. The output waveform will therefore rise from 10% to 90% of its final voltage in $2.2 \times 82.5 = 182 \text{ usec}$. Accordingly, the waveform is displayed in the form of curve A in Fig. 3. Horizontal intervals are counted from the 10% to the 90% points of maximum voltage. By determining the sweep speed (Fig. 6) and by counting the number of horizontal intervals, you can find the rise time. Here, the sweep speed was 100 usec/cm.

If the rise time is within 20% of 182 usec, the .0025-mfd capacitor is within tolerance. Thus, the value of the capacitor through the 33K resistor has been measured. This is the most practical way to make this measurement, and this test can be made at any square wave frequency.

Now, to find whether the .0025-mfd capacitor is leaky, it is best merely to make an ohmmeter check from the 33K resistor terminal to the .0025-mfd capacitor terminal. To make a leakage test at working volt-

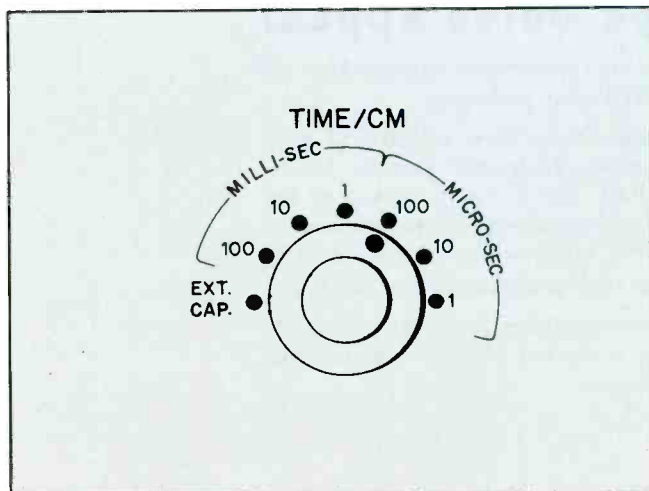
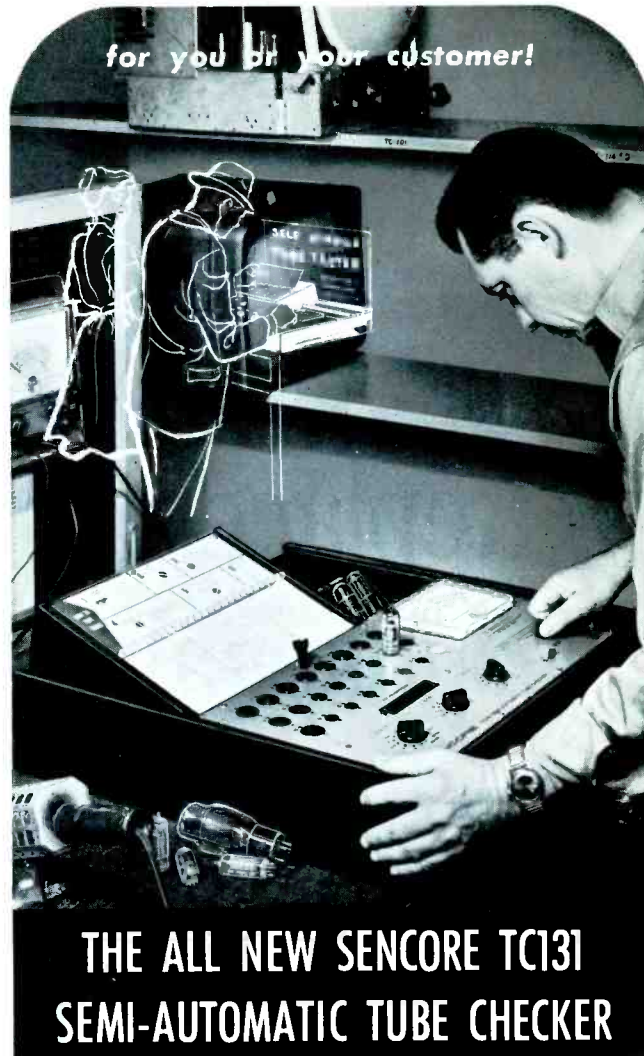

Fig. 6. Sweep of 100 usec/cm to read 182 usec rise time.

a new money-making,
traffic-building tube tester

for you or your customer!



THE ALL NEW SENCORE TC131 SEMI-AUTOMATIC TUBE CHECKER

After thousands of requests here is the "counter/bench" version of the famous Sencore Mighty Mite Tester; designed for the ultimate in tube checking thoroughness and operational simplicity! Designed for two-way use — as a professional shop tester and customer self-service unit. Tests over 2500 tubes — including Nuvistors, Compactrons, 10-pins, Novars, Magnovals and foreign tubes with a big 6-inch meter for easy reading. Semi-automatic; simply turn function control to any test and watch lighted arrow on meter automatically stop on right scale. User can't go wrong — no guess work — everything is read right on the meter (no tricky neon lights to misread); only 3 set-up controls. Easy to read, speed-indexed set-up cards make every test fast and sure. Like the famous Mighty Mite, the TC131 uses 100-megohm grid leakage sensitivity to spot those "tricky" tubes other testers miss; tests inter-element shorts and makes cathode emission tests under full operating levels. A real profit maker as a counter checker or self service tube seller in your shop . . . and it's only

\$129⁹⁵

See your distributor about the big TC131 trade-in deal.

professional quality — that's the difference!

SENCORE

426 SOUTH WESTGATE DRIVE • ADDISON, ILLINOIS

Circle 54 on literature card

October, 1965/PF REPORTER 91

Jensen **VIKING** Replacement Loudspeakers



Now in **SHOW PACK** Visual Packaging for Greater Impulse Sales Appeal

Nineteen of the most popular Jensen Viking replacement loudspeakers are now available in new **SHOW PACK** visual display packaging.

Extra sturdy cards and transparent plastic have been selected to keep your display of Jensen Viking loudspeakers dustproof. Famous Jensen Viking replacement loudspeakers in **SHOW PACK** visual packaging are perfect for display or off-the-shelf sales by electronic and automotive parts distributors and dealers . . . also simplifies inventories. **SHOW PACK** is adaptable to a variety of display mountings such as pegboard, wire racks, etc.

The line of nineteen replacement speakers includes the most commonly required speakers for automotive, radio, television and hi-fi replacement. Write for price list and further information.



JENSEN MANUFACTURING DIVISION / THE MUTER COMPANY / 6601 SOUTH LARAMIE AVENUE, CHICAGO, ILLINOIS 60638
Canada: Radio Speakers of Canada, Ltd., Toronto • Argentina: Ucoa Radio, S.A., Buenos Aires • Mexico: Fapartel, S.A., Naucalpan, Mex.

Circle 55 on literature card

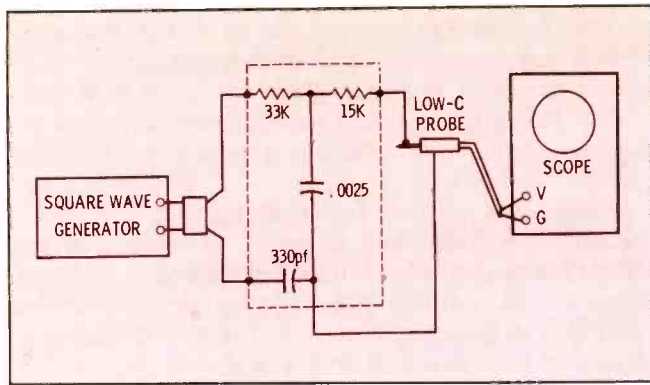

Fig. 7. 60-cps voltage across 330-pf capacitor prevents test. age, use a regular leakage tester. The capacitor tester can indicate leakage through the capacitor (via the 33K resistor), although it cannot measure the capacitance value.

If the .0025-mfd capacitor is open, the rise time will be extremely short compared to normal conditions. In such an event, the unit would be rejected, of course, without necessity for further tests.

Four-Terminal Test?

Since the unit in Fig. 5 is actually a four-terminal network, you may wonder whether it could be tested as a four-terminal device. For example, it might be considered that the test setup shown in Fig. 7 could be utilized. It cannot. In this arrangement, the "ground" lead is connected in series with the 330-pf capacitor. The ground lead of a square wave generator is at a different 60-cps level than that of the scope; hence, there would be a substantial 60-cps drop developed across the 330-pf capacitor and a large hum voltage displayed on the scope screen.

Therefore, square wave tests of four-terminal networks such as depicted in Fig. 5 must be made as three-terminal tests. Terminal connections must be selected so that the generator case is connected directly to the scope case. The common ground lead between generator and scope must not include any series capacitance or resistance.

Conclusion

You have seen in this and past articles how typical standard RC units can be checked for defects. Also you have learned a new way to measure capacitance, even through series resistance. With these basic square-wave techniques firmly in mind, you will be in a good position to consider square-wave testing of other circuits and of even more elaborate PC units.

The next article, by one of the PF REPORTER staff, will review and connect up for you the principles and practice of square-wave testing in simple networks as we've presented to date. Following that, in a final article on these principles of advanced testing, we will explain some of the sophisticated techniques used for analyzing multicomponent networks — even those with many terminals.

In the months to follow, you'll be introduced thoroughly to practical ways of using these new, advanced servicing techniques to speed and simplify unusual troubleshooting problems in present-day equipment—audio units, video amplifiers, and so on. You'll want to follow this series and learn these modern ways to analyze systems, circuits, and networks. ▲

at last...
instant color patterns
at your finger tips...
zero warm-up time



THE ALL NEW SENCORE CG135 DELUXE TRANSISTORIZED COLOR GENERATOR

The big push is on in Color TV. Equip yourself now with the new, solid state Sencore CG135 and cash in on the zooming volume of new service business as Color-TV booms! Instant, service-ready RCA standard color bars, cross-hatch, white dots and individual vertical and horizontal bars enable you to set up or trouble-shoot more Color TV sets per day; earn top money in this fast growing service field. It's an analyzer too: Color gun interruptors, unmodulated video for chroma circuit trouble isolation and unmodulated sync pulses to keep Zenith receivers in sync for this test, make color trouble shooting a snap. Sturdy all-steel construction for rugged, heavy duty in the field or shop. Another Best Buy in profit-building service instruments from Sencore at

\$149⁹⁵

COMPARE THESE FEATURES: SEE WHY THE CG135 IS IN A CLASS BY ITSELF

- Solid state construction employs high priced GE "Unijunctions" to develop six "jump out proof counters" that guarantee stable patterns at all times with no warm-up
- Standard RCA licensed patterns as shown on schematics throughout the industry
- Handy universal color gun interruptors on front panel
- Lead piercing clips insure non-obsolence
- CRT adaptors optional
- Crystal-Controlled 4.5mc Sound Carrier Analyzing Signal to insure correct setting of fine tuning control
- RF output on Channel 4 adjustable to Channel 3 or 5 from front of generator when Channel 4 is being used
- No batteries to run down; uses 115 V AC
- Less than one foot square, weighs only 8 lbs.

professional quality — that's the difference!

SENCORE
426 SOUTH WESTGATE DRIVE • ADDISON, ILLINOIS

Circle 56 on literature card

October, 1965/PF REPORTER 93

Pads and Attenuators

(Continued from page 33)

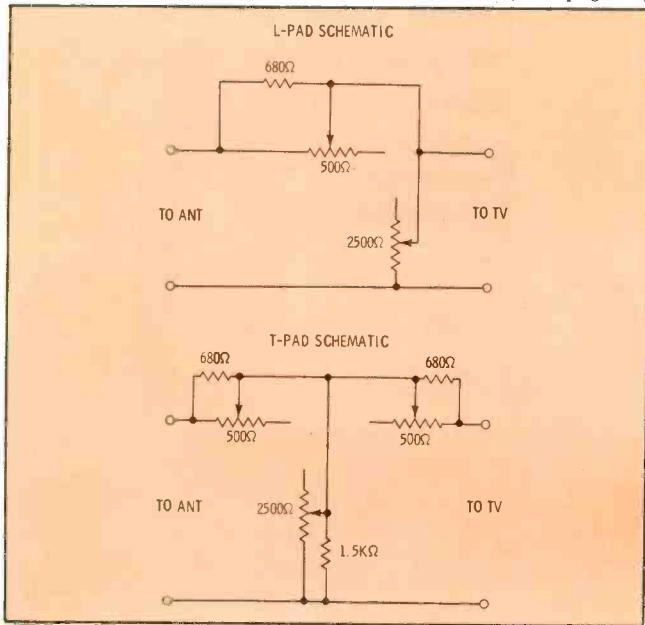

Fig. 5. L and T pads for use with TV transmission line.

attenuator can be used where boosters in strong signal areas tend to produce over-loading that causes smear, distortion, pulling, and ghosts. An easy solution to this problem is to insert the attenuator shown in Fig. 6.

Fixed-Resistor Pads

Fixed resistor pads have few uses in audio work

because carbon units are too low in wattage and wire-wound units introduce undesirable inductance which affects frequency response. Their two main uses, then, are for RF signal reduction (attenuator pads) and connecting circuits of unequal impedances (matching pads).

Where pads are used for matching, they introduce a certain unavoidable loss of power. Therefore, a pad should not be used where signal loss cannot be tolerated. For example, suppose you want to match a 72-ohm transmission line to 300-ohm input of to a TV receiver. If you are in weak-signal area, you should use a matching transformer or balun coil; if, however, there is plenty of signal, the pad will do the job.

Fig. 7 illustrates the balanced "L" pad, sometimes called the "U" pad and Table 4 gives the impedance values for matching signal generator outputs or transmission line to the 300-ohm input of a TV set or FM receiver. Matching from the receiver side into the pad avoids detuning the RF gain and band-width. The use

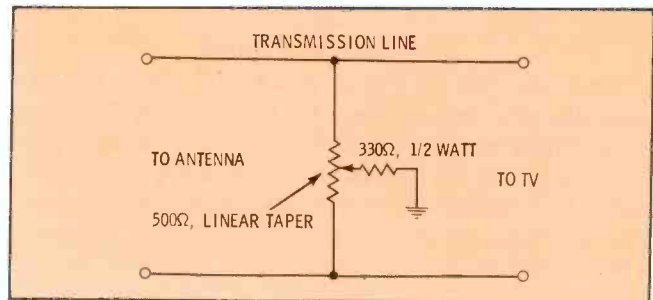

Fig. 6. Makeshift attenuator for insertion in a TV lead.

Now — FOR THE FIRST TIME...

ONE ANTENNA FOR BOTH 75 and 300 OHMS!

WITH NO MATCHING TRANSFORMER NEEDED

NOW You can make ALL the sales for both 75 and 300 ohm installations with KAY-TOWNES STARFIRE Antennas. No matching transformer necessary at antenna.

OUTPERFORMS 15-ELEMENT MODELS

The new 11-element STARFIRE is designed to eliminate the need for stocking two antennas usually necessary to satisfy both 75 and 300 ohm use and by actual test provides better performance than 15-element models of either impedance.

ELIMINATES MATCHING TRANSFORMER

The new KAY-TOWNES STARFIRE has extremely high level gain and is matched to both RG59U cable and 300 ohm lead-in wire.

- Designed for Color — Ideal for Black and White
- Cuts Your Inventory Cost
- Faster installation — comes folded, completely assembled with mast-clamp and all hardware mounted.

GENUINE GOLD ANODIZED
NOT A SPRAY TO WASH AWAY!

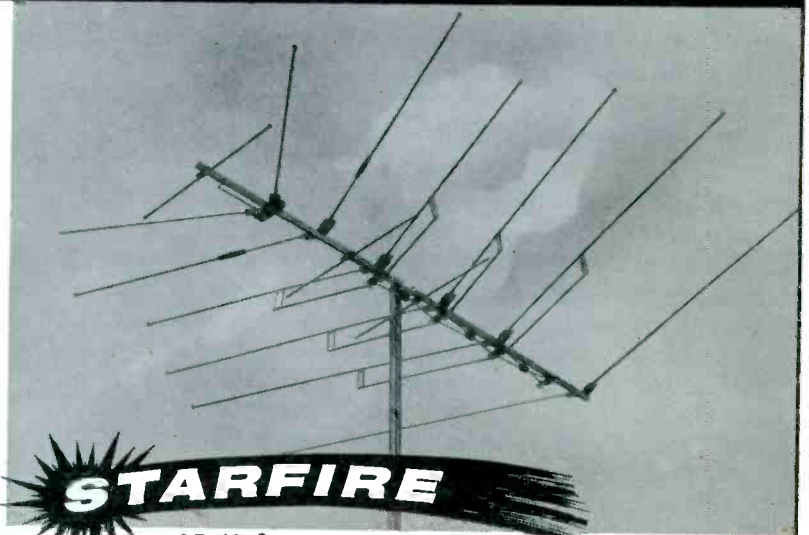

STARFIRE
SF-11-C

LIST PRICE
\$24.50



QUALITY : PERFORMANCE • ECONOMY

KAY-TOWNES
antenna company

HEADQUARTERS OFFICE AND PLANT — 1511 DEAN AVE., ROME, GA. 30162
ALSO MANUFACTURING AND SALES OFFICE IN RINCON, PUERTO RICO

OVER 800 ANTENNA MODELS FOR EVERY AREA . . . EVERY PURPOSE

Circle 57 on literature card

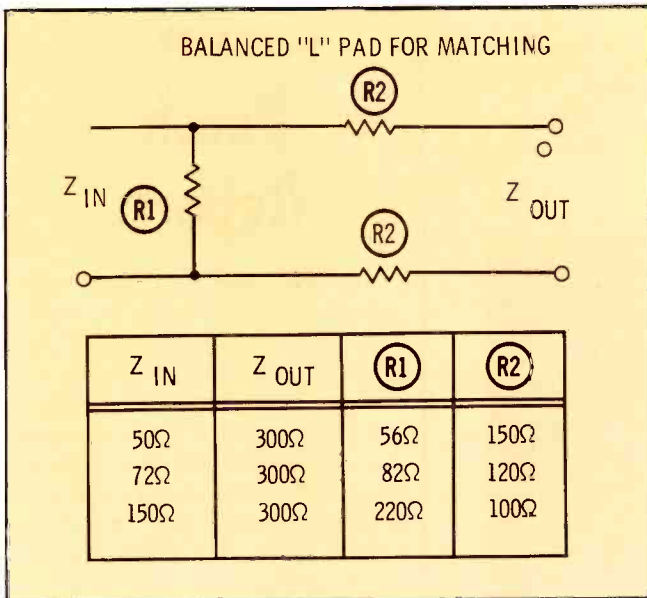

Fig. 7. L-pad matches source to load impedance of 300 ohms.

of a resistive matching pad has the advantage of allowing an impedance match that does not vary with frequency. There is, however, a 10-db insertion loss with such a matching pad. Without the pad, the mismatch would cause reflections in the line and would result in ghosts in the picture.

Where excessive antenna signal causes overloading, a fixed resistor pad can be used for any desired degree of attenuation. Fig. 8 shows the circuit configuration and Table 5 lists the resistance values for popular steps of attenuation in a 300-ohm antenna line. The amount of attenuation used is usually 6 db, 10 db, or 20 db, which corresponds to voltage-loss ratios of 1/2, 1/3, and 1/10, respectively. Pads can be cascaded to provide other values of attenuation—e.g., two 20-db pads would offer 40-db of attenuation. Carbon resistors of the smallest wattage should be used; wirewound resistors are *not* suitable because of their inductance.

Summary

The most common attenuators are of the variable "L" and "T" variety, used in audio circuits. In RF circuits, fixed "H" pads are of greatest use. With the information in the tables, you should be able to choose, design, and put together a pad or attenuator for whatever your purpose. ▲

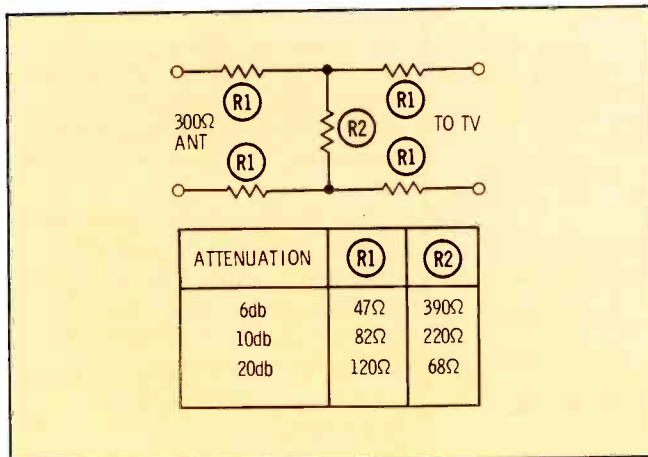
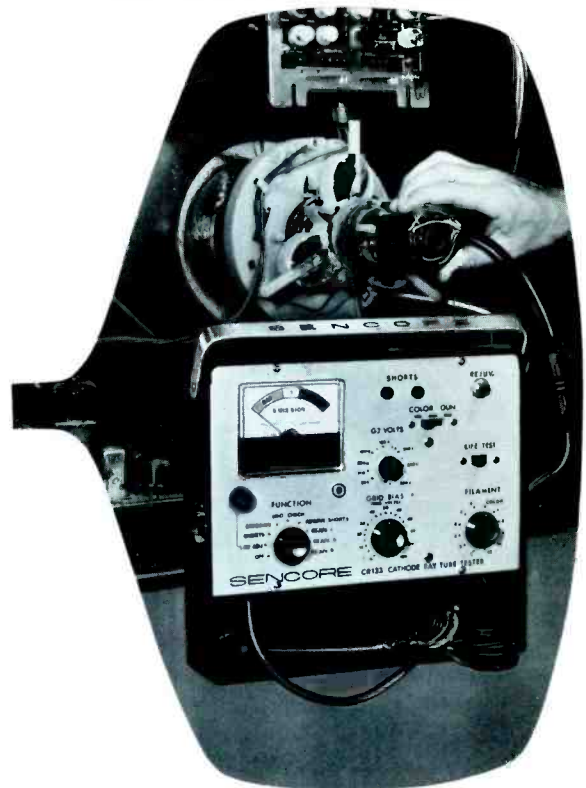

Fig. 8. H-pad reduces television signal to reduce overload.

**top money maker in
the service business**



NEW IMPROVED SENCORE CR133 CRT CHECKER & REJUVENATOR

The new, improved CR133 CRT Checker is designed to test all present picture tubes—and it's ready for future tubes too! Two plug-in replaceable cables contain all sockets required. The compact, 10 lb., CR133 checks CRT emission, inter-element shorts, control grid cut-off capabilities, gas and expected life. Checks all tubes: conventional B&W, new low drive B&W, round color tubes and new rectangular color picture tubes. Exclusive variable G2 Volts from 25 to 325 Volts insures non-obsolence when testing newly announced "semi-low" G2 CRT tubes. New Line Voltage Adjustment insures the most accurate tests possible. Uses well-filtered DC for all checks to avoid tube damage and reading errors. Color guns are individually tested as recommended by manufacturers. Exclusive automatically controlled rejuvenator applies rejuvenation (ACR) voltage as required by individual tube condition; precisely timed to prevent over-rejuvenation or tube damage. The ACR feature is most useful for color tube current equalization to insure proper tracking. Hand-wired and steel-encased for protection of meter and panel in truck or shop, the new improved CR133 is only . . . **\$89⁹⁵**

The famous CR128 CRT Checker and Rejuvenator is similar to above, but with a three position G2 slide switch and without Line Voltage Adjustment at \$69.95

professional quality — that's the difference!

SENCORE

426 SOUTH WESTGATE DRIVE • ADDISON, ILLINOIS

Circle 58 on literature card

October, 1965/PF REPORTER 95

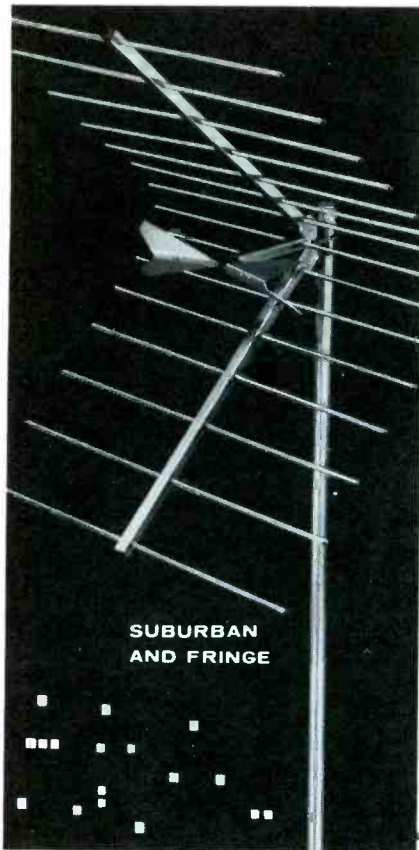

↖ New RCA Strato Star II—15 Reflector UHF antenna for suburban to fringe area reception. Stock #7B141
 New RCA Strato Star I—11 Reflector UHF antenna for urban reception. Stock #7B140
 ↘



What's
 the latest
 angle in

UHF-ANTENNAS

...and how can it make money for you?

There's a lot of money to be made in UHF antenna installation in localities where UHF is established... or is coming, because top UHF reception requires a separate antenna designed for UHF... and UHF is coming to more and more communities every week.

These two RCA UHF antennas let you cover every UHF sales possibility from urban to fringe areas.

The "Latest Angle" Increases Gain. RCA has increased corner reflector angle to 100°. This feature increases gain up to 18% on the most popular UHF channels.

A "Snap" to Install. Antenna arms snap into place and lock automatically. No rivets—no bolting—no bag of hardware. This feature alone can save valuable man hours on each installation.

Better Impedance Match... through new, improved dipole design.

Increased Directivity, plus rejection of unwanted ghosts and other types of interference, as a result of precision variable-spacing of reflector elements.

Better Front-to-Back Ratio, achieved by means of a special element at the apex of the corner reflector.

Don't miss out on UHF profits! Call your nearest Authorized RCA Antenna Distributor today.

RCA PARTS AND ACCESSORIES, DEPTFORD, N. J.



The Most Trusted Name in Electronics

PFR Bench Report

This portable instrument will measure up to 10 watts of transmitter power output; indicate the percentage of modulation; check relative field strength; and measure standing-wave ratio. It may also be used as a test oscillator for checking crystals, or as an aid in receiver alignment. It has a headphone jack; therefore, modulation quality may be monitored directly if desired.



Antenna efficiency can be calculated by observing the percent of reflected power reading when the standing-wave ratio is measured. For wattage, multiply the decimal reading on the meter by .01; then, multiply the answer by the power output reading to determine how much power is actually being radiated. The instrument does not compensate for loss in the cables, so the reflected power reading should be taken in close proximity to the antenna.

This transistorized unit operates on a 9-volt dry cell, and battery replacement is simple: merely remove four screws from the front panel and insert a fresh battery in the holder. To increase battery life, always place the power switch in the REFLECTED position when the unit is not in use.

The Model 91-07 "Signal Optimizer" comes equipped with an extendable whip antenna, connecting cable, and instruction manual. It is available from electronic distributors carrying Utica Communications CB equipment. ▲

For further information circle 150 on literature card

(Continued from page 35)

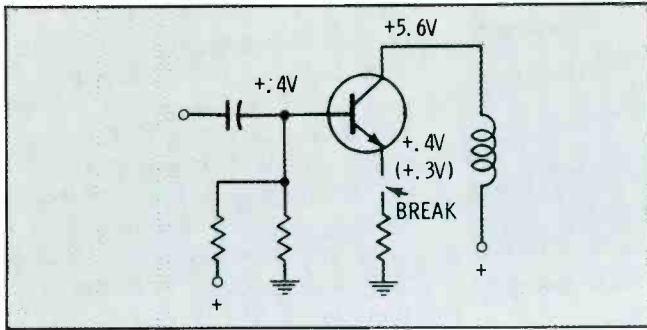

Fig. 5. Diagram shows the effects of an emitter-circuit break.

quency to display the modulation envelope of the RF signal.

When you've isolated the faulty stage, you'll want to make some qualitative checks on it. Table 1 is a checklist of voltage deviations that can often indicate quickly what's wrong in the stage. For instance, the chart says that an open emitter resistor will cause the emitter voltage of an NPN transistor to go slightly high, while the collector voltage also goes high. Fig. 5 shows why: with no emitter circuit to ground (the negative side of the power supply), the emitter assumes the voltage of the base. Since current flow through the collector circuit is almost eliminated, collector voltage increases practically to source potential.

You should also check the transistor. Substitution with a known good one is the most reliable method. A transistor tester can be as dependable as a tube tester, if you remember that neither provides a check at the operating frequency. If a transistor checks okay on a tester, then is replaced in the circuit and still doesn't work, it might have been temporarily healed by unsoldering—the remedy is to try a new one. You'll probably need a good transistor substitution guide, as it's a rare shop that has many direct replacement transistors—they're simply too numerous. Most parts distributors have replacement guides available.

A finger on the grid of a tube injects 60 cps hum, for signal tracing. But a finger on the base of a transistor seldom gets the same result, as the transistor is a low-impedance device and the base circuit isn't as susceptible to hum pickup.

You can also measure the operating voltage across the emitter circuit, which is usually common to both base and collector—a large voltage drop indicates a shorted transistor with maximum current, while little or no voltage indicates an open transistor and no current.

The ohmmeter check (of a transistor) is based on the theory that a transistor is a two-diode device, and you can check the forward-to-backward resistance of each diode. This proves only whether the transistor is open or shorted. Be careful to use a low-current VOM or VTVM, or you might burn out the transistor.

A VTVM will service all transistor sets—a VOM can be used for nearly all circuits, but the low impedance will kill the local oscillator circuit if used to measure voltages there. Modern VOMs are available with high ohm-per-volt sensitivities; some are designed especially for use in transistor circuits.

PINPOINT COLOR TV TROUBLES IN SECONDS...

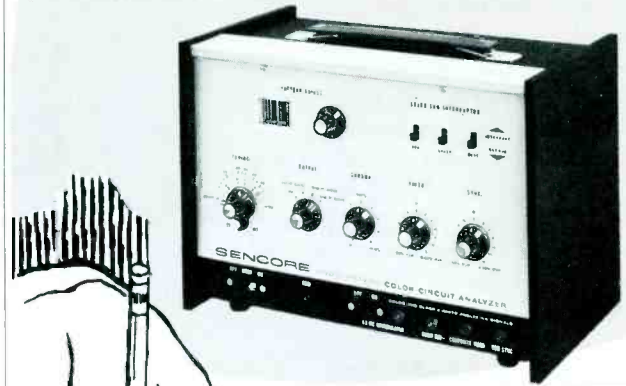

WITH THE NEW IMPROVED SENCORE CA122(A) COLOR CIRCUIT ANALYZER

It's a standard ten color bar generator; produces vertical lines, horizontal lines, crosshatch, and adjustable dots, PLUS a complete TV analyzer for color and B&W—at less money than color generators only. Here is what the CA122(A) will do for you by tried and proven signal injection into these stages.

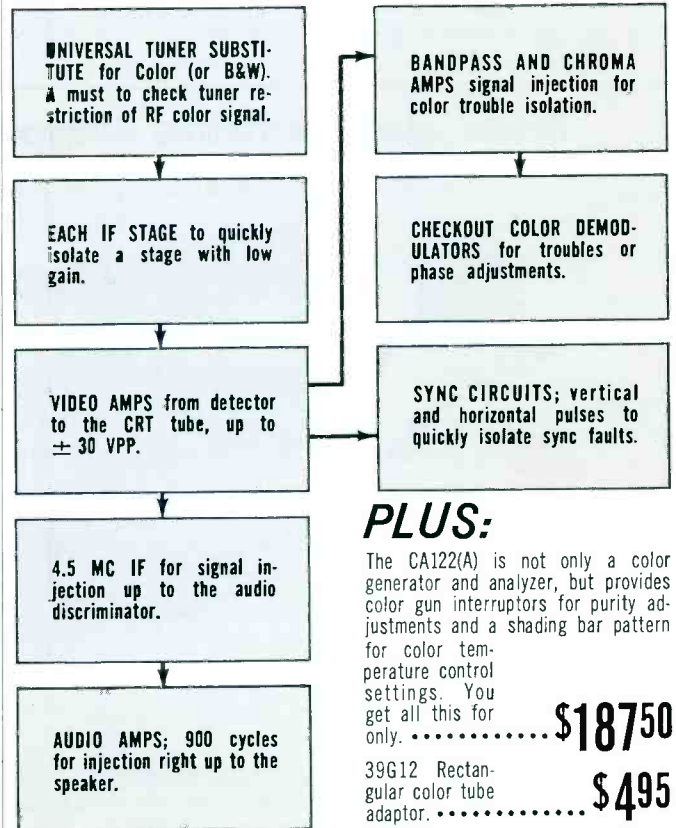

See your distributor today. He has the CA122(A) in stock now.

SENCORE

426 SOUTH WESTGATE DRIVE • ADDISON, ILLINOIS

Aside from transistors, other components can cause trouble. Resistors and capacitors are usually overrated, but as receivers get old, capacitors can fail. Open or weak capacitors cause loss of decoupling (and thus motorboating) or loss of gain. Such things as switches and speakers might seem to be rugged, but sometimes a set will be found with a defective switch. Speakers can be torn, bent, or jammed, and thus cause extreme distortion; replacement is the only cure.

FM Troubleshooting

As you would suspect, since FM operates at high frequencies, the FM local oscillator is the first thing to quit if battery voltage is even slightly low. For this reason, transistor FM's should be scope-and-sweep aligned, with the IF's broadbanded and flat-topped. For one thing, this reduces distortion on modulation peaks. Also, if you peak the transformers, FM tapers off when batteries do, quitting before AM. If you broadband them, however, leaving some freeway in alignment, the set won't

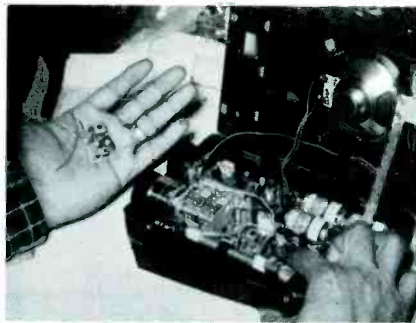

Fig. 6. Modules in modern portables.

quit so suddenly.

Watch out for differences in station signals on FM. Most of these receivers use extendable whip antennas for FM—in other words, a single vertical monopole (not dipole). Standard FM stations use horizontally-polarized antennas, and to receive them with the most signal, the receiving antenna should be horizontal. However, because of the increasing number of automobile and portable FM receivers using vertical antennas, the FCC now permits FM stations to utilize a secondary antenna which is vertically polarized. Therefore, stations using both horizontal and vertical polarization will

have a greater and more uniform signal strength in portable FM sets. Occasionally you may want to mention this to a customer.

A fairly recent development in portable FM is the use of modules like those shown in Fig. 6—small circuit boards containing all components for a given stage (transistor, IF can, resistors, and capacitors of an IF stage, for example). You may find it necessary to work on one of these in an FM IF strip. If you do factory or warranty service, you'll probably replace the entire module.

Things To Come

Modules and subassemblies are coming into portable FM. You might as well get used to them. And when you've come this far, it's but a short step to the next major service task you'll probably have—transistor TV. With the basics of AM-FM transistors in your store of knowledge, it will be easy to go on to transistor TV. Even simpler, you must admit, than making the transition from tube radio to tube TV. Here we go again . . . ▲

Now, get genuine Magnavox parts and tubes fast

through five strategically located Regional Parts Depots.

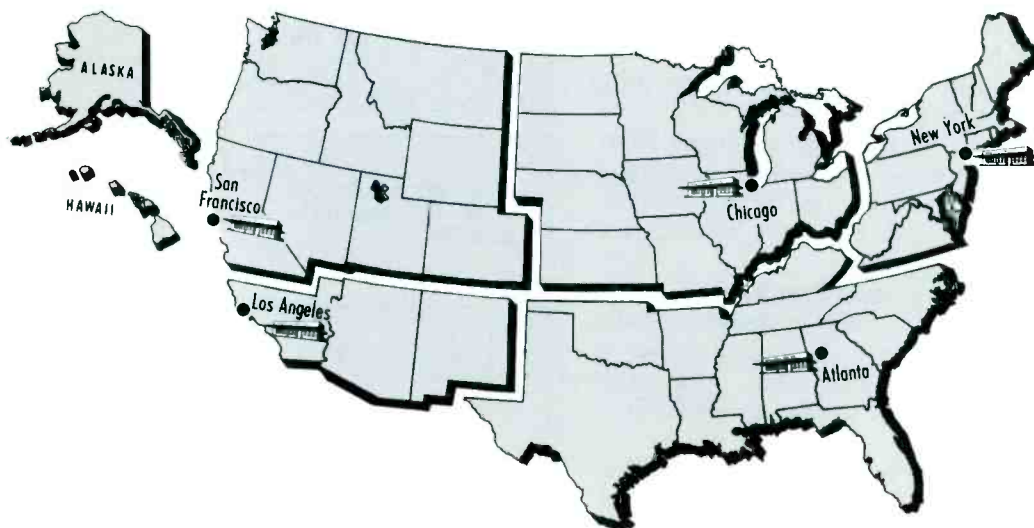

WESTERN DIVISION
Magna-Par Co.
1364 San Mateo Avenue
South San Francisco
Calif. 94080
Phone: 415 871-5080

SOUTHWESTERN DIVISION
B & D Electronics Inc.
Box 1217, Studio City Station
North Hollywood, Calif. 91604
Phones: 213 877-4794 or
213 766-3542

MIDWEST DIVISION
Certified Electronic Dist. Inc.
5959 W. Fullerton Avenue
Chicago, Illinois 60639
Phone: 312 622-2291

SOUTHERN DIVISION
Magna-Par Co.
487 Armour Circle N.E.
Atlanta, Georgia 30324
Phone: 404 875-7123

EASTERN DIVISION
Magna-Par Co.
370 North Street
Teterboro, New Jersey
07608
Phone: 201 288-4540

Phone, wire, or mail your orders to the Depot covering your area.

THE MAGNAVOX COMPANY

FORT WAYNE, INDIANA

Circle 61 on literature card

Sly Old VOX

(Continued from page 37)

switch. The voice signal is amplified in X1 and RC coupled to common-emitter amplifier X2.

After being amplified further by X2, the signal is then rectified by dual diode X3. The resultant pulsating DC is filtered by C1 and C2, creating forward bias on the base of X4, the relay-trigger transistor, and causing it to conduct. This energizes K1 and starts the tape drive motor.

When speech is stopped, C2 discharges through R1 and R2. If speech is resumed before C2 has discharged below the biasing level that keeps X4 conducting and K1 thus energized, the drive motor will continue to operate. The RC time constant is adjustable from zero to about four seconds, depending on the setting of R1, thus allowing the speaker to pause for breath without stopping the drive motor.

As you might suppose, when conversation initially begins here is also a slight delay while the capacitors charge. To avoid clipping of any of these first words, a manual-start feature is included so the operator may start the drive motor before speaking into the microphone. On one machine, a small 60-cps signal from a special secondary winding on the power transformer is applied to point A through a momentary-contact switch. This signal is rectified by X3 and supplies forward bias to X4, energizing M1 and setting the tape in motion.

Diode X5 is connected across M1. It acts as a limiter to keep any transient voltage pulses generated by the inductance of the relay coil from damaging X4.

Slide synchronization is available on this same machine. The small 60-cps signal is fed to the microphone input of the channel not being used to actuate the VOX section. When a slide change is required, the operator switches the VOX input temporarily to the opposite channel and momentarily closes a switch that inserts the 60 cps *beep*, then switches back and continues recording narrative. In playback, the narrative is picked up in one channel, while the other channel's output — containing the recorded beeps — is fed to the input of the VOX circuit where K1 is actuated and operates the slide changing mechanism of the projector.

Troubleshooting VOX

Now that you understand what VOX tape recorders do and how, let's explore why they sometimes don't do what they're supposed to.

Troubles lie in these areas:

- A. Drive motor doesn't operate
- B. Drive motor operates continuously
- C. Drive motor operates intermittently
- D. Auxiliary control doesn't function properly

Of course, you'll have all the conventional tape-recorder troubles such as loose belts, clutch adjustments, switch adjustments, etc., but VOX machines will require consideration of the additional section.

Doesn't Operate

For the first trouble, let's examine the circuit in Fig. 1. Assuming the machine works okay on MANUAL, consider what might cause the drive motor to fail to start in VOX operation. Does the relay work? Listen for it to click when you speak into the microphone. Can't hear a click? If the unit has a sealed relay, you might not hear the click, so check the slide-projector

add an fm-stereo service center
with this one new
sencore unit!



THE SENCORE MX129 FM STEREO MULTIPLEX GENERATOR & ANALYZER

FM-Stereo growth continues to mount and is fast becoming as big a field as Color TV. This means more FM-Stereo service business for you, now and in the future. Is your shop equipped? It can be — completely and economically — with the MX129, the FM-Stereo "Service Center in a Case." The instantly stable, 19-Transistor, crystal controlled MX129 is the most versatile, most portable (only 7½ pounds), most trouble free and efficient multiplex unit on the market — just like having your own FM-Stereo transmitter on your bench or in your truck. Powered by 115 volts AC, it produces all signals for trouble shooting and aligning the stereo section of the FM receiver . . . can be used to demonstrate stereo FM when no programs are being broadcast. Self-contained meter, calibrated in peak to peak volts and DB, is used to accurately set all MX129 controls and as an external meter to measure channel separator at the FM-Stereo speakers. NO OTHER EQUIPMENT IS REQUIRED. **\$169⁵⁰** only

SIGNALS AVAILABLE FOR ALIGNMENT, TROUBLE SHOOTING AND ANALYZING:

FM-RF carrier with composite multiplex audio signal with 38kc suppressed carrier, 19kc pilot and 67kc SCA signals • Multiplex signal formed by 60 or 1000 cycle internal tones or any external signal • Full control over left and right channel amplitude (modulation) • External 67kc SCA signal available for trap adjustment • Composite signals available for signal injection FM detector •

professional quality — that's the difference!

SENCORE

426 SOUTH WESTGATE DRIVE • ADDISON, ILLINOIS
Circle 63 on literature card

October, 1965/PF REPORTER 99

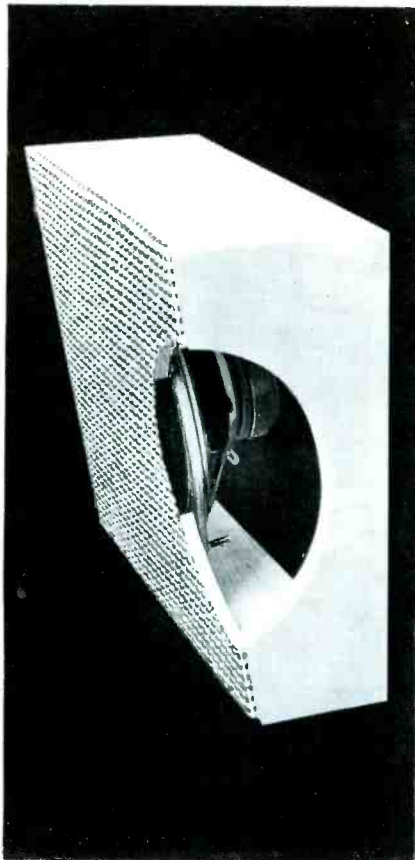

GET PLUS PERFORMANCE FROM OAKTRON SPEAKERS

All Oaktron speakers feature the exclusive Aluminum Voice Coil. This tempered, all aluminum form eliminates warpage from humidity changes and from severe overload. The unique aluminum Voice Coil also provides increased sensitivity and longer speaker life.

A complete range of sizes and styles are available in Oaktron Baffles. Styled in smart furniture finish, Oaktron Baffles feature 1/2" hardwood, double strength interlocking corners, and solid glued and stapled grills.

For complete information, write today for your FREE Catalog.



OAKTRON INDUSTRIES, INC., MONROE, WIS.

Circle 64 on literature card

jack for continuity when you speak. Even if the projector contacts show continuity, the relay could still be partially defective — it has several sets of contacts and the motor contacts may not be connecting properly. The fact that any contacts work, however, proves the VOX section is functioning.

Let's assume we didn't get continuity across the projector contacts. The relay can be inoperative for several reasons, so it's time to dig deeper.

With the VOX circuit exposed, check for bias voltage between the base and emitter of X3 while you speak into the microphone. Be sure the bias polarity is correct. If your meter reveals no voltage increase, try again between the emitter of X2 and ground. A voltage shift here, but not at the X3 emitter, indicates an open trigger transistor. (If you measure no voltage here, check first to be sure the MODE switch isn't in position 2 or 4.) A large increase in the resistance of R6 could cause X3 to become inoperative; emitter voltage in this instance would be negative with

respect to base. If X3 is open, check for excessively high negative voltage between the emitter of X2 and ground. This indicates that the emitter resistance of X2 has increased and, besides rendering the emitter-follower stage inoperative, has possibly burned out X3.

If any of the bias resistors in the unit have increased in value, they could render the section inoperative. X1 depends on proper biasing, but it can be varied; try adjusting R1 and noting if the relay pulls in when you speak into the microphone.

Another quick overall check is to push the START button. If this triggers the relay, you'll know the trouble must lie in the audio path prior to the VOX stages: Transformer T1 might have an open winding, the printed circuit could have a crack in it, or R1 might be faulty.

The PC board should receive close scrutiny as a possible trouble spot. Portable recorders can easily develop board troubles if the machine is set down too hard. A relay mounted on a PC board may exert quite a strain whenever the board is in a vertical position. Take this fact into consideration when servicing VOX circuits and check the board carefully.

Operates Continuously

What if the drive motor runs constantly in VOX mode, but manual operation is normal? The relay may be stuck. Trigger transistor X3 could have a collector-emitter short, or some other stage could be forward-biased even without the audio input. If you open the emitter circuit of a transistor and the relay de-energizes, it's a simple matter to check voltages and locate the cause of the uncontrolled conduction. An off-value resistor is the most likely culprit.

Intermittents

Intermittent operation of a unit usually strikes dread in the heart of anyone who repairs electronic equipment for a living. It's reverse psychology, but you can learn to regard an intermittent as a challenge (you can't get out of it, anyway) and actually look forward to smoking out the trouble.

In searching for intermittent troubles of the VOX circuits, the relay is what you must assume is operating erratically. It controls the drive

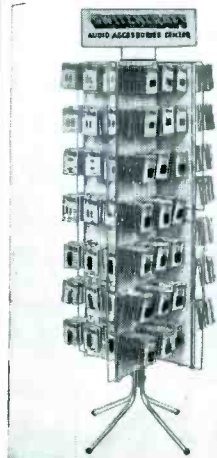
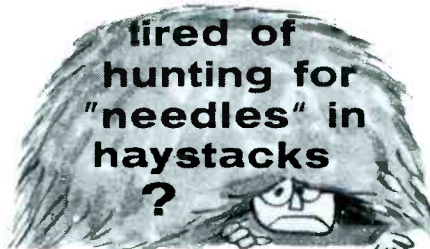

FIND THE
PRECISE
AUDIO
ACCESSORY
YOU NEED
FAST!

- Jacks
- Plugs
- Adaptors
- Couplers
- Extension
Jacks
- Speaker
Controls
- "Mini-Mix"—
mixers, etc.

look for the

SWITCHCRAFT®

AUDIO ACCESSORY SELF-SERVICE CENTER

At last! All the confusion and "wait" gone. Fail-Safe quality. Packages factory sealed, precisely labeled by name, type, mating part, price. Guaranteed.

Send for Complete Catalog:

SWITCHCRAFT, INCORPORATED
5573 No. Elston Ave., Chicago, Illinois 60630

Circle 65 on literature card

The Sly Old VOX

motor, but several other factors directly or indirectly affect relay operation. Faulty relay contacts can cause intermittent operation of the drive motor, but a sealed relay is not too likely to produce this trouble. Never discount the possibility entirely, however.

A leaky trigger transistor, however, is a common cause for intermittent operation; in fact, X1, X2, and X3 are all suspects in cases of this kind. The thermistor might be defective. If C2 or C3 were to become open or leaky, erratic relay operation could result. The old practice of flexing circuit boards will sometimes reveal an intermittent. Also, because of their extensive use, switches shouldn't be overlooked as a possible source of intermittent trouble.

Auxiliary Controls

When auxiliary controls do not function properly, a thorough examination of normal operation will usually suggest a number of possible trouble spots. Mostly, these troubles resolve to be loose jacks, dirty contacts, or bad switches. However, if component failure is suspected, resistance checks or substitution will usually find the trouble.

When you're confronted with abnormal operation of the VOX circuit and its auxiliary controls, your most effective troubleshooting aid is understanding what the circuit is supposed to do. Armed with this, you can move step by step through each action until the abnormal circuit is spotted.

The Rectified Type

Let's look for trouble possibilities in the circuit of Fig. 2. The first two stages can be treated as conventional RC-coupled audio stages, and troubleshooting them should pose no problem. A faulty rectifier diode X3 would cause insufficient forward biasing of X4. If C1, or especially C2, were to become leaky, the relay could produce a chatter. If R1 increased in value, the time constant would be very long and could not be adjusted for correct start-stop operation of the relay. Were R1 too small, no delay at all would be evident.

An increase of the stabilizing resistance between the emitter of X4 and ground would cause the relay trigger to become inoperative. If this resistance becomes too low, relay M1 will remain energized and the drive motor will run continuously.

If the relay in this machine is one with the contacts exposed, corrosion or pitting of the contacts could be a source of intermittent trouble. Using a good burnishing tool will fix them if they're not too badly pitted (a burnishing tool is the only device you should ever use to clean relay points). If the pitting is very deep, replace the relay rather than trying to file the points down—they'd just go bad again soon.

Conclusion

This article has acquainted you with VOX tape recorders and some of the servicing problems you'll find. It would be well to keep in mind that a VOX tape recorder is, in general terms, a standard-type machine to which has been added one or more stages to control its drive motor upon receiving an audio signal. Don't hesitate to accept them for repair. When you get one on the bench, you'll find the old VOX isn't so sly. ▲

**just in time for the
fm and uhf boom!
an all transistorized
field strength meter.**

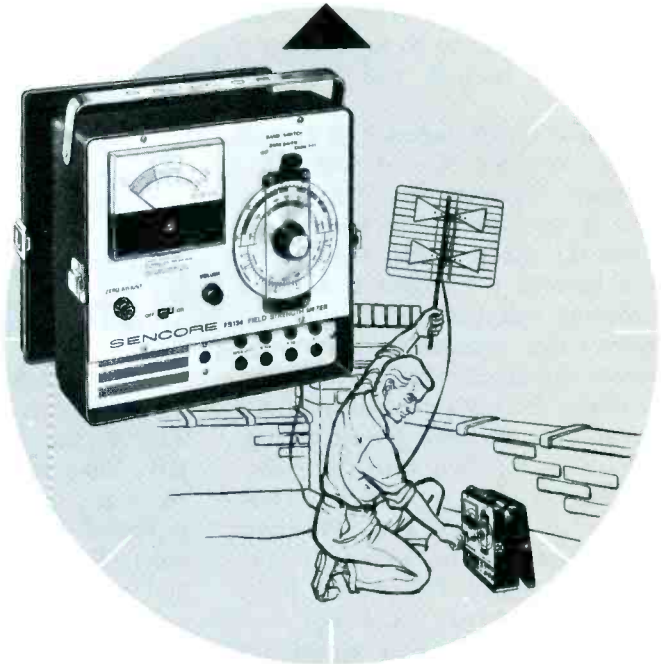

THE ALL NEW SENCORE FS134 FIELD STRENGTH METER

Once again, you can turn to the roof tops for a fast dollar in antenna installations. But this time, you can do it the easy way. No more running up and down ladders, locating cumbersome AC extension cords, lugging heavy tube operated field strength meters on the roof, or worse yet, getting the shock of your life from the AC line as you hold onto a soil pipe. Here is a new portable field strength meter to fill your every need in VHF, UHF or FM antenna installations. Many customers want all antennas on one mast thus creating interaction. Here is where the FS134 goes to work. You can optimize antenna location and orientation in seconds. Just connect the antenna, tune in the station and adjust. Self-contained speaker blasts forth the sound from the TV or FM station to insure that you have the exact signal that you are looking for. The FS134 is so light weight (only 9 lbs.) that you can take it with you up the chimney if necessary. Get rid of the assistant at the other end of the transmission line and the needless "yelling" back and forth. Get the FS134 today . . .

\$199⁵⁰
only

COMPARE TO ANY OTHER FIELD STRENGTH METER AT TWICE THE MONEY

- Sensitivity . . . 5 microvolts on VHF and FM, 15 microvolts on UHF
- Input impedance . . . 300 ohms or 75 ohms with plug-in transformer
- 500 KC band width
- Powered by easy to get "C" cells
- 4 inch meter with 2 percent accuracy calibrated in DB and microvolts.

professional quality — that's the difference!

SENCORE

426 SOUTH WESTGATE DRIVE • ADDISON, ILLINOIS
Circle 66 on literature card

October, 1965/PF REPORTER 101

(Continued from page 40)

phonic information—that is, L+R audio at frequencies from 50 to 15,000 cps. It also contains a stereo difference signal in the form of supersonic audio sidebands ranging from 23 to 53 kc. When a 38-kc carrier is added to these sidebands, the result is L-R and $-(L-R)$ signals.

In the biphase detector, a special NPN transistor is used which has bilateral characteristics. This means that it can conduct in both directions. In other words, the emitter can become the collector, and the collector can become the emitter, when the transistor is properly biased and driven with an AC signal.

For a thorough explanation, let's begin with the time shown in Fig. 9A, when terminal 4 of the transformer secondary is positive and terminal 1 is negative. The NPN transistor conducts as shown. If the composite signal is fed to the base, the high-frequency sidebands that comprise the difference signal are combined with the 38-kc subcarrier and the resulting L-R components

appear at the collector and emitter. The collector signal undergoes a phase reversal but the emitter signal remains in the original phase. This gives $-(L-R)$ at the collector and L-R at the emitter.

However, the composite signal applied to the base also contains the L+R frequencies and these are unaffected by the presence of the 38-kc subcarrier. Therefore, the L+R signal appears at both the collector and emitter, in its original form, with no phase reversal. When the difference signals and the L+R signal are combined algebraically at the emitter and collector terminals, the result is 2R at the collector and 2L at the emitter.

For the other half of the 38-kc cycle, which is shown in part B of Fig. 9, the emitter and collector have changed places and the transistor is conducting in the opposite direction. Notice that the input signal to the base is marked $-(L-R)$ and is drawn as a negative-going signal. This is to be expected since L-R consists of sidebands which are on the opposite (positive) half-cycle. The L+R signal has not

changed polarity, because it is pure audio and is not related to the 38-kc carrier.

With the transistor conducting in the opposite direction, the collector is now at the bottom and the phase-inverted version of $-(L-R)$ now appears at this terminal with the label L-R. At the top terminal, which is now the emitter, no phase inversion occurs and $-(L-R)$ still appears there. As before, L+R is unaffected and appears at both terminals. The algebraic addition of these voltages again produces 2R at the top and 2L at the bottom.

Conclusion

Stereo receivers have been changing and improving at a rapid rate in the last two years, and no doubt some of the ideas presented here as the latest circuits will be "latest" for only a short time. This is the challenge faced by repair technicians since the early days of the electronics industry. Your future depends on your ability to reapply basic principles to the understanding of each new step in the advancement of the industry. ▲

Me...? Rebuild Color Tubes???
Why Not!

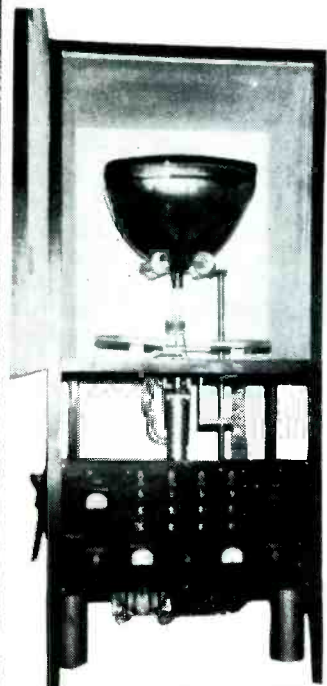

**Windsor Equipment
Handles Color & Bond-
ed-Face As Well As
Black-and-White Tubes.**

So What?

**Rebuilding with Wind-
sor is a QUALITY
PROCESS . . . and
PROFITABLE !!!**

**Rebuild Color Tubes for
a Cost of \$11.75 each
... You Sell them for???**

**Windsor Equipment
pays for itself in a few
months.**

**Financing Available
Free Training at our
Plant**

Write for our Booklet "The Open Door to TV Profits"

WINDSOR ELECTRONICS, INC.

Equipment Division
999 N. Main St., Glen Ellyn, Illinois

Circle 67 on literature card

Solutions to Problems on Page 14

(1) The unknown is the number of capacitors in the amplifier. We represent this by the letter "X." Since there are 12 more resistors than there are capacitors, the number of resistors equals the number of capacitors plus 12, or $X + 12$.

The equation can be written:

$$X + (X + 12) = 46$$

And solved:

$$2X + 12 = 46 \qquad 2X = 46 - 12 \qquad 2X = 34$$

$X = 17$, the number of capacitors in the amplifier. Since there are 12 more resistors, the number of resistors is $17 + 12 = 29$. To check: $17 + 29 = 46$ components.

(2) The technician can wire the stereo amplifier in 3 hours; so, he can do $1/3$ of the job in 1 hour. His helper can wire the amplifier in 4 hours, or $1/4$ of the job in 1 hour.

Now, since $1/3 + 1/4 = 4/12 + 3/12$, together they can do $7/12$ of the job in 1 hour.

Since they can do $7/12$ of the job in 1 hour, they can do the full job in " X " hours. The equation is:

$$(7/12) \text{ times } (X) = 1 \text{ complete job, or } \frac{7X}{12} = 1.$$

Multiplying both sides of the equation by 12 we get: $7X = 12$.

Divide both sides of the equation by 7 to get rid of the coefficient of X we get: $X = \frac{12}{7}$ or 1.57 hours, or 1:43 hours (1 hour and 43 minutes).

Ed. Note: Providing they don't get in each other's way.

(3) There was another problem hidden in the letter: If PF REPORTER readers can solve these first two problems, they have to use logic. The logic they use is of the same step-by-step nature as troubleshooting should be. Why, then, don't these same intelligent technicians use such logic in their everyday work?

Answer: The good ones do. — Ed.



The Troubleshooter

answers your servicing problems

Internal Interference

The customer's original complaint on a Motorola Chassis 542A-07 (covered in PHOTOFAC Folder 382-1) was a fuzzy picture with an intermittent herringbone pattern. When using a VTVM set for DC voltage, placing the probe on the second and third IF stages causes audio motorboating, severe herringbone pattern, and video overload.

Chapter 12, "Interference Troubles," of the Howard W. Sams book *TV Servicing Guide* indicates this symptom can be caused by signals generated within the receiver. How can I correct this trouble?

V. E. JACKENS

Miami, Fla.

The symptoms you describe indicate that the IF stages are oscillating; which causes the poor resolution and the herringbone pattern. Check the response of the complete receiver by using a sweep generator, and align it following the procedures given in PHOTOFAC. You may also find some trouble other than misalignment is causing the IF stages to oscillate. Such a symptom could be caused by an open plate, screen-grid, or AGC bypass capacitor. Try bridging all these capacitors with units known to be good; many times this will reveal the one that is defective.

Output Stage Balance

How are the AC BALANCE and DC BALANCE of H. H. Scott Model 399 (covered in PHOTOFAC Folder 526-8) adjusted for proper output when the output tubes are changed?

D. F. BURDICK

Midland, Mich.

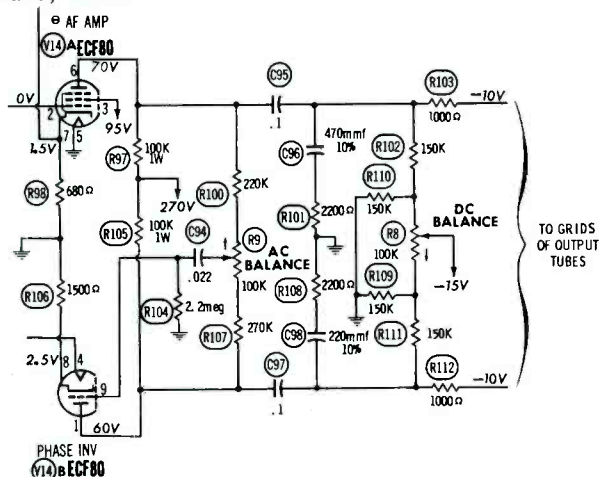

No Brightness Control

In my Philco TV Chassis 13N52 (covered in PHOTOFAC Folder 657-2), the brightness control loses control after the set has been on about eight seconds. In servicing this set for elimination of retrace lines, I substituted tubes and filters, replaced the blanking couplate, tested the vertical-output transformer, tested the yoke, and checked every connection to the retrace circuitry—including the video output circuitry. All voltages on the video output and the picture tube are correct, as are the values of all resistors.

LEON MALISZESKI

Vallejo, California

The clue to your trouble is the fact that you are unable to control the brightness of the picture tube. Check the circuitry about the brightness control. One other trouble that could cause this symptom is a short between the control grid, pin 2, and the cathode, pin 7, of the picture tube. A test of the picture tube should indicate whether or not this trouble exists.



The boss didn't believe us, so we borrowed his new Cadillac and came to a dead stop on top of one of the new all steel Sencore cases . . . and without an ounce of damage. We wanted to prove once and for all that only Sencore was rugged enough for constant field use. We doubted that you would run over your new Mighty Mite tube tester, CRT checker, solid state color generator, or any of the other fine Sencore time saving testers but we do know that you toss them around plenty . . . all day long. This requires all steel construction. Only Sencore has a complete line of all steel ruggedized testers. Wood and fabric just aren't good enough for today's technician on the go. That's why Sencore is the World's leaders in portable testers.

SENCORE ■ 426 WESTGATE ■ ADDISON, ILLINOIS

Circle 68 on literature card

Outputs of the paraphase amplifier (phase inverter) are balanced by the AC BALANCE control. First, disconnect the speaker from A channel; then connect a 16-ohm non-inductive 25-watt resistor across the 16-ohm tap. Connect a scope across the load resistor; then, inject a 1000-cps sine wave at the grid of V14A. Increase the oscillator output until clipping is just noticeable on the scope. With this condition present, adjust the AC BALANCE control until the clipping is symmetrical. Next, make the same adjustments for B channel.

DC BALANCE control adjustment is relatively simple. Merely connect a DC voltmeter between both plates of the power output stage and adjust the DC BALANCE control for minimum voltage reading. Repeat this adjustment for the opposite channel.

ARTIFICIAL RESPIRATION FOR CRT'S

CREATES MORE PROFIT FOR YOU



Easy, professional way to check and correct B&W and Color Picture Tubes

TESTS AND REJUVENATES

- all picture tubes at correct filament voltage from 1 to 12 volts.
- all Hi G-2 and Lo G-2 picture tubes, including tubes that require as low a G-2 voltage as 30 volts.
- 110° tubes and the new 19" and 23" tubes.
- color picture tubes, including the new 90° 23" 23EGP22. Checks and corrects each gun of color tube separately.



ALL-IN-ONE B&K CRT 445

THE INDUSTRY'S STANDARD
Most Widely Used Today
by Professional Servicemen

SAVES CUSTOMERS—ADDS SERVICE INCOME—MAKES NEW TUBE SALES EASIER

Does the job in a few minutes right in the home without removing tube from TV set.

Gives new life to weak or inoperative tubes. Checks for leakage, shorts, open circuits and emission. Removes inter-element shorts and leakage. Repairs open circuits and low emission. Restores emission and brightness. Life Test checks gas content and predicts remaining useful life of picture tube.

Quickly pays for itself.

Net, \$74.95

See Your B&K Distributor for Demonstration, or Write for Catalog AP21-R

Subscribe to
New
Picture Tube
Information
Service



B & K MANUFACTURING CO.
DIVISION OF DYNASCAN CORPORATION
1801 W. BELLE PLAINE AVE. • CHICAGO, ILL. 60613
Canada: Atlas Radio Corp., 50 Wingold, Toronto 19, Ont.
Export: Empire Exporters, 123 Grand St., New York 13, U.S.A.

Card 69 on literature card

Intermittent Sweep

I am having trouble with a Zenith Chassis 16D25Q (covered in PHOTOFACT Folder 466-2). The raster is normal for

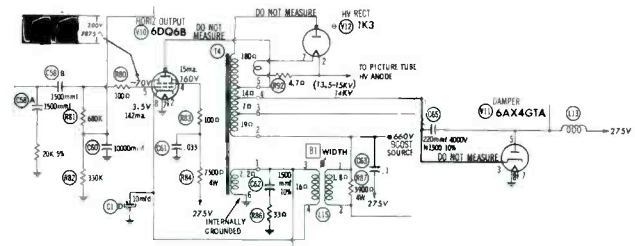

about one-half minute; then it becomes narrow and blooms, and the high voltage disappears. I changed the horizontal-output transformer because it was cooked, but that did not solve the problem. The only abnormal voltage reading is on pin 5 of V10. When the raster is normal, I get -75 volts on pin 5; then as the raster narrows, voltage drops to -25 volts.

THOMAS E. CASEDA

Nonty-Glo, Pa.

Indications are that the flyback transformer was overheating because of the reduction in grid bias. C58B could be breaking down intermittently and placing a positive potential on the grid of the horizontal-output tube. Check this capacitor by substitution. If C58 is not the cause of trouble, measure the cathode current of V10; it should be 142 ma. If the cathode current is greater than normal, check the output circuit for an excessive load. Be sure to replace the damper tube, V11. Also check the B+ boost line for additional clues.

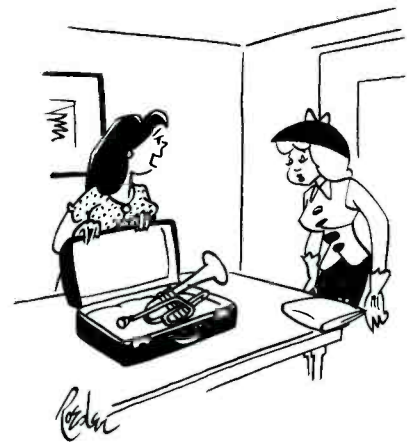

"It's a surprise. My husband's joining a Citizen's Band."

free with your purchase of a **PHOTOFACT®** Library—
the supreme gift for your family...
the famous 14-volume NEW STANDARD ENCYCLOPEDIA!

**AN INVALUABLE
 TREASURY OF
 KNOWLEDGE FOR
 ALL THE FAMILY**

sells at retail for
\$149.50

now yours

FREE with the purchase
 of a *Photofact*
 Library consisting of
225 Sets or more—

Offer for limited time only—ACT NOW!



**A HANDSOME, PRACTICAL
 HOME REFERENCE
 LIBRARY**

**Get this wonderful bonus for your family—give
 your earning power a big boost with PHOTOFACT
 —the world's finest TV-radio service data**

Now, more than ever, it pays to own a PHOTOFACT Library—the time-saving, troubleshooting partner guaranteed to help you earn more daily. Now, you can start or complete your PHOTOFACT Library the special Easy-Buy way, and get absolutely FREE with your purchase, the famous 14-volume NEW STANDARD ENCYCLOPEDIA. It's a great reference library for all the family—complete, authoritative, indispensable. Retail for \$149.50—yours absolutely FREE with the purchase of a PHOTOFACT Library consisting of 225 Sets or more!

**THERE ARE 4 CONVENIENT WAYS
 TO SELECT YOUR PHOTOFACT LIBRARY**

1. Complete your present PHOTOFACT Library.
2. Order a PHOTOFACT "Starter" Library—225 Sets (Sets 451-675—coverage from 1959 to 1964—only \$14.29 per month).
3. Order by brand name and year—see the handy selection chart at your distributor.
4. Order a complete PHOTOFACT Library—and the famous 14-Volume New Standard Encyclopedia is yours FREE!

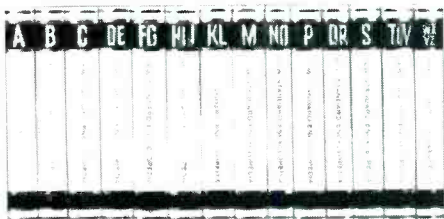

**ORDER YOUR PHOTOFACT LIBRARY NOW—
 AND GET YOUR FREE STANDARD ENCYCLOPEDIA**

See your Distributor for the full details of the PHOTOFACT-Encyclopedia Deal, or send coupon at right! Also ask about a Standing Order Subscription to current PHOTOFACT and Specialized Service Series (FREE File Cabinets available with Subscriptions). **ACT NOW!**

SEE YOUR DISTRIBUTOR OR SEND COUPON TODAY

OWN A PHOTOFACT LIBRARY THE EASY-BUY WAY:

- Only \$10 down • 30 months to pay
- No interest or carrying charges • Prepaid transportation
- Add-on privilege of a year's advance subscription to current Photofact data, on the same Easy-Buy contract
- Save 30¢ per Set—special \$1.95 price applies on Easy-Buy (instead of regular \$2.25 price)

THERE'S NEVER BEEN A DEAL TO EQUAL THIS!

**GET THE
 DETAILS
 NOW**

HOWARD W. SAMS & CO., INC.

Howard W. Sams & Co., Inc., Dept. PFF-10
 4300 W. 62nd St., Indianapolis, Ind. 46206

Send full information on the PHOTOFACT Library-Encyclopedia Deal, and details of the Easy-Buy Plan

My Distributor is: _____

Shop Name _____

Attn. _____

Address _____

City _____ State _____ Zip _____

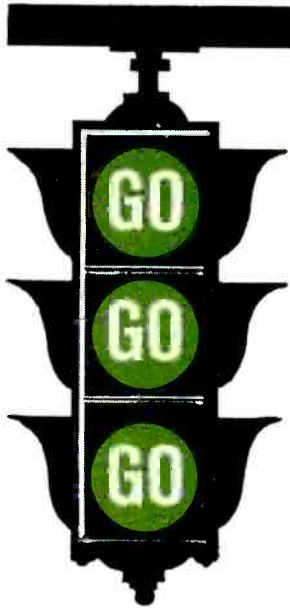

BEST ROUTE TO RELIABLE MEASUREMENTS

GO WITH THE NEW GREEN LINE

THIS WAY TO SMART NEW DESIGN
THIS WAY TO ADVANCED HIGH PERFORMANCE

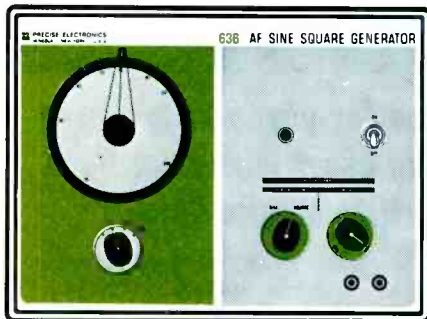

MODEL 636

AF SINE SQUARE GENERATOR — 20 cps to 200 kc in four ranges. Less than 0.25% sine wave distortion at 10 vrms into 600 ohms load.

Kit: \$45.95 Net Wired: \$61.95 Net

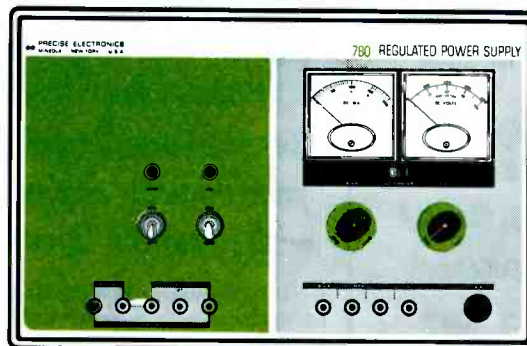

MODEL 780

CONTINUOUSLY VARIABLE REGULATED VOLTAGE SUPPLY — Regulated dc output from 0 to +400 v at 150 ma, and 0 to -150 v bias. Also provides unregulated ac. Meters for voltage and current.

Wired: \$99.95 Net

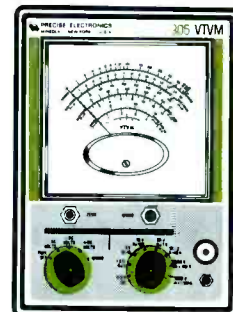

MODEL 905

VACUUM TUBE VOLTMETER — Comes with assembled dc/ac-ohms probe. Direct reading of p-p voltages. Separate ac low voltage scale. Low 0.5 vdc range for transistor circuit measurements.

Kit: \$32.95 Net Wired: \$49.95 Net

Go with the new PRECISE Green Line.

It's the scenic route for your test measurements—headed straight for value and accuracy. These unique instruments have color dynamic front panels featuring easy-on-the-eyes Green to aid readability and accuracy. New functional design and layout make operation fast and foolproof. Underneath, they're humming with sophisticated circuitry checked out for reliability. That's why, now more than ever, you'll find the going's smoothest with PRECISE test instruments. Go all the way with PRECISE scopes, VTVMs, power supplies, signal generators, tube testers, decade boxes and probes.

FREE! Tool Kit With Case

Get this compact, convertible tool set free with your purchase of any PRECISE instrument (except probes and decade boxes). Included are nutdrivers, screwdrivers and a handy tote case. Available only during our Green Line introduction. Supplies are limited, so make tracks to your PRECISE distributor and get this free gift now!



PRECISE ELECTRONICS / Division of Designatronics, Inc. / Mineola, L. I., N. Y.

Circle 71 on literature card

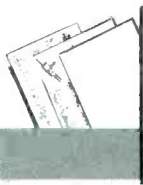

Product Report

For further information on any of the following items, circle the associated number on the Catalog & Literature Card.



Paging Microphone
(143)

A compact, dynamic microphone permits control of as many as four separate circuits for paging, dispatch, PA, audio-visual work, and ham radio operation.

The new "Mark III DBS" microphone, manufactured by **Audiophonics Corp.**, offers up to four DPDT switches, each controlling a separate circuit. It is available in ceramic, Cerra-Dynamic™, or high- or low-Z dynamic types. The base, prepared for desk mounting, also has a 1/2" flange to permit direct conduit attachment.

The cast-aluminum base of the unit is for use in industrial plants, hospitals, and other PA applications. It has an adjustable gooseneck, and brush-chromed zinc microphone body.



Tuner and Control Cleaners
(144)

Three new electronic tuner and control cleaners come with extender tubes to direct the spray into cramped working areas. Aerosol-packed, the three new items are **Quietrol "Mark II"** for tuners, "Spray-Pack" for controls and switches, and "Silitron" for general cleaning use. The new Quietrol products are harmless to plastics and metals, are nonconductive, non-flammable, and noncorrosive, and have little effect on capacitance and resistance.

Communications, mobile radio...

A First Class FCC License

...or Your Money Back!

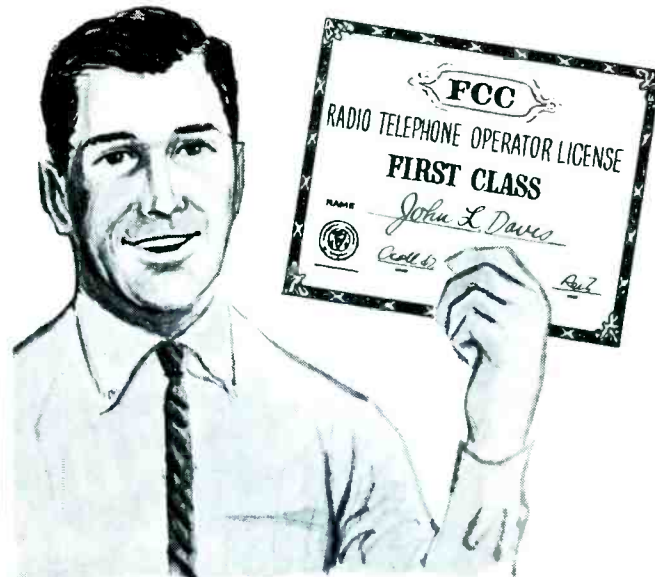

Your key to future success in electronics is a First-Class FCC License. It will permit you to operate and maintain transmitting equipment used in aviation, broadcasting, marine, microwave, mobile communications, or Citizens-Band. Cleveland Institute home study is the ideal way to get your FCC License. Here's why:

Our training programs will *quickly* prepare you for a First-Class Commercial Radio Telephone License with a Radar Endorsement. Should you fail to pass the FCC examination after completing your course, you will get a *full refund* of all tuition payments. You get an FCC License . . . or your money back!

You owe it to yourself, your family, your future to get the complete details on our "proven effective" Cleveland Institute home study. Just send the coupon below **TODAY**. There's no obligation. Cleveland Institute of Electronics, 1776 E. 17th St., Cleveland, Ohio 44114.

Mail Coupon TODAY For FREE Catalog

Cleveland Institute of Electronics
1776 E. 17th St., Dept. PF 25
Cleveland, Ohio 44114

Please send **FREE** Career Information prepared to help me get ahead in Electronics, without further obligation.

CHECK AREA OF MOST INTEREST—

- | | |
|---|--|
| <input type="checkbox"/> Electronics Technology | <input type="checkbox"/> First Class FCC License |
| <input type="checkbox"/> Industrial Electronics | <input type="checkbox"/> Electronic Communications |
| <input type="checkbox"/> Broadcast Engineering | <input type="checkbox"/> Advanced Engineering |

Your present occupation _____

Name _____ Age _____
(please print)

Address _____ County _____

City _____ State _____ Zip _____

A leader in Electronics Training . . . since 1934

How to Succeed in Electronics

Circle 72 on literature card

Tape Cleans Recording Head

(145)

A tape leader (impregnated with formula CO-05) is prespliced to the tape at both ends. It cleans oxide from recording heads on every tape run-through. The "Ferrotape" magnetic recording tape, made by **Ferrodynamics Corporation**, has reversing and stop tabs spliced in at both ends for operating the new automatic bidirectional or automatic-stop tape recorders. "Ferrotape" is available in lengths from 300' to 2400' in 1.5-mil and 1-mil acetate bases. It is also manufactured in lengths to 2400' in 1.5-mil, 1-mil, and .5-mil, mylar bases.



CB Direction-Finding Antenna

(146)

The "signal-Hunter," designed for practical and emergency use on CB frequencies, permits locating hidden transmitters, tracking down CB interference, and locating stations in distress.

Installation is quite simple; the **Gold Line Company** unit clips on the car window, then is retained by a heavy-duty suction cup. The only electrical connection is a coaxial connector plugged into the antenna socket of the CB set. An 8' cable permits mounting on either side of the car. Curved or flat windows are accommodated by an adjustable mounting bracket. Tuning is done with a knob at the top of the loop — no special tools or test equipment are needed.

The antenna is operated by tuning its directional pointer; as the loop swing, it homes in on the incoming signal. Indications are viewed on the receiver S-me-

The famous MERCURY Model 1101 TUBE TESTER NOW in a wire-it-yourself KIT!

illustrated
step-by-step
instructions
make the
Model 1101
easy-to-
build...

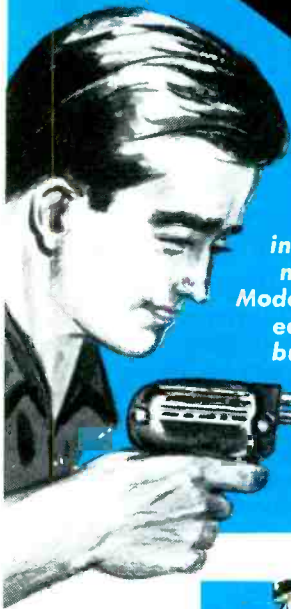

**A PORTABLE
MASTERPIECE**
Modern, airplane
luggage design
scuff-proof gray
case... Weighs
only 4 lbs. 8 1/8"
x 11 3/8" x 3 1/4".



Nothing has been spared, engineering-wise or production-wise in making the Model 1101 your best tube tester buy. Tests more tubes for dynamic cathode emission, shorts, grid leakage and gas than many testers costing hundreds of dollars. Will test the new Decals, the new 7-pin Nuvistors and the new Magnovals. Also tests Compactrons, 10-pin types, Novars, Nuvistors, battery type, auto radio hybrid tubes foreign and hi-fi tubes and industrial tube types. Includes the most complete tube chart in the field.

• Also tests all popular picture tubes

Model 1101K... Kit... **\$34.95** Net
Model 1101... Wired... **\$49.95** Net

See your parts distributor...
or write for complete catalog

MercURY ELECTRONICS CORPORATION
manufacturers of quality electronics products

315 Roslyn Road, Mineola, New York 11501

In Canada: William Cohen Corp., 8900 Park Ave., Montreal 11
Export: Morhan Exporting Corp., 458 Broadway, New York, N.Y. 10013

Circle 73 on literature card

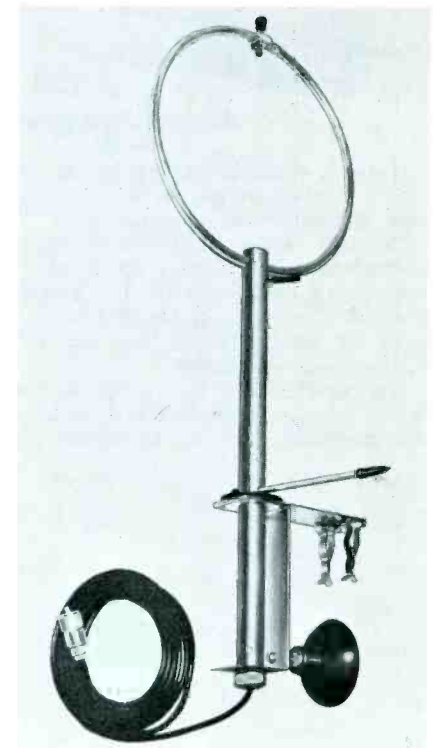

ter or heard as changes in speaker volume. If desired, the loop can be used for transmitting over short distances. The instructions provided with the antenna describe several operating and direction-finding techniques.

The price is \$9.95 and includes the coaxial connector (P1-259) and cable (RG-58/U).

23-Channel Transceiver

(147)

A new CB radio, the **Pearce-Simpson** "Director," has solid-state circuitry and requires no warmup period. Its "Hetro-sync®" circuitry utilizes two frequencies instead of three (the usual method of synthesizing in a 23-channel CB unit). For stability, a zener diode is used in

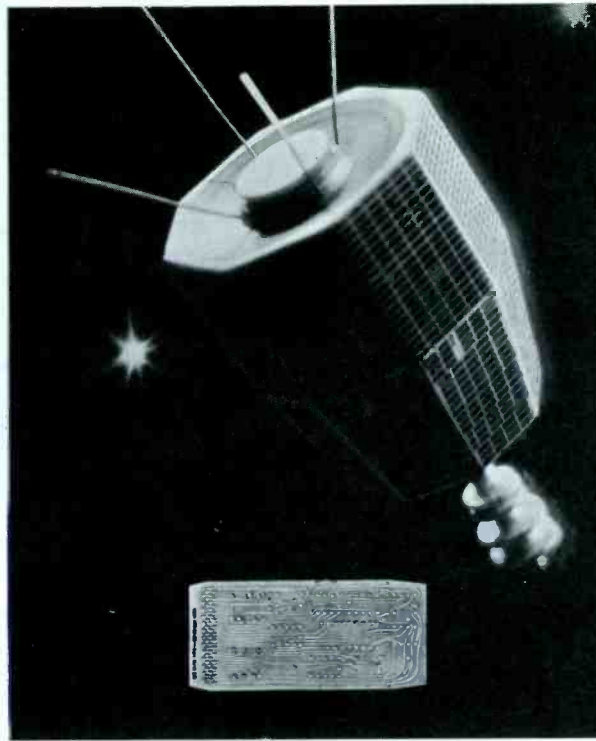

SOLID RCA CIRCUIT DESIGNED FOR RELAY

RELAY uses Solid RCA Circuits.

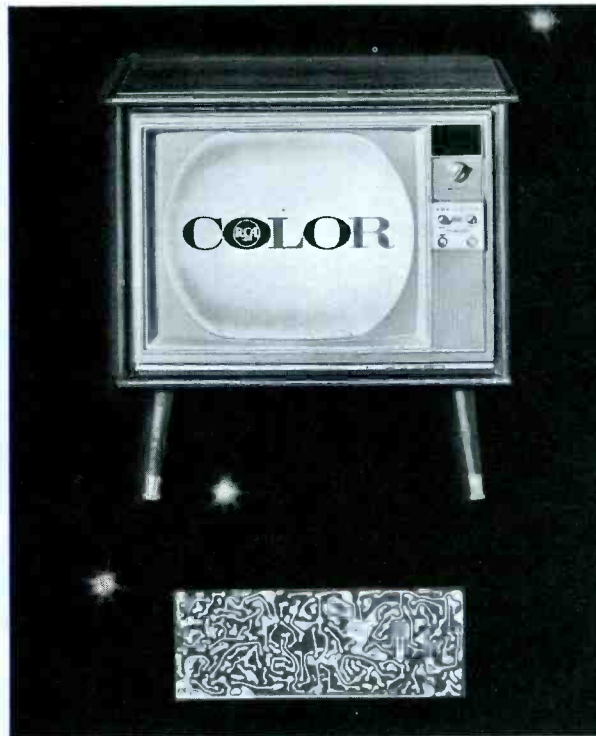

RCA Victor Color TV uses Solid Copper Circuits.

Why?

RCA Solid Copper Circuits won't come loose. Won't short circuit. Won't go haywire. They're the Space Age advance over old-fashioned "hand wiring!"



The Most Trusted Name in Electronics

TM&©

new SAMS BOOKS

Electric Guitar Amplifier Handbook



by Jack Darr. Here's all the practical information needed to enter an interesting and profitable servicing field. Fully explains how each part of an electric musical amplification system functions; provides specific service information for more than 20 commercial instruments, including detailed schematics and drawings of typical circuits, etc. Musical complaints are translated into the language of electronics—faulty components, grid bias, voltages, and waveforms. An easy to understand book by an expert; invaluable for servicemen and musicians interested in the electronics of their instruments. 144 pages; 5 1/2 x 8 1/2". Order GAD-1, only... \$295

electronics—faulty components, grid bias, voltages, and waveforms. An easy to understand book by an expert; invaluable for servicemen and musicians interested in the electronics of their instruments. 144 pages; 5 1/2 x 8 1/2". Order GAD-1, only... \$295



ABC's of Microwaves

by H. Charles Woodruff. The first readily-understandable book on microwaves for the beginner. Clearly explains this complex subject. Illustrated text describes microwave history, formation, transmission, propagation, and reception in terms anyone can understand. An ideal preparation for students, technicians, and hobbyists who may desire to advance into the more complex areas of this subject. 96 pages; 5 1/2 x 8 1/2". \$195

this subject. 96 pages; 5 1/2 x 8 1/2". \$195
Order AMW-1, only.....

RECENTLY PUBLISHED BESTSELLER

Color TV Training Manual, New Second Edition

by C. P. Oliphant & Verne M. Ray. This newly revised comprehensive manual is the most up-to-date guide available for technicians preparing to service color TV receivers. Full information on: Colorimetry; Requirements of the Composite Color Signal; Make-up of the Color Picture Signal; RF and IF Circuits; Video, Sync & Voltage-Supply Circuits; Bandpass Amplifier, Color-Sync and Color-Killer Circuits; Color Demodulation; Matrix Section; Color Picture Tube & Associated Circuits; Setup Procedure; Aligning the Color Receiver; Troubleshooting. Includes full-color illustrations invaluable for setup, alignment, and troubleshooting. 224 pages; 8 1/2 x 11". \$595
Order TVC-2, only.....

ABC's of Lasers & Masers (New 2nd Edition)

by Allan Lytel. One of the amazing developments of our times is the laser, a device which produces light radiation capable of performing astounding feats. The revised, up-to-date new edition of this popular fundamentals book explains all the basic principles of both lasers and masers in language anyone can understand. Text and illustrations introduce the reader to the various devices used to produce microwave and light radiation. Practical applications of the devices are described, such as a surgical knife, welding torch, heat ray source, etc. An informative book for students, technicians, and hobbyists. \$195
128 pages; 5 1/2 x 8 1/2". Order LAL-2, only.....

Practical Transistor Servicing (New 2nd Edition)

by William C. Caldwell. Newly revised edition of a very popular servicing book, describing the fastest, most direct methods to troubleshoot transistor radios with maximum profit. Completely practical facts throughout; explains transistor operation in simple terms; tells how to use pretested procedures to quickly and effectively service all types of transistorized equipment (including FM sets). Explains circuit components and their functions, methods for isolating troubles, the meaning of improper voltages, the testing of transistors, troubleshooting auto radios, etc. An essential book for the technician who wants to put his transistor servicing on a sound profit basis. 192 pages; 5 1/2 x 8 1/2". \$295
Order PTC-2, only.....

HOWARD W. SAMS & CO., INC.

Order from your Sams Distributor today, or mail to Howard W. Sams & Co., Inc., Dept. PF-10
4300 W. 62nd Street, Indianapolis, Ind. 46206

Send me the following books:

- GAD-1 TVC-2 PTC-2
 AMW-1 LAL-2

Send FREE Sams Booklist. \$_____ enclosed

Name _____

Address _____

City _____ State _____ Zip _____

My Distributor is _____

IN CANADA: A. C. Simmonds & Sons, Ltd., Toronto 7

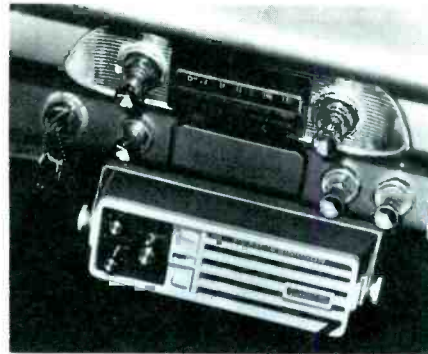

the input-power circuit, and special crystals provide a transmitter frequency tolerance of $\pm .003\%$. Power drain is .4 amp on receive, 1.5 amps on transmit. Features include dual-conversion super-het receiver design, negative-peak clipping and saturation limiting to prevent overmodulation, squelch and automatic noise limiting, TVI filter, and dustproof enclosed antenna relay. The unit is 2 3/4" high 8 1/2" wide by 8 1/2" deep, weighs 5 lb., and is priced at \$299.90.



Home Videotape Recorder (149)

Home videotape recording systems will play back recordings of live action or television broadcasts. The new Ampex line is built around a compact videotape recorder which retails at \$1095 in a one-speed tabletop model; \$1295 for a two-speed model.

The machine is approximately the size of a conventional audio tape recorder, and is designed for tape interchangeability with future color recorders. The magnetic tape moves past rotating recording and playback heads at a speed of 9.6 ips. A second speed of 4.8 ips will also be offered but this speed can't be used with color.

The recorder will play back black-and-white television programs through nearly any home television receiver, color or b-w, that has had certain connection components added (estimated cost, installed, \$25). No internal modification of receiver circuitry is necessary.

NEW!

A BETTER WAY TO REPLACE SOLDERED COMPONENTS
LENGTH 8"
WEIGHT 3 1/2 OZ.

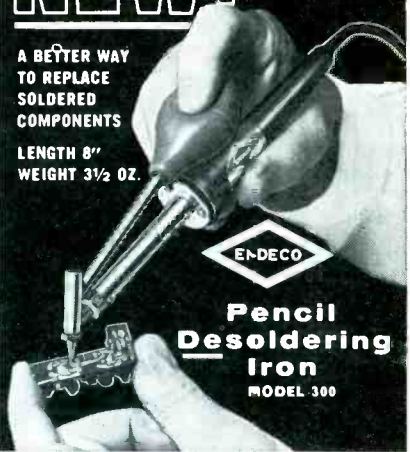

Pencil Desoldering Iron MODEL 300

Now—remove miniature soldered components in seconds—without damage

Hollow tip fits over connection; vacuums all solder for easy removal of component. Then, with 360° contact, it resolders even faster and better than regular irons. Handles miniature and standard components in printed circuit boards and conventional wiring. Self-cleaning. All parts replaceable. 40 watts, 115-v. 5 tip sizes. Pays for itself in time saved. \$9.95 net East of the Rockies.

Larger model available. See your distributor or write:

ENTERPRISE DEVELOPMENT CORPORATION
1102 E. 52nd • INDIANAPOLIS, IND. 46205
IN CANADA: A. C. Simmonds & Sons, Ltd. 100 Merton St., Toronto 7, Canada.

Circle 80 on literature card

Every No-Noise Aerosol Product

Guaranteed

Non-Flammable Non-Toxic and Won't Affect Plastics

"NO NOISE"

insist on this TRUSTED NAME BRAND
Avoid Risky "Private Labels"

"No Noise" PRODUCTS ARE PERFECT FOR COLOR-TV

- Volume Control & Contact Restorer
- Toner-Tonic with Perma-Film
- EC-44 For Electrical Contacts

FREE 5" plastic extender push-button assembly for pin-point application with all No-Noise products.

ELECTRONIC CHEMICAL CORP.
813 Communipaw Avenue, Jersey City 4, N. J.

Circle 75 on literature card

Add 10- to
20-station
intercom
facilities
to paging and
background-
music systems
with

harman kardon

POWRCOM

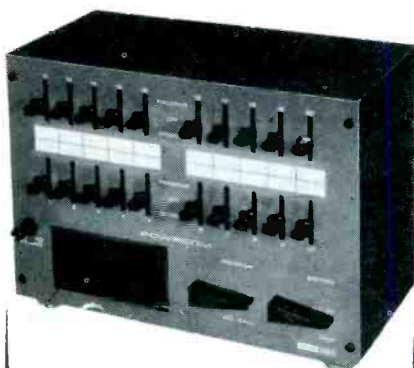

THE versatile Harman-Kardon POWRCOM eliminates the need for separate intercom and background-music/paging systems. Valuable in factories, schools, resorts, supermarkets, department stores—wherever 2-way conversation and selective monitoring are needed.

Can be used with any P.A. amplifier having balanced low-impedance microphone input and balanced output for 25v or 70v constant-voltage speakers. Basic unit has 10-station selector switchbank, expandable to 20. Full line of accessories for remote call origination, no-eavesdropping private stations, etc. POWRCOM need not be located near amplifiers or program sources.

See how POWRCOM almost sells itself in your commercial installations needing dual music-and-intercom facilities. Write for complete information.

Commercial Sound Division
HARMAN-KARDON, INC.
15th & Lehigh Ave., Phila., Pa. 19132
A subsidiary of
The Jerrold Corporation

Circle 81 on literature card

INDEX TO ADVERTISERS

OCTOBER, 1965

A. T. & T.	16
Aerovox Corp.	90
Atlas Sound	82
Amphenol-Borg Corp.	22
Antennacraft Co.	75
B & K Mfg. Co.	
Div. of Dynascan Corp.	21, 85, 89, 104
Belden Mfg. Co.	71
Blonder Tongue Labs	26
Bussmann Mfg. Div.	18, 19
Castle TV Tuner Service	15
Channel Master Corp.	20
Cleveland Institute of Electronics	65, 107
Delco Radio Div.	12
EICO Electronic Instrument Co., Inc.	Cover 2
Electronic Chemical Corp.	110
Enterprise Development Co.	110
Finney Co.	57
GC Electronics Co.	77
General Electric	58
Harmon-Kardon	111
Hickok Electrical Instrument Co.	55, 87
Injectoral Co.	88
JFD Electronics Corp.	17
Jackson Electrical Instrument Co.	50
Jensen Mfg. Co.	92
Jerrold Electronics	24, 25, 61
E. F. Johnson Co.	64
Kay-Towne Antenna Co.	94
Krylon, Inc.	84
Lectrotech, Inc.	73
Littelfuse, Inc.	Cover 4
Magnavox	98
Mercury Electronics Corp.	108
Oaktron Industries, Inc.	100
Ohmite Mfg. Co.	13
Oxford Transducer Co.	60
Perma-Power Co.	62
Philco Corp.	59
Planet Sales Co.	82
Precise Electronics	106
Precision Tuner Service	88
Quality Tuner Service	86
RCA Electronic Components and Devices	27, 63, Cover 3
RCA Parts and Accessories	96
RCA Sales Corp.	109
Rohn Mfg. Co.	78
Sams, Howard W. & Co., Inc.	105, 110
Sarkes Tarzian, Inc.	9
Seco Electronics, Inc.	74
SCORE, Inc.	65, 79, 91, 93, 95, 97, 99, 101, 103
Simpson Electric Co.	83
Sonotone Corp.	56
Sprague Products Co.	11
Standard Kollsman Industries, Inc.	51
Switchcraft, Inc.	100
Sylvania Electric Products, Inc. (insert)	41 thru 48
Weller Electric Corp.	14
Windsor Electric Co.	102
Winegard Co.	80, 81, 111
Workman Electronic Products, Inc.	86
Xcelite, Inc.	84
Zenith Radio Corp.	23, 66

Winegard
Dealer of the month

No. 41 of a series

Irv Cohen says: "I'm sold on Winegard's Twin Nuvisor Boosters for improving both long and short distance TV and FM reception."



Winegard salutes Centrale Radio Service, New London, Conn., and their distributor, Roland's Electric and TV Supplies, Uncasville, Conn.

Irv Cohen has long been a booster of Winegard TV and FM antennas. And in his area, where most of the TV and FM stations are many miles away, he's found Winegard Twin Nuvisor Antenna amplifiers to be an invaluable aid in improving picture quality.

Says Irv, "I haven't found two better combinations than Colortron TV Antennas with AP-220N boosters and Stereotron FM antennas with AP-320 boosters. They not only improve reception on distant TV and FM stations, but on the locals, too—without overloading problems. They're the most reliable boosters I've ever seen."

The confidence Irv Cohen has shown in Winegard comes from installing Winegard products and seeing them in action. He is one more important service dealer who knows Winegard's standards of excellence first hand.

Winegard Co.
Antenna Systems

3000 Kirkwood • Burlington, Iowa

Circle 76 on literature card

October, 1965/PF REPORTER 111



FREE Catalog and Literature Service

*Check "Index to Advertisers" for further information from these companies.

Please allow 60 to 90 days for delivery.

ANTENNAS & ACCESSORIES

79. **ALLIANCE** — Colorful 4-page brochure describing in detail all the features of *Tenna-Rotors*.
80. **ANTENNA-CRAFT**—Literature featuring 3 new 75-ohm, all-channel TV antennas available in factory-built or kit form.*
81. **CLEAR BEAM**—Flyers describing "Suburbanite" all-channel Yagi, and "Slim-line" and "Dynamatic" indoor antennas.
82. **FINNEY**—Catalog 20-337 covering U-Vert series UHF converters and catalog 20-338 on Model 65-1 distribution amplifier.*
83. **JERROLD**—Brochure featuring *Color-axial* system including 75-ohm antennas, matching transformers, preamplifiers, and cable.*
84. **JFD**—Literature on complete line of log-periodic antennas for VHF, UHF, FM, and FM stereo. Brochure showing converters, amplifiers, and accessories; also complete '64-'65 dealer catalog plus dealer wall chart of antenna selection by area.*
85. **MOSLEY ELECTRONICS** — Illustrated catalog giving specifications and features on large line of antennas for Citizens band, amateur, and TV applications.
86. **STANDARD KOLLSMAN** — Catalog sheet on Model TA transistorized UHF converter and transistor converter kit.*
87. **TRIO**—Brochure on installation and materials for improving UHF translator reception.
88. **WINEGARD** — Catalogs describing Chroma-Tel all-channel antennas, and "Color Match" transformer and cable packages.*
89. **ZENITH**—Information bulletins on antennas, rotors, batteries, tubes, power converters, record changers, picture tubes, wire, and cable.*

AUDIO & HI-FI

90. **ADMIRAL** — Folders describing line of '65 equipment; includes black-and-white TV, color TV, radio, and stereo hi-fi.
91. **AMECO**—Flyer describing Model PCFM preamplifier for FM receivers.
92. **GC ELECTRONICS**—Revised wall chart, No. FR-250-W, containing cross reference for tape and phono drives and belts.*
93. **JENSEN** — 24-page catalog, No. 165-K, illustrates and describes speakers and speaker system kits.*
94. **LAFAYETTE**—New 512-page 1966 catalog No. 660 listing electronics equipment for home, hobby, and industry.
95. **NUTONE**—Two full-color booklets illustrating built-in stereo music systems and intercom-radio systems. Includes specifications, installing ideas, and prices.
96. **OKTRON** — "The Blueprint to Better Sound," an 8-page catalog of loudspeakers and baffles giving detailed specifications and list prices.*
97. **OXFORD TRANSDUCER**—4-page catalog describing three lines of automobile rear-seat speaker kits.*
98. **QUAM-NICHOLS** — Catalog 65 listing replacement speakers for public address systems, hi-fi, auto radio, and radio-TV applications.

99. **SETCHELL-CARLSON** — Illustrated booklet supplying information on company's 1966 line and explaining *UNITIZED* construction.

COMMUNICATIONS

100. **EICO**—Data sheet on Model 753 *Tri-Band* transceiver and other ham gear, plus full-line catalog.*
101. **PEARCE-SIMPSON** — Specification brochure on IBC 301 business-band two-way radio. *Companion II, Director, Escort II, Guardian 23, and Sentry* Citizens-band transceivers.
102. **SPRAGUE** — Circular M-853 describes SK-1, SK-10, SK-20, and SK-30 *Supresskits* for vehicles with alternators or DC generators.*

COMPONENTS

103. **ADC** — Booklet titled "Wave Filters, Their Design and Specifications" describing methods for specifying filters, and literature listing telephone coils, jack panels, and other communications components.
104. **BUSSMANN**—Bulletin SHF-12 introducing shielded fuseholder designed to prevent radiation and reception of RF energy via the fuseholder.*
105. **COMPONENT SPECIALTIES**—Catalog featuring intercoms, speakers, earphones, and other replacement components.
106. **E-Z-HOOK**—Catalog listing full line of test connectors.
107. **LITTELFUSE** — New circuit breaker cross reference brochure.*
108. **MERIT**—Form 850, 1965-'66 general catalog and replacement guide for coils and transformers.
109. **ONEIDA**—Catalog listing line of hardware, switches, resistors, and other replacement items.
110. **SONOTONE**—Brochure titled "This Is Sonotone" illustrating production and uses of rechargeable batteries.*
111. **SWITCHCRAFT**—New product bulletin No. 153 describing Series 32000, and Series 32000TL "T-Lite" illuminated switches.*

SERVICE AIDS

112. **CASTLE**—How to get fast overhaul service on all makes and models of television tuners is described in leaflets. Shipping instructions, labels, and tags are also included.*
113. **EBY**—Literature giving details on CA-1 and CA-2 test-point adaptors for color picture tubes.
114. **ELECTRONIC CHEMICAL** — Catalog sheet describing aerosol cleaners for electrical contacts, volume controls, and tape heads.*
115. **IEH**—Specification sheet for color service adaptors and harnesses.
116. **LUBRA CLEAN**—Information on new tuner cleaner.
117. **PRECISION TUNER**—Literature supplying information on complete low-cost repair and alignment services for any TV tuner.*
118. **RAWN** — Detailed instruction sheets on TV knob and plastic repairs with *Plas-T-Pair*.
119. **YEATS**—The new "back-saving" appliance dolly Model 7 is featured in a four-page booklet describing feather-weight-aluminum construction.

SPECIAL EQUIPMENT

120. **ATR** — Descriptive literature on selling new all-transistor *Karadio* Model 707, having retail price of \$29.95. Other literature on complete line of DC-AC inverters for operating 117-volt PA systems and other electronics gear.
121. **GREYHOUND** — The complete story of the speed, convenience, and special service provided by the Greyhound Package Express routes.
122. **PERMA-POWER** — Four-page catalog, GB281, illustrating solid-state garage door operator using pulse tone modulation.*

TECHNICAL PUBLICATIONS

123. **CLEVELAND INSTITUTE OF ELECTRONICS**—Free illustrated brochure describes electronic slide rule and four lesson Instruction Course and grading service.*
124. **HOWARD W. SAMS** — Literature describing popular and informative publications on radio and TV servicing, communications, audio, hi-fi, and industrial electronics, including special new 1965 catalog of technical books on every phase of electronics.*
125. **RCA INSTITUTES** — 64-page book, "Your Career in Electronics" detailing home study courses in telecommunications, industrial electronics, TV servicing, solid-state electronics, and drafting. Preparation for FCC license, and courses in mobile communications and computer programming also available.*

TEST EQUIPMENT

126. **B & K**—New 1966 catalog featuring test equipment for color TV, auto radio, and transistor radio servicing, including tube testers designed for testing latest receiving tube types.*
127. **BLONDER-TONGUE** — Complete information on Model 4122 UHF-VHF sweep generator and other *Lab-Line* products.*
128. **HICKOK**—Specification sheets on Model 662 installer's color generator, Model 677 wideband scope, Model 470A uni-scale VTVM and Model 799 *Mustang* tube tester.*
129. **JACKSON**—New 8½" x 11" catalog listing full line of test equipment.*
130. **LECTROTECH** — Bulletins on *Meiergards, Lectrocells*, Models V-6 and V-7 color-bar generators, Model T-100 horizontal-deflection circuit meter, Model U-75 UHF translator.*
131. **MERCURY**—Complete line of test equipment contained in new 8½" x 11" catalog.*
132. **SECO**—New colorful folder describing 20 test instruments including tube testers.*
133. **SENCORE**—Latest information on TC-136 tube tester and SS137 sweep-circuit analyzer, plus catalog describing full line of products.*
134. **SIMPSON** — Complete 16-page brochure on entire line of electronic test equipment; also, catalog on line of panel meters.*

TOOLS

135. **ARROW**—Literature containing illustrations and diagrams showing uses of staple-gun tackers for electrical and electronic wiring.
136. **BERNS**—Data on unique 3-in-1 picture-tube repair tools, on *Audio Pin-Play Crimper* that enables technician to make solderless plug and ground connections, also for color and other picture tubes. Model AV-2 for RCA type phono plugs, along with C rings for shielded braided wire ground connections and LC-3 for 5/32" pin diameter.*
137. **ENTERPRISE DEVELOPMENT**—Time-saving techniques in brochure from Endeco demonstrate improved desoldering and resoldering techniques for speeding and simplifying operations on PC boards.*
138. **VACO**—Catalog listing tools for use with solderless terminals.

TUBES & TRANSISTORS

139. **WORKMAN**—Cross-reference list for entertainment-type transistor replacements.*

**Meet some of the people responsible for
RCA's personal quality performance program**

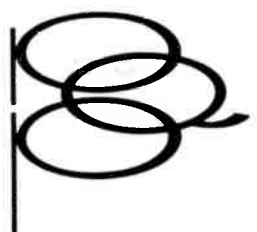
Norman Haythorn
 Roy Johnson
 Rose Manigault
 Theresa Pagano
 Jule Harris
 George Everett
 Alexander M. Collini
 Ronnie Ferguson
 Hans Weber
 Nadia Spas
 Hazel Anderson
 Elizabeth Posthigel
 Medred Sherman
 Shigeoko Strelecki
 Charles Deber
 Bernice Munnally
 Al Gunschauer
 Jean Lurski
 Corinne Quier
 Claire Wade

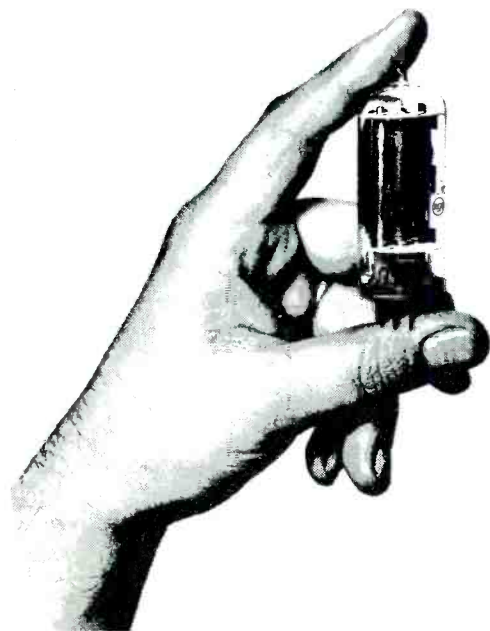

People are the prime ingredient in RCA's attempt to achieve zero defects in the production of receiving tubes. Thousands of RCA people engaged in the manufacturing of receiving tubes have deeply committed themselves to the attainment of missile-type reliability in commercial receiving tube production. They say, "I pledge to strive for error-free performance in every task I undertake through my personal quality performance."

That's why replacing with RCA receiving tubes—across the board—is your best short-cut to a satisfied customer instead of a callback.

RCA ELECTRONIC COMPONENTS AND DEVICES, HARRISON, N.J.



The Most Trusted Name in Electronics

Introducing a Complete Line of Littelfuse Quality Circuit Breakers



Actual Size
1 $\frac{3}{4}$ " x 1 $\frac{3}{16}$ " x $\frac{1}{2}$ "

Exact replacement from factory to you

Designed for the protection of television receiver circuits, the Littelfuse Manual Reset Circuit Breaker is also ideally suited as a current overload protector for model railroads and power operated toy transformers, hair dryers, small household appliances, home workshop power tools, office machines, small fractional horsepower motors and all types of electronic or electrical control wiring.

LITTELFUSE

DES PLAINES, ILLINOIS

Circle 78 on literature card