

PF Reporter™

PHOTOFACT

the magazine of electronic servicing

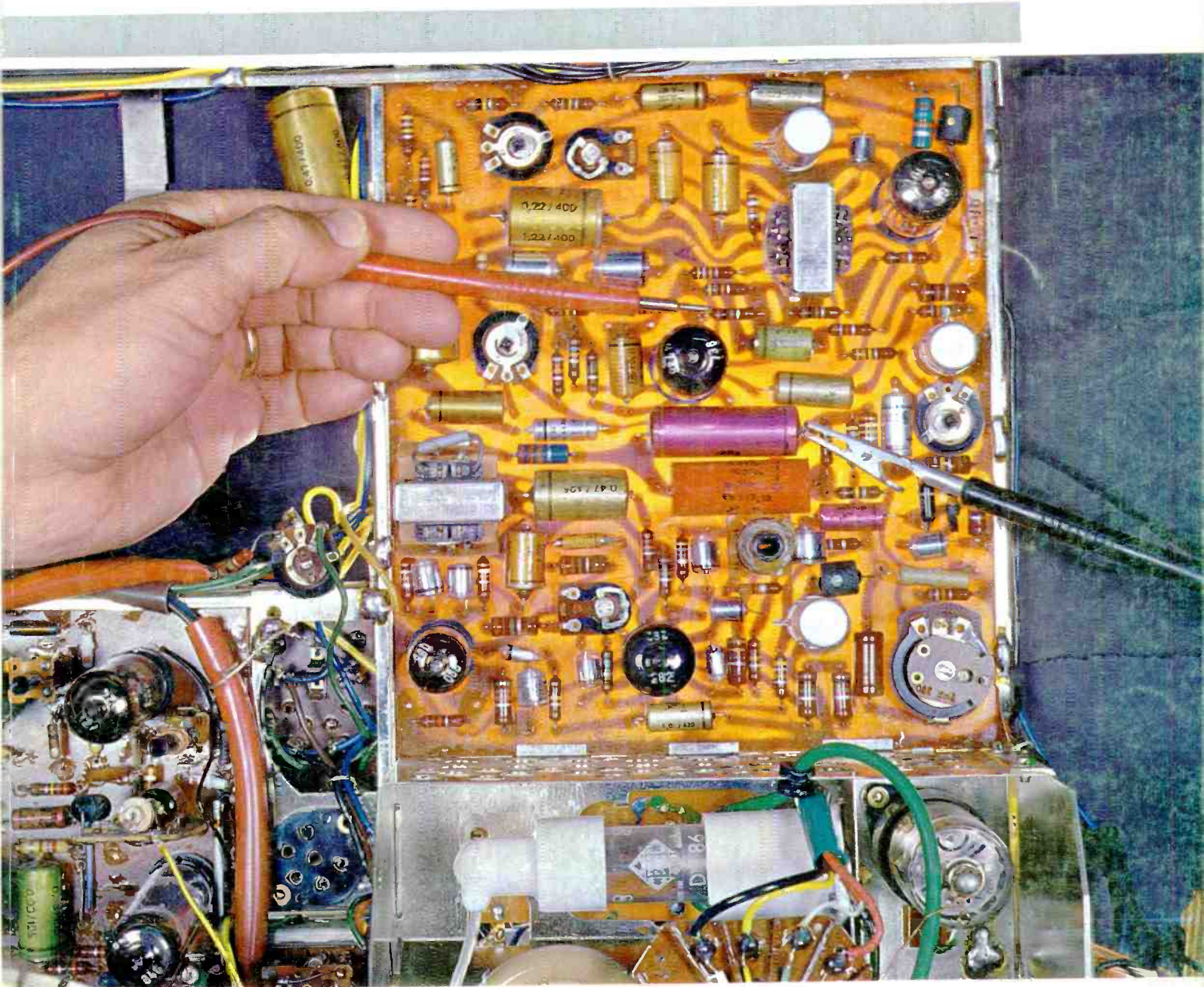

JA 2L 11C4 1266
 WM. M. DAVIS
 RAD. & TV SERV.
 118 RIVERSIDE AVE.
 CANON CITY, COLO.

- Evaluate Tubes In-Circuit
- Advanced Techniques for Future Servicing
- AGC Servicing Magic
- Stock Guide for TV Tubes
- Plus many more





How to replace top quality tubes with identical top quality tubes

Most of the quality TV sets you are presently servicing were designed around special Frame Grid tubes originated by Amperex. More and more tube types originated by Amperex are going into the sets you'll be handling in the future.

Amperex Frame Grid tubes provide 55% higher gain-bandwidth, simplify TV circuitry and speed up your servicing because their extraordinary uniformity virtually eliminates need for realignment when you replace tubes.

Amperex Frame Grid Tubes currently used by the major TV set makers include:

2ER5	2GK5	2HA5	3EH7	3GK5	3HA5	4EH7	4EJ7	4ES8	4GK5	4HA5	5GJ7
	6EH7	6EJ7	6ER5	6ES8	6FY5	6GJ7	6GK5	6HA5	6HG8	7HG8	8GJ7

If your distributor does not yet have all the Amperex types you need, please be patient—in some areas the demand keeps gaining on the supply.

Amperex Electronic Corporation, Hicksville, Long Island, New York 11802.



Circle 1 on literature card

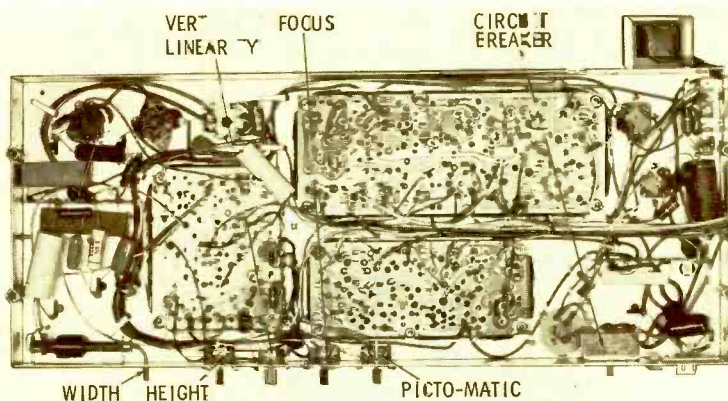
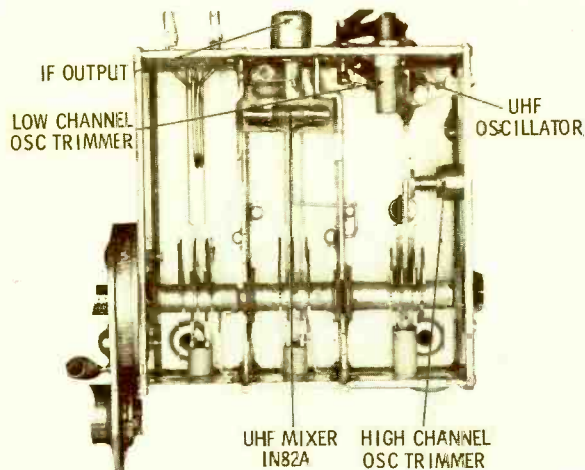
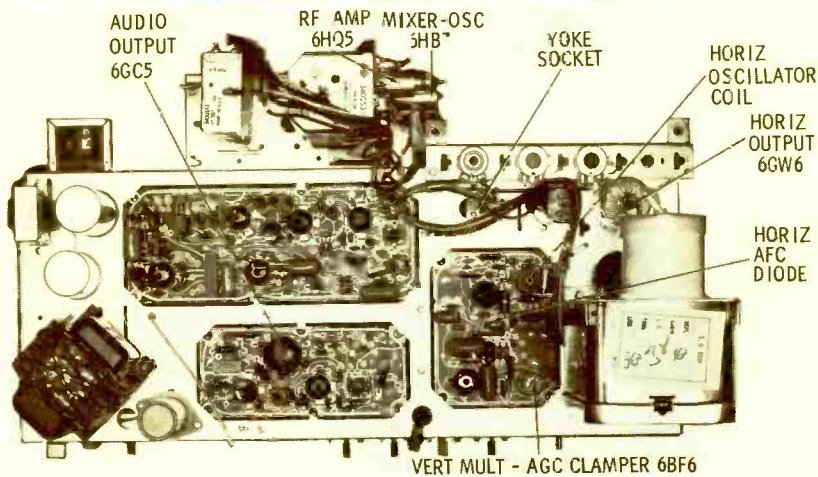
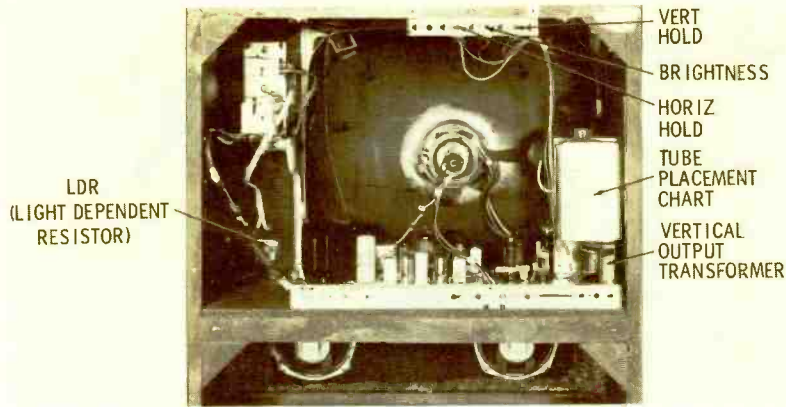

**Airline
Model GST-4615A**

Included in Airline's '65 model line is the 23" console pictured above which has a chassis considerably different from those found in previous sets sold by Montgomery Ward. The horizontal chassis contains 14 tubes mounted on three individual printed-circuit boards which are held by the main chassis frame. Most of the tubes are familiar types; however, it would be wise to check your stock for the 6GC5 uses as audio output, the 6EM5 vertical multivibrator/output, the 6BF6 AGC clamper/vertical multivibrator, and the 6GW6 horizontal output. Also, don't overlook the VHF tuner tubes—6HQ5 RF amplifier and 6HB7 mixer/oscillator. The transistorized UHF tuner uses a 24T002 as the UHF oscillator and a 1N82AG crystal diode as the mixer. (The transistor and the diode are both shown in one of the photos.)

The low-voltage supply is transformer powered and has two silicon rectifiers in a half-wave voltage-doubler arrangement. Overload protection is provided by a circuit breaker; a 5-ohm, 10-watt surge-limiting resistor protects the silicons in case of current surges. A filament fuse link protects the transformer in case of excessive filament current.

This receiver is equipped with a "Picto-Matic" (automatic brightness) circuit which consists of an LDR (light-dependent resistor) that varies the DC voltage on the CRT cathode as the ambient light level changes. A manual control is also provided; its adjustment controls the CRT screen voltage. The correct setting of the manual control is accomplished by first turning it fully clockwise, then adjusting the brightness and contrast controls for a normal picture in semi-darkness. If the picture is too light, under normal lighting conditions, the Picto-Matic control is turned counterclockwise until the contrast-to-brightness ratio remains constant throughout the normal ambient light range of the room. This control (as are the focus, vertical-linearity, height, and width controls) is adjustable from the rear of the receiver.

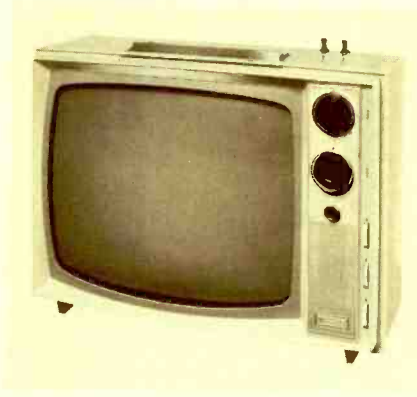

**General Electric
Model M403AVY
Chassis DA**

The 19" portable shown above, which has only 12 tubes including the CRT and VHF oscillator/mixer, is an indication of the simplified circuitry in the modern television receiver. This set has one large printed-circuit board with the majority of components mounted on it. The horizontal-output and damper circuits are mounted separately on a small subchassis located above the board.

The use of compactrons has contributed to the smaller number of tubes. First and second video IF functions are combined in a 11AR11 (the third video IF/AGC keyer is a 6JN8—not a compactron). A 15BD11 operates as video output/sound IF amplifier/sync separator, and the audio detector/output action is provided by a 17BF11. Vertical sweep is derived from a 17JZ8 which operates as multivibrator output, an 8B10 serves as horizontal AFC/multivibrator, the horizontal-output tube is a 21HB5A, the damper a 12BT3, and the high-voltage rectifier is the old and familiar 1K3. A 19DVP4 fits into the CRT socket, while the VHF tuner uses a 3GK5 as an RF amplifier and a 6EA8 performs as the mixer/oscillator.

No power transformer is used in this set; B+ is derived from a single silicon rectifier protected by both a 1.5-amp fuse and a 3.6-ohm, 7-watt fusible resistor. The 450-ma series filament is unprotected.

The UHF tuner is continuously tunable from 470 to 890 mc; output IF frequency from the oscillator (an NPN transistor) to the VHF tuner is 45 mc. The manufacturer recommends using silver-bearing solder when replacing any of the un-insulated ceramic-disc capacitors in the UHF tuner. A piece of this solder is packed with the General Electric replacement.

The customer operating controls, the VHF/UHF channel-selector and fine-tuning, on-off/volume, contrast, brightness, and vertical hold, are on the front of the cabinet. On the rear apron of the chassis are the adjustments for height, vertical linearity, and horizontal hold. A width coil provides for that adjustment, when necessary. No adjustment is provided for the AGC voltage or picture-tube focus.

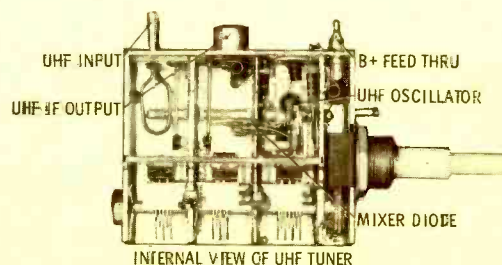
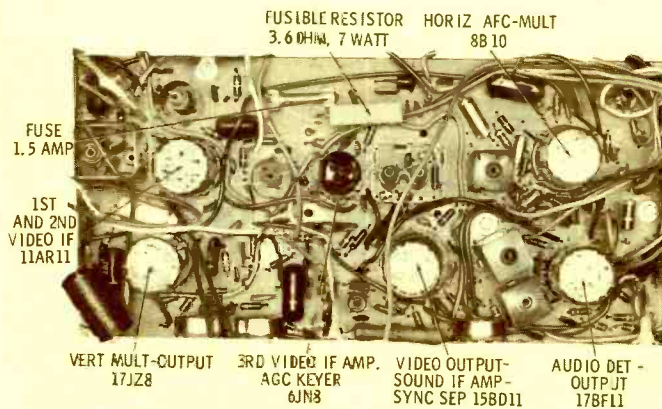
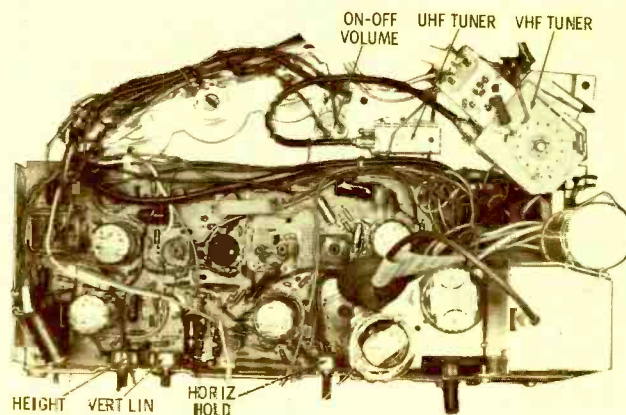
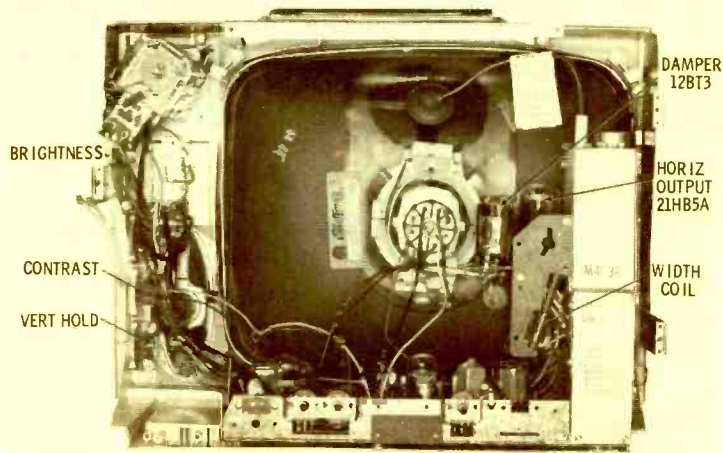

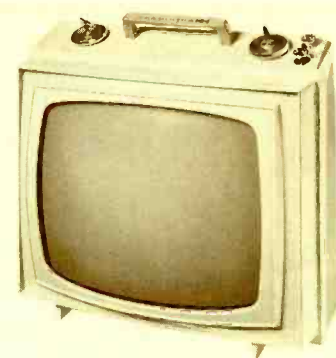
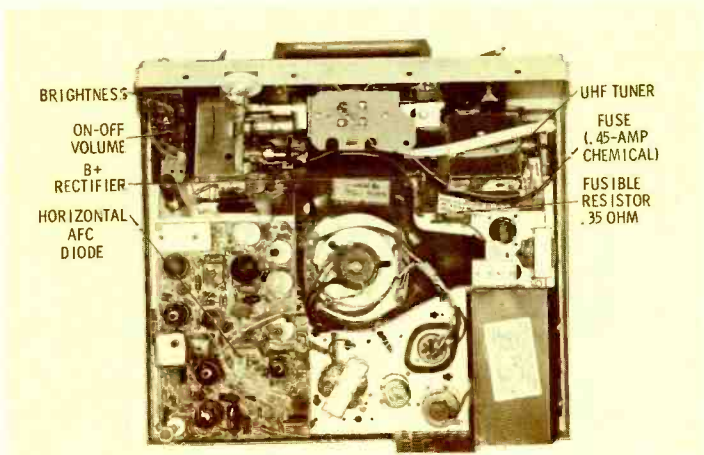

RCA
Model AF-020J
Chassis KCS152A

For the second successive year, RCA has added a 16" portable to their line of black-and-white receivers. The series-filament chassis shown here is quite similar to the KCS146 chassis of a year ago and is equipped with carrying handle and built-in monopole antenna for VHF. Terminals are provided for connecting either VHF or UHF external antennas.

Only one printed-circuit board is used, and there are several new tubes (all having 450-ma filaments) found in this chassis. The CRT is a 114° 16AYP4; a 4JD6 and a 4JC6 (both high-gain pentodes) are used in the two-stage video IF strip. The video-output stage uses the pentode section of a 11LQ8; the triode section of this same tube functions as the AGC keyer. The vertical-sweep section consists of a 15KY8. The horizontal-output tube is a 22JU6, while the damper is a 17BS3. The VHF tuner utilizes a 3GK5 for RF amplification; the functions of mixer/oscillator are performed by a 6KZ8—the 6KZ8 has considerably more gain in the mixer section than tubes of earlier vintage. The oscillator in the UHF tuner is an NPN transistor (RCA part number 113938).

Low voltage is developed from a single silicon rectifier (1N3194) as the sweep-output tubes operate from a lower-than-normal B+ voltage. The B+ side of the silicon is fused with a .45-amp chemical fuse. The AC side has a .35-ohm fusible resistor (Part No. 942924-4) in series with one side of the line. Any of these components may be replaced by removing the cabinet back—it isn't necessary to remove the chassis. No protection is provided for the series filament string.

Adjustments of vertical-hold, vertical-linearity, contrast, height, and horizontal-hold controls may be made from the rear of the receiver. These controls are made accessible by nonmetallic knobs which protrude through the rear cover of the cabinet.

Located around the neck of the picture tube, to the rear of the centering magnets, is a "spot-optimizer" magnet. This magnet shouldn't require adjustment unless it is moved accidentally or the picture tube is replaced. If adjustment should become necessary, tune the receiver to an unused channel and adjust the magnet for best detail in the center portion of the screen.

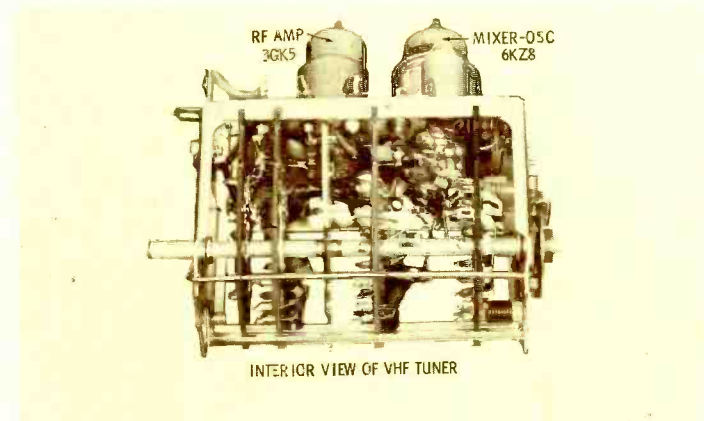
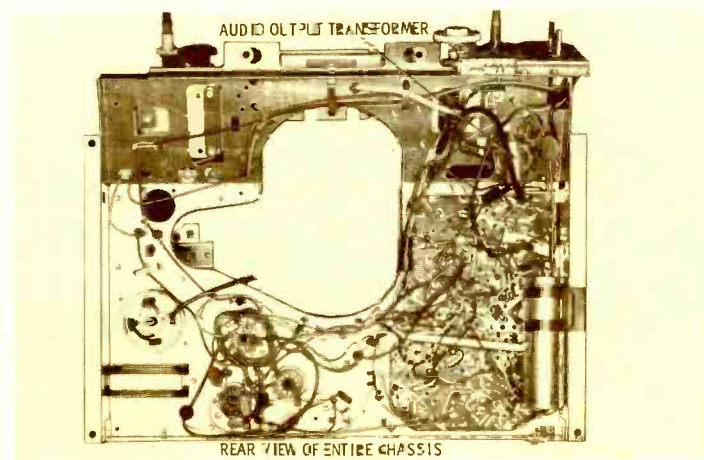
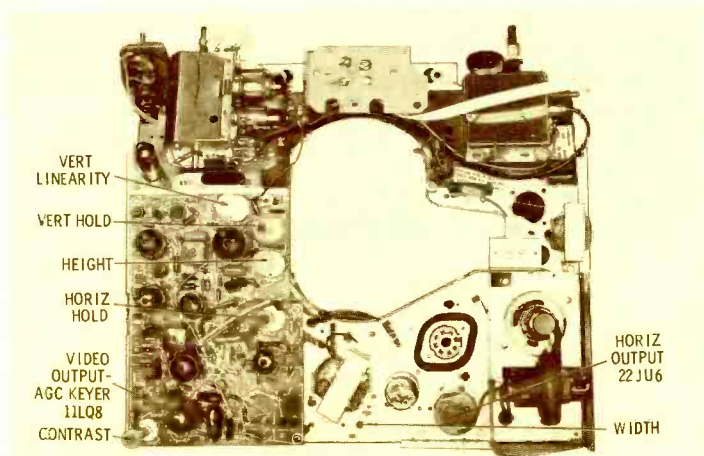



**Sylvania
Model 23L133CU
Chassis 585-1**

Part of Sylvania's 1965 line is the above-pictured 23" console. This transformer-powered set uses, as do many other large-tube models, the 585-series chassis. The receiver uses a total of 15 tubes including the 23BG4 picture tube, the 6GK5 RF amplifier, and the 6GJ7 mixer/oscillator. A 6EH7 and a 6EJ7 serve as the first and second video IF amplifiers respectively. A 6JT8 functions as video output/sync separator (previously a 6CS6 was used as sync separator). Operating as AGC keyer/sound IF amplifier is a 6KD8, while a 6DT6 and a 6AQ5 function in the audio detector and audio-output stages.

In the sweep circuits, we find a 6FM7 compactron operating as vertical multi-vibrator/output. The horizontal multi-vibrator is a 6FQ7, the horizontal output a 6GJ5, and the damper a 6AY3. The high-voltage rectifier is a 1B3/1G3. Rounding out the tube complement is the 5BC3 low-voltage rectifier.

Two NPN transistors are used: One is used as the UHF oscillator, and the second functions as a noise gate (canceller) located in the cathode circuit of the sync separator. Other semiconductors include the two 1N4092 signal diodes used in the horizontal AFC circuit and the 1N295 video detector.

Protective devices in the low-voltage power supply consist of a circuit breaker connected from the tap of the secondary winding of the power transformer to ground and two #28-size wire links, one in series with the parallel filament string and the other in series with one side of the AC line.

In addition to the normal operating controls, adjustments are also provided for width and horizontal linearity. To adjust the linearity coil, it is necessary to remove the rear cabinet cover. The correct focus-anode potential may be obtained by connecting a jumper from pin 4 of the picture tube to B+, boost, or ground.

An interconnecting plug and suitable sockets are provided for the deflection yoke and tuner subassemblies. The video IF input cable also plugs into the main chassis. A halo-light socket is available for models having this added feature.

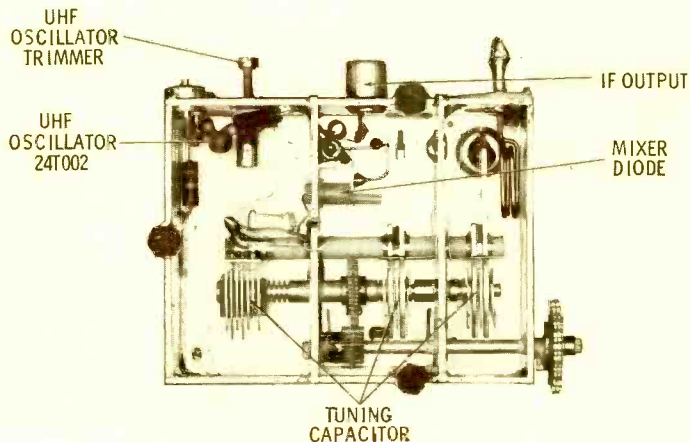
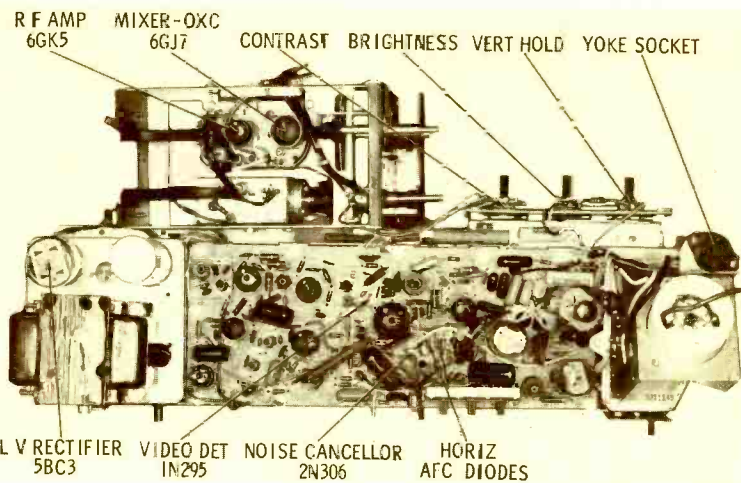
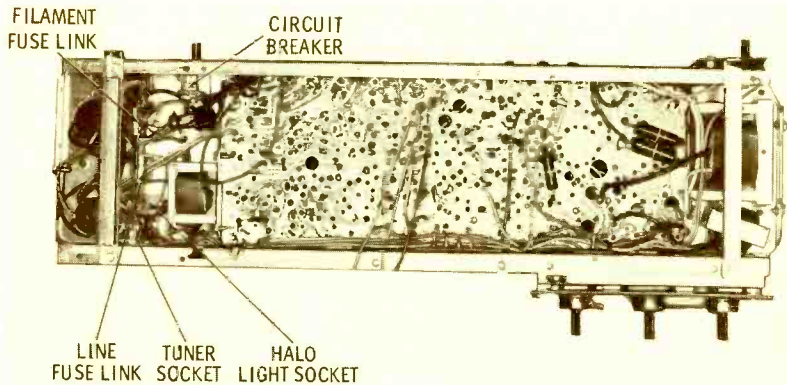
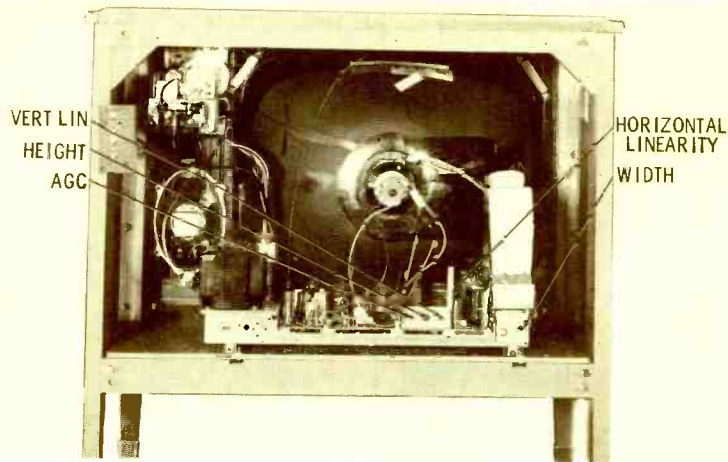

See PHOTOFACT Set 648, Folder 2

Mfr: DuMont Chassis No. 120642, -643

Card No: DM642-1

Section Affected: Vertical sync.

Symptoms: Vertical hold unstable.

Cause: Insufficient output from sync separator; remedied by circuit modification.

What To Do: Change R89 to (100K, ½ watt); remove C65 (.0022 mfd) from circuit.

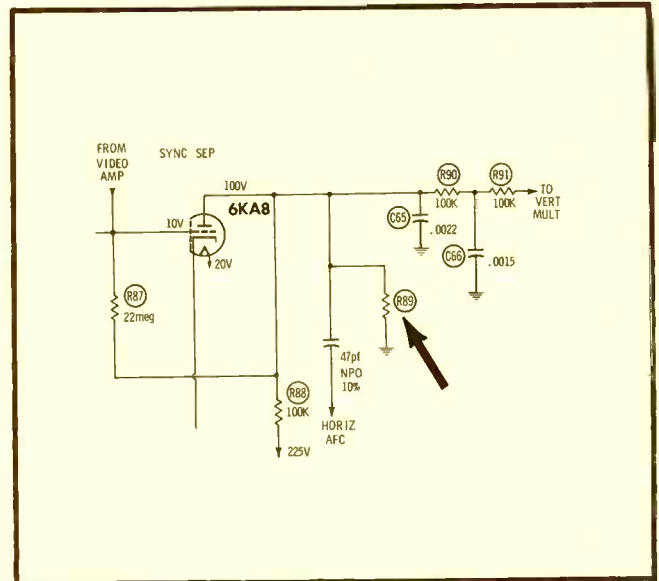

See PHOTOFACT Set 648, Folder 2

Mfr: DuMont Chassis No. 120642, -643

Card No: DM642-2

Section Affected: Raster.

Symptoms: Insufficient vertical sweep.

Cause: Vertical linearity circuit resistor increased in value.

What To Do: Replace R27 with a (2.2 meg, 2 watt) resistor.

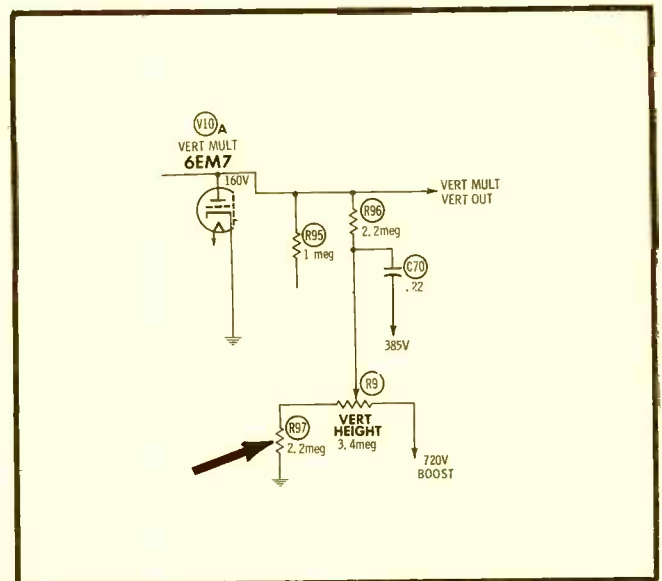

Mfr: DuMont Chassis No. 120642, -643

Card No: DM642-3

Section Affected: Vertical sync.

Symptoms: Erratic vertical hold; grid voltage (pin 6) of 6KA8 increases.

Cause: Leaky coupling capacitor.

What To Do: Replace C36 (.1 mfd).

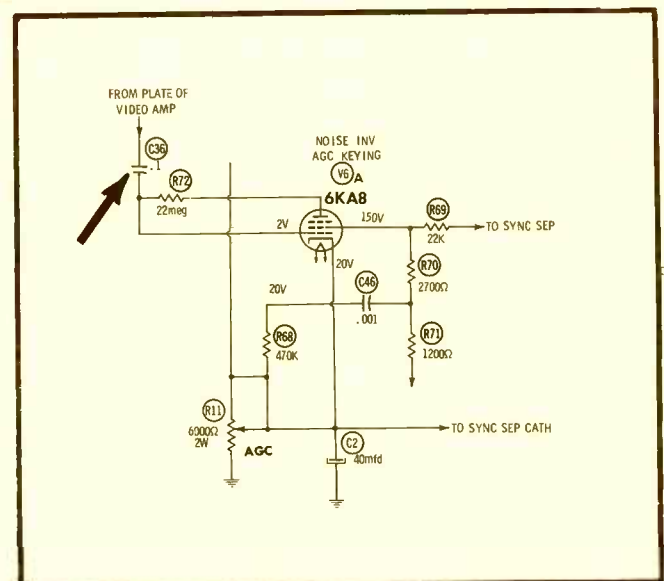

See PHOTOFACT Set 648, Folder 2

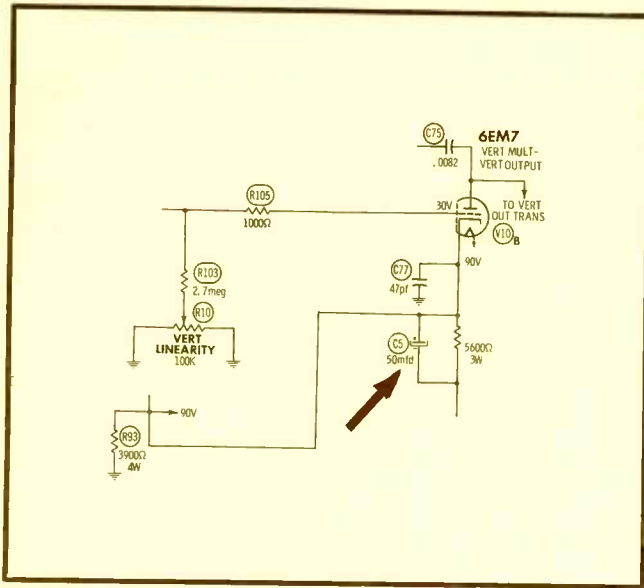

See PHOTOFACT Set 648, Folder 2

Mfr: DuMont Chassis No. 120642, -643

Card No: DM642-4

Section Affected: Raster.

Symptoms: Loss of vertical sweep.

Cause: Open cathode bypass capacitor.

What To Do: Replace C5 (50 mfd 100 V).

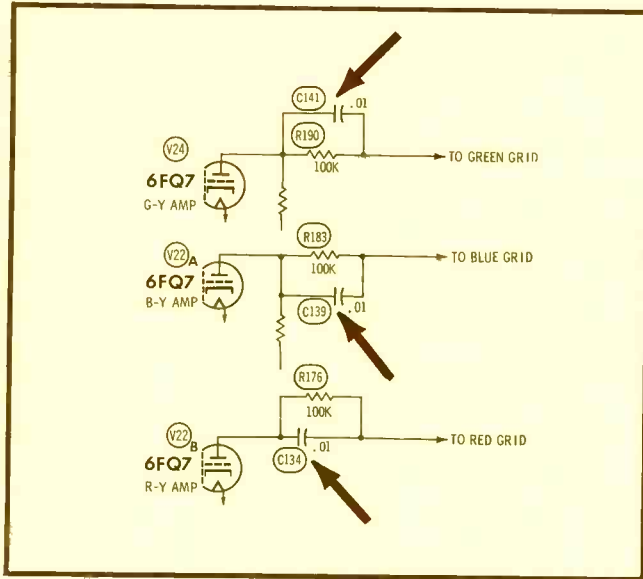

Mfr: DuMont Chassis No. 120642, -643

Card No: DM642-5

Section Affected: Pix.

Symptoms: Impurity; cannot be corrected with usual adjustments. Part of either red, blue, or green line may be missing at low brightness with Normal-Service switch in "Service" position and screen controls properly adjusted.

Cause: Open coupling capacitor to control grid of CRT.

What To Do: Replace coupling capacitor C134, C139, or C141 (.01 mfd).

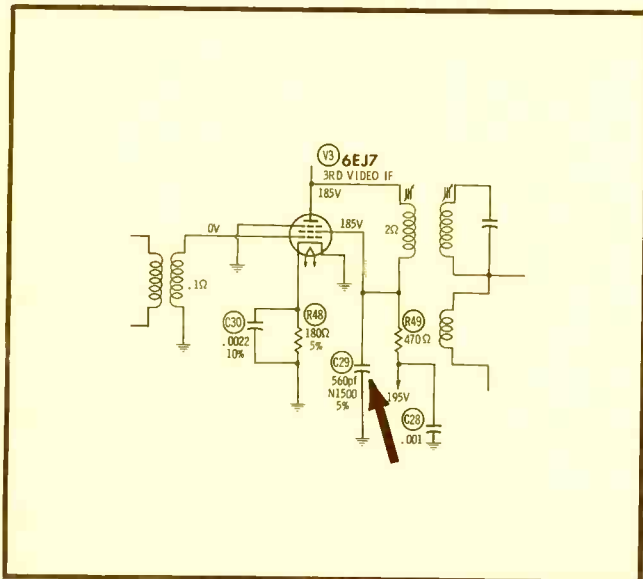

Mfr: DuMont Chassis No. 120642, -643

Card No: DM642-6

Section Affected: Sound and pix.

Symptoms: Weak or complete loss of video and sound; voltage on plate and screen decreases.

Cause: Shorted video IF screen by-pass capacitor.

What To Do: Replace C29 (560 pf—500V, N1500, 5%); also R49 (470 ohms).

See PHOTOFACT Set 698, Folder 4

Mfr: Philco Chassis No. 14M91

Card No: PH 14M91-1

Section Affected: Pix.

Symptoms: No color, insufficient brightness; brightness control has little effect.

Cause: Open common cathode resistor of Blanker and Band-Pass Amplifier.

What To Do: Replace R166 (390 ohms).

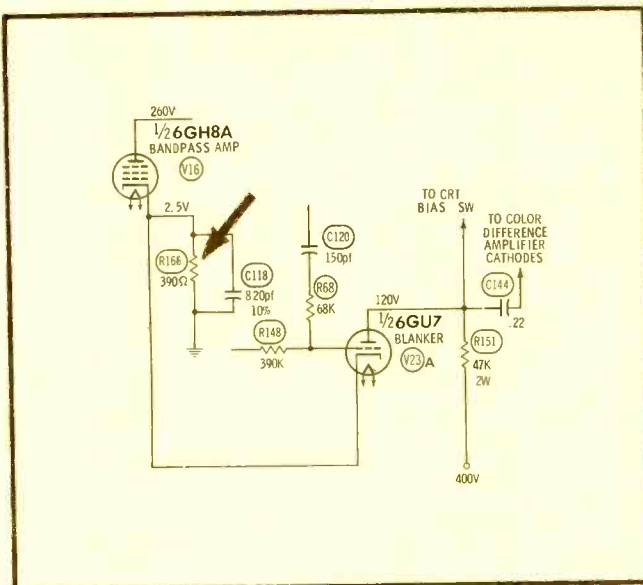

See PHOTOFACT Set 698, Folder 4

Mfr: DuMont Chassis No. 14M91

Card No: PH 14M91-2

Section Affected: Pix.

Symptoms: Severe blooming even at low setting of brightness control.

Cause: Open CRT cathode biasing resistor—decreases voltage on each cathode and causes excessive beam current.

What To Do: Replace R73 (6800 ohm, 2 watt).

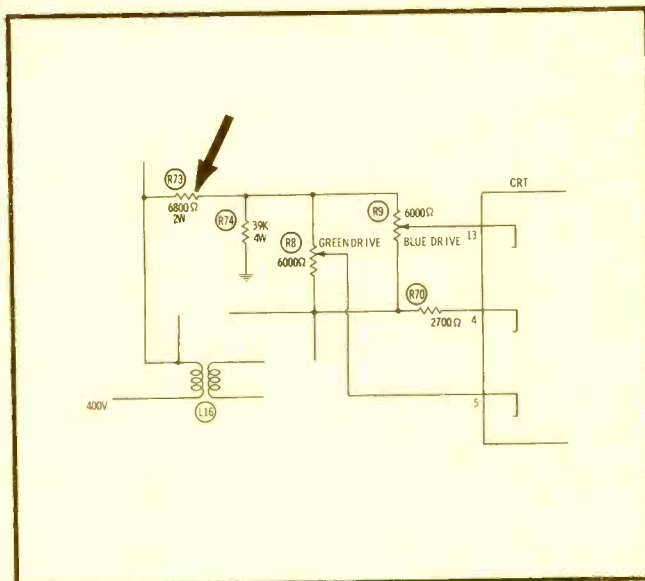

Mfr: Philco Chassis No. 14M91

Card No: PH 14M91-3

Section Affected: Pix.

Symptoms: Insufficient brightness even with controls at maximum.

Cause: Open coupling capacitor from Blanker to Color Difference Amplifiers.

What To Do: Replace capacitor C144 (.22 mfd).

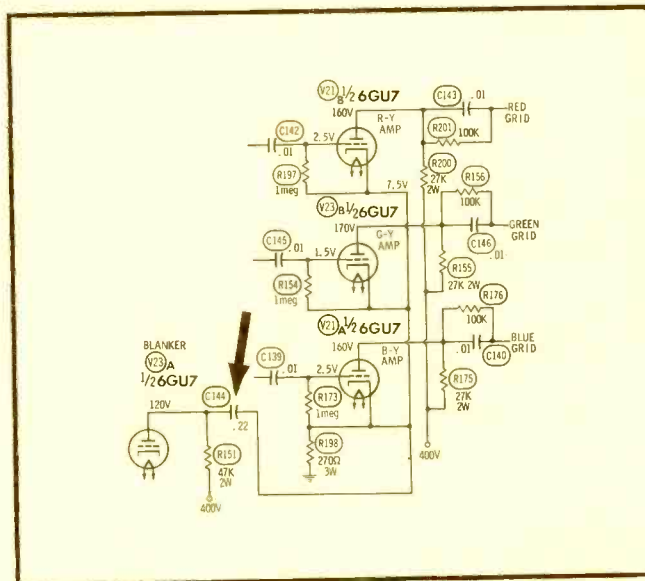

See PHOTOFACT Set 698, Folder 4

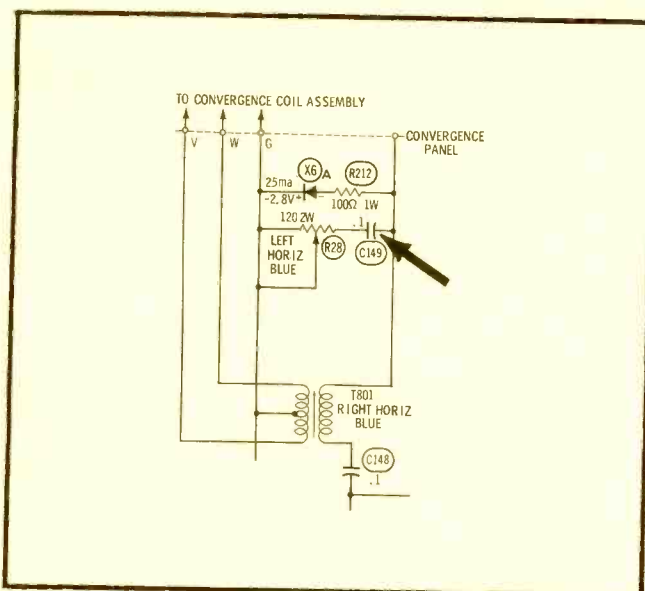

See PHOTOFACT Set 698, Folder 4

Mfr: Philco Chassis No. 14M91

Card No: PH 14M91-4

Section Affected: Raster (Convergence).

Symptoms: Poor convergence of blue horizontal lines on both sides of screen; worse on left side.

Cause: Open wave shaping capacitor in blue horizontal dynamic convergence circuit.

What To Do: Replace C149 (.1 mfd).

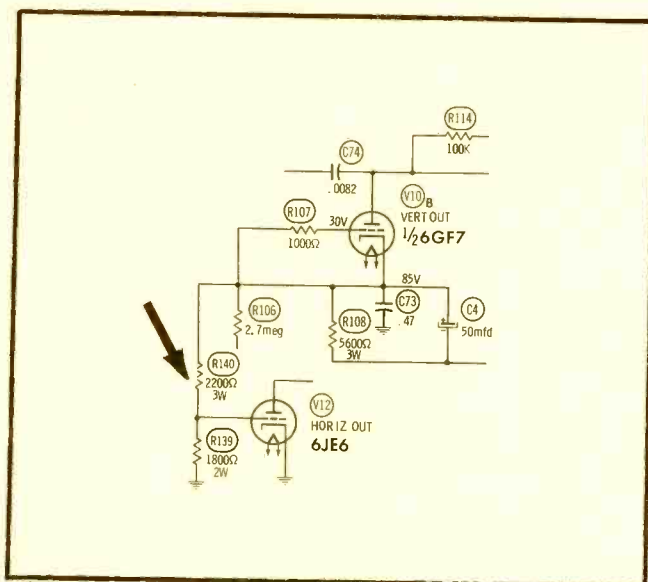

Mfr: Philco Chassis No. 14M91

Card No: PH 14M91-5

Section Affected: Raster.

Symptoms: Insufficient height.

Cause: Open resistor in vertical output cathode bias divider network.

What To Do: Replace R140 (2200 ohm, 3 watt).

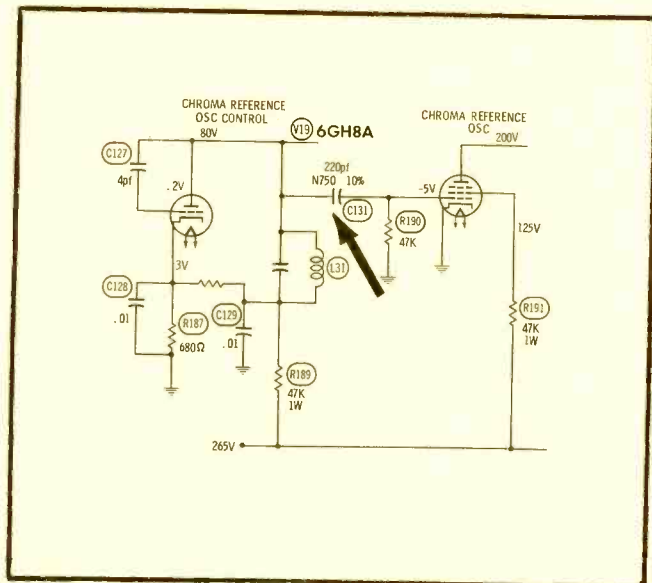

Mfr: Philco Chassis No. 14M91

Card No: PH 14M91-6

Section Affected: Color pix.

Symptoms: Black and white reception normal; no color, except possible green on strong station.

Cause: Leaky coupling capacitor from plate of reactance tube to grid of oscillator.

What To Do: Replace C131 (220 pf).

Tarzian offers
**FAST, DEPENDABLE
 TUNER REPAIR
 SERVICE (ALL
 MAKES)**

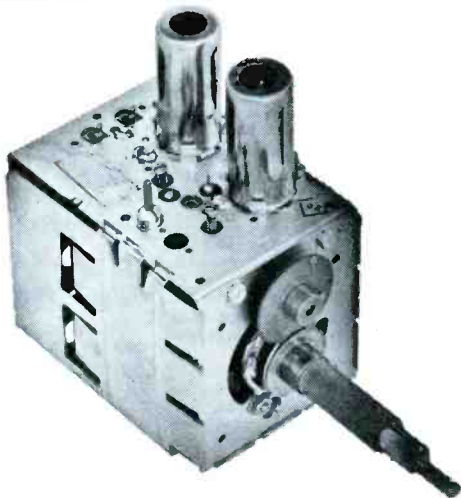

It just makes sense that a manufacturer of tuners should be better-qualified, better-equipped to offer the most dependable tuner repair and overhaul service.

Sarkes Tarzian, Inc. pioneer in the tuner business, maintains two complete, well-equipped Factory Service Centers—assisted by Engineering personnel—and staffed by specialized technicians who handle **ONLY** tuner repairs on **ALL** makes and models.

Tarzian-made tuners received one day will be repaired and shipped out the next. Allow a little more time for service on other than Tarzian-made tuners.

Tarzian offers a 12-month guarantee against defective workmanship and parts failure due to normal usage. And, compare our cost of \$9.50 and \$15 for UV combinations. There is absolutely no additional, hidden charge, for **ANY** parts except tubes. You pay shipping costs. Replacements on tuners beyond practical repair are available at low cost.

Ⓢ Tarzian-made tuners are identified by this stamping.

When inquiring about service on other tuners, always give TV make, chassis and Model number. All tuners repaired on approved, open accounts. Check with your local distributor for Sarkes Tarzian replacement tuners, replacement parts, or repair service.



SARKES TARZIAN, INC.

Bloomington, Indiana

MANUFACTURERS OF TUNERS . . . SEMICONDUCTORS . . . AIR TRIMMERS . . . FM RADIOS . . . AM/FM RADIOS . . . AUDIO TAPE . . . BROADCAST EQUIPMENT

ONLY
\$9.50
INCLUDING

ALL PARTS
 (except tubes)
and LABOR

24-HOUR SERVICE
1-YEAR WARRANTY

**TWO SERVICE CENTERS
 TO SERVE YOU BETTER**

**See your distributor, or use the
 address nearest you for fast fac-
 tory repair service**

537 South Walnut St.
 Bloomington, Indiana
 Tel: 332-6055

10654 Magnolia Blvd.
 North Hollywood, Calif.
 Tel: 769-2720

PF Reporter™

PHOTOFACT

the magazine of electronic servicing

VOLUME 15, No. 4

APRIL, 1965

CONTENTS

Previews of New Sets	1
Airline Model GST-4615A; General Electric Model M403AVY, Chassis DA; RCA Model AF020J, Chassis KCS152A; Sylvania Model 23L133CU, Chassis 585-1	
Video Speed Servicing	5
Service hints on DuMont Chassis 120642, -643, and Philco Chassis 14M91.	
Letters to the Editor	13
The Electronic Scanner	15
Stock Guide for TV Tubes	20
Symfact: Stager-Tuned IF	27
(second and third stages) See what happens to voltages and waveforms when troubles occur.	
AGC Servicing Magic	32
You can locate AGC defects more easily by using these helpful hints. Carl Babcoke	
Unwinding the Mystery of Coils	34
There's no need to be confused about these basic circuit components. Rufus P. Turner	
Advanced Techniques for Future Servicing	36
Now is the time to start learning the techniques you'll need for servicing tomorrow's sets. Forest H. Belt	
Radar Maintenance Is Easy	38
Part two reveals how surface- search radar operates.	
Repairing Amplified Antennas	44
A look inside electronic accessories that boost gain. Lon Cantor	
Notes on Test Equipment	50
Lab reports on EICO Model 369 TV-FM Sweep and Marker Generator, Hickok Model 580 Tube Tester, and Lectrotech Model V-7 Color Generator and Vectorscope. Allen B. Smith	
Hybrids on the Auto Bench	56
Try these logical procedures next time you're faced with a radio using tubes and transistors. Homer L. Davidson	
In-Circuit Tests Evaluate Tubes	62
Quicker Servicing—You can learn a lot about tubes while they're still in their sockets. Larry Allen	
The Troubleshooter	73
Color Countermeasures	77
Book Review	83
Product Report	83
Free Catalog and Literature Service	88
Monthly Index	on free literature card.

publisher

Howard W. Sams

editor

Forest H. Belt

managing editor

James M. Moore

associate editors

Major Henricks
Allen B. Smith
Norman D. Tunner

consulting editors

William E. Burke
Joe A. Graves
C. P. Oliphant

research librarian

M. D. Bishop

production manager

Esther M. Rainey
Robert W. Pool, Asst.

circulation manager

Pot Tiad

Katherine Krise, Asst.

Cora La Von Willard, Asst.

art directors

Louis J. Bas, Jr.
Robert W. Reed

advertising & editorial

assistants

Hazel Boyer
Rebecca Clingerman

photography

Paul Cornelius, Jr.

advertising sales offices

Hugh Walloce, advertising sales manager

midwestern

Robert N. Rippy
PF REPORTER, 4300 West 62nd Street,
Indianapolis, Ind., AXminster 1-3100

eastern

Gregory C. Masfield
Howard W. Sams & Co., Inc., 3 West 57th Street,
New York, N. Y., MUrray Hill 8-6350

southwestern

C. H. (Jake) Stockwell
C. H. Stockwell Co., 4916 West 64th St,
Mission, Kansas, RAndolph 2-4417

western

G. R. Holtz
The Maurice A. Kimball Co., Inc.
2550 Beverly Blvd., Los Angeles 57, Calif.
DUcklrk 8-6178; and 580 Market Street,
Room 400, San Francisco 4, Calif. EXbrook 2-3365

Address all correspondence to
PF REPORTER, 4300 W. 62nd Street
Indianapolis, Indiana 46206



Copyright© 1965 by Howard W. Sams & Co., Inc.
PF REPORTER is a trademark of Howard W. Sams
& Co., Inc. No part of PF REPORTER may be
reproduced without written permission. No patent
liability is assumed with respect to use of
information herein. Acceptance of advertising does
not in any manner signify the products, policies
and services so advertised have been approved,
endorsed or recommended by this magazine.

Subscription Prices: 1 year—\$5.00, 2 years—\$8.00,
3 years—\$10.00, in the U. S. A., its possessions and Canada.
All other foreign countries: 1 year—\$6.00, 2 years—
\$10.00, 3 years—\$13.00. Single copy 50¢; back copies 65¢.

Indexed in Lectrodex.
Printed by the Waldemar Press Div.
of Howard W. Sams & Co., Inc.

ABOUT THE COVER

Printed circuits boards and
miniaturized components are no
longer strangers to most servicemen,
but these techniques are only
forerunners of things to come.
Designs using micro-miniaturized
modules are not as far in the
future as one might think. The
progressive serviceman must be ready
for them. To get a head start,
turn to the article on page 36.



Have you tried new **QUIG**[®] connectors?

Not just another wire spring connector!

The 3-in-1 QUIG is brand new and different . . . Copperweld wire inner core, a layer of flux, and an outer jacket of solder . . . all you need is heat!

Makes one-handed soldering possible!

Once again, Sprague helps the TV-radio service industry by solving two increasingly serious problems . . . parts replacement in those "inaccessible" chassis nooks, such as crowded tube sockets, as well as soldering onto the delicate circuitry of printed wiring boards.

Mechanically sturdy and electrically reliable, the revolutionary QUIG provides fast, expertly-soldered connections as easy as A-B-C!



Ten times actual size

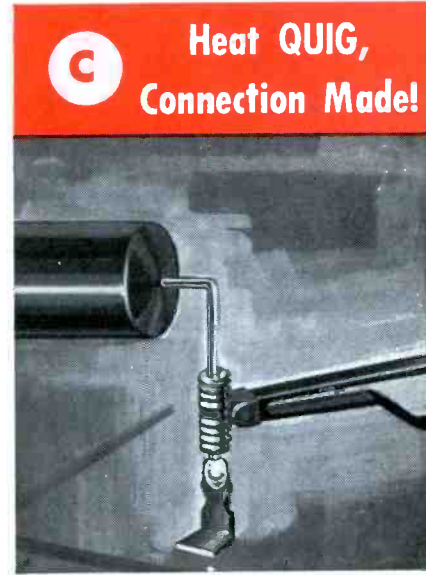
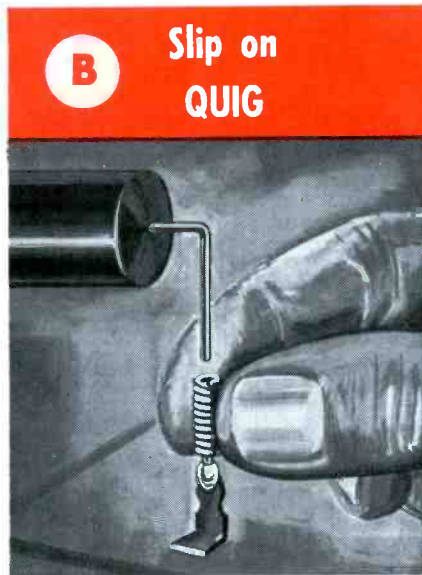
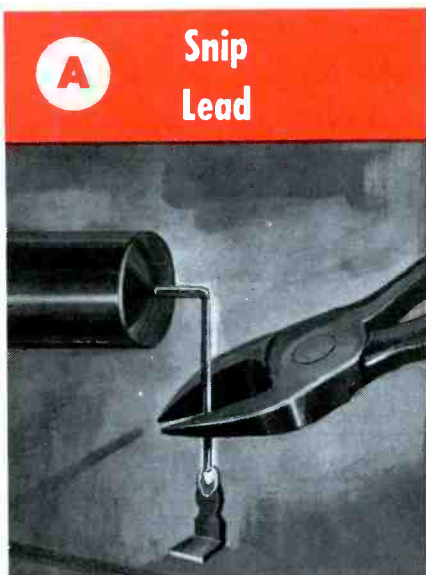

NOBODY ELSE HAS QUIG CONNECTORS...

YOU GET 'EM ONLY FROM SPRAGUE PRODUCTS!

QUIGS are now being packed with Sprague Atom[®] Capacitors *at no extra cost to you!* Whenever you need tubular electrolytics, insist on pre-packaged Sprague Atoms from your parts distributor and you'll automatically get your QUIG component connectors . . . the biggest boon to the service technician since the soldering gun!



WORLD'S LARGEST MANUFACTURER OF CAPACITORS

45-4104

Circle 3 on literature card

April, 1965/PF REPORTER 11

For window-size blow-ups
of this message, send 10¢ to
Sprague Products Co.,
105 Marshall St.,
North Adams, Mass.,
to cover handling
and mailing costs.

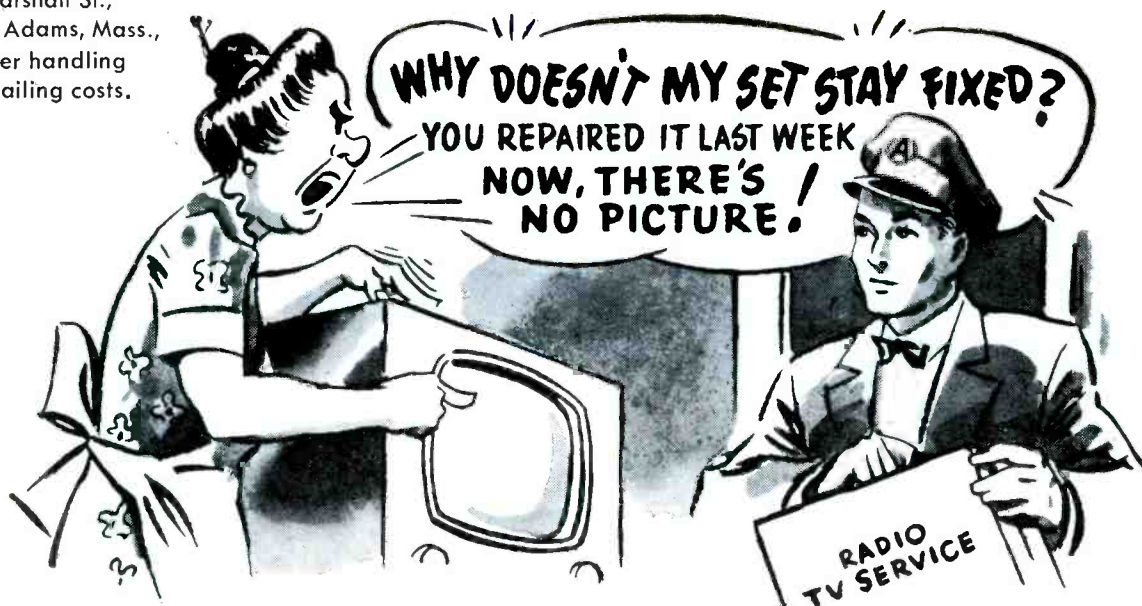

HERE'S YOUR ANSWER, MR. AND MRS. SETOWNER!

999 times out of a thousand, when this happens . . . *don't blame your service technician!*

The repair to your television receiver made several days ago or even several months ago probably had no relation to the new trouble that developed today.

Actually, there are more than 300 electrical parts in even a small table model television receiver. Trouble in any one of them might cause the picture or sound to disappear or to be received poorly.

Take your automobile for instance. Tuning up the motor today is no guarantee against a tire blowout tomorrow!

Such a thing is easier to understand because most of us are more familiar with automobiles than with today's highly com-

plicated TV and radio sets. But such unconnected troubles occur in TV and radio nevertheless—and because they are so hard to explain in non-technical terms, it is always embarrassing to your service technician when they do.

His continued business existence is based on gaining the full confidence of you and other set owners like you. He isn't in business to "gyp" you or to overcharge you. His success is based on doing each and every job to the level best of his ability, at a fair price for his skilled labor. It's only when you patronize the shops that feature "bargains" at ridiculously low prices that you need worry. Good radio and TV service can't be bought on the bargain counter! Set owners who recognize this aren't likely to get "gypped."

THIS MESSAGE WAS PREPARED BY SPRAGUE PRODUCTS COMPANY,
DISTRIBUTORS' SUPPLY SUBSIDIARY OF SPRAGUE ELECTRIC COMPANY, NORTH ADAMS, MASSACHUSETTS, FOR . . .

YOUR INDEPENDENT TV-RADIO SERVICE DEALER

85-5101

Circle 4 on literature card



Letters to the Editor

Dear Editor:

The illustration on page 52, December 1964 PF REPORTER, showing the construction of an electrolytic capacitor, is in error. The anode is okay, but the "cathode" is merely a cathodic connection, while the "dielectric" should be labeled "porous paper impregnated with electrolyte." The actual dielectric is the oxide film which forms on the anode.

The second paragraph on page 53, relating to the use of electrolytics at lower-than-rated working voltages, requires a little clarification, too. There is no longer any valid electrical reason for not using an over-rated electrolytic; modern methods of construction have eliminated the deforming prevalent in early electrolytics. However, a higher-rated unit costs more; so, for economy's sake alone, the technician is best advised to use a low-voltage electrolytic in low-voltage circuits.

WILLIAM F. MULLIN

Marketing Manager
P. R. Mallory & Co., Inc.
Indianapolis, Indiana

Dear Editor:

In regard to your article on electrolytics in the December PF REPORTER, I think the statement concerning the use of higher-voltage electrolytics in low-voltage circuits is in error. I've been assured by the distributor sales manager of a large manufacturer of capacitors that it's perfectly okay to make a substitution of that nature. Please let us know what you find out upon checking further.

JERRY RIES

Bud Electronic Supply Co.
Danville, Illinois

Thanks, fellows, for calling these matters to our attention. In the days when many of us were repairing only radios, and when production and design techniques were less dependable than they are today, we had the problems noted in the article. Modern equipment and quality-control programs, however, have eliminated this old annoyance. Tests prove that electrolytics of quality manufacture may, indeed, be substituted in lower-voltage circuit without detriment.—Ed.

Dear Editor:

Our town is being considered for a CATV system, and our city council will be deciding the issue. We local servicemen want to know whether or not we should fight CATV.

PRESTON E. DAVIES

Hampton, Va.

Dear Editor:

We would like to have your unbiased opinion on whether or not CATV would be a good thing for our community.

Isn't it going to mark the end to hopes for UHF TV?

HOMER HARTWELL

Galion, Ohio

You've got a hot one there, fellows. We can't definitely say whether or not CATV is good for any particular community. This problem must be settled by the opinion and choice of people who will be affected by CATV when and if it comes to their town. We made a report on CATV in the July 1963 issue, and another in the February 1965 issue. Both give an idea what we found in areas where CATV exists. Whether CATV will harm UHF is debated hotly; it has had an effect in some localities, none in others. At the present time, the FCC is investigating the pro's and con's of cable TV, and their final ruling will govern the outcome. It is doubtful that the FCC will leave any broadcasting medium uncontrolled. CATV, like many other businesses, is offering a service for sale; the final choice of whether or not to buy still remains in the hands of the consumer wanting or not wanting the service. Get all the information you can. Write to National Community Television Association, Inc., 535 Transportation Building, Washington 6, D. C.; National Association of Broadcasters, 1771 N Street, N.W., Washington 6, D. C.; Federal Communications Commission, New Post Office Building, Washington, D. C. 20554; and TAME, Suite 1228, 1001 Connecticut Avenue, N.W., Washington, D. C. Each has its own viewpoint. After examining all sides of the question, draw your own conclusions. Don't be swayed by any single presentation, but form your judgment on the basis of all the facts.—Ed.

Dear Editor:

My congratulations on the fine article expressing what the relationship should be between hams and TV servicemen ("Radio Amateurs Aren't So Bad"—September 1964 PF REPORTER). It hits the nail right on the head.

ERNEST C. BLIND

W7DDQ

Manager
C & G Electronics Co.
Centralia, Wash.

Perhaps the battle lines can now be erased, Ernest. We've always felt some technicians were overlooking a good source of income by trying to pretend hams don't exist.—Ed.

Dear Editor:

Just a note of appreciation for the valuable information you convey to us independent servicers. Such articles as "Solid State Rectifiers Come of Age" (September 1964), "Transistorized UHF Tuners" (September 1964), and your regular PF REPORTER SYMFACT—these articles and others too numerous to mention are mentally or physically filed away for use as troubleshooting requires them. Keep up the good work.

JAMES W. ZAWILLA

Benton Harbor, Mich.

Letters such as yours, Jim, are what keep us striving every month to bring you the kind of articles you and our tens of thousands of other readers need.—Ed.



NEW **ATR Golden Line**



FREQUENCY-STABLE INVERTER*

This ATR 12T-RME-1 INVERTER with "Frequency-Stability" and Automatically Controlled, will deliver 110-volt A.C. 60 cycle power for all popular make 11" to 13" portable TV Sets.

A.C. HOUSEHOLD ELECTRICITY Anywhere . . . in your own car, boat or plane!

- Operates Standard A.C.
 - Portable TV Sets
 - Record Players
 - Small Tape Recorders
 - Dictating Machines
 - Small Radios
 - Electric Shavers
 - Heating Pads, etc.

12T-RME-1 (12 v.d.c.) rated:—140 watts max. Shipping wgt. —14 lbs.

Special Dealer Net Price **\$29.16**

*Additional Models Available

Also NOW . . .

HAND WIRED—NO PRINTED CIRCUITRY

ATR ALL-TRANSISTOR ULTRA COMPACT UNIVERSAL MODEL 707



Karadio
IN DASH . . . UNDER DASH . . .

Complete with variable tone control . . . R. F. stage . . . Built-in speaker . . . and External speaker jack.

ATR MODEL 707N **\$25.97** Dealer Net



ATR ALL-TRANSISTOR ROOF-MOUNT and IN-DASH MODELS

TRUCK

Karadio
MODEL TR-720

FITS ALL TRUCKS • BOATS • STATION WAGONS
INSTANT PLAY . . . POWERFUL

Complete with patented antenna-yoke assembly. (U.S. Patent No. 3,087,118. Canadian Reg. 575,567)

ATR MODEL TR-720N **\$36.97** Dealer Net



ATR "A" Battery ELIMINATOR

For Demonstrating and Testing Auto Radios—TRANSISTOR or VIBRATOR OPERATED! Designed for testing D.C. Electrical Apparatus on Regular A.C. Lines.

MAY ALSO BE USED AS A BATTERY CHARGER MODEL 610C-ELIF . . . 6 volts at 10 amps. or 12 volts at 6 amps. Shipping weight 22 lbs. DEALER NET PRICE **\$55.00**

ATR AUTO RADIO and COMMUNICATION

LONGER-LIFE VIBRATORS

"The Best by Test!"



SEE YOUR ELECTRONIC PARTS DISTRIBUTOR OR WRITE FACTORY FOR LITERATURE & DEALER PRICES

ATR ELECTRONICS, INC.

Quality Products Since 1931
St. Paul, Minnesota 55101—U.S.A.

Circle 5 on literature card

April, 1965/PF REPORTER 13

you get **PRODUCT PLUS** *from your Sylvania Distributor*

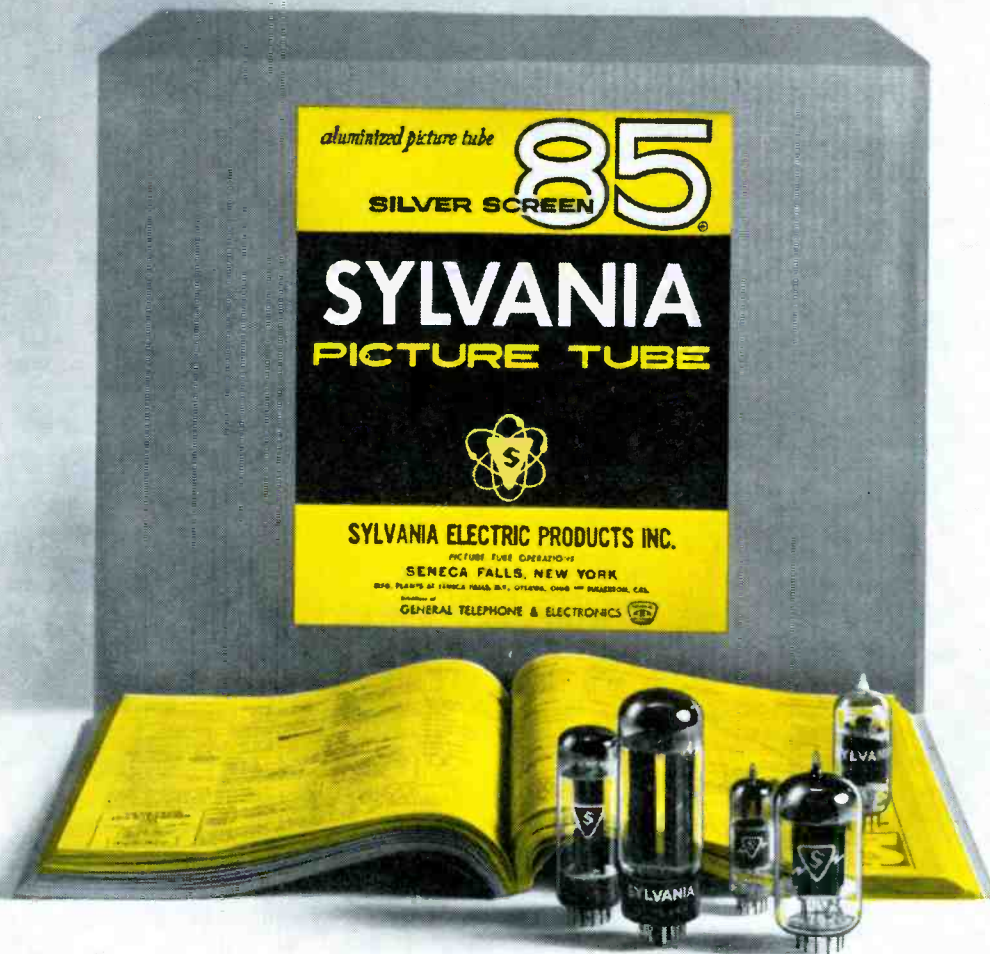

Now your Sylvania Distributor can put you in The Yellow Pages

The Yellow Pages are the first place people look *when they want to buy*. Studies show that 90% of all telephone subscribers consult their Yellow Pages when they want to find a local source for products and services. It's a fact: your potential customers let their fingers do the walking when a TV set needs professional servicing.

Here's a special program that means more customers and extra profits for you. *Our* ads appear in *your* local Yellow Pages, directing customers to you. Your Sylvania distributor can show you how your own listing may be part of the Sylvania ad.

The new Sylvania Trade Mark Heading will be seen—it's big, attractive, and descriptive. It tells

customers that you sell the dependable line of radio and TV tubes, including famous SILVER SCREEN 85® and *color bright* 85® picture tubes.

Your Sylvania distributor has full particulars on how you can share in this program designed especially for you. Check with him today.

Electronic Tube Div., Sylvania Electronic Components Group.

SYLVANIA

SUBSIDIARY OF
GENERAL TELEPHONE & ELECTRONICS **GTE**

NEW CAPABILITIES IN: ELECTRONIC TUBES • SEMICONDUCTORS • MICROWAVE DEVICES • SPECIAL COMPONENTS • DISPLAY DEVICES

Circle 6 on literature card



The Electronic Scanner

news of the servicing industry

Mobile Field-Service Corps

Standing in front of the company's new Research and Engineering building, are six service engineers of the **Delco** Division of the General Motors Corp. These six field engineers—equipped with 1965-model radios, films, tools, and test equipment—will conduct training sessions at various Delco dealerships across the country. Included in the program will be theoretical and practical discussions of new equipment, as well as troubleshooting information for all existing models. Appearances of the corps of roving technical experts will be scheduled through the Delco Division's zone service managers.



Expands Integrated-Circuit Program

The Semiconductor Division of **Sylvania Electric Products, Inc.** has earmarked the expenditure of several million dollars for a major expansion of manufacturing, engineering, and research facilities for integrated circuits.

Richard M. Osgood, vice president and division general manager, said the first phase of the expansion program involves the allocation of about 50% of the division's main facility at Woburn, Mass., for the integrated-circuit operation. In order to provide this additional space, all nonmanufacturing operations have been moved from the Woburn plant to other divisional facilities in Wakefield, Mass.

The decision to expand Sylvania's integrated-circuit operation was based on the fast growing market and the increased demand by customers in the field of computer integrated circuits. Sylvania's circuits are made on a silicon base by a monolithic epitaxial technique. With the completion of the first phase of the expansion program, Sylvania will have a facility with a capacity in excess of 100,000 circuits per month. Plans are underway to add other digital, linear, and multi-chip lines of integrated circuits.

Manufacturing Facility for Electrolytics

A new plant in Roxboro, North Carolina has been opened by **Planet Mfg. Corp.** The new facility, comprising a floor space of 46,000 sq. ft., will be devoted entirely to the manufacture of electrolytic capacitors and has been designed to lend itself to continuous production flow from aluminum-foil etching to shipping of the completed product. The new plant features automated manufacturing equipment. Corporate offices of the firm will remain in Bloomfield, N. J.



• Please turn to page 24

COMPLETE TUNER OVERHAUL

ALL MAKES — ONE PRICE

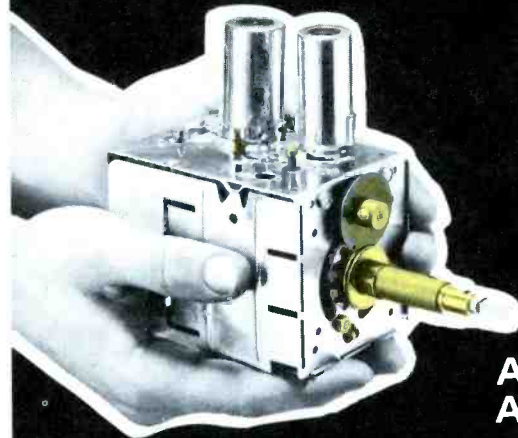

9.95

ALL LABOR AND PARTS
(EXCEPT TUBES & TRANSISTORS)*



VHF



UHF



COLOR



U-V



TRANSISTOR

COLOR TUNERS

GUARANTEED COLOR ALIGNMENT — NO ADDITIONAL CHARGE

Simply send us the defective tuner complete; include tubes, shield cover and any damaged parts with model number and complaint. Your tuner will be expertly overhauled and returned promptly, performance restored, aligned to original standards and warranted for 90 days.

UV combination tuner must be single chassis type; dismantle tandem UHF and VHF tuners and send in the defective unit only.

Exact Replacements are available for tuners unfit for overhaul. As low as \$12.95 exchange. (Replacements are new or rebuilt.)

And remember—for over a decade Castle has been the leader in this specialized field... your assurance of the best in TV tuner overhauling.

Pioneers of TV



Tuner Overhauling

CASTLE TV TUNER SERVICE, INC.

MAIN PLANT: 5701 N. Western Ave., Chicago 45, Illinois

EAST: 41-90 Vernon Blvd., Long Island City 1, N.Y.

CANADA: 136 Main Street, Toronto 13, Ontario

*Major Parts are additional in Canada

Circle 7 on literature card



247 WAYS TO MAKE MORE

From now on, color-TV work is going to bring in a bigger and bigger part of your income. And RCA has EVERYTHING to make color-TV service MORE PROFITABLE for you.

To save you money and manhours.

To increase your efficiency so you can get more jobs out in the same time.

To eliminate those time-wasting extra phone calls and trips to the distributor.

Take the famous RCA Color-TV Test Jig (large unit at right). It cuts manhours in half on a color house call. With-

out it, when you have to pull a set into the shop, it takes two men. With it, it takes just one (you pull the chassis only—leave the color tube and the cabinet). That means MONEY ... extra money for you.

Take the RCA Color Parts Rack (large unit at left). The rack is FREE when you buy the basic complement of 120 most-needed color service parts. Keeps your color parts neatly organized, all in one place. Simplifies restocking, lets you know what you're short of. No more running out of a vital part just when you need it—which slows down a job.

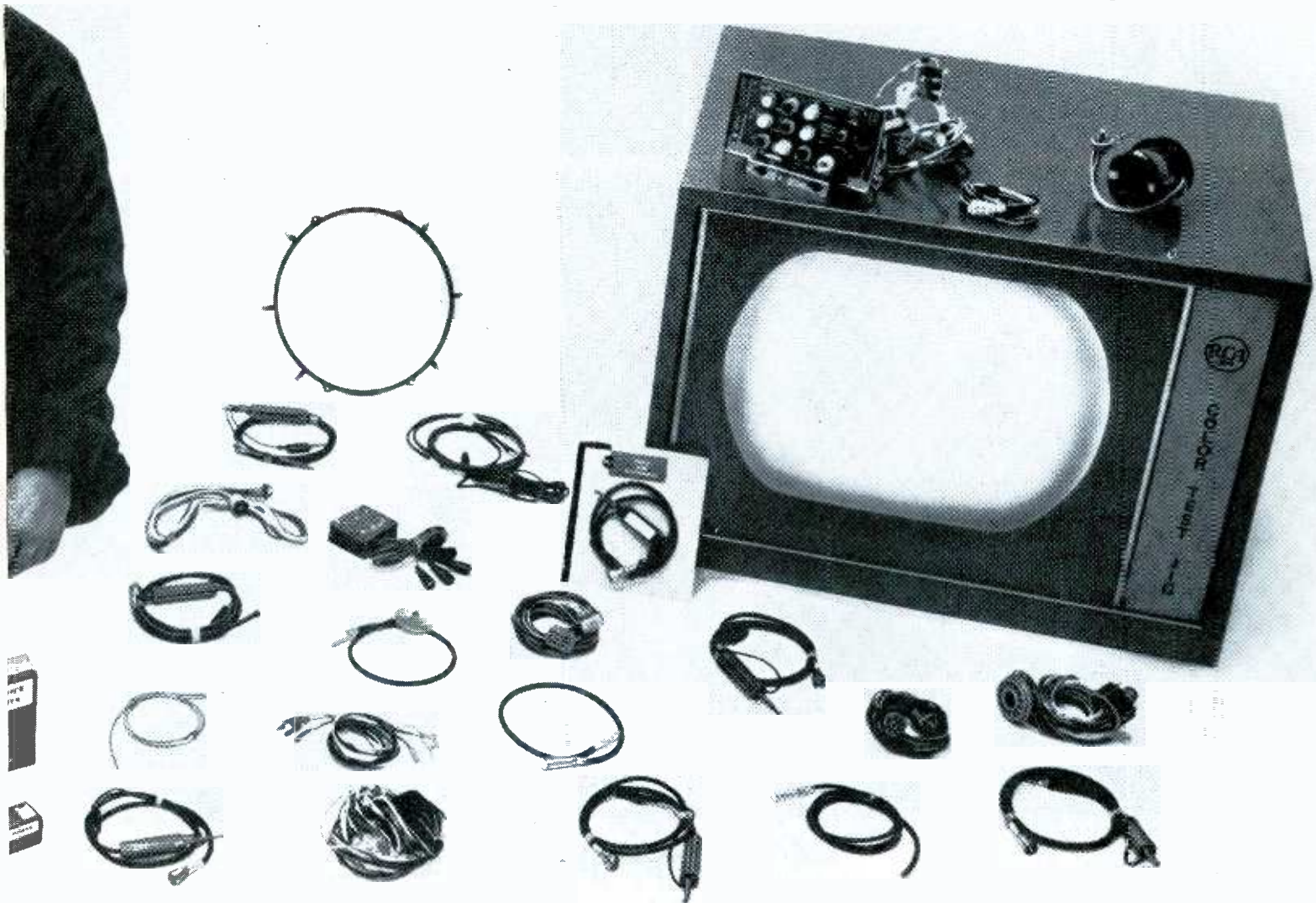

MONEY IN COLOR-TV SERVICE

That means MONEY...extra money for you.

Take the other color service parts arrayed in the photo and listed at right. Degaussing coils, transformers, chokes, yokes, connectors, cables, replacement parts...each with a special function to save you time, to increase the quality and accuracy of your work, to help you cut down on call-backs. That means MONEY...extra money for you!

245 specialized color service parts in all. The Rack and the Jig make it 247. And all of them mean MONEY...extra money for you.

RCA Parts and Accessories for color-TV service include:

- *Color Test Jig*—to test all RCA color-TV chassis
- *Color Parts Rack*—sturdy, well-organized unit containing complement of 120 most-needed color-service parts
- *Degaussing coils*—to demagnetize picture tube and chassis
- *Special-purpose extension cables*—to extend kinescope socket, deflection yoke, convergence magnet and kinescope high-voltage leads when chassis is removed from cabinet for servicing
- *Special alignment probes*—video detector test blocks, IF test blocks, sound detector test blocks, mixer grid matching pad, tuner IF input head
- *High-voltage interlock plug*—to by-pass high-voltage shorting switch
- Plus sockets, transformers, fixed and variable capacitors, reactors, resistors, diodes, switches, coils...EVERYTHING to save you time and make more money for you in color-TV service.

RCA PARTS AND ACCESSORIES, DEPTFORD, N. J.



The Most Trusted Name in Electronics

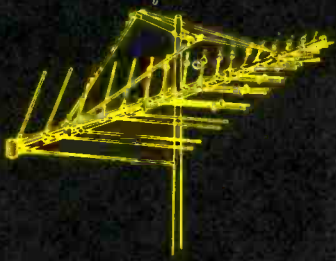

Model
LPV-VU18
List
\$69.95

Description
18 Active Cells
VHF—upto 175 miles
UHF—upto 90 miles
FM —upto 75 miles



Model
LPV-VU15
List
\$59.95

Description
15 Active Cells
VHF—upto 150 miles
UHF—upto 90 miles
FM —upto 60 miles

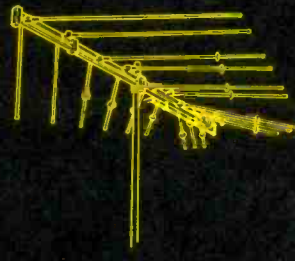

Model
LPV-VU9
List
\$39.95

Description
9 Active Cells
VHF—upto 100 miles
UHF—upto 40 miles
FM —upto 40 miles

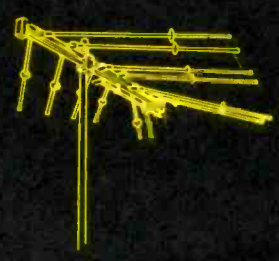

Model
LPV-VU6
List
\$27.50

Description
6 Active Cells
VHF—upto 75 miles
UHF—upto 25 miles
FM —upto 30 miles

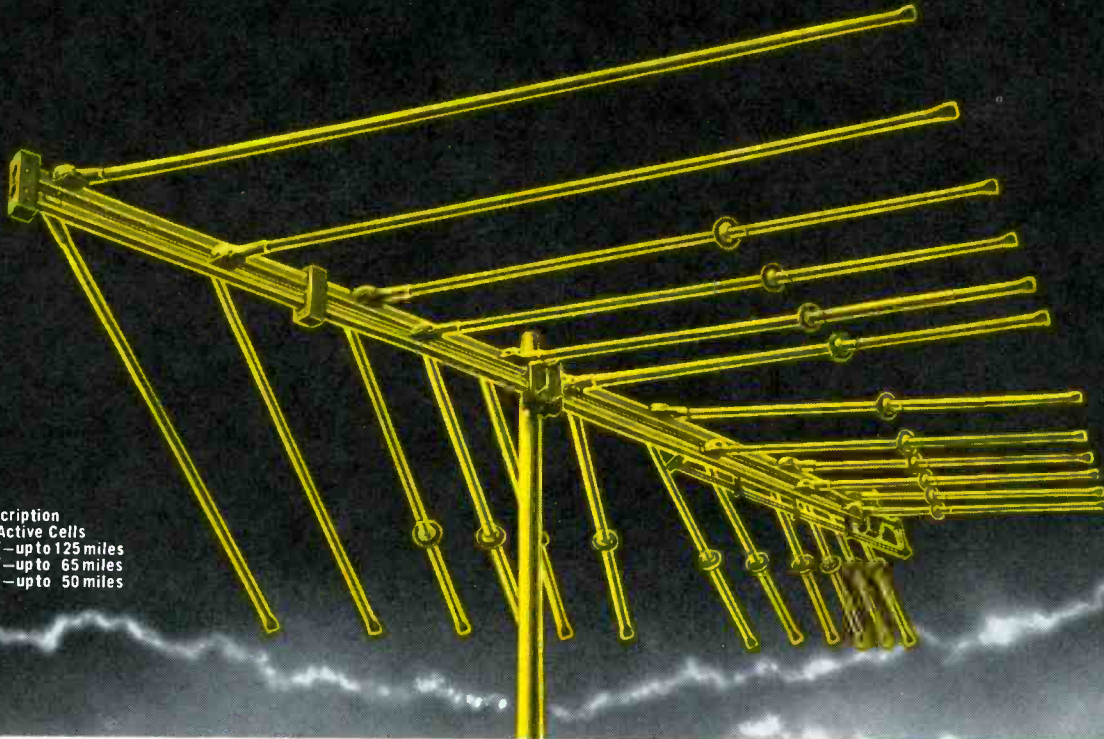

Model
LPV-VU12
List
\$49.95

Description
12 Active Cells
VHF—upto 125 miles
UHF—upto 65 miles
FM —upto 50 miles

Licensed under one or more
of U.S. patents: 2,958,001;
2,985,879; 3,011,168; 3,108,
280; 3,150,376 and additional
patents pending in U.S.A.
and Canada. Produced by
JFD Electronics Corporation
under exclusive license from
the University of Illinois
Foundation.

Who Says You Can't Have Everything You Want in a TV Antenna?

VHF? UHF? FM Stereo? Single Down-lead?

You most definitely can—when you install the remarkable new

JFD LPV-VU LOG-PERIODIC

FEATURING THE CAP-ELECTRONIC DIPOLE

Copyright 1964 by JFD

The World's first all-channel VHF/UHF/FM/Stereo antenna (with single Down-lead) is here. (And only JFD has got it!)



You can't satisfy today's complex VHF/UHF/FM reception needs with yesterday's antennas. Today's "VU" TV sets call for a single all-powerful all-band antenna that delivers the signals you need for picture-perfect reception on all channels 2 to 83—plus FM Stereo.

That's why smart installers and dealers are switching to the new JFD LPV-VU. This newest antenna advance from the JFD Champaign, Illinois R&D Laboratories, teams (1) the acclaimed JFD Log-Periodic concept with (2) a totally new antenna design principle—the capacitor-coupled electronic dipole.

Result? More driven elements than ever before possible for the most efficient performance ever on VHF, UHF, FM/Stereo—from one antenna, with one lead-in.

And you can choose from five gold alodized LPV-VU Log-Periodics to satisfy every location, any budget: model LPV-VU-18, LPV-VU-15, LPV-VU-12, LPV-VU-9 and LPV-VU-6.

New from JFD—another outstanding advance in dipole design, the capacitor-coupled electronic dipole!

By introducing parallel plate capacitors into predetermined positions along the dipoles, and by precisely adjusting the value of each capacitance:



1. More dipoles are made to resonate on the high VHF band with a corresponding increase in gain.

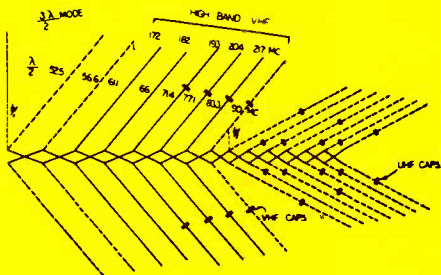

- Higher mode operation in UHF band achieves higher gain on channels 14 to 83—equal or better than that of parabolics. Improves FM stereo performance.
- More uniform gain across each band, with narrower beamwidths. High front-to-back ratios greatly improve ghost rejection—insure excellent color fidelity.

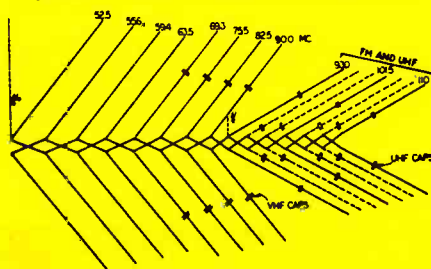

PLUS...

- Patented frequency independent Log-Periodic design maintains same high performance efficiency regardless of station or band tuned in.
- Only one downlead needed. A JFD AC80 splitter, included with each LPV-VU, permits you to tie directly into VHF, UHF and FM set inputs.
- New low-impedance twin crossarms function as crossed feeder harness. Step up gain and improve signal transfer.

LPV-VU OFFERS NEW MECHANICAL ADVANCES, TOO!

- Twin square aluminum crossarms. ■ Stainless steel terminals. ■ Oversized unbreakable Celanese "Fortiflex A" insulators. ■ Solid aluminum bus bar transformers. ■ Tubular crossarm supports on larger LPV-VU's. ■ Double U-bolts with 4 serrated-gripping profiles for 6-inch gripping span. ■ Electrically conductive gold alodizing.



INSTALLER BEWARE!

Don't spoil your VHF reception!

Addition of a separate UHF antenna to a present VHF installation may cut the VHF signal being delivered to your set. Incoming signals from a VHF transmitter may be scattered from the UHF antenna. Scattering produces less signal and multiple signals which cause ghosts.

SO WHY USE TWO WHEN ONE LPV-VU WILL DO?

Install the all-channel JFD LPV-VU and get the best VHF and UHF from one antenna with one down-lead!

A SPACE-AGE PRODUCT OF THE WORLD'S GREATEST TV/FM ANTENNA LABORATORIES



This newly completed laboratory, located on a ten acre site in Interstate Research Park, in Champaign, Illinois (home of the University of Illinois) marks a milestone in antenna history. It is dramatic proof of JFD leadership in antenna technology. Its fully staffed and equipped engineering staff, under the supervision of Dr. Paul E. Mayes, is blazing new trails in antenna design. This priceless know-how is built into each LPV-VU you sell.

The JFD LPV-VU is adapted from the geometrically derived Log-Periodic antenna formula developed by the Antenna Research Laboratories of the University of Illinois.

JFD

JFD ELECTRONICS CORPORATION

15th Avenue at 62nd Street, Brooklyn, N. Y. 11219

JFD Electronics-Southern Inc., Oxford, North Carolina

JFD International, 64-14 Woodside Ave., Woodside 77, N. Y.

JFD Canada, Ltd., 51 McCormack Street, Toronto, Ontario, Canada

SEE YOUR DISTRIBUTOR. WRITE FOR BULLETIN 806 FOR COMPLETE DETAILS.

Circle 8 on literature card

STOCK GUIDE FOR TV TUBES...

This list omits more than 100 of the rarest TV tube types, which many shops find impractical to stock. To simplify the chart as much as possible, common radio and hi-fi tube types used in TV combinations are omitted.

New tube types introduced this year are listed in the separate chart: to help you decide whether to stock these tubes, each listing specifies receivers using that particular type. If you're specializing in one or two brands, you'll pick new tubes listed for those sets and stock your shelves and caddy accordingly.

In the main chart, the figures under "Caddy Stock" suggest a stock of approximately 300 tubes (other than tubes for color sets) which should

account for close to 90% of your replacement needs. As with the rare-tube listings, you may want to carry more of a particular type if it is used in receivers you service often. We've removed some of the older types, such as 6V6, 6W4, and 6BZ7, and replaced them with more current types; also included are some that appeared in last year's new-tube list—if they were used in sets again this year. Most-used UHF tubes are also included. Tubes marked with an asterisk (*) are used also in color sets.

The figures under "Shelf Stock" are a suggested backup stock, if you're located near a parts distributor. If you can replenish your tube supply only once a week, you may wish to stock extra of the more common types.

Your volume of business will naturally determine your actual shelf stock, too. Keep in mind three main factors that will influence the demand for various tubes:

1. Relatively high failure rate of power-output and similar tubes.
2. Your specialization in certain makes of sets.
3. Average age of sets containing a particular tube type.

Temporary substitution of available types for rare types, as outlined in the Howard W. Sams book, *Tube Substitution Handbook, Vol. 8*, can also help you reduce stock requirements.

Another way to ease tube-stock headaches is to use only the latest -A or -B versions of various tubes. Types in common use are listed in the chart.

TUBE TYPE	SHELF STOCK	CADDY STOCK	TUBE TYPE	SHELF STOCK	CADDY STOCK	TUBE TYPE	SHELF STOCK	CADDY STOCK
1AD2	1	1	3HG8	1	1	6AC7	1	1
1AU2*	1	1	3HM6	1	1	6AF3	1	1
1B3GT	5	2	3HT6	1	1	6AF4B*	2	1
1G3GT	2	1	4AU6	1	1	6AF11	1	1
1J3	2	1	4BL8*	1	1	6AG5	1	1
1K3	3	1	4BQ7	1	1	6AG7*	1	1
1N2	1	1	4BU8	1	1	6AH5	2	1
1S2A	1	1	4BZ6	2	2	6AH6	1	1
1V2*	2	1	4CB6	1	1	6AK5	1	1
1X2B*	2	1	4CS6	1	1	6AL3	1	1
2AF4	1	1	4DK6	2	1	6AL5*	2	1
2AH2	1	1	4DT6	1	1	6AL11*	1	1
2AS2	1	1	4EH7	1	1	6AM8A	2	1
2CW4	1	1	4EJ7	1	1	6AN8*	1	1
2CY5	1	1	4GK5	1	1	6AQ5A*	3	3
2DS4	1	1	4GM6	1	1	6AR11	1	1
2DZ3	1	1	4GZ5	1	1	6AS5	1	1
2DZ4	1	1	4HA5*	1	1	6AS8	1	1
2FH5	1	1	4HM6	1	1	6AU4GTA*	2	2
2FS5	1	1	4HS8	1	1	6AU6A*	3	2
2GK5	2	2	4HT6	1	1	6AU8A*	1	1
2GU5	1	1	4JC6	1	1	6AV6*	2	2
2GW5	1	1	4JD6	1	1	6AW8A*	3	2
3A3*	1	2	4KN8	1	1	6AX3	1	1
3AF4	1	1	5AM8	1	1	6AX4GTB	3	3
3AJ8	1	1	5AQ5	2	2	6AY3	2	2
3AL5	1	1	5AT8	1	1	6AZ8*	1	1
3AT2*	1	1	5AU4	1	1	6B10	1	1
3AU6	2	1	5BC3	1	1	6BA6	3	1
3AW3	1	1	5BR8	1	1	6BA11*	1	1
3BN6	2	1	5CG8	3	2	6BC8*	1	1
3BU8	1	2	5CL8A	1	1	6BD11	1	1
3CB6	2	2	5DJ4	1	1	6BE3*	2	1
3CS6	1	1	5EA8	1	1	6BE6	2	1
3CY5	1	1	5EW6	1	1	6BF11	1	1
3DG4*	2	1	5FG7	2	1	6BG6GA	1	1
3DK6	2	2	5GH9	1	1	6BH9	1	1
3DT6*	1	1	5GM6	1	1	6BH11*	1	1
3DZ4	1	1	5HG8	1	1	6BJ3	2	1
3EH7	1	2	5JV8	1	1	6BJ8	1	1
3EJ7	1	2	5KD8	1	1	6BK4*	2	1
3FS5	1	1	5KE8	1	1	6BK7B	1	1
3GK5	2	2	5U4GB*	8	3	6BL7GT	2	1
3GS8	1	1	5U8	2	2	6BL8*	2	2
3HA5	1	1	5V3	1	1	6BM8A*	1	1

TUBE TYPE	SHELF STOCK	CADDY STOCK	TUBE TYPE	SHELF STOCK	CADDY STOCK	TUBE TYPE	SHELF STOCK	CADDY STOCK
6BN4	1	1	6GT5	1	1	10DX8	1	1
6BN6*	3	1	6GU5	1	1	10EG7	1	1
6BN8*	1	1	6GU7*	3	2	10EM7	1	1
6BQ5*	3	2	6GV5	2	1	10EW7	1	1
6BQ6GTB	5	3	6GW6	1	1	10GK6	1	1
6BQ7A*	2	1	6GW8	1	1	10HF8	1	1
6BR8A	1	1	6GX6*	2	1	10JA8	1	1
6BU8	3	2	6GY5	1	1	10JY8	1	1
6BX7GT	1	1	6GY6*	1	1	10KU8	1	1
6BY6*	1	1	6GZ5	1	1	11AR11	1	1
6BY8	1	1	6HA5*	1	1	11JE8	1	1
6BZ6*	8	4	6HA6	1	1	11KV8	1	1
6C4*	1	1	6HB5	2	1	12AF3	2	1
6CB5*	1	1	6HG6*	2	1	12AL11	1	1
6CB6*	3	3	6HD5	1	1	12AT7*	1	1
6CD6GA	2	2	6HE5*	3	2	12AU7	1	2
6CG7*	6	2	6HF5*	3	2	12AV5GA	1	1
6CG8A*	5	2	6HF8	1	1	12AX4GTB	3	2
6CL6*	1	1	6HG8	1	1	12AX7*	2	1
6CL8A	1	1	6HJ8	2	1	12AY3	1	1
6CM7	2	2	6HK5	1	1	12AZ7A*	1	1
6CN7*	1	1	6HL8*	1	1	12B4A	2	1
6CQ8*	1	1	6HS8*	2	1	12BE3	1	1
6CS6*	2	1	6HZ6*	1	1	12BH7A*	2	2
6CU5	2	1	6HZ8	1	1	12BQ6GTB	2	2
6CW4*	1	1	6J6	2	2	12BY7A*	2	1
6CW5*	2	1	6JB6	2	1	12C/-CU5	3	1
6CX8	1	1	6JC6*	2	1	12CA5	2	1
6CY5	1	1	6JC8	1	1	12DB5	1	1
6DA4	1	1	6JE6*	3	2	12DQ6B	3	2
6DE4	2	2	6JE8	1	1	12DT5	1	1
6DE6*	2	1	6JH6*	3	2	12FX5	1	1
6DE7	2	1	6JH8*	3	2	12GC6*	1	1
6DK6*	2	2	6JN8	1	1	12GN7*	1	1
6DM4	3	2	6JT8*	1	1	12GT5	1	1
6DN7	1	1	6JU8*	3	2	12GW6	3	2
6DQ5*	2	1	6JV8	2	1	12SN7GTA	1	1
6DQ6B*	5	3	6JZ8	1	1	12W6GT	1	1
6DR7	1	1	6K6GT	1	1	13CM5	1	1
6DS4*	2	2	6KA8*	1	1	13DE7	1	1
6DT5	1	1	6KD8	1	1	13DR7	1	1
6DT6A*	2	2	6KT8*	1	1	13EM7	2	1
6DV4*	1	1	6KU8	1	1	13FD7	1	1
6DW4*	1	1	6KZ8*	1	1	13GB5	2	1
6DX8*	1	1	6Q11(6K11)	1	1	13GF7	1	1
6DZ4	1	1	6RK19	1	1	13J10	1	1
6EA8*	3	2	6S4A	1	1	15BD11	1	1
6EB8	2	1	6SL7GT	1	1	15CW5*	2	1
6EH7*	3	2	6SN7GTB*	2	1	15DQ8*	1	1
6EH8	3	2	6T8*	1	1	15HB6*	2	1
6EJ7*	3	2	6U8A*	1	2	15KY8	2	1
6EM5	1	1	6U10*	1	1	15LE8*	1	1
6EM7*	2	2	6X8A*	2	2	16A8*	1	1
6ER5	1	1	7AU7	1	1	16AQ3	1	1
6ES8	2	1	7GU7*	1	1	16GK6	1	1
6ER7	1	1	7GV7	1	1	17AX4GT	1	1
6EV7*	1	1	8AW8A	2	1	17AY3	3	2
6EW6*	2	2	8B8	1	1	17BE3	1	1
6EW7	2	2	8B10	1	1	17BF11	1	1
6EZ5*	1	1	8BE8	1	1	17BS3	2	1
6FD7	1	1	8BQ5	2	1	17C5	1	1
6FG7*	2	1	8CG7	1	1	17DE4	1	1
6FH5*	1	1	8CW5	1	1	17DM4A	1	1
6FM7*	2	1	8CW8	1	1	17DQ6B	2	1
6FQ7*	5	2	8CX8	1	1	17GJ5	2	1
6FS5	1	1	8DX8	1	1	17GV5	1	1
6FV8	1	1	8EB8	1	1	17JB6	1	1
6FY5	1	1	8EM5	1	1	17JZ8	2	1
6FY7	1	1	8ET7	1	1	19AU4GTA*	1	1
6GB5	1	1	8FQ7	2	1	21GY5	2	1
6GC5*	1	1	8GJ7	1	1	21HJ5	1	1
6GE5	2	2	8GN8	1	1	22BH3	2	1
6GF7*	3	2	8JV8	1	1	22DE4	1	1
6GH8A*	3	2	8JZ8	1	1	22JG6	2	1
6GJ5	1	1	8KA8	1	1	25AX4GT	1	1
6GJ7*	1	1	9A8	1	1	25BQ6GTB	1	1
6GK5*	3	2	9AU7	1	1	25CD6GB	1	1
6GK6	1	1	9GV8	1	1	33GT7	1	1
6GL7*	1	1	10AL11	1	1	33GY7	2	1
6GM6*	3	2	10CW5	1	1	50C5	2	1
6GN8	2	1	10DE7	2	1			

• Please turn to page 87

**Want to make
your shop
more
profitable?**

**Mail this
coupon.**



Here's a brand-new service to help you do the better, faster work that gets you more business. A service that gives you tech data when you need it — weeks and even months before other tech services.

New Philco Tech Data Service includes everything you need — installation instructions, exploded views, parts data, timesaving service techniques — written especially for the professional service technician. And you get your data fast. New-product manuals are in your hands before the retailer gets his merchandise. You'll find the servicing of Philco Products much more profitable when you use the new Philco Tech Data Service.

Philco Tech Data Service is available in Electronics, Laundry, Appliances, and Combination Appliances and Laundry. Here's what you get:

- 10-year Philco Parts Cross-Reference Guide. Fits tube caddy or tool box. Gives all the functional parts with substitution and number data right up to date. No other service has anything like it.
 - Philco Parts Price List with complete part number identification. Issued three times a year.
 - Complete service manuals for every Philco product line. Contain general product data, separate model specs, complete line information — not just supplements.
 - A stream of Philco Service Bulletins that tell you what to expect, what to look for, give you specific "fix" information.
 - A one-year subscription to *Service Businessman* magazine. Unique in the field, not offered separately. Filled with articles on how to make an independent service business more profitable.
- You just can't get all these valuable things for the same price anywhere else. Mail the coupon today and see how soon you can begin to run a more profitable shop.

PARTS AND SERVICE DEPARTMENT

PHILCO[®]
A SUBSIDIARY OF *Ford Motor Company*

Start sending me the following Philco Tech Data Service right away.
My check or money order is enclosed. (Check the Philco Tech Data you want.)

ELECTRONICS

- | | |
|---|--|
| <input type="checkbox"/> Plan E
You receive all material on electronics published during the 12-month subscription period. For one full year, \$7.50 | <input type="checkbox"/> Plan E-1
Plan E plus all literature covering 1965 Philco Electronic Products that was published prior to your subscription date. \$10.50 |
|---|--|

LAUNDRY

- | | |
|--|---|
| <input type="checkbox"/> Plan L
You receive all material on laundry published during the 12-month subscription period. For one full year, \$12.50 | <input type="checkbox"/> Plan L-1
Plan L plus all literature covering 1965 Philco Laundry Products that was published prior to your subscription date. \$17.50 |
|--|---|

APPLIANCES

- | | |
|--|---|
| <input type="checkbox"/> Plan A
You receive all material on appliances published during the 12-month subscription period. For one year, \$12.50 | <input type="checkbox"/> Plan A-1
Plan A plus all literature covering 1965 Philco Appliance Products that was published prior to your subscription date. \$17.50 |
|--|---|

COMBINATION APPLIANCES & LAUNDRY

- | | |
|--|---|
| <input type="checkbox"/> Plan AL
You receive all material on laundry and appliances published during the 12-month subscription period. For one full year, \$20.00 | <input type="checkbox"/> Plan AL-1
Plan AL plus all literature covering 1965 Philco Appliance and Laundry Products that was published prior to your subscription date. \$30.00 |
|--|---|

Make all checks payable to Philco Corporation.
Mail to:
**PHILCO
TECH DATA SERVICE
Box 3635
Philadelphia, Pa. 19125**

Name _____
Firm Name _____
Address _____
City _____ State _____ Zip No. _____

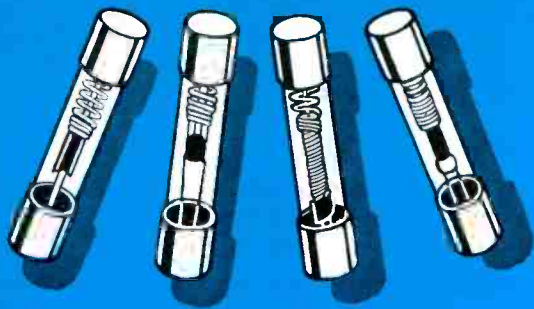

FUSETRON dual-element Fuses

time-delay type

"Slow blowing" fuses that prevent needless outages by not opening on motor starting currents or other harmless overloads—yet provide safe, protection against short-circuits or dangerous overloads.

BUSS

Write for BUSS
Bulletin SFB

BUSSMANN MFG. DIVISION, McGraw-Edison Co., St. Louis, Mo. 63107

Large-Scale CATV Modernization

One of the nation's largest operators of CATV systems, H & B American Corp., has announced a major modernization program. Five systems will be completely rebuilt, one will be partially rebuilt, and one new system will be installed. All systems will use solid-state equipment.

According to Leon Papernow, vice-president of operations, this modernization is being undertaken to provide subscribers with more program variety and improved picture quality. Once the changeover is completed, all seven systems will be capable of carrying up to 12 TV channels, plus 20 FM stations.

To implement the program, H & B has purchased from Jerrold Electronics, in the largest single equipment-purchase contract in the history of CATV, enough solid-state equipment to send signals through more than 500 miles of cables.

The five systems to be rebuilt around Jerrold 12-channel solid-state gear are: Ukiah, Cal.; Reno, Nev.; Margate, Ventnor, and Longport, N. J.; Dubuque, Iowa; and Wenatchee, Wash. Dothan, Ala. will be equipped with new solid-state trunkline amplifiers, and a completely new system will be installed in the Santa Ynez Valley, in Cal. H & B American Corp. owns 29 CATV systems serving more than 83,000 subscribers in 44 communities.

New Family of Semiconductors

A new family of solid-state electronic devices developed by RCA Electronics will make possible a new generation of transistorized AC-DC radios and phonographs, according to RCA sources. The new devices are designed to be line operated, thus avoiding the additional cost and bulk of circuit components such as power transformers and voltage-dropping resistors normally required to power AC-DC transistor sets. Complete solid-state circuitry in line-powered equipment has been generally limited to larger, higher-priced home instruments. The new, low-cost, hermetically sealed semiconductors make possible all-

BUSS: Makers of The Complete Line...

Mustang Winners

Prize winners in the Sams PHOTOFAC sales contest have been announced by Howard W. Sams, chairman of the board and president of Howard W. Sams & Co., Inc. Names of the winners were drawn by Mr. Gail S. Carter, executive vice president of NEDA, at the January contest luncheon in Indianapolis.

Grand-prize winners of Ford Mustang automobiles were Ralph E. Denenburg, service technician of R & D TV, Phila-



delphia, Pa. and Joe Taylor, distributor salesman for Tri-State Distributing Co., Greenville, Miss. Second-prize winners of luxurious mink stoles were technician Joseph Jimenez of Jimenez TV Sales & Service, Hayward, Cal. and R. Kuttruf, distributor salesman for H. L. Dalis in Long Island City, N. Y. Third awards were won by Francis C. Wolven of Saugerties, N. Y. and Stan Lesser, another distributor salesman for H. L. Dalis; each received a diamond-set Elgin ladies' watch. All six winners were notified by phone immediately following the drawing.

In the photo, Gail Carter draws the winners' names for Jack W. Merritt, vice president sales, of the Sams Co. Looking on at left are J. A. "Shine" Milling, president of the Sams division and a director of the company, and Thomas V. Surber, sales manager, distributor division.

Screw type knob designed for easy gripping, even with gloves. Has a "break-away" test prod hole in knob.



Screw type slotted knob that is recessed in holder body and requires use of screwdriver to remove or insert it.

BUSS Space Saver Panel Mounted Fuseholders

- Fuseholder only $1\frac{5}{8}$ inches long, extends just $\frac{29}{32}$ inch behind front of panel. Takes $\frac{1}{4}$ x $1\frac{1}{4}$ inch fuses. Holder rated at 15 ampere for any voltage up to 250.
- Military type available to meet all requirements of MIL-F-19207A.

BUSS

Write for BUSS
Bulletin SFH-10

BUSSMANN MFG. DIV., McGraw-Edison Co., ST. LOUIS, MO. 63107

Circle 10 on literature card

BLOCKS for BUSS FUSES



SOLDER
TERMINALS

SCREW
TERMINALS

Above standard types available in any number of poles—
From 1 to 12... plus other types for every application....

BUSS

Write for BUSS
Bulletin SFB

BUSSMANN MFG. DIV., McGraw-Edison Co., ST. LOUIS, MO. 63107

tube and placed it into production at National Video Corp. This same engineering team will set-up the new facility which, beginning next year, will be capable of producing any size rectangular color tube, but will start with the 23" size, Mr. Wavering revealed.

To provide facilities for the new tube plant, some 60,000 sq. ft. of Motorola's Franklin Park, Illinois site is being cleared. The Consumer Products Division's Parts and Service Department, now occupying this space, will be moved to another building in Franklin Park recently acquired by Motorola. The vacated Parts and Service Department building will be enlarged and remodeled to accommodate the processing and control equipment required for the production of the rectangular color picture tubes.



To Double Capacity

Doubled production capacity, made possible by a new addition slated for completion in the spring of 1965, is anticipated by Winegard Co., a leading producer of TV antennas and other TV- and FM-reception equipment. The new addition, which includes modern research laboratories, is the fourth and largest facility expansion in the company's history. The new structure will be devoted primarily to antenna production. ▲

... of Fuses of Unquestioned High Quality

solid-state, line-operated broadcast-band radio receivers and phonographs in the medium and lower price ranges. The new semiconductor package consists of four transistors and one silicon rectifier, all designed for use in circuits operating directly from the 117-volt AC line.

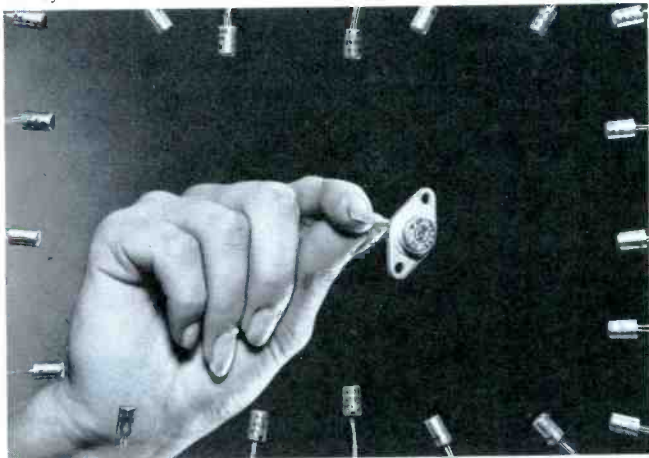

To Manufacture Color CRT's

The 23" rectangular color-television picture tube used in its current line will be manufactured by Motorola, Inc., according to Elmer H. Wavering, president of the corporation. National Video Corp. is currently sole supplier to Motorola of this color-picture tube.

The Motorola move into picture-tube manufacturing will release National Video Corp. to serve the requirements of its other customers and will, at the same time, provide a second source of supply to serve Motorola's expanding tube requirements.

Motorola engineers designed the first 23" rectangular color

VISUAL
INDICATING

BODY SIZE
ONLY
.145 x .300
INCHES

BUSS Sub-Miniature PIGTAIL TRON FUSES

For use on miniaturized devices,— or on gigantic multi-circuit electronic devices.

Glass tube construction permits visual inspection of element.

Smallest fuses available with wide ampere range. Twenty-three ampere sizes from 1/20 thru 15 amps.

Hermetically sealed for potting without danger of sealing material affecting operation. Extreme high resistance to shock or vibration. Operate without exterior venting.

BUSS

Write for BUSS
Bulletin SFB

BUSSMANN MFG. DIVISION, McGraw-Edison Co., St. Louis, Mo. 63107

Circle 10 on literature card

April, 1965/PF REPORTER 25

NO ONE CAN GUARANTEE YOUR FUTURE



— **NOT EVEN YOU!**

WE KNOW 156 MEN WHO DID THE NEXT BEST THING They Became a Part of the Lafayette Associate Store Program

Business can be a funny proposition. You're an independent businessman, like those other 156 men. Then one day you discover competition has become too big and too tough to take on by yourself. You want to fight back—launch new advertising campaigns, expand your line, send out sales literature, mail out catalogs, do something to keep the business going. But it's just too much for one man alone.

You need the know-how and support of a large corporation . . . the advantages you get as a franchised dealer in the Lafayette Radio Electronics Associate Store Program. This program enables you to own your own store in America's fastest growing chain of retail electronics centers. You enjoy every benefit of this 44-year-old organization, while you maintain your financial independence through ownership.

If you have a basic knowledge of radio, TV or electronics, you owe it to yourself to investigate the Lafayette Associate Store Program.

This Is What We Offer You:

1. **Business Stability** — Lafayette has been in business 44 years. You'll cash in on this established reputation.
2. **Product Diversification** — You can sell everything Lafayette offers . . . hi-fi stereo, citizens band, tape recorders, radios, tools, and much more. You'll attract more customers than you ever thought possible.
3. **Advertising Support** — Year 'round advertising, publicity, public relations and promotional campaigns have established Lafayette and its franchised dealers as America's Hi-Fi and Electronics Centers.
4. **Protected Territory** — Yours will be the only franchised Lafayette Radio Electronics Associate Store in your marketing area.
5. **Marketing Guidance** — We'll help you set up a complete operation to build a successful future, and maintain it. We will always be available to help you in any way possible.

We are looking for a limited number of men who want to become a part of the Lafayette Associate Store Program . . . men who are willing to invest \$10,000 to \$30,000 to make a new business career for themselves.

Mail the coupon for complete information without obligation.

Lafayette Radio Electronics Corporation
Dept. ASPFD-5
111 Jericho Turnpike
Syosset, L. I., N. Y. 11791

Mr. Robert Laub:
Please send me full information on how I can own my own profitable business. I understand there is no obligation.

Name

Address

City State Zip

Second and Third Stages

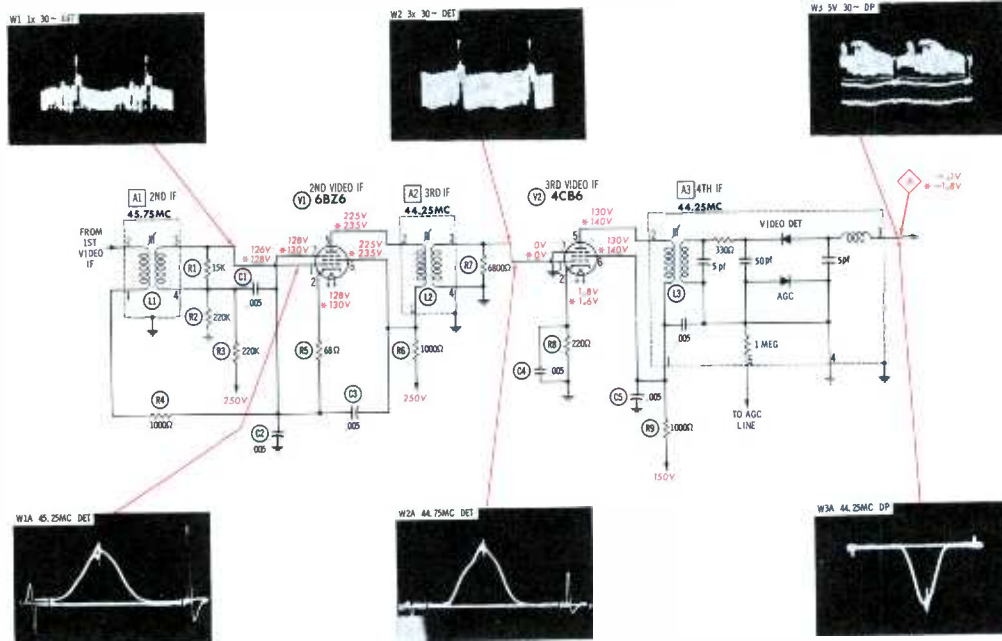

DC VOLTAGES taken with VTVM, on inactive channel; antenna terminals shorted. *Indicates voltages taken with signal present — see "Operating Variations."

WAVEFORMS taken with wideband scope; TV controls set for normal picture on CRT. DET (detector) and LC (low-capacitance) probes used where indicated.

Normal Operation

Stagger-tuned IF strip shown here (from Airline Model 2485) uses single-tuned transformers in all stages. Some receivers use overcoupled (double-tuned) transformer in final stage. First IF coil (not shown) is peaked to 43.25 mc, second to 45.75 mc, third to 44.25 mc, and final to 44.25 mc. Thus, low side of curve is peaked by first stage, high side by second stage, and center by third and final stage; result is flat overall response more than 3 mc wide at 50% points. First and second stages are in stacked B+ arrangement; plate current of second IF tube also flows through first. Stacked-stage operation was covered in October 1963 SYMFACT. Otherwise, circuit operation is similar to any video IF's. All response curves were taken with VHF oscillator disabled and sweep generator (set to center frequency of 44 mc) connected to mixer-grid test point in tuner. Marker was obtained from external signal generator, using marker adder. Sweep generator output was kept as low as possible and external bias was connected to AGC line to prevent overloading of IF stages; scope vertical gain was set to obtain workable response amplitude. Scope horizontal input was connected to horizontal output of sweep generator. Detector probe was used to obtain all waveforms except those at point A. Designation 3x indicates W2 is three times amplitude of W1. All waveforms within IF strip are shown positive in polarity because detector probe used detects only positive swing of RF signal. High-gain scope is necessary to view low-amplitude signals in IF.

Operating Variations

- PIN 1 V1** DC voltage increases slightly with signal present. Primary concern is difference in potential between grid and cathode — normally -2 volts, more negative on strong station.
- PIN 5, 6 V1** Plate and screen voltages increase when station signal is tuned, as conduction of tube is reduced. Nominal reading with signal is 235 volts, but may increase to 245 with extremely strong signal fed to antenna terminals.
- PIN 2 V2** Cathode voltage of V2 determines bias on stage as grid is virtually at DC ground — only resistance is less than 1 ohm in secondary winding of L2. Voltage is less with signal.
- PIN 5, 6 V2** Plate and screen voltages of V2 follow same pattern as those of V1. Tube current decreases with signal; therefore, voltages increase—normal reading with signal is 140 volts, but may increase to 145 with strong local station.
- WAVEFORMS** Amplitudes of W1, W2, and W3 are dependent on strength of incoming signal and thus AGC voltage. Amplitudes of W1A, W2A, and W3A are determined by generator output level and value of external bias applied to AGC line. Normal amplitude of W3 is 5 volts, but may range from 3 to 7.

Picture Weak

Reduced Sound

SYMPTOM 1

R5 Increased in Value

(Cathode Resistor — 68 ohms)

Symptom Analysis

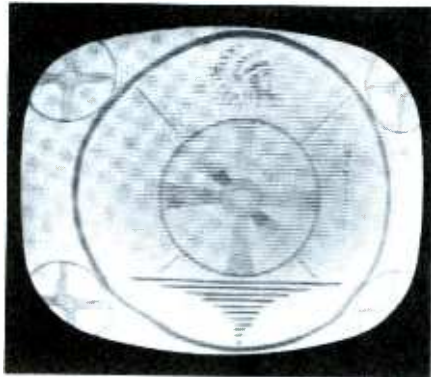

Contrast control is operative but picture has weak or washed-out appearance even at maximum setting of control. Sound may be acceptable but requires nearly maximum setting of volume control. No snow is seen in picture; therefore trouble in IF stages is suspected.

Waveform Analysis

Video-detector output (W3) is greatly reduced in amplitude — only .2 volt p-p, normal is 5 volt. Trouble is further isolated by below-normal amplitude of signal at grid of V2; only minute vertical sync pulse can be seen. Grid signal of V1 is slightly reduced in amplitude, but not nearly so much as W2, thus indicating trouble is probably in second IF stage. Scope won't pinpoint faulty component, but notice how quickly it isolates stage.

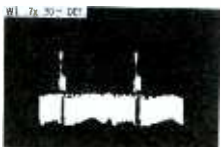
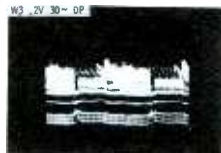

Voltage and Component Analysis

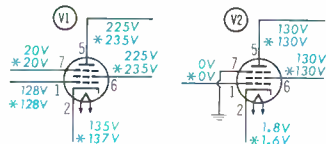

Voltage readings on V2 aren't unusual; however, close evaluation does offer slight clue in localizing defect. Plate and screen remain same, with or without signal; indicates signal isn't reaching grid, and trouble is in previous stage. Pin 7 of V1 has most unusual reading — only 20 volts. This is definite indication that R5 has increased in value. Trouble can be found with voltage measurements alone; but time can usually be saved by isolating stage with scope, then using voltage or resistance checks to locate component.

Best Bet: Scope followed by meter checks.

Video Weak

Fringe Channels Missing

SYMPTOM 2

R2 Decreased in Value

(Grid Resistor — 220K)

Symptom Analysis

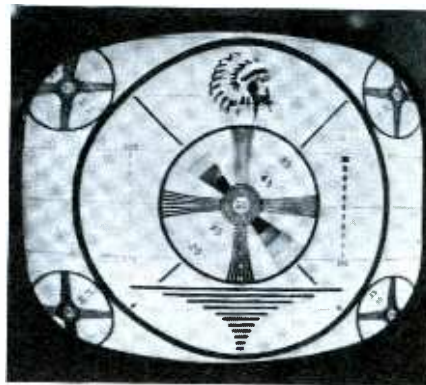

Strong stations produce weak and washed-out picture. Fringe channels are completely missing, both picture and sound. Rotating AGC control proves of no value — doesn't change indication. Contrast control is operative, indicating video output is probably okay.

Waveform Analysis

Trouble may be isolated to IF stages either with scope and station signal or with scope and sweep generator. In either instance, significant indication is reduced amplitude of signal at output of video detector (point A). Grid of V2 (W2) shows same loss of amplitude as preceding stages. Above-normal amplitude and abnormal shape of W1 is explained by fact that AGC voltage is reduced or missing at grid of first IF causing excessive amplification.

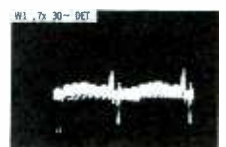

Voltage and Component Analysis

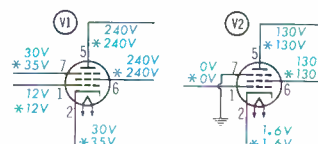

Voltage measurements on V2 give same indication as in Symptom 1 — means signal is greatly reduced or missing at grid. Significant clue is only 12-volt reading on pin 1 of V1. Voltage divider R2 and R3 should place about 125 volts on grid; either increase in value of R3 or decrease in R2 is likely cause of reduced voltage. Resistance checks from grid to ground will isolate R2. Voltages on pin 2 and pin 7 are also reduced considerably but are result of low grid voltage and don't actually contribute to loss of amplification.

Best Bet: Scope — then usual VTVM tests.

Video Weak, Smeared

Buzz in Sound — Sync Critical

SYMPTOM 3

Open Connection, Pin 2 of L2

(Third Video-IF Transformer)

Symptom Analysis

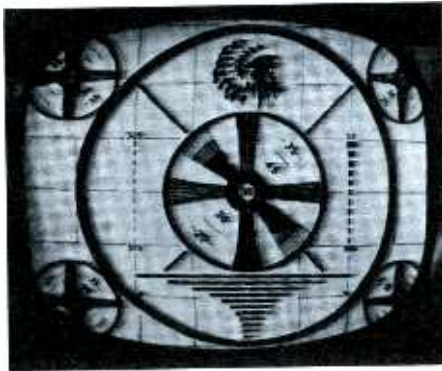

Video is extremely weak and badly smeared; sound level is reduced and is accompanied by annoying buzz. Picture intermittently loses sync, both vertical and horizontal. Symptom gives indications that misalignment may be responsible, so trouble is most likely in IF stages.

Waveform Analysis

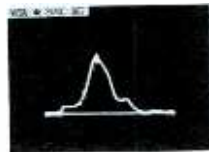
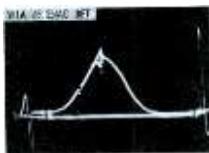

When alignment faults are suspected, it is good idea to check overall response. W3A shows response curve is abnormal in shape and center of curve is now at 46 mc. Adjusting A3 alters response but normal curve can't be obtained. A quick check of W1A indicates tuner and first IF stage are okay — response curve is normal. W2A is of low amplitude, shape is distorted, and marker is at 46.25 mc. Good clue is that A2 has virtually no effect.

Voltage and Component Analysis

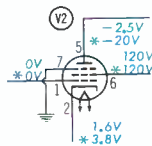

Trouble can be found with VTVM but requires circuit analysis and close examination of DV voltages. Indications, with or without signal, are low conduction — proven by increased reading on plate and screen and decreased voltage on cathode. Of utmost importance is $-.2$ volt on grid, with signal present—should be zero, as DC resistance from grid to ground is normally less than 1 ohm. Negative voltage gives clue that secondary of L2 may be open; resistance checks from grid to ground prove this is true—meter reads 6800 ohms,

Best Bet: Alignment check; then resistance measurements.

Picture and Sound Missing

No Snow in Raster

L3 Primary Open

(Final IF Transformer)

SYMPTOM 4

Symptom Analysis

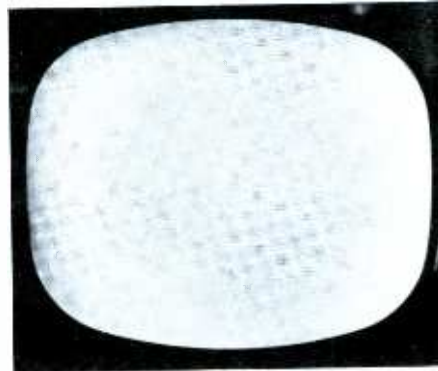

Picture and sound are completely missing on all channels. No snow can be seen in raster; symptom indicates trouble in either mixer/oscillator or video-IF stages. Contrast or AGC control have absolutely no effect. First step is to ascertain if trouble is in tuner.

Waveform Analysis

Input to second IF stage (W1) has normal content; proves tuner and first IF stage are normal (increased amplitude is due to loss of AGC voltage). W2 indicates defect is further along — it has normal content and amplitude is in correct proportion to W1. Video detector output (W3) and plate signal of V2 (not shown) prove signal isn't reaching these points. Scope won't pinpoint component, but rapidly isolates trouble to third video-IF stage.

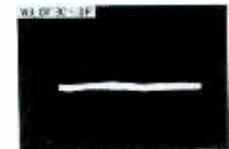

Voltage and Component Analysis

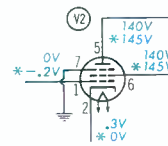

Considering information gained from scope analysis, voltage checks on V2 should reveal source of trouble. Most unusual reading is negative voltage on plate — minus 20 volts with signal, 2.5 without. With screen voltage near normal, primary of L3 has to be open. Negative plate voltage is usually sign of open circuit between plate and B+ source. Resistance measurements from plate to B+ will confirm L3 is open. When this trouble occurs, good idea is to replace tube or at least check to make sure it hasn't been shorting.

Best Bet: Scope to localize — VTVM to pinpoint.

Picture Weak or Missing

SYMPTOM 5

Horizontal Sync Critical;
Audio Weak

R8 Open

(Cathode Resistor — 220 ohms)

Symptom Analysis

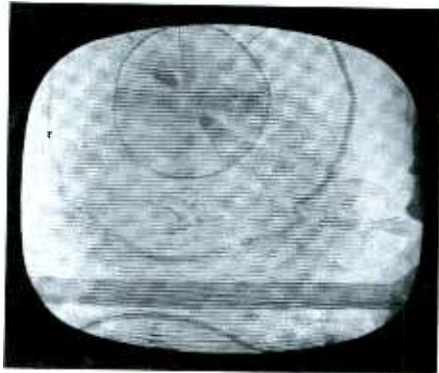

Strong local stations produce weak, washed-out picture; horizontal sync is touchy; audio is weak, accompanied by slight buzz. Fringe channels are missing, both picture and sound. Contrast control seems operative; AGC control has no effect. Trouble is probably in IF or tuner.

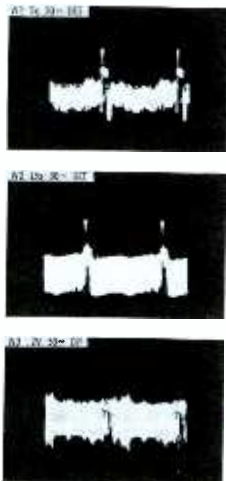

Waveform Analysis

W1 again proves trouble isn't in tuner or first IF stage, content is normal and amplitude is increased because AGC section receives false indication, as if antenna signal level were reduced. W2 at third IF grid further isolates trouble, as it too is okay. Low .2 volt p-p in W3 proves trouble is in final IF stage. Plate of V2 (not shown) contains only small amount of video—thus narrowing search to components associated directly with V2.

Voltage and Component Analysis

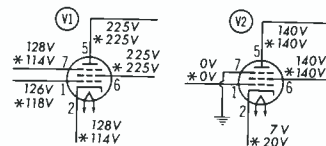

With signal, voltages on V1 aren't exactly right; negative 2-volt potential between grid and cathode is changed to positive 4 volts, causing tube to amplify more than normal. Best voltage clue is at cathode of V2 — it measures 20 volts with signal, 7 volts without. With cathode resistor open, inserting VTVM between cathode and ground causes slight cathode current to flow through meter — accounting for positive potential. Increase in value of R8 would cause similar symptom, but picture wouldn't be so weak, nor sync so critical.

Best Bet: Scope followed by voltage readings.

Ghosts in Picture

Slight Buzz in Sound

L2 and L3 Misaligned

(3rd and 4th IF Transformers)

SYMPTOM 6

Symptom Analysis

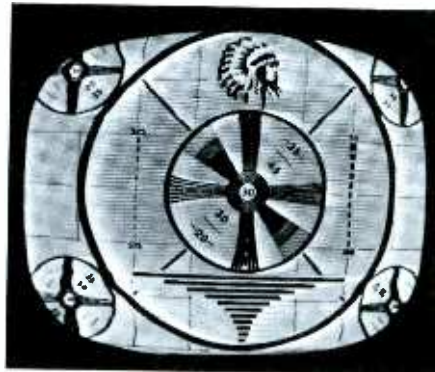

Strong stations produce multiple ghosts in picture; weaker channels give weak, washed-out appearance. Fine tuning is extremely critical; adjusting it causes images to move across the screen (commonly called *tunable ghosts*). Symptom is indicative of improper alignment.

Waveform Analysis

Overall response (W3A) is sharper than normal; of equal importance, center of curve is now at 45 mc—normal is 44.25 mc. Valuable assistance in locating trouble is gained from W1A: it is normal—misalignment must be in third and/or final IF. W2A appears to be near normal; however, amplitude is increased and marker is at 45 mc. Increase in amplitude isn't readily evident; however, shape and marker position are of extreme significance.

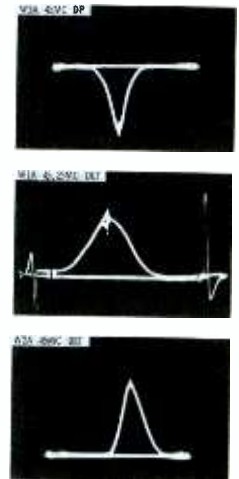

V1
NORMAL

V2
NORMAL

Voltage and Component Analysis

Improper alignment can't usually be detected with either voltage or resistance checks. However, VTVM can be useful at point A, when individual coil frequencies are known, for prepeaking IF coils. This is done by setting marker generator to frequency of individual stage and adjusting respective coil for maximum indication on meter. It is usually necessary to re-touch coils using scope for best overall sweep response, but meter can be used for initial adjustments to pre-peak coils if frequency is known.

Best Bet: Alignment equipment is necessary.



Stop banging your head against the “electronic iron curtain!”

There's an “electronic iron curtain” that stands between you and new customers. What is it? It's the manufacturer who sells to national mail order electronic catalogs.

Want proof? Just flip open any one of these books, turn to the antenna pages, and glance at the prices.

Makes you feel like banging your head against the wall in sheer helplessness, doesn't it?

These well-advertised catalog consumer prices (and those of the catalog houses' captive discount chain stores) are approximately the same as what you, the dealer, pay. And the advertised prices on rotators and boosters

—picture and receiving tubes, and other TV products—are enough to make you turn blue with frustration, too.

Because when your customer compares these catalog prices with your prices, you're lucky if you even get a chance to make the sale; much less the honest profit to which you're entitled.

What does a guy like you do then, to break down this “electronic iron curtain” that separates you from customers?

One thing you *don't* do is throw in the sponge and say to yourself, “Go fight City Hall!”

No, indeed! You fight back. How?

Sell the products of those

manufacturers who support you. Get behind Channel Master—a manufacturer who's behind you all the way. As a matter of policy, Channel Master does not sell to any outlet that by-passes the dealer and advertises to consumers at dealer prices.

This way we protect your business and let you reap a full profit. The highest in the industry, too. A good living is the very least we feel we owe the dealer who sells our products.

So stop banging your head against that wall. Are you with us? Do something!

CHANNEL MASTER
ELLENVILLE, N. Y.

Circle 11 on literature card

AGC

servicing
magic

A choice selection of
techniques that make
locating these defects easier.

by Carl Babcock

Magic is something we don't regard too highly, except as entertainment, in this enlightened age. There is, however, a simple formula that works almost as if it were magic to change those AGC "tough dogs" into good old American folding money. The only items necessary are a VTVM and a chart made from this "magic" formula. Does that sound impossible or too optimistic? Better give it a good try before you decide. The magic method tells you only which *stage* is at fault—not necessarily the exact part—but, finding the stage is usually the hardest part, anyway, with AGC faults. How many times have you mentally kicked yourself for wasting time working in the wrong circuit? Those of you who are impatient may want to turn right to the chart; however, so you can make allowances for circuits that are slightly different, we suggest you read the information which follows.

Fig. 1 shows the partial block diagram of a typical TV receiver. The main function of the tuner, IF's, and AGC is to deliver an undistorted video signal of constant amplitude from the video detector. This is amplified and used for sound, sync, and picture information. This output signal may be the most important one in the entire set, but its DC component seems to be sadly

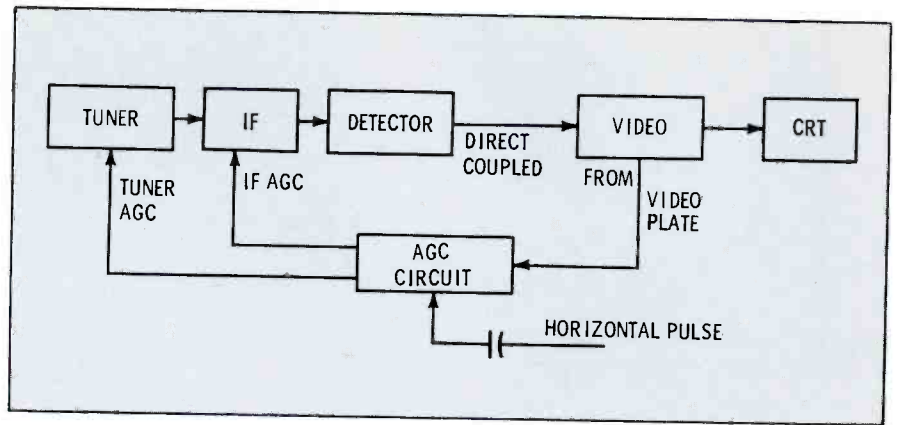

Fig. 1. Block diagram of typical AGC system from television set.

neglected during most AGC troubleshooting. If the detector voltage falls too low, the AGC reduces bias on the RF and IF stages in compensation. If the detector voltage rises, the AGC acts to decrease it by increasing RF and IF bias voltages. Sounds very simple and foolproof. Why is it, then, that we have such puzzlers as these—?

1. A negative voltage at the IF AGC pickoff point, even when the AGC keyer tube is removed from the socket?
2. Normal snow on a very weak signal, none on a strong signal, but lots of it on a moderate signal.
3. An acceptable picture on a weak signal with *either* RF or IF AGC, but *overload or snow* on a strong signal.

Two AGC Functions

Our understanding of the basic AGC function also may be confused, because the RF stage requires

a nonlinear AGC voltage. For the highest signal-to-noise ratio (least snow) on weak signals, the RF AGC voltage should be very low; but, for strong signals, it should be higher than that applied to the IF stages, in order to prevent overload of the mixer. This means there must be two separate AGC distribution circuits; one for the RF's and one for the IF's.

Now, let's review AGC theory. Fig. 2 is the AGC circuit of an imaginary modern receiver. Briefly, here is how it works: The output of detector X2 has negative-going video and a negative DC voltage which is directly coupled to the grid of the video amplifier. When the grid of V1 goes more negative, the plate becomes more positive. Its signal is coupled, through an isolation resistor, to the grid of AGC keyer V2. The cathode of V2 is clamped at the level of the low B+ so that, when the grid becomes more positive, the bias is reduced

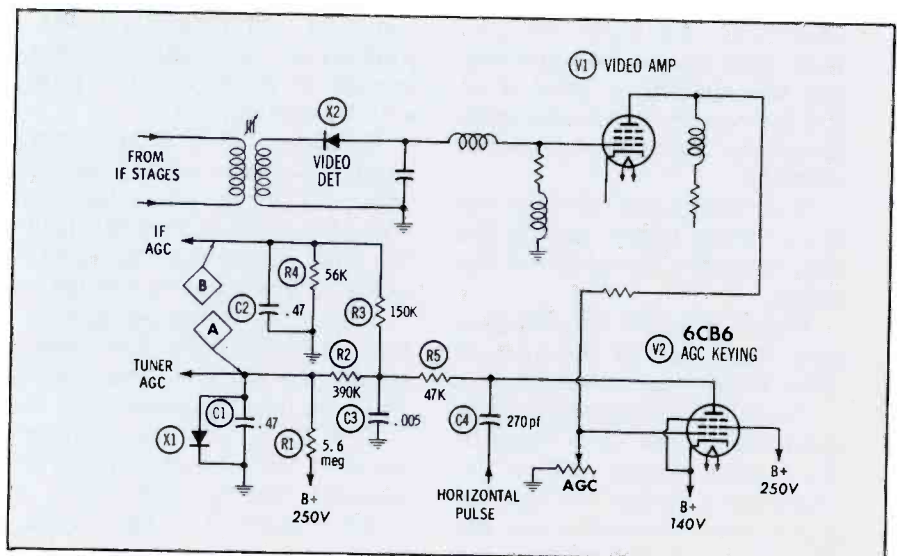

Fig. 2. The way AGC works can be seen by examining this schematic diagram which shows a portion of the circuit of a hypothetical modern television receiver.

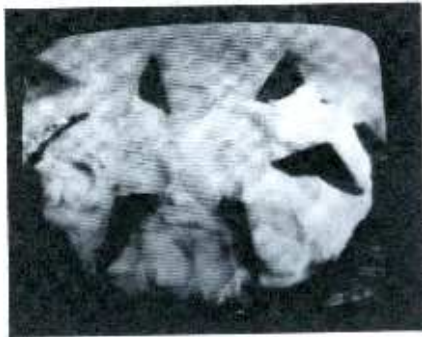

Fig. 3. Shot of cream-dessert commercial shows normal-contrast picture.

and the tube conducts more heavily during each horizontal-sync pulse. Thus, the keyer tube acts as a grid-controlled rectifier to produce a negative voltage that increases with an increase in the detector voltage. The advantage here is that a -2 -volt signal at the detector results in approximately a -30 -volt signal at the keyer plate. The AGC voltage which appears at the plate of V2 is filtered and applied to both the RF and the IF stages.

The nonlinear AGC voltage required for the RF's is developed by adding the negative AGC voltage (through R2) to a fixed positive power-supply voltage (through R1). Thus, we would expect the RF AGC to be positive on weak signals and negative on strong ones. This would be true without the clamping action of X1. The diode clamps whenever the voltage at point A goes positive; therefore, the voltage stays either zero or negative. (Some late-model sets depend on diode action of the RF-tube grid to keep this voltage from swinging positive.) The RF AGC voltage is zero until the negative voltage from the plate of V2 rises higher than the applied B+; then, beyond that point, the AGC voltage at point A rises more rapidly than does the IF AGC voltage at point B.

The full AGC voltage is excessive for application to the IF's so a



Fig. 4. Set in normal operation in a strong overloaded-signal location.

simple voltage divider (R3 and R4) reduces it to the proper amount. The RF AGC and the IF AGC both reduce receiver gain until the detector DC voltage is correct. Now we have gone full circle from detector back to detector. Not only must the AGC keep the detector voltage constant, but it must tailor the ratio of RF-to-IF AGC voltages to prevent the highly diverse problems of snow and overload.

Troubleshooting AGC

The troubleshooting tips given in Table 1 are derived from the basic functions of the AGC systems and from the following additional precepts:

1. Removal of the last IF tube should give zero video-detector voltage, and also should give zero tuner and IF AGC (unless the signal is strong enough to cause grid rectification of the first IF tube). So, we can say

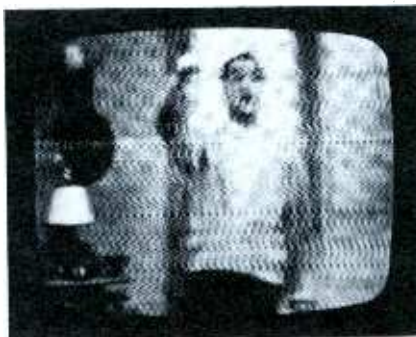

Fig. 5. Set with an AGC problem in a normal-signal location overloads.

- that all three voltages low means loss of gain.
2. Removal of the video tube would cause excessive AGC voltages and zero detector voltage—usually a blank raster as well.
3. Too great a reduction of either or both AGC voltages can cause overload.
4. No AGC at all may cause a blank raster by producing so much detector voltage that the video tube is biased to cutoff, thus showing symptoms similar to those of No. 2.

Twelve of the most-likely-to-occur problems were selected for Table 1. There are columns for visual symptoms from face of the CRT, both AGC voltages, and detector voltage; the last column shows the location of the defect and makes a guess as to the bad part.

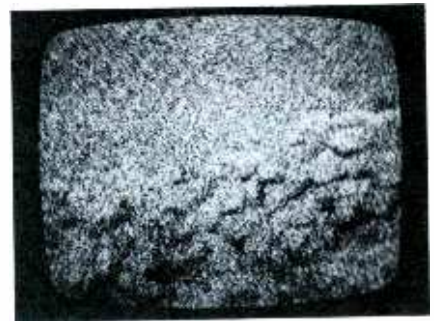

Fig. 6. With RF stage dead, tuner AGC measures zero, snow is very bad.

The important thing about these voltages is NOT their exact value, but their relative value compared to normal AGC-circuit voltages. It may seem that the list merely substitutes one mass of confusion for another, but, with only a little practice, you can use it to be certain of your diagnosis. Symptom No. 3 is a common one when an outdoor antenna is used with high-gain sets of today. Do not try to modify the circuit to eliminate the overload; use a loss pad between the antenna and the tuner instead. After you have checked the chart, examine these examples of actual case histories solved through its use:

1. Color receiver with weak contrast and little sync. Detector voltage very high and RF and IF AGC voltages both low. Trouble: Open video amplifier plate-load resistor.
2. Old b-w receiver with blank white raster and no sound. Detector voltage zero, RF and IF AGC voltages very high. Trouble: Open resistor causing AGC-keyer cathode voltage to be greatly reduced.
3. New b-w receiver with weak gain on distance and overload on strong local channel. RF, IF, and detector voltages low. Had a little snow off channel. Diagnosis: IF or mixer low in gain. Trouble: Mixer-injection volt-

• Please turn to page 78



Fig. 7. With reversed AGC diode, the sync is lost, set overloads heavily.

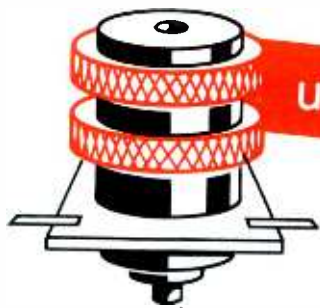

unwinding the mystery of

COILS

Facts you need to know about inductance

by Rufus P. Turner

The newcomer to electronics learns early that a magnetic field, consisting of lines of force, surrounds any current-carrying wire (Fig. 1A). He learns also that this field, collectively called *magnetic flux*, becomes stronger when this wire is wound into a coil (Fig. 1B), and that it becomes strongest when an iron core is inserted into the coil (Fig. 1C).

Later, he makes these further observations: (a) When direct current flows through the coil, the field expands out from the coil when the current starts, remains stationary about the coil as long as the current is constant, and collapses back into the coil and disappears when the current stops; and (b) when alternating current flows through the coil, the field alternately expands and collapses, reaching maximum and zero levels in step with the AC cycle.

These apparently simple effects of electromagnetism are basic phenomena in electricity and electronics. They lead directly to the properties of *induction* and *inductance*, which underlie the action of the coil (or inductor), one of the three basic components of electronic circuits.

Properties of Coils

Induction is the ability of a current-carrying coil to induce a voltage in a nearby coil although there is no physical connection between the two. The only requirement is that the coils be coupled; that is, they must be physically located close enough together that the field, sur-

rounding the current-carrying (primary) coil, passes through the turns of the other (secondary) coil. When the field from the primary coil expands, the voltage induced in the secondary has one polarity; as the field collapses, the voltage reverses polarity.

There can be no induction unless the current, and consequently the magnetic flux, is changing. For this reason, induction is commonly associated with alternating or pulsating current. (With smooth DC, induction occurs only the instant current is switched on or off and ceases when current flow is steady.)

The action just described is called *mutual induction* because it exists between two coils. Mutual induction is the heart of transformer action. A second variety, *self-induction*, is the property of a single coil. Self-induction occurs in the following manner: When current starts to flow through one turn of a coil because of an applied voltage, the expanding field cuts through the adjacent turns; the cumulative effect induces a voltage across the coil the same as in a separate coil. However, the polarity of this induced voltage is opposite to that of the applied voltage—therefore they tend to oppose each other. For this reason, the induced voltage is called *counter emf*. (electromotive force). Self-induction is the heart of single coil operation.

For a given applied voltage, the strength of the counter emf depends upon physical dimensions and characteristics of the coil, but especially

upon the number of turns—the more turns, the greater the counter emf, providing other factors are equal. The electrical property of a coil, which takes into consideration dimensions and wire characteristics, is *inductance L*. (L is measured in henrys, millihenrys, and microhenrys.) The inductance of a straight wire is quite small; of a single-layer coil, much higher; of a multilayer coil, still higher; and of a multilayer coil with iron core, highest of all.

Since the counter emf tends to oppose current flow, a short, specific interval passes—after voltage is applied—before the current flowing through a coil reaches its maximum value. A more technical way of saying this is: The voltage across the coil leads the current by 90°; or, current lags the voltage by 90°. Fig. 2 illustrates these phase (current-vs-voltage) relationships for a perfect coil. As the flux expands about the coil, energy is stored in the magnetic field; as the flux collapses into the coil, energy is returned to the circuit in which the coil is connected. Thus, no energy would be expended in operating an ideal coil. However, the wire in the coil has some resistance, and resistance consumes power. Therefore, a coil can't be perfect and the actual phase angle is something less than 90°.

From the foregoing discussion, it should be clear that because of self-induction, a coil opposes the flow of alternating current and introduces a phase shift. It is this opposition, called *inductive reactance*, (X_L), which makes the coil invaluable in electronics. Inductive reactance is expressed in ohms and varies directly with inductance (L) and frequency (f). The higher the frequency the higher the counter emf. Numerically stated, $X_L = 2\pi fL$; X_L is in ohms, f in cycles per second, and L in henrys.

Types of Coils

The principal types of RF and IF

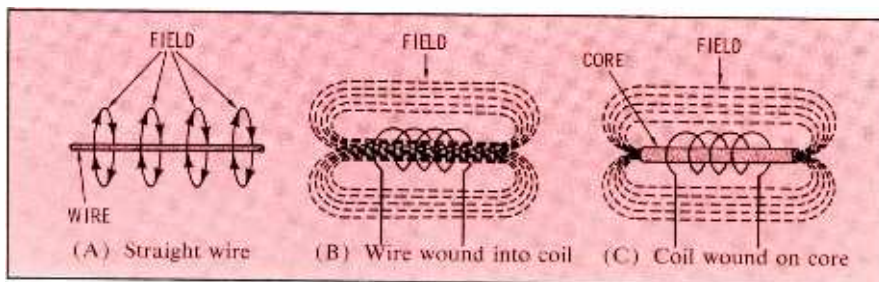

Fig. 1. Strength of magnetic field varies with different types of coils.

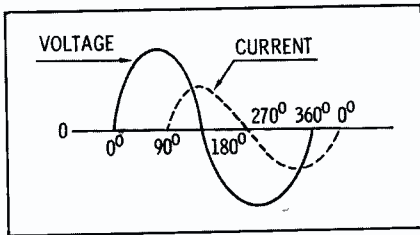

Fig. 2. Voltage leads current by 90°.

coils in present use are shown in Fig. 3. The simplest type (Fig. 3A) consists of a few turns of stiff wire wound into a spiral. Because of its form, this type is called "airwound" or "self-supporting." For mechanical rigidity, it is limited to few turns of reasonably small diameter. Single-layer airwound coils are commonly found in the tuned circuits above 10 mc.

When the number of turns and the ratio of coil diameter to wire diameter are large, the coil must be wound on a supporting core (or form) of insulating material—usually a cylinder, rod, or bobbin. Figs. 3B, 3C, and 3D show these types. In Fig. 3B, turns of insulated wire are wound tightly side by side in a single layer on a cylindrical form. In Fig. 3C, the turns are evenly spaced in a single layer on a cylindrical form. In order to obtain high inductance, many turns are close-wound in several layers on a spool or bobbin as shown in Fig. 3D. Similarly, in Fig. 3E many turns are wound in layers but are crisscrossed in each layer instead of being wound side by side. The anchoring effect of this crisscross (universal) winding holds the coil together, after cementing, without bobbin flanges. A dowel or small-diameter tube may be used for basic support, as shown in Fig. 3E. This type of coil is often supplied without any such form, having been slipped off the original winding core after cementing.

These types (covering an inductance range of .1 microhenry to 750 millihenrys) are found in RF and IF stages as tuned-circuit inductors, RF chokes, antenna coupling inductors, loading coils, interference-filtering inductors, and wavetrap inductors. The inductance may be increased by inserting iron or ferrite core into the coil. This core is arranged so it will move in and out of the coil, by means of screw action, thus allowing the inductance to be varied smoothly. A core of nonferrous metal, such as copper or brass,

will reduce inductance. Coils used at audio frequencies require high inductance (1 to 5000 henrys). They need many turns in a number of layers, either on a soft iron core or on one of the special magnetic alloys. Such coils are normally used in power-supply filters, wave filters, audio couplers, dividing networks, audio phase shifters, audio chokes, tone controls, or time-delay circuits.

Coil Quality Factors

Like other components, a coil can be good, mediocre, or bad. Some coils are good in one application and yet unsatisfactory in another. **Storage Factor**—The primary requirement of a coil is that it provide reactance (a function of its inductance at the operating frequency). Although it is undesirable, a coil does display a certain amount of inherent resistance. A useful figure of merit (Q) therefore is the ratio of this desired reactance (X_L) to the undesired resistance (R): $Q = X_L/R$. Since X_L contains a frequency term ($X_L = 2\pi fL$), a coil may have a high Q at one frequency but not so high at another. Therefore, coils for a given application should be checked for storage factor (Q) at their normal operating frequency. Resistance here means AC resistance (not reactance) and not the simple DC resistance (R_{dc}) which can be measured with an ohmmeter; however, at low audio frequencies, the AC resistance may be equal to R_{dc} . The AC resistance is the total of all in-phase resistance components and is due to DC resistance of the wire, skin effect, losses in the insulation

of the wire and in the supporting core, and losses in a shield or chassis. Since it is usually impossible to measure this R value directly with any simple instrument, Q is best determined with a Q meter.

Coil Resistance—The DC resistance of a coil, aside from the AC resistance discussed above, must be considered in many applications—especially in audio design where coils are large; audio coils contain several hundred feet of wire and are likely to have significant DC resistance. This resistance should be as low as possible, preferably less than .01% of the reactance, and may be measured approximately (but closely enough for most practical purposes) with an ohmmeter. A more accurate measurement can be made with a DC resistance bridge.

Distributed Capacitance—Adjacent turns of a coil also act like the two plates of a simple capacitor. Thus, a phantom capacitor is present between turns of a simple coil and between adjacent layers of a multilayer coil. Such capacitance effects are termed *distributed capacitance*, and must be as low as possible in a good coil. Since it acts in parallel with the inductance of the coil, it creates a self-resonant frequency, which in many applications will make the coil useless. To minimize distributed capacitance, the turns of a single-layer coil are separated (Fig. 3C), and those of a multilayer coil are crisscrossed (Fig. 3E) to minimize their adjacency.

Skin Effect — At high frequencies current tends to concentrate near

• Please turn to page 18

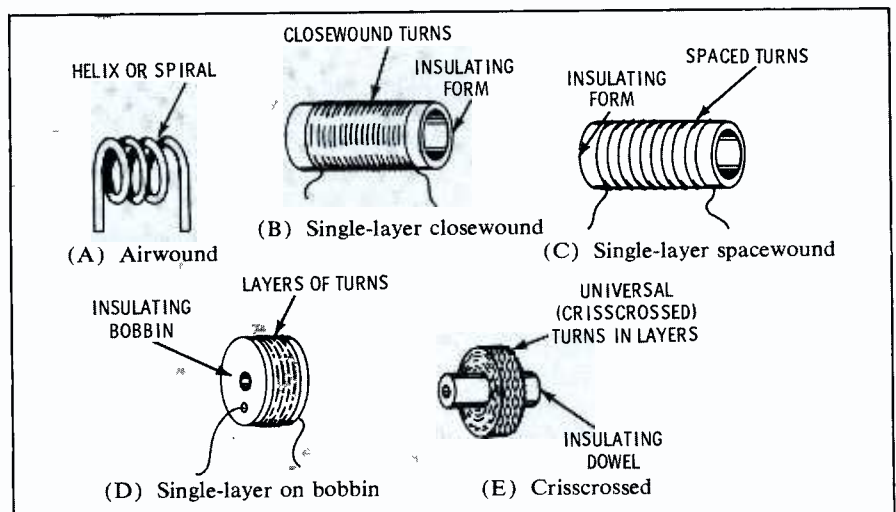

Fig. 3. Depending on application, coils are wound in several configurations.



Advanced Techniques

In the March issue, our annual Test Equipment Special Issue, the article "Learning About Triggered-Sweep Scopes" introduced you to a scope more sophisticated than any you've probably used before. That article, this one, and several to come in future issues are the beginning of a program that will greatly advance your ability as a service technician. Your survival in business may depend on how well your service techniques keep up with the expanding electronics technology.

Your need to learn advanced servicing methods doesn't stem from any lack of home-entertainment equipment. Indeed, there are more types and more sets than ever. Rather—the need arises because of rapid developments in every phase of electronics. Not only are new devices being built and sold to your customers, but the old standby's—radio, TV, hi-fi—are taking on a new appearance inside.

Modular construction has already begun. Printed component units have been around for years, and sealed, encapsulated blocks containing several ordinary components are in regular use. In sets of the future, groups of components "grown" on a single substrate layer will take the place of present-day component packages. Complex little passive networks of all sorts will be combined into small, simple-looking modules with two, three, or four terminals—or even more.

How do you service a set that's full of these little blocks of parts identified only by a number? Deciding what's in the module may be tough, but diagnosing a fault in one is likely to be even worse.

Such unorthodox testing requirements necessitate analytical procedures quite different from the single-component tests you're familiar with. We've found that the one type of testing which is most suitable for analyzing multipart component modules employs *square-wave ringing tests*.

To comprehend the advanced servicing technique of square-wave testing, you need first to know the structure of the square wave itself—its characteristics and peculiarities—and how it is affected by resistance, capacitance, and inductance. You'll need also to understand the wideband triggered scope that will be the instru-



FOR FUTURE SERVICING

by Forest H. Belt

ment of analysis. Finally, you'll want to learn the basic steps toward setting up for quick square-wave analysis.

This article will describe the square wave in detail. Along with some early comments on triggered scopes, there'll be some later information on displaying the square wave to best advantage on the scope. Study carefully this article and the "Triggered-Sweep Scopes" article in the March issue. Both will form the basis for your understanding of several subsequent articles on this new system of component and circuit testing.

A Word on Scopes

Don't let the thought of a triggered-sweep scope scare you. Once you learn all it can do, you'll probably want one for ordinary servicing. The quality and stability of the display you see on a wideband triggered scope may spoil you for an ordinary service-type scope.

Fig. 1 presents a comparison of television horizontal and vertical sync pulses displayed on: Fig. 1A—an ordinary service scope; Fig. 1B—a wideband, high quality service scope; Fig. 1C—a "low"-cost triggered-sweep scope; and Fig. 1D—a lab-type, wideband (DC to 30 mc) triggered-sweep scope. It is easy to see the difference in waveform fidelity; not portrayed in the pictures is the increased stability of the latter two displays.



(A) Ordinary service type



(B) Wideband service type

Fig. 1. Video waveforms taken with scopes of differing bandwidth styles.

The cost of a triggered-sweep instrument may leave you a little awed. A lab-type model for servicing use can cost from \$500 to \$1600. Less expensive types can cost as little as \$200 in kit form—actually not as much as higher-priced service-type scopes.

For careful analysis of square waves, in the manner we'll be discussing in subsequent articles, you'll want a triggered scope with bandwidth capability from DC to 30 mc.

Fundamental Precepts

There'll be two forms of troubleshooting you'll use with sets incorporating integrated microcircuits (modules).

Localizing or isolating a fault to a particular stage can be accomplished by conventional signal-tracing or injection procedures. Little will it matter what's in a module; you'll know what its function is and treat it accordingly. You'll expect an amplifier to increase the signal amplitude or power from input to output; an oscillator to produce a waveform of certain shape and frequency; a frequency divider to accept signals of one frequency and produce those of some submultiple; and so on.

Pinpointing trouble within a stage module will be complex, if not impossible; but it's also unnecessary in most cases. If any portion of the microcircuit is faulty, the entire module will have to be replaced anyway. Thus, pinpointing techniques will be helpful primarily in *passive* networks. It will sometimes be necessary to analyze passive microcircuits and other systems rather thoroughly just to discern whether they're working correctly or not. The square-wave analysis techniques you're going to learn will make it easy for you to diagnose faulty component modules in a minimum of time.

As you'll presently see, square-wave analysis isn't limited to the study of passive networks. Anything but! Audio, video, and other amplifying systems can be analyzed very quickly by this method, no matter what the structure or composition of their stages.

Square Waves

In preparation for learning square-wave analysis, you must develop a working knowledge of the square-wave signal itself. Shape is not the only characteristic that stamps the square wave as unique among waveforms.

A square wave is formed of a fundamental sine wave plus an infinite number of its odd-order harmonics. Fig. 2 shows the basic combination of frequencies that form a square wave. Notice that the third harmonic has only one-third the amplitude of the fundamental, that the fifth harmonic bears only one-fifth the amplitude, and so on through all the succeeding odd harmonics. Beyond the ninth harmonic, amplitude is comparatively small; although necessary to the completeness of the waveshape, harmonics beyond the ninth aren't considered especially significant in tests. Thus, the usefulness of a square wave for frequency-response testing extends only to about ten times the fundamental frequency. Even-order harmonics (second, fourth, sixth, etc.) are canceled in square-wave formation, netting zero effect on the waveshape.

Because all the peaks and valleys in a perfectly formed square wave are filled, the effective energy in the wave is equivalent to the peak value: this merely verifies that the *rms* value of a square wave is equal to its peak value (a sine wave is only 70.7% effective—its *rms* value is .707 times its peak amplitude).

Before we examine other characteristics, you should become familiar with some of the terms associated with square waves. The diagram in Fig. 3 will aid you in understanding the significance of various parts of a square wave.

No voltage can rise from zero to its peak value instantaneously; the very short time it takes for the square-wave voltage to reach its peak value is called *rise time*. The shorter the rise time, the more perfect the square wave, and the more vertical the leading edge (rise). In practice, rise time of square waves is stated as the time required for the voltage to rise from 10% to 90% of the measured peak value. Some square waves may rise in milliseconds (msec), good quality ones in microseconds (usec), and high-quality square waves may rise from 10% to 90% in mere nanoseconds (nsec).

The time required for the square-wave voltage to decay—again measured between 90% and 10% — is called the *fall time*. This is the seemingly straight right-hand side (trailing edge) of the waveform.

The flat top portion—called the duration of the square-wave pulse—is a measure of one-half the *period* of the square wave, and is related directly to the fundamental frequency. The period is measured from the start of one rise to the start of the next. The theoretical duration of the flat top is expressed by the relationship $T = \frac{1}{2f}$ where T = time and f = frequency. As we've pointed out, however, rise and fall times consume a tiny portion of the duration of each square wave, so the actual flat top is slightly shorter than the theoretical pulse duration or, stated another way, slightly less than one-half the total period. The rise time is included in considering theoretical duration of the active pulse; fall time is counted as part of the "off" time.

No circuit is perfect, and those in square-wave generators are no exception. As a consequence, there can be certain slight abnormalities in the square wave. Among these are preshoot, overshoot, ringing, rounding, and tilt—all shown (exaggerated) by dashed lines in Fig. 3.

Preshoot is the result of circuit capacitance which receives a small charge the instant the square wave starts, seeming to reduce the "off" level briefly before the rise begins. The

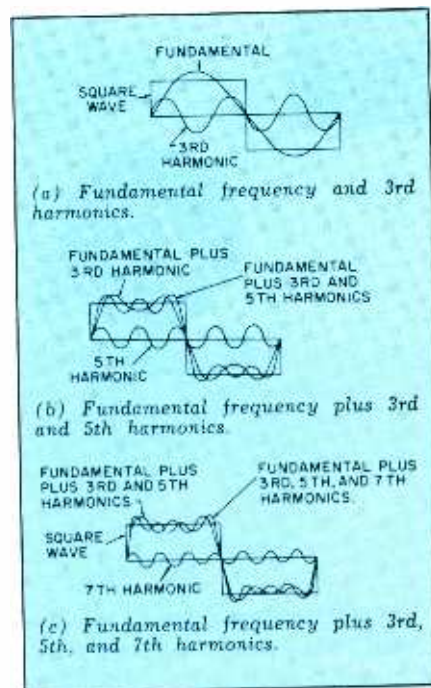

Fig. 2. Square-wave structure, elements.

significant characteristic of preshoot is its amplitude.

Overshoot is the result of normal and stray circuit inductances, which tend to counteract any sudden change—a sort of electronic inertia. Thus, when the rise suddenly ceases, any stray inductance in the circuit tries to keep it rising, and a little pip shoots out beyond the normal flat-top level. As with preshoot, the important factor of overshoot is amplitude.

If inductive effects in the circuit are proportionately significant, the overshoot may not settle back onto the flat-top portion quickly enough: if it doesn't, what results is termed *ringing*. In the matter of significance, the duration of ringing and its natural frequency are more important than its amplitude; until the ringing is damped out, the square wave doesn't have a flat top, and the unwanted, natural ringing frequencies are being added to the otherwise symmetrical odd-harmonic combination that normally forms the square waveform. The shorter (faster) the damping time, the better the square wave.

A slightly different form of flat-top distortion is called *anticipatory ringing*. Whereas ringing is an undamped oscillation triggered by overshoot, anticipatory ringing is the result of a parasitic oscillation which occurs if the flat top is sustained over a period too long for the circuit parameters. Overpeaking at a naturally resonant frequency can cause a stage to generate this form of square-wave distortion.

Rounding is an effect caused by too

• Please turn to page 79



(D) Wideband triggered type



(C) Ordinary triggered type



The waveforms appear progressively better as the scope's quality is improved.



Radar Maintenance is EASY

In the February issue, we discussed *who* needs radar service, *what* radars need service, *when* they must be serviced, *where* service must be performed, and *why* there is a need for competent technicians. You were shown the test equipment and inventory needed to offer this service. In this part, we shall look over typical radar systems and discuss *how* they operate.

Most radar systems in marine use today are basically alike. There are variations in older sets, but we shall expend our efforts toward learning generally how radar systems operate and how to service them.

The System

The block diagram shown in Fig. 1 represents the layout of most modern marine radar systems. The sequence of events taking place in a radar system begins in the timer oscillator, sometimes called the Pulse Repetition Frequency oscillator. The output of the PRF oscillator is amplified and shaped into a triggering pulse, then fed to the modulator tube.

The modulator is our first encounter with a special-purpose type tube. This tube must handle extremely large amounts of power that begin suddenly, last for the duration of the transmitter pulse, and just as abruptly end; therefore, a thyatron is well-suited to the application. Exactly what tube is used varies, depending on the power of the radar transmitter, but common types are: 4C35, KU-99 (3C45), and 4PR60.

The modulator thyatron is fired by the brief trigger pulse, and its

output is developed across a delay line, or pulse line. The length of the pulse is determined by the design of the pulse line, which controls the point at which the thyatron is extinguished. The high-amplitude, carefully timed pulse is applied to the *magnetron*, exciting it into oscillation.

The magnetron is capable of high-power oscillation at the microwave frequencies used in marine radars. It is especially able to start and stop oscillations quickly with timed pulses of the type furnished by the modulator. Magnetrons used in marine radar systems are: 2J42, 2J55, and 725A, all for the frequency range around 9375 mc. In some lake- and ocean-going radars, the 2J70 magnetron is used; its frequency is near 3070 mc. Radar systems operating at a frequency of 9375 mc are called 3-centimeter or X-band radars; those at 3070 mc are 10-centimeter or S-band radars.

The pulses of high-power high-

frequency RF are transferred from the magnetron via a length of waveguide to the radar antenna. The antenna in marine radar systems is called a *scanner*, due to the fact that it rotates continuously, scanning the surface surrounding the ship. The scanner consists essentially of a horn for terminating the waveguide; a section of a parabola which is used as a highly directional reflector, concentrating RF energy from the horn into a narrow beam; a motor for rotating the assembly; and a synchro generator for transmitting directional information to the display unit, or indicator.

During the time (between pulses) when the radar transmitter is not operating, the *duplexer* permits energy to proceed to the receiver. During pulse time, however, the duplexer keeps the receiver input shorted out, so high-power pulses of transmitter RF will not harm the delicate receiver-input crystals. Tubes used as switches in duplexers are

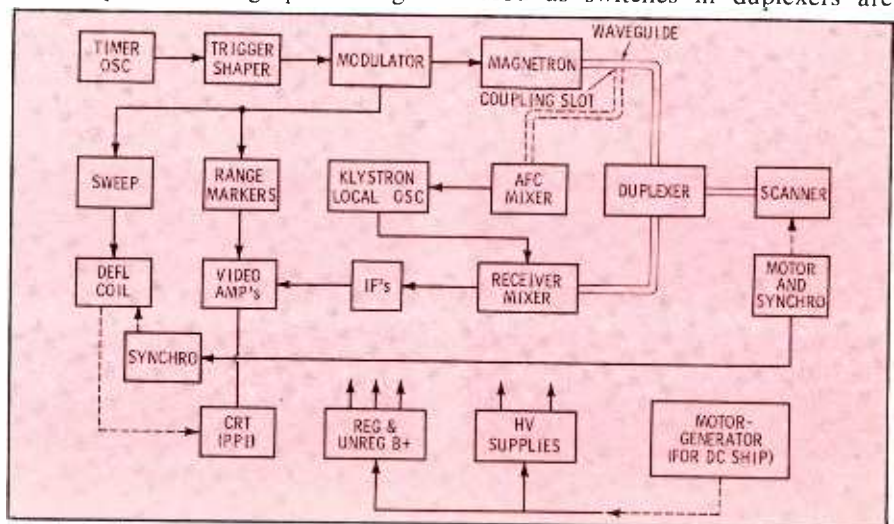

Fig. 1. Rather comprehensive radar system such as used on ships and large yachts.

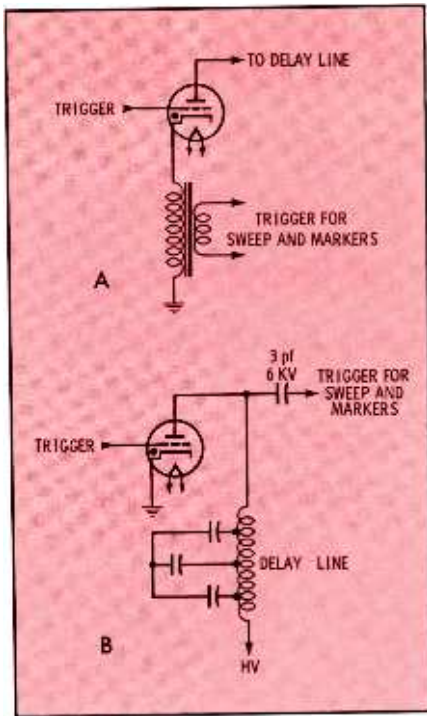

Fig. 2. Taking trigger from modulator.

the 1B24A in X-band equipment, and the 721B (BL696) in S-band sets. These tubes are called TR (transmit-receive) tubes or switches. Duplexers of X-band radars sometimes use a second tube for increasing waveguide efficiency during the time the pulse is off, while the receiver is operating. A 1B35 is used for this purpose, and is called an ATR (anti-TR) tube.

The energy which is picked up by the highly directional antenna and fed to the receiver is echo information caused by reflection of the pulsed RF energy from whatever targets exist in the direction of the beam. This minute energy is picked up by the antenna, carried down the waveguide and mixed in a signal-crystal (usually a 1N23-type) mixer with a local oscillator (LO) signal. The local oscillator is a klystron tuned to a frequency that differs from the magnetron frequency by exactly the IF of the radar system. The 2K25 (723A) is a typical LO in X-band sets, and the RK6043 is common in S-band receivers.

Following the mixer, a system of IF amplifiers amplifies the slight bits of echo or target energy. The IF amplifiers are usually fixed-tuned, wideband amplifiers designed to pass the full range (sometimes up to 10 mc) of video (target) information carried on the IF frequency.

Tubes used for IF amplifiers are usually high-gain, low-noise types

similar to those used in television. A cascode preamplifier is commonly found; this may be a 6AK5-6J6 combination or the popular 6BQ7 cascode stage. For IF amplification, 6AK5's and 6CB6's were customary, but modern high-gain types are becoming common.

A 6AL5 video detector is followed by a wideband video amplifier section, sometimes using 6AU6-6AG7 combinations, sometimes 6AU5's. The most important considerations in this section are bandwidth and gain, and modern tube types make circuitry simpler.

The amplified video still represents the echo or target information reflected back into the radar from some target. This video information is applied to the grid of a cathode-ray tube in a manner to cause the beam to be intensified for the duration of the target information.

The CRT used in marine radar systems is round, and is similar to those used in television, except the phosphor (P4 or P7) is different; the persistence is much longer. Some radar sets use scanner speeds as slow as 11 rpm. This means any video (target) information must remain on the screen at least 5½ seconds while the scanner makes another revolution and the beam is brightened again. In actual use, the persistence is even longer than this, causing a rather full "map" of the surrounding area to be painted on the face of the CRT.

But, before this picture can be painted, the beam must be swept across the face of the CRT; so far,

echo reception caused only an increase in CRT beam current, which of course brightens the phosphor where the beam is striking.

The sweep that moves the beam must start just after each pulse from the transmitter, so a place to obtain sweep-timing (trigger) voltage is at the modulator. A small sample of the modulator pulse is taken from the modulator stage and sent to the display unit for timing the sweep circuits. Fig. 2 shows in simplified form the two general methods of obtaining this trigger from the modulator.

The sweep generator is a triggered oscillator—usually a one-shot multivibrator, often a blocking oscillator—activated by trigger from the modulator. The output from the oscillator is amplified, shaped, and applied to a deflection coil which is concentric with the neck of the CRT, similar to the yoke mounting in a TV set.

The CRT is designed so that, when the focus and positioning devices are properly adjusted, the beam rests at the center of the CRT face. The radar deflection coil is made to sweep the beam in a straight line from center to outside edge. All that remains in order to paint the video or target picture, is to get this straight line rotating around the tube center, like the spoke of a wagon wheel around its hub.

Remember the synchro in the scanner? It is a 3-phase synchro transmitter that turns as the scanner turns, and its output feeds a

• Please turn to page 76

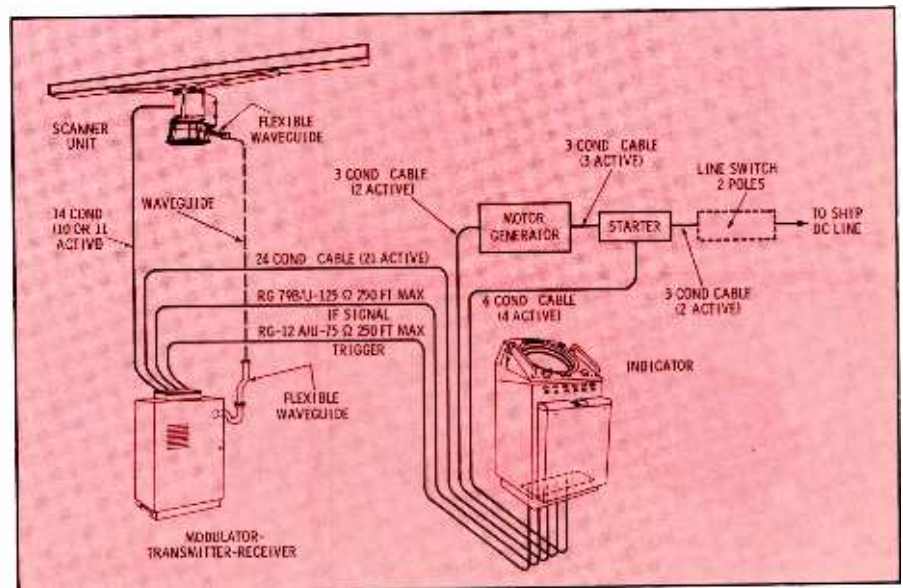
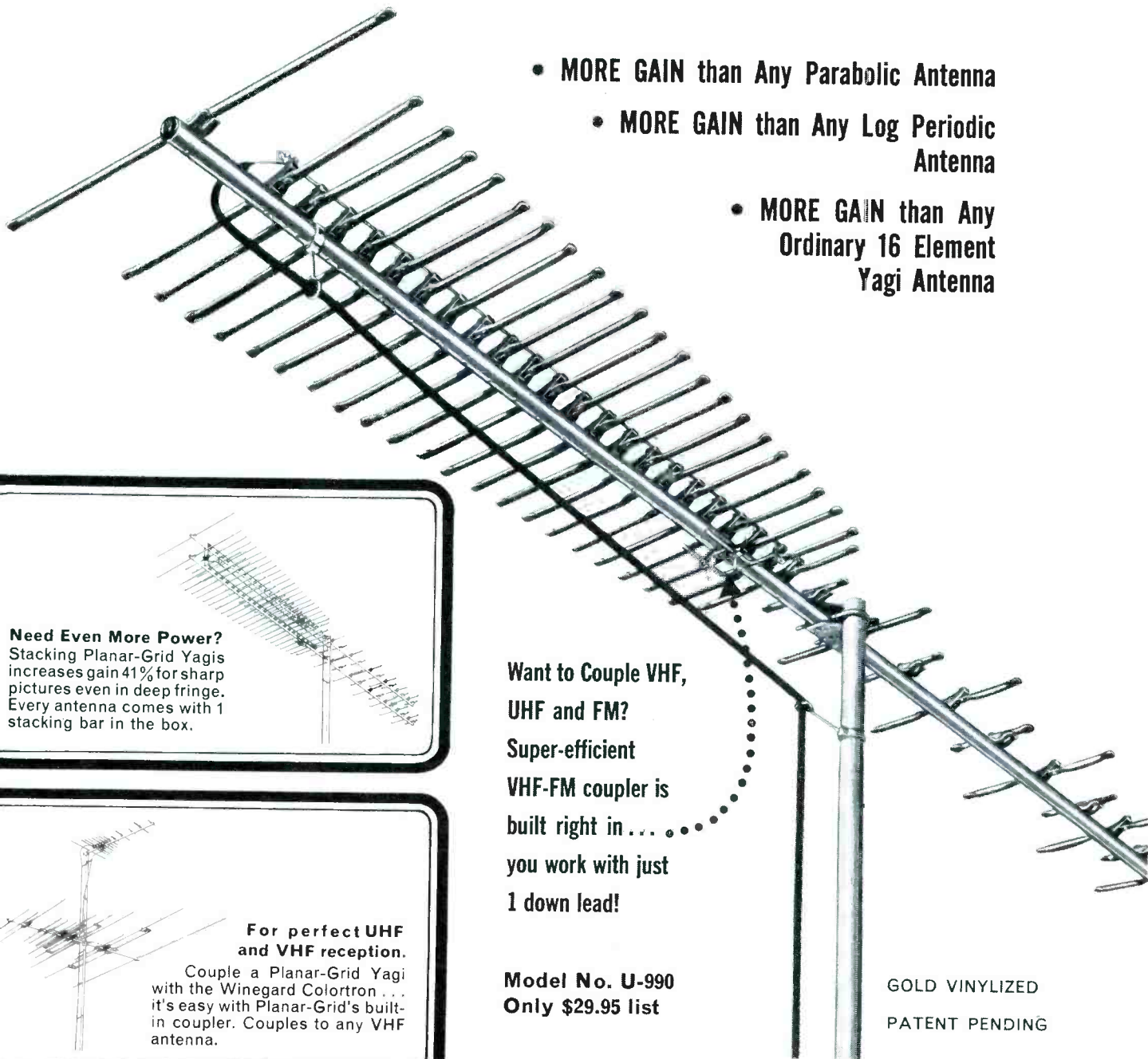

Fig. 3. Intercabling diagram showing how various radar sections are housed.

FIRST ALL-CHANNEL UHF ANTENNA BUILT

- MORE GAIN than Any Parabolic Antenna
- MORE GAIN than Any Log Periodic Antenna
- MORE GAIN than Any Ordinary 16 Element Yagi Antenna



Need Even More Power?
Stacking Planar-Grid Yagis increases gain 41% for sharp pictures even in deep fringe. Every antenna comes with 1 stacking bar in the box.

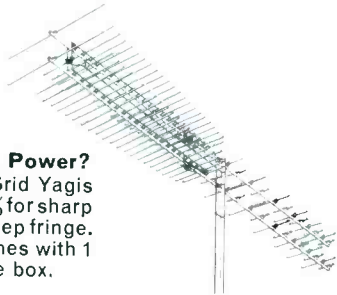

Want to Couple VHF, UHF and FM?
Super-efficient VHF-FM coupler is built right in . . . you work with just 1 down lead!

Model No. U-990
Only \$29.95 list

GOLD VINYLIZED
PATENT PENDING

For perfect UHF and VHF reception.
Couple a Planar-Grid Yagi with the Winegard Colortron . . . it's easy with Planar-Grid's built-in coupler. Couples to any VHF antenna.

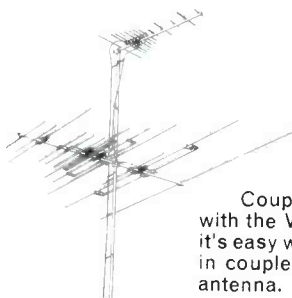

Pull in more UHF stations!
Use the Winegard UHF-212 antenna amplifier . . . Only \$44.95 list.

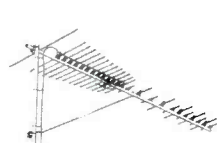

Model No. U-980
Only \$19.95 list

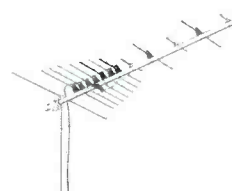

Model No. U-970
Only \$11.95 list

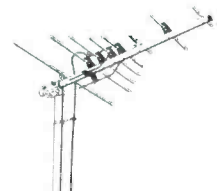

Model No. U-960
Only \$7.95 list

FOR THE CRITICAL DEMANDS OF COLOR TV

Winegard **Planar-Grid** FULL WAVE YAGIS

Unquestionably the Most
Powerful All Channel UHF Antennas Ever Made!

- First Antenna Ever Designed Using the Full Wave Planar-Grid Principle
- First Antenna With Progressive Gain Accumulation Across the Entire UHF Band from 14 to 83

Planar-Grid UHF antennas have arrived . . . a most significant advancement in UHF antenna design. These new UHF antennas have the power and critical characteristics necessary for consistently perfect color reception. And of course, the TV antennas that are best for color are best for black and white, too.

Here's how the new Planar-Grid Yagis eliminate the disadvantages of all existing UHF antennas! Examples:

THE 4-BAY BOW-TIE — and Collinear antennas lack bandwidth. They require at least two separate antennas tuned to opposite ends of the band to give good gain across the entire UHF band. Increasing the gain by stacking of a 4-Bay Bow-Tie is equally impractical because it further reduces bandwidth which is already inadequate. With Winegard's new Planar-Grid Yagis, you get the *highest gain* UHF antenna on the market *PLUS* complete bandwidth.

ORDINARY HALF-WAVE UHF YAGIS, while having high gain, are frequency sensitive and normally maintain top gain over only six or so channels. Winegard Planar-Grid Yagis are made a *full wave wide* to double the capture area. They give very high gain over *all 70 channels*.

PARABOLIC ANTENNAS, by increasing size, can theoretically increase gain, but a parabolic type comparable to the U-990 Planar-Grid Yagi would require an antenna of at least 10 ft. in dia. Parabolics are inefficient and impractical because of size, cost, high wind resistance.

CORNER REFLECTOR ANTENNAS are medium gain antennas and, unlike most basic antenna designs, an increase in size does not appreciably increase the gain. The gain of the Planar-Grid Yagis is directly proportional to size.

LOG PERIODIC AND "V" TYPE ANTENNAS, regardless of large size and total number of connected elements, have no more than two or three of their elements working on any one channel. This puts a low ceiling on the available gain for these types of antennas although they do have adequate bandwidth. Another disadvantage is the multiple lobe patterns, especially those antennas employing "V'd" elements working on the third and fifth harmonic mode. This type antenna is unable to reject interfering signals from the side because of these side lobes and can easily degrade picture quality—especially in color.

PLANAR-GRID YAGIS, in comparison, have the sharp uni-directional characteristics to insure clean, sharp pictures and perfect color. On the Planar-Grid Yagi, all parts of the antenna work together on every channel (Progressive Gain Accumulation Principle) giving it the highest gain and greatest bandwidth of any UHF antenna for a given size.

Highest Gain, Complete Bandwidth, Precision 300 ohm Impedance Match across the entire UHF band and Pin-point Directivity—are characteristic of the brand new Planar-Grid Yagis from Winegard . . . these are really color-quality UHF antennas.

WINEGARD CONSTRUCTION, TOO... Features include Winegard's exclusive wrap-around mast clamp, complete factory preassembly and our new Gold Vinylized finish to protect against weather wear.

Enter the era of UHF now with the color-quality UHF antennas—Winegard Planar-Grid Yagis! Ask your distributor or write for spec sheets today.

Winegard Co.

ANTENNA SYSTEMS
3009E Kirkwood • Burlington, Iowa
April, 1965/PF REPORTER 41



© Winegard Co.—1965

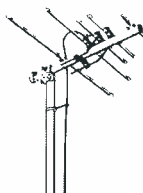

Model No. U-950
Only \$5.95 list

Circle 12 on literature card



Feather your nest this spring

With valuable premiums from General Electric Receiving Tubes



Get ready for spring fun and projects from March 1 through May 14, with top quality merchandise available only with tube purchases from your General Electric Tube Distributor.

You can choose from a wide selection of gifts for yourself, your wife, your home or your shop during these two and one-half months. Remember, there's no limit on the number of premiums you may earn.

Your G-E Distributor* is the man to contact for details. He will be able to show you how easy it is to "Feather Your Nest This Spring," and stock up on G-E Tubes at the same time.

DISTRIBUTOR SALES, OWENSBORO, KENTUCKY

*Premiums available at the option of your G-E Distributor.



WISE-GRIP® PLIERS

for home or business offer tremendous gripping power and easy adjustment. Forged steel claws lock into position for the strength of a wrench. Fast release lever enables quick readjustment. Order: ETR 4212



SEAMLESS HOSIERY

in the beautiful sun-tan shade for the woman in your life. Three pairs of sheer stretch nylons will complement the latest spring and summer fashions. One size fits all. Order: ETR 4207

**24"
COOKING
CENTER**



makes outdoor summertime meals remembered throughout the year. The beautiful metallic red and gray baked-on enamel covers a bonderized steel construction for added years of service. Five-position elevation control allows the backyard chef full opportunity for cooking perfection. Order: ETR 4211

**SABER
SAW**

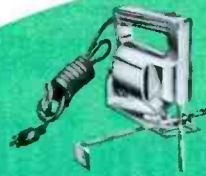

does the work of eight saws . . . rip, crosscut, jig, hack, band, coping, keyhole, and scroll. Offers built-in cooling, adjustable base, rip guide, and mitre gauge. Bevel cuts from 0° to 45°. Includes wood, scroll, and metal blades. Order: ETR 4217

19" PATIO TABLE



is ideal for year 'round use indoors or out. Stain-resistant top doubles as a beautiful serving tray. Brass legs collapse for easy storage. Order: ETR 4210

**GARCIA SPINNING ROD
AND REEL**



featuring the Mitchell 304 reel with anti-reverse control and full ball line pick-up. The 6½' two-piece medium-taper rod offers medium light action. Order: ETR 4208

**MELAMINE
DINNERWARE**



24 pieces — will add beauty to your table. This break and stain resistant set is dishwasher safe and includes four: tumblers, decorated dinner plates, cups, saucers, bread and butter plates and fruit dishes. Order: ETR 4206

**SANFORIZED
SHIRT**



for dress or play in assorted colors. Smart looking collar and permanent stays assure the fresh look even after many washings. The little or no ironing required makes it even more popular on wash day. Order: ETR 4213

**SKOTCH
KOOLER ®**



two quart capacity — is completely unbreakable. The leather textured handle and surface in white and copper-tone make it a handsome accessory for summer outings or patio use. It is light-weight and stain resistant for added convenience. Order: ETR 4209

LAWN SPRINKLER



covers an area from 20-80 feet with a full circle throw or any part of a circle. Features sturdy metal construction, sled-type runners, and rotating coupling nut. Order: ETR 4218

**LIBBY
GLASSES
AND CARRIER**



make serving beverages outdoors easy and stylish. Each glass has a lovely gold leaf design and holds 12½ ounces. Order: ETR 4216

A servicing journey thru electronic accessories that boost gain.

Repairing Amplified Antennas

by Lon Cantor

Antenna preamplifiers first came into popular use three or four years ago. Since then, they have proven a boon to the fringe-area viewer and promise to become an additional source of income to the service technician who has not previously included them in his servicing activities.

Because most antenna preamplifiers use transistors, they are quite reliable; for this reason, and because they are relatively inexpensive, few technicians attempt to repair them. Yet, preamplifiers—or *boosters* as they are commonly called—do cost more than most transistor radios. Further, they are considerably less complex and far easier to repair. Whereas a radio consists of at least five different stages, a booster has only one or more RF-amplifier stages, with passive circuits for matching impedances and filtering.

Simplest of the boosters are the single-stage indoor preamps, which have power supply and amplifier in a single unit. The indoor preamplifier provides little improvement in signal-to-noise ratio. It is used either to distribute a signal among several TV sets or to improve pictures on an older set that has poor sensitivity or poor gain.

Fig. 1, the block diagram of one of the most complex preamplifiers on the market, proves they aren't really complicated at all. The pre-



amplifier shown consists of two units: a two-transistor mast-mounted preamplifier; and, a three-transistor combination power supply and post amplifier.

While their appearances may differ considerably, all transistor boosters are essentially alike when it comes to servicing. Perhaps the biggest difference is in physical layout. Some units have components so crowded together that troubleshooting and repair are difficult—the unit shown in Fig. 2 is by no means the worst example of crowding you'll encounter. Fig. 3 shows a comparable unit, constructed on a printed board for easy accessibility.

Because antenna preamps work at very-high RF frequencies, lead length and parts placement are critical. Change the length of a resistor lead, and you've added inductance; route it too close to the chassis, and you've added capacitance. At these

frequencies, it's very easy to cause oscillation or to alter frequency response simply by moving a lead.

Antenna Amplifier Circuits

Let's dig into a typical antenna preamplifier and discuss servicing techniques that will apply to any on



Fig. 2. Some units are crowded inside.

the market. (Fig. 4 is the schematic of a popular two-transistor amplifier unit.) Since strong input signals will often cause cross modulation (Fig. 5), especially if a single transistor is used for all channels, single-transistor units generally are used only in fringe areas — those with no strong local channel. Two-transistor boosters supply little-or-no-more gain than single-transistor units, but can handle much stronger input signals without overloading. So, in preamps similar to that shown in Fig. 4, transistor X2 amplifies the low VHF band (channels 2 through 6), while X1 handles the high VHF band (channels 7 through 13).

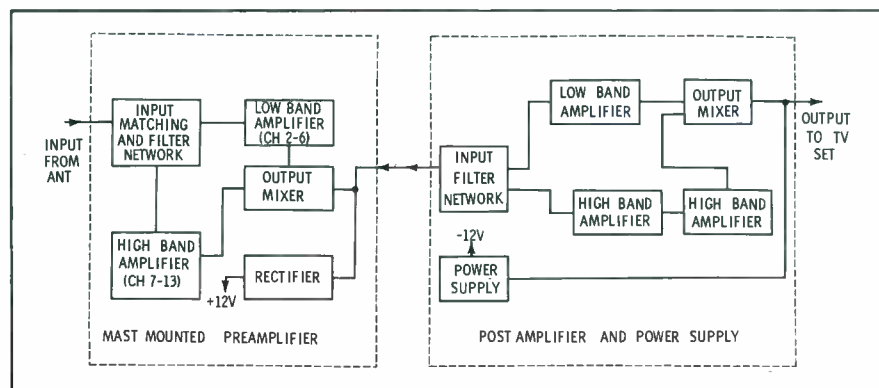

Fig. 1. Block diagram of a typical antenna preamp and associated power supply.

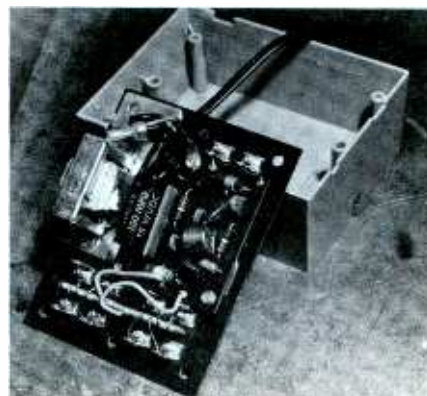

Fig. 3. Others are more neatly laid out.



Basic for the professional service shop

multiple socket
SPEED plus
*Gm** **ACCURACY**
 CREATES
MORE
PROFIT



↓ Sell more tubes per customer | *↓* Save call-backs | *↓* Satisfy more customers

B & K MODEL 700 DYNA-QUIK
DYNAMIC MUTUAL CONDUCTANCE TUBE TESTER
with obsolescence protection

**Makes test under actual set-operating conditions*

Everyday use by thousands of professional servicemen has proved its *speed . . . its accuracy . . . its efficiency.*

You can quickly check all the tubes in the set, detect hard-to-locate weak tubes that need replacement . . . and sell more tubes. Provides multiple-socket section to quick-check most of the TV and radio tube types the true dynamic mutual conductance way*—plus simplified switch section to check new tube types in Dyna-Quik emission circuit. Also includes provision for future new sockets.

Makes test under set-operating conditions. Checks each section of multi-section tubes separately. Checks for all shorts, grid emission, leakage, and gas. Makes quick "life" test. Exclusive adjustable grid emission test provides sensitivity to over 100 megohms. Insures your reputation. *Quickly pays for itself.*

Net, \$179⁹⁵

See your B & K Distributor or Write for Catalog AP21-R

- TESTS All TV and Radio Tubes, Old and New
- TESTS Nuvistors and Novars
- TESTS 10-Pin Tubes
- TESTS 12-Pin Compactrons
- TESTS European Hi-Fi Tubes, Voltage Regulators, and Most Industrial Types

NEW TUBE INFORMATION SERVICE
 Keep your tube tester up-to-date. Subscribe now to tube information service, available every 3 months.



B & K MANUFACTURING CO.
 DIVISION OF DYNASCAN CORPORATION
 1801 W. BELLE PLAINE AVE. • CHICAGO, ILL. 60613
 Canada: Atlas Radio Corp., 50 Wingold, Toronto 19, Ont.
 Export: Empire Exporters, 123 Grand St., New York 13, U.S.A.

Circle 14 on literature card

Our CB story this month
is short and sweet:



**the
beauty of
this baby
is its
18" length!**

M-130 "Mighty Mite"

18" Mobile CB antenna

- Capacity-matched to car body for excellent VSWR
- Fine-tuning adjustment
- Professional-type, 2½" stainless steel shock spring



**M-130
"Mighty Mite"**
¾" snap-in mount—
no soldering



**M-131
"Maggie Mite"**
Gutter clip mount—
hang it anywhere

**the
antenna
specialists co.**



12435 Euclid Ave., Cleveland, Ohio 44106
A division of A/S Industries, Inc.

Export Div.:
64-14 Woodside Ave.,
Woodside 77, N.Y.

"stripes of quality" ®



Circle 15 on literature card

46 PF REPORTER/April, 1965

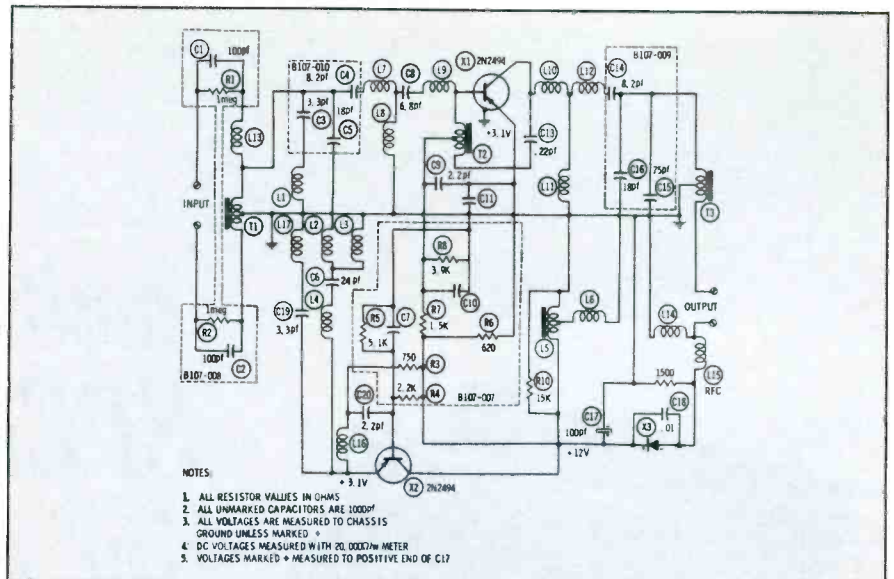

Fig. 4. Schematic of two-transistor antenna preamp found in rather common sets.

Except in rare instances, symptoms in a defective antenna preamplifier are limited to the following: (1) snowy pictures on all channels, (2) snowy pictures on certain channels, (3) poor contrast on all or some channels, (4) poor color response, (5) cross modulation (Fig. 5), and (6) top or bottom half of picture goes blank.

Preliminary Checks

Be sure trouble is actually caused by the booster. Obviously, it's a waste of time to troubleshoot a unit that is operating normally. First, check the lead-in wire—old twinlead can cause all kinds of trouble. A quick continuity check across the two wires with your ohmmeter will reveal any breaks in the line; the reading in a unit such as that shown in Fig. 4 would be approximately 1500 ohms. Remember, however, that frayed twinlead can cause considerable signal loss, especially in wet weather. Also, if the twinlead lies too close to metal or is encir-

led by metal standoffs, it can develop standing waves, which results in ghosts (often very faint). In color sets, the effects of standing waves are often more obvious—yellows may get greenish, and reds turn toward orange. If you have any reason to suspect the twinlead, it's a good idea to replace it.

Don't overlook the fact that the antenna or the TV tuner can also cause picture defects that may sug-



Fig. 5. Overload with single transistor.

PRECISION TUNER SERVICE

P. O. BOX 272

1210 S. WALNUT ST.

BLOOMINGTON, IND.

EDISON 99653

7.95
V or U
COMBO PLUS
9.95 **POSTAGE**

6 MONTH WARRANTY



All Types T.V. Tuners Cleaned, Repaired and Aligned to Factory Specifications. Same day in shop service on most Tuners. Price Includes Minor Parts, Major Parts at Cost Price. We use Original Parts if possible. State Make Model and Enclose all Parts and Tubes. Pack Well and Insure.

ALSO HAVE LARGE STOCK OF EXCHANGE TUNERS, WRITE FOR TYPES AND PRICES.

Circle 16 on literature card

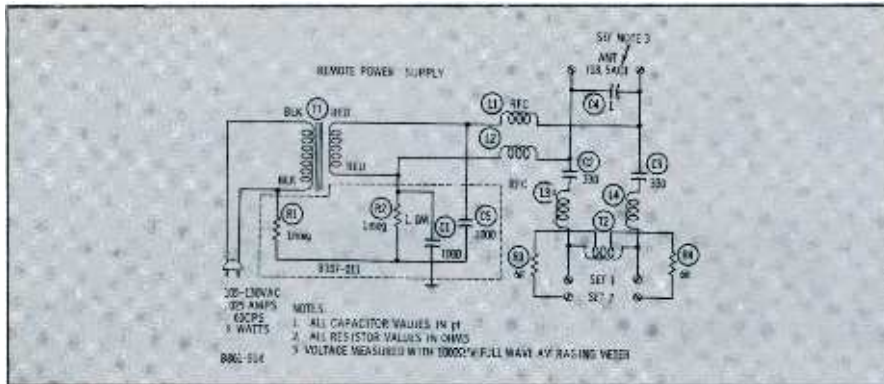

Fig. 6. Schematic of the power supply for the preamplifier shown in Fig. 4.

gest trouble in the booster. A visual inspection will usually indicate the condition of the antenna. Make sure all elements are solidly in place and all contacts — including twinlead connections — are secure.

The best way to determine whether trouble lies in the TV set or the preamplifier is to substitute another set, temporarily. If this is not possible, connect the antenna directly to the set, bypassing the preamplifier and note any change. If, for example you have "windshield wiper effect" with the booster and none without it, the booster is obviously at fault. In this case, you must trap out the local signal that causes the overload or use a booster designed to handle stronger input signals.

Let's suppose, however, that the complaint is of weak or snowy pictures. If bypassing the booster caused little difference, or if there is an improvement in picture quality, the booster is indicated as a source of trouble.

In the Preamp

Suppose we're sure the trouble is caused by the booster. How do we track it down? The power supply is a good place to start. Mast-mounted units use remote power supplies (Fig. 6). Power is sent up to the preamplifier on the same twinlead that carries the signal down.

On the bench, remove both the power supply and the preamplifier from their cases. Then, connect a short piece of twinlead between the two units, to supply power to the preamp. Now, measure the voltage at the power-supply terminals marked "ANT." This should be about 18.5 volts AC. Actually, this voltage reading may vary a bit, depending on the type of meter you use and the polarity of the probes.

If you don't measure any voltage output, check the line cord and the transformer. There's very little else to go wrong with a remote power supply of this type.

The 18.5 volts AC is fed into the preamplifier (Fig. 4, again) through the terminals marked "output." It is then rectified by X3 and filtered. As in any rectifier circuit, filters can cause trouble. If the trouble symptom is a blank half-screen—top or bottom—the filter capacitor is probably the culprit, for hum is modu-

• Please turn to page 72



Who'd expect
SUN-GLASSES
from Perma-Power,
the Britener
people?

you get them **FREE** with either of these **BRITENER PACKS**

When the sun is bright, you're uncomfortable—so Perma-Power gives you sun-glasses. When the TV picture is faded or dull, your customer is uncomfortable—so Perma-Power

gives you Vu-Brite and Tu-Brite.

For brighter TV pictures and brighter customer smiles, rely on the Brite line. Install easy to use Perma-Power Briteners.



Air Force type wrap around sun-glasses, stylish for men and women, \$2.95 value—FREE with 10 Vu-Brites, Series or Parallel, at the special \$9.95 price.

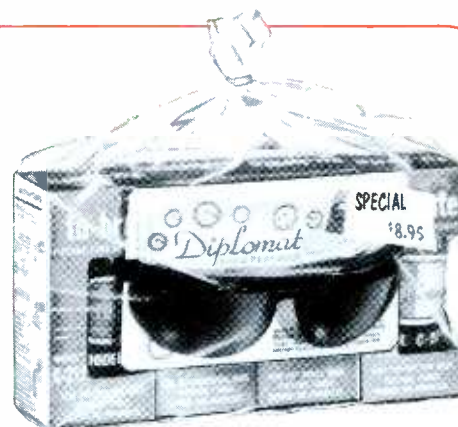

Same high quality sun-glasses FREE with 4 Tu-Brites. If the base is right, the boost is right! Only \$8.95.

See your distributor now for both these specials.

PERMA-POWER COMPANY 5740 North Tripp Avenue, Chicago, Ill. 60646
Phone (area 312) 539-7171

Circle 17 on literature card

A major breakthrough in

FINCO ALL-BAND

UHF • VHF • FM

"COLOR VE-LOG"

For the
best reception
in the world

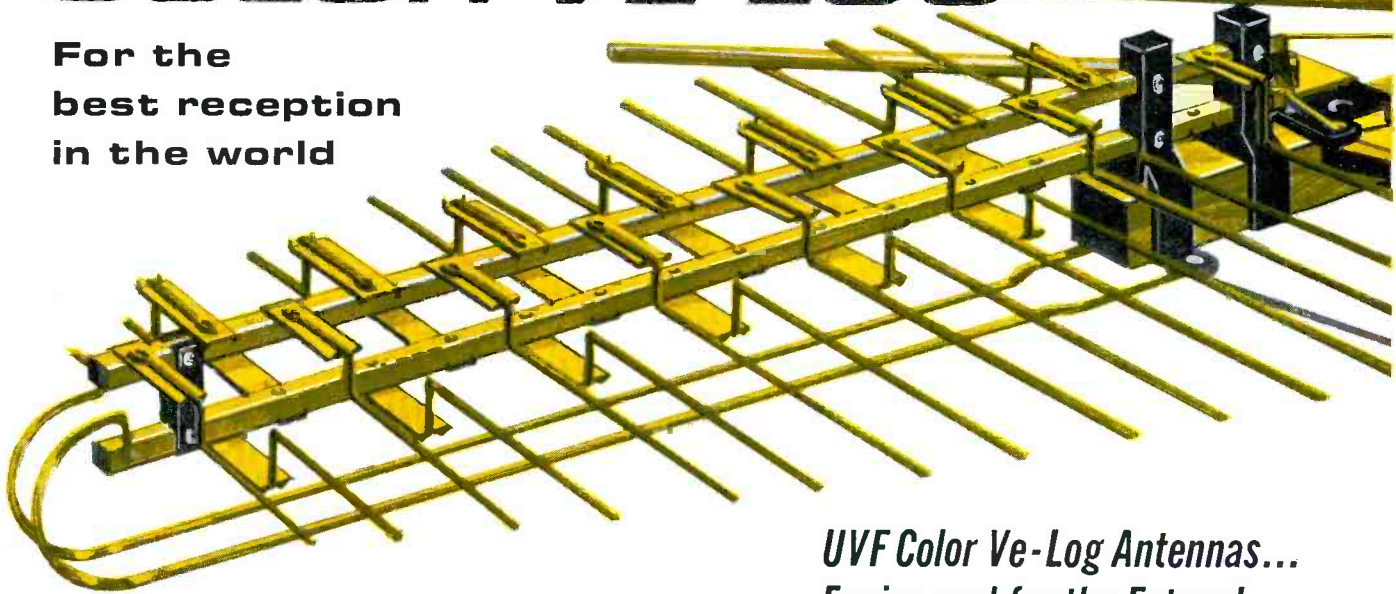

UHF Color Ve-Log Antennas... Engineered for the Future!

Finco's new All-Band Color Ve-Log Antenna does the work of three—gives startlingly clear black and white pictures and beautiful color on **both** UHF and VHF television channels. Its superlative design also assures the finest in stereophonic and monophonic FM sound reproduction. Comparison tests have proved the superiority of the All-Band UVF Series—superiority backed by Finco's guarantee of supremacy and unquestioned warranty.

- Revolutionary new UHF Section
- Heavy Aluminum reinforced insulator insert cup and heavy duty rivet
- Back-up bracket and square boom
- Finco's exclusive triple thick sleeved elements
- Lock-tite no-tilt saddle bracket
- Finco's exclusive double contact to drive line
- Continuous one-piece drive line and exclusive air insulated polystyrene cross-over spacer

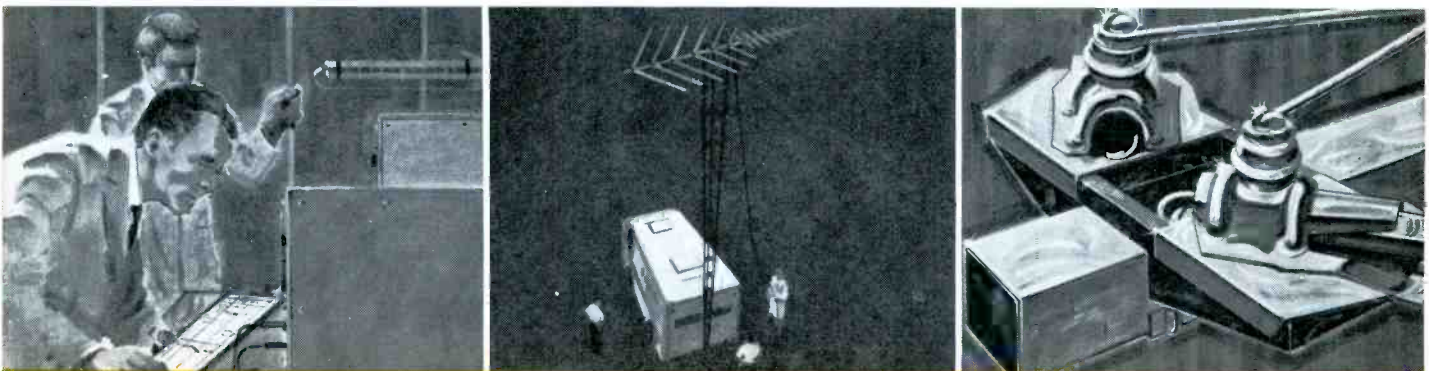

Write for beautiful color brochure Number 20-322 and Coupler-Splitter Specification sheet Number 17-2308G

Antenna design!

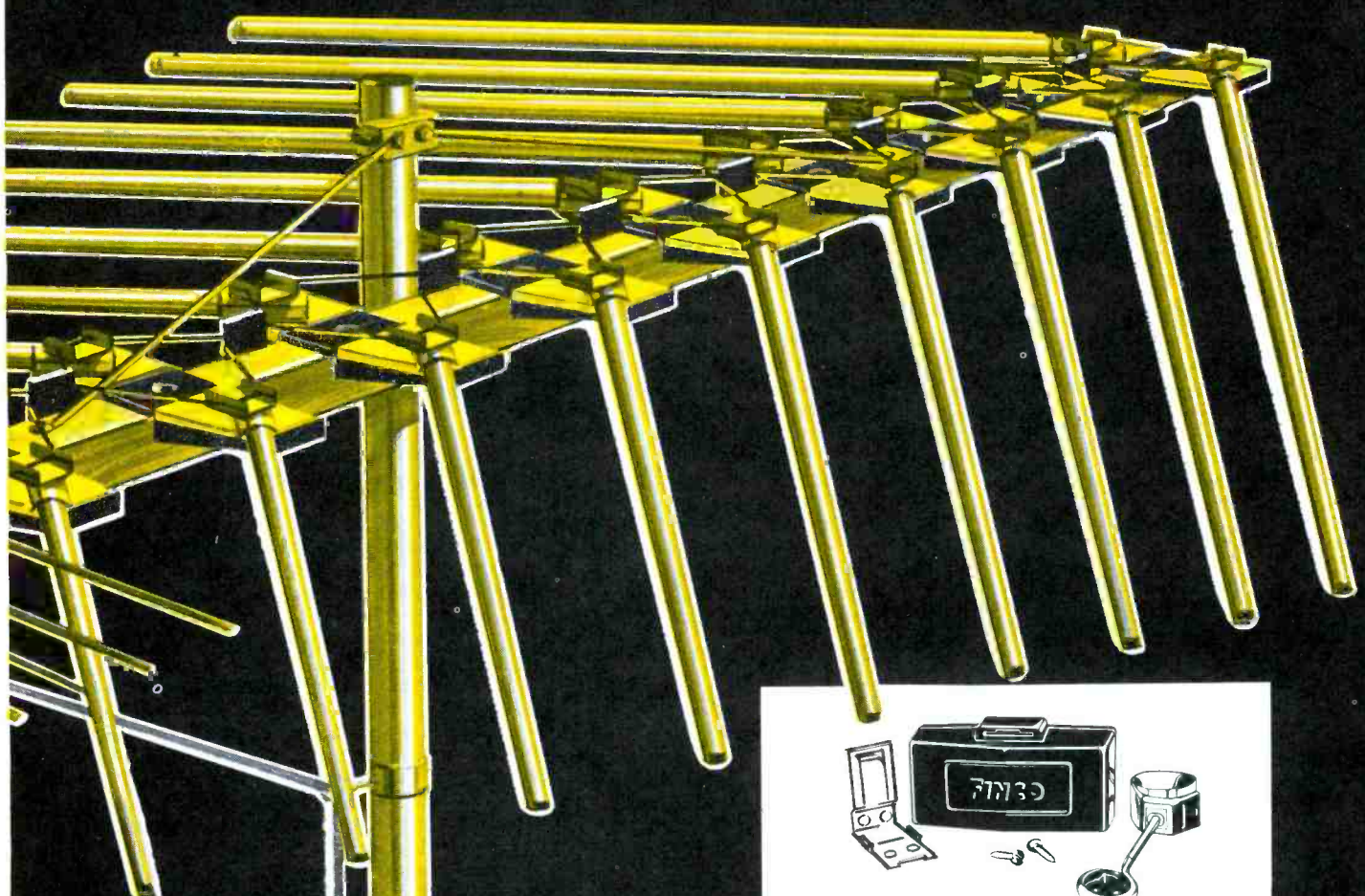

Finco Model
UVF-24

For Near Fringe and
Deep Fringe Areas

- 15 UHF Elements
Channels 14 thru 83
- 9 VHF Elements
Channels 2 thru 13
- FM Monaural and
Stereophonic
List \$59.95



For maximum performance use these
FINCO VHF - UHF - FM Coupler-Splitters

Model 3014	
UHF-VHF Coupler-Splitter	\$4.25
Model 3017	
UHF-VHF 2 Set Coupler-Splitter	6.95
Model 3018	
UHF-VHF-FM Coupler-Splitter—Low Loss	8.95
Model 3019	
UHF-VHF-FM Coupler-Splitter—Strong FM Signal	5.50

Featuring Finco's Exclusive Gold Corodizing

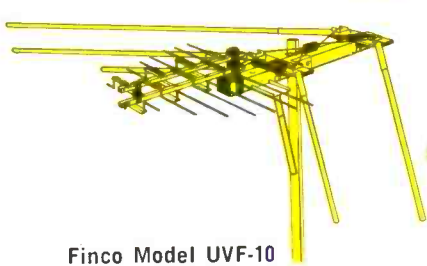

Finco Model UVF-10
For Metropolitan Areas
List \$18.50

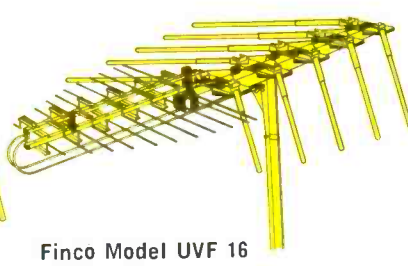

Finco Model UVF 16
For Local and Suburban Areas
List \$30.50

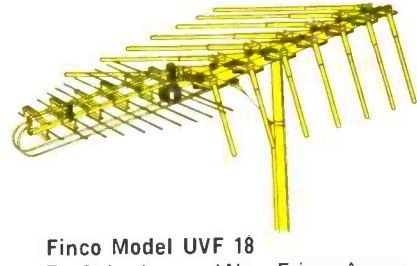

Finco Model UVF 18
For Suburban and Near Fringe Areas
List \$42.50

Prices and specifications subject to change without notice

The FINNEY Company • 34 Interstate Street • Bedford, Ohio

Notes on Test Equipment

analysis of test instruments . . . operation . . . applications

by Allen B. Smith

Sweep Waveforms and Marker Pips

Back in the good old days of yore when radio was king, things were certainly easier for the service technician.

But things just don't stand still, and the "good old days" weren't really so hot by today's standards. Equipment performance improves, circuits become more complex, and new entertainment devices (TV and FM) increase the numbers of our potentially happy customers. The problem is that some technicians prefer to keep on thumping and rattling rather than progress with the industry. One instrument which illustrates the point perhaps as well as any other is the sweep generator/marker adder used for alignment of the RF and IF sections, and filters and other tuned circuits, in TV and FM receivers.



Fig. 1. Sweep generator has 4.5-mc xtal markers and variable markers.

Typical of these units is the EICO Model 369 TV-FM Sweep and Marker Generator shown in Fig. 1. The Model 369 provides an RF-output signal variable from 3 mc to 220 mc (center frequency) with a sweep width which is variable as much as 20 mc at the higher end of its coverage. A sweep width of at least 10 mc is available at the frequencies required for all TV-channel and

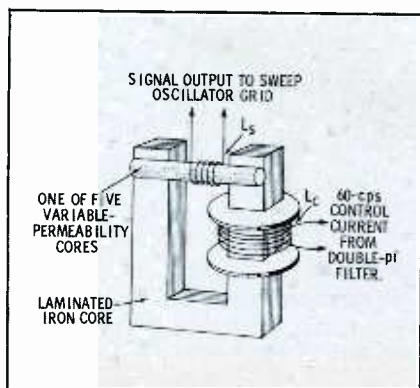

Fig. 2. Controllable inductor generates a variable-frequency signal.

IF-stage alignment. Additionally, marker pips are available from two sources: a variable-frequency generator covering 2 mc to 225 mc, and a fixed-frequency, crystal-controlled auxiliary marker generator at 4.5 mc to speed alignment of intercarrier sound IF's and discriminator adjustments.

The sweep oscillator is of a controllable-inductor type, using a specially constructed multiple-winding transformer. The transformer has cores of both laminated iron and pressed powdered iron. Fig. 2 shows a simplified representation of the special transformer. The 60-cps control winding L_c (only one half is shown; each leg of the laminated "U" core holds one-half of the total winding) receives current from the SWEEP WIDTH control which is fed via a double- π filter from the line source. The induced current controls the magnetic flux density of the "U" core, thus reducing and increasing (at a 60 cps rate) the permeability of the powdered-iron core of signal coil L_s which is bonded to the legs of the "U" core across its open end. When the

EICO Model 369 Specifications

RF Sweep-Frequency Ranges:

Band A	75 to 220 mc
Band B	36 to 95 mc
Band C	16 to 42 mc
Band D	6 to 16 mc
Band E	3 to 7.5 mc

RF Output Level:

Band A	.1 volt ± 1 db
Band B	.2 volt $\pm \frac{1}{2}$ db
Band C	.3 volt $\pm \frac{1}{2}$ db
Band D	.3 volt $\pm \frac{1}{2}$ db
Band E	.3 volt $\pm \frac{1}{2}$ db

RF Output Impedance:

50 ohms nominal

Sweep Width:

Variable as much as 20 mc, depending on range.

Marker-Frequency Ranges (variable):

Band A	2 to 6 mc
Band B	6 to 20 mc
Band C	20 to 75 mc
Band D	60 to 225 mc

Fixed Marker Frequency:

4.5 mc—crystal included with generator. Other crystals may be used for other frequencies.

Marker Injection:

Markers are added to sweep signal which has been demodulated by receiver under test and returned to the Model 369 via separate cable.

Size (HWD):

8½" x 12½" x 7"

Weight:

16 lbs

Power Requirement:

105 to 125 volts AC, 60 cps, 50 watts.

Price:

\$89.95 kit, \$139.95 wired.

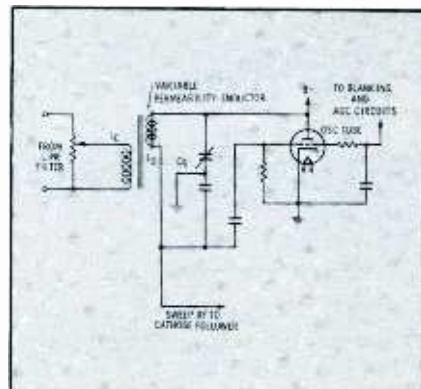

Fig. 3. Static values of L_s and C_g determine the sweep center frequency.

core's permeability drops, so does the effective inductance of the signal coil (L_s) wound around it. Since the total inductance of the signal coil determines the center frequency of the sweep signal in conjunction with C_g (see Fig. 3), the frequency of the sweep-oscillator tube (V2B) varies at the control-signal rate (60 cps). Magnitude of the frequency excursion depends upon the inductance change of L_s , which in turn is controlled by the amplitude of the control signal. The partial schematic shown is a simplified circuit used for clarity in illustrating the operation of the frequency-determining function of the oscillator section. Oscillator operation is actually controlled in part by the AGC and blanking circuits to avoid appearance of a retrace during the negative excursion of the 60-cps sine sweep. Overall operation of the Model 369 can be determined from the block diagram shown in Fig. 4.

In use, this instrument proved to be stable and accurate and demonstrated several useful control functions. Front-panel controls are provided for adjusting all signal characteristics for a quick and simple analysis of the sweep waveform. The use of the post-injection marker system assures a stable marker presentation, and the AGC circuits provide a satisfactorily constant output level across the entire frequency range of the instrument. Action of the attenuator in the Model 369 in our lab was faulty, with little change in level noticed when switching from X100 to X10 and from X10 to X1. A call to the factory assured us that normal operation shows a well-controlled step-down progression. A definite

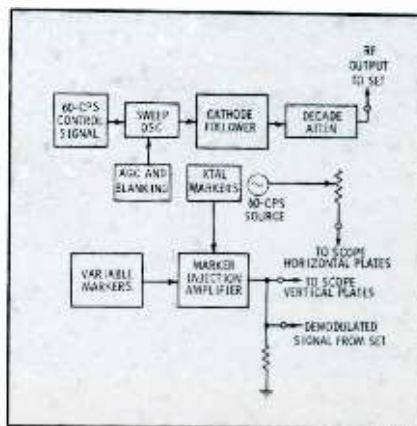

Fig. 4. Markers are added to the demodulated sweep waveform from receiver.

RCA Solid Copper Circuits



replace old-fashioned
"hand wiring"... RCA Solid
Copper Circuits are the
circuits of the space age

RCA Solid Copper Circuits are made by methods as modern as tomorrow. They give greater dependability . . . better TV performance. It's typical of the advanced design you'll find throughout every RCA Victor home instrument. It all adds up to sets that are easier to service so that owners are more satisfied with results.

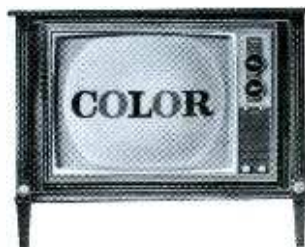

The Most Trusted Name
in Electronics

TM(s)®

More TV servicemen own RCA Victor Color TV than all other leading makes combined



plus factor is the inclusion of the crystal-controlled marker circuit which speeds sound IF and discriminator alignments and adjustments.

Total Tube Analysis

As suggested in the article on tube and CRT checkers in PF REPORTER March 1965, technicians are increasingly dependent on accurate and rapid evaluation of tubes and other active-signal devices. Last month in "Notes on Test Equipment" we covered an analyzer which, though expensive, leaves very few questions unanswered where semiconductor devices are concerned. This month we have evaluated a similarly versatile tube tester/analyzer, the Hickok Model 580 shown in Fig. 5.

As in the case of the transistor analyzer, the Model 580 is expensive. Actual test-equipment cost, however, often becomes a less important factor than how well the instrument performs its evaluation, and how quickly.

One of the most difficult problems in evaluating a complex instrument is to become familiar enough with it to know what it can and cannot do. Surprisingly enough, the operation manual doesn't always prove adequate. The instructions and circuit descriptions in the manual for the Model 580, however, are excellent. A couple of hours spent with it should give anyone an understanding, not only of the instrument's operational capabilities, but also of its circuit functions.

Operation of the Model 580 follows one of two methods, either of which will insure a complete evaluation of the tube being tested. The more familiar method, using the roll-chart information supplied, will undoubtedly be used more often. For tubes not listed on the roll chart, however, the tube-data handbook method, using information found in standard tube manuals, may be used.

Roll-chart operation is straightforward and requires only a brief review of the procedure described in the manual. Control knobs, corresponding to the index references on the bezel of the roll chart, are set to the figure indicated on the chart. A NOTES heading gives information for plate- or grip-cap connections. Before evaluating any dynamic tube condition, two preliminary tests are made: the line voltage is adjusted using the LINE TEST pushbutton switch and LINE ADJUST control; and, the filament is checked for continuity with the FILAMENT VOLTS

switch in its OFF position. All other controls are then set as indicated on the roll chart, and the series of dynamic tests is completed. Tests for leakage, Gm, gas, re-

Hickok Model 580 Specifications

Tube-Socket Complement:

9-pin novar, 12-pin compactron, 9- and 10-pin miniature, 7-pin miniature, 8-pin octal, 5- and 7-pin novistor, 8-pin octal, 8-pin round subminiature, 7-pin in-line and subminiature, 5- and 7-pin acorn, 7-pin combination, 4-, 5-, and 6-pin combination.

Tests Performed

Interelement leakage, shorts, gas, mutual conductance (Gm), life test, DIODE CHECKS 1 (signal types), DIODE CHECKS 2 (power-rectifier types), and VR (voltage-regulator) tubes.

Mutual-Conductance (Gm) Ranges:

0-3000, 0-10,000, 0-30,000, and 0-60,000 micromhos—plus two diode ranges and one voltage-regulator range.

Test Voltages:

Filament—0-117 volts AC in 19 steps; Signal (60 cps)—.28 volt rms; Plate—6.3-300 volts DC in 12 steps; Screen—same as for plate, available separately; Fixed Bias—0-50 volts DC, continuously variable in two ranges; Self Bias—by means of jack-mounted resistor.

Interelectrode Leakage Test:

Direct-reading on meter—sensitivity to 50 megohms.

Grid-Current (Gas) Test:

Reads grid current as low as .05 μ a.

Size (HWD):

7" x 19" x 15½"

Weight:

30 lbs

Power Requirement:

105-125 volts AC, 50-60 cps, 60 watts.

Price:

\$585.

serve life, rectifier efficiency, and others for special tube types are described in detail in the operating instructions.

Using the second testing method, data is taken from tube manufacturers' specification sheets or data handbooks and correlated into control-switch positions.

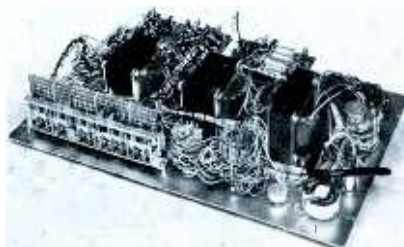

Fig. 6. Under-chassis view shows rugged construction and transformers.

using the instruction manual for reference. Charts which give the exact voltages available at each switch position are used to determine individual control settings. Several examples, using familiar

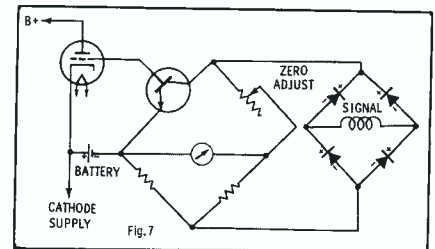

Fig. 7. Transistor is utilized as a variable resistor to indicate gas.

tube types, illustrate this method in detail. Understandably, this method is more complicated and takes more time, but it provides an excellent means for testing new and unusual tubes (don't forget obsolete types which have been removed from roll charts, too). Using one method or the other, very few tube types will present a problem.

Power rectifiers, using the tube-data method, require a rather involved procedure, but, once again, the indispensable manual comes to the rescue with an emission nomograph, complete with instructions for use. This chart makes possible an evaluation only slightly less accurate than that obtained using roll-chart information.

Construction of the Model 580 is very sturdy, with heavy-duty components providing a good reserve capability. Fig. 6 shows the underchassis arrangement, with the three power transformers dominating. One transformer provides only filament voltages, and separate units are used for the plate supply and for the combination screen, bias, and grid-signal supplies.

Circuitry is basically straightforward. The gas-test circuit is interesting, however, and uses a full-wave bridge (Fig. 7) to establish a reference point which is set using the GAS ZERO ADJ control. A transistor in one leg of the bridge is used as a variable resistance to unbalance the bridge when the tube under test draws grid current.

A very handy dual-tube test circuit is shown in Fig. 8. The use of the DUAL TEST switch eliminates the necessity for changing several control-switch positions when checking dual-section tubes.

In our lab, the Model 580 was used to check a variety of tubes, using both test methods; some were known-to-be-good types and some known-to-be-bad types. In all cases, the Model 580 confirmed the known evaluation. The Model 580 appears to be a competent though expensive, answer to the problem of evaluating thoroughly the wide variety of tubes used

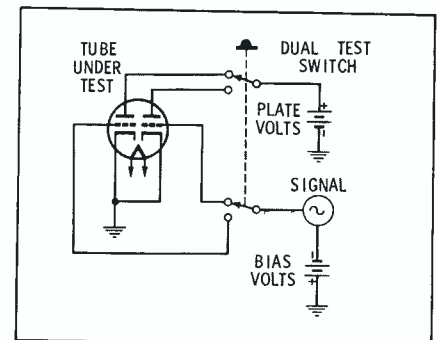

Fig. 8. Dual-Test circuit makes testing dual-section tubes simple.



Fig. 5. This tester checks tubes using roll-chart or tube-handbook data.

IT'S TIME FOR A GOOD DEAL
and Centralab has one for you!

FREE! MINUTE-MENDER TIMER

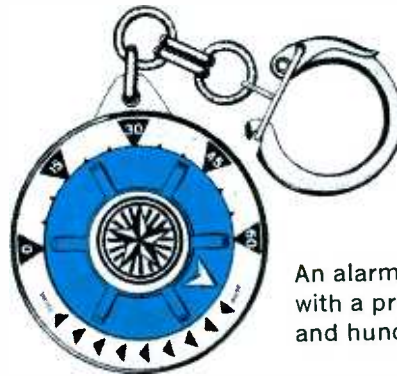

An alarm clock in your pocket with a precision Swiss movement and hundreds of practical uses:

- Check parking time
- Time that repair job
- Cook a "tough dog" for 30 minutes
- Be back on time
- Limit that long distance call
- Calculate travel time
- Take 5 and time it
- Pre-heat filaments for ten
- Form new 'lytics in five

or . . . take it home to your wife to

- Time an egg
- Cook a pizza
- Bake a cake
- Remind her to call you
- Make her happy

when you buy

this special ceramic disc HI-KAPS®
CDM-100 merchandiser kit

100 assorted Centralab Ceramic Disc HI-KAPS in a clear plastic six-compartment storage box—in the nine values you most frequently need for radio-tv servicing . . . a \$21.30 value.

Timer \$ 3.95

Kit 21.30

Total \$25.25

Your Cost \$ 16.95



Contents

100	MMF	±10%	1KV	DD-101	10 pcs
220	MMF	±10%	1KV	DD-221	5 pcs
470	MMF	±10%	1KV	DD-471	10 pcs
.001	MFD	±10%	1KV	DD-102	20 pcs
.002	MFD	±10%	1KV	DD-202	10 pcs
.005	MFD	GMV	1KV	DD-502	10 pcs
.010	MFD	GMV	1KV	DD-103	20 pcs
.020	MFD	+80—20%	600V	DD-203	10 pcs
.050	MFD	+80—20%	600V	DD-503	5 pcs
TOTAL					100 HI-KAPS

Save **\$8.30** and make more profit on repair jobs. Now's the time to ask your Centralab distributor for the Centralab Minute-Mender-Merchandiser.



DIVISION OF GLOBE-UNION INC.

P. O. Box 591 • Milwaukee, Wisconsin 53201
In Canada: Centralab Canada Ltd., P. O. Box 400, Ajax, Ontario

D-6503

Circle 19 on literature card

BUZIT TRANSISTORIZED SIGNAL TRACER

FOR ONLY \$8.70 DEALER NET
WITH BATTERIES

NO CLIPS
NO WIRES



MADE IN
U.S.A.

USED FOR TROUBLE SHOOTING

- A.F. CIRCUITS • I.F. CIRCUITS
- R.F. CIRCUITS • CONTINUITY CHECKS • SPEAKERS, ETC.

EXCELLENT FOR TRANSISTOR
RADIOS BECAUSE BUZIT USES
ONLY A 3 VOLT POWER SUPPLY

ASK YOUR ELECTRONIC
PARTS DISTRIBUTOR FOR

MODEL NO. **BZ-1**

MANUFACTURED BY
WORKMAN Electronic
SARASOTA FLORIDA PRODUCTS INC

Circle 20 on literature card

TV TUNERS

Rebuilt—Exchanged

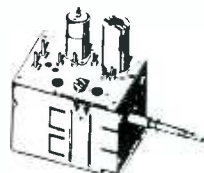

\$9.50*
Plus
Shipping
Charges

All Makes—All Models

- Includes all parts except tubes
- 90 day full warranty
- All tuners cleaned, lubed, repaired and aligned with crystal controlled factory equipment to factory specifications, by factory trained technicians.
- 1 day service

Give model number of set and complaint. Include tubes, shields, cover and all parts, broken or not.

*Practical Repairs

VALLEY TV TUNER SERVICE

5641 Cahuenga Blvd. PO 9-4730
North Hollywood, California

Circle 21 on literature card

in today's industrial and home-entertainment electronic equipment.

Visual Vectors and Color Bars

The single most difficult concept in understanding the operation of a color receiver is probably that of the phase relationships in the color-demodulator and matrix circuits. The difficulty stems from the perplexingly abstract nature of phase relationships—it is hard to demonstrate what actually occurs in each stage of the demodulator and matrix circuits at any specific instant. The instrument shown in Fig. 9, the Lectrotech Model V-7 Color Generator and Vectorscope, may assist many technicians to a better understanding of color-phase relationships and thus speed their troubleshooting procedures.

This interesting test set is a combined crystal-controlled, multiple-pattern color-bar generator and simple oscilloscope, used to give a visual display of vector phase relationships in conjunction with the keyed-rainbow pattern supplied by the generator. The usual complement of patterns for convergence and linearity checks and chroma alignment are available, and there are, in addition, several features not found in many other color generators. These include panel-mounted gun-killer switches, an adjustment to control the thickness of the horizontal lines, adjustable brightness of the vertical lines, a video-polarity switch, and provision for calibrating the various timing circuits using the vectorscope to provide waveforms. Recessed, slotted-shaft controls along the left side of the instrument provide for the adjustment of each divider multivibrator.

Basic circuit function, outlined in the block diagram shown in Fig. 10, is very similar to most keyed-rainbow generators seen previously in these pages. A 189-kc crystal oscillator provides the basic signal (chosen because of its harmonic-frequency relationship to the standard 15,750-cps horizontal-sweep and 60-cps vertical-sweep rates of television receivers). This stable frequency is divided through two separate paths to provide horizontal and vertical-synchronizing pulses.

In the horizontal path, the 189-kc signal is divided 12 times by a pulse-counting multivibrator to attain a 15,750-cps signal. This signal passes through the



Fig. 9. Simple scope provides a way to view the vector relationships.

sync mixer to the modulator. The resulting signal is used to synchronize the set under test to the generator's time base.

The vertical-sync path is less direct but really no more complex; the 189-kc signal is simply divided in three separate

Lectrotech Model V-7 Color Generator Specifications

RF Output Frequency:

Factory aligned to channel 4. Can be set to either channel 3 or channel 5 by returning the RF oscillator.

RF Output Level:

Approximately 100,000 μ v (.1 volt).

Video Output Level:

Approximately 2 volts peak-to-peak.

Special Features:

CRT for visual presentation of vector relationships, panel-mounted gun-killer switches; horizontal-lines thickness adjustment; vertical-lines brightness adjustment; calibrate switch for divider adjustments using CRT patterns.

Patterns Available:

Crosshatch; dots; vertical lines; horizontal lines; keyed-rainbow color bars; vector relationships of color bars presented visually on internal CRT.

Size (HWD):

7½" x 8¼" x 12¾"

Weight:

13 lbs

Power Requirement:

105-125 volts AC, 60 cps, 30 watts.

Price:

\$189.50

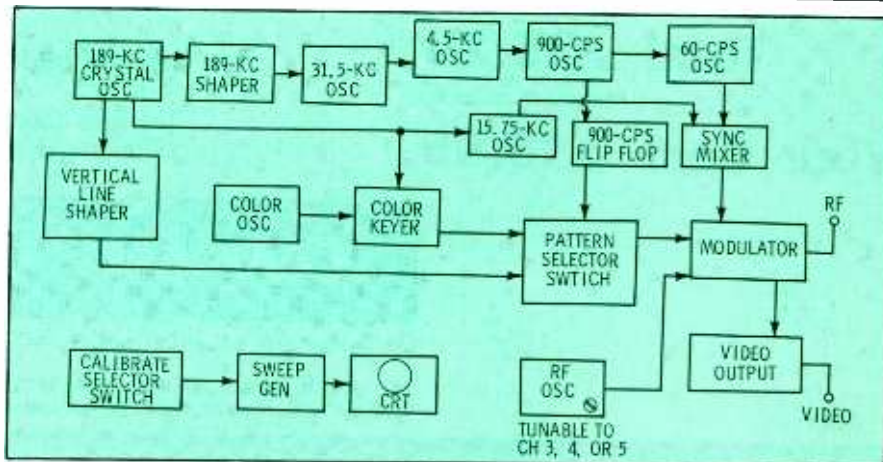

Fig. 10. 189-kc oscillator initiates all pattern and color-bar signals.

stages to attain division by a total factor of 3150. The resulting 60-cps signal also passes through the sync mixer. It provides vertical-synchronization pulses for the set under test.

Generation of the vertical and horizontal lines also begins with the basic 189-kc signal. For vertical lines, the basic signal passes through a shaper circuit, the output of which is a series of narrow pulses fed through the PATTERN SELECTOR switch to the modulator. The pulses are impressed upon the RF carrier and fed to the receiver where they brighten each horizontal-scanning line at 12 equally spaced points (only 10 appear on each trace; the other two are lost because they occur during retrace and blanking periods). The cumulative effect on the raster is a series of ten vertical lines.

Horizontal lines are derived from the basic 189-kc signal by way of the 900-cps divider and the 900-cps flip-flop multivibrator. During each vertical-scanning period (60 cps), 15 pulses from the flip-flop are fed through the selector switch to the modulator and then to the set where, during the 60-cps sweep time, 15 equally spaced lines are formed on the raster. For the crosshatch pattern, both sets of pulses (vertical and horizontal) are applied to the modulator. For dots, a diode clips the lines except at their points of intersection.

The keyed-rainbow color bars are generated by the offset-carrier method using a signal from the crystal-controlled 3.-563795-mc oscillator in the generator. This signal is fed to the receiver where the phase detector synchronizes it with the receiver's color-reference oscillator at the start of each horizontal-scanning line; the set then regards it as a color signal. Since the frequency difference between the two signals is identical to the horizontal-sweep frequency, their relative phase will vary from 0° to 360° during the time of one scanning line. The result is a color pattern on the color CRT which varies continuously from yellow, red, magenta, blue, cyan, and green. To provide bars, the color signal is keyed at a 189-kc rate, thus providing 12 bars at 30° intervals. One bar is used as color-reference burst, one is lost during retrace and blanking, and the other ten appear on the screen as the common color bar pattern.

The vectorscope is a simple cathode-ray oscilloscope, used to give a visual analysis of the phase relationship of the color-bar signals after they pass through the receiver's color-demodulator and matrixing circuits. Since the phase-relation accuracy of the input signal (generated by the instrument itself) is determined beforehand, any phase shift can be attributed to the receiver's circuits. All controls required for correct operation of the CRT display are mounted on the front panel.

A full description of the uses to which the vectorscope can be applied would require a comprehensive article in itself. However, once an understanding of the operation of the color circuits and their effect on vector position is achieved by the technician, he should be able to make rapid color-trouble analyses. ▲

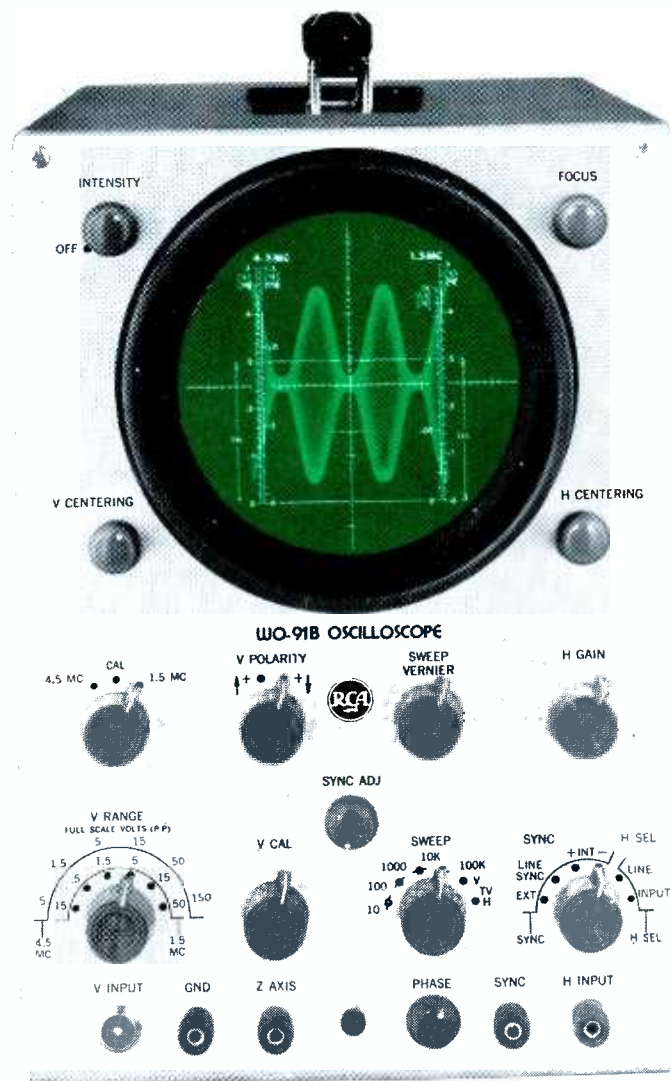

The famous RCA 5-inch scope NOW WITH MORE FEATURES TO SIMPLIFY YOUR JOB

Here's the latest model of the famous RCA 5-inch scope: the **NEW WO-91B**

- Provision for connecting signals directly to the vertical deflection plates of the CRT. Permits observation of high frequency RF waveforms, such as trapezoidal and wave-envelope modulation patterns.
- Two-stage sync separator simplifies checking of TV horizontal and vertical sweep synchronization... provides exceptionally solid lock-in action on composite TV signals.
- Choice of wide-band or high-sensitivity, narrow-band display.
- Complete with RCA WG-300B Direct/Low Cap. Probe and Cable.

• Optional at slight extra cost: RCA WG-354A slip-on capacitance-type voltage-divider probe that extends the range of the scope to permit observation of signal pulse amplitudes up to 5000 volts. RCA WG-302A slip-on RF/IF/VF signal tracing probe for RF applications from 100 Kc to 250 Mc.

- WO-91B Scope: **\$249.50***
- WG-354A Probe: **\$ 7.50***
- WG-302A Probe: **\$ 8.50***

Ask to see it at your Authorized RCA Test Equipment Distributor.

*Optional distributor resale price. All prices subject to change without notice. Prices may be slightly higher in Alaska, Hawaii and the West.

RCA Electronic Components and Devices, Harrison, N. J.



The Most Trusted Name in Electronics

QUALITY TUNER SERVICE

**24
HOUR
SERVICE**

MOST MAKES



**Includes
ALL
makes \$
ALL
parts
ALL labor**

9.50

THAT'S RIGHT:

Each tuner thoroughly cleaned, broken and defective parts replaced, all channels realigned and air checked.

WARRANTY

1 full year against defective workmanship and or parts failure (except tubes).

COSTS:

\$9.50 ea. UHF or VHF and \$14.50 UHF/VHF COMBO. Includes all parts except tubes.

Distributor write for price structure.

PLEASE NOTE:

Ship all broken parts and include model and chassis number. Replacement tuners available at minimum cost. Missing parts supplied at our cost.

Open account on approved credit.

FOR FAST EFFICIENT SERVICE
SHIP TO:
**QUALITY
TUNER SERVICE**

5142 West 25th Street
CHICAGO, ILLINOIS 60650
Area Code 312 652-7600

Circle 22 on literature card



ON THE AUTO BENCH

by Homer L. Davidson

Logical procedures for shop repair of radios with tubes and transistors.

Repairing the hybrid auto radio (one which uses transistors in the output stage and tubes in the rest of the radio) is not really difficult. With a little knowledge of transistors, a noise generator, a DC power supply, and a few tools, you can add several dollars each week to your net profit. Pulling the auto radio is often the most difficult part of auto-radio repair, but, with a little experience, this, too, will be just another small job in a good day's work.

Let's take a look at a typical case involving the hybrid auto radio. Your customer has just pulled into your driveway with a dead radio. The darn thing is stone dead—when you turn on the radio, there is no audible "thump." (If the transistor output stage of a radio is working, you will hear a "thump.") You then determine that the dial light is fed from the same line as the radio and is on. This proves the fuse is okay.

Check the antenna for an open connection or a short to ground. Disconnect it from the radio and place one lead of your ohmmeter on the antenna rod and the other on the body of the car (be sure to make

metal contact). An open reading should be obtained. Water, grease, or an intermittent lead-in connector can cause a short or low-resistance leakage path to ground. Next, touch one ohmmeter lead to antenna and the other to the center pin of the antenna plug; there should be a direct short. Move the lead-in around and notice the ohmmeter reading; an erratic indication suggests a bad connector or lead-in cable. If the lead-in is open, the broken wire is generally at either the plug end or at the base of the antenna. Cut off the plug at the male lead. See if you now have continuity. If not, pull gently on the small coaxial wire. If it comes out, replace the entire lead-in or, better yet, install a new antenna.

If you are unfamiliar with the installation, especially if you haven't pulled a hybrid radio before, take a few minutes to discover the easiest way out. If a direct way is not readily apparent, consult your manufacturer's service file or other reference for suggestions. Be sure to disconnect the "A" lead, antenna cable,



Fig. 2. Lift one end of the base resistor (this is 5.6 ohms) for test.

dial-light cable (some are fed from the panel-light circuit of the car), and speaker plug. With the main chassis out of the way, check the speaker. Some servicemen pull the speaker and move it with the chassis to the bench, and some do not. You should at least make an ohmmeter continuity check of the speaker's voice coil.

If replacement is necessary, since the impedance of hybrid-fed speakers will vary, be sure that the replacement speaker is of the same impedance as the defective one. If not, the output transistor can be quickly ruined. There are several universal-replacement speakers for hybrids, but you should replace with a factory part or reliable exact replacement, if possible.

With the antenna and speaker both checked, place the radio on

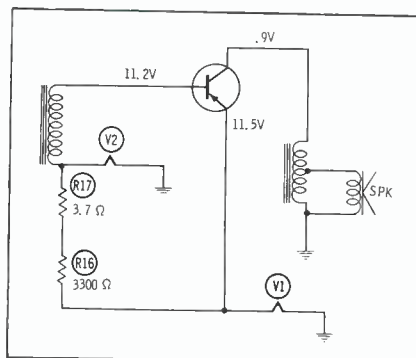

Fig. 1. Transistor-output circuit schematic shows a parallel path to ground.

the test bench. Remove the top and bottom covers, connect the "A" lead to your DC power supply, and plug in your test-setup antenna and speaker.

Since there was no "thump" when the set was turned on, we can suspect that the trouble lies in the transistor audio-output stage. A quick look at a set with similar trouble revealed a burned base resistor, but an ohmmeter check was inconclusive because of the parallel path through the transistor to ground (see Fig. 1). Generally, when the output power transistor is shorted, the base resistor gets hot and often burns open. To insure a correct check of the base resistor, remove one leg of the resistor from the PC board or chassis tie point and measure the resistance. The resistor shown in Fig. 1 should have measured 3.7 ohms, but it was open. (In many car radios the emitter or base resistor may be listed as a fuse.) Check this resistor for continuity using the method just described (see Fig. 2).

In this radio, the "A" lead current was excessive after replacing the base resistor, strongly suggesting a shorted output transistor. It was replaced, and the trouble was cured. If an original replacement isn't available, consult a transistor substitution guide for a usable replacement. Be sure to place a small amount of silicon grease between the mica insulation and the metal plate of the transistor. Also be sure the transistor is not mounted directly to ground. Use the two block insulators which are placed around the metal screws before the unit is inserted onto the chassis. Before turning the radio on, check with an ohmmeter from the outside shell of the power transistor to ground; the resistance should be 2 ohms, the forward resistance of the output transistor, if the ohmmeter leads are connected properly. Be sure to set the bias current according to the manufacturer's recommendation.

In another actual transistor-output trouble, a truck driver brought in a Ford F600 truck radio, which he had removed from the dash panel. The base resistor and power-output transistor were found to be defective and replaced. The set was bench tested and given an okay. In about 15 minutes, the customer

3 Reasons Why It Pays to Use General Electric Renewal Parts

INCREASED CUSTOMER SATISFACTION

The best customer is a satisfied one—satisfied with your service and with the quality of the parts you use. Satisfy your customers with G-E quality.



REDUCED INVENTORY AND SERVICE COST

With G.E.'s continuing parts standardization program you can stock fewer parts. Save time and money in everyday service operations.



FAST PARTS SERVICE

Need a part? Count on General Electric for quick service—your distributor will ship your order promptly.



BUILD PROFITS WITH THESE FAST MOVING TV AND PHONOGRAPH PARTS



Transistor EA15X25



Spindle EA97X174



Knob ET43X299



Polarized Extension Cord
ET90X32

These are four samples of G-E renewal parts, parts that are factory engineered, precision-fitted, and designed for long-lasting performance. Call your nearby General Electric distributor and ask him for Genuine G-E Renewal Parts.

830-38

GENERAL ELECTRIC

Circle 23 on literature card

April, 1965/PF REPORTER 57

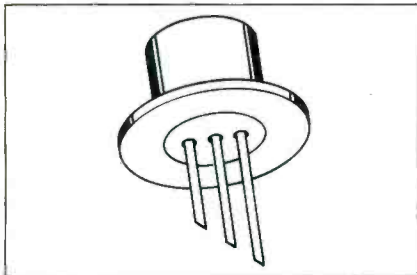

Fig. 3. Clip transistor leads to uneven lengths for easy replacement. called to say the radio still didn't work. We told him to bring the truck on down to the shop, so we could check it out.

We pulled the chassis, and it

worked perfectly on the bench. We asked the customer if the battery in his truck had been replaced or charged recently. He said it had, so we took a quick look under the hood; the cables were hooked up to the proper terminals. We clipped a voltmeter across the 12-volt battery and, as we suspected, the battery indicated a reverse polarity. If care is not taken to observe correct polarities, this reverse-charge condition can occur, with some noninterlocked chargers, whenever the battery's residual voltage has fallen to near zero.

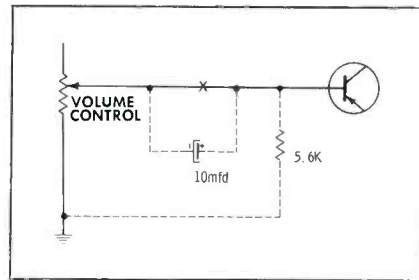

Fig. 4. Factory field changes will improve operation of some auto radios.

The next radio was from another Ford, a Model 04MD. This unit had a transistor audio driver as well as a transistor output stage. The set was dead, but the cause was not apparent so we used the following method to isolate the trouble: We fed a signal from the noise generator to the high end of the volume control. There was no audio output. (A loud audio signal will be heard if the entire audio section is good.) We moved the noise generator output lead to the base of the output transistor and got a good signal, so we knew the trouble must lie between the volume control and base connection on the final output transistor. From the base of the first audio driver, there was no signal in the speaker; but from the collector terminal of the same stage there was good audio response. It looked like a bad transistor, so we took voltage readings with a VTVM using the manufacturer's service data for reference. The base and collector readings were almost identical (indicating a collector-base short), so the transistor was pulled and a new one inserted in its place.

To replace a transistor mounted on a printed-circuit board, first remove the old one using a 25-watt soldering iron and desoldering tools, then clean out the mounting holes with a round toothpick or other pointed tool. Leave the leads on the transistor uncut and carefully work the leads through the board. Resolder using light resin-core solder and the 25-watt iron; then cut the leads close to the underside of the board, using a small pair of side cutters. If you find it difficult to insert all three transistor leads through the board at once, cut the leads to different lengths (see Fig. 3), and the job will be simple. Remember to check a reliable substitution guide, if you don't have an exact-replacement transistor.

a lot of good dealers here ...



but room for lots more

CAN YOU QUALIFY?

- Do you have a sound knowledge of radio and/or communications equipment?
- Have you the desire to install and service this unique equipment?
- Do you have an established business reputation? Good credit rating?
- Have you a real interest in dynamic new products?
- Do you want to make really big profits?

MANY PRIME AREAS STILL OPEN . . .
WRITE TODAY FOR FULL DETAILS!

Be an authorized
e.c.i. dealer
with the most
profitable
CB & BB 2-way
radio line in the
country!

Name
Address
City State

 **electronics communications, inc.**
dept. PF4, 56 hamilton ave., white plains, n. y.

Circle 24 on literature card

FULL COLOR TV COVERAGE IN PHOTOFACT[®]

gives you up-to-the-minute servicing know-how!

COLOR TV COVERAGE AVAILABLE IN PHOTOFACT THROUGH FEBRUARY 1965:*

Photofact Set	Brand	Photofact Set	Brand
252	RCA Victor	640	RCA Victor
259	Westinghouse	643	Andrea
262	Arvin	644	Westinghouse
265	Stromberg-Carlson	650	DuMont
283	Motorola	653	Magnavox
293	CBS-Columbia	655	Silvertone
299	Spartan	658	Sylvania
300	RCA Victor	660	Bradford
305	Hoffman	663	Zenith
314	RCA Victor	665	Curtis Mathes
320	Sentinel	670	Coronado
323	Magnavox	673	RCA Victor
324	Airline	678	General Electric
327	Capehart	680	Airline
344	Sentinel	683	Philco
346	Philco	685	Packard-Bell
353	RCA Victor	688	Zenith
357	Westinghouse	690	Westinghouse
358	RCA Victor	693	Sylvania
371	Motorola	695	Motorola
378	Raytheon	698	Philco
382	Truetone	700	Airline
383	Admiral	703	Admiral
385	Hoffman	705	Zenith
386	Packard-Bell	708	Magnavox
388	Silvertone	710	Magnavox
399	RCA Victor	713	Silvertone
412	Emerson	715	Setchell-Carlson
433	RCA Victor	716	Truetone
437	Westinghouse	717	Penncrest
459	RCA Victor	719	Emerson
495	Admiral	721	Motorola
517	RCA Victor	722	Zenith
540	Admiral	724	DuMont
546	Packard-Bell	726	Coronado
565	General Electric	727	Muntz
576	DuMont	729	General Electric
584	Silvertone	731	Olympic
588	Magnavox	732	Electrohome
592	Emerson	734	Andrea
596	Olympic	736	RCA Victor
599	Zenith	737	Catalina
614	Packard-Bell	739	Motorola
626	Sylvania	741	AMC
627	Delmonico		

* An average of 3 Color TV chassis now covered monthly in current PHOTOFACT

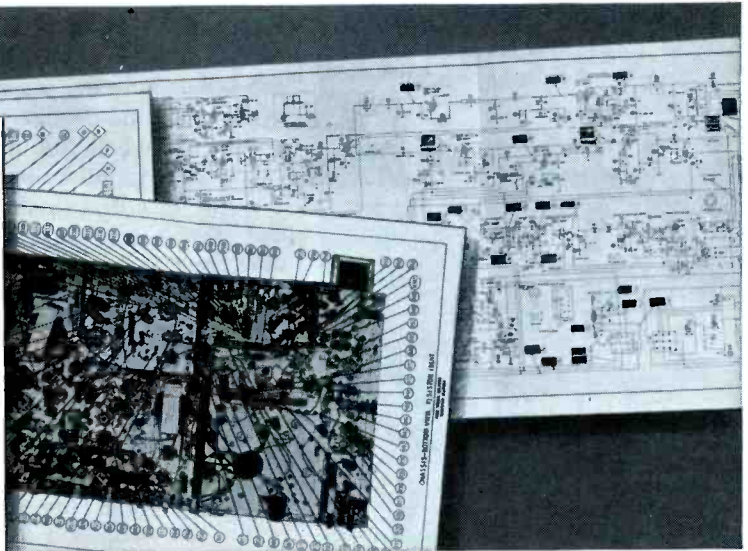

HAVE EVERYTHING YOU NEED TO PERFORM EXPERT PROFITABLE COLOR TV SERVICING!

- Famous SAMS "Standard Notation" Detailed Schematics
- Chassis View Photos
- Disassembly Instructions
- Set-up Adjustments
- Full Alignment Data
- Resistance Charts
- Tuner Schematics
- Block Diagrams
- Waveform Diagrams
- Tube Placement Charts
- Complete Parts Lists

Plus dozens of other invaluable PHOTOFACT features

FOR THE COLOR TV COVERAGE YOU NEED, check your latest PHOTOFACT Master Index—the issue dated February, 1965 includes a special section listing all Color TV makes and models now covered in PHOTOFACT—so you can instantly locate the Color TV PHOTOFACT Folder you want. See your Sams Distributor—he stocks all PHOTOFACT Sets to fill your requirements immediately.

NOW MORE THAN EVER—A PHOTOFACT LIBRARY AND SUBSCRIPTION PAYS OFF!

FREE

Deluxe new 4-drawer File Cabinet (full-drawer suspension) worth \$55—now available with your purchase of a PHOTOFACT LIBRARY consisting of 200 Sets (plus a selection of valuable Free extras!)

4 Ways to Select Your PHOTOFACT Library: 1. Complete your present PHOTOFACT Library. 2. Order a "Starter" Library—200 Sets (Nos. 401-600—coverage from 1958 to 1963—only \$12.66 per month). 3. Order by brand name and year—see handy selection chart at your Distributor. 4. Order a complete PHOTOFACT Library—get FREE file cabinets, plus a selection of valuable books and Electronics Courses.

SEE YOUR SAMS DISTRIBUTOR FOR FULL DETAILS, OR MAIL COUPON

OWN A PHOTOFACT LIBRARY THE EASY-BUY WAY

Only \$10 down • 30 months to pay • No interest or carrying charges • Prepaid transportation • Add-on privilege of a year's advance subscription to current PHOTOFACT on the same Easy-Buy contract • Save 30c per Set—special \$1.95 price applies on Easy-Buy (instead of the regular \$2.25 price).

HOWARD W. SAMS & CO., INC.

Howard W. Sams & Co., Inc. Dept. PFF-4
4300 W. 62nd St., Indianapolis, Ind. 46206

- Send FREE Photofact Cumulative Index.
 Send full details on Easy-Buy Plan.

My Distributor is: _____

Shop Name _____

Attn. _____

Address _____

City _____ State _____ Zip _____

**a tool chest
in your
pocket**

for electronic assembly
and service work

Shockproof (UL), breakproof,
plastic handles with clips

ROUND BLADE SCREWDRIVERS
3/32" and 1/8" x 2", 3", and
4" blades

PHILLIPS SCREWDRIVER
Point size #0, 2" blade

BERYLLIUM-COPPER SCREWDRIVER
Non-magnetic, non-sparking
1/8" x 2" blade

NUSTRIVERS
10 Mex sizes from 3/32" to 3/8"
1 1/2" blades
Color coded handles

TERMINAL WRENCHES
Fit 1/4" and 3/8" O.D. spanner nuts
on external antenna and phone
jacks of transistor radios

WRITE FOR LITERATURE

XCELITE®

**PROFESSIONAL
POCKET TOOLS**

XCELITE, INC., 18 Bank St., Orchard Park, N.Y.
Canada: Charles W. Pointon, Ltd., Toronto, Ont.
Circle 25 on literature card

60 PF REPORTER/April, 1965

While we are discussing the audio section, we can't ignore the volume control itself. We once had a Delco Model 98542 car radio in the shop for repair of a noisy volume control. We tried a shot of cleaner-lubricant, but the potentiometer still was noisy at the low-volume end. Replacing the control itself was simple, but a field change is factory-recommended to provide quieter operation and longer life. The modification consists of a coupling capacitor inserted between the base pin of the first audio transistor and the center tap of the volume control. A base-bias resistor is added from the base of the transistor to ground as shown in Fig. 4. All parts for the change are furnished with the factory replacement.

It is always a good policy to replace any auto volume control with exact replacement part, if possible. These can come from manufacturer of the set, of course, but there are also other manufacturers who make exact replacements which will generally do the job as well.

Checking The Front End

We once pulled an intermittent set and hooked it up to the test bench. By pressing firmly on the etched board, we could make the intermittent appear and disappear. Pushing around gently among the set's components with the eraser end of a pencil, we found that one of the IF transformers seemed to be close to the intermittent trouble. To pinpoint the troublesome section, we disconnected the antenna lead and connected our noise generator to the high end of the volume control. The audio section checked okay. We then applied the noise signal to the base of the second IF stage—here, we could induce the intermittent.

Because a transistor seldom behaves as an intermittent element (it either works, or it doesn't) we suspected the IF transformer. The transformer was replaced, and the set was restored to normal operation. Replace IF transformers with a factory part or an exact replacement.

Oscillator Bothers

To illustrate what a pain oscillators can be, let me tell you about a car radio that faded out on the high end of the band. We checked the

radio in the car; after a few minutes, the high end was dead. A few local stations at the low end played perfectly.

We pulled the radio and tied it into the test bench; in a few minutes, as it had in the car, the high end went out. The symptom is common to oscillator-tube problems in older sets, and to transistor problems in newer sets. This set used a transistor, so we replaced it, and the set played just fine on the high end of the band. To give it a severe test with the new oscillator transistor, we lowered the "A" lead DC voltage to 9 volts from the normal 12 volts, and it still played okay. (*The use of a variable transformer as a troubleshooting aid is described in a February 1964 article in PF REPORTER.* —Ed.)

Don't overlook the obvious repair. For example, another customer came in with trouble in his car's radio. There was a loud RF rushing sound, but the set would pick up no stations. The antenna checked out okay, so we pulled the set and placed it on the bench. Our preliminary examination revealed a broken lead from the oscillator tuning section. We replaced it, and the set worked like new. Total time on the bench—three minutes; and we had a satisfied customer.

A Few Do's and Don'ts

When you have completed a repair, make a few last-minute checks. Be sure the pointer runs smoothly across the dial; test for slippage at both extremes. Be sure the dial calibration is correct. Don't forget that some trucks and foreign cars use a positive ground. Check the push buttons after the radio has been installed in the car. Don't forget to adjust the antenna trimmer with the radio installed.

Last but not least, as a good customer-relations project, brush off the car seat, wipe off the dash panel, and sweep the floor mats.

Remember that most of the problems you'll find in servicing hybrid auto radios have their direct counterpart in normal tube types. Use common sense, your experience in troubleshooting tube types, and a logical signal-tracing procedure, and you'll make quick work of auto radios—hybrid types or standard models. ▲

NOW

*convergence and color adjustments
are easier, faster, more accurate!*

NEW B&K MODEL 1240 LOW PRICED PORTABLE COLOR GENERATOR

with crystal-controlled keyed rainbow color display!



Thinnest Horizontal Lines! Smallest Visible Dots!
(Just one raster scanning line thick)

**Simplifies In-Home (or Shop)
Color TV Set-Up and Servicing**

only
\$134⁹⁵
NET

You're the color TV expert when you use the "1240." You have the advantage of B&K quality—with features not available before at such surprisingly low cost.

Provides crystal-controlled keyed rainbow color display on TV screen to test color sync circuits, range of hue control, and align color demodulators. Shows ability of TV receiver to display color values.

Provides dot pattern, crosshatch, horizontal and vertical lines. Highly stable crystal-controlled count circuit with small-step count assures greater reliability and stability of color, dots, and lines. All horizontal lines and

dots are just one raster scanning line thick. Lines begin off-screen and end off-screen, with no break in line. Dot brightness is adjustable with easily accessible control. Chroma Level Control simplifies color sync trouble-shooting.

Operates on channels 3, 4, and 5, and adjustable without removing cabinet. No connection inside TV set is needed. Power transformer operated and line isolated to prevent shock hazards. Operates reliably on 105-125 VAC, 60 cps. (Color Gun Killer is available as optional accessory.) Extreme lightness and portability (9 lbs.) make it ideal for in-home servicing.



*See it at your B&K Distributor
or Write for Bulletin AP21-R*

B & K MANUFACTURING CO.
DIVISION OF DYNASCAN CORPORATION
1801W. BELLE PLAINE AVE. • CHICAGO, ILL. 60613
Canada: Atlas Radio Corp., 50 Wingold, Toronto 19, Ont.
Export: Empire Exporters, 123 Grand St., New York 13, U.S.A.

IN-CIRCUIT TESTS



Evaluate Tubes

by Larry Allen

Ever get caught with your tube tester out of whack? Or find yourself looking at the bottomside of a huge TV chassis, wondering if a tube is good or bad, and dreading the thought of grappling with its jagged corners so you could turn it over to recheck a tube? Or push a tube into your tester, beat it, bang it, thump it and bump it, see the meter needle settle at GOOD, but feel sure that same darn tube won't do the job back in its socket?

The solution to these problems is: *Test the tube right there in its socket!* You can, you know; in fact, you can test several important characteristics without pulling the tube at all. The in-circuit tests in this article run the gamut from simple quality tests to a sophisticated (yet uncomplicated) gas test.

Tube Parameters

Tube parameters is an engineering term that describes those characteristics of a tube that can be measured (or metered). Parameters of *normal* operation include: element (pin) voltages; plate, screen, cathode, grid, or filament currents; power or voltage gain (μ); transconductance or mutual conductance (G_m); etc. Tests of tubes are frequently concerned also with parameters of *abnormal* operation. Most important of these are: grid leakage or grid current; gas among the elements; and interelectrode shorts or leakage. Which of these parameters can be checked in the circuit? The answer is: All of them!

How? Consider, first, that a tube tester measures certain parameters and compares them to an average value predetermined by the tester designer. Consider, second, that the designer determines what values are average by testing production-run tube samples. He

then devises tester settings that produce a normal reading on the GOOD-BAD meter. Sometimes he studies tube specifications to arrive at settings that provide "normal operating conditions."

Now, apply these considerations to testing a tube in the circuit. If you can simulate normal operating conditions as you'd find them in the tester. . . . But, what are we talking about? In the circuit, the tube *is* operating under normal conditions. Therefore, many parameters can be evaluated without doing anything more complicated than measuring a few voltages—plus maybe some resistances—and applying a bit of Ohm's law. Other operating characteristics can be measured by introducing carefully controlled (by you) test parameters and noting their effect on other parameters.

Ohm's law and a knowledge of tests will enable you to evaluate most tubes quite adequately. Until you've built a backlog knowledge of what to expect from tests like these, you'll need a list of specifications and normal operating conditions for comparison with your test results. Receiving-tube manuals from General Electric, RCA, Sylvania, and Tung-Sol cover most receiving-type tubes you'll encounter.

Measurement Techniques

We'll tell in this section how to measure each parameter of significance to the service technician. For the sake of study, we can group the parameters into three major categories—AC power, DC distribution, and signal parameters.

AC Power Tests

The only AC power tests of any real significance are heater (filament) voltages and currents. The important fact to remember, especially with series-string filaments, is that the correct voltage must be applied to each tube heater if the other tests you make are to be dependable. If the cathode is cool, emission will be weak; if it is too hot, erratic operation may result from overemission; or, a weak tube may seem temporarily okay.

Checking heater current is more of a task than measuring heater voltage, unless you have an AC milliammeter. However, if you need to know heater current, connect an accurate 1-ohm resistor in series with the heater and measure the AC voltage across the resistor. As shown in Fig. 1, each .1 volt measured is equal to 100 ma of heater current; typical values are listed on the schematic.

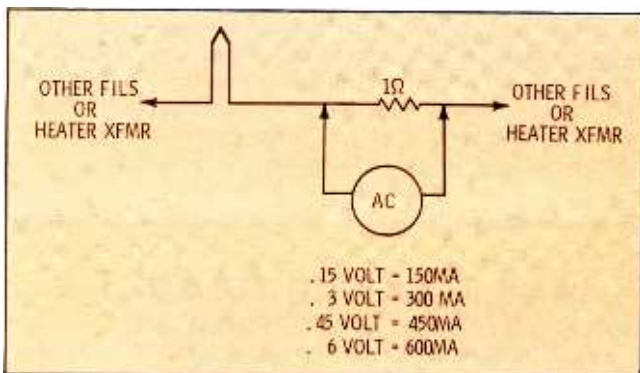

Fig. 1. Method used for measuring AC filament current.

GOOF-
PROOF

VOM



Here's the most foolproof volt-ohm-milliammeter ever made. Protection approaches 100%. It's the VOM you will want to have on hand where inexperienced people are running tests . . . or will reach for yourself on those days when you're all thumbs. The 260-5P will save you all kinds of headaches from burned out meters and resistors, bent pointers, and inaccuracies caused by overheating.

Combined Protection You Won't Find In Any Other VOM

1. Reset button pops out to indicate overload.
2. You cannot reset circuits while overload is present.
3. Protective circuit does *not require* massive overloads which can cause hidden damage to the instrument.
4. All ranges are protected except those not feasible in a portable instrument—1000 and 5000 volts DC and AC; 10 amp DC.

SIMPSON
260-5P

ONLY \$78.95

Write for Bulletin 2066

Ranges—The 260-5P has the same ranges and takes the same accessories as Simpson's famous 260-4 volt-ohm-milliammeter.

Simpson
INSTRUMENTS THAT STAY ACCURATE

Representatives in Principal Cities
...See Telephone Yellow Pages



SIMPSON ELECTRIC COMPANY

5209 W. Kinzie Street, Chicago, Ill. 60644 • Phone: (312) EStbrook 9-1121
Export Dept.: 400 W. Madison Street, Chicago, Ill. 60606 Cable, Amergaco
In Canada: Bach-Simpson Ltd., London, Ontario
In India: Ruttonsha-Simpson Private Ltd., International House, Bombay-Agra Road, Vikbrali, Bombay

WORLD'S LARGEST MANUFACTURER OF ELECTRONIC TEST EQUIPMENT

Circle 27 on literature card

April, 1965/PF REPORTER 63

a new money-making,
traffic-building tube tester

for you or your customer!



THE ALL NEW SENCORE TC131 SEMI-AUTOMATIC TUBE CHECKER

After thousands of requests here is the "counter/bench" version of the famous Sencore Mighty Mite Tester; designed for the ultimate in tube checking thoroughness and operational simplicity! Designed for two-way use — as a professional shop tester and customer self-service unit. Tests over 2500 tubes — including Nuvistors, Compactrons, 10-pins, Novars, Magnovals and foreign tubes with a big 6-inch meter for easy reading. Semi-automatic; simply turn function control to any test and watch lighted arrow on meter automatically stop on right scale. User can't go wrong — no guess work — everything is read right on the meter (no tricky neon lights to misread); only 3 set-up controls. Easy to read, speed-indexed set-up cards make every test fast and sure. Like the famous Mighty Mite, the TC131 uses 100-megohm grid leakage sensitivity to spot those "tricky" tubes other testers miss; tests inter-element shorts and makes cathode emission tests under full operating levels. A real profit maker as a counter checker or self service tube seller in your shop . . . and it's only

\$129⁹⁵

See your distributor about the big TC131 trade-in deal.

professional quality — that's the difference!

SENCORE

426 SOUTH WESTGATE DRIVE • ADDISON, ILLINOIS

Circle 28 on literature card

64 PF REPORTER/April, 1965

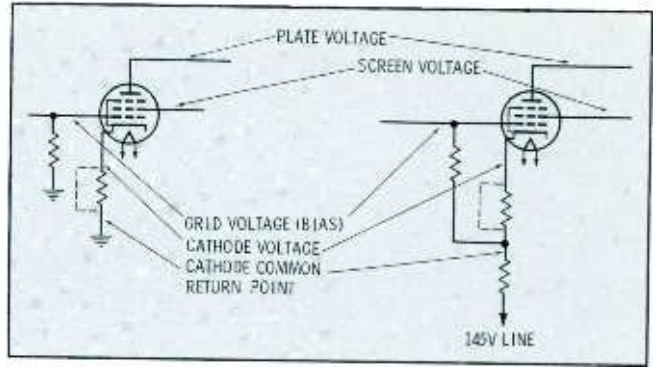

Fig. 2. Reference points for measurement of tube voltages.

DC Parameters

Measurement of DC operating voltages and currents becomes slightly involved, because some interact with others. In a pentode, for example, lower-than-normal screen voltage will not only reduce screen current but will also lower plate current; in fact, a 10-volt shift in screen voltage will have more effect on plate current than will a 10-volt change in plate voltage. A small shift in grid bias will have a greatly exaggerated effect on plate current and a considerable effect on plate voltage because of the greater or lesser voltage drop across the supply resistor as current rises or falls.

The tube-operating parameter measured more often than any other is *plate voltage*. However, this parameter is so dependent on the others, and on conditions in the associated circuit, that it assumes relative unimportance except as a clue to improper operation. Thus, if plate voltage is too high or too low, the next step is to measure other parameters—to find which is causing the plate-voltage upset. Actual plate voltage is measured with a DC voltmeter, with the negative lead connected to the cathode return point (maybe it's ground, and maybe not—see Fig. 2).

Other tube potentials are measured in the same way—with a DC voltmeter connected between the element pin and the cathode return point. *Cathode*, *screen*, and *grid* voltages are secondary clues in troubleshooting logic; they can often explain exactly why the plate voltage is incorrect, or at least direct you to the fault. Also, they are important for our in-circuit evaluations.

After plate voltage, *plate current* is probably the next most important DC parameter. There are several ways to measure plate current; some are direct and some indirect. Which you use depends on whether the circuit is printed or hand-wired, how easy it is to unsolder the circuit, what kind of plate load is used, etc. Fig. 3 shows several methods.

Inserting a milliammeter in the plate lead is the most direct way, but this requires either unsoldering the plate-pin connection or temporarily slitting the PC-board foil near the tube socket. A more convenient method is to measure voltage across the plate supply resistor (plate load, usually) and calculate the current by Ohm's law. If there is no resistor in the plate circuit, either the direct milliammeter test or an indirect method will have to be used.

One indirect, but often convenient, way to find plate current is to measure *cathode current*. This can be done (Fig. 3) by opening the cathode ground-return lead

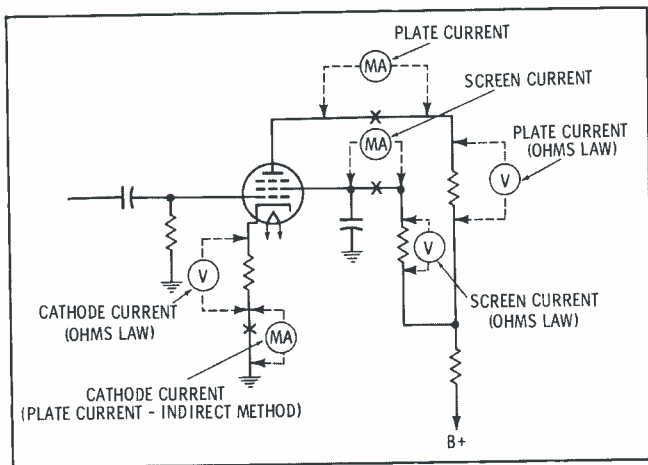

Fig. 3. Metering locations for testing a tube in its circuit.

and inserting a milliammeter, or by measuring voltage across the cathode resistor (if one is used) and calculating current by Ohm's law. However, remember that, in a pentode, cathode current isn't exactly plate current, because a small part is picked up by the screen.

The *screen current* in most pentodes is small in comparison with plate current, and can be determined by one of the means shown in Fig. 3. The voltmeter-Ohm's-law method depends on there being a screen-supply resistor; if there isn't, the milliammeter will be necessary. Keep in mind, then, that cathode current is the combined value of plate and screen currents. Just as you can calculate plate current by subtracting screen current from cathode current, you can also find screen current by subtracting plate current from cathode current.

Important to tube operation is *plate dissipation*, found by multiplying plate voltage and plate current. If the wattage given in the specifications is exceeded, tube life will be reduced seriously.

Screen dissipation can be calculated easily from screen voltage and current values by using the formula $P=EI$. This parameter is not of prime importance to evaluation, but excessive screen dissipation will destroy or reduce the life of a tube more quickly than will excessive plate dissipation. The screen is a delicate element compared to the plate.

Emission is one key to tube quality (the other is gain) because, if the cathode can't provide enough electrons, tube current won't be sufficient to support amplification. Cathode current is the handiest criterion for judging emission capability, provided operating voltages are "normal" values. In the section on Testing, we'll show how to set up tubes for evaluating emission.

Signal Parameters

Most important of all parameters in the operation of a vacuum tube is that of *gain*. Tube operation usually depends heavily on amplifying ability. Amplification can also be viewed as the ability of various tube elements—particularly the grid—to control the plate current. In engineering and design parlance, the terms *transconductance*, *mutual conductance*, and *voltage gain* (μ) or *power gain* all refer to the amplification factor of the tube. We'll show you presently how to calculate *transconductance*—the characteristic usually listed in tube manuals; thus you can compare your results easily

add an fm-stereo service center
with this one new
sencore unit!

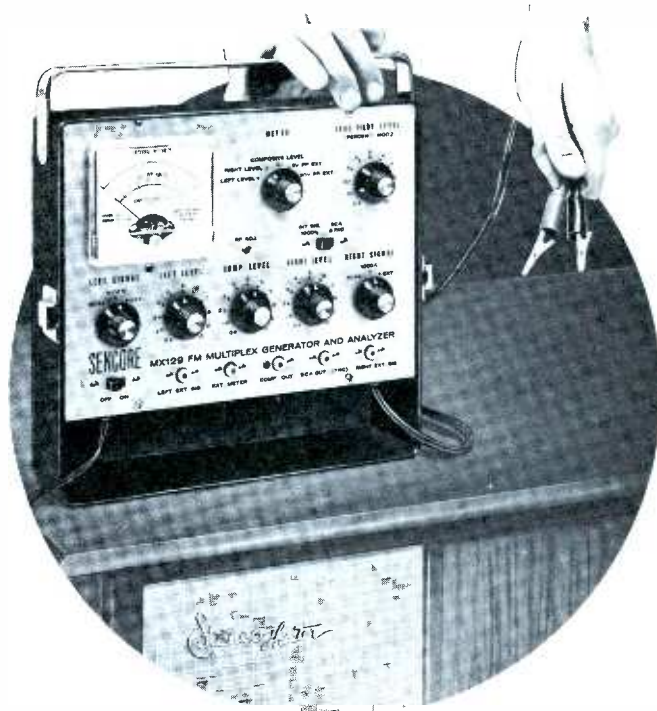

THE SENCORE MX129 FM STEREO MULTIPLEX GENERATOR & ANALYZER

FM-Stereo growth continues to mount and is fast becoming as big a field as Color TV. This means more FM-Stereo service business for you, now and in the future. Is your shop equipped? It can be—completely and economically—with the MX129, the FM-Stereo "Service Center in a Case." The instantly stable, 19-Transistor, crystal controlled MX129 is the most versatile, most portable (only 7½ pounds), most trouble free and efficient multiplex unit on the market—just like having your own FM-Stereo transmitter on your bench or in your truck. Powered by 115 volts AC, it produces all signals for trouble shooting and aligning the stereo section of the FM receiver... can be used to demonstrate stereo FM when no programs are being broadcast. Self-contained meter, calibrated in peak to peak volts and DB, is used to accurately set all MX129 controls and as an external meter to measure channel separator at the FM-Stereo speakers. NO OTHER EQUIPMENT IS REQUIRED. **\$169⁵⁰** only

SIGNALS AVAILABLE FOR ALIGNMENT, TROUBLE SHOOTING AND ANALYZING:

- FM-RF carrier with composite multiplex audio signal with 38kc suppressed carrier, 19kc pilot and 67kc SCA signals
- Multiplex signal formed by 60 or 1000 cycle internal tones or any external signal
- Full control over left and right channel amplitude (modulation)
- External 67kc SCA signal available for trap adjustment
- Composite signals available for signal injection FM detector

professional quality — that's the difference!

SENCORE

426 SOUTH WESTGATE DRIVE • ADDISON, ILLINOIS

Circle 29 on literature card

April, 1965/PF REPORTER 65

at last...
instant color patterns
at your finger tips...
zero warm-up time



THE ALL NEW SENCORE CG135 DELUXE TRANSISTORIZED COLOR GENERATOR

The big push is on in Color TV. Equip yourself now with the new, solid state Sencore CG135 and cash in on the zooming volume of new service business as Color-TV booms! Instant, service-ready RCA standard color bars, cross-hatch, white dots and individual vertical and horizontal bars enable you to set up or trouble-shoot more Color TV sets per day; earn top money in this fast growing service field. It's an analyzer too: Color gun interruptors, unmodulated video for chroma circuit trouble isolation and unmodulated sync pulses to keep Zenith receivers in sync for this test, make color trouble shooting a snap. Sturdy all-steel construction for rugged, heavy duty in the field or shop. Another Best Buy in profit-building service instruments from Sencore at

\$149⁹⁵

COMPARE THESE FEATURES: SEE WHY THE CG135 IS IN A CLASS BY ITSELF

- Solid state construction employs high priced GE "Unijunctions" to develop six "jump out proof counters" that guarantee stable patterns at all times with no warm-up
- Standard RCA licensed patterns as shown on schematics throughout the industry
- Handy universal color gun interruptors on front panel
- Lead piercing clips insure non-obliscence
- CRT adaptors optional
- Crystal-Controlled 4.5mc Sound Carrier Analyzing Signal to insure correct setting of fine tuning control
- RF output on Channel 4 adjustable to Channel 3 or 5 from front of generator when Channel 4 is being used
- No batteries to run down; uses 115 V AC
- Less than one foot square, weighs only 8 lbs.

professional quality — that's the difference!

SENCORE

426 SOUTH WESTGATE DRIVE • ADDISON, ILLINOIS

Circle 30 on literature card

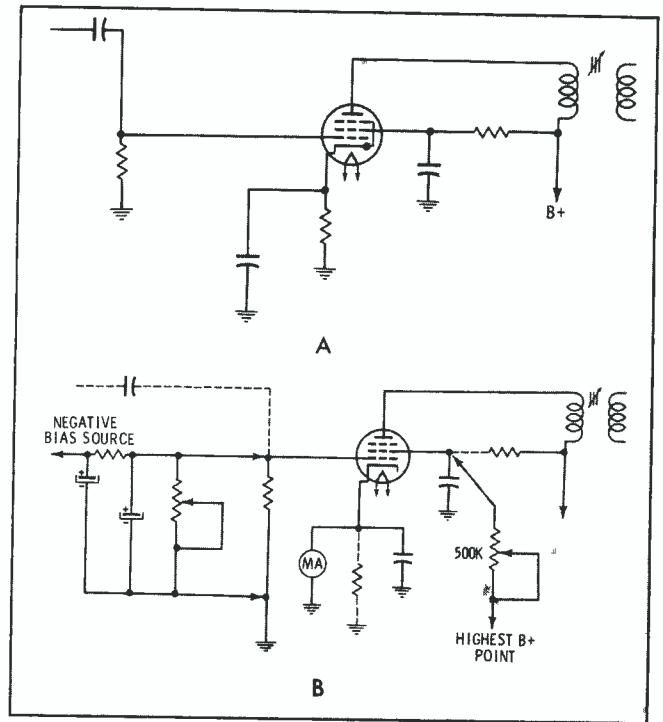

Fig. 4. To set "normal" operating values of current, voltage.

with published specifications.

The effect of the grid on plate current can be measured by feeding a signal voltage to the grid and measuring how much greater the signal is at the plate. You can do this right in the circuit, using an external signal (one you provide from a generator) or a signal source from inside the set. The external source is best, because its output level can be more easily set at any desired value.

Testing and Evaluating

Now that you understand the terminology, we can discuss evaluation tests in terms of what to expect and how to analyze your results. We'll show emission, transconductance, leakage, noise, and gas (grid emission) tests.

General Setting Up

All DC operating voltages should be the same every time you test tubes of a particular type, so the results can be evaluated on an equal basis. You must also consider the circuit in which the tube is used, but, within limits, you can set DC conditions to suit "normal operation" as specified in the tube manual.

Take a look at the typical IF amplifier in Fig. 4A. It contains a transformer-type plate load, so plate current must be measured directly or via a cathode reading. There is a screen resistor, so the Ohm's-law method will work for screen current.

Since a cathode resistor is provided, the Ohm's law method *seems* okay for measuring cathode current, too. But look again. The cathode resistor is used for bias; to set the bias at what we want it to be, we'll have to eliminate the cathode resistor temporarily and furnish bias of our own (see Fig. 4B). This in turn makes a milliammeter test more suitable for cathode current. The little device shown in Fig. 5A can apply whatever bias the tube manual suggests for the tube. The nega-

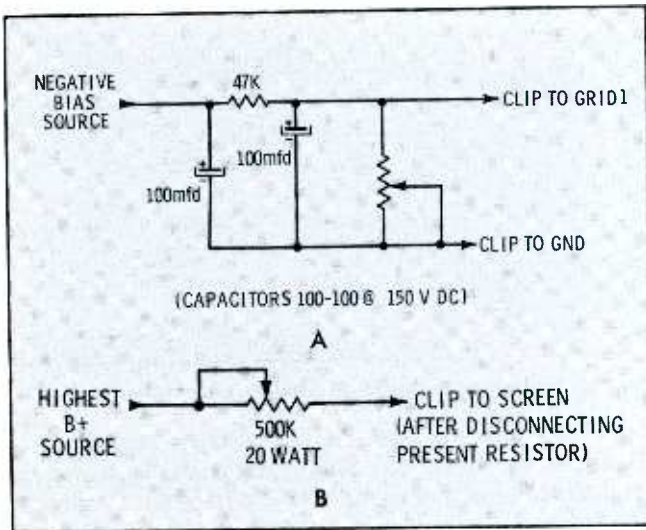

Fig. 5. Some simple devices for making in-circuit tube tests.

tive voltage source can be a bias box or any highly negative DC point in the set (the horizontal-output grid is a good place, usually).

Once bias is set at the indicated value, make sure the screen voltage is also at the specified voltage. If it isn't, use the simple device shown in Fig. 5B to set it. The circuit of Fig. 4A, after connections are made for meaningful comparison with normal ratings, looks like Fig. 4B.

Emission

Many low-cost testers evaluate only the *emission* of tubes, because no tube can function correctly unless sufficient electrons are emitted by the cathode. Since cathode current is the best measure of cathode emission, set up the tube for normal operation according to the manual and read the cathode current on a milliammeter.

Note that if bias using the cathode resistor is the same as that specified in the tube manual, there is no need to attach an external biasing device. Furthermore, there is no need to use a milliammeter; the Ohm's-law method can be used with a simple voltmeter reading across the cathode resistor.

If the tube is up to par, cathode current will be within 20% of the value indicated in the tube manual for plate and screen currents (add them). If cathode current is 30% below normal, the tube is questionable; 40% is pretty poor.

Transconductance

Cathode emission only partly determines whether a tube will actually do its job properly. Even though sufficient electrons are available in the plate-current stream, the tube won't amplify unless the grid can control them properly. Consequently, we should—to evaluate a tube adequately—have some easy way to check grid action. This controllability is revealed in the evaluation of *transconductance*.

Transconductance (Gm) is a measure of the grid-voltage swing required to cause a particular plate-current (not voltage) change. The term thus takes into consideration the plate resistance besides the amplification factor (μ). Simplified, the formula for transconductance is plate-current change divided by grid-voltage change ($G_M = I_p / E_g$). The term *mho* (pronounced

top money maker in
the service business



NEW IMPROVED SENCORE CR133 CRT CHECKER & REJUVENATOR

The new, improved CR133 CRT Checker is designed to test all present picture tubes — and it's ready for future tubes too! Two plug-in replaceable cables contain all sockets required. The compact, 10 lb., CR133 checks CRT emission, inter-element shorts, control grid cut-off capabilities, gas and expected life. Checks all tubes: conventional B&W, new low drive B&W, round color tubes and new rectangular color picture tubes. Exclusive variable G2 Volts from 25 to 325 Volts insures non-obsolescence when testing newly announced "semi-low" G2 CRT tubes. New Line Voltage Adjustment insures the most accurate tests possible. Uses well-filtered DC for all checks to avoid tube damage and reading errors. Color guns are individually tested as recommended by manufacturers. Exclusive automatically controlled rejuvenator applies rejuvenation (ACR) voltage as required by individual tube condition; precisely timed to prevent over-rejuvenation or tube damage. The ACR feature is most useful for color tube current equalization to insure proper tracking. Hand-wired and steel-encased for protection of meter and panel in truck or shop, the new improved CR133 is only . . . **\$89⁹⁵**

The famous CR128 CRT Checker and Rejuvenator is similar to above, but with a three position G2 slide switch and without Line Voltage Adjustment at \$69.95

professional quality — that's the difference!

SENCORE

426 SOUTH WESTGATE DRIVE • ADDISON, ILLINOIS

Circle 31 on literature card

April, 1965/PF REPORTER 67

just in time for the
fm and uhf boom!
an all transistorized
field strength meter.



THE ALL NEW SENCORE FS134 FIELD STRENGTH METER

Once again, you can turn to the roof tops for a fast dollar in antenna installations. But this time, you can do it the easy way. No more running up and down ladders, locating cumbersome AC extension cords, lugging heavy tube operated field strength meters on the roof, or worse yet, getting the shock of your life from the AC line as you hold onto a soil pipe. Here is a new portable field strength meter to fill your every need in VHF, UHF or FM antenna installations. Many customers want all antennas on one mast thus creating interaction. Here is where the FS134 goes to work. You can optimize antenna location and orientation in seconds. Just connect the antenna, tune in the station and adjust. Self-contained speaker blasts forth the sound from the TV or FM station to insure that you have the exact signal that you are looking for. The FS134 is so light weight (only 9 lbs.) that you can take it with you up the chimney if necessary. Get rid of the assistant at the other end of the transmission line and the needless "yelling" back and forth. Get the FS134 today . . .

only

\$199⁵⁰

COMPARE TO ANY OTHER FIELD STRENGTH METER
AT TWICE THE MONEY

- Sensitivity . . . 5 microvolts on VHF and FM, 15 microvolts on UHF
- Input impedance . . . 300 ohms or 75 ohms with plug-in transformer
- 500 KC band width
- Powered by easy to get "C" cells
- 4 inch meter with 2 percent accuracy calibrated in DB and microvolts.

professional quality — that's the difference!

SENCORE

426 SOUTH WESTGATE DRIVE • ADDISON, ILLINOIS

Circle 32 on literature card

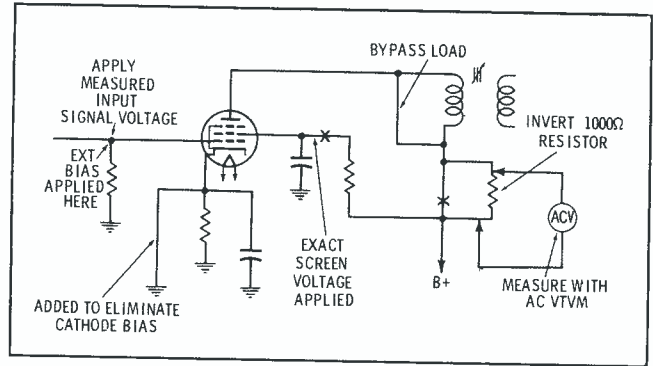

Fig. 6. Evaluating amplifying ability of a tube in circuit.

"moe"), which obviously is *ohm* spelled backward, is used to state the result. Since G_m generally is only a small fraction of a mho, the term micromho (millionth of a mho) is used.

To measure transconductance, you first apply a known signal to the grid. Then the plate-signal voltage must be measured and converted by Ohm's law to current. The test setup in Fig. 6 shows the details of this test. Note that bias and screen voltages have been set for normal operation as outlined earlier.

A sine wave is best for evaluation; so, you can feed in a 1000-cps signal from an audio generator, a 60-cps signal taken from the set's own power supply, or a signal of whatever frequency is normally used with the tube. Don't use RF or IF signals, however, unless you have a voltmeter that reads accurately at RF frequencies. Coupling from the preceding stage must be disabled to avoid having any signal other than the test signal applied to the tube.

Apply the test-signal voltage to the grid—be sure the tube doesn't overload—by raising the signal level until the plate reading ceases to rise, then backing off slightly. For our example, let's say we feed in a signal of 5 volts rms. Measure and record the applied voltage.

Next, measure the output voltage across the 1000-ohm resistor; that value of resistor was chosen so each volt rms would represent exactly 1 ma rms of plate current. We measure 100 volts rms in our example, which means that there is a signal plate current of 100 ma rms. Using the formula stated earlier, we can now calculate transconductance: $G_m = \frac{1}{5} = .02$ mho or 20,000 micromhos.

Compare the transconductance calculated from your measurements with the value listed in the tube manual. G_m should be at least 75% of rated value, or the tube is questionable. Below half, the tube ought to be replaced. Remember, too, that the test-signal frequency will affect your evaluation. That is to say, at a test frequency of 1000 cps a tube might check within 10% of its rated transconductance, but still not perform in a stage meant to operate at megacycle frequencies.

A triode has characteristics different from a pentode, since its transconductance is determined largely by the plate-load value. Consequently, the plate-load resistor should be left in the circuit instead of being jumped for the insertion of a 1000-ohm resistor. To determine signal plate current in a triode, then, just measure signal voltage across the plate load and use Ohm's law. Thus, a low-signal triode might test as follows: 500 mv of signal at the grid develops 67.5 volts of signal across

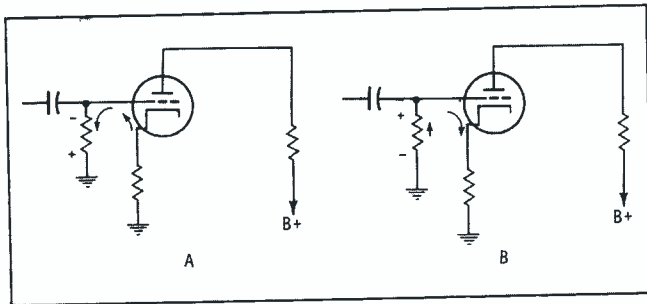

Fig. 7. Gas or grid-emission current causes positive voltage.

the plate load, which is 27K ohms. Ohm's law indicates signal current is 2.5 ma. Our Gm formula gives us $.0025/5 = .005$ or 5000 micromhos as the transconductance of this triode under these operating conditions.

Gas

Gas in a vacuum tube can cause a variety of problems, but most noticeable is grid emission. The grid is bombarded by electrons rushing toward the plate. If it is "softened" by gas, or is otherwise contaminated, the grid releases electrons of its own—thus becoming more positive than normal.

Fig. 7A shows the direction grid current (normal in certain types of operation, such as class C) would ordinarily take, and Fig. 7B shows the direction of abnormal current caused by gas or grid emission. Grid emission is causing the grid voltage in 7B to become more positive, as current flows through the grid resistor in the "wrong" direction.

This last action suggests an easy test for gas: Disconnect the grid and leave it floating, while the tube is otherwise set up for regular operation. Connect your VTVM to the grid, positive lead as probe. The 10-meg input resistance of the VTVM will act as a temporary grid resistor of high value and will show a positive voltage reading if there is any grid emission, whatever the cause. (Be sure the preceding coupling capacitor is disconnected, because even slight leakage from it will place a positive reading on the grid.)

More than 1 volt measured by a 10-meg-input VTVM would mean that gas current exceeds $1 \mu\text{a}$ —too much for a high-gain tube in a sensitive circuit. Take a controlled IF, for example. If $1.5 \mu\text{a}$ of gas current develops, voltage across a 2-meg AGC-line resistor would amount to 3 volts positive—enough to offset much of the AGC, usually. More than $5 \mu\text{a}$ of gas current would be unacceptable in most applications.

Noise

There are two very good ways to test for noise in almost any tube. We'll describe the easiest first:

Just let the tube operate in its usual manner, hold the top steady (to prevent sockets from generating noise), and thump the tube while you watch (or listen for) the effect of your thumping. A noisy tube that won't reveal itself this way isn't likely to be caught by a tube tester, either.

Another, less simple method requires a set of sensitive headphones (a 2000-ohm set will do) and a .001-mfd, 1000-volt capacitor. Clip one lead of the phones to ground and the other to one end of the capacitor. Jumper the tube grid pin temporarily to cathode (not to ground) and connect the free end of the test capac-

america's most popular tube tester

... because it
finds the
"tough dogs"
others miss!

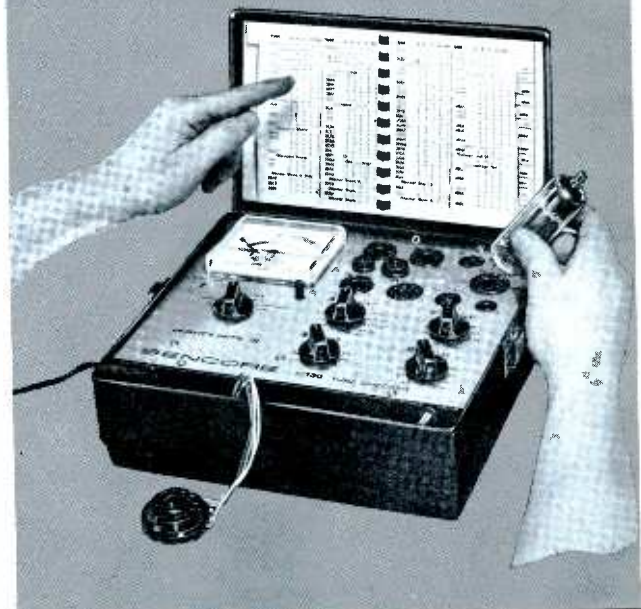

THE NEW SENCORE TC130 MIGHTY MITE III TUBE TESTER

New in looks and compactness, updated with many exclusive features. The MIGHTY MITE tester, long America's most popular tube checker because it has the versatility and reliability professional servicemen demand! The MIGHTY MITE III checks them all—more than 2,500 tubes plus picture tubes, including the new frame grid tubes (has four extra sockets for latest tubes). It's fast and thorough, checks for control grid leakage, then, with the flick of a switch, tests for interelement shorts and cathode emission at full operating levels. Uses costly moving coil meter for high sensitivity (100 megohms) to find those "tough dog" tubes other low-sensitivity testers miss. In versatility, reliability, portability and operating simplicity, the TC130 is your best buy in tube checkers at

\$74.50

COMPARE THESE MIGHTY MITE III FEATURES:

- Lower voltage for Nuvistors and all frame grid tubes
- Unique circuit tests for inter-element shorts, each and every element
- Checks cathode emission at full operating levels
- Checks control grid leakage at 100 megohms sensitivity, like "eye tube" testers.
- Speed-indexed set-up cards greatly reduce look-up time
- Simplified panel layout speeds checks, prevents errors
- Burn-out proof, stick-proof meter
- Sturdy, all-steel case, rubber feet
- Styled for modern, professional look

professional quality — that's the difference!

SENCORE

426 SOUTH WESTGATE DRIVE • ADDISON, ILLINOIS

Circle 33 on literature card

April, 1965/PF REPORTER 69

5 Transistors No Tubes 30 db Gain*



NEW JERROLD ALL-SOLID-STATE "DE-SNOWER" Model SPC-132 ... the most powerful of all antenna amplifiers

Do you remember the original and famous Jerrold De-Snower? Thousands of De-Snower preamplifiers have served fringe-area antenna systems since 1950, amplifying weak television signals at the antenna before download loss. Now every benefit of the original De-Snower, and more, is offered by the new SPC-132 all-solid-state antenna amplifier.

Jerrold has combined the ultra-sensitive twin-transistor preamp, SPC, with a compact three-transistor postamp, 132, to give you the powerful double-punch performance of this unusual new antenna amplifier—with absolutely no tubes to replace.

30 db high-band gain* • 26 db low-band gain*
• Lowest input noise figure • Highest output capability (100,000 microvolts each of 7 channels)

Use the SPC-132 on your next "tough-dog" antenna system—custom home or multi-set installation. Drive as many as 20 to 30 sets from one antenna system.

Only \$97.95 list. Ask your Jerrold distributor or write Jerrold Electronics, Distributor Sales Division, Philadelphia, Pa. 19132.

*Measured average production unit



The nation's foremost manufacturer and supplier of television antenna systems and equipment

Circle 34 on literature card

itor to the plate. Thump the tube and listen in the headset for noise and microphonics. Don't leave the grid-cathode jumper in place for more than a few seconds at a time, for it can damage some tubes.

Testing for intermittent *shorts* is handled the same as for noise. Tubes that are shorted directly should be so obvious they won't require testing.

Leakage

Leakage of any serious consequence will cause abnormal indications during tests already described, with the possible exception of heater-cathode (H-K) leakage.

In-circuit tests for H-K leakage needn't be complicated. If the tube has a cathode resistor, just jumper the grid to ground (not to cathode), and listen for hum at the plate with the headset and a .1-mfd capacitor. A scope at the plate will also reveal any 60-cps hum arising from H-K leakage. If hum is evident, ground the cathode for a moment; the hum at the plate will be nearly eliminated if H-K leakage is causing it.

If the tube cathode is normally grounded, open it temporarily and insert a 1000-ohm resistor. Then make the test as described.

Other Tests

The tests described apply mostly to triodes and pentodes. Rectifiers and multigridded vacuum tubes require slightly different treatment, although the basic intent is the same: Test the tube without removing it from the circuit or making a lot of extra connections.

Rectifiers

One easy way to test a rectifier is to measure the AC voltage applied to the plates and then measure DC voltage at the output (cathode). With a capacitor-input filter, a vacuum-tube rectifier should produce DC voltage about 10% above the AC rms voltage measured at the rectifier plate(s). With a choke-input filter, the DC output voltage should be about 90% of the applied AC rms voltage.

A better test, which applies to gas-type rectifiers as well as vacuum-tube types, is measurement of the internal resistance of the tube. Unload the B+ circuit following the second filter capacitor and connect a 10K, 50-watt (good for up to 1000 volts) resistor from the rectifier cathode to ground. Current drawn through the rectifier by this resistor will be 1 ma for every 10 volts of DC output. Thus, from a 500-volt power supply, current will amount to 50 ma; from a 270-volt supply, 27 ma.

With output current thus fixed, a voltage check across the rectifier is all that is needed to enable you to calculate the internal resistance of the tube. We'll use a 5U4 as an example. With your VTVM on AC (if you use a VOM, you may have to reverse the leads to get a true reading), clip the negative lead to pin 8 and touch the positive lead first to pin 4 and then to pin 6 (if the two readings aren't nearly equal, shift the negative lead to pin 2).

Record the AC-voltage readings. Switch the VTVM to DC and measure the voltage across the 10K resistor; divide it by 10 to determine milliamps of current being drawn through the tube. Now, divide volts by amps (Ohm's law), to find the approximate internal resist-

Add Retrace Blanking

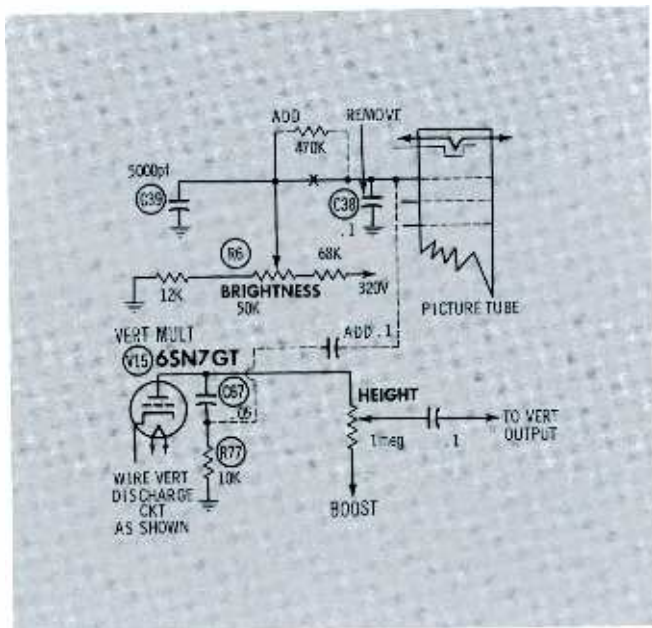

Quite a few of the older TV models have gone without vertical retrace blanking for many years, because there seemed to be no convenient way to add a blanking circuit. A case in point is the Westinghouse Chassis V-2172 (PHOTOFACT Folder 116-13). There's a slight trick to installing a blanking network in this set; once you catch on to this, you can easily add retrace blanking to satisfy the considerable number of customers who are still using these venerable receivers.

It's advisable to apply the blanking-pulse signal to the grid, and avoid mixing it with the video signal at the cathode. Therefore, you'll need negative pulses. The customary source—the "high end" of the vertical output-transformer secondary—is not usable in this chassis because the waveform at this point contains positive pulses. However, negative pulses can be obtained from the coupling circuit between the vertical multivibrator and output stages, if you make one wiring change: Transpose the position of C67 and R77 so the resistor is connected between the capacitor and ground, as shown in the schematic. Negative spikes are developed across R77 in normal operation; if you arrange to tap in directly across this resistor for a blanking signal, you'll obtain a nearly pure pulse waveform without picking up the sawtooth signal developed across C67.

The coupling circuit is installed simply by connecting a .1-mfd capacitor from the top of R77 to the CRT grid, and adding a 470K isolating resistor between this grid and the arm of the brightness control. Also remove C38 (.1 mfd) from the CRT grid circuit. Resist the temptation to utilize this old part as a pulse-coupling capacitor, since it might break down under the constant stress of the pulses. ▲

arce of the rectifier. A good 5U4, typical of many modern vacuum-tube rectifiers, has internal resistance of about 150-170 ohms. Thus, in our test, at a DC supply voltage of 300, a good 5U4 would have about 5 volts AC across it. If you calculate more than 200 ohms, the 5U4 is getting weak.

Oscillators

Evaluating tubes in oscillator circuits presents no problem. Just disable the feedback loop, whatever it may be, and treat the tube as any other amplifier. Multivibrators can be tested one section at a time by disconnecting one coupling capacitor.

Multigrid Types

Take your cue for testing multigrid tubes from the circuits in which they are used. Special-purpose types, which have become more common as set designs advance, can often be evaluated with the signals that are applied to them in normal operation. Check the effect of signal voltages at each grid, one at a time, by jumping out the signal at all others during each test. Thus, each grid can be evaluated separately for proper control.

Conclusion

Most tube types can be checked with the easily applied tests we've outlined here. Don't use these tests to eliminate your tube tester, but use them to save time and effort whenever you can avoid running to a tester. Besides, the principles you learn from such tests will help you in all your troubleshooting. ▲

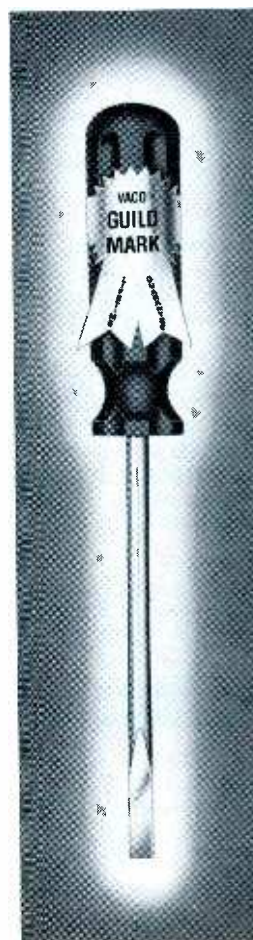

VACO[®]
announces
a major break-thru
in screw driver construction
VACO
GUILD/MARK ▽

The Solid Neoprene Handle Driver
with the Lifetime Guarantee
with These Ultimate Selling Features



Exclusive Neoprene Rubber Handle featuring famous VACO Comfortome design—impervious to oil, grease, acids . . . you can't ruin it!



Extra Comfort, Improved Grip-Power assured thru new Dual Dyrometer Process . . . most comfortable screw driver you ever used.



Chrome Vanadium Steel Blade locked in construction, beautifully polished, nickel chrome finish . . . best looking screw driver you've ever seen.



Backed by a Lifetime Guarantee, this Symbol permanently embossed in the handle . . . your protection for now and years to come.



LOOK FOR THIS BADGE OF QUALITY FOUND ONLY ON VACO GUILD/MARK SCREW DRIVERS . . . DO YOUR HAND A FAVOR . . . SEE THEM . . . TRY THEM.

Sold through better stores everywhere.
VACO PRODUCTS COMPANY
317 East Ontario Street Chicago, Ill. 60610

Circle 35 on literature card

April, 1965/PF REPORTER 71

KIT or ASSEMBLED!



Either Way, These HEATH Instruments Are Your Best Buy!

Heathkit IM-21 Laboratory AC VTVM!

• 10 voltage ranges—0.01 to 300 volts RMS full scale • ± 2 db, 10 cps to 1 mc • 10 megohm input impedance for high accuracy • Calibrated DB scale • VU-type ballistic damping of meter movement.

Kit IM-21, 5 lbs...\$33.95 Assembled IMW-21...\$52.95

Heathkit IM-11 VTVM... World's Largest Selling VTVM!

• 7 AC (RMS & Peak to Peak), 7 DC, 7 Ohms ranges • Wide frequency response ± 1 db, 25 cps to 1 mc • Easy-to-read $4\frac{1}{2}$ " 200 UA meter • 1% precision resistors • Single AC/Ohms/DC probe with switch.

Kit IM-11, 5 lbs...\$24.95 Assembled IMW-11...\$39.95

Heathkit IM-13 "Service Bench" VTVM!

• 7 AC, 7 DC, 7 Ohms ranges • Separate 1.5 & 5 v. AC scales • ± 1 db, 25 cps to 1 mc • Large 6" 200 UA meter • Tilts to any angle • 1% precision resistors • Single AC/Ohms/DC probe with switch • Mounts anywhere.

Kit IM-13, 7 lbs...\$32.95 Assembled IMW-13...\$49.95

Heathkit Variable-Voltage Regulated Power Supply!

• Ideal for design & development • B+, Bias & Filament voltages • DC output variable 0-400 volts, 125 ma max. • Output varies less than 1%, no load to full load • Ripple less than 10 mv • Voltage & Current Panel Meters.

Kit IP-32, 16 lbs...\$56.95 Assembled IPW-32...\$84.95

Heathkit "Extra-Duty" Wide Band 5" Oscilloscope!

• Professional styling & features • 5 MC bandwidth, ideal for color servicing • Rise time 8 microseconds or less • Sweep range 10 cps to 500 kc plus 2 switched preset frequencies • Push-pull vertical & horizontal output.

Kit IO-12, 24 lbs...\$76.95 Assembled IOW-12...\$126.95



FREE CATALOG

Fully describes these and over 200 other different and exciting Heathkits at savings of 50% or more! Fill out the coupon below and send for your FREE copy today!



HEATH COMPANY, Dept. 24-4
Benton Harbor, Mich. 49023

Please send my free 1965 Heathkit Catalog.
 Enclosed is \$ _____, plus postage. Please send model(s) _____

Name _____
(Please Print)

Address _____

City _____ State _____ Zip _____

TE-132

Continued from page 47



Fig. 7. Bench setup for signal tracing.

lating the RF signal and riding through to the CRT. Your scope would show you unfiltered half-wave rectification at the junction of R3, R4, and R7.

The next check should be for the 12-volt DC output of the X3. The only other tests you can make with your VTVM are of the transistor's emitter and bias voltages. Emitter voltage is easiest. If it's significantly low, the transistor is probably not conducting. These are PNP transistors, therefore the base must be negative with respect to the emitter. Forward bias should be about .2 volt. Remember, a vacuum tube with zero bias conducts heavily, but a transistor with no bias is virtually cut off.

If voltages checks have no revealed the trouble, you might try checking components with your ohmmeter — but be aware of the transistors. While non-conducting vacuum tubes offer infinite impedance, transistors affect resistance readings by offering a parallel path. Also, transistors can be damaged by some ohmmeters, especially on the low-ohm scales. All things considered, it's a good practice to disconnect two transistor terminals when you're making resistance checks.

Of course, signal tracing is one efficient way of tracking down booster troubles. Fig. 7 shows a bench setup for signal tracing. The signal generator puts out RF signals modulated a 600 cps. The photo shows a homemade detector, but a standard scope-type detector probe will do the job just as well. First, send a 74-mc signal straight through the preamp. The resulting scope trace—a nice, clean sine wave—is shown in Fig. 8.

To obtain a rough idea of the gain of the unit, we simply compare the amplitude of this scope trace with the amplitude of the trace produced by connecting the output of the signal generator directly to the detector input.

The 74-mc signal checks out the low-band portion of the preamp. To check the high-band section, we

• Please turn to page 82

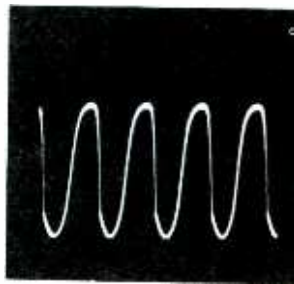

Fig. 8. Normal sine wave.



Fig. 9. A homemade probe.



The Troubleshooter

answers your servicing problems

Questions On Test Jigs

I would like to know if an RCA color test jig can be used to repair Zenith color receivers? Also, is a Zenith test jig suitable for servicing receivers of other makes? The third and final question is: Are most color test jigs interchangeable for servicing any brand of color receiver?

LEW'S RADIO-TELEVISION SERVICE

Ossining, New York

As a standard rule, you'll find that color jigs utilize only one common component—the color picture tube. Most of the receivers presently on the market use the same or a similar type of picture tube. Therefore, it is necessary only to have deflection and convergence yoke assemblies for the basic color receivers patterned after RCA chassis.

You'll find that one deflection yoke is suitable for servicing Zenith color receivers manufactured today. RCA receivers from Chassis CTC7 through CTC16 can be operated using the same deflection yoke and convergence yoke. If you plan to servicing an RCA CTC4 or CTC5 chassis, you'll need the yokes for those individual sets.

Any of the 90° 25" color receivers will require a completely different test jig—both yoke and CRT.

Needs More Channels

I would like to know if it would be possible to arrange two VHF tuners back to back, coupled IF to IF, and convert the two channels I now receive to different channels for testing purposes. We have two translators that broadcast on channels 11 and 13, a cable system that uses channels 2 and 6, and some locations near here receive direct signals on channels 3 and 8.

My shop is in the area that receives the translator signals only; however, I repair sets which receive all of the above named channels. Proper repair is sometimes difficult because I can't air check the receiver on all channels. I noticed in the June '64 PF REPORTER that Blonder Tongue uses two tuners like this to convert UHF to VHF.

CARL LINQUIST

Jackson, Wyo.

Arranging two tuners back-to-back wouldn't work. The Blonder Tongue arrangement you mentioned does work, but only because there are no amplifier tubes in the converter; all stages are passive. The tuned circuits will provide conversion. Using TV tuners, however, the signal simply would have no path through the combinations.

Perhaps additional height on your shop antenna system would enable you to bring in the channels you don't receive now. One alternative, if you feel you must have off-the-air signals for all channels, would be to build a simple mixer circuit. I have the feeling, however, that such an attempt would create as many problems as it would cure.

A second possibility, and probably the most logical of all, would be to purchase a generator which has an output for all VHF channels. One such instrument is the Hickok Model 650C.

You Stock ONE Automotive Speaker But You Can Replace THREE!

Model AT69C

That's the big advantage of selling the new Oxford Multi-Impedance Automotive Speaker . . . it will replace original units with an impedance of 10, 20 or 30 ohms. This, of course, reduces your inventory and increases your profits!

And, when you install any Oxford automotive speaker, you can be confident of having used the finest product available. Oxford is the major manufacturer of the original equipment speakers used by Detroit's "Big three." The know-how gained through producing these OEM speakers, plus the latest design innovations go into every replacement unit bearing the name Oxford. So for the ultimate in quality and design . . . be sure it's an Oxford automotive speaker.

**OXFORD
TRANSDUCER
CORPORATION**



A Subsidiary of Oxford Electric Corporation

2331 North Washtenaw Avenue • Chicago 47, Illinois

Circle 56 on literature card

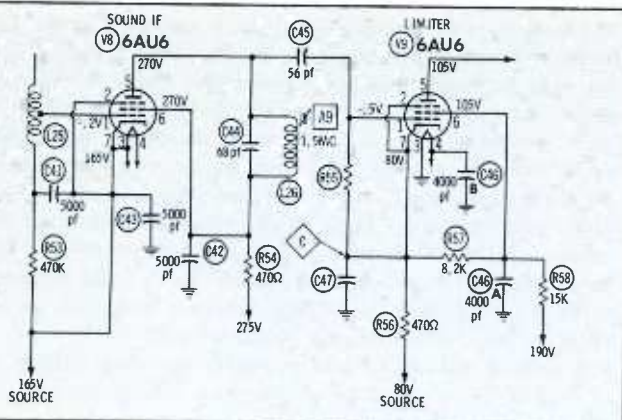

Befuddled By Source Voltage

I have a Magnavox Chassis CT372 which has a complete loss of sync. I have replaced most of the capacitors and checked resistors throughout the sync circuit with no results. Sound is weak and there is a 60-cps hum that can be heard in the speaker and that is triggering both the vertical and horizontal oscillators.

I do not understand the 80- and 165-volt sources, as these do not come from the power supply. Also, the 80-volt line reads 160 volts, and the filaments on V8, V4, and V7 read 160 volts to chassis. I have checked voltages in the sync separator circuit and they are far from normal. I would certainly appreciate any suggestion you could give me.

J. I. MANAK

Cleveland, Ohio

Your description of the symptoms in your Model CT 372 seems to indicate trouble in the 80-volt supply section.

The increase in voltage (in your Magnavox television receiver covered in PHOTOFACT Folder 205-6) from 80 volts

to 160 volts will have to be remedied before you proceed to other troubles you may have in the receiver. The sound IF amplifier and limiter are used as voltage dividers for the 160-volt and 80-volt sources respectively. Be sure to check R57, R58, and C46. This may be done quickly by disconnecting the 80-volt line at the source, the junction of R56 and R57. With this disconnected, the voltage at the open end of R57 should read approximately 80 volts. If it still reads 160 volts, check R57, R58, and C46 carefully. If the reading at the open end of R57 does drop to 80 volts when the load is removed, you will have to check along the 80-volt line to find the trouble. I don't see any possibility of the defect occurring anywhere but at the source (barring mechanical shorting of adjacent wiring in the circuit).

The filaments reading of 160 volts on tubes V4, V7, and V8 is correct, as these filaments are connected to the 160-volt line at V8 as shown on the schematic. The voltage readings on the sync separator and sync amplifier tubes won't mean a thing until the source voltage is returned to normal.

Jittery Top

I am having considerable trouble with an RCA Model 21S353. The trouble is horizontal jitter in the top half of the picture; bottom half is normal. All tubes have been substituted, but to no avail. Adjusting the horizontal-hold control to the extreme left tends to reduce the jittering, but sync is lost before the picture is completely steady. Adjusting the AGC, horizontal lock, and horizontal frequency may steady the picture but only for a short period of time. I have tried almost everything and am about ready to give up. Sure hope you can help me.

HARLESS RADIO AND TV

Bluefield, W. Va.

great profits



that's about the size of it

Microminiaturization has come to cartridge design in the new Sonotone Micro-Ceramic[®] Cartridge—a king-sized profit-maker in a tiny case. This remarkable new cartridge updates to 1965 performance almost any phonograph using a ceramic cartridge produced within the past 20 years.

The Sonotone Micro-Ceramic Cartridge embodies all the advantages of miniaturization and light weight. Designed for low mass, lightweight tonearms—it weighs less than 1 gram (without bracket). Superb stereo performance is assured by—high compliance; ability to track at the low forces required by today's modern record changers; excel-

lent separation and a smooth, clean response over the full audio range. To top it off, all Micro-Ceramic cartridges are equipped with the virtually indestructible Sono-Flex[®] stylus. For ease of installation, three different standard mounts are available.

Four Micro-Ceramic cartridges cover all of your replacement needs; the "27T," a high capacitance model for transistorized phonographs; the high compliance "25T" for deluxe stereo units; the "26T" and "28T" for replacement in a wide range of popularly priced phonographs.

For comprehensive Cartridge Replacement Guide, write:

SONOTONE[®]
audio products

Sonotone Corp., Electronic Applications Div., Elmsford, N. Y.

Your scope should isolate the defective circuit, providing a step by step procedure is followed when circuit tracing. One method is as follows:

1. Put chassis in operating condition, with the top and bottom accessible; allow it to play until the conditions you describe are apparent.
2. Check waveform (W1) for distortion and amplitude; compare to the one shown on the schematic in PHOTOFACT Folder 242-8. If this waveform is correct, the tuner and IF's are eliminated as a potential trouble source. Should this waveform be distorted or decreased in amplitude, the video-IF tubes and associated components must be checked.
3. Check waveform (W2) in the same manner; this will determine the merits of the video amplifier.
4. Observe waveform (W6); this will check the coupling circuit between the video amplifier and horizontal sync separator.
5. Scoping at the grid of the sync amplifier will determine if the horizontal sync signal is arriving at this point.
6. Check waveform (W14); the shape and amplitude of this signal is very important. Should it be distorted, an ohmmeter check of all coupling and grid circuit components must be made.
7. Check waveform (W15); if any adjustment of the horizontal frequency (B1), or horizontal waveform (B2) coils have been attempted without the use of a scope, W15 will be distorted. Adjust both these coils as outlined under "Sweep Circuit Adjustments," page 13 of PHOTOFACT.

Voltage Puzzler

I have a Westinghouse TV Model H-K3821 (covered in PHOTOFACT Folder 669-3) with good sound but no high voltage. All tubes, coils, and capacitors in the high-voltage section check normal. The only abnormal voltage readings are on pins 1 and 6 of V10 (8FQ7)—both of these plates measure only 25 volts. The voltage on the B+ side of both R92 and R96 is 270 volts. What would most likely cause a puzzling voltage like this?

ROBERT RICHARDSON

Dallas, Texas

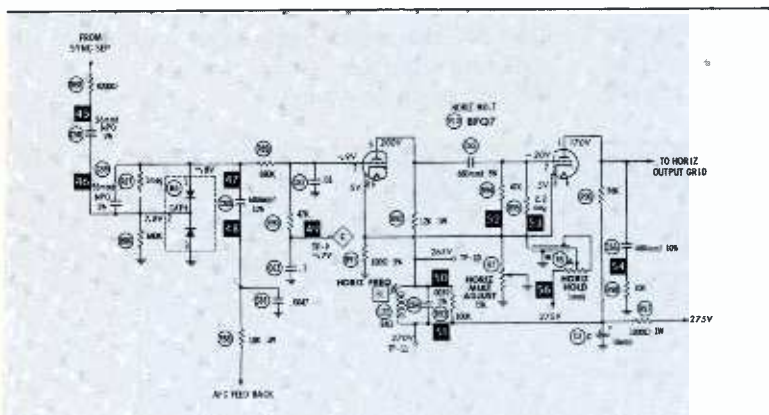

You will probably find the trouble originates in the AFC stage. For instance, if C58 is leaky, it may be placing a positive voltage on the grid (Pin 7) of V10, causing the tube to conduct excessively, in turn lowering the plate voltage. This could pull the horizontal oscillator so far off frequency it becomes inoperative, causing a loss of negative bias on the grid of the second section of V10, lowering its plate voltage, too. M5 could be defective, causing a similar reaction throughout the oscillator stage.



**“My shop’s been loaded . . .
since I’ve had
my FCC License.”**

“And I could kick myself for not getting it sooner. I’m pulling in all kinds of mobile, marine and CB business that I couldn’t touch before; have even had some calls to work on closed-circuit television. I’ve hired two new men to help out and even with them, I’m two weeks behind.”

And so it goes. Once you have that FCC Ticket, you open the door to all kinds of new business. And that’s not all. The knowledge you need to pass the FCC exam gives you a fundamental understanding of *all* electronics. You’ll find you can do more work in less time . . . work on almost *any* kind of electronics gear.

What’s the best way to get a Commercial FCC License . . . and still keep up with your work? Thousands of men will tell you “Cleveland Institute of Electronics”. CIE has been preparing men for FCC License exams since 1934. What’s more, they back their Home Study Licensing Programs with this remarkable money-back offer:

A CIE FCC License course will quickly prepare you for a Commercial FCC License. If you fail to pass the FCC examination . . . on the very first try . . . after completing your course, CIE will refund all your tuition. You get an FCC License . . . or your money back!

Send coupon today for CIE’s FREE informative booklet “HOW TO GET A COMMERCIAL FCC LICENSE”. Cleveland Institute of Electronics, Dept. PF-22, 1776 E. 17th St., Cleveland, Ohio 44114.

SEND COUPON TODAY FOR FREE BOOKLET

**Cleveland Institute
of Electronics**

1776 E. 17th St., Dept. PF-22
Cleveland, Ohio 44114

Please send FREE Booklet “HOW TO GET A COMMERCIAL FCC LICENSE”, without obligation.



Your occupation _____

Name _____ (please print) _____ Age _____

Address _____ County _____

City _____ State _____ Zip _____

A leader in Electronics Training . . . since 1934

Radar Maintenance

(Continued from page 39)

synchro receiver that is geared to the deflection coil in the indicator. The synchro receiver acts as a motor to turn the deflection coil around the neck of the CRT. Each time the scanner makes one revolution, the deflection coil, and thus the "wagon wheel," also makes one revolution. A system of synchronization is provided to be sure the sweep line points to zero degrees on the CRT face when the scanner points the RF beam over the bow of the ship.

Range markers are used to measure accurately, the distance of a target from the ship. By marking time along the sweep line, the markers also measure the time required for an echo to come back from the target, because the instant it gets back it causes a brightening on the sweep.

The trigger pulse that initiates the sweep also starts the marker. The first marker stage is a blocking oscillator that produces a chain of oscillations. This wave train is shaped and applied to the video amplifiers so that it brightens the sweep at predetermined points, accurately marking time or distance along the sweep line. As the sweep rotates, the marker pips form circles on the face of the CRT, thus the term *marker rings*, as markers are sometimes called. The timing of the marker rings, then, marks off concentric segments of the CRT face, representing miles.

Necessary to the operation of all these circuits are several power supplies. Most radar systems have two high-voltage supplies—one for the modulator, located in the transmitter, and one for the CRT, located in the display unit. All radar systems have one or more unregulated B+ voltages, and one or more regulated. Sometimes negative voltages are supplied, both regulated and unregulated.

The regulated supplies are sometimes adjustable, in which case they are some form of series regulator, often using several tubes in parallel to meet the current requirements. Typical tube complements are: 6SJ7 used as control tube, 6Y6G or 6AS7 used for regulators, and 6L6G tubes sometimes used to regulate lower voltages at lower current. For nonadjustable regulated supplies, ordinary VR tubes are used.

Housings

A large radar system usually groups its components as shown in Fig. 3. The transmitter and receiver are housed in one cabinet, while the video amplifiers, sweep components, and marker circuits are housed in the display unit with the CRT. On ships whose power is 110 or 220 volts DC instead of 117 volts AC, a rotary inverter is used. Some systems use special power converters that supply the radar system with a 400-cps voltage, rather than the standard 60-cps power.

In Fig. 4 is shown a block diagram of a different type of system housing. This system represents several of the smaller, less expensive radar sets. The major difference is the fact that the transmitter-receiver sections are in the scanner.

These radar systems are lower-powered than their larger, more expensive counterparts. Since the modulator pulse isn't so high in power, it is practical to feed it over a transmission line. It is less expensive to carry the modulator pulse to the magnetron than it is to pipe the RF output of the transmitter to the scanner through costly waveguide. So that's what is done. A special, well-insulated coaxial cable carries the modulator pulse to the scanner where the transmitter is housed, and there applies it to the magnetron in the usual manner.

The receiver is handled similarly. The klystron and mixer crystal are in the scanner housing. The duplexer operates as in any other system. The IF output of the mixer is fed into an ordinary low-loss coaxial

cable and down to the IF strip which is mounted in the display unit. There is no AFC, so the klystron repeller is tuned manually at the indicator.

Power supplies in most radar systems are housed in the unit where they are used. For example, in the radar system in Fig. 1, the CRT high-voltage supply is in the display unit, the modulator high-voltage supply is in the transmitter housing. In the system in Fig. 4, the CRT and modulator supplies are both housed in the display unit, since that is where they are used. The low-voltage supplies are usually grouped together and then connected via intercabling to the points where they are used; sometimes they are housed in the transmitter housing, sometimes in the display unit.

Servicing

We have discussed radar-system operation without getting involved in circuit detail. For the technician who plans radar servicing, books are available that explain circuits. In fact, many maintenance manuals now include a penetrating circuit analysis of their systems.

In the next and final article, you can go along on a typical radar service call. The radar system we shall service is in poor condition, having laid out the winter abroad ship; on firing it up, we'll likely find multiple troubles. We'll go through a complete check of the equipment, showing a good troubleshooting procedure for the entire equipment, and repairing troubles along the way. Be sure to come along! ▲

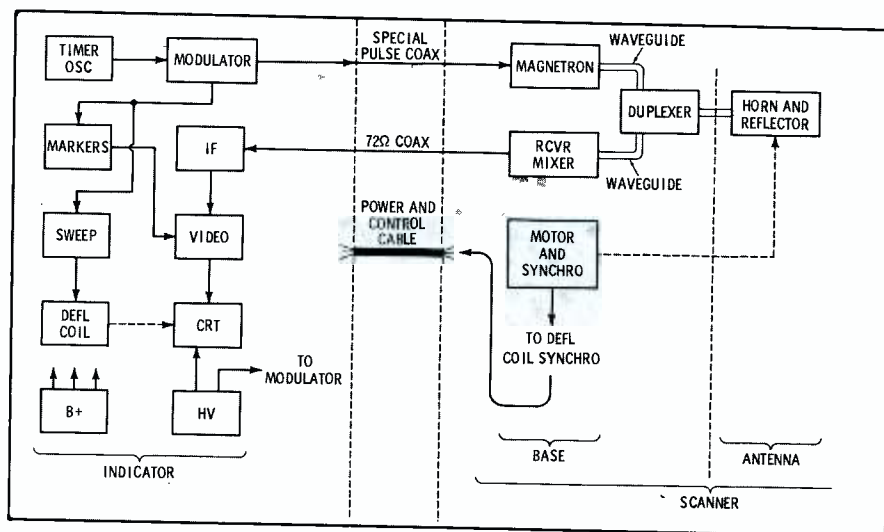

Fig. 4. Small radar has RF plumbing, maggie, and mixer housed in base of scanner.

COLOR COUNTERMEASURERS

Symptoms and service tips from actual shop experience

Chassis: Zenith 29JC20, 27KC20, 26KC20, 25LC20, 25LC30, 25MC30, 25MC33

Symptom: When channels are changed, the black and white picture precedes the color information by several seconds.

Tip: Align color sync:

1. Place color switch in "on" position. Connect color-bar generator (color-bar pattern) to antenna terminals. (Alignment can be made by using a transmitted TV-station signal.)
2. Ground test point F (Killer Voltage).
3. Connect a .01-mfd capacitor from the center tap of the burst transformer to ground.
4. Adjust color-oscillator frequency coil (A16) for zero beat as viewed on the picture-tube screen (minimum number of slanting color bars or minimum movement of color bars through the picture).

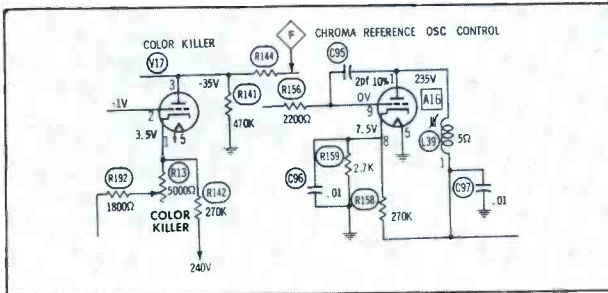

Chassis: Zenith 29JC20, 27KC20, 26KC20, 25LC20, 25LC30, 25MC30, 25MC33

Symptoms: No raster; weak high voltage; 1V2 focus rectifier burned out.

Tip: Check for shorted focus filter capacitor (150 pf. 6KV). Replace with Zenith part number 22-3578. Check for over-heated resistors in focus circuit.

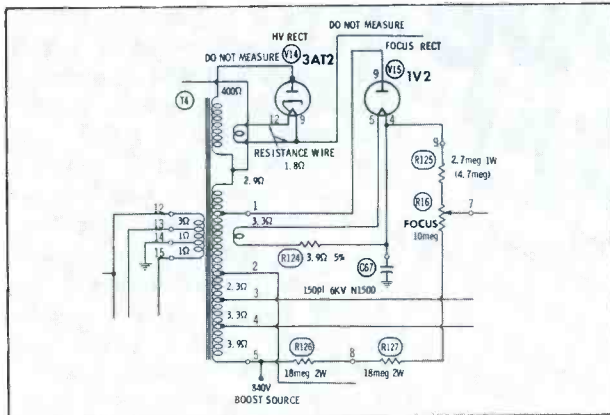

Sorry I had to call you from work, but its, the only way to get you to fix our set.

it's here! most advanced
color TV test instrument
ever developed



- OBSOLETE ALL OTHERS
- ELIMINATES ALL GUESSWORK

LECTROTECH V7*

A sensational new color generator with 4 major Lectrotech exclusives . . . plus all of the time-proven standard features . . . in one compact, portable unit. For the first time, you can install and service color TV completely, accurately and faster! Here are the facts:

EXCLUSIVE—COLOR VECTORSCOPE—Until now, available only in \$1500 testers designed for broadcast. Accurately measures color demodulation to check R-Y and B-Y plus all 10 color bars for color phase angles and amplitude. A must for total color and those hard to get skin tones.

EXCLUSIVE—SELF-CALIBRATING—Adjust timing circuit without the use of external test equipment. No need to return unit to a factory for adjustment.

EXCLUSIVE—DIAL-A-LINE—Now, you can adjust horizontal line to any width desired from 1 to 4 lines wide.

EXCLUSIVE—SOLID STATE RELIABILITY—Only two tubes are used in combination with fully transistorized diode-rectifier circuit.

PLUS— the V7 produces all Crosshatch, Dots, Vertical only, Horizontal only and Keyed Rainbow Patterns. RF at channels 3, 4 or 5. Video Output (Pos. and Neg. adjustable) for signal injection trouble-shooting. Red-Blue-Green Gun Killer. All transistor and timer circuits are voltage regulated to operate under wide voltage ranges. Lightweight, compact—only 8¼" x 7½" x 12½". Net. **189.50**

*Designed and produced by the men who introduced and developed the modern approach to TV testing—Bill Grossman and Bob Karet.

For the full story on the V7, write for complete catalog or see your distributor.



V6 Complete color bar generator with all the features of the Lectrotech V7 except the Vectorscope. Only **99.50**



Distributors: Phone or Wire Collect.

LECTROTECH, INC.

1737 Devon Ave. ■ Chicago, Ill. 60626 ■ Area 312 465-2622

Circle 38 on literature card

CAR OWNERS SAY...

*"Terrific," "Fabulous,"
"Improves radio 100%!"*



VERBA-MATIX
America's Prestige
REVERBERATION

The only system with

- 4 Transistors • Heavy 7 oz. Ceramic-Magnet Speaker • Complete Control Panel (with Reverb % Control) • No Drilling, No Screws, for easy installation • Fits all Cars, Neg. or Pos. Ground (12 volt) • All Speakers 2 to 40 ohms • No Noise Driving Over Bumps.

Made in U.S.A. For complete details see your Distributor or write PF-1



kinematix, inc.

2040 W. Washington Blvd.,
Chicago, Illinois 60612
Area Code 312 666-0066

Circle 40 on literature card

(Continued from page 33)

AGC Magic

TABLE 1
AGC VOLTAGES FOR TROUBLE ANALYSIS

Visual symptoms	Detector Voltage	IF AGC	Turner AGC	Receiver condition or general location of trouble
1. Stable picture, normal contrast and snow (see Fig. 3)	-1.5	-6	-2	Normal for moderate signal
2. Stable picture, normal contrast with slight snow	-1.5	-6	0	Normal for weak signal
3. Grainy picture with RF interference (windshield wiper) (Fig. 4)	-1.7	-6.5	-8	Normal set with very strong signal
4. Overload, little sync (windshield wiper) (Fig. 5)	-1.7	-9	0	Turner AGC too low, C1 leaky, R2 raised in value, or RF tube gassy.
5. Snow on medium strength signal, normal on distance	-1.5	-2	-10	Turner AGC too high, or IF AGC too low. C2 leaky, IF tube gassy, or R1 raised in value.
6. Blank raster on-channel, normal snow off-channel	-12	-4	0	Video or AGC keyer dead, C3 shorted, C4 leaky or open, R5 open, B+ 140 too low, or keyer grid voltage too low.
7. Blank raster	0	-12	-20	G to K short in keyer, open AGC control, or plus 140V B low. Video tube open.
8. Weak contrast, no snow	-1	-3	0	IF stage weak or dead.
9. Weak contrast, some snow	-1	-3	0	Mixer stage weak or dead.
10. Heavy snow, normal contrast (Fig. 6)	-1.2	-4	0	RF stage dead.
11. Weak contrast, little sync	0	-4	0	Detector diode bad.
12. Overload, no sync (Fig. 7)	+2	-4	0	Detector diode reversed.

Precise Scope Spectacular!

(now going on at leading electronic distributors)



Four top quality scopes (kits or wired) including a low cost color scope, Model 3151, K. \$89.95, W. \$137.95 • a top value in a 5" general radio and TV scope, Model 315, K. \$79.95, W. \$113.95 • two professional performance scopes the 7" Model 300C, K. \$169.95, W. \$222.95, and the 8½" Model 308, K. \$179.95, W. \$249.50. Prices slightly higher in West. Save now at your Precise distributor. For free 1965 catalog write:



PRECISE ELECTRONICS & DEVELOPMENT DIV. OF DESIGNATRONICS, INC
76 EAST SECOND STREET, MINEOLA, NEW YORK 11501

Circle 39 on literature card

age shorted out, making mixer B+ low.

You might ask if the chart works for some of the new sets where the IF AGC measures up to +30 volts off-channel and down to zero when on-channel. The answer is "Yes, if you measure the IF AGC from the cathode of the first IF tube to the IF AGC terminal." And, what about those sets where the AGC lead on the tuner measures a positive voltage? This positive voltage is bled to ground by the RF grid, therefore ignore any positive voltage here by regarding it as "zero reference." Any negative voltage can be used on the chart without modification.

Suggestion: When you service any set and have the schematic handy measure these three voltages (detector, IF AGC, and RF AGC) and write them on the edge of the diagram. Then, when another of the same model has an AGC trouble, you will be all ready to use the chart without wondering if allowances must be made. The next time you have an AGC or overload problem (or wonder if the AGC is really at fault) just compare the symptoms against the chart and see if the "magic" will work for you. ▲

(Continued from page 37)

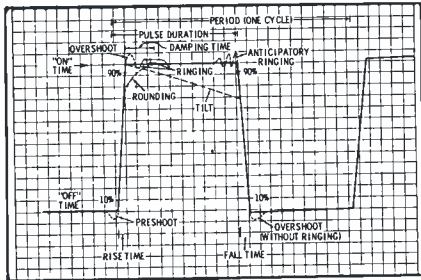

Fig. 3. Terminology of the square wave.

much capacitance. A circuit shunted by too much stray capacitance simply can't pass all the higher-order harmonics in the true square wave. A rounded corner at the top of the rise is indicative that these higher frequencies are missing in the waveform.

Tilt, a falling off in amplitude over the duration of the flat top, suggests poor low-frequency characteristics. The amplitude recedes because the circuit simply can't handle a sustained voltage at any level. If any tilt appears in a square wave, it will be worse at a lower fundamental frequency, because the duration of the flat portion of the waveform is greater (remember the $T = \frac{1}{2}f$ relationship).

Remember these characteristics of a square wave, because they'll be mentioned frequently in all discussions of square-wave analysis.

Square Wave Generators

Square waves can be formed by clipping the peaks from ordinary sine waveforms, but the sloping sides are rather poor in rise-time characteristics. The square wave in Fig. 4 was developed in this way and has a rise time of several msec—much too long. A multi-vibrator produces an output waveform that lends itself readily to being formed into a square wave, and this is the circuit commonly used in most well-equipped square-wave generators.

High-quality instruments (the only practical kind for accurate square-

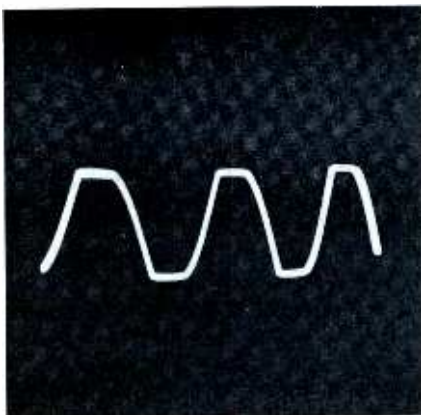
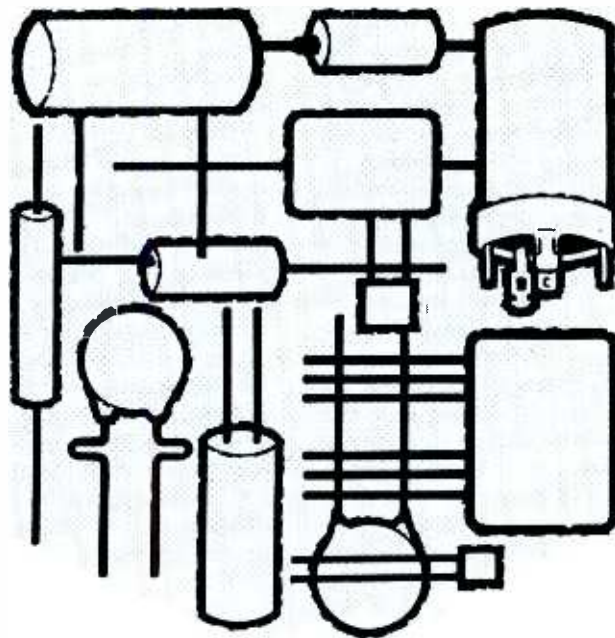

Fig. 4. Sine wave clipped for "square."



Whatever your replacement need...

CALL FOR
AEROVOX
CAPACITORS

Whatever the requirement, there is an Aerovox capacitor to satisfy it. Your Aerovox distributor can supply your every need with a complete line of in-stock capacitors that are designed and manufactured to meet the highest possible reliability standards.

And when we say "A COMPLETE LINE" we include:

ELECTROLYTIC CAPACITORS

Twist-Prong Cans
Tubular
Miniaturs
Wax Filled

BYPASS CAPACITORS

Radial & Axial Leads
Dual Dielectric
Straight Mylar

CERAMIC CAPACITORS

High Voltage
Temperature Compensating
General Purpose Discs
Tubulars

MICA CAPACITORS

Molded
Axial Lead
Dipped Radial Lead

Your local Aerovox distributor offers sure, one-stop service for all capacitor replacement. Buy the best—buy Aerovox.



AEROVOX CORPORATION
DISTRIBUTOR DIVISION NEW BEDFORD, MASS.

Technical Leadership — Manufacturing Excellence
Circle 41 on literature card

wave analysis) develop square waves having a rise time of approximately 25 nsec. (.025 usec) or faster. Pre-shoot, overshoot, ringing, rounding, and tilt must be absolutely unnoticeable when viewed on a scope with a rise time at least twice as fast (12 nsec). Generators of lesser quality are generally usable for square-wave analysis, but their slight abnormalities have to be discounted in analyses—sometimes a confusing task.

The output level of square-wave generators is seldom great, because high-amplitude (energy) signals aren't needed—they're not even desirable for most tests. One high-grade unit provides a low-impedance output at around 5 volts peak and a high-impedance level of nearly 50 volts peak.

You may have noticed the reference to square-wave voltage as a *peak* level instead of peak-to-peak. Exact terminology depends on whether you are using AC reference or DC reference. Accurate square-wave analysis generally requires response down to DC, therefore a DC-type triggered scope is most appropriate. Fig. 5 shows the difference between considering the square wave as referenced to AC and as referenced to DC. The latter is more common in high-grade instruments, and is easier to work with.

The colored markings indicate AC

reference terms, which you're probably familiar with already. The square wave centers itself symmetrically around the zero level; excursion is in a positive direction for one half-cycle and negative for the other.

With DC reference, used in most serious square-wave generators the output is clamped to ground: the pulse is considered "on" for one half-cycle and "off" the other. The labeled active pulse in Fig. 5A is shown positive-going for convenience of presentation. In actual generators, it is common to clamp zero volts to the chassis and let the negative excursion be the output (see Fig. 5B). The only difference in 5A and 5B is in where the trace will situate itself on the screen of a DC scope (A would go upward and downward from zero reference; B will extend downward only).

Square Waves in Analysis

Now that you understand the characteristics of a square wave and know how the signal is presented by a good generator, you can use a triggered scope to view the waveshape both before and after it is applied to the circuit or network to be analyzed. Your analysis will be based on how the square-wave signal is modified by the circuit to which it is applied. Your knowledge of the effects of frequency, duration, rise time, etc., will enable you to analyze changes intelligently.

Assuming the use of a good generator, you know that the waveform you feed in is perfectly square; so, any changes you observe will be caused by the circuit under test. However, it isn't always easy to recognize vague differences, so a means of comparison is handy. There are two ways—one mechanical and inexpensive, the other electronic and costly but more effective and accurate.

The mechanical method consists of making up a transparent square-wave overlay for your scope graticule. Using the generator and scope you'll use for this type of servicing, feed a square wave to the scope and adjust the controls for a pattern (two cycles is probably best) that is convenient to view on the CRT face. Trace this pattern carefully and transfer it in black ink to a stiff piece of transparent plastic film. Whenever you are analyzing with square waves, put the overlay in place, adjust the scope controls to subimpose the test display under the overlay pattern, and compare. Remember, if you change any part of your equipment or setup, you'll have to trace a new reference waveform.

The electronic method is by use of a dual-beam scope—a scope with an

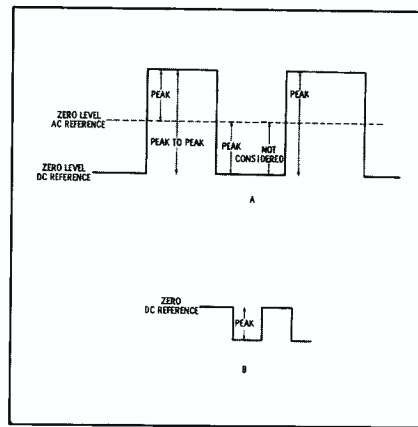

Fig. 5. Ways of considering waves.

electronic switch that presents first one input image and then the other, but does it quickly enough that they appear as two steady displays. Whenever you're analyzing by this system, just connect the generator output to one channel of the scope as well as to the circuit being tested and connect the circuit output to the other scope channel. Both will be displayed on the scope CRT, and they can even be superimposed for more critical examination.

Shape of Things to Come

Subsequent articles, beginning next month, will show you step by step how square waves are affected by various circuit elements and parameters. Starting with the simple effects of resistance, inductance, and capacitance, we'll take you all the way through testing of multiple-terminal devices that are completely unidentifiable except by this method. You'll learn how faults affect the square waves passed by these same components and networks.

Once you understand the basics of sophisticated square-wave analysis, you'll also learn to use square-wave test procedures to analyze audio, video, and chroma circuits, as well as for performing dozens of other practical circuit and servicing tests.

In the process of learning these advanced techniques, you'll learn practical facts about basic electronics that may surprise you. You'll see many functions you've only vaguely comprehended before now presented in a new light. This new understanding will better equip you to survive the onslaught of technology that sometimes threatens to engulf the service technician who tries desperately to keep up with a rapidly advancing field. These articles may prove to be the most informative and ultimately practical series we've ever presented to our readers. We certainly hope they will.

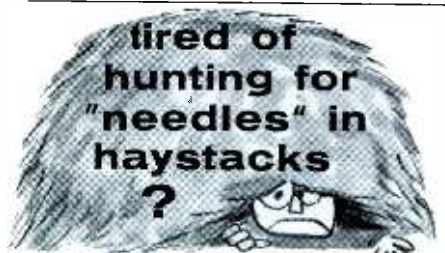

FIND THE
PRECISE
AUDIO
ACCESSORY
YOU NEED
FAST!

- Jacks
- Plugs
- Adaptors
- Couplers
- Extension Jacks
- Speaker Controls
- "Mini-Mix"—mixers, etc.

look for the

SWITCHCRAFT®

AUDIO ACCESSORY SELF-SERVICE CENTER

At last! All the confusion and "wait" gone. Fail-Safe quality. Packages factory sealed, precisely labeled by name, type, mating part, price. Guaranteed.

Send for Complete Catalog:

SWITCHCRAFT, INCORPORATED

5563 No. Elston Ave., Chicago, Illinois 60630

Circle 42 on literature card

Coils

(Continued from page 35)

the surface (skin) of the wire, causing an in-phase resistance component. To minimize this skin effect, good-conductivity solid wire (sometimes silver- or gold-plated), or Litz wire is used in certain critical coils.

Dielectric Effects—Dielectric losses are introduced by the insulation of the wire with which the coil is wound, by the insulating form on which the coil is wound, and by any insulant within the field of the coil. These losses are minimized by using a self-supporting (airwound) coil of bare wire where possible, or by employing a high-grade, moisture-resistant dielectric (polystyrene, non-hygroscopic ceramic, and the like) in the form and supports. Unessential dielectric bodies must be kept out of the coil field in any circuit at frequencies above 100 kc.

Installation Hints

The following rules will be helpful for obtaining best results.

1. Use only exact replacements.
2. Check inductance carefully with an inductance bridge or inductance meter (100 cps) or Q meter (1 mc). Change the test frequency if another is specifically recommended by the coil manufacturer.
3. In general if a coil is supplied with a shield, do not remove it. Removing the shield not only promotes interference in the circuit, but also changes the inductance of the coil.
4. If you add a shield to a coil, keep the ends of the shield at least one-half the length of the coil away from the top and bottom of the coil, and the sides of the shield at least one diameter from the sides of the coil.
5. In an RF tuned circuit, use only the highest Q (lowest-loss) coil obtainable.
6. Avoid mounting a coil close enough to a variable capacitor, chassis, or other metal object that the field of the coil will cut the chassis or object. (See dimensions in item 4 for proper separation.)
7. Mount coils rigidly.
8. Use *long*, insulated screwdriver or alignment tool when adjusting a variable inductor. ▲



It's spring TV tuneup time again!

**Now that the snow's off the roof
Get the snow off the TV screens**

Put new snap in TV reception, by replacing damaged antennas and adding a Blonder-Tongue TV signal amplifier, Golden Dart UHF antenna or the new solid-state UHF converters.

An excellent profit opportunity for service-technicians. Get details on the 2nd Annual "Blonder-Tongue Spring TV Tuneup" from your distributor.



BLONDER-TONGUE 9 AILING STREET, NEWARK, NEW JERSEY 07102

Circle 43 on literature card

new SAMS BOOKS

Color TV Training Manual, New Second Edition



by C. P. Oliphant & Verne M. Ray. This newly revised comprehensive manual is the most up-to-date guide available for technicians preparing to service color-TV receivers. Describes the science of color, requirements and make-up of the composite color signal, latest color circuits, and servicing procedures. Full-color picture tube photos are invaluable for setup and alignment procedures, as well as trouble-shooting. Chapters: Colorimetry; Requirements of the Composite Color Signal; Make-up of the Color Signal; R-F and I-F Circuits; Video, Sync & Voltage-Supply Circuits; Band pass-Amplifier, Color-Sync and Color-Killer Circuits; Color Modulation; Matrix Section; Color Picture Tube & Associated Circuits; Setup Procedure; Aligning the Color Receiver; Troubleshooting. 224 pages; \$5.95

8 1/2 x 11". Order TVC-2, only

Industrial Transistor Circuits

by Allan Lytel. Semiconductor characteristics—extremely long life and reliability, plus low power and small space requirements—make them ideal for many industrial applications. This valuable reference book describes dozens of solid-state circuits designed for reliable industrial service. Schematics and explanatory text fully outline principles and operation of each circuit. Covers solid-state circuitry for controls, amplifiers, regulators, alarms, counters, dimmers, timers, meter controls, etc. An important book for technicians, designers, and experimenters. 112 pages; 5 1/2 x 8 1/2". Order ITL-1, only \$2.50

Basic Electricity/Electronics Lab Workbook

by Training & Retraining, Inc. This comprehensive programmed-type workbook is the project-teaching supplement for the popular Sams Basic Electricity/Electronics series. The workbook includes dozens of lab projects keyed to the 5-volume series. Each project is accompanied by text explaining the principles of electricity and electronics under demonstration. Pictorial and schematic diagrams, parts lists, and step-by-step wiring instructions guide the reader through the actual construction of each practice project. Questions (and answers) help to gain understanding of the project and its principles. Workbook leads finally to construction of a superhet receiver. 256 pages; 8 1/2" x 11". \$4.95

Order ECY-W, only

Basic Electricity/Electronics Series

- Vol. 1 Basic Principles & Applications
 - Vol. 2 How AC and DC Circuits Work
 - Vol. 3 Understanding Tube & Transistor Circuits
 - Vol. 4 Understanding & Using Test Instruments
 - Vol. 5 Motors & Generators—How They Work (Each Volume, softbound \$4.50; hardbound, \$5.50)
- 5-Vol. Softbound Edition, order ECY-50, only \$19.95
5-Vol. Hardbound Edition, order ECS-50, only \$24.95

Electronic Systems for Convenience, Safety and Enjoyment

by Edward A. Altshuler. In this new book, the author forcefully points out to TV-radio technicians, distributors and manufacturers the need for a new marketing approach in the electronics industry. He shows convincingly that electronics markets will expand rapidly—requiring growing services from technicians, distributors and manufacturers—as totally integrated electronic systems are developed and adopted for entertainment, communications, control, and special services. He cites striking examples of how today's electronics technology can be applied and sold in home, plant, office, school, and hospital. "Must" reading for everyone with a stake in electronics. 256 pages; 5 1/2 x 8 1/2". \$4.95

Order SA5-1, (softbound), only \$3.95
Order SAH-1, (hardbound), only \$5.95

HOWARD W. SAMS & CO., INC.

Order from your Sams Distributor today, or mail to Howard W. Sams & Co., Inc., Dept. PF-4, 4300 W. 62nd Street, Indianapolis, Ind. 46206

Send me the following books:

- TVC-2 ECY-W ECS-50 SAH-1
 ITL-1 ECY-50 SAS-1

Send FREE Sams Booklist. \$_____ enclosed

Name _____

Address _____

City _____ State _____ Zip _____

My Distributor is _____

IN CANADA: A. C. Simmonds & Sons, Ltd., Toronto 7

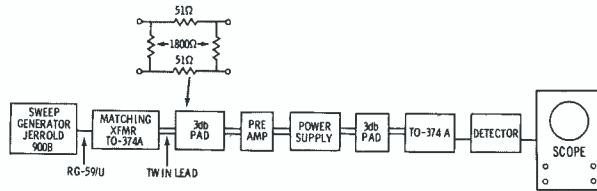

Fig. 10. Diagram of equipment set up for sweep testing described in text. a 200-mc signal. If the unit is operating properly, the scope trace should look just like Fig. 8. Gain, however, would be about half.

To trace signals within the amplifier, you'll have to build a little probe, like the one shown in Fig. 9.

Suppose, for example, that capacitor C6 were open. We'd get little low-band response with the signal going straight through the unit, but the low-band response would look approximately normal if we connected our probe directly to the emitter of X2. A point-by-point check of all the signal-carrying components between the amplifier input and X2 would quickly reveal the culprit.

The output circuits can be checked in exactly the same way. We simply inject the output of the signal generator directly into the amplifier and connect the scope probe to the detector end. Now, the scope probe can be used anywhere between the transistor collectors and the output terminals of the amplifier. The scope traces should look like those in Fig. 8 at all points where the amplifier is operating properly.

The Sweep Method

The most sophisticated method of servicing an antenna preamplifier is by using an RF sweep generator. The setup (Fig. 10) shows you the entire response of the amplifier at a glance. For gain evaluation, you can make a comparison between the di-

• Please turn to page 86

Save Time on PC Board Repairs!

MODEL 100A

Melted solder disappears up hollow tip into tube

The ENDECO Desoldering Iron Removes Soldered Components in seconds... without damage!

Endeco melts solder, then removes it by vacuum • Leaves terminals and mounting holes clean • Resolders too • One-hand operation • Temperature controlled for continuous use • Ideal for use with shrinkable tubing • 4 tip sizes • Quickly pays for itself in time saved • Only \$18.75 net.

SMALLER SIZE AVAILABLE. SEE YOUR DISTRIBUTOR OR WRITE:



ENTERPRISE DEVELOPMENT CORPORATION

1102 E. 52ND • INDIANAPOLIS, IND. 46205
IN CANADA: A. C. Simmonds & Sons, Ltd., 100 Merton St., Toronto 7, Canada.

Circle 46 on literature card

NEED SOME EXTRA MONEY?

GET IT SELLING COLMAN

AUTOMATIC COLOR PURIFIERS

FOR ALL '58-'65 COLOR SETS WITH 21" ROUND TUBES

EASY TO SELL—MOST WANTED FEATURE ON COLOR TV'S TODAY

EASY TO INSTALL—USUALLY TAKES JUST 15 MINUTES

EASY TO MAKE MONEY—SEE YOUR JOBBER TODAY

Kit DK-001 List 14.20

COLMAN ELECTRONIC PRODUCTS AMARILLO TEXAS

Circle 45 on literature card



Product Report

For further information on any of the following items, circle the associated number on the Catalog & Literature Card.



Low-Cost Tweeters (120)

Two new cone-type tweeters have been added to the line of high-fidelity speakers manufactured under the "Tempo" label by **Oxford Transducer Corp.** Both tweeters feature curvilinear cones designed for good low-end cutoff and high sensitivity in the higher-frequency range. Closed-back baskets prevent interaction with mid-range and woofer speakers in the same system. Model T 3C208 is 3" square and has a specified frequency response of 1800 to 17,000 cps. Model T 5C208 is 5" square, with a specified response of 1000 to 17,000 cps. Both units have a rated power-handling capacity of 6 watts.



Low-Cost Electronic Megaphone (121)

A transistorized megaphone, the Model MV-2 by **Fanon-Masco**, develops one full watt of audio output and is said to increase the vocal range by as much as 150 yards. The compact, hand-held unit would be useful to Boy Scouts, boaters, campers, coaches, and others who are active outdoors. The Model MV-2 operates on eight standard penlight batteries and is made of high-impact plastic. A wrist cord is attached for carrying. A talk-lock switch is provided for easy con-

tinuous talking, and a volume control permits adjustment of the output level according to the coverage required. The unit, which weighs 1½ lbs and measures 7" x 4" x 2½", is priced at \$19.95.

BOOK REVIEW

How To Make More Money In Your TV Service Business: John Markus: McGraw-Hill Book Co., Inc., New York, New York: 346 pages, hard-bound: \$7.95. Making money is one goal men choose when they begin a business for themselves. In most cases, it's not the only objective, but it certainly holds a firm position near the top of the list. The unfortunate reality is that many would-be practitioners of the art of private enterprise have only a very foggy notion of even the basic requirements necessary for success. Mr. Markus is convinced there is no reason for technicians contemplating their own service business to make the same mistakes which have caused so many of their predecessors to fail in similar ventures. For those who will take the time to read, study, and apply the precepts found in his book, success should be a far more easily attained goal.

A complete listing of the topics covered by Mr. Markus would require several lengthy paragraphs, but just a few will demonstrate the breadth of his coverage. In planning a business, Mr. Markus suggests when to begin a part-time business, how to choose a business name, when to move to full-time effort, how to rent a shop and where, how to advertise effectively, how much to charge for your work, how to attract new customers, and how to handle callbacks. He has many other useful suggestions for dealing with customers. He tells how to write ads, discourage credit, make out a bill, collect overdue accounts, set up your records, and answer common customer gripes. His advice will help to hire efficient workers, avoid legal problems, handle installment sales, and save money on your income tax. In short, this book is a well-planned and concisely written business course for those who will take the time to learn from it. Business neophytes and established shop owners alike will find much of value to build their operations and increase their incomes.

While this book has been available for nearly three years its value is such that it warrants new attention and frequent reference by all who own or operate a servicing business and by any who plan to do so.

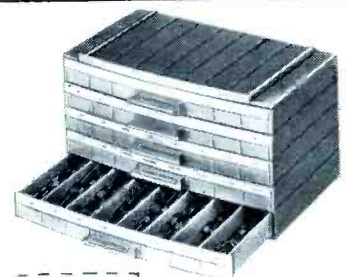

Little Devil® Composition Resistors



Type AB 2-Watt Molded Pots

five ways to
stop customer
"static"

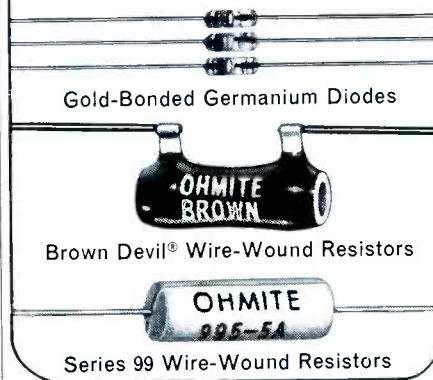

Customer "static" is hard on the ears . . . hard on profit. But you're always safe with Ohmite quality replacements in your repair jobs. Order Little Devils in handy cabinet assortments or on Tally-Tape; all popular sizes and values. Select AB Pots from 50 ohms to 5 megohms in several shaft lengths. Choose from ninety 1N types of diodes. Get Brown Devils from 3 to 20 watts in 0.5-ohm to 100K-ohm values. Order Series 99 resistors in 1½, 2¼, 3¼, 5, 11 watt sizes from 1 to 51,000 ohms. Ask your distributor for the latest edition of Ohmite's Stock Catalog 30.

Be right with



OHMITE
RHEOSTATS • RESISTORS • VARIABLE TRANSFORMERS • TAP SWITCHES TANTALUM CAPACITORS • RELAYS R.F. CHOKES • SEMICONDUCTOR DIODES

Circle 47 on literature card



FREE!



with your subscription to

PF Reporter™

HERE'S HOW SYMFACT HELPS YOU:

Symfact™ covers troubleshooting in all TV circuits

Each symptom chart in SYMFACT presents in easy-to-see form each and every possible change that can possibly occur in the circuit as a result of component failure. A symptom photo shows exactly how the CRT screen looks; actual photos of the waveforms indicate what to expect when using your scope for troubleshooting; a labelled partial schematic portrays changes in DC operating voltages; and thorough explanations tell how and why the component failed and what other components might cause similar symptoms. Every SYMFACT now contains six of these symptom charts for each circuit covered.

ACT NOW subscribe (or renew your present subscription) and receive FREE—SYMFACT Vol. 1, as well as up to three extra issues if you include payment with your order.

- Start my new subscription with your next issue. Yes, renew my subscription to PF REPORTER.

39 BIG ISSUES-ONLY \$10.00

If you include payment with order . . . you will receive:
 39 issues for \$10.00 26 issues for \$8.00 13 issues for \$5.00

OR, IF YOU PREFER:

- 36 issues \$10.00 24 issues \$8.00 12 issues \$5.00 bill me

Please check your Business Classification

- Independent Radio TV Serviceman Owner, Mgr.
 Retailer with Service Department Employee
 Industrial Elect. Service Service Mgr.
 Other (Specify occupation and title)

Above rates apply only in USA, its possessions and Canada. Add \$1.00 per year for other countries.

NAME _____ 265
 Please Print
 FIRM _____
 ADDRESS _____
 CITY _____ STATE _____ ZIP CODE _____



TYPE II . . . why use old fashioned wax end-filled cardboard capacitors in radio repairs? Avoid call-backs with Planet type II dual section tubular electrolytics . . . hermetically sealed in aluminum tubes with wax impregnated insulating jacket. Planet II's are also available in 450 volts for TV servicing. Ask for them by type number at your distributor.

PLANET SALES CORP.

225 Belleville Ave.
 Bloomfield, New Jersey

Circle 36 on literature card



Goof-Proof Multimeter (122)

An up-to-date version of the well-known line of Simpson Electric Co. Model 260 multimeters, known as the Model 260-5P, offers protective circuits to prevent nearly all meter damage. The new meter has the same voltage, current, and resistance ranges as the Model 260-4, which is still in production as a lower-priced instrument without the built-in protection. When an overload occurs, an

indicator button on the panel pops out. When the overload has been removed, the meter is reset by pressing the same button. It will not reset while the circuit is still overloaded. The Model 260-5P is priced at \$78.95 in standard configuration and at \$84.95 with a roll-top case.



Convert Tape Recorders to VOX
(123)

Conversion of any tape recorder to voice-actuated operation is now possible with the new "Voice-matic" from **Kinematix, Inc.** The "Voice-matic" permits operation of tape recorders from a distance, at leisure, or while hands are busy writing, turning pages, etc. Installation takes only a few seconds, and no tools are required for most conversions. An adjustable delay varies the hold-on time to prevent too frequent shutoff of the recorder during pauses in dictation or other continuous recording. The Model KX-5000 "Voice-matic" can be used for dictation, as a film sync device for narrated slide films, as a baby-sitter alarm or burglar alarm, or to control amateur or CB transmitters. The unit is priced at \$34.95, complete with case.



Tiny Transistor
(124)

A transistor radio, said to be the world's smallest, is being marketed by **Ross Electronics Corp.** Featuring black-and-chrome styling and measuring 2" square by 1 7/8" thick, the 7-transistor radio is about half the size of a standard cigarette package and fits comfortably within the tiniest evening purse. Suggested retail price for Model RDM-7 is \$17.95. ▲

Devant "1"

NEWEST ADVANCE IN CB COMMUNICATIONS

The All NEW DEVANT-1 From MOSLEY

The result of
continuous research
and development to bring you
Superior Quality at a

A field tested base station antenna that will equal or outperform anything available on the CB market today. Many of the features of the DEVANT "1" are built into the base section. The vertical element terminates in a phenolic sleeve which has greater strength than the aluminum element. Radials terminate into a high strength "Cyclac" base, which again, has more strength than the aluminum element. The Coax female connector is part of the (weather-proof) radial support assembly. Antenna mounting is simplified, just mount the antenna on your mast, tighten two screws and lock nuts.

Tapering the ends of the aluminum tubing (called swaging) is designed to reduce wind load, and any possibility of vibrations which would cause metal fatigue. Loading and impedance matching of the DEVANT "1" is accomplished with loops of one eight inch aluminum rods.

Available Nov. 1st.

New Low Price
\$22.76

\$14.50



27 Mcs.
CB Mobile Ant.

The Traveling Companion of the Base Station DEVANT "1" is the New Mosley DEVANT "2". This stainless steel mobile antenna has the world famous Mosley performance. A slim line beauty with built-in durability. Cash in on these outstanding engineering efforts wherever Mosley antennas are sold. For detailed specifications and performance data on the DEVANT "1" and / or DEVANT "2" clip coupon below and mail.

Please send me (FREE of charge & obligation) literature on the following antennas. DEVANT "1" DEVANT "2"

Name

Address

City/State

Mosley Electronics Inc. 4610 N. Lindbergh Blvd.,
Bridgeton, Mo. 63044

THIS SPEAKER HAS SOMETHING TO SAY



A true breakthrough in product design, ATLAS SOUND's EC-10 is an *all-American* value in performance and price. Outstanding in established applications, it opens up brand-new uses for horn speakers—in intercoms, low-power paging and talkback systems, mobile and Citizens Band transceivers. Use instead of cones. Install these extras:

Performance—Crisp, efficient, big-speaker sound from 6 watts or less . . . clean response from 400-13,000 cps.

Construction—All-weather design . . . high-impact plastic horn with permanent, molded-in color . . . die-cast metal parts for extra strength . . . tough, easily adjustable, steel mounting bracket . . . high-efficiency, ceramic magnet and reinforced phenolic diaphragm.

Utility—Compact (6³/₈" long, 6¹/₄" diameter), fits anywhere . . . available in 8 or 45 ohms . . . also specially designed T-3 (25-volt) and T-4 (70-volt) line matching transformers.

Speaker Price: \$14.25 net

For more on the EC-10 and *all* your needs in public address speakers and microphone stands, write for catalog PF-F11



ATLAS SOUND, Division of
AMERICAN TRADING AND PRODUCTION CORPORATION
1419-51 39th Street, Brooklyn, New York 11218
Canada: Atlas Radio Corporation, Toronto

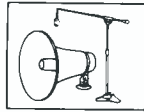

THIRTY YEARS OF LEADERSHIP IN COMMERCIAL SOUND

Circle 49 on literature card

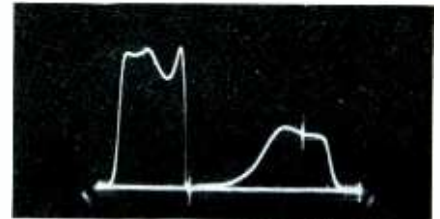

Fig. 11. Note markers 100 and 200 mc. rect output of the sweep generator and the output of the amplifier.

Fig. 11 shows the sweep response of the unit of Fig. 4 as seen on the oscilloscope. Notice the markers at 100 mc and 200 mc. These facilitate alignment, which is virtually impossible without a sweep generator.

We can use the same type of demodulator probe with this setup as

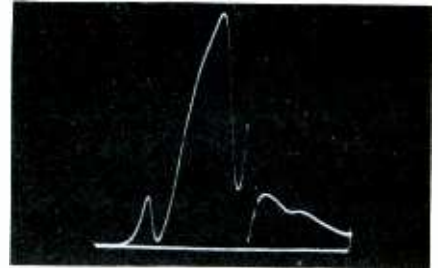

Fig. 12. Low-band curve if C6 is open.

we used for tracing with the signal generator. But scope displays are much more definitive using the sweep method. For example, with C6 open and the probe connected directly to the emitter of X2, the scope display obtained by the tracing method looked quite normal . . . remember? Fig. 12 shows how distorted the response obtained by the comparative sweep method really is.

You can also look at either the high-band or low-band response, separately. Fig. 13 shows the normal high-band response, with the signal injected at the base of X1.

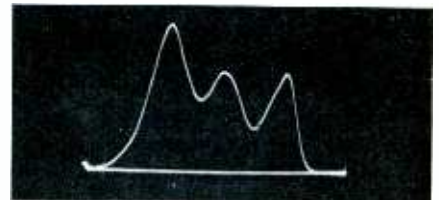

Fig. 13. Normal high-band curve. The marker in second valley is at 200 mc.

Using this method, in fact, you can take a close look at any portion of the band, sweeping as narrow a range as 10 kc.

Conclusion

If you have a reasonably-well-equipped TV shop, plus basic servicing skills, you'll probably have little difficulty in repairing antenna boosters—at a profit. ▲



Make \$4.00 Extra Profit For Each Color TV Service Call!



★ HIGH QUALITY

★ LOW COST

Hanging Clip included for back of TV set



WALSCO ELECTRONICS

DIV. OF GC-TEXTRON ELECTRONICS, INC.

Main Plant: Rockford, Ill., U.S.A. • Hicksville, L.I., N.Y. • Los Angeles, Calif.



LIST PRICE 9.95
NET PRICE 5.95
Your Profit \$4.00

Only \$5.95 NET

Circle 50 on literature card

INDEX TO ADVERTISERS

APRIL 1965

ATR Electronics, Inc.	13
Aerovox Corp.	79
Amperex Corp.	Cover 2
Antenna Specialists Co.	46
Atlas Sound	86
B & K Mfg. Co.	45, 61
Div of Dynascan Corp.	
Blonder Tongue Labs	81
Bussmann Mfg. Div.	24, 25
Castle TV Tuner Service	15
Centralab, Div. of Globe-Union, Inc.	53
Channel Master Corp.	31
Cleveland Institute of Electronics	75
Colman Electronic Products	82
Electronics Communications, Inc.	58
Enterprise Development Co.	82
Finney Co.	48, 49
General Electric	42, 43, 57
Heath Co.	72
JFD Electronics Corp.	18, 19
Jerrold Electronics	70
Kinematix, Inc.	78
Lafayette Radio Electronics Corp.	26
Lectrotech, Inc.	77
Littelfuse, Inc.	Cover 4
Mosley Electronics, Inc.	85
Ohmite Mfg. Co.	83
Oxford Transducer Co.	73
Perma-Power Co.	47
Philco Corp.	22, 23
Planet Sales Co.	84
Precise Electronics	78
Precision Tuner Service	46
Quality Tuner Service	56
RCA Entertainment	Cover 3
RCA Test Equipment	55
RCA Parts and Accessories	16, 17
RCA Sales Corp.	51
Sams, Howard W. & Co., Inc.	59, 82
Sarkes Tarzian Tuner Service	9
SENCORE, Inc.	64, 65, 66, 67, 68, 69
Simpson Electric Co.	63
Sonotone Corp.	74
Sprague Products Co.	11, 12
Switchcraft, Inc.	80
Sylvania Electric Products, Inc.	14
VACO Products Co.	71
Valley TV Tuner Service	54
Walsco Electronics Co.	86
Winegard Co.	40, 41, 87
Workman Electronic Products, Inc.	54
Xcelite, Inc.	60

(Continued from page 21)
NEW TUBE TYPES INTRODUCED IN '65 TV

1DK1	Sony
2HQ5	Airline Bradford Catalina Coronado
2VD4	Airline
3HQ5	Airline
4AF4A*	GE
4ES8	Clairtone
4HA7	Emerson
4XG7	Catalina Coronado
5AN8	Airline
5GX7	Airline
5HA7	Emerson
5HB7	Airline Bradford
5LJ8	Admiral
6C9*	Airline Ambassador
6CA4	Airline Ambassador Packard-Bell
6CM8	Airline
6EU7	RCA
6GH5	Airline
6HB7*	Magnavox
6HM5	Zenith
6HQ5*	Airline Andrea
6HD6	RCA
6JM6*	Motorola GE Zenith
6JN6*	Zenith
6JX8	Clairtone
6KE8	RCA
6KL8*	Airline Ambassador
6KZ8	RCA
6LC8	RCA
7GS7	Arvin
8A8	Arvin
8GM6*	RCA
8LC8	RCA
9JW8	Clairtone
10GN8	Airline Zenith Sylvania Philco
10JT8	Coronado
10KR8	GE
12BS3	Bradford
12BT3	Catalina
12FS5	Zenith
12JT7	Clairtone
13FM7	RCA
14GW8	Admiral
17BJ6	Coronado
17EW8	Zenith
17JG6A	Arvin
17JM6	Delmonico
17Z3	Arvin, Clairtone
18GV8	Admiral
19EA8	Admiral
20EZ7	GE
21HB5A	Airline
21HJ7	Zenith
22BW3	GE
23Z9	Arvin
25E5	Delmonico Clairtone
27GB5	Clairtone
30AE3	Admiral
38HE7	Admiral
45BW5	Admiral
5642	Channel Master

Winegard

Dealer of the month

No. 35 of a series

Boyde Crump says: "I can always depend on Winegard Colortrons and Color-Ceptors to pull in the best possible pictures."



Winegard salutes Hop's TV & Appliances, Midvale, Utah, and their supplier Standard Supply Company, Salt Lake City, Utah.

"In the mountainous terrain around Midvale, the TV signal is often uncertain... that's why I *always* recommend Winegard antennas to my customers. I know I can depend on the quality craftsmanship and engineering of these outstanding TV antennas, even when the going is really rough."

In this rugged fringe area, weak gray pictures and considerable snow are common. But Boyde says, "I'm certain that my Winegard installations will work beautifully in either color or black and white... even in our deep fringe area."

The confidence Boyde Crump, largest TV sales and service dealer in Salt Lake County, has shown in Winegard comes from using Winegard products and seeing them in action. He is one more important service dealer who knows Winegard's standards of excellence first hand.

Winegard Co.

Antenna Systems

D3009D Kirkwood • Burlington, Iowa

Circle 51 on literature card

April, 1965/PF REPORTER 87



FREE Catalog and Literature Service

*Check "Index to Advertisers" for further information from these companies.

Please allow 60 to 90 days for delivery.

ANTENNAS & ACCESSORIES

57. *ALLIANCE*—Flyer describing Model 300 broad-band VHF booster; suitable for black-and-white or color.
58. *ANTENNACRAFT*—Latest literature on *Channel-Spanner*, a new broad-band high-gain VHF-UHF TV antenna
59. *CORNELL-DUBILIER*—Replacement component selector, TV-FM reception booklet, 4-page rotor brochure, and vibrator replacement guide.
60. *FINNEY*—Catalog UVF describes new swept-element log-periodic type VHF-FM antennas.*
61. *IEH*—Catalog sheets on Model AP-25 UHF-VHF coupler and Model AP-26 TV-FM splitter-coupler.
62. *JFD*—Literature on complete line of log-periodic antennas for VHF, UHF, FM, and FM stereo. Brochure showing converters, amplifiers, and accessories; also complete '64-65 dealer catalog plus dealer wall chart of antenna selection by area.*
63. *MOSLEY ELECTRONICS*—Illustrated catalog giving specifications and features on large line of antennas for Citizens band, amateur, and TV applications.*
64. *MULTITRON*—Illustrated literature on FM-stereo antenna No. MA-44, Multituner Model M-11, and Minitenna No. MINI-4T.
65. *STANDARD KOLLSMAN*—Catalog sheet on UTC-051 transistor UHF converter kit with IF amplifier.
66. *TRIO*—Brochure on installation and materials for improving UHF translator reception.
67. *ZENITH*—Informative bulletins on universal loudspeakers and a new line of log-periodic vee-type antennas for FM and monochrome or color TV.

AUDIO & HI-FI

68. *ADMIRAL*—Folders describing line of '65 equipment; includes black-and-white TV, color TV, radio, and stereo hi-fi.
69. *ATLAS SOUND*—Catalog No. 564 contains illustrations and specifications on PA speakers, microphone stands for commercial and industrial installations, and other new products.*
70. *GIBBS SPECIAL PRODUCTS*—Folders describing C-46 and C-66 sound columns, two-way wall speaker system, and bidirectional baffle-speaker combinations.
71. *JENSEN*—24-page catalog, No. 165-K, illustrates and describes speakers and speaker system kits.
72. *NUTONE*—Two full-color booklets illustrating built-in stereo music systems and intercom-radio systems. Includes specifications, installation ideas, and prices.
73. *OAKTRON*—"The Blueprint to Better Sound," an 8-page catalog of loudspeakers and baffles giving detailed specifications and list prices.
74. *OXFORD TRANSDUCER*—Product information bulletin describing complete line of loudspeakers for all types of sound applications, including replacements for public address and intercom systems.
75. *PERMA-POWER*—New catalog sheet describing Ampli-Vox Model S-300 and Sound Cruiser sound system Model S-310.*
76. *QUAM-NICHOLS*—General catalog listing replacement speakers for public address, hi-fi, and radio-TV applications.
77. *SAMPSON*—Full-color catalog pages showing new line of Waltham transistor radios, tape recorders, and portable television sets.
78. *SHURE BROTHERS*—Folder on newly introduced hi-fi magnetic cartridge.
79. *TURNER*—New four-page, full-color catalog No. 1040 describing microphones designed for church applications.

COMMUNICATIONS

80. *PEARCE-SIMPSON*—Specification brochure on IBC 301 business-band two-way radio, *Companion 11*, *Escort*, and *Guardian 23* Citizens-band transceivers.
81. *SONAR RADIO*—Specification sheet on Model FM-40 business radio.

COMPONENTS

82. *BUSSMANN*—Bulletin SFH-10 on new compact fuseholders only 1 5/8" long, extending just 29/32" behind front of panel, and requiring only 1/2" mounting hole. Holders take 1/4" x 1 1/4" fuse and are available with either screw-type knob that is easily removed by hand or with screw-driver slot.*
83. *GC ELECTRONICS*—80-page industrial catalog FR-66-1 showing newly introduced products.
84. *INTERNATIONAL ELECTRONICS*—New expanded listing covers popular IEC and Mullard tube types for TV, AM and FM radio, and high-fidelity.
85. *J-B-T-INSTRUMENTS*—General catalog 563A has information on frequency meters, elapsed-time meters, and numerous relays and switches.
86. *RAWN*—New professional ideas for knob and plastic repair.
87. *SPRAGUE*—Latest catalog C-616 with complete listing of all stock parts for TV and radio replacement use, as well as *Transfarad* and *Tel-Ohmike* capacitor analyzers.*
88. *SWITCHCRAFT*—New product bulletin No. 150 describes a complete line of low-capacity lever switches.*
89. *WORKMAN*—Coil catalog No. 109 and cross reference for replacement of antenna coils, IF transformers, RF chokes, linearity coils, and others for FM radios, tape recorders, and color TV receivers.

SERVICE AIDS

90. *CASTLE*—How to get fast overhaul service on all makes and models of television tuners is described in leaflet *Shipping instructions*, labels, and tags are also included.
91. *ELECTRONIC CHEMICAL*—Catalog sheet on contact cleaner; brochure on tape recorder head cleaner.
92. *PRECISION TUNER*—Literature supplying information on complete, low-cost repair and alignment services for any TV tuner.*
93. *YEATS*—The new "back-saving" appliance dolly Model 7 is featured in a four-page booklet describing feather-weight-aluminum construction.

SPECIAL EQUIPMENT

94. *ATR*—Descriptive literature on selling new, all-transistor *Karadio* Model 707, having retail price of \$29.95. Other literature on complete line of DC-AC inverters for operating 117-volt PA systems and other electronics gear.*
95. *GREYHOUND*—The complete story of the speed, convenience, and special service provided by the Greyhound Package Express method of shipping, with rates and routes.
96. *ELECTRO PRODUCTS*—Information on transistorized inverter Model TI-100; converts DC to AC and has 125-watt output.
97. *SETCHELL-CARLSON*—Full-line catalog for both color and b-w receivers, plus educational receivers.

98. *STACO*—Short form catalog 2176 on line of variable transformers; complete with latest prices.
99. *TERADO*—Latest information on *Taper Rite* battery charger.
100. *VOLKSWAGEN*—Large, 60-page illustrated booklet, "The Owner's Viewpoint," describes how various VW trucks can be used to save time and money in business enterprises, including complete specifications on line of trucks.
101. *WALLIN-KNIGHT*—Folder on Reflect-O-Scope, an effective tool for static convergence of color TV receivers.

TECHNICAL PUBLICATIONS

102. *CLEVELAND INSTITUTE OF ELECTRONICS*—Free illustrated brochure describes electronic slide rule with four lesson Instruction Course and grading service.*
103. *OELRICH PUBLICATIONS*—Catalog of business forms for TV, radio, and 2-way service; also sample of new NCR service forms.
104. *RCA INSTITUTES*—64-page book, "Your Career in Electronics," detailing home study courses in TV servicing, communications, automations, drafting, and computer programming; for beginners and experienced technicians.*
105. *HOWARD W. SAMS*—Literature describing popular and informative publications on radio and TV servicing, communications, audio, hi-fi, and industrial electronics, including special catalog of technical books on every phase of electronics.*

TEST EQUIPMENT

106. *B & K*—Bulletin 108-R on Model 801 Capacitor Analyst, Bulletin No. 124-R on Model 1240 color generator, Catalog AP-21R describing uses for and specifications of Model 1076 Television Analyst, Model 1074 TV Analyst and Color Generator, Model 700 and 600 *Dyna-Quik* Tube testers, Model 445 CRT Tester-Rejuvenator, Model 960 Transistor Radio Analyst, Model 360 *I-O-Matic* VOM, Model 375 *Dynamic* VTVM, and other test instruments.*
107. *EICO*—New 1965 catalog listing over 200 products including color-bar generator, oscilloscopes, and others; all available in kit form.
108. *HICKOK*—Specification sheets on Model 662 installer's color generator, Model 677 wideband scope, Model 470A uni-scale VTVM, and Model 799 *Mustang* tube tester.
109. *JACKSON*—Complete catalog describing all types of electronic test equipment for servicing and other applications.
110. *LECTROTECH*—Bulletins on new color TV test instruments, horizontal deflection circuit meter, meter protective devices, and substitute for VTVM battery.*
111. *MERCURY*—Literature covering Model 1100A, 1101, and 202E tube testers; Model 1500 signal generator; and entire line of test equipment.
112. *SECO*—Data sheets on self-service tube testers and caddy-pack tube testers that carry over 200 tubes.
113. *SENCORE*—New 8-page catalogue No. 257 on complete line of company products; oscilloscopes, generators, testers, and many others.*
114. *SIMPSON*—Complete 16-page brochure on entire line of electronic test equipment; also, catalog on line of panel meters.*
115. *TRIPLIETT*—All new test-equipment catalog No. 46-T showing complete line of VOM's, tube testers, transistor analyzers, and signal generators.
116. *WATERMAN*—Technical data and photos on pocket-size OCA-11A industrial oscilloscope.

TOOLS

117. *ENTERPRISE DEVELOPMENT*—Time-saving techniques in brochure from Endeco demonstrate improved desoldering and resoldering techniques for speeding up and simplifying operations on PC boards.*
118. *LUXO LAMP*—New catalog No. 114-2 showing illuminated magnifiers and low-voltage lights.
119. *UNGAR*—Catalog No. 763 giving information on series of soldering irons and accessories.

DEPENDABLE  ELECTRON TUBES

DEPENDABLE  ELECTRON TUBES

EXPERT
COLOR TV
SERVICE
with
RCA TUBES

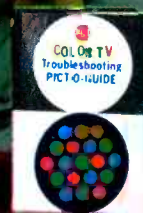
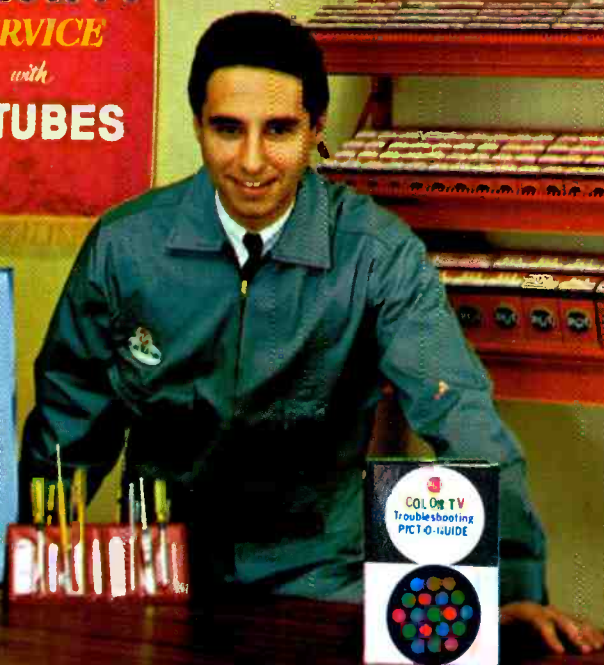

WE USE  TUBES
THE MOST TRUSTED NAME IN ELECTRONICS

LET'S GET DOWN TO BUSINESS ...in Color-TV Service

Make your shop look like it means business. You can with business-like technical, promotional, business and service aids from RCA... with the emphasis on color TV service. Remember, more and more of your service jobs will be color TV jobs.

TECHNICAL AIDS... to help you further develop your professional skills.

The famous RCA Color TV Troubleshooting Pict-O-Guide. Completely revised and updated, it's the quick and easy, all in one, profusely illustrated guide to proper troubleshooting and alignment of color TV sets. A MUST reference book, if you want to make money in color TV service. Form #1A1389.

Also available (not shown): RCA Institutes Color TV Home Study Course, the basic definitive course in color servicing; 8 graded lessons, counseling and examination service. Form #1A1325.

PROMOTIONAL AIDS... to help you attract more customers.

Illuminated Flashing Window Display (at left on counter). A real attention grabber for your window or counter. Alternates between full color and black and white to dramatize both services. Form #1A1491.

Color TV Service Banner (on wall). In rich red satin, for door, wall or window display. Form #1A1492.

Also available, (not shown) are a transparent window streamer, ad mats for local newspapers, post cards and envelope stuffers all promoting your color TV service capabilities.

BUSINESS AND SERVICE AIDS... to help make your job easier.

RCA Receiving Tube Floor Merchandiser (left) Spacious, 6 foot gravity feed metal shelving unit in bright red baked enamel finish. Seven shelves with adjustable dividers for each shelf. Helps you keep a really good supply of tubes in one well organized area. Form #1A1504.

RCA Receiving Tube Wall Merchandiser (rear) Three feet high and three feet wide, a metal gravity feed shelving unit finished in red baked enamel to hang on wall or rest on counter. Form #1A1503.

RCA TV Tool Kit (on counter) Contains 12 most needed TV tools: 3 aligners, aligning wrench, tuning wand, 3 trimming tools, standard and recessed screwdriver, solder aid, heat sink and clamping type tweezers... just about everything you need on a service call in one container; also handy in the shop. Form #1A1509.

RCA Superweld Tube Caddies. Large "Treasure Chest" caddy (1A1001A) shown on counter at right holds up to 362 receiving tubes. Junior version (1A1002A) (not shown) holds up to 234. Both feature a Superweld vinyl covering that protects like armor.

You'll also want to ask your RCA distributor about store hours signs, door knob hangers, and weekly work schedule pads from RCA.

These are the aids you really need in your business.

AVAILABLE THROUGH YOUR LOCAL AUTHORIZED RCA TUBE DISTRIBUTOR.



The Most Trusted Name in Electronics

Introducing a Complete Line of Littelfuse Quality Circuit Breakers



Actual Size
1 3/4" x 1 3/16" x 1/2"

Exact replacement from factory to you

Designed for the protection of television receiver circuits, the Littelfuse Manual Reset Circuit Breaker is also ideally suited as a current overload protector for model railroads and power operated toy transformers, hair dryers, small household appliances, home workshop power tools, office machines, small fractional horsepower motors and all types of electronic or electrical control wiring.

LITTELFUSE

DES PLAINES, ILLINOIS

Circle 52 on literature card