

AUGUST, 1959 35 CENTS



PHOTOFACT REPORTER®

Including Electronic Servicing



Including

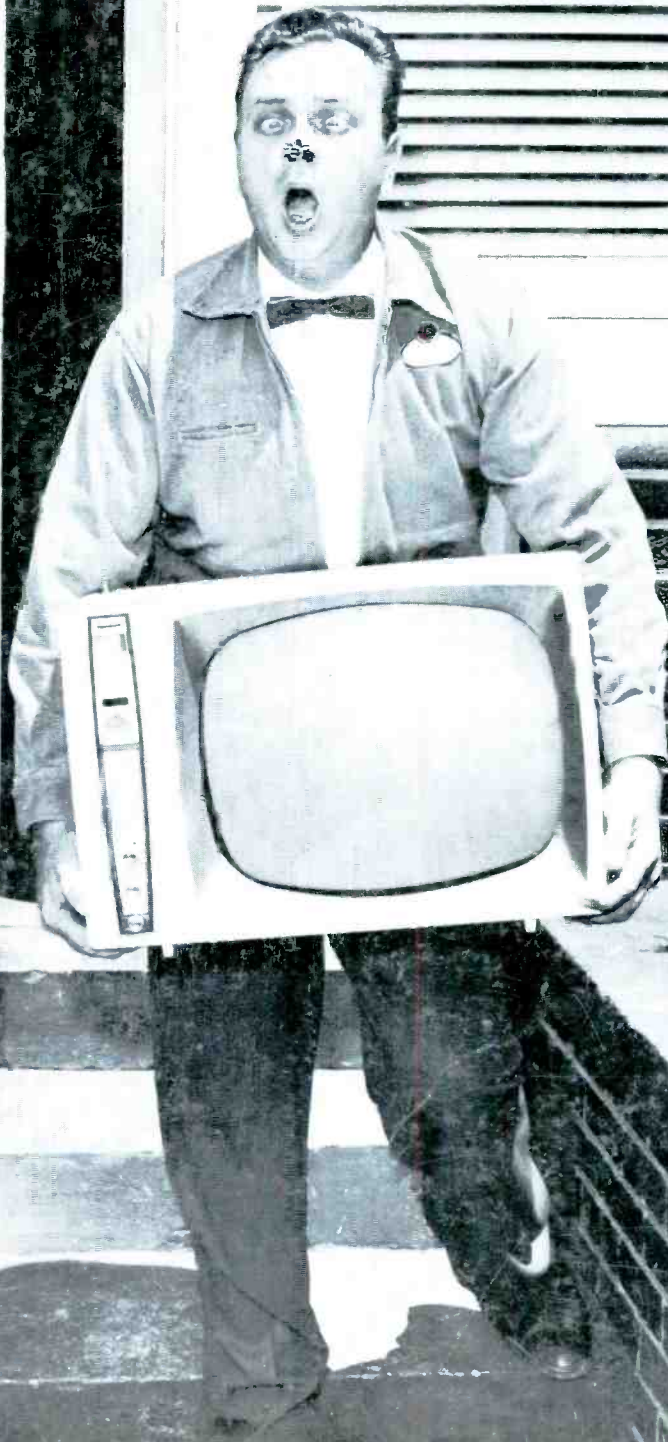

This Month's Highlights

Servicing

Vertical Sweep Systems

(see page 40)

How to Choose and Use

Microphones

(see page 42)

Scoping Modern TV Circuits

(see page 44)

Understanding the Decibel

(see page 66)

WM M DAVIS
118 RIVERSIDE AVE
CANON CITY COLO

1A 5H 635 1260E

1. Fasten Coupler to Wall or Mast

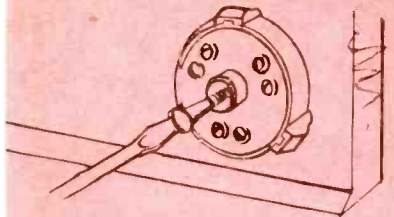

2. Measure TV or FM Leads Exactly, Then Attach to Coupler

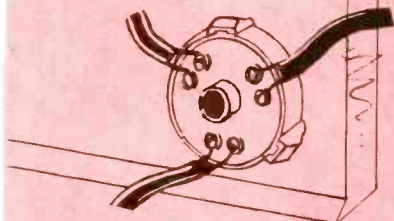

3. Snap Cap On For Easy, Neat Installation

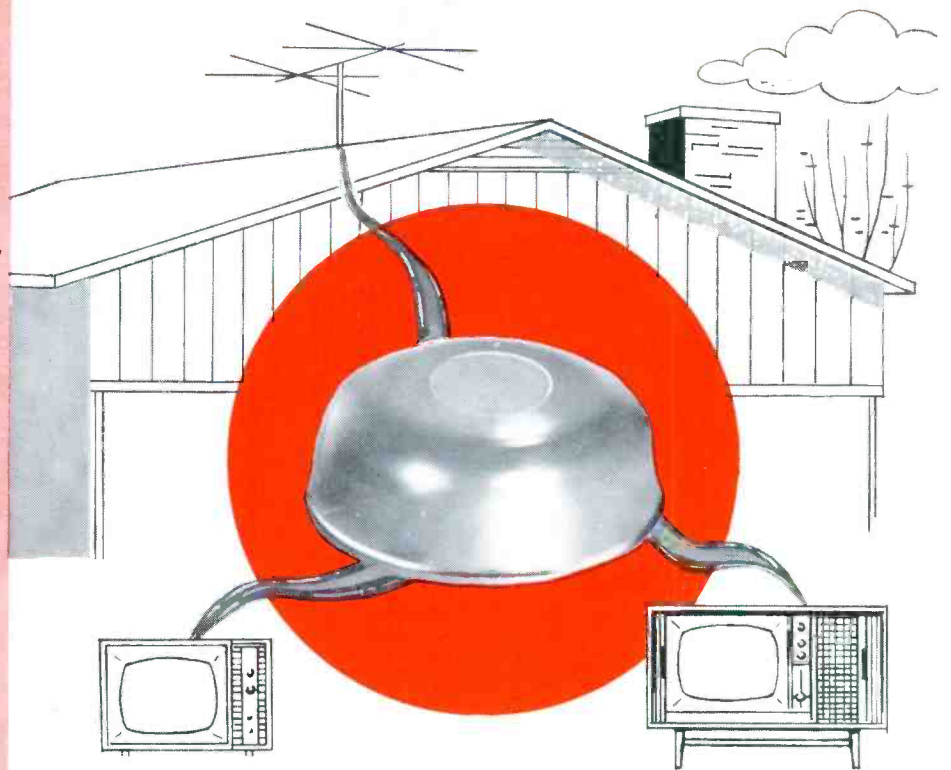
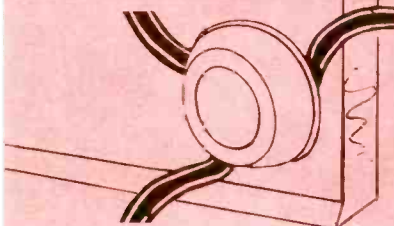

NEWLY DEVELOPED*

2-SET COUPLER

THAT GOES ON FAST AND EASY!

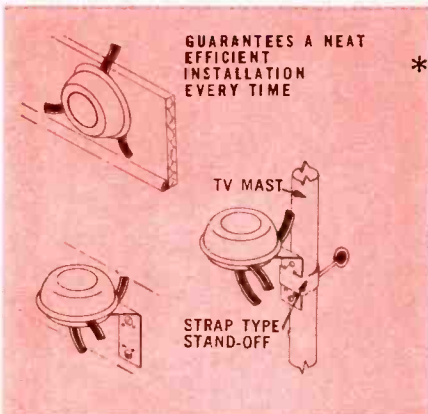

*This coupler is mounted BEFORE leads are attached.

Now at last you can get 2-Set TV or FM Couplers engineered for highest efficiency and easier, neater installations. They're designed for mounting against a wall or on a mast before attaching leads, eliminating guesswork and messy connections. Couple two TV or two FM sets, or one of each . . . enjoy greater signal strength on both!



COUPLERS ARE PACKAGED IN COLORFUL, PROTECTIVE BUBBLE PACK . . . DISPLAYED ON THIS SELF-SELLING WIRE DISPLAY.

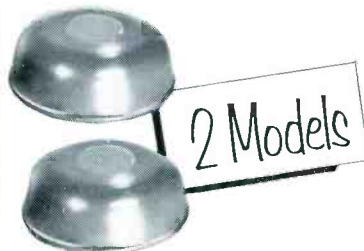

STANDARD model will couple any two sets to one antenna. Perfect match without interference. For most receiving areas.

No. 8917

List \$2.50

LOW LOSS model is similar to Standard, except it is designed and engineered specifically for fringe areas.

No. 8919

List \$3.50

GENERAL CEMENT MFG. CO.

division of Textron Inc.

Western Plant: Los Angeles 18, California

Main Plant: ROCKFORD, ILLINOIS, U.S.A.



FREE new G-C Catalog and other literature. Send postcard today!

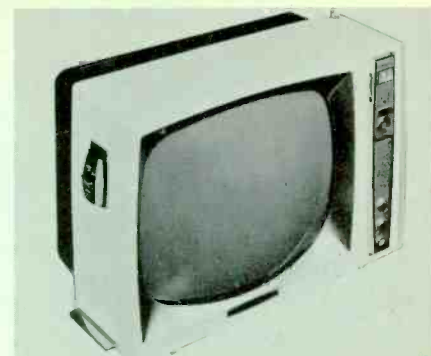
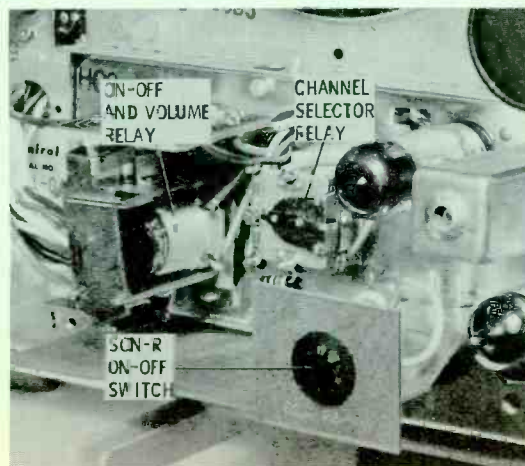
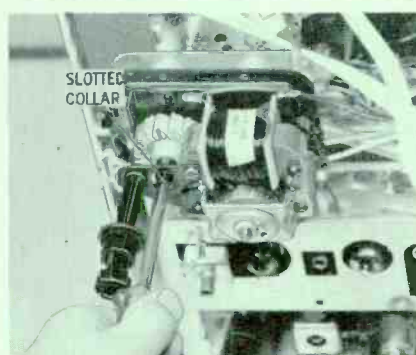
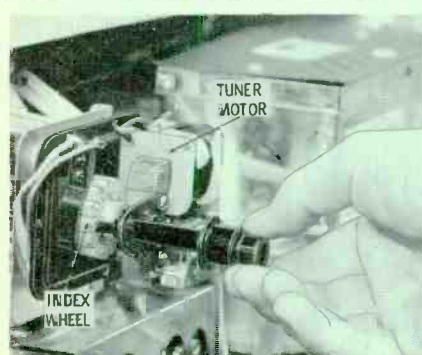
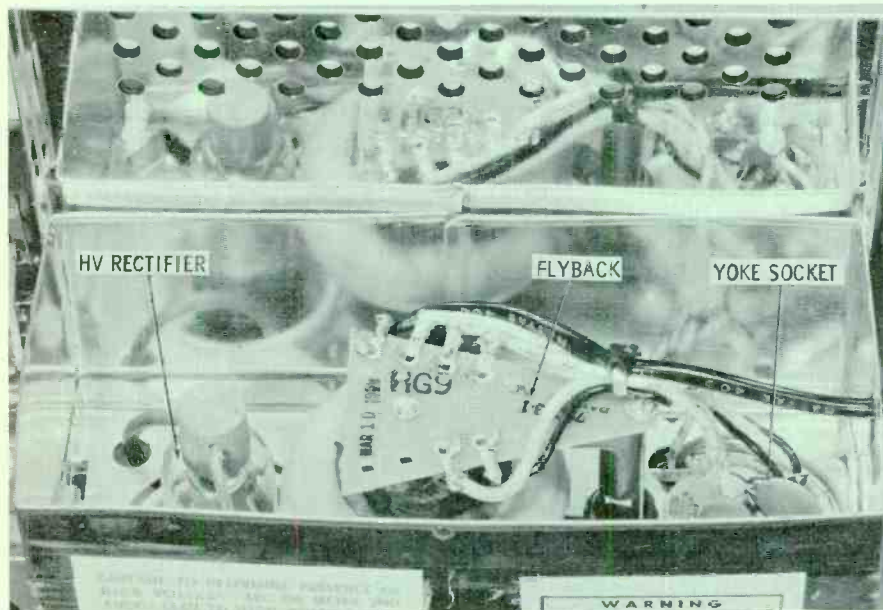
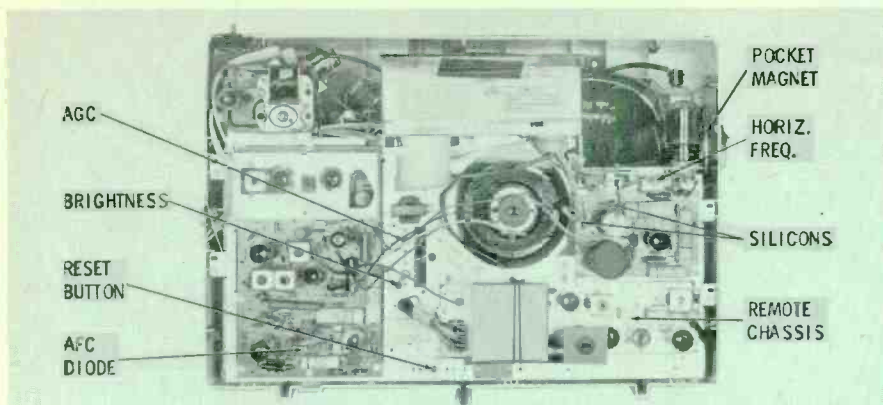

**Admiral Model PS 17F22
Chassis 15B3**

This new 17" portable features wireless remote control, plus a front push-bar for power tuning. To clean the safety glass, both chassis and picture tube must be removed.

The silicon rectifiers powering the "hot" chassis are soldered to the smaller of two printed boards employed. Without the remote transmitter in its storage place, you might wonder about the device attached inside the cabinet near the horizontal output tube. Actually, it is a magnet-like indentation on the outside of the cabinet. The reset button is used to restore power to the set should the AC circuit breaker open. An 8-ohm, 12-watt surge-limiting resistor is connected in series with this protection circuit, and is located on the wiring side of the chassis.

Lifting up the top lid of the high-voltage cage, you'll find a 1G3GT rectifier and a side-mounted flyback transformer. When called to service this set, check your caddy for a 2ER5/GG RF amplifier, 3DK6 video IF, and 10DE7 vertical sweep tube. Although you won't find a width, drive, or horizontal-linearity adjustment employed in this chassis, you will find height and vertical linearity controls, which are accessible through the hollow shafts of the contrast and vertical-hold controls on the front.

To set up the power tuner for automatic channel selection, you merely push in on the index knob and turn slightly clockwise. If the tuner skips, insert a 3/16" screwdriver blade into the hollow collar of the tuner shaft as shown, and turn to the desired channel number. Push in on the index knob and make a half turn counterclockwise until a stop is felt.

The hand unit for the *Son-R* remote control enables the operator to select channels, turn the set off and on, and vary the volume level in three steps. For proper control of volume, the manual control must be preset for a maximum desired level.

The remote amplifier chassis is positioned across the lower right section of the main chassis and employs a 12AX7, 6AV6, 6U8A, and 6BJ8. The TV may be operated without the remote chassis by connecting a jumper between pins 1, 10, and 11 of the remote socket, and another between pins 5, 9, and 12.

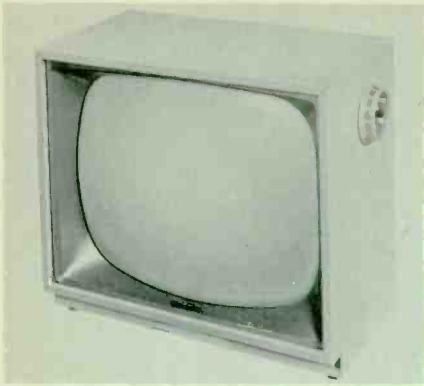

Muntz Model 21LTS

This new 21" table model features an all-metal cabinet, 110" picture tube, and operating controls all grouped within the channel selector knob on the side of the cabinet.

Since the physical layout of the chassis forms sort of a "J" pattern in the cabinet, one can see why the manufacturer refers to it as their "J" series. The chassis is conventionally wired and powered by a single silicon rectifier. Only four service adjustments are shown on the rear of the chassis because the set is designed so that width, drive, and horizontal linearity are not required. In addition to the CRT and high-voltage rectifier, the "hot" chassis employs only ten series-string tubes—a 2CY5 RF amp, 6CG8 converter, 3BZ6 video IF, 5BW8 video/sound/AFC, 6BA8A video out/sync, 6AW8A sound IF/audio out, 12AV5GA vertical, 6CG7 horizontal oscillator, 25DN6 horizontal output, and 19AU4GTA damper. It's interesting to note that the pentode section of the 5BW8 is used as both a video IF and a reflex amplifier for the first sound-IF stage.

To clean the safety glass and screen on this particular set, the cabinet must be removed from the picture tube-and-chassis assembly as shown. This is accomplished by removing the control knob assembly, the Phillips screw on the side of the cabinet, and the four bolts holding the chassis mounting board at the bottom. After unsoldering the speaker leads, lift the cabinet up and off the chassis assembly. Be very careful not to twist the cabinet frame, since the resultant strain may cause the safety glass to shatter.

To touch up the oscillator adjustment on the *Hot-Rod* tuner, the cabinet must be removed. Special holes are provided in the plastic gears on the front of the tuner so that adjustment can be made as pictured.

On the front side of the chassis you'll find a power rectifier, surge limiter and filament-dropping resistor. The silicon rectifier is a 500-ma unit with soldered leads, while the surge limiter protecting the rectifier circuit is a 5-ohm plug-in type fusible resistor. The series-filament resistor located directly behind the high-voltage cage is rated at 36 ohms—15 watts.

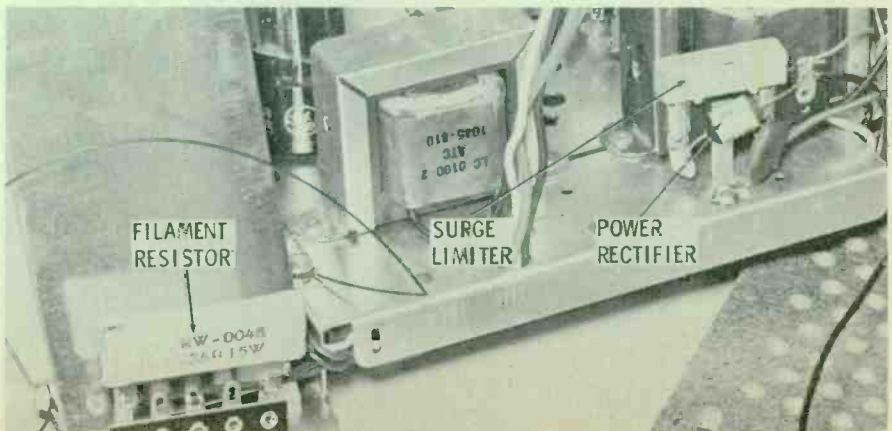
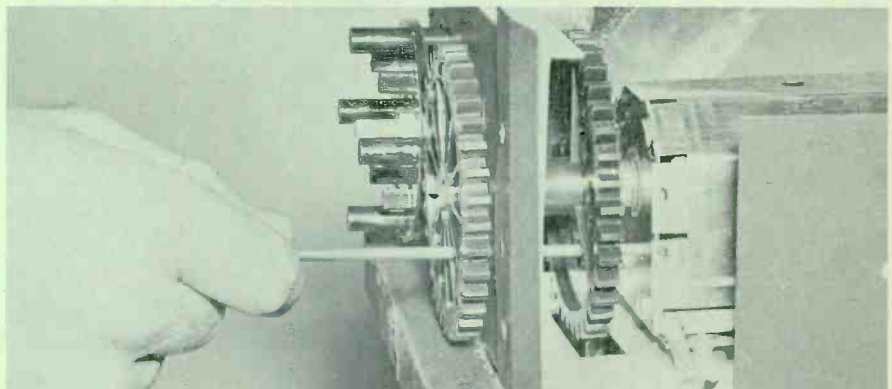
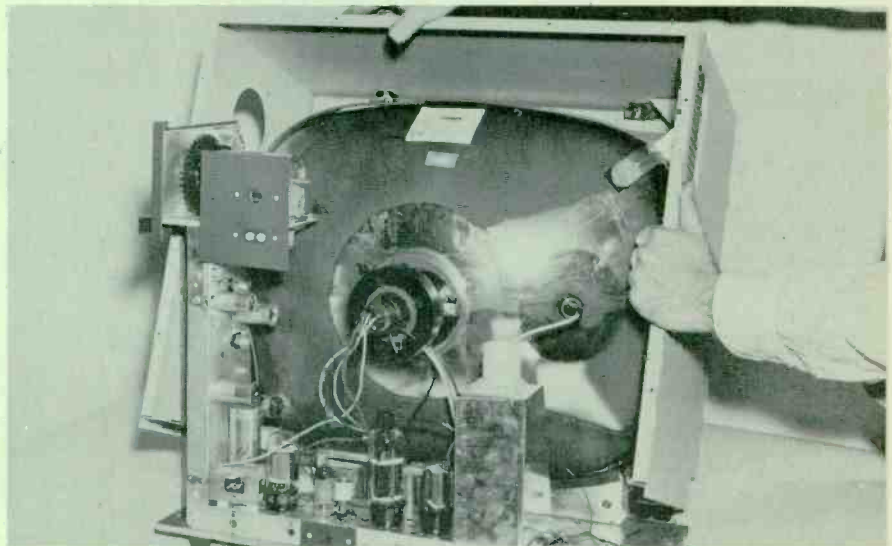
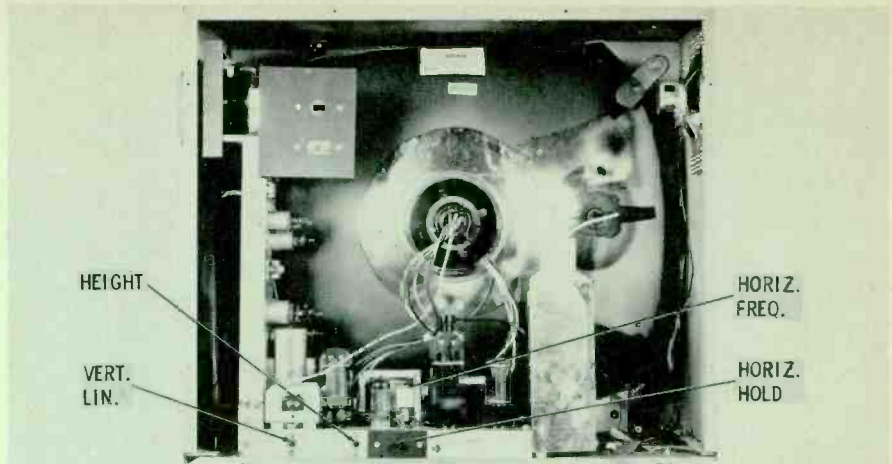



**Trav-Ler Model 1770U
Chassis 750-19**

You'll recognize this 17" portable by its two-tone metal cabinet, UHF tuning knob on top, and additional controls on one side. It also features a bar-like carrying handle and built-in telescoping antenna.

With the back off, you'll find a vertical chassis driving a 17BZP4 110° picture tube and 4" PM speaker. The chassis is "hot," and an isolation transformer should be used when operating it outside the cabinet. Although the receiver is fairly compact, no printed wiring is employed and all tubes can be easily reached. In the series-string lineup you'll find a 2BN4 and 5CG8 in the VHF tuner and a 12DB5 used as the vertical multivibrator.

Two silicon power rectifiers are soldered to a terminal board at the bottom center of the chassis. This voltage-doubler supply is protected by a plug-in fusible resistor (5.6 ohms-7 watts) positioned just left of the high-voltage cage.

As pointed out in the photograph, a special *surgistor* is mounted on top of the high-voltage cage. Appearing as a thin wire-wound resistor, the unit is a time-delay device incorporated in the power line circuit to prevent excessive current surges when the set is first turned on. Incidentally, the door of the high-voltage cage, which is held by only one 1/4" screw, slides down far enough to permit replacement of the 1B3GT rectifier without requiring removal of the chassis from the cabinet.

When you first examine the input circuit of the built-in antenna, you may wonder about the assembly mounted on a small insulating board at the top of the cabinet near the tuners. Actually, it's an antenna coupling coil composed of a few turns of wire around a powdered iron core. This tapped coil matches the single-ended antenna to the 300-ohm balanced input of the VHF tuner.

Oscillator slugs of the tuner are accessible after removal of the small metal cap or plug from the top of the cabinet as pictured. This adjustment requires a long narrow alignment tool. By the way, it might also save a little time if you know in advance that the chassis and picture tube must be removed in order to clean the safety glass and screen on this set.

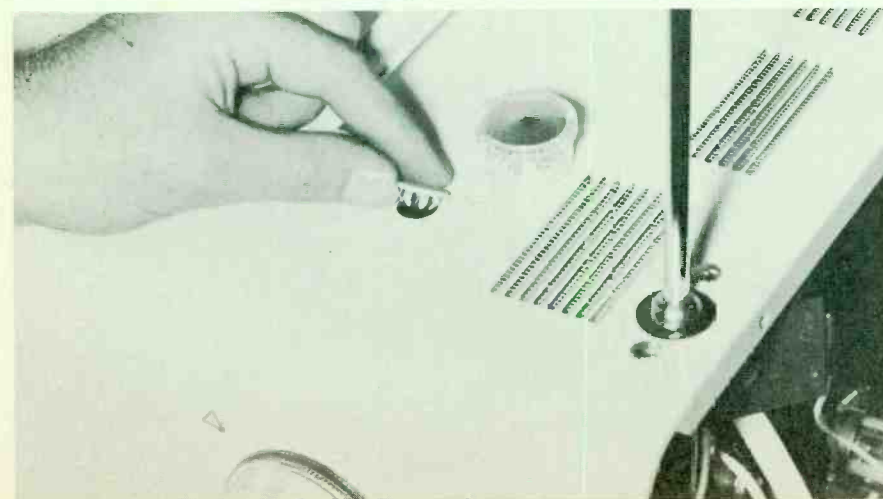
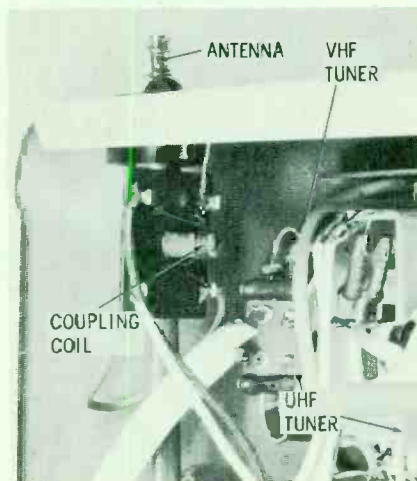
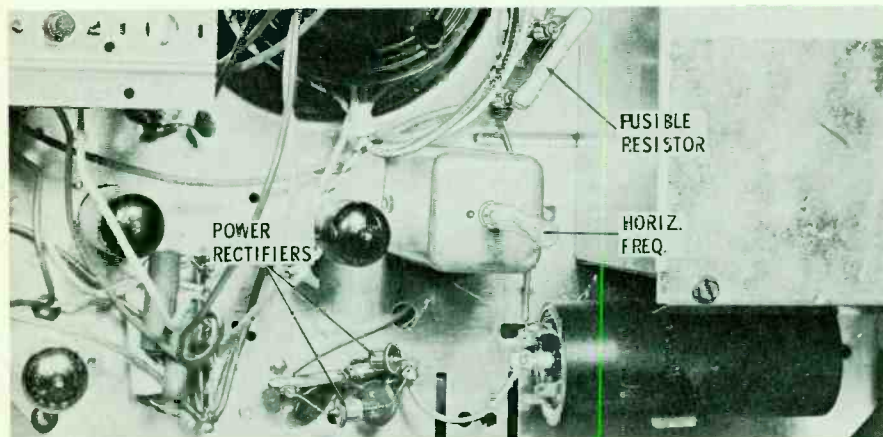
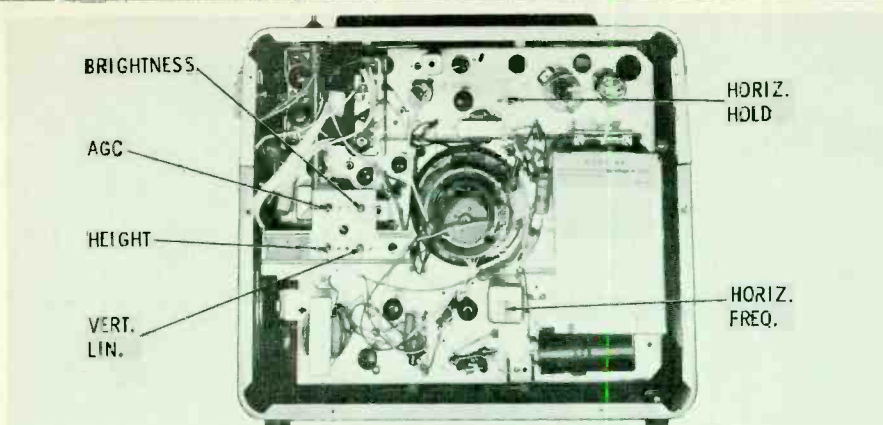

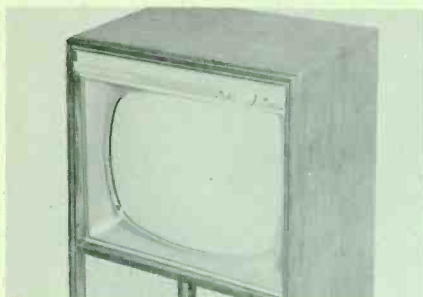

**Westinghouse
Model H21K272
Chassis V2375-1**

This vertical 21" console with both 8" and 5" speakers in a recessed sound chamber is one of the new *Wheaton* series. Operating controls, including volume with push-pull on/off, channel selector, and contrast, are positioned at the top front corner of the cabinet. Brightness, vertical hold, and horizontal hold are located near the center of the cabinet, up under the top trim strip.

With series-filament tubes and two silicon rectifiers, the chassis is basically a horizontal style employing one large printed-wiring board. Although the yoke is not supported by a direct brace of any kind, the entire chassis (including tuner, controls, and picture tube) is one complete assembly, and may be removed from the cabinet as such. Among the service adjustments on the back of the set is one labeled SYNC. This is a stability control to improve synchronization in areas with high noise levels. Although no control is provided, AGC may also be varied by removing a special jumper from across the grid resistor of the keyer tube. The horizontal multivibrator trimmer, located on top of the printed board near the horizontal frequency adjustment, is a variable capacitor with a range of from 19 to 160 mmf. This component, under certain conditions, is adjusted to obtain a zero potential on a special test point in the grid circuit of the multivibrator.

A small VHF tuner (employing 2CY5 and 5AT8 tubes) and all front operating controls are mounted to a chassis brace above the picture tube. Tuner oscillator adjustments are accessible after removing the channel selector and fine tuning knobs. You'll find that oscillator coils for all channels except 2 and 7 are series-connected, and utilize a single slug for tuning each pair (3 and 4, 5 and 6, etc.). By turning the selector knob to the desired channel, the proper oscillator slug will always appear in the adjustment hole on the front of the tuner.

To clean the safety glass on this model, take out the three 1/4" hex-head screws holding the glass retainer at the top. To remove this strip, it may be necessary to gently pry one end loose as shown in the photograph. After the top of the glass is free, tilt outward and lift up. When replacing the glass, make sure the rubber strip is in place across the top edge of the glass.

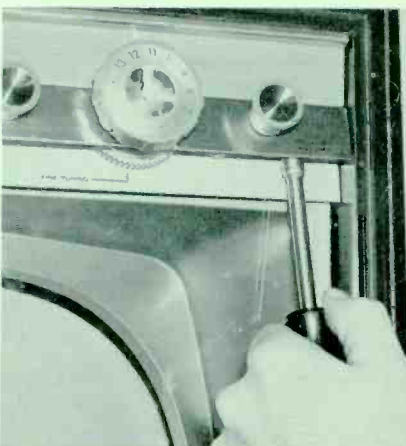
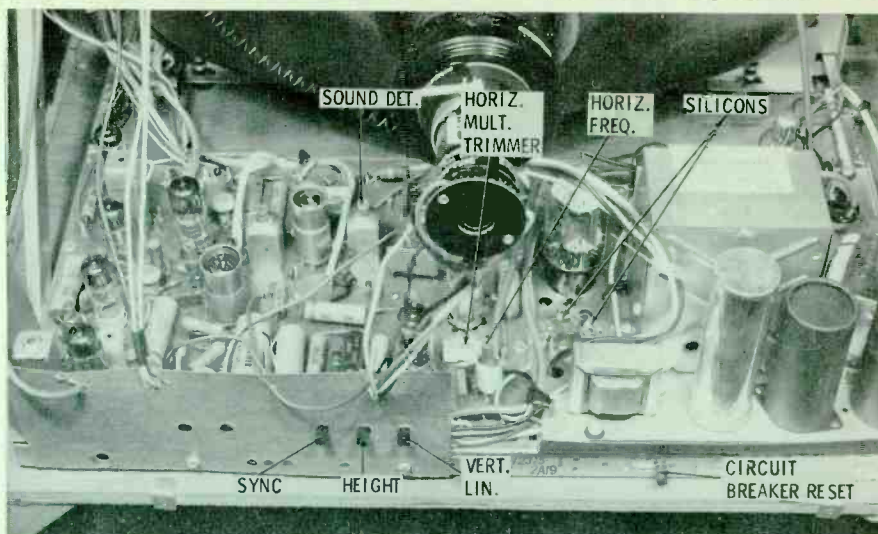

Here's how the NEW



PROGRAM

Builds Television-Radio
Repair Profits for You!

The New



Program Means

More TV-RADIO repair business for you

90-Day TV-RADIO



Every customer gets a written repair bond from you! Here is the most dynamic goodwill builder in TV servicing history—and it's exclusively yours! As a Raytheon Bonded Dealer you will have working for you the salespower of an official 90-day repair bond. You give each customer his own document, distinctively embellished in gold, along with a handsome, matching cellophane-lined envelope. The document is so impressive he'll keep it among his most important papers. The bond provides space for your itemized bill listing all parts and services, along with the Bonded Dealer Code of Ethics, and an official gold seal of the bonding company.

Never before has there been a business-building plan of this kind—backed by the largest consumer advertising program in Raytheon history.

because your service includes this exclusive

Repair Bond

The RAYTHEON Bonded Dealer Program
is a selective deal for leading independent dealers

Here at last is the profitable way for leading independent service dealers to cash in on the prestige of the nationally respected *Raytheon Brand Name*. You get all the benefits and advantages of a nationwide service program, yet you're the boss!

Only *qualified*, local independent repairmen with adequate service facilities can participate in the exclusive, protected RAYTHEON BONDED DEALER PROGRAM! This gives you the competitive advantage of being *the man* for your prospects to call. It gives you the sales-power of being local HEADQUARTERS for BONDED TV-RADIO SERVICE.

It's dynamic! The Raytheon Bonded Dealer

Program is the most complete profit plan in the industry. You get top-quality Raytheon products, technical service, sales aids, promotion materials, business-building local advertising materials, news of the latest service developments—and more. There's never been anything like it before! And, profits prove that it really pays to be a RAYTHEON BONDED SERVICE DEALER.

That's not all! Raytheon backs you with the most comprehensive advertising campaign you've ever seen. Dealers coast-to-coast are cashing in on Raytheon's dramatic advertising. It's a tremendous localized program that tells all in your town that you're the man to see for bonded TV-Radio service . . .

it features . . .



Your Name in TV



Now... FREE 90-day Repair Bond
 from Your Raytheon **BONDED** TV Service Dealer

Now there's an important TV service! Only a Raytheon Technician gives you expert repair work, including parts, for 90 days. Bonded Technicians are selected for their abilities, and integrity.

All give fair-priced, fully itemized bills; factory-warranted Raytheon tubes for the emblem of your choice. See Yellow Pages.

LOOK FOR THIS BIG DEPENDABLE SIGN



"Your set's all fixed, ma'am... and here's your Free 90-day Repair Bond"

You'll only hear these welcome words from a Raytheon Bonded TV Technician. He's the only service dealer who brings you the protection of a *written bond*. It guarantees all repair work, and all replaced parts, for 90 days—and it's backed by Raytheon, world-famous manufacturer devoted exclusively to electronics. Call any

Bonded Technician, and you'll get expert service, full facilities, fair prices, an *itemized bill*, factory-warranted Raytheon tubes, and a *written 90-day Repair Bond*! Look for the Raytheon Bonded Dealer emblem in store signs, ads, and the Yellow Pages. And save the listing on the next page! (Why miss any good program?)

LOOK FOR THIS SIGN OF DEPENDABLE SERVICE



RAYTHEON DISTRIBUTOR PRODUCTS DIVISION WESTWOOD, MASS.



TV REPAIR GUIDE
SAVE THIS LIST

- LOUISVILLE HARBOR TV REPAIR
20 State St. LO 6-5483
- JORDON'S RADIO-TV
123 Bellaire Place, SR 7-5627
- ANDERSON TV RADIO
36 Woody Lane TE 6-8925
- STANDARD TELEVISION
29 West St. LO 9-8263
- CATLIN'S TV-RADIO
298 Ivy Place HI 7-9273
- MODERN TELEVISION
Center Shopping Cen. LO 6-2345
- LEXINGTON MIKE'S TV-RADIO
28 East State St. LE 6-4856
- TRIPLE T REPAIR
298 N. Center St. HI 8-7563
- LEXINGTON TV SERVICE
29 State St. LE 9-2378
- OWENSBORO BERT'S TELEVISION
28 Main St. OW 9-3278
- HILL TV SERVICE
29 Hill St. TE 7-2378
- EVANSVILLE BENNETT TELEVISION
7 Whittish Road NA 9-4578
- MCCURRY A-1 TV SERVICE
27 North Main St. KI 8-4637
- NOBLE RADIO & TV
29-45 Saltaire St. LD 9-6452
- HARVEY RADIO REPAIR
74 East Chester Road KI 8-7564
- GEORGE'S TELEVISION
2 N. Village Road GL 8-4657
- W. R. TV REPAIR
2764 Center St. WE 8-5649
- PUCKETT TELEVISION
43 South Ave. DE 4-8567
- NEW ALBANY ART'S TELEVISION
28 North Main AL 8-5478
- LYNCH TV SERVICE
35-67 Ketchum St. HE 9-5746



TV GUIDE
24,600,000
READERS



TV REPAIR GUIDE
SAVE THIS LIST

- LOUISVILLE HARBOR TV REPAIR
20 State St. LO 6-5483
- JORDON'S RADIO-TV
123 Bellaire Place, SR 7-5627
- ANDERSON TV RADIO
36 Woody Lane TE 6-8925
- STANDARD TELEVISION
29 West St. LO 9-8263
- CATLIN'S TV-RADIO
298 Ivy Place HI 7-9273
- MODERN TELEVISION
Center Shopping Cen. LO 6-2345
- LEXINGTON MIKE'S TV-RADIO
28 East State St. LE 6-4856
- TRIPLE T REPAIR
298 N. Center St. HI 8-7563
- LEXINGTON TV SERVICE
29 State St. LE 9-2378
- OWENSBORO BERT'S TELEVISION
28 Main St. OW 9-3278
- HILL TV SERVICE
29 Hill St. TE 7-2378
- EVANSVILLE BENNETT TELEVISION
7 Whittish Road NA 9-4578
- MCCURRY A-1 TV SERVICE
27 North Main St. KI 8-4637
- NOBLE RADIO & TV
29-45 Saltaire St. LD 9-6452
- HARVEY RADIO REPAIR
74 East Chester Road KI 8-7564
- GEORGE'S TELEVISION
2 N. Village Road GL 8-4657
- W. R. TV REPAIR
2764 Center St. WE 8-5649
- PUCKETT TELEVISION
43 South Ave. DE 4-8567
- NEW ALBANY ART'S TELEVISION
28 North Main AL 8-5478
- LYNCH TV SERVICE
35-67 Ketchum St. HE 9-5746

RADIO Stars of TELEVISION MOVIES

*remind customers in your town to look for your
name in TV GUIDE and LOOK!*



Starring such personalities as

- ★ FIBBER McGEE & MOLLY ★ ED "Archie" GARDNER
- ★ ERNIE KOVACS ★ BOB & RAY
- ★ AND MANY OTHER STARS

*... ALL working for you, round-the-clock,
throughout the weekend.*

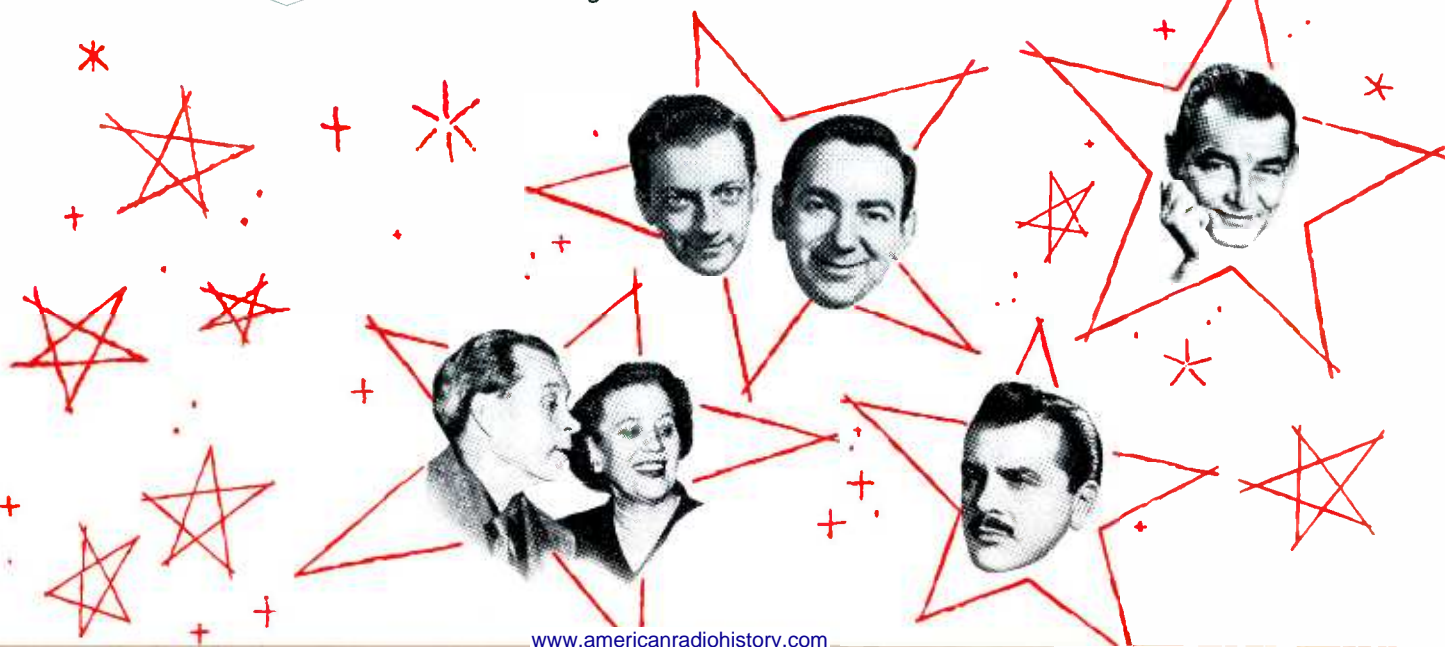



MONITOR

weekend Radio Spectacular

All weekend long they sell
the RAYTHEON Bonded Service Program for you!

It's a weekend-long show lasting from 8 p.m. Friday through 12 midnight Sunday. About once every 15 minutes throughout the weekend on Monitor, more than 10,000,000 radio listeners are told about the Raytheon Bonded TV-Radio Repair Service, the 90-day Repair Bond, and—You! Never before has such a concentrated barrage of sales messages been presented to the public. Listeners are told to look for the bonded seal in your windows, to look for your name and address in TV Guide and LOOK.

Think of it! Stars like: Ed "Archie" Gardner, Bob & Ray, Fibber McGee & Molly, Ernie Kovacs, and many others, working for you on your local NBC radio station—and Raytheon foots the bill!

Here's how you can cash in..... ►

Tune up for Profits

with the
NEW



Let every TV and Radio set owner know that you're
Headquarters for this sensational program!

YOUR PLACE
OF BUSINESS...



Here's all the advertising and promotional material you need for your own...

Local, Hi-Impact Merchandising Program

You get everything you need to tell 'em and sell 'em! Yours *free* when you sign up as a RAYTHEON BONDED SERVICE DEALER . . . identification materials, publicity, newspaper mat ads, radio and TV spot commercial scripts, window displays, the impressive, official Raytheon Bonded Certificate—and more.

All these sales-tested merchandising materials come to you in the Bonded Dealer's Merchandising Kit. These colorful advertising and promotion pieces are tailored to your needs. Each is an eye-catching, sales-building device to build your business and profits. Only Raytheon gives you this complete individualized package.

**FREE
Merchandising
Kit**



Free Merchandising

gives you everything you



Yours free, when you sign up as a Raytheon Bonded Dealer. It's a complete advertising and promotion program tailored to your needs!

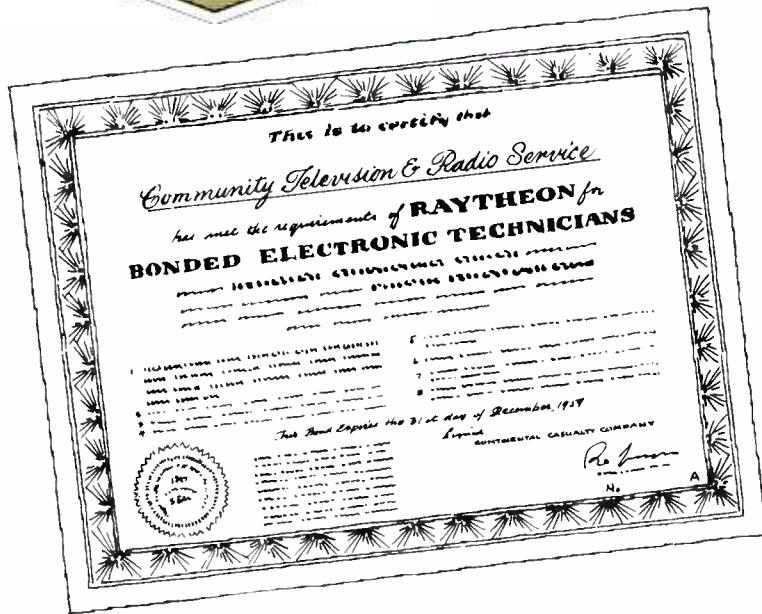

Bonded Dealer Certificate (SPQ 7202)

Certifies that you are a qualified Raytheon Bonded Service Dealer. Prominently displays your name. It's a handsome two-color, 11" x 14" certificate . . . comes in a glassine case ready for framing. Lets all who come into your place of business know that they can count on you for reliable repair service. Even has the Code of Ethics which builds customer's confidence.

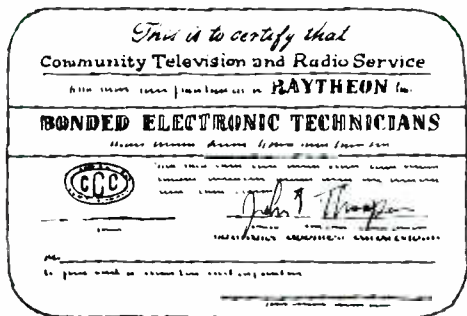

Identification Card (SPQ 7225)

Official pocket-sized card identifies you as a Bonded Service Dealer. Wherever you call, customers will see by your card that they can depend on you as a qualified TV-radio serviceman whose work is backed by the exclusive Raytheon Bond. The handy pocket pass goes wherever you go—ready for instant use.



Creed Display for Counter or Window (SPQ 7201)

This eye-catching display will let all who pass by know that you subscribe to the Raytheon Code of Ethics. They'll know that you use top-quality Raytheon tubes and replacement parts . . . charge fair prices . . . guarantee all TV-radio repair work for full

90 days. It's a brilliant full-color display, varnished to retain its beauty. Built-in easel for easy setup anywhere.

Kit . . .

need to be HQ for this profitable program!



FRANK'S RADIO SERVICE APPOINTED BONDED ELECTRONIC TECHNICIANS

Publicity Release (SPQ 7232)

Announces your appointment as a Raytheon Bonded Service Dealer. It's important news for your community. All you do is send this announcement to your local paper with your name and address. Professionally written, it gives all the details that interest prospective customers . . . tells them that you are a selected, qualified service dealer . . . tells them about your 90-day guarantee, backed by bond.



Newspaper Ad Mats

(SPQ 7266, SPQ 7267, SPQ 7268,
DLQ 7000)

They're sure to be read! They tell the facts of the Raytheon Bonded Program . . . tell everyone that you're the man to see for bonded TV-Radio repair service. And, only you can cash in on these dramatic advertisements. You get them "all set" ready to run.

YOU ALSO GET FREE

1. One hundred 90-day Customer Bonds.

(Additional quantities available through your Raytheon distributor.)

2. Business Builder Book (SPQ 7044).

3. Samples of Direct Mail Postcards.

4. Samples of Business Aids

Letterheads • Billheads
Envelopes • Calling Cards
Job Repair Tickets
Pressure-sensitive Repair Stickers

5. And a selection of lithographed displays with window streamers.



PLUS...



Window Decal (DLQ 7001)

Easy to apply, this striking red and gold decal identifies your place of business to all who pass by. Lets them all know that you have been selected as the Raytheon Bonded TV-Radio Repair Service . . . invites customers to come in and see you day and night.



Radio-TV Spot Commercial Scripts (SPQ 7233, 7238)

Just right to reach customers at home, in car or out-of-doors. You have a choice of 15-second or one-minute spots for both TV and radio. These highly listenable spots tell your prospects that you're Headquarters for the Raytheon Bonded Repair Service. Best of all, with them you can cover prospects round-the-clock.



Your Distributor backs you with

Your local Raytheon Tube Distributor is ready to pitch in with prompt service and merchandising

Your Name in Your Local Classified Telephone Book

Your name and address can be listed under the special Raytheon Bonded TV-Radio section in the Yellow Pages of the telephone book in your community. You get additional value from this deal because the telephone company carries on its own program of popularizing the Yellow Pages. Just about everyone checks the Yellow Pages for service when in need. Here's your opportunity to cash in on their reading habits.



Your Name on Outdoor Spectaculars

Colorful, eye-catching outdoor billboards in prime shopping areas . . . car and bus cards—all part of the Raytheon Bonded Service Program. And, you can have your name displayed prominently. Call your Raytheon Distributor for details on how you can have your name on these sure-fire sales builders.

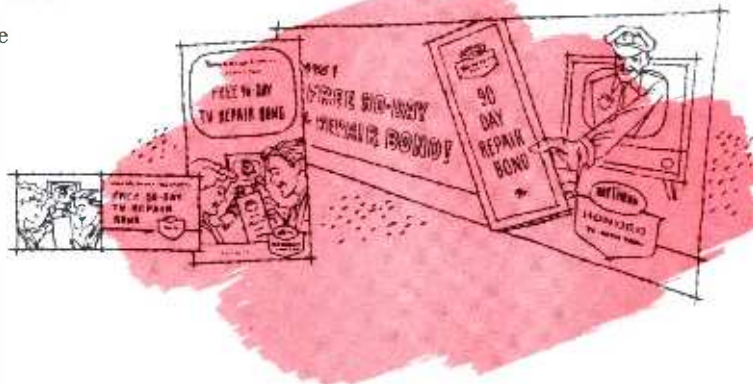

"Welcome Wagon" Working for You

Gives the "Glad Hand" to new residents in town—as they arrive. Gives you exclusive representation as the Raytheon Bonded Service Dealer. Each new resident gets a gift in your name—you get a head start towards their service business. You also get names and addresses of new homeowners for follow-up action. "Welcome Wagon" is the nationally recognized "ice-breaker" for new business.



AIDS like these!

cooperation. See him soon for profitable deals exclusive for Bonded Dealers only!

Eye-Catching Window Valance

Smartly designed in red and gold, this colorful valance will really dress up your place of business . . . will give your storefront a whole new look. It sparks up your windows, makes your entire place of business more attractive.



Outdoor Sign

Finished in colorful metal—and featuring the Raytheon Bonded Service Dealer seal. Eye-catching sign identifies your store as headquarters for the Raytheon Bonded Repair Service to all who walk or drive by. Ready for fast, easy installation on side of building, on store front or in parking area.

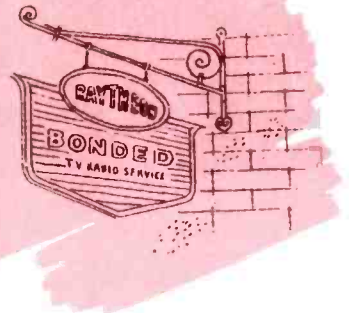

Truck Identification

Large, impressive Bonded Dealer decal, easy to apply to side of car or service truck. Weather-resistant, it will really dress up your vehicles . . . it's a traveling advertisement for your services! What's more, it identifies you as the Raytheon Bonded Service Dealer.



Direct Mail

One of the most economical methods for developing service business. You get a complete campaign that sells the bonded dealer guarantee . . . features your name and address. The informative, colorful, tested sales builders—available with or without your imprint.

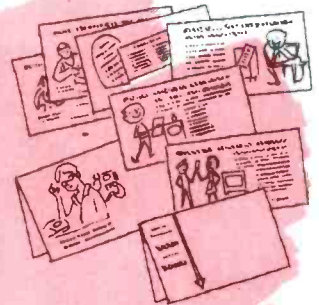

Business & Shop Aids

A complete series of professionally designed printed materials . . . business cards . . . letterheads . . . billheads . . . job repair tags . . . reminder stickers for repeat business. Everything you need to get full benefits from the Raytheon Bonded Dealer Program. CHECK FREE SAMPLES THAT YOU GET WITH YOUR ORIGINAL KIT.

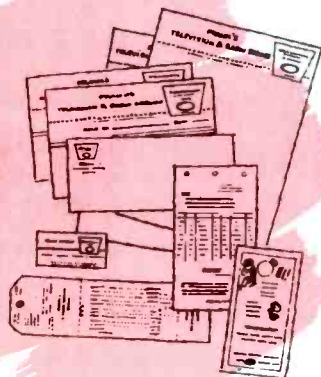

And, Coming Soon:

- RAYTHEON BONDED DEALER PUBLICATION
- BONDED DEALER AWARD PROGRAM
- TECHNICAL ADVISORY SERVICE
- INDUSTRIAL SERVICE REFERRAL PLAN

A complete program ready to go to work for you ▶

You can put this powerful bond to work building customer confidence on every call

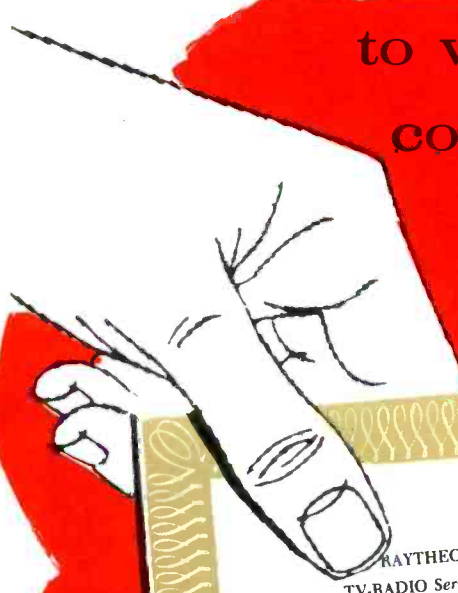



RAYTHEON BONDED
TV-RADIO Service Dealer we agree to:

1. GUARANTEE ALL OUR RADIO AND TELEVISION REPAIR WORK FOR 90 DAYS FROM DATE PERFORMED AND REPLACEMENT PARTS FOR 90 DAYS FROM DATE INSTALLED, and if such repair work is unsatisfactory to the customer within the guarantee period, with no additional charges, to correct any faulty workmanship and replace any defective materials which may be necessary to complete satisfactorily the radio and television repair work for which the customer has paid.
2. Use only parts of recognized quality in such repair work.
3. Not charge more than list price for parts installed in such repair work.
4. Test customer's tubes as accurately and reliably as possible.
5. Keep charges for labor in such repair work at a fair and reasonable level.
6. Perform only such repair work as is necessary or authorized.
7. Maintain and use service equipment essential to good repair work and reliable checking of tubes.
8. Maintain in such repair work the high quality service indicated by the experience required of all Bonded Service Dealers and the Continental Casualty Company, an Illinois Corporation, has issued a Bond on behalf of Raytheon Manufacturing Company as principal, for the benefit of customers of any Raytheon Bonded Service Dealer adhering to the Raytheon code of ethics, stated above.

This Bond covers work performed on _____
as listed in the attached invoice No. _____
This Bond expires 90 days from date of issue.

Dealer Signature _____

THIS BOND IS SUBJECT TO THE FOLLOWING CONDITIONS: Liability of Principal and of Surety with respect to the above dealer is Five Hundred and no/100ths (\$500.00) Dollars in the aggregate to all claimants in any one year and Two Hundred and Fifty Dollars and no/100ths (\$250.00) Dollars for any one claim involving any single repair job.

(DEALER MUST FURNISH ITEMIZED INVOICE WITH THIS BOND.)

The Service work which we have performed as specified on the above invoice is guaranteed against defective workmanship and material. All charges have been paid in full. This guarantee covers parts and labor installed at this time as itemized on this invoice. It does not cover damages resulting from accidents, attempted repairs, neglect or abuse by the owner.

YOUR ITEMIZED INVOICE GOES HERE

Signed _____
CONTINENTAL CASUALTY COMPANY
Principal



Illustration is one-half actual size

Remember... your customers will see and learn about this bond throughout the year in

- TV GUIDE
- NEWSPAPER ADS
- LOOK
- OUTDOOR POSTERS
- NBC MONITOR
- CAR CARDS



Sign up!

Clip . . . Fill in and Mail Coupon Today!

Join today! The RAYTHEON BONDED DEALER PROGRAM is *the* outstanding profit plan for *independent* dealers like you. There are no dues! No fees! No gimmicks! It's open to recognized local, independent service dealers who believe in serving the public with top-quality materials . . . skilled services . . . fair prices.

Your efforts will be backed by the Raytheon Bond . . . National Advertising . . . Local Promotions . . . the *FREE* Bonded Dealer Merchandising Kit . . . Display Materials . . . the best Distributor Service in the Industry . . . new bigger and better PROFITS!

All you do to join is cut out the form below, fill in, check off the materials you desire and mail to RAYTHEON. Raytheon will notify your sponsoring Raytheon Tube Distributor who will arrange all the details. If you are accepted as a Bonded Dealer, your distributor will work with you to see that you get *all* the benefits of the Raytheon Bonded Dealer Program.

That's all there is to it! It's easy—but best of all it's profitable—sign up today and cash in on this dynamic, exclusive profit program!

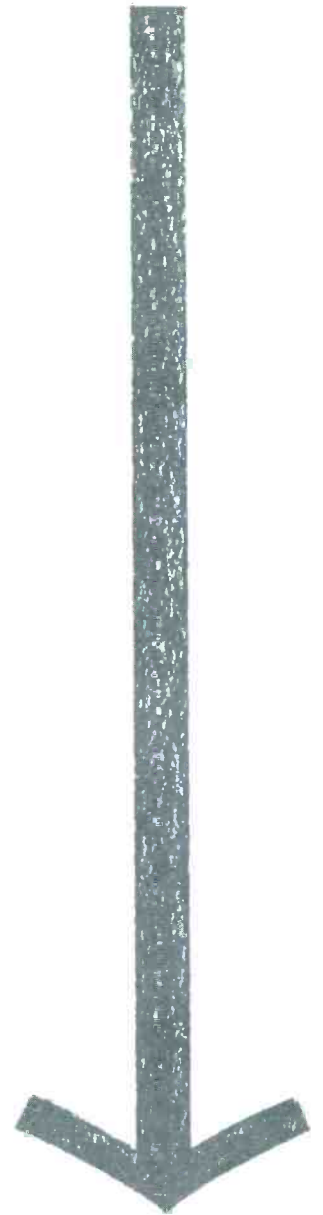

Send this form in today →

MAIL TO:

Mr. William Grey
RAYTHEON
55 Chapel St.
Newton 58,
Mass.

Cut along dotted lines



YES—I'm interested in taking full advantage of the nationally advertised Raytheon Bonded Dealer Program. I understand that there are no dues or fees involved, and that this program is limited to full-time, independent TV-Radio service dealers.

Check which you want:

- FREE Merchandising Kit*
- My name listed in TV Guide and LOOK*
- Yellow Page listing*
- Store identification*
- Truck decal*
- Direct Mail material*
- Business Aids*
- _____

FIRM NAME: _____

BUSINESS ADDRESS: _____

CITY: _____ ZONE: _____ STATE: _____

TELEPHONE NO.: _____

YOUR SIGNATURE & TITLE: _____

Mail to Mr. William Grey, Raytheon, 55 Chapel St., Newton 58, Mass.

This is the
program
you've asked for...

- builds customer confidence and repeat business for you
- puts your name before your prospects through year-round local and national advertising



- gives you the *exclusive* use of an official 90-day repair bond for each customer
- backs you with full-time promotional support.

Sign up NOW...
to build for the future!

DISTRIBUTOR PRODUCTS DIVISION
55 CHAPEL STREET • NEWTON 58, MASS.



GET *more!* DO *more!* MAKE *more!*

PROFIT PROFESSIONALLY ON EVERY CALL WITH

NEW **B&K** LOW-COST PROFESSIONAL Model 550 DYNA-QUIK

DYNAMIC MUTUAL CONDUCTANCE TUBE TESTER



Model 550

NET \$119⁹⁵

MODEL 550 DYNA-QUIK TUBE TESTER

Tests Each Section of Dual-Section Tubes Separately

Great new value in professional quick-check at small cost. Provides more tube sockets to test more tubes faster. Accurately checks most of the TV and radio tubes usually encountered in everyday service work. Tests each section of dual-section tubes separately. Measures true dynamic mutual conductance. Checks tubes for shorts, grid emission, gas content, and leakage. Completely tests each tube in seconds, checks average TV set in a few minutes, in home or shop. One switch tests everything. Fast, convenient reference listings on socket panel. Patented circuit provides automatic line voltage compensation. 7-pin and 9-pin straighteners on panel. Handsome, luggage-type carrying case. Net, \$119⁹⁵

MODEL 650 DELUXE DYNA-QUIK

Today's Finest Portable Tube and Transistor Tester

Accurately checks over 99% of the tubes most widely used in television receivers, plus popular home and portable radio tubes. Tests over 600 tube types. Lists over 125 most popular tube types, with settings, on socket panels for maximum operating speed. Complete listing in fast, index-type selector. Measures true dynamic mutual conductance. Tests each section of multiple tubes separately for GM, Shorts, Grid Emission, Gas Content and Life. Includes 16 spare sockets and ample filament voltages for future new tube types. Transistor Section checks transistors, diodes, and selenium rectifiers. Luggage-type carrying case. Net, \$169⁹⁵

Every service-technician now can easily check tubes the B&K professional way! Only with a *genuine dynamic mutual conductance tube tester* can you make a complete and accurate test under the actual dynamic operating conditions of the TV set. The compact new "550" is not just an emission checker. *It completely checks more tubes faster—with laboratory accuracy.* And the cost is so amazingly low, it pays its way over and over again! Take a tip from thousands of professional servicemen—use *B&K Dyna-Quik*. There is nothing like it.



Get More for Your Money

—IN SPEED, ACCURACY, AND VALUE



Save Customers

—SAVE CALL-BACKS, SAVE COST



Sell More Tubes

—MAKE MORE MONEY PER CALL



Model 650



B & K MANUFACTURING CO.
3726 N. Southport Ave. • Chicago 13, Illinois

Canada: Atlas Radio Corp., 50 Wingold, Toronto 10, Ont.
Export: Empire Exporters, 277 Broadway, New York 7, U.S.A.

See Your Distributor or Send Now for Bulletin ST24-R

DIFILM[®]



BLACK BEAUTY[®] CAPACITORS BEAT HEAT AND HUMIDITY

New DIFILM Black Beauty Capacitors lead the way in tubulars! The operating temperature range of these new capacitors goes up to 105 C (221 F) *without voltage derating*. Capacitance tolerance is held to $\pm 10\%$.*

- The new dual dielectric used in DIFILM Capacitors combines the proven long life of paper capacitors with the effective moisture resistance of polyester plastic film capacitors . . . to give you performance that can't be beat.

- Here's the kind of performance you can expect from DIFILM: very high insulation resistance, low power factor, moderate capacitance change with temperature,

excellent retrace under temperature cycling, and superior long-term stability . . . *all at regular prices!*

- This high performance is fully protected by HCX[®], an exclusive Sprague hydrocarbon material which impregnates the windings, filling all voids and pinholes before it polymerizes. The result is a solid rock-hard capacitor section. These capacitors are further protected by an outer molding of humidity-resistant, non-flammable phenolic.

For complete technical information on DIFILM Black Beauty Capacitors, write for Bulletin M-759 to Sprague Products Company, 105 Marshall St., North Adams, Mass.

*From .001 μ F up

The major capacitor improvements come from

SPRAGUE[®]

world's largest capacitor manufacturer

SPRAGUE RESEARCH IS CONSTANTLY PRODUCING NEW AND BETTER CAPACITORS FOR YOU

publisher
Howard W. Sams

general manager
Mal Parks, Jr.

editor
Verne M. Ray

associate editors
Leslie D. Deane
Thomas A. Lesh
Calvin C. Young, Jr.

consulting editors
William E. Burke
Robert B. Dunham
George B. Mann
C. P. Oliphant
Paul C. Smith

art director
Don W. Bradley

advertising assistant
Roma Barnes

editorial assistant
Georgeanna Caldwell

production manager
Robert N. Rippy

circulation fulfillment
Pat Tidd, Mgr.
Ann Mathews, Ass't.

photography
Robert W. Reed

advertising sales offices
Midwestern

John Groce, PF REPORTER
2201 East 46th Street, Indianapolis 6, Ind.
Clifford 3-6441

Eastern

Cliff Landis
Corning Glass Building,
717 Fifth Ave., New York 22, N. Y.
Murray Hill 8-6350

Western

The Maurice A. Kimball Co., Inc.
2550 Beverly Blvd., Los Angeles 57, Calif.
Dunkirk 8-6178; and 681 Market Street,
San Francisco 5, Calif. Exbrook 2-3365

Address all correspondence relating
to circulation and editorial to
PF REPORTER, 2201 East 46th Street,
Indianapolis 6, Indiana



Copyright © 1959 by Howard W. Sams & Co., Inc. No part of the PF REPORTER may be reproduced without written permission. No patent liability is assumed with respect to use of information herein. Acceptance of advertising does not in any manner signify the products, policies and services so advertised have been approved, endorsed, or recommended by this magazine.



PF REPORTER®

including Electronic Servicing

VOLUME 9, No. 8

AUGUST, 1959

CONTENTS

Previews of New Sets	1
In-the-home servicing data on four new sets.	
Video Speed Servicing	5
Service hints for Magnavox and Zenith chassis.	
Letters to the Editor	32
Let's Talk About Vertical Sweep Systems	40
Allan F. Kinckiner First of a "meaty" 2-part coverage that really pins down the facts.	
How to Choose and Use Microphones	42
Alan Andrews Audio Facts—Tells all about impedance, directivity, sensitivity, and frequency response.	
Scoping Modern TV Circuits	44
Analyzing signal waveforms in a -BÜ8 sync, AGC, noise-canceller circuit.	
Bench Servicing New Sets	48
Thomas A. Lesh How to save time servicing Sylvania's "duallette" table-model portable.	
Notes on Test Equipment	52
Les Deane Lab reports on the use of EICO's 1020 power supply and RCA's VTVM kit.	
Induction Heating Applications	54
Mel Whitmer Servicing Industrial Electronics—How induction heating equipment works to serve industry.	
Dollar & Sense Servicing	56
Tips For Techs	58
John A. Comstock	
Hints on Horizontal Multivibrator Servicing	62
Calvin C. Young, Jr. Quicker Servicing—Case history reports on several tricky horizontal-sync troubles.	
Understanding the Decibel	66
Jack Beever Something to help you know db figures as well as you do ohms and volts.	
Making Use of the DC Oscilloscope	70
Stan Prentiss Across the Bench—How a scope can serve as an AC-DC voltmeter.	
Coming Next Month	73
The Troubleshooter	74
Product Report	93
Free Catalog & Literature Service	96

ABOUT THE COVER

Nobody with any sense at all would go out of his way to pick on a bumblebee—but what do you do when one picks on you? Anyone got an idea that will get our cover serviceman out of this uncompromising situation without sacrificing his tender nose?



For TV Technicians

RCA PRESENTS

A New Volt-Ohm- Milliammeter

... special ranges for
transistor applications!



RCA WV-38A
VOM

ONLY \$43⁹⁵*

Also available as a KIT...
only \$29.95*
Easiest-to-assemble ever!

(includes batteries, cable and probe with slip-on alligator clip, ground lead and clip)

*User Price (Optional)

WV-38A SPECIFICATIONS

Input Resistance	• 20,000 ohms per volt on DC 5,000 ohms per volt on AC
Accuracy (full scale)	• $\pm 3\%$ DC, $\pm 5\%$ AC
Regular Scales	• 2.5, 10, 50, 250, 1000, 5000 volts, AC and DC • 50 μ a, 1, 10, 100, 500 ma, 10 amps (DC) • 250 mv. and 1 volt (dc)
Extra Scales	
Frequency Response	• AC—flat from 10 cycles to 50 Kc (usable response at 500 Kc)
Ohms	• 3 ranges: Rx1—(0-2,000 ohms), Rx100 (0-200,000 ohms), Rx10,000 (0-20,000,000 ohms)
Dimensions	• W. 5 $\frac{1}{4}$ " , H. 6 $\frac{7}{8}$ " , D. 3 $\frac{1}{8}$ "

EXCLUSIVE! Extra 1-volt and 0.25-volt (250 mv) dc ranges for servicing transistor equipment!

EXCLUSIVE! New handle clips accommodate probes and test leads for extra carrying convenience!

You'll do a more professional servicing job with this highly accurate, versatile and stable VOM—a world-beater from the world leader in electronics!

Never so many valuable features packed into a VOM!—Ohms-divider network fuse-protected. Easy-to-read scales! Extra-large 5 $\frac{1}{4}$ -inch meter. Polarity reversal switch. Improved frequency response. Full-wave bridge rectifier. Less circuit loading. Standard dbm ranges. PLUS—modern styling—it's an instrument you'll be proud to "show off" in the home or the shop!

See it at your local RCA Test Equipment Distributor!

on the go...

RCA PRESENTS

A New VoltOhmyst

... with additional scales for accurate low-voltage measurement

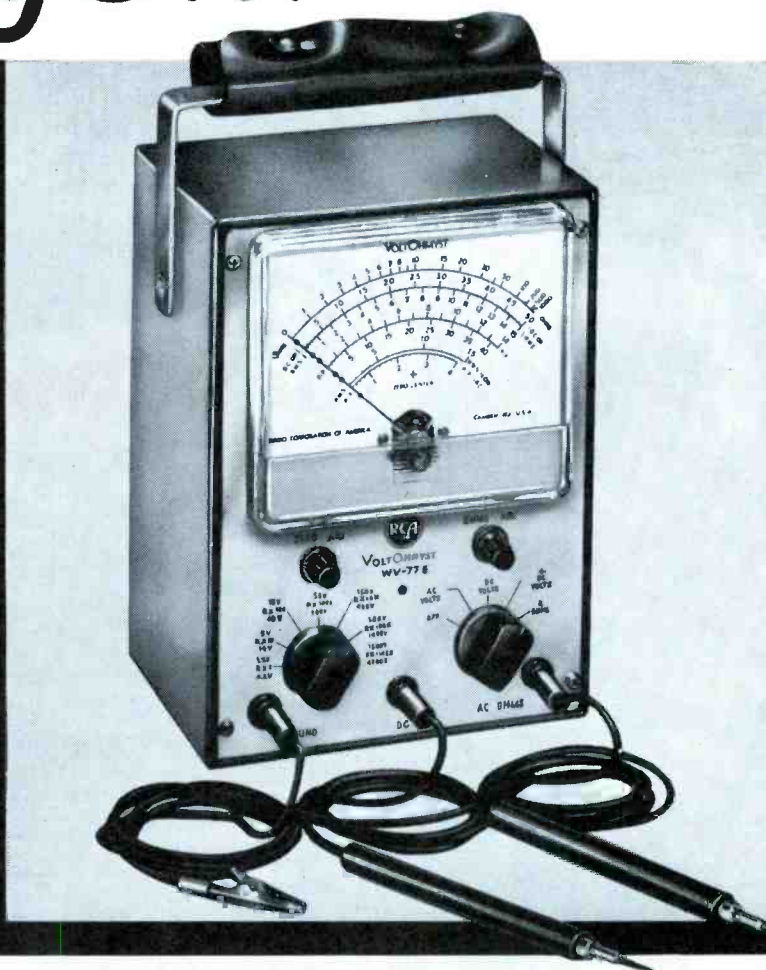

RCA WV-77E VoltOhmyst

ONLY \$49⁹⁵*

(includes test probes and leads, and ground clip and lead)

RCA WV-77E(K) VoltOhmyst Kit only \$29.95*
Easiest-to-assemble ever!
*User Price (Optional)

FREE—New Booklet, "Servicing Is Easy with an RCA VoltOhmyst" offered with the purchase of a WV-77E or WV-77E(K) (\$1.00 value).

SPECIFICATIONS

Measures:

DC Volts—0.02 volt to 1500 volts in 7 overlapping ranges

AC Volts (RMS)—0.1 volt to 1500 volts in 7 overlapping ranges

AC Volts (peak-to-peak)—0.2 volt to 4000 volts in 7 overlapping ranges

Resistance—from 0.2 ohm to 1000 megohms in 7 overlapping ranges. Zero-center indication for discriminator alignment

Accuracy—±3% of full scale on dc ranges; ±5% of full scale on ac ranges

Frequency Response—flat within ±5%, from 40 cycles to 5 Mc on the 1.5, 5, and 15-volt rms ranges and the 4, 14 and 40-volt peak-to-peak ranges

DC Input Resistance—standard 11 megohms (1 megohm resistor in probe)

Prove it to yourself! Here's a VTVM you can use almost anywhere—in the home, shop, or factory—combining flexibility, accuracy, and dependability!

Look what you get—ohms-divider network protected by fuse—ultra-slim probes and flexible leads for getting into those tight spots—leads, probes, and power cord can be stored in sleeve attached to handle for increased portability—separate scales for 1½ volts rms and 4 volts peak-to-peak maintain instrument accuracy on low ac measurements—all lettering on front panel acid-etched to last the life of the unit!

The RCA WV-77E VoltOhmyst is available "off-the-shelf" from your local RCA Test Equipment Distributor. See it, try it—bet you buy it!



RADIO CORPORATION OF AMERICA
Electron Tube Division
Harrison, N. J.

New G-E PROFIT PROGRAM

PROGRAMMED REPLENISHMENT OF INVENTORY TURNOVER

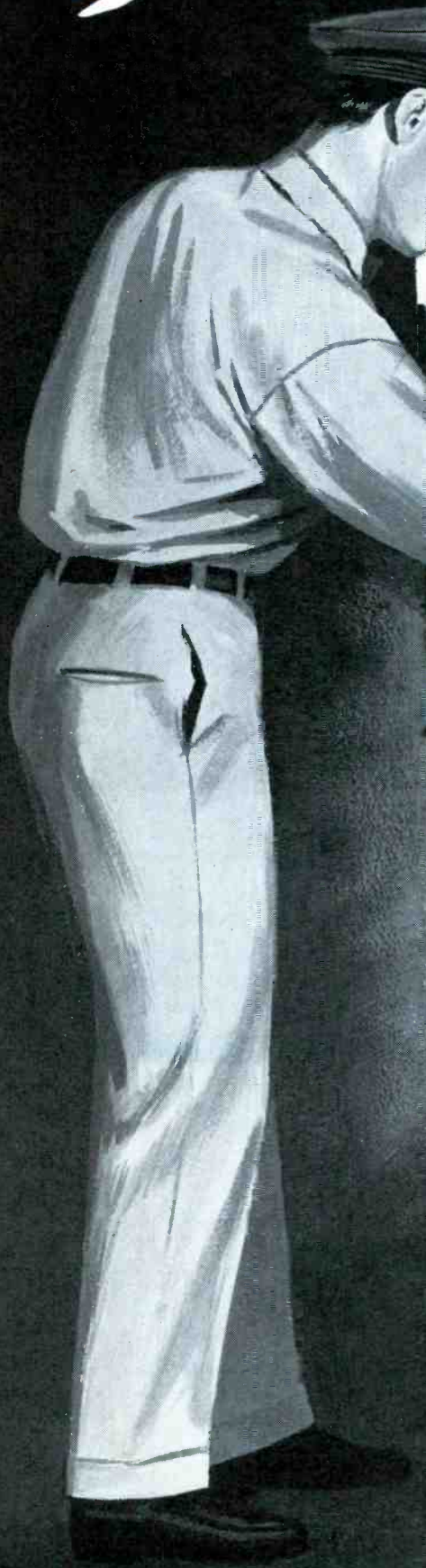

SERVICE-DESIGNED tubes

Best for any set!

Display rack: with wall hanger \$23.95, or free with purchase of 550 General Electric tubes. Rack with floor easel, \$25.95 or 700 G-E tubes.

Streamlines Your Tube Sales for Fast Turnover, Top Volume!



Missing cartons show what tube types you should reorder.

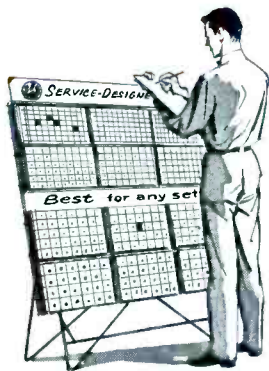

Your tube inventory can easily be checked at a glance.



A second display will accommodate additional supply of tubes.

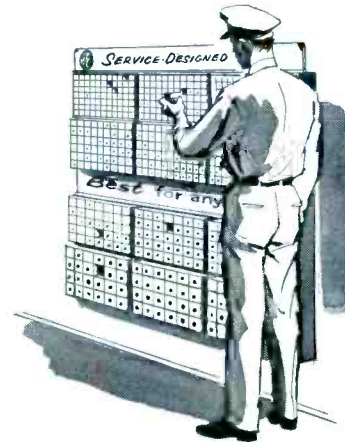

Rack can be hung on a wall if floor space is not available.

A General Electric "first"...that sells more tubes, saves record-keeping, *provides the tubes you need when you need them!* This is G.E.'s new PROFIT* Program, packaged for you in the finest, most complete tube display rack ever offered to TV technicians.

See (left) how easy it is to select types... how stock rotation is assured by orderly tube removal and replacement! Note the Display's ample dimensions—44" high plus 16" for easel base; 40½" wide—providing plenty of space for a scientifically planned tube inventory!

If you invite customer self-service, the Display is ideal for that purpose. Also, your stock

of tubes can be checked visually at any time. Missing cartons tell you what types to reorder, and how many, since the type numbers of all tubes taken out can be recorded in back. Book-keeping is virtually eliminated.

Over-stocking and tube shortages: both are banned by the Balanced Inventory feature. Your tube dollars work harder than ever before. See your nearby G-E tube distributor today about General Electric's Service-Designed Tube Display with brand-new, built-in inventory control! *Distributor Sales, Electronic Components Division, General Electric Company, Owensboro, Kentucky.*

Progress Is Our Most Important Product

GENERAL  **ELECTRIC**

2-111-222

Introducing ATR CUSTOMIZED Karadio



Can be installed
in dash or under
dash as desired!

for
small import cars
and
compact U.S. cars



There
is a trim
plate kit for
YOUR CAR!

ATR CUSTOMIZED Karadio

• VIBRATOR-OPERATED with Tone Control

The ATR Customized Karadio is a compact, new, self-contained airplane-styled radio for small import and compact American cars. This economical unit is perfect for all small cars because it can be easily and inexpensively installed in-dash or under-dash on most any make or model automobile—and its powerful 8-tube performance provides remarkable freedom from engine, static, and road noises. ATR Karadios are built to look and fit like original equipment with sleek, modern styling and solid, single-unit construction. They offer many customized features and provide highest quality fidelity—yet cost far less than comparably designed units. The ATR Customized Karadio comes complete with speaker and ready to install... and is the ideal way to add fun and value to your small import or American automobile!



ATR KARADIO
... is ideal
for small import
cars or com-
pact American
cars! Unit is

completely self-contained—extremely compact!
Can be mounted in-dash or under-dash—where-
ever space permits! For 6 volt or 12 volt!

SEE YOUR JOBBER OR WRITE FACTORY

• "A" Battery Eliminators • DC-AC Inverters • Auto Radio Vibrators

ATR AMERICAN TELEVISION & RADIO CO.
Quality Products Since 1931
SAINT PAUL 1, MINNESOTA, U. S. A.

Letters to the EDITOR

Dear Editor:

The July article "P's and Q's of Transistors" was very well done. There is one point, however, that we feel should be further clarified. On page 64, 1,000 ohms is given as the lowest figure for the forward resistance of audio power transistors (using the R x 100 ohmmeter scale). While this is essentially true of low power (small) audio units, high power types such as those used in the output stages of auto radios have considerably less forward resistance—down to 50 ohms on the R x 1 scale (with the unit disconnected from the circuit and at room temperature).

We would appreciate your bringing this to the attention of your readers, since it will be quite a serious and expensive matter if POWER transistors are tested and replaced on the basis of the information given in PF REPORTER.

W. C. CALDWELL

Delco Radio Div.
Kokomo, Indiana

An excellent point! We overlooked it because the article was prepared with portable-radio servicing in mind.—Ed.

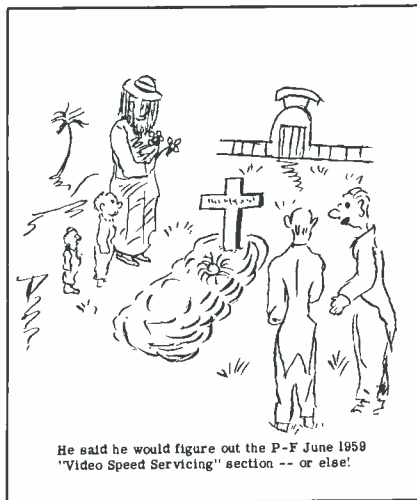

W. H. KOEHLER

Missoula, Mont.

Dear Editor:

I've just received the June issue and noted the item in the Letters to the Editor column where the Troubleshooter excuses his mistakes by saying he is testing his readers. Well, that explanation is as good as any.

However, I wonder if you are also testing the readers with the scrambled-up versions of Video Speed Servicing in the same issue?

W. P. LOVINGGOOD

Maplewood, La.

Dear Editor:

Re—Video Speed Servicing June, 1959
Section Affected—Both.
Symptoms—Confusion.
What To Do—Cut diagrams on lines;
attach Zenith diagrams to Zenith diag-
noses and RCA ditto to ditto with Scotch
tape.

Cause—SNAFU

NORMAN D. SLATER

Ogdensburg, N. Y.

Dear Editor:

Just for the record, this is the first serious mistake I've found in this magazine since I've been a subscriber. It pleases me to find out after all these years that you're human, too.

HOWARD E. SANTEE

Kalamazoo, Mich.

Dere Editerer:

I allus thut RCA und Zenith twenrnt
su mutch diffrent us yuh mak out but
then I um jest wun uf thu dumberer
wunes wat reid yur maggotzene.

Hoppin yuh mak thissun ought quik-
kerin i ded yer slo speederin paigez fur
Jun.

GESS WHOU

Denver, Colo.

Dear Editor:

It was sure fun unscrambling the Video
Speed Servicing sheets in the June issue.
Keeps a guy on the alert. Was this acci-
dental or intentional?

K. D. WRIGHT

Cheswick, Pa.

Dear Editor:

The June Video Speed Servicing ap-
pears to be "out of sync." All the dia-
grams are 180° out of phase with the
printed matter! I would like a corrected
reprint if possible, as I keep these sheets
on file and consider them very handy
service aids.

ROY C. BASSETT

Topeka, Kansas

*No excuses this time; we're not claim-
ing that the scrambled diagrams were a
test of readership. Had we any linger-
ing doubts over the "rating" of the Video
Speed Servicing feature, they were re-
moved when the letters on the Editor's
desk reached eye level. And error it was
—a genuine hand-engraved, diamond-
studded, 24-karat snafu!*

*As mentioned in this column last
month, we've prepared corrected reprints
which may be had simply for the asking.*

*We really appreciated the good-na-
tured, understanding tone of most of
your letters. Knowing we have so few
soreheads among our readers, we'll try
harder than ever to please you!—Ed.*

Dear Editor:

Lately I've noticed quite a few articles
(not in your book) about part-timers
in the radio and television repair business.
These part-time servicemen are said to
be taking away business from established
shops by charging lower prices, operating
after the regular shops are closed, and

• Please turn to page 36

ownership of a **PHOTOFACT** SERVICE DATA LIBRARY SPELLS SUCCESS FOR SERVICE TECHNICIANS

"PHOTOFACTS are a tremendous aid to a service technician in that they save hours of unnecessary work."

—E. C. Cenardo,
("Tune-In" TV-Radio
Sales & Service),
Hollywood, Calif.

*here's actual
proof from the
men who know*

"It is impossible to do business without PHOTOFACT. It is a standing order* in our shop to pull PHOTOFACT from the file for every shop job, regardless of the technician's familiarity with the set. We have proved repeatedly that it cuts time on every job."

—W. R. Schoppe,
(Lakewood Television Service),
Jacksonville, Fla.

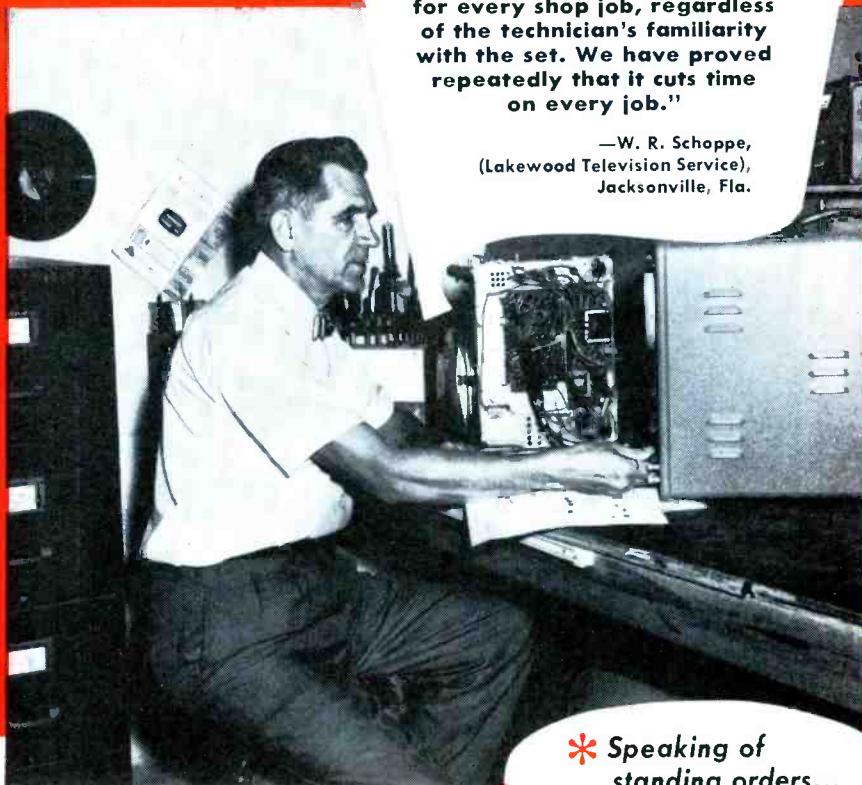
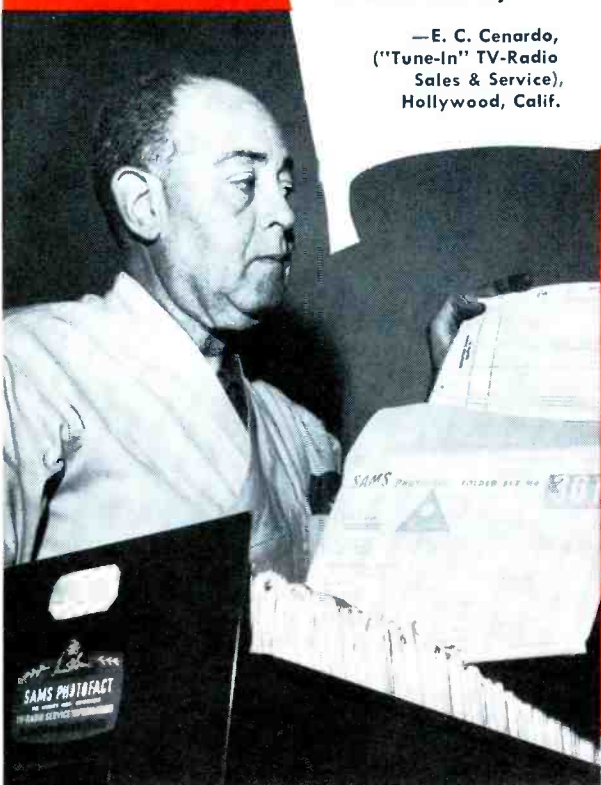

HERE'S MORE PROOF...FROM COAST-TO-COAST

"PHOTOFACTS mean so much to my business that I would not think of operating for any length of time without them."

—James G. Haynes
Leitchfield, Ky.

"The PHOTOFACTS that I have purchased on the Easy-Buy plan have been paying for themselves each month."

—Donald Johnson
Hector, Minn.

"PHOTOFACT means faster service to my customers, and more sets through my shop, which means more profit to me."

—Frank J. Schumacher
Hillsboro, Ore.

"I would be lost without SAMS PHOTOFACT. PHOTOFACT has become a part of servicing."

—Joseph S. Musil
Stamford, Texas

"PHOTOFACT means quicker and more efficient service to the customer."

—Wesley F. Scott
Logansport, Ind.

"Would not be without my PHOTOFACTS. Their return in time saved on servicing, pays for their cost many times over."

—E. R. Hayes
Clemson, S. Car.

(These are just a few of the hundreds of "Success with PHOTOFACT" letters in our files)

* Speaking of standing orders...

you'll find the truly successful Service Technicians are those who stay ahead because they're on a Standing Order Subscription with their Distributors to receive all new PHOTOFACTS as released monthly...

For Standing Order Subscription and Easy-Buy Plan details, see your Sams Distributor today, or write to Howard W. Sams...

NEW EASY-BUY PLAN!

It's the money-saving way to build your complete profit-making PHOTOFACT Library!

NO INTEREST—NO CARRYING CHARGE—AS LITTLE AS \$10 DOWN

FREE! Valuable steel file cabinets given to PHOTOFACT monthly subscribers and Library purchasers.

Valuable booklet shows you how PHOTOFACT boosts your profit-capacity

FREE

Send for it!



HOWARD W. SAMS & CO., INC.

2201 E. 46th St., Indianapolis 6, Ind.



- Send me Free booklet "Your Guide To Maximum Profits"
 I'm a Service Technician: full-time; part-time

My Distributor is: _____

Shop Name _____

Attn. _____

Address _____

City _____ Zone _____ State _____

Service Technician John Finta Says...

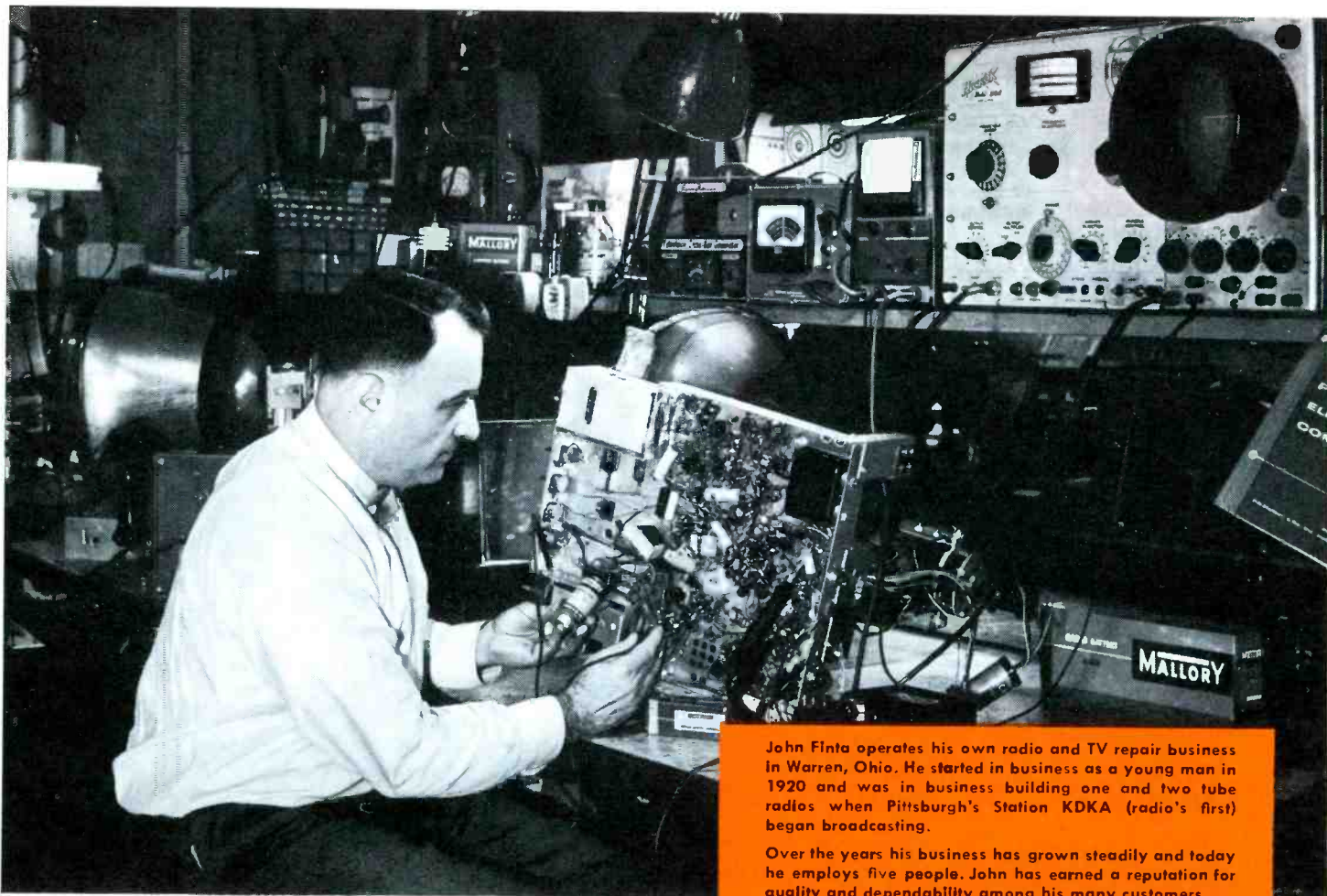

John Finta operates his own radio and TV repair business in Warren, Ohio. He started in business as a young man in 1920 and was in business building one and two tube radios when Pittsburgh's Station KDKA (radio's first) began broadcasting.

Over the years his business has grown steadily and today he employs five people. John has earned a reputation for quality and dependability among his many customers... a reputation that is bringing him new customers as well as making fast friends of the old.

Cut Call-Backs with These Quality Mallory

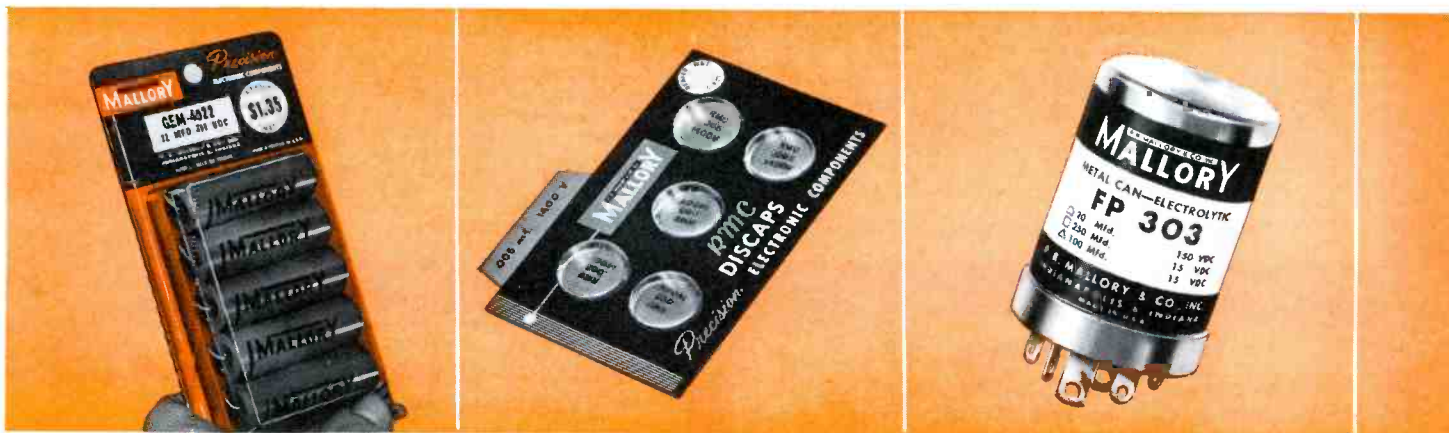

Gems—5 rugged, moistureproof, Mallory "Gem" tubular capacitors in an easy-to-use dispenser that keeps your stock fresh and clean—easy to find—no more kinks in lead wires. They're your best bet for outstanding service in buffer, bypass or coupling applications.

RMC Discaps®—are a product of the world's largest producer of ceramic disc capacitors. Long the original equipment standard, Mallory RMC Discaps are now available for replacement. They come in a handy 3" x 5" file card package... easy to stock, simple to use.

FP Electrolytics—The Mallory FP—the original 85°C capacitor—now has improved shock-resistant construction and leakproof seal. Its etched cathode construction—standard in all FP's—assures hum-free performance. High ripple current ratings fit the toughest filter circuits.

....“Mallory Components Make Every Job a ‘Sure Thing’”

“Nothing gets under your skin more—or eats into your profits deeper—than time consuming, expensive call-backs. But, there’s one sure way to stop them: use only quality replacements.

“You know you’re getting the best when you ask for Mallory . . . and you don’t pay premium prices, either. You see, Mallory components are service-

engineered to give long, trouble-free life. They’ve been thoroughly tested and ‘punished’ in the Mallory lab, far beyond any beating they’ll ever get in actual service.

“This is the kind of quality you get across the entire line of Mallory components . . . capacitors, controls, resistors, vibrators, rectifiers and batteries.”



Products...

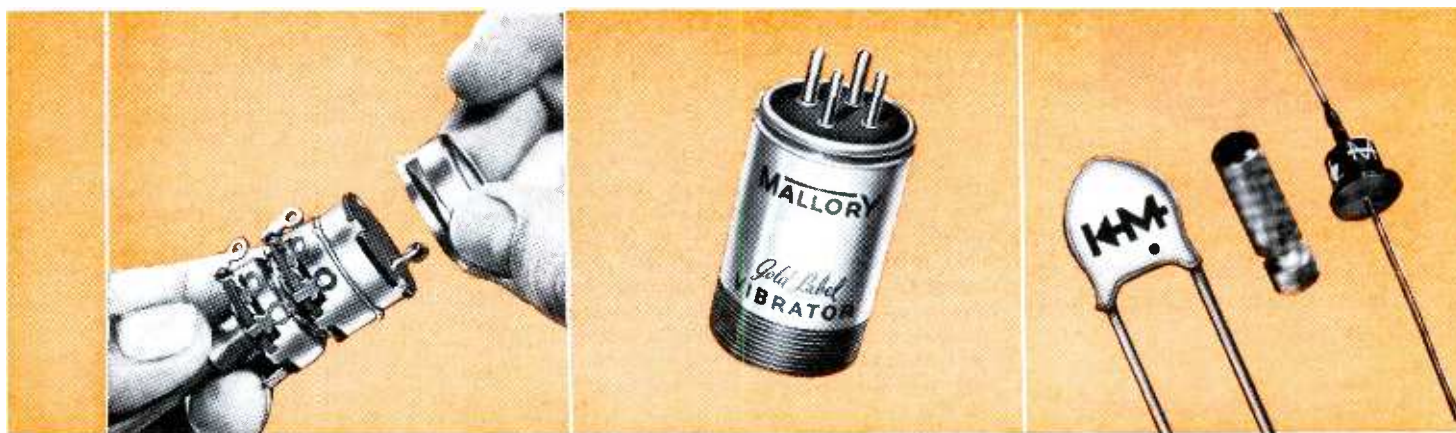

Sta-Loc* Controls—New Sta-Loc design enables your distributor to custom build, in just 30 seconds, over 38,000 combinations—eliminates waiting for out-of-stock controls. You can replace the line switch by itself, without unsoldering control connections.

Gold Label* Vibrators—On critical auto radio servicing, use the Mallory Gold Label Vibrator. It gives longer, trouble-free service life. Mallory Gold Label Vibrators feature Mallory exclusive buttonless contact design.

**Trade Mark*

Silicon Rectifiers—New Mallory design gives far longer life, lower forward voltage drop, and reverse leakage current than conventional types . . . exceed the requirements of military humidity tests. In convenient kits for replacement of selenium rectifiers in radio and TV.

Tarzian

Offers You A Complete Range of Silicon Rectifier Mounting Types

THIS...

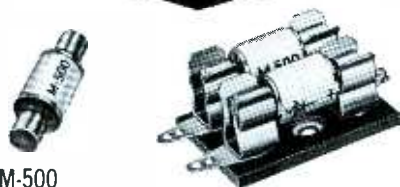

M-500

The cartridge-type Tarzian M-500 (500 ma) snaps into popular fuse holder brackets.

OR THIS...

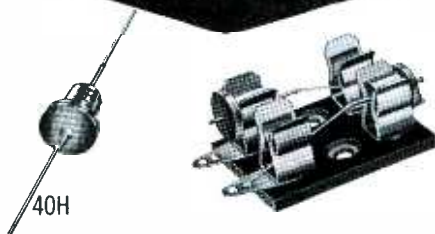

40H

Standard top-hat Tarzian 40H (750 ma) is directly interchangeable where a metal case is required.

OR THIS...



F4

Tarzian F4 (750 ma) insulated case tucks in out of the way against chassis. Leads are solder type.

Write for complete information

SARKES, TARZIAN, INC.

RECTIFIER DIVISION

DEPT. PF-6, 415 NORTH COLLEGE AVENUE
BLOOMINGTON, INDIANA

In Canada: 700 Weston Rd., Toronto 9. Tel. Roger 2-7535
Export: Ad Auriema, Inc., New York City

Letters

(Continued from page 32)

(in some cases) putting in parts which are not needed. In at least one instance, they are referred to as "night crawlers."

These articles disturbed me for awhile, but not any more. I have contacted all the full-time shops in my town (four in all), and every one of them started in as part-timers or else operated from their homes.

True, part-time service people do take away some of the work from the established shops. Here are some of the reasons why customers leave one shop and look for another TV man: Slow service, sometimes two or three days; sloppy dress; "That other TV man was arrogant and treated me like a numbskull;" "He left a mess on my clean floor;" "The other man put in three or four tubes and still my set does not work;" and so it goes on and on. Please do not put too much blame on the part-timer if he takes some of the customers away from another shop.

I am now a part-timer, but I hope to have a shop of my own some day. Then maybe I'll cuss about part-timers.

E. A. FERGUSON

Snohomish, Wash.

You may find carping comments about "night crawlers" in other publications but not in ours.

In our opinion, it makes little difference if a man operates full or part-time, providing only that he practices sound business principles, and works toward giving his customers full value and improving his technical skills.—Ed.

Dear Editor:

Right after I entered my subscription to PF REPORTER, I had on my bench a Capehart CX-88 set with a width problem. That evening, I started reading my latest copy of that "Grand Old Book," and right before my eyes was an article on the CX-88 which told what to do if proper width could not be obtained. I feel that this one article fully paid for my subscription for the next two years.

DOUGLAS E. BENNETT

Ferndale, Mich.

Naturally.—Ed.

Dear Editor:

You have the best magazine in the business, but I sure miss the statistics you used to publish. I would like to know how many sets are being sold this year compared with last year, how many CRT's and receiving tubes are being sold, and such business. It sure is nice to know what John Doe is buying; this knowledge is useful as a yardstick for your future service and selling programs.

E. D. LAMB

Tacoma, Wash.

Here are some recent statistics gathered by the Electronic Industries Association: Only 4.9 million black-and-white TV sets were produced during 1958. This figure is quite a drop from the 6.4 million sets built in '57. Total number of TV's in use at the end of 1958 was estimated

at 49.7 million. At the same time, approximately 96 million home radios, 47 million auto radios, and 29.9 million phonographs were in use.

In the first three months of 1959, the staggering total of 2,240,451 picture tubes were sold as replacements for existing units. Some 104,146,000 receiving tubes were also sold during the same period.

Any other readers agree with Mr. Lamb?—Ed.

Dear Editor:

We used to hear a lot about pay TV, but suddenly we hear no more. Is it shelved? If not, what is its present status—are we going to get it or not?

JERRY BECCIA

Waterbury, Conn.

Pay TV isn't dead, but it's suffered many discouragements in the past year. About the only successful enterprise has been big-screen closed-circuit TV, such as was used to show the recent Patterson-Johansson fight in movie theaters of various cities.

The wired pay-TV system in Bartlesville, Okla., so greatly publicized a year or so ago, has quietly starved to death. Ambitious plans to wire up Los Angeles for toll-televising Dodger games have run into snags, too.

Besides generally unfavorable public opinion, the biggest barrier standing in the way of pay TV is a hostile atmosphere in Washington. Congress has rather grudgingly okayed the FCC's proposals for allowing tests of "one pay-TV system per market—one market per system," but the test conditions are very strict. For one thing, the promoters of pay-TV setups themselves must bear the heavy financial burdens of conducting the tests, with considerable risk of losing these investments. Having been told in effect to "put up or shut up," many pay-TV interests have chosen to do the latter for the time being, but word has it that some are planning to go full steam ahead.—Ed.

Dear Editor:

I find PF REPORTER to be the best reference guide for information when working on tough troubles. Even have a special book shelf at my bench for same.

A. B. WALTHER

Malverne, N. Y.

We're flattered to know our magazine has such a place of honor.—Ed.

Dear Editor:

My congratulations to the U.S. Post Office for finally getting my copy of PF REPORTER to me in reasonably good shape. Usually, when it arrives on a rainy day, I have to iron it (after it's been on the line to dry) in order to read it.

J. M. PORACKY

Canton, Ohio

When we introduce our special tropical edition, printed on waterproof Mylar, we'll put you on the mailing list.

Meanwhile, we'll try and talk the weatherman into arranging things so your copy will be delivered on a clear day.—Ed.

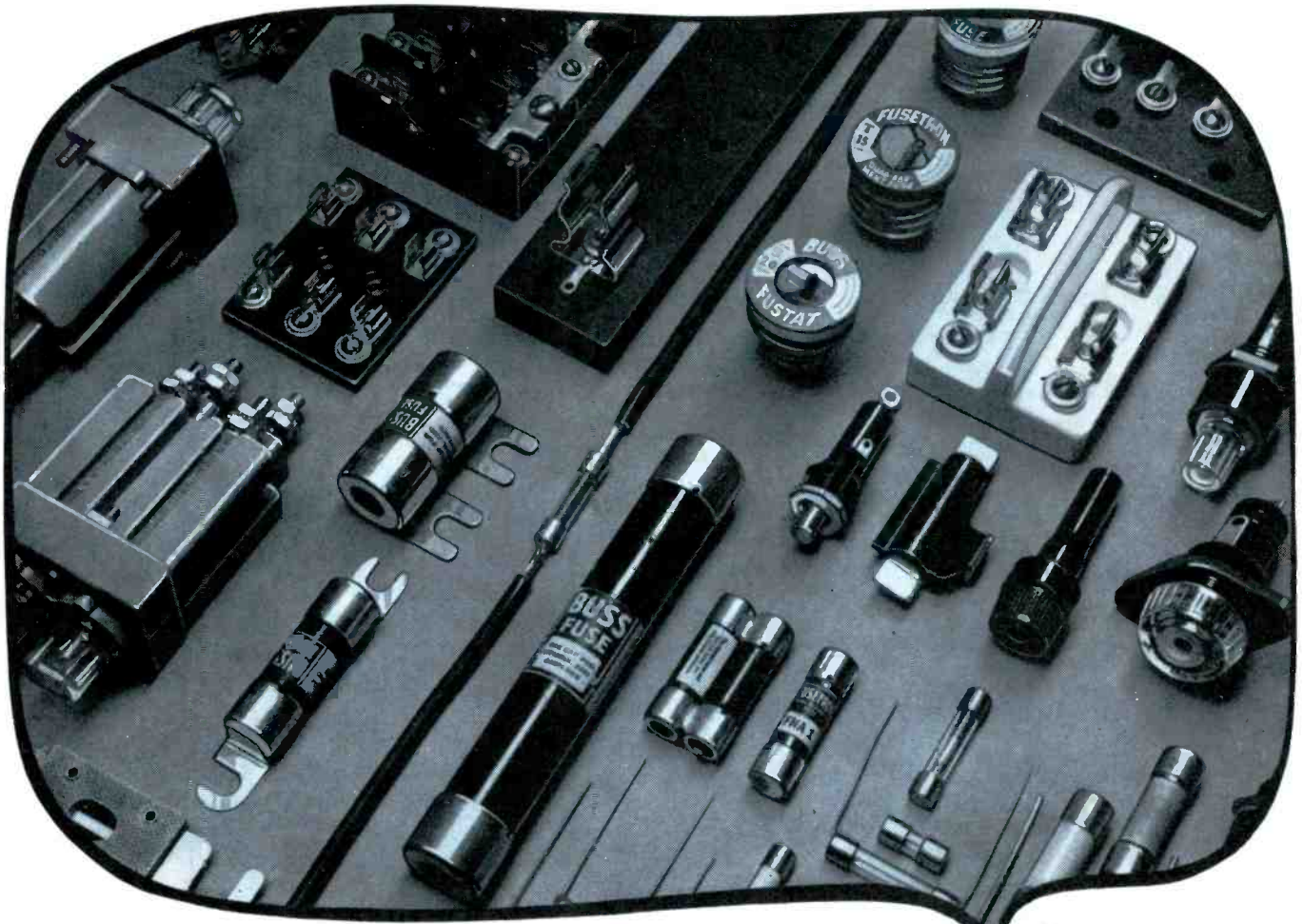

To Assure You Safe, Trouble-Free Electrical Protection

every BUSS Fuse is electronically tested!



Before a BUSS or FUSETRON fuse ever leaves the plant, it must meet our high quality control standards.

Each fuse is tested in a sensitive electronic device that automatically rejects any fuse not correctly calibrated, properly constructed and right in all physical dimensions.

Thus . . . by selling and installing BUSS and FUSETRON fuses you have one more way to help safeguard your reputation for service and reliability.

Complete Line For All Your Fuse Needs

Single-element fuses for circuits where quick-blowing is needed.

Single-element fuses for normal circuit protection.

Dual-element, slow-blowing fuses for circuits where harmless current surges occur.

Indicating fuses where signals must be given when fuses open.

BUSS fuses range in size from 1/500 amperes up — and there's a companion BUSS line of fuse clips, blocks and holders.

Your customers Know and prefer BUSS fuses

The ready acceptance of BUSS fuses is built on the millions upon millions of BUSS fuses used in homes and industry over the past 44 years. When you furnish BUSS, your customers instantly recognize that you are providing them with the finest electrical protection possible.

For more information,
write for BUSS bulletin SFB.

BUSSMANN MFG. DIVISION,
McGraw-Edison Co.
University at Jefferson, St. Louis 7, Mo.

BUSS fuses are made to protect - not to blow, needlessly.

BUSS makes a complete line of fuses for home, farm, commercial, electronic, electrical, automotive and industrial use.

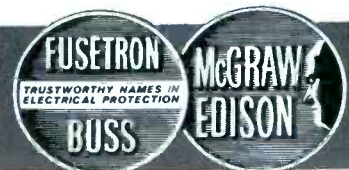

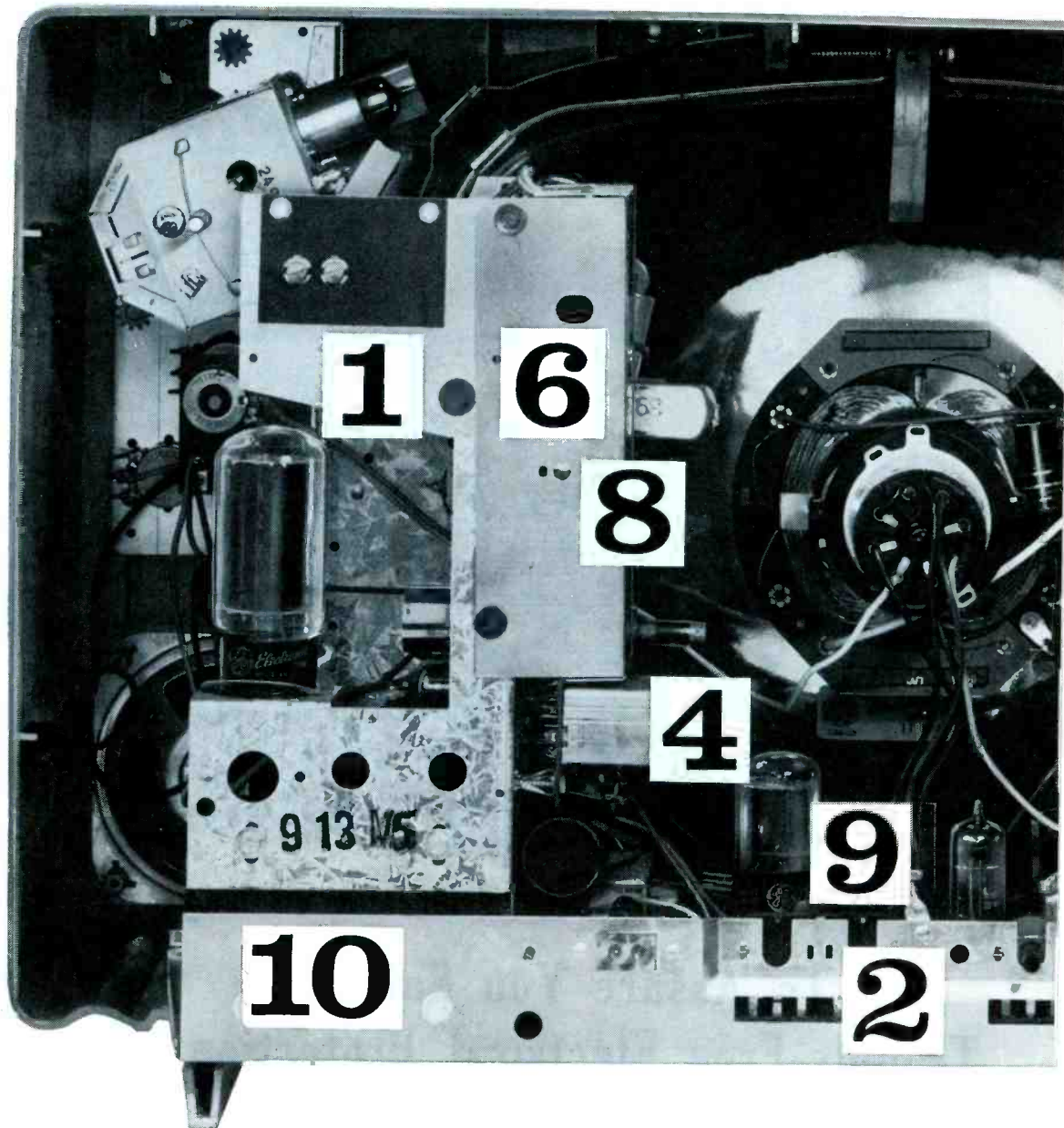

Now all 1960 General Electric TV sets have wonderful "Designer" TV serviceability! This means that in at least 9 out of 10 repairs you need not pull the chassis or the picture tube.

It's much simpler to circuit trace or replace parts, get at the key check points. Tubes are directly replaceable. And all fuses are accessible.

This leads to a higher home completion rate. Result: greater productivity. You make more calls.

Attribute this to Precision Etched Circuitry—another contribution to General Electric quality and performance.

Another thing you'll like: You can get at both sides of the printed board *while the chassis is still in the cabinet*. And the painted schematic gives you a "road map" to follow—a great time-saver in a situation where time means money,

Is it any wonder that service men are discovering that General Electric makes not only the finest sets in television—but the easiest-to-service sets, too! General Electric Company, Television Receiver Department, Syracuse, New York.

1. Both line and high-voltage fuses are readily accessible and replaceable.

2. Vertical linearity and height controls easily reached without removing back.

3. Width switch to adjust picture width to line voltage—accessible without removing back.

4. Video detector shield easily removable, and video detector may be unsoldered from circuit without removing chassis or picture tube.

5. All tubes are service designed and accessible. Tapered tube pins and special sockets insure easy

NOW! DO 9 OUT OF 10 REPAIRS WITH- OUT PULLING CHASSIS OR PIX TUBE

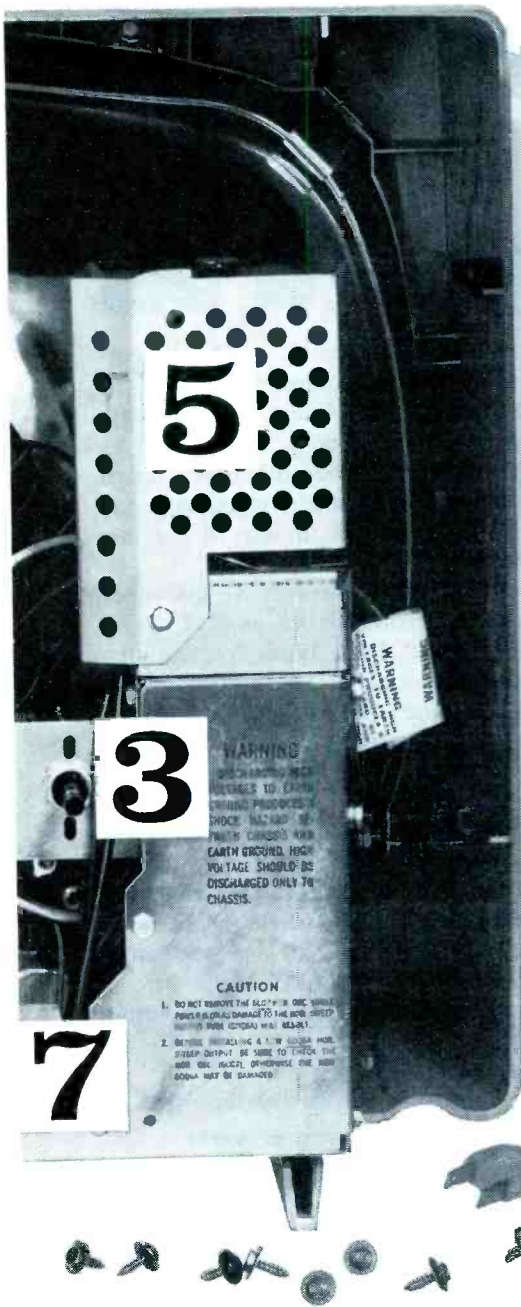

'60 GENERAL ELECTRIC TV SET!

removal and positive contact.

6. Both sides of the printed board may be reached without removing chassis or picture tube.

7. Horizontal hold control can be adjusted very easily without removing the back.

8. Precision Etched Circuitry has a painted connection diagram on component side of the board for easy circuit tracing.

9. All components are mounted on only *one* side of Precision Etched Circuitry boards.

10. Power transformer on *all* models.

Progress Is Our Most Important Product

GENERAL  ELECTRIC

Manager, Product Service
General Electric Company
Department TV 201
P.O. Box 1122, Syracuse, New York



Please send me a *free* copy of:
FACTS ABOUT PRINTED CIRCUITRY.

Name _____

Address _____

City _____ State _____

PR-8

Let's talk about

VERTICAL

Besides such well-known defects as dead oscillator, inadequate sweep, poor linearity and loss of sync, the practicing serviceman must also combat such troubles as vertical bounce, poor interlace and distorted sweep. These troubles are found in both steady-state and intermittent conditions. All are discussed in this article—some treated as specific case histories and some described in a more general vein.

The circuits in Figs. 1 through 5 are representative of the different basic vertical sweep systems used in TV receivers. Each has some design individualities worthy of discussion. In Fig. 1, for example, the sawtooth-forming network (C1 and

R1) is on the amplifier side of the coupling capacitor; it can be on either side, but is generally found in the oscillator plate circuit. In Fig. 2, amplifier plate voltage is applied midway between the two vertical-yoke windings. More often than not, it is applied to the output transformer rather than to the yoke; this circuit is shown merely to indicate the variation. Fig. 3 shows an auto-transformer used in a blocking-oscillator hookup. Take note, however, that this doesn't change circuit operation at all. The circuit in Fig. 4 uses the linearity adjustment to control bias voltage on the grid of the amplifier, rather than the more common method of varying cathode

voltage. The circuit in Fig. 5 employs a triode-connected pentode for the output amplifier, whereas quite frequently this stage is operated as a pentode. The different design characteristics just pointed out may be interchanged in any of the circuits.

In Figs. 1 through 4, the tubes are dual triodes such as SN7, CG7, BL7, and BH7 types, or the dissimilar double triodes like the CS7, CM7, or DE7 types developed especially for the vertical-sweep systems used most recently. The dissimilar double triodes contain a medium-mu low-power section and a section capable of power amplification. The circuit in Fig. 5 usually employs a dual triode such as a 12AU7 or 6SN7 for the oscillator, and a 6W6 or 6AQ5, either triode or pentode-connected, for the output stage.

Size and Linearity Troubles

Inadequate sweep or vertical size with normal linearity is the result of an inadequate yoke field, and may be traced to a defective output transformer, weak output tube, low supply voltage to the circuit, or any other abnormality that reduces deflection power to the yoke. Loss of capacity in the filters associated with the circuit should be suspected when the lack of size is accompanied by poor linearity, a symptom which can only be attributed to distortion in the shape of the sawtooth yoke current.

Poor linearity with the bottom half of the raster shortened is a condition that often stems from a less-than-normal charge being assumed by the sawtooth-forming capacitor. The cause may be leakage in the capacitor (C1 in Figs. 1 through 5), an increase in the resistance of R1 or the oscillator plate-load circuit, or slight leakage in CC, the capacitor that couples the signal

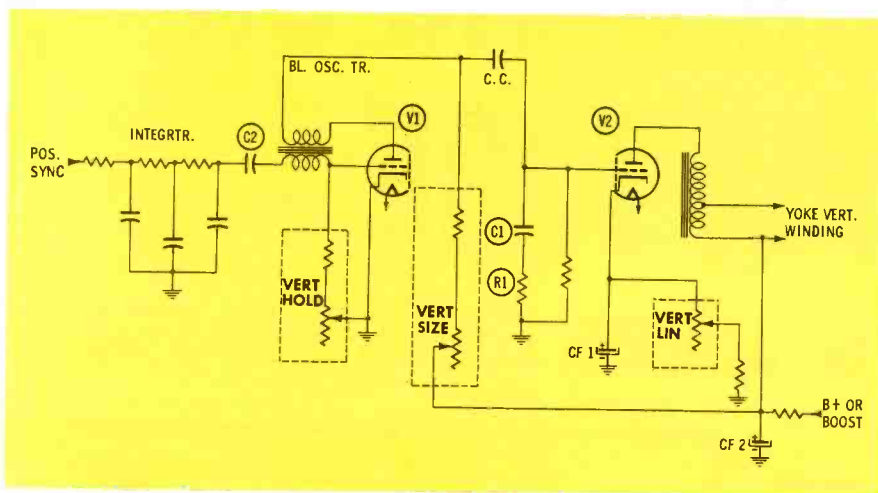

Fig. 1. Vertical-sweep circuit using a plate-coupled blocking oscillator.

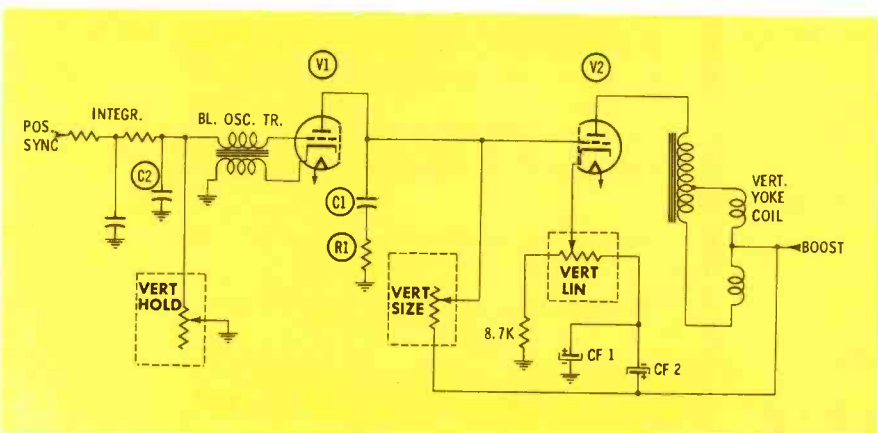

Fig. 2. Vertical-sweep circuit using a cathode-coupled blocking oscillator.

SWEEP SYSTEMS

... and pin down all those hard-to-trace trouble symptoms to specific sections and components—by Allan F. Kinckiner.

to the output amplifier. Note that word "slight." If this leakage is significant, it will cause foldover at the bottom of the raster. Any of these defects will lower the voltage to which the sawtooth capacitor can charge. Actually, this may reduce raster size linearly; however, adjustment of the linearity control will cause the top to appear normal, giving the impression that only the bottom half has reduced in size.

Poor linearity with the top half of the raster shortened is generally due to a fault in the amplifier circuit—the usual causes being too much bias on the tube, an open cathode-bypass capacitor, or insufficient voltage at the plate.

Poor linearity with bunching of the topmost raster lines (first 8 or 10 of those visible) is most often found in sets employing one of the blocking-oscillator circuits. The bunching effect is caused by improper retrace, which is often due to excessive residual magnetism of the oscillator-transformer core. If previous checks have definitely isolated the defect to the transformer, shunting the primary winding with a 10 to 20K-ohm resistor will probably eliminate the trouble. If it does, a replacement transformer should be tried. In some instances (because of original design defect or compounded circuit aging), even a new transformer won't eliminate the bunching, and you'll have to resort to the shunt resistor anyway.

Poor linearity, with bunching of raster lines at both top and bottom and the center of the raster spread out, has been found in sets where filter CF2 (Figs. 1 through 5) was open or had lost capacity. In these cases, it is often possible to attain adequate sweep, but circular images will be more square than round. Generally, an open CF2 filter is accompanied by other noticeable

• Please turn to page 78

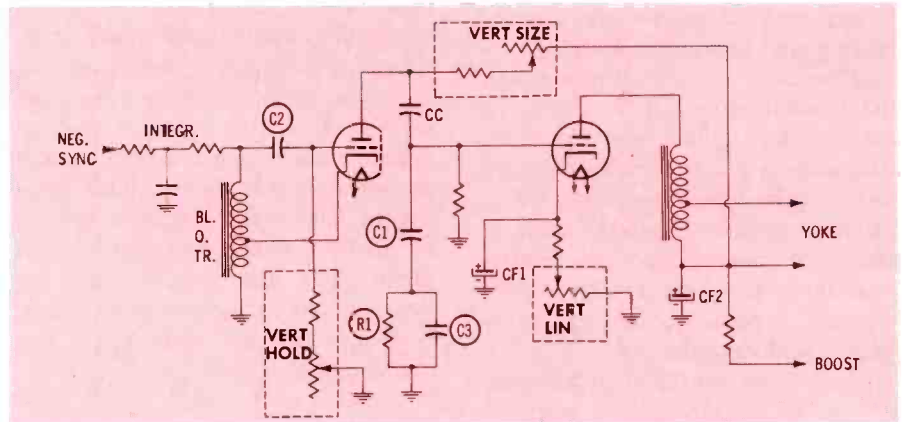

Fig. 3. Blocking oscillator circuit which uses a tapped transformer.

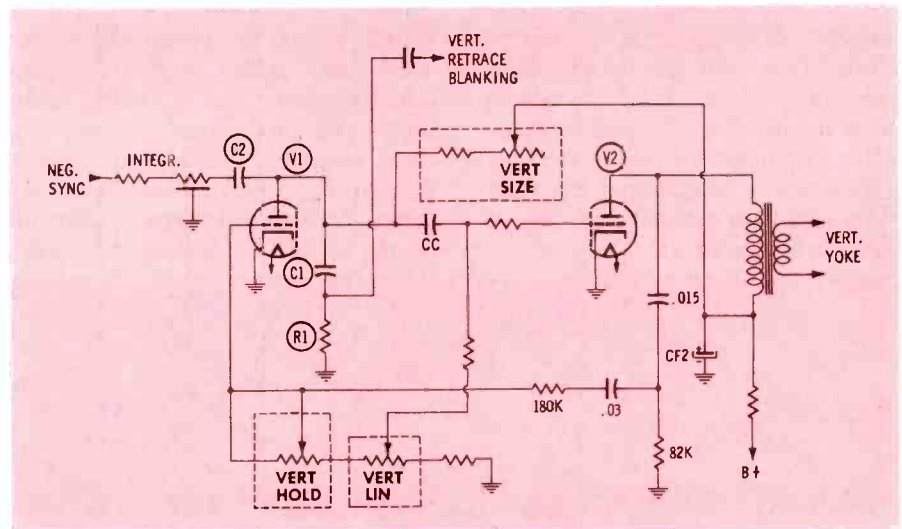

Fig. 4. Dual triode used as both multivibrator and output amplifier.

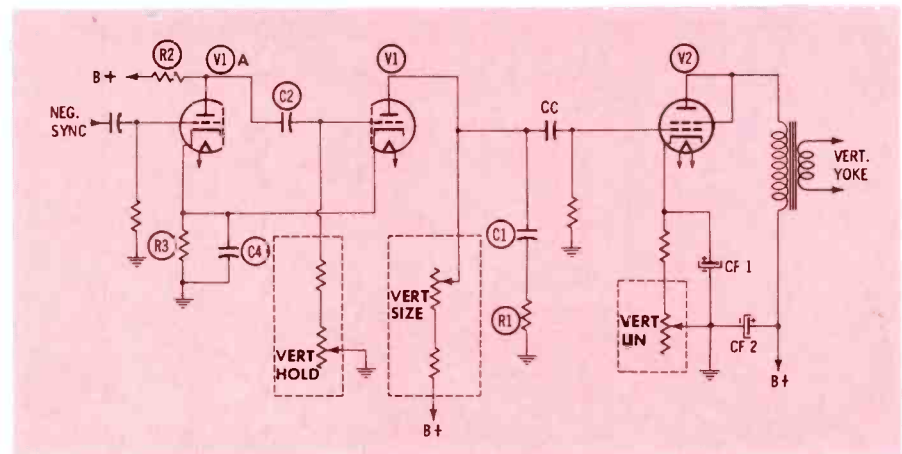

Fig. 5. Cathode-coupled multivibrator with separate tube in the output stage.

How to choose and use MICROPHONES

Microphones are used wherever sound must be converted to electrical signals—with PA systems, both indoors and out, in tape and disc recording, and in communications systems such as amateur, commercial, and broadcasting. In selecting a mike for a particular use, the audio technician has a tremendously wide variety from which to choose. The ultimate choice depends upon a number of microphone characteristics. Among these are directivity, impedance, sensitivity, frequency response, and ruggedness.

In this, and the October column, we will thoroughly discuss each of these characteristics. Then we will consider the advantages and disadvantages of each type of microphone, plus any special problems concerning usage. An audio system is no better than the microphone which originates the signal, so some consideration in choosing the right mike, and then using it correctly, is well worth the effort.

Characteristics

While price is not actually a characteristic, there is no doubt that it is an important factor in the selection of a mike for a particular use. While microphone prices vary from several dollars to several hundred dollars, many high quality mikes are available in the medium price ranges, and these are adequate for all except the most exacting requirements. The primary difference between mikes in various price ranges is the extent and linearity of frequency response.

Directivity

Some microphones can handle sound waves from any direction. These are called non-directional, omnidirectional, or polydirectional mikes, all three terms having the same meaning. This type of pickup pattern is illustrated in Fig. 1A, where "X" indicates the placement of the mike. In this arrangement,

adequate pickup is obtained from any point within a given radius.

Another type of directional pattern is shown in Fig. 1B. This is a bidirectional pattern, meaning that the unit can pick up sounds from two general directions. Adequate pickup can be obtained from any point within either of two circular areas of specified radius. Minimum response occurs for sounds originating in directions along a common tangent to the circles.

The other general type of pickup pattern is that shown in Fig. 1C, where only one side of the mike is sensitive to sound pickup. This is called a unidirectional pattern because pickup can occur from only the one direction. It is also known as a cardioid pattern because of its similarity to the shape of a heart. In some units, this pattern is obtained by using two separate mike elements in a single case — a dynamic and a ribbon, for example. Single unit cardioids achieve this pickup pattern by virtue of the mike housing design.

It is possible to obtain other patterns which are combinations of the basic ones. One such example is shown in Fig. 1D, where a bidirectional pattern is altered to provide greater pickup in one direction than in the other. Most mikes have a fixed pattern; others have patterns which can be altered with the flick of a switch.

Differential microphones are directional, but have an additional feature in that the distance between the sound source and the mike affects the pickup. Normally, these units are designed for adequate pickup close to the mike while rejecting sounds originating farther away, even in the same direction.

Virtually all microphones tend to become more directional as signal frequency increases. Best results along these lines are obtained when the physical size of the mike is small

• Please turn to page 81

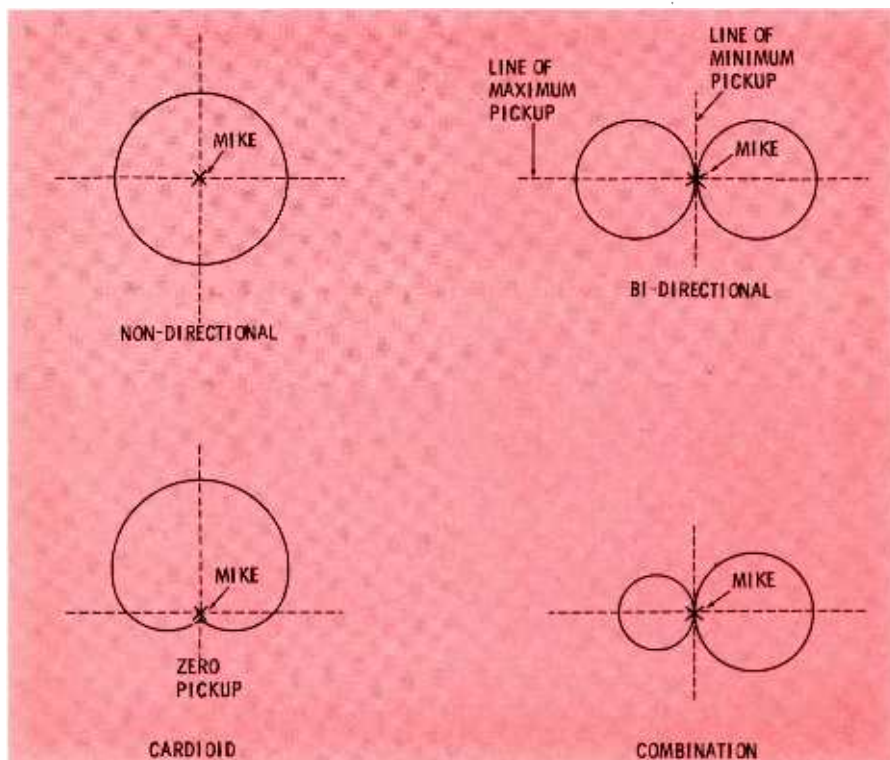

Fig. 1. The four standard microphone directional patterns in common use.



Altec-Lansing 661—dynamic
 Frequency response: 30-15,000 cps
 Output level: -55 db
 Output impedance: 30-50, 150-250, 20K
 Pickup pattern: omnidirectional



Astatic Model M-322-S—crystal
 Frequency response: 30-15,000 cps
 Output level: -54 db
 Output impedance: high
 Pickup pattern: nondirectional

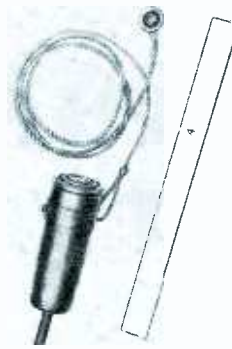

RCA Model BK-6B—dynamic
 Frequency response: 80-12,000 cps
 Output level: -67 db
 Output impedance: 30, 150, or 250 ohms
 Pickup pattern: semidirectional



Sonotone Model CM-10—ceramic
 Frequency response: 50-13,000 cps
 Output level: -62 db
 Output impedance: high
 Pickup pattern: omnidirectional



American Microphone Model D22—dynamic
 Frequency response: 50-12,000 cps
 Output level: -55 db on high Z
 Output impedance: high or low
 Pickup pattern: omnidirectional

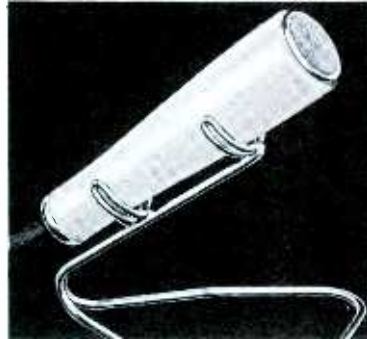

Duotone Model MIC 39-1—crystal
 Frequency response: 50-10,000 cps
 Output level: -62 db
 Output impedance: high
 Pickup pattern: omnidirectional

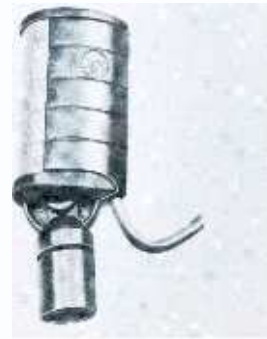

RCA Model SK-45B—dynamic
 Frequency response: 70-12,000 cps
 Output level: -56 db
 Output impedance: 150, 250, or 15K
 Pickup pattern: semidirectional



Telex Model BOW-11—dynamic
 Frequency response: 300-5,000 cps
 Output level: -52 db
 Output impedance: 25 ohms
 Pickup pattern: unidirectional



American Microphone X203—crystal
 Frequency response: 100-7,000 cps
 Output level: -55 db
 Output impedance: high
 Pickup pattern: omnidirectional



Electro-Voice Model 664—dynamic
 Frequency response: 40-15,000 cps
 Output level: -55 db
 Output impedance: 150 ohms or high
 Pickup pattern: cardioid



Shure Model 101C—carbon
 Frequency response: 300-4,000 cps
 Output level: 5 db below 1v @ 100 mb
 Output impedance: 50-100 ohms
 Pickup pattern: semidirectional



Turner Model 80—crystal
 Frequency response: 80-7,000 cps
 Output level: -54 db
 Output impedance: 25,000 ohms
 Pickup pattern: nondirectional



Astatic Model 77—dynamic
 Frequency response: 30-15,000 cps
 Output level: -52 db
 Output impedance: 30-50, 150-250, 40K
 Pickup pattern: cardioid



Electro-Voice Model 927—crystal
 Frequency response: 60-8,000 cps
 Output level: -50 db
 Output impedance: high
 Pickup pattern: omnidirectional



Shure Model 737A—crystal
 Frequency response: 60-10,000 cps
 Output level: -53 db
 Output impedance: high
 Pickup pattern: cardioid



Turner Model 200D—dynamic
 Frequency response: 60-13,000 cps
 Output level: -53 db
 Output impedance: high
 Pickup pattern: nondirectional

SCOPING MODERN TV CIRCUITS

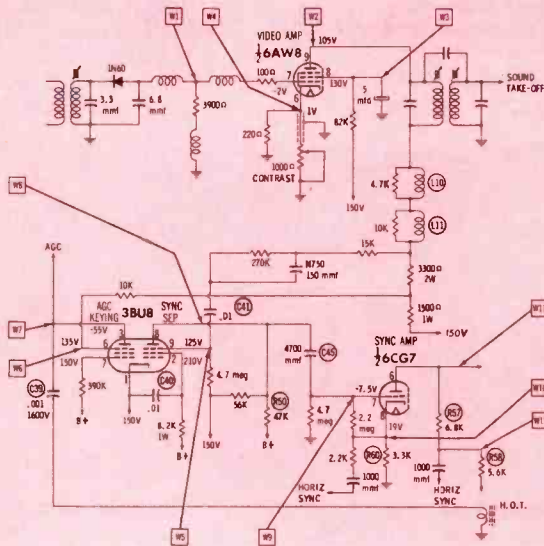

Because sync separation, noise cancellation, and AGC keying are all accomplished with the modern -BU8 circuit, troubleshooting may seem somewhat complex. Actually, it's quite simple when you use a scope and know what to look for. A study of the waveforms presented here will make analysis of this circuit a lot easier. We powered our set with 117-volts AC and clamped the AGC line at a level that provided a detector output of 1.2 volts p-p. The contrast control was adjusted for a 40-volt signal at the video amplifier plate. (These facts are given to help you duplicate the signal amplitudes for trouble analysis work.)

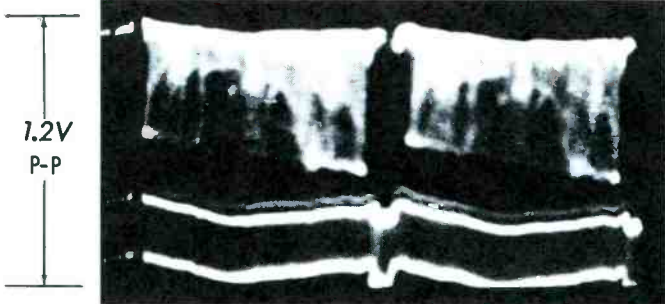

W1 gives an indication of RF-IF circuit performance. Insufficient amplitude indicates loss of gain or excessive AGC bias. Hum modulation is usually caused by heater-to-cathode leakage in one or more of the RF-IF tubes, or by poor filtering of the B+ lines to these stages.

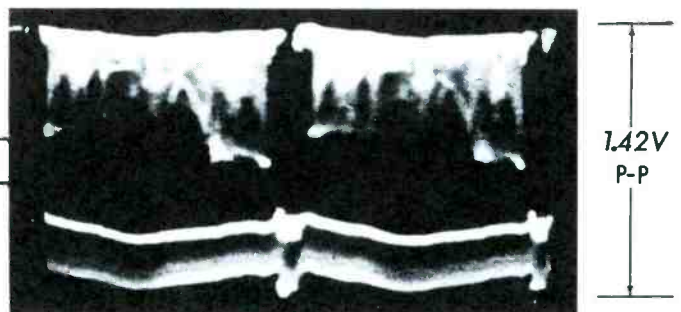

At first glance, appearance of this signal seems to be normal, but note the greater separation between video and sync information (using a standard test pattern signal), plus the excessive overall amplitude. These symptoms are the result of grid current, caused by a defective video tube.

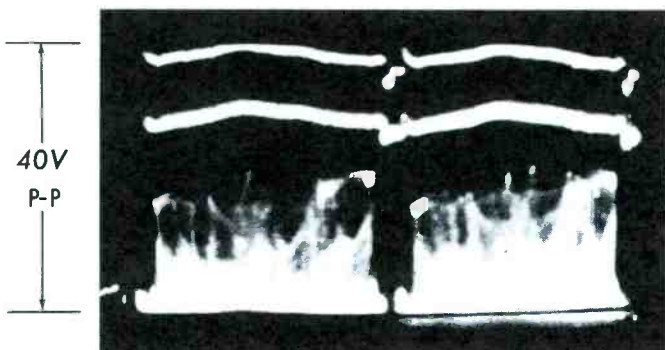

The amplitude of W2 depends on the contrast control setting. Insufficient amplitude can be attributed to a weak video amplifier, excessive stage bias, or low plate supply voltage. The initial symptom is insufficient picture contrast at normal control settings.

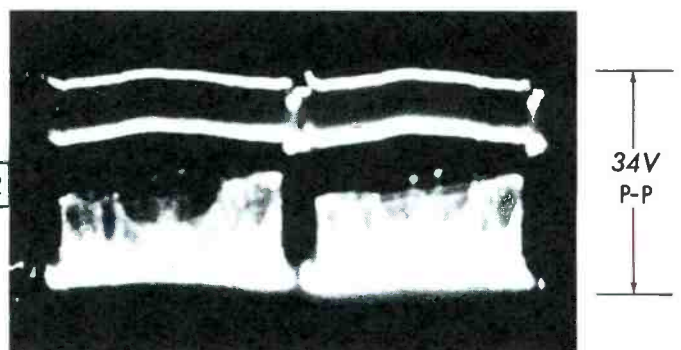

Signal amplitude is reduced by degeneration when the screen bypass capacitor opens. With this defect, picture details usually appear somewhat smeared. This is indicated, to some degree, by the run-together appearance of the video portion of this waveform.

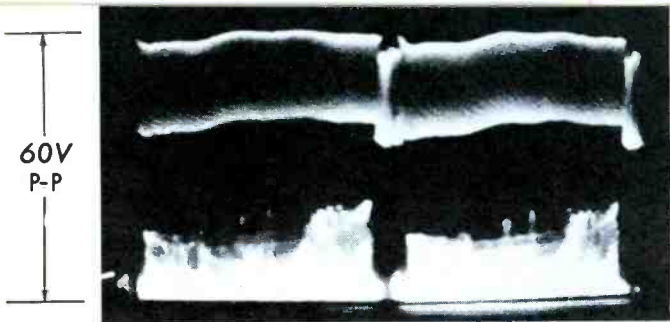

W2 W3

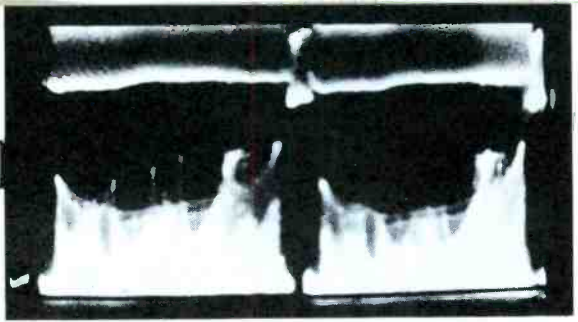

16V
P-P

Excessive W2 signal amplitude accompanied by picture smear and loss of fine detail can usually be traced to an open peaking coil. In this case, L11 opened and left the 10K-ohm shunt resistor as part of the plate load; thus, low-frequency response was increased, while high frequencies were attenuated.

Under normal conditions, W3 has an amplitude of less than one volt, indicating that the screen-bypass capacitor is doing its job. This waveform was taken with the bypass capacitor disconnected, and shows the degenerative signal (having the same phase as the plate signal) developed across the screen-dropping resistor.

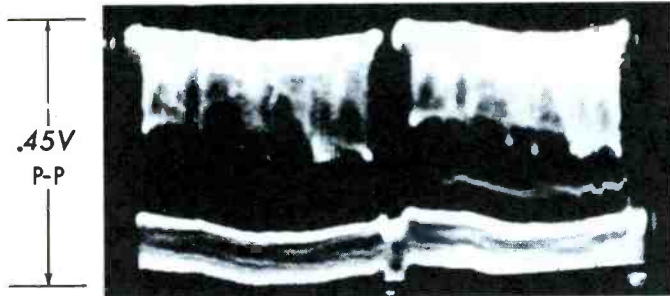

W4 W4

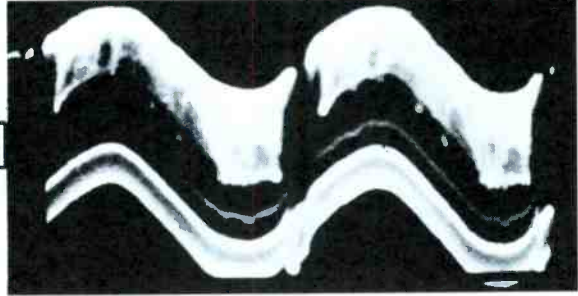

.6V
P-P

With an unbypassed cathode circuit, W4 indicates the degenerative signal developed for the purpose of reducing distortion, particularly at low frequencies. Amplitude, of course, is directly proportional to cathode resistance.

Heater-to-cathode leakage in the video-amplifier tube is easily pinpointed by the appearance of hum modulation in W4. Don't be fooled, however, since an ungrounded scope return lead will introduce the same symptom.

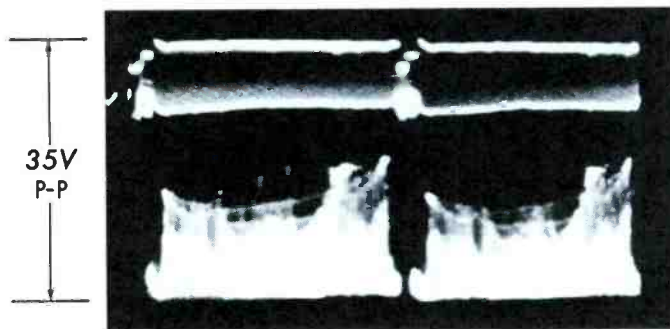

W5 W5

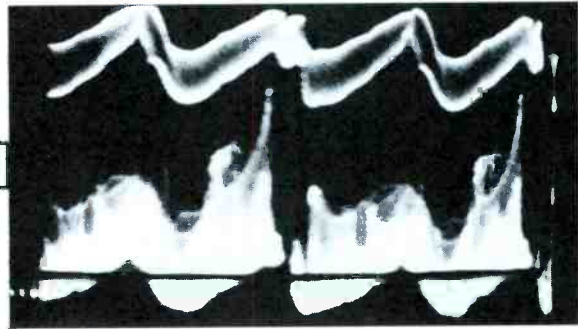

25V
P-P

W5 looks very much like W2, except for a slight reduction in amplitude. Circuit impedance at this point is quite high, and in addition to using a low-capacitance probe, you'll probably have to connect the ground lead of your scope to the low side of the grid resistor to obtain a viewable signal.

Here's what W5 looks like when C41 is leaky. The degree of sync trouble will vary from picture jitter to complete loss of sync. Since a DC voltage measurement at the grid would not be indicative of leakage, you'll have to resort to use of your ohmmeter or capacitor checker to test the coupling capacitor in this case.

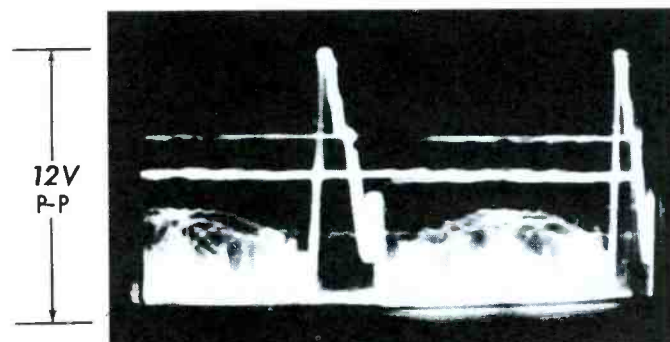

W6 W7

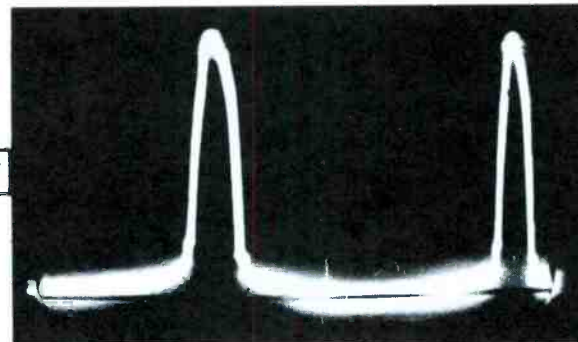

520V
P-P

The input of the AGC keyer receives this signal from the video-output circuit. The amplitude of the horizontal-sync pulse automatically adjusts the conduction level of the stage. Greater amplitude results in the development of more AGC voltage.

W7 shows the AGC-keying pulse received from the flyback transformer. It must be in phase with W6 for proper AGC action. A gassy horizontal-output tube can delay this pulse just enough to cause trouble; replacing it may save pulling the chassis.

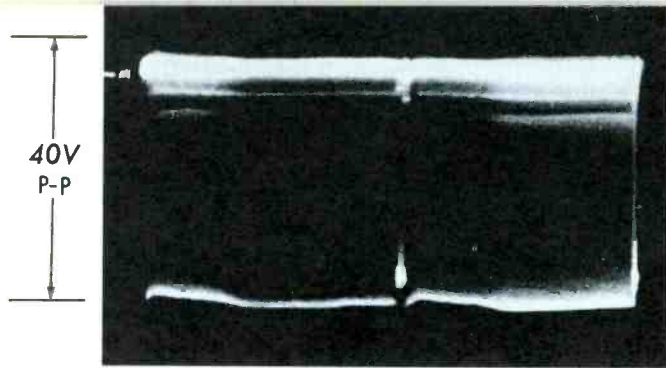

W8 W8

W8, the output of the sync separator, contains no video information—only horizontal and vertical sync pulses. This is the way the signal should look with a scope sweep frequency of 30 cps.

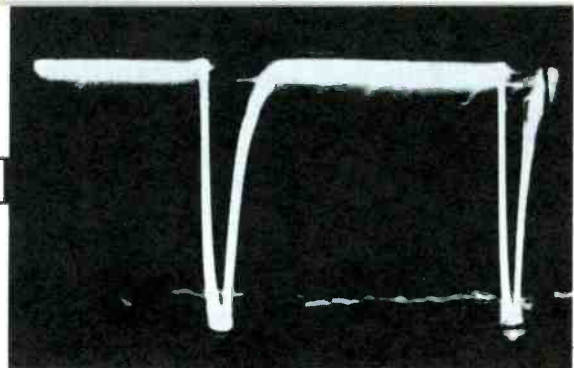

40V
P-P

With the scope sweep synchronized at 7,875 cps, W8 takes on this appearance (a clear-cut view of what the horizontal sync pulses should look like) at the output of the sync separator.

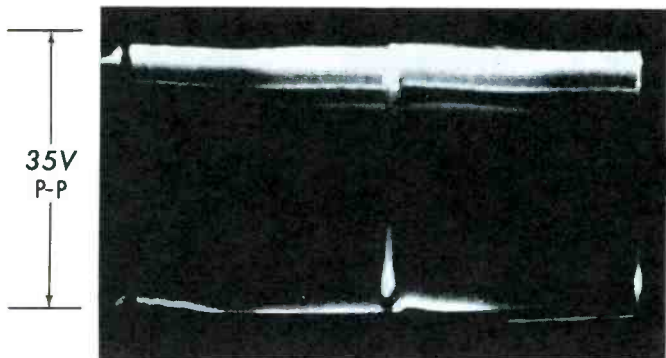

W9 W10

W9, the signal at the grid of the sync amplifier, is identical to W8, except for a slight loss in amplitude. Leakage of C43 reduces the signal further, and sync becomes a little touchy, especially in noisy or weak-signal areas.

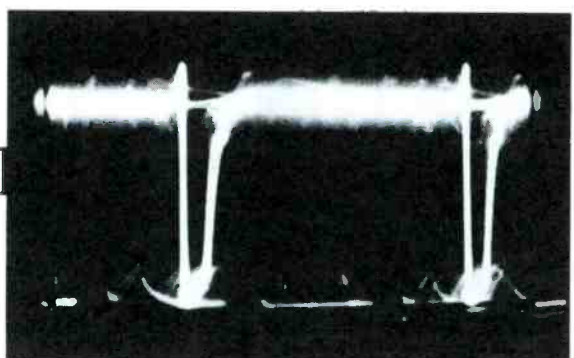

20V
P-P

Horizontal sync pulses for one-half the dual-diode AFC circuit are delivered from the 6CG7 in cathode-follower style, developing across R60, the cathode-load resistor. Amplitude is important to proper horizontal AFC action.

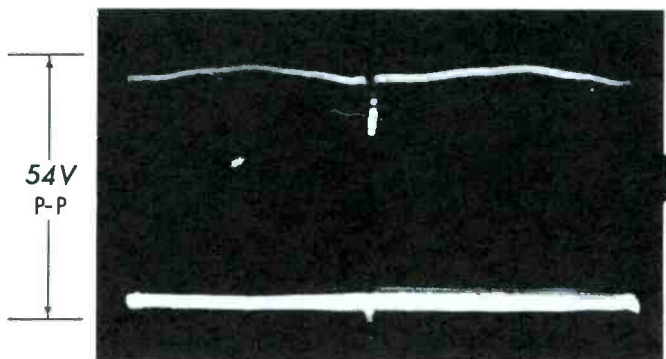

W11 W11

Here's the 6CG7 plate signal at 30 cps. Note that the signal has been increased about one and a half times, and it now has sufficient amplitude to drive the vertical integrator. Signal reduction results in intermittent flopper.

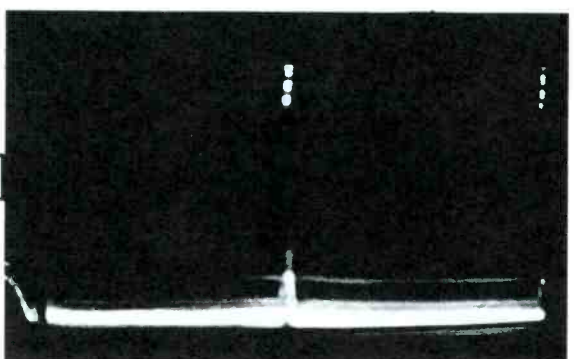

54V
P-P

Slight leakage in C43 increases the amplitude of W11, accentuating vertical pulses more than horizontal. An early symptom is picture bounce or jitter, and the need for periodic readjustment of the vertical-hold control.

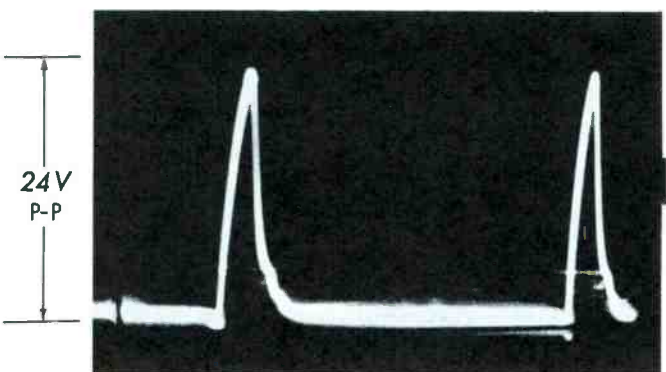

W12 W12

Amplified horizontal sync pulses are taken in proper proportion to drive the other half of the dual-diode AFC circuit from the junction of R57 and R58. If improper AFC action is noted, check the amplitudes of W10 and W12.

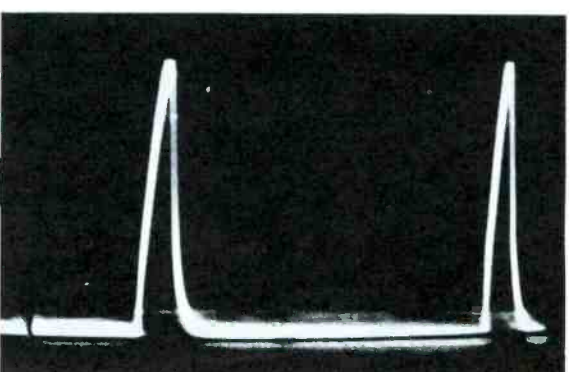

30V
P-P

Leakage in C43 increases the amplitude of W12. It also causes the pulse to become narrower, which can result in horizontal-AFC troubles. Normal appearance of W10 and W12 is a fair indication that the sync stages are okay.

NINE MILLION Portable TV's in Use . . . Plus TWO MILLION Sold Each Year Add Up To Big EXACT REPLACEMENT ANTENNA Volume! JFD Ads Like These Are Uncorking This Profitable NEW Market For JFD Distributors And Dealers!

Where would you get this portable TV antenna replacement?



OF COURSE!

. . . Because JFD supplies most of the antennas for portable TV manufacturers. Each JFD Exact Duplicate Replacement is the same as the original antenna that comes with the set. Electrically, mechanically, physically . . . they are the perfect factory-spec match to their respective models . . . hole for hole, notch for notch.

And when you install a JFD Exact Duplicate Replacement, you earn a handy profit, both on the antenna and the servicing operation. You eliminate profit-less competition with local drug stores and other discounters selling conventional indoor antennas.

Makes sense, doesn't it? to see your JFD distributor for all your exact replacement indoor antennas. Also ask him to show you how the new JFD Portable TV Antenna Merchandising Kit will make money for you in this brand new market . . . for an investment of only \$11.95!

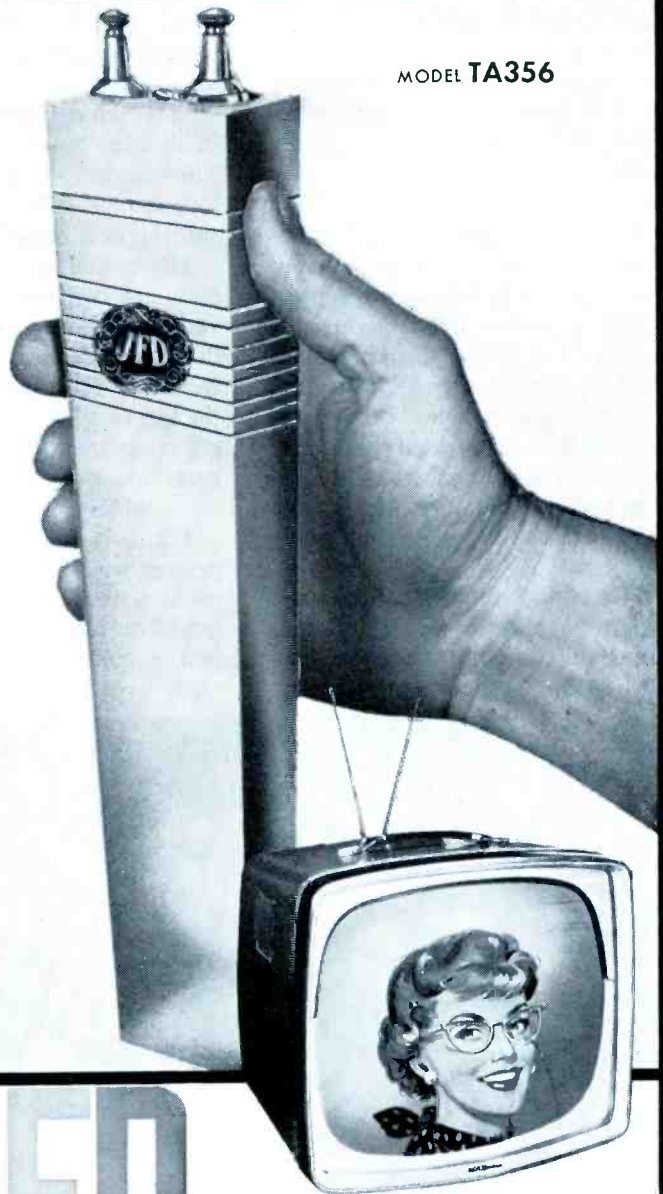

MODEL TA356

**JFD EXACT DUPLICATE
REPLACEMENT ANTENNA
FOR RCA VICTOR PORTABLE
21PT909**

MODEL TA356

\$12.95, LIST

Extends from 10" to 38"

JFD

Pioneers in Electronics since 1929

JFD ELECTRONICS CORPORATION

6101 Sixteenth Avenue Brooklyn 4, New York

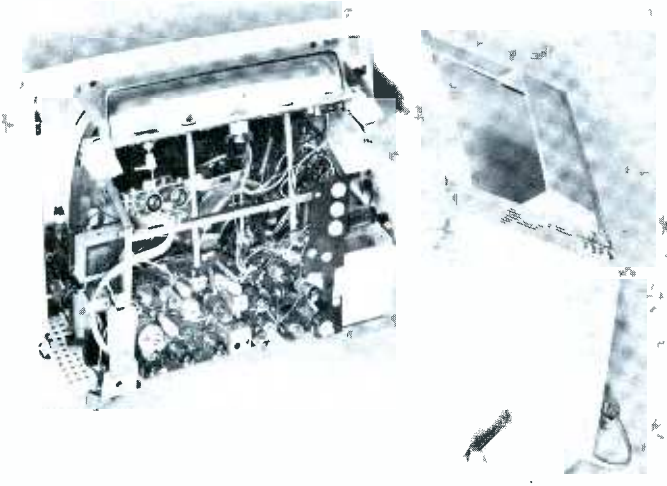

Fig. 1. When the rear cover of the *dualette* has been removed, most of the chassis is exposed.

BENCH SERVICING NEW SETS

by Thomas A. Lesh

You'll like the wrap-around rear cover of the Sylvania *dualette* portable (Chassis 1-543-1) shown in Fig. 1. When the cabinet back is removed, most of the chassis is plainly exposed to view. Several other manufacturers have also introduced slim portables with various types of contoured rear covers, so the conventional "chassis-in-a-box" concept of TV-set design is evidently giving way to some fresh new ideas. This is an encouraging trend from the standpoint of service, because it means less time wasted on disassembly when such jobs as tube replacement, IF alignment, or voltage and waveform checking are being performed.

Most of the signal circuits in the *dualette* are on a single printed-wiring board mounted almost vertically (with a slight inward tilt)

across the back of the chassis. This panel is practically identical to the top section of the double-decker "S-110" chassis which has been used in all other Sylvania sets since 1957. The only important change is a relocation of the service controls to suit the new mounting arrangement.

Horizontal and vertical sweep circuits are conventionally wired on a vertical panel, which is located on the right side of the chassis as seen from the rear. A similar panel on the left side supports the power-supply components, including a pair of germanium rectifiers wired as a voltage doubler.

Fig. 2 is a closeup of part of the printed-wiring board. Note the unusual construction of the horizontal hold control; the inner end of the plastic control knob is formed into a hexagonal rod which extends into

the horizontal frequency coil and turns the slug.

Take a close look at Fig. 2 to find out what *can* and what *can't* be serviced from the exposed side of the wiring board. Unshielded tubes can be temporarily plugged into socket adapters to permit measurement of voltages, resistances and waveforms on the various tube pins. Where a captive shield prevents use of an adapter, it's still possible to obtain readings by touching the test prod to the tube-socket lugs at the point where they pass through the board. This can be done more easily if the tip of the prod is bent slightly.

The dual selenium diode in the horizontal phase-detector stage is a plug-in type and can be replaced as easily as a tube. The quickest method of replacing a defective resistor or ceramic capacitor is to crush it and use the remaining lead stubs as connecting points for the new component. Unfortunately, this handy repair technique is not usable with paper tubular capacitors (which are mounted at right angles to the board), or with inductors. These components are flush with the board to insure rigid mounting. (In Fig. 2, note that some pairs of capacitors have even been secured together with rubber bands to minimize vibration!) To reach the leads of such components for unsoldering, further chassis disassembly is required.

Wait—don't separate the printed-wiring board from the rest of the chassis. There's a much easier way to reach the underside of the board. The whole chassis assembly can be quickly separated from the picture

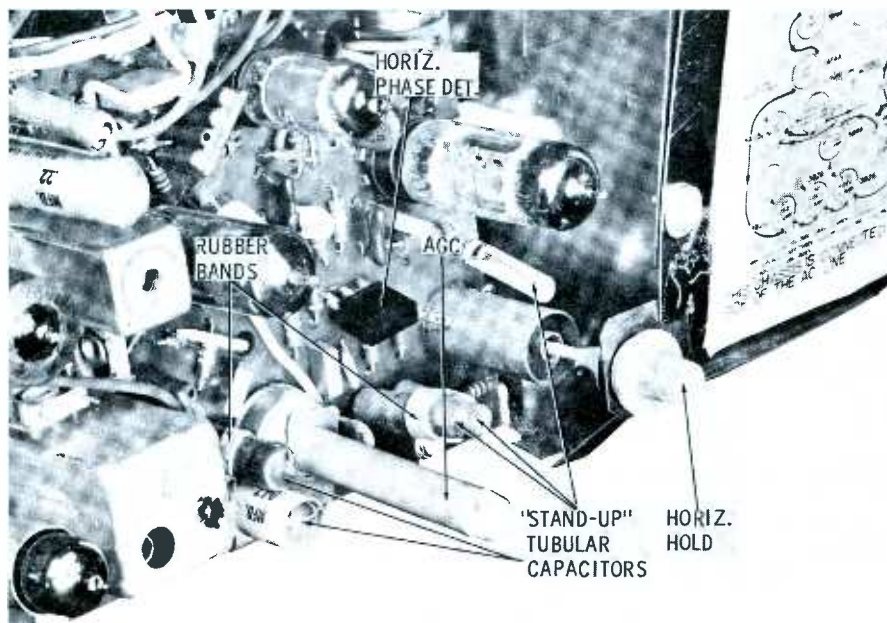

Fig. 2. Details of printed-wiring board. Note plug-in phase-detector diode.

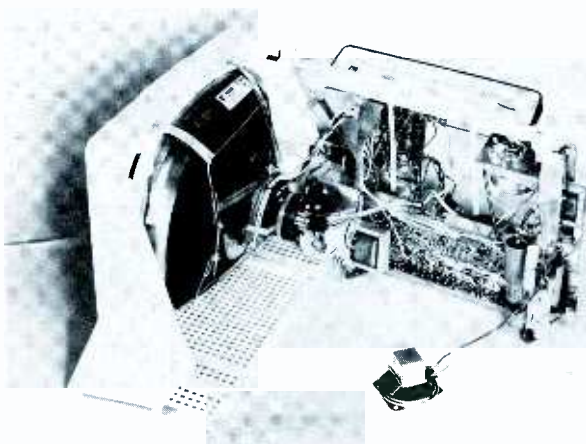

Fig. 3. Receiver can be operated in this position.

tube and the rest of the cabinet, thus enabling you to reach the front side of the chassis (see Fig. 3). The control panel and carrying handle stay with the chassis, so you *never have to remove any knobs* from this receiver, except when replacing the associated controls. The set can be operated when arranged as in Fig. 3, thereby giving easy access to the sweep circuits—if you have a 110° CRT base-socket extension. The speaker (or speakers) can be removed from the front wall of the cabinet by pushing down on a spring clip and lifting out the speaker.

Chassis removal is a snap, once you understand how it's done; but there are a couple of "hitches" to baffle the uninitiated. This should discourage all but the most determined do-it-yourselfers from fooling around with the inner reaches of the chassis. For one thing, although only two screws are used to fasten the chassis assembly to the cabinet front, they are of a type you've probably never seen before. As illustrated in Fig. 4, they're Holt-head screws—a cross-slot type with grooves which deepen toward the outside rim. (These small black

screws are visible in the far corners of the top control panel in Fig. 1.) If you don't have a Holt-type driver—and this is a safe bet—Sylvania suggests filing a shallow, concave V notch in the bit of one of your spare blade-type screwdrivers. This modified tool will enable you to extract the special screws.

Why were these odd screws used? They're strictly a safety device; according to Sylvania, they are necessary to qualify the *dualette* for the UL label. The idea is to prevent the average set owner from unwittingly taking out the main chassis screws and thus exposing himself to high-voltage shocks or serious breakage.

When the Holt-head screws have been removed, and the CRT socket and speaker leads have been unplugged, you're almost ready to pull the chassis; but it is still held in place by a small spring clip (Fig. 5) located behind the AC interlock near the bottom left corner of the chassis. This clip has a barbed edge which digs into the soft plastic cabinet and anchors the chassis. Lift up on the clip to disengage the barb so that you can slide the chassis backward. If you want to separate

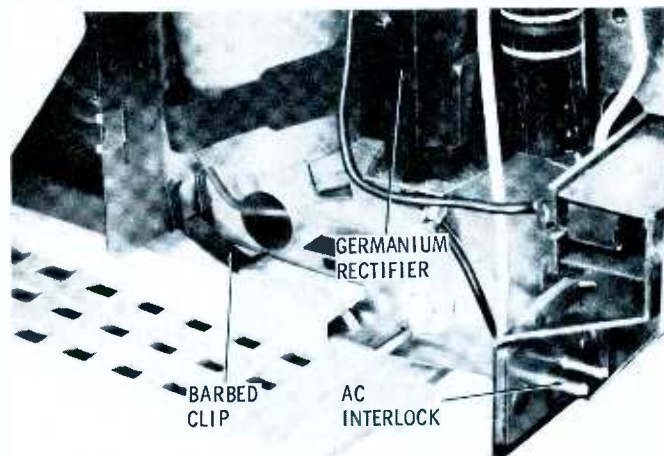

Fig. 5. Lift up on spring clip when pulling chassis.

the chassis completely from the front section of the cabinet, unplug the yoke and high-voltage leads.

Picture Tube

The 17DKP4 cathode-ray tube in the *dualette* is a new 110° type with a neck about 2" shorter than in previous 110° tubes. The reduction in neck length has been made possible by a change in electron-gun design and adoption of a new feature called *tripotential focus*. This arrangement is much simpler than it sounds; it mainly involves repositioning the focus anode in the gun structure. In conventional types of electrostatically-focused picture tubes, the high-voltage anode (the one connected to the internal aquadag coating of the tube) consists of two sections, and the focusing anode straddles the gap between the halves as shown in Fig. 6A. This type of gun might be said to have *hipotential* focusing because only two electrical potentials (those on the focusing and high-voltage anodes) play a part in producing the electrostatic field which focuses the electron beam. In the new gun, a one-piece high-voltage anode is employed, and the

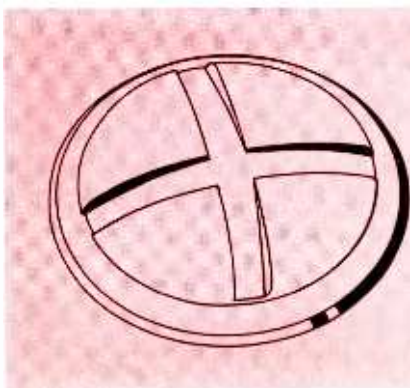

Fig. 4. Holt-head screw design.

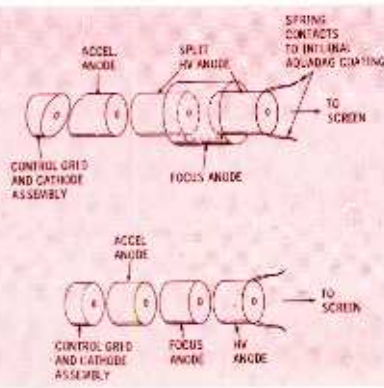

Fig. 6. Structure of CRT electron guns.

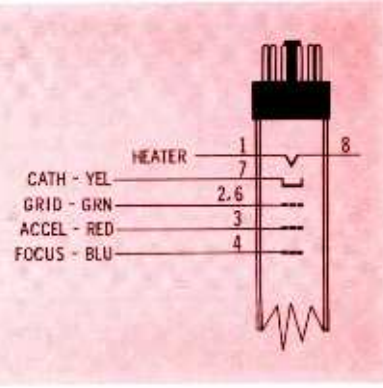

Fig. 7. Base connections of a 17DKP4.

Miller



* K-TRAN IS A REGISTERED TRADEMARK



THE FAMOUS K-TRAN^{*} I.F. TRANSFORMERS

A complete line of the finest I.F. transformers available anywhere at any price. Both standard and miniature sizes in all of the commonly used I.F. frequencies are stocked for immediate delivery. Conventional as well as printed circuit types are available for both vacuum tube and transistorized applications. Original equipment manufacturers will find the K-Tran the ideal choice for new equipment designs thus saving valuable engineering manhours and being assured of a top quality transformer designed by engineers with over 30 years of manufacturing experience in electronic components. The K-Tran also makes an excellent replacement transformer and will give results equal to or better than the original.

AVAILABLE IN THE FOLLOWING FREQUENCIES

CAT. NO. Printed Circuit Types	CAT. NO. Regular Standard Types	Dimensions: 3/4" square x 2" high	FREQ.	USE
13-PH1	12-H1		262 KC	Input transformer
13-PH2	12-H2		262 KC	Output transformer
13-PH6	12-H6		262 KC	Output transformer with diode filter
13-PC1	12-C1		455 KC	Input transformer
13-PC2	12-C2		455 KC	Output transformer
13-PC6	12-C6		455 KC	Output transformer with diode filter
13-PC7	12-C7		455 KC	Input transformer for battery radios
13-PC8	12-C8		455 KC	Output transformer for battery radios
13-PC9	12-C9		455 KC	Input transformers for AC-DC radios
13-PC10	12-C10		455 KC	Output transformer for AC-DC radios
	12-C11		455 KC	IF transformer (G.E.-RTL 143 and 163)
	12-C12		455 KC	Tapped Pri. I.F. transformer
	12-C45		455 KC	Discriminator
	13-W1		1500 KC	Input and interstage transformer
	13-W2		1500 KC	Output transformer
6203-PC	6203		4.5 MC	Input or interstage transformer
6204-PC	6204		4.5 MC	Discriminator transformer
6205-PC	6205		4.5 MC	Ratio detector transformer
6206-PC			4.5 MC	Ratio Det. (GE-RTD-026)
6207-PC			4.5 MC	Ratio Det. (GE-RTD-025)
6208-PC			4.5 MC	Ratio Det. (GE-RTD-020)
1463-PC	1463		10.7 MC	Input or interstage transformer
1464-PC	1464		10.7 MC	Discriminator transformer
	1464-WB		10.7 MC	Discriminator 900 KC Peak to Peak
1465-PC	1465		10.7 MC	Ratio detector transformer
	1465-WB		10.7 MC	Ratio detector 800 KC Peak to Peak
	6260		21.25 MC	I.F. Transformer
	6261		21.25 MC	Discriminator transformer
	6262		21.25 MC	Ratio detector transformer
6230-PC	6230		44 MC	TV Converter I.F. Transformer
6231-PC	6231		44 MC	TV First I.F. Transformer
6232-PC	6232		42.5 MC	TV second I.F. Transformer
6233-PC	6233		42.5 MC	TV third I.F. Transformer
6234-PC	6234		44 MC	TV fourth I.F. Transformer



Miniature I.F. Transformers for printed circuit transistorized applications. These miniature I.F. Transformers have tuned primary and untuned secondary windings. Proper impedance match between primary and secondary insures optimum performance.

Dimensions: 1/2" square x 3/4" high

CAT. NO.	FREQ.	SPECIFICATIONS
2031	455 KC	10K Ohm pri. to 600 Ohm Sec., Input
2032	455 KC	10K Ohm pri. to 1000 Ohm Sec., Output
2041	455 KC	25K Ohm pri. to 600 Ohm Sec., Input
2042	455 KC	25K Ohm pri. to 1000 Ohm Sec., Output
2051	455 KC	100K Ohm pri. to 1000 Ohm Sec., Input

Sub-Miniature I.F. Transformers for printed circuit transistorized applications. To our knowledge the smallest I.F. Transformers in existence. Ferrite cup core construction permits the use of extremely small shields without adversely affecting transformer operation. A high impedance, tapped primary winding coupled to a low impedance secondary provides optimum energy transfer between stages.

Dimensions: 3/8" square x 5/8" high

CAT. NO.	FREQ.	SPECIFICATIONS
9-C1	455 KC	25K Ohm pri. to 600 Ohm Sec., Input
9-C2	455 KC	25K Ohm pri. to 1000 Ohm Sec., Output

Also a sub-miniature I.F. Transformer for conventional circuitry using vacuum tubes. A 455 KC intermediate frequency transformer which has all the desirable features of the standard size I.F. and is smaller than a MINIATURE tube. Through the use of a ferrite cup core these sub-miniature I.F. Transformers offer the gain and bandwidth characteristics previously obtained only in larger I.F. assemblies. For AC-DC or battery radios.

Dimensions: 1/2" square by 1 1/2" high

CAT. NO.	FREQ.	USE
10-C1	455 KC	Input transformer
10-C2	455 KC	Output transformer

Literature on any of the above I.F. Transformers or our latest general catalog 60 — TV guide 160 — Auto guide 260 — are available on request. Over 2,000 Radio & TV parts distributors to serve you the world over.

BUY WITH CONFIDENCE — BUY MILLER.

Available Through Your Local Distributor
Miller Quality Products are recognized by the entire electronics industry as representing the finest in workmanship, performance, and dependability.

*Manufactured under K-Tran patents of and by Automatic Manufacturing Corp., Division of General Instrument Corporation.

J. W. MILLER COMPANY

EXPORT REPRESENTATIVE

Roburn Agencies, Inc.
431-435 Greenwich Street
New York 13, New York
WOrth 6-2130

FACTORY

5917 SOUTH MAIN ST., LOS ANGELES 3, CALIF.

Phone ADams 3-4294

FAX No. XCM

CANADIAN REPRESENTATIVE

Warehouse Stock
Atlas Radio Corporation, Ltd.
30 Wingold Ave.
Toronto 19, Ontario, Canada

See Us At Booth #2112 at the WESCON SHOW.



NOTES on test equipment

by Les Deane

DC Power in a Small Package

The instrument shown in use in Fig. 1 is a new transistorized power and bias supply by EICO of Long Island, New York. Designated as the Model 1020, it affords many applications in powering low-current devices such as transistor radios, hearing aids, preamplifiers, etc. as well as supplying bias potentials for both transistor and tube circuits.

Using two transistors for voltage regulation, the output of the supply is well filtered and therefore ideally suited for powering ripple-sensitive transistorized equipment. The unit comes complete (less test leads) in either kit or factory-wired form.

Specifications are:

1. Power Requirements—110/120 volts, 50/60 cps; power consumption variable with load; DC circuits protected by front panel fuse.
2. DC Output—continuously variable in two ranges from 0 to 6 volts and from 0 to 30 volts, range switch provided on front panel; maximum load currents of 300 ma at 24 to 30 VDC, 200 ma at 12 to 24 VDC, and 150 ma at 0 to 12 VDC; AC ripple 1/200 of 1% at full load.

3. Panel Features—DC voltmeter with two scales of 0 to 6 volts and 0 to 30 volts; neon lamp provided as ON-OFF indicator.
4. Size and Weight—5" x 4" x 5½", 4½ lbs.

Since low-current supplies like the Model 1020 are of more value to the serviceman today than ever before, I thought I might obtain one of the wired versions, examine it, and let you know what I felt the instrument had to offer.

Looking over its physical structure, you'll find that the unit is housed in a sturdy steel case with aluminum carrying handle. Because of its compact design, the unit should require little space on any service bench. After I removed eight Phillips-head screws from the edges of the case, I found the entire top section lifts off of an "L"-shaped front panel and base section. All chassis components are mounted to this "L" frame as pictured in Fig. 2. You can see that the two power transistors employed for voltage regulation are located at the top of a vertical metal bracket, which also

serves as a heat sink. Most of the other components are placed either on the front panel or between terminal strips attached to the vertical bracket. A power transformer and pair of silicon rectifiers, however, are positioned behind the bracket and are not visible in Fig. 2.

I have presented a complete schematic of the Model 1020 in Fig. 3 so that you will better understand the transistorized circuit of this particular supply. The AC input to the instrument is converted to DC by the full-wave rectifying action of power transformer T1 and silicon diodes M1 and M2. Input filter capacitor C2 smoothes out much of the initial AC ripple, but final filtering and regulation centers around the transistor networks.

The two PNP transistors are effectively connected in series across the full rectified voltage. Ganged controls R1A and R1B regulate collector and base potentials, which in turn control emitter current and thus total output voltage. Capacitors C3 and C4 act as bias filters for the base circuit of each transistor, and thereby limit voltage variations on the sensitive base elements. The transistors are biased so that small voltage variations or ripple in their collector circuits will not produce a noticeable change in their emitter currents. Any hum-producing ripple that might get by this smoothing network is further reduced by output filter C5.

To protect the instrument and the transistors against current overloads, a ½-amp slow-blow fuse is placed in the negative center-tap return of the power transformer. Notice, however, that the neon ON indicator in the primary circuit will remain lit even if this fuse blows.

The DC voltmeter, in series with either a dropping resistor or the range switch (depending on the position of the latter), is connected directly across the output terminals of the supply. With range switch M5 in its 6-volt position, resistor R9 is shorted out, and full-scale reading of the meter becomes 6 volts. With the switch in the 30-volt position, R9 is connected in series with the meter resistance, and full-scale deflection now represents 30 volts.

I made use of the EICO supply by powering several battery-op-

• Please turn to page 89

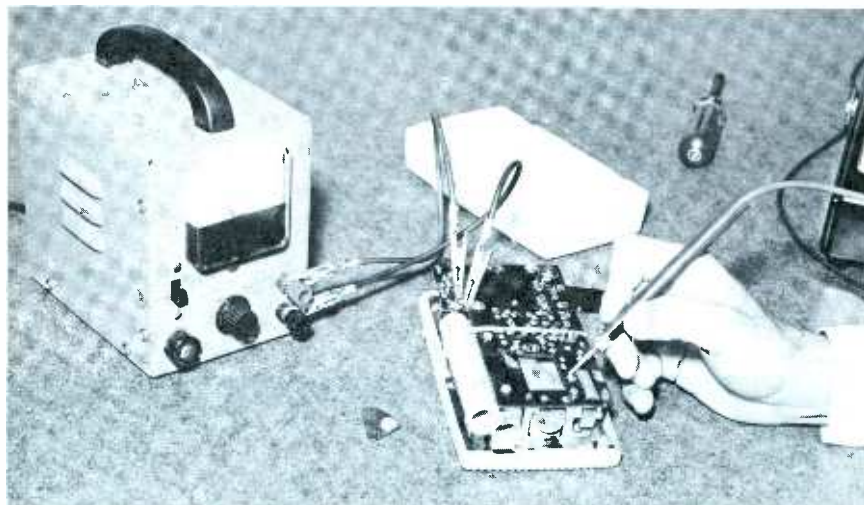
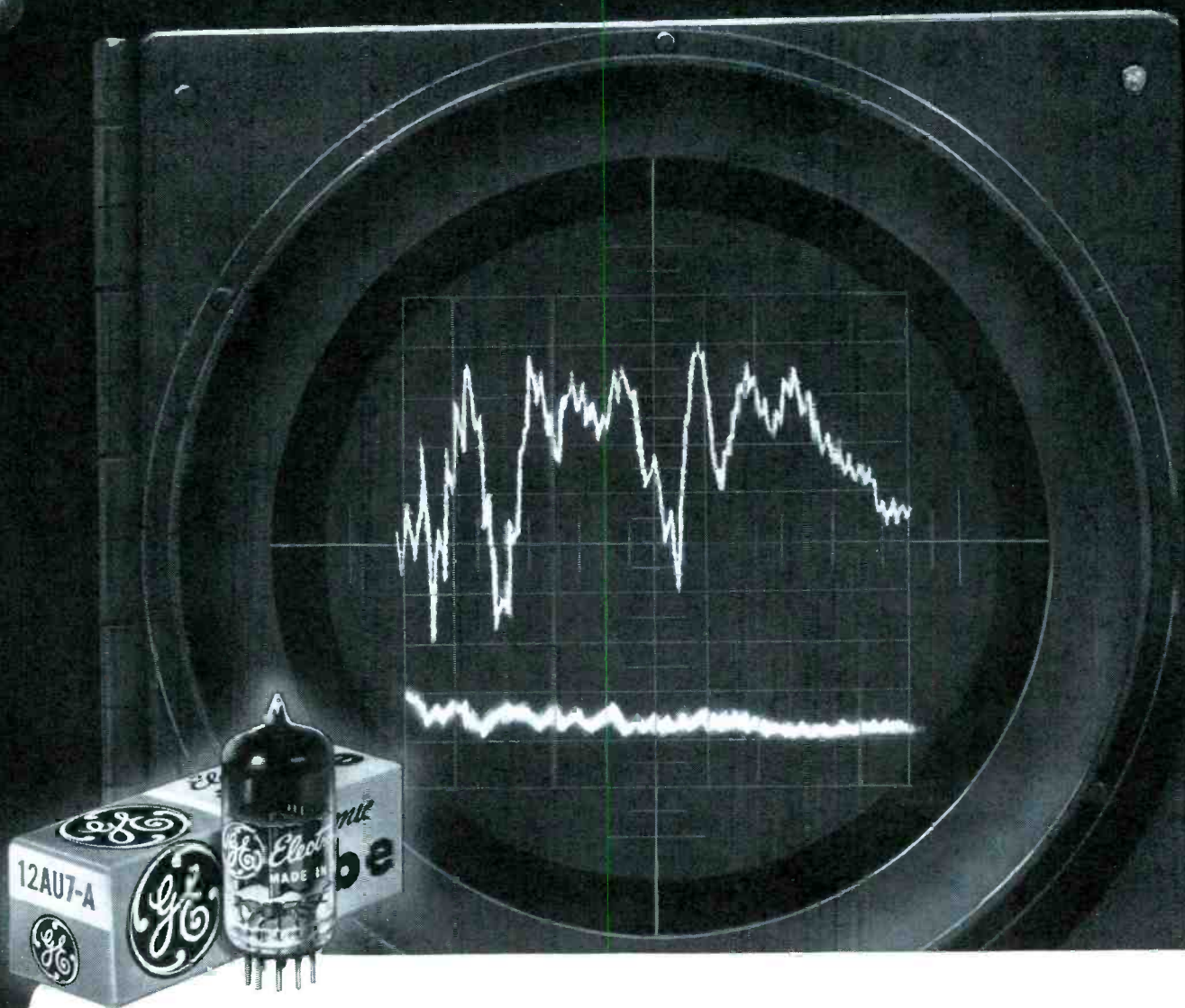

Fig. 1. With a maximum output of 30 volts, EICO's new supply features a dual-range voltmeter. Here, the unit is shown powering a pocket-size transistor radio.



SEE HOW G-E 12AU7-A's ARE BETTER!

Bottom scope trace shows Service-Designed Tube's low-microphonic performance compared with ordinary 12AU7-A (top).

APPLY equal vibration to both tubes, and you get the results shown above. General Electric's Service-Designed 12AU7-A has far lower microphonics. No more TV "shakes and jitters." In hi-fi, tone is rich, round, undistorted when you install this finer General Electric dual triode. Here's the ideal tube to create goodwill and boost your repeat business.

Heart of the Service-Designed 12AU7-A's design is a short compact cage with heavy-duty m.c.s., rigid under all conditions. And quality merely starts there! This G-E volume-seller is better manufactured, better tested. See your General Electric tube distributor! *Distributor Sales, Electronic Components Division, General Electric Company, Owensboro, Kentucky.*

Progress Is Our Most Important Product

GENERAL  ELECTRIC

2-111-206

INDUCTION HEATING APPLICATIONS

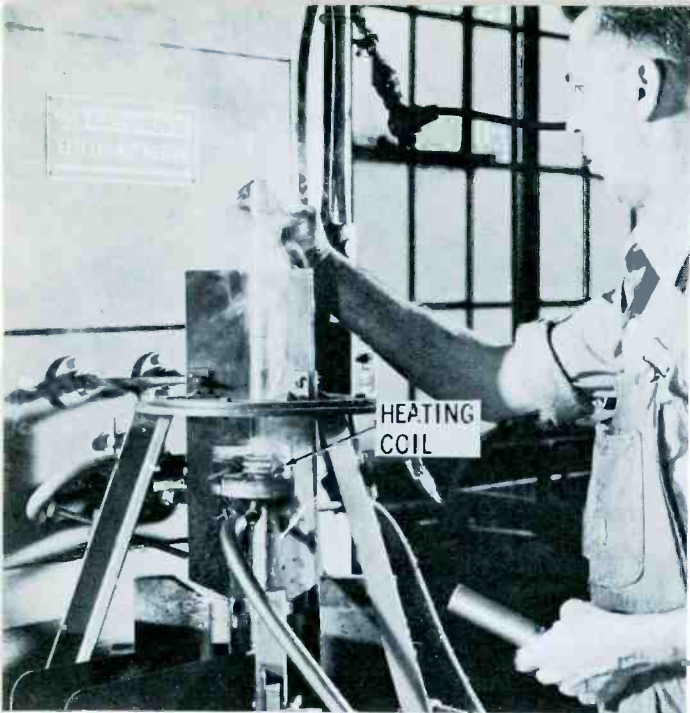

Fig. 1. This heater is used for case-hardening king pins.

In Part 15 (May issue), dielectric heating was described as a process for applying heat to non-conductive materials. Application of RF power for heating conductive materials is called *induction heating*. The methods of applying power to both non-conductive (dielectric) and conductive materials are so similar that in many applications the same electronic heater

can be used. The changes required are in the methods for coupling power to the item to be heated. Non-conductive materials must be coupled to the power source as if they were the insulation in a capacitor, while a conductive material must be considered as a shorted, single-turn secondary coil of a transformer. The power source drives the primary coil and, in ac-

cordance with the turns-ratio, power is coupled to the secondary in the form of high current at low voltage.

The main source of heat in the induction heating process is the circulating current induced in the work. If you have ever accidentally produced a short in the filament line from a transformer, the heat produced by high current at low voltage may have impressed you, particularly if the charred filament wire had to be replaced. Primary heating is, therefore, due to high current, while magnetic properties and generator frequency contribute to the exact heating characteristics.

Magnetic Materials

Conductive material which is also magnetic can be electronically heated to a specific temperature in less time than non-magnetic material. The additional heat results because of the magnetic property of metal, which involves molecular orientation. Each molecule tends to line up with the applied magnetic field. With RF power applied, the magnetic field reverses direction rapidly, and the molecules are in constant motion. Heat is thus produced in magnetic metal by both circulating current and molecular motion.

As a magnetic metal is heated, a loss of magnetic properties occurs. The temperature at which all magnetic properties are eliminated is

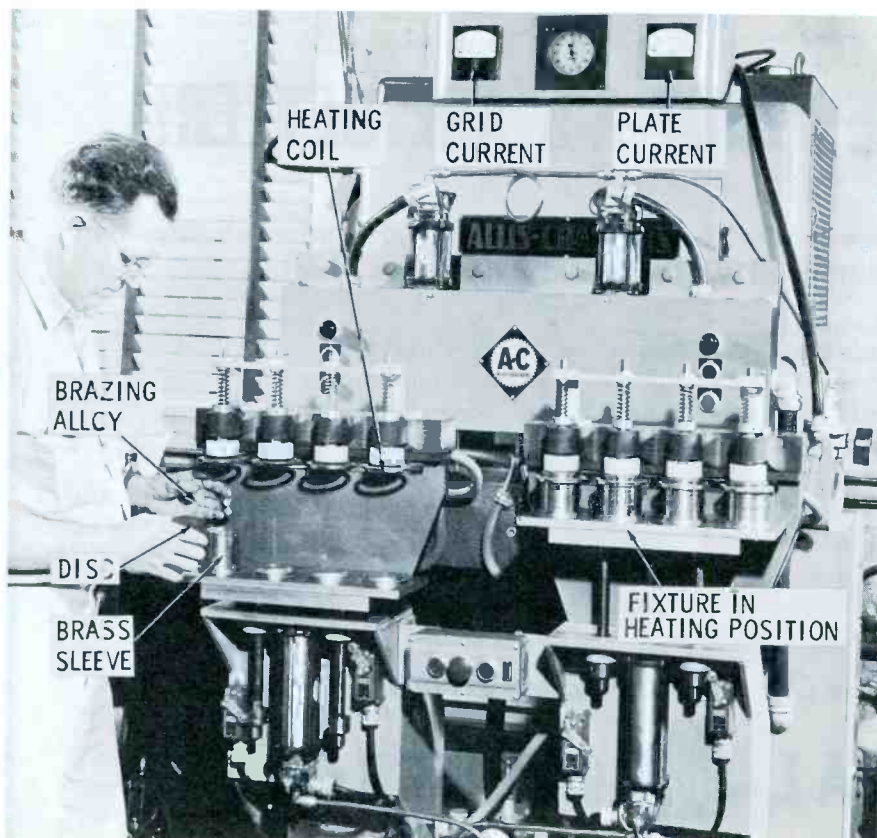

Fig. 2. Four pieces are brazed in this induction heater in only 23 seconds.

• Please turn to page 85

New Developments from



Matched Pairs for Higher Fidelity

Typical of premium-performance CBS receiving tubes are these audio output tubes. Their critical audio characteristics are matched to help minimize harmonic distortion in push-pull amplifiers. The 6BQ5, 6V6GT, 5881 and 6550 matched pairs reduce distortion even below that attainable by controls for balancing plate currents.



Professional 55 Stereo Cartridge

This is the professional's version of the popular Columbia CD. Designed for transcription turntables, it uses a .5-mil diamond stylus, and features superior linearity . . . separation . . .

needle-point impedance . . . low mass . . . freedom from hum and distortion . . . output level . . . ruggedness. Includes 4 plug-in equalizing networks. Another fine Columbia audio component.

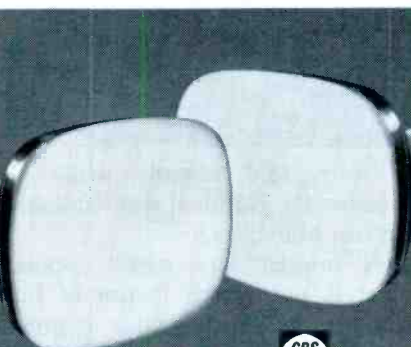

CBS
Silver Vision

Premium or Budget TV Tubes

A CBS original! Sell your customer whichever he wants: premium-performance CBS Silver Vision or budget-priced CBS Palomar. Either is easy to sell because of top brand prestige. Either stays sold because of top performance in its field. Recommend these dependable national-brand CBS picture tubes with confidence.



Ultrahigh-resolution C-R Tubes

New UHR tubes offer still another addition to CBS industrial tubes . . . most inclusive line in the industry. They can compress into 1/20 square inch all detail on the face of a 21-inch picture tube. They make practical many advanced military and industrial applications requiring resolution beyond the capabilities of the unaided human eye.



New Semiconductor Lines

Drawing on its experience in NPN switching transistors and PNP power transistors, CBS Electronics now adds a comprehensive group of NPN power transistors for use in complementary circuits. Its line of NPN switching transistors has been more than doubled to meet increasing demands by computer manufacturers.

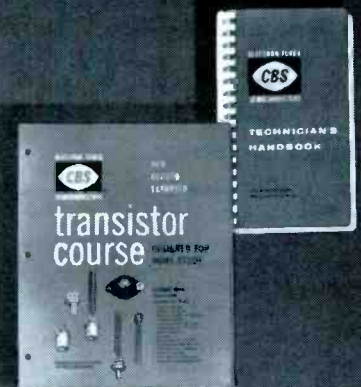

Revised Transistor Course and Technician's Handbook

Expanded CBS Transistor Home-Study Course (still only \$25.00) makes it easy to learn about transistors by making practical transistor devices from readily available parts. Opens up advancement opportunities. 1959 Technician's Handbook, designed for the technician, is compact, handy, modern. Its 550 pages include receiving, picture, special tubes and semiconductors . . . only \$1.85. See both at your distributor's.

WATCH FOR MORE *reliable products* through *Advanced-Engineering*

CBS ELECTRONICS, Danvers, Massachusetts
Electronic manufacturing division of
Columbia Broadcasting System, Inc.

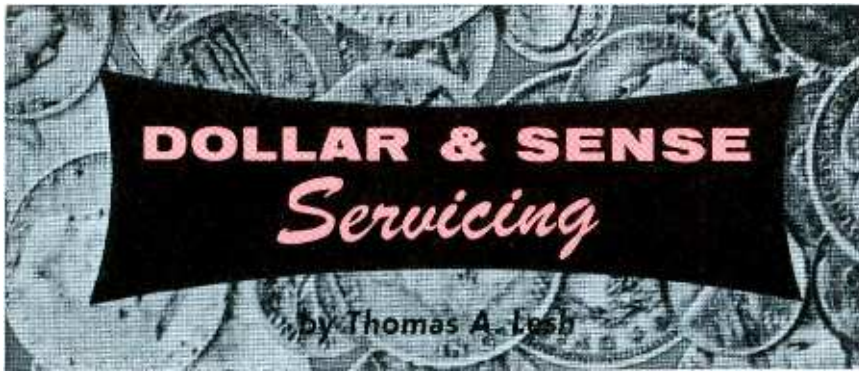

Breach of Promise. "Women are appreciative of common, ordinary courtesy. Of course, they're literal-minded too. And that's why, when you tell them you'll be there on Monday, they expect you on Monday!" Miss Willie Mae Rogers, director of the Good Housekeeping

Institute, said recently while addressing the National Association of Service Managers.

A broken service-call appointment is not just a matter of hurt feelings, as though your feminine customer had been "stood up" on a date. She generally has more im-

portant things to do than stay home all day waiting for you to show up. These days, it's even quite probable that she's holding down a job and must take time off to let the TV man into the house.

So, in spite of your own tight schedule, you should do everything in your power to be on time for firm appointments you've made. In case you're unavoidably delayed, phone ahead and explain the situation; the customer will be much less ruffled by the time you arrive.

To rescue yourself from being a slave to a timetable all day, make a point of being a little vague about your arrival time when you are first arranging the call. This will help you to spot the customers who are not too fussy about punctuality. If some people want a definite time for an appointment, let them ask for it; then make a big hit with them by showing up at the proper time.



Pay Now—Pay Later. If you sell long-term service contracts and collect payment in advance, when are you supposed to pay income tax on your receipts? The Bureau of Internal Revenue has held the position that such money should be treated as taxable income for the calendar year when collected—whether or not the work contracted for is actually performed in that year. This policy can put a businessman out on a limb every now and then, the ups and downs of business being what they are. Suppose a dealer sells a flock of one-year service contracts in the fall, and they result in very few calls until year's end. With relatively high income and low outgo, he has a healthy tax bill to pay the following spring.

Somebody has squawked about this problem—and the U.S. Court of Appeals has listened. In a decision this year (Bressner Radio Inc. vs. Commissioner of Internal Revenue), this court upheld the right of a New York City radio store to defer part of its income-tax payments on contract fees until such time as these fees "ripen into taxable income"—that is, until paid-for services are actually rendered.

If this decision holds promise of tax savings for you, better have your tax consultant check into it.

Service Survey. Have you ever wondered what the public thinks of your profession? Valuable insight into this question is provided by an impartial survey, completed just recently, which includes information on sets owned by 375 Detroit families and how they feel about TV service. To gather the data, fifteen students from Wayne State University, directed by Dr. H. Webster Johnson, visited a random sampling of homes in 15 areas of metropolitan Detroit. While the percentage figures they obtained may not reflect national averages, they are indicative of consumer thinking on several points of particular interest to the professional service technician. Here are the results:



Facts on Service Calls
Last time set was repaired:

- 46.7% Last year (1958)
- 30.7% First 4 months of 1959
- 13.2% Not since Jan. 1, 1958
- 9.3% Never
- 0.1% Don't know

- Service agency called:**
- 43.2% Local repair shop
 - 16.3% "Free-lance" serviceman
 - 11.2% Store of purchase
 - 11.2% Immediate family
 - 10.1% Factory agency
 - 8.0% Other

- Method of choosing service agency:**
- 33.9% Recommended by friend
 - 22.5% Located in neighborhood
 - 21.9% Recommended by dealer
 - 9.4% Yellow Pages
 - 1.5% Mail advertising
 - 10.8% Other or none

- Nature of service performed:**
- 32.2% Removed set from home
 - 91.3% Completed work promptly
 - 84.8% Replaced tubes
 - 32.1% Replaced other parts
 - 12.6% Don't know about other parts
 - 88.1% Dealt honestly
 - 94.3% Acted courteously

- Opinion of price charged:**
- 84% About right
 - 11.3% Too high
 - 3.1% Too low
 - 1.6% Don't know

Home-call charge considered fair:

- 2.1% Under \$3
- 22.9% \$3.00
- 1.6% \$3.50
- 25.6% \$4.00
- 24.2% \$5.00
- 0.5% \$6.00
- 21.8% Other price or don't know

General satisfaction with past service:

- 83.5% Satisfied
- 16.5% Dissatisfied

Facts on Self-Service Tube Checkers:

- 30.9% Have bought tubes at drugstore, supermarket, etc.
- 35.8% Have used self-service checkers
- 60.7% Users satisfied with checkers

Facts on Sets Owned

Number of sets per family:

- 75.8% 1
- 23.7% 2
- 0.5% 3

Kinds of sets owned:

- 56.2% Console
- 25.4% Table
- 9.3% Portable
- 9.1% Combination

Average hours used per day:

- 10.7% 0-2
- 50.8% 2-5
- 35.7% 5-10
- 2.8% Over 10

Sets under warranty: 15.5%

Sets under service contract: 10.7%

New Simpson "Add-A-Testers"

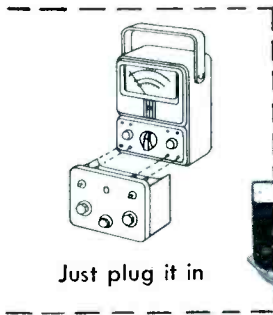

Converts your 260* into seven different testers!

Think of it! A small investment turns your 260 VOM into a whole array of testers—equipment with a quality that is found only in individual pieces of test equipment at much higher prices. The secret lies in combining an adapter with the *top-notch meter and circuitry* of your 260.

Each combination of Add-A-Tester unit and 260 is self-contained, self-powered. Each adapter goes on and off in a jiffy. No gadgets, no complicated connections. Furthermore, Add-A-Tester units require only 1/2 to 1/3 the storage space of individual testers. By reducing bench clutter, this compactness makes jobs go faster, raises shop efficiency. Make your 260 do double duty. Stop in at your Electronics Parts Distributor or write the factory for further information.

*Trademark

Simpson

ELECTRIC COMPANY

5209 West Kinzie Street • Chicago 44, Illinois
 Phone: EStebrook 9-1121
 In Canada: Bach-Simpson Ltd., London, Ontario

WORLD'S LARGEST MANUFACTURER OF ELECTRONIC TEST EQUIPMENT

TRANSISTOR TESTER, Model 650 \$26.95

Beta Ranges: 0-10, 0-50, 0-250, (F.S.)
 Beta Accuracy: $\pm 3\%$, with 260 $\pm 5\%$ nominal
 Ico Range: 0-100 μ a
 Ico Accuracy: $\pm 1\%$, with 260 $\pm 3\%$ (F.S.)

DC VTVM, Model 651 \$32.95

Voltage Ranges: 0-.5/1.0/2.5/5.0/10/25/50/100/250/500
 Accuracy: $\pm 1\%$, with 260 $\pm 3\%$ (F.S.)
 Input Impedance: greater than 10 megs all ranges

TEMPERATURE TESTER, Model 652 \$38.95

Temperature Ranges: -50°F to $+100^{\circ}\text{F}$, $+100^{\circ}\text{F}$ to $+250^{\circ}\text{F}$

Accuracy: with 260 $\pm 2^{\circ}$ (nominal)
 Three lead positions provided
 Sensing Element: thermistor

AC AMMETER, Model 653 \$18.95

Ranges: 0-0.25/1/2.5/12.5/25 amps
 Accuracy: $\pm 1\%$, with 260 $\pm 3\%$ nominal
 Frequency Range: 50 cycles to 3000 cycles

AUDIO WATTMETER, Model 654 \$18.95

Load Ranges: 4,8,16,600 ohms
 Wattage: Continuous 25 watts (8,600 ohms)
 50 watts (4,16 ohms)
 Intermittent 50 watts (8,600 ohms)
 100 watts (4,16 ohms)

MICROVOLT ATTENUATOR, Model 655 . \$18.95

Ranges: 2.5 microvolts to 250,000 microvolts
 continuously variable in decade steps
 Frequency: DC to 20 KC
 Accuracy: $\pm 1\text{db}$

BATTERY TESTER, Model 656 \$19.95

Checks all radio and hearing aid batteries up to 90 volts at the manufacturer's recommended load, or any external load.

Note: All Simpson 260 Adapters provide for normal 260 usage without disconnecting the adapter.



Dynamic! NEW ADVANCEMENT IN TV SERVICING

See the Latest,
Most Up-to-Date Method
of Servicing TV Horizontal
Sweep Troubles

The
Pioneer 250
HORIZONTAL SWEEP
QUANTALYST... by

DOSS



Only \$109⁰⁰ net

- ▲ FEATURES NEVER BEFORE OFFERED IN ANY INSTRUMENT
- ▲ TESTS THE ENTIRE SWEEP SYSTEM IN-CIRCUIT (RECEIVER ON)
- ▲ NO NEED FOR CHASSIS REMOVAL
- ▲ SIMPLY PLUG INTO DAMPER AND HORIZONTAL AMP. TUBE SOCKETS

Now BEING SHIPPED
TO YOUR DISTRIBUTOR

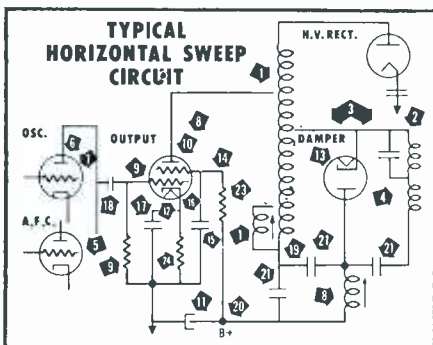

DYNAMIC IN-CIRCUIT TESTS . . . (RECEIVER ON)

- | | |
|--|--|
| 1. Flyback Transformer (Shorted Turns) | 10. Amplifier Gas Condition (Screen Re-emission) |
| 2. Yoke (Shorted Turns) | 11. Amplifier B+ Ripple |
| 3. Flyback-Yoke Match | 12. Amplifier Heater Voltage |
| 4. Yoke Inductance (mh) | 13. Damper Heater Voltage |
| 5. A.F.C. Sync. Range | 14. Amplifier Screen Voltage |
| 6. Oscillator Frequency (cps) | 15. Amplifier Cathode Condenser |
| 7. Oscillator A.C. Output | 16. Amplifier Cathode Voltage |
| 8. Amplifier Cathode Current | 17. Amplifier Cathode Condenser |
| 9. Amplifier Grid Condition | 18. Oscillator Coupling Condenser |
| | 19. Boost Voltage |
| | 20. B+ Voltage |

STATIC CIRCUIT TESTS (RECEIVER OFF)

- | | |
|--------------------------------|------------------------|
| 21. Boost to B+ Resistance | 23. Screen Resistance |
| 22. Boost to Common Resistance | 24. Cathode Resistance |

DOSS

Write DEPT. 8

ELECTRONIC RESEARCH, INC.

820 BALTIMORE • KANSAS CITY 5, MO.

For complete information including FREE Quantalyst Trouble-Shooting Chart—Please request Folder MP2

TIPS

for TECHS

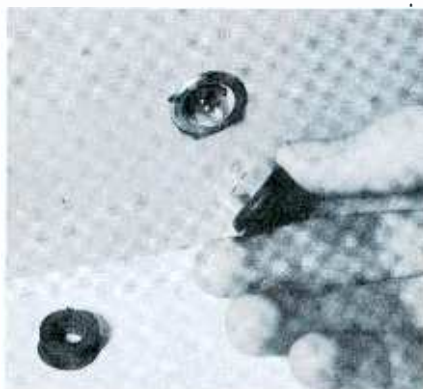

Grommet Removes Bulb Shield

Pilot lamp assemblies like the one shown have plastic screw-in bulb shields that are sometimes very difficult to remove. Should you have difficulty unscrewing one, you can get a better grip by slipping on a rubber grommet. Most pilot lamp wrenches won't fit the larger shields.

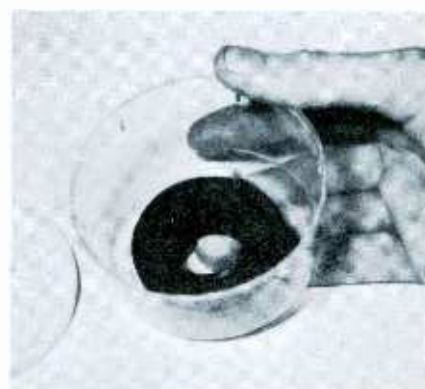

Container Preserves Tape

If a roll of friction or rubber tape is allowed to lay around in the open air, the adhesive will dry out and render the tape worthless. A plastic food container like the one shown makes a good airtight storage compartment that will keep your tape fresh for months.

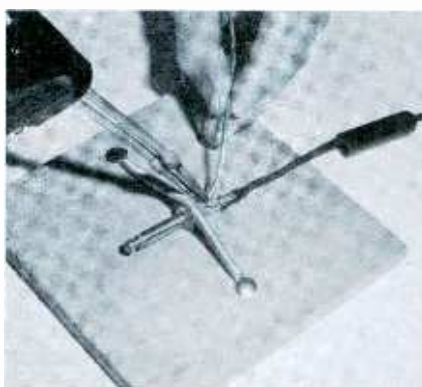

Soldering and Testing Block

A block of plywood with a length of spring tacked to it acts as a "third hand" on the bench. Small parts that have to be held for testing or soldering are slipped under the spring as shown. This soldering and testing block is almost as useful as the soldering gun or diagonal cutters.

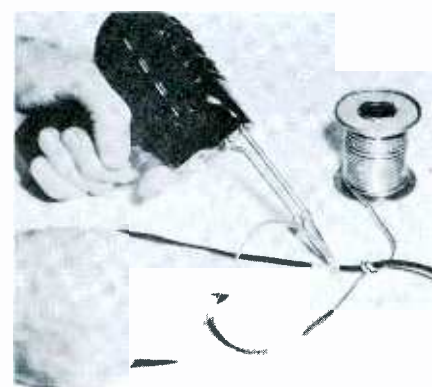

Solder Holds Wire

When you find it difficult (if not impossible) to hold a wire still while soldering or tinning it, wrap a loop of the solder around the wire and use it to hold the work as illustrated. This eliminates the need to clamp the work in a vise or to weight it down with tools.

Burned by Hot Tubes?

To avoid burning your wrist or hand on the hot bulb of a tube while trying to reach another one mounted nearby, carry along a spare tube puller in your kit and slip it down over any tube that may be in your way. If you don't happen to have a spare tube puller handy, an empty tube carton can be used.

Time-Saving Tool Stand

A clear glass tumbler makes a good holder for an assortment of alignment tools. You can see both ends of each tool and pick out the one needed at first glance. A moment or two saved on many such insignificant motions can, in time, result in more dollars in the pocket-book.

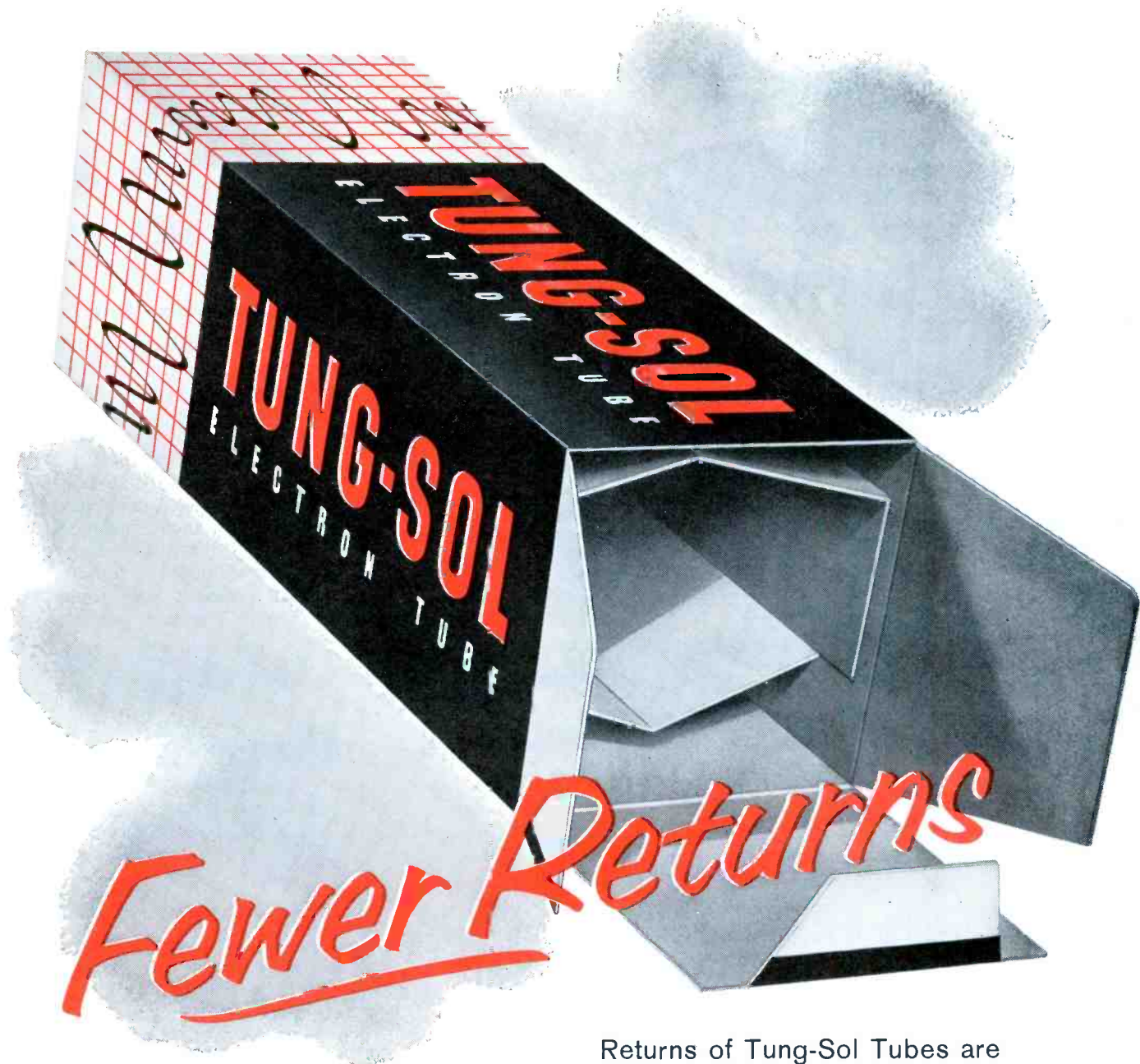

Returns of Tung-Sol Tubes are consistently lowest of all!

How about your returns?

It's no accident when servicemen the country over find that Tung-Sol Tubes consistently have the lowest return rate of all.

There's a reason for this outstanding record of performance and dependability: It's Tung-Sol *one-grade* quality. This one and *only one grade* of tubes is engineered to the highest initial equipment specifica-

tions. As a result—when you install Tung-Sol Tubes, you're installing the same type of tubes leading set makers have relied upon for a long time, too.

If call backs are costing you time, money and aggravation, it's probably time you told your distributor you'd rather have Tung-Sol Tubes. Tung-Sol Electric Inc. Newark 4, N. J.

 **TUNG-SOL[®]**

Blue Chip Quality

ELECTRON TUBES • SEMICONDUCTORS

August, 1959/PF REPORTER 59



built for **WET WEATHER!**

MARINE CORE
TWIN LEAD



— up to 93% less signal loss!

In moisture, salt spray or areas of heavy industrial contamination, AMPHENOL's new 214-103 Marine Core Twin Lead provides amazing low-loss performance. Measured signal loss of polyfoam Marine Core *submerged* is 20% less than other foam type lines, 25% less than tubular lines, and up to 93% less than standard twin leads. Marine Core gives vital signal protection where other twin leads fail!

Extremely flexible, Marine Core's performance secret is simple: Proper spacing ratios between conductors and between conductors and line surface, a discovery of AMPHENOL engineers.

A tough, brown virgin polyethylene jacket protects Marine Core's double self-sealing cores of polyfoam. Conductors are 7/28 pure copper for longer life. Availability: Coils of 50, 75 and 100 ft., put-ups of 500 and 1000 ft.

AMPHENOL

AMPHENOL DISTRIBUTOR DIVISION

Amphenol-Borg Electronics Corporation

BROADVIEW, ILLINOIS



Use for Solder "Splatters"

When you have a tiny soldering job, which requires that as little heat be applied to the work as possible (soldering transistors and such), try this: Splatter several drops of solder from the tip of your iron or gun onto an old newspaper. When the splatters cool, peel them off and place in a small container. You'll find these ultra-thin pieces of solder will melt much more rapidly than ordinary wire solder, and thus require less heat.

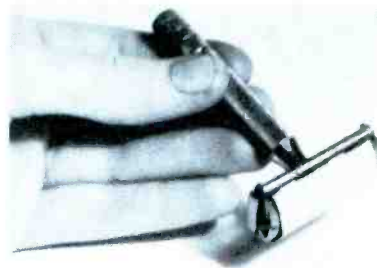

Razor as Touch-Up Sander

A safety razor makes a good touch-up sander for marred radio and TV cabinets. By inserting some sandpaper in the blade holder, the slightly rounded head of the razor makes it easy to taper off the blemish before applying touch-up enamel, shellac or varnish.

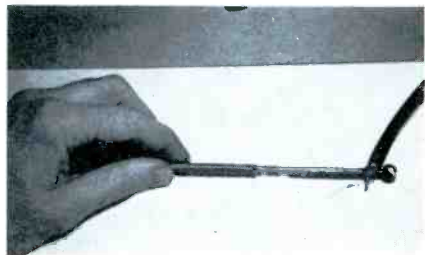

Wire-Stringing Needle

It's a cinch to string electrical, radio, TV or hi-fi wires and cables through walls and partitions when you use a round curtain rod as a "needle." The rods have a small eye at either end through which the wire can be easily threaded. Fully extended, they measure about a yard long.

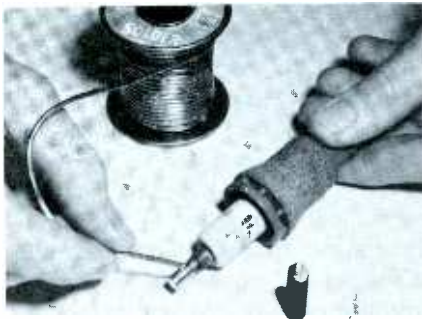

Soldering Pencil Maintenance

To keep a soldering pencil with interchangeable tip working at top efficiency, it's not only necessary to keep the tip cleaned and well tinned, but also the threaded heating-element shaft (see photo). This gives better heat conduction and also keeps the tip from "freezing" tightly in place. After the initial tinning, use only fine sandpaper or a wire brush on the heating element shaft. It is rather thin and will not withstand cleaning with a file.

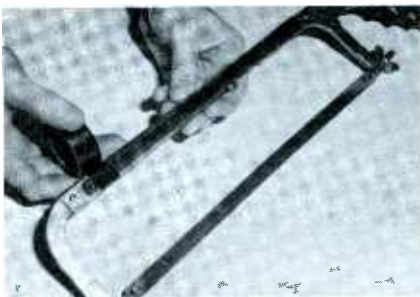

Carry Extra Saw Blades

Let a couple of extra blades ride piggy-back on the frame of your hacksaw. Then, if one breaks while you're cutting a mast or doing other work away from the shop, you can always replace it right on the spot. Use electrician's tape to bind the spare blades to the frame.

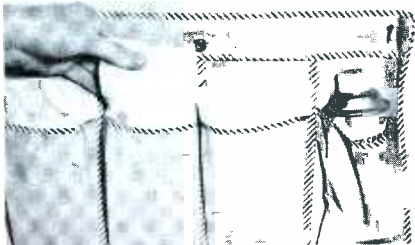

Shoe Bag Stores Cloths

Most service shops keep several clean cloths around for dusting, cleaning, etc. A shoe bag tacked to the shop wall makes a neat and handy storage place for these cloths. The bag can be cut to fit into any space you happen to have vacant, and the extra pockets can be used to hold cans of cleaning solvent.



"OFFHAND, MADAM, I'D SAY YOU
NEED A NEW NEEDLE"

Farfetched? Well, perhaps. But what a worn-out needle can do to fine discs — to say nothing of those expensive stereo platters — shouldn't happen to a dog. So be a No. 1 Hero — tell the uninformed the Webster Stereo-Ceramic cartridge not only plays the new stereos but standard LP's and 78's as well . . . plays them better than they've ever heard before. Recommend and install Websters every chance you get. They're satisfying — and profitable, too.



see it at your jobber —
NEW WEBSTER SERVICE CENTER

A new way to serve you better. Quick-reference replacement chart and display-stock case mean faster service, accurate replacement for nearly every phono cartridge.

ELECTRONICS DIVISION

WEBSTER ELECTRIC

our 55th year



RACINE · WIS

franklin adv. Y-136



QUICKER SERVICING

By Calvin C. Young, Jr.

Some Notes on Multivibrator Servicing

Even though the multivibrator-type oscillator is rather simple in operation, it can be quite troublesome at times. Take the experience I had with an Admiral 16RC1, for instance. In this set, a ringing coil is the only horizontal-frequency adjustment, and in order to synchronize the picture, the coil's adjustment slug had to be set at one end of its range. Even then, the picture had a tendency to tear and was unstable.

When oscillator tube and phase-detector diode substitution failed to cure the trouble, the chassis was taken to the shop. Because the picture would almost sync at the end setting of the frequency coil, I guessed that one of the components in the frequency-determining network (Fig. 1) had changed value. After checking the 47K-ohm resistor and finding it had the correct value, the 820-mmf capacitor was checked by substitution. This failed to improve operation, so the resistors in the plate and wave-shaping networks were checked. Failing to uncover any off-value units, I proceeded to check the 4700-mmf coupling capacitor to the output stage, and the

680-mmf sawtooth-forming capacitor by substitution. Again, this failed to cure the trouble. In desperation, the ringing coil and 3900-mmf capacitor were substituted — still no results.

Having failed to cure the trouble by guess and substitution, I came to my senses, sat down and put on the old thinking cap. A cathode-coupled multivibrator uses a combination of cathode and plate-to-grid coupling, and its frequency is mostly a function of the time required for the 820-mmf capacitor to discharge sufficiently to permit the second stage to conduct. The ringing-coil assembly is primarily a stabilizing network, and the circuit should operate even with the coil and capacitor shorted out—provided, of course, that all other components were within tolerance. At this point, I remembered that the input grid was essentially grounded for 15,750-cps signals, and that any correction voltage should vary around zero volts.

This thought process turned up a possible cause for the trouble not previously checked and eliminated, and the VTVM was now brought into play. A reading of several volts was obtained at the input grid of the multivibrator! The scope was now connected to this grid, with the result that a rather mean-looking signal—having both 60- and 15,750-cps components—appeared on the screen. Now, I was almost certain that the .047 bypass capacitor was open. As it so happened, replacement of this component cured the trouble.

As a final check on circuit balance, the ringing coil assembly was shorted out. As predicted, circuit operation was stable. This was conclusive proof that the circuit was operating on frequency.

Let this little tale save you the extra hour it took me to find a fairly simple trouble. For maximum efficiency in troubleshooting multivibrator circuits, proceed as follows: (1) Short out ringing coil and note effect. If picture flops to right, oscillator is too fast; If picture flops to left, oscillator is too slow. (2) Check signal and voltage at input of multivibrator. Presence of signal indicates an open capacitor; appreciable voltage indicates circuit unbalance. (3) Check value of all resistors, especially the grid- and plate-load units. Replace any out of tolerance. (4) Check value of coupling capacitor between stages of the oscillator. If no tester is available, substitute with a duplicate (value and type) of the original. (5) Check value or substitute capacitors in coupling and wave-forming networks.

This system of testing presupposes that you have isolated the trouble to the oscillator and have eliminated the phase detector as a possible cause.

Horizontal Sync Stability

Small defects are often more difficult to locate and cure than large ones, I realized the other day after encountering a set using the circuit shown in Fig. 2. The customer complained that the picture shimmied and shook all over. When the initial home call substantiated this complaint, tubes were substituted in the tuner, video IF, video amplifier, AGC and sync circuits. In addition, the horizontal oscillator was also checked. When this failed to produce a cure, the chassis was pulled and taken to the shop. I fully ex-

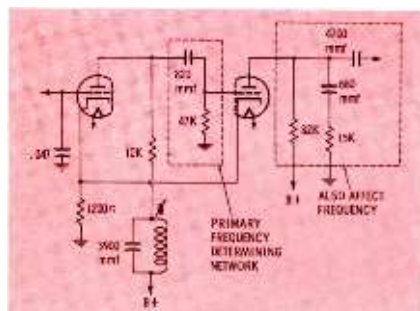

Fig. 1. Components that affect frequency in a basic horizontal multivibrator:

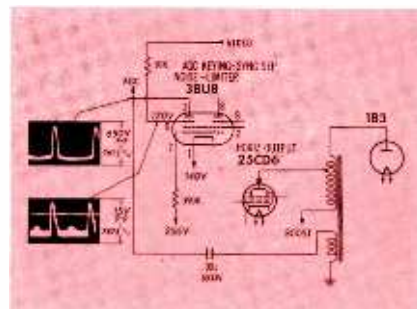

Fig. 2. AGC keyer failed to operate normally due to delayed plate pulse.

WIN everything in this picture

JUST BY ESTIMATING WHAT IT'S WORTH!



*It's still
not too late
to enter the
fabulous
Westinghouse*

GIANT JACKPOT CONTEST

You can win absolutely everything shown in this picture, simply by estimating its total retail value. The closest estimate will win it all! Enter now! Enter often! Still 2 more Giant Jackpot pictures to go!

Never before a contest so easy to enter...so easy to win! Don't miss this opportunity to win a whole truckload of valuable prizes! Final contest closes in four weeks. You can enter the two remaining contests as often as you like...win from hundreds of other prizes if you miss the top award!

Just 3 easy steps to enter...

1. Ask your Westinghouse distributor for a supply of official entry forms...several for each contest you want to enter.
2. Estimate the total dollars-and-cents retail value (exclusive of local sales and Federal excise taxes) of all the items shown and described in the picture for the contest you are entering. You'll receive an information leaflet with your entry blanks which shows photographs of all four Giant Jackpots.
3. Write your estimate on the Entry Form and mail along with the end panel from a Westinghouse 5-pak tray which reads "Westinghouse Electronic Tubes" or a reasonable facsimile to: "Jackpot," Westinghouse Electric Corp., Box 367, New York 46, New York.

That's all there is to it...Just look what you can still win!

2 first prizes: "Winner Take All"—everything shown in a Giant Jackpot picture.

2 second prizes: Your choice of Westinghouse Refrigerator, Freezer, Laundromat, Dryer, Two Different Ranges, Room Air Conditioner, Stereo-Fidelity.

2 third prizes: Your choice of Westinghouse Refrigerator, Freezer, Dryer, Range, Air Conditioner.

24 fourth prizes: Your choice of two Westinghouse Immerse-A-Matic appliances with a control unit.

50 fifth prizes: Your choice of Westinghouse Spoutless Coffee Maker or Portable Mixer.

120 runner-up prizes: Westinghouse Dog-O-Matic Hot Dog Cooker.

THIRD CONTEST STARTS AUGUST 31, 1959! GET ENTRY BLANKS AND OFFICIAL RULES FROM YOUR WESTINGHOUSE DISTRIBUTOR!

YOU CAN BE SURE...IF IT'S **Westinghouse**
Electronic Tube Division Elmira, N.Y.

If your distributor does not handle Westinghouse tubes send his name and address to Westinghouse, Box 284, Elmira, New York. Don't miss this big opportunity!

PROFESSIONAL
technicians
use
Dave Rice's
OFFICIAL
ORDER BOOKS
for every
TV-RADIO
service
call



This is the businesslike approach to service record keeping. Triplicate forms serve as order form, invoice and office record, with spaces for complete information on every job. Separate listings for receiving tubes, pix tube, parts, serial numbers, labor and tax charges, signatures, etc. 75c a book, \$6.50 for dust-proof box of 10. In stock at your distributor.

Write for your free folder describing Dave Rice's OFFICIAL ORDER BOOKS, including an actual size sample copy of the handy order form.

For customer's prices on every replacement part, plus flat rate and hourly service charge data, regional and national, Dave Rice's OFFICIAL PRICING DIGEST, listing over 63,000 items. \$2.50.

ELECTRONIC
PUBLISHING CO., INC.
180 N. WACKER DRIVE
CHICAGO 6, ILLINOIS

NOW,
THE DYNAMIC
PORTABLE TUBE
TESTER THAT DOES
EVERYTHING



New V1003 tests 99% of all radio and TV tubes plus transistors and portable radio batteries!

No other tester like it at any price. Not only helps you do better, faster TV-radio servicing, but sells more tubes. Also checks all transistors and portable batteries under load (a Vis-U-All exclusive). Does all this with just 6 sockets, 3 knobs... simplicity unequalled! New and practical features galore!

ONLY \$129.00

Write
for
Details

VIS-U-ALL
PRODUCTS CO.
640 EASTERN, S. E.
GRAND RAPIDS 6,
MICHIGAN

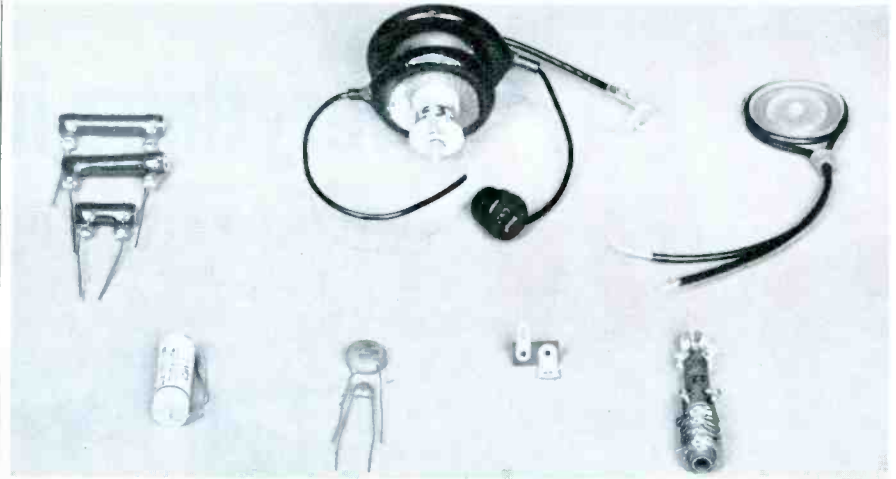

Fig. 3. Triad kit cures width and 6CD6 troubles in KCS68 and KCS81 sets.

pected to find that one of the AGC filter capacitors had opened up; however, as luck would have it, they all checked good. The next step was to check the 3BU8 circuit both for correct signals and voltages; all were normal. Because the set employed an AGC keying circuit (and this can be very troublesome at times), it was next on the list. Using a variable bias supply, the AGC line was clamped. This eliminated the shimmy, so I knew the AGC network was at fault—but where?

Since all the tubes in the tuner and video circuits that could affect AGC operation had already been replaced, and the voltages and signals at the keyer stage seemed normal, everything should be working fine—but it wasn't. There was only one thing that hadn't been checked—namely, the timing of the plate and grid pulses to the AGC keyer. I then reasoned that if the pulse to the plate of the keyer was either early or late due to a defect between the horizontal oscillator and AGC

stage, the AGC output voltage would be low and sync trouble could result.

Since the horizontal-output tube hadn't been replaced and I remembered past AGC troubles being caused by gassy output tubes, the 25CD6 was replaced. The trouble was cured at last. Simple — but tough to find. Be on guard.

Sweep Trouble in RCA KCS-68 and KCS-81 Chassis

These direct-drive type horizontal-output circuits have been a real thorn in the side of most servicemen. The most frequent complaint is that the 6CD6 output tubes last only a very short time. If you've had one of these babies in the shop and have taken the time to measure tube currents, the reason for the rapid tube failure is no secret to you. 160 ma of cathode current just isn't conducive to long tube life. If you have followed the normal path and substituted every component in the circuit, including the flyback and yoke,

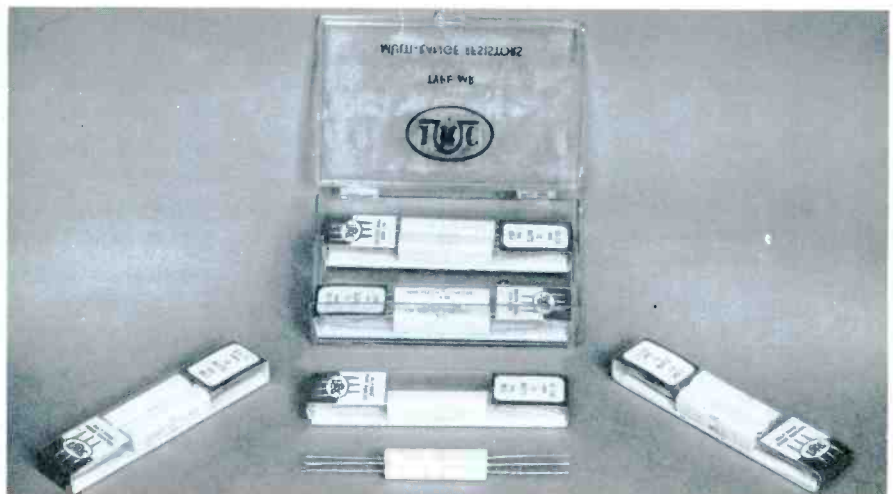

Fig. 4. IRC's 10-unit, 10-watt resistor kit replaces 203 values up to 50K.

without affecting the current to any great extent, you will at once appreciate the job Triad has done in developing their D-153 kit (Fig. 3) to cure these problems. The kit contains a new improved flyback, a new heavy-duty linearity coil, a new filament winding for the 1B3, three wire-wound resistors, three capacitors, and instructions for installation. In addition, there are complete instructions on how to adjust the new circuit for optimum width with minimum circuit current — about 100 to 110 ma with the modified circuit.

Power Resistors

If the high cost of maintaining a complete stock of power resistors has prevented you from stocking all of the standard values you might conceivably need, you will be interested to learn that IRC's type "MR" kit (Fig. 4) will enable you to replace any 10-watt resistor between .5 ohm and 50,000 ohms. This kit, with only 10 units (two of each of the five different types, permits two resistors within each range to be replaced. For example, the MR-1 unit has resistance values of 1, 2, 4, and 8 ohms, permitting resistors with values between .5 and 15 ohms to be duplicated. The MR-2 has sections with values of 10, 20, 40, and 80 ohms, permitting resistors with values between 5 and 150 ohms to be replaced. MR-3 has sections with values of 100, 200, 400, and 800 ohms to duplicate resistors with values between 50 and 1500 ohms. MR-4 has sections with values of 1,000, 2,000, 4,000, and 8,000 ohms to duplicate resistors with values between 500 and 15,000 ohms. The MR-5 unit has two sections of 10K ohms each and two sections of 15K ohms each to substitute for resistors between 3K and 50K ohms. Instructions packed with the kit tells how to duplicate 203 values within 10% tolerance. Types MR-1 through MR-4 will duplicate 47 values each and type MR-5, 15 values. In case you are wondering about size, each unit is about 1 7/8" long by 1/2" square. The eight leads (two for each section of each unit) are 1 1/2" long.

This handy kit should save you many unnecessary trips to the distributor, and thereby increase your productive (money-making) time. ▲

THERE'S GOLD IN THIS C-D TREASURE CHEST

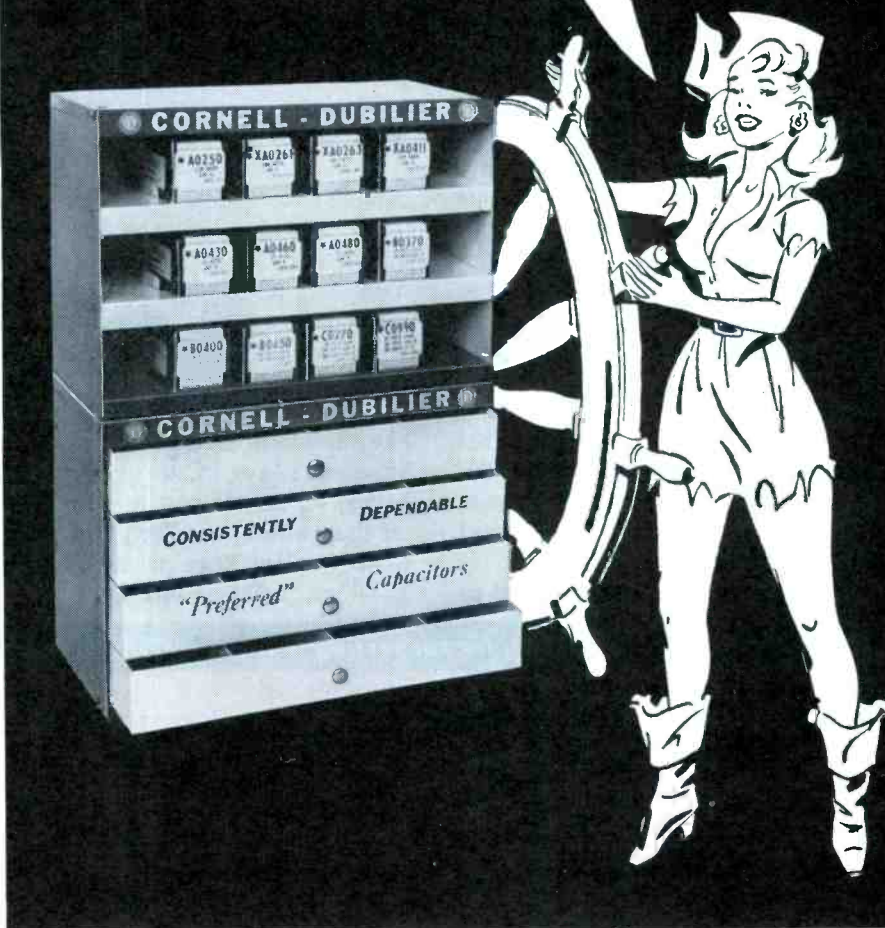

The modern way to stock and sell the world's most wanted capacitors. This efficient shop-chest tells you what's in stock and exactly where it is. No more digging for misplaced units. You get an assortment of the most popular C-D "Preferred" type twist-prongs, "Blue Beavers," and Mylar Tubulars—in handsome metal cabinets. Makes you look more efficient...makes work efficient! Best of all they're FREE with your purchase of capacitors.

See the "Treasure Chest" at your C-D distributor or write for Bulletins to Cornell-Dubilier Electric Corporation, South Plainfield, N. J.



Consistently Dependable
CORNELL-DUBILIER
SERVICE CAPACITORS

db

understanding

THE DECIBEL

Here's your chance to tame this tricky maverick and make it work for you—by Jack Beever

In the course of talking to thousands of servicemen across the country, I ran across an astoundingly prevalent blank spot in their otherwise complex body of knowledge. This blank spot, which leaves them unable to properly evaluate the characteristics of many pieces of apparatus, is a lack of understanding of the decibel—what it is, and why it's used.

Just think of the many items having characteristics described in terms of decibels. Specifications for amplifiers, antennas, transmission lines, microphones, attenuators, speakers, speaker enclosures, TV set couplers, tap-off units, phono pickups, tape recorders, response curves, trap attenuations, cross-over networks, and hum levels usually include decibel measurements. If knowledge of the decibel is one of your working tools, you can interpret these ratings and be guided accordingly.

The decibel (db) may be used to

measure voltage, current, or power. This article will concentrate on *voltage* db measurements, which are of greatest concern to the serviceman; but once you understand how to express voltage in terms of decibels, you'll find it easy to figure out what's meant by db of current or power.

The most important thing to remember about decibel numbers is that they don't follow the rules of ordinary arithmetic. For example, 46 db is twice as great as 40 db, and 52 db is twice greater than 46 db! You see, a db figure doesn't say merely "how much" or "how many" (like the "10" in 10 dollars); instead, it says "how much *more*." Thus, it implies a comparison, just like the word "better." When a TV announcer says, "Our product tastes better," it makes you wonder "Better than what?" Similarly, the figure 6 db implies "two times as great as—" or "twice as much."

Another odd thing about the db is its nonlinear nature. Look at these examples:

6 db = 2x	20 db = 10x
10 db = 3.16x	30 db = 31.62x
12 db = 4x	40 db = 100x
18 db = 8x	60 db = 1000x

The expression "plus 10 db" means "multiplied by approximately 3." If the db figure is made twice as great (20), is the multiplication factor doubled? No! According to the table, it is more than tripled—from 3.16 to 10. Another doubling of the db figure, from 20 to 40, produces a tenfold increase in the multiplication factor, from 10 to 100. This strange behavior results from the way the db is derived. Although decibels are a little hard to comprehend at first, they greatly simplify all kinds of gain and loss calculations; thus, it's to your advantage to follow the reasoning behind the db. We'll start with the formula, but don't let it scare you. If you've read

Graph for converting voltage-ratio figures to db equivalents.



this far, you know enough to follow it through:

$$db = 20 \log_{10} \frac{E1}{E2}$$

Expressing it in English, the formula goes like this: The db is equal to twenty times the common logarithm (to the base 10) of the major (larger) voltage divided by the minor (smaller) voltage. Solving it goes like this: Suppose we have an amplifier with equal input and output impedances, and we want to find its voltage gain in db. The output voltage, which is larger than the input, will be the "major" voltage. Let's substitute some typical numerical values for E1 and E2 in the formula. If the output voltage is 100 and the input 10, then $100/10 = 10$, and the formula is reduced to:

$$db = 20 \log_{10} 10.$$

Now we have to find the common logarithm of 10. This is what handicaps most TV technicians in trying to understand the decibel; they usually forget their logarithms soon after leaving school. Well, we only need a single fundamental principle anyway, so let's go on. The common log, or logarithm to the base 10, is a figure which may be written as an exponent—a little number located above and to the right of another number. (An example is the figure 2 in the expression 10^2 .) The exponent indicates that the associated number is being "raised to a certain power—i.e., multiplied by itself a certain number of times. You're probably familiar with whole-number exponents such as "squares" and "cubes":

$$10^2 = 10 \times 10 = 100;$$

$$10^3 = 10 \times 10 \times 10 = 1,000.$$

The idea behind logarithms is that you can express any number in terms of "10 raised to a certain power." In other words, 10 multiplied by itself a certain number of times will equal the desired number. The numerical examples in the preceding paragraph contained logarithms! The exponent 2 is the log of 100 because $10^2 = 100$; likewise, 3 is the log of 1,000. Other numbers can be expressed logarithmically by using *fractional* exponents:

$$10^{2.5328} = 341; \text{ therefore,}$$

$$\log_{10} 341 = 2.5328.$$

In our particular problem, we have to find $\log_{10} 10$, or the exponent by which the base 10 must be multiplied to get the number 10.



for
the
BEST
in
SERVICE



USE AEROVOX CERAMIC CAPACITORS!

If you're particular about your service... be particular about the capacitors you use. Aerovox offers you a complete line of rugged, dependable and versatile ceramic capacitors in every case style for every replacement application. Choose from a wide selection of disk types in bypass-coupling, general purpose, hi-voltage and temperature compensating. Three tubular types are available from general purpose to temperature compensating to hi-voltage units. For those special applications you have cartwheels, standoffs and feedthrus in all sizes and values. Your local Aerovox Distributor is your one-stop source of supply. Call on him today for any and all your capacitor needs. Ask him for your personal copy of the latest Aerovox Servicemen's Catalog.

BUY 'EM BY THE KIT...

two disk ceramic kits (AK-200 and AK-201HS) of popular replacement types in special 3 x 5 metal file drawers now available at your Aerovox Distributor. Pay for only the capacitors and get the file cabinet FREE.



AEROVOX CORPORATION

DISTRIBUTOR DIVISION

NEW BEDFORD, MASSACHUSETTS

Mr. SERVICEMAN
You make more profits on
Stereo pickups with
PICKERING'S NEW Program!

Think of it!...you can make 100% or more in profit on Stereo conversions and installation of Stereo pickups for replacement!



Get into the profitable stereo high fidelity business where experienced and quality conscious technicians are needed. Pickering's NEW program makes it possible for you to buy the STANTON Stereo FLUXVALVE and the STANTON Stereo KableKit from your wholesaler so you make your full markup in addition to your service charges. Call your wholesale jobber today and take full advantage of this profitable business.

EVERYTHING YOU NEED FOR STEREO CONVERSION!

STANTON STEREO KableKits

FOR CONVERTING CHANGERS



FOR CONVERTING MANUAL TONE ARMS

NEW! Low cost stereo cable assembly for converting automatic changers and manual tone arms. Prefabricated insulated and fully shielded harness assembly with all plugs and connector clips soldered... ready for instant installation! No soldering required for normal installation. Harness length 4 feet, comes complete with cable retention clips.

Model 603 Stereo KableKit for three wire systems...\$2.98

Model 604 Stereo KableKit for four wire systems...\$3.98

ASK FOR PICKERING AT YOUR JOBBER... EASIER TO SELL AND INSTALL.

FREE! Pickering Service-File, complete technical file on quality products by Pickering. Includes valuable bulletins on hum elimination, installation, maintenance, etc.

Address Dept. T89 for your free Service-File.



"For those who can hear the difference" FINE QUALITY HIGH FIDELITY PRODUCTS BY
PICKERING & COMPANY, INC., Plainview, N. Y.



Only Motorola
Torture
Tests
to Twice
Maximum
Ratings

Unique electronic testing device "works over" every Golden "M" Tube, assures 100% reliability

MOTOVAC, the Motorola-created electronic brain, torture-tests Golden "M" Tubes to specifications that are the highest in the entertainment-type tube industry.

Result? The most reliable tubes you can buy! The kind that give you far lower "in-use" and "shelf-defective" rates than ever before.

*TRADEMARK OF MOTOROLA, INC.



MOTOROLA



Parts and Accessories Division, Franklin Park, Illinois

This one's easy—it equals 1. The formula now looks like this:

$$db = 20 \times 1, \text{ and } db (\text{gain}) = 20.$$

We have found that the amplifier's gain is 20 db. Of course, if we had obtained a fractional number like 18.5 when we divided E1 by E2, we'd need a log table to find the common log of 18.5. Since log tables are somewhat cumbersome to use, you may find the conversion graph given above a welcome device. To use the graph, merely divide the major voltage by the minor voltage. Then locate the corresponding number on the bottom of the chart, follow straight up until you intersect the heavy diagonal line, and look to the right edge of the chart for the db figure.

One of the most puzzling things about the db is zero db. Zero db isn't "nothing"—it's the same as saying "there's a relationship of one to one." In other words, no gain and no loss. It works out like this, and we can use the amplifier we had before, but now we find the input is 10 volts and the output 10 volts. Thus,

$$db = 20 \log_{10} \frac{E1}{E2}$$

$$= 20 \log_{10} \frac{10}{10}$$

$$= 20 \log_{10} 1.$$

The question now is, "What exponent will raise 1 to 10?" This is a funny one, the logic of which has escaped mathematicians. They only know it works like this:

$$10^2 = 100$$

$$10^1 = 10$$

$$10^0 = 1$$

$$10^{-1} = 0.1$$

We can see the sense behind the first, second and fourth expressions, but the third makes sense only because it fits and works. Let's put it into the formula:

$$db = 20 \times 0; \text{ therefore, the amplifier's gain is zero db.}$$

What we've been leading up to is this: When we say 6 db, we are referring to a figure which is twice as great as zero db. This naturally brings up the question, "What's zero db?" The answer: Zero db is anything you choose to make it! In audio, committees of engineers have agreed upon a standard value. In TV, zero db is assigned various values according to the particular application. In dealing with the antenna signal, for instance, we could

use 1,000 microvolts measured across 75 ohms of impedance.

No matter how good your intentions, the graph for db conversion won't always be handy; but there's a trick which will let you get a quick mental approximation of the ratio represented by almost any decibel number.

The trick is based on the fact that when you add db numbers together, you are actually multiplying, just as you do when you add exponents of 10. For example, 10^2 times $10^2 = 10^{2+2} = 10^4$ or 10,000. Similarly, if you subtract db numbers, you are dividing; as in 10^6 divided by $10^2 = 10^{6-2}$ or 10^4 . Following this reasoning through, you need not know the values of all db numbers to be able to derive their values.

If you will commit to memory a few basic ones which can be added together to make the db number you need to know, you can find the gain (or loss) factor by multiplying the ratios of the known numbers.

Let's suppose you've memorized these three values (\cong means "approximately equal to"):

$$\begin{aligned} 3 \text{ db} &\cong 1.4 \times \\ 6 \text{ db} &\cong 2 \times \\ 20 \text{ db} &\cong 10 \times \end{aligned}$$

Now, if you're asked what ratio is represented by 26 db, you can quickly figure that 26 equals $20 + 6$. If 20 is ten times and 6 is two times, then 26 db equals 10×2 or 20 times. Similarly, suppose you need the ratio represented by 18 db. This is $6 + 6 + 6$, and therefore means $2 \times 2 \times 2$ or 8 times. Another one is 9 db, which would be $6 + 3$ or 2×1.4 , the equivalent of 2.8 times. Naturally, the more of these basic ratios you know, the quicker you can arrive at the ratio for a given number—and believe me, it does tend to make you look awfully intelligent. Imagine working out logarithms *mentally*! If you learn just those few used as examples in this article, you'll have it whipped. First thing you know, you'll be talking like a telephone engineer.

The only important phase we haven't discussed so far is decibels of loss. The difference here is that when talking of loss, we divide by the ratio instead of multiply.

Remember one thing more—if you know the uses and interpretation of the db, it can stand for (d)ollar (b)ills in your pocket! ▲

JERROLD

PLUG-IN ANTENNA OUTLETS

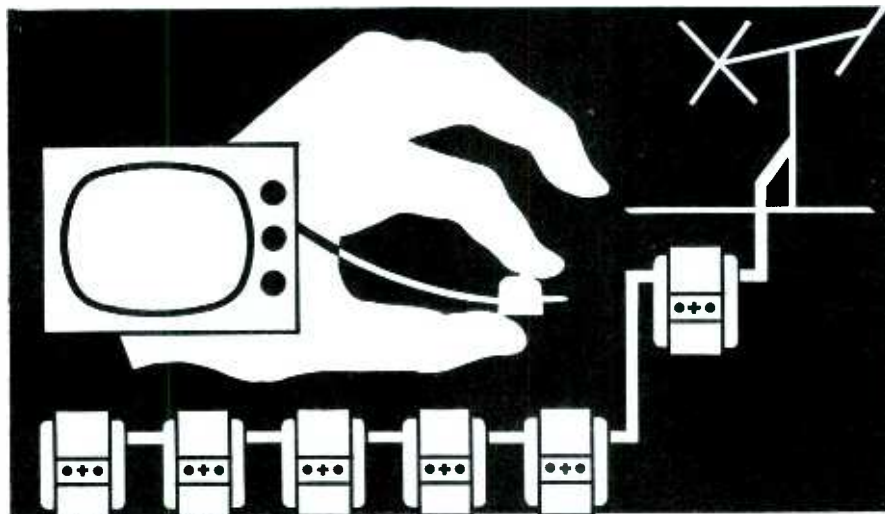

The New Plug-In TV and FM Outlet With a Built-In "Isolation Network"

JERROLD'S new PLUG-INtenna Outlet is the only TV-FM outlet that combines a "tap-off" ... and a plug-in receptacle ... in a single unit! Each PLUG-INtenna Outlet has a built-in isolation network that provides 20 db isolation between receivers ... allows outlets to be used with 1 or many TV or FM receivers!



AS A TAP-OFF UNIT
AND A PLUG-IN
RECEPTACLE!



AS A PLUG-IN
RECEPTACLE!

EASIEST INSTALLATION FOR FLUSH OR SURFACE MOUNTING!

Quick-connecting JERROLD PLUG-INtenna Outlets with Serrated Washers require no wire stripping ... no soldering ... prevent connection breakage!

FOR BETTER RECEPTION ON ONE OR MANY RECEIVERS:

1. In strong signal areas with outside antenna, use PLUG-INtenna Outlets alone.
2. In strong areas with attic antenna, use PLUG-INtenna Outlets with Jerrold Model HSA-46 Amplifier.
3. In semi-fringe or fringe areas with outside antenna, use outlets with Jerrold Model HSA-46 Amplifier.



**SURFACE MOUNTING
OUTLET HS-135**
complete with plug
\$1.95 and hard-
LIST ware.



**FLUSH MOUNTING
OUTLET HS-140**
complete with plug
\$2.45 and hard-
LIST ware.



THE PERMA-GRIP PLUG
attaches to lead with-
out stripping or solder-
ing ... cannot be plug-
ged into AC outlets!

JERROLD

For PLUG-INtenna Applications, Write for Jerrold Technical Reporter
ELECTRONICS CORPORATION
Distributor Sales Division

Dept. PD171, The Jerrold Building • Philadelphia 32, Pa.

Jerrold Electronics Corp., Ltd., Toronto, Canada

Export Representative, CBS International, N.Y. 22, N.Y.

LOOK TO JERROLD FOR AIDS TO BETTER TELEVIEWING

across the

BENCH

by Stan Prentiss

Making Use of the DC Oscilloscope

For the past several months I've been promising more information on DC oscilloscope amplifiers and how to use them. So here it is!

The abbreviation "DC" means direct current—with no transformers or capacitors for signal coupling. The blocking capacitor in the input is short-circuited, and the plate of the first amplifier is connected directly to the grid of the second amplifier. Therefore, the DC component of the signal (down to zero cps) can be amplified along with the incoming AC signal.

Now, what does this suggest? Isn't what you really have a *visual* AC-DC voltmeter? One of the most valuable assets of a DC oscilloscope is that you may read the value of, and "see" both the signal and the DC voltage at the same time. This tells you whether or not your DC voltages are correct, and simultaneously shows you what is happening as the broadcast signal is amplified,

detected, and separated for its eventual application to the deflection and video reproduction circuits. If your scope has been calibrated to show the AC signal in terms of peak-to-peak voltage values, you may obtain all troubleshooting information at one point with a single glance at the scope. With a little practice, this will make your job much easier.

Calibrating and Adjusting the Scope

If your scope sweeps linearly for at least 4" in the vertical plane (usually the height of the screen graticule on a 5" tube face), you're all set to do a thorough job of finding faults in television receivers or any other electronic equipment. Be sure, however, to use a low-capacitance probe beyond the video detector for isolation between the circuit you're investigating and the oscilloscope. My own scope is calibrated so that, with the vertical gain

control wide open and a 10-to-1 LC probe in use, true peak-to-peak voltages are read at any convenient setting of the vertical step attenuator switch—i.e., voltages between 0 and 1 are read on the x1 step, voltages between 1 and 10 are read on the x10 step, voltages between 10 and 100 are read on the x100 step and voltages over 100 on the x1000 step. Removal of the 10-to-1 probe affects amplitude readings only in that the decimal point is moved one place to the right. You do, however, have to watch your step attenuator setting since excessive potentials applied to the usual service-type oscilloscope, even through the low-capacitance probe, will cause waveform clipping if the attenuator switch isn't set at a reasonable level.

DC amplifiers have only one particularly undesirable tendency, and that is *drift*. This drift is caused by the fact that vacuum-tube characteristics, B+ and bias voltages, and values of circuit components are subject to change. A fraction of a volt change in the input of DC amplifier is magnified to several volts change at the plate. In a scope, the operating point of the last amplifier can be shifted enough to throw the trace quite far away from the center of the CRT screen.

For this reason, scopes must have some sort of compensating control adjustment. Because it must produce no phase shift, this control (usually called a *balance control*) has to be a resistance. In the typical circuit shown in Fig. 1, balance control R16 proportions the plate volt-

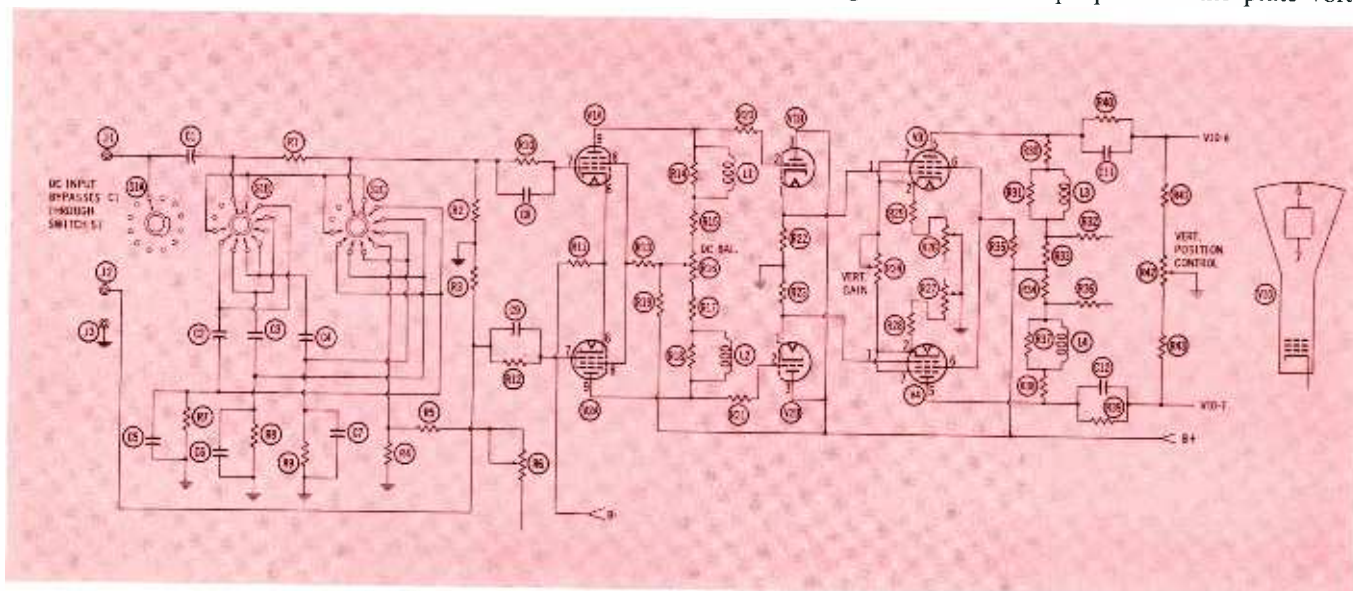

Fig. 1. Direct-coupled vertical-amplifier circuit used in an oscilloscope.

ages of the input push-pull amplifier V1.

DC Amplifier Circuit Description

The push-pull input feeds cathode followers V1B and V2B. Incoming signals are developed across identical cathode resistors R22 and R23 and fed to the grids of the output amplifiers. The plate outputs of V3 and V4 go to pins 6 and 7 of the CRT via frequency-compensating networks that include R40, C11, R31, and L3 in the V3 stage, and R39, C12, R37, and L4 in the V4 stage. The cathodes of V3 and V4 are connected to potentiometer R24, which is the vertical-gain control, and also to large, 2-watt current-limiting resistors to a ground path through bias potentiometers R26 and R27. These potentiometers must be adjusted so that there is between 1 and 2 volts of bias between the cathode and grid of each tube. The input of the oscilloscope is then short-circuited, and balance control R16 (between the plates of V1A and V2A) is adjusted to eliminate all up and down movement of the horizontal scan line. Beam trace will then remain in the center of the CRT when the vertical-gain control is rotated.

DC Amplifier Applications

Let's take a popular RCA KCS82 chassis and check its sync circuits using a DC scope at the more critical points. As you can see from the schematic in Fig. 2, the sync signal is taken from the plate of V7 and DC-coupled to the grid of the horizontal-sync separator. The same signal is also coupled to the grid of V6, the vertical-sync separator. Note that with DC coupling to V8, the grid voltage (even without the incoming AC signal added) measures 110 volts.

Now look at the grid waveform of the horizontal-sync separator (upper one in Fig. 3). It was taken with a horizontal scope sweep of 7,875 cps, and is approximately midway across the first major grid line above the center line or zero-reference level. With the scope calibrated and the vertical attenuator in the x100 position, we know that the DC level is about 100 volts (each minor division equals 20 volts), and that the waveform is riding mostly below this level. How-

You can now **guarantee** reliability if you join Pyramid's

GOLD RUSH

BURTON BROWNE/New York



Pyramid's New "Gold Standard" $\pm 10\%$ Mylar® Capacitors

Imagine, capacitors that "absolutely guarantee reliability"! Pyramid's new "Gold Standard" capacitors, designed to give a critical tolerance of $\pm 10\%$ with non-hygroscopic Mylar dielectric, plus high resistance to moisture and high insulation resistance. Standard capacity values! Standard voltage ratings! Standard tolerance of $\pm 10\%$! Previously made only on special order and at premium prices, new "Gold Standard" capacitors are now available to servicemen at a price competitive with ordinary paper capacitors.

For reliability assurance, insist on Pyramid "Gold Standard" capacitors from your distributor. Catalog available.



PYRAMID

Pyramid Electric Company, North Bergen, N.J.



An
exclusive
service
by

Amperex®
distributors:

VALVO RECEIVING TUBES

for replacement in
European radios

Many European radios and hi-fi components now popular in this country utilize the European-made VALVO tubes, which have thus far had no American distribution. As a special service to the trade, VALVO tubes are now being stocked by all franchised Amperex distributors. Replacement of the original tubes with completely identical types will assure optimum results in the repair and servicing of these European sets.



ask **Amperex**
for the name and address
of your nearest distributor

Amperex Electronic Corp.
230 Duffy Avenue Hicksville, L. I., N. Y.

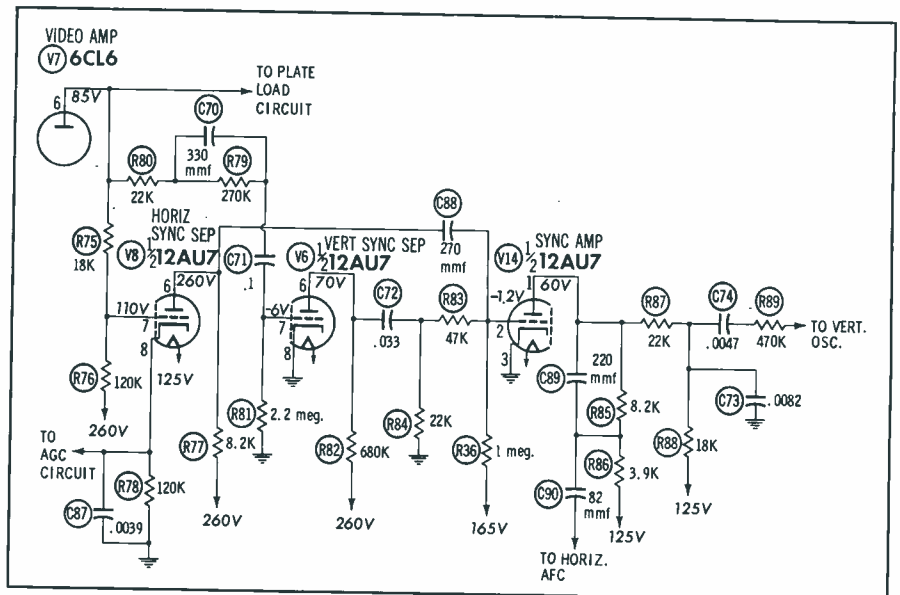

Fig. 2. A DC scope may be used to advantage in checking these RCA sync circuits.

ever, its peak approaches the 120-volt DC level. On the other hand, the signal at the grid of the vertical-sync separator, where all DC voltage is blocked, varies around the -6 volt level as shown in the lower waveform in Fig. 3 (taken with a 30-cps scope sweep). Under this condition, video information falls between the minus 50 and 90 volt levels, and the vertical-sync separator will pass only the sync pulses seen in the upper portion of the waveform. Referring again to Fig. 2, notice that DC cathode voltage of the horizontal-sync separator is 125 volts. The grid is, therefore, negative by 15 volts with respect to the cathode, and again, just as in the case of the vertical-sync separator, only the sync information above a certain level—about 100 volts in this instance—will be amplified and passed on to the sync amplifier.

Grid voltage for sync amplifier V14 is a combined result of grid conduction and the B+ divider hookup of R36, R83, and R84. The composite signal of the vertical and horizontal sync-separator outputs appears at the grid of the sync amplifier as shown in Fig. 4 (30-cps sweep rate at top, 7,875 at bottom). Notice that even though V14 is cal-

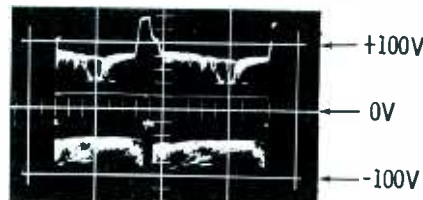

Fig. 3. Waveforms appearing at the sync-separator grids shows DC levels.

ed a sync amplifier, there is little gain afforded by this stage.

The composite sync signal at the plate of V14 travels in two directions. It is acted upon by the integrating network (R87, R88, R89, C73, and C74), and goes to the grid of the vertical multivibrator, the other half of V14. The integrating network filters and shapes it into a positive-going spike that will trigger the vertical multivibrator at the field rate of 60 cycles per second. The composite signal is also differentiated and filtered for use at the grid of the horizontal-AFC circuit in combination with the sawtooth feedback from the horizontal oscillator.

Between C89 and C90, the sync signal viewed at half the frame rate looks like the upper waveform in Fig. 5. The lower waveform in the same figure is the combined oscillator feedback and horizontal sync signal with a scope sweep of 7,875 cps. Observe that the upper waveform rides at 100 volts DC, whereas the positive peak of the lower waveform is at approximately -10 volts.

Skull Practice

As we said in the beginning, the DC oscilloscope is really an optical

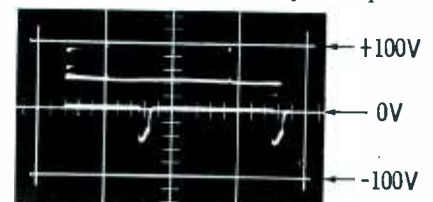

Fig. 4. Sync-amplifier plate and grid waveforms showing relative DC levels.

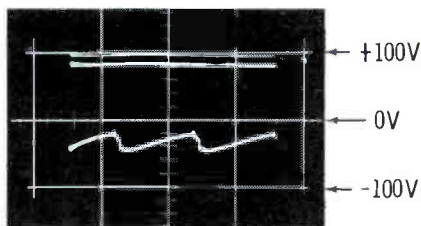

Fig. 5. Waveforms at junction of C89 and C90 and at grid of horizontal AFC.

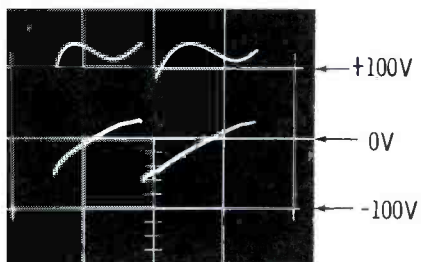
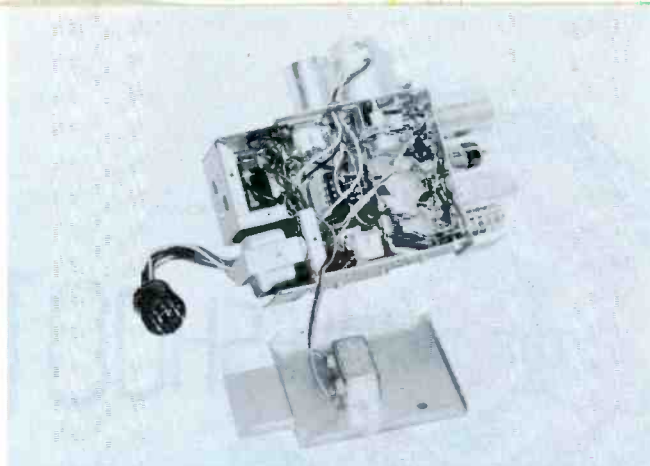

Fig. 6. Signal at grid of horizontal output tube shows DC conduction level.

AC and DC voltmeter. Consequently, you can make a quick measurement of DC voltages by merely touching your low-capacitance probe to the desired spot (use the higher vertical-attenuator ranges for best accuracy). You will also see the amount of ripple (pulsing DC) that is or is not being filtered properly. This is about the best way I know to instantly spot an open electrolytic capacitor. For instance, in the RCA chassis we've been dealing with, the power-supply ripple allowed is only 0.1 volt after filtering by both the input and output electrolytic capacitors and the choke. If you find excessive ripple, one of these filter components just isn't doing its job. To double check, switch over to the AC input momentarily to be sure that excessive DC isn't causing clipping in the scope amplifiers and obscuring some of the results. The input capacitor, of course, blocks DC and may result in a more accurate p-p reading.

Another excellent use for the DC scope is at the horizontal-output tube grid. In addition to noting whether or not the necessary sawtooth signal is arriving from the horizontal oscillator, you'll also be able to note the DC level at which the output tube will begin conduction (Fig. 6). In the upper half of Fig. 6, you can also see the general appearance of the waveform at terminal C of the oscillator transformer.

With a little practice, you'll be using DC amplifiers with the speed of an expert, and achieving really rapid repairs of difficult troubles.▲



COMING NEXT MONTH

Looking Over G-E's 1960 Remote Unit

In keeping with our policy of being "fustest with the mostest" for professional servicemen, next month's "Servicing New Designs" includes a preview of the latest in TV remote-control units and how it works (see photo above).

Short-Lived TV Tubes

Receiving tubes that consistently fail prematurely are more likely to be the result of improper circuit operation than faulty tube construction. Don't miss this one if you want to put your finger on the real cause of early tube failures.

Developing a Modus Operandi

A specific basic troubleshooting technique should be used for all ailing electronic equipment. In the "Shop Talk" series beginning with the next issue, Milt Kiver will show you how to develop and use an "M. O." for all types of TV troubles.

Let's Talk About Vertical Sweep Systems Part 2

If you read the first part of this "meaty" coverage (see page 40 of this issue), you have an idea of what the last half holds in store. Specifically, it describes causes for vertical jitter, poor interlace, and several kinds of sweep distortion.

Other informative and helpful articles include:

- Running Down AGC Trouble
- Previews of New Sets
- Video Speed Servicing
- Notes on Test Equipment
- Servicing Electronic Heater Circuits

... plus all the other regular PF REPORTER departments, to make it the ONE magazine especially prepared for the palates of electronic servicemen.

TO ENTER A NEW OR RENEWAL SUBSCRIPTION, SIMPLY FILL IN AND MAIL THE COUPON BELOW.

Please enter my subscription to PF REPORTER for:

- 1 Year \$4.00 2 Years \$7.00 3 Years \$9.00

Above rates apply only in U.S.A., its possessions, and Canada. All other countries: 1 year \$5.00, 2 years \$9.00, 3 years \$12.00

- Bill Me Remittance Enclosed Extend Present Subscription

Give to your parts distributor or mail to
PF REPORTER, 2201 E. 46th St., Indianapolis 6, Ind.

Please Check Your
Business Classification

Name _____

- Independent Radio, TV Serviceman Owner, Mgr. Serviceman

Firm _____

- Retailer with Service Department Service Mgr.

Address _____

- Industrial Electronics Service Employee Service

City _____ Zone _____ State _____

- Other (Specify occupation and title)

THE TROUBLESHOOTER

ANSWERS YOUR SERVICE PROBLEMS

Unfreezing Yokes

Some time ago, I remember seeing something in PF REPORTER about the problem of separating a "frozen" yoke from the neck of the picture tube without damage to either component. I have recently encountered such a problem, and a search through back issues for help has proved fruitless.

ROBERT W. GREGWARE

Troy, N. Y.

We dealt briefly with this problem in "Replacing Defection Yokes," May, 1958—but it's not too soon to touch on this subject again.

Anything's better than prying a yoke off by force, and we can recommend a couple of specific methods which are much safer. Unfortunately, we don't know of any foolproof method of freeing a yoke without damaging it, once the insulating varnish on the horizontal windings has become stuck to the neck of the CRT. Even if these windings don't develop short circuits during the removal process, you run the risk of a later breakdown because of damage to the insulation.

One useful technique is to run AC line current through all the yoke windings connected in series, using a 60-watt light bulb in series with the yoke to serve as a current-limiting device. The heat generated by a few seconds' application of current is usually enough to loosen the yoke from the CRT neck.

An alternate solution would be to tip up the set and drip a little varnish solvent onto the neck of the picture tube, where it will run down into the center hole of the yoke and soften the insulation.

No Fuzz Control

I have an RCA Chassis KCS47A with defective focus. This set has a permanent-magnet assembly which I tried adjusting with no success. High voltage at the CRT anode measures 12,000 volts, which is a little low. The original CRT checked very weak, so I replaced it; but that didn't improve the focus. After trying about everything else, I replaced the permanent magnet with an electromagnetic focus coil using a separate power

supply. This corrected the trouble.

Before I purchase a new permanent-magnet assembly, I would like to know whether it's normal for magnets to lose their strength over the years or whether I am only overriding some other trouble by using an electromagnetic focus coil.

LOUIS R. LUCIANO

Salem, Mass.

Your application of the electromagnetic unit was quite well thought out and is a good test to make whenever you are dubious about the condition of a permanent-magnet focusing device. These definitely can lose much of their magnetism over a long period of time, especially if they have ever been dropped or otherwise mishandled.

Erasing Retrace Lines

Would you help me design a vertical retrace-blanking circuit for a Fada Model 21L1? I have been using the article by Jesse Dines in the August, 1958 issue as a guide, but I'm having trouble applying the information to this set.

LAFON DARLAND

Harrodsburg, Ky.

The receiver in question already contains a simple, yet interesting, hookup which apparently suppresses retrace lines to some degree. As you trace the DC path from the boost B+ supply to the accelerating anode (pin 10) of the CRT, you'll notice it passes through the vertical yoke windings in parallel with the secondary of the vertical output transformer. In this way, negative-going 120-volt pulses are picked up and applied to the accelerating anode. Of course, these are unlikely to cut off beam current, but the momentary reduction in accelerating voltage evidently tends to defocus or weaken the electron-beam during retrace.

Since the set is several years old, it would probably benefit from a more positive-acting type of blanking circuit. You can obtain the necessary signal from the vertical output transformer, although you will need a hookup slightly different from the examples suggested by Mr. Dines. In this particular set, the center tap of the autotransformer (green lead) is the "low" side of the secondary—because it's the point nearest the DC sup-

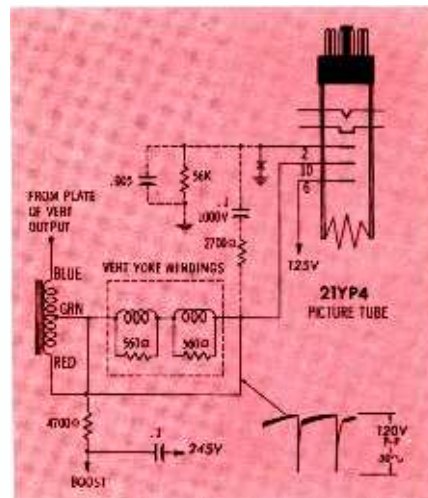

ply—and the bottom or red lead of the transformer is the "high" side of the secondary. Thus, the red-lead terminal is the correct source for the blanking pulses you need. To install the blanking network, unground the control grid of the CRT and add the components dotted-in on the schematic. This circuit is used in numerous Admiral receivers and should also work in your Fada. Component values may be juggled to some extent, but try to maintain negative-going pulses of about 50 volts p-p on the grid of the picture tube.

Picture Washout

While looking for the cause of extremely poor contrast in a Stromberg-Carlson Model 21TM, we found abnormally low plate voltage on all four video IF's and the first video amplifier. These stages are all connected to the 90-volt branch of the B+ source, and we discovered that the supply voltage on this line was down to about 50 volts. Eventually, we located the reason for the trouble. R57 in the grid circuit of the 12BY7 video output tube had increased in value from 560K to 2 megohms, thus changing all the voltages in the output-tube circuit and indirectly affecting the 90-volt line.

WALSH TV & RADIO

Taunton, Mass.

Here's a good example of what can happen when a resistor in a voltage-divider network changes value. When the resistance of R57 increased, the voltage drop across it also increased. This caused the grid voltage of the 12BY7 to become less positive, thereby increasing the bias on the tube and reducing its plate current. Low contrast? Small wonder!

To understand why the 90-volt B+ line was also affected, refer to the schematic. The video output stage forms a relatively low-resistance shunt across part of the power-supply bleeder network—the portion which lies between the 90- and 260-volt B+ sources. (You've undoubtedly seen the audio output stage in many other TV sets wired between low and high B+ in a similar manner.) Let's take the total resistance between these two source points, place it in series with the total resistance between the 90-volt line

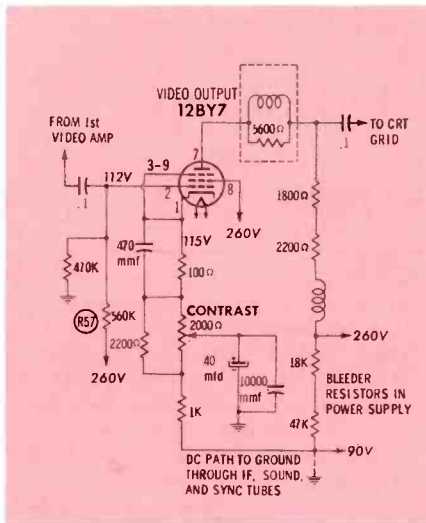

and ground, and treat this series combination as a voltage divider designed to provide 90 volts at the midpoint. The decrease in current through the 12BY7 had the same effect as an increase in resistance within the upper section of this voltage divider. Since there was no corresponding increase in the resistance of the lower section, the ratio between the two resistances was altered. A greater voltage drop then occurred across the upper section of the divider, and the potential at the midpoint became less than 90 volts.

Blanking Bar Anatomy

How about a picture of a vertical blanking bar with each portion of it clearly defined and described?

ELTON L. KENNEDY

Montoursville, Pa.

The best way to understand this bar is to compare it, line by line, with the signal which produces it — namely, the vertical blanking pulse in the composite video signal applied to the driven element of the picture tube.

The horizontal oscillator goes through 20 to 22 complete cycles during each vertical blanking pulse, so the bar on the screen will contain approximately 21 lines (see part A of drawing). At the end of each vertical frame of the picture, the leading edge of the blanking pulse arrives just as the electron beam reaches the right side of the screen. Almost immediately, a pulse occurs and triggers horizontal retrace. This is not an ordinary horizontal sync pulse, but the first of six special equalizing pulses which help maintain proper interlace. In part B of the drawing, note that these occur at twice the frequency of the regular horizontal sync pulses. Nos. 1, 3 and 5 trigger horizontal lines 1, 2 and 3 of the blanking bar. Pulses 2, 4 and 6 have no effect on sync, since they arrive in mid-line; however, they produce a small "blacker-than-black" pip in the composite video signal, which makes a visible dark spot in the first three lines of the bar.

Next comes the vertical sync pulse itself, which lasts throughout lines 4, 5



The Greater Vibrator

Radiart Vibrators are unaffected by bounce, jounce, heat, cold, moisture. There's a replacement type for every 6- and 12-volt application. Ask your Radiart Distributor for a free Radiart Vibrator Replacement Guide or write The Radiart Corporation, 2900 Columbia Avenue, Indianapolis 5, Indiana.



RADIART
TOBE
Vibrators

IMPORTANT NEW SAMS BOOKS



"Television Antenna Handbook"

by Jack Darr



A practical guidebook for the antenna installer and serviceman. Thoroughly covers the requirements of each reception area (primary, secondary, fringe and far-fringe). Chapters include: The TV Signal—From Transmitter to Receiver; Characteristics of Basic Antennas; Commercial TV

Antenna Types; Transmission Lines; Antenna Rotators; Planning the Installation; On-Location Tests; Tools and Equipment; Towers, Masts and Guying; Roof-Top Techniques and Safety; Installing Antenna and Lead-in; Noise, UHF and Color; Unusual Installations; Servicing the Antenna System. Most complete and practical book available on the subject. Illustrated; 248 pages; 5½ x 8½"; only **\$3.95**

"Photofact Television Course"

All-New 2nd Edition

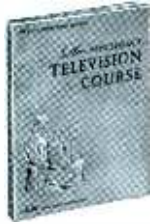

Completely revised edition of the famous Course which has helped in the training of thousands of successful technicians. Covers the complete subject of monochrome TV in three unique study sections. The emphasis is on the practical theory and operation of receiver circuits. Each section is

built around a requirement of the picture tube, until every circuit in the TV receiver is covered. The course includes step-by-step descriptions of the functions of all important circuits, supported by many schematics of actual commercial circuits. Clearly written for easy understanding. The ideal course for students, service newcomers and hobbyists. Fully illustrated; 192 pages; 8½ x 11"; only **\$3.95**

"Video Speed Servicing" Vol. 3



Latest volume in this valuable reference manual series. Presents 456 practical troubleshooting hints that will cure hard-to-find faults in some 87 chassis of late-model TV receivers. All models are indexed by brand name, model and chassis number for quick reference. An invaluable aid for shop bench use; each hint is accompanied by

an explanatory diagram or schematic. 160 pages, 8½ x 11"; only **\$2.95**

HOWARD W. SAMS & CO., INC.

Order from your Sams Distributor today, or mail to Howard W. Sams & Co., Inc., Dept. H-39 2201 E. 46th St., Indianapolis 6, Ind.

Send me the following books:

- "Television Antenna Handbook" (TAD-1)
- "Photofact Television Course" (TV-2)
- "Video Speed Servicing" (VSM-3)

\$ enclosed. Send Free Book List

Name _____

Address _____

City _____ Zone _____ State _____

(outside U.S.A. priced slightly higher)

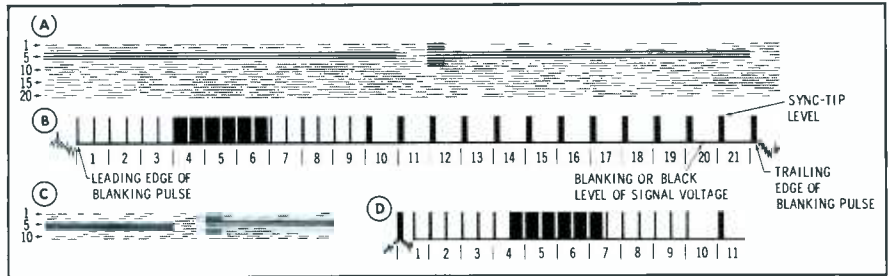

and 6. These three lines appear mostly black because the video-signal voltage stays at sync-tip level most of the time. Twice in each line, however, the signal voltage drops briefly to the blanking level to form notches or serrations. The second and fourth notches occur at the end of lines 4 and 5, and their steep, positive-going "trailing edge" serves to trigger the horizontal oscillator. Notches No. 1, 3 and 5 occur in mid-line and produce a visible gap in the center of the black area within the blanking bar.

Six more equalizing pulses follow closely behind the vertical sync pulse. Nos. 1, 3 and 5 trigger horizontal lines 7, 8 and 9, respectively. Trailing pulses 2, 4 and 6 occur in mid-line and appear as black spots on the screen.

Normal horizontal sync pulses occur at the end of lines 9 through 21. Between pulses, the video-signal voltage never varies from the blanking level; thus, the visible area in the lower part of the blanking bar is all the same shade.

After completing line 21 of the bar, the electron beam returns to the left side of the screen and begins tracing the next vertical field of the picture. The end of this field, and the beginning of the next blanking bar, occurs at an instant when the beam is centered horizontally on the screen. Parts C and D of the drawing show the first 11 lines of this next bar as well as the signal which generates it. Compare these with A and B; note that the equalizing pulses and serrations which previously occurred in mid-line will now arrive at the ends of the lines. This means that a different set of pulses synchronize the horizontal oscillator. However, the number and spacing of pulses just ahead of the vertical sync pulse are exactly the same as before; this is necessary to insure correct timing of the vertical oscillator.

When two fields are interlaced to produce a complete picture, the slightly dissimilar blanking bars A and C combine to produce a single 42-line bar having "blacker-than-black" signal elements in the first 18 lines.

Since the steep-sided sync and equalizing pulses are similar to a square-wave signal, the appearance of the darkest areas in the blanking bar give good clues to the frequency response of the video circuits. For example, weak high-frequency response causes an abnormally fuzzy or rounded appearance of the short black squares formed in lines 1-3 and 7-9; on the other hand, phase shift or poor gain at low frequencies will cause smearing of the long black bars in lines 4-6.

If the pattern at the top of the bar does

not look very much darker than the rest of the bar under conditions of high picture brightness, this indicates an insufficient voltage difference between the blanking and sync-tip levels in the composite video signal. This symptom is often an important clue to trouble ahead of the video output stage which is affecting sync.

Since practical TV designs can't be expected to have perfect horizontal sync or flawless response to extremely low and high video frequencies, you can expect to see a certain amount of distortion in even a normal blanking bar. With a little practice, you should be able to judge whether or not a given bar looks reasonably satisfactory.

Hairy Capacitor

I recently had a Bendix Model KS-21E in the shop with a bad case of vertical rolling. After considerable troubleshooting, I finally located a 680-mmf ceramic capacitor with a scarred area on it (see

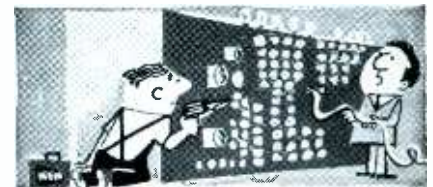

"He says it tickles!"

for power tools to your liking

SAY WEN



\$9.95

**SOLDER GUN KIT
OF A THOUSAND USES**

Over a million sold! Heats up in just 2½ seconds. Long-reach, long-life tips, automatic spotlight, sturdy, perfectly balanced plastic housing. 6 models—feather-light 100 watt to 250 watt heavy duty.

OTHER GUNS AND KITS, **\$5.95 to \$15.95**
SAY WEN FOR DRILLS, SABRE SAWS, SANDERS
5810 NORTHWEST HIGHWAY, CHICAGO 31
EXPORTED BY: SCHEEL INTERNATIONAL, CHICAGO

BURTON BROWNE ADVERTISING

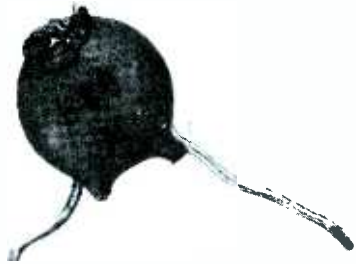

photo). Under a magnifying glass, this patch appeared to be covered with fine "whiskers." The trouble was cured by replacing the damaged component, which turned out to be a high-frequency bypass capacitor connected from the cathode of the audio output tube to ground. The bad spot was apparently produced by heat from a 150-ohm resistor mounted just above the capacitor; however, I couldn't find any charring or any other evidence of resistor overheating.

WILLIAM F. O'REGAN

Dorchester, Mass.

The capacitor grew "hair" when its plastic coating melted and became drawn out into tiny fibers. This strange formation may have been caused by an electrostatic attraction between components, or the capacitor may possibly have touched the resistor and then pulled away while the plastic was still soft.

A failure in the audio section of this set was able to affect vertical sync because the audio output tube is utilized as a voltage-dropping resistor in the power supply. The plate current of various other tubes, including the sync separator and sync phase inverter, must pass through the audio output pentode to reach the low-voltage rectifier. When this hookup is employed, the cathode of the output tube normally maintains a potential of about 135 volts and is regarded as a low B+ source point.

The 680-mmf capacitor probably developed leakage as a result of the heat injury, thereby lowering the cathode voltage of the audio output tube. This could easily reduce the plate potential on the sync stages and weaken their output signal to the point where you would lose control over vertical oscillation frequency.

Microbe Hunting, Anyone?

In an Admiral Chassis 7L1 transistorized portable radio (PHOTOFACT Set 375, Folder 6), capacitor C6 touching the rotor of the tuning capacitor during a portion of its rotation caused a noise similar to the "static" produced by dust or metal fragments between the plates. Moving C6 a fraction of an inch solved the problem. Easy—but not always obvious!

NORMAN D. SLATER

Ogdensburg, N. Y.

It's mighty easy to get into trouble when the components on these jam-packed little chassis start elbowing each other around. A good thorough physical examination under a magnifying glass should come ahead of any electrical tests on these chassis, except for basic battery-substitution and current-drain checks.

NEW FROM SECO DYNAMIC TRANSISTOR CHECKER



MODEL 100

DYNAMICALLY CHECKS WIDE RANGE OF TRANSISTOR TYPES EITHER "IN OR OUT" OF CIRCUIT!

This new low-cost checker uses an entirely new approach but a proven DYNAMIC principle for checking transistors. safely tests PNP and NPN transistors either "in or out" of the circuit. Covers wide range of types: small signal including "drift" types, medium power; and power types. Provides positive check for "opens," shorts, and gain—condition indicated by means of a visual indicator plus jacks for meter or scope. Also provides GO-NO-GO test at practical currents—and permits matching of similar transistor types. No set-up required—no further leakage tests necessary. Model 100 is compact, lightweight, complete, and ready-to-use . . . helps you cash-in on the big profits in the fast growing transistorized equipment servicing field!

MODEL 100—Wired and factory tested \$19.95 NET

NEW FROM SECO LOW COST, COMPLETE TUBE TESTER



MODEL 78

GRID CIRCUIT and TUBE MERIT TESTER

Complete test coverage of all modern TV tube types as well as all heater type radio tubes including hybrid types, using only 5 sockets. Incorporates patented Seco GRID CIRCUIT TEST plus a reliable CATHODE EMISSION test using new low impedance low test voltage circuit—also checks filament continuity and provides open element test. One easy-to-read meter indicates results for both Grid Circuit and Tube Merit Tests. Two-stage dc amplifier isolates meter from tube under test to protect meter—and makes it possible to achieve a wide range of load currents and test conditions. Complete with portable carrying case, pin straighteners, and flip-chart for quick set-up data.

MODEL 78—Wired and factory tested \$69.50 NET



MODEL 107
TUBE
TESTER

outstanding reliability, accuracy

Provides 3 important tests: amplifier types tested for gain by Dynamic Mutual Conductance method—power types tested for cathode current by Cathode Emission method—all types tested for shorts and grid error by Grid Circuit Test developed and patented by Seco. Dynamic Mutual Conductance Test pre-wired to eliminate elaborate set-up. Cathode Emission Test done by free point pin-selector method—will not be obsolete. Completely self-contained in portable carrying case.

MODEL 107—Wired and factory tested \$139.50 NET



MODEL HC-6
IN-CIRCUIT
CURRENT
CHECKER

positive, on-the-spot check of horizontal output current!

This new, low-cost current checker provides simple means for making a positive on-the-spot check of TV horizontal circuits. Can be placed into the circuit in seconds—no unsoldering of circuit wiring—immediately indicates whether horizontal tube cathode current is within manufacturer's recommended limits. Valuable as a fast, accurate indicating device when adjusting horizontal drive and linearity. Eliminates one of the most common causes of callbacks. Compact, inexpensive, easy to use.

MODEL HC-6—Wired and factory tested \$12.95 NET



MODEL GCT-8
GRID CIRCUIT
TESTER

fast check of critical "control grid" conditions

Model GCT-8 checks "control grid" condition of vacuum tubes faster, more accurately than any other tester! As many as eleven simultaneous checks—automatically! Quickly spots grid errors and leakage—stops guessing, substitution checking, and costly rechecks. Electron-Eye tube indicates faults at a glance. Truly portable. The perfect companion to any tester that employs only conventional gas and shorts test. Carry it on all calls.

MODEL GCT-8 Complete kit . . . \$19.95 NET

MODEL GCT-8 Wired and tested . \$29.95 NET

SEND FOR COMPLETE SECO STORY ON . . .

<input type="checkbox"/> Three Tube Testers <input type="checkbox"/> VTVM <input type="checkbox"/> Dynamic Transistor Checker	<input type="checkbox"/> In-Circuit Current Checker <input type="checkbox"/> 100% Accurate Flyback Checker <input type="checkbox"/> Battery Eliminator
---	--

Sold Only Thru Electronics Parts Distributors

OUTSTANDING RELIABILITY—TOP DOLLAR VALUE!

SECO SECO MANUFACTURING CO.
5015 Penn Ave. So., Minneapolis, Minn.

NAME _____

ADDRESS _____

CITY _____ ZONE _____ STATE _____

Vertical Sweep Systems

(Continued from page 41)

effects, such as bends in vertical lines or as a slightly-rounded key-stone raster with the bottom narrower than the top.

Poor linearity with bunching somewhere around the middle of the raster is probably the most difficult linearity problem to cure. Sometimes (but not often enough), this symptom can be corrected by judicious selection of a replacement amplifier tube. This trouble is prevalent in sets using low plate-resistance tubes such as the 6S4, and results

from a "knee" in the tube's operating curve. (A more detailed discussion appeared in "Keeping Up With Vertical Sweep Systems," January, 1958 PF REPORTER.) If tube replacement fails to eliminate the trouble, you'll have to resort to more unusual techniques. For instance, you may find that increasing the gap in the transformer core by insertion of paper shims will help.

For sets using the circuit in Fig. 2, the same trouble can sometimes be eliminated by decreasing the value of the large fixed-value cathode resistor (8.7K ohms in Fig. 2);

a 7K-ohm substitute cured several sets for me.

If none of these suggestions work, try adding a 20K-ohm resistor in series with a .05-mfd capacitor between the grid of the vertical amplifier and one side of the yoke winding. This addition is very much like a neutralizing network used on triodes in higher frequency applications.

Intermittent Troubles

When any of the previously-discussed troubles occur intermittently or only after the set has warmed up, it is natural to suspect a part capable of producing similar trouble in a steady state. For example, leakage in C1 often develops when the set heats up, causing the bottom half of the raster to shorten. Thus, the same defect causes the same symptom; however, this time it's thermally-induced.

Some intermittents can be more difficult. Take for instance the case involving a Westinghouse V-2313, which employs a circuit similar to the one in Fig. 5. The set produced a good picture with a full raster at first, but in a few minutes vertical sweep decreased to about half size with acceptable linearity. Barely turning the linearity control resulted in full deflection, so the control was replaced. The set operated normally for a full day before being returned to the customer. Three days later the same condition developed again; replacement of the 12BH7 seemed to be all that was needed. One week later, another complaint for the same trouble caused the set to be brought in again. This time the intermittent condition was so touchy that even application of the VTVM probe would remove or create the fault. With the scope, however, the large signal across filter capacitor CF1 indicated that it was opening



For your repair department... for your displays



All the outlets you need...
right where you want them

Electrostrip

PATENTED®

"4-FOOTER" KIT \$2.95 ➔

Here is electrical convenience you've hoped for! It's Electrostrip... so easy and economical to install, you'll want it throughout your shop.

Ideal for multiple outlets in minimum space, the Electrostrip "4-Footer" eliminates extension cords and "octopus" plugs. With just a twist of the wrist you can move outlets to the spot they're needed... anywhere along the strip.

A screwdriver is the only tool needed to install Electrostrip on walls, woodwork or workbench. The "4-Footer" Kit comes complete with 3 twist-in receptacle plugs, screws, and polarized connector. Electrostrip is safe, tested, proved—listed by Underwriters' Laboratories.

Ask your electrical supplier for Electrostrip "4-Footer" Kits... and help yourself to real convenience!

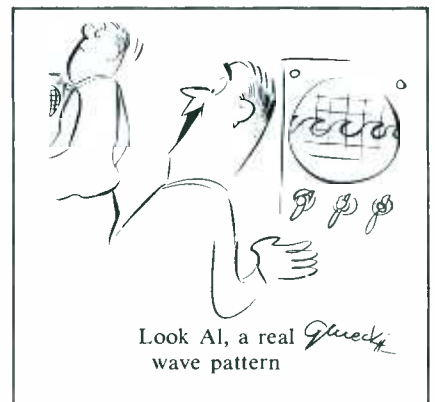

BULLDOG ELECTRIC PRODUCTS DIVISION
I-T-E CIRCUIT BREAKER COMPANY
BOX 177 • DETROIT 32, MICHIGAN

In Canada: 80 Clayson Rd.
Toronto 15, Ont. Export
Division: 13 East 40th St.
New York 16, N.Y.

intermittently. After replacing this filter and bench-checking the set for several days, we knew that at last the fault had been corrected.

In servicing intermittent troubles, it is often more expedient to seek clues that generally accompany a condition, and change the components which would logically cause the trouble, rather than to change parts indiscriminately.

Slowness in reaching full deflection is another oftentimes puzzling condition found in vertical sweep systems. The cause is often the same as the one we found in the case of an Emerson employing a 6W6 amplifier and 6SN7 oscillator in the circuit hookup of Fig. 5. The complaint was that it took several minutes for the picture to reach full vertical size. The set was turned on and each voltage in the circuit, even the filament, was monitored to determine if any change occurred in step with the increasing size. No specific clues were obtained. Next, a scope was used in the same type of monitoring procedure; again, nothing was learned. This monitoring takes a lot more time than it does to tell about it, since each point must be checked for the period it takes the set to reach normal operation. Power is then removed for a few minutes, and then applied again while another point is checked. This repetition eats up service time, and since it produced no results after a half-hour of testing the Emerson serviceman did what most others do with puzzlers—put it aside to look at it later.

Several service jobs later, the set was again placed on the firing line, but in the interim, the serviceman had been doing some speculating about this problem. He realized that in checking filament voltage he had measured from the hot side to chassis ground. On a hunch, he connect-

ed his VTVM leads directly across the tube pins. Now the fault became apparent. The reading across the 6W6 filament was only 5 volts; however, it increased in unison with vertical size. It was now obvious that the trouble was due to poor grounding of the other filament connection; the missing voltage was being dropped across a high-resistance solder joint.

Similar conditions have been found in quite a few sets, especially in those using 6W6, 6BL7 or 6AH4 tubes as vertical amplifiers. Recently, a series-filament G-E "MM"

model, in which the 40-ohm filament-dropping resistor had increased to 70 ohms, presented the same condition. Why, with low filament voltages throughout the set, only the vertical section was affected, is one of those "unexplainables" that crop up in this business.

In the blocking-oscillator circuits of Figs. 1, 2, and 3, the components primarily responsible for maintaining correct frequency are C2 and the resistance of the vertical-hold network. In the multivibrator circuit of Fig. 4, the feedback network made up of the .015-mfd and .03-

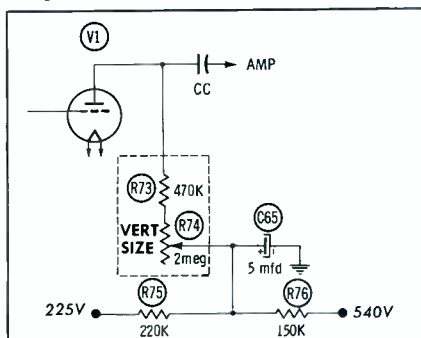



Fig. 6. Vertical overscan on an Emerson caused by open 5-mfd capacitor.

Transistor Radio Servicing CAN be Highly Profitable



The ONLY Complete Transistor Radio Service Lab

Everything you need for less than \$50

 **Check Transistors, Diodes, Rectifiers . . .**

SENCORE TRC4 TRANSISTOR CHECKER

Accurately checks all transistors in hearing aids, radios and power transistors in auto radios. Tests for opens, shorts, leakage, current gain. Measures forward-reverse current ratio on all crystal diodes. Measures forward and reverse currents on selenium rectifiers. With set-up chart for accurate checking of each transistor. Size, 5x4½x2½". With batteries. DEALER NET **17⁹⁵**



 **Replace Batteries During Repair . . .**

SENCORE PS103 BATTERY ELIMINATOR

All-new "Transi-Pak" twin to TRC4 Checker above. Provides variable DC voltage to 24 volts; 1.5-volt biasing tap (a "must" for servicing Philco and Sylvania radios). Metered current output, to 100 ma. Handles 200-ma peaks. Two 200-mfd electrolytics provide proper filtering and low output impedance. No hum or feedback problems. Ideal for alignment using station signal; adjust IF slugs for max. current, also ideal for charging nickel-cadmium batteries. Size, 5x4½x2½". DEALER NET **17⁹⁵**



 **Find Defective Stage in a Minute . . .**

SENCORE HG104 HARMONIC GENERATOR

New signal generator designed primarily for fast signal-tracing of transistor radio circuits. No need to unsolder all transistors. Provides RF, IF and audio signals *simultaneously*, drastically cutting service time. Traces from speaker to antenna. Clear 1000 cycle note signal is heard in speaker from all good stages. Signal weakens or stops at defective stage. Equally as effective for testing TV, hi-fi and other audio circuits also. Size, 3½x4½x1¾". With batteries. DEALER NET **9⁹⁵**



Turn page for other

SENCORE

Time Savers

**See your Parts
Distributor
NOW!**

SENCORE

ADDISON 2, ILLINOIS

mfd capacitors, and the 180K and 82K resistors, are the principle frequency-determining components. In all of the circuits, the values of components in the integrator network also have some effect on the frequency of the circuit. If any of them are far off value or otherwise defective, the frequency shift can be great enough to prevent the hold control from locking in the picture. A shift in the value of C1 or peaking resistor R1 has to be fairly extensive before the frequency of the circuit is affected.

We had a prime case of frequency

trouble the other day on a set (circuit similar to Fig. 3) which was brought in for intermittent rolling. A casual examination revealed that it had been recently worked on and that the parts in the integrator network as well as C2 had been replaced. While probing in the set, it was discovered that a slight pressure on C3 would cause the rolling. How the previous serviceman had missed this component is explained by the fact that it is mounted several inches away from the vertical-sweep system. Nevertheless, it is part of the sawtooth-forming network, and in

this case a replacement capacitor cured the trouble.

When a 21" Tele King receiver was serviced for rolling on some programs, it was noted that lock-in was obtained with the hold control at one end of its range. When the set was tuned to a station that gave its identification in color, the picture began its slow roll. Before proceeding further with this aspect of the trouble, however, it was decided to make the repairs necessary to center the lock-in range.

The vertical system used the circuit shown in Fig. 1. First, timing capacitor C2 and the final capacitor of the integrator were changed with some improvement in vertical-hold control centering. Then, the control was cleaned and checked. When these legitimate service procedures made no improvement, we realized that the cause was either inherent in the original design of the circuit, or in the combined aging of components. Deciding to make a minor change, a 2-meg pot was connected in series with the hold control and adjusted to sync the picture. The resistance value at which the picture synchronized was found to be 1.5 megohms, and a fixed resistor of this value was installed in place of the original 1-megohm unit. The roll condition has never recurred to our knowledge.

The customer's complaint that the set had rolled "sometimes" might have been qualified to "rolls when station is transmitting in color," but the customer just didn't know that there is a very slight difference in color transmitting standards. As a matter of fact, he didn't even know the trouble occurred mainly during color transmissions, since his was a black and white set.

There is one other condition that happens often enough to warrant mention. Some receivers using the circuit in Fig. 1 apply a small positive voltage to the return end of the vertical-hold control. Trouble arises when dust in the control creates a high-resistance leakage path to ground and throws the circuit off frequency. Merely blowing out the control with compressed air is usually all that's required.

(Editor's note: We knew you could use a breather about now, so we'll save the other half of this story for the September issue.)



You can be sure the

QUAM

Adjust-a-Cone®

SPEAKER

will fit . . .

it's listed in

COUNTERFACTS

and **PHOTOFACTS**

for your convenience

"If at first you don't succeed, try, try again" may be good advice sometimes, but it's silly when you're replacing a speaker. Instead of trying one speaker after another, just put in the right one the first time—by checking the recommendations in PHOTOFACTS or by having your distributor check the COUNTERFACTS listing for you.

These listings in COUNTERFACTS and PHOTOFACTS can save you time and effort when you're replacing a speaker. Always remember to check them first . . . and remember that this service is another QUAM exclusive. No other speaker manufacturer gives you this extra convenience . . . just as no other speaker manufacturer gives you the famous patented Adjust-a-Cone Suspension and U-shaped pot.

*QUAM is your quality line...
and your convenience line too.*

QUAM-NICHOLS COMPANY 234 E. Marquette Road, Chicago 37, Illinois

Microphones

(Continued from page 42)

in comparison to the wavelengths of the signals to be handled. When the unit is large, adequate mike action cannot be obtained for high frequency signals from angles other than those encompassed by the front hemisphere.

The directional properties of various mikes can be used to great advantage in determining which one to use for a specific job. More will be said concerning this under the heading of mike placement in the next installment.

Impedance

Microphones are rated as to the impedance of the unit. Four main ratings are available: 50, 150, and 250 ohms, plus high impedance (sometimes called grid impedance). Generally, crystal and capacitor mikes are high impedance units; carbon, dynamic, and ribbon types are low impedance types, although some dynamic and ribbon types are equipped with an internal matching transformer for high-impedance applications.

To prevent undue loss of signal, and also some types of distortion, impedance of the microphone should match the input impedance of the amplifier. Most amplifiers have high impedance inputs, so a high impedance mike could be connected directly into the input grid circuit of the amplifier. Low impedance mikes require that a matching transformer (connected step-up) be used between them and the amplifier input.

Mike impedance also may cause problems when the mike must be operated at some distance from the amplifier, necessitating the use of a long connecting cable. For low impedance mikes, a much longer cable can be used.

An impedance matching transformer can be used at the mike if a high impedance mike is used with a long cable. Physically, this imposes no great problem because small compact units are available, designed to be connected directly into the line without being mounted. This is a disadvantage if another transformer is required to provide a match between the cable and the amplifier input. In most cases, therefore, it is simpler to use a low im-

pedance mike whenever long cable runs are required.

Sensitivity

Sensitivity of a microphone is a ratio between signal output and sound input. Contrary to what we might expect, the most expensive mikes are not necessarily the most sensitive ones. They may be even less sensitive so that wider and more uniform frequency response can be achieved.

Microphone input consists of sound waves which exert a pressure on the moving element. This pres-

sure is measured in dynes per square centimeter of area. The dyne is a unit of force, so the pressure unit indicates the force applied to each square centimeter of mike area. A dyne per square centimeter is also called a microbar, and it is this unit which is most often used in microphone ratings.

Mike sensitivity is normally expressed in terms of decibels of signal output compared to a zero decibel reference level. The outputs are always below the reference level, and the normal range of ratings varies from about -48 to -75 db. A

Servicemen! SAVE TIME...SUBSTITUTE THE SENCORE WAY

The Fastest, Surest Method Known!

Substitute for Capacitors, Resistors

SENCORE H-36—THE "HANDY 36"

36 most-often-needed resistors and capacitors, for fast, easy, direct substitution in all circuits. ● Eliminates searching for replacement components for test purposes. ● Avoids unnecessary unsoldering and soldering—no more solder mess. ● Pays for itself the first month in time saved. ● Flick of a switch instantly selects any one of...

24 RESISTORS from 10 ohms to 5.6 megohms
10 CAPACITORS from 100 mmfd to .5 mfd
2 ELECTROLYTICS, 10 mfd and 40 mfd

DEALER NET..... 1275

Substitute for Electrolytic Capacitors

SENCORE ES102 ELECTRO-SUB

Usable from 2 to 450 volts, D.C.

Contains 10 electrolytics from 4 to 350 mfd. Select the correct value with the flick of a switch. Features automatic discharge, surge protector circuit. Prevents accidental "healing" of capacitor being bridged. Completely safe—no arc or spark when connecting or disconnecting. **DEALER NET..... 1595**

Substitute for Fuse Resistors During Repair

SENCORE FS3 "FUSE-SAFE" CIRCUIT TESTER

Instantly tells you whether or not it is safe to replace fuse resistors, fuses, or circuit breakers. Separate red and green scale for each commercially available fuse resistor used in radio and TV. Eliminates guesswork and wasted time. Also handy for wattage checks up to 1100 watts. **DEALER NET..... 895**

Substitute for Bias Batteries During Repair

SENCORE BE3 "ALIGN-O-PAK"

Completely isolated DC supply, with less than 0.1% ripple. Eliminates messy batteries in TV service work. Handy for alignment, AGC trouble-shooting, or checking gated sync circuits. Just dial the voltage you need, 0-18 volts, positive or negative. Covers all voltages recommended by TV set manufacturers. Size, 3½x4½x1¾". For 110-120 volts, 60 cycle AC. **DEALER NET..... 785**

UNIVERSAL TV JUMPER CORD

Fits any set from back to chassis. Box has male and female plugs for additional power source, soldering, etc. **DEALER NET 195**



Turn page for other

SENCORE
Time Savers

See your Parts Distributor Now!

SENCORE

ADDISON 2, ILLINOIS

unit rated at -48 db gives more signal output (is more sensitive) than one rated at -75 db.

For low impedance mikes, power is important, so sensitivity is usually rated with either 1 or 6 milliwatts as reference. (One milliwatt is actually the zero VU reference level.) Output is measured with a sound input of 10 microbars, which is a level comparable to normal speech at a reasonable distance from the mike. Output of high impedance mikes is most often rated using a reference of one volt output with an input sound level of either 1 or 10 microbars.

Although these two ratings seem to be entirely different, the ratings are actually about the same when we consider the output of the low impedance mike on the high side of the matching transformer. If a mike is rated using an input of 10 microbars, its level is 20 db higher than for a 1 microbar sound input. For example, a mike rated at -58 db for 1 microbar would be rated at -38 db for 10 microbars.

Frequency Response

For the most exacting requirements, two frequency response

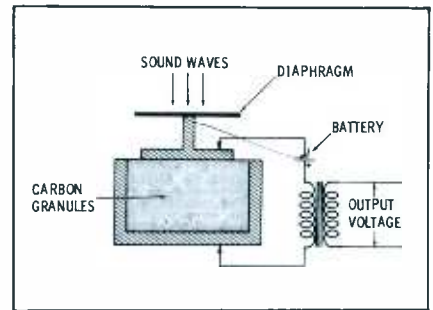

Fig. 4. Holt-head screw of type used to fasten *dualette* chassis to cabinet.

characteristics are needed. The range must be wide enough to include most of the frequencies likely to be encountered, and the response should be linear over this range. In less expensive mikes, response peaks greatly reduce the quality of the output signal. A peak in the low frequency range gives a "booming" quality. If the peak occurs in the middle of the band, both low and high frequency responses are limited, giving a "hollow" type sound similar to that of a telephone receiver. When response peaks occur in the high frequency regions, an unnatural quality exists, certain parts of speech are over-accented, and any noise present is increased in amplitude.

When purchasing a mike, the type of response required is the first factor to consider. Music contains a much wider range of frequencies than speech, so if the mike is to be used in communications work, with a PA system, or in any application involving only speech, a limited response mike should be considered.

Non-directional mikes have essentially the same frequency response characteristics for all distances within range. Unidirectional and bidirectional types tend to emphasize the low frequencies when placed close to the sound source. This is particularly true of ribbon types; modern cardioids are relatively free of this proximity effect.

Carbon Microphones

The basic construction and hookup of a carbon mike is shown in Fig. 2. This type of unit does not generate a voltage as the other types do, but modulates a direct current in accordance with variations of the input sound waves. The battery acts as the voltage source, causing current to flow through the carbon granules and the primary of the output transformer. As long as the cur-

2 new instruments from Jackson

Peak-To-Peak and RMS VTVM

- Large 7" Meter and Hairline Pointer for greatest accuracy.
- Fast warm up time — complete accuracy in less than 5 minutes.
- Single probe for all measurements.
- Accurate AC voltage readings from 20 cycles to 2 mc.
- All-new tube and silicon diode circuitry.
- Factory calibrated for guaranteed accuracy.

\$6995 NET

RANGES: DC Volts (\pm), AC volts, 1, 5, 10, 50, 100, 500, 1000 volts full scale. Separate 1V RMS Peak-To-Peak, and Zero-Center DC scales. Ohms: RX1, 10, 50, 100, 1k, 10k, 100k and 1 meg. Center of RX1 Scale, 10 ohms. Accuracy, DC and Ohms, 3% full scale; AC volts, 5% full scale.



MODEL 590



MODEL 591

Wide Range Capacitance Tester

- Tests capacity from 10 uuf to 1000 uf in 4 ranges.
- Color-coded range push-buttons match scale colors.
- Graduated leakage tests for polarized or non-polarized capacitors.
- Low voltage leakage test for transistor-type capacitors.
- Graduated Power Factor test, 0 to 60%.
- Electron Ray Tube Indicator for all tests.
- Factory Wired and calibrated for guaranteed accuracy.

\$6495 NET

Coming Soon From Jackson—More New "Service-Engineered" Test Equipment

See Your Distributor or Write Today for Literature



16-18 S. Patterson Boulevard
Dayton 2, Ohio

IN CANADA: The Canadian Marconi Company

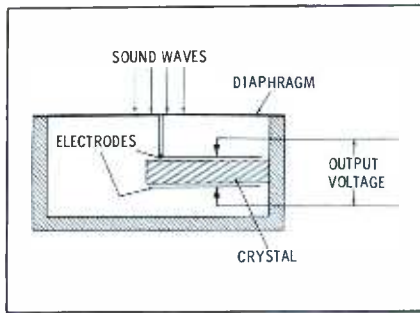

Fig. 3. Drawing illustrating construction and operation of a crystal mike.

rent remains constant, no voltage is induced into the transformer secondary; hence, there is no output. When sound waves strike the diaphragm, it vibrates, causing varying pressures on the carbon granules. As carbon compression increases, resistance decreases, and a larger current results. Less pressure on the carbon increases resistance because the granules spread farther apart; therefore, circuit current drops below normal. These changes are induced into the output circuit through the transformer. Working as a variable resistance, the carbon mike produces an output signal which is an electrical replica of the input sound waves.

The carbon mike has a number of advantages. It is rugged, develops higher output voltage than the other types, is simple in construction and operation, and can take considerable vibration without damage. In addition, it is inexpensive, and is not too easily affected by above average temperature or humidity.

However, its basis of operation limits its usefulness to certain fields. The carbon granules make only intermittent contact with each other, setting up small amounts of arcing between the granules. This causes hiss and noise as current flows through the circuit, a condition characteristic of all carbon mikes. Minimum signal which can be handled is determined by the amount of hiss and noise.

Another disadvantage is that the carbon granules sometimes become too tightly packed. Packing can be caused by excessive current (caused by shouting into the mike), or excessive moisture. Packing limits the extent of granule movement, and greatly reduces the output voltage. Sometimes jarring of the mike loosens the granules, restoring normal operation. Compared to other

types of mikes, the carbon unit has a very limited frequency response and a somewhat high distortion level. In addition, its response characteristics may vary from time to time, depending upon the position of the granules and the extent of packing.

The carbon mike requires a source of voltage, which can be considered a disadvantage, and it is essential that this voltage be pure DC. If the voltage were taken from a power supply, any ripple would modulate the mike current and cause hum in the output. Current is

usually less than 100 ma, and most often the unit is designed for 6-volt input. An adjustable resistor can be connected in series to regulate the current, and a press-to-talk switch is sometimes connected in series to permit switching the mike on and off. It is a low impedance mike, and can be either transformer or resistance coupled into the grid circuit of the audio amplifier.

Its characteristics limit this type of mike to voice use only, so it should not be considered where music is involved. For mobile communications, in amateur radio, and

Check TUBES, VIBRATORS THE SENCORE WAY

**FAST
ACCURATE
TROUBLE
SHOOTING**



America's Most Popular Tube Tester
more than 25,000 now in use

SENCORE LC3 LEAKAGE CHECKER

Whips those "tough dog" tube troubles . . .

Ask any serviceman who owns one . . . or try one for just one day of servicing in your shop. You'll see for yourself how much time the LC3 can save you. Checks for leakage between all elements, whether caused by gas, grid emission or foreign particles. Also checks leakage on all capacitors with voltage applied—including electrolytics. Provides instant filament checks in "Fil-Check" position—no need for a second filament checker. One spare pre-heating socket and new roll chart prevent obsolescence. New charts provided—no charge. Leakage sensitivity, 100 megohms, control grid to all other elements; 50,000 ohms, heater to cathode. Size, 7x6x3½". Wt., 3 lbs. For 110-120 volts, 60 cycle AC. DEALER NET **28⁹⁵**

Check Filaments of All Receiving Tubes and Picture Tubes



FC4 FILAMENT CHECKER

For fast, easy checking of all tube filaments, without pulling chassis. Neon light goes out if tube filament is good. Also acts as continuity and voltage tester. Neon lamp glows when 115 v. AC is applied by cheater cord, providing a check on power to TV set. Size, 3½x4x1". With leads. DEALER NET..... **2⁹⁵**

Check 3- and 4-Prong Vibrators . . . Faster, Easier



VB2 "VIBRA-DAPTOR"

Plugs into any tube checker; ideal for use with LC3 above. To check 6-v. vibrators, set for 6AX4 or 6SN7; for 12-v. vibrators, set for 12AX4 or 12SN7. Two No. 51 lamps indicate whether vibrator needs replacing. Instructions on front panel. Steel case. Size, 1½x1½x3". DEALER NET..... **2⁷⁵**

See your Parts Distributor NOW!

Turn page for other



SENCORE

ADDISON 2, ILLINOIS

in some PA system applications, the carbon mike produces strong output for close-up voice work. Its ruggedness is a definite advantage for uses where severe jarring or vibration is often encountered. The mike element itself is non-directional, except that in many cases it is mounted in a case to discriminate against noise and signal interference.

Crystal Microphones

The basic elements of a crystal microphone are shown in Fig. 3. Sound waves cause the diaphragm to move back and forth, and the

crystal bends with the movement. Due to the piezoelectric properties of the crystal (usually Rochelle salt), a voltage which varies with the intensity of the sound waves is produced. This voltage is taken from the electrodes which also serve to hold the crystal.

The crystal mike produces a high output, although not as high as the carbon type. It is fairly rugged and can be designed for wide response and low distortion. It requires no source of voltage and, being a high impedance unit, can be connected directly into the grid circuit of the

audio amplifier. Crystal mikes are relatively inexpensive, ranging from a few dollars up to around forty dollars, and are of the type usually supplied with tape and disc recorders. With these advantages it has many applications in amateur and commercial radio, PA systems, recording, and some broadcast work.

Although the frequency range of crystal mikes is good, there are often response peaks to contend with. In addition, the crystals pick up moisture quite easily, which tends to limit both sensitivity and response. This also means that response and sensitivity change from time to time. These disadvantages rule out its use in professional recording and broadcast work and in places where high temperature or humidity is encountered.

Crystals will not operate above about 120° F. For this reason, the use of crystal mikes with mobile radios is limited because of the high temperatures inside vehicles during the summer. Crystal mikes are reasonably rugged but can become damaged from shock.

They are high impedance units, and therefore the allowable length of mike cable is limited. If an excessively long line is necessary, a preamp with low impedance output can be used at the microphone; however, it is more advisable to use a low-impedance dynamic unit. At the amplifier or preamp, the crystal mike should be terminated in at least one megohm, otherwise the low frequency response may drop off too much. Voltage should never be applied to the crystal; even the low voltage of an ohmmeter could damage it.

The more recently developed ceramic microphones overcome some of the disadvantages of the crystal mikes. The ceramic type is not as susceptible to heat and moisture, and inherently gives better frequency response. Sensitivity of ceramic types is about 5 to 8 db less than crystal units, but this disadvantage can easily be overcome by additional amplification.

In the concluding part of this discussion, we'll have more to say about ceramic, as well as dynamic, ribbon, and capacitor mikes, plus some general hints on the use of mikes to obtain best results. ▲

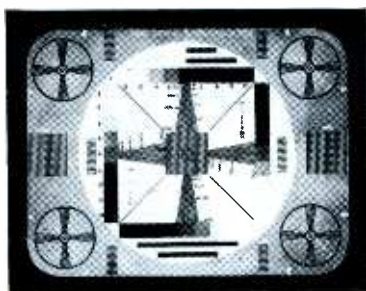

TV TIPS FROM TRIAD

NO. 4 IN A SERIES

There was a hopeful gleam in the serviceman's eye as he threw the burnt-out coil on the parts distributor's counter. "Glad to see you now have the Triad line," he said. "Do you by chance have a high-voltage coil that would stay IN that callback I picked up today?"

"Sure thing," said the counterman, examining the coil. "However, Triad's TV Guide points out that just replacing the coil on that particular flyback doesn't help much. Seems the high plate current raises the temperature of the whole flyback and 6CD6 to where something just has to give."

"One more strike and I'm out," said the serviceman. "What do I do?"

"Triad suggests their complete D-97-R unit—which gives good width and high voltage—but runs cool. As much as 50 milliamps less plate current."

"Sold. I never did like soldering high-voltage filament windings, but if it does the job, I'll buy it."

* * *

MORAL: Triad Transformer Corporation dedicates itself, in part, to making life easier for Professional Television Men, with such helps as (1) bonus information and (2) their series of Television Service Aids. Your card or letter to 4055 Redwood Avenue, Venice, California, will bring your "Callback Stopper Check Chart"—with the story of heat-reducing flybacks such as the D-97-R.

Industrial Electronics

(Continued from page 54)

called the *Curie* temperature of the metal. The rate of temperature rise changes sharply as the metal is heated above the *Curie* temperature. This sudden change is reflected back to the power oscillator as a decrease in load, and the work temperature then rises more slowly above this point unless the coupling is increased.

Surface Heating

In contrast to dielectric heating, which produces an even heat throughout the work, induction heating may heat only the surface metal. The depth of heat penetration into the work is controlled largely by the frequency of the applied power; i.e., depth of penetration decreases as frequency increases. This characteristic is used to harden surfaces of king pins without making them brittle. Fig. 1 shows a workman feeding king pins into an automatically controlled heat-timing and quench fixture. A high-frequency electronic heater supplies the RF power. Since the pins are made of steel, both circulating current and molecular motion generate the surface heat. As a result of uneven heating, the king pin becomes progressively softer from the outside to the inside. The central metal provides the toughness for shocks while the hard outer surface resists wear.

Brazing

Brazing is a method of joining metal parts by using an alloy which, when heated with the parts, melts and then forms a bond when allowed to cool. Soldering is a low temperature (350°F to 600°F) form of brazing which uses a joining alloy of lead and tin, or lead and silver.



Soldering by induction heating aids in fabricating electrolytic cans, terminal strips, etc. The metals which can be joined by soldering are copper, copper alloys, steel alloys, nickel, nickel alloys, and clad or plated aluminum.

A cleaning and protective chemical (flux) prevents oxidation and dissolves dirt during the heating process. Zinc, aluminum, and ammonium chlorides are the most active fluxes and are commonly used in paste form; however, they leave a residue which is corrosive, conductive, and hygroscopic (attracts mois-

ture from the air). In electrical applications, these properties cause trouble. The solution to this problem is to use a resin flux which leaves a harmless residue. Resin flux is less active than other types, however, and when used for heating applications, greater care must be exercised in precleaning and handling operations. A recently developed *H-series* soldering flux is more active and vaporizes during the heating process, leaving an insignificant residue.

High-temperature brazing provides a bond comparable to weld-



The missing link in TV service . . .

SENCORE SS105 SWEEP CIRCUIT TROUBLE SHOOTER

IT'S A . . . UNIVERSAL HORIZONTAL OSCILLATOR. For direct substitution. No wires to disconnect in most cases. Traces trouble right down to the defective component. Variable output from 0-200 volts, peak-to-peak.

HORIZONTAL OUTPUT CATHODE CURRENT CHECKER. A proven method that quickly checks the condition of the horizontal output tube and associated components. Adaptor socket prevents breaking wires. Easily replaceable Roll Chart gives all necessary pin, current and voltage data.

UNIVERSAL DEFLECTION YOKE. A new, simple way to determine yoke failure accurately—without removing yoke from picture tube. Merely disconnect one yoke lead and substitute. If high voltage (also bright vertical line) is restored, TV yoke is defective.

DYNAMIC FLYBACK TRANSFORMER CHECKER. Merely flip switch to "Flyback Check" and meter will indicate condition of flyback transformer, in degrees of horizontal deflection. Extremely sensitive and accurate; even shows up one shorted turn on flyback.

VOLTMETER. For testing bootstrap, screen and other voltages. Direct-reading voltmeter, 0-1000 volts.

UNIVERSAL VERTICAL OSCILLATOR. Checks oscillator, output transformer and yoke. Merely touch lead to component and check picture on screen.

Size, 7x6x3½". Wt. 4 lbs.
For 110-120 volts, 60 cycle AC.

DEALER NET 39⁵⁰



HORIZ. OSC.	VERT. OSC.
HORIZ. O.P. STAGE	VERT. O.P. STAGE
HORIZ. FLYBACK XFORMER	VERT. O.P. XFORMER
HORIZ. DEFLEC. YOKE	VERT. DEFLEC. YOKE

See Your Parts
Distributor
NOW!

SENCORE
ADDISON 2, ILLINOIS

SUBSTITUTE PARTS WITH-OUT SOLDERING
 Quickly with E-Z-Hook "SUB" Connectors. Has 1001 Uses!

Connect a speaker, or
 Substitute a
 • transformer
 • capacitor
 • resistor, or choke
 In Seconds!!

★ Makes connections instantly!
 ★ Won't pull off!
 ★ Insures positive contact!
 Saves time, money and parts in servicing, experimenting, instructing and production.

E-Z-HOOK SUB
 No. 71-1...SUB Only 69¢.
 Six Colors!-for Easy Lead-Identification
 Canadian Rep.: Len Finkler & Co., Toronto, Ontario

ORDER THROUGH YOUR PARTS DISTRIBUTOR
 E-Z-HOOK TEST PRODUCTS
 Dept. F, 1536 Woodburn Ave.
 Covington, Ky.

for your workbench . . .
NEW!
THE ALPHA WIRE
dispensA rack
 T.M.



THE ALL-PURPOSE SELF-STACKING WIRE DISPENSER

49¢
 at your radio-electronics parts distributor

- fits anywhere, any space
- unlimited combinations
- handy ruler
- no snarling—ends wire loss
- designed for all Alpha ServiceSpools

STACK 'EM . . . build them up, back to back, side by side
 MOUNT 'EM . . . on a bench, on a wall, on a peg board, under a bench

ALPHA WIRE CORPORATION
 200 Varick Street, New York 14, N. Y.

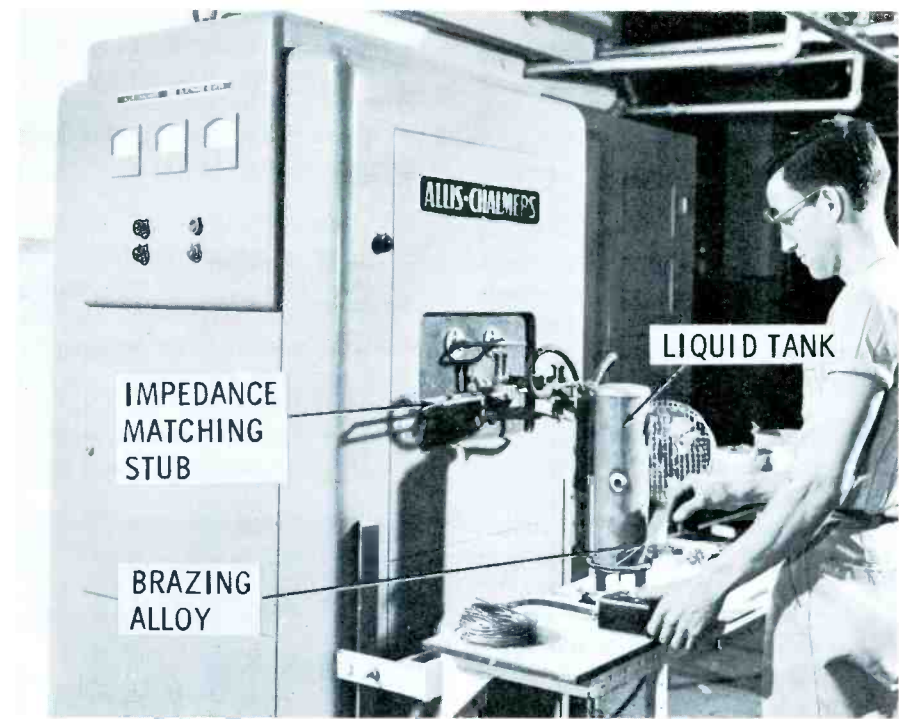

Fig. 3. No shock hazard exists here because the coil is only a few volts positive.

ing. Joining alloys for brazing are copper and silver; copper, silver, and zinc; silver and maganese; and copper. These alloys melt at temperatures ranging from 1125°F to 1980°F. Fluoride or alkali salts are generally used as brazing fluxes, although special fluxes may be required in difficult jobs.

Fig. 2 shows two fixture platforms holding four items each. One fixture is set up while the other brings the work up to the heating coils. Discs (in the operator's right hand) are being placed on brass sleeves (in the fixture) with thin rings of joining alloy (in the left hand) in between. The disc and sleeve are coated with brazing flux at the contact areas, and the application of low-frequency power provides deep heat penetration.

Another brazing operation is demonstrated in Fig. 3. The ends

of a compressor tank are brazed to the center piece in one-third the time required by older, hand-torch methods. Joining alloy is added by the operator in this application because complete, airtight sealing is required. No shock hazard is present because the work coil is only 2 to 10 volts above ground.

Frequency Selection

Electronic heater frequency is selected after considering the heating properties desired. At 300 kc/second, metal is uniformly heated. Power is easily coupled to large pieces of work at this frequency; however, as the size of the work decreases so does the coupling efficiency. The highest frequency which still results in uniform heating increases as work size decreases. Although the depth of penetration

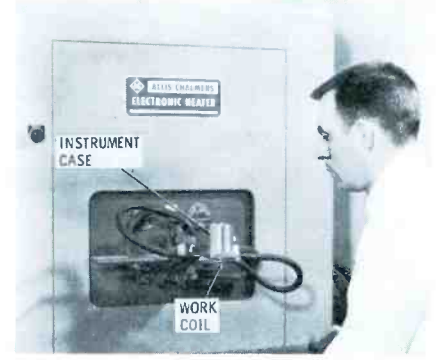

Fig. 4. This 10-kw heater seals lens in instrument case using 300-kc RF power.

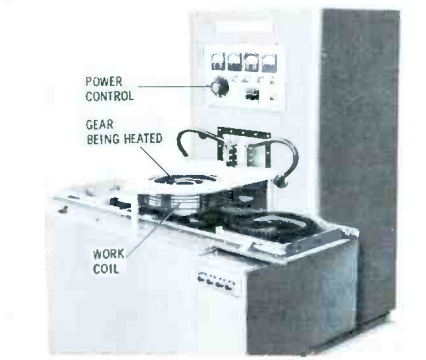

Fig. 5. Electronic heater used for case-hardening transmission-gear teeth.



Fig. 6. Heat is used to anneal gears to make them tough and wear-resistant.

is inversely proportional to frequency, smaller pieces can be heated uniformly at higher frequencies because they have smaller diameters.

Depth of penetration is constant for a given frequency and size of work; thus, a penetration of one-thousandth of an inch means that a solid circular work piece whose diameter is two-thousandths of an inch is heated uniformly, whereas work pieces with larger diameters are surface heated to a depth of one-thousandth of an inch only. Because coupling efficiency increases with frequency, and depth of penetration varies inversely with frequency, the highest possible frequency is usually selected. When a dielectric material is also present in the work-coil field, a frequency below the optimum may be chosen to reduce the heating effect on the dielectric.

In Fig. 4, the lens in an aircraft instrument is being permanently sealed in a brass tube by induction heating. Low frequency (300 kc) prevents the lens from being heated



UP FOR GOOD!

TACO TV ANTENNAS

...For your good! Nothing spells customer satisfaction as much as performance—and that's exactly what a Taco antenna provides. For more years than any other antenna manufacturer, Taco has provided the TV technician with the antennas best suited for all reception requirements. Try one on that next installation and see for yourself...

WRITE FOR COMPLETE TACO TV-FM-AMATEUR CATALOG.

TECHNICAL APPLIANCE CORPORATION, Sherburne, N. Y.

3

Type SMT SUB-MINIATURE the BEST in ELECTROLYTIC CAPACITOR DESIGN

A complete line of capacitors for all miniaturized transistor circuits.

The best in sub-miniature capacitors for replacement, development and original equipment. Outstanding features include patented construction, hermetically sealed in aluminum cases for long life; low leakage; stable through a wide temperature range and voltages.

Available from leading parts distributors everywhere. Illustrated catalog upon request.

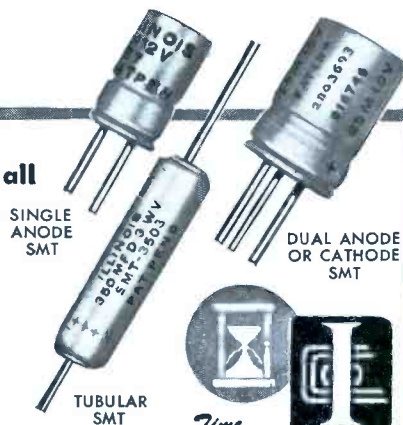

SINGLE ANODE SMT

DUAL ANODE OR CATHODE SMT

TUBULAR SMT



TWX: CG3149 *Time Tested Quality*

Telephone: EVerglade 4-1300

ILLINOIS

CONDENSER COMPANY

1616 N. Throop Street Chicago 22, Illinois

Export Department, 15 Moore Street, New York City, New York; Cable, Minthorne, New York



QUICK-SILVER FOR YOU... MERCURY FOR US

Merit shipments to all parts of the United States are jet-fast, and sure as sunrise. Mercury, the mythical god, would be pleased.

MERIT CONSISTENT QUALITY PLUS FAST DELIVERY MEANS QUICK-SILVER FOR YOU... EXTRA-DOLLARS AND BIGGER PROFITS.



COMPARE IT WITH **MERIT**
MERIT COIL AND TRANSFORMER CORP
MERIT PLAZA . HOLLYWOOD, FLORIDA

TARZIAN Offers 48-Hour, Direct Factory Service on Tuner Repairs



That's right. Net, \$7.50 per unit and \$15 for UV combinations, including ALL replacement parts. 90-day warranty against defective workmanship and parts failure. Tuners repaired on approved, open accounts. Replacements offered at these prices* on tuners not repairable:

- VHF 12 position tuner . . \$22.00
- VHF 13 or 16 position tuner 23.00
- VHF/UHF combination 25.00
- UHF only 15.50

*Subject to change



Tarzian-made tuners are easily identified by this stamping on the unit. When inquiring about replacements for other than Tarzian-made tuners, always give tube complement... shaft length... filament voltage... series or shunt heater... IF frequency and chassis identification. Use this address for fast, 48-hour service:

SARKES TARZIAN, Inc.
Att.: Service Mgr., Tuner Division
East Hillside Drive
Bloomington, Indiana

by dielectric effects. The selectiveness of frequency with relation to the heating effect is responsible for many industrial feats. For instance, the glass face of a metal cathode ray tube is fused to the metal cone by high-frequency electronic heating. These applications show that RF frequencies cannot be sharply defined as pertaining to dielectric or induction heating only. At 100 kc/second, heating is primarily by induction, while 100-mc RF is generally useful only for dielectric heating. Within these bounds there is a gradual shift of application from one form of heating to the other.

Work Coils

The matching impedance may be perfect, the frequency may be properly selected, and still the work will not be heated satisfactorily. Work material must be heated uniformly throughout a certain area before induction heating has any meaning. Shaping the work coil to fit the job is a start, but the induced field distribution will dictate the coupling provisions for specific areas. For instance, Fig. 5 shows the work coil used in hardening the teeth on a tractor transmission gear. The teeth surfaces must be hard, but at the same time penetration must be limited to a fraction of an inch. The coil is located around the circumference of the gear, and high-frequency power is applied. The table platform raises and lowers the gears to place them inside the coil. A quenching liquid is sprayed on the gear as it reaches the desired temperature. The gear is not finished with its heat treatment when the teeth are hardened. The center of the gear is heated using the work coil shown in Fig. 6. Low-frequency power is used to get deep penetration, and a single-turn work coil provides proper coupling. The gear is cooled slowly and evenly, annealing the center metal of the gear to relieve stresses which could later cause the gear to break.

The coupling coil of Fig. 6 is a link between the oscillator tank coil; it acts as a primary while the work is used as a secondary. Link-coupling similar to this is common in transmitter interstages where inductive coupling is required. The link forms a low-voltage, high-current transmission line, actually coupling

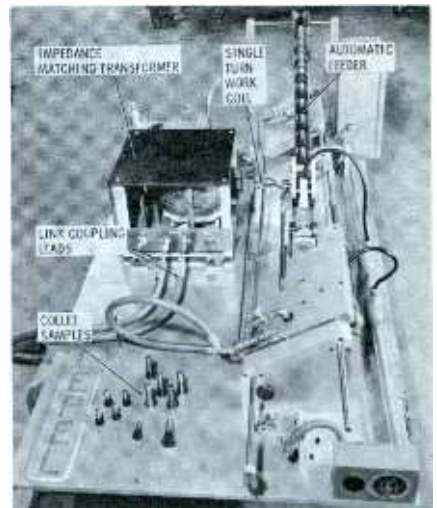
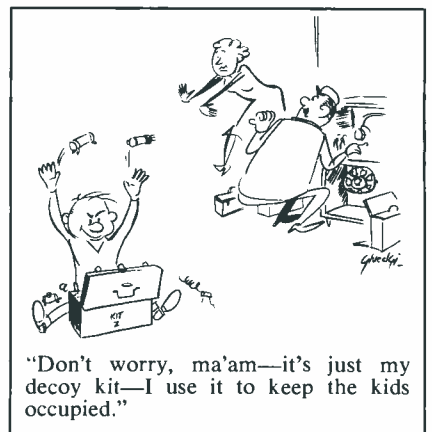

Fig. 7. Link-coupling permits the heater to be placed in a remote position.

two physically separated transformers. Dual transformer coupling by means of a link is further illustrated in Fig. 7. Two lines are identified as the link between the final transformer and the electronic heater. With this insulated link, the work table can be located away from the electronic heater without arc-over or shock-hazard problems. Collets are surface-heated and quenched in an automatic cycle, thereby providing a hard, wear-resistant surface and a tough body.

Proper work coil design enables heat treatment of manufactured items ranging in size from sewing needles to generator arbors for hydroelectric generators. Work coil shapes may be made to fit all types of contour parts encountered in brazing. Power may be concentrated by the work coil on a single area of a part so that the desired area is heated to the melting point while the unheated areas of the part may be touched with bare hands.

In the next installment, we'll discuss the circuits used in electronic heaters. ▲



Notes on Test Equipment

(Continued from page 52)

erated radios in the lab, and although the instrument is limited to certain load currents. I noted that these limitations could be ignored as far as portable transistor radios are concerned. Due to the excellent filtering and voltage-regulating features, I also found that the radios functioned without any interfering AC hum or buzz.

There are a number of applications for a small power supply such as the Model 1020 over and above those you'd normally expect. One that I used, for example, is choosing a correct bias potential for filament circuits in audio amplifiers and preamplifiers to minimize hum which could otherwise seriously affect fidelity. By biasing the AC filament circuit with a DC voltage slightly above or below its normal ground return, amplifier hum originating from this source can often be reduced. This condition usually stems from a heater-to-cathode difference in DC potential on one or more of the amplifier tubes.

To determine the right voltage for this application, I merely connected the positive terminal of the supply directly to the isolated filament circuit or, after removing its ground return, to the center tap of the filament winding on the power transformer. The negative terminal goes to chassis ground. I then adjusted the output voltage until minimum hum conditions were achieved. Reversing bias polarity by switching the power supply leads, I repeated the procedure and noted which polarity produced best results.

Since it's often difficult to ascertain slight variations by ear, I pre-



Fig. 2. The Model 1020, using two transistor regulators, is small in size.

XCELITE PLIERS

have a . . .

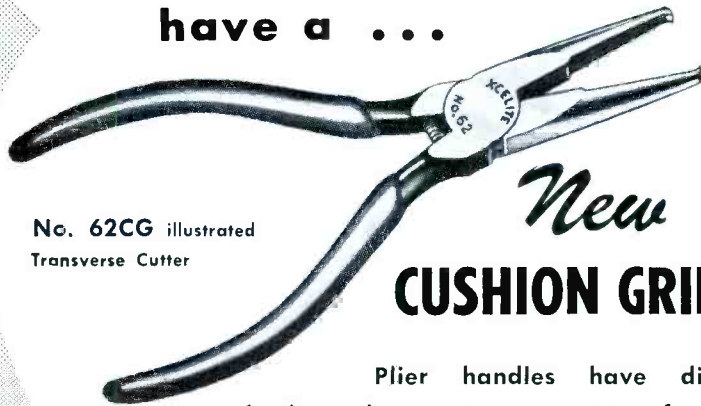

No. 62CG illustrated
Transverse Cutter

New
CUSHION GRIP!

Plier handles have dipped
plastic coating . . . permanent, comfortable.
Heads polished and buffed to a "mirror finish".
All pliers available . . . See Your Distributor!

Gives pliers a "Feel" that inspires Craftsmanship!

XCELITE, INCORPORATED
ORCHARD PARK, NEW YORK
Canada: Charles W. Pointon, Ltd., Toronto

XCELITE
Quality Hand Tools
PREFERRED BY THE EXPERTS

NEW

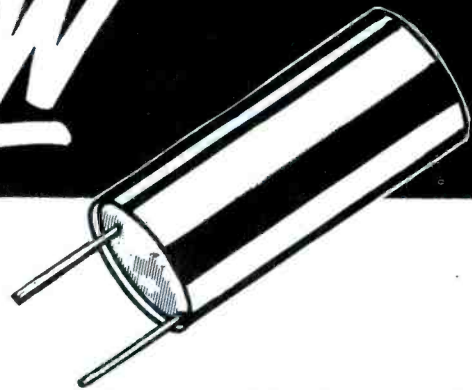

Type "SA" . . . small single section electrolytics for printed circuit boards . . . hermetically sealed in aluminum tubes covered with red kraftboard insulating jackets . . . extra heavy tinned terminals anchored for proper spacing by a high melting point wax . . . for 85°C operation . . . individually packaged. Recommended for TV, radio and industrial applications.

See Your Parts Distributor

"ENGINEERED FOR QUALITY"

GUARANTEED FOR ONE YEAR

PLANET SALES CORPORATION
225 Belleville Avenue
Bloomfield, N. J.

BERNS PERFECT PIN-CRIMPER

Picture-Tube Repair Tool

Eliminates that hard soldering job.

only \$1.25

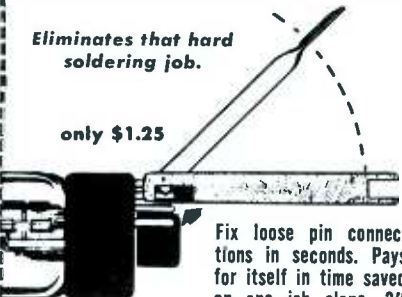

Fix loose pin connections in seconds. Pays for itself in time saved on one job alone. 3" long.

Patent 2,878,698

Intermittent operation of picture tubes due to defective solder connections at socket pins is easily corrected through the use of the Berns Perfect Pin Crimper. Actually a 3-in-1 tool that can also be used as a channel-selector wrench and screwdriver, it serves to notch pins and element leads to provide solid electrical connections. Pin keeps its original form.

IT'S DANDY . . . IT'S HANDY
"you'll like it"

Available at your parts distributor.
Another fine product from:

BERNS Mfg. Co.
9853 Chalmers,
Detroit 13, Mich

SAMS PHOTOFAC INDEX

sent direct to your shop

FREE

SEND FOR IT!

Yes, now you can have the valuable SAMS MASTER INDEX TO PHOTOFAC FOLDERS and Index Supplements sent direct to your shop at no cost to you! Just mail coupon below and you'll be sure to receive regularly your handy guide to the world's finest service data covering over 33,000 TV, Radio, Amplifier, Tuner Tape Recorder and Changer models. Send for it—it's FREE!

MAIL COUPON

Howard W. Sams & Co., Inc.
2201 East 46th St., Indianapolis 6, Ind.

Put me on your mailing list to receive the Sams Photofact Master Index and Supplements

I'm a Service Technician: _____ full time; _____ part time

My Distributor is:

Shop Name: _____

Attn: _____

Address: _____

City _____ Zone _____ State _____

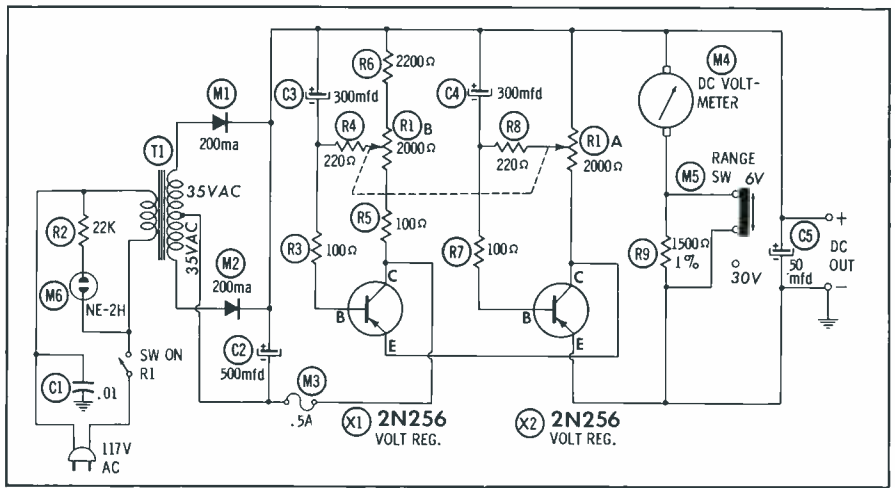

Fig. 3. Circuitry of the Model 1020, revealing the application of transistors.

fer to use an oscilloscope to monitor hum voltage. Incidentally, circuits that develop AC filament voltage with respect to chassis ground must be rewired as an isolated network before this DC biasing trick can be used.

After employing the variable DC

A Report on the "VoltOhmyst"

RCA is currently marketing a vacuum-tube voltmeter that is available as either a kit or factory-wired instrument. Pictured in Fig. 5, the Model WV-77E features a plastic holder on its carrying handle to store test leads and power cord for compact portability.

Specifications are:

1. Power Requirements—105/125 volts, 50/60 cps; power consumption approx. 5 watts; one self-contained 1.5-volt battery; ON indicator provided on front panel.
2. AC Voltmeter—rms ranges from 0 to 1.5, 5, 15, 50, 150, 500, and 1500 volts, separate scale for 0 to 1.5 volts; peak-to-peak ranges from 0 to 4, 14, 140, 400, 1400, and 4,000 volts, separate scale for 0 to 4 volts; frequency response $\pm 1/2$ db from 20 cps to 500 kc on all ranges up to 400 volts p-p; accuracy $\pm 5\%$ of full-scale deflection.
3. DC Voltmeter—ranges from 0 to 1.5, 5, 15, 50, 150, 500, and 1500 volts; input impedance 11 megohms with probe and cable; accuracy $\pm 3\%$ of full-scale deflection; zero center-scale indication provided.
4. Ohmmeter—ranges of R x 1, 10, 100, 1,000, 10K, 100K, and 1 meg; center scale 10; ohms circuit protected by $1/2$ -amp fuse; zero- and ohms-adjust controls on front panel.
5. Size and Weight—8" x 5 5/8" x 4 1/2"; approx 4 lbs.

I know that many of you are interested in building your own test equipment whenever possible, so I

supply to determine the correct polarity and voltage value, you can then obtain the needed bias from other circuits in the equipment and make a permanent modification. A few examples of hum-reducing circuits using fixed values are shown in Fig. 4.

made it a point to obtain a kit version of this RCA VTVM and built it here in our own lab.

The kit instrument is identified as Model WV-77E(K) and comes complete with tubes, test leads, and even solder. Aside from a complete parts list and schematic, I was supplied with a large instruction chart which included about a dozen drawings and over 150 detailed steps to lead me by the hand through the entire construction and calibration of the instrument. Don't let the number of assembly steps scare you, for most of them are only a short sentence representing one simple operation. Don't try to hurry through, however; allow yourself ample time to digest the instructions and complete each step before going to the next.

Most of the parts are assembled on a printed-wiring board about two-thirds the size of the front panel. As a guide in placing components on the board, I found that a symbol number for each part is printed in white ink (in its exact location) on the opposite side of the board from the etched wiring. Naturally, it takes a few hours to build the kit, but no special tools or exceptional "know-how" is necessary.

ANOTHER HUNTER FIRST!

THE ATOM

3 NUT DRIVERS in 1
IN 3 POPULAR SIZES
1/4" • 5/16" • 3/8"

... SLUG RETRIEVERS ...

Magic-Tip
SCREW HOLDING
SCREWDRIVERS
NOW IN 14 PROVEN SIZES!

9851 ALBURTIS AVE.
SANTA FE SPRINGS, CALIFORNIA

HUNTER TOOLS



"Stop playing your pancakes and start eating them, or I'll take away that Jensen Cartridge!"

The power supply of the instrument employs a transformer and single selenium rectifier. A 6AL5 functions as a full-wave rectifier for AC inputs, while a 12AU7A is used in a push-pull balanced DC bridge having a 400-ua meter movement in its plate circuit. The meter face is fairly large and easy to read with its AC and DC scales color coded to match colored voltage markings on the range selector. The function selector (also on the front panel) has both positive and negative positions for DC measurements.

I find that servicemen interested in building kit-type equipment are usually more concerned with final calibration procedures than with the more familiar mechanical and elec-

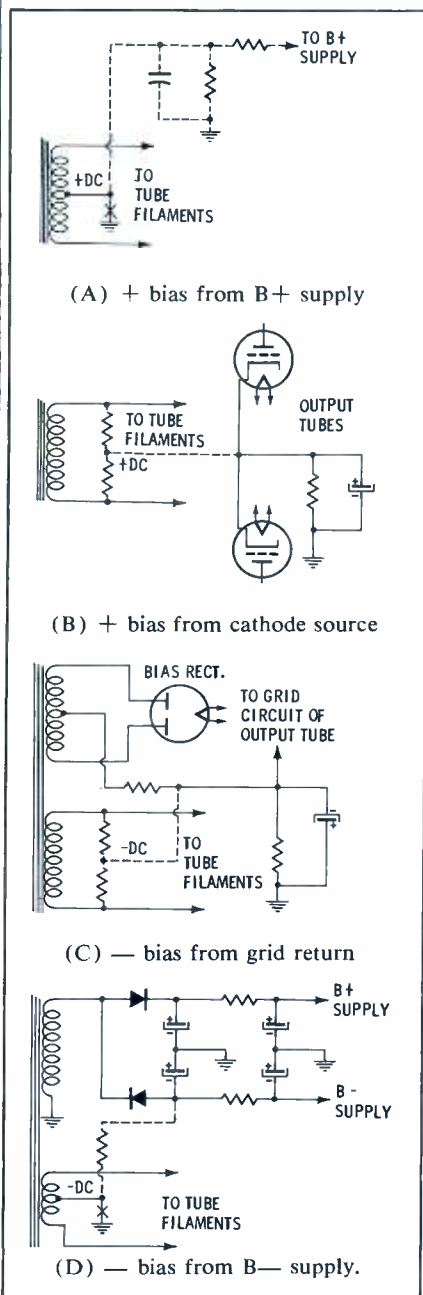

Fig. 4. Typical filament circuits.

MORE

OF EVERYTHING
YOU WANT IN A
**TRANSISTOR
CHECKER**



FOR ONLY
\$89.00

THE
PRECISION
MODEL 960

- **Direct Icbo Readings** in terms of true collector current.
- **Five Icbo Ranges** cover all types of transistors - low, medium and high power . . . n-p-n and p-n-p types.
- **17 D.C. Collector Voltages:** .5 volts DC to 100 volts DC in 17 steps.
- **Direct-Reading Gain Ranges:** 5 separate injection currents.
- **Leakage:** Reliable check of emitter to collector leakage current provides basis for accurate gain tests.
- **Crystal Diode Tests:** Separate tests for both forward and reverse currents.
- **Transistor Test Settings** listed on high speed roller chart.
- **Patchcord Selector System** and universal adapter provide for future semiconductor releases.
- **Wide-Angle, 5 1/2", 100 microampere sensitivity PACE meter.**
- **Free Transistor Test Data Subscription Service** for one full year.

MODEL 960: Complete with portable carrying case and comprehensive technical manual **Net Price: 89.00**

► Available and on display at leading electronic parts distributors. Write for complete **PRECISION** catalog.

► **PRECISION** Test Equipment carries a full year warranty!



PRECISION

Apparatus Company, Inc.
70-31 84th St., Glendale 27, L. I., N. Y.
Export: 458 Broadway, New York 13
Canada: Atlas Radio Corp., Toronto 19

NEW *
TV/FM with "Anti-Stub"
ANTENNA OUTLETS



New Type FD-1PK MOSLEY TV & FM Outlet permits multiple antenna outlets to be wired in tandem without losses due to stub effect of unused line.

*When polarized plug is inserted, the silver-plated spring leaf switch opens the circuit beyond the outlet in use. Action is positive . . . fail-safe!

Type FD-1PK, complete with polarized plug and mounting brackets. List Price \$2.20

Exclusive Features!

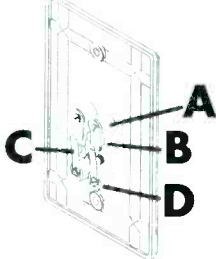

- A. Strong one-piece molded construction!
- B. Passive contacts lock in place!
- C. Contacts are silver-plated . . . positive, corrosion proof!
- D. Molded guide holds contacts parallel . . . prevents shorts!

Available at your favorite parts distributor.

Mosley Electronics, Inc.

8627 ST. CHARLES ROCK ROAD
 ST. LOUIS 14, MISSOURI

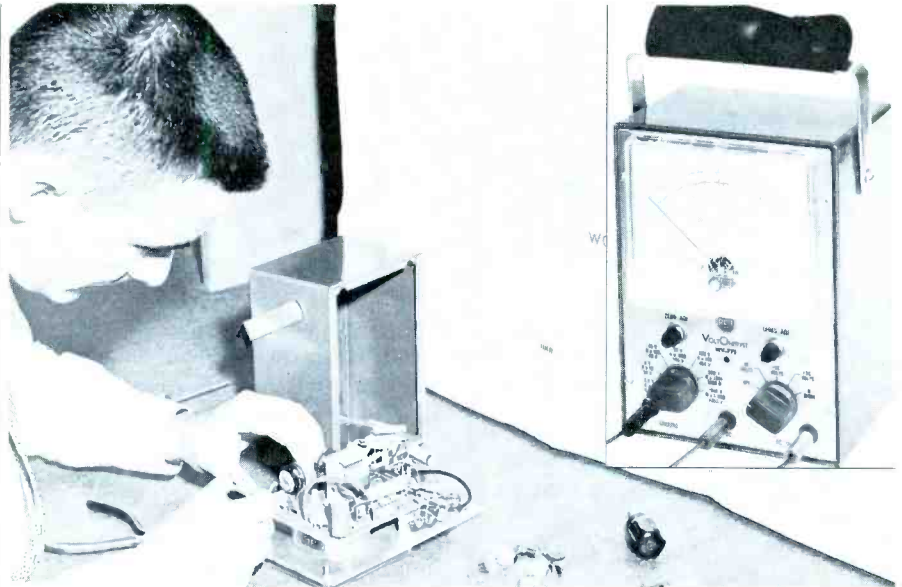

Fig. 5. RCA's new VTVM comes wired or as an easy-to-build kit. It measures DC or rms volts up to 1500V, p-p signals to 4,000V, and resistances to 1,000 megohms.

tronical construction steps involved. For this reason, I will describe some of the final touches for this VTVM kit before it can be placed in reliable and profitable service.

Before mounting the chassis in its metal case, I checked to see that the knife-edged meter needle pointed to "0" with the function switch in its OFF position. It didn't quite make it, so I adjusted the plastic screw head on the front of the meter until the pointer lined up with the zero mark at the left edge of the scale. Following instructions, I supported the front chassis panel in its normal upright operating position and inserted the AC plug into a 117-volt outlet. I then set the function switch to +DC VOLTS and placed the range selector to its 1-5-volt position.

After about a 15-minute warm-up period, I proceeded with the DC calibration and plugged in the red and black test leads to the DC and ground jacks, respectively. Connecting the tip of the DC probe (which

contains a 1-megohm isolating resistor) to the clip end of the ground lead, I zeroed the meter by manipulating the ZERO ADJ. control on the front panel. I then disconnected the DC probe from ground and touched it to the positive terminal of the instrument's 1-5-volt battery.

The final step was to adjust the DC calibration control, which is the center potentiometer of a three-section unit mounted to the printed-wiring board (see Fig. 6). This control, located in the plate circuit of the 12AU7 dual-triode, is used to balance the DC meter bridge. While holding the probe on the battery terminal, I adjusted it until the meter needle read beyond full-scale deflection—or to the recommended position shown in Fig. 7.

After completing these DC touch-ups, I also calibrated the instrument's AC and ohms circuits by two simple procedures involving the 117-volt source and the ohms adjustment on the front panel.

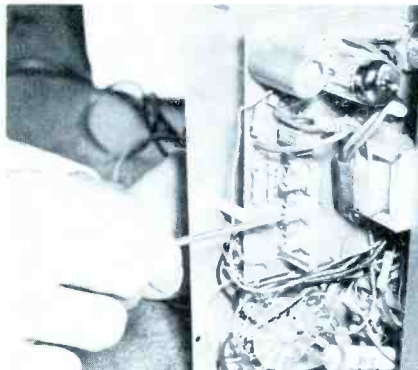

Fig. 6. Do-it-yourself adjustment of the WV-77E(K) includes DC calibration.

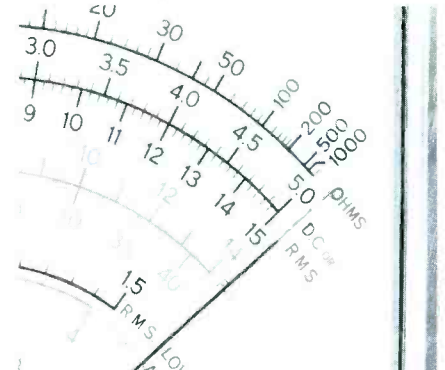

Fig. 7. Close-up of meter shows correct position of pointer for DC calibration.

PRODUCT report

For further information on any of the following items, circle the associated number on the Catalog & Literature Card.

Stereo Cartridges (38G)



Three new Astatic high-output stereo cartridges, Models 70TS, 74TS and 76TS-TB, differ from each other in mounting arrangements but have identical performance characteristics as follows: Output 2 volts, frequency response 50-10,000 cps, channel separation 20 db, and stylus pressure 10 gm. All use Astatic needles N8-7 and N8-3.

Wire Dispenser (39G)



The interlocking-type construction of Alpha *dispens-Aracks* makes it easy to fasten several of these wire-dispensing units together side-by-side, back-to-back, or in vertical stacks to provide increased storage capacity. For convenience in measuring lead lengths, an 8" ruler is printed along the top edge of the rack.

Fringe-Area Antenna (40G)

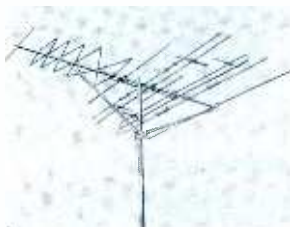

Two driven dipoles (one folded *Satellite Sleeve* and one straight rod) are used in the latest-type JFD *Power-Helix* antenna for fringe areas. List price of the basic model, PX911, is \$35; a gold-anodized aluminum version (AX911) is \$42.50; and two-bay stacked arrays are available at \$72.50 (regular finish) or \$87.50 (anodized).

Tuner Cleaner (41G)



Accessories included with each 8-oz. aerosol spray can of Chemtronics *Tun-o-lube* tuner cleaner are a flexible plastic *Spray Aid* (for directing the spray into hard-to-reach places) and a wall-mounting bracket which grasps the lip of the can. The cleaning fluid is a non-flammable formula which includes a contact lubricant. Price is \$1.98 per can.

Oval Speaker (42G)



Quam Model 48A2 is a 4" x 8" speaker which replaces original equipment in numerous recent models of auto radios as well as in certain RCA and Sylvania radio and TV sets. Power-handling capability is rated at 4.5 watts, magnet weight is 1.4 oz., over-all depth is 2 3/16", and list price is \$6.95.

Soldering Irons (43G)

Interchangeable ceramic heating elements are used with the SIDCO *Kiss'n Cool* soldering-iron handle. Some have permanently-attached soldering tips, while others are fitted with detachable 1/8"-diameter tiplets. Both series of elements are available in several ratings within the range of 25 to 50 watts.



Non-Polarized Electrolytics (44G)

Tubular, non-polarized electrolytic capacitors, Illinois Type IHTAC, are designed for use in crossover networks in high-power audio equipment. These units have "flat" characteristics over the frequency range from 30 cps to 15 kc. Several values are available—for example, 75 or 50 mfd at 25 VAC and 4 mfd at 12 VAC.



Fuse Rack (45G)

The *Fusemaster*, a clear plastic wall rack with 60 "slide-in" compartments for fuse boxes, is now available from Littelfuse. All the compartments are labeled with various fuse-type numbers to help the service dealer set up a complete, orderly inventory. A supply of blank, adhesive-backed paper strips is also provided for the dealer's convenience in modifying the labeling system to suit his needs.



Resistor Assortments (46G)

IRC *Handy-Paks* of carbon composition resistors are supplied in a number of ingeniously-packaged assortments, such as the *Resist-O-Caddy* folding plastic pouch (\$14.40), the *Resist-O-Pedia* loose-leaf binder (\$46.80 or \$55.44, depending on contents), and the *Resist-O-Chest* metal file box (\$24.48 or \$55.44).



High-Compliance Cartridge (47G)

The *Professional 55* version of the Columbia CD stereo cartridge is intended for use with transcription turntables. Special features include a small (0.5-mil) diamond stylus and a very low tracking force of 1.5 grams. Two pairs of miniaturized, plug-in equalizing networks (for both low- and high-level inputs) are supplied with each cartridge.



New Tubes in Stock (48G)

Latest additions to the Raytheon line of replacement radio-TV tubes are the following: 3CY5 tetrode RF amplifier, 6DT5 vertical-output pentode, 6EH8 triode/pentode oscillator-mixer, 6J6A twin-triode oscillator-mixer for 450-ma series-string circuits, 9AU7 dual triode for 450-ma circuits, 9BR7 dual-diode/triode for sync and horizontal AFC stages, and 12AZ7A dual-triode amplifier.

This Lamp Designed to Operate Miles Underground!

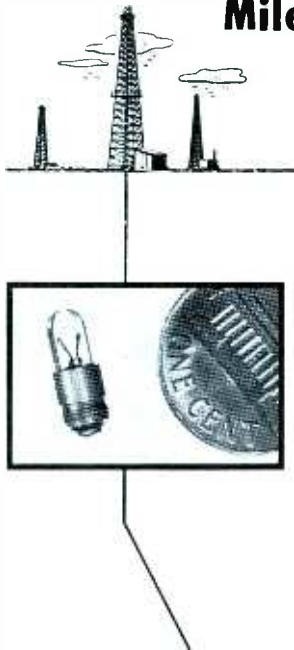

In drilling an oil well, the drill pipe often goes astray when the rotary drill is deflected by a tilted strata of hard rock. The drill crew cannot know what is happening 5 to 20 thousand feet below ground.

To check the accuracy of the drilling an instrument containing a camera, a scale indicating any deviation from the vertical and a compass to indicate the direction of the deviation, is lowered into the drill pipe. This instrument is subjected to severe shock and temperatures to 325°F.

The lamps illuminating the scale during photography were frequent casualties, much too frequently for efficiency and economy. Chicago Miniature was consulted, and produced a lamp that, without decreasing light output, increased lamp life by 1500%.

This superior quality is found in all Chicago Miniature Lamps—standard as well as special.

Always specify Chicago Miniature when ordering from your jobber!

Write for Catalog and Complete Information.



CHICAGO MINIATURE LAMP WORKS

1518 No. Ogden Ave., Chicago 10, Ill.
Miniature Lamps for every requirement



Model EFB \$120 Net

New! Super-Filtered DC for transistor design work

Less than 1/10% (10 mv.) AC ripple up to max. load

DC Power ... for precision laboratory and design work

- Dual range — 0-32 volts up to 4 amperes
0-16 volts up to 8 amperes
- Internal Impedance: 4 ohms at 32 volts
2 ohms at 16 volts
- Smooth voltage control with continuously variable carbon brush-type auto transformer
- Long-life selenium rectifiers—patented heat sink cooling

Rack Mounted Model EFB...\$145 Net

Send for new detailed Bulletin EFB!



ELECTRO PRODUCTS LABORATORIES

4501-R Ravenswood, Chicago 40, Ill., LOngbeach 1-1707
Canada: Atlas Radio Ltd., Toronto

9587

Three-Channel Stereo (49G)

Electro-Voice has developed a system whereby left and right-channel stereo signals can be matrixed together and fed to a third, centrally-located speaker to create a "three-channel stereo" effect. The system includes a complete three-channel setup comprising a pair of four-way *Patrician 700* speaker systems (each with 30" bass reproducer), a Model XT-1 mixer transformer (shown), and a three-way *Stereon 200* center-channel unit.



Transistorized Power Supply (50G)

For operating mobile radio receivers and transmitters from a 12-volt battery source, the Webster Electric Model 2D11 transistorized power converter furnishes dual outputs of 500 VDC at 150 ma and 250 VDC at 80 ma. Continuous operation is permissible up to 104° F; "two minutes on—three off" operation at 122° F. Maximum battery drain is 15 amps. The unit measures 4¾" x 4" x 8" and weighs 3½ lb.



Radial-Lead Capacitors (51G)

Arco-Elmenco *dp* capacitors, with a combination *Mylar* and paper dielectric, are about half as large as conventional tubular capacitors. The outer coating, formed by dipping into phenolic resin, is much more humidity-resistant than molded coatings. Ratings permit reliable continuous operation at full rated voltage up to 110° C. Packed in transparent *5-Pak* bags, values available are .001 to .25 mfd at 600V and .001 to .05 mfd at 1,600V.



Stylus Pressure Indicator (52G)

Tracking force may be measured with the Clevite "Walco" *Microgram Stylus Pressure Gauge*, using the following procedure: Place the gauge on the turntable, rest the stylus on the broad end of the gauge, and place the counterweight on the slender end of the gauge to achieve a balance. Read stylus pressure directly in grams. Retail price is \$1.50.



Audio Test Record (53G)

To aid servicemen in testing hi-fi equipment, Audiotex (division of GC-Textron) has introduced an unbreakable *Audiotester* LP record. One side features a recording of a metronome (for balancing stereo channels) and other test signals for pickup alignment, channel separation, frequency response, RIAA equalization, and turntable rumble. On the other side are several monophonic tests. List price is \$4.98.



TV Twin Lead (54G)

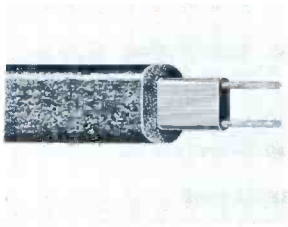

Belden *Permohm* antenna lead is designed for low signal loss under adverse conditions such as exposure to ice, smog or salt spray. The twin conductors are encased in a solid polyethylene ribbon and then embedded in a thick casing of foamed polyethylene. 50', 75', and 100' hanks, 500' cartons and 1000' spools are available.

Tiny Soldering Tip (55G)

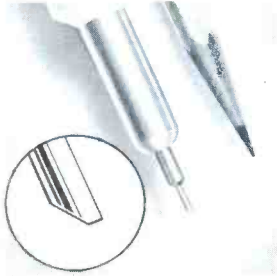

Want a *real* pencil-type soldering tip? The Ungar Type PL340 *Micro-Needle Tippler*, with an outside diameter of 3/64" and a length of 3/4", is designed for extremely delicate jobs such as soldering micro-miniature components and tiny eyelets to printed wiring boards. The bevel-edged tip, made of iron-clad, nickel-plated copper, fits Heating Units No. 4045, 1235 and 535.

5-Watt Controls (56G)



Discovery of an improved type of insulation has enabled Centralab to expand its line of WW and WN Series *Radiolab* wirewound controls. Formerly available only in resistances up to 25K ohms, these miniaturized 5-watt units are now being made in values up to 100K ohms. All controls in both series have linear taper.

Compact Stereo Speaker System (57G)



The Pilot PSV-1 *Stereo Voice* unit consists of two 3" tweeters, two 6" midrange speakers, and a 12" woofer inside a 25 3/4" x 14 1/4" x 12" cabinet which can be mounted either horizontally or vertically. The 3" and 6" speakers are arranged for wide sound dispersion. By means of an external control, they can be repositioned as needed for best stereo effect. Weight of the unit is 45 lb.; price is \$139.50.

Tape Sales-Service Package (58G)



The *Two-Way Profit Pack* offered to service dealers at \$44.40 (the price of the tape alone) by ORRadio includes 12 assorted 7" reels of *Irish* tape, a wall banner for the dealer to use in advertising his tape-recorder servicing business, and a 208-page recorder-service manual prepared especially for ORRadio by Howard W. Sams. This book includes detailed schematics, exploded views, and trouble charts for several of the most popular recorders.

Receiving Tubes (59G)

Sylvania has announced five new tube types for the radio-TV replacement market: 6AF3 damper diode, 6- and 12DT8 dual triodes for FM radio front ends, 6ES5 diode/triode RF amplifier for television tuners, and 12DY8 tetrode/triode for auto radios.

the modern approach to HI-FI STEREO servicing



AUDIO SYSTEM ANALYZER "800"

Here is a Complete Audio Laboratory of six instruments in one package! Our engineers have designed the "800" to save your *time* and to simplify the operational procedure of your shop. We know your time is your most valuable inventory. Look at the individual services the "800" performs at a fraction of the cost for all six instruments! . . . \$169.95.

- it's an AUDIO VTVM
 - it's an AUDIO OUTPUT WATT METER
 - it's an AUDIO-SIGNAL GENERATOR
 - it's an INTERMODULATION DISTORTION METER
 - it's a HARMONIC DISTORTION METER
 - it's a DB and NOISE METER
- and it's EASY to use

WINSTON ELECTRONICS

offers a complete line of test equipment

SEE YOUR LOCAL PARTS DISTRIBUTOR TODAY!

LITERATURE AVAILABLE ON REQUEST.

"820"

Dynamic sweep Circuit Analyzer . . . for color and black and white TV. Trouble shoot horizontal and vertical sweep circuits by signal substitution. This same instrument also is a complete compatible flyback and yoke tester! . . . \$69.95.



"825"

Dynamic AGC Circuit Analyzer . . . AGC trouble shooting made painless! The "825" solves complex AGC problems fast because it combines AGC test signal, AGC circuit monitor, AGC pulse indicator, Bias clamp and supply, Continuity tester and VTVM . . . \$79.95.



"82B"

Intermittent Condition Analyzer . . . the fast way to locate intermittents and "borderline" components. Gives modulated test signal for TV or RADIO. "Electro-Wand" pickup loop checks tubes for noise and intermittents. "Electro-Probe" locates faulty components and loose connections without direct circuit connection . . . \$89.95.



"850"

Induced Waveform Analyzer . . . adapts any "scope" to check waveforms from the top of the chassis. "Phantom-Probe" makes every tube a test-point without direct connection. Localizes trouble in minutes. Works on TV Channels 2 thru 13, 3.58-4.5 mc IF, 21 mc IF, 40 mc IF, Audio, Video, and Radio frequencies . . . \$169.95.



WINSTON ELECTRONICS

DIVISION OF



4000 N. W. 28th STREET • MIAMI, FLORIDA

August, 1959

Aerovox Corp. 67
 Alpha Wire Corp. 86
 American Television & Radio Co. (ATR) 32
 Amperex Electronic Corp. 72
 Amphenol-Borg Electronic Corp 60
 B & K Mfg. Co. 25
 Berns Mfg. Co. 90
 Bulldog Electric Products Div., I-T-E Circuit Breaker Co. 78
 Bussmann Mfg. Co. 37
 CBS Electronics 55
 Chicago Miniature Lamp Works 94
 Cornell-Dubilier Electric Corp. 65
 Doss Electronic Research, Inc. 58
 EICO 50
 E-Z-Hook Test Products 86
 Electro Products Laboratories, Inc. 94
 Electronic Publishing Co. 64
 General Cement Mfg. Co. 2nd Cover
 General Electric Co. Receiving Tube Dept. 30-31, 53
 Television Receiver Div. 38-39
 Hunter Tool Co. 91
 Illinois Condenser Co. 87
 JFD Electronics Corp. 47
 Jackson Electrical Instrument Co. 82, 96
 Jensen Industries, Inc. 91
 Jerrold Electronics Corp. 69
 Littelfuse, Inc. 4th Cover
 Mallory & Co., Inc., P. R. 34-35
 Merit Coil & Transformer Corp. 88
 Miller Co., J. W. 51
 Mosley Electronics, Inc. 92
 Motorola, Inc.—Parts & Accessories Div. 68
 Pickering & Co., Inc. 68
 Planet Mfg. Corp. 89
 Precision Apparatus Co. 91
 Pyramid Electric Co. 71
 Quam-Nichols Co. 80
 Radiart Corp.—Div. of Cornell-Dubilier Electric Corp. 75
 RCA Electron Tube Div. 28-29, 3rd Cover
 Raytheon Co. 9-24
 Sams & Co., Inc., Howard W. 33, 76, 90
 Sarkes Tarzian, Inc. Rectifier Div. 36
 Tuner Div. 88
 Seco Mfg. Co. 77
 Service Instruments Corp. 79, 81, 83, 85
 Simpson Electric Co. 57
 Sprague Products Co. 26
 Technical Appliance Corp. (TACO) 87
 Triad Transformer Corp. 84
 Tung-Sol Electric, Inc. 59
 Vis-U-All Products Co. 64
 Webster Electric Co. 61
 Westinghouse Electric Co. Electron Tube Div. 63
 Wintronix, a Div. of Jetrionics Industries. 95
 Xcelite, Inc. 89

ANTENNA SYSTEMS

- 1G. **AMPHENOL-BORG**—Catalog sheet on new *Marine Core* twin-lead which has up to 93% less signal loss than other types when submerged. See ad page 60.
 2G. **JERROLD**—16-page booklet on the amplified TV-FM Home System shows how to obtain optimum TV and FM reception using a number of outlets throughout the home. See ad page 69.

AUDIO & HI-FI

- 3G. **KAAR**—Brochures entitled "An Explanation of Repeater Operation in the Mobile Services," and "FCC Rules and Regulations, Effective September 11, 1958 . . . an interpretation."
 4G. **PICKERING**—Service File of helpful, informative data on audio and hi-fi. See ad page 68.
 5G. **QUAM-NICHOLS**—New 8-page catalog gives detailed specifications on 121 speakers and 27 audio transformers, including many new replacement units for transistor-radio and hi-fi units. See ad page 80.

CAPACITORS

- 6G. **CORNELL-DUBILIER**—24-page Substitution Cross Index, listing over 3,525 twist-prong and tubular-electrolytic replacements. See ad page 65.
 7G. **ILLINOIS CONDENSER**—Literature on all types of capacitors, including radio, TV, motor-start, Philco-flash, miniature, subminiature, military, computer, paper, audio-crossover network, and tantalum. See ad page 87.
 8G. **P. R. MALLORY**—Form 9-165, new capacitor catalog. See ad pages 34-35.
 9G. **SPRAGUE**—M-773 *Difilm* Mylar-Paper capacitor catalog sheet. See ad page 26.

CARTRIDGES & NEEDLES

- 10G. **CLEVITE-WALCO**—36-page 1959 needle and accessories catalog with complete cross-reference and needle-identification data.
 11G. **ELECTRO-VOICE**—Bulletin No. 267, featuring new totally-compatible stereo cartridges. Offers two series—the *Magnameric* for magnetic inputs and the standard ceramic for ceramic inputs.
 12G. **JENSEN INDUSTRIES**—1960 Wall-chart, form J-100; also, new dealer stock control and cartridge cross-reference guide, form DL-157. See ad page 91.

COILS & TRANSFORMERS

- 13G. **J. W. MILLER**—Data sheets on the latest radio and TV replacement coils. See ad page 51.
 14G. **TRIAD**—New general replacement catalog, TR-60; also new TV replacement guide, TV-60. See ad page 84.

FUSES

- 15G. **BUSSMANN**—Completely new television fuse chart describing proper fuses to use, how they are mounted, and which circuit they protect. See ad page 37.

MOVIES

- 16G. **SENCORE**—Learn all about 22-minute slide-film and when free showing will be held in your area.

SERVICE AIDS

- 17G. **CHEMTRONICS**—Flyers describing complete line of electronic servicing chemicals, including *No-Arc* hi-voltage insulator.
 18G. **E-Z-HOOK**—Convenient reference sheet titled, "How to Build the Five Most Useful Scope Probes," with schematics, mechanical component layouts, etc. See ad page 86.

SPECIAL EQUIPMENT

- 19G. **ATR**—New *KARADIO* catalog sheet describes auto radio sets for both imported and compact American cars. See ad page 32.

- 20G. **BULLDOG**—Form EH-100, descriptive folder and prices on *Electrostrip*. See ad page 78.
 21G. **SOLA**—Flyer describing the *TeleVolt* line-voltage regulator for TV sets, radios, hi-fi amplifiers, and tape recorders.

TECHNICAL PUBLICATIONS

- 22G. **CBS ELECTRONICS**—"Servicing Transistor Equipment," the latest issue of *Tech Tips* by Bud Tomer. See ad page 55.
 23G. **HOWARD W. SAMS**—Descriptive literature on all Howard W. Sams publications covering servicing of radio, TV, hi-fi, etc. Includes data on latest books, "Tape Recorder Manual, Vol. 4," "Television Antenna Handbook," "101 Ways to Use Your Signal Generator," and the new and completely revised edition of *PHOTOFACT* Television Course." See ads pages 33, 76, 90.

TEST EQUIPMENT

- 24G. **B & K**—Bulletin ST21-R gives helpful information on new point-to-point signal-injection technique with Model 1075 *TV Analyst*; other bulletins describe *Dyna-Quik* Models 500B, 650, and automatic 675 portable dynamic mutual-conductance tube and transistor tester, plus Model 400 CRT cathode-rejuvenator tester. See ad page 25.
 25G. **DOSS**—Information on the latest in test equipment, including the *Pioneer* 250 *Horizontal Systems Quantalyst*. See ad page 58.
 26G. **EICO**—20-page 1959 2-color catalog describes 65 models of professional test instruments, hi-fi, and "ham" gear in both kit and factory-wired form. Shows how to save 50%. See ad page 50.
 27G. **JACKSON**—Data sheets describing Models 598 and 658 low-cost dynamic tube testers. See ads pages 82, 96.
 28G. **RCA**—Pocket-sized folders on the WV-38A(K) volt-ohm-milliammeter and WO-33A(K) super-portable oscilloscope kits. See ads pages 28-29, 3rd cover.
 29G. **SECO**—Literature describing the new Model 100 dynamic transistor checker and Model 78 grid-circuit and tube-merit tester; also 8-page 2-color folder on company's other equipment, plus servicing information. See ad page 77.
 30G. **SERVICE INSTRUMENTS**—Catalog sheet describing the new Model HG-104 harmonic generator, which simultaneously produces RF, IF and audio signals for quickly isolating transistor-radio troubles. See ads pages 79, 81, 83, 85.
 31G. **VIS-U-ALL**—New 4-page catalog on complete line of "Business-Building Test Equipment" for service dealers. See ad page 64.

TOOLS

- 32G. **BERNS**—Data on the 3-in-1 picture tube repair tool that crimps pin and element lead to make a solid electrical connection; can also be used as screwdriver and channel selector. See ad page 90.
 33G. **HUNTER**—Catalog on subminiature tools for printed board work, etc. See ad page 91.
 34G. **XCELITE**—Latest catalog sheet on line of serviceman-designed tools, listing various types of screwdrivers, nutdrivers, pliers, and cutters. See ad page 89.

TUBES

- 35G. **AMPEREX**—12-page catalog plus detailed data sheets on line of premium-quality frame-grid tubes designed for use in exacting applications. See ad page 72.
 36G. **TUNG-SOL**—Pocket price list with July 1st suggested retail prices for approximately 1000 receiving and picture tube types; also, order form and catalog sheet for newly-published "Tube Base Connections" and "Tube Characteristics" books. See ad page 59.
 37G. **WESTINGHOUSE**—Entry blanks for "Winner Takes All" contest which offers \$50,000 in prizes. See ad page 63.



TUBE TYPE	MODEL 648 CIRCUIT		MODEL 115/715/561		E.
	FILE	PLATE	FILE	PLATE	
2ER5	2.5	A237 AC456*	2.5	3	25
3ER5	3.0	A237 AC456*	3.0	3	25
6ER5	6.3	A237 AC456*	6.3	3	25
6F5	6.3	A234 567	6.3	3	22
6F6	6.3	A234 567	6.3	3	22
6F7	6.3	A234 567	6.3	3	22
6F8	6.3	A234 567	6.3	3	22
6F9	6.3	A234 567	6.3	3	22
6F10	6.3	A234 567	6.3	3	22
6F11	6.3	A234 567	6.3	3	22
6F12	6.3	A234 567	6.3	3	22
6F13	6.3	A234 567	6.3	3	22
6F14	6.3	A234 567	6.3	3	22
6F15	6.3	A234 567	6.3	3	22
6F16	6.3	A234 567	6.3	3	22
6F17	6.3	A234 567	6.3	3	22
6F18	6.3	A234 567	6.3	3	22
6F19	6.3	A234 567	6.3	3	22
6F20	6.3	A234 567	6.3	3	22
6F21	6.3	A234 567	6.3	3	22
6F22	6.3	A234 567	6.3	3	22
6F23	6.3	A234 567	6.3	3	22
6F24	6.3	A234 567	6.3	3	22
6F25	6.3	A234 567	6.3	3	22
6F26	6.3	A234 567	6.3	3	22
6F27	6.3	A234 567	6.3	3	22
6F28	6.3	A234 567	6.3	3	22
6F29	6.3	A234 567	6.3	3	22
6F30	6.3	A234 567	6.3	3	22
6F31	6.3	A234 567	6.3	3	22
6F32	6.3	A234 567	6.3	3	22
6F33	6.3	A234 567	6.3	3	22
6F34	6.3	A234 567	6.3	3	22
6F35	6.3	A234 567	6.3	3	22
6F36	6.3	A234 567	6.3	3	22
6F37	6.3	A234 567	6.3	3	22
6F38	6.3	A234 567	6.3	3	22
6F39	6.3	A234 567	6.3	3	22
6F40	6.3	A234 567	6.3	3	22
6F41	6.3	A234 567	6.3	3	22
6F42	6.3	A234 567	6.3	3	22
6F43	6.3	A234 567	6.3	3	22
6F44	6.3	A234 567	6.3	3	22
6F45	6.3	A234 567	6.3	3	22
6F46	6.3	A234 567	6.3	3	22
6F47	6.3	A234 567	6.3	3	22
6F48	6.3	A234 567	6.3	3	22
6F49	6.3	A234 567	6.3	3	22
6F50	6.3	A234 567	6.3	3	22
6F51	6.3	A234 567	6.3	3	22
6F52	6.3	A234 567	6.3	3	22
6F53	6.3	A234 567	6.3	3	22
6F54	6.3	A234 567	6.3	3	22
6F55	6.3	A234 567	6.3	3	22
6F56	6.3	A234 567	6.3	3	22
6F57	6.3	A234 567	6.3	3	22
6F58	6.3	A234 567	6.3	3	22
6F59	6.3	A234 567	6.3	3	22
6F60	6.3	A234 567	6.3	3	22
6F61	6.3	A234 567	6.3	3	22
6F62	6.3	A234 567	6.3	3	22
6F63	6.3	A234 567	6.3	3	22
6F64	6.3	A234 567	6.3	3	22
6F65	6.3	A234 567	6.3	3	22
6F66	6.3	A234 567	6.3	3	22
6F67	6.3	A234 567	6.3	3	22
6F68	6.3	A234 567	6.3	3	22
6F69	6.3	A234 567	6.3	3	22
6F70	6.3	A234 567	6.3	3	22
6F71	6.3	A234 567	6.3	3	22
6F72	6.3	A234 567	6.3	3	22
6F73	6.3	A234 567	6.3	3	22
6F74	6.3	A234 567	6.3	3	22
6F75	6.3	A234 567	6.3	3	22
6F76	6.3	A234 567	6.3	3	22
6F77	6.3	A234 567	6.3	3	22
6F78	6.3	A234 567	6.3	3	22
6F79	6.3	A234 567	6.3	3	22
6F80	6.3	A234 567	6.3	3	22
6F81	6.3	A234 567	6.3	3	22
6F82	6.3	A234 567	6.3	3	22
6F83	6.3	A234 567	6.3	3	22
6F84	6.3	A234 567	6.3	3	22
6F85	6.3	A234 567	6.3	3	22
6F86	6.3	A234 567	6.3	3	22
6F87	6.3	A234 567	6.3	3	22
6F88	6.3	A234 567	6.3	3	22
6F89	6.3	A234 567	6.3	3	22
6F90	6.3	A234 567	6.3	3	22
6F91	6.3	A234 567	6.3	3	22
6F92	6.3	A234 567	6.3	3	22
6F93	6.3	A234 567	6.3	3	22
6F94	6.3	A234 567	6.3	3	22
6F95	6.3	A234 567	6.3	3	22
6F96	6.3	A234 567	6.3	3	22
6F97	6.3	A234 567	6.3	3	22
6F98	6.3	A234 567	6.3	3	22
6F99	6.3	A234 567	6.3	3	22
6F100	6.3	A234 567	6.3	3	22

Latest Chart Form 648-21, 115/715/561-11, 49-5

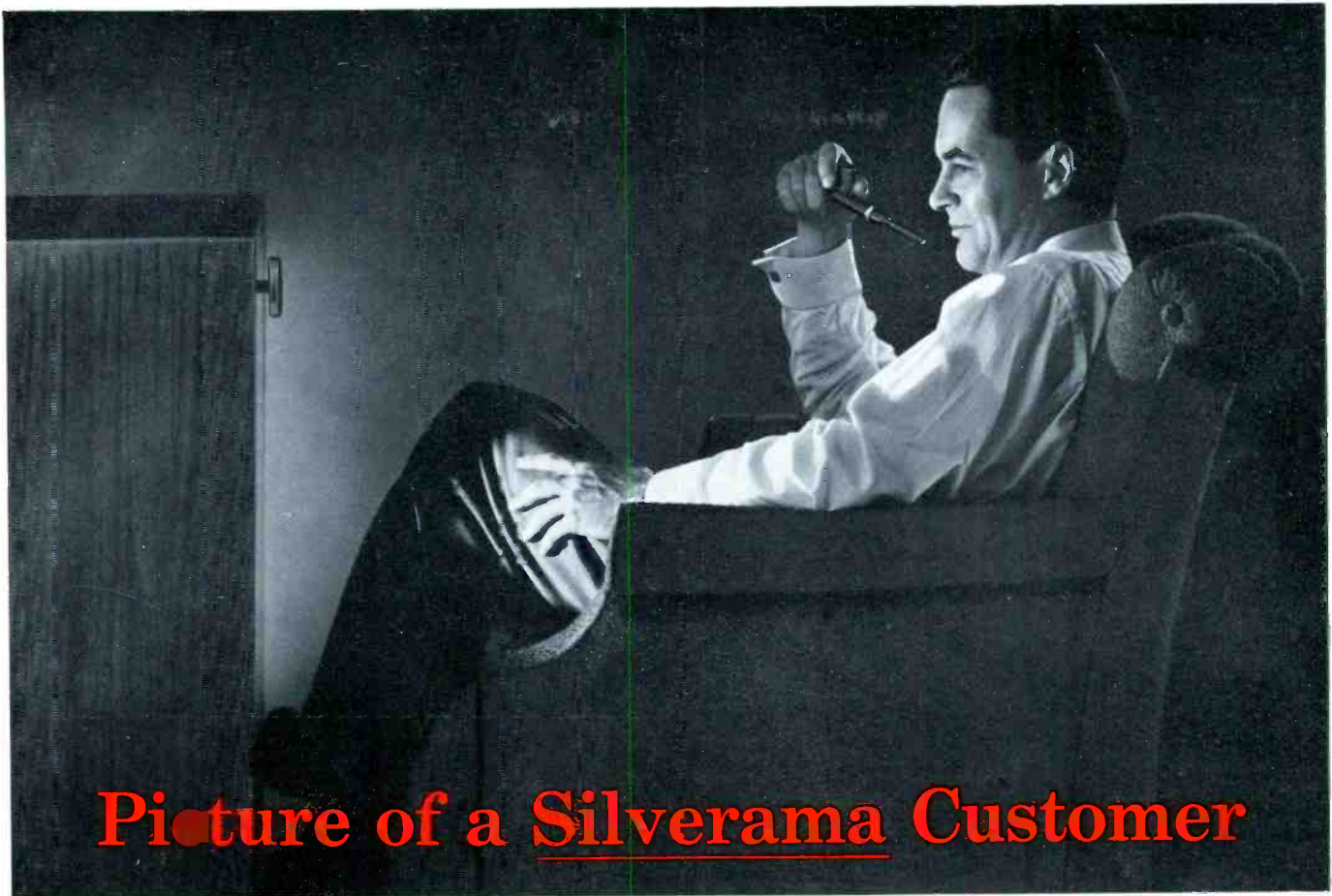

Picture of a Silverama Customer

This man needed a replacement picture tube for his TV set—and he wanted the best. So his TV technician installed an RCA Silverama—the premium picture tube made of all-new glass and all-new parts. It's the finest picture available today—just right for the customer who expects top quality and top performance.

Sell RCA Silverama with the assurance that you're delivering a completely new tube—a premium product that can command a premium price and premium profits for *you!*

★ ★ ★ ★ ★

Is your customer budget minded? Offer him an RCA Monogram—factory-rebuilt by RCA to dependable quality standards. There's no finer rebuilt made—just right for the customer whose primary consideration is price.

Sell RCA Monogram with assurance—your customers will get satisfactory performance—and you will have fewer call-backs.

Remember...

- RCA picture tubes—warranted for one full year and fit virtually every make and model TV set.
- RCA picture tubes—backed by a brand name you can sell with confidence.
- RCA picture tubes—pre-sold by an extensive and continuing national advertising campaign.

GET THE FULL DETAILS FROM YOUR AUTHORIZED RCA DISTRIBUTOR TODAY!



RADIO CORPORATION OF AMERICA
Electron Tube Division
Harrison, N. J.

dealer-serviceman's fuse rack . . .

. . . for wall mounting

LITTELFUSE

most needed



most wanted

. . . the **FUSEMASTER!**



dealer-serviceman's fuse requirements at a glance