

JANUARY, 1959

35 CENTS



PHOTOFACT

REPORTER

Including **Electronic Servicing**



HIGHLIGHTS











- Mobile Radio Installation
- Understanding Sound Systems
- Isolating Sync-Circuit Troubles
- Low-Voltage Power Supplies

1A 8H 635 1260E
 WM M DAVIS
 118 RIVERSIDE AVE
 CANON CITY COLO

<p>DR330 Dynamic Cardioid and Ribbon</p>  <p>Variable low-medium impedance and polar pattern. Frequency response 40 to 15,000 cps. Ideal for radio and TV. LIST \$250.00</p>	<p>DR332 Dynamic and Ribbon Cardioid</p>  <p>Variable impedance... low, medium, high. Unidirectional polar pattern. Frequency response 50 to 10,000 cps. For P.A. and general use. LIST \$162.50</p>	<p>R331 Ribbon—Bi-Directional</p>  <p>Variable impedance... low, medium, high. Bi-directional for P.A. and recording. Frequency response 40 to 10,000 cps. LIST \$140.00</p>	<p>TRC Series . . . Push Button Styles</p>  <p>Low or high impedance, wide response. For recording, conference, P.A. D204 Dynamic Types: LIST \$17.00—\$24.30 B204 Ceramic Types: LIST \$16.00—\$17.30 X204 Crystal Tapes: LIST \$16.00—\$18.30</p>
<p>D44 Dynamic—Omni-Directional</p>  <p>Low impedance; response 50 to 15,000 cps. For motion picture use on booms, excellent for outdoor (with wind screen). LIST \$235.00</p>	<p>D33 Dynamic—Omni-Directional</p>  <p>Variable impedance... low, medium; response 40 to 15,000 cps. For radio-TV, P.A., recording. LIST \$130.00</p>	<p>D22 Dynamic—Omni-Directional</p>  <p>Variable impedance... low, high; response 50 to 12,000 cps. For P.A., studio, general audio use. LIST \$99.50</p>	<p>D4 Dynamic—Omni-Directional</p>  <p>Low impedance; response 50 to 8,000 cps. Rugged construction, for P.A., etc. LIST \$28.00 D4T similar, but high impedance. LIST \$31.00</p>

**Your All-AMERICAN Line of MICROPHONES...
AMERICAN MICROPHONES
FOR EVERY BROADCAST, P. A., MOBILE OR RECORDING NEED**



<p>D4G Lecturer's Dynamic</p>  <p>Low impedance; response 100 to 7,500 cps. Black leather-covered neckband. LIST \$49.00 D4GT similar, but high impedance. LIST \$51.00</p>	<p>D9A Dynamic Cardioid</p>  <p>Low impedance; response 100 to 7,000 cps. For P.A. and general purpose. LIST \$82.50 D9AT similar, but high impedance. LIST \$86.50</p>	<p>D6 Dynamic Public Address</p>  <p>Low impedance; response 50 to 7,000 cps. All purpose; rugged construction. LIST \$46.00 D6T similar, but high impedance. LIST \$49.00</p>	<p>D7 Dynamic General Purpose</p>  <p>Low impedance; response 150 to 10,000 cps. Well built; useful everywhere. LIST \$46.00 D7T similar, but high impedance. LIST \$49.00</p>
<p>D7PR Dynamic . . . Handle Type</p>  <p>Low impedance; response 150 to 10,000 cps. Press-to-talk switch. LIST \$52.50 D7T similar, but high impedance. LIST \$55.00</p>	<p>D7H Dynamic General Purpose</p>  <p>Low impedance; response 150 to 10,000 cps. General use; pigtail lead. LIST \$46.00 D7TH similar, but high impedance. LIST \$49.00</p>	<p>Tape Recorder Microphone</p>  <p>High impedance; response 100 to 6,000 cps. Omni-directional; ideal for home use. X203 Crystal Types: LIST \$8.35—\$9.65 B203 Ceramic Types: LIST \$11.50—\$12.80</p>	<p>D801 Miniature Dynamic</p>  <p>Low impedance; response 250 to 6,000 cps. Compact; can be concealed. LIST \$14.75</p>
<p>Crystal Microphones</p>  <p>C7H . . . stand type (illus.) LIST \$21.75 CL2 . . . lapel type LIST \$17.25 RC . . . desk type LIST \$13.50</p>	<p>501 Series . . . Mobile Types</p>  <p>Low or high impedance; response 300 to 3,000 cps. Rugged construction. D501 Dynamic Types: LIST \$25.50—\$34.00 C501 Carbon Types: LIST \$24.50—\$33.00</p>	<p>504 Series . . . Mobile Types</p>  <p>Low impedance; response 300 to 3,000 cps. Rugged, moisture-proof. C504 Carbon Types: LIST \$31.00—\$38.00</p>	<p>Dynamic Hand Sets</p>  <p>Low impedance, for use with radio transmitters, intercoms, etc. H602 TYPES: LIST \$21.00—\$25.80</p>

**ALSO —
ACCESSORIES AND
REPLACEMENT PARTS
PHONO PICKUP ARMS
AND CARTRIDGES**



Write Today for free Catalog 58

NEW American TONE ARM ADAPTER
converts standard tone arm to stereo.
Wiring adapter with output jack.
No. 1101
LIST \$2.15

American Microphone MFG. CO. division of G-C—Textron Inc.

Western Plant: Los Angeles 18, California
Main Plant: **ROCKFORD, ILLINOIS, U.S.A.**

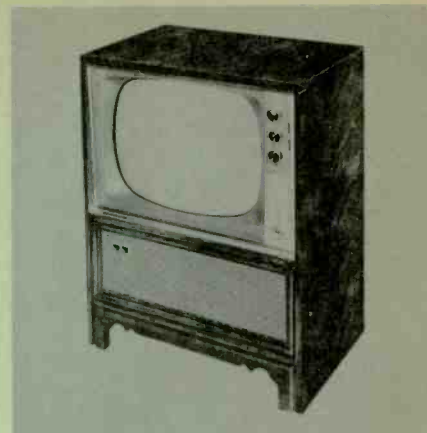
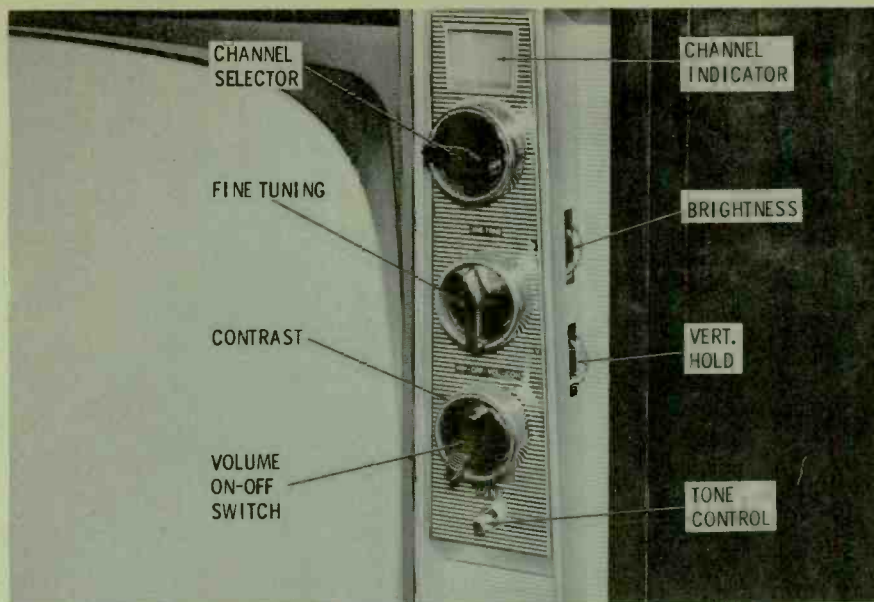

Motorola Model 21K100MA Chassis RTS-544

This new 21" console incorporates several audio features such as a tone control, both 4" and 8" speakers, and a stereo jack on the rear of the cabinet. The channel indicator is a light-projection device that shows the channel number in a small window at the top of the control panel.

On the back of the set you'll find the main chassis mounted horizontally, while the VHF tuner and operating controls are on a separate panel, positioned vertically along one side of the 21CP4A picture tube. The transformer-powered chassis uses conventional wiring, but features a number of molded component assemblies including one in the horizontal AFC stage and one in the sync section. A plug-in crystal is employed in the video detector stage, and you'll find an EL84/6BQ5 audio output and 6AF3 damper in the tube lineup.

A 5-amp slow-blow fuse is used in the primary circuit of the power transformer, while a 3/10-amp LC type is in series with two branches of the B+ supply. In addition, a short length of #26 wire, located on the wiring side of the chassis under the power transformer, acts as a fuse in the series-parallel filament network. The retaining spring, pointed out in the photo, secures the vertical output tube to its shock-mounted socket, and also aids in the dissipation of heat from the tube's envelope.

There is a slight mechanical trick to removing the tuner and control panel from the cabinet. The knobs on the brightness and vertical hold controls must clear the front escutcheon before the panel can be taken out. This is accomplished by pushing upward on the actuating lever, which in turn moves the control bracket in toward the picture tube.

The test socket located on the rear apron of the main chassis has five test points that may be very useful to the serviceman. One can easily clamp the AGC line by applying an external negative voltage between contact No. 1 and ground (contact No. 3). The socket is also used as follows when adjusting the horizontal oscillator: Jumper contact No. 4 (Horiz AFC) to No. 1 GRD. Connect a .1-mfd, 400-volt capacitor between contact No. 2 (Horiz. Osc. Coil) and contact No. 5 labeled B++. Set the hold control to lock in the picture and then remove the capacitor. Without touching the hold control, stabilize sync by adjusting the oscillator coil. Remove the jumper from contact Nos. 1 and 3, and adjust the hold control so that no picture fold-over appears on either side of the raster.

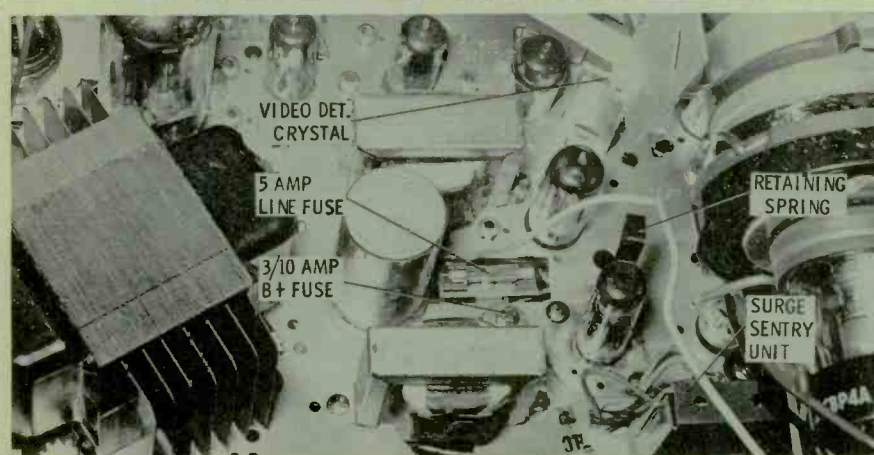
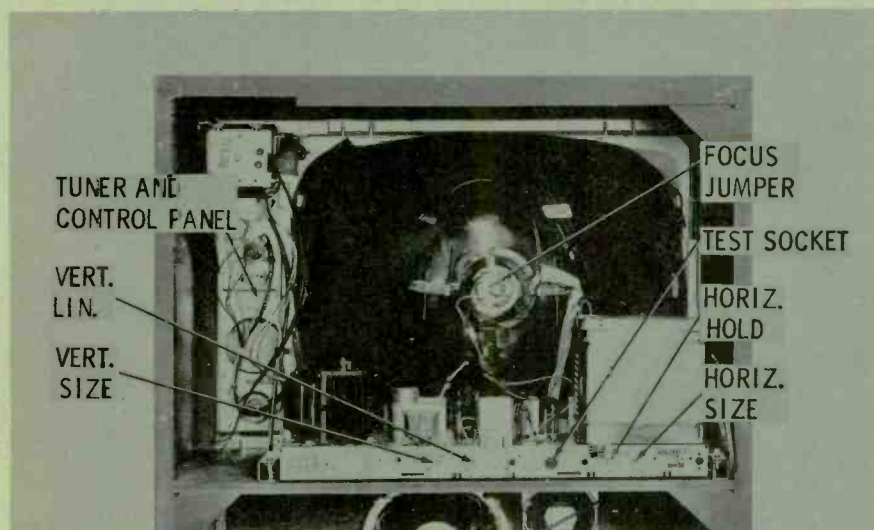



**Silvertone Model 9105AQ
Chassis 528.51550**

This new portable TV features both VHF and UHF reception, 17" 110° picture tube, and built-in "rabbit ear" antenna. The one-piece vertical chassis is positioned around the neck of the picture tube and fits snugly into a combination fiberglass and plastic cabinet. Rear service adjustments, which are few, are pointed out in the photograph. Picture width is controlled by the position of a metallic sleeve around the neck of the CRT. To make this adjustment, loosen the yoke clamp and slide the sleeve forward or backward, holding the yoke in position. The plastic corners may be bent upward making it easier to slide, but remember to keep the sleeve centered on the top half of the tube neck. The molded pack unit shown on the printed wiring board consists of resistors and capacitors used in the horizontal AFC and oscillator stages.

The control panel is attached to the side of the cabinet by two 1/4" hex-head screws, and its cable does not plug in but is fixed to the chassis by soldered connections. With knobs removed, both height and vertical linearity are adjustable through the hollow shafts of the brightness and hold controls respectively, or they can be adjusted from the rear with the use of a screwdriver.

On the back of the set, a small panel supported by two chassis brackets features an AGC control, safety interlock, and an *Automatic Power Monitor*. The latter adjustment is merely a reset button for a B+ circuit breaker. This device is electrically located in series with the AC input to the power supply, but does not protect the filaments of the series-string tubes.

The "hot" chassis, which houses two separate printed boards, makes use of a complete line of 450-ma tubes. Although most of them are new versions of more common types, the vertical oscillator-output circuit employs a 13DE7, and the damper stage a 17D4GT. Removing the chassis from the rear of the cabinet, you can examine its wiring side, where there are two silicon rectifiers, a surge-limiter resistor, and the horizontal waveform adjustment. The two silicones are not plug-in units, but are soldered between two separate terminal strips.

The front safety glass on this receiver can be taken out for cleaning by removing the top trim plate and prying out on the glass as shown. The plate is secured by three Phillips-head screws at the back and two in the front.

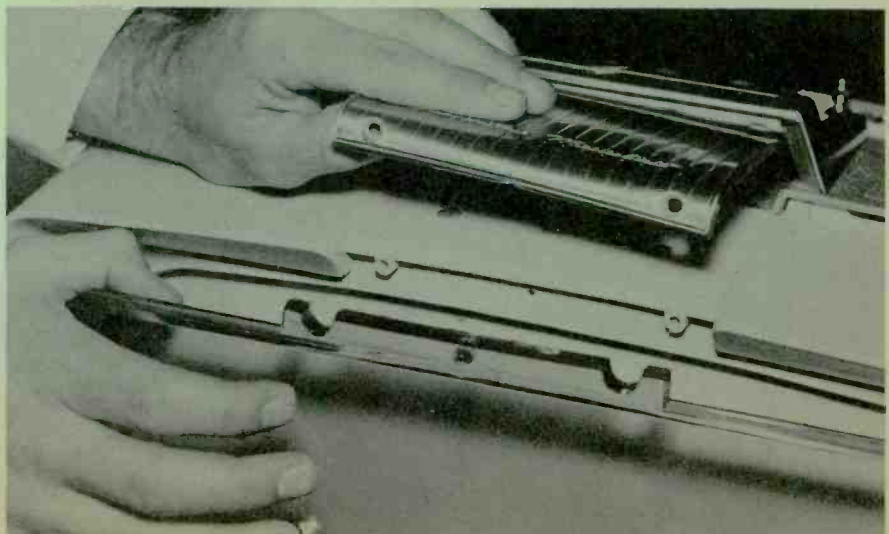
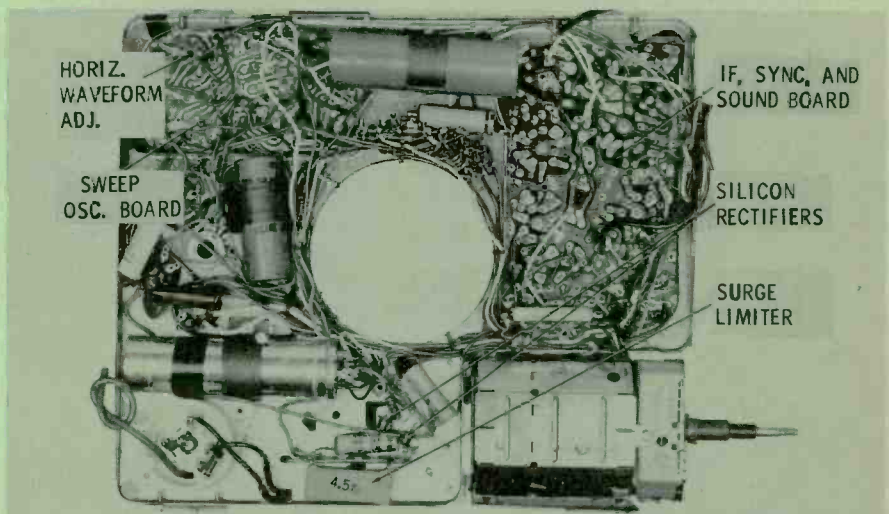
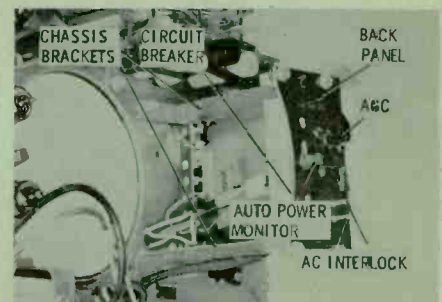
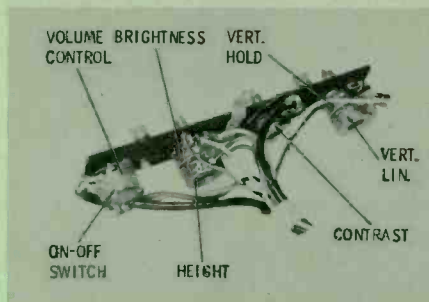
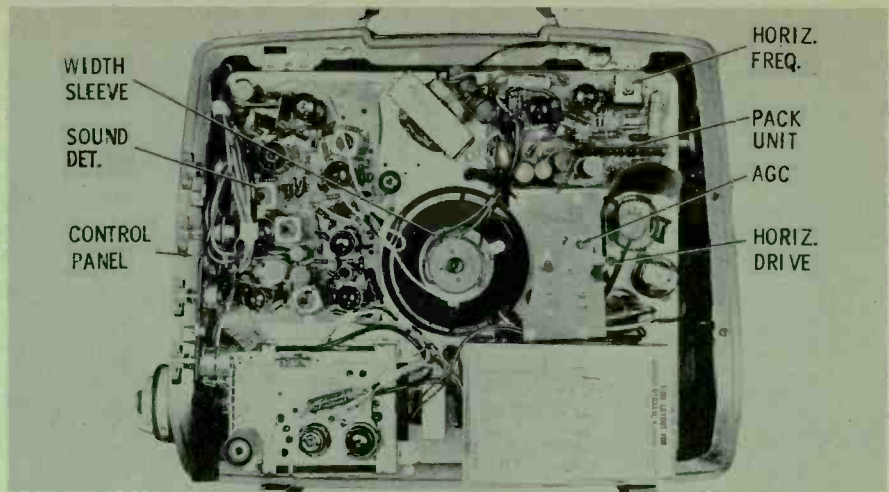

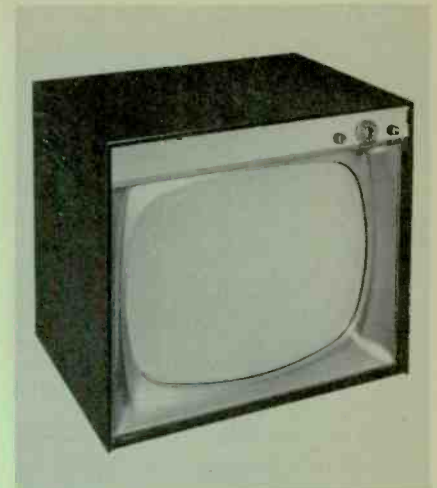
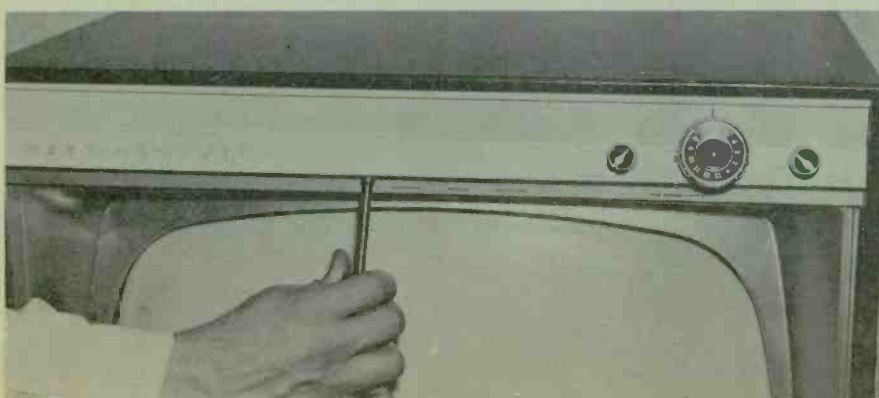
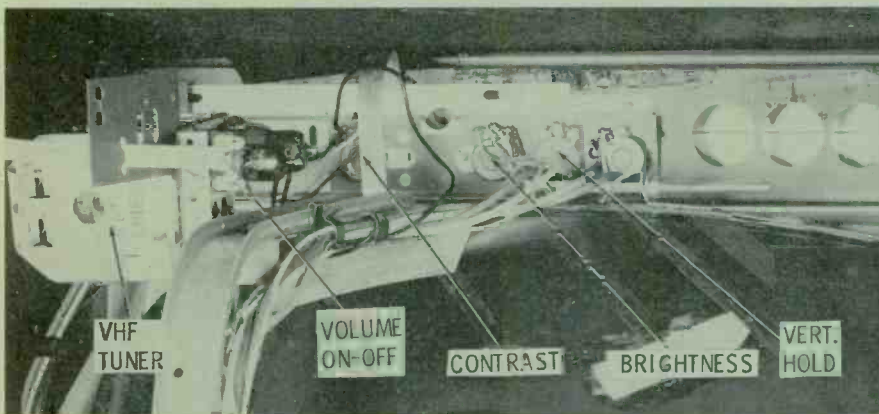
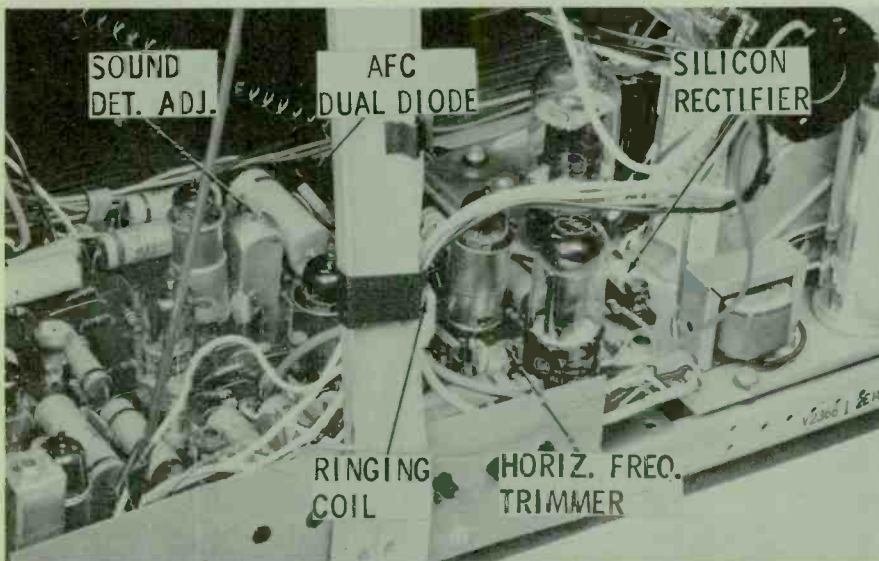
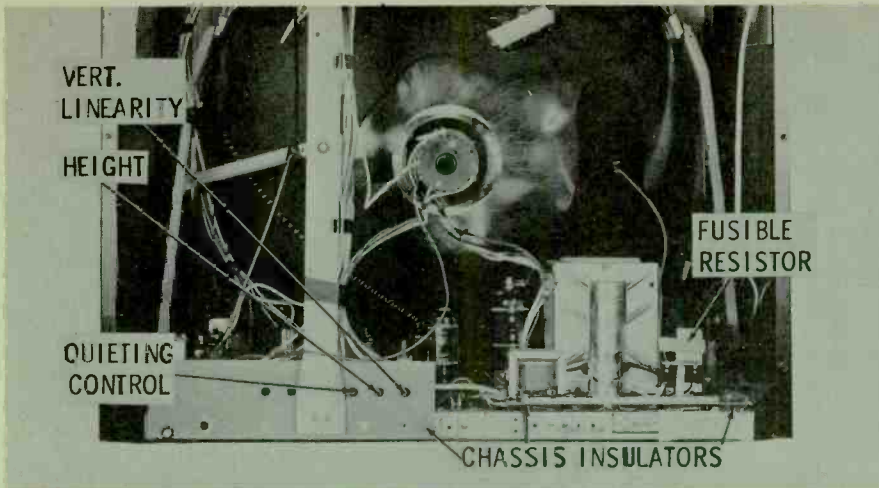

**Westinghouse
Model H-21T217
Chassis V-2366-1**

When you first encounter this new table model in a home, remember that brightness as well as vertical and horizontal hold controls are located up under the top trim strip on the front of the metal cabinet. The on-off knob is a push-pull switch, thus permitting the volume setting to remain undisturbed.

With the rear cover removed, you can easily reach all tubes. The narrow horizontal chassis bolts to the base of the cabinet, while the tuner mounts on an extended chassis bracket near the top. The only fuse protection employed is the plug-in type resistor pointed out in the photograph. This fusible component has a value of 7.5 ohms. As a word of caution, you might remember that one side of the AC power line is connected to chassis ground. After servicing the set, make sure that no short exists between the "hot" chassis and the metal cabinet or any part accessible to the operator. (Note chassis insulators shown in photo.) When servicing on the bench, always use an isolation transformer (NOT AN AUTOFORMER).

Taking a look at the top of the chassis, you'll see the remaining service adjustments. A single plug-in type silicon rectifier is used in the half-wave power supply. The horizontal frequency trimmer is a 19- to 160-mmf variable capacitor located in the horizontal multivibrator circuit. The latest tube types found in this receiver are a 3DK6 IF amplifier and a 12EN6 vertical oscillator-amplifier. These tubes are interchangeable, however, with 3CB6 and 12W6GT types, respectively. A series filament resistor of 33 ohms, 15 watts is positioned directly behind the 1B3GT high-voltage rectifier. The value of this component in UHF models is only 29 ohms.

Front operating controls are mounted on a separate panel up near the tuner. To adjust tuner oscillator frequencies, it is necessary to take off the front trim escutcheon by removing two screws inside the cabinet and three in front. When looking at the front of the tuner, the high-band adjustment, which should be made first, is located at 11 o'clock and the low band at 7 o'clock.

The safety glass for this set can be removed from the front by taking out three 1/4" screws concealed under the escutcheon. Pull the top of the glass forward and then lift out.



**Magnavox Model 1ST204H
Radio Chassis 54-03AA
Amplifier Chassis 182**

When you're called upon to service this new hi-fi set, here's hoping you know a little about stereo. The instrument is a combination radio-phonograph featuring a self-contained stereophonic reproducing system. This particular model has a three-section glass top; each section slides to one side, or can be lifted out.

Taking off the one-piece back by removing 16 wood screws, you'll find the power amplifier chassis in the lower-right of the cabinet, the AM-FM tuner at top center, and a speaker network on each side. Each speaker network consists of a 15" woofer and a 1000-cycle exponential treble horn. The amplifier chassis supplies the tuner with power, and all units are interconnected by cables and plugs. The unit also employs an H400 four-speed record changer with stereo diamond stylus.

The front of the tuner features a tuning-eye tube, timbre control with push-pull power switch, four-position bass switch, function selector, tone switch, loudness control, and AM-FM tuning. The stereo speaker switch, operated from the record changer compartment, has two positions. In the INT. ONLY position, one half the dual-channel amplifier drives the speakers on the left side of the set while the other half drives the speakers on the right side. When the switch is in the INT. EXT. position, one half the amplifier drives both speaker networks in the instrument; the other half supplies signal for an external speaker system, which may be added if desired.

The audio chassis has dual 15-watt amplifiers and separate level controls in both channel-1 and channel-2 treble circuits, as well as a bass control in the channel-2 bass section. The bass or balance control should be adjusted for an equal output from each speaker network, while the treble controls vary the high and low frequency response of each channel. The transformer-powered chassis employs eleven conventional type tubes, and all are within easy reach.

Removing the box shield from the crossover network, you'll find four filter coils—two non-adjustable units for each channel. The crossover frequency for bass and treble amplifiers of each channel is 1000 cycles. The two channel inputs come from the tuner chassis where a function switch selects either stereo, phono, FM, AM, or tape. A special socket labeled REMOTE AMP is located on the rear of the amplifier chassis and may be used for an external signal input to the channel-1 system.

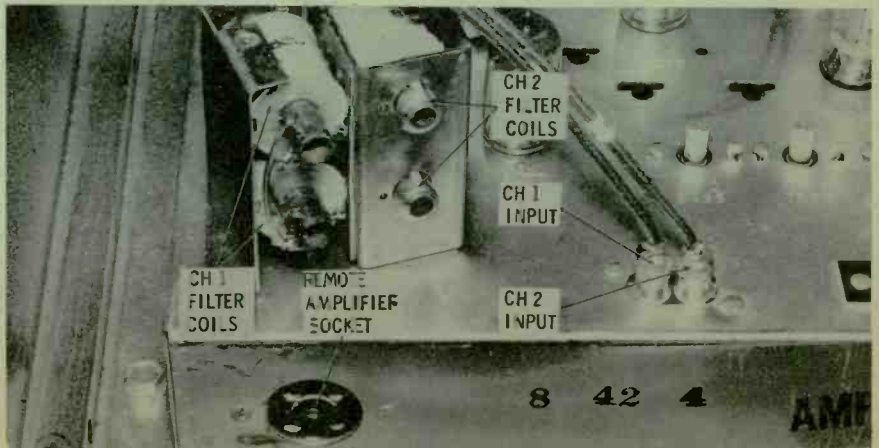
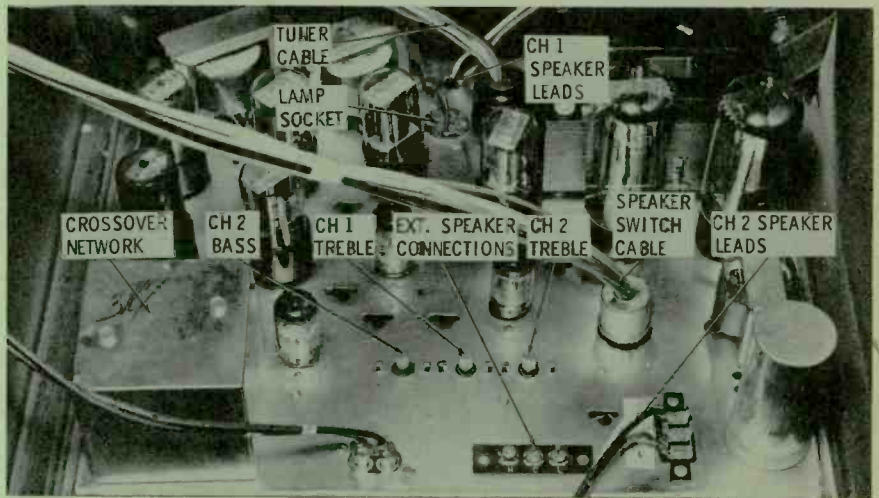
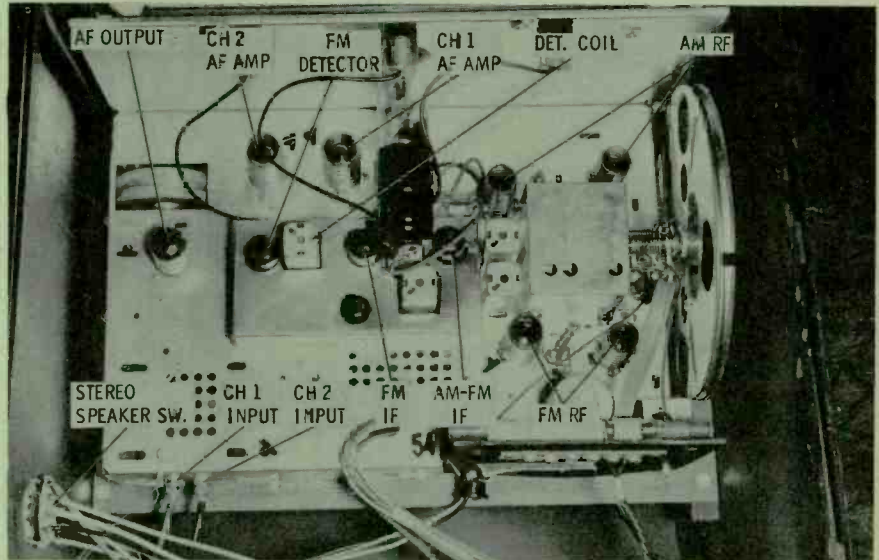
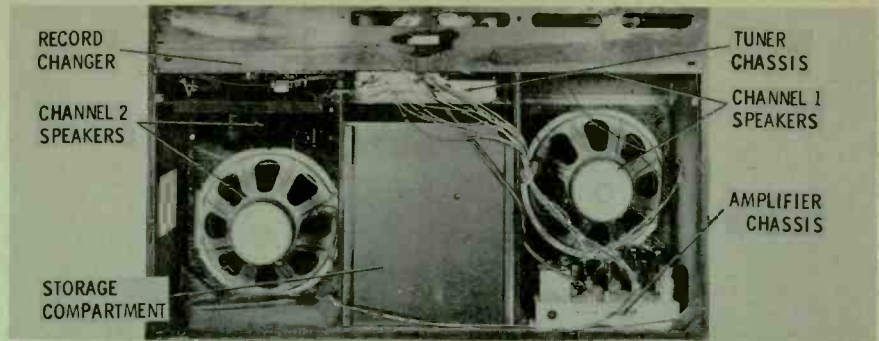

Independent TV-Radio Service Dealers:

THIS AD IS FOR YOU! *

next time you call a
TV-Radio Service Dealer...
ask yourself
these 4 questions



1 DOES HE HAVE AN ESTABLISHED BUSINESS FACILITY?

It takes a big investment to set up a properly equipped TV-Radio service operation. When the Service Dealer has a place of business—particularly in your community—you can be certain he's planning to stay. Your business is important to him. As an independent small businessman in your community he's going to do everything he can to satisfy you. It's the only way he can assure his own future.

2 DOES HE GUARANTEE HIS WORK AND PARTS?

It's standard practice to guarantee work and parts and most qualified dealers do so. Be sure to find out the duration of the guarantee so that you will know just how long you are protected. Remember, however, the guarantee covers only the parts replaced by the dealer, not everything in the set. If some other tube or component fails during the guarantee period the dealer cannot be held responsible.

3 DOES HE CHARGE A FAIR PRICE FOR A HOME SERVICE CALL?

Be sure the Service Dealer you choose makes a charge sufficient to cover his time and transportation expenses. Like any other businessman, your Service Dealer has basic costs... overhead, rent, taxes, insur-

ance, salaries, etc. . . . expenses that must be considered when he establishes his service call charges.

4 DOES HE PROVIDE AN ITEMIZED BILL?

He should, for his own protection as well as yours. Then you know exactly what work was done, which parts replaced and exactly how much each cost. You both know what replacements are covered by the guarantee in case of an early failure.

If the answer is yes to all four of these questions, the chances are you'll receive fast, competent, expert TV-Radio service at prices that are reasonable. What's more, the chances are he'll be a Raytheon Bonded Electronic Technician and that's an added bonus for you. These expert technicians offer a 90 day work and parts guarantee that is backed by a Bonded Electronic Technician and that's an added bonus for you. These expert technicians offer a 90 day issued through one of America's largest insurance companies. They observe a strict 8-Point Code of Business Ethics designed to protect you. For the quick, safe, sure solution to all TV-Radio servicing problems, call a Raytheon Bonded Electronic Technician.

For Your Convenience
Raytheon TV-Radio Service Dealers
Are Listed in The Yellow Pages of
Your Telephone Directory



Raytheon Quality TV and Radio Tubes Mean Better Set Performance for You . . . When a Service Dealer replaces old tubes with Raytheon Tubes you're sure of long life and lasting operation. Produced by Raytheon, pioneers in electronics, these fine tubes are made to the same rigid standards of quality and precision that are designed into the major Raytheon Tubes, Transistors and Diodes used in 14 of America's major missiles. A lifetime of experience in the development and production of Raytheon Tubes for military, industrial and commercial applications is behind them. That's why you are certain of satisfaction from Raytheon TV and Radio Tubes.



Excellence in Electronics

Raytheon Manufacturing Company, Distributor Products Division, 55 Chapel Street, Newton 68, Massachusetts

Raytheon is running this advertisement in the January 19, 1959 editions of NEWSWEEK and TIME magazines to help you. Read it carefully. It makes four simple suggestions to set owners that should result in substantial increases in service business for qualified Independent TV-Radio Service Dealers. It clarifies the set owners' misunderstand-

ings about the standard work and parts guarantee. Giant blow-ups of this advertisement are available from your Raytheon Tube Distributor at no cost to you. Be sure to feature one in your shop window.



BULPLATE® Printed Circuits
for all your printed circuit replacements

Sprague's new BULPLATE Printed Circuit line now includes *the most comprehensive listing of printed circuits available anywhere*. By standardizing on the Sprague BULPLATE line, you'll be able to replace practically every printed circuit found in original equipment, including . . .

antenna-chassis isolation networks
 detector-triode coupling networks
 retrace-suppression networks
 vertical feedback networks
 triode coupling networks
 detector-pentode coupling networks
 automatic gain control networks
 horizontal deflection networks
 sound i-f networks

vertical integrators
 decoupling filters
 audio output networks
 phase comparators
 parallel resistor-capacitor networks
 tone compensation networks
 diode filters
 pentode coupling networks
 sync take-off networks

Get your copy of Sprague's new BULPLATE Replacement Manual K-351 now. Original set manufacturers' part numbers are cross-referenced to



Sprague replacement part numbers . . . making Sprague BULPLATES extra-easy-to-use. Ask your distributor for a free copy, or send 10c (to cover handling and mailing costs) to Sprague Products Co., 105 Marshall St., North Adams, Massachusetts.

don't be vague . . . insist on

SPRAGUE®
the mark of reliability

SPRAGUE RESEARCH IS CONSTANTLY PRODUCING NEW AND BETTER COMPONENTS FOR YOU

publisher
Howard W. Sams
general manager
Mal Parks, Jr.

editor
Verne M. Ray
associate editors
Leslie D. Deane
Thomas A. Lesh
Calvin C. Young, Jr.

consulting editors
William E. Burke
Robert B. Dunham
George B. Mann
C. P. Oliphant
Paul C. Smith

art director
Don W. Bradley

editorial assistant
Georgeanna Caldwell

adv. production
Carol B. Gadbury

circulation fulfillment
Pat Tidd, Mgr.
Ann Mathews, Ass't.

photography
Robert W. Reed

advertising sales offices

Midwestern
PF REPORTER

2201 East 46th Street, Indianapolis 6, Ind.
Clifford 1-4531

Eastern

Paul S. Weil and Donald C. Weil
30-01 Main Street, Flushing 54, New York
Independence 3-9098

Western

The Maurice A. Kimball Co., Inc.
2550 Beverly Blvd., Los Angeles 57, Calif.
Dunkirk 8-6178, and 681 Market Street,
San Francisco 5, Calif. Exbrook 2-3365

Address all correspondence relating to circulation and editorial to PF REPORTER, 2201 East 46th Street, Indianapolis 6, Indiana

Copyright 1959 by Howard W. Sams & Co., Inc. No part of the PF REPORTER may be reproduced without written permission. No patent liability is assumed with respect to use of information herein.

As a magazine devoted to public service to the entire electronics industry, it is the obligation of PF REPORTER with Electronic Servicing to present to its readers all legitimate advertising in this field. Acceptance of advertising does not in any manner signify the products, policies and services so advertised have been approved, endorsed, or recommended by this magazine.

NEXT MONTH

Homeowner's TV Antenna Handbook

One of the most unique coverages we've ever presented, dealing with the importance of a properly designed and installed antenna system in providing quality TV signals. Heart of the story is a to-the-point 8-page booklet pictorially designed to educate and advise the consumer — your customer — regarding his TV antenna system needs.

Horizontal Sweep Circuits

Another in our popular series of down-to-earth TV-circuit troubleshooting analyses — with practical explanations of functions fulfilled by various components and networks, and time-saving hints for tracking down circuit defects.



PF REPORTER

including *Electronic Servicing*

VOLUME 9, No. 1

JANUARY, 1959

CONTENTS

Previews of New Sets	1
Advance information on four '59 Models.	
Video Speed Servicing	5
Service hints for Admiral and RCA chassis.	
Letters to the Editor	16
Shop Talk <i>Milton S. Kiver</i>	20
Pointers on servicing transistorized TV circuits.	
Isolating Sync-Circuit Troubles <i>Les Deane</i>	24
Localizing them to specific stages and components.	
Mobile Communications	26
Installation techniques for 2-way radio equipment.	
Servicing New Designs <i>Thomas A. Lesh</i>	28
Complete coverage on RCA's WIRELESS WIZARD; glimpses of a pilot GE transistor TV; Westinghouse alarm-clock radio.	
The Troubleshooter	30
Tips for Techs	32
Dollar & Sense Servicing	34
Low-Voltage Power Supplies <i>Calvin C. Young, Jr.</i>	36
A unique analysis of how the popular designs operate.	
Quicker Servicing	46
Some case histories of unusual tuner troubles, and a new instrument for checking output tube currents in-circuit.	
Understanding Sound Systems <i>L. A. Randall</i>	52
Data to help you become the specialist in your community.	
Servicing Industrial Electronics <i>Melvin Whitmer</i>	60
Part 13—Timing-control circuits for typical resistance-type spot welders.	
Product Report	78
Free Catalog & Literature Service	80

ABOUT THE COVER

Every boy, at some tender age, wants to be "just like Dad." If (as in the case depicted by this month's cover) Dad happens to be a TV serviceman, his son is probably the envy of every kid on the block. And, incidentally, Dad, don't discourage Junior from fixing up his own vehicle to imitate yours. Aside from the psychological mental block experts say you might instill, his advertising may bring in more neighborhood business than your own!



USE HANDY CARD AT BACK TO ENTER YOUR SUBSCRIPTION

www.americanradiohistory.com

25,000,000 PEOPLE SAW THIS
RECENT ADVERTISEMENT IN

LIFE



COACHES MIDGET-LEAGUE TEAM. For the past two years, Theodore W. Fickert, TV technician of Hatfield, Pa., has shown his 25-boy club how to play baseball. Active in community causes, he helped organize the Hatfield Junior Chamber of Commerce, and served as its secretary and state director; participates in the Heart Fund and other worthy drives; and is on the planning committee of St. Peter's Lutheran Evangelical Church.



A BRIGHTER, CLEANER CITY owes much to Bryce McNeely's work in connection with the Kelso, Wash., program for civic beautification. Bryce is on the mayor's committee for school and city improvement, is state JC vice president, and promotes young men's leadership training.



MAKES OTHERS' TROUBLES HIS OWN. One of the few TV technicians in an 85-mile area, T. E. "Buck" Adams of Channing, Tex., often aids in roadside emergencies, helps pen run-away cows, and has worked to improve local Baptist Church, parsonage.

CRIPPLED CHILDREN LEARN TO WALK through fund-raising efforts of Vernon E. Brooks, Norristown, Pa., who helped obtain \$100,000 to build a school for spastic paralytics. Mr. Brooks (center) is a director of the Chamber of Commerce, and a prime mover in Red Cross, Community Chest, United Fund, and Salvation Army work. As national president of the American Business Club, he helped obtain more than 100 scholarships for the training of physical and speech therapists. He is chairman of the Muscular Dystrophy unit for the Tall Cedars of Lebanon.



All-American TV Technicians

HELPED TORNADO VICTIMS. When disaster struck the area around Menomonie, Wis., on June 4, Vernon Townsend quickly organized emergency radio facilities to speed relief to the sufferers. A leading member of the Radio Amateur Civil Emergency service, he is active in Dunn County civil defense work, and also maintains a radio entertainment service for the local city-county hospital.

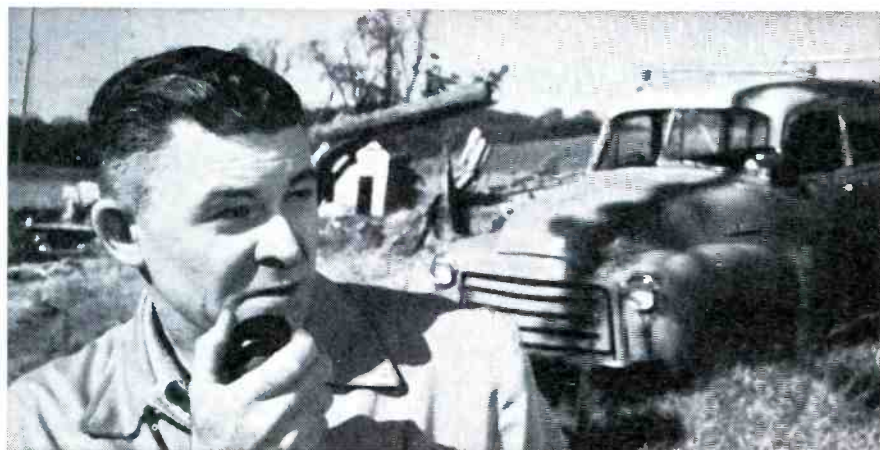



TEACHES SCOUTS RADIO. Boys in Brockton, Mass., learn Morse Code and the elements of electronics at an early age, from instruction by TV technician Albert P. Kazukonis. Much of the equipment he supplies without charge. A devoted youth and community worker, Mr. Kazukonis is treasurer and a past president of the Electronic Technicians Guild of Massachusetts, Brockton Chapter.



DONATED LOUDSPEAKER SYSTEM. The 1958 Centennial parade and pageant at Bloomington, Minn., owed much of its success to the fine amplifier system installed without charge by Edwin B. Haines. Ed is widely known for the time, effort, and equipment he has supplied for the 2,000 boys in Bloomington's sports program. He is a leader and counselor in Boy Scout work, and gives assistance to the Lions and the Bloomington Civic League.

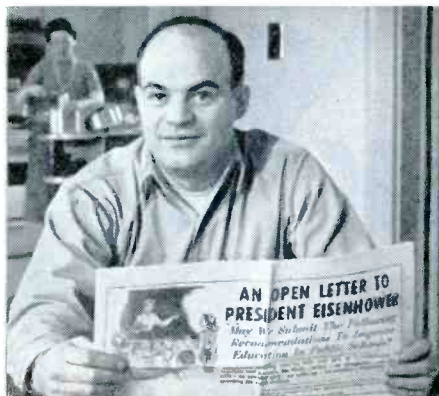

SPENDS TO PROMOTE EDUCATION. Out of his own pocket, A. George Catavalo, TV technician of Somerville, Mass., financed two full-page newspaper ads which presented to the President recommendations on public school education. Last year George contributed over 30 radios, plus his time, to teach boys electronics.



WORLD OF TOMORROW! This novel space radio-man hat, invented by Stanley Everett of Alhambra, Cal., helped publicize many worthy drives. Stanley is president of the Los Angeles Electric League; a director of the Alhambra Chamber of Commerce; past president of Kiwanis and district chairman of the United Fund drive.



COMMUNITY SERVICE is a watchword with Wayne E. Lemons of Buffalo, Mo. An active Rotarian, he works with Boy Scouts, promotes Little League baseball, and has instructed TV technicians in surrounding cities. He is West Central vice-president of the National Alliance of Television Electronic Service Associations.

Win General Electric Awards

PEOPLE the nation over nominated candidates for the 1958 All-American Awards, honoring TV service technicians. This broad response showed how important a place the television technician holds in our community life, and how widely esteemed are his efforts in aid of others.

The Award winners, shown here, were chosen by a panel of judges including John Sparkman, U. S. Senator and Chairman, Select Committee

on Small Business; Bennett Cerf, television panelist and head of Random House publishing firm; and Charles Shearer, 1957-58 president of the National Junior Chamber of Commerce.

With these Awards, General Electric pays tribute to the part played by the independent television technician in making this a better country for all. *General Electric Company, Receiving Tube Department, Owensboro, Kentucky.*

Progress Is Our Most Important Product

GENERAL  ELECTRIC

2-111-231



Winners received this trophy, \$500 for community benefit, and a trip to Wash., D.C., for luncheon with Senator John Sparkman.

BRAND NEW! READY FOR YOU NOW!

Neatest Package Yet... Greatest Convenience Ever

FOR CARBON COMPOSITION RESISTORS



HANDY-PAK*

Just the kind of package you have been asking for! New IRC Handy-Paks were designed with the up-to-date Serviceman in mind. Here is the neatest, most compact resistor package available in the whole electronics industry. And it is exclusive from IRC. Fussing and fuming over stocking small parts is all over as far as carbon composition resistors are concerned. IRC Handy-Paks are easier to buy, easier to stock, and easier to use. Ready for you now . . . added convenience for the world's finest resistors.

EASIER TO IDENTIFY!

In clear, large letters the type, resistance value and power rating are printed on every Handy-Pak. Correct identification is fast and certain with Handy-Paks.

QUICKER TO FIND!

In any stocking arrangement, Handy-Paks can be quickly indexed by power rating and resistance. Your resistor stock remains orderly from the time you buy it until you use it.

HANDIER TO USE!

IRC Handy-Paks open at both ends. The package slides out of the slimline plastic sleeve. Simply withdraw one or more resistors and slide the package back into the protective shield. Leads are kept straight, and resistors are always factory-clean.

EASIER TO CHECK INVENTORY!

The actual resistors are clearly visible. You always know what you have. Identification tab tears off conveniently for reordering reminder.

* PATENT PENDING

3
TYPES
 1/2 watt, 1 watt
 and 2 watts

★
All Handy-Paks
72¢ ea.
DEALER NET



Each IRC Handy-Pak contains several carbon composition resistors of one type and resistance value . . . to save you unnecessary shopping. Three types include: 6 1/2-watt resistors; 4 1-watt resistors; and 3 2-watt resistors.

And here's the perfect trio for keeping them at your fingertips!

IRC RESIST-O-PEDIA

Resistor Assortments in Handy Book Form

Here's unique convenience for stocking carbon composition resistors. Attractive blue and yellow hardback binder measures 9x8 1/4 x 2 7/8". 3-ring "fingered" inserts hold resistor Handy-Paks. Indexed stock saves searching... speeds servicing. Complete resistor identification always visible. Choose from 3 popular assortments—



- # 44 462 1/2-watt resistors, 77 values **\$5544**
 - # 48 308 1-watt resistors, 77 values **\$5544**
 - # 51 195 2-watt resistors, 65 values **\$4680**
- Dealer Net Price

RESIST-O-PEDIA
included FREE with
Nos. 44, 48 and 51
Handy-Pak
Stock Assortments

IRC RESIST-O-CHEST

All-Metal File in 6 Assortments

End "cigar box confusion." Select from 6 popular carbon composition resistor stocks, all in sturdy metal chests. Hinged lid and metal separators keep resistor Handy-Paks in order... right at your fingertips. Compact 5 5/8 x 3 3/8 x 6 1/4" size takes little bench space. Identification data clearly visible. Select from 6 fast-moving assortments—

- # 42 204 1/2-watt resistors, 34 values **\$2448**
 - # 43 462 1/2-watt resistors, 77 values **\$5544**
 - # 46 136 1-watt resistors, 34 values **\$2448**
 - # 47 308 1-watt resistors, 77 values **\$5544**
 - # 49 102 2-watt resistors, 34 values **\$2448**
 - # 50 195 2-watt resistors, 65 values **\$4680**
- Dealer Net Price



RESIST-O-CHEST
included FREE with
Nos. 42, 43, 46, 47,
49 & 50 Assortments

IRC RESIST-O-CADDY

Resistor Companion For Tube Caddys

Ideal for in-home servicing. Pliable plastic pouch folds to 6 3/4 x 3 7/8 x 1 1/2" ... fits easily in tube caddy or tool chest. Individual pockets hold resistor Handy-Paks secure and orderly. Accurate inventory always visible. RESIST-O-CADDY included FREE with either of these "best-seller" assortments—

- # 41 120 1/2-watt resistors, 20 values **\$1440**
 - # 45 80 1-watt resistors, 20 values **\$1440**
- Dealer Net Price



CHOOSE THE HANDY-PAK DEAL THAT SUITS YOU BEST
And Order Today From Your IRC Distributor!

Wherever the Circuit Says



INTERNATIONAL RESISTANCE CO.
Dept. 361, 401 N. Broad St., Philadelphia 8, Pa.
In Canada: International Resistance Co., Ltd., Toronto, Licensee



"A" BATTERY ELIMINATORS



For
Demonstrating and
Testing Auto Radios

TRANSISTOR OR VIBRATOR OPERATED
6 Volt or 12 Volt!

New Models . . . Designed for testing D.C. Electrical Apparatus on Regular A.C. Lines. Equipped with Full-Wave Dry Disc Type Rectifier, Assuring Noiseless, Interference-Free Operation and Extreme Long Life and Reliability.

TYPE	INPUT A.C. Volts 60 Cycles	D.C. OUTPUT		SHIP. WT.	USER PRICE
		VOLTS	AMPERES Cont. Int.		
610C-ELIF	110	6	10 20	22	\$42.95
		12	6 12		
620C-ELIT	110	6	20 40	33	59.95
		12	10 20		

SEE YOUR JOBBER OR WRITE FACTORY

✓ NEW MODELS ✓ NEW DESIGNS ✓ NEW LITERATURE
• "A" Battery Eliminators • DC-AC Inverters • Auto Radio Vibrators



AMERICAN TELEVISION & RADIO CO.
Quality Products Since 1931
SAINT PAUL 1, MINNESOTA, U. S. A.

Letters to the EDITOR

Dear Editor:

Regarding the article *Operating a Scope* in the October issue, I feel that anyone who had a scope could figure out this information for himself in a few minutes.

BYRON H. SWAIM

Maryville, Mo.

Dear Editor:

I am another of the "newer readers" you referred to in your answer to John S. Mrozko (October *Letters* column). Don't forget that many former servicemen have advanced to higher jobs in the electronics field, thus leaving a gap to be filled by newer men. If we are compelled to buy books to get basic theory, why subscribe to the magazine?

J. VISCUSI

Long Island City, N. Y.

These two letters focus attention on any Editor's constant challenge — holding the interest of all his readers, whether they're just getting started, or are old hands at the game. At PF REPORTER, we take a basic approach on many subjects so that newcomers won't be completely baffled, but we can't get too basic, else we won't interest the more advanced servicemen.

As we've said before, a magazine is no place to start learning fundamentals. To keep abreast of the rapid developments in our field, it takes schooling, practical experience, books of all kinds, and the right kind of magazines. If we can count on schools and textbooks to explain why $E=IR$, then we can concentrate on publishing reasonably-concise articles, tying in basic theory with new developments and field experiences.—Ed.

Dear Editor:

We who work in industrial instrumentation were happy when your first article on industrial electronics appeared (September, 1957). We have seen no letters published to commend these articles, but we can truthfully say that we really use and enjoy all that Mr. Whitmer has written so far. When an issue comes out with no article on industrial electronics, we are much disturbed at the possibility that the series is being discontinued.

Would you be kind enough to put these articles in handy book form? You can even put my name on the list to receive *Industrial Electronics Vol. 1*, if and when such a book is issued.

WILLIAM C. ST. ROMAIN

Baton Rouge, La.

Quell your fears, sir. We have no intention of discontinuing coverage on industrial servicing. "Servicing Industrial Electronics" now appears every other month; alternate issues include feature articles for this field.

We've planned from the start to pub-

lish a book on the subject. It is tentatively scheduled for appearance this year, and will be announced in PF REPORTER.—Ed.

Dear Editor:

I find PF REPORTER articles very easy to understand because they come right to the point. I like them fairly brief so that I don't try to cram too much information all at once.

EDWIN B. JOHNSON, JR.

Riverside, R. I.

And it ain't easy to make 'em that way, Edwin. The simpler they are to read, the harder they are to write.—Ed.

Dear Editor:

Mr. Melvin Cohen's letter in the October issue interested me greatly. I would like to have 500 reprints of his article if they are still available.

The mobile TV shop pictured in the enclosed snapshot was placed in service last January 22. Since that time, there have been only three cases where it was necessary to take a customer's set away from his home; these all involved waiting for delivery of parts from the original manufacturer. My customers have learned that excessive waiting for the return of their sets, with consequent high labor charges, is not necessary.

GEORGE V. COLDWELL

Trevose, Pa.



We're sorry, but all 150,000 reprints of Mr. Cohen's article have been distributed. Your shop on wheels looks like an efficient and roomy one—certainly looks like you have a big enough "tube caddy" to be prepared for anything on a home call!—Ed.

Dear Editor:

Your *Tube Substitution Guide* shows the 5V4GA and 5AZ4 as replacements for the 5Y3GT or 5Y3GA. Can't the 5U4G also be used to replace the 5Y3GT?

RONALD J. REED

New Orleans, La.

5U4 and 5Y3 types have considerably different filament-current requirements. 5U4's require 3 amps at 5 volts, while 5Y3's need only 2 amps at the same voltage. We hesitate to recommend a 33% increase in the current drain on the 5-volt secondary winding for EVERY transformer in EVERY application.—Ed.

Dear Editor:

In the November issue, you mention a new 12DT7 tube that replaces the 12AX7 in audio preamps. Who makes it and where can it be obtained?

A. D. HEGEL

Phoenix, Ariz.

It's made by Raytheon and is obtainable through parts distributors.—Ed.

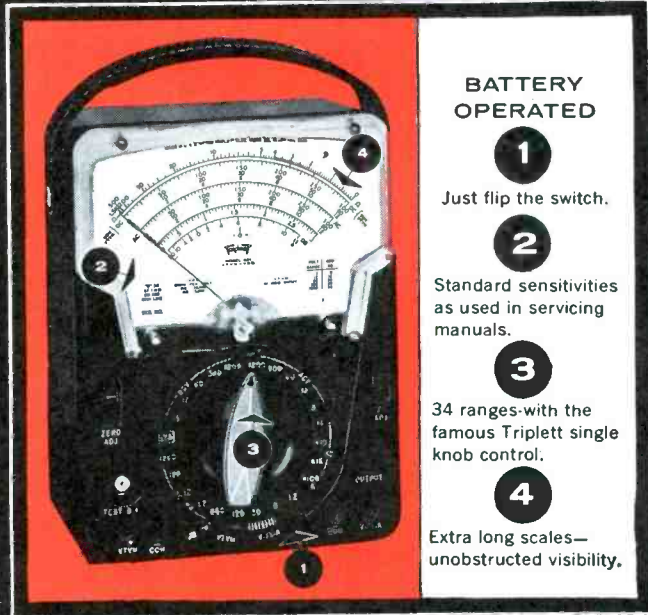

BATTERY OPERATED

- 1**
Just flip the switch.
- 2**
Standard sensitivities as used in servicing manuals.
- 3**
34 ranges-with the famous Triplet single knob control.
- 4**
Extra long scales—unobstructed visibility.

double use...half the price

Triplet Model 631 the standard Combination VOM and VTVM \$64.50. Here's the *one* instrument which will do practically *all* the measuring in your electronic projects.

A VOM is essential equipment in electronics for measuring current, resistance and voltage. A VTVM is important for voltage measurements where it is desirable that the measuring instrument cause little or no current drain.

By using the Volt-Ohm-Milliammeter for all general testing (90% of your testing) and the Vacuum Tube Voltmeter only when you need it, you have the advantage of a VTVM with extremely long battery life. Batteries are used only about one-tenth as much as in the ordinary battery-operated VTVM.

Features: Ohms, 0-1500- 15,000 (6.8-68 center scale. First division is 0.1 ohm.)

Megohms: 0-1.5 (6,800-680,000 ohms center scale.)

Galvanometer center mark "-0+" for discriminator alignment.

RF Probe permits measurements up to 250 MC. \$7.00 net extra.

Featured by leading electronic parts distributors everywhere.



53 years of experience

THE MIGHTY NINE



630



630-NA



630-A



310



630-T



666-HH



625-NA



666-R



Sylvania received Altoona's official welcome through front-page headlines and a special feature section filled with congratulations.

Why the whole town made such a fuss over

Sylvania's new tube plant



For one thing—Altoona folks know that progress by an important resident company means the whole town progresses. Sylvania's President, Don Mitchell, at the multi-million-dollar plant's formal opening called it "the largest in the receiving tube industry—containing many innovations."

This is where you come in. Because most of these innovations affect your business profit. As the world's most modern tube plant, Altoona will be producing the world's most reliable tubes in both commercial and

military types. Two of the industry's biggest bugaboos, intermittent shorts resulting from dust and lint and unstable emission caused by contamination and humidity variations during tube manufacture, promise to be vastly improved. You'll be hearing more about these developments in the future.

The Altoona plant is as much a dedication to the independent serviceman as it is to the entire tube industry. It's a modern example of why profit-minded dealers are relying on Sylvania tubes.



SYLVANIA

SYLVANIA ELECTRIC PRODUCTS INC.
1740 Broadway, New York 19, N.Y.
In Canada: P. O. Box 1190, Station "O,"
Montreal 9

LIGHTING • TELEVISION • RADIO • ELECTRONICS • PHOTOGRAPHY • ATOMIC ENERGY • CHEMISTRY-METALLURGY

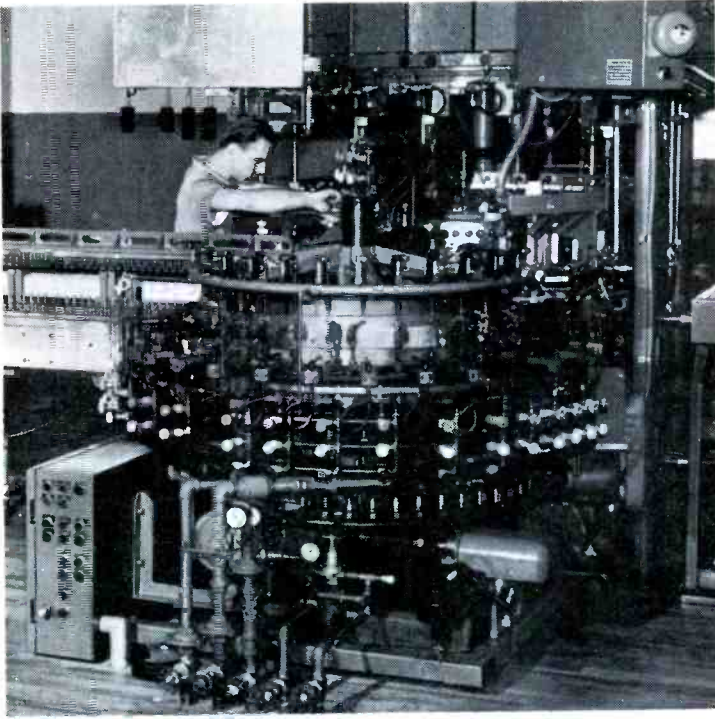

New concepts in tubemaking, which have been in development for the past decade, are put into high-speed production facilities at Altoona. The new concept bulb, in the making here, adds new tube reliability.

in Altoona



The new double-turret sealax is an important new development. Oil-diffusion pumps work in series with mechanical pumps to produce the most nearly perfect vacuum possible.

New Transistor Servicing Course

Now you can get a thorough grounding in servicing transistorized equipment with Sylvania's new 12-lesson transistor Servicing Course. Specially prepared by Sylvania engineers and the Radio-Television Training Association, it will help you cash in on the fastest growing segment of the electronics industry.

Now is the time to prepare for your share of this fast-growing business. See your authorized Sylvania Distributor or mail the coupon below for complete information on the Sylvania—RTTA Transistor Servicing Course.



Sylvania Electric Products Inc.
Dept. C35P
1740 Broadway
New York 19, N.Y.

Please send me full details on the new Sylvania—RTTA Transistor Servicing Course.

Name _____

Service Co. _____

Address _____

City _____ State _____

ShopTalk

MILTON S. KIVER

Author of . . .
How to Understand and Use TV Test Instruments and Analyzing and Tracing TV Circuits

Transistorized TV— The Service Angle

In November, we examined the stage-by-stage operation of a transistorized television receiver, and noted that its stage lineup was essentially similar to that found in vacuum-tube television receivers, although more transistors than tubes were sometimes needed to accomplish the same result. If you basically understand transistor operation, and know what happens in a television receiver, the combination of the two should not present any technical difficulties.

This month, we'll consider the servicing of a transistorized television receiver. As a start, let's see how much of what we already know can be applied, considering what we should do to locate a defect in a transistorized television receiver and comparing this with what we would have to do in a vacuum-tube set to uncover the same defect.

One of the first steps we take when presented with a defective set is to check the aural and visual outputs. Are the sound and video both

present? If not, which one is missing? Once we have this information, we can further isolate the trouble. For example, if the picture is good but there is no sound, we know that the defect must exist somewhere between the sound take-off point and the loudspeaker. By the same token, if the sound is normal but there is no picture, we would look for trouble between the sound take-off point and the picture tube. There may be some exceptions to this rule, but it will generally hold true.

Again, if both video and sound are absent but there is a raster, we can be reasonably certain the trouble is situated in some stage between the antenna input terminals and the picture tube. Our first step, then, is to check the various selector-switch positions of the RF tuner. It may be that the tuner is not functioning in one position but does operate normally in all other positions. In this case, other stations broadcasting in the vicinity would be received. This is also a good way to determine whether the source of interference or picture distortion is with-

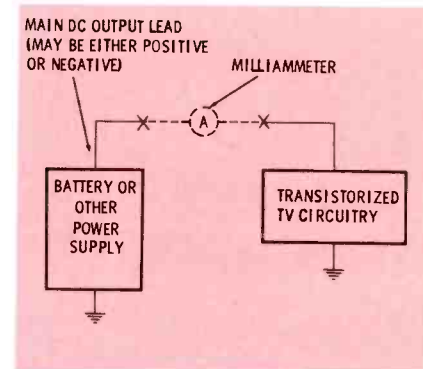

Fig. 1. Where to insert meter to check current drain of transistorized TV.

in, or outside, the receiver.

Finally, if we find that sound, video and raster are all absent, then we can generally confine our search to the power-supply circuit. One common cause of failure in vacuum-tube receivers need not be considered in transistorized sets, since transistors do not possess filaments. If the circuit is powered by batteries, we should check the battery voltage. Measurement of the overall resistance of the battery load circuit (with the battery disconnected) will tell us if a short circuit exists in the receiver. We could also check the battery current drain, which often provides a clue to the cause of trouble. This is done by opening the main lead coming from the ungrounded side of the power supply and inserting a milliammeter as shown in Fig. 1. If operating voltages are provided by a rectifier-type power supply instead of a battery, then we would apply the same troubleshooting procedures employed for a vacuum-tube set.

Due to the wide variety of battery

• Please turn to page 70

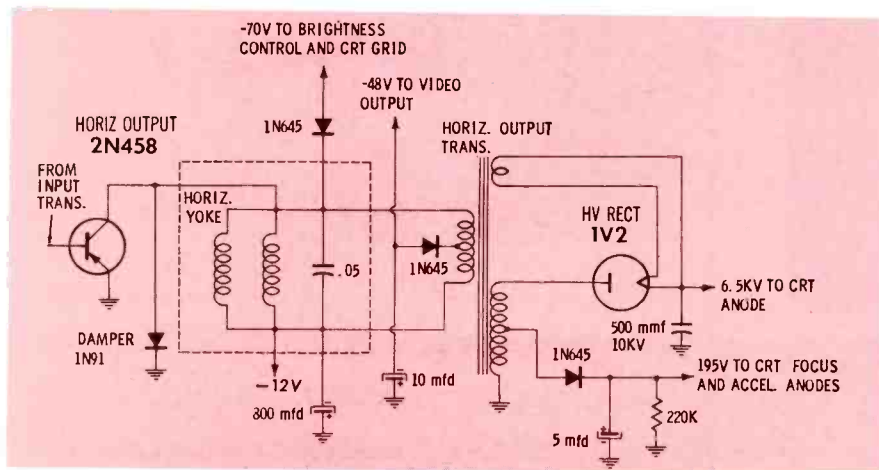

Fig. 2. High AC voltages in horizontal output circuit are rectified for use in video amplifier and CRT circuits.

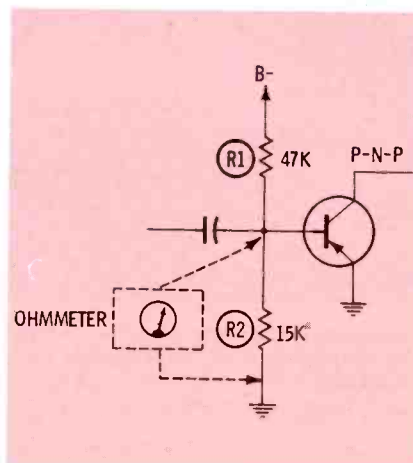
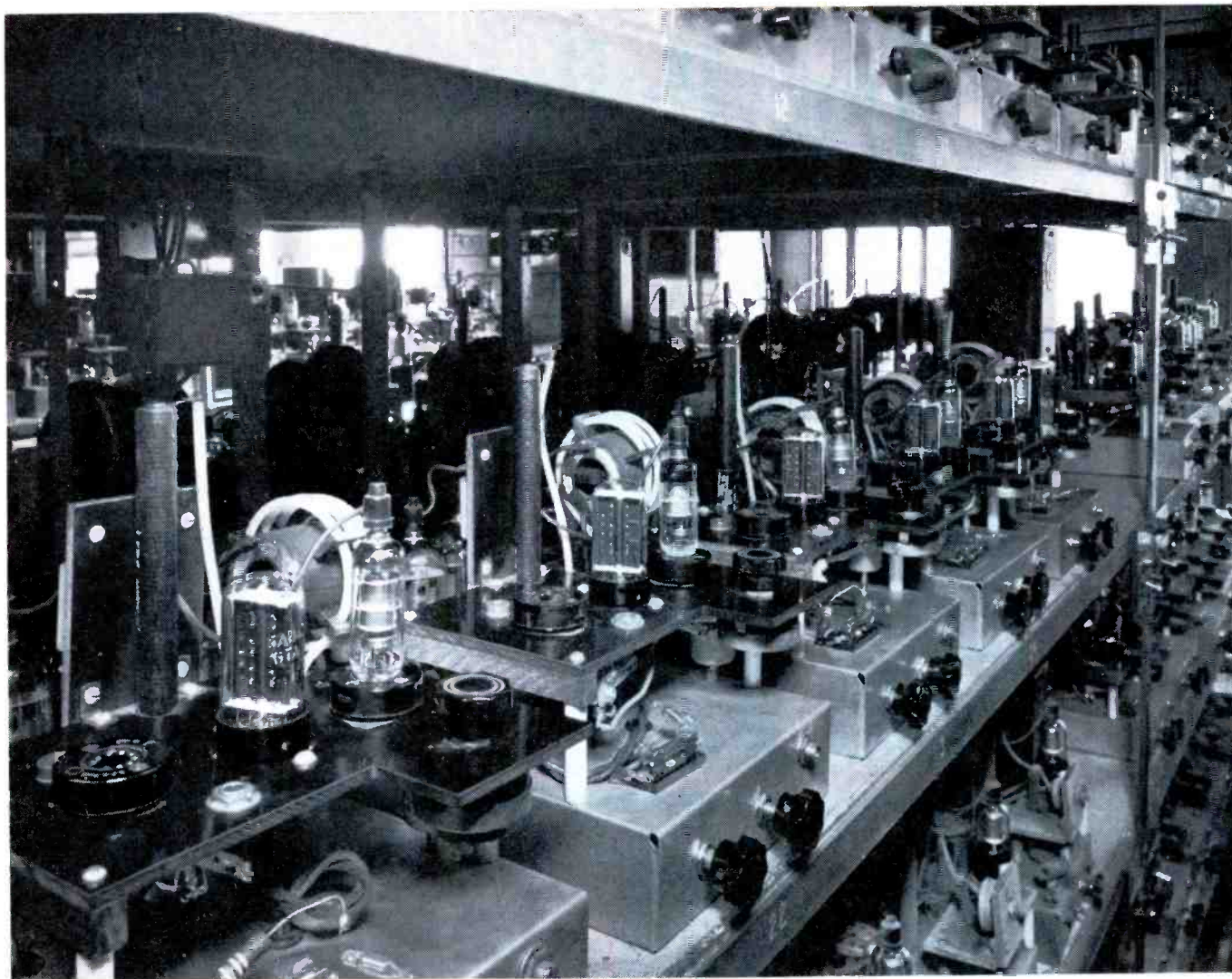

Fig. 3. Resistance reading across R2 depends on polarity of ohmmeter leads.



NEW CONTROLLED

Dynamic Life Tests...

... ASSURE UNIVERSAL TUBE REPLACEMENTS

Testing tubes in sets is good . . . but not the best way. We life-check tubes dynamically in TV sets . . . in addition to many other extensive tests for materials, production, design and static life. But there are interaction problems in set testing which obscure the causes of tube failure. And some models of TV sets operate tubes conservatively. CBS-Hytron has, therefore, developed controlled dynamic life tests to examine all important characteristics under the most stringent TV set conditions.

... HELP PINPOINT AND CORRECT FAULTS

Day in, day out, tubes are cycled and checked under accelerated conditions at low (105 v) and high (140 v) line voltages. Components and dynamic operating conditions are controlled to point the finger unrelentingly at the exact nature of tube failures. They may be opens, shorts, gas, gradual deterioration of electrical characteristics, etc. Once the tests locate the fault, the correction is

invariably the same: improvement of tube design or manufacturing techniques.

... CUT YOUR CALL-BACKS. This new controlled dynamic life testing is your answer for dependable, universal replacement tubes for all TV sets. It is a big reason why CBS-Hytron tubes can cut your call-backs. Be sure to ask for CBS-Hytron tubes.

*More reliable products through
Advanced-Engineering*

CBS-HYTRON, Danvers, Massachusetts
A Division of Columbia Broadcasting System, Inc.

New Mallory *Diffused*



Type T . . . for most economical replacement. Encapsulated in Mallo-Seal*, this lowest-priced model can stand 500 hours in boiling water. Available in handy packs of five each for mounting by leads, and in kits using plug-in rectifiers, with mounting hardware. 400 and 365 volt ratings, 0.5 ampere. Also available from 50 to 600 P.I.V. inclusive.

*Trademark of P. R. Mallory & Co. Inc.



Type P . . . for plug-in replacement. Fuse model fits sets already converted to this type of silicon unit. Available in 5-packs, and as conversion kits for half-wave, full-wave or doubler application, with fuse clip and mounting hardware. 400 and 365 volt ratings, 0.5 ampere. Also available from 50 to 600 P.I.V. inclusive.



Type E . . . for higher reliability. Military grade "top hat" rectifier, hermetically sealed for jobs where you want the absolute peak in life and dependability. Two to a pack; rating is 400 volts, 0.75 ampere. Also available from 50 to 600 P.I.V. inclusive.

Junction Silicon Rectifiers

A completely new concept in silicon rectifier design gives these new Mallory models reliability never before possible. At the heart of each is a unique diffused junction silicon element, product of extensive Mallory research in semi-conductors, which has these characteristics:

- Low reverse leakage**.....less than 250 microamperes
- Low forward drop**.....less than 0.5 volt
- Exceptional life**.....takes over 2000 hours at 85 C, with 1.5 million switching operations without failure
- Moisture-proof**.....exceeds humidity requirements by four times (MIL 202A)
- High reliability**.....100% testing eliminates premature failures, protects you against call-backs

Three different models, each designed for specific service applications, are now available to fit all television and radio circuits as replacements for metallic rectifiers.

See this display on your Mallory distributor's counter—a complete assortment—in handy see-through packs—of the full line of Mallory silicon rectifiers.



ISOLATING

sync - circuit troubles

by Les Deane

When confronted with trouble symptoms affecting picture stability, the TV serviceman usually focuses his attention on the sync circuits. He should recognize that instability may come from other sources, however. If substitution of tubes in the sync section proves ineffective, new sweep oscillator and AFC tubes should also be tried. It pays to check AGC and range adjustments if the set is so equipped. The serviceman might also make a stab in the dark and replace about a half dozen other tubes in the RF, IF, and video sections before finally deciding to pull the chassis.

Isolating the Trouble

Provided the trouble symptom permits, adjust the hold controls so that you can observe the vertical blanking bar as shown in Fig. 1A. To obtain a clear view of all detail within this bar, it may be necessary to increase brightness or decrease contrast. Either of these actions will prevent the blanking signal from cutting off the picture tube and will thus cause it to be reproduced as grey instead of black. Under these conditions, a black area will normally be seen in the middle of the blanking bar. This is due to CRT cutoff produced by the "blacker-than-black" tips of the vertical sync and equalizing pulses. A small gap will appear in the center of this black pattern because of the serrations in the vertical sync pulse. If the pulse is abnormal, it will appear as shown in Fig. 1B, and you should troubleshoot the video, IF AGC, and RF stages, in that order. Should the sweep oscillators be too far off frequency to perform this test, chances are that the fault lies in the oscillator stage itself.

If picture-tube reproduction of

the sync pulse appears reasonably normal, the next logical step is to check oscillator operation without sync control. About the easiest way to accomplish this, if the symptom warrants, is to disconnect the sync input from the oscillator or AFC circuit and adjust both hold controls for as stable a picture as possible. Check to see if the oscillator frequency will pass through the lock-in range, or if distortion (such as bending) disappears. When the frequency is off and cannot be corrected by adjustment, or if some form of sync distortion still exists, confine your search to the oscillator or AFC sections. If, on the other hand, the distortion is corrected and the action of the oscillators seem normal, i.e., they refuse to lock in but can be adjusted to sync frequencies, the trouble is most likely to be somewhere between the sync take-off point and the oscillator or AFC input.

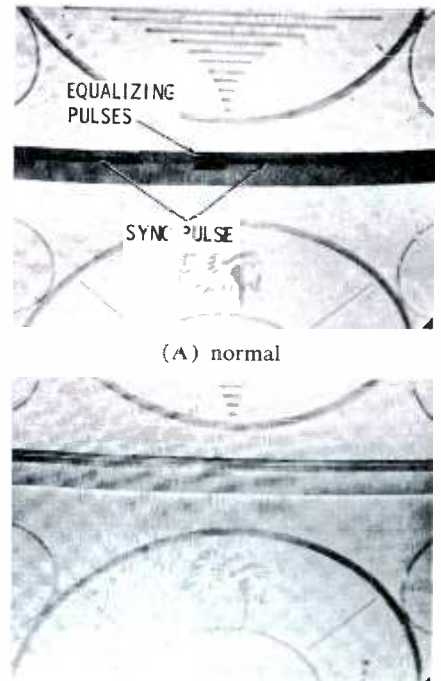

(A) normal

(B) abnormal.

Fig. 1. Condition of sync signal can be seen from blanking bar on the screen.

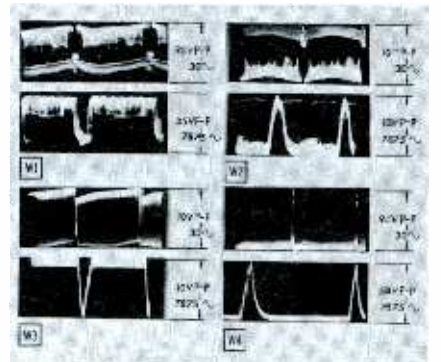

Waveforms observed in circuit of Fig. 2 at sweep rates of 30 and 7875 cps.

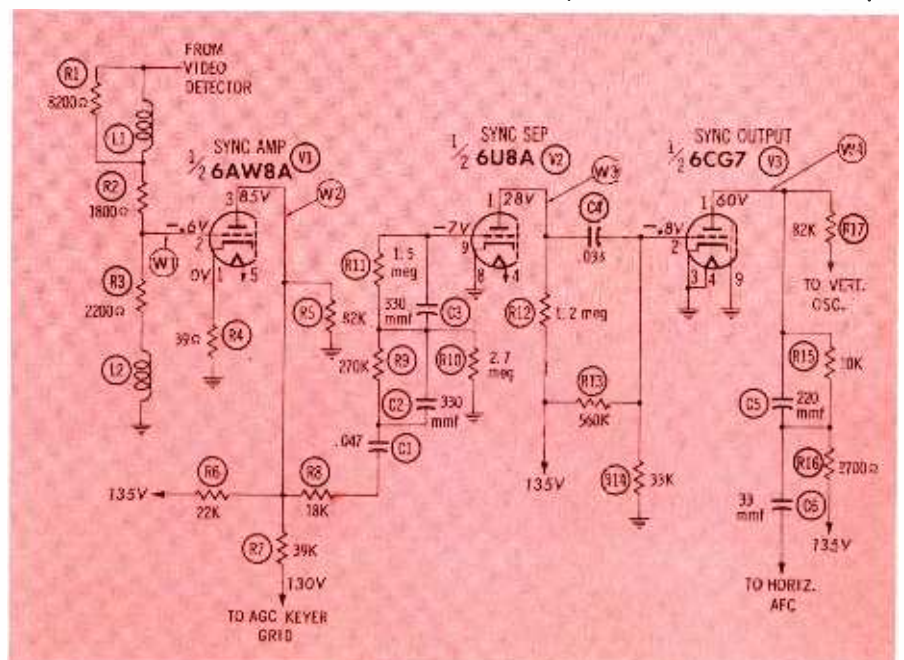

Fig. 2. Schematic of the sync circuitry employed in the RCA Chassis KCS117A.

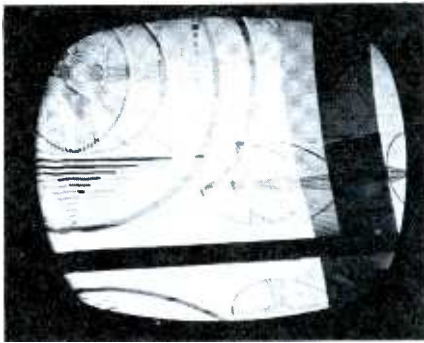

Fig. 3. Loss of picture control—typical indication of an inoperative sync stage.

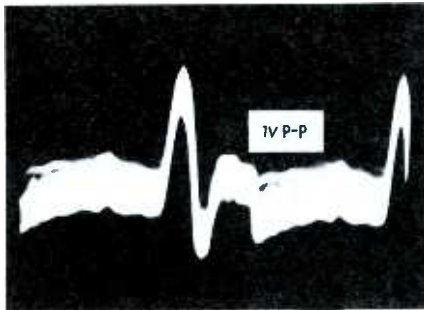

Fig. 4. V1 plate with increased load resistance (sweep rate 7875 cps.)

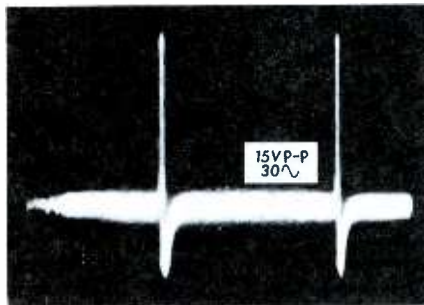

Fig. 5. Abnormal plate signal (V3). Note spike due to oscillator pulse.



Fig. 6. Plate waveform of V1 with 60-cycle modulation (Scope sweep 30 cps).

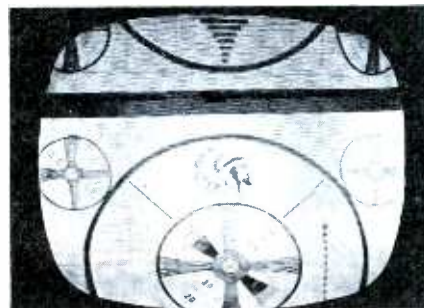

Fig. 7. Poor vertical synchronization due to leaky sync-coupling capacitor.

Another hint that may be helpful in isolating sync troubles is to check the symptom at different settings of the contrast control. If trouble is lessened when contrast is reduced, the cause lies in the video or sync sections. If the setting of the control has little effect, or if the trouble increases as contrast is reduced, the defect is probably ahead of the sync take-off point. Although this test is quick and simple, it may be of no absolute value unless the sync take-off point follows the contrast control circuit.

Perhaps the most accurate way to localize a trouble of this general nature is to examine key waveforms with an oscilloscope. With reliable service information as a guide, check for distortion and proper signal amplitude at both the input and output of suspected sections.

Circuitry

At this point, let's assume the trouble has been isolated to the sync stages. While there are many design variations in use, we have selected one of the more typical systems for this discussion. Taken from a late model receiver, the sync circuit shown in Fig. 2 utilizes three separate stages — a sync amplifier, sync separator, and sync output.

The purpose of this sync section, like most, is to amplify the composite video signal to a usable level, separate the sync pulses from the video information, and then supply vertical and horizontal pulses to the oscillators or control circuits. The actual separation of pulses from the composite sync signal is not performed in the sync tubes, but by the low- and high-pass filter circuits (better known as integrator and differentiator networks) at the input to each oscillator stage.

Since the particular circuit illustrated derives its sync input signal from the video detector, a triode amplifier is employed as the first sync stage. Direct coupling is used to bias V1 so that noise pulses greater than sync will drive the tube into cutoff. Capacitor C1 and resistor R10 form the coupling network to the second stage. Other components in this network help prevent C1 from being charged by short-duration pulses, thereby reducing the

• Please turn to page 66

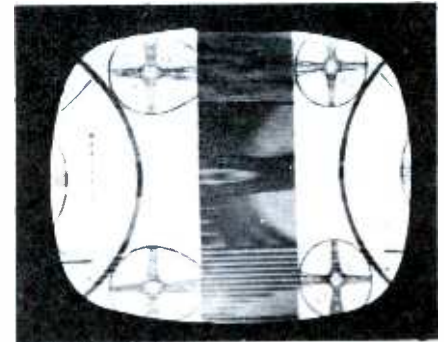
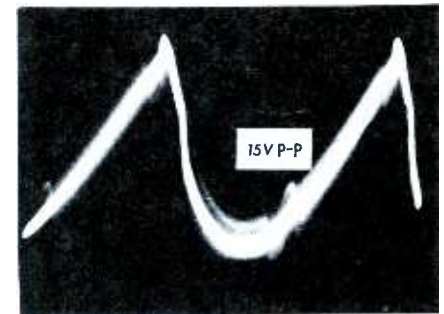
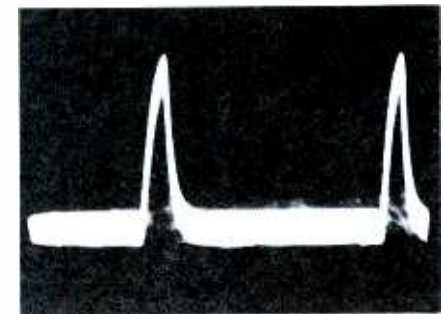

Fig. 8. Loss of horizontal sync only can still be traced to sync-section fault.



(A) normal



(B) abnormal.

Fig. 9. AFC input waveforms (7875 cps).

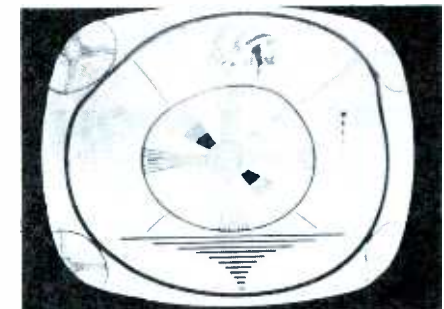

Fig. 10. Example of picture bending due to defective part in sync section.

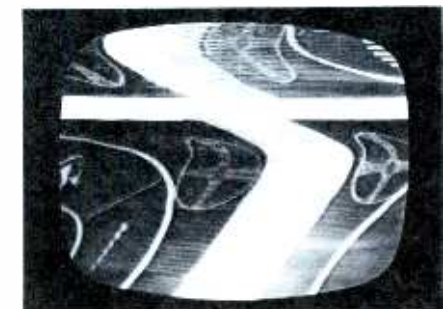

Fig. 11. Poor sync and negative picture from interaction of sync and AGC.

MOBILE COMMUNICATIONS

installing 2-WAY radio gear

The uses for two-way radio have been greatly expanded because of recent revisions made by the F.C.C. Almost any person engaged in a commercial activity, as well as those in the medical, educational and religious professions, may be licensed to own and operate two-way radio systems.

For the enterprising electronic servicing company, this means many additional opportunities to sell, install and maintain the necessary equipment. This pictorial coverage shows several typical units and techniques for their installation.

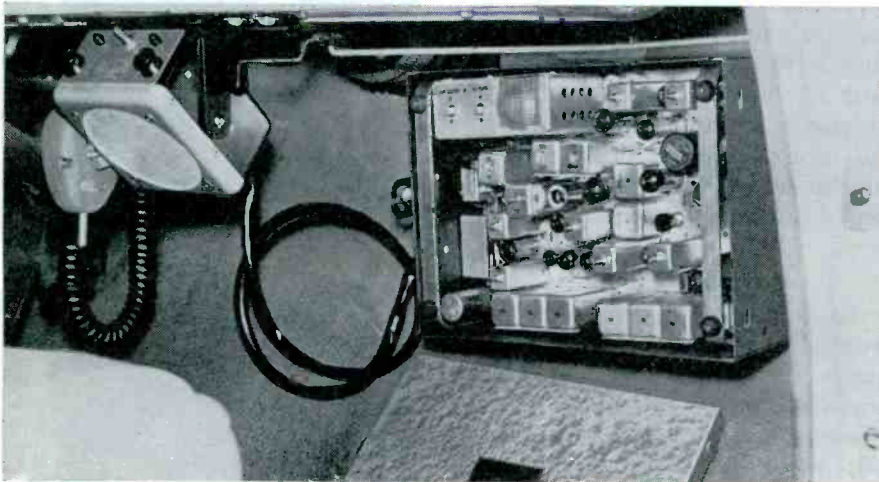

MIKE AND CONTROL HEAD

Always mount the mike and control head within easy reach of the driver. A clear space on the dash panel or control-head mounting bracket is an excellent mounting spot for the mike. Be sure to allow clearance for all vehicle controls and conveniences, such as ash trays.

RADIO MOUNTING

Front-mounting is especially desirable when trunk space is needed for other purposes (such as it is in taxi service). Their light weight and small size make 150-mc units ideal for under-dash mounting; however, the installer must be sure the mounting won't interfere with heat and air controls or vents. Passenger foot room must also be considered. If heater ductwork occupies the fire-wall space, a simple spacing bracket can be used.



HIGH FREQUENCY ANTENNA

Using the antenna base as a guide, scribe and make the mounting cut-out in the intended location. Roof-top and trunk-lid mounts are most common. For front-mount radios, upholstery and trim moldings must be loosened in order to route the antenna lead. Do not shorten this lead unless specifically called for in the installation instructions.



REMOTE RADIO OPERATION

This up-front installation consists of a microphone and a control box mounted for driver convenience. The control box has on-off switch, volume control, squelch control, pilot light and a red flasher to indicate transmitter keying. Included in the installation is a speaker assembly which may be mounted on the firewall or on the underside of the dash.

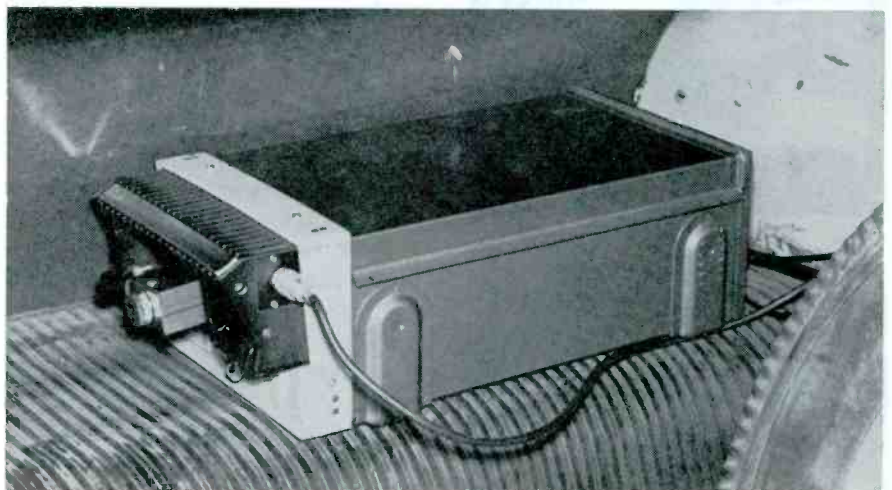

REAR-MOUNTING UNITS

Here is a trunk-mounted unit that locks in its case, the lower half of which is fastened to the trunk shelf. In this location, drilling mounting holes is simplified, since the danger of puncturing the gas tank is lessened. In addition, the unit is out of the way, leaving plenty of trunk space available for other uses.

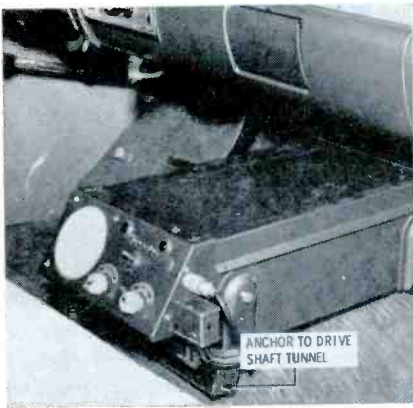

SELF-CONTAINED UNIT

This self-contained unit is of the type commonly found in taxicabs, and is complete with built-in speaker, on-off switch, volume control and squelch control. It is also ideal for use in station wagons, trucks and other vehicles not having a closed trunk space. The microphone mounts to the far side of the case. Units soon to be introduced will be transistorized, more compact, and thus better adapted to under-dash mounting.

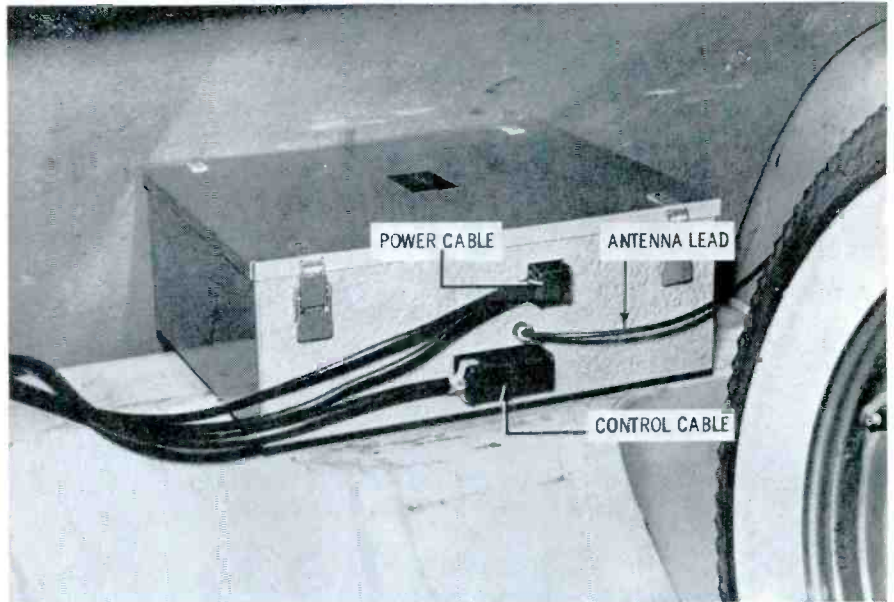

LOW-FREQUENCY UNITS

The larger and heavier units for the 25 to 50 mc bands are better suited for trunk mounting. If possible, they should be mounted on the shelf over the rear axle, thus putting them at the most forward (and out-of-the-way) position.

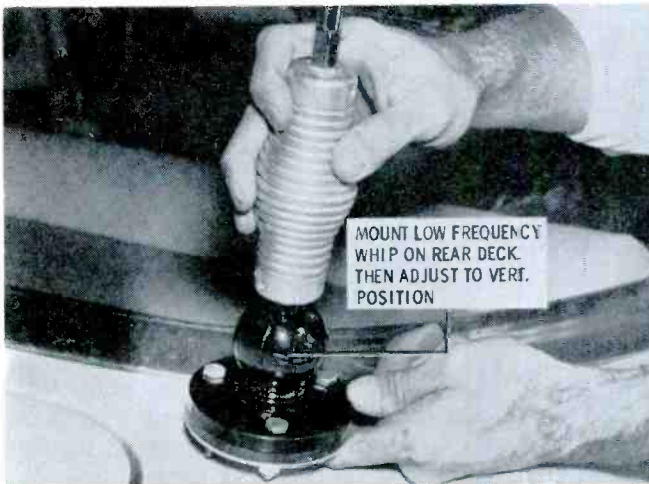

LOW-FREQUENCY WHIP

The 25 to 50 mc whip antenna should be mounted on the rear deck, which places it high enough, but the danger of having it strike low obstructions is less than if it were roof-mounted. The rear mount also makes it easy to route the antenna line to the radio.

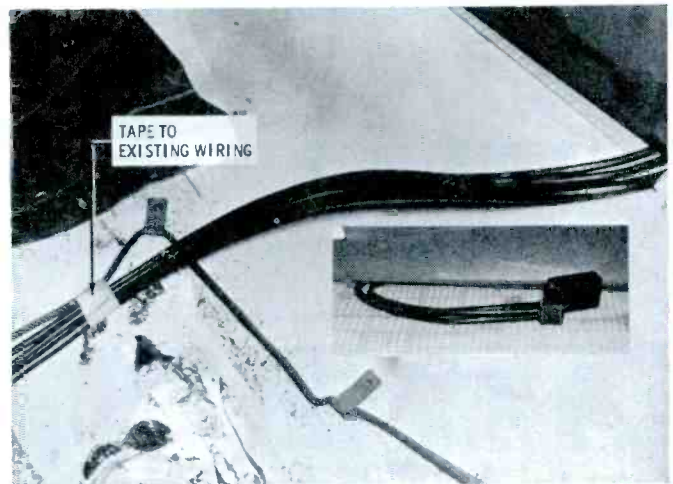

CABLES FOR REMOTE UNITS

The power and control cables for rear-mounted units should be routed along the driveshaft tunnel. This places the cables in the most protected route between the rear and front of the car. The inset shows the plug terminations on the trunk-end of the cables.

REMOTE RELAY

Units that have self-contained power supplies require a relay to act as the on-off switch. The switch on the control panel actuates the relay, which applies or removes power from the remotely located radio. This relay should be placed out of the weather as much as possible — high and dry under the hood and on the firewall is best.

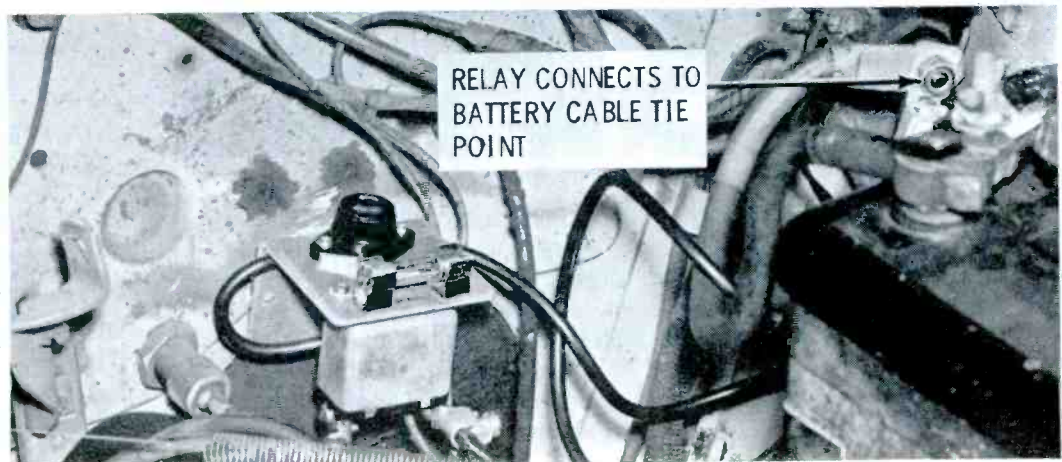

servicing NEW DESIGNS

by Thomas A. Lesh

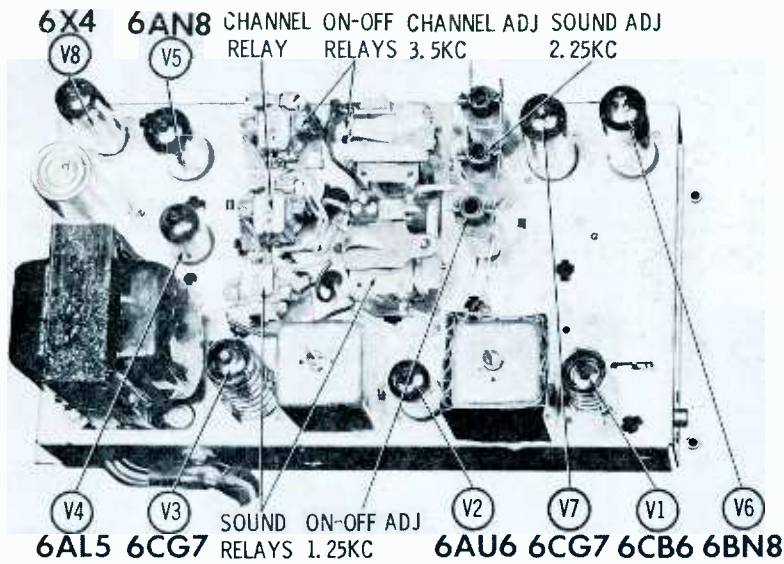
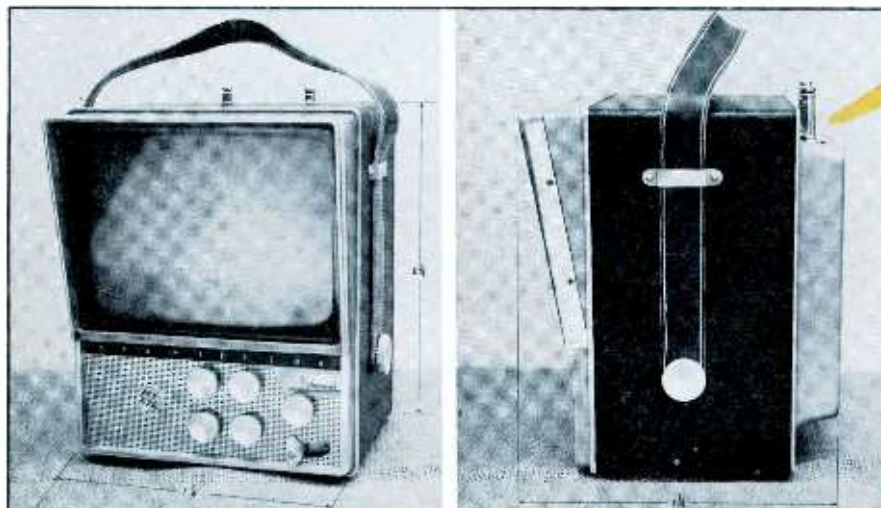

Fig. 1. *Wireless Wizard* remote control receiver has 8 tubes and 5 relays.



This One Is Really Portable

A modernistic VTVM? No, it's a completely transistorized portable TV set designed by General Electric. Although not in commercial production, this little set does give us some advance indication of what transistorized TV's will look like when they reach the market. It measures 7¼" wide by 8¾" high by 7¼" deep, contains 22 transistors, and is equipped with an 8" CRT. Power consumption is 7½ watts, and the rechargeable silver-cadmium battery is good for three or four hours of operation on each charge.

Newest TV Remote Control

The transmitter in RCA's new *Wireless Wizard* TV remote control system is a battery-powered, transistorized unit. This might lead you to believe that it emits RF radiation, but such is not the case. Instead, the transmitter circuits drive a transducer (a sort of microphone in reverse) which generates sound waves in the supersonic 40-kc range. A microphone on the front of the TV set picks up these waves, converts them back into electrical signals, and feeds them to a control receiver which amplifies and detects them. In black-and-white sets, the latter unit is an 8-tube subchassis equipped with relays for changing channels, raising or lowering the sound level, and turning the TV set on or off.

The transmitter has two separate oscillator circuits, tuned to different frequencies and employing one plug-in 2N407 transistor apiece. The outputs of both oscillators are inductively coupled to the base of a third 2N407, which amplifies the two signals and then applies them to the transducer.

A two-position switch is included in each oscillator circuit to permit a shift in its output frequency. Push-buttons are employed to reset the switches in various combinations so that the beat frequency between the two oscillator signals will have a different value for every push-button setting. This beat frequency is recovered by the detector in the control receiver and used to operate a relay in order to carry out the desired action.

The operating frequencies for the transmitter are as follows:

- ON-OFF—Osc. 1 = 41.75 kc
Osc. 2 = 40.5 kc
Difference = 1.25 kc
- SOUND—Osc. 1 = 40.5 kc
Osc. 2 = 38.25 kc
Difference = 2.25 kc
- CHANNEL—Osc. 1 = 41.75 kc
Osc. 2 = 38.25 kc
Difference = 3.5 kc

The "front end" of the control receiver includes three amplifier stages (V1, V2 and half of V3 in Fig. 1), all tuned to 40 kc. The bandpass of this amplifier is broad enough (3.5 kc) to accept all pairs of control signals. Diode detector V4A, one-half of a 6AL5, recovers the differ-

ence frequency between the two high-frequency signals.

The path of the sound-controlling signal from the detector to the appropriate relay is shown in Fig. 2. This 2.25-kc beat signal is amplified by V5A and then passed through cathode follower V5B to the low-frequency rectifier diode V6A. When this signal is impressed across the tuned circuit at the plate of V6A, the diode conducts more heavily. The resulting increase in its cathode current causes a greater positive voltage to be developed across cathode resistor R3. This positive swing of voltage is applied to the grid of relay tube V7A, causing that tube to conduct and thus energizing a relay in its plate circuit.

The other two relay-control circuits (for the on-off and channel-selector functions) are practically identical to the sound-control circuit just described, except that they operate at different frequencies. The ON-OFF and CHANNEL circuits include rectifiers V4B and V6C, and control tubes V3B and V7B, respectively.

Before we study the actual relay circuits themselves, let's stop a minute to see how the noise amplifier and noise rectifier circuits (V5B and V6B in Fig. 2) fit into the picture. A certain amount of noise normally gets through to V5B. Some of it is picked up by the microphone and some is generated by the high-frequency amplifier circuits. To prevent it from causing spurious triggering of the relays, the noise itself is utilized to develop a negative bucking voltage for application to the grids of the relay-control tubes. This voltage counterbalances any positive shift in grid voltage that may take place as a result of excessive noise getting through the receiver.

Noise voltage is amplified by V5B and is then coupled to the plate of V6B. Conduction of this tube is proportional to the amplitude of the noise, and a negative DC output voltage is developed in direct proportion to the amount of conduction. The output is applied to three parallel voltage dividers—one for each relay-control circuit. The one associated with V7A is composed of R1, R2 and R3. The portion of the noise-rectifier output that appears

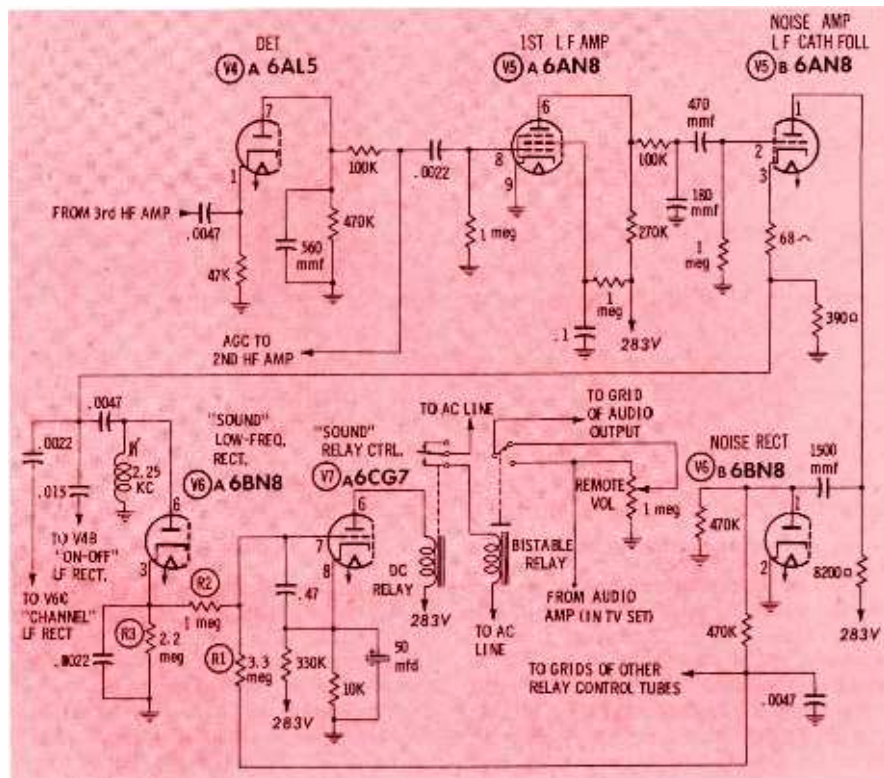

Fig. 2. The signal that controls sound level passes through these circuits.

across R2 and R3 is applied to the grid of the control tube in opposition to the voltage developed across R3 by the incoming signal. The result is a decrease in control-receiver sensitivity under very noisy conditions, but this problem is small in comparison with the trouble that would be caused by accidental operation of the relays in response to noise.

Relay Circuits

A simplified schematic of the sound-quieting circuit has been included in Fig. 2. Note that the small DC-operated relay in the plate circuit of V7A does not control the sound circuit directly; instead, its contacts complete an AC power circuit to energize a larger "bistable" or "latching" relay. This unit works like a toggle switch, requiring two separate operations of the DC relay in order to lower the sound level and then restore it to its original volume.

The input signal for the audio output tube in the TV set is fed through the contacts of the bistable relay. Connected to the fixed contacts is an auxiliary volume control which is mounted on the rear end of the control-receiver chassis. In one relay position, the audio signal is obtained from the top of this control; sound level is then determined wholly by the setting of the main

volume control on the TV receiver. In the other position of the relay, the sound signal is tapped off at the arm of the auxiliary control, and only a portion of the available signal is utilized. The remote control can be adjusted to give any desired degree of volume reduction, down to complete muting.

The on-off relay circuit of the control receiver is practically the

• Please turn to page 74

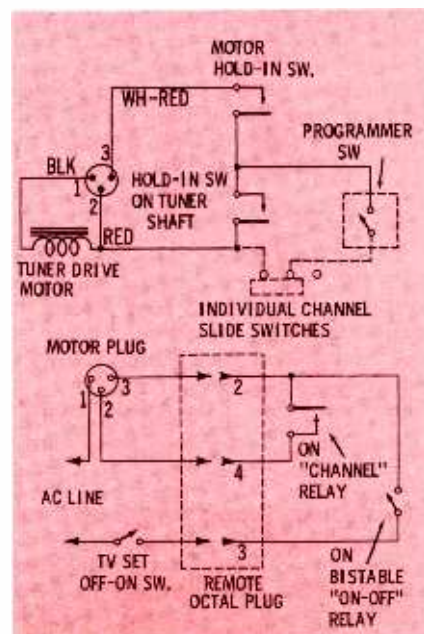

Fig. 3. Relay and switch circuitry for control of RCA tuner drive motor.

THE TROUBLESHOOTER

ANSWERS YOUR SERVICE PROBLEMS

Suppressed Sound

When an RCA Chassis KCS90 is turned on, the audio starts to come in before the raster can be seen; however, it stops abruptly about four seconds after it is first heard. After a lapse of another eight seconds or so, both sound and picture pop on at the same time like a shot out of a gun. Once the set warms up, it operates normally. I am curious about the reason for this action.

RALPH F. ALBERS

Beardstown, Ill.

This odd symptom is sometimes produced when the horizontal output tube warms up more quickly than the horizontal oscillator. The output tube conducts heavily until the oscillator begins to supply a drive signal, and it draws enough current to place a considerable load on the low-voltage power supply. Since the 5U4G has not yet warmed up enough to supply a normal amount of current, the drain produced by the output tube pulls down the B+ voltage to such a low level that the audio is killed.

If a 6SN7GTB is being used as a horizontal oscillator tube, try using an original-type 6SN7GT instead. The older -GT version of this tube has a shorter warm-up time than the new -GTB, so it should do a better job of preventing excessive output-tube current.

TV Through Hi-Fi

We have a Grundig (Majestic) Model 8058-USA hi-fi receiver and a Magnavox U74-01AA TV chassis. Is it possible to couple these two receivers together so that we can hear the TV sound through the hi-fi audio amplifier?

J. G. RODRIGUEZ

Vista, Calif.

Connecting a TV set to an external audio amplifier is often practical, but we would advise against it in this case. For one thing, the TV is a "hot-chassis" model and would require an isolation transformer in the power-supply circuit. Furthermore, the audio output stage in the TV set would have to be left in operation because it functions as part of a voltage divider in the B+ load circuit.

Touchy Sync

A Motorola Chassis TS-324B was recently in the shop with very critical horizontal sync. The hold control could not be moved more than 5% of its range without sync loss. Otherwise, the set worked very well; waveforms, peak-to-peak voltages, and resistances all checked normal. What might cause the sync to be so critical?

R. W. JENKINS

Ogden, Utah

The TS-324B and similar chassis generally have a limited horizontal lock-in range, and 5% of rotation can be considered a normal range as long as the sync doesn't drift or tend to be unstable. If holding the set in sync does become a problem, try substituting new components in the oscillator circuit.

Incidentally, the bypass capacitor C87 from the plate of the first section of the oscillator tube to ground is sometimes 220 mmf instead of 100 mmf. In addition, the plate load resistor R78 of the second section is sometimes 120K ohms instead of 100K. You might try installing whichever values are not presently in your chassis to see if this improves the range of the hold control.

Damper Failures

I am plagued with continual failure of the 19AU4 damper tube in a Motorola Chassis MTS-537. The original tube failed because of filament burnout, but the replacements break down for other reasons, such as arcing. All voltages and waveform amplitudes are within 5 volts of the values given in the PHOTOFACT Folder for the set, with the exception of the horizontal output grid signal. Its height is 170 instead of 150 volts p-p.

With my high-voltage probe, I measure 640 volts DC and 9 KV p-p at the horizontal output plate. The damper cathode readings are 640 volts DC and 7 KV p-p. CRT anode voltage is 17 KV. Are these voltages high enough to cause damper breakdown?

GEORGE R. TRUDEAU

Lynn, Mass.

Your readings indicate that either the pulse voltages are much too high or that your high-voltage probe is badly out of calibration. Peak inverse plate voltage and heater-cathode voltage ratings of the 19AU4 are only 4.5 KV, so your trouble is very possibly due to voltages exceeding the rated value.

There are several ways of attacking this problem. For one thing, you could slightly reduce the strength of the horizontal drive signal. Add a drive trimmer (about 50-150 mmf range) from the junction of R103 and C85 to ground, and use this to control signal amplitude. Cutting down the drive isn't guaranteed to reduce the pulses to a safe level, but there's a chance that it will help.

Also try varying the width adjustment on the flyback. Using a different 12DQ6 might even reduce pulse amplitudes enough to solve your problem.

If adjustments don't do the trick, connect a small-value capacitor (about 100 mmf) across the damper from pin 3 to pin 5. Its voltage rating should be as high as possible—the closer to 10 KV, the better. This component acts as a shunt across the damper for sharp voltage spikes, but presents a high impedance to the lower frequencies contained in the main signal.

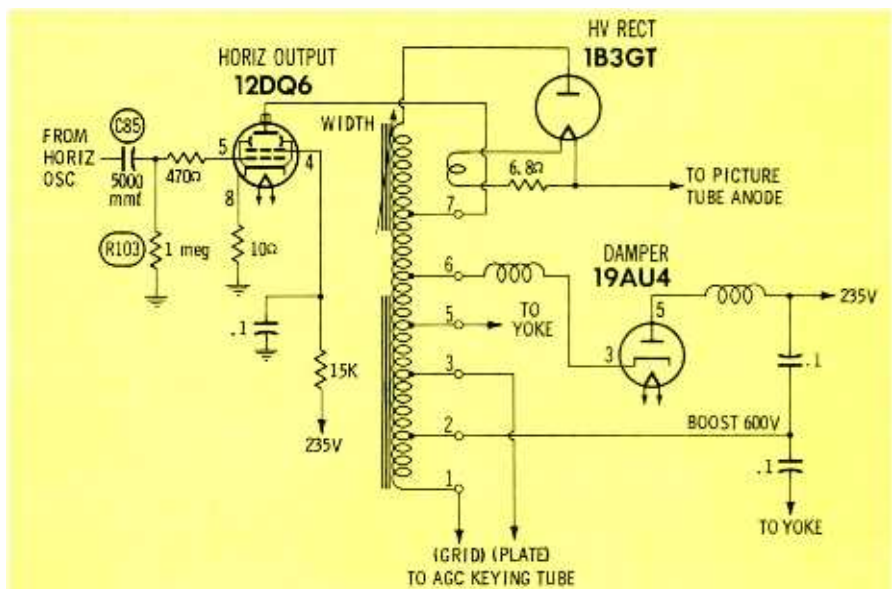

Simply by checking
all the tubes in the TV set with

B&K **DYNA-QUIK**

YOU CAN INCREASE YOUR INCOME

FAST AND ACCURATE

- Tests complete set in minutes
- Wins customer's confidence
- Saves costly call-backs
- Sells more tubes on-the-spot
- Avoids substitution testing
- Makes more money every day

\$50*
PER WEEK

*ACTUAL EXPERIENCE SHOWS
TV SERVICEMEN AVERAGE

**2 extra tube sales
PER CALL**

**5 calls per day in
5 days equal \$50**

MEASURE TRUE DYNAMIC MUTUAL CONDUCTANCE

Thousands of technicians are doing a better servicing job and are making more money today with the famous B&K DYNA-QUIK. Completely tests each tube in seconds, with laboratory accuracy, in home or shop. *Measures true dynamic mutual conductance.* Shows tube condition on "Good-Bad" scale and in micromhos. No multiple switching or roll chart. Quickly detects weak, short-life, or inoperative tubes. Shows customer the true condition and life-expectancy of tubes in the set; sells more tube replacements per call. Assures customer satisfaction and protects the service guarantee.

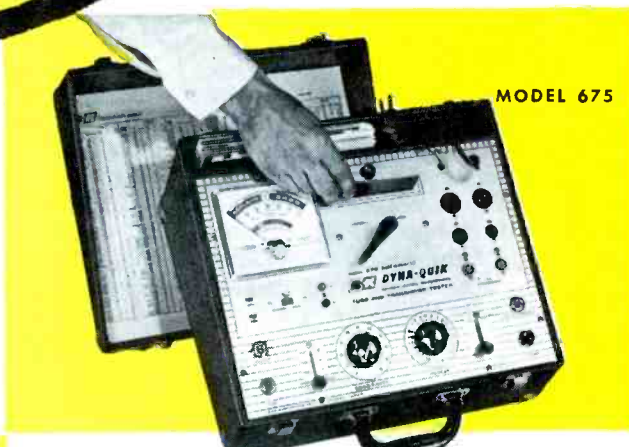

MODEL 675

Model 675 AUTOMATIC
Simplified, Portable, DYNA-QUIK
TUBE AND TRANSISTOR TESTER

With only 60 indexed phenolic Dyna-Cards, you can test over 500 tube types. Dyna-Card automatically sets socket connections for quick, accurate tube test. Checks over 99% of the tubes most widely used in television receivers, plus popular home and portable radio tubes. Easily kept up-to-date by adding new Dyna-Cards. Tests each section of multiple tubes separately for Gm, Shorts, Grid Emission, and Life. Tests each tube for Gas Content and Grid Emission simultaneously with Short Check. Provides instantaneous Heater Continuity test. Transistor Section checks junction, point contact, and barrier transistors, germanium and silicon diodes, selenium and silicon rectifiers.

Net, **\$169⁹⁵**



MODEL 650

Model 650 DYNA-QUIK
Fastest, Most Complete, Portable
TUBE AND TRANSISTOR TESTER

Checks over 99% of the tubes most widely used in television receivers, plus popular home and portable radio tubes. Tests over 500 tube types. Lists over 125 most commonly used tube types, with settings, on socket panels for maximum operating speed. Complete listing in fast telephone-index type selector. Tests each section of multiple tubes separately for Gm, Shorts, Grid Emission, and Life. Tests each tube for Gas Content. Provides instantaneous Heater Continuity check. Includes 16 spare sockets and sufficient filament voltages for future new tube types. Transistor Section checks junction, point contact and barrier transistors, germanium and silicon diodes, selenium and silicon rectifiers.

Net, **\$169⁹⁵**

Manufacturers of Tube Testers, Cathode Rejuvenator Tester, Television Analyst, Dyna-Scan, Transistor Tester, and other specialized instruments.



See your B&K Distributor or
Send now for Bulletin AP12-R

B & K MANUFACTURING CO.
3726 N. Southport Ave. • Chicago 13, Illinois

Canada: Atlas Radio Corp., 50 Wingold, Toronto 10, Ont.
Export: Empire Exporters, 458 Broadway, New York 13, U.S.A.

TIPS

for TECHS

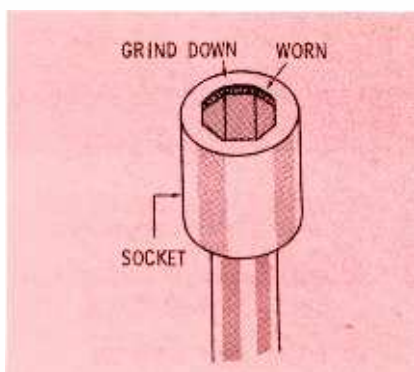

How To Renew Worn Sockets

After socket wrenches and nut drivers have seen quite a bit of use they sometimes become worn internally and slip when you try to loosen or tighten a nut. The wear usually occurs just inside the mouth of the socket to a depth about the thickness of an average-size nut. To eliminate such slippage, grind down the mouth of the socket to remove the worn portion. Be extra careful not to overheat the socket and ruin its temper.



Calibrate Your Adjustable Wrench

If you have to set and reset the jaws of your adjustable wrench every time you use it, you're wasting time. You can easily calibrate the jaws of your wrench and pre-set them to fit the nut beforehand. To do this, close the wrench jaws and grind or etch a straight-line zero mark across the movable and stationary jaws as shown. Then make four other marks on the stationary jaw exactly $\frac{1}{4}$ ", $\frac{1}{2}$ ", $\frac{3}{4}$ ", and 1" from the zero line. If you want to make the settings easier to read, fill each mark with different-colored paint.

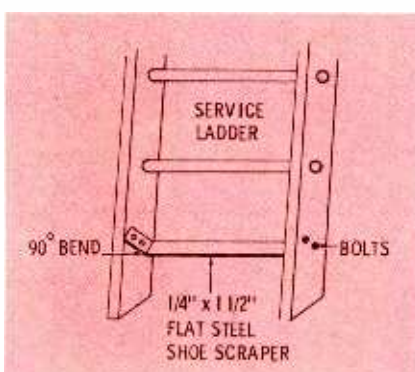

Service Ladder Safety Hint

A shoe scraper fitted to the bottom of the service ladder will prevent accidents which might be caused by tracking slippery mud onto the rungs. A suitable scraper consists of a $\frac{1}{4}$ " x $1\frac{1}{2}$ " flat steel crosspiece bent at either end and then drilled and bolted to the bottom of the ladder as shown in the drawing. This not only increases safety, but also keeps the ladder rungs clean.

Shield For Spray Mist

When you are using an aerosol spray can of paint, cleaner, or some other type of service chemical and want to protect certain spots from the spray mist, make a shield from a piece of cardboard. Cut a small opening in the center of the shield so that you can "focus" the mist on the exact area you want to hit.



Sandpaper Facilitates Lid Removal

Don't waste time when you can't get the lid off a jar of coil dope or service cement. Just take a piece of coarse-grade sandpaper and use it to grip the lid as shown. The sand grains will bite in and give you a firm grip that can't slip.

Clip-On Warning Flag

To save time when you have to put a red warning flag on objects extending from the back of your service truck, attach the flag to a large battery clip. It takes only a moment to clip the flag in place on the mast or tower, and the strong grip of the clip prevents it from being blown off.

Backstop For Spray Job

When you are spraying a chassis, antenna, panel or small cabinet with paint or plastic and don't want the spray to mess up the service bench, place the work in a large cardboard box. This backstop catches all of those extra drops of spray and keeps them from getting all over tools and equipment on the bench.

Test Prod Repair

The plastic handles of some test prods have a bad habit of working loose. In time, the inside threads become worn and the prod has to be discarded. To keep the handle from working loose, paint the threads with service cement and screw the tip back in place. If the threads haven't already become badly worn, this treatment will keep the handle from working loose again.

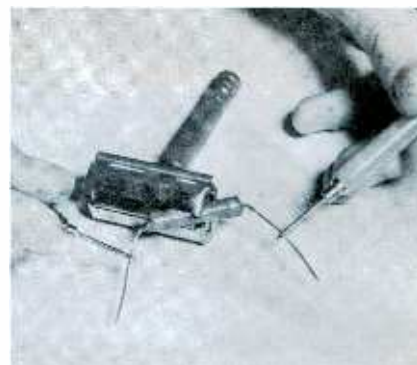

Safety Razor Bites Part

Ordinarily, when you lay a round resistor, capacitor or other small part down on the bench and place your test prods on the component's leads, the part will roll around and make it difficult to get an accurate reading. Using an ordinary safety razor as a "vise" to hold the part eliminates all this. It's also handy for holding wires while you tin them or for clamping small parts while you solder them together. If you desire a permanent location for the contraption, merely drill a hole in the bench to serve as a receptacle for the handle.

ownership of a complete and currently maintained
PHOTOFACT SERVICE DATA LIBRARY
SPELLS SUCCESS FOR SERVICE TECHNICIANS
here's actual proof from the men who know!



"We believe it is almost impossible to give fast and efficient service without PHOTOFACT. Sams PHOTOFACTS are a great help in trouble-shooting and replacement parts. They save time and money for us."

—Gerald L. Jellis, Watertown, So. Dak.
 (Operator of "Radio TV Center")

HERE'S MORE PROOF...FROM COAST-TO-COAST

OHIO

"I find SAMS PHOTOFACT an absolute necessity in doing a job quickly and accurately...extremely helpful..."
 —Dan M. Heinrich, *Westlake, Ohio*

PENNSYLVANIA

"PHOTOFACT is an invaluable 'piece of equipment' in our repair shop and it speeds our shop repairs 100%."
 —Luther W. Wilkes, *Houtzdale, Pa.*

NEW JERSEY

"PHOTOFACT is used here every day, like an extra brain."
 —Joseph M. Decker Jr., *Newton, N. J.*

MASSACHUSETTS

"I would be lost without PHOTOFACT."
 —Emilio Conzo, *Newton, Mass.*

MAINE

"Having data on sets plus parts listings, etc., means the difference between getting sets fixed and out in a reasonable length of time or having them tied up while securing such information, as I am located in a small town and have to depend on mail service for parts and information."
 —Samuel S. Sawyer, *Kezar Falls, Maine*

VIRGINIA

"I don't know how we would get along without PHOTOFACT, as we work on all makes and models."
 —Kenneth E. Jenkins, *Big Stone Gap, Va.*

CALIFORNIA

"With PHOTOFACT, the information I need is always at hand. I don't have to worry about a repair job because I know I will have a schematic that gives me correct information in the simplest possible form."
 —J. R. Stukes, *Norwalk, Calif.*

WISCONSIN

"In my business, I service all makes of TV sets. Without good service literature such as PHOTOFACT, this would be an impossible task—especially to do a quick, intelligent job. In my estimation, Sams PHOTOFACTS is unequalled. I would hate to conduct a business without them. Keep up the good work!"
 —Willard F. Dumke, *Menasha, Wis.*

ILLINOIS

"PHOTOFACT makes it possible to identify any part in any model TV... It is possible to locate trouble in almost any set through the use of Sams."
 —Sam Rogondino, *Lake Forest, Ill.*

(These are just a few of the hundreds of "Success with PHOTOFACT" letters in our files)

**SEE YOUR SAMS DISTRIBUTOR TODAY,
 OR WRITE TO HOWARD W. SAMS FOR FULL DETAILS**



HOWARD W. SAMS & CO., INC.
 2201 E. 46th St., Indianapolis 6, Ind.

- Send me Free booklet "Your Guide To Maximum Profits"
 I'm a Service Technician: full-time; part time

My Distributor is: _____

Shop name _____

Attn. _____

Address _____

City _____ Zone _____ State _____

NEW! EASY-BUY PLAN

—the money-saving way to build your complete profit-making PHOTOFACT Library!
 NO INTEREST—NO CARRYING CHARGE—AS LITTLE AS \$10 DOWN



FREE! VALUABLE STEEL FILE CABINETS FOR REGULAR PHOTOFACT SUBSCRIBERS AND PHOTOFACT LIBRARY PURCHASERS

GET THE FULL DETAILS

NEW!

Acme Electric
TRANSFORMERS

AUTOMATIC VOLTAGE STABILIZER



Compact in size, attractive in appearance. This unit rated at 200 va has capacity large enough to accommodate television receivers up to 24". Operation is noiseless and completely automatic. Fluctuation of incoming voltage over a range from 95 to 130 volts is automatically corrected ($\pm 2\%$) within 1/30th second when operated within its normal rated capacity of 200 va.

When TV set is turned off, a built-in relay automatically disconnects primary circuit, thus stopping coil magnetism. When TV set is turned on, relay automatically connects primary circuit.

Furnished complete with heavy duty primary cord and built in secondary receptacle.

Write for bulletin VA-322.

PO-3226

ACME ELECTRIC CORPORATION

941 WATER ST.

CUBA, N.Y.



Fee Pricing. Setting up a schedule of fixed charges for specified repairs is an idea that has much in its favor. For one thing, it's a good "convincer" when a sizable service bill is being presented — a printed schedule of standard fees can be used to good advantage as each portion of the service job is explained.

Being able to quote definite fees *in advance* is an asset, too, because it serves as some basis for estimating repair costs. You don't eliminate the hazard of running into trouble not foreseen in a preliminary diagnosis, but you are better able to say that a bill will probably run within a specified price range.

There's no nationwide standard for service fees, although some regional groups have had success in setting up price schedules. If you decide to set up your own standards, consider these two major factors: (1) How long does it take you, on the average, to complete specific repairs? (2) What is a sensible hourly fee for shop work? Multiply these factors together to obtain a flat-rate charge for a job. Both overhead costs and skill should enter into your estimate of a fair bench charge. Discussions with other servicemen will help you determine how much time to spend on "typical" repairs.

There are a couple of ways to set up a fixed fee system. One is based on prices for everyday, relatively simple jobs, with allowances for additional hourly charges when a trouble turns out to be rough and time-consuming. This approach permits low fees for easy jobs, but it doesn't protect the customer against sky-high charges for repairing a "dog."

You could also figure in *all* jobs, no matter how tough, when determining how long the average repair takes to perform. This would tend to raise your minimum fee, but it also would allow a maximum charge to be fixed. The disadvantage to this, of course, is that customers whose sets are easily repaired would be charged more than the value of the labor spent on the job. You wouldn't

blame a customer for getting perturbed at this state of affairs — ("You changed this little control and charged me \$22!") — but you could explain that even if the next job were a "dog" that took all day to fix, you would not charge for all the extra labor. In a sense, a strict system of flat-rate pricing has some of the elements of an insurance policy. The customer would be paying a premium price for relatively easy shop jobs, but he would be assured that he would never have to pay more than a certain stated fee.

Any workable system of fee pricing will undoubtedly be a compromise between the two extremes just described. The exact details will depend on your own customers' reactions.

If you once adopt a fee schedule, it's a smart idea to have it printed up in official-looking form for posting or for distributing as handbills. Publicizing the figures as plainly as you can lends some air of authority and gives customers a firm standard by which to judge your work.

\$ & C

Census. The radio population of the United States is just about keeping pace with the human population, according to the newest edition of *Television Factbook*. A total of 161 million sets are in use. About 40 million of these are auto receivers; it's figured that 38 million of our 57 million cars and 2 million of the 11 million trucks are radio-equipped. Ten million receivers are in various public places, and the remainder of the grand total are in homes.

Since the number of homes with radios is estimated at 48 million, there are a number of families with multiple sets. It appears that John Q. Public, U.S.A., likes to have a radio handy wherever he is — kitchen, bedroom, workshop, or anywhere. We can encourage him to get full convenience out of all these units by offering to keep them in repair.

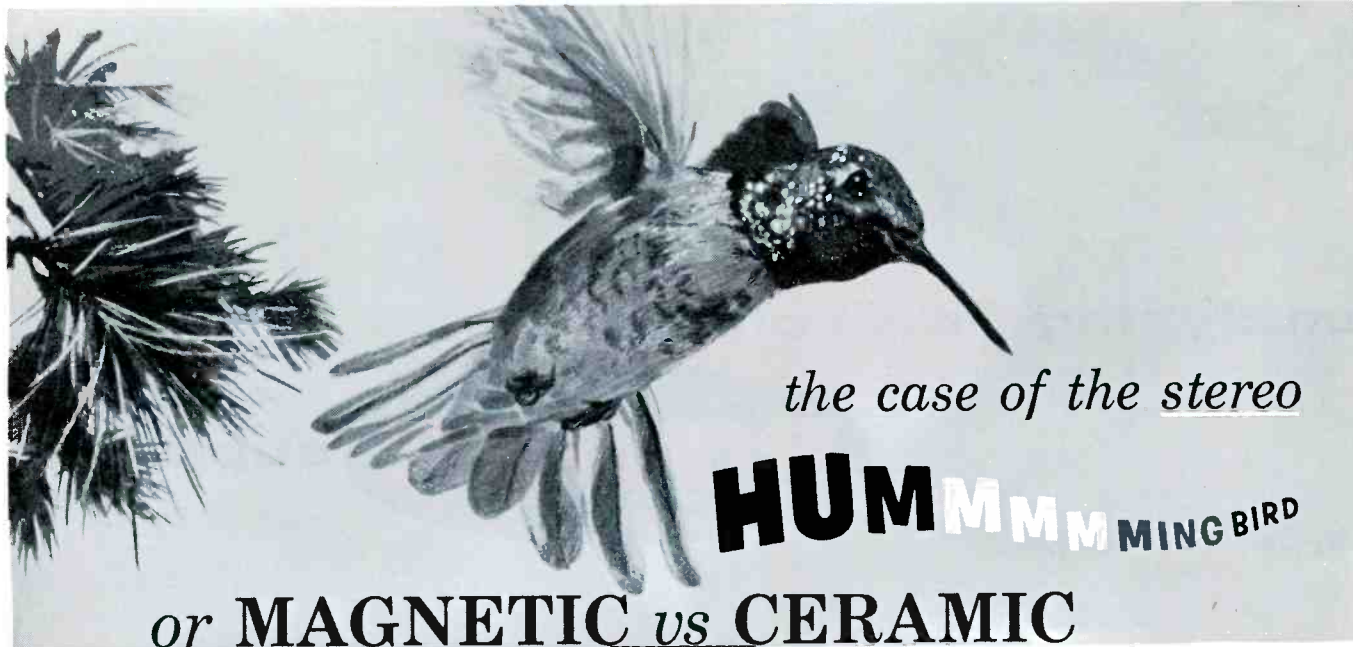

the case of the stereo

HUMMMMMMING BIRD

or MAGNETIC vs CERAMIC

You may have been reading many controversial advertisements as to the merits of various stereo cartridges... namely, the magnetic version vs. the ceramic version. Qualified claims are made by their manufacturers... and most are accurate. But how a specific cartridge *sounds* in your stereo system is really the criterion. Let's consider the real facts:

IT'S A FACT! Audio Engineers agree that magnetic stereo cartridges are excellent, costly... but burdened with *hum*. Tests prove that the new Electro-Voice Magneramic cartridge is completely hum-free. No motor or line hum can possibly be introduced to mar soft record passages, because the Magneramic is *non-inductive*.

IT'S AN ENGINEERING AXIOM! The simpler the design of a precision product, the less chance there is of manufacturing defect. Magnetic stereo cartridges are far more complicated than the comparable Electro-Voice Magneramic stereo cartridge. With E-V, you are assured years of trouble-free, high fidelity stereo performance.

IT'S POSITIVE! When the Electro-Voice corps of 60 engineers began intensive scientific stereo studies, they had the choice of either designing a magnetic or a ceramic cartridge. Knowing that two of the most vital factors for true audio reproduction were lack-of-hum and trouble-free performance, they took the positive approach and produced a stereo cartridge incorporating simple elements permitting positive, stable control for uniform output.

And so, with the advent of stereo, Electro-Voice introduced an entirely new concept in ceramic cartridges... a true high-fidelity series...

THE E-V MAGNERAMIC



which will consistently outperform the best magnetics and do away with the "hummingbird" in your stereo system.

Choose the Magneramic... a new improved E-V stereo cartridge which plugs directly into magnetic inputs. See why it's the choice of so many FM stations for critical stereo broadcasts:

- ✓ NO HUM
- ✓ BEST CHANNEL SEPARATION
Over 25 db isolation between channels
- ✓ HIGHEST COMPLIANCE
Horizontal and vertical compliance equal to or surpasses the best magnetic cartridges
- ✓ WIDEST RANGE FREQUENCY RESPONSE
Far in excess of any monaural (monophonic) or stereo record
- ✓ FLATTEST RESPONSE TO WESTREX 1A VELOCITY CURVE
From 20 cps to beyond audibility
- ✓ HIGH 20 MILLIVOLTS OUTPUT
All the voltage you need... and then some
- ✓ PROVEN SUPERIOR
for conventional monophonic records as well as stereo records
- ✓ SOLD ON MONEY-BACK GUARANTEE
We invite you to try an E-V Magneramic, with E-V's unqualified guarantee backed by over 30 years as a manufacturer.

Give the Magneramic a thorough listening test. If for any reason you aren't completely convinced of its superiority, your FRANCHISED Electro-Voice dealer is authorized to give you a full refund.

Step up to the excitement of stereo... step up to Electro-Voice Stereo... the industry's standard. Over a half-million in use, more than the total of all other stereo cartridges combined, attest to its acceptance as stereo's standard. Choose either the E-V Magneramic for magnetic inputs or the E-V Standard Stereo Cartridge for non-magnetic inputs.

21 MD with 0.7 Mil Diamond Stylus, net \$19.50; 26 MDST Turnunder with 0.7 Mil Diamond Stylus, and 3-Mil Sapphire Stylus for 78 R.P.M.'s, net \$22.50; 21 MS with 0.7 Mil Sapphire Stylus, net \$9.90; 26 MST Turnunder with 0.7 Mil Sapphire Stylus, and 3-Mil Sapphire Stylus for 78 R.P.M.'s, net \$12.90.

GOOD STEREO DEPENDS ON THESE VITAL FEATURES: FREQUENCY RESPONSE, 20-16,000 cps flat (Westrex 1A); ELEMENTS, 2 PZT Ceramic; OUTPUT VOLTS, 20 mv. Nominal; COMPLIANCE, 2 x 10⁻⁶ cm/dyne; WEIGHT, 3.4 Grams; TRACKING FORCE, 4-6 Grams; CHANNEL SEPARATION, 25 db at 1 KC; MOUNTING, EIA (RETMA) Standard 1/2"-7/16" Center; STYLUS, .7 Mil (Diamond or Sapphire); OUTPUT TERMINALS, Standard .050 Connectors; IMPEDANCE OR LOAD, 22,000 ohm or higher magnetic input.

See your High Fidelity Specialist or write Dept. PP-1



Electro-Voice®

INC., BUCHANAN, MICHIGAN
Over 1/2 Million In Use...
MORE THAN ALL OTHERS COMBINED

analyzing **low-voltage** **POWER** supplies

by Calvin C. Young, Jr.

The low-voltage power supply is the nucleus of a TV receiver because practically every circuit needs DC voltage from this source in order to operate. The relative simplicity (small number of components) tends to camouflage its importance, so it is often overlooked as a source of trouble.

There are three basic types of circuits in general use—the transformer-operated, full-wave supply using a rectifier tube; the transformerless, AC-operated, half-wave doubler circuit using semiconductor (selenium, silicon or germanium) rectifiers; and the AC-DC, half-wave circuit, also using semiconductor rectifiers.

Among the three circuits mentioned, the full-wave, transformer-operated supply is the old standby. It has probably been used in a larger percentage of sets than either of the other two. Half-wave doubler and half-wave, AC-DC designs have

been appearing in ever-increasing numbers, however, and if the present trend continues, they will eventually dominate the field.

Full-Wave Transformer Circuit

A typical full-wave transformer-type supply using a 5U4-type tube is diagrammed in Fig. 1. Basic action of the rectifier is most easily understood by studying a simplified circuit from which the filter components have been omitted, as in Fig. 2. When a 60-cps sine wave is induced in the transformer secondary, one plate of the rectifier tube will be positive during the first half cycle, and the associated section of the tube will conduct. During the next half cycle, the opposite plate will be positive and the other half of the tube will conduct. Since current in both cases will flow in the same direction through the common cathode circuit, the output voltage developed across

R will be pulsating DC—a succession of positive-going pulses similar to those in Fig. 3. Note that there are two pulses of rectified output voltage for each cycle of AC input.

This description establishes the theoretical conduction pattern of the rectifier tube, but it does not indicate a practical condition. Some sort of LC or RC filter system is always employed, and its addition causes a great change in the output waveform of the rectifier. W3 in Fig. 1 is the conduction-current waveform of a typical full-wave supply, obtained by connecting the scope across a 10-ohm resistor placed in series with the output lead. In examining W3, two things are apparent: (1) The peaks are not of equal height. (2) There is a separation between the periods of conduction. The unequal peaks are the result of a slightly unbalanced condition between the halves of the rectifier tube or transformer second-

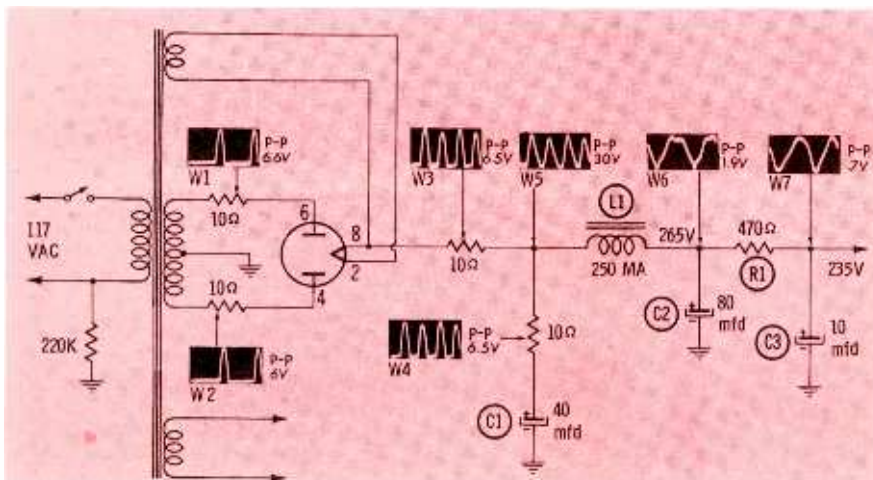

Fig. 1 Schematic of typical full-wave, transformer-operated DC power supply.

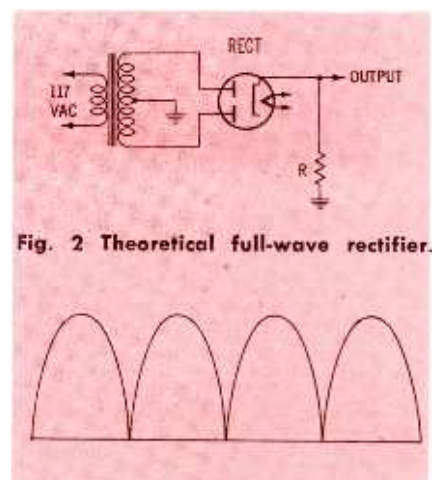
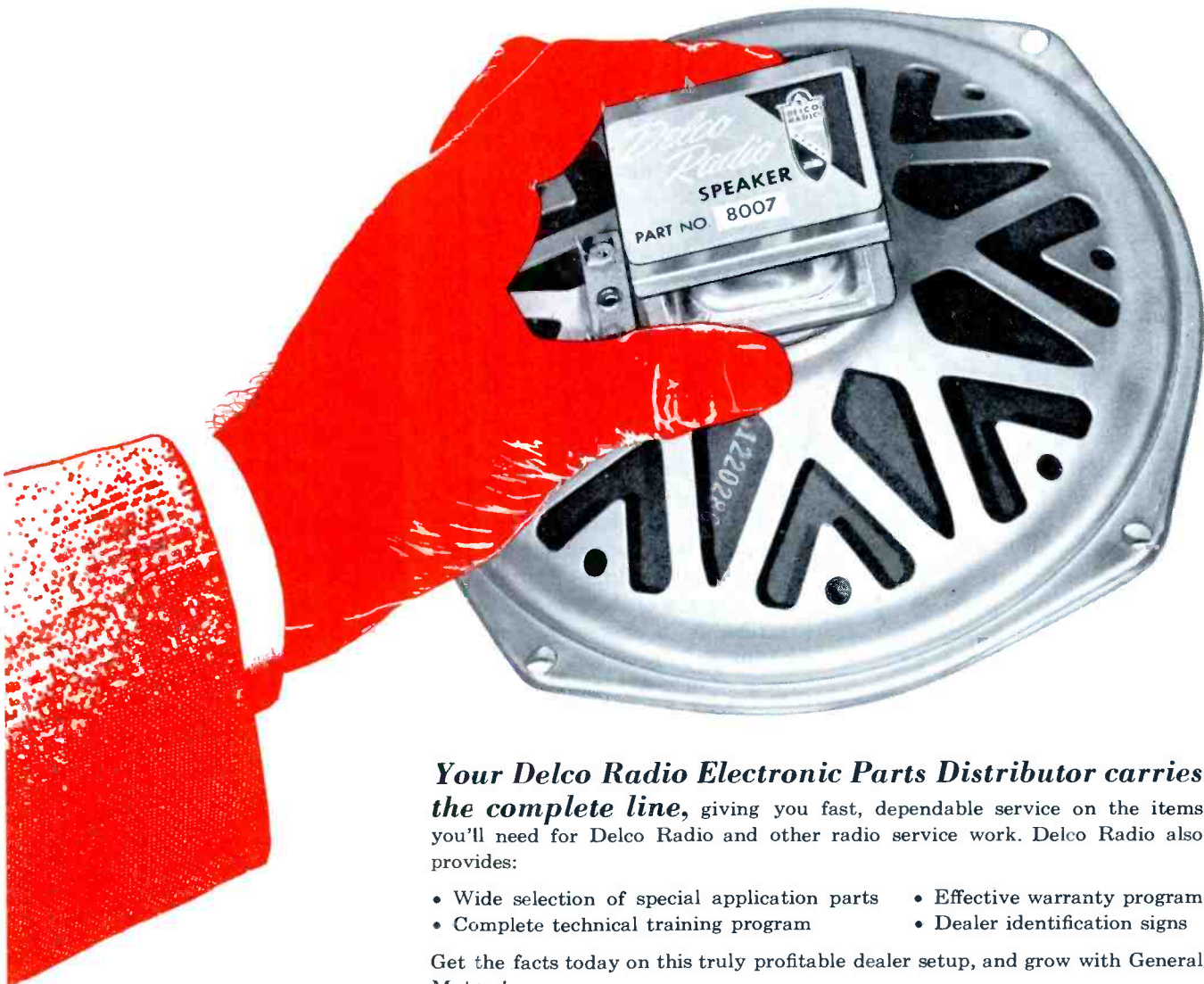

Fig. 2 Theoretical full-wave rectifier.

Fig. 3. Waveform of unfiltered output.

Use Delco Radio Service Parts!

8-inch "Hi-Fi" speaker, No. 8007 offers the most highs, the most lows, the most watts in a medium-price speaker. Designed for replacement use and high fidelity audio systems.



Your Delco Radio Electronic Parts Distributor carries the complete line, giving you fast, dependable service on the items you'll need for Delco Radio and other radio service work. Delco Radio also provides:

- Wide selection of special application parts
- Complete technical training program
- Effective warranty program
- Dealer identification signs

Get the facts today on this truly profitable dealer setup, and grow with General Motors!

Available everywhere through Electronic Distributors associated with . . .



DELCO RADIO

DIVISION OF GENERAL MOTORS, KOKOMO, INDIANA

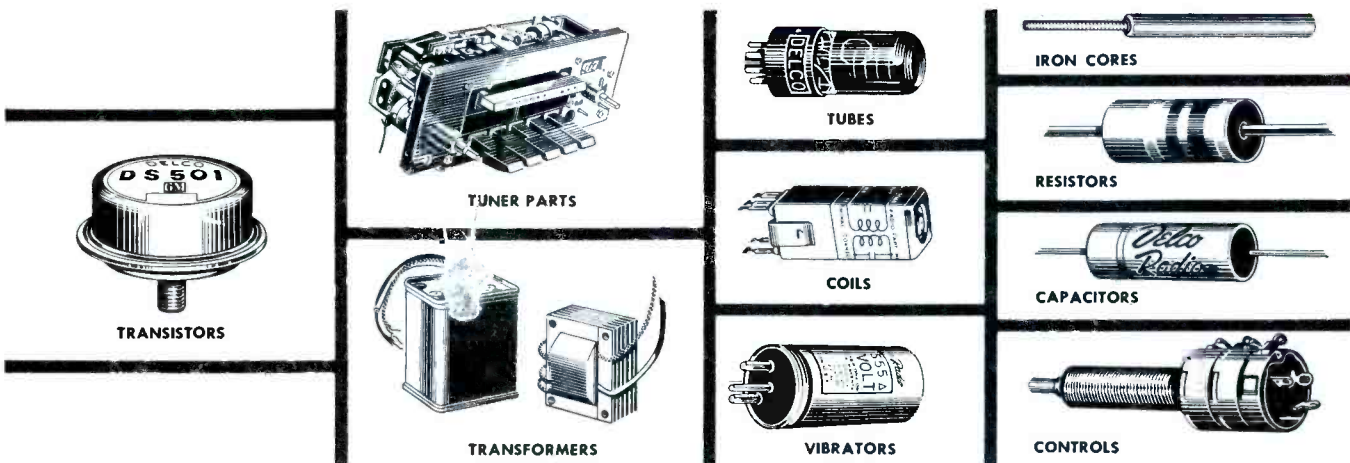

Specify Tarzian



OR

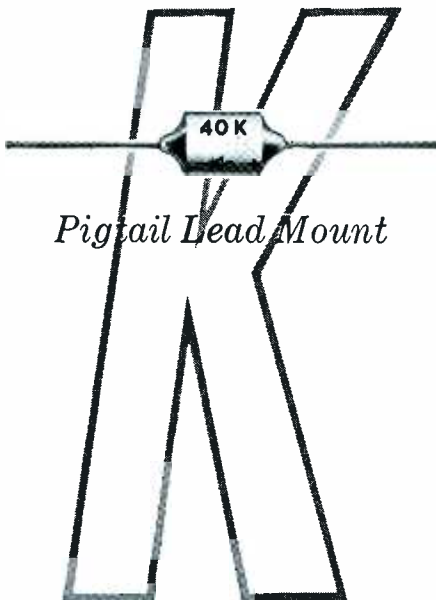

SILICON RECTIFIERS

for simplified, economical replacement of all existing radio and TV rectifiers. Only two types to stock.

WRITE FOR DATA SHEETS

SARKES TARZIAN, INC., Rectifier Division
DEPT. PF-1, 415 N. COLLEGE AVE., BLOOMINGTON, IND.

IN CANADA:

700 WESTON RD., TORONTO 9, TEL. ROGERS 2-7535
EXPORT: AD AURIEMA, INC., NEW YORK CITY

ary. The separation between the periods of conduction is due to the fact that each half of the rectifier does not conduct for an entire half cycle of the input signal, but for a much shorter period. Remember that the cathode in a practical circuit serves as the DC voltage source and thus has a high positive potential. Consequently, the rectifier tube can conduct only during the extreme peaks of the input signal, when one of the plates is positive with respect to the cathode.

Signals W1 and W2 are individual current waveforms of each half of the rectifier tube. A slightly unbalanced condition in the circuit is indicated by the different peak-to-peak amplitudes of the two waveforms (6.6 and 6.0 volts respectively).

W4 represents the charging current of the input capacitor. Note that this waveform corresponds closely to W3, emphasizing the little-known but important fact that the true function of the transformer and rectifier is to charge the input capacitor to its peak value on each half cycle of the AC signal. In reality, this charged capacitor is the DC source. The load circuit discharges it to some extent between charges.

As indicated by W5, the DC potential across C1 varies as the capacitor charges and discharges. The charge time is very fast, as illustrated by the very steep rise of the signal trace. The more gradual descent of the trace indicates that the discharge time is much slower.

The AC ripple component (W6) at the output of the pi-type filter (C1, L1, and C2) is greatly reduced in amplitude and is shaped more like a sine wave than W5. The modified shape of W6 is a result of the inductance of L1, combined with the

tendency of C2 to short-circuit any AC signal present in the output of the filter. The effects of R1 and C3 further reduce the AC ripple in the output, and the result is shown in W7.

Besides reducing AC ripple, each section of the two-step filter circuit slightly reduces the value of the DC output voltage. Therefore, if the input, midpoint, and output of the filter are all used as DC source points for different load circuits, three different values of B+ voltage are made available. The source point chosen for any particular circuit will depend on whether the greatest advantage can be obtained from maximum voltage, maximum filtering, or a compromise between the two.

Half-Wave Doubler Circuit

Transformerless, AC-operated power supplies have been employed in a large number of TV receivers in which reduction of weight, cost and space are prime considerations. Fig. 4 is a schematic of a typical half-wave voltage doubler. Current waveforms W1, W2, and W3 were obtained by inserting 10-ohm resistors (one at a time) in the places shown. Notice that W1 is actually a composite of W2 and W3, which are the charging-current waveforms for C1 and C2, respectively. Since both these currents must pass through the 10-ohm resistor used to obtain W1, and since they are opposite in polarity, their waveforms can be expected to combine into the form of W1. Any inequality noticed between W2 and W3 is due to the unbalance in forward resistance between the two rectifiers and the unbalance in leakage between capacitors C1 and C2.

From the shape of W2, we can deduce that the function of recti-

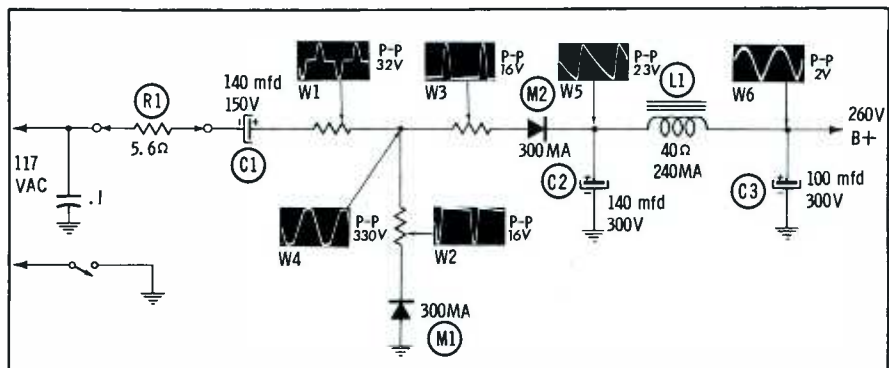

Fig. 4. Half-wave voltage-doubler circuit using two semiconductor rectifiers.

Jensen's LITTLE **BEAUTY . . . WITH THE MIGHTY HI-FI VOICE!

NEW "TRI-ette*" 3-WAY HIGH FIDELITY SPEAKER SYSTEM



Burton Brown Advertising



PERFORMANCE FAR BEYOND COST AND SIZE

If space is a problem, but only true hi-fi sound is for *you* . . . if you want to delight the eye (as well as the ear) . . . if you listen to organ music on occasion, and want the pedal notes to be *there* . . . if you thrill to the full, clean, smooth separated sounds of the orchestra in all their wonderful detail . . . then Jensen's new TR-10 TRI-ette 3-way speaker system is for you! Use one for your compact hi-fi system, a pair for space-saving high quality stereo . . . or add one to your present speaker for stereo conversion. Drives with good 10-watt or larger amplifier. Choice of Walnut, Tawny Ash or Mahogany. Net Price \$114.50. Table Base (illustrated) extra \$5.45. Floor Stand \$12.95. Send for Bulletin JH-1.

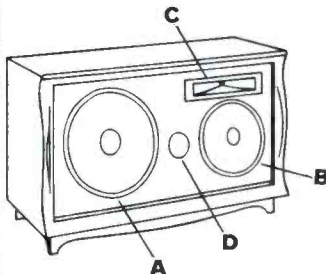

ADVANCE DESIGN 3-WAY SYSTEM COMPONENTS

- A. New 12" Flexair* high compliance superlow resonance woofer for useful response down to 25 cycles with a new low in distortion for such a small reproducer.
- B. Special 8" mid-channel unit handles the range from 600 to 4,000 cycles, through L-C crossover network.
- C. Compression-driver horn-loaded tweeter carries the response to 15,000 cycles (H-F control for balance adjustment).
- D. Tube-loaded port for amazing bass response in Jensen's new Bass-Superflex* cabinet.

**13 $\frac{1}{8}$ " H., 25" W., 11 $\frac{3}{8}$ " D (not including base)

*Trademark Jensen Mfg. Co.

Jensen
DIVISION OF THE MUTER COMPANY

MANUFACTURING COMPANY
6601 S. Laramie Avenue • Chicago 38, Illinois
In Canada: J. R. Longstaffe Co., Ltd., Toronto
In Mexico: Radios Y Television, S. A., Mexico, D. F.

Never over or underheats!

Gives
more reliable
soldering!



*with built-in MAGNASTAT
Temperature Control*

A revolutionary new soldering tool from Weller—long-time leader in the soldering field. Automatically maintains correct soldering temperature—and it's all self-contained. Sensing device is in the tip. Unmatched for reliable TV, radio, printed circuit and other precision soldering. 3 models available for all your service requirements from controlled lower temperature to heavy electrical soldering. Priced from \$8.00 list, up.

SOLDERING IRON PERFORMANCE — Temperature vs Load

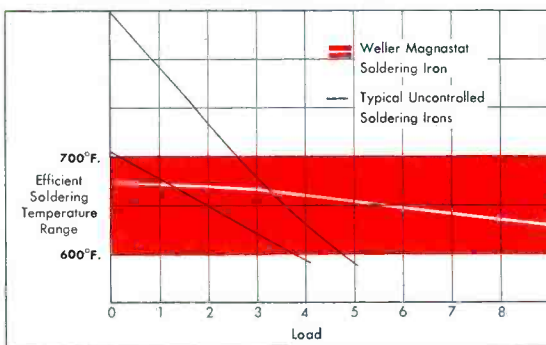

- Approximately 1/2 weight of uncontrolled iron.
- Delicate balance—cool handle.
- Cord plugs into handle.
- Saves current when idling—tips last longer.
- Reaches full heat quickly.

Order From Your Distributor or Write for Bulletin

WELLER ELECTRIC CORP. 601 STONE'S CROSSING ROAD EASTON, PA.

fier M1 is to charge C1 in the polarity shown. The capacitor charges to the full value of the line voltage (117 volts rms or approximately 160 volts peak). This action occurs on the half cycle of the input voltage in which the ground leg of the 117-volt line is positive with respect to the other leg. On the other half cycle, when the grounded leg is negative, C1 attempts to discharge. The voltage across the capacitor is placed in series with the line voltage, and the plate of rectifier M2 is thereby made positive with respect to its cathode by twice the peak value of line voltage, or 330 volts. This causes M2 to conduct heavily and charge C2 toward this 330-volt level. If no load were connected to the rectifier, the potential at the top of C2 would very nearly reach 330 volts; but the relatively heavy load on the supply shown in Fig. 4 tends to drain off the charge and allows it to maintain an average charge of only 265 volts. In addition, a small amount of voltage is lost in voltage drops across R1, M1 and M2. In supplies that employ either silicon or germanium instead of selenium rectifiers, the voltage measured at the top of C2 will be somewhat higher because of the increased efficiency of the newer units (smaller voltage drop in the forward or conducting direction).

W4 is the waveform of the voltage across the AC line. The observed peak-to-peak value of 330 volts is the same as the theoretical value obtained by multiplying the rms value (117 volts) by 2.828. W5 is the ripple signal caused by the charge and discharge of the input capacitor C2, and W6 is the ripple

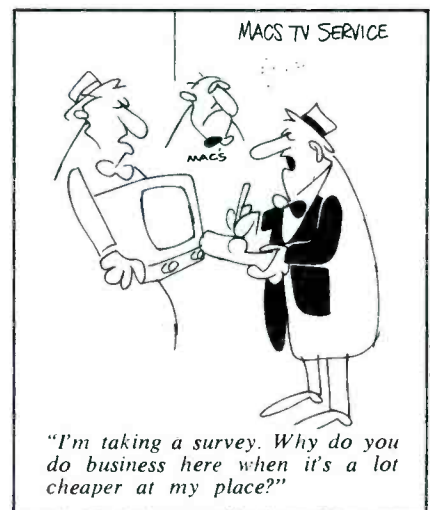

Silicon Rectifier... ... **1N2078**

NEW Tung-Sol 1N2078 designed and made for simple, speedy TV replacement!

Tung-Sol's new 1N2078 diffused junction silicon rectifier possesses distinct advantages the service industry will welcome. Optimum physical and electrical characteristics combine to make 1N2078 convenient to handle and install, and assure your TV and radio service customers the high-grade performance they want and appreciate.

Small size, easy to install. Tung-Sol's 1N2078 is smaller than most semiconductor devices, at no sacrifice in efficiency. Long

flexible leads can be quickly soldered to existing connections with no additional hardware. This is especially suited to printed circuitry.

Long life. Negligible voltage drop that remains stable over lengthy operation promotes long life. 1N2078 virtually unaffected by high current surges . . . maintains high B+ over full-length operation.

Special insulated case. Special case insulates against chassis shorts to further ease replacement. Also, 1N2078 dissipates its own heat . . . needs no heat sink . . . yet never requires derating. Only leads get hot.

You can replace any other device and, in some cases, rectifier tubes, with the new, high-quality Tung-Sol 1N2078. For complete information . . . to stock up, contact your distributor or: Tung-Sol Electric Inc., Newark 4, New Jersey.

1N2078 Maximum ratings (100°C) capacitive load:

(Similar types available with Peak Inverse Voltages ranging from 60 up to 500)

Peak Inverse Voltage	400 Volts
Continuous D. C. Reverse Working Voltage . . .	400 Volts
Average D. C. Output Current	500 mAdc
Peak Recurrent Forward Current5 Amps.
½ Cycle Surge Current	30 Amps.
Full Load Voltage Drop @ 25°C	1.1 Volts
RMS Input Voltage	130 Volts
Minimum Series Resistance (for capacitive filter)	5 ohms, 10 watt



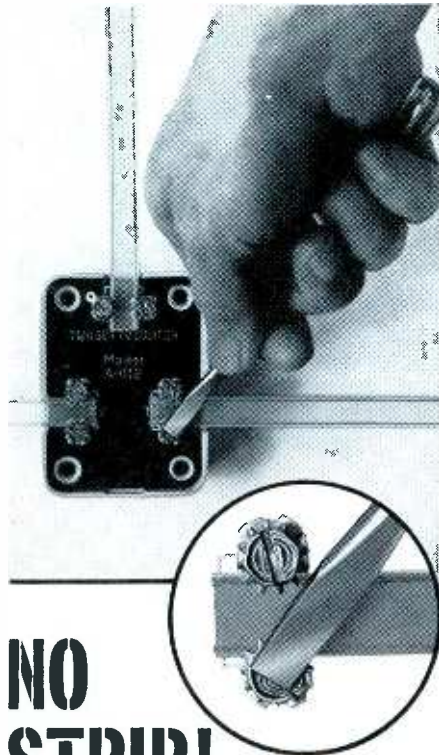

NO STRIP!

4 NEW B-T LABS. COUPLERS

In just a matter of seconds, new quality engineered B-T couplers featuring 'No-Strip' terminals provide a low loss, matched installation for superior multi-set performance.

2-SET COUPLER — maximum inter-set isolation — minimum signal loss
 Model A-102 Two-Set Coupler delivers more signal to each TV or FM set, with greater inter-set isolation than other couplers. A new original B-T circuit with phase cancellation feature automatically defeats interfering signals. No ghosts, no smears, ideal for color TV and FM.

List 2.95.

NEW B-T COUPLERS—4-SET, HI-LO & UHF-VHF A-104 FOUR SET COUPLER. Low loss 300 ohm directional coupler only 7 db insertion loss and 12-20 db inter-set isolation. Flat response 50 to 220 mc.

List 3.95

A-105 HI-LO ANTENNA COUPLER. Combines low band and high band VHF antennas or provides separate low and high outputs from a common line or antenna.

List 3.50

A-107 UHF-VHF ANTENNA COUPLER. Combines VHF and UHF antennas, or provides separate VHF and UHF outputs from a common line or antenna.

List 3.50

A-100 OUTDOOR MOUNTING KIT. Bracket and strap assembly for fast, easy mast mounting of models A-102, A-104, A-105, A-107.

List 90¢

SMARTLY STYLED WEATHERPROOF • NON-BREAKABLE CASE

Available at parts distributors.
 For further information write Dept. PF-1



BLONDER-TONGUE LABS., INC.
 9 Alling Street, Newark 2, N. J.

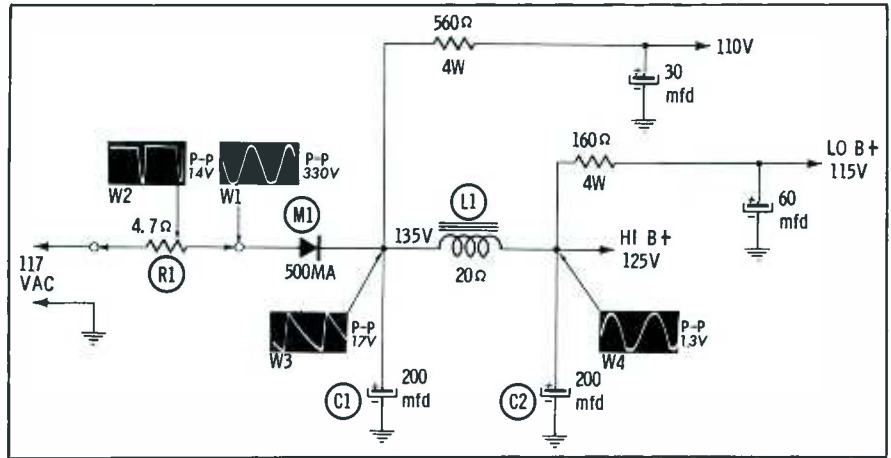

Fig. 5. Half-wave AC-DC power supply requires use of only one rectifier.

signal at the output of the conventional pi-type filter network.

The capacitors in a voltage-doubler circuit are of higher value than those normally found in the previously - mentioned transformer supply because frequency of the charging pulses is only 60 instead of 120 cps. Lower-value capacitors could not store as much charge and would therefore furnish a lower output voltage.

Half-Wave AC-DC Supply

The transformerless circuit in Fig. 5 is being used in quite a few currently - produced sets, particularly portables. This circuit operates exactly the same as the one in 5-tube AC-DC radios, except it delivers a higher DC current and has a higher output voltage. This is made possible by the use of larger filter capacitors, and rectifiers with higher current ratings. The new silicon and germanium rectifiers are excellent for use in this circuit because of their very low forward voltage drop.

As a rule, this circuit will deliver more than 125 volts DC at the output of the filter, an amount sufficient to operate specially-designed high-performance vacuum tubes of fairly recent vintage. Boost B+ is used for circuits (horizontal output, vertical output, and picture tube) requiring a higher DC potential.

The waveforms shown in Fig. 5, are similar to those described for the other supplies, and need no further explanation.

Voltage Divider and Decoupling Networks

After the AC line voltage has been processed into reasonably well-filtered DC by one of the three pre-

viously-mentioned supplies, it must be distributed to the individual circuits of the TV receiver. The block diagram in Fig. 6 shows how this may be done. Notice that several different DC voltage levels have been obtained from the original high B+ at the output of the low-voltage supply.

The audio output stage in many sets is put to use as an element in a power-supply voltage divider, and its cathode then becomes a source of low B+ voltage having about half the value of high B+. This is very economical, both in component cost and power dissipation, since no high - wattage, power - robbing, expensive bleeder-resistor network is required to obtain the desired voltage division.

An additional supply voltage, higher than high B+, is developed by the action of the horizontal fly-back circuit. This "boost B+" is applied to the plate of the horizontal output tube, to picture-tube circuits requiring voltages higher than regular B+, and often to the vertical oscillator and a few other circuits. Of course, high B+ is applied directly to many circuits in the receiver.

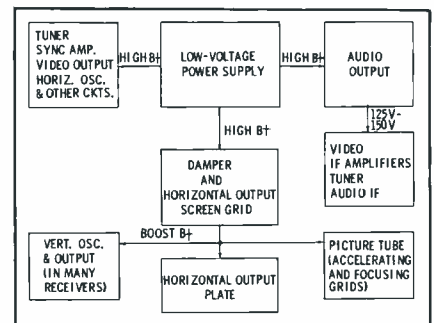

Fig. 6 Block diagram of voltage distribution system in typical TV receiver.



the sound approach in sound systems

CLAROSTAT SOUND SYSTEM CONTROLS



CONSTANT IMPEDANCE CONTROLS

Series CIT and Series CIL

L-pads and T-pads up to 10 watts audio. Continuous range from 0.5 to 30 db. attenuation. Maintains input and output of associated circuits within limits of a constant required value. Knob and dial plate furnished. From 4 ohms to 2K ohms.



CONSTANT IMPEDANCE OUTPUT ATTENUATORS

Series CIB

Output level control for power amplifiers or input attenuator for speakers in PA system. Handles up to 30 watts audio. Linear attenuation in 3 db steps up to 24 db. Equipped with dial plate and bar knob. From 6 to 600 ohms. All popular values.



THEATRE SPEAKER CONTROLS

Cat. Nos. CM8727-1, CM17083, CM17084

Drive-in theatre speaker controls for RCA, International, Motiograph and Simplex equipment. 1 1/8" diameter, 3/8" x 32 x 3/8" bushing. Shaft, round, 1 1/8" long. Available as 8-ohm L-pad, 50-ohm linear rheostat, or 35-ohm tapered rheostat.



CONSTANT IMPEDANCE ATTENUATORS

Series CIL43, CIT43, CIBT43

Reduced depth and diameter attenuators for sound systems. Ideal for use in remote controls, standard electrical boxes, etc. Will handle up to 4 watts audio. L-pads, T-pads, and Bridged T-pads.

4

MORE GOOD REASONS FOR ALWAYS SAYING

CLAROSTAT MFG. CO., INC.
DOVER, NEW HAMPSHIRE



You learn more from SAMS BOOKS

OVER 1,200,000 IN USE

JUST OUT!



"Know Your Oscilloscope"

Paul C. Smith's important new book helps you understand and get the most from your oscilloscope

This know-how, show-how book, packed with new ideas and methods really helps you master the use of this important instrument. Covers oscilloscope circuitry, adjustment, operation, application and servicing. Chapters include: General Information; Power Supplies; Sweep Systems; Synchronization; Amplifiers; Special Features; Accessories; Adjusting and Servicing; Frequency and Phase Measurements; Amplifier Testing with Square Waves and Sweep Signals; Radio and TV Alignment; Practical Applications; Service Procedures. A vital book for anyone who uses an oscilloscope. 160 pages, 5½ x 8½". Only **\$2.00**

CURRENT BEST-SELLERS



"101 Ways to Use Your Sweep Generator"

A complete and practical guide to the fullest use of your sweep generator. Each application is covered concisely with full data on connections required, additional equipment needed, proper test procedure and

evaluation of results. Specific sections cover use of the sweep generator for checking and calibrating test equipment, antenna measurements, RF and IF alignment and measurements, special uses in color receiver tests, etc. Over 250 illustrations, waveforms and diagrams. Invaluable for technicians, engineers and students. 148 p., 5½ x 8½". Only **\$2.00**



"Servicing Transistor Radios" ... Vol. 2

You'll save time, you'll earn more on Transistor Radio repairs with this complete data on 60 late models. Based on actual lab analysis of each set. You get the famous Sams Standard Notation schematics;

full photo views of each chassis; complete alignment data; full parts replacement information—everything you need to be successful in fast-growing transistorized radio servicing. Includes valuable section on transistor circuits in general, along with useful troubleshooting chart. 160 p., 8½ x 11". Only **\$2.95**

HOWARD W. SAMS & CO., INC.

Order from your Sams Distributor today, or mail to Howard W. Sams & Co., Inc., Dept. A-39 2201 E. 46th St., Indianapolis 6, Ind.

Send me the following books:
 "Know Your Oscilloscope" (KOS-1).
 "101 Ways to Use Your Sweep Generator" (TEM-1).
 "Servicing Transistor Radios." Vol. 2 (TSM-2).
 \$.....enclosed. Send Free Book List

Name.....

Address.....

City.....Zone.....State.....

(outside U.S.A. priced slightly higher)

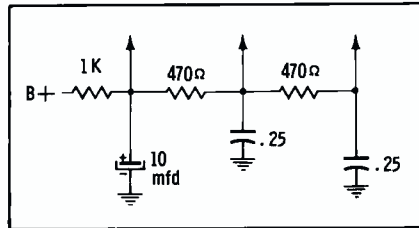

Fig. 7. Samples of decoupling networks.

The fact that some TV stages depend on other circuits for their DC potentials, instead of obtaining them directly from the DC power supply, can be a problem when troubleshooting. This can be overcome to a large degree if you will just stop and analyze the circuit and perhaps make up a simple block diagram of the B+ voltage dividers and decoupling networks. Once the general relationship between the circuits is understood, analysis and solution of the trouble becomes somewhat easier.

The matter of decoupling between circuits is no small thing. It isn't complicated, but it is important—in fact absolutely necessary if satisfactory receiver operation is to be insured. One of the most prevalent symptoms resulting from loss of decoupling between circuits is a blinking of the picture in unison with the audio (its severity being a function of the volume level). In almost every case of this type, the trouble can be traced to either an open electrolytic capacitor or a multi-section electrolytic with leakage, or a common connection between two or more of its sections. Of course, decoupling networks aren't always comprised of systems of electrolytic capacitors. As shown in Fig. 7, they can consist of a combination of electrolytic and paper capacitors to-

gether with the necessary isolating resistors.

Servicing Power Supplies

Three general types of servicing problems will be encountered: low DC output, excessive hum or ripple, and leakage or shorts. If the trouble is low output or excessive ripple, it will probably be most advantageous to check the circuit under operation with voltmeter and scope. However, if a short or leakage is causing excessive current drain, operating the receiver could result in serious damage to components. In this case, the ohmmeter should be the primary piece of test equipment.

In either case, it may be necessary to trace the entire system of voltage dividers and decoupling networks before finding and curing the trouble. Since it may be time-consuming to trace each section of the system directly from the schematic, make a simple sketch of the network (similar to Fig. 8) to work from. If the original schematic is not cluttered and is easy to follow, you may have sufficient notation space to make the separate sketch unnecessary. If you work from a sketch such as Fig. 8, you should have no trouble checking each leg of the power supply by measuring the voltage at each circuit taking power from the DC supply.

If there is any doubt about the quality of a component in a DC supply, it should be changed to avoid future troubles. Always use components with ratings at least as high as those of the original. Use higher-rated components wherever possible as double insurance against "callbackitis."

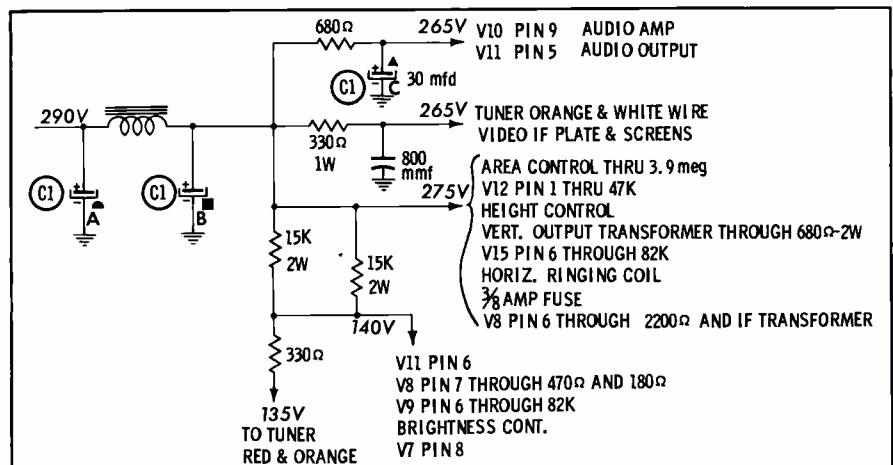

Fig. 8. A sketch of the voltage-divider system helps speed troubleshooting.



DESTROYED—NOT FIRST QUALITY! **...why General Electric ships only top-grade tubes!**

One small area in every General Electric receiving tube plant is given over to destruction. Here steel jaws chew to fragments any tubes that happen to fall short of first-quality standards. These tubes cannot be "recovered," re-branded, or used or shipped in any manner.

A single high level of quality holds for General Electric tubes. In every case, they're the top product of facilities that lead the industry. See your friendly G-E tube distributor! *Distributor Sales, Electronic Components Division, General Electric Company, Owensboro, Ky.*

Progress Is Our Most Important Product

GENERAL  **ELECTRIC**

2-111-201



SERVICING

By Calvin C. Young, Jr.

A Medley of Tuner Troubles

Tuner troubles are not only difficult to repair, but are often hard to pinpoint. The following assortment of troubles is presented to expose you to their symptoms and help simplify your troubleshooting job.

Overloaded and Snowy Picture

When one set owner reported that his picture was too dark and full of snow, visions of everything but tuner trouble flashed through the techni-

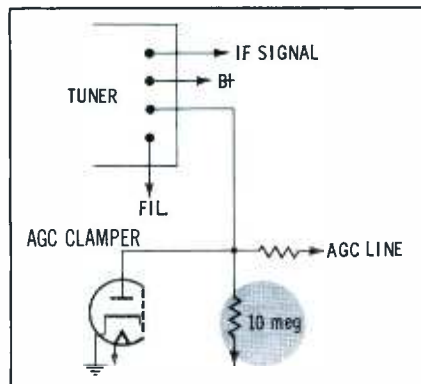

Fig. 1. Open delay resistor in the tuner AGC line causes overloading and snow.

cian's mind. He tried tube replacement in the video, AGC, IF and tuner stages without avail. A visual check of the tuner and a thorough contact cleaning likewise failed to cure the trouble. Voltages were normal except for the tuner AGC bias, which was much more negative than it should have been. Grounding the tuner AGC line removed the snow, substantiating the fact that excessive tuner AGC was the trouble. Examination of the schematic in Fig. 1 shows this could mean only one thing — the 10-meg delay resistor was open. "But how can too much AGC to the tuner cause picture overload?" you ask. Well it's like this — with tuner gain reduced, the



Fig. 2. Solidified wax on the mixer-grid wafer switch keeps it from rotating.

IF strip was running wide open. Under this condition, noise signals from the tuner were sufficient to overdrive the IF's and produce the black picture.

Poor Picture One Channel, Others Fair

The customer complained that the picture had been very poor on one channel (the set was new 6 months ago) and wasn't too clear on the other channels. A sweep-alignment check of the IF strip produced no clue to the difficulty; the response curve was almost perfect. Next, the tuner was checked using the sweep-alignment technique outlined in the service literature; the response curve was very distorted. Attempts to correct the distortion by touch-up alignment failed. Tube substitution and more touch-up adjustments were of no help. The cover was removed from the switch-type tuner to permit a visual inspection. In the course of this check, the channel-selector switch was operated; the mixer-grid section did not rotate with the balance of the switch sections.

A check with the local Philco distributor revealed that a replacement wafer section was available. Its replacement and a touch-up alignment brought the picture quality on all

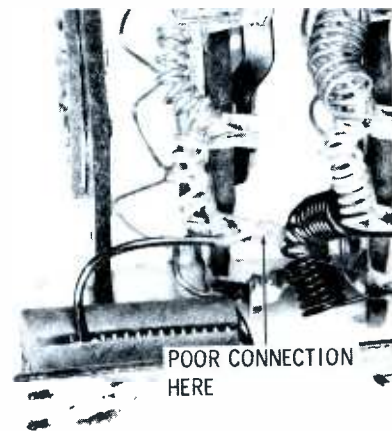

Fig. 3. A poorly-connected oscillator coil caused reception to be intermittent.

channels up to par. The defective wafer section (Fig. 2) was examined and found to be "frozen" by wax. Rotation of the detent shaft had reamed out the center hole, which explains why this section wouldn't move with the others.

Picture Won't Tune In, Sound Clear

This trouble was intermittent, and the simple process of removing and reinstalling the oscillator-mixer tube seemed to correct it for a few minutes. Cleaning and tightening the switch and tube socket contacts failed to help the situation, neither did resoldering connections in the oscillator-mixer network. Quite by accident, the oscillator coil on channel 6 was disturbed, and the picture came booming in. Further checks revealed two conditions: The two adjustment slugs in the oscillator coil section were loose (see Fig. 3), and there was a loose connection between two of the oscillator coils. A drop of solder cured the loose connection, and a drop of cement (clear plastic variety) cured the loose slugs.

Poor Sync and Washed-Out Picture

This symptom was reminiscent of AGC or video trouble, and only after these stages had been thoroughly checked was the tuner suspected. Visual inspection inside the switch-type tuner disclosed a discolored resistor. Replacement of this component improved performance slightly, but didn't cure the trouble entirely. The schematic indicated the presence of a resistor in series with the one just replaced. This second resistor was finally located (hiding behind a cluster of three small capacitors and a filament coil), and its

Mr. Service Dealer...

YOUR PHILCO DISTRIBUTOR IS HEADQUARTERS FOR A COMPLETE SELECTION OF GENUINE PARTS



Automatic Electric Washers • Automatic Electric Dryers • Duomatic Washer-Dryer Combinations • Automatic Gas Dryers • Gas Duomatic Washer-Dryer Combinations.



Radio • Television • Refrigerators • Ranges • Freezers • Air Conditioners • Automatic Dishwashers.



Automatic Electric Washers • Automatic Electric Dryers • Duomatic Washer-Dryer Combinations • Automatic Gas Dryers • Gas Duomatic Washer-Dryer Combinations.



Radio • High Fidelity • Stereophonic High Fidelity • Television • Refrigerators • Electric Ranges • Freezers • Air Conditioners • Automatic Electric Washers • Automatic Electric Dryers • Duomatic Washer-Dryer Combinations • Automatic Gas Dryers • Gas Duomatic Washer-Dryer Combinations.

Don't Settle for Less than Genuine Replacement Parts



COMPLETE PARTS CATALOGS—All models of all products listed above are completely covered in separate Philco catalogs on Electronics, Appliances and Home Laundry. See your Philco Distributor today for this valuable information.



WORLD WIDE DISTRIBUTION

Service Parts • Power-Packed Batteries • Universal Components • Long-Life Tubes • Heavy Duty Rotors • Star Bright 20/20 Picture Tubes • Long Distance Antennas • Appliance Parts • Laundry Parts • Universal Parts and Accessories.

PHILCO . . . Famous for Quality the World Over

replacement cleared up the trouble.

Even though a good visual inspection is a major part of a good troubleshooting technique, never rely on it alone. When a defective part is located visually, try to determine what caused the defect and what else might have failed. Check all related components for defects and eliminate the possibility of a recurrent trouble or a half-completed repair.

Extreme Ringing in Picture

This symptom seemed to radiate the message, "I'm in the tuner," and it was there that the first checks were

made. Voltage and resistance measurements seemed to be fairly normal. The B+ voltage was divided evenly between halves of the 6BK7 — as it should be. Still convinced that the trouble was in the tuner, the technician connected a sweep generator to the antenna terminals and a scope to the mixer-grid test point. The response curve was very distorted and couldn't be corrected by adjustment of frequency trimmers.

Probing the 6BK7 circuit (Fig. 4) with a nylon tool revealed that the neutralization capacitor, a 1.2-mmf unit between pin 1 and the lower

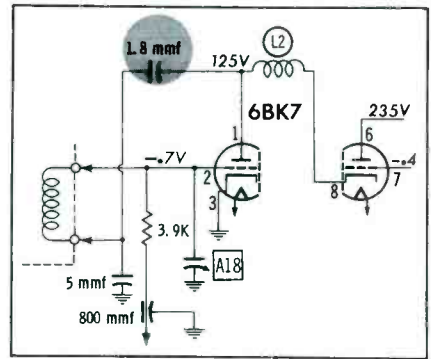

Fig. 4. Defective neutralizing capacitor results in distorted tuner response.

side of the grid coil, was broken. Replacement of this unit and realignment completed the cure.

In case you're wondering why the ringing symptom wasn't suspected as being indicative of IF trouble, the number of ghost images and the spacing between them varied with the setting of the fine tuning control. Also, the trouble was more predominant on higher channels than on low ones.

No Color, Black and White Picture Good

On calls such as this, the first step is to connect a color-bar generator to the antenna terminals and try to get a color signal through. This helps to isolate the trouble by eliminating the antenna system from suspicion. In this case, color was received using the color-bar generator, but it wasn't exactly right. Turning the fine tuning control had no effect at all on color or monochrome reproduction. Since the tuner was of the side-mounting variety, operation of the fine tuning mechanism could be viewed while the knob was rotated. This check proved that the drive string and pulleys were operating, but the fine tuning cam itself wasn't. With the tuner removed from the cabinet, the cam assembly was found to be broken — the drive pulley had become unbonded from the cam. Replacement of the entire cam assembly was required to remedy the trouble.

In another case involving the same series RCA color chassis, an identical trouble was due to a slick dial cord. The knob would turn but the string slipped on the drive pulley, impairing fine tuning action. A simple application of dial-cord dressing proved to be the cure.

Home Calls Simplified

Everytime I make a home service

ADDS INCOME 2 WAYS

1. Tests and Repairs Picture Tubes
(110° Tubes and Color Tubes too, with new C40 Adapter)
2. Makes New Tube Sales Easier



CATHODE REJUVENATOR TESTER



CRT 400 PROVES REAL MONEY-MAKER

Thousands of servicemen today make money and keep customer good-will by checking and correcting b&w picture tube troubles with the famous B&K CRT 400, right in the home without removing tube from set. Restores emission and brightness. Repairs inter-element shorts and open circuits. Checks leakage. Indicates picture quality customer can expect. Life Test checks gas content and predicts remaining useful life of picture tube. Makes new picture tube replacement sales easier!

Model 400 (without adapter) . . . Net, \$59⁹⁵

NEW MODEL C40 ADAPTER DOUBLES VALUE OF B&K CRT

Designed for use with all B&K Models 400 and 350 CRT's. Makes it easy to test and rejuvenate TV color picture tubes and 110° picture tubes. Isolates and detects difficult color troubles. Tests and rejuvenates each gun of the color picture tube separately the same way as a black & white tube.

Model C40 Adapter Net, \$9⁹⁵

See your B&K distributor, or write for Bulletin AP12-R

New C40 Adapter for
110° Tubes and Color Tubes





Makers of CRT, DYNA-QUIK, DYNA-SCAN and CALIBRATOR

B & K MANUFACTURING CO.
3726 N. Southport Ave. • Chicago 13, Illinois



How BUSS fuses help protect your profit and reputation

There are no time-consuming call-backs or adjustments or customer complaints when you sell or install BUSS fuses. BUSS fuses stay sold and your customers stay satisfied because . . . BUSS fuses are trouble-free. They open only to protect — never needlessly.

Every BUSS fuse you sell or install is tested in a sensitive electronic device. Any fuse not correctly calibrated, properly constructed and right in all

physical dimensions is automatically rejected.

BUSS fuses have ready customer acceptance

Over the past 43 years, millions upon millions of BUSS fuses have provided dependable electrical protection in homes, industries and on farms. As a result, BUSS quality is unquestioned. Furnishing BUSS, the Known brand of fuses, saves you time and

helps you build your reputation for service and reliability.

For more information on BUSS and FUSETRON Small Dimension fuses and fuseholders, write for bulletin SFB.

BUSSMANN MFG. DIVISION,
McGraw-Edison Co.
University at Jefferson, St. Louis 7, Mo.

BUSS fuses are made to protect — not to blow, needlessly



BUSS MAKES A COMPLETE LINE OF FUSES FOR HOME, FARM, COMMERCIAL, ELECTRONIC, AUTOMOTIVE AND INDUSTRIAL USE.

Wizard Set Couplers make this possible



Mr. J. A. Morris, Owner, de Ville Motel, 1128 W. 7th St., Los Angeles, California
...A fine place to stay in downtown L.A.

“we operate 31 TV sets from one antenna without amplification...and reception is excellent!”

WIZARD
300*
Electro-Magnetic
SET
COUPLER



For
Brilliant
Reception
On Any
Combination
of Black &
White, Color
or FM

EASY TO INSTALL

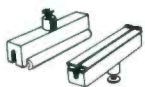

THE WIZARD SLIDES APART



PLACE TWO HALVES ON LINE AND SLIDE TOGETHER

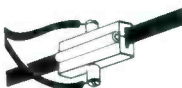

CONNECT TO SET

TO COUPLE 2 SETS

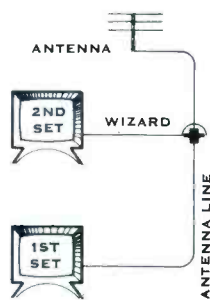

Install the Wizard anywhere on the line and connect to set.

TO COUPLE 3 OR MORE SETS

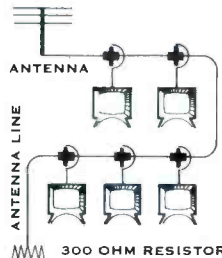

Extend antenna line through area of operation and terminate with 300 ohm resistor. Install Wizards and connect.

List Price \$1.95 • Contact Your Distributor or Write Dept. ET12

*PAT. PEND.

CHARLES ENGINEERING, INC.
6053 Melrose Avenue • Los Angeles, California

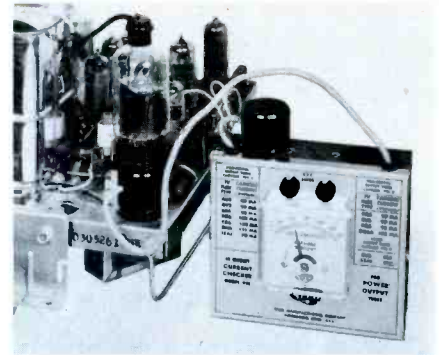

Fig. 5. Seco Model HC-6 permits metering of output-tube cathode currents.

call and have to replace either the horizontal oscillator or output tube, I wonder if the settings of the horizontal drive and linearity controls are correct. Until the introduction of the Seco Model HC-6 *In Circuit Current Checker for Power Output Tubes*, I had found no definite, positive method for checking these adjustments. With the use of this new instrument, however, inserting the proper adapter socket between the output tube and the receiver's tube socket (Fig. 5), and applying power, automatically gives an indication of the tube's cathode current.

Two adapters are provided to simplify the use of this instrument, one for tubes having the cathode connected to pin 3 and one for those with cathodes connected to pin 8. Typical cathode current readings are listed on the front panel, adjacent to the respective tube-type numbers. No numerical prefixes are given, as these only indicate heater ratings and don't affect operation of the HC-6.

When replacing horizontal output tubes, install the proper adapter plug from the unit and adjust the horizontal-drive control for minimum current, maintaining sufficient sweep width without drive lines. Adjust the horizontal linearity coil for a current dip, or to minimum current without sweep distortion. External jacks (red for positive, black for negative) are included to permit the meter to be used for other purposes.

The HC-6 is also useful for balancing currents in push-pull audio output stages using tubes such as 6V6, 6L6, 6550, 5881 and others with octal bases and pin-8 cathode connections.

The 18" cables to the adapter plugs are self-storing; the plugs themselves fit sockets in the top of the instrument when not in use. ▲

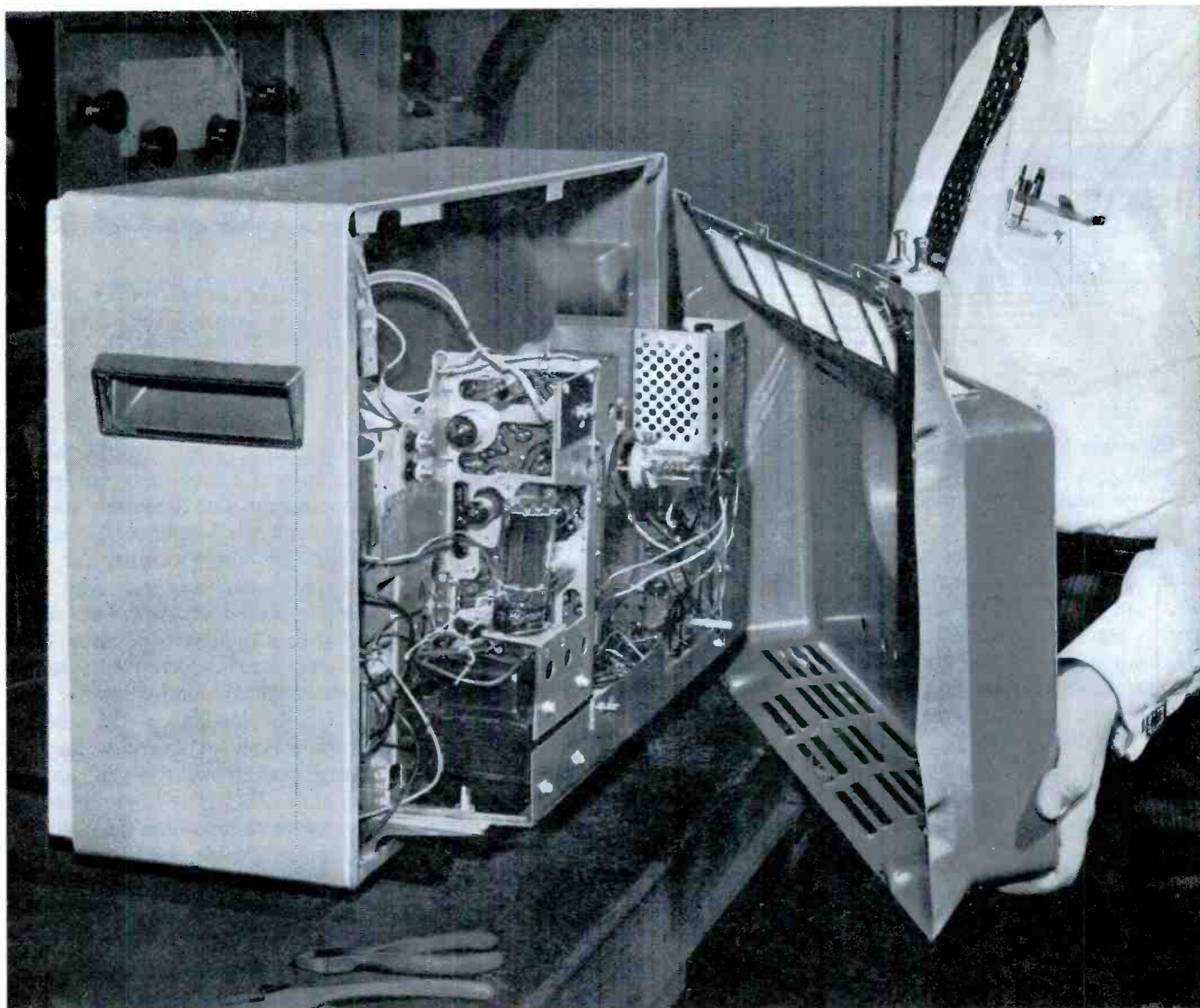

Take the back off the General Electric "Designer" TV set and you can do **85%-90% of service jobs without pulling the chassis**

You cut your time-per-repair by up to 40% . . . make more calls—and money—in the same amount of time!

Take off the back and there you are—in easy reach of up to 90% of service jobs. Look at the chart!

Look inside! Both sides of the reliable printed circuit boards are easy to reach for service.

No series string filaments—no extension cables needed . . . the new "Designers" are certainly the easiest-to-service sets in all television. You'll wish every set was a General Electric "Designer."

Progress Is Our Most Important Product

GENERAL  ELECTRIC

TEN TYPICAL JOBS THAT CAN BE DONE WITHOUT REMOVING THE CHASSIS				
JOB	G-E "Designer"	Set A	Set B	Set C
Replace most resistors	yes	no	no	no
Replace most capacitors	yes	no	no	no
Replace deflection yoke	yes	no	no	no
Replace video detector	yes	yes	no	no
Replace audio detector	yes	no	no	yes
Replace horizontal phase detector	yes	no	yes	yes
Replace power rectifier	yes	no	no	yes
Adjust tuner oscillator	yes	no	yes	yes
Replace inter-stage transformers	yes	no	no	no
Replace size and linearity controls	yes	no	yes	yes

General Electric Co., Television Receiver Dept., Syracuse, N. Y.

SOUND

Systems

pointers to help you become the sound specialist in your community

by **L. A. Randall**

Everyone knows a chain is only as strong as its weakest link. Likewise, the quality of a sound system is only as good as the quality of its individual units and the manner in which they are interconnected. This idea can be helpful to the sound-system service specialist, for by checking each link in the system, he can easily isolate or pinpoint troubles. It is not the intent of this article to discuss all the possible sources of trouble in a sound system, but to point out those most frequently overlooked or misinterpreted.

Input Devices

Input connections are always a likely source of trouble when a sound system needs servicing; plugs and connections are among the first things to check when volume drops. A poor connection in a low-impedance line can cause as much signal loss as several thousand feet of cable. The following installation instructions¹ can be applied to any similar equipment to reduce attenuation of the input devices and help provide superior operating performance:

"Using the usual shielded conductor with over-all insulation, the recommended maximum length, to avoid loss of high-frequency response, is 10' for a magnetic tape recorder, radio or television tuner, and 5' for a magnetic phonograph pickup. By substituting single-conductor, low-capacity (50 mmf or less) shielded microphone cable, length may be extended to 30' for a tuner or recorder, and 12' for a phonograph pickup."

To avoid high-frequency attenua-

1. Taken from a Stromberg-Carlson Custom 400 High-Fidelity Amplifier data sheet.

tion, 30' of low-capacity cable is about the maximum allowable length for high-impedance microphones. The data sheet also incorporates the following on volume adjustment of radio, tape and auxiliary inputs:

"At the time of installation, correct setting of the volume control on the radio tuner or other auxiliary input must be established. Place the selector switch in the position providing the desired input source. Set the amplifier volume at 7, and bass and treble at flat (mid-position). To adjust a radio or television tuner, tune in a nearby station and adjust tuner volume for an

audio output level slightly louder than normal. Leave tuner volume in this position and hereafter use the control on the amplifier. To adjust a tape (or wire) recorder for correct playback, select a tape (or wire) recorded at the correct level and with a minimum of noise. Adjust recorder controls to provide flat response and an audio-amplifier output slightly above normal. Leave recorder volume in this position and control output level from the amplifier. Note: Excessive hum and noise may be experienced if the volume-control setting on the input source is much below normal."

Many times, the poor results obtained from a sound system can be quickly traced to incorrect operation of the input devices and/or amplifier controls. If, after correctly adjusting the volume controls of an auxiliary input device and an amplifier, there is still excessive input voltage, an attenuating resistor can be placed in series with the high side of the input cable; a ¼- or ½-watt resistor can be used, its value depending on input sensitivity and impedance of the amplifier.

Microphone Phasing

Many installations use two or more microphones to pick up sound from a single source. To prevent sound cancellation, it is just as important to properly phase microphones as it is to phase loudspeakers. One microphone is used as a standard, and speaker output is compared while connecting the second microphone one way and then the other. Correct phasing is accomplished when the greatest output is realized. When a third microphone is involved, it can be tested in a

Chart I — Voltages for Given Impedances and Wattage Ratings

Output Tap R	Amplifier Output Wattage				
	15	25	30	50	60
4	8.0	10.0	11.0	14.0	15.5
8	11.0	14.0	15.0	20.0	22.0
16	15.5	20.0	22.0	28.0	31.0
250	61.0	79.0	86.0	112.0	122.0
500	86.0	112.0	122.0	158.0	173.0

Chart II — High - Pass Filter Values for Speaker Lines

Output	25-Volt Line	70-Volt Line
25 watts	10.0 mfd.	1.0 mfd.
50 watts	20.0 mfd.	2.5 mfd.
250 watts	X	12.0 mfd.

X—Won't, as a rule, have a 25-watt tap

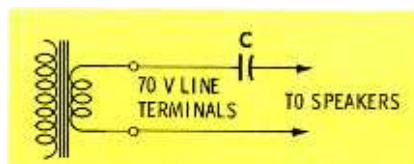

Fig. 1. Capacitor between speaker feed line and output on transformer tap acts as high-pass filter for entire system.

Assignment: Capture Utah Quality*



THANK THE KEEN-EYED SNOOPER

As little as .0035 of an inch off in the dimensions of this Utah speaker basket—and a reject hits the bin! At Utah the quality of final performance in the speaker you buy is a jealously guarded value. If you could visit our Huntington plant you'd probably agree with Ace Photographer Lieberman that Utah speakers prove rejection is the foundation of perfection.

Pre-assembly, plating, coil winding, wiring . . . at every step down the production line stand the "keen-eyed snoopers." They search ruthlessly for the tiniest defect that could mar, even minutely, the response performance of a Utah.

Make certain your next speaker is a Utah. Know that your sound will be as perfectly reproduced as human skills, controlled by rigid inspection, can produce.

See the Utah Custom Line: a quality speaker for every system need.

* ARCHIE LIEBERMAN, famous newsmagazine* photographer, was given this assignment on a recent Utah plant tour: Photograph the essence of Utah quality as you see it. The photo shown here is the result. (*Look, Life, Time, Pageant, Parade, Newsweek and many others)

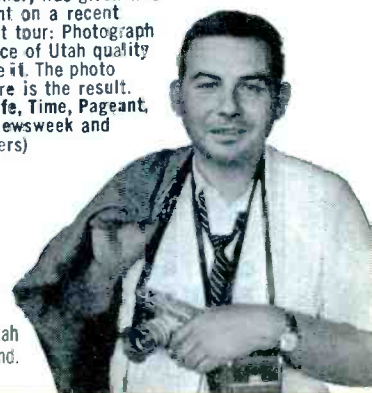

Let your ear decide **Utah** the ultimate choice

SPEAKERS



Send for the big Utah Catalog. Dept. 8, Utah Radio & Electronic Corp., Huntington, Ind.

www.americanradiohistory.com

Auto Radio Control Replacement is Child's Play

with new **Centralab**®

Exact Replacement Controls



Now one source can fill all your needs for auto radio replacement controls. CENTRALAB has a new line of exact replacements for every popular radio in use today. This is the first time in history that you have been able to get the auto radio control you need—from a control manufacturer.

It's easy to handle more auto radio repair business—and handle it profitably—when you install exact replacement controls bought from your *regular* supplier. No need to run all around town looking for the right unit—you can now be sure that your CENTRALAB distributor has it!

A complete and thorough guide listing all auto radio controls in use today, and their CENTRALAB equivalents, is now available. Pick up your free copy from your distributor—or write direct to CENTRALAB.

Centralab

® B-5902

A DIVISION OF GLOBE-UNION INC.
942A E. KEEFE AVE. • MILWAUKEE 1, WIS.
IN CANADA: 804 Mt. Pleasant Rd. • Toronto 12, Ont.

CONTROLS • ROTARY SWITCHES • CERAMIC CAPACITORS
PACKAGED ELECTRONIC CIRCUITS • ENGINEERED CERAMICS

similar manner, using a previously-phased microphone as the standard.

Amplifier Output Voltage

Volume control setting on an amplifier is not a criterion of actual output, unless the input signal is exactly that called for to provide full rated output, and the amplifier circuits are functioning at rated ability. In other words, if the input level is greater than that needed for full rated output, less than full volume-control setting should provide the rated output. With the volume control at maximum, the amplifier circuits would overload and result in distorted output. On the other hand, if the input voltage is less than that required, the amplifier will not deliver its rated output, even with the volume control set at maximum.

Whenever there is reason to suspect that the amplifier is at fault, it's a good idea to check its output voltage. It can be measured with a high impedance AC voltmeter connected across a dummy-load resistor equal in value to the output impedance. The resistor's power rating should be equal to the rated power output of the amplifier. Be sure amplifier volume is at maximum and that input device controls are properly adjusted. If the system includes more than one input device, connect each one separately to determine whether or not the resultant amplifier outputs are approximately the same. It is quite possible that some input levels are too high and result in overloading of the amplifier, while others may be too low to provide full output. If this condition is observed, follow the instructions given for input devices.

Chart I lists the approximate output voltages of popular amplifiers. Output voltages of other amplifiers can be determined by using the formula $E = \sqrt{W \times R}$, W being the rated output in watts and R the impedance value of the output tap.

Output Filters

Noise-masking level is the level which the desired signal must attain to be heard over accompanying noise. Typical masking-level charts show that a considerable amount of the masking noise is in the lower frequencies. In noisy locations, or where speech is of first considera-

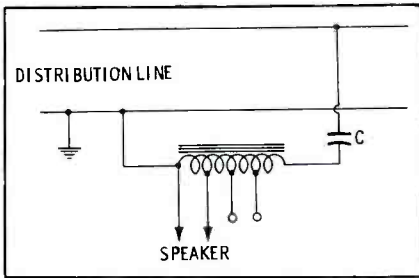

Fig. 2. Capacitor between one voice coil and its line-matching transformer is high-pass filter for that unit only.

tion, a filter installed at the output of the amplifier reduces the required audio power. A filter eliminating all frequencies below 600 cps will reduce the articulation of speech by only 2% while increasing the average gain for individual syllables by approximately 8 db. In other words, by the simple use of a high-pass filter, the level for that part of speech energy most important for communication can be increased. Experiments have shown that after eliminating frequencies below 600 cps, very little is gained by lowering high-frequency cutoff. The filter serves a highly important function. It permits audio power to the reproducer (re-entrant horn and driver) to be safely increased, often by as much as 50%.

When the filter is used at the amplifier output, the speaker-line and output-tap impedances should match reasonably well. This is not always expedient, especially when only a few of the speakers used are in noisy locations. Under such conditions, high-pass filters at only the noisy locations would better serve the purpose. Chart II provides the capacitor values needed in one side of the amplifier output line (see Fig. 1) to serve as 600-cps high-pass filters whenever a 25- or 70-volt speaker line is used. Chart III indicates capacitor values needed when a 600-cps filter is desired at the primary taps of the speaker line transformer (see Fig. 2). To determine the capacitor value required for any other impedance tap, the following formula should be used:

$$\text{Capacity (mfd)} = \frac{159,000}{\text{Cutoff} \times \text{Impedance}}$$

Cutoff is the frequency where half-power is obtained, that is, where output is 3 db lower than full power. The working voltage of the capacitor selected must be ample for the circuit in which it is inserted.

sales without selling

16 million worn out antennas are due for replacement. Here's how you can get this extra business on your regular service calls...

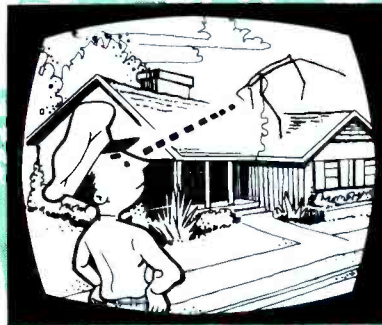

1 LOOK UP!

Look up at your customer's antenna before every service call. See if there are missing or sagging elements, corrosion or other signs of a worn out TV antenna.



2 TALK UP!

Tell your customer what you've seen... also how an antenna loses up to 50% of its efficiency after three years. Explain how much clearer their TV picture will be with a new antenna.



3 PUT UP!

Stock CLEAR BEAM Do It Yourself Kits on your truck. Make the installation while you're there... or sell kits outright to Do It Yourselfers. Either way you'll pick up extra profits.



Complete Installation Kits for
Every Popular Antenna
Conicals — Arrows — Yagis —
Inlines



CLEAR ANTENNA CORP.,
BEAM CANOGA PARK, CALIF.

WORLD FAMOUS Simpson 260!

TRADEMARK

**RUGGED
PRINTED
CIRCUIT!**

still
only
\$43.95
Complete with leads and
Operator's Manual.
Also available in
Roll-Top model at
only \$49.95



**...the VOM that outsells
all others combined**

**MANY NEW FEATURES MAKE THE 260
MORE VALUABLE THAN EVER!**

- ▶ POLARITY REVERSING SWITCH
- ▶ EASIER-TO-READ SCALES
- ▶ POPULAR DBM RANGES
- ▶ RUGGED PRINTED CIRCUIT
- ▶ 50 MICROAMPERE—250 MILLIVOLT RANGE
- ▶ LESS CIRCUIT LOADING
- ▶ FULL-WAVE BRIDGE RECTIFIER SYSTEM
- ▶ ALL COMPONENTS EASILY ACCESSIBLE

● IMPROVED FREQUENCY RESPONSE IN A. C. MEASUREMENTS

See it at your Distributor, or write

SIMPSON ELECTRIC COMPANY

5209 West Kinzie Street, Chicago 44, Illinois

Phone: EStebrook 9-1121

In Canada: Bach-Simpson Ltd., London, Ontario

WORLD'S LARGEST MANUFACTURER OF ELECTRONIC TEST EQUIPMENT



**Chart III—High-Pass Filter
Values for Speaker
Transformer**

Primary Transformer Taps	600 cps
78	3.5 mfd.
165	1.5 mfd.
250	1.0 mfd.
312	0.75 mfd.
500	0.5 mfd.
625	0.4 mfd.
1000	0.25 mfd.
1250	0.22 mfd.
2000	0.15 mfd.
2500	0.1 mfd.
5000	0.05 mfd.
10,000	0.025 mfd.

When articulation of speech is poor from a speaker in a noisy location, and the poor quality is not due to amplifier distortion or other traceable cause, try a 600-cps filter at the speaker. Remember, when the primary tap on a speaker is changed, the value of the filter capacitor must also be changed.

Speaker Matching

There is probably more information available on the subject of multiple loudspeaker matching than any other single aspect of sound system work. It is equally true that the data is frequently misinterpreted, and the fact that two (voltage and impedance) methods of multiple speaker matching are in use has not been helpful in clearing away the haze. Most multiple speaker systems require speaker line transformers. Among other things, power-handling capacity and frequency range must be adequate, and insertion loss must be minimum.

Voltage Method

Using line-matching transformers rated in power and voltage, it is only necessary to connect the chosen wattage tap on the transformer to the correct voltage tap on the amplifier. The amplifier will operate correctly, provided that the power drawn by all speakers does not exceed the power output rating of the amplifier. The total power available can be divided equally or unequally among the speakers, as desired. Speakers can be switched on or off without the necessity of providing dummy output loads, and as speakers are connected or disconnected, there will be no change in distortion or volume level.

Wattage ratings of transformers marked in impedance only can be computed by use of the formula $W = E^2/R$, where $E =$ output line voltage and $R =$ transformer impedance. For example, using a 25-volt line, E^2 equals 625; thus, a transformer with a 625-ohm primary will draw one watt from the amplifier. Using a 70-volt line (actually 70.7 volts), E^2 equals 5000, and a line transformer with a 625-ohm primary will draw 8 watts from the amplifier. Transformers rated for 25-volt lines should not be used on 70-volt circuits, since they have insufficient primary inductance and will load down the amplifier.

Impedance Method

To determine the power into any speaker, divide the impedance of the amplifier-output tap by the impedance of the speaker to be used (or tap on the speaker line-matching transformer). This is the fraction of the total amplifier power delivered to that speaker. For example, if a speaker with a 2500-ohm line transformer is connected across the 500-ohm output of an amplifier, that speaker will draw one-fifth of the power delivered by the amplifier. Thus, by proper selection of loudspeaker (or transformer) impedance, different amounts of power can be delivered to a number of speakers, all connected in parallel to the same amplifier. The rule applies equally well whether the loudspeakers are all connected to the same amplifier output tap, or to different impedance taps. The sum of all these fractions of total amplifier power should equal unity for best matching. If impedances of available taps do not permit perfect matching, the sum should be less than unity.

A direct impedance - matching method for finding power drawn by a speaker is:

$$W = \frac{Z \text{ at Ampl. Tap}}{Z \text{ at Speaker} \times \text{Ampl. Watts}}$$

Example: How much audio power is drawn by a speaker, using the 5000-ohm tap of its line transformer, from the 500-ohm output tap of a 25-watt amplifier? Using the formula above:

$$W = \frac{500}{5000 \times 25}, \text{ or } 2.5 \text{ watts}$$

If only the line transformer tap is



"RUSH CALL, GUS! DISC JOCKEY NEEDS A NEW STEREO CARTRIDGE... FANS ARE GIVING HIM THE NEEDLE!"

Never a worry in the world when you install a Webster cartridge. Even "amateur" hi-fi and stereo fans recognize professional quality reproduction when they hear it!

Recommend and install Webster cartridges every time... then you and your customers will make beautiful music together.

REPLACE WITH WEBSTER STEREO...IT PAYS!

stereo-ceramic...



SC-3D Stereo turn-under
— with .7 mil diamond and 3 mil sapphire styli.
\$25.00*



SC-2D Stereo single needle
— with .7 mil diamond stylus.
\$22.50*



MC-2 78 rpm single needle
— with 3 mil sapphire stylus.
\$7.50*

* List prices — standard discounts apply.

ELECTRONICS DIVISION

WEBSTER ELECTRIC
MELROSE 3-3611
RACINE · WIS



Franklin adv. Y-132

**FAST!
ACCURATE!**
Seco Test Equipment
Saves time . . . makes
more money for you!

WRITE TODAY FOR COMPLETE
SPECIFICATIONS AND FEATURES!

- Outstanding Reliability and Performance!
- Unique, Time-Saving Features!
- Low First Cost Makes You Money From the Start!



107 TUBE TESTER—Outstanding performance and accuracy—provides 3 important tests: amplifier types tested for gain by Dynamic Mutual Conductance method—power types tested for cathode current by Cathode Emission method—all types tested for shorts and grid error by Grid Circuit Test developed and patented by Seco. Dynamic Mutual Conductance Test pre-wired to eliminate elaborate set-up. Cathode Emission Test done by free point pin-selector method—will not be obsolete. Completely self-contained in portable carrying case. Furnished with handy flip chart for fast tube set-up data.

MODEL 107 \$139.50 NET



GCT-8 GRID CIRCUIT TUBE TESTER—Perfect companion to any tester—checks critical “control grid” condition of vacuum tubes fast, accurately. Electron eye tube indicates faults at a glance. As many as eleven simultaneous checks—automatically.

MODEL GCT-8—Kit \$19.95 NET

MODEL GCT-8—Wired & tested \$29.95 NET



208V TVM—“Foot-proof”—many new features! Easy-to-read 4½” 200 microamp meter mounted on sloping panel—7 DC, 7 AC, 7 ordinary Ohm ranges, plus RETMA (EIA) Ohm scale to check standard color-coded resistance values and tolerance limits. Specially designed “shift-lever” type function switch identifies and automatically connects proper probe. With stand, 40” leads, and common lead with clip.

MODEL 208 \$74.50 NET

Leather, felt-lined carrying case . . . \$9.95 NET



PS-2 BATTERY ELIMINATOR—Compact unit takes place of battery normally used to operate and service low-powered transistorized equipment. Supplies clean, filtered DC—can't be damaged by a short. Quickly spots faulty batteries by substitution. Output continuously variable from 0 to 15 V.—ideal for experimenters. Complete with jacks, leads, and clips.

MODEL PS-2 \$13.95 NET

FB-4 FLYBACK CIRCUIT AND INDUCTANCE ANALYZER—Quick “yes” or “no” answer on condition of flyback transformer and yoke—100% accuracy!

MODEL FB-4 \$38.95 NET

NEW! HC-6 CURRENT CHECKER

Provides positive, on-the-spot method of checking TV horizontal output circuits—fast, accurate way to adjust horizontal drive and linearity. Easy to use—can be placed in circuit in seconds—compact size. Complete, ready to use.

MODEL HC-6 \$12.95 NET

Get the complete story on Seco's exciting line of test equipment. See your distributor—or write for complete information today!

SECO MANUFACTURING CO.
5015 Penn Avenue So.
Minneapolis, Minn.

Chart IV—Maximum Length (in feet) for 1-db Speaker Line Loss

Wire Gauge	Line Impedance in Ohms							
	4	8	16	45	78	156	312	625
22	20	40	80	220	400	800	1600	3200
20	30	65	130	350	500	1000	2000	4000
19	40	80	160	425	650	1300	2600	5200
18	50	100	200	550	800	1600	3200	6400
16	80	160	320	900	1200	2400	4800	-----

changed to 2500 ohms, speaker drain becomes 5.0 watts, or if the 10,000-ohm tap is used, 1.25 watts.

Speaker Volume and Phasing

When a volume control is required at a speaker, install a rotary switch between the required primary taps of the line transformer and the amplifier output line. Line-transformer primary taps are usually in steps of 3 db, each step doubling the audio power drawn by the speaker. Here again, total power drawn by all speakers on the line must not exceed the rated output of the amplifier.

When multiple speakers are used in the same room, they must be properly phased. Speakers out of phase cancel each other's sound waves. When properly phased, all speaker cones will move in unison. Phasing is accomplished by momentarily connecting a 1½-volt dry cell across the voice-coil terminals of each speaker. Terminals which cause the cone to move in when connected to the + side of the dry cell should be marked. Connect all marked terminals to the same side of the distribution line.

Speaker-Line Wire Size

Generally, it is more economical to use speaker lines that match voice-coil impedances, unless the total resistance of the speaker line results in more than the usual 1-db insertion loss for a good-quality line transformer. Chart IV, based on less than 1-db loss, gives the maximum

recommended line length in feet for several wire sizes at various output impedances. For 2-db loss, double the line length.

When the amplifier is to supply two or more speaker lines, choose the minimum wire size for each line separately, using the termination impedance for that line. For example, it is customary in school installations to use a 25-volt line and to equip each classroom speaker with a transformer, using the 1250- or 625-ohm tap to supply .5 watt or 1 watt to the speaker. Each speaker line is brought separately to the amplifier. Wire-size calculations for any one of these lines are determined by the 1250- or 625-ohm impedance this one line presents to the amplifier, and not on the impedance of the combined speaker lines. Note: When using a 25-volt line, divide 625 by power for all speakers on the line to obtain its impedance. When using a 70-volt line, divide 5000 by total speaker power.

Shielding Loudspeaker

We know that low-impedance input (microphone) lines must be used for long runs to provide good high-frequency reproduction. Also, excessive attenuation will be experienced when using too long an input line for a high-impedance microphone, phonograph or similar input device. But what effect will the use of shielded lines have? For the answer, let's consider a typical school system installation. Use of shielded speaker lines may impose a capaci-

Chart V—Capacity and Capacitive Reactance of Speaker-Line Systems

Length of Shielded Lines in feet	Capacity in mfd.	Capacitive Load in ohms at 10,000 cps.	Capacitive Load in ohms at 5,000 cps.
20,000	1.0	15.9	31.8
10,000	0.5	31.8	63.7
5,000	0.25	63.7	127.4
2,000	0.10	159.0	318.0
1,000	0.05	318.0	636.0
200	0.01	1590.0	3180.0

tive load on the amplifier of .5 mfd or more because of capacity between conductors and between them and the shield. Effect of this capacity on frequency response can be realized if we compare its reactance with the rated output impedance of the amplifier. For good reproduction, the capacitive impedance across the line should not be less than the amplifier-tap impedance at the highest frequency to be reproduced. Chart V quickly shows that, for a large installation using 20,000' of shielded speaker line, an amplifier tap of 16-ohms or lower must be used for satisfactory high-frequency response (10,000 cps and above). The chart shows only the effect of the shield and interconductor capacity, but it clearly illustrates that, even for a line as short as 1,000' the 500-ohm output tap at the amplifier cannot be used if a 10,000-cps response is desired.

Conclusion

After a system has been serviced and is operating correctly, instruct your customer on its operation. Your reputation as a service specialist will be judged on the results experienced by the regular operator.

Maintain a file on each system serviced with any regularity. Include a complete block diagram of the system, noting the speaker lines and line-transformer taps used, a wiring diagram of any cabinet assembly, model numbers of the major components, and the location of necessary service data. A brief synopsis of each service call should also be placed in this file. Like a doctor's medical history of a patient, your history of a sound system might bring to light a chronic condition, such as excessive tube failure, that would otherwise go undetected. The time used to prepare and maintain the file will more than pay for itself on subsequent calls.

Only major considerations for sound system servicing have been covered in this article. There are others, and the number is increasing as the applications for sound equipment expand. Common sense and systematic checking will bring many of them to light, and as his experience grows, so will the demand for the sound-system specialist. His future is bright! ▲

CAPACITORS

you can
depend
upon!

PRECISION DESIGNED
for Long Life and Trouble-Free Service!



ELMENCO *Miniaturized* TUBULARS

- High Temperature Operation
- Superior Moisture Resistance
- High Insulation Resistance
- All Values $\pm 10\%$ Tolerance
- Printed Circuit Application

ELMENCO



ELMENCO High Voltage *Silvered Mica* USED IN ALL TELEVISION CIRCUITS

CAPACITY, TOLERANCE AND
VOLTAGE IMPRINTED ON EACH UNIT
Standard Tolerance $\pm 5\%$

ARCOlytic

HIGH QUALITY ELECTROLYTICS
UNCONDITIONALLY GUARANTEED FOR ONE YEAR



ARCO
ELECTRONICS INC.
64 White Street
New York 13, N. Y.
DALLAS • LOS ANGELES

Available at every REPUTABLE
distributor throughout the country!

electronically-controlled SPOT welding



"The weld is stronger than the metal."

"Resistance welding saves time in sheet metal fabrication."

These statements are indicative of industry's attitude toward precision resistance welding. The control and versatility of the medium-size spot welder is exemplified by the fact that it is used in the construction of toys, cooking utensils, automobiles, and almost every mass-produced item made of metal.

A resistance welder is shown in Fig. 1. The jaws (made of copper alloy) hold the work and carry the weld current. The junction of the two metals to be joined offers greater resistance to current than the remainder of the metal or the copper alloy jaws. A large current (30,000 amps or more), passing through the jaws and the two pieces of metal, generates sufficient heat at the junction to melt the adjacent metal. The molten metal fuses to form a bond

which is often stronger than the original metals.

Welding intervals are timed in cycles of current; thus, human control is seldom adequate for dependable welding. Electronic timers, described previously, are single-function controls. Because welding requires four timed intervals, four timer circuits are necessary. Each must control a weld function in addition to triggering the next timer. The block diagram in Fig. 2 shows the timing stages, their function in the welding sequence, and the inter-stage triggering network. The four time intervals are *squeeze*, *weld*, *hold* and *off*.

The jaws close during the *squeeze* time and apply pressure to the junction. *Weld* current is applied just long enough to melt the metal around the junction. *Hold* time allows the junction to cool and harden. *Off* time is used only for semi-automatic operation, allowing the oper-

ator to move or change the metal work pieces.

Weld Sequence Timer

The complete circuit of a four-interval timer is shown in Fig. 3. Operation of the individual stages is identical to that of the thyatron timers previously described. Capacitors C1, C2, C3, and C4 charge through the individual cathode-to-grid conduction which take place each time point A goes negative (and point B goes positive).

The weld sequence begins when the foot switch (F.S.) is closed. This action energizes relay 1CR. One set of contacts complete the circuit to the air solenoid, which clamps the welder jaws together. The other set completes the cathode circuit of T1, returning it to point B via 4TD, 5TD, and the foot switch. Capacitor C1 now begins to discharge through resistor R5, reducing the bias on T1 and permitting it to begin conduct-

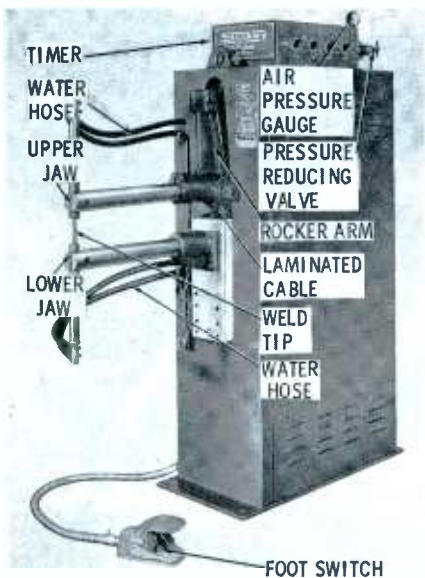

Fig. 1. A commercial rocker arm spot welder with capacity of 30 to 50 KVA.

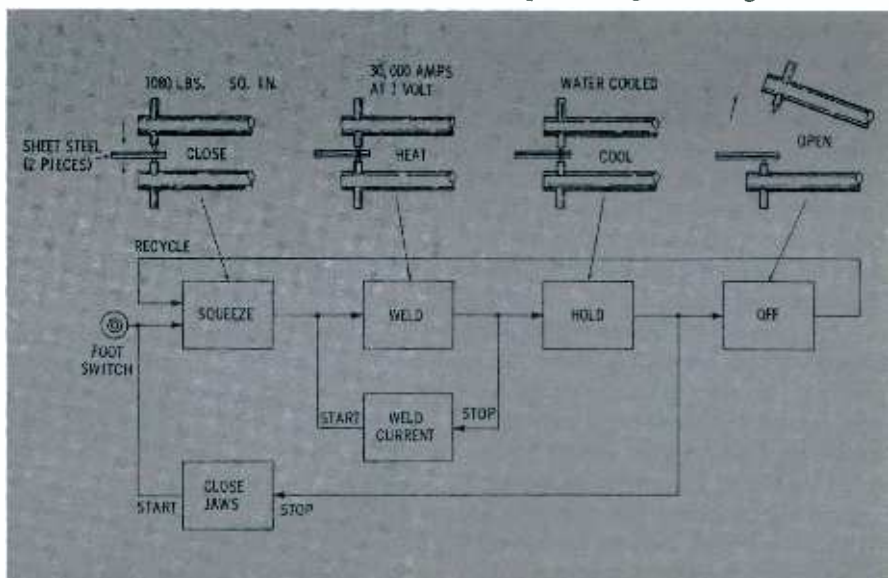

Fig. 2. Block diagram of action sequences and jaw positions for the four timed intervals of a resistance welder.

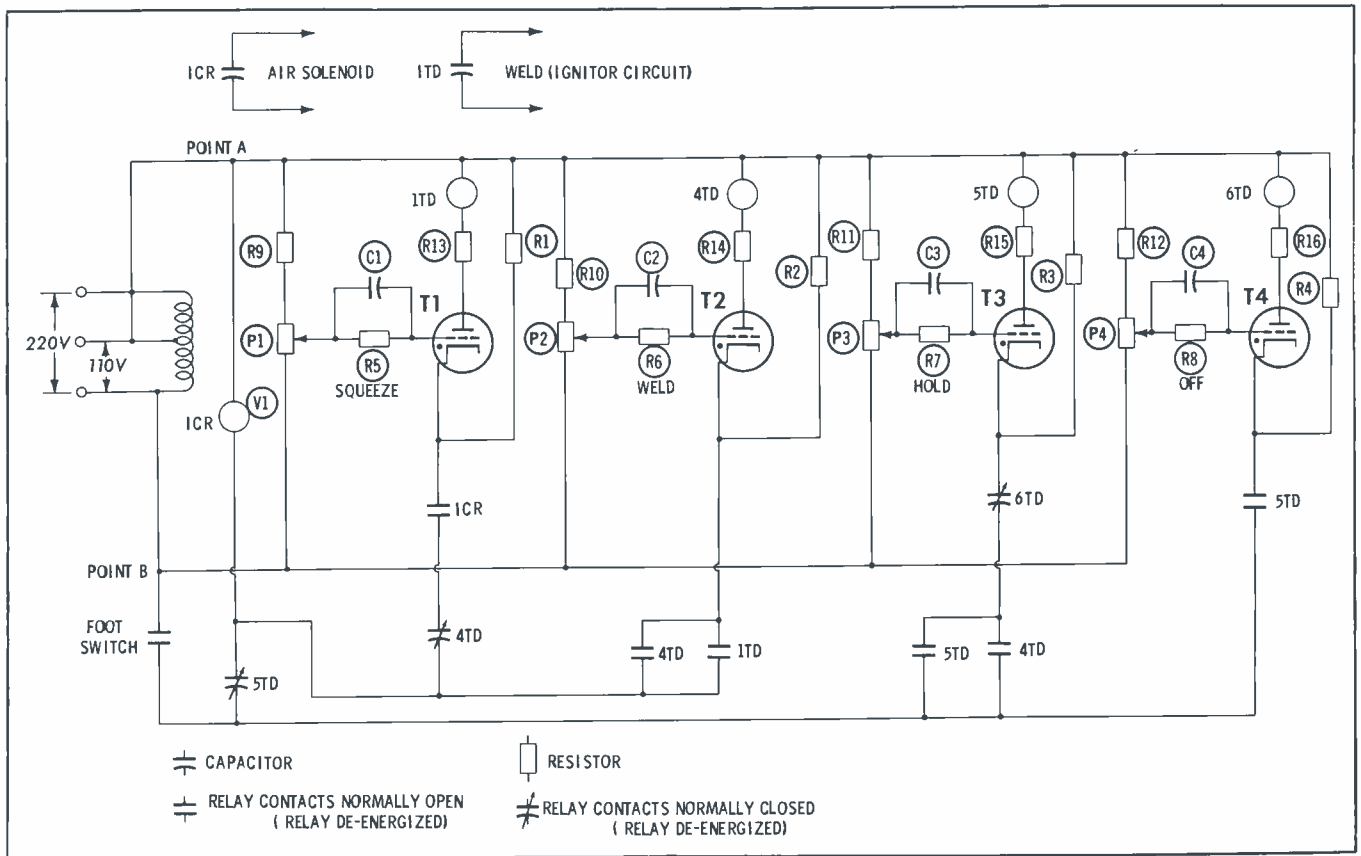

Fig. 3. A four-interval timer using relay contacts for external control and stage-to-stage advance.

for CUSTOM HI-FI installations your best buy is **EICO**

✓ PRAISED BY THE EXPERTS ✓ PRICED RIGHT FOR YOUR PROFIT

✓ LIFETIME GUARANTEE on SERVICE & ADJUSTMENT

EICO FM TUNER HFT90 with precision "eye-tronic" tuning
KIT \$39.95* Wired **\$65.95***
 *Less Cover, FET incl.

EICO Preamplifiers
HF65A KIT \$29.95, Wired **\$44.95**, with power supply:
HF65 KIT \$33.95, Wired **\$49.95**
HF61A KIT \$24.95, Wired **\$37.95** with power supply:
HF61 KIT \$29.95, Wired **\$44.95**

EICO Stereo Preamplifier HF85
KIT \$39.95 Wired **\$64.95**

"(The EICO FM Tuner provides) . . . non-critical tuning, low capture ratio (6db), close-station separation, and insensitivity to drift which are unique among FM tuner kits, to the best of our knowledge . . . one of the best buys you can get in high fidelity kits."
 — **AUDIOCRAFT Kit Report.**

"(The EICO Master Control Preamplifier's) performance rivals that of the most expensive preamps . . . All in all, here is an example of a high level of engineering skill, which has managed to achieve fine performance with simple means and low cost."
 — **Joseph Marshall, AUDIOCRAFT.**

Concerning the EICO 60-watt Power Amplifier: "Listening tests confirmed the fine instrument test results without question. Our HF-60 produced firm, well-defined bass and clear, sweet treble on the finest speaker systems available. It clipped momentary overloads very well and recovered quickly, and this gave listeners the impression of tremendous reserve power. In our opinion, it is one of the best-performing amplifiers extant; it is obviously an excellent buy."
 — **AUDIOCRAFT Kit Report.**

EICO Stereo Amplifier-Preamp HF81
KIT \$69.95 Wired **\$109.95**

EICO 60-Watt Ultra-Linear Power Amplifier HF60 with Acro T0-330 Output Transformer
KIT \$72.95 Wired **\$99.95**

"We believe the EICO HF 52 (50-watt Integrated Amplifier) should prove highly satisfactory for home music systems requiring a 50-watt amplifier. At its price, either in kit form or assembled, it represents an excellent value."
 — **Hirsch-Houck Laboratories.**

"For those who have been looking for a well-engineered yet inexpensive power amplifier, the newly-released EICO Model HF-20 unit might offer a simple solution to their problem. Not only does this unit provide 20 watts of power but the circuit incorporates a pre-amplifier and a variety of controls on a single chassis."
 — **William A. Stocklin, Editor, RADIO & TV NEWS.**

" . . . the EICO Standard (Speaker System) proved able to create a remarkable illusion of realism from all types of program material . . . String tone was reproduced with a smooth, gummy richness . . . Bass transients were well handled . . . never any sensation of two sound sources; the speakers blended faultlessly . . . an eminently musical reproducer . . . the EICO's compactness and dispersion characteristics would suggest unusual suitability for stereo application."
 — **J. Gordon Holt, Technical Editor, HIGH FIDELITY.**

EICO 50-Watt Ultra-Linear Integrated Amplifier HF52
KIT \$69.95 Wired **\$109.95**

EICO 20-Watt Ultra-Linear Integrated Amplifier HF20
KIT \$49.95 Wired **\$79.95**

EICO Standard Speaker System HFS2
 Completely factory built Mahogany or Walnut, **\$139.95** Blonde, **\$144.95**

IN STOCK! at 1900 neighborhood distributors coast to coast.

EICO, 33-00 Northern Blvd. PF-1
 L. I. C. 1, N. Y.

Show me HOW TO SAVE 50% on top-quality equipment checked: HI-FI TEST INSTRUMENTS HAM GEAR
 Send FREE literature and name of neighborhood EICO supplier.

Send for **FREE CATALOG** now

NAME _____
 ADDRESS _____
 CITY _____ ZONE _____ STATE _____

Add 5% in the West

CPFR © 1958, ELECTRONIC INSTR. CO., INC., 33-00 N. BLVD., L. I. C. 1, N. Y.

Save time and effort . . .
simplify your work

Perma-Power

MAGNEFORMER

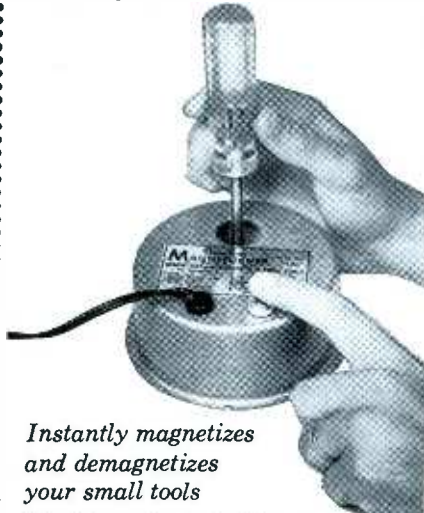

Instantly magnetizes
and demagnetizes
your small tools

Ideal for service technicians, repairmen, engineers, and hobbyists. MAGNEFORMER is indispensable to anyone who works with small parts. With this specially developed device, you can quickly magnetize a screwdriver, hex wrench, or nut runner, easily remove screws and nuts without fear of dropping into inaccessible places. Use it, too, for demagnetizing tools or iron or steel parts. Easy to operate (simple instructions are supplied) and fully guaranteed. You'll wonder how you ever got along without it.

MODEL F-100, LIST PRICE \$7.50

Return full picture height
and width

Perma-Power

300 WATT TV VOLTAGE REGULATOR



You can easily correct picture distortion caused by low or high line voltage. PERMA-POWER TV Voltage Regulator boosts 10 volts, lowers 10 volts, or feeds line through, eliminates intermittent sync and oscillator drift. Simply plug in; turns on and off automatically with set. Reduces tube failures, increases set sensitivity, lets set operate at optimum efficiency. MODEL D-101, LIST PRICE \$6.95

Engineered for quality . . . and fully guaranteed

Perma-Power
COMPANY

3102 N. ELSTON AVE., CHICAGO 18, ILL.

ing. T1 plate current energizes relay solenoid 1TD, closing its contacts to complete the cathode circuit for T2 and initiating the weld interval.

Two sets of contacts close at this time—those which complete the ignitor circuit for weld current, and those which connect the cathode of T2 to point B. C2 then discharges through R6, and T2 conducts. T2 plate current energizes relay 4TD, activating three sets of associated contacts—one set to open the cathode circuit of T1, another set to shunt contacts 1TD which open at this time because T1 stops conducting, and a third set to complete T3's cathode circuit to point B. With T1 non-conductive, relay 1TD de-energizes, which stops the weld current by permitting the ignitor circuit contacts to open.

Since the cathode circuit of T3 is now complete, C3 discharges through R7 and T3 conducts, energizing relay 5TD. This results in the opening of normally-closed contacts 5TD, and de-energization of relay 1CR. Since this opens contacts 1CR, the air solenoid is de-activated and the weld jaws open to free the work.

Simultaneously, two other sets of 5TD contacts close—one shunting contacts 4TD in the T3 cathode circuit, and the other connecting the cathode of T5 to point B. C4 discharges through R8, T4 conducts, and relay 6TD is energized. This causes the 6TD contacts in the cathode circuit of T3 to open, cutting off its plate current and allowing relay 5TD to de-energize. As a result, all stages are returned to their initial state. As long as the foot switch is depressed, the cycle of operation will continue to be repeated. You will note, incidentally, that releasing the foot switch at any

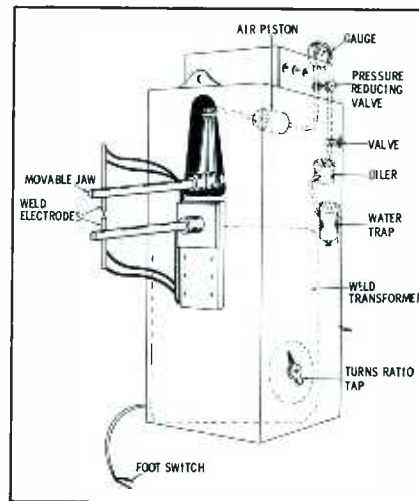

Fig. 4. Welder operated by air pressure; interval timer actuated by foot switch.

time during the cycle will restore the circuits to their initial state.

Duration of each of the four intervals depends on the time constant of the grid capacitor-resistor network and the amount of cathode-to-grid charge current. In Fig. 3, the latter is adjustable. For example, the setting of P1 determines the voltage on the grid of T1. As the arm is moved down, grid current will increase, as will the charge on the grid capacitor. This will naturally increase the time it will take the capacitor to discharge sufficiently for T1 to begin conducting after its cathode circuit is closed.

The Welder

The welder jaws are opened and closed by air pressure. Air passes through a moisture trap, an air-solenoid oiler, and a gauge to the air solenoid as shown in Fig. 4. The air-solenoid valves are moved by an electric solenoid, which is activated with the closing of contacts 1CR. When the solenoid is energized, air passes through the valves to the

SAVE
TIME
with

SENCORE

SENCORE Handy "36"

R C-Substitution Unit

"36"—Most Often Needed Components
at YOUR Fingertips!

3 Pole, 12 position switch individually
selects one of the "36" components
for direct substitution.

Contains:

- ★ 12—1 watt 10% resistors from 10 ohms to 5600 ohms
- ★ 12—½ watt 10% resistors from 10K ohms to 5.6 megohms
- ★ 10—600 volt capacitors from 100-mmfd. to .5 mfd.
- ★ 1—10 mfd., 450V Electrolytic ★ 1—40 mfd., 450V Electrolytic
- ★ For Shop, Lab, or outside service

Service Instruments Corp., 121 Official Road, Addison, Ill.



ONLY
Model H-36 \$12.95
DEALER NET

Completely Isolated
Available at all
Parts Distributors

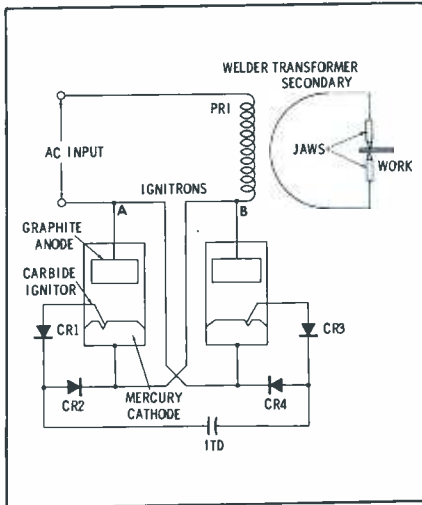

Fig. 5. Two ignitrons connected inverse-parallel provide an AC switching action.

piston. Pressure against the piston moves the rocker arm and closes the jaws. The solenoid is energized at the beginning of squeeze time and de-energized at the end of hold time.

Weld current is controlled by an electronic switch utilizing a pair of ignitrons in the primary circuit of the welder transformer. The secondary current passes through a laminated copper cable to the upper jaw, and through the work to the lower jaw, then back to the secondary. The electronic switch is controlled by the contacts of 1TD.

The ignitrons are cold cathode tubes connected in inverse parallel as shown in Fig. 5. The cathode of one tube connects to the anode of the other so that one will always have a positive anode. The cathodes are pools of mercury which supply ionized mercury gas for heavy conduction arcs. The arc cannot be formed by applying voltage between cathode and anode. The initial arc, therefore, is started by an additional tube element called the ignitor, a small rod of highly refractory material about the shape and size of the pointed end of an ordinary lead pencil. The mercury ionized by this initial arc reduces the resistance between cathode and anode, causing the arc to jump from ignitor to anode. The ignitor in ignitron A (Fig. 5) obtains its starting voltage from the power line through dry-disc rectifiers CR1 and CR4. Ignitor current for tube B passes through CR2 and CR3. The operating resistance between the ignitor and cathode is on the order of 2 to 10 ohms, and an ignitor current of 20 to 30 amps is required to "strike an arc." Thus,

SAVE TIME! SAVE TUBES!

New Vis-U-All

Picture Tube
Reactivator

ends guesswork . . .

"magic eye" tells
when to stop!



Model V200 10" high, 6" wide, 5" deep

Now test and reactivate all types of picture tubes, including 110°, quickly, efficiently, without worry or guesswork. Vis-U-All's exclusive, time-saving, tube-saving "magic eye" shows you tube's reaction to voltage as it's applied, tells you when to stop reactivating to prevent ruining with overdose. And for accurate test of tube, it measures *second* anode beam current. Convenient AC interlock included. Compact, easy-to-carry steel cabinet with instructions inside door.

Only
\$59.95

Slightly higher in West

ASK FOR DEMONSTRATION OF VIS-U-ALL V200 NOW AT YOUR DISTRIBUTOR

- | | | |
|--|--|--|
| <p>ALASKA
FAIRBANKS Polar Electronic Supply Co.</p> <p>ARKANSAS
FORT SMITH Wise Radio & TV Supply, Inc.
LITTLE ROCK Carlton Whise. Radio & TV Supply
TEXARKANA Lavender Radio & TV Supply</p> <p>CALIFORNIA
BURBANK Andrews Electronics
GLENDALE Western Electronic Supply Corp.
INGLEWOOD Cook Electronics
SAN DIEGO Nystrom Brothers Co.
VENTURA Wholesale Electronic Supply</p> <p>CONNECTICUT
NEW LONDON Aikens Electronic Supply
HARTFORD Signal Center, Inc.</p> <p>DELAWARE
WILMINGTON Wholesale Electronics, Inc.</p> <p>FLORIDA
HIALEAH Sanders Electronics Co.</p> <p>ILLINOIS
CHICAGO Howard Electronic Sales
The Lukko Sales Corp.
Radio Parts Company
OAK PARK Melvin Electronics, Inc.
SPRINGFIELD Wilson Electronics Supply Co.
WAUKEGAN Waukegan Radio Supply</p> <p>INDIANA
ELKHART Warren Radio Company
EVANSVILLE Hutch & Son, Inc.
HAMMOND Broadwin TV & Radio Co.
INDIANAPOLIS Brown Distr., Inc.
Electronic Distr., Inc.</p> <p>IOWA
CEDAR RAPIDS Iowa Radio Supply Company
DES MOINES Radio Trade Supply Co.</p> <p>KENTUCKY
HOPKINSVILLE Randolph & Hale, Inc.
LOUISVILLE Arcoy Electronics, Inc.
PADUCAH Warren Radio Co.</p> <p>LOUISIANA
NEW ORLEANS Lee's Electronic Supply
SHREVEPORT Lavender Radio & TV Supply, Inc.</p> | <p>MARYLAND
BALTIMORE Eastern Electronic Supply Co.
Radio Electric Service Co.
Revacto of Maryland, Inc.</p> <p>MASSACHUSETTS
WEST PEABODY Aladdin Electronic Supply, Inc.
NEW BEDFORD Burns Electronic Supply Co.
ALLSTON CRT Electronic Supply
MEDFORD Durrell Distributors
LYNN Des Roberts Elect. Supply
WALTHAM Linear Electronic Co.
QUINCY Pilgrim Electronic Supply
JAMAICA PLAIN Tee-Vee Supply Co.
LAWRENCE Young & Young
BOSTON Arvedon Distr., Inc.
Louis M. Herman Co., Inc.
O'Donnell Electronic Supply Co.</p> <p>MICHIGAN
BATTLE CREEK Warren Radio Co.
DETROIT Rissi Electronic Supply Co.
GRAND RAPIDS Radio Electronic Supply Co.
Warren Radio Co.
JACKSON Matteson Electronics
KALAMAZOO Warren Radio Co.
LANSING Offenbauer Company
MUSKEGON Electronic Distr., Inc.</p> <p>MINNESOTA
DULUTH Lew Bonn Co.
MANKATO Lew Bonn Co.
MINNEAPOLIS Lew Bonn Co.
ST. PAUL Lew Bonn Co.</p> <p>NEW JERSEY
NEW BRUNSWICK Bay Electronic Distr.
ELIZABETH Leader Electronics
SOMERVILLE Masters T.V. Supply Co.</p> <p>NEW YORK
NEW YORK 53 Bay Electronic Distr.
BROOKLYN Bay Electronic Distr.
T.V. Parts, Inc.
FLUSHING Bay Electronic Distr.
HICKSVILLE, L.I. Bay Electronic Distr.</p> <p>NORTH DAKOTA
FARGO Lew Bonn Co.</p> <p>OHIO
AKRON Warren Radio Co.
CANTON Burroughs Radio, Inc.
CINCINNATI Warren Radio Co.
CLEVELAND Warren Radio Co.
COLUMBUS Ace Radio Supply Co.
DAYTON Srepeco, Inc.
Stotts-Friedman Co.
LANCASTER Blatzacker Electronics, Inc.</p> | <p>LIMA Hutch & Son
MANSFIELD Wholesaling, Inc.
SPRINGFIELD Eberl's Radio Supply
TOLEDO Warren Radio Co.
ZANESVILLE Thompson Radio Supplies</p> <p>OKLAHOMA
OKLAHOMA CITY Johnson Wholesale Electronics
TULSA S & S Radio Supply</p> <p>PENNSYLVANIA
ELKINS PARK A. G. Radio Parts Co.
HARRISBURG D & H Distr. Co., Inc.
Electronic Wholesalers, Inc.
LANCASTER George D. Barbey Co., Inc.
LEBANON George D. Barbey Co., Inc.
PHILADELPHIA Radio Electric Service Co.
Raymond Rosen & Co., Inc.
POTTSTOWN George D. Barbey Co., Inc.
POTTSVILLE Schuykill Elect. Distr., Inc.
READING George D. Barbey Co., Inc.
WILKES BARRE Shelbourne Electronics, Inc.</p> <p>RHODE ISLAND
PROVIDENCE C. E. Paul Co.
Rimaco Sales Co.
Zetka Distr. of R.I.</p> <p>SOUTH CAROLINA
COLUMBIA Dixie Radio Supply</p> <p>TENNESSEE
MEMPHIS Lavender Radio & TV Supply, Inc.
NASHVILLE Electra Distr. Co.</p> <p>TEXAS
AMARILLO R & R Electronic Co.
AUSTIN Electronic Headquarters
DALLAS Adleta Co.
FORT WORTH Byron's Radio & TV Supply
Univ. Electronic Supply Co., Inc.
HOUSTON Applebaum & Co.
SAN ANTONIO Modern Electronics Co.
SHERMAN Lavender Radio & TV Supply, Inc.
TYLER Lavender Radio & TV Supply, Inc.
VICTORIA Lavender Radio & TV Supply, Inc.
WACO Best Electronics
WICHITA FALLS R & R Electronic Supply</p> <p>WISCONSIN
LA CROSSE Lew Bonn Co.</p> |
|--|--|--|

If your distributor is not listed, please have him write to us.

VIS-U-ALL PRODUCTS COMPANY 303 Fuller Ave., N.E.
Grand Rapids, Mich.

the voltage applied to the ignitor must be on the order of 60 to 300 volts; a typical case would be 30 amps at 200 volts.

The ignitor stops conducting as soon as the anode of tube B picks up the arc, because the voltage drop between the cathode and the anode of a conducting ignitron is 8 volts and the ignitor obtains its voltage from the anode side of the line. This drop is less than required to sustain forward conduction through the dry-disc rectifiers; therefore, following anode conduction, the ignitor circuit

is opened by the rectifiers.

The ignitron sustains conduction while the anode is positive, but with AC applied, the tube will de-ionize after every half cycle of conduction. The ignitor must reform the arc for each cycle; thus, ignitrons are controlled by opening or closing the ignitor circuit. The switching action is complete when two ignitrons are connected in inverse parallel. Half of the applied AC current will pass through one ignitron and half through the other.

Even though the voltage drop

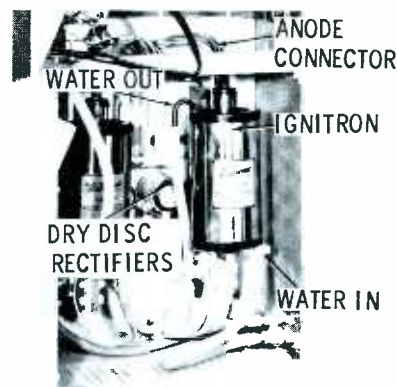

Fig. 6. Ignitrons housed in cabinet prevent shock hazard during operation.

across an ignitron is low, there is considerable power loss. Consider, for example, that with a 10 volt drop and a current flow of 100 amps (not unusual), the power loss is 1KVA or about a thousand watts. The resulting heat must be dissipated rapidly to prevent damage to the tube. Water is the coolant most often used, and the ignitron is built with a double wall for its convenient circulation.

The photo in Fig. 6 shows ignitrons mounted in a cabinet. Water flows through the two ignitrons in series, entering at the bottom of the tube jacket and leaving from the top. The tubes are bolted in place on their cathode connectors, and the dry-disc rectifiers are mounted between the tubes.

A view of the cathode connectors and copper-oxide ignitor diodes for another welder is shown in Fig. 7. The vertically-mounted metal bars provide support for the ignitrons in addition to providing conductive paths for cathode and anode currents. The ignitor circuit is fused to prevent damage to the ignitors in case arc transfer to the anode doesn't take place. The fuse holders are mounted just below the ignitor diodes.

Timer Repair

Timer servicing is usually very simple; one of the four timed operations becomes erratic or ceases to function. When the defective section is isolated, voltage and resistance measurements lead to the defective component. As an example, one timer failed to stop the *hold* time—the jaws remained closed until the operator opened the foot switch. Thyratrons indicate conduction by a

SAVE TIME with

SENCORE

See other SENCORE ads in this issue.

Service Instruments Corp. 121 Official Rd. • Addison, Ill.

New!

SENCORE Electro-Sub

Check all **ELECTROLYTIC CAPACITORS** in Seconds!

Model ES-102

ONLY **\$15.95** DEALER NET

Less than you pay for the most popular capacitors

Carry it anywhere — measures only 4 1/4" H x 4 1/4" W x 2 1/4" D

Simply select the electrolytic and substitute it. 10 big electrolytics from 4 to 350 Mfd. to safely substitute in any circuit from 2 to 450 volts.

- ... COMPLETELY SAFE—no arc or spark when connecting or disconnecting.
- ... AUTOMATIC CAPACITOR DISCHARGE—within seconds after releasing test switch by, unique surge protector circuit.
- ... NO CAPACITOR HEALING—surge protector circuit prevents accidental healing of capacitor being "bridged" in service work.



you'll find the right PA product faster in the

'59 MASTER

Complete descriptions, illustrations, prices for more profitable TV-radio-audio-industrial servicing. You can buy, sell and bill direct from the MASTER—world's largest electronic catalog at your jobber . . . only **\$3.50**. \$4.50 In Canada

FREE — 24-page **PANEL LAMP CHART** at your jobber, or send 10c to:

THE RADIO-ELECTRONIC MASTER
65 Sewell Street • Hempstead, N.Y.



"He was *not* trying to steal your new JENSEN CARTRIDGE. He was just *admiring* it."

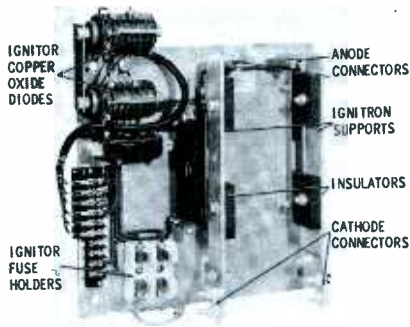

Fig. 7. Ignitron supports are heavy copper bars which also serve as conductors.

bluish glow inside the tube; close inspection revealed that one tube never conducted.

An on-the-spot test was performed by switching the *hold* tube with the *squeeze* tube. The suspected tube operated normally in the squeeze stage, so the trouble had to be in the hold circuit. A check of the normally-open set of cathode contacts indicated that they closed when the tube in the preceding stage conducted. Deciding to check the grid voltage for value and decay, a voltmeter was connected into the circuit. A normal negative voltage was indicated, decaying as it should because of grid-capacitor discharge. Then, the tube conducted. Removing the voltmeter caused the trouble to reappear on the next time-interval sequence. The voltmeter had completed the discharge path for the capacitor, and an ohmmeter check revealed that the resistor shunting the capacitor was open.

Additional Time Intervals

In addition to the time intervals described, weld time may include a low-current preheating time and a controlled low-current cooling time. When thick parts are to be welded, a single high-current weld time can melt the work around the jaw-to-metal junction because of the high

resistance introduced by surface contamination. Also, if cooling of thicker metals is too rapid, they tend to buckle. Surface damage is prevented by using three timed sub-intervals during the weld period. First, a gradual increase in weld current burns oxides, oils and dirt from the jaw-contact surface and forms a low resistance contact. Then, a full-current weld time fuses the metals. Finally, a gradual decrease in weld current controls cooling, and prevents cracking or warping. ▲

latest JACKSON tube test data

MODEL 648		MODEL 115/715/561				
TUBE TYPE	PLATE TEST	FIL. X. PLATE	YZ			
6EU8	489 32YZ	5.0	19 9LR			
6AF3	6 13W	6.3	3 18 7S			
6EU8	489 32YZ	6.3	37 2JFS			
21EX6	128 A35 18YZ	25.	19 9LR			
21EX6	124 A8369 14W	25.	8 8MPS			
TUBE TYPE	SEC. A.	B.	C.	D.	E.	CATH. SHORTS
6EU8	5.0	4	X	179	8	32
6AF3	5.0	4	X	23	6	30
6EU8	6.3	4	2	9	0	5
21EX6	6.3	4	X	179	8	32
21EX6	6.3	4	X	23	6	30
21EX6	P 25.	2	-	580	3	4

Latest Chart Form 648-20, 115/715/561-10, 49-4

THE MAXIMUM ANTENNA FOR ALL AREAS!

RMS WAVEBOOSTER 1000 SERIES ANTENNAS

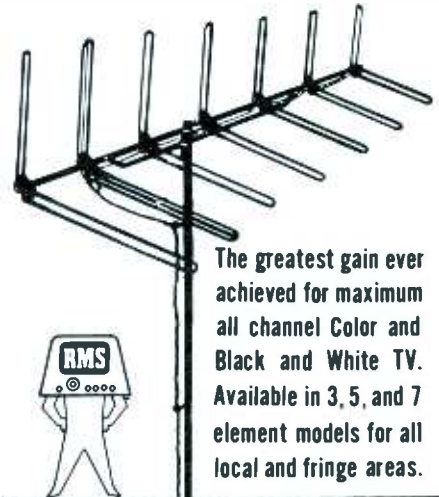

The greatest gain ever achieved for maximum all channel Color and Black and White TV. Available in 3, 5, and 7 element models for all local and fringe areas.

Licensed under United States Pat. Nos. 2,691,730 and 2,817,085 and 2,821,711 of Channel Master Corp.

MAXIMUM CONSTRUCTION



New bridged stress proof Super high impact Styrene Plastic insulators. Extra reinforced sleeved elements.

for complete details and free catalog write to

Radio Merchandise Sales Inc
New York 62, N. Y.

The Ultimate IN VENT PIPE-TV ANTENNA MOUNTING CLAMPS!

CLAMP-IT # 32

- ✓ A single clamp does it
- ✓ No guy wires necessary
- ✓ Only 1 tightening tool needed
- ✓ Square hole; ONLY nut turns
- ✓ No nail holes thru roof
- ✓ Installs in few seconds
- ✓ Pays profits in time saved

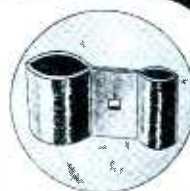

Square Hole Provides 1-hand operation



MODEL "S" Heavy 12 gauge cad plate boiler plated steel \$1

Dealers & Distributors Being Added
Dealers: The serviceman's choice—Quantity prices on request
ORDER SEVERAL • Postage Paid • SEND CHECK OR MONEY ORDER

I. T. INDUSTRIES

CLAMP-IT Division
9623 Rush St. Box 3252
El Monte 1, California



**Now YOU can get
TUNERS
repaired, or replaced,
in a hurry!
Send them to TARZIAN!**

● Sarkes Tarzian, Inc., announces a new tuner repair service and factory replacement program for Tarzian-manufactured tuners. Distributors, dealers and servicemen will welcome this direct factory service program which is designed to take delay and confusion out of the tuner repair business.

We're set up to offer a 48 hour service from the date of receipt to shipment to you.

Cost is reasonable, too. Only \$7.50 per unit (\$15 for UV combinations) and that includes ALL replacement parts! Both repaired—or exchange units if available from stock—carry a 90 day warranty against defective workmanship and part failure.

Replacements will be offered at these current prices* on units not repairable:

- VHF 12 position tuner . . . \$17.50
- VHF 13 or 16 position tuner 19.50
- VHF/UHF combination 25.00
- UHF only 15.50

*Subject to change

When inquiring about tuner service, always refer to tuner by part number. When inquiring about direct replacements for tuners other than Sarkes Tarzian-manufactured, please indicate tube complement, shaft length, filament voltage, series or shunt heater. Use this address for quickest service:

SARKES TARZIAN, Inc.

Att: Service Mgr., Tuner Division
East Hillside Drive
Bloomington, Indiana



TARZIAN Electronic Product and Services Include TELEVISION TUNERS . . . SELENIUM AND SILICON RECTIFIERS . . . BROADCAST EQUIPMENT . . . AIR TRIMMERS . . . TV STATIONS WTTV and WPTA, and RADIO STATION WTTs.

Sync Circuit Troubles

(Continued from page 25)

possibility of noise interference. With grid-leak bias and relatively low plate voltage, the second stage accomplishes separation by saturation limiting.

The final stage, V3, not only amplifies the sync signals but helps shape them for application to the two oscillator control circuits. Resistors R15 and R16 form a split plate load, and C6 couples sync to the horizontal AFC stage. Resistor R17 reduces the sync signal applied to the vertical integrator network and also isolates the two circuits to minimize double-triggering.

Many sync circuits do not depend entirely on self-bias, but are connected in some manner to the AGC system. Such is the case in our example of Fig. 2, where grid bias for the AGC keyer tube is obtained from the plate circuit of the sync amplifier. In other instances, you might find a sync stage obtaining bias from an AGC network. Regardless of the tie-in, remember that a fault in one may affect operation of the other.

Waveforms

Accompanying the schematic in Fig. 2 are signal waveforms keyed to various points in the circuit. Each signal is reproduced at sweep rates of both 30 and 7,875 cps, thus displaying two vertical and two horizontal pulses. The patterns are typical of those found in any sync system except, of course, for their amplitudes.

Since shape and amplitude of signals are both important for proper operation of the system, you should have a means for measuring peak-to-peak amplitude. A more detailed discussion on this subject appears in *Scope - Waveform Calibration*, PF REPORTER—December, 1957).

Voltages

Voltage measurements in the sync section will definitely help to isolate the troublesome stage or component. Voltage readings in Fig. 2 were taken under normal operating conditions with a VTVM.

When using service information to compare voltage readings with those in a suspected circuit, remember that several hidden factors must be con-

sidered. For example, applied signal strength, line voltage, and the accuracy of your instrument all have a bearing on voltage readings. A more thorough analysis of these and other factors can be found in an article entitled *Voltage Measurements* PF REPORTER—October, 1956).

Loss of Sync

When a sync section is not functioning properly, symptoms may vary from a slight horizontal bending or occasional flopping to a complete loss of both vertical and horizontal sync. And, although the sync stages may be responsible for both vertical and horizontal frequency control, one frequency may be affected more than the other. With these thoughts in mind, let's proceed with defective component analyses.

Suppose that neither the vertical or horizontal will lock in (Fig. 3). In this case, the picture seemingly floats across the screen in any direction. Naturally, a number of component faults can cause this condition, but let's assume that it's some component in the sync section which is not necessarily prone to breakdown. One such component is the plate-load resistor R6 in Fig. 2. If this component increases to 10 times its normal value, both vertical and horizontal sync will become unstable. Under these conditions, the plate voltage of V1 may not change appreciably, but the grid voltage will become more negative. Waveform W2 may take on the appearance of that shown in Fig. 4, becoming distorted and having only 1/10 of its normal amplitude.

Complete loss of sync will also be experienced when plate-load resistor R12 opens or increases in value. In this case, V2 plate voltage will decrease or even become slightly negative, while the grid of V3 will become slightly positive. Also, output waveform W4 will appreciably decrease in amplitude and will contain an additional negative-going pulse as shown in Fig. 5.

If resistor R15 opens or increases to a very high value, loss of vertical and horizontal sync will also result. The DC voltage reading on the plate of V3 may even become negative by as much as 125 volts, with a corresponding grid-voltage increase of 4 or 5 volts in the positive direc-

tion. The signal waveforms at the grid and plate of V3 will also decrease in amplitude.

Low-frequency modulation due to heater-to-cathode leakage in one of the tubes, or insufficient power-supply filtering, can also cause loss of both vertical and horizontal sync. About the quickest way to spot this difficulty is to look for 60- or 120-cycle ripple in the signal. The waveform of Fig. 6 is a typical example of 60-cycle distortion. Note the difference in height of the two sync pulses. With heater-to-cathode leakage in V1, a certain amount of 60-cycle signal may appear on the grid of the tube. This in turn often causes a related brightness modulation to show up on the picture tube screen.

Critical Sync

Because it is not as definite a trouble as complete loss of sync, critical lock-in is more difficult to correct. This fault, when originating in the sync section, is often the result of a leaky coupling capacitor such as C4. A decrease in the plate voltage of V2 should lead you to suspect this capacitor of being defective. Decrease in the peak-to-peak value of plate waveform W4 is another tell-tale sign.

This same symptom occurs when the value of grid resistor R14 decreases considerably. When troubleshooting for this defect, you'll generally find that the grid voltage of V3 will change to a slightly positive value, while its plate voltage will remain about normal. The plate potential of V2, however, may drop as much as 10 volts. Depending upon signal conditions, you might remember that a little increase in value of R6 can also cause critical sync action.

Vertical Roll

The trouble symptom pictured in Fig. 7 represents a loss of vertical sync, often referred to as roll or flop-over. There are a few components in the circuit of Fig. 2 that tend to affect vertical synchronization more than horizontal. One in particular is coupling capacitor C1, located in the grid circuit of the sync amplifier.

If this capacitor develops leakage, the grid voltage of V2 will be less negative. The normal amplitude of the grid signal is approximately 5

"FELLAS—THERE'S GOLD IN THESE

C-D TWIN TREASURE CHESTS"

- **FILLED WITH C-D CAPACITORS**
the finest you can use to establish customer confidence.
- **FASTER CAPACITOR TURNOVER**
because you'll always have the fast movers on hand.
- **SPEEDS UP YOUR WORK**
because replacements are easy to identify, always handy.
- **HANDSOME METAL CABINETS**
make shop neater, prevent misplaced pieces.



SUGGESTED CONTENTS:

TWIST-PRONG SECTION CONTAINS 12 popular C-D "Preferred Type" Twist-Prongs (and room for 6 more)

TUBULAR SECTION CONTAINS 16 popular C-D "Blue Beaver" Tubular Electrolytics

73 PM Mylar Tubulars

BOTH CABINETS ARE FREE. YOU PAY ONLY FOR THE PREFERRED C-D CAPACITORS.

YOUR COST: \$49.95

See C-D's "Treasure Chests" at your Cornell-Dubilier distributor or write to Cornell-Dubilier Electric Corporation, South Plainfield, N. J., Department PF1



Consistently **CORNELL-DUBILIER** Dependable
SERVICE CAPACITORS



The Greater Vibrator

Radiart Vibrators are unaffected by bounce, jounce, heat, cold, moisture. There's a replacement type for every 6- and 12-volt application. Ask your Radiart Distributor for a free Radiart Vibrator Replacement Guide or write The Radiart Corporation, 2900 Columbia Avenue, Indianapolis 5, Indiana.



RADIART
TOBE
Vibrators

volts peak-to-peak; however, with C1 leaky, it may decrease by as much as 50%. A certain amount of leakage in capacitor C4 can also produce the trouble.

If plate resistor R12 doubles in value, this too will cause vertical roll. Other symptoms pointing to such a defect would include at least a 50% reduction in plate voltage for V2, plus a slightly positive reading on the grid of V3. Peak values of V3 grid and plate signals would decrease by a third or more.

Vertical Jitter

Closely associated with loss of vertical sync is a symptom known as vertical jitter or bounce. Although the cause of this trouble will usually be found in the integrator or vertical-oscillator sections, there is at least one component in Fig. 2 that will produce this effect.

When plate-load resistor R15 increases to about 1 megohm, the picture tends to bounce and horizontal hold becomes somewhat critical. DC voltage on the plate of V3 will measure about -2 volts, while its grid will have a reading of -1.5 volts. The resulting lack of sync output causes a double-triggering of the oscillator, which in turn produces the jitter.

Loss of Horizontal Sync

The most common cause for loss of horizontal sync with little change in vertical stability is a leaky coupling capacitor to the horizontal AFC stage. The symptom may appear as that pictured in Fig. 8, or, with the oscillator way off frequency, as a maze of horizontal lines.

If capacitor C6 in Fig. 2 develops leakage, plate and grid voltages of V3 remain relatively normal, but the AFC signal (output of C6) will change in appearance. A normal signal at this point should conform to the waveform in Fig. 9A. With C6 leaky and the oscillator out of sync, it will appear more like that shown in Fig. 9B. Although the amplitude is about the same, the signal will lack the normal sine-wave component. If this fault occurs, the quickest method to remove doubt is to substitute for C6. You must check, however, to see if the capacitor has any special characteristics when making a permanent replacement.

Picture Bending

The symptom represented in the test pattern of Fig. 10 is horizontal bending or pulling near the top of the picture. When this trouble stems from a defective component in the sync section, it may also cause the picture to wave, or to produce a phasing ghost on the screen.

If plate-load resistor R6 increases to about three times its coded value, the picture will have a tendency to pull horizontally. In this case, the grid voltage on V2 will usually drop, but the plate potential of V1 will show little variation from normal.

Failure of capacitor C4 is another possible cause for this particular symptom. A slight amount of leakage in this component will often cause picture wobble. Further evidence that it is defective is loss of sync-output amplitude and a reduction in V2 plate voltage. Also check for heater-to-cathode leakage in the tubes.

Sync and AGC

Aside from merely affecting the frequency of the sweep oscillators, a defective sync section can also produce peculiar symptoms that would normally point to trouble in the AGC system. For example, if cathode resistor R4 should increase in value or open, V1 would cease to conduct, grid voltage would become zero, and plate potential would increase. Since the AGC system is tied to the plate circuit of V1, bias to the keyer tube would be upset, possibly resulting in no picture or sound.

This same condition might occur if the value of R6 or R7 should change. In some cases, however, you'll find picture and sound can be restored by merely adjusting the AGC control. In other instances, the symptom may appear as a loss of both horizontal and vertical sync accompanied by a negative picture. A typical example of this trouble is pictured in Fig. 11. In many receivers, a shorted or leaky capacitor between the AGC and sync systems will also produce a distorted picture with buzz in the sound.

Although this discussion of sync troubles and their causes involves only one particular circuit design, you'll find the basic approach to isolating faults in other designs is pretty much the same. ▲



America's Fastest-Growing Service Capacitor Line...



NEW!

TOBE MYLAR* MOLDED TUBULAR CAPACITORS

- *Molded of DuPont Mylar*, one of the finest insulation materials ever developed.
- *Thermoset Case Construction* secures leads and sections firmly to withstand extremes of handling, vibration, shock and soldering temperatures.
- *High Insulation Resistance*: Average megohm values per unit 10,000 at 25°C. Small capacitance variation with thermal change.
- *Temperature Operating Range*: -55° to +130°C.
- *Moisture Resistant*: Exceeds JAN-C-91 requirements.
- *Non-Inductive*: Extended foil construction insures low resistance connections and low RF impedance.

DESIGNED FOR SERVICE DEALERS



NEW TOBE MYLAR* CAPACITOR KIT

FREE KIT CONTAINS
80 CAPACITORS

ONLY

\$15⁸⁴

*Today, order
your Tobe Mylar
Kit from your
Tobe Distributor*

Compact, clear-plastic dispenser contains an assortment of 80 Tobe Mylar capacitors in the most popular sizes, ratings and quantities for quick, efficient servicing. Covers over 60 different ratings at 200, 400 and 600 working volts and from .0001 to 1.00 mfd. Dealer pays only for the Tobe Mylar capacitors, kit is free.



TOBE RADIART CAPACITORS

Shop Talk

(Continued from page 20)

voltage values which will undoubtedly be found in commercial designs of transistorized television sets, it will be helpful to have a low-voltage power supply available for servicing. Since battery voltage used in transistor sets seldom exceed 22½ volts, the power supply need not provide higher voltages. Current requirements would probably extend to one ampere. The voltage output of this supply should be variable and the unit should preferably be equipped with a front-panel meter to indicate

the exact output voltage. Then, when the batteries in a unit are suspected of being weak or dead, the power supply can be substituted for a quick check. In selecting a power supply for testing purposes, make certain that the output is extremely well-filtered. Because of the low DC voltage values required by a transistor circuit, even minute amounts of AC ripple can produce annoying symptoms. Excessive ripple can even damage some components in the receiver.

One of the first things to check when the raster is missing is the out-

put of the high-voltage rectifier. If the horizontal system were inoperative, high voltage would not develop and the picture-tube screen would be completely blank. On the other hand, vertical system troubles will not necessarily affect the horizontal system—as long as the latter continues to function, a thin horizontal stripe should appear on the screen. This, too, is conventional.

Voltage measurements can be made in the various circuits just as in conventional receivers. The first place to check, of course, is at the power supply or battery. Then the various circuit voltages can be checked, although in some instances the readings may not lead to any clear-cut decisions due to the extremely low voltages frequently employed. In these cases, some alternate approach, such as signal tracing, must be employed. AGC voltage is a good suspect if the signal is weak or distorted, or if overloading tends to occur. In this respect, it is interesting to note that a vacuum-tube voltmeter is not required to measure the AGC voltage. A 20,000-ohm-per volt VOM is adequate because most transistor circuits have fairly low impedances, at least between base and emitter.

Some circuits—like video amplifiers, tubes, and the deflection amplifiers—usually involve the use of fairly high voltages; these can be readily checked with conventional equipment. In the Texas Instruments receiver, diode rectifiers in various parts of the horizontal output circuit develop DC voltages utilized by the video amplifier focus anode, accelerating anode and control grid of the picture tube (see Fig. 2). These diodes should be checked if any of the associated circuits are not operating normally.

Waveform checks of transistor circuits can be made just as readily as for conventional circuits. By observing the shapes and measuring the peak-to-peak amplitudes of waveform patterns, we can tell how well each circuit is functioning. The impedance in most transistor circuits is low enough that the scope will have no visible effect, and the scope probe can be moved from point to point without disturbing the circuit. In the few places where impedance is high, the scope will not cause any more disturbance than it will in

SAVE TIME with

SENCORE

New! Improved!

TRANSISTOR CHECKER

America's newest, most popular test instrument

Simple to Operate. Controls are accurately set for each transistor by referring to replaceable set-up chart on rear. Test leads or socket provides for fast hook-up.



MODEL TRC4

\$17.95

DEALER NET

Cannot become obsolete. Approved by leading manufacturers.

NOW CHECKS:

- ★ **Transistors** for opens, shorts, leakage and current gain. Only tester that tests power transistors as used in car radio outputs.
- ★ **Crystal Diodes** checks forward to reverse current ratio on all diodes.
- ★ **Selenium Rectifiers** checks forward and reverse currents.

Service Instruments Corp., 121 Official Rd., Addison, Ill.

See other SENCORE ads in this issue.

Dave Rice's

OFFICIAL ORDER BOOK

for every TV-Radio service call

CONVENIENT! EASY TO USE!

Simplify your record-keeping with these convenient triplicate forms. They serve as order form, invoice and office record, with spaces for complete information on every job. Separate listings for receiving tubes, picture tubes, parts, serial numbers, labor and tax charges, etc. 75c a book, \$6.50 for money-saving dust-proof box of 10.



OFFICIAL ORDER BOOK

Dave Rice's Official Pricing Digest

Shows flat-rate and hourly service charges based on regional and national averages, plus up-to-date list or resale prices on over 63,000 components. \$2.50 per copy.

In stock at your distributor

ELECTRONIC PUBLISHING CO. INC.

180 North Wacker Drive Chicago 6, Illinois

SUBSTITUTE PARTS WITH-OUT SOLDERING

Quickly with *Easily*

Has 1001 Uses!

NEW E-Z-Hook "SUB" Connectors

Connect a speaker, or

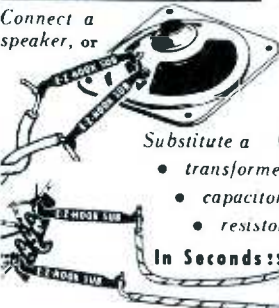

Substitute a

- transformer
- capacitor
- resistor, or *hook*

In Seconds!!

- ★ Makes connections instantly!
- ★ Won't pull off!
- ★ Insures positive contact!

Saves time, money and parts in servicing, experimenting, instructing and production.

E-Z-HOOK SUB

No. 71-1...SUB...Only 69¢ ea.

Six Colors! - for Easy Lead Identification



ORDER THROUGH YOUR PARTS DISTRIBUTOR

E-Z-HOOK TEST PRODUCTS

Dept. F, 1536 Woodburn Ave. Covington, Ky.

comparable vacuum-tube circuits. All in all, the oscilloscope will prove to be one of the most valuable test instruments the technician can use to track down troubles in a transistorized receiver.

Point-to-point resistance measurements can be employed to search for open or short circuits, or to discover a resistor that has changed value appreciably. Either VOM's or VTVM's can be used to perform such measurements; however, there is an important precaution to observe in the use of an ohmmeter. If the meter leads are applied to the circuit in such polarity as to cause the meter battery to place a forward bias on the transistor, it is possible not only to obtain an incorrect reading, but also to pass damaging current through the transistor.

To see how this can occur, consider the partial input circuit shown in Fig. 3. Let's assume that all power in the circuit has been turned off and that we wish to check the resistance of R2. Depending on which ohmmeter lead we connect to the top end of R2, the value indicated by the ohmmeter will be either zero or 15K ohms (assuming the resistor to be good). The reason for this behavior stems from the nature of transistors and the manner in which ohmmeters operate. An ohmmeter applies a voltage across the resistance to be measured, and the resistance value is determined from the resulting current flow. Suppose that the output voltage of the ohmmeter battery is three volts, a fairly common value. Now, if the positive ohmmeter lead goes to the top of R2 and the negative lead to the bottom, the meter will indicate very nearly the true value of R2 because the base-emitter circuit of the transistor is reverse-biased, i.e., a positive voltage is being applied to an N-type base while a negative voltage is going to a P-type emitter. (It reaches the emitter through the ground connection.

It should be readily apparent that, if we reverse the ohmmeter leads, the negative voltage will be applied to the base and the positive voltage to the emitter. This will forward-bias the unit and thus reduce the impedance of the base-emitter junction to an extremely low value. Since this junction is effectively shunted across R2, the measured value of total re-

sistance will be quite small. (While it was indicated above that the value obtained under these conditions would be zero, this is not exactly true. Actually, under the conditions specified, it might be on the order of 100 ohms or less; but, with the ohmmeter set to read 15K ohms, the lower reading would appear to be quite close to zero on most conventional ohmmeters.)

Another possible side effect of the second reading is damage to the transistor because of excessive current flow. To avoid this, the transistor should be removed prior to

such measurements, or care should be taken to see that the proper ohmmeter polarity is observed.

What has been stated for resistance measurements in the emitter circuits is just as true in the collector circuits. Remember that a forward-biased base-collector junction has practically the same low impedance as a forward-biased emitter-base junction. For guidance in avoiding forward bias on either of these two junctions, keep in mind the rules given in Chart I. If the polarity of the ohmmeter leads is not known, it can be determined

DESIGNED FOR THE NEW BUSINESS RADIO SERVICE



COMCO'S ALL NEW "580 FLEETCOM" VHF-FM MOBILE RADIO

The new "580" is compact, light weight, has high performance, and features an original concept in Mobile equipment packaging by combining the control head, speaker, and transistorized power supply in one small easily mounted case assembly.

\$398 f.o.b. factory

FEATURES

- ★ HIGH PERFORMANCE... meets "split channel" technical requirements, all FCC and FCDA requirements.
- ★ FULL POWER OUTPUT... 35 Watts in 25-50 Mcs. 25 Watts in 144-174 Mcs.
- ★ BUILT-IN RELIABILITY... Preproduction Models field tested in 5 states and 3 foreign countries before starting production.
- ★ SMALL AND LIGHT WEIGHT... Chassis in case 13"x9³/₁₆"x5¹/₂". Control-power Supply-Speaker case 5"x5"x3³/₁₆". Complete Mobile installations 24 lbs.
- ★ EASY TO INSTALL... "Two-unit" package so small most installations are under dash.
- ★ EFFICIENT... Transistor power supply gives high efficiency. Total standby drain 5.25 amp.
- ★ INTERCHANGEABLE CHASSIS... Mobile transmitter-receiver chassis instantly interchangeable with base stations in simplex systems.

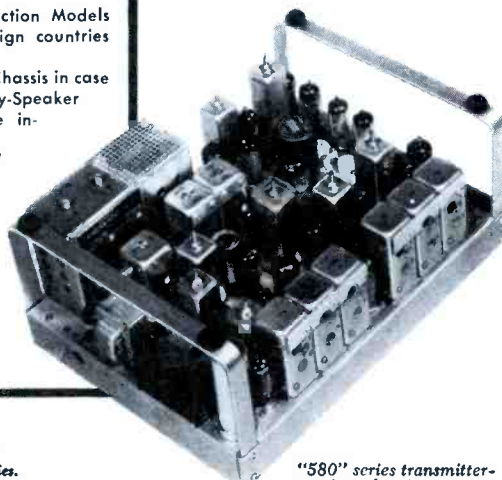

"580" series transmitter-receiver chassis.

ATTENTION DEALERS!
Write for available territories.

DESIGNERS AND MANUFACTURERS OF RADIO COMMUNICATIONS EQUIPMENT

COMMUNICATIONS COMPANY, Inc.

FOUNDED 1938 CORAL GABLES, MIAMI 34, FLORIDA

readily by connecting the leads to a DC voltmeter.

Another familiar servicing procedure which can be applied to transistorized receivers is visual inspection. Printed circuits will undoubtedly be employed because they lend themselves so well to the miniaturization, a part of every transistorized circuit. Look for such things as breaks in the printed circuitry or in the printed boards themselves. A sudden twist, a sharp jar, or an inadvertent dropping of a transistorized device can easily damage any one of a number of minia-

ture components as well as the mounting boards. A careful inspection will frequently bring these defects to light and shorten what could otherwise be a lengthy service job.

Thus far, we have been considering some of the similarities between transistorized and vacuum-tube TV receivers from a servicing standpoint. Let us now note some of the differences. Probably the most prominent of these is the fact that you cannot check a transistorized set either by touching transistors to feel if they are warm, or by inspecting them visually for some evidence of

operation. The serviceman may not realize how much reliance he places upon just such simple tests as looking for lit filaments in vacuum tubes. In fact, he probably will fully appreciate these preliminary checks only when they are no longer available for him. As an offsetting factor, however, there is less reason to suspect transistors of failure than there is for tubes. Transistors should be capable of operating for many thousands of hours without deterioration. As time goes on and manufacturing methods improve, it is entirely foreseeable that the transistor will be the component least subject to change in a receiver. When this stage is reached, the transistor will become the final component to be checked, rather than the first. However, by their very nature, transistors will always be sensitive to heat from soldering irons or other sources, and to surges of current that might develop by the careless handling of probes when voltages or resistances are measured. A slip of a probe can all too easily introduce excessive voltage into a circuit and lead to the destruction of a transistor. The heat of a soldering iron must be considered when components are added to or removed from the circuit. In fact, the transistor should be disconnected from the circuit if possible. It is expected that the transistors first used in TV receivers will be of the plug-in type. This will facilitate their removal, both for testing and for precautionary purposes.

Signal tracing is as effective in transistor circuits as it is in conventional receivers. However, a certain amount of caution must be exercised, because a strong signal will overdrive a transistor (particularly one that is normally employed in low-level stages) and result in its destruction. When injecting signals

Save Time with

SENCORE

See other SENCORE ads in this issue

SENCORE LEAKAGE CHECKER

Check these outstanding New Features

The LC3 provides all these new improved features in addition to those employed in earlier leakage or "grid circuit" testers. A must for any TV service technician.

- ★ Checks 156 different tube types—more than any other "grid circuit" type checker. Includes UHF and latest type tubes.
- ★ Checks picture tubes without removing tube from cabinet or chassis.
- ★ New Roll Chart prevents obsolescence—just dial the tube type and save time. Chart is easily replaced at no extra cost.
- ★ Provides instant filament checks on "Fil-Check" position—no need to carry a second filament checker.
- ★ Capacitor checks simplified.
- ★ Two spare preheating sockets to cut down testing time.

In stock at your local parts distributor.



Model LC-3

\$2895

DEALER NET
Really Whips
Tough Dogs

Service Instruments Corp., 121 Official Road, Addison, Ill.



For my Money

XCELITE Tools are

the Finest!

... Superbly made and designed for Radio, T.V. and Electronic Technicians. **See your Distributor** ... only one quality ... the finest—whether you choose individual items or the handy kits ...

Use the Tools the Professionals use!



XCELITE, INCORPORATED

ORCHARD PARK, NEW YORK

Canada: Charles W. Pointon, Ltd., Toronto

XCELITE

Quality Hand Tools

PREFERRED BY THE EXPERTS

Planning To Move?

If so, notify us by the 15th of the month to assure uninterrupted delivery of PF REPORTER.

Be sure to include both your old and new address. (Or better yet, enclose a current mailing label with your new address.) Send to:

PF REPORTER

Circulation Dept.
2201 E. 46th Street
Indianapolis 6, Ind.

CHART I — BIAS POLARITIES ON TRANSISTOR JUNCTIONS

For p-n-p	
Meter lead connections	Direction of bias
Negative to base; positive to either collector or emitter	Forward
Positive to base; negative to either collector or emitter	Reverse
For n-p-n	
Meter lead connections	Direction of bias
Positive to base; negative to either collector or emitter	Forward
Negative to base; positive to either collector or emitter	Reverse

into transistor circuits, therefore, start with zero generator output and gradually increase the signal level while continuously noting its effect on the circuit. If this is done carefully, trouble need never result from the use of a signal generator. To check the performance of a vacuum-tube oscillator, it is customary to measure the negative voltage developed at its control grid. The amplitude of this voltage is a fairly good indicator of how well the oscillator is functioning. In a transistorized oscillator, this type of negative bias does not exist—nor is it practical to check oscillator operation by measuring the current flow in any part of the circuit, since the difference in current between an oscillatory condition and a non-oscillatory condition is too small to be easily recognizable. Probably the best method of checking an oscillator's condition is by means of an auxiliary measurement or instrument; for example, a wavemeter will indicate whether or not an RF oscillator is functioning and, if so, at what frequency. The condition of the vertical and horizontal deflection oscillators can be determined by waveform analysis, which can be readily carried out with very little difficulty.

One final thought: In most transistor circuits, it is difficult to employ the technique of checking current

waveforms by inserting small resistances in various circuits and observing the voltages which develop across these resistances. This situation stems from the fairly low impedances of these circuits. The insertion of additional resistances, which are frequently of the same order, or greater than, the normal resistance values in the circuit, would upset conditions sufficiently to give improper indications. For example, current waveforms in the vertical and horizontal deflection circuits of vacuum-tube receivers can often be checked satisfactorily

by the resistance-insertion method; however, a glance at the resistances present in the corresponding circuits or transistorized sets will indicate that the addition of as little as one or two ohms could materially affect circuit operation.

Except for a few points such as the one just discussed, the apparent obstacles to efficient servicing of transistorized TV sets should not be too difficult for the technician to overcome. This is heartening because of the expected wide-spread use of transistors in home electronics equipment. ▲

2X NORMAL OPERATING VOLTAGE
+1000

STANCOR TRANSFORMERS STAND UP!

Every STANCOR iron core transformer gets this breakdown test as a production line operation. To assure you of reliability and safety, each unit is tested for breakdown between windings and to ground—at twice its operating voltage *plus* 1000 volts! STANCOR'S thorough testing procedures protect you against failures and call-backs . . . one more reason why experienced technicians everywhere always specify STANCOR.



CHICAGO STANDARD TRANSFORMER CORPORATION
 3503 ADDISON STREET • CHICAGO 18, ILLINOIS

NEW! ON THE SPOT CHECK OF HORIZONTAL OUTPUT CIRCUIT!

—ends most common cause of callbacks!

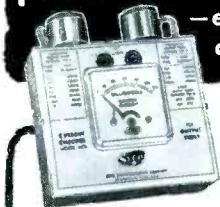

SECO HC-6 CURRENT CHECKER

- PLACE IN CIRCUIT IN SECONDS — NO DISCONNECTING OF CATHODE
- FAST, ACCURATE WAY TO ADJUST HORIZONTAL DRIVE AND LINEARITY

This new, low-cost current checker provides a positive, on-the-spot method of checking and adjusting TV horizontal output circuits — eliminates one of the most common causes of callbacks. Can be placed in circuit in seconds — without disconnecting cathode — immediately indicates whether horizontal output tube cathode current is within manufacturer's recommended limits. Insures proper picture focus, width, and stability with minimum cathode current — helps prevent premature failure of horizontal output transformer and in some cases failure of power transformer and rectifiers. HC-6 is valuable as a fast, accurate indicating device when adjusting horizontal drive and linearity. A "must" on all TV horizontal tube, transformer, or yoke replacement jobs — may also be used to balance hi-fi audio output tubes. Compact — inexpensive — easy to use — the HC-6 is a time-saving, money-making addition to your service kit. **\$12.95** NET

See your distributor . . . or write to:

SECO SECO MANUFACTURING CO.
5015 Penn Ave. S., Mpls., Minn.

Servicing New Designs (Continued from page 29)

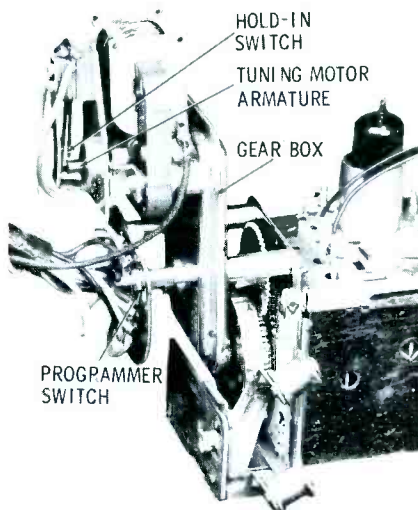

(A) Hold-in and programmer switches.

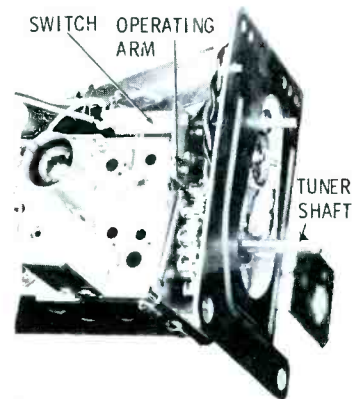

(B) Switch operated by tuner shaft.

Fig. 4. Motor-control switches on tuner.

same as the sound circuit. Tube V3B controls a DC relay that energizes a large, bistable AC relay. When the contacts of the latter are closed, a power circuit is completed between pins 2 and 3 of the octal plug connecting the control receiver to the main chassis. AC line current is furnished through this circuit to the primary of the TV set's power transformer, and current is also made available for the control circuit of the tuner drive motor.

The motor-control circuits are presented in simplified form in Fig. 3. For the motor to operate, AC power must be applied across pins 1 and 2 of the motor plug. Pin 1 is permanently connected to one side of the line, but power can reach pin 2 only by way of pin 3. The latter is connected to the opposite side of the line when the main ON-OFF switch of the TV set and the remote ON-OFF relay contacts are both closed.

The circuit between pins 2 and 3 of the motor plug includes five different switches. The first of these, on the CHANNEL relay, momentarily closes (and thus starts the motor) when the remote transmitter's CHANNEL button is pressed. The motor armature is drawn in toward the field coils as soon as power is applied; this allows the contacts of the motor hold-in switch (Fig. 4A) to close. As the tuner shaft starts to move away from the on-channel position, a cam attached to the shaft closes the switch shown in Fig.

4B. These two switches, wired in series, keep the motor circuit closed throughout the tuning cycle. As the next on-channel position is approached, the tuner shaft switch opens and breaks the motor circuit. This automatic-stop feature can be overridden by the programmer switch (a 13-position wafer switch



SUITS NEED PRESSING— MERIT DEFLECTION YOKES DO NOT!

Merit deflection yokes are cosine wound TO FORM, not pressed. Pressing can lead to distortion and poor focusing. Pressing after winding frequently causes breakdown.

MERIT COILS AND TRANSFORMERS HAVE "BUILT-IN" ADVANTAGES.



Each Merit yoke is 100% LIVE TESTED

COMPARE IT WITH **MERIT**
MERIT COIL AND TRANSFORMER CORP.
MERIT PLAZA • HOLLYWOOD, FLORIDA

ask the "Man-on-the-Roof" why he prefers *South River*

NOW! Banding Kits NEW! for EXTRA LARGE CHIMNEYS

KIT XL "ST": (Consists of)
 2—18' x 3/4" STAINLESS STEEL STRAPS with eyebolts attached
 2—Eyebolts Unattached
 4—Nuts to Fit Eyebolts
 2—KWIK KLIP Strapping Fasteners

Also available, KIT XL "G", same as above with 18' GALVANIZED STRAPS.

Universal—may be used with any chimney antenna mount.

SOUTH RIVER pioneer & outstanding producer of finest line of antenna mounts
 METAL PRODUCTS CO., INC.
 South River, New Jersey
 Canada: Len Finkler & Co., Toronto

geared to the tuner shaft), which allows the tuner to travel nonstop through unused channel positions.

There are actually 13 parallel circuits corresponding to the dotted-in lead in Fig. 3, and each one contains a slide switch. The bank of switches is mounted on the rear of the TV cabinet. When a particular channel position is to be bypassed, the slide switch corresponding to that channel is closed. Then, when the tuner reaches the appropriate position, the programmer switch places a short

corners to a limited extent. At normal viewing distances, the direction in which the transmitter is aimed makes no noticeable difference in system performance.

In case the remote system fails to function, a quick and simple check of transmitter operation can be made by holding the transducer up to one ear and pressing the push buttons one by one. Beat notes between the two supersonic frequencies are included in the acoustic output of the transmitter; these

can be heard as faint but distinct humming sounds of three different pitches. If you cannot hear these notes, remove the transmitter chassis from its case and check the AC voltage across the output-coil terminals indicated in Fig. 5. When any pushbutton is held down, a reading of 35 to 55 volts rms should be observed. If the output is deficient, the next thing to do is check the condition of the battery.

Helpful techniques for control-receiver troubleshooting include

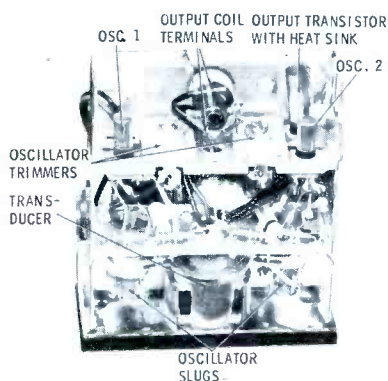

Fig. 5. Transmitter chassis showing location of transistors and adjustments.

across the tuner-shaft switch, enabling the motor to keep running. When the slide switch is left open, the programmer-switch circuit is incomplete—so the tuner will stop when it reaches the corresponding channel position.

A REMOTE ON-OFF switch is located on the back apron of the control-receiver chassis. The remote unit is inoperative when this switch is turned off, and ordinary switches and controls are used to regulate TV set operation. When the main and remote ON-OFF switches are both turned to the ON position, a red pilot light glows at the front of the set to indicate that power is being applied to the remote unit. The remote transmitter must then be keyed in order to turn the set on, and the control receiver will continue to receive power until either of the ON-OFF switches (main or remote) is turned off.

Service Observations

The remote transmitter should be able to control the TV set from a distance of 20 to 30 feet, depending upon general noise level and other factors. It can even operate around

SENCORE "Fuse Safe" CIRCUIT TESTER

Save Time with SENCORE

Save costly call backs by testing the circuit before replacing fuse, fuse resistor or circuit breaker. Individual scale for each value fuse resistor—no interpretation, just read in red or green area.

★ Measures line current and up to 1100 watts of power at 115 volts using line cord and socket. ★ Two convenient current ranges—0 to 2 amps and 0 to 10 amps. Test leads clip in place of fuse or fuse resistor. ★ 5 ohm, 10 watt resistor prevents TV circuit damage, simulates operating conditions.

SENCORE As Recommended by Leading Manufacturers

Service Instruments Corp., 121 Official Rd., Addison, Ill.



MODEL FS-3

\$8.95 DEALER NET

AC-DC or both as needed for Fuse Resistor Circuits

See other SENCORE ads in this issue



Can you Fix this radio?

You're going to get more and more calls to service transistor radios. It's easy to learn how to handle them with this new G/L Technicians' Club book. It gives you complete practical data on transistor radio servicing—from theory to advanced techniques. Includes troubleshooting charts. Increase your income. Get this book now! It retails for \$4.60—but here's

HOW TO GET THIS BOOK FOR ONLY \$3.35
Through the G/L Technicians' Book Club you can get this book and others equally valuable for only \$3.35—a 27% saving!

HOW TO JOIN

- Fill in this coupon.
- SEND NO MONEY — we send you the book on approval.
- If you like it, send your remittance; if not, return the book.
- You receive a new book every three months on the NO-RISK approval plan.
- You need take only four books during the entire membership period. No time limit.
- You may cancel any time after that.

NO-RISK COUPON

Gernsback Library Inc. PR-19
154 West 14th St., New York 11, N. Y.

Enroll me in the G/L Technicians' Book Club. Send me my copy of SERVICING TRANSISTOR RADIOS.

Send me more information on the G/L Technicians' Book Club.

Name
please print

Street

City Zone State

SERVICING TRANSISTOR RADIOS

By Leonard D'Airo
224 pages. Deluxe gold-stamped hard cover.
List price \$4.60

NEW

HICKOK

High-Speed TUBE TESTER and TRANSISTOR CHECKER



Model 6000

- ☆ Constant Indication of Line Voltage
- ☆ New, Roll Chart Grouping of Popular Tubes
- ☆ New, Transistor and Diode Check

NEW SOCKET DESIGN—With a 10-socket snap-in master panel that easily removes to expose the new type 11-pin socket that will accommodate other adapters for checking foreign or older tubes.

SCALE READINGS IN MICROMHOS—Tube quality evaluations are read directly on the 3-range micromho scales. (0 to 3000, 6000, 15000.)

RESERVE CATHODE CAPACITY TEST—By merely turning a selector control on the panel, the reserve capacity of the tube under test can be determined to weed-out those tubes which very possibly could cause trouble in the future.

NEW HIGH-SPEED, EXTRA SENSITIVE SHORTS TEST—(12 Times More Sensitive)—Five neon lights automatically indicate shorts or leakage between elements.

NEW GRID CURRENT (Gas) TEST—The gas content (grid current) is measured very accurately on the meter in terms of actual microamps.

FILAMENT CONTINUITY TEST—As soon as the tube is plugged into the test socket, user may depress the Filament Continuity button to immediately determine whether filament is "open" or not.

FILAMENT VOLTAGE—From 0.6 to 117 volts in 18 steps.

The 6000 will pay for itself in a short time... and give you many years of accurate, dependable service.

\$189.25 NET

Now is the time to...
TRADE UP TO A HICKOK

Ask for a demonstration of the new 6000 from your Authorized Hickok Distributor.

THE HICKOK ELECTRICAL INSTRUMENT CO.
10514 Dupont Ave. • Cleveland 8, Ohio

voltage checks, signal tracing, and signal injection. If the front-end and detector circuits are working normally, the detector plate voltage should shift by several volts in a negative direction when a signal arrives. A similar shift at the grid of cathode follower V5B is an indication that all circuits ahead of this point are operating.

No significant DC voltage reading will be obtained at the plate of any low-frequency rectifier diode, but the AC voltage there should increase from about 10 to approximately 30 volts rms when a signal of the proper frequency is fed in. If the incoming signal is of some frequency other than that to which the rectifier is tuned, an actual decrease in AC plate voltage will be noted. In all of the foregoing circuits, the "no-signal" voltages will vary widely according to the amount of noise present.

The cathode voltage of the low-frequency rectifiers, and the grid and cathode voltages of the relay-control tubes, should all become more positive when an appropriate signal is applied. At this time, net bias on the relay-control tube should decrease from about 20 volts (without signal) to 10 volts or less (with signal). This decrease in bias serves to increase plate current beyond the pull-in point of the plate-circuit relay.

The circuits following the detector can be rapidly checked by means of a signal-injection test using an ordinary audio oscillator. Adjust the instrument for less than one volt of output, touch the signal lead to the

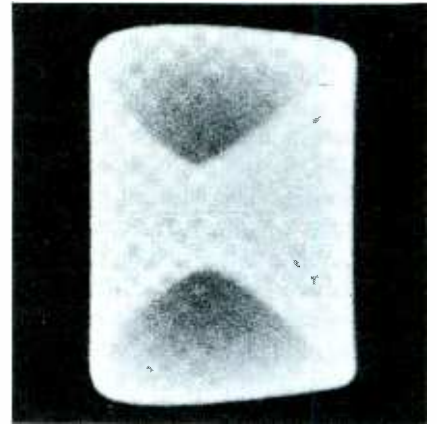

Fig. 6. Lissajous-type pattern obtained in frequency check of transmitter.

detector output circuit, and tune the oscillator through the operating frequency of the circuit you wish to check (1.25, 2.25, or 3.25 kc). When the correct frequency is reached, the relay should kick in.

If you have an oscilloscope handy, waveforms should be viewable at several points. For example, a practically pure sine wave with an amplitude on the order of 70 or 80 volts p-p normally appears at the plate of a low-frequency rectifier when the proper signal arrives. Waveforms in preceding stages are not as distinct, since they tend to be distorted by ever-present noise.

Alignment of the receiver is best performed by using a known good transmitter as a signal source. First, one oscillator in the transmitter is disabled and the other is tuned to 40.5 kc so that the high-frequency interstage transformers can be peaked at this frequency. Next, the transmitter is restored to normal operation and the low-frequency recti-

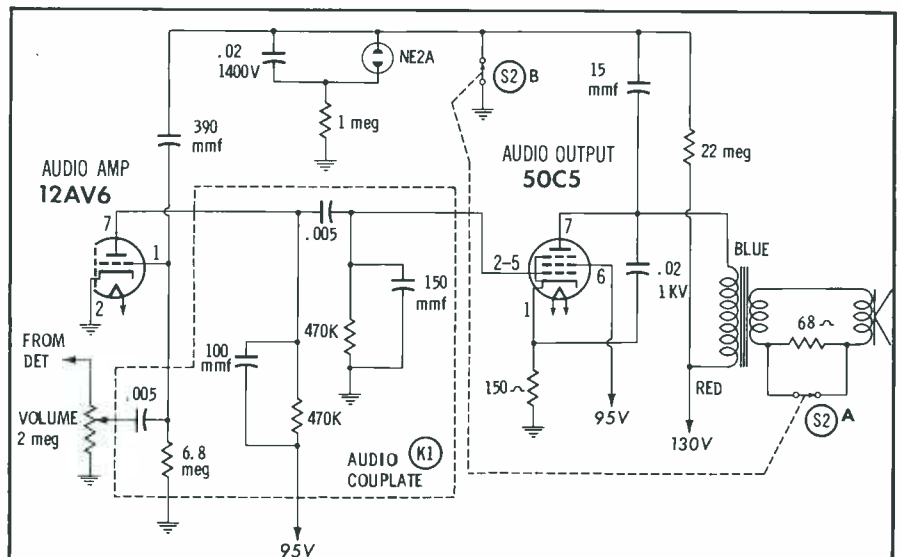

Fig. 7. "Electronic alarm bell" effect is produced by oscillation of circuit.

fier coil adjustments are peaked at the correct beat frequencies.

Transmitter alignment is somewhat more complicated. The recommended procedure is to use *two* transmitters (one of which is known to be accurate), applying their outputs through special low-pass filters to an oscilloscope — one output to the horizontal amplifier and the other to the vertical amplifier. The signals from the two transmitters form Lissajous patterns on the scope, and the unit being aligned is adjusted for a zero-beat indication. Both a slug and a trimmer are provided for oscillator adjustments.

A simplified version of this alignment procedure can be used as a rapid check to see if the oscillator frequencies are at least approximately correct. The signal across the output coil of the transmitter is fed, unfiltered, to the vertical amplifier of the scope. If an audio oscillator is then tuned to the correct beat frequency for the channel being aligned, and its output is applied to the scope's horizontal amplifier, a pattern resembling the one in Fig. 6 should be seen. This figure has the appearance of a rotating cylinder with notches in one side. The speed of rotation slows down as a true zero beat between the oscillator and transmitter signals is approached.

When examining various types of remote-control units, servicemen often want to know if the relays are ever accidentally operated by stray interfering signals. We have run into only one such case with the *Wireless Wizard*. While one of these units was on the bench being serviced, we noticed that the TV set would change channels each time it was turned on from the remote position. On investigation, we found that the squeal of the horizontal oscillator as it "took off" during warmup was the cause of the spurious action. As it passed through 3.5 kc (or a harmonic of this frequency), the oscillator evidently radiated enough signal energy to enter the low-frequency control-receiver circuits directly. We had no more trouble when we put the bottom cover plate back on the control receiver and reinstalled it in the cabinet.

Clock Radio for Sound Sleepers

When you turn the volume con-

trol on the Westinghouse Model H-678T4 clock-radio all the way down, a switch clicks, but it does not turn off the radio as you might expect. Instead, the audio circuits break into an 800-cps oscillation that pulsates at an 8-cps rate, giving the effect of an alarm clock ringing its head off.

When the clock-radio turns itself on in the morning, the volume-control setting determines whether you will be gently roused by music or jangled awake by the alarm. In the latter case, only one operation (turning up the volume) is needed in or-

der to shut off the alarm and bring in music.

Oscillation is sustained by a feedback circuit from the audio output plate to the grid of the audio amplifier, and the low-frequency pulsations are produced by a discharge network including a NE2A neon lamp. (Fig. 7). Both sections of S2 are opened when the volume control is turned fully counterclockwise. One section removes a short from the feedback circuit, and the other inserts a 68-ohm resistor in series with the speaker circuit to reduce the loudness of the alarm signal. ▲

SENCORE "Distributor of the Month"

NATION WIDE RADIO

Save Time with

This month the award goes to one of the leading distributors of the Chicago area, Nation Wide Radio Company. Nation Wide carries complete Sencore stocks in their three locations. Two in Chicago and one in Hammond, Indiana.

Says Nationwide President, Dick Bass, "Sencore has proven to us that their line is designed and built to save time and money for the serviceman. We sell and promote the complete line of Sencore Time Savers because they offer quality, dependability, economy and above all—ease of operation all needed by servicemen, our prime customers."



**Dick Bass, President
Nation Wide Radio**

SENCORE

Leading Distributors Feature SENCORE

SERVICE Instruments Corp., 121 Official Road • Addison, Ill.

IF YOU MUST SPEND YOUR MONEY

Why not get something for it?
get **QUIETROLE**



IN BOTTLES 2, 4 & 8 oz. Dropper with 2 oz. SPRAY-PACK "CAN"

QUIETROLE

TRADE MARK REG. U.S. PAT. OFF.

Costs little more than the poorest substitutes. Why take less than the BEST...

No Product can match its merit . . .
None can equal its quality . . .
It's the answer to noisy controls and switches

QUIETROLE is the original product of its kind

QUIETROLE Company
SPARTANBURG, South Carolina
IN CANADA: ACTIVE RADIO and TV DISTRIBUTORS
• 58 Spadina Ave., Toronto 28, Ontario



SANDY SAYS!
Restore picture size and brightness by selecting proper voltage.

LINE VOLTAGE ADJUSTORS

Anchor Model LA 350



Gives Instant 4-Way Selection

- 10 Volt Boost
- 10 Volt Down
- Normal Line Voltage
- Current Off

Model LA 350 List Price Only \$6.75

Stop in at your jobber today.

New LA 350 COUNTER DISPLAY

TELLS ALL ABOUT WHAT THIS UNIT CAN DO FOR YOU



anchor products co.
ELECTRONIC COMPONENTS
2712 W. Montrose • Chicago 18, Ill.

PRODUCT REPORT

For further information on any of the following items, circle the associated number on the Catalog & Literature Card.

Temperature-Stable Capacitors (No. 46Z)



Molded, film-dielectric paper-tubular capacitors that hold to within $\pm 0.5\%$ of value over an operating - temperature range from 25° to 80° C have been introduced by Sprague for use in sweep oscillators and other tuned circuits. These *Isofarad* capacitors are supplied in values from .001 to .33 mfd at a rating of 500 volts DC. Prices begin at 75c.

Auto Radio Controls (No. 47Z)



A line of 98 different exact-replacement controls for automobile radios is being marketed by G-C Electronics. A replacement guide available from the company provides information on part numbers, applications, and list prices of the new control line.

Reference Volume (No. 48Z)



The 1959 issue of the *Radio-Electronic MASTER*, the 23rd annual edition of that publication, is a 1536-page book divided into 18 product sections. Descriptions, specifications, and prices are given for more than 150,000 standard stock items sold through electronics parts distributors.

Intercom Merchandiser (No. 49Z)



A two-sided, free-standing display rack, measuring 6' x 4', is available to dealers who sell Fanon intercom systems. The rack holds dummy samples of each model in the line. Panels containing working models for demonstration purposes can be added to the display if desired.

Heavy-Duty Antenna Tower (No. 50Z)



A self-supporting antenna tower of tapered design is now available from Rohn in heights up to 130 feet. This type of tower is assembled from a series of 13 different 10' sections having various weights, strengths, and degrees of taper. Relatively short, light towers can be assembled from combinations of slender "upper" sections. If a sturdier short tower is desired, it can be made up from several of the heavier "lower" sections.

750-Ma Silicon Rectifiers (No. 51Z)

For use in color TV sets and other equipment having current-drain requirements in excess of 500 ma, International Rectifier Corp. has introduced a new version of the *Unistac TV-500* silicon rectifier that has a forward current rating of 750 ma at 130 volts DC. This unit consists of a silicon diode mounted on two large cooling fins.



Power Saw (No. 52Z)

Curved cuts can be made in wood, thin-gauge-metal, and various composition and plastic materials with the Wen Model 909 *All-Saw*. Powered by a 1/2-hp motor, the blade makes 1" strokes at the rate of 3400 per minute. The base plate furnished with the saw can be tilted 45°. Weight is 6 1/2 lb, and price is \$44.95 including 7 blades, rip guide and circle cutter.

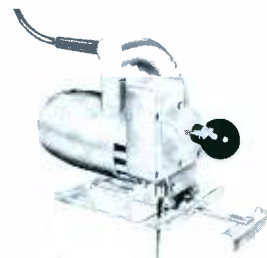

Replacement Flybacks (No. 53Z)

New Stancor exact-replacement flybacks include HO-288, for use in place of Part No. RTO-196 in General Electric and Hotpoint T-Series chassis; HO-289, which replaces Part Nos. 104326 and 972440-3 in RCA Chassis KCS113; and HO-290, a duplicate for Part Nos. 104481 and 973432-1 in RCA Chassis KCS109.



FM-AM Radio (No. 54Z)

Blonder-Tongue's Model R-98 FM-AM radio features a rear-mounted speaker for wider sound dispersion, an RF amplifier and two AGC-controlled IF stages for both FM and AM, and temperature-compensating capacitors in the oscillator circuit to minimize frequency drift. List price is \$64.50.

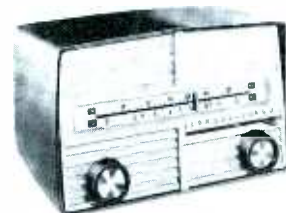

Garage-Door Opener (No. 55Z)

The latest model of Perma-Power's radio-controlled garage door opener (the G-500) features a new, quieter-running speed reducer employing a double helix gear. The light bulb mounted on the operator housing is controlled by a new time-delay mechanism that keeps the light turned on for about two minutes after the garage door closes.



Fringe-Area TV Lead-in (No. 56Z)

A balanced open-line type of 300-ohm lead-in, designed for better fringe area performance, is being marketed by New Products Co. Packaged in standard lengths of 100', 150' and 200', *Signal-Master* is available with 14 and 16 Ga. multi-strand or 16 Ga. solid copper conductors. Loss per 100' at 200 mc is less than .2db, and insulation is weatherproof and salt resistant.



Public Address System (No. 57Z)



A portable 200-watt PA system designed for industrial, military and rescue service by David Bogen contains a microphone, amplifier, loudspeaker, and rechargeable 28-volt nickel-cadmium battery in a single 45-lb. unit. A power-selector switch reduces output to as low as 25 watts when full power is not needed.

Transistor Tester (No. 58Z)



Transistors are tested for gain, leakage and shorts by the Triplett Model 690A, which also checks forward and reverse leakage of semiconductor diodes. The gain test determines the DC value of *beta*, or current gain between base and collector circuits in a common-emitter hookup. Transistors can be plugged into a socket on the instrument or connected to it by means of test leads.

Power Resistors (No. 59Z)



Wire-wound power resistors with a molded covering of high-dielectric silicone-ceramic material are made by Ohmite in three different sizes. Maximum resistances available are 10K ohms at 3 watts, 25K ohms at 5 watts, and 50K ohms at 10 watts. Several different tolerance ratings (0.1%, 0.25%, 0.5%, 1% and 3% at 25°C) are available.

Decade Boxes (No. 60Z)



Aerovox has announced a line of ten decade boxes covering the following value ranges: Capacitance from 0 to .0001, .01 or 1.0 mfd; resistance from 0 to 1, 100 or 10K ohms; and inductance from 0 to 1, 10, 100, or 1000 millihenries. Unit price of resistance and inductance boxes is \$13.75 and \$29.90, respectively, while capacitance types cost from \$13.15 to \$25.40.

Repair for Control Shafts (No. 61Z)



Clock-radio users sometimes twist control knobs too hard and break the shafts attached to the knobs. Colman *Clock-Knob Shaft Repair Tips* (Stock No. 1246-B; price 20c each), can be used to repair these breaks without requiring removal of the entire shaft. The tip is slid over the end of the shaft and secured with a drop of solder.

Tuner Cleaner (No. 62Z)



Injectorall Tuner Cleaner is now made from a new formula incorporating a wax-free lubricant. Net price of \$1.95 per can includes a detachable needle for directing a concentrated spray into hard-to-reach places. Needle comes packed in a plastic tube which provides a handy place for storing it in the tool kit.

The **NEW** **YEATS "Shorty"** STATION WAGON & PANEL PICK-UP appliance dolly



YEATS Model No. 5
Aluminum alloy
Height 47"
Weight 32 lbs.

Only 47" tall, this new YEATS dolly is designed for TV and appliance men who make deliveries by station wagon or panel truck. No need to detach appliance for loading into the "wagon" or pick-up . . . the YEATS "Shorty" will slide into your vehicle with ease. Has aluminum alloy frame with padded felt front, quick fastening (30 second) strap ratchet, and endless, rubber belt step glide. New YEATS folding platform attachment, at left, saves back-breaking work handling TV chassis or table models. Call your YEATS dealer today!



Folding platform is 13 1/2" x 24 1/2" —attaches instantly. (Platform only) \$9.95.



"Everlast" COVERS & PADS



Furniture Pad

YEATS semi-fitted covers are made of tough water repellent fabric with adjustable web straps and soft, scratchless white flannel liners. All shapes and sizes—Write.



TV Cover

SEND postcard for full information on our complete line TODAY!

YEATS appliance dolly

2103 N. 12th St.

sales co.
Milwaukee, Wis.

SAMS PHOTOFAC INDEX



sent direct to your shop

FREE

SEND FOR IT!

Yes, now you can have the valuable SAMS MASTER INDEX to PHOTOFAC FOLDERS and Index Supplements sent direct to your shop at no cost to you! Just mail coupon below and you'll be sure to receive regularly your handy guide to the world's finest service data covering over 30,000 TV, Radio, Amplifier, Tuner Tape Recorder and Changer models. Send for it—it's FREE!

MAIL COUPON

Howard W. Sams & Co., Inc.
2201 East 46th St., Indianapolis 6, Ind.

- Put me on your mailing list to receive the Sams Photofact Master Index and Supplements
- I'm a Service Technician: _____ full time; _____ part time

My Distributor is:

Shop Name: _____

Attn: _____

Address: _____

City _____ Zone _____ State _____

January, 1959

Name	Page No.
Acme Electric Corp.	34
American Television & Radio Co.	16
Anchor Products Co.	77
Arco Electronics, Inc.	59
B & K Mfg. Co.	31, 48
Blonder-Tongue Labs.	42
Bussmann Mfg. Co.	49
CBS-Hytron	21
Centralab, A Div. of Globe-Union, Inc.	54
Charles Engineering, Inc.	50
Chicago Standard Transformer Corp.	73
Clarostat Mfg. Co., Inc.	43
Clear Beam Antenna Corp.	55
Communications Co., Inc.	71
Cornell-Dubilier Electric Corp.	67
Delco Radio Div., General Motors Corp.	37
E-Z-Hook Test Products	70
Electro-Voice, Inc.	35
Electronic Publishing Co.	70
EICO	61
General Cement Mfg. Co.	2nd Cover
General Electric Co.—Electronic Components Div.	12-13, 45
General Electric Co.—Television Receiver Dept.	51
Gernsback Library, Inc.	75
Hickok Electrical Instrument Co.	76
I. T. Industries, Clamp-It Div.	65
International Resistance Co. (IRC)	14-15
Jackson Electrical Instrument Co.	65
Jensen Industries, Inc.	64
Jensen Mfg. Co.	39
Littelfuse, Inc.	4th Cover
Mallory & Co., P. R.	22-23
Merit Coil & Transformer Corp.	74
Perma-Power Co.	62
Philco Corp.—Accessory Div.	47
Quietrole Co.	77
RCA Electron Tube Div.	3rd Cover
Radiart Corp.—Div. of Cornell-Dubilier Electric Corp.	68
Radio Merchandise Sales, Inc.	65
Raytheon Mfg. Co.	9
Sams & Co., Inc., Howard W.	33, 44, 79
Sarkes Tarzian, Inc.—Rectifier Div.	38
Sarkes Tarzian, Inc.—Tuner Div.	66
Seco Mfg. Co.	58, 74
Service Instruments Corp. (Sencore)	62, 64, 70, 72, 75, 77
Simpson Electric Co.	56
South River Metal Products Co.	74
Sprague Products Co.	10
Sylvania Electric Products, Inc.	18-19
Tobe Deutschmann Corp.	69
Triplet Electrical Instrument Co.	17
Tung-Sol Electric, Inc.	41
United Catalog Publishers, Inc.	64
Utah Radio & Electronic Corp.	53
Vis-U-All Products Co.	63
Webster Electric Co.	57
Weller Electric Corp.	40
Xcelite, Inc.	72
Yeats Appliance Dolly Sales Co.	79

ACCESSORIES

1Z. **E-Z-HOOK**—Convenient reference sheet titled, "How to Build the Five Most Useful Scope Probes," with schematics, mechanical component layouts, etc. See ad page 70.

ANTENNA SYSTEMS

- 2Z. **CHARLES ENG'G**—Technical brochure No. 101 tells how to use the Wizard 300 Electro-Magnetic set coupler in installations for homes, motels, apartments, etc. See ad page 50.
- 3Z. **CLEAR BEAM** — 32-page catalog describes complete line of "Do-It-Yourself" TV and FM antennas and kits used effectively by servicemen for outright sales or installations. See ad page 55.
- 4Z. **I. T. INDUSTRIES** — Brochure tells how installing antennas is quicker and easier with new vent pipe Clamp-It #32. See ad page 65.
- 5Z. **RADIO MERCHANDISE SALES** — Color brochure on 1000 series "Wave-booster" antenna. See ad page 65.

AUDIO & HI-FI

- 6Z. **BLONDER-TONGUE** — Catalog sheets on AM-FM radio, AM-FM tuner, Hi-Fi amplifier, and twin speaker systems. See ad page 42.
- 7Z. **CBS-HYTRON** — "Hints on Using The Columbia CD Stereo Cartridge" See ad page 21.
- 8Z. **DAVID BOGEN**—Catalog 510 features current line of hi-fi equipment including amplifier-amplifier, ST 662 FM/AM tuner new stereophonic models DB230 dual pre-amp and DB130A preamplifier-amplifier.
- 9Z. **ELECTRO-VOICE** — Catalog No. 126 on public-address and general-purpose microphones. See ad page 35.
- 10Z. **JENSEN INDUSTRIES** — New 1959 Wall Chart, listing over 300 types of phonograph needles. See ad page 64.
- 11Z. **PICKERING** — Pickering Service-File, a complete technical file on company's products.
- 12Z. **SONOTONE**—Brand new booklet entitled "Stereo Simplified."
- 13Z. **UTAH RADIO** — 4-page booklet describing new stereo amplifier-enclosure system. See ad page 53.
- 14Z. **WALSCO** — Phono conversion data and wall chart. See ad page 50.

CAPACITORS

- 15Z. **ARCO**—Complete information on DP-600 Tubular stock package and DP Tubular buffer kit #16. See ad page 59.
- 16Z. **CORNELL-DUBILIER**—Data on service shop storage chests for capacitors. See ad page 67.
- 17Z. **SPRAGUE** — "Ceramicart," a wall chart of ceramic capacitor data and color codes for capacitors. See ad page 10.
- 18Z. **TOBE DEUTSCHMANN** — Cross-reference chart for twist-prong capacitors, a 24-page booklet providing over 3,525 listings of "Preferred" Tobe twist-prong and tubular electrolytics to replace 5 other major-brand types. See ad page 69.

CONTROLS

19Z. **CENTRALAB**—Auto Radio Control Replacement Guide, listing auto manufacturer, model year, original radio manufacturer, model no., original part number, Centralab replacement, and price. See ad page 54.

FUSES

20Z. **BUSSMANN**—Bulletin SFH-6 describes new space-saving fuse and fuseholder combination for circuit protection at 300 volts or less. See ad page 49.

POWER SUPPLIES

21Z. **AMERICAN TELEVISION & RADIO** —Descriptive literature on battery eliminators, DC-AC inverters, tube protectors, and other ATR products. See ad page 16.

SEMICONDUCTORS

22Z. **INTERNATIONAL RECTIFIER**—Latest edition of "Rectifier News."

SERVICE AIDS

- 23Z. **CLAROSTAT**—Form No. 755259 on 225-watt power-resistor decade box which provides values of 1 to 999,999 ohms in 1-ohm steps. See ad page 43.
- 24Z. **SERVICE INSTRUMENTS** — Descriptive literature on Sencore's new ES-102 Electro Sub. See ads pages 62, 64, 70, 72, 75, 77.
- 25Z. **YEATS** — Folding platform attachment for handling table model TV's and TV chassis. See ad page 79.

SPECIAL EQUIPMENT

- 26Z. **COMMUNICATIONS CO.**—Catalog of VHF-FM two-way mobile radio equipment for the new business radio service. See ad page 71.
- 27Z. **PERMA-POWER**—Catalog Sheet #B-126A describing improvements and new features in radio-controlled garage door openers. See ad page 62.

TEST EQUIPMENT

- 28Z. **EICO** — 20-page 1959 2-color catalog shows how to save 50% on test instruments, high-fidelity and "ham" equipment in either kit or factory-wired form. See ad page 61.
- 29Z. **HICKOK**—New Test Equipment Catalog No. 38 describes latest radio-TV and communications testers. See ad page 76.
- 30Z. **JACKSON**—Folder covering entire line of "Service Engineered" test equipment. See ad page 65.
- 31Z. **SECO** — New 2-color folder showing complete line of test equipment and service aids. See ads pages 58, 74.
- 32Z. **SIMPSON**—Brochure No. 2060 includes descriptions of latest additions to company's line. See ad page 56.
- 33Z. **TRIPLETT**—Data on new tube tester Model 3414. See ad page 17.
- 34Z. **B & K**—Bulletin AP12-R gives helpful information on new point-to-point signal-injection techniques with Model 1075 TV "Analyst"; other bulletins describe "Dyna-Quick" Models 500B, 650, and automatic 675 portable dynamic mutual conductance tube and transistor tester, plus Model 400 CRT cathode rejuvenator tester. See ads pages 31, 48.

TECHNICAL PUBLICATIONS

- 35Z. **GERNSBACK LIBRARY** — Descriptive literature on Gernsback Library books. See ad page 75.
- 36Z. **PF REPORTER** — 1958 Editorial Subject Reference Index.
- 37Z. **HOWARD W. SAMS**—Descriptive literature on all Howard Sams books covering servicing of TV, radio, hi-fi, etc. Includes data on latest books, "Auto Radio Manual, Volume 8" and "Record Changer Manual, Volume 11." See ads pages 33, 44, 79.
- 38Z. **VIS-U-ALL**—Tube Substitution Guide. See ad page 63.

TOOLS

- 39Z. **WELLER** — New Dual-Heat Soldering Gun Bulletin describes design and high-efficiency tip of model 8200K 90-125 watt. See ad page 40.
- 40Z. **XCELITE** — Catalog of hand tools for electronic servicemen. See ad page 72.

TRANSFORMERS

- 41Z. **ACME ELECTRIC** — Bulletin VA-322 explains the importance of automatic voltage stabilization to quality TV reception. See ad page 34.
- 42Z. **CHICAGO STANDARD**—100-page TV Transformer Replacement Guide, cross-referenced for over 7,000 chassis of 98 manufacturers. See ad page 73.

TUBES

- 43Z. **GENERAL ELECTRIC** — New brochure on G.E. tubes: "Here's Why General Electric Receiving Tubes are Better," and "Receiving Tube Interchangeability." See ads pages 12-13, 45.
- 44Z. **RAYTHEON** — Revised 14-page Television Picture Tube Characteristics booklet includes data on aluminized black-and-white and color tubes, face-plate deflection angle, bulb dimension, ion-trap requirements and basing diagram. See ad page 9.
- 45Z. **SYLVANIA** — European-American Receiving Tube Replacement Guide. See ad pages 18-19.

Handy PF REPORTER Subscription Order Card

Please enter my subscription to PF REPORTER for:

- 1 Year \$4.00
 2 Years \$7.00
 3 Years \$9.00
 Above rates apply only in U.S.A., its possessions, and Canada.
 All other countries: 1 year \$5.00, 2 years \$9.00, 3 years \$12.00.

- Bill Me
 Remittance Enclosed
 Extend Present Subscription

Give to your parts distributor or mail to PF REPORTER.

Name _____

Firm _____

Address _____

City _____ Zone _____ State _____

Please Check Your Business Classification

- Independent Radio, TV Serviceman
 Owner or Mgr.
 Retailer with Service Department
 Service Manager
 Industrial Electronics Service
 Employee
 Other (Specify occupation & title) _____

Please send me the literature circled below:

Please indicate number of items you have circled →

- 12 22 32 42 52 62 72 82 92 102 112 122 132 142 152
 192 202 212 222 232 242 252 262 272 282 292 302 312 322 332
 372 382 392 402 412 422 432 442 452 462 472 482 492 502 512
 552 562 572 582 592 602 612 622

Print plainly or type below

Name.....

Firm.....

Firm Address.....

City..... Zone..... State.....

Has your address changed since you last wrote us? No Yes

→ To guarantee receipt of literature please check your business class: →

- Independent Radio, TV Serviceman
 Owner or Mgr.
 Full time
 Part time
 Retailer with Service Department
 Service Manager
 Industrial Electronics Service
 Employee
 Other (Specify occupation and title) _____



FIRST CLASS
PERMIT No. 1076
(Sec. 34.9, P. L. & R.)
Indianapolis, Ind.

S I N E S S R E P L Y M A I L

No Postage Necessary If Mailed in the United States

P F R E P O R T E R

Reader's Literature Service Dept.

2201 EAST 46TH STREET

INDIANAPOLIS 6, IND.



FIRST CLASS
PERMIT No. 1076
(Sec. 34.9, P. L. & R.)
Indianapolis, Ind.

B U S I N E S S R E P L Y M A I L

No Postage Necessary If Mailed in the United States

P F R E P O R T E R

2201 EAST 46TH STREET

INDIANAPOLIS 6, IND.



They know
he's good
because he's using the best...



...RCA RECEIVING TUBES

The public doesn't look *behind* a TV set very often. But when they watch you at work, it's reassuring to see the familiar red and black carton with that RCA trademark. The one thing the public *does* know about electronics and electronic products is that RCA is the outstanding name and company in the field. To benefit from the confidence that lesser known brands could never instill in your customers, latch on to RCA's "built-in" reputation — your calling card to customer good-will. Your RCA Distributor carries a full line. Next time you order tubes, specify...RCA.



RADIO CORPORATION OF AMERICA
Electron Tube Division

Harrison, N. J.

we
see our
customers
as...

with winning ways wisely using good
merchandising to win their customers loyalty.

LITTELFUSE

Des Plaines, Illinois

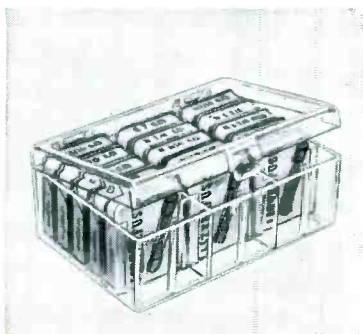

*Snap-on fuse holders, the Fuse Caddy
for your Tube caddy, the LC Fuse
Caddy and the convenient self-service
dispenser for both fuses and fuse
holders at your distributor.*