

JUNE • 1955

25 CENTS

*Lew W. Dams*



# REPORTER

*for the Electronic Service Industry*

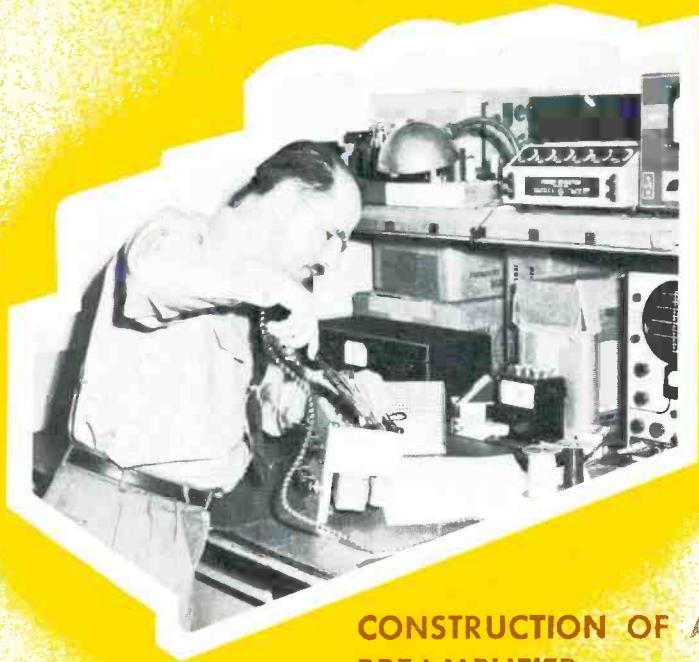

CONSTRUCTION OF A  
PREAMPLIFIER

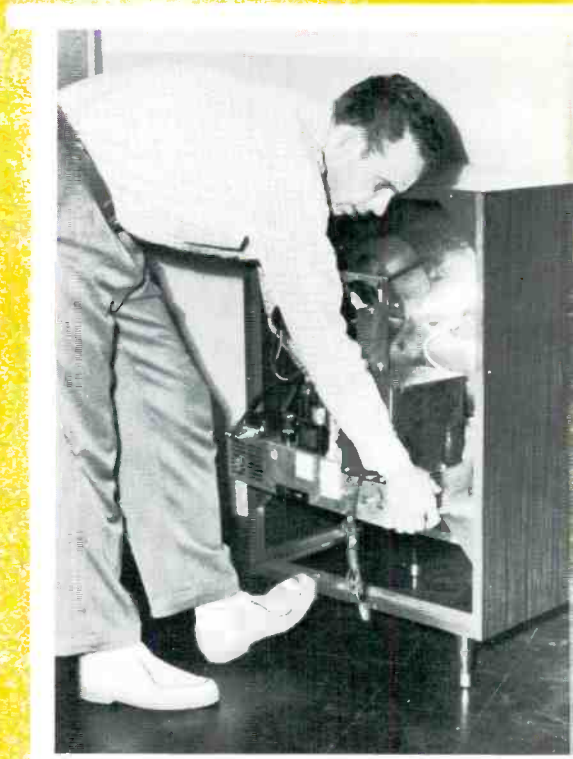

REMOVING THE TV CHASSIS

## COLOR TV TRAINING SERIES PART VIII

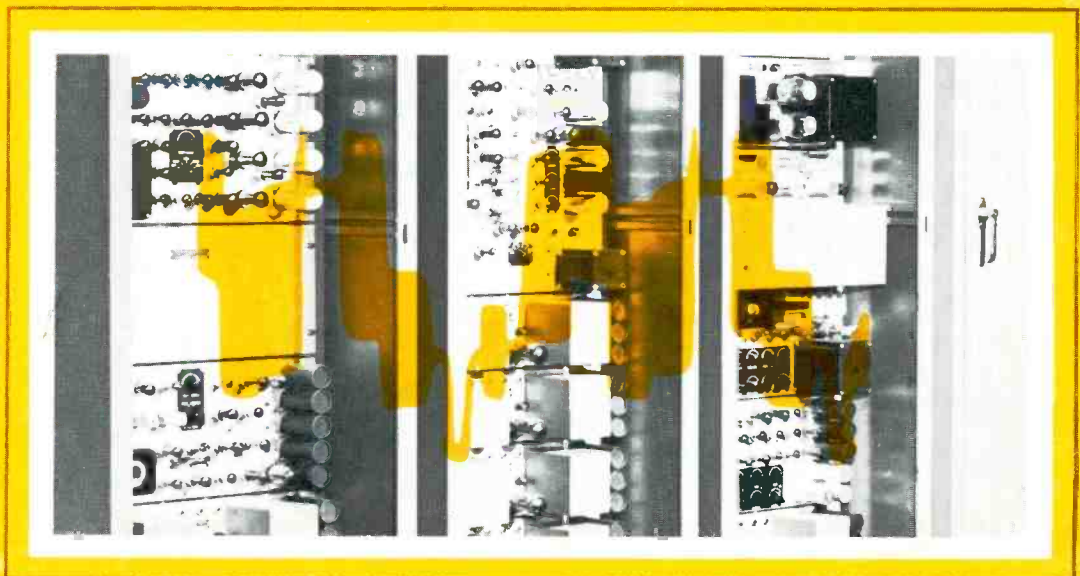

# Preferred for modern set servicing



IRC TYPE Q CONTROL

Service technicians get greater coverage with less investment; more practical service features; and easier, faster installation with the IRC Type Q Control. Here's a dependable, basic control that is directly designed for modern set servicing. For appearance, performance and price . . . there's none better. So why settle for less? Tell your Distributor you want Q Controls . . . most servicemen do.



Wherever the Circuit Says 



This 8 page catalog gives you all the facts . . . Send for your free copy now—

## INTERNATIONAL RESISTANCE CO.

Dept. 363, 401 N. Broad St., Phila. 8, Pa.

In Canada: International Resistance Co., Ltd., Toronto, licensee



### KNOBMASTER FIXED SHAFT

Q Control standard shaft is knurled, flatted and slotted — fits most knobs without alteration.



### INTERCHANGEABLE FIXED SHAFTS

Exclusive IRC convenience feature — provides fast conversion to "specials", with FIXED shaft security. 15 types available.



### 1/4" LONG BUSHING

Accommodates all small sets, yet handles large set needs perfectly.



### 7 STANDARD TAPERS

Full coverage of all taper requirements is provided in the Q Control.



### 94 RESISTANCE VALUES

For TV, AM and FM coverage, 94 values of plain and tapped controls are furnished.



### QUALITY APPEARANCE

The handsome professional appearance of IRC Q Controls lets you point to your work with pride.



### CUSHIONED TURN

The smooth, quality of "feel" of a Q Control contributes to customer confidence.



### TYPE 76 SWITCHES

Either of two type IRC switches attached as quickly and easily as a control cover — meets all your requirements.

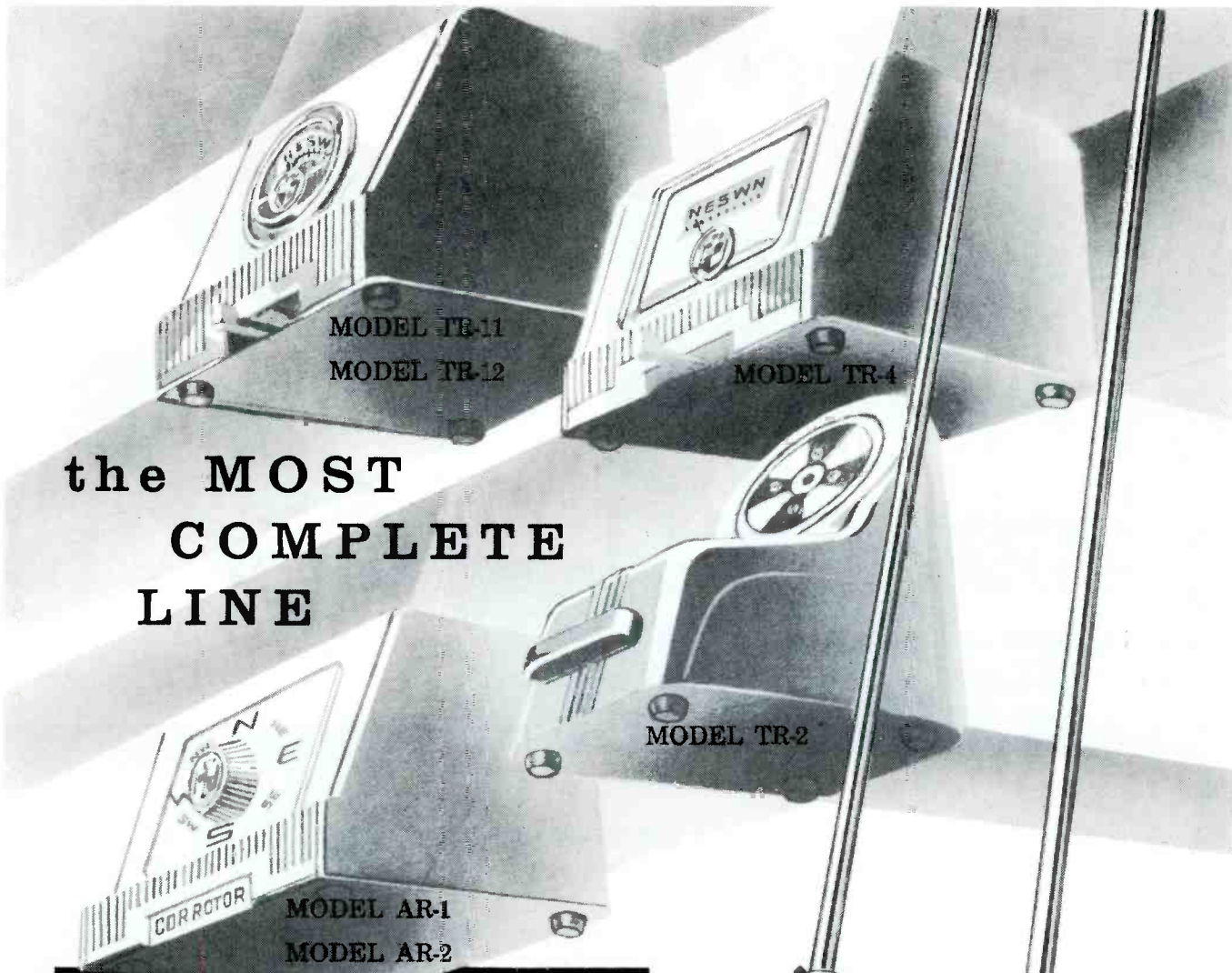

the MOST  
COMPLETE  
LINE

**C·D·R**  
**R O T O R S**

---

*featuring the SHARPEST tuning  
Automatic Rotor*

with the GREATEST TURNING POWER

Here is everything anyone – distributor . . . dealer . . .  
serviceman – could ask for in rotors . . . all in the ONE line  
. . . the CDR ROTOR LINE! A model for every need . . . ALL  
FIELD TESTED AND PROVEN to be dependable and  
superior in every respect!



*Pre-Sold* for you to millions every week  
with regular announcements in every leading  
rotor market across the nation.



**CORNELL-DUBILIER**  
SOUTH PLAINFIELD, N. J.

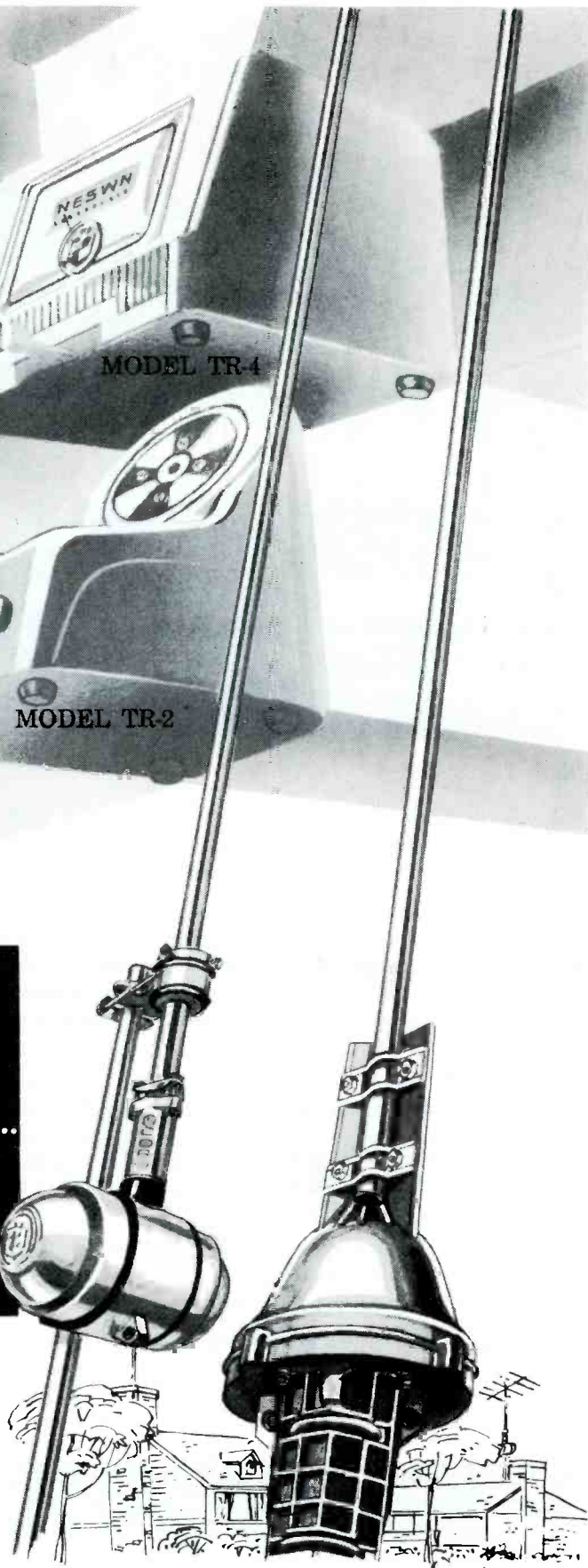

**THE RADIART CORP.**  
CLEVELAND 13, OHIO

# NOW *New* SPRAGUE CERAMIKITS

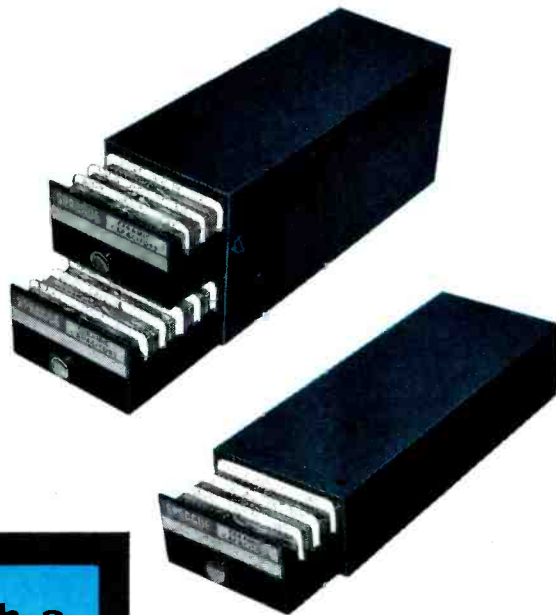

Get these cabinets **FREE** with a basic order of ceramic capacitors

● NOW . . . stock ceramics so you can find 'em when you want 'em . . . have your own neat and complete cabinet . . . at the cost of the capacitors alone.

● Sprague has pre-stocked these handsome, blue, heavy-gauge steel CERAMIKIT cabinets with its famous Ceramite capacitors. Ratings and quantities are based on popularity. No dogs! Stand-up indexes separate reusable plastic boxes. Catalog numbers and ratings can be seen at a glance.

● Whether you use many ceramics, or just a few, there's a Ceramikit sized and priced just right for you. Kit CK-2 is a two-drawer model holding 150 capacitors in 27 different ratings. Kit CK-3 is a single-drawer unit holding 75 capacitors in 12 different ratings. Remember there's not a dog in either Ceramikit.

● Kits interlock so You Can Build With Sprague as you buy your Ceramikits. Use the extra cabinets for handy indexed stocking of all your small parts.

● See your distributor *now* about Ceramikits, or request complete facts in Sheet M-711 from Sprague Products Co., 105 Marshall St., North Adams, Massachusetts.

## CERAMIKIT CK-3

CONTENTS  
3 1/2" x 9 1/4" x 2"  
\$19.25 List

Quan.	Cat. No.	Quan.	Cat. No.
5	5GA-Q1	5	5GA-T47
5	5GA-Q22	5	5GA-T5
5	5GA-Q5	10	5GA-D1
10	5GA-T1	5	5GA-D2
5	5GA-T15	5	5HK-D5
5	5GA-T22	10	5HK-S1

## CERAMIKIT CK-2

CONTENTS  
3 1/2" x 9 1/4" x 4"  
\$38.00 List

Quan.	Cat. No.	Quan.	Cat. No.
5	5GA-V5	5	5GA-T27
5	5GA-Q1	5	5GA-T33
5	5GA-Q15	5	5GA-T39
5	5GA-Q22	5	5GA-T47
5	5GA-Q33	5	5GA-T5
5	5GA-Q39	5	5GA-T68
5	5GA-Q47	10	5GA-D1
5	5GA-Q5	5	5GA-D15
5	5GA-Q68	5	5GA-D2
5	5GA-Q82	5	5GA-D33
10	5GA-T1	5	5GA-D4
5	5GA-T12	5	5HK-D5
5	5GA-T15	10	5HK-S1
5	5GA-T22		

don't be vague . . . major in

# SPRAGUE®

**YOU CAN BUILD  
WITH SPRAGUE**

JAMES R. RONK  
Editor  
LESTER H. NELSON  
Managing Editor  
W. WILLIAM HENSLER  
Technical Editor  
GLEN E. SLUTZ  
Asst. Technical Editor

Editorial Staff  
GWEN BIGHAM  
WILLIAM E. BURKE  
HENRY A. CARTER  
LESLIE D. DEANE  
ROBERT B. DUNHAM  
PHYLLIS J. HURLEY  
THOMAS A. LESH  
GEORGE B. MANN  
GLENN A. McROAN  
EVELYN S. MOUSER  
MARGARET NEFF  
C. P. OLIPHANT  
VERNE M. RAY  
PAUL C. SMITH  
CALVIN C. YOUNG, JR.  
ANTHONY M. ANDREONE  
GLENN R. SMITH  
Art Directors

ROBERT W. REED  
Photography  
ARCHIE E. CUTSHALL  
DOUGLAS G. BOLT  
HARRY A. MARTIN  
Production

★  
**HOWARD W. SAMS**  
Publisher

Business Department:  
Donald B. Shaw, V. P.  
Treasurer  
F. T. Dobbs, Secretary  
Joe H. Morin, Sales Mgr.  
Ann W. Jones, Advertising

Eastern Representatives  
Paul S. Weil and  
Donald C. Weil  
39-01 Main Street,  
Flushing 54, New York  
Independence 3-9098

Western Representatives  
Maurice A. Kimball Co., Inc.  
2550 Beverly Blvd.  
Los Angeles 57, Cal.  
DUnkirk 8-6178  
681 Market St.  
San Francisco 5, Cal.  
EXbrook 2-3365

*Howard W. Sams*  
**PF REPORTER**

for the Electronic Service Industry

VOL. 5 • NO. 6

JUNE • 1955

**CONTENTS**

Shop Talk	Milton S. Kiver	5
Color TV Training Series (Part XIII)	C. P. Oliphant and Verne M. Ray	7
Removing the TV Chassis	Calvin C. Young, Jr.	13
Notes on Test Equipment	Paul C. Smith	15
Hum Troubles in AC-DC Radios	William E. Burke	17
Examining Design Features	Leslie D. Deane	19
In the Interest of Quicker Servicing	Henry A. Carter and Calvin C. Young, Jr.	23
Audio Facts	Robert B. Dunham	24
Dollar and Sense Servicing	John Markus	29
A Stock Guide for TV Tubes		65
PHOTOFACT Colorblock Reference Chart No. 7		Insert

**SUBJECT REFERENCE**

ANTENNAS AND ACCESSORIES			Measurements of TV Receiver		
Isolation of Antenna Troubles	72		Performance	5	
COLOR TV			AGC Figure of Merit	66	
Adjusting and Servicing with Jackson			IF Rejection Ratio	66	
Models 700 and 712 Color-Bar		Insert	Image Rejection Ratio	5	
Generators			Removing the TV Chassis	13	
Alignment Procedure, Color Displays and			Replacement of 6SN7GT Vertical-		
Waveforms During	9		Output Tube	72	
Bandpass Amplifier, Alignment of	8		Scratch Repair	73	
Color-Sync Section, Alignment of	11		TELEVISION		
Dynamic-Convergence Circuit,			Olympic Model 14TD52 with Chassis AD	21	
Adjustment of	39		Performance Averages of TV Receivers	67	
Matrix Section, Adjustment of	33		TEST EQUIPMENT		
RF and IF Sections, Alignment of	41		Jackson Models 700 and 712		
Sound IF Section, Alignment of	43		Color-Bar Generators	Insert	
Test Instruments for Color-Receiver			Precision Model 88 VTVM	63	
Alignment	7		Precision Model 120 VOM	62	
CONSTRUCTION			Testers for Flyback Transformers		
Preamplifier, Construction Details of	24		and Yokes	15	
RADIO			EICO Model 944	61	
Frequency Drift in AM Radios	23		Radio City Products Model 123	61	
Hum Troubles in AC-DC Radios	17		Seco Model FB-4	15	
SERVICING			THEORY		
Field-Strength Meter, Uses of	73		Noise-Inverter Circuit in		
Low-Voltage Rectifiers in Philco			Sylvania Chassis 1-522-2	19	
Model 50T1600, Code 122	71				

Copyright 1955 by Howard W. Sams & Co., Inc.

No part of the PF REPORTER may be reproduced without written permission. No patent liability is assumed with respect to the use of information contained herein.

The PF REPORTER is published monthly by Howard W. Sams & Co., Inc., 2201 East 46th Street, Indianapolis 5, Indiana. The PF REPORTER is on sale at 25¢ a copy at 1401 jobbers of Electronic Parts throughout the United States and Canada. (In Canada 30 cents.) When available, back numbers may be obtained by sending 35¢ for each copy desired. Entered as second class matter October 11, 1954, at the Post Office at Indianapolis, Indiana, under the Act of March 3, 1879.

**SUBSCRIPTION DATA:** For those desiring the convenience of delivery to their homes or shops, each issue of the REPORTER will be mailed direct, promptly upon publication. Rates: U. S. and its Possessions, one year \$3.00. Canadian subscriptions, one year \$3.60. All other countries \$12.00 per year in American money.



When Godfrey  
tells the ladies  
... **There are  
no finer tubes  
than CBS tubes** ...  
More women  
than ever  
are going to ask for  
the tubes with the  
**Good Housekeeping  
Guaranty Seal.**



Be sure YOU have  
CBS tubes in your tube caddy.

**Arthur Godfrey's Talent Scouts  
to sell CBS Tubes**  
on both TV and Radio  
every other week starting in June

Quality products through *ADVANCED-ENGINEERING*

**CBS-HYTRON**, Danvers, Massachusetts . . . A DIVISION OF COLUMBIA BROADCASTING SYSTEM, INC.

# Shop Talk

MILTON S. KIVER

President, Television Communications Institute

## MEASUREMENTS OF RECEIVER PERFORMANCE

Service technicians are called upon from time to time to express their opinions concerning various features of television receivers. For example, the following are some of the questions asked. Is one make of set more sensitive than another? Is one type of AGC system more effective in its action than another? Is one set less prone to interference than other sets? Most of the time, whatever knowledge service technicians may have concerning receiver performance may simply be based upon observation of one or more sets in operation; and no serious attempts have usually been made to verify the opinions stated.

Occasionally, more precise information is desired. It is not particularly difficult to get this data if a signal generator with a calibrated output level is available. Generators of this type, such as the Hickok Model 292X in Fig. 1, have a meter which indicates the exact signal level within a range which is usually from zero to 100,000 microvolts. With a known input signal and with a VTVM or oscilloscope at the other end of the receiver, many important characteristics can be accurately measured.



Fig. 1. A Crystal-Controlled AM Generator. (Sample Courtesy of Hickok Electrical Instrument Company.)

## Sensitivity

Let us consider, for example, over-all receiver sensitivity. To make this measurement, you would proceed as follows. Connect the AM signal generator to the antenna input terminals, making certain that the generator impedance is matched to that of the receiver. If the generator output is balanced but its impedance is less than 300 ohms, the network

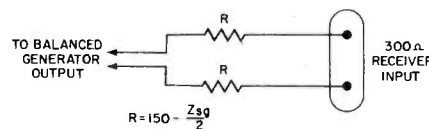

$Z_{sg}$  = OUTPUT IMPEDANCE OF SIGNAL GENERATOR

(A) With Balanced Generator Output.

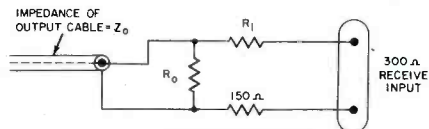

$Z_0$	$R_0$	$R_1$
50 $\Omega$	56 $\Omega$	120 $\Omega$
72 $\Omega$	82 $\Omega$	110 $\Omega$
92 $\Omega$	110 $\Omega$	100 $\Omega$

(B) With Unbalanced Generator Output.

Fig. 2. Circuits for Matching Output Impedance of Signal Generator to Input Impedance of Receiver.

shown in Fig. 2A should be employed. On the other hand, if the generator has an unbalanced output, then the arrangement shown in Fig. 2B should be employed.

For the next step, an oscilloscope is connected between the grid or cathode of the picture tube and the receiver ground. The choice of grid or cathode depends upon which element receives the video signal.

The receiver is operated at maximum gain for this test; consequently, the contrast control is turned fully clockwise. In addition, the AGC line is shorted to ground. (If the receiver develops a low negative bias of 0.5 volt or so with no input signal, then apply a DC bias of the

same value to the AGC line instead of grounding it.)

Next, tune the signal generator to the mid-frequency of the channel being checked, and adjust the unit for 30-per-cent modulation. Then rotate the fine-tuning knob on the receiver for maximum indication on the screen of the oscilloscope. The number of microvolts of generator output needed to produce a pattern having a peak-to-peak amplitude of 20 volts on the scope will be a measure of receiver sensitivity. The more sensitive the receiver, the less signal the generator will have to supply in order to produce the 20-volt signal at the picture tube. The value of 20 volts peak to peak at the picture tube is the standard established by the Institute of Radio Engineers.

In the VHF bands, it will be found that the highest receiver sensitivity will exist on channel 2 and the lowest on channel 13. Furthermore, the sensitivity on the UHF channels will be considerably poorer than on any of the VHF channels. Most of us know this; but with the sensitivity test, we can determine exactly how much difference exists between reception of different channels by the same receiver and between reception of any given channels by different receivers.

## Image-Rejection Ratio

The image-rejection ratio is another receiver characteristic that can be determined by using the same setup of instruments used to check sensitivity. This is the ratio between receiver sensitivity to a normal signal and its sensitivity to a signal at the image frequency. For example, if the intermediate frequency representing the video carrier is 45.75 megacycles, the frequency of the local oscillator will be this far above that of the video carrier in the normal signal. See Fig. 3. The image frequency would then be 45.75 megacycles above the oscillator frequency. For

\* \* Please turn to page 65 \* \*

# YOU CAN RELY ON BUSS...

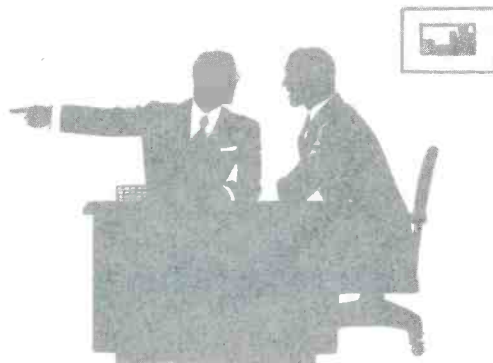

## for Fuses of Unquestioned High Quality

*Here's why*—Millions upon millions of BUSS fuses have given dependable electrical protection in homes, on farms and in industries over the past 40 years, thus establishing the unquestioned high quality of BUSS fuses.

With a reputation like this, BUSS can't afford to take a chance with faulty fuses that could injure its business and yours.

That's why every BUSS fuse, normally used by the Electronic Industries, is tested in a sensitive electronic device that automatically rejects any fuse not correctly calibrated, properly constructed and right in all physical dimensions.

Fuses that give you double protection against loss of user goodwill are the result. Not only are users guarded against damaged equipment when there is trouble on the circuit, but they are also protected against irritating shut-downs caused by needless blows.

Then why not be sure your buying and stock records specify BUSS and FUSETRON fuses . . . you'll save time and trouble by using BUSS as the one source for all your fuse needs.

Makers of a complete line of fuses for home, farm, commercial, electronic and industrial use.

**BUSSMANN MFG. CO.**



555

University at Jefferson,  
St. Louis 7, Mo.



# COLOR TV

## TRAINING SERIES

### PART XIII ALIGNING THE COLOR RECEIVER

by C. P. Oliphant and Verne M. Ray

In Part XII of this Color TV Training Series, the discussion of the setup procedures for the color picture tube was concluded. A discussion will now be given concerning the alignment of the circuits in the color receiver.

In comparing the alignment procedure for a color receiver with that for a monochrome receiver, it can be said that aligning a color receiver is more difficult. The main reason for this is that the color receiver contains a larger number of stages than does the monochrome receiver. In order to reproduce colors faithfully, the alignment of the circuits of a color receiver must be very precise. Care must be taken in order to get the best possible responses from the circuits. For instance, the video IF section must have a bandwidth of nearly 4.5 megacycles in order to pass the 3.58-mc color subcarrier and its upper sidebands. The circuits must first be designed for this bandwidth; and second, they must be properly aligned. For best results, the response of the video IF section should be flat throughout the range of 4.5 megacycles.

The sections that need to be aligned in a color receiver are the RF, IF, sound, bandpass-amplifier, color-sync, matrix, and convergence sections. The RF, IF, and sound sections have their counterparts in the monochrome receiver; therefore, the alignment procedures for these sections in both the monochrome and color receivers are very similar. The bandpass-amplifier, color-sync, matrix, and convergence sections in the color receiver are those which do not have counterparts in the monochrome receiver.

This discussion about the alignment of the circuits in color receivers will first cover those circuits that pertain to color only. The color circuits will be presented in the following order: bandpass amplifier, color synchronization, matrix, and convergence. During the discussion about a particular section, it will be assumed that all the other sections of the receiver are functioning normally and that all the components in the section under discussion are in good condition.

A Color Plate is included for the purpose of showing the way the bar patterns should appear and the various ways they actually appear as a result of misalignment in the various sections of the receiver. The signals from the Hickok Model 655XC color-bar generator were employed while the photographs appearing in the Color Plate were being taken. Figs. C-1 and C-2 give the appearance of the bar patterns when operation of the receiver is normal and should therefore be used as standards for comparison with the other photographs which show symptoms of misalignment. Fig. C-1 shows a normal color-bar pattern, and Fig. C-2 shows a normal Q and I pattern.

Before entering into the discussion about the alignment of the circuits in a color receiver, let us consider the test instruments needed for color-television work.

#### TEST INSTRUMENTS

Practically all of the equipment now used when working with monochrome receivers is also needed when working with color receivers. Most of these instruments can be used without modification and in the same applications for which they were originally designed; however, some will have to have additional features before they will meet the requirements for color-television service work. In addition, new equipment will also have to be acquired. It was necessary to develop new instruments which had to be specifically designed for use in color-television service work and which are not useful in the adjustment or service of monochrome receivers.

#### Oscilloscope

The oscilloscope is a very useful instrument in television work. In order for this instrument to be satisfactory for observing the video signals associated with color television, it must have a wide bandpass characteristic because color television utilizes a wider band of video frequencies than is common in monochrome television. Since the frequencies contained in a composite color signal vary from a few cycles to nearly 4.5 megacycles per second, the response of the oscilloscope circuits should be fairly flat over this range of frequencies. Many of the oscilloscopes which were designed for use in connection with monochrome television also fulfill the requirements needed to observe the composite color signal or any portion of this signal, such as the color burst which has a frequency of 3.58 megacycles.

For viewing response curves in color receivers, oscilloscopes with narrow bandpass characteristics can be used just as they are for this purpose in monochrome receivers. This is true because the signal which is applied to the oscilloscope during the viewing of conventional response curves is comprised for the most part of low-frequency components.

#### Sweep Generator

The sweep generator is another test instrument which is used in connection with the servicing of monochrome television receivers. Its most useful application is during alignment of the tuner and video IF stages. To be more useful in color-television service work, a sweep generator should incorporate a video range which sweeps down to 50 kilocycles or below. This video range is necessary so that the frequency response of such circuits as the video amplifier, the bandpass amplifier, the I and Q circuits (or the R - Y and B - Y circuits), and the matrix circuits can be checked.

When the response curves of these circuits are checked, frequency markers from .5 to 4.5 megacycles are very helpful. At the present time, the marker frequencies supplied by most marker generators and those incorporated in sweep generators may not be within this range; but this presents no problem, since an RF signal

generator will provide frequencies in the video range. The signal from such a generator can be injected and the generator can be tuned so that a marker will appear at practically any point on the video response curve.

### High-Voltage Probe

Another instrument which is necessary in color-television service work is the high-voltage probe. Since the ultor voltage in a color receiver is regulated at a specific value, proper operation of the high-voltage circuit is most easily determined by an actual voltage measurement. The ultor voltage in many color receivers may exceed 30 kilovolts when unregulated; therefore, a high-voltage probe which will withstand this potential and which incorporates an ample safety factor is recommended. The use of a high-voltage probe was covered in the discussion of the setup procedure for the color picture tube. This discussion appeared in Parts XI and XII in the April and May issues of the PF REPORTER.

### White-Dot and Color-Bar Generators

Oscilloscopes, sweep generators, and high-voltage probes are pieces of equipment that should be familiar to the service technician who has worked with monochrome receivers. The development of color television has brought about the need for two new types of test instruments. These are the white-dot generator and the color-bar generator.

Actually, the use of a dot generator is not new in television servicing; but the patterns which have been used in servicing monochrome receivers have consisted of black dots on white fields. Patterns consisting of white dots on dark fields are preferred for servicing color receivers because these patterns can be used not only for linearity adjustments but also for convergence adjustments. The use of a white-dot pattern was described in the discussions on convergence adjustments in Parts XI and XII of this Color TV Training Series in the April and May issues of the PF REPORTER.

A color-bar generator is very useful in checking the performance of the circuits in a color receiver. As the name implies, the color-bar generator develops a signal from which bars of various colors can be reproduced on the viewing screen of the picture tube. Most generators incorporate a function switch so that the bar patterns can be changed. One position of the switch may cause a combination of primary and secondary colors to be produced on the screen. Other positions may produce individual colors which correspond to I, Q, R - Y, and B - Y. The subcarrier oscillator in the color-bar generator is usually crystal controlled; consequently, this instrument is a reliable standard for checking the performance of the color circuits of a receiver.

### BANDPASS AMPLIFIER

The bandpass amplifier is the first stage in the chrominance channel of a color receiver. This stage extracts the chrominance signal from the composite color signal and passes it on to the demodulator section. The signal at the input of the bandpass-amplifier section consists of the chrominance and luminance signals, the sync and blanking pulses, and the color burst. At the output of the bandpass amplifier, only the chrominance signal appears. This means that the luminance signal has been blocked and that the sync and blanking pulses and the color burst have been keyed out. The chrominance signal, which consists of the subcarrier at 3.58 megacycles and of the sidebands that extend to 2.1 and 4.2 megacycles, is allowed to pass.

The bandpass-amplifier circuit shown in Fig. 11-1 is employed in the RCA Victor Models CT-100 and 21-CT-55 color receivers. This circuit was discussed in Part VI of the Color TV Training Series in the November issue of the PF REPORTER, and it will be referred to later in the discussion concerning the alignment of the bandpass-amplifier section.

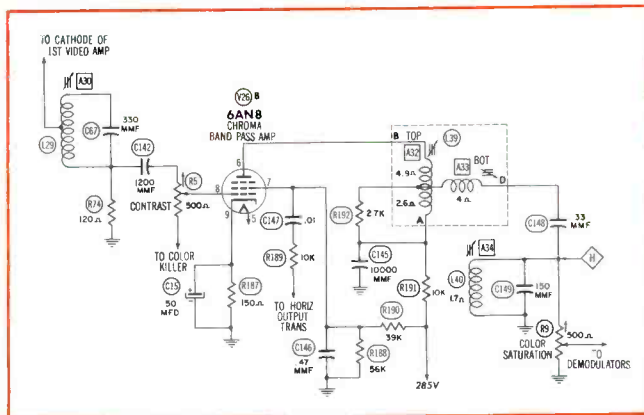

Fig. 11-1. Bandpass-Amplifier Circuit in RCA Victor Model CT-100 Color Receiver.

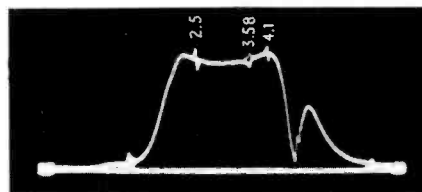
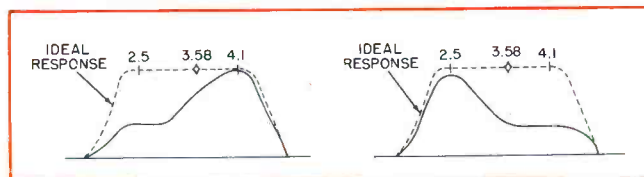

Fig. 11-2. Normal Response Curve of the Bandpass-Amplifier Circuit of Fig. 11-1.



(A) Showing Greater Attenuation at the Sideband Frequencies Far From the Subcarrier Frequency.

(B) Showing Greater Attenuation at the Sideband Frequencies Near the Subcarrier Frequency.

Fig. 11-3. Response Curves Which Are Abnormal Because of a Misadjusted Bandpass Filter.

The bandpass amplifier is similar to a conventional video amplifier, but it has components which are tunable so that the circuit can be aligned to provide the proper passband for the chrominance signal. The tunable components are contained in the bandpass filter and are designated as L39 and L40 in Fig. 11-1.

When the bandpass filter is properly aligned, all of the color signals will pass through the circuit to the color demodulators. Misalignment may cause a change in the saturation of the colors, and loss of color detail may also be present. Fig. 11-2 shows the normal response curve of the bandpass-amplifier section in Fig. 11-1.

The drawings in Fig. 11-3 illustrate abnormal response curves which may be obtained when L39 and L40 of the bandpass filter are misadjusted. Each curve in these drawings is sloped at the top instead of being flat which is the ideal response, and each is low in amplitude almost over the entire curve. With a response such as that shown

# REFERENCE PATTERNS FOR ALIGNMENT PROCEDURE

COLOR TV TRAINING SERIES

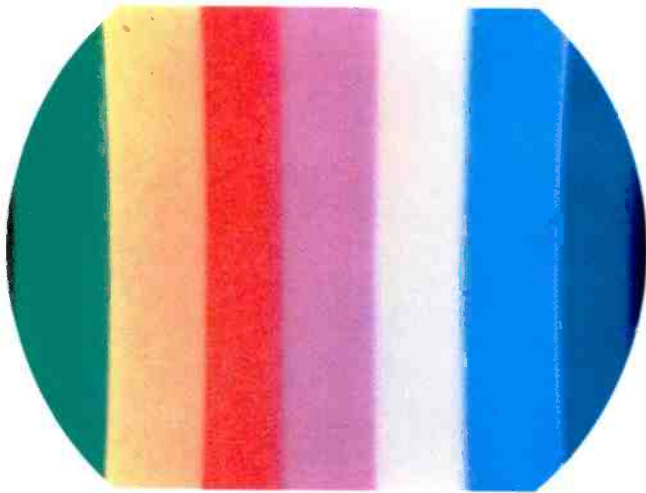

**Fig. C-1. Normal Color-Bar Pattern.**

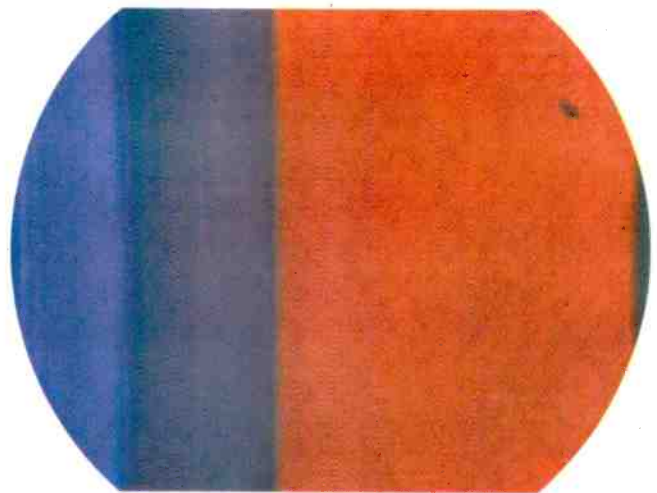

**Fig. C-2. Normal Q and I Pattern.**

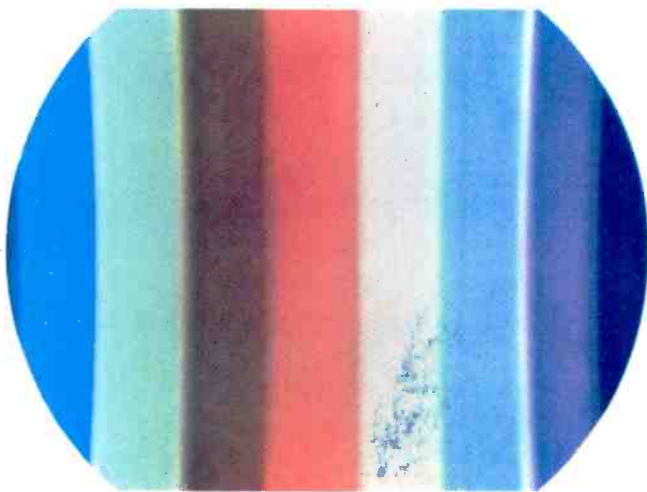

**Fig. C-3. Color-Bar Pattern Resulting From Misadjustment of the Burst-Amplifier Transformer.**

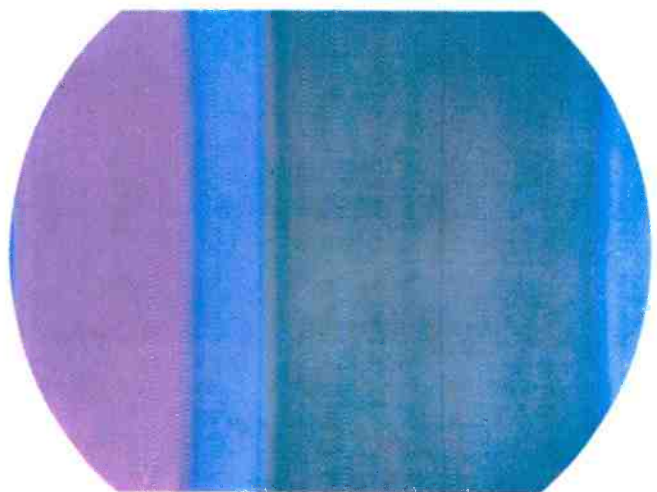

**Fig. C-4. Q and I Pattern Resulting From Misadjustment of the Burst-Amplifier Transformer.**

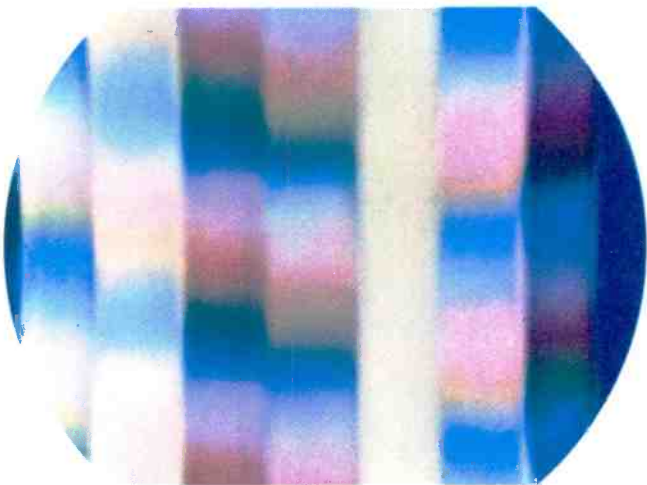

**Fig. C-5. Loss of Color Synchronization Resulting From Misadjustment of the Coil in the Plate Circuit of the Rectance Tube.**

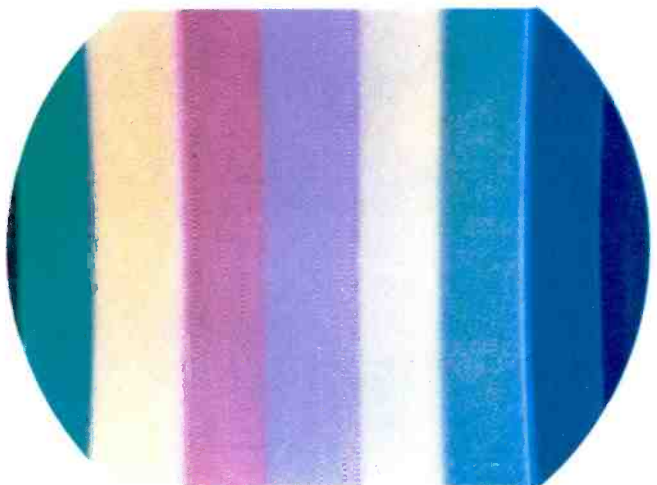

**Fig. C-6. Color-Bar Pattern Resulting From Misadjustment of Quadrature Transformer. Phase Difference of CW Reference Signals Is Less Than 90 Degrees.**

# REFERENCE PATTERNS FOR ALIGNMENT PROCEDURE

COLOR TV TRAINING SERIES

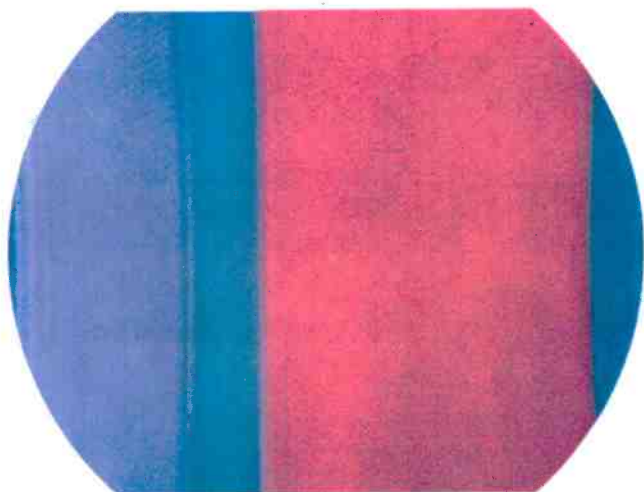

**Fig. C-7. Q and I Pattern Resulting From Misadjustment of Quadrature Transformer. Phase Difference of CW Reference Signals Is Less Than 90 Degrees.**

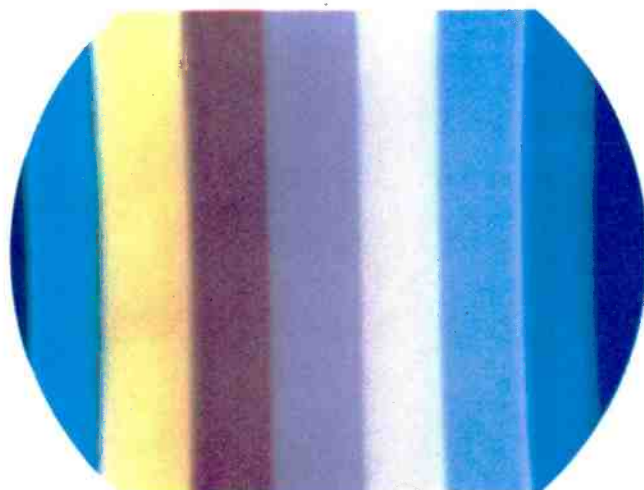

**Fig. C-8. Color-Bar Pattern Resulting From Misadjustment of Quadrature Transformer. Phase Difference of CW Reference Signals Is More Than 90 Degrees.**



**Fig. C-9. Q and I Pattern Resulting From Misadjustment of Quadrature Transformer. Phase Difference of CW Reference Signals Is More Than 90 Degrees.**

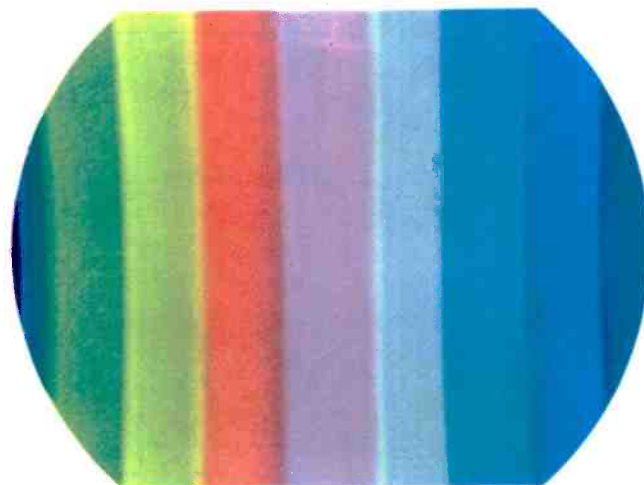

**Fig. C-10. Color-Bar Pattern Resulting From Misadjustment of Video IF Coil L20.**

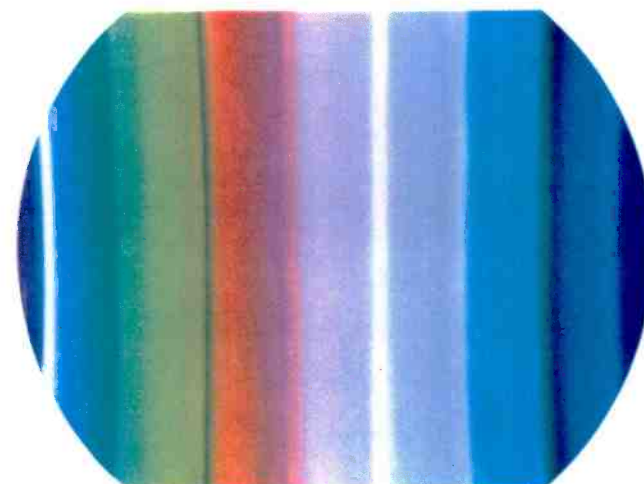

**Fig. C-11. Color-Bar Pattern Resulting From Misadjustment of Video IF Coil L21.**

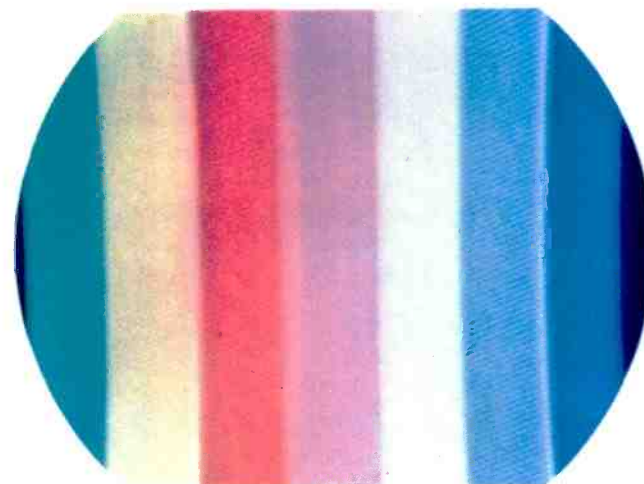
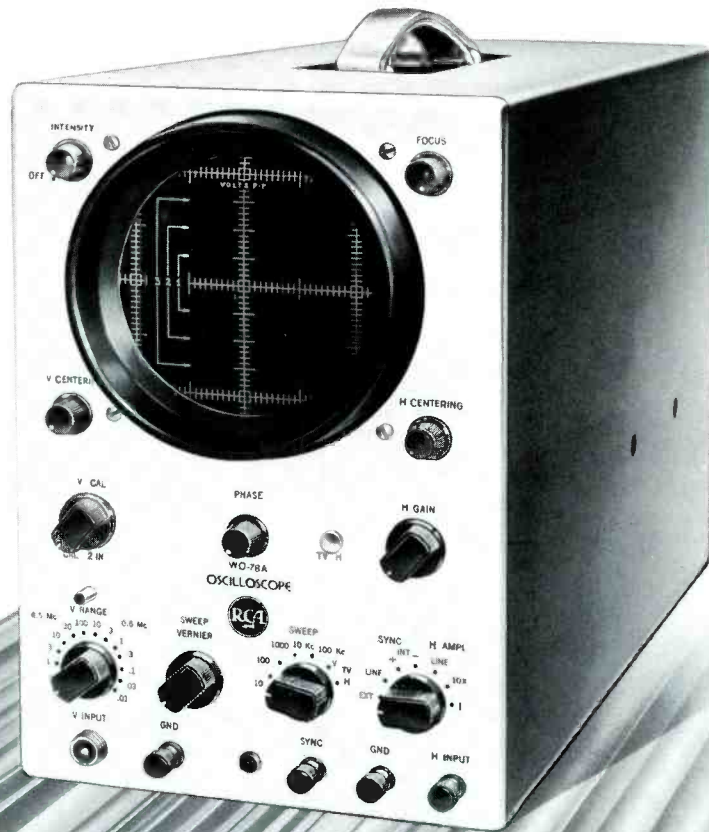

**Fig. C-12. Color-Bar Pattern Showing 920-Kc Beat.**



RCA WO-78A

'Scope



RCA-WO-78A — 5" Oscilloscope \$425.00 (suggested user price) complete with WG-294 direct probe and cable, WG-293 low-capacitance probe, alligator clip, ground cable, insulator, green graph screen, instruction book.

for BLACK and WHITE, COLOR TV

## An investment in quality that can pay its own way

Expert technicians have learned that the fastest way to isolate trouble in "tough" sets is by using a good 'scope. A quality 'scope like the WO-78A is a sound investment which can pay its own way if it saves you only a few hours of trouble-shooting a week.

Advanced design and expert engineering make the WO-78A a superior instrument which helps you deliver *top-grade TV service work in less time*. And, with the wideband WO-78A, you have an instrument especially suited for the complex circuitry of color TV—to observe color burst signals and to aid in the analysis of complicated circuit waveforms. Your safest investment for both color and black-and-white TV is to choose the finest TV service 'scope available. Here are some of the outstanding features of the WO-78A:

- **Maximum utility** . . . dual-band response; wide-band position (3 cps to 4.5

Mc, -1 db with gradual roll-off to 6 Mc) for color TV; high-sensitivity position (3 cps to .5 Mc, -3 db) for general service, black-and-white TV.

- **High sensitivity** . . . direct sensitivity of 0.01 volt peak-to-peak per in. (0.0035 rms volt per in.) in high-sensitivity position; 0.1 volt peak-to-peak per in. (0.035 rms volt per in.) in wide-band position.

- **Excellent phase and frequency response** . . . minimum ringing, negligible tilt, and overshoot.

- **Full-screen vertical deflection** . . . without distortion up to 4.5 Mc (many lab scopes provide only half-screen deflection).

- **Voltage calibrated "V" input attenuator** . . . frequency compensated 14-position (steps of 3 to 1) vertical-input attenuator.

- **Low circuit loading** . . . WG-293 Low-Capacitance probe supplied with RCA

WO-78A has impedance of 10 megohms shunted by 14  $\mu$ fd.

- **Bright sharply focused trace** . . . provided by the use of the RCA 5ABP1 flat-face cathode-ray tube which utilizes post-deflection acceleration and an ulior potential of 3000 volts.

- **Extremely simplified operation** . . . No need to disconnect the input or to apply external calibrating voltages. Push-button applies fixed input voltage to vertical amplifier for calibration. Limiter in sync circuit eliminates horizontal sync adjustments; gives positive lock. Removable graph screen calibrated in inches and tenths of an inch permits easy measurement and comparison of signal amplitudes. As speedy to read as a VTVM.

See the RCA WO-78A with the "features plus" . . . at your RCA Distributor. For technical data write RCA, Commercial Engineering, Section G33W, Harrison, N. J.



**RADIO CORPORATION of AMERICA**  
TEST EQUIPMENT  
HARRISON, N. J.

# Removing the TV CHASSIS

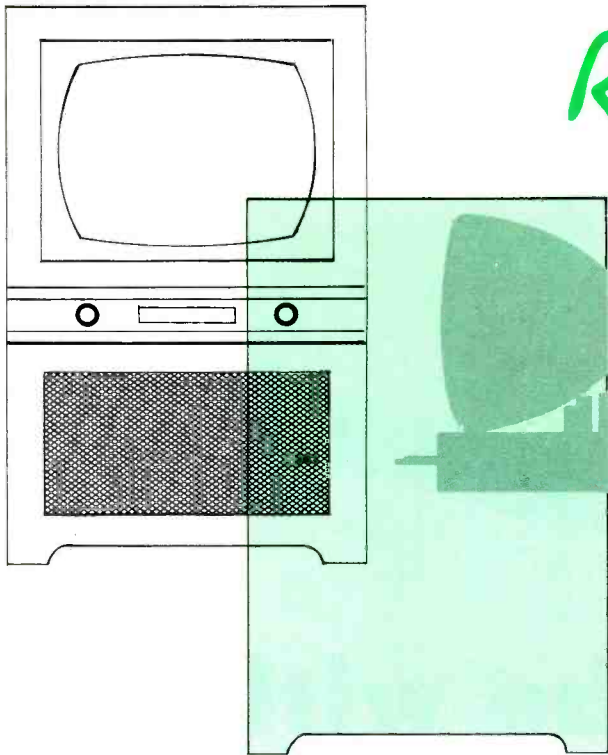

Customary Methods for All Receivers  
and Special Procedures  
for Certain Makes

BY CALVIN C. YOUNG, JR.

The task of removing a television chassis from its cabinet is very familiar to most service technicians; however, the following material is being presented in order to acquaint the reader specifically with some of the things to heed when removing chassis from particular makes and models of receivers. In addition, a general coverage of the subject is presented for the benefit of the less experienced technician.

Normally, the decision to remove a chassis is reached after the service technician has checked the controls and has substituted tubes in the receiver section which is at fault. The customer is notified that the receiver requires shop service in order to be restored to its proper operation; and upon his authorization, the procedure to remove the chassis can be started.

## Removal of Back Cover

Usually, the back cover of the receiver will have been removed by

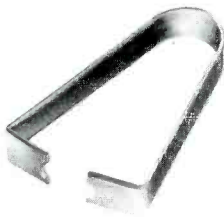

Fig. 1. Knob Puller Made by General Cement Mfg. Co.

the technician before substituting tubes; however, the antenna lead between the back cover and the tuner may still be connected to the back cover. This line is sometimes connected permanently to the tuner, and provisions are made so that it may be disconnected from the back cover as it is in some of the Philco and RCA Victor models. There are certain Sylvania models, however, in which this lead should be disconnected at the tuner instead of at the back cover. After the back cover of the receiver has been removed, the control knobs which would interfere with chassis removal should be taken off.

## Removal of Control Knobs

Some television receivers employ knobs which may simply be grasped firmly and pulled off; others use various methods for securing the knobs so that they cannot be so easily removed in this manner. There are available commercial pullers which are very valuable in removing knobs that have retaining clips or that fit tight and are hard to pull off. Such a knob puller is shown in Fig. 1. A rag or cord can be used when a commercial knob puller is not available. Fig. 2 shows a handkerchief being used for removing a knob. Prying off a knob with a screwdriver is not a good practice; there is too much danger of breaking the knob or damaging the cabinet of the receiver.

There are some cases, such as in early Magnavox models and in certain Stromberg-Carlson sets, in which the channel-selector knob is secured

with a small Allenscrew. When a receiver such as this is encountered, it is impossible to remove the chassis if the proper Allen wrench is not available; therefore, carry a set of these wrenches in the tool kit.

Some Philco and Arvin receivers employ a retaining clip on the channel-selector shaft. After the channel-selector knob is removed, the retaining clip must be removed before any attempt to remove the fine-tuning knob is made; otherwise, the fine-tuning knob may be broken. These clips are very springy, and care should be taken to guard against possible loss of one of them during removal.

## Disconnect Cables

After the knobs are removed, the various cables should be disconnected. If the antenna lead was not disconnected when the back was removed, as would be the case if the antenna terminal strip were fastened to the cabinet, it should be disconnected and secured in such a manner

\* \* Please turn to page 74 \* \*

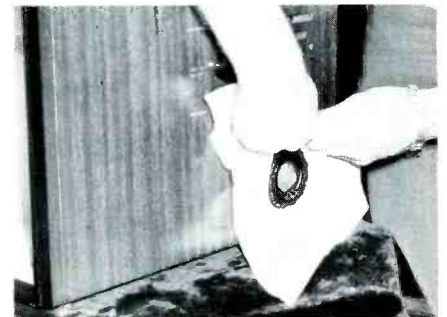



Fig. 2. Removing a Knob With a Handkerchief.



# SYLVANIA SILVER SCREEN 85

## The picture tube with Selling Power!

That's right! Sylvania's "Silver Screen 85" puts powerful, profitable salesmanship behind your personal TV service. That's because "Silver Screen 85" is the picture tube TV America knows and asks for by name.

Every week Sylvania's "Beat the Clock" show builds greater consumer recognition and demand for the "Silver Screen 85." Every week dealers benefit at the payoff point.

Put the "Silver Screen 85's" selling power to

work for you. This booklet tells your customers the benefits of Sylvania's "Silver Screen 85." Leave a copy on every service call. Order a free supply now from your Sylvania Distributor.

SYLVANIA ELECTRIC PRODUCTS INC.  
1740 Broadway, New York 19, N. Y.  
In Canada: Sylvania Electric (Canada) Ltd.,  
University Tower Building, Montreal  
LIGHTING • RADIO • ELECTRONICS  
TELEVISION • ATOMIC ENERGY



"Installing a 'Silver Screen 85' sure increases the value of a trade-in set and speeds turnover."



"'Silver Screen 85' sales are up over all other brands."

"TV service volume increased by 'Silver Screen 85' tie-in advertising."



# SYLVANIA®



... fastest growing name in sight



# Notes On

# TEST EQUIPMENT

## Presenting Information on Application, Maintenance, and Adaptability of Service Instruments

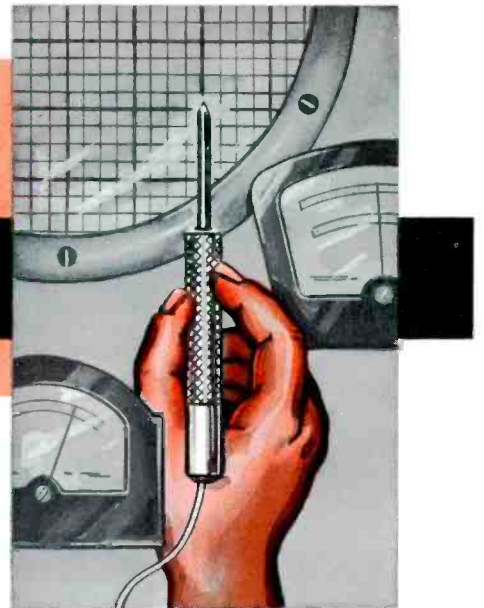

by Paul C. Smith

### TESTERS FOR FLYBACK TRANSFORMERS AND YOKES

The November-December 1951 issue of the PF INDEX (now the PF REPORTER) and the April 1955 issue of the PF REPORTER each contained an article on checking horizontal-output transformers. The method described in these articles required the use of an AC voltmeter of the VTVM type and an audio oscillator having a range extending up to at least 100 kilocycles. With this method, the presence of shorted turns in a horizontal-output transformer can be detected by measuring the resonant frequency of the transformer. One or more shorted turns result in an abnormal increase in this frequency.

A number of testers for flyback transformers and yokes have appeared on the market. Some are based upon the principle just described, and

others operate somewhat on the principle of the Q-meter or the grid-dip meter. In Fig. 1, both designs are represented in the group of testers for flyback transformers and yokes.

The transformer testers shown are designed to provide a positive check on the condition of flyback transformers and yokes. Some testers are designed so that they can be used to make continuity checks, although such checks are usually performed with an ohmmeter. This function is incorporated in these testers so that a complete check can be performed without resorting to the use of two separate instruments.

The designers of those testers that operate upon the principle of measuring the resonant frequency of the flyback transformer or of the horizontal-deflection system have taken into account the fact that all such systems have a natural resonant

frequency within a certain range. The presence of shorted turns increases this resonant frequency.

### Tester Employing Principle of Resonant Frequency

The Seco Model FB-4 flyback interval and inductance checker pictured in Fig. 1 uses the resonant-frequency principle for checking horizontal-deflection systems and for checking the inductances of yokes and flyback transformers. This instrument has a self-contained AC power supply, a multivibrator stage, a cathode-follower stage, and a 6E5 electron-eye indicator.

The frequency of the multivibrator can be adjusted by a front-panel control. This control is calibrated on the front panel with three different sectors which represent the normal resonant-frequency ranges for flyback transformers, horizontal-deflection assemblies, or yokes. Normal resonant frequency of the entire horizontal-deflection assembly should be reached when the front-panel control is in the FB-OK (flyback OK) sector. This assembly includes the flyback transformer, the yoke, the width coil, and all components associated with the horizontal-deflection system rather than just the flyback transformer alone.

The sector used for checking the flyback transformer alone covers a range from approximately 20 to 48 kilocycles, the sector for checking the horizontal-deflection system covers from 48 to 68 kilocycles, and the sector for checking the yoke covers

\* \* Please turn to page 61 \* \*



Fig. 1. Representative Group of Testers for Flyback Transformers and Yokes.

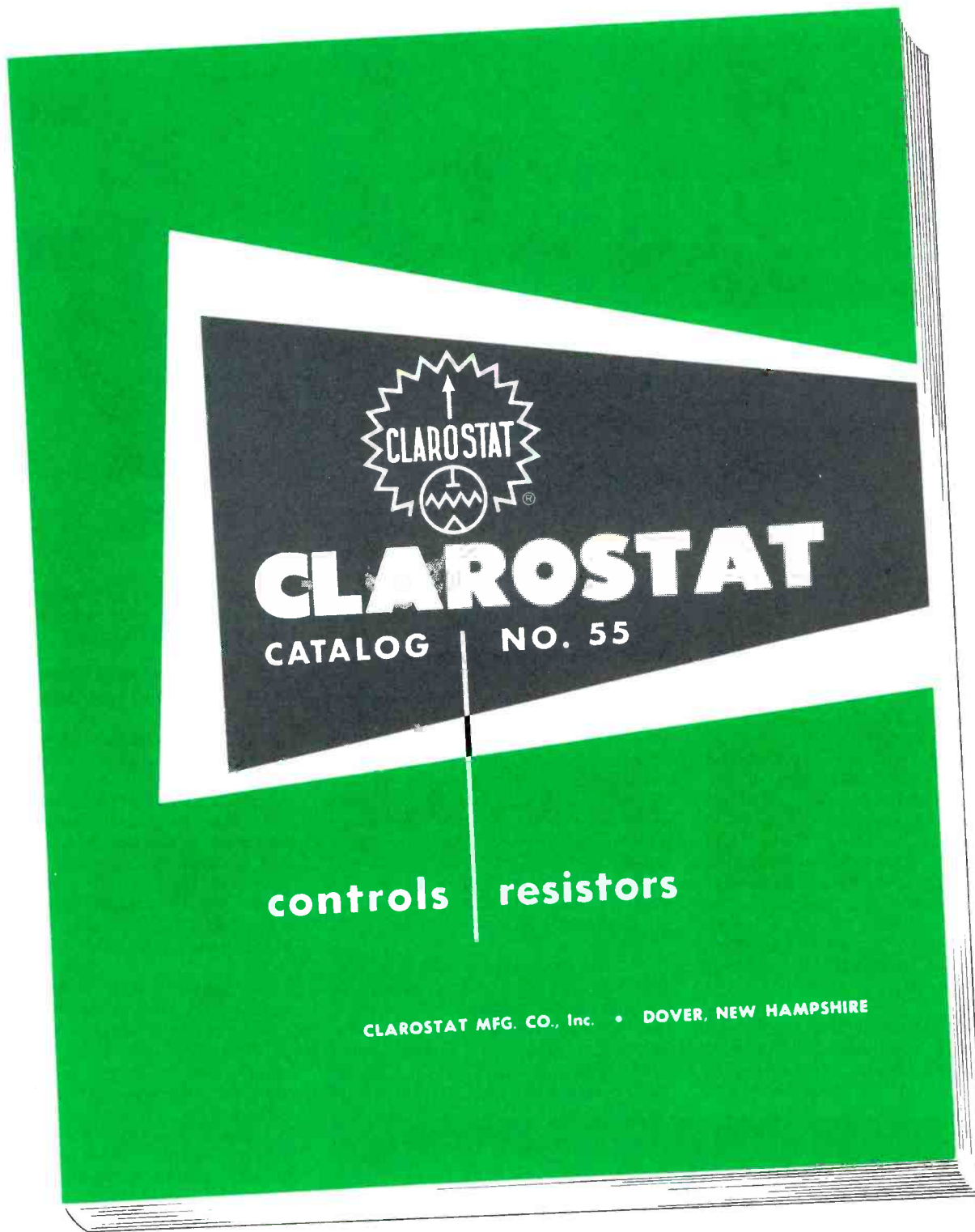

# 4,000 GOOD REASONS FOR BUYING

ASK YOUR DISTRIBUTOR  
for the new Clarostat Catalog No. 55 listing the most  
complete line of essential controls and resistors. And ask for the  
right placements for stay-put, profitable, good-will jobs.

Clarostat Mfg. Co., Inc., Dover, New Hampshire. In Canada: Canadian Marconi Co., Ltd., Toronto 17, Ont.



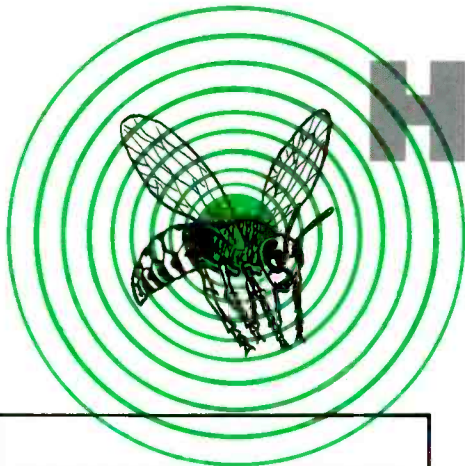

## COMMON CAUSES AND CURES

by William E. Burke

The servicing of an AC-DC radio when it develops an excessive amount of 60-cycle hum can become quite lengthy and involved, because the troubles which can produce hum can be many and varied. If the technician becomes familiar with the most common troubles, he can reduce greatly the time required for servicing receivers which do have too much 60-cycle hum. Presented here are some of the major causes of such troubles and some of the methods for removing them.

The servicing procedure should be started by determining the type of hum which is present. Hum of the 60-cycle variety can be divided into two types or categories — tunable and nontunable. The term "tunable hum" indicates one which varies in volume or in tone as a station signal is tuned in and out. Nontunable hum does not vary with a variation in tuning.

### Tunable Hum

When tunable hum exists in a receiver, it indicates that either the RF or IF signal is being modulated by the 60-cycle hum. The first step toward eliminating this trouble should be to determine whether the hum originates in the receiver or whether the signal is being modulated by the hum at a point which is external to the receiver. Another receiver which is known to be in good operating condition can be used for this check. If the hum is also found on the second receiver, the hum is from an external source; and your efforts should be directed toward removing the source of interference.

If the foregoing test proves that the receiver in question is faulty,

# HUM TROUBLES

## in AC-DC RADIOS

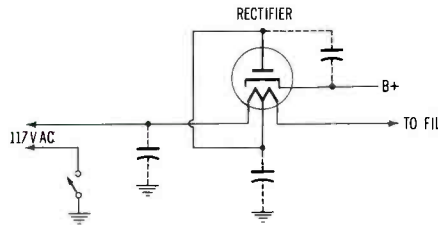

Fig. 1. Alternate Locations of Line-Filter Capacitor in Half-Wave Rectifier Circuit.

the next step would be to check by substitution the RF, converter, and IF tubes. This can usually be done without removing the chassis from the cabinet and may save some time if the hum is being caused by a faulty tube or tubes.

Further steps in the elimination of the hum will require the removal of the chassis from the cabinet, since the components and wiring on the underside of the chassis will be involved.

One frequent cause of tunable hum is a defect in the capacitor which serves as a filter in the AC power line to the receiver. This capacitor may suffer a loss in value or become open. Check it by bridging it with a good capacitor. Fig. 1 shows the three positions in which this capacitor is usually found.

There is always the possibility that some 60-cycle voltage can be introduced into the AVC line, and it will appear audibly as tunable hum. In some receivers, the frame of the tuning capacitor is connected to the AVC line and is insulated from the chassis by rubber grommets. See

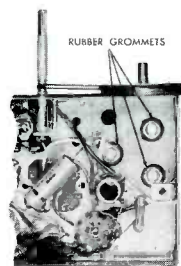

Fig. 2. Partial Underchassis-View of Typical AC-DC Radio With Rubber Grommets Which Insulate Tuning Capacitor From Chassis.

Fig. 2. The AVC line can become shorted to the chassis if the grommets deteriorate and allow the capacitor to touch the chassis. Since the chassis is connected to the AC line through the isolation capacitor and resistor, hum will sometimes appear on the AVC line.

### Nontunable Hum

If the trouble is diagnosed as nontunable hum, several remedial steps can be taken before the chassis is removed from the cabinet. Check to make sure that the polarity of the AC plug does not have too great an effect upon the hum level. Some receivers will exhibit hum when the AC plug is connected to the AC line in such a way that the high side of the line is connected to the B- line in the receiver. When the plug is reversed, the hum will disappear, or at least it will decrease in strength. When servicing a receiver, always insert the plug so that the hum is at a minimum. In this way, some confusion will be avoided.

Substitute tubes in the following order: the audio output tube, rectifier, IF, detector and audio, converter, and RF (if it is used). This order is important because it takes into account the facts that some tubes are more prone to failure than others and that some tubes have more AC voltage applied than do others. The filament string of a typical AC-DC receiver will appear somewhat as shown in Fig. 3. Note that the output tube is near the high end of the string. A heater-to-cathode short in this tube will apply a high AC voltage to the cathode circuit and hence will give rise to considerable hum from the speaker.

Glass tubes used in the audio and IF stages can introduce hum into a receiver if shields which are normally used are missing. If the hum level increases when a hand is held near or around the bulb of one of these tubes, the original hum might be originating in that tube. Install a tube shield or substitute a new metal tube, and then test the receiver.

\* \* Please turn to page 59 \* \*

P. R. MALLORY & CO. INC.  
**MALLORY**  
APPROVED PRECISION PRODUCTS

P. R. MALLORY & CO. INC.  
**MALLORY**  
APPROVED PRECISION PRODUCTS

P. R. MALLORY & CO. INC.  
**MALLORY**  
APPROVED PRECISION PRODUCTS

## Your customers will like Mallory Midgetrols® —and so will you

**NO FUSS**—Midgetrols cut replacement time to minutes. The round, tubular shaft is simple to cut to exactly the length you need . . . and it's easily adapted to split-knurl, flatted or set screw type knobs. Attaching an AC switch is a cinch, without taking the control apart.

**NO KICK-BACKS**—Midgetrols give your customers the long, trouble-free service that makes lasting friends. You can count on them for performance that equals or exceeds that of original equipment, because they're engineered to provide accurate resistance, superior stability, in any radio or TV set . . . in any climate.

**NO DOUBT ABOUT IT**—Midgetrols save you time and money. Your local Mallory distributor is ready to supply a special Mallory Control Kit that will set you up to service more than 50 models of radio and TV sets. You'll get a stock selected on the basis of set popularity in your own area . . . plus a free metal storage cabinet. Call your Mallory distributor today, or write to P.O. Box 1558, Indianapolis, Indiana.

### BE SURE TO USE . . .

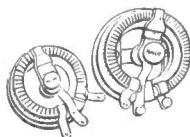

**MALLORY POWER RHEOSTATS** . . . vitreous enameled, in ratings from 25 to 500 watts, with exclusive hinged contact arm for positive contact.

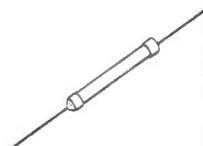

**MALLORY DEPOSITED CARBON RESISTORS** . . . high stability resistors with tolerances of 1% or 10% . . . at lower cost than wire-wounds.

P. R. MALLORY & CO. INC.  
**MALLORY**

CAPACITORS • CONTROLS • VIBRATORS • SWITCHES • RESISTORS  
RECTIFIERS • POWER SUPPLIES • FILTERS • MERCURY BATTERIES  
**APPROVED PRECISION PRODUCTS**

**P. R. MALLORY & CO. Inc., INDIANAPOLIS 6, INDIANA**



# Examining **DESIGN** Features

## NOISE-INVERTER CIRCUIT IN SYLVANIA CHASSIS 1-522-2

by **LESLIE D. DEANE**

The Sylvania Chassis 1-522-2 incorporates an interesting circuit in the sync section. This circuit appears physically as a duo-triode 12AU7 tube located close to the high-voltage cage and is referred to as a noise-inverter stage.

Noise pulses of high amplitude often occur in the composite video signal because of outside interference. If these undesired pulses are allowed to pass through the sync separator, they can cause erratic operation of both the horizontal and vertical oscillators. In order to overcome this condition, the manufacturer of this particular chassis has incorporated a noise-inverter circuit which acts upon the signal between the sync amplifier and sync separator. A schematic diagram of this circuit is shown in Fig. 1.

The operation of the noise-inverter circuit is accurately described by the title, for it utilizes the principle of signal inversion. A composite video signal is introduced into the sync section through a series resistor R84. The signal voltage is sampled at this point of input and is then applied to one triode section V15B in the 12AU7 tube. If noise pulses of excessive amplitude are present in this signal, they are inverted in polarity and are fed back to a point in

the original signal path where they cancel the incoming noise.

In conjunction with this stage, it is necessary to control the action of the inverter so that it cancels only the noise pulses and does not affect the normal sync pulses. One way to accomplish this is to vary the grid bias on the inverter V15B in accordance with any variation in signal strength. In order for the action to take place, use is made of the triode section V15A which is keyed by a positive pulse from the horizontal-output transformer.

The noise inverter V15B obtains its cathode potential from a voltage-divider network in the cathode circuit of the horizontal-output tube. A parabolic waveform may be observed at the cathode of V15B by use of an oscilloscope. The fluctuating voltage represented by this parabolic waveform varies at the rate of the horizontal frequency, and its most positive value occurs during the sync-pulse interval. When a positive sync pulse is fed to the grid of the inverter, the tube would normally conduct; but the voltage applied to the cathode becomes positive at this time and tends to hold the tube at cutoff. During the period between sync pulses, the cath-

ode voltage of the inverter swings in a negative direction. This action will cause the tube to become more sensitive to grid excitation; therefore, any noise pulse impressed on the grid during this period will cause the inverter to conduct.

A positive signal containing sync pulses and video is coupled from the sync amplifier to the plate of the keyer V15A through capacitor C73. A positive-going pulse supplied from a winding on the horizontal-output transformer is fed to the grid. This pulse is generated by the retrace currents, and it occurs only at sync-pulse time. These voltages at the plate and grid will drive V15A into conduction only during the sync-pulse interval.

When the tube conducts, capacitor C73 will charge to a value determined by the amplitude of the applied sync signal. The capacitor discharges through resistor R81 which develops a bias for the inverter grid. The bias thus produced is sufficient to place the tips of the incoming sync pulses on the same level with the cutoff voltage of the inverter, regardless of variations in signal strength. Since the inverter is not conducting during the sync interval, the sync pulses from the sync separator are coupled to the sync separator through resistor R84 and capacitor C75 in a conventional manner.

Noise peaks which have excessively high amplitude and which occur between sync pulses will be coupled to the inverter grid. The coupling capacitor C73 offers a lower impedance than the resistor R84 at the relatively high noise frequencies. The inverter triode amplifies and inverts any positive noise pulse, and the resulting negative pulse at the plate of the inverter cancels the original positive noise pulse which has been coupled to the plate through resistor

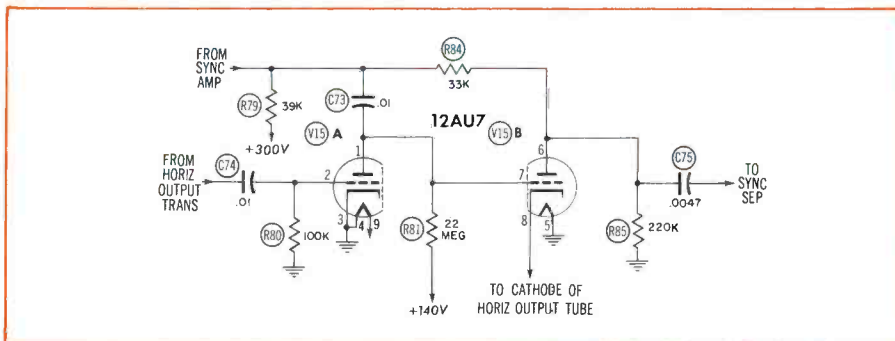
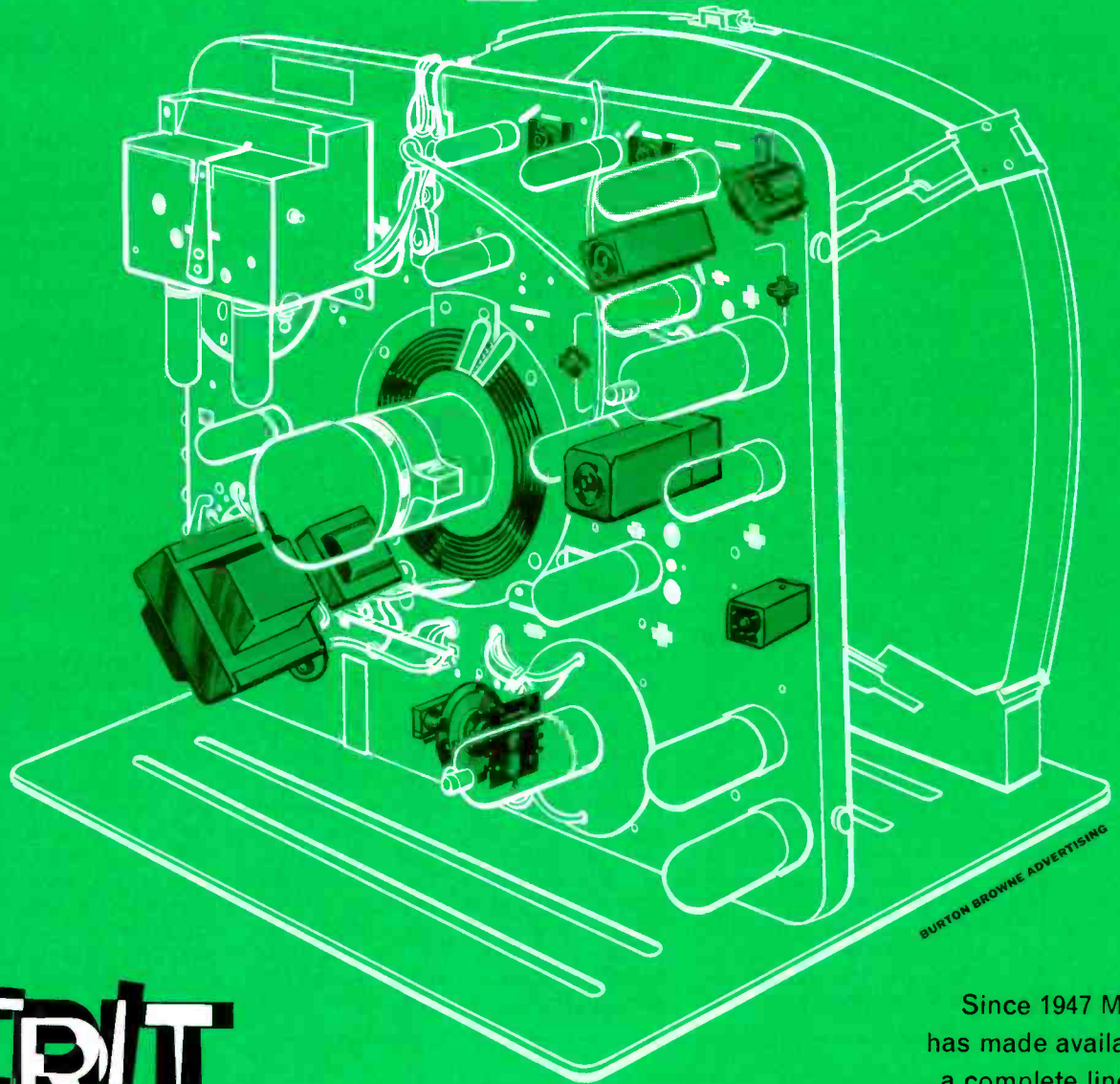

Fig. 1. Noise-Inverter Circuit in Sylvania Chassis 1-522-2.

# MERIT

Single Source  
for a complete line  
of coils and transformers



BURTON BROWNE ADVERTISING

# MERIT

COIL & TRANSFORMER CORP.  
4427 N. Clark Street  
Chicago 40, Illinois

Since 1947 Merit has made available a complete line of replacement transformers and coils.

They are available for TV sets . . . home and portable radios . . . automobile radios . . . innumerable industrial applications. Merit's three plants are geared to supply your transformer and coil replacement needs . . . when you need them . . . wherever you are.

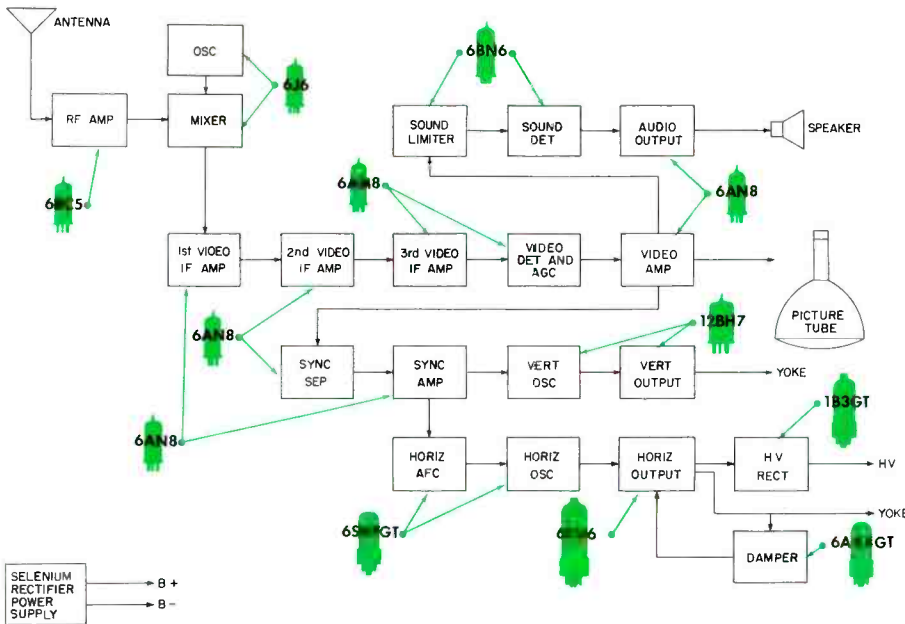

**Fig. 2. Block Diagram Showing Distribution of Dual-Purpose Tubes in Olympic Model 14TD52 Television Receiver.**

R84. The negative pulse is of greater amplitude than the original positive noise pulse because the original pulse has been attenuated by R84, and at the same time the negative pulse has been amplified; therefore, any noise pulse will appear with a negative polarity on the grid of the sync separator. This negative-going pulse will not affect the operation of the sync circuits.

The type of noise-inverter circuit just described greatly stabilizes the operation of the sync circuits in areas where the signal-to-noise ratio is poor; however, it has been noticed that in some very strong signal areas, a horizontal wiggle or vertical flop-over may be encountered.

Sync trouble of this nature may be caused by a weak or defective keyer section in the 12AU7 tube. For instance, if the keyer V15A is inoperative, the inverter section will be free to amplify and invert all sync signals present on its grid. The amplified and inverted sync pulses will override the original positive sync pulses, and negative-going sync pulses will be applied to the sync separator. The vertical and horizontal oscillator circuits will be very erratic in their operation since they require positive sync pulses for stable operation.

If a new 12AU7 tube does not correct the unstable synchronization in areas where there are strong signals, try removing the tube entirely. Removal of this tube is not given un-

qualified recommendation by the author nor by the manufacturer, although it has been found to help in severe cases.

### OLYMPIC MODEL 14TD52 WITH CHASSIS AD

One of the features that becomes apparent upon first examination of the Olympic Model 14TD52 is its small size and light weight. The receiver is not of a style that could be hung on the wall, but its design is a step in that direction. The manufacturer has developed a chassis that utilizes only 12 tubes in addition to a standard picture tube. The total number of operational stages has not been reduced; but in order to achieve such a compact electrical design, dual-purpose tubes are employed almost exclusively. A block diagram of the complete television receiver is shown in Fig. 2. This figure also presents a pictorial illustration of the dual-purpose tubes and their applications.

In Fig. 3, it may be noticed that there are no operating controls on the front of the cabinet; however, the conventional controls are accessible on the side of the cabinet. The protective glass is removable from the front of the cabinet to facilitate cleaning of the picture-tube face. The operating controls which are located on the side of the cabinet are: the vertical-hold control, horizontal-hold control, brightness control, contrast control, volume control and on-off switch, channel-selector switch, and the fine-tuning control. All of those just mentioned, except the channel-selector switch and the fine-tuning control, are mounted on a separate strip which is isolated from

\* \* Please turn to page 55 \* \*

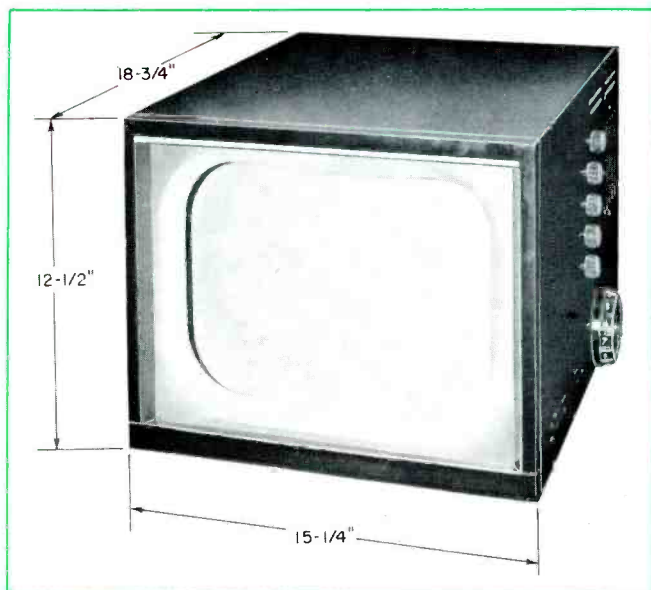

**Fig. 3. Olympic Model 14TD52 Television Receiver.**

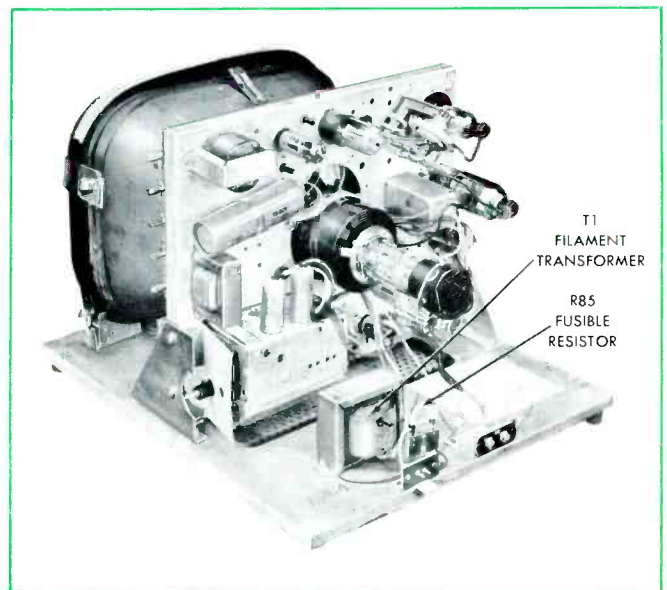

**Fig. 4. Olympic Chassis AD.**

this **RAYTHEON** "Bond" ....

pays a 10% "Dividend"\*

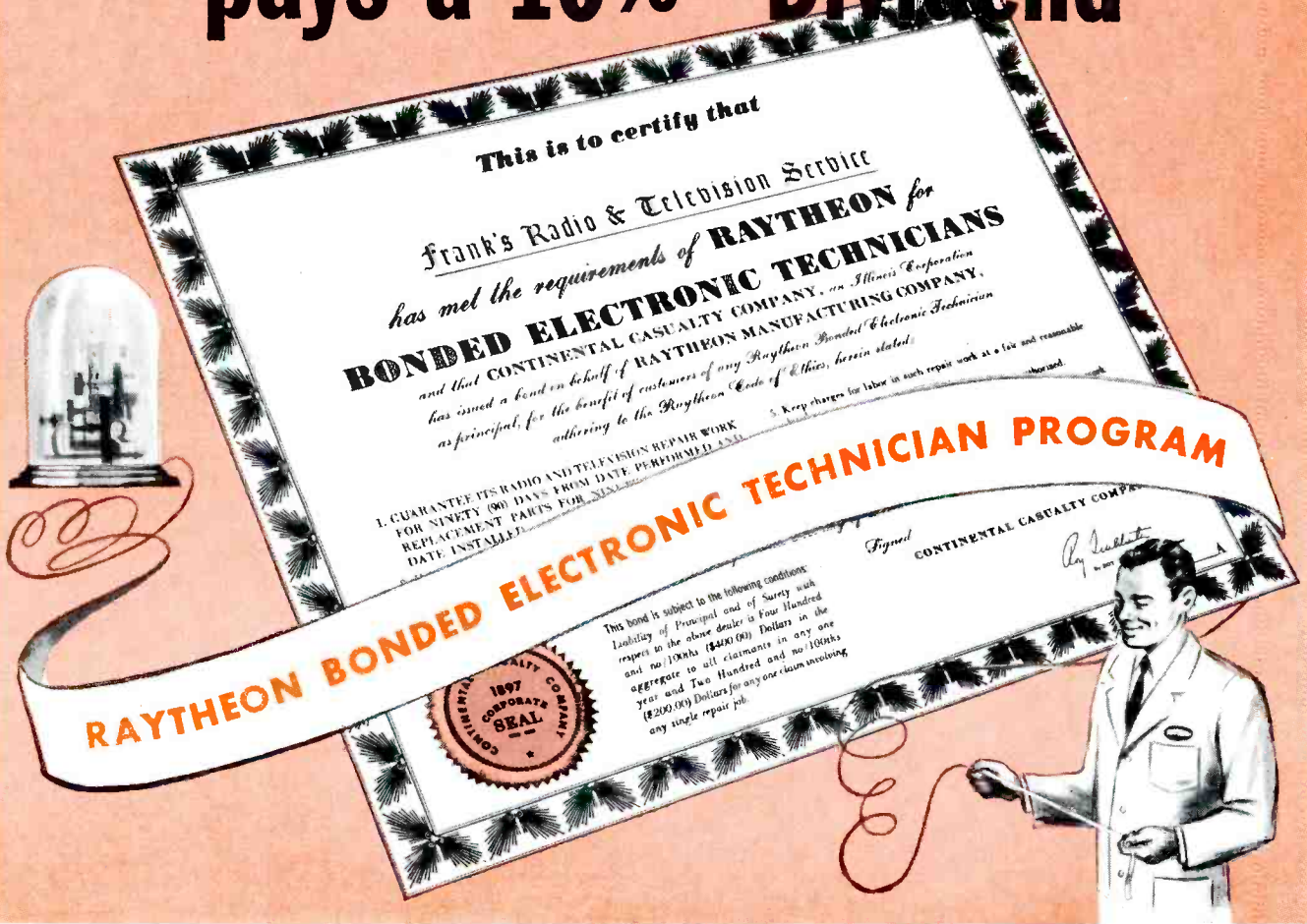

If you are interested in increasing your Radio & TV Service business and profits 10% or more call the Raytheon Tube Distributor in your area right now.

Ask him to tell you how the Raytheon Bond gives you a national backing of your 90 day guarantee, increases customer confidence in you and your shop.

Ask him to show you the many free business builders — Creed Displays, Decals, Certificate, Identification Cards, ad mats, etc. — that Raytheon makes available to you to help you tell your customers and prospects you're "Bonded".

Ask him about the Raytheon national advertising that makes it easy for you to get more business and then ask him if you can qualify for this exclusive Raytheon business builder. If you can, it costs you nothing — it's Raytheon's investment in your future.

\*Recent surveys prove the Raytheon Bonded Program improves business by at least 10 per cent.



**RAYTHEON MANUFACTURING COMPANY**  
 Receiving and Cathode Ray Tube Operations  
 Newton, Mass. • Chicago • Atlanta, Ga. • Los Angeles, Calif.  
 Raytheon makes all these: Receiving and Picture Tubes • Reliable Subminiature and Miniature Tubes • Semiconductor Diodes and Transistors • Nucleonic Tubes • Microwave Tubes





In the Interest of . . .

# Quicker Servicing

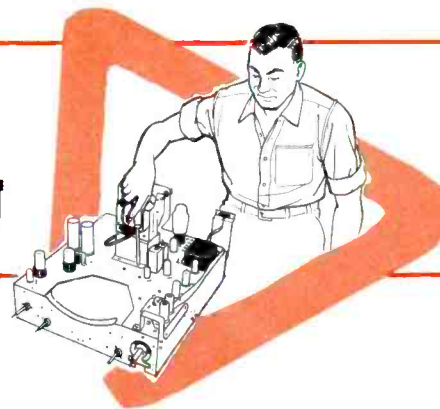

by Henry A. Carter and Calvin C. Young, Jr.

## IN THE SHOP

### Frequency Drift in AM Radios

Frequency drift in AM radios has always created a somewhat difficult service problem. The prevalence of this problem seems to have lessened to some degree in more recent years. This could be a result of several factors such as better tube designs, better tube materials, and better materials used in other components. Nevertheless, the problem still exists to some extent.

Many technicians have probably worked on radios that have had frequency drift. Often, the trouble can be cured by the simple replacement of a tube. Occasionally, tube substitution is not a remedy and other service procedures are needed.

Before we go further, let us clear up one important point. A detuning effect in an AM radio may not always be caused by a drift in the frequency of the local oscillator, although the oscillator is the most common offender. Sometimes a detuning effect may be produced by a shift in the frequency response of an

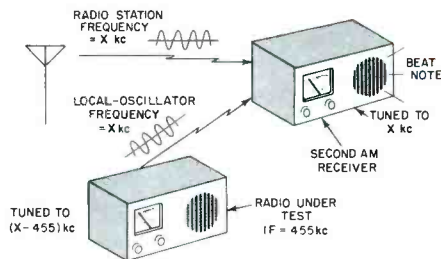

Fig. 1. Setup for Checking Oscillator Drift by Means of Second AM Receiver.

IF stage. For example, the electrical characteristics of an IF transformer may change under the influence of heat; and the resonant frequency of the transformer may vary as a result.

When confronted with a gradual frequency drift, the technician can save time by employing the following test to isolate the source of trouble to either the oscillator stage or the IF stages. A second AM radio is used in this test, and the method can be deduced from a study of the drawing in Fig. 1.

The two radios are placed side by side. The second AM radio is tuned to a station which is operating

at a certain frequency, let us say at X kilocycles. It is preferable to select a station near the high frequency end of the broadcast band. Tune the radio under test to a frequency which is less than X kilocycles by an amount equal to the intermediate frequency in this same radio. When this is done, the local oscillator in the defective radio should be operating at a frequency of X kilocycles, because most local oscillators operate at frequencies above that of the incoming signal. The signal from the local oscillator in the defective radio will radiate and will be picked up by the second radio. There, it will mix with the signal from the radio station, and a beat note will be heard from the second radio. Tune the radio under test until a condition of zero beat is obtained. If a beat note reoccurs and increases in frequency after continued operation of both radios, a drift in the frequency of the local oscillator in the defective radio is positively indicated.

It is true that a slight drift may be considered normal; but if the drift is such that the beat note attains a frequency of four or five kilocycles after ten or fifteen minutes of operation, trouble is present in the oscillator. If the beat note from the second radio remains close to a condition of zero beat during this test, the IF stages in the defective radio should be suspected as being responsible for the detuning effect.

It is not necessary to disassemble the defective radio in order to make this test; however, if the chassis is already out of the cabinet, a hair dryer may be used to accelerate the heating in order to shorten the time needed for the radio to reach full operating temperature. Fig. 2 shows the hair dryer being used for this purpose. A heat lamp may be used in place of the hair dryer; but the advantage of using a dryer is that a warm stream of air can be directed at a particular component such as an oscillator coil.

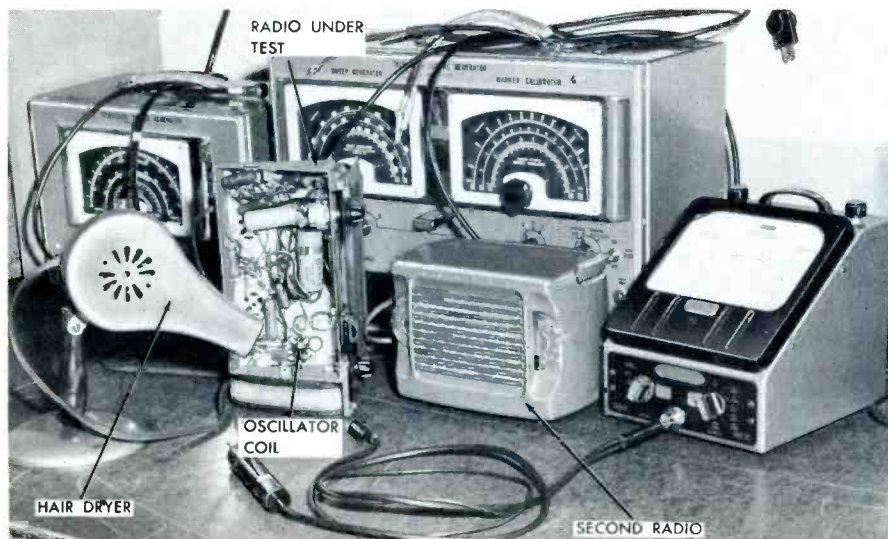

Fig. 2. Hair Dryer Being Used to Accelerate the Warm-up Time.

\* \* Please turn to page 69 \* \*

# Audio-Facts



## CONSTRUCTION DETAILS ABOUT A PREAMPLIFIER OF IMPROVED DESIGN

by **ROBERT B. DUNHAM**

The preamplifier and control unit described in the "Audio Facts" column in the July-August 1952 issue of the PF INDEX and the original unit from which it was developed have been in constant use in our laboratory since they were constructed. They

have given very consistent and satisfactory service with many different audio systems under widely differing conditions. In fact, we gain more respect for these useful pieces of equipment the more we use them in our increasing audio activities.

Three years are a long time in these days of rapid development in

high quality audio systems; therefore, in order to keep up with progress, some changes and improvements have been made in both units. Taking a cue from the number of inquiries and comments which we continue to receive concerning the preamplifier and control unit, we feel that it would be worth while to supply some information about these improvements and some detailed data for those who would like to construct a unit.

A view of the preamplifier and control unit fitted with a perforated metal cover can be seen in the heading of this article. The general construction and features of the unit can be seen in Figs. 1 and 2. Enough switches, controls, and inputs are provided to permit flexibility of operation; but not enough are provided to complicate the situation and make operation difficult rather than convenient.

The circuit of the complete unit, shown in Fig. 3, is made up of individual circuits that are mostly conventional and familiar. These individual circuits are effective and are worthy of some discussion before construction details are discussed.

### Circuit Description

Any one of the three inputs can be switched into the circuit by the channel-selector switch. Input No. 1 is for use with magnetic phono pickups. Inputs No. 2 and No. 3 have the same characteristics. They are uncompensated and are intended for use with high-output devices such as tuners, TV receivers, crystal phono pickups, and tape recorders.

Input No. 1 connects directly to the grid (pin No. 7) of V1 which is a

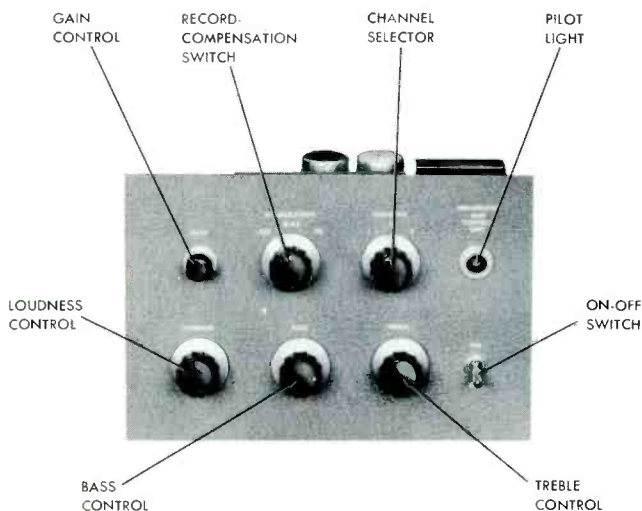

Fig. 1. Front View of Preamplifier and Control Unit.

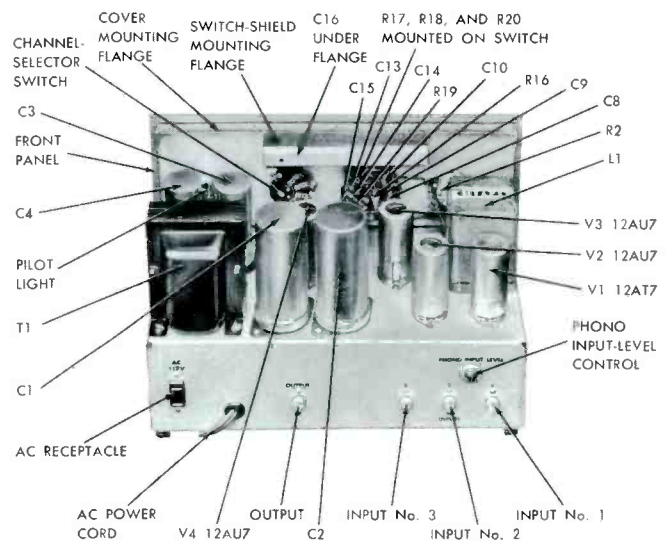

Fig. 2. Rear View of Preamplifier and Control Unit.

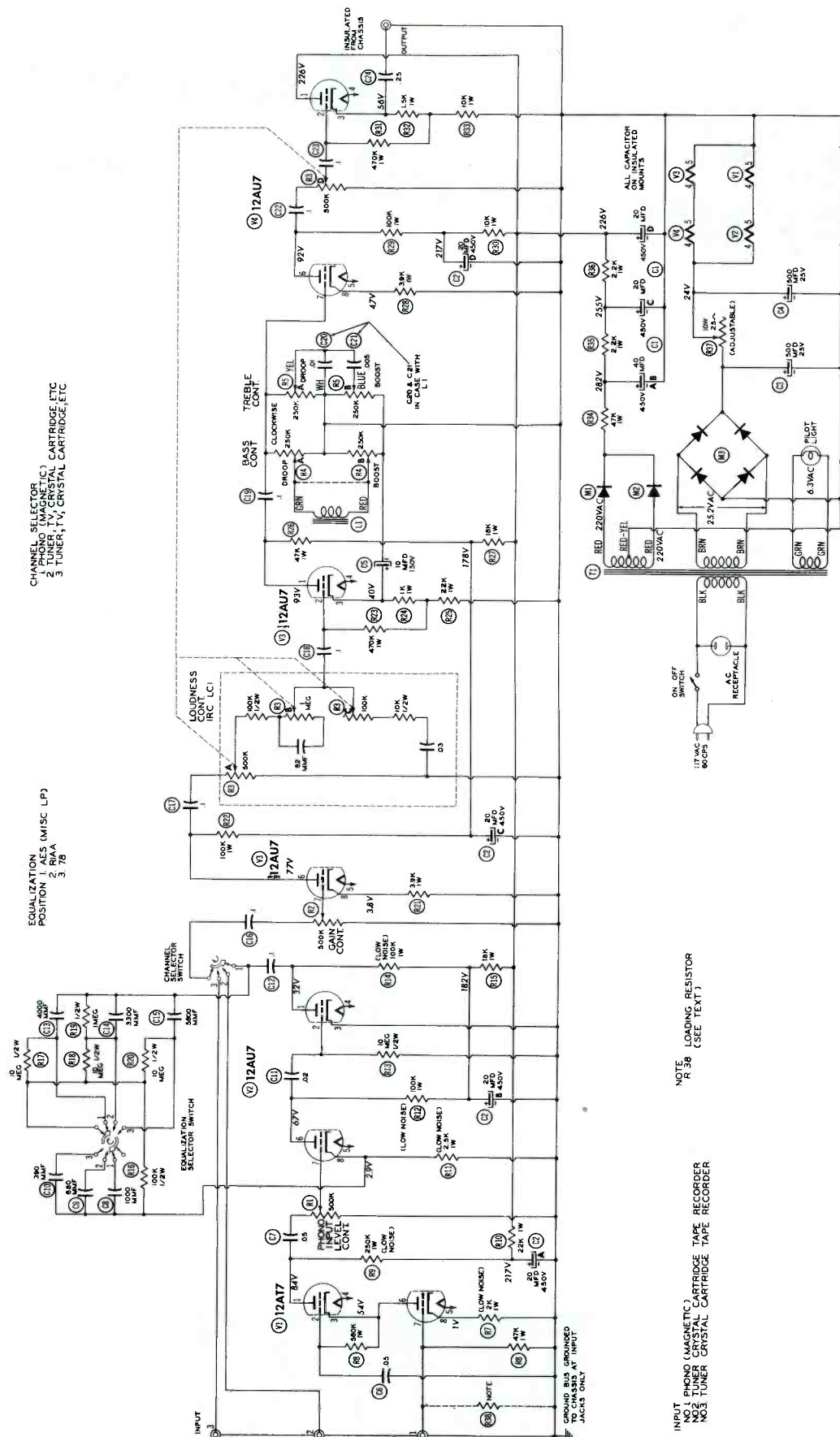

Fig. 3. Schematic Diagram of Preamplifier and Control Unit.

AGAIN *telrex* OFFERS  
MORE BECAUSE...

# THERE IS A MATERIAL DIFFERENCE!

NEW "THUNDER BIRD" "BEAMED POWER" ARRAYS FOR ALL-CHANNEL TV

"THUNDER BIRD" Antennas are loop phased, multi-element, "Beamed Power" Arrays for fringe and "sub-fringe" area TV reception. Element functions are duplexed by means of variable impedance phasing loops to produce effective high gain Yagis for Hi and Lo channel VHF Bands in an all-in-line array which actually produces superior gain and directivity — element for element — than equivalent separate units.

THUNDERBIRD  
MODEL T120

PATENT  
PENDING\*

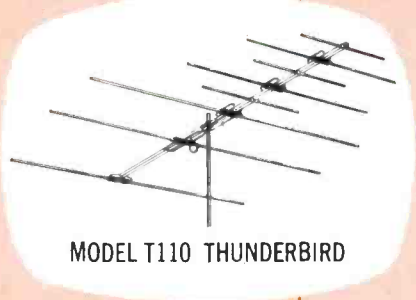

MODEL T110 THUNDERBIRD

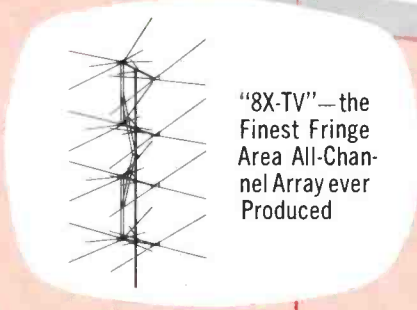

"8X-TV"—the  
Finest Fringe  
Area All-Channel  
Array ever  
Produced

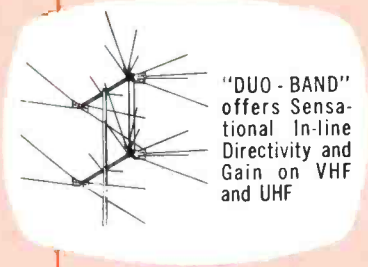

"DUO-BAND"  
offers Sensational In-line  
Directivity and  
Gain on VHF  
and UHF

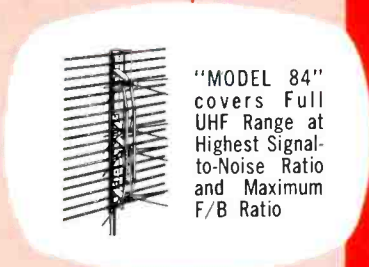

"MODEL 84"  
covers Full  
UHF Range at  
Highest Signal-to-Noise Ratio  
and Maximum  
F/B Ratio

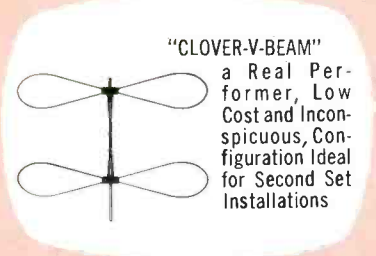

"CLOVER-V-BEAM"  
a Real Performer, Low  
Cost and Inconspicuous,  
Configuration Ideal for  
Second Set Installations

Producers of famous "BEAMED POWER" Communication Rotaries.  
Call or write for new catalogs on TV Antennas, Commercial Arrays or Amateur Rotaries.

• Top quality materials and construction plus superior performance is the TEL-REX watchword. Superb engineering combined with exhaustive laboratory and field testing assures reception quality that surpasses factory ratings. Over 100 different models are available to solve every installation problem, whether it be low cost or extra performance. Best quality materials assure peak performance rain or shine.



ASBURY PARK 10  
NEW JERSEY, U.S.A.  
Tel. PRospect 5-7252  
Canadian Distributor:  
DELHI METAL PRODUCTS,  
LTD., Delhi, Ontario

\*"Conical-V-Beams" are produced under U. S. Patent No. 23,346, Canadian Patent No. 500,436 and British Patent No. 691,485 — other patents pending. Sold only through authorized distributors.

12AT7 tube operating as a cascode amplifier. The cascode circuit is used because of its high gain, low noise, very high input impedance, and low input capacitance. These characteristics make it a logical input circuit for magnetic pickups because these normally have very low signal outputs and low output impedances. This application of the cascode circuit was discussed in more detail in "Audio Facts" in the April 1955 issue of the PF REPORTER.

R38 (which is shown by dotted lines in Fig. 3) is a loading resistor that is not needed in most cases but can be used if the high-frequency response of the pickup is excessive and if it must be rolled off. The resistance value of R38 can be the value recommended by the manufacturer of the magnetic cartridge being used. One of the best methods is to try different values until the best balance in response is obtained. For instance, it was found that a 27K-ohm, 1-watt resistor R38 reduced the high-frequency response by the correct amount when a General Electric RPX-050 cartridge was used. R38 was not used at all with a Fairchild Model 220 cartridge. R38 can be installed either inside the chassis or in some convenient location on or close to the cartridge.

The phono input-level control R1 can be adjusted to provide a satisfactory operating level for any of the usual magnetic cartridges. Compensation for the characteristics of magnetic pickups and for record-playback curves is accomplished by the adjustable feed-back circuit which feeds back from the plate (pin No. 1) of V2 through C12 to the cathode (pin No. 8) of V2. Appropriate capacitors and resistors are switched into the feed-back circuit by the equalization-selector switch to provide bass boost and high-frequency roll-off according to three different playback curves.

Position No. 1, labeled AES (Audio Engineering Society), provides equalization based on a modification of the older AES curve and is suitable for use with many of the older micro-groove recordings. Position No. 2 follows the RIAA (Record Industry Association of America) curve, now considered the standard playback curve. This position is suitable for most recent microgroove recordings. Incidentally, the new AES, orthophonic, and NARTB (National Association of Radio and Television Broadcasters) curves are identical and are the same as the RIAA curve. Position No. 3 is a compromise and is intended to be used in playing 78-rpm records.

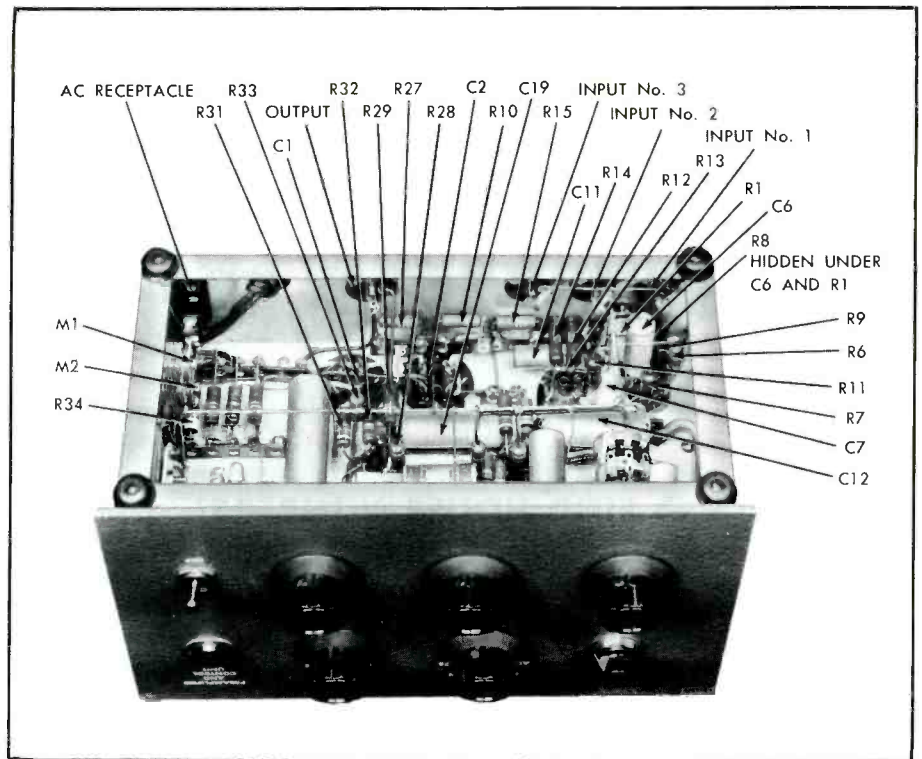

Fig. 4. Bottom View From Panel Side.

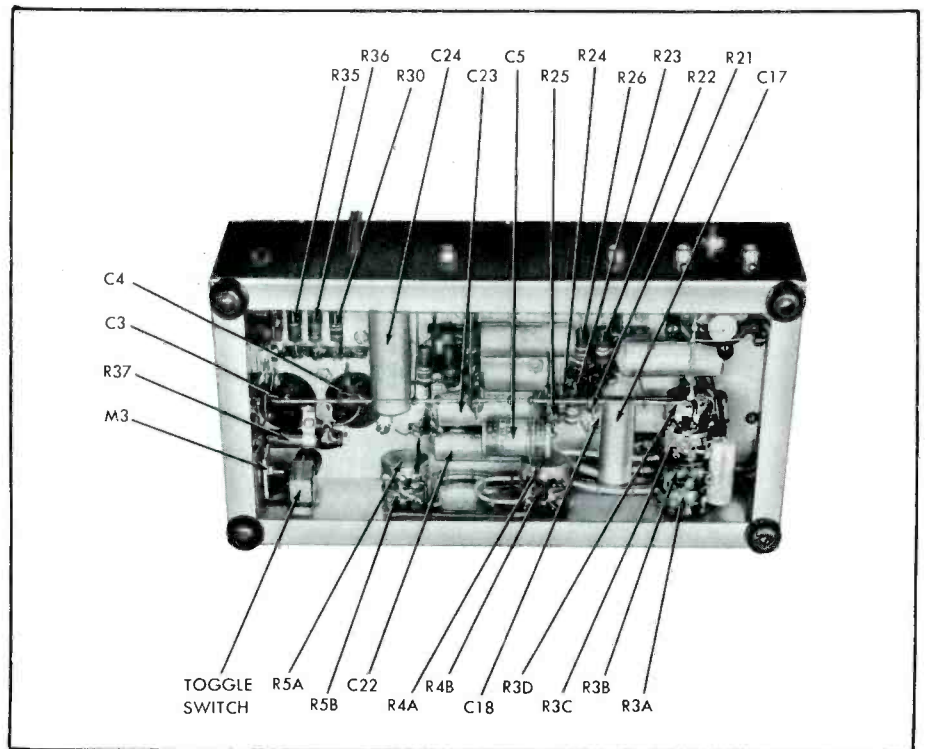

Fig. 5. Bottom View Showing Parts Located in Front Part of Chassis.

Any of these playback curves can be modified for best results by adjusting the treble and bass controls. It must be remembered that it is difficult to follow any particular recording curve when a recording is made and that conditions also make it difficult to play back a record according to a certain curve. Consequently, tone controls are useful for touching

up the playback response in order to obtain the desired results.

The gain control R2, which operates on all input channels, is mounted on the front panel in a position convenient for setting the level of the signal fed to the loudness con-

\* \* Please turn to page 50 \* \*

**A must for after-dark TV servicing**

# **G-E SERVI-SPOT**



**Electronic**  
TUBES

- **FIND HOUSE NUMBERS!**
- **READ STREET SIGNS!**
- **CHECK OUTDOOR ANTENNAS!**

\* \* \*

Plugs into the lighter socket on your dash.

Pre-focussed beam carries ¼ mile.

Compact, weighs only 6 oz., 12-ft. cord.

Manufactured by General Electric,  
world leader in lamps.

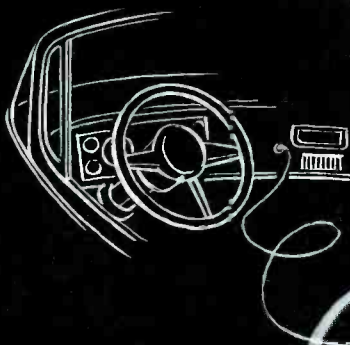

Get your SERVI-SPOT from your G-E tube distributor! General Electric Company, Tube Department, Schenectady 5, N. Y.

\* \* \*

Now G-E SERVICE-DESIGNED TUBES  
are available in 14 popular types.

Ask your G-E tube distributor for them!

**GENERAL**  **ELECTRIC**

161-1A3



# Dollar and Sense Servicing

by *John Markus*

*Editor-in-Chief, McGraw-Hill Radio Servicing Library*

**MOOD MUSIC.** For a "pick-me-up" on those mornings when you feel like biting somebody's head off, slip some of the following records (if you are fortunate enough to have them) on the phonograph while you're shaving, showering, and dressing:

Stars and Stripes Forever —  
Decca 2132-A

Grand March from Aida —  
Victor 11885-A

Humoresque —  
Victor 1170-B

Golden Age Ballet Suite - Polka —  
Victor 11-8239-B

Blue Danube Waltz —  
Victor 16658-A

Golliwog's Cake Walk —  
Victrola 7148-A

For the end of the day, if you're restless, jittery, all keyed up after a tough struggle with circuits and customers, pick your musical prescription from one of these relaxing, nostalgic, sentimental, and soothing selections:

Rhapsody in Blue —  
Victor 13835-B

Liebestraum No. 3 —  
Victor 11-8851-B

Lullaby (Brahms) —  
Victor 20174-A

Waltz of the Flowers —  
Columbia MM-395

For more musical prescriptions, particularly classical, see the article, "Music Can Make Your Mood," in the April 1955 issue of *Tape Recording*. It reports the research of Dr. A. Capurso, Director of Music at Syracuse University, on music therapy and gives his tested selections in four categories: (1) stimulating, (2) relaxing, (3) prayerful, and (4)

sad. Listen before you buy, however; some selections may revive memories in an individual and cancel out the intended effect. When you get the pieces that make you feel on top of the world, put them on tape and let them chase away the grouches. The resulting increased efficiency of your work all through the day will pay for the records many times over and make your job a lot more pleasant.



**ANTICIPATION.** "My wife gave me heck at breakfast. I can hardly wait to get down to the shop and take it out on the first customer," said one shop owner to a friend as they headed for Main Street together one morning, according to a recent cartoon.

With that sort of a start, along about five o'clock that same shop owner will probably be thinking, "Business sure was lousy today — can hardly wait to get home and take it out on the family at dinner." And that's why family life just has to be kept separate from business if both are to succeed.



**LOSS PREVENTION.** To give your service bench a real treat on its birthday, get it one of those heavy metal Scotch-tape dispensers that take rolls of tape 3/4 inch wide. Once you've had it for a week, you'll wonder how you got along without it — for sticking loose nuts, bolts, and knobs to a chassis; for attaching cards to a chassis; and for a hundred other simple jobs. Just preventing the loss of one unreplaceable bit of hardware justifies the outlay. Most stationery stores have them. They are priced around \$3, and a roll of tape comes to about \$1.20.

**LEVELING OUT TV.** Whenever production of TV sets gets too far ahead of sales, there is much moaning at the factory and much dumping in the stores, with everybody unhappy and losing money except the customer who gets a price break. When production gets caught napping and lags behind the demand, everybody is unhappy again — the customer is included this time, because he can't get the set he wants when he wants it.

To have a try at leveling out TV production, a survey company has been hired by RETMA to send out interviewers to selected retail stores once a month. These men come back with figures on actual inventory count and sales for radio and TV by type of set. By the 25th of the month, manufacturers who belong to this industry-wide association receive a 50-page booklet with detailed statistics on what moved and what didn't the prior month. The complex process of revising factory production schedules can thus get underway at least two months sooner than it did before, with a minimum of waste and confusion.



**INTERFERENCE.** In Canada, the law prohibits use of any apparatus which causes interference with the reception of a good radio signal (over 500 microvolts per meter), provided that the interference can be stopped by the manufacturer of the apparatus at a cost under \$50. When a complaint is received, the government sends one of its 50 mobile units to investigate and recommend suppression techniques. Of the 12,000 complaints received yearly, there are very few cases in which the interference cannot be eliminated economically. The manufacturer bears most or all of the cost of eliminating the trouble, and dealers maintain a stock of suppression kits.

\* \* Please turn to page 46 \* \*

THE FIRST COMPLETE ASSORTMENT OF PHONO DRIVES AND BELTS...

at  
your  
fingertips

**WALSCO**

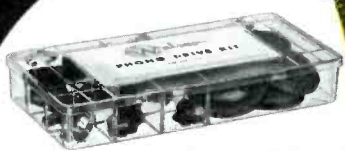

The new WALSCO Dealer Kit provides an assortment of 23 drives and belts... all packaged in a durable, transparent plastic case. This handy, compact kit with replacements for 85% of today's changers is available for only \$14.97 dealer net.



For the first time... a brand new idea in buying and selling phono-recorder drives and belts. Now there is *one* source... *one* display for a complete replacement line to service all major record changers and tape recorders. Every jobber will have the new WALSCO display on hand to fulfill, quickly and economically, the service-dealer's replacement needs.

 **Walseco**  
ELECTRONICS CORPORATION

3602 Crenshaw Blvd.,  
Los Angeles 16, California

CANADIAN REPRESENTATIVE:  
Atlas Radio Corp., Ltd.,  
50 Wingold Ave., Toronto, Canada

OVERSEAS REPRESENTATIVE:  
Ad Auriema, Inc.,  
89 Broad St., New York 4, N.Y.



## Color TV Training Series

(Continued from page 11)

Misalignment of the color-sync section is characterized by a number of indications in the reproduced picture. Such troubles as wrong colors, colors out of synchronization (a barber-pole effect), and no color can result from improper alignment of this section of the receiver. The photographs in Figs. C-3 and C-4 of the Color Plate show the appearance on the screen when wrong colors are being reproduced as a result of misalignment of a portion of the color-sync circuit. To reproduce this effect, the burst-amplifier transformer L41 was misadjusted.

Notice by comparing the photograph of Fig. C-3 of the Color Plate with the normal bar pattern of Fig. C-1 that a definite pattern of colors has resulted. The sequence of color bars in Fig. C-3 is cyan, green, brown, red, blue, and violet instead of green, yellow, red, magenta, cyan, and blue, as shown in the normal pattern of Fig. C-1. It should be remembered that the relative luminance levels of the color bars remain the same as they are in a normal bar pattern — namely, 0.59 for green, 0.89 for yellow, 0.30 for red, 0.41 for magenta, 0.70 for cyan, and 0.11 for blue. As shown in Fig. C-3, the color of a bar can change but the luminance level does not. The technician should be mindful of this condition when analyzing a color-bar pattern. For instance, the third bar of Fig. C-3 has changed from red to brown. Actually, this bar is yellow, but it is at a low level of luminance which causes it to appear brown. The luminance level of the third bar is 30 per cent; but if the luminance level were 89 per cent, a yellow bar would be present instead of a brown bar.

Let us look at the fourth bar to analyze the condition shown in Fig. C-3 of the Color Plate and to see what has happened. In the normal bar pattern, this bar is magenta; but in Fig. C-3, it is red. Referring to the color-phase diagram of Fig. 11-5, we can see that the vector representing magenta is spaced 119.9 degrees from the reference vector and that the vector representing red is spaced 76.5 degrees from the reference vector. If the phase difference between the color vector and the reference vector were decreased, the reproduced color would change from magenta to red. This condition is indicated by the bar pattern in Fig. C-3 of the Color Plate. Because of

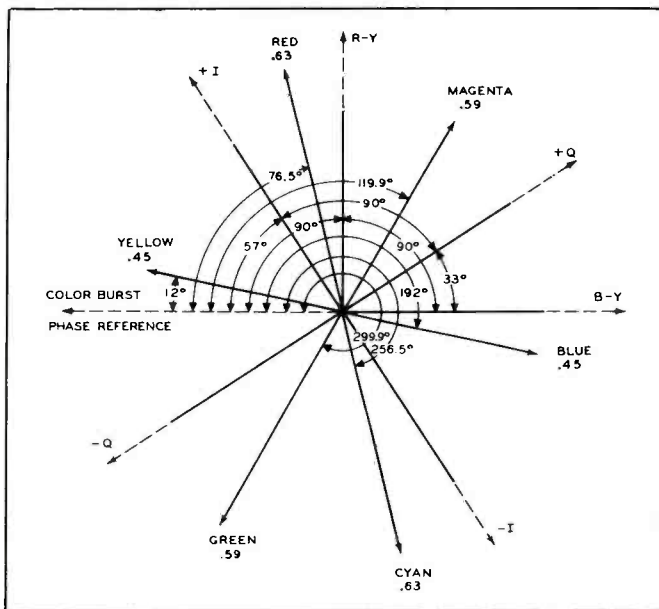

Fig. 11-5. Color-Phase Diagram.

the decreased phase difference, the receiver interprets the chrominance signal as being representative of red.

In Fig. C-3 of the Color Plate, the last bar which is normally blue has become a violet color. This result can be explained in the same manner. With a reduction in the phase difference between the chrominance vector and the reference vector, the receiver erroneously interprets the blue signal as being representative of a color which is near magenta. The wrong colors of the other bars are also caused by a reduction in the phase differences between the chrominance vectors and the reference vector.

The change in color of the Q and I bars can be noticed by comparing the photograph of Fig. C-4 with that of Fig. C-2 of the Color Plate.

Loss of color synchronization will produce the effect shown in Fig. C-5 of the Color Plate. This trouble is characterized by horizontal bands of color moving diagonally and vertically. This indicates that the 3.58-mc oscillator is operating at the wrong frequency. When the horizontal bars are few in number, it signifies that the oscillator is operating at a frequency that is only slightly off. As the diagonal bars increase in number, the frequency of the oscillator is farther from 3.58 megacycles. This condition can be caused by the misadjustment of a variable component in the color-sync section. To obtain the results shown in Fig. C-5, the reactance coil L43 was detuned.

As was mentioned previously, a condition in which there is no color may be caused by misalignment of the color-sync section. For instance, if the 3.58-mc oscillator coil L44 were badly detuned, there would be no output signal from the 3.58-mc oscillator; therefore, the color demodulators would not receive the CW reference signals which they require in order to detect the color-difference signals.

All of the abnormal conditions just discussed can also be caused by failure of components in the color-sync circuit. If any of these troubles occur and if it has been determined that component failure is not present, the alignment of the circuit is necessary.

A VTVM and a color signal from a color-bar generator or from a station telecasting in color are employed throughout the alignment procedure associated with the color-sync section. The color signal is fed to the antenna terminals, and the VTVM is connected across the output of the CW reference oscillator. First, the 3.58-mc oscillator coil L44 is tuned to produce a reading of five volts peak to peak on the VTVM. When this is done, the output of the oscillator will have sufficient amplitude.

Next, the quadrature transformer L45 is adjusted so that there is maximum transfer of energy from the quadrature amplifier to the color demodulators. The nature of the transformer and its associated circuit is such that a certain phase difference exists between the CW signal fed to one demodulator and that fed to the other demodulator after the quadrature transformer is adjusted. In the case of the circuit in Fig. 11-4, this phase difference is 90 degrees.

There are two adjustment points in the quadrature transformer. They are labeled A36 and A37. Before making the adjustments at these points, the color burst is removed from the color-sync circuit by shorting the grid of the burst amplifier V27A to the chassis. The VTVM is connected from the plate of the phase detector V28B to the chassis; then, adjustments are made at A36 for a

you can't argue with acceptance

proven quality  
100% inspected  
accurate replacement  
prompt delivery

the most  
complete  
line  
of twist mount  
dry electrolytic capacitors

Better than any claims we could make is the unqualified and enthusiastic acceptance by engineers and servicemen alike. These are some of the features on which this acceptance is based:

- Aluminum containers provide maximum protection against moisture.
- Low leakage, long shelf life.
- Designed for 85° C. operation.
- Complete with metal and bakelite mounting plates.
- Easy to mount.
- Extremely compact—yet highly dependable.

Pyramid capacitors are listed in Sams' Photofacts

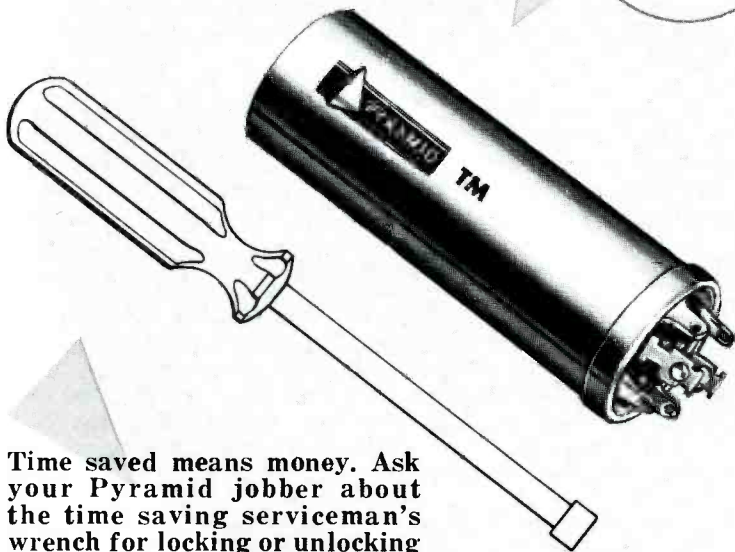

Time saved means money. Ask your Pyramid jobber about the time saving serviceman's wrench for locking or unlocking the mounting ears of Pyramid's twist mounts.

Burton Browne / New York

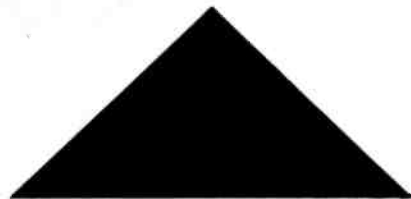

DISTRIBUTOR DIVISION

**PYRAMID**  
**ELECTRIC COMPANY**  
1445 Hudson Blvd., North Bergen, N. J.

maximum DC voltage indication on the VTVM and at A37 for a minimum indication. Reference to the schematic diagram in Fig. 11-4 will show that the phase detector V28B acts as a simple detecting device during this test. In other words, a DC voltage that is proportional to the amount of 3.58-mc signal present in one secondary of the quadrature transformer is developed across the VTVM because of the action of the phase detector.

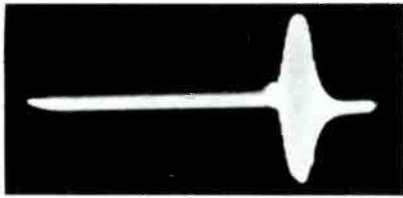

Fig. 11-6. Waveform of Burst Signal at Phase Detector in Fig. 11-4.

Adjustments at the next two points, A38 and A39, are performed in order that the color burst will be at the correct phase and amplitude when it arrives at the phase detectors. For these adjustments, the short between the grid of the burst amplifier V27A and ground is removed but the VTVM is left connected to the plate of the phase detector V28B. The hue control should be set at its mid-range position. Then, adjustment is made at A38 and A39 for maximum deflection on the VTVM. The VTVM in this case indicates a DC voltage that is proportional to the amplitude of the color-burst signal in the phase-detector circuit. As a further check, the color burst can be viewed on an oscilloscope by connecting the oscilloscope between the plate of the phase detector V28B and ground. The color burst should appear as shown in Fig. 11-6.

The next step is to make sure that the oscillator is operating at the correct frequency. This is done by adjusting the coil L43 in the plate circuit of the oscillator-control tube V29A. First, the input signal to the control tube is shorted to the chassis at point M. The VTVM is still connected to the plate of the phase detector V28B. Then, L43 is adjusted so that a zero beat between the color burst and the CW reference signal occurs in the

phase-detector circuit. This zero beat will be indicated by a slow oscillatory swing of the VTVM pointer. The beat can also be detected on the picture-tube screen — the colors on the screen will change slowly rather than rapidly when the condition of zero beat is present.

With the oscillator operating at the correct frequency, the next adjustment is to balance the phase-detector circuit. This is done by adjusting the AFC balance control R20 so that the proper grid voltage will be applied to the oscillator-control tube V29A. This tube performs most efficiently when its grid voltage under normal conditions is slightly positive. To adjust the balance control, connect the VTVM between point M and ground. Shunt the 3.58-mc crystal with a 15-mmfd capacitor so that the oscillator frequency will be lower than normal. Then, adjust the balance control R20 until the VTVM reads zero volts. Remove the 15-mmfd capacitor. The oscillator will speed up, and the phase detector will interpret the frequency change as an advance in phase. A positive correction voltage will be developed and applied to the oscillator-control tube, and the oscillator signal will be maintained in a fixed phase relationship with the color burst.

The adjustment of the AFC balance control completes the alignment of the color-sync section of the color receiver. The CW reference signals should have the same frequency as the color burst and should also have fixed phase relationships with the color burst.

## MATRIX

At the output of the I channel, there must appear a demodulated signal that is representative of only the I portion of the chrominance signal. The output of the Q channel must be a demodulated signal that is representative of only the Q portion of the chrominance signal. The signals at the outputs of the I and Q channels must also have the correct amplitudes. If the foregoing were not true, incorrect signals representative of red, green, and blue would be formed when the incorrect I and Q signals are combined with the luminance signal. The color signals will be correct when they arrive at the matrix if the necessary matrix adjustments are properly made.

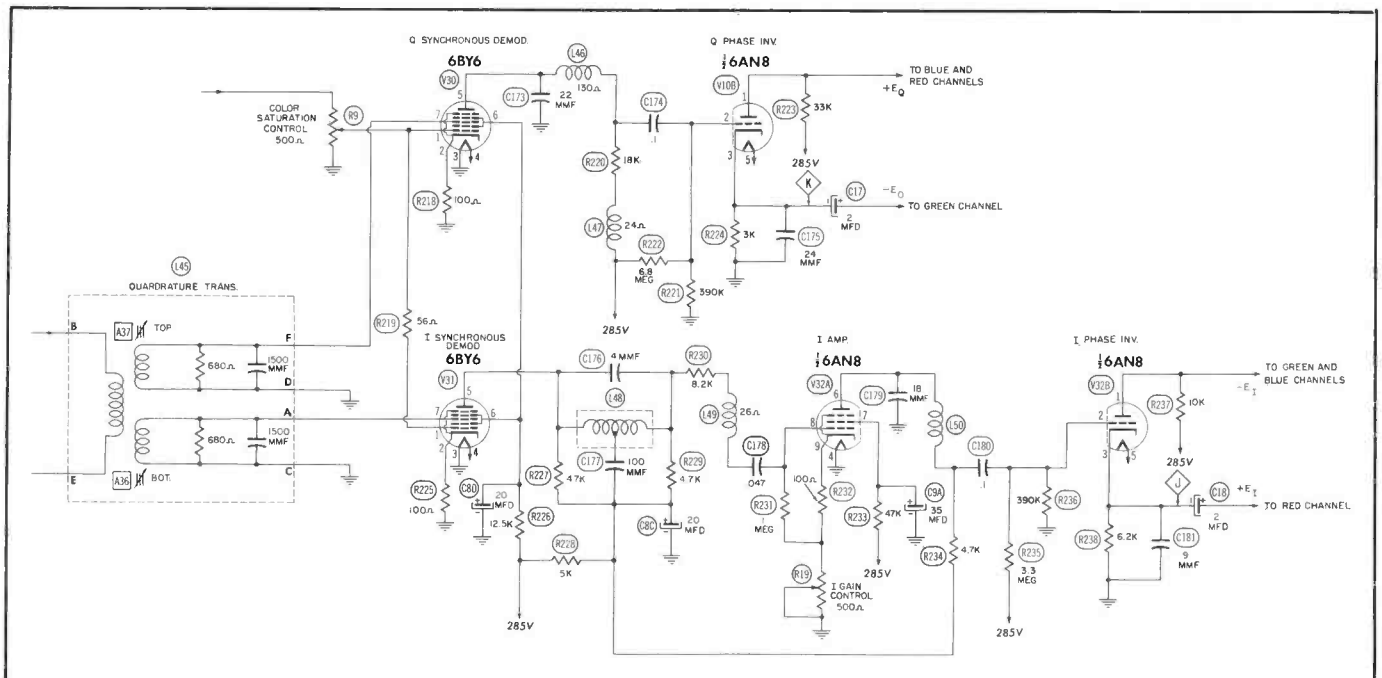

Fig. 11-7. The Circuitry of the I and Q Channels in the RCA Victor Model CT-100 Color Receiver.



**G-C VINYLITE CEMENT**  
Great adhesion; many uses.  
No. 58-2 NET \$0.39



**G-C LACQUER THINNER**  
Thins all types.  
No. 29-2 NET \$0.33

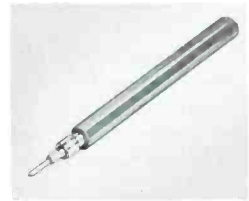

**G-C LOW-LOSS TEST PRODS**  
Excellent for high voltage.  
No. 5045 NET \$0.30



**G-C PLI-O-BOND CEMENT**  
Sticks "anything to anything".  
No. 43-2 NET \$0.39

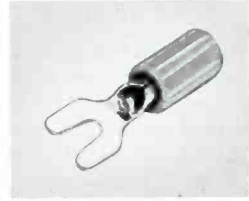

**G-C INSULATED SPADE LUG**  
Red; fits all banana plugs.  
No. 7712 NET \$0.11

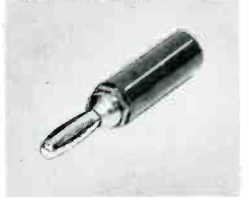

**G-C INSULATED BANANA PLUG**  
Spring type, solderless.  
No. 8994 NET \$0.21

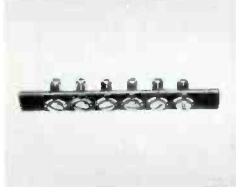

**G-C SCREW TYPE TERMINAL STRIPS**  
Has 6 contacts; others with 2-10.  
No. 1776 NET \$0.21



**G-C GRAFOLINE**  
Lubricant for metallic contacts.  
No. 120-2 NET \$0.39



**G-C SOLDERING PASTE**  
High-quality, non-corrosive.  
No. 1207 NET \$0.27



**G-C SPEAKER CONE RECONDITIONER**  
Rejuvenates dried-out cones.  
No. 25-8 NET \$0.60



**G-C KRYSAL KOAT LACQUER**  
Dries in beautiful patterns.  
No. 63-2 NET \$0.39



**G-C RADIO FRICTION TAPE**  
Narrow 3/4" Tape, 60-ft. roll.  
No. 870 NET \$0.39

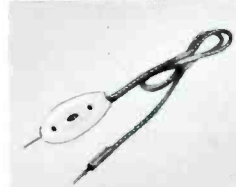

**G-C DANDY LITE TESTER**  
Heavy duty; 60 V AC, 90-550 V AC-DC.  
No. 8585 NET \$0.75



Ask For These  
**RADIO-TV SERVICE AIDS**

**CEMENT**

... at Your Jobber

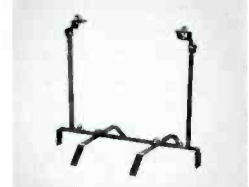

**G-C PHONO TURNTABLE STAND**  
Ideal for all turntable repairs.  
No. 5205 NET \$4.95



**G-C 'TUX' TOOL KIT**  
Carry all needed tools.  
No. 8943 NET \$2.37

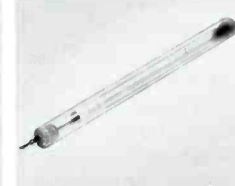

**G-C 'HI-VOLT' SAFETY PROBE**  
Neon glow for all high volt tests.  
No. 8836 NET \$1.65



**G-C 300-OHM LINE TUBING**  
Protects, waterproofs lead-in line.  
No. 625 NET \$0.66

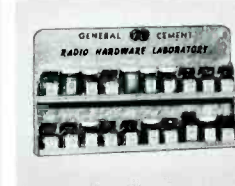

**G-C RADIO-TV HARDWARE LAB**  
Contains 20 assorted jars.  
No. 6601 NET \$10.20

Contains complete assortment of knob set, cabinet, wood and sheet metal screws; nuts; lock washers; lugs; clamps; cutters; etc.



**G-C UTILITY BOX**  
Spacious, handy, all-steel box.  
No. 4003 NET \$1.47



**G-C SPEEDEX FUSE PULLERS**  
Handy, safe for 1/2"-1/2" dia. fuses.  
No. 5525 NET \$0.42



**G-C RADIO-TV SERVICE CEMENT**  
Famed high grade adhesive.  
No. 30-2 NET \$0.39

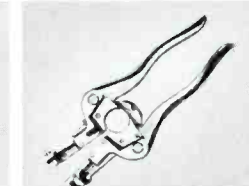

**G-C SPEEDEX WIRE STRIPPER**  
Automatic, delayed action return.  
No. 766 NET \$4.95



**G-C SPRAY-KLEEN**  
Power spray contact cleaner.  
No. 8666 NET \$1.00



**G-C KOLOID ACRYLIC SPRAY**  
Protects, insulates, prevents rust.  
No. 8665 NET \$1.19



Ask your jobber for these



**SPECIALS OF THE MONTH**

FREE! Postcard brings your big G-C Catalog.

**TELCO DELUXE CHIMNEY MOUNT**  
  
No. 8005-U NET \$1.11

**TELCO 10-PACK ANTENNA KLIPS**  
  
No. 9015-X Bag of 10 NET \$1.17

**TELCO 6-PACK LIGHTNING ARRESTORS**  
  
No. 8642-6P Pack of 6 NET \$2.25

**G-C REAR SPEAKER KIT**  
  
No. 9180 NET \$2.70



**GENERAL CEMENT MFG. CO.**

903 TAYLOR AVENUE • ROCKFORD, ILLINOIS



The adjustment points for obtaining proper matrixing are contained in the I and Q channels. The circuitry for the I and Q channels employed in the RCA Victor Model CT-100 color receiver is shown in Fig. 11-7. The quadrature transformer L45 is shown with this circuit because it will be referred to during the following discussion.

Let us investigate what would happen if an I portion of the chrominance signal were allowed to pass through the Q channel. First of all, assume that a chrominance signal that represents a Q bar and an I bar is fed to the input of the chrominance channel. With normal operation of the demodulators, the waveform at the output of the Q channel should appear as shown in Fig. 11-8A. This waveform was taken at the cathode of the Q phase inverter V10B. Notice that a negative voltage is developed during the transmission of the Q bar but that zero voltage is present during the transmission of the I bar. This is as it should be.



(A) With Proper Cancellation During Transmission of an I Bar.

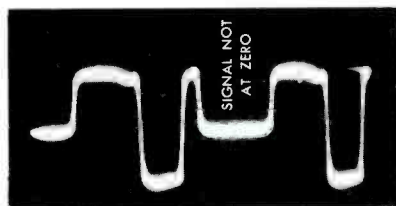

(B) With Improper Cancellation During Transmission of an I Bar.

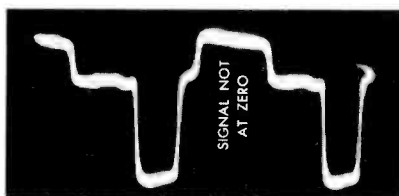

(C) With Improper Cancellation During Transmission of an I Bar.

**Fig. 11-8. Waveforms of Signals at the Cathode of the Q Phase Inverter.**

If the Q demodulator were operating improperly, however, the signal at the cathode of the Q phase inverter could appear as shown in Figs. 11-8B or 11-8C. Fig. 11-8B indicates that there is negative voltage present during the time that the I bar is being transmitted. This means that the Q demodulator has erroneously interpreted an I portion of the chrominance signal as being a Q portion. Fig. 11-8C indicates that there is positive voltage present during the time that the I bar is being transmitted. Again, this shows that the demodulation in the Q channel is in error.

In the formation of the color picture signal, the I and Q portions of the chrominance signal are spaced 90 degrees apart in phase. In order that these portions may be demodulated separately, the CW reference signals which determine the sampling times of the demodulators must also have a phase difference of 90 degrees. Then, if a chrominance signal that represents only an I signal were to arrive at the input of the demodulators, it would be passing through zero during the sampling time of the Q demodulator. This would result in no output from the

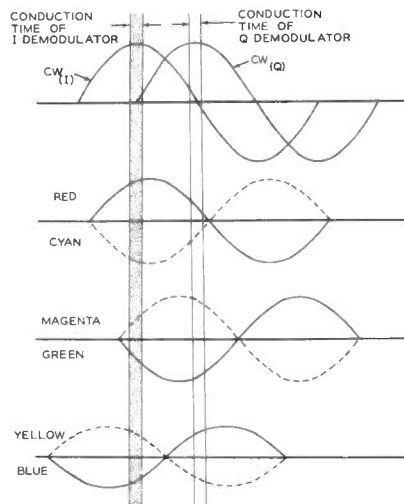

(A) With Sampling Times Which Are Correct Because CW Reference Signals Are 90 Degrees Apart.

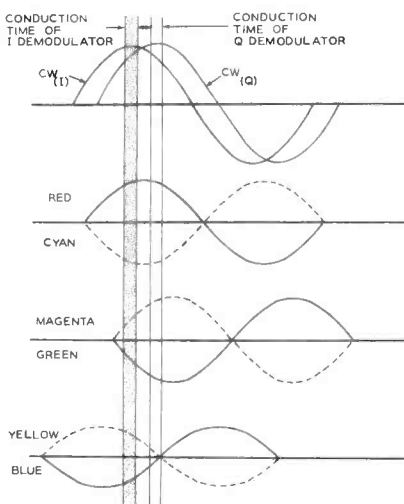

(B) With Sampling Times Which Are Incorrect Because CW Reference Signals Are Less Than 90 Degrees Apart.

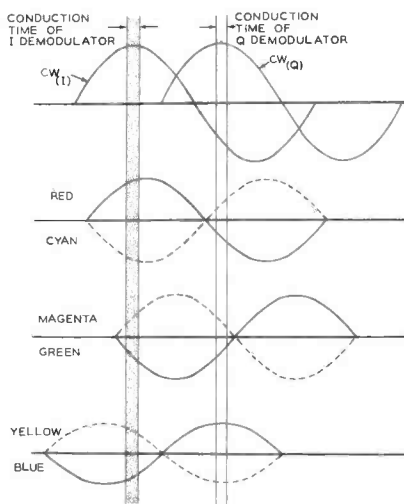

(C) With Sampling Times Which Are Incorrect Because CW Reference Signals Are More Than 90 Degrees Apart.

**Fig. 11-9. Waveforms of Chrominance and CW Reference Signals at Input of Demodulators. Sampling Times of Each Demodulator Are Indicated.**

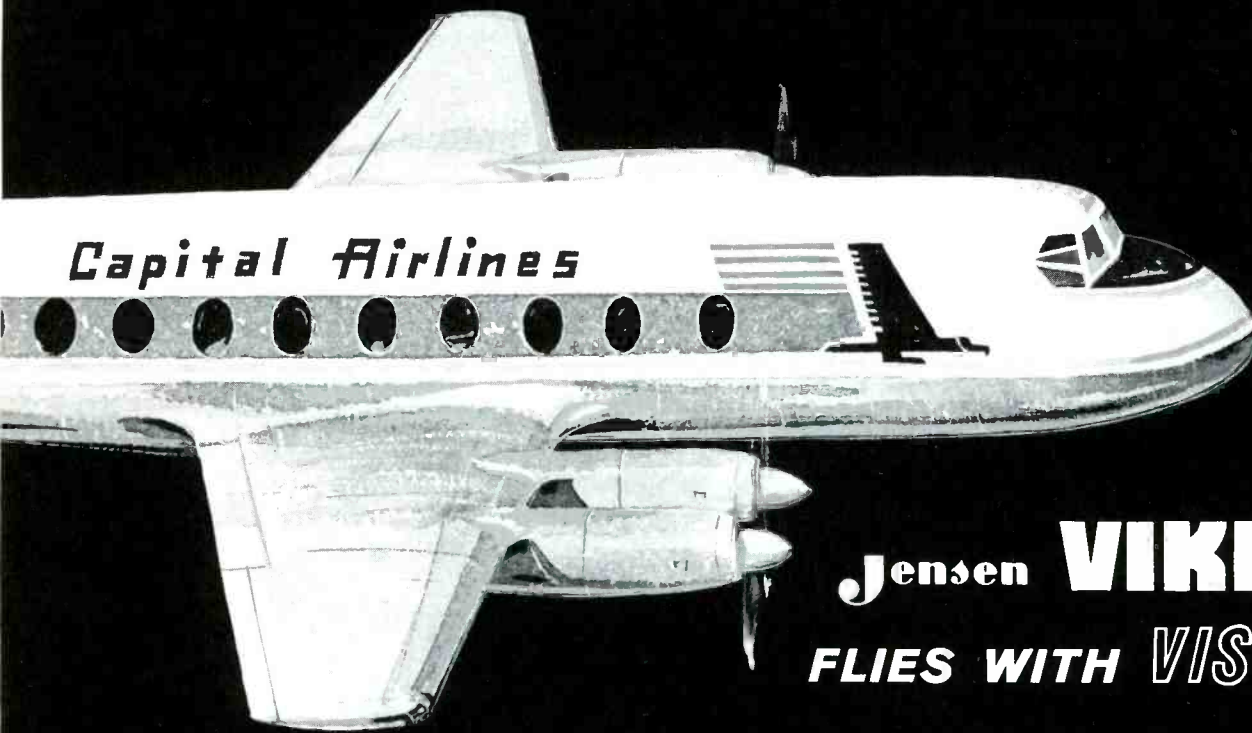

Jensen **VIKING**  
**FLIES WITH VISCOUNT**

**AN OUTSTANDING AVIATION ACHIEVEMENT!**

With the purchase of forty Vickers Viscounts, Capital Airlines culminates an extended search for the type of aircraft to best serve its millions of loyal passengers. These outstanding four propeller turbine engine aircraft will add new and important pages to aviation history.

**AN OUTSTANDING SPEAKER ACHIEVEMENT!**

Jensen Manufacturing Company is proud of Capital's selection of Viking Speakers for the audio system of this new modern aircraft. This system makes use of 22 Jensen Viking 4J6 type speakers mounted in the thin cabin walls between the windows on both sides of the cabin.

Leading parts distributors and service dealers know VIKING by Jensen as a stand-out economical replacement speaker line with compactness and efficient performance that universally qualifies VIKING for all radio and TV speaker replacements. And when you sell or install a VIKING, you get the same locked-in alignment, the same precision construction and the same dependability that led Capital to specify them for their Viscount fleet.

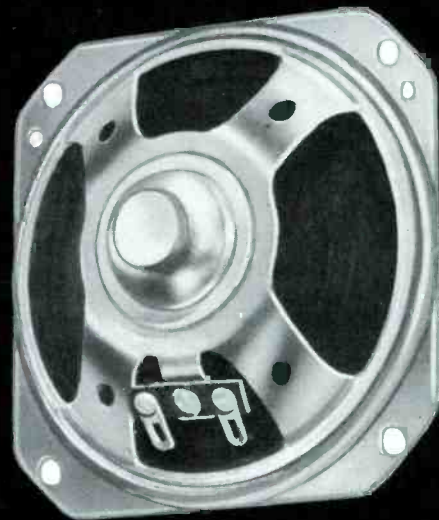

**Jensen**

MANUFACTURING COMPANY • 6601 S. Laramie • Chicago 38, Ill.

Division of the Muter Company

IN CANADA: Copper Wire Products, Ltd. Licensee

**WORLD'S QUALITY STANDARD FOR MORE THAN A QUARTER CENTURY**

Q demodulator. If the CW reference signals were either less than or more than 90 degrees apart, however, this same chrominance signal would not be passing through zero during the sampling time of the Q demodulator; therefore, the chrominance signal would be misinterpreted by the Q demodulator as having a Q portion.

When a color-bar pattern is being received, the bars will not have the correct hues if the Q demodulator samples the chrominance signal at the wrong time. The I portion in the chrominance signal will develop voltages in the Q channel, and the amplitude of the demodulated Q signal will not be correct.

The reader will recall that the three signals which drive the three guns in the color picture tube are reproduced in the receiver by combining specific proportions of the outputs from the I and Q channels with specific proportions of the luminance signal. During the transmission of a red bar, for example, the voltages which arrive at the matrix from the I, Q, and Y channels are such that the proportions available for the green gun add to zero. The proportions for the blue gun also add to zero. The proportions available to the red gun, however, combine to produce a voltage which drives this gun to conduction; and a red bar is produced on the screen.

If the voltage from the Q channel is either decreased or increased, the bar which is supposed to be red will not be a true red but will be closer to either a yellow or a magenta. This is caused by the fact that the proportions available to either the blue or greenguns no longer add to zero; hence, one or both of these guns conduct, and the hue of the bar changes.

The illustrations in Figs. 11-9A to 9C show the waveforms of various chrominance signals, and the conduction times of the I and Q demodulators are indicated with respect to these waveforms. The waveforms of the CW reference signals are also shown in these figures. In Fig. 11-9A, the CW reference signals have a phase difference of 90 degrees. In this case, the chrominance signals are sampled at the correct phase. In Fig. 11-9B, the phase of the Q reference signal is changed so that there is less than 90 degrees of phase difference between it and the I reference signal. In Fig. 11-9C, there is more than 90 degrees of phase difference between the two CW reference signals. The sampling process of the I and Q demodulators can be understood from these illustrations.

The color-phase diagram of Fig. 11-5 can be very helpful in predicting what happens to each color when the CW reference signals are changed in their phase relationship to each other. When the Q reference signal is less than 90 degrees from the I reference signal, the Q vector is effectively rotated in a clockwise direction. The color vectors rotate in the same direction; therefore, the green bar would change toward a yellow color, the cyan bar toward a green, the blue bar toward a cyan, the magenta bar toward a blue, the red bar toward a magenta, and the yellow bar toward a red.

When the Q reference signal is more than 90 degrees from the I reference signal, the Q vector is effectively rotated in a counterclockwise direction. This causes the vectors which are representative of the primary and secondary colors to be rotated also in a counterclockwise direction. Under this condition, the green bar would change toward a cyan color, the cyan bar toward a blue, the blue bar toward a magenta, the magenta bar toward a red, the red bar toward a yellow, and the yellow bar toward a green. The amount of change in the color of each bar depends upon how far the Q reference signal is rotated in a clockwise direction.

Included on the Color Plate are color patterns which show the results obtained when the Q reference signal is less than 90 degrees from the I reference signal and when it is more than 90 degrees from the I reference signal. Fig. C-6 of the Color Plate shows the color-bar pattern which results when the Q reference signal is less than 90 degrees from the I reference signal. Fig. C-7 of the Color Plate shows the Q and I pattern for the same condition as that in Fig. C-6. Fig. C-8 of the Color Plate shows the color-bar pattern which results when the Q reference signal is more than 90 degrees from the I reference signal. The Q and I pattern for the same condition is shown in Fig. C-9 of the Color Plate. The change in phase of the Q reference signal was obtained by misadjusting the top slug of the quadrature transformer L45 which is shown in Fig. 11-7.

One method of making the necessary matrix adjustments in the circuit of Fig. 11-7 is through the use of a color-bar generator and an oscilloscope. The oscilloscope is connected to point J which is located at the cathode of the I phase inverter. With an I and Q signal from a color-bar generator applied to the receiver, the hue control is adjusted until there is zero output from the I channel during the scanning time of the Q bar. The waveform on the oscilloscope should appear as shown in Fig. 11-10A. If it appears as shown in Fig. 11-10B, the setting of the hue control is incorrect.

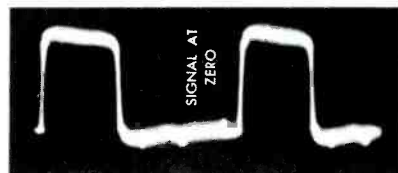

(A) With Proper Cancellation During Transmission of a Q Bar.

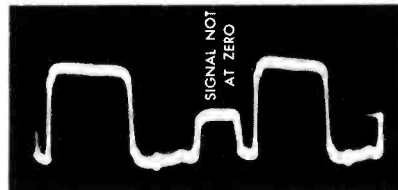

(B) With Improper Cancellation During Transmission of a Q Bar.

Fig. 11-10. Waveforms of Signals at Cathode of I Phase Inverter.

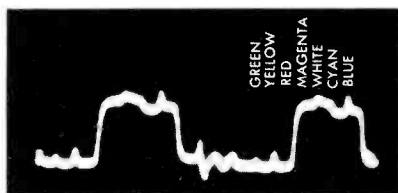

(A) Correct Signal.

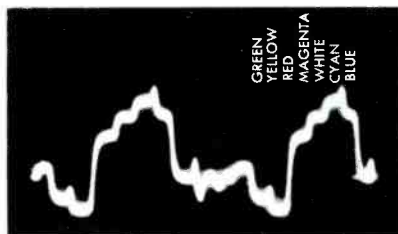

(B) Incorrect Signal.

Fig. 11-11. Waveforms of Signals at the Grid of the Blue Gun.

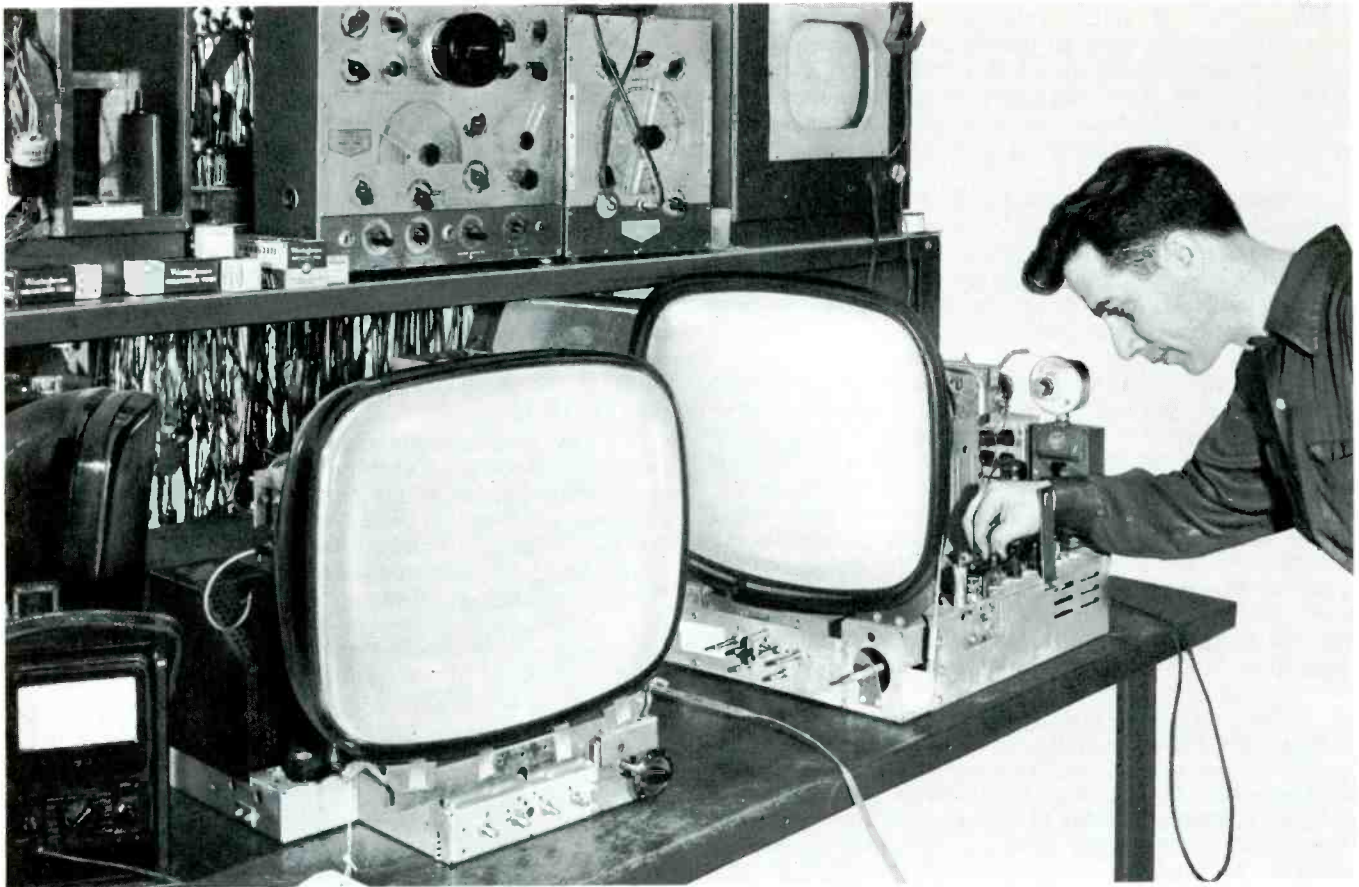

2 chassis, like the one pictured above (left) were used by Planet TV, B'klyn TV Service Center, to make their fact-finding call-back tests. The results? Planet says:

# "Westinghouse Receiving Tubes Cut Our Call-Backs by More Than 30%!"

One of the oldest and largest TV service organizations in New York—Planet TV—submitted Westinghouse Receiving Tubes and the tubes of other manufacturers to a rigorous, factual "call-back" test.

The test was set up by equipping two identical chassis; one with all Westinghouse types and the other with identical tubes of other manufacturers. The sets were turned on and operated 8 hours per day for 5 consecutive days, the average period during which Planet TV's records show that call-backs normally occur after renewal tube installation.

The chassis equipped with Westinghouse tubes showed no failures. The other chassis showed 3 tube failures—3 potentially costly Planet call-backs.

Why don't you make this simple, profitable call-back test in *your* shop. Prove to yourself, too, that Westinghouse Receiving Tubes can drastically reduce your call-back problems—and increase your profits! See your Westinghouse distributor today! Start using Westinghouse Reliatron® Tubes *right away!*

BREAKDOWNS: SET A (WESTINGHOUSE TUBES ONLY)		BREAKDOWNS: SET B (THREE COMPETITIVE BRANDS)
Monday	None	None
Tuesday	None	5U4G defective
Wednesday	None	None
Thursday	None	6AU6 defective, 5U4G soft
Friday	None	None

ET-95070

**YOU CAN BE SURE...IF IT'S**  
**Westinghouse**

**RELIATRON® TUBES**

WESTINGHOUSE ELECTRIC CORPORATION, ELECTRONIC TUBE DIVISION, ELMIRA, N. Y.



After the hue control is correctly adjusted, the oscilloscope lead is moved to point K which is at the cathode of the Q phase inverter. At alignment point A37 of the quadrature transformer, adjustment is made until there is zero output from the Q channel during the scanning time of the I bar. The waveform appearing on the oscilloscope should be the same as that which was shown in Fig. 11-8A. If the pattern is like either of those shown in Figs. 11-8B or 11-8C, the adjustment of the quadrature transformer is incorrect.

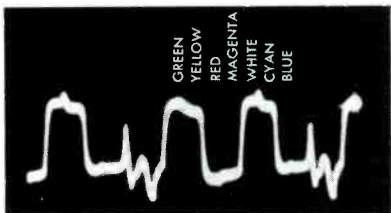

Fig. 11-12. Waveform of Correct Signal at Grid of Green Gun.

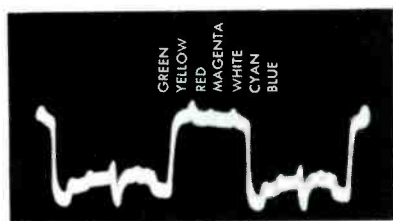

Fig. 11-13. Waveform of Correct Signal at Grid of Red Gun.

With the lead of the oscilloscope connected to the grid of the blue gun of the picture tube and with a color-bar signal applied to the input of the receiver, the next step in aligning the matrix is to balance the gains of the I and Q channels. The waveform at the grid of the blue gun should show maximum and equal amplitudes for the magenta, white, cyan, and blue bars. The amplitudes for the green, yellow, and red bars should be zero. The saturation control is adjusted for maximum cancellation of the green and yellow bars, and the I gain control is adjusted for maximum cancellation of the red bar. These

two adjustments are made alternately until the best possible cancellation is achieved. The waveform in Fig. 11-11A shows the correct signal at the grid of the blue gun. If the signal appears like the one shown in Fig. 11-11B, the adjustments of the saturation and I gain controls are incorrect.

After the correct signal at the grid of the blue gun is attained, the signals at the grids of the green and red guns should be checked. The waveform at the grid of the green gun should show maximum cancellation of the red, magenta, and blue bars with maximum and equal amplitudes for the green, yellow, white, and cyan bars. The waveform at the grid of the green gun should appear like that shown in Fig. 11-12.

The waveform at the grid of the red gun should be like that of Fig. 11-13. There should be maximum cancellation of the green, blue, and cyan bars and maximum and equal amplitudes for the yellow, red, magenta, and white bars.

After the quadrature and gain adjustments have been made, the I and Q signals arriving at the matrix should be correct. When these signals are combined with the luminance signal, the blue gun should receive a signal that contains only blue information; the red gun should receive a signal that contains only red information; and the green gun should receive a signal that contains only green information.

#### DYNAMIC-CONVERGENCE CIRCUIT

In those receivers in which convergence of the electron beams is obtained electrostatically, the circuits which supply the convergence voltages must be aligned. This is a very simple procedure involving only the use of an oscilloscope. Convergence voltages having sufficient amplitude and proper phase will be supplied to the convergence element of the picture tube if the convergence circuit is properly aligned. This alignment procedure should not be confused with the setup procedure used to obtain the final beam convergence.

In receivers which employ electromagnetic convergence, the adjustments needed to obtain dynamic conver-

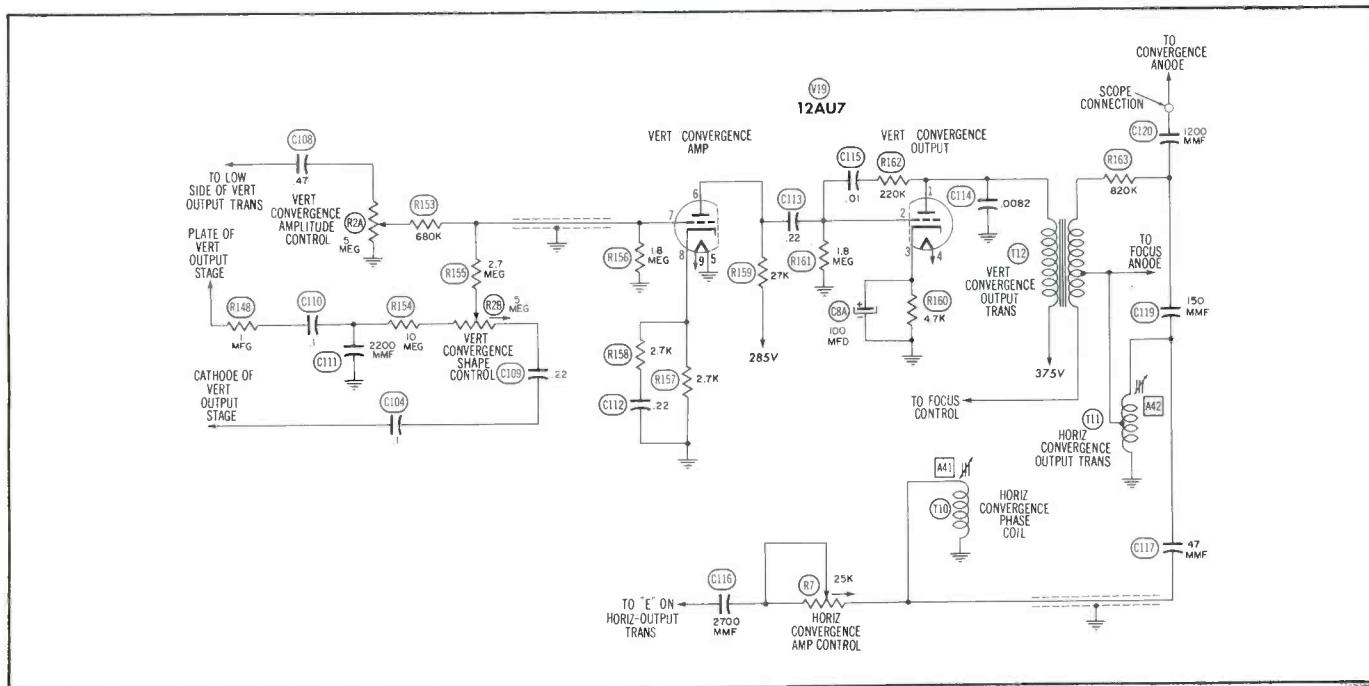

LOOK TO THE LITTLE INDIAN  FOR

THE **BIGGEST** VALUE IN

MOLDED PAPER TUBULAR CAPACITORS

the Sangamo

*Telechief*<sup>®</sup>



The Telechief will outlive all other tubulars! Major manufacturers' test and stamp of approval prove that

Telechiefs have longer life. They have a final insulation resistance value *10 to 15 times greater* than any other paper tubular—because they're molded in HUMIDITITE!

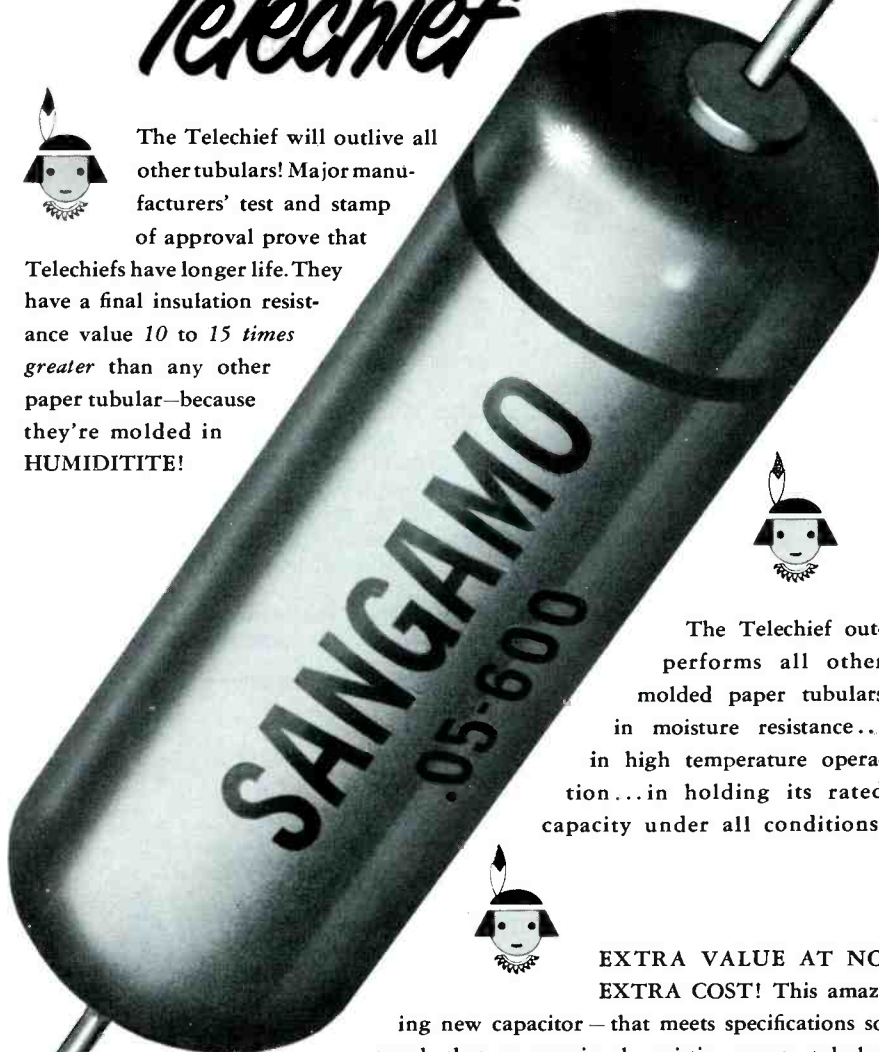

The Telechief outperforms all other molded paper tubulars in moisture resistance... in high temperature operation... in holding its rated capacity under all conditions.



EXTRA VALUE AT NO EXTRA COST! This amazing new capacitor—that meets specifications so tough that no previously existing paper tubular could approach them—is a *premium* tubular at the price of an ordinary one. See your Sangamo Distributor today!



**SANGAMO ELECTRIC COMPANY**

MARION, ILLINOIS

gence are made during the setup procedure for the picture tube. These adjustments were discussed in detail in Part XII of the Color TV Training Series in the May 1955 issue of the PF REPORTER.

The circuit of Fig. 11-14 is typical of the convergence circuits used in receivers which employ the electrostatic method to converge the electron beams. The adjustments at points labeled A41 and A42 are the ones specifically made during the alignment procedure. These adjustments are performed while observing on an oscilloscope the voltage waveform present at the convergence element of the picture tube. The convergence voltage can be coupled to the oscilloscope by clipping the vertical-input lead of the oscilloscope to the insulation of the conductor which connects to the convergence electrode of the picture tube.

Since only the horizontal-convergence voltage is affected while the convergence circuits in this receiver are being aligned, the dynamic voltage at the vertical frequency is not desired at the input of the oscilloscope. The vertical-amplitude control R2A should be turned fully counterclockwise, and the vertical-shape control R2B should be turned to the center of its range. By setting these controls as stated, no vertical-convergence voltage will be applied to the convergence element.

The horizontal-amplitude control R7 should be turned fully clockwise; then at point A41, adjustment of the horizontal-phase coil T10 may be made to obtain maximum amplitude of the horizontal sine wave that is applied to the convergence element.

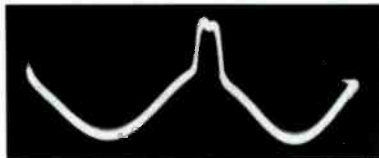

Fig. 11-15. Waveform of Signal at Convergence Electrode of Picture Tube.

Before making the adjustment at the point designated as A42, the horizontal-amplitude control R7 should be turned fully counterclockwise. Then, the core of T11 is adjusted so that the horizontal sync pulse will appear on top of the sine wave. This condition is shown by the waveform in Fig. 11-15. The horizontal-amplitude control R7 should again be turned to the maximum clockwise position. The sync pulse may be moved from the top of the sine wave by this adjustment. If it is moved, it may again be placed on top of the sine wave by adjustment of the horizontal-phase coil T10. If the sync pulse remains on top of the sine wave when the horizontal-amplitude control is turned counterclockwise, the alignment of the convergence circuit is correct.

**RF AND IF SECTIONS**

The function of the RF and IF sections in a color receiver is essentially the same as it is in a monochrome receiver. These sections must provide amplification to a band of frequencies from .75 megacycles below the frequency of the picture carrier to around 4.2 megacycles above the frequency of the picture carrier. This range of frequencies covers all of the sideband frequencies that are contained in the color picture signal and is considerably wider than the range required in a monochrome receiver.

An ideal RF and IF response curve for a color receiver is shown in Fig. 11-16A. This curve shows that the frequencies of the upper sidebands of the color sub-

carrier extend into the region of 4.2 megacycles; consequently, a flat response up to this region is needed. In actual practice, the response curve may not be quite so flat as the ideal curve; however, it should be as near to the ideal curve as possible so that equal amplification of all the frequencies will be attained. Notice that the slope of the curve in the region of the sound carrier is very steep. It must be steep because the upper limit of the sideband frequencies of the subcarrier are only .4 megacycles away from the frequency of the sound carrier.

By comparing the RF and IF response curve in Fig. 11-16A to that shown in Fig. 11-16B, it can be seen that there is quite a difference. The curve shown in Fig. 11-16B represents the RF and IF response curve of a typical present-day monochrome receiver. The band-pass usually specified by most manufacturers of monochrome receivers is around 3.25 megacycles. If the RF and IF response curve of a color receiver should begin to taper off at 3.25 megacycles, complete loss of color would result because the color subcarrier is located at 3.58 megacycles above the picture carrier.

The dotted curves in Fig. 11-16B show possible variations in the RF and IF response curve for a monochrome receiver. In one case, the high frequencies would be attenuated and the low frequencies would be overamplified. In the other case, the low frequencies would be attenuated and the high frequencies would be overamplified. In either case, if a monochrome receiver has such a response, it is possible that very little effect in the reproduced picture would be noticed. In a color receiver,

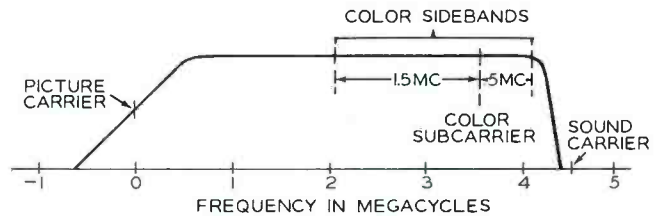

(A) Ideal Response Curve for Color Receiver.

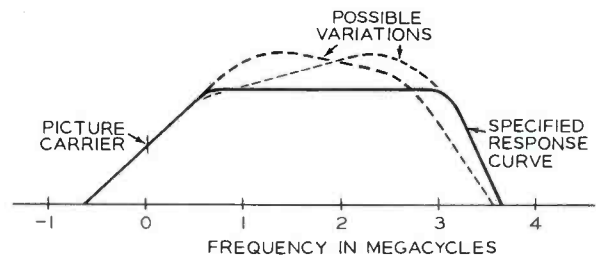

(B) Response Curve for Monochrome Receiver.

Fig. 11-16. RF and IF Response Curves for Color and Monochrome Receivers.

the effect of a sloping response curve would be noticed more readily because of the unequal amplification of the color signals.

The response of the RF tuner in a color receiver should be as flat as possible with a minimum amount of tilt and sag. An ideal response curve of a tuner used in a color receiver is shown in Fig. 11-17. A tilt or sag in the response of a tuner used in a monochrome receiver can be compensated for during the alignment of the IF section, but it is not advisable in a color receiver because a uniform response of all the color frequencies would not be attained.

Meet 90% of your phonograph  
replacement cartridge needs — and save money!



### With AMERICAN'S new "5-PAK" Service Kit



*Every thing you need in one package!*

- A 3¼x5x1¼" clear plastic box—reusable as a small-parts container
- Holds five popular AMERICAN "Clear as Crystal" replacement cartridges
- Authorized repair service window decalcomania
- Five identification cartridge labels for your company name
- Handy crystal cartridge replacement chart

Here's a new idea that will meet 9 out of 10 of your replacement cartridge service requirements . . . a new idea that puts more money in your pocket! It's AMERICAN'S new "5-PAK" Service Kit. It contains 5 of the most used replacement cartridges—all in one handy reusable box—together with other necessary items for more complete service. And you buy it all at a money-saving price. Don't forget, too, that you offer your customers the very

finest quality obtainable when you use AMERICAN "Clear as Crystal" replacement cartridges. The famous name of AMERICAN is now backed by the vast experience and resources of Elgin National Watch Co. Together, they're your greatest assurance that AMERICAN cartridges give you and your customers more for the money. Why not see your nearby AMERICAN distributor now and see the wonderful new "5-PAK" for yourself.

full vision...full sound



...where Fidelity speaks for itself!

**AMERICAN MICROPHONE CO.**

370 South Fair Oaks Ave., Pasadena 1, California

**AN ELGIN NATIONAL WATCH COMPANY AFFILIATE**

The alignment of the RF and IF sections in a color receiver is more complicated than it is for a monochrome receiver because there are more stages being employed and because there is the additional requirement of a flatter and wider bandpass. The alignment procedure for the color receiver should be followed step by step as outlined in the service literature.

The video IF and detector circuits employed in the RCA Victor Model CT-100 color receiver are shown in Fig. 11-18. The waveform shown in Fig. 11-19 represents the over-all response curve of the video IF section in Fig. 11-18. This curve shows the location of the frequencies that are passed by the IF section. The picture carrier is located at 45.75 megacycles and is placed at the 50-per-cent point on the slope of the curve. The color subcarrier is placed at 42.17 megacycles.

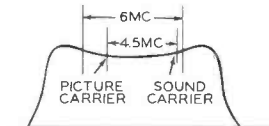

Fig. 11-17. Ideal Frequency Response Curve of Tuner Used in Color Receiver.

Figs. C-10 and C-11 of the Color Plate show the color-bar patterns obtained when the video IF section in a color receiver is improperly aligned. Compare these patterns with the normal pattern shown in Fig. C-1 of the Color Plate. The picture degradation in Fig. C-10 is not too serious — by many viewers, the picture would probably be regarded as being normal. Nevertheless, L20 was detuned at adjustment point A19 to obtain this photograph. Notice the slight ringing in the picture, particularly in the magenta bar.

There are more apparent defects in Fig. C-11. There is a large amount of ringing in the picture, and the color bars are of the wrong hues. The poor picture was caused by only slightly detuning L21 at adjustment point A10; and therefore if the alignment of the IF section is not absolutely correct, unsatisfactory results may be obtained.

The sound carrier is greatly attenuated by adjustments at A15, A7, and the sound-reject control R22 in order to reduce the 920-kc beat that is present between the sound carrier and the color subcarrier. If the sound carrier is not sufficiently attenuated, an interference pattern will be present on the screen. This beat pattern is very noticeable in Fig. C-12 of the Color Plate.

#### SOUND IF SECTION

The sound IF section of a color receiver is not necessarily different than that used in a monochrome receiver. One example is the sound IF section used in the RCA Victor Model CT-100 color receiver. This circuit is shown in Fig. 11-20. Although a separate detector circuit is used, the sound section in this receiver is fundamentally the same as those used in many monochrome receivers.

As might be expected, a conventional procedure is followed when aligning this section. Adjustments are made at points A1 through A4 so that the IF transformers will be resonant at 4.5 megacycles. The transformer secondary at A5 should be tuned so that the DC voltage measured across C82 will be zero at the same time that a 4.5-mc signal is applied between point C of L35 and ground.



### VOICE OF MUSIC MODEL 1200

Here's the changer your hi-fi customers have been asking for—in price and performance!

Here's *your* chance—*be first* to offer them precision-engineered high fidelity response . . . rich styling . . . gentle automatic record handling—at an unheard-of new low cost. —And it's easy to install!

Here are

the Features,

Judge for

Yourself!

- *New 4-speed control.* Automatically plays 33-1/3, 45, 78 and new talking book 16-2/3 rpm speeds.

- *New Easy-Lift Support Arm* for front loading convenience.

- *New Patented Drive Motor* (Pat. No. 2655812). Assures constant speed at all times with minimum wow.

- *New Low-Torque Mechanism.* Twice the life, half the wear. Rumble-free performance.

- *Aluminum Die Cast Tone Arm* • *All-Weather Dual Needle Ceramic Cartridge* • *tri-o-matic (R) Spindle* • *Manual Operation, when desired.*

Now the Price—  
Judge for Yourself!

**\$46<sup>50</sup>\***

List

\*Slightly higher  
in the west

Get **YOUR** order in—Fast!

Write for complete specifications to:

**V M** the Voice of Music CORPORATION  
Benton Harbor 7, Mich.

WORLD'S LARGEST MANUFACTURER OF PHONOGRAPHS AND RECORD CHANGERS

**UP! UP! UP GO SALES!**

**THIS MOST COMPLETE LINE OF  
GRAMER  
HALLDORSON  
EXACT REPLACEMENTS**

**COVERS ALL LEADING T-V BRANDS**

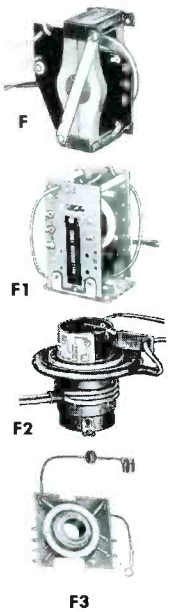

**44 EXACT REPLACEMENT FLYBACKS**

**MOUNTING STYLES:  
F to F1 to F9 plus F10, F11, F12 and F13**

**TWENTY SIX** of these Gramer-Halldorson Flybacks are brand new and are obtainable only from Gramer-Halldorson. The complete line of 44 Gramer-Halldorson Flybacks covers exact replacement needs for all name brand T-V receivers.

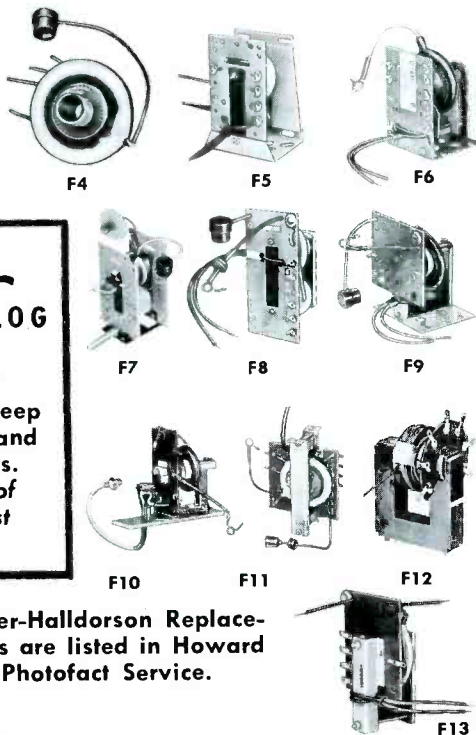

*Write*  
**FOR CATALOG  
G-24**  
listing the sweep components and transformers.  
Send name of your nearest distributor

All Gramer-Halldorson Replacement parts are listed in Howard W. Sams Photofact Service.

**GRAMER** Halldorson **TRANSFORMER CORPORATION**  
2734 NORTH PULASKI ROAD  
CHICAGO 39, ILLINOIS

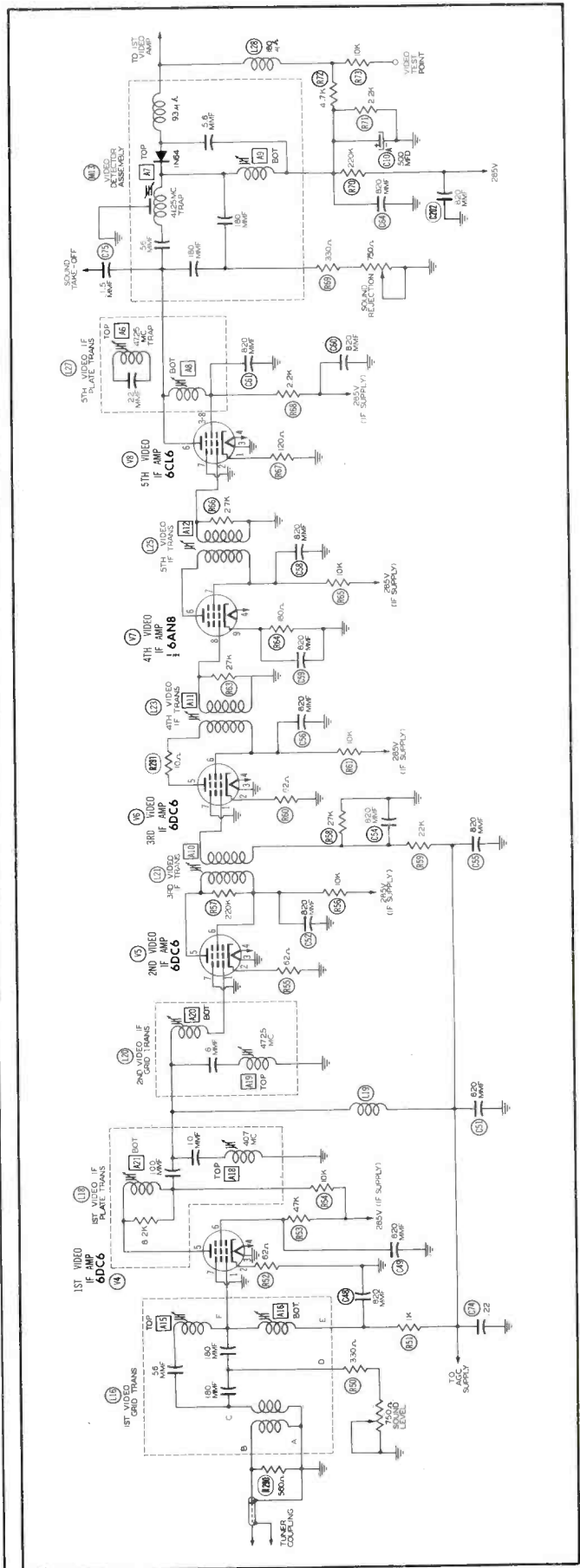

**Fig. 11-18. Video IF and Detector Circuits in RCA Victor Model CT-100 Color Receiver.**

The indications of poor alignment in the sound section are the same for color receivers as they are for monochrome receivers. For instance, a 60 cycle buzz might indicate that the secondary of the ratio-detector

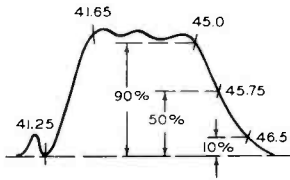

Fig. 11-19. Response Curve for Video IF Section of Color Receiver.

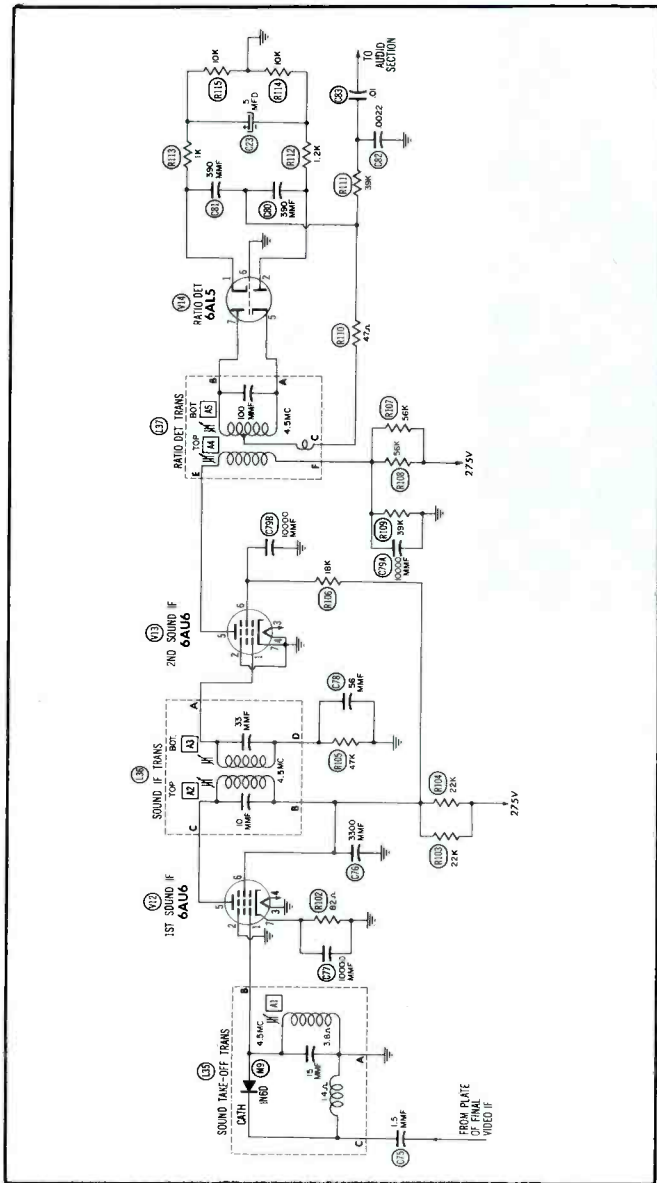

Fig. 11-20. Sound IF and Detector Circuits in RCA Victor Model CT-100 Color Receiver.

transformer is detuned. If one of the IF transformers were detuned, the sound signal would be weaker than normal.

In order to give the reader an opportunity to test himself on the material in this issue, we are including on the insert a few questions that are answered in this discussion.

C. P. OLIPHANT and VERNE M. RAY



If you take pride in the quality of your service you can't do a good job with inferior equipment. That's why it will pay you to use BUD products. All BUD products are engineered and built to give you extra value and VALUE is the important factor. Check the features of the Test Leads and Test Prods illustrated below . . . you'll see why the difference is quality.

### Super Test Leads

With vise-grip prods that screw into the plastic handles, eliminating the use of soldering iron or screw driver to replace broken or worn lead. Time is your most expensive commodity. This is where top quality pays off. Only the finest flexible, kinkless rubber covered wire is used.

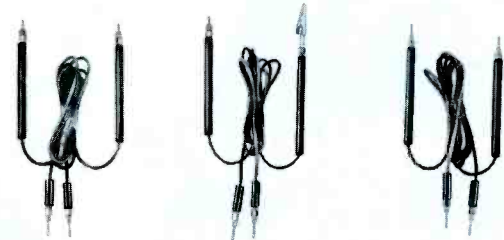

TL-178

TL-179

TL-180

TL-178 — 4" handles at one end of the wires with removable needle points and 1" handle with phone tips on other end. Dealer Net \$1.62.

TL-179 — 4" handles, one with removable needle point and other with phone tip and removable alligator clip. 1" handles have phone tips. Dealer Net \$1.62.

TL-180 — 4" handles with phone tips on one end. 1" handles have phone tips also. Dealer Net \$1.41.

### Test Prods with Plastic Handles

Prods are made of brass rods, nickle plated. All have plastic handles and feature the vise-grip method of assembly for speed and efficiency of wire replacement.



TP-95

TP-95 — Needle chuck — 4" Black or red handle. Dealer Net — 36c



TP-96

TP-96 — Phone tip — 4" Black or red handle. Dealer Net — 27c



TP-97

TP-97 — Banana plug — 4" Black or red handle. Dealer Net — 30c



TP-93

TP-93 — Needle chuck — 1" Red or black handle Dealer Net — 21c

TP-94 — Phone tip — 1" Red or black handle Dealer Net — 18c

TP-477A — Banana plug — 1" Red or black handle Dealer Net — 18c



TP-94



TP-477A

**BUD RADIO, INC.**  
2118 East 55th St. • Dept. X • Cleveland 3, Ohio



# double PROTECTION PROTECTION



**AMPHENOL**

effectively bleeds off static charges

Protection against lightning

## LIGHTNING ARRESTOR

Only one lightning arrestor offers this double protection — AMPHENOL's. Only the AMPHENOL VHF/UHF Lightning Arrestor helps guard the tv set from lightning entering the antenna system and guards the signal strength as well. Only the AMPHENOL Lightning Arrestor effectively bleeds off static charges for added set protection.

Available in wall-mounting or pipe-mounting design. Packed in an attractive counter display carton to help dealers in their merchandising. Explanatory folder available.

*Other Distinctive Features:*  
 Universal design for all types of lead-in.  
 Special cup contacts and improved sealing compound for assured operating efficiency.

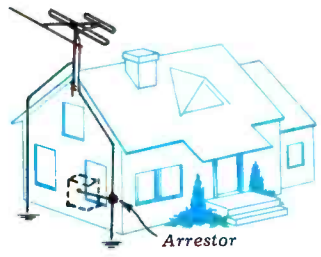

- 114-328 Lightning Arrestor, wall-mounting ..... List \$1.50
- 114-329 Same, pipe-mounting, List 1.60

At Your Distributor

**AMPHENOL**

AMERICAN PHENOLIC CORPORATION

chicago 50, illinois

In Canada: AMPHENOL CANADA LIMITED, Toronto

www.americanradiohistory.com

### Dollar and Sense Servicing

(Continued from page 29)

**ANTENNA INSURANCE.** Hurricanes of 1954 caused so much damage to TV masts that separate policies will be required in New York state for antenna coverage on new or renewal insurance. Cost will be \$5 for each \$100 in protection for antennas. The new ruling of the State Superintendent of Insurance does not affect current comprehensive fire and wind-storm policies, which still cover antennas.

Unofficially it was estimated that the big blows cost insurance companies in the state at least \$20 million in antenna damage claims last year. It is presumed that this all went to the service technicians who made the repairs. Or did it?



**APPROVAL.** Once again, the public has indicated its satisfaction with the quality, speed, and cost of TV service. The 1954 nationwide survey by Elmo Roper for RCA Service Co., showed that 90 per cent of the 5,000 sampled families fully approved of the quality of technicians who fixed their sets. Of the remainder, 6 per cent didn't know and only 4 per cent were dissatisfied. Unfortunately, it's this 4 per cent that make the most noise; and unfortunately, their complaints are justified in some cases.

Even though the average price per call was up 11 per cent over 1954, 87 per cent of the sampled families were satisfied with the prices charged. As to speed, 79 per cent got service within 3 days of their call and were satisfied with this.



**DISSATISFACTION.** Definition: That which people spread much farther than their satisfaction — and with a lot more impact on your pocketbook. On a long-term basis then, you'll make a lot more by taking your licking on one service job just to keep some grouch on your side than by sticking to your rights and letting him get out to broadcast lies about you. But take his name off your mail promotion list, and discreetly discourage his future business because you're human and can stand just so many of these chronic complainers.



**TRANSISTOR SWAPPING.** Because transistor characteristics are as unpredictable as women these days, users of the new components often play a swapping game with each other. They order perhaps five times as many transistors as they need, pick out the ones that work in their particular circuit, then swap the rest with another manufacturer who may need exactly what they don't.

The same game is played with tubes every now and then, even though it is discouraged by everyone because of the difficulty of getting selected replacement tubes for those critical circuits.

Remember the early days of TV when you didn't dare swap similar tubes for fear they had been carefully selected for their respective sockets? Today, this is no longer a worry, because no manufacturer can afford to fool around with picking out special tubes if he has to build a 21-inch set to sell for under \$150.



**SABOTAGE.** During negotiations for a new contract between a TV station and its technicians' union, things got a bit out of hand one night and the station went off the air for quite some time. Investigation revealed that more than 100 fuses had been replaced by dummies, equipment and instruction books had been hidden, tiny pieces of wire had been put into sync generators in obscure spots, good tubes had been replaced by defective ones, scores of audio circuits had been disabled, and the film-projector optical systems had been thrown out of alignment. Top engineers had to be flown in to fix the trouble.

What a trouble-shooting party that must have been! And what a party there'll be in court if the saboteurs are fully prosecuted; penalties for such acts are rather stiff, amounting to 1 year of imprisonment and/or a \$10,000 fine since the station operates under government license.



**NICKNAME.** An ear-splitting sound generator is used at the Armour Research Foundation to test performance of tubes and parts at the high sound intensities encountered in jet-engine aircraft. The technicians who have to work near the thing call it "Screaming Meemie."

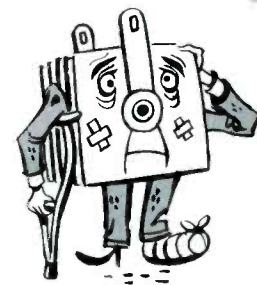
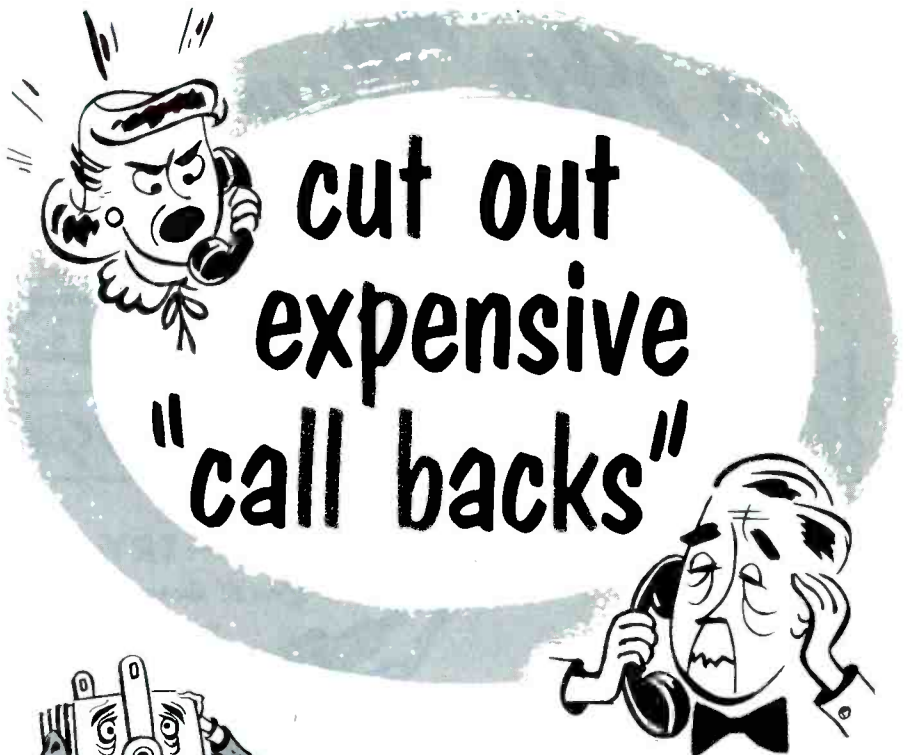

Replace those played out units with "SAFE CENTERS"

**RADIO RECEPTOR**

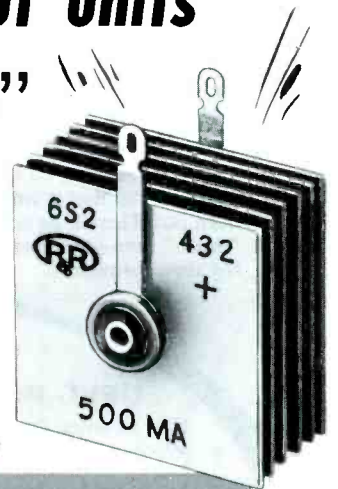

**SELENIUM RECTIFIERS**

There's a complete range of standard sizes and types for every radio and TV replacement need. Insist on RRco. rectifiers when you order from your parts jobber.



*Semiconductor Division*  
**RADIO RECEPTOR COMPANY, INC.**

*In Radio and Electronics Since 1922*  
SALES OFFICE: 251 WEST 19th STREET, NEW YORK 11  
WAtkins 4-3633 • Factories in Brooklyn, N. Y.

SELENIUM RECTIFIERS • GERMANIUM TRANSISTORS • GERMANIUM AND SILICON DIODES  
DIELECTRIC HEATING GENERATORS AND PRESSES • COMMUNICATIONS, RADAR AND NAVIGATION EQUIPMENT

# -THE *All New Gun*

**DESIGNED FROM SCRATCH  
FOR SERVICE MAN'S REQUIREMENTS**

#199



*Ideal for 90% of your work*

## *"Quick-Hot" Electronic Soldering Gun*

WORKING  
IN 2-3  
SECONDS

GET THE FEEL OF IT

**HEFT IT—TRY IT**

*You'll know at once*

that here is a "right"  
product—built to  
work well  
for years.

- *Lightest*
- *Smallest*
- *Longest reach*
- *Longest life*
- *Most dependable*

**OF ALL TRANSFORMER TYPE  
SOLDERING GUNS**

You have the satisfaction of knowing when out on the job with this gun that it won't burn out. There'll be no "down" time—no return to the shop for repairs.

**LIGHT, HANDY *New Model #199***

New patented design delivers AMPLE heat fast on 110-120 V. A.C. 60 cycle, 1.1 Amp. Max. Cools quickly too. It's light, (1½ lbs.)—handy, beautifully balanced and smaller—to slip readily into tool kit or pocket. Molded red plastic handle and case. Gun made to withstand

**HUNDREDS OF HOURS CONTINUOUS OPERATION**

Almost indestructible in ordinary use. New type, steel, extra long reach tips readily replaceable and interchangeable with special purpose tips. Gun fully guaranteed. *And that PRICE*

**Only \$7.95** LIST

**FOR HEAVY DUTY you want**

*the famous* **WEN** **MODEL #250**

Greater volume of heat obtained solders relatively heavy materials. 567 hours continuous operation. Fully guaranteed. **Retails \$12.95.**



**PRODUCTS, INC. CHICAGO 31, ILL.**

(Export sales, Scheel International, Inc., Chicago)

**SECRET RECORDER.** Actually on the market now is a leather briefcase that opens conventionally on one side for removal of papers without revealing the magnetic tape recorder concealed within it. A zipper panel on the other side provides access to the hidden recorder for loading and unloading tape and making preliminary adjustments, after which the combination slide lock and switch of the briefcase provides secret starting and stopping of the recorder. A hidden microphone in one end of the briefcase picks up conversations up to 100 feet away, according to specifications of the manufacturer—Amplifier Corp. of America, 398 Broadway, New York 13, N. Y.

A \$2.30 set of amplifier batteries is rated to last 100 hours, and a \$2.70 set of mercury type motor batteries is good for 12 to 24 hours. Frequency response is 100 to 3,000 cps, strictly for spy stuff, newspaper reporting, criminal confessions, and other investigative work. With the new long-play tape and twin-track recording, playing time is 3 hours per 5-inch reel at a recording speed of 1 7/8 inches per second.

This firm also has other completely portable models in conventional housings and with various higher tape speeds for high-fidelity work, as required by newscasters for on-the-spot interviews. These come with either battery or spring-powered motors.

Broadcast Equipment Specialities Corp., P. O. Box 149, Beacon, N. Y., is another firm selling spring-powered portable tape recorders complete with schematics and servicing instructions. In general, you can figure on \$300 to \$350 net price for a good portable tape recorder.

Companies that provide complete diagrams and servicing instructions with specialized electronic equipment deserve commendation. Their customers benefit because they can then get speedy repairs practically anywhere in the world, and service technicians benefit because they can then handle these extra-income jobs efficiently.



**AUTO RADIO.** Two out of three cars on the highway today have radios, according to the Automobile Manufacturers Association. In 1954, auto-radio sales shot over 5 million and comprised 38.7 per cent of total radio production.

**FUTURE.** Service technicians thinking of going into defense work in the electronics field will be cheered by the ten-year predictions of Sylvania's Frank Mansfield. He estimates an almost linear rise in defense expenditures in electronics from an estimated \$2.46 billion for 1955 to an estimated \$4.05 billion for 1964. This is encouraging assurance of job security, though of course individual firms will have their ups and downs in accordance with their success or failure in landing the government contracts.



**CHARGES.** Typical TV service charges are \$7.50 for replacing a 21-inch picture tube, \$8.25 to \$9 for 24 to 27 inchers, \$8 to \$10 for changing a power transformer, as estimated by Motorola's service manager Russ Hanson in NARDA News. He figures \$10.50 for the all-round average COD charge for a TV call, including parts; and he thinks that 80 to 90 per cent of the calls are now being completed in the home.



**HIRING.** Confirming our belief that it's better to get along without than to hire the wrong man, the American Management Association just announced that the average cost of a mistake in hiring a salesman is over \$6,000. This includes the cost of his training, his salary, the value of the business he didn't get, and the value of the customers he lost permanently through his blunders.



**HEAT SEEKERS.** Guided missiles depend upon a variety of different principles for guidance to their targets, but the one that intrigues us most is the heat seeker. In the nose of this missile is a souped-up modern version of the old bolometer, which gives out a voltage in proportion to the amount of heat reaching it. The missile has to be launched from behind a target jet plane to pick up its heat. Once such a missile homes on the heat source, it goes right up the tail pipe of the enemy plane, they say. Sure must be embarrassing to the enemy!

**JOHN MARKUS**

# New!

## Centralab Pocket-Edition Control Guide No. 1

**Here's the quickest way yet  
to find the right  
control replacement!**



Lists Centralab replacements by manufacturers' part numbers — for TV, radio, audio, auto radio.

Handy size, 3 3/4" x 8 1/4".

Always up to date — completely revised and printed quarterly.

Get a copy of *Centralab Pocket-Edition Control Guide No. 1* for yourself and each of your men. Ask your Centralab distributor — or order direct from

# Centralab

**A Division of Globe-Union Inc.**  
942F E. Keefe Ave., Milwaukee 1, Wis.

Send \$1.00 for the next five editions of the pocket control guide.

Send 20 cents for the current edition only.  
(Paste coins securely to cardboard.)

**HIGH ACCURACY**

**LOW COST**

With a

**HYCON  
VACUUM TUBE  
VOLT-OHMMETER**

**New Model 614**



**\$87<sup>50</sup>**

*Probes stow inside case—  
connected, ready to use*

There's value worth telling about in Hycon's new Model 614 VTVM. You read peak-to-peak voltages directly on complex wave forms, without multiplying. You get 21 ranges for versatility . . .

3% accuracy (DC and ohms) for pin-point measurements . . . large meter for easy reading.

And probes are always ready to use when you want them—out of the way when you don't. So before you buy *any* meter try the new Model 614 . . . setting new standards "where accuracy counts."

- 21 RANGES: AC, DC, OHMS (28 with p-p scales)
  - AC FREQUENCY RESPONSE TO 250 MC (with crystal probes)
- ACCURACY: DC  $\pm$  3%; AC  $\pm$  5%
- LARGE, 6½ IN. METER
- LIGHTWEIGHT, MATCHED, BENCH-STACKING CASES

The Model 614 VTVM is one of a matching set of precision instruments, which includes the Model 617 Oscilloscope (designed for color TV) and the Model 615 Digital VTVM.

Distributed through Electronic Parts Jobbers.

*Service facilities in your area.*

**Hycon Mfg. Company**

2961 EAST COLORADO STREET PASADENA 8, CALIFORNIA

*"Where Accuracy Counts"*

## Audio Facts

(Continued from page 27)

trol. Some experimenting will reveal that the loudness control will produce the most pleasing balance between highs and lows when it is operated over a certain portion of its rotation. The gain control R2 is set to the position which permits the loudness control to operate within the correct range.

R3 is a standard IRC Type LC1 loudness control which has proved to be very satisfactory in maintaining balanced treble and bass response as the loudness level is varied. This control can be purchased as a complete assembled unit or can be made up from standard components.

The front section R3A of the loudness control is a 500K-ohm control (IRC stock No. Q11-133), the second section R3B is a 1-megohm multisection (IRC stock No. M13-137), and the third section R3C is a 100K-ohm multisection (IRC stock No. M13-128). A 10K-ohm half-watt resistor, a 100K-ohm half-watt resistor, an 82-mmfd ceramic capacitor, and a .03-mfd tubular capacitor are connected to the control as shown in the schematic diagram of Fig. 3.

In this preamplifier and control unit, a fourth section R3D which is a 500K-ohm multisection (IRC stock No. M11-133) is added to the loudness control and operates in the input of the output stage to reduce noise. The noise reduction which results from the action of this control is very pronounced, especially during the absence of a signal.

A Stancor C-2332-1 tone-control unit L1 and two dual 250K-ohm controls are used in a nonresonant LCR variable equalizer circuit. The insertion loss with this type of tone control circuit is not so high as the loss experienced with a circuit employing only capacitors and resistors. We have found this circuit to be one of the most stable ever used. In addition, it provides a wide range of bass and treble boost or droop.

With the dual bass control R4 in its maximum counterclockwise position, bass is attenuated because of the high resistance in the cathode circuit of the second section of V3 and because of the shunting of the low frequencies through L1 to ground in the grid circuit of the first section of V4.

When the bass control R4 is in the maximum clockwise position, the bass receives maximum boost because of the fact that the low reactance of L1 to low frequencies reduces

**PARTS LIST**

**Tubes**

V1	12AT7
V2	12AU7
V3	12AU7
V4	12AU7

**Capacitors**

CAPACITANCE (mf)	VOLTAGE (volts)	MALLORY	PYRAMID	SANGAMO	ERIE	CENTRALAB
C1A	20					
C1B	20					
C1C	20	FP444	TM-Q20-450	Q-040		
C1D	20					
C2A	20					
C2B	20	FP444	TM-Q20-450	Q-040		
C2C	20					
C2D	20					
C3	500	WP057	TM-500-25	S-040		
C4	500	WP057	TM-500-25	S-040		
C5	10	TC42	TD-10-150	MT-1512		
C6	.05	PT-615	IMP6-S5	330615		
C7	.05	PT-615	IMP6-S5	330615		
C8	1000	UC-521				
C9	680	UC-5368				
C10	390	UC-5339				
C11	.02	PT-812	IMP6-S2	330612	GP2L-102	D6-102
C12	.1	PT-601	IMP6-P1	330601	GP2K-681	D6-681
C13	4000	UC-5240			GP2K-391	D6-391
C14	3300	UC-5233				
C15	5600	UC-525				
C16	.1	PT-601	IMP6-P1	330601	GP2-333-402	D6-402
C17	.1	PT-601	IMP6-P1	330601	GP2-333-332	D6-332
C18	.1	PT-601	IMP6-P1	330601	GP3-333-562	D6-562
C19	.1	PT-601	IMP6-P1	330601		
C20	.01	in case with L1				
C21	.005	in case with L1				
C22	.1	PT-601	IMP6-P1	330601		
C23	.1	PT-601	IMP6-P1	330601		
C24	.25	PT-6025	IMP6-P25	3306025		

**Controls**

RESISTANCE (ohms)	IRC	CLAROSTAT	CENTRALAB	MALLORY
R1	500K	A47-500K-Z		
R2	500K	FKS-1/4 (shaft)	B60	U48
		A47-500K-Z	B60	U48
		RS-2 (shaft)		
R3	500K			UF254A
R3A	1 meg			DS36 (shaft)
R3B	100K			
R3C	500K			
R3D	500K			
R4	250K	DC-8-Z	BB-103	UR254A
R4B	250K			UF254A
R5	250K	DC-8-Z	BB-103	DS36 (shaft)
R5B	250K			UR254A

**Resistors**

RESISTANCE (ohms)	WATTAGE RATING (watts)	IRC	RESISTANCE (ohms)	WATTAGE RATING (watts)	IRC
R6	47K	BTA 47K	R25	22K	BTA 22K
R7	2000	DCF 2000	R26	47K	BTA 47K
R8	560K	BTA 560K	R27	18K	BTA 18K
R9	250K	DCF 250K	R28	3900	BTA3900
R10	22K	BTA 22K	R29	100K	BTA100K
R11	2500	DCF 2500	R30	10K	BTA 10K
R12	100K	DCF 100K	R31	470K	BTA 470K
R13	10 meg	BTS 10 meg	R32	1500	BTA 1500
R14	100K	DCF 100K	R33	10K	BTA 10K
R15	18K	BTA 18K	R34	47	BW1-47
R16	100K	BTA 100K			Wire wound
R17	10 meg	BTS 10 meg	R35	2200	BTA 2200
R18	10 meg	BTS 10 meg	R36	2200	BTA 2200
R19	1 meg	BTS 1 meg	R37	25	1 3/4 AA-25
R20	10 meg	BTS 10 meg			Adjustable
R21	3900	BTA 3900			wire wound
R22	100K	BTA 100K	R38		Chosen by trial if required to roll off high-frequency response (see text)
R23	470K	BTA 470K			
R24	1000	BTA 1000			

**Selenium Rectifiers**

RADIO RECEPTOR	FEDERAL	MALLORY	SARKES TARZIAN	INTERNATIONAL
M1	(1) 16Y1 or (2) 8Y1	(2) 8S20	(2) 35	(2) CR20
M2	(1) 16Y1 or (2) 8Y1	(2) 8S20	(2) 35	(2) CR20
M3	PIBISIC	1016	304B	JD507G

**Power Transformer**

STANCOR	PRIMARY	SECONDARY 1	SECONDARY 2	SECONDARY 3
T1	PC8417	117V AC	440V AC @ 50 ma DC	25.2V AC @ .5A

**Tone Control Unit**

L1	Stancor	C-2332-1

**Miscellaneous**

QUANTITY	Description
1	2-pole, 3-position switch (Centralab -1473; Mallory - 1215L)
1	Single-pole, 3-position switch (Centralab -1461; Mallory - 1211L)
1	Single-pole, single-throw toggle switch
1	Pilot-light assembly
1	AC receptacle
4	9-pin noval tube socket
4	Phono jacks
1	AC power cord
1	Aluminum chassis, 5 by 10 by 3 inches
1	Panel, terminal strips, miscellaneous hardware, etc.

# Announcing...

## Retract-O-Matic

— the new, foolproof replacement

### Pickup



Even if you drop it... or slide it...

### Retract-O-Matic protects records and needles from damage!

WEBSTER ELECTRIC proudly offers the new, exclusive RETRACT-O-MATIC—the sensational crystal pickup that provides positive protection to record and needle, *even when it is dropped or slid* across the record surface.

Retract-O-Matic is priced to make it a *practical replacement* for installation on any manual record player.

#### THE DOME ABSORBS THE SHOCK

The unique spring-mounted construction gives absolute insurance against damage to cartridge, needle, or record. The slightest pressure on the arm automatically lifts the needle from the record's surface, and lets Retract-O-Matic's rounded "dome" absorb the shock.

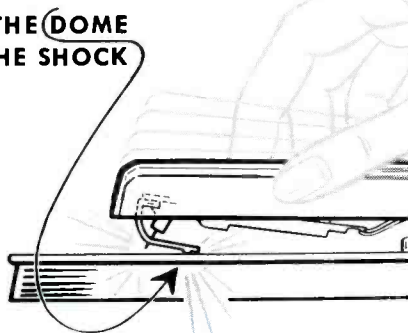

### A BIG PROFITABLE MARKET

Retract-O-Matic is a "natural" as a pickup replacement for record players, children's and portable phonographs. List price of complete assembly (tone arm, cartridge, arm rest and all parts needed for installation) is only \$6.95—little more than the price of the cartridge alone. Order a stock today. Step up your sales with Retract-O-Matic!

**WEBSTER ELECTRIC**  
RACINE WISCONSIN

the degeneration of low frequencies in the cathode circuit of the second section of V3. Furthermore, there is no loss of low frequencies in the grid circuit of the first section of V4 since L1 is, in effect, removed from the grid current.

With the dual treble control R5 in the maximum counterclockwise position, the high frequencies are given a maximum droop because of the shunting of the control section R5A by capacitors C20 and C21 and also because of the degeneration in the cathode circuit of the second section of V3.

Setting the treble control R5 to the maximum clockwise position results in maximum treble boost because of the shunting of control section R5B by capacitors C20 and C21. This shunting action reduces the degeneration of high frequencies in the cathode circuit of the second section of V3. In this position of the treble control, there is no capacitive shunting in the grid circuit of the first section of V4.

Any degree of boost or droop of the bass or treble between the extremes can be had by adjusting the appropriate control. This wide range is possible because of the dual action in the cathode circuit of the second section of V3 and because of the dual action in the grid circuit of the first section of V4. Such flexibility of control is very desirable when compensating for variations in program material and listening conditions.

The output stage (second section of V4) is a cathode follower and permits a long shielded cable to be used to connect the output of the unit to the input of a power amplifier without loss of high frequencies.

The power-supply section is similar to the supply discussed in detail in "Audio Facts" in the July 1954 issue of the PF REPORTER. Selenium rectifiers are used in conjunction with power transformer T1 to supply plate voltages and to furnish direct current to heat the tube filaments.

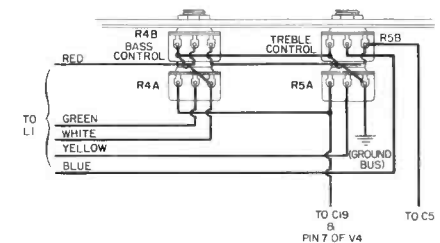

Fig. 6. Details for Correct Wiring of Bass and Treble Controls.

Two selenium rectifiers M1 and M2 are employed to supply the plate voltages. Rectifiers M1 and M2 are 16Y1 Seletron units each of which is rated at 260 volts AC input and 20 milliamperes DC output. Two 8Y1 Seletron units (each rated at 130 volts AC input and 20 milliamperes DC output) or two of any listed in the Parts List can be connected in series and used for M1 or for M2. These units will handle the input voltage of 220 volts AC from the power transformer. Sections A and B of the four-section capacitor C1 are connected in parallel to provide 40 microfarads for the input capacitor of the filter.

A bridge type of selenium rectifier M3 is used in the DC heater supply. The full-wave output of the rectifier is filtered by the network composed of C3, C4, and R37. R37 is adjusted so that 24 volts DC are applied to the tube heaters which are connected in series parallel, as shown in the schematic diagram. Anyone who has never used direct current to heat tubes in low-level stages will be surprised to find how effective this type of supply can be in keeping hum at minimum. The 6.3-volt AC secondary is used only to light the pilot light.

### Layout and Construction

The general layout of parts can be seen in the two bottom views of the unit shown in Figs. 4 and 5. Two views are used in order to show as many helpful details in layout and wiring as possible. Fig. 6 is included to show the correct method of wiring the bass and treble controls.

A ground bus, which connects to the chassis at the input jacks only, reduces the possibility of ground loops and is convenient to use when wiring the unit. All electrical grounds are made in progressive order on the ground bus. Shielded wires, with the shields grounded only at one end, are run to the input jacks and to the switches on the front panel. All electrolytic capacitors and the output jack are mounted on insulated mounts.

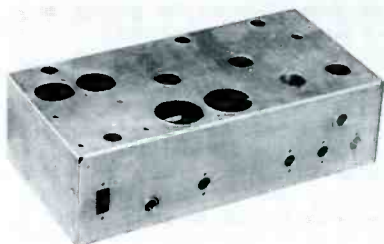

Fig. 7. Punched Chassis Before Parts Were Mounted.

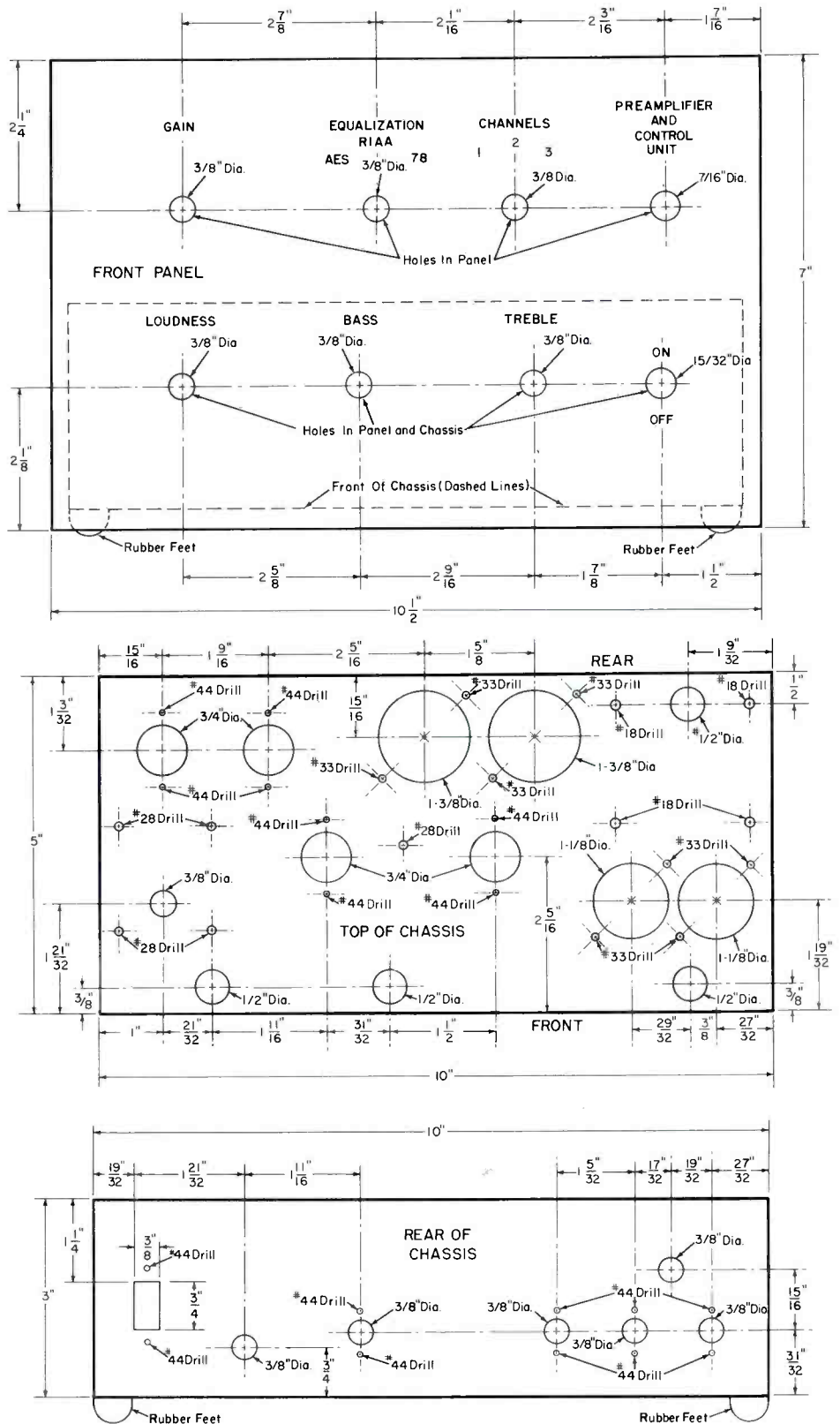

Fig. 8. Drawings Showing Locations of Holes in Chassis and Front Panel.

The phono-input circuit and preamplifier section are arranged in a small area located as far away as possible from the rest of the circuits. The layout and wiring arrangement has proved to be very satisfactory with no interaction of circuits or unwanted feedback being detected at any time.

A photograph of the punched 5-by-10-by-3-inch aluminum chassis before any parts were installed is shown in Fig. 7. The locations of all large mounting holes are given in the drawings shown in Fig. 8. Since the locations of the small holes for the machine screws used to secure the parts to the chassis will depend upon



# "555"

## metal-cased MULTIMETER

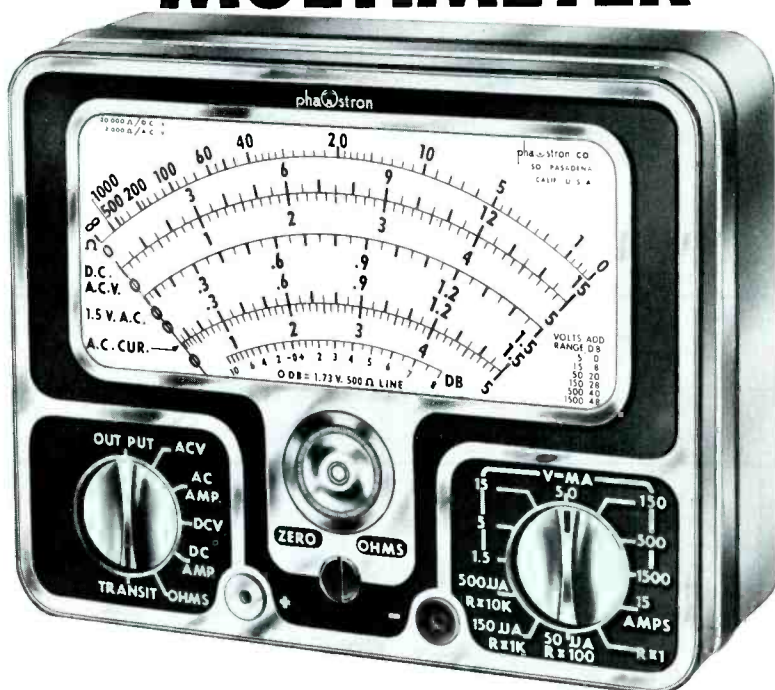

POCKET SIZE WITH A 4 7/8" LENGTH SCALE  
an instrument of **PERMANENT ACCURACY**  
in a case that **WON'T BREAK**

- ✓ AC CURRENT RANGES
- ✓ SEPARATE RANGE & FUNCTION SWITCHES
- ✓ SIMPLICITY . . . ONLY 2 JACKS
- ✓ EASY-TO-READ, LARGE 4 COLOR SCALES
- ✓ 43 UNDUPLICATED RANGES
- ✓ MAGNETIC SHIELDING
- ✓ 3% DC, 4% AC PERMANENT ACCURACY

### Accessories Available

GENUINE LEATHER CARRYING CASE \$5.95

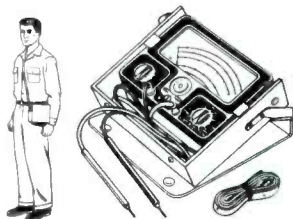

PANEL MOUNTING ADAPTER \$1.50



**"555" MULTIMETER**  
**\$39.95** complete with probes and batteries  
at your **PARTS DISTRIBUTOR**

**PHAOSTRON COMPANY** 151 PASADENA AVE., SOUTH PASADENA, CALIF. U.S.A.

the parts selected, no exact locations for these holes are indicated. Their general locations and the sizes of the drills with which they were drilled in this chassis are shown, however. Of course, the layout of parts can be changed to accommodate available components; but the arrangement shown has proved to be very satisfactory.

The front panel was cut from a standard 1/8-inch gray aluminum rack panel. It is secured to the chassis by the mounting nuts on the controls and on the ON-OFF switch. Decals made by the Tekni-Label Co., 732 S. Victory Blvd., Burbank, Cal., were applied to identify the controls and switches.

The cover, visible in the photograph in the heading of this article, was made from Reynolds perforated aluminum sheet. A sheet of paper can be folded, fitted to the unit, and used as a pattern to make a metal cover, if one is desired. A piece of sheet metal was cut and bent to serve as a mounting flange for the cover and for a small shield over the compensation and channel switches. Items such as the cover and switch shield should be tailored to fit the finished unit.

A parts list is included for those who wish to construct this useful piece of audio equipment.

**ROBERT B. DUNHAM**



VACATION. Excellent low-cost color program, which is used by Seattle's KING-TV, involves inviting people to bring in their own vacation color slides. Judicious screening of the slides beforehand by the station's picture editor invariably results in a few choice ones that have general interest. They are shown with commentary either by the photographer or the station's announcer.

What a thrill it must be to have your own pictures shown on TV with all the relatives looking in. Such a program could surely boost the sales of color film as well as stimulate color TV sales. When color TV breaks, local TV set dealers could well collaborate to sponsor such a program or split costs with the local photo-equipment shops.

MARKUS • • Dollar and Sense Servicing



## Examining Design Features

(Continued from page 21)

the chassis. The channel-selector and fine-tuning shafts are also electrically insulated from the tuner. This is done to eliminate any shock hazard arising from the fact that one side of the AC line is connected to the chassis. For this reason also, an isolation transformer should be used before attempting any service or alignment of the chassis.

The chassis is vertically mounted and surrounds the neck of the picture tube. This arrangement eliminates the need for a large mounting bracket for the yoke. It also reduces the over-all space required for the complete unit. The chassis and picture tube are fastened to a plywood mounting board one-half inch thick. This board forms the bottom of the cabinet and permits easy removal of the entire assembly from the remaining part of the cabinet. The chassis and mounting board of this receiver are shown in Fig. 4. It can be seen from this figure that there will be easy access to all the tubes after removal of the rear cover because the chassis is mounted vertically. All the tubes except those in the tuner are mounted horizontally.

### Tuner

The Olympic Chassis AD incorporates a turret type of RF tuner. This unit provides selection of all 12 of the present VHF channels. The antenna input to the tuner has a resistor-capacitor network in series with the signal path. A 470K-ohm resistor in each side of the 300-ohm transmission line serves as protection against a possibly fatal shock from the antenna terminals which would otherwise be connected through a low impedance to the chassis and to the AC line. Each 220-mfd capacitor connected in parallel with each 470K-ohm resistor is included to couple the incoming RF signal to the tuner.

The operation of this type of tuner is conventional. A 6BC5 pentode provides RF amplification, and a 6J6 dual-triode is used as an oscillator and mixer. These tubes are completely shielded, and there is a sufficient amount of decoupling to minimize radiation.

The gain of the RF amplifier is governed by the bias furnished by the AGC voltage which is fed back to this stage. The tuner also houses a tunable IF coil which is located in the plate circuit of the mixer. The tuned circuit associated with this coil and that associated with a coil in the grid cir-



## on a **TACO** antenna! For Color as well as Black and White

Proved in hurricanes Carol, Edna and Hazel along the East Coast and in many storm areas last year, the Taco spring-loaded assembly is recognized by the trade as the most rugged construction employed in any antenna — at any price! Both Trapper and Super Trapper are high-gain, broad-band antennas, unexcelled in gain across the entire VHF band. These antennas provide phenomenal picture clarity — combined with the most compact and streamlined design.

Get the facts on these two great antennas today. Write or see your Taco distributor.

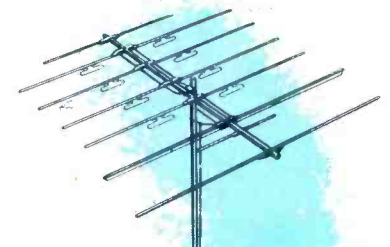

**Super TRAPPER**®

**WORLD LEADER IN  
TV ANTENNA DESIGN**

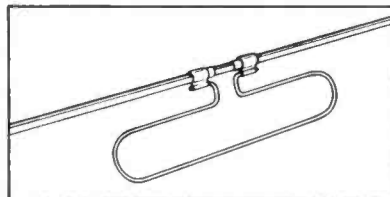

The Taco Trap® provides the means whereby streamlined Trappers outperform bedspring type antennas.

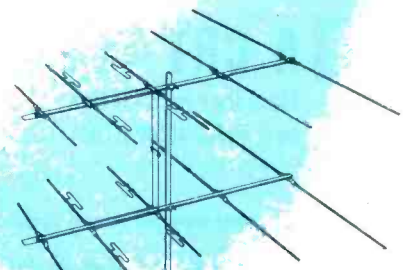

**TRAPPER**

© 1955 \*U.S. Pat. No. 2,705,283 ®

**TECHNICAL APPLIANCE CORPORATION • SHERBURNE, N. Y.**

cuit of the first video IF amplifier have a capacitor in common. This arrangement is known as common-impedance coupling and makes it possible to tune both coils for a broad frequency response.

### Video IF

The Olympic Chassis AD features an intercarrier sound system and utilizes three stages of video IF amplification. The IF transformers are stagger tuned, and proper align-

ment of the IF circuits will produce a very satisfactory over-all response.

The first and second video IF stages employ the pentode sections of two 6AN8 tubes. A 6AN8 tube combines a pentode and a triode section into one envelope. The internal construction of this tube is designed so that coupling between the two sections is virtually nonexistent and so that the tube may be mounted in any position. The AGC voltage is applied to the grids of the first two IF stages through a voltage-dividing network.

The third and final IF stage utilizes the pentode section of a 6AM8 tube. The 6AM8 is another dual-purpose type of tube, and it houses both a pentode and a diode. The pentode section has a sharp-cutoff characteristic and provides adequate gain at intermediate frequencies.

Transformer coupling is used for all three stages of IF amplification. The IF transformers are unshielded single-tuned units which are mounted on the wiring side of the chassis.

### Video Detector and Amplifier

The diode section of a 6AM8 tube is employed as a series type of video detector. A shield has been provided for this tube because this tube is also serving as the third video IF amplifier.

The signal voltage from the secondary of the third video IF transformer is impressed on the cathode of the detector. The plate is returned to ground through a 5600-ohm resistor, and the voltage developed across this diode load is capacitively coupled to the video amplifier. The AGC voltage is also derived from the output of the video detector and is filtered before application to the RF and IF circuits.

The video-amplifier stage consists of the pentode section of a 6AN8 tube. The design of this stage is relatively conventional except for the fact that the plate voltage is obtained from the boost voltage supplied by the damper tube. The composite video signal is then fed to the cathode circuit of a 14HP4 rectangular picture tube.

### Sound

The sound section of this receiver employs only two tubes. A 6BN6 gated-beam pentode serves as a limiter and FM detector, and the triode portion of a 6AN8 is used as an audio output stage. The 4.5-mc sound signal is taken from the plate of the video amplifier and is developed across a tuned circuit connected to the limiter grid. This tuned circuit also acts as a 4.5-mc trap and therefore removes the sound from the video signal before that signal reaches the picture tube.

Buzz or hum encountered in the output of the 6BN6 and caused by improper biasing may be corrected by adjustment of the buzz control located in the cathode circuit. The plate load is sufficiently bypassed for intermediate frequencies, and the DC voltage appearing across this load is directly proportional to the original modulating signal. The audio voltage

**NOW—2 FINE INSTRUMENTS  
FOR THE PRICE OF 1**

## 1 A CATHODE REJUVENATOR

Revolutionary Design! Featuring AUTHORIZED Exclusive Rejuvindicator\*

**REJUVINDICATOR**  
automatically tells you  
when the rejuvenation  
process is sufficient.

**AUTHORIZED  
CATHODE  
REJUVENATOR—  
CRT  
TESTER**

**54<sup>95</sup>**  
net



Authorized Manufacturing has so engineered the process of Rejuvenation as to provide an instrument that functions more quickly, far safer and with greatest assurance of rejuvenation accuracy.

- No question when Rejuvenation starts or is finished—with Rejuvindicator.
- Safe cathode and brightness Rejuvenation with assurance of decontamination and aging—with Rejuvindicator.
- Grid structures positively unharmed.
- Safe Cathode element rewelding when possible.

## 2 A CRT TESTER

More than pays for itself  
as a Point-of-Sale Tool

- Reveals picture tube condition conveniently, accurately without removing tube from set or carton.
- Indicates true beam current including 2nd Anode condition.
- Tests shorts in cold and hot CRT's.
- Reads High Resistance, shorts and leakage between elements.
- Tests all electromagnetic and electrostatic tubes.

All test results indicated on front panel.

Write for complete information on the Authorized Cathode Rejuvenator-CRT Tester and the complete Shop-Aid and Lab-Aid line.

**AUTHORIZED MANUFACTURING CO.**

919 Wyckoff Avenue, Brooklyn 27, N. Y.



\*Pat. Pending

thus produced is then capacitively coupled to the volume control and in turn to the output stage. The audio-output transformer drives a five-inch speaker which is mounted on the side of the cabinet.

### Synchronization

Dual-purpose tubes are again utilized in the synchronization circuits of this receiver. The triode sections of two 6AN8 tubes function as a sync separator and a sync amplifier, respectively. The purposes of these two sync stages are to separate the vertical and horizontal sync pulses from the composite video signal and to amplify them so that they are of an amplitude which is usable for controlling the sweep circuits. In the Olympic receiver being examined, the composite video signal is taken off at the output of the video amplifier and is fed to the grid circuit of the sync separator. The sync pulses, which are more positive than the picture content in the video signal, drive the grid of the 6AN8 sync separator. The tube is biased in such a manner that a clipping action takes place. The lower amplitude of the picture portion of the composite video signal is not sufficient to produce plate-current flow, and this portion will not appear in the output of this circuit. As a result of the clipping action, only sync pulses are passed.

The sync pulses from the output of the sync separator are coupled by an RC network to the sync amplifier. This stage amplifies and distributes the sync pulses to the vertical-sweep and horizontal-sweep circuits.

### Vertical Sweep

The vertical-sweep system involves only one 12BH7 tube that serves as both an oscillator and an output amplifier. The 12BH7 is a miniature dual-triode tube frequently used in television receivers. In the Olympic model, the two triode sections function together as a multivibrator circuit. The sync pulses from the sync amplifier are fed to the first triode section through a conventional integrator network. The vertical-hold control is located in the grid circuit of the first section in order to control the frequency. A height control is incorporated in the plate circuit, and by adjusting this control the amplitude of the vertical saw-tooth voltage may be varied.

The remaining triode section of the 12BH7 is employed as a vertical-output stage. To obtain a linear output from this tube, a vertical-linearity control is connected in the cathode circuit. The output of this stage is then

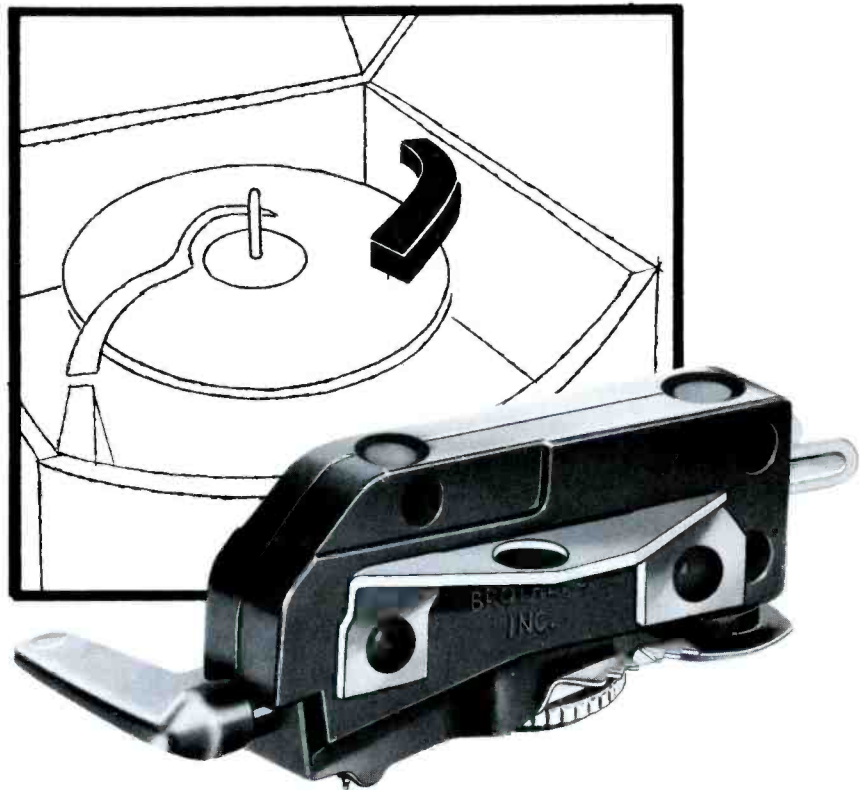

It's Dramatically New!

## SHURE 'TWIN-LEVER' Ceramic Phono Cartridge

*The most important advance in phono replacement cartridges since the introduction of 3 speeds!*

- To improve the quality of all conventional home phonographs!
- To replace 128 3-speed, plastic-cased, ceramic and crystal, turnover and single needle cartridges!

We make these strong claims: the "Twin-Lever" is the finest replacement cartridge ever developed! It sets a new high, leaving all other replacement cartridges far behind its brilliant level of tone superiority . . . individual needle compliance for superior 78 rpm and microgroove response . . . unique needle shift design . . . amazingly simple needle replacement.

The "Twin-Lever" offers you maximum replacement coverage with minimum investment because it handles the replacements for practically all 3-speed phonos using plastic-cased cartridges. New business and greater profits can be yours — because this "Twin-Lever" cartridge costs only \$9.50 list — yet it can make conventional 3-speed phonos sound better than when they were new!

See your Shure Distributor today — he has the "Twin-Lever" in stock. And here's a tip: buy more than you think you will need — or you'll have to go back for more mighty soon. That's how good this cartridge is. And don't take our word for it — ask your first "Twin-Lever" customer what he thinks!

#### MODEL WC10

List Price **\$9.50**

(including two synthesized sapphire-tipped needles)

#### MODEL WC10D

List Price **\$34.00**

(including a 1-mil diamond-tipped needle and a 3-mil synthesized sapphire-tipped needle)

**SHURE**

----- *The Mark of Quality*

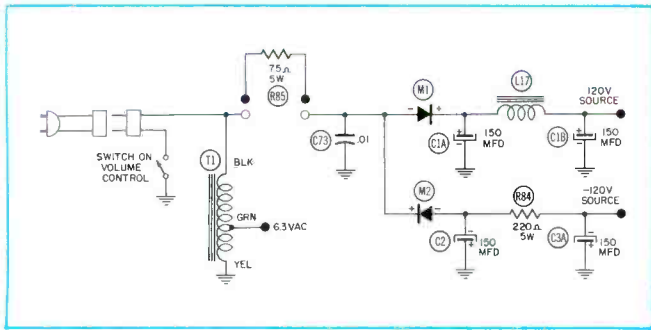

**Fig. 5. Low-Voltage Power Supply in Olympic Chassis AD.**

coupled to the yoke by means of a vertical-output transformer.

A negative pulse from the plate circuit of the first section of the

12BH7 is fed to the picture-tube grid in order to accomplish blanking during the vertical-retrace time.

### Horizontal Sweep

The sync pulses from the sync amplifier are also fed to the control tube in the horizontal-sweep circuit. This AFC stage comprises one triode section of a 6SN7GT, and it is a part of the familiar Synchroguide circuit. The horizontal oscillator is essentially a blocking oscillator, and it is controlled by a variable grid bias which is supplied by the AFC tube. The transformer associated with the horizontal oscillator has two adjustable slugs which must be set for the correct frequency and phase. In addition, the horizontal-hold control provides a fine adjustment of the oscillator frequency. The horizontal-output system of this receiver employs a 6CU6 tube. This stage is designed to operate without a drive control or drive trimmer in the grid circuit, and the cathode is returned to a negative 120-volt supply. The flyback transformer furnishes coupling to the yoke and supplies a high voltage of approximately 14 kilovolts to the picture tube. A 1B3GT tube is used for high-voltage rectification, and a 6AX4GT tube serves as a damper. Protection for the horizontal-output circuit is supplied by a 3/8-ampere fuse placed between the damper plate and the B+ supply.

The horizontal-output stage is designed to operate without the use of a width or linearity control; therefore, most of the component values involved are relatively critical.

### Power Supply

The low-voltage power supply of this receiver is shown in Fig. 5. It uses two selenium rectifiers, each one connected for half-wave rectification. M1 furnishes a positive 120 volts, and M2 supplies a negative 120 volts with respect to chassis ground. The outputs of the two rectifiers combine to produce an effect which is essentially the same as that of a conventional full-wave voltage doubler, provided that the load is connected between the points of positive and negative voltage. These selenium rectifiers are rated at 300 milliamperes, and the circuit is protected by the 7.5-ohm fusible resistor R85 which may be seen in the photograph of Fig. 3. In order to supply the filament voltage required for all the tubes, the 6.3-volt filament transformer T1 which is of the auto-transformer type has been employed. This unit is located on the mounting board of the chassis and may also be seen in the photograph of Fig. 3.

**LESLIE D. DEANE**

*Consistently Dependable*

# *Cornell-Dubilier*

*ceramic capacitors*

Only C-D can give you the "million dollar body", made by the exclusive C-D process in the world's most modern ceramic body plant—C-D's own. This close control under one roof, from raw powder to finished product, results in greater stability and uniformity, extra durability and extended service life—even down to the tiniest disc or tubular. See your classified telephone directory for nearest C-D jobber.

**INSIST ON C-D CERAMICS — THE FINEST!**

THERE ARE MORE C-D CAPACITORS IN USE TODAY THAN ANY OTHER MAKE

# **CORNELL DUBILIER** *Capacitors*

PLANTS IN SOUTH PLAINFIELD, N. J.; NEW BEDFORD, WORCESTER AND CAMBRIDGE, MASS.; PROVIDENCE AND HOPE VALLEY, R. I.; INDIANAPOLIS, IND.; FLOUAY SPRINGS AND SANFORD, N. C.; AND SUBSIDIARY THE RADIART CORPORATION, CLEVELAND, OHIO

## Hum Troubles in AC-DC Radios

(Continued from page 17)

Most receivers are constructed in such a way that the socket for the dial light is mounted on a bracket which is fastened to the chassis. Occasionally, one of these sockets will develop a high-resistance leakage path to the bracket. This condition will cause hum troubles to appear in the receiver. To test for this con-

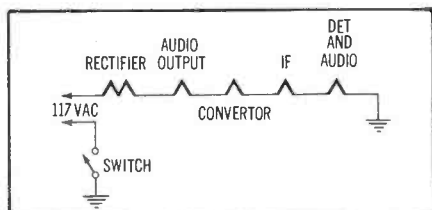

Fig. 3. Filament String in Typical AC-DC Radio.

dition, remove the socket from the bracket and position it so that it does not touch the chassis. If the hum has disappeared when the receiver is tested under this condition, the socket is faulty and should be replaced.

Dial lights can cause hum troubles to appear when they develop an intermittently open condition. The opening and closing of the filament in the light is often at a 60-cycle rate.

If the nontunable hum persists after these initial checks, remove the chassis from the cabinet. Connect an external capacitor in parallel with the input filter capacitor. The value of the external capacitor does not have to be exact, but it should be approximately equal to the value of the filter capacitor in the set. A decrease in the hum level indicates that one or more sections of the filter capacitor have diminished in value and that the entire capacitor should be replaced. Since this trouble is by far the most common cause of nontunable hum in AC-DC receivers, the filter capacitor should always be the first thing tested after the chassis is taken out of the cabinet.

If the preceding test does not eliminate the trouble, measure the voltage from B- to each side of the filter resistor. If the readings are very close, the filter resistor may have decreased in value or the two positive leads of the filter capacitor may have shorted together inside the capacitor.

Disconnect one lead of the resistor, and measure the value of the resistor. Replace the resistor with a new one if its measured value differs

from its rated value by more than 20 per cent. Measure the resistance between the two positive leads of the capacitor while the resistor is still disconnected. If the reading is zero or very low, replace the capacitor.

The average AC-DC receiver has a three-section electrolytic capacitor. Two of the sections are used as filters in the B+ circuit, and the third section is used as a bypass across the cathode resistor in the output stage. See Fig. 4. Occasionally, a high-resistance short will develop

inside the capacitor between the positive lead of one of the filter sections and the positive lead of the cathode section. A trouble of this nature will couple a 60-cycle voltage into the audio amplifier.

If the short is of low resistance, an ohmmeter measurement between the leads of the capacitor will indicate that the capacitor is faulty. The ohmmeter will not give a definite indication of trouble if the short is of high resistance. In this case, the receiver should be tested after the lead be-

## LIFE'S "LITTLE" PROBLEMS

ARE EASILY  
SOLVED  
WITH

### LITTLE SPACE

QUAM has a full line of shallow speakers, covering all popular applications.

### LITTLE TIME

QUAM speakers mount quickly and easily in the most difficult installations because of QUAM's unusual mounting bracket.

### LITTLE MONEY

QUAM speakers cost no more—and frequently cost less—than other speakers of the same size and magnet weight.

**QUAM**  
*Adjust-a-Cone*  
**SPEAKERS**

*ask for QUAM, the quality line for all your speaker needs*

Quam speakers are listed in Photofact Folders, Counterfacts, File-O-Matic, and Radio's Master.

A FREE copy of the latest QUAM catalog, listing over 100 replacement speakers, is available from your distributor, or from the Quam-Nichols Company.

**QUAM-NICHOLS COMPANY**

234 East Marquette Road Chicago 37, Illinois

tween the capacitor and the cathode terminal has been disconnected. An absence of hum will indicate that the capacitor is faulty.

Whenever a fault develops in one section of a multisection electrolytic capacitor, the entire capacitor should be replaced. In the case just mentioned, some technicians might be tempted to clip the wire to the cathode section and to install a separate single-section capacitor from the cathode terminal to B-. If this is done, there is a hazard that leakage will

develop between the two filter sections; then a free callback will be necessary to cure another case of hum in that receiver.

Some receivers of the type which have the B- line isolated from the chassis will produce hum if this line and the chassis are shorted together. There is no way of predicting which receivers will produce hum when B- is shorted to the chassis, but the possibility of this trouble should always be considered when servicing a receiver which has hum.

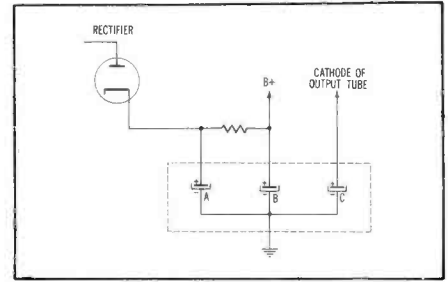

Fig. 4. Typical Connections of Three-Section Filter Capacitor.

In addition to producing tunable hum, the capacitor which filters the AC line can produce nontunable hum if this capacitor is connected from the high side of the AC line to the cathode of the rectifier and if it develops an internal short or a high value of leakage. If these conditions exist, 60-cycle voltage may enter the B+ line; and in most cases, the filter capacitor will be unable to remove all of the hum. In some extreme cases, the high AC voltage will cause the filter capacitor to fail completely.

The more obscure cases of hum will be due to such troubles as inter-element leakage within the rectifier tube, cold-solder joints, leakage between socket terminals, or an open circuit in the negative lead inside the filter capacitor. Be especially wary of those receivers in which spare terminals on the sockets of the rectifier tubes are used as tie points for components in audio circuits. The very small amount of hum voltage which might be coupled across the socket or through the rectifier tube will be amplified to a high volume by the time it emerges from the speaker.

WILLIAM E. BURKE

(Advertisement)

Sensational! The NEW...

# VACO<sup>®</sup>

## Hollow Shaft NUT DRIVERS in Color

Nothing else like them anywhere! Choice of 28 types and sizes! New plastic kit at right contains 7 most popular drivers in self-standing bag for service work or bench use.

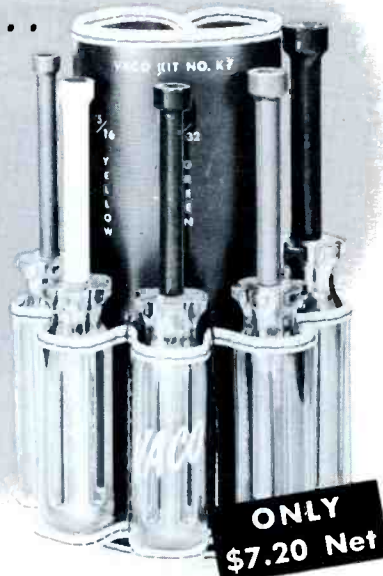

ONLY  
\$7.20 Net



No. K7 Self-Standing Service Kit  
Stands Up! Hangs Up! Folds Up!

Stands upright for easy accessibility. May be hung flat on wall or may be folded. Each driver fits in individual holder marked for size, color.

### Check These 6 Important VACO Features

NEW! Each size color-keyed!

NEW! All-hollow shafts

NEW! Extra large VACO Comfordome Handles!



NEW! Extra hard long wearing sockets!

NEW! Shafts insulated from handle to tip!

NEW! Available in 4 shaft lengths and 7 Hex sizes!

**FREE** A merchandise coupon worth \$1.20 when used to purchase the Vaco K7 Kit described above. Simply circle the Vaco number on the "Catalog and Literature Service" insert at rear of magazine.

**VACO PRODUCTS COMPANY**

317 E. Ontario St., Chicago 11, Ill. • In Canada: Vaco-Lynn Products Co., Ltd., Montreal 1, Que.

### latest JACKSON tube test data

Tube Type	MODEL 648				MODEL 715/115			
	Fil.	Circuit D	E	Plate Test	Fil.	X	Plate	YZ
6AX8	6.3	A125	C389	16WY	6.3	--	35	5HS
		A127	A46	20XZ			10	2FS
6CB5	6.3	1248	B579	15W	6.3	235	8	8JMS
6CM6	6.3	129	B346	35W	6.3	4	14	7JKS
12BR7	12.6	A123	A45	22XZ	12.6	7	25	2LQ
		127	8	60X			30	4Q
		127	9	60X			30	5Q
12BV7	12.6	A1234	B579	18XZ	12.6	47	20	5JOR
12CM6	12.6	129	B346	35W	12.6	4	14	7JKS
25CA5	25.	C123	467	20V	25.	6	16	5KMR
5881	6.3	123	456	25W	6.3	--	9	2JLMS
6550	6.3	123	456	20W	6.3	--	8	2JLMS

LATEST CHART FORM 715/115-7  
LATEST CHART FORM 648-13

## Notes on Test Equipment

(Continued from page 15)

from 68 to approximately 120 kilocycles. Resonant frequencies of most yokes and transformers fall somewhere within the prescribed ranges when these components are operating normally. The natural resonant frequency of the entire horizontal-deflection system is higher than that of the flyback transformer alone, as was pointed out in the two articles mentioned.

In practice, the Seco Model FB-4 tester is connected across the yoke or flyback circuit to be tested, the SELECTOR switch of the tester is turned to the position marked FLYBACK and TRANSF., or to YOKE, as desired; and the SENSITIVITY control is adjusted to the proper point, according to the instruction book accompanying the tester. Then the frequency control is rotated to the point at which the eye indicator opens widest, and the condition of the component under test is determined from the dial setting.

When the SELECTOR switch is turned to YOKE position, a 500-mmf capacitor in the instrument is connected in parallel with any yoke being tested. This is for the purpose of tuning the yoke so that its resonant frequency will be within the frequency limits indicated by the yoke sector. Any yoke winding having an inductance of 20 millihenrys or more may give an indication falling outside the yoke sector, but the danger of a misinterpretation of the test results under such a condition will be lessened if the rated yoke inductance is known.

The manual also offers the following suggestions in case the yoke inductance is not known. Two troubles which may be encountered in testing yokes are: (1) arc-over between horizontal and vertical coils or between the two horizontal coils themselves, and (2) shorts between adjacent turns or layers of turns. The first trouble will be manifested by a resistance between windings and can be checked with a high-resistance ohmmeter.

In checking for the second trouble, it is safe to assume that seldom will it be found that both halves of the horizontal winding in a yoke will go bad at the same time; therefore, if the windings are in normal condition, the same resonant-frequency indication will be obtained from the tester when each half is tested. A marked difference in indication between the two halves of the

winding would indicate that one is defective.

NOTE: The capacitor which is often connected across one of the windings should be removed before this comparison test is made.

The check of the horizontal-deflection system can be made with the Seco Model FB-4 without the necessity of disconnecting any components. There must be no power applied to the receiver at the time.

If it is desired to test the flyback transformer alone, a number of preliminary operations should be performed. The manual recommends:

1. Remove the plate caps on the horizontal-output tube and the high-voltage rectifier.
2. Remove the high-voltage rectifier from its socket. (The filament of this tube is operated from a winding on the flyback transformer; and if this tube is in place, a closed circuit which loads the flyback transformer is formed.)
3. Unplug or disconnect the deflection-yoke assembly.
4. Unsolder one side of the width coil.

All four steps are taken to avoid loading the flyback transformer and thereby changing its natural resonant frequency.

### Testers Employing Principle of Q-Meter and Grid-Dip Meter

The EICO Model 944 tester and the Radio City Products Model 123 tester for flyback transformers and yokes are shown in Fig. 1. They can be considered as examples of testers working on the principle of the Q-meter or of the grid-dip meter. Strictly speaking, there are certain similarities of operation among all three of the testers discussed, inasmuch as the Q of any circuit under test affects the readings on all three. The frequencies of the operating signals in the EICO Model 944 and in the Radio City Products Model 123 are further removed from the natural resonant frequency of any circuit being tested; therefore, the readings obtained when a component is being tested will be affected more by the Q of the component than by its resonant frequency.

The testing signals provided by these two instruments, the EICO and the Radio City Products models, are very similar. The first is a 600-cycle signal interrupted at a 60-

replace with...

**INTERNATIONAL**  
*Selenium Rectifiers*

the Replacement Rectifier  
that's Right!

for TV and Radio  
Replacement

all  
types  
available  
from your  
parts  
distributor

**INTERNATIONAL**  
RECTIFIER  
CORPORATION

El Segundo, Calif. ORegon 8-6281

NEW YORK • CHICAGO

World's Largest Supplier of  
Quality Industrial Rectifiers

cycle rate, and the second is a signal of approximately 1500 cycles interrupted at a 60-cycle rate. The 60-cycle interruption causes a pulsed signal which is similar to the signal present under normal operating conditions in the flyback circuits. It is claimed that such a signal is more useful in showing up intermittent conditions than a steady, nonpulsed signal would be.

When a yoke or transformer is connected across the terminals of either of these two instruments, it is

effectively coupled to the internal oscillator circuit. The output of this oscillator is indicated by a deflection of the pointer in the panel meter. A control is provided so that the pointer can be set to a calibration point on the dial before the component to be tested is connected. In the case of the EICO tester, two calibration points are used. One is for iron-core transformers, and the other is for air-core transformers.

A coil having shorted turns will load the oscillator and absorb power

from the oscillator circuit. This causes the meter needle to drop to a lower scale sector marked either BAD or REPLACE, and thus a defective component is indicated.

Operating instructions for all three of these instruments specify that any damping networks should be removed from yoke windings before testing. The damping resistors found on the vertical windings of yokes are of comparatively low value, usually 500 to 600 ohms; and their presence across the windings would reduce the Q of the circuit to the point where a reading indicative of a defective component would be obtained on the testers.

The technician will find that a flyback tester such as any of those just described will reduce the amount of guess work or experimental substitution sometimes resorted to when trouble shooting horizontal-sweep circuits. Proper application methods will enable the operator to test other inductive components in a TV receiver; for example, the Seco manual lists the values of shunt capacitances necessary to adapt the Seco FB-4 tester for checking ringing coils, linearity coils, and width coils.

#### RECENT RELEASES

##### Precision Model 120 VOM

The Precision Model 120 volt-ohm-milliammeter (VOM) shown in Fig. 2 is a product of the Precision Apparatus Company, Inc., Glendale, L.I., New York. This meter provides forty-four AC and DC ranges as follows:

DC voltage ranges at 20,000 ohms per volt; 0 to 1.2, 3, 12, 60, 300, 600, 1200, 6000 volts.



Fig. 2. Precision Model 120 Volt-Ohm-Milliammeter.

# PAYS ITS WAY from the VERY FIRST DAY

The only unit  
Proved in the Field

**18,900** CRT 350's  
NOW IN DAILY USE  
ACROSS THE NATION



**CATHODE  
REJUVENATOR  
TESTER**

### QUICKLY CHECK AND CORRECT TV PICTURE TUBE TROUBLES

*in a few minutes, right in the home  
without removing tube from set!*

Daily use by more and more servicemen proves the CRT builds profits and customer satisfaction! Compact, portable CRT quickly locates and corrects picture tube troubles, due to low emission, inter-element shorts, leakage and open circuits—gives new life to weak and inoperative tubes. *Life-Test* feature checks gas content and predicts remaining useful tube life, while *Grid Cut-Off Reading* indicates picture quality customer can expect. So simple to operate, one glance tells the story. Earns servicing dollars in minutes, cuts operating cost, eliminates tube transportation. Saves money on TV set trade-in reconditioning, too. CRT costs so little, it pays its way from the very first day!

Weights only 5 lbs.  
Size 11" x 7½" x 5"

MODEL 350  
**\$54.95**  
ONLY NET

Send for Bulletin 102-R

Watch for another  
brand new B&K  
money-maker coming  
your way soon

**B&K MFG. CO.** 3731 N. Southport  
Chicago 13, Illinois



AC voltage ranges at 5000 ohms per volt: 0 to 1.2, 3, 12, 60, 300, 600 1200, 6000 volts.

AC output ranges: same as the AC voltage ranges, but with blocking capacitor added.

DC current ranges: 0 to 60, 300 microamperes; 0 to 1.2, 12, 120, 600 milliamperes; and 0 to 12 amperes.

Resistance ranges: 0 to 200, 2000, 200,000 ohms; 0 to 2, 20 megohms.

Decibel ranges: -20 db to +77 db. Zero-db reference level is 1 milliwatt, 600 ohms.

A feature of special interest is the R x 1/10, or the lowest ohms range. This feature permits measurement of very small values of resistance. On this range, the first scale division indicates a resistance of only .025 ohm.

Jacks and plugs are of the banana type. The same COMMON jack is used for all measurements. A positive (+) jack is used for the positive lead for all ranges except the following: 12 AMPS, OUTPUT, 1200V AC, 1200V DC, 6000V AC, 6000V DC.

These six ranges are served by the use of five additional jacks on the front panel. One jack is used both for 1200 volts AC and for 1200 volts DC. An AC-DC switch on the front panel may be set for the operator's choice of either AC or DC measurements.

One position of the range-selector switch is labeled TRANSIT and provides damping for protection of the meter movement when the meter is not in use or when it is being moved about. The ADJ OHMS knob is recessed into the front panel.

The 5 1/4-inch meter is mounted in a molded black phenolic case measuring 5 3/8 by 7 by 3 1/8 inches. Panel markings are deeply engraved for maximum legibility and long life.

Accessories available for the Model 120 are: (1) TV-2B, a 30-kilovolt safety probe; (2) LC-3, a leather instrument case; and (3) ST-1, a snap-on foldaway tilt-stand.

#### Precision Model 88 VTVM

Another product of the Precision Apparatus Company, Inc., is the Model 88 vacuum-tube voltmeter (VTVM) and electronic ohmmeter shown in Fig. 3. The instrument has the

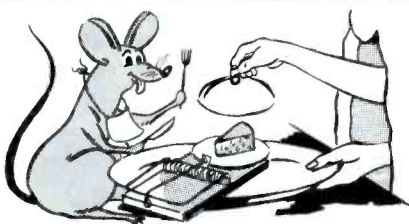

Fig. 3. Precision Model 88 VTVM.

following voltage and resistance ranges.

Zero-center DC voltage ranges at a constant 26 2/3-megohm input resistance: 0 to ±1.2, ±6, ±12, ±60, ±300, and ±1200 volts.

Left-hand zero DC voltage ranges (either positive or negative) at a constant 13 1/3-megohm input resistance: 0 to 1.2, 6, 12, 60, 300, and 1200 volts.



**MOUSE CATCHING.** Mice are clever in Kalamazoo. Even an epicure's assortment of Cheddar, Roquefort, Gruyere, Limburger, and bacon rind failed to lure their little noses under the spring. But one night the housewife in question noticed the marks of two tiny incisors on a scrap of shiny aluminum foil sticking to a piece of cheddar. Realizing then that the mice were rebelling at the lack of modern packaging on their bait, she wrapped each tempting morsel in bright clean Alcoa foil before putting it back on the trigger. That night the mice succumbed and met their doom.

Packaging and polish attract women, too. Spend a few extra minutes cleaning the glass and polishing the cabinet of each TV set you handle, and notice how much easier it is to get payment in full.

MARKUS · · Dollar and Sense Servicing

**XCELITE Hand Tools**  
PREFERRED BY THE EXPERTS



YOU'LL BE  
**"QUICK  
ON THE  
DRAW"**

with this new

**TOOL  
HOLSTER!**

- Safely holds up to 7 tools for quick use wherever you go!
- 5 pliable leather pockets — solid Russet Saddle leather back!
- Knife snap — knife attached or removed in one fast motion
- Stitched with sturdy hot wax thread, locked with steel rivets.

**XCELITE No. 150**

list \$**4.75**  
(without tools)

Ask your XCELITE supplier about this new holster — and some first-class "weapons" to carry in it!

**XCELITE, INCORPORATED**

(formerly Park  
Metalware Co., Inc.)

Dept. Q

Orchard Park, N. Y.

*For Originality*  
**LOOK TO XCELITE**

**You're Ready  
for any Service Job**

with

**JACKSON**

*"Service Engineered"  
Test Equipment*



**TVG-2  
Sweep  
Marker  
Generator**

Dealer Net \$259.95

A complete TV generator plus crystal calibrator. Sweep 30KC through 216MC. Width adjustable from 0 through 18MC. Accurate Marker 4MC through 216MC. Crystal oscillator for frequencies to 20MC. Provision for Video Modulation.

**CRO-2  
Wide Band  
High Sensitivity  
5-inch Scope**

Dealer Net \$225.00

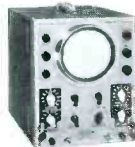

Flat within 1 db from 20 cycles through 4.5MC. Sensitivity from .018RMS volts per inch. Positive or Negative internal horizontal sync. Saw tooth sweep 20 cycles through 50KC. Many accessories including low capacity probes.



**Model 709  
Large-Meter  
VTVM**

Dealer Net \$95.00

Features 7" meter and illuminated function windows, for easiest use. 11 megohms input resistance as DC Voltmeter. Ranges from 1 volt full scale to 1000 volt full scale AC or DC. Special Peak-to-Peak ranges. Ohm Meter range from 1,000 ohms to 1,000 meg. full scale.



**Model 648P  
Dynamic®  
Tube Tester**

Dealer  
Net from \$104.50

Fastest tester on the market and featuring famous Jackson Dynamic Circuit. Meter calibrated in Good-Bad, as well as percent Transconductance. Correct test voltage for all tubes including latest 600-mil types. Line Voltage Indicator.

**JACKSON**  
ELECTRICAL INSTRUMENT CO.

World's largest exclusive makers of  
factory-built service test equipment.

16-18 S. Patterson Boulevard • Dayton 2, Ohio  
In Canada: The Canadian Marconi Co.

Rms AC voltage ranges: 0 to 1.2, 6, 12, 60, 300, 1200 volts. Input-impedance characteristics on rms AC ranges are:

RANGE (volts)	IMPEDANCE CHARACTERISTICS
up to 60	3 megohms, 90 mmf
300	1 megohm, 70 mmf
1200	4 megohms, 67 mmf

Peak-to-peak AC voltage ranges: 0 to 3.2, 16, 32, 160, 800, 3200 volts. Input-impedance characteristics on these ranges are:

RANGE (volts)	IMPEDANCE CHARACTERISTICS
up to 160	6 megohms, 90 mmf
800	1 megohm, 70 mmf
3200	4 megohms, 67 mmf

Resistance ranges: 0 to 1000, 10,000 ohms; 0 to 1, 100, and 1000 megohms.

High-frequency probe ranges: 0 to 1.2, 6, 12, 60, and 300 volts rms. These ranges require the use of the Model RF-10A high-frequency probe which is optional accessory equipment. Input capacity of this probe is stated to be approximately 5 micromicrofarads.

The eight-position function-selector switch is marked as follows: OFF, ZERO CENTER, OHMS, -DC, +DC, AC RMS, AC P-P, HF PROBE.

The ZERO ADJ and OHMS ADJ controls are recessed into the front panel.

A P-P (peak-to-peak) reset button provides for fast return of the pointer to zero position after a peak-to-peak voltage reading has been made.

The 5 1/4-inch meter is mounted in a molded black phenolic case measuring 5 3/8 by 7 by 3 1/2 inches. Panel markings are deeply engraved for maximum legibility and long life.

Accessories in addition to the Model RF-10A high-frequency probe already mentioned are a Model TV-8 60-kilovolt safety probe and a Model ST-1 snap-on foldaway tilt-stand.

PAUL C. SMITH

**Less  
than  
1%  
ripple**

AT 15 AMPS!

**Electro**  
ELECTRONIC EQUIPMENT

## DC POWER SUPPLY

continuously variable

0-28 VOLTS UP TO 15 AMPS

This all-purpose unit is widely used in service shops, industrial plants and laboratories for testing electronic equipment. Its high quality components and practically limitless utility are unmatched at the price.

A single control offers continuous voltage adjustments for different load conditions over the entire range. Patented EPL application of selenium rectifiers assures long life.



model "NF" specially filtered **\$195.00**

**FOR TESTING, SERVICING, AND OPERATING** radios and electronic units in aircraft, autos, marine craft . . . relays and solenoids . . . telephone circuits . . . laboratory and research instruments . . . low voltage devices. For plating operations and battery charging.

**Model B FILTERED  
DC POWER SUPPLY**

6 V. 1-20 Amps. cont.

Widely used for servicing  
2-way mobile radios

Descriptive Bulletins on Models NF and B

**ELECTRO PRODUCTS LABORATORIES**

4501-PF N. Ravenswood Ave.,  
Chicago 40, Ill.

Canada: Atlas Radio Ltd., Toronto

# A STOCK GUIDE FOR TV TUBES

The following chart has been compiled to serve as a guide in establishing proper tube stocks for servicing TV receivers. The figures have been derived by combining (1) a production factor (the number of models and an estimate of the total number of receivers produced by all manufacturers) and (2) a depreciation factor (based on an average life of six years for each receiver, and the figures are reduced accordingly each two months).

1. The figures shown are based on a total of 1,000 units. This was done in order to eliminate percentage figures and decimals. The figure shown for any tube type then represents a percentage of all tubes now in use. For example, a figure of 100 would imply that that particular tube type constitutes 10 per cent of all tube applications.

2. Some consideration should be given to the frequency of failure of a particular type of tube. A tube used in the horizontal-output stage will fail much more frequently than a tube used as a video detector. Thus, even though

the same figure may be given for both tubes, more of the horizontal-output type should be stocked.

3. The column headed '46 to '55 is intended for use in those areas where television broadcasting was initiated prior to the freeze. Entries in this column include all tubes used since 1946 except those having a value of less than one, which is the value of the minimum entry in this chart. The '52 to '55 column applies to the TV areas which have been opened since the freeze. Since the majority of receivers in these areas will be of the later models, only the tubes used in these newer sets are considered in this column. The minimum value of one also applies to this column.

4. The listing of a large figure for a particular tube type is not necessarily a recommendation for stocking that number of tubes. The large figure does indicate that this tube is used in many circuits and emphasizes the necessity for maintaining a stock sufficient to fill requirements between regular tube orders.

	46-55 Models	52-55 Models		46-55 Models	52-55 Models		46-55 Models	52-55 Models		46-55 Models	52-55 Models
1B3GT	41	44	c6AM8	-	-	c*6BJ7	-	-	#6T4	-	-
1X2	5	1	#6AN4	-	-	6BK5	2	3	6T8	13	14
1X2A	4	5	c6AN8	-	-	6BK7	3	5	c6U8	8	10
c1X2B	-	-	6AQ5	13	14	6BK7A	2	2	6V3	2	3
c3A3	-	-	6AQ7GT	2	2	6BL7GT	5	8	6V6GT	20	19
*3BC5	-	-	6AS5	2	2	6BN6	4	4	6W4GT	27	29
*3BN6	-	-	c6AS6	-	-	*6BQ6GA	-	-	6W6GT	6	11
*3CB6	-	-	6AT6	4	3	6BQ6GT	19	26	6X5GT	1	1
*5J6	-	-	c6AU4GT	-	-	6BQ7	6	12	6X8	5	7
c5U4G	47	49	6AU5GT	4	4	c6BQ7A	5	5	6Y6G	3	1
*5U8	-	-	c6AU6	127	118	c6BY6	-	-	7N7	2	-
5V4G	7	-	6AV5GT	2	3	6BZ7	6	7	c12AT7	14	13
5Y3GT	4	2	c6AV6	16	17	6C4	10	9	c12AU7	45	32
6AB4	3	2	*6AW8	-	-	c6CB6	106	138	12AV7	3	3
6AC7	7	7	6AX4GT	10	9	c6CD6G	9	10	12AX4GT	2	4
c#6AF4	3	3	6AX5GT	1	2	6CF6	1	1	12AX7	4	5
6AG5	29	9	6BA6	13	10	c6CL6	1	2	12AZ7	-	2
6AG7	2	2	6BC5	9	7	6CS6	1	1	*12B4	-	-
6AH4GT	3	4	c6BC7	-	-	*6CU6	-	-	c12BH7	9	13
6AH6	7	9	c6BD4	-	-	c*6DC6	-	-	12BY7	5	6
6AK5	4	3	6BE6	6	7	6J5	3	3	12BZ7	2	-
c6AL5	74	74	6BG6G	12	6	6J5GT	1	1	*12L6GT	-	-
6AL7GT	5	-	6BH6	7	-	6J6	32	29	12SN7GT	5	4
			6BJ6	1	-	6K6GT	15	9	*12W6GT	-	-
						6S4	9	10	19BG6G	3	-
						6SH7GT	1	-	*25BK5	-	-
						6SL7GT	3	2	25BQ6GT	3	4
						c6SN7GT	71	78	*25CU6	-	-
						6SN7GTA	5	5	25L6GT	5	5
						6SQ7	2	2	25W4GT	1	1
						6SQ7GT	2	2	5642	1	1

# A stock of these tubes should be maintained in UHF areas.  
\* New tubes recently introduced.  
c Tubes used in color television receivers.

## Shop Talk

(Continued from page 5)

a certain channel, let us say channel 3, the video carrier will be at 61.25 megacycles; the oscillator signal will be at 107 megacycles; and the image signal, if any, will be at 107 megacycles plus 45.75 megacycles, or 152.75 megacycles.

The method of determining the image-rejection ratio is carried out as follows. The receiver is set to receive a signal on one of the VHF or UHF channels. The signal generator,

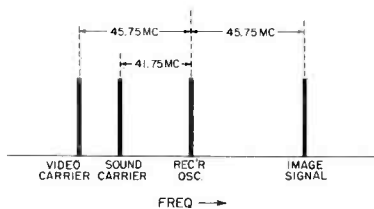

Fig. 3. Frequency Spectrum Showing Relationship Between the Desired Incoming Signal and an Image Signal.

on the other hand, is tuned to the image frequency for that channel. Generator output is increased until an indication is obtained from the re-

ceiver. The setting of the fine-tuning control on the receiver is not shifted from the position at which the control was set for reception of the normal signal. With the signal modulated, attempt to obtain at the picture tube an output signal with an amplitude of 20 volts peak to peak. Note how much input signal is required to produce this output. This amount of input signal divided by the amount of input signal at the channel frequency represents the image-rejection ratio.

If it is not possible to develop at the picture tube an amplitude of 20 volts peak to peak with an input signal

## Non-Snarling, Pre-Measured Wire Strand

WRIGHT Wire Strand uncoils like this →

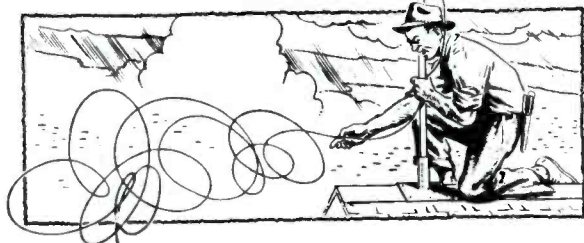
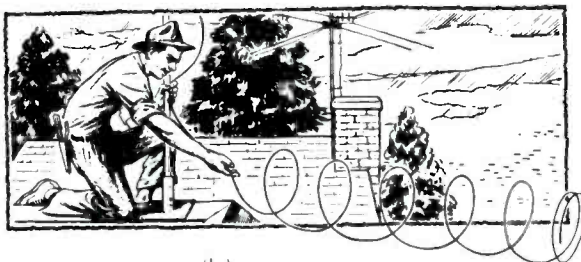

← WRIGHT unique process prevents this

Besides the important factor of no snarling, WRIGHT TV GUY WIRE is pre-measured. Every concentric coil measures two feet—time and money saver in guying antennas. WRIGHT TV GUY WIRE has great flexibility and is heavily galvanized . . . continuous connected coils.

Prompt deliveries from stocks in Worcester, Chicago, Atlanta, New Orleans, Houston, Dallas and Los Angeles.

## G. F. WRIGHT STEEL & WIRE CO.

245 Stafford St. • Worcester, Mass.

## CASH IN on Multiple TV installations

for motels, apartments, clubs

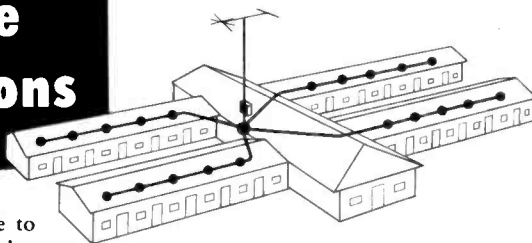

Sell terrific "come-hither" value to motels, tourist courts, apartment houses, and clubs, by equipping every room with the finest television reception! Sell the single-antenna system that does away with a roof full of costly, dangerous, unsightly separate antennas. Sell the ease of adding receivers without additional roof work.

The Jerrold TV *Multi-Outlet* System feeds snow-free signals to twenty or more sets from one antenna, with full signal strength at every receiver and with no interaction between sets. Heart of the system is the indoor-mounted 5-tube Jerrold ABD-1 Distribution Amplifier, which distributes the sharpest picture attainable in any area, on low-noise coax cable to individual line-tap impedance matchers in each TV-equipped room.

Jerrold engineering simplifies every step of your installation, from the antenna to the receivers. *You save outdoor time and equipment*, and you boost your repeat-service market on individual receivers!

The farsighted motel and apartment owner is going more and more to Jerrold *Multi-Outlet* television. Will you be there when he buys?

Write for free illustrated literature to help you sell.

**JERROLD ELECTRONICS CORPORATION**

1405 S. 26th Street

Philadelphia 46, Pa.

**JERROLD**

at the image frequency, strive for a lower amplitude, let us say 5 or 10 volts peak to peak. Then determine how much input signal at the channel frequency is required to produce the same output; and from these two input signals, the desired ratio can be obtained.

### IF Rejection Ratio

Another important gauge of the ability of a receiver to reject interference is the IF rejection ratio. This is the ratio between the normal receiver sensitivity and the sensitivity to a signal at the intermediate frequency. The procedure is carried out in the same manner as for the image-rejection ratio, except that the generator is tuned to the intermediate frequency which produces the greatest output in the receiver. Again, the generator should be set up to provide the standard output (20 volts peak to peak). If this value is not obtainable, the maximum output is recorded. Then, set the generator to the video-carrier frequency of the channel, and adjust the generator to produce the same output at the picture tube. The ratio between the two input signals (the IF input signal and the normal input signal) is the IF rejection ratio.

### AGC Figure of Merit

The ability of the AGC system to maintain a constant output with different levels of input signal can be evaluated. The Hazeltine Laboratories employ what they call an "AGC figure of merit." The greater this figure of merit, the more efficient the AGC system. The figure is determined in the following way.

With an equipment setup similar to that for a sensitivity measurement, the receiver is adjusted for operation on a particular channel. The level of the input signal is set to .1 volt (100,000 microvolts), and the contrast control of the receiver is adjusted so that there will be no overloading of the video amplifier. It is usually sufficient to set the contrast control to about 40 per cent of its maximum setting. The level of output signal is recorded, and then the input signal is gradually reduced until the output signal falls to 31.5 per cent of its previous value. The AGC figure of merit is recorded as the decibel equivalent of the ratio between the original input signal (100,000 microvolts) and the input signal required to produce this output change. The more the input signal has to be reduced to obtain this change, the greater the AGC figure of merit, and the more efficient the AGC system.

It should be noted that with simple AGC systems, sine-wave

modulation of the input signal is satisfactory; however, with keyed AGC systems, a pulse type of modulation is essential.

There are many other performance tests which may be made on receivers, but more elaborate equipment is required. For the tests described, only a VTVM or scope and a signal generator with a calibrated output level are needed.

### SUMMARY OF HAZELTINE REPORT

Each year since 1950, the Hazeltine Research Laboratories have issued a report concerning American-made television receivers, as checked in their laboratories. Some of the results are shown in Table I.

Let us consider some of the results obtained for receivers made during 1953. The report shows that 67 per cent of the sets employed 21-inch picture tubes, 27.5 per cent used 17-inch tubes, and 5.5 per cent had 24-inch tubes. All receivers were intercarrier sets. Of these, 71 per cent had an intermediate frequency of 40 megacycles, and 29 per cent had an intermediate frequency of 20 megacycles. Furthermore, the trend toward fewer tubes was indicated by the fact that 67.5 per cent of the sets tested had three tubes in their IF stages; whereas, only 32.5 per cent had four tubes.

The average receiver sensitivity to a video signal is given in this report as 91 decibels for channels 2 through 6 and as 86 decibels for channels 7 through 13. To interpret these decibel values, it is first necessary to know that each decibel figure represents the ratio between 1 volt and the input voltage needed to produce 20 volts peak to peak at the picture tube. For example, over channels 2 through 6, the input signal had a level which was 91 decibels below 1 volt. The figure of 91 decibels represents a voltage ratio of approximately 35,000. If we change 1 volt into 1,000,000 microvolts and divide by 35,000, we see that the level of the input signal was 28 microvolts.

For channels 7 through 13, the signal level was 86 decibels below 1 volt. The figure of 86 decibels represents a voltage ratio of 20,000, and this latter ratio divided into 1,000,000 microvolts gives a result of 50 microvolts which was the input level needed on the higher VHF channels to produce 20 volts peak to peak at the picture tube. This system of using decibel values below 1 volt to designate signal levels may appear awkward at first; however, if the voltage ratios that correspond to 10-, 20-, 30-, and 40-db values and so on are calculated,

TABLE I

### Comparisons Drawn by Hazeltine Research Laboratories From Sample Groups of American TV Receivers Made in 1953 and 1954

DESIGN FEATURES	1953 RECEIVERS IN GROUP SAMPLED	1954 RECEIVERS IN GROUP SAMPLED
	(per cent) (average)	(per cent) (average)
17-inch tube	27.5	42.4
21-inch tube	67.0	50.0
24-inch tube	5.5	3.8
27-inch tube		3.8
20-mc IF	29.0	50.0
40-mc IF	71.0	50.0
3-tube IF system	67.5	96.2
4-tube IF system	32.5	3.8
VHF cascode RF stage	not given	61.5
VHF pentode RF stage	not given	38.5
IF bandwidth at 6 db down	3.45 mc	3.25 mc
AGC figure of merit	64 db	63 db
Total power consumption	198 watts	166 watts

there will appear a repetitive pattern which makes the system rather simple to use.

The foregoing results are average figures for a group of typical receivers. Some sets were obviously better than the average; some were worse.

On the UHF channels, the same group of sets had sensitivities that ranged from 8 to 10 decibels lower than their VHF sensitivities. A figure of 8 decibels is equivalent to a voltage ratio of approximately 2.5, and a figure of 10 decibels corresponds to a voltage ratio of 3.2.

The following are some additional facts concerning the averages for these typical receivers that were investigated.

1. Image-rejection ratios for the lower VHF channels averaged about 55 decibels. In terms of voltage, this represents a ratio of 560, which means that an image signal would have to be 560 times stronger than the desired signal in order to produce the same voltage at the picture tube as the desired signal produces. On the higher VHF channels, the average image-rejection figure was about 48 decibels. Note that this

corresponds to a voltage ratio of 250, and hence an image signal would have to be only 250 times stronger than the desired signal. This degradation of the image-rejection ratio when the frequency increases is characteristic of all television receivers. In the UHF band, the rejection ratio drops to 33 decibels at 500 megacycles; and at 850 megacycles, it is a mere 20 decibels. The latter decibel value corresponds to a voltage ratio of only 10 to 1, which is one of the reasons that UHF television is experiencing as much trouble as it is.

2. Representative IF rejection ratios did not decrease consistently with increase in channel frequency. They were:

Lower VHF channels	— 59 db
Upper VHF channels	— 63 db
In UHF band	— 41 db

3. The average IF bandwidth at 6 decibels (50 per cent down) was 3.45 megacycles.

4. The AGC figure of merit was greater than 64 decibels. This means that the input signal had to be decreased to about 1/1600 of its original value in order for the output of



# A NEW CONCEPT IN CHEMICALS FOR ELECTRONICS by GEMCO

From the chemical laboratories of GEMCO come these all NEW 'service designed' chemicals, created exclusively for the electronic industry! A complete departure from the traditional 'souped-up' carbon-tet formulas, they are years ahead of anything else and offer a truly NEW CONCEPT in 'Chemicals for Electronics'.

## Penetrex

for cleaning volume controls.  
So potent . . . you can clean  
a control thru the shaft!



## Nu-Tuner

for cleaning band-switch type front  
ends. Cleans R.C.A. type tuners with  
no change in frequency response!



No acids!  
No corrosives!  
No gumming!

We un-conditionally guarantee that these products will clean better and keep 'em clean longer than any other product made. Try them and convince yourself NOW. You'll always be glad you did!

## Contact-Kleen

for cleaning exposed contacts.  
No abrasives . . . cleans Standard  
Tuner contacts like nothing else can!



**GREAT EASTERN MANUFACTURING CO.**  
BROOKLYN 12, NEW YORK



the receiver to decrease to 31.5 per cent of the original output voltage. This efficiency in AGC action can be considered very good. For example, if we started with an input signal of 100,000 microvolts, then this signal could have been reduced to 60 microvolts in order for the output signal to drop 68.5 per cent.

It may be of interest to compare some average characteristics of 1953 and 1954 television receivers. This is done in part in Table I, and even a casual perusal reveals a number of interesting facts. For example, the proportion of sets with 17-inch picture tubes rose from 27.5 per cent in 1953 to 42.4 per cent in 1954. On the other hand, the number of 21-inch sets dropped almost the same amount. The trend toward larger screens, which was so noticeable in recent years, seems to have been halted for the present.

Another item of interest is the fact that 61.5 per cent of all VHF tuners in 1954 receivers were of the cascode variety and 38.5 per cent were of the pentode variety. Since the noise factor of cascode tuners is 2 to 3 decibels lower than that of comparable pentode tuners, one may wonder why cascode tuners were not used exclusively. The answer can be

found in two facts. With many TV stations markedly increasing their effective radiated power, the need for low-noise tuners is not so great today as it was perhaps two or more years ago. Secondly, emphasis in recent months has been placed on lowering set cost, as all of us in the industry know. This has led to the development of the vertical chassis and to the increasing use of printed circuitry, since the latter can be fabricated automatically. It has also led to the favoring of pentode tuners because they can be produced more cheaply than cascode tuners.

Another indication of the economy trend is the increase in the number of sets using a 20-mc video IF system. In 1953, only 29.0 per cent of the sets that were checked utilized a 20-mc IF system; and 71.0 per cent had a 40-mc system. In 1954, the percentages stood at 50 per cent each. A 20-mc system is cheaper to build, and it will provide more gain (for the same number of stages) than a 40-mc system. Practically all 1954 receivers used a three-tube video IF system compared to only 67.5 per cent in 1953.

One would surmise from these figures that 1954 receivers were not so sensitive as 1953 sets, and this

belief is substantiated by comparing the picture and sound sensitivities for the two years. On the average, 1954 sets were 1 to 2 decibels (10 to 20 per cent) less sensitive than their 1953 counterparts. (If the television industry stressed receiver sensitivity in sales campaigns as much as automobile manufacturers stress horsepower, we would have had some very interesting sales copy, indeed!)

To recover some of the lost gain caused by the preceding economies, over-all IF bandwidth dropped from 3.45 megacycles in 1953 to 3.25 megacycles in 1954. This helped, but it was not enough to recapture fully all of the lost sensitivity. Actually, the only persons who were noticeably affected by this cost cutting were those who lived in fringe areas. In most of the television areas throughout the country, the lowering of set characteristics could not be visibly detected by any one not professionally in the servicing or engineering end of the business. The resulting economy not only gave the public more set per dollar spent, but it also enabled the set manufacturers as a whole to have the second best TV year in their histories.

MILTON S. KIVER

PF REPORTER - June, 1955

## In the Interest of Quicker Servicing

(Continued from page 23)

A defect in the oscillator coil is a common cause of drift of oscillator frequency. The reason for this seems to be that when some coils heat up, the windings on the coils may expand. This expansion causes a change in the distributed capacitance between windings. Although the change in capacitance may be only two or three micromicrofarads, it is enough to cause a change in oscillator frequency, particularly when the radio is tuned to some station at the high-frequency end of the broadcast band. The tuning capacitor of the oscillator is almost fully open at this time, and its capacitance may be approximately 20 micromicrofarads. The 2-mmfd change in distributed capacitance in the oscillator coil would represent a change of 10 per cent in the tuning capacitance of the oscillator. The change in frequency would be appreciable.

When the radio is tuned to a station at the low-frequency end of the broadcast band, the tuning capacitor of the oscillator may have a capacity of approximately 180 micromicrofarads or more. Under this condition, the 2-mmfd change in distributed capacitance represents only 1.1 per cent or less of the total capacitance. Hence, frequency drift may not be so noticeable when stations at the low-frequency end of the broadcast band are received.

The trimmer capacitor in the oscillator circuit should never have to be tightened excessively in order to obtain proper alignment. When such a capacitor is tightened to maximum, it becomes more susceptible to temperature changes and a drift problem can arise. Changes in temperature cause either expansion or contraction of the parts of a capacitor. When the spacing between the plates is very small, a very slight change in the amount of this spacing will produce an appreciable change in capacitance and a consequent frequency variation. The effect of a change in spacing is less when the spacing is greater; therefore, insert a small fixed capacitor in parallel with a trimmer capacitor that is too tight. This action will permit proper oscillator alignment to be obtained when the trimmer has been adjusted to a more open position.

The following is a discussion of two interesting servicing problems related to frequency drift.

### Problem No. 1

The customer complained that he always had to retune the radio to

a station several times during the first fifteen minutes after turning on the radio. When he first turned on the receiver, he tuned in the station; then during the time that the radio warmed up, the station signal would fade and have to be tuned in again. Incidentally, it so happened that all of the radio stations in this particular city were operating on frequencies above 900 kilocycles; and the drift was much more noticeable than it would have been if the station frequencies were below 900 kilocycles.

The technician suspected that the trouble was instability of the oscillator. Not being positive about this, he decided to try out the checking system that we have discussed. He obtained a second receiver to be used in the process, turned it on, and tuned in a station at a frequency of 1490 kilocycles. Next, he tuned the set under test to a frequency of 1035 kilocycles and obtained a zero beat in the second set. He then left the two receivers to operate for a short while. It was not long before the second set started to buzz. The buzz became a squeal and then a whistle and kept climbing in pitch until it could no longer be heard. As a result, the technician was sure that the trouble was in the oscillator.

The oscillator circuit of the defective radio consisted of only four components other than the tube, as may be seen in the partial schematic diagram in Fig. 3. These components were: the grid resistor R1, the oscillator coil L2, the oscillator tuning capacitor C3, and the trimmer capacitor C4.

The tuning capacitor was eliminated as a possible cause of the trouble because the value of such a

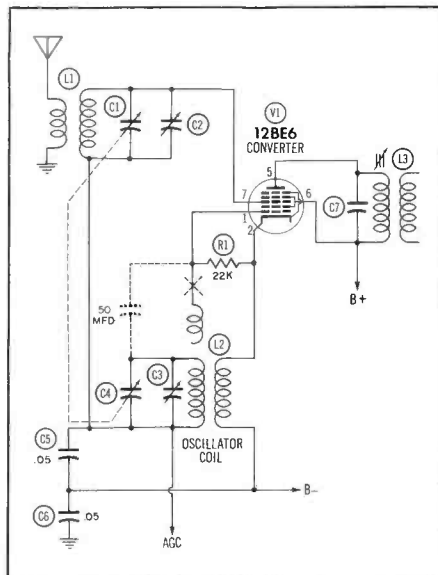

Fig. 3. Typical Converter Stage in AM Radio.

## New... Exclusive... Columbia Permaline

Eliminates need of replacing transmission lines and rotor cables. Aging tests show useful life of 20 to 50 years in outside use. No deterioration... resists sunlight... resists far below zero temperatures... extraordinary moisture resistance... resists salt air, acids, smog and abrasion... **STRONG AND TOUGH!**

### 1 "Columbia" Permaline 300 Ohm Transmission Line



### 2 In attractive spools or dust-proof sealed packages

### 3 "Columbia" Permaline Rotor Cables for all Rotors



### 4 On spools or sealed packages

### 5 "Columbia" Permaline Intercom and Telephone Wire... will not stretch... high abrasion resistance... for inside or outdoor use.



Write for your sample of the Permaline wire which is most suited for your applications.

"Columbia" Wire and Wire Products are sold through recognized distributors.

**Columbia**  
**WIRE & SUPPLY CO.**

2850 Irving Park Road, Chicago 18, Ill.  
"America's Most Complete Wire Line"



**YOU BUILD  
EICO  
KITS  
IN ONE  
EVENING-  
but they  
last a lifetime...  
and you  
save 50%**

38 Kits and 42 Instruments —  
the Industry's most complete  
line of **MATCHED  
TEST INSTRUMENTS**

1/2 - million EICO Instruments are now in use the world over! That's the proof of EICO's leadership in Value.

For latest precision engineering, finest components, smart professional appearance, lifetime performance and rock-bottom economy — see and compare the EICO line at your Jobber before you buy any higher-priced equipment! You'll agree with over 100,000 others that only EICO Kits and Instruments give you the industry's greatest values at lowest cost.

Prices 5% higher on West Coast.

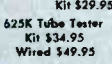

Write NOW for FREE latest Catalog PF-6



ELECTRONIC INSTRUMENT CO., Inc.  
84 Withers Street, Brooklyn 11, N. Y.

capacitor does not normally change as a result of the temperature variations in a radio. It also seemed that the resistor R1 would be an unlikely suspect because of the large amount of heat that is usually required to cause a resistor to change value. Consequently, the only components left to blame for the trouble were L2 and C4.

The chassis was removed from the cabinet and the air stream from a hair dryer was turned directly on the coil. The heat was switched on; and as a result, the station signal faded. The heat was next turned off, and cold air was permitted to blow on the coil. The station came back in as the coil cooled. This test indicated that the coil was the source of the trouble.

The service technician thought that the trouble might only be in the take-off or capacity winding of the coil. The connection of this winding can be seen in Fig. 3. The winding was disconnected, and a 50-mmfd mica capacitor was connected between the top of the secondary of the oscillator coil and the grid of the converter. This capacitor is shown connected by dotted lines in the diagram of Fig. 3. The hair dryer was again used, but the station signal still faded. The coil had to be replaced.

The replacement used was a universal oscillator coil with an adjustable core and a multiple-tapped secondary. This coil did not contain a take-off or capacity winding; therefore, the 50-mmfd mica capacitor that was used in the test was left in the circuit.

Because of the construction of the replacement coil and because of the fact that this coil contained a slug for varying the inductance, it could not be mounted in the same manner as the original coil. Instead, a hole had to be drilled in the end of the chassis where the antenna loop was mounted. This new mounting may be seen in the photograph of Fig. 4.

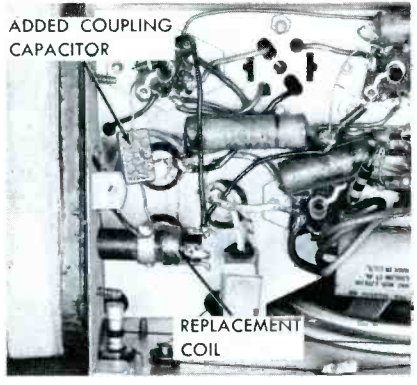
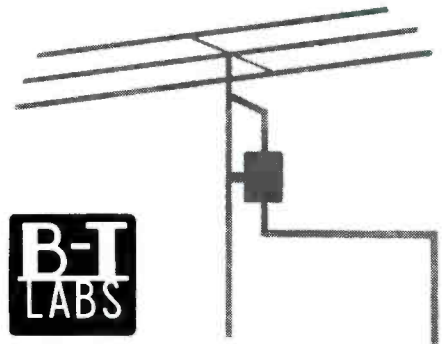

Fig. 4. Partial Bottom View of Radio Chassis Showing New Oscillator Coil and Coupling Capacitor.



**B-T LABS**

**OFFERS YOU  
FREE  
ENGINEERING  
CONSULTATION  
SERVICE  
ON  
MASTER  
TV SYSTEM  
INSTALLATIONS**



*Will discuss TV distribution problems or provide actual system layouts for specific building plans.*

Write for Free Manual

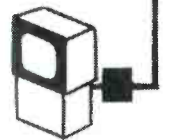

**BLONDER-TONGUE LABS., INC., Dept. DF-13**  
Westfield, New Jersey

For your FREE manual on Master TV System Installation simply circle the Blonder-Tongue number on the "Catalog and Literature Service" insert at rear of magazine.

**B-T LABS** Leading Manufacturers of Master TV System Amplifiers, Distribution Units, Converters, Boosters, and Accessories.



The photograph of Fig. 5 shows the location of the tuning slug of the replacement coil after installation. The portion of the secondary used was selected through the printed information given with the replacement coil.

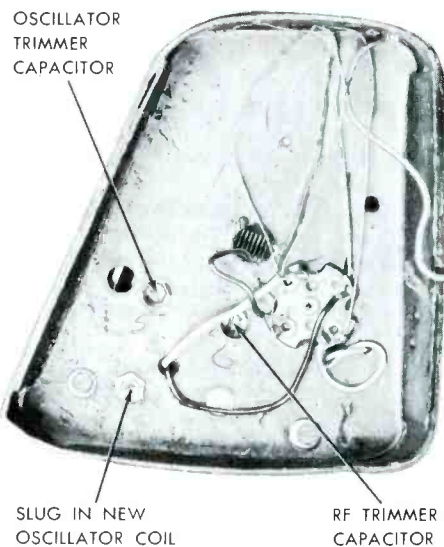

Fig. 5. Side View of Loop Antenna Showing Alignment Points.

The oscillator was aligned in the following manner. First, the IF alignment was checked in the usual way. Next, a signal generator was coupled through a capacitor to the loop antenna and was adjusted to give a modulated signal at 600 kilocycles. The receiver dial was turned to 600 kilocycles, and the slug of the oscillator coil was adjusted to obtain maximum output from the receiver. Then, the signal generator and the receiver were both set to a frequency of 1500 kilocycles, and trimmer capacitor C4 was adjusted for maximum output from the receiver. Another check of the adjustment at 600 kilocycles was made, and finally the RF trimmer capacitor C2 was set according to the standard alignment procedure.

#### Problem No. 2

The complaint concerning this set was the same as that for the radio discussed in Problem No. 1. When the radio was first turned on, a station was tuned in. Then after about ten minutes, the station would drift out of tune far enough that the sound would become distorted and carrier noise could be heard in the form of a hissing. This made it necessary to bring the station back in by adjusting the tuning control.

The first thought of the service technician was that there was oscillator trouble; however, when the radio was tested by using a second receiver, the output from this second receiver stayed close to a condition of zero beat. In other words, no

oscillator drift was indicated. This meant that the oscillator was operating satisfactorily.

There was only one other possibility. The IF bandpass was probably shifting so that the peak response was at a frequency higher or lower than the rated intermediate frequency. This condition occurs very rarely, a fact which makes the trouble even more difficult to diagnose when it is encountered. Certainly, the IF amplifier tube could not cause this condition because it has very limited frequency-determining properties. The source of trouble had to be in the IF transformers. When the transformers were replaced, the detuning effect in the radio disappeared.

The symptom most commonly encountered when the resonant frequency of an IF transformer varies is a loss in selectivity. This loss is caused by the broadening of the overall IF response. The best method to check such a condition is to use a sweep generator, marker generator, and oscilloscope. If a broadening of the IF response occurs as the radio warms up, it will be detected on the oscilloscope.

### IN THE HOME

#### Low-Voltage Rectifiers in Philco Model 50T1600 Code 122

A service technician recently made a call to service a Philco television receiver, Model 50T1600 Code 122. The receiver was an older model that used as low-voltage rectifiers three 5Y3GT tubes connected in parallel.

The customer's complaint was that the set had very weak sound and no picture. Close examination of the receiver showed that one of the 5Y3GT tubes glowed with a purplish light, a symptom which usually indicates tube failure due to excessive gas.

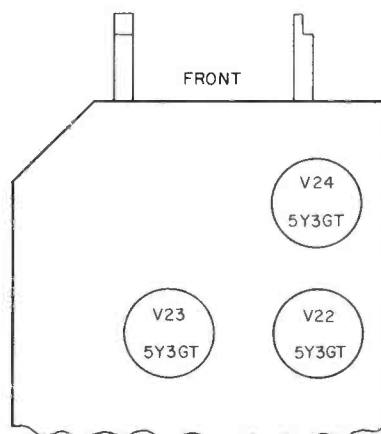

Fig. 6. Partial Tube Layout Showing Location of Three Low-Voltage Rectifiers.

**only  
vokar  
vibrators  
give  
you**

#### NEW SAHARA-PACK!

**ALL-WEATHER, LOW-VOLTAGE STARTS!** New dry-air canning developed by Vokar reduces moisture inside vibrator during manufacture. Moisture cannot condense on tungsten points causing corrosion during shipping or storage.

#### NEW VAPOR-BLOCK COATING!

**NO EARLY-LIFE FAILURES!** Applied to points by hand, Vapor-Block Coating eliminates pitting and arcing during vital first hours of vibrator operation. Result: Sure Starts! Longer Life! Higher Output!

#### NEW SWING-SUSPENSION!

**SUPER-SILENT PERFORMANCE!** Noise level is reduced to absolute minimum — whisper quiet! No hum to affect radio performance. Swing-Suspension design also means less hash, less heat!

VOKAR VIBRATORS—preferred by leading manufacturers of auto radios.

#### VOKAR QUALITY BRAND VIBRATORS\*



Produced under the same quality conditions that made Imperial quality famous!

\*Unpackaged

**VOKAR CORPORATION**  
DEXTER 3, MICHIGAN

Since the three rectifier tubes were connected in parallel, the technician felt that all three should be replaced in order to eliminate the danger of a weak tube causing a repeated failure; but investigation of the service kit revealed that there were only two 5Y3GT tubes in stock. Rather than take a chance on a combination of two new tubes and one old one, the technician decided to make an experiment.

If the drawing in Fig. 6 is consulted, the layout of the original three rectifier tubes will be found on the right front corner of the chassis. The electrical hookup of this system is shown in Fig. 7. The technician installed two 5U4G tubes in the sockets formerly occupied by V23 and V24. This was done to keep the larger 5U4G tubes from touching one another.

Two 5U4G tubes draw the same heater current that three 5Y3GT tubes do; therefore, the drain on the power transformer was not altered and a satisfactory repair was achieved. Since the total DC current capacity of two 5U4G tubes exceeds the capacity of three 5Y3GT tubes, longer rectifier life can be expected; and the cost of two 5U4G tubes is about the same as that of three 5Y3GT tubes.

### Replacement of 6SN7GT Vertical-Output Tube

A number of receivers use a single 6SN7GT tube as a vertical oscillator and vertical-output amplifier. In this application, the older type of 6SN7GT tube frequently fails for one reason or another. The new 6SN7GTA tube with its higher ratings

and more rugged construction should prove to be far superior and should reduce the number of failures of tubes in this application.

### Isolation of Antenna Troubles

Flashing or streaks through the picture and certain other troubles are often caused by trouble in the antenna system. If the technician is not careful, a considerable amount of time can be wasted looking for the trouble in the television receiver.

A good procedure to follow, when there is a possibility that the antenna system is causing the trouble, is to check it first. In this way, the trouble can definitely be isolated.

Trouble in the antenna system may be caused by a loose or broken connection, by a broken wire in the lead-in, by the lead-in wire rubbing a metal gutter, or even by foliage from a tree brushing against the antenna or lead-in. The checking of each part of the antenna could require a considerable amount of time and, in fact, could require a two-man crew. Obviously, it is not usually possible on a service call to have the extra man.

In local reception areas, substitution of an indoor antenna of known good quality will show whether or not the original antenna is at fault.

NOTE: An indoor antenna which the customer just happens to have should not be used in this testing because it may also be faulty.

In suburban or fringe areas where the signal is too low to get dependable reception with an indoor antenna, the antenna system can be checked by use of a field-strength meter. Disconnect the lead-in from the receiver at a point indicated in Fig. 8, and connect the field-strength meter to the antenna lead-in wire. A fluctuating or very low reading would indicate possible trouble in the antenna system.

Another method of testing the antenna system is to use a test receiver (a small portable television receiver) to check the antenna system.

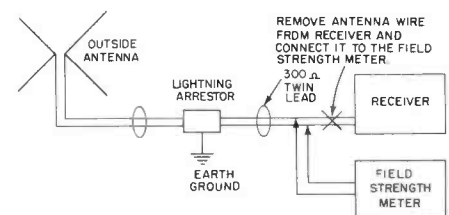

Fig. 8. Setup Used When Connecting Field-Strength Meter to Check Outside Antenna.

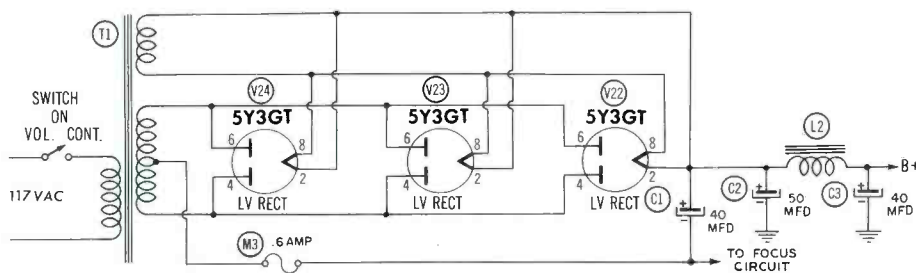

Fig. 7. Schematic Diagram of Low-Voltage Supply in Philco Model 50T1600 Code 122.

**IT PAYS FOR ITSELF FAST!**

# the VITAMETER

AN INSTRUMENT DESIGNED TO MAINTAIN, IMPROVE and VITALIZE OPERATION OF CATHODE RAY TUBES

Unique reactivator function is accomplished by dynamic sweep between cathode and grid . . . removing gas ions and stale emitting material from surface of cathode tube.

IT'S PORTABLE  
WEIGHT ONLY 10 LBS.



The VITAMETER is handsomely designed and housed in rugged steel case to insure long and dependable service. It is light, compact, portable and therefore can be used on picture tube while it is still in the cabinet. Just plug in and attach instrument socket to C.R. Tube . . . easy to read indicators tells the whole accurate story at a glance. VITAMETER repairs tubes right-on-the-spot.

## the VITAMETER

- analyzes performance characteristics
- locate and remove inter-element shorts
- repairs open elements
- welds open filaments
- restores or improves emission quality
- estimates tube life expectancy

At your distributor or write for bulletin.

only \$6995

ELECTRONIC TEST INSTRUMENT CORP. 13224 LIVERNOIS AVENUE DETROIT 38, MICHIGAN

If the trouble does not show up in the test receiver, then the customer's receiver can be assumed to be at fault.

#### Other Uses for Field-Strength Meter

The field-strength meter can be used in orienting the antenna to pick up a maximum signal. This is especially important if no rotator is used. It is also important that the antenna be located at the right height, since the signal strength may vary greatly at different heights.

A battery-operated field-strength meter is very handy because it requires no AC power, and thus a long power cord is not needed. In fact, the technician could use a battery-operated unit on the roof; and this would make it possible for a single man to install and orient a small antenna system properly. In the more complex systems using high masts or towers and heavy antennas, two or more men would be required.

#### "Plus" Services

In making home service calls, the most important job the technician must perform is satisfying the customer. Anything and everything that the technician says or does as a "plus" service should be done with this in mind. There have been cases in which excellent technicians have repaired receivers perfectly and did not achieve customer satisfaction. In this type of case, the lack of customer satisfaction may have been caused by the failure of the technician to attend to some minor details.

Whether the service call is for a new customer or for a former one, the technician should always notice such small details as an inoperative pilot light or channel-indicator light, and he should replace all faulty units.

The light that illuminates the channel numbers is often the only pilot light employed; and when this unit is inoperative, it may be very difficult to see the different channel numbers. This replacement will cause the customer to remember the service rendered because each time he changes channels he will notice the new pilot light which makes it easier for him to see the channel numbers.

Another place where attention to detail is important is the face of the picture tube and the safety glass. These may be dirty especially if it has been some time since the receiver was last serviced. Whenever the picture-tube face and safety glass are visively dirty, they should be cleaned. A discussion about cleaning the

picture-tube face and safety glass was presented in the article "In the Interest of Quicker Servicing" in the December 1954 issue of the PF REPORTER.

The cabinet of the receiver is another place where small services will cause the technician to be remembered. Products that can be used to hide scratches are available at most local distributors of electronic parts. One such product is called a "Scratch Stik" and is made by the General Cement Mfg. Co. See Fig. 9. It is made in walnut, oak, and mahogany stains which match most of



Fig. 9. "Scratch Stik" Made by General Cement Mfg. Co.

the cabinet finishes that are in common usage. This unit consists of stain in a hard form on one end and an oil-impregnated felt dauber on the other end. Through the use of a "Scratch Stik," small scratches can be stained and filled in so that they are almost invisible. Should a small scratch be located so that it is visible from the front of the receiver, the customer would be very pleased to have it covered up.

There are repair kits available which will make it possible to fill in large scratches and to eliminate other cabinet faults when properly used. A technician should be thoroughly familiar and experienced with this type of equipment before attempting to make a repair on a customer's cabinet.

Always be careful to ask the customer what his specific complaint is and to remedy that trouble first. When this has been done, give the receiver a complete checkup to make sure that all controls operate properly and that no other troubles exist in the receiver.

In addition to generating good will, this procedure will also help sell service and replacement parts and may reduce call backs within the guarantee period.

**HENRY A. CARTER and  
CALVIN C. YOUNG, JR.**

RCA SERVICE PARTS • FACTORY-TAILORED TO SAVE YOU TIME AND MONEY

take  
**CONTROLS**  
for  
example

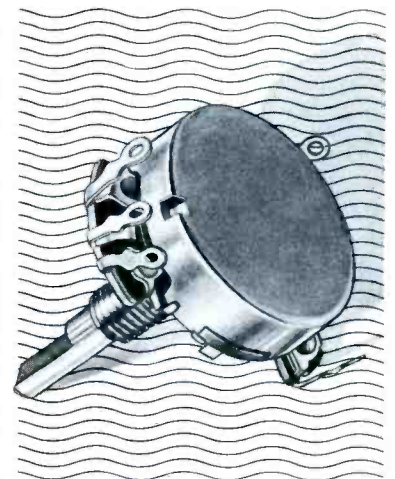

RCA Controls for RCA Victor TV receivers, radios, and phonographs are specifically designed to save you time and money by fitting right, installing fast. Controls are just one example of how every RCA Service Part is FACTORY-TAILORED to keep your servicing "on the go" profitably. Remember: RCA Service Parts are the only genuine replacement parts for RCA Victor TV receivers, radios, and phonographs.



**RADIO CORPORATION  
of AMERICA**

SERVICE PARTS

HARRISON, N. J.

## Removing the TV Chassis

(Continued from page 13)

that there will be no danger of snagging and thus breaking it. Fig. 3 illustrates an antenna lead that has been secured before removal of the chassis in order to avoid snagging.

The speaker leads are the next to be disconnected, if the speaker is not mounted on the chassis. If you are not familiar with the receiver and are not sure where these leads are to be disconnected, check at the speaker first. If the leads do not disconnect there, then trace them until the point is located. Disconnect and dress them in order to prevent difficulty when the chassis is removed.

On some combination sets, a single speaker is used for the radio, phonograph, and television sections; and in such cases, it is possible that there may be more than one set of leads connected to the speaker. Make sure that only the correct ones are disconnected.

After the speaker leads are disconnected, then disconnect all radio or phonograph cables that are connected to the TV chassis. Remember that not all of the cables may emerge

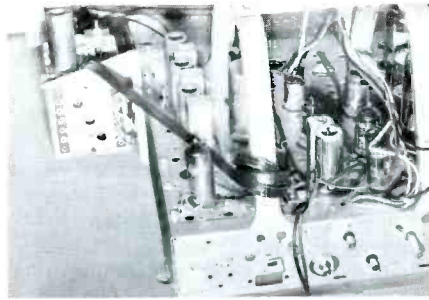

Fig. 3. Antenna Lead Secured to Prevent Snagging.

from the back of the chassis where they would be in plain sight; therefore, you may have to look for them elsewhere. On some combination models, cables may run directly through the panel that separates the television and

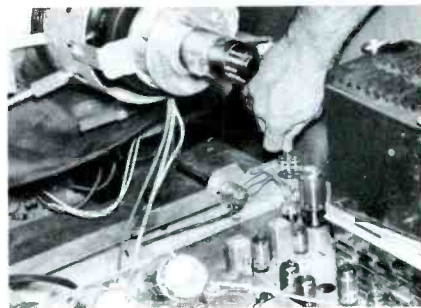

Fig. 4. Disconnecting the HaloLight Cable.

the radio or phonograph sections or down through the shelf on which the chassis rests; therefore, look for them there.

Many console television receivers have a phono socket and switch, and the customer may have an auxiliary unit plugged into this socket. Be sure that any such unit is unplugged and that the lead is properly dressed out of the way.

All accessories such as remote pilot lights, remote-control cables, the HaloLight in Sylvania receivers, and any others should be disconnected. Some of the RCA Victor console models have a small pilot light located at the bottom center of the cabinet; and unless a service technician is very careful or thoroughly familiar with these models, it is easy to overlook this light and thus damage the leads when the chassis is removed. In some Philco models, the pilot light that illuminates the channel numbers is secured to the cabinet and must be disconnected before the chassis is removed.

Many Sylvania models have the HaloLight feature. The cable for this assembly usually plugs into the front corner of the chassis, and the chassis must in most cases be pulled out

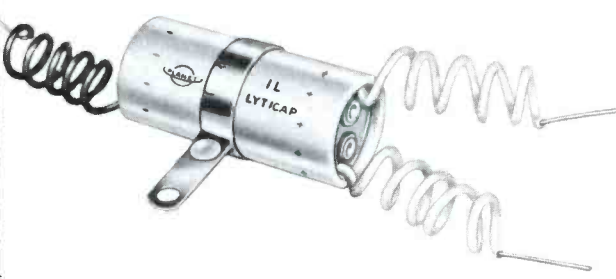

**NEW DUAL SECTION ELECTROLYTIC CAPACITORS HERMETICALLY SEALED IN ALUMINUM TUBES WITH COMPLETELY FLEXIBLE INSULATED LEADS.** By riveting the leads directly to the condenser end disc, Planet has eliminated the use of rigid terminal risers ordinarily used on this type construction. This allows Planet Type IL capacitors to fit into a smaller space and eliminates the possibility of lead breakage.

**PLANET** "ENGINEERED FOR QUALITY"  
GUARANTEED FOR ONE YEAR

**PLANET MANUFACTURING CORPORATION**  
225 BELLEVILLE AVENUE  
BLOOMFIELD, N. J.

Write for Catalog 200—Lists Specifications on Stock Items



# FREE LAYOUT SERVICE

... assures better storage facilities for less money

Take advantage of Equipto's Free Layout Service to obtain valuable advice on the number and type of storage units to buy ... complete floor plans and elevation drawings showing best way to arrange units within your allotted storage area. You will thus be able to make maximum use of your floor space, save steps, speed customer service, and simplify inventory and stock control.

If you would rather lay out your own facilities, send for fact-cramped, fully illustrated booklet, "How to Solve Your Storage Problems."

Both "assists" are further evidence of Equipto's primary concern with providing super-efficient storage facilities—not in merely selling equipment.

**Equipto** Division of Aurora Equipment Co.  
830 Prairie Avenue, Aurora, Illinois  
Steel Shelving . . . Parts Bins . . . Drawer Units

slightly so that this cable can be reached. Remember to pull out the chassis only a very short distance because moving it too far while the cable is still connected could seriously damage the HaloLight assembly. See the illustration in Fig. 4 which shows the HaloLight cable being disconnected.

### Special Problems with Cabinet-Mounted Picture Tubes

If the picture tube is cabinet mounted, then the leads of the yoke, of the picture-tube socket, and of the focus coil (if used) should be disconnected and dressed so that they will not snag when the chassis is removed.

Some receivers which have the picture tube mounted in the cabinet employ bonding straps between the chassis and the mounting brackets for the picture tube or even between the chassis and the band around the front of the tube. All of these bonding straps should be disconnected.

The type and nature of the trouble will determine whether or not the focus assembly or yoke or both should be removed and taken into the shop with the chassis. In all cases in which the nature of the trouble is such that these units are not involved, they should not be taken to the shop. This is true because a standard replacement yoke which most shops have on hand will be suitable to connect for most testing purposes. When the focus assembly and yoke are removed from the cabinet, they must be reinstalled and adjusted. This is a time-consuming job.

In the past, it has been considered necessary to take the picture tube into the shop for the correction of certain video and synchronization problems. As previously mentioned, the removal of the picture tube makes it necessary to reinstall and adjust units when the chassis is returned. In view of this, the TV-receiver check tube 5AXP4 that Sylvania has recently placed on the market is a very valuable accessory. This substitute picture tube was discussed in the January 1955 issue of the PF REPORTER. It is a universal type and will function with any size or type of television receiver that employs magnetic deflection, and it should therefore be a valuable asset.

Some receivers may have filter chokes or audio output transformers mounted on the speaker frame. If they do have, the service technician must remove the speaker and take it to the shop for most repairs, unless some arrangement has been made at the shop to have a suitable substitute to use. A substitution unit for the speaker was described in the article

entitled "A Universal Substitute Speaker" in the April 1954 issue of the PF INDEX. The use of such a unit would eliminate the need for removing any speakers unless one were suspected as being defective. Leaving speakers mounted eliminates the risk of damage in transit or even in the shop.

### Removal of Chassis Bolts

There may be any number from four to almost a dozen bolts holding down the chassis. For the most part, these bolts have hexagonal heads; and the heads will usually be either 5/16, 3/8, or 1/2 inch in size. The bolts may be easily removed with a standard driver of the correct size. There are cases, however, when the bolts will have heads of the Phillips type and will require a Phillips screwdriver for removal. Using a driver of the proper size and type will guard against damaging the head of the bolt. A damaged head makes a bolt difficult to remove. In addition to this, there is always the risk that a screwdriver that is too small may be broken if used on bolts that are too large.

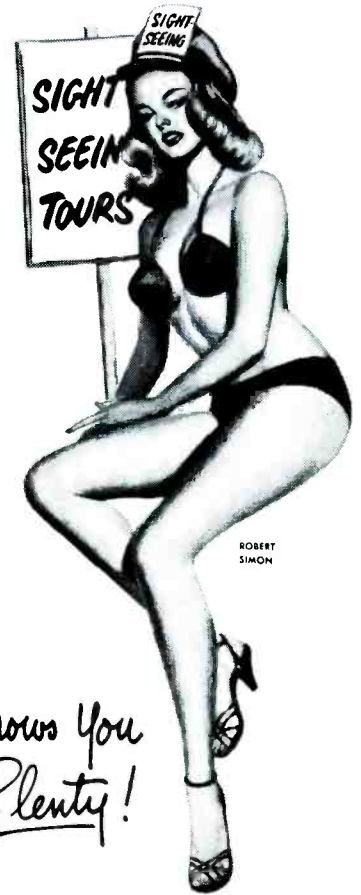

Fig. 5. Set of Socket Wrenches Made by Sylvania Electric Products Inc.

Some of the earlier Motorola combination models used a lowboy type of cabinet in which the chassis is very close to the bottom of the cabinet. In these models, a standard size of nut driver is too long to be used in removing the chassis bolts. These bolts may be removed by using either a short stubby nut driver or a socket wrench of the type shown in Fig. 5. The socket-wrench kit shown in this figure is a service kit which is available from many distributors, and similar kits are also sold by hardware stores. A kit such as this would have many other applications and should prove valuable when bolts or nuts are to be removed from places where a good grip on the handle of a nut driver is not possible or where a standard tool is too long to be used.

### Balance the Chassis in Removal

After the bolts are all removed, the chassis may be slipped out of the



Shows You  
Plenty!

Best of all, Walco shows you how to make money — *real money* — with your replacement needle business!

Walco starts you off *right* — with a needle inventory that's light in the right places, and heavy just where it *ought* to be — and then follows through with the most realistic price and discount policy in the industry.

To top it off, Walco backs you up with the strongest needle merchandising program anywhere.

You haven't seen anything, till you see the deal you'll get from Walco. Call your Walco distributor today — *he'll show you plenty!*

Write for a full size print of Hazel, the Walco cutie above, plus vital needle profit information.

NEEDLES FOR EVERY  
PHONOGRAPH BY

# Walco

Trade Name of Electrovox Company, Inc.  
60-P Franklin Street East Orange, N. J.



**Fig. 6. Balancing a Chassis During Removal.**

cabinet. If there are accessories connected at the front, do not forget to slip the chassis out a few inches and disconnect the cables before proceeding to remove it.

Many receivers have large heavy power transformers mounted in a rear corner or at one side of the chassis. When removing the chassis, the service technician should always grasp it in such a way that it will be balanced; otherwise, it might tip and the technician might drop it. Fig. 6 is an illustration of a chassis being balanced properly during removal. Note that one hand is placed near the power transformer and that the other hand is at the opposite corner under the face of the picture tube.

If it is necessary to set down the chassis after it is removed from the cabinet, a drop cloth or several pieces of newspaper should have been placed on the floor previously in order to prevent damaging the floor or soiling the rug.

#### **Storage of Knobs and Hardware**

After the chassis is removed, the knobs and all hardware except two screws should be placed in a container and set inside the cabinet where the chassis formerly rested. An example is shown in Fig. 7. The back cover should then be secured in place with the two screws. This procedure will ensure that all of the hardware and knobs will be available when the chassis is returned.

#### **Special Cases**

Some of the new table models with vertical chassis are treated somewhat differently than those with horizontal chassis. Instead of removing the chassis from the cabinet, the cabinet is removed from the rest of the receiver. Usually these table models are carried to the shop in their cabinets, and chassis removal is done at the shop.

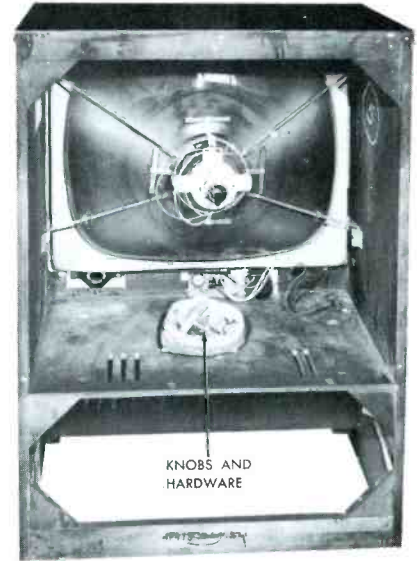

**Fig. 7. Storage Place for Knobs and Hardware.**

Some of the new Zenith table models have the cabinet constructed in three pieces: (1) the front or mask and safety glass; (2) a piece of metal that forms the top, bottom, and sides; and (3) the back cover. The first two of these pieces are shown in Fig. 8. To take one of these receivers apart,

For **SATISFIED CUSTOMERS**  
and **PROFITS too!**

INSTALL

**Mosley**  
TV ANTENNA  
ACCESSORIES



**Wall-Thru**

Cat. No. 625  
List Price \$1.95

- New, improved tube is semi-flexible — bends without breaking for easy insertion into wall openings drilled out of line!
- Neat, Convenient, Efficient! Appeals to ALL TV Owners because it's Practical!
- A Sure-Fire Profit Maker For TV Installers!

Ask your Parts Jobber or write direct for your Free copy of the new **MOSLEY Catalog 54-55.**

**MOSLEY ELECTRONICS, Inc.**  
8622 St. Charles Rock Rd., St. Louis 14, Missouri

**BETTER PICTURES**  
FROM OLD PICTURE TUBES

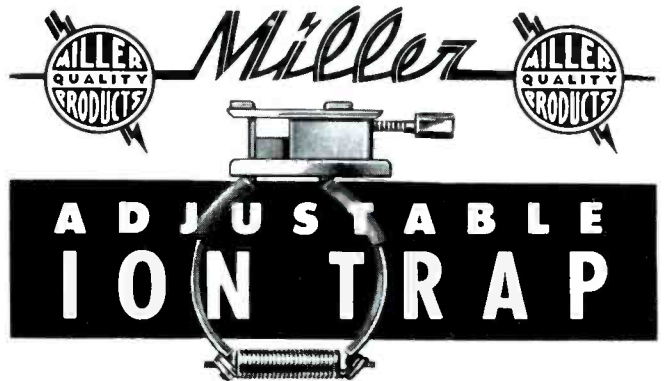

The Miller #6295 Adjustable Ion Trap is made to replace any single ion trap with gausses from 32 to 55. Most old picture tubes would give better pictures if the old ion traps were replaced and adjusted to proper gauss.

This Miller #6295 Adjustable Ion Trap, like all 850 Miller television and radio replacement parts, is unconditionally guaranteed. These adjustable ion traps may be bought singly or in an attractive counter display carton of 24 units.

Catalog No.	Description	Net Price
6295	Adjustable Ion Trap	.75

SOLD BY ALL LEADING RADIO AND TELEVISION PARTS DISTRIBUTORS  
Write for General Catalog 56

**J. W. MILLER COMPANY**  
5917 South Main Street • Los Angeles 3, California

Canadian Representative Atlas Radio Corp. Ltd. 50 Wingold Ave. Toronto 10, Ont. Canada

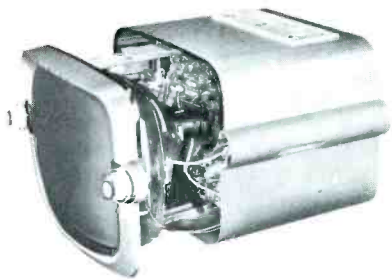

**Fig. 8. Zenith Table-Model Receiver Partially Disassembled.**

first remove the screws holding the back cover, then remove the four knobs that come through the top of the cabinet, and disconnect the speaker leads. Remove the remaining four screws that are in the back edge of the cabinet. The metal piece that forms the top, bottom, and two sides may then be pulled to the rear and removed. This leaves the chassis, the picture tube, and the front piece as one assembly.

To remove the cabinet from one of the Hallicrafters and the Crosley table models which have the vertical chassis, remove the back cover and the knobs. Disconnect the speaker leads, and remove the bolts from around the outer edge of the bottom of the cabinet. The cabinet

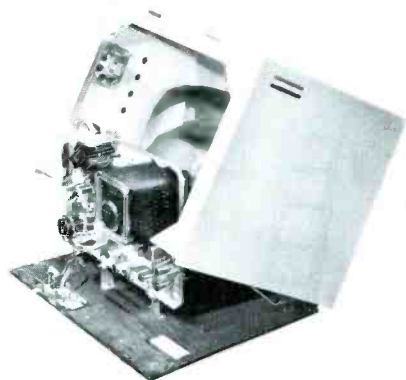

**Fig. 9. Hallicrafters Table-Model Receiver Partially Disassembled.**

can then be removed by pulling it up and toward the front. This is shown in Fig. 9. Removal of the cabinet leaves the chassis and picture tube mounted on the bottom board.

### Returning the Chassis

After the chassis has been properly repaired in the shop, it must be taken back and reinstalled in the cabinet. Generally, it is impossible to carry both the repaired chassis and the tool kit into the customer's home in one trip; therefore, it is good practice to carry the tool kit into the home first and to perform certain pre-

liminary tasks before carrying in the chassis. If the speaker was removed and taken to the shop, it could also be carried in with the tool kit and installed first, because it is often easier to install the speaker before installing the chassis. Refer to Fig. 10 for an illustration of the speaker being installed. Always position the speaker so that the wire terminals on the speaker are as near as possible to the hole which provides access to the chassis. This ensures that a maximum length of speaker cable is available for connection. Care should be exercised in order to guard against possible damage to the speaker cone when the speaker is being positioned on the hold-down studs.

In some table models, the speaker must be installed after the chassis is set in place because the chassis cannot be put into the cabinet when the speaker is in its normal position. A condition such as this should have been noted when the chassis was removed.

The cabinet should be set out away from the wall and turned so that the chassis can be readily installed. Remove the back cover, and take out the container of hardware. The hardware can be placed on the floor to one side of the cabinet where it will be readily available. Next, clean the safety glass and mask.

Prop open the entrance door of the house, or solicit the aid of the customer to hold it open. During warm weather, the chassis may then be taken into the house and immediately installed in the cabinet. This may be done because the tube face should have been cleaned in the shop and wiped off in the truck just prior to taking it into the house.

During cold weather, a problem of moisture condensation on the picture tube may be encountered when the tube is taken into a warm house. In a case such as this, the tube should be allowed to reach room temperature and then should be wiped dry before it is installed in the cabinet. A hair dryer provides a handy means of cutting short this warm-up time.

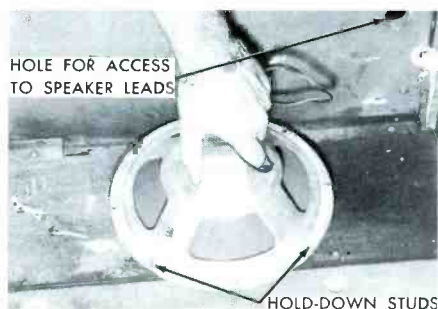

**Fig. 10. Reinstalling a Speaker.**

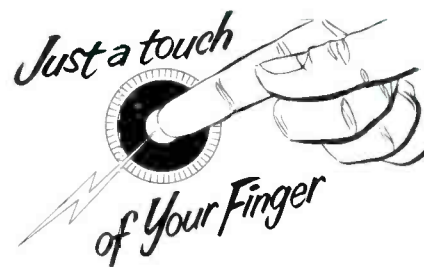

## OPENS and CLOSES YOUR GARAGE DOOR

with the



## OPEN AND CLOSE FROM YOUR OWN CAR

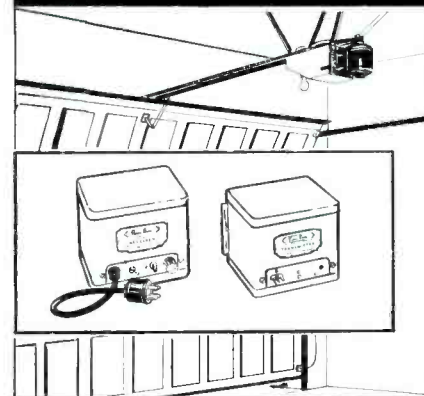

### Everyone can afford this modern convenience!

- ★ It's really simple to install . . . one man can do it easily!
- ★ Takes just an afternoon with common hand tools; no soldering.
- ★ Complete instructions assure professional-type installation.

Available from electronic parts distributors  
Illustrated literature upon request

**Perma-Power COMPANY** 4727 N. DAMEN AVE.  
CHICAGO 25, ILL.  
Manufacturers of electronic equipment since 1928

# NOT VERY BIG!

in fact... the one truly miniaturized clip in this age of miniaturization! The new

## MUELLER

# MINI-GATOR

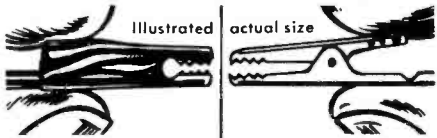

Separate skin-tight vinyl plastisol insulator covers right down to the nose. Will not tear. Slotted "lip action" tip permits full jaw opening without "baring" teeth.

Steel (cadmium plated) or solid copper. 1-1/16" long. Jaws open 3/16". Solder connection. Clinching ears for cord strain relief. For No. 20 or smaller wire.

Simply stated in Electronic terms, it's



**SIMPLIFIES TESTING OF ALL MINIATURIZED AND SUB-MINIATURIZED EQUIPMENT.**

Provides the quick convenience of a test clip in spots that are otherwise inaccessible.

**FREES THE HAND THAT HELD THE PROD!**

WRITE TO FACTORY FOR **FREE SAMPLES!**

Mueller Electric Co. 1561Y E. 31st STREET CLEVELAND 14, OHIO



### DAVE RICE'S OFFICIAL TV-RADIO SERVICE ORDER BOOK

**BEST SERVICE ORDER BOOK** because it's the only form providing for all types of service on TV-Radio, Phono or Hi-Fi equipment

**BEST SERVICE ORDER BOOK** because it's the only form providing separate listings for tubes, parts and components, plus space for picture tube and serial number

**BEST SERVICE ORDER BOOK** because it's the only form clearly separating labor and parts and allowing all state and local taxes to be added

**BEST SERVICE ORDER BOOK** because its handy size is 5 1/2" wide by 8 1/2" long. Each book contains 50 orders (in triplicate). Original white bond, duplicate yellow, triplicate pink. Numbered consecutively in sets. Two sets of carbons bound into each book. The only form packaged in dustproof boxes of ten—keeps stock clean until you need it. Sold by parts distributors at 75¢ per book or \$6.50 per box of 10. If not yet available in your area send \$6.50 for box of 10 postpaid or write for sample.

Dave Rice

ELECTRONIC PUBLISHING CO., INC.  
180 North Wacker Drive  
Chicago 6, Illinois Franklin 2-0622

The chassis is carefully slipped forward into the cabinet. Remember to hook up any accessories that must be connected at the front of the chassis before pushing it to its normal position.

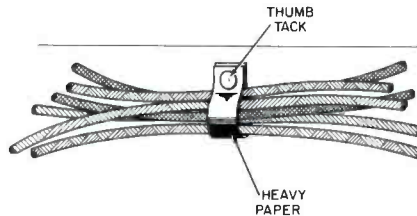

Fig. 11. Drawing Illustrating Means of Securing Cables to Cabinet.

When the chassis has been pushed forward to about its normal position, hook up the speaker, the phonograph, the radio, or any other cables. If any were originally secured to the side of the cabinet or were in clips on the chassis, they should again be secured in their former locations. In case these cables were fastened to the cabinet, a tack or wire staple will again be needed to attach them securely. Fig. 11 shows cables secured with a tack and heavy paper.

Connect the antenna lead from the tuner in its original position, connect the lead-in to the antenna terminals, and apply power to the receiver. Adjust the controls, and check for normal operation of the receiver.

Check to make sure that nothing hangs down in front of the face of the picture tube. Fig. 12 shows what happens when the dust seal that should close the crack around the face of the tube between the tube and the mask slips out of its normal position.

The chassis bolts and the knobs may next be installed. Make sure that all washers are in place on the chassis bolts. The bolts should be started carefully because the threads in the holes in the chassis can be easily stripped. Care should be taken to replace all retaining clips on the knobs in order to ensure proper operation



Fig. 12. Dust Seal Out of Place.

and to guard against possible loss of the knobs.

When the chassis bolts and the knobs have been replaced, apply the power and check the operation of the receiver again. If everything operates satisfactorily, remove the power cord and reinstall the back cover. Be careful not to disturb the setting of any of the rear controls, and also be careful not to bump the neck of the picture tube. If a focus adjustment shaft is provided, be sure that it is brought out through the hole provided for it. The same applies to the centering lever.

When the back has been replaced, connect the lead-in to the antenna terminals, and check the focusing and centering of the picture. If the levers for centering and focusing do not extend through the back cover, these adjustments should be taken care of before installing the back cover. With the back correctly replaced, locate the receiver in its original position or in a place specified by the customer; and the job is done.

CALVIN C. YOUNG, JR.



"Our stock of JENSEN NEEDLES"



**1F. AMERICAN MICROPHONE (American Microphone Co.—Affiliate Elgin Watch Co.)**

Descriptive literature on the new American "501" series of hand-held microphones. Dynamic and carbon microphones for every requirement. See advertisement page 42.

**2F. B & K (B & K Manufacturing Co.)**

Bulletin No. 102-P tells how servicemen can make money and retain customers with new low-cost, portable CRT Cathode Rejuvenator. See advertisement page 62.

**3F. BLONDER-TONGUE (Blonder Tongue Labs, Inc.)**

New TV installation manual including TV Trouble-Shooting, Master TV Systems, and Industrial (Closed-Circuit) TV. See advertisement page 70.

**4F. CBS (CBS-Hytron, a Division of Columbia Broadcasting System, Inc.)**

Broadside describing New CBS-Hytron Good Housekeeping Program. See advertisement page 4.

**5F. CENTRALAB (Centralab, Division of Globe-Union, Inc.)**

Form 42-223—Description of CRL "Fastatch" Concentric Control replacement kits with complete listing and usage data. See advertisement page 49.

**6F. CLAROSTAT (Clarostat Mfg. Co., Inc.)**

Series BE Rotary Switch Form No. 753676010. See advertisement page 16.

**7F. CORNELL-DUBILIER (Cornell-Dubilier Electric Corp.)**

Brochure—Antennas and Rotors, Form (902A-4B). See advertisement page 58.

**8F. GREAT EASTERN (Great Eastern Mfg. Co. Gemco)**

C.R.T. refractors and isolation units (picture tube boosters) Thermal resistors, (universal glo-bar replacements) and chemicals. See advertisement page 68.

**9F. HYCON (Hycon Mfg. Company)**

Catalog sheets describing instruments advertised in greater detail. See advertisement page 50.

**10F. IRC. (International Resistance Co.)**

Form S-031—Auto Radio Replacements. See advertisement 2nd Cover.

**11F. JENSEN (Jensen Industries, Inc.)**

1955 Wall Chart. See advertisement page 78.

**12F. MALLORY (P. R. Mallory & Co., Inc.)**

Brand New Replacement Parts Catalog No. 555. See advertisement page 18.

**13F. MILLER (J. W. Miller Company)**

Flyer describing the Miller Model 705-A Ferrite Rod Loop Antenna and Model 6295 Adjustable Ion Trap. See advertisement page 76.

**14F. MOSLEY (Mosley Electronics, Inc.)**

Literature describing MOSLEY "Vest Pocket" 20 Meter Rotary Beam for amateur use. See advertisement page 76.

**15F. MUELLER (Mueller Electric Co.)**

Catalog sheet No. 172 describing smallest alligator clip ever made in steel or copper, completely insulated. See advertisement page 78.

**16F. PHAOSTRON (Phaostron Co.)**

"555" Multimeter, AC-DC Metal-Cased. See advertisement page 54.

**17F. PYRAMID (Pyramid Electric Company)**

CRA 1 Capacitor-Resistor Analyzer, Kool-sel Selenium Rectifier. See advertisement page 32.

**18F. QUAM-NICHOLS (Quam-Nichols Co.)**

Catalog No. 70 listing over 100 replacement speakers. See advertisement page 59.

**19F. RADIART (The Radiart Corporation)**

F-1146-G Vibrator Guide. Vibrator Replacement Guide. See advertisement page 1.

**20F. RADIO RECEPTOR (Radio Receptor Co., Inc.)**

Design, Application and Servicing of Selenium Rectifiers. Bulletin No. 199. See advertisement page 46.

**21F. SHURE (Shure Brothers, Inc.)**

"TWIN-LEVER"—3-speed new ceramic improvement—replacement pickup Cartridge (FLYER) including technical data and replacement chart. ONE REPLACES 128! 3-speed, plastic cased turnover types. See advertisement page 57.

**22F. SPRAGUE (Sprague Products Company)**

K-200 Ceramic Capacitor and Printed Circuit Replacement Manual. Pocket size, 5½ x 8½, 64 page booklet giving recommended Sprague replacements in recent TV sets. See advertisement page 2.

**23F. TACO (Technical Appliance Corporation)**

Catalog of "Area-ized TV Antennas" for UHF and VHF complete with technical specifications. See advertisement page 55.

**24F. TELREX (Telrex, Inc.)**

New Thunder-Bird Series—a new approach to wide-band, high-gain directive arrays for Fringe and Sub-Fringe TV Receivers. See advertisement page 26.

**25F. VACO (Vaco Products Company)**

FREE A merchandise coupon worth \$1.20 when used to purchase one Vaco K7 Kit. See advertisement page 60.

**26F. WALSCO (Walsco Electronics Corp.)**

TV Antenna Catalog, Electronic Hardware & Chemicals & Accessories for Radio-TV. See advertisement page 30.

**27F. WEN (Wen Products, Inc.)**

Consolidated Data & Price Sheet—illustrating and briefly describing all items of the Wen line. Also lists accessories and replacement parts for all. See advertisement page 48.

**28F. XCELITE (Xcelite, Inc.)**

Folder describing new leather tool holster with 5 pockets and knife clip; catalog on screwdrivers, nut drivers, screwdriver and nut driver sets, pliers and wrenches. See advertisement page 63.

### JUST CHECK AND MAIL THE CARD

1. Circle or check the corresponding numbers of literature you want to receive.

2. Fill in your complete name and address.

3. Detach and mail self-addressed card. No postage necessary.

Please send me the following literature checked below:

1F	2F	3F	4F	5F	6F	7F	8F	9F	10F	11F	12F	13F	14F
15F	16F	17F	18F	19F	20F	21F	22F	23F	24F	25F	26F	27F	28F

Print plainly or type below

Name .....

Firm .....

Firm Address .....

City ..... Zone ..... State .....

Has your address changed since you last wrote us  No  Yes

To guarantee receipt of literature please check one of boxes below:

Independent Serviceman  Dealer with Service Shop  Student

Other (Please explain) .....

**OFFER GOOD ONLY UNTIL AUG. 1, 1955**

# COLOR TV TRAINING SERIES

## QUESTIONS ON PART XIII

Part XIII of the Color TV Training Series appears in this issue and should be studied prior to reading the following questions.

These questions are presented to give the reader an opportunity to test himself on the color-television material discussed in this part.

1. What new test equipment is needed for servicing color receivers?
2. How does the bandpass-amplifier section differ from a conventional video-amplifier section?
3. What effects would be noticed if the bandpass-amplifier section were misaligned?
4. What are the purposes of aligning the color-sync section?
5. What are the results which can be caused by misalignment of the color-sync section?
6. What effect will be noticed when loss of color synchronization is present?
7. What is the purpose of making the matrix adjustments?
8. If the Q demodulator interprets an I portion of the chrominance signal as being a Q portion, what effects would result?
9. If the Q reference signal is more than 90 degrees from the I reference signal, what would be the effect upon the vectors in the color-phase diagram?
10. What is the correct appearance of the waveform that is present at the grid of the blue gun during reception of a color bar pattern?
11. How does the response of the RF and IF sections of a color receiver differ from that of a monochrome receiver?
12. How could loss of color result from misalignment of the video IF section?

C.P.O. & V.M.R.



### INDEX TO ADVERTISERS

June, 1955

Advertiser	Page No.
American Microphone Co.,	
Affiliate Elgin Nat'l Watch Co. . . . .	42
American Phenolic Corp. . . . .	47
Authorized Mfrs. Service Co., Inc. . . . .	56
Belden Mfg. Co. . . . . Colorblock Insert	
B & K Mfg. Co. . . . .	62
Blonder-Tongue Labs., Inc. . . . .	70
Bud Radio, Inc. . . . .	45
Bussmann Mfg. Co. . . . .	6
CBS-Hytron . . . . .	4
Centralab,	
A Division Globe-Union, Inc. . . . .	49
Chicago Standard Trans. Corp. . . . .	
. . . . . Colorblock Insert	
Clarostat Mfg. Co., Inc. . . . .	16
Clear Beam Antenna Corp. . . . .	
. . . . . Colorblock Insert	
Columbia Wire & Supply Co. . . . .	69
Cornell-Dubilier Electric Corp. . . . .	58
Electro Products Labs. . . . .	64
Electronic Instrument Co., Inc. (EICO). . . . .	70
Electronic Publishing Co. . . . .	78
Electronic Test Instrument Corp. . . . .	72
Equipto Division,	
Aurora Equipment Co., Inc. . . . .	74
General Cement Mfg. Co. . . . .	34
General Electric Co. . . . .	28
Gramer-Halldorson Trans. Corp. . . . .	44
Great Eastern Mfg. Co. . . . .	68
Hycon Mfg. Co. . . . .	50
International Rectifier Corp. . . . .	61
International Resistance Co. . . . . 2nd Cover	
Jackson Electrical Instr. Co. . . . .	60, 64
Jensen Industries, Inc. . . . .	78
Jensen Mfg. Co. . . . .	36
Jerrold Electronics Corp. . . . .	66
Littelfuse, Inc. . . . . 4th Cover	
Mallory & Co., Inc., P. R. . . . .	18
Merit Coil & Trans Co. . . . .	20
J. W. Miller Co. . . . .	76
Mueller Electric Co. . . . .	78
Mosley Electronics, Inc. . . . .	76
Perma-Power Co. . . . .	77
Phaotron Co. . . . .	54
Planet Mfg. Corp. . . . .	74
Pyramid Electric Co. . . . .	32
Quam-Nichols Co. . . . .	59
Radiart Corp. -Cornell Dubilier Electric Corp. . . . .	1
Radio Corp. of America 12, 73, 3rd Cover	
Radio Receptor Co., Inc. . . . .	46
Raytheon Mfg. Co. . . . .	14
Sams & Co., Inc. Howard W. . . . .	
. . . . . Colorblock Insert	
Sangamo Electric Co. . . . .	40
Shure Bros., Inc. . . . .	57
Sprague Products Co. . . . .	2
Sylvania Electric Products Inc. . . . .	22
Technical Appliance Corp. . . . .	55
Telrex, Inc. . . . .	26
Vaco Products Co. . . . .	60
V-M Corp. . . . .	43
Vokar Corp. . . . .	71
Walco-Electrovox Co., Inc. . . . .	75
Walsco Electronics Corp. . . . .	30
Webster Electric Co. . . . .	52
Wen Products, Inc. . . . .	48
Westinghouse Electric Corp. . . . .	38
G. F. Wright Steel & Wire Co. . . . .	66
Xcelite, Inc. . . . .	63

FIRST CLASS  
PERMIT No. 1076  
(Sec. 34.9, P. L. & R.)  
Indianapolis, Ind.

### BUSINESS REPLY CARD

No Postage Stamp Necessary If Mailed in the United States

3¢ POSTAGE WILL BE PAID BY

### PF REPORTER

Reader's Literature Service Dept.

2201 EAST 46TH STREET

INDIANAPOLIS 5, IND.



While every precaution is taken to insure accuracy, we cannot guarantee against the possibility of an occasional change or omission in the preparation of the REPORTER.

# WHAT'S YOUR SERVICE PROBLEM?

# PHOTOFACT HELPS YOU SOLVE IT

**FASTER, EASIER, BETTER, MORE PROFITABLY!**

## THE WORLD'S FINEST SERVICE DATA



PHOTOFACT Service Data is the *only* service information based upon first-hand examination of the actual production-run receivers and equipment. It is authentic, uniform data developed through actual study and analysis by service engineers in the Howard W. Sams Laboratories. PHOTOFACT is the *only* data prepared from the practical point of view of the Service Technician.

Thousands of Service Technicians use PHOTOFACT daily for time-saving, profit-boosting service operations. If you've never used PHOTOFACT, you've never realized your full earning power—you've never given such complete customer satisfaction. So get the proof for yourself. Try PHOTOFACT—use it on any job. Your Parts Distributor has the Folder Sets you need for any of the 17,000 TV and radio receivers, changers, recorders, etc., covered in PHOTOFACT. Once you use this great service, we know you'll want the complete PHOTOFACT Library.

**ONLY \$25 DOWN**

Puts a Photofact Service Data Library in Your Shop. Ask Your Photofact Distributor—He Has the Full Easy-Pay Details.

## FREE PHOTOFACT CUMULATIVE INDEX

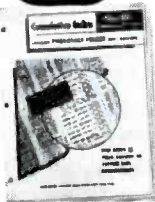

Send for it! Your guide to virtually any model ever to come into your shop; helps you locate the proper PHOTOFACT Folder you need to solve any service problem on any model. Once you have the make and chassis number, it

takes just 60 seconds to find the applicable PHOTOFACT Folder.

THESE GREAT FEATURES ARE EXCLUSIVE IN PHOTOFACT—THEY HELP YOU EARN MORE DAILY, HELP INSURE CUSTOMER SATISFACTION

### FULL SCHEMATIC COVERAGE

1. Famous "Standard Notation" uniform symbols are used in every schematic.
2. The same standard, uniform layout is used for each schematic.
3. Diagrams are clear, large, easy to read, easy to handle.

4. Wave forms are shown right on the TV schematics for quick analysis by 'scope.
5. Voltages appear on the schematics for speedy voltage analysis.
6. Transformer lead color-coding is indicated on the schematic.
7. Transformer winding resistances appear on the schematic.
8. Schematics are keyed to photos and parts lists.

### FULL PHOTOGRAPHIC COVERAGE

9. Exclusive photo coverage of all chassis views is provided for each receiver.
10. All parts are numbered and keyed to the schematic and parts lists.
11. Photo coverage provides quicker parts identifications and location.

### ALIGNMENT INSTRUCTIONS

12. Complete, detailed alignment data is standard and uniformly presented in all Folders.
13. Alignment frequencies are shown on radio photos adjacent to adjustment number—adjustments are keyed to schematic and photos.

### TUBE PLACEMENT CHARTS

14. Top and bottom views are shown. Top view is positioned as chassis would be viewed from back of cabinet.
15. Blank pin or locating key on each tube is shown on placement chart.
16. Tube charts include fuse location for quick service reference.

### TUBE FAILURE CHECK CHARTS

17. Shows common trouble symptoms and indicates tubes generally responsible for such troubles.
18. Series filament strings are schematically presented for quick reference.

### COMPLETE PARTS LISTS

19. A complete and detailed parts list is given for each receiver.
20. Proper replacement parts are listed, together with installation notes where required.
21. All parts are keyed to the photos and schematics for quick reference.

### FIELD SERVICE NOTES

22. Each Folder includes time-saving tips for servicing in the customer's home.
23. Valuable hints are given for quick access to pertinent adjustments.
24. Tips on safety glass removal and cleaning.

### TROUBLE-SHOOTING AIDS

25. Includes advice for localizing commonly recurring troubles.
26. Gives useful description of any new or unusual circuits employed in the receiver.
27. Includes hints and advice for each specific chassis.

### OUTSTANDING GENERAL FEATURES

28. Each and every PHOTOFACT Folder, regardless of receiver manufacturer, is presented in a standard, uniform layout.
29. PHOTOFACT is a *current* service—you don't have to wait a year or longer for the data you need. PHOTOFACT keeps right up with receiver production.
30. PHOTOFACT gives you complete coverage on TV, Radio, Amplifiers, Tuners, Phonos, Changers.
31. PHOTOFACT maintains an inquiry service bureau for the benefit of its customers.

**HELPS YOU EARN MORE DAILY**

# WIRE AND CABLE FOR EVERY ELECTRONIC PRODUCT

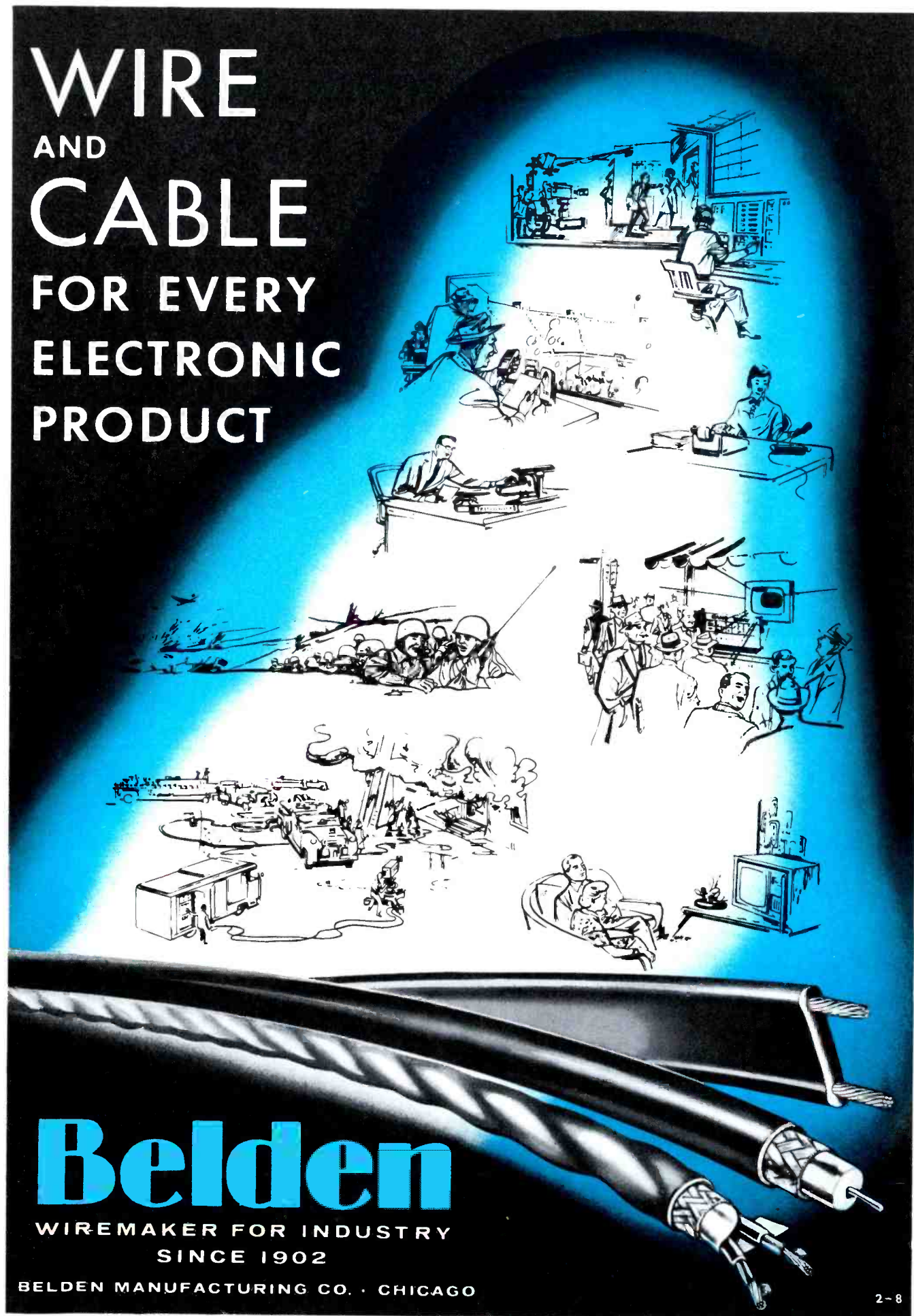

# Belden

WIREMAKER FOR INDUSTRY  
SINCE 1902

BELDEN MANUFACTURING CO. • CHICAGO

# USING THE JACKSON MODELS 700



Fig. 1. The Jackson Model 700 Color-Bar Generator.



Fig. 2. Pattern Produced by the I and Q Signal.



Fig. 3. Pattern Produced by the R-Y and B-Y Signal.



Fig. 4. Pattern Produced by the Generator.

## GENERAL DESCRIPTION

The Jackson Model 700 color-bar generator is designed to provide a variety of color signals which can be used for adjusting and testing color receivers. The unit is housed in a cabinet designed for bench use. The cabinet, however, is equipped with a carrying handle which makes the generator adaptable for portable use. The front-panel controls are neatly arranged and clearly marked to facilitate the selection of the desired signals. Fig. 1 is a photograph of the Model 700.

The Jackson Model 712 is similar in appearance to the Model 700; however, it has an additional feature in that two signals which can be used for linearity and convergence adjustments are provided. The white-crosshatch signal can be used to adjust the sweep linearities of both monochrome and color receivers. The white-dot pattern can be used to make adjustments of the convergence in color receivers. A photograph of the Model 712 is shown in Fig. 7.

## SIGNALS PROVIDED

There is a video signal of either polarity and an RF signal on channels 3, 4, or 5 available from either the Model 700 or the Model 712. Attenuators are provided to adjust the signal amplitudes for both outputs. The video signal is adjustable up to 2 volts across 90 ohms, and the RF signal is adjustable up to 100,000 microvolts across 300 ohms. A video-polarity switch is provided on the front panel so that either polarity of video signal can be obtained. The RF attenuator control has an OFF position which disables the RF portion of the generator while the video signal is being used.

The color-bar selector switch on the Model 700 has five positions. Position No. 1 is labeled MULTI, and in this position the generator produces a multibar pattern. The bars are in the following order: white, yellow, cyan, green, magenta, red, blue, and black. Fig. 4 illustrates the pattern which is viewed on a receiver that is operating normally when the switch is in position No. 1.

Position No. 2 of the color-bar selector is labeled COLOR DIFF. In this position, an I and Q signal like that seen in Fig. 2 can be obtained or an R-Y and B-Y signal like that shown in Fig. 3 can be obtained. In addition, each one of the bars can be obtained individually. This arrangement permits a positive check on the operation of the receiver without chance of error on the part of the operator in interpreting the bar pattern.

The third position of the color-bar selector produces a red bar like that shown in Fig. 28, the fourth position produces a green bar like that shown in Fig. 29, and the fifth position produces a blue bar like that shown in Fig. 30.

A sound carrier that is removed 4.5 megacycles from the video carrier can be obtained by turning the SOUND switch to the ON position. The presence of this carrier makes possible a check of the receiver to determine whether or not the sound traps are operating properly. Improper operation of the receiver will result in the production of a 920-kc beat pattern on the screen.

In order to make possible the selection either of the luminance or the chrominance signal, another switch is provided on the front panel. This switch is marked LUM. ONLY, LUM. AND CHROM., and CHROM. ONLY. The luminance signal is especially helpful when setting up the gray scale of a color receiver.

The Jackson Model 712 shown in Fig. 7 has a slightly different arrangement of the front-panel controls in order to provide the crosshatch and dot patterns. The color-bar selector is a 10-position switch and provides signals in the following order: multicolor bar, R-Y and B-Y, R-Y, B-Y, I and Q, I, Q, red bar, green bar, and blue bar. These signals are obtained when the switch for CROSSHATCH, DOT, AND COLOR BAR is in the COLOR-BAR position. By turning this switch to the DOT position, a white-dot pattern is obtained. With the switch in the CROSSHATCH position, a white-crosshatch signal is obtained. Any one of these signals is available as either a video signal of plus or minus polarity or as a modulated RF signal. The tuning dials on both the Models 700 and 712 are for the purpose of setting the RF output frequency. The carrier frequencies for channels 3, 4, and 5 are clearly marked on the dial in order to aid in tuning.

The multicolor-bar pattern generated by both the Models 700 and 712 conforms to the NTSC Standards with regard to luminance and chrominance amplitudes. All color-difference signals are produced at zero luminance and at a relative chrominance amplitude of .25. The red, green, and blue bars are produced at a luminance amplitude of .3 and at a relative chrominance amplitude of .5. These bars occupy approximately 60 per cent of the screen width.

On the rear panel of the Model 712, there are two jacks from which can be obtained the 3.58-mc subcarrier signal at burst phase and a horizontal-sync signal. The subcarrier signal can be used as a reference signal in testing color synchronizing circuits in color receivers. The horizontal-sync signal can be employed

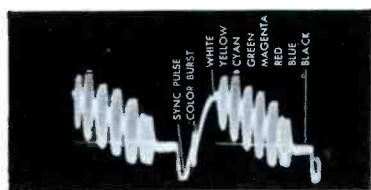

Fig. 8. Waveform Produced by the Multibar Signal.

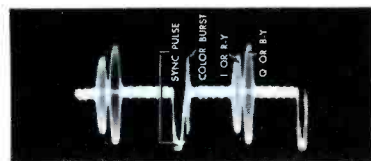

Fig. 9. Waveform Produced by the I and Q or the R-Y and B-Y Signal.

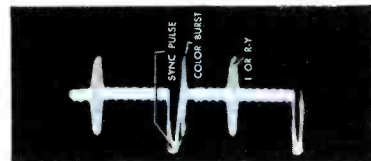

Fig. 10. Waveform Produced by the I or R-Y Signal.

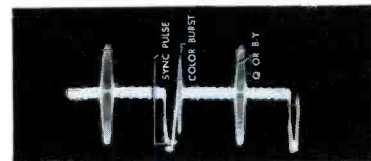

Fig. 11. Waveform Produced by the Q or B-Y Signal.

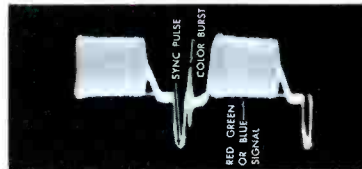

Fig. 12. Waveform Produced by the Signal Which Generates the Red, Green, or Blue Bar.

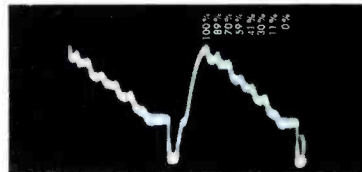

Fig. 13. Luminance Signal Only.

to synchronize the horizontal-sweep section of the oscilloscope, if desired.

Figs. 8 through 13 show the waveforms of the video signals which are available from either the Model 700 or 712. Fig. 8 shows the waveform for the video signal which is obtained in the multibar position. The sync pulse, sync burst, and various colors are identified. Fig. 9 illustrates the waveform that is obtained when an I and Q or an R-Y and B-Y signal is being produced. Fig. 10 illustrates the waveform that is obtained when a Q or B-Y signal is being generated. Note that the individual bars shown in the waveforms of Figs. 10 and 11 are placed in the same relative positions as they were for the corresponding signals in the waveform shown in Fig. 9.

Fig. 12 shows the waveform that is produced by the signals for the red, green, or blue bar. On the oscilloscope, all of these appear the same because the only difference is in the phase of the chrominance signal. Fig. 13 shows the luminance portion of the multibar signal.

## CHECKING RECEIVER OPERATION

Turn on the generator, and allow the 15-minute warm-up period. Connect the RF output of the generator to the antenna terminals of the receiver under test. Set the RF attenuator to maximum and the color-bar selector switch to the MULTI position. Set the switch to the LUM. AND CHROM. position. Turn the SOUND switch to the ON position, and set the HORIZ. SPEED control to the proper setting. Usually this control will not need to be adjusted, particularly after the generator has been given sufficient warm-up time. Set the RF tuning control to the desired channel. Set the channel selector of the receiver to the same channel, and adjust the fine-tuning control of the receiver to obtain a minimum 920-kc beat in the picture. After the fine-tuning control has been adjusted, the SOUND switch may be turned to the OFF position.

Adjust the brightness, contrast, saturation, and hue controls of the receiver in an attempt to produce the proper pattern illustrated in Fig. 4. If the receiver produces a satisfactory pattern, its operation can be considered normal.

If a satisfactory picture cannot be produced, analyze the symptoms in order to determine what section of the receiver is not operating properly. All color troubles will fall into these three main categories: (1) loss of color, (2) wrong color, and (3) loss of color synchronization. After determining the proper category of

the symptom, substitute tubes in the stages involved. If no improvement is noted, proceed as outlined in the servicing section.

## SERVICING

The operation of all of the color stages can be checked with the signals provided by the Jackson Model 700 or Model 712 color-bar generator. In every case, it is assumed that the receiver operates normally when receiving a monochrome transmission.

## NO COLOR

If no color can be produced by injecting an RF signal at the antenna terminals, inject a video signal across the video-detector load. If color can be obtained by injecting the signal at this point, the trouble must lie in the IF stages or in the tuner. Do not overlook the possibility that the tuning range of the tuner might be insufficient. Reconnect the RF output of the generator to the antenna terminals, and check the setting of the fine-tuning slug or trimmer. If color cannot be received even though the fine-tuning range is known to be correct, check the alignment of the tuner and IF amplifier.

If color cannot be received by injecting a video signal at the videodetector, check the input of the signal at the demodulator stages. Fig. 14 illustrates the signal which should be present at the input of the demodulators. If the signal is not present, check the operation of the bandpass amplifier and locate the point at which the signal is being lost. If the receiver employs a color-killer stage, check to see that this stage is not cutting off the bandpass amplifier. If such should be the case, check the operation of the color-sync section as outlined under "Loss of Color Sync."

Color demodulation should take place if both the chrominance signal (Fig. 14) and the CW signal (Fig. 15) are present at the demodulators. If either is absent, locate the defective stage by signal tracing backward through the circuits. After the defective stage is located, voltage and resistance measurements will usually identify the defective component.

## WRONG COLOR

Defects associated with wrong color can be classified into two main categories.

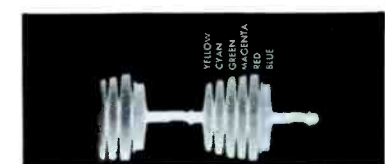

Fig. 14. Chrominance Signal at Input of Demodulators.

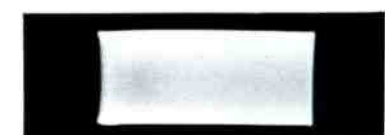

Fig. 15. CW Signal at Input of Demodulators.

Fig. 28. Pattern Produced by the Red Bar.



Fig. 29. Pattern Produced by the Green Bar.



Fig. 30. Pattern Produced by the Blue Bar.



Fig. 30. Pattern Produced by the Blue Bar.

They are: (1) complete loss of color, (2) a phase error in the signal that is applied to the CW reference signal, and (3) a phase error in the demodulated signal.

The fact that a color bar is produced indicates that the receiver is operating and that at least one of the color channels is present. This can be done by tracing the pattern as the bars are produced. In receivers that are not capable of a wide range as the Model 700, if only one of the color channels is present, each of the colors will be predominantly present.

If the receiver is not operating properly, the I and Q axes and if the

# CK Reference Chart No. 7

## AND 712 COLOR-BAR GENERATORS

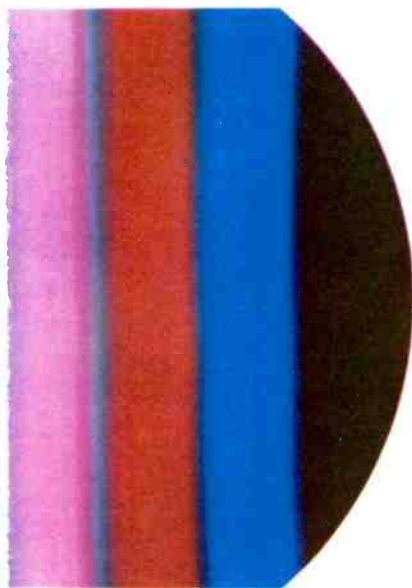

Produced by the Multibar Signal.

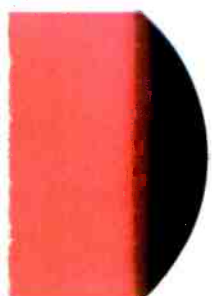

Produced by the Red-Bar Signal.



Produced by the Green-Bar Signal.

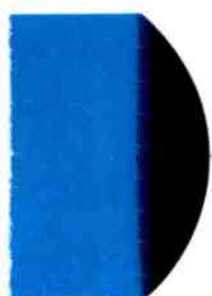

Produced by the Blue-Bar Signal.

Complete or partial loss of color difference signals, and changes in the chrominance of the demodulators produce signals that are different.

When there is any color produced by the CW reference signal and that the reference signals are being fed to the demodulators. The operator should note the effects on the color control is rotated. When operating normally, the color will vary through the hue control is varied. Color-difference signals that are lost when the color bars will result in one of two hues.

When demodulates on the I or Q signal is being lost,

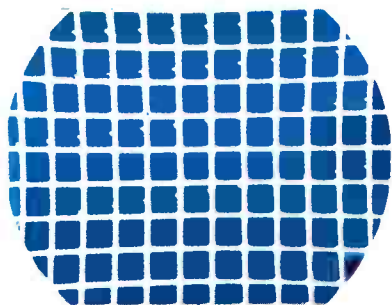

Fig. 5. Pattern Produced by the Crosshatch Signal.

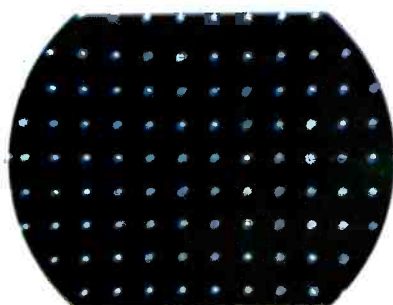

Fig. 6. Pattern Produced by the Dot Signal.



Fig. 7. The Jackson Model 712 Color Bar/Dot Generator.

all the color bars will appear predominantly an orange or a cyan color. If the I signal is being lost, the color bars will appear predominantly green or magenta. As the hue control is varied, the green and magenta bars will appear to vary in saturation and some of them may take on the opposite hue.

If the receiver demodulates on the R - Y and B - Y axes and if either of the demodulator sections fail, a condition similar to that described in the previous paragraph will exist. The only difference will be in the hues of the color produced. If the B - Y signal is lost, the bars will appear predominantly red or cyan. If the R - Y signal is lost, the bars will appear predominantly greenish yellow or blue. If desired, the switch can be set to the CHROM. ONLY position during the tests just outlined.

Another significant thing that will be noted when checking a receiver that has lost one of the color-difference signals is that some of the bars may lose all color at certain settings of the hue control. After it has been determined which signal is absent, a signal-tracing procedure should disclose the faulty stage.

### Checking Demodulator Action

Defects associated with phase errors in the CW reference signal or the chrominance signal can be located through the use of the signals produced by the generator. If (after adjustment of the contrast, brightness, hue, and saturation controls) the receiver cannot produce a pattern such as that shown in Fig. 4, check the operation of the demodulators. Inject a signal into the receiver, and set the generator to provide a Q and I or B - Y and R - Y signal depending upon the type of demodulators used in the set. Using an oscilloscope, check the signal at the plate of the I (or R - Y) demodulator. Adjust the hue control to obtain a zero signal during the scanning time of the Q (or B - Y) bar. Fig. 16 illustrates the pattern that will be obtained under these conditions. Fig. 17 illustrates a pattern that will be obtained when there is incorrect setting of the hue control. As the hue control is rotated on either side of the correct setting, the polarity of the signal during the scanning time of the Q (or B - Y) bar will go alternately positive and negative.



Fig. 16. Signal at Plate of I-Demodulator Illustrating Proper Cancellation of Q Signal.



Fig. 17. Signal at Plate of I-Demodulator Illustrating Improper Cancellation of Q Signal.



Fig. 18. Signal at Plate of Q-Demodulator Illustrating Proper Cancellation of I Signal.



Fig. 19. Signal at Plate of Q-Demodulator Illustrating Improper Cancellation of I Signal.

With the hue control set so that the I (or R - Y) signal is at zero during the scanning time of the Q (or B - Y) bar, connect the scope to the plate of the Q (or B - Y) demodulator. Without readjusting the hue control, check to see that there is zero signal during the scanning time of the I (or R - Y) bar. Fig. 18 is a waveform illustrating such a condition. The result of an incorrect condition is shown in the waveform of Fig. 19.

If the signal is not zero during the scanning time of the I (or R - Y) bar, an adjustment of the quadrature transformer must be made. (In some receivers, the order of checking the signals at the plates of the demodulators may be reversed. Consult the receiver service data to determine the proper order.)

Refer to Fig. 2, and note that the Q signal appears at the right and that the I signal appears at the left. The R - Y and B - Y signals are in the same relative positions as the I and Q signals, respectively. This can be seen in Fig. 3. To aid further

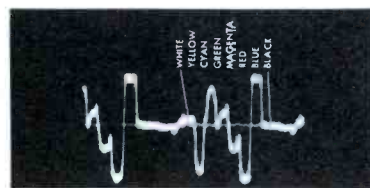

Fig. 20. A Minus I Signal.

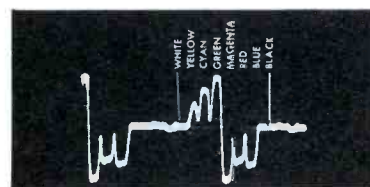

Fig. 21. A Minus Q Signal.

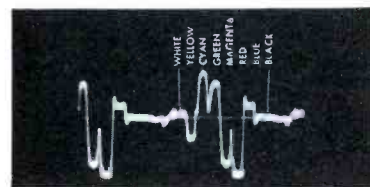

Fig. 22. A Minus R-Y Signal.



Fig. 23. A Minus B-Y Signal.

in identifying the signals properly, individual color bars can be obtained. When checking for cancellation of one of the signals, turn off that signal and note any change in the pattern. If a change is noted, complete cancellation is not being obtained.

After making the quadrature adjustment, set the hue control to its proper position by adjusting it for cancellation of the unwanted signal at the plate of one of the demodulators. Set the color-bar selector switch to the MULTI position. Adjust the contrast, brightness, hue, and saturation controls to obtain a pattern approximating that of Fig. 4. If the colors obtained are not satisfactory, check the operation and alignment of the matrix in the manner specified in the receiver service data.

Figs. 20 through 23 illustrate color-difference signals that are obtained when using the Jackson Models 700 or 712 color-bar generators. Fig. 20 shows a minus I signal, Fig. 21 shows a minus Q signal, Fig. 22 shows a minus R - Y signal, and Fig. 23 shows a minus B - Y signal. These waveforms can be referred to when checking demodulator operation, when adjusting the matrix, and when checking the operation of the color-difference amplifiers. Figs. 24 through 26 illustrate the waveforms that are present on the grids of the color picture tube of a receiver in which matrixing is not performed in the picture tube itself. An analysis of the waveforms which are present on the grids of the picture-tube guns can be very helpful in locating causes for incorrect colors.

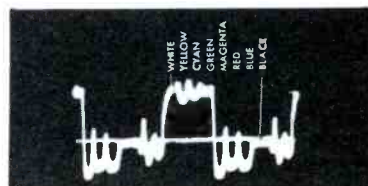

Fig. 24. Signal at Grid of Green Gun.



Fig. 25. Signal at Grid of Blue Gun.

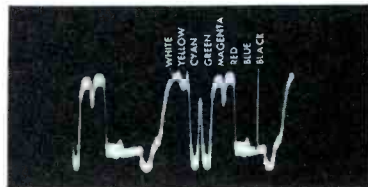

Fig. 26. Signal at Grid of Red Gun.

### LOSS OF COLOR SYNCHRONIZATION

If the reference oscillator of the receiver does not synchronize with the color-burst signal, color demodulation takes place at a random rate. Under these conditions, diagonal or horizontal stripes of variegated colors appear in the picture. These stripes may or may not move, depending upon the operating frequency of the reference oscillator. When loss of color synchronization is experienced, trouble in the burst amplifier or color-synchronizing stages should be suspected.

Because of the fact that some color is produced, two things are known: (1) the color signal is being applied to the demodulators and (2) the CW reference oscillator is operating. The problem is to find out why the color burst does not synchronize the CW oscillator.



Fig. 27. Signal at Plate of Burst Amplifier.

Fig. 27 illustrates the waveform present on the plate of the burst amplifier. The large spike is caused by the keying pulse obtained from the horizontal-output stage. Note the color-burst position at the tip of the spike. If the color burst is not present, rotate the horizontal-hold control and note whether the color burst appears. When checking some receivers or when using an oscilloscope which has only medium gain at 3.58 megacycles, it may be necessary to increase the vertical gain of the oscilloscope to maximum in order to see the color burst. Position the pattern so that the tip of the spike is visible, and then check to see if the color burst is visible.

If the color burst is present in the output of the burst amplifier, trace the signal to the color-synchronizing section. The type of synchronizing circuit used in the receiver being serviced will dictate the servicing procedure that should be used in the color-sync stages; but in the majority of receivers, voltage and resistance checks will disclose the defective component.

### SETTING CONVERGENCE

As previously stated, the Jackson Model 712 produces a white-crosshatch pattern and a white-dot pattern. These signals can be used to adjust the linearity of a receiver and to check and adjust the convergence amplifiers in the receiver. Fig. 5 illustrates the crosshatch pattern which is obtained, and Fig. 6 illustrates the dot pattern. Since the adjustment procedure for the convergence circuits varies with different receivers, the service data for the particular receiver being serviced should be consulted.

## PHOTOFACT\* COLORBLOCK

\*TRADE MARK

### Reference Chart No. 7

A COLORBLOCK Which Outlines the Uses of the Jackson Model 700 Color-Bar Generator and the Jackson Model 712 Color Bar/Dot Generator in Adjusting and Servicing Color Receivers.

Prepared by the Editorial Staff of the  
PF REPORTER for the Electronic Service Industry—June, 1955

TAKE THE ROAD TO  
**EXTRA PROFITS...**

**REPAIR  
AUTO RADIOS  
quickly, easily with  
STANCOR  
EXACT REPLACEMENT  
AUTO VIBRATOR  
TRANSFORMERS**



*free!*

New STANCOR Auto Radio Transformer Replacement Guide, the most complete ever published. This valuable book lists accurate replacement data for over 540 car radios, built or used by over 40 manufacturers. Both vibrator powers and audio outputs are included. It's available **FREE** from your CHICAGO STANDARD distributor

You can increase your auto radio repair profits by reducing installation time with STANCOR exact replacement vibrator transformers. Like STANCOR flybacks, STANCOR auto vibrator transformers are faithful duplicates of the originals they are designed to replace.

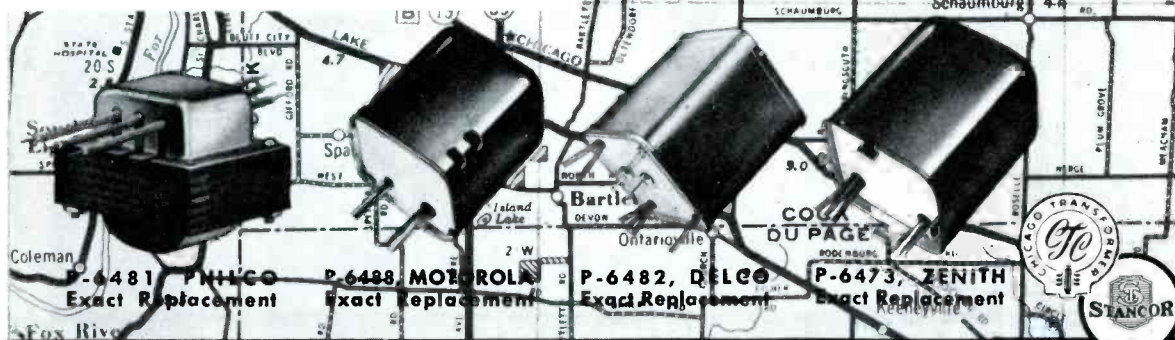

**CHICAGO STANDARD TRANSFORMER CORPORATION**

3594 ELSTON AVENUE

CHICAGO 18, ILLINOIS

Export Sales: Roburn Agencies, Inc., 431 Greenwich St., New York 13, N.Y.

**SETTING THE PACE...**  
in **ALL-CHANNEL**  
fringe antennas!

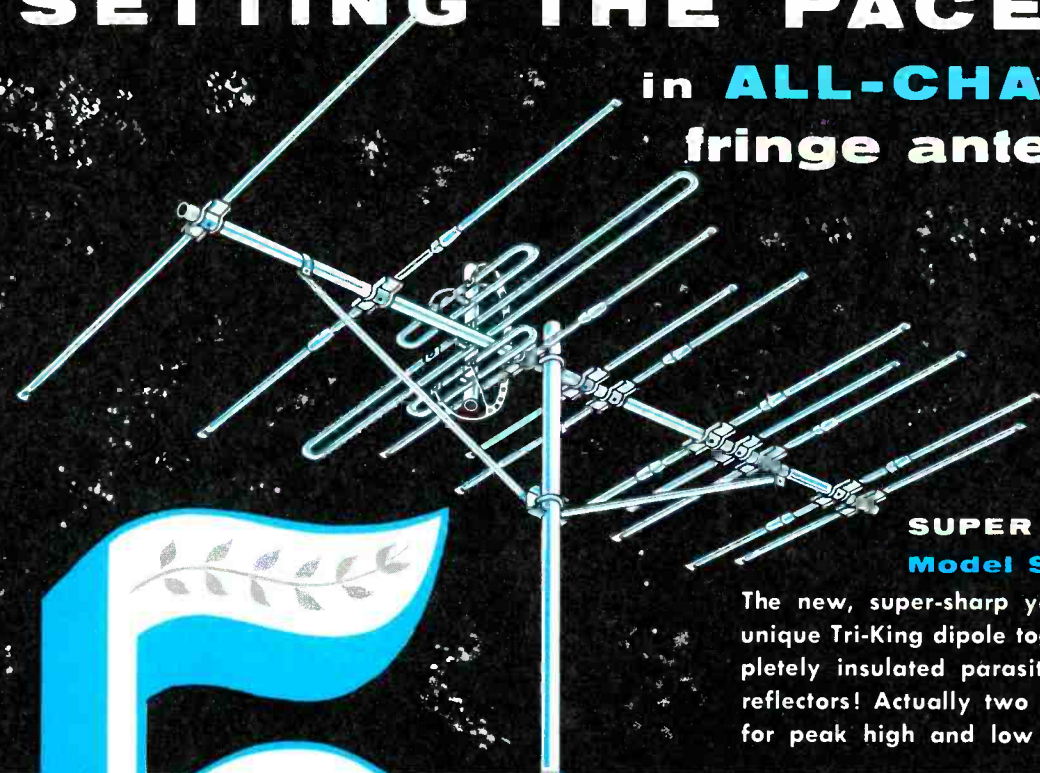

**SUPER SUN BEAM  
Model SB662**

The new, super-sharp yagi utilizing the unique Tri-King dipole together with completely insulated parasitic directors and reflectors! Actually two antennas in one for peak high and low band reception.



Clear Beam's **5** peak performers solve all fringe problems\*...

**TRI-KING  
Model TK1500**

Highest gain of the big screen antennas! Half wave electrical spacing. Eliminates ghosts and co-channel interference. Full radar screen - wind tunnel tested!

**BIG CHIEF  
Model BC12-2**

An advanced conical-Yagi with element diameters varied for precision tuning, matched sensitivity and peak performance on high and low band!

**SKY SWEEP  
Model MYS80**

A deep fringe yagi incorporating the new magnetic "Focal-Sharp" design for concentrating signal strength!

**HUNTER Model MYH50**

New wave trap principle gives extremely high gain, sharp directivity, in-phase tuning on all channels. New, flat design for low wind resistance!

\*Spectrum-tested for balanced color reception!



**CLEAR** ANTENNA CORP.

**BEAM**

Canoga Park, Calif. • Chicago, Ill.

affiliated with  
TEMPO TV products

Warehouses in Seattle, Portland, San Francisco, Honolulu, Dallas, Kansas City, Chicago, Detroit, Baltimore

# YOU CAN SELL THEM ...IF YOU TELL THEM

You can sell your customers portable-radio batteries only if you tell them that you sell them. And doesn't it stand to reason that you can sell them easier if you tell them you sell the best?

RCA Batteries carry the selling power of the greatest name in radio. And only RCA backs this selling power with the most colorful, the most varied group of display materials and merchandising aids ever created for this business of selling batteries. Start boosting your battery profits now with RCA Battery window streamers, displays, and advertising aids. Use them to tell your customers that you carry fresh, long-life RCA Batteries for every leading portable on the market today.

Your RCA Distributor is ready now to help you promote bigger sales for bigger profits with RCA Batteries. See him soon, and ask for your free copy of "This Business of Selling Batteries." It's filled with business tips, selling hints, and sure-fire promotional ideas. Or write directly to RCA Commercial Engineering, Section F33N, Harrison, New Jersey.



**RADIO CORPORATION of AMERICA**  
RADIO BATTERIES  
HARRISON, N.J.

# AGAIN — LITTELFUSE

Services for your profit have always been a first thought with Littelfuse... the one call kit, the snap on TV fuse holders in a box, the serviceman's box, the revolving drum, listings in Sams' Photofact folders.

And now, again... single channel dispensers for you to mount in any multiple arrangements you need right above your bench.

Ask your jobber.

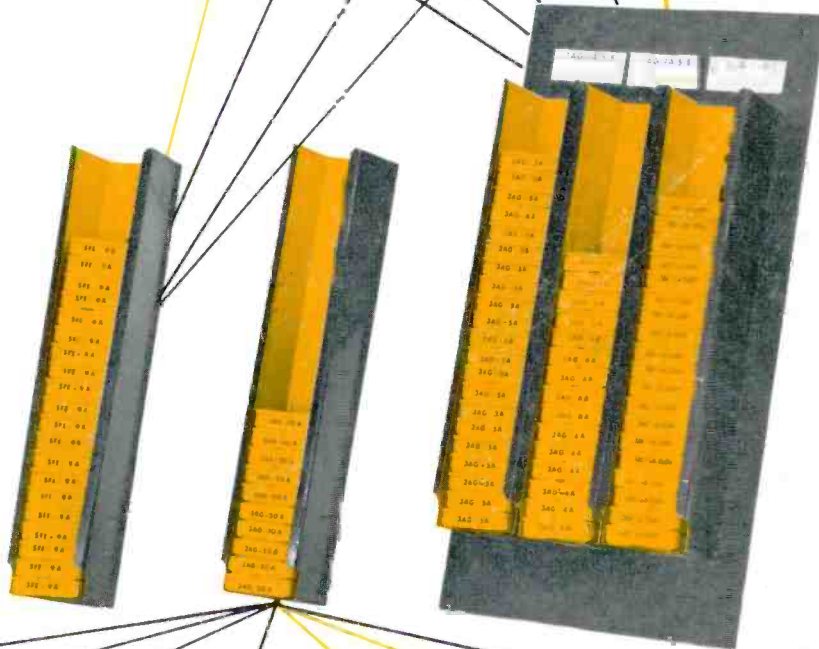
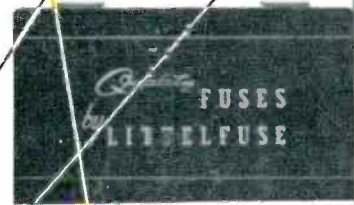
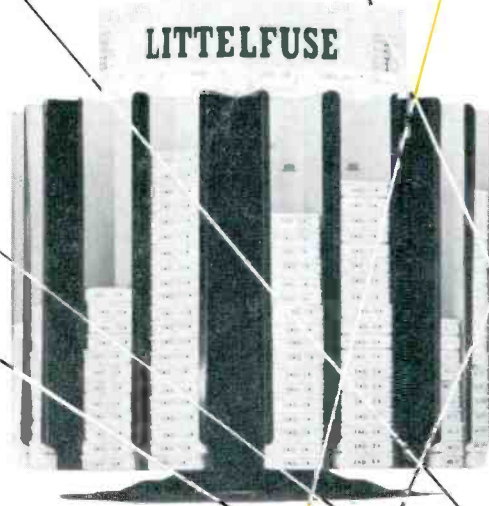

BURTON BROWNE ADVERTISING

# LITTELFUSE

Des Plaines, Ill.