

THE MAGAZINE FOR PROFESSIONAL ELECTRONIC AND COMPUTER SERVICERS

# ELECTRONIC™

## Servicing & Technology

April 2001

DVD Video Player Circuits

Set Top Boxes For HDTV



**DISTRIBUTION  
SHOWCASE**  
AN ADVERTISING  
SECTION

- **Designing a Showcase Site**
- **Closed Circuit TV**
- **EDS Preview**
- **50 YEAR HISTORY: PART 2  
Electronic Projection Technology**

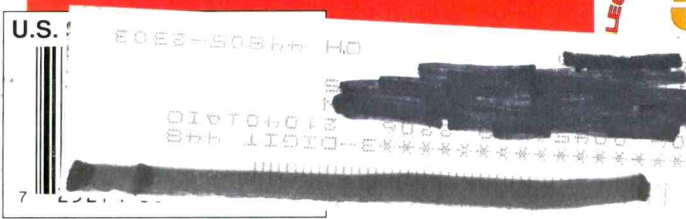
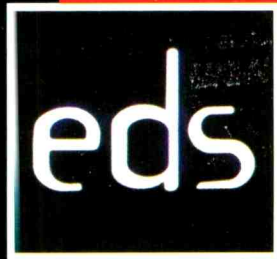

BASCOM  
CH 4100

**PROFAX**  
HITACHI  
Projection Color  
Television  
50SBX78B  
60SBX78B



### Synthesized In-Circuit LCR/ESR Meter

First handheld unit to incorporate bench performance on the market

- Measures Z, L, C, DCR, ESR, D, Q and 0
- Tests 100Hz, 120Hz, 1kHz, 1Vrms, 0.25Vrms, 0.05Vrms
- Dual LCD display
- Infrared RS-232 interface capability
- SMD tweezer probe included

**Model 885**

Circle (1) on Reply Card



### Test Bench High Performance DMM

Heavy duty design with double injection molding for better grip and shock protection.

- True RMS
- Resistance measurement
- RS-232 - PC link interface for data acquisition
- Logic probe
- Data hold

**Model 390A**

Circle (2) on Reply Card

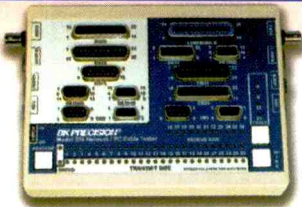

**Model 206**

### Network/PC Cable Tester

- Tests printer, monitor, modem, mouse extension, BNC coax, RJ45, 1394 & USB cables
- Detects open, short, miswire, continuity, game and pin configuration
- LED display
- Reverse test
- Auto and manual modes

Circle (3) on Reply Card



**Model 1651A**

### Triple Output DC Power Supply

- Two 0VDC to 24VDC outputs
- Fixed 5V output
- Adjustable current limiting
- Short circuit protection
- Connect outputs in series for higher voltage output or in parallel for higher current output

Circle (4) on Reply Card



**Model 4040A**

### 20 MHz Sweep/Function Generator

- 0.2Hz to 20MHz
- AM and FM modulation
- Burst operation
- External frequency counter to 30MHz
- 5 digit LED display

Circle (5) on Reply Card

# B&K Makes Child's Play out of Bench Testing

New, attractive and compact, B&K Precision's family of bench instruments allow you to build your own test lab.

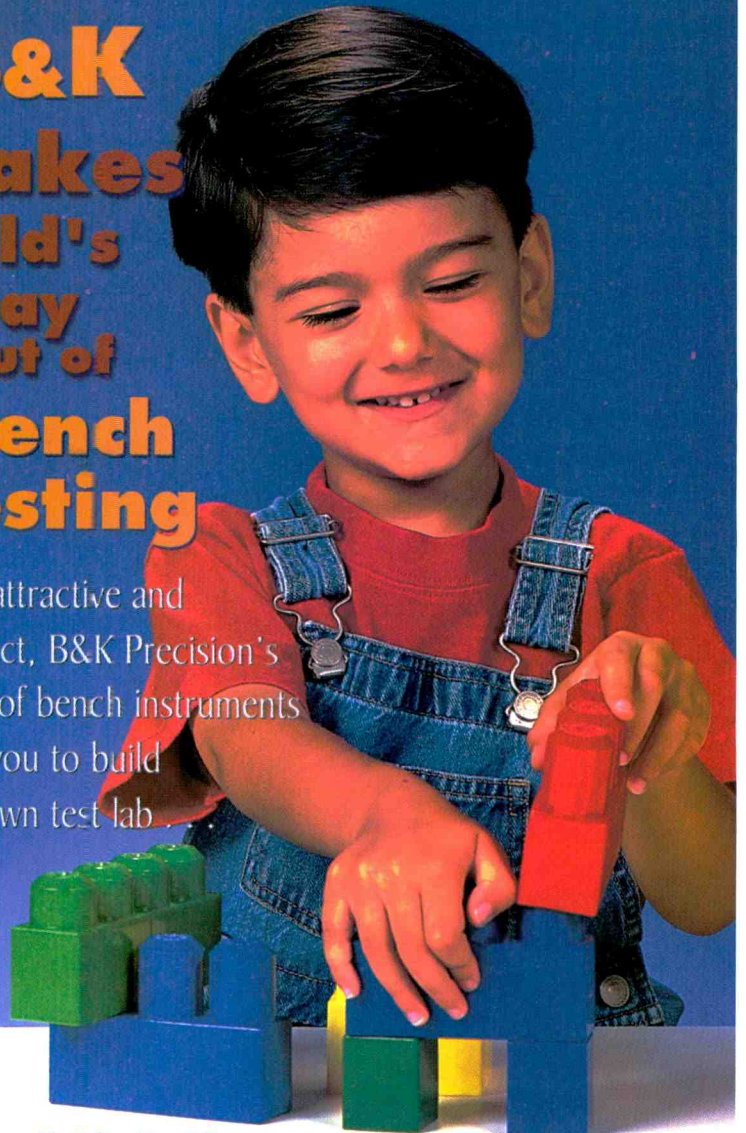

## No Kidding.

B&K Precision's line of Bench Test Equipment has a new modern look with all of the same great features such as large, bright, easy-to-read displays and simple easy-to-use controls. The new power supplies provide the versatility and reliability required for a broad spectrum of laboratory and service applications.

B&K Precision offers an extensive line of high performance signal generators including function, sweep/function, RF, audio, and arbitrary waveform generators.

And the versatile Bench Digital Multimeters (DMM) offer a variety of important features at attractive prices.

For more information on how you can change bench testing from a chore into child's play, visit our Web Site at [bkprecision.com](http://bkprecision.com) or call us toll-free at **(800) 462-9832** for a new full line catalog.

**BK PRECISION®**

1031 Segovia Circle, Placentia, CA 92870

(714) 237-9220 Fax: (714) 237-9214

[bkprecision.com](http://bkprecision.com)

Circle (6) on Reply Card



## CONTENTS

### FEATURES

#### REWITABLE DISK SYSTEMS DVD VIDEO PLAYER CIRCUITS \_\_\_\_\_ 7

John A. Ross

John Ross examines the operation of DVD video player systems and the integration involved in typical DVD video player operations.

#### CLOSED CIRCUIT TV \_\_\_\_\_ 14

ES&T Staff

CCTV systems can be a crime deterrent and a help to authorities but only if they are well maintained, thus representing a business opportunity for Consumer Electronics Service Professionals.

#### SET TOP BOXES FOR HDTV \_\_\_\_\_ 16

ES&T Staff

With the 2006 mandate for broadcasting exclusively in HDTV, there will be many older TV sets dependent on one of these Set Top boxes. This is a brief review of their components and features.

#### DISTRIBUTION SHOWCASE \_\_\_\_\_ 18

An Advertising Section

Distributors and Manufacturers selling through distributors provide information on their offerings and operations for the Consumer Electronics Service Professional.

#### A HISTORY OF ELECTRONIC PROJECTION DISPLAY TECHNOLOGY \_\_\_\_\_ 22

This is the second of a series of *ES&T* retrospective articles celebrating 50 years of Professional Electronics Servicing. This chapter covers light valve technology and the remarkable effort that went into its development. This article adapted by *ES&T* from material produced by Texas Instruments.

#### DESIGNING YOUR SHOWCASE \_\_\_\_\_ 39

ES&T Staff

You have read and heard it before...a professional looking showroom and the right location mean a lot if you are going to be a success in this arena. The *ES&T* staff reviews the basics.

### SHOWS/EVENTS

#### ELECTRONIC DISTRIBUTION SHOW AND CONFERENCE \_\_\_\_\_ 38

Once a year the distributors who keep products coming to the professional servicer, meet at EDS in Las Vegas. They add and drop lines, products, services and systems based on input from you, the manufacturers and others. This might be a good time for you to give your "wish list" to your favorite distributor.

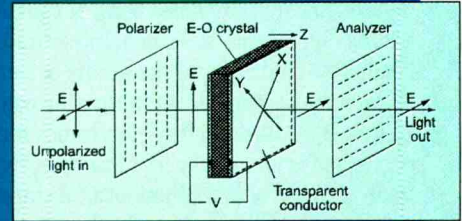
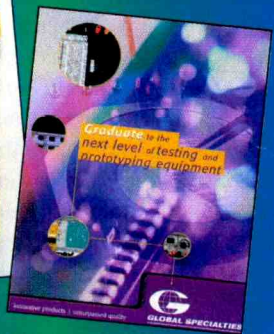
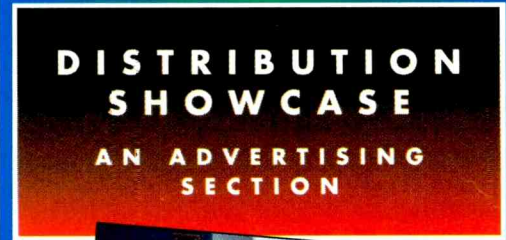

Cover Photos Courtesy of Thomson multimedia & Yamaha

### DEPARTMENTS

Advertisers Index .....	56	Editorial .....	2	News .....	4
Association News .....	49	Editorial Calendar .....	37	Reader's Exchange .....	52
Books .....	48	ES&T Readers Speakout.....	53	Profax.....	25
Calendar of Events .....	42	Help Line .....	47	Viewpoint .....	55
Classified .....	54	Literature .....	49		
Display Classified .....	56	New Products .....	46		

by Nils Conrad Persson

## CAN GPS ASSIST AN EDITOR LOST IN THOUGHT?

I was headed to downtown Kansas City last Saturday. Just before I reached my exit, traffic in front of me had come to almost a complete stop. I had left plenty of room between me and the car in front of me, so I was able to slow quickly, alerting the driver behind me that there was trouble ahead, then proceed slowly, eventually changing lanes to exit the highway a couple of exits before I had originally intended to exit.

The problem was some kind of accident. There was a wrecked car in the center lane, and several emergency vehicles with lights flashing.

I wonder what might have happened if I had a device in my car that allowed me to check a map of the area, and I was looking at that device instead of keeping my full attention on the road ahead. I had only a few seconds to see the problem and take my foot off the accelerator and move it to the brake while I decided if I should change lanes or stay in my lane. If my attention had been directed to something in the car, instead of the rapidly changing situation outside, even for a few seconds, I might have plowed right into the rear end of the car in front of me.

Of course, that kind of thing happens now. People do all kinds of things while they're driving: read, shave, eat, drink, talk on the cell phone, and if they're not paying attention and an emergency situation crops up, they could easily have an accident.

If the trend in electronics continues as it seems to be going, the potential for distraction in automobiles will increase. A number of things are happening on the automotive electronics front that may soon result in an increase in the number of electronics products in cars. For starters, if they haven't already completed the effort, electronics manufacturers and auto manufacturers are working together to design a standard bus that will allow all of the electronics devices in a car to be interconnected without the need to make the maze of wires in a car even more complex than it already is.

Another factor contributing to the proliferation of electronics devices in cars (and elsewhere, of course) is the simplification of adding electronics functions. Integrated circuit fabrication has become so routine, and the ability of semiconductor manufacturers to manufacture ICs of increasing complexity and functionality, that the cost of adding electronics functions to products has decreased dramatically. For example, in an editorial in an earlier issue of *ES&T* about "Bluetooth," a standard for adding communications capability to computer-based devices, we reported that this communications capability could be added without appreciably increasing the cost of the device. Semiconductor manufacturers are quick to recognize opportunities for them to produce inexpensive, easy to adapt, devices that increase the functionality of products, so manufacturers of all kinds of products, from automobiles to home appliances can offer these added functions quickly and with little fuss.

Advancing bandwidth capacity is another factor cited in the increasing numbers of devices that use and transmit and receive information. Certainly, bandwidth is increasing in a number of ways. High data capacity telephone lines, cable modems, and satellite modems provide huge pipes for data to flow through.

Another phenomenon providing increased bandwidth is the efficient use of what bandwidth is available. For example, cellular telephone systems use the same frequencies over and over in the different spatially separated "cells," thus conserving what radio spectrum resources there are.

Moreover, people want these things. A consumer with children looks at a minivan or SUV that has a video screen and a VCR or DVD player in it for the back seat, and recognize that if they can play "Toy Story," or "The Lion King," or "The Little Mermaid" while they're on a trip, they might be able to get through an entire day without hearing the little ones saying "Are we there yet?," or "Mommmmmmmmmmy, Chuckie's looking at me."

There's more afoot than just the addition of consumer electronics in cars, however. Already, it's possible to subscribe to a service that uses a global positioning system to keep track of where the car is at all times. A future plan is to equip cars so that they can connect to the Internet. That's not necessarily a bad thing. In fact, it's probably a good thing, as long as drivers use such capabilities wisely.

It probably isn't any more dangerous for a driver to access the Internet while he's driving than it is for a driver to try unfolding a paper map and try to figure out where he's going. However, being an extremely cautious driver, I think it's a bad idea to do either one. It makes a lot more sense to find a safe place to stop, then use the map, or connect to the Internet and download a map than to keep driving while trying to do either.

The automobile is only a special case of using today's technology to remain connected to the world via the Internet. Here's what a page at the website of a company called Xilinx has to say about the proliferation of "information appliances". "Information appliances are an emerging category of digital consumer electronics that provide the consumer with a low-cost, easy-to-use, instant on device, providing lightweight, reliable, special purpose access to the features and benefits of the internet. These consumer devices enable infotainment. They provide the ability to access e-mail on the move, check driving directions when on the road, manage appointments and schedules when waiting at the doctor's office, and play video games while relaxing on the sofa."

Every once in a while, I find myself wishing that engineers and manufacturers of these devices would just slow down, let us mere mortals catch our collective breath, and learn to cope with all of the wonders they've already provided us with before inventing the next wave of awe-inspiring electronics products. But, of course, I know that that will never happen. The endless stream of technical innovation is self sustaining. So all any of us can do is to try to deal with all the innovation even while it's in full flow.

And, just in case the guy in the next car isn't as smart and as cautious as we are, and might be looking at an internet-generated map while he's driving, instead of giving his full attention to the road, maybe we should all give ourselves an extra car length or two.

Conrad Persson

THE MAGAZINE FOR PROFESSIONAL ELECTRONIC AND COMPUTER SERVICERS

# ELECTRONIC

Servicing & Technology

**Electronic Servicing & Technology** is edited for servicing professionals and managers who service consumer electronics equipment. This includes owners, managers, service technicians, field service personnel and avid servicing enthusiasts who repair and maintain audio, video, computer and the new digital consumer electronics equipment.

A publication of

MAINLY MARKETING ENTERPRISES INC.  
403 Main Street, 2nd Floor  
Port Washington, NY 11050 USA  
516-883-3382 Fax 516-883-2162  
mmei@mainlymarketing.com

## EDITORIAL

Editor: NILS CONRAD PERSSON  
P.O. Box 12487, Overland Park, KS 66212  
913-492-4857  
cpersedit@aol.com

## CONSULTING EDITORS

TV Servicing Consultant: BOB ROSE  
TV Servicing Consultant: HOMER L. DAVIDSON  
Components Consultant: VICTOR MEELDIJK  
Audio Consultant: ALVIN G. SYDNOR

## BUSINESS

Publisher: MARIE MARCELLINO  
mmarcellino@mainlymarketing.com

President: DAVID L. ALLEN  
dallen@mainlymarketing.com

## CIRCULATION

Circulation Coordinator: MARY TALI  
admin@mainlymarketing.com

## PRODUCTION

Production Manager: MARIANNE MEADOWS  
mmeadows@mainlymarketing.com

## SALES STAFF

Sales Director: DAVID L. ALLEN  
dallen@mainlymarketing.com

Sales: JONI JONES  
P.O. Box 346, Port Washington, NY 11050  
Tel: 516-944-8068 Fax: 516-944-2739  
jmjones@ix.netcom.com

Sales: BARBARA ARNOLD  
60 Thoreau Street, Concord, MA 01742  
Tel: 781-259-9207 Fax: 781-259-9883  
bhacat@tiac.net

International: JAY FEBRER  
jfebrer@mail.com

Classified/Display Classified: LYNDIANE PAOLETTI  
admin@mainlymarketing.com

Sales Coordinator: LYNDIANE PAOLETTI  
admin@mainlymarketing.com

**FOR SUBSCRIPTIONS** — new or renewal — use our  
subscription website: [www.electronic-servicing.com](http://www.electronic-servicing.com)

Electronic Servicing & Technology (ISSN 0278-9922) is published monthly by Mainly Marketing, 403 Main Street, Port Washington, NY, 11050. Telephone 516-883-3382. Periodical class postage paid at Port Washington, NY and additional offices. Canada: Postage agreement number 1885766. Subscription prices (payable in US dollars only): Domestic—one year \$26.95, two years \$49.95, Canadian—one year \$36.95, two years \$69.95. Foreign Air Post—one year \$44.95, two years \$85.95. Allow six weeks for delivery of first issue and for change of address. Entire contents copyright 2001 by Mainly Marketing. Electronic Servicing & Technology or Mainly Marketing assumes no responsibility for unsolicited manuscripts.

Printed in the United States of America.

Postmaster: Please send change of address notice to Electronic Servicing & Technology, Circulation Department, Suite 405, 25 Newbridge Road, Hicksville, NY 11801.



National Electronics Service  
**NESDA**  
Dealers Association, Inc.  
Member, Electronic Servicing  
Dealers Association

# INDUSTRIAL POWER

IGBT modules,  
Darlington packs,  
Thyristor modules,  
Stud mount diodes,  
Three phase bridges,  
Fast recovery diodes,  
Bipolar transistor modules,  
MOSFET modules,  
Zero crossing optical couplers

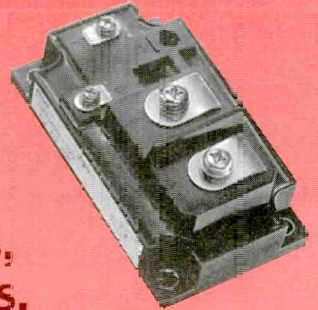

made by:

Fuji • Mitsubishi • Sansha (Sanrex)  
Toshiba • Shindengen • I.R. (and others)

Please visit our website at:  
[www.bdent.com](http://www.bdent.com)

# B&D

## ENTERPRISES



**AUTHORIZED DISTRIBUTOR FOR**

**NEC Shindengen**  
**SANYO SanKen AND OTHERS**

P.O. Box 460 Main & Liberty, Russell, PA 16345

TECH SUPPORT: 814-757-8300

FAX: 814-757-5400

**Call today for your FREE Catalog**

# 1-888-815-0508

Circle (7) on Reply Card

## Japan's Aiwa To Slash Work Force

TOKYO - based on increased price-cutting competition from manufacturers in China and a worldwide economic slowdown, Japanese electronics maker Aiwa Co. will reduce by half its global work force to about 5,000 within the year combining operations into one factory.

Hurt by dropping demand for the company's products, the Sony Corp. subsidiary will also cut back output of unprofitable televisions and other items, shifting to more profitable digital products, including a portable audio player, said Aiwa spokesman Masahiro Ashino.

Aiwa estimates the restructuring will reduce annual sales by about 30 percent

to approximately 200 billion yen (\$1.6 billion) in fiscal 2002 from its current 300 billion yen (\$2.4 billion), Ashino said.

By March 2002, Aiwa said it will shift operations from its main factories in

northern Japan, Malaysia and Indonesia into one factory, Ashino said. The company has yet to choose that location.

Sony holds a 50.5 percent stake in Aiwa, which was founded in 1951.

## Jensen Transformers Promotes Dave Hill to General Manager

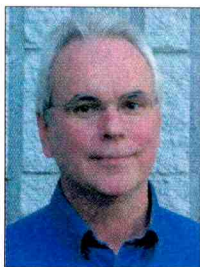

Van Nuys, Calif., Jensen Transformers, announces the promotion of Dave Hill to the position of General Manager.

Bill Whitlock, president of Jensen stated: "Dave has been with us for over 20 years and he has contributed significantly to the growth and profitability of the company. I have complete confidence in Dave's ability to both manage the company and help to pioneer new markets for our growing port-

folio of products."

As the General Manager, Hill's responsibilities include overseeing all sales, marketing, trade show, personnel, and inventory management operations.

Hill joined Jensen Transformers in June of 1980 and became VP of Operations in July of 1989. During his tenure, Hill built the Company's customer support system and was instrumental in developing the ISO-MAX® line of audio and video ground isolators.

Jensen Transformers, founded in 1974, is a leading manufacturer and developer of high performance audio transformers.

## Sears Will Acquire Montgomery Ward A&E

Sears, Roebuck & Company plans to buy 18 former Montgomery Ward department stores and 10 auto centers from the failed retailer. Sears also said it would acquire Ward's repair business, A&E Signature Service, and that it reached an agreement in which it could provide service to 2.4 million customers who had service contracts for home appliances, electronics and other products with Ward, based in Chicago, filed for bankruptcy protection Dec. 28 and has closed the last of its 250 stores.

## Rolling Electric Blackouts Affects Service Availability

Hitachi's Walt Herrin reported "rolling blackouts" throughout California on March 19 amid predictions that they will continue. While no one has advance warnings as to when these blackouts will appear, Hitachi has provided these guidelines as to the affect on its response capability:

1) Blackouts in the San Francisco/Bay area may affect their Service Division e-

mail; and the Corporate website, [www.hitachi/CE.com](http://www.hitachi/CE.com).

2) Blackouts in the San Diego area may affect their Service Division Website [www.hitachiserviceusa.com](http://www.hitachiserviceusa.com); on-line Parts Ordering system; and the telephone service within their building (Technical support, parts, warranty, etc.)

Herrin asked for everyone's patience and understanding during these periods.

## Panja Closes \$5 Million Private Equity Placement

Richardson, TX - Panja Inc. (Nasdaq:PNJA) announced the closing of a \$5.0 million private equity placement. The investor group led by Scott Miller, the company's founder, president and chief executive officer has purchased 1,161,116 shares of common stock. The transaction had previously been announced as a \$5.5 million capital commitment on February 23, 2001. Panja plans to use the proceeds of the private placement to supplement the company's working capital and to fund the development of the company's products.

Panja designs, develops, and markets advanced electronic equipment software that extend Internet content to non-PC devices that target both the consumer and

enterprise markets. These devices deliver information and entertainment direct to existing electronic devices, including stereos and televisions, to optimize the benefits of broadband access. Panja's

strategy is broadband entertainment applications, further integrate its products with other devices, and lead the creation of solutions that extend the Internet beyond the PC.

## NTE Electronics Purchases ECG Bloomfield

Bloomfield, NJ-NTE Electronics, Inc., worldwide supplier of electronic components, has officially announced the completion of its acquisition of ECG. All assets, trademarks and registrations will now be under NTE's ownership and have been transferred to the company's New Jersey headquarters.

ECG had been a supplier of replacement components for the commercial,

industrial OEM/MRO, computer, and communication industries. Some ECG products will be assimilated under the NTE name and brand while others will remain under the ECG name.

NTE supplies private label semiconductors, relays, capacitors, resistors, and hook-up wire. Additionally, NTE has master distribution agreements with other major brands.

# ELECTRONIC DISTRIBUTION IS IN MOTION

...GOING GLOBAL, GOING ON LINE, AND ABOVE ALL, GOING TO LAS VEGAS FOR...

## EDS2001

### Electronic Distribution Show & Conference

**May 15-16-17**  
Las Vegas  
Hilton Hotel,  
Las Vegas, Nevada

The electronic distribution industry knows that EDS is the place you've got to be. Distributors, manufacturers, representatives involved with components, instruments, datacom, MFO and production products sold through the electronic distribution channel gather 6000 strong at the trade show/conference where decision makers meet.

Go right now to [www.ecsconnect.com](http://www.ecsconnect.com), to register for the event that's connecting electronic distribution worldwide

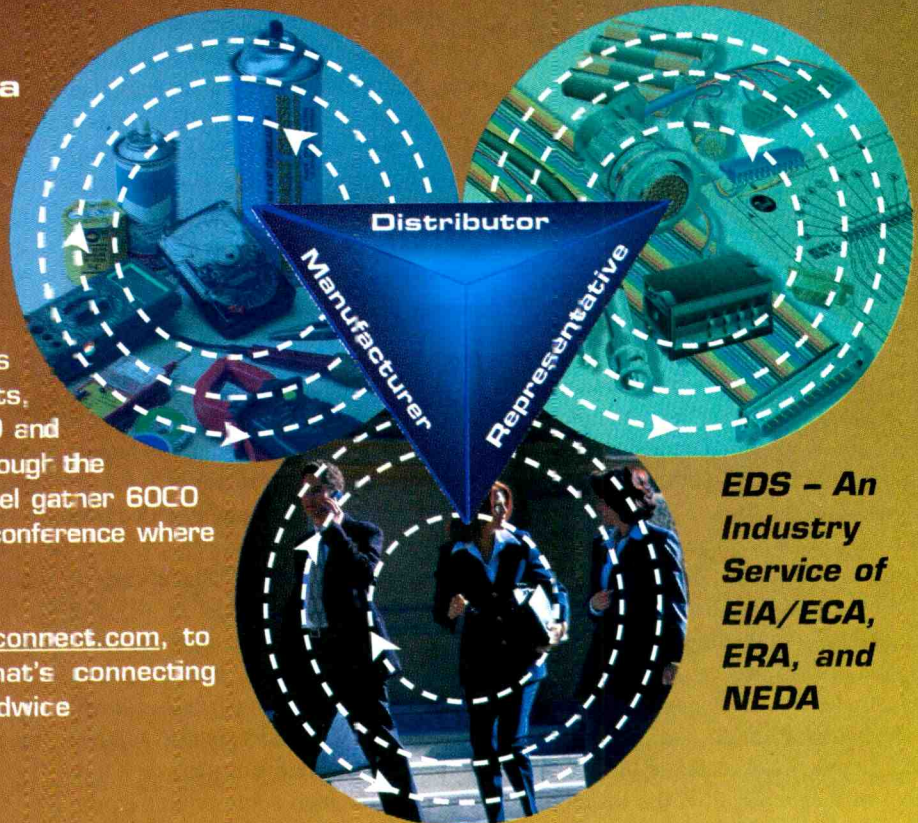

**EDS - An  
Industry  
Service of  
EIA/ECA,  
ERA, and  
NEDA**

**EXHIBITS • CONFERENCES • SEMINARS • NETWORKING**

**Nothing can replace the benefits of face-to-face, and EDS is the face-to-face marketplace**

222 South Riverside Plaza, Suite 2160, Chicago, IL 60606

Tel: 312.648.1140 • Fax: 312.648.4282 • Email: [eds@edsc.org](mailto:eds@edsc.org)

Web: [www.edsc.org](http://www.edsc.org) or [www.edsconnect.com](http://www.edsconnect.com)

## **CEA and JEDEC Cooperate on New Conference to Showcase Technology**

The Consumer Electronics Association (CEA) and JEDEC announced a joint partnership to create a new conference entitled EdgeTech: Emerging Technologies Showcase. The conference, showcasing the latest semiconductors to hit the market in the next year, will be held August 19-21, 2001 at the Aladdin Resort & Casino in Las Vegas, NV.

EdgeTech will provide companies, engineers, semiconductor buyers, financial market analysts, sales and marketing

executives and product managers the opportunity to display their innovative new technologies and devices, while offering the industry the chance to learn about these exciting new products while they are still in development.

EdgeTech will consist of three tracks, the first educating attendees on how to build the technology, the second explaining how to produce and sell the technology, and the final track will showcase technology in the marketplace.

Companies can display new technologies recently available on the market in five-minute demonstrations as well. The tracks will feature experts and leaders from all aspects of the consumer and semiconductor technology industry.

"Registration for EdgeTech will open online in May. Companies interested in showcasing their technology at EdgeTech should contact Lisa McKellar at CEA at (703) 907-7047 or e-mail at [lmckellar@ce.org](mailto:lmckellar@ce.org).

## **HomePlug Powerline Alliance Joined by Xilinx**

*"Residential powerlines are the most pervasive network in the world today and offer a cost-effective, easy-to-use home networking solution for consumers," said Robert Bielby, director of strategic applications for Xilinx, Inc.*

Xilinx announced today its membership in the HomePlug Powerline Alliance, Inc. HomePlug is a nonprofit corporation established to provide a forum for the creation of specifications for worldwide home powerline networking products and services and to accelerate the demand for these products and services through the sponsorship of market and user education programs. HomePlug has chosen Intellon's high-speed powerline networking technology as the baseline upon which to build the first-generation specification offering 10 Mbps data rate, clear compatibility, and ease of implementation.

"Industry leaders in technology, silicon, software, hardware, retail, and services are working together to accelerate the establishment of a specification, the development of products, and the adoption by consumers of home powerline networking," said Alberto Mantovani, president of HomePlug and division director of Small Business and Consumer Networking and Personal Computing for Conexant Systems, Inc. "Xilinx reaffirms the strength of HomePlug's membership and we are very pleased to have this industry-leading company joining the alliance."

"Residential powerlines are the most pervasive network in the world today and offer

a cost-effective, easy-to-use home networking solution for consumers," said Robert Bielby, director of strategic applications for Xilinx, Inc. "Membership in consortia such as HomePlug is an important aspect of our eSP initiative, allowing us to provide designers with insight into emerging and evolving standards, along with relevant resources and solutions through our highly successful eSP web portal."

HomePlug Powerline Alliance, Inc. is a nonprofit corporation established to provide

a forum for the creation of specifications for home powerline networking products and services; and, to accelerate the demand for these products and services through the sponsorship of market and user education programs. HomePlug founding member companies are: 3Com, AMD, Cisco Systems, Compaq, Conexant, Enikia, Intel, Intellon, Motorola, Panasonic, SONICblue, RadioShack, and Texas Instruments. Additional information about the alliance is available at <http://www.homeplug.org/>.

## **IBM Unveils Family of MPEG-2 Encoder Chips for Professional Broadcast Industry**

IBM announces a new family of single-chip video encoders that can help broadcasters generate higher quality video over existing communications lines.

Called the IBM eNV SD encoders, these products are the latest in a line of IBM solutions designed to meet the needs of the communications and broadcast industries in improving video quality. IBM's eNV SD encoders are also suitable for applications requiring lower bandwidth such as video conferencing equipment, cable head-ends and satellite news gathering.

"IBM has long been a leading supplier of MPEG-2 encoders, having brought multiple encoders and decoders to the marketplace for broadcast applications," said Christine Harasymczuk, marketing manager, Digital Video Products Group, IBM Microelectronics. "IBM's new 4:2:2 and 4:2:0 MPEG-2 video encoder chips are a compact, high quality solution that offer more integrated features for stan-

dard definition (SD) applications, compared to previous-generation encoders."

IBM's newly-announced eNV SD encoders offer a host of integrated features such as:

- A common hardware platform for the 4:2:2 and 4:2:0 chip packages, making it possible for makers of professional video equipment to develop a single board design for multiple products.

- Encoding support up to 4:2:2P@ML with a search range of up to +/-200H and +/-128V.

- Integrated resizing and noise reduction filtering options which produce higher visual quality at lower bit rates.

- A single memory interface provides economies through critical board space savings, and reduces overall board design complexity.

- Packetized Elementary Stream (PES) output support, which helps simplify video time stamping and A/V synchronization functions.



# Rewritable Disk Systems

# DVD Video Player Circuits

by John A. Ross

While examining the operation of DVD video player system, this article shows the integration involved with typical DVD video player operations. DVD video players and recording systems contain a wide variety of circuits including optics, servos, digital signal processors, microcontrollers, video and audio encoders and decoders, and amplifiers. Using the block diagram of a Zenith DVD video player as a template, we can illustrate how the individual circuits affect the operation of DVD systems. Figure 1 is a block diagram of the player.

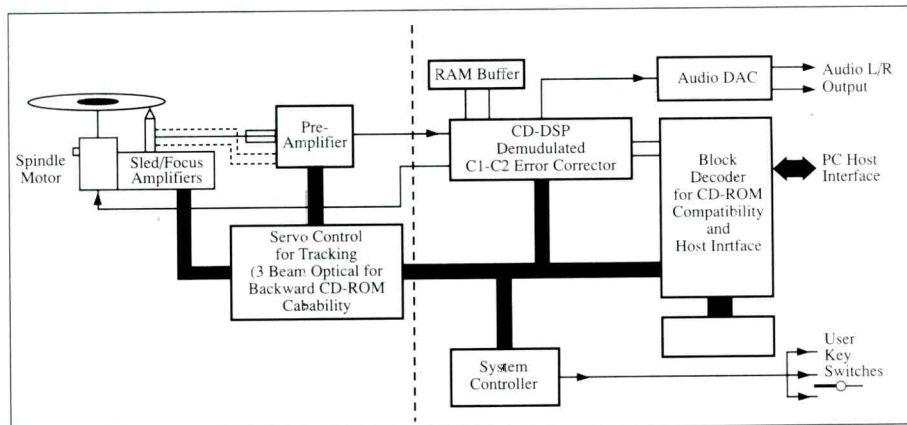

Figure 1. Block diagram of a DVD player.

## Optical Pick-Up and Servo Electronics

The optical electronics features the optical unit, the servo motor assemblies, and a five-channel motor drive IC. The KA3032 motor drive IC (Figure 2) uses a transformerless BTL driver to drive the

tracking actuator, focus actuator, sled motor, spindle motor, and tray motor. The device features built-in thermal shut-down, voltage lockout, overvoltage protection and mute circuits. A fully integrated digital servo controls the spindle motor speed and responds to the disc rotational speed.

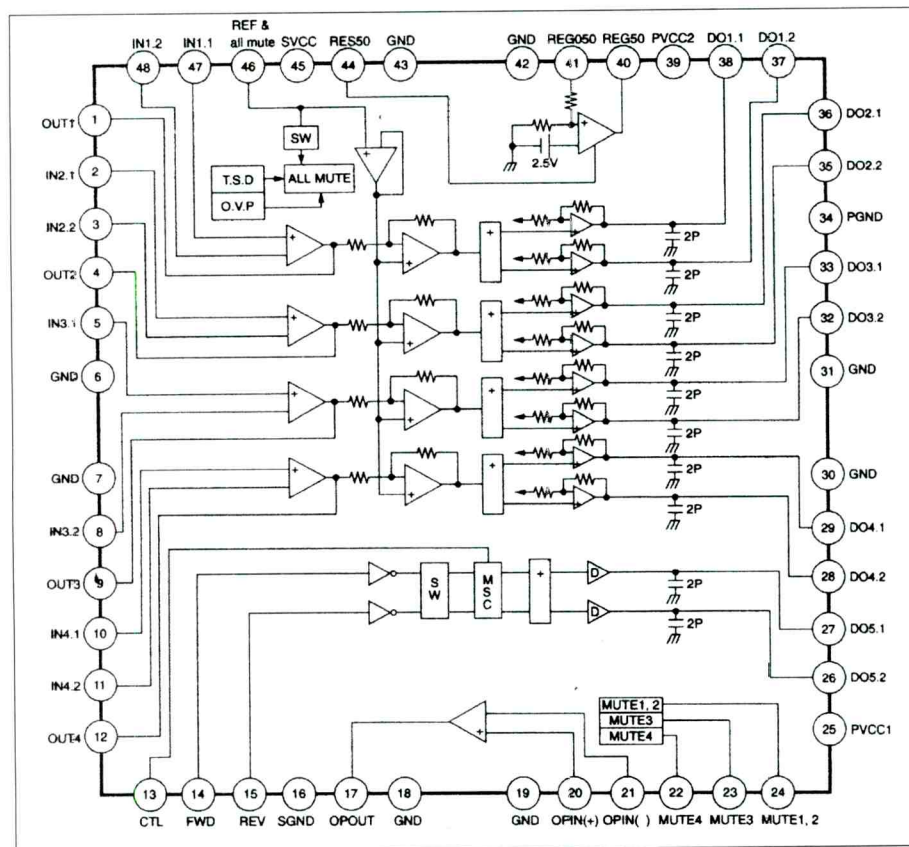

Figure 2. KA3032 motor drive IC.

## Signal Processing

The video signal begins with information accumulated by the pick-up assembly from the disc (Figure 3). From there, the signal progresses through the RF Signal Processor and to the DVDDSP (digital signal processor). Output signals from the DVD DSP travel to the system microcontroller and the MPEG decoder.

## RF Signal Processor

Information embedded in an RF signal transfers from the OPU to the main circuit board through a ribbon cable to IC 2A1, the RF Signal Processor. IC 2A1 amplifies and equalizes the RF signal before the signal exits to IC201, the DVD-DSP. In addition, the circuit includes Internal RF AGC circuits, an internal APC circuit, an internal auto asymmetry circuit, an internal disc defect detector, and internal focus protect function against disc defects. Figure 4 is a schematic diagram of the RF Signal Processor.

## DVD Digital Signal Processor

IC201 provides a number of functions for the DVD video player (Figure 5). The analog front-end converts the high frequency input signal to the digital domain through the use of an 8-bit analog-to-digital converter. An AGC circuit operating before the ADC circuit establishes the gain control needed for obtaining optimum performance from the converter. An ADCCLC circuit

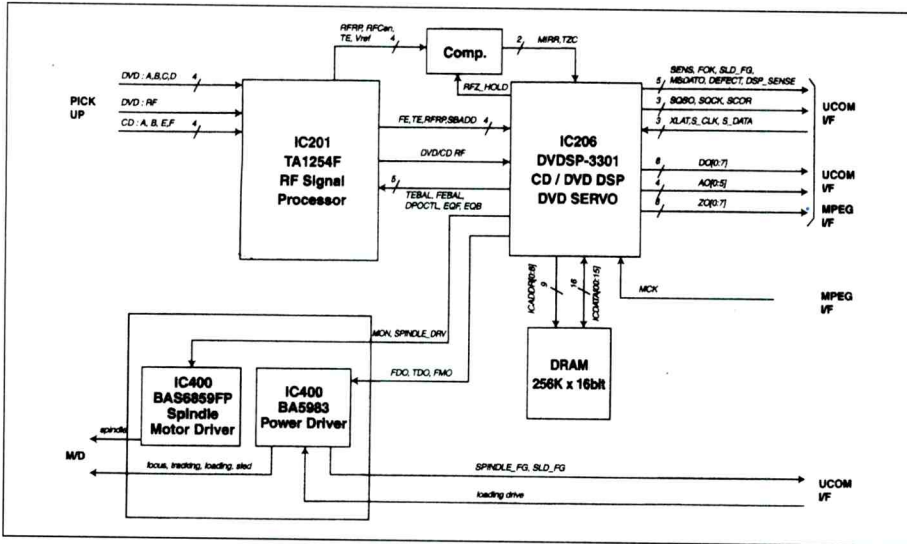

Figure 3. Block diagram of the DVD player video signal.

provides the clocking synchronization for the operation.

When the amplified and equalized RF signal enters the DVD DSP circuit, a portion of the DSP serves as a data slicer, functions as a 16-to-8 bit decoder, and establishes error correction. With the playback information still embedded in the RF signal, the data slicer retrieves the embedded data and temporarily stores the data in the memory found at IC205. From that point, the data travels to the 16-to-8 bit demodulator located within IC201.

A phase-locked loop and bit detector form a subsystem that recovers data from the channel stream. The block corrects asymmetry, performs noise filtering and equalization and finally recovers the bit clock and data from the channel through the PLL. The advanced bit detector offers improved data recovery for multi-layer discs and contains two extra detection circuits to increase the margins in the bit recovery block:

### 16-to-8 Bit Demodulator

Two synchronization counters work within the DSP to detect the frame synchronization signals. A coincidence counter detects the coincidence of successive sync frames and generates a sync coincidence signal when two syncs occur 1488 +/- EFT+ clocks apart. The main counter partitions the EFM+ signal into 16-bit words and resets after the generation of a sync coincidence and after find-

ing a sync within +/-10 EFM+ clocks of the expected sync position.

As a whole, the demodulator decodes the 16-bit EFM+ data and subcode words into 8-bit symbols. The DVD header processor accumulates a selection of bytes from the beginning of the DVD sector. In

addition, the DVD header processor defines two header modes for reading the normal sector headers and for filtering the disc physical format information from the control data block in the lead-in area.

### Error Correction

Once the decoding has occurred, the signal progresses through error correction for the restoration of any lost bits of data. The double-pass C1-C2 error correction corrects as many as 5 C1 frame errors and 16 C2 frame errors. At the first stage, a Cross Interleave Reed-Solomon error correction decoder uses four of the error correction bytes to check for correctable errors that could occur during the encoding/decoding process. With interleaving, the 24 data bytes and remaining error correction bytes pass through a set of delay circuits before going through another Reed-Solomon decoder. Each delay circuit causes the interleaving of the data so that long error bursts spread through multiple passes of the second decoder.

The second decoder relies on the

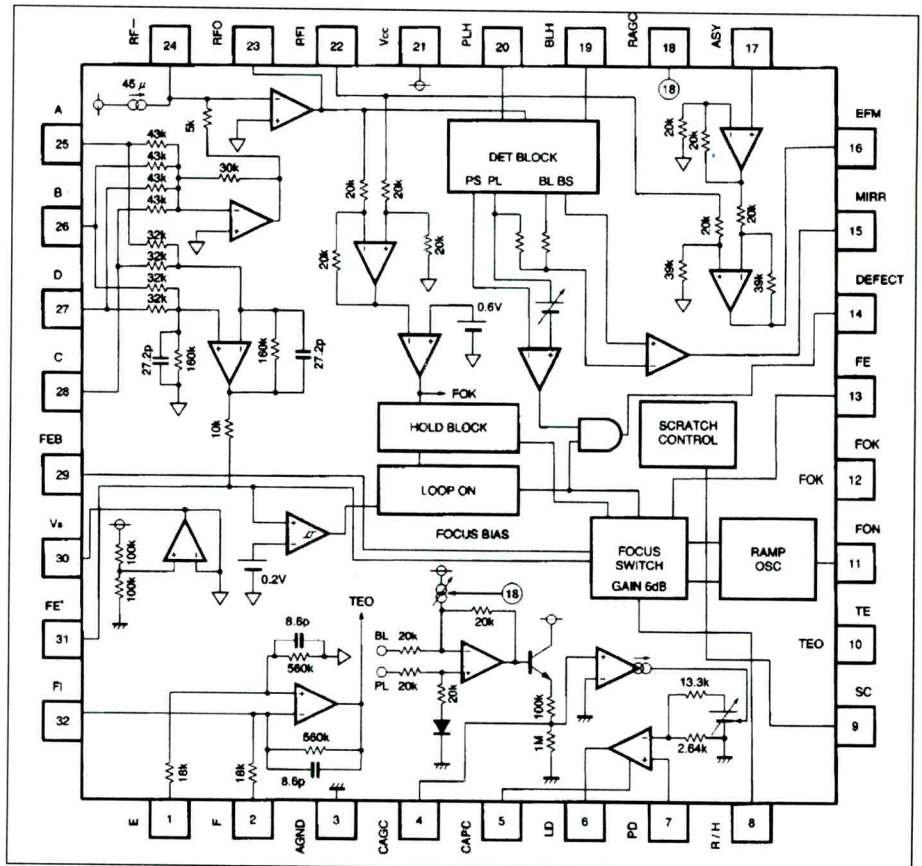

Figure 4. Schematic diagram of the RF signal processor.

remaining error correction bytes to correct any other errors that may occur in the data bytes. Within the second decoder, interpolation reconstructs bad data that is surrounded by good data. If large amounts of data test as bad, the second decoder signals the microcontroller and the audio mutes for a fraction of a second. After the data bytes exit from the second error correction stage, de-interleaving restores the data bytes to the correct order.

Full depth PI and PO error correction allows 5 corrections per PI row and full depth  $(2t + e)$  lesser than or equal to the 16 corrections performed per PO column. The error corrector also contains a flag controller and assigns flags to symbols when the error corrector cannot determine the validity of the symbols. C1 generates output flags that C2 reads after de-interleaving for the purpose of generating C2 output flags. An interpolator uses the output

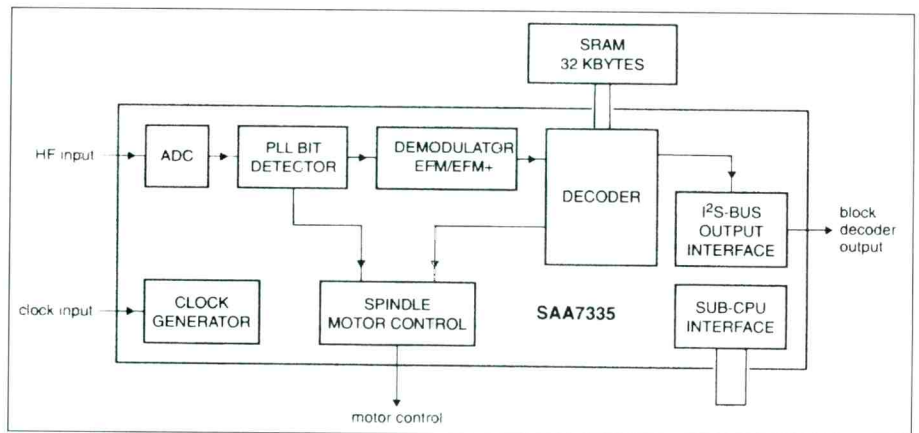

Figure 5. Schematic diagram of the DVD DSP.

flags to conceal non-correctable errors.

The DVD header processor accumulates a selection of bytes from the beginning of the DVD sector. From there, the processor defines two header modes. One header mode allows the reading of the normal sector headers while

the other enables the filtering of the disk physical format information obtained from the control data block in the lead-in area.

controls and the remote control circuits. As the microcontroller accepts user commands through the interface IC, it sends clock and data signals along the main bus to the servo control and signal processing circuits found within the DVD DSP. In addition, the microcontroller also sends clock, data, and reset signals to the ZiVA-3 MPEG Decoder. Flash ROM, EEPROM, and DRAM store static and dynamic commands for the microcontroller.

The SH6417034 microcontroller utilizes a RISC-type instruction set and integrates the functions required for system configuration onto a single integrated circuit. During operation, the microcontroller executes most instructions in one system clock cycle and features a 32-bit internal architecture for enhanced data-processing capabilities.

With the device controlling all system configuration functions, it also includes peripheral functions such as large-capacity read-only and random-access memories, a direct memory access controller, timers, a serial communication interface, an analog-to-digital converter, an interrupt controller, and input/output ports. External memory access support functions allow direct connection to SRAM and DRAM devices. In addition, the microcontroller accepts data from EEPROM devices programmed by users.

The SH6417034 includes a built-in clock pulse generator that supplies the microcontroller and any connected external devices with clock pulses. As the schematic shows, the clock pulse generator consists of an oscillator and a duty cycle correction circuit.

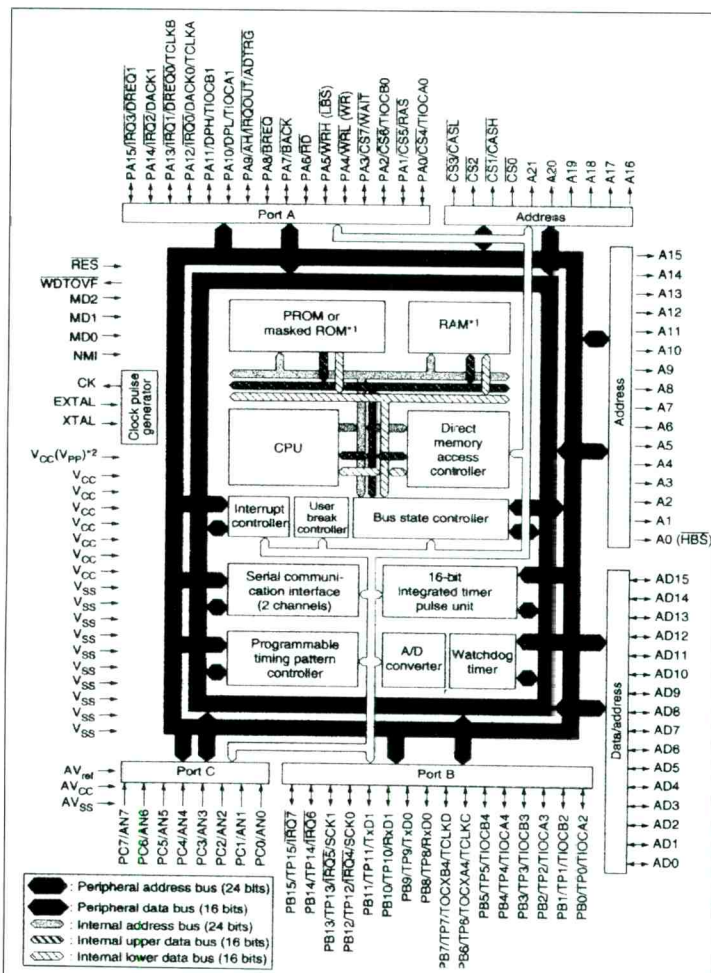

Figure 6. Block diagram of operation of a Hitachi SH6417034 Super H RISC-based microcontroller.

## Control Circuits

The block diagram shown in Figure 6 depicts the operation of a Hitachi SH6417034 Super H RISC-based microcontroller that provides all control functions for the player. Working from left to right, the microcontroller accepts input signals from IC506, an interface IC connected to the front panel

Through the use of the oscillator, the microcontroller synchronizes to the oscillation frequency of the crystal resonator.

An integrated bus state controller, or BSC, divides address space and provides control signals for memory and peripheral circuits. The functions found within the bus state controller allow the connection of the microcontroller directly to DRAM, SRAM, ROM, or peripheral devices that require address or data multiplexing. The elimination of external interface circuits through the use of the BSC decreases the operating cost of the microcontroller and facilitates high-speed data transfers.

Given the bus arbitration characteristics of the microcontroller, the device can release the bus to external devices as requested. The SH6417034 utilizes two internal bus masters with priority given to the bus master residing within the main processor. A second bus master resides within the direct memory access controller. An external device has priority when generating a BREQ bus request.

The four-channel direct memory access controller operates in place of the processor and performs high-speed burst transfers between external devices. The devices must utilize a DACK transfer request acknowledge signal and have access to external memory, include on-chip memory, and utilize on-chip supporting modules. Using the DMAC reduces the burden on the CPU and increases overall operating efficiency.

In addition to communicating through the main bus, the microcontroller also relies on a serial communication interface, or SCI. Given two independent but identical channels, the serial communication interface supports asynchronous and synchronous serial communication. Moreover, the SCI has a multiprocessor communication function that establishes serial communication between the microcontroller and the DVD DSP.

An analog-to-digital converter module located within the SH6417034 accepts analog signals over a maximum of eight channels. Operating by successive approximation with a 10-bit resolution, the A/D converter has a single mode and a scan mode. In the single mode, the module performs analog-to-digital conversion

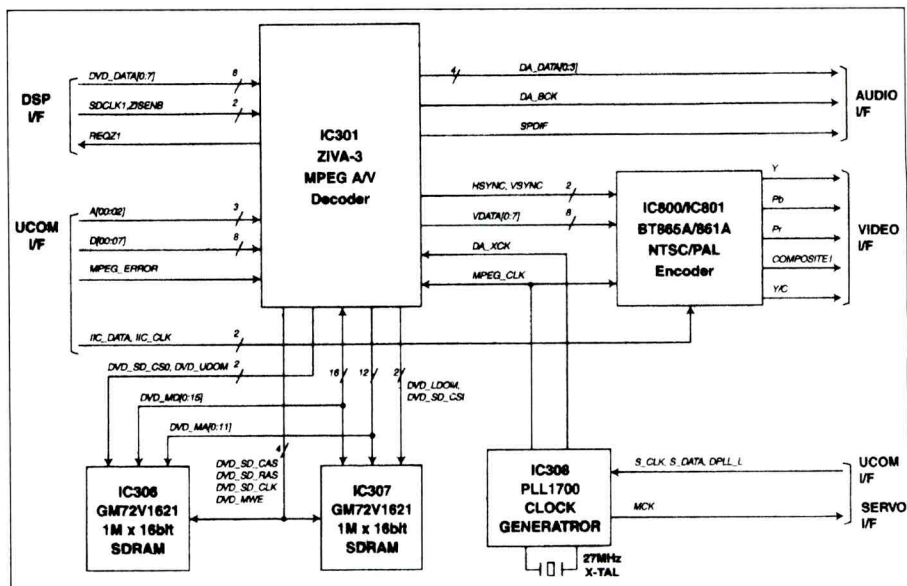

Figure 7. Block diagram of the video encoding and decoding portion of the player.

on a single channel. In the scan mode, the module monitors analog inputs on one or more channels. Analog-to-digital conversion begins with the first channel in the group and, once the first channel conversion has completed, continues cyclically with the next selected channels.

### DVD-Video, NTSC, and PAL

DVD technologies rely on MPEG-2 encoding and decoding to ensure the high quality reproduction of movies and other video programming. Each disc contains one track of MPEG-2 compressed digital video either in the constant bit rate or variable bit rate format. Because the encoding process relies on a 24 frame per second progressive source from the original film, the MPEG-2 encoder embeds flags into the video stream to ensure compatibility with either 60Hz or 50Hz video standards.

A DVD manufacturer has the capability to include additional video and audio so that the disc will play in either a NTSC or PAL standard player. However, including additional video or audio information decreases the amount of available space for the playback of the desired programming. In almost all cases, the MPEG-2 video will be stored in either the NTSC or PAL format.

Players using the PAL/SECAM standard can play NTSC formatted as well as PAL formatted discs. To accomplish this, the player partially converts the NTSC signal to a 60 Hz PAL signal. The play-

er uses the PAL 4.43 color encoding format at a 60 Hz scanning rate with 525 lines. Modern PAL standard televisions can reproduce a picture given through this type of signal. With all this, an NTSC formatted disc will play in a PAL standard player while a PAL formatted disc will not play in an NTSC standard player.

### Encoding and Decoding

The video encoding and decoding portion of the player consists of the ZiVA-3 MPEG A/V Decoder IC, the Philips SAA7126 NTSC/PAL Encoder, two Rohm BA7660FS 6dB Amplifier ICs, a Clock Generator, and two sets of SDRAM (Figure 7). Data travels to the circuits from the Hitachi RISC microcontroller. Outputs for the circuits include the Audio I/F signals, the Audio/Video I/F connectors, and the Servo I/F signals.

The audio decoding portion of the player includes the Burr-Brown PCM1716 and PCM1600 audio digital-to-analog converters and four operational amplifiers (Figure 8). Input signals travel from the system microcontroller and the MPEG A/V decoder. Dolby Digital AC-3, Linear PCM, or MPEG-2 audio output signals travel to the audio/video connectors and support the attachment of home theater systems.

### MPEG Audio/Video Decoding

The ZiVA-3 decoder, manufactured by C-Cube (Figure 9), implements 3D audio,

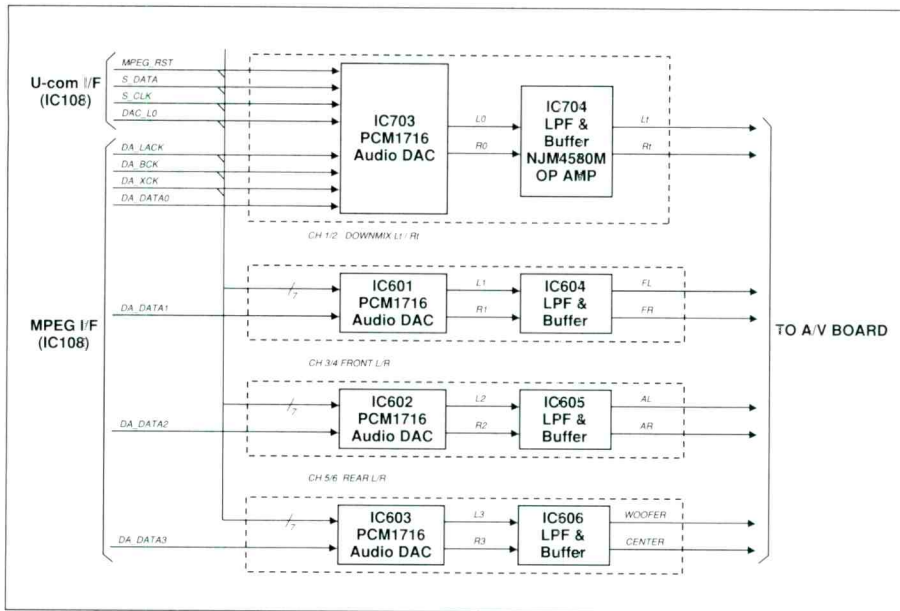

Figure 8. Block diagram of the audio decoding portion of the player.

karaoke functions, and DVD-Audio in the player (Table 1). In addition, the ZiVA-3 decoder provides full NTSC and PAL decoding in a 16-Mbit SDRAM environment. The ZiVA-3 decoder supports full disc playback compatibility with DVD, VCD, and CD-DA formats.

At the input, the ZiVa-3 Decoder accepts 8-bit compressed data with the data transfer rates varying according to the interface. While a DVD interface has a compressed data rate of 16 megabits per second, an 8-bit host interface with burst

TABLE ONE — ZiVa-3 DECODER FEATURES	
• Karaoke functions including vocal harmony, chorus, scoring, flange, reverb, and simulated stereo	
• Home theater effects including concert hall, dynamic range compression, and graphic equalizer	
• Dedicated Dolby Digital 5.1-channel decoder	
• Digital Theater Sound output	
• 2/4/8-bits per pixel On-screen Display	
• Zoom and fade-in/fade-out functions for still and motion pictures	
• MPEG-2, DVD-Audio, and CD-DA Output Channels — Dolby Digital or MPEG-2 2-channel — 6 channel Linear PCM	
• Sample Rates 44.1, 48, 88.2, 96, 176.4, 192 kHz	

data achieves a data transfer rate of 80 megabits per second. Burst data at the DVD interface increases the data rate to over 100 megabits per second.

### NTSC/PAL Video Encoding

Figure 10 shows a schematic diagram of the Philips SAA7126 NTSC/PAL digital

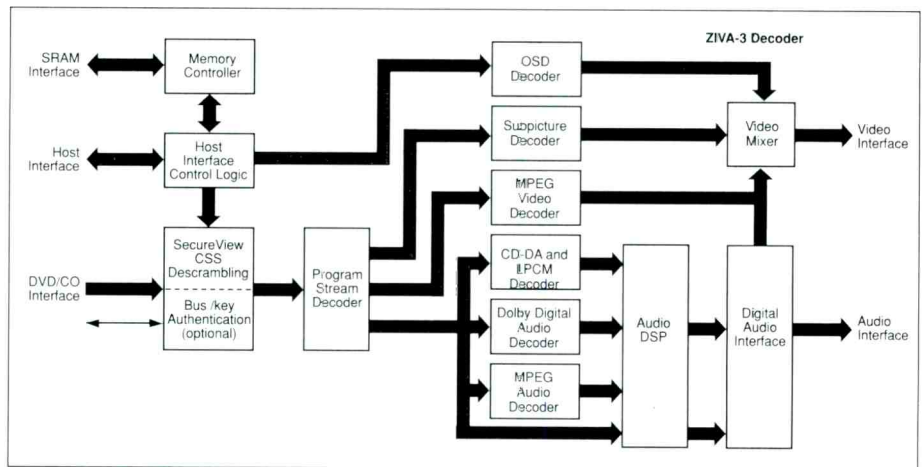

Figure 9. Functional block diagram of the ZiVA-3 decoder.

video encoder used within the DVD player. Basic encoding functions involve subcarrier generation, color modulation, and the insertion of synchronization signals. The SAA7126 encodes digital luminance and color difference signals into analog CVBS, S-video and simultaneous RGB or Cr-Y-Cb signals while supporting NTSC

and PAL standards. As a result, the Encoder also supports interlaced and non-interlaced scanning formats.

### Input Signals

The video decoder expects digital Y, Cb, Cr data with digital codes that meet the CCIR 601 standard. Signals travel to and from the Encoder through the I<sup>2</sup>C-bus interface. Operating as a standard slave transceiver, the bus supports 7-bit slave addresses and a guaranteed 400 kilobit per second transfer rate. The bus relies on 8-bit subaddressing and includes with write and readable registers.

For the chrominance and Composite Video Baseband Signal, or CVBS, outputs, deviating amplitudes of the color difference signals can be compensated by independent gain control setting, while gain for luminance is set to predefined values. The respectively Cr-Y-Cb path features a gain setting individually for luminance and color difference signals.

### Encoder Video Path

The SAA7126 Encoder uses the Y, U and V baseband signals to generate luminance and color subcarrier output signals

suitable for use as CVBS or separate luminance and chrominance signals. Utilizing gain levels achieved through the programmable setting of different black signal levels, the encoder modifies the luminance signal. After inserting a fixed synchronization pulse tip level, the circuit sets the

blanking level. To enable easy analog post filtering, the encoder interpolates the luminance signal from a 13.5 MHz data rate to a 27 MHz data rate and provides a 10-bit resolution luminance output signal.

Circuitry within the encoder again uses different gain levels to modify the chrominance signal. To accomplish this, the Encoder inserts a standard dependent burst signal before the interpolation of baseband color signals occurs. Given programmable amplitude for the purpose of providing either standard signals or special effects, the baseband color signals interpolate from a 6.75 MHz data rate to a 27 MHz data rate. Bypassing one of the interpolation stages makes a higher color bandwidth available for the luminance/chrominance output.

### RGB Processing

The RGB processing block dematrixes the digital red and blue color difference signals and the luminance signal to produce red, green and blue signals. Before the dematrix operation occurs, the circuit applies individual gain adjustments for the signals along. In addition, the block provides two times oversampling for the luminance signal and four times oversampling for the color difference signals.

At the output of the processing block, software controls or minimum output voltages control the output signal given by digital-to-analog converters. Along with converting the encoded luminance and chrominance signals from the digital format to an analog form with 10-bit resolu-

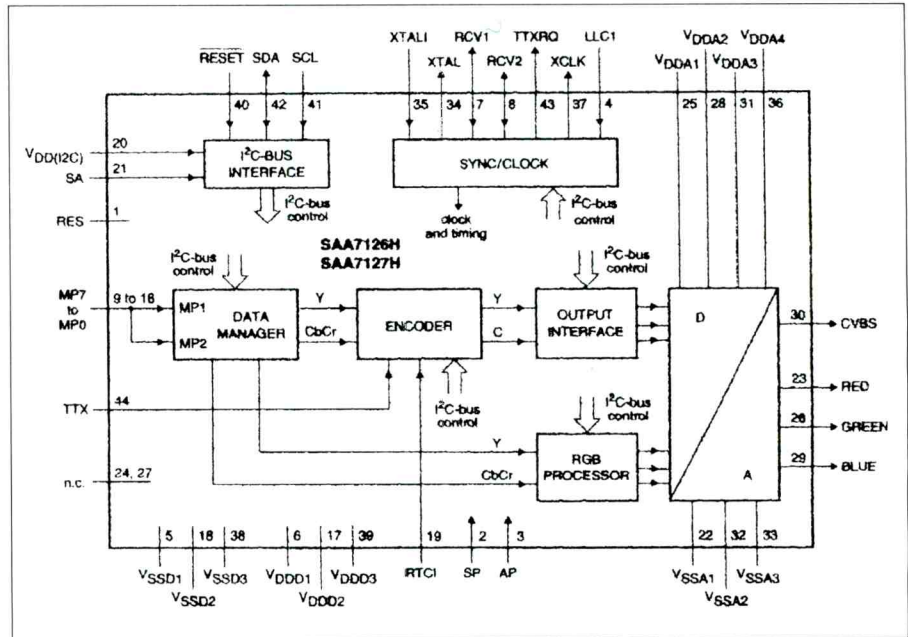

Figure 10. Schematic diagram of the Philips SAA7126 NTSC/PAL digital video encoder.

tion, the converters also convert the red, green and blue signals from digital-to-analog at a 9-bit resolution. The processor combines the luminance and chrominance signals to produce a 10-bit CVBS signal.

### Synchronization

The synchronization circuit operates in either slave mode or master mode. When operating in the master mode, the circuit generates all necessary timing signals. As a result, the video signal can provide timing signals at the RCV1 and RCV2 ports. In slave mode, the circuit accepts timing information either from the RCV pins or from the embedded timing data found

within the video data stream. The slave mode operation also allows the interface circuit to set a vertical sync, odd/even, or field sequence signal at the RCV1 pin.

### Filtering The Luminance and Chrominance Signals

At input port LLC1, the encoder accepts signals either from the PLL clock generator through the MPEG decoder or from the buffered on-chip clock designated as XCLK. As the encoder processes two independent data streams, the rising edge of LLC1 latches one data stream and the falling edge of LLC1 latches the other. As a result, the encoder can forward one of the data streams containing both video and on-screen display (OSD) information to the RGB outputs.

### Audio Decoding

The Burr-Brown PCM1716 stereo audio digital-to-analog converter (Figure 11) includes a phase-locked loop circuit that derives the system clock from an external 27MHz reference frequency. The converter works well for applications that combine compressed audio and video data such as DVD, DVD-ROM, set-top boxes and MPEG sound cards. In brief, the PCM1716 contains a third-order Delta-Sigma modulator, a digital interpolation filter, and an analog output amplifier.

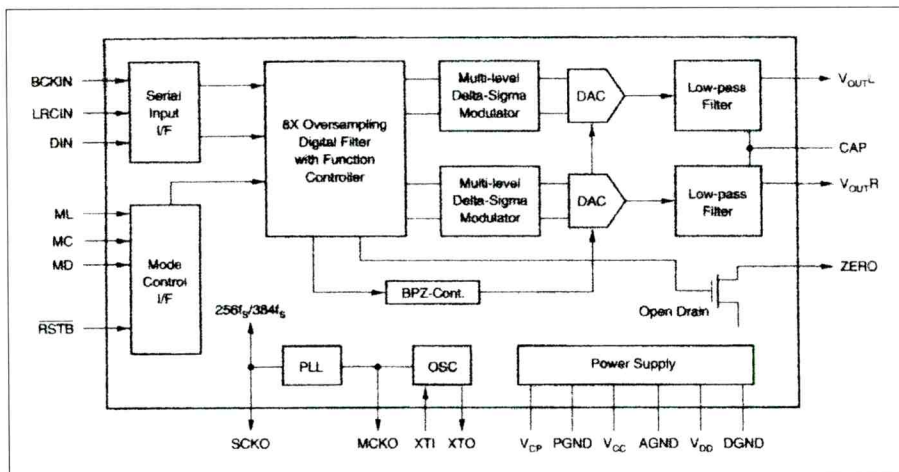

Figure 11. Burr-Brown PCM1716 stereo audio digital-to-analog converter.

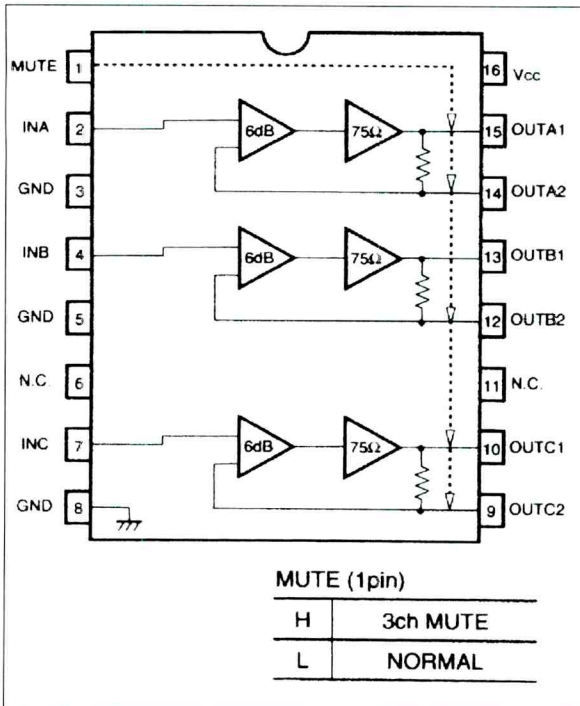

Figure 12. Rohm BA7660FS amplifier.

While the modulator can accept 16-, 20-, or 24-bit input data, the digital filter performs

an 8X interpolation function and includes selectable features such as soft mute, digital attenuation and digital de-emphasis. The PLL accepts programming for sampling at standard digital audio frequencies as well as one-half and double sampling frequencies.

### Amplifying the Video Signal

The Rohm BA7660FS amplifier (Figure 12) operates as a 75 ohm driver that includes a 6dB amplifier and three internal circuits. The circuit drives the composite luminance and chrominance signals, as well as RGB signals. Each load can drive two circuits while using a sag correction function to reduce the capacitance of the output coupling capacitor.

Because the amplifier operates from an input voltage ranging from 0Vdc to

1.5Vdc, it can connect directly to the output of a digital-to-analog converter. An internal power-saving circuit provides simultaneous muting on all three channels, and output pin shorting protection. In addition, the circuit features an internal output protection circuit.

### Conclusion

As the article shows, DVD video players and recording systems employ complex circuitry because of the need to process the combination of optical, mechanical, video, and audio signals found within the DVD structure. Although DVD players have consistently dropped in price, DVD recording systems continue to range from the approximate \$200 range for PC drives to more than \$5,000 for stand-alone DVD recording systems. Given the relative infancy of the DVD system market, service opportunities may exist. The combination of your experience and an understanding of the processes operating within the DVD system will ease the transition into this service arena. ■

### ADVERTISEMENT

## The Standard for checking Capacitors in-circuit



Good enough to be the choice of Panasonic, Pioneer, NBC, ABC, Ford, JVC, NASA and thousands of independent service technicians.

Inexpensive enough to pay for itself in just one day's repairs. At \$179, it's affordable.

And with a 60 day trial period, satisfaction guaranteed or money-back policy, the only thing you can lose is all the time you're currently spending on trying to repair all those dogs you've given up on.

### CapAnalyzer 88A

Available at your distributor, or call 561-487-6103

Electronic Design Specialists

## Locate shorted or leaky components or conditions to the exact spot in-circuit

Still cutting up the pcb, and unsoldering every part trying to guess at where the short is?

\$179



Your DVM shows the same shorted reading all along the pcb trace. LeakSeeker 82B has the resolution to find the defective component. Touch pads along the trace, and LeakSeeker beeps highest in pitch at the defect's pad. Now you can locate a shorted part only a quarter of an inch away from a good part. Short can be from 0 to 150 ohms

### LeakSeeker 82B

[www.eds-inc.com](http://www.eds-inc.com)

Circle (9) on Reply Card

# Closed-Circuit TV

by the ES&T Staff

## CCTV Systems Represent a Business Opportunity for Consumer Electronics Service Centers

It's interesting to watch the news on TV when there's a report of a robbery at one of the local 24-hour a day convenience stores. As often as not, you watch the perpetrator walk into the store and do his thing, then the commentator says something like "If anyone has information about this individual, please call the TIPS hotline at 555-5555." But there's no way anyone could recognize the culprit. Not even his mother. Not from the poor quality images on that videotape. Kinda makes you wonder why that surveillance system is there in the first place.

It doesn't have to be that way, of course. Surveillance cameras are capable of producing a good, useful, image. And the VCRs used to tape the output from the camera are capable of reproducing a good image. The problem is that many of these systems just aren't maintained the way they need to be. Those VCRs operate continuously, sometimes 24 hours a day. They need to be cleaned, lubed, adjusted periodically, but sometimes they're neglected.

CCTV systems represent a business opportunity for consumer electronics service centers. The following provides some ideas on the subject.

### Keeping an Eye on Things

In this complex, crazy, go-go world of today, it's sometimes hard to watch all the things we need to watch. If you're in your home office, and your sick child is asleep in the nursery, how do you keep an eye on him. If you have a nanny and you suspect her of being abusive to your child, or pilfering your things, how do you find out for sure. If your parents are elderly and frail and you want to make sure they're okay, but you have to work, or attend to your own home, how do you monitor them.

The answer to all of those things is: a closed circuit TV system. A closed circuit TV system provides people with a way to have eyes in more than one place at one

time. Here's another example of a CCTV system: the various "cams" that the local TV stations have to show traffic, or weather. They can be mounted high on buildings, on the station's broadcast tower, and

pany install a camera, adequately cooled, in the oven to monitor the oven. The next time the pileup occurred, the camera recorded the cause. The belt had sprocket holes at each edge. Sprockets fed the

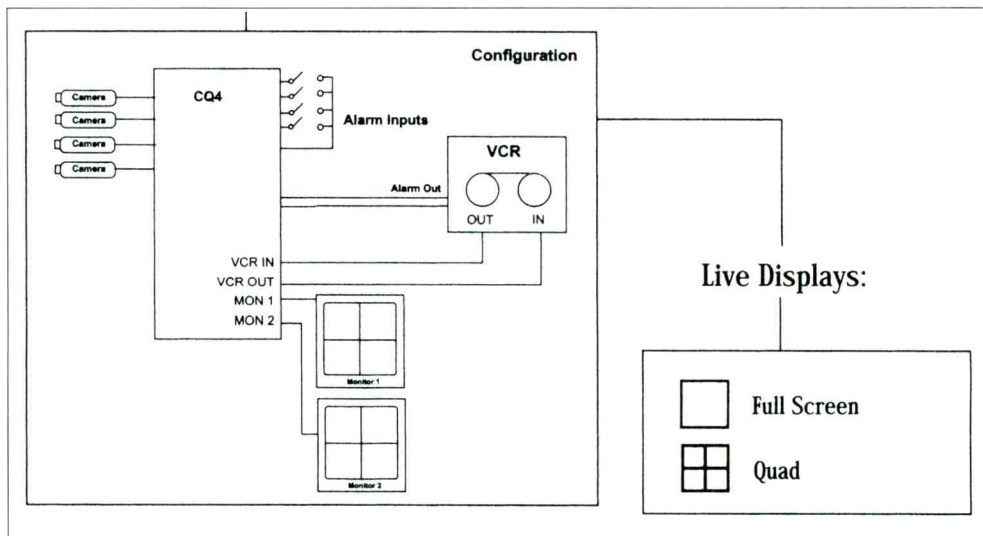

**Figure 1.** A "quad" can accept input from up to four video cameras. The output, which includes a matrix of all four images, can be sent to a monitor, and recorded on a single video tape.

are frequently used to show time-lapse sequences of how storm clouds developed and then dissipated, or even how snow accumulates then melts on a given day.

Here in the city of Overland Park, KS, there's a move afoot to link the TV cameras that are used to monitor traffic at major intersections to the internet so that citizens can look at the traffic patterns before they venture out, and adjust their routes accordingly.

And, of course, there are lots of other places that could use video surveillance: the front door of the home, the pool area. The website [www.cctv-information.co.uk](http://www.cctv-information.co.uk), mentioned below mentions an innovative use of a CCTV system. A bakery was having a problem with a continuous, unattended, oven. Every once in a while, there would be a pileup of product, and that product, and everything else being fed in on the conveyor belt was ruined. A loss of a lot of product.

The bakery couldn't figure out what the problem was. So they had a CCTV com-

belt through the oven. At the time the pile-up occurred, one sprocket hole that was defective lined up with one sprocket finger that was defective and the belt malfunctioned. The oven could go for long periods of time without malfunction because the alignment of the two defects occurred only rarely. Replacement of the defective parts eliminated the problem.

The applications of CCTV systems are limited only by the imagination of people working with the systems.

### A Simple System

A CCTV system can be very simple, or it can be quite complex. And they can be diabolically clever. One website we visited ([www.cctvwholsalers.com](http://www.cctvwholsalers.com)) offers a system, so simple that just about anyone could install it. The system consists of a clandestine camera, and a radio-frequency transmitter, built into a clock radio, and a receiver that can pick up the signal up to several hundred feet away. The receiver has a connector that lets it be connected to a VCR.



If your customer suspects that the nanny is pilfering the good silver, or inflicting corporal punishment on the precious little one, you can install a system such as this with no fuss or muss, and let them catch her in the act.

### A Complex System

CCTV systems can easily become quite complex. If a large installation; factory, hotel, hospital, airport, wishes to keep track of activity at a number of points within the facility, designing a system that can monitor all of them has to be complex. In this case, the output of two or more cameras can be routed to a multiplexer, and from there to the receiver, and thence to the videotape machine.

In CCTV parlance, a multiplexer that can accept input from two cameras is called a "duplexer." A multiplexer that can accept input from four cameras is called a "quad." Figure 1 is a block diagram of a quad. The output of, say, a quad, is such that the images from all four cameras can be recorded in multiplexed fashion on the videotape. Moreover, the signal that is fed to the monitor will show all four images on a single monitor screen.

### Maintenance of CCTV Systems

Even if a consumer electronics company didn't want to get into installation of these systems, it might be possible to add to the company's bottom line by providing time-ly maintenance on them. A couple of ways to look into this would be to:

- 1) talk to several companies in the area that install CCTV systems, or
- 2) approach companies that use CCTV systems, to see if there is any opportunity in maintenance of the systems.

Here are a few thoughts on maintenance of CCTV systems that we adapted from the Advanced Technology Video, Inc. website.

- CCTV systems are built to be used for long periods of continuous use, often in adverse conditions.
- Use high grade (professional grade) tapes.
- Make sure tapes are rotated. They suggest that in an installation recording at a speed that gives 24 hours of

recording on a tape, that the facility have 31 tapes, one for each day of the month, and use a new tape every day. That keeps tapes from being used continuously, and gives the user one month's worth of tape record.

- The VCR should be cleaned regularly. The best policy here is to follow the manufacturer's recommendations. Unlike a home VCR that runs for a few hours or less at a time, a CCTV VCR in a security system runs continuously, every day. The heads get dirty, and the mechanical parts all suffer wear. Frequent maintenance can keep the unit from failing, or from needing more expensive repairs caused by neglect. And the likelihood that the tape will be able to provide a useful image in case a security event needs to be resolved, will be much greater.
- As the system ages, performance of the system may suffer. Cable connectors may deteriorate. The performance of the system may suffer in wet weather because of ground loops. The system can't be installed and forgotten. Its performance must be evaluated regularly.

### CCTV Via Telephone and theNet

It was intimated above that individuals can monitor children, elderly parents, or just the security of their home from a remote location. Advances in technology have made this a reality. CCTV companies are able to provide equipment that makes it possible to connect from a distant location to a CCTV camera via either a standard dial-up telephone line or via the internet. With such equipment, an individual who has, say, an elderly parent who needs to be monitored in their home in case of falls or other accidents, but who can't take time off from work, can connect from work to cameras in the parent's home from time to time to observe how things are going.

### For Further Information

There is a lot of good information on CCTV on the internet, and some of these companies are hungry to find outlets for their products. So much so that they offer

extensive training. One of the companies named here, Pelco, offers a "CCTV Institute," at no cost to the attendee.

Here's what their website says:

"In 1996, Pelco opened its doors to yet another CCTV industry first. The Pelco Institute of CCTV has proven to be a valuable experience. And now, to meet customer needs, the Institute offers seven courses at two locations: Clovis, California and Orangeburg, NY.

"This is your chance to gain incredible insights into establishing and operating a thriving CCTV business - for free. Your enrollment at the Pelco Institute includes up-close instruction and a dialog with CCTV industry leaders, a tour of the largest CCTV manufacturing facility in the world, hotel accommodations, meals and a Certificate of Completion. You pay for your transportation, Pelco takes care of everything else."

Of course, this is not an altruistic thing, as the more people there are in the world trained, by Pelco, the more Pelco products get sold.

One suspects that other similar companies offer similar deals.

Here are addresses and/or website information for a few CCTV manufacturers and dealers.

Advanced Technology Video, Inc.  
15110 NE 95th Street  
Redmond, WA 98052  
425-885-7000  
888-288-7644  
Fax: 425-881-7014  
e-mail: sales@atvideo.com  
Website: www.atvideo.com

Pelco - California  
Worldwide Headquarters  
3500 Pelco Way  
Clovis, CA 93612-5699  
800-289-9100  
www.pelco.com

Pelco - New York  
10 Corporate Drive  
Orangeburg, NY 10962  
845-398-8700

CCTV Wholesalers  
www.cctvwholesalers.com

The information below is for a company in the UK that has a highly informative website [www.cctv-information.co.uk](http://www.cctv-information.co.uk) ■

# Set Top Boxes for HDTV

by the ES&T Staff

As regards high-definition television, the United States is in a period of transition. Most terrestrial broadcast TV is still broadcast in the NTSC (National Television System Committee) format. A number of stations in major markets are now broadcasting high-definition (HDTV) programs at least part of the time. Broadcast stations have received the mandate that they must be broadcasting HDTV by the year 2006, but that's still a little ways off.

Manufacturers are manufacturing digital television (DTV) sets that are capable of displaying HDTV. Some sets, marketed as HDTV sets come equipped with both NTSC and HDTV tuners. Because of this transition period, however, many DTV sets are marketed as "HDTV ready." These sets have an NTSC tuner (or in the case of a set that has picture-in-picture capability, two NTSC tuners), but

signals that aren't available?

When the time comes that broadcasters cease broadcasting NTSC altogether, and viewers who chose not to buy DTV sets, manufacturers will offer to the market inexpensive set top boxes that do nothing but convert the ATSC (Advanced Television System Committee) to NTSC so the viewer can watch the ATSC broadcast in standard definition (SD). For the time being, however, set top boxes are primarily designed to receive a number of signal formats and output audio and video in a number of formats.

## Components for the Set Top Boxes

For those of you who remember Jimmy Durante, you may remember one of his tag lines "Everybody wants ta get into de act," delivered while he turned his head toward the heavens and shook his head. It seems to be

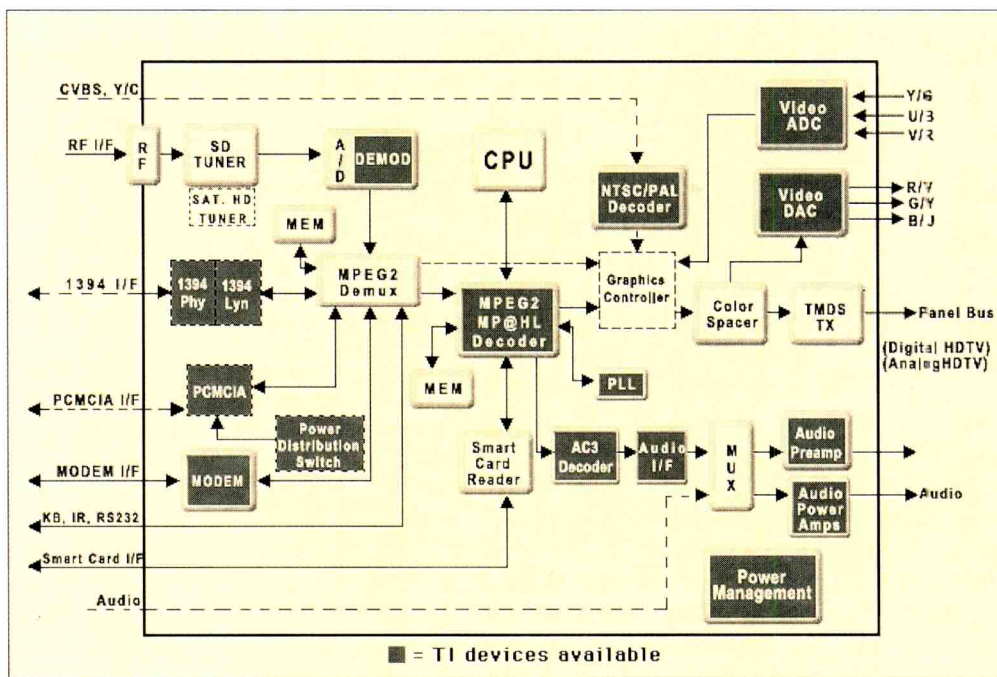

Figure 1. Block diagram of conception of a set top box using chips from Texas Instruments.

are not equipped with HDTV tuners. This approach makes a great deal of sense, considering the fact that the HDTV tuner will add hundreds of dollars to the price of the HDTV set, and many smaller markets will not have any kind of HDTV broadcast signals available for several years. Why pay to be able to receive

that way with HDTV and set top boxes. A number of semiconductor manufacturers have announced that they have developed integrated circuits that, taken together, provide the functions of a set top box, in their parlance, HDTV chipset solutions.

One of these manufacturers, Philips

## Features of a Set Top Box

Here's a description of a set top box offered by Panasonic, the TU-HDS20. When I saw this product on the internet, the manufacturer's suggested retail price was \$1099.95. Following are the features claimed for this unit:

- Receives and decodes all ATSC formats
- Designed to enable viewing of digital programming on analog and digital-compatible televisions.
- Built in DirecTV satellite tuner.
- Built in ATSC/NTSC tuner.
- Advanced program guide allows seamless navigation of NTSC, ATSC and Satellite channels.
- Can convert all ATSC input signal formats to any ATSC output format.
- Can down-convert HD to SD or NTSC formats.
- Built in modem and smart card.
- DTV component A/V outputs (Y, PB, PR).
- 5.1 channel digital audio output (optical).
- RGB output jacks (with H & V sync).
- S-video output jack.
- Variable audio output jacks.
- A/V output jacks (composite video)
- 2 rf antenna inputs (ATSC/NTSC and satellite)
- Roller Guide menu system.

Semiconductors, in April of 1999 announced "...the industry's first two-chip hybrid analog and digital TV front end solution; the TDA8980 input processor and TDA8961 DTV demodulator/decoder, that supports both ATSC vestigial sideband (VSB) and NTSC channel decoding."

Designed for use in HDTV set to box (STB) and multimedia PC applications, the chipset offers designers of DTV and receiver modules a complete front end receiver solution for a range of broadcast signals for North American and other ATSC-based markets.

Other manufacturers of chipsets for use with set top boxes are Texas Instruments, Mitsubishi and Broadcom.

Figure 1 is a block diagram of an HDTV set top box using Texas Instruments semi-conductors. Figure 2 is a block diagram of a set top box using Mitsubishi semi-conductors. ■

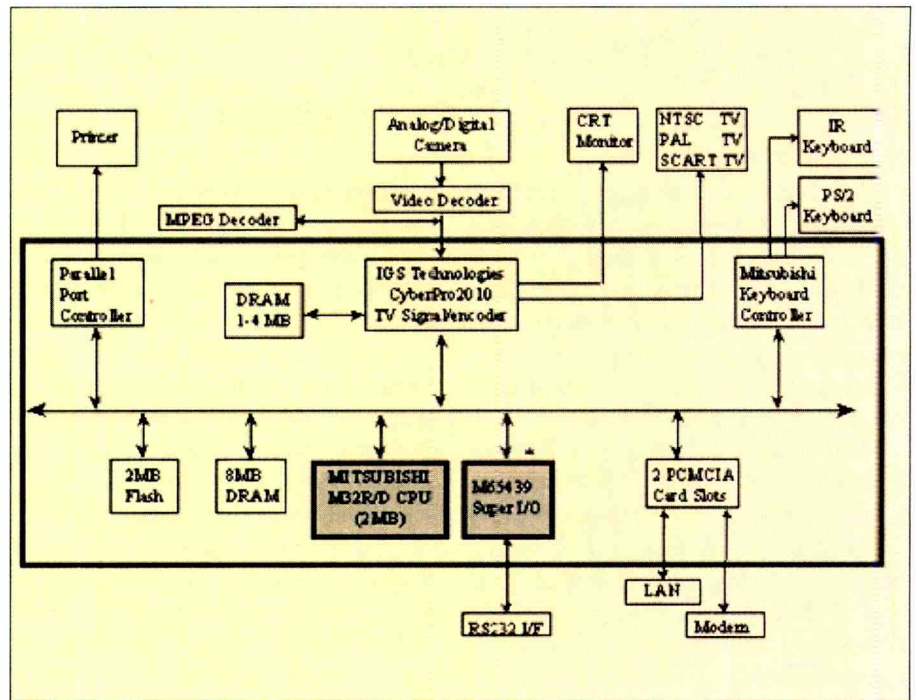
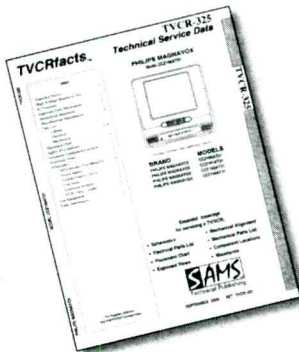

Figure 2. Block diagram of what a set top box might look like using the Mitsubishi chipset.

# **YOU** asked for it!



TVCRfacts™ addresses the need for service literature for the growing number of TV/VCR combination units being sold in today's marketplace. As the affordability of this versatile product has grown and its applications have become more widespread, the need for repair literature has also grown.

TVCRfacts™ is included in PHOTOFAC™ of the Month and can be ordered separately from your local participating electronics parts distributor, or directly from SAMS Technical Publishing.

Please contact your local distributor or Sams Customer Care Center for availability and models covered.

Call us at 800.428.SAMS and visit us online at [www.samswebsite.com](http://www.samswebsite.com)



# Distributors — The Servicers Primary Source

**A**s technology advances, everything about a class of product tends to change: the way it's engineered, the way it's manufactured, the components used in the product, the knowledge, test equipment and tools required to service it. This is certainly true in the case of consumer electronics products.

There was a time, when circuits were hand wired and vacuum tubes constituted the only active devices in the product, that technicians always performed troubleshooting to the component level. There was no choice. Those old sets were built on a metal chassis with everything interconnected by wires. There were no modules, no subcircuits. It was all a single unit.

Of course, those products were relatively simple, and straightforward. If a set failed it wasn't because the start-up circuit didn't work. There was no start-up circuit. And it didn't fail because the shut-down circuit operated to shut the set down. There was no shut-down circuit. And you didn't have to worry about hot chassis. The rectifier circuit consisted of a single rectifier element and its associated resistors and capacitors, so there was no requirement for an isolation transformer to isolate the test equipment ground from the chassis ground.

Another factor that made these sets relatively easy to work on was the fact that they were based on a handful of vacuum tubes. Because vacuum tubes were inherently unreliable, most fixes consisted of pulling the suspected tube and testing it in the tube tester. If it didn't meet the specs, it was replaced. Sometime is made sense to test all the tubes. If one was questionable, it might make sense to replace it, rather than wait until it failed and have to come back to replace it. Preventive actions frequently saved the customer money.

## Finding Replacement Parts

In those halcyon days, finding replacement parts was also relatively simple. All manufacturers used the same vacuum

tubes, resistors, capacitors and other components to build their sets. There were few, if any, proprietary components, so you could go to pretty much any distributor and get everything you needed.

Of course, we all know that things have changed dramatically over the years. TV sets, and other consumer electronics products of today, contain large numbers of proprietary components. These have to be ordered from a distributor who carries that particular manufacturer's line of components. Even more recently, in many cases, such as is true with EEPROMS and EAROMS, once you've obtained the correct component, you're still not finished. You may have to program it so that the set works properly.

Because of the way things have evolved, a service center can spend an inordinate amount of time finding a replacement for a failed part. If the service center doesn't have the appropriate service literature, it may not even be possible to identify the part that has failed so that it may be ordered. If the part can't be identified and ordered, all of the preliminary work that the technician has performed to ascertain the cause of the problem is wasted, because the unit can't be fixed.

## The Role of the Distributor

When the set is a less well-known product, and the service literature is not available, and the service procedure has come to a grinding halt, the service center may be able to get help from a distributor. Some distributors offer the service technician a variety of aids in finding the needed replacement. Others are less helpful. It's important that the technician have some way of knowing which is which.

The distributors who have advertised in this special advertising supplement have done so because they would like to tell you more about themselves than they can in an ad. They want service centers to know what kind of facilities they have, what kinds of people work for the com-

pany, the efforts they are making at customer satisfaction, and how to contact them when you need a replacement component.

## Food for Thought

Keep some of these questions in mind when you're looking for a distributor. You want to find someone you can count on for reliability, convenience and service. Merely locating someone who stocks the part isn't the only consideration. For example, if the distributor requires a large minimum order, or if you have to wait weeks for the part to arrive, you'll have that defective product sitting around the service center for a long time without earning you any profit, and the customer will not be pleased with the wait.

Here are some of the questions you should ask distributors:

- How often are they able to fill orders from stock?
- What payment options do they offer: open order account, credit card?
- How soon after receipt of an order to they ship?
- Do they add a shipping surcharge?
- Do they have a toll free number?
- What ordering options do they offer?
- What is their return policy?
- Do they offer a warranty?
- Is there a minimum order amount?
- Do they have a minimum line charge?
- What shipping options do they offer?
- What special services do they offer?
- Do they have a research department to help technicians find a specific part?

If you require "same day" delivery it may be important to know their closest inventory location. For "next day" delivery you should know their base, or minimum rate.

It might be tempting to order from the first distributor that comes to mind, but if you will take the time to ask a few questions it might save time, money and aggravation. The following section will give you a head start in answering some of those questions.

**ae andrews electronics**

25158 Avenue Stanford  
 Santa Clarita, CA 91355  
 Phone: 800-289-0300  
 Fax: 800-289-0301  
 www.andrewselectronics.com

Andrews Electronics is housed in 50,000 square feet of warehousing and office space. Miles of shelving are arranged for immediate identification and easy accessibility for over 250,000 different parts that we carry.

Maintaining an inventory of this size has been the cornerstone of our success as the O.E.M. parts distribution industry leader. It provides us with an average first pass fill rate of above 90% and makes us the largest supplier in America for the manufacturers we represent. Our fill rate is calculated on not only everything that is ordered but also on every call or fax we receive for availability, even if it isn't ordered! Our dealer order desk has 32 available sales representatives to handle all of your ordering needs.

We've built our reputation on a very simple philosophy...service. Not very fancy, but very effective. Our constant growth attests to it. You see, all of our policies that have been developed over the years have been based on that one simple thought: "How may we better serve the industry?" How about:

- 14 major brands to save you time, frustration, and money with "one-stop shopping."
- Orders placed before 2:30 PST are routinely shipped the same day.
- A freight program that offers free and discounted shipping.
- No minimum orders or handling charges.
- Automatic backorder reports with ETA's mailed bi-weekly.
- A fast, highly-efficient research department, second to none.
- A program that converts make/model descriptions to part numbers instantly for the majority of research requests.
- 24-hour toll-free phone and fax order lines.
- Over 100 full-time employees waiting to serve your needs.

Our already outstanding freight program has been drastically improved! The minimum qualifying amount has been cut in half and the 2 day air discount has been almost doubled! With this type of shipping program, we're a lot closer than you might think.

In case you've heard this elsewhere before, now's the time to let us prove it to you. By investing a mere two minutes of your time, you can discover what thousands of others have: that there is a difference. When you place your next order with your local supplier, check the availability of all the items. Then call or fax Andrews and check out our stock levels. We believe you'll be pleasantly surprised! Wouldn't getting those extra units repaired

a week or two sooner be good for reputation? Sure it would! And we can help! After all is said and done, it is performance that counts. We know that your ability to perform your job depends on how well we perform ours. Our regular office hours are from 8:15 to 4:45 PST and we're closed for lunch between 12:00 and 12:30.

**When you think of electronic parts...think of Andrews.**



**ae andrews electronics**

*Stocking the Largest Inventory of O.E.M. Parts, Accessories, and Service Literature in the Country!*

<b>SONY</b>	<b>JVC</b>
<b>TOSHIBA</b>	<b>AIWA</b>
<b>TECHNICS</b>	<b>SHARP</b>
<b>PANASONIC</b>	<b>ZENITH</b>
<b>QUASAR</b>	<b>HITACHI</b>
<b>RCA/GE PROSCAN*</b>	
<i>*Premier Distributor</i>	

- |   |   |
|---|---|
| ➔ <b>Over a 90% Fill Rate</b>               | ➔ <b>No Minimum Orders</b>                            |
| ➔ <b>FREE or Discounted Freight Program</b> | ➔ <b>Backorder Reports with ETA's Mailed Biweekly</b> |
| ➔ <b>Factory Authorized</b>                 | ➔ <b>No Handling Charges</b>                          |
| ➔ <b>Fast, Efficient Research</b>           |   |

**Over 1/4 MILLION Different Parts in Stock**  
*Shipped the Same Day\*!*

*\*We routinely ship over 90% of all orders the same day.*

**Phone (800) 289-0300 Fax (800) 289-0301**  
 25158 Avenue Stanford, Santa Clarita, CA 91355  
**orders@andrewselectronics.com**

Circle (12) on Reply Card

# B & D ENTERPRISES

P.O. Box 460  
Main & Liberty Street  
Russell, PA 16345  
Phone: 800-458-6053  
Fax: 814-757-5400  
E-mail: sales@bdent.com  
Website: www.bdent.com



**B&D Enterprises** is your **Semiconductor** specialist. Filling your semiconductor requirement is our #1 priority. Our objective is to meet the consumer and industrial repair market's demand for a price competitive, well-stocked, highly knowledgeable, factory authorized distributor.

## JAPANESE SEMICONDUCTORS

B&D Enterprises stocks more than 15,000 line items. Specializing in Japanese semiconductors, we can help you solve your component problems.

Since 1976, B&D Enterprises and their parent company have been entrusted by the manufacturers to be the authorized distributor in the United States. Companies such as Sanyo Semiconductors, Sanken Electric, Shindengen America, and NEC Electronics trust us to handle the ever-growing need for a dependable, customer service oriented stocking distributor. At B&D, you'll find 25+ years of accumulated product knowledge and factory direct supported sales.

We also carry an extensive inventory of hard-to-find and discontinued products, as well as many components made by non-Japanese manufacturers.

## PRODUCT KNOWLEDGE

Our sales staff is technically trained. To service the OEM customers, we have to be. We have the largest library of semiconductor

manuals in the market available to support our sales. Hundreds of parts cross references are in our database. We back what we say. When we offer a cross, we know it's right and can send you the specifications to prove it. Feel free to talk to our Engineering/Technical Support office at 814-757-8300.

## PRODUCT RELIABILITY

As a factory authorized distributor, we only sell original quality manufactured parts. NO "rebrands," NO "off-brand" imitation manufacturers, just original components. We feel that our customers deserve a part that works, not one that's close.

## CONVENIENCE

To better serve our customers we offer them the WEBSITE — at [www.bdent.com](http://www.bdent.com) you will find our ENTIRE INVENTORY for you to view, 24 hours a day, 7 days a week, you can check prices, request quotes, and place orders on a secure server.

We update our site DAILY with new parts and prices.

Go factory direct with B&D and get the price you need with the factory authorized service you deserve!

Call today for our FREE 2001 CATALOG and see what a difference we can make! Selling a lot of things doesn't make us better, just diversified. at B&D, we do one thing, and we do it right.



Circle (13) on Reply Card

# SENCORE

3200 Sencore Drive  
 Sioux Falls, SD 57107  
 Phone: 1-800-736-2673  
 Website: www.sencore.com

Over the past few years the Sencore Home Electronics Division (formally Electronic Test & Measurement Division) has shifted focus and has developed a suite of tools for commercial and residential A/V Installers. Many of these tools will be very familiar to the Electronics Servicers that read ES&T. We here at Sencore think it would be a worthwhile investment of your time to check into this booming market that many you already possess the skills to excel in.

The following article covers the development of the Sencore Home Theater Tool Suite.

## The Product:

**Describe the product. What events led up to the development of this product?**

The Home Theater Installer's Tool Suite is a compilation of test instruments to assist the home theater installer in making professional home theater installations and calibrations. The Tool Suite includes a color analyzer, HDTV video generator, sound analyzer and RF signal level meter. The instruments are housed in a ruggedized, carrying case for easy transport between installs.

## What inspired its creation?

A number market factors inspired the creation of the Home Installer's Tool Suite: 1) the sales growth of expensive, high-end consumer electronics products, 2) the growing numbers of home theater installers, 3) the growth of the concept of the 'electronic home' and 4) the lack of innovative, time-saving test instruments that enabled the installer to make a high-quality, professional installation.

## What needs does this product meet?

Generally, installers needed a comprehensive solution for helping them perform a high quality, professional home theater installation. They also need a means for setting their business apart from their competition. Specifically they needed products for aligning and color balancing the video display; maximizing the performance of the surround sound system; and testing the verifying the RF signal levels in the home's RF network.

## What is revolutionary about this product?

The Home Theater Installer's Tool Suite is revolutionary in three ways (two dealing with the Tool Suite and the third dealing with Sencore's delivery method to the installer market). First, before the Tool Suite individual tools existed that performed calibration tasks on the individual products in the home theater system. No one system addressed all of the testing requirements and provided a single solution for all of the installer's calibration needs. Second, in the past home theater calibration tools have been priced

exorbitantly high, keeping them out of the hands of the typical home theater installer. Sencore's Tool Suite is priced affordably to put precision test instruments into the hands of the mainstream installer. Third, in addition to providing the Tool Suite instruments Sencore also provides in depth training for installers on how to actually use the test instruments in a home theater install. Training provides installers with the knowledge required for installing, calibrating and documenting a home theater system.

## What were the major challenges/obstacles that you faced during the product development process? How did you overcome them?

It was a challenge to develop test instruments that incorporated the features and functions to fulfill the industry's various testing and calibration requirements.

We overcame these challenges by listening carefully to our customers and their needs as they used the test instruments in the Tool Suite and responded quickly with updates and enhancements to product features and functions.

## Why is the product going to change the world?

The Home Theater Installer's Tool Suite will improve the quality of home theater installations and professionalism of home theater installer.

## What demographics is your company targeting with the product?

Home Electronics Installation and Consumer A/V Installation.



## HA2500 Universal Horizontal Analyzer

- HDTV Ready - service all horizontal circuits regardless of frequency
- Dead Set Test - complete horizontal load test with the chassis unplugged
- Patented Ringer Test
- Exclusive "Dynamic Tests" catch even subtle power supply, noise and drive signal defects

## VP300 Video Pro Multimedia Video Generator

- All ATSC HDTV and SDTV Formats (1080i, 720p, etc.)
- 4:3 and 16:9 Aspect Ratios
- Component Video (YPbPr) and RGB Video Output
- Composite and S-Video NTSC/PAL Outputs
- Monitor Output (SVGA, XGA, etc.)
- Setup and Alignment Test Patterns
- Hand-Held, Portable and Battery Operated (8 hours)
- Format and Pattern Update Ready (RS232 Interface)

**SENCORE**

1-800-SENCORE • www.sencore.com  
 email: hdtvservice@sencore.com

Circle (14) on Reply Card

## A History of Electronic Projection Display Technology (Part 2)

# Light Valve Technology, From the Eidophor to the Photoactivated Liquid-Crystal Light Valve

**A**dapted, with the permission of Texas Instruments, from an article by Dr. Larry J. Hornbeck which originally appeared in the Texas Instruments Technical Journal of July-September 1998. Dr. Hornbeck was the inventor of the Digital Micromirror Device(tm) optical switch which is at the heart of Digital Light Processing™ technology.

In the January issue we published the first of a four-part series of articles that would describe the history of electronic projection display technology. The series is based on the article cited above. This segment will cover light valve technology, from the Eidophor to the photoactivated liquid-crystal light valve

### The Light-Valve Technology Matrix

The third category of projection display technology is the light valve, for which the Eidophor, discussed earlier in this article, is the archetype.

The Eidophor was the first commercially successful light-valve technology. Because of its success, the Eidophor inspired numerous attempts to develop light valves that were more efficient, compact, less expensive and weighed less. (A modern Eidophor weighs more than 1000 pounds, excluding the electronics and power supply for the xenon arc lamp.)

The creative energy that went into the effort to develop an alternative light-valve technology is truly remarkable. The variations are so numerous that some way of organizing these technologies in a chart is useful before giving examples. Light valves are also known as spatial light modulators (SLMs), because their function is to take incoming unmodulated light and to modulate the light according to the position in the x-y plane of the SLM.

Light valves are categorized in Figure 11

*“The creative energy that went into the effort to develop an alternative light-valve technology is truly remarkable.”*

according to address technology, the light-valve (or control-layer) technology and whether or not a converter is required. The address technology may be a charge input from a modulated and rasterized e-beam such as the one used in the Eidophor to address the oil film or from a charge-coupled device (CCD). It may be an optical input such as the modulated light from a CRT or a scanned laser beam. The address technology may be electrical in nature, such as an x-y matrix of electrodes that is either passive or active. The active matrix contains a transistor switch at the intersection of each row and column electrode.

Converters are sometimes required

between the address structure and the light valve. The photoconductor performs an optical-to-voltage conversion. The pin-grid matrix performs a charge-to-voltage conversion. The photocathode/microchannel plate converter consists of two stages. The photocathode performs an optical-to-charge conversion, and the microchannel plate acts as an electron multiplier to enhance the effective light sensitivity.

Numerous light-valve or control-layer technologies are listed in Figure 11. The oil film control layer has been described in conjunction with the Eidophor and the Talaria. The acousto-optic light valve has been described as it applied to the Scopphony and the laser projector.

As shown in Figure 12, the light-modulating property varies with the type of light valve. The control layer may randomly scatter light, or a periodic pattern may be developed within each pixel of the control layer to diffract light. The control layer may change the direction of polarization, or it may act to beam steer or defocus the light.

Some of the control layers attempt to directly mimic the Eidophor oil-film control layer by providing another way of producing an addressable diffraction grating. Examples are the elastomer con-

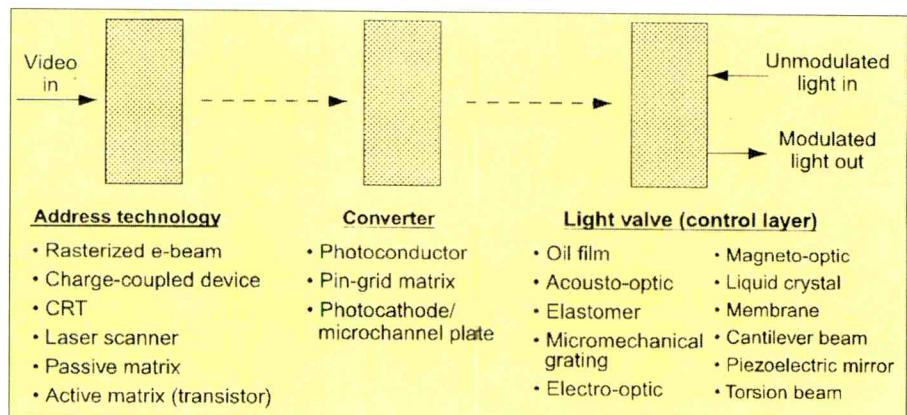

Figure 11. The light-valve technology matrix.



# B&K Precision Makes Child's Play Out of Cable Testers

Lightweight, portable and battery-operated, B&K Precision's new family of deluxe cable testers go anywhere, fit conveniently in any toolbox, and are quick and easy to use...

**No Kidding.**

B&K Precision's Cable Testers can be used to test network cables such as 10baseT, 100Base2, RJ45, RJ11, 356A, TIA-568A, TIA-568B and Token Ring. One will test Ethernet twisted pair cable status over a variety of cable lengths, while another can trace cable faults even when cables are in bundles or in punch down blocks or wall plates. B&K Precision's universal cable tester will test just about any cable or harness

in a fraction of a second. There is a model for testing popular PC data cables and one that will detect digital/analog phone lines in offices, hotels, airports, etc. to protect a modem from damage.

For more information on how you can change cable testing from a chore into child's play, visit our Web Site at [bkprecision.com](http://bkprecision.com) or call us toll-free at **(800) 462-9832**.



**BK PRECISION®**

1031 Segovia Circle, Placentia, CA 92870  
(714) 237-9220 Fax: (714) 237-9214  
[bkprecision.com](http://bkprecision.com)

Circle (10) on Reply Card

control layer, the micromechanical grating and certain classes of diffractive liquid-crystal light valves. We begin with a description of the elastomer light valves.

### Elastomer Light Valves

Elastomers are a flexible organic polymer material and have long been regarded as good solid-state replacement candidates for the fluid control layer used in the oil-film projectors. Elastomer light valves have been demonstrated with metal electrode, e-beam and optical addressing. An elastomer with metal electrode addressing is shown in Figure 13 to illustrate the basic principle of operation. Two pixels are shown, one energized and the other non-energized.

The elastomer is metallized with a thin reflecting layer that serves as both a mirror

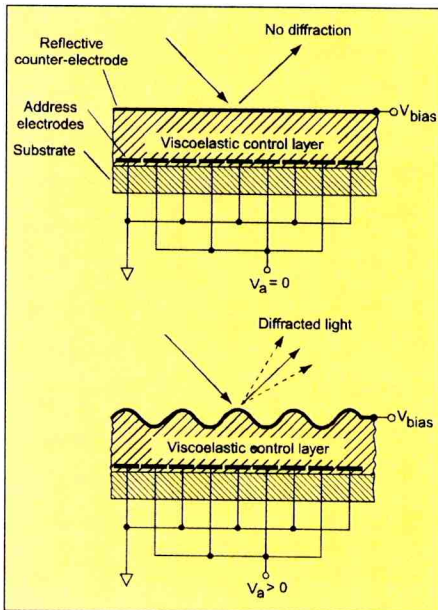

Figure 13. Electrode-addressed elastomer light valve

and a counter-electrode. A voltage is placed on every other address electrode of the addressed pixel to produce a deformation pattern. The elastomer is squeezed by the electrostatic force developed between the energized address electrodes and counter-electrode. Because the elastomer is incompressible, it protrudes

into the spaces between the energized electrodes. The result is a diffraction grating effect for the energized pixel. The elastomer surface of the non-energized pixel remains flat. The thickness of the elastomer layer and the spatial frequency of the address electrodes are chosen to maximize the response of the elastomer to the applied voltage.

The optics of the elastomer light valve are similar to the Eidophor optical system. The diffraction grating of the energized pixel causes light to be diffracted around the optical stop of the Schlieren projection optics. Thus the energized pixel appears bright at the projection screen. The non-energized pixel appears dark. Gray scale is achieved by varying the voltage on the address electrodes.

The address voltage is periodically shifted at the video frame rate between pairs of electrodes so that the regions of compression are not always at the same location. This technique avoids a gradual imprint of the surface that would lead to a residual image effect at the projection screen.

Although work on elastomer light valves has been carried out for more than 30 years, the possibility of producing a commercially viable projection display with this technology has been elusive.

### Micromechanical Grating Light Valve

The micromechanical grating light valve, first described in 1992, is another technology that modulates light by diffraction, but unlike other diffraction-

based technologies, it is digital. The commercial name for this technology is Grating Light Valve™ (GLV™). Figure 14 shows a cross section of one GLV pixel for an energized and non-energized state. Electrostatically deflectable microbridges are made from silicon nitride that is deposited in tension over a silicon dioxide sacrificial spacer. The bridges are overcoated with aluminum for reflectivity. The air gaps are formed by using an isotropic wet etch to selectively remove the sacrificial spacer.

The GLV is passive-matrix addressed by a set of row and column electrodes. Every other microbridge in the pixel is addressable. The others are held at a fixed bias voltage so that they cannot be energized by the column address electrodes of the passive matrix. When a pixel is selected by the combined effect of the row and column address voltages, the air gap voltage of the selected microbridges exceeds a threshold level. The movable bridges deflect through one-quarter the wavelength of the incident light and touch down onto the substrate. They remain there, electro-mechanically latched, as long as a minimum holding voltage is maintained by the row electrode.

Light, which is reflected from an energized pixel, is strongly diffracted because the optical path difference upon reflection between pairs of microbridges is one-half of a wavelength (destructive interference

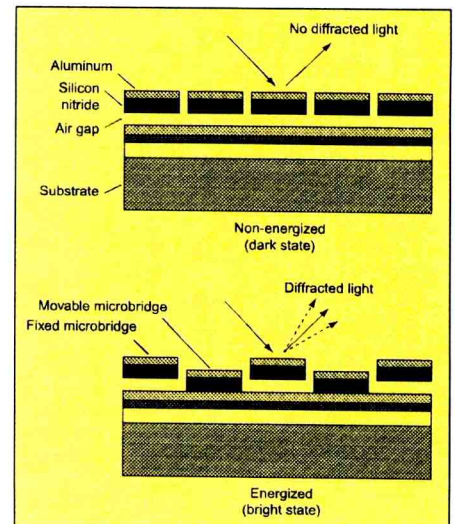
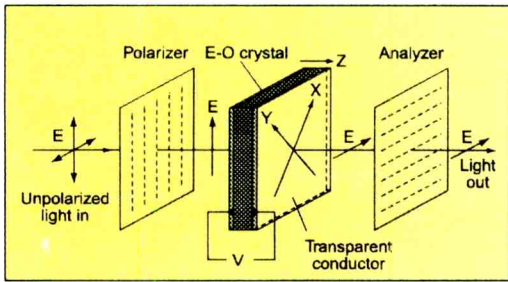

Figure 14. Grating Light Valve™ (one pixel).

Light Valve (Control Panel)	LIGHT MODULATING METHOD			Beam Steering or Defocus
	Scattering	Diffraction	Polarization	
Oil Film		X		
Acousto-Optic		X		
Elastomer		X		
Micromechanical Grating		X		
Electro-Optic			X	
Magneto-Optic			X	
Liquid Crystal	X	X	X	
Membrane				X
Cantilever Beam				X
Piezoelectric Mirror				X
Torsion Beam				X

Figure 12. Light-modulation properties of control layers.



**Figure 15.** Ferroelectric light valve (shown for condition of maximum transmission).

condition at that wavelength). For the non-energized state, the microbridges are coplanar and the light is specularly reflected. A Schlieren optical system is used to block the specularly reflected light and to image the diffracted light. The optical states are digital and therefore gray scale is produced by using pulsewidth modulation.

Because the inertia of the microbridges is small and they only need to move over small distances, the switching speed from one mechanical or optical state to the other is on the order of 20 nanoseconds. With this high switching speed and the latching property of the microbridges, it is not necessary to use active-matrix addressing. GLV technology has recently been demonstrated using a one-dimensional array of GLV pixels in conjunction with a white-light laser source and a polygon scanner.

### Electro-Optic Light Valves

Electro-optic light valves were proposed in the 1930s using zinc selenide (ZnSe), but it was not a practical display material because of its low electro-optic sensitivity and the difficulty of growing sufficiently large crystals. In the 1970s the availability of ferroelectric materials belonging to the family of potassium-dihydrogen-phosphate (KDP) compounds solved these problems. Large crystals could be grown, and large electro-optic sensitivities could be obtained by operation just above the Curie temperature of the crystal, at which the crystal is monostable and analog operation is possible. Below the Curie temperature the crystal is bistable, and in this temperature regime it can be used for storage displays.

In the early 1970s several KDP-based

light-valve projection displays were demonstrated, either e-beam addressed or light-addressed using a photoconductor/ KDP sandwich structure. Operation of these displays is based on the Pockels effect. (As we shall see later, certain types of liquid crystal displays use the same effect to modulate light.) A voltage (V) is placed across the faces of the crystal as shown in Figure 15, which in turn induces an electric field within the crystal. At zero applied voltage, the refractive index in the plane of the crystal face is independent of direction. But with applied voltage, the field causes the refractive index to vary with direction and the crystal is said to be "birefringent." The variation in refractive index with direction is proportional to the applied field.

To make use of the Pockels effect for light modulation, the crystal is placed between a polarizer and a "crossed" analyzer. The polarizer passes plane-polarized light to the crystal face. At zero voltage the plane-polarized light passes through the crystal undisturbed and is blocked by the analyzer. This is the off state for the light valve. As the crystal becomes more birefringent with applied voltage, the light becomes more elliptically polarized. The light output increases because its electric field (E) has an increasing component that is parallel to the analyzer. The condition of maximum brightness (shown in Figure 15) occurs when the light has become plane-polarized again, but rotated at 90 degrees relative to the input light.

Electro-optic light valves using single-crystal materials have a number of limitations. These include high-voltage addressing, nonuniformities caused by imperfections in the crystal and the requirement for cooling below room temperature to maximize sensitivity.

Another class of ferroelectric materials, lanthanum-modified lead zirconate-titanate (PLZT) ceramics, has also been developed. These show good electro-optic sensitivity at room temperature, can be driven at lower voltages and are easier to fabricate than single-crystal ferroelectric materials. PLZT relies for its operation on the Kerr electro-optic effect that is similar to the Pockels effect, except

that the applied electric field is transverse rather than parallel to the direction of optical propagation. PLZT-based projection display architectures and fabrication techniques have been proposed and test devices have been characterized. To date such displays have not proven practical.

### Magneto-Optic Light Valves

Magneto-optic light valves use the Faraday effect to digitally modulate light by rotating the polarization direction as light passes through the transparent magnetic material. The light valve is placed between crossed polarizers in the same optical arrangement used for electro-optic light valves. This digital technology was developed in the 1980s for opti-

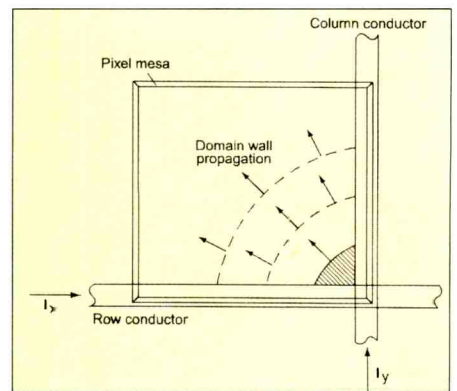

**Figure 16.** Switching principle of the magneto-optic light valve.

cal signal processing and potential projection display applications.

The light valve is formed from a transparent magnetic iron-garnet film supported on a non-magnetic transparent substrate. The magnetic film is etched into a two-dimensional array of mesas. The mesas are addressed by a passive matrix consisting of a two-dimensional array of conductors, as shown in Figure 16. At the cross point of two conductors that are both carrying current, a sufficient magnetic field is developed to locally switch a corner of the mesa from one magnetization direction to the other. An external magnetic field is then applied to complete the switching action, driving the magnetic domain wall across the entire mesa. Because this technology is inherently digital, gray scale would be produced by

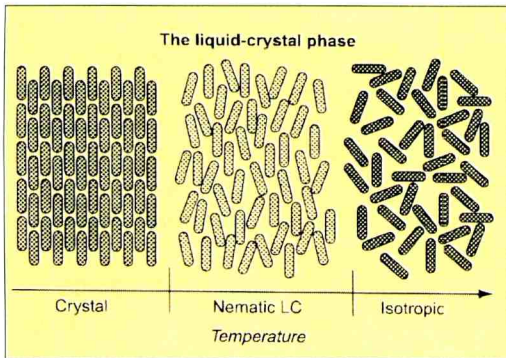

**Figure 17.** The phases of a nematic liquid crystal as a function of temperature.

using pulsedwidth modulation.

Although the application of this technology has been proposed for pulsedwidth modulation projection displays, the magneto-optic light valve is probably not a good candidate. In large array sizes it is subject to excessive heating caused by the current flowing in the passive matrix conductors. Furthermore, because of the lack of integrated current drivers for the row and column conductors, packaging would be prohibitively expensive.

### Liquid-Crystal Light Valves

Only a few years after the discovery of cathode rays, an Austrian botanist, Friedrich Reinitzer, correctly concluded in 1888 that there existed an intermediate phase between solid and liquid in a cholesterol-related material that he was studying. Two melting points were observed. One where the solid melted into a milky looking liquid, and a second melting point at a higher temperature at which the cloudy liquid turned into a clear liquid. The intermediate liquid phase that appeared cloudy was later named the liquid-crystal phase.

It took a mere 21 years from the discovery of cathode rays to their first display implementation. In contrast, nearly 80 years passed between the discovery of the liquid-crystal phase and its implementation as a liquid crystal display. In the 1920s and 1930s there was much research on the electro-optic properties of liquid-crystal materials. This work led to what is probably the first patent on a single-element light valve that used liquid crystals. It was awarded to the Marconi Wireless Telegraph Company in 1936. Its

application was for "electro-optical translating systems," and its stated advantage was as a low-voltage and more sensitive replacement for electro-optic materials such as the liquid nitrobenzene.

It wasn't until the pioneering work at RCA Laboratories of George Heilmeier and a team of his associates that the ideas were put together for the first liquid crystal displays. During the period 1964 to 1968 they discovered many of the effects that would later be commercialized, including dynamic scattering, dichroic dye (guest-host) LCDs and phase-change displays. Until that time there were no known materials that had a liquid-crystal

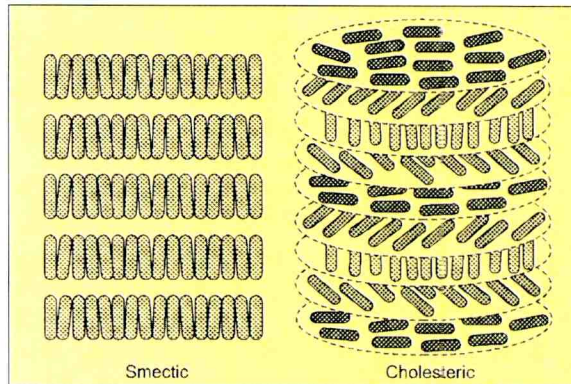

**Figure 18.** Smectic and chiral nematic (cholesteric) liquid crystals.

phase at room temperature. (The Marconi patent describes a heater for keeping the material in its liquid-crystal state.) Heilmeier's team discovered that by mixing pure liquid-crystal materials together, they could produce liquid-crystal solutions that would operate over a broad temperature range, including room temperature.

### Liquid-Crystal State

What is the liquid-crystal state? An example of a "nematic" liquid crystal is shown in Figure 17. Its phases are shown as a function of increasing temperature. The organic molecules are long, planar rod-like structures. In

the solid state, the molecules of a liquid crystal are rigidly aligned in a repetitive pattern. They behave as any other crystalline material. As the temperature is increased, the material melts into an intermediate or liquid-crystal phase. Here the molecules are free to move but are constrained to having their long axes pointed in generally the same direction. Nematic is from the Greek word for "thread" because in the liquid-crystal phase, this material appears thread-like when viewed under a microscope. Finally, as the temperature is further increased, the material melts into an isotropic liquid state, in which the molecules are randomly oriented and free to move around. A nonliquid-crystal material melts directly from the crystalline solid state into the isotropic liquid state.

The liquid-crystal phase can have other types of spatial ordering besides nematic, as shown in Figure 18. "Smectic" liquid crystals (from the Greek word for "soap") are aligned with their long axes generally in the same direction, and are arranged in layers as well. "Cholesteric" liquid crystals are similar to smectic liquid crystals, except the direction

of alignment in each layer slowly changes from layer to layer to form a helical structure. The name cholesteric was given to this class of liquid crystals because they were originally associated with cholesterol. Perhaps it is more appropriate to call them chiral nematic.

The property that makes liquid crystals

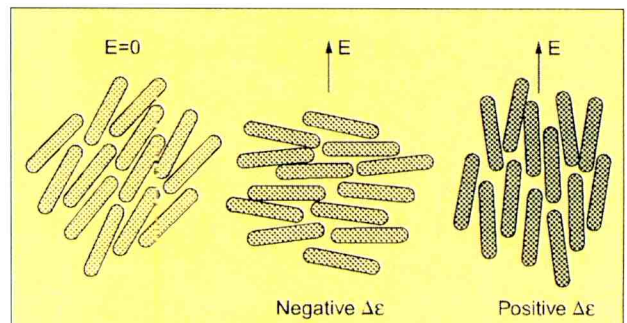

**Figure 19.** Effect of electric field on orientation of nematic liquid crystals.

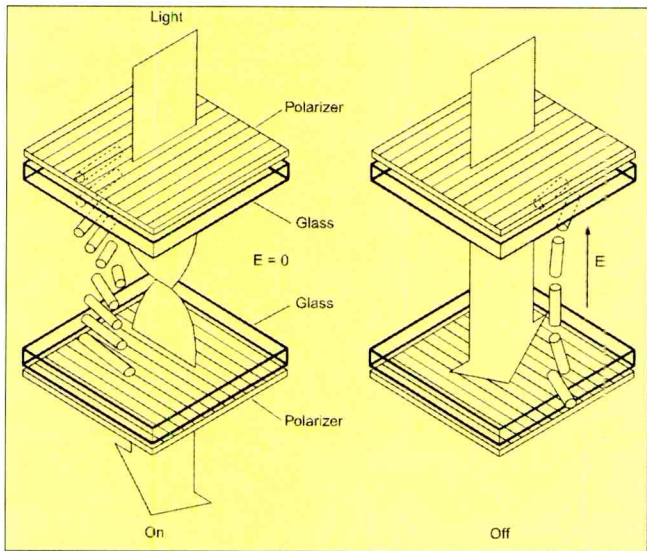

Figure 20. The twisted nematic LCD.

useful for displays is their highly anisotropic dielectric constant. Because the molecules are in the liquid state and have dielectric anisotropy, they can be oriented by an externally applied electric field ( $E$ ), much as metal filings can be oriented in a magnetic field. If the dielectric constant ( $\epsilon$ ) is larger along the long axis (or director) of the molecule compared to the short axis, the liquid crystal is said to have positive dielectric anisotropy. For this class of materials the long axis of the molecule tends to align parallel to an applied electric field as shown in Figure 19. For materials in which the dielectric constant is smaller along the long axis compared to the short axis, the dielectric anisotropy is negative and the molecule tends to align with its long axis orthogonal to the field.

### Guest-Host and Dynamic Scattering

Heilmeier's original interest was in nematic liquid crystals that were altered with the addition of a special dye consisting of long molecules that tended to align parallel to the long molecules of the liquid crystal. He formed a cell by placing the mixture between two glass plates that were coated with transparent conducting layers of tin oxide for address electrodes. When a voltage was applied to the electrodes of the cell, the liquid crystal molecules were reoriented by the electric field and the dye molecules were carried along.

He demonstrated what is now called the guest-host liquid-crystal effect. To make the effect visible, the cell was illuminated with polarized light. Depending on whether the polarization direction was parallel or perpendicular to the long axis of the dye molecules, the light was absorbed or not absorbed by the dye and the color of incident white light could be modulated.

During their investigations, Heilmeier and his co-workers discovered the "dynamic scattering" effect. In certain nematic materials, as the voltage was increased, the applied field produced turbulence rather than molecular reorientation and light was scattered by the variations in the index of refraction. They discovered that charge impurities in the material were accelerated in the electric field, creating a breakup of the material into domains having randomly directed axes.

When the pixel was activated, it appeared milky white. By replacing one of the transparent electrodes with a reflective conducting material, the liquid-crystal cell could be made reflective and used with ordinary room light without polarizers. Although contrast was low, the dynamic scattering LCD found immediate application in early wristwatch and portable calculator displays. It was clearly visible with conventional overhead lighting. It had low power consumption compared to the existing technology, light-emitting diode displays. The announcement of the dynamic scattering effect was made by RCA in 1968, generating lots of excitement in the display community.

That same year a direct view, reflective dynamic scattering display was demonstrated using e-beam addressing and a pin-grid matrix

converter. Both stationary and live television programming were displayed in this first-of-a-kind demonstration of LCD technology.

### Transmissive, Twisted Nematic LCDs

In 1969 another major breakthrough in liquid-crystal development was made, with the invention of the twisted-nematic (TN) field effect alignment mode for display applications. Much controversy has ensued over the years regarding the rightful inventor(s), James L. Fergason or Wolfgang Helfrich and Martin Schadt. Even litigation has not settled this issue in the minds of many.

TN technology soon displaced dynamic scattering LCDs because of its inherently higher contrast and higher long-term reliability.

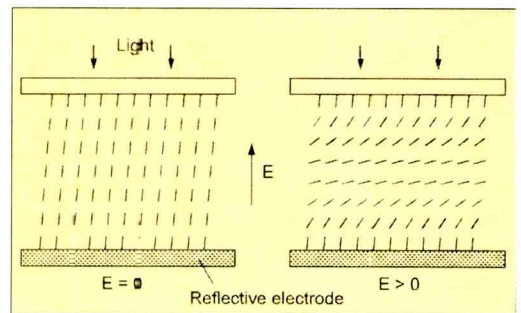

Figure 21. The homeotropic alignment mode.

The TN-LCD shown in Figure 20 is the most commonly used LCD mode for transmissive projection display light valves.

As in the Heilmeier guest-host dye and dynamic scattering cells, the liquid crystal is contained between two glass plates coated with transparent conducting layers for

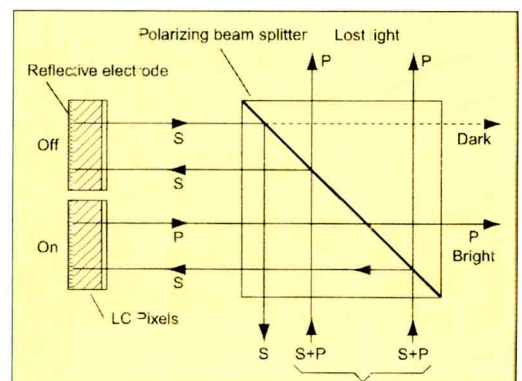

Figure 22. Reflective LCD light modulation (shown for condition of maximum brightness).

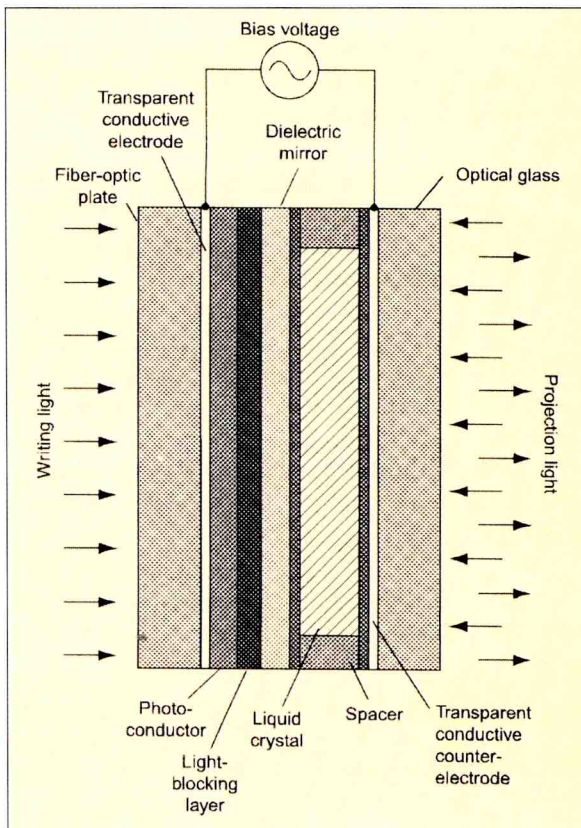

Figure 23. Photoactivated liquid-crystal light valve.

the address electrodes. To make the twisted nematic alignment mode work, the liquid-crystal molecules at the surface of each plate must align with a particular direction in the plane of the plate. To ensure this alignment, a polymer is deposited on both electrodes and rubbed along the desired alignment direction to produce microgrooves in the surface. The long axes of the liquid-crystal molecules that are in contact with the alignment layer tend to line up with the rubbing direction. The glass plates are oriented with their alignment direction at 90 degrees with respect to one another so that the molecules are twisted by 90 degrees in going from one electrode to the other. A polarizer is oriented so that plane- (linearly) polarized light enters the twisted nematic cell with its polarization direction parallel to the alignment direction of the entrance plate.

In the absence of an applied field, the electric vector of the polarized light follows the twist of the liquid-crystal molecules and exits at 90 degrees relative to its original direction. If an exit polarizer (analyzer) is oriented at 90 degrees rela-

tive to the entrance polarizer, the light is undisturbed and transmitted through the exit polarizer. (The polarization direction follows the twist because of the high dielectric constant along the long axis of the molecules. This is sometimes called "wave-guiding").

On the other hand, if a sufficiently large electric field is applied, the molecules are disrupted from their 90-degree twist, and because they have positive dielectric anisotropy, the long axes of the molecules align parallel to the electric field (E). The polarization direction is no longer rotated and the light is blocked at the exit polarizer. Intermediate levels of light transmission (for gray scale) are achieved by using lower voltages so as not to completely remove the 90-degree twist.

### Reflective LCDs

A reflective LCD light valve is created when one of the transparent electrodes is replaced with a reflective electrode. Reflective LCDs require special alignment modes. The 90-degree twisted nematic mode is not used for reflective applications because of its inability to fully modulate the light, which results in reduced brightness. Two alignment modes have found widespread use for reflective applications, the 45-degree twisted nematic and the homeotropic mode.

The homeotropic alignment mode is illustrated in Figure 21. Over the years it has also been called tilted perpendicular alignment (TPA), deformation of aligned phase (DAP) or electric-field controlled birefringence (ECB). In the absence of an applied electric field, nematic liquid crystal molecules are aligned with their long axes nearly perpendicular to the address electrodes. An alignment layer processed on the surface of the electrodes is engineered to give the molecules a small initial pretilt angle, important in preventing disinclination of the

molecules near pixel electrode edges. In this near-vertical alignment, the index of refraction is independent of direction for incident light normal to the surface.

A nematic liquid crystal with a negative dielectric anisotropy is chosen so that, as the electric field increases, the long axes of the molecules rotate in the direction orthogonal to the field. The molecular reorientation results in an index of refraction that is no longer independent of direction (the liquid crystal is now birefringent). The variation in refractive index with direction is a function of the applied field.

To make use of the homeotropic or other alignment modes in a reflective configuration, a polarizing beam splitter is required, as shown in Figure 22. Unpolarized light enters the beam splitter and plane-polarized light (s-wave component) is reflected into the liquid-crystal cell. In the case of homeotropic alignment, with no applied voltage to the cell, the index of refraction is independent of direction and therefore the s-wave is undisturbed. It is reflected at the polarizing beam splitter and back into the light source. This is the dark state, as no light reaches the projection lens.

A voltage applied to the cell causes the liquid crystal to become birefringent and the plane-polarized s-wave becomes elliptically polarized. In this condition, the light has both s-wave and p-wave components. The p-wave (90-degree rotated s-wave) is able to pass unreflected through the polarizing beam splitter and into the projection lens. As the applied voltage increases, the amplitude of the p-wave increases and that of the s-wave diminishes until all of the light is p-wave. This is the condition of maximum brightness.

Another alignment mode used for reflective LCDs is the 45-degree twisted nematic mode, also known as the hybrid field effect mode. It employs a 45-degree twist for the off state and an untwisted, birefringent state for the on state. Other twist angles have been employed that are optimized for the polarizer orientation and birefringence-thickness product of the liquid crystal.

## The Photoactivated Liquid-Crystal Light valve

One of the earliest and most successful LCD projectors is the photoactivated liquid-crystal light valve (LCLV). Developed by Hughes Research Laboratories, this reflective LCD technology was first reported in 1973. It used a CRT-addressed photoconductor to modulate the voltage across a dynamic scattering liquid crystal.

In 1975 the display contrast was improved by replacing the dynamic scattering liquid crystal with a homeotropic mode, nematic liquid crystal. But because the near-vertical alignment of the liquid-crystal molecules was not photostable, the homeotropic mode was used for only a short time. In 1977 it was replaced with the 45-degree twist, hybrid field effect mode. Finally in 1990, a homeotropic alignment mode process was developed with improved photostability and with higher contrast ratio than was possible for the 45-degree twist mode.

The photoactivated LCLV is currently known as the Hughes-JVC Image Light Amplifier™ (ILA™). It has provided an alternative to the oil-film projectors for high-brightness, color projection display applications and is similar to the oil-film technology in two respects. Both the liquid crystal and the oil-film layer are con-

tinuous, non-pixelated surfaces. Through the use of a light-to-voltage converter, the photoactivated LCLV is addressed by the light output from a CRT. Therefore, the source of addressing for both the photoactivated LCLV and the oil-film technology is a rasterized e-beam.

A cross section of the photoactivated LCLV is shown in Figure 23. A photoconductor film and a homeotropically aligned nematic liquid crystal are separated by a light-blocking layer and dielectric mirror. The photoconductor acts as a light-controlled voltage modulator for the liquid crystal. The dielectric mirror reflects the projection light and the light-blocking layer rejects residual projection light from entering the photoconductor.

An ac bias voltage is applied across the transparent electrodes. When there is no light on the photoconductor, it has a high resistivity and there is only a small amount of ac voltage drop across the liquid crystal. Most of the drop is across the photoconductor. But when part of the photoconductor is illuminated, its resis-

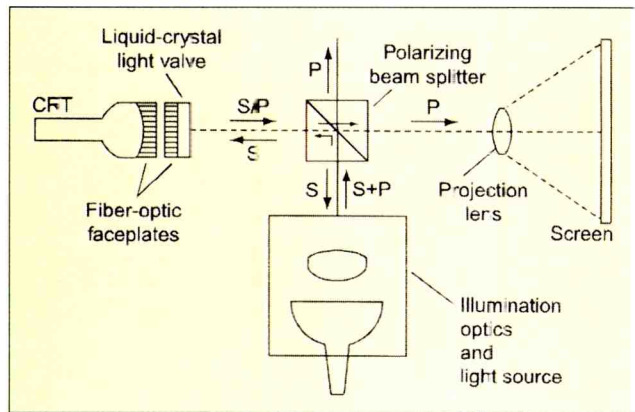

Figure 24. Monochrome photoactivated LCLV projector.

tivity is reduced in proportion to the intensity of the light, and the ac voltage drop across the liquid crystal in the vicinity of the illumination is increased.

A simplified schematic of a simple monochrome projection system is shown in Figure 24. A description of the homeotropic alignment mode and polarizing beam splitter were presented earlier in this section. An advantage of the photoactivated LCLV is the fact that its resolution is not fixed by a built-in pixel structure. Therefore, systems can be designed with addressing provided by extremely high-resolution CRTs or laser scanners for high-information-content display applications. ■

## ES&T Calendar of Industry Events

**CABLE-TEC EXPO 2001**  
**MAY 8 — 11, 2001**  
 Orlando, FL  
 Society of Cable  
 Telecommunications Eng.  
 140 Phillips Road  
 Exton, PA 19341  
 610-363-6888  
[www.EXPO2001info@scte.org](http://www.EXPO2001info@scte.org)



**ELECTRONIC DISTRIBUTION SHOW & CONFERENCE (EDS)**  
**MAY 15 — 17, 2001**  
 Educational Programs  
**May 14**  
**Las Vegas Hilton**  
**Las Vegas, NV**  
 Electronic Distribution  
 Show Corp.  
 222 South Riverside Plaza  
 Suite 2160  
 Chicago, IL 60606  
 312-648-1140  
[www.edsc.org](http://www.edsc.org)  
**ES&T Booth #6205**



**MID-ATLANTIC ELECTRONICS CONFERENCE**  
**JUNE 14 — 17, 2001**  
 Portsmouth, VA  
**Holiday Inn Olde Towne**  
**Portsmouth**  
 Virginia Professional  
 Electronics Association  
 13665 Warwick Boulevard  
 Newport News, VA 23602  
 757-874-8818  
[www.convention@colorandsound.net](http://www.convention@colorandsound.net)



**NATIONAL PROFESSIONAL SERVICE CONFERENCE (NPSC)**  
**JULY 30 — AUGUST 4, 2001**  
**Riviera Hotel**  
**Las Vegas, NV**  
 National Electronics Service  
 Dealers Association (NESDA)  
 2708 Berry Street  
 Fort Worth, TX 76109  
 817-921-9061  
[www.nesda.com](http://www.nesda.com)



**CUSTOM ELECTRONICS DESIGN AND INSTALLATION ASSOCIATION (CEDIA)**  
**SEPTEMBER 5 — 9, 2001**  
**Indianapolis Convention Center**  
**Indianapolis, IN**  
 CEDIA Headquarters  
 9802 N Meridian Street  
 Suite 200  
 Indianapolis, IN 46260  
 800-669-5329  
[www.cedia.org](http://www.cedia.org)

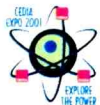

THE MAGAZINE FOR PROFESSIONAL ELECTRONIC AND COMPUTER SERVICERS  
**ELECTRONIC**  
 Servicing & Technology

Send Your Events Announcements to  
**ES&T Calendar of Events**  
[mmei@mainlymarketing.com](mailto:mmei@mainlymarketing.com) • Fax: 516-883-2162

Circle (15) on Reply Card

# Electronic Distribution Show and Conference

**EDS** is the annual meeting-place and marketplace for the worldwide community of manufacturers of electronic components, instruments and accessories and the electronic distributors through whom these products are brought to market. It includes exhibits, educational programs, and scheduled meetings or conferences between participating companies.

While no servicers attend EDS, the decisions, agreements and input generated between the component manufacturer and distributors greatly affects the price and availability of products to servicers.

## Who Exhibits at EDS

Close to 500 manufacturers who sell through electronic distributors exhibit at EDS. Products and people represented at EDS include:

Passive and electromechanical components, instruments, datacom products, accessories, active components, publications, suppliers who sell to electronic distributors, value added equipment, data processing equipment and software, office and warehouse equipment, con-

### The 2001 Electronic Distribution Show and Conference (EDS):

May 14th to 18th, 2001  
Las Vegas Hilton Hotel  
Las Vegas, Nevada, U.S.A.  
Exhibition Days:  
Tuesday 1:00 p.m. - 5:30 p.m.  
Wednesday 9:00 a.m. - 5:50 p.m.  
Thursday 9:00 a.m. - 4:00 p.m.  
**Visit ES&T Booth #6205**

sulting services, and master distributors authorized to sell to other distributors.

Exhibitors at EDS 2001 are primarily manufacturers of electronic components (wire, cable, capacitors, resistors, batteries, etc.; test equipment; accessories; publications; etc.) plus suppliers of goods and services used by distributors.

## Who's EDS For?

EDS is for distributors: national, regional, local and specialized — OEM and MRO. EDS is for: owners and presidents, sales/marketing and product managers.

Attendees are electronic distributors, who purchase and stock electronic components and related products for resale,

primarily to industrial, commercial and institutional customers. Distributor attendance at EDS 2000 was about 1700 people from over 700 companies.

About 6500 individuals participate in EDS each year. EDS is not open to the public (engineers, students, consumers, etc.). Although EDS includes conventional trade show exhibits, it is dominated by pre-scheduled meetings.

EDS is for manufacturers' representatives, also an important part of the EDS community. These independent contractors sell the products of one or more EDS participants on a commission basis, in a defined territory. EDS is an ideal venue for recruiting reps and for rep sales meetings.

## EDS Sponsors and Administrating Agency

EDS is sponsored by Electronic Components, Assemblies & Materials Association, Electronics Representatives Association, and the National Electronic Distributors Association

EDS is administered by:

Electronic Distribution Show Corporation  
(312) 648-1140, eds@edsc.org. ■

## TENTATIVE SCHEDULE OF EDS EVENTS

### SEMINARS AND WORKSHOPS MAY 14-17, 2001

#### MONDAY, MAY 14

**12:45 PM to 1:45 PM** *Marketing Electronics Worldwide — participating in the Global Market*

**1:00 PM to 3:00 PM**

*RosettaNet: the E-Business Standard for the Electronic Supply Chain*  
Presenter: Barney Martin, NEDA VP for Industry Practices, former director of Partner Relations at RosettaNet

**3:15 PM to 4:30 PM**

*The Changing Role of Procurement in the Supply Chain*  
Presenters: Panel of purchasing executives  
Moderator: Robin Gray, Executive Vice-President, NEDA

**5:00 PM to 6:00 PM**

EDS Welcome Reception  
Sponsored by ECA

#### TUESDAY, MAY 15

**10:00 AM to 11:30 AM**

EBN presents an exclusive research report  
*Globalize to Grow Your Business*

**11:45 AM to 12:45 PM**

Keynote Luncheon  
*How Outsourced Manufacturing Affects Your Future in Electronic Distribution*

**2:00 PM to 3:00 PM**

*Selling Electronics in the USA (for international visitors)*

**5:00 PM to 6:00 PM**

*Exhibit Area Get-Together*

#### WEDNESDAY, MAY 16

**7:00 AM to 8:45 AM**

NEDA Breakfast Meeting For Distributors

*NEDA Business Session and Presentation on Industry Statistics from EBN.*

**10:00 AM to 11:00 AM**

*EBN Opportunities for the Electronic Industry in China Panel Discussion*  
Moderator: Bruce Rayner, Editor-in-Chief, EBN

**2:00 PM to 3:00 PM**

Cahners research report  
*New Paradigms for Distribution in a Technologically Enabled Global Marketplace*  
Presenter: Susan Mulcahey, Research/Editorial Director, Cahners Business Information

**3:00 PM to 4:30 PM**

ERA and its Small Rep Special Interest Group present an open forum  
*What's Going in the Industry, and How Does it Affect the Smaller Rep Firm?*

#### THURSDAY, MAY 17

**6:45 AM to 8:00 AM**

*Manufacturers' Representatives Breakfast and ERA Membership Meeting*

**10:00 AM to 11:00 AM**

Electronic News presents an industry panel discussion  
*The Role of Distribution in Product Development*  
Moderator: Jonathan Cassell, Editor-in-Chief, Electronic News  
Panelists: top executives from OEMs, CEMs, semiconductor companies, and distribution.

**2:00 PM to 3:00 PM**

EBN presents an exclusive research report  
*How Your Customers Use the Internet.*  
Presenter: Steve Cholas, Publisher, EBN

#### FRIDAY, MAY 18

8:00 AM Golf Outing - Wild Horse Golf Club



# Designing Your Showcase Site

by the ES&T Staff

It's no secret that operating a business for servicing consumer electronics products gets tougher and tougher. The answer to staying in business for a number of service centers has been to branch out into related areas of business. For example, some service centers have added electrically-operated riding toys to the mix of products they service. Another service center we know services the electronics used in those drive throughs at fast food places like McDonald's, Burger King, etc. Today, with so many people adding home theater to their homes, a number of service centers have found that selling and installing home theater systems is a logical extension to the services they offer.

## What Is a Home Theater?

Home theater is a broad term that describes a home installation that delivers high-quality audio and video, not unlike the experience that a viewer would have in a movie theater. Ideally, the video would be in the 16 X 9 digital video format, but in this period of transition from NTSC to ATSC, or high definition TV (HDTV), the TV sets and video monitors that most people own are in the standard TV format. Of course, on these units, the 16 X 9 programs can be shown in letter-

box fashion.

The audio is one of the things that sets these installations apart from ordinary television watching. In a true home theater installation, the audio portion will be capable of delivering high-fidelity audio in a 5.1 channel format. The idea of 5.1 channels is one of those somewhat cute designations that engineers think up. The five channels are left front, right front, center front, left rear, and right rear. The extra .1 channel is the subwoofer, which only puts out a small portion of the entire audio spectrum, at low frequency.

## Creating an Attractive Home Theater Showcase

It has been said before in these pages, borrowed from people who know what it takes to sell a product or service: "People come where they're invited, and stay where they feel welcome." That quote makes a great deal of sense; and if you



Figure 1. The well maintained customer service counter allows Continental Video staff to work with customers in a professional environment.

want to sell expensive products such as home theater systems, you have to first invite the potential customers in, and make them feel welcome. Let them watch and listen to a high quality, video and audio, program in an atmosphere that resembles a home theater setting. Let them work the controls.

One of the most important factors

in creating an atmosphere in which people will feel comfortable is to make sure that it's clean and neat. Many service centers have a cluttered look. The nature of the business is such that sometimes that can't be helped. But if you're going to sell expensive new products like home theater systems, that part of the business should be apart from the service center, and should have a clean uncluttered look.

But not only should it be free of clutter, everything should be new, and clean and bright. When people are looking to buy a home theater system, they will be looking at the video screen, the receiver, and the speaker system with the thought of how they will look in their own homes. If the carpet is worn, or dingy, or if the walls of the showcase need a coat of paint, the picture the customer will have in their mind of how the system will look in their home will not be pleasing, and they might decide to look elsewhere.

## Lighting

Lighting can make or break a home theater showcase, or any other store where atmosphere is important. It's particularly important in a place where home entertainment systems are being displayed. Fluorescent lighting gives a harsh, cold, look to a space, and is unlike the type of lighting found in most homes. Lighting must be adequate to allow the customer to view the product, but it should be sub-



Figure 2. All of the video displays in the facility were carefully arranged and properly adjusted for maximum visual impact. Not shown because of difficulties in photographing it is a viewing room with comfortable chairs and a 73-inch wide screen rear projection HDTV ready set connected to an HDTV demonstration channel via satellite. High fidelity audio in the room is provided by a 5.1 channel surround sound system.



**Figure 3.** The lighting in the store contributed to the warm, atmosphere and inviting displays of products.

duced to mimic the lighting that the customer will have in his home theater.

It would be best if the lights in viewing areas are adjustable so that the customer can adjust them to a level that's right for him, so that he may form a better mental picture of what the viewing experience will be in his home. Keep in mind, too, that the walls of the rooms should be lighted. That defines the space and makes it comfortable to be in. Dark walls look cold and spooky.

Lighting is such an important aspect of a store in which you are planning to display and demonstrate high-priced merchandise that is designed to be viewed that it might be a good idea to hire a lighting designer to make sure that the lighting is done right.

### Offer a Variety of Products at Different Prices

It seems logical to assume that most people would like to have a theater system in their homes; whether they're wealthy people who own a home worth in the millions of dollars, or if they're people of more modest means. Different homes and different budgets require different types of home theater systems. If a large home has a cavernous room in which to install the home theater system, a small video screen, low-power amplifier and low-power speakers wouldn't do. They'd look lost in a large room and the audio would be inadequate to fill the room with sound.

On the other hand, if a customer has a more modest home with a small room for

the home theater system, a screen that's too large would make viewing uncomfortable, and huge speakers with a high-power amplifier would be wasted.

Moreover, someone with a large home would generally have a larger budget for buying a home theater system.

Because of these variations in room size and means to buy, it makes sense for a company offering home theater systems to display a variety of products, and to have sales people on staff who can help a customer find a system that's suited for his home environment and budget.

### Continental Video

We visited a successful video/home theater store in the Kansas City area to see what such a store might be like. The name of the store is Continental Video Center, owned by Mark Brummel. It's an unassuming, but neat, place from the outside, with minimal signage, but the windows, which have been covered, carry the names of the products sold.

The products are not the types of products found in the typical discount store. They're a level or so higher in quality. The store sells a line of Mitsubishi TV/video products, everything from larger-screen direct view sets in NTSC format up to a 73-inch HDTV ready rear projection unit in 16 X 9 format. The mix includes plasma display units.

The audio offerings include products made by Marantz, Atlantic Technology and NHT.

### Installation service

In addition, the business offers whatever level of installation the customer prefers. If the customer is technically proficient, he can walk out of the store with the products he has selected and go home and install them. If the customer prefers, Continental will deliver and install the system.

Typically, an installer, one of five technical specialists that Continental employs full time, will visit the customer's home and do a "walk through." In this procedure, the installer evaluates the room where the system will be installed, taking notes and making sketches as appropriate. Those notes and sketches are turned into a formal proposal by Continental and presented to the customer.

If the customer approves of the proposal, he then visits the store to examine the products and select those that have the desired colors and appearance.

The installers work on a time and material basis, so the billing properly represents the cost to do the job.

### Location, Location, Location

Real estate agents say that there are three important factors in selling a house: location, location, location. According to Brummel, the same is true of retail. Part of the secret to the success of Continental Video is its location. It's in Johnson County, KS, which is a fairly affluent area. Many residents have a considerable amount of disposable income, and are willing to spend it on home entertainment.



**Figure 4.** Accessories were neatly displayed so that customers could browse and find just the connection or cable they needed.



**Figure 5.** The signage on the building is minimal, but the neat appearance and the list of products sold in the windows attest to the potential customer this is a well managed operation.

### Marketing the Business

Continental Video markets its business in three ways:

- newspaper advertising,
- direct mail,
- referrals.

from wasting its money by advertising to people in parts of the city who would be unlikely to travel a long distance to make a purchase.

Every time a satisfied customer leaves the store, a salesman gives him some busi-

ness cards and asks them to refer any friends, relatives or acquaintances who might be thinking about buying an audio/video system to consider Continental Video.

### Working with Builders/Remodelers

Brummel has forged alliances with a number of builders and remodelers in the area, and works with them on several levels. If a builder is building a home that will include a home theater system, Continental will work with the builder to pre-install wiring and any associated fixtures during the construction of the house.

In the same way, if a remodeler is remodeling a home, in a job that includes a home theater system, Continental will work with the remodeler to install wiring and fixtures as the work is being done.

### House Calls

As part of its advertising, Continental

**NOW AVAILABLE!**  
*Electro//Horizons//Publications*  
**GLOSSARY**  
**OF TERMS & SYMBOLS**  
*Written and compiled by Sy Levine*  
**FROM A LIBRARY ON BASIC ELECTRONICS**

**72 PAGE REFERENCE BOOK**

- *Glossary of electronic terms*
- *Glossary of electronic symbols*
- *Listing of Greek symbols and alphabet used in electronics*

**\$24.95**

**To order call:**  
 Electro//Horizons//Publications  
 c/o Mary Tali at MMEI  
 P.O. Box 748  
 Port Washington, NY 11050-3111  
**800-462-4659 • Fax: 516-883-2162**

Circle (16) on Reply Card



**Your Ticket to**  
**SUCCESS**

More than 40,000 technicians worldwide are Certified Electronics Technicians. IS CET offers Journeyman certification in Consumer Electronics, Industrial, Medical, Communications, Radar, Computer and Video. For more information, contact the International Society of Certified Electronics Technicians, 2708 West Berry Street, Fort Worth TX 76109; (817) 921-9101.

Name \_\_\_\_\_  
 Address \_\_\_\_\_  
 City \_\_\_\_\_  
 State \_\_\_\_\_ ZIP \_\_\_\_\_

Send material about IS CET and becoming certified  
 Send one "Study Guide for the Associate Level CET Test." Enclosed is \$14.95 (includes postage/handling). **TX residents — include 8.25% sales tax.**

ES&T

Circle (17) on Reply Card

includes something Brummel calls "House Calls." It's an invitation to readers to contact Continental for any type of work that they might need done on any audio/video

system. Whether the person has bought components and decided that they aren't skilled enough to connect them, or if they have recently moved into the area and need

to have their system reconnected, or if they are having some kind of problems and need troubleshooting to correct the problem, Continental will provide the solution.

### Smart Home Getting Smarter

JP Davis & Co., producer of press receptions at major technology tradeshows, and real estate giant, PacTrust, today announced the grand opening of their "Smart Home" venture at Orenco Station in Hillsboro OR. The townhouse, located in the heart of the Silicon Forest, is wired and ready with the technology that will digitally enhance future homes and make living "smarter." The grand opening was scheduled to be held at the home the weekend of April 6 - 8, 2001.

Several dynamic technology companies already have their products installed in the three-story townhouse that is a part of Orenco Station, a critically applauded example of "new urbanism" that is sweeping the country. Building on their successful Smart\*Home press reception held during the Consumer Electronic Show in Las Vegas, JP Davis & Co. invited companies to provide technology products that are instrumental in making a dwelling a smart home.

"We looked for companies that not only had leading edge products," explains John Davis, president and founder of JP Davis & Co., "We also looked for products that were practical for real people in a real home."

Companies showcasing their products at the Smart\*Home include: HP Pavilion 8860 - The HP Pavilion 8860 desktop PC makes an impression with a lightning-fast AMD Athlon processor 1GHz and 128MB RAM. With it, viewers can enjoy theater-quality movies on a PC with the 12x max. speed DVD-ROM drive and Premium Polk Audio stereo speakers, record music CDs with the HP CD-Writer drive, as well as playing the latest games with its powerful nVidia TNT2 Vanta 3D-accelerator card, and instant access to favorite Web sites.

The Intel AnyPoint(tm) Wireless Home Network lets users share Internet access, files, drives, printers and more, without

wires, and from anywhere in the home, even the back yard or patio. Whether choosing wireless or phone line, both are easy to install and require no new wires.

The Xerox WorkCentre M950 Color Inkjet Printer/Copier/Scanner/PC Fax brings high-quality color to the home office and features a 20-sheet document feeder. The network-ready WorkCentre M950 offers many new technological advances including eXpress Mode(tm), with speeds up to 50 percent faster than the competition's normal mode and InkLogic(tm), which uses individual ink tanks to eliminate ink waste and save consumers money.

What home would be complete without a pet? For the Smart Home, it's AIBO, the robotic dog from Sony. The rebirth of the original pop-culture phenomenon is alive in Sony's next generation series of AIBO Entertainment Robots, featuring a sleek new design in three different colors, advanced emotion and communication functionality, the ability to recognize up to 50 spoken words, take pictures, and react to wireless LAN control, among a variety of other advanced features and accessories.

Friendly Robotics develops products that liberate consumers from routine chores. With the introduction of the company's first product, Robomower, Friendly Robotics moves from futuristic concept to today's reality. Safe, simple, convenient - Robomower mows the lawn automatically. No push, no sweat.

BeIA delivers powerful functionality, including a comprehensive web browser, support for popular streaming media formats, application support and remote device management all in an exceptionally compact footprint. Compaq's iPaq IA-1 is powered by BeIA and sits on the kitchen counter, giving quick and easy access to the Internet.

From Home Automation, Inc., the OmniPro is an integrated security and control system designed for commercial

and high-end residential applications. Based on the reliable Omni platform, the system utilizes standard sensors for security, fire protection, and environmental control, plus offers comprehensive management of lighting, HVAC and other mechanicals. The OmniPro is a full-featured facilities management system which operates by "modes" like Weekday, Weekend Day, Night, Away or Vacation. Any given mode can be programmed to define specific temperature parameters, lighting sequences and the appropriate security functions.

American Power Conversion (APC) has provided the Back-UPS CS 500VA, a new line of desktop uninterruptible power supplies (UPS) specifically designed for small business and corporate environments. The Back-UPS CS 350 and 500 offer reliable battery backup power in a smaller, sleeker form factor.

The IP VideoPhone from Innomedia is a compact, all-in-one desktop phone that takes the complexity out of videoconferencing, placing free person-to-person video calls anywhere in the world over a broadband connection. Simply plug it into a quality-of-service enabled broadband IP network; pick up the phone and dial. The plug-and-play system delivers high-quality video, convenient, cost-effective, face-to-face communication without the expense or requirement of a PC.

"Orenco Station provided us with the perfect opportunity to showcase these products," continues Davis, also a resident at the urban housing development. "New technology will play a key role in the development of communities from here on out."

Orenco Station, a new pedestrian and transit oriented community in East Hillsboro, Ore., takes "new urbanism" to the next level with the Smart\*Home demonstration. In 1999, the National Association of Homebuilders named Orenco Station the "Masterplanned Community of the Year." ■

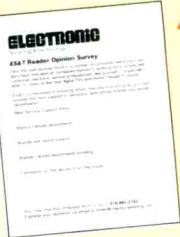

## AND THE WINNERS ARE...

In January, we asked our subscribers to let us know which consumer electronics manufacturers provide the best and worst support, and which brands our readers would recommend, or recommend avoiding.

While, admittedly, not a scientific survey, here are the Top Ten for Best Support Service and Brands Recommended in descending order. *ES&T* did not ask which manufacturer provided the best service remuneration. That will be another survey.

As this was a write-in questionnaire, the answers presented here are basically the brand names the respondent provided. No effort has been made to combine brands or abbreviations under one firm or another.

### BEST SUPPORT SERVICE

1. Sony
2. Panasonic
3. Philips
4. Thomson
5. Zenith
6. RCA
7. Hitachi
8. Magnavox
9. JVC
10. TCE

### WOULD RECOMMEND

1. Sony
2. RCA
3. Panasonic
4. Magnavox
5. Philips
6. JVC
7. Thomson
8. Toshiba
9. Hitachi
10. Sharp

A related question was asked in October regarding:

### THE TEN MOST WANTED PRODUCT SCHEMATICS BY MANUFACTURER ARE:

- |            |                             |
|------------|-----------------------------|
| 1. Sony    | 6. Toshiba                  |
| 2. RCA     | 7. Zenith                   |
| 3. Sanyo   | 8. Magnavox                 |
| 4. Emerson | 9. Samsung                  |
| 5. JVC     | 10. Panasonic/Philips (tie) |

### THE TEN MOST WANTED SCHEMATICS BY PRODUCT ARE:

- |                      |                         |
|----------------------|-------------------------|
| 1. TVs               | 6. DVD                  |
| 2. Computer Monitors | 7. Projection/Large TVs |
| 3. VCRs              | 8. CDs                  |
| 4. TV/VCR Combos     | 9. HDTV                 |
| 5. Camcorders        | 10. Home Theater        |

The full list included: Printers, Receiver Amps, Cordless Telephones, AV Amps Audio Products, Computer Power Supplies, Digital Antennas, Faxes, Public Address Systems, Radio-Cassettes, Stereos, Tuners, Car VCRs, Home Power Supplies, Video Products and more.

*ES&T* is working to provide information to help you perform profitable, professional service and insure consumer good will for the consumer electronics industry. Input from Professional Servicers, Distributors, and Consumer Electronics Manufacturers is welcome.

## To Order Back Issues

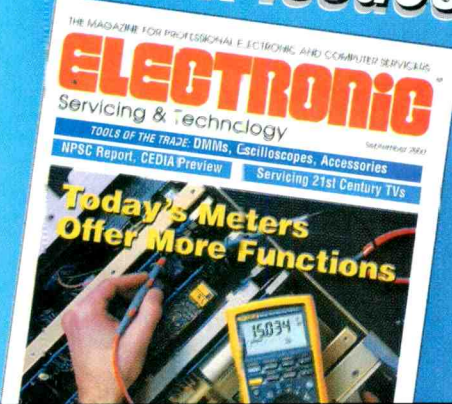

**ONLY \$5.00 PER ISSUE**

### COMPLETE YOUR COLLECTION TODAY.

Check, Money Order, Mastercard, VISA, Discover and AMEX accepted

Electronic Servicing & Technology

Attention: Mary Tali

P.O. Box 748

Port Washington, NY 10050

**CALL: 800-462-4659**

For Fastest Service

**FAX 516-883-2162**

## Electronic Technicians Association – ETA

and

Satellite Dealers Association - SDA

present

The **Ultimate** Customer Service Specialist Study Guide

## CSS-2

The second edition of this popular CSS Study Guide is now in print.



Twice the number of pages

Twice the chapters

Dozens of new practice quiz questions

Sales-marketing-service relationships; Technoliteracy; Safety; Company standards; Dependability; Teamwork; Work ethics; Problem solving; Company loyalty; Telephone techniques; Controlling your emotions; Communications; Record keeping; Safety; Decision making; Customer service techniques; Hygiene, and more

**No Service Business Should be Without One of These Unique Guides to World Class Service!**

to order

**Call 800 288 3824**

eta@indy.tdsnet

**ETA-I**

602 N Jackson, Greencastle, IN 46135

Circle (18) on Reply Card

# New Products

## Single Phase Power Quality Logger

The PQL 100 Series from AEMC is a single Power Quality Logger designed to



measure and log from a complete suite of electrical and power quality parameters. The PQL 100 measures, records and stores the

selected parameters. The recorded information is retrieved via a computer using an RS-232 serial link. The report compliant DataView Lite software package, which provides graphs, waveforms and pre-configured reports, is supplied with the loggers.

The series is designed for North American commercial, industrial and residential applications, and is plugged into a standard receptacle. The logger is line powered from the voltage source that is connected to, with an internal battery to protect data integrity during power outages and programmed configuration for up to 1 year

AEMC Instruments  
Circle (19) on Reply Card

## Analog Digital Storage Oscilloscope

B&K Precision Corporation, announces the addition of the Model 5105A, a cost-effective 150 MHz analog digital storage oscilloscope. This compact, versatile, easy to use benchtop unit incorporates a high-end Digital scope with a 200MS/s sampling rate.

A built-in RS-232 PC interface allows for the use of a personal computer to capture waveforms or to control the unit. The scope, manufactured in Germany, appropriate for use in education, design, field service, maintenance, manufacturing and quality control.

Upon start-up, the scope automatically undergoes a diagnostic self test to ensure proper operating conditions. It

offers the benefits of both Analog and Digital operation in one unit. A single button is used to switch from Analog to Digital storage operation.

AUTOSET, another feature, provides automatic setup of time base, vertical axis, and trigger parameters of the signal being measured. The user can then readjust the time base and vertical axis as required. Up to 17 automatic measurements are displayed by readouts on the



screen. The unit also offers many user benefits including the capacity to store waveforms for analysis, the ability to view/store pre-trigger information, the ability to detect/display/capture complex waveforms, the ability to obtain hard copy printouts of the capture signal, the ability to view slow event, and the ability to view one time event.

B&K Precision Corporation  
Circle (20) on Reply Card

## Bench Top Ionizer

The new Desco Bench Top Ionizer XL (Item #19540) provides maximum neu-

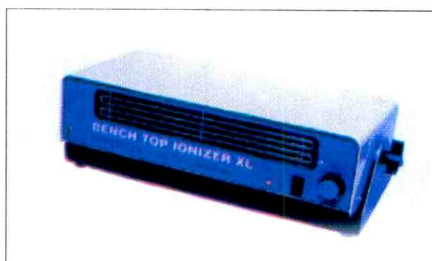

tralization of electrostatic charges in the workplace. It features a patented Faraday balance system that provides for an automatically balanced ion output. The XL emits ions in a true laminar flow that reduces ion recombination and emitter contamination. A fixed temperature heater removes chill from air, thus enhancing worker comfort and produc-

tivity. The ionizer uses an ac ionizing system thus neutralizing static charges at great distances. The unit is UL listed.

Desco  
Circle (21) on Reply Card

## Data Logger Test Station

The Desco Data Logger Test Station will automatically log ESD results from wrist strap and foot grounder tests. The Data Logger eliminates non-productive time of manually logging test results. The user can input data in three ways:

1. Card with magnetic stripe
2. PIN number
3. Scan a bar code

The test station connects to almost any PC using serial port and standard modular phone cord. No special interface cards are needed. Setup software is included. Output data can be sorted, viewed, and

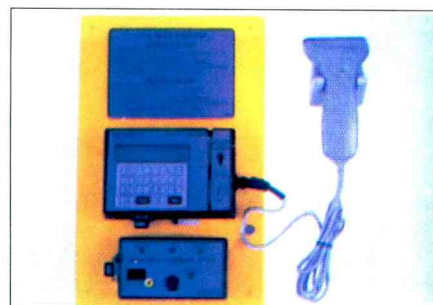

printed in Windows format. The Data Logger makes it easy to comply with ISO 9000 requirements and audits. Up to 15 Data Loggers may be connected to a single PC.

Desco  
Circle (22) on Reply Card

## Auto Calibration Unit

The Auto Calibration Unit, item #43469 from ESD Systems.com is designed to simplify the calibration



process. With its closed-loop calibration, the Auto Calibration Unit instantly cali-

# New Products

brates CE Ionizers to conditions at the workstation. The colorful visual balance indicator makes for an easy to read display of the ionizer's balance. The unit it derives its power from the ionizer under test, thus eliminating batteries and power supplies.

ESD Systems.com  
Circle (23) on Reply Card

## AC Outlet Analyzer & Wrist Strap Tester

The Pilgrim GAM-2A AC Outlet Analyzer and Wrist Strap Tester from



EDS Systems. Com is designed to test the integrity of the building ground and to verify the wrist strap connection to the operation. It also tests smocks to ensure continuity throughout the garment. Since it plugs into a 120Vac outlet, it allows the operator to test their wrist strap without leaving the workstation. At the same time, the unit verifies that the outlet has a good building ground. The resistance limits are 500 kilohms to 50 megohms +/-5%.

ESD Systems.com  
Circle (24) on Reply Card

## Tone Generator and Amplifier Probe Kit

Extech's Tone Generator and Amplifier Probe Kit, Model 40180, is used to trace cables, do continuity tests, and to test telephone lines for clear, busy, or ringing signals. The installer can select

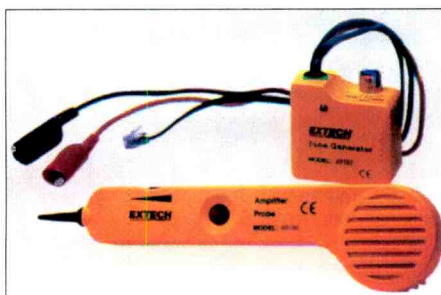

continuous or variable tone generation. The probe is equipped with a built-in speaker with sensitivity control. The insulated probe tip prevents shorting conductors. Features include alligator test leads, RJ11, and RJ45 as well as modular phone connector cables and output jack for headphones. Complete with 9V batteries and carrying pouch.

Extech Instruments  
Circle (25) on Reply Card

## Multifunction Calibrator

Extech's new Precision Multifunction Calibrator, Model 422123, provides an accurate calibration source for thermocouple, mA, mV, V, and Frequency devices. The unit sources 4 to 20mA, to 20mA, or 0 to 24mA with 0.001mA resolution.

Thermocouple types K, J, T, or E can be selected for precision calibrations in F or C. The frequency source ranges from 1Hz to 62.5kHz in over 700 steps. Voltage outputs range from 0 to 100mV, 0 to 1V, or 0 to 10V. A self-contained 24V loop power supply drives current loads up to 1000 ohms. The user can easily set output steps from 1% to 100%. Additional features include step and auto ramp, and an alarm if the load is open with mA output or shorted with V output. Complete with 9V battery, external battery pack, carrying case, alligator clips, and Type K & Type J test cables.

Extech Instruments  
Circle (26) on Reply Card

## Digital Multimeters

Fluke Corporation introduces the 170 Series Digital Multimeters (DMMs). The tough and accurate tools designed specifically for front-line industrial, electrical and electronic technicians and engineers.

The Series, which includes the 175, 177 and 179 models, was developed for use in environments that range from relatively

"clean" bench areas to some of the harshest work environments known. In addition to performing as the primary meter for many techni-



cians and engineers, the Series is also within the price range of the growing consumer segment of occasional users and do-it-yourselfers who require a quality, feature-rich DMM.

The meters feature an exclusive Fluke-designed True-rms engine, boasts 0.09% accuracy (Models 177 and 179) with 6,000 counts of resolution on a bright, backlit display says the manufacturer. In addition, the meters offer a Min/Max/Avg mode for enhanced troubleshooting.

The meters provide Vac range from 0.1 mV to 1000V as well as frequency range from 2 Hz to 100kHz, and capacitance ranges from 1nF to 9,999 uF. The 179 Model also measures temperature with sensor leads plugged into the front panel sockets.

While operating in the Min/Max/Avg mode, the meters emit an audible tone to signal a new minimum or maximum reading has been sensed and stored. Users can select response time (the minimum time a signal must be present to be recorded) between 100 milliseconds and 1 second.

As a company, Fluke corporation has long focused on safety in all its products, and has sought industry-wide protection measures to ensure safe working conditions and products. The meters comply with the EN61010 Second Edition standard, which addresses CATIV overvoltage requirements. All inputs are designed to withstand an impulse voltage in excess of 8kV which complies with CAT IV 600V requirements.

Fluke Corporation  
Circle (27) on Reply Card

# New Products

## Anti-Static Yellow Cellulose Tape

The new Desco Anti-static Yellow Cellulose Tape with symbols is designed to be used as a warning on items being

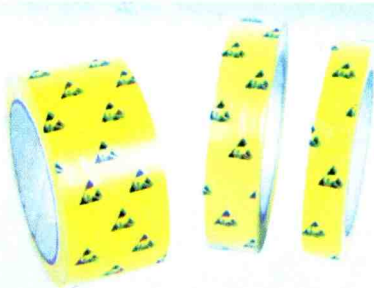

packaged that may have ESD susceptibility. This tape comes in four different widths: 0.5", 0.75", 1" and 2". Each roll of tape is 72 yards long and comes wrapped on a 3" paper core. Its rubber-based adhesive absorbs moisture, allowing the tape to stick longer. The recommended temperature for cellulose tape usage is 10C-50C (50F-122F). The ESD susceptibility symbols are printed in between the film and adhesive layers and will not rub off. This tape is also available in an anti-static Clear Cellulose.

Desco  
Circle (28) on Reply Card

## Fiber-Optic Inspection Scope

The Provision 100 from Jensen tools a high-quality, flexible borescope/fiber-scope with a built-in illuminator that

allows detailed viewing into holes and confined spaces with as little as 1/2" clearance. See behind walls, inside machinery, and more without disassembly. A high-resolution lens provides clear images of objects at distances ranging from 3/4" to 1' away with a wide, 40-degree field of view. The powerful 2.4V lamp illuminates dark spaces on demand with a pushbutton on the handle. The 18" cable adjusts to any position and maintains that position until readjusted. Th

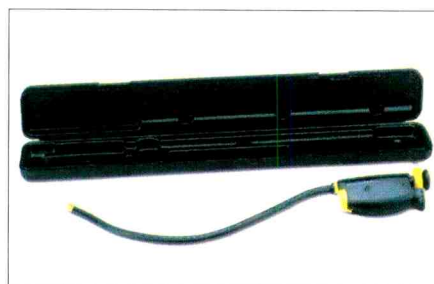

sealed lens is submersible. The scope features a one-handed focus ring and comfort-designed non-slip handle, and comes with a rugged storage case.

Jensen Tools  
Circle (29) on Reply Card

## Digital Multimeters

Fluke Corporation, introduces the Fluke 110 series Digital Multimeters (DMM), a new line of tools designed for industrial, electrical and electronic technicians, as well as for do-it-yourselfers.

The Series 110 boasts 0.7% basic dc accuracy, 6000 counts of resolution and backlit display (112 model). In addition, the meters meet international safety requirements.

The new meters comply with the EN61010 Second Edition standard, which address CAT IV overvoltage requirements. All inputs are designed to withstand an impulse voltage in excess of 6kV which complies with CAT IV 600V requirements.

Fluke Corporation  
Circle (30) on Reply Card



**ELECTRONIC**  
Servicing & Technology

**ES&T is Available  
ELECTRONICALLY from  
Bell & Howell/University  
Microfilms Inc.**

800-521-0600 or 734-761-4700 Ext. 2888  
[www.infolearning.com](http://www.infolearning.com)

THE MAGAZINE FOR PROFESSIONAL ELECTRONIC AND COMPUTER SERVICERS  
**ELECTRONIC**  
Servicing & Technology

**50**  
**ES&T**  
**YEARS**  
of Service

## WATCH FOR THESE FEATURES...

### MAY, 2001

Ad Space Closing: April 16, 2001  
Materials Due: April 18, 2001

COMDEX Review  
Cable-Tec Show Issue  
EDS Show Issue  
Network+Interop Show Issue  
**15th Annual Web and Buyer's Guide**  
Monitors  
Marine Electronics  
Electronic Servicing Supplies  
Audio/Sound Installation and Maintenance  
Cost of Service Today

### JUNE, 2001

Ad Space Closing: May 22, 2001  
Materials Due: May 24, 2001

EDS Review  
COMDEX Review  
Cable-Tec Review  
Network+Interop Review  
GPS/Auto, Marine  
Camcorders  
Soldering Desolder  
Network Installation and Maintenance  
Learning Programs

**For Advertising Information Rates and Reservations:** Contact Joni Jones at 516-944-8068, [jmjones@ix.netcom.com](mailto:jmjones@ix.netcom.com), Barbara Arnold at 781-259-9207, [bhacat@tiac.net](mailto:bhacat@tiac.net) or Dave Allen at 516-883-3332, [dallen@mainlymarketing.com](mailto:dallen@mainlymarketing.com)  
**Editorial Contact:** Nils Conrad Persson at 913-492-4857, [cpe'sedit@aol.com](mailto:cpe'sedit@aol.com).

Circle (31) on Reply Card



# Literature

## Components Catalog

A new 184 page catalog from Jameco feature thousands of ICs and other electronic components, tools, test equipment and computer products ideal for OEM and MRO applications. More than 450 new products have been added including: ICs, transformers, kits, keyboards, motors, computer cables, tools, motherboards, computer cards, switch boxes, speakers, connectors, and wire management accessories. It also features a selection of brand name products including Statico anti-static equipment, Fluke test equipment, Airpax circuit breakers, Ohmite resistors, Gordos I/O modules, 3Com Ethernet Cards, Intel networking equipment, Bourns and Clarostat potentiometers, relays by Omron, MEC, Crydom, and Amperite and relay sockets by Potter & Brumfield.

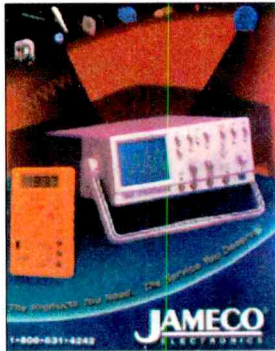

Jameco Electronics  
Circle (33) on Reply Card

## Automotive Application Brochure

Complete Control-By-Wire Automotive and Off-Road Solutions using Thomson Linear motion products are highlighted in a new four-color brochure issued by the company.

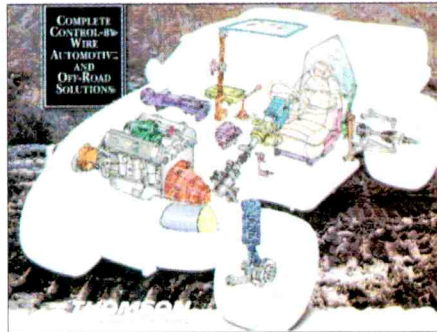

Directed at the automotive design engineer, the piece gives detailed renderings of typical applications where the company's products have been specified to provide control for throttle, brake actuation and traction, HVAC and pump, transmission and lighting functions. A separate section on actuators for use in off-road and marine applications also is included.

The brochure illustrates how linear motion products (such as ball screws, actuators, motors, engineered polymer

bearings, and precision balls) can be used either: 1) off-the-shelf, or 2) innovatively combined to engineer a low cost, high performance, highly reliable single source solution for "control-by-control" and other automotive applications.

Thomson Industries, Inc.  
Circle (34) on Reply Card

## Educational Product Guide

Global Specialties has released a new multi-color product-specific Educational Product Guide.

This new, easy to read tri-fold product guide features over forty innovative state-of-the-art prototyping and test equipment models.

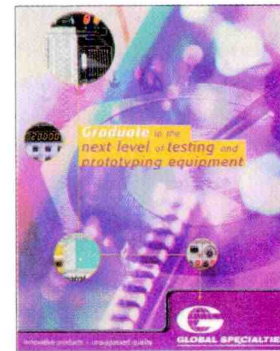

Many models offer functions and features needed by many levels of educational institutions that are not offered by other manufacturers.

Global Specialties  
Circle (35) on Reply Card

## HELP LINE

Dear Sirs, This probably is inconsistent with your magazine's purpose but I would like to know if anyone knows who to contact regarding electronic material sold by the defunct Montgomery Ward Company. I need schematics on some old radios. Also, I appreciate such informative and interesting articles as "product File: Capacitors" appearing in your February 2001 Issue.

F.H.C. - Enfield, NC

Have Lafayette stereo #LR1000T with no stereo sound separation and cannot locate the schematic.

David Conover 609-894-4321

We have been looking for a simple FET Tester. Does anyone manufacture one or has anyone built a home made tester? We have found a number of instruments that purport to test a variety of products including FETs, but none designed to effectively test FETs exclusively.

Respond to ES&T 516-883-3382  
dallen@mainlymarketing.com

## New Web Sites

### Website Dedicated to Clear Speech Technology

NCT Group announces the launch of a new website, [www.nctclearspeech.com](http://www.nctclearspeech.com), dedicated to the ClearSpeech technology developed by the NCT Algorithm Group which specializes in the research and development of signal processing algorithms for enhancing voice communications.

The suite of algorithms enhances voice communications by removal of interfering noise or signal. The suite includes ClearSpeech Adaptive Speech Filter ("ASF"), which removes background stationary noise from speech, ClearSpeech Acoustic Echo Cancellation ("AEC"), which removes unwanted echo from full-duplex hands-free communications, and ClearSpeech Referenced Noise Filter ("RNF"),

which removes noise from speech where a reference signal from the noise-producing source is available. All of the algorithms are developed using ANSI C to facilitate portability.

The new website provides fact sheets for each of the algorithms, wave files which demonstrate the ability of the algorithms to remove noise from speech communication signals, and access to the newly released Windows-based software program, ClearSpeech-PC. This program provides a convenient way for customers to evaluate the performance of the algorithms using either the supplied, or their own wavefiles.

NCT Group, Inc.  
Circle (36) on Reply Card

# Books

## Telecommunications Demystified

A Streamlined Course in Digital Communications (and Some Analog) for E.E. Students and Practicing Engineers by Carl Nassar is a radically new treatment of telecommunications. Published in February by LLH Technology Publishing, it provides a comprehensive tutorial covering the "big picture" of modern communications theory and applications for a wide base of technically oriented readers. "Most communications engineering textbooks are dry and difficult to read, with tons of heavy math and theory to wade through", says Nassar. "I tried to balance a theoretical treatment with practical applications and write a text with some personality. I'm hoping this book helps to shake engineering writing out of the rut it's in." Dr. Nassar, an engineering professor at Colorado State, is also the director of the RAWCom (Research in Advanced Wireless Communications) Laboratory, where he and his graduate students carry out research to advance the art and science of wireless telecommunications.

Telecommunications Demystified is suitable for professionals needing an introduction or "brush up" on telecommunications as well as students desiring a more readable text. It uses intuitive explanations to develop a fundamental understanding of the field. Explanations are followed by illustrations, first teaching the fundamental rules and process, and then building upon them to describe more complex systems. The math is rigorous, but "just-in-time" math refreshers are included. The book discusses such topics as telecom networks, source coding/decoding, modulators and demodulators, channel coding/decoding, trellis-coded modulation, channel filtering and equalizers, estimation and synchronization, and multiple access schemes. A chapter on analog communications rounds out the comprehensive survey of telecommunications theory.

The accompanying Windows CE-ROM contains MATLAB tutorials supporting topics in the text, and a complete searchable Deluxe eBook version of the book, with hyperlinked references and

bookmarks. In addition, a web site for this book can be found at [www.TelecommunicationsDemystified.com](http://www.TelecommunicationsDemystified.com). This site covers new developments, offers supplemental materials, and provides a forum for readers to discuss issues concerning communications engineering.

The list price for the print version of Telecommunications Demystified is \$59.95. The Deluxe eBook version of the book costs \$44.95. It is fully searchable, printable, and contains the full text of the book and accompanying software.

Circle (37) on Reply Card

## Newnes Guide to Television and Video Technology

Third Edition

ISBN 0-7506-4810-4

464 pages

\$29.95

Newnes is pleased to announce the upcoming publication of Newnes Guide to Television and Video Technology by Eugene Trundle.

A truly accessible guide to TV technology and the Digital revolution.

Essential information for all servicing students and professionals.

Includes full coverage of analog systems (terrestrial, satellite and cable)

Newnes Guide to Television and Video Technology explores the fundamentals of Digital TV (satellite, cable and terrestrial) and Digital Video, as well as providing a thorough grounding in analog systems. It is essential reading for service engineers and electronic servicing students.

The readable style of this book makes it the first choice for a wide range of readers working in TV manufacturing, broadcasting and retail. It also makes fascinating reading for anyone who wants to discover the technical side of the Digital revolution, gain a better understanding of their home video equipment, or simply learn more about how their TV works.

CONTENTS: Preface; Basic television; Light and color; Reading and writing in three colors; The PAL system; Transmission and reception; Color decoding; TV display systems; The TV receiver; Teletext; PAL-Plus, MAC and enhanced TV; TV sound systems;

Digital television; Satellite TV; Cable TV; Development of video tape recording; Magnetic tape basics and video signals; Video tape: tracks and transport; Signal processing: video; Signal processing: audio; Servo systems and motor drive; System control for VCRs; The complete VCR; Analogue camcorders and home video; Digital tape formats and computer editing; Tape formats compared; DVD players; Care, operation and maintenance; Interconnection and compatibility.

Circle (38) on Reply Card

## Sensors and Transducers

Third Edition

ISBN 0-7506-4932-1

pages 320, 90 line drawings

\$47.95

Newnes announces the publication of Sensors and Transducers by Ian Sinclair.

Get up to speed in this key topic through this leading practical guide

Understand the range of technologies and applications before specifying

Gain a working knowledge with a minimum of maths

In this book Ian Sinclair provides the practical know how required by technician engineers, system designers and students. The focus is firmly on understanding the technologies and their different applications, not a mathematical approach. The result is a highly readable text which provides a unique introduction to the selection and application of sensors, transducers and switches, and a grounding in the practicalities of designing with these devices.

The devices covered encompass heat, light and motion, environmental sensing, sensing in industrial control, and signal-carrying and non-signal switches.

CONTENTS: Preface; Strain and pressure; Position, direction and motion; Light and associated radiation; Temperature sensors and thermal transducers; Sound, infrasound and ultrasound; Solids, liquids and gases; Environmental sensors; Other sensing techniques; Instrumentation techniques; Non-signal switches; Signal carrying switches; Index .

Circle (39) on Reply Card

## **NEDA Elects New Board of Directors**

Atlanta, GA- The National Electronic Distributors Association (NEDA) has elected a new Board of Directors for its fiscal year 2002 to 2003. NEDA's fiscal year 2002 begins April 1, 2001.

Craig Conrad of ITT was named President of NEDA. Previously, Conrad served as NEDA's Vice President.

Skip Streber of Arrow Electronics moves from the president slot to Chairman of the Board; Dave Herring of Projections Unlimited Inc. is Vice President; Steve Church of Avnet, Inc. is Treasurer and Kevin Glynn of Glynn Electronics is Secretary.

Distributors Directors include Scott Campbell of GC/Waldom Electronics, Inc.; Kathy Ericksen of Capsco Materials Management; Rich Hightower of Kent Electronics; Tom Pitera of Pioneer-Standards Electronics, Inc; Greg Provenzano of Memec/Insight Electronics and Howard Taxe of RS Electronics. The Manufacturer Directors are Bill Hickey of Molex, Inc. and John Simari of Texas Instruments.

As President of the NEDA Education Foundation, Frank Flynn of Sager Electronics has a seat on the NEDA Board. Frank Studer of CamBar is the

chair from the Industrial MRO Division and Art Pierard of Allied Electronics is the chair from the Test, Measurement and Control Division. Don Honbarrier of Xtal Technologies represents the Southeast Chapter and James Goss of

Prime Electro Products represents the SoCal Chapter.

"The new Board represents the excitement and diversity of the authorized electronic distribution industry," said NEDA Executive Vice President Robin B. Gray, Jr.

## **AFSM International Names New President, New Board Members**

AFSM International announced that John Schoenewald, senior consultant, Hahn Consulting, has been named chairman and president of the 2001 international board of directors. In addition, two vice presidents have been added to the board. Toni Stone, director strategic planning and sales development for Rainmaker Systems, has been appointed vice president Americas West. Dan Vredberg, manager, support Compaq Global Services, Compaq Australia, now serves as vice president Australasia.

John Schoenewald has over 30 years of experience in the high-tech service business.

Previously to Hahn Consulting, John worked at Imation, where he directed the OEM/third-party service business.

Toni Stone has over 14 years of technology sales, marketing, and product line management experience for leading companies such as Applied Materials and Varian Associates.

Dan Vredberg is responsible for leading customer services support for Compaq Australia, which encompasses hardware support and technical support, remote diagnosis, software and system support, service delivery operations, second-and third-level technical support, and the customer advocacy department.

A non-profit organization headquartered in Fort Myers, Florida, AFSM International has over 5,000 members representing more than 1,500 organizations in 47 countries.

## **NESDA's Mike Webber Reports Sharp's Response to Service Providers**

Dear NESDA members:

I received a response from Chuck Shaefer March 24 via fax.

In his response, I feel there is nothing concrete regarding negotiated rates for in warranty repair of Sharp products. On March 9, 2001, in Chicago, I asked Sharp to help restore a damaged relationship between Sharp and the independent servicer by "negotiating a reasonable rate of reimbursement with it's service centers on all of Sharp's product lines." There is reference to improvements to the Master Servicer Program, but nothing for the independent service center.

I personally feel that this is a promise that will only be delivered in lip service, as we have heard this same promise many times before. I contend that this is history repeating itself!

As a Master Service Center in Fort

Worth, Texas, I want the membership of NESDA to know that I don't feel that Sharp's warranty repair rates deserve first class service. After figuring the average labor on Sharp warranty repairs for year 2000, I discovered that what I am being paid is below my cost of doing business. Sharp is wanting a quick turn around time on their warranty repairs, and I'm wanting more money. At today's rate of reimbursement, Sharp is on standby status at my service center. This will increase my turn around time on repairs of Sharp products. If this leads to my cancellation as an authorized service center, what have I lost? At the same time, I will be able to improve the turn around time for those who pay better rates.

At the convention in Las Vegas, I will have a campaign button that will have the slogan "First Class, Coach, or Standby."

I ask that everyone that is coming to the convention to bring your cost of doing business. I suspect that the national average will be somewhere around \$75 per hour. I contend that the average repair on all products takes at least one hour. How can you afford to repair something for \$40?

It is time that we as an association do something other than complain. This is business, and as business people, we must be prepared to give the manufacturers the type of service they are willing to pay for. We cannot continue to give the same level of service to all manufacturers. Why would anyone be willing to pay more when others don't? See how successful you are getting to Las Vegas flying first class on the airlines by paying coach fare. Think what would happen if you were to go standby. You always get what you pay for in this world, let's make it happen in our industry.

## **NPSC Roundtable With 3rd Party Administrators Proposed By Tech-Tron's Narciso**

I would like to introduce myself, I am Pat Narciso, and I am President of Tech-Tron TV, Inc. I have been in the electronic service business since 1959.

I served on the Industry Relations Committee 1999-2000 under Wayne Markman's administration.

This year as always, our President, Mike Webber, will sit down with his committee at a roundtable with all the manufacturers to discuss all our service center needs and problems in the industry, as we have done year after year.

Some people would say there are two sides to every story, but my opinion is that there are three sides to every story... "Manufacturers," "Third Party Administrators" and you, the "Service."

I would like to introduce a roundtable this year at the NPSC for the Third Party Administrators to discuss our needs and their needs, and communicate on a mutual level. We would use the same format as we do with the Manufacturers Roundtable.

What I'm requesting from all NESDA members are the questions they would like the committee to ask, such as policy and procedures and any pertinent other information each administrator the individual servicer is servicing.

In closing, I personally feel this is an important step in communicating our problems on a mutual level and believe it is in our best interest to do so this year and to incorporate this Roundtable in future years.

The last conference we the servicers has was in Las Vegas 1982, at that time Fay Wood was the Chairperson who helped put together a "Servicers Bill of Rights." I have a copy of that and it is available at NESDA Fort Worth. I have been in contact with Fay Wood regarding this subject and she would like to assist us in accomplishing this goal, along with the Service Contract Industry Council.

Please contact me if you are interested in this summit so as I can advise our President, Mike Webber, to make arrangements to include this at our convention in August and so that we can make arrangements with the appropriate Service Administrators as soon as possible.

Pat Narciso, Tech-Tron TV, 98 Quenton Road, Brooklyn, NY 11223. 718-265-0264, 718-265-0985 (fax), [TTRONTV@AOL.COM](mailto:TTRONTV@AOL.COM).

*To: ES&T Readers.... For your convenience here is a copy of the Warranty Servicers Bill of Rights referred to in the article.*

### **Warranty Servicers' Bill of Rights**

1. Servicer is entitled to in-warranty reimbursement at their normal repair labor rate, negotiated only to allow for good faith discounts.
2. Servicer is entitled a reasonable profit on parts used in the repair. Suggest the Sperry Markup Table, below.
3. Servicer is entitled to be reimbursed for freight and handling on in-warranty parts repair (suggest a minimum of \$3 or amount shown on provided invoice).
4. Servicer is entitled to reimbursement for supplies used in repairs, such as solder, chemicals, cleaner, etc. (Suggest a fee not to exceed \$5).
5. Servicer is entitled to be paid in a timely manner, not to exceed 30 days from date invoice is submitted for payment.
6. Servicer is entitled to be paid a negotiated rate for diagnostic fees on estimated repairs that are declined. (Suggest a standard "minor" rate.)
7. Servicer is entitled to be paid a negotiated rate when repairs are uncompleted due to unavailable parts.
8. Servicer is entitled to have disputed claims returned promptly and, when corrected and resubmitted, receive priority status for immediate payment.
9. Servicer is entitled to receive a binder of insurance as part of any agreement between the service company and a third party insurance company, and to receive a financial disclosure statement from a third party administrators.
10. Servicer is entitled to an annually negotiated and duly signed one-year contract with third party administrators.

### **Sperry Parts Markup Table #4**

Dealer Price	X= Times	Gross Margin	Dealer Price	X= (Times)	Gross Margin
.00 - .15	12.50	92.0%	2.01 - 3.50	2.86	65.0%
.16 - .18	10.00	90.0%	3.51 - 5.01	2.67	62.5%
.19 - .22	8.33	88.0%	5.01 - 7.50	2.50	60.0%
.23 - .27	7.14	86.0%	7.51 - 10.50	2.35	57.5%
.28 - .33	6.25	84.0%	10.51 - 14.00	2.22	55.0%
.34 - .40	5.60	82.0%	14.01 - 18.00	2.11	52.5%
.41 - .48	5.00	80.0%	18.01 - 22.50	2.00	50.0%
.49 - .57	4.44	77.5%	22.51 - 27.50	1.90	47.5%
.58 - .67	4.00	75.0%	27.51 - 33.00	1.82	45.0%
.68 - .78	3.63	72.5%	33.01 - 40.00	1.74	42.5%
.79 - 1.25	3.33	70.0%	Over 40.00	1.67	40.0%
1.26 - 2.00	3.08	67.5%			

# READERS' EXCHANGE

Readers' Exchange is a free service for ES&T paid subscribers only. Please include a copy of a recent address label with your Readers' Exchange Copy. The following restrictions apply to Readers' Exchange:

- Only individual readers may use Readers' Exchange, and items must be restricted to those that are ordinarily associated with consumer electronics as a business or hobby. If you're in business to sell the item(s) you

want to offer for sale, the appropriate place for your message is in a paid advertisement, not Readers' Exchange.

- Readers' Exchange items must be restricted to no more than three items each for wanted and for sale.
- All submissions must be typed or printed clearly!

**Send your Readers' Exchange submissions to:  
Readers' Exchange  
Electronic Servicing & Technology • 403 Main Street, 2nd Floor, Port Washington, NY 11050  
Tel: 516-883-3382 Fax: 516-883-2162**

## FOR SALE

Sencore VA62A Universal Video Analyzer with all manuals & probes. Excellent condition \$800.00 plus shipping. Hickok Tube Tester. Model #533A with manuals \$30.00 plus shipping. Sams Photofact Sets #1095 to #1366. All 84 sets for \$50.00 plus shipping. John Brouzakis, 247 Valley Circle, Charleroi, PA 15022. 724-483-3072.

Duplicate Sams photofacts, and other duplicate service manuals. Send sase for list. Also other duplicate service test instruments. N. Young, 214 E. Robertson St., Brandon, FL 33511.

Sencore CVA94 Camcorder analyzer with Sencore VR940 Video reference in mint condition. Sencore CM2125 Monitor Analyzer. Sencore HA2500 Horizontal Output Analyzer. All equipment includes original manuals, schematics, and accessories. Will sell together all separately for best offer. Call Rich at 636-561-8413 or email at abori@ninenet.com.

Sencore SC-61 wave form analyzer, 60 MH Band width, and VA-62 Video analyzer. \$495 each. B&K 4673-meter CRT tester. \$160. Call 1-870-246-7234.

H.W. Sams manuals for sale. TSM (24-151) \$100 for all. AR (19-308) \$250 for all. Photofacts (1-2000) a very few missing between 1 and 100. \$750 for all. A few cabinets included. Dave at 218-643-6904, e-mail djnls@702com.net.

Sencore (ALL FORMAT VCR ANALYZER) VC93 VCR Analyzer, like new, all probes, manual, video tapes. \$550.00 {includes shipping}. Contact James at 845-831-5981 or fax 845-831-6865.

Sencore VC93 VCR analyzer in excellent condition, used very little. Includes all manuals, test tapes and leads. \$500.00 OBO. Call Darrell@ (814) 448-2881 or (814) 669-4916 or Fax: (814) 669-4260.

Sencore equipment for sale. SC3100 Oscilloscope, new, never used, still in box, \$2000.00. -CR7000 Picture tube tester/restorer, new, never used, still in box, \$1750.00. -LC103 z-Meter, very new condition, used little \$1750.00. LC102 Capacitor/Inductor tester, new condition, used \$1250.00. -VG91 Video Generator, used little, new condition, \$1750.00. -TVA92 TV Accessory, used little, new condition, \$1500.00. PR570 Isolation Transformer, used, new condition, \$500.00. -SCR250 Triac Accessory, used, new condition, free with LC102. All probes and attachments go with corresponding instrument. James Scanlan, 45 21st Street North, RR1 Box 674 A Edgartown, MA 02539.

## WANTED

Used TV-Audio-Electronics Repair Training Video needed. Will purchase at a reasonable price. Contact Al @ (718) 854-9857 or abay97@aol.com.

Toshiba t6400dx2/200 model# pal604u unit or screen. Contact: Jim Stults (770) 489-1175, stultsjims@aol.com.

Sams CB photofacts #CB-222, CB-251 and CB-263. Will buy either of those or some of the other duplicate copies you have. Please write: Tony Hudson #263236, MCRC H.U.4, P.O. Box 2000, Wartburg, TN 37887.

Service manual/schematic for Pioneer TV SD-P4044. Carver service manual CS5, 1 sub woofer. N. Young, 214 E. Robertson St., Brandon, FL 33511.

Schematic for Macintosh computer color display family NO. M1212. Contact G. Fakhreddin, #272914 168 Frontage Road Newark, NJ 07114.

Sencore TVA 92 or HA 2500 at a good reasonable price. Bob Autry 10 Roling Acres Weaverville NC 28787. 828-645-7909.

Manual for EMC, Electronic Measurements Corp. Tube Tester Model 213/215. Will buy or copy/return. Victor Meeldijk, v.meeldijk@diagnostic.com, 973-967-6412.

Schematic/service manual for a symphonic color TV model#SV19M. Ray's TV Box 70, LaCombe, LA 90445. e-mail: www.3334@yahoo.com.

## DON'T MISS A SINGLE ISSUE OF ELECTRONIC SERVICING & TECHNOLOGY

THE MAGAZINE FOR PROFESSIONAL ELECTRONIC AND COMPUTER SERVICERS

# ELECTRONIC

Servicing & Technology

**As a subscriber to ES&T you don't want to miss a single issue of the trouble shooting, diagnostics or profax information in every issue...**

## Renew Your Subscription Now!

**BY PHONE:** (516) 681-2922  
**BY FAX:** (516) 681-2926  
**BY MAIL:** ES&T Circulation, Suite 405  
25 Newbridge Rd., Hicksville, NY 11801

**Check your label for your expiration date!  
Your expiration date is here:**

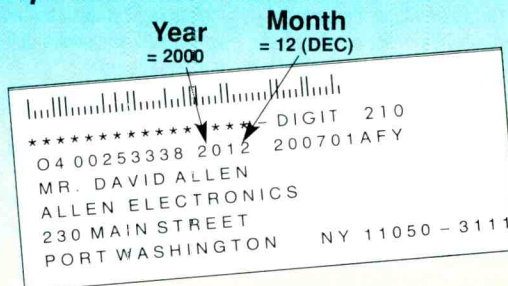

**BY WEB:** [www.electronic-servicing.com](http://www.electronic-servicing.com)  
Please Include you name, address, check, or credit card information (including expiration date), and an address label if available.

# ES&T Readers Speakout

## READER OPINION SURVEY/COMMENTS

Hi Conrad.

I read with interest your retrospective on the 50th anniversary of the magazine, and you are right that you are all too young to have been there at the outset. Even a senior citizen like me didn't come on the scene until 1954; but I remember the publishing scene of that time in the service field somewhat differently. In that era, Stral Advertising was placing service-dealer-oriented advertising for Quam loudspeakers and Stancor transformers, to name just 2 of those early clients. (Shure, Centralab, and PermaPower followed later.)

My recollection is that there were two established vertical magazines for radio-tv service, Service Magazine, published and/or edited by Lew Winner, and Service Dealer, published by Cowan Publications, as a sister book to CQ. PF Reporter was the upstart, produced with much higher production values and probably "cleaner" editorial. Electronic Technician came on the scene a little later (and didn't add Dealer to its name until after it acquired Service Dealer from Cowan). The burgeoning TV market was supporting 4 verticals for a while there-but eventually that was too many, and just as ET became ETD, so PF Reporter acquired Service.

Keep in mind, too, that there were two well-established horizontal

publications as well, serving professional service as well as hobbyists-Ziff-Davis' Radio & TV News, later Electronics World, and Gernsback's Radio-Electronics. And right around the time I came on the scene, so did Ziff-Davis' other entry, Popular Electronics.

With all these "user" magazines fighting for a piece of the ad budget (and a \$30K budget was a big budget, at least to us), there were also 4 publications serving the jobber function, Jobber News, Parts Jobber, NEDA Journal, and Radio and TV Weekly.

The established OEM book was Electronics (McGraw Hill), and Z-D tried to challenge with a RTV News spin-off, Radio Electronic Engineering; but that folded fairly rapidly. Electronic Design was a more successful challenger, and Chilton had a third-place book, I think TeleTech. EDN came along transitioning from Electrical (not Electronic) Design News. Other debuts that I remember are E News (they eventually had a salesman in Chicago named Dave Allen), EBN, ECN-the mind boggles.

Anyway, thanks for sending me off on a nostalgia trip. I assume you'll be in Las Vegas for EDS, and look forward to seeing you there.

Laurence Kaufman  
Kaufman Ryan Stral Inc./  
BigWorld Communications  
Chicago IL 60610

Really enjoy your magazine every month but feel it is somewhat slow at arriving here. It is now the end of December and just got my November issue last week in December. Would really appreciate the month's issues on a timely basis, like December issue in December. Anyway keep up the great articles, especially the TV and VCR fault tips as well as audio.

Thank you and have a great year in 2001.

Terry Onda - Saskatoon, Canada

To whom it may concern:

I have enjoyed your magazine since 1983, but I am sorry I will be canceling my subscription at the end of my renewal date, June 2001. I have changed careers and no longer will be in need of your magazine for information. During the last 18 years I have had my

subscription, I have encountered many great employees on your magazine. I would like to thank Homer L. Davidson, I really enjoyed him as a person and also the wonderful articles he would write. I also want to send a special thanks to Sam Wilson. And to the magazine thank you very much and keep up the great work!

Jimmie Lee Johnson - Opa Locka, FL

### DECEMBER

I as a Bio-Medical Engineer Technician would like to see issues on the Bio-Medical field. D.H. - Orlando, FL

### JANUARY, 2001

**THE ES&T Survey card asked which manufactures have the best support, brands you would recommend, etc. The statistical tabulation will be pub-**

**lished upon completion. Here are additional comments on this question, and the overall issue.**

Your magazine is valuable to me and you are trying to get it to run smoothly, however, it hasn't happened yet. Keep trying, we do need your presence. TV/VCR Fixer - Virginia Beach, VA

It's disgusting to be charged for a "900" call to these people to get assistance needed to repair "Their" product. NOT all companies do this either. D.C.H. - Carmel, IN

Rated excellent, however have the publication delivered sooner, not in the middle of the following month!!!

R.M.H. - Manistique, MI

Very good issue. R.D. - Athens, GA

I use Sony when I have a problem with the brand, and I get a good support service. S. P. Herndon, VA

Monitor service information. Must be written more often.

F.C. - Baldwin Park, CA

Hitachi TV's are OK, but tech. support is questionable. JVC is the worst of the lot. L.H. - Clinton, MD

Replacement parts servicing information source guide excellent!

A.B.L. - New Windsor, NY

Please run the results of this census in a future issue. Please run a census or an article on what repair charges are now running with electronics prices dropping.

Goodrich Electronics - Labbock, TX

I found the following articles useful or interesting. History of Projection Display, Servicing Playstations, DVD Servicing, Parts Source Guide, Review Cap analyzer.

E.C.F. - Hialeah, FL

Want Symcure Features back, they were of great interest. What happened? Also, why did you drop peel off labels? BRS - Dresher, PA

### ES&T Response:

**We are looking to bring back Symcure in the next few months. We are also revisiting the peel off label question.**

Would like to see DTV, HDTV theory articles. Thanks.

A.I.A. - Cincinnati, OH

Most MFG do not offer support and those who do are not too helpful.

General Electronics Corp. -  
Brandon, FL

Support bad when you are not authorized service depot.

S.B.B. - New Brunswick, Canada

### FEBRUARY, 2001

**Survey card asked you which associations you belong to and which shows you attend. The full tabulation will be published when completed. Following are the additional comments on the questions and ES&T.**

Where are the PS schematics in the Profax? D.C.S. - Milwaukee, WI

Shows are too far away. In Canada shows aren't relevant enough to go to. J.C. Electronics

Troubleshooting, TV/VCR combo. E.A.L. - Shasta Lake City, CA

How about some information on some of the many tech "help" disks and websites.

C.W. - Pine Knot, KY

We need more tips on repairs of new models of TV's. P.S. Also updates on new models and brands.

Dyckman TV Corp. - New York, NY

Enjoyed TV/VCR info. These "wonders" are the bane of my existence.

ANON

Love troubleshooting problems VCR - TV - cameras. Keep it up.

J.H. - St. Zenon, P.Q.

I like the topic: capacitors and I want it to be continued on March Issue.

C.F. - Brooklyn, NY

ES&T Readers are invited to respond to any of the above or make additional comments. Wherever possible, we will put interested parties together.

Send to:  
ES&T Readers Speakout  
403 Main Street, 2nd Floor  
Port Washington, NY 11050  
Fax: 516-883-2162  
Email: dallen@mainlymarketing.com.

Watch for these Features, Special Reports, Technical Updates and other articles designed to help Consumer Electronics Service and Maintenance Professionals stay current and grow.

ISSUE	INDUSTRY EVENTS COVERAGE	SPECIALS	COMPUTERS/ NETWORKING/ AUTOMOBILE ELECTRONICS	CONSUMER ELECTRONICS	TOOLS/ EQUIPMENT COMPONENTS	HOME THEATER	50TH ANNIVERSARY	SHOWS/ CONFERENCES
<b>JAN</b>	CES SHOW ISSUE NASC PREVIEW	2000 ANNUAL INDEX OF ARTICLES AND PROFAX SCHEMATICS	DVD	Playstations	Materials Handling: ESD to Moving Equipment		50th Anniversary – History Part 1	CONSUMER ELECTRONICS SHOW (CES) 2001 January 6-9, Las Vegas Convention Center, Alexis Park & Riviera, Las Vegas NV
<b>FEB</b>	NASC SHOW ISSUE	REFERENCE ISSUE on Service Tips: CD's, Webs and OEM contacts	Scanners	VCR/TV Combos	Service Management Software	Phone Systems	Service Center Management Trends	NATIONAL ALL SERVICE CONVENTION (NASC), February 7-11, Delta Resort, Orlando, FL
<b>MAR</b>	COMDEX PREVIEW NASC REVIEW	TOOLS AND TOOLCASE SHOWCASE and Review	Printers	VCRs	Test Equipment Update	Designing Your Showcase Site	Circuit Board Rework Opportunities, Solutions	ELECTRONIC HOME EXPO March 7-10, Orange County Convention Center Orlando, FL NSCA National Systems Integration Expo, Mar 8-10, Orange County Conv. Center, Orlando FL.
<b>APR</b>	COMDEX SHOW ISSUE EDS PREVIEW	DISTRIBUTION SHOWCASE and Review	Rewritable Disk Systems	CCTV	Test Probes/ Accessories Update	Antennas/ Top Boxes for HDTV	50th Anniversary – History Part 2	COMDEX/CHICAGO 2001 (Formerly COMDEX-Spring) April 3-5, McCormick Place, Chicago, IL
<b>MAY</b>	COMDEX REVIEW, CABLE-TEC SHOW ISSUE, EDS SHOW ISSUE, NETWORK+INTEROP SHOW ISSUE	15th ANNUAL WEB and BUYER'S GUIDE. Includes multiple manufacturer/ distributor listings in the Product Directory and a Company Contact Directory, including Web and Email addresses	Monitors	Marine Electronics	Electronic Servicing Supplies	Audio/Sound Installation and Maintenance	Cost of Service Today	CABLE-TEC EXPO 2001, May 8-11, Orlando, FL. ELECTRONIC DISTRIBUTION SHOW & CONFERENCE (EDS), May 15-17 (May 14 Educ.), Las Vegas Hilton, Las Vegas, NV NETWORK+INTEROP, May 6-11, Las Vegas Conv. Center, Las Vegas, NV
<b>JUN</b>	EDS, COMDEX, CABLE-TEC & NETWORK+INTEROP REVIEWS		GPS/Auto, Marine, etc.	Camcorders	Soldering Desoldering	Network Installation and Maintenance	Learning Programs	MID-ATLANTIC ELECTRONICS CONFERENCE, June 14-17, Holiday Inn Olde Towne Portsmouth, Portsmouth, VA
<b>JUL</b>	NPSC PREVIEW		AutoComputer Systems	Microwave Ovens	Oscilloscope Update	Servers	50th Anniversary History Part 3	
<b>AUG</b>	NPSC SHOW ISSUE CEDIA PREVIEW EDGETECH	REPLACEMENT PARTS SHOWCASE and Directory	Firewire	Digital TV	Multimeter Update	Lighting	Complying with Environmental Considerations	NPSC (NESDA/ISCET) Conf., July 30-Aug. 4, Riviera Hotel, Las Vegas, NV EDGETECH, Aug. 19-21, Aladdin, Las Vegas, NV
<b>SEP</b>	CEDIA SHOW, NETWORK+INTEROP SHOW ISSUE	HOME THEATRE SHOWCASE and Review	Telecom Test Equipment	HDTV	Transformers	Power Management	Home Theatre Opportunities	CEDIA, Sept 5-9, Indianapolis Convention Center, Indianapolis, IN. NETWORK+INTEROP, Sept. 9-14, Atlanta, GA
<b>OCT</b>	CEDIA, NETWORK+INTEROP REVIEW, COMDEX PREVIEW	MANUFACTURERS PRODUCT BRAND Directory	PC Testing Tips	Keyboards/ Organs	SMD	Servicing \$10,000+ TVs	50th Anniversary – History Part 4	ELECTRONIC HOUSE EXPO October 25-27, Long Beach Convention Center, Long Beach, CA
<b>NOV</b>	COMDEX SHOW ISSUE		Computer Software Diagnostics	Cassette Mechanisms	Power Supplies	Rear Projection	Servicing TVs Today	COMDEX-FALL 2001, Nov. 12-15, Las Vegas Convention Center, Las Vegas, NV
<b>DEC</b>	COMDEX REVIEW CES PREVIEW	TEST EQUIPMENT SHOWCASE and Review	Internet Access	CD Players	MPU's	Security	New Technology Update	

**IN EVERY ISSUE:** New Products, New Literature, News, Book Reviews, Photofacts and Profax.

To be scheduled or added as available: Test Your Electronics Knowledge (TYEK), Troubleshooting Tips, Video Corner, Computer Corner, Audio Corner, Business Corner, Communications Corner, The Smart Building, Successful Servicing, What Do You Know About Electronics (WDYKAE), Service Organization Profiles.  
Advertising Space Reservations: 10th of the month preceding issue. Materials Due: 15th of month preceding issue.

# CLASSIFIED

**CLASSIFIED ADVERTISING** By the word. \$1.65 per word, per insertion, pre-paid. Minimum charge is \$35 per insertion. Initials and abbreviations count as full words. Indicate free category heading (For Sale, Business Opportunities, Miscellaneous, Wanted). Blind ads (replies sent to ES&T for forwarding) are \$40 additional. No agency discounts are allowed for classified advertising. For further information, or to place your order, contact:

**Lyndiane Paoletti, Electronic Servicing & Technology**  
403 Main Street, 2nd Floor, Port Washington, NY 11050  
Tel: 516-883-3382 Fax: 516-883-2162

## FOR SALE

For Sale Great Condition: 1VG91 Video generator, 1 TVA92 TV Analyzer, 1 TP212 Probe 10kv, 1 HP200 Probe, High Voltage, 50kv. \$2700.00 or best offer. Call Matt @ 800-753-7702

**\*\*SERVICE TIPS plus GRAPHICS\*\*** 100,000 tips PLUS High Resolution Graphic Images. **NO OTHER PROGRAM OFFERS THIS FEATURE.** Locate the problem, discover the solution & VISUALLY SEE the board, parts, Sams# & troubleshooting information all on one template. **Special till May 15, 2001 ONLY \$219.95** plus s&h. Call **1-800-621-8477** for more information. Electronic Software Developers Inc 826 Main St Farmingdale NY 11735.

**TV CASE HISTORIES:** Volume 8 with 3,325+ histories. Satisfaction assured. Only \$59.75 (plus \$3.95 shipping). Over 11,900 books and supplements sold with only 1 returned for a refund! **Mike's Repair Service**, P.O. Box 217, Aberdeen Proving Ground, MD 21005. Same mailing address 37+ years. Send SASE for samples. 410-272-4984, 1-800-2-FIX-TV 11a.m.-9 p.m. (<http://mikesrs.webjump.com>)

**ANY Tuner we rebuild is \$25, YES \$25, YES \$25, YES \$25!** Includes FREE Shipping and Handling. \*BUY - SELL - TRADE\* **Tip Top TV**, 18441 Sherman Way, Reseda, CA 91335. **818-345-1974.**

**IN-CIRCUIT CAPACITOR TESTER** - Find bad caps FAST and RELIABLY with the Capacitor Wizard in-circuit ESR Tester! Great for monitors, switching power supplies, TV, etc. Still only \$179.95. MC/VISA. **Independence Electronics Inc. 800-833-1094. www.awiz.com.**

**SENCORE, TEKTRONIX, HEWLETT PACKARD** (all models). We **BUY, SELL, & TRADE.** Please call "**CHOICE ELECTRONICS**" for all of your test equipment needs. Complete financing options available. Call 1-800-609-0677, 605-361-6386 ask for Lance Tople.

**TEST EQUIPMENT FOR SALE: REASONABLE PRICES SENCORE, TEKTRONIX, HP and MUCH MORE.** View complete list at: <http://www.astglobal.com> or contact: **AST GLOBAL ELECTRONICS.** Voice: 888-216-7159; Fax 814-398-1176; e-mail: [sales@astglobal.com](mailto:sales@astglobal.com)

## WANTED

**WANTED: USED TEST EQUIPMENT. TURN IDLE OR EXCESS EQUIPMENT INTO CASH.** **AST GLOBAL ELECTRONICS.** Voice: 888-216-7159; Fax 814-398-1176; e-mail: [sales@astglobal.com](mailto:sales@astglobal.com).

## EMPLOYMENT

**ELECTRONIC TECHNICIANS.** Component level repair. Performance Incentives. Syracuse, NY. Apply at [www.unitedradio.com](http://www.unitedradio.com).

## BUSINESS OPPORTUNITIES

West Chester Pennsylvania TV Audio VCR Satellite Service since 1954. Good location and money maker. Asking \$25,000 — moving reason. Tel (610) 696-5218.

Well established, fully equipped CB radio and scanner sales and service shop. Excellent location in Hudson Valley, NY. 48 hour work week => \$200k/yr. Owner willing to train. (845) 457-3317.

**Florida TV/Electronics Business** 2 buildings, 2 sheds, parking lot, 2 ways in and out. On main drag. A steal at 75k. 863-385-0359.

# MOVING?

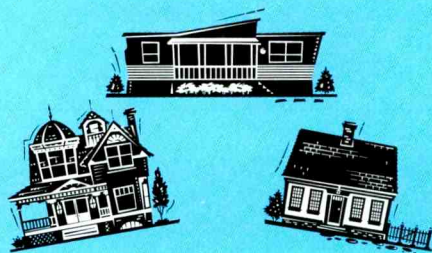

If you're planning a move in the near future, don't risk missing an issue of

**Electronic Servicing & Technology.**

Please give us 6-8 weeks notice if you're planning on changing your address. Just write us with your new address.

**AND YOUR SUBSCRIPTION MAILING LABEL, to:**

**ELECTRONIC SERVICING & TECHNOLOGY**  
Circulation Dept., Suite 405  
25 Newbridge Road  
Hicksville, NY 11801

(Old zip code needed for change of address.)

## To Order Back Issues

**ELECTRONIC**  
Servicing & Technology  
World of the Trade Dealer, Technicians, and  
NIPC Repair, CD/DVD Programs, Servicing 21st  
**Today's Meters Offer More Functions**  
**ONLY \$5.00 PER ISSUE**

**COMPLETE YOUR COLLECTION TODAY.**

**Check, Money Order, Mastercard, VISA, Discover and AMEX accepted**

**Electronic Servicing & Technology**  
Attention: Mary Tali

P.O. Box 748, Port Washington, NY 10050

**CALL: 800-462-4659**

**For Fastest Service**  
**FAX 516-883-2162**



THE MAGAZINE FOR PROFESSIONAL ELECTRONIC AND COMPUTER SERVICERS™

# ELECTRONIC

Servicing & Technology



## Six Month Report

Just over 6 months ago we acquired *Electronic Servicing & Technology* magazine. Since then it has been a fast track in many ways. We have learned a great deal about you, the subscribers and readers of this magazine, and attempted to learn as much as possible about the service business. This isn't easy in a constantly changing environment.

Even so, here are a few items we have learned:

- You, the readers of *ES&T* have a pride of ownership with this publication.
- As part of that ownership, you want to receive the publication you subscribed to. Yes, you will accept and even embrace change, but it had better fit your needs and desires and not be perceived as based on some abstract publishing principal or economy.
- Profax is important to many of you...we changed to the same paper as the run of the publication and you let us know your displeasure in no uncertain terms. Many thought it was an economy measure — it wasn't. Many of you still pull these Profax schematics out of the issues, so, you wanted them on flat, 'no glare' paper, and you wanted to be able to spot them easily...thus the yellow look.
- There is a wide divergence in your interests. Many subscribers want technical input, repair and troubleshooting editorial on products like VCRs and microwave ovens (see page 43). At the same time many are moving into home theater, smart home, computer, networking and other convergence technologies and seeking technical and business information on this aspect of your profession.

During the past 6 months we have improved the paper and the look of the magazine. We have added four-color availability on all pages, added Help Line, Readers Speakout, and expanded the New Products and News sections.

Conrad, our editor, has been terrific in embracing new ideas and maintaining solid values.

Your response has been quite positive through personal comments, comment cards and in the use of the inquiry card. Which, as you know, many advertisers use as a gauge of your interest and readership of *ES&T*.

During the first 5 months since our acquisition, here is how you have increased your response on the inquiry card:

Total Cards received per issue:	UP 26.4%	Ad Inquiries per issue:	UP 49.9%
Total Inquiries received per issue:	UP 42.3%	New Product Inquiries per issue:	UP 92.1%

Considering the impact the web has had on the overall inquiry business, these numbers are truly significant, and we thank you. (More to come on *ES&T* and the web in the next issue.)

### Lots of Room for Improvement

There are many items on our agenda to improve your magazine, and we know you, our subscribers, have your own list of things for us to accomplish.

Our first list includes: improving the delivery schedule and cleaning up the typos and computer translation errors that slip into articles. We will also increase the coverage of people and business news that affects your ability to operate profitably as a professional.

Finally, we recognize the buffeting you have taken over the past several years. Without sacrificing the technical help and troubleshooting content of *ES&T*, we want to work with you to rekindle the professional view of, and among, today's Consumer Electronics Service Professionals.

Thank you for your help and patience.

*Marc Marcellino*

*Paul Allen*

# DISPLAY CLASSIFIED MARKETPLACE

**DISPLAY CLASSIFIED MARKETPLACE** Display Classified Marketplace \$260.00 per column inch per insertion. Frequency rates available. 2 columns per page, 3 1/2" column width. Minimum size accepted: 1 column inch. Additional sizes billed in 1/4" increments. Maximum height per ad is 4", maximum width per ad is 1 column (3 1/2"). Agency discounts paid to recognized agencies if finished materials are provided. We accept AMEX, MasterCard, VISA and Discover. Optional color (determined by ES&T) \$150.00 per insertion. For more information, or to place your order, contact:

**Lyndiane Paoletti**  
 Electronic Servicing & Technology  
 403 Main Street, 2nd Floor, Port Washington, NY 11050  
 Tel: 516-883-3382 Fax: 516-883-2162

## Do You Repair Electronics?

Repair databases for TV, VCR, Monitor, UL Audio, FCC, and more.

- Over 76,000 records
- Private user forums
- Live on-line chat rooms

### RepairWorld.com

Electronix Corp., 1 Herald Square, Fairborn, OH 45324 (937) 878-9878

Circle (40) on Reply Card

**www.stairclimber.com**  
 Escalera Stair Climbing Forklifts & Handtrucks



**FREE VIDEO** online or call 800-622-1359 FAX 530-673-6376

1200 lb. Capacity Big Wheel Attachment

60 Day Money Back Trial

POWER WITH STEPS TO CLIMB

Circle (41) on Reply Card

Visit the Herman/Panson Cyberwarehouse and THE PROS to order your original replacement parts and service accessories online!



**www.hermanpanson.com**

Circle (42) on Reply Card

# ELECTRONIC™

Servicing & Technology

**TO PLACE YOUR  
 BUSINESS CARD AD HERE  
 EVERY MONTH CALL:**

**Lyndiane Paoletti**  
**ELECTRONIC SERVICING & TECHNOLOGY**  
 403 Main Street, 2nd Floor  
 Port Washington, NY 11050  
 Tel: 516-883-3382 • Fax: 516-883-2162

## ADVERTISERS INDEX

COMPANY	PAGE NUMBER	READER SERVICE NUMBER	ADVERTISER HOTLINE
ANDREWS ELECTRONICS	19	12	(800) 289-0300
B&D	3	7	(888) 815-0508
B&D	20	13	(800) 458-6053
B&K PRECISION	IFC	1-6	(800) 462-9832
B&K PRECISION	23	10	(800) 462-9832
ELECTRO/HORIZONS/PUBLICATIONS:			
GLOSSARY	41	16	(800) 462-4659
ELECTRONIC DESIGN	13	9	(516) 487-6103
ELECTRONIC DISTRIBUTION SHOW (EDS)	5	8	(312) 648-1140
ELECTRONIC SERVICING & TECHNOLOGY:			
BOOK SHOP	IBC		(800) 462-4659
CALENDAR	37	15	(800) 462-4659
UPCOMING FEATURES	46	31	(800) 462-4659
ELECTRONIC TECHNICIANS ASSOCIATION	43	18	(800) 288-3824
ELECTRONIX CORP.	56	40	(937) 878-9878
"ESCALERA, STAIRCLIMBER"	56	41	(800) 622-1359
HERMAN ELECTRONICS	56	42	(800) 938-4376
ISCET	41	17	(817) 921-9101
SAMS TECHNICAL PUBLISHING	17	11	(800) 428-SAMS
SENCORE	21	14	(800) SENCORE
THOMSON MULTIMEDIA INC.	BC	32	(800) 336-1900

**WE'D LIKE TO SEE YOUR COMPANY LISTED HERE TOO!**

**CALL:** Joni Jones, 516-944-8068, e-mail: [jmjones@ix.netcom.com](mailto:jmjones@ix.netcom.com),  
 Barbara Arnold, 781-259-9207, e-mail: [bhacat@tiac.net](mailto:bhacat@tiac.net)

or  
 David Allen, Sales Director, 516-883-3382,  
 e-mail: [dallen@mainlymarketing.com](mailto:dallen@mainlymarketing.com)

**TO WORK OUT AN ADVERTISING PROGRAM  
 TAILORED TO SUIT YOUR NEEDS.**

To Order Call Toll Free 800-462-4659

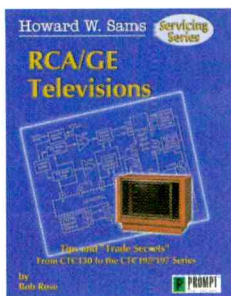

**Servicing Zenith Televisions**  
(Sams Servicing Series)  
by Bob Rose

Expanding on the Sams Servicing Series, author Bob Rose takes an in-depth look at Zenith TVs, with coverage of manufacturer hr shop in Fort Dodge, IA for 38 years. He is the author of more than 43 books and more than 1,000 articles printed in 48 different magazines. He currently is the TV servicing consultant for Electronic Servicing & Technology magazine.

Paperback • 320 pages • ISBN 0790612240 • Sams # 61224 • \$34.95 US • \$53.95 CAN

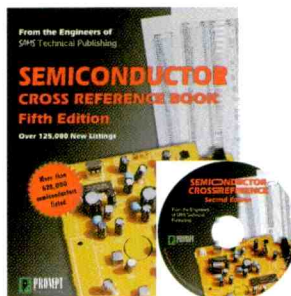

**Semiconductor Cross Reference Book**  
Paperback or CD-ROM  
by Sams Technical Publishing

The perfect companion for anyone involved in electronics! Sams has compiled years of information to help you make the most of your stock of semiconductors. Both paper and CD-ROM versions of this tool contain an additional 128,000 parts listings over the previous editions.

Paperback, 5/E • 876 pages • ISBN 0790611392 • Sams 61139 • \$39.95 US/\$61.95 CAN  
CD-ROM, 2/E • ISBN 0790612313 • Sams # 61231 • \$39.95 US/\$61.95 CAN

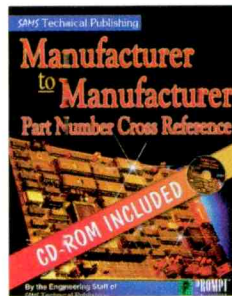

**Manufacturer to Manufacturer Part Number Cross Reference**

with CD-ROM from the Engineering Staff at Sams Technical Publishing

Sams Technical Publishing has compiled part number information, from years of service documentation development to help repair technicians better utilize their parts inventory. Part numbers from various manufacturers are cross referenced for use in many electronics devices. A valued reference for any repair technician.

Paperback • 320 pages • ISBN 0790612321 • Sams # 61232 • \$39.95 US • \$61.95 CAN

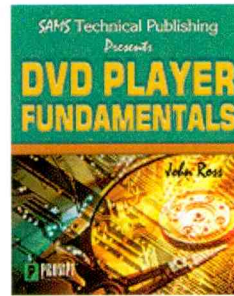

**DVD Player Fundamentals**  
by John Ross

DVD Player Fundamentals covers every aspect of the Digital Versatile Disc starting with features, specifications, hookup, operation, user error, and more. For the professional, specific technical information includes: DVD track structure and disc construction, optical head and lens features and specifications, video signal processing, MPEG-2 technology, audio signal processing, decoding, audio path and reference signals, switch-mode power supply, tracking servo, transverse servo, system control circuits, etc. Paperback • 304 pages • ISBN 0790611945 • Sams # 61194 • \$29.95 US/\$46.50 CAN

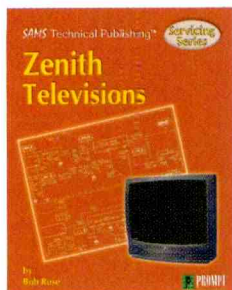

**Servicing Zenith Televisions**  
(Sams Servicing Series)  
by Bob Rose

Expanding on the Sams Servicing Series, author Bob Rose takes an in-depth look at Zenith TVs, with coverage of manufacturer OEM parts versus generic parts.

Paperback • 352 pages • ISBN 0790611716 • Sams# 61171 • \$34.95 US/\$53.95 CAN

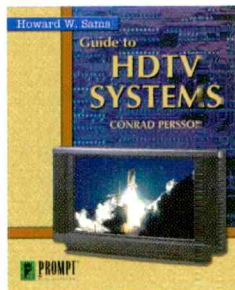

**Guide to HDTV Systems**  
by Conrad Persson

As HDTV is developed, refined and becomes more available to the masses, technicians will be required to service them. Up until now, precious little information has been available on the subject. This book provides a detailed background on what HDTV is, the technical standards involved, how HDTV signals are generated and transmitted, and a generalized description of the circuitry an HDTV set consists of.

Paperback • 323 pages • ISBN 079061166X • Sams# 61166 • \$34.95 US/\$53.95 CAN

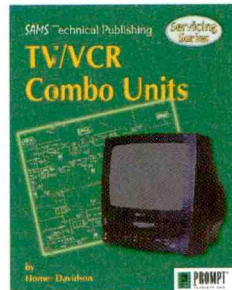

**Servicing TV/VCR Combo Units**  
(Sams Servicing Series)  
by Homer Davidson

Part of Sams Servicing Series, Servicing TV/VCR Combo Units covers the servicing issues surrounding this popular electronic device. TV/VCR combo units have become smaller, more affordable, and functional. They are now used in new ways, including applications in autos, campers, kitchens, and other non-traditional locations. Homer Davidson uses his vast knowledge to cover this subject in a way no one else can.

Paperback • 320 pages • ISBN 0790612240 • Sams # 61224 • \$34.95 US • \$53.95 CAN

**ORDER TOLL FREE  
1-800-462-4659**

Make your selections and include your name, address and telephone with order.

Check, Money Order, MC, VISA, AMEX and Discover accepted. Include CC# and Expiration with order. Make checks payable to: **Electronic Servicing and Technology.**

Shipping: FREE on US orders over \$50. Smaller orders = \$4.00. Foreign shipping charged at actual cost (less \$4.00 for orders over \$50).

Call or mail order to:  
**Mary Tali**  
ES&T c/o MMEI  
P.O. Box 748  
Port Washington, NY 11050  
Fax: 516-883-2162  
**Tel: 800-462-4659**

Video Heads

# Pick A Number Any Number

When you're looking for a replacement head, SK Series is way ahead of the competition.

SK Series replacement video heads cross over to 4,500 different models and 68 different brands.

And when you're in need of any exact semiconductors, belts, tires, flyback transformers or video replacement parts, we have them too.

But we don't stop there.

Every SK Series product comes with the quality assurance and accuracy you expect from all Thomson products.

For more information on SK Series products, contact your nearest Thomson Distributor.

SK Series...The parts you need to do the job. "Trust me!"



Thomson multimedia Inc.

# M2120

Circle (32) on Reply Card

