

# Broadcast Programming & Production

JANUARY / FEBRUARY 1976  
VOLUME 2 / NUMBER 1

**Why Are  
You Playing  
That Record?**

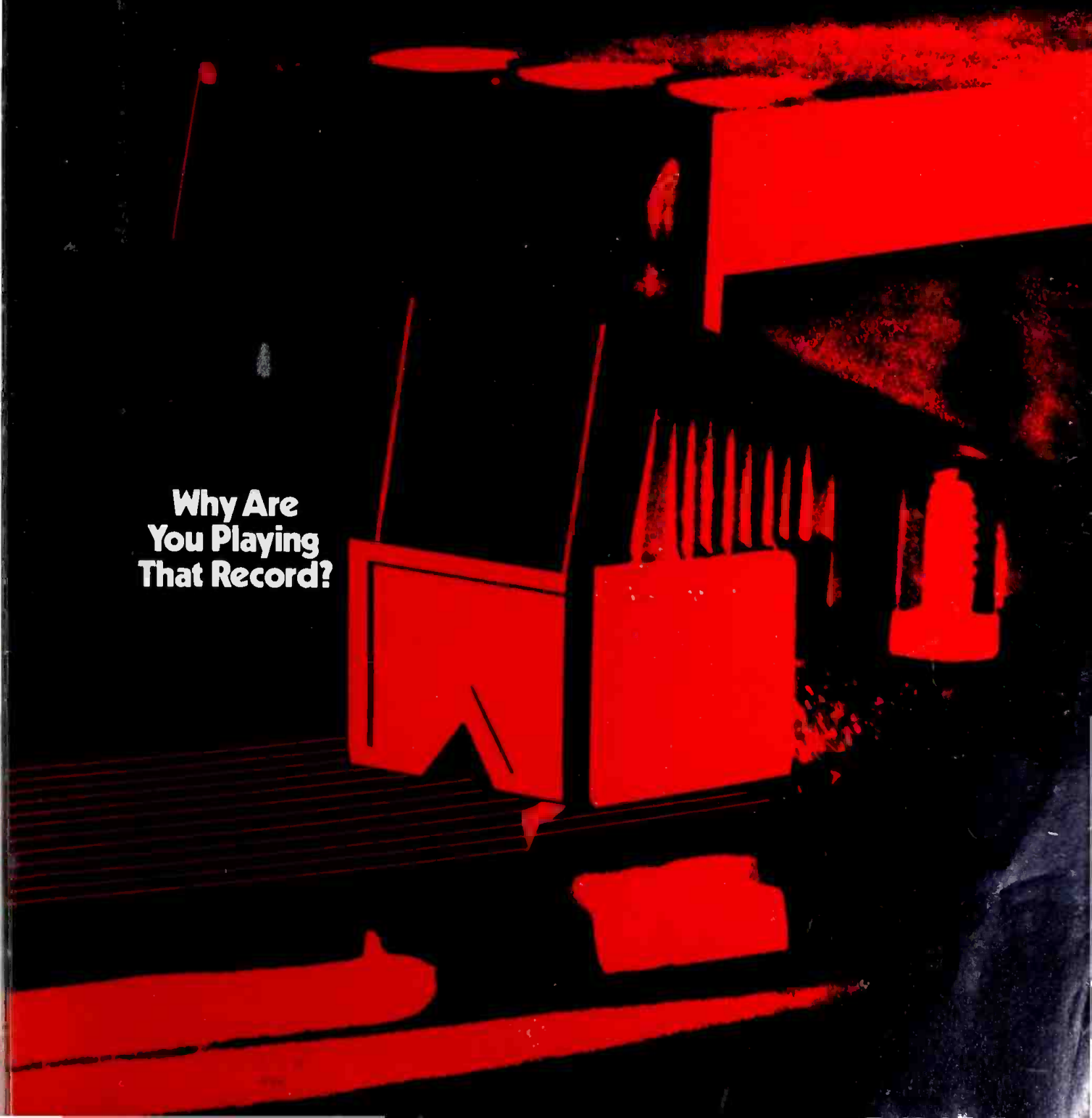

# It's all in your hands now.

These essential music-making tools let you get in, around, and behind your music. One part, one track at a time. Then when all the elements are the best they can be, you blend them together and generate the finished product. A process that involves your innermost sensitivities and perceptions. A personal statement.

The 3340 has undoubtedly helped more people make more demos and masters than any other tape recorder. Our new model, A-3340S, has extended high end frequency response in the sync mode, plus manual cueing. The Model 2 is about the best value going in small mixers—6-in, 4-out with full panning and multiple patch points. Plug in a few high quality TEAC ME-Series electret condenser mics, and you could be quite literally in business.

Just call toll free  
(800) 447-4700,  
in Illinois, 322-4400  
for the name of  
your nearest  
TEAC dealer.  
When you have  
the right tools,  
the work is  
more productive.

## TEAC®

The leader. Always has been.

TEAC Corporation of America  
7733 Telegraph Road, Montebello, Calif. 90640  
©TEAC 1975



- Broadcast  
PROGRAMMING & PRODUCTION  
Programming: The competition for audience.  
Production: The implementation of competitive programming.
- Broadcast  
PROGRAMMING & PRODUCTION  
relating programming software and production hardware to the competition for today's broadcast audience.
- Broadcast  
PROGRAMMING & PRODUCTION  
the broadcast magazine that begins where basic broadcast operation ends.

Editor/Co-Publisher GARY KLEINMAN  
 Publisher . . . . . MARTIN GALLAY  
 Business Manager . . . V.L. GAFFNEY  
 Circulation Manager LARRY DOUGLAS  
 Reader Service  
 Manager . . . . . DEBRA LYNNE  
 Production  
 Manager . . . MARGE ANDERSON

BROADCAST PROGRAMMING & PRODUCTION is published bi-monthly (every other month) by Recording & Broadcasting Publications, 1850 N. Whitley Ave., Suite 220, Hollywood, CA 90028, and is sent to qualified recipients. Subscription rates: United States, \$7.00 per year; Foreign, \$8.50 per year; Airmail, \$13.00 per year. Material appearing in BP&P may not be reproduced without written permission of the Publisher.

BROADCAST PROGRAMMING & PRODUCTION is not responsible for any claim made by any person based upon the publication by BROADCAST PROGRAMMING & PRODUCTION of material submitted for publication.

Controlled Circulation postage paid at Los Angeles.

Address All Correspondence to:

**BROADCAST PROGRAMMING  
& PRODUCTION**  
 P.O. Box 2449  
 Hollywood, CA 90028  
 (213) 467-1111

# Contents

WHY ARE YOU PLAYING  
 THAT RECORD? 6 *Betty Breneman*

CUE TONES  
 AND THE "TIGHT"  
 AUTOMATION FORMAT 13 *Ron Lewis*

TELEVISION NEWS GATHERING  
*New Films =  
 Lower Light +  
 Faster Process* 16 *Robert Fisher*

NOTES ON BECOMING  
 A PRODUCTION PRO 20 *Mike Starling*

Letters 4  
 New Products & Services 29  
 Classified 35

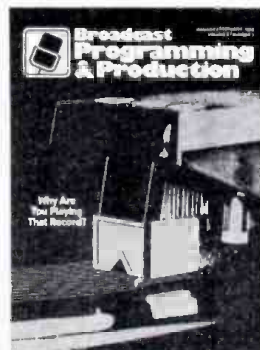

**ON THE COVER:**

*Close-up view of a Shure cartridge tracking the grooves of a record. . . reflecting Betty Breneman's article, "Why Are You Playing That Record," beginning on page 6.*

Photography and Graphics: Gary Kleinman

**ADVERTISERS INDEX**

ACCURATE SOUND	35	MICRO-TRAK	25
AUDIO CONCEPTS/ DAVE KELSEY SOUND	23	MORE MUSIC ENTS.	17, 35
AUDIO/VIDEO PROGRAMMING	26	OPAMP LABS	35
BILL BALLANCE SHOW	26	ORBAN/PARASOUND	14
BROADCAST ELECTRONICS	22	RADIO ARTS	CVR. 4
CAVOX STEREO PRODS.	11, 15, 23, 32	RUSSCO	21
CROWN	5	SCHAFFER ELECTRONICS	4
DON ELLIOT CREATIVE SERV.	35	SYSTEMS MARKETING CORP.	8
JAM PRODUCTIONS	12	SPHERE	29
KRISHANE ENTS.	35	TEAC CORPORATION	CVR. 2
		UREI	7
		THOMAS J. VALENTINO INC.	11

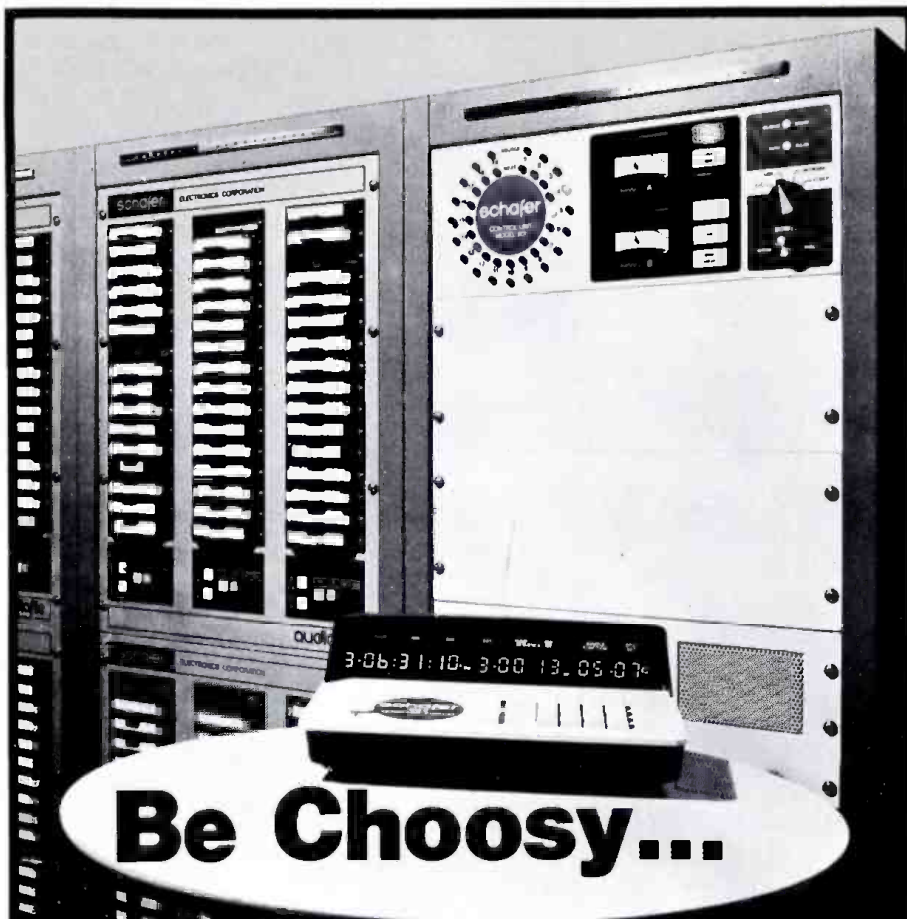

# Be Choosy...

Choosing the right automation system for your station is not easy. We know that.

That's why Schafer offers a wide range of different models, each with different capabilities.

That's why Schafer has specialists in automation . . . all with radio backgrounds . . . to work with you in making the right decision for your station and format.

YES! I want to be choosy . . . show me your '76 lineup.

NAME \_\_\_\_\_

TITLE \_\_\_\_\_

STATION \_\_\_\_\_

ADDRESS \_\_\_\_\_

CITY \_\_\_\_\_

STATE \_\_\_\_\_

ZIP \_\_\_\_\_

That's also why we offer professional programming assistance, and have written a booklet called, "The Financial Advantages of Schafer Automation," which outlines tax and operating savings that you should know about.

There are a lot of good reasons to be choosy when you're making an important investment in your radio station. That's why the people at Schafer do much more than just make the best automation. Find out for yourself. Our automation specialists are as close as your telephone. We can make the right decision a lot easier for you.



**Schafer Electronics Corporation**  
75 Castilian Drive, Santa Barbara Research Park  
Goleta, California 93017 (805) 968-0755

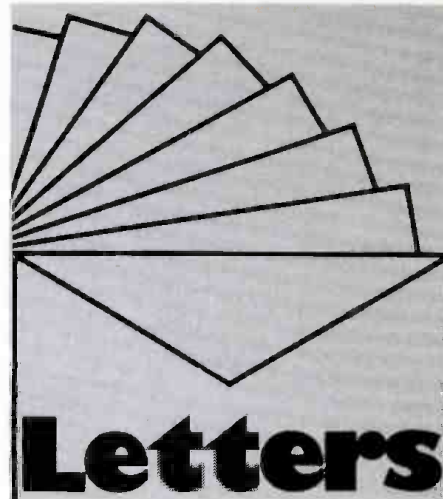

**FROM: Walt Brown**  
Program Director  
WRFS-AM/TV  
Alexander City, Ala.

First let me congratulate you on a truly terrific publication. I only wish it came out monthly!

In reference to several different articles concerning all the "tight" play-lists today which are outrageously stupid when such powerful products are available, I'd like to get my two-cents worth in for those of us that still believe in giving the public a chance to decide what is good.

I program a small station in Central Alabama. It's bad enough to have to go out and buy music to play without even hearing it first. If a record has appeal, it will get air-play on our station. We have actually gone out and bought records, played them, and charted them before any other station in this area even plays them.

It does us little good. Record people don't care because our market is small and other stations don't give the product air-play for the same reason. The only people who really benefit are our listeners, and come to think of it, they're all that really count.

I know contemporary music, and I'll keep on buying it, and I'll keep on playing it, no matter what size the market. Maybe a few others will do the same.

**FROM: Dave Land**  
Account Executive  
WFIW AM & FM  
Fairfield, IL

This is another avid reader of BP&P and I certainly enjoyed the Atlanta report. Just one thing I want to mention in reference to the WQXI interview . . . Mr. Shannon mentioned Jim Wolfert of Jam Productions. His name is not Jim . . . it's Jon. Only a minor thing, but WFIW is using a Jam package and it has to be one of the greatest packages that I've heard. And I'm one of those strange people that collect jingle packages. I certainly hope you do more "city" interviews like your report on Atlanta radio.

**FROM: Don Kelly, President**  
The Don Kelly Organization  
Los Angeles

I just received my November/December, 1975 issue of Broadcast Programming & Production, and my personal congratulations to you on your "Radio Programming in Atlanta." It's excellent.

**FROM: Wes Osborn**  
Production Director  
WRFD Radio  
Columbus, OH

For years I have admired the genius of Dick Orkin and the Chicago Radio Syndicate. Virtually everything they have created has been a timeless work of radio art . . . I steal from him constantly! That's why I applaud your article ("Radio Comedy Is A Serious Business" November/December 1975) on Mr. Orkin and Company. Thanks for giving us a look into Orkin's and Berdis's corporate head.



# crown audio equipment Tested... by ear...

Test instruments and specifications provide many little bits of information about audio equipment performance. Crown equipment always shows up well on this spec-by-spec comparison.

But there is only one instrument that can evaluate total sound performance. That's your ears!

And your ears deserve, indeed must have, the very best equipment in your studio to record, playback and amplify sound. We think you deserve Crown.

For over twenty-five years, Crown has manufactured audio equipment for recording and broadcast studios. Crown reliability, low distortion and ruggedness is well-known. But most users like Crown simply because it sounds good. They've tested it — by ear.

But, judge for yourself. Only *your ears* can really tell you how good Crown equipment is.

**Amplifiers** for studio monitors, headphones, paging systems. Designed for dependable service. Circuits designed for protection against shorts or mismatches. IM distortion less than .05% over the entire bandwidth. 19" rack mount. 3-year warranty on parts, labor and round-trip shipping.



### D-150A Stereo Amplifier

80 watts RMS per channel into 8 ohms, 1 Hz to 20 kHz. 5 1/4 inches high. 25 pounds. Rear-mounted switch converts to mono mode (160 watts).



### D-60 Stereo Amplifier

The ideal headphone amp. 30 watts per channel into 8 ohms. 1 3/4 inches high. 10 pounds, 60 watts mono.



### DC-300A Stereo Amplifier

155 watts per channel into 8 ohms, 1 Hz to 20 kHz. 7 inches high. 48 pounds. Simple wiring change converts to mono mode (310 watts).



### M-600 Single- Channel Amplifier

The latest addition to the Crown family of amplifiers. 600 watts into 8 ohms, 1 Hz-20 kHz 92 pounds. Built-in cooling. Peak-catching meter and threshold lights for convenient monitoring.

### VFX-2 Crossover for bi-amping monitors



Continuously variable filters can perform either crossover or bandpass functions. Dual channels, two filters per channel continuously variable from 20 Hz to 20 kHz. Filter rolloff at 18 dB/octave. Maximum output 6.4 volts into 600 ohms.

**Transports** for 1/4" tape handling. Professional design for day-in, day-out use. Rugged, heavy front panel (19" rack mount) for stable, trouble-free alignment. Three-motor design. One-piece fly-wheel and capstan. Electro-magnetic braking. Heads available for 4, 2 or 1 channels; 1/2, 1/4 or full track.



### 800 series

Computer-logic controls allow any command sequence, prevent tape breakage. Feather-touch push buttons. Photo-cell sensing for automatic shut-off in all modes. Remotely controllable. Suitable for automatic operation.



### 700 series

Mechanical interlock. Push-button mode controls. Play and stop modes remotely controllable. Automatic shutoff in play mode.

### Recorder electronics

for versatile off-the-shelf design. Four different electronic packages, which can be combined with either transport for just the capabilities you need. 19" rack mount. Headphone output jack on all models.



### CX series

Two channel record/playback • Plug-in modules for all functions • Built-in remote record (CX-800's) for no thumps on tape at beginning or end of record mode • Available with 600 or 250 ohm balanced XLR cannon inputs and outputs as an accessory.



### SX series

Two channel record/playback • All circuit functions on four permanently mounted printed circuit cards • Rear panel bias adjust • 2 HI-Z unbalanced mics per channel.



### SX mono series

Single channel record/playback • SX construction • Balanced and unbalanced line outputs •



### SP Player

Two channel playback only • Three-speed equalization • 600 ohm balanced output.

Call us today at 219/294-5571,  
or write for complete specs.

When listening  
becomes an art



# CROWN

Box 1000, Elkhart, Indiana 46514

Want more details? Circle 102 on Product Info. Card



Music programming for contemporary rock radio has been the topic of countless forums, panels, articles and discussions. There's really no mystique about it. What makes it confusing is the followers . . . not the leaders. I suppose the same could be said about followers and leaders in almost anything. The leaders — that is — the commercially successful radio stations select and program their music with valid reasons for doing so — the followers follow the leader in playing the same records with or without any other reasons and expect the same success to automatically come as a result. But alas! Such is not the case.

What do you mean valid reasons? What could be more valid than the fact that radio station XXXX is on the record? Good question!

The term "music research" is used far too loosely. In the first place, many who do "music research" are simply calling record stores and asking whoever answers the phone what is selling. That is NOT music research. OK, what *is* music research? Let's start with the dictionary's definition of the word research. It states . . . "research is a careful search; a close searching; studious inquiry; usually critical and exhaustive investigation or experimentation having for its aim the revision of accepted conclusions, in the light of newly discovered facts." We can see immediately, then, that the act of calling the local record stores and asking the person who answers the phone what's selling obviously does not justify itself as research. It is a beginning surely. Make arrangements with the store manager, buyer or a particular clerk to collect and note sales information as accurately as

possible for you. Notify them when you will be calling, be sure to speak to that same person each time . . . try to call at a time when it's convenient for them to talk with you, not when they're rushed. Take the sales information they have for you, but then ask questions that would give you more information . . . i.e., was there stock available on the new records you've been playing . . . were there any requests for records you're not playing or that were not in stock, what records were returned (by the store). These are just some very general questions that may be helpful but the thing to keep in mind is to include questions that are pertinent to YOUR particular situation. And don't stop with just getting the sales information from the record stores . . . research your phones or get groups of students to collect opinions of their peers. Research methods are really up to you to devise . . . the point is that the results give you information that really *tells* you something. Secondly, we have mis-placed the emphasis . . . research for research's sake is a waste of time. To be satisfied to accumulate facts and figures in nice, neat columns and allow that to make decisions for you is immature and irresponsible. The fact is, intelligent, thorough and useful research must be done . . . placed in nice, neat columns, if you wish . . . analyzed and interpreted insofar as what significance the findings have for your current music programming . . . what changes, if any, are indicated in the choice of music, the frequency of rotation, the day-parting, etc. For instance, records to which the audience responds quickly and then tire of just as quickly can be detected by the overall research

picture . . . and should receive airplay that reflects the audience's quick response and burn-out point. Many times in these cases a record will continue to be reported well in sales but other sources indicate the value of the record as a programming tool has diminished to the point of becoming negative. That's why it's important for you to see the *total* information . . . from all sources available to you . . . and then to analyze and interpret that information with your past programming experience and knowledge of your community as your guide. Then the work BEGINS. The findings of your research mark the beginning — not the end — of your music selection and programming job.

Many successful radio programmers seem to oversimplify answers while others struggling for answers tend to over-complicate. To wit — the very well-known and successful Jay Cook, Program Director of WFIL, I recall was once asked how they select the records they play . . . why one record over another. Jay's answer was simple, ". . . we play the records that are best for our radio station at that particular time." Obviously the questioner was not looking for such a seemingly vague, simple answer. But Jay had answered the question quite frankly and satisfactorily. What he was saying is what many programmers seem to lose sight of . . . best for the RADIO STATION . . . to aid in the success of the RADIO STATION. Isn't that the programmer's primary job — to make the radio station successful?

George Wilson, of Bartell, used to say in part, success would come if you ". . . play the right records and don't buy the

disc jockey." Isn't that over-simplification! But isn't it at least part of the truth!

Some programmers struggling for answers tend to over-complicate — usually because they're seeking to answer their individual questions with someone else's set of tools, i.e., in seeking to play the right music, plays the same music the "big guys" are playing based on the fact that the "big guys" have researched it and wouldn't play it if it wasn't right. Could be that's true. But if the big guy has researched the music — it has been researched with his market in mind, not yours. Yes, there are similarities in markets, yes, generalities can be made — yes, a hit is a hit is a hit, etc. But as well as having similarities to other markets — your market is **UNIQUE** — your radio station is **UNIQUE** — **YOU** are **UNIQUE!** The demographics of the population, the peculiarities of the area due to geographics or industry and your signal coverage are just a few of the factors which combine to make your particular situation unique. Keep all this in mind when devising your research plan. There are certain products that are relateable more in one area than another . . . surely the same can be true of records. National compilations and charts should be used as another source of information giving you a broad picture of active records . . . it seems perhaps the top ten can usually be regarded as generally valuable programming for most . . . but below that it takes a combination of sources of information to sort out the most valid records for your needs at any particular point in time. I'm certainly not saying don't play the same music others are playing — what I am saying is play what is right for you *because* it is right for you and know *why* it is right for you.

It may not seem so to the uninformed but radio groups that utilize national music coordinators provide probably the best examples of reflecting the uniqueness of each market. The national music coordinator or director supplies valuable information from a national overview . . . passes along regional and individual market information as well. But is consistently prodding the local staff in each area to dig for and reflect that which is developing in their own area. While utilizing the information from the national office the PD involved with a national music coordinator is being constantly encouraged to display his awareness of his own market. Two of the most well-known broadcast groups using national music coordinators today are RKO Radio with Mardi Nehrbass and Bartell Radio with Rochelle Staub. Among the myriad of responsibilities that go with such a position I think both of these ladies would agree that one of their most important functions as it relates to their whole group is to aid the local PD in discovering, developing and reflecting

# The Mod One Is The Flexible One

Start With The Console Format You Need Now, Expand Later.

Modular design lets you select a wide range of input modules and plug-in amplifier cards as you grow. 10 mixing positions with up to 30 inputs. Modern vertical faders; silent operating switches; state-of-the-art circuitry.

Custom features and options with off-the-shelf availability. Monaural, stereo, or quad. Meets all FCC - AM and FM standards. UREI quality, of course.

Available through your UREI dealer.



UREI "Instrumental in Audio"

11922 Valerio Street, No. Hollywood, California 91605 (213) 764-1500  
Exclusive export agent: Gotham Export Corporation, New York

Want more details? Circle 103 on Product Info. Card

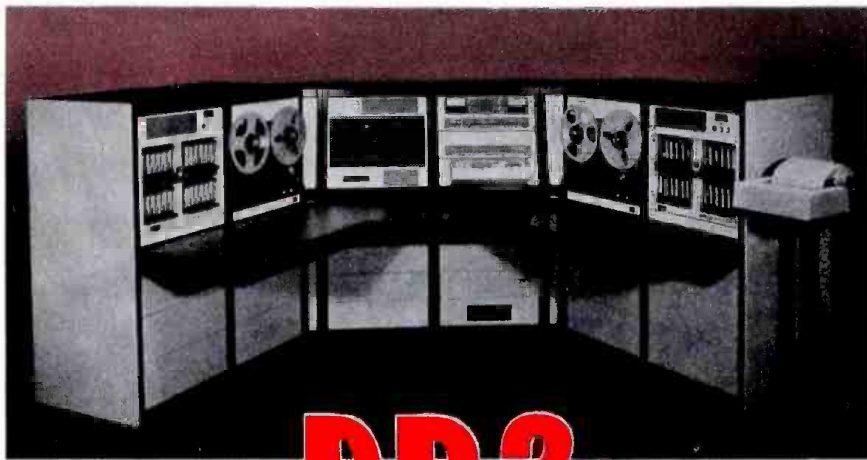

# DP-2

## all new automation system from

It's here! The all-new DP-2. Microprocessor controlled, it offers more custom features than any other unit available today... features such as 8,000 event capacity; built-in external function control; automatic record of network; automatic transmitter logging option; mag tape, paper tape and solid state storage facilities; interfacing to business computers; sub-routines in any size; video readouts and programming; and up to forty audio channels.

The DP-2 is available in low-boy console with desk as shown or in standard racks. It's versatile and inexpensive... and it's from the people who invented computer assisted broadcasting—SMC. It's loaded with features that will "hype" your station's air sound and profits.

Get all the facts on the new DP-2 system for yourself. Return the attached coupon today for more information.



**Systems Marketing Corporation**  
1005 W. Washington Street  
Bloomington, Illinois 61701  
309-829-6373

*Broadcast Automation—  
our only business*

**YES** I want to know more about DP-2.  
Send complete information and  
have your Representative call me.

Name

Station

Address

Zip  Phone (area code)

75-105

Want more details? Circle 104 on Product Info. Card

his community's unique image.

There are two areas you always utilize to help you arrive at decisions. First is the objective — which consists of your individual market research, data compiled from other sources, pro and con, national and local... any and all information you can accumulate that is from valid sources, is pertinent to the situation and is free from system malfunctions and emotions. The second area you will deal with is on the subjective level. That is your opinion, your 'gut feeling,' your intuitive response, your emotional reaction, your judgment

based on past broadcasting experience and those responses of others involved in the decision making regarding music selection and rotation. Here is where we seem to have lost our confidence... in this hey-day of research-mania. True, an undisciplined, inexperienced person may tend to over-indulge in this area. But there is no reason why a programmer with successful broadcast experience, reasonable logic and sound judgement should not exercise those same qualities. Indeed he is derelict in his duty if he does not. Obviously, some opinions are more

valid than others because of the source. Your opinion as a radio programmer is more valid than the gas station attendant's when it comes to new records and their appeal to the radio listening audience. That may seem absurdly oversimplified but we do tend to lose sight of it. A valid opinion has experience at its base. Consider the source of the opinion. So armed with these two factions — you wrestle to decisions. But going strictly by computer readouts or by quantitative values assigned to records is just as senseless as "flying by the seat of your pants" without regard to *any* research or statistics.

I keep referring to the importance of validity... valid reasons, valid information, valid opinions, etc. I believe the source of your information or opinion is as important as the information or opinion itself. How does knowing the source of information affect the validity of it? It's as simple as trustworthiness or reputation, in some cases. If you know that one source tends to lead record sales faster than their actual pace for instance, you'll treat that information a bit differently than the information you get from a source that gives you actual units sold to the consumer (if you can get that!). Know each store you call for record sales information — their geographic location... is it in a shopping center, near a school, in an area of high density ethnic population... what is its volume, in some stores selling five copies of a record is a pretty good sign while in others selling twenty copies doesn't mean much. Know the foot traffic pattern of the area, the store hours, know the buyer, the clerks who actually deal with the customer, be familiar with the general stock they carry... how and where they advertise. There are other considerations as well, but the point is the better you know your source the better you are equipped to evaluate the information received. It all sounds very involved and time-consuming but it really isn't once it's set up. Personal visits to the stores, setting up a rapport with the people in the store you'll be talking with and just hangin' around observing the clientele is time well-spent. There may be stores you want to eliminate or new ones to add after you know them on a first-hand basis.

In-store or in-club observation can provide you with some interesting information. I think too many of us in radio programming are naive when it comes to knowing the record buying public, those on whom we lean so heavily for information. In-store observation can tell you what kind of client frequents a particular location thereby affecting the resulting sales information. For example you'll get a different clientele at a full service music store located in a suburban shopping mall than at a totally youth-oriented posterbedecked, funny smelling, funky record





**ABOUT THE AUTHOR:**

**BETTY BRENEMAN** is currently a partner in Breneman Radio Services, a multi-faceted broadcast services company, specializing in music programming and supply. She is also the editor of The 'New' BRS Review: a weekly publication concerning record airplay activity and new record reviews.

For six years she held the position of National Music Coordinator for all the Drake-Chenault consulted radio stations including RKO Radio, with both Bill Drake and Paul Drew, and prior to that, she was Music Director for KHJ in Los Angeles.

shop somewhere else.

Information from both shops should be sought and is useful . . . but if you are not aware of the clientele differences you're really not getting the most from the information. Knowing that kind of information as well as age and sex of the consumer can be helpful in the daypart programming of records, particularly in the early stages. Put the product where it will appeal to the greatest available audience.

There are person-to-person surveys which have been done by radio stations seeking information on music tastes in their community. Here again, it's a waste of time unless you know what you're doing. Don't be satisfied with someone else's set of questions or approach. Seek out your local college or university's classes dealing with research, statistics and the like to help you develop a pertinent, meaningful survey for your needs, if you choose that route.

There are some radio stations today utilizing the services of companies equipped to test records (and other areas of programming) in laboratory-like situations. Some very interesting information has come from these sources . . . and the stations using these services are, for the most part, enthused. At the present time, however, the costs for such services are prohibitive for all but a very few.

The telephone is another source of information. Much of this information, though, can be misleading if you are not aware of the pitfalls it provides at the outset. First of all we know that a small minority of the audience telephones radio stations. Most of the requesters are

young . . . usually female . . . and usually call more than once. So rather than just accepting the requests and tallying them up at the end of the day or week and letting it go at that, use that time on the telephone with the caller to ask some pertinent questions . . . after you take the request, of course. When possible, note the age and sex of the caller and if an ethnic affiliation is obvious. Some questions which have been used with success include . . . What other stations do you listen to? . . . about how long each day do you listen? . . . who is listening with you? . . . what is their favorite record? . . . favorite oldie? . . . what was the last record you (they) purchased? etc. Again, given some thought, I'm sure you could come up with more. It's helpful for the person taking the phone information to be sensitive to the caller . . . that is, rather than rattling off a list of questions in a machine-like manner, use a conversational technique. Also, the one taking the calls must be able to quickly note hypes, fan club activity and pranksters.

Other possible sources of information are your local schools . . . high schools, colleges, etc., and places like discos or any local bar, restaurant, or any favorite socializing, convening places for the people of your community where music is provided. There have been many attempts to utilize juke box play information. Some more successful than others. As in any other of the research areas . . . seeking juke box play information has its own set of problems . . . some of which are finding locations you can depend on for getting good information, knowing the general crowd that frequents the location, being able to get a weekly play count and knowing how the juke box is programmed (i.e., from national charts, local radio exposure, patrons requests, route man's decisions, etc.). When using juke box information, again your best bet is knowing someone at the location you can depend on. That will help you ascertain such things as . . . if the same guy comes in every night and plays the same record ten times . . . suddenly those fifty plays at the end of the week aren't as impressive as they seemed initially when they might have represented fifty different people.

All your sources of research can offer useful information . . . all you have to do is know how to get it and how to use it when you do get it. Record companies and distributors can also offer useful information . . . the key is, of course, credibility. If you have learned that a particular distributor or label continually offers information that you can rely on or is substantiated from other sources, don't hesitate to go to them seeking early information. Knowing the source of your information helps to keep the information from being distorted, i.e., if you are aware that a particular list of active records comes from discos and bars and

**CAVOX**  
**is PROFIT-PROGRAMMED MUSIC**  
**for Automated or Live Radio**  
 Complete Library Service • 6 MOR Formats • Mono or Stereo  
 Call (213) 776-6933, CAVOX Stereo Productions,  
 502 S. Isis, Inglewood, CA 90301.  
 Ask for Bob Moyfield.

*Want more details?*  
**Circle 105 on Product Info. Card**

another comes from record shops near campuses, you are better equipped to utilize that information for daypart, programming than if you were not aware of the sources. Realize that disco information, for instance, is useful only to a degree because of several factors . . . one, many times the exposure of product at discos is the result of only two things, what product is serviced to the disco and the personal choice of the disco d.j.; two, customers exposed to product at a disco are exposed to a total experience different than that of a radio listener . . . the disco patron is immersed in and motivated to expression by the music . . . the music is part of the total picture of socializing and may not evoke the same positive response from the radio listener during another time of day. To the casual radio listener music of the same general type all begins to sound the same . . . creating a stereotyped, monotonous

**PRODUCTION MUSIC**

Library on LP's & Tape for Radio, TV & Films

Over 3,000 titles: jazz, contemporary, rock, classic, every mood and style.

A complete 18 album Sound Effects library for a low \$108.00

A new Bicentennial music library too!

*Major Records*

For free catalogs and rate cards write to:

**Thomas J. Valentino Inc.**  
 151 West 46th St., New York, N.Y. 10036

*Want more details?*  
**Circle 106 on Product Info. Card**

sound.

Don't be afraid to seek information applicable to particular groups most available during certain dayparts . . . don't limit your quest for information and tastes to one group, then use that information to influence your whole day's programming.

Be aware also that the radio listener is not NECESSARILY a record buyer. I didn't say IS not . . . I said is not NECESSARILY a record buyer . . . yet we allow the total radio audience to be represented by the choices of the record buyer. Again, not necessarily wrong to use that information as a guide — as a representation of what people interested in current music like to hear but to address ourselves totally to record sales information without regard to where the information comes from, or to not seek other areas of information reflecting music preferences, or not to use a programming judgement . . . "an ear," if you will . . . is not doing a professional job and is not prone to nor deserving of success.

Above all, *listen* . . . listen to the records you are considering . . . listen over and over . . . as long as you are considering them. Listen to them both as a single unit and as a part of your particular programming image. I don't care how many volumes of information you may have on a record . . . you can't make an intelligent decision on its programming

value for your situation until you hear it.

Now you have all this great information from your super research . . . at what point do you decide to go on a record? First of all, it's my opinion that reserving all your decisions and changes regarding music programming for a particular hour of a particular day of the week is archaic. For ease of communicating with the rest of the industry or to make things easier to handle technically within the radio station, i.e., changing playlists, cards, changing record numbers, carting, etc., having a set music day for the majority of re-shuffling that goes on on a weekly basis is a valid solution to the problem. But not to react to information that indicates a change in a record's day-part programming or in its addition or deletion to the programming would be beneficial because it isn't music day is not wise.

One of the major problems music programmers always have is getting too far ahead of the public. We hear the records over and over and over and over usually before they even get on the air . . . then we constantly hear them as we monitor our own station as well as others so we tire of them rather quickly. More often than not the impulse is to delete the record before it wears out on the listener. But usually when we are sick of it, it has just become familiar to the bulk of the audience . . . that, of course, is a broad generalization and would not hold

true for all records. But getting ahead of the audience is a much more common problem than lagging behind them. There just is no substitute for knowing your audience, "feeling the pulse of the people" as one PD puts it. There is no easy set of rules telling us when we should go on records . . . to be early, late or whatever. View your data as objectively and intelligently as possible, pit the possibilities against one another in a process of elimination and theoretically you emerge with the strongest contenders . . . technically. Bearing in mind that that new record you're considering adding has to be stronger than any other of the new records . . . but also more of a programming asset at that point than the older record it might be replacing! As well as looking right on paper . . . if you're a RADIO PROGRAMMER it has to "feel" right, too. You can't be content to be either a statistician or an artist . . . you must be BOTH.

Bill Gavin once quoted part of a comment made by Ken Dowe, then of KLIF-I believe, on music research. I don't recall it exactly but the gist of it was . . . research is like a lamppost . . . it sheds light to see more clearly . . . but it's not meant to lean on.

A successful programmer can always tell you WHY he's playing that record. To be a leader takes work . . . but it sure beats being a follower. □

## ***The Best Kept Secret In Broadcasting ...?***

Over the past few months, we've done the jingles for some of the top radio stations in the country. But chances are you haven't heard about us yet. That's because instead of spending our energy raving about what we've done, we put our effort into creating some of the best jingles available. Perhaps that's why JAM Productions now does the jingles for . . .

WABC New York, WPEN and WMGK Philadelphia, WHNE Detroit, KYA San Francisco  
WQXI Atlanta, WXLW Indianapolis, WHAS Louisville, WQUD Memphis, WTOD Toledo  
KCPX Salt Lake City, WJAX AM & FM Jacksonville, WNDR Syracuse, WTRY Troy  
WAKY Louisville, WOHO Toledo, KAKE Wichita, and many, many more.

If you want to hear opinions on what we've done, call any of the stations we've ever produced for. If you want to hear samples of what we can do for you, call us. We're a secret worth knowing about!

### **JAM Creative Productions, Inc.**

7319 - C Hines Place, Suite 202  
Dallas, Texas 75235  
Phone (214) 630-5260



Want more details? Circle 107 on Product Info. Card

# Cue Tones and the "Tight" Automation Format

By Ron Lewis, More Music Enterprises

If your station is automated, you are either obtaining your programming materials from a syndication firm, or are preparing your own automation tapes. Regardless of where your programming originates, you know that the key to a "tight" sounding format is the placement of the inaudible 25Hz tone that cues each deck to start at the correct time. If the tones are not in proper places, the programming will sound sloppy . . . voices may overlap with other voices, or dead air might appear between selections.

If you are preparing your own automation tapes, you are probably aware of the problem in placing the cue tones in exactly the right spots . . . *consistently*.

More Music Enterprises produces several automated formats for radio stations, and we have developed a simple timing and cue tone placing system constructed out of easily accessible parts.

Before we get into the timer itself, let's briefly run through an overview of how automation tapes are generally set up. For the want of simplicity, we will concern ourselves with a back-announced format, where each musical selection is identified with an announcer's outro, for example: (music fading out) "That was John Denver, and 'Fly Away'."

As the announcer's tag comes to an end, the tone must cue the next event to start . . . perhaps another musical selection, commercial, promo, or what have you.

In order for the next event to start, it must be triggered by the cue tone. The cue tone must begin exactly one second prior to the end of the announcer's tag, and the tone must continue for one full second . . . the remaining second of the announcer outro. After the tone and the voice track end, that tape deck continues to roll (over silence) for an additional two seconds before it shuts off. There is one more second of silence (1-second start-up) before the program material



#### The Author:

Ron Lewis is presently Vice President and General Manager of More Music Enterprises, producers of automated radio programming, syndicated specials, and national radio and television commercials.

Prior to that, he was General Manager of Special Products Division of the Custom Fidelity Co., Inc. He has held positions varying from Music Director, Production Director, Announcer, and Assistant Program Director at such stations as KDAY, KSFV, KVFM, KPFK, and KBLA, in Los Angeles.

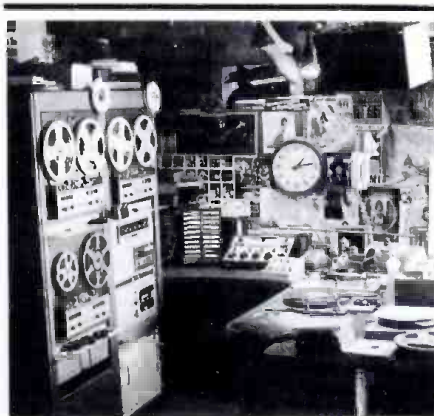

More Music Enterprises' production studio where automation tapes are assembled.

on that same tape starts up again. Every tape is structured the same way, so when the next selection is triggered by the tone, there is always one second before the audio begins (this gives the triggered machine a second to get up to proper speed, and avoid "wooving"). The one second cue tone on the first reel, and the one second dead roll on the cued (next) reel compensate for each other . . . so as soon as the announcer outro has ended on the first reel, the audio on the next reel has begun (see Fig. 1).

After understanding where the tones go in relation to the programming itself, you can hopefully see why the proper placement of these tones is so crucial. The exact placement of the tones can vary according to how you want your format to sound . . . whether or not you want dead air or overlapping of selections . . . but the problem still remains placing the tone exactly where you want it.

No matter where you place your tones, the timing system we have developed *will* put the tone at the desired point.

There are several existing ways to place the tone from a tone generator. If you are recording on a four-track machine, you can dub your music on the first two channels (in stereo), the voice track on the third channel, and the tones on the fourth channel. This must then be mixed back down to two tracks. Using four-track equipment gives you extra flexibility, but chances are you don't have four-track machines available. If you are constructing your automation tapes on two-track decks, then you are probably just guessing where the tone should go, and triggering the tone generator manually. That method has its obvious drawbacks: inaccuracy and inconsistency.

The heart of our cue tone placement system is an "EPOI PRINTROL ENLARGEMENT TIMER." It's the kind you buy in a camera store for a dark-

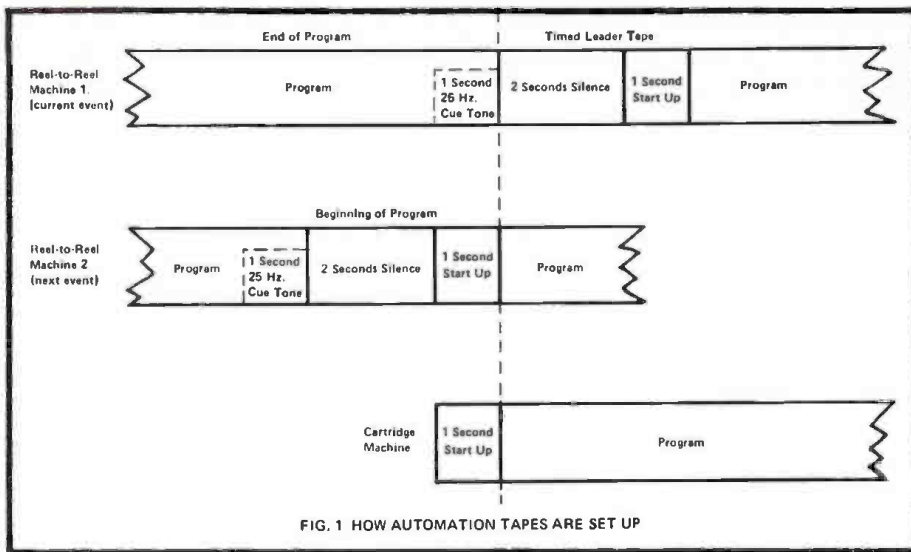
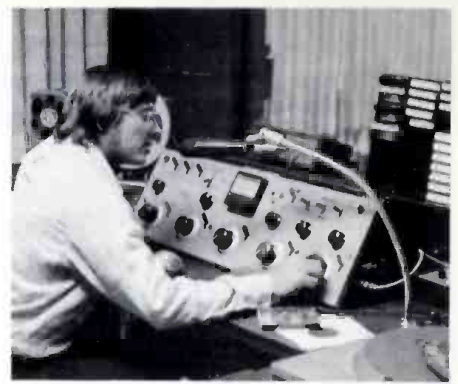

FIG. 1 HOW AUTOMATION TAPES ARE SET UP



Jay Stevens, President of More Music Enterprises and afternoon radio personality at KIIS AM/FM Los Angeles, preparing voice tracks for one of More Music's automated formats.

room. The EPOI is a precise electronic timer that can be set for a specific time (in our case a few seconds), and when the set time has elapsed an internal switch will trigger an attached appliance to start (as opposed to the kind of timer that simply rings a bell when the time has elapsed). The switch in the EPOI timer is used to turn on the tone generator's signal at the desired time (see block diagram, Fig. 2).

The timer has to be precise, and therefore rules out the inexpensive mechanical timers which are off by several seconds.

In tests, the EPOI timer consistently proved to be exact, and therefore was chosen for the system. (For a schematic of the system, see Fig. 3).

Next, let's look at how we put the cue tones on with the timer, and you should then understand how the system works. We have our voice track announcer record all of his voice tracks on one reel... remember that in this case they are all outros. We end up with a reel of a series of voiced tags for each musical selection.

The reel of voice tracks is placed on one playback deck (deck A). The music

to which the tags will be added is on record, cued up on a turntable. A 25Hz tone generator is standing by, and the levels from all these sources are set on a console, and fed into the input of an additional reel-to-reel deck (deck B) with a blank reel of tape. Deck B will record the mixed music, announcer tags, and cue tones on what will become the master reel.

For the sake of consistency, let's use the same example of John Denver's recent hit, "Fly Away." The record is cued up and ready to go. But first we must time the announcer tag for the song,

## Orban/Parasound solves the Stereo Tape Cartridge Dilemma

Just use one track of your existing stereo cart machines — or, ideally, mono machines. Then, add the Orban/Parasound Stereo Synthesizer to the output bus of your bank of cart players.

The result is a highly seductive pseudo-stereophonic effect for stereo listeners. And listeners with mono receivers receive perfect reproduction of the original mono tracks — without any phase cancellation or quality loss.

You can also use the Stereo Synthesizer for converting announce mikes, mono discs, and mono agency spots to pseudo-stereo. Try it to generate a stereo effect from your mono remotes or network feeds. The results will delight your listeners!

At \$299, the Orban/Parasound Stereo Synthesizer pays for itself in reduced cart machine maintenance and in increased sponsor satisfaction with the air quality of his spots.

We also make a proven Spring Reverb with an excellent reputation for quality and reliability. Also, our Parametric Equalizer combines reasonable cost with unprecedented versatility for production work, line and remote equalization, "air-sound" frequency contouring, and dozens of other applications. And our Dynamic Sibilance Controller lets you equalize your announce mike and production work for stand-out impact without excessive "ess" sounds.

Four rather interesting products from Orban/Parasound — the price/performance leader.

For further information, contact:

**orban/parasound**

680 Beach Street, San Francisco, CA 94109. (415) 776-2808 or your local Orban/Parasound professional products distributor.



Want more details? Circle 108 on Product Info. Card

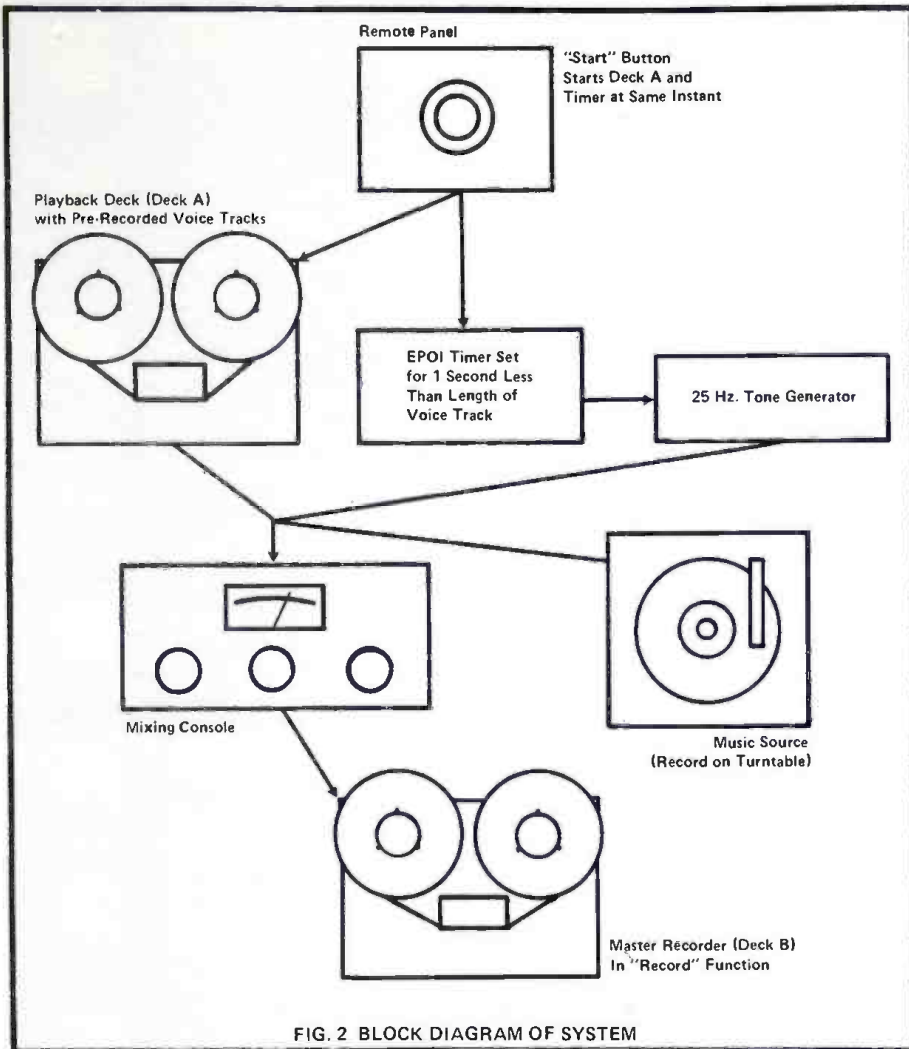

FIG. 2 BLOCK DIAGRAM OF SYSTEM

which comes out to, say, 7 seconds. That means that we want the 25Hz tone to begin at 6 seconds from the beginning of the outro (remember how the tapes are set up). This will allow for the tone to continue during the last second of the announcer outro.

The timer is set for 6 seconds (in this system it is always set for one second less

than the length of the voice track). The voiced outro for "Fly Away" is then rerecorded on deck A, ready and standing by.

The next step is to engage the master recorder (deck B) in "record," start the turntable, and begin dubbing "Fly Away." When the end of the song approaches, and the music starts to fade at the point where we want the announcer

**CAVOX**  
**is PROFIT-PROGRAMMED MUSIC**  
**for Automated or Live Radio**  
 Complete Library Service · 6 MOR Formats · Mono or Stereo  
 Call (213) 776-6933, CAVOX Stereo Productions,  
 502 S. Isis, Inglewood, CA 90301.  
 Ask for Bob Mayfield.

Want more details?  
 Circle 105 on Product Info. Card

tag to come in, we will then push one specially wired "start" button on a remote panel (see schematic). This button all at once starts the voice track deck (deck A) to play, mixing the outro over the music fade, and at the same instant starts the timer counting to six seconds. At the end of six seconds, the timer clicks on the signal from the tone generator, and we end up with a perfectly placed 25Hz cue tone . . . beginning exactly one second before the end of the outro.

After the tone is recorded, it is then necessary to, 1) stop the tone after it has transferred for one second (at the same point the voice track ends), and 2) pro-

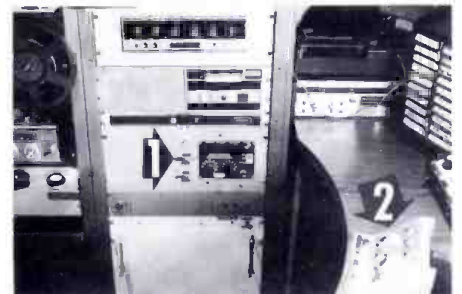

Arrow 1 points to EPOI Printrol Timer mounted in rack panel. Arrow 2 points to remote "start" switch (see text).

vide exactly three seconds in between the selections on the master reel. The easiest way to stop the tone and provide three seconds is to simply cut the tape at the very end of the voice track, and splice in three seconds of timed leader tape.

Some tone generators are designed to cue the operator at the end of three seconds. Once again, to avoid human inaccuracy, we have chosen the more precise method of timed leader tape.

If you are developing your own programming and constructing your own automation tapes, you will find this timing system to be simple, accurate, and flexible. It is a means of properly placing cue tones for a "tight" automation format.

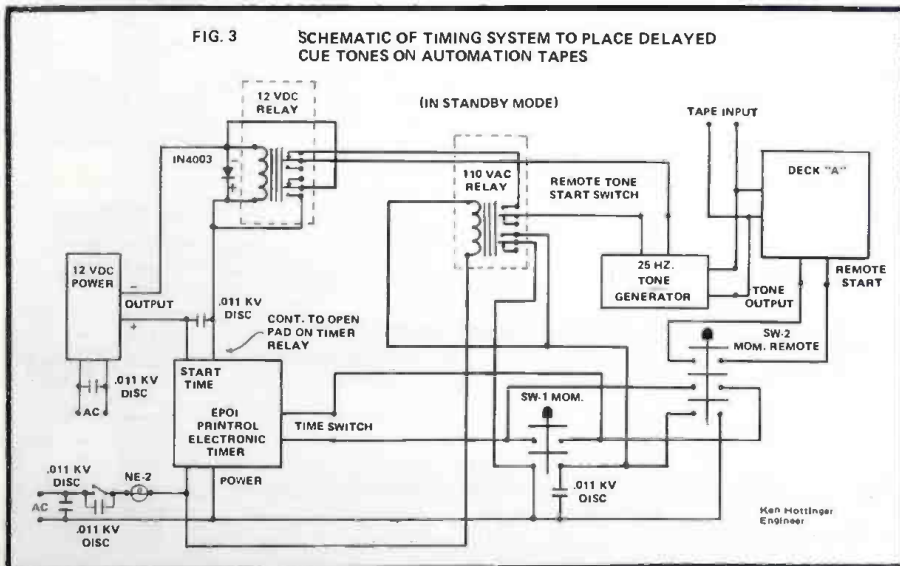

FIG. 3 SCHEMATIC OF TIMING SYSTEM TO PLACE DELAYED CUE TONES ON AUTOMATION TAPES

Ken Hottlinger  
 Engineer

TELL YOUR  
 GENERAL MANAGER  
 ABOUT

**Broadcast  
 Programming  
 & Production**

# TELEVISION NEWS GATHERING

## ***New Films: Lower Light + Faster Process.***

by Robert Fisher

In Detroit, a news cameraman crouches on top of a switch tower overlooking a section of industrial railroad tracks. A well-hidden camera is focused on the activities of a gang filmed in the act of removing new tires from a freight car.

In San Diego, a two-person news crew responds to an alert that a police department S.W.A.T. team is closing in on an armed man holed up in a motel. It is pitch-dark; however, the crew is able to capture the moment of arrest on film, using as its sole illumination, a spotlight from a patrol car.

In Sacramento, a news editor assigns four film crews to cover an appearance of President Gerald R. Ford when he visits the state capitol. They are there when an assassination attempt is made on the President's life, and responding quickly the crews scoop visiting news teams from across the nation. An hour after the gun is pointed, the first film is delivered to the station, processed and ready for editing.

More and more television news departments are focusing on what is happening as the events occur. They are also looking for ways to probe behind official statements so audiences can better understand the events that affect their lives. The standup interview is rapidly being obsoleted by the indepth visual report.

Ron Mires, News Director at KGTV,

in San Diego, says it all: "The essence of our work is that one person with a camera can virtually go anyplace and record anything under any conditions."

He explains that during the past few years, the NBC affiliate has made its news shows less formal, better paced and more *visually oriented*. If a story is about pollution of lakes, that's what the visuals should illustrate, he notes.

During the past year, much of the attention of people in the television industry has been focused upon the impact of electronic news gathering (ENG). Yet, in all three of the illustrations that started this story, the medium was news film. It is unlikely that the same type of news coverage as those just described could be done with current state-of-the-art ENG equipment.

This article is not meant to be interpreted as a "plug" for news film, or a criticism of ENG. Each has its definite advantages and disadvantages, and should probably be used hand-in-hand for flexibility in live and recorded news events. A hinderance unique to news film is its long processing time and losses attributed to its relative non-immediacy. A problem

---

*The author:*  
Robert Fisher is a freelance writer, involved in the areas of television and motion picture production.

with both film and ENG has been the inability to photograph important, rare news happenings due to insufficient lighting conditions. Unfortunately, news events are not staged, and cannot be repeated if lighting wasn't just right the first time through. This, of course, causes many invaluable stories to be missed, leaving only the non-action standup interview as coverage of the story.

The purpose of this article is to make broadcasters aware that there is a new solution to the reduction of film processing time, and the recording of events with very little available light: Kodak Ektachrome video news film 7240 (tungsten), or equivalent.

Beginning early in 1975, a significant experiment took place at seven television stations, which field-tested the new color news film and a fast process for getting it on the air.

In addition to KGTV, WXYZ-TV in Detroit, KOVR-TV in Sacramento, KXAS-TV in Fort Worth, WNJT in Trenton, WMAQ-TV in Chicago and WSM-TV in Nashville have been using the recently introduced film and process VNF-1 since last April. The film is rated for a recommended exposure index of 125 in 3200 K tungsten illumination and 80 in daylight with a Wratten 85B filter.

News department personnel for the stations that tested the new film report that it appears to be finer grained than existing films when processed to accommodate larger exposure indexes. This characteristic pays special dividends in *low-light situations*. Several stations are normally rating the film for an exposure index of 250 in tungsten light, and one, KOVR, has modified one of its two processing machines, so the film can be rated for an EI of 500. At KOVR, it takes less than a minute to make a connection which runs the film through a second liter tank of first developer.

KOVR Chief of Photography, Witold Marczewski, explains that the new video news film allows cameramen to record "good images" with as little as five foot-candles. He says that the station, which has facilities and news staffers in Stockton as well as Sacramento, used to occasionally push Ektachrome EF film 7242, however, it tended to get grainy at a higher exposure index.

Cameramen are now more willing to take chances, he emphasizes. The payoff is considerable. In emergency situations, stories can be covered with illumination provided by *car headlights, street lamps* or even a *fire*. He points out that more than covering emergencies at low-light levels is at stake. Marczewski recalls when a group of tired Vietnamese refugees arrived in Sacramento late at night. Previously, under these circumstances, an official spokesman would probably have made a standup statement and a reporter would have conducted an interview under artificial lights. This

**FEW LEFT**

**ONE INCH  
B & W VIDEOTAPE RECORDERS**



**AMPEX**

**7000  
VIDEOTAPE RECORDER**

A compact, portable videotape recorder for all closed-circuit applications. Low cost, instant playback, easy to operate. Used.

**YOUR PRICE ONLY**  
**\$198<sup>00</sup>**

COLOR VTR's, MONITORS, and MISC. GEAR ALSO AVAILABLE!!!

---

**NEW  
MAJOR BRAND  
Video Cassettes**  
HIGH ENERGY

c-60 **\$19.75**

**BUY 12 & YOU GET 1 FREE !!**  
plus shipping - 6% sales tax in Calif.

---

Call Ron Lewis or Jeff Alan  
**MORE MUSIC ENTERPRISES**  
5315 Laurel Canyon Blvd. / N. Hollywood, CA 91607 (213) 985-3300

*Want more details? Circle 109 on Product Info. Card*

time, the cameraman rated his film for an EI of 500, and recorded the poignant arrival scene just the way it happened.

This new film also provides some other significant advances. The manufacturer reports that the film is prehardened during formulation. This has allowed some important changes in the chemical process: The prehardener and neutralizer steps are eliminated. Other than these changes, process VNF-1 uses the same chemicals as process ME-4. In addition, some stations have also shortened the drying time.

The impact is substantial. Dry-to-dry process time at the seven stations was shortened by seven to nine minutes depending upon the equipment used. Typical dry-to-dry times range from 15 to 19 minutes, and on tight deadlines most stations have gotten film out of their machines even faster.

Consider the bright, sunny morning when President Ford stepped from the lobby of the Senator Hotel in downtown Sacramento to start a short walk to the state capitol building. A throng of several hundred, including many newsmen, waited to greet him. President Ford moved into the friendly crowd, shaking hands and smiling. Suddenly someone stepped forward pointing a Colt .45 pistol. The time was around 10:10 a.m.

Secret service men pushed the Presi-

dent away and up the steps of the capitol building, while a brief scuffle erupted around the woman holding the gun. She was quickly disarmed, handcuffed, hustled into a squad car and driven away. Less than five minutes elapsed. However, KOVR was ready.

News Editor Norman Hartman had assigned four crews each consisting of a reporter and film sound person operating a CP-16A camera to cover every step of the President's visit. One crew was walking with the President. They recorded the assassination attempt. Another crew was covering the crowd's reactions; the

KOVR reporter Suzan Harris and Newfilm Supervisor Arsen Mateljan were part of the team which covered the Presidential assassination attempt. Mateljan was inside the capitol building when President Ford and his party came sweeping in. Harris was working with newfilm cameraman George Nyberg, following the President's walk to the capitol building.



# "PRODUCT INFORMATION CARDS"

## Bring You More Facts Fast!



Want more details on products and services seen in this issue of BP&P? Simply tear out the enclosed "PRODUCT INFORMATION CARD," and circle the numbers that correspond to those found at the bottom of the advertisement or editorial item in which you are interested. Then mail it, postage-free, and more information will be rushed to you—at no cost or obligation!!!

Circle the Numbers

TELL YOUR PROGRAM DIRECTOR ABOUT



**Broadcast Programming & Production**

This group helped to put together KOVR's startling newfilm coverage of the Presidential assassination attempt. Cameraman George Nyberg is seated at the viewer while, from left, reporter Loretta Noffsigner, Assignment Editor Bob McCafferty and News Editor Norman Hartman look on.



camera operator reacted immediately and filmed the capture of the suspect. A third crew waited inside the doors of the capitol building. They caught the action as the President was swept into the building. The fourth crew was recording the scene from a fifth floor window of the capitol building.

The first bulletin about the assassination attempt was aired at around 10:15 a.m. Between 10:25 and 10:30 a.m. the first several film magazines were sent back to the station. These arrived at around 10:50. The Houston Fearless Colormaster processing machine at the Sacramento facility usually is operated at 60 feet a minute. This time, Marczewski speeded it up to between 110 and 120 feet per minute as soon as the film cleared the first developer. Dry-to-dry time was shortened to around 15-minutes. The first film was being edited by 11:10, and it could have been on the air by 11:15. Instead, a mini-documentary was put together and aired at 11:30 preceding the President's live address to a joint meeting of the state assembly and senate.

Other related news was filmed during the day, and by the time the 5:30 p.m. news show rolled around, a comprehensive report was ready. That was followed with a 30-minute special at 8 p.m.

By then, it was clear that KOVR had outdone visiting news crews from all over the nation. Hartman estimates that there were between 40 and 50 requests for the station's film and for interviews with reporters who were at the scene. This was in addition to a videotape transfer of much of the best coverage, which was distributed for network pickup.

At WXYZ, the film was put to the test soon after the station began participating in the field-testing program. News Film Operations Director, Joseph Doneth, had planned a series of investigative reports on industrial thefts. One of the first subjects was a gang that was successfully looting freight cars at night.

The highly organized gang used two-way radios and 10-speed bicycles. They spotted freight cars carrying valuables they wanted, and triggered the air brakes to make them stop at pre-determined places. Then, gang members rushed up, grabbed their loot and fled before railroad police arrived.

Doneth wanted to document this on film. The work was going to have to be done at night with whatever light happened to be shining in the freight yard. And, of course, the camera operator had to remain out of sight of the suspects. Doneth considered using an electronic nightscope but was dissatisfied with the image quality.

Instead, a camera operator was perched on top of the switch tower armed with a CP-16 camera with a 12-120 mm Canon zoom lens and a 300 mm fixed-focal-length lens. The video news

film was rated for an EI of 250.

The filmed coverage of the theft was recorded with the lens wide open. The results, Doneth says, were comparable to shooting Ektachrome EF 7242 (tungsten) at its normal EI of 125. He feels that the new film exhibited finer grain, better contrast and truer colors.

Furthermore, processing time has been shortened from around 26 to 28 minutes to 18 minutes. On tight deadlines, 150 feet of film has been received, processed and ready for editing in less than 15 minutes.

Quicker access to processed film plus the flexibility of capturing stories in low-light situations is important since WXYZ runs up to 24 film stories daily. The ABC-owned and operated station has seven crews providing news footage for an hour-long 6 p.m. news program and the 11 p.m. "Action News" show as well as for locally-made documentaries.

Most film is shot single system sound using wireless mikes. And stories are usually A and B roll edited to eliminate lip flutter and to add visual impact.

The importance of visual impact is also illustrated by KGTV's coverage of the S.W.A.T. team's night action. It was the kind of unusual situation, where either the story is recorded as it happens or it becomes history narrated verbally by an eye-witness.

The two-person KGTV crew arrived just before the S.W.A.T. team made its move. It was pitch dark, but the cameraman could see the shadows of police officers closing in on the armed man's room. He zoomed his camera lens and waited. Suddenly, the officers made their move while a spotlight from a patrol car illuminated the scene.

The film documenting the capture was rated for an exposure index of 1000, and it told the story like they never could before.

At the start of the test, KGTV rated the film for an EI of 125. Later, as fall arrived, and the days became shorter, the process was modified for an EI of 250. This allows news crews, which record an average of 22 stories daily, to use available light on fast-breaking stories.

Dry-to-dry film processing time at the station has been trimmed to around 19 minutes, which is about seven minutes faster than the old process.

Vic Marczewski reports that the new films are more "pushable" than Ektachrome EF film 7242.

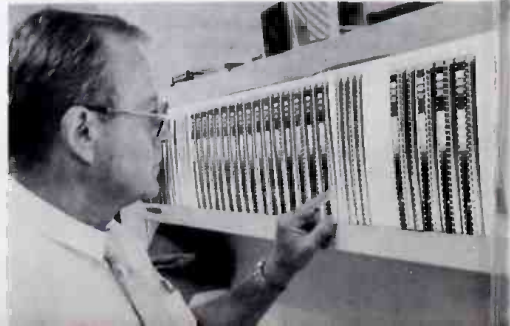



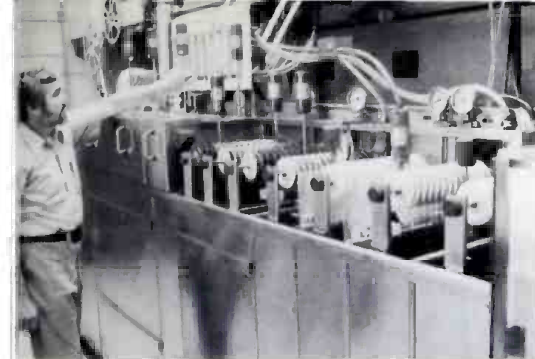

The Houston Fearless Colormaster processing machine at the KOVR Sacramento facility is usually operated at 60 feet per minute. On September 5th, the machine was speeded up after the film left the first developer, making the dry-to-dry time around 15 minutes.

KGTV also operates an Instacam. Ron Mires says that the electronic equipment is bulkier and heavier than film cameras, and line of sight microwave transmission is limited by the many hills in San Diego. On the other hand, he calls it invaluable for late-breaking news which can be covered live, and predicts that neither medium is likely to supplant the other.

At WNJT, a public broadcasting service covering the entire state of New Jersey, the new process has shortened deadlines in two ways. Director of news services George Perkins says that crews are shooting more in natural-light situations, pushing the film up to three stops, using only a spotlight on the camera to fill in eye shadow. This saves set up time on late-breaking stories, he says. On the other end, around six minutes have been trimmed from the processing time.

WNJT operates channels in Trenton, Monclair, New Brunswick, and in Southern New Jersey, and it fills a unique news need. There aren't any commercial broadcasting stations in the state, so WNJT is the only source of local television news.

Four film crews cover most of the stories for two daily weekday newscasts, and two other crews produce footage for public service and cultural affairs programs. Around a million feet of film is produced annually, using converted Auricon and CP-16A cameras. At the start of the field test, WNJT camera operators rated the new film for an EI of 125, however, last fall they switched to 250.

Perkins notes that WNJT is also able to produce program material that might have been beyond reach before the new film. For example, a feature was made in a steel mill where there was little available light, and many areas were too large to effectively light. The film was rated for an EI of 1000, and the story was told.

KXAS News Director Russ Thornton says that NBC affiliate has cut around four minutes from its processing time with process VNF-1. This isn't much on a day-to-day basis, he comments, however, when you are trying to beat a deadline, it

really makes a difference.

The station's news camera people use mainly CP-16A cameras, although some modified Auricons are still utilized. Camera operators work either with reporters or alone, depending upon the nature of the story.

Because there is a lot of sunshine in the area, this station rates the film for an EI of 125. Thornton says that they would rather push the film when more latitude is needed than have to use neutral-density filters outside on bright days.

For one mini-documentary produced in an air traffic controllers' room at the Dallas-Fort Worth airport, the film was rated for an EI of 1000. The light level in the room is kept dim, so scopes can be read more easily, and no artificial illumination is allowed. Pushing the film was the only way this documentary could be done, he comments.

KXAS is also experimenting with ENG equipment for the live transmission of appropriate stories. Here, too, Thornton relates, it is a trade-off between the portability and flexibility of film equipment, and ENG's ability to transmit live.

WSM not only takes its news seriously. It is also taken seriously. Last May's Arbitron ratings ranked the NBC affiliate's 10 p.m. news program second behind "The Waltons," but ahead of "All in the Family." Six camera operators use a Frezzolini camera primarily, and shoot around 90,000 feet of news film monthly, all rated for an EI of 250.

In addition to the other advantages, Film Director Russ McCown says the film yields superior flesh tones over the television transmission system.

The most neutral reaction from the seven stations that field-tested the new film and process comes from WMAQ. This NBC owned-and-operated station has 12 crews, supported by 18 editors and assistants and eight lab technicians. The station produces two half-hour programs and an hour-long newscast daily, and also at least one 30-minute local documentary every week. Manager-News Technical Operations W. B. Carter decided to operate both the new and the old processes.

Four crews used the new Ektachrome 7240, while the others continued to shoot Ektachrome EF film 7242. The new film is "warmer," he says, although, he finds that it also looks bluer when exposed in shadows.

WMAQ covers City Council meetings with the available illumination — 200-watt bulbs. The only way to do this is to work at an EI of 1000 at the widest aperture. This means they can't filter for color balance. It is a matter of taste, Carter says, but under these conditions they prefer the look of the old film. He added, however, that he isn't disappointed with the new film, and anticipates that with more time and experience, it will be used in difficult and low-light situations. □

## BP&P BOOKSHOP

**HANDBOOK OF MULTICHANNEL RECORDING** by F. Alton Everest. Covering everything to know about making highest quality professional audio tape recordings. Including modern techniques in dubbing, special effects, mixing, reverb, echo, and synthesis — for both stereo and quad. Recommended for all broadcast recording applications. Order No. 781 Hardbound \$10.95

**HANDBOOK OF RADIO PUBLICITY AND PROMOTION** By Jack Macdonald. An encyclopedia of radio promotion, covering contests, outside stunts, fun promotions for special days, weeks, etc. Order No. 213 Complete set \$29.95

**RADIO PROMOTION HANDBOOK** by William Peck. Jam packed with hundreds of ideas, and complete with factual examples of new ways of promoting a station, both on and off the air. Order No. 267 Comb-bound \$9.95

**RADIO PROGRAM IDEA BOOK** by Hal Fisher. All the programming ideas you need to build and hold an audience. A virtual thesaurus of ideas on radio showmanship to help boost ratings. Order No. 268 Hardbound \$12.95

**ORGANIZATION & OPERATION OF BROADCAST STATIONS** By Jay Hoffer. An exhaustive examination of the responsibilities and capabilities required in each job classification. A guide for station executives and managers. Order No. 533 Hardbound \$12.95

**GUIDE TO PROFESSIONAL RADIO & TV NEWSCASTING** By Robert Siller. A practical guide covering all aspects of broadcast journalism. Order No. 535 Hardbound \$9.95

**RADIO ADVERTISING— HOW TO WRITE AND SELL IT.** By Sol Robinson. This comprehensive volume presents an extremely practical approach to radio advertising sales— to obtain better results for the salesman, station, and sponsor. Order No. 565 Hardbound \$12.95

**THE BUSINESS OF RADIO BROADCASTING** By Edd Routh. How to operate a station as a profitable business and serve the public. The first text to deal with broadcast station operation from beginning to end. Order No. 587 Hardbound \$12.95

**MODERN RADIO PROGRAMMING** By J. Gaines. Every aspect of radio programming, from format layout to selecting DJs, is detailed in this comprehensive book. Applies to all radio formats. Order No. 623 Hardbound \$9.95

**ACOUSTIC TECHNIQUES FOR HOME & STUDIO** By H. Everest. Complete coverage for professional broadcast and recording studio. Emphasis is placed on the fidelity of final reproduction and the design of the listener's room. Order No. 646 Hardbound \$7.95

**RADIO PRODUCTION TECHNIQUES** By Jay Hoffer. Covers every phase of radio production from announcements to the overall station 'sound'. Special emphasis on sales and production expertise. Order No. 661 Hardbound \$12.95

BP&P BOOKS / PO Box 2449  
Hollywood, CA 90028

Please send me books circled below:

213 267 268 533 535 565  
587 623 646 661 781

My full remittance in the amount of \$\_\_\_\_\_ is enclosed. (California residents add 6% sales tax; foreign orders add \$1.00).

Sorry, we cannot bill you for books.

Name \_\_\_\_\_

Address \_\_\_\_\_

City \_\_\_\_\_

State \_\_\_\_\_ Zip \_\_\_\_\_

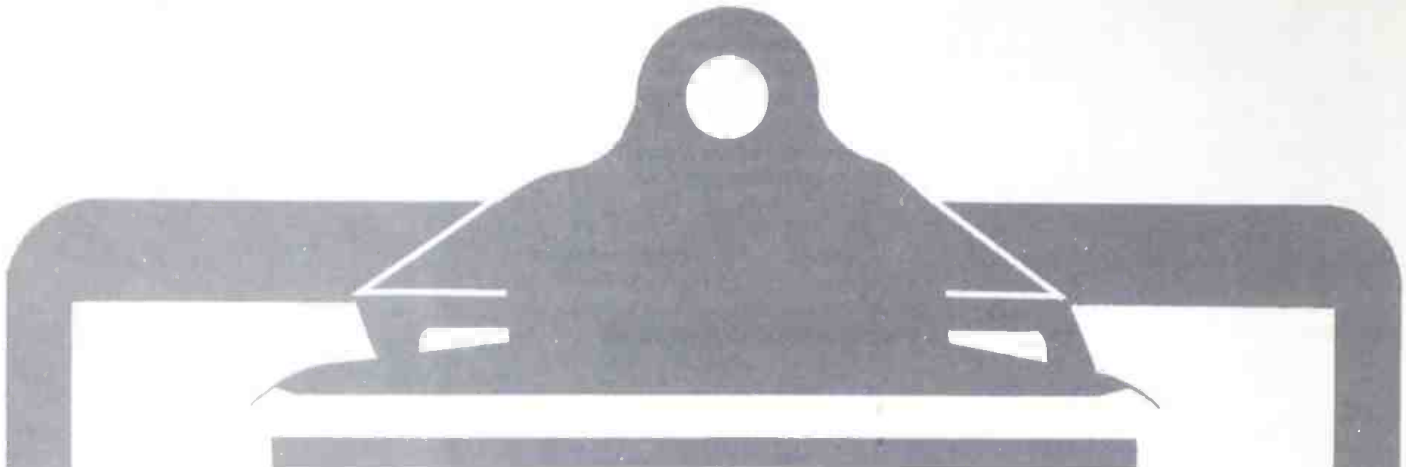

# Notes on Becoming a Production Pro.

by MIKE STARLING

Mutual Broadcasting System, Washington D.C.

How does a production pro convey the aural image so striking that he dazzles the ear and imagination of the listeners?

There are three basic elements to being a production pro: creativity, technical skills, and discrimination. You already have a certain degree of creativity. Technical skills and elements of discrimination can be partially instilled through instruction.

Aristotle said "no excellent soul is exempt from a mixture of madness." Neither are production pros. In this area you hopefully already have a basic plus: you're *crazy!*

Once past the ego tripping phases of a novice broadcaster you must realize no sane person would tolerate a feudal salary system, ceaseless eleventh-hour air-shifts, and a full range of executive lunacy. Broadcasters are inherently insane! But it's good since this distorted perception of reality can often be channeled into creative energy!

You must also possess accurate timing instincts and steady manual reflexes. You must be able to determine technical quality and have the uncompromising dedication to get the job done properly. As such you are then both a pro and an artist. You create worlds.

But let's analyze the production pro further. In addition to his unique brand of creativity he carries a ceaseless dedication to do it right. Not just adequate — but perfect. It is his nature, his hobby, and his career.

But production pros are also artists. Their product exhibits exceptional skill, creativity, and discrimination. They are adroit in the art of enticing ears with a craving impulse to crawl inside the speaker and into the infinite realm of the creative imaginations.

Being creative requires being original. To properly execute a good conception you must fully grasp the full range of tasks required for good production. Your ear must feel comfortable on tape.

It takes time to become a production expert . . . a long time. It also takes taking your time.

Tape looping a nice music bed and dubbing over two voices with clever dialogue isn't enough. Every element has to be just right.

Take your time. Inflections, acoustic balance, naturalness, and crispness must be perfect. Any music must set the proper atmosphere.

If after an hour of work you find something isn't quite right, don't put it in the rack and go home.

Analyze the problem. Bad idea? Start again with something different. Or was it a good idea poorly executed? BP&P's production articles might present a potential problem solver, but then you will have missed the hours of attempts, even days of repetition required to make it as vivid as your mind's conception.

The broadcast industry is overburdened with people who push platters,

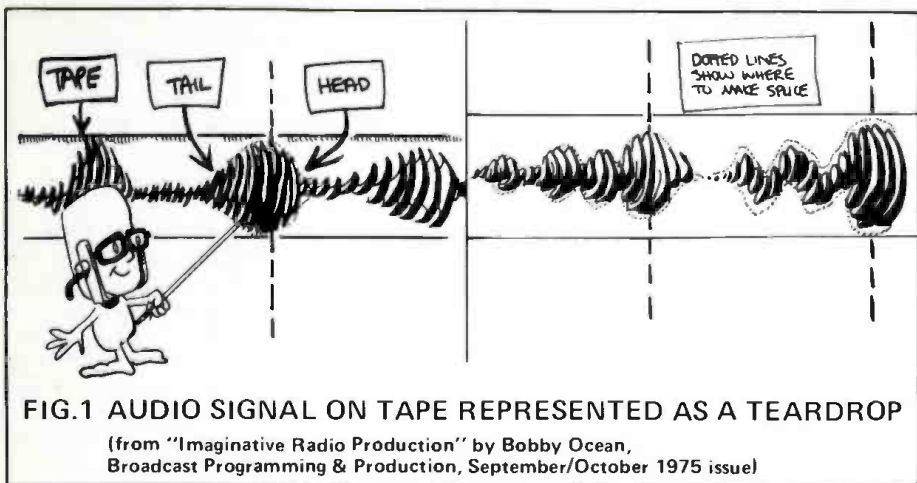

Mike Starling's broadcast experience includes that of Music Director and morning dj for WBMD in Baltimore, announcing at WASA in Havre de Grace, Maryland, and production and air work for WGTB in Washington D.C. He is currently employed at the Mutual Broadcasting System in Washington where he has advanced to Engineering Supervisor. Mike is also the President and Operations Director of Amherst Broadcasting Associates, applicant for a new AM in Amherst, Virginia.

pin meters, and read the time and temperature in several sub-octaves of their normal voice. They are a dime a dozen and paid accordingly.

But if you know the difference between good and bad production, the addition of patience, skill, and a pinch of insanity, may add up to being a professional producer.

While being supremely patient in working towards the final product, the pro is also highly efficient. His work is elegant. Maximum listenability is derived with minimal input.

To be efficient you must weed out all extraneous elements. Background noise,

key clicks, and "p"-popping must be eliminated. They are needless sources of distraction.

In short, you have to be a good engineer. You should value clarity, a bright sense of presence, naturally crisp highs, and resoundingly mellow lows.

If you can't discern the difference between good and adequate production, you will forever sound awkward to both you and your program director's dismay.

But for those competent in the basics, no other medium provides for the solo effort so often as radio. Most in-house production is a one person affair: writing, announcing, producing, and engineering.

It is a one person show, so show off!

Put all of your creative energy and production skills into one spot after another. The more you produce, the keener your skills become. Your imagination broadens. You become faster, more efficient — you are becoming a production pro.

You'll love working with

**RUSSCO**



Equipment designed by RUSSCO professional broadcast engineers really does the job for you! RUSSCO manufactures the turntables that are the industry standard for quality and reliability. You'll find the same Russco-rugged construction in our audio amplifiers, preamps and mono and stereo mixers. Write us and be surprised how little it costs for this kind of modern trouble-free performance!

● RUSSCO Electronics, Inc., 1070 Brookhaven, Clovis, Calif. 93612 Phone (209) 299-2167.

Spotmaster®

## VERSA CONSOLE



Compact rack-mount single channel mixer ideal for CATV, CCTV, film studios and remote broadcasts. Transformer coupled inputs with externally switchable levels. Line and PA outputs.

## 50 SERIES MONO



Complete small console for production, on-air, educational or CATV use. 8 switch selectable inputs to four sealed mixers with cue detents. Built in muting relay and monitor amps. Rack mount available.

## 100/200 SERIES MONO & STEREO



Full dual channel consoles with 5 or 8 mixers. Pushbutton selected inputs available to high or low level (switchable) plug-in preamps. FET switching for quiet operation. Dual channel outputs at over +18 dBm peak. Complete internal monitoring and muting functions. Stereo models provide in-phase stereo from mono sources.

## SLIDE TYPE CONSOLES



Available mono or stereo with plug-in mixers for expansion after purchase. Conductive plastic linear faders with cue switch. Built in muting, monitor and intercom/talkback provision.

ALSO TAPE CARTRIDGE MACHINES AND STUDIO ACCESSORIES

BROADCAST ELECTRONICS, INC.

— A FILMWAYS COMPANY —  
8810 BROOKVILLE ROAD  
SILVER SPRING, MD. 20910  
PHONE 301-588-4983

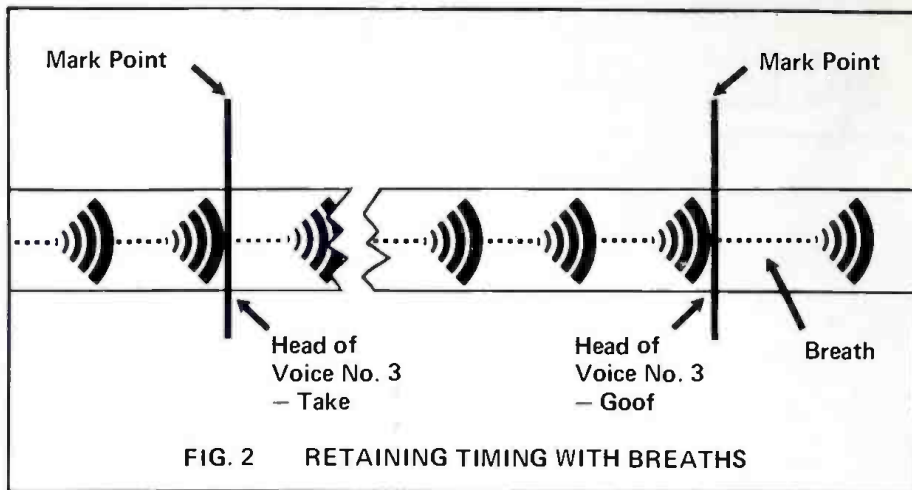

FIG. 2 RETAINING TIMING WITH BREATHS

Back to some basics:

Tape editing, perhaps more than any other production skill, is largely a matter of practice. Your reflexes and feel for the audio envelope improves with time.

In editing voice you are principally concerned with retaining the natural spaces involved with the rhythmic flow of speech.

Example: Perhaps you're not able to rapidly change from one voice to another and retain natural inflections. A competent tape editor doesn't have to. Let's say while doing voice No. 3 you goof. Rather than starting from scratch you can forgo the vocal exercise utilizing some editing to finish in a reasonable time. While still recording, you repeat voice No. 3 a few times until you hit the inflections just right. Now George Washington really does sound cold and worried at Valley Forge. It takes practice to imitate a man who's got to find shoes for several thousand frostbitten soldiers.

Afterwords, go back and mark the tape at the head (first) part of the audio teardrop (see Fig. 1, or page 11 of Bobby Ocean's article, "Imaginative Radio Production," Broadcast Programming & Production, September/October 1976) of the Voice No. 3 goof. Then mark the teardrop head from your good take and splice them together. (See Fig. 2). You now have a very natural and undetectable edit.

If this sounds a bit too precise, it's not. Virtually all broadcast outlets utilize some form of audio compression, which will emphasize breaths. A pro will eliminate all possible distractions.

Basic good engineering practices will preclude or remedy many forms of needless distractions.

For example, let's suppose you're just finishing a good production piece when some joker reaches in the door and kills the light. So what you think . . . that is until you hear the "pop" created on your tape by turning off the light.

But all isn't lost. You can fix it by using a tight vertical splice instead of the general purpose diagonal cut. After

slowly passing the "pop" point over your playback head, mark the edges of the pop (very carefully) and cut out this narrow slit with the vertical slot on your splicing block (see Fig. 3.) If you used 7½ or 15 ips it should be an unnoticeable loss.

This isn't the only tape of distraction that should be eliminated.

Production scriptures dictate you should never, *never* commit the cardinal sin of talking over vocals. It is the worst of all distractions; the voices must compete for the listener's attention. The ear becomes irritated. Whichever voice the listener prefers is being trampled by the other.

Since being creative requires being original you shouldn't use musical beds which are strongly familiar. Again the listener might rather hear the music bed instead of the announcer blasting away for MOM's Apple Pies. That makes you the distraction, which isn't exactly a desired result.

There is enough generally unheard music to fill every bed in radio without having to resort to favorites. Don't. Instead stick your head in the library and search. And don't always settle for a decent 30 or 60 second instrumental section of some cut. Produce unique beds by splicing or cross-fading two or more complementary segments from different cuts.

Don't spoil a good production with the mistakes of a beginning engineer. Erase and splice-cue all carts properly before recording the spot. This will eliminate a basic source of noise and dropouts.

Energize the erasing field of your bulk erase before bringing the cart near. Smoothly bring the cart into the field and make several slow circular motions. The number of wipes required for a clean cart depends on the strength of the field and your individual knack for erasing carts. Again experiment and practice.

As you finish the given number of rotations on one side of the cart, slowly spiral the cart out of the field and re-

enter it to repeat the process for the other side of the cart. In a weak field it is also advisable to wipe the edge where the tape passes to contact the cart deck heads. It is crucial that carts be removed *slowly* from the field, while *continuing* the circular motion. (See Fig. 4)

Only when the cart is well beyond the erase field should the bulk eraser be shut off. Before splicing the cart, check the noise level to insure a good erase. With your monitor and master wide open, if all you hear is a constant level of hiss (no swishing or recurring audio blips) the cart is clean and ready to be splice cued before recording. A commercial splice cuing device senses the added thickness of the splice while running at 15 i.p.s., and will stop the cart as the splice passes the head contact point. Otherwise, it is a matter of running the cart in the play mode until you see the splice run past the heads and start to re-enter the center loop. Stop the cart, and you are now ready for recording. (See Fig. 5).

In any production work you should always adjust levels slowly. Never jerk the music in and out when adding voice.

Fade all pots. Despite some horrible examples you may find on network tv and radio a true pro will never clip his audio.

As an artist he will strive for natural fadeouts. If your board has stepped position pots you can save that final nasty clip as the pot fades by turning down the master gain in unison with the source pot. A little practice will pay off with a smoothly natural fade.

Production pros care about the transition into and out of their spots. Think

# Now Over 55 Major Pro Audio Lines In Stock

## AUDIO CONCEPTS/ DAVE KELSEY SOUND

7138 Santa Monica Boulevard  
Hollywood · California 90046 · (213) 851-7172

*"The Professional Sound People"*

*Want more details? Circle 112 on Product Info. Card*

about the types of buffers inherent in the music you select.

Numerous spots have an ascending pace which will attain a climax and quickly fade out with a tag line. It is a formula package which can fit in a variety of rhythmic and tonal situations. But remember being creative necessitates more than filling a format — vary your approach as you do your clothes.

In equalizing to improve technical quality you must be very discriminatory and utilize a sensitive ear. Equalizers can assist natural reproduction or create distortion, depending on the ear and skills of the user. A basic rule of thumb: if there is any strain whatsoever to understand any part of the spot upon playing it back in the studio, do it over. Material you must even slightly strain for will

probably be unintelligible by the time it reaches a car speaker.

Production experts are expected to be highly efficient. One way you can improve your efficiency is to connect an external amp and speaker to the playback electronics of your cart deck, or plug the cart deck output into the audition channel of your board. In this fashion, you will be able to check the actual playback quality of the spot as it is recorded. Thus, the record head encounters the tape before the reproduce head . . . you can monitor your recorded signal a fraction of a second after its transcription. In utilizing this setup, you must be on guard against the dirty cart. If you use this layout to prevent having to replay the cart after recording . . . beware! An improperly erased cart may hold a previous stop cue signal which can falsely cycle the cart to something other than the beginning.

If you're lucky enough to produce a spot for several stations you can speed up your dubbing time by playing your master in reverse (tails out) while duping. Thus after recording the spot backwards onto one or more five inch reels you need simply cut the tape on the slave recorders and now have a dub ready for forward play. You will also have additional tape left on your 7" or 10" slave supply reels for recording additional dubs in this fashion.

If you produce a spot which allows for a changing tag on sale items (or whatever) a pro with good reflexes can add the tag

FIG. 3

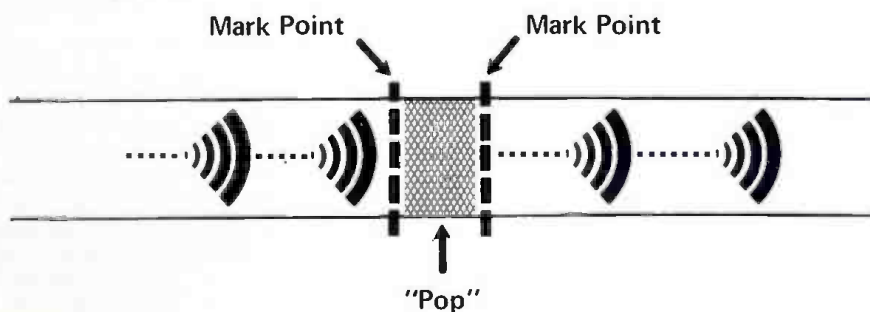

Use Vertical Slot for Splice

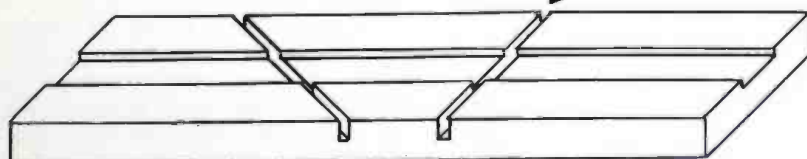

Splicing Block

### CAVOX

is PROFIT-PROGRAMMED MUSIC  
for Automated or Live Radio

Complete Library Service · 6 MOR Formats · Mono or Stereo  
Call (213) 776-6933. CAVOX Stereo Productions,  
502 S. Isis, Inglewood, CA 90301.  
Ask for Bob Mayfield.

*Want more details?*

*Circle 105 on Product Info. Card*

TELL YOUR  
CHIEF ENGINEER  
ABOUT



**Broadcast  
Programming  
& Production**

quickly and efficiently with a form of electronic editing. While playing the tape in cue or headphones, press the record mode on the tape deck slightly before the last instant of the retained audio and add the tag live or from another source. Adding tags in this fashion requires a fairly decent tape deck (most any Ampex will do) which won't add a pop as it enters record. If you're adding the tag live it will also require being able to complete whole sentences while hearing yourself in tape delay.

In Bobby Ocean's previously noted article, he mentioned the use of reverse echo to create a prespoken effect on the first word of a spot. A variation: by playing your tape backwards while recording with the pot open at 15 ips (or 7½ ips), you can create reverse echo on the entire spot. Then replay the reversed-echo dub forwards while recording on another machine with the pot open at 7½ (or 3¾ ips). A little creepy music or sound effects will create a very eerie spot for Halloween. It becomes even more eerie if you add some variable speed effects on the voice anywhere down the line.

Wouldn't it be a real time saver to be able to accurately mark the tape for editing without having to use a grease pencil?

If you study your deck's head housing you will always find some fairly prominent edge. Cue your tape to a word, mark the playback gap with a grease pencil and press the tape against the housing edge or corner to crease the tape.

Place the tape in the splicing block for cutting. Note where your crease appears.

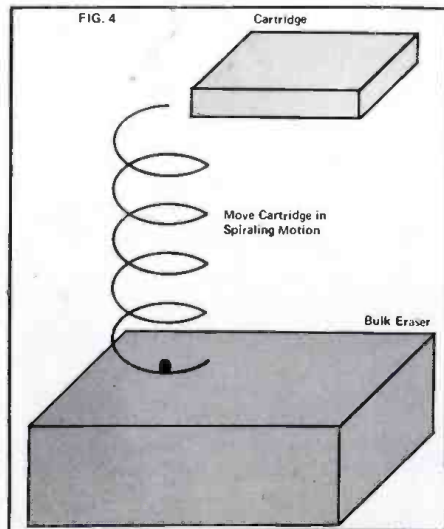

FIG. 4

Mark your splicing block at that point as a reference. Now by cuing to any point you can crease the tape, line it up with your crease mark on the block and cut away, quickly and accurately.

But be careful how hard you crease the tape — you don't want to cause any momentary dropouts because a heavy crease damaged the tape. Like all production skills, practice and patience will lead to finesse.

Any time you record a show or commercial for broadcast you should keep with standard production procedures. Before recording, place a "0" (zero) VU reference tone on the tape for setting levels. After you complete the good take you should mark it with a short burst of tones. Some professional recording studios mark the good take with a 60 cycle tone so that in rewind the tones will make a clear and strong contrast with the other audio. This makes for quick and easy spotting.

You should keep all master tapes, labelling them with the subject, date, and machine you recorded on. In this manner you will be able to track down certain timing and distortion problems to specific machines, plus you'll always have a perfect copy of each spot in case something happens to the air copy.

Remember being efficient is being professional. Keep that noise down! If you've got a turntable that rumbles as it starts, practice your timing, back it up and keep the pot down until just before the audio starts.

You can re-live the golden days of radio and create your own sound effects if you keep noise at a minimum and experiment. You will have to mike very closely to retain presence. You can often use an equalizer to bring out certain special effects on high and low frequencies. Here are a few ways to make some different sound effects: *rainfall*: simulate by pouring buckshot onto a sheet of parchment; *waves*: roll BB shot on a copper screen; *fire*: crackle cellophane gently.

Now several pointers on remote production.

When you are sent on a remote assignment to feed a live broadcast or record for subsequent playback there are several techniques you should be familiar with. If, for example, you are feeding a live sports broadcast the use of your microphones will largely determine the overall quality of the broadcast.

On any sports event, noise cancelling microphones are preferred. These mikes contain two microphone elements connected electrically out of phase, and positioned in relation to each other so as to cancel sound at distances beyond 3 to 6 inches. Obviously you are going to have problems if the sportscaster won't stay closely on-mike. You will first lose the bass and then the entire audio as the

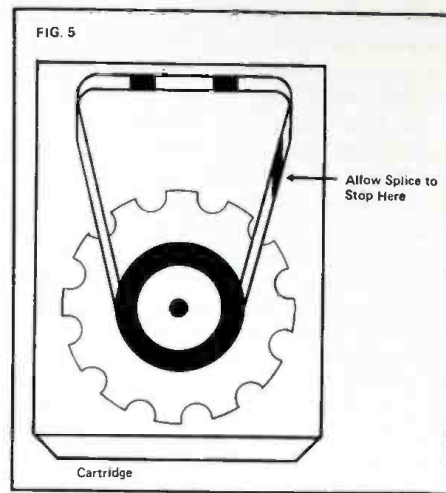

FIG. 5

source is moved away from a noise cancelling mic.

If you don't have access to noise cancelling mics you must mic very closely with a cardioid or uni-directional microphone. You will have enough problems keeping the noise down so stay away from omni-directional microphones. Their sensitivity is equally poor in all directions (including the announcer's).

Place the microphone on-axis to the announcer's mouth. With most mikes pointed directly at the announcer's mouth, if the mike is horizontally more than 15 degrees from directly in front of the mouth, you will lose presence. This goes for mikes vertically displaced more than 30 degrees from the level of the mouth.

This is a very critical procedure, because the reference of 15 degrees horizontally, and 30 degrees vertically refers to the added displacement of the microphone's angle in relation to the direction of the mouth, as well as the mouth's angle to the direction of the microphone. (See Fig. 6).

Here are some important facts about microphone phasing you can use to your advantage:

1) If you are using two microphones less than ten feet apart, they must be electrically in phase. This means the three pins on the mikes must have the same pin count in regards to the shield, high, and low output connections. Mikes will basically appear in two varieties (see Fig. 7).

If the mikes aren't in phase electrically, they will distort and reflect a loss in output level. Even if the mikes are in phase, a cable which is improperly wired on one end will result in phasing problems.

To determine if mikes are connected in phase, first adjust the mixer level for a normal reading as someone speaks into one of the mikes. Keep the pot down on the other mike. Note the setting, close the pot and follow the same procedure for the first mike. Then open both mikes to these settings. An out of phase setup

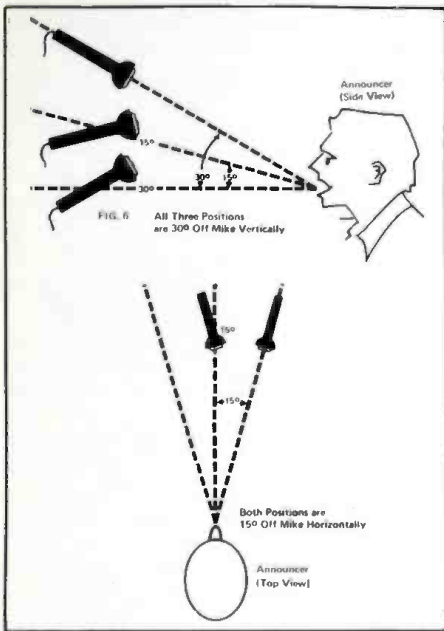

will sound distorted and lower in level. If they are in phase the sound will be clear and louder.

If the mikes are out of phase, you can either reverse the connections to one or insert a phase inverter in line which will bring them in phase.

Be sure you take windscreens to the remote site. They will almost always be needed even if it isn't windy. Sports broadcasters have the habit of becoming very excited and scream as often as not. A windscreen will help prevent "p"-popping.

If you find yourself situated just in front of the air conditioning unit, you might well discover your equipment is picking up a low frequency rumble. This will sap your output power and possibly be heard on the air. Many good microphones have a lo-cut filter installed within their housing, switched in and out by moving a small slide switch on the casing. Some mixers have lo-cut filters switchable on each pot. But if your mikes don't have such filters, you can obtain from most manufacturers, a lo-cut adapter to place in line with the microphone. They come in small housings, the same diameter as the microphone (the same with phase inverters).

On arriving at the site you should feed

the local telephone company a "O" VU tone from your mixer in the plus 8 or plus 10dB output mode. You will later cut the mixer back to plus 4dB output. This will allow you an added 4 or 6dB of badly needed head room on the program loop. This procedure is necessary because Ma Bell drives most of her amplifiers just below the saturation level. You can better handle the increased noise level back at the station with an equalizer or noise filter, than you can remove distortion.

For heaven's sake if you have anything to do with it, make sure all cues are checked out before hand. That means all commercial breaks, theme cues, station ID's, etc. It takes a few minutes to check, but nothing sounds worse than poor production due to inadequate preparation of the cue sheets.

If you are the mixing engineer for the announcer(s), watch them first (so they won't cough in the mike), and your levels second. Sorry, but even pros get caught off-guard, so pretty girls don't count until after the game. If you aren't yet a pro, you'll have to be even more attentive. The final product will reflect your dedication.

If you are burdened with airing an open or close, commercial inserts, or half-time interviews with just one cart machine you might (depending on how strict your format will be) consider making a combo cart. Take a long cart and record the different items in the exact order they will be played. Then lightly mark the edge of the tape with a felt marker 1, 2, 3, etc. as the cart recues, making a list of what each number corresponds to.

You can now use a single combo cart which will recue to each new insert upon completion of the last one. Be careful not to let it get out of sequence. That's why you marked and listened to the cuts. A disadvantage to combo carts is that you will be out of business should your deck eat the cart, or should a splice break loose. Therefore, it would be a good idea to make a safety dub and take it along.

If you are sent on a remote assignment to record a local speaker or town meeting you should also take a pair of clip leads. If the mayor announces a new plant will be opening in the area at 11:45 a.m. you probably won't make it back in time to

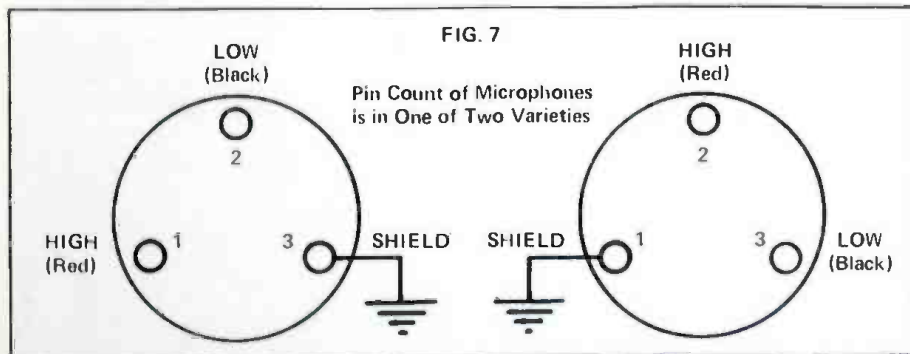

**DON'T MIX THE GOOD  
SOUND WITH ANYTHING  
BUT THE BEST**



**THE  
MODEL 6444 STEREO AUDIO  
CONTROL CONSOLE**

Micro-Trak's new 6444 Professional Audio Console; The console to pick for your small studio, remote, portable or production four channel, stereo board. With its two turntable, two microphone, and three auxiliary inputs coupled to four high quality mixing channels, it makes the ideal choice for that, use everywhere, broadcast console.

Totally professional from design...to application of the highest quality components...to its heritage from a company that's been providing broadcasters with the finest audio equipment for over thirty years, the 6444 has it all....

Smooth pots...FET audio switching Panel laid out for the Pro...Metered plus four dBm output, balanced to drive 600 ohms...Monitor output... Inbuilt cue amp and speaker...noise so low its virtually not there... Built to take all you can give it and still come up swinging . . . . . And best of all the 6444-BT is only \$895.00 and our mono version, the 6454-BT is only \$745.00 . . . . .

See your Micro-Trak dealer for specifications, or write directly to our marketing department, or

SEE US AT NAB BOOTH 815

**MICRO-TRAK**



620 RACE STREET  
HOLYOKE, MA. 01040

Want more details?

Circle 113 on Product Info. Card

## FREE & EXCLUSIVE



AN ENTERTAINING WAY TO HELP FULFILL  
YOUR PUBLIC AFFAIRS/NEWS COMMITMENT

## RECORD REPORT

3½ MINUTE DROP-IN  
HOSTED BY ROBERT W. MORGAN

Sponsored by Certs & Trident

Now in 165 U.S. Markets with planned expansion to 200

**ADD YOUR STATION TO THIS NATIONAL NETWORK TODAY!**

Record Report is the "music magazine-of-radio" filled with news, stories, actualities, and comments from the top contemporary music superstars whose music you play all day.

Record Report fits any format, any schedule... during or after the news, between records, in place of a record. 3½ minutes a report, ten reports a week. **FREE** and **EXCLUSIVE**.

**IMPORTANT! YOU CAN HEAR A "RECORD REPORT" DEMO  
BY CALLING THIS SPECIAL NUMBER RIGHT NOW:  
(213) 461-4767 OR WRITE TO:**

AUDIO/VIDEO PROGRAMMING  
6362 Hollywood Blvd. • Hollywood, CA 90028 • (213) 461-3121

↑ Want more details? Circle 130 on Product Info. Card

cart it and have ready for the lead story in the noon newscast. But if you took clipleads you can call the station, unscrew the telephone mouthpiece, hook the clip leads to the terminals and feed back to the station for recording off the phone line.

Since you are going to be using a low-grade phone line, it will be best to feed the line with as hot a level as permissible without distortion to decrease the noise level. This will have to be co-ordinated with whoever is recording it back at the station. If you wonder how you are going to do so with the clip leads attached, you will have to insure that it be a standard procedure for them to simply give you instruction until they are satisfied with the level. You will still be able to hear them. Or if you have a fairly decent tape unit, you will be able to place it in the record mode without starting the tape, and talk directly back through the microphone and electronics of the machine.

Perhaps a further word should be mentioned on levels and distortion. I indicated that you should feed hot when clip leading to send audio down a normal phone line, and that you should reduce output level from plus 8 to plus 4 when feeding long distance program loops. You might wonder if there aren't other times when you can adjust levels differently than might be first considered for improved sound. Generally, the answer is no.

Only after you've spent years in the studio does your ear become extremely sensitive to distortion and dynamic range. Only then should you start bending the rules. And then only very carefully. Many studio recording engineers drive their meters to the pins with all distortion lights blinking. This doesn't mean they are a bunch of unprofessional jerks. To the contrary, they are the best of their kind. Their equipment is good, so good in fact they might have 10 or 15 dB of headroom before the audio distorts. So they record very hot and push the noise level 10 to 15 dB down. Noise is very critical in high fidelity applications. So while professional engineers often have equipment that can record in the red, and ears extremely sensitive to distortion, what *you* have available at this point probably can't handle it. So, until you start recording albums, let the VU meter be your guardian.

You should now have another goodie or two in your bag of production techniques.

May you use them well.

But always spend a fair amount of your time just experimenting. Sounds are limited only by the studio flexibility, patience, and skill of the operator... and don't forget the pinch of insanity!

If you are picky, patient, and efficient, then the artistry in your madness may enroll you with that select breed of communicator called the *production pro*.

## A Broadcast Phenomenon With a Money-Back GUARANTEE!!!

Your station will achieve results with The BILL BALLANCE SHOW... or we will suffer a rebate penalty!!!

Sixth year in the L.A. market - Now on KABC radio

**#1** TOTAL PERSONS  
165,000 Avg. Per Quarter-Hour  
TOTAL WOMEN  
Sept./Oct. '75 Pulse



Now increase YOUR ratings and revenue with the unique BILL BALLANCE SHOW that fits all formats!! Results are guaranteed!!

## the Bill Ballance show

In syndication. For availability in your market, call  
Creative Radio Shows / 9121 Sunset Blvd. / Hollywood, CA 90069

→ → CALL COLLECT NOW: (213) 276-5022

↑ Want more details? Circle 114 on Product Info. Card



# NEW PRODUCTS & SERVICES

## "D COMPACT" AUDIO CONTROL CENTER FROM MICRO-TRAK

Micro-Trak Corporation of Holyoke, Massachusetts is pleased to announce addition of the "D Compact" to its product line. This totally professional unit is the first in a series of System D Audio Control Centers. The D Compact is a complete audio control package incorporating a "64" Series Broadcast Audio Control Console with two Micro-Trak 740 Turntables and a professional microphone in a portable design.



With a highly stable fold up leg structure the D Compact is arranged so that it can be used by itself, stand alone, or if desired, it can be set up on any available table top. Best of all when folded it fits very nicely in the back of virtually any station wagon. With the D compact your man can be on site set up and ready to go in minutes.

All audio terminations are XLR type connectors for fast reliable hookup. The D Compact accepts inputs from three auxiliary units such as tape machines, and an additional microphone right along with its own turntables and primary microphone. You have the choice of any of Micro-Trak's "64" series audio consoles, the 6444, Broadcast Stereo, the 6454, Broadcast Mono, or the 6440 series of discotheque consoles.

From its depth of experience in broadcast equipment, Micro-Trak's engineering department has outdone themselves to give you broadcast reliability and performance plus the most versatility possible in the D Compact Audio Control Center. The case is covered with durable Formica brand high pressure laminates

for beauty, edge protected with a durable soft vinyl bumper all around. The front arm rest is a padded vinyl cushion for operator comfort. The layout is for fast, accurate operation and as the name implies the system is "Compact."

We'll have more for you soon too. Visit our booth at NAB, number 815, and see the "D Compact" and the other new System D Audio Control Centers. MICRO-TRAK CORP., 620 RACE ST., HOLYOKE, MA 01040 (413)536-3551.

*Want more details?  
Circle 116 on Product Info. Card*

## DIGITAL CLOCK/THERMOMETER

ESE, Inglewood, California, has introduced the ES 142: DIGITAL CLOCK/THERMOMETER, displaying 12 or 24 hour time in six digits, and Fahrenheit or Celsius temperature in three digits, from -50 degrees Fahrenheit to +150 degrees Fahrenheit.



The displays used are planar gas discharge, .55" in height.

Included is a temperature probe and 25 feet of cable, which connects to the rear of the unit. Any length cable up to 500 feet may be ordered.

The unit is enclosed in an aluminum case with simulated walnut sides and top, and sells for \$225.00. Delivery is three weeks.

The thermometer may be purchased separately, at a cost of \$150.00. The part number is ES 240.

ESE, 505 1/2 CENTINELA AVE., INGLEWOOD, CA 90302. (213) 674-3021.

*Want more details?  
Circle 117 on Product Info. Card*

## "INSTANT REPLAY" COLOR DISC RECORDER UNVEILED BY EIGEN VIDEO

The first "Instant Replay" color disc recorder under \$10,000 was announced today by Eigen Video, Grass Valley, California. The magnetic disc recorder can do jitter free forward and reverse slow-motion as well as freeze-frame. At this price level, "Instant Replay" is now feasible for commercial television, industrial TV studios, animation studios, race tracks, and CATV sports origination.

The recorder has a time capacity of 10 seconds, twice the length of an average football play, and a variable range of record/play rates from 60 fields per second down to still image. The signal to noise ratio is greater than 46dB. The recorder uses standard video inputs and the output can be used directly in a non-broadcast application, or time-base corrected for broadcast use. The recorder locks to station vertical sync.

A TV studio would use the disc recorder not only for sports "Instant Re-



play," but also could add interesting animation, time-lapse and electronic slides for titles, commercials and station promos. Any news show could add the "instant Replay" effect to sports film and tape even though the original was shot at standard rates.

In video production work, discs are valuable for accurately locating exact edit points and timing video to audio. Freeze frame is a very common effect achieved through a disc recorder. The \$10,000 price allows editors to own a disc without having to go outside to rent one. The superior 46dB signal to noise ratio allows additional generations of dubbing.

Animation effects can be built up

# ALPHA SERIES



## THE BEGINNING OF A NEW ERA IN PROFESSIONAL QUALITY MIXING CONSOLES.

Remotes or a permanent system, the new Alpha series mixers have more features than we have space to tell you about them.

Write us or circle the number. We'll send complete information on the compact Alpha.

Good things come in small packages. From the Console Company...

**Sphere**  
ELECTRONICS

EASTERN REP  
SPHERE AUDIO SALES  
478 DEVENS DRIVE  
BRENTWOOD TENN 37027  
(615) 794-0155 (NASHVILLE)

20201 1/2 PRAIRIE AVE.  
CHATSWORTH, CALIF. 91311  
(213) 349-4747

*Want more details?  
Circle 115 on Product Info. Card*

easily, allowing televised preview of pencil tests, or actual color production on disc for release on video tape.

The Eigen disc is flexible, differing from the other sports "Instant Replay" disc recorders. This prevents head "crashing," a common cause of downtime for conventional discs. The disc material is in a cassette, which allows an operator to change a disc within a minute. Replacement discs, in the cassettes, cost \$75.00 each; cassettes can be reloaded.

EIGEN VIDEO, P.O. BOX 1027, GRASS VALLEY, CA 95945.

*Want more details?*

**Circle 118 on Product Info. Card**

## SOUND EFFECTS AND MUSIC LIBRARY EXPANDS

The Thomas J. Valentino Inc., Major Production Music and Sound Effects Libraries have recently expanded to include 142 LPs in the Music Library and 18 LPs in the Sound Effects Library.

The very complete Music Library contains over 3,000 selections of openings, closing, titles and bridges as well as full length selections in every idiom including original "Disco" and "beautiful music" stylings. The library is used very frequently on programming and production by every aspect of radio and TV.

The famous Sound Effects Library now has over 600 different effects on 18 LPs and contains everything from a

toilet flush to a roller coaster.

All catalogs for both libraries are free on request.

THOMAS J. VALENTINO INC., 151 WEST 46th ST., NY, NY 10036.

*Want more details?*

**Circle 119 on Product Info. Card**

## TWO NEW SHURE HEAD-WORN BROADCAST MICROPHONES ANNOUNCED

Shure Brothers, Inc., Evanston, IL, has combined highly efficient background noise control and top quality vocal pick-up and transmission in two new, light-weight head-worn microphones for studio and remote professional broadcasting applications.

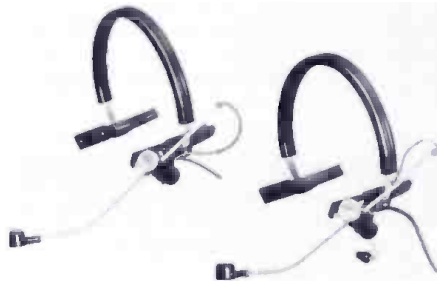

The new units are available as the Model SM10, which consists of a headband and microphone only, and the Model SM12, which has a headband, microphone, and earphone and is designed

for applications where it is important for the user to receive as well as transmit. Also available is an accessory cough button, Model A10CH.

Both units feature unidirectional pick-up patterns that reject unwanted background noise and miniature windscreens that block out wind noise and explosive breath sounds.

The SM10 and the SM12 are low impedance models, allowing extra-long lengths of microphone cable to be used. To prevent the microphone wires from getting in the way, each microphone is equipped with a snap-on connector that fastens to the user's belt or shirt. For maximum flexibility, the microphones are engineered to pivot and extend to fit any head and face.

Each complete unit weighs less than three ounces and is made of durable stainless steel, aluminum, and high-impact thermoplastic.

U.S. list price of the Shure Model SM10 is \$72.00; the Model SM12 \$96.00; the Model A10CH \$24.00.

SHURE BROTHERS INC., 222 HARTREY AVE., EVANSTON, IL 60204.

*Want more details?*

**Circle 120 on Product Info. Card**

## NEW AM BROADCAST LIMITER MAXIMIZES TRANSMITTER EFFICIENCY AND EXTENDS RANGE

The new UREI MODULIMITER

## BOOK REVIEW

### THE MINI-DOCUMENTARY—SERIALIZING TV NEWS

BY STANLEY FIELD

PUBLISHED OCTOBER 1975.

Little or nothing has as yet been written on the mini-documentary per se. "The Mini-Documentary—Serializing TV News," by Stanley Field, is designed to fill that void.

This television form has been in existence for more than a decade and it has had a profound influence on the betterment of the community. Many television news directors believe it will replace the local full-length half-hour or hour documentary as a news special. The networks may even see fit to continue the fine art form of the documentary indefinitely. The mini-documentary is almost entirely the province of the local television station, although there are scattered instances of network productions.

Now one can learn all there is to know about making a mini-documentary from experts who are engaged daily in the production of this newly emerging and highly effective communications medium. The author — an information specialist for radio and television in government service — brings to the reader interviews with producers, cameramen, editors, and sound men — professionals with hands-

on contact with the mini-documentary. In addition, he has distilled the years of experience and talent of mini-documentary producers from the four commercial television stations in the nation's capital.

Actual written or transcribed on-air scripts for eight mini-documentary series — many of them award-winners — are part of this valuable text.

Equipment and techniques for undercover shooting and sound recording and every other news-gathering situation are fully explained. The advantages and disadvantages of film and videotape are detailed perhaps better than in any other book presently available. Aerial photography, crane shots, infrared, mini-cam techniques, and undercover tips are but a few of the things explained in this fact-packed book.

The do's and don'ts of film and videotape editing of the mini-documentary — its concept, historical background, and structure, including themes, content, research, recapitulation, and follow-ups — are but a few more of the highlights. An Appendix with the results of a national survey of television news directors on the mini-documentary, and script abbreviations, are some of the additional features. A 27-entry bibliography and a complete Index round out the text.

CONTENTS: THE DOCUMENTARY — THE STRUCTURE OF THE MINI-DOCUMENTARY SERIES: Opening

Statements; Research; Talking Heads; Content; Variations On a Theme; Recapitulation; Follow-Ups; Camera; Summation — THE INTERVIEWER — THE MINI-DOCUMENTARY APPROACH OF ABC AFFILIATE WMAL-TV: The Reporter's Viewpoint; Americans In Exile: A Report From Canada; The Camera Perspective; Sound; The Auto Repair Go-Round; You and Auto Repair; Time Span; Alcoholism: DC Area; Editing the Mini-Documentary — THE MINI-DOCUMENTARY APPROACH OF NBC AFFILIATE WRC-TV: Uncle Sam Is a Slumlord; The Mentally Retarded; Perceptive Photography; The Creative Film Editor — THE MINI-DOCUMENTARY APPROACH OF CBS AFFILIATE WTOP-TV: Reporting; Undercover Technique; Commentary; Photographic Technique; Film Editing — THE MINI-DOCUMENTARY APPROACH OF INDEPENDENT WTTG: Reporter/Producer/Writer; A Way to Say Goodbye; The Pressured Photographer — MINI-DOCUMENTARY SURVEY — BIBLIOGRAPHY — INDEX.

252 pages, 28 illustrations.

This book is available from:

BP&P BOOKS

P.O. BOX 2449

HOLLYWOOD, CA 90028

PRICE: \$12.95 Hardbound

(Check or Money Order must be included with order.)

Model BL-40 is an "automatic" limiter that, unlike "factory set automatic" limiters, provides adjustments for tailoring the modulation envelope to any program format or transmitter characteristics: constant full modulation or a more conservative approach (hard rock to classical).

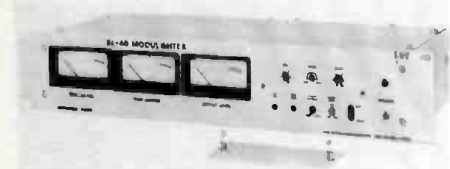

Modulimiter eliminates unwanted overmodulation without clipping. Independent adjustments are provided for RMS and peak limiting and for variable positive overmodulation up to 125%. The BL-40 patented Electro-optical attenuator offers unobtrusive, smooth, true RMS limiting. An ultra-fast F.E.T. peak limiting section assures absolute protection from unwanted overmodulation with no peak clipping. Attack time is essentially instantaneous. A Phase Optimizer maintains most favorable signal polarity, automatically and silently reversing polarity to maintain maximum upward modulation.

Modulimiter features low noise, low distortion integrated circuitry designed for maximum reliability and long life. All critical adjustments are located behind a removable security panel. A limiting "bypass" switch is furnished. Modulimiter is also ideal for application in T.V. and CCTV audio signal processing, background music systems and commercial sound systems.

UREI, 11922 VALERIO STREET, NO. HOLLYWOOD, CA 91605.

*Want more details?*

*Circle 121 on Product Info. Card*

#### NEW PROGRAMMING INFORMATION SERVICE FROM BRENEMAN RADIO SERVICES

Breneman Radio Services, long time record and programming service for radio stations, is now offering a publication, the "New" BRS Review. Referred to as the "Yellow Pages of Music Radio," the review is published weekly and provides important record information that is credible, easy to work with, and comprehensive.

The "New BRS Review" is coordinated by Betty Breneman, noted and respected radio music programmer. More information on the Review, as well as other numerous services offered, is available from:

BRENEMAN RADIO SERVICES, 23117 COLLINS ST., WOODLAND HILLS, CA 91364.

*Want more details?*

*Circle 122 on Product Info. Card*

#### DBX ANNOUNCES ADD-ON NOISE REDUCTION FOR NAGRA IV-S

A direct bolt-on professional noise reduction package designed by dbx for the Nagra\* IV-S portable stereo tape recorder permits the already excellent Nagra unit to produce master tapes on location which have a signal-to-noise ratio surpassing that of the most expensive studio recorders using other noise reduction systems.

The dbx 192 is a two channel switchable record or playback system identical in performance to dbx studio noise reduction systems. It combines 30 dB of broadband noise reduction with a 10 dB increase in tape recorder headroom, requires no level matching, and contains only one control, a record/play switch.



The accessory package is slightly over one inch thick and bolts directly to existing tapped holes in the Nagra case using hardware supplied. The dbx 192 is designed without an independent power supply to keep weight to a minimum. Its one-third watt power requirement is taken from the Nagra supply. A single seven-pin DIN conductor and cable is supplied to mate with the Nagra noise reduction connector.

The dbx 192 is built to survive the rigors of location recording, including one-eighth inch thick anodized aluminum case, computer grade glass epoxy circuit boards, metal cased, hermetically sealed semiconductors and integrated circuits. The unit is available from dbx dealers or the factory for \$600.

\*Nagra is a trademark of Kudelski, S.A. of Switzerland.

DBX, INCORPORATED, 296 NEWTON ST., WALTHAM, MA 02154.

*Want more details?*

*Circle 123 on Product Info. Card*

#### EXPANDED AUTOMATION SERVICES FOR BROADCASTERS

Studio West, California based automation and programming service for broadcasters nationwide, is expanding their format spectrum, especially in light of the recent FCC ruling, requiring certain stations to break off their AM-FM simulcast operations. Such services are designed to be of special value to many



*Studio West*

**Want  
MORE INFO.  
on Products &  
Services Seen  
in this Issue??**



If you would like more information on the products and services advertised in BP&P, just circle the appropriate numbers on the "PRODUCT INFORMATION CARD" enclosed in this issue. Mail it, postage-free, and BP&P's reader service will speed the details to you —without cost or obligation!!!

*Circle the Numbers*

**TELL YOUR  
PRODUCTION DIRECTOR  
ABOUT**



**Broadcast  
Programming  
& Production**

affected broadcasters.

Studio West is releasing a new customized voice track concept, adding to their already diversified M.O.R. (Easy Listening, Traditional and Contemporary) formats, and Rock formats (Adult Rock, Gold Rock and Soft Rock), each customized for the specific market contracting their services.

Major market talent will provide the 'voicing' as well as the music programming for Studio West affiliates nationwide. Special sales promotions and 'Weekend Specials' are being offered. In addition, Studio West is already experiencing some production activity for both Europe and the Orient, as well as Canada, reports Studio West President, Jim Meeker.

Studio West's programming services

**CAVOX****Is PROFIT-PROGRAMMED MUSIC  
for Automated or Live Radio**Complete Library Service · 6 MOR Formats · Mono or Stereo  
Call (213) 776-6933, CAVOX Stereo Productions,  
502 S. Isis, Inglewood, CA 90301.  
Ask for Bob Mayfield.*Want more details?***Circle 105 on Product Info. Card**

are designed to be an economic, as well as creative boon to broadcasters. Studio West formats and productions are bringing major market talent, plus years of commercial experience and music programming know-how to the smaller broadcast markets.

**STUDIO WEST: CREATIVE SERVICES,  
5929 TIBER DRIVE, ANAHEIM, CA  
92807.**

*Want more details?***Circle 124 on Product Info. Card****NEW SPECTRA SONICS MODEL 3000  
MONITOR SYSTEM**

SPECTRA SONICS announces a new, tri-amplified, monitor, loudspeaker system. This system is designed for external crossover networks and for separate power amplifiers for each of the low, mid-range, and high frequency trans-



ducers. Superb American craftsmanship is distinctly apparent in the cabinet construction. The enclosure is sturdily constructed of one inch plywood and is covered in gunstock walnut formica for strength and appearance. The grill cover is removable for easy access to the speakers and a centrally located termination panel at the rear permits simple installation.

The Model 3000 is available now, competitively priced at \$846.00.  
**SPECTRA SONICS, 770 WALL AVE.,  
OGDEN, UTAH 84404 (801)392-7531.**

*Want more details?***Circle 125 on Product Info. Card****NEW MUSIC PROGRAMMING SERVICE**

Music Programmers, Inc., a Phoenix based firm, has developed a system to help each broadcaster with his individual station music problems. Music Programmers, Inc. says the new system could save hundreds of hours for Radio Station Program Directors and Music Directors. It's designed to aid programming by

matching a station's library to pre-selected programming determined by the client/station. Music Programmers, Inc. produces an hourly playlist with proper rotation, balance and consistency nearly impossible by manual means.

**MUSIC PROGRAMMERS, INC., 6020  
S. 45th STREET, PHOENIX, ARIZONA  
85040.**

*Want more details?***Circle 126 on Product Info. Card****MODULAR AUDIO PRODUCTS AN-  
NOUNCES NEW SERIES OF RECORD-  
ING CONSOLE MODULES**

The new series of MAP 8422 Console Control Modules provide comprehensive switching and control facilities for multi-track recording, quad-stereo-mono mix-down, and monitoring required in today's recording and production consoles. They are available from Modular Audio Products, a unit of Modular Devices, Inc., Bohemia, New York.

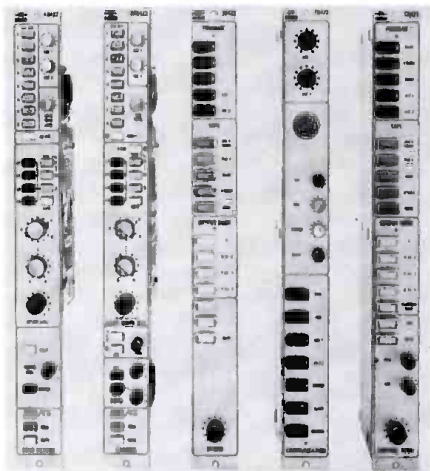

System features of the 8422 Series include: selectable Mic/High Level inputs with programmable LED peak level indication; an internal power network for condenser mic's; switchable 70Hz Hi Pass Filters; Channel Mute and Solo on all inputs; Quad Panning and Quad/4 Track/Stereo mode selection; Direct Track Feed; two independent Echo channels with pre-post fader selection, delay, echo and monitor send and return functions; two independent Cue channels; and self contained Multi-track mixing amplifiers with full range rotary Submaster level controls. Complete control facilities for Control Room and Studio Monitoring, Talkback and Slate are also provided.

The entire series has been designed for direct plug-in to printed circuit motherboards, simplifying console layout, assembly and troubleshooting.

Modular's Sales Manager, Rick Belmont, states that "the 8422 Series represents a new concept in recording console design, in which all of the switching, amplification, and control functions have been incorporated into one set of easy to install modules. This enables the designer or "do-it-yourselfer" to plan for economical console construc-

tion and allowing for easy expansion in the future. The faders, equalizers and/or compressors are omitted from the input modules, to allow the user to select the models best suited to his particular requirements."

Technical data, prices and delivery information on the 8422 Series modules are available on request.

**MODULAR AUDIO PRODUCTS, INC.,  
1385 LAKELAND AVENUE,  
NEW YORK 11716.**

*Want more details?***Circle 127 on Product Info. Card****EARTH NEWS INAUGURATES AUDIO  
FEATURE SERVICE**

EARTH NEWS, the five-year-old San Francisco-based alternative news service, which provides daily dispatches to over 400 radio stations, has announced the creation of an EARTH NEWS Audio Feature Service. The proposed audio service, not to be confused with Lew Irwin's highly successful EARTH NEWS Radio out of L.A., will provide the dispatch service with a much-needed audio equivalent.

The service will consist of 12 five-minute features a week. Each will contain a 60-second national spot and three-and-a-half minutes of feature material. The service will be available free to one carefully-selected station in each market. Many of the features will consist of highlights from interviews and produced programs from any number of stations and independent producers. Just about anything ear-catching, timely and out of the ordinary might fit in — political, environmental, mystical, satirical, and music-related material. Nationally respected news personality David McQueen of KSAN in San Francisco will host and provide continuity for the series. Each installment will be a timely, self-contained magazine-like feature rather than a current "hard news" story.

**EARTH NEWS, 210 CALIFORNIA ST.,  
SUITE 306, SAN FRANCISCO, CA  
94111.**

*Want more details?***Circle 128 on Product Info. Card****REVOX 3500 MICROPHONE**

Revox Corporation now have available their new 3500 dynamic unidirectional

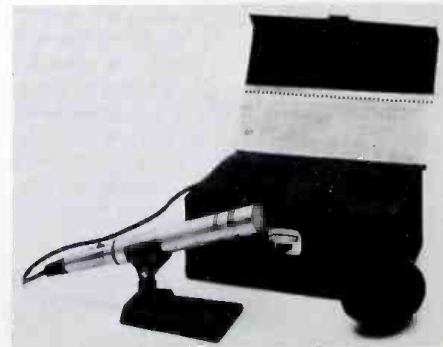

moving coil microphone.

This microphone features wide, flat frequency range, high output and true cardioid characteristics and has been designed for the most exacting use. Its outstanding performance in relation to its small size has been achieved by the development of a specially constructed pressure gradient transducer. Despite the small size of the diaphragm, sensitivity is maintained at a high level by means of a highly efficient magnetic circuit.

The 3500 is ideally suited to tape recording applications, where good intelligibility and full range ability is required. The unique construction of the 3500 housing reduces handling noise to a minimum and the microphone may be used either stand mounted or handheld. The 3500 is designed to withstand the rigours of years of hard use and is completely unaffected by extremes of atmospheric conditions. Overall dimensions are 6.3" long by 0.945" diameter.

The 3500 comes complete with colored windshield, clamp, table stand and presentation case; termination is cannon XLR type; impedance: 600 ohms. Each microphone comes with its own frequency response curve.

Frequency response: 40-18000Hz.

Price: \$165.00.

REVOX CORP., 155 MICHAEL DR., SYOSSET, NY 11791.

*Want more details?*

*Circle 129 on Product Info. Card*

**KRISHANE ENTERPRISES ANNOUNCES NEW BROADCAST SERIES**

Krishane Enterprises, Inc., a California based creative services corporation announces the availability of some of its new features and services for both broadcasters and advertising agencies.



Some of the broadcast services available consists of their customized Program Aid Package, which includes dynamic-impact I.D.'s, Promo's Intro's, and innovative concept cuts for any format application or programming situation. For station syndication, 2 shows are available, "THE WAY WE WERE," which is a 5 minute nostalgic feature, highlighting the music and news events from 1955 to the present, and "LOVE IS THE MESSAGE," which is a package containing 365 (:60 second) features dealing with expressions of love for use each day of the year. Presently in production is a super station image jingle package which will be available to radio stations shortly.

From a Radio/TV commercial standpoint, Kris Erik Stevens, President of

# Subscribe to



Receive your own personal subscription to BP&P, and start a useful reference library of production techniques, programming profiles, equipment, services, and a variety of information on successful broadcasting!!!

Check or Money Order must be included with your subscription order. Subscriptions cannot begin with back issues. Clip coupon below and mail to: Broadcast Programming & Production, P.O. Box 2449, Hollywood, CA 90028.

BP&P / P.O. Box 2449 / Hollywood, CA 90028

Start my personal subscription to  
BROADCAST PROGRAMMING & PRODUCTION

UNITED STATES:

- 3 Years (18 issues) \$18
- 2 Years (12 issues) \$13
- 1 Year (6 issues) \$7
- 1 Year via Air Mail \$13

FOREIGN:

- 1 Year (6 issues) \$8.50

I have enclosed \$ \_\_\_\_\_

Name		Title	
Station/Company		<input type="checkbox"/> New <input type="checkbox"/> Renewal	
Address		<input type="checkbox"/> Home <input type="checkbox"/> Office	
City	State/Province/Country	Zip	

Please Check Appropriate Category:

- Radio:  AM  FM  Stereo  Live  Automated  Production Co.  
 Manufacturer/Distributor  Syndicator  
 Other \_\_\_\_\_ Format: \_\_\_\_\_

- Television:  VHF  UHF  Production Co.  Manufacturer/Distributor  
 Syndicator  Other \_\_\_\_\_

Krishane, has announced the availability of many of their services and facilities to ad agencies in the Los Angeles area. Krishane offers full studio facilities, creative commercial concepts, copywriting, jingles, production, duplication, plus professional voice talent people. Demo's available on request.

**KRISHANE ENTERPRISES, 4601 WILLIS AVE., SUITE 309, SHERMAN OAKS, CA 91403.**

*Want more details?*

*Circle 131 on Product Info. Card*

#### NEW HEADPHONES FROM TELEVISION EQUIPMENT ASSOCIATES

Radio stations looking for really rugged headphones can get them at Television Equipment Associates. The Astrolite Hi-Fi phones are available either stereo double phone, or single side. The headphone has a frequency response of 50-15,000 Hz and impedance of 200 ohm (or, optionally, 6,000 ohm).



Lightweight Rugged Construction. The Astrolite stereo phone weighs only eight ounces and, like the range of the Astrolite headsets, is fabricated from practically unbreakable components such as all-nylon plastics (that won't break when you drop them), a steel headband with padded cover, and tinsel cable.

Interchangeable Foam Cushions.

Astrolite offers a choice of ear-enveloping cushions or ventilated cushions which eliminate perspiration and accommodate eyeglass frames.

**TELEVISION EQUIPMENT ASSOCIATES, P.O. BOX 1391, BAYVILLE, NY 11709.**

*Want more details?*

*Circle 132 on Product Info. Card*

#### IGM UNVEILS "MANUAL ASSIST REMOTE CONTROL" AUTOMATION SYSTEM

IGM/Northwestern Technology, Inc. of Bellingham, Washington, a recognized leader in broadcast automation and cartridge handling systems, will unveil a

totally new concept for broadcasters.

Designated the MARC VII (Manual Assist Remote Control), the system is designed to provide electronic access and automatic sequencing of program elements in live studio or control room operations. This removes much of the pressure from the operator, and allows him to pre-set switching instructions so that he may concentrate on the creative aspects of programming rather than the mechanics.

With its TV display and simple entry keyboard, the MARC VII will allow access to any of seven audio sources, each with up to 99 sub-sources, and is designed to interface with and control single tape decks, cartridge machines, or random access cartridge handling devices, such as IGM's Instacart or Go-Cart. The operator may sequence these devices in any order desired, up to 18 events in advance, and may make changes, deletions or substitutions instantly at will. The display screen projects a constant picture of events scheduled, and incorporates a digital timer as well. An external series of station monitor circuits may be inputted also, appearing on the operator's screen as various alarm messages.

For further information, contact Steve Grayson, Manager, Marketing and Sales. **IGM/NTI, 4041 HOME ROAD, BELLINGHAM, WA 98225 (206) 733-4567.**

*Want more details?*

*Circle 133 on Product Info. Card*

#### CONTINENTAL RECORDINGS UNVEILS NEW SALES AID PACKAGE

MOTIVATORS II is a new sales aid package available to broadcast stations from Continental Recordings, Inc.

MOTIVATORS II is a custom music logos tailored for individual advertisers on a market by market basis. These high quality music logos can improve the effectiveness of advertising up to five times. The combination of music and lyrics makes it easy to remember.

## motivators II

MOTIVATORS II motivates your sales staff to sell, and motivates your client to buy.

Continental guarantees immediate follow-up, 75 mile protection, no residuals and customer satisfaction.

MOTIVATORS II is a way for your salespeople to generate long-term advertising. It creates good radio advertisers and shows your customers that you care about them.

For details call (617) 879-2430 and ask for Debbie or write for details to: **CONTINENTAL RECORDINGS, INC. 12 IRVING SQUARE, FRAMINGHAM, MA 01701.**

*Want more details?*

*Circle 134 on Product Info. Card*

#### STATIC-FREE RECORDS WITH STATICMASTER CLEANER

The STATICMASTER MODEL 3C500 is a truly unique record cleaning brush. It contains an active POLONIUM 210 element which totally neutralizes static charges on the surface of any record. Since these charges are largely responsible for the attraction and adhesion of dust to the record, their neutralization frees the dust for easy removal by Staticmaster's integral, natural-bristle brush. Regular Staticmaster treatment keeps s clean records clean — without build-up of any kind — thereby extending stylus and record life and reducing surface noise.



Staticmaster operates in seconds, without any washing, spraying or rubbing. Static charges are "bled" from the record via a path of ionized air that is created by alpha particles emitted by the Polonium 210 element.

Nuclear Products Company has just recently entered the audio market, however the firm has been a leading manufacturer of static elimination products for photographic, printing and related fields for over 25 years.

Price for the Staticmaster 3C500 is \$14.95.

**NUCLEAR PRODUCTS COMPANY, P. O. BOX 5178, EL MONTE, CA 91734 (213) 283-2603.**

*Want more details?*

*Circle 135 on Product Info. Card*

#### BROADCAST ANTENNA CURRENT INSTRUMENTS INTRODUCED BY DELTA

Delta Electronics, Inc. announces the introduction of the new Models TCA and TCA-XM radio frequency measuring instruments designed to measure currents in broadcast antenna systems. These instruments are intended for applications where conventional thermocouple meters are ordinarily used. The TCA and TCA-XM are substantially more accurate for all operating conditions, and they meet FCC requirements of 2% accuracy. Calibration at broadcast frequencies assures that there are no errors due to frequency effects when using these instruments.

Antenna current samples are taken from the current carrying conductor by a

toroidal current transformer that requires no interruption of the RF circuit. An integral lightning protection switch on the indicator eliminates the requirement for a meter switch in the RF circuit. Current samples are transported to a 50 ohm terminating resistor by a six foot 50 ohm coaxial cable. The voltage developed across the terminating resistor is rectified

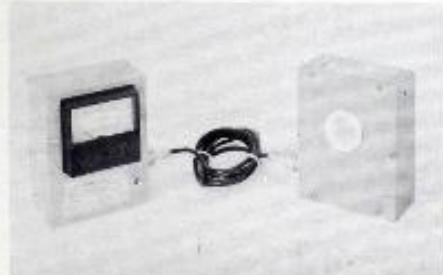

by a special temperature compensated silicon diode rectifier circuit and displayed on a mirror scale taut band indicating instrument. The rectifier circuit and indicating instrument are housed in a shielded enclosure for the TCA models. For the TCA-XM models, the rectifier circuit is housed in a small shielded enclosure, and the indicating instrument is separate for panel mounting.

These new instruments are available in 5 ranges up to 80 amperes. DELTA ELECTRONICS, INC., 5534 PORT ROYAL RD., SPRINGFIELD, VA 22151.

*Want more details?*

*Circle 136 on Product Info. Card*

## Classified

### CLASSIFIED ADVERTISING RATES

Prepaid\* with submitted copy:  
 One Column Inch (1" x 2 1/4") ... \$27.50  
 1/2 Column Inch (1/2" x 2 1/4") ... 20.00  
 \*(If billing is required add 20%)

### RADIO PROGRAMS

*A Chronology of  
 American Music*  
**THE No. 1**  
**BI-CENTENNIAL SPECIAL**  
**ALL THE No. 1 HITS...  
 IN STEREO**  
 more music  
 enterprises  
 515 Laurel Canyon Blvd., N. Hollywood, CA 91607  
 (818) 985-1100

*Want more details?*

*Circle 137 on Product Info. Card*

## EQUIPMENT

### FREE CATALOG & AUDIO APPLICATIONS



CONSOLES  
 KITS & WIRED  
 AMPLIFIERS  
 MIC., EQ, ACN,  
 LINE, TAPE, DISC,  
 POWER  
 OSCILLATORS  
 AUDIO  
 TAPE BIAS  
 POWER SUPPLIES

OPAMP LABS, INC.  
 1033 N. SYCAMORE AVE  
 LOS ANGELES, CALIF. 90038  
 (213) 937-2560

*Want more details?*

*Circle 138 on Product Info. Card*

### RECORDING TAPE SPECIAL

1 Mil Mylar, 3,600 Foot on 10 1/2 x 1/4  
 Plastic Reels, Splice-Free

100 Lot . . . . . \$1.60 ea.

1,000 Lot . . . . . \$1.25 ea.

ACCURATE SOUND CO.

114 5th Avenue  
 Redwood City, CA 94063  
 (415) 365-2843

*Want more details?*

*Circle 139 on Product Info. Card*

### SONY MX20 MIXER

8 in, 4 out., with EQ, Pan, Slide Faders.  
 Never used, in original carton. \$875

AMPEX FOUR TRACK RECORDER  
 Ampex 351 - 4 track, 300 deck, 1/2-  
 inch. New Taber heads. Sel-Sync. Best  
 offer or trade for Tascam Model 10  
 Board.

DON ELLIOT

P.O. BOX 666, Hollywood, CA 90028  
 (213) 851-7768

## STATION SERVICES

### CREATIVE SERVICES AND CUSTOM PROGRAM CONCEPTS BROADCAST SERVICES:

Professional Program Aids  
 ID's DJ Intro's Promos  
 Wild Tracks  
 Station Image Jingles  
 Airchecks

Syndicated Features  
 Music Services

### COMMERCIAL PRODUCTIONS:

Full Studio Facilities  
 Commercial Jingles  
 Professional Name Voice Talent  
 Concepts & Copywriting  
 Sound Effects  
 Production Expertise

DEMO & RATES ON REQUEST  
 KRISHANE ENTERPRISES, INC.

4601 Willis Ave., Suite 309  
 Sherman Oaks, CA 91403  
 (213) 981-8255

*Want more details?*

*Circle 140 on Product Info. Card*

## DON ELLIOT

Creative

Services

3330 BARHAM BLVD. • HOLLYWOOD, CALIF 90068  
 BOX 862 • HOLLYWOOD, CALIF. 90028 • (213) 851-SPOT

- FULL STUDIO FACILITIES
- COMMERCIAL PRODUCTION
- LOCAL BUYING SERVICES
- PROMOTIONS & JINGLES
- BROADCAST CONSULTING
- SYNDICATION

Features Available:  
 "JUST A MINUTE" - with contemporary  
 artists, and "A MINUTE OF AMERICA"  
 bicentennial feature, both hosted by  
 Charlie Tuna.

Plus MOR program-length features with  
 artist interviews.

### DEMOS ON REQUEST

Programs available free (bartered) or on  
 cash buyout for local sale.

*Want more details?*

*Circle 141 on Product Info. Card*

### ARTIST-GROUP DISCOGRAPHIES

A Unique and Informative Service  
 Full of Rock 'n' Roll History.

An Excellent Reference Source Showing  
**EVERY 45** Record Released by the  
 Major Artists of the 50's, 60's & 70's.

Send for FREE Catalog

of Artists Available

RICHMAN PRODUCTIONS

P.O. Box 4425

North Hollywood, CA 91607

*Want more details?*

*Circle 142 on Product Info. Card*

### BACK ISSUES OF BROADCAST PROGRAMMING & PRODUCTION

Back issues of BP&P are available for  
 \$1.50 each. Specify issue(s) desired by  
 date or volume and number. Payment  
 must be enclosed (no billing).

### BACK ISSUES

Broadcast Programming & Production  
 P.O. Box 2449  
 Hollywood, CA 90028

### INFORMATION SERVICE

Interested in any products or ser-  
 vices advertised in this issue of BP&P?  
 For more information, circle the num-  
 bers on the enclosed "PRODUCT IN-  
 FORMATION CARD" that correspond  
 to the advertisements that interest you.

Mail the card, postage-free, and more  
 facts about those products and services  
 will be rushed to you.

RADIO ARTS PRESENTS

the  
**ENTERTAINERS** 



**Station after station  
reports powerful market impact!**

"What Radio Arts has done with  
The Entertainers makes running an  
MOR station a pleasure once again."

— Ansley D. Cohen, Jr.  
General Manager, WNCG  
N. Charleston, S. Carolina

"We've been looking long and hard  
for a format that can give us some-  
thing special and something extra...  
The Entertainers does both!"

— Gordon Faulkner  
V.P. General Manager  
WITH, Baltimore, Md.

"The best 25+ MOR music mix  
we've seen. Reaction from audience  
and advertisers has been terrific!"

— John C. Davis  
General Manager, KSRM  
Soldotna, Alaska

Today's new MOR stars are blended  
with the all-time greats in an exciting,  
popular adult sound. The most  
familiar music of our time.

Join **The Entertainers'** bandwagon.  
Make your station your market's  
"Entertainer."

**Mail This Coupon  
or Phone Collect  
to Learn if Your Market  
is Still Available**

Radio Arts, Inc.  
210 N. Pass Avenue  
Burbank, California 91505  
Yes! I'd like a copy of "The Entertainers"  
Demo tape.

Name \_\_\_\_\_

Title \_\_\_\_\_

Station \_\_\_\_\_ Present Format \_\_\_\_\_

Address \_\_\_\_\_

City \_\_\_\_\_ State \_\_\_\_\_ Zip \_\_\_\_\_

Telephone \_\_\_\_\_

**A Complete Format Service for Automated & Non-Automated Radio Stations**



For further information call collect  
to Phillip Koener, Radio Arts' General Sales Manager.

**Radio Arts, Inc.**

Suite 104, 210 North Pass Avenue, Burbank, California 91505 (213) 841-0225

Want more details? Circle 143 on Product Info. Card