

Theodore E. Rose  
Editor

J. F. Thompson  
Associate Editor

J. B. Straughn  
Technical Editor

L. L. Menne  
Editor Emeritus

# NRI NEWS

Vol. 19, No. 2

April-May, 1960

Published every other month by the National Radio Institute, 3939 Wisconsin Ave., N.W., Washington 16, D. C. Subscription \$1.00 a year. Printed in U.S.A. Second class postage paid at Washington, D. C.

## Electronic Technicians Wanted

Well-known Communications  
Firm Asks NRI To Help Find  
Technicians

See page 3

## THAT SOMETHING EXTRA

"He profits most who serves best."

That old adage is as true today as ever. No one can gain promotion or build a successful business unless he constantly tries to give a little more than his employer or his customers expect.

The fellow who jumps too eagerly at the chance for an extra dollar without giving full return in his time and effort can never be a success. Why? Because a man who cheats on petty things is slowly but surely tearing down his own moral fibre. He may fool his employer or customers occasionally but can't hope to fool himself and his own conscience. He eventually loses that spark—that vitality—that strong sense of well-being possessed by men who have nothing to hide or fear.

When scales are balanced evenly, an ounce of extra weight on one side will overbalance the scale in that direction just as effectively as would tons of extra weight.

So too, a little better value—a little extra effort—makes a man or his business stand out above the average. It pays to give a little more than seems necessary—to work a bit harder than is expected.

We are proud of the reputation of NRI students and graduates. For forty-six years, we have been advocating truth and honesty in all business dealings. Our records—our reputation—stand as definite proof that thousands of NRI men have profited by this counsel. Let every student and graduate continue to uphold these standards and by doing so, bring rich rewards upon himself.

J. E. Smith  
Founder

## Meeting Competition From Abroad

Countries all over the world—some of which have never had any industry to speak of—are straining to build up their productive capacity. Not only Soviet Russia, which brags of its intention to "bury" the United States economically if not otherwise, but most of the Western European nations have built up their production to the point where they are looking for (and finding) markets beyond their own borders.

To put it briefly, competition has once again become world-wide. The edge we had on the rest of the world for a long time after World War II is getting smaller. The inflow of the small foreign cars is the most obvious example, but by no means the only one.

Is the United States in danger of losing its industrial lead, its ability to outproduce the rest of the world? Hardly. But the ability to produce a great volume of goods is not the whole story.

Goods must be sold at competitive prices. That means when American production costs grow bigger, prices of the products must go higher—too high, perhaps, to compete with products made abroad.

*(Continued page three)*

**"Success in any business or profession is not geared to the lack of education. It is dependent on education! Abe Lincoln was not great because he was born in a cabin—but because he was able to get out of it."**

**Elmer S. Crowley**

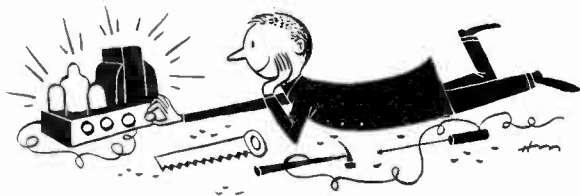

# Hi-Fi Corner

by John G. Dodgson

## This Month — Product Evaluations

*The Empire 98 Tone Arm.* This arm, called their Stereo/Balance Transcription Arm by Audio Empire, is an unusual arm in several respects—including its appearance. At first glance it appeared disproportioned to me with the pivot structure “poking out” to one side. Closer examination though showed that despite the unbalanced appearance, it has functional beauty giving the air of a “precision machine.”

The “98” is a dynamically balanced arm. After balancing the arm by sliding a counter-weight at the end of the arm the stylus pressure is adjusted by a special spring system. Thus, the pressure does not depend on gravity and there is no need to level the turntable. The “98” will properly play a record no matter how the turntable is tilted—even upside-down. Since I didn’t want to glue a record to the table I didn’t try this but I did set the turntable on its edge and at this 90° angle the “98” tracked perfectly.

This dynamic balancing is not a gimmick or fodder for advertising but rather it insures correct seating of the cartridge stylus in the record groove and correct pressure on both walls of the groove. Incorrect seating and pressure will not only cause stylus and record wear, but will result in unequal output from the stereo channels, and will even decrease the crosstalk attenuation (reduce the stereo effect).

Of course it isn’t necessary to use dynamic balancing for proper tracking—providing your turntable is leveled, are you sure it is?

The specifications of the “98” leave little to be desired, particularly the minute tracking error of 0.75°. No trouble was encountered in either mounting or using the “98” with any cartridge, and I tried practically every magnetic stereo type on the market.

Incidentally, when the designer of the “98,” Mr. H. Horowitz, was with a different company, he designed the tone arm chosen by the leading consumer’s magazine as

“the best.” As might be expected the “98” is a definite improvement over this “first version.”

In conclusion, there might be an arm as good as the Empire 98 (I haven’t seen it yet) but, without doubt, I have never seen a better arm. At the present time, it is “the arm” for the best systems.

Note: A tone arm is not just something to hold the cartridge. It is as important as any other “link in the chain” and a poor arm can cause poor reproduction, besides undue record wear. When considering the price of any arm, keep in mind that it is well worth the additional price of one or two stereo records to insure a long life for all your records and to get the most from your stereo cartridge

*Pickering 380A Cartridge.* This is a variable-reluctance type cartridge recently released by Pickering as their new “Collectors’ Series” at a somewhat higher price than their standard “Fluxvalve” models—it is worth the difference in price!

Little useful information is supplied by Pickering in the “Specifications” other than the frequency response—20-20KC,  $\pm$  2DB; separation—25DB minimum; and tracking force—2 grams.

The unit is almost completely enclosed in a mu-metal case and thus free from hum pickup. In addition the output signal is exceptionally high.

When I first listened to this cartridge with the pressure set to 2 grams, RIAA equalization and the tone controls flat, I was disappointed with the somewhat shrill, empty sound from my speaker systems (which normally have a bright, up-front texture). Checking showed some break-up at 2 grams on heavily modulated sweep tones and a slight drop in bass response on frequency checks.

Increasing the stylus pressure to 3 grams cleared up the break-up and a slight increase of the bass control brought up the low end. (Incidentally, 3 gram pressure is still sufficiently low so far as I am concerned.)

(Page ten please)

## INCOME TAX DEDUCTION FOR NRI TUITION

It is our understanding of the Income Tax Law that a person may take a deduction from his income for the costs of education or training undertaken primarily for maintaining or improving the skills required in his trade or business or employment. Deduction is denied, however, where education or training is undertaken primarily for obtaining a new position, or to fulfill the general educational aspirations of the taxpayer.

If in 1959 you were employed in the Radio-Television-Electronics field or operated your own Radio-TV service business, tuition you paid on your NRI course during that year may be a deductible expense. But if you were taking the course to prepare yourself for work in the Radio-TV-Electronics field, or to advance in position, the tuition you paid would not be deductible.

For official information or help on this or any other tax problem, we suggest you consult the nearest office of the Internal Revenue Service. Your local Post Office can tell you what IRS office to contact.

## Electronic Technicians Wanted

### Well-known Communications Firm Asks NRI To Help Find Technicians

One of America's largest consulting-engineering companies in the Communications field has asked NRI to help find men qualified for positions as Technical Representatives or Contract-Technicians for work in Far East, Near East, Middle East, Europe, Greenland, Iceland, Northern Canada, Alaska.

Duties: operation and maintenance of military and civilian electronics and communications equipment.

Starting salary: over \$6000 a year plus generous per diem allowance. No income tax to pay on 18-month oversea assignments.

Qualifications: must be a high school graduate and a graduate of NRI course in Communications or Servicing. Preference given Communications course graduates. Some experience in Radio-TV-Electronics desirable, such as service work, ham radio or broadcast station technician.

To qualified graduates interested in these positions: write a brief letter about your

educational background, experience and present position. State that you are answering the notice "Electronic Technicians Wanted" appearing in the NRI News. Send your letter to NRI; we will forward it to the company. The company probably will *not* contact you unless it decides to consider employing you.

### Competition—Cont'd from page one

The key to the situation is not production alone but "productivity." Productivity is the measure of the efficiency of production, as miles-per-gallon represents the efficiency of your automobile engine.

American industry's lead in productivity is the reason why American workers have been able to earn considerably more than workers in other countries. It has come about mostly because of huge investment in new machines and methods. However, there is nothing to prevent foreign nations from adopting American methods, using similar machines, and investing in new and better equipment.

And that is just what they have done.

Take the fact that many nations abroad have done pretty well in catching up with American production methods, and the fact that their wage scales are much lower, and you have the reason why foreign manufacturers can cut into our domestic markets and cause the loss of American jobs.

But the United States has met and beaten competition before. We can do so again. However, it is necessary not only to have the most productive machines and methods, but to use them most efficiently. For every man-hour used effectively is a contribution to better productivity; every man-hour that is not properly utilized is merely a cost.

## Index

| Article  | Page |
|--|------|
| Editorial .....                                | 1    |
| Hi-Fi Corner .....                             | 2    |
| Professional Servicing Techniques ....         | 4    |
| How To Build An Intercom .....                 | 11   |
| NRI Professional Model 71<br>Tube Tester ..... | 16   |
| NRI Alumni News, Chopter Chatter ....          | 21   |
| Servicing With the Model 12 VTVM ..            | 25   |

# Professional Servicing Techniques

by  
**Art Widmann**  
NRI Editorial Staff

Every service technician develops his own pet short cuts for locating receiver troubles. This is good. The habit of observing closely each trouble symptom and pushing on to rapidly locate the trouble keeps your interest high. Each new short cut adds to your store of know-how. It's part of the fascination of electronics work.

Using short cuts is fine as long as it doesn't waste your time. If trying to locate the trouble by short cut methods leads you up a blind alley, you can waste more time on that one job than you saved on many short-cut jobs.

For example, suppose the signal at the output of the tuner is shorted to ground. You could spend an hour or so needlessly checking the tuner. A short can easily develop in the coax lead between the tuner and the 1st I.F. stage (See Fig. 1). With the center lead of the coax shorted to the outside braid, the control grid of the 1st I.F. is grounded and the IF signal from the tuner is lost. Since the signal from the tuner is normally very small anyhow, it might seem reasonable to suspect the tuner. A high gain scope with a demodulator probe will give some indication of the output of a tuner. By disconnecting the output lead from the tuner and checking with a scope you can definitely determine whether the defect is in the tuner or some later stage. The signal from the tuner is not very large, but if you are in a reasonably high signal area and know what to expect on your test scope you can definitely determine whether the tuner is working.

You cannot afford to waste time locating circuit defects because time is most important to profitable service work. It is important that you be able to complete each service job rapidly so that you will have the necessary time to perfect your service techniques and still find time to keep up with the rapid changes that are always taking place in the electronics field. You can find the time you need if you complete each job rapidly by using



Art Widmann

professional servicing techniques. These techniques enable you to locate the trouble by a systematic approach. It still allows you to use all your short cuts but prevents you from going up blind alleys that waste time.

Systematic professional servicing techniques provide other advantages besides shortening the repair time. It enables you to give the customer better service without increasing the average time spent per job. You give the customer more for his money and at the same time make more money for yourself because you operate efficiently.

The experienced technician as well as a beginner can profit by reviewing his techniques to make sure he is taking advantage of systematic servicing procedures. Below are listed seven steps for systematically locating and repairing defects in radio and TV receivers. The steps could be further divided to make ten or more but these seven make a convenient check list. The order in which they appear is important. You can waste time if you attempt to skip steps. However, this procedure still allows you to use your short cuts.

1. Observe the trouble
2. Inspect the chassis
3. Isolate the defective section
4. Isolate the defective stage
5. Locate and replace the defective part
6. Try to determine why the part failed
7. Check the operation of the receiver

Let's consider each step separately:

**Observe the trouble.** A customer's description of a receiver's trouble can often give you a clue to the cause. However, his idea of hum, distortion, dark picture, etc., can also be misleading. By all means, listen to his complaint carefully, but there is no substitute for carefully observing the operation of the set before you work on it. Operate the controls and observe the effect the controls have on the trouble symptoms. During this time you will be using your effect-to-cause reasoning. With experience, you can often pinpoint the defect directly from observing the trouble.

The most important thing to determine before leaving this first step is to make sure you observe all the symptoms of the trouble. If the receiver defect produces two or more symptoms, each of them will help point the way toward the defective area. Being aware of all the symptoms saves you time because each symptom usually tells you something about a section of the receiver. For example, it is a waste of time to check the H.V. section of a TV receiver when there is no light on the screen if at the same time you

have no sound. The defect is most likely in a portion of the set that is common to both H.V. and sound—probably the low voltage power supply.

Once you have observed the symptoms, you can move right on to the second step of inspecting the chassis. If you are in the customer's home, all that is necessary is to check that the line cord and antenna are properly connected. If you are working at the bench with the set out of the cabinet you can do much more.

**Inspect the chassis.** It takes only minutes to look over the entire chassis carefully. Use plenty of light. Look for charred or discolored resistors. If the set uses printed circuitry, inspect both the component side and the foil side of the board. Look for breaks in the printed circuit and bad solder joints. It is surprising the number of times a careful visual check will lead you directly to the circuit defect.

Even if it doesn't, the time is not wasted. This visual inspection acquaints you with the circuit layout and eliminates trouble caused by physical damage. Often it uncovers poorly soldered or partially broken

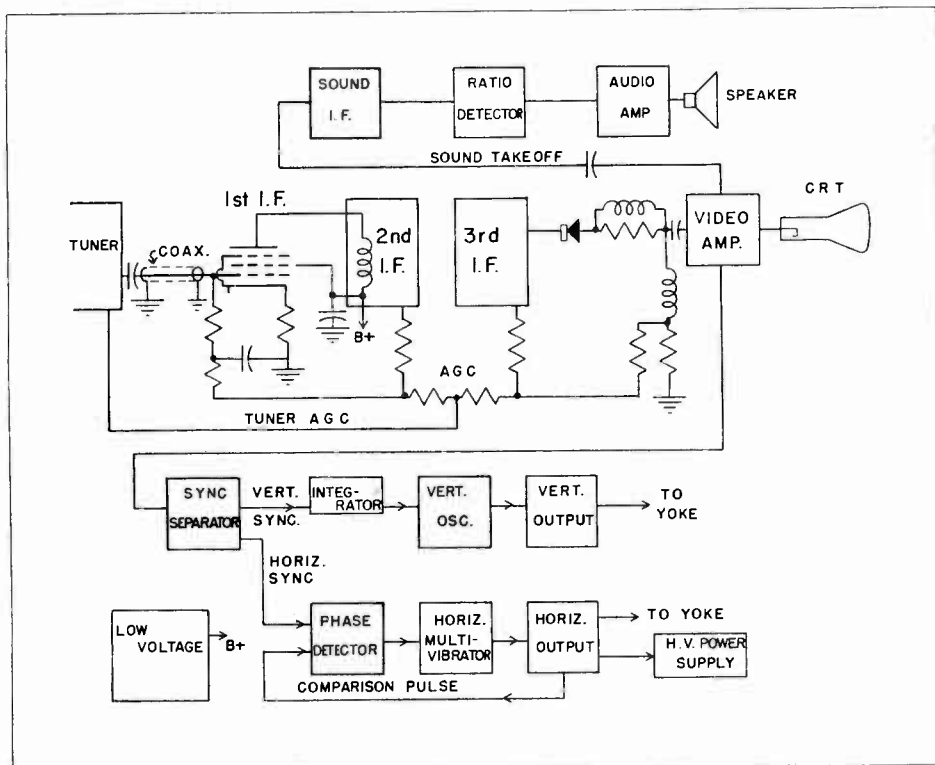

Fig. 1. Partial block diagram of TV receiver.

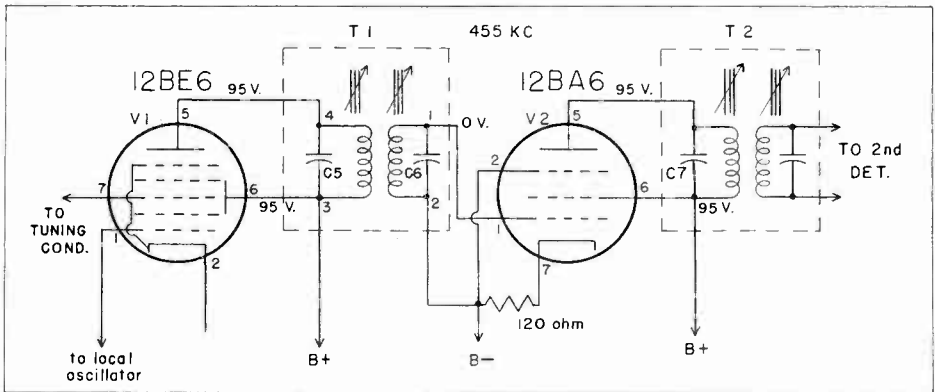

Fig. 2. Partial schematic of typical A.C.-D.C. radio receiver.

leads that could disable the set when you deliver it. If a lead breaks when you are installing a chassis in a customer's home, you not only waste your time but it has a bad effect on the customer's confidence in you. It is much better to spend the few extra minutes on the bench resoldering the connection.

The visual inspection need not take long but it pays off too often to ignore it. In a way it is a short cut method of locating the trouble without going through the isolation steps.

**Isolate the defective section.** This is probably the most important time saver of all. It eliminates the needless time spent in checking sections of a receiver that have nothing to do with the trouble. A defect in one section of a receiver will often upset voltage readings in a good section of the receiver. Of course, cause to effect reasoning and careful back tracking will eventually lead you to the trouble. However, a more direct method is to perform checks that will isolate the defect to one of the large sections of the set.

The kind of check to make is dictated by the type of trouble. If the set is dead use a voltmeter. If the trouble is in the signal path use the scope. The signal path includes not only sound and picture but also sweep circuits and sync—anything that allows you to observe waveforms. Let's look at the reasons behind the choice of test equipment.

If the set is dead—not even a slight hum in the speaker—the power supply is the logical section to suspect. You can confirm this by one voltage reading at the rectifier or filter. Since the rectifier is usually easy to locate, a voltage reading here gives you a point to work from. A

zero reading directs you back toward the AC line while a normal reading directs you out the B+ line. A normal reading on the B+ line eliminates the power supply section. In this case, the next logical suspect is the speaker or output stage.

If the symptom is in a signal path, an oscilloscope will isolate the defective section faster than a VTVM. The scope indications help you identify pin connections and allow you to make a rapid check of large sections of the receiver. For example, suppose you are checking a TV set that has sync trouble. Let's look at Fig. 1 to see where to check with a scope to narrow the trouble down to a small section of the receiver. The first place to check is the video input to the sync separator. Observe the sync pulse carefully. Does the pedestal and horizontal sync pulse rise well above the video? A gassy tube in the I.F. strip can compress the sync signal. With decreased height of the sync pulses, the sync separator cannot do its job. Video will get by the separator and upset sync.

A good video signal at the input to the sync separator eliminates the tuner, I.F. stages and video stages. Your next check point is the output of the sync separator. Is a sync signal present and is there video between the sync pulses? Many sync separators do not remove all of the video but it should be of very low amplitude.

If the sync trouble affects the vertical you will want to check the sync input to the vertical oscillator. After the vertical sync pulses have passed through the integrator they are so small that they cannot be distinguished from the kick back pulse of the vertical oscillator. By moving vertical hold until the picture rolls slowly, you should see the vertical sync pulses slowly moving up (or down) the vertical sweep.

If the sync trouble affects the horizontal you will want to check the sync input to the horizontal phase detector. Since the horizontal sync is much more critical than vertical, trouble in the sync separator or previous stages will have more effect on horizontal sync than on vertical sync. A defect in the vertical section can allow the kick back from the vertical oscillator to get into the horizontal sync. This may cause a hook at the top of the picture or upset horizontal sync.

If clean horizontal sync pulses are getting to the phase detector, the defect must be in the phase detector or horizontal multi-vibrator. While you are at the phase detector you can check to see if the comparison pulse from the horizontal output stage is getting to the phase detector.

Isolating the defect to a section of the receiver can also be accomplished by using the signal injection method. In this method you supply suitable signals to various points in the receiver. If the section of the receiver following the injection point works OK on this injected signal that section is eliminated. In general, you work from the output sections back toward the input. When you reach an injection point that produces faulty operation, the defect lies between that check point and the last good check point. For example, in Fig. 1, if injecting horizontal sync pulses at the phase detector produces a stable horizontal sync you move to the input to the sync separator. If injecting video to the sync separator produces an unstable horizontal sync, the trouble must be in the sync separator section.

Signal injection methods give results comparable to using the scope. Some technicians prefer using signal injection and for some troubles it is better. Much depends on what the technician gets used to.

Before leaving the section isolation step you should be sure which section of the receiver is defective. In radios these sections include the R.F. section, the mixer, including the local oscillator, the I.F. section, 2nd detector, AVC, audio section, and power supply. In a TV set the sections include: low voltage power supply, H.V. power supply, tuner, I.F. strip, 2nd detector, sound section, video, AGC, sync, vertical deflection, and horizontal deflection.

Once you have definitely isolated the defect to one of these sections, you can safely work into the section to determine what stage in the section is faulty.

**Isolate the defective stage.** This step often proves easier than locating the section. Once you are in the right section, the

faulty stage is usually quite obvious. Signal tracing into a faulty section should bring you close to the trouble. The place where the signal is lost or distorted provides you with a number of probable causes.

Suppose you are checking a radio receiver that has very low output. The customer reported that the set worked OK when he went on a vacation two weeks ago—now he can't get anything. When checking the operation of the set, you are able to hear faintly only two local stations. While you are checking the tubes, you examine the antenna connections to be sure they are not broken.

Since tubes do not correct the trouble, you remove the chassis from the cabinet. Careful inspection of the chassis reveals nothing. You plug in the set and with volume control advanced you touch the center lead of the volume control pot. This causes a loud popping noise from the speaker so you figure that the audio section is probably OK. Since you are able to get two stations faintly, the local oscillator must be working. This line of reasoning indicates that the trouble is in the I.F. section.

**Learning is like rowing upstream. Not to advance is to drop back.**

Many possible defects could produce this symptom but the most probable cause is that the I.F. stage is not amplifying properly. You check to see if there is any evidence that the tuning slugs of the I.F. transformers have been tampered with.

Fig. 2 shows a partial schematic of the ac-dc radio you have on the bench. You tune the set to a station you can hear faintly and touch the scope probe to the plate of  $V_1$ . With the scope gain turned up, you get only a very small signal. Moving the probe to grid 1 of  $V_2$  produces no visible signal. On plate 5 of  $V_2$ , the scope shows only a small signal. This shows that  $V_2$  is amplifying what little signal is getting to its control grid. You could also check the local oscillator and R.F. input signal with the scope. Touching the scope probe to pin 1 of  $V_1$  shows a sizable signal from the local oscillator. Pin 7 shows the normal small incoming R.F. signal.

The scope has served its purpose and further checking can best be done with a VTVM. The defect is pretty well isolated to stage  $V_1$  or transformer  $T_1$ . A voltage check shows normal readings at the plate, screen and grid of  $V_1$ . You unplug the

set and check the resistance of the I.F. coils. The secondary of  $T_1$  (terminals 1 and 2) reads a little over 16 ohms. The service literature gives 18 ohms as the proper resistance. This ohmmeter reading is not very conclusive but since you can find nothing else wrong with the stage you suspect the I.F. transformer is partially shorted.

This is a rather common failure with small I.F. cans. The capacitors  $C_5$  and  $C_6$  are built into the base of the transformer. The capacitor plates are deposited on thin layers of dielectric. When corrosion bridges the dielectric it shorts the plates of the capacitor. In the example in Fig. 2, if this short was as low as 200 ohms, the parallel resistance with the 18 ohm coil would be about 16 ohms. This 200 ohm short will load down the transformer and practically kill the I.F. signal.

While it is possible to disassemble the capacitor and clear the short, the usual procedure would be to replace the transformer.

#### Locate and replace the defective part.

Once you have definitely located the defective stage, you still have the problem of locating the defective part that keeps the stage from functioning properly. Careful resistance readings will uncover opens, shorts, and changed value of resistors. Special techniques apply to checking each type part. Often it is necessary to disconnect the suspected part to confirm resistance reading. In other cases it may be necessary to apply heat to the part if the trouble appears only after several minutes of operation. Suspected condensers are usually easier to check by substitution. Condensers may short or open only

when the operating voltage is applied and check OK otherwise.

A last resort in checking a suspected wired part is part substitution. If a replacement part is available, it can be used to confirm that the suspected part is bad. In many cases part substitution is a fast and reliable way to check some parts. However, random part replacement wastes time. When you have isolated the defect to a particular stage, voltage and resistance readings will either pinpoint the defective part or eliminate most of the parts in the stage. At the most, only one or two parts may have to be checked by substitution.

When the defective part has been located, experience and understanding of the circuit operation will help you select a suitable replacement.

For example, suppose the defective part is an open coupling capacitor to the first audio amplifier in a three way portable radio. Fig. 3 shows a partial schematic of the 1st audio stage of a typical ac-dc-battery portable. The .0047 Mfd capacitor  $C_1$  is the defective part. It is a small paper tubular capacitor with no d.c. voltage rating. You have a .0047 Mfd capacitor rated at 600 volts. You know this would be satisfactory but in the cramped space in this set there is not room for it. How about a .001 Mfd at 200 volts? From your understanding of the circuit operation you know that the 200 volt d.c. rating would be all right because very little voltage is applied to the capacitor. However, the .001 Mfd capacitor is only about one-fifth the electrical size of the .0047. Since the capacitor is used to couple an audio signal, the smaller capacitor could cause a loss of low frequency response.

You also have a .005 Mfd disc ceramic on hand. This capacitor is small and will fit easily into the available space. How about electrical size? The .005 is .0003 Mfd larger than the .0047. You know that most capacitors have a 20% tolerance so the disc ceramic will probably be as close to the value of the original as another .0047 capacitor. The disc ceramic is a suitable replacement.

In general, when an exact replacement part is not available, a standard replacement part will almost always give equivalent circuit operation. The time and expense required to obtain an exact replacement is seldom justified.

**Try to determine why the part failed.** This step can save a great deal of time and customer irritation. If the cause for a part failure is not corrected, the new part







outward appearance look good in addition to doing a good technical job.

By using professional servicing techniques you can save enough time on the trouble

— n r i —

### Hi-Fi Corner

(Continued from page two)

Under these conditions, the 380A took on a new sound; it was now smooth and full-bodied—no shrillness at all. It is still a bright sounding cartridge, particularly in the mid-range. This bright sound is not excessive to the point of dissonance. However, when used in systems employing 2- or 3-way speaker systems (except AR-2 and AR-3), slight adjustment of the Presence (mid-range) and Brilliance (tweeter) controls should be tried.

All in all, the 380A is aptly named—it is a top cartridge when the stylus pressure is slightly increased. Be sure to mount it carefully in the tone arm and make certain the arm is mounted correctly with respect to the turntable since there is very little clearance be-

— n r i —

shooting phase of the job so that you can do these extras on the set. Each job you turn out will have a professional touch that will enhance your reputation as a service technician.

— n r i —

tween the body of the cartridge and the record even when properly mounted. Finally take a little time to try different settings of the amplifier bass control and speaker level controls.

*Manufacturer's Comments.* "As you point out, proper mounting of the cartridge is critical and to assure satisfactory stereo reproduction, the stylus should be perpendicular to the record plane when viewed from up forward.

It is certainly understandable that some fair percentage of the D-3807A styli will require something more than two grams. It is difficult to insure that all of these styli will track all levels at two grams, while I am quite certain that they will track at three. Compliance of the 380A is  $6 \times 10^{-6}$  cent. per dyne, output is 15 millivolts per channel, and channel separation is 35 DB."

— n r i —

**A favorite with Radio-TV men  
everywhere—**

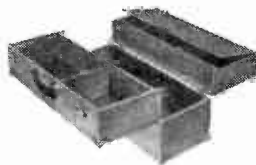

## ARGOS Tube Caddies

The easy, orderly way to store tubes or carry tubes and tools on service calls. Perfect for spare-time servicing. Argos Caddies make work easier and quicker—make you more efficient. Divided sections give tube inventory at a glance. Missing cartons are easily spotted.

Argos Caddies are covered with good-looking, tough, luggage-type pyroxilin—resistant to wear and soiling. Constructed

of durable  $\frac{5}{8}$ " and  $\frac{1}{4}$ " plywood. Built for years of service.

The NRI Supply Division offers you a choice of two caddies. Carry-All Caddy is 21" x 15" x 8"—holds 262 tubes. Your price including postage—just \$13.95.

The Junior Tube Caddy holds 143 tubes. Size: 15 $\frac{3}{4}$ " x 12 $\frac{1}{2}$ " x 8". Price including postage—\$9.95.

Order from:





John G. Dodgson

# How To Build An Intercom

by  
John G. Dodgson

There are different types of inter-com systems. One type, designed for large factories, railroad yards, etc., is quite complicated and generally consists of all "master" stations. The type designed for home or small office use, however, is a comparatively simple device. It consists of one master station and one or more remote stations. The master station, so called because it controls the system, contains a loudspeaker, which is also used as the microphone, an audio amplifier, and a special switching system. This switching system provides for the amplification of either the incoming signal from the remote station or the outgoing signal of the master station—depending on who is talking and who is listening.

The remote station is comprised of only a loudspeaker and sometimes a switch connected to the master station with a two or three conductor transmission line.

## "Build It Yourself"

First of all, let us consider the disadvantages of building your own inter-com. The primary disadvantage is that it is probably going to cost more money to build

your own inter-com than it would to purchase an inter-com kit. It is possible though to build your own for less than the cost of a factory-built unit. It is generally impossible to save any money building your own electronic equipment unless a kit is purchased. The tremendous purchasing power of large kit manufacturers permits these companies to purchase components at an unbelievably low price as compared to standard wholesale cost. Thus, the manufacturers can offer kits (and sometimes even factory-built units) cheaper than most people could buy the parts for them. Usually, the only time any money is saved in building your own equipment is when you happen to have a considerable number of "junk box" components that can be used in the equipment.

There are, of course, some advantages to building your own electronic equipment. The chief advantage, perhaps, is the personal satisfaction which cannot be measured in dollars and cents. Another definite advantage is that the equipment can be designed to suit one's own purpose. Not only can the exterior be customized to fit the personal taste of the owner but the

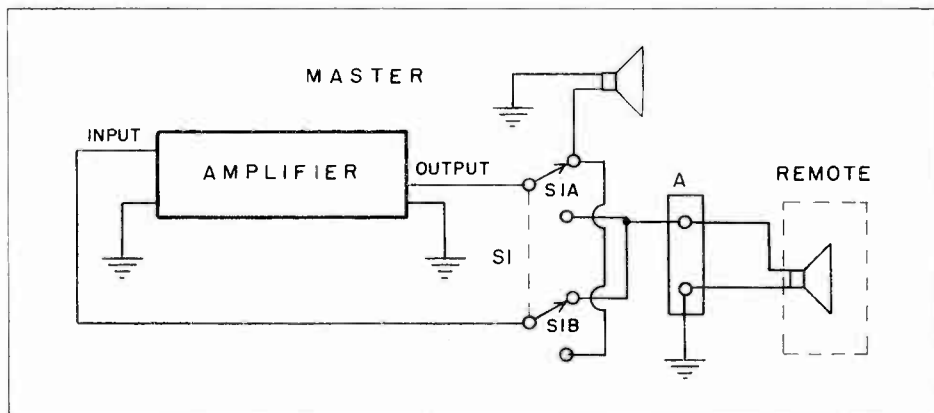

Fig. 1. Intercom switching system with non-private remote stations.

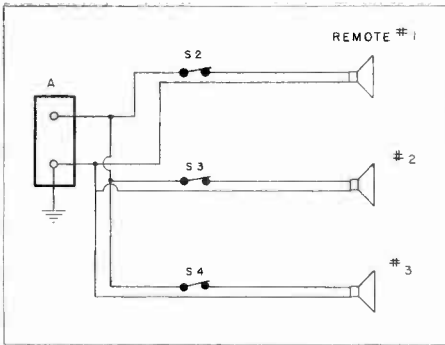

Fig. 2. Adding additional remote stations to the intercom of Fig. 1.

electronic operation can also be altered (to a degree) to what the owner considers most convenient and desirable. Furthermore, there can be some advantage in ease of maintenance and repair gained by building your own. By actually assembling each stage of the equipment, little time is wasted in trying to figure out which part is which when it breaks down—and all equipment, no matter how well built, will eventually become defective.

There are actually two different types of switching systems used in small intercoms. In one type, the remote station, simply consists of a speaker connected to the master through a two-conductor transmission line.

Figure 1, page 11, shows this type of intercom. Notice that it consists of an amplifier and a switching system. With the “listen-

talk” switch in the listen position, as shown, anyone speaking into the remote speaker would cause it to act as a microphone and generate an electrical signal. This signal would be fed through the two conductor transmission line to the master station. This signal would pass through the bottom section (S1B) of the listen-talk switch to the input. The amplified version of the signal, from the amplifier output would then be fed through the top section of the switch (S1A) to the loudspeaker in the master station and thus be converted to audible sound.

With the listen-talk switch in the talk position, the loudspeaker in the master station becomes the source of signal which is fed to the amplifier. The amplified output signal is fed to the remote station instead of to the loudspeaker in the master station.

Should it be desirable to use more than one remote station additional ones can easily be added as shown in Fig. 2.

This illustration shows how three remote stations could be added to the system of Fig. 1. For simplicity's sake, only the master station output terminal strip (A) is shown here. Notice that each remote station simply requires a single-pole, single-throw switch.

These switches to the remote station, labeled S2 through S4, are all shown in the closed positions which indicates that all remote stations are being “monitored.” This is actually not the normal situation since all of the remote stations would

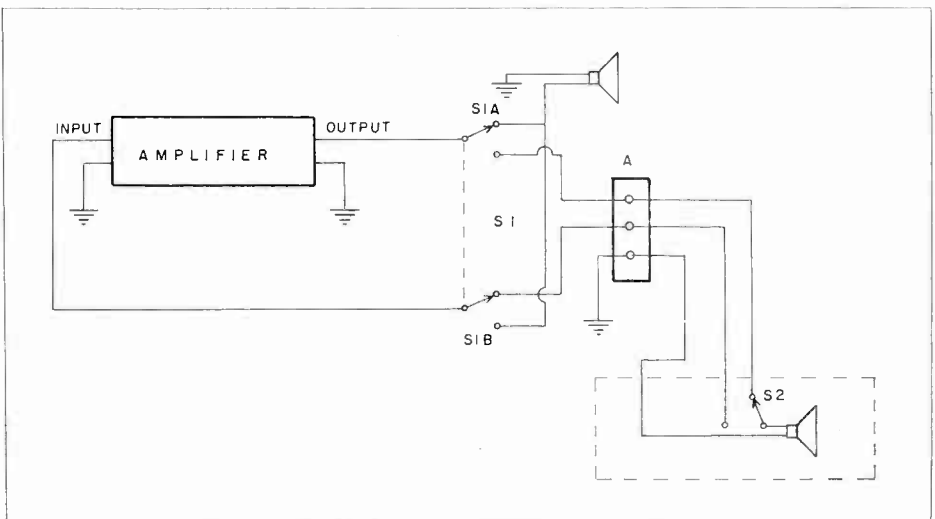

Fig. 3. Intercom switching system featuring private remote stations.

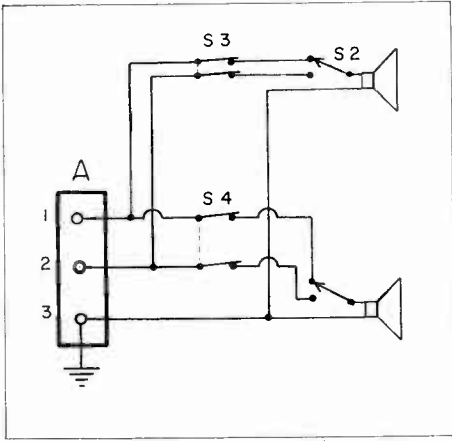

Fig. 4. Additional remote stations added to the intercom of Fig. 3.

seldom need to be monitored at the same time. For example, should a speaker be placed outside the front door, it would not usually be put in operation until someone knocked on the door or rang the bell. Similarly, there would be no need to monitor a speaker in, say, the recreation room when no one was in there.

Normally then, the listen-talk switch of the master station is kept in the listen position and the switches S2 through S4 are closed according to the remote speakers that are desired to be monitored. This type intercom system has one great disadvantage—the “master” alone has complete control. Each “remote” can be monitored by the master simply by closing its corresponding switch—each remote is thus “non-private.”

Fig. 5 (below). The master station showing the amplifier, power supply and listen-talk switch wiring.

Sometimes, however, it is desirable to have the remote, and the room it is in, “private” so far as the “master” is concerned. To accomplish this, some intercom systems use a different type of switching system such as the one shown in Fig. 3.

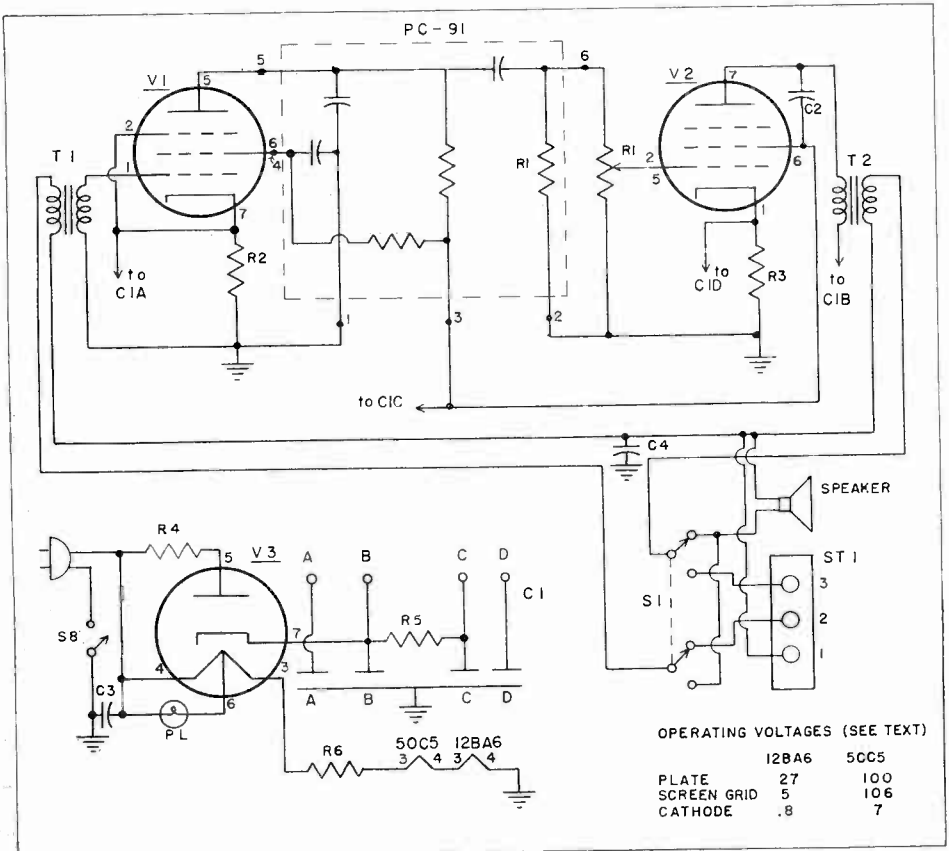

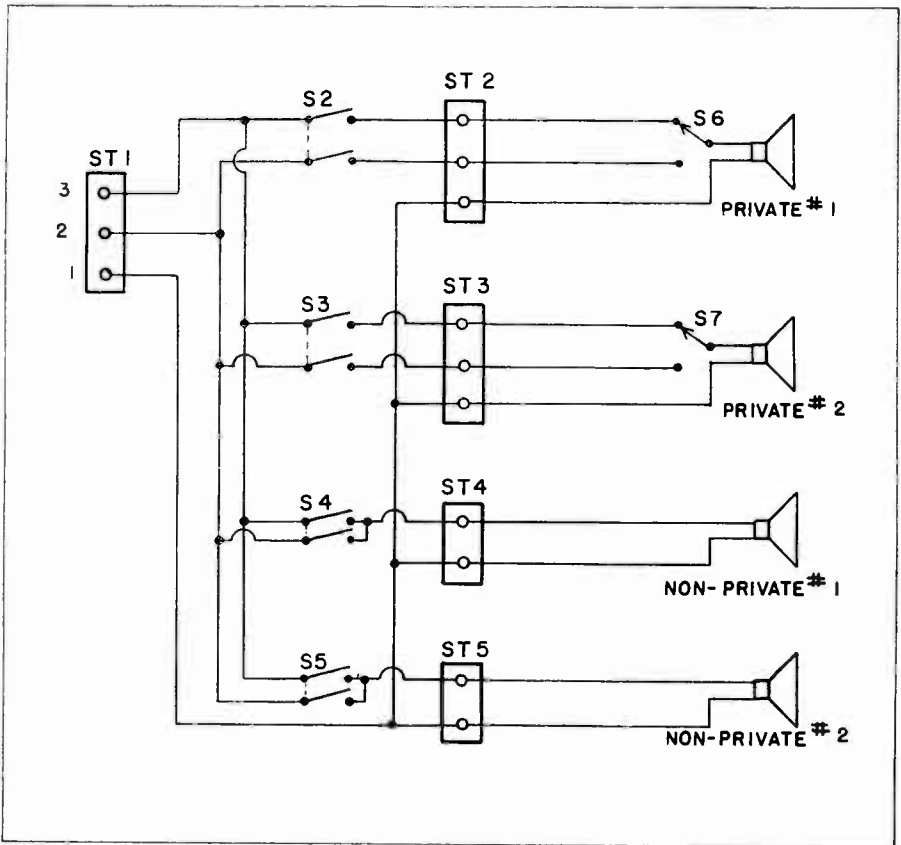

Fig. 6. How to add both private and non-private remote stations to the intercom of Fig. 5.

Notice that, although this system uses a SP-ST listen-talk switch (S1) it is wired slightly different than in Fig. 1. The most significant difference between this system and Fig. 1, however, is the use of a 3-conductor transmission line and a "listen-talk" switch in the remote station.

This remote switch is in the "listen" position (as is the switch in the master). While in this position it is not possible for the master to "listen in" on the remote. The remote is then a "private" station until its switch is thrown to the "talk" position.

The intercom system of Fig. 3 can be expanded to more than one station by adding appropriate switches as was done to the system of Fig. 1. However since a 3-conductor transmission line is used here, it is necessary to use double-pole switches as shown in Fig. 4.

Although this type intercom system does offer privacy it requires proper switching

of the remote station "listen-talk" switch for two-way conversation. Such a set-up might not be desirable in all locations—for example, in the children's room.

It is evident that the most useful type intercom would be a combination of systems of Figures 1 and 3.

Figures 5 and 6 illustrate a complete intercom featuring a switching system providing both "private" and "non-private" stations.

The amplifier is a simple two-stage AC-DC type unit while the switching system shown in Fig. 6 is a combination of Figures 1 and 3 (or Figures 2 and 4).

Since B— in the unit connects directly to one side of the power line it is important to isolate the switching system, and thereby the transmission line from B—. Otherwise, with the power cord plug in the outlet "the wrong way," the transmission lines to the remote stations would be

"hot" and there would be shock and fire hazards. This isolation is accomplished by connecting all of the normally grounded points in the switching system together and connecting this common junction to B— through a capacitor (C4 in Fig. 5). As can be seen in the schematic, the normally grounded points are one lead each of the input transformer, output transformer and loudspeaker as well as one terminal of each of the remote station output terminal strips.

The amplifier and its power supply are simple straightforward stages except, perhaps, for the printed circuit type couplate. The use of this couplate reduces the cost of the unit and simplifies the wiring. These units also seem to stand up better than individual components. The small size of the couplate is not important, however, since there is no great need to miniaturize the master station.

The printed circuit couplate does have some minor disadvantages. First of all, it reduces the maximum gain that could have been obtained with the 12BA6 stage if individual parts were chosen. However, even with this reduction the voltage gain is still somewhat over 50 and is more than enough. The over-all voltage gain of the amplifier, by the way, is about one thousand. Another disadvantage of the couplate is that it was designed for battery type tubes and the built-in grid resistor (for the output stage) is very high, which would in normal circumstances cause grid current in the output stage.

However, this high grid resistor can be ignored since it is connected in parallel with the volume control thereby lowering the over-all grid circuit resistance and eliminating any possibility of grid current.

The power supply is of the ac-dc receiver variety employing a 35W4 halfwave rectifier tube. The small 22-ohm, ½-watt resistor connected in series between the line and the 35W4 tube plate acts as a protection against surges. The filament voltage dropping resistor R6, of course, reduces the filament voltage for the tubes. The pilot lamp shown connected between pins 4 and 6 of the 35W4 tube is not necessary and may be omitted if desired.

### CONSTRUCTION

As mentioned previously, the schematic diagram of a complete intercom system is shown in Figures 5 and 6. Fig. 5 contains the R-C coupled amplifier, the listen-talk switch wiring and output terminal strip (ST1). Fig. 6 shows how the intercom can be used with four remote stations; two

FIG. 7

### Parts List

- V1 12BA6 tube
- V2 50C5 tube
- V3 35W4 tube
- T1 Input transformer, 4-ohm to grid; Stancor A-4744
- T2 Output transformer, 2500-ohm to 4-ohm
- PC-91 Centralab Couplate
- S1 DP-DT listen-talk switch Mallory 3122J
- S2-S5 DP-ST slide or rotary switches
- S6-S7 SP-DT slide or rotary switches
- C1 Filter capacitor, Mallory FP411.3
  - A. 40-mfd, 150V
  - B. 80-mfd, 150V
  - C. 40-mfd, 25V
  - D. 20-mfd, 25V
- PL Pilot lamp, No. 40 or No. 47
- C2 .001-mfd, disc
- C3 .01-mfd, disc
- C4 .05-mfd, 600V
- R1 500K-ohm, volume control with switch (S8)
- R2 6.8K-ohm
- R3 150-ohm
- R4 22-ohm
- R5 2.2K-ohm
- R6 150-ohm, 5-watt

(Note: Parts not available from NRI)

private stations and two non-private stations. The entire amplifier is not repeated in this illustration: just the output terminal strip, ST1, is shown.

Electronic equipment is generally built on aluminum or steel chassis except sometimes when printed circuits are used. This is probably the best way since aluminum chassis are sufficiently rigid and easy to work with. However, in order to use an aluminum chassis for electronic equipment, it is necessary to have a number of hand tools including drills and punches to cut the type holes used for tube sockets and filter capacitors. Rather than use a metal chassis base for this intercom, the author chose to use a simple piece of ¼-inch plywood for the chassis so that anyone not having the proper tools could easily build the unit. Of course, if you desire to build the intercom and you have the necessary tools (along with some experience) there is no reason why you should not use aluminum.

Figures 10 and 11 show the intercom built by the author using the wooden chassis. As shown in Fig. 10, the intercom is housed in a small radio-type cabinet—generally available from wholesalers and mail order houses. Of course it is not necessary to use such a cabinet for the unit—any cabinet conveniently available can be used. If one is not available, it could easily be constructed from plywood. (Incidentally, the wooden cabinet available from the NRI Supply Division for the 7E or 7W receiver is quite satisfactory for an intercom even though it is somewhat larger than necessary.) The wiring of the intercom shown in Fig. 11 is not quite as complicated as it seems!

(Continued page eighteen)

Speed, Accuracy, Dependability - - and Low Price - -

# NRI Professional Tube Tester

**Model 71**

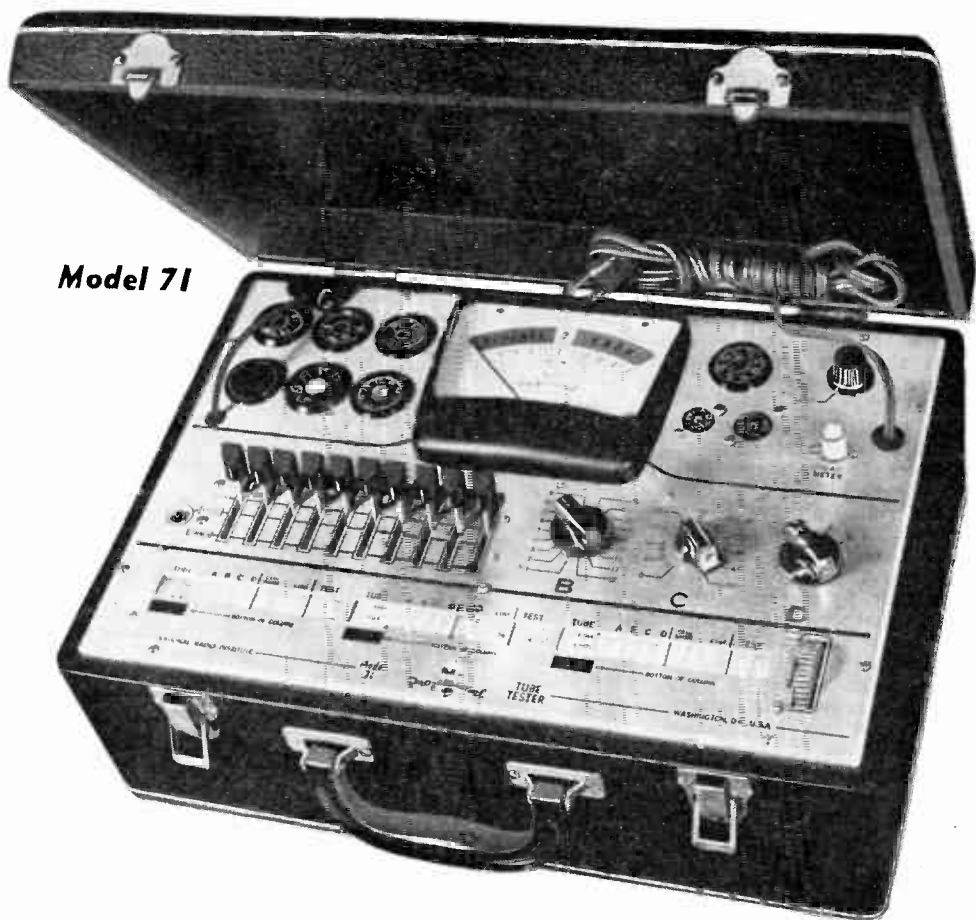

This versatile, easy-to-operate, Tube Tester is recognized by NRI students and graduates as a superb value for the home, shop, or lab.

Professional in appearance as well as performance, the Model 71 was designed to meet rigid specifications set down by our own engineers and is built by one of the better-known test equipment manufacturers. In designing the Model 71, we were primarily concerned with (1) Completeness of the test; (2) Ease of operation; (3) Long life; (4) Appearance; and last but far from least—Cost.

The modern highly-flexible test circuit in the Model 71 makes use of ten four-post-

tion lever-type element switches. These fast-acting switches provide individual control for each tube under test. Seventeen filament voltages are available for tubes now in use or to be developed in the foreseeable future. Many flexible features make the Model 71 almost obsolescence proof.

## Uses Approved EIA Emission Test Circuit

Years of experience have convinced us that a tube tester designed around the Electronic Industries Association's emission circuit is best suited for rapid service work. NRI recommends this type circuit—used in the Model 71—as best suited for Radio-TV servicing.



### Outstanding Appearance

Appearance is important in a tube tester. Customers will frequently watch you at work. They will be impressed by the smooth action, the beauty and streamlined proportions of this instrument. The panel is handsome brushed aluminum with black enameled deep etched lettering. Lettering cannot rub off! The beautifully finished leatherette covered case equals the quality used in the finest engineering instruments. The Model 71 is recognized immediately as a professional test unit.

### Top Performance—Low Cost

In offering the Model 71 at the low price of \$59.50, we feel we are giving NRI men the opportunity to purchase an instru-

ment which will serve them faithfully and give them an excellent value for their investment.

### 70°-90° Picture Tube Adapter And

### Companion 110° Adapter Available

Enables you to test a Television picture tube in a receiver, or in the original factory carton. This test includes a cathode emission check, and a check for shorts between the various elements of the tube. Price of 70°-90° Adapter—only \$4.98.

Using the 110° Adapter *with* the 70°-90° Adapter, you can also test the latest type 110° picture tubes. Both Adapters for \$9.75. (Note: You must have the 70°-90° Adapter in order to use the 110° Adapter.)

### SPECIFICATIONS

1. Employs Standardized EIA Emission Test Circuit—Ten separate four-position tube element switches make tube prong connections flexible—take care of future electrode connections.
2. Eight Tube Test Sockets—Test 4, 5, 6, 7, and 7L prong tubes; plus octal, loctal, 7-prong miniature; and 9-prong miniature tubes.
3. Test Electric Eyes and Gaseous Rectifiers.
4. Eighteen filament Voltages—0.69, 1.5, 2, 2.5, 3.3, 4.2, 5.0, 6.3, 7.5, 10, 12.6, 18.5, 25, 30, 50, 70, 85, and 110 volts; filament voltages for all receiver tubes.
5. Double Jeweled D'Arsonval Meter Movement—Giant type 4½ inch ±2% accuracy.
6. Short and Leakage Test—Between all elements while the tube is "hot."
7. Value Test—Reads directly REPLACE†, or GOOD. Meter is calibrated for comparison tests.

8. Manual Line Voltage Adjustment—uses test meter as a voltmeter.
9. Separate Tests for Multi-function tubes—individual tests for each diode in full-wave rectifiers. Separate checks on each section of multiple tubes.
10. Filament Continuity Test and Open Element Test.
11. Handsome streamlined black leatherette covered wooden case. Size: 15¼" x 10½" x 6". 14 gauge brushed aluminum panel, deep etched black filled lettering.
12. Actual Weight—11 pounds. Shipping weight 15 pounds.
13. Power Requirements—50-60 cycle, 110-120 volts A.C. required. (Cannot be operated on D.C. or 25 cycle A.C.)
14. High Speed, Triple Window Roll Chart.
15. Standard 90 day EIA Warranty—covers entire tube tester.
16. Detailed Instruction Manual—included with each tube tester.

### ORDER BLANK

**National Radio Institute, Supply Division**  
**3939 Wisconsin Ave.**  
**Washington 16, D. C.**

11TE

I enclose \$..... (check, money order, or bank draft) for which send me, express collect, the items I have checked.

- |                          |  |         |
|--------------------------|--|---------|
| <input type="checkbox"/> | One Model 71 NRI Professional Tube Tester .....  | \$59.50 |
| <input type="checkbox"/> | Model 71 Tube Tester with 70°-90° Adapter .....  | 64.48   |
| <input type="checkbox"/> | Model 71 Tube Tester with 70°-90° & 110° Adapters .....  | 69.25   |
|                          | If you live in Washington, D. C., add 2% Sales Tax.  |         |
| <input type="checkbox"/> | <div style="border: 1px solid black; padding: 2px;">Tell me how I can buy this equipment on monthly terms.</div> |         |
|                          | Total  | _____   |

Name ..... Student Number .....

Address .....

City ..... Zone ..... State .....

Express Office .....

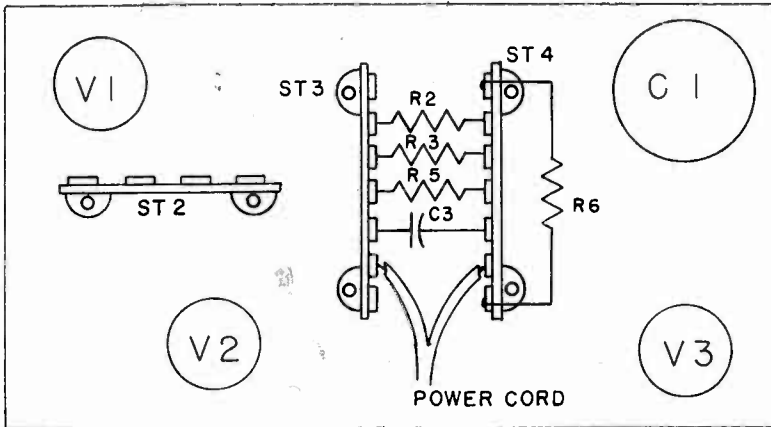

Fig. 8. Rough layout used by the author for the intercom in Figure 10 and 11.

Both the input (T1) and output (T2) transformers were mounted under the wooden chassis to act as feet. Should a larger chassis be used, there would probably be room on top of the chassis for these transformers.

Fig. 8 shows a rough layout used by the author for the intercom. Of course, this layout need not be used since the wiring is not particularly critical. As with all electronic equipment, it is important to

keep the input and output leads away from each other to prevent oscillation and any leads carrying high ac voltage such as the filament or power line should be kept away from the grid circuits.

As can be seen in Figures 8 and 11, few parts were connected to the tube sockets. Terminal strips were used to hold most of the parts and leads were then run from the tube socket lugs to the terminal strips.

Since an aluminum chassis was not used, the tube sockets could not be mounted in holes on the chassis with the lugs protruding underneath the chassis. Instead 1¼-inch, 4-40 machine screws were used to mount the tube sockets as shown in Fig. 9B. The type tube socket not using a center shield was chosen and the machine screw was placed in the hole in the center of the socket. The locations of the hex nuts necessary to hold the socket above the wooden chassis is shown in Fig. 9B. The lugs of the socket were then bent out at approximately 45° so that wires could be soldered to the socket lugs.

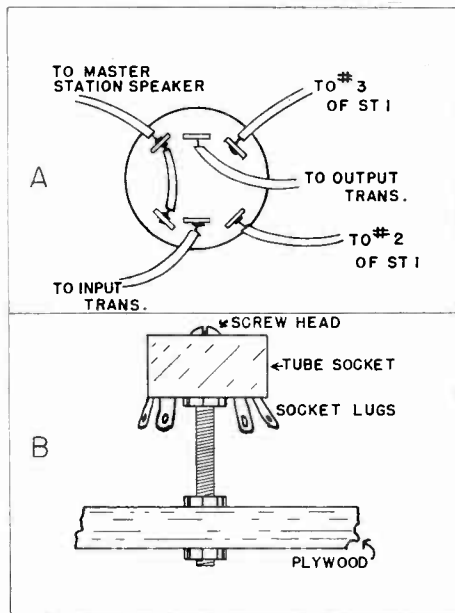

Fig. 9. (a) How to wire the listen-talk switch and (b) how to mount the tube sockets if a plywood chassis is used.

Fig. 9A shows how to wire the "listen-talk" switch S1. As shown in Fig. 9B, the head of the mounting screw projects above the socket. However the tube pins will still make good contact. If you wish, file down the screw head.

The can-type electrolytic capacitor was mounted somewhat like the tube sockets. The normal insulating type mounting wafer was attached to the capacitor as shown in Fig. 10 and the capacitor was mounted off the chassis just as the tube sockets were mounted.

The printed circuit type couplate was connected to terminal strip ST2. After con-

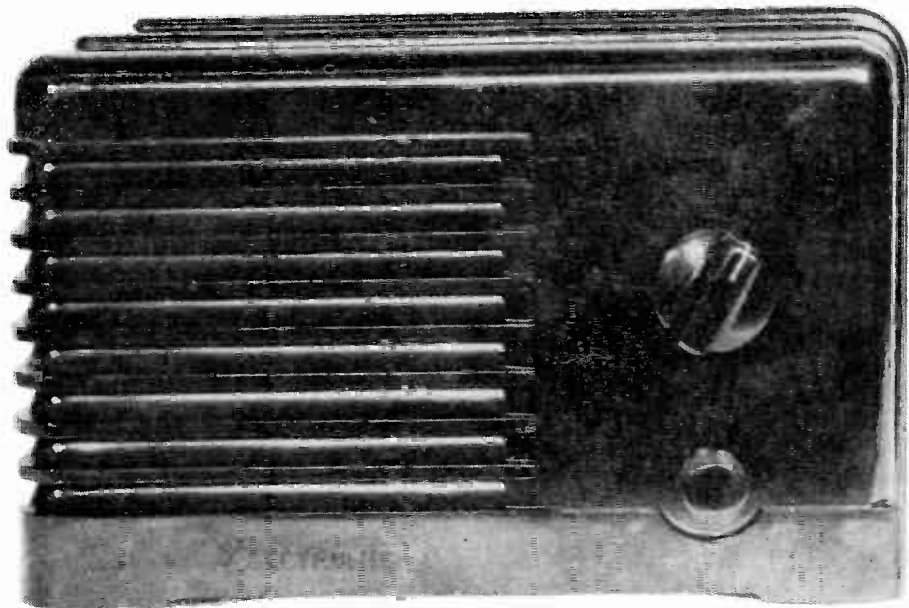

Fig. 1D. View of the intercom in a radio-type cabinet.

necting the couplate to the strip, the appropriate leads from the strip were run to tube socket V1 and the volume control. Resistors R2, R3, R5, R6 and capacitor C3 were connected between the terminals of strips ST3 and ST4 as shown in this illustration. After the parts were connected

in place, the proper leads were run to the other terminals where necessary.

Of course, this particular layout and interconnection of parts is not at all necessary but might give you some help in planning the construction of the unit.

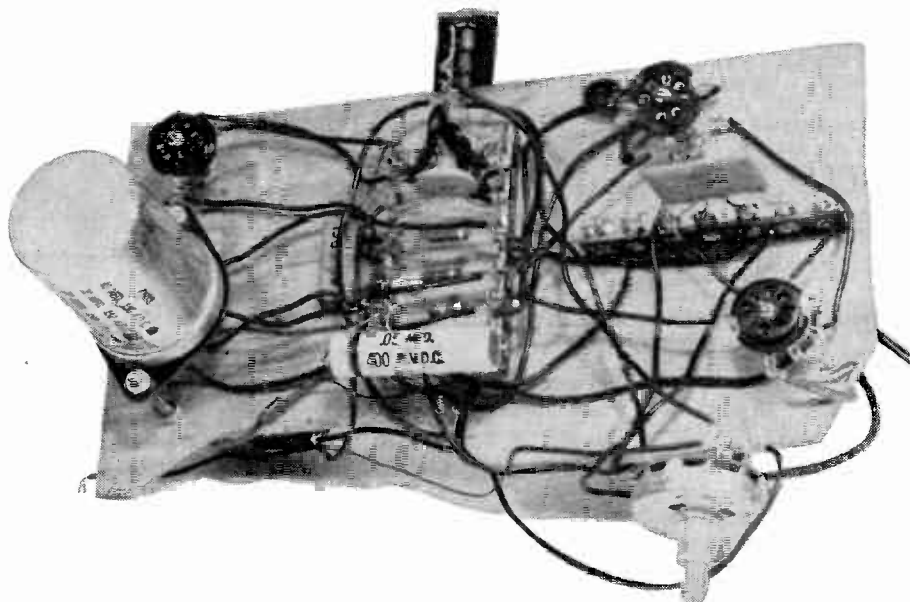

Fig. 11. Top view of the intercom built on a wooden chassis.

The chassis used by the author was approximately 4 inches wide and 8 inches long. If this is the first electronic project you have attempted without step-by-step instructions, it would be better to use a larger chassis to avoid trouble. It is also a good idea to place a check mark in pencil on each lead, connection, and component in the diagram as you wire it to prevent any errors or omissions. Be particularly careful to use the correct terminals of the electrolytic capacitor. Also be sure that you do not accidentally interchange the leads of the input transformer and make certain that the electrolytic capacitor negative terminal is properly grounded to B-. Speaking of grounding, it is best to use one terminal in the entire unit as a central ground point and run any necessary ground leads from terminals, socket lugs, etc., to this point with separate hookup wire to prevent ground loops from causing hum.

If you use a wooden chassis and mount the sockets as shown in Fig. 9B be sure to count the socket lugs correctly from the bottom.

#### Checking and Troubleshooting

It is usually necessary to enlist someone to help check the unit after it is built. The master station must be in a different room than any remote stations or audible feedback will cause howling. This can also occur in adjacent rooms when the volume control is set up too high. If, for some unforeseeable accident, the device does not work after it is built, troubleshooting is not difficult. Just keep in mind that the master station is only a simple two-stage RC coupled amplifier with a special switching system. Circuit disturbance, signal injection, etc., and other such methods are readily adaptable to track down any

trouble. Due to the high gain of the unit, excess hum is a possible defect and can usually be traced to defective filter condensers, cathode-to-heater leakage in the tubes, and incorrect wiring. Some hum is unavoidable.

Needless to say, wiring errors can cause considerable difficulty. It is not particularly difficult to wire the switches incorrectly, which can cause all sorts of weird troubles or to completely reverse the connections on the input transformer which drops the gain to about nothing. A defective component is not too hard to obtain at a wholesaler's and a poor "ground" connection can cause unbelievably loud hum.

The operating voltages shown on the diagram of Fig. 5 will vary somewhat according to the parts tolerances, line voltage, and tester accuracy. Due to the high resistor values in the plate and screen circuits of the 12BA6 stage, you'll notice the voltage values are quite low. Even lower values will be obtained if a VOM is used instead of a VTVM.

Who knows, you may find that it works the first time; or on the other hand, you may find, after some difficulty, a wiring error, poorly soldered connection, defective component, or any of the other reasons for gray hair!

As previous pointed out, all of the components used in the article are available from your local radio wholesaler or a mail order house; **they are not available from NRI.**

The loudspeaker is not included in the parts list on the following page. Any four or five-inch unit with a 3-4 ohm voice coil is suitable. All resistors except R6 are ½-watt.

— n r i —

#### RADIO-TV SERVICE BUSINESS FOR SALE

Owner retiring from this 37 year old well-established business in a midwest shopping area of 200,000 people. \$3500 for stock, parts, and equipment. If interested, write Mr. Jim Reeder, Reeder Radio and TV, Highway 149, Cedar Rapids, Iowa. For references, contact any Cedar Rapids radio distributor, the Chamber of Commerce, Peoples Bank and Trust, or Dun & Bradstreet.

#### TAX-TAKE

The government has come up with a new simplified simple tax form known as A 40,011-2 for persons who have money left over at the end of the year. This new income tax form has only two questions to be completed and a statement to be followed.

1. How much did you make last year?
2. How much did you have left?
3. Mail it in.

# NRI ALUMNI NEWS



Thomas Hull ..... President  
 F. Earl Oliver ..... Vice President  
 John Babcock ..... Vice President  
 Roland Tomlinson ..... Vice President  
 Howard Smith ..... Vice President  
 Theodore E. Rose ..... Executive Sect.

## Chapter Chatter

**NEW ORLEANS CHAPTER** was host to Ted Rose, Executive Secretary of the NRIAA, and J. B. Straughn, Assistant Director of the NRI Instruction Department. Mr. Straughn, who interrupted his Florida vacation and flew to New Orleans to attend this meeting, delivered a talk on the NRI Model 250 Oscilloscope, which he also demonstrated. In the demonstration he was ably assisted by the Chapter's technical advisor, Gaston Galjour.

**CHICAGO CHAPTER'S** Chairman Charles Teresi opened a discussion to determine what the members thought of starting a program devoted primarily to the transistor. It was suggested that this should be a flexible program so that other phases of servicing could be brought in as the need arises. The members were enthusiastic about this setup.

It was also suggested that the members immediately re-wire the Chapter's demonstration board Radio Receiver so that the Chapter could get started with some trouble-shooting sessions.

**PHILADELPHIA - CAMDEN CHAPTER** members are still talking about the party held for them by the Philadelphia branch of the General Electric Company. The Company, through the courtesy of George Walker, Special Products Electronic Supervisor, and with the help of Floyd Anderson, Tube Department, Vince Novak, Sales, Jack Abramson, Technician, and George Reid, Eastern District Manager, played host to the Chapter at the first GE Television Forum for the year.

GE designated this as the "National Radio Institute Alumni Night." Over one hundred members of the Chapter were present and, according to reports of many of the individual members, it was one of the most entertaining as well as educational meetings they ever attended. Besides receiving a pen and pencil set, literature, and a world of information, they were treated to an excellent supper. All the members were warm in their praise of GE and its evident desire to help and work with the Radio-TV serviceman.



General Electric Co. representatives at the "National Radio Institute Alumni Night" put on by GE for the Philadelphia-Camden Chapter. L to r: George Reid, Eastern District Manager; George Walker, Special Products Electronic Supervisor; Jack Abramson, Technician.

Like most such Philadelphia-Camden programs, this one was largely the result of the efforts of the Chapter's energetic Secretary, Jules Cohen. Jules is due a rousing vote of thanks for having promoted a program of this caliber.

**MINNEAPOLIS-ST. PAUL (TWIN CITY) CHAPTER'S** John Berka demonstrated the dynamic sweep circuit analyzer and showed how effectively it can be used to quickly isolate sweep circuit troubles to a stage and then to a component. The interest taken in this demonstration by the members was evident from the discussion that was entered into on sweep circuit problems.

At the following meeting Chairman Walter Berbee and John Berka collaborated in a discussion and demonstration on how to speed up servicing with an oscilloscope. They demonstrated the use of the various probes and where each should be used, pointed out things to look for in

the scope traces and explained the difference in what would be visible if a defect were present. This was an excellent program, thanks to Chairman Berbee and John Berka.

**NEW YORK CITY CHAPTER** is humming along in its usual high spirits, due to the fine job done by the Executive Committee in scheduling lectures and demonstrations by its own members who are experienced speakers as well as Radio-TV men. Talks are accompanied by discussions during which questions and suggestions by the members present are encouraged.

Tom Hull, always in demand as a speaker at the meetings, has lately been devoting his lectures to "Basic Fundamentals"—something all the members need every now and then. Treasurer Frank Catalano demonstrated how to check selenium rectifiers on his tube tester; Jim Eaddy, the Chapter's transistor expert, is still going strong on his trouble-shooting series on transistor Radios. For entertainment the members rely on Willie Fox's accounts of his experiences in TV Servicing.

There is never a dull moment at the meetings of the New York City Chapter!

**PITTSBURGH CHAPTER'S** Chairman Tom Schnader led a discussion on stereo-sound and characteristics of various type cartridges.

At the next meeting he serviced a dead

transistor radio receiver while Secretary Ray Bender worked on the Chapter's TV receiver and mounted a control panel for injecting defects into the set for demonstration purposes. There was a very good attendance at this meeting and all the members present thought highly of both of these demonstrations.

For a limited time the Chapter has been having its meetings announced on the Radio Station WEEP Community Service Bulletin Board, in a further effort to contact NRI students and graduates who may be interested in attending the meetings or becoming members.

**SPRINGFIELD (MASS.) CHAPTER'S** Technical Advisor John Michnovetz delivered a talk that was highly informative as well as entertaining on "Electrons At Work." John explained the part that the electron plays in the formation of matter of how the free electrons in an element or part of matter determine its conductivity or the lack of it, etc. This was indeed an absorbing lecture.

As the Springfield Chapter was chartered on April 14, 1954, a combined dinner and Ladies Night is being planned for the Chapter's sixth anniversary this April. The entertainment committee decided that since April 14 falls during Lent, it would be better to hold the dinner shortly after Easter. The Chapter extends a cordial invitation to all NRI students and graduates who care to attend. The price of the



Pittsburgh Chapter officers for 1960. Seated, l to r: Tom Schnader, Chair.; Howard Tate, Vice-Chair.; Jack Fox, Treas.; Ray Bender, Sec'y. Back row: William Lundy, Ex. Comm.; Earl Uhl, Ex. Comm.; visitor Ted Rose, Ex. Sec'y of the NRIAA; and Charles Kelly, Ex. Comm.

tickets and a definite date have not yet been set, but a card addressed to the Secretary will assure those interested of getting the desired information. The Secretary is Howard B. Smith, 53 Bangor Street, Springfield 8, Mass.

**HAGERSTOWN (CUMBERLAND VALLEY) CHAPTER** held its Annual Banquet at which it also elected its officers for the current year. The turkey dinner was the greatest — everything country style — and anyone who left hungry didn't know how to say "Pass the turkey."

The officers elected were: J. Howard Sheeler, Chairman; Harry W. Straub, Vice-Chairman; Richard Handshew, Secretary; and Robert J. Saum, Treasurer. Our congratulations to these officers!

The Chapter has made a change in the scheduling of its programs. This change is expected to result in considerable improvement in the programs.

**MILWAUKEE CHAPTER** of late has been devoting its meetings to general discussions of TV circuits and service problems. Chairman Philip Rinke, Slavko Petrich, Stanley Ward and James Lasky have been participating in these discussions.

**SOUTHEASTERN MASSACHUSETTS CHAPTER** held the first of a new series of black board talks. This first one was on TV tuners and was conducted by Walter Adamiec. Diagrams were drawn on the blackboard, starting with the antenna on through to the output, to the IF section. Walter discussed the different types of tuners, their advantages and disadvantages. He indicated probable troubles and gave the remedies. A question-and-answer session followed so that all the members could participate.

The following officers were elected for the current year: Arthur Hubert, Chairman; Ernest McKay, Vice-Chairman; Lester Cory, Secretary; Hubert St. Pierre, Treasurer; George Inglis and Harvey Cole, Financial Committee. Congratulations to these gentlemen!

A. Habib was recently admitted to membership in the Chapter. A warm welcome to you, Ace.

**DETROIT CHAPTER** reports that the officers for the current year are: James Kelley, Chairman; Ellsworth Umbreit,



Some of the Detroit Chapter officers for 1960 taking the oath of office, l to r, with hands raised: Earl Oliver, George Langlois, James Kelly, Price Bray. Charlie Mills is administering the oath.

Vice-Chairman; George Langlois, Recording Secretary; Edward Atkinson, Assistant Secretary; Earl Oliver, Treasurer; Charles Mills, Sergeant-At-Arms; Prince Bray, Librarian; John Stanish and Asa Belton, Financial Committee. Our congratulations to these successful candidates for office.

The members were pleased to welcome as a guest speaker Mr. Wayne B. Middleton, Equipment Engineer of the Bell Telephone Company. Mr. Middleton delivered a talk on "The Mighty Midget, The Transistor" which included an excellent demonstration on the use of transistors in place of tubes in different circuits. This talk and demonstration were such a success and so well received by the members that the Bell Telephone Company is planning another demonstration for the Chapter. The Chapter is also planning a few tours through Bell Telephone stations. These tours should also prove very interesting.

**LOS ANGELES CHAPTER**, in addition to a regular meeting on the second Friday of each month as in the past, now also holds a regular meeting on the last Saturday of each month.

The Chapter has also inaugurated a series of classes in mathematics related to Radio and Television. These classes are held on the Saturdays falling between the regular meeting nights. Chairman Eugene DeCaussin, Kenneth Williams, and Treasurer Lee Chavez volunteered to conduct the classes, which have already started. It is apparent from the enthusiastic response and support of the members that these math classes are proving to be popular.

Group discussion and work on members' dog sets and Radio-TV service problems continues. Indeed, this is one of the most

# NRI ALUMNI NEWS

## Chapter Chatter (Cont'd)

important activities of the Chapter. But for the present this phase of the Chapter's activities is limited to the regular meetings and is not permitted to interfere with the math classes.

The latest members to be admitted to membership are Vicente Nunez and Ira Moss. A cordial welcome to these new members!

**SAN FRANCISCO CHAPTER** wants special mention made of the fact that it has changed its meeting place and now holds its meetings in the Meeting Room of the Bay Federal Savings and Loan Association, Palm Avenue and Geary St.

The officers serving for 1960 are: J. Arthur Ragsdale, Chairman; Edward Persau, Vice-Chairman; Phil Stearns, Secretary; Anderson Royal, Assistant Secretary; George Chessen, Treasurer; Isaiah Randolph and Shuck Joe, Financial Committee. Congratulations to these officers! Incidentally, this is the second term for most of them.

Chairman Ragsdale undertook a discussion of TV remote control; he drew a block diagram of the control on the blackboard and explained how the equipment works. Anderson Royal demonstrated on the blackboard the working and control of a discriminator circuit consisting of an RC time constant and resonance circuit. The members enjoyed both of these demonstrations.

George Law suggested that the members make a study of transistors and experiment with them. He volunteered to get booklets on the subject showing the assembling of transistors, etc. The following meeting was scheduled as a combination "dog" session and study of transistors, at which another member who has taken a course on the subject volunteered to talk on transistors.

The latest member to join the Chapter is Bob Kelly. Welcome to the Chapter, Bob!

— n r i —

*"Many imagine that the higher you go, the easier the climb. Don't be governed by that theory unless you have a soft place to fall back into."*

J. L. Boggus

## Directory of Local Chapters

*Local chapters of the NRI Alumni Association cordially welcome visits from all NRI students and graduates as guests or prospective members. For more information contact the Chairman of the chapter you would like to visit or consider joining.*

**CHICAGO CHAPTER** meets 8:00 P.M., second and fourth Wednesday of each month, 666 Lakeshore Dr., West Entrance, 33rd Floor, Chicago. Chairman: Charles Teresi, 3001 N. Norica, Chicago, Ill.

**DETROIT CHAPTER** meets 8:00 P.M., second and fourth Friday of each month, St. Andrews Hall, 431 E. Congress St., Detroit. Chairman: James Kelley, 1140 Livernois, Detroit, Mich.

**FLINT (SAGINAW VALLEY) CHAPTER** meets 7:30 P.M., second Saturday of each month, 3149 Richfield, Flint. Chairman: William Neuman, 1613 S. Klazel, Bay City, Mich.

**HAGERSTOWN (CUMBERLAND VALLEY) CHAPTER** meets 7:30 P.M., second Thursday of each month, North Hagerstown Senior High School, Hagerstown, Md. Chairman: J. Howard Sheeler, 300 Walnut St., Shippensburg, Pa.

**LOS ANGELES CHAPTER** meets 8:00 P.M., second Friday and last Saturday of each month, 11523 $\frac{1}{2}$  S. Broadway, Los Angeles. Chairman: Eugene DeCaussin, 5570 Franklin Ave., Apt. 407, Hollywood, Calif.

**MILWAUKEE CHAPTER** meets 8:00 P.M., third Monday of each month, Radio-TV Store & Shop of S. J. Petrich, 5901 W. Villet St., Milwaukee. Chairman: Philip Rinke, RFD 3, Box 356, Pewaukee, Wis.

**MINNEAPOLIS-ST. PAUL (TWIN CITY) CHAPTER** meets 8:00 P.M., second Thursday of each month, Walt Berbee's Radio-TV Shop, 915 St. Clair St., St. Paul. Chairman: Walter Berbee, 328 E. Co. Rd., A-2, St. Paul, Minn.

**NEW ORLEANS CHAPTER** meets 8:00 P.M., second Tuesday of each month, home of Louis Grossman, 2229 Napoleon Ave., New Orleans. Chairman: Herman Blackford, 5301 Tchoupitoulas St., New Orleans, La.

**NEW YORK CITY CHAPTER** meets 8:30 P.M., first and third Thursday of each month, St. Marks Community Center, 12 St. Marks Pl., New York City. Chairman: David Spitzer, 2052 81st St., Brooklyn, N. Y.

**PHILADELPHIA-CAMDEN CHAPTER** meets 8:00 P.M., second and fourth Monday of each month, Knights of Columbus Hall, Tulip & Tyson Sts., Philadelphia. Chairman: Herbert Emrich, 2826 Garden Lane, Cornwell Heights, Pa.

**PITTSBURGH CHAPTER** meets 8:00 P.M., first Thursday of each month, 134 Market Pl., Pittsburgh. Chairman: Thomas D. Schnader, R.D. 3, Irwin, Pa.

**SAN FRANCISCO CHAPTER** meets 8:00 P.M., first Wednesday of each month, Palm Ave. & Geary St., San Francisco. Chairman: J. Arthur Ragsdale, 1526 27th Ave., San Francisco, Calif.

**SOUTHEASTERN MASSACHUSETTS CHAPTER** meets 8:00 P.M., last Wednesday of each month, home of John Alves, 57 Allen Blvd., Swansea, Mass. Chairman: Arthur Hubert, 1566 Pleasant St., Fall River, Mass.

**SPRINGFIELD (MASS.) CHAPTER** meets 7:00 P.M., first Friday of each month, U. S. Army Hdqts. Building, 50 East St., Springfield, and on Saturday following the third Friday of each month at a member's shop. Chairman: Rupert McLellan, 233 Grove St., Chicopee Falls, Mass.



# Servicing With the NRI Model 12 Vacuum Tube Voltmeter

by J. B. Straughn

A vacuum tube voltmeter is an instrument that uses the amplifying properties of a vacuum tube to increase the sensitivity of a meter. In its simplest form, the vacuum tube voltmeter, or VTVM as it is more commonly known, is a dc amplifier with an indicating meter in the plate circuit.

Fig. 1 shows the basic circuit of such a simple VTVM. The voltage to be measured is applied across resistor  $R_1$ , which effectively places it in series with the bias developed by resistor  $R_2$ . The resulting change in cathode-grid voltage causes the plate current to change, which is indicated by the meter connected in that circuit.

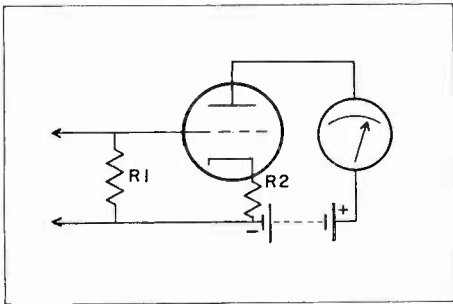

Fig. 1. Basic VTVM circuit.

This basic VTVM has many shortcomings. Some of the more obvious disadvantages are: (1) the dc input voltage is limited to the value that will cause saturation of the tube, or cut-off of the tube. (2) The full sensitivity of the meter is not used; that is, there will be a certain steady plate current even when no signal is applied to the input of the instrument. (3) No provision is made for covering the multitude of ranges that are necessary in service work. (4) The accuracy of the instrument will vary as the vacuum tube ages, and as the battery deteriorates.

Because of these disadvantages, and others, the basic vacuum tube voltmeter has undergone many changes in the never-ending search for greater accuracy and lower cost. One of the best circuits that has been evolved so far is the one shown in Fig. 2. You will notice that this circuit resembles the familiar Wheatstone bridge.

With no signal applied to the input circuit (between point X and point Y), resistor  $R_{11}$

is adjusted so that equal currents flow in the two sections of the bridge. This means that no current will flow through the indicating meter, and the meter will read zero.

Now, if the grid of  $VT_1$  is made more positive by coupling an external source to the circuit, the plate current of this tube will increase. This unbalances the bridge circuit, and current flows through the indicating meter. At the same time that the bias of  $VT_1$  is decreased by the external voltage, the increased current flow through resistor  $R_7$  causes the cathode of  $VT_2$  to become more positive, which effectively causes the grid of  $VT_2$  to become more negative. This causes the bridge to become even more unbalanced.

The effect of applying an input signal is to decrease the plate resistance of  $VT_1$  at the same time that the plate resistance of  $VT_2$  is increased. Therefore, the circuit becomes much more unbalanced for a given input voltage than any other type of vacuum tube voltmeter circuit.

The circuit of Fig. 2 also includes a provision for more than one voltage range. By tapping down on the voltage divider (consisting of  $R_{12}$ ,  $R_{13}$ , and  $R_{14}$ ), we can apply

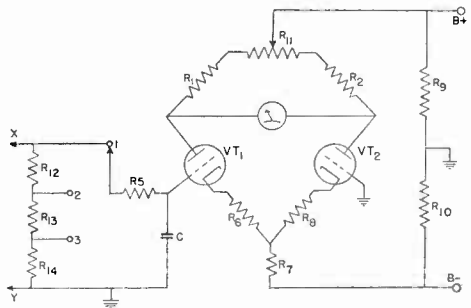

Fig. 2. A simplified version of the circuit used in most VTVM's such as the NRI Model 12.

certain selected portions of the voltage between X and Y to the grid of  $VT_1$ .

When an ac voltage is applied to the input, resistor  $R_5$  and capacitor C act as a filter to keep this ac voltage from appearing at the grid of tube  $VT_1$ .

This basic circuit has become the most popular one for use in a vacuum tube voltmeter where stability, accuracy, and ease

of operation are primary points of consideration.

The most important advantage of a vacuum tube voltmeter is that the input resistance is held constant at a high level. The total value of  $R_{12}$  plus  $R_{13}$  plus  $R_{14}$  (Fig. 2) is the only part of the entire VTVM circuit which is applied directly across the points to be measured. The total resistance of this voltage divider can be made quite high—as high as 10 megohms. If the instrument is designed to have a basic range of 3 volts when the switch is set at point 1, this means that we have an input sensitivity of 3.3 megohms per volt on this range. Compare this with the input resistance of a standard 1000 ohm-per-volt instrument set for the 3 volt range—input resistance 3000 ohms!

Because the voltage to be measured is amplified before being applied to the meter, a meter of less sensitivity can be used in a vacuum tube voltmeter. This decreases the cost of the meter required, and makes the instrument more rugged. Generally, the more sensitive a meter is, in terms of current required for full-scale deflection, the more likely it will be affected by mechanical shock. Therefore, use of a meter of lower sensitivity gives us an instrument that will stand more abuse.

Once a VTVM like that in Fig. 2 has been calibrated, it will maintain calibration over long periods of time. A dual triode tube is normally used instead of two separate tubes, as shown in Fig. 2.

As the tube ages and the current flow through it decreases, it decreases equally in both sections. This means that the bridge will maintain its balance even though the current has changed. If two tubes were used, they probably would age differently, the current in the two sections would decrease at different rates, and the bridge would become unbalanced.

Another important advantage of the VTVM is the ease with which it may be adapted for other measurements. A simple rectifier converts it into a sensitive ac voltmeter. The addition of a few resistors and a battery converts it into a wide range ohmmeter.

These are some of the basic reasons why the VTVM has become such a popular test instrument for modern circuitry. It allows measurements to be made in many circuits where they would be impossible with any other type of instrument. Also, most measurements can be made without affecting circuit operation—this is often quite important in oscillator circuits and high frequency rf amplifier circuits.



Fig. 3. The Model 12 NRI Professional Vacuum Tube Voltmeter.

Fig. 3 shows an instrument of the type that we have been discussing. This instrument has dc voltage ranges from 3 volts to 1200 volts in 5 ranges designed for maximum usefulness. It has 5 ac rms ranges from 3 volts to 1200 volts and 5 peak-to-peak ac ranges from 8 to 3200 V peak-to-peak.

An rf probe is available for this instrument that extends the frequency range to 250 megacycles. A high voltage probe is also available to permit measuring up to 30,000 volts dc.

The instrument has a wide range ohmmeter scale that will measure resistance as high as 1000 megohms. One of the special features is the zero center scale that has been especially designed for use in FM alignment work.

The input impedance of the instrument for all dc measurements is  $13\frac{1}{3}$  megohms, and there is a provision for reversing the meter polarity. That is, by turning a switch you can convert the instrument to read voltages that are negative with respect to the point where the common lead of the instrument is connected.

Before using any VTVM it must be properly adjusted to zero. The technique for doing this is explained in the operating instructions and should be carefully followed.

Of course, the entire instruction or operat-

ing manual should be thoroughly read before any measurement is made. Although most VTVM's operate in a similar manner, some have special features that cannot be fully understood or utilized unless the manufacturer's instructions and suggestions are followed.

For example, the Model 12 NRI Professional Vacuum Tube Voltmeter features a unique universal test probe containing a switch that must be thrown to one position for dc and the other for ac and ohmmeter readings. This switch places a 1.33 megohm resistor in series when placed in the dc position to minimize the effect of input capacity. Most other VTVM's use this isolating technique, but instead of featuring a switch-type probe it is often necessary to use a third test lead or slip on an additional probe.

For all dc voltage measurements, the common lead of the instrument should be attached to B— of the equipment under test. In ac power transformer-operated equipment, the B— point is usually the chassis while in ac-dc equipment, the B— is usually the negative lead of the filter condenser, or any point connected to it.

When using a VTVM, or in fact an meter, the range switch should be first set to the highest voltage range. The setting can then be progressively reduced until there is sufficient deflection to obtain a

convenient reading. When making readings where the highest accuracy is desired (always use a range that will deflect the meter pointer into the right half of the scale. This deflection gives the greatest accuracy.

In explaining the procedures to be used for dc voltage measurements in a receiver, the circuit of Fig. 4 will be used as an example. The reader will probably find it helpful to refer back to this circuit occasionally as information regarding the various types of measurements is given.

Let us see how the VTVM can be used to check the operating potentials throughout the receiver.

With the common lead connected to B—, the dc probe may be moved from one place to another in a circuit to make measurements at various points. The normal place to start is at the cathode of the rectifier. If the voltage is low at this point, it signifies that the voltage is low throughout the entire set, and further checks will locate the defective part. For example, if the voltage available at the cathode of the rectifier tube VT5 in Fig. 4 is low, but is considerably greater than the voltage at the screen grid of the audio output tube VT4, this means that some component on the "set side" of the filter resistor R3 is shorted. Likewise, if the voltage is normal at the screen grid of the audio

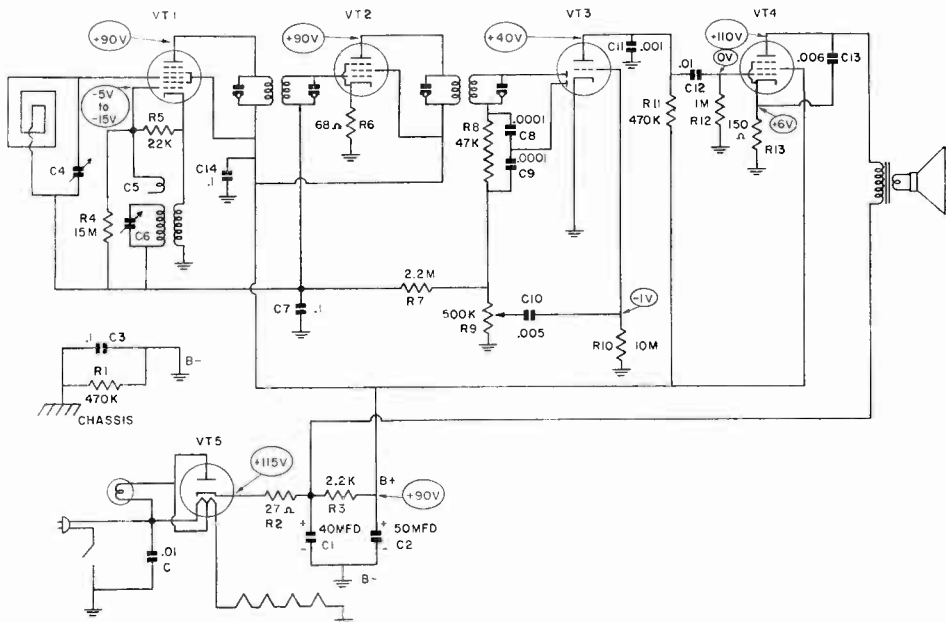

Fig. 4. Schematic of a typical AC-DC receiver.

output tube VT4, but is low at the plate of the first audio tube VT3, this signifies that leakage exists directly at the plate of VT3. (The usual cause for readings of this type is a defective plate by-pass capacitor.)

To determine whether the output stage of the receiver is drawing sufficient plate current, touch the voltmeter probe to the cathode of the tube in that stage. At the cathode of the tube VT4 in Fig. 4, a positive potential of approximately 6 volts should exist. If it does not, insufficient current is flowing through the cathode bias resistor, and the usual cause is a defective tube. However, before installing a new tube it would be well to make certain that the correct potentials are available at the plate and screen of the tube.

The above test will, of course, apply only when the circuit is designed to have cathode bias. In all other cases, set the function switch to —DC, connect the COMMON lead of the vacuum tube voltmeter to the cathode of the tube, and the test probe to the grid of the tube. The meter will then read the bias that is available for that tube.

This same procedure of voltage checking can be applied to all of the other tubes in a receiver. Check the operating potential available in each circuit, and if the voltage is low in any one circuit, check that circuit for the cause.

By switching the instrument to —DC, and connecting the probe to the oscillator grid (the first grid of tube VT1 in Fig. 4), you can quickly determine whether or not the local oscillator in the receiver is operating. If the local oscillator is operating, there will be enough voltage so that the grid of the tube will be negative with respect to the cathode. If the oscillator is not operating, this voltage will not exist.

Another useful check that can be made when the instrument is set to the —DC position is measurement of the avc voltage. Touch the test prod to the control grid pin of the i-f amplifier tube VT2, and slowly tune the receiver across the broadcast band. If a change in the dc voltage available at the grid of this tube is noted as the receiver is tuned past the

frequencies of local broadcast stations, all sections of the receiver up to the second detector are operating properly. You can be certain of this because the voltage is developed in the second detector circuit of the receiver, and all sections previous to that one must be operating if avc is available.

This same procedure can be used to check agc voltages in television receivers. By checking for a change in agc voltage as the set is tuned from channel to channel, you can quickly determine whether or not the stages up to the second detector are operating properly.

Here is a simple way of checking the various parts used in an avc or agc network. Tune the set to a strong station. Measure the voltage on the "source" side of the avc (agc) filter resistor first, then the voltage of the "set" side of the resistor. If voltage is available on the source side, and not on the set side, this indicates that the resistor is open, or the avc (agc) by-pass capacitor is shorted. A simple ohmmeter check will indicate which.

The coupling capacitor used in the audio output stage of a receiver can also be checked by means of the VTVM. To do this, set the instrument for +DC measurements and touch the probe to the grid pin of the audio output tube (VT4 in Fig. 4). If a positive voltage is noted at this point in the circuit, disconnect coupling capacitor and check again at the grid of the tube. If the positive voltage has disappeared, the coupling capacitor is defective; if the positive voltage remains, the tube is gassy and must be replaced.

There is another important use for the dc voltage scale that will be further explained when we discuss alignment.

One special feature of the NRI Model 12 Vacuum Tube Voltmeter is that no blocking capacitor is necessary in series with the test lead when making ac readings. Instead, the blocking capacitor is included in the instrument. (This is not true of some voltmeters. If you are uncertain about a particular model, check the manufacturer's instruction sheet furnished with the instrument.)

By setting the function switch to the ac position and the range switch to a position that will accommodate the voltage to be measured, you can measure ac voltages over a wide range. Because of the wide frequency range of the instrument, it can be used as an audio voltmeter for many types of work.



To measure the ac output of a power transformer, attach the common lead of the voltmeter to one side of the winding and the test prod to the other side. When checking transformers in this manner, always use the highest ac voltage range for the initial measurement. The range switch can be reset, if necessary, to obtain a usable reading.

When this instrument is set for ac measurements, it will also measure voltages at audio frequencies. This feature makes it possible to directly "signal trace" in the audio stages of a receiver.

To do this, feed a signal into the set and check the signal voltage as each audio tube. If an audio voltage is available at the grid of a tube, and not at the plate of that tube, some defect exists in that circuit.

Another useful test can be performed by the "audio voltmeter" is the checking of the electrical balance of a push-pull audio stage. To do this, check the audio voltage at the plate of first one tube, then the the other. These two voltages should be substantially equal. If they are not, check the audio voltages at the grid of each stage. If they are equal, the defect lies in that stage, but if they are unequal, the defect is probably in the preceding stage or the coupling system between the two stages. Balance is necessary in a push-pull audio stage if the advantages of push-pull operation are to be fully realized.

Another use of the audio voltmeter will be given in the section on AM alignment.

The ohmmeter section of the NRI Model 12 VTVM will measure resistances ranging from  $\frac{1}{2}$  ohm to 1000 megohms. This wide range of resistance measurements allows you to make any resistance measurements you are likely to need in the repair of AM, FM, or TV receivers.

To adjust a VTVM for ohmmeter readings, set the function switch to OHMS, and the range switch to the lowest setting. Then adjust OHMS ADJ. so that the meter pointer is at the full scale point. By setting the range switch to the appropriate position, you can make resistance readings as necessary.

When making ohmmeter measurements, always use the test lead that is designed for use with the ohmmeter section of the meter. In the case of the NRI Model 12, simply push the probe slide switch to the "AC- $\Omega$ " position.

To measure a resistor, connect the two test leads to the two ends of the resistor.

Adjust the range switch until the meter pointer is on an easily read section of the scale (near the middle.) Mentally apply the necessary multiplying factor to the reading observed on the meter. For example, if the needle comes to rest at 10 on the OHMS scale, and the range switch is set to R X 100, multiply 10 by 100 to get the value—1000 ohms. Most vacuum tube voltmeters have the resistance ranges arranged in steps that are multiples of 10. This makes it easy for you to apply the multiplying factor by adding the appropriate number of zeros to the reading observed on the scale.

The high ohmmeter ranges of the vacuum tube voltmeter will often be useful in checking for leakage. For example, to check a capacitor for leakage, disconnect one side of the capacitor, set the instrument to the highest ohmmeter range, and connect the test leads across the capacitor. The reading will be the leakage resistance of the capacitor.

This same procedure can be used with coils, i-f transformers, etc., but the unit under test must be completely disconnected. Connect one ohmmeter lead to one winding, and the remaining lead to the other winding. The scale reading will be the leakage resistance between the two windings.

When using the ohmmeter for continuity checks, you should not use the R X 1 scale too often, because use of this scale will cause somewhat more rapid discharge of the ohmmeter cell. In normal use, the cell in the ohmmeter circuit will last its "shelf life." Note: Since the Model 12 NRI VTVM uses an ordinary flashlight cell replacement is a simple problem.

The zero center dc voltage scale of the Model 12 VTVM is arranged so that the zero center mark on the scale is at the center, and the meter reads positive voltages by deflecting the pointer to the right, and negative voltages by deflecting the pointer to the left.

To use the zero center dc voltage scale of the instrument, set the function switch to "ZERO CENTER" and turn the probe switch to "DC." The instrument is now set up so that you can measure voltages that are either positive or negative, without moving the test leads or resetting the function switch.

This zero center scale is very useful in aligning FM discriminators and ratio detectors. To adjust a discriminator, connect the input of the zero centered vacuum tube voltmeter across the discriminator load resistor. Then feed an unmodulated i-f sig-

nal into the receiver. If the meter shifts from zero when connected across the discriminator load resistor, the discriminator is not properly aligned. Adjust the trimmer on the secondary of the discriminator transformer until you get zero voltage reading. This signifies correct alignment of the stage.

In aligning an AM receiver, the VTVM must be used in conjunction with an AM signal generator which supplies signals at the frequencies required for the alignment of that particular receiver.

One way of using the VTVM in alignment is by setting the instrument for avc measurements, and connecting the test prod to the proper point of the circuit. Feed an rf (or i-f) signal into the proper section of the receiver, and align the various trimmers for maximum reading on the voltmeter scale. When the instrument is connected, the setting of the range switch should be reduced one step at a time until the 3-volt scale is reached. The output of the signal generator should be adjusted for a reading of approximately 2 volts on the meter. As the trimmers in the receiver are adjusted, the output of the generator will have to be reduced to maintain this value of avc voltage

Do *not* set the VTVM range switch to a progressively higher range as the trimmers are aligned—reduce the input signal of the signal generator.

As an audio voltmeter, the vacuum tube voltmeter can be used as an output meter for alignment purposes by connecting the test leads directly across the voice coil of the speaker, or directly from the plate of the audio output stage to B minus. The connection used in each particular case will depend upon the preference of the user, and the convenience of the connection.

During alignment, feed a modulated signal into the proper section of the receiver, and align the various trimmers for maximum reading. It will probably be necessary that the output of the signal generator be reduced as the various stages are brought into alignment. Again, always reduce the output of the signal generator, rather than increase the setting of the range switch.

For FM i-f alignment, connect the VTVM across the limiter grid resistor, and feed into the receiver an unmodulated signal at the i-f frequency (usually 10.7 megacycles). The various trimmers of the i-f circuit of the receiver should be adjusted to give maximum reading on the voltmeter. In aligning FM limiters it is necessary that sufficient signal be available at the limiter,

or the desired limiting action will not occur. The alignment of discriminators in FM receivers was discussed above, in the section covering the zero center scale.

An FM receiver having a ratio detector can also be aligned with the use of a VTVM and an AM generator. The oscilloscope and FM *sweep* generator method gives more accurate results, but the VTVM system of alignment will suffice when an oscilloscope and a sweep generator are not available.

To align the ratio detector, feed an amplitude modulated signal into the i-f section of the receiver. Then adjust the various i-f trimmers to give maximum voltage across ratio detector load resistor. Then connect VTVM to the audio stages as an audio voltmeter (as explained previously), and adjust the secondary of the ratio detector transformer to get minimum audio output. This gives the best FM detection with the least susceptibility to AM signals.

There are rf probes available for some VTVM's vacuum tube voltmeters (including the NRI Model 12) that extend the frequency range. The rf probe will be useful to a serviceman who wants the ultimate in test equipment.

To use the rf probe, set the function switch as in the manufacturer's instructions, and the range switch to the appropriate division. There is a voltage limit on the crystal contained in the rf probe. It is 120 volts peak (85 volts rms) for the probe for the NRI Model 12. This peak voltage should never be exceeded in testing. For all rf voltage measurements, attach the probe ground lead to the closest B— point.

By feeding a known signal into the input of a receiver and measuring the strength of the signal available at the plate of each successive stage, you can get an idea of the gain of the receiver.

You will need some experience in signal tracing before you can fully evaluate the readings. However, by making a series of signal voltage measurements in a receiver known to be in good operating condition, you become familiar with the rf voltages that you can expect to find at various points in the receiver. A general rule to use in the beginning is that at least 3 volts should be available at the plate of the second detector for proper operation.

You can check the effectiveness of by-pass capacitors by touching the rf probe to the point where by-passing is desired. If you get a reading on the voltmeter, it is due to unby-passed energy, and the by-pass ca-

pacitor at that point in the circuit should be replaced.

To check an rf or i-f stage for suspected parasitic oscillation, stop the receiver local oscillator, and check for the presence of an rf voltage at the plate of the suspected stage. If an rf voltage is present, the stage is oscillating.

The output of the local oscillator in a receiver can be checked directly at the grid of the oscillator tube with the rf probe. Connect the negative lead of the probe to B-, and touch the tip of the probe to the oscillator grid. You will get a reading of 10 to 25 volts. The exact voltage will vary from set to set, and some experience with this measurement will be necessary before you can fully evaluate the readings.

Another accessory that is available for most VTVM's is a high voltage probe designed to extend the dc voltage range of the instrument up to 30,000 volts for TV servicing.

The high voltage probe for the NRI Model 12 VTVM comes with its own cable and cable connector. To use it the standard universal probe and cable must be removed and the high voltage cable and probe connected in its place. Some VTVM's use a special probe that clips onto one of the regular probes.

The high voltage probe of the Model 12 multiplies all basic ranges by 100. For example, with the range switch set to 60V, voltages up to 6000 volts can be measured. For TV servicing the 300 V range is generally used permitting readings up to 30,000 volts.

There are many special uses for a VTVM. For example, the percentage of ripple of a power supply can be determined.

To measure the percentage of ripple of a power supply, first check the dc voltage available at the output of the supply, then the ac voltage available across the same two points. The ac voltage will probably be quite low, so a careful reading will be necessary. Dividing the ac voltage by the dc voltage will give the percentage of ripple.

For example, let us consider a power supply that has a dc output of 380 volts, and a ac component of 7 volts. Divide 7 (ac component) by 380 (dc component), and multiply by 100 to obtain the percentage of ripple—in this case, 1.84%. This method of measuring the percentage of ripple of a power supply can be applied to any supply on which the dc output is not over 1200 volts.

With an instrument such as the NRI Model 12 VTVM, you will be able to measure any supply voltage in a receiver or other piece of equipment, usually without disturbing the operation of the circuit. You can also measure any ac supply voltage in

**KNOWLEDGE**  
What you don't know doesn't hurt you—  
until you find out someone else is getting  
paid for knowing what you don't.

the receiver, any resistor you are likely to encounter in service work, and many of the signal voltages in the receiver. In TV work a VTVM is especially valuable. In fact, it is almost a necessity, because no other instrument can be used to check voltages in many TV circuits without upsetting the operation of the circuit under test.

As you can see just from the examples given in this article, a VTVM is one of the most useful test instruments a serviceman can own. It will repay its cost many times over. Further information about the NRI Model 12 Vacuum Tube Voltmeter may be obtained by writing to NRI Supply Division, National Radio Institute, 3939 Wisconsin Avenue, Washington, D. C.

— n r i —

— n r i —

## THE ART OF FAILURE

He who hopes to avoid all failure and misfortune is trying to live in a fairyland; the wise man realistically accepts failures as a part of life and builds a philosophy to meet them and make the most of them.

He lives on the principle of "nothing attempted, nothing gained," and is resolved that if he fails, he is going to fail while trying to succeed.

He does not set for himself the impossible ideal of always being successful. He does

the best he can and then with a serene spirit accepts what comes.

He finds courage in the pages of biography which indicate that our greatest men failed many times. For instance, Louis Pasteur was described as a "scientific Phoenix who arose triumphant from the ashes of his own mistakes."

He recognizes that, although he cannot always control what happens to him, he can always control how he responds to his failures.

Wilfred A. Peterson

**NRI NEWS**

3939 Wisconsin Ave.  
Washington, D. C.

Forwarding Postage Guaranteed

Mr. Lester N. Rodgers  
3 Sadsury Ave.  
Christiana, Penna.

E30-D332-G

4A

Second-class mail  
privileges authorized  
at Washington, D. C.