

National RADIO-TV NEWS



IN THIS ISSUE

Analysis of the Tele-Tone Model 165 Radio Receiver

How to Build Your Own Etched-Circuit Radio

NRI Alumni Association News

June-July
1955

VOL. 16
No. 9



Tomorrow Never Comes

I have long felt that the fellow who coined the phrase, "Don't put off 'til tomorrow what you can do today," was one of the world's wisest men, for as a sure-fire formula for success he certainly hit the nail on the head.

It has occurred to me that perhaps NRI men may sometimes wonder why I repeat this warning so often, this warning not to "put off." It is simply because of all the reasons for failure, this is, I am firmly convinced, the greatest—and one that we must continually be on our guard against.

Sure, we can always find a good excuse. We can easily convince ourselves that we are too tired or that we don't feel well, or that it's too hot, or that we have too much to do, or use any of the thousand-and-one reasons to justify our not working *now*—or *today*. But the *reason* is not important. The fact that we are "putting off" is important.

This "putting off" is simply a habit, an attitude that, too oft-repeated, becomes a *fixed* state of mind. First you start by one day saying, "Oh, I don't *have* to do this or do that today. I'll do it tomorrow." A week later you'll say the same thing—and a little while after that you'll repeat the process. Soon, from habit, you'll promise yourself *every day* to do it "tomorrow"—and before long, "tomorrow" won't mean "the next day," but will really mean a day that will never come.

Everyone who ever undertook anything has been faced with this temptation to "do it later," or "some other time." Whether he was eventually a success or a failure, depends on whether the temptation was too much for him or whether he was too much for the temptation. Certainly it would be impossible for an individual to "arrive" unless he was of the latter class, regardless of what other conditions might be necessary for success.

The best—in fact, the only way—to master this temptation is never to succumb to it. The first time you find yourself saying, "Why bother with studying tonight—I'll skip tonight and do twice as much tomorrow evening," that is the very time to go right after your lessons and study twice as hard as you ordinarily would. Soon you'll find you no longer have to fight temptation; it will no longer exist; it just won't ever occur to you to say, "I'll do it tomorrow." Instead, you will find yourself automatically saying, "I'll do it *now*," and actually *doing* it.

J. E. SMITH,
President

Analysis of the Tele-Tone Model 165 Radio Receiver

By J. B. STRAUGHN
Chief, NRI Consultation Service

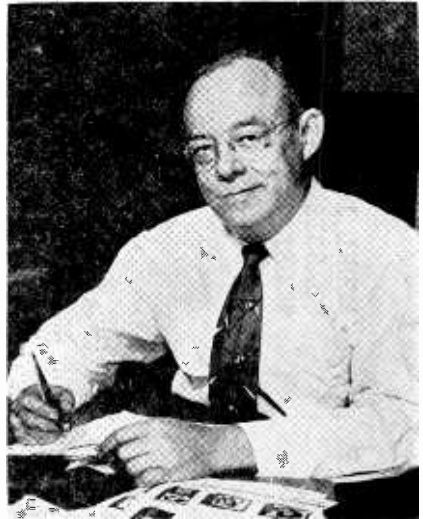

J. B. Straughn

THIS article is primarily written for beginners, to aid them in understanding receiver circuit actions. However, it represents an excellent opportunity for advanced students and graduates to review circuit analysis and to learn the ins and outs of a receiver typical of many they will service.

General Description

The TeleTone Model 165, chassis AD, is a 4-tube, ac-dc operated, superheterodyne receiver. It uses a 12BE6 tube as a mixer oscillator, a 12AT6 as a combination avc, second detector and first audio tube, a 50B5 as the power output tube, and a 35W4 rectifier.

An examination of the schematic diagram on page 4 shows that the receiver is unique in that it does not use a stage of i-f amplification. Modifications of this sort in superheterodyne circuits are fairly common in inexpensive receivers. The receiver gain is limited, but reception of local stations is satisfactory and the selectivity is adequate, being far better than could be obtained with a TRF receiver using two or even three stages of rf amplification.



Courtesy Tele-Tone Radio Corp.

Signal Circuits

Signals picked up by the antenna cause a current to flow through the primary of the antenna transformer marked LA-5 in the diagram. By mutual induction a voltage will be induced into the secondary, and only the signal tuned in will undergo resonant step-up. The resonant circuit consists of the secondary, tuning condenser C10

and the two series bypass condensers marked C4, between the lower end of the secondary and the chassis to which the tuning condenser connects. The size of these condensers is so large that they have no effect on the tuning.

The signal is applied to the control grid and the cathode of the 12BE6 tube, the cathode connection being through the oscillator feedback coil and bypass condenser C4.

The oscillator is of the tuned grid, cathode feedback type. The cathode current flowing through the feedback coil induces a voltage into the tuned circuit and this circuit is coupled to the oscillator grid capacitively through the small

TELE-TONE RADIO CORP.

MODEL 165 Early,
CHASSIS AD
MODEL 148,
CHASSIS S

MODEL 165 Early

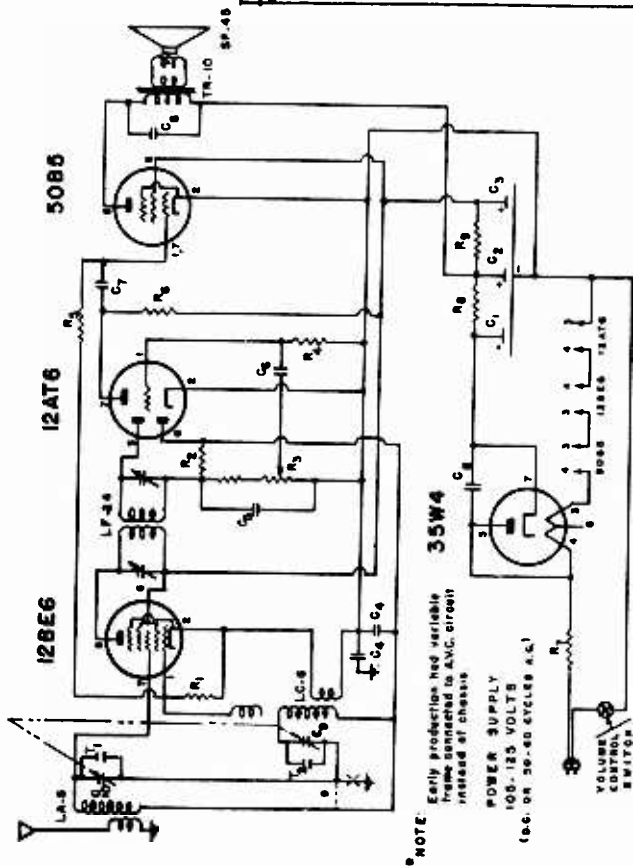

NOTE: Early production had variable frame connected to AVC circuit instead of chassis

POWER SUPPLY
100-125 VOLTS
(e.g. ON 50-60 CYCLES A.C.)

VOLUME CONTROL SWITCH

I.F. 455 K.C.

FREQ. RANGE - 1620 KC. - 532.5 KC.
ALIGN 1/2 - 1620 KC.
T₁ - 1400 KC.
TRACK - 600 K.C.

ITEM	DESCRIPTION	PT. NO.
T ₁	5X20 MFD 150 VOLT ELECTROLYTIC	CE-11
C ₂	.05 MFD. 200 VOLT PAPER COND.	CP-503-4
C ₄	.00015 MFD. 500 VOLT MICA COND.	CM-131-1
C ₅	.002 MFD. 400 VOLT PAPER COND.	CP-208-2
C ₇	.005 MFD. 200 VOLT PAPER COND.	CP-508-3
C ₈	.02 MFD. 400 VOLT PAPER COND.	CP-203-1
LA-5	ANTENNA COIL	LA-5
LC-8	OSCILLATOR COIL	LC-8
LF-24	I.F. TRANSFORMER	LF-24
R ₁	22,000 OHMS 1/2 W. RESISTOR	RC-223-2
R ₂	4.7 MEG OHMS 1/2 W. RESISTOR	RC-475-1
R ₃	2 MEG. VOL. CONTROL-100K STOP	VC-11
R ₄	10 MEG. OHMS 1/2 W. RESISTOR	RC-108-1
R ₅	330,000 OHMS 1/2 W. RESISTOR	RC-334-1
R ₆	220,000 OHMS 1/2 W. RESISTOR	RC-224-1
R ₇	33 OHMS 2 W. WIREWRES.	RW-330-9
R ₈	120 OHMS 1/2 W. RESISTOR	RC-121-2
R ₉	1500 OHMS 1/2 W. RESISTOR	RC-152-1
SP-45	SPEAKER	SP-45
TR-10	OUTPUT TRANSFORMER	TR-10
C ₉	VARIABLE CONDENSER	
T ₁ , T ₂	TRIMMERS	CV-14

CHASSIS SERIES 'AD'

Courtesy Tele-Tone Radio Corp.

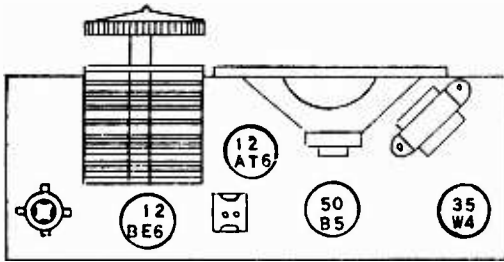

Remove back to replace tubes.

coil, shown connected to grid pin #1 and adjacent to the tuned circuit. Actually this capacity consists of several turns of wire around the top of the tuned coil. The action, however, is to give capacity coupling and there is no appreciable inductive effect. The resulting variations in oscillator grid voltage cause further changes in the cathode current and in this way oscillation is maintained. Bias for the oscillator tube is developed across resistor R1 when grid current flows through the resistor.

The incoming and oscillator signals are mixed inside the tube and the resultant 455-kc beat develops a large voltage at this frequency across the primary of the i-f transformer, which acts as a parallel-resonant circuit. Signals at off-resonant frequencies encounter a low reactance path and little voltage is developed across the i-f primary at frequencies above or below 455 kc. A voltage is induced into the secondary, which is tuned to the same frequency as the primary, and resonant step-up occurs, a large signal at 455 kc being developed across the entire secondary. This is applied to diode plate 5 and to the cathode of the 12AT6 through by-pass condenser C5. When the applied signal makes diode plate 5 positive, current flows from the cathode, to this diode plate, through the secondary of the transformer, through the volume control and back to the cathode of the tube. When the voltage reverses in polarity and diode plate 5 is negative there is no current flow. Thus rectification occurs in this circuit and we have the audio modulation of the signal appearing across the volume control.

The dc component, of the detected signal, is filtered by R2 and C4, so pure dc may be applied to the control grid of the 12BE6 as an avc voltage. As the signal strength increases, the avc voltage also increases, thus preventing overloading of the 12BE6 by reducing its gain. When the signal decreases in strength there is less avc voltage available for application to the control grid of the 12BE6 and the gain in this stage goes up.

Tube Pin Voltages

Pin No.	12BE6	12AT6	50B5	35W4
1	-5VDC	-5VDC	-1.4VDC	0V
2	0V	0V	0V	0V
3	25VAC	0V	25VAC	75VAC
4	12VAC	12VAC	75VAC	117VAC
5	90VDC	-.6VDC	105VDC	117VAC
6	90VDC	-.6VDC	90VDC	108VAC
7	-.6VDC	50VDC	-1.4VDC	120VDC

Note, the direct connection of diode plate 6 to the avc network. This diode plate and the cathode of the 12AT6 function as a gas gate. If the 12BE6 tube becomes gassy there will be current flow in the control grid circuit and this current passing through resistor R2 and the diode load (consisting of volume control R3) will develop a voltage which makes the control grid of the 12BE6 positive. Continued application of a positive voltage to the 12BE6 aggravates the gas condition and will soon wear out the cathode since it will be bombarded by heavy gas ions.

As soon as a positive potential appears, diode plate 6 and the cathode of the 12AT6 tube become conductive, effectively maintaining the control grid of the 12BE6 at the potential of the diode load. Thus the tube still has the correct bias, and will continue to operate for a long time. Of course diode plate 6 does not conduct when it is negative with respect to its cathode. This is the normal condition.

By turning the knob which adjusts the slider of volume control R3 any amount of the available audio signal across the control can be transferred through coupling condenser C6 and will appear across grid resistor R4. In this way the signal is applied between the control grid and cathode of the 12AT6. The audio signal is amplified by this section of the tube, which functions as a high gain triode, and the amplified signal appears across plate load resistor R6. The signal across R6 is applied to the control grid and cathode of the 50B5 through coupling condenser C7 and output filter condenser C3.

The application of the varying audio signal to the grid-cathode of the 50B5 results in a large release of power at the audio frequency in the plate circuit. This large audio current flowing through the primary of the output transformer induces a voltage into the secondary. The resulting current flow through the voice coil of the PM speaker causes the voice coil and attached cone to move back and forth, thus producing sound waves.

SIGNAL GENERATOR				SETTING TUNER	ADJUST TRIMMERS TO MAXIMUM OUTPUT (in order shown)
Frequency	Coupling Factor	Connection to Receiver	Ground Connection		
455 kc	.1 mfd	12BE6 Grid	B—	Rotor full open (Plates out of mesh)	Input and output trimmers on IF cans
1620 kc	.1 mfd	12BE6 Grid	B—	Rotor full open (Plates out of mesh)	Oscillator trimmer T2
1400 kc	75 mmf	Hank	B—	1400 kc	Antenna trimmer T1

Tracing Supply Circuits

We have already shown how the oscillator bias is developed and how avc voltage is applied to the control grid of the 12BE6 tube.

Looking again at this circuit, you will see that the plate and screen grid of the 12BE6 tube receive their positive potential from the cathode of the rectifier, through filter resistors R9 and R8. These resistors act in conjunction with electrolytic condensers C1, C2 and C3 to deliver a steady dc voltage to the tube electrodes.

You will note that the cathode of the 12AT6 tube connects directly to B— as does the control grid, through resistor R4. This is a 10-megohm resistor and some of the electrons which would normally reach the plate strike the control grid wires and are trapped there. The electrons flow through resistor R4 back to the cathode. In doing so they "develop" a voltage drop across R4 which makes the control grid negative with respect to the cathode.

The plate of the 12AT6 is supplied in much the same manner as the plate and screen of the 12BE6, the connections being through plate load resistor R6 and filter resistors R9 and R8.

An odd method of biasing the 50B5 is employed. Note that the bias voltage for the oscillator section of the 12BE6 is developed across R1. However, R1 is in series with grid resistor R5 of the 50B5 tube. Therefore any dc voltage across resistor R1 is applied between the cathode and control grid of the 50B5. The bias developed across R1 is approximately correct for the 50B5 tube. This saves the price of a cathode resistor and an electrolytic condenser which would normally be used for cathode by-pass purposes.

Note that the screen of the 50B5 is supplied with dc from the cathode of the rectifier through filter resistors R8 and R9. The plate, however, is supplied through the primary of the output transformer and resistor R8. Slightly more ac ripple voltage is present across electrolytic filter condenser C2 than across C3. However, the plate is fairly insensitive to variations in voltage and this does not result in hum in the re-

ceiver. Furthermore, because the plate current of the tube does not flow through R9 a large voltage drop does not occur across R9 and more voltage is available for the other tube electrodes. Degeneration is not introduced into the 50B5 circuit and this makes R8 and C1 necessary. If degeneration were present, the B+ lead of the output transformer could be fed directly from the cathode of the 35W5 without prior filtering.

The balance of the power supply is typical of that found in the usual ac dc receiver. The 35W4 functions as a half-wave rectifier. Note, however, that the filaments of the mixer, second detector and power output tubes are not drawn in the circuit. Instead the connections to the filament leads are numbered according to the filament pins. You must, in this case, imagine that the filaments are present, as they are in the actual receiver, so you can visualize the current flow through the entire filament string.

Resistor R7 is in both the filament string and the plate circuit of the 35W4. This resistor is not required to limit the filament current but it does serve to limit the plate current of the rectifier tube. If the set is turned off, condenser C1 will rapidly discharge, while the cathode of the rectifier may remain hot. If the set is then turned on, at the moment when the ac line is at a peak that makes the plate highly positive, there could be a damaging flow of current through the tube in charging condenser C1. However, the presence of resistor R7 limits this current so that no damage to the tube results.

Notice by-pass condenser C8 connected between the plate and cathode of the rectifier tube. It would be more usual to place this condenser directly across the power line since its purpose is to prevent signals entering the power line from reaching the receiver circuits. It is, of course, just as effective when connected as shown in the schematic because the rf path to the other side of the power line is completed through C1.

Alignment

The alignment procedure (top of page six) contains full information on adjusting the tuned circuits with a signal generator. Note, that as

in all superheterodynes, the i-f is first aligned and the oscillator and antenna trimmers are next adjusted. Since there is no low frequency padder condenser, this completes the alignment.

An output meter may be used if desired (either an ac voltmeter connected across the voice coil or a high resistance dc voltmeter connected across the volume control). In either case the adjustments are made for maximum voltage.

In the alignment procedure you will note capacity values listed under "coupling factor." This simply indicates that a condenser of the specified size be placed in series with the hot lead of the signal generator and the connection point in the receiver.

When aligning at 1400 kc, you will note that the connection to the receiver is specified as being made to the "Hank". The Hank is simply the long wire connected to the primary of the antenna transformer.

You will also note in the heading, "Adjust Trimmers to Maximum Output", that for the i-f, it is specified the input and output trimmers on the i-f can be adjusted. This, of course, is a misprint as there is only one i-f can (i-f transformer shield) in the receiver. This point is made because it shows you must be alert and must not be confused by obvious misstatements in service data.

The oscillator and antenna trimmers are mounted right on the sections of the condenser gang with which they are used. You may distinguish between the oscillator and antenna trimmers easily because the rotor (movable) plates of the oscillator gang section on which the oscillator trimmer is mounted will be considerably smaller than those of the rf gang section.

The dc operating voltages are given in chart form. These voltages should be measured from the pins indicated to B— which may be taken as the set side of the on-off switch or any other easily identifiable point connected thereto. The negative leads of the electrolytic filter condensers would be a B— point, easy to identify, because of the size of the condensers. Also you could use pin 2 of the 50B5 or pin 2 of the 12AT6. The B— lead of the volume control could, in addition, be found without difficulty.

If a relatively low resistance voltmeter, such as a 20,000 ohm-per-volt unit, were used instead of a vacuum tube voltmeter some of the measured voltages would be less than those shown in the chart. This is particularly true in the case of the control grid voltage of the 50B5. A low resistance meter connected between the control grid and cathode of this tube would draw considerable current through resistor R5 and the resulting drop across it would be subtracted from the

actual voltage. When the meter is removed from the circuit, current is no longer drawn through R5 and the entire voltage across R1 is applied between the 50B5 control grid and cathode.

Also the connection of a low resistance meter between pin 1 of the 12AT6 and B— would reduce the resistance in the control grid circuit and lower the voltage while the meter was connected. A slight decrease from the voltage given in the chart would result when you measured the plate-to-cathode voltage of the 12AT6. However, when using such an instrument the serviceman soon becomes used to its action as a load on the circuit and automatically discounts such variations in readings.

Continuity Tests

Complete continuity tests, and for that matter complete voltage measurements, are not made by experienced servicemen. The nature of the complaint plus previous experience will lead them to one particular stage where they may make voltage measurements. If the voltage measurements indicate trouble in the circuit, continuity tests will be made. Of course there are some voltage measurements which might not show up troubles that could be located with an ohmmeter. For example, you would find normal plate voltage on the 12BE6 with the primary of the i-f transformer shorted. However, a check with the ohmmeter between the plate and screen grid would indicate the presence of a short. Normally you should measure about 20 or 30 ohms between these points—the dc resistance of the i-f transformer primary.

As in all other receivers, those tube electrodes receiving a positive potential should have continuity to the cathode of the rectifier. Thus, with one ohmmeter test probe attached to the cathode of the rectifier (the receiver must, of course, be turned off when making ohmmeter measurements) the other ohmmeter test probe may be touched to the plate and screen of the 12BE6, the plate of the 12AT6 and the plate and screen of the 50B5. By looking at the diagram you can see what resistance readings should be observed.

In the case of the 12BE6 the plate-to-cathode resistance will be equal to the sum of the resistances of the i-f transformer primary and resistors R9 and R8. Of course, if the primary of the i-f transformer is shorted the resistance will be about the same as when the primary is in good condition. This is due to the fact that the resistance of the primary is so small when compared to that of resistors R8 and R9. Where you suspect a shorted primary you would check directly between the screen and plate. The resistance from the plate of the 12AT6 to the rectifier cathode would mainly be governed by the value of R6 and would actually be equal to R6, plus R8, plus R9.

The resistance between the screen of the 50B5 and the cathode of the rectifier would be equal to R8+R9 while between the plate of the 50B5 and the rectifier cathode we would measure the resistance of the primary of the output transformer—about 500 ohms—plus the value of R8.

Those tube electrodes receiving a negative or zero potential should show continuity to B— which, as we have said before, is the set side of the on-off switch. Checking from pin 1 of the 12BE6 we would measure the resistance of R1 plus the feedback winding on the oscillator coil. Between pin 7 of the 12BE6 and B— we would measure the resistance of the secondary of the antenna coil plus R2, plus the value of the volume control. 10 megohms, the value of R4, should be measured between pin 1 of the 12AT6 and B—. The resistance between the control grid of the 50B5 and B— should be equal to that between pin 1 of the 12BE6 and B— plus the value of resistor R5.

Expected Performance

In examining the schematic of the receiver we would not expect a great deal in the way of tone quality, since the set has obviously been manufactured to sell at a low price. This means that a small speaker would be used and due to the lack of degeneration in the 50B5 circuit some non-linearity in this tube would be expected. However, the tone quality should be adequate.

The lack of a stage of i-f amplification means that the sensitivity of the receiver is not great. Its ability to bring in distant stations would be strictly limited and sets of this type would only find a ready market where there were a number of local stations.

Since the receiver is a superheterodyne the selectivity would be entirely satisfactory. Local stations are always separated enough in frequency so that a superheterodyne receiver with only one i-f transformer will not experience interference between local stations.

However, the receiver will not provide separation between stations 10 kc apart and consequently strong stations on adjacent channels may interfere. However, one of the stations is likely to be a semi-distant station and its signal strength may be low enough with respect to the nearby station so reception from the latter is satisfactory.

While the sensitivity of the receiver will not be great, volume on local stations will be sufficiently loud for all home listening purposes.

Servicing Hints

In any ac-dc receiver the majority of service complaints are due to tubes with burned-out filaments. When a tube has an open filament, none

of the tubes in the receiver will light and the set, of course, will be dead.

The next most common cause of trouble lies in defective electrolytic condensers. These condensers may develop a high power factor, may lose capacity or become open or may become leaky. In the latter case the receiver will be either very weak or quite dead. If condenser C2 shorts, resistor R8 may burn out. If condenser C1 becomes shorted, the rectifier tube may be ruined or resistor R7, in series with the plate of the rectifier tube, may open, due to excess current flow through it.

If leakage or a short develops in output filter condenser C3 the receiver will be dead because of reduced plate voltages and resistors R8, R9 and R7 may burn out. The chances are, however, that these resistors will simply overheat since their combined resistance is large enough to limit the flow of current to a safe value, if C3 is only partially shorted.

If condenser C1 loses capacity, opens, or develops a high power factor, the dc operating voltages will be reduced markedly and the receiver will be dead or extremely weak. On the other hand, an open, loss of capacity or high power factor in condenser C2 would result in considerable ac ripple voltage appearing at this point and being applied to the plate of the 50B5. Although the plate of the tube is remarkably insensitive to voltage variations, enough ac ripple at this point would cause ripple current to flow through the primary of the transformer. As a result, hum would be reproduced by the loudspeaker.

An open, loss in capacity or high power factor, in condenser C3 would definitely result in hum, and, since this condenser is also a plate bypass for the 12BE6 and 12AT6 tubes, oscillation might result.

When you suspect any of these condensers of being open, you may check them quickly by shunting them with other condensers of about the same size known to be in good condition. If the trouble clears up, when you connect across some condenser, that one is definitely defective and should be replaced. It is not wise to connect a discharged test condenser directly in parallel with C1 since too much current might be drawn through the rectifier tube. First touch the positive lead of your test condenser to the positive lead of C3 or C2. The test condenser will be charged through the series resistors. While the condenser is charged you may safely connect it across the leads of C1 to check the condition of C1. Observe polarity markings when using test condensers. The *positive* lead of the test condenser goes to the *positive* lead of the condenser in the set.

When a short or leakage is present in one of these filter condensers, nothing will happen if you shunt them with other condensers. To make a check for leakage or a short it is necessary to unsolder the positive lead of the suspected condenser and connect your ohmmeter across its positive and negative leads. The ohmmeter reading should be in excess of 100,000 ohms. If the reading is less than this, too much leakage exists and the condenser should be replaced.

In the case of hum, you would, of course, check the electrolytic condensers individually for an open as previously described. However, shorts and leakage sometimes exist between the positive plates of the condensers. This would tend to by-pass the filtering effect of resistors R8 and R9. You cannot make a check with an ohmmeter and locate such trouble. Where it is suspected, disconnect the positive leads of all three condensers and temporarily substitute new condensers.

Another difficulty in tubular-cased electrolytic condensers arises from the fact that leakage may take place between the condensers and the metal mounting strap which surrounds the condenser case and which is riveted to the chassis. You can work the condenser through the strap until the portion formerly under the strap is exposed. If any green corroded spots are noted on the condenser case, leakage was present. The condenser may work very well when it is pushed through the strap so the leakage path is opened, but eventually it will go bad, so in such a case replacement is indicated.

Distortion is a frequent complaint in small compact receivers. The heat existing in the chassis often causes leakage in the various paper condensers. If condenser C7 becomes leaky, some of the plate voltage of the 12AT6 tube will be transferred to the control grid of the 50B5, reducing the net negative voltage between the control grid and cathode of this tube. As a result the tube no longer works on the straight part of its Eg- I_p curve and distortion becomes evident or the receiver may go dead due to oscillator failure. This would be due to the connection of R5 to the oscillator control grid. In receivers using a different type circuit, the oscillator operation would not be affected. Gas in the 50B5 will give the same effect as leakage in coupling condenser C7. It is very easy to check for these two defects with a dc voltmeter. Connect your dc voltmeter across grid resistor R5 so the positive meter probe goes to the control grid of the 50B5. Normally you should not measure any voltage. If you do, disconnect condenser C7. If the voltage drops to zero, C7 was leaky. If the voltage remains unchanged, the 50B5 is gassy. If there is a decrease but some voltage is still present with C7 disconnected you have a condition of gas in the 50B5, as well as leakage

in condenser C7. Both the condenser and tube, in this case, should be replaced.

Frequently in ac-dc receivers you will notice symptoms that indicate a short in the B supply exists, yet a check across the filter condensers shows that no short is present. Such a condition, if not caused by a short, is the result of excess current being drawn by the 50B5. This may be due to gas in the tube or leakage in coupling condenser C7. Note, however, that the oscillator grid voltage of the 12BE6 biases the 50B5. Any defect in the oscillator circuit which stops oscillation will remove the bias from the 50B5 and cause it to draw excess plate current. Where a circuit of this sort is used, you may check the oscillator by measuring the dc voltage across resistor R1, the negative probe of your voltmeter going to the grid end of R1.

You will normally measure between 5 and 15 volts dc across this resistor. If no voltage is measured, the oscillator is not functioning. If you measure a small voltage and are still uncertain of the oscillator condition, actually stop the oscillator by shorting the oscillator tuning condenser. If the dc voltage across R1 is still present or does not decrease appreciably you know that it was not due to oscillator drive on the grid of the tube. However, if the voltage drops when you short the oscillator tuning condenser, the oscillator was working.

Causes for oscillator failure may be due to cathode-to-heater leakage in the 12BE6. If such leakage exists the feedback coil will be partially shorted and, of course, no oscillator voltage will be induced into the tuned circuit.

You should also be on the lookout for a short in the tuning condenser gang and for an open in the windings on the oscillator coil. In those cases where everything seems to test all right, the trouble is probably due to low Q in the oscillator coil, caused by moisture absorption. Since a serviceman does not usually have the means of checking the Q of coils, you would in this case install a replacement oscillator coil. Naturally you would try to get an exact duplicate from the manufacturer or his distributor. If one is not readily available, the thing to do is to install a universal replacement oscillator coil. These may be obtained from any Parts Supply House and come complete with instructions for their installation and adjustment. There is one point, however, which should be brought out. The small capacity winding which connects to pin 1 of the 12BE6 will not be found in most universal replacement coils. After installing the universal replacement oscillator coil, connect a condenser having a capacity of about 50 mmf to the end of the coil, which goes to the stator of the tuning condenser, and to pin 1 of the 12BE6. This condenser replaces the capacity winding in the original circuit and satisfactory results will be obtained.

TROUBLESHOOTING THE TV SET OWNER

You May Be a Sensation With Sick Sets—
But How Do You Rate On Handling People?

By M. E. WIRT

Reprinted by permission from TECHNICIAN & Circuit Digests, February, 1955. Copyright Caldwell-Clements, Inc., 480 Lexington Ave., New York 17, N. Y.



WE'VE all heard of the surly, grouchy genius who is a whiz at servicing, but is completely independent as to when he will condescend to lend his touch to a service call, and who, nevertheless, is swamped with demands. According to reports, customers will stand for his insults and verbal abuse willingly, in order to have his magnificent skill brought to bear on their set. *This simply isn't true.* Many a technician with only fair skill is making a good living simply because he knows how to get along with people. And many an expert is wondering when things will pick up for him, without giving a thought to the question of why the customer always calls someone else the next time. Advertising plays an important role in securing a fair share of business, but the best advertisement possible is the technician himself.

It goes without saying that cleanliness, good manners, and courtesy are *musts*; no elaboration is necessary. However, although the technician is there to render a service, he is still in the position of a salesman, with only his future service to sell. Because of this, many of the rules of selling may be adapted to TV servicing in general.

Let's get down to facts and situations. When a service call is made, regardless of how explicit the service order may be as to the customer's complaint, *always* ask for symptoms. Listen carefully, look interested, and no matter how weird the explanation, don't make any disparaging remarks. Don't laugh at what the customer is saying, unless he is making an obvious attempt at humor. Don't say, "What's wrong with your set?" You're leaving yourself open for any one

of several remarks such as, "That's what I called you for." Instead, ask, "How does the set act?"

The request for symptoms serves two purposes. First, it gives you the chance to make a tentative diagnosis before turning the set on, in case there is a short or an arc. The service order may be wrong, since in many cases, the call has been taken by a person who is no more familiar with the set than the customer.

Second, and equally important from a psychological standpoint, it gives the customer a chance to unload all the pent-up gripe he has been harboring against the set for having gone out before, or during, his favorite program. Don't forget, too, if it's your first call on this particular customer, that he may have had previous service by another technician who left him with a feeling of dissatisfaction; and he'll probably say so. Don't make the same mistake as the other guy! Listen to the customer's comments. Don't make any derogatory remarks concerning work done before your call. The customer will be much easier to handle after he has "gotten it off his chest." Ever watch a doctor listen to a patient's symptoms?

Show Confidence

Next, without being obvious about it, and while the customer is talking, visually locate the off-on switch, volume control, etc. With an unfamiliar set it makes a show of confidence much easier if you don't have to hunt for the various controls. When the trouble shows up, regardless of how uncertain you may feel, or how much it may look like a long, tough job, remove the back with speed and dispatch, and make your

TELEVISION SERVICE ORDER

No. [REDACTED]

Name *Mr.* [REDACTED]

Date [REDACTED]

Address [REDACTED]

Phone [REDACTED]

C.O.D. CHARGE NO CHARGE		MAKE	MODEL	SERIAL NO.	DEALER
<input checked="" type="checkbox"/>		[REDACTED]	[REDACTED]		
WARRANTY YES	BROUGHT IN NO.	PICKED UP	CALL TAKEN BY	SERVICEMAN	RECEIPT NO.
			[REDACTED]	<i>Wint</i>	
No Raster	Low Brightness	PARTS USED AND SERVICE PERFORMED			PRICE
No Picture	No Sound				
Intermittent Pix	Intermittent Sound	1- 6BQ7A Tube			3.50
Snowy Pix	Distorted Sound	1- 4CB6 "			2.15
Lacks Width	Lacks Height				
No Vert. Sync	No Hor. Sync				
No Vert. Sweep	Poor Focus				
SPECIAL INSTRUCTIONS:		<p><i>Analyze, replace intermittent RF amplifier tube, replace weak 3rd video IF amplifier, adjust horizontal centering, set vertical height midlinearity controls, center horizontal hold control action, remove safety glass & clean picture tube and glass, set H.G.C. control, repair noisy volume control.</i></p> <p><i>Thank You</i></p>			
<i>Check for noisy volume control</i>					
					
Terms are Cash on Completion.					
OUR GUARANTEE:					
<p>ALL work done and all parts installed are guaranteed for 90 days from date of completion. We do not guarantee the entire set, and breakdown of other components will be charged for at the regular rates, plus labor.</p>					
<p>SERVICE PERFORMED AND SET OPERATION AT FACTORY.</p>					
<p>CUSTOMER'S SIGNATURE X [REDACTED]</p>					
<p>DATE [REDACTED]</p>					
				PARTS TOTAL	5.65
				PARTS TAX	.17
				SERVICE CALL	5.00
				LABOR	
				TOTAL	10.82

tube substitutions the same way. Don't break your neck, and possibly a tube, by trying to rush. Just don't waste any time.

Be crisp and professional, and put a snap into whatever you do. Act confident. Chances are the customer doesn't know what circuit the trouble is in, which could be true of you, too—but don't let *him* know it. If you try the wrong tube, let the new one work for a few seconds before replacing the original; and during the course of your checks you might comment on how, in some

respects, your work resembles a detective's, requiring, as it does, a process of elimination.

Be sure you have whatever tubes, tools, etc., you may need tucked away in your kit. Carry a quick-heat soldering gun in your car, or truck, and a few assorted condensers and resistors. Many sets use selenium rectifiers, so carry at least a couple for replacement on those jobs way out in the country, where the cost of a shop repair would be prohibitive. Bring along some video detector crystals for the same reason.



Home Repair Headaches

The writer doesn't hold with the feeling that extensive repair work should be done in the home. Hot solder can burn a rug as well as make an electrical connection, and it's impossible to look dignified with the chassis on the floor and your caboose in the air.

Take elaborate pains with your tools, and placement of tubes and screws removed from the set; be careful of lamps or knick-knacks on top of the cabinet. Ask the customer to please remove them, adding a comment on the beauty or utility of one of the objects; but don't gush, or act as if you expect a "thank you."

If the trouble is intermittent, and doesn't show up, try to duplicate the symptoms described by the customer, manipulating one or more controls to get some understanding of the complaint. If the trouble fails to show within a reasonable length of time (20 minutes), make out your bill, adding a clearly visible notation to the effect that partial credit will be allowed for this visit on a future service call, when the set *does* break down. This is done, of course, to give the customer an incentive to ring you when the trouble shows up again. It will pay in the long run to be completely honest about the matter, too. Do whatever you said you'd do, without adding anything to the bill to make up for it.

You could, if the customer is a man, offer him a running explanation as to the cause of the trouble, and what you are doing to correct it, using terms that are as non-technical as possible. The inference is that he, being a brainy kind of guy, can readily understand what went wrong. The men often eat this up, look wise, and agree with anything you say. On the other hand, with a woman some statement like "Your trouble was caused by this tube" is usually sufficient. Don't try to "snow her under" with an exhibition of knowledge. She'll lose interest immediately.

In the majority of cases, your service call will be made while only the lady of the house is home. Probably 80% of the requests for service are made by a woman, and she is the one to whom your service and personality must appeal. By the same token, a woman is apt to be your best ad-

vertising medium in her neighborhood. Women appreciate a business-like attitude even more than the men, but a sincere compliment on furnishings, a vase or lamp, or the TV set itself, lets them know you approve of their taste, and they will remember you for it.

Common Questions

Many questions are asked concerning TV reception, various troubles the customer has had or heard of, and the possibility of future trouble in the set. These questions must be answered. However, never make a statement that you may be called upon to back up with a free call, such as "You won't have any more trouble now." *Nothing* can be predicted with certainty about any given TV set. New tubes installed may fail five minutes after you leave, or other components in the same circuit give up the ghost before you even get the chassis back in the cabinet, often with the same symptoms produced by the original fault. It's much wiser to tell the customer in advance that the cause of "no light on the screen" may be the fault of other tubes, including the picture tube, besides the one you've just installed. The tube you put in, of course, carries your standard guarantee, but a failure of any of the other tubes will be charged for at your regular service rate, plus parts. Softening the blow ahead of time in this way has saved the writer some terrific headaches. In fact, it often happens that people sell *themselves* on the idea that future trouble is a thing to be expected, and they may as well be resigned to it.

Some of the explanations used in answering the most frequently-asked questions are listed herewith. Variations, of course, may be used, and should be. Don't fall into the habit of making a pat answer to an often-heard question. It soon sounds mechanical and rehearsed, losing the effect intended.

Q. Why does my picture look snowy?

A. (We are assuming that a legitimate reason



for the "snow"—a fringe-area signal—is present.) What we call "snow" in a picture is electrical noise that is seen, rather than heard. It is produced mostly in the set itself (and the converter or booster, if used). This "snow" can only be hidden by a signal of sufficient strength. The more signal at the antenna, the less "snow" in the picture. If everything has been done to take advantage of every bit of signal available, and we still have "snow," the situation would be comparable to running an automobile on kerosene—the car will work, but it can't do its best.

Q. Why do I have so much trouble with this set? (They ask this one even when the set has required one call per year.)

A. The main cause of trouble in any TV set is "heat rise" in the set itself—in other words, high operating temperature. Sometimes, due to room arrangement, it's impossible to keep the receiver well-ventilated, and external heat contributes to high operating temperature. This may be due to heating in the home, or high summer temperatures may be responsible. Such heating, added to the normal heat rise in the set, may cause parts or tubes to break down. The surprising part is not that receiver components develop trouble, but that they work as well as they do under these conditions.

Q. I've only had this set 3 weeks (or 3 days, or 3 months). If it's giving trouble so soon, maybe I should get another set.

A. A TV set, like an automobile, has a "break-in" period. During shipment, tubes are jarred; after installation, a tube may quit working if any element has been jarred out of line. It's perfectly normal for this to happen, and almost invariably a set will develop at least one trouble during the first months of its operation. That's why a set carries a guarantee. Changing sets will only prolong the "break-in" time.

Q. Why did you put so many tubes in my set? It took only one to start it working again.

A. Well, you might call it preventive maintenance. I'm trained to recognize some troubles before they start, so I try to prevent your set from giving you trouble in the near future. This way you pay for only one call, instead of two or three.

The above questions cover a very small percentage of what you may be asked, but most of the others will bear some relationship to one or more of those listed. The main thing to remember and be guided by is that you want to instill a feeling of confidence and trust in yourself and your service.

Now, assuming that you have repaired the set, let us use a little more service psychology. For

instance, on sets that have a removable safety glass, remove it, and clean the picture tube and the glass. Do this with the set turned off, and have the glass back in place before turning it on again. Aside from the safety angle, the difference in picture clarity has a certain shock value that makes customers remember you.

Any screws left over should be dropped in your kit unobtrusively. Don't leave them about to arouse suspicion. Check for and tighten loose knobs. Re-adjust external controls wherever necessary; also touch up adjustments, if needed, like the ion trap, focus, fine tuning and oscillator slugs; center the external horizontal hold control to mid-range by using internal auxiliary con-

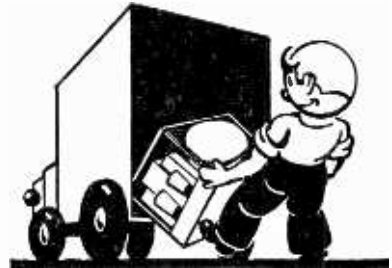

trols. Then step back and admire the set. A comment on how well it works is not out of place. Make the owner feel that he or she has something special. There is always at least one thing you can sincerely admire, thus implying a compliment on the owner's taste or judgment in picking the set. As a final touch, wipe off any finger prints with your polishing cloth. If the set is on the dusty side, however, don't let your actions show that you have spotted this fact.

Collection Techniques

The roughest part of most calls is presenting the bill. A bill for services is always hard to pay because the customer has no new acquisition to show for the money. Therein lies the reason for the extras you have just performed. The writer has had printed up an invoice like the one accompanying this article. Nowadays, similar ones are available which require only your own imprint, at less cost than a full printing job.

The invoice should list all parts and tubes used with their prices and an explanation of work performed. *The more items you can list, the less will seem the total charge in proportion.* Don't list anything you haven't done—but don't overlook minor adjustments and other details. Readjusting the horizontal oscillator, restoring a noisy control, setting height and linearity, refocusing, cleaning the pix tube and safety glass—all of these belong on the bill.

(Page 21, please)

How to Build Your Own Etched Circuit Radio Receiver

By LEO M. CONNER

NRI Consultant



Leo M. Conner

It has long been known that the greater part of the cost and time involved in the assembling of electronic or electrical equipment is found in the "hand wiring" of the circuits. The hand wiring operation is also the source of a high percentage of errors which make it necessary to add costly inspection procedures.

The elimination of hand wiring can result in a reduction of as much as 50% in production costs. This is not the only benefit because assemblies can be simplified and the actual assembly time shortened. Rejection of faulty assemblies would be minimized and the amount of inspection time would be reduced resulting in a more uniform product.

In the early days of radio one firm stamped leads from copper sheets and then riveted these leads to bakelite bases. This form of wiring was expensive and it never became popular.

Then, during the war, it became necessary to miniaturize equipment and to make it more shockproof. One item was the proximity fuse which was used in shells for anti-aircraft guns.

This fuse was composed of a small transmitter and receiver arranged so that the impulses from the transmitter were reflected back to the receiver by the target causing the shells to explode when it came within a specified distance of the target. In this manner shells coming within 75 feet or so of an aircraft would be exploded and the burst of shrapnel would score hits which otherwise would not be made.

Ordinary wiring would not be suitable for an application of this type because of its bulk and because the wiring might be torn loose by the rapid acceleration when the projectile was fired.

Scientists set to work on the problem and came up with what is known as a printed circuit. In this type of circuit a ceramic plate was used as the basic "chassis." The circuit was printed on this plate using conductive ink and then the circuit was electroplated to form the conductive leads. The process went one step further since resistors and condensers were printed in much the same manner as the circuit. However, it was difficult to control the amount of resistance produced in this manner and it was also very costly because it was necessary to grind the resistance by hand in order to get it to the desired value. It is easy to see why this particular method is not suited for the production of a large volume of items such as television or radio receivers.

Further experimentation showed that it was possible to bond a thin sheet of copper to a sheet of insulating material and then print the desired circuit pattern on the copper with acid resistant ink. The plate was then immersed in an etching solution and all of the copper which was not covered by ink was eaten away. Circuits prepared in this manner are known as "etched circuits."

After the unwanted copper has been removed by the etching process the acid resistant ink is removed leaving the copper foil in the desired metallic circuit pattern.

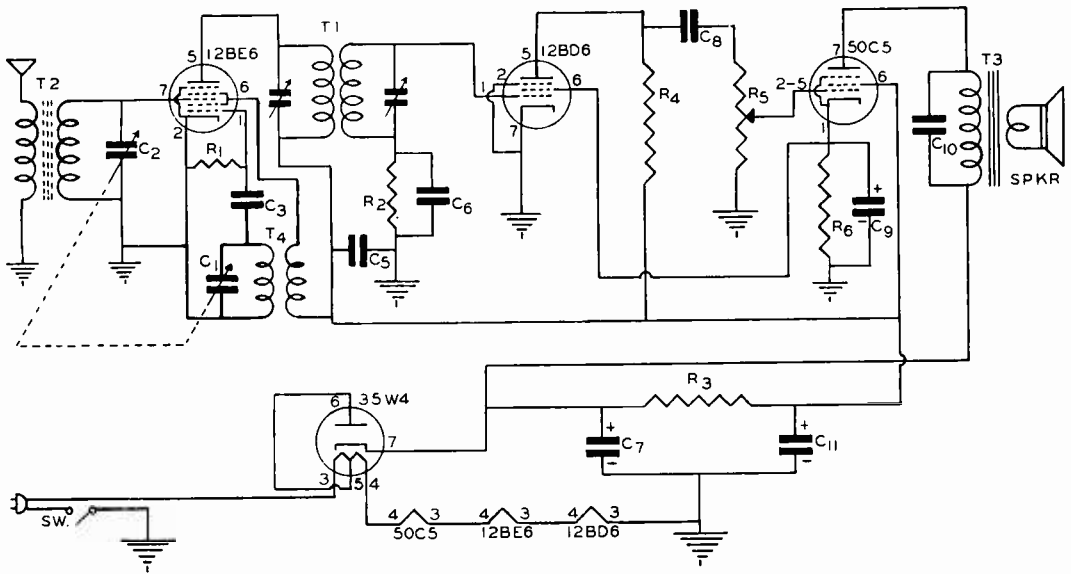

Fig. 1. This superheterodyne circuit, selected because of its simplicity, is used in the construction of the receiver described in this article.

Holes and slots are then punched at the proper points on the circuit. Following the punching operation parts are then assembled on the sheet, and as soon as the parts are soldered into the circuit the wiring is complete.

The latest techniques have many of the parts mounted on the plate by means of a machine and then the entire assembly is dipped into molten solder which solders all of the connections at one time. This process is known as "dip soldering."

It is possible, within certain limits, to print capacitors and inductance coils at the same time the circuit is printed. Such techniques are useful in TV antenna cross-over-networks, wave traps, filters, i-f transformers using a high frequency and radio frequency coils for TV channels.

Due to the great interest in the subject it was decided to see if it were possible to build a simple receiver, in a home workshop, using etched circuitry. The results show that it is possible and, if reasonable care is used, any one can etch the circuit and build the receiver described in this article.

The circuit shown in Figure 1 was selected because it contains few parts, is a simple basic circuit and because the original model which used conventional wiring, performed quite well. If you have some other circuit there is no reason why you should not use it. On the other hand, if you wish to build the receiver using a conventional chassis and conventional wiring there is

no reason why you should not do so.

The instructions which are to follow apply in the case of an etched circuit.

Drawing the Circuit

Once you have selected the circuit the next step should be to acquire *all of the parts*. This is most important because you will draw the circuit to fit the parts you will use and it is rather embarrassing to find, after you have etched the circuit, that the part is not available to fit your circuit.

While it is possible to draw a circuit free hand much better looking results will be obtained if conventional drawing equipment is used. A drawing board, T-square, 45 degree triangle and drawing instruments were used to make the circuit shown in this article. All of the illustrations were drawn with conventional drafting instruments. Figure 2 shows a full size outline circuit for the receiver and it is possible to remove the center page from this magazine and actually trace the pattern on the copper sheet from this drawing.

Conventional etched circuitry practice calls for making the original circuit drawing at least twice full size. It is easier to draw to twice full scale than to draw the circuit in its actual size. Then, the drawing is reduced photographically to the full size pattern. In this manner any errors are reduced by one-half in the finished circuit.

All of the connecting leads in this receiver are

one-sixteenth inch wide. This means that in the original drawing they would be drawn one-eighth inch wide for a twice full-size drawing.

The cheapest method of getting the drawing reduced photographically is by means of a photostat. However, it is necessary to be certain that the photostat lens do not distort the drawing. In other words, the half-size reduction must be the same in all dimensions. In one case the photostat machine reduction was perfect along one dimension and out one-quarter inch in four inches in the other dimension. A change in photostating establishments cured this particular trouble. However, some photostat paper shrinks more in one direction than the other so it would be well, if you use this means, to discuss the situation with the photostat operator.

The various connections for the parts should be accurately determined by measuring the part first. Make sure that there is room for the part to fit since it is rather easy to locate parts so that there is insufficient room for individual items. When a prepared circuit is used, the parts must have the same dimensions as the original parts.

Preparation of the Copper

The material used for the circuit work is known as Natural XXXP-26 Dilecto. It is one-sixteenth inch in thickness plus the .0035 inch copper coating.

The circuit that you have prepared is to be traced on the copper by using carbon paper between the drawing and the copper. However, before tracing, it is necessary to prepare the copper for etching.

As received from the mill, the copper is smooth and it is possible that it will be corroded. In order for the etching solution to get a good "bite" the surface of the copper must be roughened. This is done by scouring the copper vigorously with a small, stiff brush which has been wet and then dipped in powdered pumice stone. Put some pressure on the brush and roughen the surface until it appears quite scratched when you look at it through a magnifying glass. The tendency is to roughen the circuit too little rather than too much.

It is a good idea to rinse the board occasionally and examine the copper to see how the roughing process is coming along. When the surface has been roughened sufficiently, the pumice stone should be carefully rinsed and the board dried by placing it under a lamp or by drying it with an old towel. Be sure that it is completely dried before you go to the next step.

Tracing the Circuit

Carbon paper is used to transfer the pattern

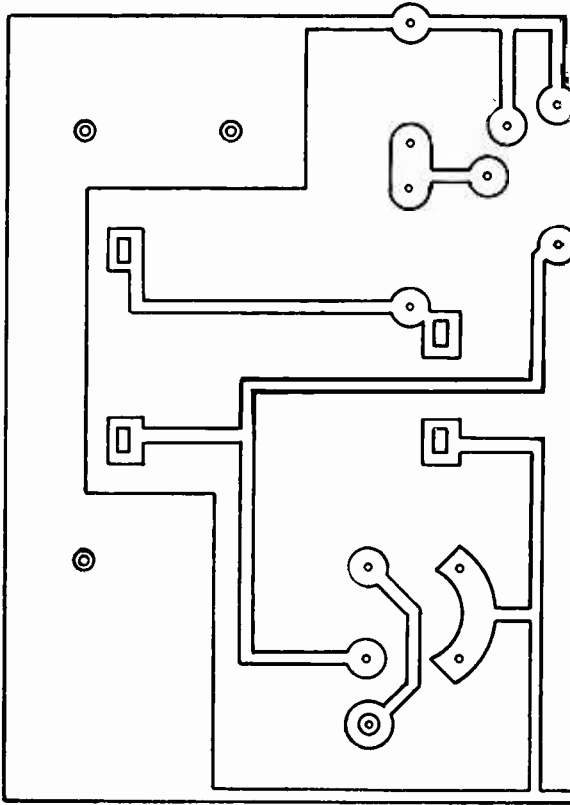

from the drawing to the copper foil. However, the ordinary typewriter carbon paper is not suitable. The proper carbon paper is the type known as "pencil carbon." It is soft to the touch and is coated on both sides. The carbon paper should be placed on the copper sheet after trimming the paper to the size of the sheet. The circuit which is to be traced is then placed on top of the carbon paper and the drawing, carbon paper and copper held firmly in the correct position with "scotch" tape. It is most important that the papers and copper do not change position while you are tracing since this would alter the position of some of the parts and make it difficult to get the proper mounting.

It has been found most convenient to use a sharp pointed 4H pencil in making the tracing.

Use a straight edge so that the lines will not be "wavy" and trace all of the horizontal marks first. Then trace in all of the vertical marks. After the vertical marks are traced, trace in any marks that are at an angle and finish up by tracing the circles. The small circles which are inside the larger circles and at other points in

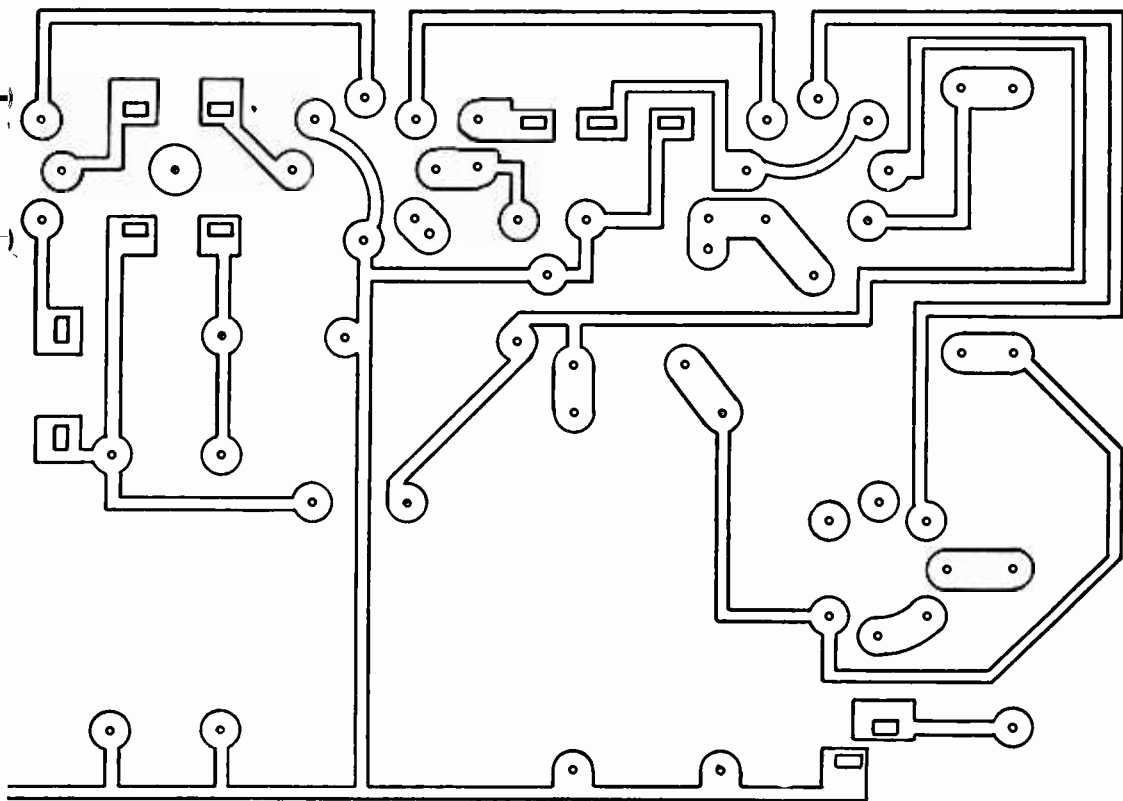

Fig. 2. An actual size outline drawing of the etched circuit used in this project. By removing pages 16 and 17 from this magazine you can trace the proper pattern on a copper sheet.

the wiring are centering marks so that the holes, which are to be drilled later, will appear in the proper positions.

If you care to do so, you can mark these hole center locations by using a sharp pointed tool and punching right through the tracing and the carbon paper into the copper. Hit the marking tool only hard enough to get the mark on the copper and be sure that you have the circuit board backed up with a solid board when you locate the holes.

When you remove the pattern lift it from one end leaving the other end fastened in position. You can then raise up the carbon paper and make certain that all of the marks have traced and that you have all of the hole centers located. If not, pull the pattern back down into its original position and refasten the end that you have just loosened. This will allow you to fill in the omissions without shifting the pattern positions.

After you are sure that all of the lines have been transferred to the copper it is ready for inking. The ink that is used is acid resistant and it may be applied with a small brush or regular ruling pen. The important thing is to completely cover all of the copper that is to be preserved. The sharpness of the finished lines will be determined by the sharpness of the ink work so considerable care should be used to get a smooth, even line. Be sure to fill in the punch marks on the copper because the acid will attack anything which is not covered by the ink. After the ink work is completed, dry the plate under a lamp. Then examine the plate for errors by comparing it to Figure 3. Any errors that are present may be removed with a hard eraser and the corrections made by re-inking the circuit to its correct form.

Etching the Circuit

The copper is etched with Ferric Chloride. This material is available in lump form or in liquid

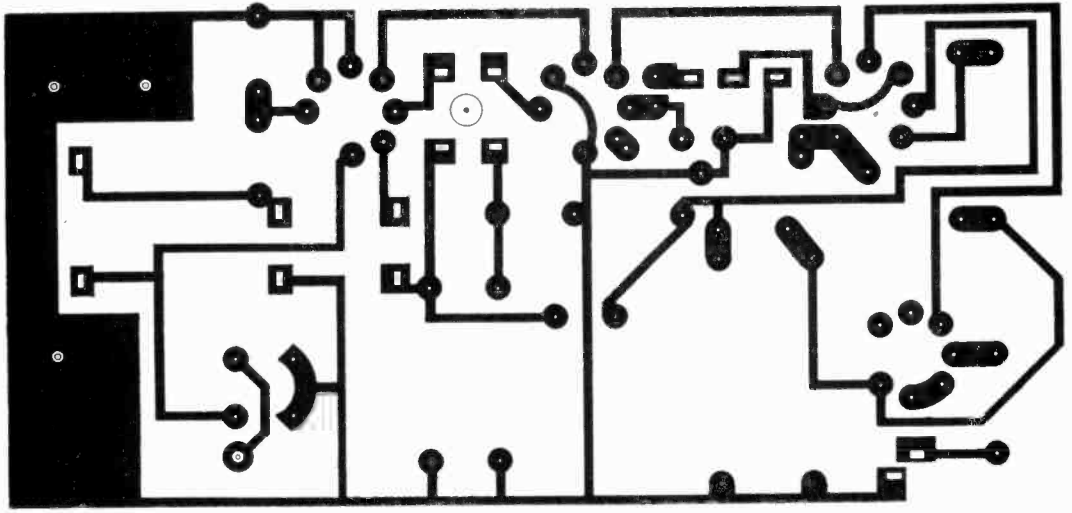

Fig. 3. This is the appearance of the drawing made on the copper sheet after ink work has been completed.

form, which is the easiest to use. It is used by commercial engravers and is known as 42% Ferric Chloride. In the original form the material is rather thick and it should be cut by adding water. One pint of water to one-half gallon of Ferric Chloride is about right.

The acid is "bitey" and it will sting if it gets on your skin. It is best to wear rubber gloves and old clothes as a matter of precaution. The acid should be placed in a glass or enamel pan which is slightly larger than the board that is to be etched. The etching action will be faster if the solution is warmed to about 120 degrees. One of the easiest ways to warm up the solution is to add hot water when the solution is thinned. When the solution is ready, place the board in the acid while wearing rubber gloves and then gently "rock" the board around so that the surface which is to be removed has acid running over it continuously. This agitation speeds up the etching process and only a few minutes will be required. The surplus copper should be gone in less than ten minutes. It is desirable to have the etching action as fast as possible in order to prevent the acid from attacking the ink surface. The copper will be removed if the board is simply placed in the solution and left for a half hour or so. However, this method is not so desirable because of the additional time will allow the ink to be attacked by the acid.

After the etching is completed, remove the board and rinse it with clear water. The board should then be dried under a lamp. After drying the ink should be removed from the copper with steel

wool or pumice stone. When the ink is completely removed, you are ready to drill and slot the board.

Drilling and Slotting the Board

The holes for the tube socket pins and the wire leads are first drilled with a No. 40 drill. The centering marks which you made with the punch before removing the pattern from the board are used as a guide. The No. 40 drill will not clear the tube socket pins and the No. 40 holes should be enlarged with a No. 45 drill. The No. 45 drill is also used to drill holes at the end of the slots which are used for the volume control connections, the tuning condenser connections, the i-f transformer connections and the oscillator transformer connections. The space in between the holes at the end of the slotted area is then removed with a small rat-tail file. By working carefully a good slot can be made in this manner. Be sure to carefully examine the board and see that all openings have been made before you start to mount any of the parts. It would also be well to make trial fits as you go along to make certain that the openings are in the correct positions.

Mounting the Parts

There are two wire jumpers used on the circuit board and these should be installed first. The first jumper provides a means of getting B+ across the lead which runs from the No. 7 pin of the 12BD6 tube socket to the common return lead which goes to the "bus" which serves to connect

all of the returns on the on-off switch terminal. This jumper is one-half inch long and a piece of push-back hookup wire should be used to make the jumper. Use a piece about one-inch long and push insulation from each end toward the center until the insulation is hunched up to approximately a one-half inch length. Then make sharp right angle bends in the bare wire and push the bare ends down through holes from the top side of the chassis. Cut off all but approximately one-eighth inch of the bare wire which sticks through on the etched side of the board and then bend these wire ends over sharply against the copper pattern. Use a 25-watt iron to solder because excessive heat will loosen the copper from the base. Of course, rosin core solder should be used.

The second jumper is used to bring the screen voltage for the 12BD6 tube from the cathode of the 50C5 tube. This jumper is approximately 1 and 7/16ths inches long and it should be prepared in the same manner as the short jumper. The connection is from the opening on pin 6 of the 12BD6 tube socket to the connection on pin 1 of the type 50C5 tube socket. Small ears project out from each of these points so that the connection can be made.

After you have the two jumpers in place mount all of the tube sockets. These are mounted by pushing the pins through the holes in the board from the top. The sharp points will stick out from the copper pattern and you need not bend them over. Solder the connections at pin 1 and pin 5 first while holding the board down firmly against the socket which should rest on your work surface. Then, solder pins 3 and 7 to tighten opposite points. The remaining connections to the tube socket can then be soldered in any convenient manner. Repeat this process at each tube socket.

Any order can be used to mount the remainder of the parts but it is easier if you save the coils and tuning condenser to the last. In mounting the volume control straighten the terminals so that they are lined up at a 90 degree angle to the volume control shaft. The control should then be held vertically and the connections soldered to the copper pattern. Excess lead can be trimmed off with diagonal cutters. Incidentally, when the circuit was drawn, the connections for the volume control were inadvertently reversed. Therefore, maximum volume occurs in the full counter-clockwise position of the control.

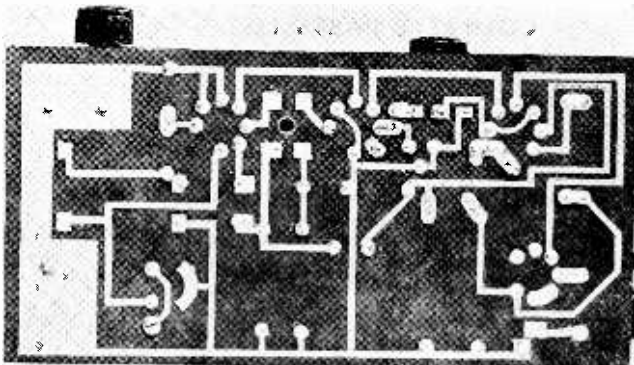

Fig. 4. A bottom view of the completed receiver, showing the etched circuit and soldered connections.

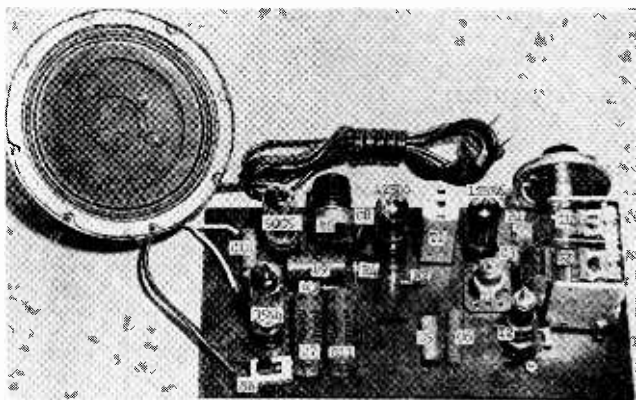

Fig. 5. Top view of the completed receiver.

Number 27 holes should be drilled in the three openings in the large copper section. These holes pass the screw section of the spade bolts which should be bolted to the tuning condenser with 6-32 machine screws. Be careful when you pull up the nuts and make sure that the connections for the tuning condenser sections are entering the openings in the board. Do not pull the nuts too tight since the spade section of the spade bolt may break through the board. If you care to do so, you could put tight fitting washers on the spade bolts before inserting them into the holes in order to prevent this possibility.

The On-Off switch has ears for mounting to a conventional panel or chassis. If you so desire, you can cut the ears off by holding the switch upside down in a vise and cutting them off with a hack-saw. The rough edges can then be smoothed with a file. The switch shown in the photograph has been treated in this manner. In mounting the switch the terminals should be

COMPLETE PARTS LIST ETCHED CIRCUIT RECEIVER

CONDENSERS:

- C1-C2 Sections of 2-gang Philmore #9045 tuning condenser
 C3 50-mmf tubular ceramic condenser
 C5 .005-mfd, 400V paper condenser
 C6 .0005-mfd, 400V paper condenser
 C7 20-mfd, 150V electrolytic condenser
 C8 .01-mfd ceramic disc type condenser
 C9 10-mfd, 25V electrolytic condenser
 C10 .01-mfd, 400V paper condenser
 C11 20-mfd, 150V electrolytic condenser

RESISTORS:

- R1 22,000-ohm, 1/2-watt resistor
 R2 3.3-megohm, 1/2-watt resistor
 R3 2200-ohm, 1/2-watt resistor
 R4 390,000-ohm, 1/2-watt resistor
 R5 1-megohm volume control
 R6 150-ohm, 1/2-watt resistor

TRANSFORMERS:

- T1 IF Transformer—Ambassador K—Trans. 455 kc
 T2 Antenna Coil—Meissner # 14-1056
 T3 Output Trans. to match 50C5 plate to voice coil
 T4 Oscillator Trans.—Meissner # 14-4034

SPEAKER:

- SPKR 5-inch PM dynamic speaker

MISCELLANEOUS:

- SW Single pole—single throw slide type switch
 1 5-ft. line cord and plug
 2 round control knobs
 3 6-32 spade bolts
 1 6-32 machine screw
 5 6-32 hexagonal nuts
 4 tube sockets for etched circuit
 1 4 1/2"x9"x1/16" copper-coated phenolic (chassis)

TUBES:

- 1 12BE6 tube
 1 12BD6 tube
 1 50C5 tube
 1 35W4 tube

pushed through the holes and then pushed over sharply so that they are in contact with the copper foil before soldering. The power cord should be connected by pushing the tinned ends of the leads through the proper holes. Be sure to push the lead down until the rubber is against the board. Cut off all but one eighth inch of the wire protruding on the pattern side of the board and solder the connection.

The tubes should now be placed in the sockets. The type 35W4 tube goes in the socket which is closest to the on-off switch. The type 50C5 tube should be inserted in the socket which is next to the 35W4 tube socket while the type 12BE6 tube goes in the socket which is in the center of the tube line. The 12BE6 tube, of course, goes in the remaining socket.

Incidentally, the output transformer is mounted on the loudspeaker itself and a twisted pair of leads run from the plate and the B+ terminals on the etched chassis up to the output transformer primary.

As soon as the tubes are in the sockets and the speaker is connected you can apply power to the receiver. It is a good idea to block up the board so that the wiring will not be short circuited by parts lying on the bench or by metal objects.

An antenna should be connected to the 6-32 screw which comes through the board and it would be a good idea to use a .005-mfd. condenser in series with the antenna since it is possible that the antenna may be hot because the ground return is connected to one side of the AC line and to the antenna post through the coil. With the condenser in the circuit you can use an outside antenna or any other antenna without fear of electric shock when you touch the antenna.

After the tubes have warmed up, tune the condenser throughout its tuning range. If you have a high frequency local station in your area tune around on the high end of the dial where you know this station is operating. If the station comes in, adjust the antenna trimmer (mounted on top of the rear section of the gang) with a screwdriver for maximum signal strength. Then go down to the low frequency end of the broadcast band and see if you can pick up a station. If you pick up a station at this point adjust the slug in the antenna coil for maximum volume. Then repeat these adjustments several times at each end of the band until the receiver is operating normally. Of course, if you have a signal generator, you can align the set in a conventional manner.

Should you find that a station is picked up but seems to come in at the wrong dial setting, tune the tuning knob in the direction of the correct setting until the station can barely be heard. Then adjust both the trimmer condensers for maximum signal strength from that station. Keep repeating this retuning and adjusting process until the station is received at a point which you believe to be the correct location.

You may find that reversing the line plug cord position in the wall outlet increases the volume in certain cases.

The finished receiver may be mounted in any convenient manner and because of its small size it might be built into some cabinet that has been designed for other purposes. The speaker can be mounted in any desired position.

The complete parts list shows items that were purchased from local radio wholesalers. All of these items were also listed in the current Allied Radio Corporation catalog. If you do not have a copy of this catalog you can obtain one by addressing this firm at 100 N. Western Avenue, Chicago 80, Illinois. The critical items are listed by brand name and part number so that you can duplicate the receiver should you care to do so. The only items not available in this manner are the board, tube sockets, ink and Ferric Chloride. These items may be obtained from the following firms. Board and tube sockets, Harcon, Brandywine, Maryland; the price of the board and tube sockets is \$1.75 postpaid and this firm will also supply an etched chassis and tube sockets for \$2.75 postpaid in the event that you do not wish to etch your own. The ink is Superior, Trojan Grade, Special Marking Ink, obtainable from R. A. Stewart and Co., 80 Duane Street, New York 7, New York. The price of the ink is \$4.50 per pint. The Ferric Chloride can be obtained from engravers or engraving supply houses. The price is \$3 per gallon. A half-gallon will be enough to etch many circuits.

A simple receiver, such as the one described, is a good starting item for experience in etched service work. However, phonograph amplifiers, capacity operated relays, phonograph oscillators and similar items have all been constructed using the methods described here. This is something relatively new in the home construction field and has been found to be a lot of fun. No doubt the materials for this type of work will become more plentiful as time goes on and we will see more and more home builders etching their own circuits. Keep in mind that the National Radio Institute cannot supply any of the items for this project.

— n r i —

Do You Want to Travel for a Leading Component Manufacturer?

Nationally known company needs personable, bright young men with good TV training to travel, making talks before groups of service technicians, etc. Please give full resume of experience and education in first letter. Single men 21 to 28 preferred. Write direct to: Harry P. Bridge Advertising Agency, Attention Walter J. Werbos, Vice President, 1201 Chestnut Street, Philadelphia, Penna.

Troubleshooting the TV Set Owner

(Continued from page 13)

In listing replaced tubes and parts, *be sure to identify the circuits in which they are located.* Explain that many tubes and parts with identical numbers are used in the set, that this further identification is therefore needed for the benefit of all concerned. In case of premature failure, for example, you can guarantee the 6SN7 you just replaced, but not the other three in the set.

Any recommended repairs that the customer does not wish to authorize at the present time should be noted plainly on the service order. The existence of weak selenium rectifiers, for example, that have caused the picture to shrink, should be noted. This can be a future reminder to the customer; it also takes you off the hook as far as later taking the blame for the condition is concerned.

The service order should also have a place for the customer's signature, above which should be a printed statement to the effect that the set is operating satisfactorily except as noted. *Always* have the order signed, even on C.O.D. calls. This protects you on later claims, and on call-backs. If the call is made on a charge basis—which sometimes cannot be avoided—the customer is at least bound by his own signature. Be sure you explain the guarantee, which must appear on the bill anyhow.

Finally, don't linger to discuss the ball game, the weather or how the fish are biting. This will spoil the impression that you are a busy professional man, with other calls to make, whose time is valuable, and that the customer was fortunate in securing your services.

It's much easier and more profitable to handle a customer who likes and trusts you. Building up the right attitude on his part is one of the important secrets—if it is a secret—to building up a successful business.

— n r i —

Daughter: "What should I do if the brakes give way?"

Father: "Steer for something cheap."

— n r i —

On his deathbed old man Fosdick was harassed by fear because he had harbored a grudge against a neighbor for years. He sent for the neighbor and made overtures of peace. The two of them shook hands in friendship. But as the visitor left the room, Fosdick called after him, "Remember, if I get over this, the old quarrel stands."

Our Cover Photograph

NRI graduate Floyd W. Cox, of 745 North Huntley Drive, Hollywood 46, California, was recently caught by the camera in an informal pose beside his well-equipped service truck and incidentally with his best canine pal. Floyd is not only an outstanding example of an NRI graduate who, through his technical training, has established a fine spare-time business, but he is also an example of one who practices sound customer relations and makes the "Golden Rule" pay off in everyday life. Graduate Cox recently wrote to NRI as follows:

"Before I started my course with NRI, I consulted students from several Radio and TV schools, and looked over some of their lessons. I had only \$150 in the bank, and I took some of that to start my course with NRI.

"I read the little notes from Mr. Smith on the back of each NRI lesson. To me, they were a

guiding light to success. I have built my business on the foundation of the Golden Rule and have found the general public hungry for someone they can trust to do their radio and TV work.

"I now have more spare-time business than I can handle by myself, so I call on a friend who helps me when I get swamped. I have averaged \$150 per month net for the past two years from spare-time Radio and TV servicing, and this was long before I finished my course with NRI.

"The NRI course has been worth more to me than anything I have ever done in my life; morally, physically, and financially. I have my shop complete with every piece of equipment that I need. I have bought a new car and a truck, and I am also buying my home. I give all the credit to Mr. Smith and his fine staff at NRI."

Floyd W. Cox
745 North Huntley Drive
Hollywood 46, California

— n r i —

— n r i —

What to Expect from Automation

In one Columbus, Ohio, plant 27 miles of conveyors link 2,613 machines, and refrigerators come out at the rate of two a minute.

In a Dearborn, Mich., foundry and engine plant, virtually all lifting and carrying has been transferred to conveyors. Automatic controls regulate the flow of raw materials and parts as well as the machines that perform the intricate operations to turn out automobile engines. Jobs? The plant has 8,000 employees. Production as always, depends on men—and women. Automatic equipment just helps them produce more and do a better job.

In insurance offices, calculations that took days by old methods, are now done in minutes or seconds by the new "electronic brains." Similarly, in physics, chemistry, and market analysis, equations that would have taken a lifetime to develop can be had in minutes. Office paper work has been increasing by leaps and bounds. Now the prospects are that much of the dull routine of record keeping, reproduction of copies and filing will be lightened by new equipment.

Yes, new day is a comin'. But let's be realistic about it. The changes will be evolutionary rather than revolutionary. Only a small fraction of all industrial processes lend themselves to complete automation. It takes a long time to invent and perfect new equipment. Then people must be sold on its advantages.

Many jobs tomorrow will be different, and better. There will be more opportunity for talent—technical ability. The proportion of the labor force in unskilled occupations has been declining for forty years. The unskilled farm hand is gone. In industry there are 100,000 fewer unskilled laborers than in 1940, although total industrial employment has risen by seven million.

Automation demands more education. As the standard of living rises, the opportunity to get it increases. Education—child and adult—is growing faster than any major industry.

Occupations will change, as they always have, and in a technological civilization they change for the better. Tomorrow there will be a premium on technical ability. In fact, shortage of technical personnel is a major bottleneck in the advancement of automation today. Industry needs more engineers, inventors, draftsmen, and men and women who can make and service electronic equipment—people with brains that are trained or trainable.

Automation is in the direct line of descent of all great inventions and industrial developments—the wheel, printing from moveable type, the steam engine, interchangeable parts, and the internal combustion engine. Looking back, no one questions the advantages of the great developments of the past. Automation should be seen in the same perspective. It's good for you. Help America make the most of it.

Attention, Owners of NRI Professional Tube Testers

New 1955 Tube Test Charts and TV Picture Tube Adapter Now Available from NRI

A tube tester is no better than the tube test information which is available for it. Recognizing this very important factor, NRI tries to bring out freshly revised tube test information for all models as frequently as we can do so. For Models 66, 67 and 68, there are now available completely new charts, all information being contained in one booklet, eliminating the need for extra sheets.



NRI TV Picture Tube Adapter

These were printed in April, 1955. A new roll chart, revised in March, 1955, is now available for the Model 69. A new roll chart for the Model 70 tube tester, printed in March, 1955, is also now available.

NRI can supply a Television Picture Tube Adapter which may be used with all NRI Professional Tube Testers, Models 66 through 70. (Not usable with NRI Model 1185.) This Adapter enables you to test a Television picture tube in a receiver, or in the original factory carton. The test includes a cathode emission check and a check for shorts between the various elements in the tube. Manufacturers do not claim that a Television Picture Tube Adapter is a fool-proof means of testing Television picture tubes. There are certain comparatively infrequent troubles in picture tubes which an Adapter will not detect. It is, nevertheless, a popular and useful accessory.

In ordering either a new tube test chart for your NRI Tube Tester, or a Television Picture Tube Adapter, please use the convenient order blank included on this page. Be sure to include the proper remittance, and in ordering tube test charts, be absolutely certain to mention the model number of your tube tester.

How to Install New Roll Chart in Model 70 Tube Tester. (Retain these instructions if you order a new Roll Chart.) First, remove the instrument from its wood case by taking out the eight Phillips wood screws from around the edge of the front panel. The panel will now be free and can be removed from the instrument case. For better accessibility, you can remove the complete Roll Chart mechanism from the instrument. However, this is not necessary.

The Roll Chart is held securely to the wooden rollers by means of three brass spring clips.

These can easily be removed with the fingers, or by means of a pair of pliers. Note the amount of tension in the old paper Roll Chart before removing it. You will want to include the same amount of tension in the new Chart.

How to Install New Roll Chart in Model 69 Tube Tester. Remove the front panel of the instrument by taking out the screws found in the four corners of the panel. Closely observe the mechanical operation of the old Roll Chart and the tension of the paper before removing the old Roll Chart. Fasten the new Chart to the wooden rollers using scotch tape. Reassemble the instrument.

ORDER BLANK FOR OWNERS OF NRI PROFESSIONAL TUBE TESTERS

National Radio Institute, Supply Division
16th & U Streets, N.W.
Washington 9, D. C.

Enclosed is \$..... for which send me the following material, as checked:

- Paper Roll Chart for Model 70 NRI Professional Tube Tester. Revised March, 1955. Price \$1.25, postpaid.
- Paper Roll Chart for Model 69 NRI Professional Tube Tester. Revised March, 1955. Price \$1.25, postpaid.
- Completely revised test data, in one booklet, for Models 67 and 68 NRI Professional Tube Testers. Revised April, 1955. Price \$1, postpaid.
- Completely revised test data, in one booklet, for Model 66 NRI Professional Tube Tester. Revised in April, 1955. Price \$1, postpaid.
- Television Picture Tube Adapter. May be used with all NRI Professional Tube Testers, Models 66 through 70. Includes instructions. Price \$4.98, postpaid.

Name Student No.

Address

City Zone State

*If you live in Washington, D. C., add 2% for D. C. Sales Tax.

NRI Graduates Receive Good Wages, Hold Good Jobs, Attain Independence

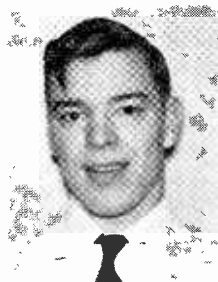

Receives
"Top Wages"
as
Trouble Shooter
in
TV Plant

"For the past two years I have been working for FCA's TV Plant in Prescott, Ontario—the biggest TV plant in Canada. I am a TV troubleshooter and receive top wages.

"I sure got the right start in the Electronic field through NRI. Your course is very well explained and easy for the ambitious to understand."

ZOLTEN DAKIN
Box #1069
Prescott, Ont., Canada



Supervises
the Repair of
Guided Missile
Equipment

"I am employed in radar and anti-aircraft remote control equipment repair. My job now is supervising the repair of guided missile equipment at an Army Ordnance installation.

"I feel proud that I have advanced as I have in such a short time and particularly at my age. Your course was the beginning in Electronics for me. It might please you to know that I have three boys under my supervision who are at present students of your course."

W. L. JARVIS
5137 Third Street, N.
Arlington, Virginia

Grossed Nearly \$1,000 in One Year's Spare-Time TV Servicing



"Quite early in my training, about three years ago, I started to take in some work in Radio, and it was not long after that until I tackled a TV set. During the past three years, with no advertising on my part, spare-time work has been increasing steadily. As an example, I took in a gross of about \$140 in two weeks and it appears that my gross for the year may exceed \$1,000.

"I find Radio and especially TV work very fascinating. I think your course is complete and exceptionally easy to grasp."

EMERSON A. BREA
5133 N. Defiance Ave.
Takoma 7, Washington

NRI Training
Has Helped
Tremendously in
Industrial Work



Has One of
Best Equipped
Radio-TV Shops
In Town



"I am a hoist and crane electrician and have had the job only three years. Lately I have been given all unusual jobs on hoists and cranes which involve problems in schematic form. I get all the big jobs with automatic limits, relays, and other devices. This is very unusual as we have other men with up to thirty years service on the same type work.

"I have your diploma framed and am quite proud of it. Your course has been a tremendous help to me at the shop as well as at home."

JAMES MOONEY
528 Linden Avenue
Springfield, Ohio

"I want to thank you for teaching me Radio and Television Servicing. I have one of the best equipped repair shops in town. I started servicing Radio receivers when I was in my sixteenth lesson and have made enough money to pay for all my equipment and parts."

"I have expanded into larger quarters and have a dealership carrying three popular brands of Radio and Television receivers. We do a lot of service work. Now have two trucks on the road and cannot keep up with our work. I owe my good future to NRI."

JOSEPH J. DEANGELIS
8 Prospect Street
Brattleboro, Vermont

— n r i —

— n r i —

Averages Nearly \$100 Per Week in Own Business

"Mr. Smith, here's thanking you for what your training did for me. Since my graduation in December, 1947, I have been in business for myself. Radio and TV Servicing is a booming business.

"I average about \$100 a week and have more work than I can do. If there is any doubt in the mind of any of your prospects as to what NRI training will do, you may show them this letter."

JOHN N. DAVIS
1009 12th Avenue, S.
Nashville, Tennessee



As space permits, from time to time, we plan to devote a page or two in NR-TV News to short success stories such as above. They are taken from testimonial letters we have on file. Photographs and letters of this kind are always greatly appreciated by us. We feel we should pass them on to our readers for the inspiration to be gained from a reading of them.

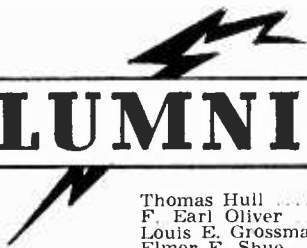

N.R.I. ALUMNI NEWS

Thomas Hull	President
F. Earl Oliver	Vice Pres.
Louis E. Grossman	Vice Pres.
Elmer E. Shue	Vice Pres.
Herbert Garvin	Vice Pres.
Louis L. Menne	Executive Secretary

TWO OF OUR NRI ALUMNI ASSOCIATION NATIONAL VICE PRESIDENTS



F. Earl Oliver,
of Detroit, Mich.



Elmer E. Shue,
of Baltimore, Md.

Mr. F. Earl Oliver is one of the leading pillars in Detroit Chapter where he has held just about every office, including several terms as Secretary and Chairman.

Mr. Oliver graduated in 1928. In 1937 he succeeded to National Vice President. He was reelected in '38, '39, '40 and '41. In 1943 he was elected President. He was out of National Office until 1951 when he was again elected a National Vice President and reelected each succeeding year to date. His counsel is sought by many NRI Alumni members in Detroit.

Earl is an outstanding Radio and Television technician. He is also very active in civic affairs and Captain of his bowling team in a church league. He is the kind of fellow who likes to carry more than his share in anything he attempts to do. A substantial American citizen—that's Earl Oliver.

Mr. Elmer E. Shue, one of the four National Vice Presidents of the NRI Alumni Association for 1955, is regarded as one of the truly great luminaries of Baltimore Chapter.

Upon his graduation from NRI in 1944 he joined the Baltimore Chapter and has distinguished himself as a devoted and hard-working member.

Mr. Shue, who resides at Green Pastures Drive, Towson, Maryland, is employed as Chief Electrician at Black and Decker Manufacturing Co., in Towson, Maryland. After hours, he can be found in his well organized and spacious work shop repairing Television and Radio Receivers. He does a thriving business.

Mr. Shue is highly regarded by members of Baltimore Chapter. He is an inspiration to the other members of this organization.

Chapter Chatter

New York Chapter, under the able leadership of Tommy Hull, who is also the National President of the NRI Alumni Association, offers the kind of meetings that are always well attended. The members of this local are solidly behind their leaders. Not only are the programs interesting and highly educational but the good fellowship that is present is a genuine inspiration to new members and visitors.

The Executive Committee now consists of ten members including present officers and the fine group of men who led the chapter for the previous twelve years. Thus the experience of the old is mingled with the spirit of the new which augurs well for the members of the chapter.

At a recent Executive Committee meeting, attended by Executive Secretary, L. L. Menne, the following were present. Thomas Hull, Chairman, Phil Spampinato, Vice Chairman, Frank Catalano, Treasurer, Emile Paul, Secretary, Bert Wappler, Past Chairman, Lou Kunert, Past Secretary-Treasurer, Frank Zimmer, Past Assistant Secretary-Treasurer and the three additional members of the Executive Committee, Emile Ruocco, Alex Remer and William Fox. Following the Executive Committee meeting the officers presided at a regular meeting of the members held, as usual, at St. Marks Community Center, 12 St. Marks Place, in New York.

Tommy Hull spoke on Radio servicing problems, Alex Remer spoke on Television servicing, Phil Spampinato spoke on the Vacuum Tube Voltmeter, William Fox, in a lighter vein, related some of his unusual and humorous experiences. Frank Zimmer made a very compelling talk on the importance of regular attendance and he awarded prizes to Alfred E. Volpe, and Charles Frankiewicz, who received first prizes for best attendance, John Bulman, Harry Quinsel, and Albert Ferrita, who received second prizes. Runners-up were D. Kopyn, Harold Grundy, Joseph Faltin and Cres Gomez.

At other meetings David Spitzer spoke on TV trouble-shooting, William Fox again gave some of his TV field experiences. Ed McAdams spoke on financing chapter equipment and Thomas Hull again conducted his Radio clinic.

Meetings are held on the first and third Thursday of each month at St. Marks Community Center, 12 St. Marks Place, between Second and Third Avenues in New York City.

New Orleans Chapter members are following the NRI course in Professional Television Servicing. Their recent meeting was devoted to the operation of the oscilloscope. The members are very much interested in these meetings which

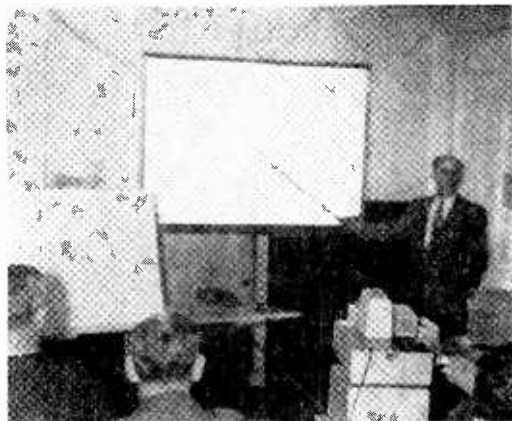

Bill Heath, Westinghouse Service Supervisor, in a talk to Phila-Camden members on Westinghouse Color TV.

are never brought to a close without the informal question and answer discussion in which all members are invited to participate.

Meetings are held in the Recreation room in the home of Chairman Louis E. Grossman, 2229 Napoleon Ave. Students and graduates in the New Orleans area who would like to attend meetings are invited to get in touch with Mr. Grossman or Secretary Anthony H. Buckley, 2817 Burgundy Street in New Orleans.

Philadelphia-Camden Chapter, following the example of New York Chapter, has a record of the attendance of every member. At the end of the year prizes will be awarded to those who have attended most frequently and this very likely will include a considerable number who have perfect attendance records.

We have some very good lectures coming up in the months ahead. So far this year we have had terrific meetings. We have had a guest speaker at every meeting with the exception of last month. That was for the purpose of enabling our members to visit the establishment of Henry Whalen. Mr. Whalen is an NRI graduate, and a very prominent TV service technician who has a very fine establishment.

Mr. Whalen not only gave our members an opportunity to see his equipment in operation but he entertained us in other ways. He had movies for us through the courtesy of the Bell Telephone Co. He had a sixteen millimeter sound projector film on the Bell Telephone coast-to-coast hookup on microwave transmission which was very interesting. Also a film on Mobile telephone which Mr. Whalen installs for the Bell Telephone company. Fortunately Mr. Whalen had one of these Mobile units in his shop

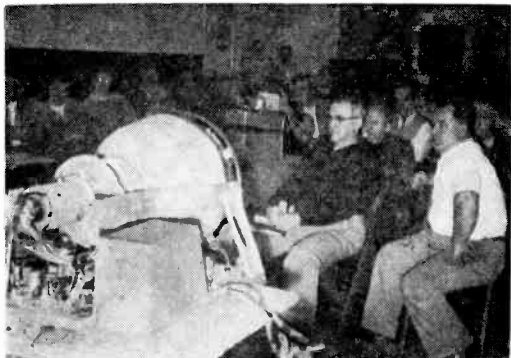

And this is indicative of the interest manifested by Phila.-Camden chapter members while Bill Heath demonstrated the Westinghouse TV color receiver.

which was to be installed the following day.

Besides his TV work Mr. Whalen does the service work on car radios for eighty-five dealers in and near Philadelphia. He has a very elaborate set up. Included is an automatic phone secretary which is something to see in action.

We have made arrangements with a representative of the Bell Telephone Company to speak to us on transistors at our next meeting.

Our big social meeting is planned for June 13. All members are requested to make a note of the date and be present for this always pleasant get-together.

Mr. Bernie Bycer, Design Engineer, for Raymond Rosen Company gave us a fine talk on vertical output circuit defects and their remedies.

New members are Stanley F. Rogowski and Thomas E. Maher, both of Philadelphia and Herbert L. Enrich, Chief Store Keeper, with the U. S. Navy, who is on duty here in the Philadelphia Navy Yard.

Secretary Jules Cohen can be reached at 7124 Souder Street in Philadelphia. Meetings are held on the second and fourth Monday of each month at the Knights of Columbus Hall, Tulip and Tyson Streets.

Springfield-Mass. Chapter had as its principal speaker Mr. William L. O'Connor, a TV service specialist, who spoke on the use of the oscilloscope. It was a very interesting talk and Mr. O'Connor has consented to return for the next meeting to resume his demonstration and explanations.

Plans are going forward for holding a picnic

Page Twenty-eight

this summer. Members will be notified by the Chairman. Address Chairman Howard B. Smith at 53 Bangor Street or Secretary A. L. Brosseau, 56 Gardner Street, both in Springfield. Meetings are held on the first and third Friday of each month, beginning at 7:30 P.M., at the U. S. Army Reserve Headquarters, 50 East Street, Springfield.

Chapter members are pleased to have visits from NRI students and graduates and particularly invite those from Hartford, Orange and vicinity to join with us even if they cannot attend meetings regularly.

Milwaukee Chapter reports an interesting talk by S. Petrich, who spoke on the use of the oscilloscope, based on the article written for NR-TV News by Mr. B. van Sutphin, NRI Consultant.

The members are very much pleased with the nice quarters they enjoy at the business estab-

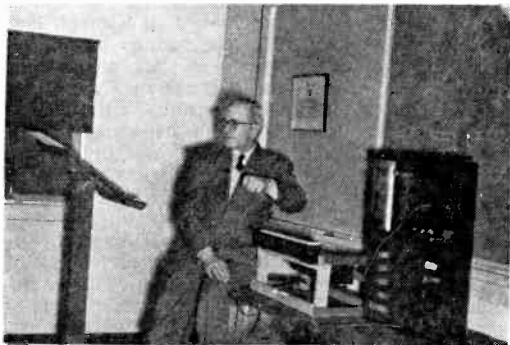

This gentleman in the casual pose is Ray Nystrom, Vice Chairman of Springfield, Mass. chapter, who is making a talk on the electronic organ.

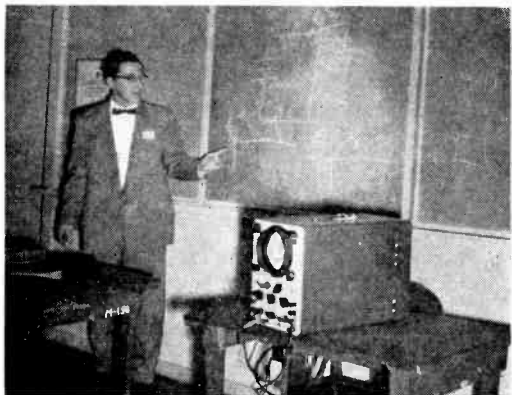

Mr. Wm. O'Connor demonstrates the operation of an Oscilloscope at Springfield, Mass. chapter.



Springfield, Mass. Chapter members in the studios of WHYN-TV. Mr. Hal Schumacher, Chief Engineer, took our group on a very interesting tour of the station.

ishment of Mr. Petrich, 5901 W. Vliet Street, Milwaukee.

A Weller Soldering Gun was donated by Acme Radio Supply Company as a door prize. A vote of appreciation is extended to these fine people for their cooperation. Mr. Guenther Opperman suggested the distribution of mimeograph copies containing the names and addresses of all chapter members so that they can contact one another in their locality in case assistance should be needed for one reason or another. Mr. Gilbert Nelson offered his services in preparing such a list, having it mimeographed and brought to the meeting for distribution.

Members are urged to bring in any radio or TV set that is particularly troublesome for discussion in our Service Forum. The Secretary is Wallace H. Smith, 1710 East Newport Ave. in Milwaukee. Students and graduates in this area interested in attending meetings are asked to get in touch with Secretary Smith or Chairman Philip J. Rinke, Route 3, Box 356, Pewaukee, Wisconsin.

Pittsburgh Chapter reports the following activities. Vice Chairman William Elter spoke on Antenna Installations. Thomas Schnader demonstrated the use of probe leads and scope for signal tracing. Mr. Clement McKelvey, Instructor, Allegheny Tech TV School and in the Pittsburgh Public Schools, spoke on Output Transformers. Mr. McKelvey made a big hit with our members, so much so he was accepted as an honorary member of the chapter. The talks by Mr. Elter and Mr. Schnader were equally interesting.

At another meeting Mr. Bert Bregenzer, Presi-

dent of the Pennsylvania Federation of Radio and TV Service Association, and an honorary member of Pittsburgh Chapter, spoke on servicing ac-dc sets. Mr. Bregenzer gave an interesting demonstration by taking a small receiver and simulating actual troubles, such as open grid circuits, open decoupling condensers, leaky coupling condensers, etc., and then operating the receiver showing what happens.

At a near future meeting there will be a demonstration of the use of new instruments for color TV servicing.

Pittsburgh Chapter is fortunate to have so many capable members upon whom to call for a worthwhile talk or demonstration.

The Chairman is Frank Skolnik, 932 Spring Garden Avenue. The Secretary is William L. Roberts, 2521 Wenzell Ave., Pittsburgh.

Chicago Chapter members continue to meet on the second Wednesday of each month at 8 PM on the thirty-third floor, Tower Space, of the American Furniture Mart Building, 666 Lake Shore Drive. Entrance through the west door.

Members are urged to bring in Radio and TV receivers regarding which they would like to ask questions or relate their experience for the benefit of members.

The Chairman is Charles C. Mead, Room 228, 666 North Lake Shore Drive, who has provided the meeting place and offers other facilities for the benefit of our Chicago members. Mr. Mead will be very pleased to have you get in touch with him.

Flint, Michigan members drawing on such cities as Bay City, Saginaw, Lapeer, Attica, Chesaning, New Lothrop and others adjacent to Flint, report their membership expanding. Students and graduates in any of these cities or others in the Flint, Michigan area, are invited to get in touch with any of the officers who will be very glad to give information regarding meetings. By expanding to take in nearby cities the Flint group prefer to be designated as the Saginaw Valley Chapter.

At least one picnic is being planned for this summer so that members of families can become acquainted.

Members of this chapter are doing very well in the field of Radio and TV Servicing. All members report good business. The chapter prides

itself in its policy to uphold the standard of reasonable charges for professional work.

The Chairman is Warren A. Williamson, 1201 Allen Street, Flint 7, Michigan, the Vice Chairman is William Jones, 328½ Perry Court, Flint, Michigan, the Secretary is David J. Nagel, 3135 East Mt. Morris Road, Mt. Morris, Michigan and the Treasurer is M. E. Sevens, 2401 Nebraska, Flint 6, Michigan.

Because members were very busy and found it difficult to attend meetings regularly on work days, during the week, at the time the chapter was organized it was decided to experiment by holding meetings on Sundays. The experiment has proved successful and is being continued. All NRI men in this area are invited to participate.

St. Paul-Minneapolis Chapter, as this is written, is making big plans for celebrating its first anniversary on May 12.

Mr. George Larson, Service Manager for Reinhard Brothers, distributor for Zenith in the Twin City area, supplied a 1955 chassis which Chairman Berka used for demonstration purposes. Mr. Berka, assisted by Robert Cheeseman, a member of our entertainment committee and a serviceman for Reinhard Bros., gave our members a splendid talk.

A door prize donated by Lew Bonn Company of Minneapolis was won by our member Elmer Buck.

Ray Thompson of Amery, Wisconsin again made the long trip to visit our Chapter as our guest. We are always glad to welcome NRI students and graduates as visitors. Officers elected for the coming year are:

John Berka, Chairman
Robert Cheeseman, Vice Chairman
John Babcock, Secretary
Walter Berbee, Treasurer
Robert Jansen, Sgt.-at-Arms

These officers will be installed at the annual meeting on May 12 which will be preceded by a dinner. L. L. Menne and J. B. Straughn from Headquarters will be with us on this occasion. Mr. Menne will install the officers.

Meetings are held on the second Thursday of each month at the Midway, YMCA, in St. Paul. The Secretary is John I. Babcock, 3157 32nd Ave., So. Minneapolis 6, Minn. Mr. Babcock is a tremendously enthusiastic worker and he will be very pleased to have you get in touch with him regarding joining the Chapter.

Detroit Chapter is making big plans for the annual social meeting which is scheduled for

June 24. All members of the Chapter are urged to attend this meeting to renew acquaintances with some of the old timers we always expect at this special event.

Vice President F. Earl Oliver read from a recent issue of Service Magazine an item printed during the observation of National Television Service Men's Week which was cited as a mighty tribute to the integrity and spirit of the vast army of highly trained and skilled servicemen who install and maintain TV receivers. The article pointed out that a nation-wide survey disclosed that 90% of the nation's TV set owners who were interviewed expressed complete approval of the Serviceman. This approval pertained to the promptness, quality, prices and courtesy of the TV serviceman. Detroit chapter members are pledged to maintain this fine reputation of Radio and TV servicemen.

The Chairman of Detroit Chapter is Stanley S. Szafran, 2660 Holmes, Hamtramck, Michigan. The Secretary is Jack Shupak, 4075 Tuxedo, Detroit 4, Michigan.

Hagerstown, Maryland, Chapter meets on the first Thursday of each month at the YMCA in Hagerstown.

The Chairman is Edward M. Kemp, 618 Sunset Ave., Hagerstown. The Secretary is Leonard D. Thomas, 300 Bryon Place, Hagerstown. These officers are very much interested in hearing from students and graduates in the Cumberland Valley area.

Baltimore Chapter has plans for a speaker to talk on the subject of printed circuits. We expect to have a speaker for this assignment to preside next month.

Mr. H. J. Rathbun and Mr. Elmer E. Shue each gave an interesting talk on transistors. This was followed by the usual question and answer forum conducted by Mr. Rathbun.

From time to time Baltimore chapter members bring in Radio and Television material for which they have no great use but which could be very useful to some other members. It is reported that some months ago Treasurer John E. Harp loaned the Chapter a TV set for the purpose of conducting a series of experimental demonstrations. The speaker of this TV set, which is easily detachable, somehow wound up in the box of materials that were being offered for sale. The speaker caught the eye of one prospective buyer who promptly asked the sale price. Mr. Rathbun, after a short examination of the object said, "It has a very small rip in the cone, but that won't hurt it any. Let it go for a dollar." The eager buyer snapped it up. He was given a bill of sale by Mr. Shue and stepped over to Mr. Harp, the
(Page 31, please)



Here and There Among Alumni Members

Bert Wappler calls ye editor's attention to a slight error in reporting that he, Lou Kurnert and Frank Zimmer held the principal offices in New

York Chapter for eleven consecutive years. Bert wants it known it was twelve consecutive years. We don't blame him. They left a record to be proud of.

----- n r i -----

Harry M. Andrew, of Stroudsburg, Penna., is manager of Radio-TV Service for the Sears, Roebuck store in his city. Also doing a lot of custom Hi-Fi work.

----- n r i -----

Alvin W. Coleman, of Greggton, Texas, is enjoying his work as a TV Technician at Brown TV-Radio Service in Greggton. Values NRI training very highly.

----- n r i -----

Delbert L. Allen, of Alamosa, Colorado, is now Manager and Chief Engineer of Radio Station KGIW.

----- n r i -----

John A. Greany, of Norfolk, Va., is now a Chief Radioman in the U. S. Navy. Says his NRI training was of great help in getting his promotion.

----- n r i -----

C. A. Laidlow, Jr., of Medford, Mass., is now Service Manager of Central Radio Co., in Woburn, Mass.

----- n r i -----

Andrew E. Jackovich, of Braddock Hills, Pittsburgh, Penna., writes that he is doing sound system engineering work, and is well established with a Radio-TV firm.

----- n r i -----

Mr. J. Hearn Hill, of Waco, Texas, has opened a Radio-TV shop. He sent us some photos. Our best wishes to him.

----- n r i -----

Harold A. Jones is now an Electronic Mechanic at the Long Beach Naval Shipyard, Long Beach, Calif.

----- n r i -----

Mr. Porter J. Flynt, who graduated in 1940, has been successful in his Radio-TV business which is steadily growing. Mr. Flynt sent us the enrollment of one of his employees, Mr. John Wade Swaim. They have a mighty fine business letterhead.

Herman C. Shoemaker, of Mapleton Depot, Penna., writes that he is doing fine in Radio-TV work. Servicing work is increasing each week.

----- n r i -----

J. Thomas Stacey, of Hamilton, Ont., Canada, is now Assistant Chief Engineer of Television Station CHCH-TV.

----- n r i -----

Graduate Elmer L. Armstrong, of Springfield, Illinois, is employed full time repairing meters at the Springfield Instrument Bearing Co. He is specializing in this type of work. He also gets all the extra jobs he can handle from the Springfield Testing Laboratory.

----- n r i -----

Harold E. Van Guilder, of Middletown Springs, Vermont, holds amateur license W1APZ. Has worked 28 States and 3 Canadian Provinces. Code speed 18 wpm.

----- n r i -----

Steve H. Banks, of Pine Bluff, Arkansas, is now doing a large volume in his Radio-TV business.

----- n r i -----

Graduate Gene Szorosy, of Passaic, N. J., is at present employed in Industrial Electronics with the Daven Co., Newark, N. J. He is a Production Technician Group Leader in Final Test and Calibration Department.

----- n r i -----

Joseph H. Bingham, of Twin Falls, Idaho, is pleased with his job as Superintendent of a sugar factory. His plant uses many electronic instruments and controls, and Mr. Bingham mentions that he would be lost without his NRI training.

----- n r i -----

Logan P. Stowe, of Winston-Salem, N. C., is now a Bench man for Triangle Television. Likes his new position, and doing quite well.

Chapter Chatter: Continued from page 30.

Treasurer, to complete the transaction. Mr. Harp commented, "That's a pretty good looking speaker at that price—you got a good buy there." Not until the next meeting did Mr. Harp find out he was a party to the embarrassing situation of selling his own speaker. The chapter squared things with Mr. Harp and everyone present had a good laugh.

Baltimore Chapter meets once a month on the second Tuesday at 100 N. Paca Street. The Chairman is Joseph B. Dolivka, 717 N. Montford Ave., Baltimore.

NATIONAL RADIO-TV NEWS

16th & U Sfs., N.W.

Washington 9, D. C

Forwarding Postage Guaranteed

For:

Blk Rt
U. S. POSTAGE
1½c PAID
Washington, D. C.
Permit No. 7052

POSTMASTER—FORM 3547 REQUESTED

National **RADIO-TV NEWS**

Vol. 16

June-July, 1955

No. 9

Published every other month in the interest of the students
and Alumni Association of the

NATIONAL RADIO INSTITUTE
Washington 9, D. C.

The Official Organ of the N R I Alumni Association.
Editorial and Business Office, 16th & You Sts., N. W.,
Washington 9, D. C.

L. L. MENNE, EDITOR

H. L. EMERSON, ASSOCIATE EDITOR

J. B. STRAUCHN, TECHNICAL EDITOR

NATIONAL RADIO-TV News accepts no paid advertising. Articles referring to products of manufacturers, wholesalers, etc., are included for readers' information only, and we assume no responsibility for these companies or their products.

Index

Article	Page
Editorial	2
Analysis of the Tele-Tone Model 165 Radio Receiver	3
Troubleshooting the TV Set Owner	10
How to Build Your Own Etched-Circuit Radio Receiver	14
Our Cover Photo	22
Attention, Owners of NRI Professional Tube Testers, New Test Data Available	23
NRI Graduate Page	24
NRI Alumni Association News	26
Chapter Chatter	27
Here and There Among Alumni Association Members	31

Printed in U.S.A