

National RADIO-TV NEWS



HOLY NIGHT

Anacanto *A. Adam*

1. Oh, ho - ly night the stars are bright and shin - ing, it is the
2. Led by the light of faith we tread the path with the low - lying

Allegro

... night of the dear Sav - iour's birth
... hearts by His gra - ce - d - we st

IN THIS ISSUE

Mobile Two-Way Radio

New Trends in Television Receivers

Alumni Association News

Dec.-Jan.
1950-1951

VOL. 14
No. 6



I wish you a
very merry Christmas
and a happy prosperous
New Year
J. E. Smith.

Mobile

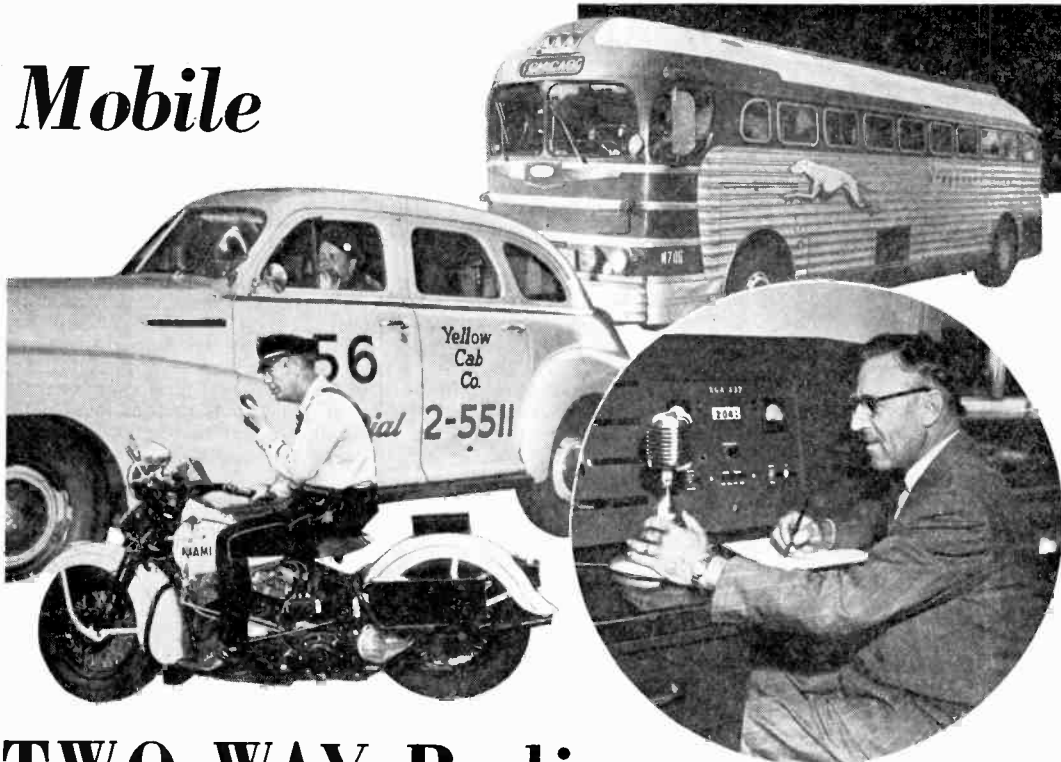

TWO-WAY Radio

By DOMENIC R. RIPANI, Rockford Communications Co., Rockford, Ill.

*Reprinted from Radio and Television News
through courtesy of that publication.*

WHEN the FCC lifted the temporary freeze on commercial two-way radio activities last May, it changed many groups from an experimental to a permanent status. While commercial mobile radio operations had expanded considerably since the war, this relaxation of the rules and more liberal issuance of licenses, was like a "shot-in-the-arm" for these groups and spurred them on to further activity.

Prior to the war, two-way radio was considered principally as a necessary tool for the law-enforcement bodies throughout the country. Today we find industry turning more and more to this method of communication as an important addition to their operations. Transportation companies are finding that radio-dispatched vehicles result in more economical operations because the movement of the trucks can be controlled while in transit. Taxicab companies have found that

radio-equipped cabs reduce the amount of dead mileage and also reduce customer waiting time. Utilities have discovered that radio-controlled trucks and service cars can be moved more quickly and efficiently during emergencies. An important user of radio, the Greyhound Bus Line, has found that not only do radio-controlled buses reduce operating expenses, but customer goodwill and sense of security have increased. As Fire Chief Wayne Swanson of the Rockford Fire Department so ably puts it, "FM two-way radio, as used in the fire service, in my opinion, is one of the greatest appliances given to the fire fighter since the change-over from horses to automotive equipment." A. I. Koch, president of one of the first cab fleets to go 100 percent radio, the Rockford Yellow Cab Company, and former president of the American Taxi-Cab Association, expresses fully the general opinion of the cab industry by stating, "The addition of mobile radio



FIG. 1. An independent service shop operated by Bill Wallingford of Rockford, handles mobile radio servicing for small municipalities as well as those for private firms.

equipment to cab operation has increased revenue by 50 percent, decreased operating costs, and has helped to build customer good-will to a high level."

These reasons will give some indication why industry is turning more and more to some type of radio-controlled operation.

Many more specific examples of mobile and portable operation could be cited, but it is sufficient to say that the field, expanding as rapidly as it is, has a great need for many more competent men. Many of the smaller radio-equipped companies "farm out" their radio service on a contract basis and it is to these organizations that the service shop should turn for additional revenue. On the other hand, many of the larger organizations hire their own full time radio technicians and it is with one of these groups that the interested individual should become associated. It is surprising to find that in many communities there are mobile units being maintained by technicians who must come from some other community to service mobile equipment. This, in communities where radio service shops already are established!

The owner of a local radio shop, if of a truly progressive nature, will investigate the possibilities of adding this type of service, not only from a monetary point of view but from the standpoint of the greater service he can offer to his community.

Mobile radio equipment, in the majority of cases, uses FM today. In the early days of two-way radio, AM was the predominant method of communication, but with the possible exception of a few police AM systems operating around 1700 kc., most installations are now FM. Mobile equipment and the associated land station units are constructed along similar lines by the various manufacturers. The minimum requirements set

forth by the FCC, coupled with the specific demands of industry, have resulted in a fairly uniform line of equipment both mechanically and electrically. Transmitters and receivers fall into two broad categories. They are: the low frequency units covering roughly a band of frequencies between 25 and 45 mc. and the high frequency units covering a band between 152 and 162 mc. This is not to be construed as the only available equipment, but only that the majority of operations fall into these two categories. Important users of the low bands include the sheriff networks, and the Greyhound Bus Lines. On the high band frequencies, 152-162 mc., will be found a great many types of services such as local police and fire departments, utilities, and the many cab companies.

The typical transmitter starts with a crystal-controlled oscillator, operating generally somewhere between 3 and 9 mc. Proper frequency multiplying in the following stages brings the frequency up to the correct operating band. Modulation is accomplished with a single button carbon microphone. Depending on the range desired and the economical limitations of the installation, transmitters are available with a power output of from $\frac{1}{2}$ watt (the "walkie-talkie" variety) to the 50 watt heavy duty unit. However, the two popular types of transmitters in use today are the 7 watt transmitter using a single 2E26 in the final and the 30 watt mobile unit using either an 807 or push-pull 2E26's in the final. (Some types of 30 watt units use the quick-heating 5516 in the final.)

The primary source of power for these units is the car battery. Where a heavy drain of power is needed for proper operation of not only the radio equipment, but the various electrical accessories, many installations use the "a.c.-d.c." method of supplying power instead of the standard "battery-generator" system. In the a.c. system, the vehicle is equipped with a 3-phase alternator, the output of which is rectified by a dry-disc rectifier. The work of the car battery is reduced to that of supplying excitation to the alternator, and also for starting purposes. A further advantage of this system is that full output may be obtained even when the car engine is idling. The high voltage is generally developed by a vibrator in the case of a low power transmitter, while a dynamotor produces the necessary power for the larger type units. The antenna found to be most efficient and the type widely used is the quarter-wave, end-loaded type. A 52 ohm shielded line feeds the power from the transmitter to the antenna. This coaxial line connects to a coax relay at the transmitter, thus making it possible to switch the antenna from "transmit" to "re-

ceive" instantaneously.

The receivers are the crystal-controlled, fixed frequency types, possessing a high degree of selectivity.

The selectivity is necessary if interference from adjacent channel operations is to be reduced to a minimum. While a few makes of receivers will be found using Magmotors to develop the proper "B" voltages, the majority will be found to contain vibrator supplies.

The actual work of installing mobile radio equipment in cars and trucks will present no problems that are not encountered in the installation of the ordinary car radio. The main difference lies in the fact that the units are installed in the trunk of the car and are connected by means of control cables to the control head mounted on the dashboard. The carbon microphone, containing a push-to-talk switch, is connected to this control head as is the loudspeaker. Depressing the microphone switch actuates the necessary relays in the transmitter for proper operation.

The two important things to keep in mind when installing these units are to make certain that all grounding is mechanically and electrically tied securely to the car body and to be sure that all control cables are protected against possible breaks or shorts. Avoid sharp bends in cabling as they will always be the source of trouble.

The basic circuits of the land base stations do not differ greatly from that of the mobile units. The differences lie primarily in the power supply systems used, a little difference in the relay control circuits, and possibly in the fact that a little more power output is obtained. The equipment of some manufacturers is such that there is hardly any difference in mobile units and land stations. One company produces a 30 watt station transmitter which is identical to its 30 watt mobile unit. This simplifies maintenance and reduces the amount of replacement items a radio shop must have on hand. This same manufacturer goes further and supplies a ¼ kw. final which may be driven to full output with this same 30 watt exciter without any changes to the equipment.

Installation of base stations is not a difficult job. With the equipment included detailed instructions and all necessary notations to enable the service technician to install the gear properly. As further protection, a

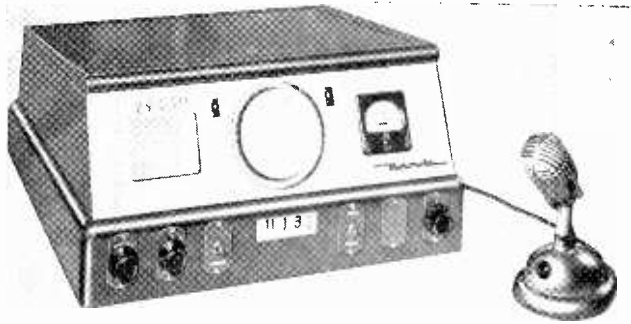

FIG. 2. A local control base station which is manufactured commercially by Motorola, Inc.

quick call to the manufacturer's field representative in case of trouble will bring him immediately to help in the solution of any specific problems. The only really difficult phase of the installation is in the erection of the tower, if a tower supported antenna is included in the plans. Many technicians do not bother with this part of the job, but turn it over immediately to some firm equipped to do the work. However, in most cases, particularly small taxi-cab companies, the antenna desired will be a ground-plane or turnstile mounted on a small mast at some point near the transmitter site. Incidentally, an ideal and popular site for the antenna, if available, is a water tower.

The first consideration in any installation is to determine where the point of operations is to be located—with due regard given to accessibility to power lines and antenna cable routing. If the selected site is in the vicinity of the operating

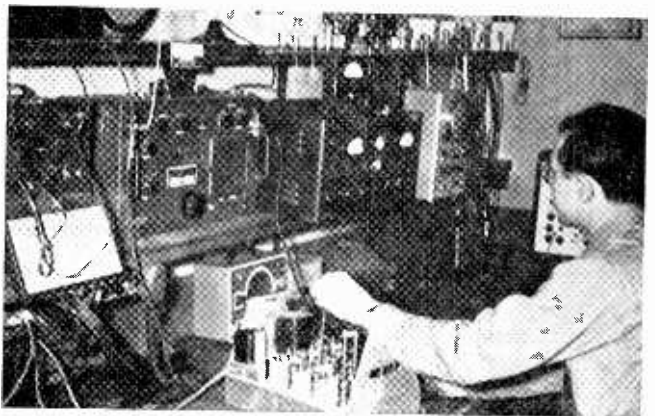

Fig. 3. The author's service shop. To the left of the oscilloscope is a Doolittle frequency monitor. To the left of the monitor is the I-122 high-frequency generator and to the left of that is the BC-221 which is used for low-frequency work.

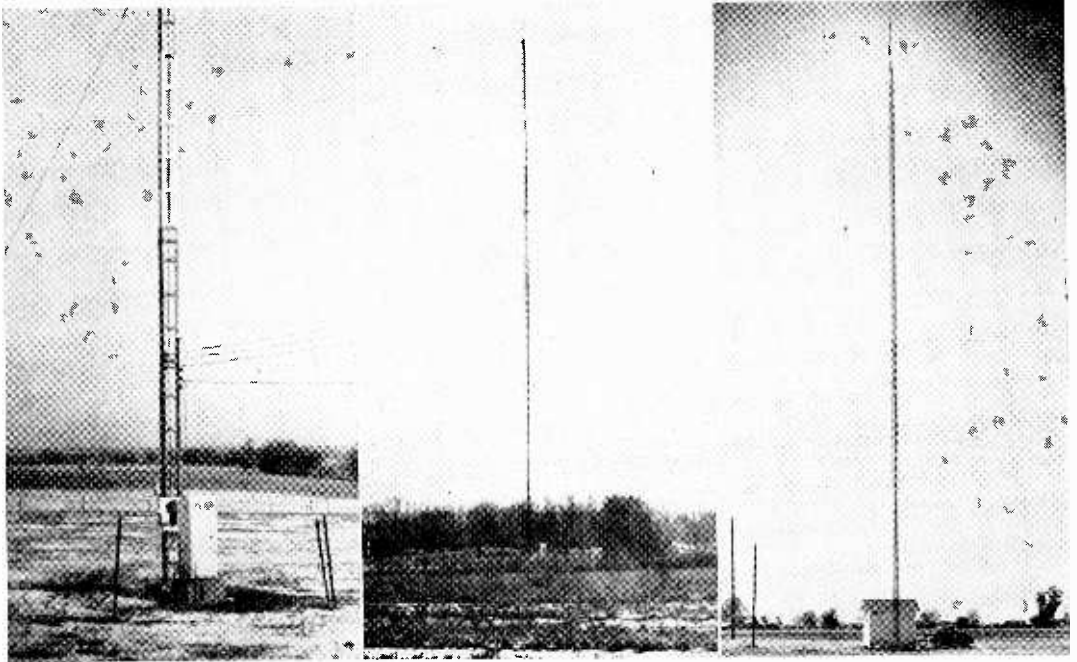

FIG. 4. Remote transmitter installation (left) with equipment housed in a weatherproof cabinet. Tower lights are automatically turned on and off by means of a photoelectric cell located on left side of tower. (Center) Where extended range is an important consideration the antenna must be mounted as high as possible. In this case the tower is 150 feet high on top of which is mounted a ground plane antenna. Transmitter is connected to control point by telephone lines. (Right) Remote installation with equipment located in a small "dog house." Tower is 150 feet high on which is mounted a Motorola triple-skirt colinear coaxial antenna. This is an REA installation near Hayti, Mo.

room, then the transmitter-receiver console can be installed directly in this room. However, due to noise level conditions at the point of operation or if greater range is desired, in many cases the transmitter proper is located outside the city limits, the equipment being installed in a "dog house" or weatherproof cabinet at the selected site. A telephone line is then connected between these units and a small preamplifier installed at the point of operations. The preamplifier amplifies the incoming signals from the receiver and on "transmit" sends a small current down this line which actuates the necessary relays for transmitter operation. When the transmitter is to be controlled at two or more locations, then several of these remote preamplifiers are connected in parallel. In this case though, the FCC regulations require that one operating location be designated as the control point. This control point must be able to monitor all activities of the station, and be able to make the transmitter inoperative at will.

Maintenance of two-way radio equipment is not as difficult as it might seem at first glance. In

general, the units found in the field are well constructed and can withstand a considerable amount of abuse. Component parts work with a large margin of safety and seldom give trouble. In fact, it will be found that about 90 percent of the troubles are directly caused by defective tubes and vibrators. The technician, however, will be wise if he sets up a preventative maintenance program. This will reduce to a minimum the number of breakdowns on equipment and also keep the "out-of-service" time of the vehicles low. An extremely helpful tool, incorporated in practically all equipment nowadays, is the metering system. It is because of this systemized metering arrangement that the service technician can quickly locate a faulty stage. In fact, with this method, the trouble in a mobile unit can be located and repaired more rapidly than most home radios.

As a specific example, one popular manufacturer provides a jack on his transmitters into which is inserted a 50 microampere meter. Located near this jack is a meter switch with a number of positions. Each switch position reads the grid

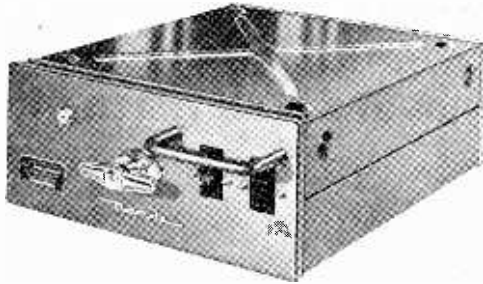

FIG. 5. A combination receiver and 30-watt transmitter for mobile installations. Complete unit may be removed in one simple motion.

current of a specific tube. A separate jack is provided for reading the plate current of the final amplifier. A quick check of all meter positions will show which stage is defective. The receiving equipment contains a similar arrangement permitting a rapid check of the over-all receiver performance. However, a fortunate condition exists in the maintenance of mobile gear in general. It will be found, after a little experience, that most troubles fall into very definite categories and may be located very quickly upon visual inspection.

It was mentioned earlier that a preventative maintenance program was advisable. This program is necessary not only from the standpoint of reducing the number of breakdowns, but also to conform with certain specific regulations of the FCC. These rules call for a check, every six months, of the transmitter frequency of both the land station and the mobile units, the power input to the final stage (the product of the plate voltage and total plate current is acceptable) and the total modulation deviation (in the case of FM). To properly handle these requirements both legally and ethically, the service technician should periodically remove the units from the vehicles and check them completely on the work bench. In this way they can be checked for legal requirements and also be given a systematic cleaning, adjustment, etc. Obviously, certain pieces of test equipment will be required to maintain this gear. The test equipment found in the average shop can still be put to good use, such as the v.t.v.m., tube checker, and signal generator. In addition, however, there should be available a stable low frequency generator and a stable high frequency generator. For low frequency work, the BC-221 is good and for high frequencies, the I-122 is satisfactory. The FCC requires that a stable monitor be available to measure the transmitter frequency within the tolerable limits and also an accurate device for measuring the modulation. Perhaps the most stringent regulation set down by the FCC is that a license of the grade of 2nd class radiotelephone,

or higher, is required by personnel making repairs or adjustments to a transmitter which might affect the frequency of operation. Under the law, however, a non-licensed man may make repairs and adjustments under the direct supervision of a duly licensed operator of the proper grade.

The radio technician who has had car radio experience, in addition to experience on home AM and FM receivers, will find that the knowledge acquired will provide most of the "know-how" needed to satisfactorily install and maintain mobile radio gear and their associated land stations. Most manufacturers of mobile radio equipment, anxious to have their equipment serviced properly in the field, authorize competent service shops in the various territories throughout the country to handle the work on their equipment. The radio shop owner would be wise in contacting the various companies to arrange for official recognition by one of these radio concerns. Advantages such as complete technical data on

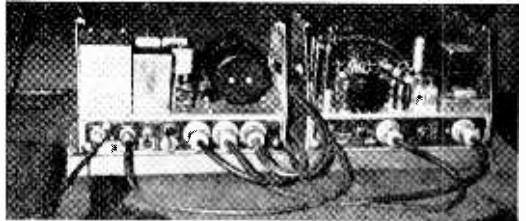

FIG. 6. Interior view of taxi trunk. The 30-watt transmitter is at left and receiver is at right. Cabs operate in the 152-162 mc. band.

new gear, factory assistance when needed, and consideration on receiving the new installations as they are sold in the territory, become available when the shop becomes affiliated.

Whether you contemplate seeking a position with some firm engaged in two-way radio work, or whether you operate your own independent service shop and are looking for additional steady business, you will find this work interesting and varied. You will experience the deep satisfaction that comes when the "big switch" is thrown and you've put a station and its private network on the air. So pause now and consider the many opportunities in this progressive field and begin making plans to take your place in its ranks.



Firmness—An admirable quality in ourselves that's regarded as pure stubbornness in others.

Advice—What a man gives when he gets too old to set a bad example.

Read How NRI Graduates Are Forging Ahead in Radio and Television



Full Time Job With
Radio - TV Service
Company

"I am employed with Harley's Radio and TV Service. I work for 70% of my labor tickets. My wage for one week recently was \$80.50.

"We have about all the work we can take care of, and have one of the best stocked and equipped shops in this tri-state area. We do about all of the retail dealers and auto dealers repair work here, and we think that our total work is as much, if not more, than all the other shops here."

CLEONE E. YOUNG,
1819 Bank Street,
Keokuk, Iowa.

— n r i —



Chief
Maintenance
Operator

"In my mind I have thanked NRI hundreds of times for my training. I am now Chief Maintenance operator for Station KIA 452 in Mountain City, Tenn., and KIA 453 at Newland, N. C. These two stations operate in the power radio service. I also have eight mobile stations to maintain.

"Am also the proud holder of a 2nd class commercial Radiotelephone operators license. That speaks well for NRI and its able staff."

LEASON S. GREGG,
RFD #3,
Mountain City, Tenn.

— n r i —

Spare Time Earnings Paid for Course

"Before I finished the NRI Course, I was taking in Radios and making \$5 to \$10 each week. This paid for the course and all the test equipment one needs in a Radio Shop, also a complete set of Rider's Manuals. In the future, I plan to go into Radio service work full time, and sell electrical appliances.

"I am very proud of my radio work and am glad to recommend NRI to anyone interested in Radio. Recently I received my Diploma from Chevrolet Division of General Motors as an approved technician on their radios. Thank you for the splendid help I received during my studies."

CHARLES M. BROWN,
405 Sylvania Ave.,
Charlotte, N. C.



**NRI Kits
Gave Him
"Know-how"**



"I am working as a salaried Technician and have a sideline of my own repairing and installing auto receivers, as the shop where I am employed does not handle this type of repairing. I earn from \$5 to \$15 per week extra doing this. Am also active in the National Guard.

"The NRI experimental kits are the most practical way that a fellow can experience at first hand the actual working conditions of radio circuits. The kits taught me how to measure voltages, spot troubles, and find my way around inside of a radio.

"Television has entered our town, and we are doing quite a bit of work in that line. Coupled together with my little experience and my NRI Training, I can say that the field of Television servicing looks quite promising."

WILLIAM COPELAND,
RFD #1,
Cleveland, Alabama.

— n r i —

**Former Cook Now Has Own Radio and
TV Business**

"At the time that I started NRI Training, I was employed as a cook, but always felt attracted to Radio. NRI guided my efforts and ambitions until today I own my truck, shop, and equipment, and have five men assisting me, part time.

"I can truthfully say that without NRI I would still be just wishing. Yours for continued success in helping others."

HENRY BOHN,
114-46 Rockaway Blvd.,
Ozone Park, New York.

— n r i —

**Television
Field Service
Engineer**



"I am employed as a Field Service Engineer for Sylvania Television and I am very much pleased with my position. It is a wonderful company to work for.

"I would like to express my heartiest appreciation to your very fine school as your Course was the foundation for my knowledge and success in Radio and Television work. I highly recommend your school to anyone who wishes to become successful in this type of work."

J. M. TICKNOR,
165 Woodside Ave.,
Buffalo, N. Y.

— n r i —



As space permits, from time to time, we plan to devote a page or two in NR-TV News to short success stories such as above. They are taken from testimonial letters we have on file. Photographs and letters of this kind are always greatly appreciated by us. We feel we should pass them on to our readers for the inspiration to be gained from a reading of them.

New Trends

In

Television Receivers

By
DON E. QUADE
NRI Instruction Department



Don E. Quade

IN 1946, when Television started on its post-war road to popularity, it was difficult to predict exactly how the public would react, or what influence this reaction would have on the design of future receivers. At that time, the receiver employing a seven-inch electrostatic picture tube was quite popular, with the ten-inch electromagnetic set rivaling it, and eventually exceeding it in popularity. Receivers using larger picture tubes were desired, but their prices were generally beyond the means of most of the buying public. Then, too, at that time, commercial picture tubes were glass tubes (metal cone tubes were not yet available), and the manufacture of cathode-ray tubes had not yet reached the real mass production stage where great savings in production costs could be effected.

Now, four years later, TV receiver design is starting to crystallize, and the modern trends are, for the most part, dictated by the desires of the buying public. The TV service man should be familiar with these trends, for he will then be in a better position to understand why circuit changes are made in commercial receivers, and he will be better able to answer the questions of prospective customers.

Practically all the changes in TV circuitry, cabinets, and components have been dictated by the demand for "Bigger and Better pictures for less money."

The use of the seven-inch electrostatic tube has practically died out and is being replaced by electromagnetic tubes in almost all the newer sets. Even the once-popular ten-inch tube is falling into disfavor and the tendency is toward

sixteen inch, nineteen inch, and even larger tubes. Some manufacturers are experimenting with twenty-four inch and thirty-inch, direct-view picture tubes for taverns, clubs, and other public gathering places.

The desire for larger pictures first manifested itself for a time in a brisk business in the sale of magnifiers for 7- and 10-inch receivers. (See Fig. 1). These magnifiers are actually lenses which enlarge the picture optically; the majority of them are made from molded plastic filled with mineral oil.

As the demand for cathode-ray tubes increased, real mass production quantities were reached, and the cost of picture tubes dropped correspondingly. In addition to this, the advent of the metal



Fig. 1. Illustration of a once-popular plastic magnifier used to enlarge pictures obtained on cathode-ray picture tubes.

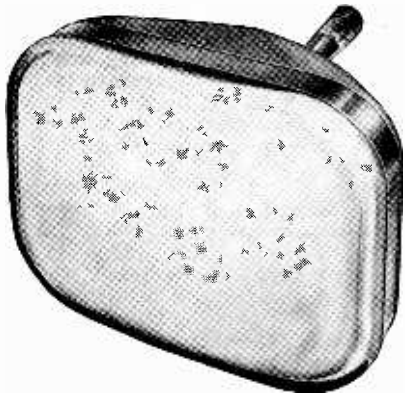

Fig. 2. A glass, rectangular picture tube.

cone picture tube helped to further reduce receiver prices and contributed to some extent to the drop in the price of conventional glass tubes.

Some idea of the present demand for larger picture tubes may be obtained by referring to the RTMA report of TV picture tube sales. This report reveals that 767,051 picture tubes were sold to manufacturers during August, 1950, eighty-seven per cent of which were sixteen inch or larger. Fifty-one per cent of these tubes were rectangular tubes.

Why Rectangular Tubes Were Developed

When the standards for television were set up, it was decided to maintain the same ratio of height to width as is used in the motion picture industry. This resulted in the $\frac{3}{4}$ aspect ratio with a rectangular picture being transmitted.

If we maintain a perfect $\frac{3}{4}$ ratio between the height and the width, and also try to reproduce a perfectly rectangular picture, the outline of the picture on a round picture tube will be somewhat as shown at "A" in Fig. 3. Note that a good deal of the picture tube face is wasted. Regardless of this, the first TV receivers manufactured would often maintain this perfectly rectangular picture with a $\frac{3}{4}$ aspect ratio. Later, set manufacturers started using more of the picture tube face at the expense of a slight loss of the picture in the corners by using rounded corners. Thus, the picture outline became as shown at "B" in Fig. 3.

Finally, in an attempt to utilize as much of the picture tube face area as possible, manufacturers began using the so-called "expanded" picture. The correct aspect ratio is maintained, but the picture is expanded horizontally until the edges of the picture touch the edges of the picture tube and the picture assumes the form shown at "C" in Fig. 3. Practically all of the corner detail of the picture is lost, but a much larger picture is

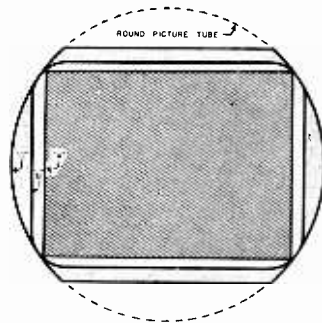

Fig. 3. Various "mask" openings used for different-size pictures on a round picture tube of fixed size. The perfect rectangular picture is shown at A while the picture with rounded corners and a slightly greater area is shown at B. The "expanded" picture utilizing the maximum area of the picture tube with a $\frac{3}{4}$ aspect ratio is shown at C.

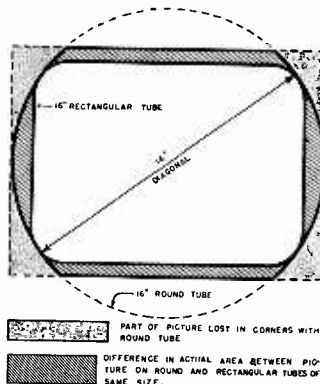

Fig. 4. An illustration showing the relationship in picture area between a picture using a 16-inch rectangular tube and a set using a 16-inch round tube with an "expanded" picture. As can be seen, a good deal of the corner area of the picture is lost with the round tube, but since most of the action is kept centered, this is not so important. It was this difference in picture area that brought about the introduction of the 17-inch rectangular tube.

obtained for a given size picture tube. Since the camera is kept centered on the action, the loss of the corner detail is not important for most television program material.

Since a rectangular picture is transmitted, it became evident that the cathode-ray tube face could be utilized with maximum efficiency if the tube face itself had a rectangular shape. Hence, the manufacture of glass rectangular tubes was started (See Fig. 2).

Although the possibility of manufacturing a

rectangular tube had been known for some time, and some experimental tubes had been manufactured even before the war, such tubes were not commercially available. The first rectangular tubes manufactured were the sixteen-inch and the fourteen-inch tubes. The dimension of these tubes is measured at the diagonal of the round-cornered rectangle formed by the face of the tube (See Fig. 4). The actual picture area is somewhat less than that for a round picture tube of corresponding size with an "expanded" picture. You can see why this is so by referring to Fig. 4.

Here, the face of a sixteen-inch, rectangular tube is shown superimposed upon the face of a sixteen-inch round tube. An approximation of the difference in the size of the actual picture area is shown by the slanting lines. Remember, however, that the corners of the picture are lost where the round tube is used. Hence, the parts of the picture shown by the dotted area are not seen on the round tube. A part of this area is not seen on the rectangular tube because of the rounded corners, but the lost portion of the picture is comparatively smaller. Nevertheless, the fact remains that the actual picture area on the round tube is slightly greater than the picture area on a rectangular tube of corresponding size. This would not be a disadvantage had not most manufacturers been advertising TV receiver picture size in "square inches" rather than in actual picture tube size. This, in turn, resulted in the difference in the shaping of the picture as shown in Fig. 3. Hence, three given sets manufactured by three different manufacturers and all employing the same size picture tube could possibly have three different sizes of pictures as far as picture area is concerned.

Because of the public acceptance of "picture area" rather than "picture tube size," sets employing the sixteen-inch rectangular tubes could be sold only at a disadvantage when compared to sets using the sixteen-inch round tube. Although the difference in picture area is small (See Fig. 4), it seems appreciable when the area is considered in square inches. This led to the development of the seventeen-inch rectangular tube which has approximately the same picture area as the sixteen-inch round tube.

Other Changes in Picture Tubes

It seems definite now that the sixteen-inch and even larger tubes will be the most popular in the future with a definite tendency toward the use of rectangular tubes. Some manufacturers are experimenting with metal-cone rectangular tubes in order to reduce production costs and also the weight of the picture tube.

Because the rectangular picture tube eliminates the waste area on the face of the tube, it enables the manufacturers to offer the buyer a

larger picture in a smaller, more compact cabinet. In a further attempt to reduce cabinet size, and hence reduce cabinet cost, manufacturers started using tubes with a greater "deflection angle." (Note: *Deflection angle is the angle through which the electron beam is swept in order to cover the face of the picture tube.*)

The effect of the deflection angle on the picture tube length can be easily seen by referring to Fig. 5. With the earlier tubes such as the 10BP4 and 16LP4, a deflection angle of fifty-two degrees is employed as shown in this figure. The length (L_1) of the picture tube is determined by the length of the neck plus the length of the "funnel." With this deflection angle, the length of the funnel must be a certain size for a given tube diameter.

With the seventy-degree deflection angle now employed, the funnel of the picture tube becomes shorter, and even if the length of the neck remains the same, the over-all length (L_2) is reduced.

An example of the savings in picture tube length that may be obtained with a greater deflection angle can be obtained by comparing two tubes of the same face diameter, but with different deflection angles. The 16LP4 has a deflection angle of fifty-two degrees and is twenty-two and one-

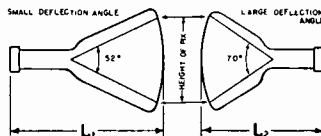

Fig. 5. Here is how a shorter tube can be obtained if a greater deflection angle is employed. Some of the new large tubes (24-inch and 30-inch) may employ deflection angles as great as 90 degrees.

quarter inches long. The 16SP4A, on the other hand, has a deflection angle of seventy degrees, and is only fifteen and seven-eighths inches long. A deflection angle of 90° has been proposed for the new large tubes.

In addition to these changes in the shape and physical size of the picture tube, other changes have been made in order to improve the quality of the picture obtained. As you know, the picture obtained on a cathode-ray tube depends on the brightness as well as on the color of the glowing screen. The "blacks" are not actually black but are the natural color of the picture tube screen. If the picture tube screen is made actually black or dark gray, then a greater contrast between the "blacks" and the "whites" is obtained in the reproduced picture.

Some manufacturers have used tinted glass for

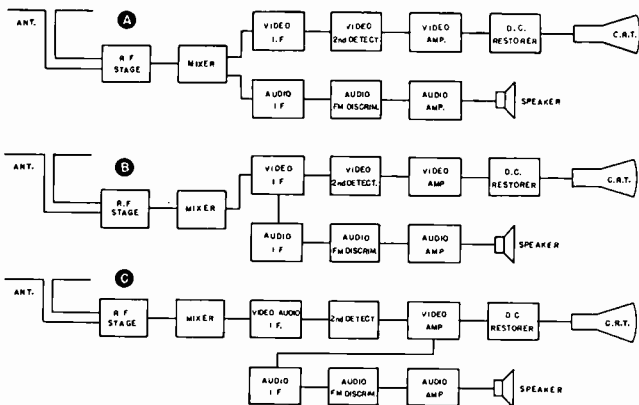

Fig. 6. Block diagrams of the signal circuits in three popular types of TV receivers. Types A and B use the conventional sound system while Type C employs the intermodulation or intercarrier sound system.

the picture tube face in order to darken the appearance of the "normal" screen. Still other manufacturers have used a dark or "black" binder for the fluorescent chemicals used in coating the screen of the cathode-ray tube, resulting in the so-called "black" picture tubes. Still others have actually incorporated built-in transparent "filters." These filters are generally placed in front of the picture tube screen, and may be either between the screen and the safety glass used in the front of the set, or in front of the safety glass screen.

Separate filters of the last described type are also useful for cutting down reflections and glare from the glass picture tube face. This improves the contrast and picture clarity.

The quality of the pictures obtained has been further improved by the use of a metallic reflector deposited behind the fluorescent screen. This reflector reflects forward light that was formerly lost inside the picture tube, and thus increases the brightness of the picture. These tubes are called "daylight" tubes.

Some manufacturers have even combined the "black" and the "daylight" characteristics of the picture tube to produce the so-called "black-daylight" picture tubes.

Especially designed deflection yokes have offered another improvement in picture quality. With a conventional deflection yoke, there is some tendency for the spot size to change as the electron beam is deflected over large angles. Hence, with the larger picture tubes, there is a definite tendency for the picture to be "out of focus" on the sides; this is particularly noticeable in the corners. There is also some over-all distortion of

the picture. Experiments have been made with the deflection yokes in an effort to overcome many of these defects. It is expected that in the future more and more manufacturers will use these special "anastigmatic" deflection yokes.

Simplification of Circuit-Reduction in Tubes and Stages Used

In an effort to reduce the cost of TV receivers without sacrificing the quality of the picture obtained, set manufacturers have tried a number of different circuits. Experiments along this line have been so successful that the number of tubes used in receivers has been reduced from about thirty to nineteen, or twenty-one in the newer receivers. This has been accomplished without a loss of picture quality or sensitivity. In fact, in some cases the receiver sensitivity has actually been improved.

One of the first steps taken to reduce the number of stages and the number of tubes required was to make some changes in the sound system. In Fig. 6A is shown a block diagram of the audio and video channels of one of the earlier TV receivers. The sweep circuits, sync circuits, and the power supply circuits are not shown. A separate audio i.f. channel is used, and the audio i.f. signal is obtained from the mixer stage. Because a separate channel is used, as many as three audio i.f. amplifier stages were employed in the sets using circuits of this general type.

In later sets, it was found possible to utilize one or two of the video i.f. amplifier stages as common amplifiers for both audio and video signals. Thus the sound take-off was transferred from the mixer to the video i.f. section as shown in Fig. 6B. This allowed a reduction of one or two tubes in the sound i.f. stages without a loss of audio gain.

Still other manufacturers have gone over to the "inter-carrier" sound system in which the 4.5 megacycle "beat" between the audio and the video i.f. carriers is used as the audio i.f. signal. In such sets, not only is the video i.f. common to both the video and the audio signals, but often the video amplifier is also a common channel to both signals. The signal circuit block diagram for sets of this type is shown in Fig. 6C. In such sets, it is seldom that more than one stage of audio i.f. amplification is used ahead of the audio i.f. second detector (f.m. discriminator). Further savings in tubes and components have been made in newer receivers by employing somewhat different and more efficient circuits.

As an example, in the famous RCA 630TS tele-

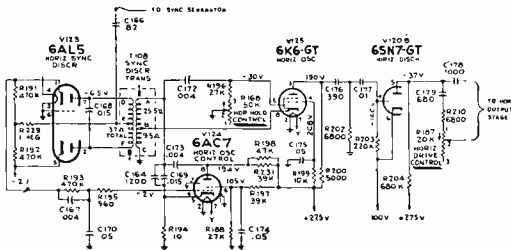

ment appears to be a variable condenser in the photograph, it is actually a variable inductance. The inductance coils consist of "printed" or stamped spiral coils on thin fiber plates. The copper plates of the rotor move in and out between the flat spiral coils, and increase or decrease the inductance of the coils.

Thus, by using more efficient circuits, many manufacturers have actually been able to increase the gain of the front-ends used in their receivers while, at the same time, improving the interference rejection and reducing the cost of the units.

As a further aid towards reducing interference, some manufacturers have started to use higher intermediate frequency values. For a time, almost all the sets used a video i.f. of 25.75 mc. and an audio i.f. of 21.25 mc. In many newer sets, the video i.f. and the audio i.f. have been higher than 40 megacycles. By using higher i.f. values, it is easier to obtain the broad-band response desired while, at the same time, reducing interference.

Component Changes

There is an increasing use of miniature tubes in TV receivers. Even in the case of the high-voltage rectifier tubes used to obtain the high second anode voltage required for the cathode-ray picture tubes, miniature tubes are being used in increasing quantities. Since the peak voltage of such tubes is limited, voltage doubler circuits employing the miniature tubes are often used in some sets.

An idea of the physical sizes of the miniature and the regular size high voltage rectifier tubes may be obtained by comparing the two tubes shown in Fig. 10.

At the same time an increased use is being made of substitutes for tubes. Many sets use germanium diodes such as the 1N34 in place of diode tubes for the second detector. And more sets are using selenium rectifiers in place of the low-voltage rectifier tubes.

By using the new highly efficient ceramic iron core, it has been possible to reduce the amount of core material used in the horizontal sweep output transformer while increasing the efficiency of this transformer. An example of a conventional powdered iron core horizontal output transformer and the new ceramic core horizontal output transformer is shown in Fig. 11.

The use of the more efficient horizontal output transformer has permitted smaller tubes to be used for the horizontal output amplifier while permitting the greater deflection angles used in the newer cathode-ray picture tubes. Printed "integrating" and "differentiating" circuits have been used by some manufacturers to reduce re-

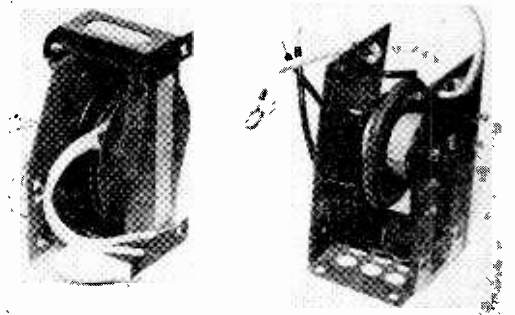

Fig. 11. Two types of horizontal output transformers used in TV receivers. The transformer with the larger core has a conventional powdered iron core, and is not as efficient as the transformer with the smaller core which is of the new ceramic material.

ceiver assembly time and over-all cost.

More and more manufacturers are using the new "disc" ceramic by-pass condensers and the small tubular "ceramicon" condensers in place of paper condensers. In Fig. 12, the tubular paper condenser and a ceramicon condenser having the same electrical value are shown. Note the comparatively small size of the ceramic condenser. Next to these two condensers is shown a molded paper condenser and a "disc" ceramic condenser having the same electrical size.

Where paper condensers are still used, the tendency is toward an increasing use of "molded" condensers and away from "conventional" condensers consisting of a wax-impregnated cardboard tube in which the condenser is mounted. The newer paper condensers are molded in special plastic compounds.

Another trend is noted in the increasing use of permanent magnet focus "coils" in place of the electromagnetic coil popular for so long (See Fig. 13). Where electromagnetic focus coils are employed, many manufacturers have also incorporated an electrical focus control as well as electrical horizontal and vertical centering controls. The new permanent magnet focus coil may be adjusted to center the picture (as well as to focus the electron beam) by mechanical adjustments which are a part of the focus coil itself. This reduces the amount of wiring in the receiver, simplifies assembly, and generally results in an over-all reduction in cost.

Even small component changes have been made in order to reduce the over-all cost. Hence, most modern TV receivers have a "partial" cathode-ray tube socket rather than a complete socket. The partial socket is designed to include only the used pins on the cathode-ray tube base and is

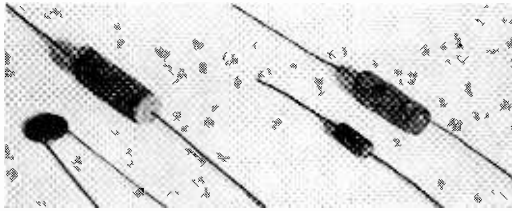

Fig. 12. An illustration showing the comparative sizes of paper and ceramic condensers of equal electrical size. The small tubular ceramic condenser and the paper condenser beside it (Right). The disc ceramic condenser and the paper condenser beside it (Left). Ceramic condensers are being used in increasing quantities in modern television receivers.

generally about half the size of a more conventional socket. The size of the vertical output transformer has also been reduced in the newer sets.

In some sets, the use of comparatively high impedance deflection yokes has permitted direct coupling between the horizontal and/or vertical output amplifier tube and the deflection yoke, thus eliminating the use of output transformers. In other instances, auto-transformers are used for the horizontal output, so that a separate secondary winding for the deflection yoke is not required.

Trend Towards Simpler Operation

Most manufacturers have attempted to reduce the number of controls on the front panel of the receiver—that is, those controls which the owner of the set needs to operate. While many of the sets first manufactured had controls such as *horizontal hold, vertical hold, focus, contrast, brightness, fine-tuning, channel selector, volume*, and similar controls on the front panel, some of the newer sets have as few as three or four controls.

The functions of many of the controls have been taken over by "automatic" circuits such as horizontal automatic frequency control circuits, automatic gain control circuits, and automatic brightness control circuits. In other instances, circuits have been made sufficiently stable so that readjustment of the receiver in operation is not necessary.

This trend toward simpler operation of TV receivers has also emanated from the public demand that sets be easier for the layman to operate and obtain good pictures. In many instances, TV receiver owners accustomed to operating simple two-control radio receivers have found it difficult to adapt themselves to the multiple controls of a TV receiver.

Page Sixteen

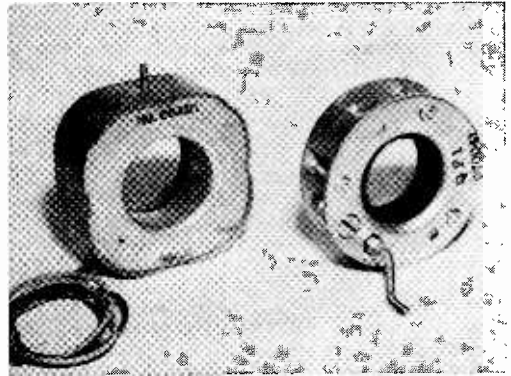

Figure 13. (Left) A conventional electro-magnetic type focus coil. (Right) The new permanent magnet type focus coil employed in the more modern TV receivers.

Simplified Installation

In order to reduce the problems encountered in installing and "setting-up" TV receivers, most manufacturers are now shipping the TV receivers with the picture tube already mounted in place. When Television first became popular, many of the receivers were shipped with the picture tube separate. It was necessary for the serviceman to remove the tube and the receiver from their respective shipping cartons and then mount the tube in the receiver before the receiver could be "set-up."

Many of the newer sets have provision for both 75-ohm and 300-ohm input so that either "twin lead" or coaxial cable may be used for transmission line.

In order to reduce the necessity for an outside antenna in comparatively strong signal areas, TV manufacturers have increased the gain of the receivers by using more efficient circuits and newer high gain tubes such as the 6CB6. By using higher gain front-ends, the sensitivity of some TV receivers has been improved as much as two or three times. This increase in gain has permitted a greater use of indoor antennas.

Many manufacturers are now equipping their sets with built-in antennas, so that even the simple "bug" or "rabbit ear" antenna is not needed. Some of the built-in antennas are little more than a folded dipole made of twin-lead, while others are fairly complicated, and even provide tuning for optimum reception on each channel.

Easier Servicing

The Television manufacturers are making a real

effort to make the servicing of TV receivers easier for the Technician. This is a definite trend which will probably continue.

Some manufacturers are building the separate sections on individual sub-chassis so that a complete section may be removed from the TV receiver for easy servicing. Other manufacturers, while not carrying the construction to quite this extreme, are building some circuits on sub-chassis.

Still other manufacturers, in order to make it easier to handle the TV receiver, are building the major sections on two or more comparatively small chassis rather than on one large chassis. Such construction makes it easier for the serviceman to remove the chassis since a small chassis is easier to handle than a large one. Other TV manufacturers have made an effort to arrange the receiver chassis lay-out so that fixed adjustments are easier to reach, and so that the parts will be more accessible for servicing.

All manufacturers seem to be making a greater effort to get available service data on the receivers to the service men as soon as the sets are on the market. In the past, TV receivers would often be sold for a year or longer before instruction manuals and schematic diagrams were available.

Since it takes considerable time to prepare a service manual, it is easy to understand this delay. In order to get the service data in the hands of the service man when the sets go on the market, many manufacturers have started issuing *preliminary service manuals* in which the schematic diagram and other vital data is given, to be followed later by a more complete conventional service manual.

Other Trends

In line with the policy of manufacturers to reduce the prices of TV sets while maintaining quality of operation, many manufacturers have gone to molded plastic and to metal cabinets for their lower-priced model receivers. Plastic cabinets have proved so successful in some cases that even console receivers have been manufactured using molded plastic one-piece cabinets. A console receiver is one designed to be placed on the floor yet smaller than a conventional console.

Summary: Manufacturers are attempting to produce better television receivers at lower prices. Technically, the improvements consist of more efficient circuits using fewer tubes to get the same results, less expensive components, and improvements in lay-out and wiring so that smaller chassis and hence smaller cabinets may be used. At the same time, the sensitivity of receivers has been improved and more efficient

types of built-in antennas have been developed so as to reduce installation costs and time required for installing and setting-up a receiver.

More and more "automatic circuits" are being employed so as to reduce the number of controls that must be adjusted by the TV receiver owner in order to obtain a good picture. This makes the receiver easier and simpler to operate, and thus more appealing to the general public.

There is a definite trend toward larger picture tubes with the sixteen-inch tube and larger tubes becoming more popular. Rectangular tubes are increasing rapidly in popularity.

The relative size of TV cabinets has become smaller with respect to the size of the picture obtained. This is because of an attempt to use smaller cabinets, and thus to reduce cabinet costs, and also because of the use of smaller and more efficient components and particular attention to lay-out and wiring.

Except for theater projection, TV receiver projection seems to be falling into disfavor to a large extent. Although there are "conversion kits" for changing a direct view receiver to projection, few manufacturers are now making projection sets for general distribution.

However, even with these definite trends in Television receiver manufacture, TV receivers are far from being standardized in design. A wide number of different circuits and designs are in use, and newer circuits are being developed constantly. The service man, therefore, must continue to keep himself informed about new developments in TV so that he will be abreast of the times.



Growing Demand for TV Technicians

According to a publication of the Radio-Electronics magazine (Weekly Business Letter, 11/5/50) the servicing branch of the Radio-TV industry may soon reach a crisis because of:

1. The increasing drain of skilled manpower by the armed services and defense industries.
2. Growing demand for service technicians as more and more TV sets are put into use.
3. Insufficient training of some service technicians.



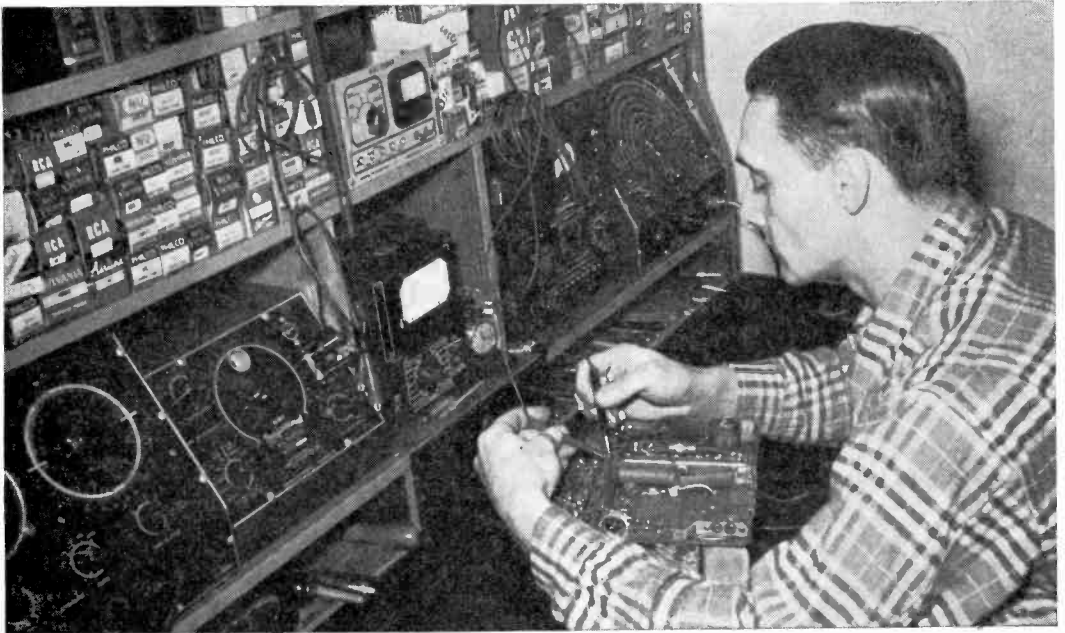

NRI Graduate Kenneth L. Kacel, 5700 St. Clair, Detroit, Mich., and five of his NRI test instruments. Mr. Kacel says, "I have used NRI instruments for three years without failure. They are simpler to use than any others I have seen on the market. Dollar for dollar they are the best buy in comparison to other instruments."

PLACE CHRISTMAS ORDERS EARLY

It is customary for us to receive, at this time of the year, many letters from students and graduates, members of their families and friends inquiring about NRI professional testing instruments, and other NRI services, because these items are desired for Christmas presents. Last year we gave condensed information about each item available through our Supply Division. This proved very popular and we are glad to do it again this year. See following pages.

Those of our readers who are prepared to send orders for these items are urged to do so now. For those who must wait until nearer Christmas, we promise to try to make shipments within one day of receiving the order. That means Monday's orders, for example, are shipped Tuesday. Tuesday's orders are shipped Wednesday, etc., but Friday's orders are shipped Monday. The Institute is closed on Saturday's.

We remind you that mail moves slower at this season than at other times. A letter may take a day or two longer to reach us. Likewise, shipments move slower, too. More time must be allowed for delivery. We will do everything we

can to rush shipments but please help us avoid impossible situations. Every year we receive orders within a few days of Christmas marked "Christmas present, please rush" or "must get here before Christmas," with not enough time for the shipment to get there. That leads to disappointments, and awkward explanations.

Remember, we do not sell to those who are not students or graduates except when the item is bought for a student or a graduate. That means a father, mother, wife, sweetheart or friend may purchase any of these items for a student or a graduate but we must have the student's name and student number as part of our record.

These items make excellent Christmas presents. To help keep the purchase secret from the student, the shipment may be sent, if desired, to any relative or friend, just so we have the name and address or student number of the student. Convenient order blank is on page 23. Mail your orders early—the earlier the better. We will extend every possible cooperation to help the lucky recipient of the shipment have a Merry Christmas and happy holiday season.

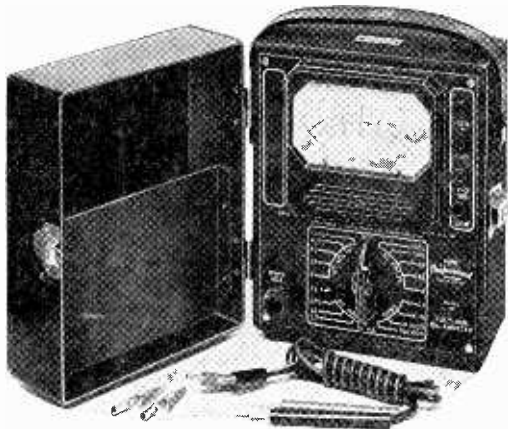

MODEL 45

NRI Professional Volt-Ohm-Mil-Ammeter

IDEAL FOR RADIO OR TELEVISION WORK

We are proud to offer such a fine instrument at this reasonable price. A Volt-Ohm-Mil-Ammeter is a basic instrument, actually seven separate instruments built into one. Each section of the instrument is instantly available merely by turning the center selector switch. Specifications:

1. Five d.c. voltmeter ranges, at 20,000 ohms per volt. Maximum d.c. range 1200 volts.
2. Five a.c. voltmeter ranges available, sensitivity 5000 ohms per volt. Maximum range 1200 volts.
3. Micro-amperes 0-60.
4. Milliamperes, d.c.—0-1.2; 0-12; and 0-120.
5. Amperes: 0-12.
6. Four well divided ohmmeter ranges, with maximum range of 100 megohms. Zero adjust control on front panel.
7. Attractive maroon crackle finish—nickel plated hardware—6 $\frac{1}{2}$ inches wide, 7 $\frac{1}{2}$ inches high, 4 $\frac{1}{4}$ inches deep.
8. Shipped complete with operating instructions, test leads, alligator clips, and detachable cover.
9. Portable. Actual weight 5 pounds, shipping weight, 11 pounds. Shipped express, collect.

Price \$39.95

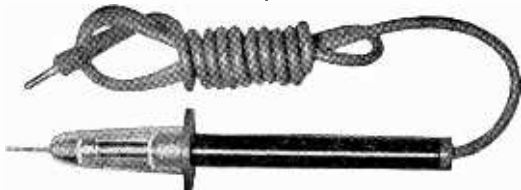

Television High Voltage Probe. Extends range of Model 45 to 30,000 volts. \$7.00 postpaid.



Announcing the New Model 69 NRI Professional Tube Tester

WITH BUILT-IN ROLL CHART

Designed to test the latest Radio and Television tubes. Convenient, built-in roll chart quickly furnishes information for testing well over 700 tubes. Comes complete with detailed instruction manual and procedure for adding your own chart listings as new tubes are introduced. Approved RMA emission circuit keeps the possibility of obsolescence at the very minimum. Specifications:

1. Has 8 tube test sockets, including socket for nine pin miniature tubes used in FM and TV.
2. Thirteen filament voltage taps—for all receiving tubes.
3. Manual line voltage adjustment.
4. Separate tests for multi-function tubes.
5. Beautiful maroon crackle finish, including removable cover. Size 10" x 10" x 6 $\frac{1}{2}$ ".
6. Actual weight 11 $\frac{1}{2}$ pounds, shipping weight, 15 pounds. Shipped express, collect.
7. Power requirements—50 to 60 cycle, 110-120 volts a.c. only. (Cannot be used on d.c. power.)

Price \$49.50

Our newest model tube tester has been engineered and priced exclusively for NRI men. It is a truly professional test instrument—one which will give your customers confidence in your work. Ideal for beginners or "old hands." Please use order blank on page 23.

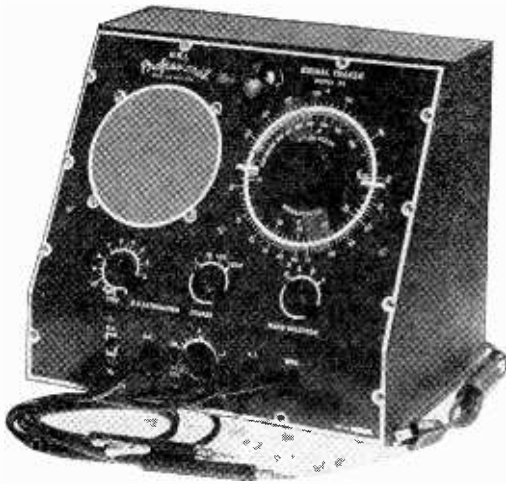

MODEL 34

NRI Professional Signal Tracer

TUNED CIRCUITS—GIVE HIGH PERFORMANCE

Signals can be traced from antenna to loudspeaker. Trouble is quickly localized in dead receivers. Greatly assists beginner or experienced serviceman in finding stubborn cases of hum, noise, or distortion. Sources of oscillation in r.f. or i.f. stages can be quickly isolated. Two separate inputs make the instrument ideal for tracing down intermittent trouble.

One special use for this instrument is in measuring the "gain-per-stage." Also, because this instrument uses two stages of tuned radio frequency amplification, it can readily be used for alignment purposes. A Signal Generator is not essential. The actual broadcast station signal is used instead. The instrument is practically fool proof—anyone can safely use it. Detailed instruction manual is included. Specifications:

1. Power requirements—50 to 60 cycle, 110-120 volts a.c., only.
2. Sturdy maroon crackle finish case—12" x 8¼" x 10¼". Handsomely etched aluminum panel.
3. Tubes included: 2—6BA6; 1—6SQ7; 1—6K6-G; 1—6E5; and 1—5Y3-G.
4. Frequency coverage is 170 kc. to 11.3 mc., in four bands.
5. Five inch dynamic loudspeaker provides audio output. Also has visual output indicator.

Price \$52.50

Actual weight—15 lbs. Shipping weight—20 lbs. Shipped by express, collect. Please use order blank on page 23.

Page Twenty



MODEL 112

NRI Professional R-C Tester

No Radio and Television service shop is complete without a reliable resistor-condenser tester. Such an instrument speeds up your service work, enabling you to increase your profits and your customer goodwill.

Here's what you can do with this instrument: (1) Measure power factor of electrolytic condensers. (2) Measure capacity of all types of condensers. (3) Check all types of condensers for leakage or break-down by applying actual d.c. working voltage. (4) Accurately measure resistor values in ohms and megohms.

Specifications:

1. Capacity Ranges: .0001 microfarad to 200 microfarad, in six ranges.
2. Resistance Ranges: 10 ohms to 20 megohms, in six ranges.
3. Bridge Type Circuit, linear calibrated main scale.
4. D.C. voltage up to 600 volts for leakage test.
5. Complete with four tubes: 1-V, 6Y6G, 6SL7, and 6E5.
6. Power requirements: 110 to 120 volts, 50-60 cycle a.c. only.
7. Maroon colored, crackle finish cabinet. Measures 10 inches by 8 inches by 7½ inches.
8. Actual weight 11 pounds. Shipping weight, 13 pounds.
9. Complete with instruction manual, rubber covered test leads, and special test plugs.

Only \$34.25

Shipped by express, collect.



MODEL 88

NRI Professional Signal Generator

FUNDAMENTALS: 170 KCS. TO 60 MCS.

Designed specifically for rapid, easy alignment of radio receivers. Extremely accurate and easy to operate. Frequency coverage ideal for all AM servicing, as well as i.f. used in FM and Television. Strong harmonics and accurate calibration make the instrument useful up to 120 mc.

Invaluable in isolating the defective stage in a "dead" receiver, or in checking an audio amplifier. A stable Hartley electron-coupled oscillator circuit is used, with a cathode follower output stage. Single output jack with detachable coaxial lead. Coarse and fine r.f. attenuators. R.F. modulated, R.F. unmodulated, and 800 cycle audio output. Specifications:

1. Frequency coverage: 170 kc. to 60 mc. In six carefully selected bands.
2. Tubes included: 1-6BE6; 1-6SN7; 1-5Y3.
3. Sturdy maroon crackle finish case with handsomely etched aluminum panel. Size 12 inches by 8 $\frac{1}{4}$ inches by 10 $\frac{1}{4}$ inches.
4. Actual weight 14 pounds. Shipping weight 17 pounds. Shipped complete with detailed instruction manual.

Only \$39.85

Shipped by railway express, collect. Please use order form on page 23.

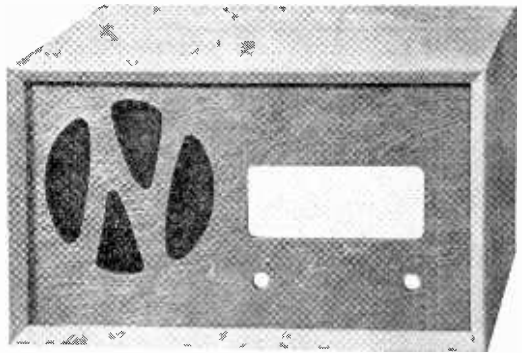

Cabinet for Your 5-Tube NRI Receiver

YOUR NRI RADIO WILL LOOK BETTER—SOUND BETTER IN THIS ATTRACTIVE CABINET

Our boys have been asking, "Where can I get a cabinet to house my NRI Radio?" Mail order houses do not have the right size. So, the answer was to have one designed and built especially for the 5-tube NRI Radio Receiver which students build after receiving kit 7-RK.

Luckily we found a cabinet maker whose shop is out in the country—out of the high rent districts—whose overhead is low. We wanted to keep the price down, and that's not easy when quality workmanship is specified.

The four sides, top, and bottom of this beautiful cabinet are made of $\frac{1}{2}$ inch Idaho white pine sanded to a smooth finish. The front panel is sand blasted plywood, a process that raises the grain of the wood by rubbing away the soft fibers.

The grille cloth is rich green, harmonizing with the color of your dial scale.

Three coats of alcohol resistant lacquer give a natural finish. The cabinet may be re-finished, if you wish, to match other furniture in your home. Corners are glued, miter joints—truly a cabinet maker's job. Rubber bumpers prevent scratching or marring furniture.

Since this cabinet is designed especially to fit your NRI Receiver, slipping it into the cabinet is a two-minute job. You'll notice an improvement in tone immediately.

Price \$4.95

Shipped by parcel post, prepaid. Please use order form on page 23.



Radio Replacement Parts Kit

INCLUDES STURDY STEEL TOOL BOX

Commonly needed Radio replacement parts. Ideal for the man who wants to get an inexpensive start. Also just the thing for a man already doing Radio and TV service work. If this kit were bought from a Radio parts distributor, it would cost approximately \$35. We offer it for only \$19.75. The parts are standard, fresh, first-quality—they are not surplus. Made by well-known manufacturers. Many parts packed in manufacturer's cartons. Here is what the kit includes:

1. Study steel tool box, 16 inches by 7 inches by 7 inches, with pop-up tray.
2. Two 456 kc. i.f. transformers, one standard size, and one miniature size.
3. A matched set of 2 r.f. replacement coils for t.r.f. receivers.
4. Two 25 ft. rolls of flexible indoor antenna wire, wound on antenna hanks.
5. One antenna coil and one oscillator coil (matched) for either a.c.-d.c. or a.c. sets.
6. Box containing 10 assorted pilot lamps.
7. Dial cord and belt replacement kit, including springs, fasteners, and other hardware.
8. Paper tubular condensers—twenty-five most popular sizes, rated at 600 volts.
9. Fixed resistors—one hundred popular sizes and wattage ratings.
10. Electrolytic condensers — eight widely used types for a.c. and a.c.-d.c. receivers.
11. Two high-grade plastic line cords.
12. One universal output transformer for either single-ended or push-pull output.
13. One A.C.-D.C. output transformer.
14. Scratch filler, for hiding cabinet scratches.
15. One tube of speaker cement and one bottle of solvent.
16. Volume control kit—six popular volume controls, four switches, eight assorted shafts.
17. Two popular types of selenium rectifiers.
18. Two jars full of standard radio hardware.

Only \$19.75

Shipping weight is 15 pounds. All Replacement Parts Kits are shipped express, collect. Not sent outside of the United States. Please use order form on page 23.

Page Twenty-two

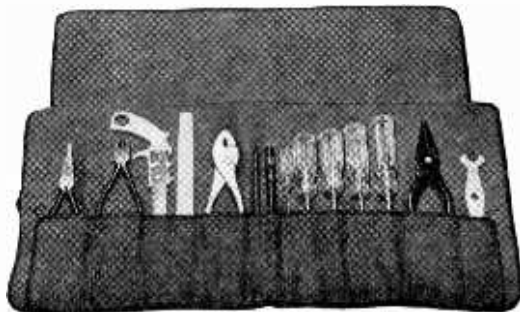

NRI Professional Tool Kit

INCLUDES ROLL-UP CARRYING CASE

A kit of fourteen carefully selected, good quality tools, complete with roll-up carrying case. You will be proud to own this fine kit of tools. They are just what NRI recommends for doing your experiments. Will last well into your professional Radio and Television Servicing career.

This is a real money-saving value. If bought at dealer's net price, it would cost at least \$10.00. Yet NRI's price, for a short time longer, is only \$7.95, including the strong canvas carrying case. The items included in the kit are as follows:

1. Long nose pliers. Professional grade, precision made, of tool steel. Polished head. Smooth handles.
2. Diagonal cutters. Precision made from tool steel. Professional quality.
3. Metal cutting saw. Removable, four position blade. Light, but very sturdy.
4. Eight inch file. An indispensable item.
5. Slip joint pliers. For general utility.
6. Double blade neutralizing tool. Designed for new miniature i.f. transformers.
7. Four-in-one bone fibre neutralizing tool. Necessary for aligning receivers.
8. Small screwdriver. Slender four-inch blade.
9. Nut driver. For five-sixteenths inch hex nuts. Good quality, plastic handle.
10. Nut driver. Same as above, for one-fourth inch hex nuts.
11. Phillips screwdriver. For special Phillips screws widely used in Radios. Plastic handle.
12. General utility screw driver. Good quality.
13. Plastic long nose pliers. Shock proof. Used to move "hot" wires in Radio and Television sets.
14. Volume control wrench. Correct size for tightening volume controls and toggle switches.

Now Only \$7.95. Price advances Jan. 1

Tool kit shipped, complete with carrying case, by parcel post, prepaid. Individual tools or carrying case not sold separately. Cannot be shipped to Canada because of Canadian import regulations. Please use order blank on page 23.



NRI Service Manuals Save You Time and Money

NOW—TWO BIG NRI SERVICE MANUALS

NRI service manuals contain radio circuit diagrams and information which is most frequently requested from NRI. This is our answer to your radio diagram problem. More than 10,000 NRI students and graduates have already purchased one or both of these manuals. Volume II follows Volume I to bring this diagram service up to date. They are companion books you will be proud to own.

Volume I contains most frequently needed diagrams of receivers built before 1946.

Volume II contains most frequently needed diagrams of receivers built during 1946-1949.

These are big, sturdy manuals. Circuit diagrams are in detail, with parts values, and many illustrations. I.F. values and alignment data are included. A complete, cumulative index is also included with each manual.

\$14.50 Each

Sent parcel post, prepaid. Please use Order Blank at right.

Use Order Blank Below For Ordering NRI Equipment

All test instruments and the NRI Parts Kit are shipped by Railway Express, charges collect. This is for fast, safe service.

Tool kits, Diagram Manuals, and the NRI Receiver Cabinet are shipped by parcel post, prepaid.

Please indicate on your order blank the amount of your remittance. Check those items requested. Give full information as to name, student number, address, and express office. Please make remittance in the form of a certified check, money-order, or bank draft.

We are very sorry, but the items mentioned on the preceding pages cannot be sent to Canada at this time. This is because of Canadian Import Regulations.

ORDER BLANK

**National Radio Institute,
Supply Division,
16th and U Streets, N.W.,
Washington 9, D. C.**

I enclose _____ (certified check, money-order or bank draft). Please send me the following material, as checked.

- Model 45 NRI Professional Volt-Ohm-Mil-Ammeter, express collect. Price \$39.95.
- High Voltage Television Probe for Model 45. Parcel post, prepaid. Price \$7.00.
- Model 69 NRI Professional Tube Tester, express collect. Price \$49.50.
- Model 34 NRI Professional Signal Tracer, express collect. Price \$52.50.
- Model 112 NRI Professional Resistor-Condenser Tester, express collect. Price \$34.25.
- Model 88 NRI Professional Signal Generator, express collect. Price \$39.85.
- Cabinet for 5-Tube NRI Receiver, parcel post, prepaid. Price \$4.95.
- NRI Professional Replacement Parts Kit, express collect. Price \$19.75.
- NRI Professional Tool Kit, parcel post, prepaid. Price \$7.95. Price advances Jan. 1, 1951.
- Volume I NRI Service Manual, parcel post, prepaid. Price \$14.50.
- Volume 2 NRI Service Manual, parcel post, prepaid. Price \$14.50.

Name Student No.....

Address

City Zone.... State.....

Express Office

If you live in Washington, D. C., add 2% for D. C. Sales Tax.

Making Voltage Measurements in Set Servicing

By ERNEST B. MULLINGS

W4MKZ

NRI Consultant



Ernest B. Mullings

THE beginner in servicing seldom takes full advantage of his voltmeter and ohmmeter. Agreed, he starts out like a house afire and buys himself a very nice multimeter or vacuum tube voltmeter. He begins using it in his servicing. But because it takes so long to "systematically" measure the plate, screen grid, cathode, control grid, and filament voltage of each tube, and check the resistance through each branch of the circuit and the voltage across each part, he may become discouraged. He might even feel that he could locate the trouble faster by the trial and error or "guess and guess again" method.

Good test equipment is not an answer in itself. A voltmeter and ohmmeter can only save you time and trouble *if they are used properly*. You cannot service sets with any amount of speed if you're going to measure *every* voltage and resistance in each set you service. It takes too much time! Although it may seem logical and systematic to go through a set and make all these tests, it really is not that at all. If you think about it a moment I'm sure you will see that it is a haphazard way of servicing because you don't even know what you're looking for in the way of trouble. Time is money, and you can really save it by using the servicing procedures developed from NRI's long experience in the field.

The real time saver is "effect to cause" reasoning. The idea here is to note the symptoms, and by a few fundamental deductions and tests, go directly to the defective section of the circuit. Sometimes you can go directly to the stage or

even the part that is defective. It all depends on the trouble in the receiver and how obvious these symptoms may be.

Generally speaking, though, you can almost always determine the defective section, and many times the defective stage. This means that you won't have to go through the tedious procedure of measuring all the voltages and resistances in the receiver circuit. You can concentrate on the section or stage containing the defect. It is this phase of servicing that I would like to touch on in this article; the measurement of voltage and resistance in the set after the trouble has been localized. A typical receiver diagram which you can refer to while reading this material is shown in Fig. 1.

Measuring DC Plate Voltages

The DC plate voltage in a tube circuit is usually measured between the plate terminal and chassis unless otherwise specified. The voltage can also be measured from the plate to the cathode, but unless the cathode connects directly to the chassis (ground) the reading will be slightly different. The manufacturer usually gives the plate voltage reading as the value between the plate and the chassis.

If you do not use a test instrument with the sensitivity that the manufacturer recommends on the service information sheet (20,000 ohms per volt, etc.) you must allow for it in your results. You see, connecting the meter from the plate to

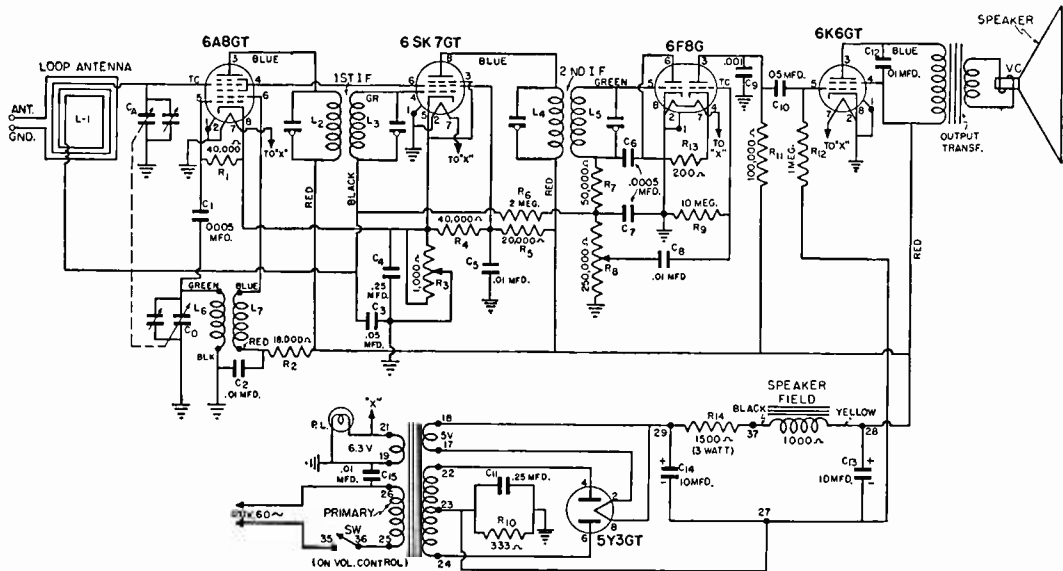

Fig. 1. Typical schematic diagram.

ground is actually the same as connecting a resistance from the plate to ground. The value of the resistance will depend, of course, on the type of meter being used. The lower the resistance of the meter, the more effect it will have on the circuit being tested.

This is an important fact to take into consideration because it will actually influence the readings you get as compared to the readings the set manufacturer supplies in the servicing data. As an example; in a voltage amplifier plate circuit the plate load resistor is usually very large, but the plate current is very low so there is not an unreasonable drop across the load resistor. However, if you connect a low resistance meter (a test instrument with a low input resistance) between the plate and the chassis you will increase the current flow through the plate load resistor. This causes the voltage drop across this resistor to increase so that the plate voltage decreases. The plate voltage on the stage may be perfectly all right, but it will change to a lower than normal value as soon as the meter is connected.

Of course, if the manufacturer used a test instrument with low input resistance and you used one also, your readings will check even though the result is not the *true* plate voltage as it might be measured with a test instrument having a higher input resistance.

From this you can see that you must make allowances for the type of meter used when it is

not the same as the one the manufacturer specifies. In most tube circuits the meter resistance won't make an appreciable difference in the readings. It is only noticeable where you encounter amplifiers having a high plate resistance and low plate current. The right hand section of the 6F8 tube in Figure 1 is a good example of this. The voltage amplifier used ahead of the power amplifier in most receivers will usually be of this type.

No Plate Voltage

When you are checking a particular stage in a receiver and you do not get any plate voltage at all, check to see if the power supply is giving you B+ voltage. If this is all right, it leaves only two possibilities. Either the plate circuit is *open* or it is *grounded*. Here is where the ohmmeter comes in handy. By measuring the resistance between B+ and the plate terminal you can tell if the circuit is open. If it is, check each individual part and wire in the plate circuit with the ohmmeter to find the defect.

On the other hand, if the plate circuit is not open, it must be grounded. Measure the resistance between each terminal in the plate circuit, and the chassis until you find the grounded one.

Be sure to use the schematic diagram as your guide when making these tests. This will enable you to determine just what amount of resistance should be measured between any two points in

the circuit. Simply trace out the DC path between the two points and note what resistances are encountered.

High Plate Voltage

If you should find the plate voltage to be equal to the full high voltage output of the power supply (B+) it usually means that there is no plate current flowing. Make sure the tube filament is lighting and check the cathode to ground circuit to be sure the cathode circuit is not open. Check the bias on the stage too, for if the control grid becomes so negative as to stop all electron flow from cathode to plate this will prevent any plate current flow and the plate voltage will be high.

Low Plate Voltage

If the plate voltage is considerably lower than normal, but is not zero, you may have a leaky plate by-pass condenser. The suspected condenser can be tested for leakage with your ohmmeter if it is first disconnected from the circuit.

Measuring Screen Grid Voltages

The screen grid voltage on a particular stage is measured between the screen grid and the chassis (ground).

When the screen grid voltage is zero you should consider the same possibility as in the case where the plate voltage was zero; the screen grid circuit is either open or grounded. Since there is almost always a screen grid by-pass condenser in the circuit, a short in this part is not uncommon. However, the screen grid circuit can be open, just like the plate circuit.

Measuring Cathode Bias Voltage

Cathode bias is a DC voltage and is usually measured from the cathode to the chassis, although it can be measured from the cathode to the control grid of the tube. The voltage involved is much smaller than the plate or screen grid voltage.

When you cannot measure any bias voltage across a cathode resistor it usually indicates that the cathode terminal of the tube socket is grounded, that the resistor itself is defective, or that the cathode by-pass condenser is shorted. Any of these possibilities may be checked with the ohmmeter.

Measuring DC Grid Bias Voltage

In modern Radio receivers the only stage using grid bias is usually the oscillator stage. In an oscillator circuit you will only get grid bias when the oscillator is working. Therefore, by simply measuring the DC voltage across the oscillator grid resistor you can determine if the oscillator

6K6GT (SG)	225
(P)	215
6F8G (P)	45
6SK7GT (P)	225
(SG)	85
(K)	3.5
6A8GT (P)	225
(SG)	85
(OP)	140
(K)	3.5
6K6GT BIAS	16.5
A. C. FILAMENT VOLTAGE	6.2

Fig. 2. Typical Voltage Table

is working. This is a convenient test that you'll want to keep in mind and use.

The DC voltage developed across the grid bias resistor is the result of current flow away from the grid toward ground. Therefore the grid end of the resistor will be negative with respect to the other end. The polarity of the voltmeter leads should correspond to this when you attempt to measure the bias voltage. R1 is the oscillator grid resistor in figure 1.

AC Filament Voltage Measurement

The filament voltage is generally AC, and should be measured between the two filament terminals on each tube socket, not between the filament terminals and the chassis. Of course, in a receiver where the filaments are all connected in parallel and one side of the filament string is grounded, you can measure from the hot filament terminal to the chassis. An example of this type of filament hook-up is shown in the receiver in figure 1. Many receivers are not connected up in the manner described above, however, so it is best to identify the two filament terminals of the tube by referring to a tube chart so that you can measure the voltage directly at the terminals of the tube socket.

Resistance Measurements

As you can see, resistance measurements usually follow voltage tests. You measure the voltages in a stage, and if any are unusual you follow up with resistance tests to locate the actual defect.

Of course, there will be times when symptoms lead you to suspect a certain part even before a voltage test has been made. In such cases you would go directly to the part and check it with the ohmmeter.

How Do You Judge The Results You Get?

In Fig. 2 you will find a typical voltage table such as the manufacturer might furnish in his service data. The service data is most desirable when servicing because it usually gives this information, and sometimes even a table of resistance measurements. These voltage and resistance readings should be used as your "standards" whenever they are available. However, when you cannot get the manufacturer's data, a tube chart or manual will often help. You can't tell exactly what the various voltages should be but you can get a *rough idea* from the "typical operation" information given for most tubes. You might also find the same tube used similarly in another receiver for which the voltages are available. There is not too much variation in voltage from one circuit to another using the same tube types.

Other Voltages

Other voltages you might want to measure in a receiver would be the a.v.c. voltage or the audio output voltage. The former is most often used as a guide in aligning the circuit, although the audio output voltage can be used. The a.v.c. voltage is a negative DC value. As the strength of the signal reaching the detector increases the a.v.c. voltage also increases. This makes it a simple matter to align the set for maximum a.v.c. voltage.

The a.v.c. circuit in the receiver shown in Fig. 1 consists of R8, R6, L3, C3, and L1. The voltage is developed across R8 and is fed to the control grids of the 6A8 and 6SK7 tubes. The a.v.c. voltage can be measured between almost any point along this circuit and the chassis.

The audio output voltage is usually measured between the plate of the output tube (the 6K6 in the case of Fig. 1) and the chassis. However since there is DC voltage at the plate terminal as well as *audio* (AC) voltage, you must use the proper multitester jacks so as to provide some means of blocking the DC from the meter. Most commercial testers have jacks marked "out" or "output." These are the ones you should use because they are so arranged that when you use them a condenser is connected in series with one of the test leads. A condenser will block DC and pass AC, so the DC plate voltage of the output tube will not register on the meter. If such jacks are not provided on the test instrument you can connect a condenser in series with one of the leads externally. As with the a.v.c. voltage, the audio output voltage increases as the signal reaching the detector increases.

The only trouble is that with an ordinary broadcast station signal the audio voltage is constantly fluctuating with the music or voice modulating the r-f carrier. This sometimes makes alignment

difficult unless a signal generator is used. The fact that the modulation is a constant tone in the signal generator makes the audio in the output stage hold constant.

Of course the appropriate operating procedure must be followed for both voltage and resistance measurements. These vary from one test instrument to the next, so there is little that can be said here about it. However, you should thoroughly study all the information that comes with the test instrument, and even write to the manufacturer if there are any points that are not clear to you. It is most important that you understand how all types of tests are made with the tester.

Get plenty of practice in making voltage and resistance measurements by experimenting on sets whenever you get a chance. Learn how to read the ohmmeter and voltmeter scales quickly and practice until you know approximately which range to use for each of the various types of operating voltage measurements encountered in typical receivers.

Always keep in mind that there will be only a few cases where *all* the operating voltages in the set will have to be measured. Generally a simple deduction, a circuit disturbance test, or some obvious symptom, will tell you the approximate location of the trouble. From there on your voltmeter and ohmmeter will take over.



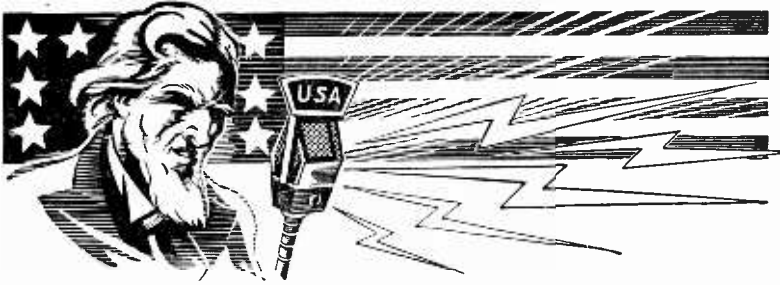

THE VETERAN'S PAGE

Devoted to news items and information of special interest to veterans taking NRI courses under the GI Bill of Rights.

The Old Year Ends

AS 1950 draws to a close each G.I. student should give special thought to his own particular situation. How is he making out? Is he "getting there" as rapidly as he should?

The ending of a calendar year, and the starting of a new one suggests New Year's resolutions, but *this is a special year*. For one thing, the first half of *your* century is ending. The second half now begins. A few of those who read this may be around when the next half century ends, but they'll be far beyond the prime of life. For most readers we may say "This is a grand occasion for resolutions; it will not come again—ever—under the same conditions."

It just happens too, that this particular New Year has special significance to any veteran who proposes to start a course—at NRI or elsewhere—under the G.I. Bill. As the law stands, most veterans will *not* be permitted to start courses or even to resume previously interrupted courses after July 25, 1951.

The significance for G.I. students now enrolled is that they should so schedule their progress that they will finish their *present* courses in time to be lined up for any new course before the deadline. By June, if you have 20 lessons to complete, you *just won't be able* to complete the first course *in time* to get enrolled for a second.

There is nothing the Institute can do about getting students or graduates enrolled before the cut-off date; there *is* something the student or graduate can do! Plan—and work!

These steps are now required before you can take a second course:

1. You furnish Form 7-1905e to the VA but it must show you completed (or interrupted) your course.
2. The VA considers your request (a normal delay follows).
3. The VA issues you a Certificate of Eligibility.
4. You must get the Certificate of Eligibility to the Institution and be enrolled by July 25, 1951.

The first three steps don't count unless number 4 is also completed—as regulations now stand. You can't apply for another course while you're still in training—you must complete the first course or interrupt so that 7-1905e can be supplied to you.

These warnings are published in each issue of NATIONAL RADIO-TV NEWS so that you may be saved from disappointment on July 26, 1951.

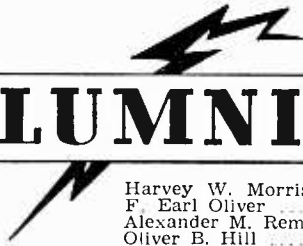

N.R.I. ALUMNI NEWS

Harvey W. Morris	President
F. Earl Oliver	Vice Pres.
Alexander M. Remer	Vice Pres.
Oliver B. Hill	Vice Pres.
Claude Longstreet	Vice Pres.
Louis L. Menne	Executive Secretary

RATHBUN OF BALTIMORE IS PRESIDENT-ELECT OF THE NRI ALUMNI ASSOCIATION

Oliver of Detroit, Kraft of Philadelphia, Longstreet of Westfield, New Jersey and Kunert of New York are elected vice-presidents

ON October 25 the balloting for officers to lead the NRI Alumni Association during 1951 came to a close. The results this year were no great surprise. Our members should be congratulated upon having again chosen fine leaders. 1951 will be another banner year.

Mr. H. J. Rathbun, who is elected president, has been very active in our Alumni Association for many years. He has held several principle offices in Baltimore chapter. He was Chairman for a number of years. He also served a number of terms as a national vice-president. He is a good Radio and Television man and can always be depended upon for a fine talk or demonstration. In Baltimore he has built a very strong following because of his willingness to give a talk to the members, or demonstrate the use of equipment, and to give genuine attention to individual problems. Mr. Rathbun has never been too busy to extend a helping hand to a fellow member. He is an ideal man for president.

Rathbun will succeed Harvey W. Morris of Philadelphia, who will complete his term as President on December 31st, 1950.

Harvey will not step aside entirely. He will continue to serve the members of Phila-Camden Chapter as he has for so many years. Harvey Morris is a grand fellow. He has had a splendid year as President of our organization.

Of course all of our members know F. Earl Oliver of Detroit who had done such excellent work in our local chapter there. Norman Kraft is a member of long standing in Philadelphia-Camden chapter. The recognition given to him by elevating him to the office of vice-president is well deserved. Mr. Kraft lives in Perkasio, Penn-

sylvania which is some thirty-five or forty miles from Philadelphia. This distance however does not keep Kraft from attending meetings regularly even during the severest winter weather. He has been a most faithful member of our Alumni Association.

Claude W. Longstreet of Westfield, New Jersey, served as vice-president this year and it is gratifying to have him re-elected for 1951. Mr. Longstreet has the distinction of being the only national officer who does not have a chapter affiliation. Louis J. Kunert of New York is an old reliable who is coming to the front once more. Mr. Kunert is a past president of the NRI Alumni Association, was also vice-president a number of terms and for many years has been the faithful secretary of New York chapter. Our many members in New York Chapter will be pleased to know that they again have a representative in our official family.

Mr. Alexander Remer, who ran a good race against Mr. Rathbun will be a strong candidate for president a year hence. Men like Remer cannot be denied.

1951 promises to be a very interesting year. Radio-Television is moving forward by leaps and bounds. The affairs of our Alumni Association will be in good hands to live up to the preamble of our constitution and bylaws which is "to cultivate fraternal relations among the alumni of the National Radio Institute, to foster the spirit of unity among the alumni, to encourage and aid the Institute in the dissemination of radio knowledge, to consider and foster new ideas and trends in radio, and by the interchange of helpful information promote the welfare of the Institute and each alumnus."

Chapter Chatter

Chicago Chapter is swinging into the winter season with increased tempo. New officers have been elected . . . programs planned in advance . . . Chicago Chapter is rolling again.

Charles C. Mead, who did such an excellent job as Secretary last year, has been elevated to the office of Chairman. Raymond Brooks, a new man who has become tremendously interested in our Chapter, has been elected Secretary. Clark A. Adamson is Treasurer, Louis Brodhage is Librarian and Harry Andresen is Sergeant-at-Arms. A very fine group of men.

Already attendance is picking up. An excellent entertainment committee composed of Louis Gold, Louis Brodhage and Charles C. Mead have been appointed and they promise that refreshments will be served at most of the meetings. . . . Highlights of recent meetings were as follows . . . a discussion on Servicing of Automobile Radios . . . an entire meeting devoted to an open Service Forum . . . a talk by one of our own members on Antennas.

Chicago Chapter meets on the second and fourth Wednesday of each month at 8:00 P.M., at 666 Lakeshore Drive, in the Tower space. This is in the American Furniture Mart Bldg. Enter building through the west door.

From Philadelphia comes information that their permanent place of meeting now is in the K of C Hall, Tulip and Tyson Streets in Philadelphia. This place offers excellent facilities and is easy to reach by streetcar . . . meeting nights are the second and fourth Monday of each month.

Detroit Chapter got under way for the fall and winter season with a stag party which was held at Chrymoto Club in Windsor, Ontario, Canada. This was an interesting affair with one group of fellows watching a boxing match on Television, another group watching a night football game which was taking place in the stadium across the street, others playing billiards and pool, and the customary crowd entertaining themselves with cards. It was a fine get-together. Bob Mains showed us movies of our last two parties.

Financial Secretary F. Earl Oliver submitted a financial report which shows the Chapter in excellent condition. Some swell work by Chairman Clarence McMaster and Recording Secretary Harry Stephens, too. Fine officers in Detroit Chapter.

Some lively discussions on the TV color decision of the FCC, also the proposed ordinance to license TV servicemen in Detroit . . . which ordinance most of our members vigorously oppose. Harold Chase was on the committee which went



L. L. Menne and Frank Cook at recent meeting of Phila-Camden Chapter. Mr. Cook, Chief of Training, NRI, addressed the chapter on this occasion.

to the city council to oppose this licensing law. . . . Chase, incidentally, gave us a bang-up talk on "The business end of TV servicing" . . . Meetings on the second and fourth Friday of each month at Electronics Institute, 21 Henry Street, at Woodward.

Secretary Thomas P. Kelly of **Baltimore Chapter** is always regular with his reports . . . a good secretary means much to a local Chapter . . . Tom Clark and C. M. Witt gave a talk and demonstration on Tracing Sync Pulses with the Oscilloscope . . . A special meeting on October 24 at which time refreshments were served. . . . A bigger meeting and dinner party scheduled to honor Mr. H. J. Rathbun, who is President-elect of the NRI Alumni Association for 1951. . . . You are missing something if you fail to attend meetings of Baltimore Chapter held on each Tuesday night of the month (except the first Tuesday of the month) at Redman's Hall, 745 West Baltimore Street.

New York Chapter is hustling along, as usual . . . Thomas Hull, Jr, a member who is quite a lecturer, delivered a series of talks extending over four meetings covering "Power Supply Circuits," "Audio Frequency," "R.F. and Oscillators," and "I.F. Circuits." These were fine lectures demonstrated on the board, also through the use of an oscilloscope and meters.

New York Chapter meets on the first and third Thursday of each month at St. Marks Community Center, 12 St. Marks Place, between Second and Third Avenues, in New York City.



Here And There Among Alumni Members

Secretary Harry R. Stephens, of Detroit Chapter, writes: "Today I went out to see our former Chairman, Harold Chase, to arrange for him to make

a talk on the business end of TV servicing at our next meeting. Chase, as you know, has a fine store, and is in Television servicing up to his ears. I was amazed at the activity. Four phones going constantly—a continual stream of people going in and out and a regular beehive with servicemen buzzing around. Harold has forty-five people working for him now and eight trucks on the road. That fellow is really doing things—big things."

—n r i—

Graduate Charles P. Buffington, of Union Bridge, Maryland, recently accepted a position with a television service company in Frederick, Md.

—n r i—

Joe W. Vann of Little Rock, Arkansas, has been in the Electrical Construction and Repair field since 1929, but is gradually changing over to Radio and Television which is alive and more productive financially. He is ready for an upswing in TV when it reaches his city.

—n r i—

Alumnus Gilford H. Bennett, of Sioux City, Iowa, is a radio inspector with the Wincharger Corporation of Sioux City, a subsidiary of the Zenith Corporation.

—n r i—

Here is something unusual in the line of combination jobs. Alvin B. Fletcher, of Denison, Texas, is a Patrolman for the U. S. Fish and Wildlife Service in Texas. He does Radio work on the side. Guess which he likes best. Radio! That's right!

—n r i—

Nicholas J. Costa of Brooklyn was recently employed by Capital Television as an Installation man.

—n r i—

NRI Graduate James Bangley, Jr., and NRI Student Roland Greene have a very successful Television servicing business in Suffolk, Virginia. Their business is growing by leaps and bounds. In addition, both are engineers at Station WLPM, Suffolk, Virginia.

—n r i—

Alumnus J. E. Sullivan, of Chattanooga, Tennessee,

has a nice spare-time shop paying about \$20 a week. Finds the NRI Receiver one of his best advertisements.

—n r i—

Graduate William R. Wolfenbarger, is making good in Oklahoma City, Oklahoma. He has just been made Service Manager of the Oklahoma City Branch of the Jenkins Wholesale Division.

—n r i—

Graduate Grant A. Colton, Gouverneur, New York, is doing well as a Radio Repairman for Sears, Roebuck & Company.

—n r i—

W. F. Barnett, of Richmond, Indiana reports picking up satisfactory pictures from Television stations in Detroit, Columbus, Cincinnati, Louisville, Kentucky, and other distant stations. This is real "DX". Barnett built his own Television receiver using the RCA type 630TS circuit.

—n r i—

Alumnus Joseph Jarzabek, of Buffalo, New York, tells us of his plans for proceeding from his spare-time business into a full-time business partnership. Says things are progressing beyond his expectations.

—n r i—

Graduate James E. Kottinger, of Mt. Shasta, California, participated recently in a "hamfest" held in his city. Twenty-three mobile stations were present for the meet. By coincidence, a large forest fire occurred in the same vicinity, and an emergency communications network was immediately set up. The hams were of great assistance to the Forest Rangers in getting the fire under control.

—n r i—

Graduate Edward Baclawski, of Ansonia, Connecticut, recent NRI visitor, is doing well. Has his own Radio and Television service business — full time. His brother operates a music shop in connection with the same business establishment.

—n r i—

George E. Fitch, Key West, Florida, is employed by the U. S. Navy through Civil Service, as an Electronics Engineer. He is also interested in amateur Radio.

—n r i—

And now, from all of us here at the National Radio Institute, may we add our very best wishes for a Holiday Season filled with good cheer. We've enjoyed working with you.

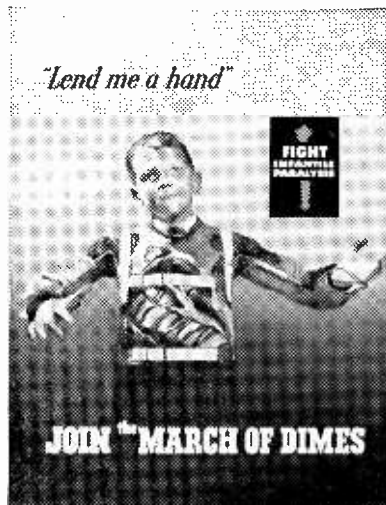

NATIONAL RADIO-TV NEWS

16th & U Sts., N.W.

Washington 9, D. C.

Sec. 36.44, P. L. & R.
U. S. POSTAGE
1c PAID
Washington, D. C.
Permit No. 7052

For:

Mr. Francis H. Fingado
611 17th St.
Denver 2, Colo.

25236

4

POSTMASTER: If addressee has removed, notify sender on FORM 3547 postage for which is guaranteed.



Vol. 14 December-January, 1950-1951 No. 6

Published every other month in the interest of the students and Alumni Association of the

NATIONAL RADIO INSTITUTE
Washington 9, D. C.

The Official Organ of the N R I Alumni Association.
Editorial and Business Office, 16th & You Sts., N. W.,
Washington 9, D. C.

L. L. MENNE, EDITOR
J. B. STRAUGHN, TECHNICAL EDITOR

NATIONAL RADIO-TV NEWS accepts no paid advertising. Articles referring to products of manufacturers, wholesalers, etc., are included for readers' information only, and we assume no responsibility for these companies or their products.

<i>Index</i>	
Article	Page
Mobile Two-Way Radio	3
How NRI Graduates are Forging Ahead ..	8
New Trends in Television Receivers	10
NRI Test Instruments and Supplies	18
Making Voltage Measurements in Set Servicing	24
The Veterans' Page	28
NRI Alumni Association Election Results..	29
Chapter Chatter	30
Here and There Among Alumni Members..	31

Printed in U.S.A.