

# NATIONAL RADIO NEWS

June-July, 1934

Volume 6  
Number 2



TWENTIETH ANNI-  
VERSARY YEAR

OF THE NATIONAL  
RADIO INSTITUTE



## . . . the power of the group is always stronger than the power of the individual . . .

From a talk by J. E. Smith, President of N. R. I., before a meeting of the Baltimore Chapter of the N. R. I. Alumni Association. It appears below in full.

---

J. E. Smith

---

I WAS particularly pleased at the reception given me tonight. This is the first opportunity I have had to visit a Local Chapter of our Association and to say merely that it is an honor to be here is putting it very mildly indeed.

The Alumni Association of N. R. I. has had its problems—its ups and downs—but it has always come out on top. Why during the business crisis, last year, the bank in which Alumni funds were deposited closed its doors and tied up about \$600 of Alumni Association funds. But with the N. R. I. backing it—and with the able guidance of Mr. Murray, the Association's Executive Secretary, it has passed the stumbling block and forged ahead. This alone is sufficient proof that the Alumni plan is right, otherwise it would not succeed.

You have made a wise selection in your officers of this Local. Mr. Dunn, your Chairman, conducts his meeting in a manner which would do credit to any business executive. And Mr. Ruehl, your Secretary, even in the short time which has been at his disposal, is already putting the affairs of the Association in very commendable shape.

You men of the Baltimore Chapter have a wonderful opportunity to do good: first, for yourselves; second, for each other; third, for your Association, and finally, for the Radio Industry.

You help yourselves every time you attend one of these meetings—and you benefit by the fact that you belong to this Association. I doubt if there is a man here who can come to one of these meetings without learning something—something that he can really put to use and which will mean dollars and cents in his pockets. You help your fellow member by the close association which gives you an opportunity to give him the benefit of your

ideas—the benefit of your experience. You help yourself and your fellow member by the power you have created—in organizing this Local—the power of a group, which is always stronger than the power of an individual.

You benefit your Alumni Association by making your Chapter something to be looked up to by other Alumni Members. You make your Chapter a pride to yourself, and consequently a pride—and a big advertisement—to the N. R. I. Alumni Association as a whole.

And finally, by banding together in this manner—you aid the Radio Industry, because you place just one more obstacle in the path of the unethical Radio man—that type to which Mr. Murray so descriptively referred as “the gyp artist.” I believe that every man who is a member of this Baltimore Local fully realizes his responsibility along the lines I have just mentioned. And I have the utmost confidence in you to come through as N. R. I. expects you to.

Some of you have been less successful than others—but conditions are definitely on the up trend and every one of you should profit materially in the coming era. I have the utmost faith in the ability of this country to return to its normal and deserved prosperity. I believe in this country. I believe in Radio and I believe in the ability of every one of you to succeed in Radio. But let me say that you could not follow a better method to help along your success than by maintaining this Local Chapter and working hard for its success.

One thing that has most impressed me at this meeting was the apparent unselfishness which exists. Every man among you seems to have a sympathetic interest in the problems of your brother members, and if this isn't the spirit which will take you forward to success—then I don't know what is. It is the spirit upon which your Alumni Association was formed—it's the spirit upon which it has grown, and it is the spirit upon which its future success will depend.

Maybe this is looking a long way into the future—but I've been in Radio so long—been connected with the National Radio Institute so long—that I am used to looking to the future. It is with all sincerity that I say to you members of the Baltimore Chapter of the

(Page 15, please)

# Heat Wave

By S. M. ARMSTRONG, N. R. I. Director of Student Service

SUMMER is well on its way. In some parts it is "already here." Hot weather—lazy weather!

There's a great tendency—a very human tendency to get like the weather, indolent, sleepy; indulge in a good long spell of "spring fever."

When the thermometer is around 90 there's a great temptation to succumb to the allurements of a cool swimming pool—to heed the call of summer sports—to vacation from study—to surrender to the Heat Wave.

Can you afford to pay \$450.00 this summer for merely taking it easy? I know I wouldn't want to spend that much—and neither will you. But that's the price the fellow will pay who puts pleasure ahead of the business of studying for success. It works out this way:

The average fellow who is studying Radio is doing so to increase his earning capacity. The more knowledge he obtains—the more money he will make. The sooner he gets the knowledge, the sooner he will be able to cash in on it and reach his goal of increased earnings.

Most N. R. I. students set their goals at weekly earnings anywhere between \$25.00 and \$50.00 a week more than they are making now. Let's assume that you are an average fellow and have set your goal at an earnings increase of \$37.50 a week. Many N. R. I. graduates have increased their earning capacity this much and more.

Now suppose you let the Heat Wave get you and you lay aside your studies for the hot months—June, July and August. You retard your progress just three months and consequently you lose \$37.50 a week for 12 weeks, or \$450.00. Rather expensive vacationing, isn't it? But that's not all:

Just as long as you keep going—keep studying—you will make progress toward your success goal. When you take a lay off—you not only lose that time and the money which would eventually be earned, but you retard your progress even more because it takes time



---

S. M. Armstrong

---

to pick up the loose ends, getting back into the routine of study again.

The other fellow, the one who studies this summer, will finish up his training and get into the money more than three months ahead of the "summer restler," because he goes right on through. An express train makes good time not only because it loses no time waiting at a station, but because it wastes no time and effort getting started after a stop. It does not require much energy to keep an engine running smoothly, but tremendous power is required to start it once it has stopped—to say nothing of the loss of time and its the same with studying.

I know it's not the easiest thing to keep going when summer calls you to the outdoors—when others are playing. But remember your progress, remember your aims, remember your future, and remember the cost of inactivity. You can get out and have some fun—you can indulge in summer sports—you deserve that, but make it secondary to study. Set aside certain hours for study, a certain time for play—but STUDY and PROGRESS come first.

When you see PROGRESS—your GOAL in sight—envision SUCCESS as the ultimate result of your effort—you'll let the other fellow waste his time as he goes down under the effect of the HEAT WAVE while you'll study and go on in high gear to the goal you have set for yourself—SUCCESS IN RADIO.



# A Few Words With The N.R.I. Director

---

E. R. Haas,  
Vice-President  
and Director

---

A FEW days ago, I had my first opportunity to address one of the Local Chapters of the N. R. I. Alumni Association. I was particularly impressed by the manner in which the men brought their problems up for discussion—and the willingness of the others to give advice and help solve the problems of their fellow members. Not only were they willing to give assistance but they were sensible enough to accept the other fellows' viewpoints and profit by them.

It reminded me of the old story about Napoleon Bonaparte. Napoleon had sufficient brains to win many battles; he had the courage to cross the Alps when other men said it could not be done; skill enough to build great armies—but lacking in one great and most necessary qualification. He had absolutely no capacity for new ideas.

History relates how he stood on the French side of the English Channel fretting and fuming because he lacked the necessary equipment to transport his troops to English soil. While so distressed, he was told that an American wanted to speak with him about a new idea. Napoleon's reply was that he would give the American just two minutes.

Two short minutes to hear and pass judgment upon a new idea. Had Napoleon been the type of man to give new ideas their just due, he would have welcomed the American with the new idea. As it was, he merely heard enough of the man's story to see in the idea folly—not enough to make him realize the full possibilities.

The American in question was none other than our own Robert Fulton, whose idea was to propel Napoleon's ships by steam rather than by sails. Had Napoleon listened to him fully, the history of mankind might have been greatly altered.

Those Alumni Association members—meeting at their Local Chapter room were seeking ideas. They were open to them. They were operating on the often mentioned theory that if two men each have an idea—they have only one idea apiece; whereas, if they exchange ideas—each will have two—neither loses—both gain.

If the Alumni Association did nothing else than cause the interchange of helpful ideas, then it would be serving a very helpful purpose. But they go far beyond that point and render many helpful services to their members and to Radio. It is therefore my ardent wish that every graduate of this Institute join his Alumni Association—and share in the benefits it has to offer.

---

## Deep Water

A number of years ago a gentleman, going down the Mississippi got into conversation with the pilot of the river steamer. He asked how long the man had been a pilot on the Mississippi.

"Thirty-five years," was the reply.

"Then you probably know every rock and sand bank in the river."

"No," replied the pilot, "I don't worry about that. There would be too many to look out for. All I need to know is where the deep water is to keep from running aground."

I often wonder if people don't waste a lot of time worrying about the difficulties which might befall them, and thereby miss out on a lot of the fun of life. Whereas, if they only bothered about steering a course in the safe water they'd have more time to watch the scenery.

---

## Nine Reasons Why Ezeniah Q.

### Glumpp Failed in Business

1. He thought the old ways were always best.
2. No one could tell him anything.
3. He had no time for reading.
4. He took things just as they came.
5. He figured that good things sell themselves.
6. He wouldn't pay good wages.
7. He let his creditors wait for their money.
8. He said there is no sentiment in business.
9. His motto was, "It can't be done."

And any one of the nine would have been reason enough for failure.

# Radio Expert Dies

Maj. Gen. George O. Squier. Noted Inventor, Was Member National Radio Institute Advisory Board

**MAJ. GEN. GEORGE O. SQUIER**, retired chief of the Army Air Service during most of the World War, a distinguished scientist in the field of electrical communication, famous inventor and member of the National Radio Institute Advisory Board, passed away at George Washington University Hospital after an illness of about two weeks. He was sixty-nine years of age.

Born in Dryden, Michigan, March 21, 1865, he entered the United States Military Academy at the age of 18. Graduating in 1887, he was appointed a second lieutenant in the Third Artillery. During the Spanish-American War he served as a lieutenant-colonel with the Signal Officers Volunteer.

From 1900 to 1902 General Squier commanded the United States Cable Ship Burnside during the laying of the Philippine cable telegraph system. He was appointed a military attache to London in 1912 and a year later was named commander of the Army Signal Corps with rank of lieutenant-colonel. In 1917 he was made Chief Signal Officer with the rank of Brigadier General, and from May 20, 1916, to May 20, 1918, was in charge of the Army Air Service.

General Squier was the first passenger to be flown by Orville Wright, pioneer designer and pilot of airplanes. This occurred at Fort Myer in 1908. General Squier was the inventor of the "Monophone" for broadcasting over telephones and power wires; the "wired" wireless; and the "Quickaid" kit for Army and Red Cross Nurse aid work. He was technical advisor to the American Delegation at the International Conference on Electrical Communications in Washington in 1920.

In 1921 General Squier represented the State Department at sessions of the International Conference on Electrical Communications in Paris, and in the same year was expert assistant to the American Delegation at the Conference on Limitation of Armament, held in Washington.



---

Major-General  
George Owen Squier

---

General Squier was a Fellow of Johns Hopkins University, and received an honorary degree from Dartmouth College. He was a member of the National Academy of Sciences, royal institution of Great Britain. He held the Distinguished Service Medal of the United States; was a Knight Commander of St. Michael and St. George of Great Britain; Commander of the Order of the Crown of Italy; and a Commander in the French Legion of Honor.

One of General Squier's hobbies was a "country Club for country people," which he established in his native State, Michigan. It is reported to be very popular, drawing hundreds of persons daily during the summer months. Recreational facilities for games, boating, swimming and many other pursuits have been provided.

During his later years, General Squier found time for considerable writing and research work. And he has contributed much to the present training value of the National Radio Institute Course.

In the beautiful Mt. St. Alban Episcopal Cathedral in Washington, funeral services were held. Burial was in Arlington National Cemetery, Arlington, Va., with full military honors.

The youth of America has lost a great friend in General Squier, who has always taken a keen interest in their welfare. He was a member of the National Council of the Boy Scouts of America and a great advocate of specialized training for young men.

# Intermittent Fading Of Radio Signals

By J. B. STRAUGHN, N. R. I. Radio Servicing Consultant

**I**N THE previous article intermittent reception was presented in a broad, general way. To round out our knowledge of this hardest of service problems an intensive, condensed study, based on what has gone before will be necessary.

Every trouble shooting job is simplified and half licked if we know the type of defect causing the complaint. Then we have something to start on and do not have to work haphazardly.

There are various types of intermittent reception, namely:

1. Set plays, cuts off and plays, at regular intervals.

2. Set plays, cuts off and doesn't play until the set is jarred. Mechanical disturbance.

3. Set plays, cuts off and doesn't play until the main power switch is turned off and on, a control grid cap is touched, some tube is pulled out of the socket to insert an analyzer plug, or some light or electrical device is snapped on and off on the same power line as the set. Electrical disturbance.

Frankly the isolation of this third defect causing intermittent reception is the most intangible, most elusive sort of job that a serviceman may tackle.

If the set cuts off and plays, cuts off and plays at a definite time rate, you will invariably find the trouble due to a thermostatic electrical connection. In general, you will find it in a circuit which carries current. Thermostatic joints are those which make contact intermittently due to heat expansion of dissimilar material, for example, solder and copper. When the receiver, tubes or any part or any connection is at room temperature the connection is complete. When the temperature rises, dissimilar expansion opens the connection. If the temperature rise is due to heat produced at the joint, the cut-off will be of short time duration. If the temperature rise is due to the average heat of the chassis, the cut-off will be of longer duration. In the first case we probably have a break in a supply current carrying joint, and in the second case probably a signal carrying joint.

Tubes are often to blame for intermittent reception. If any of the welds between the elements and the support to the lead conductor should open or short because of expansion, the

Page Six



*A previous article on this same subject by Mr. Straughn appeared in the April-May, 1934, issue of National Radio News.*

amplifying action of the tube is destroyed and the set cuts off. As soon as the tube cools off the connection is restored, or the short opens and the set plays. The set may not cut off entirely, merely fade to a low sound level.

Resistors or coils carrying current may open up after carrying current for a short while. Any contact connection is subject to thermostatic action. One serviceman in an attempt to associate the time of cut-off with the probable cause of a thermostatic joint gives the following table:

PERIOD	PROBABLE CAUSE
0 - 3 min.	Defective tube, supply current carrying joint.
3 - 5 min.	Resistors that are slow to heat up, particularly types with large heat radiation surfaces. Series filament resistors in universal D.C. and battery sets.
Over 5 min.	Transformers, coil, or joints that are affected by the surrounding temperature or carry only weak currents.

In some cases the joint after opening up will stay open, because the joint has no spring to return the lead that moved away. Such connections may remain open until the set is mechanically jarred. You may track this down by a stage by stage elimination procedure, being extremely careful to prevent mechanical jarring.

Where the set is started up again by an electrical disturbance (try a mechanical disturbance first), reception may be restored because the electrical surge results in an arc connection closing an open circuit or because the surge breaks on an arc connection which was causing a short. Look for sparks in the chassis—best done in a dark room. Noise will probably accompany the restoration of performance. An open circuit connection, like an open grid resistor or coil, may still permit the re-

(Page 10, please)

# RADIO-TRICIAN SERVICE SHEET

REG. U. S. PAT. OFF. COMPILLED SOLELY FOR STUDENTS & GRADUATES

## Emerson "Mickey Mouse" Universal Four-Tube Radio Receiver Models 409-410-411

The Emerson "Mickey Mouse" Radio is a Universal Compact All-Electric Receiver specially designed to operate on direct current or alternating current, 105-130 volts. It may also be used on 200 volts by attaching the extra ballast resistor.

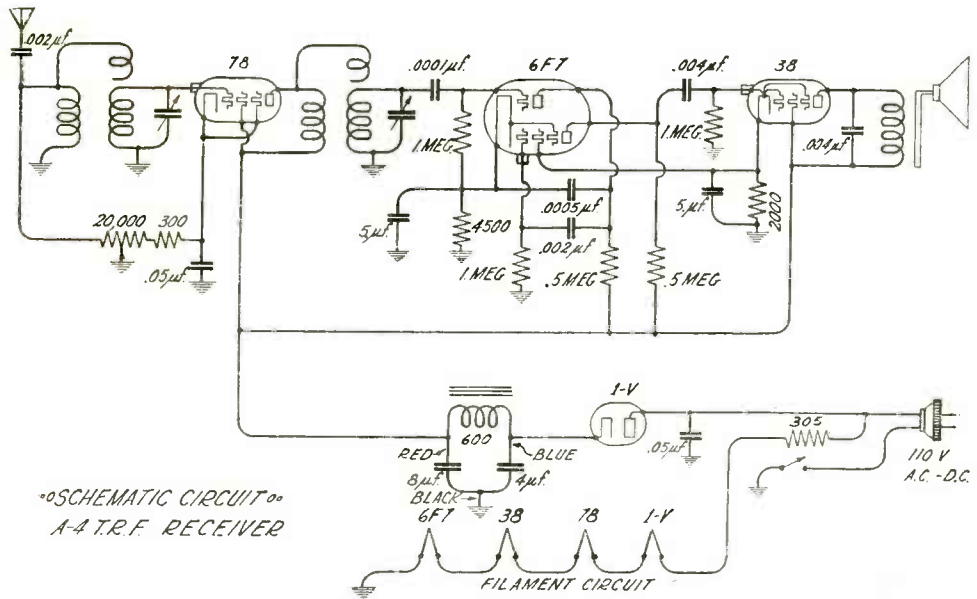

### TUBES

The tubes employed are as follows: 1—78 R. F. Pentode as first Radio frequency amplifier; 1—6F7 Triode-Pentode as detector and first audio amplifier; 1—38 Power Pentode as output-power tube; 1—1V Rectifier as rectifier.

### VOLTAGE READING

All readings were made with a voltmeter having a resistance of 1,000 ohms per volt, and are subject to slight variations. Line voltage, 115 A. C.

Scale	300 Volts Plate	300 Volts Screen	30 Volts Cathode	30 Volts Suppressor
78.....	105	105	2.5	2.5
6F7 Triode.....	15	...	1.5	..
6F7 Pentode.....	35	11	1.5	..
38.....	103	105	11.	..

All above voltages measured to chassis

Readers who file Service Data in separate binders remove page carefully; trim on dotted line for same size as Data published heretofore.

# Emerson Model L-AC-4 and SL

The L-AC-4 is a four-tube receiver, employing the following tubes:

- 1 type 58 Pentode R. F. Amplifier Tube
- 1 type 57 Pentode Detector Tube
- 1 type 47 Pentode Power Tube
- 1 type Rectifier Tube

The set is designed to operate on from 110 to 120 volt, 60 cycle A. C., and to cover the regular broadcast band of 200 to 500 meters.

DO NOT CONNECT TO DIRECT CURRENT (D. C.).

## VOLTAGE READINGS

Readings should be taken with volume control all the way on and tuning control set for high wave length stations. Use a 250-volt D. C. meter having a resistance of 1,000 ohms per volt.

	Plate	Screen	Cathode
47 Tube—ground to.....	215	237	none
58 Tube—ground to.....	237	92	2
57 Tube—ground to.....	115	92	4.5

Line voltage, 119

The bias on the pentode cannot be read on the voltmeter.

These readings are approximate and will vary slightly with sets, tubes, etc.

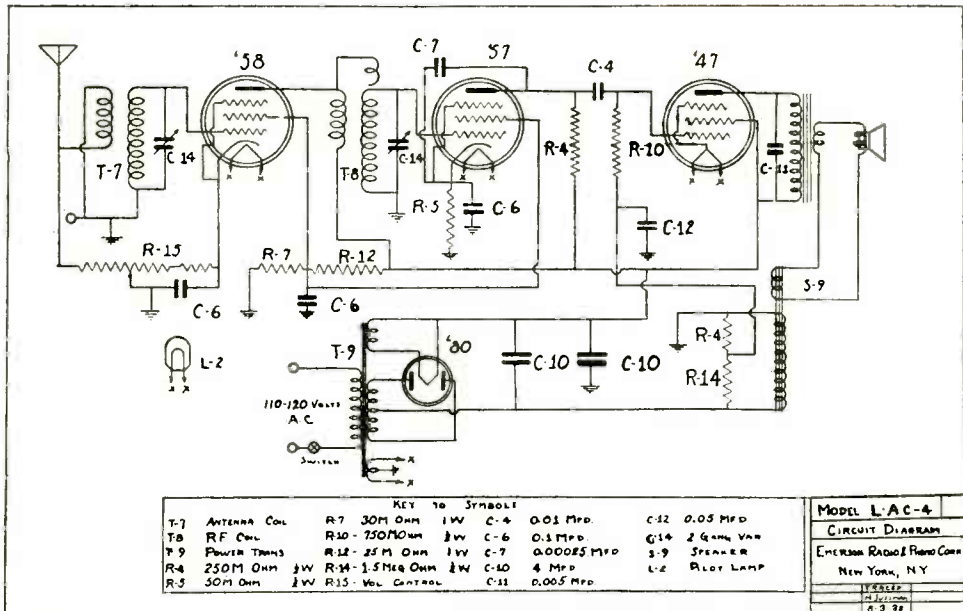



## This Month's Cover

The photograph on the cover of this issue of National Radio News is of the new United States Department of Commerce Building, in Washington, D. C.

This edifice is a part of the new Government Building Program and it was erected at a cost of \$17,500,000. The cost of the ground on which the Department of Commerce Building is situated was \$2,459,831.08. It was purchased in 1910.

In this structure are housed the offices of the National Recovery Administration; the Home Loan Office; the Patent Office; the Bureau of Fisheries; the Bureau of the Census; Navigation and Steamship Inspection; Bureau of Aeronautics; Coast and Geodetic Survey; Foreign and Domestic Commerce; and the Bureau of Lighthouses.

---

## Correction

We wish to call the attention of our readers to an error in our February-March issue, page 9. In paragraph 3 of the answer to the second question we stated, "However if a conductor is included in the circuit, the lamp will only light when direct current is applied." This should read, "will only light when **alternating** current is applied."

---

In the meeting which marked the opening of the New York City and Brooklyn (N. Y.) Chapter of the N. R. I. Alumni Association, we were materially assisted by the cooperation of the Hotel New Yorker, Thirty-fourth Street at Eighth Avenue, New York City. It is suggested that students and graduates of N. R. I. reciprocate this cooperation by stopping at the New Yorker whenever business or pleasure takes them to New York City.

---

## About WLW's New Transmitter

Here are a few interesting facts about the giant new 500,000-watt broadcasting transmitter, the most powerful ever built, just completed for WLW in Cincinnati.

Its signal strength will be three and a quarter times as strong as that of the present 50,000-watt WLW transmitter. The area covered by it will be increased 1,000 per cent.

Its design and construction required more than two years and a total expense of nearly \$500,000.

The transmitter has a peak output capacity of 2,000,000 watts.

(Page 15, please)

## QUERIES and ANSWERS



*Question: I find it troublesome to bring in speakers (especially dynamic) to the shop when I bring sets in for repair. Could I arrange a speaker in my shop which would take care of all jobs?*

**Answer:** It might be possible to do this, but you would have to have a number of output transformers to match the shop speaker to various outputs. The speaker field should have a high inductive value and a low D. C. resistance. A power rheostat should be placed in series with the speaker field to bring its resistance up to that of the set's speaker field. This is necessary to prevent any upset in filter output voltages.

A special external field supply must be available to energize the speaker field when the set has no provision for a dynamic.

Taking everything into consideration it is best to bring the set speaker in. If you don't happen to find the trouble and it reappears after you take the set back you will be pretty certain to bring in the set speaker on the second trip unless the trouble is obviously elsewhere. Then, too, on most jobs it is well worth while to recenter the speaker cone and blow out all dust and dirt from around the pole pieces. This is, of course, a shop job; one for which the customer is generally willing to pay for extra.



*Question: Why do we say electrons flow from negative to positive but current flows from positive to negative terminals?*

**Answer:** The reason is that in the early days of electricity, physicists assumed that current was due to the movement of a positive electrical particle which, of course, had to move from a positive to a negative terminal. When the existence of the negative particle was discovered, it was found unnecessary to change electrical laws of electricity except to change directions.

As the foundation and operating principles in the development of electrical engineering were founded on the old theory, this custom cannot well be changed, so we still speak of the current as flowing from the positive terminal to the negative terminal, covering the action of motors, generators, transformers, batteries, even Radio circuits. However, the up-to-date Radio-Trician is not confused by this in the least. When speaking about the action in a vacuum tube, think of the electrons as traveling from the negative filament to the positive plate and so on around the circuit. As far as the external electrical circuits are concerned we may, if we wish to apply electrical circuit laws, think of a current flowing in the opposite direction.

## INTERMITTENT FADING—Continued from page 6

ceiver to work until some electrode, particularly the control grid or screen grid of a detector develops a charge sufficient to block the operation of the stage. Any slight electrical disturbance will unblock the stage, restoring operation. In superheterodyne circuits the local oscillator may block and thus stop operation—line voltage fluctuations will cause the oscillator to block. Any electrical disturbance or another change in line voltage may re-establish oscillation.

If intermittent fading is observed, then you may have an open by-pass condenser. Intermittent rises in volume above normal may be caused in the same way. Be sure that antenna and ground system is intact. Shake the aerial and ground leads, listening for noise, or better still connect a signal generator to the input after the fading appears. Thermostatic joints in coupling condensers invariably destroy reception and defects here may easily be confused with resistor and coil opens. Only a replacement condenser will check such defects.

A systematic procedure for isolating the defect of intermittent reception is recommended.

1. Start with a search of possible surface defects, (those visible to the eye) including an inspection for a defective pickup system.

2. By an effect to cause reasoning you may be able to tell what and perhaps where the trouble may be.

3. Check the tubes. Put in a new set of tubes and leave them play for a time greater than the cut-off period. If the set does not cut off then replace the old tubes one at a time, each tube tested for a reasonable period.

4. Open the chassis. Look for sparks and arcs. Look for corroded or resin joints. Check condensers for opens by shunting them with ones known to be in good condition. Be sure in the latter case that you make this substitution while the set has cut off.

5. Try a stage isolation procedure. In A.V. C. sets using a visual indicator, watch the indicator before and after cut-off takes place. In other circuits place a plate milliammeter in each stage. Where the number of meters are limited you will have to check one stage at a time. A change in any supply circuit will generally show up as a change in plate current in the defective stage. Defects in signal circuits which do not carry an electrode current

or complete a voltage connection can only be checked with a vacuum tube voltmeter.

You may start with the signal generator connected to the detector and leave the set on for a reasonable period. If the cut-off does not appear, advance the signal generator to the input of the previous stage. When reception is restored by the least touch or electrical disturbance, a stage elimination test is about the most reasonable procedure to take.

6. After the defective stage is found, inspect every circuit component. You may have to change every part in the circuit. Do so one at a time. In tuning circuits a poor connection between the rotors of the variable condenser and the chassis is often responsible for intermittent cut-off or intermittent oscillations.

7. When you feel that the defect has been repaired, play the receiver for at least three to four hours over the cut-off period, before approving the job.

Keep a record of all defects for future reference. Be sure to record the make and type of receiver. Weakness in certain designs may result in intermittent reception. If you consult the service manager of the local distributor of the receiver you are working on, he may give you some valuable clues to the possible trouble.

It may take you ten minutes or ten days to correct an intermittent defect. Most of the time will be lost in waiting for the receiver to cut-off. So always do such jobs along with other bench repair jobs. Intermittent reception defects traced to internal defects are best located at the bench and to one side so as not to interfere with your regular work. Be sure that the chassis is open, and on end so that you see and can get at every part. Don't get discouraged, the best service technicians realize that a defect of this kind has no mercy on their patience.

---

"The N. R. I. Alumni Association is the real thing—it is what we have always needed. National Radio News, the official organ of the Association can't be beat."—G. H. LATIMER, Alta., Canada.

---

Student H. F. Nelson, Lamesa, Texas, is operating Amateur Radio Station W5DSV.

# The Birth of A New Tube

Circuit Study, Tube Possibilities and Production Problems Co-ordinated in  
Fitting a Tube to Receiver Requirements

By BEN. KIEVIT, Jr., Ph. D.

In Charge, Circuit Application Laboratory, Hygrade Sylvania Corporation

NEW tubes are usually the cart rather than the horse. Circuits are thought about or actually developed calling for certain tube characteristics, and it remains for tube engineers to supply the demand. A new tube type may be the product of months of study and experimentation and test, of circuits and tubes alike. Also, it is a monument to ingenious compromise and constant diplomacy. Circuit designer, tube engineer and tube production staff all have their roles to play in the conception of a new tube; and only by reconciling these and other factors can a practical tube make its bow to Radio trade.

Since circuit requirements generally bring about the birth of a new type tube, tube manufacturers must keep in closest touch with the research and engineering staffs of Radio set manufacturers. As new circuits are developed, tube engineers are called in for tube advice and engineering collaboration. Circuits are critically analyzed from the standpoint of tube functions and characteristics. Circuit alterations are balanced against the need for a new type of tube. As far as possible, circuits are changed so as to operate with existing types, for the tube manufacturers are generally none too anxious to complicate the problems of the Radio trade with a still greater variety of tubes.

Fortunately, there is a wide variety of tubes today from which to select a wide range of operating characteristics. The many new types introduced during 1932 and 1933 can take care of almost any circuit that may be introduced in the immediate future, short of a revolutionary innovation. The job of the tube engineer, therefore, is to see that existing tubes are exploited to the utmost in improved and refined circuits. Usually the critical circuit analysis results in minor changes here and there permitting of the adaptation of existing tube types.

Where circuit requirements are such that no existing tube will do, a new type must be designed. The foundation for such a new type rests largely in the characteristics specified. The kind of cathode required, the filament or heater voltage and current drain, the plate voltage and current, the mutual conductance, the screen grid requirements—these and other factors set down on paper must now be translated into terms of tube elements. It is largely

a matter of mathematics, plus mechanical ingenuity, in striking a happy compromise between the best possible tube structure and production limitations.

Referring to production limitations, the development engineers endeavor as far as possible to utilize standardized plates, grids, cathodes, screen, support wires and other components, so as to avoid new and costly dies, jigs, fixtures, cams and other production equipment. The matter of a different grid, for example, means an entirely new set-up in the grid-winding department, which is already turning out dozens of different kinds of grids or presumably a sufficient variety to meet almost any new requirement with just a little ingenuity in tube design.

The most critical tube element is the emitter or source of electrons. The choice of emitter requires careful study. In some instances a filament form is employed, which may be of tungsten, thoriated tungsten or oxide coated. In other instances the heater or indirect-heated cathode is preferable, with the heater filament placed inside the seamless nickel sleeve or cylinder which in turn carries the oxide coating or emitter.

The required plate, grids, screens, mica spacers, glass press and other components are considered in turn. Even the chemist is called into conference, for the functioning of the present-day tube is quite critical as to chemical considerations. The tube chemist may recommend certain alloys or pure metals; the carbonizing of certain elements; the lacquering of mica spacers so that perspiration from the fingers of operators may not be permanently imprinted on the mica itself but rather evaporated with the lacquer during the bombardment, eliminating one source of inter-electrode leakage and noise.

With the various elements accounted for, the tube can now be assembled. The first consideration here is the stem mount, or the assembly of the "innards" of the tube. The various components must be properly and permanently positioned. Present-day tube characteristics are rigidly held to within narrow limits. Mechanical tolerances of much less than one one-thousandth of an inch are commonplace. For example, the diameter of nickel or molybdenum wire for grids is held to within

(Page 14, please)

# Piezo Crystals in Speakers, Pho

## Phonograph Pickups

THE crystal element used in the phonograph pickup consists of two bars of Rochelle salt, each having a thickness of one-eighth inch, cut for sheer sensitivity, and cemented together in opposition with a thin aluminum vane between them. Fig. 12 shows this construction. One end of the vane is fastened to a lead slug serving as a mechanical reactance, while the other end is pivoted and carries a short extension, which is attached to a stylus chuck, for holding the needle, and for picking up transverse as well as horizontal vibrations from the phonograph record. Terminal connections are made from the vane and from the two outer foiled surfaces of the crystal element, in a manner similar to that used in the sound cell.

The pickup unit is mounted within a metal case, which is attached to a counter-balanced arm. In the past, it has been the practice in reproducing lateral-cut phonograph records electrically, to use an iron armature moving in a magnetic field, to convert the mechanical movement of the stylus into electrical energy. Due to the great mass of the iron armature, it was necessary to use mechanical damping in order to achieve a fairly uniform and satisfactory response. This meant that the reproducer had to have a large mass in order to reproduce the lower frequencies. This was reflected in severe wear on the record, and in many instances, where the record was recorded with a shallow groove and maximum amplitude, the reproducer failed to follow the groove, and jumped or skidded with consequent damage to the record.

In magnetic devices with moving armatures, the output or response is not proportional to the movement of the armature, but more to the velocity. In the crystal element reproducer, an extremely light stylus chuck is used. Due to the flexibility of the crystal element, and the small mass of the stylus chuck, very little mechanical damping is required, which results in a reproducer having a uniform response over practically the whole audible range of frequencies, and a unit so freely damp that it will handle maximum amplitudes even at the lowest frequencies, with as low as one and one-half ounces of weight on the stylus.

The possibilities of such pickup devices can well be appreciated when it is realized that the deformation of a Rochelle salt crystal can easily produce voltages sufficient to discharge through a 90-volt neon tube, and may even produce a small jump spark in air.

The second and concluding installment of an  
Cleveland, Ohio. Mr. Anderson was formerl

Developments in the field of public address have now reached the point where it is possible to record sounds over a wider range of frequencies than that over which they can be reproduced. This is particularly true of electrical transcription and sound film, where the present range of recording covers a band 30 to 10,000 cycles, while the reproducing band extends from 30 to 8,500 cycles. Broadcasting stations are working to improve their equipment, beginning with microphones and amplifiers, and extending through their entire systems.

## Crystal Loudspeakers

The present conventional types of loudspeakers no longer cover a sufficient range to

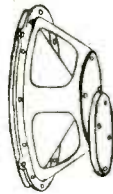

Fig. 16. Crystal Loudspeaker with single "motor" unit and B' cone.

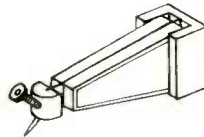

Fig. 12. Construction of Crystal Sound Unit for Phonograph Pickup.

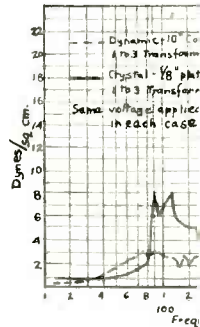

Fig. 15. Comparison of Frequency Response for Crystal and Dynamic Loudspeakers.

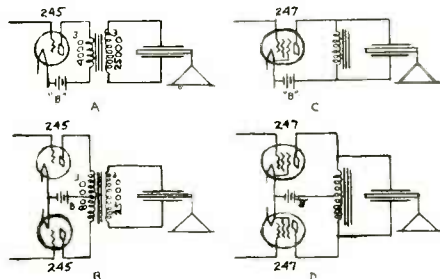

Fig. 14. Suggestions for operating Crystal Loudspeakers. 245 & Pentode - single & push-pull.



Fig. 18. Crystal for Reproduction.

# Phono Pick-ups and Microphones

article by N. R. I. student L. W. Anderson,  
 y with the Brush Laboratories of that city.

be able to reproduce voice and music with the quality which should be required. This is particularly true in theatres using sound film, and in a somewhat smaller way in the field of public address.

The crystal speaker is very well adapted to meet the demand for quality reproduction. By using the piezo-electric properties of Rochelle salt crystals. There is no theoretical limit, within the audible band of frequencies, to the possible frequency range of such speakers, and the only limiting factors are those imposed by conventional requirements of size and shape.

When Rochelle salt units are used for loud-speaker elements, much larger sections are re-

quired than those used in the sound cell. For example, the crystal element used in one of the commercial crystal speakers, consists of two crystal sections about 3 inches square and one-eighth inch thick, cut for shear sensitivity, as in the phonograph pickup unit previously described. Unlike the pickup unit, no central vane is employed, but the two tin-foiled surfaces are cemented directly together and in opposition, as in the sound cell. A strip of foil makes contact with the two inner surfaces, while the two outer surfaces are connected together to produce the other terminal. The crystal element is then coated with bakelite varnish to protect it from moisture.

Fig. 13 shows the relation of the various parts of the loudspeaker crystal "motor." Referring to Fig. 13, it will be seen that the crystal element acts in shear, or rather in a combination of shearing and twisting. The crystal element is mounted in a metal case so that three of its corners are prevented from moving by means of sponge rubber pads. To the fourth corner, which is free to move, is cemented a hickory tone arm, extending diagonally across the crystal, and leading to the apex of the cone. Such units, when connected to a parchment cone, and provided with a suitable baffle-board, equal, and in many cases excel the dynamic type of loudspeaker in range, sensitivity and tone quality.

The typical two-plate crystal speaker unit acting in shear, has a characteristic which may be represented by a somewhat leaky capacity of about 0.20 mf. This leakage, however, is rather small. Consequently, the impedance of such a unit will vary with the frequency, about as would a condenser. The impedance may be as high as 130,000 ohms at 60 cycles, but will decrease to about 20,000 ohms at 500 cycles. The impedance behavior is, therefore, exactly opposite to that of the various electro-magnetic speakers, whose impedance decreases at low frequencies, but becomes very great at high frequencies. A small crystal speaker may therefore be operated in parallel with a dynamic speaker, to improve both the power factor and the high frequency reproduction.

Crystal speakers may be operated directly from the choke of a high impedance tube, and the new pentodes are well adapted to this purpose. When it is desired to operate a crystal speaker from type 245 tubes in push-pull, resort must be had, as in the case with the dynamic speaker, to a transformer. Such transformer is required to step up the voltage. A 3-to-1 ratio transformer is satisfactory.

(Page 14, please)

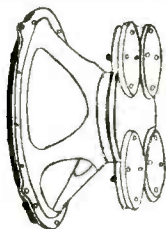
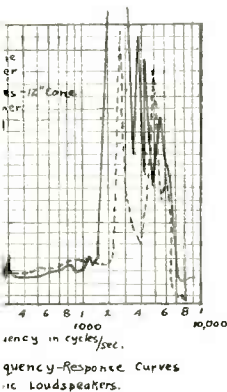
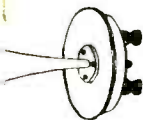

Fig 17. Crystal Loudspeaker using four "motor" units and 12" cone.



Fig 19. Crystal Loudspeaker with four "motor" units designed for use with large Exponential Horn.



Crystal Loudspeaker designed for reproduction of High Frequencies.

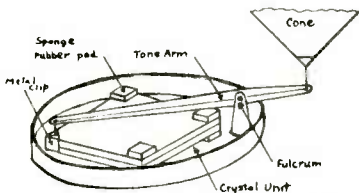

Fig 13. Construction of Sound Unit or "motor" used in Crystal Loudspeakers.

## Birth of a Tube

(Continued from page 11)

two ten-thousandths of an inch. The nickel support wires are held to within one ten-thousandth of an inch. These tolerances may seem superfluous, but when it is noted how closely spaced are the turns in most grids and screen grids, it is immediately appreciated that a slight difference in the diameter of the wire must make a considerable difference in tube characteristics.

The precision in the components themselves must be carried out in the mounting of those components. The present-day tubes generally employ mica spacers, accurately punched to shape with the necessary holes for the precise positioning of the components. The use of the new dome-shaped glass envelope contributes to a more rugged mount, since positive rigidity is provided by the mica washer at the top which fits snugly into the dome, as well as by the usual glass press at the bottom.

The new tube is usually assembled, sealed, exhausted, aged and tested in part of the plant given over to tube development work, rather than in the production department. The development section is really a miniature tube production unit under the most critical engineering supervision. Like the production tube, the experimental tube begins with the mount or assembly of internal parts. Next, the mount is sealed in the glass envelope or bulb, and subsequently exhausted, bombarded and tipped off. Then comes the basing, followed by aging and testing.

Samples of the new tube are submitted to interested parties in and out of the tube plant. Exhaustive tests are made in our own laboratory not only with regard to tube characteristics, but also with regard to operation in the circuit for which it has been developed. Life tests are conducted to determine how long the tube should last in typical use. Circuit designers and engineers have ample opportunity of trying out the new tube.

If everyone is satisfied, a new tube is born. It is usually a matter of several months from the original circuit demand to the finished tube. If the new tube proves satisfactory to everyone concerned, it goes to the production engineering section. Here it is torn apart. Specifications are drawn up. Elaborate schedules of the number of parts required per one thousand tubes are made up. The tool department gets orders for necessary dies, jigs, fixtures, grid-winding cams and other production requisites. Production routine is organized. The operators are trained in the assembly and other handling of the new type. In due course the new tube is being duplicated by the thousands and tens of thousands. A new type appears in the Radio press, in tube lists, and in the latest receivers, thus bringing figurative horse and cart together.

Page Fourteen ▶

## Piezo Crystals

(Continued from page 13)

Fig. 14 shows suggested methods of supplying the crystal speaker by means of the 245 tube, used alone or in push-pull, and similar conditions using the 247 pentode.

Fig. 15 shows frequency-response curve for the crystal speaker as compared with those for a good grade of dynamic speaker. With reference to the curves, it is apparent that the crystal speaker has, on the whole, a greater sensitivity, as well as a more peaked response than the dynamic. Since the characteristic of the transformer will affect the curve, these characteristics must be taken into consideration. For instance, the transformer has a tendency to cut off response in the low frequencies. In reality, the crystal speaker has a good response even at frequencies as low as 40 cycles. At the extreme high-frequency end of the curve, the crystal speaker, even without the transformer connection, exhibits an output superior to that of the dynamic. Moreover, in other work, experiments have shown that the crystal itself responds far into the inaudible range, so there seems to be no limit to the high frequency response, should such become desirable.

The maximum displacement of the cone of the larger crystal units, is somewhat over one-eighth of an inch, and occurs at low frequencies. Displacements of the cone are, in general, at any given frequency, strictly proportional to the applied voltage. The force of displacement is very large, and so permits the use of heavy cones and connecting levers which would be impossible with other types of speakers.

Over the musical range, the maximum output of the crystal element is the same as that of the average dynamic speaker for use in Radio receiving sets. All crystal elements will stand the full undistorted output of two 245 tubes in push-pull with 250 volts on the plate, should it be desired to use such output.

Fig. 16 shows a crystal type speaker having a single "motor" unit and an 8-inch cone. It can be used in parallel with a dynamic speaker to increase the power factor and the frequency range. Having characteristics of impedance opposite to that of the dynamic, it helps the lower and middle registers, and reproduces high frequencies above the range of the dynamic speaker.

Fig. 17 shows a crystal speaker having a four "motor" drive and using a 12-inch cone. It is designed for use with a large baffle-board. It has a frequency range of from 30 to 7,000 cycles and a reproduction at greater undistorted volume on equivalent power, than any dynamic speaker of similar size.

(Page 22, please)

## WLW's New Transmitter

(Continued from page 9)

The output of the Radio frequency amplifier is transmitted to the antenna proper by a concentric type transmission line, the first to be used for broadcasting.

The transmitter itself is controlled automatically. Momentary failures such as "arc-overs" or "tube-flashes" that can be cleared by removal of power are corrected automatically, the power being shut off and then on again in one-fifth second.

In case of failure in one of the three audio frequency units, the disabled unit is automatically isolated, the transmitter continuing to operate at slightly reduced power.

The transmitter utilizes the largest audio transformer ever built, weighing more than 100,000 pounds and containing 1,400 gallons of oil.

Twenty huge 100,000-watt tubes, costing more than \$35,000, are used in the transmitter.

22,500 cubic feet of air and 1,200 gallons of water are circulated each minute through the transmitter in order to cool tubes and various parts. A million gallons of water are pumped through the cooling system daily. During the winter the transmitter plant will be heated entirely from the heat generated by the transmitter.

Verifications and reports from listeners following continuous night tests have established the fact that the new 500-KW transmitter can be heard clearly in virtually every section of the United States.

The accuracy with which the transmitter is maintained on its assigned frequency of 700 kilocycles prevents its interference with other stations.

## Group Stronger Than Individual

(Continued from page 2)

N. R. I. Association that I hope ten or fifteen years from now we can still find the same faces at a meeting of the Baltimore Local of the N. R. I. A. A., together with hundreds of new faces—which would only indicate that the Baltimore Chapter has had the logical growth which it deserves—a growth which would only be natural to an organization founded upon the high ideals of your N. R. I. Alumni Association.

## IT'S A "GRAND AND GLORIOUS FEELING" . . .

. . . to know that when in a jam you have such good friends as the N. R. I. Alumni members. I am a student, only having completed sixteen lessons and feeling now that I can handle some service work, I have started taking in sets to be repaired. Last week I got one that was a great problem to me, and after trying in vain to make the set play in customer's premises (although it played fine in my place) I called on Mr. Webster, one of the members of the N. R. I. Alumni Local in Detroit, and what I learned in the short time I was with him was more than sufficient to cover my problem.

Besides, the generous way he checked the set and then balanced same with his modulated oscillator, an instrument I have not yet been able to purchase, makes me feel that acknowledgement of my appreciation through National Radio News would be most appropriate.

Also, many thanks to Mr. Schachtner of the same Local Chapter for his valuable advice.

I trust that students who run into any difficulties will remember that members of the Alumni Association are behind them 100 per cent.

Student WALTER FARRELL, Detroit, Mich.

## Thanks, Foley

I like National Radio News very much. I am not much of a hand at writing letters, but if I could talk to you personally I could tell you better just what I think of our Alumni Association magazine.

Everything that is printed in the News is very interesting and educational to the Radio Serviceman. I look forward to every issue knowing full well that there will be plenty of interesting information for me in it.

Incidentally, I think the Mail Bag is one of the best pages in the News. I get many usable tips from it which help me in my service work. More power and great success is my wish for the News of the future.

WILLIAM J. FOLEY, Holyoke, Mass.

## Pittsburgh Reports

The Pittsburgh Local will shortly elect a Financial Secretary to handle the treasury of the Local. Our previous Secretary-Treasurer was forced to resign due to ill health.

As Mr. Winchell would say: "An orchid to our friends of the Baltimore Local for their new publication 'The Baltimore Bulletin'." It was real interesting and it is bound to grow with real workers like the Baltimore boys behind it.

The ruling by National Headquarters whereby the "Charter Renewal Fee" has been eliminated is a good move in the right direction and meets with the hearty approval of the Pittsburgh Chapter. It is just one more proof of the willingness and desire of National Headquarters to co-operate with the members out in the field.

T. A. DESCHANTZ,  
Chairman, Pittsburgh Local.

## Buffalo Chapter

The next meeting will be a "big night" at the Buffalo Local headquarters. Some lucky person is going to receive a midget Radio receiver.

Members and friends of the Local have been selling tickets to this raffle—and the purpose is a real summer outing for members after a hard winter's work. As a result of this method of financing there will be no charge to members for the summer outing and nothing will be taken from the Local Treasury.

Speaking of the Treasury, we are proud to report that Buffalo's is in very good condition.

It will be remembered that we did quite some financing last year in a somewhat similar manner. We ran a card party, and we have placed the new undertaking in the hands of the same hard working member who made the card party a success, Mr. George Clohessy. George is particularly well liked and has all the fellows working with him.

And we must say a good word for our new Treasurer, Jack Pollard, one of the Charter members of the Local. Jack, incidentally, has been responsible for bringing no less than six new members into the Local.

We have voted to discontinue holding regular meetings during the hot months, but our Executive Secretary, P. J. Murray of National Headquarters in Washington, has promised to pay us a visit during the second week in August and a special meeting will be held at that time.

T. J. TELAAK,  
Buffalo N. R. I. A. A. Chairman.

## New Department to be Started in National Radio News

The next issue of National Radio News will carry a new department which has been instituted by popular demand. It will be known as "Effect and Cause" and will be a great assistance to all Radio Servicemen.

It will bring you information which, as its name implies, catalogs the "Effects" of improper operation of receivers, and from this point lists the probable "Causes" and methods of correction.

Wide awake servicemen have been using this system for some time and we are going to make available a wealth of material on this subject. Save every bit of it. You'll be surprised how it speeds up your Service Work.

## Marconi Predicts

Marquis Guglielmo Marconi, generally known as the father of Radio, at the celebration of his sixtieth birthday, made the following statement:

"Radio has made tremendous strides in the last twenty-five years, yet it is still in its infancy. I believe it has a boundless future.

"The micro-waves with which I am experimenting afford us the key to future developments. Wireless has not reached perfection. No science could in such a short time. Many wonders are in store for us that today exist only in the brain and vision of searchers.

"I expect a good deal from my study of the ultra-short waves. They are not affected by atmospheric disturbances and are restricted to a very small band. They have unsurpassed directional properties and, above all, their transmission and reception require extremely small apparatus and power in comparison with medium and long wave bands.

"Their range does not appear to be limited to so-called optical distance. This opens a large vista for the future application of Radio."

## The Boomerang

When a bit of sunshine hits ye,  
After passing a cloud,  
When a fit of laughter gits ye,  
And ye'r spine is feelin' proud,  
Don't forget to up and fling it  
At a soul that's feelin' blue,  
For the minit that ye sling it  
It's a boomerang to you.

—Capt. Jack Crawford.



# RADIO-TRICIAN SERVICE SHEET

REG. U. S. PAT. OFF.

COMPILED SOLELY FOR STUDENTS & GRADUATES

R. C. A. Victor "Allwave" Models 140-141-141E-240 and AVR-1. General Electric K80-K80X-K85.

## Line-up Capacitor Adjustments

This receiver is aligned in a similar manner to that of a standard broadcast receiver. That is, the three main tuning capacitors are aligned by means of three trimmers in each band and on the three lowest frequency bands a series trimmer is adjusted for aligning the oscillator circuit. The other two bands do not require this low frequency trimmer, it being fixed in value. In the case of band D, it is necessary to adjust four trimmers, due to the additional R. F. stage used. The intermediate frequency amplifier is aligned at 445 K. C.

The output of the external oscillator should be at minimum value necessary to obtain a deflection in output meter when the volume control is at maximum. The external oscillator output should be connected between antenna and ground for

R. F. and oscillator adjustments and between first detector grid and ground for I. F. adjustments. All adjustments are made for a maximum deflection in the output meter.

The accuracy of line-up of each band may be checked without touching the trimmer condensers, by the use of tuning wand, Stock No. 6679.

One end of the wand consists of a brass cylinder. When this is inserted in a coil the effective inductance of the coil is lowered.

The other end of the wand contains a special finely divided iron, suitable for use at Radio frequencies. When this is inserted in a coil the inductance is raised.

To use the tuning wand a signal is first tuned in at the frequency at which a check is desired on alignment. The wand is then inserted slowly in the Antenna and R. F. transformers, using first one end and then the other end of the wand. Unless alignment is perfect, it will be found that the power output indicated by the meter will be increased to a peak for a critical position of the wand in the coils. The end of the wand required indicates whether the coil is high or low.

Alignment correction at the high frequency end of a tuning range should be accomplished by the use of the trimmer condenser. If alignment correction should be required at the low frequency end of a tuning range it may be accomplished by sliding the end coil of the transformer. The winding toward the trimmer panel is pushed toward the trimmer panel to increase the inductance and farther away to decrease the inductance. On band D coils, the last two or three turns may be pushed in a similar manner to obtain the proper inductance.

This adjustment should not be attempted unless a quite appreciable improvement will result (as shown by the tuning wand).

Chart A gives the details of all line-up adjustments. The receiver should be lined up in the order of the adjustments given on the chart. Refer to Figure A for the location of the line-up capacitors.

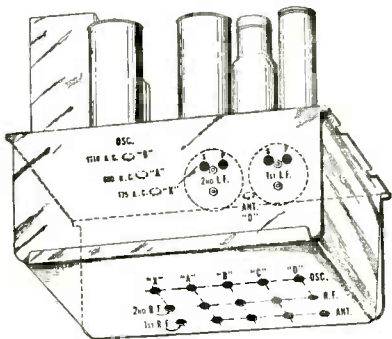

Figure "A"

Location of Line-up Capacitors

External Oscillator Frequency	Dial Setting	Location of Line-Up Capacitors	Position of Selector Switch	Adjust for	Number of Adjustments To Be Made
445 K. C.	Any setting that does not bring in station.	At rear of chassis	Any position that does not bring in station.	Maximum output.	4
370 K. C.	370 K. C.	Bottom of chassis	X	Maximum output.	3
175 K. C.	Set for signal.	Top of chassis.	X	Maximum output while rocking dial back and forth.	1
1400 K. C.	1400 K. C.	Bottom of chassis.	A	Maximum output.	3
600 K. C.	Set for signal.	Top of chassis.	A	Maximum output while rocking dial back and forth.	1
3900 K. C.	3900 K. C.	Bottom of chassis.	B	Maximum output.	3
1710 K. C.	Set for signal.	Top of chassis.	B	Maximum output while rocking dial back and forth.	1
10 M. C.	10 M. C.	Bottom of chassis.	C	Maximum output.	3
15 or 18 M. C.	15 or 18 M. C.	Bottom end top.	D	Maximum output. Adjust each late trimmer until two points are noted where signal is heard. Use for adjustment the higher frequency of these two points. This will be the point lying counter-clockwise from the other point.	4

CHART "A"

Readers who file Service Data in separate binders remove page carefully: trim on dotted line for same size as Data published heretofore.

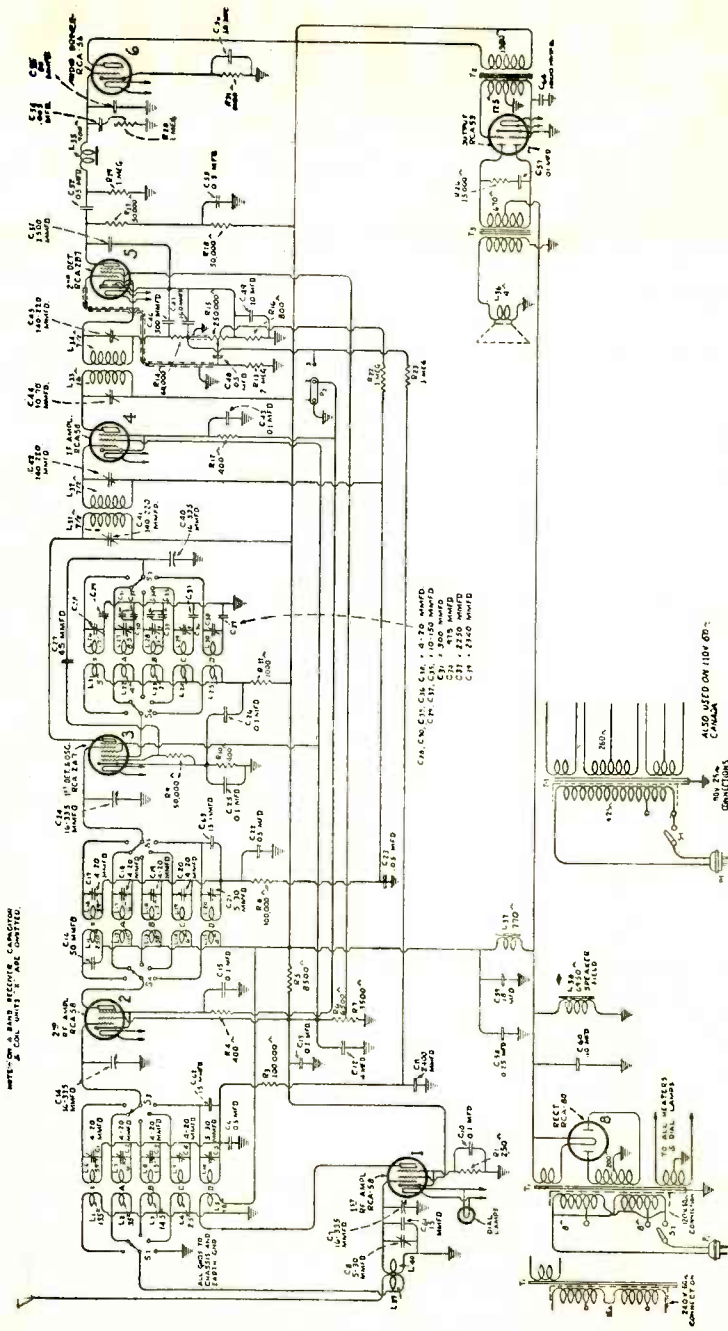

# N. R. I. ALUMNI

## News

### Detroit Local

Since our Charter was issued the Detroit Chapter of the N. R. I. A. A. is making fine progress.

We have adopted a letterhead patterned after the one used by National Headquarters and by the Buffalo Chapter and find the name of our organization on our letterheads adds quite a bit of prestige. We have much more favorable responses from manufacturers, wholesalers, etc., since using it.

It is our recommendation that all Locals follow this example. Write to National Headquarters and have them show you the "set-up" for a good letterhead. You can have them printed locally, very inexpensively and they help a lot.

A new Local membership card which was invented by our Local Secretary, Mr. Geo. Hassar, is working out very well indeed. It has been found of great value in contacting wholesalers for special arrangements on discounts.

Our Local library is growing and our Librarian, Mr. Wm. Webster, has become a very important officer. He is kept busy issuing books because our library is very popular with the members.

Detroit wants to extend congratulations to our fellow members in the new Baltimore Local. Call on us, Baltimore, if we can be of any service—and best of luck to you.

And here's our best wish for the quick recovery of Charles Jesse, Chairman of the Cleveland Local.

FRANK X. SCHACHTNER, Jr.,  
N. R. I. A. A., Detroit.

The Radio Apparatus Company, Brayton Park, Ossining, New York, of which N. R. I. Graduate Harry Y. Haight is a partner, has placed upon the market an A.C. operated short wave converter and is anxious to secure greater distribution. N. R. I. graduates may obtain full particulars, together with prices and discounts by writing the Radio Apparatus Company direct.

### A New Service for Members

Beginning with this issue of National Radio News and in keeping with its policy to be of ever-increasing value to its members the N. R. I. Alumni brings a brand new service.

All members of the Association will receive with this copy of "The News" the first issue of the "Alumni Association News and Information Service." We hope you'll find it of value in your work.

If this service meets the approval of our members it will be continued and additional bulletins sent whenever sufficient material is available.

### Chicago Reporting

Everything is running fine, now at the Chicago Local, and we have settled down to a program of education. Our systematic review of Radio text books is meeting with a great deal of enthusiasm, especially among the N. R. I. students who are members of our Chapter. It is also



popular with the old-timers, giving them a chance to review their Radio knowledge from A to Z.

Mr. Samuel Juricek has been elected to the post of Secretary of this Local to fill the vacancy caused by the resignation of Mr. Mueller. As Mr. Juricek has had considerable experience in this type of work, in connection with clubs and other associations we have full confidence in his ability to handle the job to the entire satisfaction of all our members. In addition he is well liked by the members which helps a lot on his job.

Our Membership Committee has been elected and will now make a concentrated drive for

(Page 20, please)

## Honorable Mention

The following Alumni Association members are deserving of this Honorable Mention for having extended their membership three, four or five years. Here's our list of "long timers.":

### Five-Year Memberships

W. F. Berens	Washington, D. C.
Charles Sikosky	Bayside, L. I., N. Y.
Herman Johannsen	Sheboygan, Wis.
Wm. Dyson	Pawtucket, R. I.
Paul Koetsch	Springfield, Mass.
A. P. Anderson	Alexandria, Va.
Herbert P. French	Potsdam, N. Y.
Wm. L. Kent	Pontiac, Mich.
Alvin G. Irwin	Windsor, Ont., Canada
William Beff	Dunmore, Pa.
R. H. Rood	Los Angeles, Calif.
Peter H. Graf	Glendale, N. Y.
William Prescott	Paterson, N. J.
Paul K. Dine	Detroit, Mich.
Hylton L. Adams	Indianapolis, Ind.
Charles Conradson	Bloomfield, N. J.
K. M. King	Wichita, Kans.
A. R. Giles	Corinth, N. Y.
H. C. Dyer	Preston, Ont., Canada
Arthur Wieland	Elizabeth, N. J.
John H. Strickler	Bucyrus, Ohio
J. B. Shuck	Elsberry, Mo.
Andrew Cooper	Yonkers, N. Y.
H. N. Baney	Muncie, Ind.
T. J. Koski	Montreal, Wis.
A. D. MacNicol	Ft. William, Ont., Canada
A. H. Wilson	Colorado Springs, Colo.
G. H. Latimer	Streamstown, Alta., Canada
G. W. Wilson	Portland, Ore.
Vincent A. Morano	Poughkeepsie, N. Y.
Erland Fraser	Phillips, Me.
Frank R. Waugh	Cincinnati, Ohio
Richard Becker	York, Pa.
John I. Judge	East St. Louis, Ill.
C. F. Owocki	Detroit, Mich.
C. B. Morehead	Chicago, Ill.
A. O. Saxton	Teaneck, N. J.
A. H. Fraser	Milwaukee, Wis.
R. J. Roecker	Glen Flora, Tex.
Alex Gregulski	Schumaker, Ont., Canada
R. Von Dohlen	Port Richmond, S. I., N. Y.
G. A. H. Griffiths	Montreal, P. Q., Canada
Wm. F. Kope	Cleveland, Ohio
Earl E. Hudson	Baltimore, Md.
R. F. Kirkcaldy	Springfield, Mass.
Archie W. Brown	Seattle, Wash.
Henry Reidman	St. John, Ky.
Fred G. Conklin	Hartford, Conn.
John Muehlke	Tuckahoe, N. Y.
Carl H. Rose	Johnstown, Pa.

### Four-Year Memberships

Delbert Delanoy	Weehawken, N. J.
Charles N. Bace	Coco Solo, C. Z.

Page Twenty ▶

## Three-Year Memberships

Wm. F. Mellott	Holmesville, Ohio
Peter L. Munier	Passaic, N. J.
J. R. Morse	Rochester, N. Y.
Harry E. Zang	Raspeburg, Md.
F. B. Hatch, Jr.	Rayville, La.
Jos. Adamski	LaSalle, Ill.
Edward J. Meyer	St. Louis, Mo.
H. C. Aylor	Florence, Ky.
Louis Pavan	Brooklyn, N. Y.
M. O. Laursen	Providence, R. I.
Warren W. Wehr	Allentown, Pa.
A. C. B. Verney	Toronto, Ont., Canada
Ralph Schena	Brooklyn, N. Y.
R. H. Walker	Columbus, Ohio
O. A. Grendahl	Duluth, Minn.
B. H. Rosenburg	Baltimore, Md.
Andrew Sabol	Mahanoy City, Pa.
William Mackie	Pelham, N. Y.
Charles Campbell	Barberton, Ohio
Otto Lott	Buffalo, N. Y.
C. H. Swallow	San Francisco, Calif.
W. F. Forbes	Buhl, Idaho
H. B. Backer	Corydon, Ind.
Everett Burrhus	Walton, N. Y.
G. H. Montgomery	Carleton Place, Ont., Can.
Leo Lacourse	Trois Rivieres, P. Q., Canada
Harry Lagerquist	Brooklyn, N. Y.
A. P. Caldwell	Buchanan, Va.
Ray A. Meyers	Severn, Md.
Fred Haushalter	Swickley, Pa.
R. J. Terou	Hamilton, Mont.
C. L. Walker	St. Joseph, Mo.

This is all we have space for in this issue. But we have more names entitled to Honorable Mention—will bring them to you in the next issue.

## Chicago Reporting

(Continued from page 19)

new members. This Committee will also function as an Entertainment Committee.

Due to the large territory covered by this Local, we plan to rotate our meetings in different parts of the city thereby making the distance to be travelled by members more equitable.

This Chapter invites any members of other Chapters, who are planning to attend the World's Fair this year to visit us while here, and if possible to attend one of our meetings.

And Members of other Chapters, and this also includes officers of the National Association, who get to Chicago for the Fair will do us a big favor if they will get in touch with me personally while here. I'd like to meet them and exchange Local Chapter ideas. Call me, day or night, at Greenleaf 4900.

EARL BENNETT, Chairman,  
N. R. I. A. A., Chicago.

## Philadelphia-Camden

At a joint meeting of the Philadelphia, Pa., and Camden, N. J., graduates of the N. R. I., a Charter was issued those cities for a Local Chapter Organization.

The educational facilities of the Philadelphia-Camden Local will be extremely good, as quite a number of the members of this organization are employees of the Philco, R. C. A.-Victor, and Atwater-Kent factories, and as such can bring first-hand information to their fellow members on factory servicing procedure, etc.

Mr. Louis Lyet was selected as the temporary secretary to take charge of the affairs of the Association until the next meeting, at which regular officers will be elected for the balance of 1934.

The meeting was held in the Grand Fraternity Building in Philadelphia and in spite of a violent thunder storm was attended by a good number of members. In our next issue we hope to be able to bring you the names of the charter members of this organization, as well as the names of the officers who will direct the organization.

Graduates who were unable to attend the first meeting should get in touch with Mr. Lyet for information about the next meeting. His address is Kenderton Apartments, Seventeenth and Tioga Streets, Philadelphia, Pa.

## New York Local Formed

A Charter for a Local Chapter of the N. R. I. Alumni Association has been issued to the graduates in the New York-Brooklyn area. This shows possibilities of being a very large Local—and one which will do a lot of good.

The New York graduates have several important problems with which to cope, but the men behind the organization there are capable and experienced and we expect them to do much to elevate the Radio servicing standards in their locality.

At the first meeting, which was held in the North Ballroom of the Hotel New Yorker, a temporary Chairman was appointed, Mr. James Kearns, of Brooklyn, N. Y. Mr. Kearns will handle the reins of the organization until the next meeting, at which time permanent officers will be appointed to serve until January, 1935.

The New York Local Chapter has in their organization a very unusual case. They believe that they are unique in having the only woman member of an N. R. I. Alumni Association Local Chapter. We shall try to bring this lady's complete story to you a little later.



P. J. Dunn,  
Baltimore Chairman

## Baltimore, Md.,

### Local

We are trying out a new plan, at the Baltimore Local, for notifying our members of meetings. At the beginning of each month, we contemplate getting out a little paper to be known as the "Baltimore Bulletin," which will go to all our members, giving the date of the meetings for the month as well as the names and topics of the principal speakers. In addition, the Bulletin will carry news of our members and their activities—servicing hints—editorials and items of general interest.

With the assistance of National Headquarters we have already gotten out our first issue and we feel sure it will be favorably received by our members. This is the first step we have taken in our plan to make the Baltimore Local Chapter the "Key Chapter" of the N. R. I. Alumni Association. As a Local Chapter we are still mighty young—but we serve notice here that we are really going to do things in Baltimore and the older Chapters of the N. R. I. Alumni Association will have to look to their laurels if they intend to keep up with us.

The following officers have been elected to serve the Local Chapter until January 1, 1935: P. J. Dunn, Chairman; Frank M. Coonan, Vice-Chairman; George C. Ruehl, Jr., Secretary-Treasurer; John B. Gough, Librarian; John W. Ganz, Sergeant-at-Arms. Our Financial Committeemen will be Philip Bisesi and Carl Vonderheide.

We are following one of the plans which were originated at the Chicago Chapter—that of having technical reviews of various parts of the N. R. I. Course. We thank you for the idea, Chicago—it is very popular at our meetings.

And here is something else that we are going to do. We are going to advertise in the Baltimore paper, "Guaranteed Radio service." We will list the names of all of our members in the ads, requesting that persons having service work to be done call upon the nearest man. In the ad will also be stated that since we guarantee satisfaction on the service calls, if a job should not be satisfactory it is only necessary to call the Secretary of the Association who will have a man make the job satisfactory without delay or embarrassment.

Since all of our members are high grade servicemen, we are sure that we can make this guarantee offer without fear of any large amount of call backs on service jobs.

## Protect Your Money!

Do you always use money orders or checks when sending money through the mail? You should, otherwise your remittances are not protected.

Or, you can register your letter—and thus protect the money you are sending, but this is slightly more expensive than the use of checks or money orders, particularly when the amounts are small.

Post Office Department Money Orders are the ideal method of sending money for those who do not have checking accounts in banks. For 8 cents the Post Office Department guarantees the safe delivery of \$5; for 11 cents you have the assurance that \$10 will reach its destination in safety.

Don't send cash through the mails without protection. You may get away with it for a while—but sooner or later one remittance is going to be lost, or go astray, and you're going to be *out* that much because there is absolutely **NO WAY TO TRACE CURRENCY SENT THROUGH THE MAILS UNPROTECTED.**

Play safe. When sending money, send a Post Office Money Order, or, if you have a checking account—send a check. Of course, if you so desire, you can register your letter and send cash—but **DON'T SEND CASH THROUGH THE MAILS UNLESS IT IS REGISTERED.**

## Piezo Crystals

(Continued from page 14)

Fig. 18 shows a small crystal unit, having an exponential horn, and using the crystal element itself as a diaphragm, to generate frequencies of from 3,000 to 15,000 cycles. This range is important, particularly for theatre installations, to reproduce the higher frequencies being recorded on sound film, and to perfect the articulations of the voice. This unit may be connected across the output of the sound-reproducing apparatus.

The four "motor" element may also be procured for use with a 4 to 12 foot exponential horn, and in such units a special diaphragm of bakelite-cloth composition enclosed within the metal case of the speaker assembly is used. Fig. 19 illustrates this type of speaker. It is particularly well adapted for public address installations.

Page Twenty-two

# NATIONAL RADIO NEWS

Vol. 6  
No. 2

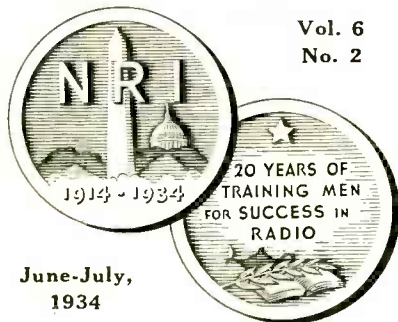

June-July,  
1934

Published bi-monthly in the interest of the students  
and Alumni Association of the

NATIONAL RADIO INSTITUTE  
Washington, D. C.

The Official Organ of the N. R. I. Alumni Association

P. J. Murray, *Managing Editor*

*Associate Editors:*

T. A. DeSchantz, Pittsburgh      T. J. Telaak, Buffalo  
Chas. Jesse, Cleveland          E. R. Bennett, Chicago  
F. X. Schachtner, Detroit        P. J. Dunn, Baltimore

## Index

Article	Page
The Power of the Group.....	2
Heat Wave .....	3
A Few Words with the Director.....	4
Radio Expert Dies.....	5
Intermittent Fading .....	6-10
Data Sheet "Emerson" 409-410-411..	7
Data Sheet "Emerson" L-AC-4 & SL	8
This Month's Cover.....	9
WLW's New Transmitter.....	9
Queries and Answers.....	9
Birth of a New Tube.....	11
Piezo Crystals .....	12-13
Data Sheet—RCA-Victor and General Electric (Various).....	17-18
Alumni News.....	16-19-20-21
Mailbag .....	23
Calcaterra Service .....	24

# The Mailbag . . .

## More Hams

All N. R. I. students and graduates who own and operate amateur stations are requested to register here for information of their fellow students and graduates. Here's the list received since last issue:

Howard P. Ross, W1HLT, Lincolnville, Me.  
Carl Drumm, W8IET, Kenton, Ohio.

Robert Alcock, W9PNU, Iowa City, Iowa.

Joseph Dugan, Jr., W2CML, Manalapan, N. J.

W. L. Sonnenstuhl, W9OSN, Lidgerwood, N. D.

Bernard Masters, W3CTZ, Annapolis, Md.

Donald Hutchins, W6JUC, Springerville, Ariz.

John P. Kelly, W4BFD, Pensacola, Fla.

Herbert Lord, W1FNP, West Enfield, Me.

Carl W. Bischoff, W8IZH, Marietta, Ohio.

Incidentally, Graduate Bischoff reports that the hams in his city have organized an amateur club and have fourteen members.

At the time I started this Course I had never serviced a Radio. Now I do spare time work and am able to take of any job that comes my way.

JOHN HANILYN, Center Point, Texas.

## Philco 5, Auto Radio

One day I was called when visiting my cousin in Long Island, to look over a Philco Auto-Radio, Model 5. The owner could only get one or two nearby stations. The aerial was under the running board. I disconnected the receiver and tried it on a regular outdoor aerial; the set played perfectly. I tried a small piece of copper mesh, and no results. I tested the first intermediate transformer and found an "open." On repairing this, the trouble was over. I sold some Radios down there after that and there's more business waiting for me. I have been dealing with the Philco Company and will soon open a store in my town. I have bought a truck and I'm going to install a public address system in it for advertisement.

BERNARD VALOUR, Sloatsburg, N. Y.

*Every bit of amplification possible should be squeezed out of an automobile Radio. If an auto set is made to work on a plate antenna and a good pick-up is not obtained, testing and peaking the I. F. stages may be tried (with reliable equipment only). Here is a case where a break-down was found.—EDITOR.*

## Majestic 25B

On a Majestic 25B, after thtting, Model O. K., there wa checked poor reception. I very ume. This I four vol-sitting solid on my as due to the chassis four rubber washers t bench. By taking serting one under each e cabinet and in- wonderful. Be sure to m- the volume was rubber cushions for best re-  
M. CLIVE KEEMER, Majestics on

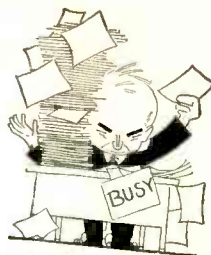

## Helps Experienced M. Ohio.

I have been working with Radio fo. years and din't know there was so much. learn until I took your training. I can s- now the trained man is the only man who can hold a position of any importance.

Ever since I entered Radio I have wanted to be a Radio Engineer and now I feel sure that some day my goal will be reached through the training I am receiving from your Institute.

R. W. NICKERSON,  
Munroe Falls Park, Ohio.

## An Unsolicited Bouquet

National Radio Institute,  
Washington, D. C.  
Gentlemen:

Attention:  
J. E. Smith, Pres.

I am taking the liberty of writing you today sending you my best wishes and success to you for the manner in which you train your students for Radio servicing and repairing. One of your students who lives in this vicinity, Mr. Harold Slough, called at my home a few days ago and I advised him I had a 9-tube McMillan Radio I purchased 3½ years ago and this set never worked right since I purchased it.

I had Radio servicemen look over it on three different occasions, but they were never able to help it any. Mr. Slough spent several hours on this Radio and it certainly is wonderful. I was on the verge of disposing of it, but certainly would not do so now.

Again wishing you much future success in your school of training.

Yours very truly,

J. F. C., Alliance, Ohio.

*This gentleman's name is on file at the National Radio Institute, but he requested it not be published.—EDITOR.*

# Build Yourself a Valuable Radio Library with these Helpful FREE MANUFACTURERS' BOOKLETS and CATALOGS

## A FREE SERVICE DESIGN TO SAVE YOU TIME AND MONEY

The cooperation of the manufacturers this page, logs, literature and booklets are listed on this page, and the courtesy of the Calcatera Alumni Association has made it possible for the N. R. Radio News a publication to offer to readers of National Radio Association and money-saving service to obtain the manufacturers' literature. All that is necessary for on this page is to logs or other literature

write the numbers of the items in which you are interested on the coupon, fill in the information asked for and MAIL IT TO THE CALCATERA CATALOG SERVICE. DO NOT MAIL COUPONS TO THE NATIONAL RADIO INSTITUTE, AS THAT WILL DELAY THE FILLING OF YOUR ORDER. Stocks of the publications listed are kept on hand and they will be sent to you promptly, as long as the supply lasts.

- 2. HAMMARLUND TRANSFORMERS, CHOKES, ETC., FOR INTERMEDIATE FREQUENCIES. 15 TO 200 METER BAND. Specially for laboratory, newspaper, steamship use.
- 3. COMET "FD" 1934 CATALOG. 16 pages. Standard receiver design volume controls, Truvalt adjustable resistance dividers, vitreous enamelled fixed resistance address systems, etc.
- 4. PERITE REAL LINE VOLTAGE CONTROL. Characteristics, uses and chart showing the correct Amperage recommended by set manufacturers for their sets.
- 5. INTERNATIONAL 1934 RESISTOR CATALOG. Specifications and prices on International Metallized Precision wire wound and enamelled wire wound resistors, motor radio noise suppressors and resistor kits.
- 6. INFORMATION ON THE SUPPRESSION OF MOTOR RADIO NOISES. Circuits and data published by the International Resistance Company on how to overcome troublesome motor noises in auto radio installations.

- 7. LYNCH RMA STANDARD RESISTOR COLOR CODE CHART. Handy postcard size. Simplifies job of identifying resistance values of coded resistors. Gives a list of most commonly used resistor values and colors.
- 8. LYNCH NOISE-REDUCING ANTENNA SYSTEMS. This folder describes the two types of noise-reducing antenna systems perfected by the Lynch Mfg. Co. for both broadcast and short-wave reception. The transposition type system can be used on both long and short waves while the shielded transmission line type is especially suited for broadcast receivers.
- 9. LYNCH AUTO RADIO ANTENNAS, FILTERS AND NOISE SUPPRESSORS. This folder describes a complete line of Lynch antennas, filters and ignition noise suppressors, especially designed for motor Radio installations. Complete data on how to eliminate motor Radio noise is included.
- 10. ELECTRAD SERVICEMEN'S REPLACEMENT VOLUME CONTROL GUIDE. A 44-page vest-pocket size booklet containing a revised, complete list, in alphabetical order, of over 2,000 different receiver models with the proper type of Electrad Control to use for replacements.
- 11. HOW TO BUILD THE ECONOMY "EIGHT." A folder prepared by the Wholesale Radio Service Co., which gives complete data on how to build this efficient eight-tube receiver from a kit costing only \$13.75. These receivers can be built and sold in spare time at a profit.
- 12. HOW TO BUILD USEFUL SERVICING AND TESTING INSTRUMENTS WITH SIMPLE, STANDARD METERS. A folder prepared by the Lynch Mfg. Co. giving circuits and explanations showing how to increase the usefulness of simple meters to measure current, voltage or resistance through any desired range.
- 13. THE I. R. C. SERVICER. A free monthly house organ published by the International Resistance Co. A sample copy will be sent on request through this service, after which you can subscribe to it, if you like it, by writing direct to the International Resistance Co.
- 14. SUPREME SERVICING AND TESTING INSTRUMENTS. A catalog containing complete descriptions of a new line of Supreme low-price analyzers, set testers, tube testers, ohmmeters, capacity testers, oscillators and universal ohms.
- 15. HOW TO BUILD A HIGH-QUALITY CONDENSER OR RIBBON MICROPHONE. This circular describes the Superior Microphone Kit and instruction sheets with which it is possible to build, quickly and easily, a high quality condenser or ribbon microphone. The kit is made by the Bruno Division of the Amperite Corporation.
- 16. AMERTRAN AUDIO AND POWER TRANSFORMERS AND CHOKE COILS FOR USE IN PUBLIC ADDRESS AMPLIFIERS AND RECEIVERS. A folder containing very complete information on the characteristics of a wide variety of AmerTran De Luxe and Silcor (popular priced line) audio and power transformers and chokes.
- 17. HOW TO MAKE MONEY ON PUBLIC ADDRESS SYSTEMS. This 16-page book contains a number of valuable articles on how to make money with public address equipment, together with complete descriptions and prices of a wide variety of Lafayette amplifiers and public address systems available through Wholesale Radio Service Co., Inc. It also tells how to obtain a copy of the book, "Sound, Its Fundamentals and Methods of Application."

(Please Use Pencil and Print in Filling in Coupon)  
THE CALCATERA SERVICE NRN-634  
Thornwood, N. Y.

Please send me, without charge or obligation, the catalogs, booklets, etc., whose numbers I have filled in below.  
Booklet Numbers: .....

- My connection in Radio is checked off below.
- ( ) Serviceman operating own business
  - ( ) Serviceman employed by:
    - ( ) Manufacturer
    - ( ) Jobber
    - ( ) Dealer
    - ( ) Servicing organization
  - ( ) Dealer
  - ( ) Jobber
  - ( ) Radio Engineer
  - ( ) Experimenter
  - ( ) Laboratory Technician
  - ( ) Professional or Amateur Set Builder
  - ( ) Licensed Amateur
  - ( ) Station Operator
  - ( ) Manufacturers' Executive
  - ( ) Student
  - ( ) Public Address Work
  - ( ) .....
  - ( ) .....

I buy approximately \$ ..... of Radio material a month.

(Please answer above without exaggeration or not at all.)

Name.....  
Address.....  
State.....