

- ENTER the Auto Radio Specialist
- . . . and now More Profitable Spare-Time Servicing
- Successful Kit Building



journal
May/June 1977

From **LEADER**

FIVE-INCH SOLID-STATE TRIGGERED OSCILLOSCOPE/VECTORSCOPE



Only **\$339.50**

Stock No.501WT
Shipped UPS
Prepaid

**Quantities
Limited!**

The triggered scope is an improved type of cathode-ray oscilloscope with a one-shot sweep circuit. The electron beam remains in a stationary position and does not deflect until "triggered on" by an input waveform or transient. When turned on, the beam sweeps across the CRT, displaying the incoming waveshape, and then returns to rest. Each succeeding pulse will cause the beam to deflect again, giving the effect of a repetitive waveform. The triggered sweep feature makes it possible to observe non-recurring transients and to synchronize on either the high-frequency or low-frequency components of complex waveforms. The horizontal deflection is calibrated in time, making it possible to measure the frequency or duration of waveforms and pulses. The vertical is calibrated in volts per centimeter, making precise amplitude measurements possible. It is also possible to operate the sweep in an automatic or conventional free-running state.

SPECIFICATIONS

VERTICAL AMPLIFIER: Sensitivity: 20 mv p-p/cm to 10 v p-p/cm, 9 steps in 2-5-10 sequence and uncalibrated continuous adjuster. **Bandwidth:** DC or 2 Hz to 10 MHz. **Rise time:** 35 nsec. **Input impedance:** 1 megohm, shunted by 33 pf. **CALIBRATION:** Square-wave voltage: 0.05, 0.5, and 5 v p-p; 1 kHz approx. **HORIZONTAL AMPLIFIER:** Sensitivity: 200 mv p-p/cm or better. **Bandwidth:** 2 Hz to 200 kHz. **Input impedance:** 1 megohm shunted by 40 pf. **TIME BASE.** Sweep speeds: 1 usec/cm to 0.2 sec/cm, 17 steps in 1-2-5 sequence and uncalibrated continuous adjuster. **TV:** V (for 30 Hz) and H (for 15.75 kHz/2). **Magnification:** x5 (maximum speed 0.2 usec/cm). **Sweep mode:** triggered and automatic (slope + and -). **Synchronization:** internal and external: + and -. **POWER SUPPLY:** 115/230 v; 50/60 Hz; 50 va approx. **SIZE:** 10½" high by 8" wide by 16½" deep. **WEIGHT:** 30 pounds.



journal

May/June 1977
Volume 35, No.3



<i>Cory Banks</i>	2	ENTER THE AUTO RADIO SPECIALIST
<i>James D. Crudup</i>	10	... AND NOW MORE PROFITABLE SPARE-TIME SERVICING
<i>Laurence M. Frazier</i>	18	SUCCESSFUL KIT BUILDING
	23	NRI HONORS PROGRAMS AWARDS
<i>Ted Beach</i>	25	HAM NEWS
<i>Tom Nolan</i>	28	ALUMNI NEWS

EDITOR AND PUBLISHER

William F. Dunn

TECHNICAL EDITOR

Ted Beach

MANAGING EDITOR

Kathy Waugh

EDITORIAL ASSISTANTS

Laura Blalock

Mildred Duncan

Laurie Munk

Audrey Rothstein

Sarit Sichel

Cynthia Thompson

Carol Volkman

James Whalen

STAFF ARTISTS

Ernie Blaine

Bill Massey

Peter Schmidt

Arthur Susser

GRAPHICS CONSULTANT

Stephanie Cox

In this issue, the *NRI Journal* introduces free-lance writer Cory Banks, who adds another dimension to profitable servicing — the auto radio. James Crudup displays his Midas touch in another article in his continuing series on profitable spare-time servicing. And, electronics instructor Laurence Frazier debuts with advice about successful kit building.

The NRI Journal is published bimonthly by the National Radio Institute, a division of the McGraw-Hill Continuing Education Center, 3939 Wisconsin Avenue, Washington, D.C. 20016. The subscription price is two dollars yearly or 35 cents per single copy. Second-class postage is paid at Washington, D.C.



ENTER the
Auto Radio
Specialist
by
Cory Banks

Let's face it — not everyone wants to be a television repair technician. Fortunately for those of us who have chosen the electronic servicing field, several other areas of electronic servicing are open to us. Auto radio servicing is a neglected area of electronic servicing.

There are very few shops that specialize in auto radio repair — just look around your town. How many shops are there that specialize in auto radio repair? Generally, auto radios are repaired in the television shop right along with televisions, tape recorders, stereos, audio amplifiers, and every other consumer electronics product that a customer can lug into the shop. As a matter of fact, when I ran a shop, I recall one customer that brought in a typewriter for repair, another brought in a vacuum cleaner, and another even brought in an air conditioner. My batting average wasn't bad — I fixed the typewriter and the vacuum cleaner.

There are millions of auto radios out there to be repaired. And more on the way — 98 percent of the cars off the assembly line have some type of auto radio installed. Surprisingly, though, most auto dealerships do not have personnel to repair radios. Most auto radio repair work is farmed out to television repair shops or they are sent back to the factory. Right there, you have a huge virtually untapped market if you want to do this type of work.

There are several advantages to servicing auto radios as opposed to servicing televisions. First, auto radios are smaller and take up less work space. This is great if you can't lift heavy objects or if you have limited space in your workshop. Also, because there are fewer stages in an auto radio, they are not as complicated as televisions. Finally, the test equipment that you would need to get started servicing auto radios is not as expensive as the test equipment needed for a television business.

TEST EQUIPMENT NEEDED

You will need the following equipment — test instruments and material — to get started servicing auto radios. You can add to it as you find it necessary.

- 1 Bench type regulated power supply (0 to 15 volts dc and at least 3 amps).
- 2 Signal tracer.
- 3 Signal generator (must provide an audio tone, 455 kHz and 10.7 MHz).
- 4 Transistor tester.
- 5 Auto radio schematics and service data.
- 6 VTVM or equivalent.
- 7 Substitute loudspeaker.
- 8 You will also need a few hand tools, most of which you already have such as wrenches, nut drivers, screwdrivers, needle nose pliers, diagonal cutters, a soldering gun, and a soldering iron.

You will also need an auto radio antenna installed at your workbench. You can purchase one from Lafayette, Radio Shack, or your electronic parts supplier. Figure 1 shows one way the antenna can be mounted on your workbench.

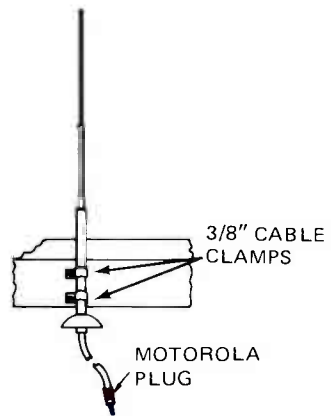

FIGURE 1. AN EASY WAY OF MOUNTING A STANDARD AUTO ANTENNA ON A WOODEN BENCH.

KINDS OF SERVICE PROBLEMS TO EXPECT

A basic AM auto radio is shown in simplified form in Fig.2. As you can see, there are not very many circuits for problems to develop in. As a matter of fact, there are four usual troubles that occur in auto radios and they are shown in Chart 1 along with the most likely causes of trouble. Before we discuss a few of the troubles and how to pinpoint them, let's take a look at another important aspect of auto radio servicing — getting the radio out of the car.

REMOVING THE RADIO

Many technicians refuse to do auto service work. This is not because the actual servicing of the auto receiver is that difficult, but rather because the job of removing the radio from the car and putting it back in the car after the repair has been made is so time consuming. In some cases, heater hoses or air-conditioning ducts must be removed.

There are two ways to deal with this. First, if you don't want to be bothered with removing and installing auto radios, it should be made clear when you advertise for business. This may turn a few customers away, but many of them will be willing and capable of removing their own radios to save a few dollars. If, on the other hand, you do remove and install radios, charge the customer a certain amount for removing the radio and putting it back into the car even if you do no work on the radio. This charge is justified because removal and installation is labor. That way, if the customer decides not to have the radio fixed after it has been removed from the car, it is not just wasted time.

You will probably be a little slow removing and installing your first few radios. However, as you gain experience,

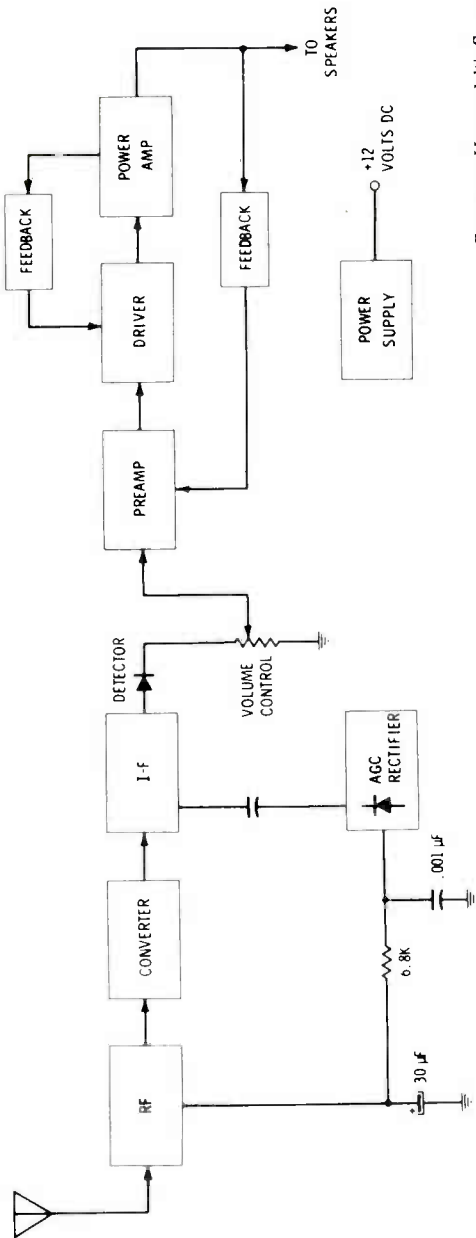

Courtesy Howard W. Samis

FIGURE 2. A BASIC AM AUTO RADIO.

CHART 1 – TROUBLE CHART

AUTO RECEIVER TROUBLE	CHECK FOR POSSIBLE TROUBLE
1. DEAD RECEIVER	<ol style="list-style-type: none"> 1. FUSE 2. OPEN SPEAKER 3. CHECK AUDIO OUTPUT STAGE 4. FUSIBLE BIAS RESISTOR 5. FRONT END OF RECEIVER
2. WEAK RECEPTION	<ol style="list-style-type: none"> 1. CHECK AUTO ANTENNA 2. RF TRANSISTOR 3. RF TUNING CIRCUITS 4. THE AUDIO STAGES
3. INTERMITTENT RECEPTION	<ol style="list-style-type: none"> 1. SPRAY TRANSISTORS WITH FREEZE MIST 2. CRACKED PC BOARD OR LOOSE CONNECTIONS 3. LOOSE WIRES 4. I-F TRANSFORMERS 5. COUPLING CAPACITORS
4. DISTORTED RECEPTION	<ol style="list-style-type: none"> 1. AUDIO OUTPUT TRANSISTOR 2. BIAS RESISTOR 3. AF STAGE 4. ELECTROLYTIC COUPLING CAPACITORS

you will learn that certain car manufacturers use essentially the same method of mounting the radios in many models of their cars. Frequently, they use the same method for a number of years so that once you have done one or two of these jobs, you will know exactly how to go about getting the radio out, repaired, and back in the car.

CHECKING THE FUSE, ANTENNA, AND SPEAKER

Experienced technicians do not start removing the radio immediately. First, they must determine whether the fuse, antenna, speaker, or radio is at fault.

Therefore, turn the radio on and listen for a slight “thump” in the speaker as power is applied. Even if no thump occurs, see if the radio picks up stations. If it does not, then check the fuse with an ohmmeter. An open fuse is the most likely cause of trouble. If a thump was heard but you can’t tune in a station, check the antenna before removing the

radio for further testing.

An ohmmeter can be used to check the antenna for an open lead-in and, in some cases, for high resistance leakage from center wire to the outside shielded cable. An open auto lead-in will pick up only strong local radio stations. If moisture accumulates inside the antenna or lead-in, the results will be similar. Sometimes the ohmmeter will not show leakage caused by moisture but the antenna, if suspected, should be removed and checked.

If the antenna checks open, the lead-in will usually be broken at the plug that goes into the radio or at the bottom of the antenna mounting assembly. If the lead-in is open, it is better to install a completely new antenna.

Special Note About Antennas: If the antenna is not mounted tightly on the body of the car, or if the lead-in is not screwed tightly on the base of antenna, the shield on the antenna lead will not be grounded well. This can cause *motor noise pick-up*, or turn signal *flasher noise* in the speaker of the radio.

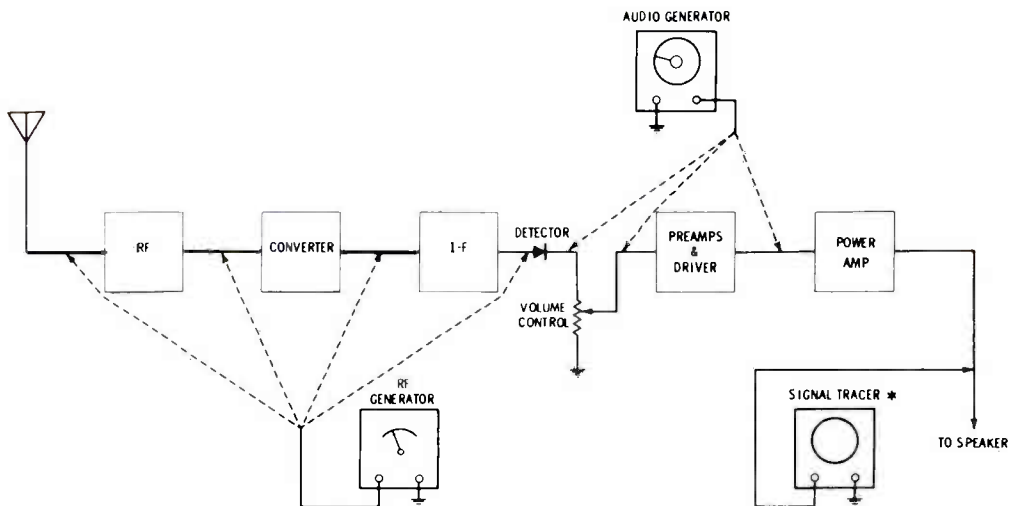

Courtesy Howard W. Sams

FIGURE 3. INJECTING SIGNALS INTO VARIOUS STAGES USING SIGNAL GENERATORS.

SPEAKER PROBLEMS

An open speaker voice coil will render an auto radio dead. The impedances of transistorized auto radio speakers run from about 8 to 40 ohms. Although the speaker cannot be checked for reproduction quality while mounted in the auto, a continuity check can be made to determine if the voice coil is open. Many situations arise with inexperienced technicians where the car radio is removed from the car and when connected on the bench it operates perfectly — the trouble being back in the car.

Speaker troubles will show up usually as open voice coils, cone vibration, or “mushy” distortion. Under various kinds of weather conditions the speaker cone may warp and drag on the center pole piece. Sometimes only the cone will vibrate loose and can be re-glued again. Low- or high-note vibrations can be caused by split or torn speaker cones.

Check intermittent speakers by pressing gently on the cone while the speaker is operating.

ISOLATING TROUBLES

Assuming that the trouble is in the radio, we must quickly determine which section it is in, and then track it down to the exact stage and component. When the chassis is first removed, take time to look it over carefully. You’ll be surprised at how many problems have been pinpointed by sight and smell.

Once you have the radio on the bench and before you turn it on:

- 1 Make sure you have an antenna connected.
- 2 Make sure the polarity of the supply voltage is correct.
- 3 Make sure the speaker is connected properly.
- 4 Make sure the rated input voltage is used while measuring voltages; but

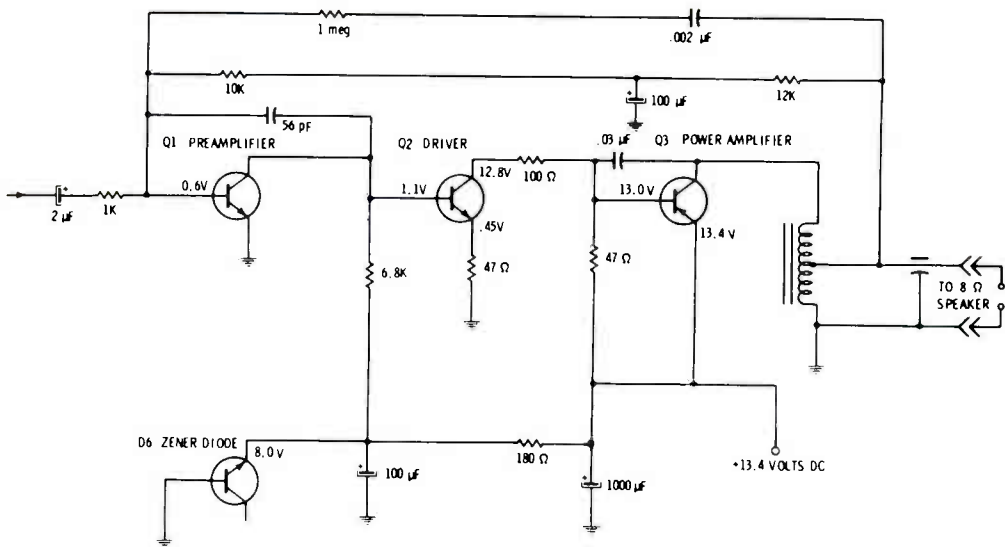

Courtesy Howard W. Sams

FIGURE 4. AUDIO OUTPUT STAGE OF A TYPICAL AUTO RADIO.

vary the input above and below that voltage before releasing the radio to owner (car voltages do not remain constant).

Now, let's assume that you still have not found the problem. The radio is on the work bench and it is properly hooked up and should work if it did not have a defective component or stage. If you did not hear characteristic speaker thump when you turned the radio on and couldn't get any kind of sound out of the radio, a good place to start is the audio circuit.

To begin troubleshooting, go directly to the volume control. Inject an audio signal here with a generator and check out the audio stages. This procedure is shown in Fig.3. With the volume control wide open, a loud signal should be heard. If so, all the audio stages are functioning. Now, proceed toward the detector, i-f, and converter stages using a modulated rf

signal as shown in Fig.3. If you do not get a loud signal from the speaker with a signal injected at the volume control, then proceed toward the speaker, from base to collector of each audio transistor, until the signal is heard. At this point, you have located the defective stage.

Let's assume that you do not receive a signal at the volume control. Use the schematic in Fig.4. In a logical manner, move to the base and collector of the preamp. There is still nothing. Next, move to the base of the driver (Q2). Again, nothing is found. Moving to the collector of the driver a tone is heard from the speaker. It's safe to assume that the problem is located in the driver circuit. Proper use of your vtvm and the schematic will easily allow you to pinpoint the defective component or components.

Many auto radios use direct-coupled stages. In troubleshooting these stages, it must be remembered that any defect in the audio section will affect the dc

conditions throughout the amplifier. For example, should Q2 become shorted (collector to emitter), the base voltage of the output transistor will be reduced. Since the output transistor is a pnp, the forward-bias on Q3 will increase by whatever voltage is removed from the base. Such a condition will drive Q3 into saturation and make it appear shorted.

Transistor Q1 can also affect the output transistor. If it ceases to conduct, its collector voltage will rise because of the decreased voltage drop across the 6.8K collector load resistor. This could saturate Q2, causing it to draw excessive collector current. With an increase in collector current, Q2 will have a considerable decrease in collector voltage. This reduces the Q3 base voltage (increasing Q3 forward-bias) to a point where Q3 is saturated and appears shorted. A collector-to-emitter short at Q1 also shorts the base of Q2 to ground. This causes Q2, an npn transistor, to cut off. Since almost zero collector current will flow in Q2 under these conditions, the base voltage of Q3 will rise to a point where Q3 is cut off. It pays to examine the schematic for each radio. A major part of efficient troubleshooting is understanding how the circuit works. Well, we've saved the worst for last — troubleshooting the intermittent. Let's see how this type of problem can be tackled.

SOLVING INTERMITTENT TROUBLES

Intermittent problems are generally one of three types; vibration sensitive, heat sensitive, and cold sensitive. Vibration sensitive defects can be found in most instances by tapping the printed-circuit board with a lightweight insulated tool such as the handle of a small screwdriver, or rubber tipped end of a pencil. Also,

flexing the PC board is often helpful in locating intermittents.

Heat problems can often be located by bringing heat near the suspect parts. Use either a soldering iron or a heat lamp. Stage isolation can be performed by allowing the radio to operate under a heat lamp while you monitor voltages until the failure occurs. Radios that fail to play when cold can present a bit of a problem. Parts that are suspected can be cooled off by the use of one of the freon aerosols (Freeze Mist is a trade name) used for this purpose. Even if the precise part that is defective is not located, you should be able to isolate the problem to a stage. The few remaining components can be examined with the freeze spray until the bad one is located.

CONCLUSION

By now, you should have a pretty good idea what the life of an auto radio specialist is like. I'll bet you are wondering about the pay. The pay isn't bad — the average service charge for radio repair is between \$15 and \$30. This, of course, depends on the complexity of the radio. AM/FM stereo radios are harder to fix; thus, the service fee is generally higher. As in any field, good technicians can write their own ticket.

Once you make yourself known as an auto radio specialist, you will probably be called upon to work on or install other types of automotive electronic equipment such as eight-track tape players, cassette players, and Citizens Band radio equipment. Of course, you must have an FCC First or Second Class Radiotelephone Operator's License to work on any radio transmitter. NRI has an excellent course that will prepare you to pass the FCC exam. The opportunities are unlimited if you just make up your mind to get started.

Helpful Hints 10

A Solderless Plug – What Next? It's been said that necessity is the mother of invention and I'm inclined to agree. One good example is the new Amphenol® UHF plug, type 83-58 FCP. It is a direct solderless replacement for the PL 259 (83-1SP). You may be familiar with the PL 259 which is commonly used in CB and amateur radio for connecting RG-58/U to cable equipment. This new plug should be available from your local electronic wholesaler if you need one. The following instructions show how the plug is attached.

—James D. Crudup

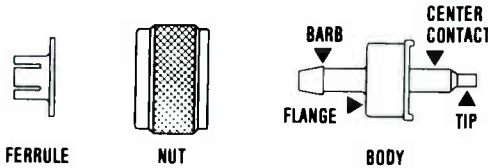
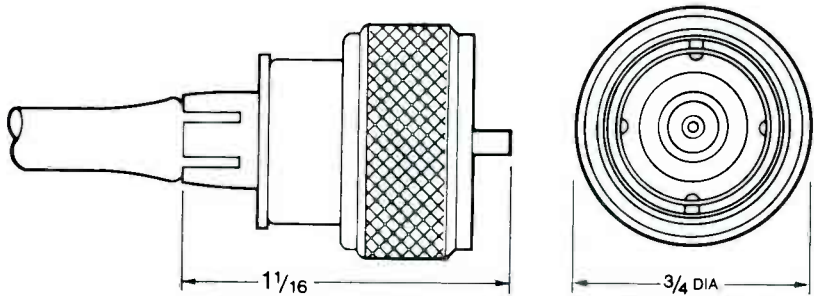

ASSEMBLY INSTRUCTIONS

1. Slide ferrule over cable end, slotted end first. Slide nut over cable end, retaining shoulder end first.

2. Strip cable to dimensions shown. Flare braid slightly by rotating center conductor and insulator in a circular motion (do not twist). Leave center conductor straight.

3. Slide body on insulation with barb going *under* flared braid. Push body until flange is against outer jacket. Braid will flare out against body flange.

4. Slide nut forward over body. Grasp cable with hand and push ferrule over barb until braid is captured between ferrule and body flange.

5. Squeeze-crimp center contact (tip only) with pliers. Trim center conductor. Assembly is complete.

Alternate 5. Solder conductor to center contact tip. Trim conductor. Connector may be disassembled and reused. Grasp tip with pliers and push nut back to unseat ferrule. Unsolder conductor.

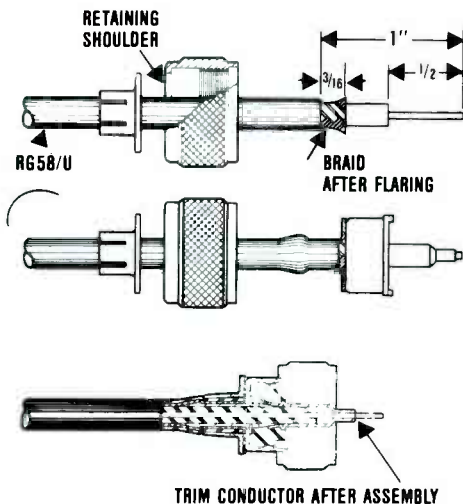

TRIM CONDUCTOR AFTER ASSEMBLY

Courtesy Bunker Ramo Corporation

... and now **More PROFITABLE
Spare-Time Servicing**

by
**James D.
Crudup**



The intent of my servicing articles may not be clear to some of you, so I will take the time to explain. My primary purpose is to provide you with the benefit of my servicing experiences. Hopefully, you will see some logic in how I handle my spare-time service business and this information will be of some help to you. I think of it as though I'm taking you with me on each service call. Luckily though, I don't have to split my profit with you!

Profit is the other purpose of my articles. I want to let you new service technicians know that there is money to be made in spare-time television servicing without cheating people. And, the best part is that you can work just about as often or as little as you like.

KEEP ON LEARNING

Your education shouldn't stop once you've completed your NRI course. The more you learn about a trade, the easier your job becomes. I suggest you subscribe to the electronic magazines that are devoted to helping and informing the electronic technician. Two fine magazines are *Radio Electronics* and *Electronic Servicing*. You can pick up a great deal of servicing information from these publications. You can read about how other technicians have solved service problems that you might encounter in the future. Also, these magazines keep you up to date on new developments in the trade.

There is a host of reference books on electronic servicing on the market, but few can compare with the selection available from the Howard W. Sams Company. A couple of Sams books that I keep on my workbench, which are available from Conar, have paid for themselves many times over because of the helpful material in them. They are *Color TV Servicing Guide* by Robert G. Middleton, and *Photofact Guide to TV Troubles* by the Howard W. Sams editorial staff. Take it from me, the successful technician is the one that takes time to read.

KEEP APPOINTMENTS

This was a chilly Saturday morning and although I didn't want to leave the house, I knew I had to. I had scheduled three service calls for that day, therefore, I was committed. I learned many years ago, when I first started servicing television receivers, that customers expect you to keep your word. By all means, if you tell someone that you are going to be there at a certain time on a certain day — be there. If for some reason you're going to be late or you just can't make it, be sure to call and let the customer know. Be considerate of your customers or you'll

soon find that you are losing business. After all, you are in a competitive market and if you don't fix the set, someone else will. Now let's see how those three service calls were handled.

ADMIRAL 1G6

This first set was an Admiral black-and-white console which was about ten years old. Earlier in the week, when the customer had contacted me about the set, I was told that it had been playing really well before it went out and although it was old, he wanted it fixed. I turned on the set and examined the picture. The problem didn't look too serious but it wasn't what I had expected. The customer had said there was no picture but there was a raster and good sound. As I saw it, a better description would have been that the horizontal oscillator was way off frequency. Well, I thought, you can't depend 100 percent on a customer's description of a television problem.

I adjusted the horizontal hold coil located on the back of the set and brought the frequency as close as possible to the correct point but the picture wouldn't lock in. It continued rolling horizontally. The picture drifted slowly from side-to-side.

I didn't bring a schematic because I didn't think that I would need one; however, now I was beginning to wonder. Three possible causes of this trouble came to mind: a sync-separator problem, a defective horizontal phase-detector diode or if I was lucky, a bad horizontal oscillator tube. As shown in Fig.1, the horizontal oscillator was an 8FQ7, a very popular tube, and I had one in my tube caddy. I replaced it, but the problem was still present, so I put the old tube back in the socket.

This set was easy to work on. All of the components were mounted on a

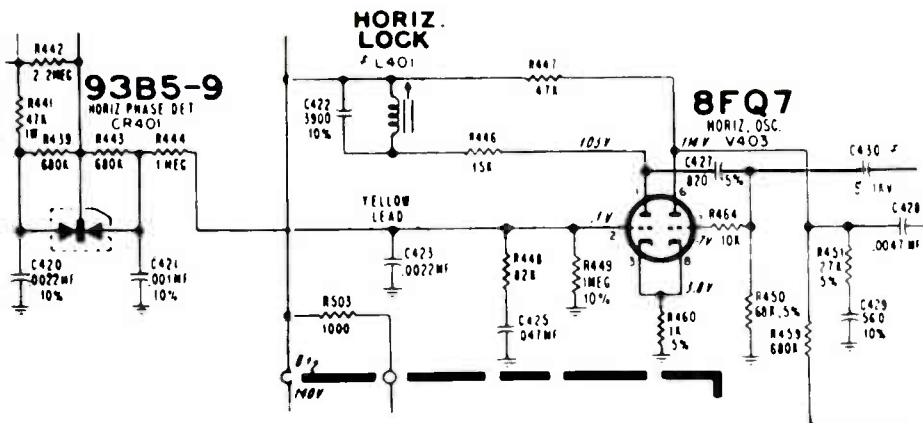

Courtesy Howard W. Sams

FIGURE 1. HORIZONTAL PHASE DETECTOR AND OSCILLATOR OF AN ADMIRAL IG6.

single circuit board and the horizontal phase-detector diodes stared me in the face. This was one of those three-terminal dual diodes with the schematic symbol printed both on the part and on the circuit board. This made the job a little bit easier for me since I didn't have a schematic. I disconnected power from the set, removed my vom from the tool box, and prepared to check the dual diode. I didn't bother to unsolder it from the circuit. Instead, I simply cut the center lead of the dual diode about halfway. This isolated the part from the circuit and prevented parallel resistance paths. Cutting the terminal about halfway would allow me to solder it back into the circuit if it wasn't defective. I checked the dual diode by taking four resistance readings. Figure 2 shows what reading to expect from a good diode if the RX10K or higher resistance range of your ohmmeter is used. The dual diode in this set failed the test. One side of the dual diode measured greater than 5 meg in one direction and 50K in the other direction while the other side measured 500K in one direction and 100K in the reverse direction. A good dual diode would have a similar front-to-back resistance reading

with at least a 10 to 1 ratio. This was less than a 10 to 1 front-to-back ratio which meant this side of the dual diode was defective. I didn't have a replacement dual diode and I didn't want to make a return trip for a simple job like this. From previous experience, I was aware that these diodes could be made of selenium or germanium and from the resistance reading of the good diode, I could tell this unit was germanium. Perhaps I was in luck – I carry a few 1N60 germanium diodes in my tool box as spare parts. You guessed it – I soldered a single germanium diode right to the terminals of the dual diode from the top of the circuit board. I visually checked to make sure nothing was shorted out and that I hadn't dropped solder on the circuit. Then, I connected a cheater cord and turned on the set. The picture came on in sync. I switched channels and turned the set on and off to check how well the horizontal phase detector circuit worked. I declared it fixed and reinstalled the back cover.

I looked at my watch as I began to write out the bill. Since I was going to put in a new dual diode the next time I was in the neighborhood, I made out the

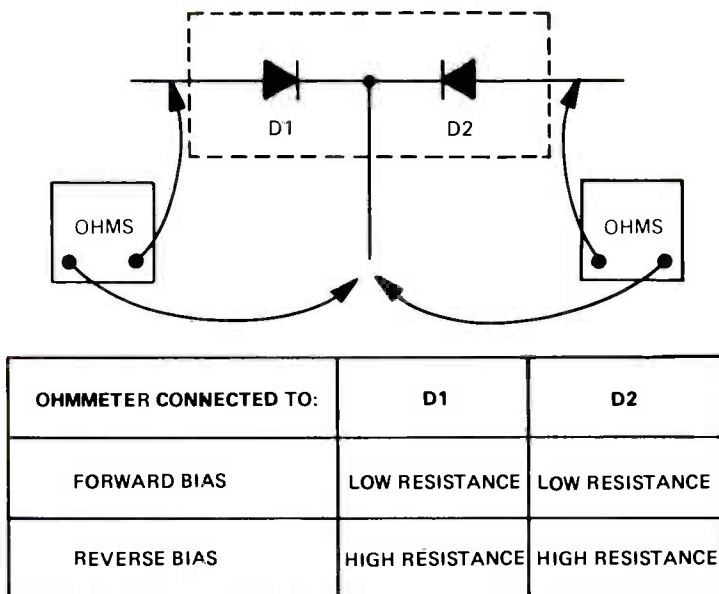

FIGURE 2. A MOTOROLA TS914.

repair bill accordingly.

Recently, because of inflation, I raised my fees from \$12.50 for a service call, which covers the first half hour, to \$15. However, I still charge \$15 an hour labor charge. My rates are still a lot cheaper than most service shops in my area which are now charging between \$22 and \$35 just for a service call. I can understand why – the price of everything just keeps going up. We do-gooders can only push efficiency so far and then we have to raise our prices or working just isn't worthwhile.

I had been in the customer's house just over 50 minutes when I started writing the bill. So, to play it safe and allow for the time it would take for me to install the dual diode next week, I charged the customer for a half hour's labor in addition to the cost of the service call. I didn't know exactly what the part would cost but I guessed it would be about \$4. I figured this was a conservative guess since an RCA (SK) replacement 1N60 costs 55 cents. The bill

looked like this:

\$15.00	service call
7.50	1/2 hour labor
4.00	part
\$26.50	

Notice that I didn't show taxes; this is because I pay taxes on the parts when I purchase them. I charge the customer the list price for the part although I get it at a discount. Therefore, I make a profit on the part and enough to cover the taxes. Fortunately, this system works well for me because it simplifies my bookkeeping. The last time I checked with the county government about my spare-time business, I was informed that I did not make enough from this business each year to file county or state tax forms. Of course, this was fine with me.

If you are going into the television business on a part- or full-time basis, check with your county, state, and federal governments to find out about your tax and business responsibilities.

EMERSON BLACK-AND-WHITE

For some reason it seemed like today was black-and-white day. From the description of the symptoms that I had received on the set earlier in the week, I arrived on the scene thinking perhaps this problem would be one of “no high voltage” – but again I was wrong. I turned the Emerson on and the sound came up in about 45 seconds but the picture didn’t. I adjusted the brightness and contrast which had no effect. Then, just as I was about to turn the set off I could detect a faint picture on the screen. I didn’t need to see any more. I’ve seen this symptom many times before – it was definitely a bad picture tube.

I don’t suggest you newcomers make this type of diagnosis. There are other causes of a dim picture which you should check for. I suggest checking a picture tube with a picture-tube tester before it is labeled defective. I can’t think of too many things more embarrassing than to have replaced a picture tube and then to turn the set on with the customer watching and find that the same symptoms exist. It could be costly too – many wholesalers won’t give cash refunds if you have to return a part for whatever reason. They will simply exchange returned merchandise or credit it to your account.

I pulled the back off the set and jotted down the picture tube number. In this case, it was 23HWP4. I visually checked closely to see if I might need anything else, such as a new, high voltage connector, yoke, or centering ring. This was an old set and sometimes parts just fall apart when you try to remove them. That means you, the technician, have to run out at the last minute and pick up the necessary parts. What’s worse is that you have to add these charges to the customer’s bill. Believe me, the average customer doesn’t like post-facto billing.

After I made my diagnosis and had a

good idea of the work involved, I informed the customer that the set needed a new picture tube and the total cost of the job would be from \$70 to \$80 plus which included the service call. This estimate was off the top of my head. I really didn’t expect them to want it replaced since the set was about 10 years old, but I was given the okay to do the job. I asked if next Saturday about the same time would be convenient. The customer said yes, but at the same time asked if it would be possible for me to replace the picture tube today. I said I would try, and I got on the phone to the wholesaler.

I found out that the wholesaler did not have any new tubes but did have three different-priced rebuilt tubes. The three were made by different manufacturers and each carried a different warranty. In the past I had been successful with rebuilt Sylvania tubes so I decided to get this type. It carried a two year warranty. I was told that the tube would be \$45.20 and \$5 for the dud. (The dud is the old picture tube.) Since I didn’t have much time, I immediately proceeded to remove the old picture tube. It was a snap to take it out. The chassis was wrapped around the picture tube, mounted vertically and held in place by four screws. I removed the screws, picture tube socket, centering ring, and yoke and moved them aside. Then I discharged the picture tube. Next, I removed the four bolts holding the picture tube in place and, as a precautionary measure, I discharged the picture tube a second time. There was a little spark left. I removed the second anode connector, positioned the chassis out of the way, and removed the picture tube. I was sure to note which side the second anode connector was on when the tube was in the cabinet. It’s possible to put a picture tube in the wrong way and I won’t even tell you how I know this.

I was careful with the tube. I even have an old blanket in my car for just such

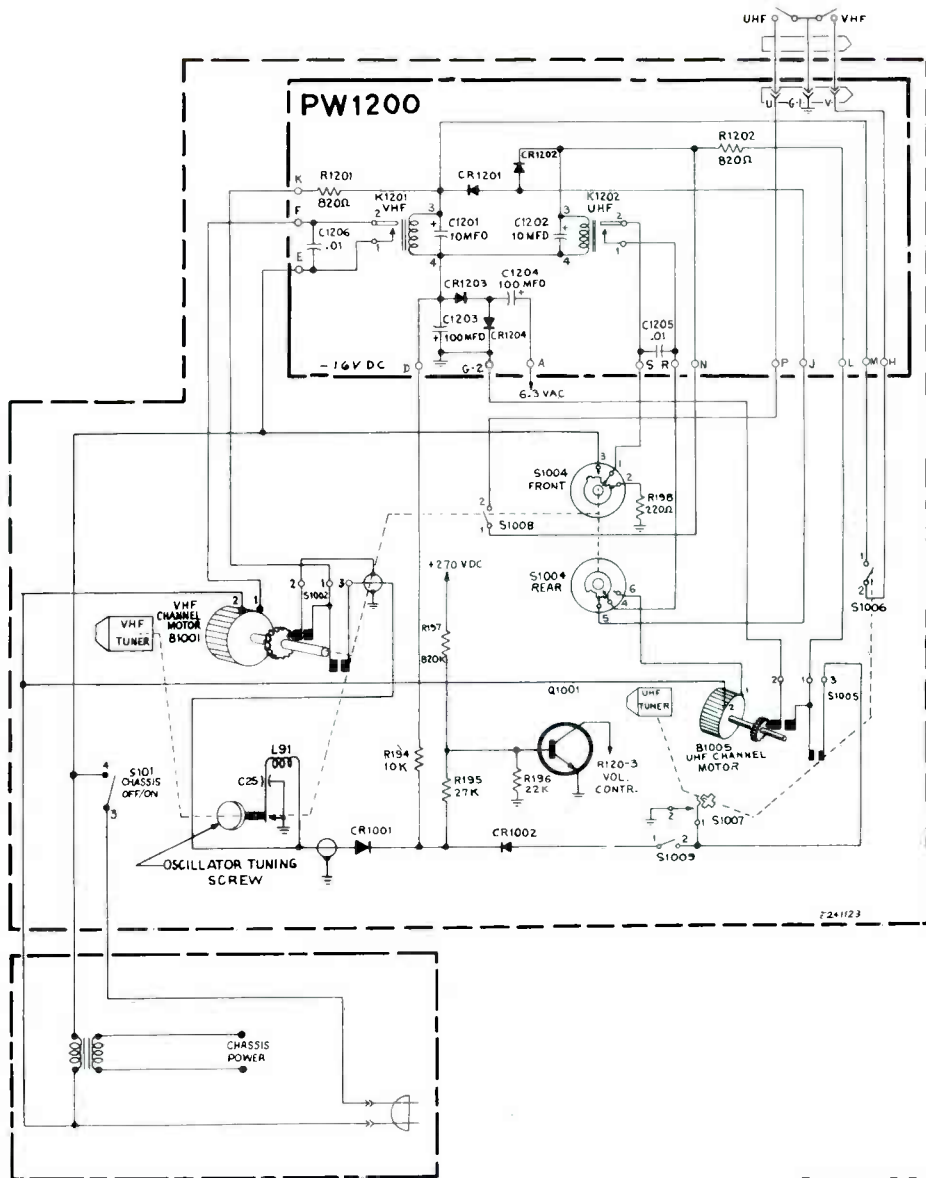

Courtesy RCA

FIGURE 3. A DIAGRAM OF THE POWER TUNING CIRCUIT IN THE CTC 30.

occasions. I wrapped the blanket around the tube and placed it on the seat of my car so it couldn't move. Little did I know that a surprise was in store for me when I arrived at the wholesaler. I carted the picture tube in and waited my turn. The

counterman went to get the tube but he returned empty handed. "We don't have any more Sylvania's," he said.

"I just called about one-half hour ago," I said.

"Did you tell us to hold the tube?" the

counterman responded. I could tell I should have stayed in bed.

"No, I didn't," I said. "Well what do you have?"

"We have a \$56 replacement I can let you have," the counterman replied. I took that, got credit for the dud and headed back to the customer's house.

Now's a good time for me to point out the mistake that I made. When I called about the tube I should have asked the wholesaler to hold the tube because I was on my way to pick it up. Since I was a regular customer they would have gladly done that. Well, that was my mistake. However, it's hard for me to believe the wholesaler had sold two 10-year-old black-and-white picture tubes of the same type in the same day, but I guess it's possible. Another possibility is that the salesman, or whoever answered the phone at the wholesaler's, didn't actually check to see if the picture tube was in stock. He may have just checked the inventory card which may not have been up to date. If I had asked him to hold it for me, he would have made an effort to verify that it was actually there — especially if I had asked who I was talking to or who should I ask for when I arrive to pick it up.

Anyway, things worked out okay. The customer's total bill was \$81. My profit was reduced from \$40 to \$30 because of the \$10 lost due to the picture tube price. I should have made \$15 for the service call, \$5 mark up for the picture tube, and \$20 for the 45 minutes it took for installation.

Another mistake I made was giving the customer such a close estimate — \$70 to \$80. Allow yourself at least a \$10 margin of error for estimates of small jobs (under \$40) and increase it for larger ones.

RCA CTC 30

I saved this job for last because I had a feeling it would be a rough one. This 25-inch color console had power tuning —

you simply push the button and the channels are automatically changed. The channels can also be changed manually. The problem was the power tuning didn't work and the sound was distorted. I had brought the complete schematic with me, so I was well prepared. My first step was to remove the tuners and the power tuning circuitry. There wasn't much slack in the wiring so I had to work inside the console.

The schematic for the power tuning and muting circuit is shown in Fig.3. I was hoping this job wouldn't turn out to be a dog. After all, things had already gone wrong once today. My first check was to see if I had the right voltages. The 270 volts dc, 6.3 volts ac, and 117 volts ac were all reaching the power tuning and sound muting circuit. I was just about to dig in for the long haul when I decided to check the -16 volts dc supply. Well, what do you know, there wasn't any -16 volts dc source. That was odd because I had the 6.3 volts ac input voltage. The problem was staring me in the face. One of the diodes in the -16 volts dc rectifier circuit was cracked in two. It didn't look like it had overheated. It looked more like it had just cracked because of old age or normal deterioration. I carry a few spare low-current silicon diodes like the SK3080 in my tool box. They come in handy for applications such as these. I cut out the defective diode with my diagonal cutters, soldered in a new diode, and fixed the set without putting the tuners and power tuning assembly back in place. The set came on and the power tuning worked like new.

I put things back in place, put the back on the set, and wrote out a bill. The diode was \$2, the service call was \$15, and labor for a half hour was \$12.50. The total came to \$29.50 and just about all of that was profit. My work was done and it was still early. I headed home in a much better mood than I had been in a couple of hours ago.

NOW

Conar offers **SENCORE's** line of all-American manufactured test equipment.

Here are selections from **SENCORE's** complete line.

HYBRIDER TUBE/TRANSISTOR/FET TESTER

PATENTED

*THE ONLY AMPLIFIER TESTER
FOR TUBE, SOLID STATE, AND
HYBRID CIRCUITS.*

- Tests tube, transistor, or hybrid circuits.
- Two reliable testers in one:
 - ▶ Mighty-Mite with all tests shown on big "Good-Bad" scales on the meter.
 - ▶ Cricket tester for in- or out-of-circuit testing of transistors or FETs.
- Saves time in setup and testing.
- Costs less than two equivalent testers.

Only \$275

PLUS \$2.50 SHIPPING AND HANDLING
STOCK NO. WT285



PORTA-PAK UNIVERSAL RECHARGEABLE BATTERY

*THE ONLY SUPPLY ESPECIALLY
DESIGNED FOR SOLID STATE
CIRCUIT DESIGN AND SERVICING.*

- Powers virtually all solid-state equipment.
- Highly regulated and filtered dc.
- Hum-free power for PC boards, modules, production line, IC testing, TV biasing.
- Provides 6 V, 12 V, and two independent 15 V supplies with 0.6 V taps.
- All outputs are 200 ma continuous and 5 amp peak.

Only \$98

PLUS \$2 SHIPPING AND HANDLING
STOCK NO. WT043

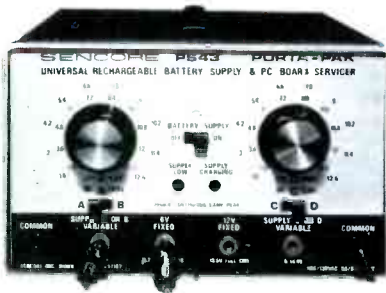

Successful Kit Building



By Laurence M. Frazier



Every kit builder is anxious with hope the first time power is applied to a completed kit. When the kit works properly, the builder is proud of a job well done. However, sometimes the kit doesn't work properly, and the beginner is frustrated and disappointed with the results. It is rare that a bad part is the cause of the problem. Frequently the problem results from an error the builder made when the kit was put together. Fortunately, by following a careful and methodical approach to kit building, you can get good results almost every time.

The biggest stumbling block in a kit is the soldering. Poor soldering is the major cause of a newly constructed kit's failure to work when first completed. Poor connections are sometimes the most difficult problem to troubleshoot. An improperly made solder joint can have a high resistance, be an open circuit or a short circuit to an adjacent foil, or it can be intermittent. A bad solder joint is sometimes hard to spot. By using proper soldering techniques you can make solder joints that are good every time. I will discuss soldering technique later in detail.

Frequently a kit builder opens the kit, dumps all the parts into a pile, grabs the instruction book, and looks for the first picture of a completed assembly. This is the worst approach you could take. Leave the parts wrapped up. Find the instruction packet. Read through the special instructions and notices first, if there are any. Thumb through the instruction book a few minutes. Sometimes the special



instructions will tell you that a different part has been substituted for one that is no longer manufactured. These instructions often warn you against making the same mistakes that others have made in the past. A few moments spent reading the information can save you disappointment later.

Start at the very beginning of the instruction book. If the instruction book tells you to take parts from bag one, then locate bag one, and use the parts from this bag only. In more complicated kits, parts are grouped so that you will not use a wrong (but similar) part in any section. Read each step all the way through, and be sure you understand it before you do what it says. Don't just skim over the step, but actually read each and every word. Put a check mark next to the step as it is completed.

SOLDERING

Soldering is an art that requires an understanding of the techniques, and a lot of practice to do a good job. Soldering is the most important part of building any kit, as solder connections are relied upon to make both electrical and mechanical connections. The first step in effective soldering is the selection of a soldering iron. If you use a soldering gun, you may as well throw the kit away. Soldering guns are for repairing appliances and for heavy duty electrical repairs. Soldering guns are about the worst



thing a beginner could use for work on printed circuit boards. They are difficult to control, apply too much heat, and are inconvenient to keep clean due to the shape of the tip. For working on printed circuit boards, one of the smaller pencil type irons will do a fine job. A 15-watt iron is ideal for PC boards, and a 40-watt to 60-watt iron is useful for terminal strips and capacitor lugs.

Both Weller and Ungar make some very nice, yet inexpensive soldering pencils. (Both types are available from Conar). One with a chisel shaped 1/8-inch tip is a good choice. But, an iron with a special iron plated tip is preferable, though not absolutely necessary. An iron plated tip will last until the plating is nicked, or until the plating is allowed to burn off. A copper tip tends to dissolve into the solder connections, and therefore requires frequent replacement. Be sure that the iron you choose has replacement tips available. Many of the imported irons look like a bargain, but new tips for these are not available.

While you are shopping for an iron, buy a stand to place the iron in while it is idling. The stand will help keep the iron from overheating, and will prevent inadvertent burning of fingers, tables, clothes, etc. One more thing you should get is a soldering sponge. Both Ungar and Weller sell soldering sponges, or a regular household cleaning sponge can be used. Once you have the proper tools for the job, your chance of making good connections are much better.

It is essential that the iron tip be kept clean and well tinned. Tinning the iron means that the tip has a solder coating over its working surface, and about one-half inch up the shank of the tip. You tin the iron by applying an excess of solder to the brand new tip, and then wiping the excess solder off on the dampened soldering sponge. This step is repeated until a thorough coating of solder protects the tip. A copper tip can be filed to shape or

cleaned with emery cloth before tinning, but a plated iron tip must never be filed. If a plated tip becomes corroded and will not take solder, it must be replaced.

The iron is tinned before it is used because the heat will not conduct to the connection fast enough through corrosion, burned flux, or dirt. Always maintain a good tinning on the iron. Apply an excess of solder to the iron before it is left to idle in its stand to protect the tip from pitting and corrosion. Then, before using the iron on the next connection, wipe off this excess solder.

To make good solder connections there are a few important rules to remember. Keep the tip of the iron clean! Your soldering sponge should be kept nearby for this purpose. Keep the sponge damp but not soaking. This keeps it soft and prevents it from burning. It is handy to cut some slices in the sponge with a razor blade, so that the tip can be wiped on all sides by passing it through the sponge.

When you are soldering connections, you are not glueing metal to metal. You are actually doing a form of brazing. Solder is flowed into the connection. The entire connection must come up to the temperature of molten solder, or else the

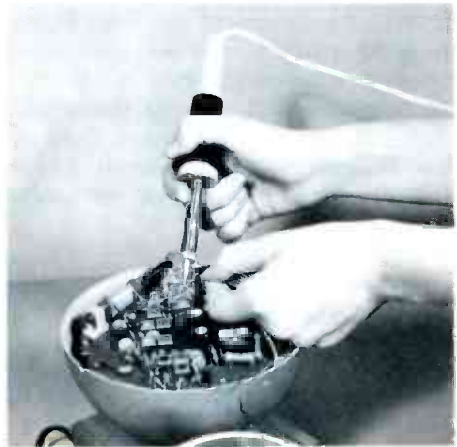

SOLDERING IS THE MOST IMPORTANT PART OF BUILDING ANY KIT.

connection will be bad. Never apply solder to the tip, and from the tip to the connection. Wipe the iron tip on the sponge. Then, place the tip against the connection, and add just a little solder between the tip and the connection. Now, as the connection heats up, add more solder to the connection, itself, not the iron tip. The solder should flow over and through the entire connection, and coat all the surfaces.

A good connection will cover the entire soldering pad of a PC board, while not going down the narrow trace. On a solder lug it will close the eye. A good solder joint will have a bright appearance. A dull appearance means that too much heat has been applied, and the tin and lead alloy have started to separate; or the connection was allowed to move as the connection was cooling. Notice I said cooling, not drying! Solder does not dry like glue, it cools, and becomes a solid, just as water that is allowed to cool becomes ice. If a connection should have a dull appearance, heat it up and remove the old solder with a de-soldering bulb, solderwick, or a soldervac. Then make the connection over again with fresh solder.

OTHER TOOLS

There are some other tools that are essential for kit building, and should be a part of your electronics tool box. You should have small diagonal cutters that are made for electronics, not electrical work. They should be capable of making a clean cut on fine wire, and should not gnaw through the wire. These should be used only for cutting small gauge copper wire. Other materials will spoil the edge of the tool, and make the tool useless.

You will also need a small pair of needle nose pliers. These should be used for bending hooks in wires, for connecting them to terminal strips, for crimping the wire against the terminal lug, and similar light duty tasks. They can

be used for holding a nut for starting, but never, never use them to tighten a nut, or to hold a nut that you are tightening. This is a very good way to ruin a pair of needle nose pliers.

Another tool that you should have is a wire stripper. It can be used for cutting off lengths of wire, and for stripping the insulation from hookup wire. Most wire strippers will require careful adjustment of the stop, for stripping the size wire that you are using. An incorrectly set wire stripper will nick the wire, and the wire will break the next time it is stressed. Wire strippers cannot cut component leads close enough to terminal strips, or PC boards, so the diagonal cutters should be used for these purposes.

You should have a set of flat-blade screwdrivers. One with a 1/8-inch blade is required for tightening set screws in knobs. One with a 1/4-inch wide blade will be useful for most of the other hardware that will be supplied in a kit. A screwdriver with a 3/8-inch blade is useful for large screws, such as the ones power transformers are mounted with. The blade of a screwdriver should be the same width as the head of the screw, and should be of a thickness that will fit the slot without too much play. Needless to say, the screwdrivers should never be used as a chisel or pry bar. It is perfectly okay to use a crescent wrench on the shank of a square shank screwdriver to loosen stuck screws, but never attack the handle or shank of a round shank screwdriver with pliers.

A complete nut driver set is a handy thing to have around, but at the very least, your tool kit should include a 1/4-inch and a 5/16-inch nut driver, as these two sizes are very popular in electronics work. A 1/2-inch nut driver is useful for tightening potentiometer and control nuts. Using a nut driver reduces the chances of inadvertently scarring the front panel of your kit. These tools mentioned are in the "need to have" category.



NUTDRIVER, PHILLIPS-HEAD SCREWDRIVER AND FLAT BLADE SCREWDRIVER.

WORKING CONDITIONS

Before you dive right in and start building your kit, clear off a work area. The kitchen table, work bench, or a desk will do, just as long as it is kept free of other papers, parts, etc. Your work area must be well lighted. Poor lighting will cause you to tire quickly, make poor soldering connections, and quite probably it will cause you to misidentify resistor color bands.

FINAL HINTS

While assembling the kit, remember that transistors must be oriented with the emitter base, and collector connected to the proper points in the circuit. Check with the instructions for the correct lead identification on transistors. They are not always the same. Some transistors have the collector in the center, while others have the collector on the end.

Diodes must be installed with the cathode, or banded end, oriented correctly. When bending the leads on diodes, use needle nose pliers to hold the diode lead, so that the lead is not stressed where it enters the plastic, glass, or epoxy case. Resistors can be installed without regard to orientation; however, it is desirable to orient them so the color bands read from left to right, or top to bottom. This makes it easier to check your work later. Electrolytic capacitors must be oriented with the red lead, or plus (+) lead, facing the correct way. Integrated circuits have a notch, tab, or dot which locates or identifies which is pin 1.

These must be installed correctly, as each pin has a different function.

Silicon transistors are fairly rugged devices, and can be installed without using a heat sink. Soldering should be done quickly, however. Resistors do not go bad from soldering heat, but they can change value somewhat. The more heat that gets to the resistor, the more the resistance change could be. Resistors can be soldered without a heat sink, but should be soldered quickly.

Capacitors can generally be soldered without heatsinking leads, with two exceptions. Polystyrene capacitors can short out due to the plastic melting if they are soldered without using a heat sink. Also, it has been found that tantalum slug capacitors will short out, or go bad prematurely if a heat sink is not used during soldering. You can use an alligator clip, or needle nose pliers as a heat sink. Place it between the component body and the solder joint. Incidentally, it is normal for the paraffin coating to soften while soldering disc ceramic capacitors. This is of no consequence, but should not be wiped off of the capacitor. The disc capacitor is covered with paraffin to protect it from humidity. Except where noted in the instructions for a kit, all parts should be mounted flush against the PC board, or in the case of the chassis mounted component, should have minimum lead length. In the i-f of a television set, at 45 MHz, a component lead of one-inch total length is like adding five ohms of reactance in series with the component. The circuit may not tolerate this!

If you follow these suggestions on your next kit, you should be greeted with a properly functioning kit.



NRI HONORS PROGRAM AWARDS

For outstanding grades throughout their NRI courses of study, the following January and February graduates were given Certificates of Distinction with their NRI Electronics Diplomas.

WITH HIGHEST HONORS

Edwin C. Brinker, West Palm Beach FL
Gerald Gardner, Cranbury NJ
Lowell D. Gehman, Terre Hill PA
Oswald Donald Hodges, Balboa Canal Zone
Donald K. Richardson, Minden LA
T. D. Sutton, Springfield MO
Dino A. Larosi, Toronto ON CANADA

WITH HIGH HONORS

Carl Barrington, Jr., Atlanta TX
John J. Blair, McAllen TX
A. E. Bolton, Jr., Titusville FL
John M. Conklin II, Charleston SC
William L. Dye, Orange TX
Bruce R. Fitch, Virginia Beach VA
Freddy Lee Fox, Conroe TX
Benjamin P. Franco, Brooklyn NY
Harold H. Gates, Pocatello ID
Joseph R. Hall, Jr., Columbia SC
Charles G. Harkey, Cicero IL
Floyd M. Heafner, Mechanicsburg IL
Odell F. Jackson, Lebanon TN
Robert G. Krieger, Sr., Goldsboro NC
Barry Karl Krueger, Tulsa OK
William E. Lancaster, Saint Petersburg FL
Jack L. Lawson, Bartlesville OK
J. F. McKenna, Weems VA
Thomas Perillo, Woodhaven NY
Edwin Reed, Jr., Milton LA
Albert D. Rich, Pearl City HI
Richard A. Schaak, Vaughn WA
Cecil D. Tefertiller, Amarillo TX
Arthur M. Wakerlig, Coronado CA
Edwin E. Thorne, Chicago IL

WITH HONORS

Maynard W. Beich, Minnetonka MN
Robert John Blalock, Easton PA
La Vern R. Blinsky, Wishek ND
Johnny Bogan, Jonesville SC
Leroy Broom, Lufkin TX
William B. Butcher, Manassas VA
Prentice M. Chumney, Woodbridge VA
Allen E. Click, Edingburg VA
Gerald W. Coleman, Linda CA
Michael E. Cooper, Lexington, Park MD
Robert Czekaj, Brick Town NJ
William G. Deiter, Chaddsford PA
Francis P. Donnelly, Pittsburgh PA
Richard Drennan, Lorain OH

Larry W. Ferguson, Washington IL
Thomas C. Fichthorn, Temple PA
Patrick A. Frederick, Greencastle PA
Sueo Fujii, Honolulu HI
Allen A. Gourley, Watsonville CA
Edward K. Herrman, Wappinger Falls NY
Verlean Hillary, Richmond CA
R. L. Hise, Dayton OH
Carl E. Horger, Jr., Whitman MA
Darel L. Jimerson, Bloomington IL
George R. Johanson, North Massapequa NY
Ralph E. Kandt, Petoskey MI
Zan Key, Franklin NC
Gary P. Klimek, Buckhannon WV
Andrew A. Kominiak, Flanders NJ
L. Laframboise, Espanola ON CANADA
Oran D. Lambing, Santa Maria CA
Gary B. Langstaff, Cape May NJ
Stan J. Layton, Houston TX
D. L. Leuba, Memphis TN
Norris A. Lockman, South Bend IN
Rex M. Mapes, Lafayette IN
David E. Mattos, Citrus Heights CA
Joseph G. Maxi, Brooklyn NY
Hubert F. McAllister, Brockville ON CANADA
Joseph A. McCool, Plattsburgh NE
William Albert Merritt, Los Angeles CA
Richard J. Mettler, Olean NY
David Allen Moody, Indianapolis IN
Jerrold D. Moore, Petaluma CA
Edwin Naito, Honolulu HI
Carl E. Nay, Bettsville OH
Richard J. Novak, Wilkes-Barre PA
Ross M. Owens, Indian Head MD
Paul V. Partington II, Mt. Vernon IN
Kenneth S. Peister, Brighton ON CANADA
Michael A. Perez, Brooklyn NY
William V. Perrine, Hurrigan WV
Aubrey F. Phillips, Brewton AL
Leland H. Plowman, Kincheloe AFB MI
William R. Reed, Lansing MI
Robbin D. Riley, Moss Point MS
Richard K. Rowan, Imperial Beach CA
Floyd E. Seabolt, Tulsa OK
Merle A. Steely, Warrenville IL
Charles F. Stohl, Helena MT
Henry C. Storch, Westminster CA
John Tavares, Toronto ON CANADA
George Tomich, New Brighton MN
Ronald J. Vaillancourt, Front Royal VA
Richard J. Walsh, Williamsville NY
Edward Weber, Gwinn MI
Samuel I. Williams, Landover MD
Edwin E. Wittick, Middlesex NJ

SENCORE

yoke/flyback tester

Have you ever lost your customer, or your shirt because you couldn't quickly and **reliably check** a yoke or flyback?

- In & Out of circuit tests for both tube and solid state saves guesswork.
- Approved by leading yoke & flyback manufacturers.
- Peak-to-peak drive scales to 300VP-P for sweep circuit analyzing.
- Color-coded scales insure accurate tests.

PATENTED



ringer

only \$195

(plus \$2 shipping charge)

stock no. WT33

GET THE RINGER and take the tough dogs out of sweep problems !!!!!



ONLY \$49.50

(plus \$1.50 shipping & handling)

stock no. WT156

The world's most popular DC bias box is seven supplies in one for **FAST ALIGNMENT WORK** in any stage of any set — tube or solid state. This compact unit has three independently controlled positive or negative outputs, plus -75V for chroma amplifiers.

align-o-pak 7-in-1 DC bias
world's most popular

HAM NEWS

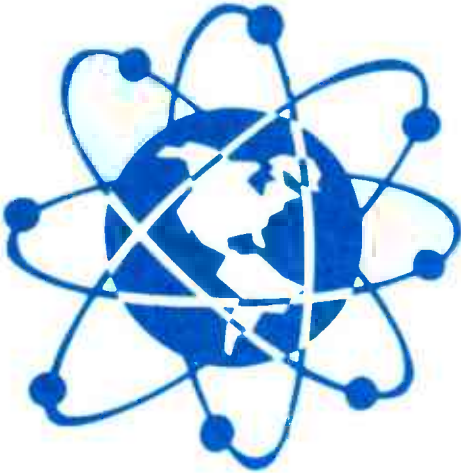

By **Ted Beach** **K4MKX**

Although I said last time that I would add a few more words about the proposed frequency allocations for 1979 WARC and about further FCC proposals, I think I'll have to back down and do it next time instead. One reason for this is that there are a couple of further developments "in the wind" which may be of some consequence, so let's wait and see what happens with them first.

A second note, as I look at the last issue of the *NRI Journal*, is that the Field Day call of our club station this year was N4GA/4 instead of W4DRW/4. Seems as if old Gerry (the owner of the call) decided he wanted one of those new two-letter calls, even if it did start with an "N." He *did* get his initials, however, and on cw the call sounds pretty good.

Speaking of cw, one of the more recent things I have done with the KIM-1 micro-computer is make it send cw. This was not on my list of things to do; however, an article by Jim Pollack (WB2DFA) in the January issue of *73* magazine was called to my attention as having a program written specifically for the KIM-1. I couldn't pass that up! Unfortunately, the program used an ASCII keyboard as an input device and as yet I don't have one. However, our newest staff ham, Ken

Bigelow (WB3EXX), volunteered to lend me his keyboard to try the program out. But, there was a glitch or two somewhere in the interface between his keyboard and the KIM, and typing in a character would cause the machine to dump out the entire contents of the 256 character first-in-first-out buffer. Bad news. Anyway, I was surprised the thing worked at all with all of the clip leads and wires floating all over the place.

By changing a couple of instructions in the program, we found we could load the buffer register directly with ASCII characters using the built-in keyboard of the KIM. Used in this manner, the computer essentially stores a 256 character message and sends it out on command as Morse characters. The speed is adjustable (under program control) from about 10 words per minute to (according to the author) 1000 words per minute! All it takes is another computer at the other end to listen to it (I'm still working on that project). I wonder what the bandwidth of a 1000 wpm cw signal would be.

At any rate, the program for generating Morse code works, and I think I'll have to gear up next for an ASCII keyboard so I can use it the way it was intended to be used. Oh me, so many different things to

work on! No wonder so few ever get done.

The CMOS synthesizer project has reached a halt also. I have built a circuit board and everything works just fine. The problem now being that I don't want to carve up the Wilson to interface with the synthesizer since I would lose the "hand carry" capability of the rig. I've already got a few ideas down on paper for a receiver, and maybe I'll buy a VHF Engineering transmitter strip to go with it. Yipes! Another project!

One of these days I'll probably finish *one* project before I start another, but I really don't know when that day will come. I think perhaps I do too much reading. I see all these new things that are coming out and feel that I just *have* to get involved myself. Oh, well...

To sort of complete the report on "things I'm currently involved with," the other two projects in the wings are the Baudot printer for the KIM and the microprocessor controlled video display. Both of these are in just about the same state they were when first reported in the January/February issue. I've done a lot of pencil pushing and head scratching on the terminal, but it is a long way from the hardware stage. Everything looks good on paper, but there are a few things still to be ironed out. The Baudot printer has not progressed further because I have not located a machine at the right price. I had a couple of nibbles for a "free" machine,

but both of these fell through at the last minute. I'll keep looking.

As you can see by the very small list of new people this time, I have had hardly any mail since the last issue of the *Journal*. I know there are more of you hams out there who haven't written in to give your call and just pass on information about your activities, so write!

As usual, those whose names appear first in the list are students and graduates of the NRI Amateur Radio courses. The last three are from the ranks of "other" NRI students and graduates.

I mentioned in the January/February issue that if enough people showed interest in the discount purchase of ham gear that there might possibly be a way we could arrange it. Well, the response has been underwhelming thus far. In that list of nine people below, only one expressed an interest in such a venture! It may be just as well, because in my usual neat way I have misplaced the name and address of the student who phoned me from Omaha with the idea in the first place. When he phoned, he put it to me like I put it to you in the *Journal*. That is, that if there were enough interest he would be willing to make the offer of new gear at 10 percent over cost. With the un-response received here so far, it doesn't look like I really need his name and address. However, if the person who made the offer would please put it in writing and send it

Jack	WA1YYK	N	Agawam, MA
Paul	WA2IZW	N	Albany, NY
Rick	WB3AAC	A*	Pittsburgh, PA
David	K3ZXP	T	Laurel, DE
Dorothy	WD5AHE	T	Albuquerque, NM
John	WB0YLG	N	Fountain, CO
George	WB3FRY	N	Wilmerding, PA
Ken	WB5INX	—	Louisville, MS
Bob	WA6QIM	A	San Rafael, CA

* Just upgraded — congratulations!

off to me, I'm sure everyone would appreciate it if all of a sudden we start getting loads of mail.

Not listed in the names above is Bill, WB4PUH, with whom I chatted on two meters the other day. I didn't have time to get full details on license and QTH from Bill. He is enrolled in our Communications course, and I had chatted with him on one or two other occasions, not knowing that he was an NRI student. Nice to have you aboard, Bill, and I'm sure I'll hear you more and more on the local repeaters.

WA1YYK writes that he got his Novice ticket at the tender age of 59 years young, a not too difficult task with the help of the course material. Jack says that the code is still his big stumbling block, but that he hopes to pass the 13 wpm hurdle by his 61st birthday. It shouldn't be any problem, Jack, now that you can get some on-the-air practice. I know that's how I made it, and if I would only get on and do it some more I feel sure I'd get up to the magic 20 wpm real quickly!

Rick, WB3AAC, sent us just a short note saying that he had just passed his Advanced test, going directly from Novice. He also let us know that he is running a full-house Heath shack with SB104, SB614, and SB634. Joining all this to whatever he's using for an antenna (and it could be almost anything!) is a Murch UT2000A transmatch. That's great.

K3ZXP writes that he has been a ham for several years, but has not had enough code or theory to upgrade. That's why David enrolled in the NRI course. He says "I have renewed my interest in ham radio and found the NRI Amateur Course to be both complete and easily understood. I expect to upgrade my ticket shortly and would never thought it possible without your course." Thanks, David, that's music to our ears.

Dorothy, WD5AHE, writes that she tried for General in January but couldn't quite make the 13 wpm at that time.

However, she missed only two questions on the Technician written exam, so things look good for a second sitting for the code test. Maybe by the time the examiners get back to Albuquerque they may be using the comprehensive cw test, Dorothy. You should really fly through it.

Well, I thought the FCC had bettered themselves with the new post office box number for Amateurs' use, but WB3FRY thinks differently. George mailed in his Novice exam September 1, 1976 and *finally* got his license on January 30, 1977 — total waiting time: five months!

As if that weren't enough grief, George's rig gave up the ghost the second day he had his new ticket. It should be back in working condition by now, and George would like to try a Novice NRI Net (NNN?). This has been tried in the past with varying degrees of success, but perhaps George is the one who can make a go of it. For the present, he suggests Saturday mornings at 1000 hours Eastern time on 40 meters, 7.140 MHz. He will try to coordinate, by calling "CQ NRI." Anyone interested should show up at the appointed time and frequency or write George F. Cheripka, Jr., 70 Morningside Avenue, Wilmerding, Pennsylvania 15148. He also asked for a QSL card from me, but unfortunately I'm fresh out. Have to do something about that one of these days.

Finally, WA6QIM writes that he recently passed the Second Class Commercial exam and hopes to go for First Class in the near future. Bob has also been fairly active on 40 cw from San Rafael, running 150 watts to an end-fed antenna. He also built an electronic keyer from the *ARRL Handbook* to make it all go. Sounds real good, Bob, and we'll wish you the best of luck when you sit for the Commercial exam.

That wraps it up for now. Let us hear from you, as this is *your* column — tell us what you like or don't like, and we'll try to make everyone happy. Until next time, very 73 and we'll BCNU. Ted — K4MKX

DIRECTORY OF ALUMNI CHAPTERS

DETROIT CHAPTER meets at 8 p.m. on the second Friday of each month at St. Andrews Hall, 431 E. Congress St., Detroit. Chairman: James Kelley, 1140 Livernois, Detroit, Michigan. 841-4972.

FLINT (SAGINAW VALLEY) CHAPTER meets 7:30 p.m. the second Wednesday of each month at Andy's Radio and TV Shop, G-5507 S.Saginaw Rd., Flint, Michigan. Chairman: Roger D. Donaven.

NEW YORK CITY CHAPTER meets at 8:30 p.m., first Thursday of each month, at 1669 45th Street, Brooklyn, New York. Chairman: Sam Antman, 1669 45th Street, Brooklyn, New York.

NORTH JERSEY CHAPTER meets at 8 p.m. on the second Friday of each month at the Players Club, located on Washington Square in Kearny, New Jersey. Chairman: Al Mould. Telephone 991-9299 or 384-8112.

PHILADELPHIA-CAMDEN CHAPTER meets on the fourth Monday of each month at 8 p.m. at the home of Chairman Boyd A. Bingaman, 426 Crotzer Avenue, Folcroft, Penna. Telephone LU 3-7165.

PITTSBURGH CHAPTER meets at 8 p.m. on the first Thursday of each month in the basement of the U.P. Church of Verona, Pa., corner of South Ave. and Second Street. Chairman: James Wheeler.

SAN ANTONIO (ALAMO) CHAPTER meets at 7 p.m., fourth Thursday of each month, at the Alamo Heights Christian Church Scout House, 350 Primrose St., 6500 block of N. New Braunfels St. (three blocks north of Austin Hwy.), San Antonio. Chairman: Robert Bonge, 222 Amador Lane, San Antonio. All San Antonio area NRI students are always welcome. A free annual chapter membership will be given to all NRI graduates attending within three months of their graduation.

SOUTHEASTERN MASSACHUSETTS CHAPTER meets at 8 p.m. on the last Wednesday of each month at the home of Chairman Daniel DeJesus, 12 Brookview St., Fairhaven, Mass. 02719.

SPRINGFIELD (MASS.) CHAPTER meets at 7:30 p.m. on the second Saturday of each month at the shop of Norman Charest, 74 Redfern Drive, Springfield, Mass. 01109. Telephone (413) 734-2609. Chairman: Preston Atwood.

TORONTO CHAPTER meets at McGraw-Hill CEC, 330 Progress Avenue, Scarborough, Ontario, Canada. Chairman: Branko Lebar. For information contact Stewart J. Kenmuir, (416) 293-1911.



FLINT/SAGINAW VALLEY SOLVES ELECTRONIC PROBLEMS

At the February 2 meeting, Andy Jobbagg introduced a new product, a printed circuit board cleaner. He also showed how to make a heat sink when substituting a different type of transistor in a circuit.

Some of the new members were shown how to test old television yokes. Both the vertical and horizontal sections of the yoke were identified so that they may be used in other receivers.

The Chapter is taking on a new line of service work. Douglas Gram and Andy Jobbagg are experimenting with some new burglar alarm systems which include a panic button to call the police department. Some Chapter members, such as Dennis Besser and Cash Laferty, are obtaining new employment through knowledge gained at the NRIAA meetings. Dennis is now working at air conditioning and refrigeration. Cash, in his job at the General Motors plant, is getting into electronics maintenance – repairing automatic programming control devices used on machinery.

NRIAA OFFICERS

J.B. Straughn	President
Eldred M. Breese	Vice President
Branko Lebar	Vice President
Joseph A. Crusco	Vice President
Les Lederna	Vice President
Tom Nolan	Executive Secretary

Alumni News

At the February 16 meeting, Andy worked on a Philco Model 40-180, which was manufactured in 1939. It had a built-in directional antenna (which was a fore-runner of the loopstick), a push button selector for the station, a police band, a short-wave band and a variable tone control.

Andy also displayed a Majestic radio model 90, which was built in 1928 by the Grisby Grunow Company.

An auto radio, made by the Automatic Radio Company, had two bad output transistors, but when they were replaced, it still had very low volume and bad sound. The problem was in the output transformer, which apparently had been damaged when the transistors went out. Unfortunately, another transformer was not available, but thanks to Douglas Gram, who rewound the transformer by hand, the radio works fine.

A Scott AM-FM stereo set was inoperative and had four shorted output transistors. The hard-to-find schematic was finally located at the local library. After replacing further parts, it performed like a charm.

What does this Chapter do with old television and radio receivers? They are

recycled by saving the yokes, speakers, transformers, coils, copper, bolts, and accessories that can be sold or used in the repair of other units. One Chapter member, John Gonsansky, made a phonograph record cabinet and a bookcase out of old television cabinets.

At the March meeting, many problems were studied and solved. A 6BK4 voltage regulator tube shorted out and blew a fuse. An RCA set played for a few minutes, after which high voltage would decrease. What was thought to be a shorted cathode ray tube turned out to be the video amplifier output tube, a 12HG7. This was overdriving the picture tube when it went bad.

After March 2, the Chapter suspended meetings for a few weeks until Andy got back from his vacation in Honolulu. Aloha.

DETROIT CHAPTER STUDIES OLD WIRE RECORDERS

Two wire recorders were brought in by John Nagy for an evening project. One could not be operated because someone had hammered the top of the drive spindle and they were flared oversize. The

spindles were dressed down to size and made usable. By utilizing both recorders at once — the drive on one and the head on the other — a wire recording was made to play.

John was contacted by one of the Detroit newspapers following requests from several people looking for someone to make wire-to-wire reproductions. It is almost impossible to find any wire recorders today, due to wide usage of the tape recorder.

Ed Quinn was welcomed as a new member after he had participated in several meetings as a visitor. Ed is near the end of his NRI TV/Audio course and is completing his 19" Conar Color Television. He had a couple of problems while building it, which members helped him solve.

Members are still involved in dissecting and analyzing television receivers. While having fun, they are learning something new.

PITTSBURGH CHAPTER HAS MAGNETIC TAPES ON ZENITH TUNERS

At the March 3 meeting, the Pittsburgh Chapter heard tapes which were furnished by Zenith. These tapes explained the various tuners used in the 13" and larger televisions (both black-and-white and color).

During December, January, and February, the snows were so bad, and so few members showed up, that officers were unable to be elected until March.

The officers for 1977 are as follows: Jack Benoit, Vice-Chairman; Joe Burnellis, Secretary; and Jerald Genelli, Treasurer. Board members are George McElwain, David Benes, and James Brugh.

NORTH JERSEY CHAPTER HAS ELECTION OF OFFICERS

The new officers of the North Jersey Chapter of NRIAA are as follows: Chairman, Al Mould, 16 Argyle Place, Kearny; Vice-Chairman, Harry Ala, 285 Davis Avenue, Kearny; Treasurer, Richard Wagstaff, 36 Lafayette Place, Lindhurst; and Secretary, Richard Lennon, 572 Gregory Avenue, Weehawken.

At the February 11 meeting, a troubleshooting session was held and a General Electric color television and a Panasonic black-and-white television were repaired. In both cases, the problems were solved by members working together.

SPRINGFIELD CHAPTER HAS TRAINING SESSION

At the February 12 meeting, Bill Planzo celebrated his 12th year as treasurer of the Chapter.

The club is now having a program to train members in i-f and color alignment of color television receivers.

Preparations were also being made for the annual picnic.

New officers elected for 1977-79, effective in September, are as follows: Norman Charest, Chairman; John T. Park, Secretary; and William Planzo, Treasurer.

Help your
Heart...Help your

Heart Fund
American Heart Association



CONAR

A Division of the National Radio Institute
3939 Wisconsin Avenue
Washington, D.C. 20016

CHECK ONE:

- Cash order
 COD (20% deposit required)
 Select-A-Plan order

CHECK ONE:

- New Conar account
 Add-on Conar account
 Reopen Conar account

PLEASE PRINT

_____ NRI Student or Graduate No. _____

Name _____

Address _____

City _____ State _____ Zip code _____

Social Security No. _____

Ship to another address? Give directions here: _____

Name _____

Address _____

City _____ State _____ Zip Code _____

c/o _____

Moved since last order?

Previous address _____ City _____ State _____ Zip code _____

1.	Name of Item	2. Stock No.	3. How Many?	4. Price Each	5. Total	6.

IMPORTANT:

To speed handling, any correspondence should be on separate paper.
 All prices are net FOB, Washington, D.C.
 Please include postage for weight shown and insurance on Parcel Post orders.
 A 20% deposit is required on COD orders. Select-A-Plan orders: Please complete reverse side and sign payment agreement below. Thank you for your order.

6. Total cash price for merchandise		
7. Parcel Post and insurance (Do not remit for items shipped Express Collect)		
8. 10% cash down payment and Parcel Post costs required on new Conar accounts.		
9. Unpaid balance of cash price (Items 6 and 7 less item 8)		
10. Sales tax (Washington, D.C. residents only)		
11. Unpaid balance (Amount to be financed) (Item 9 plus item 10)		

Prices in the Conar catalog and Select-A-Plan time payment privileges apply only to residents of the United States and Canada. Residents of Canada and foreign countries are responsible for customs charges.

PAYMENT AGREEMENT

Enclosed is a down payment of \$ _____ on the merchandise I have listed on the Conar Order Form. I will pay Conar a minimum payment of 7% of the beginning unpaid balance or \$5 per month, whichever is greater, until the full balance plus applicable interest is paid. Title to and right of possession of the merchandise shall remain in Conar Instruments until all payments have been made. If I do not make the payments as agreed, Conar may declare the entire balance immediately due and payable. In satisfaction of the balance, Conar may, at its option, take back the merchandise, which I agree to return upon request. I agree that the above conditions shall apply to any add-on purchases to my account. The statements on my credit application are true and are made for the purpose of receiving credit.

Date _____ Buyer sign here _____

Please do not write in this space.

RETAIL INSTALLMENT CONTRACT AND SECURITY AGREEMENT

CONAR SELECT-A-PLAN

SELECT YOUR TERMS TO FIT YOUR BUDGET

CONAR FINANCIAL RATES

The Finance Charge on balances up to \$500 is 1½% per month. On any portion of a balance over \$500, the rate is 1% per month. This is an Annual Rate of 18% and 12% respectively. The Finance Charge is computed on the month end balance of your billing cycle. You will receive a statement each month approximately 10 days before your payment is due. It will give you the current balance, finance charge, list payments made during billing cycle, date your payment is due, and amount of minimum payment due.

HOW TO DETERMINE THE AMOUNT OF YOUR MONTHLY PAYMENT

The minimum monthly payment on a Conar account is 7% of the original unpaid balance or \$5, whichever is greater. The 7% is calculated to the nearest dollar. For example, if your original balance is \$140, your payment would be \$10. If your original balance is \$160, your payment would be \$11.

And remember—every purchase carries the Conar Guarantee—"the best in the industry."

TO SPEED SHIPMENT

1. Complete other side of this sheet.
2. Insert amount of down payment (at least 10% of total order) and other information in Payment Agreement on other side.
3. Sign Payment Agreement and fill in Credit Application.

IMPORTANT: Additional purchases—Once your credit is established and you have made at least three payments on your account, you can "add on" to your account with purchases of \$20 or more. No down payment is required for add-ons of less than \$100. If you are under 21, please have the Payment Agreement and credit application filled out and signed by a person over 21. He can make the purchase for you and will be responsible for payment. If you have a Conar account open or recently paid in full, just sign the Payment Agreement.

NOTICE TO THE BUYER: (1) Do not sign this agreement before you read it or if it contains any blank space. (2) You are entitled to a copy of this agreement.

IT'S AS EASY AS **A - B - C** TO OPEN A CONAR ACCOUNT

PLEASE ALLOW ADEQUATE TIME FOR NORMAL ROUTINE CREDIT CHECK. ONCE YOUR CREDIT IS ESTABLISHED, ONLY YOUR SIGNATURE IS NEEDED TO ADD ON PURCHASES.

WHERE DO YOU LIVE?

Print full name _____ Age _____

Home address _____ City _____ State _____ Zip code _____

A ➔ Home Phone _____ How long at this address? _____ () Own home () Rent

Rent or mortgage payments \$ _____ per month. () Married () Single Wife's name _____

No. dependent children _____ Previous address _____ How long? _____

WHERE DO YOU WORK?

Your employer _____ Monthly income \$ _____

B ➔ Employer's address _____

How many years on present job? _____ Position _____

Previous employer _____

Wife's employer _____ Monthly income \$ _____

WHERE DO YOU TRADE?

Bank account with _____ () Checking

() Savings

() Loan

C ➔ Address _____

Credit account with _____ Address _____

Credit account with _____ Address _____

Total of all monthly payments including car \$ _____

New

TELEMATIC VHF/UHF TUNERMATE

SOLVE TUNER PROBLEMS FAST

The VHF/UHF TunerMate allows direct substitution of the TV's tuner for fast, positive localizing of front end trouble. It tunes channels 2 thru 83 with standard 40 MHz output. Switching is provided to select internal or external tuners.

Weights only 3-1/2 lbs.
Operates from 105 to 125 volts.



VHF/UHF Tuner Checker
I-F Trouble-Shooter

STOCK #WT 765

Only \$49.95 Plus \$2.50 shipping
& handling.

CRYS-MATE

CRYSTAL CHECKER
& FREQUENCY

STANDARD



STOCK #WT 720

Only \$21.95

Plus \$1.50 shipping
& handling.

- Portable
- Solid State
- Crystal Tester
- Battery Powered
- CB/TV/FM Marker
- Power-Saver Circuitry
- "Indicator" Lamp Tells
If Crystal Is Good or Bad

CONAR

AUDIO COLOR



The Conar Audio Color was the first — and many believe the best — of the color-to-music units.

While you listen to your favorite melody, beautiful hues of red, orange, yellow, blue, green and violet move across the Audio Color screen in a breathtaking variety of patterns. A frosted screen eliminates glare without filtering the colors.

But Audio Color *does more* than paint the music. It also reproduces the tempo. With each *torrid* beat of the bongos . . . with each *clash* of the cymbals, the colors grow brighter. If the tempo mounts slowly, the colors brighten gradually. A *sharp rise* in volume is matched by a *sudden flash* of colors—bass on the right, treble on the left.

Order the Audio Color in kit form and build it yourself in a few short hours.

limited quantities

FINAL CLOSE-OUT

DELIVERY PREPAID IN THE U.S.

STOCK # 103 UK

\$29.95



NRI JOURNAL
3939 Wisconsin Avenue
Washington, D.C. 20016

MR LAWRENCE T ANDERSON
3453 BALSAM NE
GRAND RAPIDS MI 49505

B198-F124 G

Second-class
postage paid
at Washington, D.C.
and additional entry