

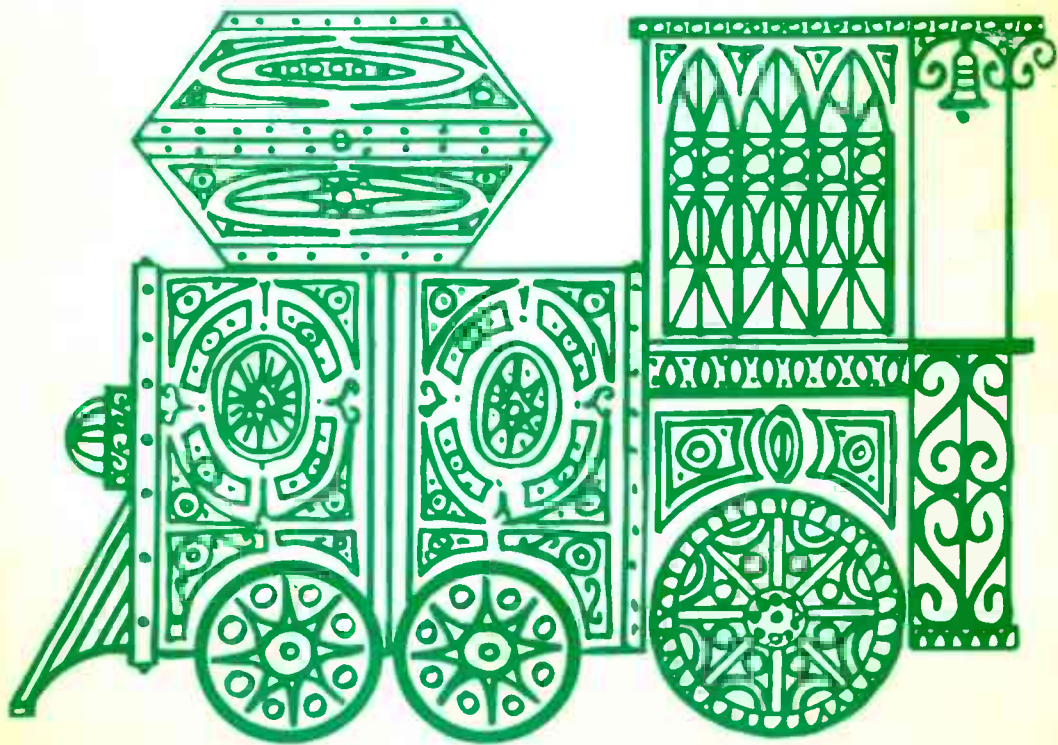

journal

USE
CHRISTMAS
SEALS



November/December 1967 35 Cents

SETTING THE PACE FOR COLOR GENERATORS FOR YEARS TO COME

Completely
New from
CONAR

INTEGRATED CIRCUIT
COLOR GENERATOR

MODEL 680

KIT 680UK
\$83⁵⁰

WIRED 680WT
\$114⁵⁰



Terms as Low as \$5 Per Month

Available Jan. 1, 1968

Only the 680 Has All These Features At Any Price!

- EXCLUSIVE Digital Integrated Circuits
- EXCLUSIVE 4 Crystal Controlled Oscillators
- EXCLUSIVE AC or Battery Operation Standard
- Completely Solid State
- Color Amplitude Control
- Color Phase Adjustment
- Regulated Power Supply
- Stability Control
- TV Station Sync and Blanking Pulses
- Nine Patterns
- Red, Blue and Green Gun Killers
- Compact, Lightweight, Portable

CONAR 5"
WIDE BAND
OSCILLOSCOPE



KIT 250UK
\$89⁵⁰
Exp. Coll.

As Low As
\$5
Month

WIRED 250WT
\$139⁵⁰
Exp. Coll.

- Uses 2400 volts on the cathode ray tube—50% more than most scopes.
- Vertical gain control is calibrated for direct reading of peak-to-peak voltages.
- Two-stage retrace blanking amplifier gives 100% retrace blanking at all frequencies produced by the scope sweep generator.
- Accurately measures ripple output of power supplies; checks auto radio vibrators dynamically.
- Intensity and focus controls use special insulated high voltage potentiometers to eliminate leakage and shock hazards.
- Has push-pull outputs balanced by separate phase splitter tubes in both horizontal and vertical amplifiers.
- Built-in flyback checker gives rapid, in-circuit testing of flybacks, transformers, yokes, coils, loopsticks.
- Sweep range—10 cps to 500 kc.

CONAR CATHODE CONDUCTANCE TUBE TESTER

KIT 223UK
13 lbs., P.P. Ins. **\$45⁵⁰**

WIRED 223WT
13 lbs., P.P. Ins. **\$63⁵⁰**

PAY AS LITTLE AS \$5 PER MONTH

Completely new, modestly-priced Tube Tester Kit, designed by men with *unequaled* experience in training technicians.

Tests all series string and up-to-date tubes as well as the standard base types—4, 5, 6, 7-pin large octal, local, 7, 9, and 10-pin miniatures, 5 pin novistor, novar and Compactron. Checks 17 individual filament voltages from .75 to 110 volts. Tests multi-section tubes, gas rectifiers and remote control gaseous types. Has open-close "eye" tests for cathode ray indicator tubes, and visible filament continuity check to show up open filaments regardless of pin position.

12 level element selector-distribution system enables you to select the individual elements of the tube you're checking and simplifies cathode leakage tests and inter-element short tests.

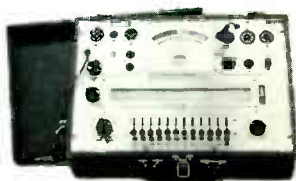

COLOR TV ... and the X-Ray

Reprinted Courtesy General Electric

A characteristic of certain components of all color television receivers is the capability of producing X-rays.

As these X-rays serve no useful purpose, the set is designed to control possible emission of X-rays and to contain them within the receiver by the use of shielding and other techniques. With these normal safeguards, the viewer can use his color TV receiver with complete safety.

However, in servicing a color television receiver there are certain precautions that the electronic service technician should observe so that the receiver is always in a safe operating condition when power is applied either in the service shop or in the customer's home.

WHAT IS AN X-RAY?

An X-ray is a type of radiation which is produced when a beam of electrons (typically in a vacuum tube) strikes some material at a relatively high velocity. Generally speaking, accelerating voltages above 10 to 15KV are required before any significant quantity of X-rays is emitted. Due to absorption of X-rays by glass tube envelopes, there is normally no significant escape of X-rays from tubes until voltages are in the range of 20KV or higher.

Measurement of X-rays at relatively low energy levels such as are involved in TV receivers requires instruments which have the capability of making accurate readings at these energy levels. Many radiation measuring instruments do not read accurately in this energy spectrum. Furthermore, the circuitry of many such devices will respond to RF radiation in addition to X-rays. Care should be taken to avoid drawing inaccurate conclusions because of mistaking the two types of radiation.

The Roentgen (R) is the international unit used in measuring X-rays.

One milliroentgen (mR) equals one thousandth (.001) roentgen. X-ray measurements in the area of a color TV receiver would be measured in the milliroentgen range.

HOW X-RAYS ARE PRODUCED

When electron particles bombard material such as a metal target, some of the energy of these electrons is converted to X-rays. Unless shielded or otherwise absorbed, these X-rays are emitted from the target in all directions. The energy of an X-ray is proportional to the voltage which has accelerated the electron. The quantity of X-rays produced is very sensitive to voltage and a given increase in voltage produces a much greater proportional increase in X-rays. Therefore, it is important that the high voltage in color TV receivers should not be set above specified levels.

ATTENUATION OF X-RAYS

X-rays are attenuated or reduced by any material placed in the X-ray field. Materials used as X-ray shields include metal, glass, ceramic, etc., all of which are used in the chassis of television receivers. The degree of attenuation is determined by the type, density, and thickness of the material and the energy of the X-rays involved.

X-RAYS IN A COLOR TV RECEIVER

In color television receivers, X-rays may be emitted from three possible sources: (1) the high voltage regulator tube; (2) the high voltage rectifier tube; (3) the picture tube.

Emission of X-rays from the regulator tube will vary with voltage and tube current. Maximum X-radiation from the regulator tube will occur when the picture is dark.

The emission of X-rays from the rectifier tube occurs during the portion of the cycle when small reverse currents occur.

X-ray radiation from the picture tube depends upon beam current and voltage. Maximum emissions at rated tube voltage will occur when there is a bright picture on the screen. These emissions may be further increased if a condition exists where the picture does not completely fill the screen.

As noted previously, high voltage in excess of that specified creates even greater quantities of X-radiation. Conditions such as an excessive high voltage setting, certain types of regulator tube failures or unusually high line voltages can increase the potential of X-rays very significantly.

SERVICING COLOR TV IN THE SHOP

When servicing a color TV receiver in the service shop, precautions should be taken to provide protection from X-ray radiation for the electronic technician and for his co-workers in the adjacent work area.

A color television receiver presents no X-ray hazards if it is operated at the specified power line voltage and has all the original factory installed shields and equipment in place. Therefore, the following precautions should be taken to provide maximum protection for the technician and his co-workers:

1. Never apply power to the receiver unless the high voltage compartment is completely assembled with the door closed and with all other originally factory-installed shields in place. These shields may be additional shields on the outside of the high voltage compartment, a shield surrounding the high voltage rectifier tube or the barium ferrite shield inside the plastic tube cap. If a shield is missing from a set, it should be replaced at once as standard servicing procedure. (To effect a repair it is sometimes necessary to disassemble the high voltage compartment or remove certain metal shields.)
2. The high voltage must never be adjusted to exceed the specified kilovolts with the brightness and contrast adjusted to maximum (no illumination of

picture tube screen), Refer to the manufacturer's service manuals for specific instructions.

If the high voltage check indicates a malfunction or improper adjustment, this fault must be corrected before any other service procedure such as picture tube set-up, yoke adjustment, or troubleshooting is performed.

3. Whenever tube replacement is necessary, replace the regulator tube, picture tube, and high voltage rectifier tube only with the tube types specified for the particular receiver.

The correct tube type to use should be determined either from the tube location label attached to the inside of the receiver or from the information in the receiver service manual, since the tube being replaced may be an incorrect type previously installed by someone else.

4. To locate a suspected but difficult trouble, it is the practice of many technicians to apply a line voltage to the set which often exceeds the manufacturer's specifications. The excessive line voltage is derived from a variable step-up transformer. With the voltage applied, the set is allowed to "cook" until the suspected component fails completely. Never resort to this practice when servicing a color television set.

SERVICING COLOR TV IN THE HOME

When servicing a color television receiver in the customer's home, always take the precautions and perform the tests listed below.

1. All factory installed shields must be in place.
2. The high voltage compartment door must be closed and captivated.
3. Before applying power to the receiver, check the power line voltage at the wall outlet to make sure that it does not exceed the input voltage rating of the receiver (the power company may have increased the voltage since your last service call). If the power line voltage is excessive ask the power company to adjust the line voltage to the proper level, or set transformer tap as specified by the set manufacturer so that the receiver is operating within the manufacturer's specified ratings.
4. Check and if necessary adjust the high voltage to make sure that it does not exceed the kilovolts at specified power line voltage and with the brightness and contrast adjusted for minimum (no illumination on the picture tube screen).

If the high voltage check indicates a malfunction or improper adjustment, this fault must be corrected before any other service procedure such as picture tube set-up yoke adjustment or troubleshooting is performed.

5. Replace the regulator tube, high voltage rectifier tube and picture tube only with the tube types specified on the tube location label inside the receiver or in the manufacturer's service manual.
6. Make any other safety checks as instructed in labels attached to the receiver or in the service manual.

Stereo Amplifier Circuits

By William F. Dunn

The modern stereo amplifiers being manufactured today use two identical solid-state amplifiers. Many of these amplifiers use circuits which are quite different from those found in vacuum tube amplifiers. This article describes a few of the circuits that will be found in transistor amplifiers.

A TWO-STAGE AMPLIFIER

A low cost two-transistor amplifier which uses a PNP transistor and an NPN transistor is shown in Fig. 1. This amplifier makes use of the characteristics of the two different transistors to eliminate the coupling capacitor usually found between amplifier stages, and in so doing also eliminates distortion due to the capacitor.

In the circuit shown, the input impedance is controlled at high frequencies by R_5 . C_1 and C_2 have a low reactance at middle and high frequencies, so the total impedance across the input at high frequencies will be equal to the resistance of R_5 . At low frequencies, R_1 varies the input impedance. By varying the setting of R_1 , the input impedance (and hence the amplitude of any low-frequency input signal) can be varied. Thus R_1 serves as a bass or

low-frequency tone control. R_4 is in the input circuit between the input and the volume control. It can be bypassed at high frequencies by the setting of R_5 .

When the sliding contact is up towards C_1 , C_1 provides an effective bypass around R_4 at high frequencies. When the sliding contact is down at the other end, R_4 and R_5 are essentially in parallel at high frequencies, and this tends to reduce the amplitude of the high-frequency signals. Thus, R_5 serves as a high-frequency tone control, which is usually called a treble control.

R_7 is the volume control. Notice that this control has a tap on it, and that C_3 and R_6 are connected between the tap and ground. This type of circuit is referred to as automatic bass compensation. When you turn the volume control to the low-volume position, the low-frequency sounds appear weaker than the high-frequency sounds. The higher-frequency signals are attenuated by means of C_3 and R_6 , so that there is a tendency to equalize the loudness of the high-frequency and low-frequency signals.

Actually, the low-frequency signals are given greater amplification to compen-

Fig. 1. Two-stage transistor amplifier,

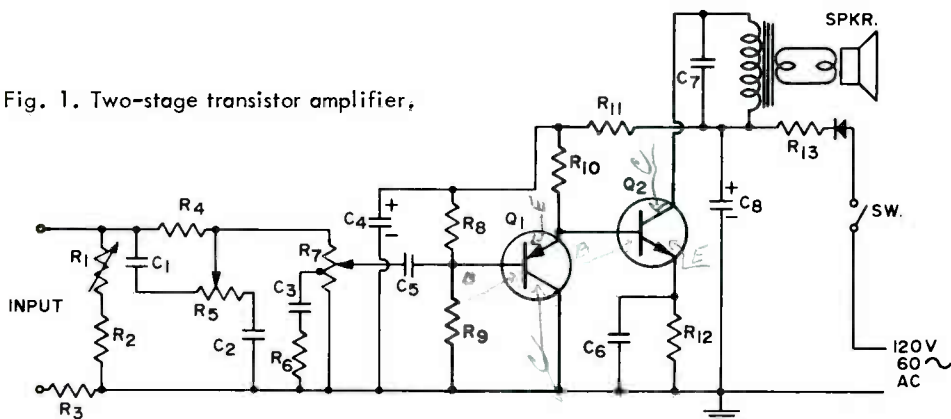

*NPN Electron is carrier
PNP HOLES ARE carriers*

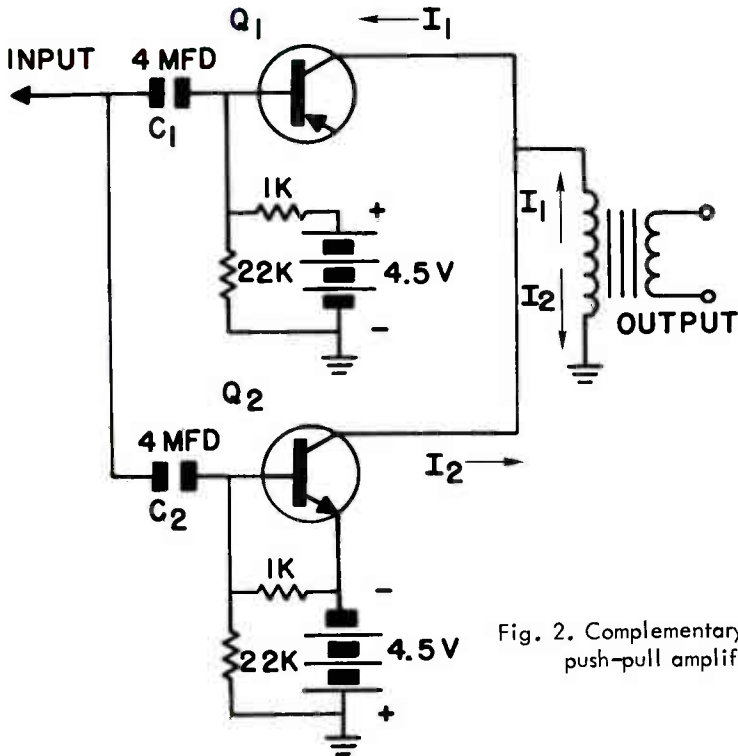

Fig. 2. Complementary-symmetry push-pull amplifier.

sate for the fact that they are less noticeable at low volume levels. The transistor Q_1 is used in a common collector circuit. The input signal is fed to the base through C_5 and to the emitter through C_4 and R_{10} . The output is taken across the emitter resistor (R_{10}) and fed directly to the base of Q_2 , which is a power transistor used in a common-emitter circuit.

The two-stage amplifier is designed to operate directly from the 120-volt power line. Notice that a half-wave rectifier circuit using a silicon rectifier is shown. Resistor R_{13} is a series resistor to limit the charging current through the rectifier when the equipment is turned on. C_8 is the input filter capacitor; C_4 , the output filter capacitor. R_{11} is the filter resistor. The supply voltage applied to the collector of Q_2 is not filtered as well as the voltage fed to Q_1 . The voltage fed to Q_2 does not require the filtering because if there is hum volt-

age present with the dc, it does not receive any amplification. However, any hum voltage on the dc applied to Q_1 will be amplified and will result in an objectionable hum in the output. An amplifier of this type will be used with a high output ceramic phono cartridge.

PUSH-PULL OUTPUT STAGE

Another transistor circuit of interest is the one shown in Fig. 2. This circuit is referred to as a complementary-symmetry push-pull amplifier. Here an NPN transistor and a PNP transistor are used. This type of output stage may be found in higher powered amplifiers as well as in portable receivers.

When the input signal drives the base of Q_1 in a positive direction, the current through Q_1 will decrease, because this transistor is a PNP transistor and the positive voltage applied to the base of the transistor tends to decrease the for-

ward bias applied to it. At the same time, the positive input signal is fed to the base of Q_2 , and this increases the emitter-base forward bias and causes the current through this transistor to increase. This current is represented by i_2 and flows through the output transformer primary in the direction shown. In the next half-cycle, when the signal swings negative, this will subtract from the forward bias across Q_2 , reducing the current flow through it, and increase the forward bias across the emitter-base of Q_1 , causing the hole flow through it to increase. The increase in hole flow through the transistor results in an increase in current flow i_1 through the primary of the output transformer in the direction shown.

If the transistors shown in Fig. 2 are balanced and biased essentially so that they are cut off without any signal flow, there will be no current flow through the primary of the transformer until a signal is applied. Then the current will flow through the transformer; the direction of flow will depend upon whether the signal is positive-going or negative-going. During one half-cycle the current will flow through the primary of the output transformer in one direction, and during the other half-cycle it will flow through the primary of the transformer in the opposite direction.

Notice that this type of circuit eliminates the input transformer, yet we still have a push-pull power amplifier. In a circuit designed for power line operation, batteries would not be used and a single power supply capable of supplying the required positive and negative voltage would be used.

ELIMINATING THE OUTPUT TRANSFORMER

Another transistor circuit of interest is shown in Fig. 3. In this circuit the need for an output transformer has been eliminated. Notice that a negative voltage has been supplied to the collector of Q_2 and a positive voltage to the emitter of Q_3 through R_{10} . The negative voltage

has the same value as the positive voltage with respect to ground. The resistors R_5 and R_6 are equal in value to resistors R_7 and R_8 so that the junction of R_6 and R_7 will be at ground potential. Similarly, R_{10} is equal to R_9 , and Q_2 and Q_3 are similar transistors, so that there is an equal voltage drop across the emitter resistor and transistor in each case. The junction of the collector of Q_3 and resistor R_9 are also at ground potential. The junction of R_6 and R_7 and the collector of Q_3 and R_9 are connected together at terminal A. The speaker is connected between terminals A and B.

BIAS LIMITS CURRENT FLOW

With no signal the transistors are biased essentially at cut-off so that there is little or no current flow through the transistors or through the speaker. When a signal is applied to the input circuit, it is amplified by Q_1 and fed to the transformer T_1 . For example, suppose that the input signal drives the base of Q_1 in a positive direction. Since the transistor is a PNP transistor, this will reduce the forward bias across the emitter-base junction. This means that the number of holes reaching the collector will decrease and hence the current flowing through the primary of T_1 will decrease.

The two secondary windings on T_1 are phased so that when this happens the voltage applied to the base of Q_3 will swing in a positive direction, and the voltage applied to the base of Q_2 will swing in a negative direction. If Q_3 is already biased close to cut-off, the positive voltage on the base will reduce the emitter-base junction forward bias still further. Thus if there is any current flowing through this transistor, it will drop even lower. On the other hand, the negative voltage applied to the base of Q_2 will increase the forward bias across the emitter-base junction. This will cause the number of holes crossing the junction to increase; the number of electrons flowing from the emitter of Q_2 through R_9 to terminal A and through the speaker to ground will also increase.

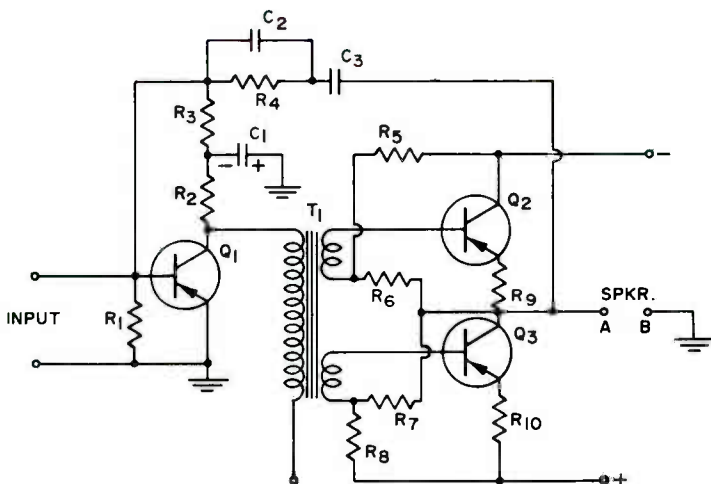

Fig. 3. Three transistor amplifiers where there is no output transformer.

The current flowing through the speaker will develop a voltage drop across it so that the end connected to terminal A will be negative. This negative signal voltage will be fed through C_3 and the parallel combination of C_2 and R_4 back to the base of Q_1 , where it will subtract from the input signal. Thus, this is an inverse feedback path.

When the signal swings in the opposite direction and drives the base of Q_1 in a negative direction the number of holes crossing the emitter-base junction will increase and hence the electron current through the primary of T_1 will increase. This will cause the base of Q_3 to swing in a negative direction. When this happens the number of holes crossing the emitter-base junction of Q_3 must increase.

Therefore the number of electrons flowing from terminal B through the speaker to terminal A to the collector of Q_3 must increase. In flowing through the speaker in this direction, the electrons will develop a voltage so that terminal A is positive. This voltage is fed back to the input of Q_1 and will once again subtract from the input voltage.

The circuit is interesting in that the output transformer has been eliminated. The

output transformer is one of the primary causes of distortion in low-frequency power amplifiers. Usually, there is more distortion developed in the output transformer than in the input transformer, because dc current flowing through the output transformer will be much higher than the dc current flowing through the input transformer. Also, there is more of a tendency to produce core saturation, which in turn produces more non-linearity in the output transformer than in an input transformer.

A circuit of the type shown in Fig. 3 is not possible with vacuum tubes because of the high output impedance encountered in tubes. However, transistors are comparatively low-impedance devices, which makes this type of circuit practical.

SUMMARY

The circuits shown in this article are all practical circuits. They are the type of amplifiers you are likely to encounter in high-fidelity and stereo equipment which you will be called upon to service. You should be familiar with the operation of these circuits so that when you come across them you will know how they work, and be able to proceed to the cause of the trouble in a logical manner.

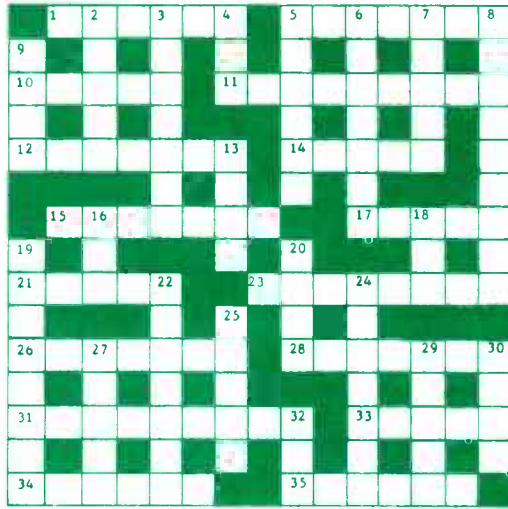

(Solution on Page 32)

ELECTRONICS CROSSWORD PUZZLE

By Michael Kresila

ACROSS

1. Device with two electrodes, the cathode and the plate or anode.
5. Non-metallic element which is a semiconductor, used as transistor material.
10. Used to indicate the current amplification factor of a transistor.
11. Three-element gas tube.
12. Electron-emitting electrode of a semiconductor device.
14. Quantity for measuring purposes.
15. Wire-wound resistor, usually wrapped in paper and encased in metal.
17. Service device using a CRT.
21. Sends forth, as radio signals.
23. Stage in a receiver in which demodulation takes place.
26. Solvent used to dissolve the unwanted part of copper on a printed circuit board.
28. The input winding of a transformer.
31. Fittings to which electrical connections are made.
33. The portion of a magnetic tape that passes under the read-write head.
34. Full-toned or sonorous.
35. Device holding channel strips on a TV front end.

DOWN

2. The point at which a signal is fed into a circuit.
3. A type of stylus used in recording.
4. A radio receiving apparatus.
5. The needle of a recorder or play-back unit.
6. The plural portion of an outside antenna system that connects to the input of a receiver.
7. Materials on which coils are wound.
8. A detector is a _____ device.
9. Used for dusting purposes.
13. Repetition of a received radio signal.
16. He is associated with forty thieves.
18. Phase relation of grid and plate signals of a grounded cathode amplifier.
19. Deserter.
20. To retain or hold.
22. Assembly of radio transmitting equipment and its transmitting antenna.
24. One of the end sections of a transistor.
25. Water in the form of gas or vapor.
27. Unit of weight for precious stones.
29. Colored or marked quartz.
30. Fits on the neck of a CRT.
32. A toper.

After achieving the goal of graduation from one of the NRI Electronics, Servicing or Communications Courses, the farsighted graduate will keep sharpening his technical skills by taking advantage of the many helpful articles and features appearing in good professional electronic service magazines and publications.

The technical information in these publications covers a wide range of areas providing considerable help to radio and television technicians as well as industrial and communication maintenance technicians. To become familiar with typical technical articles and features, let us briefly review the contents of some of the recent issues of these publications.

The latest feature introduced in the "PF Reporter", an outstanding monthly electronics servicing magazine, is a tube substitution supplement covering new tubes. Basic diagrams and operating characteristics are given for these new tubes, and substitutes (which are normally in existing tube stocks) are listed. Hence, if you are checking a brand new television model and do not have exact replacements for some of the set's new tubes, you can refer to the PF Reporter's Tube Substitution Supplement and install a tube you already have in stock. This information can be a real time and money saver.

The recent graduate starting to stock up on replacement parts needs a list of the most popular television tube types. In a recent issue, PF Reporter carried just such a list covering not only early and current tube types but also those tubes introduced in '67 models.

The PF Reporter also offers several continuing features, one of which includes articles on industrial electronics. This fresh material on industrial electronic circuits keeps the graduate of the NRI Military-Industrial Electronics Course up to date. Also reviewed in each issue is new test equipment giving specifications and operating characteristics.

TOWARD MORE EFFICIENT SERVICING

..... SOME GUIDELINES

by Joseph Schek

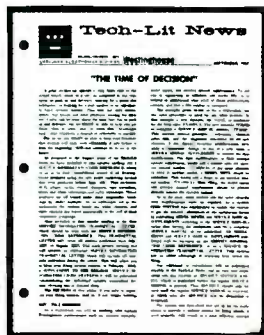
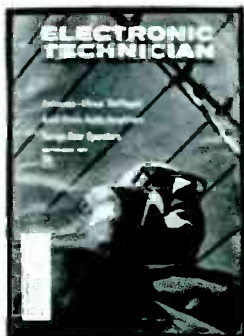

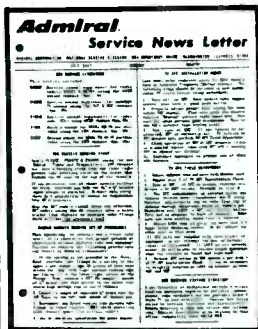
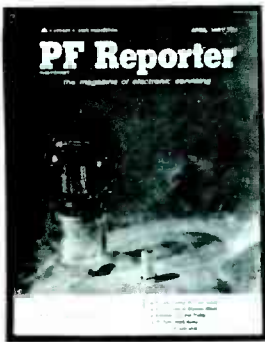
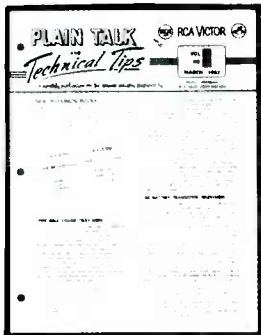

Probably the most helpful of these continuing features is PF Reporter's Symfact. In each Symfact article a specific section of a receiver is completely analyzed; this material covers basic operation, numerous typical circuit faults and methods of using scope waveforms and vtm readings to make correct circuit checks to pinpoint the cause of the circuit faults.

Because of the value of this information to television technicians, Symfact is compiled once every two years into a manual published by Sams Publishing Company, Indianapolis, Indiana, which also puts out the PF Reporter and a variety of other servicing books.

Like NRI, the magazine offers a technical consultant service in the form of their "TroubleShooter" column. Readers describe their service troubles and the magazine's staff provides illustrated procedures to pinpoint and clear up the causes of these problems.

Although electronics parts and test equipment manufacturers may not provide direct servicing information, it is most beneficial to the technician to keep informed of the latest developments in antennas, Citizen Band equipment, test equipment, servicing aids, tools, technical information, etc. To make getting this information as easy and inexpensive as possible, PF Reporter provides a stamped multi-order postcard listing catalogs and associated information covering each catalog. All the reader has to do is check his preference and mail the card to PF Reporter, who in turn notifies the individual manufacturers of the readers interest in specific literature.

A yearly subscription to PF Reporter is \$5; order from 4300 W. 62nd St., Indianapolis, Ind. 42606.

Another outstanding example of a professional service technician's magazine is "Electronic Technician." Although

this monthly publication offers effective articles on servicing in each issue, many technicians subscribe to this magazine because each issue contains about six full double-page television receiver diagrams covering current models.

Scanning the titles of the features and articles in a recent issue of "Electronic Technician" shows the servicing material covering new troubleshooting techniques and checks out the latest color television circuitry to help you make repairs and adjustments rapidly and more accurately.

An article on servicing antenna rotators is also offered in this issue. Then, for basic training, Electronic Technician provides a continuous series of articles on solid-state characteristics, leading into the area of integrated circuitry.

Currently the magazine is also offering a series of in-depth articles on AGC circuits, entitled "Understanding Modern AGC Circuits", and another series on servicing closed-circuit television equipment.

A yearly subscription is \$5 from the publisher, "Electronic Technician", Ojibway Bldg., Duluth, Minn. 55802.

Besides the servicing magazines, another valuable source of up-to-date technical information for servicing technicians, particularly those in Radio-Television Servicing, are the bulletins prepared by the General Electric, Philco, RCA, Westinghouse and Sylvania Companies.

Although each of these manufacturers' bulletins contains only eight pages, each article is crammed with useful servicing information. Frequently, these articles are written by field service managers.

The name of the General Electric Bulletin (issued several times a year) is "Techni-

Talk." Here is a representative list of articles appearing in the General Electric Techni-Talk over the past several years: AFC Circuits; Color Television (a series of 20 articles); Component Testing; Vertical Circuits; Television Sound Systems; and many others.

Because the material in these articles has been proven to be continually helpful to service technicians, General Electric has prepared files of Techni-Talk back issues, and these back issues are available as complete sets at \$6.25 per set.

The set can be ordered from Techni-Talk Cashier, General Electric Company, 316 East 9th St., Owensboro, Ky. 42301.

Philco-Ford Company provides considerable help through its Philco Tech-Data Service. By enrolling in this service data supply plan, the technician receives not only complete information on all current Philco Models but also should he ever need a special "odd ball" part for any Philco Set, the Philco Parts and Service Department ships the required part within 48 hours.

Helpful advice on service business practices and management is given in Philco's popular Service Business Magazine.

To subscribe to Philco's Tech-Data Service, write to Tioga and C Sts., Philadelphia, Pa. 19134.

The Radio Corporation of America (RCA) makes available to service technicians an excellent bulletin published several times each year. The contents of each issue are well prepared and fulfill their purpose of providing technicians with up-to-date service procedures, particularly with regard to RCA Color Sets.

For example, in a recent issue, color television information was given on high voltage regulation, special B+ boost cir-

cuts, video peaking and also on how to eliminate "snivets" (wormy vertical lines in the raster) which are frequently prevalent during uhf receiver operation.

To subscribe to the RCA Technical Bulletin, write RCA Electronics Components and Devices, 415 S. 5th St., Harrison, N.J.

The RCA Company also prepares Service Information Sheets, giving parts and circuit tips.

Write to RCA Sales Corporation, Product Performance, 600 N. Sherman Dr., Indianapolis, Ind.

Still another major home electronics product manufacturer helping to keep service technicians up-to-date is the Admiral Corporation. Admiral prepares an effective monthly bulletin called Admiral Service News Letter.

In each issue, information is given listing new Admiral Service literature, production changes for improved performance and how to improve color service techniques.

To acquire the Admiral Service News Letter, write to its National Service Division, 903 Morrissey Dr., Bloomington, Ill. 71702.

Recognizing the responsibility of TV manufacturers to constantly improve the skills of technicians, the Westinghouse Company has recently reorganized their service information department. Each month the Westinghouse Company issues its Tech-Lit News. It is published by the Service Department of Westinghouse.

To receive Westinghouse Tech-Lit News each month, you subscribe to the complete technical literature mailing program for \$5.25 per year. Write Westinghouse Tech-Lit, P.O. Box 71, Metuchen, N.J.

One of the oldest and an outstanding example of a television manufacturer's

long standing effort to keep technicians knowledge up-to-date is Sylvania News. The technical and servicing articles in Sylvania News are usually complete and authoritative.

For example, in the Fall-1967 issue you will find a complete 4-page article on Practical Tips in carrying out Color TV Purity Adjustments. Because the related illustrations are all in color, the information is particularly effective in showing the results when proper purity is achieved and when improper purity adjustments are made.

The manufacturers, realizing the importance of their service literature in upgrading skills and technical knowledge of technicians, keep on hand back issues for at least two or three years. Hence, since the information is very helpful in a practical way, professional technicians should seek to not only make arrangements to receive current issues but to order as many back issues as are available.

Sylvania's Service Notebook is published monthly at a cost of \$4 per year by the Service Dept. of the Entertainment Products Division, 700 Ellicott St., Batavia, N.Y. Write attention Vic Bell, Editor.

A yearly home communications and auto electronics servicing handbook has recently appeared. It is called "Electronics Installation and Servicing". It averages about 150 pages of useful information. Its publisher is the Davis Publishing Co., 1 Park Avenue, New York, N.Y. 10016.

In the 1967 issue, you will find eight chapters. Each chapter is devoted to one of the multiple service and installation activities usually carried out by technicians.

Comprehensive and profusely illustrated information is given on test equipment, on new techniques in servicing color and monochrome sets, on AM/FM Radio Servicing, on antenna installations and

maintenance, on car and home stereo tape checking and installation procedures, on Citizens-Band equipment installation, and on servicing intercom and public address systems.

The many illustrations in the articles on Color TV Servicing are arranged to show exactly the effect of normal and faulty color circuit operation and adjustments.

"Electronics Installation and Servicing" is published by Davis Publishing Co., 1 Park Ave., New York, N.Y. 10016. The price for each yearly issue is \$1.25.

Keeping up with publications such as those here described will go a long way toward helping the service technician carry out his service work more efficiently and profitably.

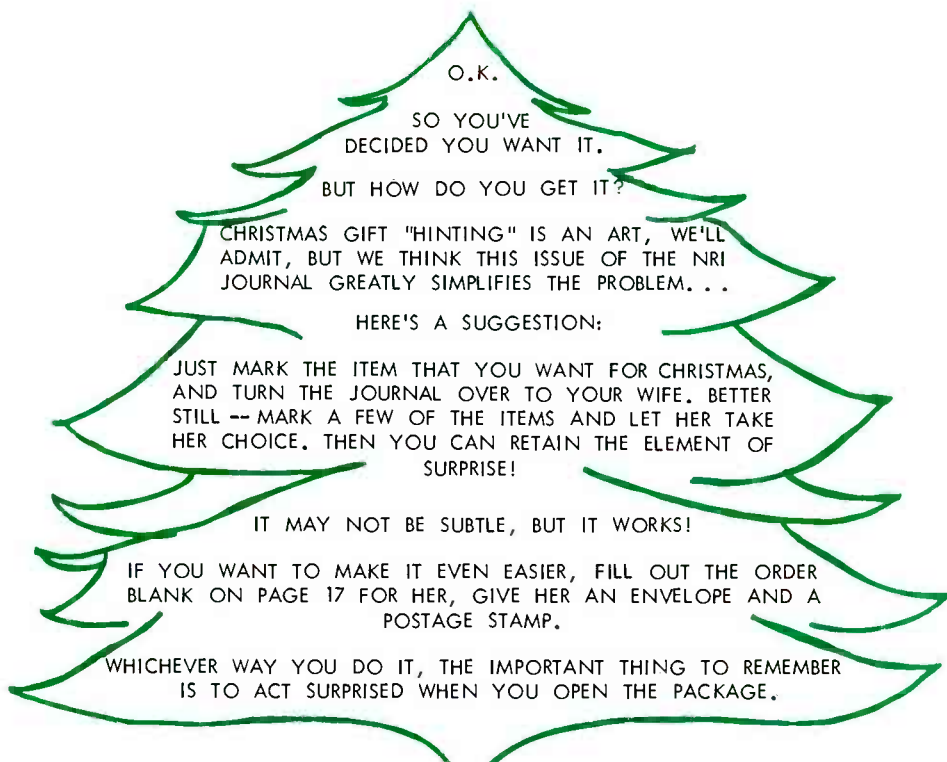

Let CONAR make your Holidays merrier!

FOR TRACKERS, ALL IN THE DAY'S WORK. . .

Engineers and Scientists on Three Continents Juggled Helium Leak, Telemetry, and A Storm To Bring Two Spacecraft Down Successfully

Compiled From NASA Reports

WASHINGTON, D. C. -- Engineers and scientists of three continents went far beyond the normal day's work one recent weekend to save two faltering United States space projects and bring them to a successful conclusion. The work involved hundreds of men in tracking stations and control centers in the United States, South America, and Australia.

The projects, Surveyor V on the moon and Biosatellite II, were launched by two widely separated NASA teams (Jet Propulsion Laboratory at Pasadena, Calif. and Goddard Space Flight Center at Greenbelt, Md.) at different times and flight plans, but reached their crises at about the same time.

For Surveyor II, trouble started shortly after its three small vernier (fine tuning) rockets were fired to stabilize the spacecraft preparatory to a soft landing on the moon. The unmanned spacecraft reported, from more than 100,000 miles away, that its helium gas supply, used to pressurize the rockets, had developed a leak.

Telemetry--the language of spacecraft ---coded the report in numbers, which were in turn processed into radio signals, transmitted to ground stations, and translated by computers into teletype "words". One such word looked like this: 40103950395.

At a glance, Surveyor flight controllers could isolate the problem to helium leakage, and tell that the leak had reduced pressure in the gas container to 2,350

pounds-per-square-inch (psi) ---some 1,000 pounds below what was needed in midcourse. On the Surveyor, 200 tiny instruments at vital points kept measuring temperatures, voltages, currents, pressures, switch positions, and other indications of the craft's health.

In the teletype word, "4" meant that a propulsion measurement was being reported, "01" localized the problem to probable helium pressure, and the reading, "0395", was repeated in case of a mistake in the first four letters. The telemetered counts were translated into psi on a conversion chart.

Within seconds after the leak was reported, systems analysts were looking for cause and cure. One group tried to stop the leak, while others worked to develop a modified soft landing if the leak should continue. In a few hours, relief valves were set at 830 psi maximum, allowing the leaking helium to drain into the propellant tanks and bleed off into space.

A new descent profile had to be developed in record time, and the critical decision made on the altitude of the retrorocket burnout. Normally scheduled at about 35,000 feet, calculations were that it would have to be around 2,000 feet. The Surveyor's solid fuel rockets have unpredictable burn time. While their burnout can be predicted within a second or two, a second's variance could mean a variance of 9,000 feet in burnout altitude. Thus, if the burnout was only a few tenths of a second late, Surveyor would impact the moon with the retro still burning.

Tests, analyses, round-the-clock cal-

SURVEYOR

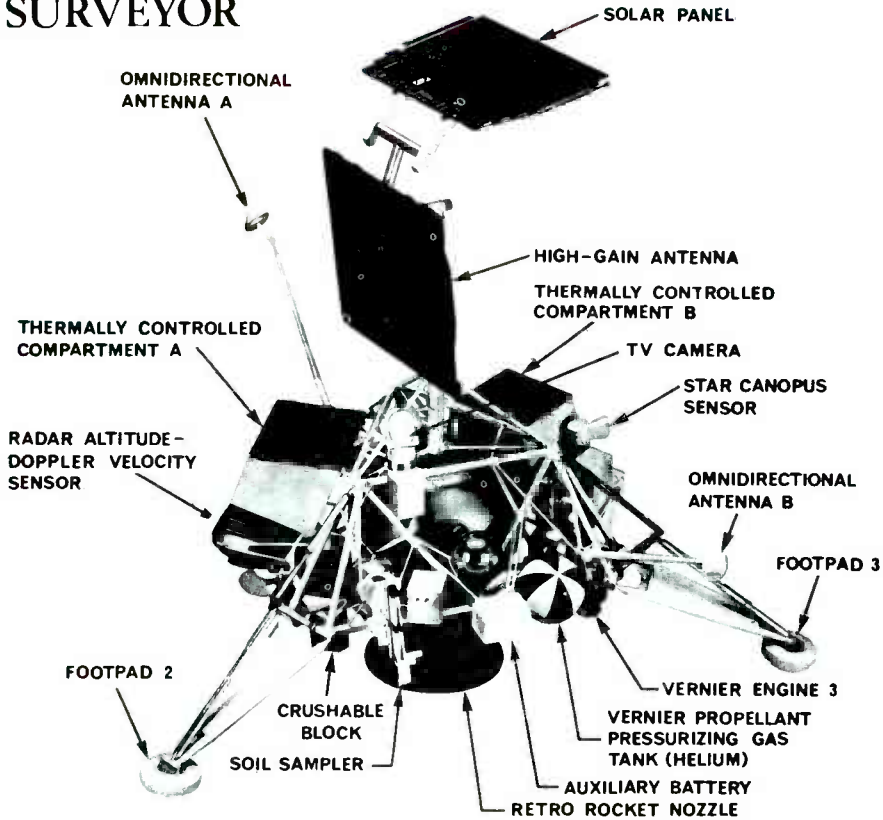

culations with computers at several stations, and every known trick in the propulsion handbook paid off in pounds and half-pounds of propellant which could be used for the descent---enough to raise the retro burnout altitude to 4,400 feet.

That problem solved, a new one cropped up: its effect on the Radar Altimeter and Doppler Velocity Sensor. RADVS, by directing four beams of radar at the moon, in effect acted as a traffic cop to stabilize the spacecraft. The green light decision: a few seconds before burnout, send a taped command, synchronized with the altitude mark, to fire the explosive bolts to jettison the big solid motor. Results: It went like clockwork, a soft landing on time at a speed just over eight miles an hour, and within 18 miles of the original target site.

Meanwhile, back at Goddard, a few hours after the JPLs started tussling with the Surveyor problem, the Biosatellite II engineers faced the problem of terminating its flight a day prematurely. A combination of circumstances--continuing problems in getting the spacecraft to accept ground signals, and a tropical storm moving rapidly into the recovery side---led officials to decide to end the mission. (NASA's ATS-1 satellite photographs of the storm assisted control personnel in their recovery decision.)

A new recovery point was computed; recovery aircraft were scrambled out of Hawaii. Tracking station personnel in Woomera, Australia, were routed out at midnight to monitor the de-orbit sequence.

MOTOROLA FM STEREO AUTO RADIO

Complete with 2 5 1/4" Wide Range Speakers



\$129.95

900EN
Express
Collect

All transistor circuitry with voltage regulation circuit, stereo indicator light, AFC, automatic squelch circuit. Frequency response 50-10,000 Hz. Easily installed under dash. Pay as little as \$6 month.

NEW CONCORD TG-093

- 100 MW **\$29.95**
- 9 Transistors
- 5-Mile Range 93RT, 1 lb. Par. Post Ins.

Not much larger than a pack of cigarettes, but circuitry gives extra power. Antenna has built-in loading coil for reception up to 20 miles over water. Channel 9 crystals and battery included.

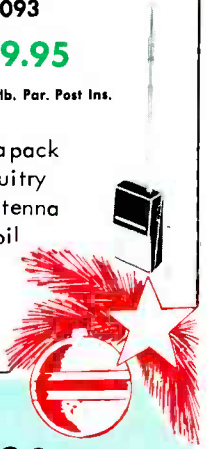

GIFT SUGGESTIONS FROM CONAR

Magnus Model 1500 Solid State Chord Organ **\$199.95**

FREE MUSIC BOOK INCLUDED

Shipped Prepaid
Continental U.S. \$9 MO.



Full year warranty on this solid state, all electronic organ with 37 treble keys, 12 chord buttons, three voices, vibrato and expression. Hand rubbed walnut finish and matching music rack. Superb value at low cost.

UP TO 2 YEARS TO PAY

ORDER BLANK ON PAGE 17

IT'S A RADIO!
IT'S A LAMP! **\$19.95**

Top performance from a powerful solid state radio, plus a fully adjustable high intensity lamp. For home, shop, office, bedside, den, study.

644EN, 3 lbs. P.P. Ins.

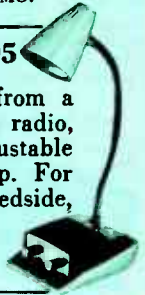

LEAR JET CAR CARTRIDGE PLAYER

No other system provides the quality of sound, the full dimensional stereo, the completely automatic operation. The undisputed leader in the tape cartridge field. Up to an hour and 20 minutes of music without changing.

WITH 4 SPEAKERS
1830EN, Exp. Coll.

\$129.95

LESS RADIO

Features Automatic
8-Track Changing!

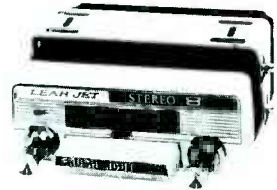

LEAR JET STEREO 8 CARTRIDGE DECK

Brilliant reproduction through your own amplifier. Features automatic switching and handsome simulated wood finish to enhance the looks of your stereo system.

900EN, Exp. Coll.

\$79.95

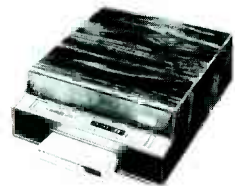

EASY CREDIT TERMS—SEE PAGE 18

**A CONAR FEATURE—FAMOUS
“CONCORD” TAPE EQUIPMENT!**

MODEL 776
776EN, Exp. Coll.

\$299⁵⁰

\$12 mo.

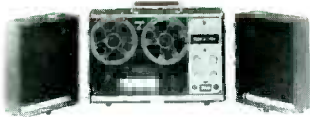

AUTOMATICALLY REVERSES ON RECORD & PLAY

Four heads, two speeds, frequency response 30 to 20,000 Hz. An unparalleled value at this low price. Comes complete with detachable speakers, two dynamic cardioid microphones and stands, two patch cords, take-up reel. All solid state.

THE CONCORD MODEL 700

700EN
Exp. Coll.

\$199⁵⁰

\$9 mo.

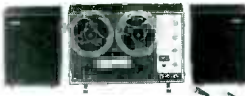

Outstanding stereo record and playback quality in an all transistor unit with detachable speakers. Frequency response 50-15,000 Hz. Comes with two mikes and stands, two patch cords, take-up reel. Features 3 tape speeds, trans-a-track recording.

F-100 CARTRIDGE RECORDER

1100EN, 4 lbs., P.P. Ins.

\$79⁵⁰ \$5 mo.

FREE AC ADAPTOR
\$14.95 Value With
Your Purchase

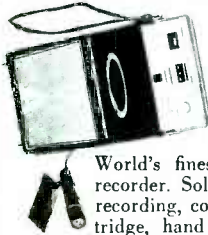

World's finest portable cartridge tape recorder. Solid state, up to 2 hours of recording, comes with mike, stand, cartridge, hand strap, patch cord, mike pouch. Frequency response 60-10,000 Hz.

**CONCORD
RADIORECORDER**

NEW!
SOLID STATE!

90EN
7 lbs.
P.P. Ins.

\$69⁵⁰ \$5 mo.



Records from its own AM radio while you listen. Operates on AC or battery. Over 2 hours recording on 1 reel. Comes with take-up reel, mike, stand and mike pouch. All transistor.

EASY CREDIT TERMS AVAILABLE
SEE PAGE 18

THE SOUND COMMAND SWITCH

Amazing Sonuswitch turns any electric appliance on or off with a clap of the hands or the blowing of a high frequency whistle. 700 watts capacity. Unlimited uses in the home and office. Makes your life easier and amazes friends.

Sonuswitch

16AC
2 lbs.
P.P. Ins.

\$29⁹⁵



**EXCLUSIVELY FROM CONAR
AUDIOCOLOR**

*Lets You
See The Music!*

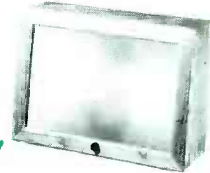

CONAR's famous Audiocolor lets you see the music in brilliant ever-changing colors while you listen. Simple to install—simple to build—it connects to speaker terminals and reproduces the tempo as well as paints the music. In handsome walnut finished cabinet.

KIT \$44.95
103UK, Exp. Coll.

WIRED \$54.95
103WT, Exp. Coll.

**Minolta Fully
Automatic “500” CAMERA**

**PERFECT PICTURES
EVERY TIME**



\$39⁹⁵

Uses
Kodapak
Type
Cartridge

500PY, 1 lb. P.P. Ins.

The world's most completely automatic camera. If you can push a button you can get a perfect picture every time. Uses flashcubes and Kodapak cartridge. Even flash photos are automatic. Sharp F/2.8 lens, electric eye control. A fine gift.

ORDER BLANK PAGE 17

High Fidelity Sound From Your TV
HI FI-TV ADAPTOR Easy To Install



\$34.75

480AD,
7 lbs. P.P. Ins.

Now you can enjoy your favorite TV program and REALLY hear the music! The Stratford Model 480 reproduces TV sound in true high fidelity through a HiFi amplifier or receiver without disturbing the wiring of the TV receiver or HiFi components. TV stations broadcast in high fidelity FM, but most TV sets will not reproduce it. The adaptor picks up the HiFi signal in the TV set and feeds it to the amplifier or receiver. Tape recording enthusiasts may now tape programs of their choice with full fidelity. All that is needed is to connect the adaptor to the TV set and to the tape recorder input. Place the Model 480 at the TV set or at the amplifier or tape recorder. No adjustments are required and installation is simple.

ORDER BLANK ON PAGE 17

**UNIVERSITY "MUSTANG"
 SPEAKER KIT SPECIAL!**

\$44.90 • 2 M8 SPEAKERS
 • 2 ENCLOSURE KITS

188SK
Exp. Coll.
Reg. \$62.50

—SAVE \$17.60



Designed for the Mustang M-8 and M-8D speakers, the University Model M8K2 enclosure is a heavy-duty acoustic chamber to provide extended range high fidelity sound.

Easy to assemble in less than two hours, it is entirely pre-finished in oiled walnut. Simple, step-by-step instructions and drawings and precision cut parts assure a clean and professional job with only a hammer and screwdriver. The internal area is ample to provide deep, rich and natural bass response. Overall dimensions are 17½" wide by 9½" high by 6¼" deep. All 4 sides are finished so that the enclosure may be placed on a shelf vertically or horizontally or located on a floor as a free standing unit. Acoustical grill cloth supplied.

**'AUTOMATIC'
 FM AUTO RADIO TUNER**



\$44.95

5099EN
5 lbs. P.P. Ins.



Hi-Fi FM reception is now available for most makes of cars . . . smart and compact in design, this FM converter operates with present auto radio and antenna. Mounts easily under dash . . . and just plug into present radio antenna jack for the finest in FM listening.

SPECIFICATIONS

8 Transistors and 5 Diodes for extreme sensitivity to operate in most signal areas . . . 3 Gang Tuner for unchallenged selectivity . . . Full Automatic Gain Control to eliminate overload in exceptionally strong signal areas . . . Advanced designed Automatic Frequency Control that prevents frequency drift with full range of automobile battery voltage variations . . . 10-minute, easy installation in all autos, trucks or boats with 12-volt negative ground polarity systems . . . Requires no special antenna under average reception conditions . . . Output jack for multiplex reception . . . 13 tuned circuits for unsurpassed performance . . . covers stand 88 to 108 Megacycle FM Band . . . overall size 6½" x 4¾".

**CORDOMATIC
 Handy-Lite Reel**

WITH
20 FEET **\$7.95**
OF CORD

500AC, 4½ lbs., P.P. Ins.



Designed for automatic convenience anywhere—in the shop as well as the home. The Handy-Lite Reel is ruggedly built for lifetime use. You'll find it useful in work-shop, basement,

garage, attic, garden or patio. The Cordomatic eliminates the inconvenience and hazards of tangled cords. Wherever portable light or power is needed, you simply hang it up and plug it in. No junction box is needed. There's a handy outlet on the handle for power tools and other electrical equipment.

EASY TERMS—SEE PAGE 18

Gifts By Taylor

BAROMETER

Decorative barometer, thermometer and humidity instruments in brown plastic case with gold and brown dials. 7" x 4", boxed.



6503AC
2 lbs., P.P. Ins.
\$9.95

INDOOR — OUTDOOR THERMOMETER

5B38AC 1 lb., P.P. Ins. **\$9.95**

Tells both inside and outside temperatures, also humidity. Walnut finish with gold trim. 13" x 3 1/2". Boxed.



NAVIGATOR COMPASS

2976AC
1 lb., P.P. Ins. **\$6.95**

With push-button light. Easy to adjust. Universal mounting bracket, battery included. For auto or boat. Boxed.



Hanson Tachometers



A—DWELL TESTER & TACHOMETER

45TO
3 lbs., P.P. Ins.

\$39.95

A specially designed instrument that combines two testers in one. Tests dwell angle and engine speed on 4, 6, 8 cyl. engines, 6, 12 volt systems.

B—MODEL 80 TACHOMETER

80AC
2 lbs., P.P. Ins.

\$25.85

Features functional design and finest quality. 3" dial. Accurate and easy to mount. Completely electronic for years of trouble-free performance.

Top quality . . . easy to use. Complete with instructions.

For all engines, all systems, all positions.

Dremel Moto Tool Kit

\$25.95

- Grinds
- Drills
- Carves
- Engraves
- Polishes
- Sharpens
- Pocket-size machine shop



1002TO
5 lbs., Par. Post



SWINGLINE Riveting Plier

3002TO
2 lbs., Par. Post

\$4.95 Triple head for 3 rivet sizes. For plastic, wood, metal, leather.

Staple Gun Kit

8002TO
4 lbs., Par. Post

\$10.95



Drives 5 staple sizes. Features handle lock, snap open load, staple extractor. Comes in durable box with carrying handle and 2 boxes of staples.

EASY TERMS—SEE PAGE 18

World Time Zone Clock

\$11.95



Gives the correct time anywhere in the world . . . without computing!

18AC
2 lbs., P.P. Ins.

FREE BOOKLET

Gives you the time zones for all the countries, cities and islands not listed on the clock face.

Unique world time zone clock shows at a glance correct time for any city anywhere in the world without computing. GE movement. Hangs or stands up. An ideal gift for the amateur radio fan.

ORDER BLANK ON PAGE 17

Like all spacecraft controllers, they then went into their "contingency mode". (For each phase of a flight there is always a planned control center response in the event all does not go as expected.) In this case, the critical command to bring back the precious cargo of delicate biological experiments was a prearranged series of binary code zeroes and ones.

To get Biosatellite ready for this command the station at Quito, Ecuador, was ordered to transmit the "clock-set" command. Unfortunately, the command didn't get through. At this point the NASA worldwide voice communications system, "SCAMA", was called into the Carnavon station.

The original 18-digit reentry command code was reduced to the 10 most important digits (the equivalent of dropping the last four decimal places of a very large number). Carnavon, by adjusting the radio frequency shift, was receiving

signal responses at that point; Woomera reported it had received telemetry data that on-board systems were working.

On the next pass over Carnavon the abbreviated command, along with the deboost sequence, was inserted, and the slowdown-disconnect series began. Aerial recovery by an Air Force plane was made approximately 15 miles from the recomputed impact point over the mid-Pacific.

From Surveyor V, the scientific information gathered about the lunar surface will have many far-reaching effects; for Biosatellite II, the return of hundreds of thousands of organisms, apparently alive and vigorous after their brief space journey, is expected to reveal important new knowledge about how weightlessness affects living things.

For the trackers, it was almost---but not quite---all in the day's work.

CONAR EASY PAYMENT PLAN

IM

Note: Easy payment contracts cannot be accepted from persons under 21 years of age. If you are under 21, have this sheet filled in by a person of legal age and regularly employed.

Enclosed is a down payment of \$_____ on the equipment I have listed on the reverse side. Beginning 30 days from the date of shipment I will pay you \$_____ each month until the total payment price is paid. You will retain title of this equipment until this amount is fully paid. If I do not make the payments as agreed, you may declare the entire unpaid balance immediately due and payable, or at your option, repossess the equipment. Your acceptance of this will be effected by your shipment to me of the equipment I have listed.

Date _____ Your written signature _____

CREDIT APPLICATION

Print Full Name _____ Age _____

Home Address _____

City & State _____ How long at this address? _____

Previous Address _____

City & State _____ How long at this address? _____

Present Employer _____ Position _____ Monthly Income _____

Business Address _____ How Long Employed? _____

If in business for self, what business? _____ How Long? _____

Bank Account with _____ Savings Checking

CREDIT REFERENCE (Give 2 Merchants, Firms or Finance Companies with whom you have or have had accounts.)

Credit Acct. with _____ Highest Credit _____

(Name) (Address)

Credit Acct. with _____ Highest Credit _____

(Name) (Address)

COLOR TV TRAINING TOPIC OF TOUR

J. B. Straughn and Ted Rose are continuing their annual visits to chapters of the NRI Alumni Association. In what is probably the most exciting tour in the NRIAA's history, Mr. Straughn has been explaining to members just what NRI's new Color TV Training course covers and has been demonstrating new Color TV Kits designed specifically for training purposes.

Servicemen who have been searching for the past several years for complete and thorough training in Color TV Servicing may discover that NRI now has the answers to their urgent demands.

Remember--you're cordially welcomed at these meetings whether you are a student or a graduate, and you don't have to be a member of the NRI Alumni Association to attend. Bring a friend if you like.

Here's the schedule of remaining visits:

CHAPTER	DATE
Hagerstown	November 9
Philadelphia-Camden	November 13
Springfield (Mass.)	December 6
New York City	December 7
New Orleans	April 9
North Jersey	April 26
Pittsburgh	May 9

CONAR ORDER BLANK

DIVISION OF NATIONAL RADIO INSTITUTE, 3939 WISCONSIN AVE., WASHINGTON 16, D.C.

PLEASE PRINT

NRI STUDENT NUMBER

NAME _____

- CASH
- C.O.D. (20% Deposit required)
- EASY PAYMENT PLAN (10% Deposit)

ADDRESS _____

CITY _____ ZONE _____ STATE _____

Quantity		Name of Item	Price Each	Total
If you live in Washington, D.C., add 3% sales tax. All prices are net, F.O.B. Washington, D.C.				TOTAL

ON TIME PAYMENT ORDERS please be sure to complete the Easy Payment Plan credit information form on the reverse side of this page and include 10% down payment with your order

Fully Developed Electronics Department Seen As Standard Equipment for Future Observatory



THE ASTRONOMICAL EXPLORATION of our universe, including the planets of our sun, has been linked with electronics since the 1930's. In fact, electronics is so essential to the astronomer today that scientists foresee the observatory of the future equipped with a fully developed electronics department along with its library and instrument-making shop.

THE DELUGE of electronics into astronomy came with electric drives using power amplifiers, and with phototubes using highly stable voltage amplifiers.

THE COURTSHIP of electronics and astronomy began during basic demonstrations of time and frequency, but the affair became really serious as scientists became aware of the importance of electronics in the operation and development of telescopes. The first tentative application of electronics in 1931 was in standard speed drives tracking stars at the rate of the earth's rotation.

PHOTOTUBES WERE BIG ADVANCE

PIONEERS in photoelectric measurements of the brightness of stars were really magicians who linked hand-made photocells to hand-made electrometers in fully evacuated systems, and sat at 100-inch telescopes for hours to find out how bright was an eighth-magnitude star. All observatories were changed by the invention of the multiplier-type phototube. Possession of a good phototube, in a modern observatory today, enables man to observe a star 10,000 times fainter (noise limited) than eighth-magnitude in twenty minutes instead of hours, and with a precision 50 times greater.

IF A PHOTOTUBE is four times as sensitive as its predecessor at the same signal-to-noise ratio, then it has automatically doubled the effective size of the telescope. This is why the astronomer keeps hounding phototube manufacturers with persistence for the development of even better products. The average life of a phototube is twenty years.

EMPLOY LATEST TECHNIQUES

SCIENTISTS SAY that the application of electronics to astronomy is now limited only by the time of astronomers to read industry literature and to confer with electronics engineers. Today the full range of TV techniques, information retrieval and storage, analogue computing and data processing are employed by the modern observatory.

THE HOTTEST THING in astronomy today is the image converter which combines ability to accumulate the effect of light on a photo plate with the high quantum efficiency of a photo electric surface. The photographic plate gives the scientist a tremendous advantage, because it enables light to be stored and improves the signal-to-noise ratio. Astronomers and engineers working together have found themselves at the forefront of technology in high vacuum technique, electron optics, photographic processes, photo cathode manufacturings, and cryogenics (the study of materials at temperatures near absolute zero).

OBSERVATORY USES SIX TELESCOPES

THE NAVAL OBSERVATORY in Washington uses six basic telescopes including the 26-inch refractor star camera, the 15-inch refractor, the 12-inch refractor, the 6-inch transit circle, and the moon camera, all controlled electronically in their drives and functions.

ANOTHER APPLICATION of electronics as a support function to astronomers is the room-size Semi-Automatic Measuring Engine which has been developed for measuring distances between stars. Receiving information from a telescope, it measures photographic plates to obtain distances to specific stars. The information is recorded on punch cards which are fed for reduction into a computer.

ELECTRONICS WILL PLAY AN IMPORTANT ROLE in the operation and future of the Observatory 6-inch transit circle. Also called meridian circles, transit circles have been used for over 150 years as the chief means of determining fundamental star positions. Nineteenth century methods of reducing transit circle observations and deducing the motion of the stars are used today with modifications.

DURING A SIX-HOUR TOUR OF DUTY, an astronomer can average between 100 and 150 observations. In a typical year the Observation Transit Circle Division makes about 9,000.

PROJECT MAJOR IMPROVEMENTS

TWO MAJOR IMPROVEMENTS in the 6-inch circle are contemplated at the Observatory, the first being an electronic system to indicate the pointing of the telescope, eliminating time-consuming photographic recordings of circle readings. The second is the installation of a photoelectric tracking device to eliminate the observer at the eyepiece. Plans for these are approaching the testing and evaluation stage.

THOUSANDS OF YEARS AGO astronomers in Babylon using the naked eye made records of their observations. Modern man has searched for the story of the universe in records of rock fossils 200-billion years old, and he has examined the radioactive elements in rocks which take the story back six billion years. Twentieth century man is also looking outward for the "why" and "when" of his earth and its universe by observing the noise-limited flow of electro-magnetic radiation upon earth from outside the solar system. The farther his telescope carries him, the more he is able to extend his knowledge. To this end, modern astronomy which began with Galileo has moved into the age of electronics.

Official U.S. Navy Photographs

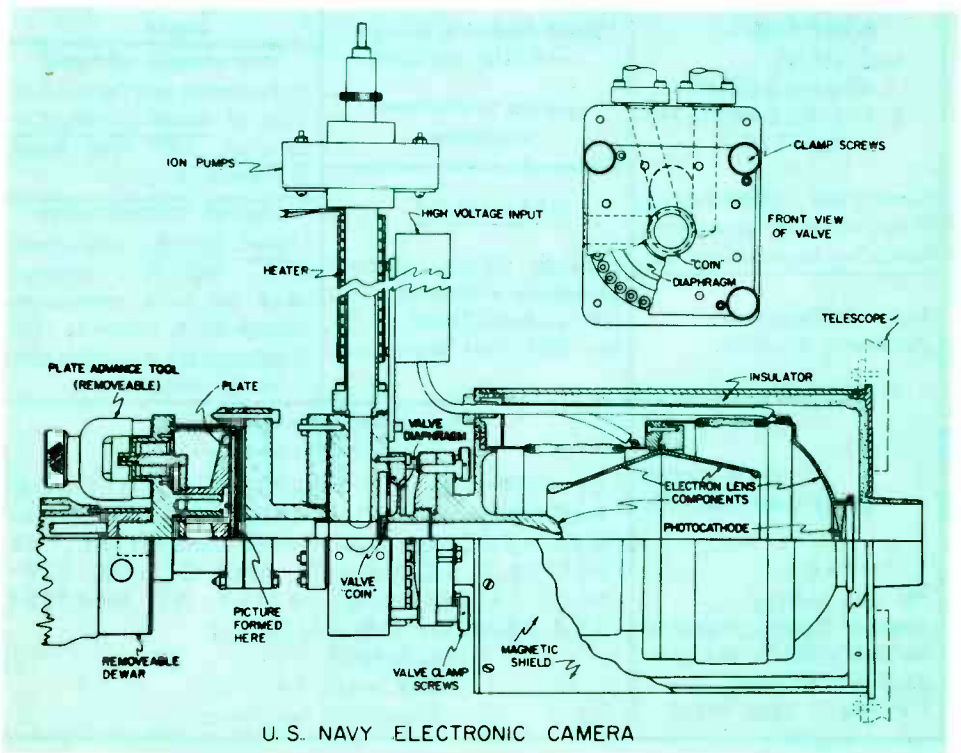

--- HELP WANTED ---	--- HELP WANTED ---	--- HELP WANTED ---
<p align="center">Do You Have an FCC License?</p> <p>Immediate openings in TV, Audio, 2-way radio, etc. at Communications Engineering Co., a division of Sylvan Electronics. Located at 306 Kennedy St. N.W., Washington, D.C. Call Mr. Brown, 451-5700.</p>		<p><i>Looking for a New Job?</i></p> <p>Polito Communications, Inc. 101 Walnut St., Rochester, New York needs 4 or 5 technicians to service two-way radio equipment. Minimum requirement: Second class radiotelephone license. Call or write Joseph Carl Polito.</p>
<p>Looking for a Chance For Advancement?</p> <p>Weinschel Engineering Company Inc., Gaithersburg, Md. 20760, has immediate openings in Test, Engineering & Repair Departments.</p> <p align="center">PERMANENT POSITIONS EXCELLENT ADVANCEMENT EVENING & WEEKEND INTERVIEWS</p> <p>Contact Mrs. Karen Syence, (301) 948-3434, or write to Weinschel Engineering, Inc.</p>	<p align="center">Electronics Technicians --- Positions Available ---</p> <p>WESTERN UNION Telegraph Co., Write or phone B.L. Krise, Manager of Technical Services, 1405 G Street, N.W. Washington, D.C.</p>	<p>STATION WKRZ, Oil City, Pa. Needs several first-class engineers.</p> <p>STATION WFMD, Frederick, Md. Needs technicians with first-class licenses.</p>
	<p>sun electric corporation 5708B frederick avenue rockville, maryland</p> <p align="center">openings for electronic technicians</p>	<p>Technicians Production Engineers Development Engineers *** SIMPSON ELECTRIC CO. 5200 Kinzie St., Chicago, Ill. 60644</p>
<p>Radio-TV Grads and Advanced Students.....</p>	<p align="center"><u>OPENINGS</u></p> <p>Exchange Office, General Telephone of Indiana, Inc. 501 Tecumseh Street, P.O. Box 1201, Fort Wayne, Ind.</p>	<p align="center">REPAIRMEN NEEDED</p> <p>In Richmond and Roanoke offices of <u>Audio Fidelity Corporation</u>, 6521 West Broad, Richmond, Virginia.</p>
<p align="center">positions available throughout U.S. good wages above aver. benefits</p> <p>CONTACT: Mr. Bob Barkley Regional Training Instructor MONTGOMERY WARD 2600 W. 7th Street Fort Worth, Texas 76101</p>	<p align="center">RCA SERVICE COMPANY, Camden, New Jersey . . .</p> <p>TV SERVICEMEN NEEDED IN MOST RCA FACTORY SERVICE BRANCHES. TECHNICAL SCHOOL TRAINING ESSENTIAL. WE PREFER BLACK/WHITE AND COLOR SERVICE EXPERIENCE. APPLY AT NEAREST RCA BRANCH OR WRITE TO</p> <p align="center">W. R. Speck RCA Service Co. Cherry Hill, New Jersey</p>	<p align="center">RADIO TECHNICIANS</p> <p><u>United Airlines</u>, Washington, D.C., expects a continual need for radio technicians throughout its system in 1967. Graduates are invited to come in for an interview.</p>



BY
STEVE
BAILEY

DEAR STEVE:

I have had a great deal of trouble remembering formulas for Ohm's Law and when to use them. Is there any shortcut I can use, or do I have to memorize each one? Also how do I know when to use each one?

R. R., Calif.

A simple chart that many new students in Electronics have found to be extremely helpful in learning the Ohm's Law formulas is shown below. In addition to helping you find the formula you need, this chart will help you to memorize them more quickly.

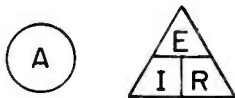

To use it, you simply cover the block containing the letter that represents the value you are trying to find. If the remaining letters are side by side, you multiply the values they represent. If one letter is above another, you divide the bottom value into the one above it.

For example:

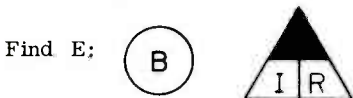

therefore, $E = I \times R$

Find I:



therefore, $I = \frac{E}{R}$

Find R:

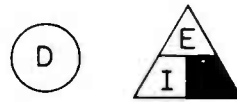

therefore, $R = \frac{E}{I}$

As far as choosing the correct formula to use is concerned, you should always follow a set procedure. First, read the problem carefully and be sure you understand what the problem is. Next, write down on a piece of paper what information is given, plus the formula for finding the unknown value.

Then see if you can use the information or values that are given directly in the formula. If you can, fine. Insert the values and do the required multiplication or division. If you can't, then use the values that are given to find the value you need.

For example, assume that you are to find

the source voltage in the circuit shown in Fig. 2:

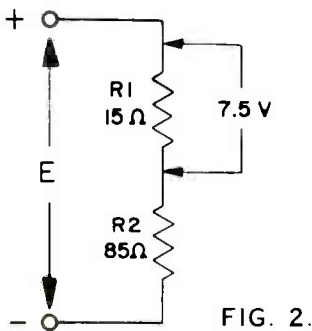

FIG. 2.

Note that you have two resistors, R_1 (15 ohms) and R_2 (25 ohms) connected in series and that the voltage drop across R_1 is 7.5 volts. Find the formula you need now. According to the chart, $E = I \times R$. You need to find the values of I and R now. R can be found easily since the values of R_1 and R_2 are given. Since they are connected in series, you add them together to get the total resistance.

$$15 \text{ ohms} + 25 \text{ ohms} = 40 \text{ ohms}$$

Next, you need the current value. This is not given, so consult the chart for the right formula. It is $I = \frac{E}{R}$. When you insert the values, you have:

$$I = \frac{7.5}{15} = .5 \text{ ampere}$$

Since this is a series circuit, the same current will flow through R_1 and R_2 . Thus, the current through R_2 is .5 ampere. Since the value of R_2 is given, we can find the voltage drop across it. The chart indicates that the formula for voltage is:

$$\begin{aligned} E &= I \times R \\ &= .5 \times 25 \\ &= 12.5 \text{ volts} \end{aligned}$$

Now, to find the source voltage, we add the voltage drops. Adding $7.5 + 12.5$ gives us 20 volts. This is the same as the answer we received using the first method.

If you practice using the formulas and follow a planned procedure for problems you solve, you will find yourself following these steps automatically. As many advanced students who faced this same problem will tell you, it's merely a matter of practice.

DEAR STEVE,

What are the main types of grid bias currently used in electronic circuits?

P. M., Md.

There are three main types of bias now being used. These are cathode bias, convection bias, and grid-leak bias.

Cathode Bias.

When the cathode of a tube is biased positive with respect to the grid, the tube acts as though an equivalent negative bias is applied to the grid. Since current flow is always from the cathode to the plate, a resistor can be connected between the cathode and B- to produce a voltage drop which will bias the cathode positive with respect to the grid. The grid will be negative with respect to the cathode the same amount as the cathode is made positive by the voltage drop across the cathode resistance.

Convection Bias.

The plate voltage of a tube does not control the number of electrons emitted by the cathode. All of these electrons may not travel through the tube and strike the plate. Some are emitted with insufficient force to cause them to travel far from the cathode. Also other electrons are repelled back to the cathode by a negative signal voltage on the grid.

The result of this is to cause an electron cloud to develop between the grid and the cathode. The grid, being close to the cloud, will assume its potential. The electron cloud will develop a negative charge between the cathode and the grid so as to keep the grid at a certain negative potential. This potential serves as the bias required for the tube.

Grid Leak.

The grid and the cathode can form a diode rectifier circuit to keep a constant negative bias on the grid. When this method is used, the grid acts as the plate of the diode, while the cathode serves its normal function. The action of this circuit can be compared to the operation of a half-wave rectifier with a single filter circuit. An equivalent circuit is shown in Fig. 3A.

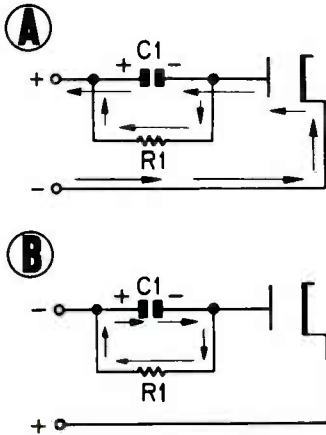

FIG. 3.

For this circuit, current will flow from the cathode to the plate of the diode. C1 has a low reactance in comparison to the value of R1. So, most of the diode current will flow into C1 and charge it to the peak of the input signal voltage. A few electrons will flow through R1 and bypass C1. The capacitor will be charged with the indicated polarity, placing a negative voltage on the grid.

During the next half-cycle, as shown in Fig. 3B, the polarity of the input voltage reverses. The diode will not conduct now. However, as soon as the input voltage drops below the level of the charge across C1, the capacitor will discharge through R1. The discharge rate will be slow due to the high time constant of C1-R1. This high time constant is due to the fact that R1 has a value of several megohms.

Thus, the voltage across C1 remains almost constant, dropping only slightly during the discharge period. This condition will exist until the input voltage reverses and the cycle starts over with C1 being charged as described in the first part of this discussion.

Remember that as soon as the voltage across C1 drops below the applied signal voltage level, the difference between the two voltages is seen by the grid and it controls the flow of plate current. This type of bias is used only in Class A voltage amplifiers, oscillators and grid-leak detectors.

These are the main types of bias you will encounter. In addition to these, you should know about fixed bias. This can be developed using a separate C battery between the grid and B-. Also, the negative voltage can be supplied from a negative source in the main power supply or from a separate C power supply.

DEAR STEVE,

How do full-wave and half-wave voltage doubler circuits work?

M. B., Va.

In Fig. 4D, I have shown a full-wave voltage doubler circuit. In operation C1 and C2 will each charge up to the value of the source voltage. Their polarities will be such that these voltages will add as shown in Fig. 4A. The output is taken from across both capacitors, so it will be equal to twice the source voltage.

Fig. 4B shows how C1 is charged when the applied voltage has the polarity shown. This occurs during the positive half-cycle of the applied voltage.

In Fig. 4C, I have shown how C2 is charged during the next half-cycle. This is during the negative portion of the applied voltage.

As you can see, C1 and C2 are charged during each cycle of the input voltage.

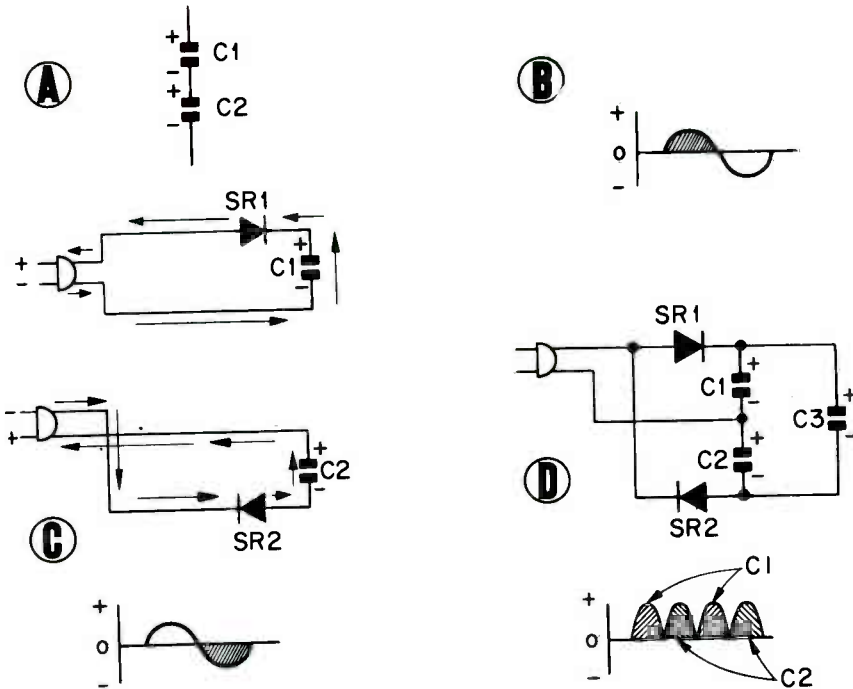

FIG. 4.

C3 in Fig. 4D is charged to a value equal to the sum of the voltages across C1 and C2. Since each is charged to the value of the applied voltage, the voltage across C3 is twice the value of the applied voltage. Also, since both half-cycles of the input voltage are used, this is a full-wave circuit. Thus, we have a full-wave voltage doubler circuit.

Fig. 5 shows a half-wave doubler circuit. Here, the voltages across C1 and C2 will add up to twice the applied or line voltage.

When prong 1 is negative, current will flow through C1 and SR1, to prong 2,

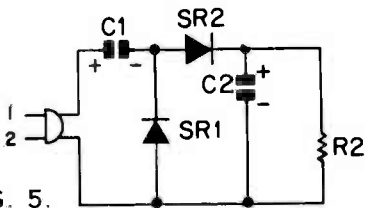

FIG. 5.

charging C1 to the value of the applied voltage. Then, when the applied voltage reverses, making prong 2 negative, current will flow through C2, SR2 and C1 back to prong 1. However, the voltage across C1 will add to the applied voltage, thus doubling the actual voltage applied to C2. Therefore, the voltage across C2 and RL will be equal to twice the line voltage.

**Radio Station WETT
Ocean City, Md.**

**For holder of
First-Class License**
Challenging position with growth potential.
Some announcing in addition to maintenance.

Contact: Mr. or Mrs. Grazier
Station WETT, Box M
Ocean City, Md. 20011

NRI HONORS PROGRAM AWARDS

For outstanding grades throughout their NRI course of study, the following July and August graduates received Certificates of Distinction along with their NRI Electronics Diplomas.

WITH HIGHEST HONORS

R.W. Adams, St. Marys, Ohio
Lars Blomstrom, Port Washington, N.Y.
Sidney S. Boyd, Belton, Texas
Woody H. Burke, Elgin, Texas
Hershall Wayne Cotten, Palestine, Texas
Lowell D. Hughes, Dallas, Texas
Raymond W. Kennell, Lansing, Mich.
G. Alphonso Murphy, Patrick AFB, Fla.
Stephen Nemeth, Denver, Colo.
Ralph W. Pancoast, Salem, N.J.
Gene R. Stilwell, Medway, Mass.
Albert R. Taggart, FPO San Francisco
Gary A. Whitt, Kirkland, Wash.
Alice M. Wlodarski, Cleveland, Ohio

WITH HIGH HONORS

Edmund N. Addo, Accra, Ghana
Richard G. Ballou, York, Pa.
Elton H. Barnard, Rochester, Mich.
Thomas C. Bates, Beeville, Texas
John N. Behrens, Dabneys, Va.
Fred L. Blood, Philadelphia, Pa.
Daniel W. Brown, Morrow, Ohio
John B. Bussard, Waverly, Ohio
Robert B. Causey, Orlando, Fla.
George Chernich, E. St. Louis, Ill.
Don Leroy Clink, Fremont, Ohio
Robert H. Christensen, Salt Lake City, Utah
Dennis A. Corsello, Cleveland Heights, Ohio
William S. Creager, Joppa, Md.
H.T. Curtis, The Dalles, Oreg.
Richard B. Dobson, Maryville, Calif.
George Fenwick, Pointe Claire, P.Q., Can.
James W. Frasier, Eureka, Calif.
Mack W. Gill, Lucedale, Miss.
Charles F. Hamilton, Lincoln, Ill.
Willis D. Hinrichs, Grand Forks, N. Dak.
Otis O. Holmes, Jayess, Miss.
Jack H. Horner, Carlos, Ind.

James Jennings, Jr., Hampton, Va.
Robert Joseph Kastner, Wabash, Ind.
Jimmie N. Kirkham, Houston, Texas
David E. Kramer, North Olmsted, Ohio
Robert P. Lacher, Hayward, Calif.
Bruce Lucas, APO New York
George W. McRae, Montreal, P.Q., Can.
Edward Norquay, Vedder Crossing, B.C., Can.
Thomas M. Pell, APO New York
Joan M. Pistner, St. Marys, Pa.
Dale Price, Grand Coulee, Wash.
Albert Roth, Aldan, Pa.
Robert L. Rutherford, APO San Francisco
Hans J. Siepmann, APO San Francisco
Edward J. Sinclair, Fredericksburg, Va.
Carl D. Smith, Houston, Texas
Billy N. Spears, Kansas City, Kans.
Harold W. Tucker, Greenwood, Miss.
W. J. Varner, Sayre, Pa.
William Vencill, Ironton, Ohio
James C. Villneff, Troy, Mich.
Carroll E. Whittington, Jr., Aurora, Colo.
David J. Wieckhorst, Memphis, Mich.
Robert N. Wing, Lewiston, Idaho
Edward J. Wroblewski, Poughkeepsie, N.Y.

WITH HONORS

Kenneth D. Adams, Sapulpa, Okla.
Charles Andersen, Gowen, Mich.
William H. Anensen, Hyattsville, Md.
James R. Arndt, Appleton, Wis.
Harvey H. Becker, Kingsville, Texas
Baxter J. Bledsoe, North Charleston, S.C.
Joseph R. Boston, Middletown, Pa.
Marshall Bottoms, Saugus, Calif.
Edward S. Broyles, Denver, Colo.
William Delma Burgess, Boones Mill, Va.
Achille J. Caniglia, Ravenna, Ohio
Donald W. Carleton, Reese AFB, Texas
Charles H. Chapman, Charlottesville, Va.
Henry Christiansen, Kitchener, Ont., Can.
Vincent P. Cincotta, New York, N.Y.
Donald R. Cunningham, Frankfort, Ind.

Francis E. Curran, Jr., East Lansdowne, Pa.
 Joseph F. Dahill, Anaheim, Calif.
 Harold J. Demel, Gillette, Wyo.
 Albert E. Deschenes, Pawtucket, R.I.
 John P. Drago, Miami, Fla.
 R. Lester Eford, Winston-Salem, N.C.
 Alfredo Espalin, APO New York
 Scott A. Ferguson, Jr., Monroe, Mich.
 Richard L. Ford, Goldsboro, N.C.
 Joe Forgy, Texarkana, Texas
 John T. Foss, Victoria, B.C., Can.
 Steve P. Gecewicz, Ravenswood, W.Va.
 James M. Gibson, Rienzi, Miss.
 John N. Gowans, Pleasant Valley, N.Y.
 Stephen F. Gross, Anchorage, Alaska
 H. Ross Gustafson, Brockton, Mass.
 L.D. Harris, Borger, Texas
 Elery R. Horning, Marine City, Mich.
 Malvin Hughey, Calhoun, Ga.
 Bob Hutchison, Norwalk, Calif.
 D.R. Hutchinson, W. Riverview, N.B., Can.
 Warrington W. Jackson, Salley, S.C.
 Tim Jennings, Midland, Texas
 A.D. Johnson, Somerville, Ala.
 Philip Karcesky, Jr., Baltimore, Md.
 Daniel Paul Kidwell, Richmond, Va.
 Rudolph C. Korb, E. Falmouth, Mass.
 Alfred Koury, Jr., Seattle, Wash.
 Charles Latyak, Clifton, N.J.
 A.J. Lee, London, Ont., Can.
 Thomas J. Lonas, Farina, Ill.
 John W. Luben, Sidney, Nebr.
 Robert G. Maldonado, South Gate, Calif.
 Frank Marten, Foss, Okla.
 Kenton A. Martinsson, Las Vegas, Nev.
 John P. McFadden, Milwaukee, Wis.
 George S. McInerney, New Orleans, La.
 Frank A. McKenney, Richmond, Va.
 Clifton E. Morgan, Washington, D.C.
 James E. Musick, Abilene, Texas
 Earl L. Nealis, College Park, Md.
 Kenneth C. Nelson, Jamestown, N.Y.
 Frank Nobles, Springfield, Mo.
 George L. Norman, APO New York
 Harlan D. Ohlson, Ketchikan, Alaska
 David R. Perry, Schertz, Texas
 Rex R. Post, Umatilla, Fla.
 Matthew J. Prim, Halifax, N.S., Can.
 Rainer H. Reischert, Astoria, L.I.C., N.Y.
 E.A. Richardson, Pasadena, Texas
 William E. Roark, Denver, Colo.
 Eldon H. Roberson, Chicago, Ill.
 Edward P. Roberts, Jr., Bremerton, Wash.
 Rexford D. Roberts, Alexandria, Va.
 Rodney R. Rydell, Kingsville, Texas
 John V. St. Amour, Oswego, N.Y.
 William F. Sanders, Memphis, Tenn.
 Clifford R. Schmalfeldt, Maquoketa, Iowa
 George A. Setzer, Chesapeake, Va.
 Edward L. Skidmore, Manhattan, Kans.
 Arthur R. Smith, Falcon Heights, Texas
 Lester C. Strand, Portland, Oreg.
 Roger A. Strunk, Bergstrom AFB, Texas
 Gary E. Studanski, St. Cloud, Minn.
 Edward D. Tate, South Tacoma, Wash.
 Peter A. Tauriello, Covina, Calif.
 Arlis L. Troglin, Bentonville, Ark.
 Nicholas J. Van Horn, Baltimore, Md.
 Ruth Von Canon, Charlotte, N.C.
 Albert Anthony Wagner, Utica, N.Y.
 Robert F. Wallace, Indianapolis, Ind.
 Arthur E. Wellman, Newfane, Vt.
 Charles W. West, Adelphi, Md.
 C.E. Wilson, Estevan, Sask., Can.
 Robert Winhaber, Rochester, N.Y.
 Thomas E. Woodhead, Ellwood City, Pa.
 Fred E. Yates, South Gate, Calif.
 Kulven Young, Honolulu, Hawaii

ENGINEERS, DRAFTSMEN, TECHNICIANS

If you're interested in a new job in the New York State area, Stanley J. Klein Associates, Inc., Management Consultants, will help you in relocating. The assignments are immediate and challenging, the fee is paid, the attention given to each applicant is personal and confidential. For further information, write to 1694 Highland Avenue, Rochester, New York 14618, or phone 716-244-3580.



Alumni News

Eugene de Caussin	President
Edward Bednarz	Vice President
Isaiah Randolph	Vice President
Joseph Bradley	Vice President
Harvey Morris	Vice President
Theodore E. Rose	Executive Sec.

PRIMARY PUTS PIRRUNG AND SALVOTTI AHEAD AS PRESIDENTIAL NOMINEES

Because of the unavoidable delay in mailing the July-August 1967 issue of the Journal, the deadline for the primary election was moved up to September 25. Results are now in, and the following members are eligible for national offices (see election ballot on Page 32):

The two candidates for President are John Pirrung and Peter Salvotti. John has never run for national office in the Alumni Association before, and he is right out there in front. A long-time member of the Philadelphia-Camden Chapter, and its president for the past six years, John is an industrious and dedicated Alumni Association member.

The second candidate for President, Peter Salvotti, was a charter member of the San Francisco Chapter and has been a strong and active supporter since then. Although Pete has been a past chairman

of his local chapter, this is the first time he has run for national office.

In addition, the primary election has yielded a completely new slate of nominations for Vice Presidents. These nominees are:

Thomas B. Love, San Antonio, Texas; Franklin Lucas, East Orange, N. J.; James J. Kelley, Detroit, Mich.; Aaron Grollman, Baltimore, Md.; Roy DaSilva, New York, N. Y.; Arthur C. Howard, Gadsden, Ala.; E. J. Meyer, St. Louis, Mo.; and John R. Berry, Memphis, Tenn.

As in previous Association elections, members can vote for any other members they choose, whether or not they are included on the list of nominees. Just make sure all ballots reach Washington, D. C. no later than November 25. The winners will be announced in the January-February '68 Journal.

ALUMNI AGENDA: VARIED WINTER SCHEDULE

DETROIT CHAPTER'S John Nagy delivered a talk about switches at a recent meeting. Because the subject matter was quite new to most of the members, every-

one was very interested in John's treatment of switches and was able to answer the questions which he asked at the close of his lecture.



In its coming events of interest, the Chapter intends to proceed with its transistor program, and to add a new program about switches. Looks like quite a workout for members if things proceed on schedule!

Newly elected officers for this season are as follows: James J. Kelley, Chairman; John Nagy, Vice-Chairman; F. Earl Oliver, Treasurer; Charles Cope, Secretary; Leo Blevins and Asa Belton, Financial Committee; Prince Bray, Librarian; Asa Belton, Sergeant-at-Arms. Our congratulations to you, gentlemen!

LOS ANGELES REVIEWS SERVICING TECHNIQUES

LOS ANGELES CHAPTER was pleased to admit two new members. They are Jonathan Huerta and Frank McGrew. Welcome to the Chapter, gentlemen!

At this meeting the members went to work on two sets brought in for troubleshooting by club members. One was a Silver-tone TV receiver with no high voltage. The trouble was traced to the horizontal oscillator coil. This was replaced and a few minor adjustments put the set in good working condition.

The other set was a dead Philco radio receiver. By tracing the voltage it was revealed that a 150-ohm, 2-1/2-watt resistor and rectifier were defective. Replacement of these brought the receiver back to life.

NEW YORK GLIMPSES IBM TYPEWRITER SYSTEM

NEW YORK CITY CHAPTER inaugurated its first meeting of the 1967-1968 season with a lecture by Mr. Lionel Williams, who introduced the members to the Baudot System as used in IBM teletypewriters.

Mr. Williams explained the use of the 5-band code and the stop and start pulses thoroughly before he discussed both the sending and receiving mechanisms. He touched upon both the wire and radio transmissions of these code units.

At the close of his talk he pointed out the need for service people in this field and suggested that it was worthwhile investigating these possibilities more fully.

TWO NEW MEMBERS JOIN SAN FRANCISCO CHAPTER

SAN FRANCISCO CHAPTER, not to be outdone by the Los Angeles Chapter, also reports the admission of two new members, Joe Lemay and John Parker. Glad to count you among the members of the Chapter, gentlemen!

John gave a good indication of what can be expected from him in the way of contributing to the Chapter by delivering a fine talk on troubleshooting of the vertical circuit of TV receivers. Following this talk the members enjoyed a general discussion on the subject.



In Memoriam

Since the last issue of the Journal we have received word that the following members of the Alumni Association have passed away. We extend the sympathy of the Alumni Association to their families.

Mr. Carmen Vartuli, Winooski, Vt.
Mr. Martin J. Bayliss, Maple Shade, N. J.
Mr. Harold Sedgwick, Taunton, Mass.
Mr. Louis J. Choiniere, Barton, Vt.
Mr. Erwin Kapheim, Milwaukee, Wisc.

Mr. L. R. Brackman, Pea Ridge, Ark.
Mr. Arthur G. Hinkle, Fernwood, Pa.
Mr. Joe Woodward, Silver Spring, Md.
Mr. James Shortland, W. Palm Beach, Fla.
Mr. Francis T. Poltorak, Jamaica, N. Y.

DIRECTORY OF ALUMNI CHAPTERS

Detroit Chapter meets 8:00 P.M., 2nd Friday of each month, St. Andrews Hall, 431 E. Congress St., Detroit. Chairman: James Kelley, 1140 Livercis, Detroit. VI-1-4972.

Flint (Saginaw Valley) Chapter meets 8:00 P.M., 2nd Wednesday of each month at shop of Andrew Jabbagy, G-5507 S. Saginaw Rd., Flint. Chairman: Clyde Morrisett, 514 Gorton Ct., Flint. 235-3074.

Hagerstown (Cumberland Valley) Chapter meets 7:30 P.M., 2nd Thursday of each month at George Fulk's Radio-TV Service Shop, Boonsboro, Md. Chairman: Robert McHenry, RR2, Kearneysville, W.Va. 25430.

Los Angeles Chapter meets 8:00 P.M., 2nd and last Saturday of each month, at Chairman Eugene DeCaussin's Radio - TV Shop, 4912 Fountain Ave., L.A.

New Orleans Chapter meets 8:00 P.M., 2nd Tuesday of each month, at Galjour's TV, 809 N. Broad St., New Orleans. Chairman: Herman Blackford, 5301 Tschoupitoula St., New Orleans.

New York City Chapter meets 8:30 P.M., 1st & 3rd Thursday of each month, St. Marks Community Center, 12 St. Marks Place, N.Y.C. Chairman: Samuel Antman, 1669 45th St., Brooklyn.

North Jersey Chapter meets 8:00 P.M., last Friday of each month, Players Club, Washington Square (1/2 block west of

Washington & Kearney Avenues), Kearney. Chairman: William Colton, 191 Prospect Avenue, North Arlington, N.J.

Philadelphia-Camden Chapter meets 8:00 P.M., 2nd & 4th Monday of each month, K of C Hall, Tulip & Tyson Sts., Philadelphia. Chairman: John Pirrung, 2923 Longshore Avenue, Philadelphia.

Pittsburgh Chapter meets 8:00 P.M., 1st Thursday of each month, 436 Forbes Ave., Pittsburgh. Chairman: Joseph Burnelis, 2268 Whited St., Pittsburgh.

San Antonio (Alamo) Chapter meets 7:00 P.M., 4th Friday of each month, Beethoven Home, 422 Pereira, San Antonio. Chairman: Sam Stinebaugh, 318 Early Trail, San Antonio.

San Francisco Chapter meets 8:00 P.M., 2nd Wednesday of each month, at home of J. Arthur Ragsdale, 1526 27th Ave., San Francisco. Chairman: Isaiah Randolph, 523 Ivy St., San Francisco.

Southeastern Massachusetts Chapter meets 8:00 P.M., last Wednesday of each month at home of John Alves, 57 Allen Blvd., Swansea. Chairman: Walter Adamiec, 109 Taunton St., Middleboro.

Springfield (Mass.) Chapter meets 7:00 P.M., last Saturday of each month at shop of Norman Charest, 74 Redfern Drive, Springfield. Chairman: Joseph Gaze, 6B Worthen St., Springfield.

ALUMNI ELECTION BALLOT

FOR PRESIDENT (VOTE FOR ONE MAN):

John Pirrung, Philadelphia, Pa.

Peter Salvotti, San Francisco, Calif.

FOR VICE-PRESIDENT (VOTE FOR FOUR):

Thomas B. Love, San Antonio, Texas

Roy DaSilva, New York, N.Y.

Franklin Lucas, East Orange, N.J.

Arthur C. Howard, Gadsden, Ala.

James J. Kelley, Detroit, Mich.

E. J. Meyer, St. Louis, Mo.

Aaron Grallman, Baltimore, Md.

John R. Berry, Memphis, Tenn.

POLLS CLOSE NOVEMBER 25, 1967

MAIL YOUR COMPLETE BALLOT TO:

(Sign Here:)

T. E. Rose, Executive Secretary

Your Name _____

NRI Alumni Association

Your Address _____

3939 Wisconsin Avenue, N.W.

City _____ State _____ Zip _____

Washington, D.C. 20016

SOLUTION TO CROSSWORD PUZZLE

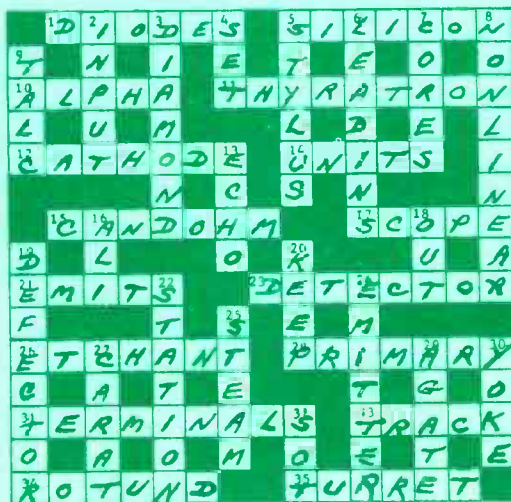

CHRISTMAS
VALUES
FROM

CONAR

DIVISION OF NATIONAL RADIO INSTITUTE

MODEL 230

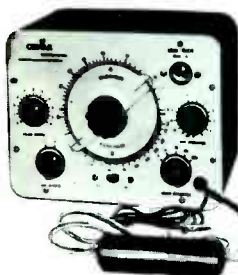

\$4 Down—\$5 Mo.

CONAR Tuned Signal Tracer

Only tuned tracer on the market anywhere near the price. Exclusive cathode-follower probe gives outstanding sensitivity. Easily connects to any RF or IF stage with absolute minimum of detuning. Features audio tracing method through built-in 4" PM speaker plus visual indicator using "eye" tube. Quickly locates sources of hum, noise and distortion. Tracks down intermittents, measures gain per stage, accurately aligns radios without signal generator. (Tracer may also be used as sensitive AM radio.) Has two stages of RF amplification. Assembly-operating instructions include more than 12 pages on uses of Model 230. For beginners as well as experienced technicians.

SPECIFICATIONS

FREQUENCY: 170 kc to 1500 kc (2 bands)
TUNING: Planetary Drive, 3:1 ratio

RF TRANSFORMERS: Permeability tuned

ATTENUATORS: Calibrated RF and AF

TUBES: (2) 6GM6, (1) 6AV6, (1) 6AQ5, (1) 6E5, (1) 6X4, (1) 6AB4

CONTROLS: Volume, Band Selector, Main Tuning, Fine Attenuator On-Off, Coarse Attenuator, RF-AF switch

CABINET: Steel, blue finish with satin finish panel, red lettering

DIMENSIONS: 9 $\frac{1}{4}$ " x 7 $\frac{1}{2}$ " x 6 $\frac{1}{2}$ "

POWER SOURCE: 110-120, 60 cycle

\$39.95

Kit—230UK Assem.—230WT, \$59.95

MODEL 280

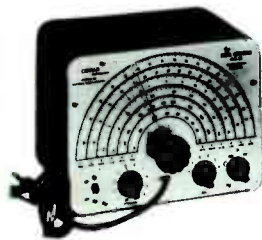

\$2.50 Down—\$5 Mo.

CONAR Signal Generator

Widely acclaimed as most accurate signal generator near the price. Uses Hartley type oscillator circuit with six separate coils and capacitors to give accuracy within 1% after easy calibration. High output of the Model 280 simplifies signal injection for rapid alignment and troubleshooting of transistor and tube receivers. Covers 170 kc to 60 mc in six ranges with harmonic frequency coverage over 120 mc. Ideally suited as marker generator for TV alignment. Tuning dial features planetary drive with 6:1 ratio for greater accuracy and elimination of backlash. Scale is full 9" wide with transparent hairline pointer. Has single cable for all outputs, no need to change leads when switching from 400 cycle audio to modulated or unmodulated RF.

SPECIFICATIONS

CONTROLS: High-Low Output Selector, Main-Tuning Dial, Band Selector—A thru F, Output Selector—Mod, RF, Audio, Attenuator/On-Off switch

TUBES: 6BE6, 12AU7

CIRCUIT: Slug adjusted RF coils with mica trimmers on low bands. Ceramic trimmers on high bands

CABINET: Steel, baked-on blue finish; satin finish panel with red lettering

DIMENSIONS: 9 $\frac{1}{4}$ " x 7 $\frac{1}{2}$ " x 6 $\frac{1}{2}$ "

POWER SUPPLY: solid state 110-120 V, 60 cycle AC

\$24.95

Kit—280UK Assem.—280WT, \$35.95

MODEL 311



\$2.20 Down—\$5 Mo.

CONAR Resistor-Capacitor Tester

The Model 311 gives fast, accurate, reliable test on all resistors and capacitors. Measures capacity of mica, ceramic, paper, oil-filled and electrolytics from 10 mmfd. to 1500 mfd, 0-450 volts. Checks for leakage, measures power factor and useful life. Shows exact value of resistors from 1 ohm to 150 megohms. Clearly indicates opens and shorts. Has "floating chassis" design to greatly reduce shock hazards. The Model 311 will also apply actual DC test voltage to capacitors to reveal break-down under normal circuit conditions, a feature far superior to many R-C testers which give low voltage "continuity" tests. Can be used for in-circuit tests in many applications and circuits

SPECIFICATIONS

RESISTANCE RANGES: 0-500 ohms, 100-50K, 10K-5M, 1.8M-150M (extended range)

CAPACITY RANGES: 0.1-50 mfd, .001-5 mfd, .00001-0.05 mfd, 18-1500 mfd (extended range)

CONTROLS: Range Selector, Leakage Test Voltage (0-450), Power Factor (0-60%)

TUBES: 6E5 "eye" indicator 6X4

BINDING POSTS: Special 5-way type

CABINET: Steel, smooth blue

DIMENSIONS: 9 $\frac{1}{4}$ " x 7 $\frac{1}{2}$ " x 6 $\frac{1}{2}$ "

POWER SUPPLY: 110-120 V, 60 cycle AC

\$21.95

Kit—311UK Assem.—311WT, \$33.50

USE HANDY ORDER FORM ON PAGE 17—CASH OR TERMS

GIVE A CONAR "300" STEREO SYSTEM

INCLUDES ALL THIS

- CONAR 10-Watt Power Amplifier Kit
- 2 Full Range CONAR Speakers in Enclosures
- Garrard Model 40MK2 Turntable
- Electrovoice Ceramic Stereo Cartridge
- All Cable, Wire, Jacks

KIT

Stock 1300UK
Express Collect

WIRED— \$123.50
1300WT, Exp. Coll.

\$111.00

\$5
MONTH



FREE CARTRIDGE INCLUDED

Electro-Voice 126A Diamond-Sapphire; \$10 Value!



**SAVE
\$9.50**

Stradford fully assembled tuner—Reg. \$86.50—
NOW \$77 with "300" System. Complete outfit,
including tuner, \$188.

Here is quality stereo to complement your tastes for good listening and fit any budget. A precision engineered system with carefully matched components; yet ruggedly built as a home entertainment center for the entire family.

Whether it's violin, piano solo or bass drum—Beethoven, Belafonte or Brubeck—the "300" urges and invites your comparison with stereo systems costing considerably more. Let your EARS judge the living sound, superb channel separation, the startling realism that only good component stereo can bring.

Mr. Willard F. Velline
1322 S. 14th
Fargo, N. Dak. 58101

25923-0

NRI JOURNAL
3939 Wisconsin Ave.
Washington D. C. 20016

Second-class
postage paid
at Washington, D. C.