

## Translators and Boosters in the Broadcast Services

### TELEVISION TRANSLATORS

Stephen Koppelman and Robert M. Unetich  
*EMCEE Broadcast Products*  
 Division of  
*Electronics, Missiles and Communications, Inc.*  
 White Haven, Pennsylvania

### FM TRANSLATORS AND FM BOOSTERS

Robert A. Jones, PE  
*Consulting Engineer*  
 LaGrange, Illinois

#### TELEVISION TRANSLATORS

There has been a need for an automatic unattended device to rebroadcast television signals to shadowed communities since the inception of television broadcasting.

Translators get their name from their function of receiving an "Off-the-Air" signal and converting (translating) it to a new channel in the VHF or UHF Television Band.

The translator is comprised of a television receiver and television transmitter integrated into one equipment with the necessary ancillary circuits. Translators range in power output from 1 to 1000 watts.

The translator station is usually located on a hill or mountain, where available, that offers a "Line of Sight" path to the community to be served while simultaneously providing a good "Off-the-Air" primary signal to the translator input.

#### FCC Licensing Requirements

Translators are licensed by the Federal Communications Commission under Part 74 Subpart G of the Commissions Rules and Regulations. Applications for new translator stations are filed using FCC form 346 for Construction Permit. Such application may be filed by any individual, public group, civil governmental body or broadcaster. The application requires that the applicant make a brief showing of his financial capability to promptly and properly construct and

operate such a station in addition to the necessary legal and engineering information.

While both VHF and UHF channels are available to translators, the FCC encourages the use of UHF channels by giving more "latitude" to UHF translators. As an example, UHF translators are

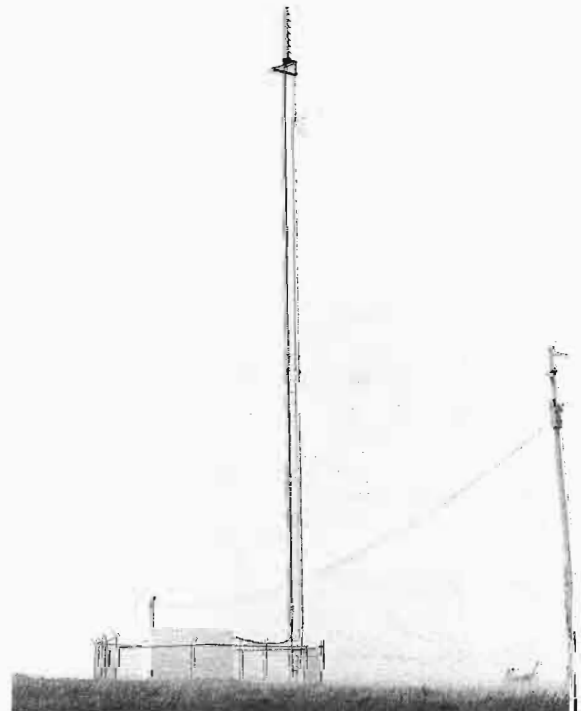

Fig. 1. 2,000 watt ERP, UHF, TV translator station.  
 (Photo courtesy of WVIA-TV.)

# TRANSLATOR STATION COVERAGE CHARTS

## HOW TO SELECT THE PROPER TRANSLATOR AND TRANSMIT ANTENNA

- STEP 1) Determine Output Band
  - A. CH-2 to CH-6 (Band I)
  - B. CH-7 to CH-13 (Band III)
  - C. CH-14 to CH-83 (Bands IV, V)
- STEP 2) Determine Height "H" of transmitting antenna above community (s) to be served.
- STEP 3) Determine desired Distance "D" from Transmitter/Translator to furthestmost boundary of community to be served.
- STEP 4) On appropriate Coverage Chart (either Band I, Band IV, V or Band III) locate curve approximating Height "H" determined in Step 2.
- STEP 5) On same Chart locate Distance "D" along horizontal axis and draw a vertical line intersecting the appropriate "H" curve selected in Step 2.
- STEP 6) Draw horizontal line from the above intersection to the left hand vertical axis indicating required "Effective Radiated Power" (ERP).
- STEP 7) Locate the appropriate horizontal antenna pattern which will encompass the community to be served.
- STEP 8) Select the antenna which offers this horizontal pattern with the necessary Power Gain (above a dipole) to deliver the "ERP" (in Step 8) when used with the selected transmitter.

### NOTES: (APPLICABLE TO BOTH GRAPHS)

- A. ERP is determined by multiplying transmitter or translator power output by antenna power gain (relative to halfwave dipole).  $P \times G = ERP$  (expressed in watts). Do not use gain expressed in dB.
- B. For purposes of simplicity, transmission line losses have been ignored.
- C. H = Height of transmitting antenna above area to be served, in meters (1 meter = 3.28 feet).
- D. Coverage specified is defined as follows:
  - BAND I (50-88 MHz): +47 dBu (relative to 1 microvolt per meter) field intensity
  - BAND III (170-230 MHz): +56 dBu (relative to 1 microvolt per meter) field intensity
  - BAND IV, V (470-890 MHz): +64 dBu (relative to 1 microvolt per meter) field intensity
 The above field intensities are sufficient to deliver a satisfactory picture taking into account receiver noise, cosmic noise, receiving antenna gain and line loss.

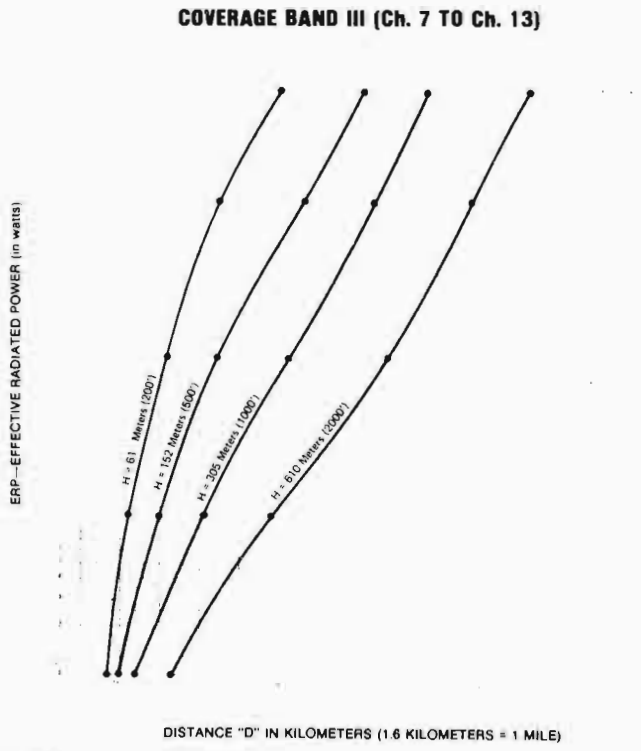
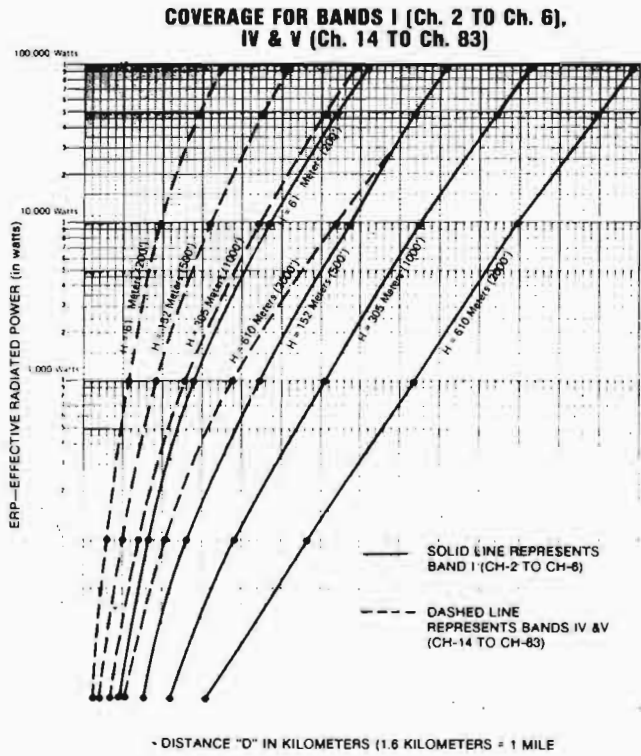

Fig. 2. Translator station coverage charts.

allowed to originate local 30-sec. advertisements once each hour to help defray the cost of operation. At present there are bills pending in Con-

gress to further enhance and exploit the television translator. UHF translators may be operated at power outputs of 1000 watts maximum while

VHF translators are limited to 1 watt east of the Mississippi, 10 watts west of the Mississippi, and 100 watts on unused channel assignments.

The television translator may rebroadcast the "Off-the-Air" signal of

- A. The primary broadcast transmitter
- B. Another translator station
- C. 2000 MHz Translator Relay station

Only translators that are FCC Typed Accepted are licensable by the Commission for the translator broadcast service.

### Translator Relay Station

The FCC has provided for the use of 2000 MHz (see Table of Frequencies) microwave relay stations under Part 74 Subpart F of the FCC Rules and Regulations. FCC form 313 is used for applications in this service. These stations are intended to provide an A5F3 microwave feed for translators that do not have adequate signal from the primary broadcast station or another translator.

The relay is designed to pick up an "Off-Air" signal and retransmit it, via a heterodyne process to a distant translator, at microwave frequencies.

### Translator Station Design

A. *Site selection.* The site should be chosen such that:

1. It affords a line of sight path to the community to be served.

2. There is adequate primary received signal available for the translator input.

3. There is adequate road access wherever possible.

4. There is reasonable availability of primary power wherever possible.

5. There is adequate space and soil conditions for the needed antenna supporting structure.

B. *Tower height.* Tower height, when added to the site height above the average terrain should be such that when combined with the chosen ERP (effective radiated power) and plotted on the FCC (50, 50) curves provide the desired coverage. It is obviously advantageous to minimize tower height by exploiting available terrain elevation.

C. *Transmitting antenna.* The transmitting antenna should be selected to deliver the necessary gain in those directions where coverage is needed thereby maximizing the signal in the coverage area. Many variations of pattern are available from omnidirectional through highly directive. Wide bandwidth antennas are available for multiplex operation of several translators using only one transmission line and antenna to reduce cost and load on the tower. Both electrical beam tilt and null fill should be available, where needed, by the antenna manufacturer.

Antenna gain when combined with the translator output power determines the ERP and

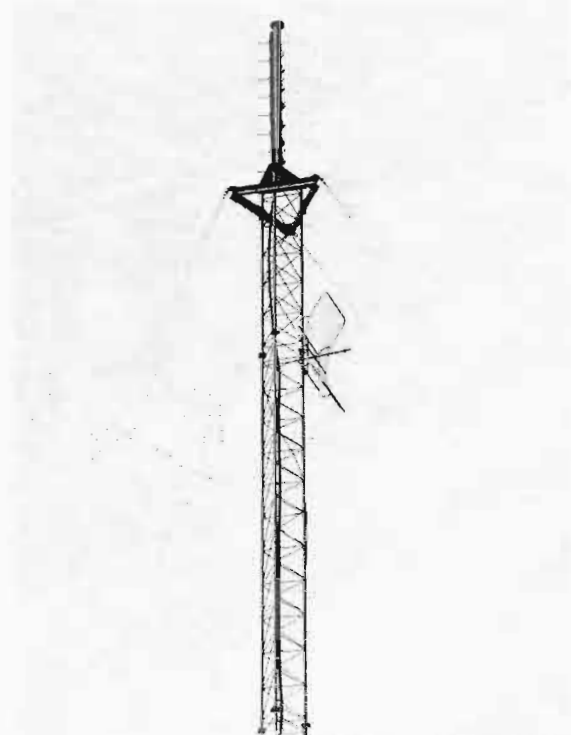

Fig. 3. Close-up view of cylindrical parabolic receive antenna and Bogner slot array transmitting antenna.

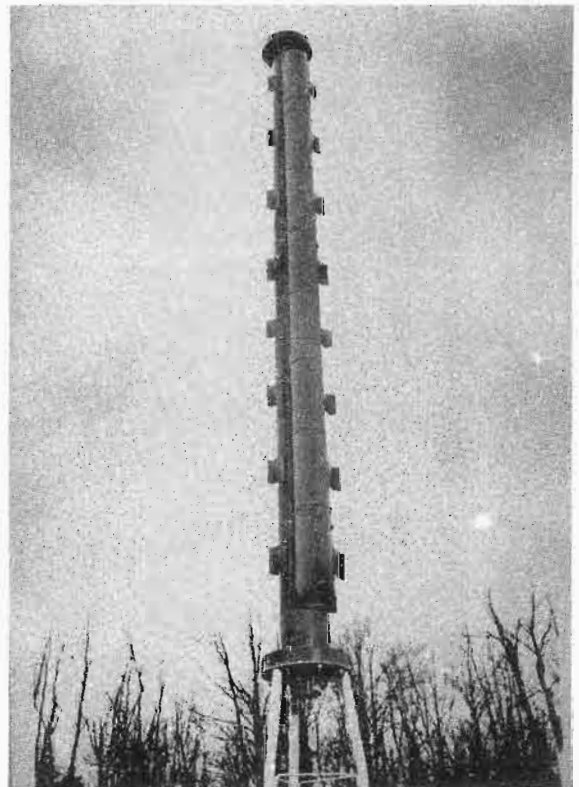
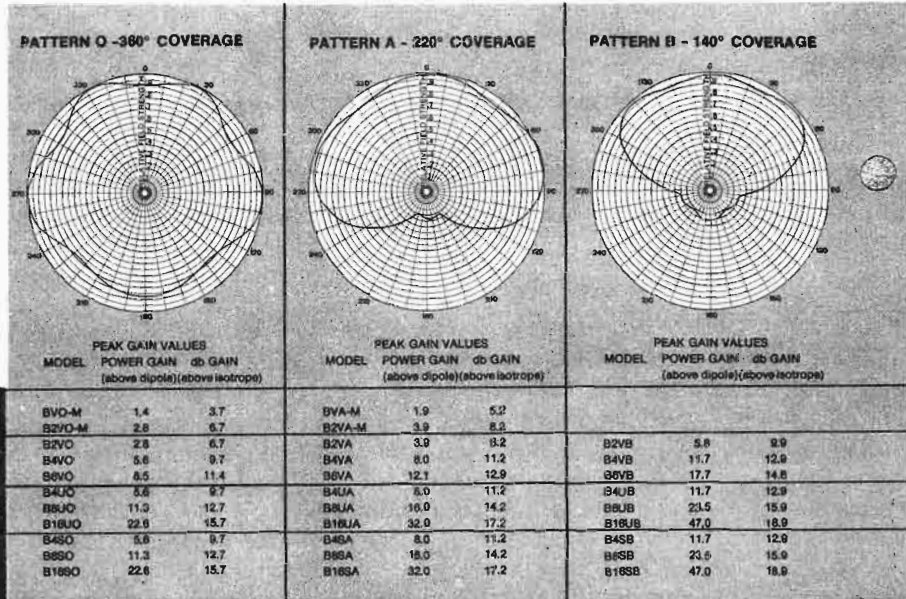

Fig. 4. Detail of Bogner, eight-bay UHF, slot array transmitting antenna.

**SLOT ARRAYS  
HORIZONTAL  
PLANE  
RADIATION  
PATTERNS**



LOW VHF (BAND I)  
50 to 88 MHz  
HIGH VHF (BAND III)  
170 to 230 MHz  
UHF (BANDS IV & V)  
470 to 890 MHz  
SHF (ITFS & MDS)  
2000 to 2700 MHz

**DIPOLE ARRAYS  
HORIZONTAL  
PLANE  
RADIATION  
PATTERNS**

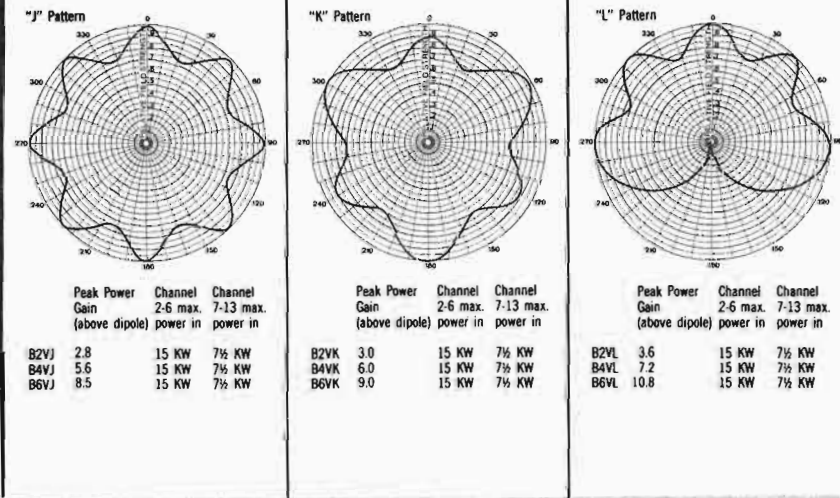

**SLOT ARRAYS—  
VERTICAL PLANE PATTERNS**

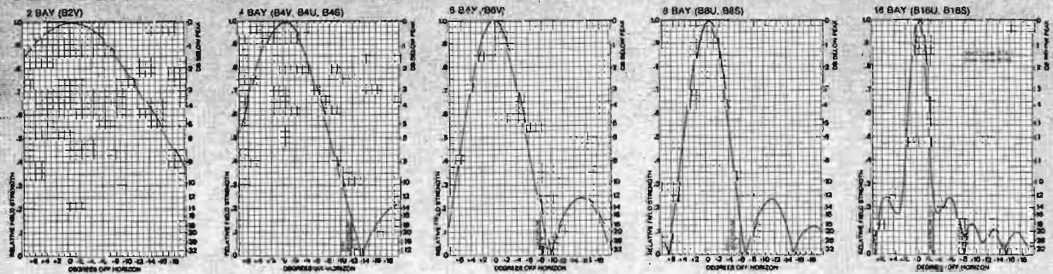

Fig. 5a shows slot arrays horizontal plane radiation patterns and dipole array horizontal plane radiation patterns.

coverage as determined from the FCC (50, 50) curves for a particular height above average terrain. (See Fig. 2 for coverage estimates.)

Typical maximum VSWR of 1.1 to 1 for single channel operation and 1.3 to 1 for three alternate channels are desirable.

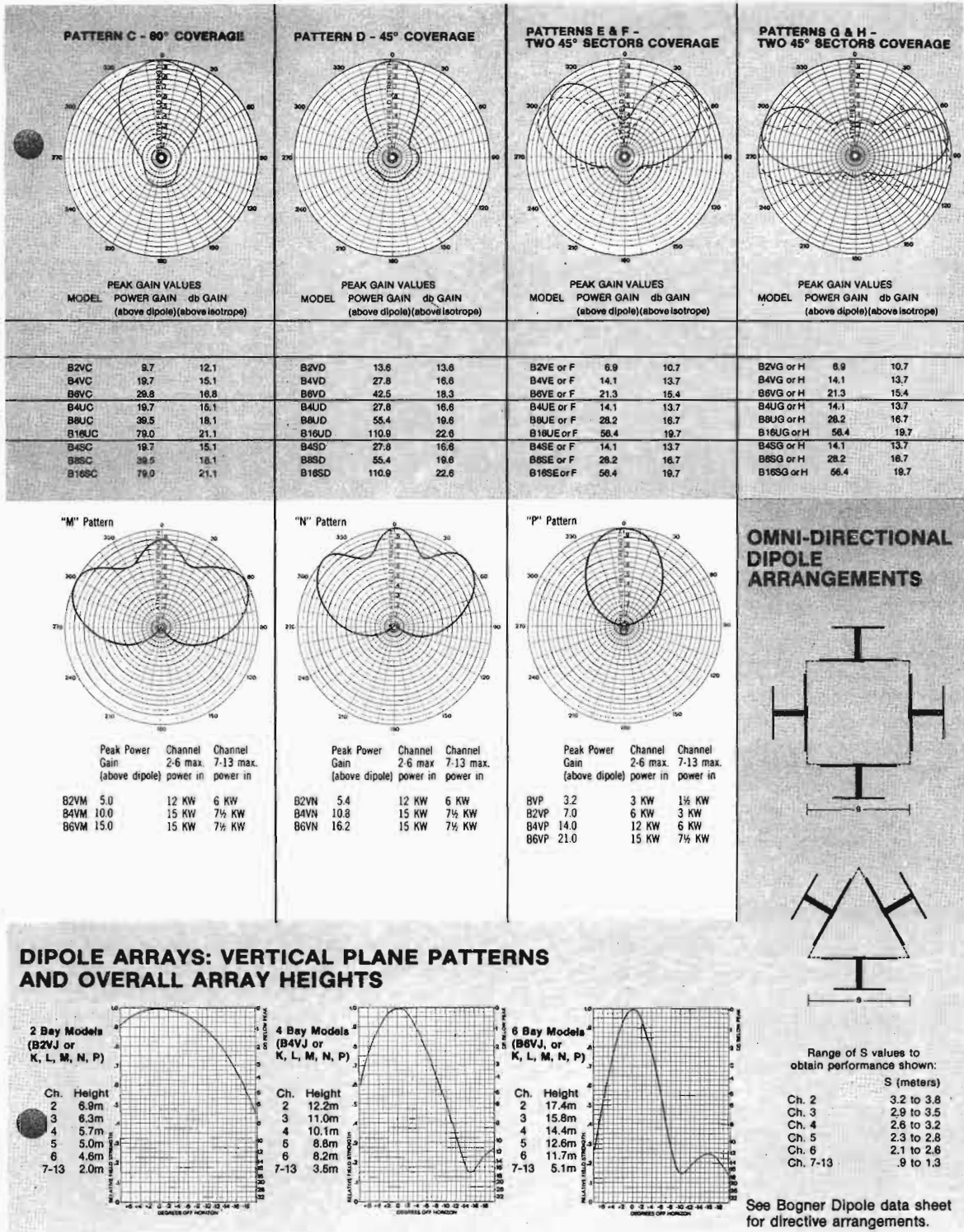

Fig. 5b shows omnidirectional dipole arrangements and dipole arrays: vertical plane patterns and overall array heights.

D. *Transmission line.* Semiflexible transmission lines are preferred for their lower cost and lower installation costs. Modern semiflexible lines offer low VSWR and attenuation.

One-half inch and 7/8 in. lines are most commonly used for VHF transmission and 7/8 in. and

1-5/8 in. lines are used for UHF transmission. The diameter determined by the length of the line. Seven-eighths EIA and 1-5/8 EIA connectors are preferred due to their relative immunity to damage during the construction phase. VSWRs

of 1.05:1 are available and desirable in the transmission system.

E. *Receiving antenna.* The receiving antenna should be of heavy-duty construction able to withstand icing and wind conditions while providing the necessary gain for a snow free picture. Where high gain narrow beamwidth antennas are contemplated, adequate provisions should be made for supporting the receive antenna to prevent rotation in high wind conditions.

F. *The equipment building.* The building should provide the following:

1. Protection against rain, snow, sun and wind.
2. Adequate filtered air into the building sufficient to match the air flow requirements of the translator.
3. Provision for ducting exhaust hot air outside of the building.
4. Sufficient electrical service for the translator, test equipment lighting and building heater. Electrical service should be adequately grounded and protected against transients (both direct and induced).

*Note:* Transient operation cannot be overemphasized for high reliability operation.

5. Adequate space for maintenance and storage of spare parts and test equipment.

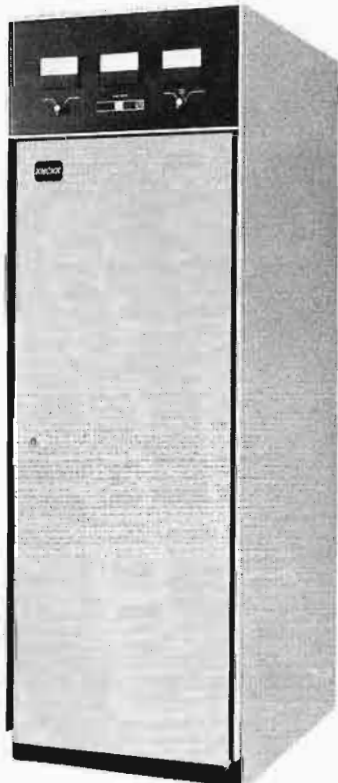

Fig. 6. 100 watt UHF Translator (EMCEE Type TU-100UA).

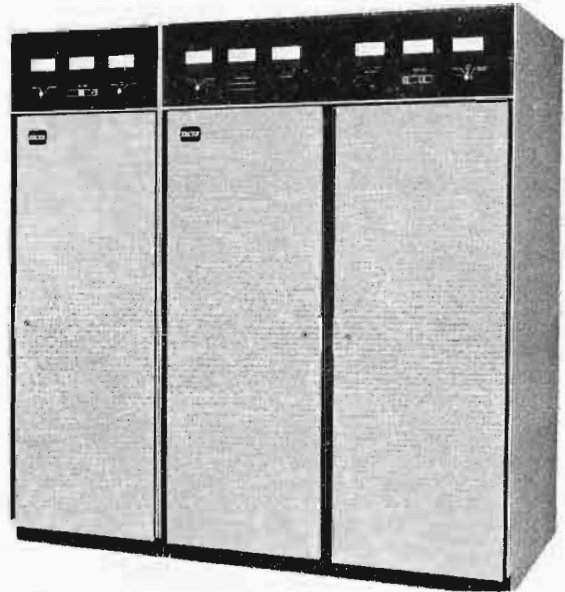

Fig. 7. 1000 watt UHF translator (EMCEE Type TU-1000U).

### System Considerations

Once the input and output channels and the site location have been selected, it should be determined if a sufficient input signal level is present. Input levels on the order of 700 microvolts into 75-ohms or more are desirable for best noise

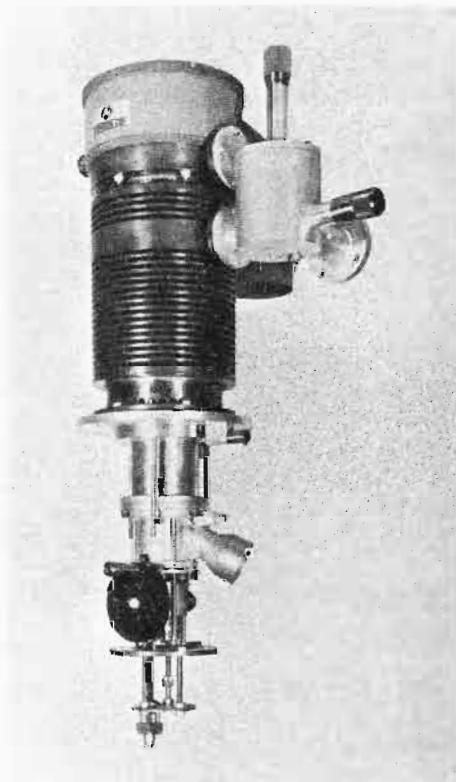

Fig. 8. 1 kilowatt, UHF, cavity (EMCEE).

characteristics but 150 to 200 microvolts will also prove adequate in many cases. Signal-to-noise ratio of the translated output signal is determined by the input S/N and the receiver's noise figure. Of course, if the input signal has a poor S/N due to the noise characteristics of originating transmitter, the translator's output S/N will be poor. However, if the input signal was transmitted with a high S/N, the received signal's S/N will be determined by the effective noise power of the receiver antenna system, and the receiver will degrade the S/N by an amount known as its NOISE FACTOR or its decibel equivalent to Noise Figure. The Noise Figure will typically have a value ranging from 3.0 to 10 dB and is primarily dependent on the noise characteristics of the receiver's input circuitry.

Typical practice is to employ a low-noise pre-amplifier at the receive antenna to minimize losses and optimize noise performance. The overall noise figure of the translator can be found by use of the following formula:

$$F_T = F_1 + \frac{F_2-1}{G_1} + \frac{F_3-1}{G_1 G_2} \dots$$

- where  $F_1$  is the noise factor of the preamplifier;
- $F_2$  is the noise factor of the receive line;
- $F_3$  is the noise factor of the receiver;
- $G_1$  is the gain of the preamplifier;
- $G_2$  is the loss of the receive line.

Note: For this case where  $G_2$  is a loss

$$G_2 = \frac{1}{F_2}$$

As can be seen in the following calculation, the overall noise performance of a translator is primarily but not completely determined by the preamplifier's noise figure:

$$\begin{aligned} F_1 &= 2.5 \text{ (4 dB noise figure preamp)} \\ G_1 &= 40 \text{ (16 dB gain in preamplifier)} \\ F_2 &= 4 \text{ (6 dB loss in down-lead)} \\ G_2 &= 0.25 \text{ (6 dB loss in down-lead)} \\ F_3 &= 10 \text{ (10 dB receiver noise figure)} \\ F_T &= 2.5 + \frac{4-1}{40} + \frac{10-1}{(0.25)(40)} \\ &= 2.5 + .075 + .9 \\ &= 3.475 \end{aligned}$$

converting to decibels

$$10 \log_{10}(3.475) = 5.4 \text{ dB Noise Figure.}$$

The noise figure of a translator can be utilized to determine the S/N of the translated signal by calculating the effective input noise power, determining the input S/N and then reducing the S/N by the Noise Figure.

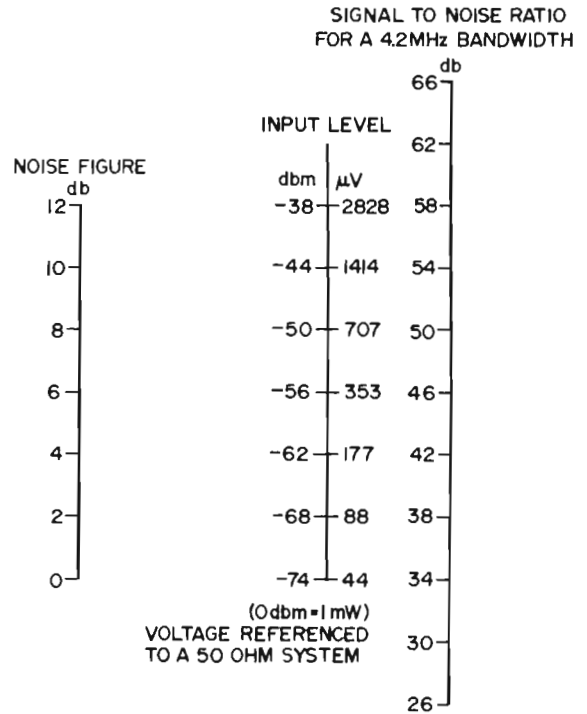

Fig. 9. Noise figure nomogram.

The effective input noise power is

$$N = kTB$$

where  $k$  is Boltzmann's constant,  $B$  is the bandwidth, and  $T$  is the effective temperature in degrees Kelvin.

This formula can also be expressed in its more convenient form:

$$\begin{aligned} \text{Noise input in dBm} &= -198.6 + 10 \log B \\ &+ 10 \log T \end{aligned}$$

As an example, for a receiving system with a noise figure of 5 dB and a 4.2 MHz bandwidth:

$$\begin{aligned} \text{ENI} = \text{EFF. Noise Input} &= -198.6 + 10 \log \\ &4 \times 10^6 + 10 \log \\ &298^\circ\text{K} \\ &= -107.6 \text{ dBm} \end{aligned}$$

If the input signal is  $300\mu\text{v}$  (-57 dBm), the input S/N is:

$$(-57 \text{ dBm}) - (-107.6 \text{ dBm}) = 50.6 \text{ dB}$$

and the output S/N is

$$\frac{S}{N}(\text{in}) - NF = 50.6 \text{ dB} - 5 \text{ dB} = 45.6 \text{ dB}$$

The nomogram (see Fig. 9) of Noise Figure and Input Signal will be useful in determining the output S/N. It assumes a 4.2 MHz bandwidth.

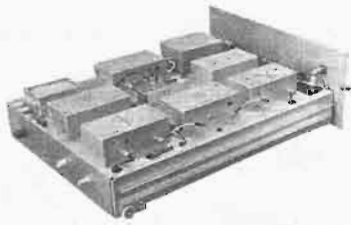

Fig. 10. Receiver drawer assembly showing modular construction.

It should be clearly understood that the S/N of the translator output is also dependent on the input S/N and that cascading of translators will further degrade the S/N of the signal.

This effect can be seen by looking at the equation for Noise Factor of cascaded networks, shown earlier to be:

$$F_T = F_1 + \frac{F_2 - 1}{G_1} + \frac{F_3 - 1}{G_1 G_2} + \dots$$

### Multihop Translators

If two translators are cascaded, the total system  $F_T$  is:

$$F_T = F_1 + \frac{F_2 - 1}{G_1} + \frac{F_3 - 1}{G_1 G_2}$$

where  $F_T$  is the system noise factor;

$F_1$  is the noise factor of the first translator;

$F_2$  is the net combination of the antenna gains and the path loss;

$F_3$  is the noise figure of the second translator;

$G_1$  is the overall operating gain of the first translator;

$G_2$  is the net gain of the antennas and path loss (usually a loss).

In general for multihop translator service, it can be shown that, if each translator has the same input level and the same noise figure (a reasonable case in system design), then the overall S/N will degrade by 3 dB each time the number of hops is doubled.

*Determining effective radiated power.* Selection of the output power is based on several factors, the primary one being the size of the area to be covered. Of course, coverage area, terrain, antenna gain, and tower height are interdependent, and the best approach is to estimate field strengths in the coverage area using the FCC (50, 50) curves and to plot several path profiles to a sample of receive sites. The necessary effective radiated power (ERP) can then be estimated and the necessary antenna pattern can be determined. It may be found in the process that beam tilt and null fill are desirable and these can normally be supplied by the antenna manufacturer.

Typical output powers for translators range from 1 watt to 1000-watts peak visual power. Average aural output power is usually 10 percent of the peak visual output power. Other site restrictions may influence the choice of operating power; e.g., availability of ac power. The combination of antenna gain, line losses, and output power will determine the ERP.

Modern television translators use transistors in all but the highest level amplifier stages. Completely solid-state translators are available up to 100 watts on VHF channels and up to 10 watts on UHF channels. Additionally, units are available for operation from thermoelectric power and storage batteries employing various charging means.

### Translator Circuit Description

The general approach used in translators is to receive a VHF or UHF input channel through a low-noise preamplifier-filter combination, mix the signal with a local oscillator in a balanced mixer, filter and amplify the signal at the Intermediate Frequency, and then convert the signal to the desired output channel in another balanced mixer for amplification and retransmission.

*Preamplifiers.* Since the preamplifier operates in the proximity of the translator output antenna, its input must be well filtered. Normally a multi-section bandpass filter of low insertion loss is ahead of the amplifier stage or stages. The preamplifier stages must utilize transistors capable of handling the largest input signals expected while providing the lowest practical noise figure. Either 50 or 75-ohm preamplifiers are available. Power is usually duplexed onto the preamplifier output cable, and is supplied by the receiver or by a separate power supply.

*Input cable.* The cable interconnecting the preamplifier and the translator need not be of exceptionally low loss type as long as the loss is much less than the gain of the preamplifier.

*Receiver.* The receiver performs a variety of important functions. It receives the input signal either directly from a receiving antenna or from a preamplifier and provides input selectivity before heterodyne conversion to an IF. This conversion is usually accomplished in a balanced mixer to

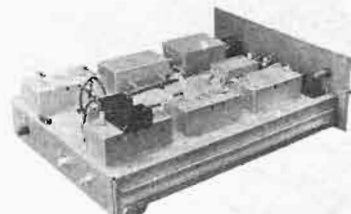

Fig. 11. One watt, UHF upconverter amplifier drawer.



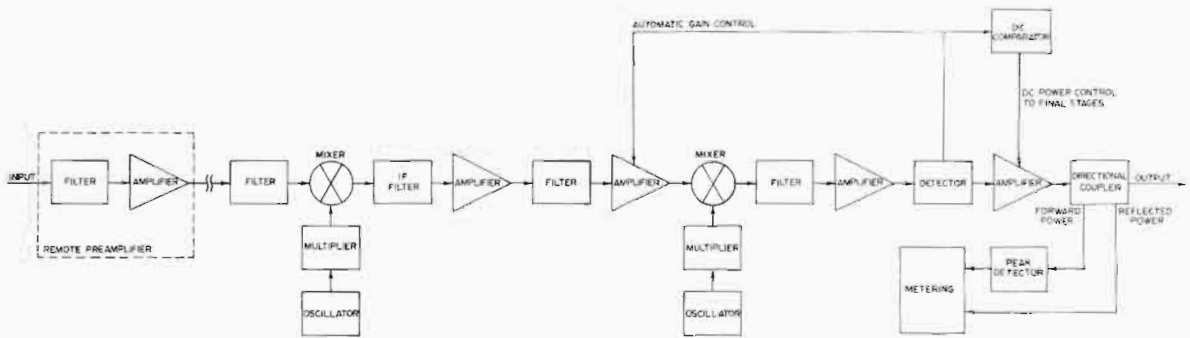

Fig. 12. Typical functional block diagram.

maximize local oscillator isolation. The output of the mixer at IF is filtered to remove undesired mixing products and amplified in a low-noise amplifier stage or stages before further processing. This is necessary to minimize the receiver's input noise figure. Extensive filtering is then usually performed to reject energy outside of the desired channel. This is usually done in a multistaged bandpass filter, and often includes an aural trap for reducing the amount of aural power present if desired. Automatic gain control of the level is then performed. This is done in a broadband cascode current controlled stage which is capable of 50 dB of gain variation. Use of a broadband amplifier insures that the frequency response of the IF strip is not level dependent. The level control voltage or AGC voltage is derived from a following amplifier stage, which is either at the IF output of the receiver in the UHF output translators or at a VHF low level stage in the VHF output translators. The technique utilized in the AGC detector is to sample and peak detect the signal and compare the resulting detected dc voltage to a reference voltage in a high gain comparator/integrator. The reference voltage is

manually adjustable and temperature compensated. The output of the comparator is the AGC voltage, and has the effect of continuously adjusting the gain of the gain controlled IF stage to maintain the detected dc voltage, and therefore the output signal, at a constant value independent of input signal level. In the translator, the detection process also involves frequency selective circuitry which is tuned to the visual carrier IF or VHF frequency.

*Automatic operation.* The AGC voltage is dependent on the presence of an input on visual carrier frequency, and this voltage is compared to a reference voltage in another comparator/integrator which controls a relay. After the reference voltage has been exceeded for the time constant of the integrator, the relay actuates and begins the turn on sequence of the higher level stages of the translator output circuitry.

*Up-conversion.* The IF signal is converted to the desired output channel by another balanced mixing process and is filtered and amplified.

*Amplification.* The amplifier stages in the translator output section must provide linear stable amplification of the signal. Class A amplifier stages are used extensively, even at the 1 kw output level, to insure distortion free performance. Transistor power amplifiers employ negative feedback bias control circuitry to insure reliable performance over a wide temperature range. This normally takes the form of the circuit in Fig. 14.

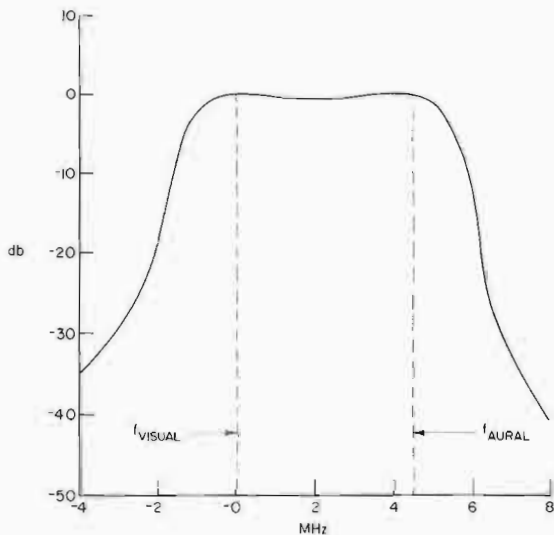

Fig. 13. Typical translator frequency response.

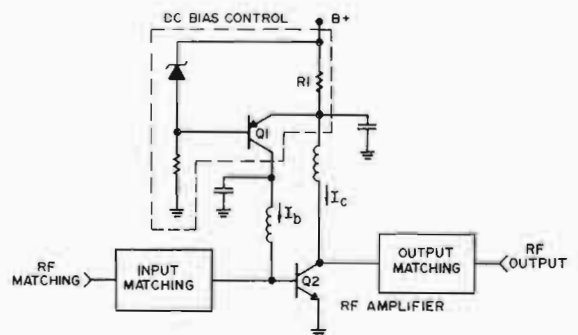

Fig. 14. RF amplifier with feedback bias control.

*Bias circuit description.* In this circuit the base of the bias control transistor is fixed at a dc voltage below that of B + by the zener diode. Since the base-emitter drop of the device is reasonably constant, the voltage across the resistor  $R_1$  is constant. This results in a constant current flow through  $R_1$ . This current flow is divided between emitter current of  $Q_1$  and collector current of  $Q_2$ . Since the emitter current of  $Q_1$  is approximately equal to its collector current and since its collector current is also the base current of  $Q_2$  we have:

$$I_b + I_c = \text{constant}$$

where  $I_b$  is  $Q_2$ 's base current and  $I_c$  is  $Q_2$ 's collector current, but

$$I_b \approx \frac{I_c}{\beta}$$

where  $\beta$  is the transistor beta.

Since  $\beta$  of RF transistors is reasonably high,  $I_b$  is relatively small and we have:

$$I_c = \text{constant.}$$

*High power amplifications.* Higher power solid-state amplifiers often employ parallel amplifiers with appropriate combining circuitry. Eight Class A VHF amplifiers operate in parallel in the EMCEE Model TV-100-VA television translator. A significant advantage of this arrangement is that, in case of a component failure in one of the amplifiers, the remaining amplifiers will continue to operate and the translator will remain on the air.

Vacuum tube amplifiers are used at the 1 kw level and their gain is sufficient to allow a 100 watt translator to be used as the driver. Since these higher power stages must operate reliable at unattended sites, extensive use is made of voltage regulation and protection circuitry. The EMCEE Model TOA-1000A UHF 1 kw amplifier utilizes a Thompson CSF TH-331 ceramic tetrode

in a double-tuned coaxial cavity. This tube operates Class A for optimum linearity and requires only 60 watts of drive. Forced air cooling is employed and fault detection circuitry with five automatic reset steps protects the tube and power supplies.

*Monitoring.* Measurement of important voltages and output power is done on VHF and UHF amplifiers. Peak visual output power, combined visual and aural power, and reflected power is normally monitored. In the solid-state amplifiers emitter ballasted transistors are employed which are capable of operating under high output VSWR conditions. Higher power tube amplifiers employ VSWR sensing circuitry to protect the tube from high reflected power conditions.

**Distortions**

Several forms of distortion can be seen on a signal after passage through a television translator. An understanding of these distortions and their respective causes will aid in proper adjustment, operation, and planning.

*Linearity distortions.* Since all amplifiers have some degree of nonlinearity in their transfer function, some amplitude and phase distortion will occur on a translated signal. Classic video distortions such as differential gain, differential phase, and sync compression normally occur in linear amplifiers as they are driven to higher powers. Since most translators employ common visual aural amplification in final stages, intermodulation distortion is present to some extent. Modern television translators are designed to handle color television signals, and maintain extremely low distortion products. As in the case of noise addition in cascaded translators, distortion levels are also affected by cascading translators, and this often places a new constraint on the tolerable level of distortion in an individual translator. It has been found, for instance, that the 920-kHz intermodulation distortion level generated on one translator is often in phase with the intermodulation level generated in a second, cascaded translator.

Since reduction in output power usually results in substantial reduction in distortion products, operation of cascaded translators below their rated power should be considered.

*Delay distortions.* Translators normally have steep frequency response skirts which result in phase variations near the passband edge. Additionally, the ripple in the passband response is related to the phase variation versus frequency characteristics.

The derivative of the phase with respect to frequency is time delay and can be measured to some reasonable accuracy by observing the waveform of the demodulated 2T and 12.5T pulse. (See Figs. 16 and 17.)

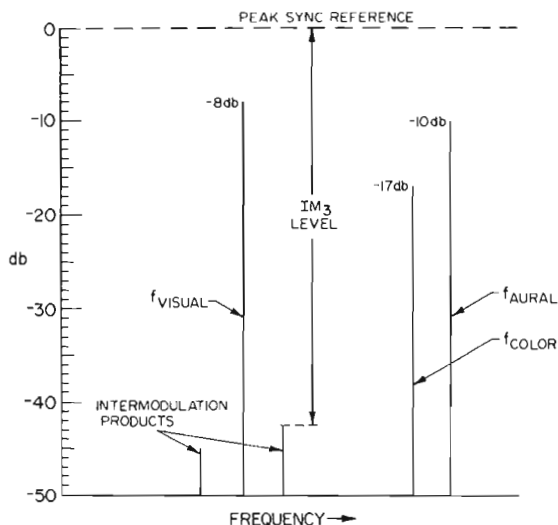

Fig. 15. Three tone intermodulation test.

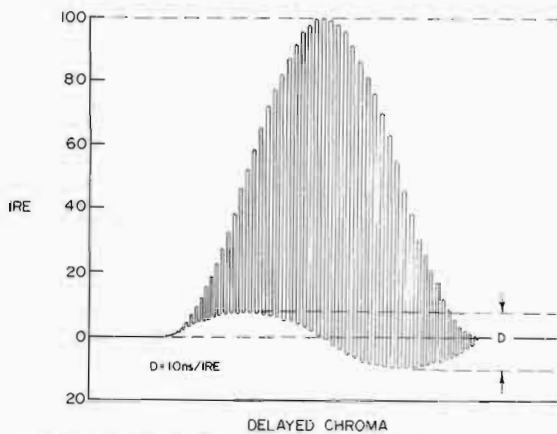

Fig. 16. Delay distortion of a 3.58 MHz modulated 12.5T pulse.

*Minimizing delay distortion.* Adjusting the frequency response of a translator for a reasonable “flat” bandpass characteristic will normally minimize delay variations. Delay distortions are additive in nature and the cascading of translators will tend to increase the amplitude of the delay variations across the television channel.

**Conversion Accuracy**

Another consideration in cascaded translators is frequency accuracy. Use of oven controlled oscillators in all translators in a system will tend to maintain conversion accuracy. Since crystal aging tends to diminish after the first year of operation, it is wise to reset the oscillator frequency of new translators several times during the first year of operation then only as needed to multihop systems. Phase lock techniques have been developed to maintain frequency accuracy in 2 GHz translator relay systems.

The translator has, in recent years, proved itself as a valuable tool to the broadcaster. It offers the broadcaster the opportunity to fill in coverage “Holes” as a “Crest Effective” alternative to CATV.

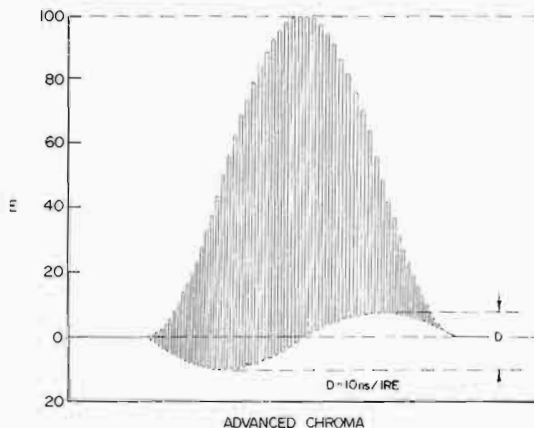
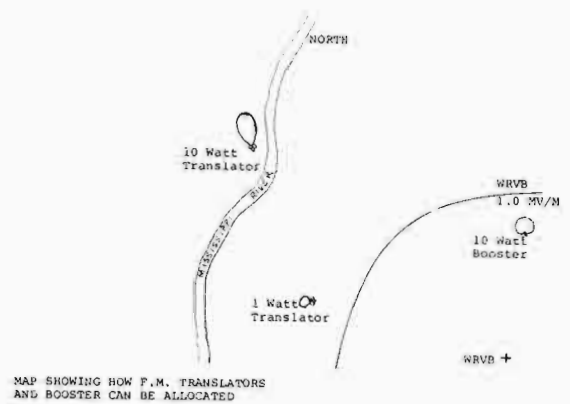

Fig. 17. Delay distortion of a 3.58 MHz modulated 12.5T pulse.



MAP SHOWING HOW F.M. TRANSLATORS AND BOOSTER CAN BE ALLOCATED

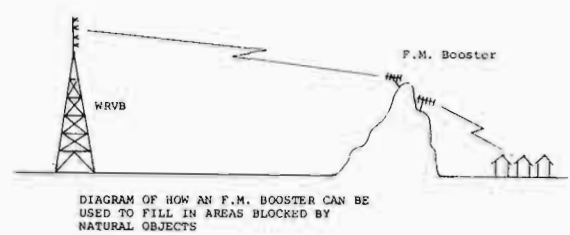

DIAGRAM OF HOW AN F.M. BOOSTER CAN BE USED TO FILL IN AREAS BLOCKED BY NATURAL OBJECTS

Fig. 18. FM translators and boosters.

**FM TRANSLATORS/FM BOOSTERS**

**FM Translators**

Unlike TV translators, FM translators have only been legal in the United States since 1970. But, in Haiti, Missionary Dave Hartt had pioneered and had utilized FM translators since the early 1960s.

Through the efforts of FM Broadcasters, the FCC was persuaded that a need for low cost repeaters did exist in the FM aural service. Just as with TV, FM being a line-of-sight transmission, poor service was being rendered to remote areas as well as to areas affected by hilly or mountainous terrain (Fig. 18). In many ways the FCC attempted to duplicate the TV Translator Rules, but the two services are not the same. The FM translator may well be the last new electronic broadcast service ever granted by the FCC.

An FM translator is really a combination of an FM receiver coupled to an FM transmitter, being designed to extend the coverage of the originating station by amplification of the primary signal and rebroadcasting same (Fig. 19). The receiver part of an FM translator receives the signal transmitted by the FM broadcast station. It then changes the frequency of the incoming signal down to some intermediate frequency. The IF signal is then fed to the transmitter section of the FM translator. In the case of TV translators, the FCC found that it is more practical to employ a different output than input

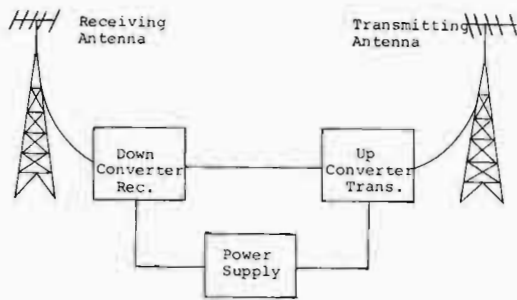

Fig. 19. FM translator block diagram.

frequency to avoid feedback problems. The transmitter section of the translator then converts the IF signal back up to the FM band. The FM Booster differs from the FM Translator in that its input and output frequencies are identical.

**FCC Rules Covering FM Translators/FM Boosters**

Any FM broadcaster, licensee, civil government, association or individual is eligible to apply for a license to erect and own an FM translator. The basic concerns are that the applicant be legally and financially qualified.

An FM translator is intended to serve the general public and is not intended as a vehicle to relay programs or special services from one station to another. Operations are subject to the FCC rules, as enumerated in Subpart L, Section 74.1201 thru 74.1284. Below is a brief synopsis of these rules.

**1. Licensing Policies**

- a. FM translators may be used only for the purpose of retransmitting the signals of an FM station or another FM translator.
- b. Transmissions are intended for direct reception by the general public. Any other use shall be incidental thereto.

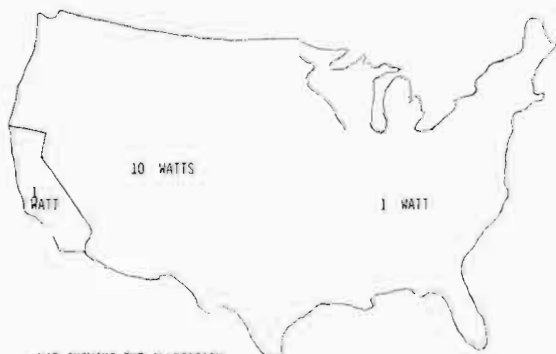

MAP SHOWING THE ALLOCATION OF TRANSLATOR POWER BY LOCATION

Fig. 20. US map of power limits.

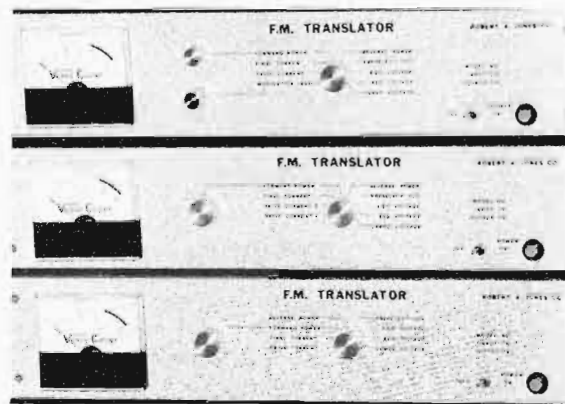

Fig. 21. 10-watt translator (RA Jones).

c. The technical operation of a translator shall not deliberately alter the characteristics of the retransmitted FM signal including stereo and SCA.

d. FM Booster stations will provide a means of extending service to areas of low signal intensity within the primary station's predicted 1.0 mv/m contour.

**2. Eligibility and Licensing**

- a. An FM translator license will be issued to any qualified individual, organization, FM licensee, or civic governmental body.
- b. More than one FM translator may be licensed to the same applicant, even though they may serve substantially the same area.
- c. FM translators will not be licensed to FM licensees if they are located beyond their predicted 1.0 mv/m contour and within the 1.0 mv/m contour of another FM station.
- d. An FM booster will be licensed only to the primary FM broadcast station.
- e. Unattended operation is permitted, providing certain requirements are met.
- f. Power limitations are 10 watts except FM translators serving areas east of the Mississippi River and in Zone 1-A. These will be limited to 1 watt.
- g. No limit is placed upon the effective radiated power or antenna polarity that may be used. There is no requirement that horizontal polarity must be used, as there is with regular FM stations.
- h. Only FCC type accepted equipment will be licensed.

**3. Other Requirements**

- a. Written permission must be obtained from the FM station to be rebroadcast.
- b. The FM broadcaster may contribute financially, may render technical advice or main-

tenance to a translator station operated by another licensee. But, he cannot provide technical assistance or provide financial help to cover the costs of a license application, or the purchase and installation of equipment.

c. An unlicensed operator may observe the operation of an unattended FM translator. An attended FM translator shall be operated by a person holding at least a valid restricted radio telephone operator permit.

d. Local origination of spot announcements is permitted, as long as they do not exceed 30 secs. in any one hour period. Aural material transmitted shall be limited to solicitation of contributions to defray expenses. A contributor may advertise his own business or service.

e. Antennas and transmission lines are not FCC type accepted. Translators, boosters, and multiple amplifiers are FCC type accepted.

f. Station identification may be given by the primary FM station, three times per day, with the exception that translators of 1.0 watt or less require no identification. Ten watt translators can employ mechanical identification. Boosters require no identification.

g. Rebroadcasting of an FM station is not permitted without written consent. Translators are limited to the retransmission of a single FM broadcast station and may not retransmit other stations of other classes.

### Design Consideration of an FM Translator Station

#### Service Area

A study should be undertaken of the area to be served. This should include population data, available FM service from other broadcast stations, and a topographic study of the area. It is wise to also obtain topographic maps of the area between the originating station and the translator site.

#### Site Consideration

It is important to carefully consider the selection of a potential FM translator site. The most important factors are these:

1. The site should be as close as possible to the intended service area.
2. Where natural elevations such as hills or mountains exist, advantage should be taken of them. Advantage can also be taken of existing towers, tall buildings, grain elevators, etc., as possible FM translator sites.
3. The proposed site should have a clear path back to the originating station. Where possible, it is recommended that 6/10 first Fresnel Zone clearance be achieved.

The selection of an ideal site is not always possible and often compromise is necessary. In the consideration of the various site availabilities, they should be visited to ascertain ease of access, right of way, existence of all weather roads, electric power, proximity of other radio towers or services, etc. Other considerations are the necessity of clearing trees from the site, soil problems associated with tower or building erection, and other environmental factors. Sites where boulders have to be moved, guy anchors blasted in solid rock or swampy areas, may prove to be uneconomical sites.

The next step, once the site is selected, is to determine the path clearance back to the primary station. By use of a 4/3 earth "profile" graph paper and topographic maps a profile can be plotted of the path between the primary stations' tower and the FM translator site. The reason we employ 4/3's earth radius for these graphs is to account for normal atmospheric bending of the FM signal. (Fig. 22)

The height of the originating stations' transmitting antenna is drawn on the profile graph at zero miles. This is normally the left-hand edge of the graph. By drawing a straight line from the center of radiation of the originating stations' antenna to the FM translator site, the various path obstructions can readily be seen. In order to calculate the first Fresnel Zone radius, the following formula can be used:

$$R_1 = 2280 \frac{d_1 d_2}{(d_1 + d_2) F}^{1/2} \quad [1]$$

- Where  $R_1$  = first Fresnel Zone radius in feet  
 $d_1$  = distance in miles, obstruction to FM station  
 $d_2$  = distance in miles, obstruction to FM translator  
 $F$  = signal frequency in MHz

The minimum path clearance for satisfactory results should be at least 6/10  $R_1$ . It should not exceed 13/10  $R_1$ , for within this range one can expect the signal received at the translator to be equal to a free space path. Keep in mind that extra clearance must be allowed for trees, buildings, etc., at each path obstruction point. Usually a figure of +50 ft. will account for such objects.

If the above study reveals that inadequate path clearance exists to the FM translator site; then the receiving antenna can be elevated by installing it on a tower, high enough to overcome the path obstructions. This height can be determined from the path profile plot. In some cases it is impossible to elevate the receiving antenna high enough to achieve 6/10  $R_1$  clearance. Lower heights will result in some additive loss in the received signal. These losses

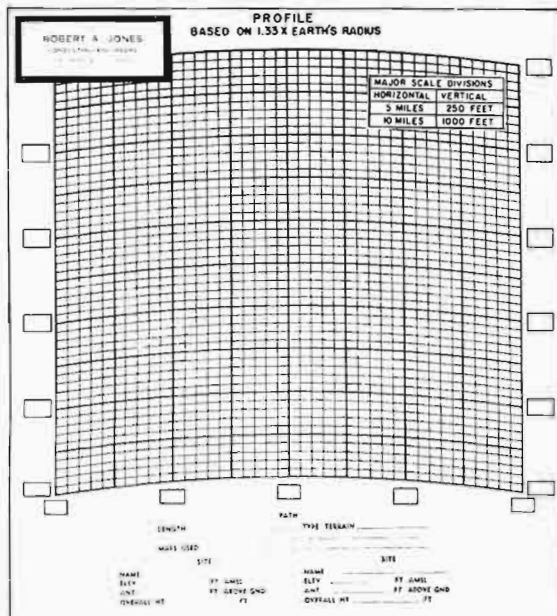

Fig. 22. 4/3 Earth profile graph.

will increase from 0 dB at  $6/10 R_1$  to  $-19$  dB at  $0/10 R_1$ .

It is often possible to receive a satisfactory FM signal under conditions of less than adequate path clearance. This is particularly true when the primary station employs very high ERP. These "over the horizon" signals are more susceptible to fading, and may be dependent upon weather conditions. FM reception is not affected by selective fading as is TV reception. For this reason several FM translators are in use today having no path clearance. This results from a propagation phenomenon termed the "knife edge" effect.

The next step is to study the path clearance from the translator site to the area to be served. This analysis should be undertaken in the same fashion as the above primary station—translator site path studies. Because normally one chooses to serve a wide area, rather than just a single path, it is best to consider several path profiles, at say  $30^\circ$  to  $45^\circ$  intervals. Care should be taken if special terrain features are present. The necessary minimum height of the transmitting FM translator antenna may be selected from the results of these profiles. The FCC has not established service area contours for translators nor defined minimum or maximum reception requirements.

The proposed translator transmitting antenna should be high enough to clear all objects which would be illuminated in the immediate foreground, such as trees, houses, etc.

As with the erection of any tower, notice of applicable FAA rules or local zoning requirements should be met.

## Output Channel Selection

The FCC rules call for the output channel to be one of the 20 Class "A" channels. There is an exception if the originating station is an educational FM station operating in the spectrum between Channel 201 and 220. Then the translator applicant has a choice. He can select either a Class "A" channel or one of the educational channels as his output channel.

Those FM translator stations located east of the Mississippi River or in Zone I-A (southern California) are limited to 1 watt output power. Ten watts of power are allowed west of the Mississippi River, in Alaska, and Hawaii.

In selecting the output channel, engineering judgment must be used to pick a channel that is clear. That is, one that is not presently in use within 45-65 miles cochannel, or three channels either side of the desired class "A." In some parts of the country there is actually a shortage of class "A" channels. In the absence of a usable Class "A" channel, the FCC can grant a waiver to utilize a Class "B" or "C" channel. Care should also be taken to select an output channel that is not 10.6 - 10.8 MHz removed in frequency from the input channel. This of course would result in IF interference.

## Output Requirements

The translator power output when multiplied by the antenna gain, less the transmission line attenuation, yields the effective radiated power (ERP). Knowledge of the output power is necessary in order to calculate the effective coverage of the translator.

There have been two common methods of determining the true coverage to be expected. The first method depends upon use of the FCC's  $F(50, 50)$  curves. These show the estimated field strength exceeded at 50 percent of the receiver locations for a minimum of 50 percent of the time, based upon an assumed receiving antenna height of 30 feet. The assumed transmitter ERP is 1,000 watts, for this FCC curve. (Fig. 23)

The next logical question is what is a minimum usable FM field intensity for acceptable coverage? In the FM rules the FCC has stated that primary stations are limited to their 1.0 mv/m contour (60 dBu). Experience has shown that with FM a signal for 34-40 dBu will achieve satisfactory reception, even with a stereo signal. If the FM listener has an outside antenna, having some "gain," he could very likely receive a 20 dBu signal and enjoy good receptive quality. Since almost all FM translators are located in small cities or remote areas, where there is a scarcity of outside FM signals, what would otherwise be considered a

weak signal is accepted by the listener as a strong signal.

To utilize the FCC  $F(50, 50)$  curve you must first determine the transmitting antenna height above average terrain, between 2 and 10 miles. This would be from the FM translator site along the above path profiles. Keeping in mind that the  $F(50, 50)$  curve is based upon 1 kw ERP, for radiated powers other than 1 kw, the curves should be scaled up or down. This is borne out by the following example.

Assume the area to be served extends from 5 to 15 miles from the translator site, and that the site is on a hill 1,000 feet above mean sea level. The average elevation, as determined from a path profile thru the desired listening area for 2 to 10 miles, shows 600 ft. above mean sea level. This yields an FM translator antenna height of 400 ft. above the average elevation. Using the curves of Fig. 23, the distance to the 34 dBu contour for 1 kw ERP would be 42 miles. Let's assume we have a 10 watt FM translator with an antenna gain of 10, or 100 watts ERP: we then look up a chart value of 44 dBu (34 + 10 dB) at height of 400 ft., to find the correct distance to the 34 dBu contour. In this example we could expect to serve to a distance of 29 miles. If we encountered a situation where the ERP was not adequate to serve all the desired area, then the ERP required can be determined from the chart. Once having de-

termined the ERP it is then necessary to work back to determine the translator power output and the antenna gain. The following generalized formula can be used:

$$ERP = dBw + G - L \quad [2]$$

- Where ERP = dB above 1 watt
- dBw = translator power output in dB above 1 watt
- G = transmitting antenna gain in dB
- L = transmission line loss in dB

Knowing any of the above figures one can easily calculate the others.

A second method of estimating the true coverage of a given FM translator is to calculate the point-to-point signal, i.e., path losses. For this method one assumes at least 6/10 first Fresnel Zone radius clearance. The following general equation can be employed to calculate the signal available at the listener's receiving antenna.<sup>1</sup>

$$P_i = ERP - (36.6 + 20 \text{ Log } F + 20 \text{ Log } D) \quad [3]$$

- Where  $P_i$  = Power at an isotropic receiving antenna in dB below 1 watt
- ERP = is in dB above 1 watt
- F = frequency in MHz
- D = path length in miles

As an example let's assume from the previous problem the distance is 15 miles at a frequency of 100 MHz, and the ERP is 100 watts (+20 dBw).

$$P_i = +20 - (36.6 + 20 \text{ Log } 100 + 20 \text{ Log } 15)$$

According to this calculation the received power at 15 miles will be -80.1 dBw. This will exceed the desired level of 34 dBu by +2.9 dB.

The  $F(50,50)$  curves are generally considered to be conservative. They allow for some nonideal propagation paths. In areas where outdoor receiving antennas are used with low-loss lead-in lines from the antenna to the receiver, more optimistic coverage will prevail.

### Receiving Antenna Requirements

In order to determine the necessary receiving antenna gain, the following standard equation may be employed:

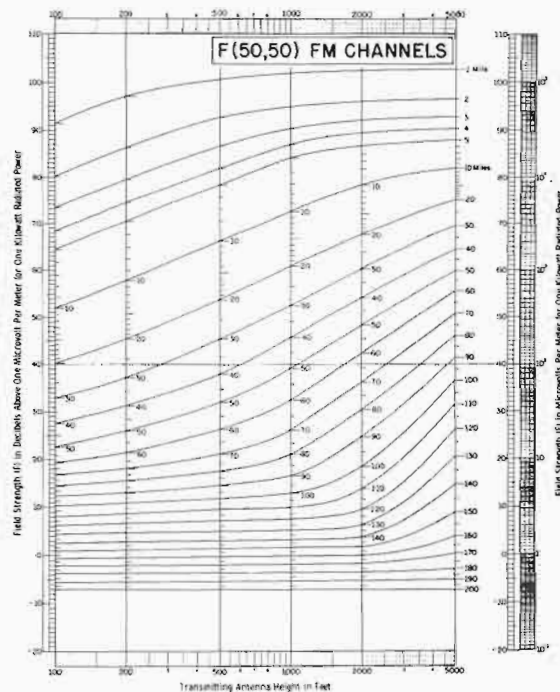

Fig. 23. FCC (50,50) graphs.

<sup>1</sup>At 100 MHz a signal level of 34 dBu is represented by -83.0 dB below 1.0 watt of power available from an isotropic receiving antenna.

$$G_R = ERP_M - (36.6 + 20 \text{ Log } F + 20 \text{ Log } D) - f - L_r \quad [4]$$

- Where  $G_R$  = the receiving antenna gain
- $\text{dBw}_r$  = the translator power below 1 watt to yield a satisfactory signal to noise ratio
- $L_r$  = lead-in line loss in dB
- $ERP_M$  = ERP of originating station in dB above 1 watt
- $F$  = frequency in MHz
- $D$  = path length in miles
- $f$  = loss in dB due to inadequate path clearance.

An ideal signal to noise factor of 40 dB would require  $-92 \text{ dBw}_r$  or 178 mv across 50 ohms, with a system noise factor of 6 dB.

The system noise factor is the ideal noise factor of a translator receiver, modified by the effective antenna temperature, galactic noise, and other extra-terrestrial noise.

The use of Eq. 4 is illustrated as follows. Assume an originating station operates at 100 MHz with an ERP of 100 kw and the distance from the FM translator site is 90 miles. Assume that the first Fresnel Zone clearance is calculated from Eq. 1, and that an additional "f" loss of 2 dB can be expected. Assume also a system noise factor of 6 dB and a lead-in line loss of 1 dB. If a 40 dB signal to noise ratio is required, the following calculation results:

$$G_R = 10 \text{ Log } (100,000) - (36.6 + 20 \text{ Log } 100 + 20 \text{ Log } 90) - 2 - 1 + 92$$

This yields a required receiving antenna gain of +23.3 dB.

### Design Considerations for an FM Booster Station

Basically all that has been said which pertains to FM translators also applies equally to FM boosters. There is one major new consideration. The receiving antenna and transmitting antenna must be physically separated by at least 300 ft. The FM translator by contrast can utilize the same tower for both antennas.

The booster antennas should take advantage of natural features to aid signal isolation. For example antennas can be erected on opposite sides of a mountain peak or a large building. Other standard techniques include cross-polarization of the two antennas and "nulling" of the two antennas. One should achieve at least 60 dB of isolation between antennas.

## Translator-Booster Antennas

### General Characteristics

**Antenna Gain.** This is commonly defined as the gain over an isotropic antenna. Directional antennas exhibit gain by virtue of their ability to concentrate the available power in a particular direction.

**Horizontal Beam Width.** In all cases except those using a nondirectional antenna, this is a measure of the angle encompassed between the half-power points of the major lobe. These are defined as those points at which the radiated power is one-half of that at the bearing of the maximum signal. This is 70.7 percent of the field intensity, when expressed in voltage, in lieu of power.

Nondirectional antennas, while they are assumed to be perfectly circular, are not. The variation from a perfect circle is expressed as so many plus or minus dB of circularity.

**Vertical Beam Width.** This is expressed as the angle encompassed between the elevations at which one-half power is radiated. As with the horizontal beam width, this is 70.7 percent of the maximum field radiated. It is only important to know the angle below the horizon where the one-half power point occurs, for it is this angle which can affect satisfactory reception to nearby receiving sites. If a directional antenna has very high gain, or a nondirectional antenna has reasonable gain, this will result in improper coverage to nearby receiving sites. They will be overshadowed.

**Input Impedance-VSWR.** The output stage of a typical FM translator is designed to deliver power to a resistance load of 70-ohms, having negligible reactance.

Regardless of how long the transmission line may be, if it has the same characteristic impedance and is matched at the antenna end, it will

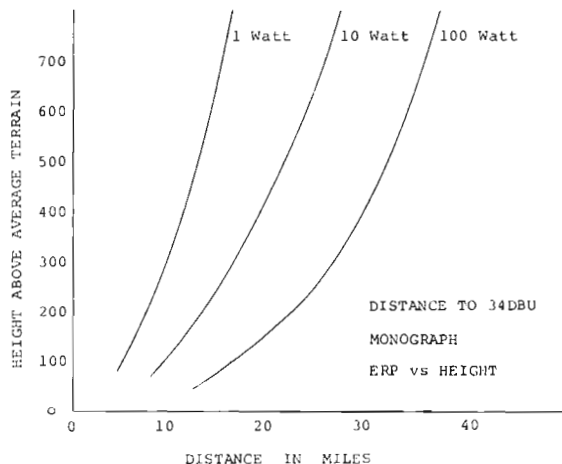

Fig. 24. Monograph of coverage.



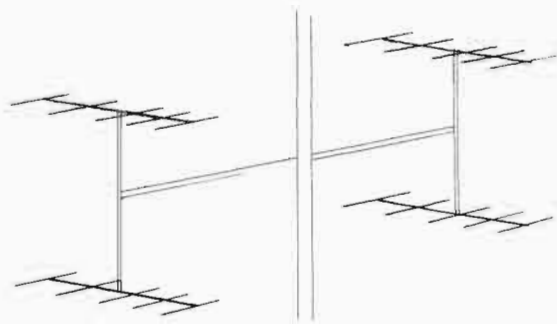

Fig. 25. Antenna stacking.

accept the full power. In the event the antenna does not perfectly match the impedance of the transmission line, standing waves will appear. These will not normally affect an FM signal unless it is stereo or SCA. For example, a line that has a VSWR of 2:1, or impedance, of either one-half or twice the correct impedance, with varying amounts of reactance, depending upon the line length. This will effect the linearity and efficiency of the final amplifier.

**Power Capability.** Professional grade FM translator antennas are designed to accept power levels up to 100 watts. Type N coaxial fittings are commonly used for connecting to transmission lines.

**Antenna Types—Transmitting.** FM translator and FM booster antennas tend to be of the type which use reflectors, driven elements, and directors commonly known as Yagi antenna beams. These are used both singly, in pairs stacked vertically or horizontally, or as quads. Nondirectional types consist of simple horizontal ring antennas which have from one to four bays stacked vertically. This type of antenna produces a nondirectional signal.

The Yagi antenna has the advantage of a narrow band width. This helps discriminate against unwanted signals. The Yagi generally can provide gains of 10 dB or more over an isotropic, depending upon the number of elements. By exciting two Yagis, in phase, the gain is increased by 3 dB. Every time the number of elements is doubled, the gain is increased by 3 dB, as shown in Table 1.

TABLE 1

Number of Yagis	dB Gain
Single yagi	10
Two yagis	13
Four yagis	16
Eight yagis	19
Sixteen yagis	22

The horizontal beam width of a single Yagi antenna is approximately 30° between the one-

half power points. Increasing the number of Yagis decreases this beam width. In the event this beam width needs to be increased beyond 30°, this is accomplished by skewing two Yagi antennas. Care must be taken to be sure the proper phase is maintained. Otherwise holes may occur in the coverage pattern, due to signal cancellation.

The FCC has permitted dual polarity. This is accomplished by constructing a Yagi with elements in both planes on the same boom, or by coupling two Yagis, one oriented horizontally and the other vertically, in close proximity.

**Antenna Types—Receiving.** The foregoing discussion on transmitting type antennas applies equally to receiving antennas. The formation of multiple arrays is desirable, since high directivity is desired. This is to help discriminate against unwanted signals.

**Vertical Stacking**—the resulting horizontal directivity is unaffected, but the vertical beam width is decreased. For receiving sites close to the ground, as well as ones where the received signal is from beyond the horizon, some advantage will occur from "space diversity." If the incoming signal is exhibiting layering, one or more of the antennas may receive a relatively strong signal while the other may not. Thus they will tend to average out the received signal.

**Horizontal Stacking**—in this case the vertical directivity is unchanged while the horizontal beam width is decreased. By proper spacing cancellation of incoming signals along any one bearing can occur, with the gain reduced to almost zero. This phenomenon can be useful in minimizing unwanted interfering signals. Fig. 26 shows how a null is produced along a bearing A. The Equation is:

$$D = N \frac{\lambda}{2 \sin A} \quad [5]$$

Where *D* = Distance in feet between Yagis  
*λ* = Wavelength in feet  
*N* = Any odd number.

For example, assume an interfering FM station operates at 100 MHz, bears 30° from the desired FM signal, and let "N" be three. This calculates to an antenna spacing of 29.5 ft. This is a practical spacing. Keep in mind that these offsets can be used to cancel adjacent channel signals or cochannel signals. To achieve the maximum null depth, vernier adjustments must be added. These are in the form of line stretchers to one of the feed lines, to allow phase adjustment, plus attenuators to each line to allow for amplitude adjustment.

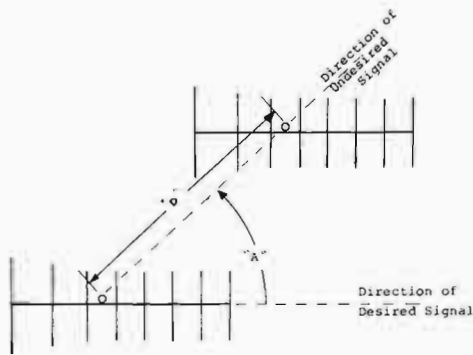

DIAGRAM SHOWING HOW TWO YAGI ANTENNAS CAN BE PLACED TO ACHIEVE CANCELLATION OF UNDESIRABLE SIGNAL

Fig. 26. Antenna offsets.

**Transmission Lines**

It is best to reduce losses in both receiving and transmitting transmission lines as much as possible. This is normally done by employing flexible coaxial cables of RG-8 or RG-11 types. These are quite good up to 100 ft. or so. Beyond these lengths it is more efficient to use larger diameter coaxial cables with either foam or air dielectric. For any given diameter the air dielectric has the lowest loss. Air dielectric has the disadvantage of requiring pressurization with dry gas to avoid moisture and corrosion.

Losses in typical cables at 100 MHz are:

TABLE 2

Type	Loss/100 ft.
RG-8/ $\mu$ (Foam)	1.80 dB
RG-11/ $\mu$ (Foam)	1.50 dB
7/8 Foam	0.435 dB
7/8 Air	0.370 dB
1-5/8 Foam	0.305 dB
1-5/8 Air	0.207 dB

**FM Translator Circuit Description**

**General**

In FM translators there were no early beginnings or changes in the basic approach as with TV translators. All FM translators employ single conversion with intermediate frequencies of 10.7 MHz, and consist of three basic parts. These are the receiver-down converter, the transmitter-up converter, and the power supply.

**Basic Circuit**

Fig. 27 shows a block diagram of a 10 watt translator.

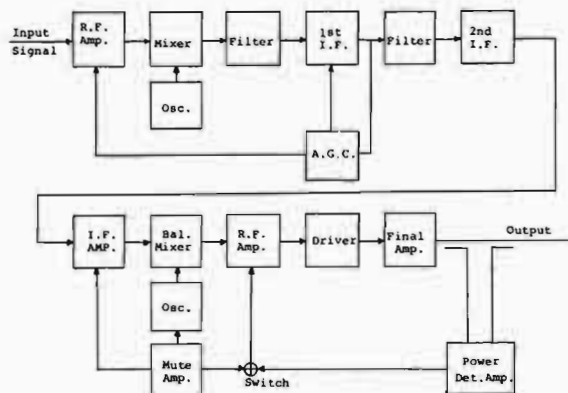

Fig. 27. Basic block diagram, translator.

*Receiver-Down Converter.* The received signal is amplified, then mixed with the down converter oscillator and converted to an intermediate frequency of 10.7 MHz. The down oscillator operates below the incoming frequency by the difference of the IF frequency. It is then processed through a highly selective lumped constant filter, amplified, filtered again, and amplified again before being coupled to the up converter transmitter.

*Up Converter-Transmitter.* The IF signal passed through two IF stages, is then coupled to a balanced mixer, where it is mixed with the up oscillator output and heterodyned to the transmitting frequency. This sum frequency is then amplified through three stages before being applied to the final 10 watt amplifier. The signal then passes through the output coupling where the required band pass is achieved and spurious signals are eliminated. The directional coupler enables front panel measurement of forward power and reverse power.

Automatic Gain Control is achieved by virtue of a double loop. The AGC signal in the receiver is coupled from the AGC detector to both the RF and IF amplifiers to control variations in received signal levels. The second AGC amplifier is in the transmitter. Its output is coupled to the muting switch which in turn shuts off the drive to the output stage when a loss of incoming signal occurs.

An output from the reflectometer circuit is coupled through an IC amplifier to regulate the bias applied to the driver stage. This method is capable of regulating power output within  $\pm 1$  percent. The reflectometer also couples a signal through an IC amplifier to provide protection against an open or short circuit in the load. This is accomplished by reducing the drive to the final which in turn alters the bias. This in effect turns down the power when a large mismatch load is present. The power supply provides a low

dc voltage. It remains constantly energized, even though the FM translator may be in the "off" mode. The down-converter receiver, front end local oscillators and IF amplifier remain powered, while the up-converter transmitter, high level output circuits are deenergized until turned on by the muting circuit when an incoming signal appears. The voltage output of the power supply is regulated to maintain constant operation, at 18 v.

**FM Booster Circuit Diagram**

There are only two major differences between the circuit employed in a booster and that of a translator. One is the fact that there is only one oscillator. Since in a booster the incoming signal is at the same frequency as the output, there is no need for more than one oscillator. The crystal is mounted in the down-converter receiver module. The oscillator signal is coupled to the up-converter transmitter by a coax cable.

The second major difference is that the input and output modules are not mounted in the same chassis. Our experiments, with early designs, showed that to achieve the separation required between input and output one must physically locate these two modules 300 ft. apart. There is no other way to keep the output from "talking" back to the input unless one employs physical separation. The IF signal is coupled between the two modules by a 300 ft. plus length of coaxial cable.

The output circuit and tune-up procedure is the same as with the translator.

**Test Equipment and Alignment**

For on-site adjustments the following test equipment is necessary:

1. Test meter (V.O.M.), Simpson 260 or equivalent
2. Signal Generator, Boonton 210A or equivalent
3. Alignment tools and non-magnetic screw drivers

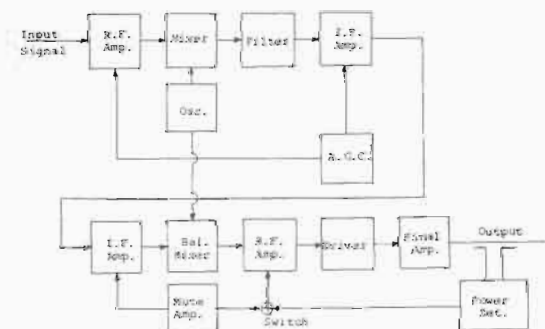

Fig. 28. Basic block diagram, booster.

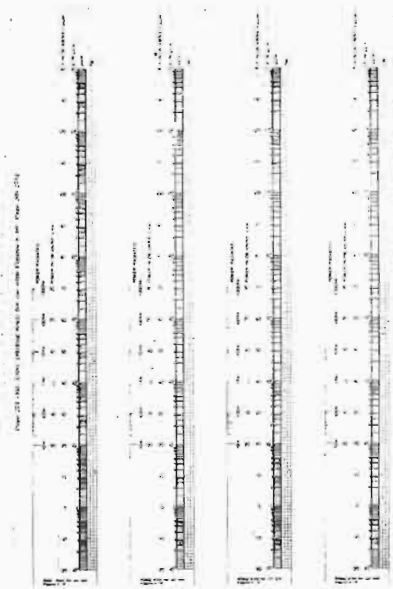

Fig. 29. FCC 74.1236 curve.

4. Low VSWR dummy load capable of dissipating 10 watts output power from the translator.

The FM translator is aligned by adjusting it into the dummy load. Final adjustments are made by connecting the translator to the antenna, with the final amplifier plate circuit retuned to match the load presented by the antenna.

*Power Supply.* The power supply is checked first. The input dc voltage can be read directly

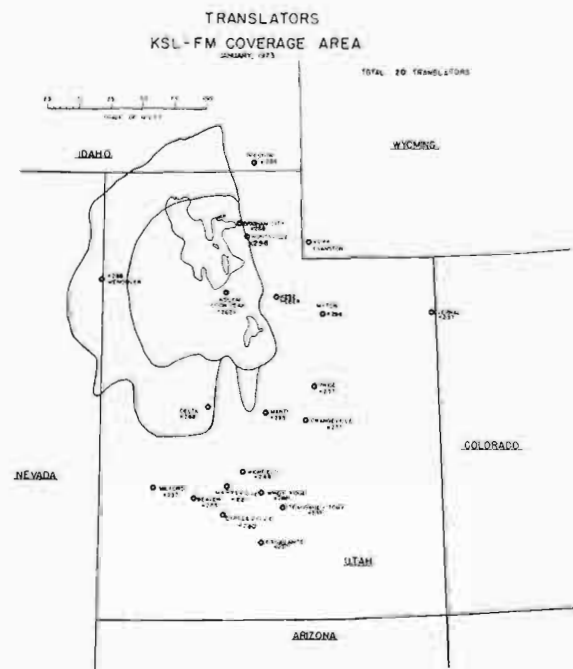

Fig. 30. KSL coverage map.

from the front panel multimeter. This should normally read +28 v. The multimeter should then be set to read regulated voltage. This should read +18 v. These voltages can be checked with the test meter. If the regulated voltage is not +18 v, it can be adjusted by R-11.

*Down-Converter Receiver.* The next step is to verify the operation of the local oscillator. The test meter is used to verify the oscillator output. The signal generator is then coupled to the FM translator input and set to the required input frequency.

The RF gain control is set to maximum gain, and the output of the signal generator reduced to a point of indicating two major divisions, as read on the front panel multimeter. The RF tuned circuits are then adjusted for maximum deflection as shown on the front panel meter.

The signal generator is then removed and the FM antenna reconnected. The RF gain control is then adjusted for normal gain. In some cases this gain must be increased or decreased to afford best performance without interference from local stations.

*Up-Converter Transmitter.* As with the receiver, the first step is to verify the operation of the up-oscillator with the test meter. The front panel meter should be set to read drive No. 1 current. This stage is then adjusted for maximum indication. This is repeated by setting the front panel meter to read drive No. 2. Again the stage is tuned for maximum indication. The front panel meter is then set to read forward power. In this position this output power is adjusted by the front panel control to read precisely 10 watts. A portable FM radio can then be employed to verify clean operation.