

Antennas for FM Broadcasting

Peter K. Onnigian, PE
President, Jampro Antenna Company
Subsidiary of Cetec Corporation
Sacramento, California

This chapter is directed to the broadcasting engineer who must make technical decisions regarding frequency modulated transmitting antennas. The practical aspects of several types of FM antennas are discussed, together with their installation, operation, and propagation characteristics.

We are concerned here with transmitting antennas which provide a means of radiating FM power from a broadcast transmitter. These antennas are designed for operation in the FM band from 88 to 108 MHz in the western hemisphere. In the remainder of the world, the allocated frequency under CCIR recommendations for Band II vary but are generally confined between 87.5 and 100 MHz.

FM broadcast service has some distinct advantages over AM (medium wave) amplitude modulated broadcast service. These advantages stem from propagation characteristics of FM frequencies, as well as the modulation system. There is essentially no difference between day and night propagation conditions. FM stations have relatively uniform day and night service areas.

FM broadcasting was first authorized in the United States in 1940 by the Federal Communications Commission. The first FM station began operation in 1941. In 1945, the FM service was assigned to the 88 to 108 MHz band and divided into 100 channels, each 200 kHz wide.

There were 3,575 FM broadcasting stations operating in the United States at the beginning of 1976. About 99 percent of their antennas are nonsymmetrical, being mounted on one side of a steel structure. FM antennas outside the western hemisphere are usually symmetrical, installed on the four sides of a square steel support mast, or around a concrete cylinder. Both schemes are capable of providing excellent omnidirectional azimuth patterns.

Antennas for FM sound broadcasting use linear horizontal, vertical or circular polarization. In some countries horizontal and vertical polarization (Hpol and Vpol) are used as a

means to prevent cochannel and adjacent channel interference. Circular polarization (Cpol) together with its special form, elliptical polarization (Epol) was introduced in the mid-sixties as a means of providing greater signal penetration into the many forms of FM receiving antennas, found in the broadcasters service area.

Receiving antenna types have proliferated as have the receivers. In the ten-year period between 1966 and 1976, there were 172 million FM radios sold in the United States, of which 18 million were automobile FM radios!¹

The FM antennas presently manufactured in the United States consist of a number of radiators, which are omnidirectional in the horizontal plane, when measured in free space. By stacking these in the vertical axis, the elevation pattern is compressed, and additional gain is obtained over a single radiating element.

Antennas for FM broadcasting must be chosen carefully, in order to cover the service areas properly. The maximum effective radiated power (ERP) should be achieved with proper balance between antenna gain and transmitter power. The height of the antenna over the service area, distances to areas of population, the ERP, and the economics are items that must be considered.

Antennas currently available in the United States differ considerably from those to be found in Europe. The various American types are discussed briefly so that the engineer will be informed on the subject. Considerable advances have been made in recent years in the design and fabrication of FM antennas. These improvements provide greater penetration of signal into automobile FM radios as well as popular small FM transistor radios, of all kinds. The newer FM broadcasting antennas must meet the more stringent requirements for FM stereo and quadrasonic broadcasting.²

¹1975 EIA *Consumers Electronics Annual Review*.

²Vol. 1, National Quadraphonic Radio Committee, Report to the Federal Communications Commission, Nov. 1975, EIA, 2001 Eye Street, N.W., Washington, D.C. 20006.

Circular polarization for FM broadcasting has come of age. Most established broadcasting stations in the western hemisphere have converted their antennas to Cpol. For this reason, the discussion of antenna types will be on this class of antennas, following propagation and other matters.

PROPAGATION

FM propagation includes everything that can happen to the energy radiated from the transmitting antenna during its journey to the receiving antennas. It includes the free space path attenuation of the wave with distance, and encompasses such factors as refraction, reflection, interference, diffraction, absorption, scattering, Fresnel zone clearances, grazing, and Brewster angle problems.

Propagation is therefore dependent upon all these properties out to approximately 40 miles (65 km). Some additional factors enter the picture with longer service ranges. Radio wave propagation is further complicated because some of these propagation factors are functions of frequency or polarization, or both, and may have location and time variations.

The technical intent of the broadcaster is to put a signal into FM receivers of sufficient strength to overcome noise and to provide adequate limiting for at least a 20 dB signal-to-noise ratio. This RF signal level varies from about 2 μv per meter for high sensitivity FM stereo tuners, to about 50 μv for less sensitive transistorized portables, as well as most automobile receivers.

FM antenna manufacturers do not guarantee coverage. They provide antennas which radiate a signal meeting certain levels depending on the antenna power gain and the transmitter power put into it. This is indicated as a free space value for 1 kw of input power, assuming a circular azimuth radiation pattern. These free space values are shown in the catalogs for reference purposes, and are achieved in practice only, when measured on a good antenna test range.

Some manufacturers in the United States provide azimuth pattern adjustment service, to insure a circularity of ± 4 dB, when mounted on the side of a specific tower or pole.³ It must be pointed out that this radiation pattern and gain is for free space conditions, one that is completely free from any obstructions to propagation. This is rarely found in actual installations. The radiation pattern and propagation are two distinctly separate parameters. They should not be confused as one and the same. They are not.

The radiation pattern is that which is transmitted by a given antenna, without any propagation limitations, on a good antenna test range. The propagation problems are conditions existing between the transmitting antenna and the receivers, and indicated in the first paragraph, under *Propagation*.

The actual service area signal strengths are based upon two probability factors. Contours are not solid signal areas. For example, the FCC FM signal coverage charts are based upon a probability of 50 percent of the locations, 50 percent of the time. This means that at any one given location the signal has a 50 percent chance to measure up to the predicted contour level. Furthermore, half the time at that location it may reach the level predicted while at other times at the same location, it may be lower or higher in strength.

These FCC charts are also based upon the assumption that excellent propagation conditions exist. One or more of the conditions mentioned in the first paragraph under this heading may reduce the measured signal strength from those predicted values.

PROPAGATION SPACE LOSS

Prediction charts, in addition to utilizing roughness factors, use space loss with distance as the limiting value. The power radiated from a FM transmitting station is ordinarily spread over a relatively large area. The power reaching the receiving antenna is a very small percentage of the total radiated power. Furthermore, the radio transmission loss may vary from 97 dB for 10 miles (16 km) to 112 dB for 50 miles (80 km). For various other distances, see Fig. 1. Notice that the path loss is a function of frequency.

At 100 MHz, and a distance of 30 miles (48 km), the figures indicate the path loss to be 106 dB. Doubling the distance increases the space loss by exactly 6 dB. The path loss does not attenuate the signal with distance as much as some other factors. Path loss between an earth station and a satellite is a classic book example of a 6 dB loss every time the distance is doubled. But a typical FM station signal travels over a perfect dielectric (air) and the imperfect earth's surface (ground). Herein lies the FM radio propagation problem.

With one wavelength spacing between the transmitting and receiving dipole antennas, the path loss is 19.85 dB. This loss increases in free space removed from the effect of the earth's surface by a 6 dB factor as the spacing is doubled, as indicated in the nomogram.

³As of January 1, 1976, firms such as Collins Radio Company, Harris Corporation and Jampro Antenna Company.

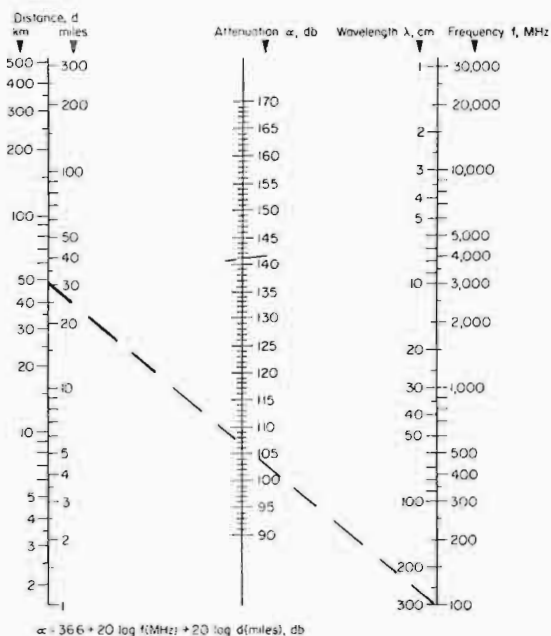

Fig. 1. Space loss as a function of frequency and distance. Dashed line shows space attenuation at 100 MHz.

PROPAGATION—LOSS THROUGH VEGETATION

Signal loss due to foliage has been well known to UHF broadcasters for many years.⁴ This same condition exists for FM broadcasting, but with much less effect. Trees, shrubs, and other foliage on hills, or smooth terrain affect the reflected as well as the lateral signal loss with distance. With average values of permittivity and conductivity in both foliage and ground, a loss of about 2.5 dB was found to exist, at the FM frequencies.⁵ The height gain factor is increased with heights above the foliage. Considerable depolarization takes place because the transmission through or reflections from ground foliage is a diffracted field contribution.

MULTIPATH PROBLEMS

The ideal reception condition is a strong direct single source signal. When signals from two or more paths due to reflections reach the receiver, a condition called multipath reception occurs. Poor reception takes place when there is insufficient strength difference between the direct and the reflected signals.

⁴The Influence of Trees on TV Field Strengths at UHF, Howard T. Head, *Proceedings of the IRE*, Vol. 48, Page 1016-1020, June, 1960.

⁵Radio Wave Propagation in Forest Environments, Theodor Tamir, *IEEE Transactions on Antennas and Propagation*, Vol. Ap-15, No. 6, Nov. 1967.

Nothing is more important in the way of broadcasting facilities than the location of the transmitting antenna. Great care should be exercised to find a suitable site. Poor reflection can result in very unfavorable signal propagation, and negate the entire project.

For example the transmitter should not be located so that strong reflections take place from nearby mountains. This can happen when the transmitter is placed on one side of a large city and the other side of the city has a high mountain range. Radiation into the city directly from the transmitting antenna, as well as reflections from the nearby hills and mountains will create two or more signal paths. These reflections can be as strong as -6 dB below the direct signal, and cause severe multipath reflections.

A TV station in this same location would experience unusable signals due to extremely heavy ghosting, even with directional receiving antennas, which exhibit strong pickup from their back sides. This is illustrated in Fig. 2.

The multipath example shown in the sketch was an actual case. The site was chosen by the FM broadcaster without proper engineering guidance because the hill was developed with power and road facilities. In fact, it had a UHF TV station once located there. Further examination revealed that the TV station failed due to extremely heavy ghosting in the principal city. The high mountain range caused severe multipath signals for the FM station.

A much better FM transmitting site could be located on the hills between the high mountains and the city using a directional transmitting antenna with very little radiation towards the mountains, thus greatly reducing reflections.

Multipath reflections are very easy to spot. On an automobile radio, the signal will appear and disappear with distance, which is quite rhythmic. It is sometimes called picketing, as it reacts like a picket fence stopping and letting the signal pass. A field strength meter will usually reveal great variations of signal when moving say 100 ft. (30 m) in a line with the transmitter. Cyclic variations over quite uniformly spaced intervals on the ground as great as 40 dB have been observed by the author.



Fig. 2. Example of poor station location causing severe multipath propagation.

The large variation in signal levels is caused by the reflections adding and subtracting from direct path signal. This is indeed caused by propagation problems existing in the path between transmitter and receiver. It really has nothing to do with the transmitting antenna.

A minor form of what appears to be multipath can be traced to high injection levels of the stereo subcarrier. The problem may be easily detected by simply switching the exciter from stereo to mono, and observing the field strength in the same suspected areas. If the mono operation reduces the multipath effects, then the stereo subcarrier injection level is too high and the modulation monitor should be checked for accuracy. Injection levels of 28 percent have been known to cause multipath signal variations as great as 23 dB, and disappeared when the level was reduced to 8 percent. This problem is caused by the differences in frequencies of the main and stereo subcarrier, which cause addition and cancellation in the signal field entering the front end of the receiver.

Propagation requirements dictate that the site must be free from reflections caused by hills and mountains, which can cause multipath conditions. The location and tower must also provide sufficient height over and to the service area for first Fresnel zone clearance, which is much more demanding than simple line of sight conditions.

GROUND REFLECTIONS

In the elevation plane between transmitter and receiver nearly all FM signal coverage lies within 10° below the horizontal plane. Generally the higher the transmitting antenna above the service area the greater will be this angle. Called the grazing angle, it lies between the horizontal plane and the earth's surface. The angle's of incidence and reflection are nearly the same. The depression angle and the grazing angle are not equal as would be the case for a flat earth. Reflections from these angles play an important part in the strength and quality of the received signal in FM broadcasting with Cpol.

The ground which causes reflections at these grazing angles does not treat Hpol and Vpol in the same manner. The Vpol is attenuated considerably more than the Hpol and the phase of the Vpol changes substantially with angle, while Hpol remains nearly the same. See Fig. 3. At these useful low propagation angles, there is considerably less Vpol signal than Hpol signal when grazing reflections take place. Field measurements confirm this fact.⁶

⁶Study of Electromagnetic Wave Propagation at 112 MHz, A. Armstrong and H. Ziesing, April 1969, *Proceedings of IREE*, Australia, pages 105 to 110.

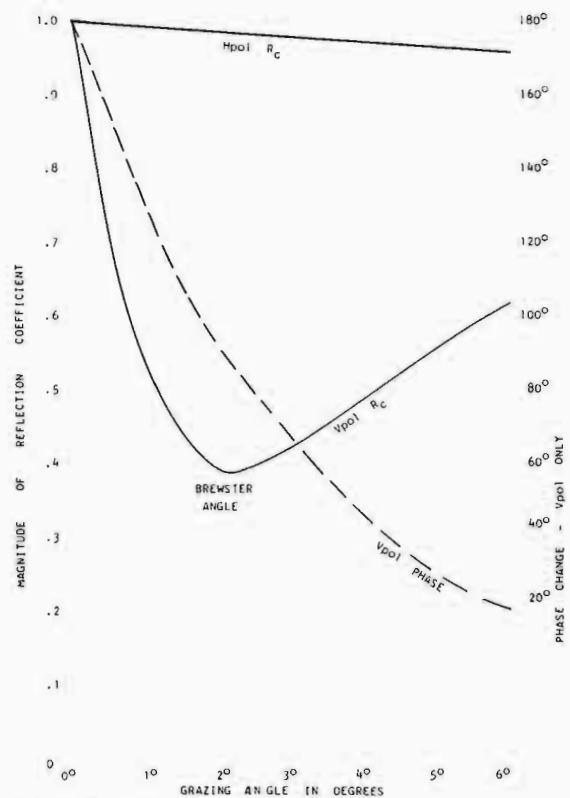

Fig. 3. Magnitude of reflection coefficient and phase change, as a function of grazing angle for Hpol and Vpol, at 100 MHz with a soil conductivity of 10 millimhos per meter.

When ground reflections take place the polarization and axial ratios are considerably different from those which left the transmitting FM antenna. In service areas with larger reflection angles, the ratios also are different than at smaller angles.

It is quite difficult to predict accurately the reflection coefficient of the soil. The ground reflection coefficient can vary considerably as a function of polarization, frequency, grazing angle, surface roughness, soil type, moisture content, vegetation growth, weather and season. These are complex formulas for predicting the ground and the soil conductivity at the frequency of interest. For 100 MHz a value of 10 millimhos per meter ground conductivity was used, with a permittivity of 25, as being about average for the continental United States. When the soil conditions vary, the Brewster angle varies.

The chart in Fig. 3 shows how much the earth's surface affects the Vpol while there is little reflection loss or phase change for Hpol. At low reflection angles the phase of Vpol changes

The Effect of Ground Reflections on Antenna Test Range Measurements. A. Moeller, March 1966, *Microwave Journal*, pages 47 to 54.

drastically, causing further reduction in the received Vpol signal in Cpol.

It should be pointed out that the reflection coefficient is a function of the electromagnetic qualities of the soil where reflection at low angles takes place. There are of course reflections taking place from nonsoil surfaces. Objects such as buildings, billboards, metal fences, also cause changes in the received axial ratios. Therefore it is quite common to find variations in polarization and axial ratios in different parts of the service area of an FM station due solely to the electromagnetic properties of the soil and objects on it.

Ground reflections caused by grazing angles also cause multipath signal problems, discussed under another heading. These problems can be greatly reduced by proper site selection together with adequate tower heights.

Referring to Fig. 3 again, notice that the minimum reflection coefficient occurs at a grazing angle of about 2° . Below this angle, the reflection coefficient rapidly increases to unity. The angle at which the minimum reflection coefficient occurs is called the Brewster or polarizing angle. The greatest attenuation for Vpol from ground reflection occurs at this angle.

Field measurements of Vpol signals will usually show a greater ratio of Hpol to Vpol due to this Brewster angle. It must be borne in mind that the Brewster angle is a function of soil conductivity and may change from place to place in the service area as well as during various seasons of the year.⁷

It is important then that for Vpol the transmitter site and antenna height above the service area provide grazing angles which are less than the Brewster angle. Otherwise the Vpol will be degraded and the radiation will be much more elliptically polarized.

SOIL CONDUCTIVITY

The conductivity and permittivity of the ground plays a part in the attenuation of FM signals, as they pass over it. Average soil has a dielectric constant of about 15 and a conductivity of about 10 mmhos per meter at 100 Mhz.⁸ By removing the receiving antenna above the effects of the soil, the signal level is increased. It has been found by actual measurements that a received signal on 93.7 MHz increased 9 dB, when the

test dipole was raised from 3.3 ft. (1 meter) to 30 ft. (10 meters).⁹

BREWSTER ANGLE

For polarization with electric field normal to the plane of incidence, there is no angle that will yield an equality of impedances for earth materials with different dielectric constants but like permeabilities. A wave incident at angle θ_p with both polarizations present has some of the second polarization component but little of the first reflected. The reflected wave at this angle is thus plane polarized with the electric field normal to the plane of incidence and the angle θ_p is the polarizing angle. It is also known as the Brewster angle, after the Englishman who first discovered this phenomenon in optics.¹⁰

For ground reflections occurring near the Brewster angle, the reflection coefficient is much smaller for Vpol than for Hpol. Therefore, the Vpol signal components of Cpol are attenuated considerably. This Brewster angle occurs about 2° below the grazing angle. See Fig. 3. The soil above the earth's surface, while varying greatly, has a dielectric constant between 2 and 15 mmhos at 100 MHz. It will also change from dry to moist conditions which further affect this constant, which in turn changes the Brewster angle. The Vpol component in Cpol transmissions is therefore attenuated considerably more than the Hpol.¹¹

FRESNEL ZONE REQUIREMENTS

The presence of the earth's surface changes the propagation of radiation at FM frequencies and the field intensity is nearly always considerably less than the calculated free space value. A signal propagating over a flat earth consists of the direct wave plus the surface wave, the reflected waves and the induction fields and secondary effects of the ground. The surface wave is somewhat affected by the type of polarization, and the ground constants. When the wave is traveling at grazing angles (as is the typical case for FM), there is further loss, unless the receiving antenna is more than 5 wavelengths (about 50 ft., 15m) above ground.

⁹S. Ramo and J. Whinnery, *Fields and Waves in Modern Radio*, John Wiley and Sons, Inc., New York, New York, pages 312, 1960 and 301.

¹⁰Fields, and Waves in Communication Electronics, by Ramo, Whinnery, and Van Duzer, published by John Wiley & Sons, New York, 1967, page 364 and 365.

¹¹VHF Field Strengths for Line of Sight Reception, R. Aitchison, *Proceedings of IREE*, Australia, July 1975, pages 225 to 231.

⁷*Ultra High Frequency Propagation*, Reed, Russell, 2nd Edition, Boston Technical Publishers, 1964, pages 223 to 238.

⁸Characteristics of Signal Strength and Dipole Antenna at VHF Near the Ground, A.H. LaGrone and D.M. Schwartz, *IEEE Transactions on Broadcasting*, December 1964.

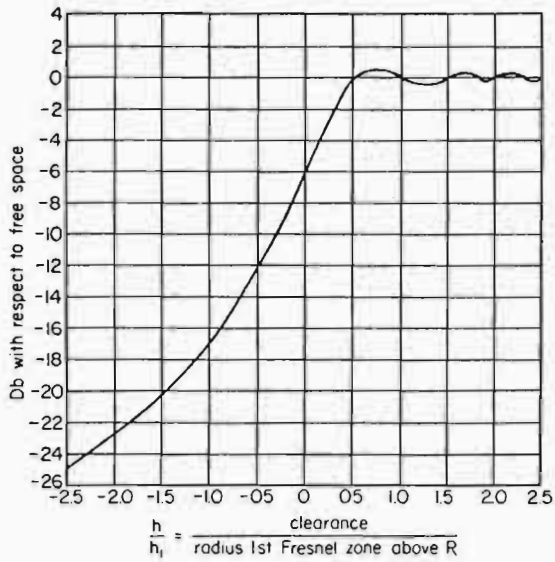

Fig. 4. Attenuation of FM propagation when the path between transmitter and receiver lacks Fresnel zone clearance in the ratios shown.

For instance, if the line of sight exists between receiver and transmitter in overland paths, there is no assurance that a strong signal will be present unless one-half or more Fresnel zone clearances are also present between the line of sight path and any obstacle. That is, there must be no large obstruction inserted into the volume occupied by the signal. There is considerable loss, typically 12 dB, when the Fresnel zone clearance is only one half of what it should be.¹² If the clearance is less than twice, the loss is nearly 22 dB. This requirement is not commonly understood. Fig. 4 shows the attenuation versus the ratio of the Fresnel zone clearance. The zone

clearance may be achieved by increasing the height of the receiver, but this is not practical, so the transmitting antenna height must be increased.

The amount of clearance above ground or the path obstacle is described as the Fresnel Zone after the French scientist who discovered this phenomenon in optics. Fresnel zones are circular areas surrounding the direct line of sight path of a radius such that the path length from the zone perimeter is a multiple of one-half wavelength longer than the direct path. This is shown in Fig. 5. The zone diameter varies with frequency and path length.

Referring to Fig. 5 if TAR is the line of sight path, then TBR represents a path which is half a wavelength longer than TAR. The circle radius AB is called the first Fresnel zone. Signals with paths through this zone will tend to reinforce the direct signal.

The path TCR is one wavelength longer than the direct path. The area outside the first Fresnel zone but within the circle radius AC is called the second Fresnel Zone. We can similarly draw third, fourth, fifth Fresnel zones and so on, if the radius permits. The areas become progressively smaller so that only the first two zones need be considered in FM broadcasting.

The total energy contributed by all Fresnel zones is equal to half the energy contained in the first zone.

The Fresnel zone is frequency and distance dependent since the signal in the boundary must be multiples of one-half wavelength. The expression for determining the first Fresnel zone radius at the midpath point is given by:

$$R = 1,140 (d/F)^{1/2}$$

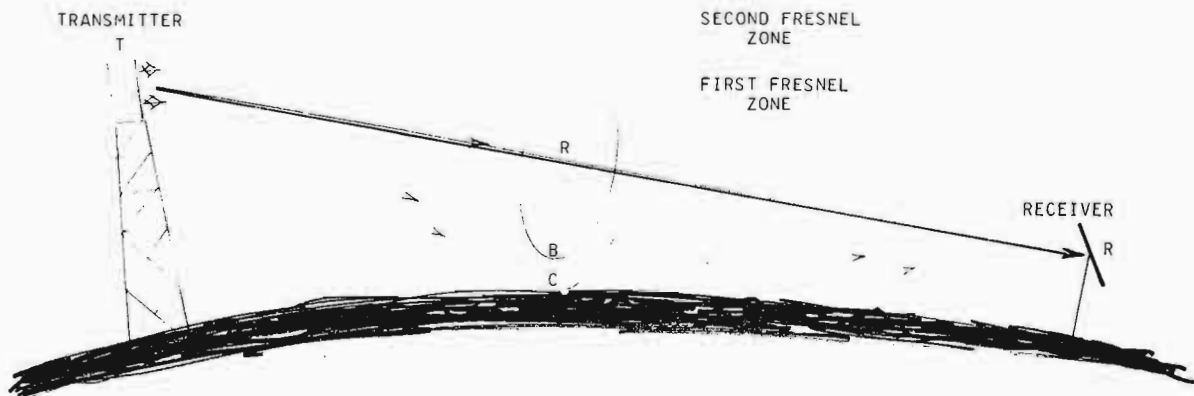

Fig. 5. Sketch showing Fresnel zones. Note that mid-path had complete first and second zone clearance.

¹²Study of Electromagnetic Wave Propagation at 122 MHz, B. Armstrong and H. Ziesing, *Proceedings of IRE*, Australia, April 1969.

Where: *R* is the Fresnel zone radius in ft.
d is the half path distance in miles
F is the frequency in megacycles.

For example, a 30 mile (48 km) path will require a first Fresnel zone radius clearance over the ground at the mid-path of 171 ft. (52 m), at 100 MHz. It is important to note that this is the maximum radius. As the point of observation is moved towards the receiver, or towards the transmitter, the radius becomes smaller, as illustrated in Fig. 5.

The height of the receiving antenna is beyond the control of the broadcaster. Therefore, in order to furnish adequate signal strength, the broadcaster must use sufficient tower height over average terrain, so as to permit first Fresnel zone clearance at the mid-path point, to his outer service area, from the antenna center of radiation.

The tower heights shown in Table 1 are strongly recommended. These minimum heights are based on relatively smooth terrain paths, using 4/3 earth curvature. Use of these tower heights will generally provide the signal levels predicted by the FCC 50/50 FM propagation charts, or the recommended CCIR tables.

TABLE 1
Recommended Tower Heights for First Fresnel Zone Requirements

Tower height recommended		Distance to service area		Midpath Fresnel zone clearance	
Ft.	Meters	Miles	Kilometers	Ft.	Meters
152	46.3	10	16.2	57	17.4
228	69.5	15	24.2	86	26.2
304	92.6	20	32.2	114	34.7
380	115.8	25	40.3	143	43.5
456	140.0	30	48.4	171	52.1
532	162.1	35	56.5	200	60.9
608	185.3	40	64.5	228	69.5
684	208.5	45	72.6	257	78.3
760	231.6	50	80.6	285	86.9

If it is not possible to provide these tower heights, then the signal will suffer due to attenuation caused by lack of Fresnel clearance. This loss can be considerable. Fig. 4 shows the attenuation to be expected with adequate clearance as well as marginal values. The loss increases rapidly as the clearance is reduced.

The important consideration for proper signal coverage is to provide sufficient tower height so as to insure first Fresnel zone clearance to all service areas.

Tower heights of 150 ft. or less should be avoided unless the location is a mountain top or other prominent point providing the necessary clearance. Mere line of sight conditions between the receiver and transmitter are not sufficient. Adequate Fresnel zone clearance must be used if anticipated signal levels are to be achieved.

The importance of Fresnel zone clearance has been stressed because it is very important in FM installations. It is not clearly understood by many engineers who pick out transmitter sites, yet is vitally important, in assuring good signal strength, within the service area.

Signal Strength Variations with Time

It has been found that there is as much as 4.78 dB change in the ratios between vertical and horizontal polarization, over a one month continuous measurement period, in the FM band. Eighteen FM stations signals were measured on a daily basis for a month's time,¹³ in Washington, D.C. The FM stations ranged from 0.8 km to 62.8 km distant (1.29 miles to 101 miles). ERP was 2.3 to 50 kw, and antenna height above average terrain from 85 to 194 meters (278 ft. to 635 ft.). The further away the station, the more the polarization ratio varied with time. It may be concluded from this that depolarization does indeed take place, and with a given path, will vary from day to day over a month period.

STRENGTH VARIATIONS DUE TO TERRAIN ROUGHNESS

Normally, the field strength in large samples, over relatively smooth terrain, may vary as much as 6 dB from the predicted values for 50 percent of the locations, 50 percent of the time (FCC 50/50 prediction curves). However, the rougher the terrain, the greater the variation becomes. Measurements made at 30 ft. (10m) on 87.75 MHz in the Denver, Colorado, area had the following variations, 50 percent of the locations where measurements were made.¹⁴

Field Strength Variation at 50 Percent of Measured Locations Versus Type of Terrain

Relatively smooth earth.....	6 dB
Hilly, small mountains.....	12 dB
Mountainous areas.....	23 dB

The above measurements were made in two radii of 25 (40 km) and 36 miles (58 km) from a 50 kw transmitter. These variations of signal are primarily due to ground reflections, which cause the received signal to go into quiet limiting, where cancellations take place, into the

¹³Signal Polarizations in the VHF and UHF Broadcast Spectrum, Richard A. Tell, *IEEE Transactions on Broadcasting*, December 1974, Volume BC-20, Number 4.

¹⁴Measurement of Service Area for Television Broadcasting, Robert S. Kirby, National Bureau of Standards, Boulder, Colorado, *IRE Transactions on Broadcast Transmission Systems*, February 1957, pages 23 to 30.

noise. It is apparent that the rougher the terrain, the more the variations. A 23 dB signal variation is a voltage ratio of 14.1 times on the increase and 7 percent on the decrease ratio.

Radio propagation over irregular terrain at FM frequencies like TV, is subject to many variations, the fine details being essentially unpredictable. Within approximately 31 miles (50 km), depending on the height of the antenna, these signal variations are almost entirely due to terrain conditions between the transmitting antenna and the FM receiver. Terrain factors include roughness, actual blockage by hills, reflections from nearby hills, or mountains, and lack of Fresnel zone clearance of the direct path.

The FCC has for many years used signal strength prediction charts which were based upon smooth earth techniques. In Docket 16004 in mid-1975, the FCC ordered that the signal strength predictions for FM as well as TV be based upon more accurate methods, utilizing a terrain roughness factor. This roughness was that encountered between 6 miles (10 km) and 31 miles (50 km). For FM a roughness factor of 410 ft. (125 m) indicates a correction of the predicted signal by a 3 dB reduction.

Due to several complaints by consulting engineers as well as broadcasters, the FCC has reset the implementation of these new curves starting from May 1976. Since there is some doubt as to exactly when and in what form they will be used, they have been omitted from this chapter. It is very noteworthy that the FCC has at long last taken a step forward in improving the accuracy of these curves. The CCIR, however, does recommend a terrain roughness factor for predicting service ranges for FM broadcasting. The CCIR also recommends the use of soil conductivity in computing contours since the soil does play an important part in the reflections present at low grazing and reflection angles.

The ideal approach to radio propagation contour predictions would be to have complete data. This would include all the necessary geodetic information, plus the electrical soil data, and a mathematical model which would permit a highly accurate path loss calculation.¹⁵ Realistically, radio propagation is not that well defined.

CALCULATING SERVICE CONTOURS

From the FCC coverage prediction charts, it is possible to draw contours of the various grades of service for a given ERP from its height above average terrain. These are best guess predictions, at 50 percent of the locations at 50 percent of

the time. The FCC has tried to make these charts more accurate, by introducing a terrain roughness factor in late 1975. This was suspended by the FCC until mid-1976. It is not known what curves will be finally used. To avoid confusion, they have been omitted from this chapter at this time.

If contour predictions are desired, it is suggested that the old curves from the Commission's Technical Rules be used, until new ones are finally instituted.

It must be pointed out that Cpol radiation does not increase the distances of the FCC service contours. Interference and allocation contours are not changed. The service contours are predictions, based upon the Hpol energy, with reference to a Hpol dipole in the field. The Cpol radiation is disregarded in these measurements, as well as predictions. The ERP of the station is only based upon the Hpol radiation, even when using a Cpol transmitting antenna.

UNITED STATES TECHNICAL STANDARDS

The FCC permits certain combinations of maximum ERP from maximum heights above average terrain from 2 to 10 miles (3.22 km to 16.1 km). The Technical Standards specify an ERP of 100 kw at 2,000 ft. (609 m) in Zone II. The FCC has divided the United States into three zones for the purpose of determining maximum power depending on height above average terrain, for co-channel and adjacent channel interference allocation purposes. Zone I is generally the eastern United States, east of the Mississippi River. Zone II covers the remainder of the United States, except the Gulf Coast area which is Zone IIA, and has abnormal propagation due to refractive indexes. Table 2 indicates the maximum ERP values at maximum heights for the different zones and classes of stations. Class D is for educational institutions, such as college and university campuses. Classes A, B, and C are for both educational, noncommercial and commercial FM broadcasting stations.

Some stations are using much more ERP than those shown in the table. This is due to the grandfathering privilege granted by the FCC, before these rules went into effect. There are several dozen stations with ERPs in excess of 100 kw operating in the United States.

Fig. 6 shows the FCC maximum ERP power allowed, versus the average height over the 2 to 10 miles terrain radials. (3.22 to 16.1 km). This is the FCC's Fig. 3, Section 73.333 revised in February 1970.

¹⁵Practical Approach to Radio Propagation Measurements, Robert Forrest, *IEEE Transaction on Vehicular Technology*, Vol. VT-24, No. 4, November 1975.

TABLE 2
Maximum FM ERP and Height above Average Terrain

Class of station	Zone I		Zone IA ^a		Zone II	
	Max. ERP	Maximum height	Max. ERP	Maximum height	Max. ERP	Maximum height
A	3 kw	300 ft. 91 m	3 kw	300 ft. 91 m	3 kw	300 ft. 91 m
B	50 kw	500 ft. 153 m	50 kw	500 ft. 153 m	—	None —
C	—	—	—	—	100 kw	200 ft. 619 m
D	10w ^a	—	10w ^b	—	10w ^b	—

^aExcluding Puerto Rico and the U.S. Virgin Islands.
^bMaximum transmitter output power. No antenna restriction.

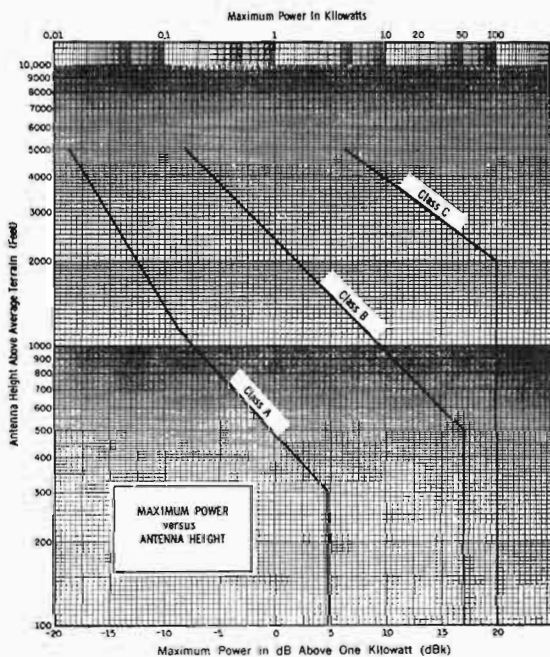

Fig. 6. Maximum power versus antenna height.

MEASUREMENT HEIGHTS

The signal received in an automobile whip antenna at 5 ft. (1.5 m) above ground is unfortunately much lower than one that may be received at 30 ft. (9.14 m). Of course, it is impossible to have receiving mobile antennas at the higher height. But in very smooth terrain there is nearly a direct relationship with height, and in the example, the signal at the standard dipole measurement height will be nearly 6 times stronger (7.78 dB). However, in areas where there is terrain roughness or in mountainous areas, there is even greater increases with the same height increase.¹⁶

¹⁶Measurement of Service Area for Television Broadcasting, Robert S. Kirby, National Bureau of Standards, Boulder, Colorado, *IRE Transaction on Broadcast Transmission Systems*, February 1957, pages 23 to 30.

It is highly recommended that field strength measurements be made by sampling field strength at 30 ft. (9.14 m or 10 m), instead of low heights, and multiplying by a ratio.

ANTENNA POLARIZATION MEASUREMENT

An antenna's polarization property is defined by the nature of the wave it radiates. However, it may be more convenient to measure the required component amplitudes by testing the receiving response under illumination by waves of various polarizations. In practice the vertically and horizontally linear amplitudes are measured separately and together with the phase difference. The linear incident fields must be set up parallel in space, with the appropriate coordinate system defined with respect to the antenna under test.¹⁷

FM BROADCASTING FROM SATELLITES

Much has been written about direct FM broadcasting from satellites to homes. Present technology presents several limitations.¹⁸ There is a technical limit of about 2 kw at 100 MHz for RF breakdown. An ERP of about 420 Mw is required from the satellite to provide a 1 mv signal into a dipole on earth! This is due to the 165 dB of space loss in the 22,300 miles (36,000 km) between the earth and the geostationary satellite.

However, a large receiving antenna with the necessary amplifiers could produce a useable signal from an ERP of 2 kw, for community FM distribution or for network operation.

¹⁷Antenna Polarization Analysis by Amplitude Measurement of Multiple Components, Dr. L. Clayton and S. Hollis, The ESSAY, published by Scientific-Atlanta, Inc., Georgia, January 1975.

¹⁸Report of U.S.A. USSG/BC-837 CCIR Study Group Report, Questions 34-1/10 and 23-1/11, December 18, 1975. Broadcasting Satellite Service, Sound and Television.

It is possible to have a clean line of sight path without any propagation problems from the earth to the satellite. But with 100 kw ERP, the signal on earth would be about $16\mu v$, due to propagation space loss, not quite strong enough to provide a useful signal in ordinary FM receivers.

ANTENNA POLARIZATION

Three primary types of polarization are found in FM broadcasting. Cpol is rapidly becoming the most popular in the western hemisphere. This is followed by Hpol in Europe, Asia, and Africa, then Vpol. A mixture of vertical and horizontal is used in some countries for allocation purposes to increase the signal interference protection by receiving antenna discrimination.

The reader may wish to supplement his reading of the following paragraphs on polarization with in-depth articles about various types of polarization. Several excellent chapters may be found in some antenna books. Please refer to Footnote 19 for additional well written information.

Linear Polarization

In order to properly understand Cpol, linear polarized antenna radiation should be discussed first. If the electric field vector of the radiated wave lies in a given plane parallel to the direction of propagation, the wave is said to be linearly polarized. In Fig. 8, Vpol radiation is depicted. All the waves propagate in the same direction and with the same frequency. The magnitude of all the E and H vectors (electric and magnetic fields) can change with time but they cannot change direction. It is customary to describe the polarization of a wave according to the direction of the total electric field vector.

Between two satellites, two dipoles have linear polarization. The earth reference is missing so they cannot be described as either Hpol or Vpol. They are therefore linear polarized antennas because they respond to each other most when in the same plane.

For convenience linear waves are referenced to the earth plane. Hpol waves have the electric

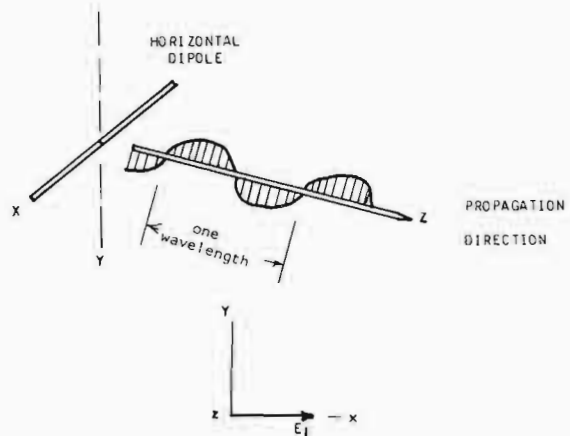

Fig. 7. Horizontal polarization. The field vector E_x is horizontal and there is no vector in the Y axis. The propagation towards Z is horizontally polarized and is linear.

field horizontal with the earth's surface, while Vpol waves have electric fields which are vertical to the earth's surface. A dipole placed parallel with the ground is an example of a Hpol antenna, as in Fig. 7. Rotating it 90° places the E vector vertical, and it thus becomes a Vpol antenna as shown in Fig. 8.

Circular Polarization

Circular polarization (Cpol) is quite different. If there are two plane waves of the same frequency but of different phases, amplitudes and orientations of the field vectors, the superposition of these waves is called an elliptically polarized wave.

If these two plane waves combine so that the magnitudes of Vpol and Hpol of the electric fields are equal, and one (either Hpol or Vpol)

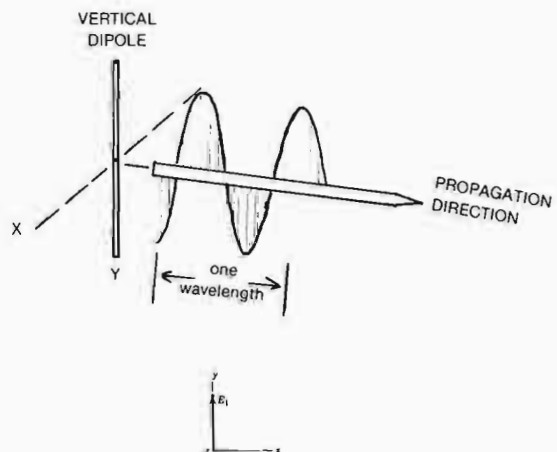

Fig. 8. Vertical polarization. The field vector E_y is vertical and there is no vector in the X axis. The propagation towards Z is vertically polarized and is linear.

¹⁹References for Circularly Polarized articles:

Ultra High Frequency Propagation, Reed, Russell, Boston Technical Publishers, 1964, Chapter 8, pages 313-335.

Antenna Engineering Handbook, Jasik, McGraw-Hill, 1961, Chapter 17, pages 17-1 thru 17-26.

Electromagnetics, John Kraus, McGraw-Hill, 1953, Chapter 9, pages 344-390.

Reference Data for Radio Engineers, Sixth Edition, Howard Sams, ITT, 1975, Chapter 27, pages 27-1 to 27-5.

Fields and Waves in Communication Electronics, Ramo, Whinnery, and Van Duzer, John Wiley & Sons, 1967, pages 322-327.

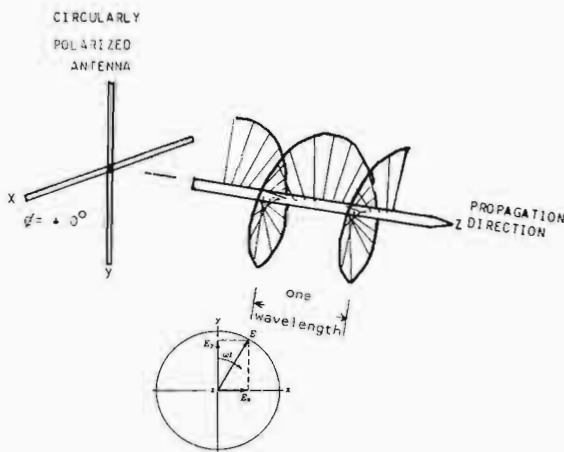

Fig. 9A. Circular polarization. The field vector E_x leads the field vector E_y by 90° , so the polarization is right hand circular.

leads or lags the other by 90 electrical degrees, the wave is Cpol. The vector addition of the two fields at 90° is somewhat larger than either field considered alone, (Fig. 9) even if both had the same amplitude. It is this vector enlarged field that rotates at the carrier frequency, as depicted in Fig. 9A, traveling one wavelength.

The angular rotation of the resultant E vector in the plane of the propagation is the circularly polarized (Cpol) field. If it were possible to stop the propagation for an instant, the polarization of the wave could be anything between horizontal and vertical, depending on when it stopped. As time progresses, the plane of polarization changes through a circle, for each RF cycle of the carrier frequency, hence, the name circular. The Cpol E vector rotates unlike Vpol or Hpol which remain constant.

It is this rotation which changes the sense of polarization that gives Cpol its signal penetrating qualities, so useful in FM broadcasting.

Fig. 9 shows how the electric field rotates in a clockwise direction, as shown in the vector diagram. The E_x vector is shorter than the E_y vector because it is lagging by 90° at the instant shown.

Polarization and Axial Ratios

The polarization ellipse is oftentimes used to illustrate the variation in amplitude found in Vpol. Fig. 10 shows how the quality of Cpol is demonstrated after measurements or in theory. The *polarization ratio* is the voltage ratio of the vertical and horizontal components. It is measured on the antenna range with a reference dipole rotated from vertical to horizontal earth references. The *axial ratio* is that ratio between maximum and minimum voltage components at any orientation of the reference dipole perpendicular to the direction of propagation. Both terms are needed to adequately define the Cpol performance. The axial ratio is shown in Fig. 11.

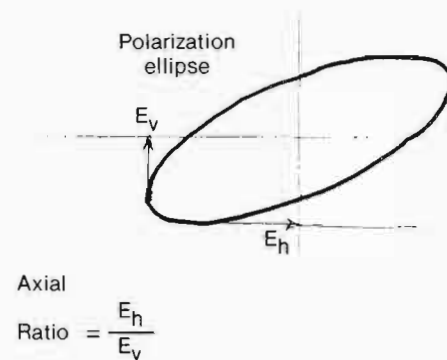

Fig. 10. Polarization ratio. The larger voltage E_v of the vertically polarized component divided by the smaller voltage E_h , expressed in dB, with the plus or minus sign omitted.

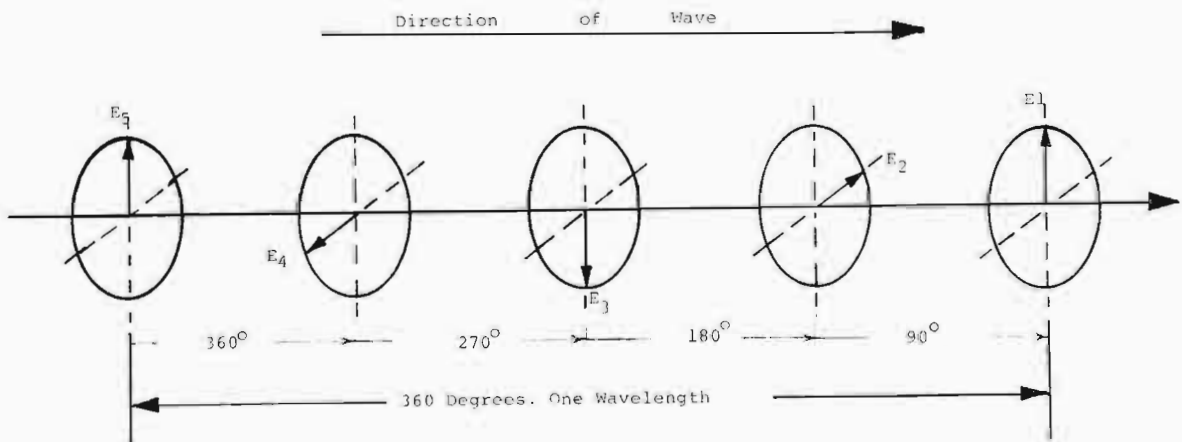

Fig. 9B. Propagation of a circularly polarized wave.

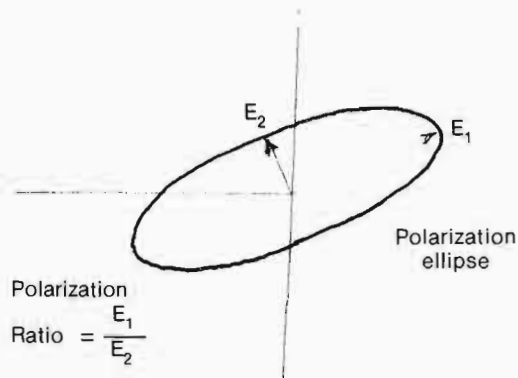

Fig. 11. Axial ratio. The larger voltage E divided by the smaller voltage E equals the axial ratio, usually expressed in dB.

For a perfect Cpol radiator, the axial and polarization ratios would be unity or 0dB. In practice the ratios may vary as much as 1.75 to 1 or 4.9 dB. This is still quite good for FM broadcasting.

It should be pointed out that these ratio measurements should only be made on the antenna test range under ideal conditions. Once the transmitting antenna is installed, the propagation conditions may change both ratios drastically.

Another factor is ellipticity. When the magnitude and the pointing of the voltage vector varies during each cycle, the wave is elliptically polarized. When this ellipticity and thus the axial ratio become infinite or nearly infinite, the wave is linearly polarized. If the ellipticity or axial ratio is 1, then the wave is Cpol.

When attempting to produce Cpol, elliptical polarization resulting from poor axial ratios of 1.75 or greater, are thought of as imperfect Cpol.²⁰

In the beginning of FM many homes had Hpol outdoor receiving antennas. Then home receivers with built-in antennas came along, as FM broadcasters increased their ERPs. The auto radio with its whip antenna requires Vpol signals. There were 33 million FM automobile radios in the United States as of January 1, 1976.²¹ With these developments, the need for Cpol became evident and is now a requirement for successful FM broadcasting.

CHOOSING A FM ANTENNA

There are several different makes and types of FM antennas offered to the broadcaster. In

²⁰Opinion Research Corp., Study Commissioned by ABC-FM Spot Sales Report, distributed by NRBA, January 8, 1976.

²¹*Antenna Engineering Handbook*, Henry Jasik, Editor, McGraw-Hill, 1961, page 17-3.

deciding which one to specify or purchase, the engineer should consider the power gain, azimuth and elevation patterns, beam tilt and null fill requirements. Deicing requirements, if any, as well as the choice between heaters and radomes should be decided. Fig. 12 shows an antenna specification sheet, which may be used to gather firm quotations from sellers, all bidding on the same specifications.

Gain

The question of using a high power transmitter with a low gain antenna, or a high gain antenna with a low power transmitter, to achieve the same ERP is an old one. It is usually decided without solid engineering information. If the presence of the ground is disregarded, there would be no electrical difference what combination of transmitter power and antenna gain is used for a given ERP. Therefore, the nature of the terrain determines the final choice from an engineering viewpoint.

Many believe that the highest transmitter power should be used with the lowest antenna gain. Half the ERP power produced is wasted, since it occurs above the useful elevation pattern and goes into outer space! The other half strikes the ground where it is reflected by the terrain, which reflects some of the signal, causing multipath conditions.

If the Cpol antenna gain is low (1 or 2), considerable energy will strike the ground to be reflected from the terrain near the transmitting site. Hill and mountain top locations should therefore use antennas with moderate gains whose elevation pattern concentrates the signal into the service area. Fig. 13 shows the effect of wide elevation patterns in Fig. 13A, and with a narrower pattern in Fig. 13B. Notice that in Fig. 13B there are less reflections into the service area because there is little radiation near the tower. While the sketch shows an elevation view, there are also reflections from nearby hills which would be seen in a plot view of Fig. 13B.

Many nontechnical people believe that the higher the transmitter output power, the stronger the signal into the service area, for the same ERP. This is simply not true! The ERP is the sum of the transmitter power times the antenna gain, less the transmission line loss. Any number of combinations will achieve the same ERP. See Table 3, for Cpol antenna-transmitter combinations.

What will change with higher transmitter powers is the width of the elevation pattern as shown in Fig. 13A. Wide antenna widths from low gain antennas may in fact be undesirable,

FM ANTENNA SPECIFICATIONS

PROPOSAL _____	REV. _____	DATE _____	FREQ. _____
ANTENNA _____	TYPE NO. _____	NUMBER OF BAYS _____	
CUSTOMER _____	LOCATION _____		
REPRESENTATIVE _____	CONSULTANT _____		
SKETCH _____	V-PATTERN _____	H-PATTERN _____	

ELECTRICAL SPECIFICATIONS	
1. Required Maximum ERP for Station	_____
2. Minimum ERP (if Directional) and Azimuth	_____
3. Antenna Peak Power Gain Ratio (Vg X Hg)	_____
4. Antenna RMS Power Gain Ratio (Vg)	_____
5. Horizontal Peak Power Gain Ratio (Hg)	_____
6. Horizontal Plane Pattern Circularity	_____
7. Antenna Electrical Beam Tilt	_____
8. Antenna Null Fill, Angle and Percentage	_____
9. Required Antenna Input Power for ERP	_____
10. Antenna Safe Input Power Rating	_____
11. Antenna VSWR, Across \pm 200 KHz, No Ice	_____
12. Transmission Line Type and Length in Feet	_____
13. Line Efficiency at Operating Frequency	_____
14. Transmitter Output Power for Required ERP	_____

MECHANICAL SPECIFICATIONS	
1. Antenna Net Weight, Estimated	_____
2. Wind Load at 85 Mph thrust	_____
3. Antenna Input Connector Size, EIA, 50 Ohms	_____
4. Radomes or Deicers	_____
5. Height, Top to Bottom Input Connector	_____

Fig. 12. FM antenna specifications.

TABLE 3
Transmitter Powers with Various Antennas for Same ERP

Transmitter power	Antenna input	Number of bays	Antenna gain	ERP	Elevation beamwidth
10 kw	9.09 kw	10	5.5	50 kw	6.1°
20 kw	18.52 kw	5	2.7	50 kw	12.2°
40 kw	33.3 kw	3	1.5	50 kw	20.0°

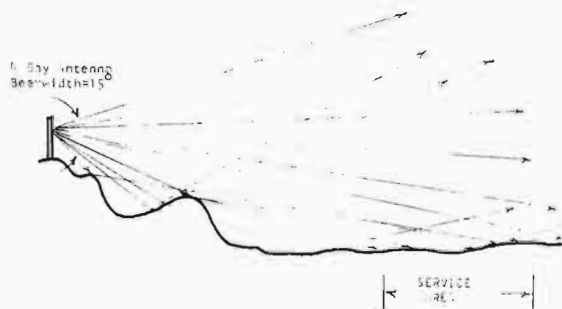

Fig. 13A.

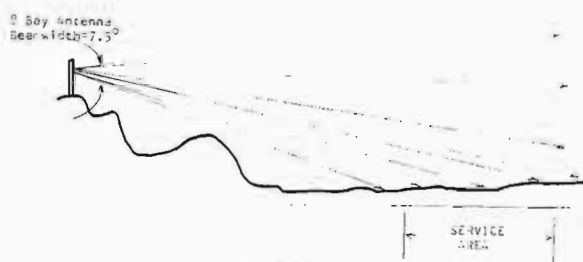

Fig. 13B.

causing multipath reflections and associated problems.

This problem of antenna gain, site location, and site height has been thoroughly investigated in Europe both for FM and TV broadcasting by several governments. The European Broadcasting Union strongly recommends the highest height be used with sufficient antenna gain to put a proper signal into the nearest part of the service area.²² High power transmitter low gain antenna combinations are not recommended.

Exceptionally high transmitter locations on the periphery of the service area are exceptions to this rule. The elevation angles, for example, required from Mt. Wilson antenna farms for Los Angeles illustrate this point. From a height of nearly 5,800 ft. (1,767 m), the service area is from -2 to -14° of elevation.

To conclude this discussion, the antenna should be chosen whose gain and thus its elevation envelope covers *only* the desired service area. Antennas with wide elevation angles (lower gain) may cause multipath problems depending on terrain conditions. High power transmitters with low gain antennas, also have a continuing expense through operating power consumption costs.

Site

Another factor which is related to the choice of antennas is the transmitting site location. In general, the higher the height over the service area, the stronger the signal at a given distance. The FCC has equalized the signal strengths, by reducing the allowable ERP values, as the transmitting height is increased. This is shown in Fig. 6. The choice of height then dictates the desirable antenna elevation pattern, to prevent avoidable terrain reflections. From the antenna gain, the transmitter output power can be determined, allowing for the transmission line efficiency.

It must be pointed out the Cpol radiation does not increase the distance to a given FCC signal service contour. Interferences and allocation contours are not changed. The service area contours are established by prediction methods or measurements of the Hpol radiation of a given amount of power and height.

DIRECTIONAL ANTENNAS

In the United States the FCC permits directional antennas for use by certain stations for cochannel and adjacent channel protection, to existing stations. This type of directional antenna is not permitted for TV and they are unique to FM broadcasting.

Several manufacturers make suitable FM antennas for this purpose. The FCC authorization requires that a completely measured azimuth Hpol pattern be submitted, so that the amount of ERP towards the protected station will meet the specifications of the construction permit. The elevation pattern need not be measured, but may be calculated.

In Fig. 14 the directionalized azimuth pattern of an Hpol antenna is shown. Dashed lines ex-

²²Site Selection, by K.H. Kaltbeitzler (I.R.T.), Technical Monograph 3104, European Broadcasting Union, Technical Center, 32 Avenue Albert Lancaster, Brussels, 18, Belgium.

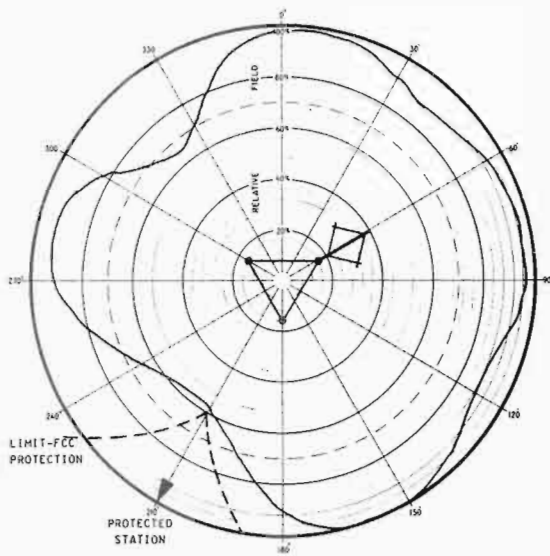

Fig. 14 Directionalized FM antenna, Hpol azimuth pattern. Azimuth power gain = 1.346. Peak power gain = 2.02 null gain † 0.68.

tending from 210° indicate the maximum allowable rate of field increase from the protection null as 2dB per 10° of azimuth. Another FCC requirement is that the ERP in any azimuth in a directional antenna not exceed the maximum authorized ERP. This nearly always occurs in nondirectional antennas because the antenna is rated on an RMS basis of the azimuth pattern.

Prior engineering by the station's consultant indicated that the maximum allowable ERP toward the protected station was 1,000 watts. The Class A station had a maximum ERP of 3,000 watts. The antenna was designed and adjusted so that the radiation towards the protected direction, 210°, would be 1,000 watts or less. The maximum ERP occurred between 150 and 165°. The antenna and operating parameters are shown below:

SAMPLE DIRECTIONAL ANTENNA PARAMETERS

Maximum ERP, Hpol	3,000 watts
Maximum ERP, Hpol, towards protected azimuth	1,000 watts
Peak antenna power gain, Hpol ... (1.50 × 1.346).....	2.02 (3.05dB)
Antenna input power for 3,000 watts peak ERP.....	1,485 watts
Coaxial transmission line efficiency	66%
Required transmitter power output.....	2,250 watts

This is a typical directional FM antenna, although the values may change with the requirements. Notice that the Hpol values are used for ERP as well as protection. The Commission

has informally adopted a rule that the measured Vpol azimuth pattern in a directional FM antenna may not exceed the Hpol values by more than 1 dB. This requires additional work but is easily accomplished.

Directional FM broadcasting antennas have worked out quite well over the years. They provide an excellent means of maximum allowable ERP for the directional stations coverage area, while good site location permits reduction to co-channel or adjacent channel stations to operate without interference. The day and night time signals do not change in FM. Only one pattern is required and stability is excellent.

The directionalizing is usually accomplished by the use of parasitic elements for both the Hpol and Vpol, when a Cpol antenna is used. When the antenna maker does the directionalizing, they will submit a certificate by a registered professional engineer (PE) that the measured pattern is as shown in the polar plot, and taken from antenna test range measurements.

Since the antenna is directionalized, the peak power gain must be used, and not the RMS gain, when computing the ERP. In omni antennas, the RMS power gain ratio is used for ERP calculations.

Azimuth Patterns

Nonsymmetrical side-mounted FM antennas are much more economical than screen dipole antennas. Side-mounted antennas suffer from poor azimuth patterns. This is due to reflections and other effects of the supporting steel tower.

It is very difficult to predict, without measurements, the azimuth pattern of such an antenna. Simply leg mounting it does not insure good azimuth patterns away from that leg. Circularities as poor as ±24 dB have been measured on five ft. (1.52 meter) wide towers. Small towers tend in general to provide somewhat more uniform patterns, but they all produce strong lobes and deep nulls as great as ±12 dB.

The answer to this problem is to get pattern adjustment or optimization service from the manufacturer. This is fully described under *antenna pattern service*. To simply install an antenna on a particular face or leg of a tower, hoping to get at least the RMS value of ERP towards the main service areas is very risky.

Beam Tilt

The elevation pattern in some installations may be tilted so that the peak value strikes the farthest part of the service area. A standard FM antenna without any beam tilt normally radiates

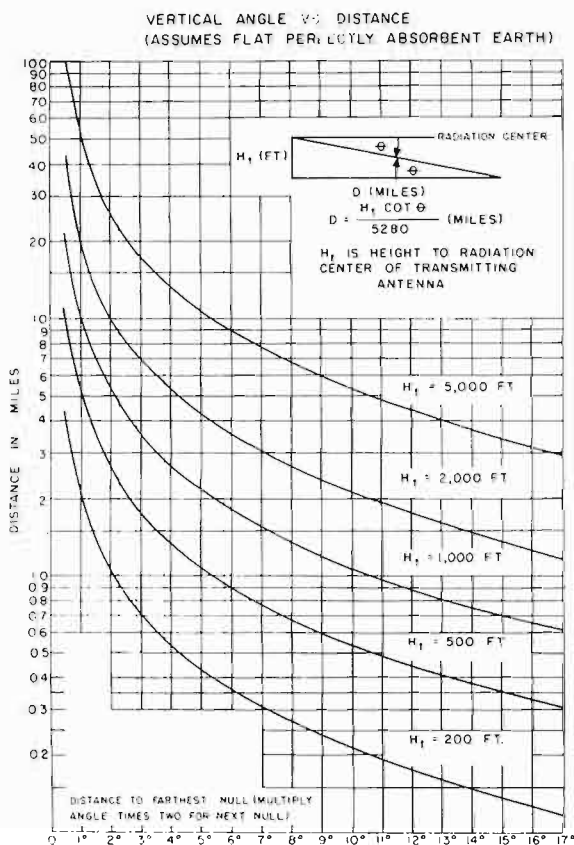

Fig. 15. Elevation angles to terrain from various heights assuming flat earth conditions.

more than half of its power above the horizon. All this power is lost.

The higher the antenna above its average terrain, the further it can serve. It also follows that the higher the antenna above terrain, the greater is the elevation angle down to the earth's horizon. This is shown in sketch form in Fig. 15. In order to hit the service target near the horizon, the elevation pattern may be tilted downward in all azimuths, by using electrical beam tilt. This is done by delaying the current to the lower elements in the antenna array, in such amounts and sequence as to produce the correct amount of tilt. The farthest service areas require the greatest amount of power. Beam tilt is the antenna designer's tool to accomplish this goal.

Consulting engineers who are familiar with this problem can easily work out the required amount of beam tilt, if it is necessary. Practical values are one-half and three-quarters of one degree, depending on height and antenna elevation pattern. Beam tilt is usually not required for antennas with 8 or less bays, since the half power beam width is approximately 7.6° or 3.8° below the horizontal plane value for 8 bays. It is wider as the number of bays is decreased.

Null Fill

The power gain of the antenna determines the shape of the elevation pattern, as a result of the phase and amplitude of each bay. This determines the elevation angles, in which little or no radiation occurs, due to the antenna arraying factor. The elevation patterns for all antennas are available from the manufacturers. If these patterns indicate nulls, which strike the present or future population areas, they should be filled in. The amount of fill-in depends on the distance to the population, and therefore, the required ERP for a satisfactory signal level. In problem areas, the first null below the peak is filled from 5 to 15 percent field, 10 percent being quite common. In some rare cases of extremely high transmitter locations above service areas, the second null may require fill-in of about 5 percent. Null fill reduces the peak power gain of the antenna by putting some of the power into the nulls. This reduction is usually less than 5 percent, however. Since the service areas at the null angles fall quite close to the transmitter, very little ERP is required for satisfactory signals.

The reader is referred to the next chapter for a discussion on television antennas, whose horizontal (azimuth) and elevation (vertical) pattern requirements are identical for FM broadcasting.

ANTENNA PATTERN SERVICE

Simply mounting the FM antenna on the face or leg nearest the principal city does not insure radiating the strongest signal in that direction. In many cases the opposite may be true. Some towers will exhibit a null in the least expected azimuth. Patterns are moderately frequency sensitive. They are affected by the cross-sectional shape and size of the tower, as well as the type of bracing. Generally, the vertical tower members including conduits, elevator rails, or other coaxial lines affect the Vpol azimuth pattern. The tower cross sectional shape, size, type of bracing whether X or zig zag or horizontal girts, ladders and self-supporting tower tapers, all affect the Hpol azimuth pattern. Tower reflections from Cpol antennas present special problems since the reflection is the opposite sense of rotation. The radiator must be treated with parasitic elements which are responsive to linear polarization. A screen reflector cannot be used, with Cpol radiators, to shape azimuth patterns.

Some American antenna manufacturers have for several years offered pattern adjustment service.²³ This service consists of duplicating

²³For example, Jampro Antenna Company, since 1966.

about 20 ft. (6 m) of the tower with all of its accessory items, from information supplied by the customer. This duplication must be exact. Then one or two bays of the antenna are mounted on one side of the tower or pole. The azimuth pattern is measured in both planes of polarization for a Cpol antenna, on the antenna test range on frequency. The mounting of the radiators is changed by distance or orientation, face or leg, plus the installation of parasitic elements, in order to achieve a useful azimuth pattern. This work may take several days or several weeks, depending on the frequency, type of tower or pole and desired pattern. Every attempt is made to make the azimuth pattern as circular as possible or to put the radiation in the most desirable azimuth directions. By using Vpol parasitics, the Vpol azimuth pattern is shaped to conform as well as possible with the Hpol azimuth pattern.

Fig. 16A shows typical 5 ft. (1.5 m) triangular tower patterns. Notice that the original measured pattern has a Hpol azimuth circularity of ± 13 dB, with a Vpol of 12.2 dB. After pattern treatment there is considerable improvement. The deep nulls were removed, as shown in Fig. 16B with a Hpol circularity of ± 3.47 dB and a Vpol circularity of ± 3.87 dB. The strongest radiation is towards the desired directions, indicated by the shaded lines.

When buying a new FM antenna, pattern measurement service should also be ordered to insure a useful azimuth pattern. Otherwise it will be quite unpredictable.

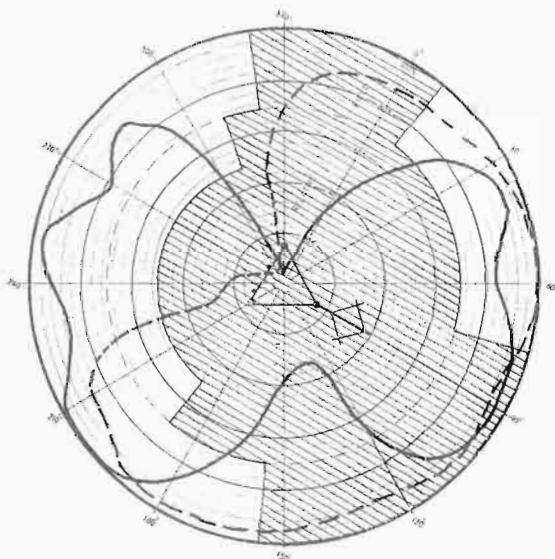

Fig. 16A. Measured azimuth pattern of Cpol antenna before pattern optimization. Solid curve indicates Hpol, with circularity of ± 13.0 dB. Dash curve indicates Vpol, with circularity of ± 12.2 dB. Shaded area shows broadcasters desired coverage 5 ft. (1.52M) tower width. Frequency, 97.5 MHz.

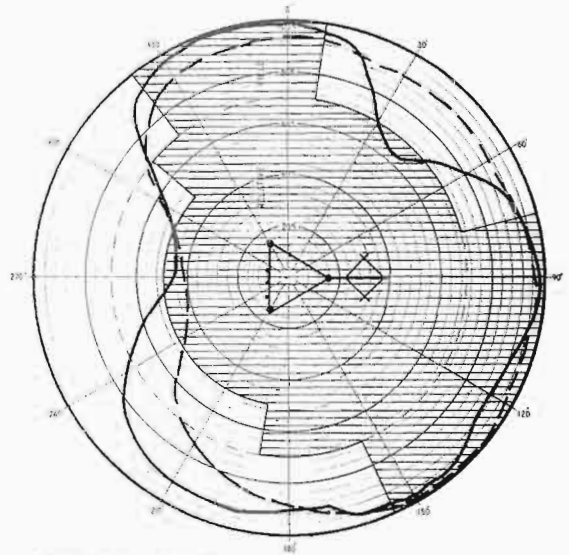

Fig. 16B. Measured azimuth pattern of Cpol antenna after pattern optimization. Solid curve indicates Hpol, with circularity of ± 3.47 dB. Dash curve indicates Vpol, with circularity of ± 3.87 dB. Shaded area shows broadcasters desired coverage 5 ft. (1.52M) tower width. Frequency, 97.5 MHz.

Screen dipole panel antennas mounted around the sides of the support exhibit excellent azimuth patterns. However, their cost is considerably higher than a typical nonsymmetrical antenna with pattern service.

ANTENNA FEED SYSTEMS

In the United States, nonsymmetrical FM antennas use the transmission line shunt method of feeding. The radiating elements are simply shunted every one wavelength across a rigid section of line. The radiating elements, however, are either high impedance or low impedance, and require different methods of compensation at the feed point.

High Impedance Method

This permits the shunting of several radiating elements directly across one large coaxial transmission line. Moderate power capacity and simplicity are easily achieved.

When a transmission line is not well matched, the voltages integral wavelengths apart, on that line, will be in phase. If loads are shunted across a transmission line, at spots which are integral numbers of wavelengths apart, they will appear to be electrically in parallel. This is the load that appears from the sending end of the transmission line.

By shunting the radiating elements exactly one wavelength apart across the line, all the elements are fed in phase. However, the im-

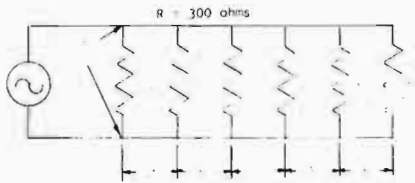

Fig. 17. Shunt feed system, using high impedance elements.

pedances of each load must be equal so that they all receive the same amount of current. This is accomplished by finding an impedance match on the radiating element.

Let us assume that a six-bay antenna is to be constructed, and shunt fed by a 50-ohm transmission line. Each element is tuned to six times the line impedance, ($6 \times 50 = 300$ -ohms), and connected one wavelength from the next. The transmission line will thus be automatically matched at the bottom element point to 50 ohms, (six 300-ohms loads in parallel equalling 50-ohms). Each element will also receive 1/6th of the total power, if the loads are all equal to 300-ohms (See Fig. 17.)

The above method works well, if the individual elements can be matched to rather high impedances of up to 400-ohms each, for an eight-bay antenna. Over this number, the antenna is split and fed in the center, making possible 16-bays using this same method. The high-feed impedance is susceptible to degradation in VSWR, from heavy fog and rain, and most certainly by ice or snow unless radomes or deicers are used.

This method of shunt feeding reduces the VSWR bandwidth since each radiating element must be exactly one wavelength apart. With deviation of the FM carrier, this factor becomes an important consideration. The radiating elements must have rather high Q values in order to present the high impedance necessary for matching across the main coaxial line.

Low Impedance Method

A better way to shunt feed the elements and overcome the adverse effects of high-impedance elements is through the use of one or more step



Fig. 18. Step transformer method, used to feed 50 ohm radiating elements.

transformers. This method is shown in Fig. 18. The radiating elements are all 50-ohms. They are shunted across the main coax feeder as in the case of the high-impedance shunt fed system. The spacing is also one wavelength so that the phasing, on the operating frequency, is the same for all elements.

The impedances among the several elements are the same, and therefore, the current is the same. The impedances are reflected across each shunt point. The example shows six 50-ohm elements, leaving $50/6$ or 8.33-ohms across the lowest element.

A simple one step quarter wave transformer of 20.4-ohms is placed below the lowest shunted element. This transforms the 50-ohms transmission line down to the 8.33-ohms of the load, thus matching it.

This low impedance method has several advantages. The radiating elements are matched to the low value of 50-ohms and have low Q. Because of this, they are not troubled with the moisture environment, which may change the dielectric constant, and thus, the resonant frequency with rain or fog to change.

The 50-ohm loads presented by each radiator are easy to match out during fabrication. All the radiators are electrically the same, although they may vary a bit at their feed points due to the mutually coupling adjustments. To achieve wider bandwidth, step transformers may be used after the fourth bay, as one manufacturer does (Jampro). While this increases the cost, the VSWR bandwidth of ± 200 kHz is easily achieved.

To insure proper gain, and elevation pattern, some firms measure the phase and amplitude of the rigid coaxial section on the operating frequency, before the radiating elements are attached, at the factory.

Other Feed Systems

Screen dipole panel antennas are usually fed through a corporate feed system, with branching feeds and semiflexible cables. By using phase impedance compensation in the feed system, it is possible to achieve excellent VSWR over the entire 20 MHz FM band. The individual screen dipole VSWR values need not be more than one megacycle wide. This method originated with the Europeans, who use it for wideband screen dipole television antennas.

CIRCULARLY POLARIZED FM ANTENNA TYPES

There are several types of Cpol antennas available to the industry. Some are more suitable to

FM broadcasting than others. For example, an end fire helical antenna would produce Cpol radiation but would not be suitable because it has high gain and directivity. On the other hand, a side fire spiral antenna²⁴ will produce excellent axial and polarization ratios, has good azimuth and elevation patterns, and does not use dipoles to produce the Cpol type of radiation. It should be quite clear that Cpol radiation does not necessarily come from two crossed dipoles, or ring stub antennas.

If one recalls that the field voltage vector is rotating at all times with respect to the earth plane, then it can be visualized that Cpol radiation is not limited to linear dipoles or ring stubs. It was easy to develop antennas from existing linear horizontal and Vpol towards Cpol. Crossed dipoles backed by a screen was such an early embodiment. Another was to use an existing horizontal ring and simply add vertical stubs. Other construction included a short side fire helix and the patented²⁵ two half wave crossed dipoles fed in phase quadrature. This last Cpol radiator is perhaps unique, and is described in detail under Cpol antennas.

COMMERCIALY AVAILABLE CIRCULARLY POLARIZED FM ANTENNAS

In 1976 there were about six different types of FM broadcasting antennas made in the United States. These antennas have many things in common. For example all the nonsymmetrical antennas are designed for side mounting to a steel tower or pole. The radiating elements are shunted across a common main rigid coax line. This has eliminated the problems associated with the older corporate feed system with its semiflexible lines.

By using the technique described earlier, shunting elements every one wavelength across a transmission line makes matching easy. Bandwidth is limited by the VSWR bandwidth of the individual element, and the use of internal transformers.

With more than about eight-bays the matching problem becomes difficult and there is some beam squint. That is, the elevation pattern begins to change slightly with the deviating frequency. Therefore, antennas with more than about 8-bays are fed from or near the center, dividing the phase change in half and eliminating the beam squint. Center feeding also simplifies the VSWR matching problem.

There are three basic types of Cpol radiating elements. The most common is the ring with stubs. The two half wave crossed dipole and the short side fire helix are the other two. The latter are

more symmetrical physically and electrically than the ring stub types and have better axial and polarization ratios when measured in free space.

Other common factors include mounting brackets, which are made special in some cases, or universal to accept a wide assortment of tower legs or faces.

Electrical deicing equipment is supplied as an additional item. They are usually factory installed. Kits are furnished for interbay connections, but the broadcaster must supply power from the building to the center of large arrays, or the bottom element on smaller antennas. Local electrical codes should be followed.

A thermostat is used with small deicer wattages. With larger power, thermostatically operated power relays are used. Then there are more sophisticated deicer control systems which operate only when temperature and humidity conditions produce sleet or icing.

Most deicers use a resistance heating element which is inserted into the antenna radiator arms. One supplier uses a different method dropping 115/230 volts to a few volts with a transformer located at each bay. The low voltage is passed thru the ice sensitive arms of the radiator and connected to the far ends, by a teflon insulated wire. The current return is by the stainless steel antenna element, whose ohmic resistance is sufficient to produce enough power loss to supply the required heat.

In addition to deicers, all antennas are available with plastic radomes, for sleet and ice protection.

Wideband FM antennas are not very popular in the United States, but some are in use, in the larger cities, where a high location is available. These include New York City, Salt Lake City, Utah, and Houston, Texas, where high buildings or a favorable mountain site provide excellent common antenna locations. Several makes of screen backed dipoles are available, which may be used for this purpose. Using phase impedance compensation similar to the European scheme, the entire 88 to 108 MHz band may be covered with one antenna with a VSWR of 1.1 to 1 or better. Power ratings are sufficient to accept several 25 or 40 kw transmitters. These antennas may also be installed on the faces of a triangular tower, or around a cylinder. One manufacturer uses a number of continuous spiral arms supported around a cylinder as a Cpol antenna. (See Fig. 19.) This antenna may also be used for community stations, with high power transmitters operating at several different frequencies in the band.

A means for tuning out reactances after the antenna has been installed on the side of a steel support is also common. They are located at the input to the antenna and consist of adjustable location dielectric slugs, or fixed position variable capacitors.

²⁴US Patent No. 3,906,509, to Jampro Antenna Company.

²⁵US Patent No. 2,637,533, Jampro Antenna Company.

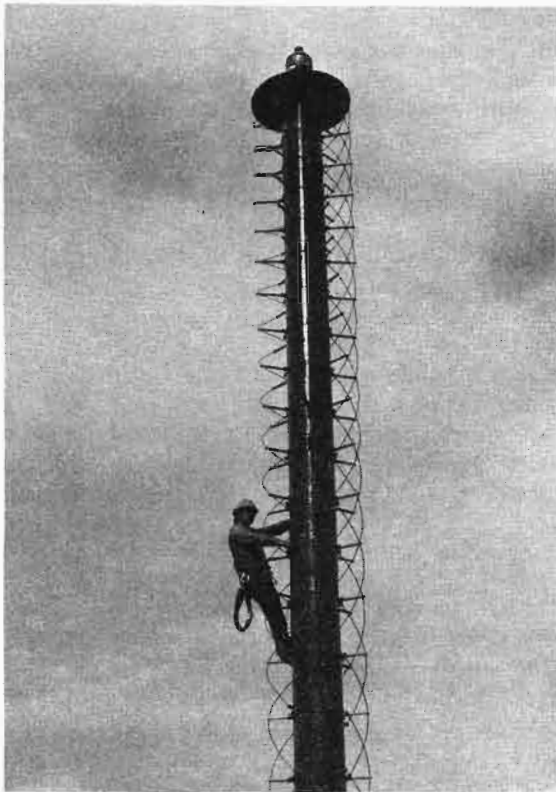

Fig. 19. Cpol omnidirectional antenna for wide band FM use, 88 to 108 MHz.

In the following pages some of the more popular American antenna types are described in some detail. It should be clear that each seller has other types and models which vary in electrical and mechanical characteristics. Table 4 gives electrical and mechanical information about several makes of six-bay Cpol antennas, of the side-mounted nonsymmetrical type.

COLLINS FM ANTENNAS

This firm offers a Cpol antenna, made by ERI, under US patent 3,474,452. The antennas are designed for use in monaural, stereo, and multiplex FM broadcasting. They have a 1.1 to 1 VSWR bandwidth for ± 100 KHz.

The basic radiating element is a ring, with two stubs, one pointing downwards, and the other upwards. The ring is fed thru a short balun, to equalize the power to each half of the radiator. The balun is protected from the weather thru the use of plastic cover plates. Fig. 20 shows the typical mounting of this high power Cpol antenna, to a pole. Notice the universal type of mounting bracket.

The Collins²⁶ G4CPH antenna radiates a Cpol wave. The element is designed to withstand wind

²⁶Collins Radio Group, Dallas, Texas 75207.

TABLE 4
Electrical and Mechanical Specifications for Some Cpol FM Antennas
(Six-Bay Models)

Brand Name	Collins	Harris	Jampro	RCA	Phelps Dodge
Type No.	37CP-6	FMS-6	JSCP-6	BFG-6	CFM HP-6
SPECIFICATION					
<i>Electrical:</i>					
Frequency Range, factory tuned any one FM channel	88-108 MHz	88-108 MHz	88-108 MHz	88-108 MHz	88-108 MHz
Free Space Azimuth Circularity	± 2 dB	± 2 dB	± 1 dB	± 1 dB	± 1 dB
Safe Input Power rating	40 kw	40 kw	40 kw	36 kw	30 kw
VSWR Bandwidth after field trimming for 1.1/1	± 100 KHz	± 100 kHz	± 400 kHz	± 100 kHz	N/A
<i>Mechanical:</i>					
Net weight, without radomes or deicers but with standard mounting brackets	Pounds kgs 544 247	Pounds kgs 520 236	Pounds kgs 498 226	Pounds kgs 381 173	Pounds kgs 404 184
Wind Loading at 112 mph (180 km/hr)					
a. without radomes & deicers	1,014 460	945 430	730 332	920 418	780 355
b. complete with deicers	N/A N/A	N/A N/A	851 387	1,040 473	930 423
c. complete with radomes	1,740 791	1,699 772	1,210 550	Radomes not recommended	1,170 532

Notes: All above antennas are circularly polarized right hand—clockwise. They are supplied with normal tower mounting brackets. All have 3-1/8 in. EIA input connectors, 50 ohms. Information taken from sales literature and other sources, in early 1976. N/A = Not available from printed information.

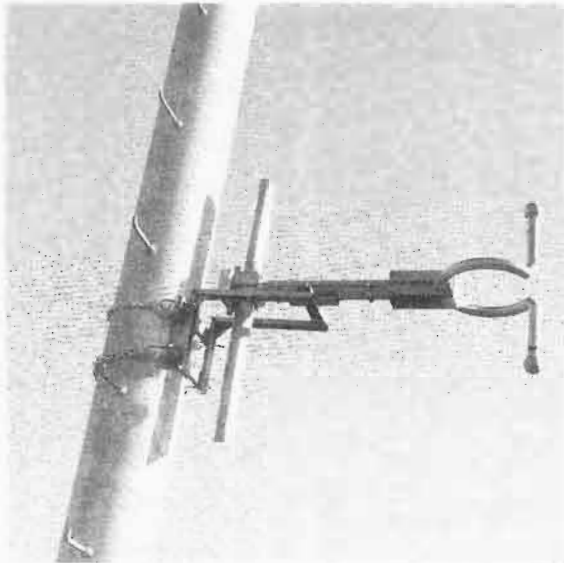

Fig. 20. Single ring stub type Cpol Collins Radio FM antenna, with typical pole mounting.

velocities of over 100 mph (161 km/h). Antennas with up to 16 bays are available. Antennas of 8 bays or less are normally fed from the bottom. A six foot (2 m) matching transformer is connected to the bottom bay, and the input is 3-1/8 in. 50 ohms EIA flange. Antennas with 9 bays or more are center fed if an even number of bays, or at a point one-half bay below the antenna center if an odd number of bays. A 10 ft. (3 m) matching transformer is connected to an elbow attached to the center-feed tee.

Factory installed deicers are available using either 300 or 500 watts per bay. Complete interbay heater-cable junction boxes and other items are included. The element to tower mounting brackets are of stainless steel.

Other FM products by Collins include a lower power version, educational FM antennas, and FM/AM antenna isolators. See Table 4 for more electrical and mechanical specifications of a six-bay antenna.

HARRIS FM ANTENNAS

The high power Cpol antenna marketed by Harris Corporation (formerly Gates Radio Company)²⁷ is offered in one thru 16 bays. Antennas with null fill, beam tilt, and special ratios of Hpol to Vpol power (elliptical polarization) are available by special order.

The type FMS called the dual-cycloid consists of two basic parts: the radiating element and the interconnecting rigid transmission line sections. In

²⁷Harris Corporation, Broadcast Products Div., 123 Hampshire Street, Quincy, Illinois 62301.

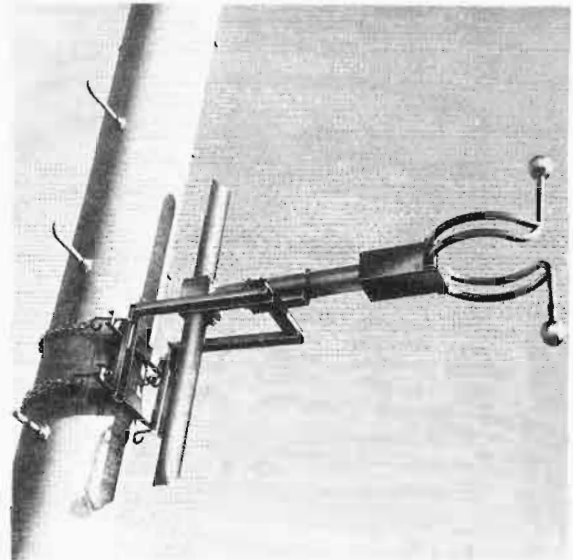

Fig. 21. Double ring stub type Cpol Harris FM antenna showing typical pole mounting.

Fig. 21 a single FMS element is shown with a section of rigid transmission line mounted to a pole. The radiating elements are all identical in any one antenna. The element uses a ring design as the basic unit. Two vertical elements have replaced the fixed end plates of the former ring Hpol element. The rear terminal block is now a matching balun, mating the antenna impedance to the interconnecting transmission line.

The vertical elements have adjustable caps for fine adjustment of the horizontal to vertical radiation ratio which is set at the factory. Corona suppression balls are included as a standard item. All antenna elements are fabricated from a weather resistant brass alloy. As is common with other antennas of this type using one coaxial feed line, the antenna elements are shunted one wavelength vertically. The main feed line has a standard 3-1/8 in. EIA female flange and the input impedance is 50 ohms.

The antenna is supplied with mounting brackets for standard types of uniform cross-section towers. Brackets for other types of tower or poles are also available.

Antennas with eight or less bays are usually fed from the bottom thru 6 ft. (1.8 m) long matching transformers. Antennas with nine or more bays are fed near the center. A 10 ft. (3 m) transformer is connected to an elbow attached to the center feed tee, and is part of the antenna.

The antenna is available for any one frequency in the 88 to 108 MHz FM band with clockwise Cpol. The power gains are with respect to a horizontal dipole. The VSWR at the input with side

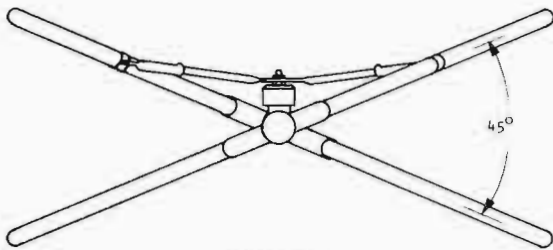

Fig. 22A.

mounting to a steel tower is 1.5 to 1 or better without field trimming, and 1.1 to 1 or better after field trimming for ± 100 kHz bandwidth. These Harris antennas are manufactured by Electronic Research, Inc., under US Patent 3,474,452.

Electrical deicers are made for operation on either 115 or 230 volts as specified in the purchase order. The deicers are factory installed and include shielded interbay cable in the kit. Plastic radomes are also offered in the event that electrical heaters are not desired, in ice or sleet environments.

Notch filters, multiplexers and other filter components for use in FM systems are supplied by Harris. Pattern optimization and measurement service is also available. For more information of a typical six-bay antenna, see Table 4 for electrical and mechanical specifications.

JAMPRO FM ANTENNAS

The most popular FM antenna fabricated and sold by Jampro Antenna Company²⁸ is the Type

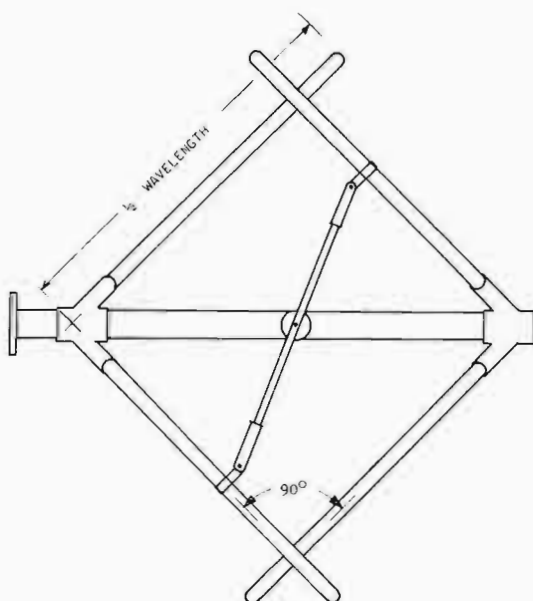

Fig. 22B.



Fig. 23A. Rigger installing Cpol radiator to lower leg.

JSCP, called the Penetrator. This Cpol antenna consists of four quarter wave arms which form the four sides of a square. The square has two driven arms while the other two are parasitic. The feed system is such that the radiation is in 90° phase quadrature with equal amplitudes meeting all the requirements for a Cpol radiating antenna element.

The angle between the arms is 45° . Both arms shown in Fig. 22A are fed from one point. This element has two half wave dipoles, both driven. The aperture efficiency is high due to its large cross sectional electrical size being 0.38 wavelengths. See Fig. 23.

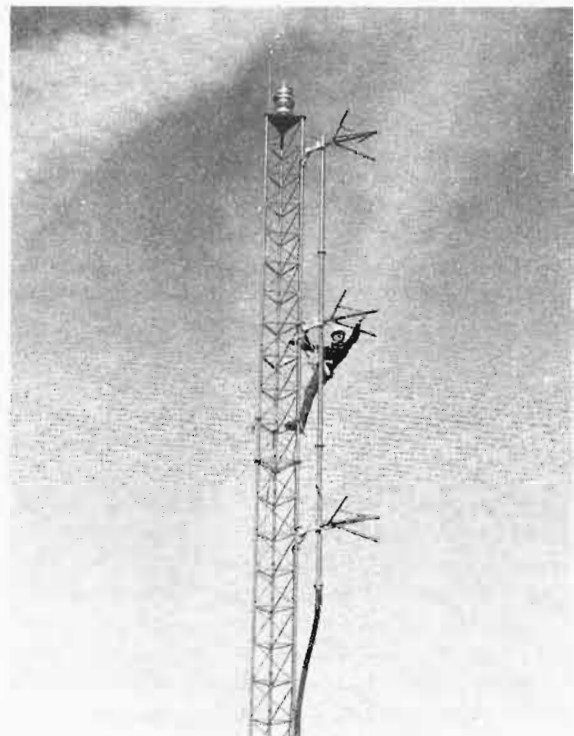

Fig. 23B. Typical nonsymmetrical Cpol antenna leg mounted to tower.

²⁸Jampro Antenna Company, subsidiary of Cetec Corporation, 6939 Power Inn Road, Sacramento, California 95828.

The Cpol is a result of the 45° angle between the two dipole planes and is a patented feature, in the United States, Canada, and United Kingdom. If the four arms were in the same plane and parallel with the earth plane, the radiation would be Hpol. The key to Cpol comes from the 45° angle while Vpol would result if the arms were opened up to about 180° with each other.

The antenna is ruggedly constructed using heavy wall marine brass tubing. See Fig. 23A. The arm casting is also of brass. The feed system permits dry air pressurization to the center Teflon insulated feed bushing. Due to the low Q, the VSWR is not affected in any measurable way by heavy fog or rain. Small end tuning stubs permit the radiators to be field trimmed after installation. The wishbone feed arms can also be adjusted for further VSWR improvement or to move the resonant frequency up or down one channel, ± 200 kHz. The element has a standard 1-5/8 in. EIA input connector.

This antenna is stacked vertically for increased elevation pattern gain. Cpol power gain ratios up to 7.8 (8.92 dB) are available, which require a 14-bay antenna. A three-bay JSCP-3 antenna is shown in Fig. 23B.

The aimuth pattern of a single penetrator antenna, supported in its center by a small diameter pipe, has been measured to be within ± 0.5 dB. Using the same mounting, the single element produced an axial ratio of 1.20 to 1 together with a polarization ratio of 1.32 to 1.

During fabrication the entire antenna is mounted on a tower similar to that to be used by the broadcaster. The VSWR of the system is adjusted and a final VSWR plot made. This chart appears in each of the two instruction booklets sent out with the antenna.

Jampro also offers a high power version of the Penetrator, Type JHCP, called the Brute, which is also Cpol. It uses 2 in. (5 cm) radiating arms and has a 3-1/8 in. EIA Input connector. It is rated at 40 kw for 2-bays, and is shunted across a 6-1/8 in. main feed line.

The spiral FM antenna Type JSS is for wideband use and covers 87.5 to 108 MHz. Using several arms around a steel support cylinder, the power rating is 70 kw per bay. A two-bay version with a Cpol gain of 3.1 is rated at 140 kw and may be used by several stations at one time. Fig. 19 shows typical construction.

The screen dipole panel antenna Type JSD may be mounted on the sides of a triangular or square tower or the sides of a large cylinder. These too are wideband antennas and may be used simultaneously by several broadcasters anywhere in the 87.5 to 108 MHz band. It has a VSWR of 1.1 to 1 or better across the entire 20 MHz FM band (CCIR Band II). It is Cpol, but may be furnished either Hpol or Vpol as required.

A ring stub antenna Type JLCP rated at 2 kw per bay is available for low power educational use.

Deicers

Electrical heating elements are inserted at the factory into the four quarter wave arms and one is put into the support boom near the feed through insulator. Each heater is rated at 100 watts with 230 volts ac, 50/60 cycles for a total wattage of 500 watts per bay. For light heating, 115 volts may be applied with a total of 125 watts.

The resistance heaters are impervious to moisture, use welded glass insulation and meet US government MIL specs for enclosed heating devices.

A deicer kit, to be installed on the tower by the rigger, includes pigtails, conduit connection boxes as well as interbay power cable. The broadcaster has a choice of deicer switching equipment, varying from a simple thermostat for small antennas to temperature and humidity controlled relays.

Radomes

Glass reinforced plastic (GRP) radomes may be supplied. These two-piece radomes are supported by the special shape element support boom. The aerodynamically designed radome produces a very low drag coefficient. See Fig. 24.

As with all its antennas, Jampro installs the radomes on the antenna during the final phases of the VSWR tune out and adjustments at the plant, on the test towers. This procedure yields a measured VSWR plot for the instruction booklet, with the radomes in place. The radomes change the VSWR, and therefore must be compensated by the element tuning.



Fig. 24. Radome used on single bay FM antenna.

The broadcaster must verify the fact that the proposed supporting structure will indeed safely hold the antenna with deicers or radomes, by using a qualified structural engineer and checking the entire plan.

Antenna Test Range

Only by measuring on a test range can the azimuth pattern be verified.²⁹ After installation, the antenna pattern cannot be predicted from field measurements due to propagation factors. One cannot work back to the antenna radiation pattern from what is measured in the field. In addition to the azimuth pattern, this is also true of the axial and polarization ratios.

MCI FM ANTENNAS

Micro Communications Inc. of Manchester, New Hampshire³⁰ designs and manufactures, as well as sells a screen-backed crossed-dipole Cpol antenna. Designed to be installed on the faces of a triangular tower or other supporting structure, the antenna exhibits excellent azimuth patterns. Each bay uses three-panel antennas.

Fig. 25 shows a single bay, consisting of three of the arrow head dipole design, under the radomes, mounted on three sides of a triangular tower. For additional power gain, several bays are stacked vertically on the faces of the tower, approximately one wavelength. A corporate feed system, with semiflexible interbay cables, is used to feed the radiators.

Other products by MCI for FM broadcasting include high power diplexers for combining several stations into one of these antenna systems.

PHELPS DODGE FM ANTENNAS

This firm has a Cpol radiator which is basically $1\frac{1}{2}$ turn helixes mounted on one wavelength shunt feed lines. Each Phelps Dodge³¹ radiator is adjusted so as to be 50-ohms times the total number of elements. For example, an 8-bay antenna would have 400-ohm elements. This is accomplished by the ground loop feed system,

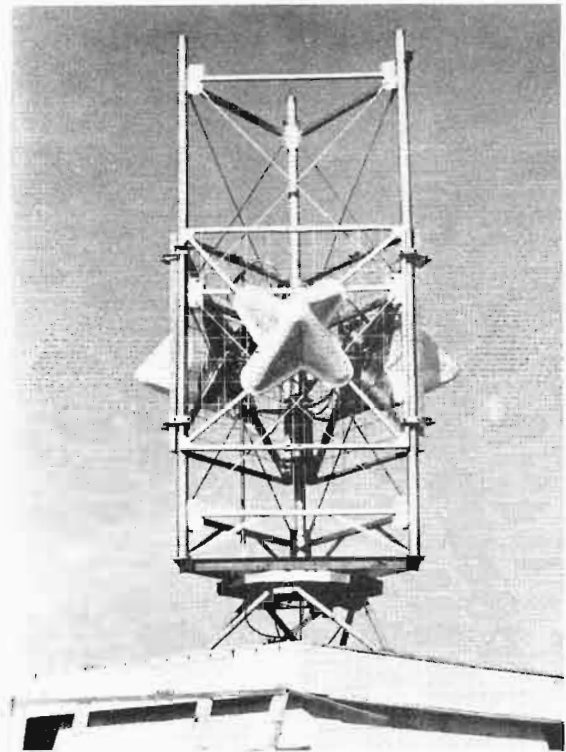

Fig. 25. Crossed dipole screen panel with bond FM antenna, single bay mounted on face of a triangular tower. (Courtesy MCI)

used to excite each element, thru a coaxial arm, with porcelain insulation.

Each radiator is constructed of 1-5/8-in.-diameter copper tubing with spherical ends to eliminate corona problems. Each antenna array contains a matching transformer approximately 6 ft. (2 m) long, which is used to adjust the VSWR after installation.

Antennas with up to 8-bays are fed from the lowest bay, and larger antennas are center fed. If beam tilt or null fill is required, the multi-element array needed to provide the required pattern is center fed with appropriate power divider and phaser supplied at additional cost. See Table 4 for additional information.

Electrical deicers for operation on 230 volts with 500 watts of power consumption per bay, are available as options. The company also offers Hpol antennas, along with low-power, low-cost educational antennas.

RCA FM ANTENNAS

RCA³² markets several types of Cpol antennas. These include panel as well as the non-

²⁹Test Procedure for Antennas, IEEE Publications, No. 149, January 1965, IEEE, 345 East 47th Street, New York, New York 10017.

³⁰Micro Communications Inc., Grenier Field, Manchester, New Hampshire 03103.

³¹Phelps Dodge Communications Co., Route 79, Marlboro, New Jersey 07746.

³²RCA, Broadcast Systems, Camden, New Jersey 08102.

symmetrical side-mounted FM antennas. In addition it also sells multistation panel antennas and AM/FM tower isolation units.

Four versions of a side-fire short-helix type antenna element shunted across a rigid coaxial line are offered. The helix diameter, number of arms, and the size of the main coax line determine the safe power handling capacity. The power gain ratio remains the same according to published data regardless of the helix diameter, which varies from 17 in. (432 mm) for the educational BFI-C 500 watt unit to 25 in. (635 mm) for the higher power 6 kw unit, model BFG. The aperture cross sectional size at the center of the FM band is 0.2 wavelengths. All radiators are made of stainless steel.

The antenna may be mounted on one side of a triangular tower, either on the face or leg, or it may be pole-mounted. The antenna is bottom fed with up to 7 bays. With 8 or more bays, it is fed near the center. The input is a 3-1/8 in. EIA 50 ohm flange.

The high power BFG antenna is a three pole system. That is, the helix has three fed arms and three parasitic arms. See the photograph Fig. 26, which shows a similar model BFC-B, with four arms. These arms may be tilted to produce more Hpol than Vpol, where Epol is desired.

The electrical deicers when ordered are factory installed. The deicing system in the BFG, BFH, BFI, and BFC series, do not have an internal heating element. The heat is produced by the ohmic resistance of the stainless steel radiating element. Voltage step-down transformers are mounted near the element to shunt coax line mounting flange. These operate at 208/240 volts 50/60 cycles and produce a low voltage which is passed through the radiating

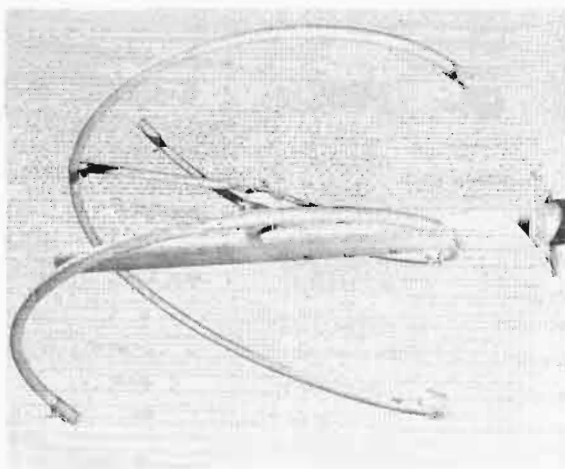

Fig. 26. Single stainless steel radiator, using four arms, (RCA Cpol type BFC-B.)

element arms with heavy gauge wire with Teflon insulation. The ohmic resistances of the radiating stainless steel element produces the power loss, and thus the heat for deicing purposes.

Radomes are not available for the high power BFG series, so deicers must be used if sleet or ice conditions prevail. The BFC series is available with radomes, which changes the safe power rating from 4 kw to 10 kw, for each bay of bays of four or less. These radomes increase the wind loading by 134 pounds (60 kg) per bay at 112 mph (180 km/hr).

The company's popular BFG series is power rated at 104 degrees F, (40 degrees C) ambient, for 6 kw for each radiator, and 40 kw maximum for any antenna. For higher temperatures there is a derating factor of 0.8 for temperatures of 122 degrees F (50 degrees C).

The free-space azimuth pattern circularity is ± 1 dB. However, the actual azimuth pattern, as will all side-mounted antennas, depends largely on the tower or pole environment. They recommend the antenna be mounted above the guys; or if guys go through the antenna, that these be broken up with insulators.

The VSWR of the antenna is adjustable after installation on the tower or pole to meet their published specifications of 1.1 to 1 for a ± 100 kHz bandwidth.

Beam tilt and/or null fill are optional extra items in the BFG series. They are usually desirable in the higher gain antennas with 8 or more bays. If beam tilt or null fill is required in seven or less bays, the antenna is near center fed at additional cost.

RCA also furnishes directional arrays which are custom built to the broadcaster's requirements.

SHIVELY FM ANTENNAS

The Shively³³ antenna Type 6810 has an input power rating of 10 kw, for each bay. It is of the ring stub variety, and uses a coupling loop, to match impedance as well as provide the proper amount of coupling to the vertical 3-1/8 in. main coaxial feed line.

The antenna consists of a single transmission line with individual bays separated approximately ten feet (3 m) from each other. Each element is constructed of copper and brass. Eight bays or less are end fed from the bottom, and the

³³Shively Laboratories, Inc., Raymond, Maine 04071.

larger antennas from the center. The manufacturer states the ± 150 kHz bandwidth to be 1.1 to 1, after trimming with adjustable transformer, which is supplied with the antenna. The Hpol azimuth pattern is ± 1.5 dB in free space.

Cpol RECEIVING ANTENNAS

The benefits of Cpol transmitting antennas may be further improved through the use of Cpol receiving antennas. FM receiving antennas of the Cpol type were not available for sale in early 1976. Undoubtedly, as soon as Cpol is authorized for television, there will be an ample supply of Cpol for TV as well as FM reception.

A Cpol receiving antenna will yield a 3 dB increase in signal when receiving a Cpol signal if the sense of polarization is correct. This type of receiving antenna will also provide better signal to noise ratios since multipath is greatly reduced. They will make excellent receiving antennas for fringe areas because of their inherent gain and noise reduction qualities.

ANTENNA SYSTEM VSWR BANDWIDTH

The antenna system VSWR does not affect the coverage unless the VSWR is very high (2.0 to 1 or greater) and there is considerable transmission line loss, 3 dB or greater. In most modern day FM installations these conditions do not prevail. Therefore, we are concerned here only on the performance of the transmitted audio.

The necessary VSWR of the antenna system as presented to the FM transmitter has been established unofficially by common usage as 1.1 to 1. This is a reflection coefficient of 5 percent, which equals a reflection of -26.5 dB. This combines all the reflection presented by the antenna, transmission line, harmonic filter, directional coupler, and other coaxial items, as the FM transmitter load. There is no known FCC specification, or CCIR recommendation.

The FCC assignment channels are spaced 200 kHz, but this is not in any way a system bandwidth limit. With modulation indexes of greater than 15, RF energy extends beyond ± 200 kHz. In Fig. 2C, Warrent Bruene in Chapter 18, (*FM Broadcast Transmitters*) indicates the RF power distribution for an audio frequency of 5 kHz.

With lower audio frequencies, the modulation index is even greater and power distribution is wider. The antenna system VSWR must respond to a greater bandwidth if the third significant side band is considered at the higher modulation indexes.

Transmitter Bandwidth

In FM modulation, the bandwidth is theoretically infinite. In practice the amplitudes of the side band frequencies beyond the maximum swing become small. (Please see Chapter 18, page 434-436 on FM Modulation theory.) Even for small swings (FM deviation) the bandwidth must be sufficient to fully include the first order sidebands or no intelligence will be transmitted.

During modulation of the FM carrier, the power in the side bands is greater than that at the FM center frequency. For example, at a given instant the maximum power may be in one of the upper sidebands, 165 kHz above the carrier frequency. The antenna system must perform properly at this frequency as well as 165 kHz below where the power also appears.³⁴

The -30 dB bandwidth with 100 Hz of audio on a quadraphonic FM carrier, using the 95 kHz AM subcarrier, is ± 200 kHz. The antenna bandwidth therefore for quad depends on what significant sideband power is to be considered. Nevertheless, the important levels are certainly at -30 dB or less, requiring an antenna bandwidth of at least ± 200 kHz.

The basic problem due to high VSWR is reflected signals which cause the transmitter RF amplifiers to look into a reactive load, with non-linear phase and impedance characteristics.

In stereo and quadraphonic broadcasting, the separation and noise between and in each channel is affected by the antenna system VSWR and the electrical time delay of the transmission line. The problem is somewhat like that of television ghosting. If the time delay is quite great, a very low reflection ghost may be clearly seen. If the delay is very short, a large amount of reflection may be tolerated.

In addition to this, synchron noise (a European CCIR term) may be present in narrow VSWR bandwidth systems. The carrier, when deviating with modulation, causes higher amplitudes of reflection, with wider frequency excursions. This causes amplitude modulation with FM modulation, due to the narrow VSWR bandwidth of the antenna system. Typical European specifications are 55 dB below 100 percent modulation, for AM noise produced with 400 Hz audio modulation of the FM carrier.

Tests have indicated that the transmitting antenna system VSWR at the carrier frequency produces cross talk, as a function of the VSWR value.³⁵ The tests were made with a FM station

³⁴Measuring Wide Bandwidth FM Deviation, C.N. Charest, Philco-Ford, Electronic Design News Magazine, March 1, 1969.

³⁵Transmitting Antenna VSWR Effects on FM Stereo, Peter Onnigian, IEEE Transactions on Broadcasting, August 1963, pages 1 through 6.

operating on 96.9 MHz with an ERP of 75 kw. The FM antenna was fed through 300 ft. (90 m) of 1-5/8-in. rigid coaxial transmission line. Receiving tests were made with a high performance FM receiver 15 miles (25 km) across the city.

In the measurements, good stereo separation (greater than 30 dB) was obtained with VSWR values of 1.1 to 1 across ± 200 kHz, from 50 to 11,000 Hz. With an antenna system VSWR of 1.2 to 1 the 30 dB separation was reduced to 7,500 Hz. At 1.5 to 1 VSWR it was impossible to measure any audio tones whose stereo separation was better than 26 dB. See Fig. 27.

Unfortunately, the transmission line length could not be extended, to measure the effects with a given VSWR value. The cause of the crosstalk (reflection) would be delayed further and become more measureable, with longer transmission lines. These tests proved the desirability of low VSWR for the FM channel, and its significant deviation sidebands. Quadraphonic FM broadcasting is more demanding of VSWR bandwidth. The present FCC biphonic (stereo) 100 percent modulation represents 75 kHz deviation of the main carrier with a 38 kHz subcarrier for the stereo information.

Some music service firms have noticed a definite crispness in the music of their client's stations which have good antenna VSWR values. This characteristic is difficult to measure but is audibly observed. It is due to a lack of distortion and crosstalk as a result of reduced reflections from the antenna system.

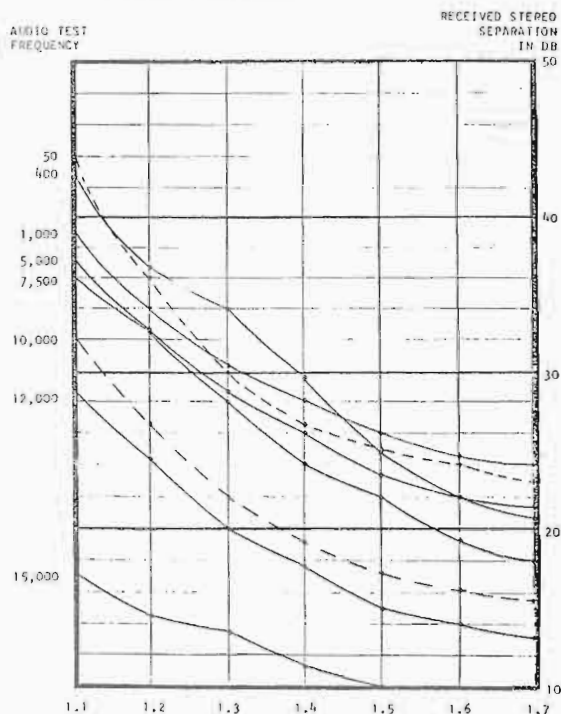

Fig. 27. Stereo separation versus antenna system VSWR.

At this writing, (early 1976) five basic proposals were made to the FCC for quadraphonic sound, producing four discrete sound channels through the FM receiver. All proposed systems have a baseband frequency spectrum of 95 kHz, which is 20 kHz more than the present 75 kHz FCC pilot carrier stereo system. Some of the proposals call for a subcarrier at 95 kHz to be frequency modulated.³⁶

VSWR Recommendation

There are no industry or government standards for VSWR bandwidths for FM broadcasting antenna systems. It is therefore recommended that for stereo or quadraphonic sound, the industry adopt a maximum VSWR value of 1.1 to 1, for a minimum bandwidth of ± 200 kHz. This would be measured at the coaxial line flange, normally connected to the transmitter. It would include the reflectometer coupling, harmonic filter, all coaxial transmission line components and the FM antenna.

This VSWR will prevent undue degradation due to crosstalk, reflections, phase delays, and synchron noise, with transmission lines of up to 328 ft. (100 m). Antennas with transmission lines up to 650 ft. (200 m) should have even lower VSWR values; 1.08 to 1 across ± 200 kHz is recommended for these longer lengths.

These values are easily obtainable with some of the present state of the art narrow band non-symmetrical antennas. A measured VSWR plot of an installed six-bay Cpol antenna, together with 625 ft. (190 m) of 3-in. heliax line, is shown in Fig. 28. It has a VSWR bandwidth of ± 375 kHz, under 1.1 to 1 and 1.08 to 1 for ± 250 kHz.

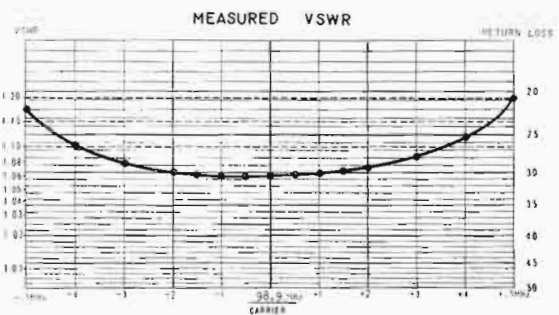

Fig. 28. Measured VSWR plot of six-bay FM antenna, together with 625 feet (190m) of 3 inch heliax coaxial line.

³⁶Vol. 1, Report of National Quadraphonic Radio Committee, Nov. 1975, EIA, 2001 Eye Street, N.W., Washington, D.C. 20006.

DUAL ANTENNAS AND MISCELLANEOUS FEED SYSTEMS

In Europe, Asia, and Africa, it is quite common to find antennas which have an upper half and lower half, with two transmission lines of equal length to the transmitter room. These two lines are normally fed by a power splitter. The upper half and lower half work as a common antenna, through the power splitter located in the transmitter room instead of in the antenna, as is common in American systems. This dual feed system has the advantage of providing a spare antenna half, in the event that one transmission line or one-half of the antenna becomes defective or requires maintenance. With one-half of the antenna and full power fed to it, the ERP is reduced 3 dB.

Another method is to feed each half of the antenna with a separate amplifier and line. A common driver and exciter are used to feed, for example, two 20 kw amplifiers, for a total of 40 kw transmitter power. This has the additional advantage of providing a means for transmitting with one amplifier into the entire antenna system (through proper coaxial switching), while doing maintenance work on one amplifier. Here again the ERP is reduced only 3 dB. If each amplifier feeds one-half of the antenna, without switching, and one amplifier line or antenna half stops working, then the ERP drops 6 dB. This is an ideal situation for remote controlled stations in difficult to get to mountain sites.

The electrical phase of the carrier must be kept equal to each antenna half, in order that serious beam tilt does not occur. This may be accomplished with monitoring devices.³⁷ These systems are quite practical with 2×20 kw transmitters, and high power nonsymmetrical FM antennas, offered by American manufacturers. They also work very well with the multi-channel wideband symmetrical panel antennas, popular in Europe, and also available from some American antenna makers.

ANTENNA VSWR TUNEUP

The immediate metallic environment of the side-mounted FM antenna affects its VSWR. All currently produced FM antennas in the United States have provisions for field trimming the VSWR. Some manufacturers completely assemble the antenna, install it on a tower similar to the one to be used, and tune the various elements for conformity to establish quality control VSWR values. Others do not. VSWR transformers (fine tuners) as well as means to tune the individual radiating elements are found

on some antennas. All these antennas may be tuned for their best VSWR on the tower from which they are to operate.

To properly tune an FM antenna, after installation, requires test equipment not normally found in stations. A test package would consist of a signal generator, counter and a 35 dB or better directional coupler. If such equipment is available, it should be connected to the main transmission line at the point beyond the harmonic filter. The entire antenna and transmission line can then be tested. If the VSWR does not meet the specifications, then the transmission line should be terminated in its characteristic impedance (usually 50-ohms), and the line should be checked. This should indicate where the difficulty lies.

If proper test equipment is not available, then the reflectometer in the transmitter may be used as an indicator of second choice. Reflectometers are of various types, and some permit expansion of the reflected reading, without upsetting the calibrated value. After the entire system is working and power has been applied to the antenna, the reflectometer should be calibrated in accordance with the transmitter manufacturer's suggestions. The reflected value should be noted. If this value is above 1.1 to 1, the station engineer may want to fine tune the antenna. If the value is above 1.7 to 1, the rigger should inspect the installation.

If the antenna system is to be field tuned, it is recommended that the normal forward (incident) value be obtained on the transmitter reflectometer. The reflectometer should then be switched to reflected position and expanded if the meter circuitry permits this without upsetting the calibration of forward power. The rigger must be below the antenna by at least 5 ft. at all times during these adjustments.

The tuning steps are those recommended by the antenna fabricator, or the following method may be used. After noting the reflected initial reading, the fine tuner or matching transformer should be adjusted, until the lowest value is found. If this is not satisfactory, then the individual elements should be adjusted, if this is possible. In all cases, one or both of these adjustments should bring the VSWR down to 1.1 to 1 or better. If not, then the manufacturer should be consulted.

FM transmitter reflectometers used in the above manner suffer two problems. First, they must be placed *after* the harmonic filter in the transmission line, otherwise harmonics are picked up by the reflectometer. The single channel antennas also reject harmonics, making the reflectometer read high VSWR values, when the harmonic filter is not working properly.

³⁷Parallel FM Transmitters 3 Parts, Tom Polino, *Broadcasting Engineering*, July, August, September 1975.

Another cause of difficulty with transmitter reflectometers is their poor directivity. That is their ability to tell the difference between forward and reflected power. Most transmitter reflectometers have directivities of about 20 dB. For test purposes and to read 1.1 or 1.08 to 1 more accurately, a coupler with at least 40 dB of directivity is required.

If the FM transmitter emits spurious signals, these will be reflected by the single channel antenna, and show up as increased VSWR. A wideband screen antenna will absorb this power, as will the station dummy load. This confusion can be clarified by looking at the radiated power into the antenna with a spectrum analyzer, when in doubt.³⁸

TRANSMISSION LINE SYSTEMS

For FM antenna systems, two basic methods have come into common use. One uses rigid coaxial line sections in 20 ft. (6.09 m) lengths, with elbows, flanges, spring hangers and other devices. The other has a semiflexible coaxial transmission line. Both systems work out quite well. These two methods of providing power to the antenna are shown in Fig. 29.

For more details about transmission lines, see Chapter 12.

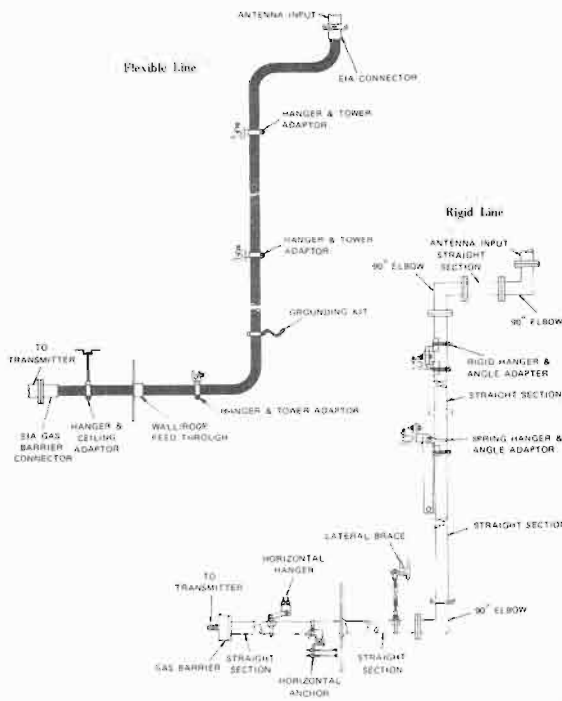

Fig. 29. Typical installations of flexible and rigid coaxial transmission lines to feed FM antennas.

³⁸“Spurious Radiation From FM Broadcast Transmitters,” Eldon Kanago, pages 77 through 81, *Proceedings of the 1967 NAB Engineering Conference*, National Association of Broadcasters, Washington, D.C.

FM ANTENNA INSTALLATION ON AM TOWERS

In many cases, it may be economical and convenient to install the FM antenna on a tower used for AM broadcasting. If the steel tower is insulated, the FM power may be transferred across the base insulator without upsetting the AM tower operation.

The easiest way is to use a device marketed by several firms called an AM/FM isolator or FM isolation transformer. It has two tightly coupled RF coils which are resonant at the FM operating frequency. An adequate air gap is provided for the medium wave AM power thru the resonant loops.

Fig 30 shows the internal construction of a typical isolation transformer. The insulation for AM for the top of the box is high density polyethylene. This top provides a rain shield as well as protection from dust and mud. The spacing between loops is greater than the base arcovers due to static and high modulation peaks would take place across the loops.

A typical installation using an isolation transformer is shown in Fig. 31. The FM coax going to the box from the transmitter building is grounded. The top of the box, which is insulated from the remainder of the box, is connected to the tower. The isolation transformer is physically and electrically shunted across the tower base. The FM coaxial line runs from the top of the box to the antenna using metallic hangers. Care must be taken to allow for the copper line expansion, if rigid line is used, by letting the box move with the expansion. With semiflexible line, this is not a problem since the flexible line does not exert undue stress.

Insertion loss at the FM frequency is typically less than 0.15 dB, with a VSWR of 1.05 to 1 or

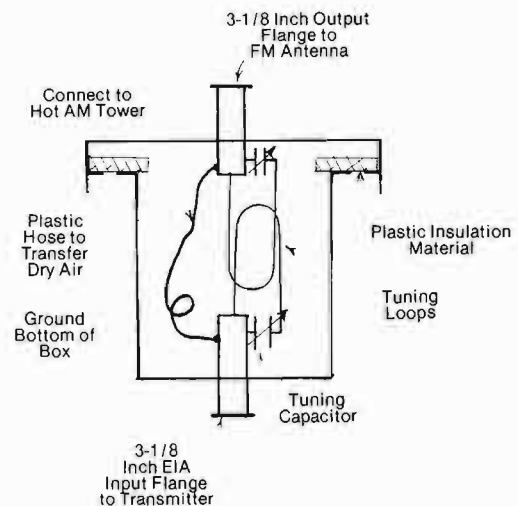

Fig. 30. Typical FM/AM isolation transformer.

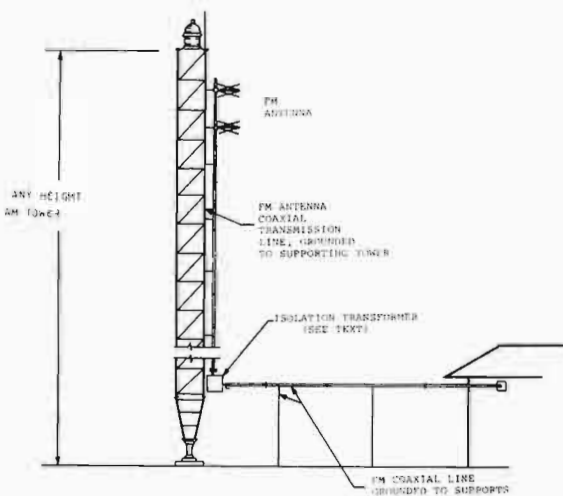

Fig. 31. FM antenna fed thru isolation transformer using conventionally installed FM coaxial transmission line.

better, when terminated in a 50-ohm load for a bandwidth of ± 0.5 MHz. The shunt loss at the AM frequency is about 30 dB, while the shunt capacity will vary from about 40 to 200 mmfd depending on the make and model. Safe AM power ratings are 7.5 to 50 kw with FM ratings of 10 to 40 kw.

A less popular method is to use the technique of quarter wavelength transmission lines. Simply stated, the opposite end of a shorted quarter wavelength line has high impedance. This high impedance is placed across the AM tower base and may be successfully used to provide isolation.

In Fig. 32 there is a vertical run of rigid FM transmission line, which is a quarter wavelength long on the AM frequency. The grounding of the FM coax strap is adjusted during AM base impedance readjustment. The remainder of the coax is on insulated hangers. If the AM support tower at the FM coax ground is shorter than 75° then a capacitor is used to adjust the electrical length to 90° . In practice only about 75° of insulated line is required since the coax line hangers and distributed capacity of the line tend to increase the electrical length.

The isolation transformer method is more popular because it has two distinct advantages, and is not more expensive in the average installation than the insulated quarter waveline technique. The small capacitance of the isolation transformer does not upset the AM tower base impedance. It has the further advantage in directional arrays of not causing any undesired AM radiation which may change the protection nulls.

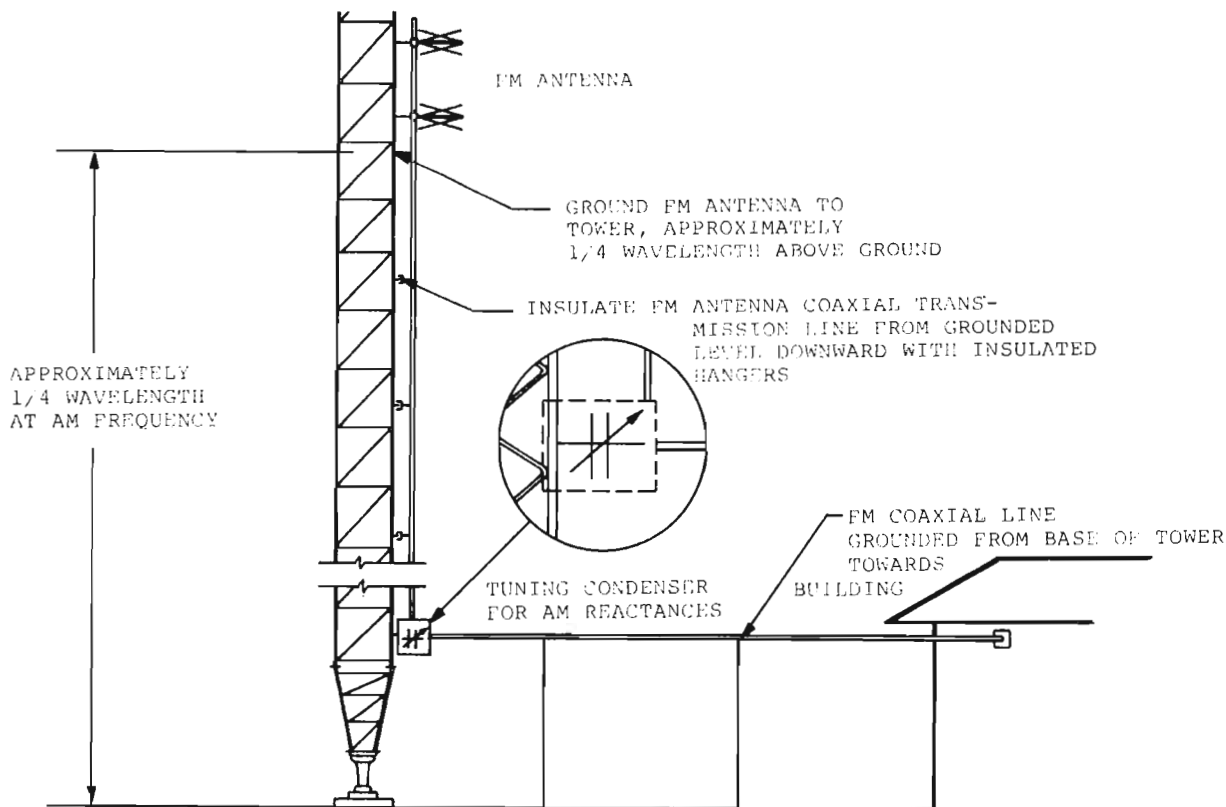

Fig. 32. Insulated FM coaxial line used to isolate FM antenna from AM tower.

An isolation transformer has been in use on a single 50 kw AM tower with a 40 kw FM transmitter for several years. What makes its use even more notable is that the tower is located about one-half mile (0.8 km) away from a cement factory. The dusty environment has not caused any insulation problems.

After the FM antenna and line have been installed with either method, the AM tower operation must be checked and adjusted as necessary with proper test equipment. There is always some additional shunt capacity which must be tuned out of the AM antenna tuning units (ATU).

STRUCTURAL CONSIDERATIONS

Most FM antennas in the western hemisphere are installed on the sides of a steel supporting structure, between 18 and 60 in. (45 to 152 cm). The antenna and its transmission line as well as the mounting brackets introduce wind loading, in addition to their dead weight. The total load must be considered in the safety of the overall tower structure. The wind loading is a result of the amount of physical surface presented to the wind. It is sometimes called the wind catch area. It consists of either flat or round antenna members, coaxial lines and mounting brackets and hardware.

The dead weight of these antennas is significant, but not as important as the live load, which is the load as a result of winds. The dead weight is always present. The live load is added when the wind comes up, and is usually much greater than the dead load. See Table 4 for wind loads for a typical six-bay antenna.

A guyed triangular tower of 300 ft. (91 m) height may have a downward load on the tower legs of 40,000 pounds (18,180 kg). This will consist of the dead weight of the tower and all its attachments, plus the pull from the guy cables. It can be seen that adding several hundred pounds of FM antenna to the existing dead tower load is not overly important.

Tower wind loads are important and the resulting live wind loads should be considered. The wind acts not only on the FM antenna but on the supporting tower. For example, a 10-bay Cpol antenna has a net weight of 1,074 pounds (488 kg) with radomes. With a 112 mph (180 km/hr) wind, the resulting wind load of the antenna is 2,065 pounds (938 kgs), nearly twice that without the customary rated wind velocity.

One of the advantages of the single channel nonsymmetrical FM antenna is its simple tower requirements. A wideband 10-bay screen dipole FM antenna, with radomes, has a wind load of 7,527 pounds (3,421 kg), nearly 3.65 times that

of a 10-bay nonsymmetrical side-mounted antenna.

When an existing or new tower is to be used to support an antenna, a structural engineer familiar with towers and mast should be retained to make the necessary calculations and determine if the tower is suitable. The tower supplier will usually work with the broadcaster when a new tower is furnished. In an event, structural engineering is strongly recommended to prevent damage to equipment and possible loss of life by using EIA Standard RS-222B or its latest amendments, in addition to local building code requirements. In Europe, the Middle East and Africa, British Standards Institute 4360/2642 may be used, and in Canada S-37, 1965.

GUY CABLES IN ANTENNA APERTURE

The presence of steel guy cables going thru the antenna aperture on a guyed steel structure was studied by Jampro Antenna Company during 1968. It was found that guy cables had less than ± 0.3 dB in either the azimuth or elevation pattern of a Hpol antenna. On Vpol antennas it is approximately ± 0.9 dB on the azimuth pattern. The strongest effect is on Cpol where azimuth and elevation pattern distortions as great as ± 1.7 dB were measured.

Guy cables are small in wavelength and do not cause blockage. They do pick up and re-radiate energy if the polarization is correct, but the greatest cause is due to brute force excitation.

In addition to pattern anomalies the guy cables being RF excited re-radiate near the ground. This may cause RF feedback problems in some high power installations with low level audio equipment located in a building near the tower base.

It is recommended that any guy cable going thru the antenna aperture be insulated, in the areas shown in Fig. 33. Plastic fiberglass (GRP) insulating rods as well as flexible plastic rope covered with a PVC jacket are available. The black jacket prevents deterioration due to ultra violet sunlight radiation. Tracking problems, which are sometimes found with AM (medium wave) broadcast tower use, have not been observed in FM use.

Strengths exceeding the steel cable with which the plastic is to be used should be specified. See Table 5 for strength details. Porcelain insulators may also be used every 30 in. (830 mm) but they are expensive, bulky, and increase the system wind load.

Both of the above types of insulated lines are available with suitable metal end fittings, for

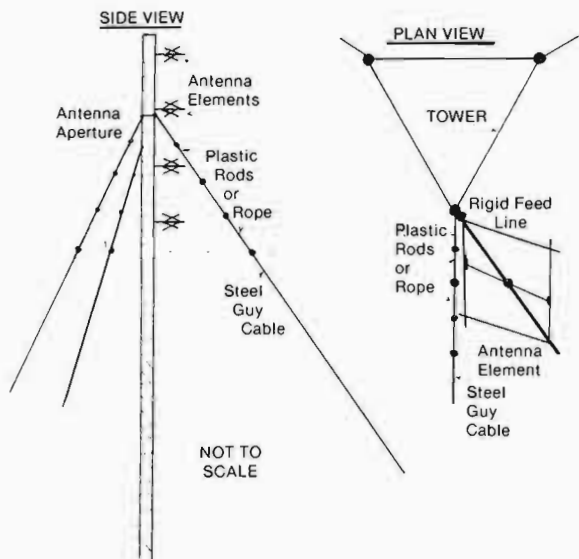

Fig. 33. Plastic Guy Rods or Rope Insulation to break up steel guys.

TABLE 5
Plastic Guy Cables and Rods

Maker and type no.	Working strength	Dielectric constant	Dielectric strength
<i>Phillystran</i> ^a			
PS29-6x19x	30,000 pounds (13,636 kg)	3.5	470 volts/mil
PS29-6x37x	55,000 pounds (25,000 kg)	3.5	470 volts/mil
<i>Joslyn</i> ^b			
900	60,000 pounds (27,270 kg)	4.8	350 volts/mil

^aPhiladelphia Resins Corporation, Commerce Drive, Montgomeryville, Pennsylvania, 18936.

^bJoslyn Mfg. and Supply Company, 155 North Wacker Drive, Chicago, Illinois 60606.

use with a tower on one end, and a steel cable on the other end. Both eye and jaw type fittings are available. The plastic rods come in lengths from 3 ft. (1 m) to about 14 ft. (4.26 m). Several may be put in series to reach the required length. They are stiff and shipped in straight lengths.

The Phillystran is available in continuous lengths of up to 1,000 ft. (304 m) and kits are available for putting on end fittings in the field, if so desired. Otherwise they may be put on pre-cut ordered lengths from the factory. The Phillystran plastic cable has low stretch. A black plastic cover is used to protect it from the sun's rays as well as corrosive atmospheres. With low power dissipation factors they are transparent to RF energy. The plastic rope is very flexible. It

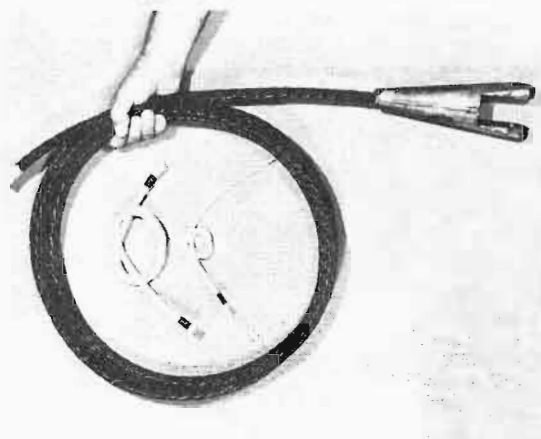

Fig. 34. Length of PHILLYSTRAN plastic guy cable rated at 55,000 pounds (25,000 Kgs) with PVC jacket and end jaw termination. Two unjacketed smaller cables are shown in center.

may be shipped in a coil or reel and is quite lightweight, as shown in Fig. 34.

For safety the plastic break-up insulator working strength should be greater than the steel cable with which it is used. Ample strength in various sizes is available. The manufacturer should be consulted for their recommendations for proper use.

LIGHTNING

Lightning is a natural phenomenon that has always fascinated man. It performs the function of maintaining a balance in the global electrical system. But apart from this, lightning is an extremely destructive force—annually killing an estimated six thousand people and inflicting a billion dollars in property losses—including FM antennas.

Because FM towers are usually located on high ground, hilltops, or high buildings, they require lightning protection since they are likely recipients of lightning strikes. The type of damage that can be caused by lightning to a FM tower is varied. Smaller coaxial lines will usually melt; larger coax, (1-5/8, 3-1/8) will also melt in some cases, and others will conduct the heavy current into the transmitter building to do damage there. The FM antenna itself may heat, arc, melt, and otherwise be damaged. Holes in the other conductor, burns and melting at flanges, are common. Teflon insulation will burn, depositing a film of carbon, causing further damage if RF from the transmitter continues after the strike.

Protection of the FM antenna system may be provided to some degree, by taking several precautions. The top of the tower should have a lightning rod, about a ft. (0.3 m) higher than the uppermost obstruction light. The FM

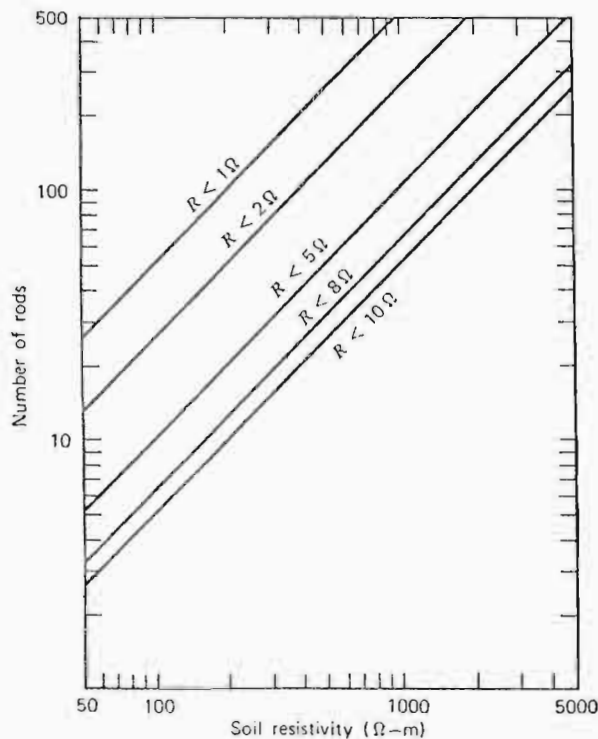

Fig. 35. Number of rods (10 ft. long, 0.75 in. diameter, spaced more than 20 ft. apart) needed to attain a required resistance value R for any value of soil resistivity.

antenna itself should be firmly grounded to the tower, or it should have excellent connections, so as to handle very high currents, for 1 or 2 seconds. If the coaxial cable is buried between the tower and the transmitter building, it must be at least six feet away from any tower base grounding system.³⁹

A ground system should be located immediately around the base of the tower. This should have a direct current loss of 10-ohms or less. Low resistance may be obtained by using ground wires buried in the soil. Six radials, spaced 60°, buried as deep in the soil as possible and running out up to 150 (45.7 m) ft. each, should provide a ground system with less than 10-ohms, if the soil is shallow, or rocky. Fig. 35 shows the number of equally spaced ground rods, required for any known soil conductivity, for a 10-ohm ground connection. Guyed tower anchors should also be grounded. This is shown in Fig. 49, page 172, in Chapter 8, Design, Erection and Maintenance of Antennas Structures, by Walter Guzewicz, in this book. It is important to install the proper number of ground rods to obtain at least 10-ohms contact with the earth at the base of the tower plus at

least one ground rod at each guy anchor if the tower is guyed.

If the FM antenna is located on an AM insulated base tower, then the spark gap should be set at the lowest point providing protection at the highest AM modulation peak. In these cases a FM coaxial transmission line isolator should be used to carry FM power across the tower base. These FM isolators may sometimes burn due to lightning charges or strokes. Since the internal spacing between input and output is so close for minimum RF insertion loss at the FM frequency, arcing may occur due to lightning strokes in these isolators. Therefore, it is highly desirable to set the AM tower base spark gap horn or balls, at 3/8 in. (1 cm) or less, if possible.

Another way to protect the FM transmission line isolator is to use an RF choke across the tower AM base. This tends to reduce the static build-up voltages due to passing thunderstorm clouds, snow, hail, or dust storms. Arc overs due to these sources usually do not cause damage, but may trip the FM transmitter reflectometer since they will create a current flow through the reflectometer circuitry.

ELECTRICAL DEICERS

A covering of ice over the active antenna radiating elements usually increases the VSWR. This is due to the fact that the electrical resonance of the antenna is lowered in frequency with the ice coating, which slows the velocity factor on the active elements, making them electrically longer. A means therefore should be provided to protect the transmitter from VSWR increases due to ice with persistent coatings over 1/16th of an inch (1.5 mm).

Two methods of deicing are in common usage. One uses electrical heaters inside the active parts of the antenna. This is economical in initial purchase and does not appreciably increase the wind catch area. It has a continuing cost when ice is present, as electrical power must be used to provide heating. The other method uses a plastic covering around the active parts of the antenna, and thus keeps the ice off. All American-made FM antennas are available with electrical deicers or plastic covers. The choice depends on cost factors.

Electrical deicers are furnished as a separate accessory item. They are designed for operation with 110/120 volts 50/60 Hz power sources. When heavy deicer loads are present, deicers may be ordered for use with 220/240 volts, single phase power circuits.

Single bay deicer power requirements vary from 300 watts up to 1,500 watts, depending on

³⁹Lightning Protection, J.L. Marshall, John Wiley & Sons, New York, 1973, Chapter 7, pages 114 through 144.



Fig. 36. Typical electrical tie in box with interbay cable.

the ice loads and conditions. Power wattage should be chosen with care. Deicers are supplied with a complete interbay kit, consisting of power junction boxes, conduit, clamps, etc, to tie power lines between bays. Fig. 36 shows a typical installation.

Deicers must be ordered at the time the antenna is ordered since they are installed at the factory. Optional items include power relays, low/high temperature thermostats, and humidity sensors.

Deicers usually provide years of trouble free service if properly installed. Actual deicer heating element defects are quite rare.

Poorly dressed deicer wiring cables can cause RF burns in the power cable, as well as the wall of adjacent coax, causing air leaks, and associated problems. Interbay conduit should be thoroughly grounded to the supporting tower or pole, to prevent RF burns. Deicer installation is electrical work and must not be left to tower riggers who are not familiar with it. It should be supervised by a competent person, knowledgeable in electrical matters.

RADOMES

Plastic covers, commonly called radomes, protect antennas from environmental exposure, principally ice. A covering of ice over the active antenna radiating elements usually increases the VSWR. The electrical resonance of the antenna is lowered in frequency, since the ice coating slows the velocity factor on the elements, making them appear electrically longer than they are physically without ice. Radomes do not normally degrade the performance of the antenna.

The plastic material available for use in radomes is quite transparent at the relatively low FM frequencies. Therefore, transmission loss due to absorption is usually not measurable.

Most manufacturers make certain that the shape, dimensions, and the type of material is such that very low reflections are present, which are tuned out during final adjustments, so as not to impair the VSWR of the antenna with radomes.

A radome is subject to thermal and structural loads. Ambient temperatures from below freezing to perhaps 110° F (45° C) must be safely survived, without physical distortion, and cracking. Glass-reinforced plastic (GRP) is the material of choice. Polyethylene tends to soften and distort in high ambient temperatures, with operation of the antenna at high power levels.

Environmental problems caused by rain, ice, snow, hail, lightning, vibration, and winds are problems for radomes. Well-designed and manufactured radomes can survive these acts of nature.

By far, wind loads produce the most severe stresses both to the antenna and its supporting tower. FM antenna suppliers show wind loads to be expected in their literature with no ice conditions at 112 mph wind velocity (180 km/h) as a standard. If the maximum wind velocity is higher or lower than this value, the correction can be made by using a factor of 50 pounds per square foot, round surfaces at this velocity (244 kg per square meter). If the resulting windload is higher than rated in their specifications, the antenna manufacturer should be consulted to determine, if the radome can withstand the higher wind velocity.

The supporting structure should be evaluated by a structural engineer to determine if the radomed antenna can be safely supported. Not only is there greater windloading, but the additional torque load may be too much. This twisting of the tower leg or face is a very important structural consideration. A typical FM antenna radome is shown as Fig. 24. Made of glass-reinforced plastic (GRP), this Jampro radome has a white protective gel coat.

The radome is coated with an ice resistant paint. This paint usually has titanium dioxide to make it white and reflective to ultraviolet radiation, which deteriorates polyethylene radomes, unless thus protected. A white gel coat over the fibreglass radome not only inhibits ice coatings, but prevents ultraviolet radiation from deteriorating the plastic.⁴⁰

It is interesting to note that water has a dielectric constant of 63 with a loss tangent of 0.55. When air is mixed with water and frozen as in snow, the dielectric constant goes down to 1.3, while the loss tangent is a low 0.0005. When

⁴⁰Radomes for Microwave Application, A. Holtum and K. McKee, Bulletin 600, June 1964, Andrew Corporation, Orland Park, Illinois.

frozen in the form of water, the dielectric constant is 3.2 and the loss tangent is a low 0.008⁴¹. This indicates that snow and ice do not present significant RF loss, when coating a radome, but do present some reflection because of the dielectric ratios of 1.3 and 3.2 times that of air.

Plastic radomes provide an effective way to overcome icing problems, without measurable RF loss or VSWR detuning effects for FM broadcasting antennas.

INSTALLATION PROCEDURES

The suppliers furnish detailed installation procedures with their antenna products. These instructions should be closely followed by the riggers. Many factors relating to the installation are taken for granted. The following items are specifically called to the attention of the broadcaster's engineer to insure proper installation and good performance for many years.

1. Follow manufacturer's instructions. See that the riggers also read these instructions.
2. Do not leave antenna parts where rain or moisture can enter. Store indoors or keep units capped as received.
3. Do not allow dirt or other foreign matter to enter any coaxial part.
4. Protect all antenna parts from physical damage and abuse.
5. Hoist antenna members carefully, with a tag line to prevent damage by striking against the tower.
6. Install on the tower as indicated by the manufacturer's instructions, remembering that bay number 1 is the uppermost top unit.
7. Riggers should lubricate "O" rings with a small amount of silicone grease before mating the flanges.
8. The full complement of flange bolts should be used and they should be as tight as possible.
9. Tuners or individual element devices, if used, should be adjusted only after the entire antenna and tower installation has been complete.
10. Rigid transmission lines should be properly installed with two hangers, per 20 ft. (6 m) length, and with the inner conductor retaining pin, if any, on the top of each section. One hanger should be approximately 1 ft. away from a flange. These lines must not be dented during installation. If dented, replace or straighten out with a round metal plug, several thousands of an inch smaller than the ID of the outer conductor.
11. If semiflexible cable such as heliack is used, it should be firmly tied down at least every

5 ft. (1.5 m) for 3-in. line and every 3 ft. (1 m) for 1-5/8-in. line. Also tie it down where it comes in contact with any sharp metallic member of the tower.

12. After physical installation has been completed, in accordance with the manufacturer's recommendations, the main transmission line should be pressurized with dry air through a dehydrator, air pump, or by using nitrogen gas.

13. Dry air (or gas) pressure should be maintained at all times. Some antenna warranties are not valid unless this is done. Dry air prevents the entrance of moisture. A sudden drop of air pressure indicates a leak, which should be located and remedied. Leaks come about from many sources. They include lightning damage, chafing through mechanical movement, cracks due to vibration, and copper fatigue. Even stray bullets from carelessly handled guns can cause problems.

14. While the recommended level of air pressure varies, its purpose is to keep moisture out and to signal the presence of more serious trouble. Moisture within a coaxial line may cause electrical breakdown by flashing across internal insulation. Moist air, over a long period of time, will cause the copper conductor to oxidize, causing considerable loss in electrical efficiency, as well as heating in high power installations.

15. When initially putting dry air (or gas) in the line, the coaxial transmission line system should be purged. This can be done through the use of valves provided for this purpose by some firms, or loosening one of the uppermost flanges so it leaks air. The extent of purging should be sufficient to let all the trapped moist air escape to be replaced by the dry air from the pressurizing system.

16. The antenna system should be checked by a qualified rigger everytime the obstruction lights are replaced, or if lights are not used, at least once a year. The rigger should look for vibration and storm damage such as loose or broken coaxial line hangers, loose tiedowns or semiflexible lines, and signs of arcing across any exposed insulator. These insulators should be wiped off with a dry rag to remove any dust or dirt which may have accumulated. In corrosive air environments, it may be desirable to clean these insulators with carbon tetrachloride liquid.

RADIATION HAZARDS

Exposure to high power VHF-UHF electromagnetic radiation can be harmful to people, due to the effects of overheating upon the living tissue. Heating is a function of the

⁴¹RADAR Handbook, Merrill and Skolnik, pages 14-30, McGraw-Hill Book Co., New York, 1970, New York.

radiated field. It is generally expressed in terms of the average power flow per unit of the incident area, and indicated in milliwatts per square centimeter. In the United States, OSHA (Occupational Safety and Health Act of 1970, Department of Health, Education and Welfare) has set a maximum level for nonionizing radiation of 10 mw per square centimeter. For FM broadcasting, this is equal to 200 volts per meter, if measured by a suitable field strength meter. The US Bureau of Radiological Health⁴² has suggested methods of measuring this radiation level with an accuracy of better than 0.69 dB.

There is considerable difference of opinion as to the safe level of radiation as a function of frequency. However, the duration of the level has been generally indicated as ten minutes, by the developed nations. Power at different frequencies is additive for heating hazards. The eyes are the most sensitive to damage, followed by the testes.

The most direct approach to providing protection from radiation exposure is to determine the minimum safe distance from the closest FM radiating element. The protection distance from an antenna depends on the peak radiation direction and distance. The peak ERP does not occur at the base of an FM tower, but at the horizontal in most cases. Fig. 37 shows the recommended distances for radiation of less than 10 mw per square centimeter. This was taken from the FCC guideline for VHF-UHF Radiation Hazards.⁴³

A recent proposal for the installation of four different FM stations, using a common antenna with 100 kw ERP each (400 kw total ERP) mounted on a building roof, was disapproved by OSHA. It was determined by computer analysis that the radiation level on the roof would be in excess of 200 volts per meter, in some areas, due to reflections which would double the total field in some spots. The lowest element of the

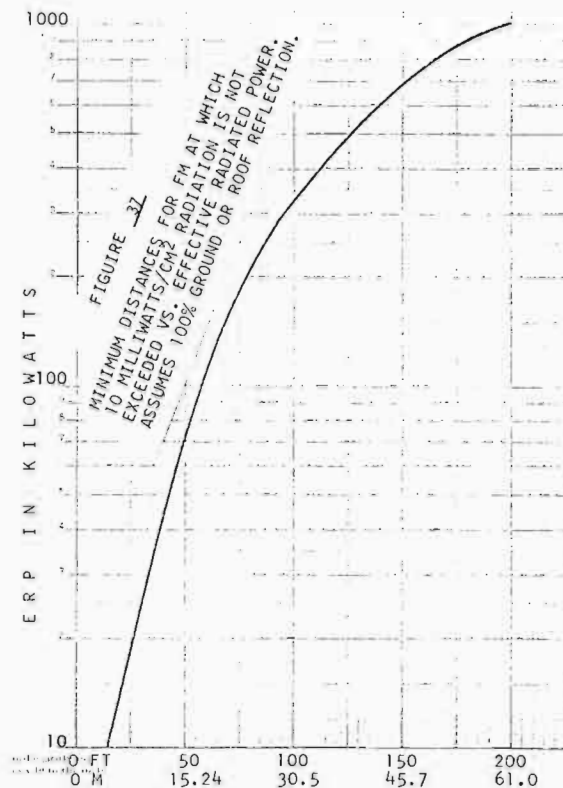

Fig. 37. Minimum distances for FM at which 10 milliwatts/cm² radiation is not exceeded versus effective radiated power, assumes 100 percent ground or roof reflection.

common antenna was raised to a height of 100 ft. (30 m) in order to meet the safe level.

Roof-mounted or high mountain installations with relatively short towers may present similar radiation hazards, when a total of 300 kw or more is being transmitted from several broadcast stations. Medium to high gain antennas, on towers of 100 ft. (30 m) or higher will usually not present radiation hazards at the current United States safe level of 10 mw/cm² (ten milliwatts per centimeter squared).⁴⁴

⁴²Precise Microwave Power Density Calibration Method Using the Power Equation Techniques, W. Herman and H. Bassen, U.S. Dept. of HEW, DHEW Publication FDB 75-8028, March 1975.

⁴³Report 7104, VHF-UHF Radiation Hazards and Safety Guidelines, Federal Communications Commission, Washington, D.C. 20554.

⁴⁴Computation of the Electromagnetic Fields and Induced Temperatures within the Human Eye, Taflove and Brodwin, *Microwave Theory and Techniques*, Vol. MTT-23, Number 11, *IEEE Transactions*, November 1975.