

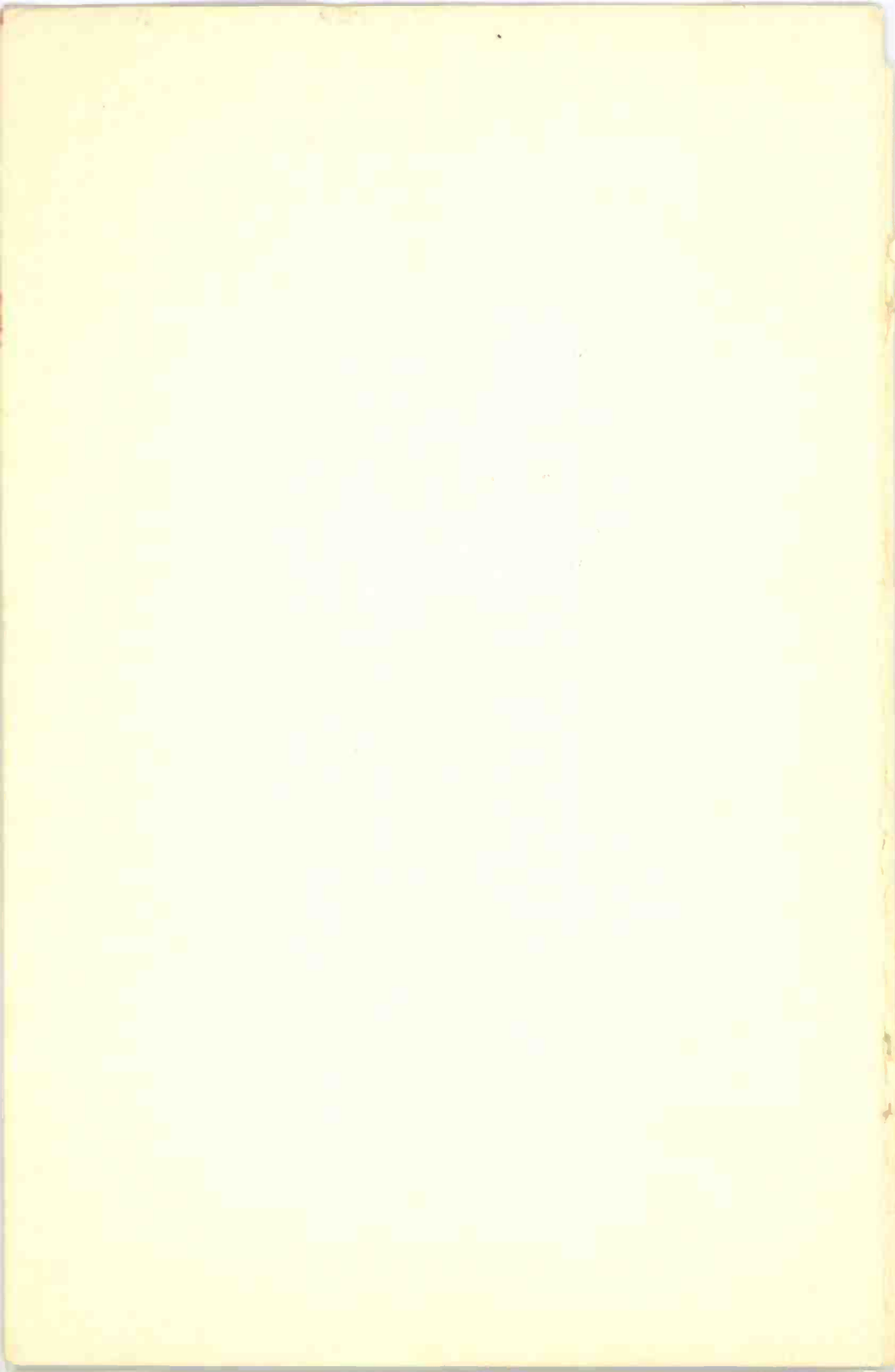

INSTRUCTION & OPERATING MANUAL



KAAR ENGINEERING CORP., Palo Alto, Calif., U.S.A.



CONALERT II
OPERATING MANUAL

Model Designations

Cabinet Style: 117R905

Relay Rack Style: 117R906

Mfd. by Kaar Engineering Corporation
2995 Middlefield Road, Palo Alto, California, U.S.A.

TABLE OF CONTENTS

Paragraph	Page
INTRODUCTION	1
1. DESCRIPTION OF THE CONELRAD SYSTEMS	3
2. THE CONALERT FUNCTION	3
3. INSTALLATION	4
a. General	4
b. Antenna	4
c. Earth Ground	6
d. External Speaker	6
e. External Alarm	6
f. External Reset	6
4. OPERATING INSTRUCTIONS	6
a. General	6
b. Initial Installation	6
c. To Monitor a Key Station	6
d. How CONELRAD Alarms are Indicated	7
e. To Restore Monitoring Conditions	7
f. Identification of True CONELRAD Alarms	7
g. Tests for Alarm Function	8
5. INITIAL CHANNEL TUNEUP	8
a. General	8
b. Tuning Procedure	10
c. Channel RF Gain Control Adjustment	10
d. Modification for Crystal Control	10

ILLUSTRATIONS

Figure	Page
1 Front View, CONALERT II	2
2 CONALERT II, Channel Tuning Controls	9

APPENDIX: TECHNICAL DATA

Technical data for use by electronic technicians is appended to the back of the book. This consists of a schematic diagram of the Conalert II, a parts list, and other data which may be required for maintenance purposes.

INTRODUCTION

The CONALERT II is a sensitive instrument which is designed for a specific purpose, that of monitoring radio broadcasting and automatically responding to CONELRAD air raid defense procedures. The CONELRAD procedures are described briefly in this booklet, together with a description of how the CONALERT responds to them. In addition, all data which may be required for installation and operation of the unit are described in sufficient detail so that proper operation may, in most cases, be obtained without the help of skilled radio technicians.

Since the CONALERT performs a role which may be vital to the safety of many lives, every design factor which makes for the utmost reliability has been incorporated into the unit. The result is an instrument which performs its monitoring function more reliably than any human operator who might be assigned to the task; it even sounds its warning if a failure occurs within itself, or when a failure occurs at the broadcast station which it monitors. It cannot, of course, think for itself in the fashion of a human operator, hence it cannot differentiate between a true CONALERT alarm and certain technical faults which sometimes occur at the monitored station. In such cases, it sounds the alarm as though a true CONELRAD alarm has taken place, and the human operator must determine if the alarm is "real" or "false". This booklet accordingly includes a thorough description of what might be expected in these matters.

CONELRAD ALARM Warning Indicator
Glowes red to indicate Conelrad Alert.
Speaker also comes on, as well as external alarm circuits. Tone signal and announcement will authenticate alarm. If nothing is heard, switch CHANNEL switch to another station observe instructions for MONITOR switch.

CHANNEL switch
Select A, B, or C positions according to schedule. After Conelrad Alert starts, these positions will be silent; turn to the Conelrad positions (640 kc or 1240 kc) to hear Civil Defense broadcasts.

SCHEDULE
Lists operating hours of key broadcast stations



POWER indicator (green) must glow at all times while monitoring.

EXTERNAL ALARM switch: External alarm circuits will not operate if this switch is OFF.

VOLUME control
Adjust for comfortable level if using aural monitoring, louder if using silent monitoring.

MONITOR switch
Push up to listen. Push down to reinstate monitoring function -- Red CONELRAD ALARM indication will cease if key station is back on the air. Central or SILENT position is used for silent monitoring only after setting VOLUME high and listening to make sure that a Conelrad Alert is not in progress.

Figure 1 - Front View, CONALERT II

1. DESCRIPTION OF THE CONELRAD SYSTEM

The word CONELRAD is a coined term which stands for "CONtrol of ELectromagnetic RADiations". It is a civil defense procedure which permits civil defense broadcasting to continue during an air raid, while at the same time rendering these broadcasts useless for navigational purposes. For civil defense purposes, the country is divided into areas; each civil defense area is under the control of an Air Defense Control Center, from which an Air Division (Defense) Commander supervises and coordinates air defense activities. At the beginning of a period of imminent air attack, the commander may initiate a CONELRAD alert, through direct communication with designated "key stations". The key station immediately executes the CONELRAD sequence, which consists of the following steps:

- (1) Discontinue normal program.
- (2) Cut the transmitter carrier for approximately five seconds.
- (3) Return carrier to the air for approximately five seconds.
- (4) Cut the transmitter carrier for approximately five seconds.
- (5) Return carrier to the air.
- (6) Broadcast 1000 cycle steady state tone for 15 seconds.
- (7) Broadcast the CONELRAD Radio Alert Message as follows: "We interrupt our normal program to cooperate in Security and Civil Defense measures as requested by the United States Government . . . this is a CONELRAD Radio Alert. Normal broadcasting will now be discontinued for an indefinite period. Civil Defense information will be broadcast in most areas at 640 or 1240 on your regular radio receiver."
- (8) Cut transmitter carrier (regular broadcasting ceases until the "all clear").

All radio stations in the area must intercept this CONELRAD warning. Immediately upon receipt of this warning, various Civil Defense procedures are placed into effect. All radio broadcasting ceases, except the controlled broadcasts on the frequencies 640 and 1240 kc for civil defense purposes. When these measures are no longer necessary, the Air Division (Defense) Commander initiates an "all clear" order which is broadcast on the CONELRAD frequencies, and later repeated by all of the standard AM, FM, and TV broadcast stations as they resume normal operation.

2. THE CONALERT FUNCTION

As described above, the all-important link in the CONELRAD chain of events is the immediate and positive detection of the CONELRAD warning sequence at the time it is executed by the key station. This is the prime function of the CONALERT II. It is capable of maintaining a continuous watch over the transmissions from the key station, without need for continuous listening to normal program material. It consists of a special receiver coupled to a sensitive triggering device, so designed that it responds to CONELRAD alert

warnings. When such warning signals are received, the audible warning announcements are automatically coupled to the speakers, a warning light flashes, and external alarms are energized. All design factors which make for maximum reliability in performing this function are incorporated into the CONALERT. The radio receiving circuits it contains are equal to those used in the finest home broadcast receivers, so that it is capable of monitoring signals from distant key stations where the incoming signal is weak, while at the same time discriminating against strong local interfering signals. These local signals accordingly have little or no effect on the monitoring function, so that the danger of missing a CONELRAD alert is reduced. The alarm circuits are arranged so that the CONELRAD alarm circuits are automatically energized whenever the transmitter at the key station being monitored is turned off. To reduce false alarms, a delay period of 2-1/2 seconds is introduced into these circuits. Because of this arrangement, momentary interruptions of key station transmissions or short time fading do not cause the alarm to sound. Once set up, the CONALERT may be operated with speaker turned off, so that it is not necessary to listen to the key station under normal broadcasting conditions.

3. INSTALLATION

a. General. There are several variations in installation procedures. In areas where the key station is reasonably strong at all times, the installation may be performed by non-technical personnel. Where more elaborate procedures are indicated, the installation should be performed by experienced technical personnel. Installation details, such as the proper routing of wires, coaxial cable terminations, etc., will vary from installation to installation, hence a detailed description of such factors cannot be included in this book.

b. Antenna. Antenna type depends on strength of signal from key stations to be monitored, and amount of interfering signals present. If all key stations are local, signals are generally strong enough to override all interference, even with a simple wire antenna. For such installations, a 10 to 25 foot wire which is stretched out and hidden in the vicinity of the Conalert will be adequate. Connect one end of this wire to the ANT terminal marked HI. This antenna will not be satisfactory, however, if any one of the following conditions exist:

- Condition I: The signal from one or more key stations drops to a low value at any time.
- Condition II: Strong electrical interference is present in the immediate area of the Conalert.
- Condition III: The desired key station is blanketed by a strong interfering signal which is on, or nearly on, the same frequency.

Where these conditions exist, the Conalert should be provided with a more elaborate antenna such as one of those shown on the opposite page. For weak signal areas, an outdoor whip antenna with a 50-75 ohm coaxial cable lead-in (such as RG-58/U) will be justified. Such antennas deliver a stronger signal to the receiver, and at the same time are insensitive to strong local interference (Conditions I and II). In medium signal strength areas, a simple and relatively inexpensive indoor loop arrangement is recommended, particularly if tests of the simple wire antenna reveal local noise interference pickup.

The loop is made up of shielded phonolead, such as Belden No. 8431 cable, connected as shown in the diagram in the figure below. The lead-in portion may be as long as necessary (up to 25 feet) to enable placement of the loop on a wall or other convenient position. The loop should be mounted in an approximate rectangular shape. Loops of this type have directional properties, hence its position should be determined by moving it about to various positions while checking for best reception (or highest AVC voltage reading) on all channels. In certain positions, the loop may even be used to eliminate an interfering signal (Condition III). Permanent indoor mounting of the loop in this critical position is not usually feasible, however, hence the construction must be changed to permit placing the loop outdoors. The loop in this case is made up entirely from 50-75 ohm coaxial cable such as Type RG-58/U. The loop should be 15 to 20 feet long, and supported on a pole in a circular or rectangular position by two or more cross bars. The lead-in portion may be any length up to 100 feet, as necessary to permit mounting the loop well clear of obstructions. With the Conalert in operation, the loop is rotated until the interfering signal drops out. In some cases, it may also be necessary to tilt the loop. In almost all cases, a loop position can be found in which the interfering signal is eliminated, while retaining adequate signal from the desired key station.

NOTE: In extreme cases, as in some broadcast station installations, it may also be necessary to install a wave trap in the antenna input. A space is provided for this purpose on the Conalert II chassis (opening near Transformer T1).

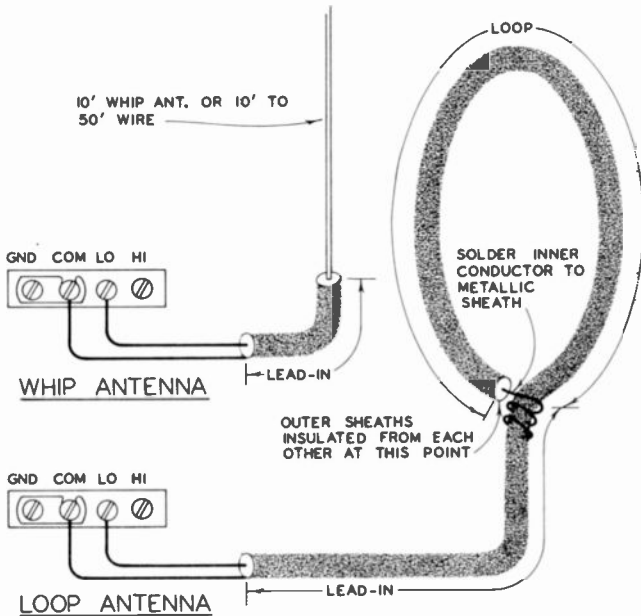

SEE TEXT FOR DETAILS ON TYPE OF CABLE, LENGTH OF LOOP, AND LENGTH OF LEAD-IN.

c. Earth Ground. An earth ground is not essential to proper operation. In order to conform to established safety standards, however, an earth ground connection should be made to the GND terminal, particularly in cases where there are grounded metallic objects within a radius of 10 feet from the unit. In most cases a suitable earth ground will consist of a wire connection to a clamp on a water pipe.

d. External Speaker. An external speaker (PM type, 3-4 ohm voice coil) may be connected to terminals 7 and 8 to duplicate operation of the panel speaker. Ordinary zip cord will normally serve for the interconnecting wire. If continuous operation of the external speaker is required, even when silent monitoring is employed (panel speaker silenced), connect to terminals 8 and 9.

e. External Alarm. An external alarm is not required for proper operation of the unit. For greater convenience, however, it may be desirable to install an alarm device at a remote point. Any device which requires 6.3 volts a-c at no more than one ampere (a 6.3 volt indicator light, for example) may be connected to terminals 2 and 3 on the back of the unit. The required 6.3 volts is supplied to these two terminals when a CONELRAD alarm occurs. When an alarm occurs, a connection is also completed between terminals 5 and 6 on the back of the unit. The latter arrangement may be used to complete the alarm circuit of any self-contained alarm system. An ordinary door bell, for example, may be connected in series with a battery of the proper voltage, and the two wires which would normally connect to the push button are extended to terminals 5 and 6. This arrangement has the advantage that the alarm will be indicated when a power failure occurs. If alarm with power failure is not important, a step-down transformer may be substituted for the battery.

f. External Reset. An external reset facility is available, if required. This may be a button type momentary contact switch located at any convenient operating position. A suitable switch could be a SPST switch, normally closed, with a spring return, such as Switchcraft No. 102 or 103 connected SPST, normally closed. Ground one side of this switch to the common earth ground, or connect by means of wires to terminal 2 and return other side of switch to terminal 1.

4. OPERATING INSTRUCTIONS

a. General. This section includes the complete operating instructions as applied to the unit after the initial installation tuning has been completed.

b. Initial Installation. The installing operator must be familiar with the function of the various controls before tuning can be performed, hence it is suggested that the operator follow the procedures given here, with due allowance being made for absence of normal responses due to lack of tuning. After becoming familiar with the functions of the various controls, the installing operator may then proceed to the tuning instructions which are given in the next section.

c. To Monitor a Key Station. To set up the CONALERT II for purposes of monitoring any CONELRAD key station, perform the following steps:

- (1) Turn ON by rotating VOLUME control clockwise. Both green and red indicator lights will glow.

NOTE

GREEN POWER INDICATOR MUST GLOW AT ALL TIMES WHILE MONITORING.

- (2) Check schedule; select Channel A, B, or C (any key station in operation).
- (3) Adjust VOLUME control for listening, or if silent monitoring is desired, set volume well above room noise level.
- (4) Push MONITOR lever down to RESET position. Red CONELRAD ALARM indicator light will go out, and speaker will be silenced. Push MONITOR lever up to AURAL position if continuous listening is desired, or allow to remain in central SILENT position, if silent monitoring is desired (in this case, the speaker will come on automatically at the time that a CONELRAD alarm occurs).
- (5) Disconnect or connect external alarms as required by rotating EXTERNAL ALARM switch. External alarms do not operate when this switch is in the OFF position.

d. How CONELRAD Alarms Are Indicated. When a CONELRAD alarm occurs, three actions occur automatically:

- (1) Speaker comes on, so warning tone and announcement will be heard.
- (2) CONELRAD ALARM indicator (red panel light) will glow.
- (3) External alarms will be activated, provided the EXTERNAL ALARM switch has been left in the ON position.

NOTE

These conditions will continue until operator takes action.

e. To Restore Monitoring Conditions. If announcements indicate that an alarm was for test purposes, or if listening indicates that alarm occurred for other reasons (as for example, when signal failure occurs for a period of time greater than 2-1/2 seconds), depress MONITOR lever to RESET position momentarily. If key station is back on the air, alarm indications will cease.

f. Identification of True CONELRAD Alarms. True CONELRAD alarms may be identified by the CONELRAD sequence (see page 3). After the steady state tone and the radio alert message, the key station will leave the air, and Civil Defense broadcasting will be heard on the CONELRAD frequencies 640 kc and 1240 kc (the CHANNEL switch must now be rotated to one of these positions). An important point to note is that the key station will not be broadcasting on its regular frequency after the warning announcement. If this alarm and announcement escapes attention, there will be no sound from the speaker, but the red CONELRAD ALARM indicator will be glowing, and external alarms will be indicating alarm conditions (if EXTERNAL ALARM switch is ON). To

confirm alarm, turn CHANNEL switch to another key station, if one is in operation, to determine if it, too, has left the air. If nothing is heard, switch to the CONELRAD ALARM frequencies 640 kc and 1240 kc, where Civil Defense transmissions will be heard if CONELRAD procedures are in force. This procedure is suggested in order to eliminate undue alarm in cases where an extended breakdown at the key station has occurred.

g. Tests for Alarm Function. A number of observations are available for purposes of confirming that the CONALERT II is operating properly. These are as follows:

- (1) The best test for proper operation of the CONALERT II is an actual CONELRAD alarm test, performed by the key station. In most areas, such tests will be performed at least twice a week. Alarm indications can occur without official tests, as for example, when short term faults occur at the key transmitter. Such faults occur frequently in the course of most broadcasting services; they are generally of such short duration that the break in program is not noticeable. They will cause no alarm indication if the duration of the fault is less than 2-1/2 seconds. An occasional alarm indication may be expected, however, due to breaks which exceed this time limit. These alarm indications may be regarded as assurance that the CONALERT II is operating properly.
- (2) In areas where there are only two key stations, the third channel may be detuned so that no signals can be heard. A satisfactory alarm test then consists of rotating the CHANNEL switch to this position. After a delay period of 2-1/2 seconds, the alarm circuits will be energized.
- (3) In areas where all three key channels are tuned to key stations, the alarm may be tested by disconnecting the antenna, or by shorting it to ground, for a period of more than 2-1/2 seconds.
- (4) Primary 117 volt a-c power failures or interruptions of more than 2-1/2 seconds duration will also cause alarm circuits to close. This will account for an occasional alarm, but should not be regarded as a proper test of the alarm function.

5. INITIAL CHANNEL TUNEUP

a. General. As shipped from the factory, all possible tuning adjustments have been completed. This does not, however, include the tuning of the A - B - C Channels to local key stations. This portion of the tuning process must be completed by the person who installs the CONALERT II. No technical knowledge is required to perform the task; it is necessary only to follow the instructions given here and in Figure 2. The call signs and frequencies of local CONELRAD key stations may be obtained from any local broadcast station, if this is not known (all broadcast stations are required to monitor the key stations). All adjustments may be performed by means of a small screwdriver. Before tuning starts, the RF GAIN controls (4) should be rotated to the full counterclockwise position for all channels (A - B - C). After tuning has been completed, these controls are reset according to procedures given below.

<u>CHANNEL</u>	<u>TUNING RANGE</u>	<u>FACTORY SETTING</u>
A	535 TO 1650 KC	680
B	535 TO 1650 KC	740
C	800 TO 1650 KC	810

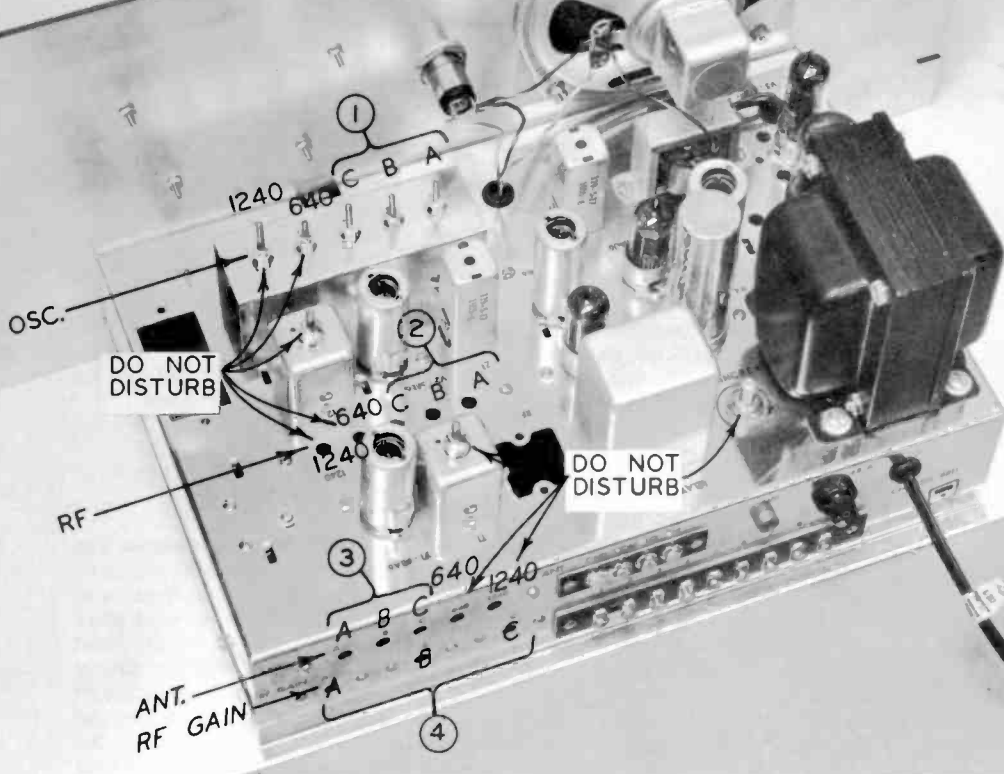

Figure 2. CONALERT II - Channel Tuning Adjustments

b. Tuning Procedure. Tune Channel A as the first step by first setting the front panel controls for aural monitoring on this channel, and setting the volume control to a comfortable level. Reset volume occasionally as tuning progresses, to a reasonably low volume. Tune according to the following procedure:

- (1) Note factory setting of controls according to the chart in Figure 2. Compare with the frequency of the local key station which is to be tuned in on Channel A. If frequency of key station is lower than factory setting, turn OSC adjustment for Channel A only (① A in Figure 2) in a clockwise direction; if frequency of key station is higher than factory setting, turn counterclockwise.

NOTE

OSC control ① tunes through the broadcast band, starting with the full-in position at the low end (approximately 535 kc for Channels A and B, and 800 kc for Channel C) and ending at the full-out position at the high end (approximately 1650 kc).

Turn only two or three turns at a time. After each two or three turns, tune RF ② and ANT ③ adjustments (for Channel A only) for maximum sound or noise. Keep repeating these adjustments in sequence (RF - OSC - ANT) ① - ② - ③ until desired key station is heard.

- (2) As final adjustment, rotate OSC control ① completely through point where desired station is heard. Note two control positions where station is just audible, and rotate control to the halfway position between these two points. Rotate the RF and ANT adjustments ② and ③ in a similar manner to obtain the central point of maximum volume.

Now repeat the entire procedure for Channel B and for Channel C in turn, starting with the setting of the front panel controls.

c. Channel RF GAIN Control Adjustment. The channel gain controls are screwdriver type controls on the back of the chassis. In the fully counterclockwise position, these controls allow the receiving circuits to operate at fullest sensitivity (e.g., the alarm circuits are able to operate on very weak key station signals). For average and strong signals, an adjustment of these controls is desirable. Under some conditions, it may be possible for the alarm circuits to "hang-up" on noise (the static and rushing sounds which are heard when the key station is off the air); although the possibility for this happening is very remote, the channel gain controls (labeled RF GAIN on the back of the chassis) have been added to eliminate this danger. Rotation of these controls in a clockwise direction, in effect, reduces the strength of the incoming signal. Where the incoming signal is strong, this signal strength may be reduced considerably without affecting the alarm performance. There are four possible adjustment procedures. These are as follows:

- (1) If signal from any key station is weak, leave control for that channel in the fully counterclockwise position.
- (2) If signal from any key station is of average strength, the RF GAIN control may be rotated in a clockwise direction approximately one-eighth of a turn.

- (3) If signal for any key station is strong, the RF GAIN control for that channel should be rotated clockwise until reception of this station is approximately the same as that of weaker stations.
- (4) If a test voltmeter is available, the voltage between the AVC test jack and the chassis may be determined. The meter should be a 20,000 ohm-per-volt type, or better. The RF GAIN control for each channel is set for a reading of approximately minus 2 volts. Where reading is less than this value, with the RF GAIN control in the full counterclockwise position, no further adjustment is needed. It may also be noted that the minus 2 volt level is appropriate for average installations. In some rare instances, a different level may be desirable (minus 4 volts, for example), if it is found that response to CONELRAD scheduled tests is faulty.

The first three methods may be performed by any person without test instruments, with accuracy enough for all practical purposes. If in doubt concerning these adjustments, and the fourth method cannot be employed, simply observe performance of the CONALERT II on each channel at the time of a scheduled CONELRAD test, as conducted by the key stations in each area.

d. Modification for Crystal Control. In areas where one or more key stations are very weak, it may be desirable to replace the OSC (①) adjustment with a crystal. This will not ordinarily be necessary, since the CONALERT II is designed to accurately hold its tuning for long periods of time. The addition of a crystal, however, would further reduce any possibilities for error to negligible proportions, and may thus be desirable in some situations. The modification for this purpose should be performed by a qualified radio technician, using the instructions which are included with the technical data sheets accompanying the CONALERT II. If any channel has been modified for crystal controlled operation, the OSC adjustment (①) will be inoperative; the crystal accurately tunes this portion of the set. The alignment procedure must accordingly be modified; the RF and ANT adjustments (② and ③) are simply adjusted for maximum volume.

W A R R A N T Y

All KAAR equipment has been thoroughly tested and found to be in proper operating condition upon shipment from the factory and is guaranteed to be free from any defect in workmanship and material that may defective within this period shall be replaced without charge when subjected to examination at our factory, providing such defect in our opinion is due to faulty material or workmanship, and not caused by tampering, abuse or normal wear. All such adjustments are to be made F.O.B. the factory. The replacement of tubes, vibrators and dynamotors will be in accordance with the warranty of the original manufacturer. No further guarantee or warranty is suggested or implied. In accepting delivery of the equipment, the purchaser assumes full responsibility for proper installations, proper installation adjustments and service arrangements.

Shipments are made F.O.B. factory, and are insured unless otherwise instructed by the purchaser. Acceptance by the carrier constitutes delivery to the purchaser. Claims for visible or concealed damage should be filed with the carrier, by the purchaser, within five days after receipt of goods; claims for loss in transit should be filed in a similar manner. Forms for filing claims can be obtained from the carrier. The factory will gladly assist the purchaser upon request. All packing is in accordance with the requirements of the Consolidated Freight Classifications.

Should it be necessary to return the equipment or any parts to the factory, contact the dealer from whom the equipment was purchased. He must obtain authorization from the factory before making any returns. Should the equipment require adjustments, contact your dealer who has complete technical data. The dealer, in turn, will contact the factory if necessary.

Kaar Engineering Corporation radiotelephone equipment is licensed under the patents of the American Telephone and Telegraph Company, Radio Corporation of America, the Hazeltine Corporation, and other licensors for radiotelephone and radiotelegraphy transmitting and receiving, radio goniometry, depth sounding and broadcast receiving.

Kaar Engineering Corporation reserves the privilege of making revisions in current production of equipment and assumes no obligation to incorporate these revisions in earlier models.

KAAR ENGINEERING CORPORATION

Palo Alto, California

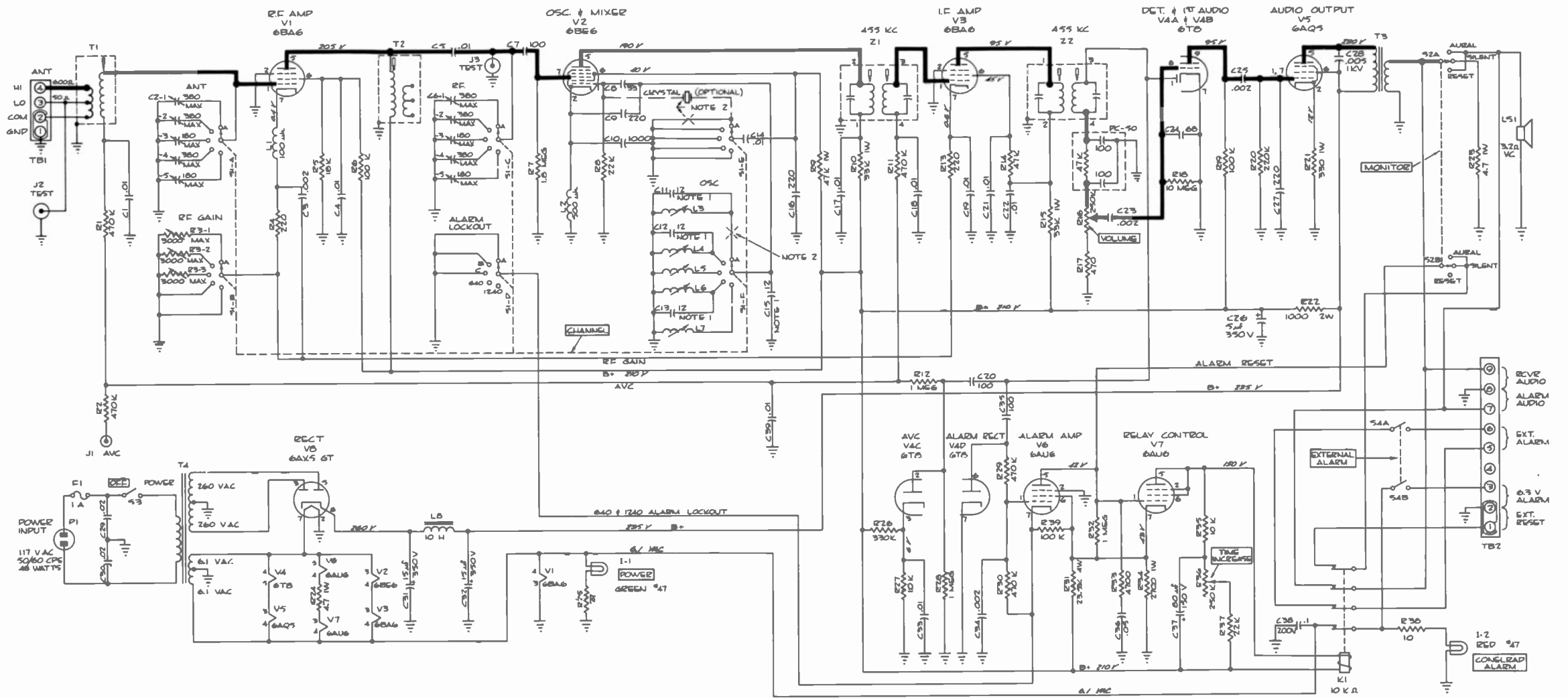

NOTE 1
CAPACITOR, TEMPERATURE COMPENSATING;
12 MFD ±10%, TYPE N100, EPC STYLE 331
OR EQUAL. FOR CHANNEL FREQUENCIES
ABOVE 1000 KC, THE CAPACITOR ACROSS
THE COIL MAY BE DISCONNECTED FOR
SLIGHTLY GREATER STABILITY.

NOTE 2
TO CONVERT FOR CRYSTAL CONTROLLED
OPERATION, BREAK SWITCH CONNECTIONS
AT "X" AND CONNECT CRYSTAL AS
SHOWN BY DASHED LINE (SHOWN FOR
CHANNEL "A" ONLY).

NOTE 3
UNLESS OTHERWISE INDICATED, RESISTANCE
VALUES IN OHMS & RESISTORS & WATT
CAPACITANCE VALUES ONE & OVER IN
MICRO-MICROFARADS, LESS THAN ONE
IN MICROFARADS & CAPACITORS 400 VDC.

NOTE 4
ALL DC VOLTAGES MEASURED WITH A
VTVM WITH RESPECT TO CHASSIS,
UNDER NO SIGNAL CONDITION.

NOTE 5
HEAVY LINES INDICATE MAJOR
SIGNAL PATH.

REVISED 4-18-56 7-16-56	SCHEMATIC DIAGRAM CONALEST II
K&E ENGINEERING CORP. PALO ALTO, CALIF., U.S.A.	
DATE 12-28-55	SERIAL NOS. 131 & UP
DRAWN BY VCL	CHKD BY JAC
CHECKED BY JAC	APPROVED BY JAC
	3-8811-1

MAINTENANCE DATA

Conalert II

Cabinet Style:
Model 117R905

Relay Rack Style:
Model 117R906

Purpose: - This sheet, together with schematic diagram on reverse side, provides technical maintenance data for use by electronic technicians.

Installation and Operation: - See Operating Manual.

Serial Numbers: - The serial number should be given in any correspondence concerning this item. Number is stamped on chassis below power transformer.

Replacement Parts: - Use standard replacement parts with ratings shown on schematic diagram. Parts list below includes all items on which additional information is required. Replacement parts may be obtained from Kaar or from original manufacturer using identification given.

K1	RELAY, 4B with 10K ohm coil; Kaar #5502; Mfr, C.P. Clare and Co., 4719 W. Sunnyside Ave., Chicago 30, Ill. Alter- nate: Phillips Control Corp., Dept EB1420, Joliet, Ill.	S2	SELECTOR SWITCH, Spring Spring Return 2P3Pos, CRL #1466, Mfr: CRL
L3, L4	OSC. COIL, Kaar No. 2109;	S4	ROTARY SWITCH, 2P2Pos, Kaar #3012; Mfr: CRL
L5, L6	Mfr: Western Coil Products,	T1, T2	ANTENNA COIL, Kaar #2108; Mfr: Western Coil Products
L7	2989 Middlefield Road, Palo Alto, Calif.	T3	OUTPUT TRANSFORMER, Kaar #1030; Mfr: Excel
L8	FILTER CHOKE, 10H at 75 ma., Kaar #1039; Mfr: Excel Trans- former Co., 2567 38th Ave., Oakland, Calif.	T4	POWER TRANSFORMER, Kaar #1055; Mfr: General Transformer Corp., 18240 Harwood Ave., Homewood, Ill.
S1	BAND SWITCH, 6P5Pos; Kaar #3008; Mfr: Centralab (CRL), 900 E. Keefe Ave., Milwaukee, Wisconsin	Z1, Z2	I-F TRANSFORMER, #1655-6; Mfr: Automatic Mfg. Corp., 65 Gouverneur St., Newark 4, N.J.

Brightness of Indicator Lights. - The brightness of the indicator lights may be increased or decreased by adjusting the value of R25 and R38. Some production units may be supplied with resistors whose values differ from those shown on the schematic, in order to compensate for variations in the plastic indicator lens.

Crystal Control: - Use low drift crystal ground for 32 uufd input cap., frequency 455 kc. above desired key station frequency. Install crystal socket in opening above channel selector switch. Disconnect oscillator coil; connect crystal according to Note 2 on the schematic.

Alignment: - CONELRAD and I-F adjustments have been accurately made at the factory. Re-tuning is not ordinarily required in the field unless unauthorized tampering has taken place. Use standard procedure for I-F's; peak for maximum d-c voltage at AVC TEST jack with 455 kc signal, using 20,000 ohm/volt meter or better. If unit has been modified for crystal control, I-F alignment must be exact at 455 kc. For alignment of Channels A, B, and C, tune to CONELRAD KEY stations according to instructions in operating manual. Channels 640 and 1240 are tuned to these frequencies (exact); avoid re-tuning unless tampering has taken place.

Time Set: - Factory set for 2-1/2 second delay from time r-f carrier is cut to time relay is de-energized.

Production Changes: - Applied to Serial Nos. 1311 and up; R30 returned to pin 7 of V6 instead of to ground, R39 added. R35 was 22K; J2 and J3 added. Changes at V6 stabilize cathode emission slightly; other changes are for convenience in production. Conversion of earlier serial numbers is not recommended.

KAAR ENGINEERING CORPORATION
2995 Middlefield Road, Palo Alto, California, U.S.A.