

ICD 08559

OCTOBER 1990 \$2.95

CANADA \$3.95

MODERN ELECTRONICS™

THE MAGAZINE FOR ELECTRONICS & COMPUTER ENTHUSIASTS

Stand-Alone Burner Programs PROMs

Video From Mono with Sound Effects

Construction Plans:

1. Video Frame Grabber 2. Remote Controller 3. Power On/Off



Stand-Alone PROM Programmer (p. 17)



Power-On/Off IR Remote Controller (p. 34)



Single Channel Sound Exploder (p. 25)

100% 07VOLD
326 STEIN DRIVE
ENDICUTT
NY 13760

*****3-DIGIT 137
03 00677405 9110 9010 AFE

Railk Rate
U.S. Postage
PAID
Permit No. 79
Gordonsville, VA
22942

Plus: Evaluating Borland's "Quattro Pro" Software and Logitech's Trackball • A High-Sensitivity Lightwave Receiver • Lightmeter DMM Add-On, Part II • New Technical Books & Literature ... more.

If only your broken VCR, Computer or TV...could talk.

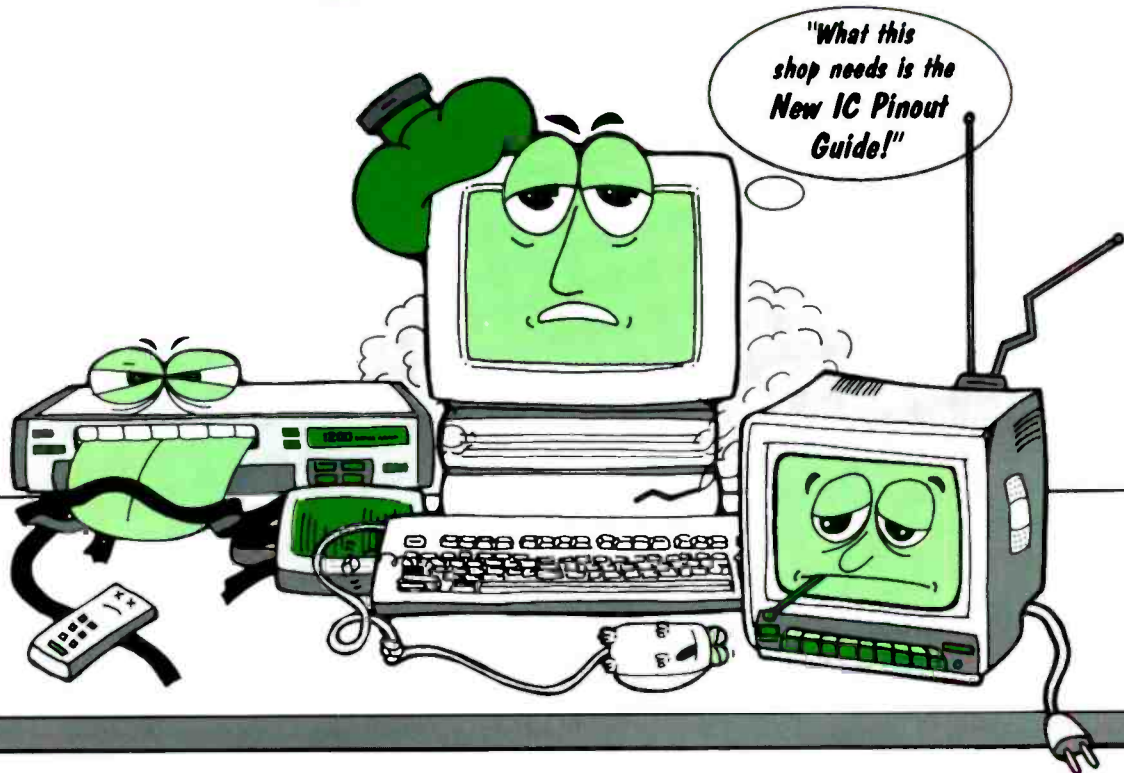

Finally, one book with all the information you need for fast repair jobs. At the very low, introductory price of

\$99!

The new IC Pinout Guide tells you what you need to know to replace ICs in your customers' equipment:

- IC circuit connection data—pinouts—for over 170,000 ICs currently in use worldwide. At the \$99 introductory price—you're paying only one nickel for info on one hundred ICs.



Complete, Compact, Easy-to-Use

This valuable new repair tool also provides package style drawings, IC descriptions, and manufacturer information.

30-day money-back guarantee

If you're not satisfied with the new IC Pinout Guide, just contact us within 30 days. We'll refund your purchase price (less shipping and handling, in U.S. only).

Global Engineering

2805 McGaw Ave., Irvine, CA 92714
Telephone: **714-261-1455**; Toll-free **800-854-7179**

NEW IC Pinout Guide: Tells you what your broken equipment can't.

Mail this coupon to: **Global Engineering**, 2805 McGaw Ave., Irvine, CA 92714

- Yes, I want quick answers to my IC replacement questions!
Send me _____ copies of the new IC Pinout Guide!
Introductory price applies through November 1990—ORDER TODAY!

IC Pinout Guide . . .	List Price	Intro Price	Quantity	Total
	\$149	\$99	_____	_____
			Subtotal	_____
			Shipping and Handling (5% of total order value)	_____
			CA customers add 6.25% tax	_____
			Total	_____

- Payment enclosed
 Bill my company
Purchase Order Number _____

For credit cards, call toll-free 800-854-7179

Company: _____
Name: _____
Title: _____ Dept.: _____
Address: _____
City: _____ State: _____ Zip: _____
Phone: (____) _____
Signature: _____

(Required for all orders without purchase order.)

Radio Shack Parts Place SM

YOUR SOURCE FOR PROJECT AND REPAIR ELECTRONICS
Try Our Special-Order "Hotline"

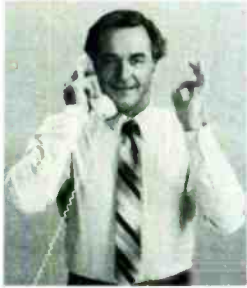

ICs, Crystals, Tubes, Much More

Your Radio Shack store manager can special-order a wide variety of parts and accessories from our main warehouse. Over 200,000 items are available including vacuum tubes, ICs, microprocessors, phono cartridges and styli, crystals for scanners and computers, even SAMS Photofacts® manuals. Best of all, there are no handling charges or minimum order requirements. Your order is sent directly to the Radio Shack near you and we notify you when it arrives. Delivery time for most items is about a week.

Battery Special-Order Service



Hundreds of Types Available

In addition to our large in-store stock, Radio Shack can now supply almost any currently manufactured consumer-type battery—for cordless phones, computer memory, camcorders, walkie-talkies, pagers and more. Batteries are sent from our main warehouse to the Radio Shack near you. We notify you when they arrive and there's no postage or handling charge.

Infrared Module

Complete, Easy-to-Use IR Detector



Heart of a remote-control project! Combines detector, limiter, band-pass, demod, integrator and comparator in a compact 3-lead module. #276-137 3.49

Neater Wiring



(1) Heat-Shrink Tubing. 1/16 to 1/2" sizes. #278-1627 Pkg. of 7/1.79
 (2) Cable Tie/Markers. For cables up to 3/8" dia. #278-1648 Pkg. of 10/2.49
 (3) Wire Markers. 630 "peel and stick" characters. #278-1650 Set/1.79

Tantalum Caps



High capacitance in a tiny size.

µF	WVDC	Cat. No.	Each
0.1	35	272-1432	59
0.47	35	272-1433	59
1.0	35	272-1434	59
2.2	35	272-1435	69
10	16	272-1436	79
22	16	272-1437	1 19

"Snap" RFI Choke



Snap-Together Toroid Cores. Effective "roadblock" to radio-frequency interference. Just wind on AC, phone, computer, coax or audio cable. Then snap choke together. #273-104 Set of 2/7.95

Resistance Items

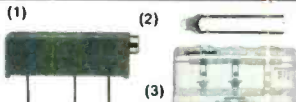

(1) 15-Turn Trimmers. 1k. #271-342, 10k. #271-343, 20k. #271-340, Each 1.49
 (2) Precision Thermistor. Resistance changes in proportion to temperature. -50 to +110° C. #271-110 1.99
 (3) Color-Code Decoder. #271-1210 79c

Shielded D-Sub Hoods

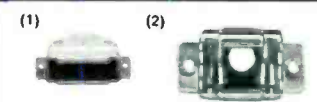

Fig.	Description	Cat. No.	Each
1	9-Position Metal	276-1508	2 19
	25-Position Metal	276-1510	2 79
2	9-Pos. Metalized	276-1513	1 49
	25-Pos. Metalized	276-1536	1 99

"Ding-Dong" Chime

Great Entry Alserter



This IC and mini-speaker combo has a pleasant chime output and it's ideal for a customer-entry alert, doorbell or event indicator. Operates from 6 to 18 VDC. Produces 80 dB sound pressure at 12 VDC. 5" leads. #273-071 8.99

Rod Antennas



For projects or replacing damaged antennas on cordless handsets and bases, walkie-talkies and radios. We have over a dozen styles in stock. For example:

Sections	Extended	Cat. No.	Each
5	13"	270-1407	2 79
6	17 3/4"	270-1409	2 59
4	34 3/4"	270-1402	3 79

TNC and Mini-UHF Connectors



(1) TNC Twist-On Male for RG-58 Cable. #278-140 1.99
 (2) TNC Double-Female. #278-142 1.99

Fig.	Accepts	Fits TNC	Cat. No.	Each
3	PL-259 Female	Female	278-118	3 49
4	BNC Male	Female	278-145	4 99

(5) Mini-UHF Double-Female. Joins two male mini-UHFs. #278-172 2.49
 (6) Mini-UHF T Adapter. Female-male-female power divider. #278-173 3.99
 (7) UHF Adapter. Accepts PL-259. Fits female Mini-UHF. #278-174 3.99

Solderless IDC-Type Connectors

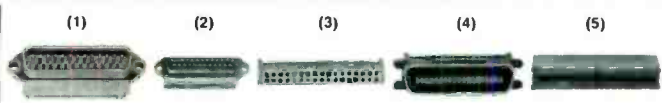

Fig.	Description	Cat. No.	Each
1	25-Position D-Sub Male	276-1559	3 99
2	25-Position D-Sub Female	276-1565	3 99
3	34-Position Header	276-1525	2 49
4	36-Position Male Printer Connector	276-1533	4 99
5	34-Position Card-Edge Connector	276-1564	1 99

Electronic Counter Module



Prewired! Great for a traffic or event counter. Counts up to 99,999. Advanced (or reset) by external switch closure or digital circuit. Accepts count rate up to 7 Hz. Has 1/2" liquid crystal display. Requires "AA" battery. With data #277-302 16.95

Foldup Autoranging DVM



Select the function and this precision Micronta® meter sets the range. Has automatic power-off when shut. Detented hinge for best viewing angle. Measures to 1000 VDC, 500 VAC, 10A AC/DC, 2 meg-ohms resistance. Requires 2 "AA" batteries. #22-193 69.95

Dual-Power Soldering Iron



Go from 15 to 30 watts with the flick of a switch. Has replaceable tip. 8 1/4" long. UL listed AC. #64-2055 9.49
 Replacement Tip. #64-2065 1.19
 Chisel Tip. #64-2056 1.19

Since 1921 Radio Shack has been the place to obtain up-to-date electronic parts as well as quality tools, test equipment and accessories. Today, with our big in-store selection and convenient special-order service, Radio Shack continues its tradition of supplying high-tech products at competitive prices. We're America's Technology Store with over 7000 locations—NOBODY COMPARES

Radio Shack
AMERICA'S
TECHNOLOGY
STORE SM

Prices apply at participating Radio Shack stores and dealers. Radio Shack is a division of Tandy Corporation

CIRCLE NO. 14 ON FREE INFORMATION CARD



25



40



62

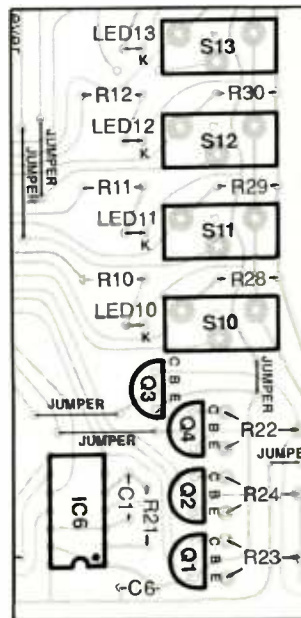

17

FEATURES

- 17 A Stand-Alone PROM Burner**
Manually program 54/74S472 PROMs for applications that do not require massive non-volatile data storage. *By Walter W. Schopp*
- 25 Single-Channel Sound Exploder**
Simulates full stereo sound and control capabilities from a mono source and can be cascaded to provide four-channel sound effect. *By Michael Swartzendruber*
- 34 Power On/Off IR Remote Controller**
Control the on/off state of any electrically powered device using invisible infrared energy. *By James Melton*
- 40 Add Light-Meter Modules to Any Digital Voltmeter (Conclusion)**
Construction, checkout and calibration. *By Tom Fox*
- 44 A Real-Time Video Frame Grabber**
Low-cost monochrome video imaging system for VGA and MCGA PC-graphics systems. *By Crady Von Pawlak*

PRODUCT EVALUATIONS

- 68 Logitech's Trackball**
By Art Salsberg

COLUMNS

- 51 Electronics Notebook**
A High-Sensitivity Lightwave Receiver. *By Forrest M. Mims III*
- 59 Solid-State Devices**
Comparators, Clocks and Clock Drives. *By Joseph Desposito*
- 62 PC Capers**
A Cautionary Tale. *By Ted Needleman*
- 65 Software Focus**
Quattro Pro: Everything But The Kitchen Sink. *By Joseph Desposito*

DEPARTMENTS

- 5 Modern Electronics News**
- 6 Editorial**
By Art Salsberg
- 7 Letters**
- 8 New Products**
- 72 Books & Literature**
- 82 Advertisers Index**

EDITORIAL STAFF

- Art Salsberg**
Editor-in-Chief
- Alexander W. Burawa**
Managing Editor
- Dorothy Kehrwieler**
Production Manager
- Elizabeth Ryan**
Art Director
- Barbara Terzo**
Artist
- Pat Le Blanc**
Florence V. Martin
Phototypographers
- Hal Keith**
Illustrator
- Bruce Morgan**
Photographer
- Joe Desposito, Forrest Mims III,**
Ted Needleman
Contributing Editors

BUSINESS STAFF

- Richard A. Ross**
Publisher
- Art Salsberg**
Associate Publisher
- Dorothy Kehrwieler**
General Manager
- Frank V. Fuzia**
Controller
- Catherine Ross**
Circulation Director
- Melissa Kehrwieler**
Data Processing
- Kathleen Bell**
Customer Service

SALES OFFICE

Modern Electronics
76 North Broadway
Hicksville, NY 11801
(516) 681-2922
FAX: (516) 681-2926

Jonathan Kummer
Advertising Manager

Emily Kreutz
Sales Assistant

Offices: 76 North Broadway, Hicksville, NY 11801. Telephone: (516) 681-2922. FAX (516) 681-2926. Modern Electronics (ISSN 0748-9889) is published monthly by CQ Communications, Inc. Subscription prices (payable in US Dollars only): Domestic—one year \$18.97, two years \$36.00, three years \$53.00; Canada/Mexico—one year \$21.00, two years \$40.00, three years \$59.00; Foreign—one year \$23.00, two years \$44.00, three years \$65.00. Foreign Air Mail—one year \$76.00, two years \$150.00, three years \$224.00.

Entire contents copyright 1990 by CQ Communications, Inc. Modern Electronics or CQ Communications Inc. assumes no responsibility for unsolicited manuscripts. Allow six weeks for delivery of first issue and for change of address. Printed in the United States of America.

Postmaster: Please send change of address notice to Modern Electronics, 76 North Broadway, Hicksville, NY 11801.

CQ Communications, Inc. is publisher of CQ The Radio Amateurs Journal, Popular Communications, Modern Electronics, CQ Radio Amateur (Spanish CQ), and the CQ Amateur Radio Buyer's Guides.

FREEZING LCDs. Liquid crystal displays (LCDs) are used in a wide variety of applications, although we're most familiar with them as digital displays on multimeters. A widespread use, for example, is on gasoline pumps, where they can freeze and become unreadable during cold, moist weather. Another cold-weather use is on instrument panels of fork-lift trucks that operate in warehouse freezers. Elwood Sensors, Pawtucket, RI, has developed a new line of transparent heaters designed for such industrial and transportation applications. Made out of polyester, the new heaters provide top-to-bottom heat to keep LCDs readable during severely cold periods.

ZONING INFO FOR DISH OWNERS. The American Home Satellite Association has published an information package on zoning regulations affecting satellite TV dish ownership and use. It's a resource to help one defend the right to install such systems, and includes model zoning ordinance and an 11-page legal background memorandum. Material covers types of signals, dish operation, size, and location and screening requirements. The extensive zoning info package costs \$39.95 from American Home Satellite Assoc., Valhalla, NY (phone 800-321-AHSA, ext. 2472).

TO RUSSIA WITH DOS. The Cherry Corp. (Waukegan, IL) now makes available the first full-function IBM PC, XT, AT, PS/2 compatible keyboard to completely support the new Russian version of MS-DOS announced by Microsoft Corp. The 101-key keyboard, Model G80-3000, uses the Cyrillic symbols that appear on monitors driven by the new DOS. Corresponding versions in Ukrainian and Belorussian can be configured with additional keycaps included with each keyboard.

NEW VIDEO SERVICES. Tengen Inc., a subsidiary of Atari Games Corp. that publishes video arcade hits for all home video game systems, announced that it will now distribute its games through video rental stores. Expect to see them marketed like video cassette movies with movie-style posters and point-of-purchase displays. Customers will be able to rent game cartridges and apply the rental fee against the cartridge's purchase price.

General Instrument Corp.'s Videocipher Division announces that Request TV will be serving the home dish market with pay-per-view programming of first-run movies and special events using VideoCipher II Plus descramblers.

PC SOFTWARE DIRECTORY FOR ENGINEERING & MANUFACTURING. PC Techware, published by Information Age Publishing, (Exeter, NH), focuses on personal computer software products for the engineering and manufacturing community. The directory contains descriptions of 2200 programs, divided into 84 product categories. Information includes a product description, system requirements, pricing information and company contact. Arrangements have been made for its readers to receive discounts from 10% to 25% on select software. \$39.95 plus \$3.75 S&H (phone 603-778-1186).



340 E. FIRST ST.
DAYTON, OHIO 45402

IDLER TIRE KIT

This popular kit contains 170 of the most popular idler tires (10 each of 17 different sizes).



Save time and money by having the right tire in stock. Also included is a comprehensive cross reference listing over 80 manufacturers' assembly numbers and over 200 model numbers. (All tires are available individually for reorder.)

#MM-400-900 \$49⁹⁵

VCR REPAIR PARTS KIT

With this convenient kit you can do most of your VCR repair jobs the same day.



Commonly used parts for RCA, Hitachi, Fisher, Sanyo, Lloyds, Panasonic, Sony, Sharp, JVC, and more. Over 45 parts in all. (All parts are available individually for reorder.)

#MM-400-950 \$89⁹⁵

VCR SPRING ASSMT

A wide assortment of springs used in many name brand VCRs.



Clutch springs, idler springs, tension springs, etc. 11 tension springs and 5 pressure springs.

#MM-430-300 \$1⁵⁰

VCR WASHER ASSMT

A wide assortment of plastic washers used in VCR



clutch assemblies and idlers. 150 pieces, split ring and regular.

#MM-430-305 \$5⁹⁰



CALL
TOLL FREE
FREE CATALOG

1-800-338-0531

CIRCLE NO. 12 ON FREE INFORMATION CARD

EDITORIAL

Beating the Drums

About 15 years ago, I proclaimed in an Editorial headline that "The Home Computer Is Here!" That was when I featured on a magazine cover the Altair computer, the first powerful, low-cost computer to be widely available.

The announcement was premature.

Some years later, IBM debuted PCjr, which exhibited a host of flaws, but really wasn't as terrible a machine as the "in" press made it to be. It died on the shelf. A while later, I expressed reservations about there being a computer for home (non-business or non-educational) use at all.

Now for more than a year, a company named Vendex has been touting its Headstart computers as machines whose accompanying software insulates the user from the confusion brought on by the disk operating system's arcane "language." It does, too. Apple Computer's Macintosh did it right from the start, of course, with a graphics interface that uses a mouse. Microsoft's Windows software did the same later on for IBM-type computers, though not very well (the latest version, Windows 3.0, comes much closer). Tandy had introduced its DeskMate software, a sort of Windows-like product that recently applied the famous Lotus 1-2-3 to it.

With this as a backdrop, could the real "home" computer be far behind? The distant publicity drums, which you probably now hear quite loudly, send a repeated message that it *has* finally arrived.

Coming off a Tandy Corporation press meeting yesterday, they say it's indeed here with its new-generation Tandy 1000 RL! IBM announced it is so, too, with its new PS/1 line. Apple, it's promised, is right behind with an about-to-be-announced one. Others will doubtlessly enter the fray for a piece of some 60-million households that are thought to be ripe targets for a "home" computer.

Is it truly here? Well, maybe no, but probably yes. It all depends on your perspective and the realities of life in this country.

Does one need a food processor? A CD player for an automobile? A cellular mobile telephone for non-business purposes? A Call-Waiting option for a telephone? A Wok for cooking? Designer jeans? Artificial fingernails?

You may well say "No!" at first blush. But as the drums beat incessantly, and more and more people are pulled in to their hypnotic circle, you will likely succumb and accept the premise, perhaps even revel in it.

I feel this way about the "home" computer. It's an attractive posit. Judging first-hand from Tandy's entry, it indeed simplifies using a computer so that it becomes an easy and fun device to use rather than a fearful, challenging one to a non-technically inclined person.

The key to Tandy's home machine is its broad, practical software/firmware package of easy-to-use applications that all share the same Windows-like graphical interface that works with a mouse. Add to this a respectable if not powerful computer, wide distribution (7,000 nationwide stores) and moderate prices (as low as \$750 if you forego a hard disk drive and color monitor). In addition to dealer staff to demonstrate models and answer questions for customers, owners with a modem can contact technical staff through PC Link for any help needed.

IBM, too, takes a similar route, more or less. Its computer is more costly, with the bottom-of-the-line hard-diskless, monochrome monitor model priced at \$999 to a top-line base of \$2,000. It, too, ensures wide distribution through Sears, Dayton-Hudson and other large department store chains as well as its authorized dealer outlets. Furthermore, IBM promises to field customer questions through a toll-free 800 telephone number. Its mouse-driven IBM developed graphical interface also shields a user from DOS. Microsoft Works and DOS 4.01, the latter in ROM, are included as part of the system.

Each competitor has its comparative strengths and weaknesses. Both Tandy and IBM "home" computers boot up DOS automatically, but display graphical choices to click on with a mouse instead of a plain old prompt indicator. This is analogous to being given a choice of a, b or c rather than facing a blank that has to be filled in without a hint of what's required. IBM employs a 10 MHz 80286 CPU, while Tandy has an 8086; IBM uses DOS 4.01; Tandy, DOS 3.3; IBM features VGA video, while Tandy has en-

(Continued on page 82)

Eliminate False Triggering

• After purchasing a GPIUS2X receiving module (mentioned in the "Infrared-Detector Event Counter" article in the June issue), for a personal project, it didn't take long for me to realize that the IR module was totally useless due to false triggering caused by fluorescent lighting and other electromagnetic radiation sources. I found that by soldering a short ground wire from the case of the device to pin 3 eliminated all false triggering. The IR module now functions as I had expected it to. Grounding of the case makes it possible for experimenters to have an inexpensive, simple and reliable IR receiver module for their projects.

Richard W. Cleveland
S. Bethany, DE

Another Way To Go

• I enjoy *Modera Electronics* and find the construction articles very helpful. My particular thanks to Jeff Orthober for his simple "Infrared Detector" described in



the October 1989 issue. I was unable to obtain the MRD750 IR detector chip specified in the Parts List of his article. However, I found an IR detector and photo-transistor at Radio Shack (Cat. No. 276-142 and 276-145, respectively) that

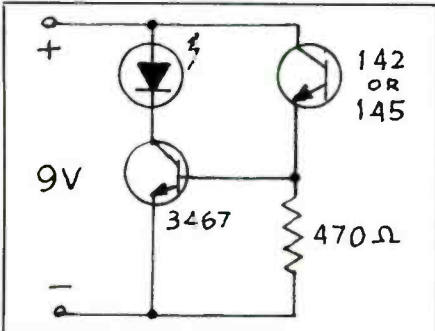

worked beautifully in the circuit shown here schematically and in the photo. An additional feature of my circuit is that ambient light will cause the LED to glow continuously when the battery is con-

nected, indicating that the tester is working. When activated by an IR remote controller, the LED blinks. Of course, testing of this circuit should be performed in subdued light.

Edward A. Bollinger, WA4HMO
Seattle Beach, FL

No-Code Feedback

• Here's my response to "New No-Code Ham License Proposed" that appeared in the July 1990 issue. Having been a ham radio operator for a number of years

(Continued on page 77)

ELENCO & HITACHI PRODUCTS AT DISCOUNT PRICES

NEW! RSOs (Real-Time & Storage Oscilloscopes) From HITACHI **NEW!**

The RSO - its the new solution
View, Acquire, Test, Transfer and Document Your Waveform Data

4 Channel, 100MS/s Model	100MS/s (25MS/s on 4 channels simultaneously)	100MHz, 4kx x 1ch, 2kx x 2ch, 1kx x 4ch	Introductory Price
VC-6145			\$4,695.00

Compact Series Scopes

Model	Price
VC-6045	\$3,049.00
VC-6025	\$2,295.00
VC-6024	\$2,049.00
VC-6023	\$1,749.00

Low Cost/High Value Models

Model	Price
VC-6024	\$2,049.00
VC-6023	\$1,749.00

RSOs from Hitachi feature such functions as roll mode, averaging, save memory, smoothing, interpolation, pre-triggering, cursor measurements, plotter interface, and RS-232C interface. With the comfort of analog and the power of digital.

Hitachi Portable Scopes

Model	Price
V-212	\$435
V-525	\$1,025
V-523	\$995
V-522	\$895

Elenco 35MHz Dual Trace **\$495**
MO-1252

Elenco 20MHz Oscilloscope **\$375**
MO-1251

FREE DMM with purchase of ANY SCOPE

SCOPE PROBES
P-1 65MHz, 1x, 10x \$19.95
P-2 100MHz, 1x, 10x \$23.95

All scopes include probes, schematics, operators manual, and 3 year (2 yrs for Elenco scopes) world wide warranty on parts & labor. Many accessories available for all Hitachi scopes. Call or write for complete specifications on these and many other line oscilloscopes.

WE NOW CARRY COMPLETE LINE OF FLUKE MULTIMETERS Models	True RMS 4 1/2 Digit Multimeter M-7000 \$135 0.5% DC Accuracy 1% Resistance with Freq. Counter and deluxe case	10 Function Multimeter CM-365 \$65 AC + DC Voltage & Amps Resistance to 2000MΩ Diode, Logic, & Trans test Capacitance to 200μF	Digital Capacitance Meter CM-1550 \$58.95 4 Ranges 1pF-20,000μF 5% basic accy Zero control with case	Digital LCR Meter LC-1801 \$125 Measure: Coil, 1μF-200μH Caps, 1pF-200μF Res. 0.1-20M
---	--	---	---	--

Function Generator Box #9600 \$28.95 Provides sine, triangle, square wave from 1Hz to 1MHz AM or FM capability	Audio Generator SG-9200 \$129 Low distortion (< 0.5%) 10-1MHz Sine/Square Wave 600 ohm Output impedance, high Output Voltage	Wide Band Signal Generators SG-9000 \$129 RF Freq 100K-50MHz AM Modulation of 10KHz Variable RF output
---	---	--

Soldering Station Teperature Controlled SL-30 \$99 Digital display Temp range 300F-900F Grounded tip Overheat protect	Color Convergence Generator SG-200 \$69.95 Finest in the industry 10 rock steady patterns	10MHz Oscilloscope S-3000 \$275 10MHz DC or AC Triggered Sweep Calibrated Volt & Hoz Reads Volts & Freq.	Temperature Probe M-110CF \$29.95 Semiconductor type Range -50F-302F Fits most digital multimeters	Autorangeing DMM M-5000 \$45 9 Functions Memory and Data hold 1/2 % basic acc 3 1/2 digit LCD
--	--	---	--	--

AC Current Meter ST-1010 \$69.95 1000 Amps Date & Peak hold 8 Functions Deluxe Case	Decade Box #9610 or #9620 \$18.95 #9610 Resistor Box 47 ohm to 1M & 100k pot #9620 Capacitor Box 47pf to 10MFD	Quad Power Supply XP-580 \$59.95 2-20V at 2A 12V at 1A 5V at 3A 5V at 5A Fully regulated and short circuit protected XP-575 without meters \$39.95	AM/FM TRANSISTOR RADIO KIT with TRAINING COURSE Model AM/FM-108 Makes a great school project
--	---	---	---

Digital Triple Power Supply XP-765 \$249 Fully regulated, Short circuit protected with 2 limit control, 3 separate supplies XP-660 with Analog Meters \$175	GF-8016 Function Generator with Freq. Counter \$249 Sine, Square, Triangle Pulse, Ramp, 2 to 2MHz Freq. Counter, 1-10MHz GF-8015 without Freq. Meter \$179	7 Transistor AM RADIO KIT \$16.95
--	--	--

WE WILL NOT BE UNDERSOLD!
UPS Shipping: 48 States 5%
(\$10 Max) IL Res., 7% Tax

C & S SALES INC.
1245 Rosewood, Deerfield, IL 60015
(800) 292-7711 (708) 541-0710

15 Day Money Back Guarantee
2 Year Warranty
Prices subject to change
WRITE FOR FREE CATALOG

CIRCLE NO. 3 ON FREE INFORMATION CARD

For more information on products described, please circle the appropriate number on the Free Information Card bound into this issue or write to the manufacturer.

DRAM Chip Tester

Aristo Computers, Inc. (Beaverton, OR) now has a low-cost Single Chip Adapter for testing individual chips in its Simcheck Memory Module tester. The adapter permits testing of 64K, 256K, 1M and 4M DRAM chips, expanding on the standard eight- or nine-bit 64K, 256K, 1M, 4M and 16M memory module tests the



basic Simcheck performs. The Single Chip Adapter plugs into the SIP socket located on the Simcheck, making available all tests, including a unique chip-heat test that warms the chips to working temperature.

An internal high-speed 16-bit processor controls the complex test routines, and a two-line LCD window displays instructions and test results, including actual access time and chip type. ZIF sockets are used for fast, safe operation. Automatic current limiters and programmable dual-voltage sources protect the module/chip under test. \$99.

CIRCLE NO. 40 ON FREE INFORMATION CARD

Low-Light CCD Camera

CCTV Corp. (New York, NY) has a new CCD video camera that is claimed to excel in applications that demand small size, high sensitivity, ruggedness and reliability. The Model CCD-500B is rated to deliver a usable picture with as little as 0.002



foot-candles of faceplate illumination, with virtually no lag and no image burn-in. The CCD pickup element inside the camera has a 610 (horizontal) \times 483 (vertical) pixel array that gives the equivalent of 500 lines of resolution in the corners as well as the center of the picture.

The video amplifier has been designed so that the black level and white peak are rigidly controlled so that blacks are black and whites are white, regardless of light level, temperature and other variables in the operating environment. An agc amplifier gives the equivalent of six F stops of adjustment range to permit the camera to automatically adjust over a wide range after the automatic-iris lens is completely opened.

This second-generation camera is housed inside a rugged one-piece extruded aluminum case. It features Genlock, adjustable Gamma and selectable manual/automatic gain control. Operating power can be either 12 volts dc or 117 volts ac. The camera comes with the industry standard C mount and is equipped with a jack to permit operation with automatic-iris and manual lenses. It measures $3\frac{1}{2}$ "L \times $2\frac{3}{4}$ "W \times $2\frac{1}{2}$ "H and weighs just 11.5 ounces. \$650.

CIRCLE NO. 41 ON FREE INFORMATION CARD

Pull-Out Car Stereo

Profile Consumer Electronics (Cypress, CA) has a pull-out car stereo that offers all the benefits of such devices without the bulk. Its Model DN-928 Detachable Function System (D-F-S) enables the control section of the car stereo to slip on and

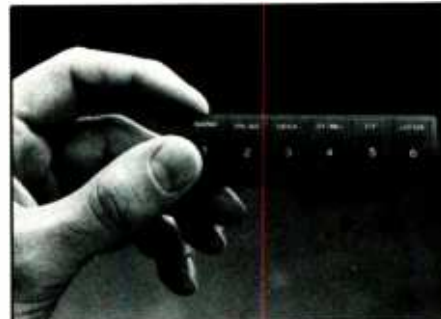

off its mount by moving a lever. Only a few inches long and thinner than a ruler, the D-F-S can be conveniently slipped into a pocket or purse. Removal of this device renders the remainder of the car stereo unusable.

The DN-928 includes such features as a PLL synthesizer tuner with digital numeric display, up/down scan tuning, 30 station presets, seek tuning and local/distance switch. It also offers an auto-reverse tape player. Output power is rated at 25 watts/channel. \$279.

CIRCLE NO. 43 ON FREE INFORMATION CARD

Diagnostic Monitor

Belkin Components (Gardena, CA) has a low-cost solution to the problem of monitoring Ethernet system acti-

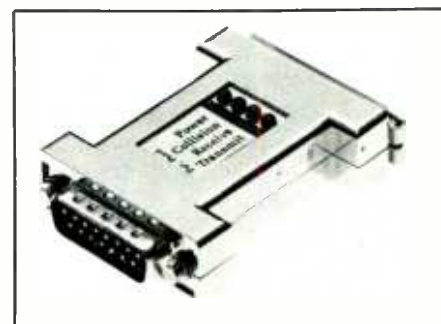

ivity and failure with its Remote Ethernet Diagnostic Monitor. Compact in size, the Monitor has DB15 male and female ports to permit it to be connected directly between the network card and AUI cable assembly. It can also be mounted between card and transceiver when used with the company's twisted-pair transceivers.

This Remote Diagnostic Monitor requires no power. It provides visual indication of transmit, receive, pow-

Tandy Home Computer

Radio Shack stores are now offering the Tandy 1000 RL, a home computer that is billed to be "so easy to use, it guarantees success." The IBM PC-compatible 8086 computer consists of an integrated system of hardware and software developed for the home user; it also runs other PC-compatible business and personal software.

What makes this computer into a "home" unit is its mouse-driven graphical interface that shields the user from DOS, and the special software that comes with it. The latter consists of 24 programs total—all specially designed for home applications, and with all having the same graphical interface:

Financial programs itemize expenses and calculate them on bar or pie charts. They maintain account information, record checks and balance a checkbook. They also maintain and manage stock and investment portfolios.

Personal programs catalog collections, maintain a private password-access diary, keep an inventory of valuable articles for insurance, maintain an itemized list of possessions, and plan trips with telephone numbers of airlines, hotels and car-rental agencies.

Kitchen programs include a cookbook that adjusts recipes for number of servings, a grocery list organizer, and a meal planner. Sample recipes from *The New Good Housekeeping Cookbook* are included.

Mathcard programs develop and



calculate a personal savings plan, determine interest rates and payments and plan retirement income. They also make 31 mathematical conversions and determine calculations like miles per gallon, discounts and percentages. An information center provides a calendar, notepad for messages, important telephone numbers and a message board.

For the more enterprising home user who wants to operate in a business-like environment, Tandy provides its DeskMate program. This integrated software contains a word processor, address book, draw program, an educational computer game and others.

Operating at 9.54 MHz and supplied with 512K or user RAM (expandable to 768K), the 1000 RL has a 10" XT-compatible expansion slot and comes with a 3.5" 720K floppy-disk drive; 101-key keyboard; TCGA/CGA video; three-voice analog and eight-bit digital sound capabilities; serial, parallel, mouse and two joystick ports; and headphone

and microphone jacks. Available as an extra-cost option is a 20MB hard-disk.

In its basic configuration, the Tandy 1000 RL comes with one floppy-disk drive that automatically senses if a diskette is present; MS-DOS 3.3, DeskMate Graphical User Interface, FORMAT and DISK-COPY utilities and 90,000-word spelling list in ROM; GW-BASIC, remaining MS-DOS utilities, DeskMate applications and 24 home programs on diskette (or already loaded onto the hard disk); Tandy-Enhanced CGA video with 640 x 200-pixel resolution in 16- or 4-color format; 720 x 348-pixel Hercules graphics support; and Phoenix BIOS. It includes recording and playback of speech and other sounds and color video. A "sleep" function turns off the video screen. After a period of inactivity, the hard-drive version also shuts itself off as well. In sleep mode, the silent computer, which has no fan, consumes no more power than a clock radio. To reactivate the computer, you simply press any key on the keyboard.

Available in four configurations, the Tandy 1000 RL offers a choice of floppy-disk-only or floppy-disk and internal user-installable 20-MB IDE hard disk, both with monochrome or color monitor. Prices range from \$750 to \$1,299, depending on configuration. Available options include: memory upgrade to 768K (\$59.95), internal 2,400-bps modem (\$149.95) and 20-MB IDE hard disk (\$399.95).

CIRCLE NO. 44 ON FREE INFORMATION CARD

er and collision on the Ethernet line. With it, users and network administrators can quickly determine the operating status of each node simply by interpreting what the four LEDs on the unit mean, using a troubleshooting chart supplied with the unit. \$99.

CIRCLE NO. 30 ON FREE INFORMATION CARD

Language Translator

A new Multi-Language Translator from Seiko Instruments Inc. (Torrance, CA) can remove language barriers for international travelers who visit countries in which English, French, Japanese and Spanish are

spoken. The hand-held Model TR-320 Translator provides instant translations among the four languages for which it is programmed. The user simply keys in the word to be translated and presses a translator key to obtain the translation of the word in the language needed. The

Learn to troubleshoot and service today's computer systems as you build a fully AT-compatible micro, complete with 1 meg RAM, and powerful 20 meg hard drive

Train the NRI Way— and Earn Good Money Servicing Any Brand of Computer

Jobs for computer service technicians will almost double in the next 10 years according to Department of Labor statistics, making computer service one of the top 10 growth fields in the nation.

Now you can cash in on this exciting opportunity— either as a full-time industry technician or in a computer service business of your own—once you've mastered electronics and computers the NRI way.

NRI's practical combination of "reason-why" theory and hands-on building skills starts you with the fundamentals of electronics, then guides you through more sophisticated circuitry all the way up to the latest advances in computer technology.

Train With a Powerful AT-Compatible—Now with 20 Meg Hard Drive and 1 Meg RAM!

To give you hands-on training with the absolute in state-of-the-art computer technology, NRI includes the powerful West Coast 1010 ES computer as the centerpiece of your training. As you assemble this fully IBM AT-compatible micro from the keyboard on up, you actually see for yourself how every section of your computer works.



You build this powerful West Coast 1010 ES computer, all the while gaining a true mastery of computer electronics. Best of all, it's yours to keep for all your professional and personal computing needs.



You assemble and test your computer's "intelligent" keyboard, install the power supply and 5¼" disk drive, then interface the high-resolution monitor. But that's not all.

Your hands-on training continues as you install a powerful 20 megabyte hard disk drive—today's most-wanted computer peripheral—now included in your course to dramatically increase the data storage capacity of your computer while giving you lightning-quick data access. Plus you work with exclusive word processing, database, and spreadsheet software, yours to use for your own professional and personal applications.

As you build your computer, performing key demonstrations and experiments at each stage of assembly, you get the confidence-building, real-

Your NRI computer training includes all this: • NRI's unique Discovery Lab[®] for circuit design and diagnosis • NRI's hand-held digital multimeter featuring "talk-you-through" instructions on audio cassette • A digital logic probe that lets you visually examine computer circuits • The new AT-compatible West Coast 1010 ES computer with high-speed 80286 CPU, 101-key "intelligent" keyboard, 1.2 meg high-density floppy disk drive, 1 meg RAM (expandable to 4 meg), 64K ROM • 20 megabyte hard disk drive • MS-DOS, GW-BASIC, word processing, spreadsheet, and database software • Reference manuals with programming guidelines and schematics

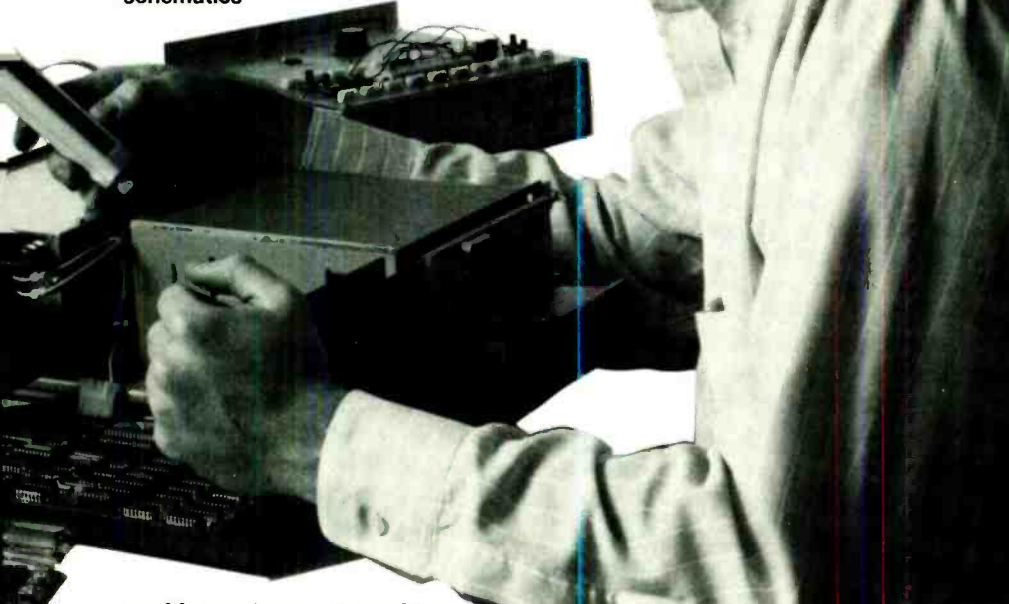

NOW!
AT-compatible
computer and 20
meg hard drive!

prepared to take advantage of today's opportunities in computer service. You learn at your own convenience in your own home.

No classroom pressures, no night school, no need to quit your present job until you're ready to make your move. And all throughout your training, you've got the full support of your personal NRI instructor and the NRI technical staff, always ready to answer your questions and help you whenever you need it.

FREE 100-Page Catalog Tells More

Send today for NRI's big, 100-page catalog that describes every aspect of NRI's innovative computer training, as well as hands-on training in other growing high-tech career fields. If the coupon is missing, write to: NRI School of Electronics, McGraw-Hill Continuing Education Center, 4401 Connecticut Avenue, NW, Washington, DC 20008.

world experience you need to work with, troubleshoot, and service today's most widely used computer systems.

New! Explore the Latest Advances in Voice Synthesis

Now NRI also includes innovative hands-on training in voice synthesis, one of today's most exciting and widely applied new developments in computer technology.

You now train with and keep a full-featured 8-bit D/A converter that attaches in-line with your computer's parallel printer port. Working with the exclusive text-to-speech software also included with your course, you explore the fascinating technology behind both digitized and synthesized computer speech.

NRI's new hands-on training in voice synthesis is just one more way you get the confidence-building experience you need to feel at home with the latest advances in computer technology.

No Experience Needed, NRI Builds It In

This is the kind of practical, hands-on experience that makes you uniquely

NRI School of Electronics

McGraw-Hill Continuing Education Center
 4401 Connecticut Avenue, NW
 Washington, DC 20008

IBM and AT are registered trademarks of International Business Machines Corporation

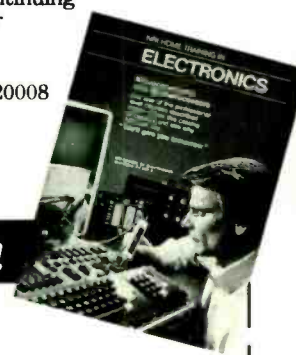

SEND TODAY FOR FREE CATALOG!

NRI

McGraw-Hill Continuing Education Center
 4401 Connecticut Avenue, NW, Washington, DC 20008

For Career courses approved under GI Bill
 check for details.

✓ CHECK ONE FREE CATALOG ONLY

- Computer Electronics
- TV/Video/Audio Servicing
- Robotics
- Electronic Music Technology
- Security Electronics
- Digital Electronics Servicing

- Telecommunications
- Industrial Electronics
- Electronic Circuit Design
- Basic Electronics
- Bookkeeping & Accounting
- Building Construction
- Automotive Servicing

- Air Conditioning, Heating, & Refrigeration
- Small Engine Repair
- Electrician
- Locksmithing
- Travel Careers
- Writing
- Paralegal
- Computer Programming

Name (Please print) _____ Age _____
 Street _____
 City/State/Zip _____ We'll give you tomorrow. _____ Accredited Member National Home Study Council _____ 4-100 _____

NEW PRODUCTS...

translator keys contain the language name and a picture of the country's flag. The Translator then displays it in an LCD window that can display two lines of text. If the input word is misspelled, the Translator will take a



guess and add a question mark to the displayed word. A comma appears in the display if there are multiple meanings or synonyms for the keyed-in word.

The Translator contains more than 5,200 words in each of its four pre-

programmed languages. It offers two translation options for Japanese: the Katakana phonetic character set and the Romaji English alphabet for phonetic pronunciation by Westerners. Other functions provided in the Translator include: word search for either locating a word or scrolling through memory to learn new words; a backspace key for erasing errors; a built-in calculator with memory and currency exchanger; and automatic power-off to conserve battery power. Power is supplied by two long-life lithium cells. \$109.99.

CIRCLE NO. 45 ON FREE INFORMATION CARD

Hands Free Digital Multimeter

Beckman Industrial's new Model 223 auto-ranging hand-held DMM features hands-free operation via auto-ranging and audible and visible sig-



nal indicators. It has a 3½-decade LCD display, a self-resetting fuse in current mode and a custom-designed fast D/A converter for fast range selection. The converter signals are also amplified to produce a tone whose frequency is proportional to

Macintosh Laser Printers

Macintosh computer users have a choice of two new laser printers recently introduced by Apple Computer, Inc. The Personal LaserWriter SC meets basic productivity and simple desktop-publishing needs of single users, while Personal LaserWriter NT is a multi-user printer for individuals and small work groups with more advanced needs.

Personal LaserWriter SC, delivering a throughput of 4 ppm, is suited for users who require high-quality output but have no need for networking or more advanced text and graphics capabilities. It uses internal Macintosh QuickDraw™ graphics routines to create text and images. It has a 68000 microprocessor, the 1MB of RAM required for imaging a full page of text and graphics at 300 dpi. Times, Helvetica, Courier and Symbol fonts in 9 through 24 points come with the printer on floppy disks. An SCSI interface provides high-speed data transfers and the ability to

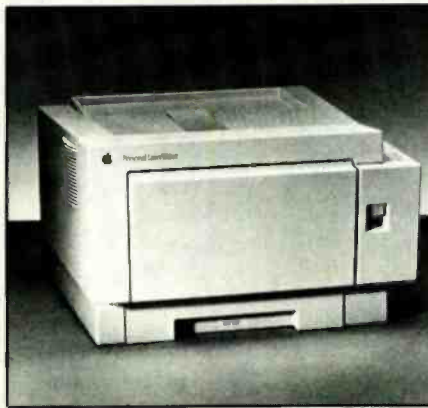

daisy-chain up to six additional peripherals. Upgrade to the LaserWriter NT is done by replacing the controller board.

Personal LaserWriter NT doubles throughput to 8 ppm and includes Adobe PostScript page-description language and AppleTalk, the latter to allow printer sharing among small groups of Macintosh and IIe and IIgs users via a built-in LocalTalk connector. This printer can be used in a mixed environment (Macs, MS-DOS, OS/2 and Unix-based machines) via an optional LocalTalk

peripheral card. An RS-232 port permits non-Apple computers to use the printer for printing non-PostScript documents using built-in HP LaserJet Plus or Diablo 630 printer emulation. It has a 68000 microprocessor and 2MB of RAM and can be upgraded to 8MB of RAM to improve speed and provide additional room to download fonts. Included are 35 standard typefaces plus two others that are used in Diablo 630 ECS emulation. The printer also supports downloadable fonts available from third-party typography companies.

Both printers use the Canon LBP-LX laser engine. They take up only 18.3" x 15" of desktop space and require only top and front access. They are also compatible with all Macintosh computers, virtually all Macintosh applications and all other LaserWriter printers. An automatic-feed 250-sheet paper cassette and multi-purpose paper tray come standard. \$1,999, Personal LaserWriter SC; \$3,299, Personal LaserWriter NT.

CIRCLE NO. 46 ON FREE INFORMATION CARD

the magnitude of the reading displayed in the LCD window.

A built-in detector captures TTL and CMOS pulses down to 50 ns in duration and signals their presence with an audible high beep tone for high logic and low tone for low logic levels. Audible signaling also detects intermittent voltages, currents or resistances by emitting a "crackling" sound. Capacitors are checked by a changing-frequency tone as the charge builds-up and bleeds-off. No change in tone indicates that the capacitor is either shorted or open. An Automatic-off Battery Saver feature shuts down the meter after an hour of no input activity. When less than 100 hours of battery life remain, the decimal point in the display blinks as a warning indicator.

The meter measures dc potentials to 200 mV, 2 volts, 20 volts, 200 volts and 1,000 volts full-scale with 100- μ V resolution and 0.25% accuracy. Ac voltage ranges are the same, except that the highest goes to 750 volts rms. Resolution is also the same, and accuracy is rated at 2% from 45 Hz to 1 kHz. Ac and dc current ranges are 20 mA, 200 mA and 10 amperes at a resolution of 10 μ A. Meter dimensions are 6.8"H \times 2.8"W \times 1.25"D and weight is less than 12 ounces. \$149.

CIRCLE NO. 47 ON FREE INFORMATION CARD

Concert Grand In a Box

Proformance from E-mu Systems (Scotts Valley, CA) is a stereo module that connects to any MIDI electronic keyboard to provide "grand piano in a box" capabilities. It contains stereo recordings stored in computer memory to capture the experience of playing a concert grand piano.

Two models are available. The Proformance/1 offers a variety of piano sounds, including classic, rock, honky-tonk blues, jazz and others. Proformance/1+ includes all the capabilities of the Proformance/1 plus such additional sounds as electric piano, organ, vibes and acoustic and electric basses. Sound quality is



claimed to be suitable for professional music production.

Proformance products use sampling techniques to record original sounds in computer memory and to play them back digitally. Front-panel controls include: Volume; Fine Tune (± 1 semitone); Transpose (± 2 octaves, ± 1 octave in semitones); MIDI Channel selector; Split Point selector (/1+ model only); and Preset selector. There are also a power switch and MIDI activity indicator. Outputs include mono mix and headphones. Data encoding is 16-bit linear for true stereo, and audio channels available number 32 (16 stereo), S/N is rated at greater than 90 dB, dynamic range at greater than 90 dB and THD at less than 0.05%. The units measure 8.5"W \times 8.5"D \times 1.75"H and weigh 1.75 lbs. \$499, Proformance/1; \$599, Proformance/1+.

CIRCLE NO. 48 ON FREE INFORMATION CARD

SW & Scanner Antennas

According to Electron Processing (Cedar, MI), greatly improved signals for shortwave and scanner listening are possible with the com-



pany's Antenna Plus-2 and Antenna Plus-3 antennas. Using a 20-ft. wire (supplied), Antenna Plus-2 brings in SW signals like much larger antennas do. Reception is peaked for SW fre-

Which symbol represents a variable inductor?

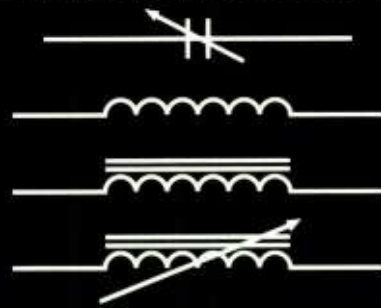

What is the principle disadvantage of neon lights?

What are out-of-phase signals?

Heath Video Courses speed your learning curve!

Learn basic electronics at home at your own pace with four, 60-minute video tapes. Know the variable inductor symbol. Recognize a PN junction. Understand oscillator fundamentals. Clearly SEE what most basic electronic books can only describe.

DC ELECTRONICS. Covers electron movement to troubleshooting and repairing a simple electronic circuit. EV-3101-A.

AC ELECTRONICS. Follow-up to DC Electronics. Covers the principles of AC, voltage and electrical measurement. Includes motors, generators and test instrument meter movements. EV-3102-A.

SEMICONDUCTORS. Complete the DC/AC videos and you're ready to learn how semiconductor devices are made, plus the principles of discrete devices, integrated circuits & optoelectronic devices. EV-3103-A.

ELECTRONIC CIRCUITS. Complete the basic course with amplifier configurations, biasing, coupling, audio amplifiers, closed-loop vs. open-loop operation and more. EV-3104-A.

An activity-filled workbook and explanation of how to solve each problem comes with each tape so you learn three ways — video, workbook and hands-on!

Order today!
Call Toll free,
24-hours a day.
1-800-253-0570.

We accept VISA, MasterCard, American Express and Heath Revolving Charge card. Use Order Code 601-031

VIDEO TAPES
\$39.95
EACH

Heath®

Benton Harbor, MI

Call for a FREE catalog 1-800-44HEATH.

*Price does not include shipping and handling, or applicable sales tax.

©1990, Heath Company
Subsidiary of Bull Data Systems, Inc.

CIRCLE NO. 11 ON FREE INFORMATION CARD

E field STRENGTH ESTIMATION

There is an unexpected relationship between field strength and output indication when the Spectrum Probe® is fitted with a short antenna.

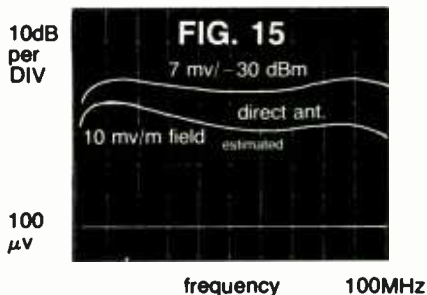

A 10" piece of #18 bus, with a female contact from an appropriate connector, extends straight from the probe's pin. Fig. 15 shows the probe output when this assembly is exposed to a 10 mV/m field strength. Also recorded is the probe output when fed by a terminated voltage source of 7 mv/-30dBm. This nearly constant antenna factor ($\approx 15\text{dB/m}$) and high sensitivity allows calibration of the probe to read field strength and is permitted by the high impedance of the Spectrum Probe®.

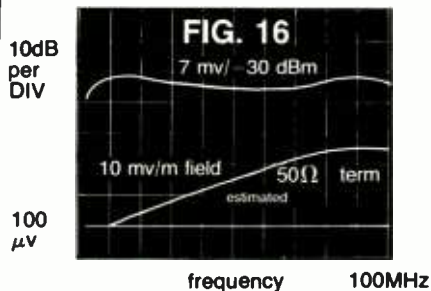

If, however, the input impedance of the analyzer is altered by the addition of shunt 50 ohms, the reduced sensitivity of fig. 16 results. (This system is not FCC certification accuracy, primarily due to vagaries in the ground plane, polarization and near field control.) The shielded pair connecting the Spectrum Probe® and scope (and wall transformer) may be extended to allow probing the field at least 50' from the scope.

107 SPECTRUM PROBE®
converts your scope into a
100MHz spectrum analyzer

\$199 direct

Smith Design 1324 Harris
Dresher, PA 19025 (215) 643-6340

CIRCLE NO. 15 ON FREE INFORMATION CARD

NEW PRODUCTS...

quencies and is enhanced by a filter that eliminates interference caused by FM and vhf and uhf TV transmitters. An internal 15- to 22-dB amplifier covers the band from 300 kHz to 30 MHz.

Antenna Plus-3 is a 36" whip for strengthening weak scanner signals. It is optimized for scanner frequencies and includes a filter that eliminates interference from local AM broadcast band and SW transmitters. An internal 15- to 20-dB amplifier provides coverage from 30 MHz through 2,000 MHz.

Both antennas install quickly and easily. Extra-cost adapting cables are available for most receivers. Cable terminations are available in a choice of BNC, SO239 (uhf), N and F. The antennas are powered from the ac line. Versions with a built-in antenna splitter and second output jack are also available. \$89.95, standard models; \$109.95, dual-output models.

CIRCLE NO. 35 ON FREE INFORMATION CARD

Adjustable Wrist Strap

It is a simple procedure to secure a new strap to a wrist with the new HUB Material Co. (Canton, MA) conductive wrist strap. The user sim-



ply feeds the end of the strap through a loop, folds over and squeezes together the Velcro surface to provide a snug fit without the irritation that often accompanies the use of elastic

bands. One size band fits all wrist sizes. The strap has a 360° swivel and a quick-release snap with 1-megohm resistor. It comes with a 6-ft. coil cord, banana plug and alligator clip.

CIRCLE NO. 36 ON FREE INFORMATION CARD

Decade Resistance Boxes

Brunelle Instruments Inc. (Newport, VT) now has two decade resistance boxes of interest to service personnel, circuit designers and others involved in electronics. The Model 42 box cov-

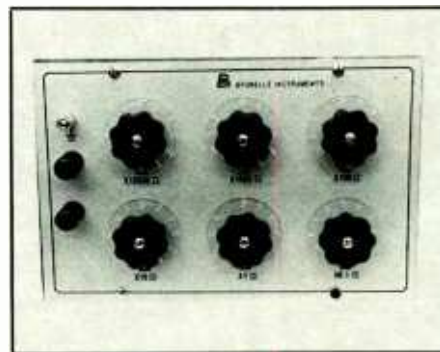

ers a resistance range from 0.01 ohm through 1,000 ohms, while the Model 43 covers the range from 0.1 to 10,000 ohms. Both are rated to have an accuracy of 0.1% of reading plus 0.005. Each provides six 10-position rotary switches for selecting resistance over its six-decade range. Both feature gold-plated contacts.

CIRCLE NO. 50 ON FREE INFORMATION CARD

Computer Security Device

The Stealth Security Pad from Ark International, Inc. (Lisle, IL) is a computer-enhancing security device that features an interlocking swivel base that permanently secures a computer system unit to a work surface. Mounting a computer system unit on the Pad increases ventilation by raising it 1.375" above the work surface for increased air circulation and heat dissipation. Doing this also makes the system unit take up less space. The base rotates 90° in either direction so that a user can position the monitor for minimum screen glare.

(Continued on page 81)

A Stand-Alone PROM Burner

Lets you manually program the 54/74S472 PROM for applications that do not require massive non-volatile data storage

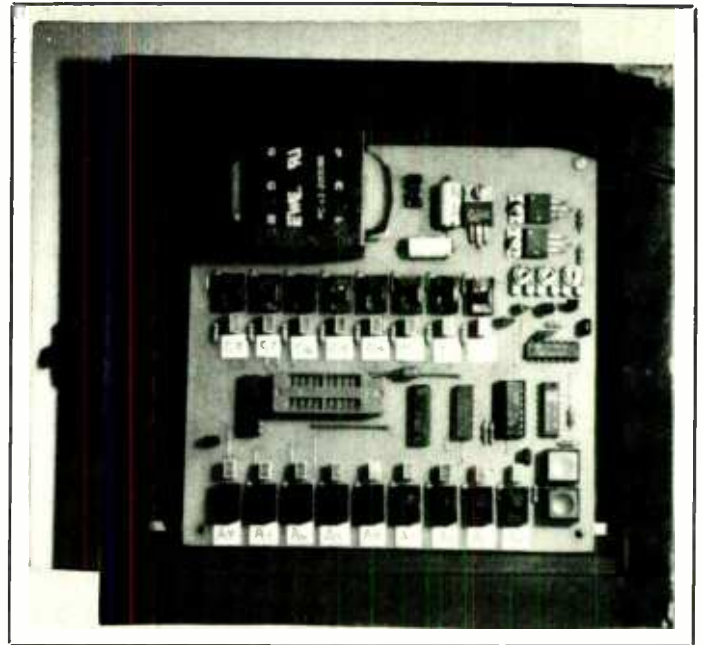

By Walter W. Schopp

Electronics technology has a way of galloping into the future, leaving behind a lot of good stuff. Often, a step backwards can be advantageous. One example is the drift away from the simple PROM to EPROMS with huge storage capability. Using a large-storage-capacity EPROM in a circuit that requires just a small amount of memory storage is wasteful, especially if thousands of bits of storage capability go unused. It is in just such applications that old-fashioned non-erasable PROMs shine. They are excellent to store small, simple fixed programs, among other applications.

Commercial PROM burners are, therefore, disappearing fast. To make matters worse, an EPROM programmer is not equipped to burn open the programming links in the PROM. Fortunately, though, you can build the Stand-Alone PROM Burner described here.

Our PROM Burner is manually operated. You program it by flipping

a set of switches to program the address and another set of switches to set up the data to be programmed into that address. This done, you press a programming button to burn open fusible links inside the PROM with the desired data at the selected location. LEDs provide a visual means for verifying address and data to be programmed.

Comparisons & Cautions

Bipolar PROMS have some advantages over EPROMS. To begin with, they are faster in operation and a more permanent storage medium than EPROMS. PROMS cost half as much and are much smaller physically if circuit-board real estate is at a premium. Of course, PROMS also have disadvantages, too, not the least of which is that they are slow to program and unforgiving of programming errors. If you make a programming error, you cannot erase the PROM and reprogram it. You must start over with a new PROM and chuck the old one.

By selecting a large storage PROM

and using only the address and data lines required, the price and size advantage still remains, no matter what format is required, up to the 4,096-bit limit. For this project, the 512 × 8 bipolar (4,096-bit) 54/74S472 PROM was chosen. This easy-to-obtain 20-pin DIP IC has 0.3-inch spacing between pin rows, which is small compared to the 0.600-inch spacing for 24- and 28-pin EPROMS.

In its new state, the 54/74S472 PROM has all its outputs set to low, much as is the case for the new EPROM. To obtain a high condition on the programmed data output when the desired address is applied, you must burn open a fuse link in the PROM. Once the link is open, the high condition it creates is permanent and cannot be reversed. Therefore, programming must be done carefully to avoid errors.

Fuse links inside the 54/74S472 PROM are composed of a titanium/tungsten alloy. They must be blown open by applying a precise voltage using a particular timing pattern on the programmed elements of the PROM. The link must be blown

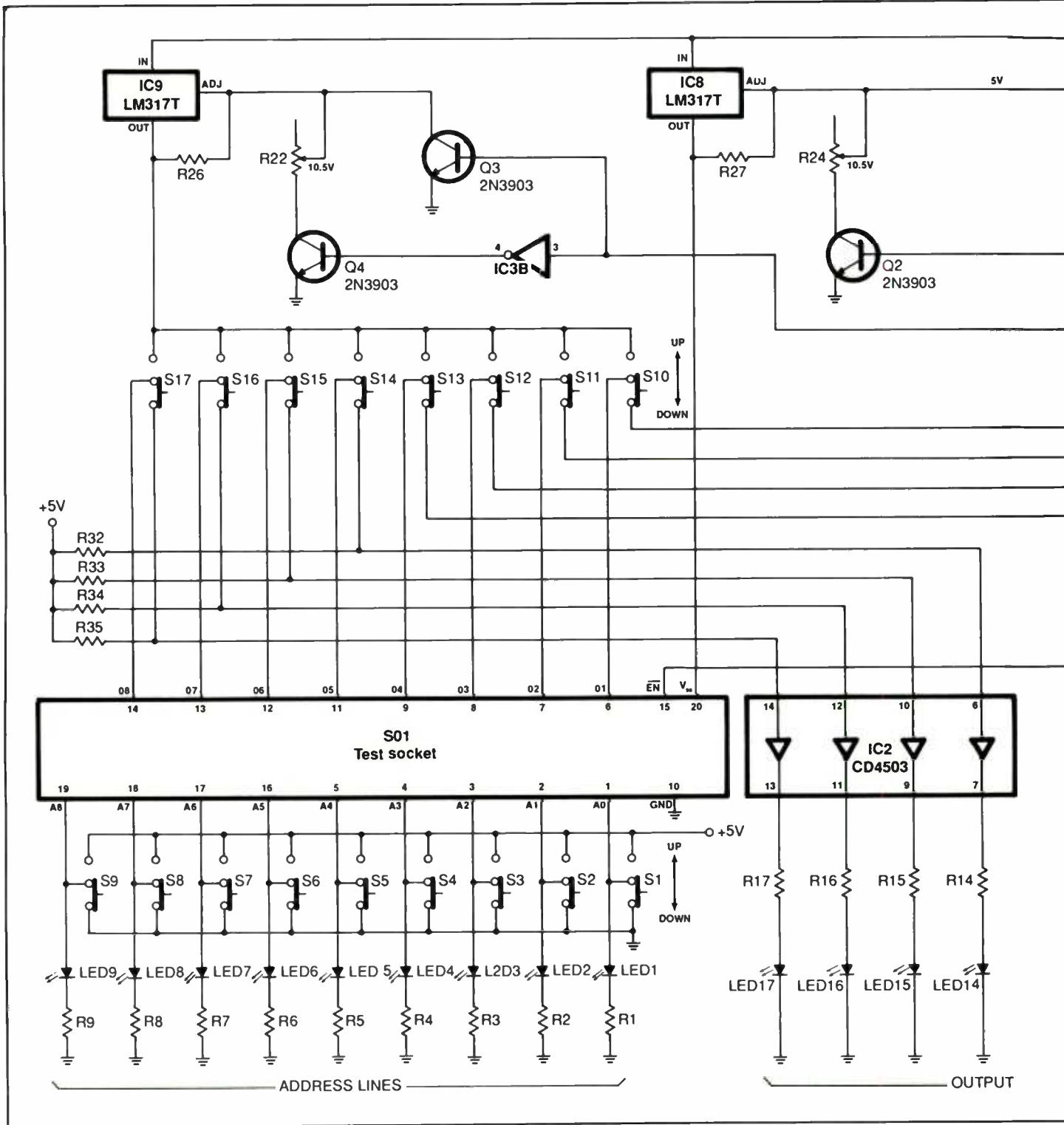

Fig. 1. Complete schematic of circuitry used in the Stand-Alone PROM Burner.

cleanly to prevent shorts in other parts of the chip. The particular PROM for which our PROM Burner is designed is programmed by raising

the supply voltage, applying a greater-than-normal voltage to the data output lead that is being programmed and then enabling the PROM with a

very short pulse. This must be done in the proper sequence to successfully program the PROM.

Programming the PROM with this

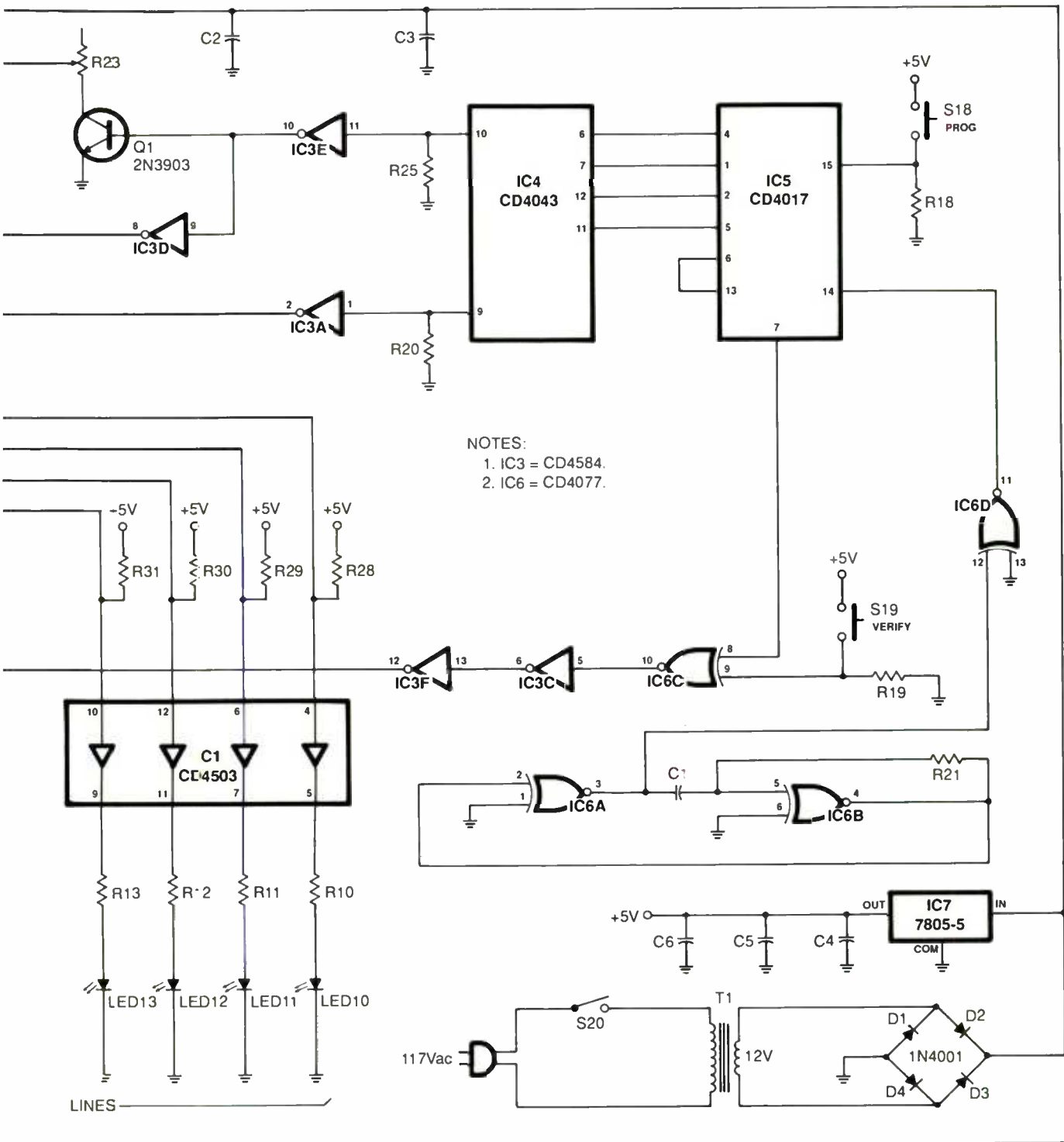

PROM Burner takes a great deal longer time than the modern computer-controlled EPROM programmer because each data line must be pro-

grammed individually. The reason why this is so is that the internal bus lines of the chip cannot withstand the heat generated by programming

many data lines simultaneously.

The PROM Burner described below is a bare-bones unit. It was designed simply to do a reliable job of

PARTS LIST

Semiconductors

D1 thru D4—1N4001 or similar silicon rectifier diode
IC1, IC2—CD4503 tri-state hex buffer
IC3—CD4584 hex inverting Schmitt-trigger buffer
IC4—CD4043 quad RS flip-flop
IC5—CD4017 decade counter
IC6—CD4077 quad exclusive-NOR gate
IC7—7805 fixed +5-volt regulator
IC8, IC9—LM317T adjustable regulator
LED1 thru LED17—Light-emitting diode (Jameco Electronics Cat. No. XC57124R or similar—see text)
Q1 thru Q4—2N3903 or similar general-purpose npn silicon transistor

Capacitors

C1—100-pF, 50-volt ceramic disc
C2, C3—100- μ F, 16-volt electrolytic
C4, C5, C6—0.1- μ F, 50-volt ceramic disc or polyester

Resistors (1/4-watt, 5% tolerance)

R1 thru R17—150 ohms
R18, R19, R20, R25, R28 thru R35—10,000 ohms
R21—120,000 ohms
R26, R27—240 ohms
R22, R23, R24—5,000-ohm miniature pc-mount trimmer potentiometer (Digi-Key Cat. No. K4A53 or similar)

Miscellaneous

S1 thru S17—Spdt slide switch (Digi-Key Cat. No. SW101-ND or similar)
S18, S19—Normally-open, momentary-action spst pushbutton switch
S20—Spst slide or toggle switch (optional—see text)
SO1—20-pin ZIF socket
T1—Power transformer (Digi-Key Cat. No. T121-ND)
Printed-circuit board or perforated board with holes on 0.1" centers and suitable Wire Wrap or soldering hardware (see text); sockets for all DIP ICs; ac line cord with plug; zip cord (optional if S20 is used—see text); suitable enclosure or materials for frame (see text); hardware; hook-up wire; solder; etc.

Component Suppliers

Jameco Electronics

1355 Shoreway Rd.
Belmont, CA 94002
415-592-8097

Digi-Key Corp.

701 Brooks Ave. N.
P.O. Box 677
Thief River Falls, MN 56701-0677
1-800-344-4539

mal operating voltage is 5 volts, but 4.5 volts is used to verify programming under worst-case conditions.

An identical switching power supply built around IC9, R22, Q3 and Q4 is used for raising the data potential from 1.25 volts to 10.5 volts on the data line being programmed. The seventh pulse from the counter is fed to the enable input of the counter that stops the count.

Manual addressing of the PROM is accomplished with switches S1 to S9. Each switch has a LED above it that indicates address line status. Sliding the switch to the upper position puts a 1 on that particular address line, while sliding it to the lower position places a 0 on the line.

Data lines to be programmed are connected with switches S10 to S17 to the programming voltage supplied by IC9. The programmed data voltage from IC9 is fed directly through the chosen data switch to the selected data line. Light-emitting diodes LED10 through LED17 below each switch allow the status of the data lines to be read after programming. These switches are kept in the down position, except for the data line being programmed high, which is set to the up position. In the down position, the switches connect through IC1 and IC2 tri-state buffers to the status LEDs and data lines.

The power supply, shown at the lower-right in Fig. 1, must furnish at least 750 milliamperes during the programming cycle. Therefore, a husky power-supply transformer was chosen for T1 (see Parts List).

Construction

There is nothing critical with regard to component layout and lead/conductor routing in this project. Therefore, you can use any traditional wiring technique that suits you to build your PROM Burner. If you wish, you can mount the components on perforated board that has holes on 0.1-inch centers and use Wire Wrap

programming the 54/74S472 without costing too much.

About the Circuit

The complete schematic diagram of the Stand-Alone PROM Burner is shown in Fig. 1. As with any other programmer, the programming voltage and timing of its application are very important. The heart of the PROM Burner is the sequence generator made up of IC4 and IC5. When reset, decade counter IC5 counts six pulses and stops. These six pulses are fed to the set/reset flip-flops in IC4 that control the voltages on the supply, data outputs and negative programming pulse to the enable input of the PROM plugged into SO1.

The outputs of the IC4/IC5 gener-

ator are shown in Fig. 2. Note that the V_{SS} voltage is raised first and is followed by the programming voltage on the data line. While these two voltages are in the high state, the negative programming pulse is applied to the ENABLE pin of the PROM being programmed.

The output from one of the IC4 flip-flops feeds the dual switching power supply composed of IC8, R23, R24, Q1 and Q2. At rest, Q2 is held in cutoff and Q1 is conducting. With Q1 on, R23 must be adjusted to produce 4.5 volts at the supply terminal of the PROM.

During the programming sequence, Q1 is sent into cutoff and Q2 is sent into conduction. The V_{SS} pin on the PROM is raised from 4.5 volts to 10.5 volts, adjusted via R24. Nor-

or soldering hardware to hard wire them together. Alternatively, you can fabricate a printed-circuit board using the actual-size etching-and-drilling guide shown in Fig. 3.

Whichever wiring technique you use, it is a good idea to have a socket on-board for each DIP IC. Also, use a ZIF (zero-insertion-force) socket for *SO1*. Shown in Fig. 4 is the wiring guide for the pc-board version. If you use perforated board instead of a pc board, arrange the components on it in roughly the same layout as shown in Fig. 4, but refer back to Fig. 1 for wiring together the components. From this point on, we will assume you are using a pc board on which to mount the components.

Before you install any component on the board, install the wire jumpers and solder them into place. If you do not do this at the outset, you will not be able to install jumpers that are either fully or partially hidden under other components. Use solid bare bus wire for the jumpers.

Once the jumpers are installed, proceed to installing and soldering into place the IC sockets and ZIF socket, the latter in the *SO1* location. Do plug the ICs in to their respective sockets until after you have conducted voltage tests and are certain that the circuit has been properly wired.

Next, install and solder into place the resistors and then the capacitors. Make certain that all electrolytic capacitors are properly oriented before soldering their leads into place. Install the four diodes and four transistors in their respective locations. Again, make sure the diodes are properly oriented and the transistors are properly based before soldering any leads into place.

Now install and solder into place the LEDs. A note of caution: if you use the rectangular LEDs specified in the Parts List, keep in mind that the *long* lead is the cathode. This is just the opposite of most LEDs, which assign the long lead to the anode. When you are done installing the LEDs, in-

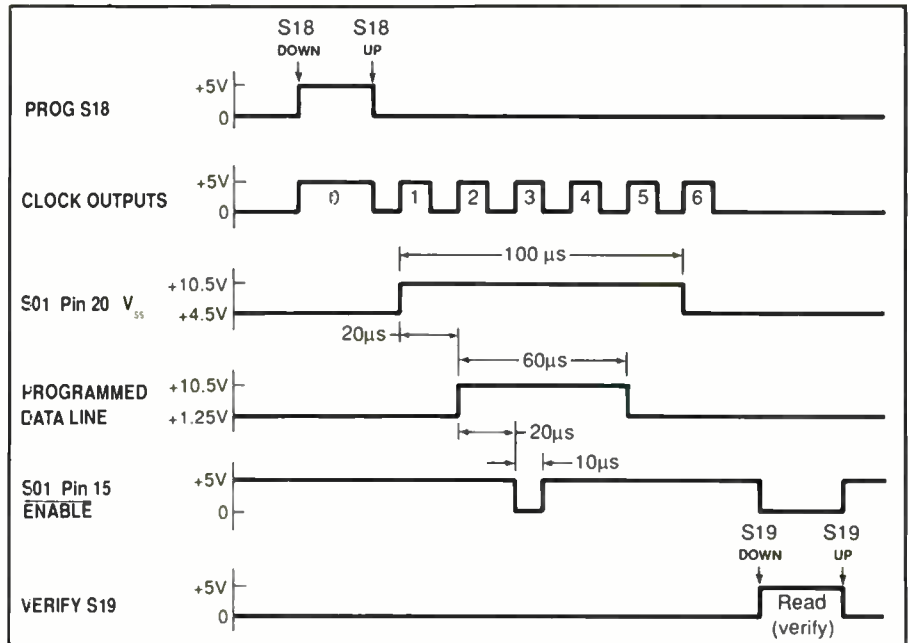

Fig. 2. Timing signals for sequence generator.

stall and solder into place the switches, including the two at the lower-right and solder them into place.

Pads are provided across the bottom of the board under the transformer for a reinforcement strip. Solder a 1/4-inch strip of printed-circuit board blank on-edge to these pads to strengthen the board under the transformer. Of course, first notch the strip with a file where it might intersect copper traces on the board to prevent short circuits. This done, mount the power transformer matching the pin numbers with the numbers shown for them in Fig. 4. Solder the transformer pins in to place.

When you finish wiring the circuit-board assembly, label the slide switches on top of the board for easy identification. Starting with the OUTPUT switches in the center of the board, label the switch on the right-hand end O1. Moving towards the left, label the remaining switches in this arrangement with successive legends up to O8. Similarly, label the ADDRESS switches along the bottom of the board A0 through A8, starting from the right and working towards the left. The

address and output lines are etched on the solder side of the board for double checking.

Check over the circuit-board assembly to make sure that each component is in its proper location and, where required, is properly oriented. Turn over the board and check all soldering. Solder any connection you might have missed and reflow the solder on any connection that appears suspicious. If you locate any solder bridges, especially between the closely spaced pads of the IC sockets, remove them with desoldering braid or a vacuum-type desoldering tool.

You can mount the circuit-board assembly in any type of arrangement that pleases you. Because access is required to a large portion of the top of the board, it is best if you mount the circuit-board assembly in a frame. You can easily make this from 1 x 2- or 1 x 1 pine lumber, if you wish, using a bottom panel made from 1/4-inch or thinner Masonite or plywood.

The circuit board has provisions on it for adding a POWER switch to the ac-line side of *T1*. If you wish to use this switch, find a way to mount

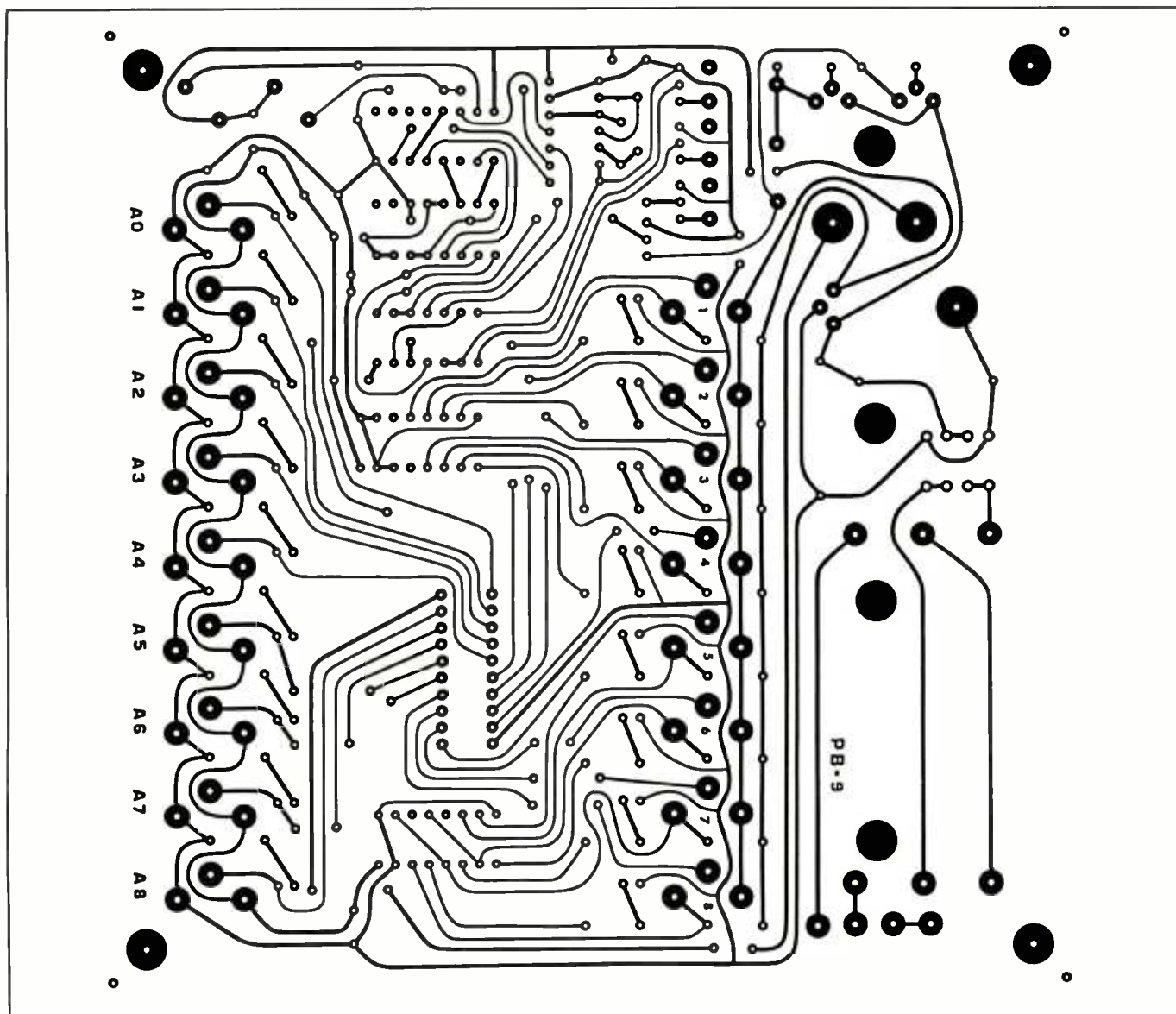

Fig. 3. Actual-size etching-and-drilling guide for fabricating printed-circuit board for project.

the switch on the enclosure or frame used for the circuit-board assembly. Then use zip cord or individual hook-up wires for the leads that go from the switch lugs to the pads labeled B and C on the circuit-board assembly; the conductors of the ac line cord go to the holes labeled A and D. Should you opt not to use the POWER switch, simply solder the conductors of the ac line cord to pads C and D. Solder the line-cord and POWER switch conductors to the pads on the bottom of

the board. Do *not* plug them into the holes at these locations. By soldering to the pads without going through the holes, you eliminate the possibility of hazardous ac line voltage from appearing on the accessible top surface of the board.

Checkout & Calibration

Plug all ICs, except IC4, into their respective sockets on the circuit-board assembly. Make certain each is prop-

erly oriented and that no pins overhang the sockets or fold under between ICs and sockets.

Before you can put your PROM Burner into service, you must calibrate the programming voltages. Because IC4 is currently out of the circuit, Q1 and Q3 will turn on when power is applied to the project. With power applied, adjust the setting of trimmer control R23 for a 4.5-volt output to IC8. You can measure the output voltage of IC8 by touching

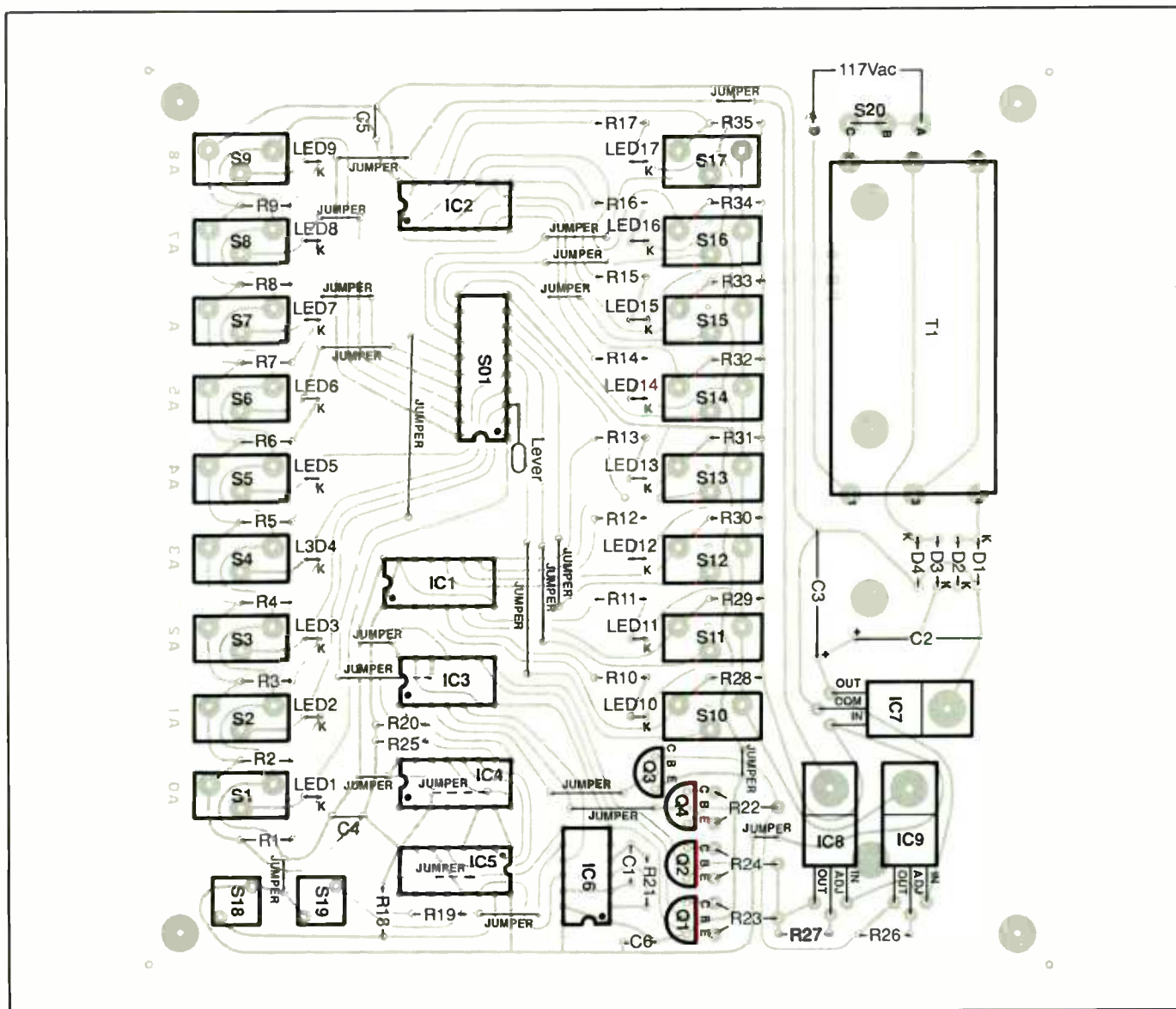

Fig. 4. Wiring guide for pc board.

the "hot" probe of the meter to the mounting tab of IC8 and the common lead to ground.

Use a clip lead attached to the positive OUT pin of IC7 or anywhere along the +5-volt bus to apply V+ to pin 1 of IC3. Doing this turns on Q4. While Q4 is conducting, adjust R22 for a +10.5-volt reading at the output of IC9. (Measure the output of IC9 also at the mounting tab.)

Remove the +5 volts from pin 1 of IC3 and apply it to pin 11 of IC3.

Now adjust R24 for a reading of +10.5 volts from the OUT pin of IC8 to ground. Remove the voltage and plug IC4 into its socket. (Note: Always remove power from the circuit when plugging in or removing any IC to prevent component damage.)

The output voltage from IC8 should measure 4.5 volts, and the output of IC9 should read 1.25 volts with IC4 in the circuit. Calibration of the power supplies is now complete. Use a small drop of fingernail enamel

to paint-lock the small trimmer controls in their calibrated positions.

Using the Burner

Use of your programmer is easy if your program is first written down on paper, with addresses and data entered in binary form. An example of how to write a program is illustrated in Fig. 5.

Once the program is written down on paper, the address to be pro-

grammed is set up by moving *S1* through *S9* to their appropriate positions. The LED above each switch indicates if the line is high (1) or low (0), with a LED that is on indicating a high (1) for that particular line.

As an example of programming, consider the following. We will assume that your program begins at address 0010 0101. This being the case, set address switches *A0*, *A2* and *A5* to their up position and all other switches in this array to the down position. This sets the proper address for binary 0010 0101. These switches are arranged in the same order as the binary number representing the address, with the least-significant bit (LSB) on the right end of the array. Once you have set the address, leave the switches in their set positions until all data outputs requiring a high for that address are programmed.

Next, program the outputs for that

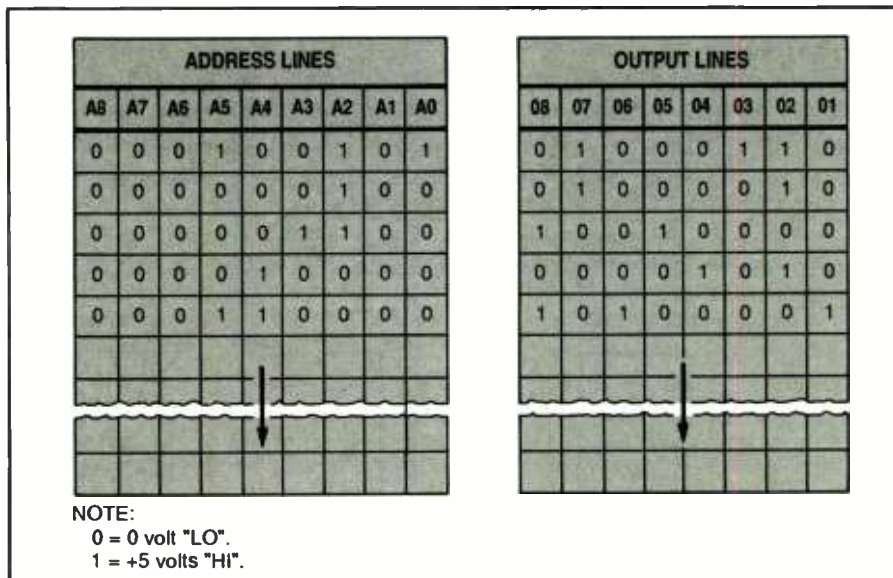

Fig. 5. Example of output-line programming for each address to be programmed into a PROM. Before programming is attempted, complete program should be written down on paper in manner shown here.

particular address. Assume the data to be stored at this address is binary 0100 0110. Since the chip is furnished with all outputs low, only outputs 2, 3 and 7 require programming to the high state for this address. This being the case, start with data switches *O1* through *O8* set the down position. This disconnects the programming voltage from the data inputs. The DATA LEDs will all be on because they are connected to the floating outputs of the PROM, unless ENABLE switch *S19* is pressed.

Starting from the right-end least-significant data line, set the *O2* line switch to its up position and momentarily press and release PROGRAM switch *S18*. This initiates the program cycle and should burn open the appropriate fusible link inside the PROM being programmed to make *O2* high at this address.

Set the *O2* switch to its down position. To verify the programming has successfully taken, press VERIFY switch *S19*. If programming is successful, the *O2* LED will come on when *S19* is pressed and all low outputs will go low while this switch is held down. Keep in mind that pro-

gramming may require more than one and as many as ten programming pulses for successful link burning.

When the high is verified, set the *O2* switch to its up position and press and release *S18* five more times. This ensures complete separation of the fuse link. Set the *O2* switch to down to complete *O2* line programming.

Without changing the address, program output *O3* next in the same manner. Remember that the outputs float, unless the PROM is enabled by pressing down on the VERIFY button. Each time this button is pressed, the LEDs for all previously outputs that were programmed to be high will come on, permitting you to read the condition of the outputs.

One precaution you must take during programming is to set output switches *S10* through *S17*, except the output that is being programmed for a high condition, to the down position. If you fail to do this after programming, the next attempt at programming could damage the PROM or mess up your program. Other than this, programming PROMs is a straightforward procedure, albeit a tedious one with fairly long programs.

Be an FCC LICENSED ELECTRONIC TECHNICIAN!

Earn up to \$30 an hour and more!

Learn at home in spare time. No previous experience needed!

No costly school. No commuting to class. The Original Home-Study course prepares you for the "FCC Commercial Radiotelephone License." This valuable license is your professional "ticket" to thousands of exciting jobs in Communications, Radio-TV, Microwave, Maritime, Radar, Avionics and more...even start your own business! You don't need a college degree to qualify, but you do need an FCC License.

No Need to Quit Your Job or Go To School This proven course is easy, fast and low cost! **GUARANTEED PASS**—You get your FCC License or money refunded. **Send for FREE facts now. MAIL COUPON TODAY!**

COMMAND PRODUCTIONS
 FCC LICENSE TRAINING, Dept. 206
 P.O. Box 2824, San Francisco, CA 94126
 Please rush FREE details immediately!

NAME _____
 ADDRESS _____
 CITY _____ STATE _____ ZIP _____

Single-Channel Sound Exploder

Simulates full stereo sound and control capabilities from a mono source and can be cascaded to provide a four-channel surround-sound effect

By Michael Swartzendruber

Sound-generation and processing devices have traditionally been popular among project builders. Some have been stand-alone units, others computer-driven. One thing most such projects have in common is that they are single-channel devices and, thus, offer limited spatial dimension. Our Sound Exploder, described here, offers a new dimension in spatial depth by making any single-channel sound source into full stereo and, optionally, four-channel surround sound. It provides a full range of effects, including reverb enhancement, bass and treble boost and cut, channel balancing and four-way fading.

The circuitry for the Sound Exploder is built around two specialized integrated circuits: a TDA-3810 pseudo-stereo processor and a TDA-1524 stereo control chip. Together, these chips create a pseudo-stereo signal with full stereo control from any monophonic source. Cascading Sound Exploder devices lets you put together a four-way sound system. Full construction and installation details follow.

About the Circuit

The complete schematic diagram of the circuitry used in the Sound Exploder is shown in Fig. 1. The TDA-3810, shown as *IC1* and *IC2*, is

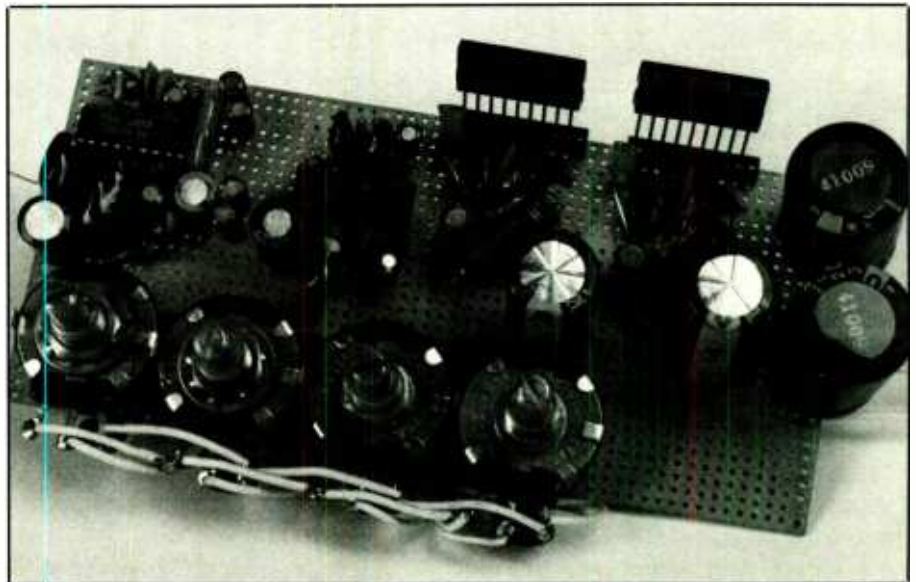

an amplifier that operates in one of three logic-controlled modes: spatial stereo enhancement; regular stereo and pseudo-stereo. In the Sound Exploder, we use the spatial enhancement and pseudo-stereo modes to obtain the desired effects.

Specific logic levels at pins 11 and 12 of *IC1* and *IC2* determine which mode these chips operate under. The different logic-state inputs and their resultant modes of operation for the TDA-3810 are detailed in the Table.

As the Table shows, whenever pin 11 is high and pin 12 is low, the chip is placed into its pseudo-stereo mode. This mode of operation is used in *IC1*, while *IC2* is made to operate in

either regular stereo or spatial stereo mode, depending on the logic level applied to its pin 11 input. The state of pin 11 of *IC2* is set by *SI*.

Pseudo-stereo mode accepts a monophonic (single-channel) audio signal across pins 1 and 17 of *IC1*. This signal is processed by amplifiers internal to the chip. The signal for these amplifiers is processed by phase shifting and signal balancing in the external T networks made up of the discrete-component RC networks connected to *IC1*. The signal is then passed through the second-stage pseudo-stereo amplifiers inside the integrated circuit.

There are three second-stage am-

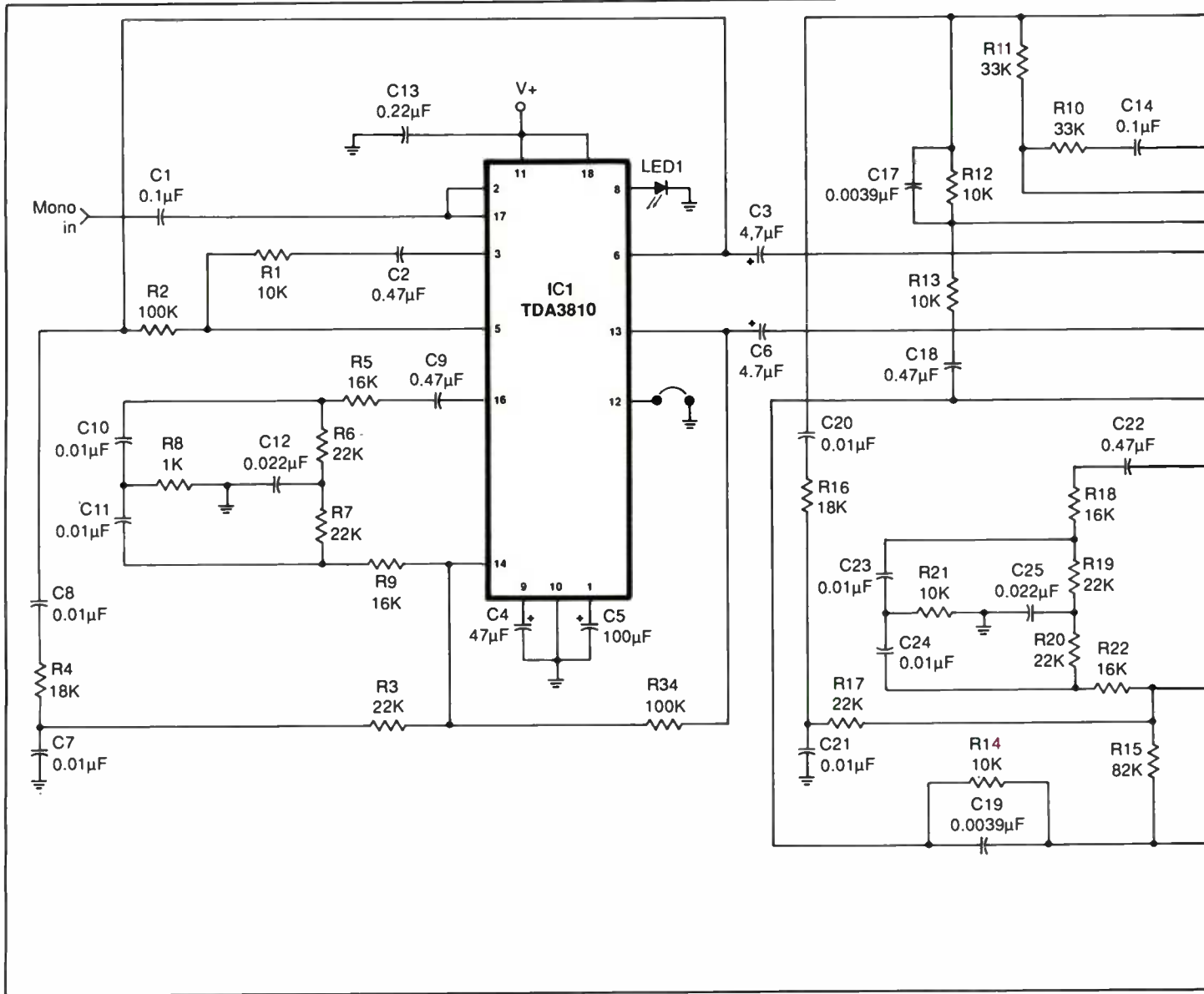

Fig. 1. Complete schematic diagram, minus its dc power supply, of the Sound Exploder circuitry.

plifiers inside the TDA-3810, one for each mode of operation detailed in the Table. The signal is routed through each of these amplifiers. However, the control logic determines which amplifier output will be passed to the final amplifier stage on the chip.

The three second-stage amplifier outputs are multiplexed, and an internal analog switch selects which of the three amplifier output signals will be passed to the final amplifier stage

of the device. A small portion of the output signal from the final on-chip output stage is mixed with the input signal at the T networks.

The second TDA-3810, IC2, is used in this circuit to configure it so that it can operate in a spatial-enhancement mode. This mode mixes the original input signal with a delayed sample of the input signal to create an echo effect. The echo effect is amplified internally and output through the final internal amplifier

stage of IC2. You can enable and disable the spatial-enhancement mode at will by changing the setting of S1, which sets the logic level on pin 11 of the chip and, in turn, selects the regular or spatial operating mode.

A variety of internal amplifiers and filter circuits make up the TDA-1524 stereo audio control chip used for IC3. Trim and gain level of the internal circuitry is set by an external potentiometer, which is used to adjust the dc biasing applied to the in-

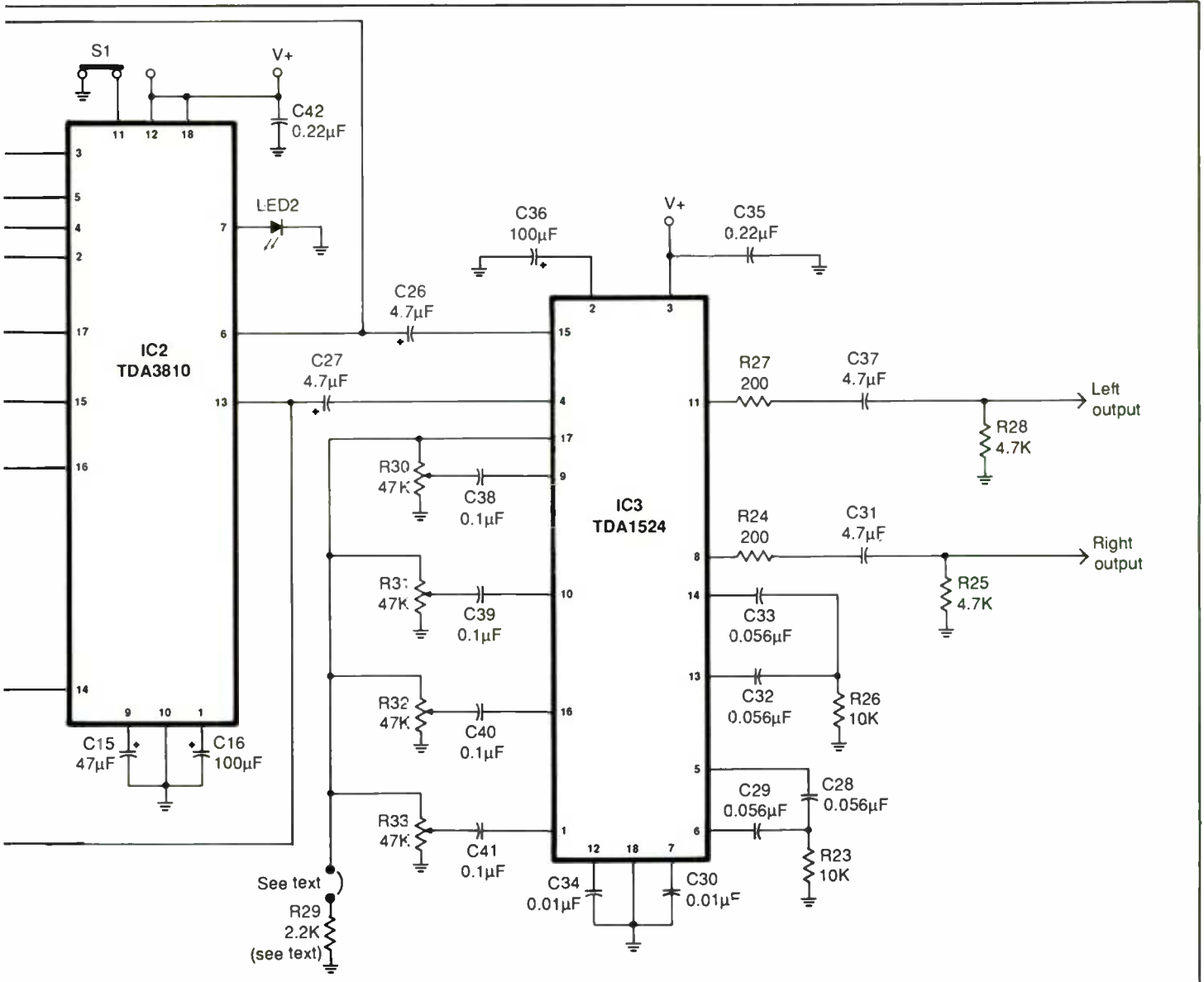

ternal amplifiers. Changing biasing effects the action the chip takes on any signals passing through IC3.

Signal levels of VOLUME and BALANCE controls R30 and R31 are sensed by a volume and balance control-voltage level converter inside the device. This internal control has two outputs that set the gain of the first on-chip amplifier stages. The audio signal is then passed to a bass/treble control-amplifier stage.

Action of the bass/treble amplifier

stage is controlled by the setting of BASS and TREBLE potentiometers R33 and R32. The bass/treble amplifier consists of two on-chip amplifier modules, each of which operates on different portions of the signal spectrum. Rolloff of this stage is determined by internal circuitry that connects to filter circuits connected at pins 13 and 14 and pins 5 and 6. The signals from the two internal modules are mixed at an internal push-pull amplifier arrangement and pre-

sented as an output signal.

This signal is the output of the entire circuit. It can be used to drive an audio power amplifier directly, since it is at line level. Alternatively, if a four-way system is desired, you can feed the two outputs from a single assembly to the inputs of two more identical assemblies, as illustrated in Fig. 2. This provides a four-way system by splitting each of the two outputs from the first assembly into two more assemblies that each output

PARTS LIST

Semiconductors

IC1, IC2—TDA-3810 pseudo-stereo processor
IC3—TDA1524 stereo controller
LED1, LED2—Jumbo light-emitting diode (any color)

Capacitors

C1, C14, C38, C39, C40, C41—0.1- μ F ceramic disc
C2, C9, C18, C22—0.47- μ F polyester
C3, C6, C26, C27, C31, C37—4.7- μ F, 25-volt electrolytic
C4, C15—47- μ F, 25-volt electrolytic
C5, C16, C36—100- μ F, 25-volt electrolytic
C7, C8, C10, C11, C20, C21, C23, C24, C30, C34—0.01- μ F ceramic disc
C12, C25—0.002- μ F polyester
C13, C35—0.22- μ F polyester
C17, C19—0.0039- μ F polyester
C28, C29, C32, C33—0.056- μ F polyester

Resistors ($\frac{1}{4}$ -watt, 10% tolerance)

R1, R12, R13, R14, R21, R23, R26—10,000 ohms
R2—100,000 ohms
R3, R6, R7, R17, R19, R20—22,000 ohms
R4, R16—18,000 ohms
R5, R9, R18, R22—16,000 ohms
R8—1,000 ohms
R10, R11—33,000 ohms
R15—82,000 ohms
R24, R27—200 ohms
R25, R28—4,700 ohms
R29—2,200 ohms
R30 thru R33—47,000-ohm audio-taper potentiometer (see text)

Miscellaneous

S1—Spdt slide or toggle switch
Printed-circuit board(s) or perforated board with holes on 0.1" centers and suitable Wire Wrap or soldering hardware (see text); 12-volt dc power supply (see text); suitable enclosure; spst POWER switch; sockets for all ICs; phono jacks for input and outputs; chassis-mount jack for power supply (optional; see text); dry-transfer lettering kit and clear spray acrylic; spacers; machine hardware; hookup wire; solder; etc.

Note: Items listed are for stereo-only version of project. If you build four-way version, you need three circuit-board assemblies (see text).

two signals for a total of four. Note in the table that accompanies Fig. 2 that you obtain full control over volume, balance, treble, bass and front-to-rear fading.

Power for the circuit can be obtained from virtually any single-ended regulated 12-volt dc supply.

Any traditional construction technique can be used to assemble the circuitry. The easiest means is printed-circuit construction. If you wish to go this route, fabricate your board(s) using the actual-size etching-and-drilling guide shown in Fig. 3. Then wire the board(s) according to Fig. 4.

A good alternative to printed-circuit construction is to use perforated board that has holes on 0.1-inch centers and suitable Wire Wrap or soldering hardware. Of course, if you elect this point-to-point wiring technique, make sure that the audio paths are kept as short as possible as you lay out the components on the board(s), as shown in the lead photo. Try to keep components arranged on the board as near as possible to the layout shown in Fig. 4.

Whichever construction technique you decide to use, it is a good idea to install the ICs into the circuit via sockets. From here on, we will assume that you are using printed-circuit construction.

If you are building a stereo-only version of the project, you need only one board. If you are building a four-way version, you need three boards, all wired identically.

Begin populating the board(s) by installing and soldering into place the DIP sockets for the ICs. Do *not* plug the ICs into the sockets until after you have conducted preliminary voltage checks and are satisfied that each board is properly wired.

Next, install and solder into place the various jumper wires. Use insulated solid hookup wire for the jumpers. If you are using audio-taper potentiometers for R30 through R33, omit the jumper with the asterisk next to it and R29, and cut through

the trace shown with an X through it. The jumper, resistor and trace are required only if you use *linear-taper* potentiometers.

Install the resistors in their respective locations. As you examine Fig. 4, note that some resistors mount on-end instead of flat on the board(s). Now install and solder into place the capacitors. Start with the ceramic-disc and polystyrene types and then finish up with the electrolytic type. Make sure with the last that each is installed in the proper orientation before soldering its leads to the copper pads on the bottom of the board.

Install S1 via three wires that are lone enough to permit mounting the switch on the front panel of the enclosure in which the project is to be housed. Slide a 1-inch length of small-diameter heat-shrinkable or other insulating tubing over the free ends of the wires coming from the LED locations on the board(s).

Identify the cathode leads of the LEDs and trim them to $\frac{1}{2}$ inch in length. Form a small hook in all cathode leads. Then crimp the cathode leads to the cathode wires (identified with a "K" next to the pad for them) and solder the connections. Do the same for the anode leads of the LEDs and their wires. When the connections cool, slide the tubing up over them until the tubing rests against the bottom of the LED cases and shrink into place.

If you are building the four-way version of the project, use pc-mount trimmer potentiometers for R30, R32 and R33. Use 10-inch hookup wires for the connections to R31 on this board. Note that the circuit-board assembly with this arrangement is Board 1 in Fig. 2.

Strip $\frac{1}{4}$ inch of insulation from both ends of 16 8-inch lengths of hookup wire for the single board for the stereo-only version or 16 10-inch wires for two of the three boards and seven 10-inch wires for the remaining board required for the four-way version. (You may need two more wires

NOTE:

Use shielded cable throughout. Shields go to circuit ground in all cases.

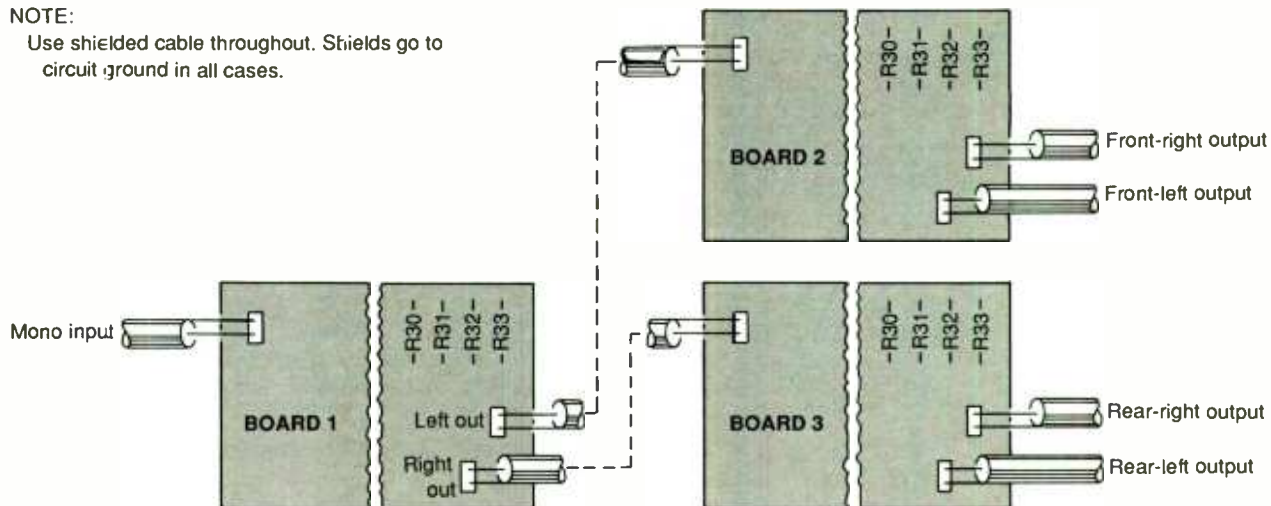

CONTROL	FUNCTION		
	Board 1	Board 2	Board 3
R30	Prestage volume	Front volume	Rear volume
R31	Front-rear fade	Front balance	Rear balance
R32	Prestage treble	Front treble	Rear treble
R33	Prestage bass	Front bass	Rear bass

Fig. 2. Details for wiring together a four-way system using identical circuit-board assemblies to obtain front and rear stereo sound capabilities.

per board if you plan on using a jack/plug arrangement for the power supply for connection to the chassis-mounted jack.) If possible, use wire that is color coded to reduce confusion during the wiring operation. If you use stranded hookup wire, tightly twist together the fine conductors at both ends of all wires and sparingly tin with solder.

Plug one end of these wires into the holes labeled LED1, LED2, R30 through R33, V+ and GND and solder into place. Loosely twist together the three wires for each potentiometer control, leaving about 1 inch of untwisted wire at the free end.

Next, prepare as many shielded audio cables as are needed for the project as follows. (You need only three cable lengths for the stereo version, seven lengths for the four-way version.) First, cut all cables to a length of 8 inches. Carefully remove

Operating Mode Details				
Mode of Operation	Control Input State		LED Spatial	LED Pseudo
	Pin 11	Pin 12		
Mono/pseudo stereo	high	low	off	on
Spatial Stereo	high	high	on	off
Stereo	low	x	off	off

x is a don't care (either high or low) state.

1 inch of outer plastic jacket from both ends of all cables. Separate the shield wires back to the cut-off jackets, tightly twist together these wires and sparingly tin with solder. Strip 1/4 inch of insulation from the ends of all inner conductors, tightly twist together the exposed fine wires and sparingly tin with solder.

Plug one end of the cables into the holes for the input and output and solder into place. If you are building

the four-way version of the project, install the inter-board connections at this time. Make sure that the shields in all cases go to circuit ground.

You can use any type of enclosure that will accommodate the project configuration you built and has sufficient front-panel space on which to mount the potentiometer controls, switches and LEDs. You can use an external plug-in modular 12-volt supply to power the project, so there is

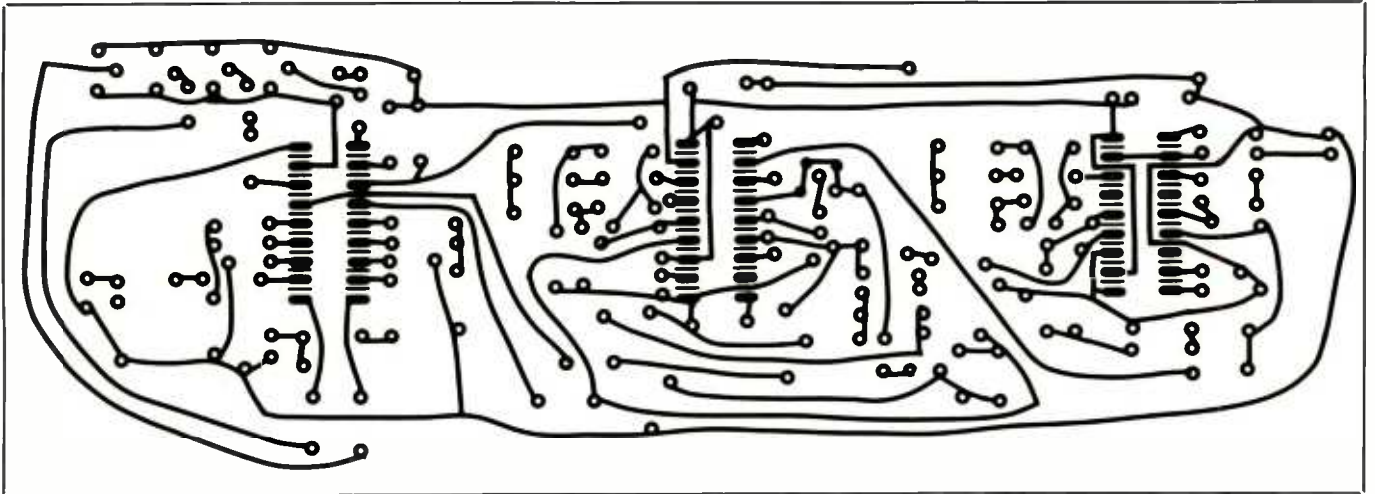

Fig. 3. Actual-size etching-and-drilling guide for fabricating a printed-circuit board for the project.

no need to consider room inside the enclosure for the supply.

Machine the enclosure as needed. That is, drill mounting holes through the front panel for the potentiometer controls, switches and LEDs. Drill a hole in which to mount a POWER switch (not shown in Fig. 1.) Arrange the layout of the front panel so that the controls are grouped in a logical manner (see the table that accompanies Fig. 2 for suggested legends for the controls). That is, arrange the front and rear controls, along with their LEDs in separate groupings.

Drill mounting holes through the

floor of the enclosure for the circuit board(s). If you wish, you can stack the assemblies for a four-way system, using threaded spacers to separate them from each other. Then drill mounting holes through the rear panel for the various input and output jacks and a power-supply jack hole through the panel.

Deburr all holes drilled through metal panels to remove sharp edges. If you are going to route the cord from the power supply through a hole, place a rubber grommet in it.

When you are finished machining the enclosure, use a dry-transfer let-

tering kit to label the front-panel switch, potentiometer and LED locations with suitable legends. Repeat for the input and output jack locations on the rear panel. Spray two or more light coats of clear acrylic over the legends to protect them from abrasion while the project is in use. Allow each coat to dry before spraying on the next.

When the spray acrylic has completely dried, mount a suitable jack on the rear panel for the external plug-in power supply cable. Alternatively, cut off the connector on the end of the supply cord and pass the

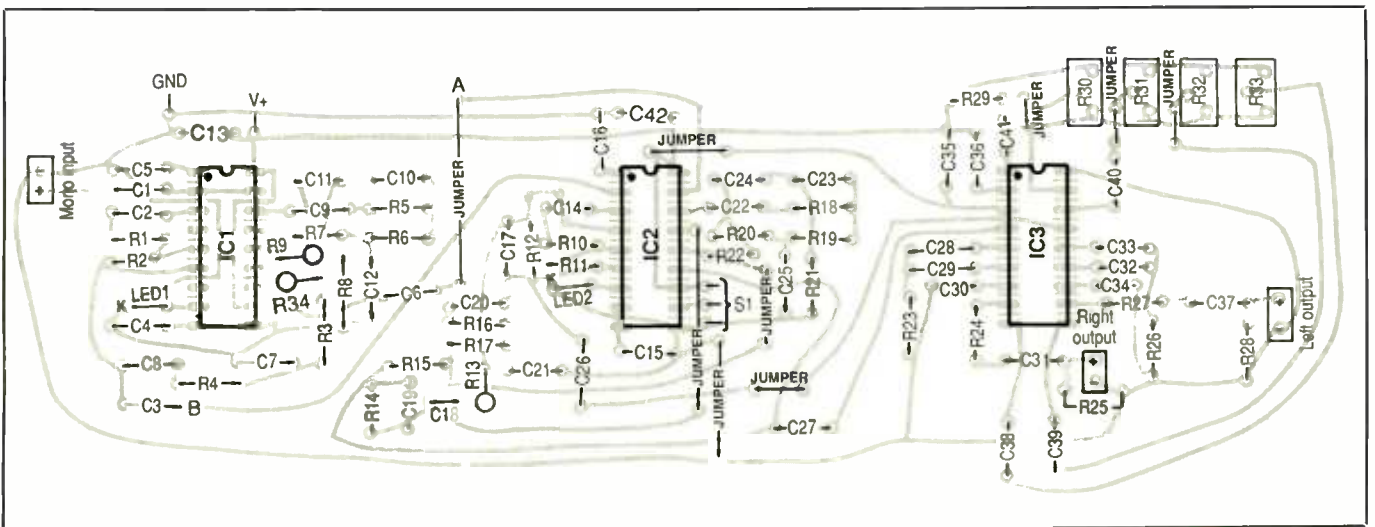

Fig. 4. Wiring guide for pc board. Use this as a rough guide to component layout and conductor routing if you assemble project on perforated board.

cord through its grommet-lined hole and tie a knot in it about 10 inches from the cut end inside the enclosure. Separate the cable leads a distance of 8 inches and strip ¼ inch of insulation from both conductors. Tightly twist together the fine wires in each conductor and sparingly tin with solder.

Use a dc voltmeter or multimeter set to the dc-volts function to determine the polarity of the supply cable. Label the conductors accordingly.

Mount the switches, LEDs and potentiometer controls on the front panel and the input and output jacks on the rear panel. Route the + power-supply cable conductor to the POWER switch and crimp and solder it to one lug of this switch. Crimp and solder one end of a suitable length of hookup wire to the other lug of the POWER switch and terminate the other end in the V+ hole(s) in the circuit board(s). Plug the free end of the - conductor of the cable into the GND hole(s) of the circuit board(s) and solder the connection(s).

If you are using a jack/plug arrangement for the power supply, crimp and solder a suitable length of wire to the + lug of the chassis-mounted jack and one lug of the POWER switch. Then crimp and solder the free end of the V+ wire(s) coming from the circuit board(s) to the other lug of the switch. Crimp and solder the GND wire(s) to the - lug of the jack.

Terminate the free ends of the wires coming from the circuit boards at the appropriate lugs of the switches and controls mounted on the front panel of the enclosure. Plug the domes of the LEDs into their respective holes in the panel. If they do not remain in place by friction, apply a small dot of fast-setting epoxy or other suitable cement to secure them in place.

Terminate the free ends of the shielded cables in the appropriate jacks on the rear panel. Again, make sure the shields in all cases tie to the ground lugs of the jacks. If you

are using a metal enclosure, cut a piece of heavy cardboard to size and line the interior of the enclosure with it until you are ready to mount the circuit board(s) to the floor. This will insulate the circuitry from the enclosure during checkout and power-up adjustments.

Carefully check the circuit board(s) to ascertain that all components are installed in the correct locations and that polarity-sensitive components are properly oriented. Turn over the board(s) and check your soldering. Solder any connection you might have missed and reflow the solder on any suspicious connection. If you locate any solder bridges, especially between the closely spaced pads of the IC sockets, remove them with a vacuum-type desoldering tool or desoldering braid.

Checkout & Use

Connect the common lead of a dc voltmeter or multimeter set to the dc-volts function to any convenient point that is at circuit ground. Make sure that no ICs are plugged in.

Plug the power supply into an ac outlet and set the POWER switch to "on." Touch the "hot" probe of the meter to pins 11 and 18 of the IC1 socket, pins 12 and 18 of the IC2 socket and pin 3 of the IC3 socket. You should obtain a reading of +12 volts in all cases. If you do not, power down and correct the problem.

Once you are certain that the circuitry has been correctly wired, power down and install the ICs in their respective sockets. Make sure each is properly oriented and that no pins overhang the sockets or fold under between ICs and sockets.

If you built a four-way version of the project, the controls for Board 1 (see Fig. 2) must be initially set as follows. Set FRONT-REAR FADE and PRESTAGE VOLUME controls R31 and R30 to about the middle of rotation. For the same board, set PRESTAGE

TREBLE and PRESTAGE BASS controls R32 and R33 to just past the middle of rotation.

Connect the ground lead of an oscilloscope to circuit ground. Then power up the project and the oscilloscope and inject a 5-kHz sine-wave signal with an amplitude of not more than 10 millivolts into the MONO INPUT. Touch the input probe of the oscilloscope to points A and B on Board 1 and slowly adjust the setting of PRESTAGE VOLUME control R30 until distortion of the signal just becomes visible. (It helps if you use a dual-channel oscilloscope for this operation so that you can monitor points A and B simultaneously.) Then back off on the control until the distortion just disappears.

With the circuit adjusted, power down the Sound Exploder and mount the circuit board(s) in place.

Connect the MONO INPUT of the project to any monophonic signal source that is at preamplified level and the OUTPUTS to the inputs of your power amplifier(s), using shielded cable. Set the VOLUME control of your music system for a low level and all other controls to about midpoint. Turn on your sound system and the Sound Exploder. Always using this power-up procedure minimizes the possibility of damage to the input stage of the Sound Explorer.

Adjust the controls on the Sound Exploder for the most desirable effect. If necessary, adjust the volume level from the music source to obtain a listenable level as you do this. Now experiment with various control settings. Bear in mind that the board-mounted VOLUME, TREBLE and BASS controls on Board 1 have greatest impact on overall sound quality in a four-way system; so experiment with the settings of these controls with care.

As you become familiar with how the Sound Exploder performs and its use, you will discover that it adds an entirely new dimension to programmable sound generators, computer games and voice synthesizers. **ME**

Power On/Off IR Remote Controller

Lets you control the on/off state of any electrically powered device using an invisible beam of infrared energy

By James Melton

Now that you have remote control for your TV receiver, VCR, hi-fi system and perhaps even your ceiling fan, there are probably electrical appliances around your house to which you would like to add the convenience of remote control. If all you want is a single on/off control function for them, you might want to build the Simple Infrared Remote Controller described here. It costs very little for components, is easy to build and even easier to install.

Our IR Remote Controller offers just two states of control for a single device: on and off. Furthermore, it uses no coding or decoding of the IR signal as multi-function controllers require. This design is greatly simplified. Further simplifying design is the use of a commonly available preassembled module that serves as the "front end" of the receiver section.

If you have more than one device to be controlled, whether in different rooms or even in the same room, you can build multiple receivers and control all of them from the same IR transmitter.

About the Circuit

The Simple Infrared Remote Controller system consists of basically two sections—a transmitter and a receiver. The schematic diagram for the receiver section is shown in Fig. 1,



along with its ac power supply.

At the heart of the receiver section is a Radio Shack Cat. No. 276-137 infrared receiver module, *MOD1*, that greatly simplifies project construction. Because this module comes preassembled, all you need do is connect a source of power (V+ and ground) to it and route its output to external circuitry that customizes it for your application.

The infrared receiver module accepts a 40-kHz IR carrier signal that is modulated at 4 kHz. When a 40-kHz signal is received, the OUT lead of the receiver module goes low for as long as the signal is received.

Because of its high gain, the IR

module also presents very-short-duration "false" signals. In this project, the "false signal pass-through" is used to prevent the transmitted signal from interfering with existing infrared controllers.

The transmitter (see Fig. 2 schematic diagram for circuit details of this section) transmits a carrier signal composed of a series of pulses generated at a rate of approximately 7 kHz. This signal "swamps" (overloads) *MOD1* in the receiver section long enough to present a series of low pulses. These pulses are similar to noise, but they are at a much more frequent and predictable rate of 7 kHz. This frequency did not interfere

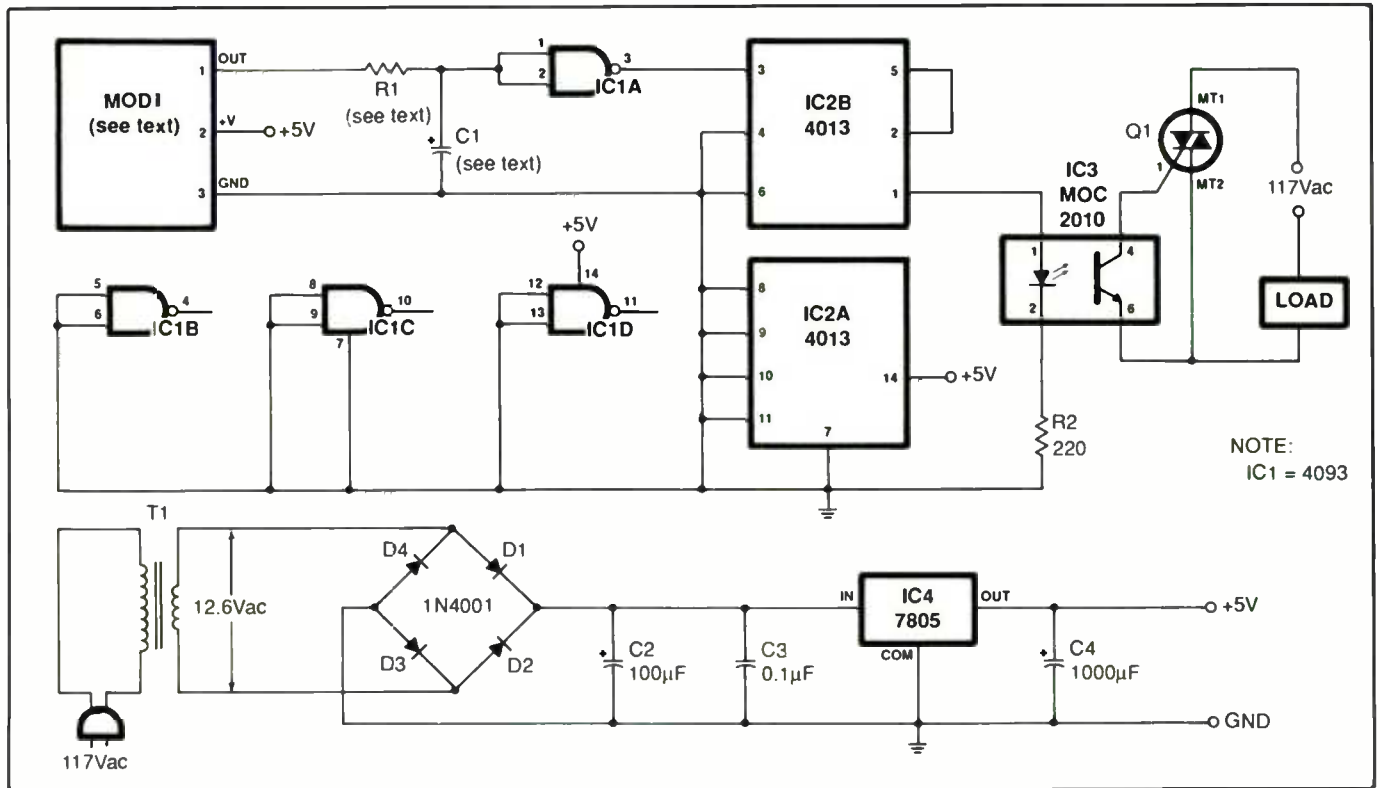

Fig. 1. Complete schematic diagram of IR receiver circuitry. This circuit is greatly simplified as a result of MOD1, a commercially available, preassembled IR receiver module.

with any existing remote controller tested by the author.

A small amount of infrared energy, such as that produced by an incandescent lamp, is sufficient to overload the front end of the Radio Shack module. This will bring low the output of the module for just a millisecond or so several times per second. To relieve this problem of falsing, an RC circuit made up of *R1* and *C1* in Fig. 1 is used to integrate the signal. The output of the integrator network is fed to one gate of a 4013 CMOS NAND Schmitt trigger (*IC1A*), which provides a predictable and stable output for delivery to 4093 D-type flip-flop stage *IC2A*.

Flip-flop *IC2A* is used to toggle back and forth every time a signal is received by the IR module. The output of *IC2A* drives MOC3010 optical coupler *IC3*. The output of *IC3*, in turn, drives power triac *Q1*.

The particular triac you use for *Q1* depends on how much power you want the device to control. Therefore, select this component accordingly. Bear in mind that it is much better to use a heavier-duty power triac than is called for to maintain a comfortable margin of safety. A good rule-of-thumb to follow here is to select a triac that can safely handle at least 50 percent more current than the load to which it is connected will draw. Also, if you wish to control a device that draws more than, say, 3 amperes of power, it is best to use a medium-power triac that, in turn, drives a power relay than to directly control the appliance with a high-power triac.

As shown at the bottom of Fig. 1, the receiver section is powered by its own built-in ac power supply. The circuit for this supply has a standard full-wave configuration. Incoming

117 volts ac is stepped down to 12.6 volts ac by the bridge-rectifier circuit composed of diodes *D1* through *D4*. The resulting pulsating dc is smoothed to pure dc by filter capacitor *C2*. The pure dc is regulated to a fixed +5 volts by *IC4*, stabilized by *C4* and delivered to the rest of the receiver circuitry as needed.

As can be seen in Fig. 2, the transmitter section is a very simple affair. It is built around 555 timer *IC5*, which is configured here as an astable multivibrator. The 555 chip does not drive infrared-emitting diode *IREDI* directly. Instead, power for *IREDI* is derived from general-purpose 2N2222 transistor *Q2*. Any general-purpose infrared-emitting diode can be selected for *IREDI*.

Resistor *R6* in the collector circuit of *Q2* limits current flow through *IREDI* to a safe level. The 100-ohm value shown was for the particular

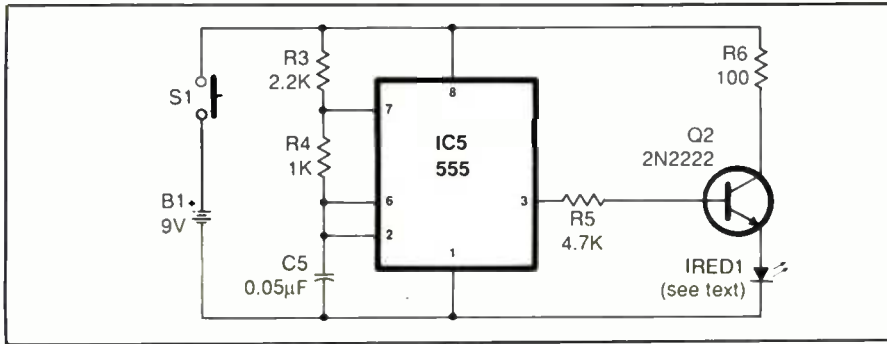

Fig. 2. Complete schematic diagram of IR transmitter circuitry.

IR-emitting diode used in the prototype. If you use any other IR-emitting diode, you may have to change the value of $R6$ to allow $IRED1$ to generate sufficient IR energy to provide reliable remote control.

Power for the portable transmitter section is provided by 9-volt alkaline battery $B1$. Power is applied to the circuit through switch $S1$. This momentary-action pushbutton switch automatically disconnects power

from the circuit when you lift your finger from the button, thus preventing rapid depletion of power from the battery.

Construction

There is nothing critical about component placement or conductor routing in either the transmitter or the receiver. Therefore, you can use any wiring scheme that suits you to as-

semble the circuitry. If you wish, you can fabricate a pair of printed-circuit boards for the project, using the actual-size etching-and-drilling guides shown in Fig. 3. Alternatively, you can assemble the circuitry on perforated board that has holes on 0.1-inch centers, using suitable Wire Wrap or soldering hardware. Whichever way you go, though, it is a good idea to use sockets for all DIP ICs.

From here on, we will assume that you are using pc construction. With this in mind, refer to Fig. 4(A) for details on wiring the receiver circuitry. Begin by installing and soldering into place the DIP IC sockets. Do *not* plug the ICs in their sockets until after you have conducted preliminary voltage checks and are certain that your wiring is correct, especially if you use point-to-point wiring.

Once the sockets are installed, mount into place the resistors, capacitors and diodes. Make certain that the diodes and any electrolytic capacitors are properly oriented before soldering their leads into place. Next, install the voltage regulator and power triac. Make certain each is properly based (note the positions of the metal tabs on both devices, shown as a heavier line in the case outlines). Solder their pins into place.

If you are using a medium-power triac for $Q1$, be sure to fit it with an appropriate heat sink to carry away heat. Strip $\frac{1}{4}$ inch of insulation from both ends of two heavy-duty 6-inch-long hookup wires. Tightly twist together the fine conductors at both ends, and sparingly tin with solder. Plug one end of these wires into the holes labeled **LOAD** and **HOT** and solder into place.

You can either build the receiver into an existing electrical device for its exclusive use (assuming it has enough interior space to accommodate the circuit-board assembly and, if used, power relay) or house the project inside its own separate enclosure. If you opt for the latter, use an enclosure that blends in with the elec-

PARTS LIST

Semiconductors

D1 thru D4—1N4001 or similar silicon rectifier diode

IRED1—Infrared-emitting diode (any general-purpose type)

IC1—CD4093 quad Schmitt-trigger NAND gate

IC2—CD4013 dual D-type flip-flop

IC3—MOC3010 optical isolator

(Motorola)

IC4—7805 fixed +5-volt regulator

IC5—555 timer

Q1—Triac (see text)

Q2—2N2222 or similar npn silicon general-purpose transistor

Capacitors

C1—See text

C2—100- μ F, 16-volt electrolytic

C3—0.1- μ F ceramic disc

C4—1,000- μ F, 16-volt electrolytic

C5—0.05- μ F ceramic disc or Mylar

Resistors ($\frac{1}{4}$ -watt, 10% tolerance)

R1—See text

R2—220 ohms

R3—2,200 ohms

R4—1,000 ohms

R5—4,700 ohms

R6—100 ohms

Miscellaneous

B1—9-volt alkaline battery

MOD1—Infrared receiver module (Radio Shack Cat. No. 276-137)

S1—Spst normally-open, momentary-contact pushbutton switch

T1—12.6-volt, 250-mA power transformer

Printed-circuit boards or perforated board with holes on 0.1" centers and suitable Wire Wrap or soldering hardware (see text); suitable enclosures (see text); sockets for all DIP ICs; ac line cord with plug; chassis-mount ac receptacle (optional—see text); 117-volt power relay (optional—see text); magnifying lens and transparent red plastic or glass filter (see text); snap connector for B1; spacers; double-sided foam tape; machine hardware; hookup wire; solder; etc.

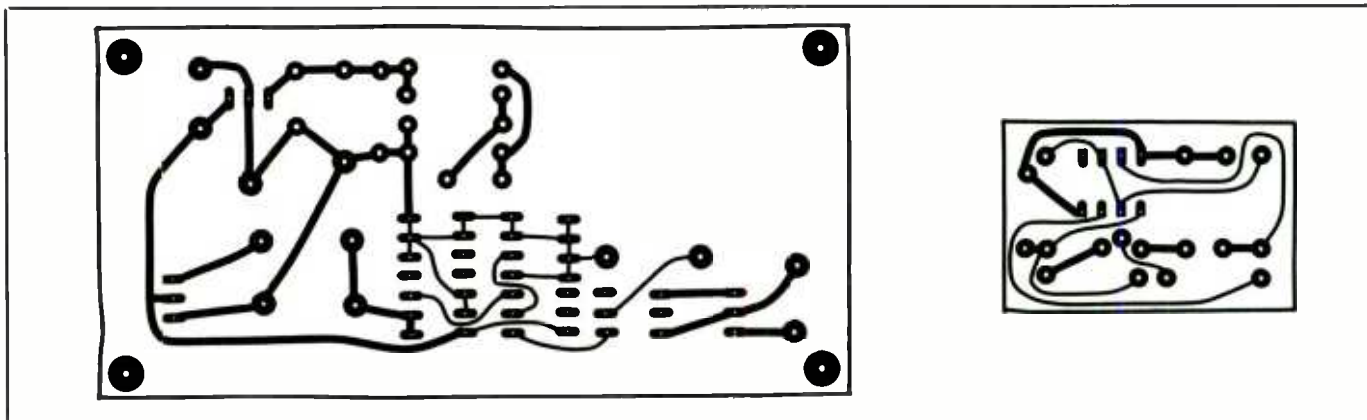

Fig. 3. Actual-size etching-and-drilling guides for (A) receiver and (B) transmitter printed-circuit boards.

trical device that the receiver will be used with and is large enough to accommodate the circuit-board assembly, Radio Shack IR receiver module and, if used, the power relay. Alternatively, use a standard project box, as shown in the lead photo. Whatever your enclosure of choice, if you use a medium-power triac for *Q1*, make sure that at least one panel is metal to use as a heat sink for the triac.

Machine the enclosure as needed. Drill mounting holes for the circuit-board assembly (and off-the-board power relay, if used) and entry holes for the ac line cord and the wiring to the device that is to be controlled. Also drill a 1/2-inch-diameter hole to permit the IR energy from the transmitter to reach the pickup located on the receiver module.

If you mount the IR receiver module very close to the 1/2-inch-diameter hole, it will have a very wide field of view. Mounting it farther back from the hole will limit its field of view and make it more selective. Keep this in mind when planning the mounting location for this module. Before drilling the IR entry hole, temporarily set the module in place and determine exactly where it is to be drilled.

If you wish to use the receiver with different appliances at different times, consider mounting an ac receptacle on the rear wall of the enclosure and use this to make connection with the device to be controlled. Assuming you go this route, make a cutout in the rear panel in which to mount the receptacle.

When you are finished machining

the enclosure, deburr all holes and cutouts made through metal to remove sharp edges. If the entry holes for the line cord and the cord going to the device to be controlled are drilled through a metal panel, line them with small rubber grommets. Then route the unfinished end of the line cord through the grommet into the enclosure and tie a strain-relieving knot in it about 6 inches from the end inside the enclosure. Tightly twist together the fine wires in each line-cord conductor and tin with solder.

Place the power transformer in the open area at the upper-left of the circuit-board assembly and use a pencil to trace the holes in its mounting tabs onto the board. Remove and set aside the transformer and drill suitable-size holes at both marked locations.

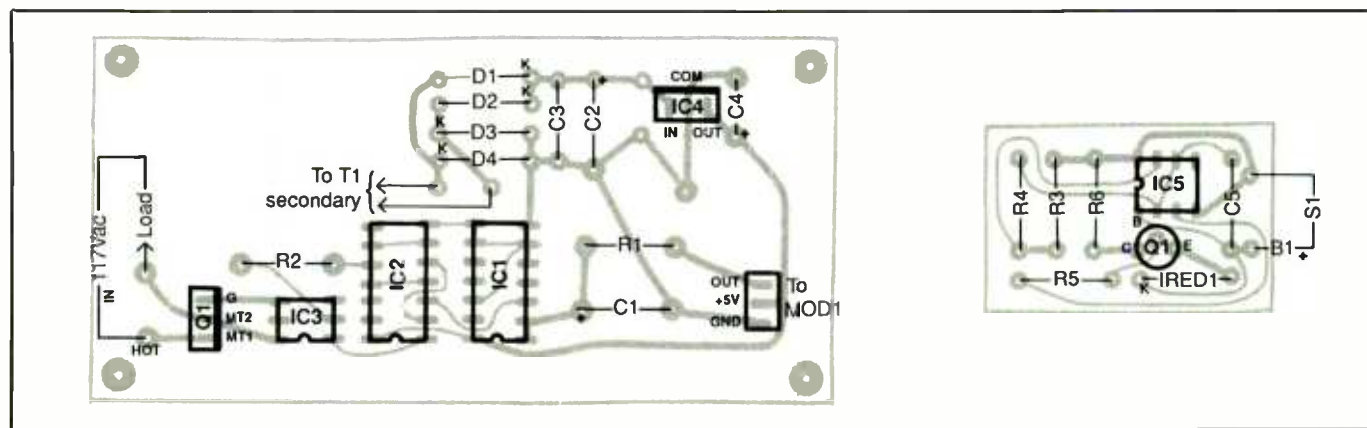
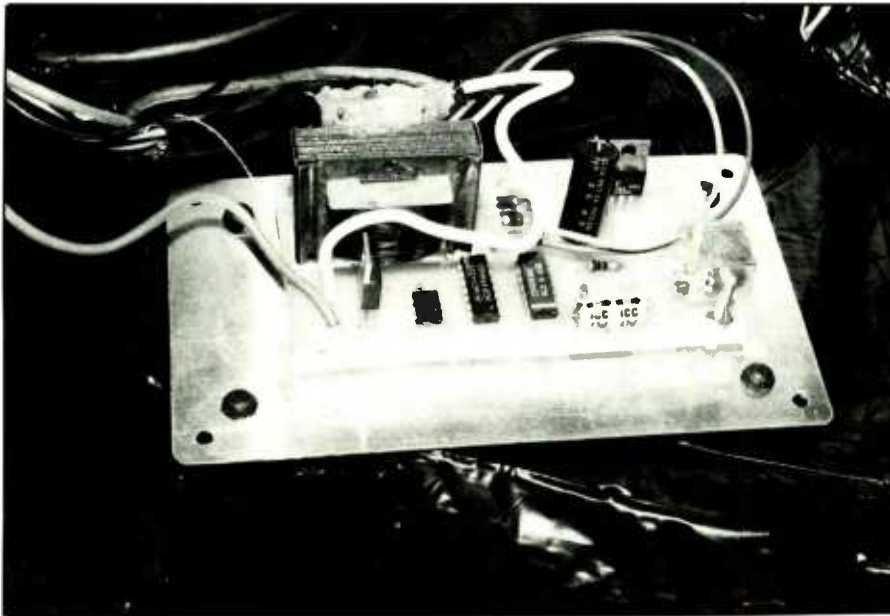

Fig. 4. Wiring diagrams for (A) receiver and (B) transmitter pc boards.



Fully assembled receiver circuit-board assembly mounted on metal lid of common project box.

Plug the secondary leads of the transformer into the indicated holes on the circuit-board assembly. Do *not* confuse the primary and secondary leads. Solder both leads into place. Then use suitable machine hardware to mount the transformer to the circuit-board assembly.

Slip a 1½- to 2-inch length of small-diameter heat-shrinkable or other insulating tubing over each line cord conductor. Twist together one power transformer primary lead and one line cord conductor and solder the connection. Repeat with the other transformer primary lead and the other line cord conductor. Do not slide the tubing over the connections at this time. You will do so later, after taps have been made to the device to be controlled.

Plug the leads coming from the Radio Shack IR receiver module into their respective holes at the lower-left of the circuit-board assembly. Make absolutely certain that each lead goes into the appropriate hole. Then solder all three leads to the pads on the bottom of the board.

Mount the circuit-board assembly

in place, using ½-inch spacers and 4-40 × ¼-inch machine screws, nuts and lockwashers. Also mount the IR receiver module into place. If you incorporated them into your project, mount the external power relay and chassis-mount ac receptacle in their respective locations.

Crimp and solder the free end of the lead coming from the LOAD hole on the circuit-board assembly to one lug of the chassis-mounted ac receptacle. Strip ¾ inch of insulation from one end and ¼ inch of insulation from the other end of a heavy-duty 6-inch-long stranded hookup wire. Twist together the fine conductors at both ends and tin with solder.

Wrap the end of the wire from which ¾ inch of insulation was removed around one of the connections you made to the line cord and transformer primary leads and the free end of the wire coming from the hole labeled HOT around the other line-cord/primary-lead connection. Solder both connections. When the connections cool, slide the tubing over them to completely insulate them and shrink solidly into place.

Then crimp and solder the free end of the last wire you prepared to the remaining lug of the chassis-mounted ac receptacle.

If you are dedicating the receiver unit for control of a specific appliance, you can directly wire the device to the receiver as follows. First, cut off and discard the plug from the line cord of the device. Separate the conductors a distance of about 3 inches. Strip ¾ inch of insulation from the ends of both conductors, tightly twist together the exposed fine wires and sparingly tin with solder.

Slide a 1½- to 2-inch length of tubing over one conductor. Twist together this conductor and the wire coming from the hole labeled LOAD and solder the connection. When the connection has cooled, slide the tubing over it to completely insulate it and shrink into place. Then terminate the free end of the wire coming from the HOT hole in the circuit board and the other line-cord conductor of the appliance at the project line-cord/transformer-primary connections, as described above. Solder the connections and, when cool, slide the tubing over them and shrink solidly into place.

Now wire the transmitter circuit board, as illustrated in Fig. 4(B). Again, use a socket for IC5 but do *not* plug the timer chip into it just yet. Next, install and solder into place the resistors, capacitor and IR-emitting diode. Make sure the transistor is properly based and the diode is properly oriented before soldering their leads into place. Leave the leads of the IR-emitting diode about 1½ inches long.

Plug the red-insulated lead of a 9-volt battery snap connector into the hole labeled B1+ on the circuit-board assembly and solder into place. Crimp and solder the black-insulated lead of the snap connector to one lug of a normally-open pushbutton switch. Finally, strip ¼ inch of insulation from both ends of a 3-inch-long hookup wire and use

this to bridge from the other lead of the switch and the hole labeled S1 on the circuit-board assembly.

The enclosure for the transmitter should be small so that it is comfortable in your hand. There are a number of plastic project boxes that fit this description, such as the one illustrated in the lead photo. The only machining required for the enclosure is to drill mounting holes for the IR-emitting LED and the switch through one end and the top panel of the enclosure, respectively.

Once machining is done, mount the circuit-board assembly to the floor of the enclosure with a wide strip of thick double-sided foam tape. Gently position the IR-emitting LED so that its dome fits into the hole you drilled for it. If the fit is not tight, use a drop or two of fast-setting epoxy cement or silicone adhesive to secure the LED in the hole on the *inside* of the enclosure.

Mount the switch in its hole in the top panel of the enclosure, using the hardware supplied with it and snap a fresh 9-volt alkaline battery into its connector to finish building the transmitter.

Checkout & Use

Clip the common lead of a dc voltmeter or multimeter set to the dc-volts function to the negative (-) lead of C2 on the receiver circuit-board assembly. Plug the line cord of the receiver into an ac outlet and touch the "hot" probe of the meter to pin 14 of the IC1 and IC2 sockets. You should obtain a reading of approximately +5 volts in both cases. If not, touch the "hot" probe to the OUT pin of regulator IC4, where you should now obtain a +5-volt reading.

If you fail to obtain the proper reading at any of the indicated points, disconnect power from the receiver unit and troubleshoot it to correct the problem. Do not proceed until you are certain that the problem no longer exists.



Tiny transmitter circuit-board assembly and battery fit snugly into a palm-size project box.

When you do obtain the proper voltage readings, power down the receiver unit and plug the ICs and optical isolator into their respective sockets. Make sure each is properly oriented and that no pins overhang the sockets or fold under between devices and sockets.

Now connect the common lead of the meter to the cathode lead of the IR-emitting diode on the circuit-board assembly inside the transmitter unit. While pressing the button on the switch, touch the "hot" probe of the meter to pin 8 of the IC5 socket. You should obtain a reading of approximately +9 volts. If not, power down and rectify the problem. Again, do not proceed until you are certain that everything is okay. This done, plug the 555 timer chip into its socket, properly orienting it and making sure that no pins overhang the socket or fold under between IC and socket.

Plug the line cord of the receiver unit into a convenient ac receptacle. If you mounted an ac receptacle on the rear of this unit, plug the line cord of a table lamp into it (turn on the

lamp before you do this to make sure that it is on and working and leave it in this state). If the lamp turns on immediately, check to make sure that infrared energy is not entering the IR receiver module from a nearby lamp or other source of strong IR energy.

If you cannot prevent the lamp from turning on, or it turns on and off erratically when the transmitter is not in use, you may have to change the value of either R1 or C1 or both, depending on the agc (automatic gain control) action of the Radio Shack IR receiver module. Some modules are very active, while others have very "quiet" outputs. To keep some prototype receiver units from turning on inadvertently, up to a 10,000-ohm value was needed for R1 and up to a 40-microfarad value was needed for C1. You may have to experiment with the values of these components to tame the behavior of your receiver.

When the receiver unit is operating properly, step back about 10 feet, point the IR-emitting LED of the transmitter at the entry hole for the IR energy in the receiver unit and press the pushbutton switch on the

(Continued on page 77)

Add Light-Meter Modules To Any Digital Voltmeter

(Part 2, Conclusion)

Construction, checkout and calibration procedures

By Tom Fox

Last month in Part 1 of this article, we discussed how light is measured, the nature of light and two similar low-cost precision light meter adapters for use with any digital dc voltmeter or multimeter. This month, we conclude with construction, checkout and calibration details for both modules.

Construction

Both modules are assembled in a similar manner, each using the same-size (but slightly differently configured) printed-circuit board. Though you can build either version of the project on perforated board that has holes on 0.1-inch centers using suitable Wire Wrap or soldering hardware, pc construction is recommended to assure stability.

You can etch and drill your own pc board for the version you wish to build using either of the actual-size etching-and-drilling guides shown in Fig. 4. Before you do this, however, check the spacing between the two large circular pads labeled P1 and P2 in Fig. 5 to make sure it is correct for the banana jacks on the meter you plan to use with this project. If it is not, make suitable adjustments in the etching-and-drilling guide.

When your choice of board is ready, begin populating it by installing and soldering into place the sockets for IC1 and IC4, as shown in the



appropriate wiring guide shown in Fig. 5. Do not plug the ICs into the sockets until after you have conducted initial voltage checks and are satisfied that the circuit-board assembly has been wired properly.

Note in Fig. 5 that all components, except sensor PC1, mount directly on

the pc board, including the two banana plugs that connect to the meter you will be using with this project.

Once the IC sockets are in place, install and solder into place the resistors and then the capacitors. Make sure that all electrolytic capacitors are properly polarized before solder-

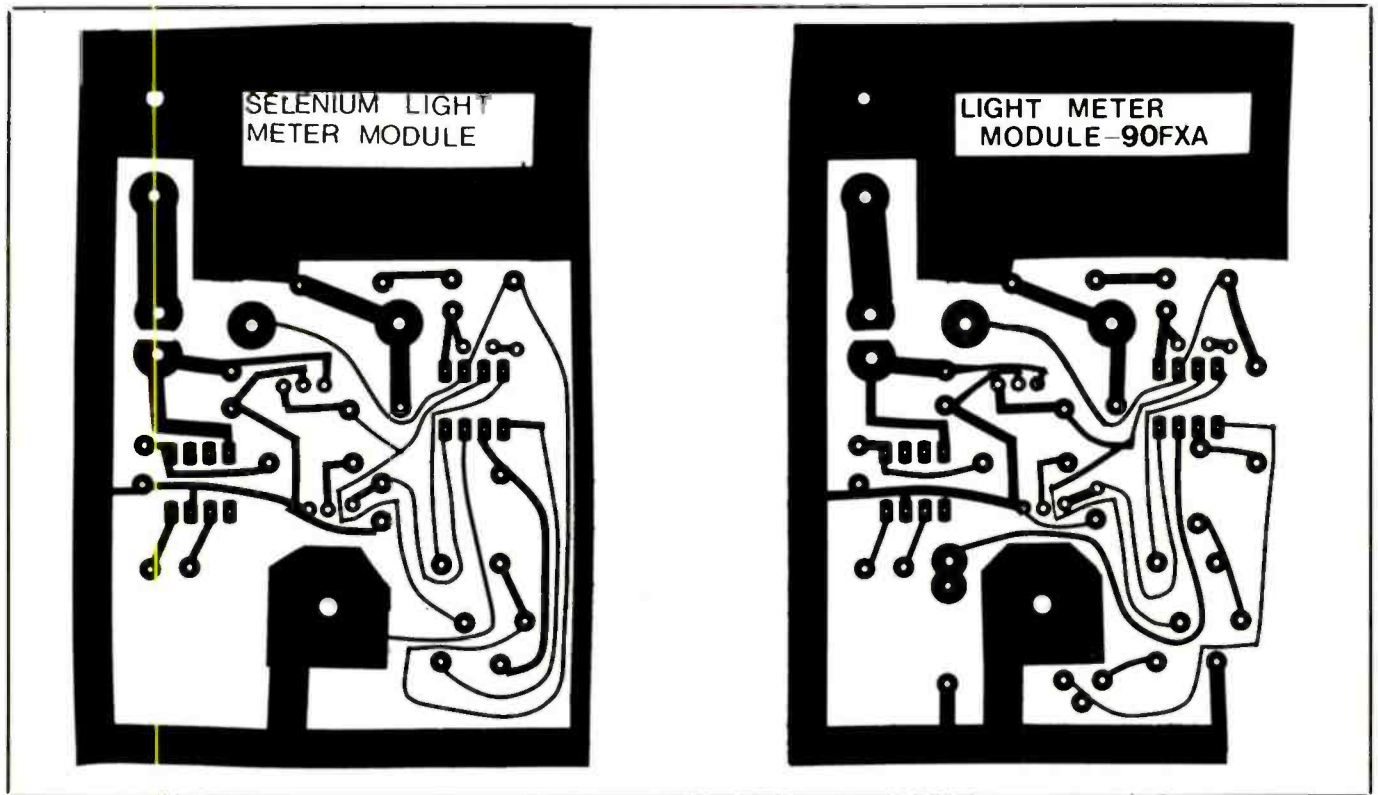

Fig. 4. Actual-size etching-and-drilling guides for silicon solar-cell (A) and selenium-cell (B) versions of project.

ing their leads to the copper pads on the bottom of the board. If you cannot obtain a 0.5-ohm resistor to use for *R1*, wire in parallel two 1-ohm resistors and treat the assembly as a single resistor.

Next, install and solder into place the trimmer controls, switch and then the three-pin voltage regulators. Take care to properly base each regulator before soldering its pins into place (see detail drawings in Fig. 5 for pinout details).

You can mount the battery on the board using a standard chassis-mount battery holder or a strip of double-sided foam tape. In either case, you must wire into the circuit a 9-volt battery snap-type connector. Observe polarity when you do this! Do *not* snap the connector onto the battery or install the battery on the board just yet.

Referring to Fig. 6, mount the phono jack in the J1 location on the board. Then use a short length of in-

sulated hookup wire to bridge from the center-conductor lug of the jack to hole HH1 or KK1, depending on the version of the project you are building. Mount the banana plugs on the circuit-board assembly in holes P1 and P2 from the solder side.

No enclosure is required for this project, though it would be a good idea to house it and the sensor in a protective case during storage.

Just about any silicon solar cell can be used for the sensor, but a commercially encapsulated solar cell is recommended. Since the sensor is portable and can be easily damaged when transporting it from one location to another, the silicon variety should have some form of protection. Selenium cells, on the other hand, are very durable and need no or minimal protection.

You can use a small piece of 1 × 4-inch clear pine to provide protection for the silicon solar cell. Carve a shallow depression in the pine with a

wood chisel or hobby knife to accommodate the sensor and a channel for the cable that is to interconnect the cell with the circuit-board assembly. Connect and solder one end of a 36-inch or so length of flexible two-conductor cable to the leads of the cell. Tie a strain-relieving knot in the cable about 1 inch from the end connected to the cell. Place the cell in the depression and route the cable down the channel you cut for it.

Now mount a small piece of 1/8-inch G-10 epoxy-Fiberglas pc-board material from which all copper has been completely etched over the sensor. This provides additional physical protection for the sensor, helps diffuse light and reduces the amount of infrared energy that reaches the sensitive surface of the sensor. A piece of frosted or gray acrylic sheeting can also be used in lieu of the G-10 material.

If you use a blue photography filter, place it between the G-10 materi-

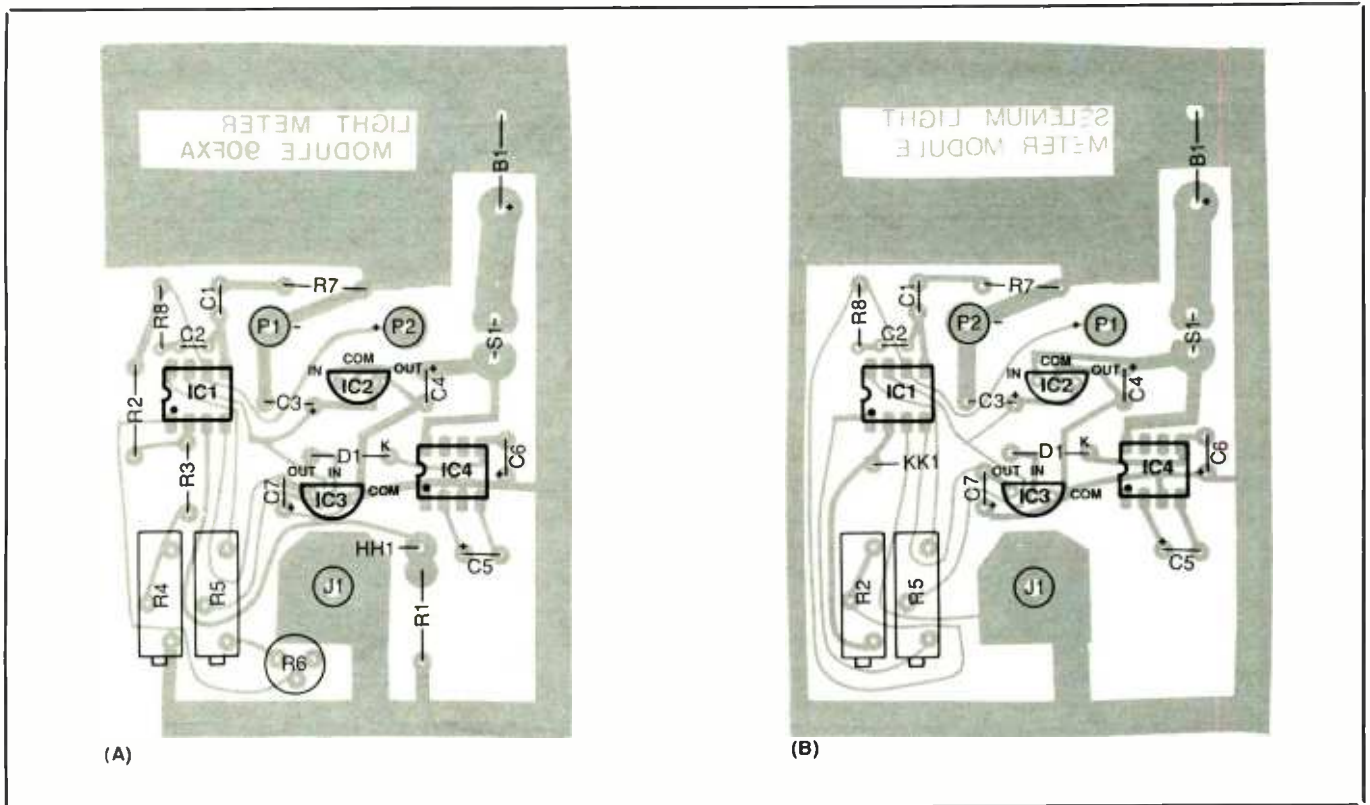

Fig. 5. Wiring guides for silicon solar-cell (A) and selenium-cell (B) pc boards.

al or acrylic sheet and sensor. Use four small screws to hold the filter in place. When you are done, terminate the other end of the cable in a standard phono plug.

Checkout & Calibration

Plug the DIP ICs into their respective sockets. Make sure each IC is properly oriented and that no pins overhang the sockets or fold under between ICs and sockets. Snap a 9-volt alkaline battery into the connector on the circuit-board assembly, and plug the sensor cable into the phono jack on the board.

Set all controls to approximately the middle of their ranges and then plug the module into a digital voltmeter or DMM and set the meter to its 200-millivolt dc full-scale range. Depending upon your requirements and calibration procedure, each millivolt equates to either 1 fc or 10 lux. Keep in mind that 1 fc equals 10.764 lux.

Most of the following discussion assumes you are calibrating the project to display fc directly. For initial calibration, use a GE 100-watt crystal clear bulb with an average lumen rating of 1,750.

When you turn on the project and meter, the latter should display a greater voltage when the sensor is subjected to bright light than when the lighting is dim. If it does, the module is probably working okay. If not, power down and carefully check over all your work to isolate the problem. Do not proceed until you have corrected any problem encountered.

In a dimly lit room, put your hand over the sensor. Set R5 for a meter reading of 0.00. Then turn on the 100-watt bulb, making it the only light in the room.

Place the sensor exactly 2 feet from the bulb and in the same horizontal plane as the filament. Light intensity should be about 50 fc. Now alternately adjust GAIN control R4 on the

silicon cell module or R2 on the selenium-cell module and ZERO control R5 for a meter reading of 50 millivolts when measuring the light from the bulb and 0.00 millivolts when your hand is blocking all light from reaching the sensor.

Each control may have to be adjusted several times until you obtain the correct results. Once you have the controls properly adjusted, place the sensor 1 foot from the light. The meter should now indicate within about 5 millivolts of 200 millivolts.

If you have access to a light meter that has a rated accuracy of greater than $\pm 5\%$, use it to take a few light measurements at a distance of about 2 to 3 feet from several clear light-bulbs and calibrate the module to correspond with the readings obtained with the light meter. Bear in mind that most light meters that cost \$50 or less are not accurate. Unless you are certain that the light meter you are using is, indeed, a high-quality preci-

sion instrument, leave the calibration just as it was after the initial calibration procedure described above.

An alternative is to use a light bulb that has a measured light output. Most manufacturers of light bulbs list average lumens on the package. Theoretically, you can simply divide the lumens by 12.57 to achieve the MSCP (mean spherical candlepower) output of the bulb. Be aware, though, that lumens is just an average and MSCP is the average candlepower in all directions, including directly toward its base.

Having taken measurements of many bulbs, I have found that the apparent (measured) candlepower in the horizontal direction is usually 30 to 35 percent greater than that calculated. If a light meter were to be calibrated using this purely "theoretical" procedure, the meter will consistently record values 30 to 35 percent too low!

The National Bureau of Standards and private testing laboratories have tungsten lamps that are measured for their candlepower output at a controlled voltage and current. If you can obtain one of these, you can build a precision light meter that will rival many moderately priced commercial models.

If you do not require extreme accuracy, you can use an inexpensive flashlight bulb to calibrate the project. Such bulbs are rated in MSCP under certain specified conditions. For example, the PR13 lamp is rated at 2.2 MSCP when operated at 4.75 volts and 0.50 amperes. Since PR13 bulbs are much closer to a point source of light than the larger 117-volt ac bulbs, actual horizontal output is closer to the theoretical. On average, a 2.2 MSCP bulb puts out about 2.65 cp when measured in the horizontal position.

If a 10-percent accuracy can be tolerated, just assume that the average PR13 lamp has a light output of 2.65 horizontal candlepower at 0.50 ampere. (Applying 5 volts to the PR13



Fig. 6. Banana jacks that connect circuit-board assembly to meter mount on copper side of circuit board. After mounting phono jack on board, use short length of insulated hookup wire to connect its center-conductor lug to appropriate hole in board.

lamp results in an average horizontal candlepower of about 3.6.) If greater accuracy is required, Magicland has PR13 flashlight lamps with a measured light output. Average measured horizontal candlepower is supplied with each lamp.

A typical calibration setup is shown in Fig. 7. The base is a length of 2 x 4-inch pine. A 10-inch length of a 1/4-inch wood dowel, with a 1/8-inch hole drilled in its end holds the PR13 lamp. Although you can use a socket, feel free to solder wires directly to the lamp. A 1-inch hole drilled in the 2 x 4 supports the dowel. Starting 3 inches from the center of the large hole, 21 1/4-inch holes are spaced exactly 1 inch apart and support the 1/4-inch dowel attached to the sensor assemblies.

Notice that the labeling on the base indicates both distance and a conversion factor. When multiplied by the horizontal candlepower of the lamp, the conversion factor results in the number of foot-candles of light intensity at the particular distance (see also Table 2). While such an elabor-

ate test setup is not really needed, some type of setup must be used to hold lamp and sensor steady so measurements can be reliably made.

Once your test setup is ready, connect the wires from the lamp to a suitable power source. To achieve any degree of accuracy, you must have a means of measuring current and/or voltage. While it is not essential, a way of controlling voltage and current is helpful. One common source of a controlled voltage is the +5V, 1A or greater regulated voltage supply frequently used in digital circuits. Make sure the conductors you use to make the connections between power source and lamp is 18 gauge or heavy-

(Continued on page 76)

Table 2.
Calibration Conversion Factors

Distance* (inches)	Conversion Factor
3	16.00
4	9.00
5	5.76
6	4.00
7	2.94
8	2.25
9	1.78
10	1.44
11	1.19
12	1.0 (fc = cp)
13	0.85
14	0.73
15	0.64
16	0.56
17	0.50
18	0.44
19	0.40
20	0.36
21	0.33
22	0.30
23	0.27
24	0.25
36	0.11

To determine level of illumination in foot-candles (fc), measure horizontal distance from known light source (in candlepower, or cp) and multiply cp by conversion factor. Assuming a cp of 3.6 and distance of 10", $fc = 1.44 \times 3.6 = 5.184$.

* Horizontal distance from center of filament.

A Real-Time Video Frame Grabber

A low-cost monochrome video imaging system for VGA and MCGA PC-graphics systems

By Crady Von Pawlak

One of the more interesting and fun applications for a PC is capturing video images taken with, say, a camcorder. Graphics displays capable of faithfully reproducing such captured video images were prohibitively expensive not too long ago. Owing to low-cost VGA and MCGA analog graphics for IBM PCs and compatibles, costs are now within reach of many computer users.

Nevertheless, to perform a video frame capture in 1/30th of a second real-time from composite video alone requires sophisticated imaging hardware. Cheap video capture systems using the slow-scan method originally intended for packet-radio transmission or systems that require an external horizontal sync pulse that is not available on common VCRs and camcorders are obviously unsatisfactory for most users. The "PC Studio-64" presented here employs the sophisticated electronic design needed for true real-time computer imaging performance. Moreover, it is inexpensive, costing \$100 at most to build, and probably a lot less if you choose your suppliers carefully. All parts, by the way, are readily obtainable ones.

Captured images have a displayable resolution of roughly 250 × 200 pixels in 64 shades of gray and can be viewed on any PC equipped with VGA or MCGA graphics. To help ease the burden of test and use, the

control/display software for the PC Studio-64 is presented in Microsoft QuickBASIC. It can easily be modified to perform more sophisticated functions, such as false-coloring or a software contrast/brightness adjust.

Images can be saved in BLOAD format. Alternatively, if you have a modem, you can download one of the popular shareware GIF-file creation programs (GIF stands for Graphics Interchange Format and is the registered trademark of CompuServe) from your local BBS or CompuServe. The only other requirement is an RS-170/NTSC-standard composite video source, which can be any consumer VCR or video camera with composite video output available.

About the Circuit

Due to the relative complexity of the circuitry, the complete schematic diagram for the PC Studio-64 shown in Fig. 1, is composed of four parts. As you follow the details of circuit operation (and later when you wire together the circuit), refer to the appropriate part of Fig. 1.

As shown in Fig. 1(A), the video signal to PC Studio-64 enters through *J1*, is terminated at 75 ohms by *R1* and is fed directly into a 3.58-MHz chroma trap made up of *R14*, *L1*, *C39*, *C40* and *R13*. Coil *L2* and capacitor *C41* attenuate the 7.16-MHz first harmonic of the chroma signal.

If the 3.58-MHz colorburst chroma signal is not attenuated, the image will display an unwanted herring-

bone pattern. Once properly filtered, the video signal is passed to buffer amplifier *U18B* and noninverting amplifier *U19A*. The latter amplifies the video signal by a factor of 2 to bring it to a usable level for A/D converter *U23* in Fig. 1(B).

The output of *U19A* is then distributed between sample-and-hold chip *U21* and differential amplifier *U19B*. The latter is clocked by the delayed trailing edge of the horizontal sync pulse provided by *U21* and generates the video black-level for each horizontal line. This black-level is then subtracted from the picture information by *U19B*, leaving only the filtered luminance for processing by *U23*. Switching diode *CRI* clamps any negative-going voltages from the luminance signal that could damage the converter.

Op amp *U18B* feeds the filtered video to LM1881 video timing generator *U21*, which now provides a number of interesting signals that are referenced to the incoming horizontal sync pulse. All are at TTL-logic compatible levels when the device is powered from a 5-volt dc supply.

Signals available from *U21* are as follows: Pin 7 supplies the odd/even video frame timing that tells the project when to begin sampling. Pin 1 provides a stripped horizontal sync pulse, and pin 3 provides the vertical

Fig. 1. Complete schematic diagram of PC Studio-64 frame-grabber circuitry, is shown here in four parts.

Fig. 1(A).

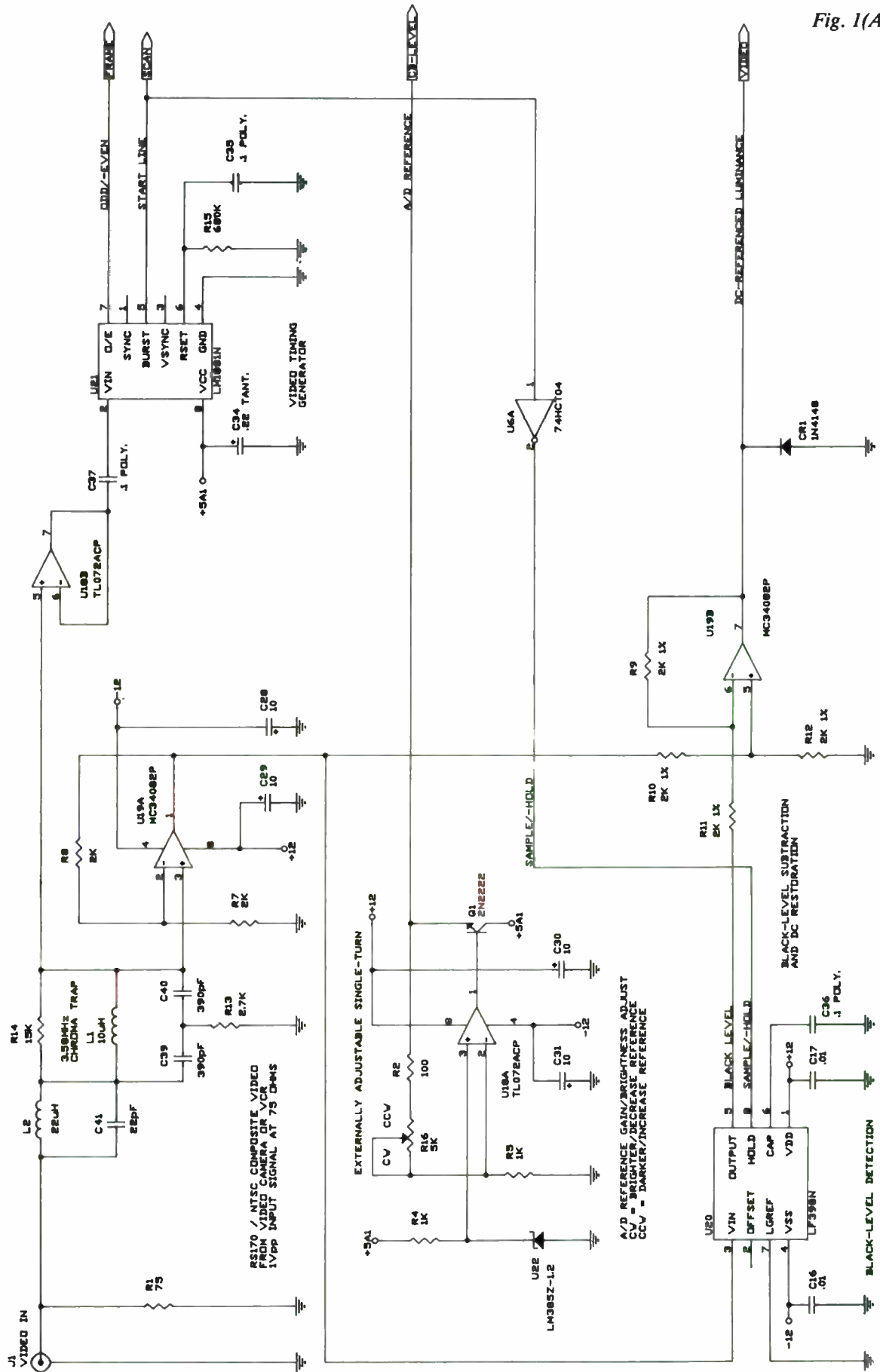

Fig. 1(B).

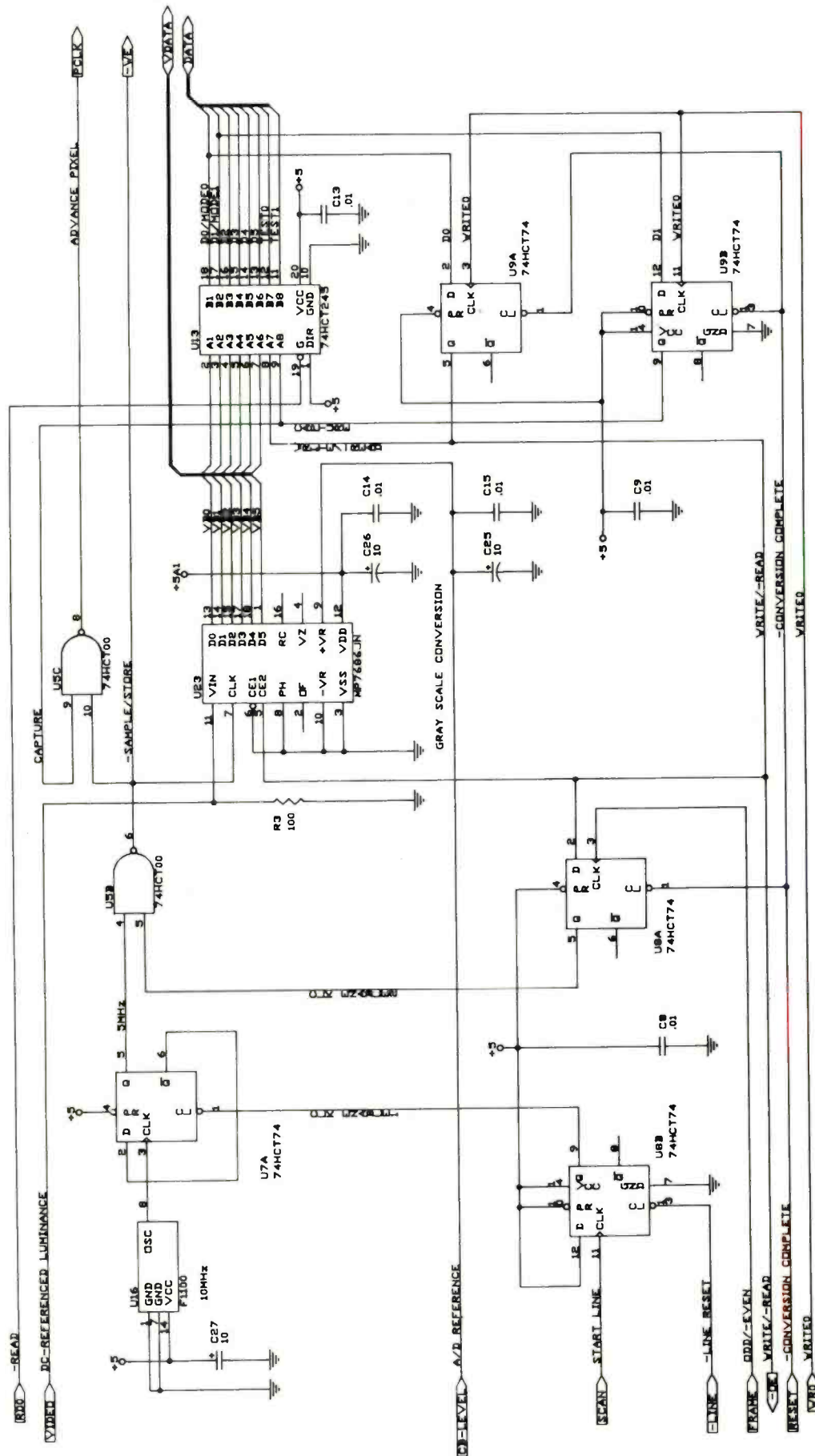
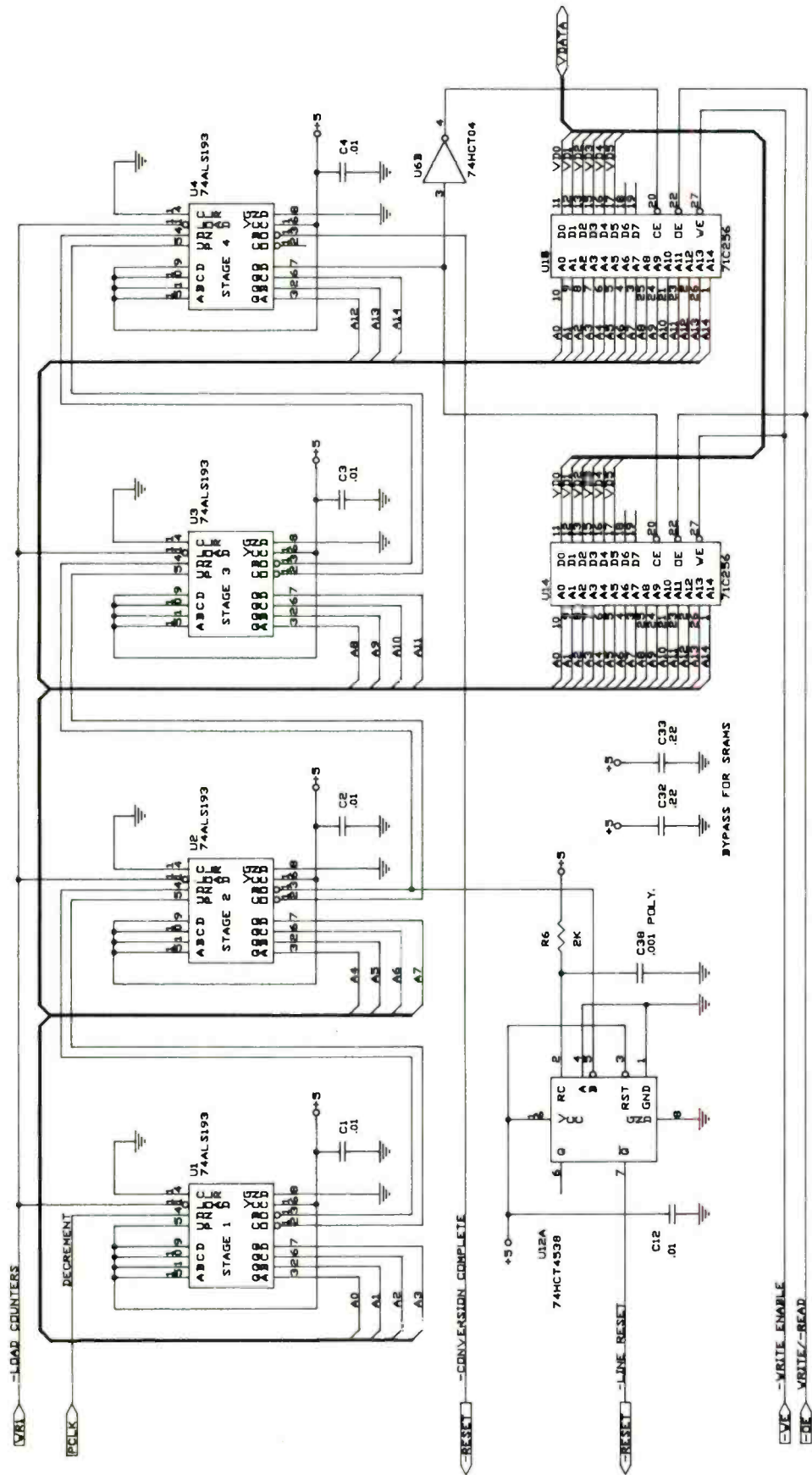

Fig. 1(C).



sync. Pin 5 outputs a pulse where the chroma signal normally appears. This last signal is then inverted and passed to the sample-and-hold circuit for black-level detection. The noninverted pulse from pin 5 tells the system when to begin sampling each horizontal line of video information.

A disadvantage of the LM1881 is that it generates its timing by referencing the incoming horizontal sync to an RC network. This makes the device highly susceptible to video and power-supply noise. To add stability to the circuit, a quiet +5 volts is provided by regulator U17. Because switching supplies in PCs can generate several hundred millivolts of noise, regulation is an important design factor. This stabilized voltage is also used to power the A/D converter, further assuring noise-free sampling of the video image.

All other ICs that require +5 volts derive power from the computer's switching power supply. Use of 74HCTXX series devices ensures low power consumption and aids in overall quiet operation of the capture circuitry.

To provide an infinitely-variable gain/brightness control, U18A and current amplifier Q1 are configured as a variable voltage reference for U23. This combination allows the reference to be varied from just below +1 volt to a maximum of just below +5 volts. Because the reference input to U23 is at a very low impedance, it must be driven either from a power op amp or a fixed reference that provides sufficient current drive.

If the reference to U23 is lowered, the peak white level can approach or surpass that of the reference, causing the stored image to appear brighter. The opposite occurs if the reference is increased, which moves the peak white level further away. When the reference is set so that blackest-black is converted to binary zero, and whitest-white is converted to binary 63, a normal unaltered image is captured with 64 total shades of gray (the max-

Fig. 1(D).

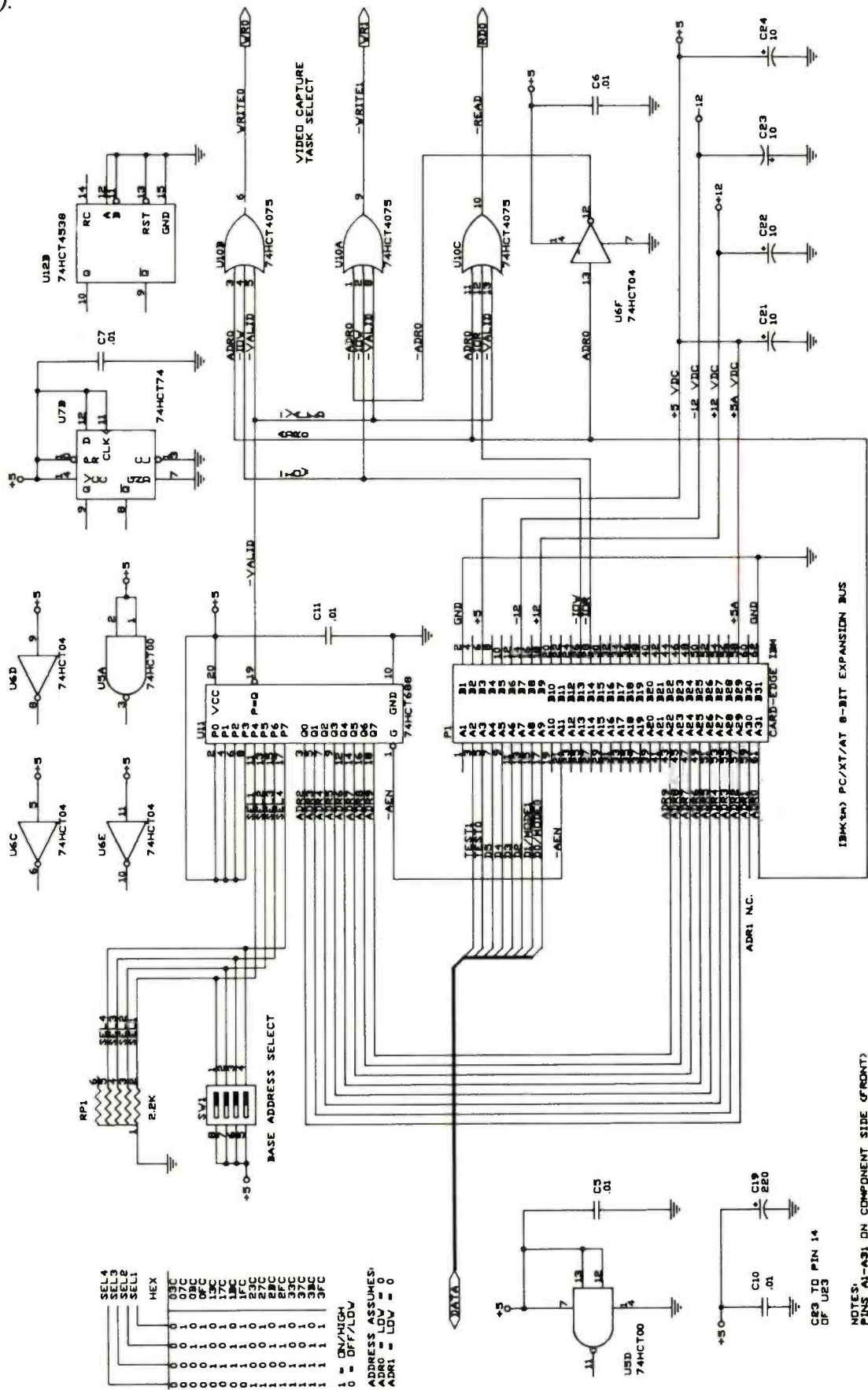

IBM™ PC/XT/AT 8-BIT EXPANSION BUS

NOTES:
 PINS A1-A31 ON COMPONENT SIDE (FRONT)
 PINS A1-A31 ON COMPONENT SIDE (BACK)
 PINS A1-A31 ARE TANTALUM 50V/DC
 ALL CAPS. VALUED IN Ω ARE SILVER MICA
 ALL RESISTORS 1/4W 5% TOL. UNLESS OTHERWISE STATED
 ALL CAPACITORS RATED 50V/DC MIN.
 USE NO WIREBOUND RESISTORS

C83 TO PIN 14
 OF U23

PARTS LIST

Semiconductors

CR1—1N4148 or 1N914 high-speed switching diode
 Q1—2N2222 or similar npn silicon small-signal transistor
 U1 thru U4—74ALS193 modulo-16 binary counter
 U5—74HCT00 NAND gate
 U6—74HCT04 hex inverter
 U7,U8,U9—74HCT74 dual-D flip-flop
 U10—74HCT4075 triple 3-input OR gate
 U11—74HCT688 8-bit magnitude comparator
 U12—74HCT4538 dual precision monostable multivibrator
 U13—74HCT245 octal 3-state bus transceiver
 U14,U15—256K (32K × 8) 100-ns or faster static RAM
 U16—10-MHz TTL crystal oscillator
 U17—LM7805 + 5-volt regulator
 U18—TL072ACP dual FET-input op amp (4-MHz bandwidth)
 U19—MC34082P dual FET-input op amp (8-MHz bandwidth)
 U20—LF398 sample-and-hold amplifier
 U21—LM1881 video timing generator
 U22—LM385Z-1.2 precision 1.2-volt reference
 U23—MP7686JN (or CA3306CE) 6-bit flash (video speed) A/D converter

Capacitors

C1 thru C18—0.01- μ F monolithic ceramic
 C19—220- μ F, 16-volt electrolytic (place far from card-edge connector)
 C20—22- μ F, 16-volt electrolytic
 C21 thru C31—10- μ F, 25-volt tantalum (place close to card-edge connector)

C32,C33—0.22- μ F monolithic ceramic
 C34—0.22- μ F, 16-volt tantalum
 C35,C36,C37—0.1- μ F, 25-volt polystyrene, polypropylene or Mylar
 C38—0.001- μ F, 25-volt polystyrene, polypropylene or polyester
 C39,C40—390-pF silver-mica
 C41—22-pF silver-mica

Resistors (1/4-watt, 5% tolerance)

R1—75 ohms
 R2,R3—100 ohms
 R4,R5—1,000 ohms
 R6,R7,R8—2,000 ohms (R7 can optionally be 1,000 ohms for greater signal gain)
 R9 thru R12—2,000 ohms, 1% metal-oxide or carbon-film
 R13—2,700 ohms
 R14—15,000 ohms
 R15—680,000 ohms
 R16—5,000-ohm Clarostat No. 408N-5K-S or similar pc-mount miniature potentiometer with long shaft
 RP1—2,200-ohm 6-pin SIP resistor network

Miscellaneous

J1—Right-angle, pc-mount, RCA phono jack
 L1—10- μ H iron-core choke (Digi-Key Cat. No. -TK3915 or similar)
 L1—22- μ H iron-core choke (Digi-Key Cat. No. -TK3919 or similar)
 IBM-style prototyping expansion card with mounting bracket with 1/2" diameter cable opening (available from JDR Microdevices); sockets for all DIP ICs; control knob for R16; Wire Wrap hardware; wrap wire; solder; etc.

imum number of gray shades that can be displayed in 256-color VGA/MCGA mode).

To initiate a capture, a two-bit control word is written to D-type flip-flops *U9A* and *U9B*, followed by a pulse from *WRITE1*, which clocks the data to the outputs of the flip-flops, as shown in Fig. 1(B). When both bits are set high, *U8A* waits for a rising edge at pin 7 of *U21* (indicating a new field is starting) to en-

able the 5-MHz clock output of NAND gate *U5B*.

The clock circuit is now ready to be toggled by the *START LINE* signal from pin 5 of *U22*. Its rising edge clocks the data at pin 12 of *U8B* onto its output at pin 9 to enable the 10-MHz master oscillator divide-by-two circuit made up of *U7A* to provide the base 5-MHz system clock. Aside from acting as a gated frequency divider, *U7A* also provides some

clock-phase/synchronization control.

As long as pin 1 of flip-flop *U7A* is held low, the Q output at pin 5 is held in a reset (low) state. When pin 1 goes high, *U7B* comes out of reset and the next rising edge of the oscillator clocks in the data at pin 2 to cause the output at pin 5 to go high. This effectively guarantees that the 5-MHz clock will always be in-phase with the beginning of each horizontal line.

The preceding is critical because random start points of the clock will cause horizontal pixel "jitter" to appear in the displayed image. Although this simple method of synchronization works well here, higher-resolution systems usually employ a phase-locked-loop (PLL) to exactly synchronize the pixel clock with the beginning of each line of horizontal video information.

When this occurs, the process of sampling one line of video begins. With each pulse of the clock, address counters *U1* through *U4* in Fig. 1(C) are decremented, a sample is taken by flash converter *U23* and its latched output is stored in one memory location of the 64K-byte image buffer made up of high-speed 32K-byte by eight-bit static RAMs *U14* and *U15*. A benefit of using SRAMS here is that the last image captured remains in the buffer even if you exit the control program or press the *RESET* button on your computer.

After 256 horizontal samples, the borrow-out (BO) at pin 13 of *U2* goes low to trigger precision monostable multivibrator *U12A*. The one-shot output at pin 7 of *U12A* signals the end of each line and resets *U8B*, which temporarily disables the sample clock until the next *START LINE* pulse appears at pin 5 of *U21*.

After 32K samples have been taken (one-half of the complete odd frame), pin 7 of *U4* changes states and, via inverter *U6A*, switches banks in the static-RAM image buffer. This process continues until the 256 lines of the odd frame have been sampled and stored in the image buffer and a

Imaging Software & Camera For Astronomers

Tycho imaging software from Prime Focus Imaging (Camden, NY) has been optimized for use with the Electrim (Princeton, NJ) Model EDC-1000 CCD camera for astronomy use. Software and camera are compatible with any IBM PC or compatible computer equipped with a VGA graphics card and monitor.

Using the software takes advantage of the camera's exposure control feature and can extend exposure time to longer than 8 minutes. This feature optimizes detection of low-light-level observations. Images acquired are saved to a file in a standard astronomical FITS file data format. An image-format utility is included for translating FITS images to such other standards as PCX, GIF, IFF and TIFF.

Included in the software are image-enhancement routines. These include image background subtraction, streak removal, contrast enhancement, image

sharpening, noise reduction and a star-location routine that measures the brightness and relative location of a star.

The image-acquisition software is also available as "HVEN" to gather images with a PC that has only floppy-disk drives and EGA graphics. With HVEN, images can be acquired and stored on floppy disk for later processing.

The EDC-1000 asynchronous camera and interface card operate entirely under computer control. Upon command from a PC, image exposure takes place and 256 gray-level image data is read directly into RAM memory in the computer. No additional A/D, D/A or other hardware is required. The camera has a 192 X 165-pixel CCD pickup for maximum reliability, durability, sensitivity and geometric fidelity. Software and camera are available for less than \$550. Optional accessories, including camera telescope adapter and filters, are also available.

CIRCLE NO. 37 ON FREE INFORMATION CARD

CONVERSION COMPLETE is signaled by pin 13 of counter *U4*, resetting the system and terminating the process.

Board address decoding, as shown in Fig. 1(D), is quite simple. As the PC Studio-64 is I/O mapped (as opposed to memory-mapped), there is a need to decode only one of two addresses. Single magnitude comparator *U11* is ORed with address line zero (0), PC -IOW (write) and -IOR (read) active-low read/write lines. A valid address must match the value set by DIP switch *S1* and/or this value plus 1 (address line zero high) to allow writing to or reading from the capture system.

Construction

Printed-circuit construction is ideal for a project as complex as this one, not only to make a neat layout but also to minimize the possibility of wiring errors. However, because of the

relatively low resolution of the images (any minor circuit noise will not be visible) and slow conversion rate of the 6-bit flash A/D converter the prototype of the project was assembled using point-to-point wiring, which proved to be an eminently practical alternative. Therefore, no effort was made to draw up artwork for a pc board. If you wish, you can do so, though.

If you wire the project point-to-point, use a standard IBM PC-type prototyping board and suitable Wire Wrap hardware. Plan the physical layout of the components before mounting and of them into place, making sure to separate the analog and digital sections on the board.

Potentiometer *R16* should be mounted on the board so that its control shaft projects out behind your PC to provide easy access for adjustment purposes. Trial fitting of this component should be performed

with the board plugged into a bus slot in your unpowered PC prior to wiring the board to determine an ideal location for it. Once the potentiometer is mounted, a control knob can be placed on its shaft.

All components specified in the Parts List can be obtained from Digi-Key, either exactly as specified or as pin-for-pin substitutes. For example, the A/D converter shown in Fig. 1(B) is a Micro Power component and is guaranteed to function with reference levels as low as 1 volt. The Harris-RCA equivalent CA3306CE will work equally well, with the exception of requiring a higher reference voltage. This, of course would limit the usable range of the variable brightness/contrast control.

The Motorola op amp specified for *U19* can be replaced with a TL072 op amp at the expense of some image clarity. Because the bandwidth of the TL072 is only half that of the MC34082, fine details may be lost or appear slightly "fuzzy." If you cannot readily locate the MC34082, a TL072 should suffice until you can obtain the preferred chip.

When you are satisfied with the physical layout, assemble the circuitry on the board, carefully following the schematic diagram. Begin by installing the sockets for the ICs, but do *not* plug the ICs in the sockets until after the circuit is fully assembled and voltage checks assure you that the board is properly wired.

As you install each component and make each conductor run, strike it off on the particular part of Fig. 1 (or photocopy of it) that applies. Make sure polarity- and orientation-sensitive components are properly located.

When you are finished wiring the board, go over it to make sure everything is okay. If everything appears to be okay, make an initial operational checkout of the board. Power down your computer and open its system box. Plug the PC Studio-64 into an open bus slot in your comput-

(Continued on page 70)

A High-Sensitivity Lightwave Receiver

By Forrest M. Mims, III

Near-infrared and visible lightwaves can be used to remotely control toys, garage doors, television sets, video recorders and audio equipment. They can also be used to transmit data between computers and audio signals from receivers to wireless speakers and headphones. The free-space operating range of most of these optical links usually doesn't exceed a few tens of meters. Injecting the radiation into an optical fiber can increase the range to a kilometer or more.

There are several ways to greatly increase the operating range of free-space lightwave links, several of which will be discussed here. Included will be a description of a miniature lightwave transmitter and a very sensitive lightwave receiver that you can assemble. These two units will allow you to conduct many interesting experiments in lightwave communications. In the process, you will learn much more about the practical aspects of this fascinating subject than any article or book can teach.

Visible Light vs. Near-IR

The human eye can sense the optical wavelengths that range from around 380 nanometers to around 750 nm. I was careful to specify "around" because the human eye can actually see beyond these limits if the radiation is sufficiently intense. For example, the 780-nm radiation emitted by most of the laser diodes used in compact-disk players is clearly visible as a bright red light.

Near-infrared is the radiation that falls just beyond visible red light. In other words, near-infrared radiation is invisible to the human eye.

Light-emitting diodes emit either visible or near-infrared radiation. They are well suited for lightwave communications, since they are easily modulated and emit relatively monochromatic light. Until a few years ago, however, LEDs that emit visible wavelengths were not often used in free-space links, due to their very low output power. That all changed with the development of high-power alumi-

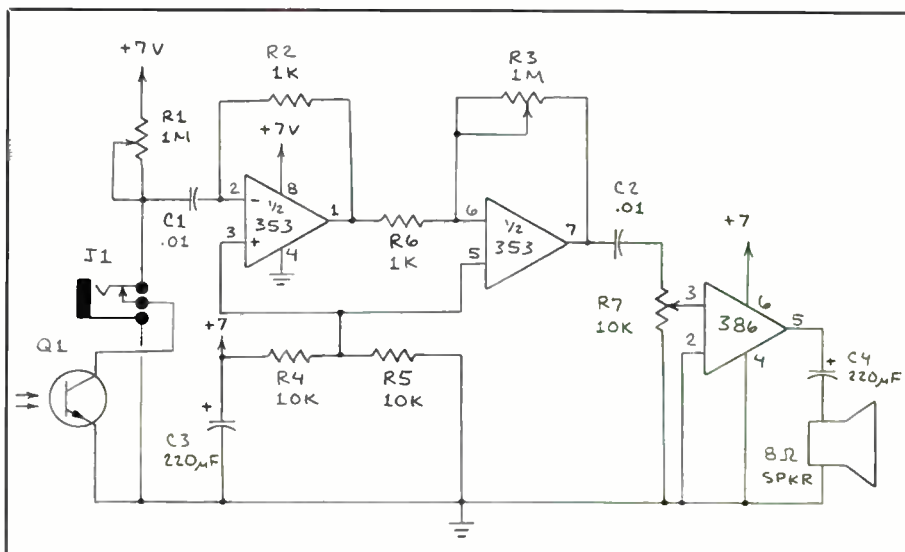

Fig. 1. High-sensitivity lightwave receiver.

num-gallium-arsenide (AlGaAs) superbright red LEDs. These new LEDs have an output power of several milliwatts or more, making them just as powerful as some near-infrared emitting diodes.

If you have built near-infrared lightwave communicators, you already know that trying to point an invisible beam at a distant receiver is very difficult unless you have an infrared image converter. The reverse procedure is just as difficult. Switching to 660 nm greatly simplifies alignment, since the bright red beam is visible over a considerable distance.

For obvious reasons, near-infrared emitting diodes have long been of high interest to the military. For example, one of the most common military applications for high-power near-infrared emitting diodes is in illuminators that emit narrow beams of intense but invisible near-infrared. These invisible beams supply the illumination for various kinds of viewing devices. They also function as designators for weapons that can home onto a target illuminated by an invisible beam.

Naturalists use near-infrared viewing devices and illuminators to observe nocturnal creatures without disturbing them. Forensic scientists use the same kind of equipment to inspect suspect documents. Various kinds of ink respond differently

to near-infrared, some being almost transparent. Observing a document in the near-infrared can sometimes permit differences in ink to be detected. It can also make visible words, letters and numbers that have been covered by ink or other writing.

Some covert security systems use cameras that are sensitive to near-infrared. Near-infrared illuminators provide the illumination. Vidicons that have a light-sensitive surface with what is known as an extended red response can be used for this purpose. So can solid-state CCD-array cameras. CCD cameras are an ideal choice, since the silicon from which the sensor array is made has its peak optical sensitivity in the near-infrared around 850 to 900 nm.

Incidentally, monochrome CCD arrays are much better sensors of near-infrared than are color CCD arrays because the color filters applied to the CCD sensors block near-infrared. At least this is the case with the color CCD camcorder I have. If the CCD array retained its very high sensitivity to near-infrared, the resulting video image of the scene focused on it would not always be representative of its actual colors as perceived by the human eye.

Vegetation, for example, is a much bet-

ter reflector of near-infrared wavelengths than green wavelengths. If the near-infrared wavelengths are not attenuated, the color balance of the resulting video image might be significantly distorted. Then there is the interesting fact that all shades of human skin have a similar reflectance in the near-infrared. No matter what your skin color happens to be, we all look various shades of green when someone looks at us through a near-infrared image converter.

A field of healthy grass appears bright green when displayed on a monitor connected to a color CCD camera. Since grass reflects slightly more than half the near-infrared radiation that strikes it, the same field appears white when a monochrome CCD camera is used.

Light-Emitting Diodes

The most common near-infrared-emitting diodes are made from AlGaAs and silicon-compensated gallium arsenide (GaAs:Si). Most near-infrared AlGaAs diodes emit radiation with a wavelength ranging from 850 to 880 nm. AlGaAs diodes, however, can also be designed to efficiently emit radiation down to 660 nm, the wavelength of so-called super-bright red LEDs.

Near-infrared GaAs:Si diodes emit radiation with a wavelength ranging from 930 to 940 nm. While GaAs:Si emitters are several times as efficient as the GaAs diodes they have largely replaced, they are not as efficient as AlGaAs devices.

It is interesting to note that GaAs:Si diodes produce radiation that is more invisible than that emitted by AlGaAs diodes. This is because the radiation from LEDs is not perfectly monochromatic and the human eye can perceive as a red glow some of the low-wavelength edge of the radiation emitted by AlGaAs emitters. At least this is the case with some high-power AlGaAs I have observed.

A High-Sensitivity Near-IR Receiver

Figure 1 is the schematic diagram for a straightforward but highly sensitive

lightwave receiver circuit that can be assembled in a housing that measures only 5 centimeters (2 inches) square and 2 cm (0.75 inch) thick. Though this circuit shows a phototransistor detector (*Q1*), it will work with various kinds of junction photodiodes and phototransistors. It includes features that permit both its sensitivity and gain to be easily adjusted.

Referring to Fig. 1, the detector converts the incoming near-infrared radiation into a photocurrent, which appears as a voltage at the junction of *Q1*'s collector and load resistor *R1*. If the signal is pulsed, *C1* transfers it directly to the inverting (-) input of one of the two op amps inside an LM353. The amplified signal is then passed to the second stage of the LM353 for additional amplification. The gain at this stage is controlled by the setting of *R3*. Finally, the signal is passed to the 386 audio amplifier chip that directly drives a small speaker. The signal level admitted to the 386, hence the volume from the speaker is controlled by voltage divider *R7*.

If you have previously built lightwave receivers, you might be wondering why a

potentiometer is used for load resistor *R1*. The reason for this is to permit the receiver to work well with lightwave transmitters that emit pulses that have different durations. A high load resistance provides high sensitivity, but its response time is slower than a small load resistance. Since *R1* is a potentiometer, you can tune it for optimum results with the transmitter you are using. For example, I have found that a load resistance of around 180,000 to 210,000 ohms works best when the receiver detects pulses with a duration of around 17 microseconds.

Figure 2 shows the assembled receiver installed in a small plastic box with the dimensions given above. The pencil points to potentiometer *R1*. The two miniature potentiometers adjacent to *R1* along the side of the box are *R3* and *R7*. Access to their tiny screwdriver-adjustable rotors is provided by two small holes bored through the side of the enclosure.

The two ICs and the various other components are installed on a perforated board that measures 34 by 45 millimeters (1.3 by 1.75 inches). Located between *R1* and the jack labeled IN is *Q1*. The point-

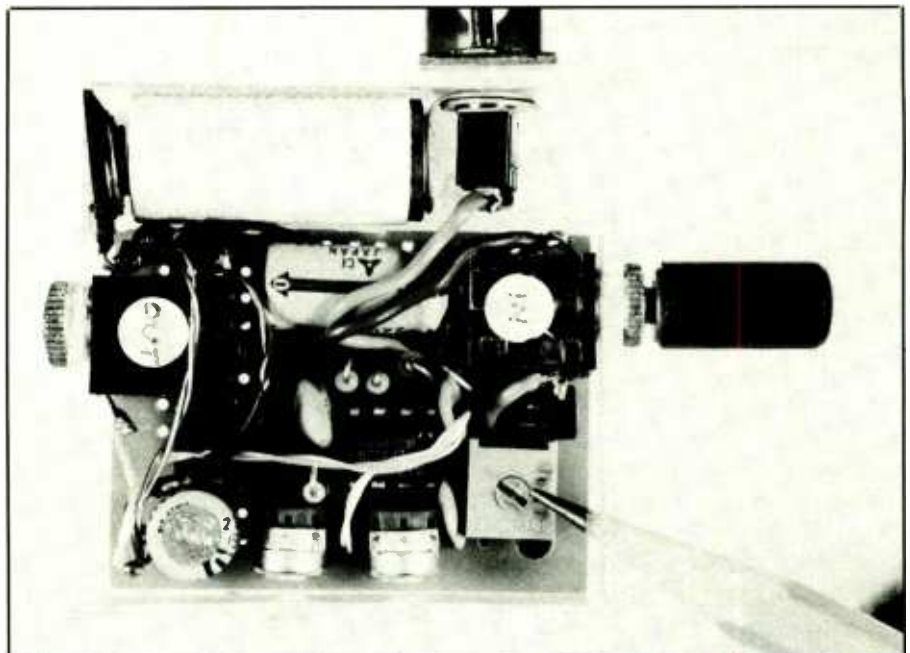

Fig. 2. Assembled version of the lightwave receiver in Fig. 1.

to-point wiring is not as neat as an etched circuit board, but it allowed me to build the receiver in one evening.

A single TR175 7-volt mercury battery powers the receiver. Though Fig. 1 does not show one, a miniature spst switch should be installed between the battery's positive (+) terminal and the circuit. The battery holder is made from a spring terminal salvaged from a plastic battery holder and a bent solder lug mounted on the switch. (Details for doing this are given later on.)

The jack labeled IN in Fig. 2 is J1 in Fig. 1. This jack permits you to connect various detectors to the circuit. Connecting an external detector automatically disables internal detector Q1.

Note that the photo of the receiver in Fig. 2 shows a jack labeled OUT, which is not shown in Fig. 1 and is not absolutely necessary since a tiny, flat speaker only 30 millimeters (1.2 inches) square is not visible in the photo. I installed the jack so the receiver could be used to drive an earphone, external audio amplifier or tape recorder. The jack is a three-terminal unit connected so that the speaker is disabled when a plug is inserted into it.

You do not have to install the receiver in a miniature housing, as I did. And if you don't, there is no need to use miniaturized components. For example, you can use larger potentiometers and a standard 9-volt transistor radio battery if you install the circuit in a larger housing. In any event, be sure to keep the leads between the battery and the circuit short. Keep the leads between C1, the photodetector and pin 2 of the LM353 as short as possible. And do not route the output leads anywhere near the circuit's input wiring. These steps will prevent the circuit from oscillating.

The easiest way to test the assembled receiver is to set the power switch to on when the unit is in the presence of a fluorescent lamp. First adjust R1 and R3 for a high resistance, and set R7 to near its midpoint. The speaker should emit a fairly loud buzz when Q1 detects pulsations from the lamp. Block Q1 with a finger, and the buzz level should decrease.

If the receiver does not produce a buzzing sound, check to make sure the battery is fresh and installed in the correct direction. Then carefully check the circuit's wiring. It is possible the terminals on the input jack may have been connected incorrectly. Another possibility is a short-circuit between closely spaced terminals or leads on the circuit board.

Refer back to Fig. 2 for a moment and you will see a black plastic phone plug inserted in the jack labeled IN. This plug houses a photodetector. Figure 3 shows how you can make a miniature external photodetector like this by installing a photodiode or phototransistor inside a 1/8-inch phone plug housing. I have used this technique for many years, and it works well—if you make sure the detector lead soldered to the center terminal does not touch the plug's cap if it is the metal variety.

Note that Fig. 3 shows a small filter. If the receiver is intended to detect near-infrared signals, this is a small circle punched from a piece of unexposed, developed color film. If the receiver is intended to detect the red light (660 nm) from an AlGaAs emitter, you can use a circle punched from red acetate. You can also use other kinds of filters. Filters are so important that they warrant more discussion before moving on to describing a miniature lightwave tone transmitter.

Optical Filters

Refer back to Fig. 1 for a moment and note that C1 freely transmits fluctuating signals while blocking those that are continuous. For example, the signal from a modulated near-infrared source might be riding atop a steady level of sunlight. Capacitor C1 passes the modulated light signal while blocking the sunlight signal.

If the steady signal from sunlight or an incandescent light source is sufficiently intense, it may saturate Q1 and prevent detection of the intended, fluctuating signal. For this reason, the receiver works best when bright sources of near-infrared energy are not present.

One way to help the receiver to function in the presence of bright light is to

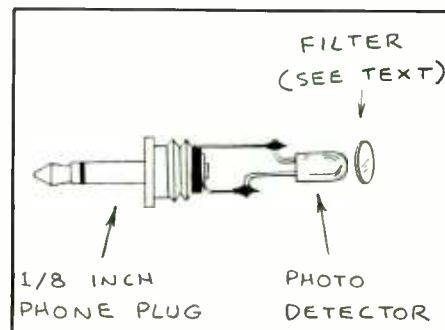

Fig. 3. How to install a photodetector inside a phone plug.

place over the detector a filter that freely transmits the wavelengths of light emitted by the transmitter while blocking other wavelengths. For best results, a plastic or glass transmission filter designed specifically for this purpose should be used. Two principal types of filters are available.

Long-pass color glass absorption filters block all the wavelengths below a certain point while transmitting those beyond that point. These filters designed for near-infrared applications appear black or deep red to the human eye.

Narrow-bandpass interference filters transmit only a narrow band of wavelengths. Typical interference filters have a bandpass of around 10 nanometers at the half transmission point. Interference filters have a mirror-like surface on both sides. Ordinarily, only one surface appears shiny since the other is usually covered by a glass or silica absorption filter that blocks harmonic wavelengths also transmitted by the interference filter.

Both glass absorption and interference filters are available from Edmund Scientific Co. (101 E. Gloucester Pike, Barrington, NJ 08007-1380). According to Edmund's 1990 catalog, the price for a 25.4-mm (1-inch) diameter absorption filter with a cutoff wavelength of 850 nm is \$23. The price for a 25.4-mm diameter 880-nm interference filter with a bandpass of 10 nm is \$78. Many kinds of visible-wavelength filters are also available from Edmund. Visible-wavelength interference filters cost \$38, a significant savings over the near-infrared variety.

You can make a very inexpensive near-infrared absorption filter from a small piece of unexposed, developed color slide or negative film. This material exhibits practically no transmission below approximately 700 nm, and its transmission beyond 900 nm is excellent.

Some time ago, I tested a piece of developed Kodacolor negative film with various kinds of LEDs. If any of the light from green and yellow LEDs penetrated a single layer of this film, I could not see or measure it. The film transmitted only 0.2 percent of the radiation from a super-bright red LED that emitted at 660 nm (Stanley HK1).

The film became almost transparent when tested with near-infrared LEDs. It transmitted 79.3 percent of the 880-nm radiation emitted by an AlGaAs diode. And it transmitted 87.7 percent of the 940-nm energy from a GaAs:Si diode.

The filter shown in Fig. 3 was made by using a hole punch to cut a circle of film from a larger piece. For best results, use a sandwich of two or three layers of film. While this will block some of the near-infrared, the blocking effect on other wavelengths will be much greater.

Remember, of course, that the receiver needs a filter only when competing light sources are present. At night or inside darkened rooms, you can remove the filter and increase the receiver's range.

The best possible combination for an optical link is to combine a narrow-band source, such as a laser, with a receiver equipped with a narrow-bandpass filter. You can easily see the resulting improvement in signal-to-noise ratio with the help of an oscilloscope, and you can notice it during field tests.

A more dramatic proof is to observe a low-power laser outdoors on a sunny day with and without a narrow bandpass filter. I once did this with a GaAs laser diode that emits at 904 nm. The beam from the laser was collimated into a very tight beam by a small lens. The laser was mounted on a tripod around 300 meters (1,000 feet) away.

When the laser was viewed through a near-infrared image converter, it was barely visible against the sunlight-bathed

landscape that dominated the view through the converter tube. This changed dramatically when I placed a 904-nm interference filter over the sensitive face of the image converter tube. The once-bright landscape became a dull grey and the laser became a brilliant point of light.

A note of caution is needed here. In spite of many safety warnings, I occasionally read of instances in which the eyes of professional laser workers are injured by lasers. You should never look directly into the beam from any laser unless the beam has spread out sufficiently so that its intensity is well below the level that might damage your eyes. This means you must be able to measure or calculate the level of radiation that might enter your eye. You must then be able to compare what you measure or calculate with the recommended safe viewing levels established by the Laser Safety Committee of the Laser Institute of America, the American National Standards Institute and other organizations. If you are unable to take these steps, play it safe and *never* look directly into the beam from any laser. For additional information, see "Laser Safety Guide," a publication of the Laser Institute of America. Call 1-800-34-LASER for information about ordering this booklet.

A Lightwave Tone Transmitter

Shown in Fig. 4 is the schematic diagram for an ultra-simple two-transistor lightwave tone transmitter whose design will be familiar to long-time readers of this column. This circuit can be easily installed in a plastic case that measures only $5 \times 2.5 \times 1.8$ cm ($2 \times 1 \times 0.7$ inches).

When the value of $C1$ in Fig. 4 is 0.002 microfarad, the circuit drives the LED with pulses that have a duration of around 40 microseconds. The duration of the pulses is increased and the pulse rate reduced when $C1$'s value is increased. For example, when $C1$ is 0.03 microfarad (three 0.01-microfarad capacitors in parallel), the pulse rate is less than 100 Hz.

The LED should be an AlGaAs 660 red or 880 near-infrared emitter. Be sure to observe proper polarity when soldering

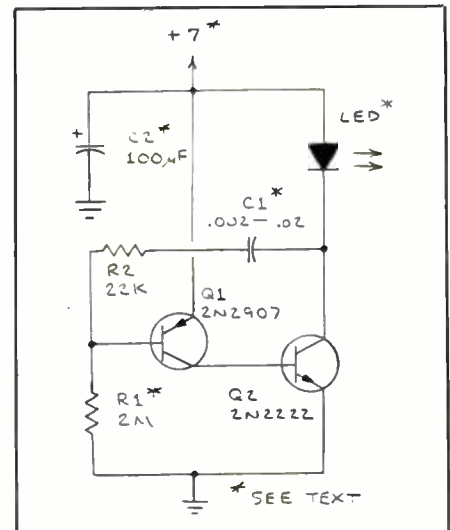

Fig. 4. High-current LED tone transmitter.

the LED into the circuit. If you want the option of exchanging LEDs, solder a LED socket into the circuit. You can make a LED socket from two short lengths of thin brass tubing soldered to the circuit board. Brass tubing is available at most hobby shops. Take a LED along when you visit the hobby shop to ascertain that its leads will fit snugly inside the tubing.

When the circuit is powered by a 9-volt battery, the peak current through the LED is around 650 milliamperes. This level is reduced somewhat when the circuit is powered by the TR175 7-volt battery you will need to use if you install the circuit in a miniature housing as I did.

Capacitor $C2$, which is connected across the battery, is not absolutely essential. When used, it provides a reservoir of charge that helps flatten out the top of the pulses through the LED.

A pictorial view of the Fig. 4 circuit is shown in Fig. 5. The components are installed on a perforated board that measures 2.7×1 cm (1×0.4 inches). Note in particular how the battery holder is made from the spring end of a plastic AA or AAA battery holder and a bent solder lug. The solder lug of the battery holder for the receiver circuit shown in Fig. 2 is attached to the switch. The solder lug

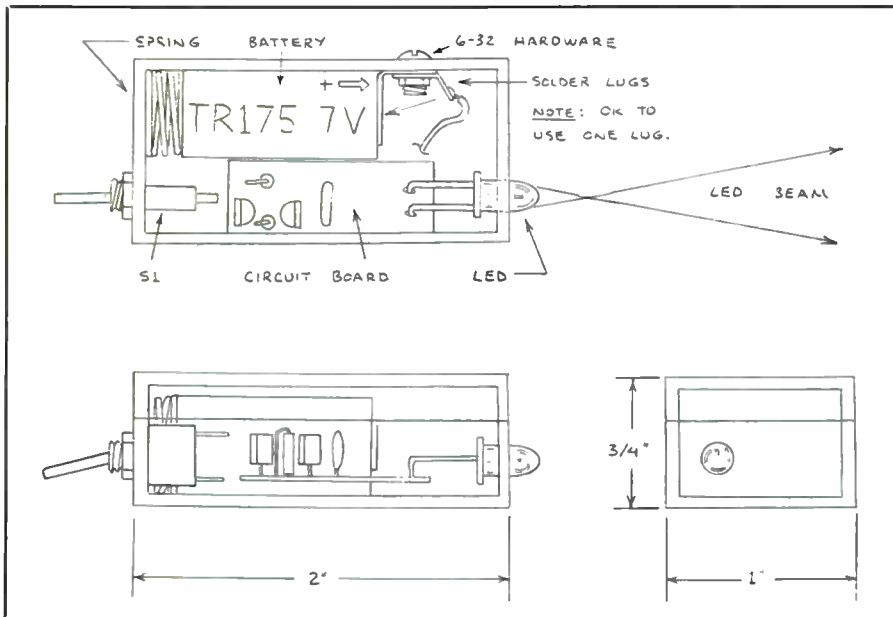

Fig. 5. Pictorial view of the LED tone transmitter in Fig. 4.

shown in Fig. 5 is attached to the side of the housing with a small screw and nut. Figure 6 is a photograph of an assembled version of the Fig. 4 circuit.

Testing the System

When both the transmitter and receiver are switched on, the receiver should emit a buzz or tone if it is near the transmitter. Even if the two units are not pointed at one another, plenty of stray light from the transmitter should find its way to the receiver's detector.

If the transmitter does not appear to be working, switch the power off and check to make sure the battery is fresh and installed correctly. If you used a visible red LED that glows when the power is applied but does not elicit a tone from the receiver, it is possible the tone frequency is above the range of your hearing. In-

DMMs, Counters, Generators

DM-4500 4.5 Digit DMM \$349

TRMS, 0.03% Accuracy, Full DMM, Bench Style

RFC-1000 1GHz COUNTER \$349

Reciprocal, Multi-Function, 8-Digit Bench Counter

FG-2000 2MHz GENERATOR \$349

Sine/Square/Triangle Sweep & Function Generator

Great Quality at Great Prices!

2 Year Warranty with 30 day Money-Back Guarantee.
Special Offer! Get any 3 for just \$900! Visa accepted.
To order today, call ...

ZTEST

(416) 238-3543

(416) 238-1377 (FAX)

KENWOOD OSCILLOSCOPES



KENWOOD CS-4025
20 MHz, DUAL
CHANNEL SCOPE
REG. \$560.00

SALE
\$349.95

ANALOG OSCILLOSCOPES W/O READOUT

MODEL CS-5135
40 MHz, Dual Channel,
Delayed Sweep.
REG. \$895.00 SALE \$719.95

MODEL CS-5155
50 MHz, 3 Channel,
6-Trace, Delayed Sweep.
REG. \$995.00 SALE \$819.95

MODEL CS-5165
60 MHz, 3 Channel,
6-Trace, Delayed Sweep.
REG. \$1095.00 SALE \$899.95

MODEL CS-5175
100 MHz, Dual Channel,
4-Trace, Delayed Sweep.
REG. \$1295.00
SALE = CALL FOR CURRENT PRICE

MODEL CS-2150
150 MHz, 4 Channel,
8-Trace, Delayed Sweep.
REG. \$2395.00 SALE \$1495.95

ANALOG OSCILLOSCOPES W/READOUT/Cursors

MODEL CS-5130
40 MHz, Dual Channel,
4-Trace, Delayed Sweep.
REG. \$1095.00 SALE \$899.95

MODEL CS-5170
100 MHz, Dual Channel,
4-Trace, Delayed Sweep.
REG. \$1695.00 SALE \$1399.95

PRINT™

Products International
8931 Brookville Rd.
Silver Spring, MD 20910
(800)638-2020 (301)587-7824
FAX# 301-585-5402
EASY ORDER FAX LINE (800)545-0058

800-638-2020



CIRCLE NO. 20 ON FREE INFORMATION CARD

Say You Saw It In Modern Electronics

CIRCLE NO. 13 ON FREE INFORMATION CARD

October 1990 / MODERN ELECTRONICS / 57

crease the value of $C1$ to around 0.03 microfarad to reduce the frequency.

If you have used a super-bright red LED in the transmitter, aligning the transmitter and receiver will be simple. One way I do this is to mount the transmitter on a camera tripod. Use tape if you are in a hurry. For better results, unscrew the nut on the on/off switch, place a small brass angle bracket over the threads and replace the nut. Then use a 10-20 wing nut to mount the angle bracket on the tripod. You can use this same method to mount the receiver.

After the transmitter is mounted on the tripod, you can easily aim it anywhere you choose. For initial tests, place a plastic bicycle reflector where you intend to receive the signal. Then adjust the transmitter until you see the reflection of its red beam from the reflector. Make sure the transmitter is firmly in place, walk to the reflector location and place the receiver in front of the reflector. You should hear the transmitter's tone from the receiver's speaker.

If you cannot receive the tone beyond a certain distance, you must add a lens to either the transmitter or the receiver. For very long ranges, you must add a lens to both the transmitter and receiver. A lens at the transmitter reduces the divergence of the LED's beam. A lens at the receiver collects more light from the LED. Either way, adding a lens makes pointing the two units at each other much more tricky.

You can use inexpensive lenses from

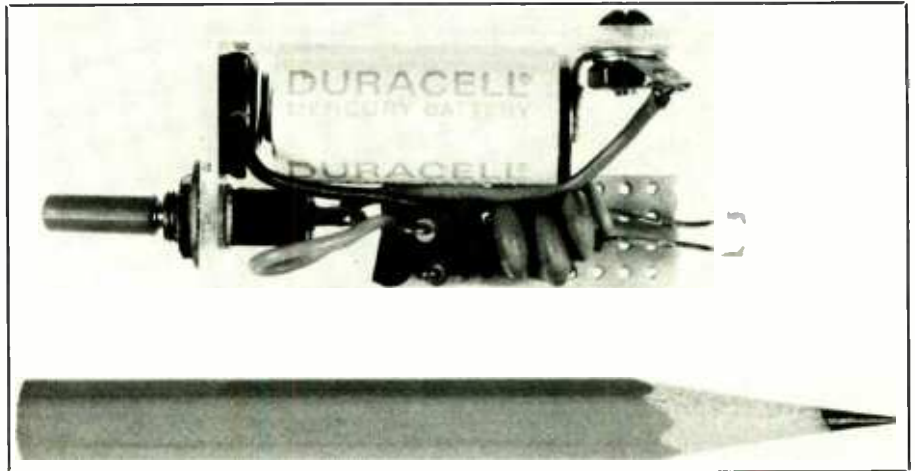

Fig. 6. Assembled version of the LED transmitter in Fig. 4.

department store magnifiers if your optical source is a LED. Glass lenses usually have better quality, but plastic lenses will also work. You can even use flat plastic Fresnel lenses. If you use a laser diode tone transmitter like the one I described in the December 1985 and January 1986 installments of this column, you will have much better results by using a better-quality glass lens, such as those available from Edmund Scientific and others.

Going Further

The miniature lightwave transmitter and receiver described here provide an excellent means for learning much about the

practical aspects of lightwave communication and control links. Besides adding lenses, you might want to try reflecting the transmitter beam from nearby objects and surfaces to see how far away the receiver can detect the reflected radiation.

You will soon find that shiny surfaces, such as waxed cars and windows, reflect the beam much like a mirror. This means you can detect the reflected beam over a considerable distance, but only if the transmitter and receiver are carefully aligned. Diffuse surfaces, such as fabric and wood, reflect the oncoming beam into a broad pattern that can be detected over a shorter distance but over a much wider angle.

Besides simple experiments like these, you may want to modify the receiver to include a threshold circuit that triggers an alarm when the beam is broken. A 555 timer connected as a missing-pulse detector works well in this application (see *Mini-Engineer's Notebook: 555 Timer Circuits*, Radio Shack). For amplitude-modulated voice communication, you can use the receiver without modification. The transmitter can be any straightforward circuit that amplitude-modulates a LED, laser or incandescent lamp (see *Engineer's Mini-Notebook: Optoelectronics Circuits* and *Engineer's Mini-Notebook: Communications Projects*, Radio Shack.)

ME

BACK ISSUE ORDER FORM

Please send me the following issues @ \$3.50 each:

Month(s) & Year(s): _____

Number ordered @ \$3.50 each: _____ Total Payment Enclosed: _____

NAME: _____

ADDRESS: _____

CITY: _____ STATE: _____ ZIP: _____

Comparators, Clocks and Clock Drivers

By Joseph Desposito

Maxim Integrated Products' (120 San Gabriel Dr., Sunnyvale, CA 94086) new MAX900 and MAX901 high-speed quad TTL comparators are the first of a line of monolithic products built using the company's new 6-GHz complementary bipolar process. This dense $\pm 5V$ process allows for integration of four comparators without power dissipation problems and enables input common-mode voltage range to extend down to the negative rail. The quad construction of the devices also reduces cost to as little as \$1.50 per comparator (for the MAX901 in 1,000-and-up quantities).

The comparators save board space and consume only a seventh the power of equivalent single and dual comparator combinations, according to the company. Propagation delays are 8ns with a 5mV overdrive, and power consumption is only 18mW per comparator.

The MAX900/901 devices contain differential inputs and TTL-compatible outputs with internal active pull-ups. The comparators can be powered from separate analog and digital supplies, or from a single +5V supply. With an input voltage range that includes ground in single supply operation, the requirement for a negative supply to increase the input voltage range is eliminated in many applications.

Because of the large gain-bandwidth transfer function of the MAX900/MAX901, special precautions must be taken if the full high-speed capability of the devices is to be realized. A printed-circuit board with a good low-inductance ground plane should be considered mandatory. All decoupling capacitors (the small 100 nF ceramic type is a good choice) should be mounted as close as possible to the power-supply pins, with the return side short and straight to the ground plane.

Separate positive supplies for analog V_{CC} and for digital V_{DD} are also recommended. Close attention should be paid to the bandwidth of the decoupling and terminating components. Short lead lengths on the inputs and outputs are essential in avoiding unwanted parasitic feedback around the comparators. It is

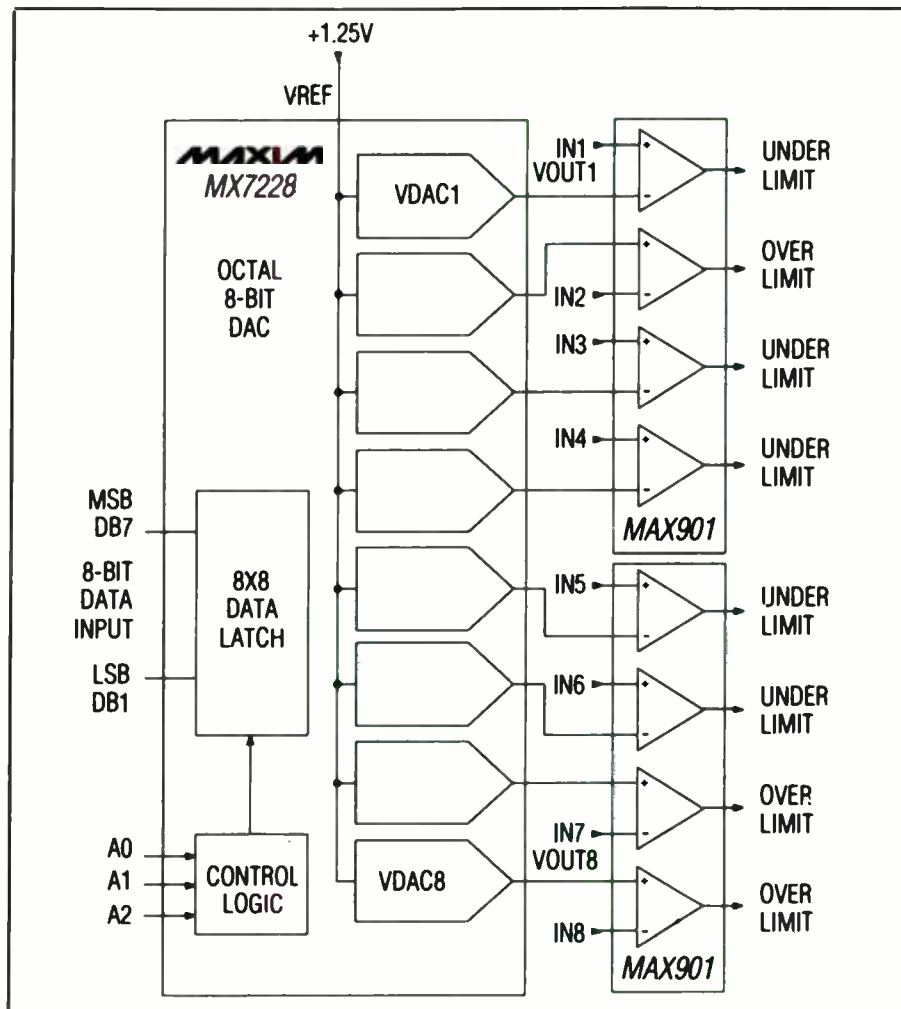

Fig. 1. Maxim Integrated Products' MX7228 high-speed integrated comparator has an octal eight-bit converter to provide several alarm and limit-defect functions simultaneously without external adjustments.

preferable to solder the device directly to the pc board instead of using a socket.

As with all high-speed comparators, the high gain-bandwidth product of the MAX900/MAX901 can create oscillation problems when the input traverses through the linear region. For clean output switching without oscillation or steps in the output waveform, the input must meet certain minimum slew-rate requirements. The tendency of the device to oscillate is a function of the board layout and of the coupled source impedance and stray input capacitance. Both poor layout and large source impedance will cause the device to oscillate and increase the

minimum slew-rate requirement. In some applications, it may be helpful to apply some positive feedback around the device. This pushes the output through the transition region cleanly, but it applies a hysteresis in threshold seen at the input terminals.

By combining two quad analog comparators with an octal, eight-bit D/A converter like the MX7228 shown in Fig. 1, several alarm and limit-defect functions can be performed simultaneously without external adjustments. The MX7228's internal latches allow the system processor to set limit points for each comparator independently and update

SOLID-STATE DEVICES...

them at any time. You can set the upper and lower thresholds for a single transducer by pairing the D/A converter and comparator sections.

Other applications for the MAX900/901 include high-speed A/D and V/F converters, line receivers and high-speed data sampling. For applications that require synchronous operation, the MAX900 provides a latch-enable function.

The MAX900 and MAX901 comparators are offered in 20-pin (MAX900) and 16-pin (MAX901) plastic DIP, CERDIP, and small outline (SO) packages in commercial (0° to +70° C), extended industrial (40° to +85° C), and military (55° to +125° C) temperature ranges. Prices (1000 and up) start at \$5.98 for MAX901 and \$7.01 for MAX900.

Dual Line Receiver

Linear Technology Corp. (1630 McCanby Blvd., Milpitas, CA 95035) has intro-

duced the LT1015, a dual comparator in an eight-pin mini-DIP package. The LT1015 is intended for use as a dual backplane line receiver or in other fast comparator functions, such as high-speed differential line receivers, pulse height/width discriminators, timing and delay generator circuits and analog-to-digital interfaces.

The LT1015 is high in speed (10ns response time) and has TTL-compatible outputs. It operates from a single 5V power supply. The LT1015's output stage design virtually eliminates power-supply glitching during transitions, which greatly reduces instability and crosstalk problems in multiple-line applications. No minimum input slew rate is required, as in previous versions of TTL output comparators.

For retaining output data, the LT1015 has a true-latch pin, with a setup time of only 2ns, which allows the comparators to capture data much faster than the actu-

al flow-through response time.

The LT1015 dual high-speed comparator is available in an eight-pin mini-DIP in the commercial temperature range. Pricing in 100-and-up quantities is \$4.20.

Permanently-Powered PC Timekeeper

Dallas Semiconductor (4350 Beltwood Pkwy. S., Dallas, TX 75244) has developed a real-time clock with 4KB of additional nonvolatile memory to store information vital to a computer. The DS1387 RAMified Real-Time Clock is compatible with PC hardware and software operating systems. Memory in the DS1387 stores configuration data that defines the nature of the input/output devices, version number of the operating system, specific setup information, how much disk storage is available and personalized information.

There is another function for the addi-

Over 75,000 active amateurs in over 125 countries throughout the world read and enjoy a different kind of ham magazine every month. They read CQ.

It's more than just a magazine. It's an institution.

SUBSCRIBE TODAY!



CQ The Radio Amateur's Journal
76 N. Broadway, Hicksville, NY 11801

Please send me CQ for Life 3 Years 2 Years 1 Year
 New Renewal Start with _____ issue 1 year - 12 issues \$22.95 Save \$12.45
 2 years - 24 issues \$43.00 Save \$27.80
 3 years - 36 issues \$63.00 Save \$43.20

Name _____ Call _____
 Street _____
 City _____ State _____ Zip _____

Charge My Order To: Payment Enclosed \$ _____
 MasterCard My account number is: _____
 VISA



tional memory: asset management. Users can store information about the type of computer, the factory where the machine was made, serial number, password, status of components, how many and what type of add-in boards and what software resides on the system.

A follow-up to Dallas Semiconductor's DS1287 Real-Time Clock, the DS1387 RAMified Real-Time Clock is a self-contained subsystem that includes lithium, quartz and a CMOS chip. It counts seconds, minutes, hours, day of the week, date, month and year, with leap year compensation.

Through micro energy management techniques, the DS1387 retains data for more than 10 years in the absence of external power. A special freshness seal extends life by preventing lithium consumption until the PC is first powered up. Thereafter, no lithium is consumed as long as system power is present. This feature eliminates unnecessary drain on the energy source during shipping and warehousing of the device, or during regular PC use. Because of this longevity—much more than 10 years in a typical installation—PC manufacturers don't have to design provisions for battery replacement into their products.

The DS1387 merges 4KB of SRAM into the PC architecture without presenting compatibility problems with either hardware or software for AT, PS2 and EISA computers. The DS1387 RAMified Real-Time Clock sells for \$13.75 in 1,000-piece quantities.

CMOS Clock Driver For 88000

Motorola (2200 W. Broadway, Mesa, AZ) has introduced the MC88913 Low-Skew Clock Driver, the first device in a planned series of high-performance CMOS clock driver ICs. With system clock frequencies regularly reaching 33 MHz and approaching the 40 to 50 MHz range in today's high-end RISC and CISC microprocessor-based systems, this device can significantly ease the burden on the system designer who must provide well-controlled and precise clock signals to maintain reliable synchronous

system performance.

Responding to needs in many applications for input clock duty cycles held tightly to 50%, the MC88913 device contains six divide-by-two flip-flops driving four noninverting and two inverting outputs having closely-matched propagation delays. As a consequence of the matched propagation delay feature, the duty cycles of the device's output waveforms are symmetrical within 1ns, making it ideal for 88000 RISC or other CISC/RISC applications.

Reliable operation of the MC88913 Clock Driver is specified over a range of supply potentials from 4.5V to 5.5V. When operated at 5V in a one-to-six clock fanout configuration, skew is guaranteed to be a maximum of 1.0ns between three of the six outputs (Q0, Q1, and Q2), and a

maximum of 1.5ns on all six clock outputs at a 50pF load. The device specifications also guarantee a device-to-device skew of 3.0ns maximum, thus minimizing clock skew in a multiple-clock system.

Maximum frequency of the input clock to the MC88913 device is 110 MHz, allowing it to drive processors with low-skew clock signals up to a guaranteed 55 MHz. Its six flip-flops are triggered on the positive edge transition of the input clock, which may have a minimum high or low pulse width of 3ns.

Each of the MC88913 clock output lines is rated at a sink/source drive capability of 24mA. The MC88913 CMOS Clock Driver IC is available in 14-pin plastic DIP and small-outline plastic packages. Price in quantities of 1 to 25 is \$12.53 (DIP) and \$12.97 (SOIC). **ME**



FREE CATALOG TEST INSTRUMENTS & HARD-TO-FIND TOOLS

Packed with over 10,000 quality products for testing, repairing, and assembling electronic equipment. A full selection of test instruments, power protection equipment, precision hand tools, tool kits, soldering supplies, and much more. Products are shown in full color with detailed descriptions and pricing. All products come with a 100% satisfaction guarantee. SAME-DAY shipment program.

In a hurry to receive your catalog?

Call (800) 225-5370

In Massachusetts call (508) 682-2000

Contact East, Inc., Dept. R456
335 Willow St., No. Andover, MA 01845

CIRCLE NO. 7 ON FREE INFORMATION CARD

SUPER LONG PLAY TAPE RECORDERS

**12 Hour Model —
USES D-120 TAPE
\$119.00***

Modified Panasonic Slimline, high quality AC-DC provide 6 continuous hours of quality recording & playback on each side of cassette for 12 hours total. Includes • Voice level control • Digital counter, etc. TDK D-120 Cassette Furnished.



PHONE RECORDING ADAPTER

Records calls automatically. All Solid state connects to your telephone jack and tape recorder. Starts recording when phone is lifted. Stops when you hang up. **\$28.50*** FCC APPROVED

VOX VOICE ACTIVATED CONTROL SWITCH

Solid state. Self contained. Adjustable sensitivity. Voices or other sounds automatically activate and control or remote mike. **\$28.50***

*Add for ship & hdg. Phone Adapter & Vox \$1.50 ea. Recordings \$4.00 ea. Cal. Res. add tax. Mail order. VISA, M/C, COD's OK. Money Back Guarantee. Qty. disc. avail. Dealer inquiries invited. Free data.

AMC SALES INC. Dept. M 9335 Lubec St.
Rox 928, Downey, CA 90241
Phone (213) 869-6519
FAX (213) 923-1478

CIRCLE NO. 1 ON FREE INFORMATION CARD

A Cautionary Tale

By Ted Needleman

Needleman's definition of an expert is someone who has fallen on his face often enough to develop calluses on his nose. A couple of weeks ago, I got another layer of callus on mine. I was so enthused about Rupp's BatPak battery system that I decided to add one to my home system. As detailed in a previous column, it takes only about five minutes to install. Problems started when I powered up the system after changing the battery and received a message that I had to re-run SETUP. The power interruption had let my CMOS setup table disappear.

Normally, this would be no problem, I'd just reinitialize the CMOS table with the correct configuration. Except that my home system has a strange combination of hard-disk drives, including an old CDC Wren that I salvaged from an old Tecmar hard-disk/tape-drive combo. Added to this, both drives were partitioned with SpeedStor, which lets you use partitions greater than 32MB with DOS3.x but has its own way of setting up the drives' file allocation tables (FATs).

Needless to say, I spent the better part of a weekend trying to work out the correct values of the drive parameters that are required by the CMOS table. Also needless to say, I didn't have this CMOS information written down, as I routinely do in the office. Nor did I have the 120MB of files backed up (as I also routinely do in the office). After more than 20 hours of fiddling with different diagnostic programs (all of which gave different parameters for the CDC drive), I finally gave up and reformatted the drives. After all, hadn't I been meaning to upgrade most of the applications I had at home anyway?

Stupidity has its own rewards. They just aren't pleasant ones. Right now, while you think of it, run SETUP on every machine you own or use and record the drive setup information on a sticky label for each system. Someday you might need it, and when that happens, you'll be glad you have it written down. Believe me, I know from experience.

North Atlantic Treaty Organization (NATO)

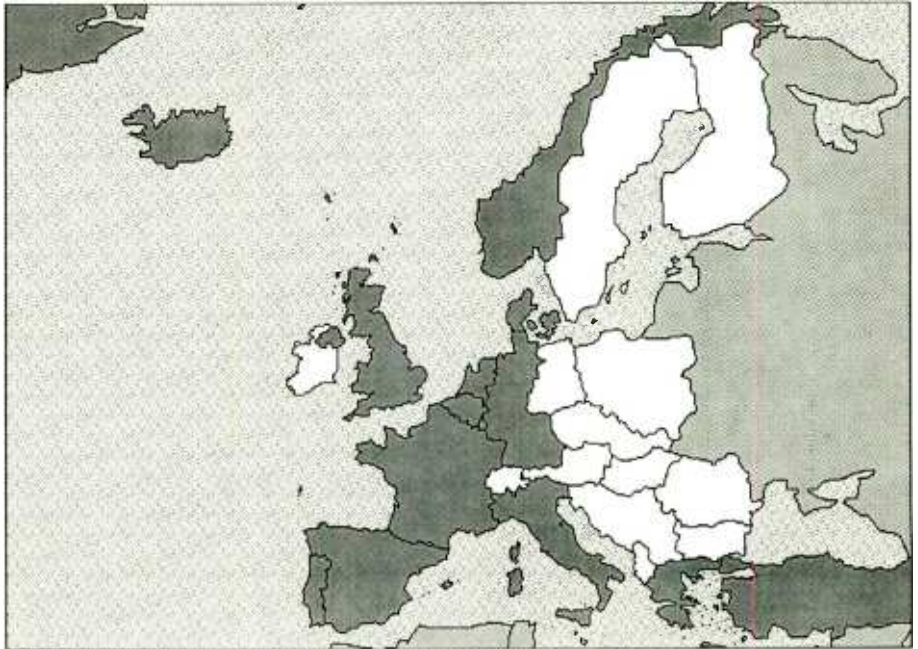

Distance = 9,627 miles Bearing = 274.0 degrees

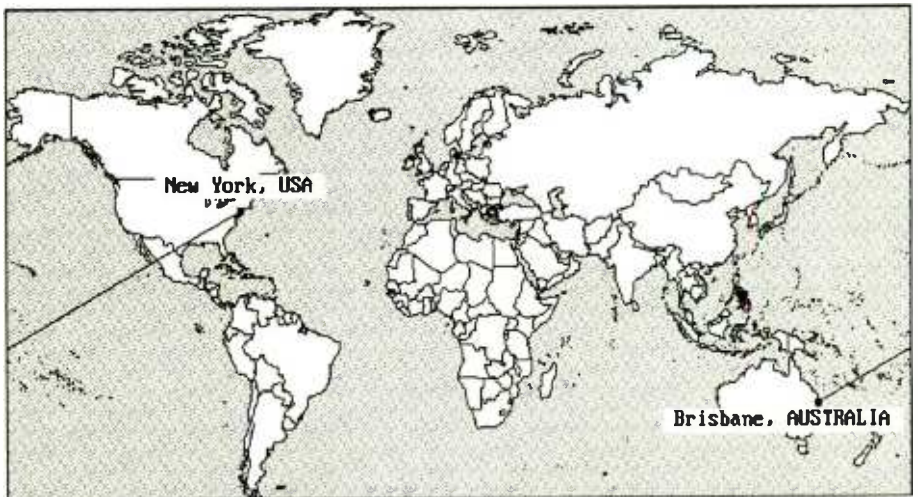

Two printouts obtained using PC Globe software from PC Globe, Inc.

Some Laptop Enhancements

Back in the September column, I reviewed my current laptop, the Epson LT-286. In the few months that have

passed, Epson has taken back the 286 and loaned me its newest laptop—the Equity LT-386SX. This laptop is almost identical to the 286 in both form and function, but features a 386SX CPU

operating at 16 MHz, rather than the 286's 12-MHz clock rate.

For most tasks, there's little difference between the two systems. After all, a 12-MHz 286 is plenty fast for running WordStar and most of the applications I tend to use. Where the 386SX's power really makes a difference is running Windows and Windows-based applications, such as Microsoft's terrific Word for Windows.

Regardless of the particular CPU in it, I tend to use a laptop fairly often. The most frequent use is the one I'm putting the LT-386SX to right now—catching up on my writing upstairs on the kitchen table. I have a pretty terrific home office downstairs. In fact, I spent the better part of last summer studding out walls, installing furring strips into cement walls, paneling, and installing a suspended ceiling.

My large 386 system with its Multiscan color monitor and laser printer are in my downstairs office, as is my Macintosh. Everything I need is pretty much close at hand, and it's nice and quiet. And that's the problem. After spending a long day at the office, sometimes I want to be around my four kids, even if I can't play with them. So the kitchen table gets wiped off, and the laptop gets pulled out.

One problem with using a laptop has been the 3.5-inch diskettes they all use. Every other system I use has 5.25-inch diskette drives. Another problem has been that many of the applications I use supply either 5.25- or 3.5-inch diskettes, but not both. As the majority of systems I use have the 5.25-inch units, that's the media I usually request. Later on, if I decide I need to install the application on the laptop, I need to transfer each disk to the appropriate smaller-sized media so that the application can be correctly installed.

In the past, I've used Traveling Software's LapLink for these chores. It works well, but it's a pain in the neck to lug the 18-pound laptop up and down the stairs just to transfer a file or two. And if it's an entire set of application disks that need to be moved to different-size media, it really starts to become a bother. I received a set of solutions, albeit from dif-

ferent sides of the problem, from Manzana Microsystems.

Manzana Microsystems is another of those small companies that has been around for years, quietly doing business and not arousing very much attention. The company has specialized in floppy-drive systems, and its two solutions to my problem where an internal 3.5-inch drive for my desktop and an external 5.25-inch drive for the laptop.

The external drive, being the easiest to install, is the one I'll describe first. It comes in its own case with its own power supply. Just plug in the power cord, plug the drive into the laptop, and run the laptop's setup program. Set Drive B: as an external drive, and you're ready to use the Manzana drive. That's all there is to it. The instruction sheet that comes with the drive is only one paragraph long, and it's sufficient for the task.

The Manzana external drive comes in 3.5-inch (720KB and 1.44MB) and 5.25-inch (360K and 1.2MB) models and is available for all popular laptops that support an external drive. This is a new product, and pricing isn't firm at the time this is being written, but it should all be in the area of about \$350. Mine was the 5.25-inch 1.2MB model, and it works perfectly, making the installation of 5.25-inch-based applications a snap and transfer of information from system to system a breeze.

Installing an internal 3.5-inch drive can be a bit more work, depending on whether the drive is the second or third drive installed in a PC, whether you're installing the drive in a PC/XT-style machine or an AT-type system, and whether or not your system's BIOS supports 3.5-inch drives.

In my case, installation was fast and easy. Because my 386 desktop uses AT-style guide rails on one side of the drive, I had to mount one rail on the left side of the drive. Unfortunately, the rails provided by Manzana were the wrong size; they were a bit too narrow. Luckily, however, I had a spare set of rails provided by the PC's vendor, which worked just fine. The right side of the drive was secured with four screws provided with the drive.

Put Professional Knowledge and a
COLLEGE DEGREE
in your Technical Career through
**HOME
STUDY**

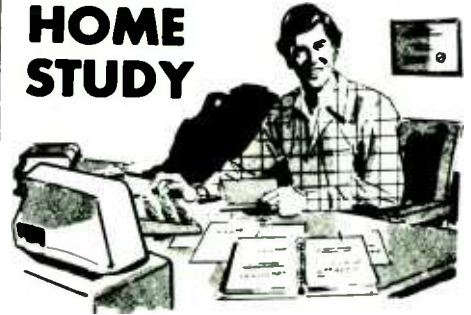

Add prestige and earning power to your technical career by earning your Associate or Bachelor degree through directed home study.

Grantham College of Engineering awards accredited degrees in
electronics and computers.

An important part of being prepared to *move up* is holding the right college degree, and the absolutely necessary part is knowing your field. Grantham can help you both ways—to learn more and to earn your degree in the process.

Grantham offers two degree programs—one with major emphasis in **electronics**, the other with major emphasis in **computers**. Associate and bachelor degrees are awarded in each program, and both programs are available completely by correspondence.

No commuting to class. Study at your own pace, while continuing on your present job. Learn from easy-to-understand lessons, with help from your Grantham instructors when you need it.

Write for our free catalog (see address below), or phone us at toll-free 1-800-955-2527 (for catalog requests only) and ask for our "degree catalog."

Accredited by
the Accrediting Commission of the
National Home Study Council

GRANTHAM
College of Engineering
250 Frontage Road
Slidell, LA 70460

More QSO's More QSL's More Fun



when you speak their language.

- Add extra spice to your DX QSO's
- Let your DX friends know you care enough about them to learn their language. (After all, they've gone out of *their* way to learn English!)
- Break the phone pile-up with a few carefully chosen words in the DX station's own language. You'll be amazed at the difference. it's like adding 3 dB to your signal.

The Radio Amateur's Conversation Guide by OH1BR and OH3BAD gives you the 147 most often used phrases in eight languages: English, German, French, Italian, Spanish, Portuguese, Cyrillic Russian, Phonetic Russian, Phonetic Japanese. Phonetic alphabets and eight-language dictionary included in this rugged spiral-bound manual a MUST for any serious DXer or Contestor. Beat the competition. Order yours today. Only \$10.00 plus \$2.00 per order shipping.

Supplements available in less-used languages: Dutch/Flemish, Danish, Finnish, Swedish, Serbocroatian. \$4.00 per supplement. Be sure to state which language supplement you need.



New cassette tapes in eight languages

Now you can hear the exact pronunciation of the sentences, phrases and words covered in *The Radio Amateur's Conversation Guide*. Each high quality language tape is recorded with proper dialect and usage in one of the languages in the Conversation Guide.

Tapes available in each of these languages:

- German
- Portuguese
- French
- Russian
- Spanish
- Japanese
- Finnish
- Swedish



CQ Book Shop
76 North Broadway
Hicksville, NY 11801

Please send the following:

- Conversation Guide Book \$10

Language Tapes
@ \$10 each

- German
 French
 Spanish
 Finnish
 Portuguese
 Russian
 Japanese
 Swedish

Supplements
@ \$4 each

- Dutch/Flemish
 Danish
 Finnish
 Serbocroatian
 Swedish

Add \$2 for postage and handling in North America

Total _____
Name _____
Address _____
City _____ State _____ Zip _____

PC CAPERS...

As this was the second floppy drive to be installed in the machine, I just plugged the additional connector on the floppy cable into the 3.5-inch drive. If it had been the third drive, I would have had to use one of Manzana's controller cards, either the HDC-1, a replacement floppy controller that supports up to four floppies, or the HDC-2. The HDC-2 is a secondary floppy controller that doesn't require that the system's original floppy controller be disabled and supports up to an additional two floppy drives. Manzana also makes two equivalent cards for PS/2 systems, the PS2-C1 and PS2-C2.

The final step for me was to bring up my desktop's CMOS setup table and define drive B as a 1.44MB 3.5-inch drive. The drive worked perfectly, and total installation time was about 25 minutes, mostly taking the cover off the system and putting it back on again.

Depending on how old your system is, its BIOS may not support 3.5-inch drives, or if it does, it may only support the older 720K drives and not the more recent 1.44MB ones. If this is the case, you'll have to go through one more step and install a device driver, which Manzana supplies with each drive. This is as simple as inserting a single line into your CONFIG.SYS file so that your system will recognize the newly installed drive on bootup.

The 3.5-inch internal drive, like the 5.25-inch external drive, is warrenteed for a year and costs \$200. The HDC-2 card, if needed, costs another \$85.

The Whole World In Your Hands

At the recent PC Expo here in New York, I was strolling the aisles when I was accosted by Richard Burger, Vice President of Marketing of PC Globe, Inc. Spotting my Press badge, he immediately dumped several boxes of software into my arms, with an order to "Go home and play with these . . . your readers will want to know about them!" I usually disregard this type of hyperbole, but this time I went home and played with them. And he was right. You will want to know about PC-Globe 3.0, PC Nations, and PC USA.

PC Globe and PC USA are computerized atlases of the world and the United States. But just saying what they are doesn't really tell you how much fun they are to use. PC Globe and PC USA let you zero in on a particular country (or state) and obtain a wealth of economic, social and cultural information about the area selected. You can generate elevation maps, or bring up major cities, lakes and rivers. Do you need the time zone and/or area code for Zimbabwe? PC Globe will let you find it easily. Want to know the point-to-point distance between New York City and Brisbane, Australia in miles or kilometers?

If you're an armchair explorer, you need PC Globe and PC USA. If you're a frequent traveler, you need it even more. And if you have children in the house, as I do, you owe it to them to get one or both of these products. At \$69.95, they're as entertaining as many games, and a lot more educational.

The PC Nations program, at \$29.95, is a companion to PC Globe. It displays the national flags of 175 countries. At the same time it displays the flag, it plays the national anthem of the country selected. Unless you're really into flags and anthems, save your money on this one, and buy both PC Globe and PC USA.

PC Globe and PC USA require an IBM or compatible system with 512K RAM, floppy drive and/or hard disk, DOS 2.0 or later and Hercules, CGA, EGA, or VGA display. Demo disks are available for \$3 each in either 5.25- or 3.5-inch floppy-disk format.

Company Addresses

**External Laptop Drive
Internal 3.5-inch drive**
Manzana Microsystems, Inc.
P.O. Box 2117
Goleta, CA 93118
(805) 968-1387

PC Globe; PC USA; PC Nation
PC-Globe, Inc.
4700 S. McClintock
Tempe, AZ 85282
800-255-2789

Quattro Pro: Everything But the Kitchen Sink

By Joseph Desposito

More than ten years have passed since introduction of the first personal computer spreadsheet, a product called VisiCalc. VisiCalc had such an impact that it encouraged business people to use small computers. Lotus Development's spreadsheet played the same role when IBM introduced its PC. Competitive software products cropped up, of course. But it has been only within the last year or so, however, that spreadsheets have shown really dramatic increases in power. One of these new powerful spreadsheets is Quattro Pro, from Borland International (1800 Green Hills Rd., P.O. Box 660001, Scotts Valley, CA 95066).

Borland, you may recall, made its fame with SideKick, a TSR (terminate and stay resident) program for PCs that included such functions as a notepad, calculator, and address book, as well as its Turbo languages. In 1987, Borland released its first spreadsheet, Quattro, which had power comparable to the then leading spreadsheets, but at about half the price.

In its quest to develop a more-powerful product for corporation use, the company acquired the rights to Surpass, a spreadsheet with advanced features. Quattro Pro is essentially a combination of Surpass and Quattro 1.0 technology. The suggested retail price for this new package is \$495. For all its power, though, it can operate on a slow 8088-based CPU computer with only 512K of memory. Whatever the processor, DOS 2.0 or later and a hard-disk drive are required.

Quattro Pro Overview

Like most other top-quality spreadsheets, Quattro Pro also provides graphics and database functions. The spreadsheet area is 8,192 rows by 256 columns. Above the spreadsheet window area is a horizontal menu bar with nine choices.

To access any of the choices in the spreadsheet window, you press the menu key (/) and then the first letter of the menu choice. This causes a drop-down menu to appear with further choices, which you also select by typing the first (or sometimes another) letter of the

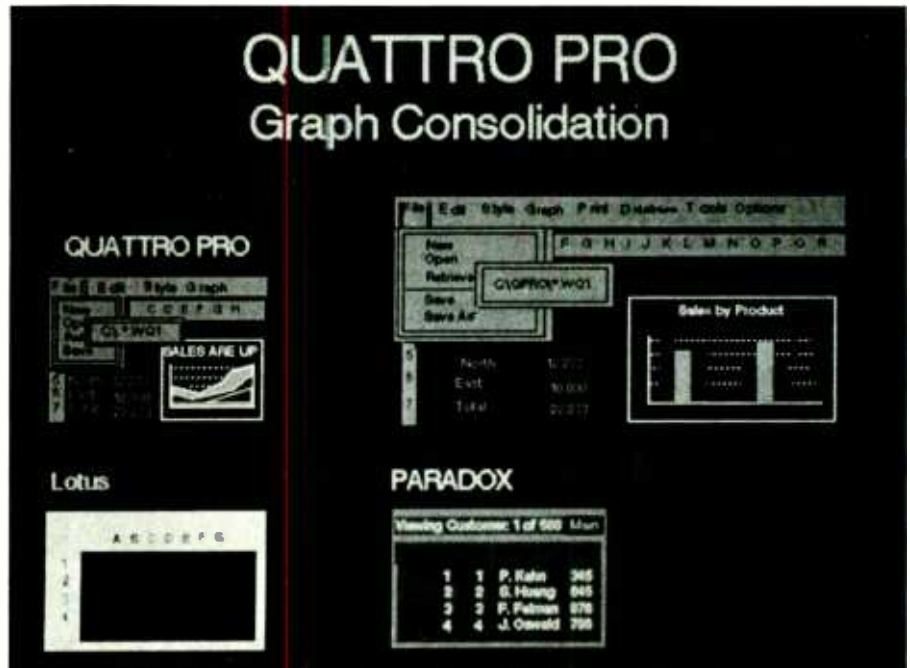

choice. Alternately, you can select choices with the "point-and-shoot" method; that is, you use the cursor keys to select the choice and then press Enter. Another way of selecting menu choices is with a mouse, which Quattro Pro supports if you have installed a mouse driver and attached a mouse to your PC.

Since Quattro Pro has so many standard and advanced features in each of its spreadsheet, graphics and database categories, we'll address these areas separately later in this review.

Installation & Use

You install Quattro Pro with either eight 5.25-inch 360K floppies or four 3.5-inch 720K floppies. The program includes both sets of disks. The installation procedure is a simple one: you type INSTALL at the DOS prompt and then answer questions about your display, printer and graphics options. Any time you want to change an option, you can do so from within the program by choosing Options from the menu bar.

To start the program, you type "q" at the DOS prompt. A colorful window appears, assuming your monitor is not monochrome (which is also supported). The spreadsheet area is in blue, the current cell is in red and borders are in gray (these colors can be changed, if desired). To retrieve a file you press / to activate the menu bar, choose F for the menu's file and R for the subsequent choices. A fast /FR does it just as with its Lotus rivals. If you want to start a new file, you simply begin typing information into a cell on the spreadsheet.

To include a formula, you type "+" and enter the appropriate cell references. To use Quattro Pro's built-in functions (math, logic, financial, etc.), you type and then enter the function name and the appropriate parameters. If you can't remember the name of a particular function or don't want to enter it manually, you can type Alt-F3 and a list of functions will appear. You choose a function by pointing to it and pressing Enter.

Beyond the basics of spreadsheet operation, Quattro Pro offers many sophisti-



cated features. The phrase that comes to mind is "everything but the kitchen sink."

Spreadsheet Features

One of the big problems with early spreadsheets was their inability to consolidate information from multiple spreadsheet files. In other words, if you had spreadsheets from several sales regions, there was no way to link these figures into a summary sheet. Quattro Pro solves this problem by letting you load as many as 32 spreadsheets into memory simultaneously and by letting you create links between these spreadsheets. To load additional spreadsheets into memory, you simply select File Open or File New. To move among different sheets, you press Shift-F6.

When you have more than one spreadsheet in memory, there is a problem seeing information on the sheet. Quattro Pro lets you view sheets in two ways, side-by-side (tiled) or overlapping (stacked). For example, if you have three sheets in memory, you can arrange them so that

one-half of one and one-fourth of each of the other two are showing. You can obtain a full picture of the active sheet by selecting Window Zoom.

You link cells from different sheets with a linking formula that uses the sheet name and the appropriate cell. For example, if you want to link the total from a REGION1 sheet with a SUMMARY sheet, you enter a formula like:

$$+ [\text{REGION1}]F20$$

where REGION1 is the name of the sheet and F20 is the cell's column and row number. You can also use a special "3-D" link character, an asterisk (*), to create a link. For example, if you want to add the value stored in cell F6 in all the open spreadsheets, you type the formula:

$$@\text{SUM}([\ast]F6)$$

where @SUM is summing function, * is the linking character and F6 is the cell address.

Quattro Pro also allows you to perform free-form consolidation. For exam-

ple, you could create a formula in a SUMMARY sheet such as:

$$+ [\text{REGION1}](D3 + G3) - [\text{REGION2}]E2.$$

This formula pulls information from two cells of a REGION1 sheet and one cell of a REGION2 sheet.

Whether you are working with one or more spreadsheets at a time, Quattro Pro offers a long list of spreadsheet functions, ranging from simple ones, such as changing column widths and inserting rows, to advanced ones, such as performing linear regression and linear programming. To select linear regression, for example, you choose Tools, Advanced Math, and Regression from the menus.

Automation is always a big part of spreadsheet work. Quattro Pro lets you create macros, or automated sequences of commands, by manually typing them into the spreadsheet or with a feature called Record. To record a macro, you select Tools, Macro and Record from the menu. This feature records each action you take until you exit record by selecting it from the menu again. You then choose Paste to store the macro in a spreadsheet. Besides the standard spreadsheet commands, macros can include programming commands such as FOR, IF and BRANCH.

If your macro doesn't work right the first time, you can debug it by choosing Tools, Macro and Debugger. Some menu choices have shortcuts, too. For example, you can invoke the debugger by pressing Shift-F2.

One convenient spreadsheet feature is called SQZ!. This allows you to save disk space by compressing the file. You select it with File, Utilities, SQZ!. We used the SQZ! function to compress a file from 140K to 25K.

Once you create a spreadsheet, you often want to print it. Quattro Pro offers you many ways to enhance the look of your printout. First of all, you can draw single or double lines and boxes anywhere on the sheet. This is done by selecting Style and Line Drawing. Secondly, you can change the print style of any part of the spreadsheet. This is done by selecting

Style and Font. With the Screen Preview command, you will get a snapshot of just what will be printed, font style and all. But you will have to use a zoom-in to read much of the text.

Quattro Pro uses Bitstream fonts (nine fonts come with QP) and also supports native fonts of the HP LaserJet and Apple Laserwriter printers. Font sizes can be used from 6 to 72 points.

If you want to print your spreadsheet sideways, you select Print, Layout, Orientation, Landscape from the menus. Sideways printing uses your printer's graphics mode and usually takes much longer than standard printing, naturally, especially if you are printing in high resolution on a dot-matrix printer.

Keep in mind that features such as compressing files, changing fonts and printing sideways can often be done with other spreadsheet brands only by buying third-party software. This can add significantly to their cost.

Graphics Features

Quattro Pro has gone way beyond simple graphics displays and actually rivals some of the top graphing packages. There are many types of graphs you can create, including line, bar, xy, stacked bar, pie, area, rotated bar and high-low. The bar and pie graphs are drawn with a three-dimensional effect, although they are not true three-dimensional graphs. Graphs are created by choosing Graph from the main menu and several other items from the pull-down menu.

Graphs are not the whole story with Quattro Pro. Any graph you create can be embellished by selecting Annotate from the Graph menu. This brings up a mini-drawing program, which gives you complete freedom in manipulating and annotating different parts of the graph with different fonts, colors and objects. For example, you can insert an arrow into the graph to point out a particularly noteworthy number, and add text to explain it. This is done by selecting objects from icon-based menus. It is much easier to use this drawing program with a mouse than from the keyboard.

Any graph you create, whether anno-

tated or not, can stand alone or be pasted into a spreadsheet by selecting Graph and Insert. To view a graph in the spreadsheet, you must change your display mode from text to graphics. Graphics display mode is also more appropriate when you are using a mouse.

The annotator can also be used to create graphics, such as bulleted lists, hand-drawn graphs and other drawings. These drawings can then be incorporated into a slide-show presentation by choosing Graph, Name and Slide. Quattro Pro also includes a sampler of 30 clip-art images from Marketing Graphics, Inc.'s Picture Pak electronic art libraries.

Database Features

Quattro Pro offers the standard array of database features, such as Sort and Query. But, again, the program offers something special. You can use the linking features of Quattro Pro to query a database file created with Paradox, Reflex or dBASE. This lets you access database information without having to translate the database into a spreadsheet file first. You just include the name of the file when specifying the data you want to query. You do this by selecting Data, Query and Block. Then you type in the name of the file you want to query in the following way:

```
[FILENAME]A1..A2
```

where FILENAME is the name of the outside file and A1..A2 is a dummy block range.

Compatibility Issues

Everyone knows that Lotus 1-2-3 in all of its versions is the spreadsheet standard. For Quattro Pro or any other spreadsheet to be seriously considered as a business application, it must, therefore, have a high degree of compatibility with the standard. Quattro Pro does have this.

You can load 1-2-3 files, just as if they were Quattro files; no transformations are needed. You can also duplicate the menu structure found in 1-2-3 by starting Quattro with ql23 instead of q. The

menus are still the pull-down type, but they follow the order used in 1-2-3. When we loaded several 1-2-3 Release 2.2 spreadsheets into Quattro Pro, we found no compatibility problems.

Besides 1-2-3, Quattro Pro maintains compatibility with most of the major programs, including Symphony and Excel. It can also import DIF and SYLK files.

Other Considerations

Quattro Pro comes with three manuals, all of which are well-written and illustrated. There is also a quick reference guide and keyboard templates. Screen help is always available by pressing F1. Borland also maintains a free technical support hotline and has a SIG (special-interest group) on CompuServe.

As powerful as it is, Quattro Pro does not need a powerful computer system to run on. It can run on any model of PC from 8088 to 80486 with 512K RAM and a hard disk. It also supports the LIM 4.0 expanded memory standard. Additionally, Quattro Pro has a feature called VROOMM, for virtual real-time object oriented memory manager.

The latter gives the user the ability to load very large spreadsheets and access advanced spreadsheet features in as little as 512K memory. The way it works is that certain spreadsheet modules are stored on-disk and are not brought into memory until needed. Although VROOMM is not a traditional overlay system, and typically performs speedily, it sometimes causes a delay of several seconds when accessing certain commands from disk.

Conclusions

As mentioned earlier, Quattro Pro gives you everything except the kitchen sink. I can't think of any function that is missing. There is the usual standard array of features. Added to these are the ability to load up to 32 sheets and link them together. There are very strong graphics features. There are the extras, such as SQZ! and sideways printing. You can operate in either text or graphics modes, and even use a mouse. **ME**

CIRCLE NO. 38 ON FREE INFORMATION CARD

Logitech's Trackball

By Art Salsberg

The "mouse," a hand-size pointing device with a cable "tail" plugged into a computer's proper input port, is moved about on a desktop surface to cause a related cursor (usually an arrowhead) to move on-screen.

When a button atop it is pressed and released ("clicked") while the arrowhead is on a screen symbol of some kind or a menu listing, it causes a chosen action to take place just as if a command is typed on other kinds of computers. One can also "drag" screen matter from one location to another position, draw curves, and make possible other actions that are, at best, cumbersome to do with a keyboard's arrow keys. The video display with its icons, other symbols and menus is generated by a graphics program that shields the user from inanities of MS-DOS.

Popularized by Apple Macintosh computers, it was the envy of users of IBM and compatible computer types. In time, the mouse, appropriate graphics programs, and a bevy of application programs that used a mouse advantageously were introduced for MS-DOS computers. However, until the very recent introduction of Windows 3.0 and justifiably anticipated application software for use with it, a mouse on an MS-DOS computer could not approach the overall operating quality displayed by a Mac. Now, however, with at least a '286-based machine, a mouse will likely become a much more popular device.

There are mice and there are mice. A drawback of any standard mouse is the extra desktop room it takes to move it around. Optical types even require a special mat in order for them to function. And then came the trackball mouse. This is a pointing device that doesn't have to be moved about. It remains stationary, wherever you place it. The pointing movement is achieved by rolling a small round ball built into the device instead of moving the mouse itself. Some computer keyboards even have such a device built in.

Logitech, Inc. has long made a plain old mouse, upgrading it along the way.



More recently, it introduced a stationary mouse that it calls "Trackman." Wider than the sleek Logitech mouse, it nevertheless takes up much less space because you don't move it around. Your thumb movement on the small ball does the work, while your fingers are at the ready on the controls (there are three buttons arranged in a line).

You can install this Trackman mouse into a variety of IBM or compatible computers, choosing among three versions. The bus version (\$149) comes with a plug-in board that has a nine-pin mini DIN input connector. It can be installed in IBM PC, XT, AT, and models 25 and 30 PS/2 types of computers. A PS/2 version has a six-pin DIN connector for attaching to an IBM PS/2 or compatible computer's mouse port. A third type, the serial version (\$139), connects to the COM1 OR COM2 serial port of an IBM AT or compatible with a nine-pin connector, and a PC or XT with a supplied 9-to-25-pin serial adapter.

PC or MS-DOS 3.3 or later is required for PS/2 computer models, while 2.1 or later is needed for other models. Memory needs are only 256K, and the program works with a variety of graphics adapters: Hercules Monochrome, CGA, EGA,

MCGA and VGA. It'll work fine with two floppy drives or one floppy and one hard disk. Resolution is 300 dpi.

Each package contains "MouseWare" program disks on a 3.5-inch disk and on two 5.25-inch disks, as well as three manuals: "Getting Started," "Getting The Most From Your Mouse," and "Mouse 1-2-3 Manual." The last is for use with Lotus 1-2-3 spreadsheet programs, displaying a pop-up menu for Trackman use when the middle button is pressed.

Using the Trackball

I used the serial-port version of Trackman. Installing it was simple. Just plug the connector into a serial port, load the software that comes with the device by typing Install and pressing the Enter/Return key is all it takes.

The choice of mouse driver is done automatically, along with installing Logi-menu and Click files. The Install Main Menu that's displayed allows you to install MouseWare Application Menus from among 24 selections, to create a .bat file, and to install a mouse shell for Lotus 1-2-3. There are manual instructions on creating your own Mouse Menu, too.

There are manual changes you can

make, such as changing a COM port, modifying screen colors, and controlling the speed and precision of your trackball. To do the last, you can bring up the Mouse Control Panel by holding down Control and Alternate keys and pressing Trackman's middle button. A pop-up menu then appears, allowing you to select the Sensitivity you want through a choice of 0 to 10 (5 is the default), and Ballistics with a choice of Off, Low and High. Settings also can be made without calling up the menu. You can also switch buttons 1 and 2 if you wish to.

The Sensitivity range determines the cursor's speed when the ball is moved, while Ballistics permits you to control the speed of the cursor with a slow movement when moving the ball slowly and a much speeded up movement when rotating the ball quickly.

I found that the Sensitivity default of 5 was fine for me. To observe any difference in cursor speed required me to select either a very low or very high number. Setting Ballistics on Low was to my liking. On High, I moved the cursor kind of jerkily although there is indeed more precise control when moving very slowly.

Trackman is to my liking, as compared to a conventional mouse. There's not quite as much control achievable as when using a moving mouse, but using my thumb on the ball did not present me with any problem.

With somewhat less control, your cursor-moving speed won't be as fast as when using a moving mouse, of course. But the tradeoff of using a mouse while taking up less desk space is well worth it, I think. I can place Trackman at an angle on some objects lying on my computer table and still work very well, thank you.

The documentation that accompanies the device is complete and clearly written and illustrated. A very experienced mouse user, especially a heavy-user type, might still prefer the conventional type of mouse for the operating speed he can achieve. For the occasional user, like me, however, a stationary mouse is more to my liking, all things considered. **ME**

CIRCLE NO. 39 ON FREE INFORMATION CARD

LEARN ELECTRONICS FROM VHS VIDEO TAPES!

At
Ucando
your Success
is our
Business!

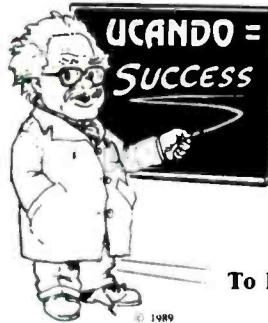

Our Video Tapes
Are Designed
To Make Learning Electronics
Fun and Easy!

- | | |
|---|--|
| <ul style="list-style-type: none"> • PART 1-DC, 53 min......\$32.95
Electronics and You—VT-201 • PART 2-AC, 71 min......\$32.95
Electronics and You—VT-202 • PART 3-SEMICONDUCTORS, 47 min......\$32.95
Electronics and You—VT-205 • PART 4-POWER SUPPLY 55 min......\$32.95
Electronics and You—VT-206 | <ul style="list-style-type: none"> • PART 5-AMPLIFIERS 52 min......\$32.95
Electronics and You—VT-207 • PART 6-OSCILLATORS 54 min......\$32.95
Electronics and You—VT-208 • VCR MAINTENANCE & REPAIR VT-203—54 min......\$32.95 • INTRODUCTION TO VCR REPAIR VT-204—110 Min......\$59.95 |
|---|--|

ORDER NOW!

CALL TOLL FREE AT

1-800-678-6113

OR

mail check or money order to:

UCANDO VIDEOS

P.O. BOX 928 • GREENVILLE, OH 45331

VISA
AND
MASTERCARD
ACCEPTED

CIRCLE NO. 17 ON FREE INFORMATION CARD

Double your income! Computer maintenance/service — a \$10 billion industry.

If you are presently servicing office machines or any other electronic equipment, computer repair can **double your income.**

National research results indicate that computer technicians bill out at double the hourly rate of office machine technicians.

Tech-Serv can put you into computer repair quickly, economically and efficiently and with a complete support program including a **proven marketing plan.**
We provide:

RECOGNITION

Nationally recognized trademarks and logos give you immediate recognition as a professional computer repair specialist by being a Tech-Serv Authorized Computer Repair Center in your market area.

DOCUMENTATION

We provide manuals, schematics, documentation and advanced diagnostic software.

NEW HARDWARE

CPU's: IBM, Apple, Compaq, and others.
Printers: Okidata, Epson, HP Lasers and others at huge discounts.

PARTS & BOARD REPAIR

Single source for parts and board repair.
24-hour express turnaround.

TRAINING

Hands on training: IBM, Compaq, Apple, and compatibles at 3 separate levels:

Level 1: 8086-8088 Based Machines

DOS System Configuration and upgrades

Level 2: 80286/80386 Machines, Letter Quality and Laser Printers

Level 3: System Networks Configuration, Installation and Repair

FINANCING

Available for qualified businesses.

OVER 125 DEALERS WORLDWIDE

Find out why more and more electronic professionals are adding computer repair to their businesses or starting their own computer repair businesses.

Call Tech-Serv at (212)967-1865 now.

tech serv AUTHORIZED DEALER
SERVICING THE WORLD OF MICROSSM

253 West 28th Street, New York, NY 10001

©1989 Tech-Serv Corp.

CIRCLE NO. 16 ON FREE INFORMATION CARD

Simple QuickBASIC Program For Operating Studio-64 Frame Grabber

```

DEFINT A-Z
SCREEN 0: WIDTH 80: COLOR 1, 7: CLS
' See schematic for HEX address values. Experiment to find non-conflicting
' address with your PC.

PRINT : INPUT " Enter board
address in HEXADECIMAL (i.e., &Hvalue):"; WR0
  WR1 = WR0 + 1
  RD0 = WR0

PRINT " Do you want to display current image or perform capture? [ D ] [ C ]"

DO
  a$ = UCASE$(INKEY$)
  IF a$ = "D" OR a$ = "C" THEN EXIT DO
LOOP

IF a$ = "D" THEN GOSUB Display
START:
SCREEN 0: WIDTH 80: COLOR 17, 7: CLS

PRINT : PRINT " Press any key to grab a frame or press [ Esc ] to EXIT"
GOSUB L1
GOSUB GRAB
COLOR 1: CLS
PRINT : PRINT " Frame in capture buffer."
PRINT " Press [ Esc ] to EXIT or any other key to display image . . ."
GOSUB L1
GOSUB Display

L4:
a$ = INKEY$
IF a$ = "" THEN GOTO L4
SCREEN 0: WIDTH 80: COLOR 1, 7: CLS
INPUT " Do you want to save the image [ Y / N ]?"; a$
a$ = UCASE$(a$)
IF LEFT$(a$, 1) = "Y" THEN GOSUB SAVE
GOTO START

L1:
a$ = INKEY$
IF a$ = "" THEN GOTO L1:
IF a$ = CHR$(27) THEN COLOR 15, 1: CLS: END
RETURN

GRAB:
' If BEEP not heard immediately then video source not connected or board
' address incorrectly set. Press the Escape key to exit loop.

OUT WR1, 0
OUT WR0, 3
DO
  IF (INP(RD0) AND &HC0) = 0 THEN EXIT DO
  IF INKEY$ = CHR$(27) THEN EXIT DO
LOOP
BEEP
IF (INP(RD0) AND &HC0) = 0 THEN GOTO START
RETURN

Display:
' Set VGA/MCGA display mode to 320x256 256-color mode (64 grey-shades)
SCREEN 13

' Set colors 1 to 64 to 64 individual grey shades for incoming data values
FOR grey = 0 TO 63
  weight! = 65536 * grey + 256 * grey + grey
  PALETTE grey + 1, weight!
NEXT

' Make background color paper-white (optional)
background! = 65536 * 63 + 256 * 63 + 63
PALETTE 0, background!

' Make graphics text magenta (optional)
text! = 65536 * 39 + 256 * 0 + 63
PALETTE 65, text!

COLOR 65
PRINT "P"
PRINT "C"
PRINT ""
PRINT "S"
PRINT "T"
PRINT "U"
PRINT "D"
PRINT "I"
PRINT "O"
PRINT ""
PRINT "6"
PRINT "4"
    
```

er via an extender board for easy access to the component side.

Clip the common lead of a dc voltmeter or multimeter set to the dc volts function to any convenient point on the board that is supposed to be at ground potential. Power up your computer and touch the "hot" probe of the meter to the following points and note if you obtain the required + 5-volt reading:

- U1 thru U4 pins 1,9,10,15,16
- U5 pin 2
- U6 pin 14
- U7 pins 4,10,11,12,14

- U8 pins 4,10,12,14
- U9 pins 4,10,14
- U10 pin 14
- U11 pins 2,4,6,8,20
- U12 pin 16
- U13 pins 1,20
- U14 & U15 pin 28
- U16 pin 14
- U21 pin 8
- U23 pin 12

Then touch the "hot" probe of the meter to the following points and note whether or not you obtain the readings shown in parentheses:

- U18 pin 4 (- 12V); pin 8 (+ 12V)

- U19 pin 4 (- 12V); pin 8 (+ 12V)
- U20 pin 1 (+ 12V); pin 4 (- 12V)

Missing from the above listings are *U17* and *U22*, which are a + 5-volt regulator and a precision 1.2-volt reference, respectively. Touch the "hot" probe of the meter at the OUT pin of *U17* to verify that + 5 volts is available there and the cathode lead of *U22* to verify that + 1.2 volts is available there.

If you fail to obtain the proper reading at any of the above mentioned points, power down the circuit

```
LOCATE 1, 40: PRINT "R";
LOCATE 2, 40: PRINT "e";
LOCATE 3, 40: PRINT "a";
LOCATE 4, 40: PRINT "l";
```

```
LOCATE 6, 40: PRINT "t";
LOCATE 7, 40: PRINT "i";
LOCATE 8, 40: PRINT "m";
LOCATE 9, 40: PRINT "e";
```

```
LOCATE 11, 40: PRINT "l";
LOCATE 12, 40: PRINT "m";
LOCATE 13, 40: PRINT "a";
LOCATE 14, 40: PRINT "g";
LOCATE 15, 40: PRINT "e";
```

```
LOCATE 17, 40: PRINT "C";
LOCATE 18, 40: PRINT "a";
LOCATE 19, 40: PRINT "p";
LOCATE 20, 40: PRINT "t";
LOCATE 21, 40: PRINT "u";
LOCATE 22, 40: PRINT "r";
LOCATE 23, 40: PRINT "e";
```

```
'Reset capture board
OUT WR1, 0
OUT WR0, 0
```

```
'Strip top 18 lines of image (non-picture data)
FOR S = 1 TO (256 * 18)
  OUT WR0, 2
  OUT WR0, 0
NEXT S
```

```
'Begin reading data from board and displaying image with nested loops
FOR VerticalY = -1 TO 198
FOR HorizontalX = 0 TO 255
```

```
'Decrement board RAM-address counters
OUT WR0, 2
OUT WR0, 0
```

```
'Read image data BYTE and assign to variable "PixelValue"
PixelValue = (INP(RD0))
```

```
'Offset image to center of screen
IF HorizontalX > 128 THEN x = HorizontalX - 128 ELSE x = HorizontalX
IF HorizontalX < 128 THEN y = VerticalY ELSE y = VerticalY + 1
```

```
IF HorizontalX = 128 AND VerticalY = 198 THEN EXIT FOR
```

```
'Ignore first 4 pixels of line (non-image data)
```

```
IF x < 4 THEN
```

```
  'Write each pixel to screen
```

```
  PSET (x + 30, y), PixelValue + 1
```

```
  'Add 1 to data to match PALETTE assignments
```

```
END IF
```

```
NEXT HorizontalX
```

```
NEXT VerticalY
```

```
'Audible alert that image is finished
```

```
BEEP
```

```
'Test for desire to save image
```

```
IF file = 1 THEN GOTO Complete
```

```
'Wait for pressing of the Escape key if not saving to disk ...
```

```
DO: LOOP UNTIL INKEY$ = CHR$(27)
```

```
Complete:
```

```
RETURN
```

```
'Write image to disk in BASIC-readable BLOAD format
```

```
SAVE:
```

```
file = 1: CLS
```

```
PRINT "Image will be re-displayed then written to disk."
```

```
PRINT: INPUT "Enter filename and extension "; N$
```

```
GOSUB Display
```

```
file = 0
```

```
DEF SEG = &HA000
```

```
B$AVE N$, 0, 65535
```

```
DEF SEG
```

```
SCREEN 0: WIDTH 80, 25
```

```
COLOR 1, 7: CLS
```

```
RETURN
```

```
'End of program
```

and remove it from your computer. Then troubleshoot it to locate and rectify the problem before proceeding.

The Software

A listing for the simplest possible control program to operate the PC Studio-64 is given elsewhere in this article. Written in Microsoft QuickBASIC, it can display a fine black-and-white image on the screen of a video monitor.

This program grabs a frame using the PC Studio-64 capture system and displays the image in VGA/MCGA

screen mode 13. Images can be saved in BLOAD format for re-display or importation into other BASIC programs. The capture system is I/O-mapped so that simple INP/OUT machine-port statements can be used.

Conclusion

While color on a screen is great, do not underestimate the impact of photographic-like black-and-white pictures appearing on the screen of a VGA monitor. Furthermore, the monochrome video imaging project described here is relatively cheap—

for less than \$100, you have added an extraordinary dimension to a computer.

By all means, get a picture file viewing program for .GIF programs. You can contact Compuserve Inc.'s Graphics Department (5000 Arlington Center Blvd., Columbus, OH 43220) for more information on the Graphics Interchange Format. For a nice picture file viewing shareware program, "VPIC," send \$19 to Bob Montgomery, 132 Parsons Rd., Longwood, FL 32779. It is available on a 360K or 1.2M floppy disk; so specify which format you use. **ME**

Digital Bus Handbook. Edited by Joseph G. Giacomo. (McGraw-Hill Publishing Co. Hard cover. 608 pages. \$64.50.)

This thick technical book represents the efforts of 20 specialists on collecting and transferring data to produce high-performance computer systems. It is a one-stop reference that treats the topic of buses as a total concept. It describes the rules for transferring digital data, examines the basic terminology and ideas used in the field and discusses the electrical designs of the most useful buses currently available. Coverage includes the VME-bus, Multibus I and II, NuBus, IBM Micro Channel Architecture (MCA), DEC buses, Futurebus and FASTBUS, among others. The notable (and unfortunate) exception to this list is the EISA bus, which is not mentioned.

Part I, consisting of nine chapters, focuses on specific buses. For each bus discussed, the book defines functional structure, electrical specifications, format and capabilities. It describes how standards control the variety and complexity of buses, analyzes the factors that determine bus performance and identifies methods for selecting a bus for specific needs.

The five chapters that make up Part 2 deal with digital bus issues: printed-circuit interconnection design, transmission line reflections, pulse crosstalk, connector design and transceiver technology

and design. The remaining four chapters that make up Part 3 cover bus user issues: bus standards, bus guidelines and trends in bus caching and the limits of performance for backplane buses.

Throughout, the book is nicely illustrated with drawings, diagrams, photos, tables and graphs. Extensive references for further reading close most chapters.

Using Video in Your Home. By Gordon McComb. (Master Publishing, Inc., 14 Canyon Creek Village, M/S-31, Richardson, TX 75080. Soft cover. 192 pages. \$12.95 + \$1.50 P&H.)

To get the most out of a modern home video system that can interface with a wide variety of different components can tax one's ingenuity. If you are not familiar with setting up a VCR system, this guide can give you insights into the chore. It takes into account a variety of equipment that might be used with a modern video system, including TV receiver, VCR, video disc player, satellite-TV and cable feeds, and video camera and camcorder. Coverage also includes such accessories as video/audio signal processors and pattern generators.

The main thrust of this book is to show one how to get the most out of his video system and to prepare for any future additions to the system. The author succeeds in this endeavor, using a lot of

hand-holding to guide the reader.

Aside from offering advice in selecting components and integrating them into a well-designed video system, this book is fun to read. It begins with two interesting chapters that take a then-and-now look at home video entertainment and then proceeds to an in-depth look at the receiving antenna, cable and satellite signals and uses this to launch itself into more complex material on VCRs and video disc players, video cameras, and video/audio processors and selectors.

One chapter shows the reader how to plan his video system and is followed with another chapter on typical video systems. The closing chapter tells the reader how to troubleshoot his system in the event a problem occurs. It is basically composed of a series of very useful troubleshooting charts for the various elements that can make up a system.

The book closes with three appendices: Sources for Additional Information; VCR Upkeep (which serves as a practical maintenance guide for the most vulnerable device in a typical system); and a Glossary of technical terms. This well-rounded book is unusually well-illustrated and *informative*. It is well worth its modest cost, considering the wear and tear on one's nerves it can eliminate. Its clearly written and easy-to-follow text is well-supported with explicit drawings and photographs.

NEW LITERATURE

Kit & Computer Catalog. Almost 100 electronic kits are listed and described in this full-color 32-page catalog from Tapto Corp. Kit types range from automotive and audio, to telephone and remote control, to counters and thermometers, and more. Additionally, an eight-page black-and-white insert gives a price list and order form and lists products for Apple computers, computer memory modules, PC, AT and 80386 computer kits and peripherals. For a free copy, write to: Tapto Corp., P.O. Box 44247, Dept. ME, Denver, CO 80201.

Stepper-Motor Control. Two new eight-page bulletins from Bodine Electric Co. present application notes on how the

company's Series 3000 Stepper Motor Control (driver) with a Digital Feature Card can be combined with a computer to form a powerful motor-control system. Bulletin ST-PC1 contains detailed information on linking the stepper motor control to an IBM PC, while Bulletin ST-PC2 offers similar information on linking to an Apple IIe. Both bulletins give step-by-step instructions that show how to wire interface connections, make the system operational and exercise the stepper motor and control. Each application note includes instructions for setting up the Digital Feature Card's communication parameters, connecting the I/O ports to the user's machine interface, communication with the stepper motor control, programmable I/O ports, and

rate-change and status registers. For a free copy, write to: Bodine Electric Co., 2500 W. Bradley Pl., Chicago, IL 60618.

Calibrator & Reference Catalog. Electronic Development Corp.'s 1988/1989 catalog lists a complete line of current, voltage and resistance instruments for alternating and direct current. Listed and fully described are manually operated and remotely programmable devices, the latter microprocessor controlled via IEEE-488 or GPIB interfaces. Other instruments include a watt-hour calibration system and resistance calibrator that can be manually operated or be programmed. Outputs of the various cali-

(Continued on page 77)

SELECT 5 BOOKS

for only \$4⁹⁵

(values to \$129.70)
and get a **FREE Gift!**

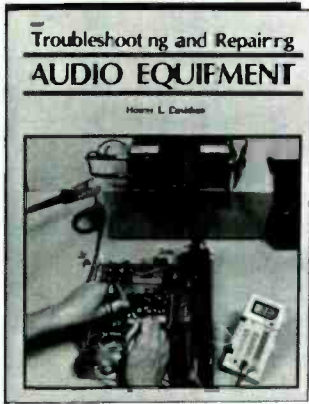
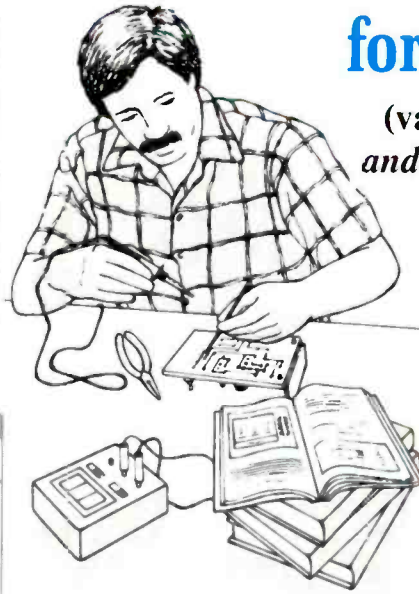

2867F \$18.95



2809 \$29.95
Counts as 2



2613P \$17.95

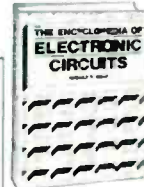

1938 \$66.00
Counts as 2



3370 \$25.95
Counts as 2



3157P \$16.95



1536P \$11.95



1367P \$24.95



3044P \$11.95

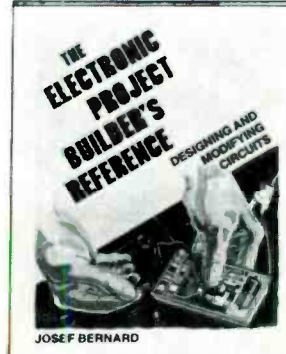

3260 \$22.95

For over 25 years, your most complete source for electronics books.

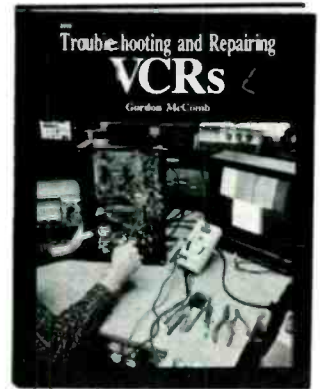

2960 \$27.95
Counts as 2



9290 \$36.00
Counts as 2



1897P \$14.95



2980P \$19.95



3374 \$24.95

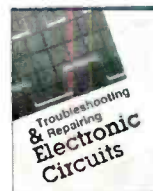

3258 \$27.95
Counts as 2



3145 \$19.95



804P \$21.95
Counts as 2



2890P \$15.95



2880P \$17.95



3275 \$22.95



2800P \$16.95

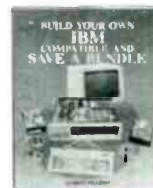

2831P \$15.95



1625P \$22.95



2925P \$9.95

FREE when you join the ELECTRONICS BOOK CLUBSM!

15 Practical Electronics Projects from Delton T. Horn

Projects you can build—some unique, some old favorites—from the author's vast treasury of electronics know-how.

A \$7.95 Value!



2707 \$26.95
Counts as 2



3241P \$16.95



2826P \$16.95

Membership Benefits • Big Savings. In addition to this introductory offer, you keep saving substantially with members' prices of up to 50% off the publishers' prices. • **Bonus Books.** Starting immediately, you will be eligible for our Bonus Book Plan, with savings of up to 80% off publishers' prices. • **Club News Bulletins.** 15 times per year you will receive the Book Club News, describing all the current selections—mains, alternates, extras—plus bonus offers and special sales, with scores of titles to choose from. • **Automatic Order.** If you want the Main Selection, do nothing and it will be sent to you automatically. If you prefer another selection, or no book at all, simply indicate your choice on the reply form provided. You will have at least 10 days to decide. As a member, you agree to purchase at least 3 books within the next 12 months and may resign at any time thereafter. • **Ironclad No-Risk Guarantee.** If not satisfied with your books, return them within 10 days without obligation! • **Exceptional Quality.** All books are quality publishers' editions especially selected by our Editorial Board.

MDNE1090



3312 \$23.95



3205 \$24.95



2707 \$26.95
Counts as 2



3219 \$27.95
Counts as 2



1532P \$14.95

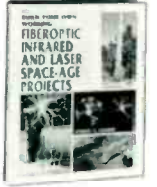

2724P \$16.95

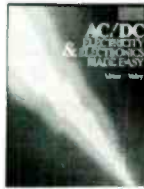

3285 \$25.95
Counts as 2



3155 \$19.95

All books are hardcover unless number is followed by a "P" for paperback. (Publishers' Prices Shown) A shipping/handling charge and sales tax will be added to all orders.

©1990 ELECTRONICS BOOK CLUB, Blue Ridge Summit, PA 17294-0810

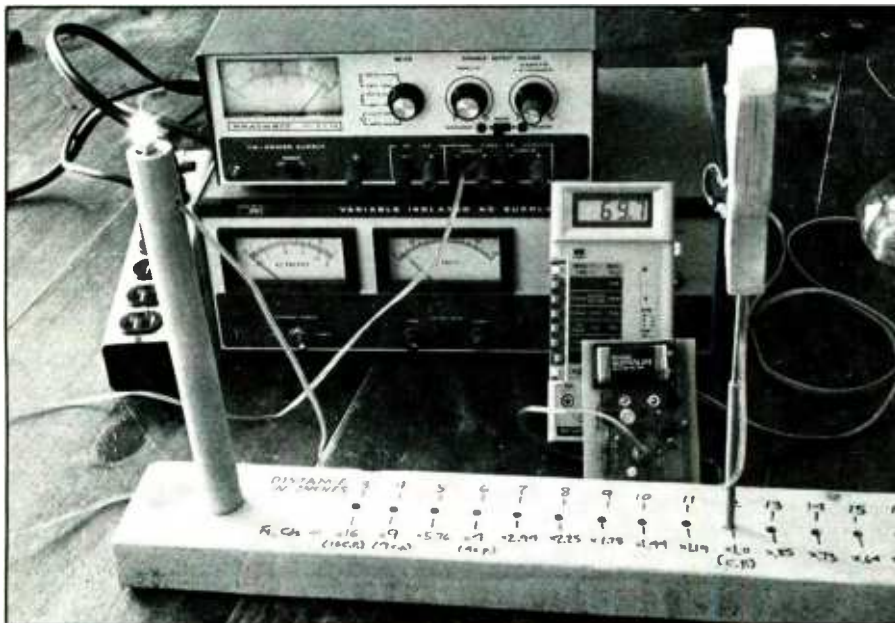

Fig. 7. Typical calibration setup for project can be fabricated from commonly available pine lumber and wood dowels.

millivolt when all light is excluded (sensor is covered). Moving the sensor so that it is exactly 6 inches from the lamp should cause the meter to display a reading of 14.4 millivolts. If the reading is off by more than 0.1 millivolt, redo calibration.

It is easy to calibrate this project to register lux (meter-candles) instead of fc. To convert from foot-candles to lux simply multiply the fc by 10.764. Each millivolt displayed by the meter will now stand for 10 lux, and 1 lux will be 1/10 millivolt. Perform calibration as above, but first multiply by 10.764 to convert all fc readings to lux before adjusting the controls.

Finally, adjust the controls to have the meter display the correct lux value. For instance, for the initial calibration at 2 feet from the 100-watt lamp, adjust the controls to display 53.8 millivolts ($50 \times 10.764 = 538$ lux) on the meter.

Some things you can do to increase accuracy of the project include use of a suitable filter, keeping the sensors covered when not in use and the use of a high-quality calibration standard. On a more basic level, you can consider using 1-percent metal-film resistors in the circuitry and take measurements only when the temperature is between 60° and 80° F. At temperature extremes, photovoltaic cell output increases with a decrease in temperature.

When using this project, exercise care as you expose the sensor to extremely intense light, such as direct bright sunlight. Remember to turn off the project before you remove it from the meter and before turning off the meter. This saves battery power because it reduces the possibility of the module being left powered for an extended period of time.

Assuming you do not use a special wavelength selective filter, the selenium cell version of the project has the potential of being the more accurate because its spectrum response closely matches that of the human eye. **ME**

LEARN VCR
CLEANING/MAINTENANCE/REPAIR
 EARN UP TO \$1000 A WEEK, WORKING PART TIME FROM YOUR OWN HOME!

Secrets Revealed!
 NO Special Tools or Equipment Needed.

EARN UP TO \$60 AN HOUR AND MORE!

THE MONEY MAKING OPPORTUNITY OF THE 1990'S

IF you are able to work with common small hand tools, and are familiar with basic electronics (i.e. able to use voltmeter, understand DC electronics) ...

IF you possess average mechanical ability, and have a VCR on which to practice and learn ... then we can teach YOU VCR maintenance and repair!

FACT: up to 90% of ALL VCR malfunctions are due to simple MECHANICAL or ELECTRO-MECHANICAL breakdowns!

FACT: over 77 million VCRs in use today nationwide! Average VCR needs service or repair every 12 to 18 months!

Viejo's 400 PAGE TRAINING MANUAL (over 500 photos and illustrations) and AWARD-WINNING VIDEO TRAINING TAPE reveals the SECRETS of VCR maintenance and repair—"real-world" information that is NOT available elsewhere!

Also includes all the info you'll need regarding the BUSINESS-SIDE of running a successful service operation!

FREE INFORMATION
 CALL TOLL-FREE 1-800-537-0589
 Or write to:
 Viejo Publications
 5329 Fountain Ave., Dept. ME
 Los Angeles, CA 90029

er and that they are as short as possible. On average, 5 volts applied to a PR13 lamp should produce 3.6 cp when measured in a horizontal plane with the filament.

For simplicity, assume you are working with a PR13 lamp that has a measured output of 3.6 cp at 5 volts. (Tests have shown that the average output of the Chicago Miniature PR13 lamps operated at 5 volts dc is close to 3.6 cp. Two 24-inch-long No. 18 copper wires were used to make the connections between the power source and lamp during these tests.) Perform the calibration procedure during the hours of darkness.

To increase accuracy, keep both sensors covered until you use them. Place the lamp in a stable location, either in a large dark room or in front of an open window that has no outside light coming in. Place the sensor 12 inches from the filament of the lamp and position it in the same horizontal plane.

Adjust the GAIN and ZERO controls for a reading of exactly 3.6 millivolts on the meter display when light is striking the sensor and 0.0

CIRCLE NO. 19 ON FREE INFORMATION CARD

IR Remote (from page 39)

transmitter. If everything is okay, the lamp should turn on. If the lamp fails to turn on, move closer to the receiver unit and try again with the transmitter. If you still fail to obtain a response, power down and correct any wiring or component-installation problem you may have made in either the receiver unit, the transmitter unit, or both.

In use, the transmitter unit should not cause any IR-powered remote-controlled device to operate when it should not. However, if you use this transmitter with another transmitter from a commercial product, you may discover that the two interfere with each other. The solution to this, of course, is to use only one transmitter at a time.

When you use another IR remote-control transmitter in the vicinity of this IR receiver unit, the latter will often toggle to its alternate state. This is because this project does not use decoding of the received signal. At first, this might appear to be a disadvantage. However, this shortcoming can be used to advantage. Since the IR signal is very directional, you can simply arrange the receiver so that it intercepts the signal from your commercial remote-control transmitter only when it is pointing in the proper direction. This way, you can use the remote controller you have to control two or more appliances.

If you wish to obtain greater range from your system, you can do either or both of two things. Firstly, you can collimate the incoming IR-energy beam with a magnifying lens cemented over the 1/2-inch-diameter hole in the housing of the receiver. Secondly, distance can often be increased by making the receiver more discriminating to a particular kind of IR energy. This can easily be accomplished by cementing a transparent red plastic or glass filter between the source of the IR energy and the pick-up on the IR receiver module. Experiment with both approaches to optimize your system. **ME**

LETTERS...

(from page 7)

now, I think the FCC is moving in the right direction with no-code licensing. This should attract the youth into the hobby and, therefore, keep it alive. However, since it is (and always has been) a technical hobby, let's not convert ham radio into glorified CB! Let's make the technical tests more difficult, commensurate with the level of decreased code testing. Let's carry this one step further and allow all license holders to move up the ranks not based on code proficiency but on technical merit alone! If some die-hard old timers want to use code, let them have certain portions of the bands for code-only operations and let the others share in the other frequencies, advancing in grade as they advance technically.

Frank Muratore
Copaigue, NY

LITERATURE

(from page 72)

brators and references range from 10 nV dc to 1,500 volts dc; 1 mV ac to 1,200 V ac; 1 A ac to 100 A ac; and 1 ohm to 10 megohms. Dc accuracies start at 0.002%, ac at 0.05%. For a copy, write to: Mr. Robert B. Ross, Electronic Development Corp., 11 Hamlin St., Boston, MA 02127.

DTP Catalog. ImageSoft Inc. has a colorful DeskTop Publishing Catalog that contains comprehensive listings and samplings for hundreds of desktop publishing and laser printer programs for DTP and PostScript-related applications for the IBM PC family, Mac series and selected workstations. Products listed include: CAD/CAM, clip art, communication, font editor/utility, font library, form generation, graphics/illustration, image processing/OCR, printer utility, memory/accelerator, PostScript/utility, presentation, text processing, windowing system, word processing, etc., software, as well as books and font cartridges. Attention is paid to providing a complete set of tools for LaserJet and PostScript and compatible laser printers. For a copy, write to: Joshua Caldwell Allen, ImageSoft Inc., 2 Haven Ave., Port Washington, NY 11050.

CONSOLIDATED ELECTRONICS



VOLUME I - TEST EQUIPMENT

CONSUMER & INDUSTRIAL ELECTRONICS 18TH EDITION
95 30

"Volume I-Test Equipment"

112 pages packed with specifications on the most popular test equipment like B&K, Beckman, ARI, Simpson, Mercer, Soar, Goldstar and Vector/Viz. Choose from hundreds of multimeters, oscilloscopes, frequency counters, function generators, power supplies & more. Send \$5.00 check or money order, or call 1-800-543-3568 today & use your Mastercard or Visa. Consolidated Electronics, Incorporated
705 Watervliet Avenue., Dayton, Ohio 45420-2599

NAME _____

ADDRESS _____

CITY _____

STATE _____

ZIP _____

CIRCLE NO. 6 ON FREE INFORMATION CARD

ATTENTION! ELECTRONICS TECHNICIANS

EARN YOUR B.S.E.E. DEGREE

THROUGH HOME STUDY

Our New and Highly Effective Advanced-Placement Program for experienced Electronic Technicians grants credit for previous Schooling and Professional Experience, and can greatly reduce the time required to complete Program and reach graduation. No residence schooling required for qualified Electronic Technicians. Through this Special Program you can pull all of the loose ends of your electronics background together and earn your B.S.E.E. Degree. Upgrade your status and pay to the Engineering Level. Advance Rapidly! Many finish in 12 months or less. Students and graduates in all 50 States and throughout the World. Established Over 40 Years! Write for free Descriptive Literature.

COOK'S INSTITUTE OF ELECTRONICS ENGINEERING



4251 CYPRESS DRIVE
JACKSON, MISSISSIPPI 39212

CIRCLE NO. 8 ON FREE INFORMATION CARD

CABLE TV DESCRAMBLERS! BARGAIN HEADQUARTERS!



- JERROLD™ •TOCOM •HAMLIN
- OAK •ZENITH
- SCIENTIFIC ATLANTA

6 month warranty! We ship C.O.D.!
Lowest retail/wholesale prices!

FREE CATALOG:
Global Cable Network
1032 Irving St. Suite 109
S.F., CA 94122
NO CALIFORNIA SALES!!!

ORDER TODAY! 800-327-8544

CIRCLE NO. 21 ON FREE INFORMATION CARD

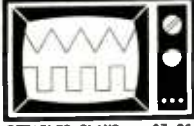

FINALLY!

An interesting and worthwhile project. This EASY-TO-BUILD circuit lets you use any regular TV set as a simple OSCILLOSCOPE. No modifications to TV! Tiny, 9v battery powered. Goes anywhere! Order now! Ask for our FREE CATALOG of other plans and kits!

DETAILED PLANS: \$7.95

TV-SCOPE

PENN RESEARCH, Box 3543
WilliamSPORT, PA 17701

CABLE T.V. CONVERTERS

Jerrold®, Oak, Scientific Atlantic, Zenith, & many others. *New* MTS stereo add-on: mute & volume. Ideal for 400 & 450 owners!

1-800-826-7623

B & B INC.

4030 Beau-D-Rue Drive, Eagan, MN 55122

Order Back Issues of



Surface Mount Chip Component Prototyping Kits—

Only
\$49.95



CC-1 Capacitor Kit contains 365 pieces, 5 ea. of every 10% value from 1pf to .33µf. CR-1 Resistor Kit contains 1540 pieces; 10 ea. of every 5% value from 10Ω to 10 megΩ. Sizes are 0805 and 1206. Each kit is ONLY \$49.95 and available for Immediate One Day Delivery!

Order by toll-free phone, FAX, or mail. We accept VISA, MC, AMEX, COD, or Pre-paid orders. Company P.O.'s accepted with approved credit. Call for free detailed brochure

COMMUNICATIONS SPECIALISTS, INC.
426 West Taft Ave. • Orange, CA 92665-4296
Local (714) 998-3021 • FAX (714) 974-3420

Entire USA 1-800-854-0547

CIRCLE NO. 5 ON FREE INFORMATION CARD

MODERN ELECTRONICS MART

Classified Commercial Rates: \$1 per word, 15-word minimum (\$15.00) prepaid. (Word count includes name and address; ZIP code and abbreviation each count as one word; P.O. Box number and telephone number count as two words each.) Indicate free category heading (Computers, Communications, Electronics, Video or Miscellaneous). A special heading is available for a \$6 surcharge. First word only is set boldface caps at no charge. Add 20% for additional boldface words.

Non-Commercial Rates: FREE to subscribers, as space permits; maximum 15 words. A recent MODERN ELECTRONICS mailing label must accompany ad.

(All advertisers with P.O. Box addresses must supply permanent address and telephone number. Copy is subject to publisher approval.)

Mailing Information: Copy must be received by the publisher by the 25th of the third month preceding the cover date. Send Advertising material with check or money order or credit card information (Visa or MasterCard only) with number and expiration date to: MODERN ELECTRONICS, Classified Department, 76 N. Broadway, Hicksville, NY 11801.

VIDEO

PROJECTION TV . . . Convert your TV to project 7 foot picture . . . Easy! . . . Results comparable to \$2,500 projectors . . . **PLANS AND 8" LENS \$27.95 . . .** Professional Systems available . . . Illustrated Catalog FREE . . . **MACROCOMA**, 15MB Main Street, Washington Crossing, Pennsylvania 18977. Creditcard Orders 24 HRS. (215) 736-3979.

T.V. NOTCH FILTERS, SURVEILLANCE EQUIPMENT, BROCHURE \$1.00. D. K. VIDEO, BOX 63/6025, MARGATE, FL 33063 1-(305) 752-9202.

ELECTRONICS

SURVEILLANCE Countersurveillance Equipment Catalog \$5.00. Eavesdropping Detection Equipment, P.O. Box 1087, Williamsville, NY 14231.

TUBES, New, up to 90% off, S.A.S.E., Kerby, 298 West Carmel Drive, Carmel, IN 46032.

KINETIKITS from KINETICO: electronic kits outputting light or sound. Free catalog: KINETICO, P.O. Box 1634, NY, NY 10114-0508.

MINIATURE FM TRANSMITTERS! Tracking Transmitters! Voice Disguisers! Bug Detectors! Phone Devices! More! Available in kits or assembled and tested! Catalog \$2.00: XANDI ELECTRONICS, Box 25647, "B4", Tempe, AZ 85285-5647.

SURVEILLANCE - COUNTERSURVEILLANCE. Guaranteed lowest prices! Unbelievable, Detectors, Jammers, Transmitters, Phone Security, Cameras, Personal Protection, Books, More! Huge catalog \$5.00 (Refundable) PROTECTOR P.O. Box 520294-B, Salt Lake City, UT 84152.

WANTED-OLD (Antique) Radios and TV's Pre 1950. Any Condition. Repair Same. Old Tubes For Sale. Thrifty TV, 11 E. Marie St., Hicksville, NY 11801 516-822-4501.

RECEIVE all cordless telephones on your scanner. Send \$2 for frequencies to: Adler Electronics, 5253 Eagledale Avenue, Unit 3A, Los Angeles, CA 90041.

SURVEILLANCE / COUNTERSURVEILLANCE devices catalog. Cameras, bug detectors, video camera detectors, transmitters, communications, and much more. Catalog \$3.00. DSP, P.O. Box 1275-ME, Redondo Beach, CA 90278.

STRANGE STUFF Get the advantage! Laser listener, surveillance, descrambling, underground information. Plans, kits, complete items. Informational package \$3.00 refundable. DIRIJO/BOND, Box 212, Lowell, NC 28098.

REMOVE LEAD VOCALS from standard stereo records, CD's, tapes, FM broadcasts, so YOU can be the lead singer of your favorite band. Detailed plans \$6.95. PC Board and Parts also available. WEEDER TECHNOLOGIES, Dept. E, 14773, Lindsey, Mt. Orab, Ohio 45154.

LASERS. 1mw to 2kw, worlds largest selection of new and used surplus. FREE CATALOG. MWK Industries, 1269 Pomona Rd., Corona, CA 714-278-0563.

MINIATURE Electronics like James Bond. Catalog \$4.00, refundable. F & P Enterprises, Box 51272, Palo Alto, CA 94303-H.

UNIQUE projects. Build an Infrared Motion Detector, Ultrasonic Distance Meter, Digital Rain Gauge. Complete plans, PCB layout. \$4.00 each. Others available. K. Kemp, 13772 Goldenwest St., #549, Westminster, CA 92683.

POWERFUL single-chip FM room transmitter, size of a postage stamp, transmits to any FM radio up to one mile away. Complete kit \$19.95 postpaid. Hertz Microdevices, Department RT, Box 41771, Los Angeles, CA 90041.

UNIQUE car alarm that thieves don't know about. For instructions send \$2.00 to Innovative Think Tank, P.O. Box 750543, Houston, TX 77275-ME10.

70 WATT Audio Amplifier. Simple and easy to build. Plans \$4.00. T.J.L. Enterprises, 1902 Ridge Rd. Suite 302ME, West Seneca, NY 14224.

SURVEILLANCE—Audio/Video Equipment—Debugging. Industrial or Private. 500 Item Catalog \$7.00. Security Systems, 3017D Hudson, New Orleans, LA 70131.

COMMUNICATIONS

MORSE Code? No Problem. You can increase your speed, no matter how many times you've failed before. **Results guaranteed** when you follow the instructions. **PASS Publishing's CW Mental-Block Buster** program helps you **explode mental blocks** that hold you back. Based on 40 years of research, the **CW Mental-Block Buster** uses guided meditation, dynamic visualizations, and powerful affirmations to blast through mental blocks. **You can do code!** That means new bands, more contacts, more fun! (This is not a CW practice tape.) The **CW Mental-Block Buster** audio cassette and practice booklet are only \$24.95 ppd. in the US (NY residents add \$1.87 sales tax). (Quantity discounts available for classes.) **PASS Publishing, P.O. Box 570, Stony Brook, NY 11780.**

HUGE COMMUNICATIONS CATALOG. 88 pages including amateur, shortwave and scanner equipment. Universal Radio, 1280 Aida Drive #ME, Reynoldsburg, OH 43068.

COMPUTERS

EQUIPMENT assortment. Electronic, computer, test, descrambler. Catalog \$3.00. Refundable. B & R Enterprise, P.O. Box 662, Portage, MI 49081.

WRITE YOUR OWN PROGRAMS . . . with EngLan, the easy-to-learn computer language for IBM compatible computers. Version 2 is \$49.00, Version 1 is \$19.00. Gentry Software, Box 4485, Springfield, MO 65808, 800-346-9475 (V/Mc).

SYMMETRY software and models. Escher Sketcher symmetry drawing program for PC with source in Turbo Pascal. Booklet and 32 paper (cut and paste) models on point symmetry (crystals, molecules, Platonic solids). Each \$11.90 + \$1.50 S&H. Zenofugue, Inc., 3872 Raleigh Dr., Okemos, MI 48864.

PROTOQUICK Z8, single board computer with prototype area, \$69.00. Software Science, 3750 Roundbottom Road, Cincinnati, OH 45244 (513) 561-2060.

FREE IBM SOFTWARE CATALOG 2000 + Disks Toll Free 1-800-345-2983 24 Hours! In Colorado Please Call: (303) 934-5507 **MEGA-BYTE INC. PC SOFTWARE SUPPLY**, 3601 Morrison Road., Denver, CO 80219 FAX: (303) 936-7049.

ENGINEERING Software, PC/MSDOS. Hobbyists-Students-Engineers. Circuit Design \$49, PCB Layout \$99, Logic Simulation \$29, Mathematics \$39, Circuit Analysis \$29. Call or Write For Free Catalog. (614) 491-0832, **BSOFT SOFTWARE**, 444 Colton Road, Columbus, OH 43207.

ELECTRONIC SURVEILLANCE

ELECTRONIC SURVEILLANCE. 40+ complete construction plans from America's #1 designer of electronic spy equipment. **FREE CATALOG.** Wilson-E, P.O. Box 5264, Augusta, GA 30906.

ZENITH DESCRABLERS

ZENITH cable boxes will work where others failed. All units are warranted with remote control \$175.00. Call (213) 478-2506.



PICKS UP A WHISPER 50 FEET AWAY!

The model **WAT-50** miniature FM transmitter uses a 4-stage circuit **NOT** to be confused with a simple wireless microphone. Simply snap the unit on top of a 9V battery and you can hear every sound in an entire house up to 1 mile away! Use with any FM radio. Tunes to any frequency from 70mhz - 130mhz. Easy to assemble kit includes all parts and instructions. Only 29.98 tax incl.



The **WIRELESS TELEPHONE TRANSMITTER** model **WTT-20** is only about the size of a dime, yet transmits both sides of a telephone conversation to any FM radio with crystal clarity. Completely automatic. Uses power from the telephone line itself - never needs a battery! Up to 1/4 mile range. Tunes from 70mhz - 130mhz. Easy to assemble kit includes all parts and instructions. Only \$29.98 tax incl.

Call or send **MO, VISA, MC** for immediate delivery. **Single kit orders include \$1.50 S&H. FREE SHIPPING** on orders of 2 or more. All orders shipped by U.S. Mail. **COD add \$4.00.** Personal checks allow 21 days.

DECO INDUSTRIES
BOX 607, BEDFORD HILLS, NY 10507
914-232-3878

CIRCLE NO. 9 ON FREE INFORMATION CARD

Cable Converters And Descramblers

Why Pay a High Monthly Fee?
For **FREE** Catalog Call or Write

CABLE CONNECTION

1304 E. CHICAGO ST. SUITE 301
ALGONQUIN, IL 60102
(708) 658-2365
No Illinois Orders

MODERN ELECTRONICS

76 N. Broadway, Hicksville, NY 11801

FREE INFORMATION SERVICE

For further information on products, dealers, or literature in this issue, circle the appropriate numbers below. Be sure to include your name and address before mailing.

1	2	3	4	5	6	7	8	9	10	11	12
13	14	15	16	17	18	19	20	21	22	23	24
25	26	27	28	29	30	31	32	33	34	34	36
37	38	39	40	41	42	43	44	45	46	47	48
49	50	51	52	53	54	55	56	57	58	59	60
61	62	63	64	65	66	67	68	69	70	71	72
73	74	75	76	77	78	79	80	81	82	83	84
85	86	87	88	89	90	91	92	93	94	95	96
97	98	99	100	101	102	103	104	105	106	107	108
109	110	111	112	113	114	115	116	117	118	119	120
121	122	123	124	125	126	127	128	129	130	131	132
133	134	135	136	137	138	139	140	141	142	143	144
145	146	147	148	149	150	151	152	153	154	155	156
157	158	159	160	161	162	163	164	165	166	167	168
169	170	171	172	173	174	175	176	177	178	179	180

Insert Issue date here _____

(month) (year)

(must be completed to process)

Name _____

Company Name _____

Address _____

City _____ State _____ Zip _____

Phone _____

Say You Saw It In Modern Electronics

QUALITY PARTS • DISCOUNT PRICES • FAST SHIPPING

ALL ELECTRONICS CORP.

P.O. Box 567 • Van Nuys, CA • 91408

12 VDC GEAR MOTOR

Soho# GBL 35-DH-21080-10Y

Powerful little gearhead motor.

40 RPM @

12 Vdc. (no load).

32 RPM with load. Operates at lower voltages with reduced speed and torque.

6.3 pound inches torque. Stall: 27 pound inches. 3.1" long X 1.375" diameter.

Shaft: 0.187" dia. CAT# MOTG-14

\$11.50 each - 10 for \$100.00

OPTO-ISOLATORS

Clairnex# CLM-6000

LED-photoconductor

isolator. Off resistance: 500 ohms. On resistance: 500K ohms. 2000 volt isolation.

Forward voltage: 2 Vdc. CAT# CLM-6000

\$2.50 each - 10 for \$22.00

Sigma# 301T-12B1. Signal applied to the input is coupled by means of light to isolated photo conductive cell. High reliability switching. 12 Vdc.

CAT# OP-301 \$1.50

OPTO SENSOR

U shaped package with mounting ears. 1/8" opening.

3/4" mounting ears. CAT# OSU-6

50c each - 10 for \$4.50 - 100 for \$40.00

INSTRUMENT ENCLOSURES

Molded ABS instrument enclosures. Matching front and rear panels.

Integrated PC board standoffs and two sets of vertical mounting slots for front and rear sub panel PC boards. All enclosures are 6" wide X 6 1/4" deep. Available in black, ivory, blue, and beige. Specify color.

FRONT & REAR PANEL HEIGHT

2 1/4" CAT# MB-A \$7.50 each 10 for \$65.00

2 5/8" CAT# MB-B \$7.75 each 10 for \$67.50

3" CAT# MB-C \$8.00 each 10 for \$70.00

PHOTOFASH CAP.

Rubicon CE 210 MFD 330 V

0.79" dia. X 1.1" high. New, prepped with 1.4" black and red wire leads soldered to the terminals.

CAT# PPC-210 \$2.50 each

10 for \$22.50 - 100 for \$200.00

STEPPING MOTOR

Airpax# C82711-M1

17 Vdc 23.25 ohm dual coil P.M. motor.

7.5 degrees per step. 2.25" dia. X .91" thick.

0.25" dia. shaft .6 wire leads.

CAT# SMT-6 \$6.00 each - 10 for \$50.00

ORDER TOLL FREE 1-800-826-5432

FAX (818) 781-2653 Terms: Phone orders must be charged to Visa, MasterCard, or Discover. Minimum order \$10.00 - CA residents add sales tax - 48 Continental States Add \$3.50 for shipping/handling - All Others Including AK and HI pay full shipping - Quantities limited - No C.O.D.

CALL TOLL FREE FOR A FREE 60 PAGE CATALOG!

CIRCLE NO. 2 ON FREE INFORMATION CARD

AC/DC VOLTAGE
AC/DC CURRENT
DIODE TEST
LOGIC TEST
LED TEST GOOD/BAD
5 FREQ RANGES
5 CAPACITANCE RANGES
LOW BATTERY Warning
CONTINUITY TEST/BUZZER
TRANSISTOR CHECKER
20 MHZ FREQ COUNTER

Stock No. 990092

\$69.95

30 DAY
MONEY BACK
GUARANTEE!

KELVIN Electronics
7 Fairchild Ave., Plainville, NY 11803
(516) 349-7620 1(800) 645-9212
FAX (516) 349-7830



*****PRESENTING*****
**CABLE TV
DESCRAMBLERS**
*****STARRING*****
JERROLD, HAMLIN, OAK
AND OTHER FAMOUS MANUFACTURERS

- FINEST WARRANTY PROGRAM AVAILABLE
- LOWEST RETAIL/WHOLESALE PRICES IN U.S.
- ORDERS SHIPPED FROM STOCK WITHIN 24 HOURS

FOR FREE CATALOG ONLY 1-800-345-8927
FOR ALL INFORMATION 1-818-709-9937

PACIFIC CABLE CO. INC.
7325 1/2 RESEDA BLVD., DEPT. 1203
RESEDA, CA 91335



SATELLITE TV
SYSTEMS-UPGRADES-PARTS
PLUS BOOKS & TAPES
INSTALLATION VIDEO \$33.95 ADD \$2.5/H
(VIDEO FREE WITH SYSTEMS)
CALL/WRITE TODAY
800-334-6455 US
218-739-5231 MN
SKYVISION INC.®
2014 COLLEGE WAY
FERGUS FALLS, MN 56537

FREE CATALOG
SAVE 40%-50%

YOU CAN
INSTALL - UPDATE - REPAIR - YOURSELF



FREE! IBM SOFTWARE CATALOG FREE!
2000 + DISKS
TOLL FREE 1-800-345-2983 24 HOURS!
IN COLORADO PLEASE CALL: (303) 934-5507

MEGA-BYTE INC.
PC SOFTWARE SUPPLY
3601 MORRISON ROAD
DENVER, CO 80219
FREE! FAX: (303) 936-7049 FREE!

SURVEILLANCE TELEPHONE

This is a normal functioning telephone!
EXCEPT it has a secret built in monitor
Only YOU can call and monitor all conversations, using a
secret code, and never be detected! Range Unlimited

\$175.00 - 6 month Warranty - Phone Tap Catalog \$3.00
LISTEN ELECTRONICS, 883 Elgin, Muskegon, MI 49441
1-800-633-TAPS



CABLE-MATE, INC.
Are You Tired of Paying
Outrageous Fees?

All makes and models of cable
equipment shipped within 24 hrs.
Quantity discounts. For free
catalog send S.A.S.E. to:
Cable-Mate, Inc., 450 Shag Bark
Algonquin, IL 60102
C.O.D. orders accepted
CALL FOR PRICES TODAY!!
800-422-0525
(708) 658-2121
*No Illinois orders
Hours—8:00 am-5:00 pm central time



CABLE TV EQUIPMENT

CABLE. TV converters and descramblers discount center. Jerrold, Tocom, Hamlin, Scientific Atlantic, Oak, Zenith. Order yours today 800-962-6836.

CABLE EQUIPMENT

CABLE TV SECRETS—the outlaw publication the cable companies tried to ban. HBO, Movie Channel, Showtime, Descramblers, Converters, etc. Suppliers list included. \$9.95. Cable Facts, Box 711-ME, Pataskala, Ohio 43062.

CABLE

CABLE Booster - 10 dB gain, 50-45 MHz, \$11.50 ea. (Includes SH!) Send check to: Grace Dist., 661 Grant St., Hazelton, PA 18201 (717) 454-5172.

HELP WANTED

ATTENTION: EASY WORK EXCELLENT PAY! Assemble products at home. Details. (1) 602-838-8885 Ext. W-11147.

ATTENTION: GOVERNMENT JOBS—YOUR AREA! \$17,840 - \$69,485. Call (1) 602-838-8885, Ext. R-11147.

MOBILE Electronics Specialist: Design, install, adjust, test and repair audio systems, radio transmitting and receiving equipment, mobile telephones, and security systems in cars, planes, and boats. Use handtools and testing equipment. Design and follow wiring diagrams. Adjust controls and test frequencies. Test equipment with instruments such as audiometers and voltmeters. Repair and install components of audio, radio transmitting and receiving equipment and intercommunication telephone system. Must have two years experience. \$15.00 per hour, \$22.50 per hour overtime, 40 hours per week, 9:00 a.m. to 5:00 p.m. Send resume only to: Job Service of Florida, 105 East Broward Blvd., Fort Lauderdale, FL 33301-3502. ATTN: Job Order #FL 0313338.

FOR SALE

LOTTERY—IBM COMPUTER DISK FOR ALL LOTTERIES \$10.00. ROBERTS, Box 63/6025, MARGATE, FL 33063.

FOR SALE

DESCRAMBLERS. All brands. Special: Combo Jerrold 400 and SB3 \$165. Complete cable descrambler kit \$39. Complete satellite descrambler kit \$45. Free Catalog. MJO INDUSTRY, Box 531, Bronx, NY 10461-0208.

CABLE

TOCOM VIP TEST CHIP. For Models 5503 VIP and 5507. Unlike any other turn-on, this one works! Easily installs in just seconds. \$50.00 each. No Calif. sales. Call (213) 867-0081.

CABLE DESCRAMBLERS - Jerrold 400, 450, Tri-Bi SB-3. Scientific Atlanta, Oak, Tocom. Lowest Prices. Example: Jerrold from \$25.00. No Calif. Sales. Call us last and see! (213) 867-0081.

ZENITH Z-Tac. Special "test" board installs easily in minutes, and turns-on decoder for all modes. Great for "flashing" problems. Only \$50. No Calif. Sales. Call (213) 867-0081.

CABLE TV EQUIPMENT

CONVERTERS All major brands. Information orders 1-800-782-0552. Freeway, Inc. SMP, P.O. Box 5036, Burnsville, MN 55337.

MISCELLANEOUS

ENGINEERS, programmers, technicians. Silicon Valley, CA needs YOU! For free sample of current listing write Excel Services, P.O. Box 36046, San Jose, CA 95158.

ATTRACTIVE ORIENTAL LADIES seeking correspondence, marriage. Professional introductions since 1984. Asian Experience, Box 1214TZ, Novato, CA 94948. (415) 897-2742.

CHEAP ham equipment. SASE gets list. Jim Braddy WA4DSO/4, 3037 Audrey Drive, Gastonia, NC 28054.

PENPALS, inexpensive personalized service. U.S., world. Satisfaction guaranteed. FPS, Box 83, Tujunga, CA 91043.

ASIAN LADIES want correspondence for friendship, marriage. SUNSHINE INTERNATIONAL-Dept. TW, Box 5500, Kailua-Kona, Hawaii 96745. (808) 325-7707.

USE YOUR FREE INFORMATION CARD



Free Product Information

Readers can obtain free information on products advertised, as well as for some editorially mentioned products. Simply circle the appropriate number printed below an advertisement onto the **ME** "Free Information Service" card bound into this issue. After filling in your name and address, just mail the postpaid card. Your request will be forwarded directly to the advertiser with a mailing label prepared by our reader-service department.

NEW PRODUCTS ●●● (from page 16)

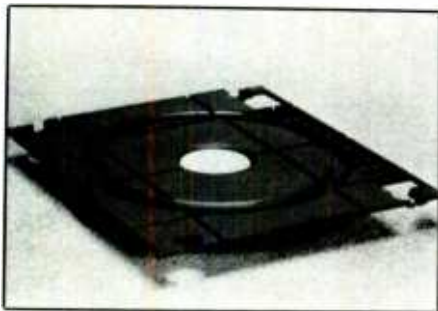

Permanent installation of the Stealth Security Pad to the work surface is accomplished without tools via an adhesive strip. A similar strip secures the top of the Pad to the bottom of the system unit. Within 72 hours, Pad bonding is permanent. Thereafter, special instructions and a special tool must be used to disassemble the Pad.

CIRCLE NO. 32 ON FREE INFORMATION CARD

Camcorder Battery Charger

The Arkor Model TC-200 Turbo Camcharger™ from Arkon Resources (Arcadia, CA) is claimed to be the first camcorder battery charger that has special circuitry that eliminates memory build-up of Ni-Cd rechargeable batteries. Reconditioning circuitry that controls the charge/discharge process eliminates the battery memory effect while preventing cell

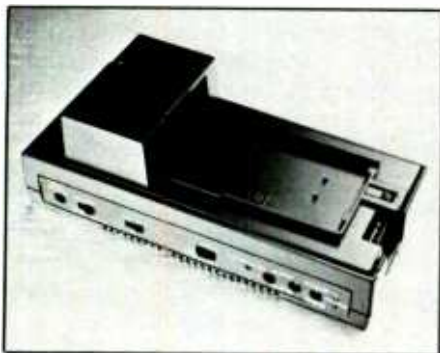

reversal. A full deep-cycle charge is said to be achieved every time. The unit can restore full charge capacity to Ni-Cd batteries that have already fallen victim to memory build-up.

Features include: a "quick-charge" mode for fast recharging; ac/dc capability for use at home and on the road; and regulated voltage output to provide direct power to cam-

orders and other types of portable equipment.

Two versions are available. The Model TC200-6 is for use with Sony-type batteries, including the No. NP-22/55/77, and 6-volt Canon No. E77K type. The Model TC200-12 is for 12-volt Panasonic-, RCA- and Hitachi-type batteries. Both measure 7.5" x 3.5" x 3" and weigh 12 ozs. \$99.95; \$119.95 with included ac power supply.

CIRCLE NO. 33 ON FREE INFORMATION CARD

Versatile Computerized Temperature Instrument

A new desktop instrument from Rodco Products Co. (Columbus, NB) combines an inside/outside thermometer, calendar, digital clock, computer-type memory, alarm function and large digital-numeric LCD display into a single device package. The

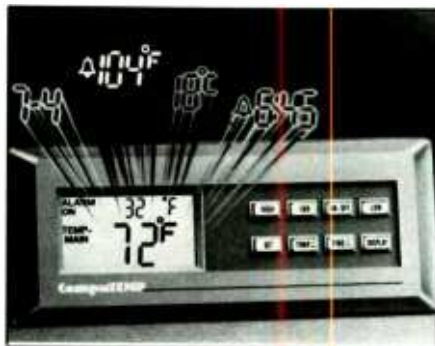

visual display in Computer Plus™ reports on how hot/cold outside/inside temperatures are, when temperature reached its highest/lowest for the day, Celsius and Fahrenheit temperatures, date, and time. Also, both audible and visible alarms report when a critical temperature occurs.

Computer Plus operates on a 9-volt battery and can be either wall mounted or placed on a desk or table.

CIRCLE NO. 34 ON FREE INFORMATION CARD

TVRO Programs

Software for IBM and compatible computers that can be useful in TVRO system analysis and antenna aiming has been released by Baylin Publications (Boulder, CO). The an-

Cable TV Descramblers

If you find a better deal, we'll better our deal.

*Jerrold *Tocom *Hamlin *Oak
*Scientific Atlanta *Zenith
Ask about our extended warranty program.

COD, Visa, M/C welcome.
Free Call - Free Catalog.

Video Tech **800-562-6884**

2702 S. Virginia St., Ste. 160-304
Reno, NV 89502.

CIRCLE NO. 18 ON FREE INFORMATION CARD

CB TRICKS OF THE TRADE I & II

Tricks I and Tricks II, plus a free set of plans for CB Super Modulation.

Special: \$40.00

Order each book separately for \$19.95

C.O.D. Orders Accepted



Medicine Man CB
P.O. Box 37, Dept. A
Clarksville, AR 72830
(501) 754-2076



CABLE DESCRAMBLERS OAK M35B COMBO \$39.95

Jerrold, Zenith, Hamlin, Sci. Atlanta, Pioneer & MORE! OUR PRICES ARE BELOW WHOLESALE!

CABLE PLUS

14417 Chase St. #481-C Panorama City, CA 91402
1-800-822-9955 • Other Info. 1-818-785-4500
NO CALIF. SALES - DEALERS WANTED

CABLE-TV BOXES

Descramblers • Converters
FREE CATALOG

TRANS-WORLD CABLE CO.
12062 Southwest 117th Ct., Suite 126
Miami, Florida 33186
800-442-9333

REMOTE CONTROL KEYCHAIN



Complete w/mini-transmitter and +5 vdc RF receiver
Fully assembled including plans to build your own auto alarm
Write for more information
Quantity discounts available

Check, Visa or M/C
30 days refund
Add \$3 shipping

ONLY \$24.95
VISITECT INC. / Dept. M. (415) 872-0128
PO BOX 5442, SO. SAN FRAN., CA 94080

FREE CATALOG! 1-800-648-7938 JERROLD HAMLIN OAK ETC CABLE TV DESCRAMBLERS

- Special Dealer Prices!
- Compare our Low Retail Prices!
- Guaranteed Prices & Warranties!
- Orders Shipped Immediately!

REPUBLIC CABLE PRODUCTS, INC.

4080 Paradise Rd. #15, Dept. 903
Las Vegas, NV 89109

For all other information (702) 362-9026



ADVERTISERS' INDEX

RS#	Page #
1	AMC Sales.....61
2	All Electronics.....79
-	B & B Electronics.....80
3	C&S Sales.....7
-	Cable Connection.....79
-	Cable-Mate Inc.....80
-	Cable Plus.....81
-	Cleveland Inst. of Elec.Cov. III
-	Command Productions....24
5	Communications Specialists.78
6	Consolidated Electronics....77
7	Contact East.....61
8	Cook's Institute.....77
9	Deco Industries.....79
-	Electronics Book Club.....75
21	Global Cable Network.....78
-	Global Engineering....Cov. II
-	Grantham63
11	Heath Co.....15
-	Kelvin Electronics.....80
10	Kenwood.....Cov. IV
-	Listen Electronics.....80
-	Medicine Man CB.....81
-	Mega-Byte, Inc.....80
-	NRI Schools.....11, 12
-	Pacific Cable Co., Inc.....80
12	Parts Express International...6
-	Penn Research.....78
13	Print Products.....57
14	Radio Shack.....3
14	Republic Cable.....81
-	Skyvision80
15	Smith Design.....16
16	Tech Serv.....69
-	Trans World Cable Co.....81
17	Ucando69
18	Video Tech.....81
19	Viejo Publications.....76
-	Visitect Inc.....81
20	Z Test Electronics.....57

We'd like to see your company listed here too. Contact Jonathan Kummer at 516-681-2922 to work out an advertising program tailored to suit your needs.

Free Product Information

Readers can obtain free information on products advertised by the above companies, as well as for some editorially mentioned products. Simply circle the appropriate number printed below an advertisement onto the Modern Electronics "Free Information Service" card bound into this issue.

NEW PRODUCTS...



alysis software is for predicting performance when viewing signals from a weak satellite. It is said to accurately calculate picture quality from footprint maps and such system parameters as LNB noise temperature and antenna diameter. It prompts a user to enter 10 parameters required for analysis and then to choose one of these parameters to be varied while the others are held con-

stant. The effect of the variable is shown in slant distance, path loss, antenna gain, G/T, C/N, S/N and fade margin. English or metric units can be selected. The TASO study of C/N vs. picture quality is printed for comparison.

The aiming software calculates azimuth and elevation angles and range to all satellites within view of a TVRO station. Names and latitudes of all worldwide C- and Ku-band broadcast satellites, presently in service or to be launched by 1995, are listed. A user simply enters TVRO latitude and longitude. Locations of future satellites can be entered by the user.

The software is available on 5.25" and 3.5" floppy disks. \$49.95. A free catalog that lists books and educational aids on satellite and private cable TV is available on request.

CIRCLE NO. 26 ON FREE INFORMATION CARD

EDITORIAL...

(from page 6)

hanced CGA video. IBM's 3½" disk drive has a 1.44MB capacity, whereas Tandy's is a 720K drive. Therefore, IBM has slight edges in each category.

Also, IBMs come with a 2400-bps modem and a mouse, which costs \$200 more as options for the Tandy. But a Tandy is equipped with two joystick ports, which costs \$289 to add to an IBM. Tandy has an 8-bit DAC for digital sound, which IBM lacks. Both have mouse ports, but Tandy has an extra serial port. Neither has much expansion provisions. Tandy has a slot for a 10" board, while IBM has none (a \$169 adapter card unit handles three boards). IBM located the computer power supply in the video monitor, which is a twist that harkens back to Coleco placing the power supply of its Adam computer in the system's separate dot-matrix printer case. This makes the monitor kind of heavy so that a swivel stand would have been desirable. Both have nice 101-key keyboards.

Going beyond spec sheets, I felt that Tandy's super CGA video displayed text that was surprisingly satisfactory, though not a match for VGA's crispness. Some other welcome features that Tandy offers is an automatic screen blanker and

hard-disk shutdown. As a result, you can keep the machine on all the time while drawing little current and without risk of "burning" the CRT phosphor. Interestingly, the Tandy machine does not have a cooling fan. It's not needed, say Tandy representatives.

Tandy's programs, 24 of them, are a decided plus for home users without any or much computer operating experience. They all have the same familiar graphical interface, which makes everything simpler. Moreover, they have been thoughtfully produced, and are very practical.

Are these the computers that will invade millions and millions of homes? Probably. The promotional drums will be too strong to resist. Will they fall into disuse and become dust collectors in time, kissing cousins to those old Altairs and Commodores? We'll find out soon enough.

Are these the computers that will invade millions and millions of homes? Probably. The promotional drums will be too strong to resist. Will they fall into disuse and become dust collectors in time, kissing cousins to those old Altairs and Commodores? We'll soon find out.

Art Salsberg

Discover Your Career Potential In The Fast-Growing Field Of High-Tech Electronics!

CIE Gives You The Training You Need to *Succeed...*
At Your Own Pace...& In Your Own Home!

If you're anxious to get ahead...and build a *real* career...you owe it to yourself to find out about the Cleveland Institute of Electronics!

CIE can help you discover *your* career potential in the fast growing field of high-tech electronics. A career that will challenge and excite you every day...reward you with a powerful feeling of personal accomplishment...and deliver a level of financial security you may have only dreamed of before!

As the leading school in home-study electronics, CIE has helped over 150,000 students in the U.S.A. and over 70 foreign countries get started in this exciting field. To find out how CIE could be helping you...read on...then send for a CIE catalog TODAY!

A Growing Need For Trained Professionals!

The career opportunities shown here are only a few of the challenging, high-paying careers you could enjoy as an electronics technician.

You could be the "brains" behind the scenes of an exciting TV broadcast...trouble-shoot life-saving medical equipment...design exotic new aeronautics systems...CIE's job-oriented programs offer you the quickest possible path to the career of your dreams! And CIE also features military and union re-training, to build on what you already know.

Dozens Of Fascinating Careers To Choose From!

Even if you aren't sure which career is best for you, CIE can get you started with core lessons applicable to *all* areas of electronics. As you advance, CIE makes job opportunities available to you through the bimonthly school paper, *The Electron*.

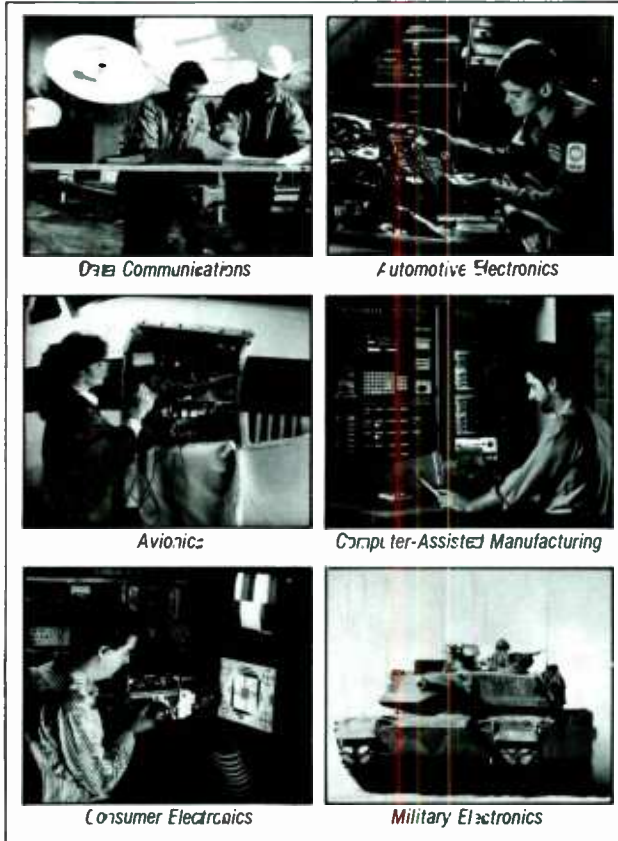

☎ Communications

Automotive Electronics

Avionics

Computer-Assisted Manufacturing

Consumer Electronics

Military Electronics

Personal Training From A Renowned Faculty.

Unlike the impersonal approach of large classroom study, CIE offers you one-on-one instructional help 6 days a week, toll-free. Each CIE lesson is authored by an independent specialist, backed by CIE instructors who work directly with you to answer your questions and provide technical assistance when you need it.

Practical Training... At Your Own Pace.

Through CIE, you can train for your new career while you keep your present job. Each course allows a generous completion time, and there are no limitations on how fast you can study. Should you already have some electronics experience, CIE offers several courses which start at the intermediate level.

"State-Of-The-Art" Facilities & Equipment.

In 1969, CIE pioneered the first electronics laboratory course, and in 1984, the first Microprocessor Laboratory. Today, no other home study school can match CIE's state-of-the-art equipment. And all your laboratory equipment is included in your tuition cost. There is no extra charge—it's yours to use while you study at home and on the job after you complete your course!

Earn Your Degree To Become A Professional In Electronics!

Every CIE course you take earns you credit towards the completion of your Associate in Applied Science Degree, so you can work towards your degree in stages. And CIE is the only school that awards you for fast study, which can save you thousands of dollars in obtaining the same electronics education found in four-year Bachelor's Degree programs! Write for details today!

Send For Your Catalog Today!

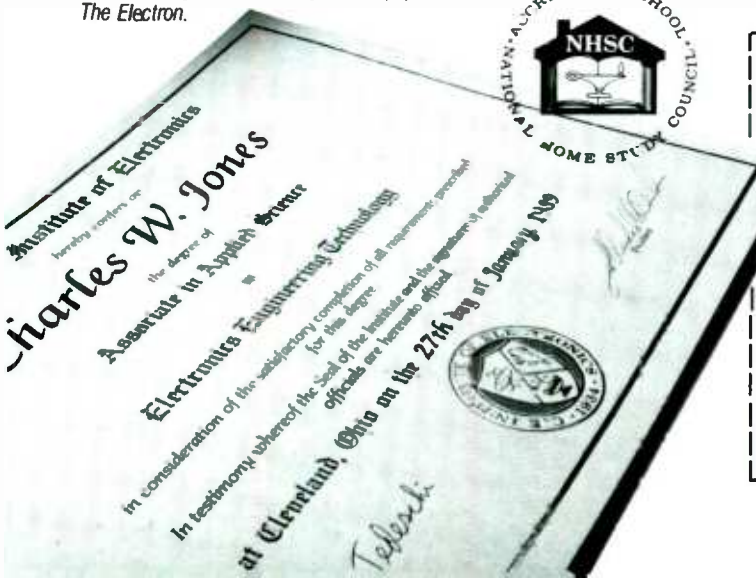

CIE World Headquarters

Cleveland Institute of Electronics, Inc.
1776 East 17th St., Cleveland, Ohio 44114

YES! Please send me your independent study catalog (For your convenience, CIE will have a representative contact you—there is no obligation.)

Print Name _____

Address _____ Apt # _____

City/State/Zip _____

Area Code/Phone No. _____

Check box for G.I. Bill bulletin on educational benefits: Veteran Active Duty

Mail This Coupon Today!

AMO-177

KENWOOD

...pacesetter in Amateur Radio

NEW
RZ-1 Wide-Band
Receiver.

Hear it All!



R-5000
R-2000
High performance
receivers.

Scan the world bands with Kenwood's R-5000, R-2000 and RZ-1. Listen in on foreign music, news, and commentary. Monitor local police, fire, and other public safety services, as well as the Marine channels, and the many other services 50 MHz and above.

(The VHF converter options must be used in the R-5000 and R-2000.)

R-5000

The R-5000 is a high performance, top-of-the-line receiver, with 100 memory channels, and direct keyboard or main dial tuning—makes station selection



R-2000

The R-2000 is an all band, all mode receiver with 10 memory channels and many deluxe features such as programmable scanning, dual 24-hour clocks with timer, all-mode squelch and noise blankers, a large, front-mounted speaker, 110 volt AC or 12 volt DC operation (with the DCK-1 cable kit and 118-174 MHz VHF capability with VC-10 option).

Optional Accessories R-2000:

- VC-10 VHF converter
- DCK-1 DC cable kit for 12 volt DC use.

R-5000:

- VC-20 VHF converter
- VS-1 Voice module
- DCK-2 for 12 volt DC operation
- YK-88A-1 AM filter
- YK-88SN SSB filter
- YK-88C CW filter
- MB-430 Mounting bracket.

Other Accessories:

- SP-430 External speaker
- SP-41 Compact mobile speaker
- SP-50B Mobile speaker
- HS-5 Deluxe headphones
- HS-6 Lightweight headphones

super easy! Other useful features include programmable scanning, large, built-in speaker, 110 volt AC or 12 volt DC operation (with optional DCK-2 cable), VHF capability (108-174 MHz) with the VC-20 option, dual 24-hour clocks with timer, and even voice frequency readout with the VS-1 option.

RZ-1

Wide-band scanning receiver



The RZ-1 wide-band, scanning receiver covers 500 kHz-905 MHz, in AM, and narrow or wideband FM. The automatic mode selection function makes listening

easier. One hundred memory channels with message and band marker, direct keyboard or VFO frequency entry, and versatile scanning functions, such as memory channel and band scan, with four types of scan stop. The RZ-1 is a 12 volt DC operated, compact unit, with built-in speaker, front-mounted phones jack, switchable AGC, squelch for narrow FM, illuminated keys, and a "beeper" to confirm keyboard operation.

- Optional Accessory**
- PG-2N Extra DC cable

KENWOOD

CIRCLE 10 ON READER SERVICE CARD

KENWOOD U.S.A. CORPORATION
COMMUNICATIONS & TEST EQUIPMENT GROUP
P.O. BOX 22745, 2201 E. Dominguez Street
Long Beach, CA 90801-5745
KENWOOD ELECTRONICS CANADA INC.
P.O. BOX 1075, 959 Gana Court
Mississauga, Ontario, Canada L4T 4C2