

ICD 08559

JANUARY 1989 \$2.50  
CANADA \$3.50

# MODERN ELECTRONICS

TM

THE MAGAZINE FOR ELECTRONICS & COMPUTER ENTHUSIASTS

- Forrest Mims Experiments With New \$10 Speech-*Recognition* Chip
- Build a "Meter" to Sound Tones Proportional to Voltage Values
- Make a Digital Barometer for Highly Accurate Weather Forecasts

*Also In This Issue:*

- Personal-Belongings Intrusion Detector
- Motorcycle Headlight Safety Flasher
- Shaping Waveforms Electronically
- Transformer Troubleshooting Guide

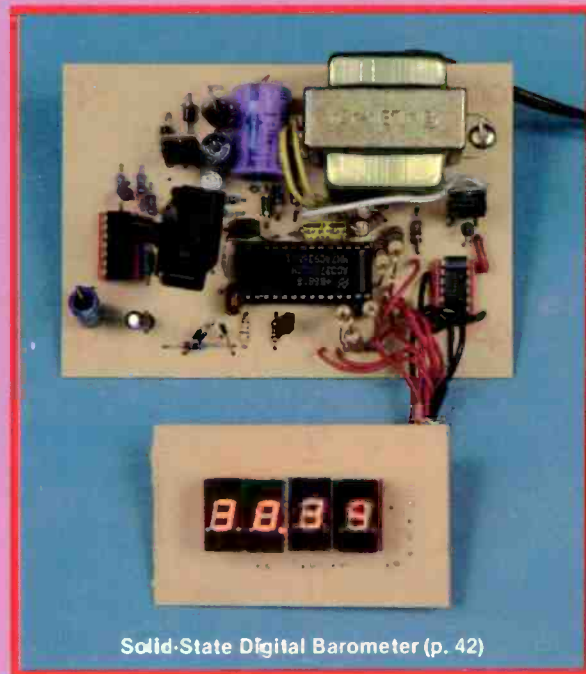

Plus: Audible Light Detector for the Blind • VHF Communications Repeaters  
 • Computer Fix Gets Color From Software Restricting CGA to White on Black  
 • Experiences with "PageMaker" Desktop Publishing Software • Electronics & Computer News • Latest Technical Books & Free Literature Reviews.

# NEW

OPTOELECTRONICS INC.

# FREQUENCY COUNTERS TO 2.4 GHz

**POCKET SIZE**  
SIZE: 4" H x 3.5" W x 1" D  
MADE IN USA

#TA-100S



**8 LED DIGITS • 2 GATE TIMES**  
**ALUMINUM CABINET**  
**INTERNAL NI-CAD BATTERIES INCLUDED**  
**AC ADAPTER/CHARGER INCLUDED**

**EXCELLENT SENSITIVITY & ACCURACY**

**AC-DC • PORTABLE OPERATION**

Small enough to fit into a shirt pocket, our new 1.3 GHz and 2.4 GHz, 8 digit frequency counters are not toys! They can actually out perform units many times their size and price! Included are rechargeable Ni-Cad batteries installed inside the unit for hours of portable, cordless operation. The batteries are easily recharged using the AC adapter/charger supplied with the unit.

The excellent sensitivity of the 1300H/A makes it ideal for use with the telescoping RF pick-up antenna; accurately and easily measure transmit frequencies from handheld, fixed, or mobile radios such as: Police, firefighters, Ham, taxi, car telephone, aircraft, marine, etc. May be used for counter surveillance, locating hidden "bug" transmitters. Use with grid dip oscillator when designing and tuning antennas. May be used with a probe for measuring clock frequencies in computers, various digital circuitry or oscillators. Can be built into transmitters, signal generators and other devices to accurately monitor frequency.

The size, price and performance of these new instruments make them indispensable for technicians, engineers, schools, Hams, CBers, electronic hobbyists, short wave listeners, law enforcement personnel and many others.

**STOCK NO:**

- #1300H/A Model 1300H/A 1-1300 MHz counter with preamp, sensitivity, < 1mV, 27MHz to 450MHz includes Ni-Cad batteries and AC adapter ..... **\$169.95**
- #2400H Model 2400H 10-2400 MHz microwave counter includes Ni-Cad batteries and AC adapter ..... **\$299.95**
- #CCA Model CCA counter/counter, for debugging, ultra sensitive, < 50 micro volts at 150MHz | 1-600 MHz with adjustable threshold, RF indicator LED. Includes Ni-Cad batteries and AC adapter ..... **\$299.95**

**ACCESSORIES:**

- #TA-100S Telescoping RF pick-up antenna with BNC connector ..... **\$12.00**
- #P-100 Probe, direct connection 50 ohm, BNC connector ..... **\$20.00**
- #CC-12 Carrying case, gray vinyl with zipper opening. Will hold a counter and #TA-1000S antenna. .... **\$10.00**



FLA (305) 771-2050  
**ORDER FACTORY DIRECT**  
**1-800-327-5912**



**AVAILABLE NOW!**

**OPTOELECTRONICS INC.**

5821 N.E. 14th Avenue  
Ft. Lauderdale, Florida 33334

Orders to US and Canada add 5% of total (\$2 min, \$10 max)  
Florida residents add 6% sales tax. COD fee \$2.  
Foreign orders add 15%

### Function Generator



- Sine, sq. triangle
- .5 Hz - .5 MHz
- DC offset
- 20 Vpp output
- 120 VAC power
- includes test leads
- External inputs can control AM (VCA) or FM (VCF) and produce AM, FM, sweep, ASK, or FSK signals

NOVEX FG2020A only \$149.95 + \$4 S&H

### DM 4061 Dip Meter



only \$79.95

list \$99.45

- 1.5 to 250 MHz
- check coils, tanks, antennas
- use as RF signal generator
- 2 kHz audio tone

### FC 5600A Counter



\$269.95

list \$399.95

- 10 Hz to 500 MHz
- accuracy to  $\pm$  count
- 20 MV sensitivity to 100 MHz
- 50 MV sensitivity to 500 MHz

### SG 4160 RF Signal Generator



\$149.95

list \$199.25

- 100 kHz to 150 MHz
- harmonics to 450 MHz
- 100 MV RF output
- selectable int/ext modulation

### PM 330 RF Power Meter



\$99.95

list \$119.45

- 1.8 to 500 MHz
- 50 $\Omega$  impedance
- 5/20/120 ranges
- use as dummy load

### RF Signal Generator/Counter



- .1 - 150 MHz
- Harmonics to 450
- AM modulation
- XTAL input/check
- Digital readout

NOVEX SG4162D only \$249.95 + \$4 S&H

NOVEX SG4160A same as above except no digital readout/counter only \$149.95 + \$4 S&H

### NOVEX SWR 3P SWR/Power/Field Strength



\$19.95

list \$29.45

- 10 & 100 watt scales
- 1.7 to 150 MHz
- SO-239 connectors
- SWR accuracy  $\pm$  5%

### AF Audio Generator/Counter



- 10 Hz - 1 MHz
- Sine - sq wave
- Low distortion
- 8V RMS output
- Digital readout

NOVEX AG2603AD only \$249.95 + \$4 S&H

NOVEX AG2601A similar to above except no digital readout counter only \$149.95 + \$4 S&H

### FC 5250 Counter



\$129.95

list \$156.75

- 10 Hz to 150 MHz
- accuracy to  $\pm$  1 count
- 120 VAC or 9 VDC  
(adapter included)

### OS 7305 Oscilloscope



\$199.95

list \$229.95

- DC to 7 MHz bandwidth
- 10 Hz to 100 kHz sweep
- int/ext sync
- 3 inch CRT

### RT 8815 RF Attenuator for your next fox hunt



for only \$149.95

list \$199.90

- DC to 500 kHz
- 0 to 81 dB attenuation
- 50 $\Omega$  impedance
- BNC connectors
- .5 watts



---minutes from Wash., DC

516 Mill St., NE  
Vienna, VA 22180  
Phone: (703) 938-3350  
Orders: 800-368-3270

\* prices subject to change

# HAM RADIO IS FUN!

It's even more fun for beginners now that they can operate voice and link computers just as soon as they obtain their Novice class license. You can talk to hams all over the world when conditions permit, then switch to a repeater for local coverage, perhaps using a transceiver in your car or handheld unit.



Your passport to ham radio adventure is TUNE-IN THE WORLD WITH HAM RADIO. The book tells what you need to know in order to pass your Novice exam. Two cassettes teach the code quickly and easily.

Enclosed is my check or money order for \$15.00 or charge my  
 VISA  Mastercard  Am. Express  
 Signature \_\_\_\_\_  
 Acct. No. \_\_\_\_\_  
 Good from \_\_\_\_\_ Expires \_\_\_\_\_  
 Name \_\_\_\_\_  
 Address \_\_\_\_\_  
 \_\_\_\_\_  
 City \_\_\_\_\_ State \_\_\_\_\_ Zip \_\_\_\_\_

THE AMERICAN RADIO RELAY LEAGUE  
 225 MAIN ST.  
 NEWINGTON, CT 06111

CIRCLE NO. 133 ON FREE INFORMATION CARD

# MODERN ELECTRONICS

THE MAGAZINE FOR ELECTRONICS & COMPUTER ENTHUSIASTS

JANUARY 1989

VOLUME 6, NUMBER 1

## FEATURES

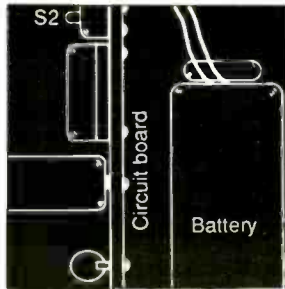

52

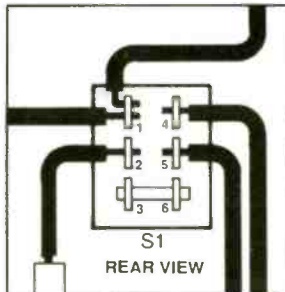

55

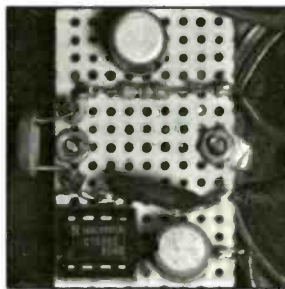

60

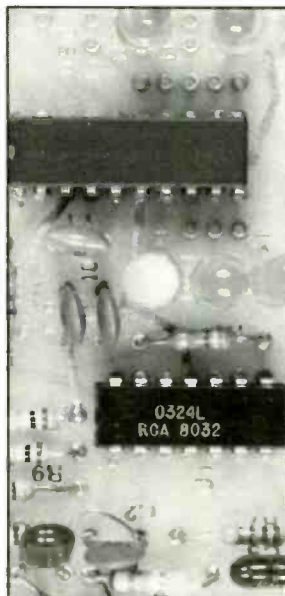

64

- 18 An Audible ac/dc Voltmeter**  
Sounds a tone whose frequency is proportional to the voltage being measured. *By Jan Axelson & Jim Hughes*
- 28 Wave-Shaping Circuit Action**  
How waveforms are shaped electronically and interpreting their results on an oscilloscope. *By Robert G. Middleton*
- 36 The Absent CGA Color Text**  
How to get color text with new programs that restrict color graphics adapters to white-on-black displays. *By Paul Danzer*
- 39 Transformer Theory**  
A service guide to troubleshooting transformers in electronic gear. *By Christopher H. Fenton*
- 42 Solid-State Digital Barometer**  
Weather-forecasting instrument accurately detects and displays small changes in atmospheric pressure. *By Anthony J. Caristi*
- 52 Personal Intrusion Detector**  
Lets you know when someone has gone through your important business or personal belongings without authorization. *By Charles Shoemaker*
- 55 Motorcycle Headlight Flasher**  
Makes motorcycles more visible to other traffic to reduce accidents. *By James H. Brown*
- 60 Light Minder for the Blind**  
Simple project indicates when lights are on and where. *By Adolph A. Mangieri*

## COLUMNS

- 64 Electronics Notebook**  
A Speaker-Independent Speech-Recognition Chip. *By Forrest M. Mims III*
- 71 Solid-State Devices**  
Hall Effect & Infrared Sensors. *By Art Salsberg*
- 72 Electronics Omnibus**  
VHF Repeaters and Ham Radio. *By Curt Phillips*
- 74 PC Capers**  
Thoughts for the New Year & Aldus' "PageMaker" Desktop-Publishing Software. *By Ted Needleman*

## DEPARTMENTS

- 6 Editorial**  
*By Art Salsberg*
- 7 Letters**
- 8 Modern Electronics News**
- 14 New Products**
- 80 Books & Literature**
- 86 Advertisers Index**

Say You Saw It In Modern Electronics



## The Active Reader's Guide

There are two kinds of readers: active and passive. Most *Modern Electronics* readers are in the former category. That is, they do something in response to what they read.

What's done varies, of course. A reader might be motivated to do one of a number of things, as follows:

- Build a construction project from plans presented in an issue;
- Request more information on a product that's advertised or mentioned editorially by filling out the postage-paid card bound into every issue or by directly contacting the company;
- Start a subscription by using the bound-in envelope provided in the magazine;
- Get a free classified advertisement (non-commercial only) of up to 15 words;
- Purchase a product advertised or written about.
- Write to the Editor about an article you'd like to author, wish to see written, or whatever.

There are a few special considerations you should keep in mind for some of the activities cited above. For example, be sure to enter the month and year of the issue on the Reader Service Card you're mailing in order to get free information about products. Without this data, the card can't be processed.

For a free classified advertisement to, say, locate a difficult-to-find part, you must attach a subscriber's mailing label to your ad request.

To obtain a fairly prompt response to most queries, locate a to enclose a stamped/self-addressed envelope with your request. Please do not ask authors or editors to design a circuit for your application, however. None of us has time to provide such consulting services.

If you wish to author an article, it's best to send us a detailed outline of your proposal and some information about your technical background before writing it so that we can guide you. Remember, you don't have to be a polished writer in order to share your technical knowledge and experience with readers. Editors here will do the polishing. Our free Author's Guide will be especially helpful in preparing an article. Just request it.

Finally, if you ordered something by mail, keep a handy record of it, dates and all. Although most mail-order suppliers ship merchandise very quickly, buyers often forget that there's mail travel time to and from the supplier. You should figure one working day per zone if shipment is made by United Parcel Service (UPS), for example. Also, shipment is sometimes delayed if payment is made with a personal check because the supplier might wait for the check to clear before fulfillment of the order.

So do be realistic about the time it takes for the arrival of your order. Chances are that it's worth the wait either because you're saving a lot of money or what you've ordered isn't sold locally.

Happy New Year to all!

*Art Salsberg*

## ATTENTION VCR TECHNICIANS



### VCR REPAIR PARTS KIT

Now you can do most of your VCR repair jobs the **same day**. Parts Express VCR Parts Kit makes this possible. It contains over 45 of the most commonly used parts to repair RCA, Hitachi, Fisher, Sanyo, Lloyds, Panasonic, Sony, Sharp, JVC, Samsung, TMK, GE, Magnavox and more. Idler assemblies, pinch roller, sensing transistors, switches, and lamps are included in this comprehensive kit. You also save over \$20.00

Kit contains replacements for Sharp (2) NIDL0005 (2) NIDL0006 (1) NPLY V0051 Panasonic (2) VXP0329 (2) VXP0401 (2) VXP0344 (2) VXP0521 RCA (1) 150614 (1) 164113 (1) 150650 Hitachi (1) 641311 Fisher/Sanyo (1) 143 0-4204-00300 (2) 143 0-4804-00100 (1) 143 0-4904-00500 (1) 143 0-7411-20002 RCA/Hitachi (2) up/down switch (5) 161757 sensing transistors Panasonic lamps (2) XAMQ27P150W (5) XAMV0019 (5) XAMV125 (1) Molybdenum grease. Normal dealer cost of over \$110.00 (All parts are available individually for reorderers.)

Order #  
400-950

**\$89<sup>95</sup>**  
Plus shipping



### VCR IDLER TIRE KIT

This popular kit contains 150 of the most popular idler tires (10 each of 15 different sizes) With this kit in your stock room, you can do over 90% of VCR repair jobs the same day, saving time and money! Also included is our comprehensive cross reference listing over 80 manufacturers' assembly numbers and over 200 model numbers. A \$400.00 retail value. (All tires are available individually for reorderers.)

Order #  
400-900

**\$55<sup>00</sup>**  
Plus shipping

FREE  
CATALOG



**Parts  
Express**  
International Inc

CALL TOLL FREE  
**1-800-338-0531**

340 E. First St., Dayton OH 45402  
Local—1-513-222-0173

CIRCLE NO. 135 ON FREE INFORMATION CARD

## Completed Projects

• Rarely, if ever, do we see photos of your completed projects built by readers. So I've taken some of recent projects that I've built from *Modern Electronics* articles. Here are two. The first is the Bus-Line Tracer featured in the August 1988 issue. I named my tracer the "Squawker." It works very well for such a simple circuit. If one small modification is made in building and operating it, the need for very-low-resistance probes and cables is negated. By bringing out three leads from the unit (one from R3, another from the junction of R1 and pin 7 of IC4 and the third from ground), the resistance of the test leads has no bearing on results. The + lead from R1 and ground lead are soldered onto the pc board being tested. The third lead, with an inexpensive probe of almost any kind, is used to trace the circuit to the fault.

The second photo shows my completed 200-Watt Digital Amplifier featured in the December 1987 issue. This unit I built totally from scratch. I made the pc board, wound the power trans-

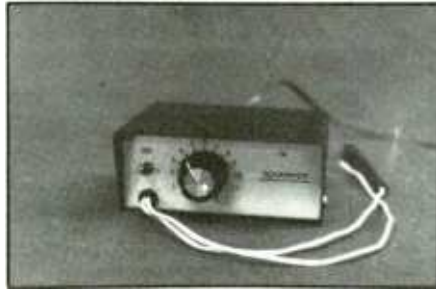

former (using a Variac core) and output toroids, fabricated and painted the cabinet, etc. The amplifier works well and has received compliments from people

who have seen and heard it. The original amplifier had some problems, which I solved by using a double-sided pc blank and etching only one side. I use the side that isn't etched as a ground plane, which eliminated any instabilities.

Robert M. Harkey  
Charlotte, NC

## Errata

• I like the more technically oriented articles that are published in *Modern Electronics*. The material by Forrest Mims is always very interesting to me, and the more technical the better. While I was leafing through the October 1988 issue, I noted that there seems to be something wrong with the circuit shown for the "Phone Line 'Busy' Indicator."

George Sedlack  
Syracuse, NY

*Transistor Q1 is a pnp device (not npn as shown); the 2N3906 number is correct as are the emitter, base and collector con-*

(Continued on page 86)

CALL FOR FREE CATALOG

ALL SALES SUBJECT TO THE TERMS OF OUR 90 DAY LIMITED WARRANTY. FREE COPY UPON REQUEST

### TEXT TO SPEECH BOARD!

PC/XT COMPATIBLE. MAKE YOUR COMPUTER TALK!

A VERY POWERFUL AND AMAZING SPEECH CARD. USES THE NEW GENERAL INSTRUMENTS SPO256-AL2 SPEECH CHIP AND THE CTS256A-AL2 TEXT TO SPEECH CONVERTER.

THIS BOARD USES ONE SLOT ON THE MOTHERBOARD AND REQUIRES A COM SERIAL PORT. BOARD MAY ALSO BE USED IN A STAND ALONE ENVIRONMENT WITH ALMOST ANY COMPUTER THAT HAS A RS232 SERIAL PORT. FEATURES ON BOARD AUDIO AMP OR MAY BE USED WITH EXTERNAL AMPS. DEMONSTRATION SOFTWARE AND A LIBRARY BUILDING PROGRAM ARE INCLUDED ON A 5 1/4" INCH PC/XT DISKETTE. FULL DOCUMENTATION AND SCHEMATICS ARE ALSO INCLUDED.



NEW!

PRICE CUT!

\$69.95  
ASSEMBLED  
& TESTED

### NEW! IC TESTER! \$149.00

SIMILAR TO BELOW EPROM PROGRAMMER. PLUGS IN TO YOUR PC OR XT. TESTS ALMOST ALL 14, 16, AND 20 PIN 74XX SERIES. INCLUDES STANDARD POWER, "S" AND "LS" DEVICES. ALSO TESTS CD4000 SERIES CMOS. SOFTWARE INCLUDED CAN EVEN DETERMINE PART NUMBERS OF MOST UNMARKED AND HOUSE NUMBERED DEVICES WITH SIMPLE MOD. THIS UNIT CAN ALSO TEST 6.4K AND 256K DRAMS! WITH MANUAL AND SOFTWARE: \$149. PERFECT FOR SCHOOLS.

### PC/XT EPROM PROGRAMMER \$169



ASK ABOUT  
OUR NEW  
PAL  
PROGRAMMER!

• LATEST DESIGN • PROGRAMS UP TO 4 DEVICES AT ONE TIME • FEATURES EASY TO USE MENU DRIVEN SOFTWARE THAT RUNS UNDER PC OR MS-DOS. • USES AN INTELLIGENT PROGRAMMING ALGORITHM FOR SUPER FAST (8X) EPROM BURNING. • THIS PLUG-IN BOARD ATTACHES TO AN EXTERNAL MINI CHASSIS CONTAINING 4 TEXTUOL Z.I.F. SOCKETS. • NO PERSONALITY MODULES REQUIRED • AUTOMATIC VPP SELECTION: 12.5V, 21V, OR 25V. • EPROM DATA CAN ALSO BE LOADED FROM OR SAVED TO A DISKETTE. • PROGRAMMING SOFTWARE SUPPORTS: 2716, 2732, 2732A, 2764, 2764A, 27128, 27128A, 27256, 27256A, 27512, AND 27512A. • ASSEMBLED AND TESTED, BURNED IN WITH MANUAL. \$169 WITH SOFTWARE.

JUST RECEIVED. SAME AS ABOVE PROGRAMMER, BUT PROGRAMS 8 UNITS AT ONE TIME - \$299.

## Digital Research Computers

P.O. BOX 381450 • DUNCANVILLE, TX 75138 • (214) 225-2309

TERMS: Add \$3.00 postage. We pay balance. Orders under \$15 add 75¢ handling. No C.O.D. We accept Visa and MasterCard. Texas Res. add 6-1/4% Tax. Foreign orders (except Canada) add 20% P & H. Orders over \$50 add 85¢ for insurance.

CIRCLE 45 ON FREE INFORMATION CARD

## ALL ELECTRONICS CORP.

### SEND FOR FREE CATALOG



### ITT PUSH BUTTON

ITT MDPL series. 3/4" X 1/2" gray rectangular key cap. S.P.S.T.N.O Push to close  
Rated: 0.1 amp switching.  
0.25 amp carry current. P.C. mount  
CAT# PB-8 65¢ each  
10 for \$6.00

### PIEZO WARNING DEVICE

Murata Erie # PKB8-4A0  
High pitched audible alarm  
Operates on  
3 - 20 Vdc @ 20 ma  
1" high x 7/8" dia  
P.C. board mount  
CAT# PBZ-84 \$1.75 each

### XENON TUBE



1" long flashtube prepped with 3 1/2" red and black leads. Ideal for electronic flash or strobe projects  
CAT# FLT-3 2 for \$1.00

### 24 VOLT D.C. SOLENOID

Intermittent duty cycle. 240 ohm coil. Mounting flange is 1 1/8" wide. Solenoid body 1 1/2" X 1/2" X 1/2"  
CAT# SOL-34 \$1.00 each  
10 for \$8.50 • 100 for \$75.00  
Large Quantity Available

### 10 AMP SOLID STATE RELAY

ELECTROL #S2161  
CONTROL 5.5 - 10 Vdc  
(will operate 3-32Vdc)  
LOAD: 10 Amp @ 240 Vac  
2 1/4" X 1 3/4" X 7/8"  
CAT# SSRLY-10B \$9.50 each  
10 for \$85.00 • 25 for \$175.00  
50 for \$300.00 • 100 for \$500.00



### N-CHANNEL MOSFET

IRF-511 TO-220 case  
CAT# IRF 511  
\$1.00 each  
10 for \$9.00  
LARGE QUANTITY AVAILABLE

MAIL ORDERS TO:  
ALL ELECTRONICS  
P.O. BOX 567  
VAN NUYS, CA 91408

TWX-5101010163(ALL ELECTRONIC)

OUTSIDE THE U.S.A.  
SEND \$1.50 POSTAGE  
FOR A CATALOG!!

### ORDER TOLL FREE 800-826-5432

INFO: (818)904-0524  
FAX: (818)781-2653  
MINIMUM ORDER \$10.00  
QUANTITIES LIMITED  
CALIF. ADD SALES TAX  
USA: \$3.00 SHIPPING  
FOREIGN ORDERS  
INCLUDE SUFFICIENT  
SHIPPING. NO C.O.D.



CIRCLE 39 ON FREE INFORMATION CARD

**ZENITH'S COMPATIBLE HDTV.** Amid all the jockeying for an acceptable high-definition TV system in the U.S., Zenith Electronics' proposal to the FCC's Advisory Committee on Advanced Television Services (ATS) a few months ago aroused considerable excitement. It can coexist with the 160-million TV sets in the U.S. that use the 6-MHz bandwidth channel allocation standard, while still producing 30 MHz of video and audio data within a 6-MHz bandwidth for HDTV set owners.

Zenith calls this neat trick "Spectrum Compatible." Explaining how this is done, a spokesman notes that it's based on encoding the 30-MHz data needed for HDTV and transmitting converted information on an unallocated 6-MHz channel. An HDTV receiver automatically decodes the signal for playback with many times the video resolution of standard TV sets and with compact-disc audio quality, as well as accommodating wide-screen imagery. At the same time, the regular TV signal could be sent to conventional TV sets on existing channels.

Utilizing unused TV channels is made possible because Zenith's technique reduces power required for the HDTV signal by more than 90%. This eliminates interference problems that made it mandatory to limit spectrum use to alternate VHF channel space and every sixth UHF channel. Hence, every existing NTSC (National Television Standards Committee) broadcast station could have a second 6-MHz channel for transmitting high-definition TV simultaneously. The HDTV display would be 787.5 lines, progressively scanned at 59.94 Hz, which is equivalent to an interlaced display of 1,000+ lines. This contrasts with our standard NTSC 525-line, interlaced display of 262.5 lines per 59.94-Hz field.

**EMERGING TRENDS.** The Institute of Electrical and Electronics Engineers, Inc. (IEEE) held its annual briefing on electrotechnology a few months ago. Among the seven session topics discussed, the future of photonics was viewed as having promise of being the second technology in our lifetime (semiconductors is the first) to completely change the world of technology. Innovations cited that are now under development were a car that "drives itself," a personal computer workstation that recognizes and records human speech, and creating and manipulating video images in offices and schools through linking supercomputers to personal computers and workstations.

**BLOW-'EM-UP SPEAKERS.** Leading the new-development list this month are inflatable loudspeakers by Hyman Products (St. Louis, MO). Called "Airwaves," they come in various sizes, styles and colors, and are designed to be easily portable. Just inflate them with air and plug into standard stereo equipment, says a company spokesman. One of the larger models, standing 3-1/2 ft. high when inflated, resembles a Wurlitzer juke box. It incorporates a two-way, 8-ohm speaker rated for 25 watts. The line also includes a speaker that looks like a palm tree.



# Surplus HP Gear—up to 90% off!!!

Now you can afford a

- 9114B HP-IL 3 1/2" Disc Drive
- 2225B HP-IL ThinkJet Printer
- HP-75D Portable Computer/RAM/Pod Package

## Here's the story—

These units were recently installed in a chain of stores for point-of-sale inventory control until a corporate decision to change accounting methods prematurely retired them.

It's a shame. But we lucked out to get them at a truly low price. This corporate mistake is your opportunity—however, you must act fast.

Used, yes—but believe me, this industrial-grade equipment is in excellent, near-new condition—perfect operating shape—and every unit comes with our 30-day guarantee. If your unit fails to operate properly in any way whatsoever, we'll replace it FREE.

This liquidation means you can have that IL Disc Drive or ThinkJet that you've wanted, and that full-memory HP-75 to experiment with—these units are really affordable! But do not delay—we must limit these fantastic savings to stock on hand. Let us know right away that you want one.

**3 1/2" Disc Drive—** this is the current model (HP-9114B), and it comes with everything: rechargeable batteries, recharger, disc, HP-IL cable, manual.

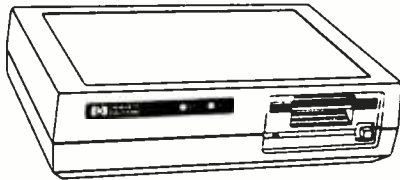

It is HP-IL driven, so you can use it with the the HP-75D and also with the HP-41, HP-71 or HP-110. Easily portable, it weighs only 6 lb, is battery powered, 3" high and its footprint is the size of typewriter paper. 2-sided flexible discs hold 630K, and the drive automatically monitors wear and checks for defects at each use. Data access time is 1/2 sec and transfer rate is 6K/sec. List price new is \$695, so you buy this used unit at a whopping 57% discount!

Stock # 9114BU [Used 3 1/2" Disc Drive].....\$295

**IL ThinkJet Printer—** this is the current production model (HP-2225B) that is so popular.



It prints 80 columns and is HP-IL driven, so you can use it with the HP-75D and also with the HP-41, HP-71 or HP-110. Completely portable, it weighs only 5 1/2 lb and it's battery operated. Yet it's so quiet and so robust that you see it as a public-access printer in many libraries, and it has a life of 100,000 pages! It's fast, 150 characters per second, and has high quality print with an 11x12 dot matrix (bidirectional, logic-seeking, 1K buffer, and it does underlining or boldface in 1 pass). There's no ribbon—you simply replace the printhead for \$11.

List price new is \$495, so you can have fast, quiet IL printing now at this giant 60% discount!

Stock #2225BU [Used ThinkJet Printer].....\$195

## Portable Computer/RAM/Pod Package—

loaded with extras! You get the HP-75D computer, plus the 8K RAM Expansion Module that plugs into its battery compartment, plus the Expansion Pod that adds a modem, barcode decoders, and a huge 64K RAM disc full of super-fast memory, plus the Barcode Wand! That's a lot, so I'll display the list here for you (remember, you are getting the whole package)—



1. (HP-75D) Portable Computer
2. (HP-82700) 8K RAM Memory Module
3. (HP-82718B) Expansion Pod
4. (HP-92267B) Barcode Wand

**HP-75D** is 5x10x1 1/4 inches, 26 oz, with 16K RAM built in. It has a card reader, wand interface and port, touch-type keyboard (the keyboards on these units have never been used). Comes with manual, battery pack and adapter/recharger, IL cables.

**Expansion Pod** fits as a cradle on your 75, has 300 baud, direct-connect modem and decoders for 3 of 9 Code and Code 11.

**Barcode Wand** is medium resolution (0.19 mm min width of narrow element) for code produced on dot-matrix printers.

The total list price for this gear new is \$2715—so your cost is discounted an unbelievable 90% !!!

Stock #HP-75DU [Used Computer Package].....\$275

**Who is EduCALC?** In 12 years we have become one of the largest HP dealers in the world. You see, we guarantee you'll be completely satisfied with your purchase, or your money back!

**Order by mail:** Californians add 6% tax. Add \$4 for UPS delivery (no extra charge for multiple items). Allow 12 days for personal checks to clear, or send your MC/Visa number and card address.

For fastest service, call during west-coast business hours at (714)582-2637. Or, for all days/all hours call toll-free (800)633-2252, ext. 356, with your MC or VISA card. Of course, if you live in Southern California, drop by in person and pick up your new HP gear.

**I guarantee you'll be delighted—or your money back within 15 days, no questions asked.**

*Jim Carter*

EduCALC Mail Store-Dept. 56  
27953 Cabot Road  
Laguna Niguel, CA 92677

# Learn to troubleshoot and service today's computer systems as you build a fully XT-compatible micro, complete with 512K RAM and powerful 20 meg hard drive

## Train the NRI Way— and Earn Good Money Servicing Any Brand of Computer

Jobs for computer service technicians will almost double in the next 10 years according to Department of Labor statistics, making computer service one of the top 10 growth fields in the nation.

Now you can cash in on this exciting opportunity— either as a full-time industry technician or in a computer service business of your own—once you've mastered electronics and computers the NRI way.

NRI's practical combination of "reason-why" theory and hands-on building skills starts you with the fundamentals of electronics, then guides you through more sophisticated circuitry all the way up to the latest advances in computer technology. You even learn to program in BASIC and machine language, the essential language for troubleshooting and repair.

---

**Train With a Powerful  
XT-Compatible —  
Now With 20  
Meg Hard Drive!**

---

To give you hands-on training with the absolute in state-of-the-art computer



**You build this powerful Packard Bell VX88 computer, all the while gaining a true mastery of computer electronics. Best of all, it's yours to keep for all your professional and personal computing needs.**



technology, NRI includes the powerful new Packard Bell VX88 computer as the centerpiece of your training. As you assemble this fully IBM XT-compatible micro from the keyboard up, you actually see for yourself how every section of your computer works.

You assemble and test your computer's "intelligent" keyboard, install the power supply and 5¼" disk drive, then interface the high-resolution monitor. But that's not all.

Your hands-on training continues as you install a powerful 20 megabyte hard disk drive—today's most-wanted computer peripheral—now included in your course to dramatically increase

Your NRI computer training includes all this: • NRI's unique Discovery Lab<sup>®</sup> for circuit design and diagnosis • NRI's hand-held digital multimeter featuring "talk-you-through" instructions on audio cassette • A digital logic probe that lets you visually examine computer circuits • The new Packard Bell VX88 computer with "intelligent" keyboard, 360K double-sided, double-density disk drive, 512K RAM, 16K ROM • 20 megabyte hard disk drive • Bundled software including MS-DOS, GW-BASIC, word processing, spreadsheet, and database programs • Packard Bell reference manuals with programming guidelines and schematics.

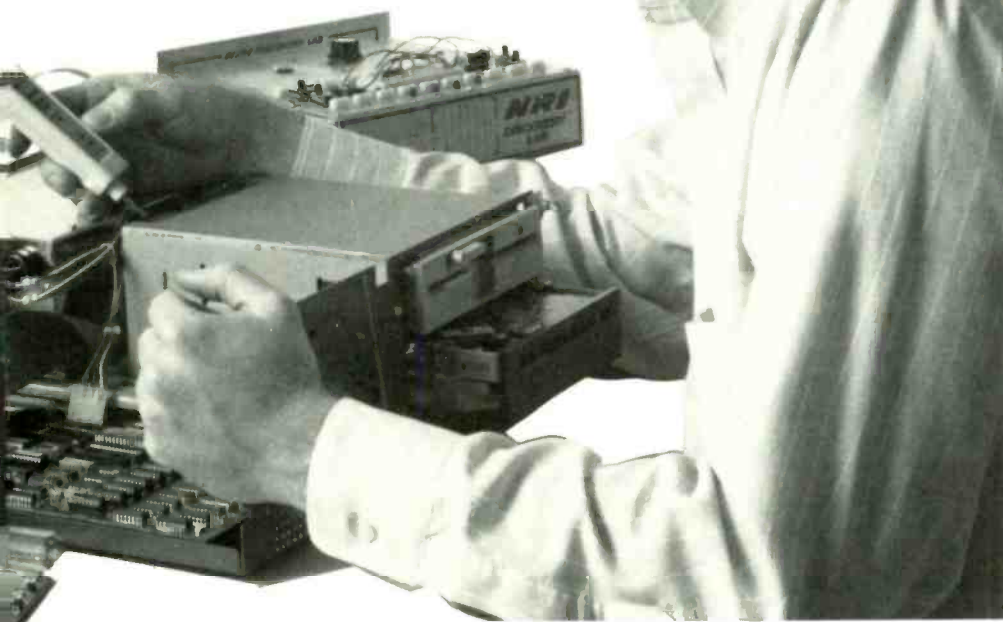

**NEW!**

**Includes 20 meg Hard Drive**

throughout your training, you've got the full support of your personal NRI instructor and the NRI technical staff, always ready to answer your questions and help you whenever you need it.

**FREE 100-Page Catalog Tells More**

Send today for NRI's big, 100-page, full-color catalog that describes every aspect of NRI's innovative computer training, as well as hands-on training in robotics, video/audio servicing, electronic music technology, security electronics, data communications, and other growing high-tech career fields. If the coupon is missing, write to: NRI School of Electronics, McGraw-Hill Continuing Education Center, 3939 Wisconsin Avenue, Washington, DC 20016.

**NRI** School of Electronics

McGraw-Hill Continuing Education Center  
3939 Wisconsin Avenue,  
Washington D.C. 20016

IBM is a registered trademark of International Business Machines Corporation

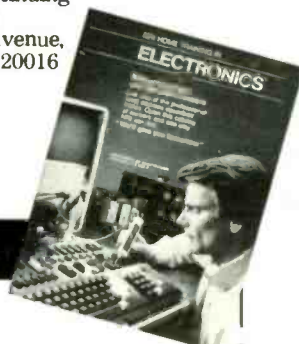

the data storage capacity of your computer while giving you lightning-quick data access. Plus you work with exclusive word processing, database, and spreadsheet software, yours to use for your own professional and personal applications.

As you build your computer, performing key demonstrations and experiments at each stage of assembly, you get the confidence-building, real-world experience you need to work with, troubleshoot, and service today's most widely used computer systems.

**No Experience Needed, NRI Builds It In**

This is the kind of practical, hands-on experience that makes you uniquely prepared to take advantage of today's opportunities in computer

service. You learn at your own convenience in your own home.

No classroom pressures, no night school, no need to quit your present job until you're ready to make your move. And all

**SEND TODAY FOR FREE CATALOG!**

**NRI**

McGraw-Hill Continuing Education Center  
3939 Wisconsin Avenue, NW, Washington, DC 20016

For Career courses approved under GI Bill  
 check for details.



**CHECK ONE FREE CATALOG ONLY**

- Comput. Electronics**
- TV/Video/Audio Servicing
- Robotics
- Electronic Music Technology
- Security Electronics
- Digital Electronics Servicing

- Electronic Design Technology
- Industrial Electronics
- Communications Electronics
- Basic Electronics
- Bookkeeping and Accounting
- Building Construction
- Automotive Servicing

- Air Conditioning, Heating & Refrigeration
- Small Engine Repair
- Electrician
- Locksmithing & Electronic Security
- Travel Careers
- Telephone Servicing
- Paralegal

Name (Please print) \_\_\_\_\_

Age \_\_\_\_\_

Street \_\_\_\_\_

City/State/Zip \_\_\_\_\_

We'll give you tomorrow.

Accredited by the National Home Study Council

4-019

For more information on products described, please circle the appropriate number on the Free Information Card bound into this issue or write to the manufacturer.

## Laptop Computer Kit

The first kit laptop computer to be offered by a major manufacturer is now available from the Heath Company. The new Model HS-2860 kit, when assembled, is claimed to do everything a desktop computer can do. Fully PC and AT compatible, the

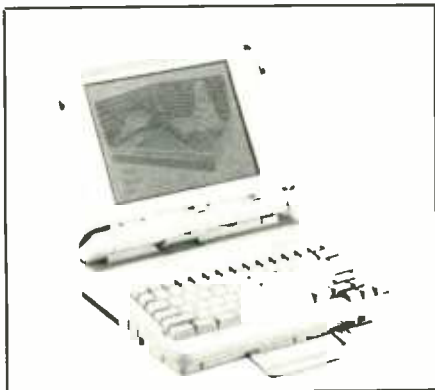

new computer is built around a 12-MHz 80286 microprocessor and 1 megabyte of RAM standard, expandable to 3 megabytes on the main board.

Standard features of the new laptop computer include: 3.5-inch 1.4-megabyte floppy disk drive; 640 × 400-pixel supertwist LCD display screen; removable battery pack that provides power for up to 6 hours continuously; Expanded Memory Specification (EMS); one each parallel and serial ports; RGB video port; external floppy-disk-drive jack; and 50/60-Hz ac adapter. Available options include a second internal floppy-disk drive and 20- and 40-megabyte internal hard disks. Dimensions of the closed computer are 15.4 × 12.2 × 3.07 inches. \$2,995.

CIRCLE 100 ON FREE INFORMATION CARD

## DMM Temperature Adapter

Philips ECG's Model DT-200 tem-

perature adapter converts any digital multimeter that has a 2-volt dc scale and an input resistance of not less than 10 megohms into a direct-reading thermometer. It has a linear 1.0-mV/degree output and plugs into



any DMM that has banana input jacks on standard spacing via three output jacks on both the top and rear of the accessory.

A slide switch allows temperatures to be displayed in either Fahrenheit or Celsius degrees. This switch also has a center position that disconnects power when the accessory is not being used. Measurement range is from -58 to +2,372 degrees Fahrenheit and -50 to +1,300 degrees Celsius. Resolution is rated at 0.1 degree with a DMM scale of 200 mV dc and 1.0 degree at 2.0 volts. This accessory is equipped with a TC-50P type K thermocouple bead probe and comes with instruction manual and carrying case. Power is supplied by a 9-volt battery.

CIRCLE NO. 101 ON FREE INFORMATION CARD

## Camcorder Light

Packtronics' (Dexter, MI) Model LT-3 is a video light that mounts directly on a dc camcorder via its hot-shoe connector to provide light for taping. The 11-ounce light is said to have an efficient 50-watt dc lamp that provides bright, even illumina-

tion while eliminating harsh shadows. The bulb and reflector are claimed to be computer matched to provide optimum coverage with no hot spots. Mounted either directly on a camcorder or on a light stand, the LT-3 light can also be used for bounce lighting by rotating the light head upward, to a maximum of 180 degrees.

Completely portable, the LT-3 runs on a rechargeable lead-acid battery. It comes with a plug that connects to an optional 12-volt dc bat-



tery pack that provides 45 minutes of continuous operation. There is no need for a blower to cool the lamp, allowing noise-free operation. The 11-ounce light measures 3½ × 2¾ × 2¾ inches and comes with a 6-foot power cord for use with a dc battery pack and has a safety glass screen. Optional accessories include four-way rotating barn doors for more precise light control and an adapter for powering the light from the 117-volt ac line. \$79.95.

CIRCLE NO. 102 ON FREE INFORMATION CARD

## Applications Workstation Converter For PCs

Global Specialties' new "BOA" allows an IBM PC or compatible to be converted into a fully functioning microcomputer applications workstation. Supplied with a buffer card

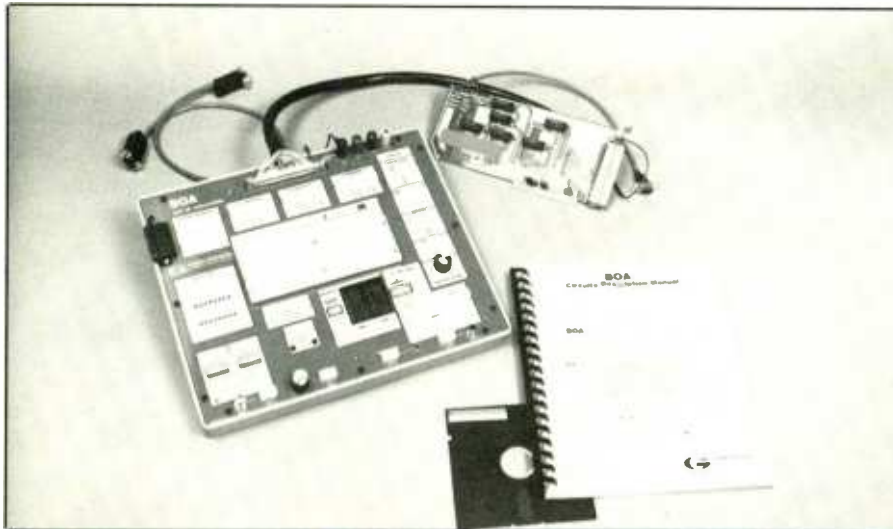

that plugs into the computer and connecting cables, installation of BOA is a snap. Once installed, BOA requires no special consideration and allows the computer to be used for all its normal applications.

Operation of the system is simple. The user just loads a program from a supplied diskette into the computer and keys in a few commands. Once it is up and running, BOA provides computer hardware subsystems in modular form to create larger system functions, permitting direct access to

the PC bus with no danger of electrical shock or damage to the computer.

Included on the hardware console are digital-to-analog (D/A) and analog-to-digital (A/D) converters, a digitally programmable gain circuit, a sine/TTL-output-level function generator, a microphone and audio amplifiers, a generous solderless breadboarding socket area, switch-selectable I/O decoder and more. Supplied are all hardware, software, cables and operating manuals.

CIRCLE NO. 103 ON FREE INFORMATION CARD

## Autosound Crossovers

Pioneer Electronics' new Models CD-630 and CD-620 active crossovers for autosound enthusiasts separate the audio signal into bandwidths each speaker in the system can reproduce before feeding the signal to the amplifiers. This allows individ-



ual component speakers to respond to only the frequencies each was designed to reproduce.

The Model CD-630 features stereo/mono switching to provide for a monaural subwoofer. It provides six different crossover frequency points (50/500, 80/800 and 120/1,200 Hz) between midrange and woofer/subwoofer using a 10-times multiplier and three crossover points (3.2, 5 and 8 kHz) between midrange and tweeter/supertweeter. The Model CD-620 offers many of the same features as the CD-630, with two-way operation for low- and high-frequency separation and offering three crossover points (50, 80 and 120 Hz).

Both active electronic crossover networks feature phase switching to synchronize drivers and permit a wide variety of mounting location options. The component approach made possible by the new crossover line allows the autosound enthusiast to run individual amplifiers for each speaker system using phono connectors. With the Model CD-630, the

## Hi-Res Micro-Ohmmeter

Simpson Electric's new Model 444 Micro-Ohmmeter is specially designed for low-resistance measurement applications where high accuracy and repeatability of results are required. It can measure switch and relay contact resistance, conductive coatings, earth bonds and ground resistances, to name just a few. Tests are performed at 100 microvolts and 5 milliamperes maximum to ensure against "punching through" any contamination or corrosion.

Features of the new micro-ohmmeter include: a 4½-digit liquid-crystal display that gives a maximum 19,999 count; four resistance ranges (from 20 milliohms to 20 ohms) with 1 microhm resolution; user-adjust-



able setpoints to activate audible and/or visible alarms for resistances that go above or below chosen setpoints; ac/dc mode switching with separate polarity switching for the dc mode. The meter is powered by a Ni-Cd battery for portable field use and is rechargeable from 117/240-volt ac sources. \$1,195.

CIRCLE NO. 104 ON FREE INFORMATION CARD

## NEW PRODUCTS ...

choice of either two- or three-way connection permits later expansion of the network control from two- to three-component speaker systems.

Model CD-630 \$160; Model CD-620 \$100.

CIRCLE NO. 105 ON FREE INFORMATION CARD

### Locking Parts Bins

"Lock-A-Bin" from Alacra Systems (Ambler, PA) is a locking bin designed for storage, handling and transport of small parts, including electronic components. The bins are available in both regular and conductive molded polypropylene plastic. Each bin is molded in one piece and is designed to improve pick time on an assembly line, minimize parts handling and maximize parts protection.

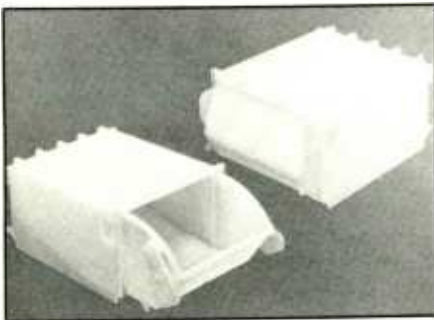

A specially shaped hopper is said to allow assemblers to pick parts at a rate up to 28 percent faster than from conventional bins.

Lock-A-Bin is stackable and can be connected horizontally or/and vertically with other such bins in any configuration.

The bin protects its contents from dust, dirt, mixing with parts from other bins and spilling (objects as small as 0.040 inch in diameter cannot fall out). In addition to their use as storage and transport containers, Lock-A-Bins can be used as shipping containers. They meet the static decay requirements of MIL-B-81705B and conductive material requirements of ANSI-ASTM-D-257 and are said to be excellent for clean-room applications.

CIRCLE NO. 106 ON FREE INFORMATION CARD

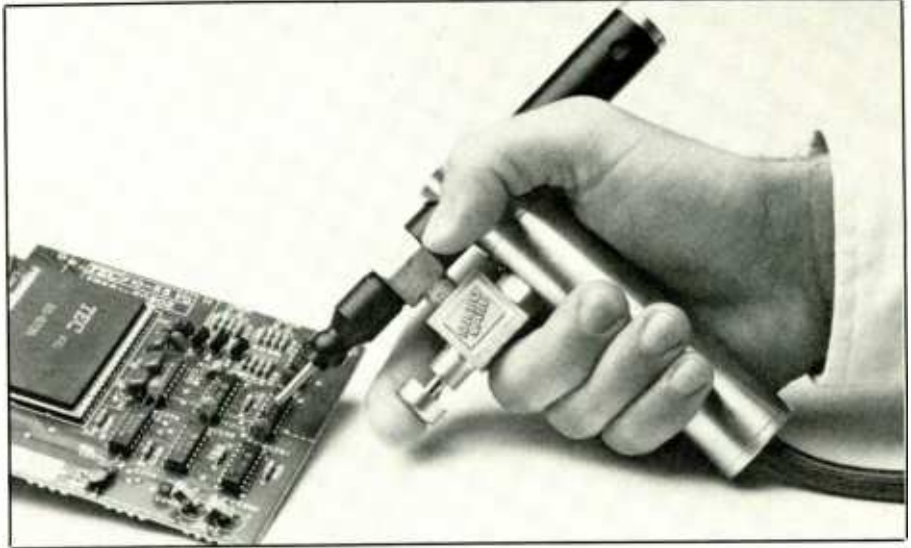

### Safe IC "Freeze" Gun

Cryo-Grip™ from Micro Care (Bristol, CT) is a new "freeze" gun designed to replace ozone-depleting aerosol freeze sprays for use in electronics troubleshooting. The product is meant for quick-freezing ICs on pc boards to isolate sources of intermittent failure. The hand-held

heat exchanger forces ordinary compressed air through a vortex chamber to generate a jet of super-cooled dry air. Micro Care claims that the Cryo-Grip will chill components down to -25 degrees Fahrenheit in less than 10 seconds without using harmful chemicals and without leaving any residue.

CIRCLE NO. 108 ON FREE INFORMATION CARD

### Logic Comparator

3M Electronic Products Division's full-spectrum TTL Logic Comparator dynamically tests ICs under actual operating conditions while in a circuit and operating at system speed. Unlike conventional logic comparators, this one requires no extra switches, program cards or custom sockets to differentiate inputs from outputs on the IC under test. The only switch settings needed involve directly tying V+ and ground from the IC under test to the reference IC.

The 3M Logic Comparator accommodates 8-, 14-, 16-, 18- and 20-pin DIP TTL and TTL-compatible ICs. Fast, easy connection to the reference IC is through the unit's zero-insertion-force (ZIF) socket. Faulty lines are indicated by lit LEDs. Adding to its versatility, the unit's mem-

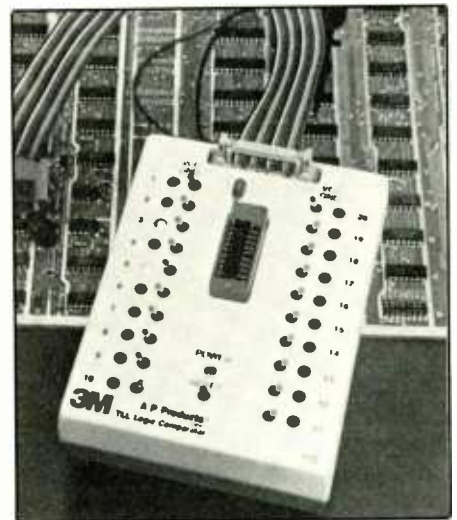

ory feature permits unattended operation until testing is complete. The 3M Logic Comparator is supplied with 20- and 16-pin test clips and a cable for attachment to in-circuit ICs.

CIRCLE NO. 109 ON FREE INFORMATION CARD

## Energy-Loss Detector

The "Air Snooper" hand-held energy-loss detector from Microwave Systems, Inc. (Dallas, TX) uses a hybrid thermistor that is said to be capable of detecting temperature variations of as little as 0.25° Fahrenheit. It permits the user to locate heating



and cooling losses around doors, windows, ducts and air-conditioning units. The unit is powered by a 9-volt battery. A single control turns on and off power and serves as the means for adjusting to normal conditions. The display is an edgewise analog meter movement.

CIRCLE NO. 112 ON FREE INFORMATION CARD

## Electronic Power Conditioners

Sola (Elk Grove Village, IL) has a series of electronic power conditioners that offer 94% efficiency at full load and high in-rush overload capacity with output capacities of 500, 1,000 and 2,000 volt-amperes. They are designed to protect sensitive electronic equipment from virtually all ac power problems except total power failure. All 60-Hz models are UL listed, CSA certified and conform to FCC Class B requirements, and all 50-Hz models conform to VDE and IEC re-

quirements. Utilizing microprocessors, the EPCs are said to combine high-efficiency voltage regulation with exceptional surge protection. Output voltage is continuously measured and corrected every 16 ms and is held to within  $\pm 5\%$  for input voltage variations to  $+15\%$  and  $-25\%$ . Class A and Class B input surge voltages are suppressed to safe levels up to 6,000 volts peak.

Electrical noise attenuation is claimed to exceed 50 dB for transverse-mode and 130 dB for common-mode noise. The EPCs are also claimed to maintain sine-wave outputs that have less than 0.5% harmonic distortion. Overload capacity ranges from 300% for 600 cycles to 1,400% for one cycle for protection against in-rush load. The units are programmed to shut down the out-



put when input voltage exceeds 24% above to about 40% below nominal input voltage to protect against extreme over/under-voltage conditions. Output voltage is automatically restored when the input voltage returns to the acceptable range. Red, yellow and green status LEDs indicate operating and fault conditions.

Nominal outputs of 120, 208 and 240 volts are available for 60-Hz models, 110, 220, 230 and 240 volts for 50-Hz models. \$599 to \$1,279.

CIRCLE NO. 110 ON FREE INFORMATION CARD

(Continued on page 86)

## NEW! A SUPERCONTROLLER MULTIFUNCTION CHIP!

THE



- DC DIMMER
- AC DIMMER
- 16 CHANNEL CONTROLLER
- 64 CHANNEL MATRIX
- PULSE COUNTER
- SERIAL IN / 16 CH OUT
- 4 CHASING ROUTINES
- SERIAL ENCODER
- SERIAL DECODER

In addition, the ZR2 provides:

3 OPERATION MODES—  
AUTO/SYNC/MANUAL;  
VARIABLE SPEEDS;  
100% SOFTWARE COMPATIBLE;  
REQUIRES ONLY +5V AND  
SINGLE CRYSTAL

THE ZR2 REPLACES MULTIPLE  
AND COSTLY DISCRETE PARTS.

IDEAL FOR ROBOTICS, LIGHT AND  
MOTOR CONTROL, MULTIMEDIA,  
DATA TRANSFER, AND MORE.

THE ZR2 IS TRULY A TOOL FOR  
THE TECHNICAL IMAGINATION!

ONLY \$34.95

(SPECIAL OFFER!  
GET \$5 OFF EACH UNIT (\$29.95) WITH THIS AD!)



ALX DIGITAL 12285 S DIXIE HWY #922  
MIAMI FL 33156 305 553 3380

(please print clearly)

NAME \_\_\_\_\_

ADDRESS \_\_\_\_\_

CITY \_\_\_\_\_

STATE, ZIP \_\_\_\_\_  
Send \$29.95 per ZR2 + \$1.55 Shipping; FLORIDA  
RESIDENTS ADD 6% SALES TAX. Check or Money Order

CIRCLE NO. 148 ON FREE INFORMATION CARD

# An Audible ac/dc Voltmeter

*Sounds a tone whose frequency is proportional to the voltage being measured*

By Jan Axelson & Jim Hughes

The "Voltone" audible voltmeter presented here can extend your voltage-measuring capabilities. It enables you to listen to a tone whose frequency is proportional to the measured voltage instead of viewing a display.

This feature is very useful when you wish to monitor a circuit device to learn if it's the cause of an intermittent problem. It's also an efficient instrument for tuning a resonant circuit to maximum or minimum output, checking voltages quickly on a crowded circuit board, and other instances where it's not necessary to observe a meter's display.

Both ac and dc measurements can be made, and a tricolor light-emitting diode tells you whether the voltage being measured is positive, negative or ac. You can use the project by itself or connect it in parallel with a digital voltmeter or multimeter for visual as well as audible indications. For convenience, the project is powered by a battery.

Four input ranges are provided: 200 millivolts and 2, 20 and 200 volts. Input impedance is a constant 10 megohms. The audio output ranges from around 800 Hz at 0 volt to around 1,800 Hz at full-scale. With most users being able to distinguish a just few Hertz difference in frequency, "resolution" can be less than 1 millivolt on the project's lowest range.

## About the Circuit

As shown in the schematic diagram

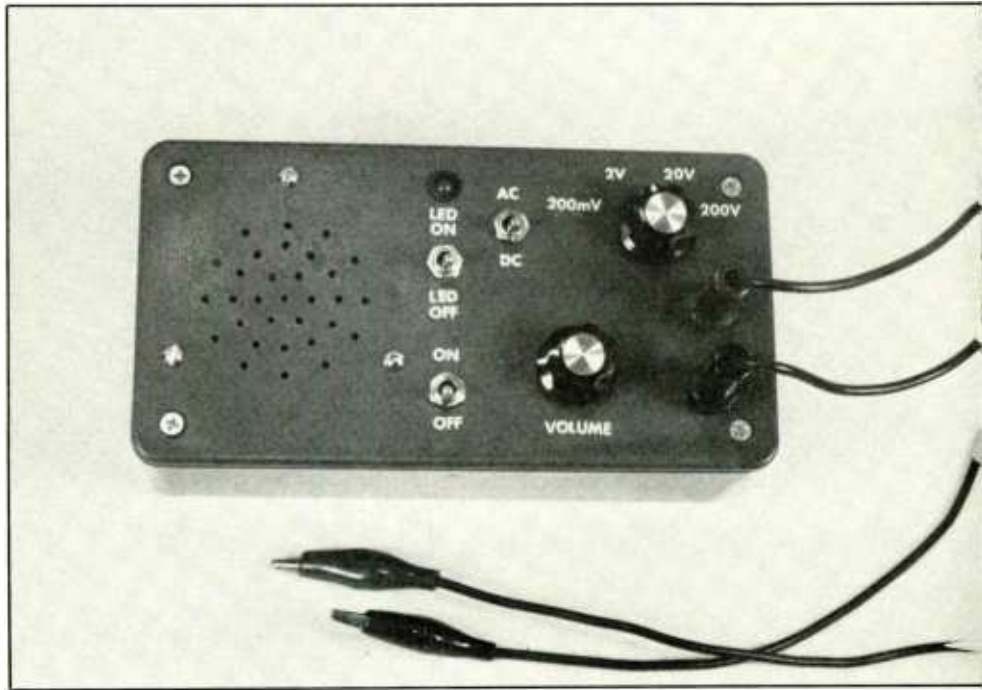

in Fig. 1, the Voltone is built around just three integrated circuits: an LF411 operational amplifier (*IC1*), which serves as an input amplifier; an LM324 quad operational amplifier (*IC2*), which provides a polarity indicator, rectifier, biasing circuit and power amplifier; and a 556 function generator (*IC3*), which generates a tone that can be heard through the speaker.

Batteries *B1* and *B2* provide separate +9 volts and -9 volts to power the circuitry. The voltage being measured connects to the circuit across jacks *J1* and *J2*. Plugs *P1* and *P2* provide a means for connecting the Voltone in parallel with a digital voltmeter or multimeter (DVM or DMM). The contacts of switch *S2A*

must be open when making ac measurements to allow capacitor *C1* to filter out any dc offset voltage that might be present in the input signal.

RANGE SELECT switch *S3* allows you to select an input signal from the voltage divider made up of resistors *R1* through *R4*. With *S3* set to position 1—the 200-millivolt range—the entire input voltage is fed to *IC1*. Positions 2, 3 and 4 (2-volt, 20-volt and 200-volt ranges) provide successive division so that  $\frac{1}{10}$ th,  $\frac{1}{100}$ th and  $\frac{1}{1,000}$ th of the input signal voltage is fed into *IC1*. With *S3* selecting the appropriate range, the voltage at *R5* is always 200 millivolts or less.

Resistor *R5* and diodes *D1* and *D2* help to protect the Voltone from damage due to user error. The diodes



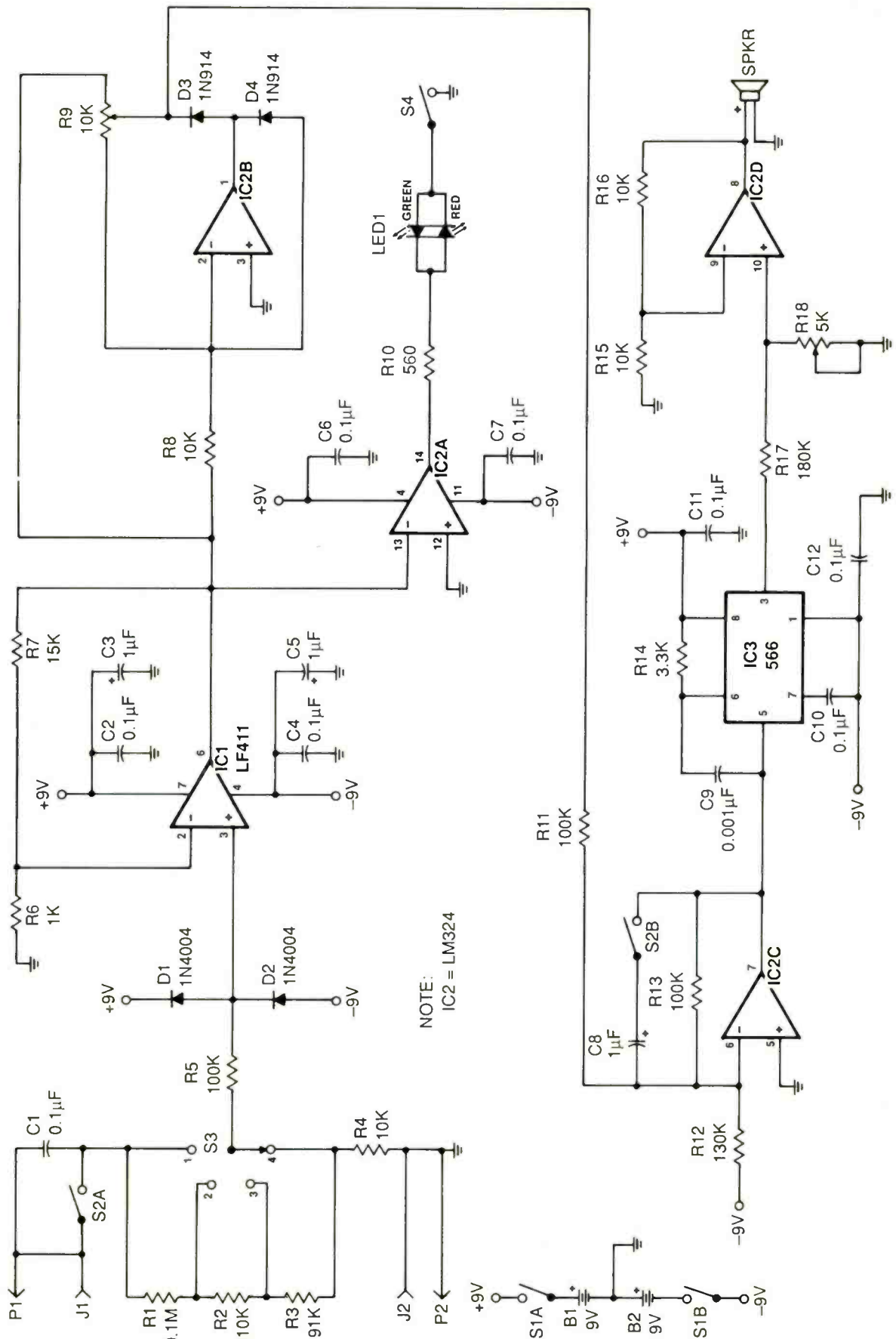

Fig. 1. Complete schematic diagram of the Audible Voltmeter.

## PARTS LIST

### Semiconductors

D1,D2—1N4004 or similar 400-PIV rectifier diode  
 D3,D4—1N914 or similar signal diode  
 LED1—Tricolor light-emitting diode with two leads (see text)  
 IC1—LF411 JFET-input operational amplifier  
 IC2—LM324 quad operational amplifier  
 IC3—566 function generator

### Capacitors

C1—0.1- $\mu$ F, 250-volt polyester film  
 C2,C4,C6,C7,C10,C11,C12—0.1- $\mu$ F, 25-volt ceramic  
 C3,C5,C8—1- $\mu$ F, 25-volt electrolytic  
 C9—0.001- $\mu$ F, 25-volt ceramic

### Resistors $\frac{1}{4}$ -watt, 10% tolerance)

R1—9.1 megohms  
 R2—910,000 ohms  
 R3—91,000 ohms  
 R4,R8,R15,R16—10,000 ohms  
 R5,R11,R13—100,000 ohms  
 R6—1,000 ohms  
 R7—15,000 ohms  
 R9—10,000-ohm potentiometer  
 R10—560 ohms

R12—130,000 ohms  
 R14—3,300 ohms  
 R17—180,000 ohms  
 R18—5,000-ohm, audio-taper, panel-mount potentiometer

### Miscellaneous

B1,B2—9-volt battery  
 J1,J2—banana jack  
 P1,P2—banana plug  
 S1—Miniature dpst toggle or slide switch  
 S2—Miniature dpdt toggle or slide switch  
 S3—Miniature 4pst panel-mount rotary switch  
 S4—Miniature spst toggle or slide switch  
 SPKR—8-ohm speaker

Printed-circuit board or perforated board with holes on 0.1-inch centers and suitable soldering or Wire Wrap hardware; sockets for ICs; suitable enclosure; 9-volt battery holders (2); battery snaps (2); panel-mount LED holder; pointer-type control knobs (2); 8-inch length of shielded cable; labeling kit and clear acrylic spray;  $\frac{1}{2}$ -inch spacers; machine hardware; hookup wire; solder; etc.

clamp pin 3 of *IC1* to 9 volts if a large, overrange input is applied, and *R5* limits the input current to a safe value.

An LF411 op amp was chosen for *IC1* because of its high-impedance JFET inputs. Resistors *R6* and *R7* set the gain of *IC1* to 15, giving an output at pin 6 of 3 volts for a 200-millivolt (full-scale) input. Figure 2 shows several signals measured at different points in the Voltone. (A) and (B) show the response of *IC1* to an ac input.

Since the output tone gives no indication of the polarity of the measured signal, a visual indicator is provided. Operational amplifier *IC2A* is configured as a comparator whose output drives tricolor *LED1*, which consists of red and green LEDs connected in reverse parallel inside the same package.

The control input of *IC2A* at pin

13 is proportional to the Voltone's input, and the reference input at pin 12 is grounded. If pin 13 goes positive, the output at pin 14 goes negative and lights the green element inside *LED1*. If pin 13 is negative, pin 14 goes positive and the red LED element lights. With ac signals, both LEDs are on alternately, resulting in a yellow glow, which accounts for the third color in the "tricolor" LED.

Resistor *R10* limits LED current to a safe value. Switch *S4* allows the LED to be turned off, to save on battery power.

Op amp *IC2B* functions as a full-wave rectifier to produce a positive voltage that is proportional to inputs of either polarity. Gain of the circuit is set at 0.7 by adjusting potentiometer *R9* so that 70 percent of its resistance lies between its wiper and pin 2 of *IC2B*.

Operation of the circuit varies for

positive and negative inputs. When the input at *R8* is positive, *D4* provides a feedback path for the op amp and *D3* is off. The output of the rectifier, which is controlled by the setting of *R9*, equals  $0.7V_{in}$ .

For negative inputs, *D4* is off and feedback current flows through *D3* and part of *R9* (between *D3* and pin 2 of *IC2B*). Now the output of the rectifier is  $-0.7V_{in}$ .

For both positive and negative inputs, the cathode of *D3* is at a positive voltage that is directly proportional to the input. Figure 2(C) illustrates this.

Op amp *IC2C* adds a bias voltage to the rectifier's output, to provide the proper control voltages for voltage-controlled oscillator (vco) *IC3*. The frequency of the vco's output signal at pin 3 varies with the magnitude of the voltage at its pin 5 control input. For proper operation, this potential must be between 75 percent of the total supply voltage and  $V+$ , or in this case, between +6.75 and +9 volts.

To provide the control voltage, op amp *IC2C* is configured to operate as an inverting summing amplifier. The current through *R13* is the sum of *R12*'s current (which generates the bias voltage) and *R11*'s current (which varies according to the measured voltage). The result is that the output at pin 7 varies from +7 to +5 volts as the rectifier's output varies from 0 to 2 volts. These levels are safely within the range required.

For ac measurements, switch *S2B* is closed to connect capacitor *C8* in parallel with resistor *R13*. This causes the signal on pin 7 of *IC2C* to be a dc voltage that is proportional to the ac input.

At *IC3*, the values of *R14* and *C10* determine the frequency range of the output. With the values specified, the output at pin 3 oscillates at around 800 Hz with an input of 5 volts and at around 1,800 Hz with an input of 7 volts. Figures 2(D) and 2(E) show a control input to *IC3* and

# SELECT 5 BOOKS

for only \$3<sup>95</sup>

(values to \$135.70)  
and get a **FREE Gift!**



1625P \$16.95



2975 \$24.95

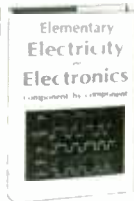

2753 \$23.95



2735P \$13.95



2900 \$36.95  
Counts as 2

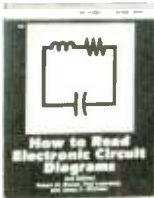

2880 \$20.95



2865 \$21.95



2910 \$24.95



3017 \$15.95



2922P \$15.95



2885 \$16.95



3002 \$49.50  
Counts as 2



2925 \$16.95

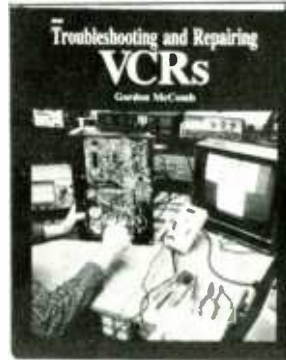

2960 \$26.95



1218P \$16.95



2947 \$21.95



3031 \$24.95



2795 \$29.95  
Counts as 2



2853 \$23.95



2781 \$18.95

Electronics projects . . . ideas . . . the latest technology  
all at up to 50% off publishers' prices!

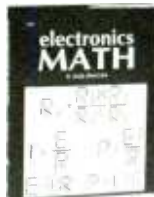

1962 \$22.95

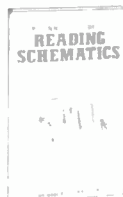

1536P \$9.95



2809 \$26.95  
Counts as 2



2895 \$14.95

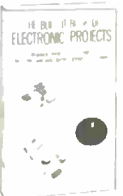

1498P \$11.95

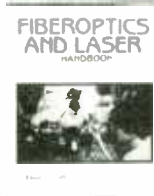

2981 \$24.95



3033 \$14.95



2660P \$19.95



2613 \$24.95



2867 \$25.95



2750P \$17.95



2985 \$24.95



2992 \$24.95



2972 \$23.95



2965 \$24.95

## FREE when you join the ELECTRONICS BOOK CLUB!

15 Easy Electronic Projects  
from Delton T. Horn

Projects you can build—some unique,  
some old favorites—from the author's  
vast treasury of electronics know-how.



**Membership Benefits • Big Savings.** In addition to this introductory offer, you keep saving substantially with members' prices of up to 50% off the publishers' prices. • **Bonus Books.** Starting immediately, you will be eligible for our Bonus Book Plan, with savings of up to 80% off publishers' prices. • **Club News Bulletins.** 14 times per year you will receive the Book Club News, describing all the current selections—mains, alternates, extras—plus bonus offers and special sales, with hundreds of titles to choose from. • **Automatic Order.** If you want the Main Selection, do nothing and it will be sent to you automatically. If you prefer another selection, or no book at all, simply indicate your choice on the reply form provided. As a member, you agree to purchase at least 3 books within the next 12 months and may resign at any time thereafter. • **Ironclad No-Risk Guarantee.** If not satisfied with your books, return them within 10 days without obligation! • **Exceptional Quality.** All books are quality publishers' editions especially selected by our Editorial Board.

MONE-189

All books are hardcover unless numbers are followed by a "P" for paperback (Publishers' Prices Shown)  
© 1989 ELECTRONICS BOOK CLUB, Blue Ridge Summit, PA 17294-0810

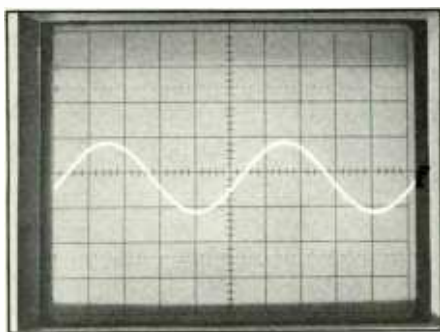

(A)

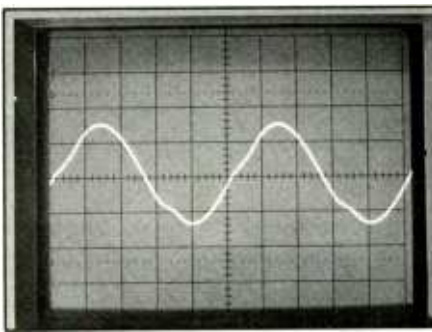

(B)

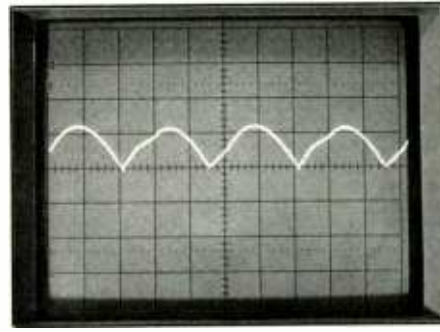

(C)

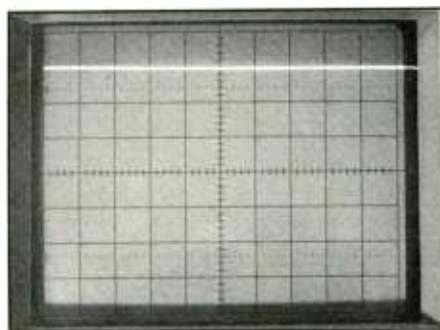

(D)

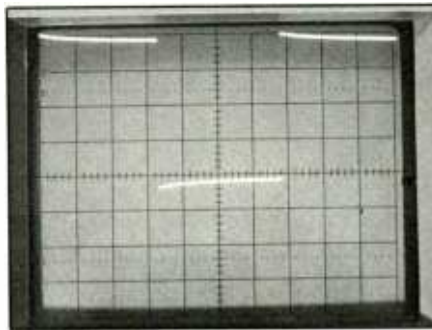

(E)

Fig. 2. Oscilloscope traces illustrate operation of the Project. Settings are the same for all photos (2 V/div, with center graticule at 0 V, and 0.1 ms/div): (A) shows an input to the project; (B) is the response of the input amplifier at pin 6 of IC1; (C) is the rectified signal at the cathode of D3; (D) shows the vco's control voltage at pin 5 of IC3; and (E) is the output that results at pin 3 of IC3.

Fig. 2(E) shows the output that results. Capacitor *C9* prevents unwanted high-frequency oscillations.

Power-amplifier stage *IC2D* drives speaker *SPKR*. Resistor *R17* and potentiometer *R18* divide the input to *IC2D*, with *R18* serving as the project's VOLUME control. Resistors *R15* and *R16* give the amplifier a gain of one. Finally, *C2* through *C7*, *C11* and *C12* serve as bypass capacitors.

### Construction

Component values for the Voltone are not super-critical, though changes in values from those specified in the Parts List may alter the exact response of the circuitry. If necessary, you can change the value of *R7* to match the input ranges of your DVM or DMM. For instance, for a meter that uses 300-mV and 3-, 30- and 300-volt scales, change *R7*'s value to 10,000 ohms. Sockets are recommended for all ICs. Also, when selecting the *LED1* device use the two-lead tricolor variety that contains two LEDs that are wired in reverse

parallel, rather than the three-lead type in which the cathodes of two LEDs are wired together.

Shown in Fig. 3 is the actual-size etching-and-drilling guide to use for fabricating the printed-circuit board on which you will mount and wire together the project's components. While drilling the component-lead holes in the board, also drill  $\frac{1}{8}$ -inch mounting holes in the corners near where *C12* and *R12* will mount and below where *C2* and *C3* will mount (see Fig. 4). Alternatively, you can wire the circuit on perforated board that has holes on 0.1-inch centers using suitable Wire Wrap or soldering hardware and a point-to-point wiring technique.

Refer to Fig. 4 for wiring details for the pc-board version of the project. (Note: Use Fig. 4 as a rough guide to component layout if you are using perforated board, but refer back to Fig. 1 for wiring details.) Begin wiring the board by installing and soldering into place the IC sockets and resistors.

Before installing trimmer potentiometer

*R9*, connect an ohmmeter between its center and either outer lugs and adjust it for a 7,000/3,000-ohm split. Without disturbing the setting, install the trimmer so that the 7,000-ohm section is between pin 2 of *IC2* and *D3*. Next, install and solder into place the capacitors and diodes, observing proper orientation for *D1* through *D4*, *C3*, *C5* and *C8*. Do not install the ICs in the sockets until after preliminary voltage checks have been made and you are sure the circuit has been correctly wired.

Strip  $\frac{1}{4}$  inch of insulation from both ends of nine 6-inch-long hookup wires. If you are using stranded hookup wire, tightly twist together the fine conductors at both ends of all wires and sparingly tin with solder. Plug one end of these wires into all unoccupied holes in the board and solder into place. The other ends will be connected later, after the circuit-board assembly has been mounted in place inside its enclosure.

You can use any type of enclosure that will accommodate all elements of the project without interference

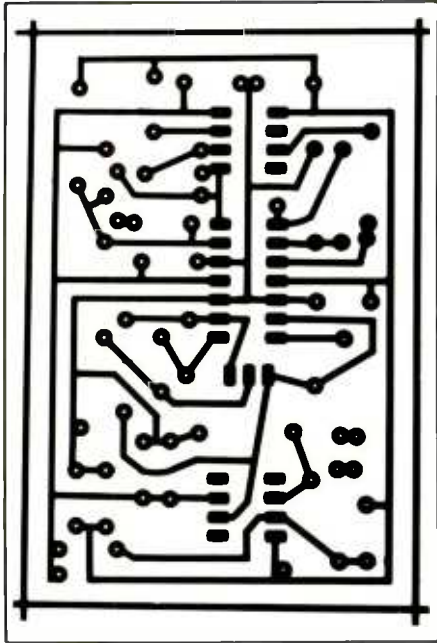

Fig. 3. Use this actual-size etching-and-drilling guide to fabricate a printed-circuit board for the project.

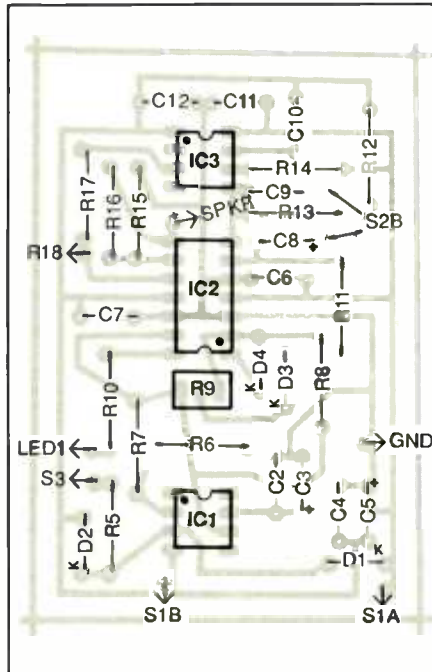

Fig. 4. Wire the printed-circuit board as shown here.

with each other and has adequate panel space on which to mount the LED, switches, potentiometer, speaker and connectors. A suitable enclosure is the all-plastic project box shown in the lead photo.

Prepare the enclosure by drilling mounting holes for *S1* through *S4*, *R18*, *J1*, *J2* and the holders for *LED1* and the batteries. You can mount the speaker either with machine hardware or a bead of silicone adhesive. If you do the former, drill three holes spaced in the front panel equidistant from each other for mounting screws around the the speaker (see Fig. 5). Whichever mounting method you choose, make a pattern of small holes in the panel where the speaker will be mounted to permit the sound to escape.

Temporarily mount the controls on the front panel and place on the shaft of the potentiometer a pointer-type control knob to determine where to put the identifying legends. Mark the panel as needed. Then remove and set aside the controls. Use a dry-

transfer lettering kit to label the panel. Spray over the entire surface of the panel two or more light coats of clear acrylic to protect the legends from abrasion. Allow each coat to dry before spraying on the next. If you use a tape labeler, you can forego the protective acrylic spray.

With the front panel machined, machine the remainder of the project box. Drill holes in the floor for mounting the circuit-board assembly and the two holders for the batteries. Then drill mounting holes for banana jacks *P1* and *P2*. Figure 5 shows a suggested layout for the components inside the enclosure. If possible, space the holes for *P1* and *P2* so the Voltone accessory can plug directly into your DVM or DMM, as shown in the photo on the cover. Otherwise, use a pair of test leads that exit the project box and are terminated in banana plugs. If you have more than one meter with which you wish to use the accessory and their jack spacings are different, you might want to go the latter route.

Trim to length and crimp the leads of resistors *R1* through *R4* directly to the lugs on rotary switch *S3*. Then to minimize noise pickup by the high-impedance input, make the connection from *S3* to *R5* with shielded cable. Carefully cut and remove about 1/2 inch of the outer plastic jacket from one end of a length of shielded cable, trim away the exposed shield (only one end of the shield will be grounded), and remove 1/4 inch of insulation from the center conductor. Tightly twist together the fine wires in this conductor and sparingly tin with solder.

Remove from the other end of this coaxial cable 1/4 inch of outer plastic jacket. If the shield is made of braided wire, separate it back to what remains of the outer jacket, tightly twist together all conductors and sparingly tin with solder. Strip 1/4 inch of insulation from the center conductor at this end of the cable, twist together the exposed wires and tin them with solder.

Plug the center conductor at the end of the cable from which you trimmed the shield into the hole labeled *S3* on the circuit-board assembly and solder into place. Loop the shield at the other end of the cable around the lead of *R4* that is not connected to any lug on *S3* and solder the connection. Trim off any excess shield wire. Arrange things so that the shield cannot touch any other parts of the circuit when *S3* is installed on the panel. If necessary, insulate it with electrical tape. Crimp and solder this conductor to the lug on *S3* that goes to the rotor contact.

Mount the circuit-board assembly on the floor of the enclosure with three 1/2-inch spacers and 4-40 x 1/4-inch machine hardware. Mount the battery clips in place with suitable hardware. Twist together the red-insulated wire from one battery snap connector and the black-insulated wire from the other battery connector.

Mount the speaker, LED, switches,

potentiometer and banana jacks in their respective locations on the front panel of the enclosure. If you are using silicone adhesive to secure the speaker in place, wait until the project has been completely assembled to mount the speaker.

Crimp and solder the red/black-insulated pair of battery connector leads to the solder lug on banana jack *J2*. Do *not* solder the connection. Next, crimp and solder the remaining red and black-insulated battery connector leads to contact of *S1A* and *S1B*, respectively. Referring to Fig. 4, identify the wire coming from the hole in the circuit board labeled *S1A* (lower right); crimp the free end of this wire to the other *S1A* lug and solder the connection. Do the same with the *S1B* wire and lug.

Now, referring to Fig. 1 and Fig. 4, crimp and solder the free ends of the remaining wires coming from the circuit-board assembly to the lugs of the potentiometer and switches. Then wire into the circuit the LED and banana jacks. Make all ground (GND) connections at *J2*, soldering this multiple connection only after all wires have been connected to it. Use Fig. 1 as a wiring guide.

Wire *S2* so that for dc inputs, *S2A* is closed and *S2B* is open, while for ac inputs the reverse is true. Mount *C1* on *S2A*. Before wiring *LED1*, determine which end is which by connecting it across a 9-volt battery in series with a 560-ohm resistor. If it lights red, plug the positive lead of the LED into specified hole near *R10* on the circuit board and solder the connection. If it glows green, solder the *negative* lead into the specified hole. In either case, crimp and solder the remaining LED lead to one lug of *S4*, and connect a hookup wire from the other *S4* lug to the *J2* lug. Similarly, use hookup wires to connect the speaker into the circuit, as specified in Fig. 1.

With all wiring complete and the ICs still not installed in their sockets, double-check your work to ascertain

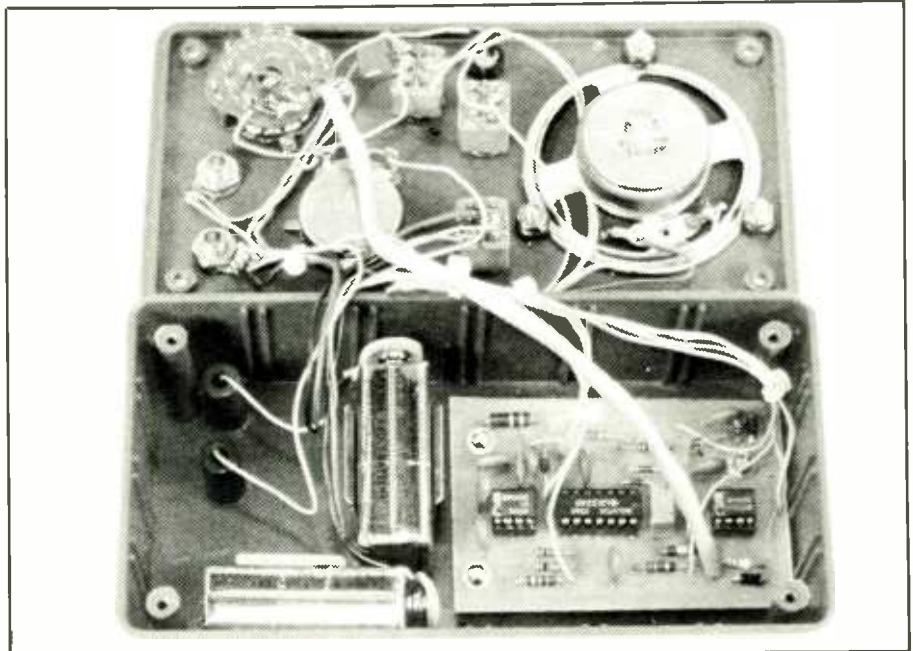

*Fig. 5. Circuit board, batteries and plugs for connecting to a DVM or DMM mount on the floor of the enclosure. Front-panel controls and the speaker mount on the enclosure's cover panel.*

that all components are installed in the right places and in the correct orientation where required and that all wiring is properly executed.

A few plastic cable ties or some waxed lacing cord will help keep things neat. Use electrical tape or pieces of non-conductive foam to insulate any parts that may short together when the cover is put on.

### Checkout & Use

Before conducting an operational check, perform voltage checks to make sure the battery supply has been wired into the circuit properly. Clip the common lead of a dc voltmeter or multimeter set to the dc volts function to the lug on *J2*. Snap fresh 9-volt batteries into the connectors and set POWER switch *S1* to ON. Touch the meter's "hot" probe to pin 7 of the *IC1*, pin 4 of the *IC2* and pin 8 of the *IC3* sockets. In all three cases, you should obtain a reading of approximately +9 volts. Then touch

the probe to pin 4 of the *IC1*, pin 11 of the *IC2* and pin 7 of the *IC3* sockets. This time, the reading should be -9 volts in all three cases.

If you do not obtain the correct reading at any one of the points specified above, set *S1* to OFF and remove the batteries from the circuit. Rectify the problem before proceeding.

Once the proper readings have been obtained, plug the ICs into their respective sockets. Observe proper orientation and make sure that no pins overhang the sockets or fold under between the ICs and sockets.

Operation of the project can most easily be checked with it connected in parallel with a DVM or DMM, the latter set to dc volts, via *P1* and *P2*. Push these banana plugs into the input jacks on your DVM or DMM and plug the meter's test leads into *J1* and *J2* on the project. You'll also need a variable voltage source, which can be as simple as a potentiometer connected across a battery and the "output" taken between the wiper and either of the other two lugs on

the potentiometer.

This project is used in much the same manner as you would use any other voltmeter. That is, set the input scale to a value greater than the voltage you expect to measure, and connect the signal to be measured to the input jacks via the meter's test leads. A low-frequency tone indicates a low voltage, while a high-frequency tone indicates a higher voltage. So, when using the instrument for peaking or nulling purposes, a rising tone tells you that the input voltage is increasing, and a falling tone means it's decreasing.

To begin operational checkout, set both your DVM or DMM and the project to the 200-millivolt scale for dc volts. Set the project's VOLUME control to minimum, and turn on both units.

Adjust the variable voltage source

you're using for a 0-volt output and connect your meter probes to measure it. Turn up the volume, and you should hear a tone—at a frequency of about 800 Hz.

Slowly increasing the output of the voltage source should make the project emit a tone that rises in frequency until the input reaches approximately 200 millivolts, at which point it will hold constant at a frequency of around 1,800 Hz. The exact frequencies heard aren't critical, and the cut-off voltage may be somewhat higher than 200 millivolts. What's important is that the frequency varies throughout the full input range.

On the 2-volt range, you should hear the same frequency range as you adjust the variable voltage source for an input that ranges from 0 to 2 volts. The 20-volt and 200-volt ranges operate similarly. With S2 set

to AC, you can measure ac signals independently of any dc offset.

Using the project in parallel with a DVM or DMM increases the loading effect on the circuit being measured (compared to using just one meter). In most cases, however, the effect will still be negligible.

For audible-only measurements, unplug the DVM or DMM and use the project by itself. The LED polarity indicator tells you if *J1* is more positive (red), more negative (green), or ac (yellow) with respect to *J2*.

If the frequency remains constant as you adjust the measured voltage, either the voltage being measured is constant, or the magnitude of the input voltage is too large for the range selected. You'll soon learn to recognize your meter's maximum frequency, which lets you know it's time to change ranges. **ME**



## CHEMICAL SOLUTIONS

### FREE CHEMTRONICS CATALOG!

Comprehensive new source for over 200 products used in electronic manufacturing and field service. Precision cleaning agents, flux removers, bulk solvents, circuit refrigerants, precision dusters, non-residual wipers, foam swabs, premoistened pads swabs, antistatic compounds, conformal coatings, lubricants, adhesives, desoldering braids, rosin core solder and solder masking agents. Complete with technical specifications and application guide.



**Chemtronics Inc.**  
681 Old Willets Path  
Hauppauge, N.Y. 11788  
516-582-3322

CIRCLE 46 ON FREE INFORMATION CARD

Say You Saw It In Modern Electronics

## They're Here! FUN PROJECTS

You'll want these two exciting project books, packed with complete plans for building a wide variety of useful electronic devices.

Look at what you can build & take pride in:

- \*Digital voltmeter accessories—high-frequency ac probe, true-rms adapter, temperature probe
- \*Car projects—anti-theft alarms, engine tachometer
- \*Life-saving detectors—gases & microwave leaks

The Fun Projects are capped by introductory information on building projects and kits (tools needed, parts sources, etc.) and advanced design techniques that illustrate how a designer thinks and plans when putting together a practical end product.

From beginning to end, MODERN ELECTRONICS FUN PROJECT BOOKS are for you! Order them today for a fast start in the world of electronics.

### MODERN ELECTRONICS

76 N. Broadway, Hicksville, NY 11801

Order Date: \_\_\_\_\_

Name \_\_\_\_\_  
Address \_\_\_\_\_  
City \_\_\_\_\_  
State \_\_\_\_\_ Zip \_\_\_\_\_  
( ) Check ( ) MasterCard ( ) VISA  
Card No. \_\_\_\_\_  
Expires \_\_\_\_\_  
Signature \_\_\_\_\_

QTY	Title	Price	Total
	First Book of Modern Electronics Fun Projects	\$12.95 ea.	
	Second Book of Modern Electronics Fun Projects	\$12.95 ea.	
		<b>Total</b>	
		*Shipping	
		<b>Grand Total</b>	

(Signature required on all charge orders)

\*Shipping charges \$2 per order. Orders processed day received, but please allow 30 days for delivery.

# Wave-Shaping Circuit Action

*How waveforms are shaped electronically and interpreting their results—good and bad— on an oscilloscope*

By Robert G. Middleton

**W**ave-shaping circuits are extensively used in most areas of electronics. This article illustrates how they work and what they produce, using an oscilloscope, when they're operating properly and when there's a defect that distorts the trace. Such information will be especially important to electronics technicians in many fields since it will take some of the mystery out of vertical-sweep functions and malfunctions.

Perhaps the simplest example of these is the peak clipper shown in Fig. 1. Clipping action occurs in such a circuit because the shunt resistor has a value that is much less than the reverse resistance of the diode but is much greater than the forward resistance of the diode.

If the diode in Fig. 1 develops junction leakage, the output waveform is incompletely clipped. If the diode is shorted, no clipping action occurs. Note that this is an example of a *non-linear* wave-shaping circuit.

Now observe the parallel diode clipper circuits shown in Fig. 2. Clipping action occurs in these circuits because the series resistor has a value that is much less than the reverse resistance of the diode but is much greater than the forward resistance of the diode. As in the series-circuit arrangement, if the diode develops junction leakage, the output waveform is incompletely clipped. Too, if the diode is shorted, zero output is obtained. This is another example of a nonlinear wave-shaping circuit.

Reverse-biased diode clippers are

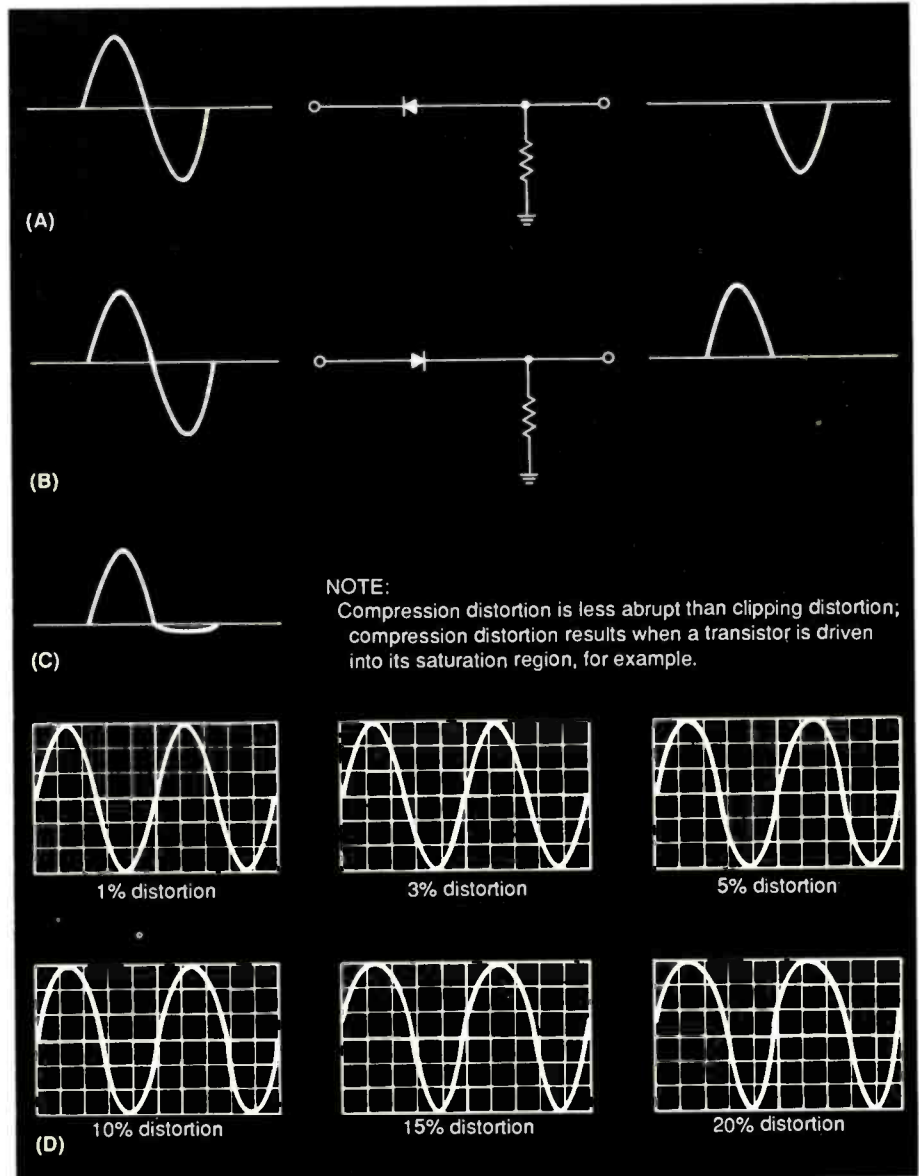

*Fig. 1. Series-diode peak-clipper circuits: (A) positive and negative (B) peak-clippers; (C) distorted output waveform from negative peak clipper resulting from junction leakage; (D) peak compression waveforms with different percentages of distortion. In (D), compression distortion is less abrupt than clipping distortion and results when a transistor is driven into its saturation region, for example.*



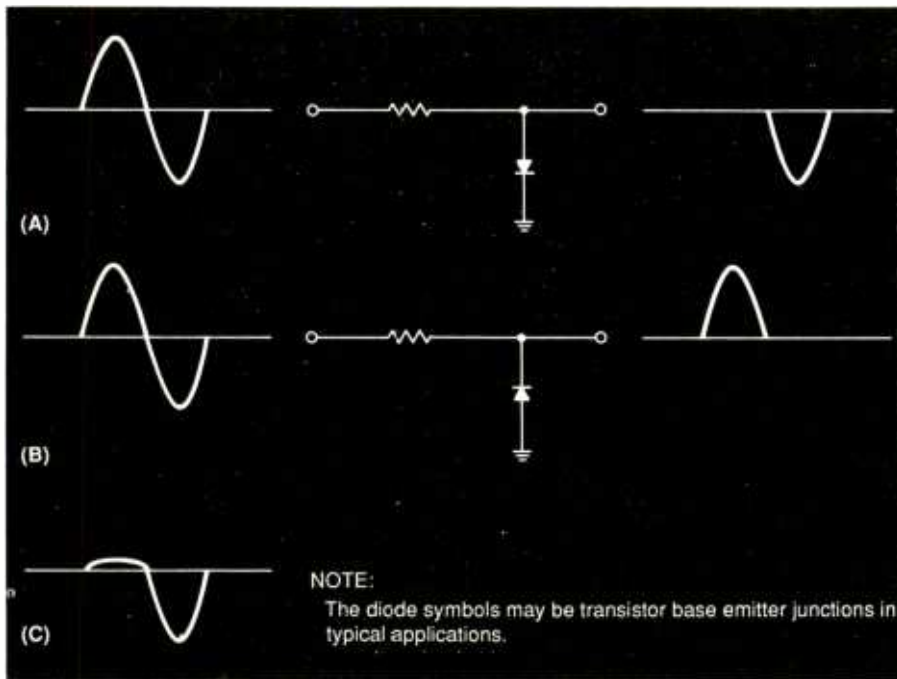

Fig. 2. Parallel-diode clipper circuits: (A) positive and (B) negative-peak clippers; (C) distorted output from positive-peak clipper due to junction leakage. Diodes in (A) and (B) may be transistor base-emitter junctions in actual circuits.

used for partial peak clipping, as illustrated in Fig. 3, which shows basically parallel diode-clipper circuits. The clipping level is determined by the value of the back-bias voltage. If the diode junction develops leakage, the clipping level is shifted, as illustrated in (C). Note that junction leakage also results in attenuated output. If the diode is shorted, the output voltage is 0. If the diode is open-circuited, the output voltage is not attenuated and no clipping action occurs.

### Sync-Clipper Circuit Action

The basic sync-clipper circuit uses a reverse-biased diode, as shown in Fig. 4. Although it isn't obviously reverse biased, signal-developed bias voltage effectively reverse-biases the diode. When the RC time constant of the coupling circuit is correct, the value of the reverse-bias voltage then provides a clipping level at the "porch" of the sync pulse. In turn, only the sync tip

appears in the output. The sync pedestal and any associated video signal are rejected. This circuit action is accomplished as follows.

After several sync pulses have been processed, the "steady state" has been established in the sync separator and the coupling capacitor maintains an average back-bias negative voltage that cuts off the diode except for the duration of the sync tip. Stated another way, the incoming sync pulse "sees" a conducting diode only when its instantaneous voltage exceeds the porch level.

Circuit action in Fig. 4 occurs because diode conduction during the sync-tip passage recharges the coupling capacitor, which partially discharges during the idle time from one sync pulse to the next. Immediately after the sync tip has passed, the coupling capacitor has been charged to the peak voltage of the sync pulse.

Signal-developed reverse bias provides an important advantage when the incoming video signal level is sub-

jected to change from one channel to another. Thus, the peak potential level on one channel might be 2 volts and the peak potential level on another channel might be 0.75 volt.

Despite the prevailing video-signal level, the sync circuitry requires reception of a clean sync tip that is free from spurious components. This requirement is met from a practical standpoint by use of signal-developed reverse bias since the reverse-bias level then "follows" the prevailing video signal.

If a circuit fault develops, such as diode junction leakage, the output waveform will display spurious components, as illustrated in Fig. 4(B). Leakage resistance shifts the clipping level and permits part of the sync pedestal and white video peaks to pass through the clipper. It is evident that if the clipping diodes were to become shorted, there would be no clipping action whatsoever and the input video signal would pass unaltered into the output circuit. The diode in Fig. 4 is more likely to be a transistor to develop gain in the clipper section.

### Wave-Shaping and Negative Feedback

Another basic type of wave-shaping circuitry is shown in Fig. 5, which illustrates one method of generating a vertical-sweep waveform, as in a TV receiver. It consists of a gated RC integrating circuit that produces an exponential (semi-sawtooth) waveform.

Since the semi-sawtooth waveform in Fig. 5 is convex, it would compress the image displayed on the TV receiver's picture tube toward the bottom of the screen. Accordingly, the initial waveform must be linearized by some means. Two methods of accomplishing this are commonly employed—negative feedback and predistortion correction.

The basic negative-feedback linearization arrangement is shown in Fig. 5(A). Partial linearization is accomplished by feeding back part of

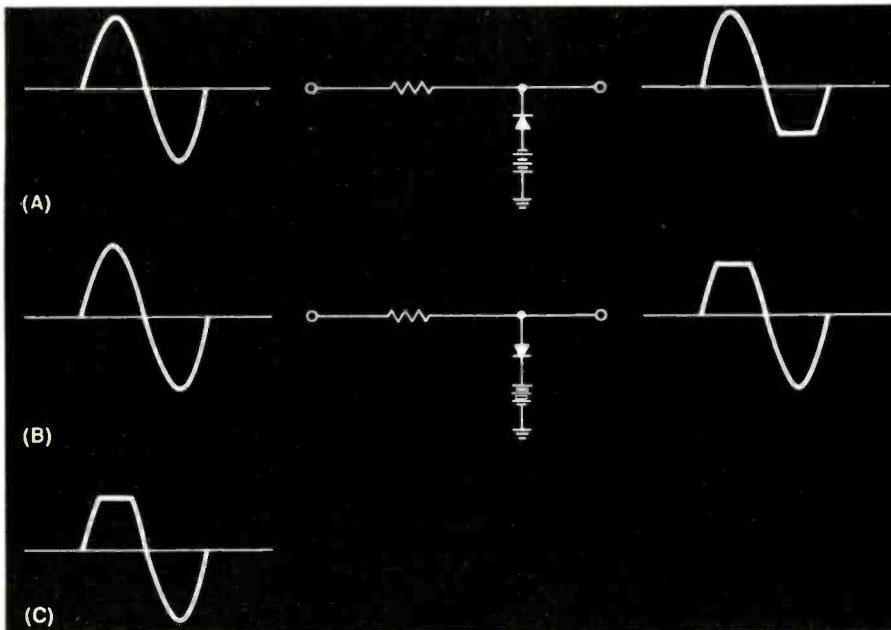

Fig. 3. Reverse-biased diode clipper circuits: (A) negative and (B) positive peak clippers; (C) distorted output (shifted clipping level) from positive peak clipper due to junction leakage.

the output voltage and combining it with the input voltage.

In theory, a semi-sawtooth waveform could be completely linearized by negative feedback. In practice, however, excessive production costs

would be incurred, inasmuch as a prohibitively high-powered output amplifier would be required, resulting in a linearization/power tradeoff.

Because of the linearization/power tradeoff, a moderate amount of neg-

ative feedback is used in practical circuits. Then the partially linearized sweep waveform is further linearized by means of predistorting circuitry, as shown in Fig. 6. Note here that predistorting circuits are non-linear wave-shaping arrangements, whereas negative-feedback wave-shaping circuits are basically linear configurations.

### Wave Shaping in Predistorting Circuits

Observe in Fig. 6 that the dynamic transfer characteristic for a bipolar transistor is concave at low bias values and is convex for high for high bias values. Thus, if a linearity control biases the vertical driver stage at point R', for example, the output waveform will be concave in comparison to the input waveform. Or if the vertical driver stage is biased at point X', for example, the output waveform will be convex in comparison to the input waveform. In turn, a partially linearized sawtooth waveform with residual convex distortion can be further linearized by passing it through a driver stage with a low bias setting.

Bear in mind that predistortion wave shaping does not provide complete linearization of the applied semi-sawtooth waveform. This is because the curvature in the dynamic transfer characteristic only approximates the exponential curvature present in the semi-sawtooth waveform. Accordingly, practical vertical driver circuitry typically includes negative feedback to provide optimum curvature in its dynamic transfer characteristic.

As an illustration of the above, a widely used configuration employs appreciable negative feedback from collector to base plus a small amount of emitter feedback. The emitter feedback is further modified by injection of some deflection-coil current.

A common variation on the foregoing wave-shaping circuit uses fixed bias on the driver transistor, with the linearity control in the collector-to-

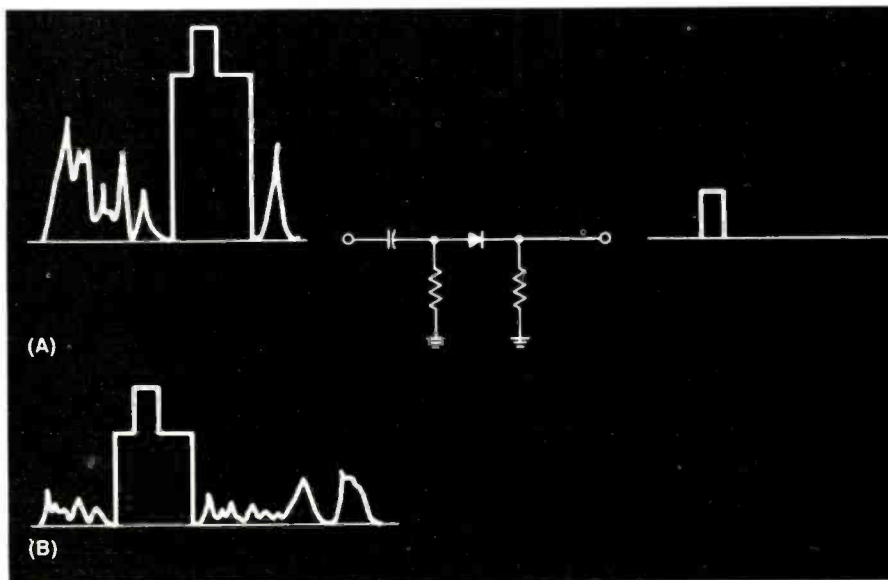

Fig. 4. Sync-separator arrangement with reverse-biased diode type of circuit action: (A) basic configuration; (B) output waveform with spurious components resulting from junction leakage.

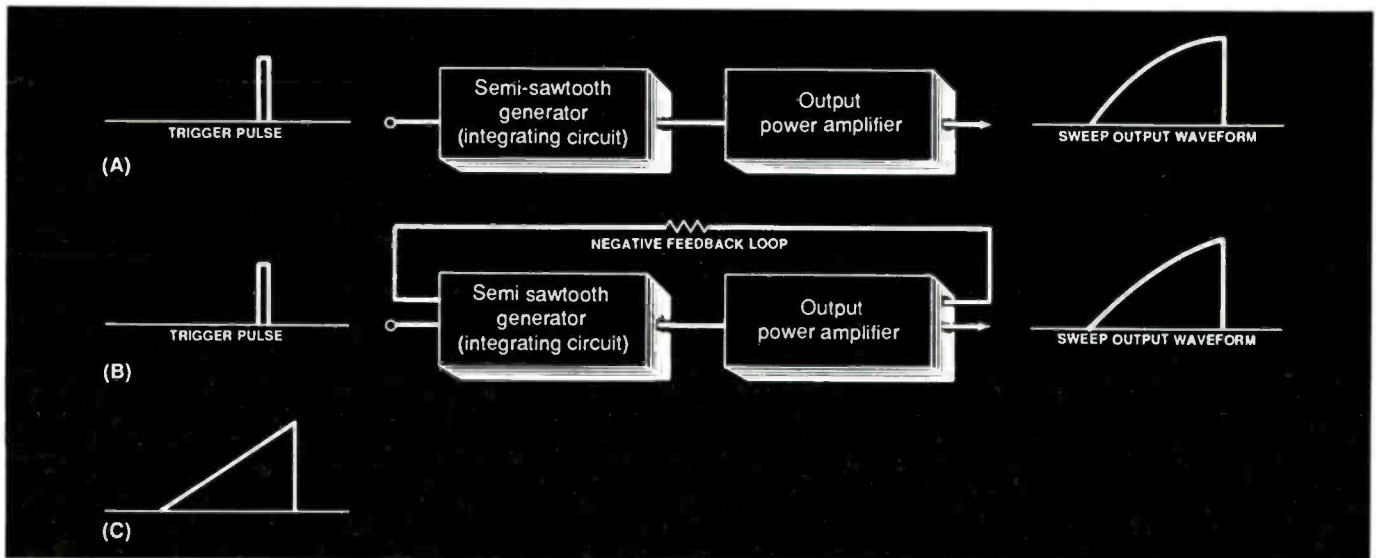

Fig. 5. Wave shaping in a vertical-sweep section of a TV receiver: (A) basic arrangement; (B) a sawtooth waveform shown partially linearized by negative feedback; (C) an ideal sawtooth waveform would be generated when an unlimited amount of negative feedback is used in the circuit.

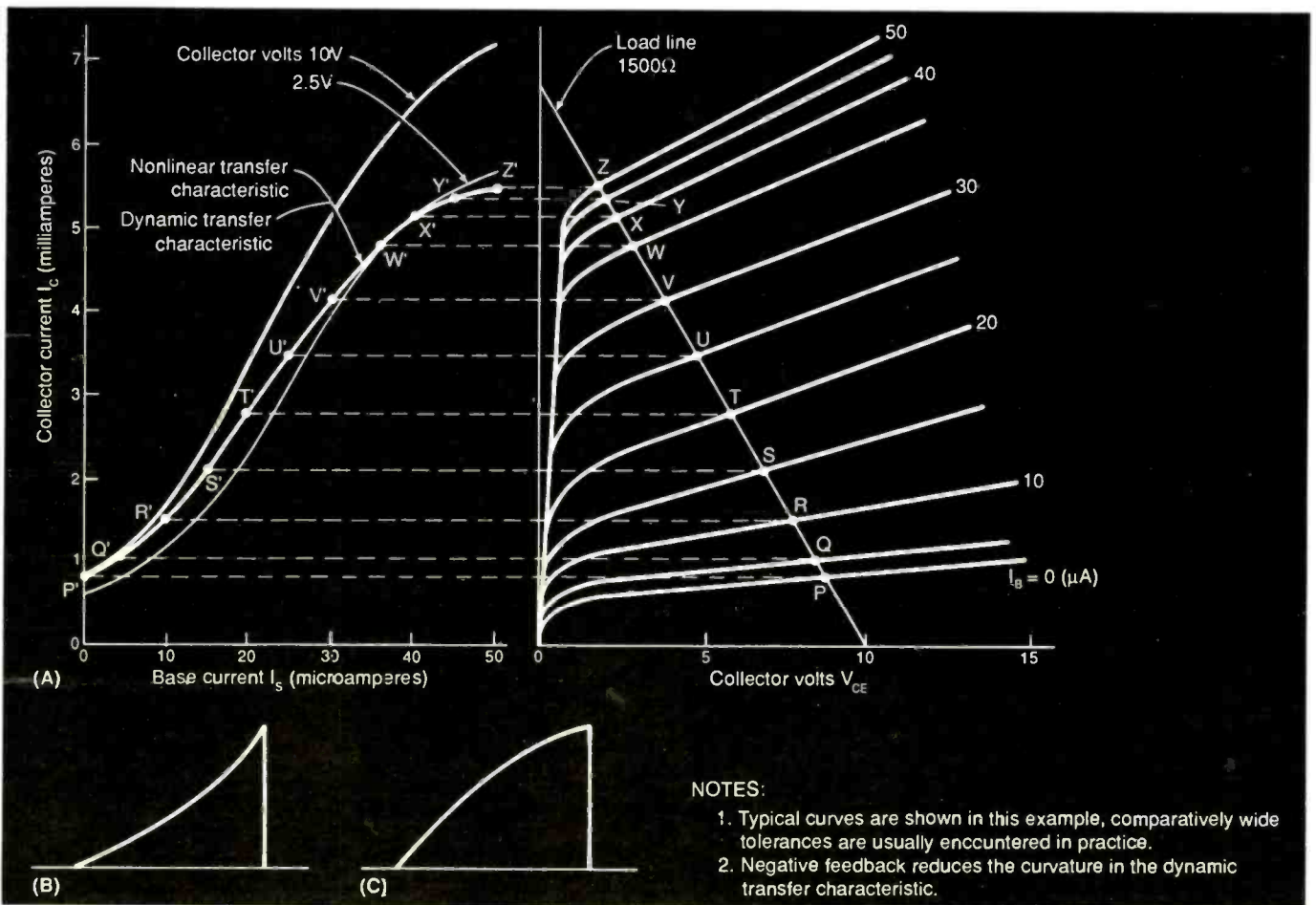

Fig. 6. Predistortion wave-shaping process: (A) dynamic transfer characteristic for a bipolar transistor; (B) low-bias predistortion; (C) high-pass predistortion. Negative feedback reduces curvatures in the dynamic transfer characteristic.



Fig. 7. Basic peaked-sawtooth wave-shaper (A) and low-amplitude peaking pulse (B) results from capacitor leakage.

base feedback loop. With this arrangement, the amount of concave predistortion is determined by the amount of negative feedback that is used. In either implementation, the amplitude of the sawtooth is determined by the amount of semi-sawtooth drive voltage fed to the base of the driver transistor.

The semi-sawtooth waveform is generally developed by an emitter-follower circuit that has a partially bypassed emitter resistor. This sawtooth-generator maker provides low source resistance, which is an advantage in driving power-type transistors.

It follows that reading oscilloscope waveforms in wave-shaping circuitry can depend considerably on your knowledge of the details in the circuit being investigated insofar as interpreting distorted waveforms is concerned. That is, the same distortion factor that points to incorrect bias in one variation of the basic circuit can be misleading in another variation of the basic circuit.

Sectional interaction can also be confusing when reading scope waveforms. Interaction is most prominent in two-stage systems and may be only a minor factor in three-stage systems. There is always some degree of interaction to be taken into consideration merely because all vertical wave-

shaping circuits employ more or less negative feedback.

### Peaked Sawtooth Wave Shaping

Current waveforms differ from voltage waveforms in reactive circuits that contain an inductance or/and capacitance. Thus, a sawtooth voltage drives a sawtooth current waveform through a purely resistive circuit, but a pulse voltage drives a sawtooth current through a purely inductive circuit. The vertical-deflection coils in a TV receiver, for example, are both inductive and resistive. As might be anticipated, a combination pulse-and-sawtooth voltage waveform is required to drive a sawtooth current waveform through vertical-deflection coils. This combination waveform is called a "peaked sawtooth."

The basic peaked-sawtooth wave-shaping circuit is shown in Fig. 7. It consists of a series RC branch network in shunt to the output of the driver stage. Observe that during the rise of the input and output sawtooth waveforms, the peaking capacitor charges up to nearly the peak voltage of the sawtooth output.

When the input sawtooth waveform suddenly falls, the output sawtooth cannot instantly fall to ground

potential because the peaking capacitor has a terminal voltage that first must drain off to ground via the peaking resistor. Since the time constant of the peaking circuit is comparatively short, drain-off is rapid, and this interval generates a "spike" or peak at the beginning of the next sawtooth waveform.

In a variation of the basic circuit, its equivalent RL configuration is employed. The inductive "kick-back," in turn, generates the spike for the peaked sawtooth waveform.

### Blanking-Pulse Wave Shaping

After the peaked-sawtooth waveform has been generated, it is frequently processed to form vertical-retrace blanking pulses. This blanking-pulse wave-shaping circuit has the basic configuration shown in Fig. 8. Note here that the circuit shown is essentially a differentiating circuit that has a time constant that permits passage of the narrow peaking pulses or spikes but rejects the broad ramp portion of the waveform. This is just another way of saying that narrow pulses are built up from comparatively high-frequency harmonics, whereas the ramp is built up from comparatively low-frequency harmonics of the sweep repetition rate.

ME

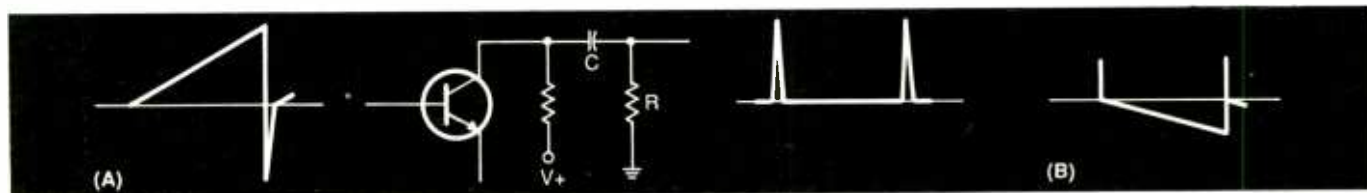
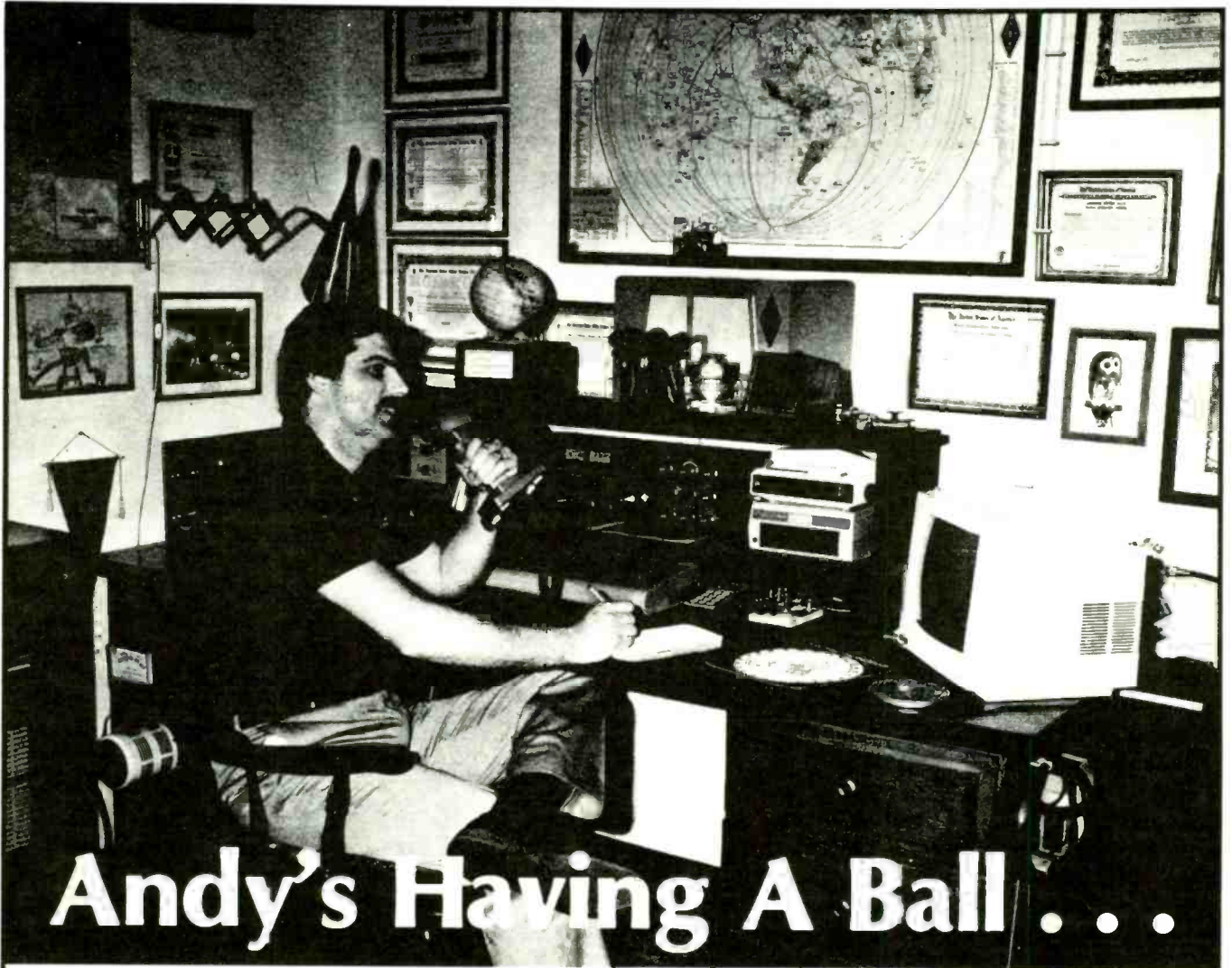

Fig. 8. A basic retrace blanking-pulse wave-shaping circuit (A) and distorted output waveform with attenuated pulse and spurious sawtooth components (B) resulting from capacitor leakage.



# Andy's Having A Ball . . .

## and you can too!

Andy is a Ham Radio operator and he's having the time of his life talking to new and old friends in this country and around the world.

You can do it too! Join Andy as he communicates with the world. Enjoy the many unique and exclusive amateur bands . . . the millions of frequencies that Hams are allowed to use. Choose the frequency and time of day that are just right to talk to anywhere you wish. Only Amateur Radio operators get this kind of freedom of choice. And if it's friends you're looking to meet and talk

with, Amateur Radio is the hobby for you. The world is waiting for you.

If you'd like to be part of the fun . . . if you'd like to feel the excitement . . . we can help you. We've got all the information you'll need to get your Ham license. Let us help you join more than a million other Hams around the world and here at home. Who are we? We're the American Radio Relay League, a non-profit representative organization of Amateur Radio operators.

For information on becoming a Ham operator  
circle number 11 on the reader service card or write to:

**AMERICAN RADIO RELAY LEAGUE** Dept CQ, 225 Main Street  
Newington, Conn. 06111.

# The Absent CGA Color Text

*How to get color text with many new programs that restrict color graphics adapters to white-on-black displays*

By Paul Danzer

As personal computers move along to higher-resolution color displays, the original color graphics adapters (CGA) seem to be ignored by software writers. A lot of new software that provides color text on EGA and VGA monitors will only produce white on black with CGA/RGB color monitor systems.

Although text is not as sharply produced with CGA, many standard RGB color monitors used with the adapter compound the resolution problem when text is displayed as white and black. White, it seems, appears unusually grainy, making it hard on the operator's eyes. There is an under-\$10 hardware fix, however, that lets you convert harsh white/black displays to green/black, blue/black, yellow/black, or any combination of two of the three colors on your color monitor.

## About the Circuit

When a PC provides a white signal through its CGA (color graphics adapter), the RGB video monitor connected to it "sees" a logic high of approximately +5 volts on its R (red), G (green) and B (blue) lines. If a logic low (approximately ground potential) appears on one or two of these lines, the displayed image will be in a color other than white, which is the principle employed in this project. By placing switches in the RED, GREEN and BLUE lines, as shown in the schematic diagram, any one or two of these lines can be grounded, effectively forcing it or them to logic

low. The effects of grounding one or two lines are summarized in the Table.

With three switches wired into the circuit as shown, eight possible setting combinations exist, ranging from all on to all off. The first is of no interest because it is the "normal" CGA/color-monitor condition we are trying to get away from. Similarly, the last is of no practical use because, with all three switches set to OFF, nothing would be displayed on the monitor's screen. The second through seventh switch setting combinations provide enough choice of colors to suit just about any operator viewing preference.

Bear in mind that the colors listed in the Output Color column are only approximate. Each video monitor manufacturer balances its displays differently. Therefore, what might appear to be yellow on the screen of one monitor might well be amber on another monitor. The only true-color switch combinations are those for red, green and blue.

As you can see in the schematic, the project is very simple in design. It consists simply of male and female 9-contact (DB-9) connectors, a length of 9-conductor cable and three switches. This cable/switch arrangement connects between the computer and color video display monitor via P1 and S01, respectively. The three switches then provide the means by which the R (red), G (green) and B (blue) color lines going to the video display monitor can be independently controlled.

With all three switches in the up position as shown, the project oper-

ates as though the usual "normal-through" cable is being used. That is, whatever signals are being output by the computer on the RED, GREEN and BLUE lines will pass to the video monitor without being affected. To choose a color other than white for the video display, you simply flip one or two of the switches to its OFF position.

## Construction

Being very simple in design (low component count), the project is also very simple to build, nor is there anything critical about layout. The entire project can be built inside a 1 x 2 x 3-inch plastic project box with aluminum top panel.

Start construction by drilling mounting holes for the switches.

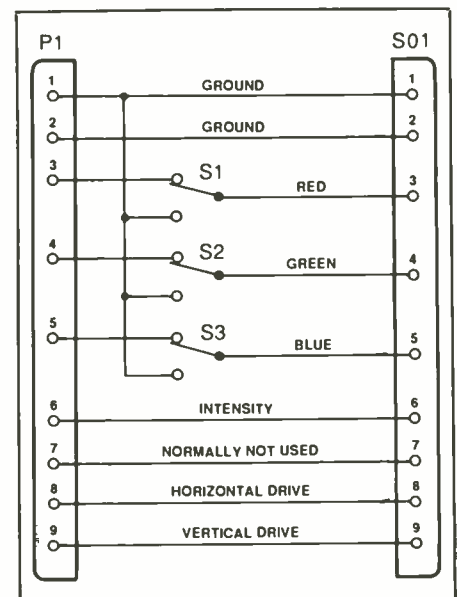

Complete schematic diagram of project.

### PARTS LIST

P1—Male DB-9 subminiature solder- or IDC-type plug

S1,S2,S3—Spdt miniature toggle switch

SO1—Female DB-9 subminiature solder- or IDC-type jack

Misc.—Suitable enclosure (Radio Shack Cat. No. 270-230 or similar); connector hoods for P1 and SO1; 9-conductor ribbon cable; lettering kit; hookup wire; solder; etc.

**Note:** A commercial cable can be used instead of individual P1 and SO1 connectors and ribbon cable, as explained in text.

### Colors Available With Different Switch Setting Combinations

S1 (RED)	S2 (Green)	S3 (Blue)	Output Color*
on	on	on	White
on	on	off	Yellow
on	off	on	Pink
on	off	off	Red
off	on	on	Aqua
off	on	off	Green
off	off	on	Blue
off	off	off	Black

\*Color of text on black background.

Center these holes in a line on the long axis of the panel and space them far enough apart so that the miniature switches will not interfere with each other. Deburr the holes and thoroughly clean the panel. Then use a dry-transfer lettering kit or tape labeler to label the holes RED, GREEN and BLUE from left to right.

If you use a dry-transfer lettering kit to label the panel, spray two or more *light* coats of clear acrylic over the entire panel to protect the lettering. Allow each coat to completely dry before spraying on the next.

How you machine the enclosure for entry and exit of the cable depends on whether you use the existing commercial cable that has DB-9 male and female connectors at opposite ends or you make a cable from scratch with ribbon cable and connectors. Commercial cables usually have a round cross-section that requires round holes. If you use one of these, cut the cable in half and feed the two cut ends through their separate holes into the enclosure.

A home-made cable will most likely start with flat ribbon cable, for which shallow slots should be made at opposite ends of the enclosure to make a pressure fit between the aluminum panel and enclosure, with the cable sandwiched between the two. Use a 15-inch length of 9-conductor ribbon cable, affixing to the opposite ends male and female DB-9 connectors.

Regardless of whether you use solder-type or IDC-type connectors, make certain that the conductors interconnect like-numbered pins on both connectors. When you are finished making the cable, use an ohmmeter or continuity checker to double check the interconnections. Also, if you used solder-type connectors, check for inadvertent short circuits between the closely spaced pins. Make a final wiring check by inserting the new cable in series with your existing monitor cable. If all is okay, there should be no difference in system operation.

Now wire the three switches to the cable. If you are using a commercial cable, remove about 2 inches of outer plastic jacket from both cut ends and identify the pin to which each conductor goes. Strip ½ inch of insulation from all conductors, except strip ¼ inch of insulation from those conductors that go to pins 3, 4 and 5 of both connectors. Twist together the fine wires in each conductor and sparingly tin with solder.

Slide a 1-inch length of small-diameter heat-shrinkable tubing or insulating plastic tubing over the conductors from which ½ inch of insulation was removed on one cable. Then twist together the two wires that go to pins 1 of both connectors and solder the connection. Do the same for the wires that go to pins 2, then pins 6, 7, 8 and 9.

Strip ½ and ¼ inch of insulation

from both ends of a 3-inch length of hookup wire. Twist the first end around the conductors that go to pins 1 of the connectors and solder into place. Slide the tubing over the connections to completely insulate them and shrink solidly into place.

Run a length of bare solid hookup wire through the OFF position lugs of all three switches. Solder this wire to the lugs of the center and one end switch. Then crimp the free end of the hookup wire connected to the pin 1 conductors to the lug of the remaining switch and solder both wires into place. Referring to the schematic diagram, wire the pins 2, 3 and 4 conductors from both connectors to the appropriate lugs of the switches.

If you are using a home-made cable, fold it in half and crease the center point of the cable. Now use a sharp utility or hobby knife to carefully separate the conductor that goes to pins 1 of both connectors from the remainder of the cable about an inch or so at the center. Do the same for the conductors that go to pins 3, 4 and 5, also separating each of these from the other.

Carefully remove ¼ inch of insulation from the center of the pin 1 conductor. Remove ¼ inch of insulation from both ends of a 3-inch hookup. Connect and solder one end of this wire to the exposed conductors of the pin 1 conductor. When the connection cools, insulate it with tape.

Separate the pins 3, 4 and 5 conductors an additional 1½ inches, split them at their center points and strip from each cut end ¼ inch of insulation. Tightly twist together the fine wires in each case and sparingly tin with solder. As detailed above, run a length of bare solid hookup wire through the OFF position lugs, solder it to the lugs of the center and one end switch, and crimp and solder the hookup wire connected to the pin 1 conductors to the lug of the remaining switch. Wire the pins 2, 3 and 4 conductors from the ribbon cable to the appropriate lugs of the switches.

# Now Available!



The First Annual



## Amateur Radio Buyers Guide

### The Active Ham's Complete Annual Reference Master

This valuable new master directory and buyer's guide will serve you day in and day out in searching out new gear, comparing new models, locating dealers near you and mail-order retailers around the country. It'll help you buy more wisely with its multi-reference concept to help you wend your way through the buying maze.

#### COMPLETE PRODUCT INFORMATION

It's a single-volume source book of the latest Amateur Radio gear all sectioned by equipment type for easy reference by the seasoned editorial staff of CQ:

- Complete product descriptions.
- Technical specifications.
- Retail prices.
- Equipment photographs.

#### WHO'S WHO IN THE AMATEUR RADIO BUSINESS

It's a Buyer's Guide filled with the kind of support information you've always needed, but couldn't easily get: Dealer listings state-by-state (including branches), names and calls for key personnel, top lines carried, whether or not trade-ins are accepted or on-site repairs are made . . . and so on.

#### BUYING TIPS FROM THE EXPERTS

Great articles on the in's and out's of purchasing Amateur equipment. The experts give you the inside scoop on everything from antennas to transceivers to making your first packet contact . . . and lots more.

#### ORDER YOUR BUYER'S GUIDE TODAY!

Don't miss the single most valuable buying guide in the Amateur Radio field. Send only **\$3.95** today.

-----  
**YES, please send my copy of AMATEUR RADIO BUYER'S GUIDE 1989 for only \$3.95 postage paid.**

Date \_\_\_\_\_ Number of Copies \_\_\_\_\_

Name \_\_\_\_\_ Call \_\_\_\_\_

Address \_\_\_\_\_

City \_\_\_\_\_ State \_\_\_\_\_ Zip \_\_\_\_\_

Check       MasterCard       VISA

Card No. \_\_\_\_\_ Expires \_\_\_\_\_

Signature \_\_\_\_\_

(Signature required on all charge orders)

**Mail to: CQ Communications, Inc.  
 76 North Broadway, Hicksville, NY 11801**

Assemble the enclosure to complete instruction. Connect the project between your computer and color monitor. If you made your own ribbon cable, use the existing cable to make the connection.

Set all three switches on the project to their ON positions. Now boot your computer, without the AUTOEXEC.-BAT file if it is used to set a default screen color, or run a software package that provides white characters on a black background. Toggle the project's three switches to their OFF positions according to the switch combinations detailed in the table while observing a screen partially or fully filled with characters and note the colors displayed in each case. Select the color that feels easiest on the eye and has the most pleasant effect. Do not forget to return all three switches to their ON positions to run a program that calls up color characters or/and graphics. **ME**

### WORLD'S SMALLEST WEATHER STATION



*THE AMAZING WEATHER COMPUTER THAT YOU CAN HOLD IN THE PALM OF YOUR HAND.*

DIGITAR's new TWR-3 Micro Weather Station includes a computer, precision wind vane and speed sensor with mounting hardware, and 40 feet of cable. For only **\$159.95**. With the optional, automatic-emptying RG-2 Rain Collector (\$49.95) you can even monitor rainfall!

- WIND SPEED
- WIND DIRECTION
- WIND CHILL
- WIND GUST RECORD
- TEMPERATURE
- HI/LOW TEMP RECORD
- RAINFALL (Optional)
- TIME OF DAY
- AUTO SCAN
- METRIC / STANDARD
- NICAD READY
- ONE YEAR WARRANTY

MAGNAPHASE INDUSTRIES, INC.

1502 PIKE STREET N.W.  
 MADE IN U.S.A. AUBURN, WA 98001 M/C & VISA

ORDERS ONLY: 800-322-1502  
 INFORMATION: 206-735-0374 FAX: 206-735-9044



# Transformer Theory

## *A service guide to troubleshooting transformers in electronic gear*

By Christopher H. Fenton

As long as they don't burn up or obviously malfunction, transformers are usually the last item to be checked out in ac-line-operated electronic equipment. Deceptively simple, the basic principles behind the transformer haven't changed very much since these devices were first put into service. So by understanding a few basic principles, it's possible for you to quickly determine whether or not the transformer is a cause of trouble in a circuit.

Let's explore these principles in detail, with the object of providing useful troubleshooting information to help you in isolating transformer problems. Though relatively technical (some elementary algebra is used to get the point across), our discussion is geared to *practical* transformer troubleshooting procedures.

### *Some Preliminaries*

Despite the transformer's innocent appearance, it can be a very dangerous device. Therefore, a few words of caution are in order before getting into actual theory.

A typical current transformer may have a harmless voltage across its secondary winding and applied to the load, but when the load is removed, this can dramatically increase by several hundred times the load voltage. In most cases, the secondary winding of a low-power, low-voltage transformer will not give you a shock if you touch both secondary leads simultaneously. An exception is if the secondary winding is joined

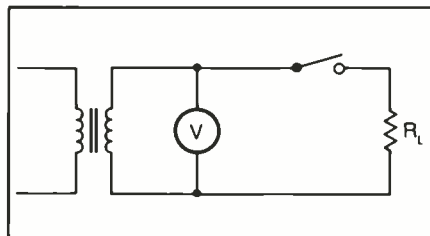

*Fig. 1. An example of a test setup for checking a transformer. This arrangement is not very useful in practical testing situations because  $R_L$  often must have a very low ohmic value and very high power rating.*

to the primary winding in the style of an autotransformer or if a short circuit exists that electrically connects the transformer's primary and secondary windings together.

The real electrical danger is not so much voltage but the current behind it. A short circuit that appears across the output winding of a transformer can cause an overload of current in the secondary winding that could immediately "fry" the load circuit. With this type of malfunction, the current drawn by the transformer will rarely "pop" a circuit breaker in your ac power line and, as a result, can often go undetected until the load circuitry has been damaged.

A power transformer that converts 117 volts ac into 6 volts ac has as much as 250 amperes flowing in the secondary winding, while the current in the primary winding remains 12.5 amperes, which is insufficient in magnitude to trip a standard 15-ampere circuit breaker. For this reason, transformers often have built into their primary windings fuses whose elements blow at a cur-

rent that is based on "normal" operating current.

A transformer's internal fuse is not replaceable without completely disassembling the transformer—a task that is beyond the scope of most service technicians' abilities. Therefore, a transformer with a blown fuse must be scrapped and replaced with a new unit.

As a general rule, the most common way to check a transformer is to measure the output voltage across its secondary winding while the primary is being driven by the ac power source. Readings should be taken both at initial start-up and after the transformer has run continuously for a period of time as you check out whether or not excessive heating is taking place.

If the transformer doesn't smell like it is burning up and no smoke is curling off it, the service technician generally declares it to be "good" and proceeds to check out the rest of the circuits in a malfunctioning piece of electronic gear. While this approach may be okay if a transformer is being used for a simple application, a more accurate way of determining a transformer's specifications is needed when it is being used in such applications as powering microchips and other devices where strict control of the output voltage is needed.

Output voltage regulation is the most critical measurement one can make on a transformer. Regulation is usually expressed by the formula: Regulation = (No-Load Voltage - Full-Load Voltage)/Full-load voltage. In this formula, regulation is expressed as a percentage figure. The

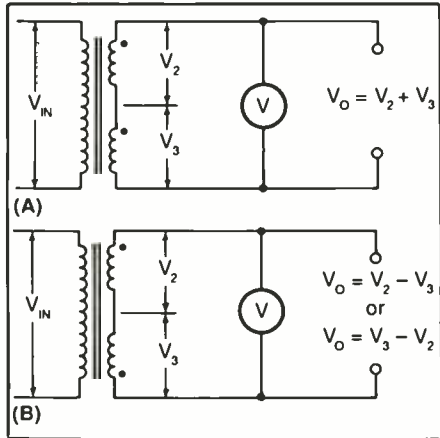

Fig. 2. Setups for determining relative polarities of transformer's secondary windings: (A) illustrates additive-coil arrangement, (B) subtractive arrangement.

higher the figure, the better the performance of the transformer.

### Troubleshooting Theory

In Fig. 1 is shown a simple circuit in which load resistance  $R_L$  is used to pass the rated secondary current of the transformer at the predetermined voltage. This arrangement is fine for example purposes only. In real application, however, this setup can lead to a problem. That is, if the rated current is 10 amperes and secondary potential is 12 volts ac, the resistance is  $10/12 = 1.2$  ohms, based on the equation  $R_L = V/I$  where  $V$  and  $I$  are the rated voltage and current, respectively. By extension,  $R_L$  will dissipate 120 watts, based on the equation  $P = IV$ , where  $P$  is power in

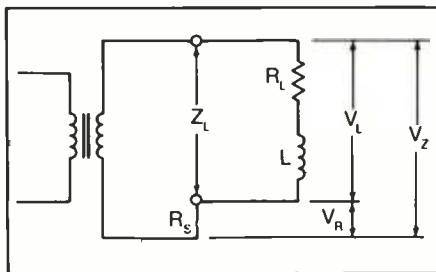

Fig. 3. Test setup for determining the inductance of  $L$ .

watts. Therefore, the problem with the Fig. 1 test arrangement is that 1.2-ohm, 120-watt resistors are virtually nonexistent.

At the service bench, the transformer should be tested while it is operated with the load (circuitry) for which it was designed to be used. The circuit is substituted for  $R_L$  and the switch is temporarily connected between the two as shown in Fig. 1. Inclusion of the switch permits the person doing the testing to check on-load and off-load voltages. This arrangement is better than using an artificial load because the voltage parameter is the one actually used in the circuit.

When performing such a test, the transformer should be allowed to warm up and reach operating temperature because heat can change the resistance of the transformer's windings. Any change in winding resistance results in a corresponding change in output voltage from the transformer.

Another important point to take into consideration when troubleshooting a transformer is the relative polarity (phasing) of the secondary windings in a dual- or multiple-secondary winding transformer. By connecting together the secondary windings in series with each other, as shown in Fig. 2, it is possible to determine what the relative polarity of the output is simply by measuring the voltage with a voltmeter or multimeter set to the ac voltage function.

If the transformer's secondary windings are wired to be additive, the meter will indicate the sum of the voltages across the separate secondary windings. That is,  $V_O = V_2 + V_3$ , where  $V_O$  is the output voltage and  $V_2$  and  $V_3$  are the individual secondary voltages. If the windings are wired to be subtractive, the meter will indicate the difference between the potentials that appear across the secondary windings:  $V_O = V_2 - V_3$  or  $V_O = V_3 - V_2$ . The two formulas reflect the fact that any two second-

dary potentials may not be the same magnitude; so whichever is the smaller is subtracted from the larger. If the two secondary windings are exactly balanced, the output potential indicated by the meter will be 0 volt.

When conducting an additive or subtractive test, it is important that you make sure the input voltage to the primary winding of the transformer is within required tolerance. If the input voltage is unknown, apply a small voltage from another transformer's secondary winding just long enough to obtain the required measurements. After the polarities of the secondary windings have been determined, label the transformer's leads accordingly so that you will know what they are later on when it comes time to install the transformer in the circuit.

In most servicing applications, bridge circuits are used to find inductance. Unfortunately, instruments to measure inductance are usually not found on the testbench. However, there are other methods that don't require an investment in yet another piece of expensive equipment. The simplest method one can use for determining inductance uses a high-impedance voltmeter, a resistor of known value and an ac power supply that delivers the required voltage.

The value of the resistor should be roughly the same as the impedance of the inductor, which is expressed as  $Z_L$ . Use the following formula to find the impedance of the inductor:

$$Z_L = \sqrt{X_L^2 + R_L^2}$$

The resulting inductive reactance,  $X_L$ , is calculated using the formula  $X_L = 2\pi fL$ , where  $\pi$  is a constant (approximately 2.14),  $f$  is frequency and  $L$  is inductance.

Let's assume  $L$  is about 50 Henrys and  $R_L$  is about 450 ohms. Using the formula for reactance ( $f = 75$  Hz),  $Z_L = \sqrt{(2 \times 3.14 \times 75 \times 50)^2 + 450^2}$

Factored out, the result is approximately 19,370 ohms.

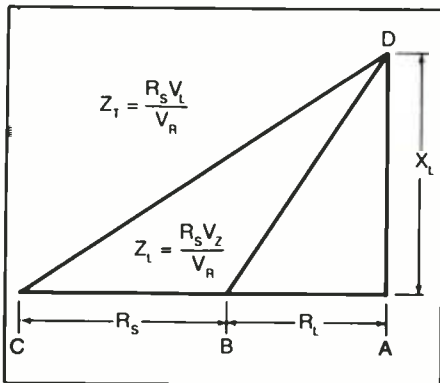

Fig. 4. An impedance triangle like this is a very helpful in determining the impedance of an inductor, given certain information.

Use an ac voltmeter and the test arrangement illustrated in Fig. 3 to determine the inductance of  $R_s$ ,  $L$  and across both nodes to obtain the three values for the equation. To calculate the impedance, it's best to draw an impedance triangle (see Fig. 4).

After defining  $R_s$  as a set number of units, use  $R_s V_L / V_R$  and the same number of units to strike an arc with its radius on the opposite end of the  $R_s$  line. Then calculate the result of  $R_s V_Z / V_R$  ohms, convert the result into scale and strike an arc with its radius on the opposite end of the  $R_s$  line to intersect with the previously struck arc.

From the intersection of the two arcs, draw a perpendicular line to the base line of  $R_s$ . This line represents the reactance of  $X_L$ . By converting your units back into ohms and plugging the result into the equation  $X_L = 2\pi fL$ , you can calculate the inductance.

If  $R_L$  can be measured accurately, inductance can be found without drawing the impedance triangle because  $Z_T^2 = X_L^2 + (R_L + R_s)^2$ , and you can use the equation

$$X_L = \sqrt{Z_T^2 - (R_L + R_s)^2}$$

The same method can be applied if direct current is flowing through the transformer's windings. By applying the required voltage and measuring the results with a voltmeter, it's pos-

sible to determine the inductance of the secondary winding. When using a voltmeter, direct current should be prevented from entering the meter by placing a blocking capacitor in series with the meter's "hot" probe and the test point in the circuit.

### Other Considerations

Leakage inductance is an important consideration with transformers used in audio-frequency applications. To measure leakage inductance, short together the secondary winding of the transformer and determine the primary's inductance. Direct current is not required because leakage inductance is indepen-

dent of the saturation effects of the transformer's core. Leakage inductance is also frequency-independent; so you can use any input frequency.

By using an inexpensive RC bridge designed to measure inductance against a preset value and an inductor whose value is already known as a starting point, you can accurately determine small values of leakage inductance.

Simply by learning a few basic formulas, you can quickly solve transformer problems quickly and efficiently. A couple of minutes spent checking a transformer for a potential problem can save a great deal of time and effort and prevent costly mistakes.

**ME**

# Organize and Protect Your Copies of **MODERN ELECTRONICS**

Now there's an easy way to organize and keep copies of your favorite magazine readily available for future reference.

Designed exclusively for **ME** by Jesse Jones Industries, these custom-made titled cases and binders provide the luxury look that makes them attractive additions to your bookshelf, desk or any location in your home or office.

Whether you choose cases or binders, you'll have a storage system that's durable and well organized to help protect your valuable copies from damage.

**MODERN ELECTRONICS**  
Jesse Jones Industries, Dept. Mod-E  
499 East Erie Avenue, Philadelphia, PA 19134

Please send \_\_\_\_\_ cases; \_\_\_\_\_ binders  
for Modern Electronics Magazine.

Enclosed is \$ \_\_\_\_\_.

Charge my: (Minimum \$15)

American Express  Visa  
 MasterCard  Diners Club

Card # \_\_\_\_\_ Exp. Date \_\_\_\_\_

Signature \_\_\_\_\_

Charge Orders: Call TOLL FREE 7 days, 24 hours 1-800-972-5858

Print Name \_\_\_\_\_

Address \_\_\_\_\_

No P.O. Box Numbers Please

City/State/Zip \_\_\_\_\_

PA residents add 6% sales tax

**SATISFACTION GUARANTEED**

Quantity	Cases	Binders
One	\$ 7.95	\$ 9.95
Three	\$21.95	\$27.95
Six	\$39.95	\$52.95

Add \$1 per case/binder postage and handling. Outside USA \$2.50 per case/binder. (U.S. funds only.)

# Solid-State Digital Barometer

*Weather-forecasting instrument accurately detects and displays small changes in atmospheric pressure*

By Anthony J. Caristi

Most home barometers do not accurately or reliably detect small changes in atmospheric pressure that are important factors in forecasting weather. The *Digital Barometer* presented here has been designed to address the deficiencies of such analog units.

Behind the design of our Digital Barometer are a relatively low-cost solid-state pressure sensor, a simple differential amplifier and an analog-to-digital (A/D) converter. This arrangement, along with a digital numeric display, can detect and display changes in barometric pressure of as little as 0.02 inch of mercury.

Power for the project is provided by the 117-volt ac line. Though very little power is actually drawn by the project, this type of instrument is usually left continuously powered to provide a constant display of atmospheric pressure. Thus, the ac line is a much more economical power source than a battery that requires frequent replacement. If the project is to be used only intermittently to take spot readings, however, battery powering can be an economical alternative to ac line power.

## About the Circuit

Before you can understand how this Digital Barometer operates, it is important that you first understand the workings of the absolute pressure sensor. Most people are accustomed to the concept of differential (gauge) pressure. Therefore, the following discussion is in order.

The familiar pressure gauge that

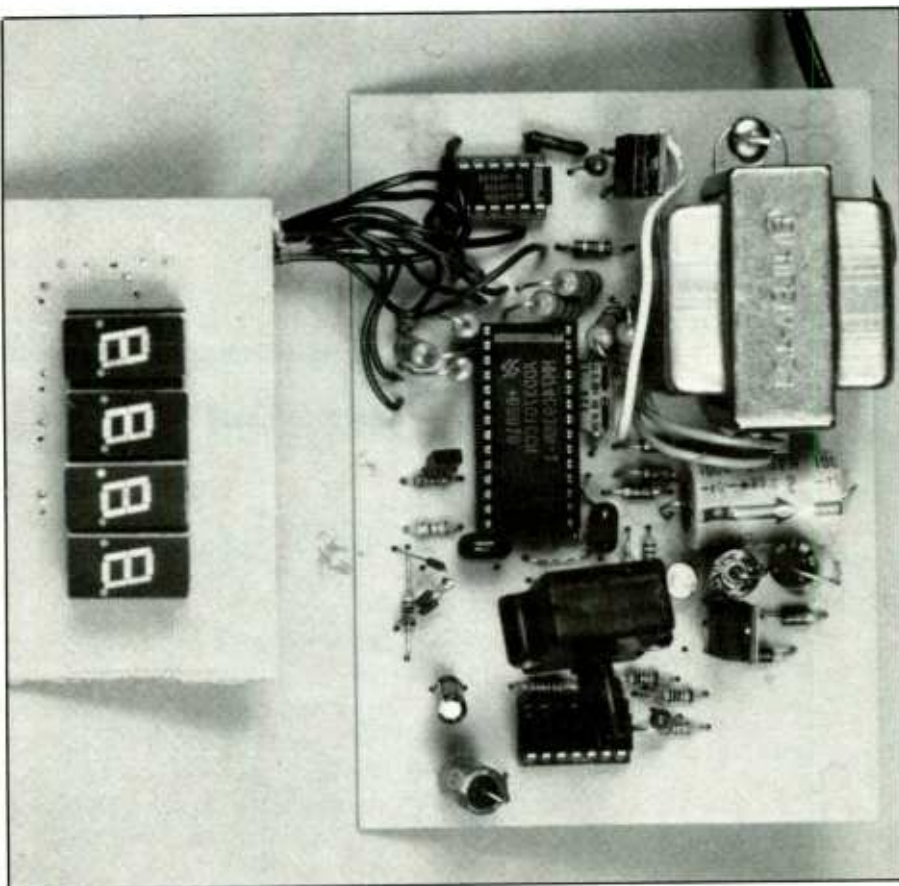

always indicates zero pressure when it is not connected to anything is in reality a "differential" gauge because it indicates the difference in pressure between the atmosphere (which is 14.7 pounds per square inch at sea level) and the pressure applied to the input port of the gauge.

When zero pressure is applied to a gauge, the instrument reads zero. The reading of such a gauge is usually referred to as "pounds per square inch differential" (PSID) or "pounds per square inch gauge"

(PSIG). Such an instrument would not be practical to use as a barometer because we are interested in the absolute pressure (14.7 PSI) and not the differential pressure (zero).

Absolute pressure is defined as the pressure measured relative to a perfect vacuum. An absolute pressure gauge, therefore, must be designed as a differential pressure gauge with one small but important difference. That is, it requires a reference pressure of zero PSI absolute (a perfect vacuum) so that it can react to any pressure

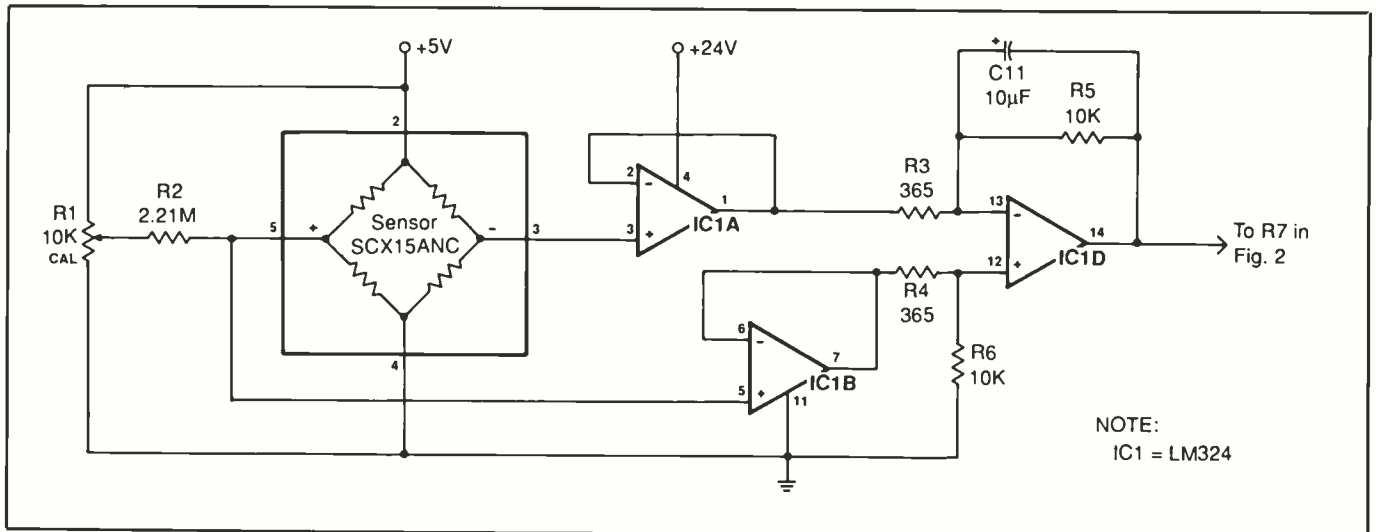

Fig. 1. Schematic diagram of analog portion of digital barometer's circuitry.

from zero to the maximum amount allowed by the design of the instrument. Since the absolute-pressure gauge is referenced to as perfect a vacuum as can be obtained with modern manufacturing techniques, it will indicate the absolute pressure of its surroundings, which at sea level is about 14.7 PSI.

Pressure can also be expressed in many other ways, and barometers are often calibrated in inches of mercury. With 14.7 PSI being equivalent to 29.92 inches of mercury, this is the atmospheric pressure at zero altitude (sea level) under standard conditions.

Now refer to the schematic diagram of the detection portion of the project shown in Fig. 1. The pressure sensor used here employs integrated-circuit technology. It consists of four resistors on a ceramic substrate and connected in a Wheatstone bridge configuration. This bridge circuit is driven by a stable 15-volt dc source.

When pressure is applied to the ceramic diaphragm that separates the vacuum chamber from ambient pressure, the values of the resistors change in accordance with the amount of pressure applied.

If the pressure input port of the sensor is connected to a source of perfect vacuum (0 PSI absolute), the

Wheatstone bridge would be balanced and the voltage output from the sensor, taken between terminals 5 and 3, would be essentially zero. At 14.7 PSI, the bridge's output is about 10 millivolts, which will vary linearly with changes in atmospheric pressure.

Since you wish to calibrate your barometer in inches of mercury and not pounds per square inch, an amplifier is used to provide a fixed gain of about 27 to the output of the bridge. This gain factor provides an output that varies linearly with barometric pressure measured in inches of mercury.

The output of the amplifier, taken at pin 14 of quad op amp *IC1*, is about 3 volts when the barometric pressure reading is at standard pressure (29.92 inches of mercury) and the barometer is at sea level.

Since the pressure sensor is not a perfect device, however, there will always be some offset error in the positive or negative direction in its output voltage. Also, to allow the barometer to be used at elevations other than sea level, the circuit must have built into it a means of adjustment that will remove the effect of altitude from the reading. Both of these conditions are corrected through use of OFFSET potentiometer *R1*, which allows the

output of the bridge circuit to be corrected for variations in pressure sensors and altitude. Once the OFFSET control has been properly adjusted, the barometer's reading will vary in accordance with changes in atmospheric pressure.

The differential output from the bridge arrangement is passed through voltage followers *IC1A* and *IC1B*, each of which has a gain of one and provides essentially zero output impedance to differential amplifier circuit *IC1D*. The gain of the amplifier is determined by the ratio of the *R5* to *R3* values and is about 27. This produces a single-ended output of about 3 volts, which can be used to drive *IC2*.

To provide a direct-reading numeric display of the measured barometric reading, an analog-to-digital converter IC is incorporated into the project. This chip, *IC2* in Fig. 2, is a 3 $\frac{3}{4}$ -digit A/D converter that can be used to provide a display of readings up to 3999. By permanently wiring the decimal place in the display decades, a digitally-generated numeric reading of up to 39.99 will be possible with *IC2*. Readings are updated every second or so to provide a continuous display of current atmospheric pressure.

**U2: Rattle & Hum** • New live set includes the hit *Desire*. Still Haven't Found What I'm Looking For. more. Island 200596

**Anita Baker: Rapture** • Sweet Love. Caught Up In The Rapture. You Bring Me Joy. Been So Long. Mystery. more. Elektra 173404

**Itzhak Perlman: French Violin Showpieces** • Carmen Fantasy. Tzigane. Poeme. Havanaise. more. DG DIGITAL 115457

**Tracy Chapman** • Extraordinary singer/songwriter with hit *Fast Car*. Talkin' Bout A Revolution. Baby Can I Hold You. Mountains O' Things. Why?. etc. Elektra 153582

**Guns N' Roses: Appetite For Destruction** Welcome To The Jungle. Sweet Child O' Mine. It's So Easy. more. Geffen 170348

**Jerry Lee Lewis: Original Sun Greatest Hits** • Whole Lotta Shakin' Goin On. Great Balls Of Fire. more. Rhino 154118

**Kitaro: The Light Of The Spirit** • Sundance. Mysterious Encounter. The Field. In The Beginning. etc. Geffen DIGITAL 164228

**Richard Marx** • Endless Summer Nights. Should've Known Better. Don't Mean Nothing. etc. EMI-Manhattan 134073

**Jimmy Page: Outrider** • Wasting My Time. The Only One. Prison Blues. more. Geffen 123721

**Robert Plant: Now And Zen** • Dance On My Own. Heaven Knows. Tall Cool One. Ship Of Fools. etc. Es Paranza 134392

**Led Zeppelin: Houses Of The Holy** Dyer Maker. Over The Hills And Far Away. etc. Atlantic 134321

**George Harrison: Cloud Nine** • Title song. I Got My Mind Set On You. When We Was Fab. more. Warner/Dark Horse 174328



**Steve Winwood: Roll With It** 154633

**Liz Story: Speechless** • Forgiveness. Speechless. Welcome Home. Back Porch. Vigil. Frog Park. more. RCA/Novus 100494

**Decade/Best Of Steely Dan** MCA 154135

**Beethoven, Symphony No. 7: Coriolan & Prometheus Overtures** • Royal Philharmonic/Previn. RCA DIGITAL 153621

**Jethro Tull: Aqualung** Chrysalis 124705

**Whitney Houston: Whitney** • I Wanna Dance With Somebody (Who Loves Me). Didn't We Almost Have It All. more. Arista 152854

**Metallica: ...And Justice For All** • One. Blackened. title song. To Live Is To Die. Shortest Straw. more. Elektra 200478

**Talking Heads: Naked** • (Nothing But) Flowers. Mr. Jones. Totally Nude. Blind. The Democratic Circus. The Facts Of Life. etc. Fly/Sire DIGITAL 153810

**David Sanborn: Close-Up** • Lush jazz sax effort! Slam. You Are Everything. J.T. Goodbye. Same Girl. etc. Warner Bros. 134408

**Dwight Yoakam: Buenas Noches From A Lonely Room** • Title Song. Streets Of Bakersfield (with Buck Owens). more. Reprise 100009

**The Best Of The Band** Capitol 134485

**Classic Old & Gold, Vol. 1** • 20 hits! A Little Bit Of Soul. He's So Fine. A Teenager In Love. Sweet Talkin' Guy. etc. Laurie 134627

**INXS: Kick** • Need You Tonight. Devil Inside. New Sensation. title song. Never Tear Us Apart. The Loved One. Wild Life. etc. Atlantic DIGITAL 153606

**The Glenn Miller Orchestra: In The Digital Mood** • In The Mood. Chattanooga Choo Choo. more. GRP DIGITAL 143293

**Tangerine Dream: Phaedra** 100510

**Steve Winwood: Chronicles** • Higher Love. Valerie. While You See A Chance. My Love's Leavin'. Talking Back To The Night. more. Island 134501

**Pictures At An Exhibition, Night On The Bare Mountain** • Montreal Symphony/Dutoit. London DIGITAL 125314

**Whitesnake** • Here I Go Again. Still Of The Night. Give Me All Your Love. Crying In The Rain. Bad Boys. more. Geffen 163629

**ZZ Top: Afterburner** Warner Bros. 164042

**Carly Simon: Greatest Hits Live** Anticipation. You're So Vaing. Coming Around Again. Nobody Does It Better. etc. Arista 154537

**Huey Lewis: Small World** • Perfect World. Walking With The Kid. World To Me. Better Be True. Old Antone's. etc. Chrysalis 134347



**Horowitz Plays Mozart** 115436

**Najee: Day By Day** • Personality. title song. That's The Way Of The World. Tonight I'm Yours. Gina. Najee's Nasty Groove. etc. EMI-Manhattan 100001

**Genesis: Invisible Touch** • Land Of Confusion. title song. etc. Atlantic 153740

**More Dirty Dancing** • Do You Love Me. Love Man. Big Girls Don't Cry. Wipeout. Some Kind Of Wonderful. Cry To Me. more. RCA 130766

**The Who's Greatest Hits** MCA 164160

**Tchaikovsky. 1812 Overture; Romeo & Juliet: Nutcracker Suite** • Chicago Symphony/Solti. London DIGITAL 125179

**James Galway: Greatest Hits** RCA 173233

**The Moody Blues: Sur La Mer** • I Know You're Out There Somewhere. No More Lies. Here Comes The Weekend. Vintage Wine. etc. Polydor 124546

**The Beach Boys: Endless Summer** California Girls. Help Me Rhonda. Surfer Girl. more. Capitol 223559

**Cinderella: Long Cold Winter** • Gypsy Road. Don't Know What You Got (Till It's Gone). The Last Mile. etc. Mercury 114780



**Bon Jovi: New Jersey** 100516

**Strauss. Also sprach Zarathustra** Chicago Symphony Orchestra/Reiner. RCA 163627

**Charlie Parker & Dizzy Gillespie: Bird & Diz** • Leap Frog. My Melancholy Baby. Mohawk. etc. Verve 173413

**Robert Palmer: Heavy Nova** • Simply Irresistible. Disturbing Behavior. She Makes My Day. More Than Ever. Change His Ways. etc. EMI-Manhattan 100035

**The Very Best Of The Everly Brothers** Bye Bye Love. Crying In The Rain. Bird Dog. others. Warner Bros. 103826

**Kenny G: Silhouette** • We've Saved The Best For Last. title song. Tradewinds. Pastel. Against Doctor's Orders. Let Go. more. Arista 100603

**D.J. Jazzy Jeff & The Fresh Prince: He's The D.J., I'm The Rapper** • Parents Just Don't Understand. Nightmare On My Street. etc. Jive 264134

**Raffi: Singable Songs For The Very Young** Shoreline 144494

**Elton John: Reg Strikes Back** • A Word In Spanish. I Don't Wanna Go On With You Like That. Goodbye Marlon Brando. Town Of Plenty. etc. MCA DIGITAL 100602

**Elton John: Greatest Hits, Vol. 1** MCA 163322

**Vivaldi, The Four Seasons** • English Concert/Pinnock. Archiv DIGITAL 115356

**Joe Cocker: Classics** Contains 13 Hits! A&M 104887

**Bruce Hornsby And The Range: Scenes From The Southside** • The Valley Road and Jacob's Ladder. plus others. RCA 180187

**Crosby, Stills, Nash & Young: Greatest Hits (So Far)** • Suite: Judy Blue Eyes. etc. Atlantic 130230

**New Age Bach: The Goldberg Variations** Joel Spiegelman plays the Kurzweil 250 Digital Keyboard. East-West 100488

**John Cougar Mellencamp: The Lonesome Jubilee** • Paper In Fire. Check It Out. Cherry Bomb. Rooty Toot Toot. etc. Mercury 134420

**Elvis: 18 Number One Hits** RCA 172190

**Robert Cray: Don't Be Afraid Of The Dark** Title song. Don't You Even Care. more. Mercury/Hightone 100471

**Jimi Hendrix: Kiss The Sky** • Purple Haze. All Along The Watchtower. Voodoo Child. Are You Experienced. etc. Reprise 161349

**Parton/Ronstadt/Harris: Trio** • To Know Him Is To Love Him. etc. Warner Bros. 114804

**Chicago 19** • I Don't Wanna Live Without Your Love. Heart In Pieces. etc. Reprise 154404

**Peter Cetera: One More Story** • One Good Woman. more. Warner Bros. 100463

**Buckwheat Zydeco: Taking It Home** Why Does Love Got To Be So Sad? (with Eric Clapton). Creole Country. more. Island 100597

**The Sound Of Music/Orig. Soundtrack** RCA 100046



**Phil Collins: Buster** 100517

**James Taylor's Greatest Hits** Warner Bros. 123790

**Dire Straits: Brothers In Arms** • Money For Nothing. Walk Of Life. So Far Away. more. Warner Bros. DIGITAL 114734

**Pops In Space** • John Williams & The Boston Pops. Music from Close Encounters, Star Wars, others. Philips DIGITAL 105392

**Rod Stewart: Greatest Hits** • Do Ya Think I'm Sexy?. Tonight's The Night. Maggie May. Hot Legs. etc. Warner Bros. 133779

**Andres Segovia Plays Bach** • Includes the famous Chaconne. MCA 163600

**Poison: Open Up And Say...Ahh** • Nothin' But A Good Time. Good Love. Fallen Angel. Love On The Rocks. etc. Capitol/Enigma 173989

**Bobby McFerrin: Simple Pleasures** Don't Worry Be Happy. All I Want. Drive My Car. title song. Good Lovin'. more. EMI-Manhattan 164165

**Cream: Disraeli Gears** • Sunshine Of Your Love. more. Polydor 104898

**Simon & Garfunkel: The Concert In Central Park** • Mrs. Robinson. Bridge Over Troubled Water. etc. Warner Bros. 244006

**Alabama: Live** RCA 160027

**Previn: Gershwin** • Rhapsody In Blue. Concerto in F. more. Philips DIGITAL 115437

**Eagles Greatest Hits, Vol. 1** Asylum 123481

**Keith Richards: Talk Is Cheap** • Big Enough. How I Wish. Take It So Hard. Struggle. I Could Have Stood You Up. more. Virgin 100518



**Randy Travis: Old 8x10** 100008

**The Police: Every Breath You Take—The Singles** • Don't Stand So Close To Me ('86). Roxanne. etc. A&M 173924

**Sting: Nothing Like The Sun** • We'll Be Together. They Dance Alone. Be Still My Beating Heart. more. A&M 273965

**Mozart, Overtures** • Academy of St. Martin/Marriner. Marriage Of Figaro. 8 more. Angel DIGITAL 134267

## START NOW WITH 4 COMPACT DISCS!

Yes, pick any 4 compact discs shown here! You need buy just one selection at regular Club prices (usually \$14.98–\$15.98) . . . and take up to one full year to do it. Then you can choose another CD free as a bonus. That's 6 compact discs for the price of 1 and there's nothing more to buy . . . ever! (Shipping & handling added to each shipment.)

## HOW THE CLUB OPERATES

You select from hundreds of exciting compact discs described in the Club's magazine and mailed to you approximately every 3 weeks (19 times a year). Each issue highlights a Featured Selection in your preferred music category, plus alternate selections. If you'd like the Featured Selection, do nothing. It will be sent to you automatically. If you'd prefer an alternate selection, or none at all, just return the

ultimate in savings...



GET **6**  
**COMPACT DISCS**  
**FOR THE PRICE OF 1**  
**WITH NOTHING MORE TO BUY...EVER!**

Start with **4** COMPACT DISCS now!  
pay just shipping & handling with Club membership.  
 Buy just **1** smash hit in one year's time.  
 Then get **1** bonus CD of your choice.  
 Enjoy **6** CDs for the price of one.

**Nothing more to buy...EVER!**

**Steve Miller: Born 2 B Blue** • Ya Ya, Born To Be Blue, Just A Little Bit, Goid Bless The Child, Filthy McNasty, etc. Capitol 100591

**Anthrax: State Of Euphoria** • Be All, End All, Make Me Laugh, Out Of Sight, Out Of Mind, Schism, more. Island/Megaforce 100589

**Johnny Cash: Classic Cash** • Folsom Prison Blues, Ring Of Fire, I Walk The Line, Get Rhythm, Cry, Cry, Cry, more. Mercury 100595

**Procol Harum: Classics** • 12 great hits! A&M 134445

**Special EFX: Double Feature** • The Lady And The Sea, Passages, Golden Days, Mirrors, more. GRP DIGITAL 100016

**Jazz CD Sampler** • Over 67 minutes of jazz, with 15 classic performances by Ella, Armstrong, Basie, Getz, etc. PolyGram 173406

**The Judds: Greatest Hits** RCA 144578

**Allman Brothers Band: Eat A Peach** Melissa, Blue Sky, Ain't Wastin' Time No More, etc. Polydor 163353



**Dirty Dancing/Soundtrack** 182522

**Scott Joplin, Piano Rags** • Joshua Rifkin plays The Entertainer, Maple Leaf Rag, Gladiolus Rag, 14 more. Nonesuch 164055

**Eric Clapton: Time Pieces (The Best Of)** Layla, I Shot The Sheriff, After Midnight, Cocaine, etc. Polydor 123385

card enclosed with each issue of your magazine by the date specified on the card. You will have at least 10 days to decide, or you may return your Featured Selection at our expense. Cancel your membership at any time after completing your membership agreement, simply by writing to us.

**FREE 10-DAY TRIAL**

Listen to your 4 introductory selections for a full 10 days. If not satisfied, return them with no further obligation. You send no money now, so complete the coupon and mail it today.

**SAVE 50%** **INSTANT HALF-PRICE BONUS PLAN**  
 Unlike other clubs, you get 50%-off Bonus Savings with every CD you buy at regular Club prices, effective with your first full-price purchase!



**YOUR SAVINGS START HERE**

Mail to: BMG Compact Disc Club  
 P.O. Box 91412 • Indianapolis, IN 46219

**YES**, please accept my membership in the BMG Compact Disc Club and send me the four Compact Discs I've indicated here, billing me for just shipping and handling under the terms of this ad. I need buy just 1 CD at regular Club prices during the next year—after which I can choose a FREE bonus CD! That's 6 for the price of 1...with nothing more to buy ever! (Shipping & handling is added to each shipment.)

**RUSH ME THESE 4 CDs** (Indicate by number)

D	D	D	D
---	---	---	---

I am most interested in the musical category checked here—but I am always free to choose from any (check one only):

**EASY LISTENING** (Instrumental Vocal Moods)  **COUNTRY**  
 **HARD ROCK**  **POP/SOFT ROCK**  **CLASSICAL**

MR.  MRS.  MISS First Name Initial Last Name (PLEASE PRINT)

Address \_\_\_\_\_

City \_\_\_\_\_ State \_\_\_\_\_ Zip \_\_\_\_\_

Telephone ( ) \_\_\_\_\_ Area Code

Signature \_\_\_\_\_

Limited to new members, continental USA only. Current CD Club members not eligible for this offer. One membership per family. We reserve the right to request additional information or reject any applications. Local taxes, if any, will be added.

YAT95 BU

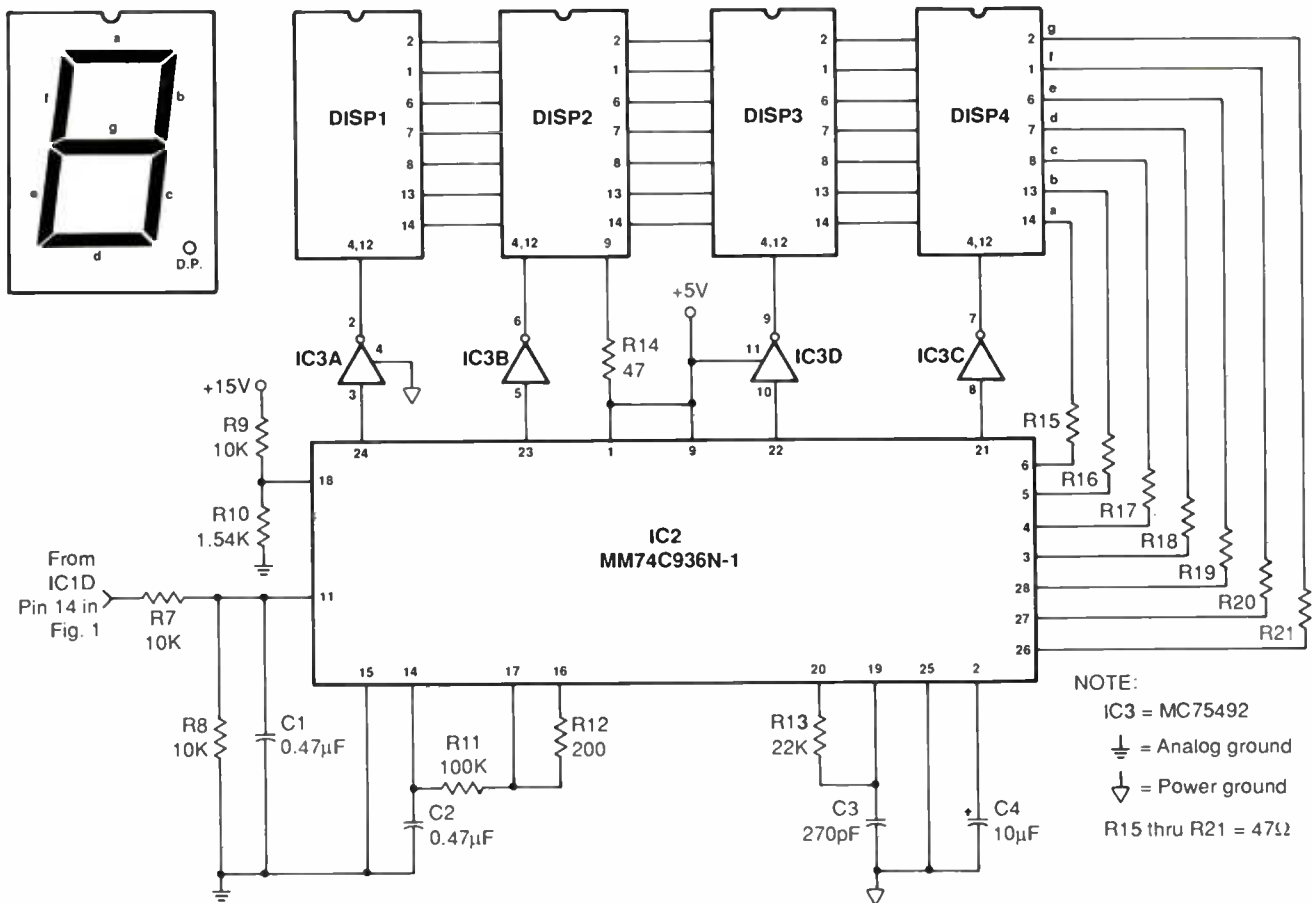

### PARTS LIST

#### Semiconductors

D1 thru D5—1N4004 or similar rectifier diode  
 DISP1 thru DISP4—7-segment common-cathode numeric display (Radio Shack Cat. No. 276-1365 or equivalent)  
 IC1—LM324 quad operational amplifier  
 IC2—MM74C936N-1 A/D converter (National)  
 IC3—MC75492 inverter/buffer or equivalent (Motorola)  
 IC4—LM7805CT + 5-volt regulator  
 IC5—MC78T15CT + 15-volt regulator (Motorola—do not substitute; see text)

#### Capacitors

C1, C2—0.47- $\mu$ F, 50-volt Mylar or metallized film  
 C3—270-pF, 50-volt ceramic disc  
 C4, C9—10- $\mu$ F, 25-volt electrolytic

C5—1,000- $\mu$ F, 16-volt electrolytic  
 C6, C7—220- $\mu$ F, 25-volt electrolytic  
 C8—100- $\mu$ F, 35-volt electrolytic  
 C10—0.1- $\mu$ F, 50-volt ceramic disc  
 C11—10- $\mu$ F, 16-volt low-leakage electrolytic (Panasonic Type Z or similar)

#### Resistors

*1/4-watt, 1% tolerance metal-film:*  
 R2—2.21 megohms  
 R3, R4—365 ohms  
 R5 thru R9—10,000 ohms  
 R10—1,540 ohms  
 R11—100,000 ohms  
*1/4-watt, 5% tolerance carbon:*  
 R12—200 ohms  
 R13—22,000 ohms  
 R14 thru R27—47 ohms  
 R1—10,000-ohm cermet trimmer potentiometer

#### Miscellaneous

F1—1-ampere slow-blow fuse  
 S1—Spst miniature toggle or slide switch (optional—see text)

T1—12.6-volt, 250-mA center-tapped transformer (Radio Shack Cat. No. 273-1365 or equivalent)  
 SCX15ANC 15 PSI absolute pressure sensor (available from SenSym Corp., 1255 Reamwood Ave., Sunnysvale, CA 94089); printed-circuit boards (see text); suitable enclosure (see text); sockets for all DIP ICs and numeric displays; red filter material; fuse block; rubber grommet; spacers; 4-40 machine hardware; stranded hookup wire; solder; etc.

**Note:** The following items are available from A. Caristi, 69 White Pond Rd., Waldwick, NJ 07463: Pressure sensor, \$37; main pc board, \$9.95; display pc board, \$9.95; LM324, \$2; MM74C936N-1, \$24; MC75492, \$3.50; LM7805CT, \$2; MC78T15CT, \$11; set of 10 1% metal-film resistors (R2 thru R11), \$3.50. Add \$2 P&H per order. New Jersey residents, please add state sales tax.

Fig. 2. Schematic diagram of analog-to-digital converter and display circuitry.



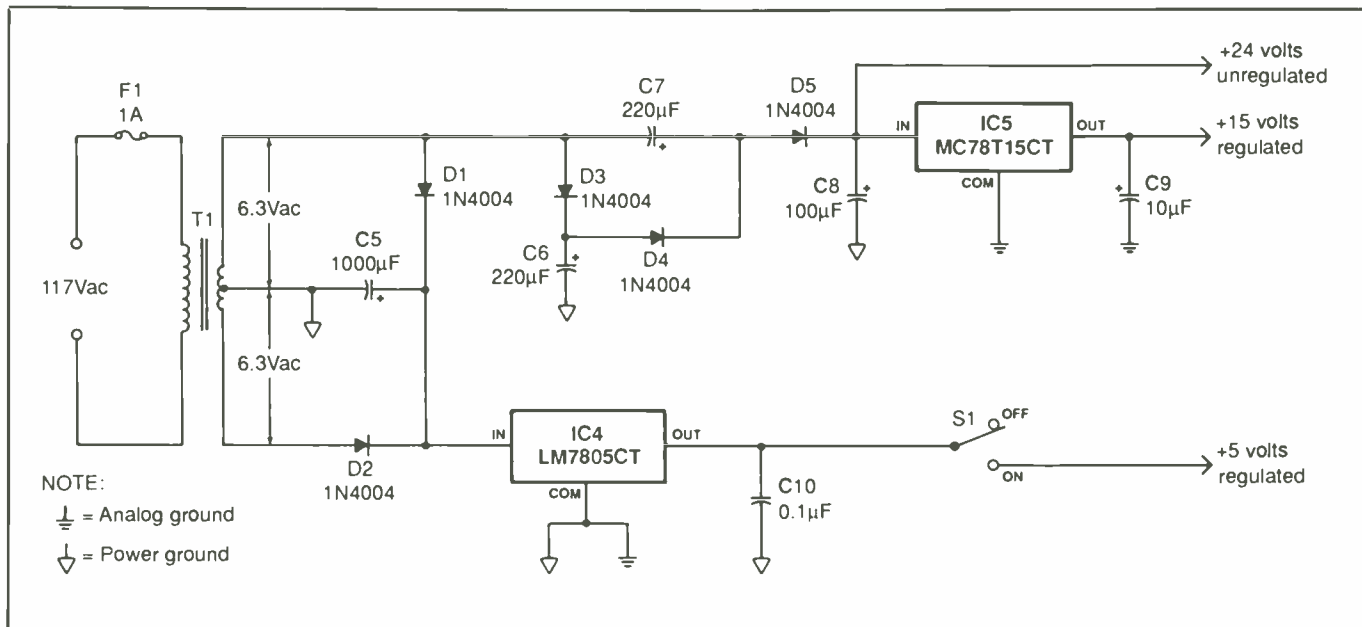

Fig. 3. Schematic of power supply. Note that supply outputs +5 and +15 volts regulated and +24 volts unregulated.

Since the circuit constants associated with *IC2* provide a sensitivity of 3.999/2 volts for its full-scale output display of 3999, a 2:1 voltage divider is used at the input at pin 11 of *IC2* to drop the output voltage from *IC1D* from about 3 to 1.5 volts. This produces the desired readout of barometric pressure, 30.00, more or less according to actual weather conditions at the time.

Drive current available from the outputs of *IC1* is insufficient to directly drive the LED elements in the numeric display. Therefore, *IC3* is used to interface the chip to the display and, in so doing, provide the drive current required. The *IC3* chip contains a group of inverter/buffers that provide sufficient current from the 5-volt regulated supply line to power the LEDs in the display.

To reduce the number of conductors required to connect between the A/D converter and LED numeric display, a multiplexing technique is used. This is a system whereby all like segments of each digit are connected in parallel with each other and each decade is turned on in sequence by means of its common cathode con-

nection. This action occurs so fast that the human eye perceives all digits to be energized simultaneously. All multiplexing circuitry is contained inside *IC2*.

As shown in Fig. 3, three voltage sources are required to power this circuit: 5, 15 and 24 volts dc. The first two voltage buses are regulated by *IC4* and *IC5*, respectively. Since calibration of the barometer depends upon the stability of the 15-volt regulated source, *IC5* must be carefully selected to have high temperature stability to hold its output voltage relatively constant with normal changes in temperature, as would be experienced inside a home.

To provide sufficient potential to drive *IC1* and *IC4*, a voltage-tripler circuit is used to multiply the 6.3 volts rms output from the secondary side of power transformer *T1*. This tripler provides about 24 volts of unregulated dc to power the two chips.

### Construction

The project is best assembled using printed-circuit wiring. Two pc boards are needed to accomplish

this, both single-sided. Except for the four numeric displays, switch and fuse holder, all analog, digital and power-supply components mount and wire together on the larger main pc board. The displays, of course, go on the separate smaller board, and the switch and fuse holder mount anywhere convenient on the walls of the enclosure selected for the project. The two-board arrangement permits the project to be housed inside a small enclosure with the display located behind the front panel and visible through a window in the panel.

Though it might be possible to successfully build the project on perforated board using point-to-point wiring, it is recommended that you use only pc construction. The reason for this is that the A/D converter chip is very sensitive to spurious voltages that might be generated as a result of power-supply ground-loop currents. The conductor pattern for the main board, shown in Fig. 4, has been laid out to obviate this problem.

Figure 4 contains the actual-size etching-and-drilling guides for both pc boards. You can etch and drill your own boards using this artwork.

Alternatively, you can purchase ready-to-wire boards from the source given in the Note at the end of the Parts List.

Figure 5 shows the wiring guides for the smaller display board. The guide on the left illustrates how the four numeric displays and wire jumpers are to be installed on the unclad side of the board, while the guide on the right shows the points to which the free ends of the wires coming from the main board are to connect.

The displays can be mounted and soldered directly into place. However, it is a good idea to use sockets instead. This will permit easy removal and replacement should this ever become necessary. Before sockets can be mounted on this board, you must clip away from each of them pins 3, 5, 10 and 11. There are no holes in the board for these pins. Then install the four wire jumpers identified by the legends J as shown in the wiring guide on the left.

Flip over the display board and orient it as shown in the wiring guide on the right in Fig. 4. Strip  $\frac{1}{4}$  inch of insulation from both ends of 12 8-inch lengths of stranded hookup wire. Tightly twist together the fine conductors at both ends of each wire and sparingly tin with solder. Plug the free ends of these wires into the holes labeled a through g, K1 through K4 and DP and solder into place. Note that these wires plug into the *solder* side of the board.

Turn over the board and orient it as shown in the wiring guide on the left in Fig. 4. Plug the displays into the sockets. Make sure that all displays are oriented so that their decimal points are toward the bottom edge of the board (edge nearest you). Also, make sure that no pins overhang the sockets or fold under between displays and sockets as the displays are solidly seated in the sockets. Set the display circuit-board assembly aside.

Now, referring to Fig. 6, proceed to wiring the main board. Begin by

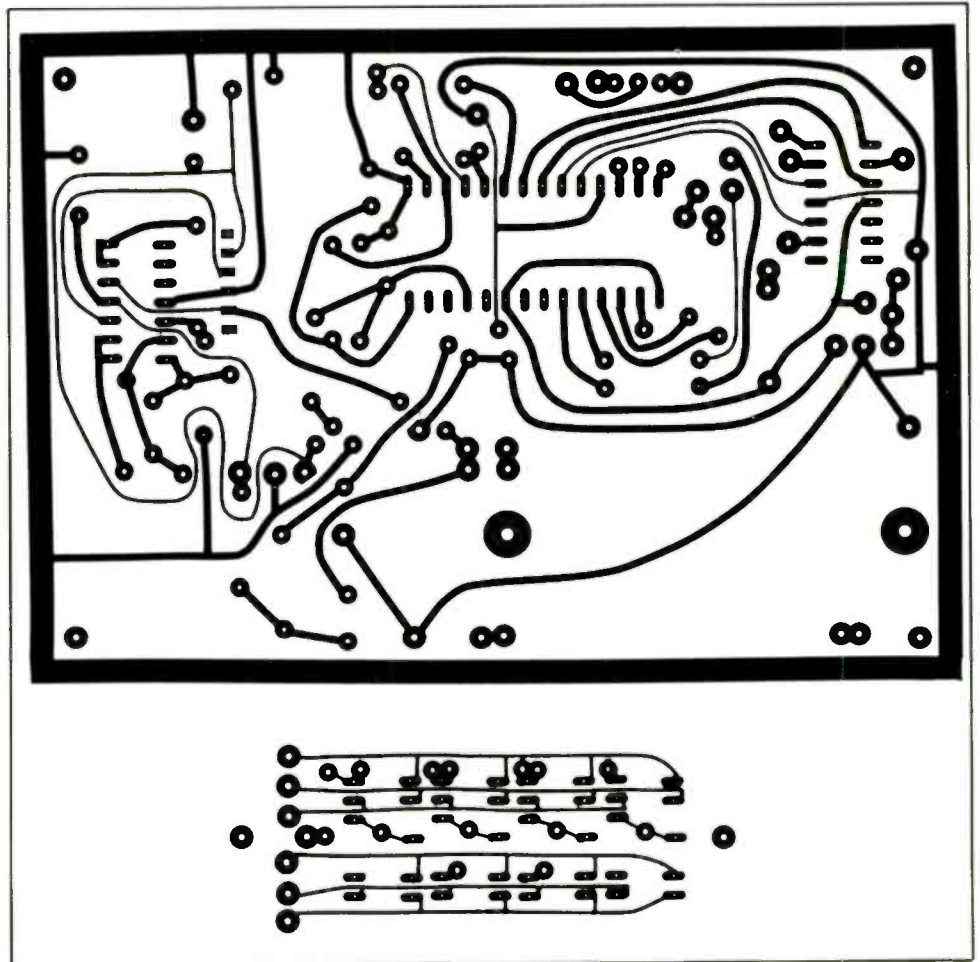

Fig. 4. Actual-size etching-and-drilling guides for main (large) and display (small) printed-circuit boards.

installing and soldering into place sockets in the IC1 through IC3 locations. Though you can forego use of sockets for the DIP ICs, it is best to use them should it ever become necessary to replace one of these devices. Do *not* install the ICs in their sockets until after preliminary voltage checks have been made.

Next, install and solder into place the resistors and diodes, followed by the capacitors and trimmer potentiometer R1. Make sure the diodes and electrolytic capacitors are properly polarized before soldering their leads to the pads on the bottom of the board. Should any of these be incorrectly oriented, the project will not

operate as it should and may possibly suffer component damage.

The project's circuitry has been designed to yield the greatest possible accuracy and stability of the barometric pressure reading. Part of the design includes several 1-percent-tolerance metal-film resistors, which have very low temperature coefficient of resistance (see Parts List). The amplification of IC1D and calibration of IC2 depend upon the values of the resistors in these circuits. Therefore, do not use ordinary carbon where metal-film resistors are specified.

Note that the pressure sensor has six pins, which are numbered from 1 to 6 with pin 1 plainly identified on

the body of the sensor. All six pins must be soldered into the circuit in the location specified on the Fig. 6 wiring guide. Pins 1 and 6 are not used in this project. Keep in mind that the pins on the sensor are fragile and must not be severely distorted during handling and/or installation. However, you can gently bend the pins slightly to allow the sensor to be installed on the board in the correct orientation.

No connections will be made to the input pressure ports of the sensor. These will be exposed to atmospheric pressure at all times.

When you install and solder into place three-pin regulators *IC4* and *IC5*, make sure these devices are properly oriented. Note that their metal tabs should face away from you when the board is oriented as shown. Also, make certain that the metal tabs do not contact any other components on the board.

Do not substitute a different regulator for the one specified for *IC5*. This fixed +15-volt regulator has been selected for its excellent temperature stability. Calibration of your barometer depends upon the voltage delivered to both the bridge circuit inside the sensor and A/D converter by *IC5*. A regulator that is not stable will output a voltage that is not stable and, thus, will produce an error in the barometric reading.

There is no need to heat sink *IC4* and *IC5*. Simply solder these regulators directly into place in their respective locations on the main board.

Trim the leads of the power transformer to the lengths needed. Strip 1/4 inch of insulation from all leads, twist together the fine wires of each and sparingly tin with solder. Mount the transformer in the indicated location using 4-40 x 1/2-inch machine screws, lockwashers and nuts. Plug the transformer's leads into the indicated holes and solder into place.

Strip 1/4 inch of insulation from both ends of three 6-inch lengths of stranded hookup wire. Tightly twist

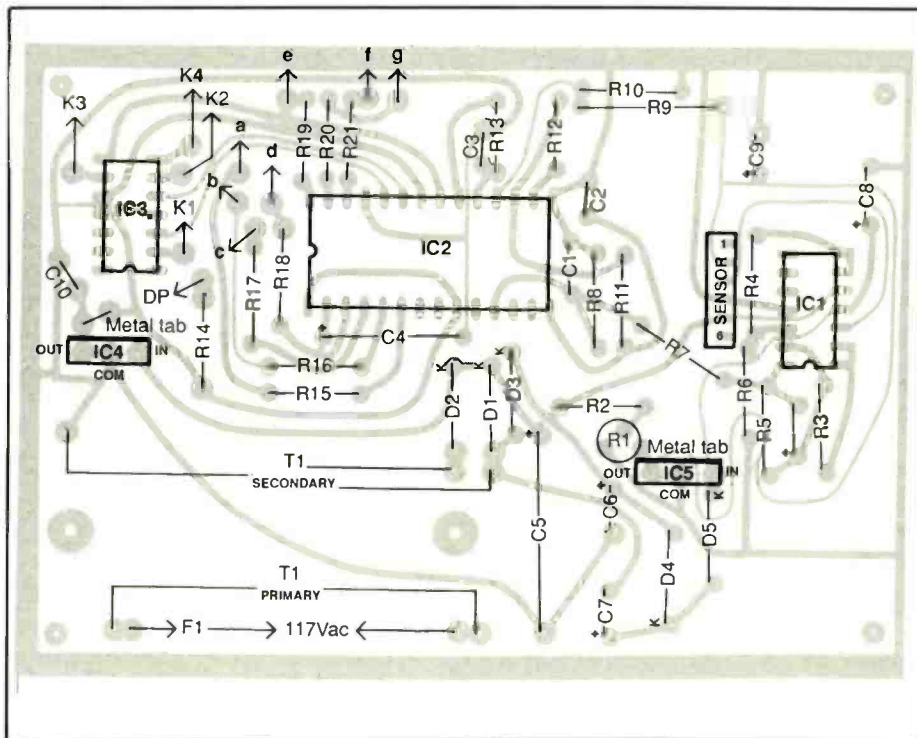

Fig. 5. Wiring guide for main board. This board contains all power-supply, analog and digital circuitry, including the sensor.

together the fine conductors at both ends of each wire and sparingly tin with solder. Plug one end of two wires into the holes labeled S1 and solder into place. Similarly, plug one end of the remaining wire into the hole labeled F1 and solder into place.

You have the option of including or omitting ON/OFF switch *S1* as desired. If you wish to be able to turn off your barometer, the switch can be wired in series with the +5-volt regulated power bus as shown in Fig. 3 via the wires connected to the pads labeled S1 in Fig. 6. If you prefer to have the project displaying barometric pressure at all times, omit the switch and replace the two wires in the S1 holes with a single jumper wire that shorts together these two pads on the board, simulating a permanently on switch.

Referring back to Figures 2 and 3, you will note that *S1* is located in the circuit so that it enables and disables only the A/D chip and numeric dis-

plays are affected by its action. The reason for this odd arrangement is that you want the +15-volt bus active and powering the sensor circuit at all times to obviate any possible turn-on drift as the circuit heats up and stabilizes.

Place the two circuit-board assemblies side by side. Referring to Fig. 5 locate and identify the wire coming from the DP pad on the display board and plug it into the hole labeled DP in the main board, as indicated in Fig. 6. Repeat with the remaining wires coming from the display board and the holes in the main board with the same legends.

Before mounting the circuit-board assemblies inside an enclosure, carefully examine them for improperly installed components, poorly soldered connections and solder bridges between closely spaced pads and conductors. If you locate any connections that are suspicious, reflow the solder on them. Remove any solder

bridges with a wicking-type desoldering braid or vacuum-type desoldering tool.

Any enclosure that measures at least 5 × 4 × 2 inches can be used to house the digital barometer. It can be all-plastic, a plastic utility box with aluminum cover or all-metal. Which ever you choose, drill four holes through its bottom panel for mounting the main circuit-board assembly and two or three holes through the rear wall for entry of the ac line cord, mounting the fuse block and mounting the switch (the last if used). Additionally, you will have to cut a 2 × 1-inch window in the front panel behind which to mount the display board and a pair of small holes ¼ inch away from the shorter sides and centered between the longer sides of the window for mounting the board in place.

If you are using a metal enclosure, deburr all holes and smooth the display window with a file. Cut a thin transparent red plastic sheet to dimensions of 1½ × 3 inches. Center this over the display window, mark the board-mounting hole locations on it, and drill holes at the marked locations. Place this contrast-enhancing lens over the display window and pass through the holes in both the filter and panel 4-40 × 1-inch machine screws from the outside of the enclosure. Follow with a pair of ½-inch spacers, the display board, lock-washers and 4-40 machine nuts.

Mount the fuse block and switch if used on the rear wall of the enclosure. Route the ac line cord through its hole. If you are using a metal enclosure, first line the hole with a rubber grommet. Tie a knot in the cord about 6 inches from the free end inside the enclosure to serve as a strain relief. Tightly twist together the fine wires in each line-cord conductor and tin with solder. Plug one conductor into the hole labeled 117 V ac in the main board and solder into place.

Crimp and solder the other line cord conductor to one lug of the fuse

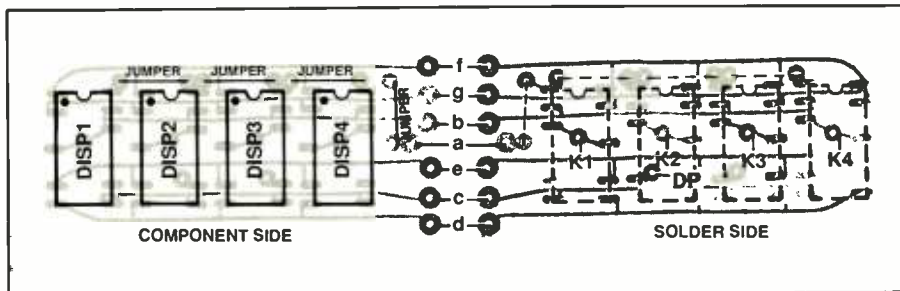

Fig. 6. Wiring guides for display board: left shows how displays and jumper wires install on component side; right shows points to which connections are made with holes in main board that have the same legends.

block. Then locate the wire coming from the hole labeled F1 on the main board and crimp and solder its free end to the other lug of the fuse holder. Place a fuse in the holder. If you have decided to use S1 in your project, crimp and solder to its lugs the free ends of the wires coming from the holes labeled S1 on the main circuit board.

Use 4-40 × ¾-inch machine screws, ½-inch spacers and nuts to mount the main circuit-board assembly to the floor of the enclosure.

### Checkout & Use

You are now ready to perform preliminary voltage checks on your project. Make sure that the DIP ICs are still not installed in the IC1 through IC3 sockets. Use a digital or analog dc voltmeter or multimeter set to the dc volts function to perform all voltage checks.

Clip the meter's common lead to power-supply ground at the negative (-) lead of C5. Plug the project's line cord into an ac outlet. Now use the meter's "hot" probe to check the voltage of the unregulated power supply at the positive (+) lead of C8. You should obtain a reading of approximately +24 volts. Next, measure the outputs of the regulated supplies at the positive leads of C9 and C10, which should yield readings of +15 and +5 volts, respectively, both within a 0.5-volt tolerance.

If you do not obtain the correct reading at any given point in the power-supply circuit, power down the project by unplugging it from the ac receptacle. Rectify the problem before proceeding.

If the power supply is not delivering the correct voltages, check the orientations of rectifier diodes D1 through D5, capacitors C5 through C10, and regulators IC4 and IC5. Measure the output voltage from the secondary of the power transformer at the anodes of D1 and D4 with an ac voltmeter to make sure that about 6 volts rms appears between the center-tap and each secondary winding lead. Also, make sure that you have not inadvertently transposed the transformer's center tap with either of the other two secondary leads, and check the fuse to be sure it is not defective.

When you are satisfied that the power supply is operating at it should, disconnect the line cord from the ac receptacle and allow the electrolytic capacitors in the circuit to discharge. Then carefully install the ICs in their respective sockets on the main board. Make sure each is properly oriented (see Fig. 6) and that no pins overhang the sockets or fold under between ICs and sockets.

With the ICs installed, set trimmer potentiometer R1 to the center of its rotation. Plug the project's line cord back into the ac receptacle and close S1 if you incorporated this switch into your project. Observe the proj-

ect's display; it should indicate 29 or 30, with the decimal point on between the second and third decades (it is actually a part of the second digit's display). Slowly adjust the setting of *R1* while observing the display. As you adjust from one rotation extreme to the other, you should be able to vary the display range from a low of 28 to a high of 31.

If you obtain the correct results, initial checkout is complete. If not, troubleshoot the circuit and rectify the problem.

To use your digital barometer, allow the circuit to stabilize for at least 10 minutes after initial start-up. Then adjust the setting of *R1* so that the displayed number agrees with a current barometric pressure reading reported on a radio or TV weather report. If you do not want to wait until a report is being broadcast, try calling the meteorology department of a local airport and request this information.

Once *R1* has been properly set, your project will require no further attention. It will faithfully indicate the current barometric-pressure reading at all times. You may notice that the least-significant decade—the one farthest to the right—may “bobble” between two consecutive numbers. This is a normal condition of the A/D converter used in the project. As you use it, you will notice that the digital barometer is a lot more sensitive than its analog counterpart. It will give instantaneous updated reading of barometric pressure every second, allowing you to see and track small changes in readings as the ambient air pressure in the vicinity of the project varies.

To use your barometer for weather forecasting, simply make note of the direction of change in pressure readings an hour or more apart. A rising barometer (increasing readings) usually indicates fair weather ahead. A falling barometer (decreasing readings) indicate stormy or unstable weather ahead.

**ME**

## HITACHI SCOPES AT DISCOUNT PRICES

 <p><b>V-212</b> <b>\$379</b> List \$560 Save \$181</p> <p><b>20MHz Dual Trace Oscilloscope</b> All Hitachi scopes include probes, schematics and Hitachi's 3 year warranty on parts and labor. Many accessories available for all scopes.</p>	 <p><b>V-425</b> List \$995 <b>\$835</b></p> <p><b>20MHz Dual Trace Oscilloscope</b> V-223 20MHz D.T., 1mV sens. Delayed Sweep, DC Offset, Vert. Mode Trigger V-422 40MHz D.T., 1mV sens. DC Offset, Vert. Mode Trigger, All Mag V-423 40MHz D.T., 1mV sens. Delayed Sweep, DC Offset, All Mag V-660 60MHz D.T., 2mV sens. Delayed Sweep, CRT Readout V-1065 100MHz D.T., 2mV sens. Delayed Sweep, CRT Readout, Cursor Meas V-1100A 100MHz Q.T., 1mV sens. Delayed Sweep, CRT Readout, DVM, Counter V-1150 150MHz Q.T., 1mV sens. Delayed Sweep, Cursor Meas, DVM, Counter</p>	 <p><b>V-1060</b> List \$1595 <b>\$1,285</b></p> <p><b>35MHz Dual Trace Oscilloscope</b> • DC to 100MHz • Dual Channel • Delayed Sweep • CRT Readout • Sweep Time Autorange • Trigger Lock • 2mV Sensitivity</p>
--	--	---

## ELENCO PRODUCTS AT DISCOUNT PRICES

 <p><b>20MHz Dual Trace Oscilloscope</b> <b>\$349</b> <b>MO-1251</b> • 6" CRT • Built in component tester • TV Sync</p>	<p><b>SCOPE PROBES</b> P-1 65MHz, 1x, 10x \$19.95 P-2 100MHz, 1x, 10x \$23.95 with 5 accessories 10 Meg ohm input impedance Fits all scopes with BNC connector TL-3 BNC to Minigrabber \$3.49</p>	 <p><b>35MHz Dual Trace Oscilloscope</b> <b>\$498</b> <b>MO-1252</b> • High luminance 6" CRT • 1mV Sensitivity • 6KV Acceleration Voltage • 10ns Rise Time • X-Y Operation + 2 Axis • Delayed Triggering Sweep</p>				
<p><b>NEW! Autoranging DMM</b> <b>M-5000</b> <b>\$45</b> 9 Functions Memory and Data hold 1/2% basic acc 3 1/2 digit LCD</p>	<p><b>True RMS 4 1/2 Digit Multimeter</b> <b>M-7000</b> <b>\$135</b> 0.5% DC Accuracy 1% Resistance with Freq. Counter and deluxe case</p>	<p><b>Multimeter with Capacitance and Resistor Tester</b> <b>\$55 CM-1500A</b> Reads Volts, Ohms, Current, Capacitors, Transistors and Diodes with case</p>	<p><b>Digital Capacitance Meter</b> <b>CM-1550</b> <b>\$58.95</b> 9 Ranges 1pF-20,000uF 5% basic accy Zero control with case</p>	<p><b>Digital LCR Meter</b> <b>LC-1800</b> <b>\$138</b> Measures Coils 1uH-200H Caps 1pF-200uF Res 0.1-20M</p>		
<p><b>NEW! AC Clamp-On Current Adapter</b> <b>ST-265</b> <b>\$22</b> 0-1000A AC Works with most DMM</p>	<p><b>NEW! Bench DMMS</b> <b>M-3500</b> <b>\$125</b> <b>M-4500</b> <b>\$175</b> 3 1/2 digit 1% accy 4 1/2 digit 0.5% accy</p>	<p><b>50MHz Logic Probe</b> <b>LP-700</b> <b>\$23</b> Logic Puzer LP-800 \$23</p>	<p><b>Solderless Breadboards</b> 9430 100 pins \$15 9432 2170 pins \$25 9436 2880 pins \$35 All have color coded posts</p>	<p><b>Low Cost Multimeter</b> <b>M-1600</b> <b>\$25</b> 3 1/2 digit LCD 1% DC Accy 10A Scale Auto zero /polarity</p>		
<p><b>NEW! Wide Band Signal Generators</b> <b>SG-9000</b> <b>\$119</b> RF Freq 100K-450MHz AM Modulation of 1KHz Variable RF output <b>SG-9500 with Digital Display and 150MHz built-in Freq Ctr \$249</b></p>	<p><b>3 1/2 Digit Probe Type DMM</b> <b>M-1900</b> <b>\$45</b> Convenient one hand operation Measures DCV, ACV, Ohms Audible continuity check, Data hold</p>	<p><b>GF-8016 Function Generator with Freq. Counter</b> <b>\$239</b> Sine, Square, Triangle Pulse, Ramp, 2 to 2MHz Freq Counter .1 - 10MHz</p>	<p><b>GF-8015 without Freq. Meter \$179</b></p>	<p><b>Digital Triple Power Supply</b> <b>XP-765</b> <b>\$249</b> 0-20V at 1A 0-20V at 1A 5V at 5A Fully Regulated, Short circuit protected with 2 Limit Cont., 3 Separate supplies <b>XP-660 with Analog Meters \$175</b></p>	<p><b>Quad Power Supply</b> <b>XP-580</b> <b>\$59.95</b> 2-20V at 2A 12V at 1A 5V at 3A -5V at 5A Fully regulated and short circuit protected <b>XP-575 without meters \$44.95</b></p>	<p><b>Four-Function Frequency Counters</b> <b>F-1000 1.28M</b> <b>\$259</b> <b>F-100 120MHz</b> <b>\$179</b> Frequency, Period, Totalize, Self Check with High Stabilized Crystal Oven Oscillator, 8 digit LED display</p>
<p><b>NEW!</b> All box interlock to make your design work a snap. You can change the configuration</p>	<p><b>9550 7.50</b> 500 tie pins</p>	<p><b>9600 28.95</b> <b>9610 18.95</b> <b>9620 18.95</b> <b>9630 22.95</b> <b>9640 22.95</b> <b>9650 19.95</b> FUNCTION GENERATOR 1 to 1MHz sine, sq wave RESISTOR DECADE BLOX 20 resistors 47-1M ohm CAPACITOR DECADE BLOX 20 capacitors 47pF-10mfd DIGITAL CLOCK BLOX pulses from 1Hz to 50MHz LOGIC PROBE BLOX 4 logic level ind POWER BLOX 5V at 1A, 5 at 4A 12V at 3A</p>				

WE WILL NOT BE UNDERSOLD! UPS Shipping: US 5% (\$10 Max) IL Res., 7% Tax **C & S SALES INC.** 1245 Rosewood, Deerfield, IL 60015 (800) 292-7711 (312) 541-0710 15 Day Money Back Guarantee 2 Year Warranty WRITE FOR FREE CATALOG

CIRCLE NO. 134 ON FREE INFORMATION CARD

# MODERN ELECTRONICS

## Order Back Issues

### BACK ISSUE ORDER FORM

Please send me the following issues of *Modern Electronics* @ \$2.50 each:

Month(s) & Year(s): \_\_\_\_\_

Number ordered @ \$2.50 each: \_\_\_\_\_

Total Payment Enclosed: \_\_\_\_\_ (Your order may be tax deductible.)  
(Check or M.O. only.)

NAME: \_\_\_\_\_

STREET ADDRESS: \_\_\_\_\_

CITY: \_\_\_\_\_ STATE: \_\_\_\_\_ ZIP: \_\_\_\_\_

# Personal Intrusion Detector

*Lets you know when someone has gone through your important business or personal belongings without authorization*

By Charles Shoemaker, D.Ed.

**H**ave you ever wondered if confidential documents stacked on an office desk or in a drawer were examined by unauthorized persons? In the home, too, there are doubtlessly some intrusions you would like to know about, such as someone being in the cookie jar after the evening meal. The Personal Intruder Detector described here is designed to monitor such intrusions.

This handy device looks like an old pill container (or other box) you are using as a paperweight. Arm it and it patiently waits for an unwary intruder to lift it up or tip it over, either of which causes a tell-tale light-emitting diode to blink to let you know that an intrusion has been detected.

Battery powered and very compact, our Personal Intruder Detector is virtually foolproof. Once tripped, the Detector's LED can be extinguished and the project be rearmed only by flipping switches in a specific sequence. Should an intruder disable power to the project, this will tell you that an intrusion has occurred. Our Personal Intrusion Detector is not a preventive device itself; however, it does inform you when it is time to take remedial action.

## About the Circuit

Shown in Fig. 1 is the complete schematic diagram of the battery-powered Personal Intrusion Detector. The 555 timer chip used for *IC1* in this circuit is configured as a free-running low-speed oscillator that,

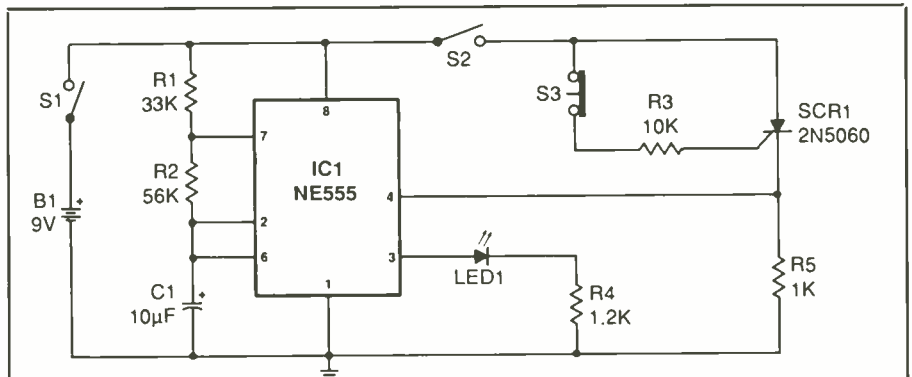

## PARTS LIST

### Semiconductors

IC1—NE555 timer  
LED1—Red light-emitting diode  
SCR1—SK3950 (RCA) or 2N5060 silicon-controlled rectifier in TO-92 case

### Capacitors

C1—10-µF, 15-volt electrolytic  
Resistors (¼-watt, 5% tolerance)

R1—33,000 ohms  
R2—56,000 ohms  
R3—10,000 ohms  
R4—1,200 ohms  
R5—1,000 ohms

### Miscellaneous

B1—9-volt alkaline battery  
S1, S2—Miniature pc-mount spst slide switch  
S3—Spdt lever switch (Radio Shack Cat. No. 276-016 or equivalent)  
Printed-circuit board or perforated board and suitable Wire-Wrap or soldering hardware (see text); suitable enclosure (see text); socket for IC1 (optional); snap connector for B1; nail or rivet (see text); hookup wire; solder; etc.

Fig. 1. Complete schematic diagram of the Personal Intrusion Detector.

when enabled, flashes light-emitting diode *LED1* on and off at a predetermined rate. When the output at pin 3 of *IC1* is in the positive cycle of the square wave generated by the timer, current flows from circuit ground through *R4* to light the LED.

Flash rate of the LED is determined with the formula  $t = 0.7(R1 + R2) \times C1 = 0.7(33,000 + 56,000) \times 0.00001$ , or 0.623 second. This works out to about 10 flashes every 6 seconds or so.

Power is applied to the circuit by closing *S1*. The oscillator is disabled when pin 4 of *IC1* is brought to ground through *R5*. This pin is held low (disabled state) because silicon-controlled rectifier *SCR1* blocks current flow to the positive power rail.

ARM switch *S3* is normally closed but is held open by the weight of the project bearing down on its lever (more about this later) when the project is armed and sitting in an upright position. Lifting the project or tip-

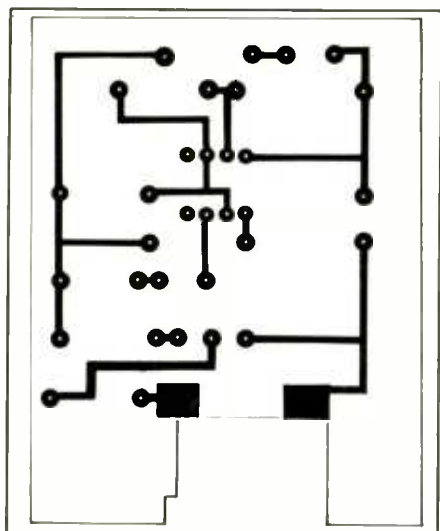

Fig. 2. Actual-size etching-and-drilling guide for project's printed-circuit board.

ping it over on its side removes the weight holding the switch open and automatically closes *S3*. This completes the gate circuit of the SCR to ground and allows current to flow from ground through *R5* to *SCR1*'s gate and *R3* to the positive rail. In turn, this causes current to flow

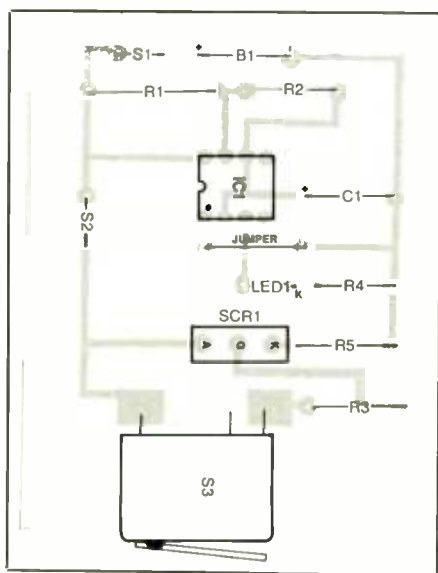

Fig. 3. Wiring guide for pc board. Use this as a rough guide to component layout if project is assembled on perforated board.

through *SCR1*. When this occurs, *R5* drops about 8.28 volts, enabling the oscillator and causing *LED1* to flash.

When gated on, *SCR1* latches in the energized state by the dc holding current. Therefore, repositioning the project in its upright position will *not* return the Alarm to its armed condition. Once tripped, the project remains energized until power is switched off by opening *S1*.

The circuit is very sensitive, which accounts for inclusion of *S2*. This switch isolates the enabling circuit until it is finally set in the armed mode. When arming the project, *S2* is the last switch to be set.

### Construction

Component layout is not critical. Therefore, just about any traditional wiring technique can be used to build this project. If you wish, you can fabricate a printed-circuit board for it, using the actual-size etching-and-drilling guide shown in Fig. 2. Alternatively, you can use perforated board that has holes on 0.1-inch centers and suitable Wire Wrap or soldering hardware. Whichever approach you use, however, it is a good idea to use a socket for *IC1*.

This project's pc board is so simple that its resist pattern can be laid out directly on the copper side of the blank using Radio Shack's Cat. No. 276-1577 or other dry-transfer resist patterns. In fact, if you wish, you can even lay out the resist pattern free-hand using a resist pen.

From here on, we will assume that pc construction is being used. Refer to Fig. 3 for wiring instructions for this board. (Note: If you use perforated board, use the Fig. 3 wiring diagram as a rough guide to component layout and refer back to Fig. 1 for wiring details.)

You will note in Fig. 2 that a rectangular cutout must be made in one end of the pc board, which adds to the fabrication task. Make this cutout after etching and trimming to

size the board but before drilling any holes. The best way to make the cutout is with a nibbling tool, though you can use a coping saw or even a Moto-Tool with a thin saw or abrasive wheel. Smooth the edges of the cutout with a fine file.

Start wiring the board by installing and soldering into place the IC socket. Do *not* install the IC in the socket until after the preliminary voltage check has been performed. Then install and solder into place the resistors and capacitor. Make certain that the capacitor is properly oriented before soldering its leads to the copper pads on the bottom of the board.

Next, identify the leads of the SCR. (The RCA SK3950 device specified for *SCR1* is housed inside a TO-92 case, which conserves space on the circuit-board layout. If you cannot find this particular SCR, try to obtain a substitute that has the same case.) Plug the leads of the SCR into the holes in the board provided for them and solder them into place. Similarly, identify the leads of the LED. Plug them into the appropriate holes in the board and solder.

All switches in this project mount directly on the pc board. Lever switch *S3* mounts in the cutout at the end of the board, with its toggle facing outward as shown. Take careful note of the orientation of this switch with reference to the pads on the pc board. This spdt switch has both normally-closed and normally-open contacts. You want to wire to the normally-closed contacts. With the switch oriented as shown, the normally-open contact lug will not be wired into the circuit. The other two switches are simply pc-mount devices whose lugs plug into the board's holes and are soldered into place.

Tightly twist together the fine wires at the ends of the battery snap connector's leads and tin with solder. Plug the leads of the snap connector into the holes labeled *B1*, red into the pad identified with a "+"

sign and black into the pad identified with a “-” sign, and solder both in to place. This completes wiring of the circuit-board assembly.

The only other machining required for the pill container used as the project's enclosure is to drill two holes in it. (You can use a different type of container if you wish, such as a small plastic project box.) One hole is for the plunger that operates the lever toggle on S3, as shown in Fig. 4, the other for viewing the status of the LED. Be sure to accurately locate both holes before drilling them and make them only large enough to serve their purposes, and use a broad-head nail, tack or rivet as the switch pin. Whichever you use, make it only as long as needed for full travel of the switch lever without tilting the pill container.

Slide the circuit-board assembly in-

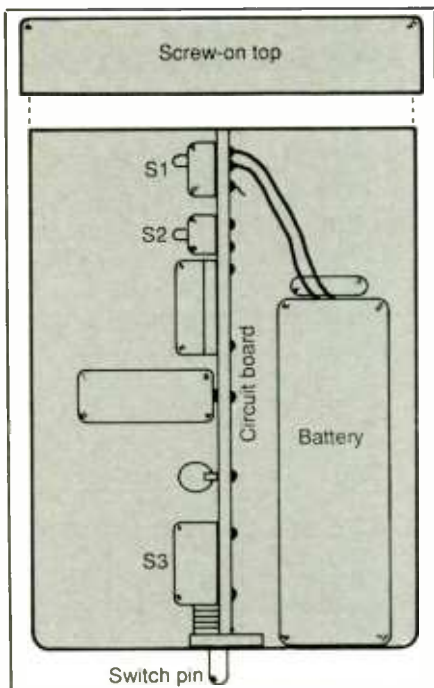

Fig. 4. Circuit-board assembly and battery mount inside plastic pill container. Lever on S3 is held in pressed state by weight of project and protruding shortened nail or rivet.

to the container and check for proper operation of the lever on S3. When you are satisfied that the pill container is properly prepared, proceed to initial checkout.

### Checkout & Use

Clip the common lead of a dc voltmeter to the lead of R1 that is farther away from the center of the board. The timer should *not* be plugged into the IC socket at this time. Plug a 9-volt battery into the battery connector and set S1 to “on.” Touch the meter’s “hot” probe tip to pins 2, 6, 7 and 8 of the IC socket and note the reading obtained; it should be +9 volts. Close S2 and check the potential at the anode of SCR1; again, the reading should be +9 volts. If you do not obtain the proper reading at any given point, disconnect the meter, remove the battery from

the circuit and rectify the problem before proceeding.

When you are certain the project has been properly wired, power it down and install the 555 timer in its socket. Make sure it is properly oriented, as shown in Fig. 3, and that no pins overhang the socket or fold under between IC and socket.

Place a thin piece of non-conducting foam tape on the bottom of the circuit-board assembly to insulate it from the battery's case. Then slide the assembly and battery into the pill container and position it so that the toggle lever on S3 operates freely.

You set your Personal Intrusion Detector by placing it upright on a flat surface so that its weight is on the switch pin that opens the normally-closed contacts of S3. With S3 held open, set S2 and finally S3 to their “on” positions in that order. This arms the alarm.

Always keep in mind that this detector is very sensitive and that S2 must be toggled to “on” as the last step in the arming procedure. Of course, LED1 must be off during the arming operation.

Once the project is armed, any tipping or lifting of its container that causes S3 to close will enable the oscillator and cause LED1 to flash. Replacing the container in its original location and orientation will have no effect on the operating status of the alarm. That is, the LED will continue to flash until the circuit is reset. Even if the person who triggers the Detector should open the container and see the switches, he is not likely to know the rearming procedure.

To disarm the Personal Intrusion Detector, you must switch S2 to its “off” position. This interrupts current flow through SCR1 and disables the output at pin 3 of IC1. Another way to disable the Detector is to switch S1 to “off,” which removes power from the entire circuit. Whenever the alarm is not in use, S1 should always be set to “off.”

ME

## Be an FCC LICENSED ELECTRONIC TECHNICIAN!



Earn up to \$30 an hour and more!

Learn at home in spare time. No previous experience needed!

No costly School. No commuting to class. The Original Home-Study course prepares you for the “FCC Commercial Radiotelephone License”. This valuable license is your “ticket” to thousands of exciting jobs in Communications, Radio-TV, Microwave, Computers, Radar, Avionics and more! You don't need a college degree to qualify, but you do need an FCC License. **No Need to Quit Your Job or Go To School** This proven course is easy, fast and low cost! **GUARANTEED PASS** — You get your FCC License or money refunded. **Send for FREE facts now. MAIL COUPON TODAY!**

**COMMAND PRODUCTIONS**  
 FCC LICENSE TRAINING, Dept. 220  
 P.O. Box 2824, San Francisco, CA 94126  
 Please rush FREE details immediately!

NAME \_\_\_\_\_  
 ADDRESS \_\_\_\_\_  
 CITY \_\_\_\_\_ STATE \_\_\_\_\_ ZIP \_\_\_\_\_



# Motorcycle Headlight Flasher

*Retrofit accessory makes motorcycles more visible to other traffic to reduce accidents*

By James H. Brown

As more and more cars are on the road, motorcyclists are increasingly exposed to being hit head-on or by a vehicle sharply moving in front of them from another lane. Such risk is especially great at night, even with a headlight shining, probably because the cycle's silhouette is relatively small.

To capture other drivers' attention, a headlight flasher can be used when traffic gets heavy. The one presented here can change a headlight's constant-on operation at the flip of a switch to causing the light to flash about 1.5 times per second. Another switch toggle, and the cyclist restores the constant-on headlight mode.

## About the Circuit

Shown in Fig. 1 is the complete schematic diagram of the Motorcycle Headlight Flasher circuit. The main elements in this circuit are 555 timer *IC1* and SK9438 power Darlington transistor *Q1*. The timer is configured to operate as an astable oscillator at a frequency of approximately 1.5 Hz. Duty cycle or on time of the oscillator is roughly 0.25 second, which is also the on-time of the motorcycle's headlight during each oscillator cycle. The project can be operated either manually or automatically, depending on the position to which switch *S1* is set.

The Flasher connects to the "hot" or + side of the motorcycle's electrical system across a blown (or otherwise open) fuse, identified in Fig. 1 as *F1*, via the toggles at lugs 2 and 5 of *S1A* and *S1B*. The circuit is complet-

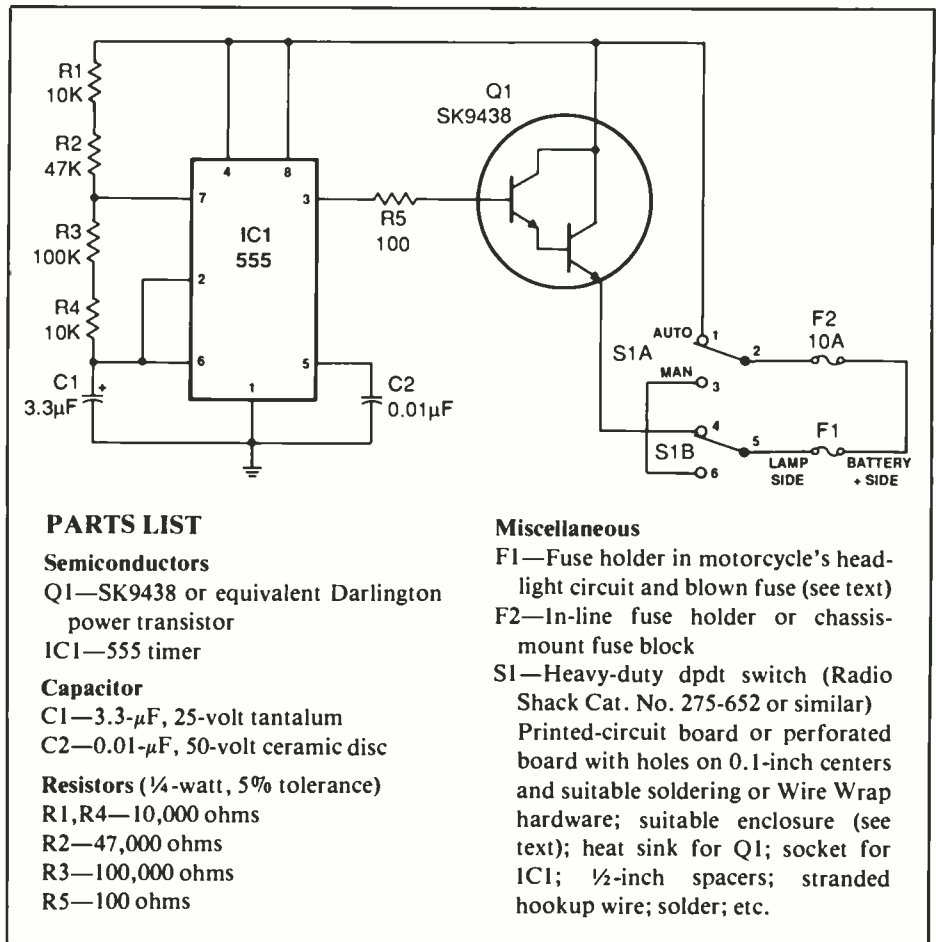

Fig. 1. Complete schematic diagram of project.

ed to chassis ground via a separate wire. This arrangement makes it easy to install the Headlight Flasher without requiring you to modify your motorcycle's headlight wiring harness. Simply pull out the good headlight fuse and replace it with an open fuse, making sure the toggle side of *S1A* and fuse *F2* are across the + 12-volt bus.

With *S1* set to AUTO (automatic),

drive power for the motorcycle's headlight is through *Q1*, which is turned on and off as the square-wave output signal from pin 3 of *IC1* toggles from approximately +5 volts to ground.

Setting *S1* to MANUAL completes the return side of the headlight circuit to the positive (+) side of the motorcycle's electrical system and keeps the headlight on continuously.

## Construction

Because of the simplicity of its circuitry, this is a very easy project to build. With nothing critical about component layout, you can use any traditional construction technique that suits you. If you wish to fabricate a printed-circuit board, use the actual-size etching-and-drilling guide shown in Fig. 2. Alternatively, you can use perforated board that has holes on 0.1-inch centers and suitable Wire Wrap or soldering hardware to build the circuit. Regardless of the wiring techniques chosen, it is a good idea to use a socket for the 555 Timer Chip.

We will assume in this article that you are wiring the project's circuit on a pc Board and direct our description of the construction procedure to this. With the board oriented as shown in Fig. 3, plug an 8-pin DIP socket into the IC1 location and solder it into place. Be careful to avoid creating solder bridges between the closely spaced copper pads on the Bottom of the Board as you solder the socket into place. Do *not* plug the 555 IC into the socket until after preliminary voltage checks have been made.

Once the socket has been installed on the board, install and solder into place the resistors and then the capacitors. Make sure that *C1* is properly polarized before soldering its leads to the pads on the bottom of the board. Double check the circuit-board assembly for correct wiring and component placement. Then plug the 555 IC into its socket. Make sure the chip is properly oriented and that no pins overhang the socket or fold under between IC and socket as you push the 555 home.

The entire project, except for *F1*, *F2* and *S1*, can be housed in any enclosure that will accommodate the circuit-board assembly, the transistor on its heat sink, and fuse *F2* in its holder. An ordinary plastic project box that has a removable aluminum panel is a good choice, as is an all-

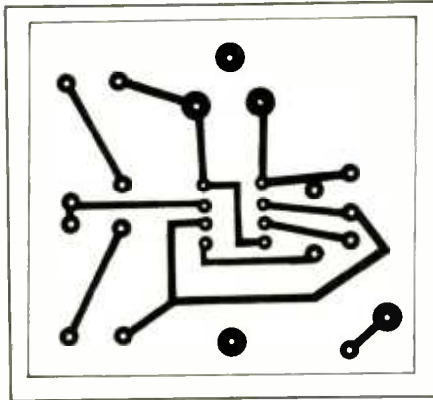

Fig. 2. Actual-size etching-and-drilling guide for fabricating a printed-circuit board for the project.

metal utility box. The metal of each provides a convenient mounting base for the transistor's heat sink and helps in dissipating heat.

Drill mounting holes for the circuit-board assembly, the Darlington power transistor and its heat sink (and the fuse holder for *F2* if you do not use an external in-line fuse holder for it), and entry holes for the wires that go to the switch, *F1* and chassis ground. If any of these holes is drilled through a metal panel, deburr them to remove all rough edges, and line the entry hole for any wires with a small rubber grommet to protect the wires from abrasion that can cut through the insulation and cause a short circuit.

When Darlington power transistor switches on, it conducts a fairly high current that results in rapid heating. To prevent the transistor from burning up due to thermal runaway, make certain you mount it on a fairly hefty heat sink that, in turn, mounts on the outside of the enclosure. Also, make sure to electrically insulate the transistor from the heat sink with a mica or plastic spacer and shoulder fiber washers designed for this purpose. Liberally coat both sides of the insulator with thermal-transfer grease or paste before placing it between the transistor and heat sink.

Solder a 3-inch length of stranded

hookup wire to a ring lug and place the lug under the head of one of the two screws that secure the transistor to the heat-sink. The wire connected to the ring lug serves as the means for connecting the transistor's collector into the circuit. Connections to the emitter (E) and base (B) pins of *Q1* are made by directly crimping and soldering 3-inch hookup wires to them and insulating the connections with small-diameter heat-shrinkable or plastic tubing.

Determine how long the interconnecting wires between the circuit-board assembly and all other components must be and cut each to length. (Note: Because of the mechanical stresses which the project will normally be subjected to on the road, all wiring except for the short link that bridges lugs 3 and 6 of the switch must be *stranded* hookup wire. After cutting each wire to length, strip ¼ inch of insulation from both ends. Tightly twist together the fine conductors at both ends of each wire and sparingly tin with solder. Use bare solid hookup wire or cut-off resistor or capacitor lead for the link between lugs 3 and 6 of the switch.)

Pre-wire the switch as shown in Fig. 3. For the connections to lug 1 of the switch, you can use either two wires that run the full length between the switch and circuit-board assembly and collector of the transistor (as shown) or run a single full-length wire from the switch to the transistor's collector and another shorter wire from here to the indicated hole in the circuit board.

Once the switch is wired, mount it in whatever location you have chosen for it on your motorcycle. Route the wires from lugs 1, 2 and 4 to where the project's enclosure will be mounted. Choose a protected location. Then pass the three wires from the switch through the holes drilled for them in the enclosure. Depending on how the wiring is done to the collector of the transistor, either plug the free end of the wire connected to

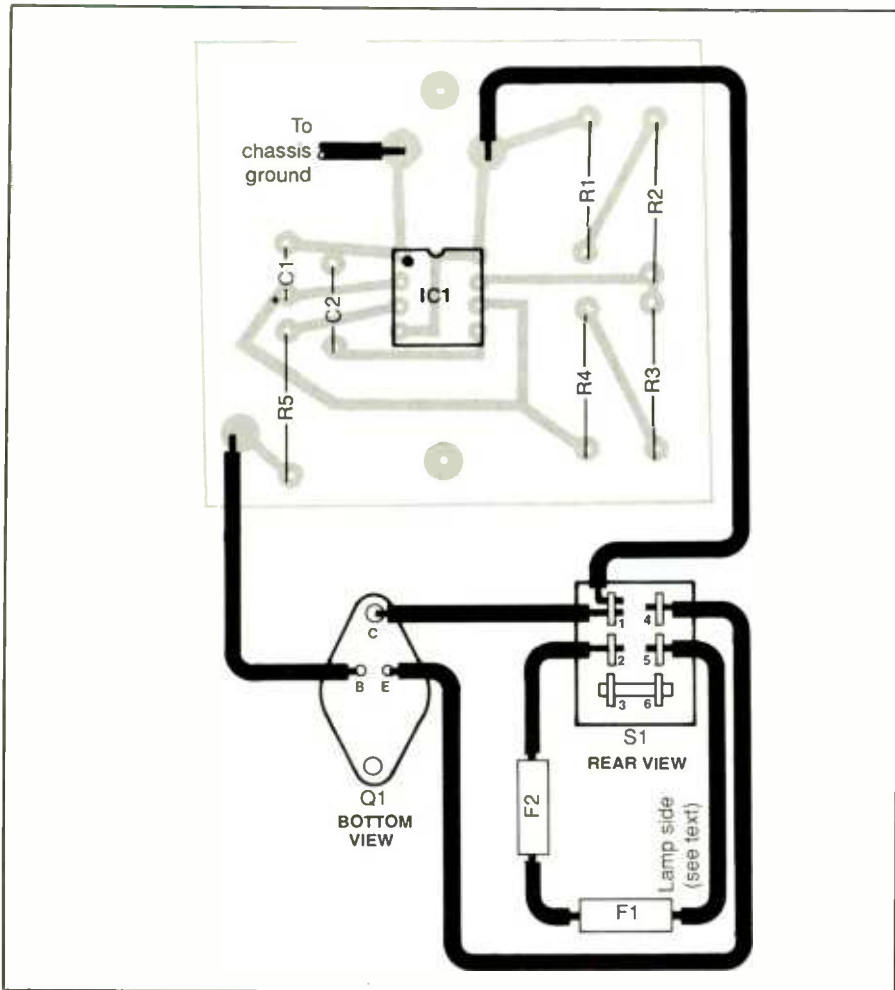

Fig. 3. Wiring guide for pc board. The switch, transistor and fuse holders mount off the board and that F1 is actually the headlight fuse holder in your motorcycle's electrical system.

Plug 1 of the switch into the circuit-board hole labeled CHASSIS GROUND and solder into place, or crimp and solder it and a shorter wire to a ring lug and secure the lug under the head of one of the screws that mount the transistor in place on the heat sink and plug the short wire into the indicated hole and solder into place.

If you are using an internal chassis-mounted fuse holder for it, route the wire that goes to F2 through a hole in the enclosure and crimp and solder its free end to one lug of the fuse holder. Otherwise, wire an external in-line holder for this fuse. Prepare another wire to interconnect F2 with F1 (the latter is the fuse that already

exists in your motorcycle's headlight system). Route one end of this wire into the enclosure and crimp and solder it to the other lug of the F1 fuse holder.

Prepare a 12-inch or so length of hookup wire as described above. Terminate one end of this wire in a No. 6 chassis lug. Feed the other end through a hole in the enclosure, plug it into the CHASSIS GROUND hole in the circuit-board and solder into place.

Remove the fuse from the headlight circuit of your motorcycle and plug it into the fuse holder inside the project. Mount the circuit-board assembly into place on the floor of the

enclosure with 1/2-inch spacers and suitable 4-40 machine hardware, using toothed lockwashers between the screw heads and enclosure and nuts and circuit-board assembly. Then mount the project into place inside the motorcycle's fairing.

Terminate the free ends of the two remaining wires that go to F1 in 1/4 x 3/4-inch strips of sheet copper. Alternatively, strip an additional 1/4 inch of insulation from the ends of these wires and tin the exposed conductors with solder and hammer both flat. Wrap the copper or flattened conductors around the metal caps of a blown fuse of the same physical dimensions as the one you removed. Plug this fuse into the vacated holder on your motorcycle, making sure that the one that goes to F2 is on the +12-volt—not the lamp—side of the cycle's fuse holder.

The easiest way to keep the project's enclosure from moving around in your motorcycle's fairing is to use VelcroR hook-and-loop strips. However, you can use metal clamps and suitable hardware if you desire a more permanent installation. If you do this, shock mount the project with a strip of foam rubber between it and the fairing.

### Checkout & Use

Plug the ignition key into the motorcycle's keyswitch and turn it to the ACC (accessory) position. At this point, the motorcycle's headlight will be flashing or be on continuously. If the light is flashing, label the position of the toggle on the project's switch as AUTO and the other position as MANUAL. Obviously, if the headlight is continuously on, reverse the switch labeling, but make sure first that in the alternate position of the switch the headlight does, indeed, flash as it should.

Operation of the project is as simple as turning on your motorcycle's ignition and flipping the switch to the desired position.

# A Light Minder for the Blind

*Simple project indicates when lights are on and where*

By Adolph A. Mangieri

A blind person can check the status of lights by touching wall switches, by listening for the hum of fluorescent lights, and by feeling for heat radiated by turned-on table lamps. However, stairwells often have three-way switches that make it impossible for a blind person to be absolutely sure if the light is on or off. Too, a blind person cannot tell if the bulb in a ceiling fixture has burnt out. The Light Minder described here helps to alleviate at least these two of the many uncertainties with which blind people must contend.

The Light Minder detects ambient lighting and audibly signals whether it is on or off. It can be swept around an area to permit the user to locate the direction from which the light is coming. Additionally, it can signal light intensities between full on and full off by sounding tones of different frequencies.

It is simple in design, low in cost and easy to build. It requires very little time and no special skills to learn how to use it effectively. With it, a blind person can feel more in step with his environment as he provides the lighting needed by visitors and knows when to turn it off when no sighted people are around.

## About the Circuit

Shown in Fig. 1 is the complete schematic diagram of the Light Minder. CMOS 555 timer *IC1* is configured here to operate as a continuously running multivibrator. When normally open pushbutton switch *SI* is pressed, capacitor *C1* begins to

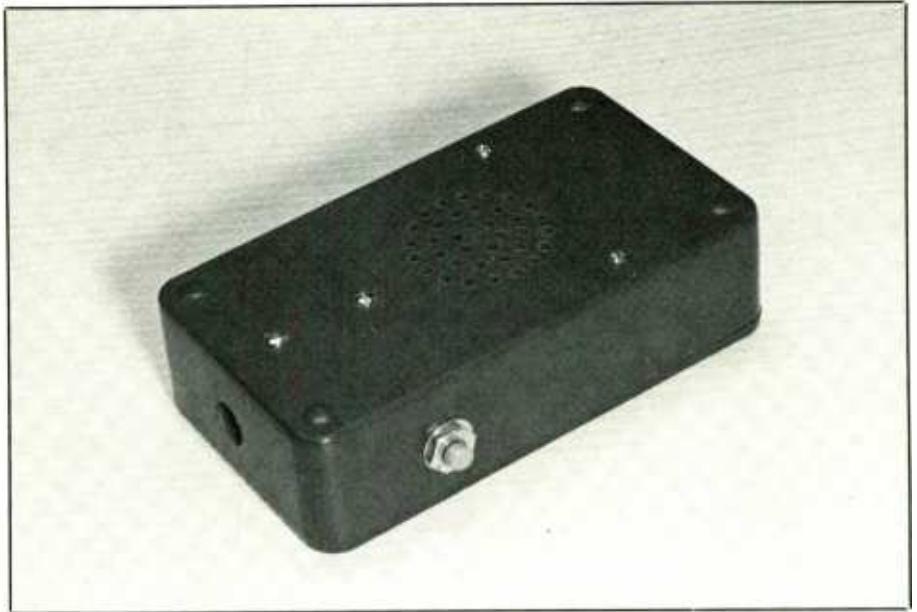

charge at a rate determined by the sum of the values of resistor *R1* and the values of the parallel combination of resistor *R2* and cadmium-sulfide light-dependent resistor *LDRI*.

When the potential across *C1* reaches  $0.667V_{CC}$ , the capacitor discharges to  $0.033V_{CC}$  through *R2* and *PC1*. The capacitor then charges up again and discharges at  $0.667V_{CC}$ , and the cycle repeats for as long as power is applied to the circuit.

A sawtooth-like waveform voltage developed across *C1* is fed into *IC1* at trigger pin 2 and controls an output flip-flop in the timer. This flip-flop delivers a square-wave output voltage at pin 3, which is applied to speaker *SPKR* through dc blocking capacitor *C2*.

The resistance of the light-dependent resistor decreases with increasing

light. This causes the frequency of the audio signal generated by the timer chip to increase. In total darkness, *LDRI*'s resistance rises to greater than 4 megohms.

The audio output from *IC1* is a train of brief non-symmetrical pulses that occur at a rate of one or two per second. The value of resistor *R2* assures that the pulse rate is never less than one per second, which, in turn, assures the user that the Light Minder is operating as it should.

At medium light-intensity levels, the resistance of *LDRI* is comparable to that of *R1*, resulting in a square-wave output from *IC1* at a middle audio frequency. Under high light-level conditions, *LDRI*'s resistance is well below that of *R1*, now resulting in a non-symmetrical square wave at high audio frequency. Thus,

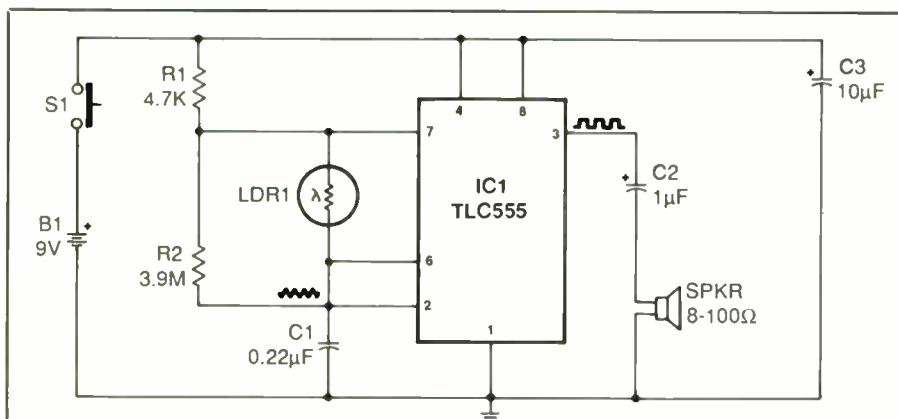

#### PARTS LIST

- |  |   |
|--|---|
| B1—9-volt battery  | ance resistor   |
| C1—0.22- $\mu$ F, 15-volt ceramic disc capacitor   | R2—3.9-megohm, $\frac{1}{4}$ -watt, 5% tolerance resistor   |
| C2—1- $\mu$ F, 15-volt electrolytic capacitor  | S1—Normally open spst pushbutton switch   |
| C3—10- $\mu$ F, 15-volt electrolytic capacitor   | SPKR—Miniature 8- to 100-ohm speaker  |
| IC1—TLC555 CMOS timer (Radio Shack Cat. No. 276-1718 or equivalent)                      | Misc.—Printed-circuit board or perforated board and suitable soldering or Wire Wrap hardware (see text); socket for IC1; snap connector and mounting clip for B1; suitable enclosure (see text); spacers; machine hardware; hookup wire; solder; etc. |
| LDR1—Cadmium-sulfide light-dependent resistor (Radio Shack Cat. No. 276-1657 or similar) |   |
| R1—4,700-ohm, $\frac{1}{4}$ -watt, 5% tolerance resistor                                 |   |

Fig. 1. Complete schematic diagram of Light Minder's circuit.

the user knows simply by the pitch of the generated tone whether lights are on or off.

### Construction

The Light Minder's circuit is very simple in terms of component count and requires no special component placement during assembly. Therefore, you can assemble the project using any traditional wiring technique that suits. If you wish, you can fabricate a printed-circuit board for the project, using the actual-size etching-and-drilling guide shown in Fig. 2 and wire it as shown in Fig. 3. Alternatively, you can mount the components on perforated board that has holes on 0.1-inch centers using suitable soldering or Wire Wrap hardware, as was done for the origi-

nal prototype of the Light Minder shown in Fig. 4.

Whichever wiring technique you decide to use, it is a good idea to use a socket for IC1 both to facilitate easy troubleshooting should this become necessary and to make it easy to replace the timer chip as needed.

If you make your own pc board, wire it exactly as shown in Fig. 3, starting with the IC socket and proceeding with the resistors, capacitors and light-dependent resistor. (You can use any cadmium-sulfide unit that has a resistance of between 200 and 2,000 ohms under average room lighting conditions for LDR1.) Make sure you install electrolytic capacitors C2 and C3 in the correct polarity. Do *not* install the timer chip in the socket yet.

Strip  $\frac{1}{4}$  inch of insulation from

both ends of six 4-inch-long hookup wires. If you are using stranded hookup wire, twist together the fine conductors at both ends of all wires and the leads of the battery snap connector and sparingly tin with solder. Plug one end of the wires into the holes labeled S1, LDR1 and SPKR and solder them into place. Then, taking care to observe proper polarity, plug the leads of the battery snap connector into the holes labeled B1 and solder them into place.

Clip the common lead of a dc voltmeter or a multimeter set to the dc volts function to the free end of the wire coming from the SPKR hole near the edge of the board. Make sure the other SPKR wire and the two LDR1 wires touch nothing in the circuit. Temporarily short together the free ends of the two S1 wires and snap a fresh 9-volt battery into the connector. Then touch the meter's "hot" probe to pins 4 and 8 of the IC1 socket and note the reading in both cases. If all is well, the readings should both be +9 volts. If not, power down the circuit and rectify the problem before proceeding.

When the correct voltages appear at pins 4 and 8 of the IC socket, power down the circuit by removing the battery from the connector. Then temporarily short-circuit C3 with a wire jumper and plug the timer chip into the socket, observing correct orientation and making sure that no pins overhang the the socket or fold under between IC and socket. Separate the S1 wires. (Note: If you assemble and wire the circuit on perforated board, use the same general component layout shown in Fig. 3 and wire the components together by referring back to Fig. 1.)

Use any enclosure that will comfortably accommodate the circuit-board assembly, battery, speaker and switch. An old defunct shirt-pocket-size radio makes an ideal enclosure, after removing from it the electronic circuitry but leaving in place the speaker. (You can use any

miniature speaker rated at between 8 and 100 ohms with this project.)

Machine the enclosure for mounting the components, using a metal clip for holding the battery in place. If you use a standard utility box, drill mounting holes for the circuit-board assembly and switch, a number of holes in the area over which the speaker will be mounted to allow the sound to escape, and a 1/8-inch-diameter hole directly over the light-dependent resistor when the circuit-board assembly is mounted in place. If you are not using a salvaged pocket radio case, mount the speaker in place with a narrow bead of silicone adhesive around its frame.

After mounting the speaker and switch in their respective locations, mount the circuit-board assembly in place, using short spacers and No. 4 machine hardware. Then determine exactly where to drill the hole directly in line with the LDR in the other wall of the enclosure. Drill that hole.

Crimp and solder the two wires coming from the holes labeled S1 on the circuit-board assembly to the lugs of the switch. Similarly, crimp and solder the wires coming from the holes labeled SPKR to the lugs of the speaker. The "+" wire goes to the identified "hot" lug on the speaker, the other wire to the remaining lug. If you are using the case of a pocket radio, use black plastic electrical tape to block all light from entering the case through the transparent bezel or hole in the case. The only light that should enter the enclosure should do so through the 1/8-inch hole you drilled for the LDR.

Snap a battery into the connector and assemble the enclosure.

### Using the Project

At night, place the Light Minder in total darkness for several minutes to allow the resistance of the LDR to increase to near its maximum value. Press and hold the button on S1 to verify that an audio tone of one to three ticks per second is being

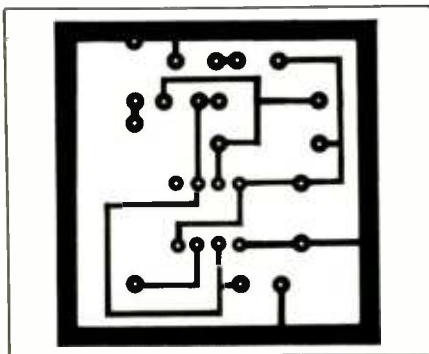

Fig. 2. Actual-size etching-and-drilling guide for fabricating printed-circuit board.

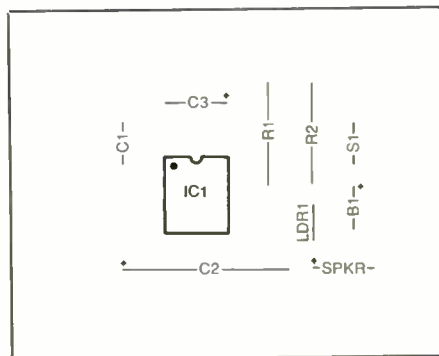

Fig. 3. Wiring guide for pc board. Use this as a rough guide to component layout when assembling project on perforated board.

generated. If the tone is much higher in frequency, reduce it by using a larger capacitance value for C1. Do this by shunting the capacitor already in place with another one of smaller value. Of course, if the tick rate is much slower than the one to three ticks it should be, remove the existing capacitor from the C1 location and replace it with a capacitor of lower value.

While you are at it, check the volume of the tone under average room lighting. If it is objectionably loud,

decrease the value of C2 to 0.5 microfarads or to suit.

The circuit draws 3 milliamperes of current when using a CMOS version of the popular 555 timer chip and 12 milliamperes when using the bipolar version. Obviously, the CMOS version is preferable and will allow an alkaline battery for B1 to last about a year under normal conditions.

Perform operational tests at night with an adjoining darkened room. As the project is swept past the en-

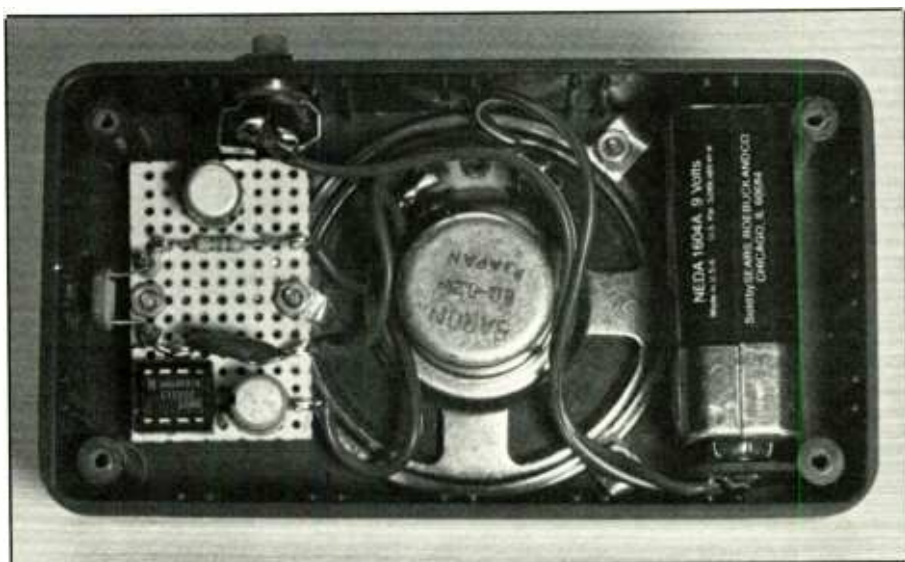

Fig. 4. Interior view of author's prototype housed inside a project box. This project was assembled using perforated board and point-to-point wiring.

trance to the darkened room, the pitch of the tone emitted by it should suddenly drop. In effect, the Light Minder is using audio tones to "map" the environment as the project is swept completely around the room. Thus, although a blind person may know his orientation in a room by touch, the Light Minder can confirm and reinforce that knowledge.

A user might be interested in equating the audio tones with light levels so that he can adjust lighting to suit the needs of sighted individuals. To this end, describe the lighting conditions while the blind user scans his environment with the project. The typical blind person should easily be able to discern and interpret at least three—and probably as many as five—light levels (audio tones).

A ticking sound that occurs less than two times per second indicates total or near total darkness, or a condition under which a sighted person will not be able to or just barely be able to make out objects. A rapid tick or low-frequency buzz in the range of 10 to 100 Hz indicates that there is enough light to see objects but not enough to read printed matter. At audio tones of about 400 Hz and beyond, the lighting should be sufficient for reading purposes. Tones of around 2 kHz indicate that the light level is quite high, as when the project is detecting a bright light source. Direct sunlight and very close detection of a bright lamp will cause the project to generate even higher-pitched tones.

From the foregoing, it should be obvious that the Light Minder is a very utilitarian project for the sight impaired. It not only lets a blind user know when lights are on, it can also be used to scan the environment to inform the user of the direction from which the light is coming. Additionally, the unsighted user can use the project to scan his entire environment to assist him in becoming familiar with a new or different room.

Of course, the Light Minder is not

a panacea for the blind. Some users may become intrigued with the project and attempt to extract whatever information they can from it. But caution any user that the Light Minder can supplement but does *not* replace normal procedures for estab-

lishing one's orientation and movement within a given environment. If any confusion occurs when using the Light Minder, instruct the blind user to ignore the project and return to normal procedures for determining orientation. **ME**

## CABLE TV SPECIALS

### CONVERTERS

	JRX-3 DIC—36 Channel Corded Remote . . . . .	\$119.95
	RCA 58-3 58 channel set top with Jerrold Decode . . . . .	\$99.95
	SB-3 — 'The Real Thing' . . . . .	\$109.95
	SB-3-Taiwan Copy . . . . .	\$89.95
	DRZ-3-DIC—68 Channel Wireless with Decoder . . . . .	\$189.95
ZENITH:	Z-TAC Cable Add-On . . . . .	\$169.95
VIEW STAR:	MXC 2001—65 Channel Wireless— with Parental Lockout . . . . .	\$89.95
	MXC 2001 A-B—Same as above with A-B Switch . . . . .	\$109.95
	MXC 2501—65 Channel Wireless with Volume . . . . .	\$119.95
	Universal V7472—72 Channel Wireless Remote MTS Stereo Converter-Full Feature Decoder Compatible . . . . .	\$129.95

### MISCELLANEOUS

OAK:	ECONO-3V Mini-Code . . . . .	\$79.95
	ECONO-3V Mini-Code Vari-Sync . . . . .	\$89.95
	ECONO-3V Mini-Code Vari-Sync Plus Auto On-Off . . . . .	\$119.95
OAK:	Sine-wave Anti-Jammer Kit . . . . .	\$39.95
JERROLD:	400 & 450 Handheld Transmitters . . . . .	\$29.95
HAMLIN:	MLD-1200 Channels 2 or 3 . . . . .	\$89.95
NEW ITEMS:	Scientific Atlanta SA-3 . . . . .	\$119.95
GENERAL	INSTRUMENTS: VCU Amplified Video Switch Signal Amplifier . . . . .	\$59.95

**ALL UNITS GUARANTEED. QUANTITY PRICES AVAILABLE.**

## UNITED ELECTRONIC SUPPLY

P.O. BOX 1206-ME • ELGIN, ILLINOIS 60121 • 312-697-0600

CIRCLE 47 ON FREE INFORMATION CARD

## A Speaker-Independent Speech-Recognition Chip

By Forrest M. Mims III

Various types of speech-recognition circuits have been available for many years now and such circuits were among the earliest of peripheral cards to be developed for use with personal computers. As anyone who has designed or used a speech-recognition circuit or system is likely to testify, electronic speech recognition is not a trivial task.

When designing or using such systems, the first thing one learns to appreciate is the remarkable ability of the human ear and brain to instantly detect and interpret, with virtually no errors, tens of thousands of words. What is especially amazing is that all this can take place with a high degree of accuracy when the signal level of the spoken words is immersed in an even higher level of background "noise," such as the sea of voices at a party.

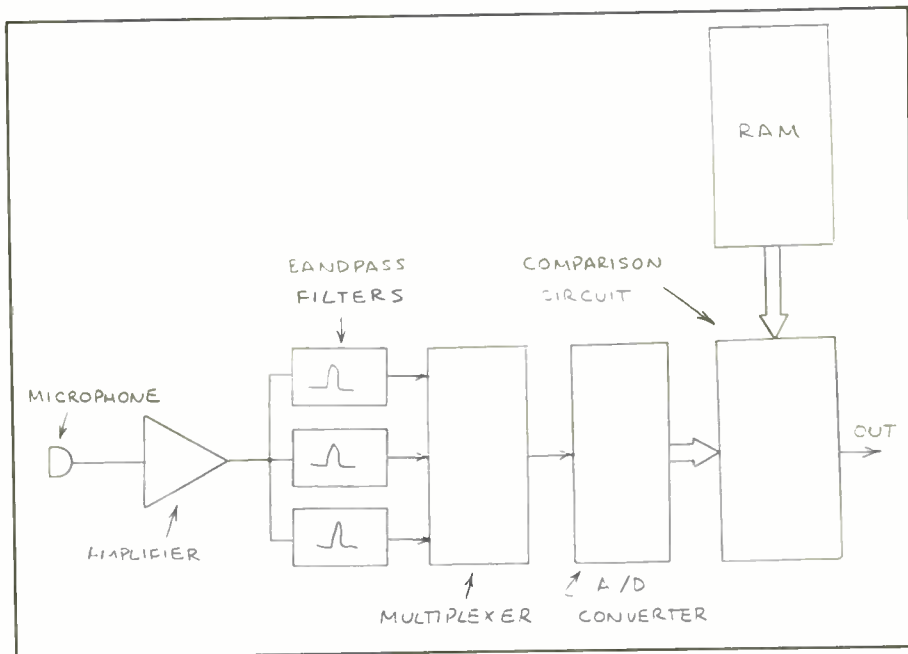

Fig. 1. Simplified block diagram of a speaker-dependent speech-recognition system.

### Speech-Recognition Technology

A common kind of speech-recognition system uses the "template" method. A typical template recognition system might contain some or all of the elements detailed in Fig. 1. Speech energy intercepted by a microphone is transformed into an electrical signal that is subsequently amplified and sent to a parallel array of band-pass filters. The filters make up a spectrum analyzer that "slices" the incoming signal into some of its respective frequencies. The output from the filters is sequentially sampled at intervals of a few tens of milliseconds and sent to an analog-to-digital (A/D) converter.

Since speech is composed of a complex range of frequencies, each with its own amplitude, the amplitude of the signals at the outputs of the band-pass filters varies according to the incoming signal. Therefore, the sequence of bit patterns at the output of the A/D converters forms a template that is unique for each word. The template is compared with bit patterns previously stored in RAM, often inside a computer, until a match is made.

This account is highly simplified. A working system requires precise timing and control circuits. A method of creating and storing a vocabulary of templates is required. Furthermore, the method of comparing the bit patterns of spoken words with the bit patterns stored in

RAM must be sufficiently flexible to allow for the slight variations in the signal each time a word is spoken.

An electronic speech-recognition system like this is *speaker-dependent*. The system must be trained to recognize individual words spoken by the person who

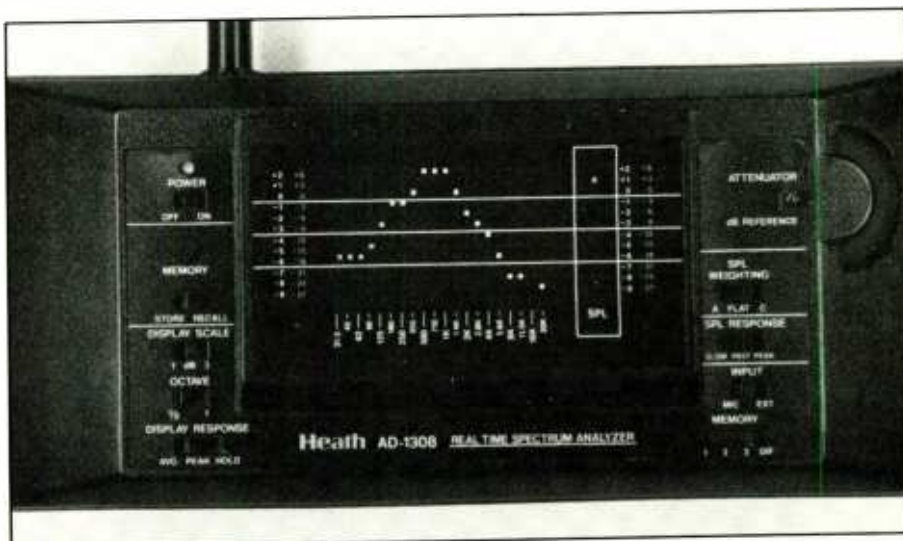

Fig. 2. The Heath Model AD-1308 graphic audio spectrum analyzer.



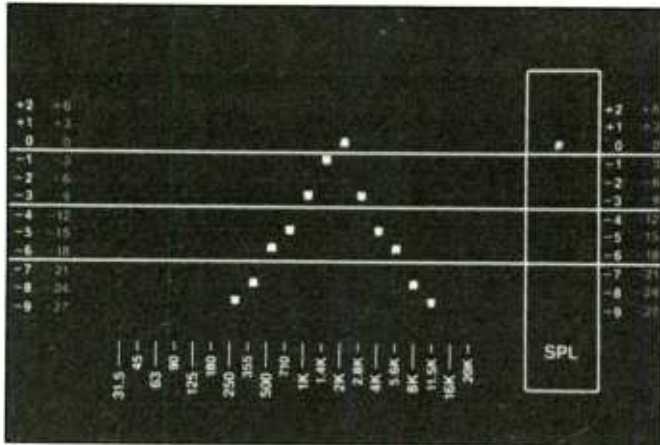

Fig. 3. The spectrogram of a whistled tone.

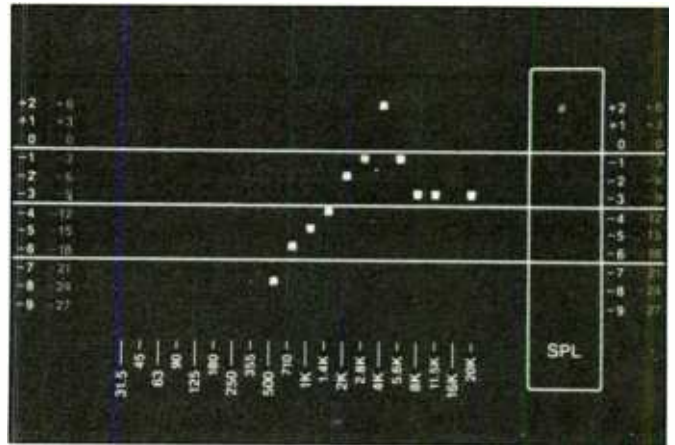

Fig. 4. The spectrogram of the tone emitted by a piezoelectric tone generator.

will use the system. A properly trained speaker-dependent system can have a recognition rate of 90 percent or greater. The recognition rate of the system will probably range from poor to zero when a person who has not trained the system attempts to use it. Even a person who has trained the system will be unable to use it should the characteristics of his or her voice be changed by a cold or stress.

The ideal electronic speech-recognition system would have an unlimited vocabulary and be speaker-independent. It would recognize thousands of spoken words without previous training and when anyone speaks them. In practice, the vocabulary of most speaker-dependent speech-recognition systems is limited by the size of the random-access memory (RAM) system available to it.

While there is no ideal speech-recognition system in existence yet, there are single-chip systems that can recognize a very limited number of vocalized words. We'll look at one such chip shortly. First, however, let's discuss a key tool of speech-recognition research, commonly referred to as an "audio spectrum analyzer."

### Audio Spectrum Analyzers

Spectrum analyzers display on a cathode-ray tube (CRT) or other type of electronic graphics display or paper recorder the

amplitude of a range of adjacent frequencies within a signal. These instruments respond to only those signals within the range of human hearing.

Audio spectrum analyzers are commonly used to monitor the performance of public-address and sound systems in auditoriums. They are also used to check high-fidelity systems.

Tests are conducted by connecting a source of pink or white noise to the sound system amplifier's input. The spectrum analyzer then "listens" to the signal reproduced by the sound system's speaker(s) through a microphone that has been specially calibrated for the purpose of providing a flat display in the presence of many frequencies that are all at the same acoustic amplitude. The analyzer's display then reveals any frequencies in the signal both by frequencies and amplitudes. Finally, audio spectrum analyzers are a key tool in the development of speech-recognition systems.

For this column, I had the use of a Heath Model AD-1308 audio spectrum analyzer. This remarkable instrument functioned as a sound-pressure-level (SPL) meter and a real-time audio spectrum analyzer. The microprocessor-controlled instrument is compact and battery-powered, thereby making it ideal for making measurements outdoors and inside large rooms and auditoriums.

Capabilities of the Model AD-1308 analyzer are remarkable, particularly in view of the instrument's compact size. The analyzer comes with a calibrated microphone. It can store three separate spectra in its internal RAM system. When operated in the difference mode, the instrument can display the difference between a stored signal and an input signal.

The AD-1308's flat plasma display panel is organized into 20 columns horizontally by 12 vertical elements. The frequency response of the columns ranges from 31.5 Hz to 20 kHz. An additional column on the far right end of the display functions as a bar-graph indicator of sound-pressure level in decibels.

Operation and performance of this instrument were reviewed by Len Feldman in the March 1985 issue of *Modern Electronics*. Len observed that the Model AD-1308 audio spectrum analyzer, which sells for \$249.95 in kit form, represents a price breakthrough for this type of instrument.

The AD-1308 is available only in kit form. Alexander Burawa, Managing Editor of *Modern Electronics*, assembled the kit and gave his observations of the task in the April 1985 issue. Al reported that it took him 17.5 hours to assemble the kit, which is considerably more time that might be implied by the relatively small size of the instrument. Al reported

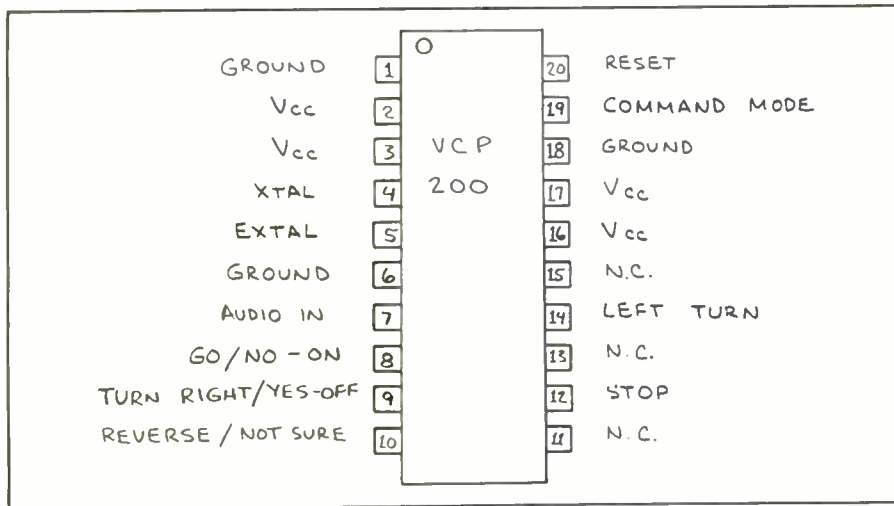

Fig. 5. Case configuration and pinouts of the VCP200 speech-recognition chip.

that while assembly of the unit was straightforward, wiring of the analog board became rather tedious. That's because this board contains more than 320 components and requires more than 825 solder connections to be made. Almost 2,000 solder connections are required to assemble the entire instrument.

Even though the Model AD-1308 is a challenging kit to build, it still represents an excellent buy. As AI wrote, "... when you're finished assembling the analyzer, you've saved considerably on the price of an equivalent factory-assembled product—assuming you can find an equivalent analyzer for less than \$1,000."

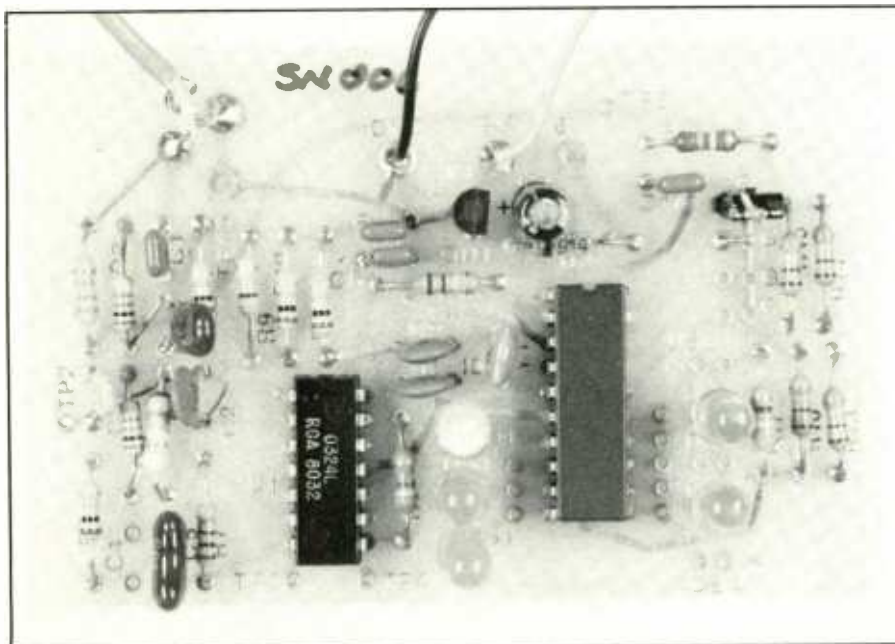

Fig. 6. The assembled VCP200 voice-recognition circuit board.

Figure 2 pictures the Model AD-1308 audio spectrum analyzer that AI assembled. After AI's review was published, he sent the unit to me and I have since used it to dissect the sound of everything from the human voice to jet aircraft. For example, the frequency spectrum of the word "stop" is shown on the instrument's display in Fig. 2, while Fig. 3 is a photograph of the spectrogram of a whistle tone and Fig. 4 shows the spectrum emitted by a miniature piezoelectric tone generator. The spectra shown in these photos were stored in the instrument's RAM and recalled later when the photos were taken.

## Word-Recognition Chip

The ability of Heath's Model AD-1308 spectrum analyzer to display the frequency spectrum of a spoken word proved to be useful when I recently experimented with a VCP200 sound-recognition integrated circuit from Radio Shack. I'll explain why later. For now, let's look at the details of the VCP200.

This speech-recognition chip has two unusual features. The first is that it's inexpensive and easy to use. The second is that its operation is speaker-independent. In other words, it does not need to be trained to understand the same set of words vocalized by different speakers. These advantages are important, but they're balanced by the VCP200's very limited vocabulary of only nine words and phrases.

While the VCP200 can be fooled into accepting words that are outside its vocabulary set, it is specified to accept the following words and phrases.

Motion	Command
go	yes or on
stop	no or off
reverse	
turn right	
left turn	

Though this vocabulary may be quite limited, it is adequate for controlling motorized toys, appliances, lights and motors. Its five outputs can also be connected to the data bus or joystick fire buttons of a computer.

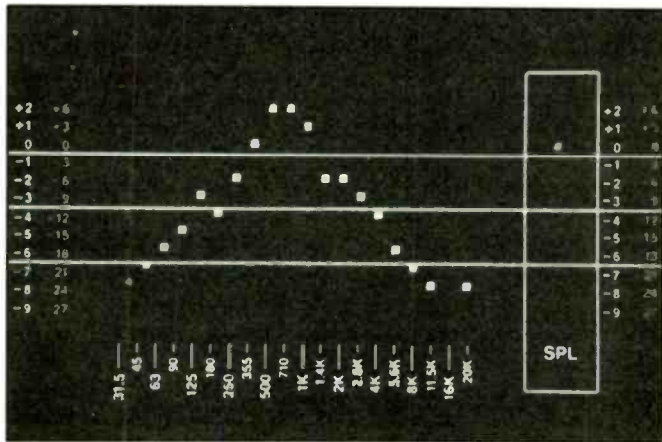

Fig. 7. The audio spectrogram of the word "off."

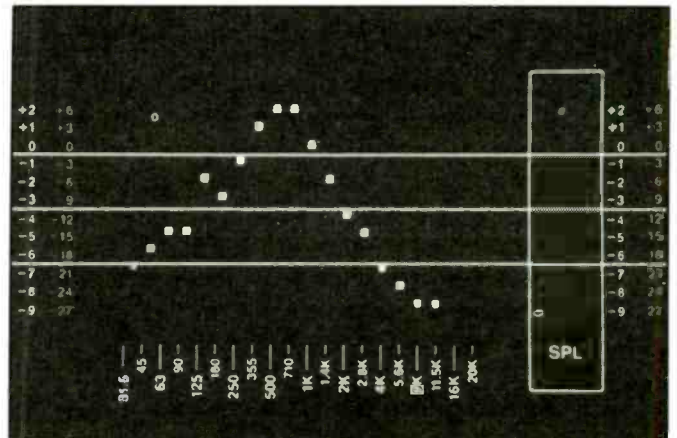

Fig. 8. The audio spectrogram of the word "no."

The VCP200 has two speech-recognition modes. Its "motion" instructions are recognized in one mode, its "command" instructions in the second mode. The chip has five outputs, only two of which are used when it is in the command instruction mode. In this mode, the VCP200 recognizes "yes" and "on" as the same word and both "no" and "off" as another word. The chip also indicates when the spoken input is not recognized as being one of these four words.

Figure 5 illustrates the package configuration and pinouts for the VCP200. Note that pin 19 is the command control input. When this pin is low, the VCP200 recognizes the five motion instructions.

When it is high, it recognizes the four command instructions.

Outputs of the VCP200 are on pins 8, 9, 10, 12 and 14. Each of the outputs, which are low when active, can sink up to 10 milliamperes of current. This means that the chip can directly drive indicator LEDs so long as a series resistor is used to keep the current below the 10-milliamper level. Motors and relays can be driven by adding a suitable interface transistor to the various outputs.

Technical data supplied by Radio Shack with the VCP200 is very complete. In addition to a description of the chip and its operation, the technical data includes a circuit diagram for an input am-

plifier. This amplifier is designed to limit the amplitude of the signal applied to the VCP200 to avoid exceeding the maximum input voltage of the chip. Printed-circuit board layouts are also included with the chip.

If the VCP200 is to be used to control a voice-controlled car, it's often necessary for two of the outputs to be active simultaneously. For example, for the car to make a left turn, "go" pin 8 and "left turn" pin 14 must both be active. Since only one of the VCP200's outputs can be active at any given time, it's necessary to add an interface latch for applications that require two simultaneously active outputs. The data Radio Shack provides

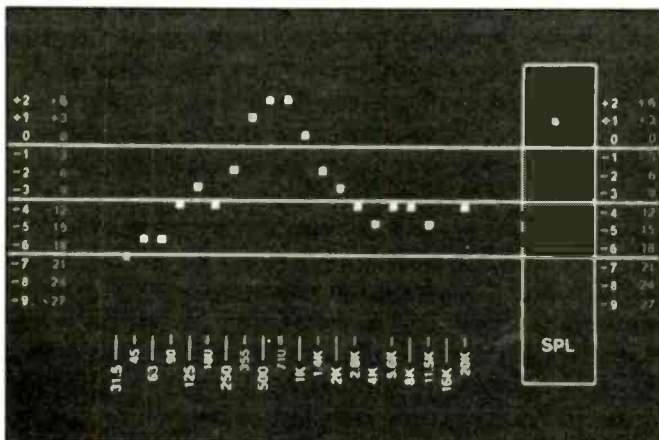

Fig. 9. The audio spectrogram of the word "on."

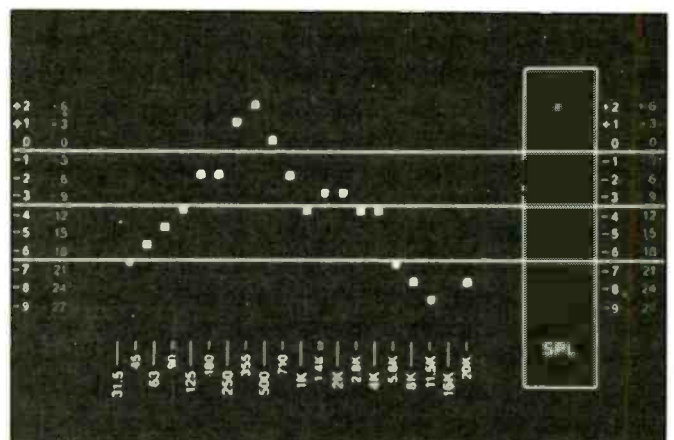

Fig. 10. The audio spectrogram of the word "yes."

with the VCP200 includes a simple latch circuit built around a 4027 dual flip-flop.

In practice, it's impractical to use the VCP200 to control a toy car by voice when the system itself is installed inside the car. This is because the system responds well to voice only when the source of the command is within 12 to 24 inches of the microphone used as the pickup. Also, the noise produced by the car and its motor can cause interference.

The VCP200, however, can be used in many other applications. For example, one can imagine a voice-controlled wheelchair. Another possibility is voice control over common computer functions, such as cursor movement. Yet another possibility is a voice-activated light switch that allows you to turn on lights when your hands are full.

Exactly how the VCP200 recognizes the words in its vocabulary is proprietary to

the company that manufactures it for Radio Shack (Voice Control Products, Inc., 1140 Broadway, Suite 1402, New York, NY 10001). According to the manufacturer's literature, the VCP200 "... performs a crude spectral analysis of the incoming speech signal over the frequency range of 300 Hz to 5500 Hz, determines the membership of phoneme classes based on spectral shape, forms strings of these classes and compares the strings to the prestored strings of selected vocabulary words."

## Using the VCP200

Figure 6 is a photograph of an assembled VCP200 speech-recognition system. Radio Shack provides the layout for this board in the literature supplied with the chip. The board is powered by a 9-volt battery, and the microphone is an inexpensive electret element installed in a plastic tube. A foamed plastic cup placed over the microphone helps to reduce the adverse effect of ambient noise.

For best results, the VCP200 should be used in a quiet room. Hold the microphone close to your mouth and speak directly into and across it. A windscreen placed over the microphone will help to block some noise sources.

Fans, motors, traffic, loud radios, talking and other background noise will interfere with operation of the device. Reducing the gain of the input amplifier somewhat may help reduce the effect of steady noise sources. Noise sources like slamming doors and falling objects are much more difficult to deal with since they can cause false triggering of the device.

I was surprised to discover that the VCP200 did not respond when the microphone was placed close to a radio tuned to a talk show. But the background noise created by the radio interfered with the circuit's response to my voice.

Since the VCP200 is not a precision speech-recognition device, it will respond to many words besides the ones in its stored vocabulary. For example, I found that the "no" output could be activated by saying many of the words that rhyme with "no" (low, blow, crow, flow, glow,

etc.). Words that rhyme with "no" and begin with an "s" (snow, show, sew, slow, etc.) produced a "not sure" output. I could activate the "no" output by saying many other seemingly different words (hit, toy, flat, broke, rock, among others).

Because the VCP200 will respond to these and many other words, you can create your own vocabulary. As long as you use only the words in the chip's built-in vocabulary, the VCP 200 should be able to distinguish between them. But if you try to deceive the VCP200, you'll frequently succeed.

In an effort to better understand the response of the VCP200, I made a series of audio spectrograms with the help of the Heath AD-1308 audio spectrum analyzer. Figure 7 is the spectrogram of the word "off," and Fig. 8 is the spectrogram of the word "no." Even though these words sound very different, the spectrograms are very similar, as you can see. Both envelopes have a similar shape, and both show a peak frequency of around 710 Hz. Note that both spectrograms also show a spike at 125 Hz.

Figure 9 is the spectrogram of the word "on," and Fig. 10 is the spectrogram of the word "yes." Once again, both spectrograms are very similar. Both envelopes peak near 500 Hz, both show spikes near 125 Hz, and both form half-power plateaus on the high-frequency side of the peak.

These spectrograms don't tell the whole story since they're merely snapshots taken near the beginning of each spoken word. Nevertheless, the similarities they reveal in the audio spectra of different words are quite fascinating.

## Going Further

The speaker-independent VCP200 is a fascinating chip with both practical and tutorial applications. If you want to go further in the field of speech recognition, check out some of the voice-recognition add-on cards for personal computers. Some computer stores sell voice-recognition products for computers. You can find ads for voice-recognition products in computer magazines as well. **ME**

## CONSOLIDATED ELECTRONICS



## GET THE ULTIMATE ELECTRONICS CATALOG.

Order your 260 page catalogue packed with over 10,000 money saving electronic parts and equipment. Send \$3.00 check or money order, or call 1-800-543-3568 today and use your Mastercard or Visa.  
Consolidated Electronics, Incorporated  
705 Watervliet Ave., Dayton, Ohio 45420-2599

NAME \_\_\_\_\_  
ADDRESS \_\_\_\_\_  
CITY \_\_\_\_\_  
STATE \_\_\_\_\_ ZIP \_\_\_\_\_

CIRCLE 48 ON FREE INFORMATION CARD

## Hall-Effect & Infrared Sensors

By Art Salsberg

Transducers or sensors are often key elements in electronic circuits. There are many types, each operating on different principles. The Hall-effect transducer, for example, responds to changes in magnetic fields. Its principle, discovered by Edward Hall in 1879, is that a magnet placed perpendicular to one side of a current-carrying conductor will cause a voltage to appear at the opposite side that's proportional to the current and the magnetic field's flux density.

Such transducers, called Hall generators, are made of semiconductor material today. They're used for a variety of applications, including sensing of speed and as switches. For example, a Hall-effect device could be used to determine a motor's speed or as a solid-state keyboard switch.

Sprague Electric Co. (70 Pembroke Rd., Concord, NH 03301) developed a variety of Hall-effect switches with exceptional performance characteristics. Its type 3119 and 3120 switches come in several different package options. Each includes a voltage regulator, Hall generator, temperature stability circuit, signal amplifier, Schmitt trigger and open-collector output on a single silicon chip. The devices require supply voltages of 4.5 to 24 V and the output can sink up to 20 mA at 100-kHz min. The 3119s are for applications that provide steep magnetic slopes and low residual levels of magnetic flux density, while the 3120 switches are for uses that require precise switch points.

A third new type, the ultra-sensitive 3140, is designed to be used with small, low-cost magnets or in applications where large distances separate the Hall device and the magnet. Another new Hall sensor, type 3131, is claimed to be the world's most sensitive Hall-effect switch. Its npn output can be used directly with bipolar and CMOS logic.

### Light-Sensitive Sensors

There are transducers to meet virtually any sensing need: pressure, temperature, moisture, radiation, light, and so on. Optoelectronic devices are particularly interesting since so many consumer devices

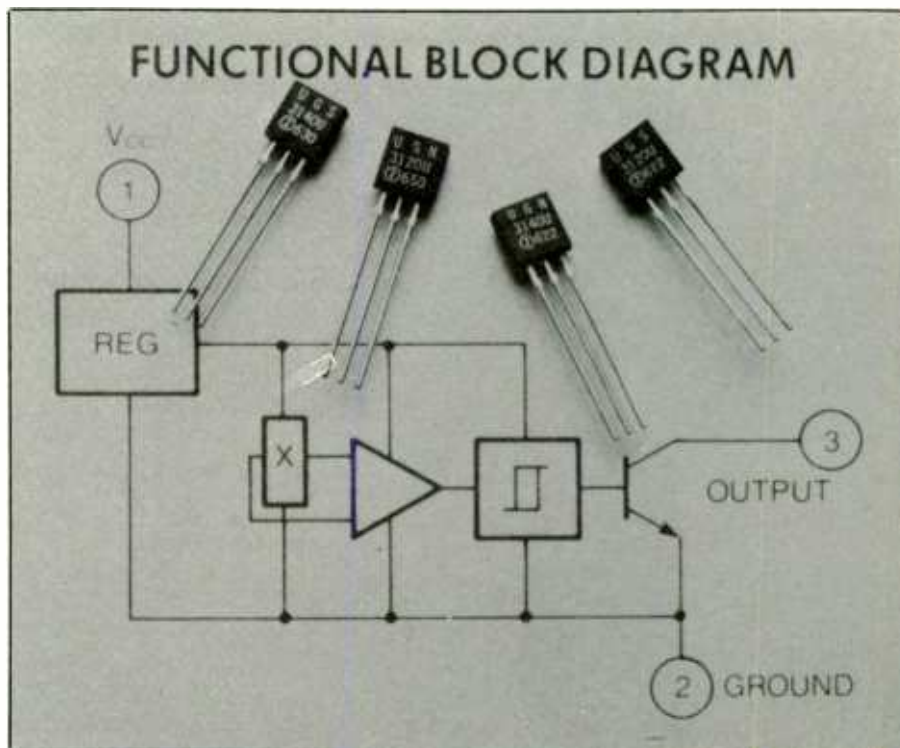

Sprague's Hall-effect switches come in a variety of package configurations.

employ them. Infrared sensors, in particular, have widespread applications in the security and safety fields.

Everything emits infrared radiation, though such "light" is invisible to the eye. Its electromagnetic waves are beyond visible light, which has a wavelength of about 4000 to 7700 angstroms (an angstrom is  $\frac{1}{10}$ th of a nanometer or  $1 \times 10^{-10}$  meters). Infrared pyrometers that consist of multiple thermistors and complex circuitry are commonly used in industry where extreme accuracy and far-wavelength infrared detection are important. Much less costly pyroelectric devices have been developed, though, for applications that do not require pinpoint accuracy or responsiveness to longer-wave infrared radiation.

Among the pyroelectric devices that can be used in an inexpensive system are lithium tantalate detectors. These devices perform well in the middle infrared ranges, around 10 micrometers. Eltec Instruments, a leading supplier of these de-

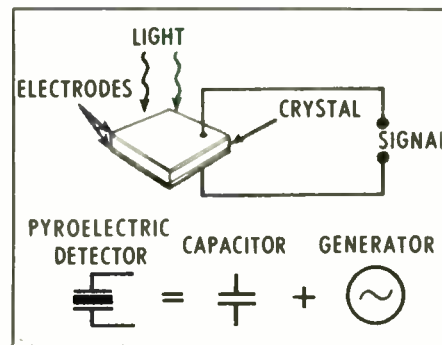

Pyroelectric devices are used to detect infrared radiation.

vices, has some literature on the subject that should interest engineers and technicians. The 6-page brochure (Elteccdata #100) discusses basics of pyroelectric detectors and how they operate, the latter including laser applications. For a free copy, write to Eltec Instruments, P.O. Box 9610, Daytona Beach, FL 32020, or call 1-800-874-7780. **ME**

## VHF Repeaters and Ham Radio

By Curt Phillips

Though I go through very busy periods when I don't have time to sit down in my radio room and talk to the world, there is one part of ham radio that is ingrained into my everyday life: vhf FM operation. With small vhf FM transceivers in both my cars, I'm able to easily talk with friends or listen in to discussions (often on electronics, computers and other technical topics) while adhering to my schedule. A major contributing factor to the usefulness of vhf FM is the existence of "repeaters."

A repeater is a device that automatically retransmits received signals. The vast majority of repeaters used in amateur radio vhf FM operation retransmit the incoming signal instantaneously, in real time, on another frequency. Although the incoming signal may have originated from a low-power mobile or even a hand-held transceiver, it is rebroadcast with the power and antenna advantages of a fixed station.

A primary advantage gained by most repeater stations is antenna location. Here in North Carolina, we have several repeaters with antennas approaching 2,000 feet in elevation, using television transmitting towers as host sites. These dominating positions allow the repeaters to be accessed by little battery-powered 1-watt walkie-talkies (more commonly called "handie-talkies," or HTs by hams) 25 or more miles away. Handie-talkies are even able to use inefficient but compact and convenient vinyl-covered helix antennas that are often referred to as "rubber ducky" antennas.

Usually, the repeater not only has an advantageous antenna site, but more power than the mobile and portable stations using them. In the example in Fig. 1, the primary concern of the user of Portable "A" is being able to put a readable signal into the repeater antenna. Given the repeater location and the characteristics of FM operation, very often the portable's signal will be noise-free.

Once the repeater has retransmitted the signal, the portable user has all the advantages of the repeater's location and power, making it possible for the hand-

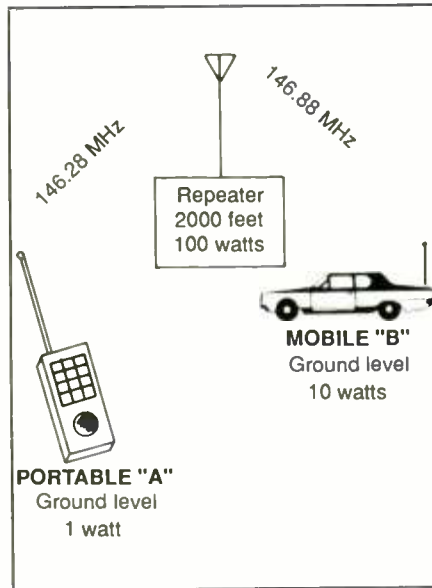

Fig. 1. A typical repeater setup in which hand-held portable ("A") and mobile ("B") transceivers communicate with each other through the repeater on frequencies that are 600 kHz apart.

held unit to engage in noise-free communication with Mobile "B" at distances ranging up to more than 100 miles.

As soon as Portable "A" completes transmitting, the HT automatically switches to the receiving frequency, which in this example is 146.88 MHz. As Mobile "B" presses the push-to-talk switch on the transceiver's microphone, the transceiver automatically adjusts to the transmit frequency, which is 146.28 MHz in this example. Although the repeater is both receiving and transmitting at the same time, both the units in communication are only performing one function at a time. Hence, operation is the half-duplex common in radio communication, not duplex like in telephones.

### How It Works

Hooking the output of a receiver into the input of a transmitter and getting it to work seems simple enough at first glance, but there are substantial problems to be overcome.

Amateur radio repeaters usually oper-

ate with both the input frequency (the frequency it receives input signals on) and the output frequency (the frequency it transmits on) in the same band. On the most commonly used band, 2 meters (144 to 148 MHz), the receiving and transmitting frequencies are usually 600 kHz apart. With this spacing the transmitting and receiving antennas need to be separated a significant distance to prevent the transmitter from overloading or desensitizing the receiver. Because tower space is limited, a duplexer is used to isolate the transmitter from the receiver and, in many cases, allows the same antenna to be used for both transmitting and receiving.

A duplexer is a combination of two or more coaxial filters, tuned to prevent the energy from the transmitter from reaching the receiver. A common type of coaxial filter, also known as a cavity resonator, uses copper pipe (often with silver plating inside) for the coaxial "shield" and a threaded rod for the center conductor. The outer conductor is usually one-quarter wavelength long, and the center conductor is adjusted to tune the cavity to the desired frequency. Each cavity acts as a band-reject or frequency-absorption filter. In a properly designed multiplexer configuration, it can yield attenuation in excess of 90 dB with an insertion loss of less than 2 dB.

As you can see in Fig. 2, there is more involved in a repeater than just a duplexer, a receiver and a transmitter. The receiver-to-transmitter connection is triggered by a carrier-operated relay (COR), sometimes called a squelch relay. The timer in the control circuit serves two functions. First, it provides a time delay on the COR so that short signal drop-outs won't cause the transmitter to toggle on and off. Its second function is to time-out the transmitter after a period of continuous transmission (often 3 minutes) so that a hung transceiver won't capture and lock up the repeater.

The control interface allows the repeater owner or trustee to shut down and otherwise control the repeater via a telephone link or a radio link on another band. This allows the responsible party positive control to override repeater operation if things go awry.

Many repeaters now offer an auto-

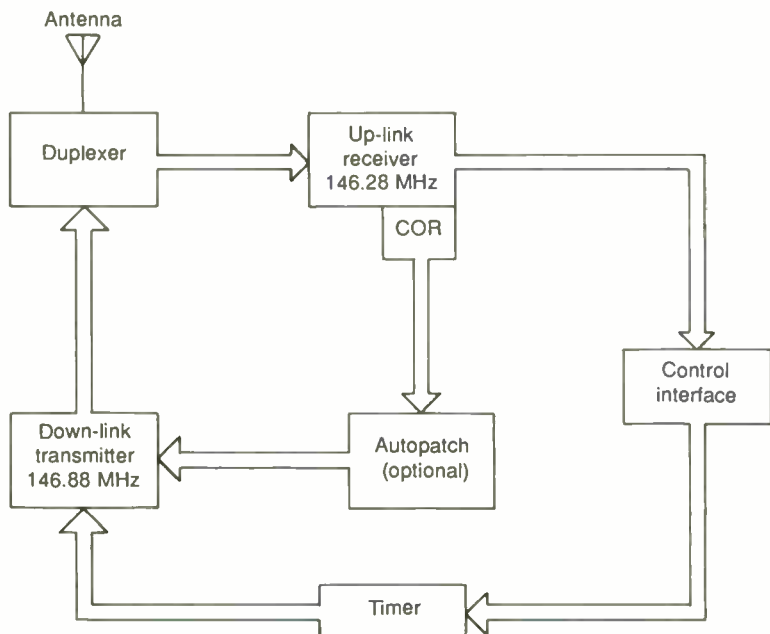

Fig. 2. Simplified block diagram of a typical repeater.

patch or automatic phone-patch function. A ham with a Touch Tone generator connected to his transceiver can, by using the appropriate control tones, activate the interface with a phone line at the repeater site. Once the autopatch is activated, the Touch Tone "pad" is used to dial the desired number. At the end of the phone call, another tone sequence deactivates the phone connection.

As with all amateur radio, use of the autopatch for business purposes is prohibited. Since the autopatch also doesn't allow for incoming calls from the repeater site, repeaters with autopatch aren't quite as versatile as a cellular telephone, but they're a lot cheaper for the user. For emergency communication, an autopatch can save important seconds in summoning help.

### Where They Are

The three primary bands where repeater operation takes place is the previously mentioned 2-meter band (144 to 148 MHz), the 220 band (220 to 225 MHz), which is occasionally called the 1½-meter band, and the 440 band (420.0 to 450.0 MHz), which is even more rarely called the 70-centimeter band. On each of these bands there are standard repeater frequencies and standard transmitter and receiver frequency offsets that have been established by "gentlemen's agreements."

The 2-meter band overwhelmingly predominates in the number of repeaters in use, and on 2 meters a shorthand has evolved for referring to the standard repeater frequencies. Typically, the input and output frequencies are abbreviated,

#### Common 2-Meter Repeater Frequencies

146.61 MHz	146.64 MHz	146.67 MHz	146.70 MHz	146.73 MHz
146.76 MHz	146.79 MHz	146.82 MHz	146.85 MHz	146.88 MHz
146.91 MHz	146.94 MHz	146.97 MHz	147.03 MHz	147.12 MHz
147.15 MHz	147.18 MHz	147.24 MHz	147.27 MHz	

such that our example (146.28-MHz input and 146.88-MHz output) would be called the 28-88 (two-eight, eight-eight) repeater. Many hams attempt to further shorten that to "the eight-eight repeater" by using just its output frequency. But that can be confusing because there are repeaters with outputs on 145.27 MHz and others with outputs on 147.27 MHz, hence "two-seven repeaters."

For those of you with scanners interested in listening to activities on 2-meter repeaters, the most common frequencies are listed in the Table. The American Radio Relay League (ARRL, Newington, CT 06111) publishes a national directory of repeaters that can give you the specific frequencies used in your state.

As always, your comments and suggestions are welcome. You can contact me at P.O. Box 678, Garner, NC 27529, or by computer on Delphi (CURTPHIL), CompuServe (73167,2050) or The Source (BDK887).

ME

## "Made in U.S.A."



Since  
1965

We've been supplying quality crystals since 1965 — long before the flood of cheap imports.

We're still supplying quality crystals with

- Quick Turnaround
- Low Price
- High Quality

TO SOLVE  
CRYSTAL  
PROBLEMS,  
GET THIS  
CATALOG



**JAN CRYSTALS**  
P.O. Box 06017  
Ft. Myers, FL 33906  
(813) 936-2397

VISA

MasterCard

CALL 1-800-237-3063  
FREE (Except Florida)

CIRCLE 50 ON FREE INFORMATION CARD

## Thoughts for the New Year & Aldus' "PageMaker" Desktop-Publishing Software

By Ted Needleman

**Happy New Year!** The year just ended brought some interesting developments. Computers based on the Intel 80286 microprocessor became the new basic-model standard, supplanting the venerable 8088. And '386 systems became ever more affordable. On the Motorola side of the street, Apple announced its Macintosh IIx computer, which uses the Motorola 68030 processor.

At the same time, the RAM chips that make it possible to get the best use out of these powerful CPUs are still priced 400% more than what they cost about 14 months ago. With the need for ever-more user memory, and the capacity of new CPUs to handle this extended memory, affordable "personal" computing may be coming to an end.

The past year also saw the emergence of a multitude of FAX boards, scanners, laptops, and high-speed modems. Everyone has been waiting for the laptop market to really take off. After all, it is convenient to have the equivalent of a desk unit in a package you can carry to and from work, clients, or to drag to school or on a business or vacation trip. I can vouch for this because the Epson Equity LT I've had use of for a while now has really been a life saver several times.

Laptops sell well in the marketplace, but not spectacularly so. The major reason for this is price. The Equity LT I often drag around with me costs almost \$3,000 in the EL (electroluminescent) back-lit version I have. Just this last week I attended two press conferences announcing new laptops. The first was Toshiba, introducing two new laptops. One was an 80286-based system, the other an 80386 computer. Both were expensive. Later in the week, I saw several new NEC laptops. The least expensive system they introduced was the new Ultralite. At a little over 4 pounds and with a price tag of \$3,000, it costs \$750 per pound!

With sales rising, perhaps someone will bring out a laptop that's priced more

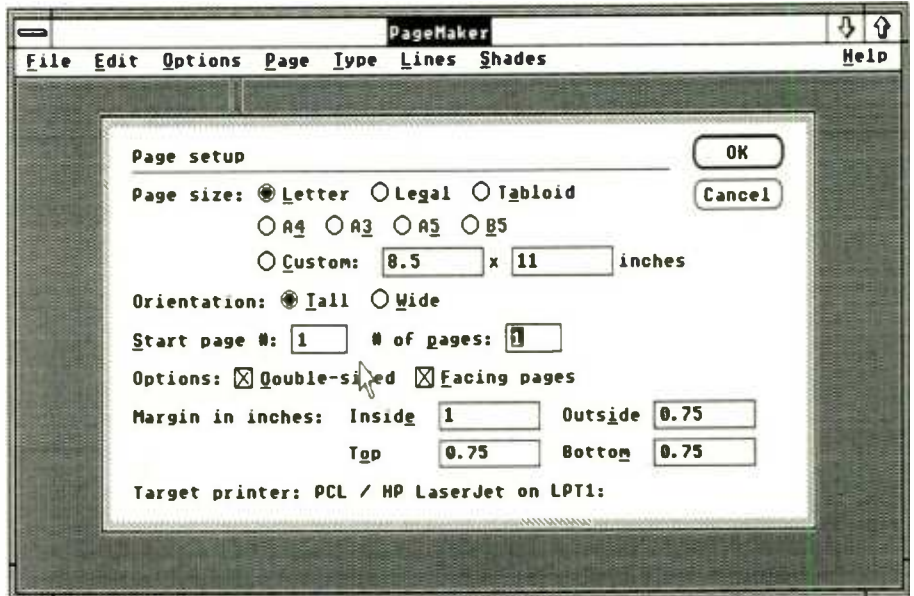

PageMaker's Setup screen gives user wide choice of page formats.

in line with desktop systems. After all, if I can buy an Acer 1100 386-based desktop with a 40 MB hard disk for \$4,000, I'd have to really need the convenience and power to spend \$9,000 on Toshiba's laptop equivalent.

I don't really anticipate this happening in '89. What I do expect to see in 1989, though, is the growing attractiveness of 9,600-baud modems. At present, they have two major shortcomings. The first is their expense. While you can purchase a 2,400-baud modem for between \$150 and \$250, the next big step up to 9,600-baud jumps the price to \$800 and beyond. This is a hefty tag for those not into heavy business use.

Additionally, each vendor's 9,600-baud unit uses a proprietary method to achieve this speed, rendering them incapable of talking to other brands of 9,600-baud modems. Thus, the compatibility that exists in the 2,400-baud modem market just isn't there when it comes to high-speed communications.

I think, though, that this standard will

emerge this year. When it does (if it does), the competition and economies of volume production and sales will drive high-speed modem prices down. After all, several years ago 2,400-baud modems were very expensive too. Now they are widely available at reasonable prices. As long as the government doesn't choose modem chips as its next dumping target (which is unlikely, as many of these are manufactured by Rockwell), affordable high-speed communicating should really take off in the fairly near future.

### PageMaker Version 3

Back in the August '88 issue, another column contained a review of Xerox's Ventura Publisher package for desktop publishing. While VP is a fine, feature-full package, I'm more familiar with its chief competitor, Aldus' (Aldus Corp., 411 First Ave. South, Seattle, WA 98104; tel.: 206-622-5500) PageMaker (PM). I've used PM since it was first introduced for the Macintosh. This includes several



upgrades, both in the Macintosh version and, more recently, the PC version. Currently, most of my use is on the PC side, though the Macintosh version 3 of PageMaker is almost identical in both appearance and operation.

PageMaker, like Ventura Publisher, is a page layout program. It allows you to place both text and graphics elements onto pages within a document. Working with PageMaker is akin to using an electronic analog of a graphic artist's layout board. The process parallels the manual approach, with a few improvements.

When a new "publication" is opened on a computer using PageMaker, you are asked for information about its size, number of pages, and whether these pages are double-sided and/or facing. Depending on the type of monitor you've specified during the initial set-up, you are then presented with the image of a page, or a set of facing pages.

PageMaker can provide a variety of different page views. Initially, an image of the entire page (and the layout board that surrounds it) is presented on the video monitor. Through use of a pull-down menu, you can also choose to view a portion of the page in either actual size, or reduced to 50, 75 or 200 percent of actual size. Also, by clicking the right-hand mouse button you can conveniently switch between viewing part of a page or a representation of the entire page.

With most video monitors, the full-page view of text and graphics areas laid out on the page are indecipherable. They're there for layout purposes, not for actual reading. Thus, the matter is "Greeked" (lines of Xs for text and boxes for graphics). To actually see text and graphics, you must use a partial view of the page, though ultra-high-resolution monitors, such as the Wyse 700, LaserView, and others are capable of displaying actual text in the full-page mode. With these monitors, the text is very small, but usually readable.

The first step in creating a PageMaker document is to define document characteristics that were previously cited, such

as page size, single- or double-sided pages, facing pages, number of pages the document will have (though you can add or delete pages at any time), and page orientation (portrait or landscape).

The next step is to define the Master Items (if any) that will appear on every page in the document. If you have set up the publication/document to have facing pages, the right and left page Master Items are set up separately. At the bottom of PageMaker's display, there is a row of small numbered pages, representing the pages in your document (though only 20 pages at a time are shown—this can be scrolled left and right when publications are longer).

The page(s) currently being worked on are blacked out. If you specified Master Pages, they're represented by a page icon at the extreme left of the small page line. Master Items are those things that are designed to appear on every page. These might include line rules, publication name along with page number, etc. By following the page number text with a control key string (different for the PC and Macintosh versions), you can direct PageMaker to automatically number your pages.

Once all Master Items have been defined, you decide if you want single- or multiple-column format. If every page will have the same format, column guides are defined on the Master Pages. If pages will vary in format, you must set columns on the pages, rather than the Master. PageMaker gives you a great deal of latitude as to setting up columns. You can let PageMaker do it by pulling down a menu and specifying how many columns you want. Alternatively, you can use the mouse to "pull" horizontal and vertical guides from the side of the PageMaker window. When you place text and graphics into a page with these guides, the material will stay within the guide setting unless you deliberately move them into different areas.

Text and graphics are put onto the pages using a "place" command from one of the pull-down menus. Since Page-

Maker flows text around graphics already in place, any graphics used in your document should be placed first. When you're satisfied with the position of the graphics, you then place the text contained in files you created with one of the popular word processors. You can use a command to put the text into the document either a column at a time, or to place the whole document at once. With the latter option, PageMaker will automatically continue to fill empty columns if there's overflow matter, even if it has to go to following pages.

You can then maneuver columns, paragraphs, lines, and even individual words and letters until you are satisfied with the appearance of your publication. If you use a word processor that PageMaker supports, such as Microsoft's Word, WordPerfect, or WordStar, PageMaker will keep the format that you have set up in the word-processed document (such as bold, underline, and subscripts). ASCII text, however, is placed with just the line and paragraph breaks.

PageMaker is easy to use on an elementary level, but as you gain experience with it, you begin to appreciate how complex and powerful it is. For example, I've been using it through various versions for over two years, producing a large variety of different documents such as letterheads, business cards, labels, and even a 44-page newsletter. Yet, every time I create a new document I find myself learning about a new feature.

All of this power has its own price. PageMaker carries a \$695 "list" in the PC version. Along with this, it requires more hefty machine resources than some prospective users might have: 640KB of RAM minimum, a hard disk, and a computer with at least an 80286 microprocessor. PageMaker runs under Microsoft Windows, a run-time version of which is included with the program. Windows *will* run on an 8088-based computer, but it does so too slowly to make the effort worthwhile.

PageMaker will drive any printer supported under MS-Windows. This is a

## Macrovision ... Now you see it, now you don't.

Remove copy-protection from video cassettes.



- Digital Filter Type, removes only Macrovision pulses
- No adjustments, crystal controlled
- Compatible with all VCR's, uses automatic vertical blanking level

Macro-Scrubber Kit - Assembles in less than three hours.

**MS1-KIT.....\$29.95**

Includes all the parts, pc board, AC adaptor and instructions from a published construction article in Radio Electronics magazine.

**JMAK-4 Black Box...\$14.95**

Original box as shown in ad with 2 feet and 4 screws to mount pc board.

Add \$2.50 shipping and handling;

\$5.50 Canadian orders.

Note: Unauthorized duplication of copyrighted material is illegal. Use Macro-Scrubber for viewing only.

**72 CHANNEL MC-702 CONVERTER CABLE CONVERTER ...\$79.95 WITH INFRA-RED REMOTE**



Add \$3.50 shipping & handling  
\$9.50 Canadian orders

- 72-channel capability
- Wireless, Infra-Red remote control
- Channel output 2 or 3 switchable

- Microprocessor controlled PLL operation
- Skip channel memory eliminates unused channels
- Parental control for all channels
- Last channel recall
- Fine tune memory
- UL listed/FCC approved
- Simple installation with any TV
- Includes battery and 3 foot coax cable

**UNIKA SR-234 .....\$79.95 CABLE-READY STEREO DECODER**



Add \$3.50 shipping & handling;  
\$11.50 Canadian orders.

Connects directly to your cable box, eliminating the need for a stereo ready TV. MPX compatible too. Order today because sound does make a difference.

**CABLEMASTER....\$19.95 Cable/VCR Timer**

- Record multiple premium play channels
- Turns cable box on and off
- Selects channel for unattended recording
- Thousands sold nationally for \$99.95

Specify Cable TV Converter when ordering.

Add \$3.50 shipping & handling  
\$8.50 Canadian orders

**ORDER TOLL FREE ANYTIME  
1-800-227-8529**

Inside MA: 508-695-8699

FAX: 508-695-9694

VISA, MASTERCARD,  
or C.O.D.

**J & W  
ELECTRONICS, INC.**

100 NEW RD. • MANDERLY, MA 02148

© Copyright 1988 by J&W Electronics Inc.

CIRCLE 49 ON FREE INFORMATION CARD

## PC CAPERS...

considerable number of currently available dot-matrix and laser printers. For the most acceptable-looking output you need a laser printer with a considerable amount of RAM. The larger the printer's RAM, the more fonts and graphic area you can print on a page. You can produce nice-looking pages with limited amounts of graphics on a Hewlett-Packard LaserJet (or compatible) with 512KB RAM, but to really get the most out of PageMaker's abilities, you'll need 2 megabytes or more of printer memory.

PageMaker also supports PostScript printers, such as Apple's LaserWriters and the QMS postscript printers. These are really the best printers to use with PageMaker as they allow you a great number of built-in fonts (and adjustable point sizes), and enable you to enlarge and reduce the page at print time. PostScript printers will also produce better shading of boxes (when specified) than H-Ps or compatibles. However, the basic printer is much costlier to buy.

You can also print the PageMaker document to disk, of course (though setting this up is a bit awkward). Consequently, you can print the file out at a later time or send it to a typesetter to be printed at the

much higher resolution that a typesetting system produces.

As you know by now, I like PageMaker. It's far from perfect, though, especially in the way it handles graphics elements. For instance, when a graphic element is moved after text has been placed, the text doesn't automatically reflow around the graphic. And since lines and boxes are considered graphic elements, they're subject to the above limitation, too. This can be frustrating, especially in a complex publication.

Even with this and other annoyances, PageMaker is fun to use. Of course, using this or any other page layout program won't guarantee that your documents will be visually appealing—the software can only simplify the task of putting text and graphics on a page, not automatically compensate for those who have no skill or gift for visual design. But even here there is help. The documentation comes with a guide to design that details the basics for laying out an attractive page and publication. To give you an even greater edge, PageMaker also comes with a large selection of templates. These are already laid-out pages for producing newsletters, catalog pages, fliers, name tags, business cards, and a multitude of other documents. You just call them up and substitute your text and graphics for theirs.

Since PageMaker is available in both PC and Macintosh versions, it has a special plus for some users that rival Xerox Ventura Publisher doesn't offer. These versions run almost identically on the two computer systems (to the limit in which MS-Windows mimics Apple's FINDER); documents created on one system can be transferred to the other with a software/cable combination such as Traveling Software's LapLink-Mac. Once the document has been moved, you can open it and work on it regardless of where it was originally created. You may, however, have to reformat it to work with a different printer having a different set of fonts available.

In any case, PageMaker is certainly a leader among extraordinarily powerful desktop publishing software packages on the market.

### D-80

AC DC Voltage & Current, Resistance, Capacitance and Frequency, 0.5% 1-inch LCD, 3999 counts. AT1 and 20 amp with case and bar graph, under \$90.



### D-3650

AC DC Voltage & Current, Resistance, Frequency, 0.3%, large 3 1/4" audio range. Digital multimeter with case, 3999 counts, 20 amps, 1-inch LCD, under \$110.



### D-3900

AC DC Voltage & Current, Resistance, 3% Frequency. High low tach dwell, 1-inch LCD, 1999 counts, 20 amp with case, under \$100.



Write for Free Catalog  
Available at local distributors.

**EMCO Electronics**  
31 Sheer Plaza  
Plainville, NY 11803  
516-845-7080

CIRCLE NO. 177 ON FREE INFORMATION CARD

# MASTER THE NEW ELECTRONICS WITH MCGRAW-HILL'S Contemporary Electronics Series

The fast, easy and low cost way to meet the challenges of today's electronic innovations. A unique learning series that's as innovative as the circuitry it explains, as fascinating as the experiments you build and explore.

From digital logic to the latest 32-bit microprocessor, the McGraw-Hill Contemporary Electronics Series puts you into the electronic picture one easy step at a time. Fifteen unique Concept Modules, sent to you one every 4-6 weeks, give you a handle on subjects like optoelectronics, robotics, integrated circuits, lasers, fiber optics and more.

Each Concept Module goes right to the heart of the matter. You waste no time on extraneous material or outdated history. It's a fast, efficient, and lively learning experience... a non-traditional approach to the most modern of subject matter.

## Unique Interactive Instruction

With each module, you receive a McGraw-Hill Action Audio Cassette. Each tape is a dynamic discussion that drives home the key facts about the subject. Your learning

With your first module, you get this solderless breadboarding system. You'll use it throughout the series to build electronic circuits and bring concepts to life.

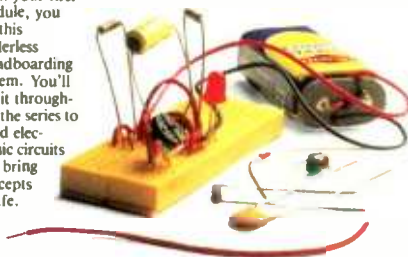

experience is reinforced through interaction with vividly illustrated text, audio cassettes, and actual electronic experiments. Indexed binders preserve backup material, notes, and tapes for convenient referral.

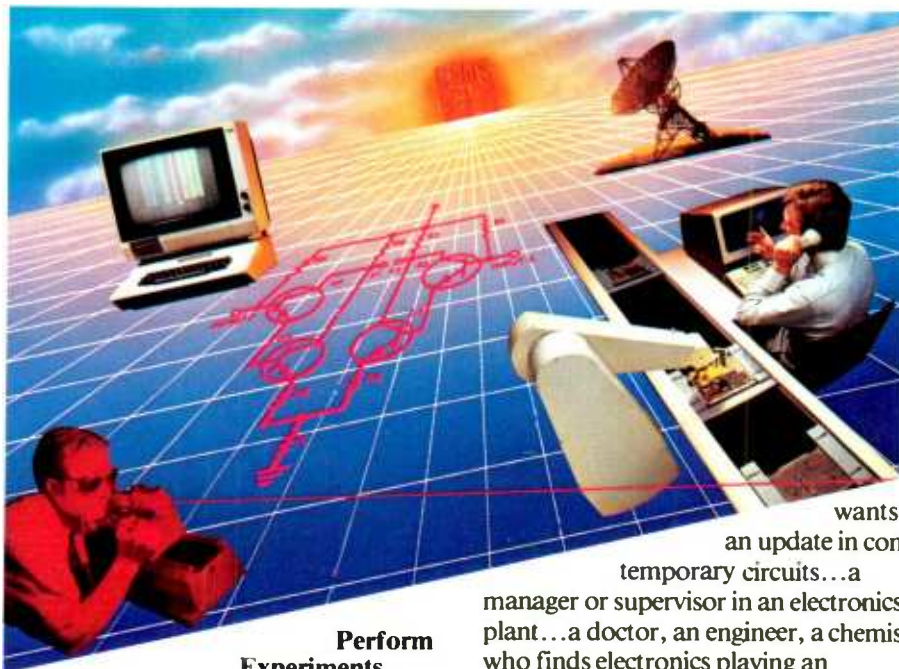

## Perform Experiments in Contemporary Electronics

Throughout your series, laboratory experiments reinforce every significant point. This essential experience... dynamic, hands-on demonstrations of theory in practice... will help you master principles that apply all the way up to tomorrow's latest VLSI (Very Large Scale Integrated) circuitry.

In your very first module, you'll use integrated circuits to build a digital oscillator, verifying its operation with a light emitting diode (LED). You'll learn to identify passive and active components, understand concepts common to all electronic circuits.

## For Anyone Interested in Electronics

The Contemporary Electronics Series is designed for anyone from hobbyist to professional. It's for you if you're looking for new fields of interest... if you're a teacher who

wants an update in contemporary circuits... a manager or supervisor in an electronics plant... a doctor, an engineer, a chemist who finds electronics playing an increasingly important role in your work. It's even for electronics engineers or technicians who feel their training needs freshening up. It's the quickest, most convenient, probably least expensive way to do it. And the only one that gives you hands-on experience.

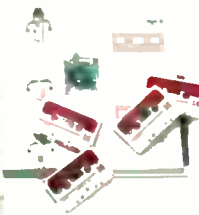

## 15-Day No-Risk Trial

To order your first module without risk, send the card today. Examine it for 15 days under the terms of the order form and see how the Contemporary Electronics Series gets you into today's electronics. If card has been used, write us for ordering information.



McGraw-Hill  
Continuing Education Center  
3939 Wisconsin Ave.  
Washington, D.C. 20016

# NEW! All Band Scanner by AOR

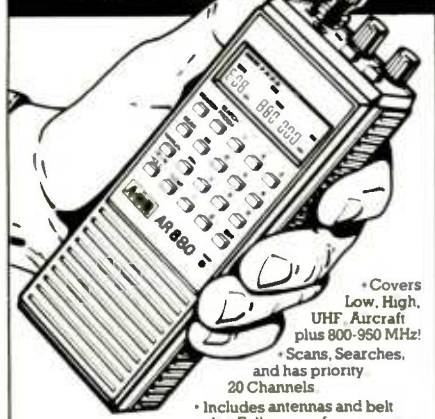

- \* Covers Low, High, UHF Aircraft plus 800-950 MHz!
- \* Scans, Searches, and has priority 20 Channels
- \* Includes antennas and belt clip Full range of accessories available
- \* No Frequencies cut out or excluded
- \* 25 Day Satisfaction Guarantee. Full refund if not satisfied.
- \* Size: 2" x 5 1/4" x 1 1/2" wt 12 oz
- \* Uses 4 AAA batteries, not included.

**AR880**  
Total Price, Freight Prepaid  
(Express Shipping Optional)  
**\$199.00**



COMMUNICATIONS  
10707 E. 106th St. Indpls., IN 46256

Toll Free 800-445-7717

Visa and MasterCard  
(COD slightly higher)

In Indiana 317-849-2570 Collect FAX (317) 849-8794

CIRCLE 38 ON FREE INFORMATION CARD

## NEW SUPER LONG PLAY TAPE RECORDERS

12 Hour Model — \$119.00\*  
USES D-120 TAPE

Modified Panasonic Slimline,  
high quality, AC-DC  
Recorders provide 6  
continuous hours of quality  
recording & playback on  
each side of cassette for a  
total of 12 hours.  
Built-in features include  
• Voice level control • Digital  
counter, etc. TDK DC 120  
Cassette Furnished.



### PHONE RECORDING ADAPTER

Records calls automatically. All Solid  
state connects to your telephone  
jack and tape recorder. Starts  
recording when phone is lifted.  
Stops when you hang up. **\$24.95\***



VOX VOICE ACTIVATED CONTROL SWITCH  
Solid state Self contained Adjust-  
able sensitivity. Voices or other  
sounds automatically activate and  
control recorder. Uses either re-  
corder or remote mike. **\$28.50\***



\* Add for ship & hdg. Phone Adapter & Vox \$1.50 ea.  
Recorders \$4.00 ea. Cal. Res. add tax. Mail order. VISA  
M/C. COD's OK. Money Back Guarantee. Free data  
avail. Dealer inquiries invited. Free data  
**AMC SALES INC. Dept. M9335 Lubec**  
St., Box 928, Downey, CA  
90241 Phone (213)  
869 8519

CIRCLE 37 ON FREE INFORMATION CARD

# BOOKS

**Audio Engineering Handbook** edited by **K. Blair Benson**. (McGraw-Hill, Inc. Hard cover. 1040 pages. \$79.50.)

This is a massive book, not so much in size and weight (though it has lots of both) but in its coverage of audio-related topics. It spans every topic you can think of in the professional audio arena, from basic amplifiers to zoom microphones, emphasizing practical applications and practices rather than electronics theory, though theory is covered, too. Instead of following the alphabetic topic format used in one-volume "encyclopedia" reference works as this book at first appears to be, it treats the subject matter in chapters. Each of its 17 chapters deals with a specific topic. As would be expected, the opening chapters deal with the basics of sound and hearing and the audio spectrum.

In keeping with the professional thrust of the book, the third chapter introduces architectural acoustic principles and then moves on to such topics as digital audio, broadcast technology, microphones and amplifiers, sound reproducers, analog and digital disk and magnetic-tape recording and reproduction, and other equipment and techniques used in professional audio. Since it contains material on both theory and practice, the core of the book can serve as a basic tutorial in the "art" of audio for professionals who need to extend their knowledge in these areas.

Intended for audio engineering professionals, rather than amateurs, the book also contains extensive chapters on film recording, sound recording studios, post-production systems and editing, noise reduction and audio tests and measurements. The closing chapter includes a tabulation of applicable audio standards and recommended practices in the U.S.

The text is written by 33 experts and edited by a leading audio consultant. Its content is presented in a brisk, concise style. It is amply supported by 722 illustrations—photos, tables, charts, graphs, drawings, block diagrams and just a smattering of schematics. The last makes it clear that this is not a circuit designer's manual. None of the text deals with the elements of design at the individual circuit level. Emphasis throughout is on practical applications of equipment, environment and techniques—or the "art" rather than the "technology" side of audio. As such, this book eminently ful-

fills its objective and is well worth the rather steep price for anyone who is involved (hopes to be) in audio at the professional level.

**Inside Xerox Ventura Publisher** by **James Cavuoto & Jesse Berst**. (Micro Publishing and New Riders Publishing. 328 pages. \$19.95.)

Xerox Ventura Publisher is a leading software package for serious desktop publishing with IBM-type personal computers. This guide provides a fine hands-on look at this powerful and, therefore, complex program.

Using a down-to-earth writing style that makes good, easy reading to begin with, and large type that makes it all the more inviting to read, the book is a good start point for any beginning user of the program. It's satisfactorily illustrated, too. As such, it makes it easier to get started with the program. Too bad, though, that its price is on the steep side.

**Publishing Power with Ventura** by **Martha Lubow & Jesse Berst**. (New Riders Publishing. 480 pages. \$24.95.)

A second Xerox Ventura Publisher guide book by the same publisher, this one contains more complete information than the foregoing one reviewed here. Type is smaller, though still large enough to read with ease; there are more illustrations (about 360 of them), and lots more operating detail.

We did not find the text as easy to get into as the less-complete book reviewed above. It's written more on the order of what a software maker would produce with material that accompanies the product, though it's "friendly" enough as these things go.

With nine chapters, the authors do a good job in digging rather deep into the sophisticated program, and supplying many excellent working examples that one can practice with. Nonetheless, we're still taken somewhat aback by the high prices of computer books in general, especially when the software maker does such a nice job itself, as Xerox did with its desktop publishing package. It seems to us that computer book publishers are parroting the early software makers' high prices, which is a shame since books such as this one are so welcome. If you need such books, however, there isn't much choice but to pay the money.

## NEW LITERATURE

**Resistive Component Catalog.** The new "Resistive Components Selection Guide" from Bourns contains the latest specifications and applications information for trimmer potentiometers, precision potentiometers, panel controls, resistor networks and chip resistors. It provides element type, resistance range and package configuration for each device listed. Helpful schematic diagrams make it easy to understand the important characteristics of each device and ensure proper selection. Also included is information on digital contacting encoders. For a free copy, write to: Bourns, Inc., 1200 Columbia Ave., Riverside, CA 92507.

**Finite Element Analysis Brochure.** "How To Improve Your Product Design: ANSYS® Finite Element Analysis" from Swanson Analysis Systems is a full-color, 24-page brochure that describes how a company can use finite element methods to get its product to market faster while keeping cost down. A brief explanation of finite element theory and four case histories are presented. Section topics include getting to market faster, reducing product development and production costs, and improving the final product. Descriptions and photos of ANSYS program applications in the automotive, electronics, aerospace and biomedical industries illustrate each point. Other information covered includes FEA's position in the typical development cycle, applications suitable for FEA, and correlation between FEA results and experimental data. For a copy, write to: Swanson Analysis Systems, Inc., Johnson Rd., P.O. Box 65, Houston, PA 15342-0065.

**PC-to-Mainframe Data Exchange Brochure.** Telebyte Technology has a new brochure that describes three different approaches to handling bulk data transfers between PCs and mainframes. Software solutions are included for DOS and XENIX-based PC systems, including the Dataverter data format conversion program that allows conversion of mainframe tapes into usable PC formats. Filetrans's capability of selective file-base backup is also covered. Hardware solutions include three different tape systems, each of which is described in detail. For a free copy, write to: Telebyte Technology, Inc., 270 E. Pulaski Rd., Greenlawn, NY 11740.

**SUBSCRIBE NOW & SAVE! - Twelve Issues \$17.97**



*Your ticket to a huge selection of electronic parts.*

## MCM ELECTRONICS

The all-new MCM Electronics Catalog is like having your own reserved, front-row seat to the best electronics parts and components show in town! With nearly 11,000 items (most of them in-stock and ready for shipment in 24 hours), you'll be able to spend less time looking for the products you need and more time watching your profits and customer satisfaction grow! So, order your **FREE** copy today and discover why MCM gets nothing but standing ovations from our customers!

**For your FREE copy,  
call TOLL-FREE  
1-800-543-4330**

In Ohio, call 1-800-762-4315  
In Alaska or Hawaii, call 1-800-858-1849



**MCM ELECTRONICS**  
858 E. CONGRESS PARK DR.  
CENTERVILLE, OH 45459-4072  
A PREMIER Company

Source No. ME-43

# ATTENTION! ELECTRONICS TECHNICIANS

EARN YOUR  
**B.S.E.E.  
DEGREE**

THROUGH HOME STUDY

Our New and Highly Effective Advanced-Placement Program for experienced Electronic Technicians grants credit for previous Schooling and Professional Experience, and can greatly reduce the time required to complete Program and reach graduation. No residence schooling required for qualified Electronic Technicians. Through this Special Program you can pull all of the loose ends of your electronics background together and earn your B.S.E.E. Degree. Upgrade your status and pay to the Engineering Level. Advance Rapidly! Many finish in 12 months or less. Students and graduates in all 50 States and throughout the World. Established Over 40 Years! Write for free Descriptive Literature

**COOK'S INSTITUTE**  
OF ELECTRONICS ENGINEERING

**CI** 4251 CYPRESS DRIVE  
JACKSON, MISSISSIPPI 39212

CIRCLE 4 ON FREE INFORMATION CARD



### Free Product Information

Readers can obtain free information on products advertised, as well as for some editorially mentioned products. Simply circle the appropriate number printed below an advertisement onto the **ME** "Free Information Service" card bound into this issue. After filling in your name and address, just mail the postpaid card. Your request will be forwarded directly to the advertiser with a mailing label prepared by our reader-service department.

# MODERN ELECTRONICS MART

**Classified Commercial Rates:** \$1 per word, 15-word minimum (\$15.00) prepaid. (Word count includes name and address; ZIP code and abbreviation each count as one word; P.O. Box number and telephone number count as two words each.) Indicate free category heading (**Computers, Communications, Electronics, Video** or **Miscellaneous**). A special heading is available for a \$6 surcharge. First word only is set boldface caps at no charge. Add 20% for additional boldface words.

**Non-Commercial Rates:** FREE to subscribers, as space permits; maximum 15 words. A recent MODERN ELECTRONICS mailing label must accompany ad.

(All advertisers with P.O. Box addresses must supply permanent address and telephone number. Copy is subject to publisher approval.)

**Mailing Information:** Copy must be received by the publisher by the 25th of the third month preceding the cover date. Send Advertising material with check or money order or credit card information (Visa or MasterCard only) with number and expiration date to: MODERN ELECTRONICS, Classified Department, 76 N. Broadway, Hicksville, NY 11801.

## VIDEO

**TV/VCR REPAIR TIPS VOLUMES I AND II.** Each with 1,000 up-to-date problems/cures listed by model and chassis for quick easy lookup. \$29.95 per volume. Add \$2.50 postage and handling. Computer Assistance, Box 232026, Anchorage, AK 99523.

**COMPUTER TV/VCR REPAIR TIPS DATABASE PROGRAM** (IBM Compatible w/hard drive). Scan symptoms and cures by model or chassis. Add, change, delete, print out. \$49.95 for program. \$69.95 includes database with over 1,000 up-to-date repair tips. Add \$2.50 postage and handling. Computer Assistance, Box 232026, Anchorage, AK 99523.

**CABLE TV CONVERTER/DESCRAMBLERS - FREE CATALOG** Zenith, Tocom, Scientific Atlanta, Oak, Jerrold, Pioneer, Panasonic, Video Accessories, Kits, Best Buys/Service, Monthly Specials. ARIZONA VIDEO, 3661 N. Campbell, #310-H, Tucson, Arizona 85719. (602) 323-3330.

**PROJECTION TV . . .** Convert your TV to project 7 foot picture . . . Easy! . . . Results comparable to \$2,500 projectors . . . **PLANS AND 8" LENS \$24.95 . . .** Professional Systems available . . . Illustrated Catalog FREE . . . **MACROCOMA** 15ME Main Street, Washington Crossing, Pennsylvania 18977. Creditcard Orders 24 HRS. (215) 736-3979.

**RENTAL MOVIE STABILIZER.** Connect between VCRs or to monitor. Satisfaction Guaranteed. \$59.95, \$4 handling. 1-800-338-8751.

## ELECTRONICS

**GET your "F.C.C. Commercial General Radiotelephone License." Electronics Home Study.** Fast, inexpensive! "Free" details. **COMMAND, D-221, Box 2824, San Francisco, CA 94126.**

**PROTECT YOURSELF FROM ELECTRONIC EAVESDROPPING!** Scrambler phones, transmitter detector, tape recorder detectors, executive security products, surveillance books and much more! Catalog \$3.00 (refundable). **DIVERSIFIED WHOLESALE PRODUCTS, PO Box 1275-ME, Redondo Beach, CA 90278.**

**LONG Range Listening "Tube", Mini-Tube, RF Sniffer, BC Magnum Booster, Scanmate, Voice scramblers/descramblers, Sequential LED's, FM TX, Kits, Plans and File notes.** Catalog \$1.00. **KRYSTAL KITS, P.O. Box 445, BENTONVILLE, AR 72712.**

**ELECTRONICS - Computer - Energy - Security - Weaponry - Medical Publications, Services, Hardware, Software.** Catalogs \$2 (100+ Offers). **CONSUMERTRONICS, 2011 Crescent, Alamogordo, NM 88310. (505) 434-0234.**

**PICTURE** flyer lists quality electronic parts at low prices. Since 1970. Send for 3 sample issues. **Star-Tronics, Box 683, McMinnville, OR 97128.**

**LOW Prices - Capacitors, ICs, Transistors, Switches.** Eprom Sale: 2716 - \$1.35, 27128 - \$3.00. **Flyer SASE - Santech, 11 Revere Place, Tappan, NY 10983 914-359-1130.**

**\$\$\$\$\$ SUPER SAVINGS \$\$\$\$\$** on electronic parts, components, supplies and computer accessories. Free 40-page catalog for self-addressed and stamped envelope. Get on our mailing list. **BCD ELECTRO, P.O. Box 830119, Richardson, TX 75083 or call (214) 343-1770.**

**TUBES, Name Brands, New, 80% Off List, Kerby, 298 West Carmel Drive, Carmel, IN 46032.**

**SURVEILLANCE, Electronics, Debugging, Protection.** Latest High Tech - Kits. Catalog \$5.00. **TECHNOLOGY SERVICES, 829 Ginette Street, Gretna, LA 70056.**

**VOICE Disguisers! FM Bugs! Telephone Transmitters! Phone Snoops! More! Catalog \$1.00: XANDI ELECTRONICS, Box 25647, "EE", Tempe, AZ 85285-5647.**

## COMPUTERS

**SECRET** commands for your C64!! Free details write Dawn Technologies, Box 10425-M, Rochester, New York 14610.

**BUILD turbo XT microcomputers!** FREE information: Art's Publications, 13540 Hubbard, Suite 12A, Sylmar, CA 91342.

**TRS-80 color computer software.** Low prices! Huge selection! Free catalog. **TD Software, P.O. Box 1256, Holland, MI 49422.**



1-800-344-4539 AK, Puerto Rico - 218 681 6674 Telex - 6287914 FAX - 218 681 3380 TWX - 91050882 DIGI KEY CORP

INTEGRATED CIRCUITS

Table with columns: Part No., Price, Description. Includes 7400 TTL, 74000 TTL, and 74000 CMOS.

7400 TTL

Table with columns: Part No., Price, Description. Lists various 7400 TTL ICs.

74000 TTL

Table with columns: Part No., Price, Description. Lists various 74000 TTL ICs.

74000 CMOS

Table with columns: Part No., Price, Description. Lists various 74000 CMOS ICs.

4000 CMOS

Table with columns: Part No., Price, Description. Lists various 4000 CMOS ICs.

74000 TTL

Table with columns: Part No., Price, Description. Lists various 74000 TTL ICs.

74000 CMOS

Table with columns: Part No., Price, Description. Lists various 74000 CMOS ICs.

74150 TTL

Table with columns: Part No., Price, Description. Lists various 74150 TTL ICs.

74150 CMOS

Table with columns: Part No., Price, Description. Lists various 74150 CMOS ICs.

74150 TTL

Table with columns: Part No., Price, Description. Lists various 74150 TTL ICs.

74150 CMOS

Table with columns: Part No., Price, Description. Lists various 74150 CMOS ICs.

74150 TTL

Table with columns: Part No., Price, Description. Lists various 74150 TTL ICs.

74150 CMOS

Table with columns: Part No., Price, Description. Lists various 74150 CMOS ICs.

74150 TTL

Table with columns: Part No., Price, Description. Lists various 74150 TTL ICs.

When ordering by phone call 1-800-344-4539... DIGI KEY CORPORATION... SERVICE CHARGES... VOLUME DISCOUNT...

CIRCLE NO. 120 ON FREE INFORMATION CARD

## LEARN VCR

**CLEANING/MAINTENANCE/REPAIR**  
EARN UP TO \$1000 A WEEK, WORKING PART TIME FROM YOUR OWN HOME!



NO Knowledge of Electronics Necessary.  
NO Special Tools or Equipment Needed

**EARN UP TO \$80 AN HOUR AND MORE!**

### THE MONEY MAKING OPPORTUNITY OF THE 1990'S

IF you are able to work with common small hand tools

IF you possess average mechanical ability, and have a VCR on which to practice and learn then we can teach YOU VCR maintenance and repair!

FACT: up to 90% of ALL VCR malfunctions are due to simple MECHANICAL or ELECTRO-MECHANICAL breakdowns!

FACT: over 77 million VCRs in use today nationwide! Average VCR needs cleaning/maintenance or repair every 12 to 18 months!

VIEJO'S 400 PAGE TRAINING MANUAL (over 500 photos and illustrations) AND COMPANION VIDEO TRAINING TAPE REVEALS THE SECRETS OF VCR MAINTENANCE AND REPAIR - "REAL-WORLD" INFORMATION, THAT IS NOT AVAILABLE ELSEWHERE! ALSO INCLUDES ALL THE INFO YOU'LL NEED REGARDING THE BUSINESS SIDE OF RUNNING A SUCCESSFUL SERVICE BUSINESS!

FREE INFORMATION  
CALL TOLL FREE 1-800-537-0589

Or write to: Viejo Publications • 217 E. 86th St.  
Suite 272 Dept. ME • New York, NY 10028

CIRCLE 53 ON FREE INFORMATION CARD

### CABLE TV CONVERTERS • RECEIVE MORE CHANNELS

Stocking all types of converters — Panasonic, Jerrold, Tocom, Pioneer, Scientific Atlanta, Zenith, Oak, Hamlin, Eagle, and others brands available.

Call or write for **FREE CATALOG**  
10 a.m. to 6 p.m. Eastern Time  
Monday thru Friday

## AC/DC Inc.

Suite 310, 366 N. Broadway  
Jericho, N.Y. 11753  
Tel: (516) 625-3550

CIRCLE 52 ON FREE INFORMATION CARD

### ATTENTION TECHNOCRATS

#### INDUCTIVE AUDIO TRACER

The SHMAGUE audio tracer lets you listen to magnetic fields. Just hold the probe next to a wire or component passing audio currents and hear the sound! Battery operated with internal speaker. Only \$89.95



Kathy sees Satisfaction Guaranteed!

#### SIGNAL INTENSIFIER RF PREAMPLIFIERS

RFTR - CB coverage improvement \$49.95  
RFA-16B Scanner \$29.95  
RFA-20 Shortwave \$29.95

MANY MORE MODELS!  
SEND FOR SPECS!

#### APARTMENT ANTENNA!

Suction cup mount VAK-TENNA mounts on glass!

VAK-TENNA \$29.95  
30-600MHz For Scanner, Ham, TV, FM. Specify connector UHF, BNC, F, Motorola.

SUPER VAK-TENNA \$149.95

0.5-800MHz AMPLIFIED active 14dB gain. For Shortwave, AM, Scanner, TV, FM. Receive only 110VAC or 12VDC powered. ADD \$3 S/H & Tax if NY

**ET** ELECTRON PROCESSING INC  
P.O. BOX 708  
MEDFORD, NY 11763  
(516) 764-0708

SEND FOR FULL DETAILS!

CIRCLE 58 ON FREE INFORMATION CARD

## FINALLY!



An interesting and worthwhile project. This EASY-TO-BUILD circuit lets you use any regular TV set as a simple OSCILLOSCOPE. Build for less than \$10. NO MODIFICATIONS TO TV! Single or dual trace.

DETAILED PLANS: \$4.95  
**TV-SCOPE**  
PENN RESEARCH, Box 3543  
Williamsport, PA 17701

Send for FREE CATALOG of other plans and kits

## ROOM SURVEILLANCE TELEPHONE



This is a normal functioning telephone! EXCEPT it has a secret built in room monitor. Only YOU can call and monitor all room conversations, using a secret code, and never be detected!

\$175.00 - 6 month Warranty - Phone Tap Catalog \$3.00  
LISTEN ELECTRONICS, 603 Elgin, Muskegon, OK 74401  
**1-800-633-TAPS**

## CABLE-TV BOXES

### Descramblers • Converters

### FREE CATALOG

TRANS-WORLD CABLE CO.  
12062 Southwest 117th Ct., Suite 126  
Miami, Florida 33186  
800-442-9333

## NEURAL NETWORKS ELECTRONICS

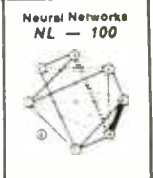

Neural Networks  
NL - 100

- Build an artificial retina
- Simulate nerve "motor" control
- Construct associative memory
- Expand simulator — design your own experiments

DETAILED PLANS  
• Theory  
• Assembly  
• Experiments

Send \$15 for 1 set of plans to:  
L.P. Weber • Box 621 • Allenwood, NJ 08720

**COMPUTER REPAIR DEPOT.** IBM, Compaq, Apple, AT & T, and many others. Call Bi-Tronix, Inc. (408) 236-3385 or (209) 952-7116, PO Box 23069, San Jose, CA 95153.

**SOFTWARE PC/MS-DOS** 143 programs including Deskteam with full documentation \$22 P/P. R&M Harper, P.O. Box 2624, Decatur, AL 35602.

**QUALITY IBM software.** \$2/disk. Send \$1 for catalog. AMERICAN ASSOCIATES, Box 18A182-F, Los Angeles, CA 90018.

**ENGINEERING SOFTWARE.** IBM compatibles. CompDes - Circuit Design, Basic electricity through circuit designs. CompMath - Mathematics, General mathematics through statistics. CompView - Digital Analysis of waveforms and filters. \$49 each. (614) 491-0832, BSOFT SOFTWARE, 444 Colton Road, Columbus, OH 43207.

**SOFTWARE, Schematic Fonts, Electronics Programs, Electronics Dictionary.** For C64 or C128 with GEOS(tm). Send \$19.95 or write for info. THOMAS SOFTWARE, 1375 Beasley Rd., Jackson, MS 39206.

## COMMUNICATIONS

**COMMUNICATIONS PLANS, BOOKS, KITS!** AM/FM broadcasting (licensed/unlicensed), 1750 Meter transceivers, ham/CB amplifiers, surveillance bugs, more! FREE catalog, PAN-COM, Box 130-ME12, Paradise, CA 95967.

**SATELLITE DESCRAMBLING—CABLE DESCRAMBLING.** Send Stamp For Free Catalog. Communications Engineering, 76 Boulevard, Hudson Falls, NY 12839.

## CLASSIFIED ADVERTISING ORDER FORM

Mail this form with payment to MODERN ELECTRONICS, Classified Dept., 76 N. Broadway, Hicksville, NY 11801.

Name: \_\_\_\_\_

Street Address: \_\_\_\_\_

City: \_\_\_\_\_ State: \_\_\_\_\_ Zip: \_\_\_\_\_

Check category you wish to be listed under or note a special heading (\$6 additional) you want.

( ) Audio ( ) Communications ( ) Computers ( ) Electronics ( ) Video  
( ) Miscellaneous ( ) Wanted ( ) Special Heading \_\_\_\_\_

PRINT EACH WORD SEPARATELY. Note that P.O. Box numbers\* and telephone numbers must be counted as two words each. Circle additional words you wish boldfaced at 20% more each (initial boldface word is free). Minimum charge is for 15 words.

Free Boldface	2	3	4
5	6	7	8
9	10	11	12
13	14	15 (\$15)	16 (\$16)
17 (\$17)	18 (\$18)	19 (\$19)	20 (\$20)



**CB RADIO OWNERS!** We specialize in technical information, parts and services for CBs. Repair/modification books, plans, kits, 10-Meter and FM conversions, high-performance accessories. Catalog \$2. CBCI, Box 31500ME, Phoenix, AZ 85046.

**SURVEILLANCE - COUNTERSURVEILLANCE:** Send \$2.00 for catalog of state of the art equipment, books. Sherwood, Box 535M, Southampton, PA 18966, telephone number 215-357-9065.

### VIDEOCIPHER II

**VIDEOCIPHER II** Manuals. Volume 1 - hardware, Volume 2 - software. Either \$32.45. Both \$54.95. **NEW!** Volume 3 - Projects/software - \$42.50. All-\$89.95. CODs - 1-602-782-2316. Catalog-\$3.00 **TELECODE** Box 6426-ME, Yuma, AZ 85366-6426.

### CABLE

**CABLE TV Secrets** - the outlaw publication the Cable Companies tried to Ban. HBO, Movie Channel, Showtime, Descramblers, Converters, etc. Suppliers List Included. \$8.95. Cable Facts, Box 711-ME, Pataskala, Ohio 43062.

### CABLE TV EQUIPMENT

**CABLE DESCRAMBLER LIQUIDATION.** Major makes and models available. Industry pricing! (Example: Hamlin Combo's, \$44 each . . . minimum 10 orders). **DEALERS ONLY!** Call West Coast Electronics, (818) 709-1758.

### CABLE TV

**CA TV converters & descramblers.** Quality products. Professional service. Call 1-800-541-5487. VISA M/C accepted. Mountain-tech Inc., Box 5074, Mt. Crested Butte, CO 81225.

### INVENTORS

**INVENTORS!** Can you profit from your idea? Call **AMERICAN INVENTORS CORPORATION** for free information. Over a decade of service, 1-800-338-5656. In Massachusetts or Canada call (413) 568-3753.

### SHAPE MEMORY ALLOYS

**ROBOTICS!** Engines! Inventions! Memory Metals contract like muscles when electrically stimulated. Send SASE for catalog. Mondotronics, 1014 Morse Ave., Suite 11-M, Sunnyvale, CA 94089.

### MISCELLANEOUS

**ASIAN LADIES** want correspondence for friendship, marriage, **SUNSHINE INTERNATIONAL**, Dept. TW, Box 5500, Kailua-Kona, HI 96745. (808) 325-7707.

**NEWS Flash . . . Industrial Secret Revealed!** "How to get the best screwdriving bit for any screw." Complimentary report. Write: "The President", Shockley's, 5841 Longford Road, Dayton, Ohio 45424. (513) 236-2983.

**IDEAS, inventions, technology wanted!** Call free 1-800-288-IDEA. ISC-MOEL, 903 Liberty, Pittsburgh, PA 15222.

## ELECTRONIC EAVESDROPPING EQUIPMENT DESIGN

If you have been looking for the "real thing" in electronic eavesdropping equipment design, then this book is for you. All 58 schematics presented are Sheffield Electronics's surveillance devices. Circuits explained. Transmitters are pens to 1-mile VOX's including crystal, subcarrier, carrier current, infrared, firefly and automobile. Demodulators given. Cube tap and duplex mains powered transmitters shown. 18 telephone transmitters are leech and battery types including crystal and subcarrier. Chapter on countermeasures. Much more. This 8 1/2 x 11-inch 110-page book is illustrated with photographs.

First Class Mail Used Price \$30.00  
S & H \$4.00

For 1-day processing, pay with Money Order or Cashier's Check.

**SEND TO: WINSTON ARRINGTON**  
7223 STONY ISLAND AVE.,  
CHICAGO, IL 60649



### PICKS UP A WHISPER 50 FEET AWAY!

The model WAT-50 miniature FM transmitter uses a 4-stage circuit NOT to be confused with a simple wireless microphone. Simply snap the unit on top of a 9V battery and you can hear every sound in an entire house up to 1 mile away! Use with any FM radio. Tunes to any frequency from 70mhz - 130mhz. Easy to assemble kit includes all parts and instructions. Only 29.98 tax incl.



The **WIRELESS TELEPHONE TRANSMITTER** model WTT-20 is only about the size of a dime, yet transmits both sides of a telephone conversation to any FM radio with crystal clarity. Completely automatic. Uses power from the telephone line itself - never needs a battery! Up to 1/4 mile range. Tunes from 70mhz - 130mhz. Easy to assemble kit includes all parts and instructions. Only \$29.98 tax incl.

Call or send MO, VISA, MC for immediate delivery. Single kit orders include \$1.50 S&H. FREE SHIPPING on orders of 2 or more. All orders shipped by U.S. Mail. COD add \$4.00. Personal checks allow 21 days.

**DECO INDUSTRIES**  
BOX 607, BEDFORD HILLS, NY 10507  
914-232-3878

CIRCLE 2 ON FREE INFORMATION CARD

## CABLE T.V. CONVERTERS WHY PAY A HIGH MONTHLY FEE?

All Jerrold, Oak, Hamlin, Zenith, Scientific Atlanta, Magnavox and all specialized cable equipment available for shipment within 24 hours. For fast service MC/VISA or C.O.D. telephone orders accepted 800-648-3030 60 Day Warranty (Quantity Discounts) 8 A.M. to 5 P.M. Monday through Friday Central Time. Stamp Envelope (60¢ postage) for FREE Catalog.

**Midwest Electronics Inc.**  
5143 W. Diversey • Chicago, IL 60639  
No Illinois Orders Accepted

CIRCLE 3 ON FREE INFORMATION CARD

**KeproClad**  
by Kepro Circuit Systems, Inc.

# The Power and The Glory

**1-800-325-3878**

**1-314-343-1630 MO**

For the dealer nearest you.



Kepro Circuit Systems, Inc.

## Make PCB's In Your Home!

**KeproClad™** gives you the *power* to produce industrial quality printed circuit boards at home. PCB's you can use for nearly any electronic construction project — from simple power supplies to sophisticated lasers. And when you're done, you'll know the *glory* that comes from top performance assured by the use of KeproClad PCB's.

KeproClad is the quick, easy and inexpensive system for production of quality printed circuit boards. KeproClad has all the supplies and instructions you need to create professional boards at home.

All KeproClad products are safe, easy to use and come with an unconditional guarantee. When you want to build the best, choose KeproClad. KeproClad gives you the power. You get the glory.

For your free KeproClad catalog and name of the KeproClad dealer nearest you, call Kepro.

630 Axminister Drive, Fenton, MO 63026-2992

CIRCLE 65 ON FREE INFORMATION CARD

## ADVERTISERS' INDEX

RS#		Page #
52	AC/DC	84
148	ALX Digital	17
37	AMC Sales	80
133	ARRL	4
38	Ace Communications	80
39	All Electronics	7
-	BGM Marketing	44, 45
134	C&S Sales	51
46	Chemtronics, Inc.	27
98	Cleveland Institute of Elec	Cov. III
-	Command Productions	54
48	Consolidated Electronics	70
4	Cook's Institute	82
2	Deco Industries	85
120	Digi-Key Corp.	83
45	Digital Research Computers	7
177	EMCO Electronics	76
-	EduCalc	9
-	Electronic Book Club	23
125	Electronic Equipment Bank	3
58	Electronic Processing	84
117	Heath Company	Cov. IV
49	J & W Electronics, Inc.	76
50	Jan Crystals	73
-	Listen Electronics	84
142	MCM Electronics	81
-	Magnaphase Ind., Inc.	38
-	McGraw-Hill Cont. Elec.	79
3	Midwest Electronics	85
-	NRI Schools	10, 13
74	OptoElectronics	Cov. II
-	Pacific Cable Co., Inc.	5
135	Parts Express International	6
-	Penn Research	84
-	Sheffield Electronics	85
-	Trans World Cable Co.	84
47	United Electronic Supply	63
53	Viejo Publications	84
-	Weber, L. P.	84

## LETTERS...

(from page 7)

nections into the circuit. Also, place near the input terminals that connect the Telephone line to R1 and R2 with "+" and "-" signs, respectively.—Ed.

• While devouring the October 1988 issue of *Modern Electronics*, I noticed an apparent error in Figures 4 and 5 of the "Troubleshooting With a dc Voltmeter" article, as well as in the accompanying description on page 20. I fail to see how a reverse bias on the base-emitter junction of a transistor can result in proper circuit operation. Shouldn't  $V_{ee}$  be  $-16$  and  $-30$  volts in Figures 4 and 5, respectively, to provide forward bias since the bases of the transistors are grounded? If the foregoing is true, the text in the first paragraph under Emitter-Bias Circuit should read "...  $V_E$  is 0.67 volt below ground."

Joe Thorn, Jr.  
San Francisco, CA

You're correct about the  $V_{ee}$  potentials being negative voltages.—Ed.

## NEW PRODUCTS... (from page 17)

### SMD Repair Station

Utilizing a conductive-heating tweezer with a wide selection of tip styles, Pace's (Laurel, MD) new Model PR-10 surface-mounted-device (SMD) repair station provides a power supply with high-duty-cycle temperature controller. Any desired temperature can be simply dialed in by the user,



and a convenient foot-pedal is said to instantaneously pulse-heat the tweezer tips.

This new station's tweezer handpieces are designed to stay cool in operation. Adding to user comfort is the slim diameter of the handpiece assembly. The tweezer handles are made from anti-static materials to eliminate the possibility of static damage to sensitive components.

CIRCLE NO. 113 ON FREE INFORMATION CARD

### Lab Design Kit

Designers who need a wide assortment of trimmer resistors will appreciate the Trim Bin™ Lab Design Kit from Bourns Trimpot. The Kit contains 124 trimmers that represent 50

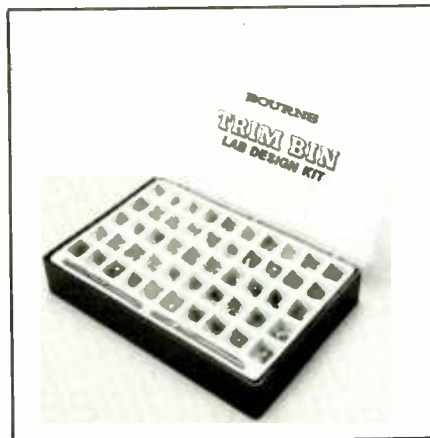

resistance ranges and pin styles. Both single- and multi-turn trimmers are included. Also included are two trimmer adjustment tools and product literature.

Surface-mount trimmers in the Kit include 0.25-inch-square sealed cermet Model 3269 multi-turn devices that feature high-temperature body material suitable for reflow soldering. These can be supplied in plastic tubes for insertion with automatic assembly equipment. Several devices in the Trim Bin are available for tape-and-reel packaging. \$113.

CIRCLE NO. 114 ON FREE INFORMATION CARD

### Mini Function Generator

Sibex's (Safety Harbor, FL) new Model FG-1 hand-held, battery-powered function generator is small enough to be carried in a shirt pocket. It provides sine, square and tri-



angular waveforms at a continuously variable frequency of from 1 Hz to 1 MHz in six switch-selectable frequency ranges. The output is TTL compatible. Three rotary controls permit selection of the output waveform, frequency range and varying of the frequency in the selected range. Power is applied and removed with a separate miniature toggle switch. The generator uses a standard 9-volt battery. \$96.95.

CIRCLE NO. 115 ON FREE INFORMATION CARD

# EXPAND YOUR CAREER HORIZONS...



*The CIE Microprocessor Trainer helps you to learn how circuits with microprocessors function in computers.*

## START WITH CIE.

Microprocessor Technology. Satellite Communications. Robotics. Wherever you want to go in electronics... start first with CIE.

Why CIE? Because we're the leader in teaching electronics through independent study. Consider this. We teach over 25,000 students from all over the United States and in over 70 foreign countries. And we've been doing it for over 50 years, helping thousands of men and women get started in electronics careers.

We offer flexible training to meet your needs. You can start at the beginner level or, if you already know something about electronics, you may want to start at a higher level. But wherever you start, you can go as far as you like. You can even earn your Associate in Applied Science Degree in Electronics.

Let us get you started today. Just call toll-free **1-800-321-2155** (in Ohio, 1-800-362-2105) or mail in

CIRCLE 98 ON FREE INFORMATION CARD

the handy reply coupon or card below to:  
Cleveland Institute of Electronics,  
1776 East 17th Street, Cleveland, Ohio 44114.

### CIE

**World Headquarters**

AMO-127

**Cleveland Institute of Electronics, Inc.**  
1776 East 17th Street • Cleveland, Ohio 44114

Please send your independent study catalog.  
For your convenience, CIE will try to have a representative contact you — there is no obligation.

Print Name \_\_\_\_\_

Address \_\_\_\_\_ Apt. \_\_\_\_\_

City \_\_\_\_\_ State \_\_\_\_\_ Zip \_\_\_\_\_

Age \_\_\_\_\_ Area Code/Phone No. \_\_\_\_\_

Check box for G.I. Bill bulletin on Educational Benefits

Veteran  Active Duty **MAIL TODAY!**

Just call toll-free **1-800-321-2155** (in Ohio, 1-800-362-2105)

# Heathkit®



## Anyone Can Buy Top Notch Audio. Now *You* Can Build It.

With Heath's new build-them-yourself stereo components, you create your own sound system.

Specially designed for Heath by industry leader Harman Kardon, our new stereo line exceeds the standards of even the most discerning audiophile. And because most of the components come in kit form, you experience firsthand how electronic craftsmanship results in premium hi-fi performance.

Build the power amplifier, preamplifier and stereo tuner. Prewired and pretested circuit boards and minimal soldering mean each component takes only a few evenings to build.

And, your success is guaranteed. Our precise, step-by-step manuals are industry-recognized, and our technical assistance team is just a phone call away.

To complete your sound system, add the remote control compact disc player, cassette deck and any of our fine speakers and headphones.

Technical excellence. Do-it-yourself pride. That's what we promise. That's what you get.

Heath Company brings you a wide range of innovative electronic products, each backed by our 40-year reputation for excellence in design, quality and durability.

Heath's new hi-tech audio components are just a few of the fine products you'll see in the Heathkit catalog. Discover 108 pages packed with TVs, VCRs, computers, test instruments, radio control vehicles and so much more. For your **FREE** copy call 24 hours a day TOLL-FREE:

**1-800-44-HEATH** (1-800-444-3284)

CIRCLE NO. 117 ON FREE INFORMATION CARD

**Heath Company**