

ICD 08559

MAY 1988 \$2.50

CANADA \$3.50

# MODERN ELECTRONICS™

THE MAGAZINE FOR ELECTRONICS & COMPUTER ENTHUSIASTS

- Build an IR-Switching Brushless DC Motor
- Enhance Car-Engine Power With Air-Conditioner Controller

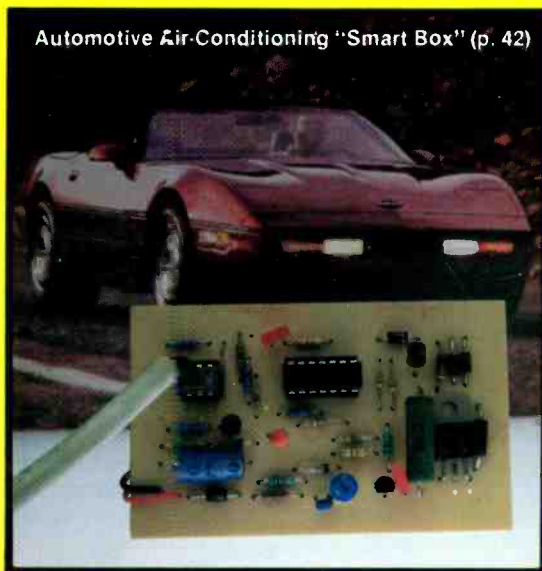

Automotive Air-Conditioning "Smart Box" (p. 42)

- Channel TTL Logic Tracer
- Lights Hazard Warner
- Semiconductor Analyzer (Conclusion)

- Testing Disk-Drive Power Supplies
- Converting Current to Voltage for Applications

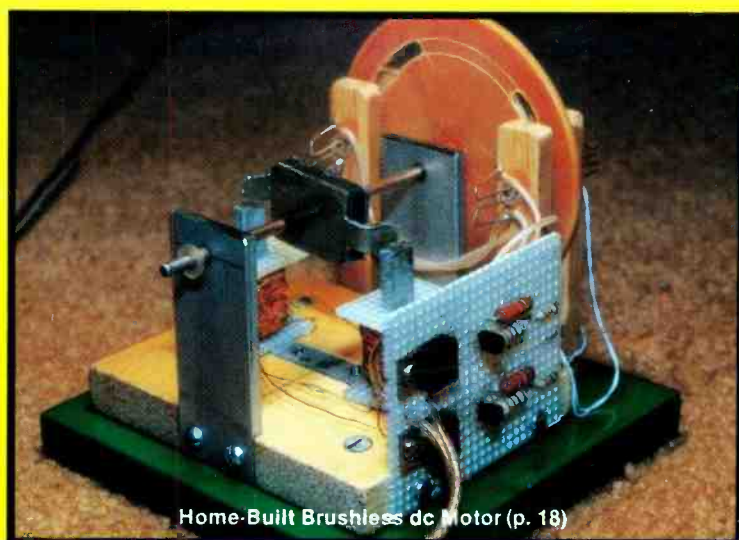

Home-Built Brushless dc Motor (p. 18)

SEP88 ME 708 P 00054376 05  
 MR DUNN  
 42 N MAIN ST  
 CASTLETON-ON-HUDSON NY 12033

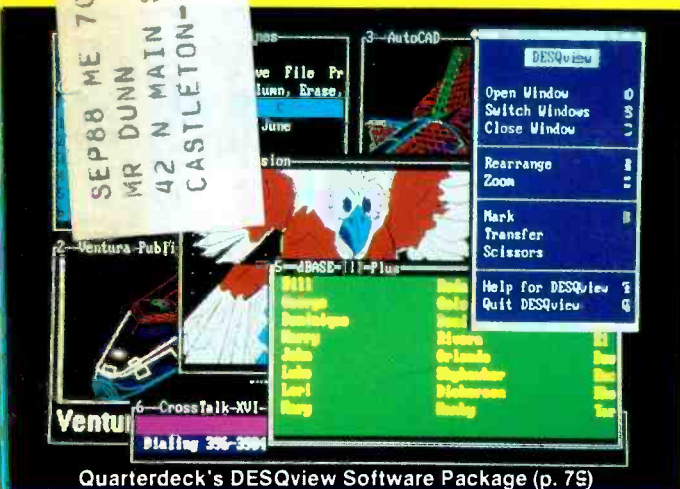

Quarterdeck's DESQview Software Package (p. 79)

Bulk Rate  
 Permit No. 79  
 U.S. Postage Paid  
 Gordonsville, VA 22942

Also: Forrest Mims' 16-Step Programmable Digital Controller • Evaluating Videotrax' Video Tape Hard-Disk Backup, Hercules' InColor Video Text/Graphics Board, and the Latest Windows/Multitasking DESQview Software • English-Language International SW Broadcasts • Latest Books & Literature • Electronic & Computer News . . . more.

OPTOelectronics inc

# FREQUENCY COUNTERS TO 1.3 GHZ

## NEW POCKET SIZE

SIZE: 4" H x 3.5" W x 1" D  
MADE IN USA

\$99<sup>95</sup> - \$150<sup>00</sup>

8 LED DIGITS • 2 GATE TIMES  
ANODIZED ALUMINUM CABINET  
INTERNAL NI-CAD BATTERIES INCLUDED  
AC ADAPTER/CHARGER INCLUDED



#TA-1005

#1200H 1.2 GHZ

EXCELLENT SENSITIVITY & ACCURACY

AC-DC • PORTABLE OPERATION



#AC-1200 AC ADAPTER CHARGER

Small enough to fit into a shirt pocket, our new 1.2 GHz and 1.3 GHz, 8 digit frequency counters are not toys! They can actually out perform units many times their size and price! Included are rechargeable Ni-Cad batteries installed inside the unit for hours of portable, cordless operation. The batteries are easily recharged using the AC adapter/charger supplied with the unit.

The excellent sensitivity of the 1200H makes it ideal for use with the telescoping RF pick-up antenna; accurately and easily measure transmit frequencies from handheld, fixed, or mobile radios such as: Police, firefighters, Ham, taxi, car telephone, aircraft, marine, etc. May be used for counter surveillance, locating hidden "bug" transmitters. Use with grid dip oscillator when designing and tuning antennas. May be used with a probe for measuring clock frequencies in computers, various digital circuitry or oscillators. Can be built into transmitters, signal generators and other devices to accurately monitor frequency.

The size, price and performance of these new instruments make them indispensable for technicians, engineers, schools, Hams, CBers, electronic hobbyists, short wave listeners, law enforcement personnel and many others.

### STOCK NO:

- #1200HKC Model 1200H in kit form, 1-1200 MHz counter complete including all parts, cabinet, Ni-Cad batteries, AC adapter-battery charger and instructions ..... \$ 99.95
- #1200HC Model 1200H factory assembled 1-1200 MHz counter, tested and calibrated, complete including Ni-Cad batteries and AC adapter/battery charger ..... \$137.50
- #1300HC Model 1300H factory assembled 1-1300 MHz counter, tested and calibrated, complete including Ni-Cad batteries and AC adapter/battery charger ..... \$150.00

### ACCESSORIES:

- #TA-1005 Telescoping RF pick-up antenna with BNC connector ..... \$12.00
- #P-100 Probe, direct connection 50 ohm, BNC connector ..... \$18.00
- #CC-70 Carrying case, black vinyl with zipper opening. Will hold a counter and accessories ..... \$10.00

## 1.3 GHZ

#1300H



ORDER FACTORY DIRECT

## 1-800-327-5912

FLA (305) 771-2050



**OPTOelectronics inc**  
5821 N.E. 14th Avenue  
Ft. Lauderdale, Florida 33334



AVAILABLE NOW!

Orders to US and Canada add 5% of total (\$2 min., \$10 max)  
Florida residents add 5% sales tax. COD fee \$2.

CIRCLE 8 ON READER SERVICE CARD

www.americanradiohistory.com

# Don't make your customers hate their VCR's guts.

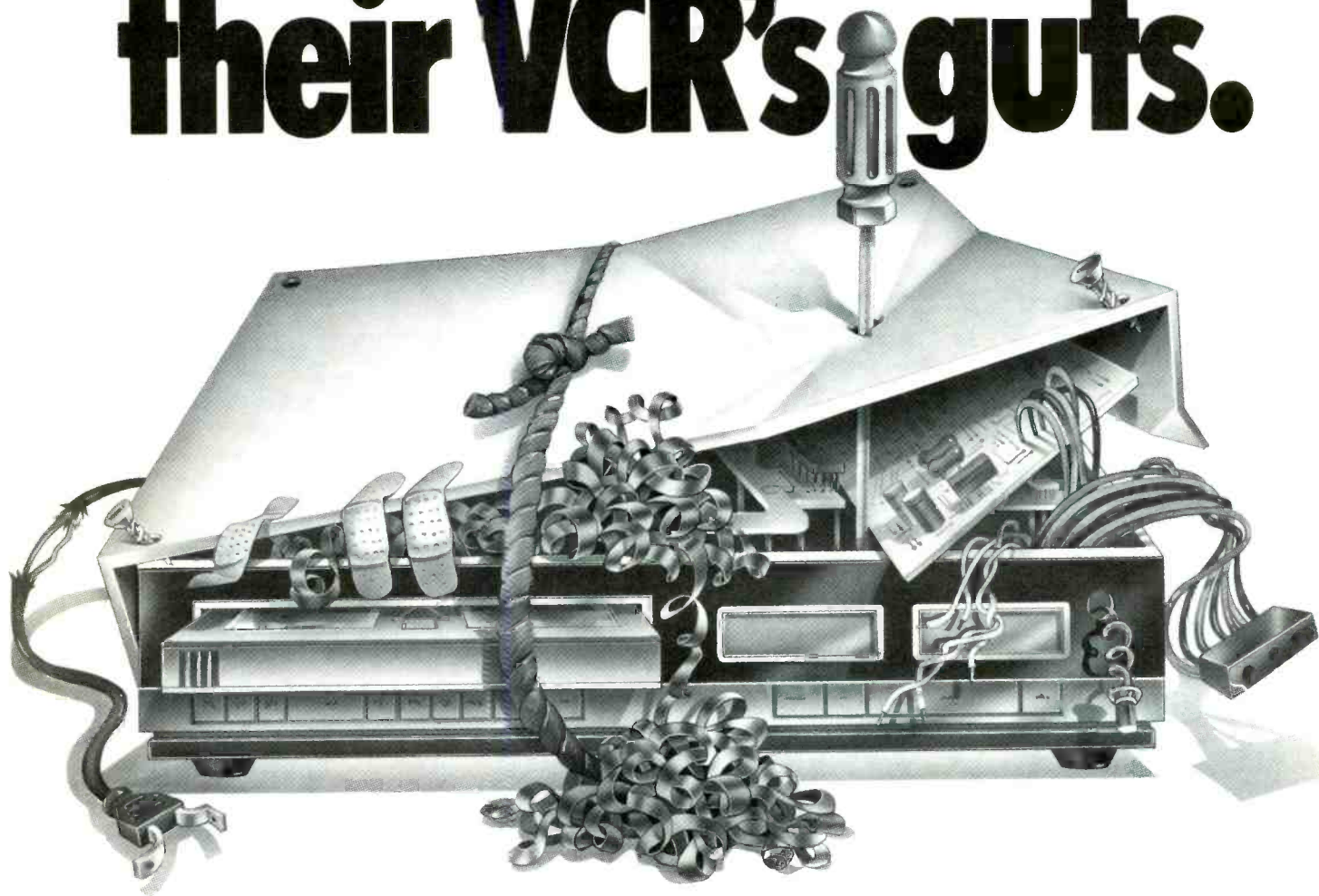

## Use authentic RCA/GE brand exact replacement parts.

The last thing your customers want to see after having their VCRs repaired is an instant replay of the original problem.

But that's what can happen when you use off-brand replacement parts. Mailings from unknown discounters may offer incredibly low prices. Brochures from unproven aftermarket manufacturers may look very attractive, too. But that second-rate quality and service may also cost you your customers.

That's why you should depend on RCA/GE exact replacement parts for VCRs. No one in the industry offers a wider, more reliable product line. With RCA/GE parts you'll not only keep your customers happy, you'll also keep them loving their VCRs — inside and out.

To learn more, see your local RCA/GE Parts Distributor. Or write: Thomson Consumer Electronics, Sales Promotion Services, Distributor and Special Products, 2000 Clements Bridge Road, Deptford, N.J. 08096-2088.



**VCR Replacement Parts**

CIRCLE 63 ON FREE INFORMATION CARD

## FEATURES



18

### 18 Brushless dc Motor

Home-built motor uses infrared switching for science-fair and other demonstrations.

By Robert S. Tschannen

### 28 Converting Current to Voltage

By Duane M. Perkins

### 30 Multi-Channel TTL Logic Tracer

Digital test instrument incorporates six "logic-probe" channels and can be expanded as needed.

By Peter A. Lovelock

### 36 Troubleshooting Disk-Drive Power Supplies

Cranky floppy-disk-drive write's and read's are sometimes caused by marginal power supplies.

By Ralph Tenny

### 42 An Automotive Air-Conditioning "Smart Box"

Optimizes air conditioning to driving conditions to conserve fuel and make full engine power available when it is needed most.

By Anthony J. Caristi

### 50 Dual Flashing Lights

Device uses LEDs and optional incandescent lamps to lend realism to model layouts and toys and warn of danger.

By Charles Shoemaker

### 54 The Semianalyzer (Conclusion)

Final assembly, checkout, calibration and use for this versatile benchtop troubleshooting instrument.

By David Miga

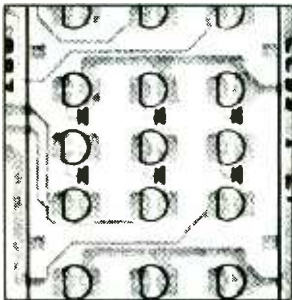

54

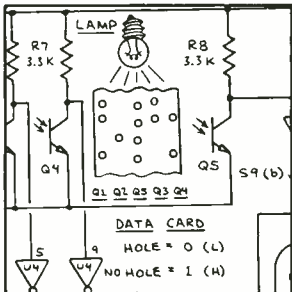

62

## PRODUCT EVALUATIONS

### 60 Videotrax: Video Tape Backup for Hard Disks

By John McCormick

## COLUMNS

### 62 Electronics Notebook

A 16-Step Programmable Digital Controller

By Forrest M. Mims III

### 67 Solid-State Devices

Tone-ringer IC applications and an IBM PS/2-compatible Chip Set.

By Harry Helms

### 70 Electronics Omnibus

Compact-disc quality; RLL hard-disk controllers; safety precautions for electronics technicians.

By Curt Phillips

### 74 PC Capers

Serial networking techniques; first looks at Hercules' InColor text/graphics board.

By Ted Needleman

### 79 Software Focus

Quarterdeck's DESQview.

By John McCormick

### 84 Communications

A Sampling of Spring 1988 English-Language International Shortwave Broadcasts.

By Gerry L. Dexter

## DEPARTMENTS

### 6 Editorial

By Art Salsberg

### 7 Letters

### 8 Modern Electronics News

### 14 New Products

### 72 Books & Literature

### 94 Advertisers Index



79

## EDITORIAL STAFF

Art Salsberg

Editor-in-Chief

Alexander W. Burawa

Managing Editor

Dorothy Kehrwieler

Production Manager

Elizabeth Ryan

Art Director

Barbara Scully

Artist

Pat Le Blanc

Florence V. Martin

Phototypographers

Hal Keith

Illustrator

Bruce Morgan

Photographer

Leonard Feldman, Harry Helms,

Forrest Mims III, Ted Needleman,

Curt Phillips

Contributing Editors

## BUSINESS STAFF

Richard A. Ross

Publisher

Art Salsberg

Associate Publisher

Dorothy Kehrwieler

General Manager

Frank V. Fuzia

Controller

Arlene Caggiano

Accounting

Catherine Ross

Circulation Director

## SALES OFFICES

Modern Electronics

76 North Broadway

Hicksville, NY 11801

(516) 681-2922

Advertising Manager

Peter Conn

Sales Assistant

Kathleen O'Lenahan

76 North Broadway

Hicksville, NY 11801

(516) 681-2922

Offices: 76 North Broadway, Hicksville, NY 11801. Telephone: (516) 681-2922. FAX (516) 681-2926. Modern Electronics (ISSN 0748-9889) is published monthly by CQ Communications, Inc. Application to mail at second class rates pending at Hicksville, NY and other points. Subscription prices (payable in US Dollars only): Domestic—one year \$17.97, two years \$33.00, three years \$48.00; Canada/Mexico—one year \$20.00, two years \$37.00, three years \$54.00; Foreign—one year \$22.00, two years \$41.00, three years \$60.00. Foreign Air Mail—one year \$75.00, two years \$147.00, three years \$219.00.

Entire contents copyright 1988 by CQ Communications, Inc. Modern Electronics or CQ Communications Inc. assumes no responsibility for unsolicited manuscripts. Allow six weeks for delivery of first issue and for change of address. Printed in the United States of America.

Postmaster: Please send change of address notice to Modern Electronics, 76 North Broadway, Hicksville, NY 11801.

# uniden® CB Radios & Scanners

Communications Electronics,™  
the world's largest distributor of radio  
scanners, introduces new models of  
CB, radar detectors and scanners.

## NEW! Bearcat® 760XLT-SA3

List price \$499.95/CE price \$279.95/SPECIAL  
12-Band, 100 Channel • Crystalless • AC/DC  
Frequency range: 29-54, 118-174, 406-512, 806-956 MHz.  
Excludes 823.9875-849.0125 and 868.9875-894.0125 MHz.

The Bearcat 760XLT has 100 programmable channels organized as five channel banks for easy use, and 12 bands of coverage including the 800 MHz. band. You also get automatic scanning of preprogrammed aircraft, police, marine, and emergency services. It also includes Weather Search, Priority, Squelch, Lockout and Delay. It has automatic and manual band search to find new active frequencies in other areas of the radio spectrum. The Bearcat 760XLT mounts neatly under the dash and connects directly to fuse block or battery. The unit also has an AC adaptor, flip down stand and telescopic antenna for desk top use. 6-5/16" W x 1 1/4" H x 7 3/8" D. Model BC 580XLT-SA is a similar version without the 800 MHz. band for only \$219.95.

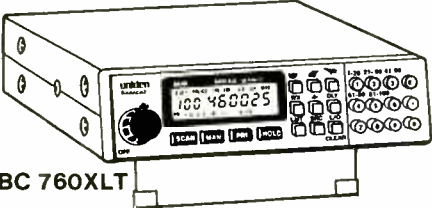

BC 760XLT

## Regency® TS2-SA

List price \$499.95/CE price \$309.95/SPECIAL  
12-Band, 75 Channel • Crystalless • AC/DC  
Frequency range: 29-54, 118-175, 406-512, 806-950 MHz.

The Regency TS2 scanner lets you monitor Military, Space Satellites, Government, Railroad, Justice Department, State Department, Fish & Game, Immigration, Marine, Police and Fire Departments, Aeronautical AM band, Paramedics, Amateur Radio, plus thousands of other radio frequencies most scanners can't pick up. The Regency TS2 features new 40 channel per second Turbo Scan™ so you won't miss any of the action. Model TS1-SA is a 35 channel version of this radio without the 800 MHz. band and costs only \$239.95.

## Regency® RH256B-SA

List price \$799.95/CE price \$329.95/SPECIAL  
16 Channel • 25 Watt Transceiver • Priority  
The Regency RH256B is a sixteen-channel VHF land mobile transceiver designed to cover any frequency between 150 to 162 MHz. Since this radio is synthesized, no expensive crystals are needed to store up to 16 frequencies without battery backup. All radios come with CTCSS tone and scanning capabilities. A monitor and night/day switch is also standard. This transceiver even has a priority function. The RH256 makes an ideal radio for any police or fire department volunteer because of its low cost and high performance. A 60 Watt VHF 150-162 MHz. version called the RH606B-SA is available for \$429.95. A UHF 15 watt, 10 channel version of this radio called the RU150B-SA is also available and covers 450-482 MHz. but the cost is \$419.95

## SALE Bearcat® 100XL-SA

List price \$349.95/CE price \$159.95/CLOSEOUT  
9-Band, 16 Channel • Priority • Scan Delay  
Search • Limit • Hold • Lockout • AC/DC  
Frequency range: 30-50, 118-174, 406-512 MHz.  
Uniden has authorized CEI to closeout the famous Bearcat 100XL to make room for new models. This scanner has a full 16 channels with frequency coverage that includes all public service bands. Wow... what a scanner! Included in our low CE price is a sturdy carrying case, earphone, battery charger/AC adapter, six AA Ni-cad batteries and flexible antenna. Since this is a special closeout price on our last 200 pieces, you must order your Bearcat today to take advantage of this excellent scanner opportunity.

## ★★★ Uniden CB Radios ★★★

The Uniden line of Citizens Band Radio transceivers is styled to compliment other mobile audio equipment. Uniden CB radios are so reliable that they have a two year limited warranty. From the feature packed PRO 540e to the 310e handheld, there is no better Citizens Band radio on the market today.

PRO310E-SA Uniden 40 Ch. Portable/Mobile CB... \$85.95  
PRO330E-SA Uniden 40 Ch. Remote mount CB... \$109.95  
NINJA-SA PRO310E with rechargeable battery pack \$99.95  
B-10-SA 1.2 V AA Ni-cad battery for Ninja (set of 10) ... \$20.95  
KARATE-SA Uniden 40 channel rescue radio ... \$69.95  
PRO10E-SA Uniden 40 channel CB Mobile... \$49.95  
PRO520E-SA Uniden 40 channel CB Mobile... \$59.95  
PRO540E-SA Uniden 40 channel CB Mobile... \$119.95  
PRO40E-SA Uniden 40 channel SSB CB Mobile... \$159.95  
PRO10E-SA Uniden 40 channel CB Base... \$119.95  
PRO810E-SA Uniden 40 channel SSB CB Base... \$179.95

## ★★★ Uniden Radar Detectors★★★

Buy the finest Uniden radar detectors from CEI today.  
RD7-SA Uniden visor mount radar detector ... \$109.95  
RD9-SA Uniden "Passport" size radar detector... \$129.95  
RD9XL-SA Uniden "micro" size radar detector ... \$159.95  
RD25-SA Uniden visor mount radar detector... \$59.95  
RD500-SA Uniden visor mount radar detector... \$79.95

## NEW! Bearcat® 200XLT-SA

List price \$509.95/CE price \$299.95  
12-Band, 200 Channel • 800 MHz. Handheld  
Search • Limit • Hold • Priority • Lockout  
Frequency range: 29-54, 118-174, 406-512, 806-956 MHz.  
Excludes 823.9875-849.0125 and 868.9875-894.0125 MHz.

The Bearcat 200XLT sets a new standard for handheld scanners in performance and dependability. This full featured unit has 200 programmable channels with 20 scanning banks and 12 band coverage. If you want a very similar model without the 800 MHz. band and 100 channels, order the BC 100XLT-SA3 for only \$199.95. Includes antenna, carrying case with belt loop, Ni-cad battery pack, AC adapter and earphone. Order your scanner now.

## Bearcat® 800XLT-SA

List price \$549.95/CE price \$259.95/SPECIAL  
12-Band, 40 Channel • No-crystal scanner  
Priority control • Search/Scan • AC/DC  
Bands: 29-54, 118-174, 406-512, 806-912 MHz.  
The Uniden 800XLT receives 40 channels in two banks. Scans 15 channels per second. Size 9 1/4" x 4 1/2" x 1 1/2". If you do not need the 800 MHz. band, a similar model called the BC 210XLT-SA is available for \$196.95.

## Bearcat® 145XL-SA

List price \$189.95/CE price \$98.95/SPECIAL  
10-Band, 16 Channel • No-crystal scanner  
Priority control • Weather search • AC/DC  
Bands: 29-54, 136-174, 406-512 MHz.

The Bearcat 145XL is a 16 channel, programmable scanner covering ten frequency bands. The unit features a built-in delay function that adds a three second delay on all channels to prevent missed transmissions.

## Bearcat® 175XL-SA

List price \$279.95/CE price \$156.95/SPECIAL  
11-Band, 16 Channel • Weather Search  
Priority control • Search/Scan • AC/DC  
Bands: 29-54, 118-174, 406-512 MHz.

The Bearcat 175XL has an automatic search feature to locate new frequencies. Priority, lock out, delay and scan speed are all included.

## Regency® Informant™ Scanners

Frequency coverage: 35-54, 136-174 406-512 MHz.  
The new Regency Informant scanners cover virtually all the standard police, fire, emergency and weather frequencies. These special scanners are preprogrammed by state in the units memory. Just pick a state and a category. The Informant does the rest. All Informant radios have a feature called Turbo Scan™ to scan up to 40 channels per second. The INF1-SA3 is ideal for truckers and is only \$179.95. The new INF2-SA3 is a deluxe model and has ham radio, a weather alert and other exciting features built in for only \$219.95. For base station use, the INF5-SA3 is only \$129.95 and for those who can afford the best, the INF3-SA3 at \$149.95, is a state-of-the-art, receiver that spells out what service you're listening to such as Military, Airphone, Paging, State Police, Coast Guard or Press.

## Regency® HX1500-SA

List price \$369.95/CE price \$179.95/SPECIAL  
11-Band, 55 Channel • Handheld/Portable  
Search • Lockout • Priority • Bank Select  
Sidelit liquid crystal display • EAROM Memory  
Direct Channel Access Feature • Scan delay  
Bands: 29-54, 118-136, 144-174, 406-420, 440-512 MHz.

The new handheld Regency HX1500 scanner is fully keyboard programmable for the ultimate in versatility. You can scan up to 55 channels at the same time including the AM aircraft band. The LCD display is even sidelit for night use. Includes belt clip, flexible antenna and earphone. Operates on 8 1.2 Volt rechargeable Ni-cad batteries (not included). Be sure to order batteries and battery charger from the accessory list in this ad.

## ★★★ Uniden Cordless Phones ★★★

A major consumer magazine did a comparison study on cordless phones. The check points included clarity, efficiency and price. Uniden was rated best buy.

XE300-SA Uniden Cordless Phone ... \$69.95  
XE500-SA Uniden Cordless Phone with paging... \$64.95  
XE700-SA Uniden Cordless Phone with speaker ... \$114.95

## ★★★ Extended Warranty Program ★★★

If you purchase a scanner, CB, radar detector or cordless phone from any store in the U.S. or Canada within the last 30 days, you can get up to three years of extended warranty service from Warrantec. This service extension plan begins after the manufacturer's warranty expires. Warrantec will perform all necessary labor and will not charge for return shipping. Extended warranties are non-refundable and apply only to the original purchaser. A two year extended warranty on a mobile or base scanner is \$29.99 and three years is \$39.99. For handheld scanners, 2 years is \$59.99 and 3 years is \$79.99. For radar detectors, two years is \$29.99. For CB radios, 2 years is \$39.99. For cordless phones, 3 years is \$34.99. Order your warranty for your merchandise today.

## OTHER RADIOS AND ACCESSORIES

BC 55XL-SA Bearcat 10 channel scanner... \$114.95  
BC 70XLT-SA Bearcat 20 channel scanner... \$169.95  
R1090-SA Regency 45 ch. scanner... CLOSEOUT \$119.95  
Z60-SA Regency 60 ch. scanner... CLOSEOUT \$129.95  
UC102-SA Regency VHF 2 ch. 1 Watt transceiver... \$117.95  
BP55-SA Regency 16 amp. reg. power supply... \$169.95  
MA549-SA Drop-in charger for HX1200 & HX1500... \$64.95  
MA518-SA Wall charger for HX1500 scanner... \$14.95  
MA553-SA Carrying case for HX1500 scanner... \$19.95  
MA257-SA Cigarette lighter cord for HX12/1500... \$19.95  
MA917-SA Ni-Cad battery pack for HX1000/1200... \$34.95  
BP205 Ni-Cad battery pack for BC200/BC100XLT... \$49.95  
B-8-SA 1.2 V AA Ni-Cad batteries (set of eight)... \$17.95  
FB-E-SA Frequency Directory for Eastern U.S.A. ... \$14.95  
FB-W-SA Frequency Directory for Western U.S.A. ... \$14.95  
ASD-SA Air Scan Directory... \$14.95  
SRF-SA Survival Radio Frequency Directory... \$14.95  
TSG-SA "Top Secret" Registry of U.S. Govt. Freq... \$14.95  
TIC-SA Techniques for Intercepting Comm... \$14.95  
RRF-SA Railroad frequency directory... \$14.95  
EEC-SA Embassy & Espionage Communications... \$14.95  
CIE-SA Covert Intelligence, Elect. Eavesdropping... \$14.95  
MFF-SA Midwest Federal Frequency directory... \$14.95  
A60-SA Magnet mount mobile scanner antenna... \$35.95  
A70-SA Base station scanner antenna... \$35.95  
USAMM-SA Mag mount VHF ant. w/ 12' cable... \$39.95  
USA-K-SA 3/4" hole mount VHF ant. w/ 17' cable... \$35.95  
USA-K450-SA 3/4" hole mount UHF ant. w/ 17' cable... \$35.95  
Add \$3.00 shipping for all accessories ordered at the same time.  
Add \$7.00 shipping per radio and \$3.00 per antenna.

## BUY WITH CONFIDENCE

To get the fastest delivery from CE of any scanner, send or phone your order directly to our Scanner Distribution Center.™ Michigan residents please add 4% sales tax or supply your tax I.D. number. Written purchase orders are accepted from approved government agencies and most well rated firms at a 10% surcharge for net 10 billing. All sales are subject to availability, acceptance and verification. All sales on accessories are final. Prices, terms and specifications are subject to change without notice. All prices are in U.S. dollars. Out of stock items will be placed on backorder automatically unless CE is instructed differently. A \$5.00 additional handling fee will be charged for all orders with a merchandise total under \$50.00. Shipments are F.O.B. Ann Arbor, Michigan. No COD's. Most products that we sell have a manufacturer's warranty. Free copies of warranties on these products are available prior to purchase by writing to CE. Non-certified checks require bank clearance. Not responsible for typographical errors.

**Mail orders to:** Communications Electronics,™ Box 1045, Ann Arbor, Michigan 48106 U.S.A. Add \$7.00 per scanner for R.P.S./U.P.S. ground shipping and handling in the continental U.S.A. For Canada, Puerto Rico, Hawaii, Alaska, or APO/FPO delivery, shipping charges are three times continental U.S. rates. If you have a Discover, Visa or Master Card, you may call and place a credit card order. Order toll-free in the U.S. Dial 800-USA-SCAN. In Canada, order toll-free by calling 800-221-3475. FAX anytime, dial 313-971-6000. If you are outside the U.S. or in Michigan dial 313-973-8888. Order today.

Scanner Distribution Center™ and CEI logos are trademarks of Communications Electronics Inc.  
† Bearcat is a registered trademark of Uniden Corporation.  
‡ Regency and Turbo Scan are registered trademarks of Regency Electronics Inc. AD #041588-SA3  
Copyright © 1988 Communications Electronics Inc.

For credit card orders call  
**1-800-USA-SCAN**

**COMMUNICATIONS  
ELECTRONICS INC.**

**Consumer Products Division**  
P.O. Box 1045 □ Ann Arbor, Michigan 48106-1045 U.S.A.  
For orders call 313-973-8888 or FAX 313-971-6000

# HAM RADIO IS FUN!

It's even more fun for beginners now that they can operate voice and link computers just as soon as they obtain their Novice class license. You can talk to hams all over the world when conditions permit, then switch to a repeater for local coverage, perhaps using a transceiver in your car or handheld unit.



Your passport to ham radio adventure is TUNE-IN THE WORLD WITH HAM RADIO. The book tells what you need to know in order to pass your Novice exam. Two cassettes teach the code quickly and easily.

Enclosed is my check or money order for \$15.00 or charge my

( ) VISA ( ) Mastercard ( ) Am. Express

Signature \_\_\_\_\_

Acct. No. \_\_\_\_\_

Good from \_\_\_\_\_ Expires \_\_\_\_\_

Name \_\_\_\_\_

Address \_\_\_\_\_

\_\_\_\_\_

City \_\_\_\_\_ State \_\_\_\_\_ Zip \_\_\_\_\_

THE AMERICAN RADIO RELAY LEAGUE  
225 MAIN ST.  
NEWINGTON, CT 06111

CIRCLE NO. 135 ON FREE INFORMATION CARD

# EDITORIAL

## Will It Work?

When you bought a new piece of electronic equipment many years ago, you expected it to work well from Day One. Today, however, it's apparent that our confidence in a product operating flawlessly from the outset has been shaken. This has been compounded by compatibility problems.

In my youth, whether or not an audio tone control precisely tracked an RIAA curve standard generated some anxiety. Another cause for concern was matching a speaker system's impedance, power-handling capacity and efficiency to an amplifier. Matching an antenna's impedance to a TV receiver was another challenge. In retrospect, these were minuscule considerations.

The most serious compatibility problems that touch us today concern personal computers. I say "us" because our reader studies indicate that about 75% of you own at least one computer, 27% of you plan to buy one or more in the next 12 months, and a significant percentage of owners plan to upgrade their machines with hard-disk drives, speedup boards, etc. In particular, these difficulties relate to the open-architecture IBM compatibles, especially the XT and AT model types that IBM no longer produces (but are fast-selling machines nevertheless in their non-IBM-made reincarnation).

These computers are now unequivocal bargains in terms of price and performance. If they're not wholly compatible with *de facto* standards established by IBM's designs, however, they are obviously less of a bargain. Running on Microsoft's disk operating system (MS-DOS), for example, is no assurance that a computer is highly compatible with widely sold software and boards. Some earlier MS-DOS-based machines won't run most standard MS-DOS programs, in fact. These include early models from Heath/Zenith, Tandy, Sanyo, Texas Instruments, and others. Most (but not all) have since embraced IBM compatibility, though even here there are some zingers (the Tandy 1000's expansion boards aren't the same length as the IBM's, as an example).

A key to compatibility is the ROM BIOS IC contained in the machine. IBM's copyrighted ones have to be emulated to perform properly without legal

infringements. This is easier said than done. A handful of companies specialize in making such ROMs; some are less compatible than others, of course.

Even if the foregoing passes muster, there's the question of hardware compatibility. Some so-called compatibles don't have a perfect IBM-hardware interface, with inputs and outputs handled differently. As a result, they fall down with certain software that bypasses the ROM BIOS for whatever reason (generally to increase operating speed).

You also have to be concerned about the compatibility of new boards, drives and software, too, naturally. The original IBM PC's ROM BIOS, for example, did not handle hard-disk drives. You might buy a bargain-priced clearance-sale bare-bones computer with a ROM BIOS that doesn't support an EGA monitor you plan to use. Or a machine with a fast clock that doesn't have provisions to slow it down to 4.77 MHz to handle some programs and even some modems that require the old PC standard. Moreover, models in the same general family may not be completely compatible.

All this requires some buying smarts. Be sure (in writing if possible) that the machine will indeed run your favorite programs and popular ones you plan to buy. And that a graphics board you want to buy will do the same in your machine. Otherwise, you might be charged a restocking fee (say, 20% of what you paid) if you return it for a refund should it not meet these needs.

As a result of these variances, many computer buyers are playing it safe with known-to-work equipment, much as corporate buyers used to "buy IBM" rather than compatibles as a safe measure even though these models were outrageously priced at one time. This means getting a computer with a Phoenix or Award ROM BIOS, an EGA board with graphics chips by Chips & Technologies, etc. In sum, play it cool so that you get the best value you can in a world where the word "compatible" does not necessarily mean 100% compatible.

*Art Salsberg*

# LETTERS

## Project Modifications

• After making suitable corrections to the circuit [see below] that appeared in "Interfacing Commodore's User Port" (January 1988), I built a unit to read a gas chromatograph in my laboratory. It works beautifully! This project solved an important problem for me, and I really appreciate it.

John A. Brown  
Berkeley Heights, NJ

• There are several errors in "Interfacing Commodore's User Port" (January 1988): in Fig. 2(B), pin 6 of the TLC548 should connect to pin M (CB2) of the User Port and the pins on the right side of the User Port connectors in both Figs. 2(A) and 2(B) should read A, B, C, D, E, F, H, J, K, L, M and N from bottom to top; Commodore does not use the letters G and I for the Port pins; the program listings also appear to be mislabeled.

Whit A. Tipton  
Cincinnati, OH

Add to these observations that pin 2—not pin 1—should be the +5V line and move SP-2 and CNT2 to pins 7 and 6, respectively, of the User Port in Fig. 2(A). To clarify, Listing 2 is the Machine-Language Loader for VIC-20, while the other Listings are BASIC Programs for the C-128, C-64 and VIC-20. —John Iovine.

• I noticed that the Parts List for the "\$149 Digital Stereo Amplifier" (December 1987) gives the value for trimmers R55 and R63 as 100,000 ohms, while the schematic gives them as 10,000 ohms. Which is correct?

Walter Montgomery  
Baltimore, MD

Go with the 10,000-ohm value. The 100,000 ohms given in the Parts List is a typo.—Ed.

• The Fig. 3 etching-and-drilling guide for "A Battery Charger Controller" (November 1987) has an error in it. There should be a connecting trace or wire between the cathode of D1 and the cathode of D5. Without this connection, no +12 volts dc will be applied to the relay's coil.

Ed Drennan  
Agincourt, Ontario, Canada

(Continued on page 94)

# CABLE-TV



# BONANZA!

ITEM	1 UNIT	10 OR MORE
RCA 36 CHANNEL CONVERTER (Ch. 3 output only)	29.00	18.00
PANASONIC WIRELESS CONVERTER (our best buy)	88.00	69.00
400 OR 450 CONVERTER (manual fine tune)	88.00	69.00
*JERROLD 400 COMBO	169.00	119.00
JERROLD 400 HAND REMOTE CONTROL	29.00	18.00
*JERROLD 450 COMBO	199.00	139.00
*JERROLD 450 HAND REMOTE CONTROL	29.00	18.00
JERROLD SB-ADD-ON	89.00	58.00
*JERROLD SB-ADD-ON WITH TRIMODE	99.00	70.00
*M-35 B COMBO UNIT (Ch. 3 output only)	99.00	70.00
*M-35 B COMBO UNIT WITH VARISYNC	109.00	75.00
*MINICODE (N-12)	89.00	58.00
*MINICODE (N-12) WITH VARISYNC	99.00	62.00
*MINICODE VARISYNC WITH AUTO ON-OFF	145.00	105.00
ECONOCODE (minicode substitute)	69.00	42.00
ECONOCODE WITH VARISYNC	79.00	46.00
*MLD-1200-3 (Ch. 3 output)	99.00	58.00
*MLD-1200-2 (Ch. 2 output)	99.00	58.00
*ZENITH SSAVI CABLE READY	175.00	125.00
INTERFERENCE FILTERS (Ch. 3 only)	24.00	14.00
*EAGLE PD-3 DESCRAMBLER (Ch. 3 output only)	119.00	65.00
*SCIENTIFIC ATLANTA ADD-ON REPLACEMENT DESCRAMBLER	119.00	75.00

\*CALL FOR AVAILABILITY

Quantity	Item	Output Channel	Price Each	TOTAL PRICE

California Penal Code #593-D forbids us from shipping any cable descrambling unit to anyone residing in the state of California.

Prices subject to change without notice.

SUBTOTAL	
Shipping Add \$3.00 per unit	
COD & Credit Cards — Add 5%	
TOTAL	

PLEASE PRINT

Name \_\_\_\_\_

Address \_\_\_\_\_ City \_\_\_\_\_

State \_\_\_\_\_ Zip \_\_\_\_\_ Phone Number (     ) \_\_\_\_\_

Cashier's Check     Money Order     COD     Visa     Mastercard

Acct # \_\_\_\_\_ Exp. Date \_\_\_\_\_

Signature \_\_\_\_\_

FOR OUR RECORDS:

DECLARATION OF AUTHORIZED USE — I, the undersigned, do hereby declare under penalty of perjury that all products purchased, now and in the future, will only be used on cable TV systems with proper authorization from local officials or cable company officials in accordance with all applicable federal and state laws. FEDERAL AND VARIOUS STATE LAWS PROVIDE FOR SUBSTANTIAL CRIMINAL AND CIVIL PENALTIES FOR UNAUTHORIZED USE.

Dated: \_\_\_\_\_ Signed: \_\_\_\_\_

## Pacific Cable Company, Inc.

7325½ RESEDA BLVD., DEPT. #ME • RESEDA, CA 91335  
(818) 716-5914 • No Collect Calls • (818) 716-5140

**IMPORTANT: WHEN CALLING FOR INFORMATION**  
Please have the make and model # of the equipment used in your area. Thank You

**ANTI-PIRACY HOTLINE.** The Satellite Broadcasting and Communication Association of America (SBCA), assisted by General Instrument, established two national, toll-free telephone hotlines to promote purchasing legitimate and legal home satellite systems. One is for STV dealers (1-800-356-3160); the second for consumers (1-800-533-4584). Hours are 9 a.m. to 9 p.m., Monday through Friday. Issues addressed include how to tell a legal system from an illegal one and identifying legitimate dealers and retailers.

**PC-AT SHUTDOWNS.** In a few months, according to International Battery Corp., eight out of ten original IBM PC-AT and AT clone computers about 1 1/2-million units will shut down and lose their configuration files due to a small internal battery sales are soaring. In addition to losing Config.Sys files, the clock/calendar is affected when the battery gives out. Lithium batteries, preferred over alkaline, have a working life of about two years or so, with a ten-year shelf life.

**NATIONAL TECH DAY.** ISCET cited electronics technicians on March 8, 1988 by celebrating National Electronics Technicians Day. The International Society of Certified Electronics Technicians set the day aside as a national testing day for certification of techs across the country who demonstrate their professionalism by taking its CET exam.

**PROTOTYPE VIDEO TELEPHONE.** Ricoh Company Ltd., the Tokyo parent of Ricoh Corp. in the U.S. has developed the first device to send and receive still-color video images as well as voice over telephone lines. The prototype model, whose availability and price hasn't been determined, is said to transmit color images in one to four seconds.

**UK SMART RADIO SYSTEM.** England is now set up to permit radio receivers to automatically tune to the best transmitted signal. Called the Radio Data System (RDS), it was installed by the British Broadcasting System and is expected to be operational in about six months. Essentially, it provides pushbutton tuning for radios, which also can visually indicate station name, time and date. The system at this time is primarily pointed toward use in automobile radios, which will also be able to have the option of tuned-in stations being interrupted by local travel news flashes. Scotland, Wales and North Ireland RDS installations will follow.

**VIDEO BUYING & SELLING.** American Home Network added new services to its American People/Link nationwide on-line network service of clubs, forums, etc. These include on-line shopping and airline reservation systems. Its Electronic Travel Agency has been launched, too, where subscribers can purchase discounted cruises and tours, gift items and other travel-related products....A new company, Salesnet Inc., was started by International Images Inc. to transmit data and sales or training videos for linkup with TV and Cable TV networks. A small board fits inside an IBM PC or compatible or MAC computer to convert the TV signal back to data. Data is said to be transmitted at the rate of 82,000 bits per second compared to phone modems' 300, 1200 or 2400 bps.



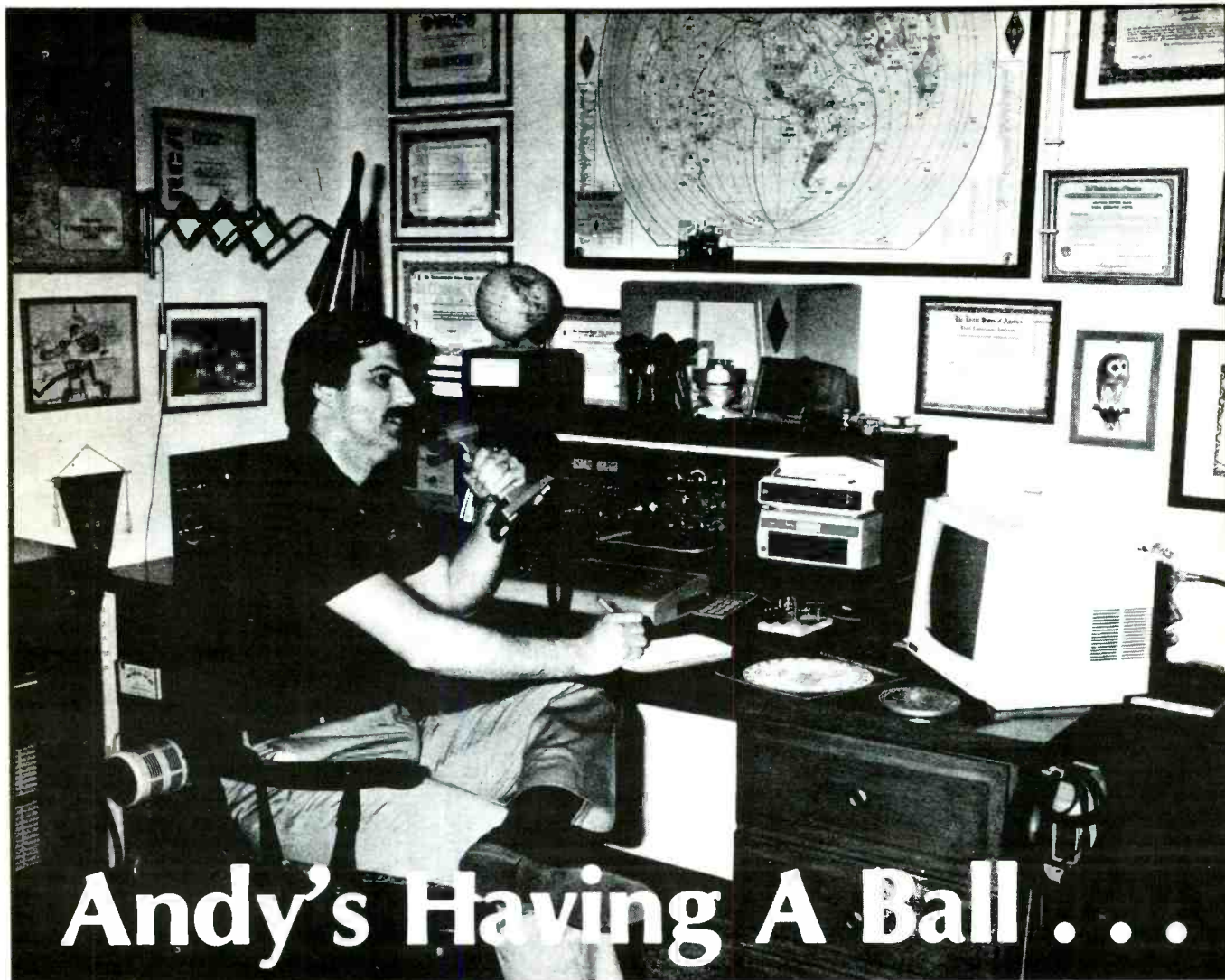

# Andy's Having A Ball . . .

## and you can too!

Andy is a Ham Radio operator and he's having the time of his life talking to new and old friends in this country and around the world.

You can do it too! Join Andy as he communicates with the world. Enjoy the many unique and exclusive amateur bands . . . the millions of frequencies that Hams are allowed to use. Choose the frequency and time of day that are just right to talk to anywhere you wish. Only Amateur Radio operators get this kind of freedom of choice. And if it's friends you're looking to meet and talk

with, Amateur Radio is the hobby for you. The world is waiting for you.

If you'd like to be part of the fun . . . if you'd like to feel the excitement . . . we can help you. We've got all the information you'll need to get your Ham license. Let us help you join more than a million other Hams around the world and here at home. Who are we? We're the American Radio Relay League, a non-profit representative organization of Amateur Radio operators.

For information on becoming a Ham operator  
circle number 110 on the reader service card or write to:

**AMERICAN RADIO RELAY LEAGUE**

Dept CQ, 225 Main Street  
Newington, Conn. 06111.

This space donated by this publication in cooperation with the American Radio Relay League.

# *NRI Trains You At Home—As You Build Your Own IBM PC Compatible Computer*

# GET THE KNOW-HOW TO SERVICE EVERY COMPUTER ON THIS PAGE... AND MORE!

## **Learn the Basics the NRI Way— and Earn Good Money Troubleshooting Any Brand of Computer**

The demand for trained computer service technicians continues to surge forward. Computer service ranks high on the Department of Labor's list of top growth fields, with accelerated demand expected to create more than 30,000 *new* jobs in the next 10 years.

You can cash in on this opportunity—either as a full-time corporate technician or an independent service-person—once you've learned all the basics of computers the NRI way. NRI's practical combination of "reason-why" theory and "hands-on" building skills starts you with the fundamentals of electronics, then guides you through advanced electronic circuitry and on into computer electronics. You also learn to program in BASIC and machine language, the essential languages for troubleshooting and repair.

## **Total Computer Systems Training, Only From NRI**

No computer stands alone. . . it's part of a total system. To really service computers, you have to understand computer *systems*. And only NRI includes a powerful computer system as part of your training, centered around the new, fully IBM PC compatible Sanyo 880 Series computer.



IBM is a Registered Trademark of IBM Corporation.  
Epson is a Registered Trademark of Epson America, Inc.  
Apple and the Apple logo are Registered Trademarks of Apple Computer, Inc.  
Compaq is a Registered Trademark of COMPAQ Computer Corporation.  
© 1985 AT&T Technologies, Inc.

**NEW!**  
20 Meg  
Hard Disk  
Included!

You start with the step-by-step assembly of your highly rated Sanyo computer. You build and test the "intelligent" keyboard, install the power supply and 360K 5 1/4" floppy disk drive, and interface the high-resolution monitor. But that's not all. You go on to install a powerful 20 megabyte hard disk drive—today's most-wanted computer peripheral—now included as part of your hands-on training to dramatically increase your computer's data storage capacity while at the same time giving you lightning-quick data access. With your computer now up and running, you're ready to begin using the valuable software also included as part of your total systems training.

It all adds up to confidence-building, real-world experience that includes training in programming, circuit design, and peripheral maintenance. You'll be learning about, working with, servicing, and troubleshooting an entire computer

system—monitor, keyboard, computer, disk drive, power



supply—to ensure that you have all the essential skills you need to succeed as a professional computer service technician.

### No Experience Needed, NRI Builds It In

This is the kind of practical, hands-on experience that makes you uniquely prepared, with the skills and confidence you need for success. You learn at your own convenience in your own home. No classroom pressures, no night school, no need to quit your present job until you're ready to make your move. Your training is backed by your personal NRI instructor and the NRI technical staff, ready to answer your questions and help you when you need it. You get it all with NRI at-home training.

### Free 100-Page Catalog Tells More

Send the postage-paid reply card today for NRI's big, 100-page, color catalog on NRI's electronics training, which gives you all the facts about NRI courses in Microcomputers, Robotics, Data Communications, TV/Audio/Video Servicing, and other growing, high-tech career fields. If the reply card is missing, write to the address below.

Your NRI total systems training includes: • NRI Discovery Lab to design and modify circuits • Four-function digital multimeter with walk-you-through instruction on audio tape • Digital logic probe for visual examination of keyboard circuits • Sanyo 880 Series computer with "intelligent" keyboard and 360K, 5 1/4" floppy disk drive • 20 megabyte hard disk drive you install internally • High-resolution monochrome monitor • 8K ROM, 256K RAM • Bundled software • Reference manuals, schematics, and bite-sized lessons.



## SEND COUPON TODAY FOR FREE NRI CATALOG!

**NRI** SCHOOLS

McGraw-Hill Continuing Education Center  
3939 Wisconsin Avenue, NW, Washington, DC 20016



For Career courses  
approved under GI Bill  
 check for details.

CHECK ONE FREE CATALOG ONLY

- |  |   |
|--|---|
| <input type="checkbox"/> Computer Electronics          | <input type="checkbox"/> Bookkeeping & Accounting           |
| <input type="checkbox"/> TV/Video/Audio Servicing      | <input type="checkbox"/> Electrician                        |
| <input type="checkbox"/> Robotics                      | <input type="checkbox"/> Air Conditioning, Heating & Ref.   |
| <input type="checkbox"/> Electronic Music Technology   | <input type="checkbox"/> Locksmithing & Electronic Security |
| <input type="checkbox"/> Satellite Electronics         | <input type="checkbox"/> Travel Careers                     |
| <input type="checkbox"/> Digital Electronics Servicing | <input type="checkbox"/> Small Engine Repair                |
| <input type="checkbox"/> Telephone Servicing           | <input type="checkbox"/> Paralegal                          |

Name (Please print) \_\_\_\_\_

Age \_\_\_\_\_

Street \_\_\_\_\_

City/State/Zip \_\_\_\_\_

We'll give you tomorrow. Accredited by the National Home Study Council #4-058

For more information on products described, please circle the appropriate number on the Free Information Card bound into this issue or write to the manufacturer.

## Miniature EPROM Eraser

"Palm-Erase" from Logical Devices, Inc. (Ft. Lauderdale, FL) is claimed to be the industry's smallest ultraviolet EPROM eraser, measuring only 4"L x 2"W x 2"H. The 7-ounce eraser is for use in servicing and engineering applications where space is at a premium. It is very fast, erasing an EPROM in less than 3 minutes.



Built into the ac-line-operated eraser is a small tray that can accommodate a 24- or 28-pin EPROM. Erasure is done one EPROM at a time, using a UV lamp whose intensity is 1.7 microwatt per square centimeter. Average lamp life is rated at 3,000 hours. \$49.95.

CIRCLE 23 ON FREE INFORMATION CARD

## Audio Mixers

Audio-Technica U.S., Inc. has added two new audio mixers to its ATUS line: the high-end Model AM500E and low-end Model AM50.

The Model AM500E replaces the Model AM500 and brings electronic echo effect to the line. This is a six-channel wood-paneled console-type stereo mixer that can handle two turntables with phono cross-fader, two microphones (with a priority talk feature) and two auxiliary

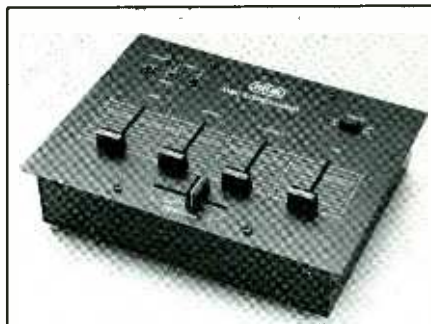

sources. It features separate left/right five-band equalizers, two VU meters, individual and master gain controls, monitor circuit, adjustable amplifier output level and a headphone jack. \$409.95.

For the novice home DJ, the Model AM50 is a four-channel stereo mixer that can handle two turntables, a stereo microphone with "talk-over" and an auxiliary source. It features a phono cross-fader, amplifier and tape-recorder outputs and a headphone jack. \$89.95.

CIRCLE 24 ON FREE INFORMATION CARD

## New Hand-Held Scanner

The Bearcat BC 55 XLT hand-held, portable scanner from Uniden Corp. is a new 10-channel programmable



model. It covers all public-service, four Amateur radio, federal government and military land mobile bands. Patented "Track" tuning is said to allow the scanner to peak on each transmission for better reception at band edges.

Features include: two-digit LCD numeric display; a review function that checks the frequency entered on each channel; an audible low-battery warning device that beeps every few seconds when the battery is low; a memory back-up that retains entered frequencies for 30 minutes with no battery installed; and a keyboard lock switch to prevent accidental programming. Scanning speed is at a rate of 15 channels per second. The scanner is powered from either five standard or five rechargeable Ni-Cd AA cells. It measures 6.75" x 2.625" x 1.5" and weighs only 10.5 ounces without battery. \$219.95.

CIRCLE 25 ON FREE INFORMATION CARD

## A/D, D/A & DI/O Board

A new high-density analog converter board for PC-bus computers from Industrial Computer Designs, Inc. (Westlake Village, CA) provides 32 single-ended or 16 differential input signals at 12-bit+ resolution, two 8-bit latching D/A output signals and 32 TTL-level parallel I/O lines. Featuring add-on intelligence, the Model A/D12B32 board is capable of scanning inputs of up to 10,000 reads per second, with gain and input configuration adjustable in real time.

With this new board, IBM PC, XT, AT and compatible bus computers can continuously monitor up to 32 input signals over a -5- to +5-volt dc range with 12-bit accuracy (4096 voltage steps). A differential (or "double-ended") mode can be selected for reading floating reference signals. Programmable gains of 1x, 2x, 5x and 10x are standard.

The board's 32 TTL-level I/O lines are plug-compatible with opto-

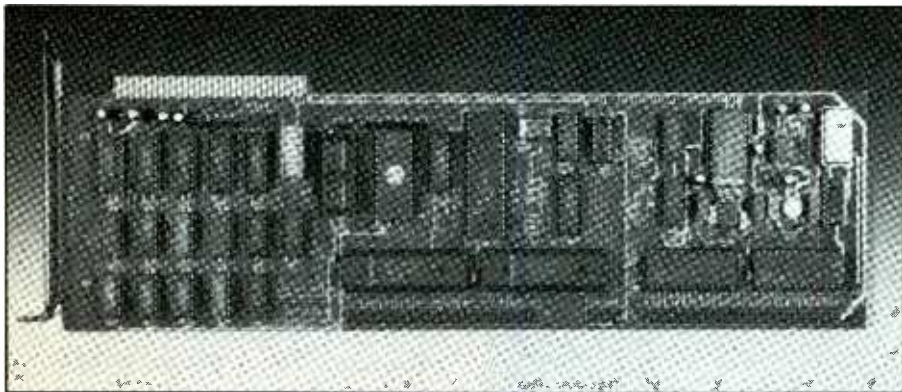

isolator modules manufactured by the company, and its two 8-bit analog outputs have a 0- to +5-volt dc range.

Simple software commands can be used to operate the board, and menu-driven and installation software is provided. \$995.

CIRCLE 26 ON FREE INFORMATION CARD

### Integrated Stereo Amplifier

Yamaha's new Model AX-500U integrated stereo amplifier features a low-impedance drive capability that ensures that the amplifier will handle fluctuating impedance loads down to 2 ohms. Output power is rated at 85 watts/channel continuously into 8 ohms at 0.015% THD, and MC/MM/CD S/N are rated at 73/90/100 dB. Dynamic power at 8 ohms is specified as 140 watts; at 4 ohms speaker impedance, it's 200 watts.

Six sources can be connected to the amplifier, including two tape decks, the audio portion of a VCR or video disc player, any other high-level source and either a moving-magnet

(MM) or a moving-coil (MC) phono cartridge. In addition, a new CD-Direct input goes straight to the output amplifier stage, bypassing the tone controls and filter, providing the purest possible signal path. Other features include a record-out selector that allows the user to record one source while listening to another; two-way dubbing from one tape deck to another; tone bypass switch and center-defeat bass and treble controls; subsonic filter; a 40-dB continuously variable output control; and accessory output loop. The amplifier measures 17 1/8" W x 13 1/8" D x 5 1/2" H and weighs 17 lbs. \$349.

CIRCLE 27 ON FREE INFORMATION CARD



### Enhanced Pocket DMM

Beckman Industrial's enhanced Model DM78 credit-card-sized digital multimeter has a host of new features. They include an ultra-high impedance that exceeds 1,000 megohms on the 200-mV dc range; 200-ohm and 20-megohm ranges; ac overload protection to 700 volts; and a case insulation to 2,000 volts ac to protect against arcing.

A versatile set of functions/ranges is provided: dc volts to 200 mV, 2 V, 20 V, 200 V and 400 V; ac volts the

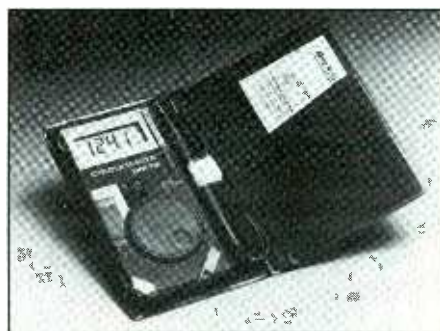

same except no 200-mV range; and resistance to 200, 2K, 20K, 200K, 2M and 20M ohms. Rated accuracy is 0.7 percent on dc volts. Test functions are also included for diodes and continuity, and autoranging capability is built in.

Flame-resistant materials are used for the DM78's case. The DMM measures only 4.25" L x 2.13" W x 0.4" D and weighs just 3.5 ozs., including carrying case. \$29.95.

CIRCLE 28 ON FREE INFORMATION CARD

### Dictionary/Thesaurus

WordFinder from SelecTronics, Inc., is a new pocket-size electronic dictionary/thesaurus that features a 100,000-word lexicon and 220,000-synonym thesaurus. The ROM-based product carries on one chip the complete spelling list and thesaurus previously developed for IBM PC and Apple Macintosh computers.

To use WordFinder, the user just types in a word on the device's keyboard, presses the SPELL or SYNONYM key. WordFinder's 20-charac-

## NEW PRODUCTS...

ter LCD screen verifies the word's spelling, offers alternative spellings of phonetically similar words or displays synonyms for the word entered. Using arrow keys, users can scroll through the synonym choices or can press SYNONYM again to view synonyms of the synonym displayed. It features proper names (first and last), major cities and all states and most foreign countries. A jumble key is provided for unscrambling words.



Weighing just 6 ounces, the device measures just  $6\frac{1}{8}$ "H  $\times$  5"W  $\times$   $\frac{1}{2}$ "D. The battery-powered WordFinder uses two microprocessors for instant response. It comes with 4.5 megabytes of information compressed onto a 256K chip. Power is supplied by four AAA cells that come with the product. Less than \$100.

CIRCLE 29 ON FREE INFORMATION CARD

### Radio Telescope Kit

Edmund Scientific Co. (Barrington, NJ) has a 400-MHz radio telescope kit that can be used for observation of radio sources ranging from solar flares to stellar objects several million light years distant. With it, a user can listen to the sounds of stars and the electromagnetic disturbances of the Sun and Jupiter, as well as a number of sources that are not visible by optical means—under any weather conditions. No special technical knowledge is required to install or use the radio telescope.

Supplied in the kit are: two 10-element helical antennas; antenna

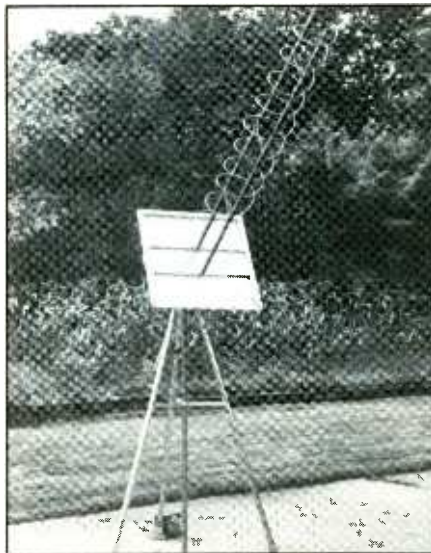

mounting structures; 400-MHz low-noise preamplifier; 400-MHz-to-30-MHz frequency converter; 30-MHz i-f amplifiers; square-law demodulator; dc amplifier and comparator; adjustable time-constant integrator; calibration noise-source reference; regulated power supplies; coaxial cable with connectors; and required fittings. Also included is a manual that is claimed to comprehensively cover both the supporting theory and operating procedures for each project. \$1,200.

CIRCLE 30 ON FREE INFORMATION CARD

### PC/XT-Compatible Single-Board Computer

Functionally equivalent to a turbo PC-XT motherboard, Ampro's (Sunnyvale, CA) Little Board/PC single-board computer can be used with standard IBM PC expansion cards in a stacked physical arrangement. With the StackPlane/PC extension adapter, PC plug-in cards install parallel to the microcomputer board to produce an extremely compact system suitable to the tight space and power constraints of embedded microcomputer applications.

Use of the StackPlane/PC expansion adapter permits addition of expansion cards without incurring the bulk and expense of a backplane and card cage. The result is an assembly that measures only  $8 \times 5\frac{1}{2}$  inches

and occupies approximately the same volume as a single half-height 5.25-inch floppy-disk drive.

The Little Board/PC CMOS processor module contains: an 8088-compatible microprocessor running at 8 MHz; 256K (expandable to 768K) DRAM; support for 32K to 288K EPROM; keyboard interface; speaker interface; one RS232C serial and one parallel printer port; and PC expansion bus. Options include a



CMOS four-mode video display controller; additional on-board DRAM; a second on-board serial port; an on-board floppy-disk drive controller; and an on-board SCSI controller.

IBM PC DOS is supported by the board's ROM BIOS as the operating system. Drivers in the BIOS permit the system to boot from floppy disk, SCSI drive, bubble memory or on-board EPROM solid-state disk. Support for the solid-state disk (to be announced) permits completely diskless operation.

The Little Board/PC processor module is available in eight versions. The StackPlane/PC expansion adapter is available separately.

CIRCLE 31 ON FREE INFORMATION CARD

### Low-Cost CD Player

CBM America Corp. (Los Angeles, CA), a Division of Citizen Watch Co., introduced a new Model CBM-777 light-weight compact-disc player priced low enough for everyone to buy one. It features double oversampling digital filtering, a three-beam laser head and a 16-bit

A/D converter. Its control complement includes: play/pause, stop, forward/backward skip, fast forward, reverse, repeat, headphone volume and power. An illuminated LCD window displays what is currently happening and what will occur next. Additionally, the player has in-



put and line output jacks for headphones or connection into a stereo system.

Technical specifications: frequency response, 20 Hz to 20 kHz +1/-3 dB; THD, 0.08 percent at 1 kHz; S/N ratio, 80 dB. The player measures 170 x 148 x 44.5 mm and weighs less than 3 pounds. It comes with an ac adapter, and optional accessories include a battery pack, cassette adapter, automobile adapter and FM transmitter \$169.

CIRCLE 32 ON FREE INFORMATION CARD

### Dot-Matrix Printers

Star Micronics America introduced a pair of modestly priced nine-wire dot-matrix text/graphics printers that offer multiple fonts. The Model NX-1000 can be used with most computers with a Centronics-compatible parallel printer port, while the Model NX-1000C is for use with Commodore C-64 and C-128 computers that have 6-pin serial printer ports.

Both printers provide NLQ and draft printing at speeds of 36 and 144 characters per second, respectively, in 12 characters per inch. Featured are four internal fonts (Courier, sans serif, Orator I and Orator II), a 4K buffer and a paper-parking provision that allows users to feed single-

sheet paper without removing tractor-feed paper. Font selection is via the printers' front control panel. Italic printing is available in both draft and NLQ.



The parallel-feed NX-1000 incorporates Epson (ESC/P) and IBM Proprinter II emulations. The NX-1000C features Commodore MPS-1000 emulation. Other provisions common to both printers include: automatic paper loading, adjustable push-type tractor paper feed, front panel for easy access to all printer functions. An optional cut-sheet feeder is available. \$289.

CIRCLE 33 ON FREE INFORMATION CARD

### Overcurrent Protector Plug

The "Protect-O-Plug" from JDS Products, Inc. (El Dorado Hills, CA) is an electrical safety device designed to solve the OEM problem of providing overcurrent protection for the line cord as well as the equipment being manufactured. This device has

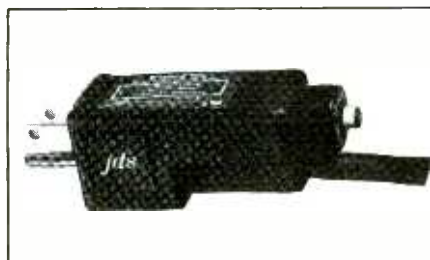

"resettable" overcurrent protection molded into the power plug as well as a No. 18-3 SJT flexible power cord. It is available in 13 different current ratings ranging from 0.25 to 10 amperes at 117 volts ac and is UL listed under file No. E104780.

CIRCLE 34 ON FREE INFORMATION CARD

## HITACHI SCOPES

15-25% Discount



V1060  
100MHz  
\$1375

V660 60MHz Dual Trace \$990  
V422 40MHz Dual Trace \$699  
V212 20MHz Dual Trace \$475

## ELENCO PRODUCTS AT DISCOUNT PRICES!



\$498  
MO-1252

### Scopes

MO-1253 40MHz Dual Trace \$550  
Delayed Sweep 12KV HV, More  
MO-1252 35MHz Dual Trace \$498  
MO-1251 20MHz Dual Trace \$349  
w/ Two 1x, 10x 100MHz probes, manual  
S-3000 10MHz fully calibrated \$239

### GF-8016 Function Generator with Freq. Counter



\$239.95

Sine, Square, Triangle  
Pulse, Ramp, .2 to 2MHz  
Frequency .1 thru 10MHz

GF-8015 without Freq. Meter \$179

### Digital Triple Power Supply

Model XP-765 \$239.95



0-20V @ 1A  
0-20V @ 1A  
5V @ 5A

Fully Regulated, Short Circuit Protected  
with 2 Limit Cont. 3 Separate Supplies  
XP-660 w/ Analog Meters \$169.95

### Multi-Function Counters F-1000



1.2GHz  
\$259.95  
F-100  
120MHz  
\$179.95

Frequency, Period, Totalize, Self Check with High-Stabilized Crystal Oven Oscillator, 8 Digit LED Dis

### Digital LCR Meter

\$138.00  
Model  
LC-1800  
Measures  
Inductors,  
Capacitors,  
Resistors



### Multimeter with Cap. and Trans. Tester

\$59.95  
Model  
CM-1500A  
8 Functions  
with Case



C&S Sales Inc., 1245 Rosewood  
Deerfield, IL 60015 (312) 459-9040  
800-292-7711 ASK FOR CATALOG

15 Day Money Back Guarantee  
2 Year Limited Guarantee  
Add 5% for Postage (\$10 max)  
IL Res.. 7% Tax



CIRCLE 7 ON FREE INFORMATION CARD

# Brushless dc Motor

*This build-it-yourself motor uses infrared switching for science-fair and other demonstrations*

By Robert F. Tschannen

A conventional dc motor uses a commutator to switch current in its armature coils in a timed sequence. This arrangement permits attraction and/or repulsion of armature poles with respect to field poles. The result is rotary—or “motor”—action of a shaft. In contrast, the motor to be described does *not* have a commutator or brushes. Instead, it uses a slotted disc that alternately passes and interrupts an invisible infrared beam that impinges on infrared phototransistors to produce switching signals. These signals are amplified and used to switch currents through a pair of motor field coils, producing much the same results normally obtained with a commutator and brushes.

We will describe here how to build this novel brushless dc motor, using readily available electronic components and a number of mechanical elements you can easily fabricate at home with very basic woodworking tools and only modest shop skills. The amount of torque delivered by this motor is very small, making the project fairly impractical to use as a driver for any but the smallest of loads. However, your motor will make an excellent science-fair project and can be used for other demonstrations.

## How It Works

The motor's armature has two poles made up of a pair of pole pieces cemented to the flat faces of a ceramic magnet. The armature and a

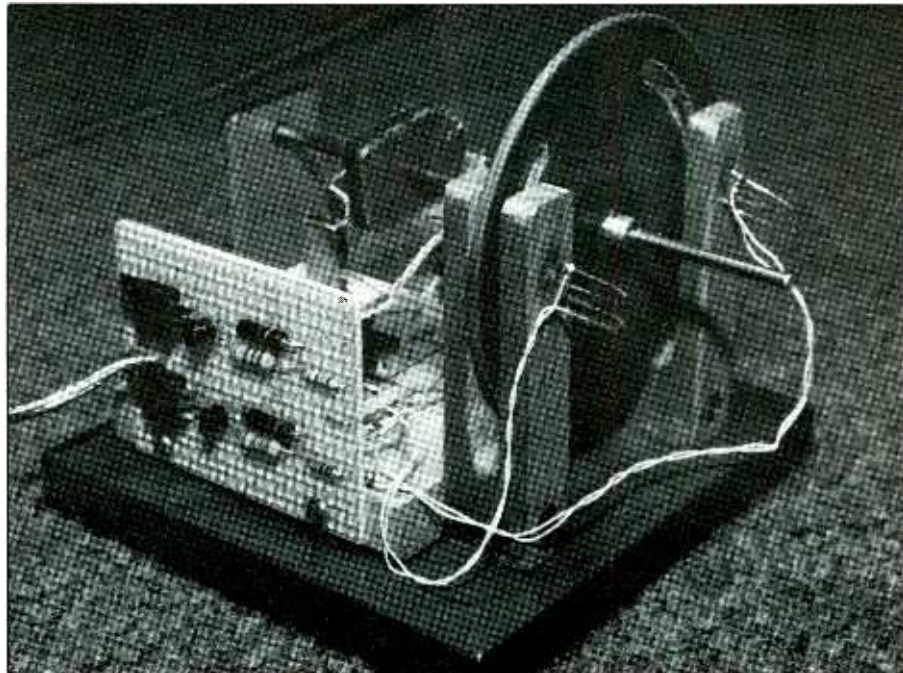

slotted disc mount on a shaft that turns as a common assembly. With this arrangement, it is essential that the slot positions in the disc be properly timed with respect to the armature poles so that switching occurs at precise intervals.

The motor's field coil, or stator, is somewhat unusual in that each pole piece is wound with a pair of coils that are connected in a manner that the field can be reversed when called for by switching circuitry.

Figure 1(A) is the schematic diagram of the electronic circuitry that performs the switching and powering of the motor's field coils. Infrared-emitting diodes *LED1* and *LED2* are continuously powered from a 5-volt dc source through cur-

rent-limiting resistors *R1* and *R2*. The infrared energy from these IR emitters is allowed to pass through to the respective infrared phototransistors on the other side of the optical disc, depending on the positions of the slots in the latter. Phototransistors *Q1* and *Q4* are the receptors in this circuit.

On start-up, power from the +5-volt dc source flows through the infrared-emitting circuit at the left. IR energy from *LED1* and *LED2* focuses toward the disc. If we assume that the disc's slots are positioned so that the IR energy is able to fall on the active surface of *Q1* but not *Q4*, *Q1* will turn on while *Q2* will be held in cutoff. Thus, when *Q1* conducts, it causes the driver/power-amplifier



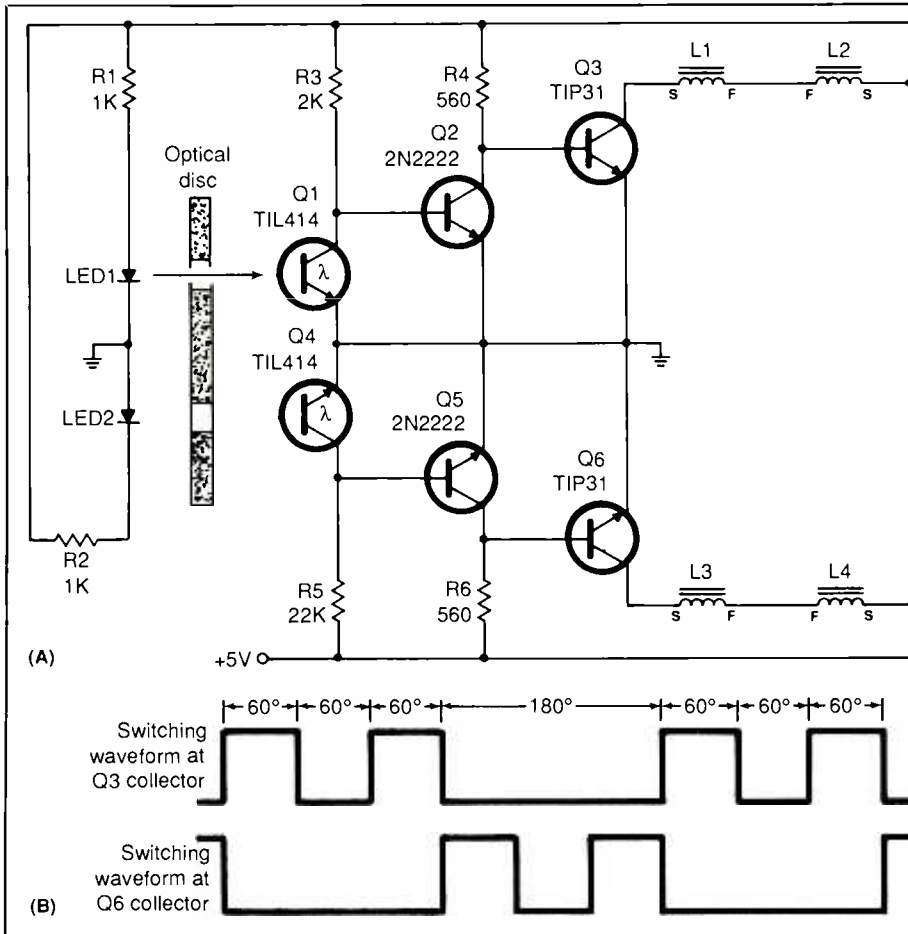

**PARTS LIST**

- LED1, LED2—SEP8703-1 infrared-emitting diode (Radio Shack Cat. No. 276-143)
- Q1, Q4—TIL-414 phototransistor (Radio Shack Cat. No. 276-145)
- Q2, Q5—2N2222 or similar silicon npn switching transistor
- Q3, Q6—TIP31 or similar silicon npn power transistor
- R1, R2—1,000-ohm, 1/2-watt, 10% tolerance resistor
- R3, R5—22,000-ohm, 1/2-watt, 10% tolerance resistor
- R4, R6—560-ohm, 1/2-watt, 10% tolerance resistor
- Misc.—No. 28 or 30 enameled wire; perforated board; 1" rectangular ceramic magnet (Radio Shack Cat. No. 64-1875 or similar); lumber for base and sub-base plates and yokes (see text); steel, brass or aluminum stock for bearings; mild steel for field-coil and pole pieces; Bakelite, phenolic board, sheet aluminum or heavy poster board for optical disc (see text); perforated board or heavy poster board for optional bobbin guides; plastic electrical tape; super glue; woodscrews (see text); hookup wire; solder; etc.

Fig. 1. Schematic diagram of motor's electronics in (A) shows orientation of optical disc with reference to IR-emitter LEDs and receptor phototransistors. Detail (B) illustrates switching waveforms at collectors of power transistors resulting from pattern produced by slots in optical disc.

circuit composed of Q2 and Q3 to turn on. With Q3 conducting, current from the 5-volt dc source passes through field coils L1 and L2.

When current flows through L1 and L2, electromagnetic action attracts the rotor's pole piece, resulting in the rotor making a partial turn. Because the optical disc is physically fixed to the same shaft shared by the rotor assembly, any rotation also causes the switching signal sequence to change as well. Consequently, as the shaft turns and changes the switching pattern, Q1 will cease conducting as IR energy from LED1 is cut off from its active surface by an opaque portion of the optical disc intervening between the two.

In operation, the shaft will turn

enough for the optical disc's slot to appear between LED2 and Q4. The result is that IR energy will activate the other set of field coils. The sequence of events is the same for the driver/power-amplifier Q5/Q6 circuit and field coils L3 and L4.

The switching waveforms for the circuit, taken at the collectors of Q3 and Q6 are also shown in Fig. 1(B). Note that, on turn-on, the optical disc causes a pair of square-wave pulses, each 60 degrees in duration and separated by a 60-degree interval to be generated by phototransistor Q1. During this period, no IR energy reaches Q4 and, thus, this section of the circuit is held in cutoff.

Next comes a 180-degree interval during which no pulses occur in the

Q1/Q2/Q3 circuit. During this off period, the the lower half of the circuit is activated in the exact same manner as the upper half was during its off period.

The above sequence of events will repeat for as long as power is applied to the circuit. The optical disc will pass or interrupt the IR-energy beams to Q1 and Q4 in the sequence described by the switching waveform sequence in Fig. 1(B) so that first one and then the other leg of the circuit is active at any given moment.

**Construction**

As illustrated in the lead photo, you build the motor on a wooden base, adding an optional sub-base for

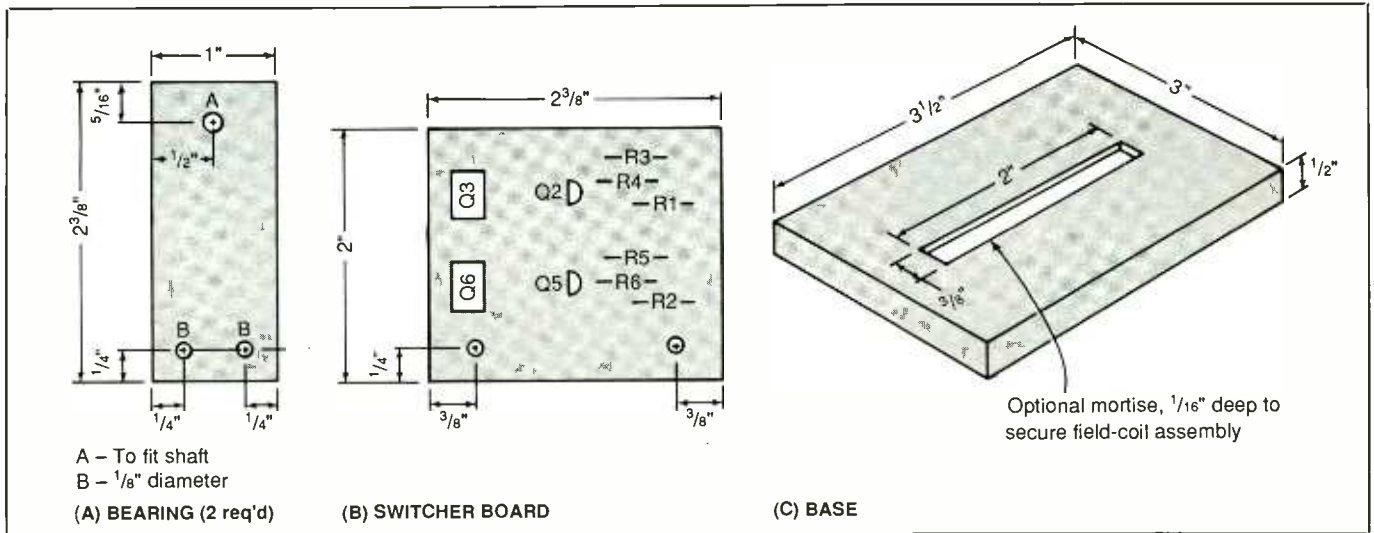

Fig. 2. Fabrication details for bearings (A), circuit-board assembly (B) and base plate (C).

handling convenience. Simple bearings secured to the wood base with woodscrews support the armature assembly.

All switching transistors and associated components are best mounted and wired together on a small piece of perforated board. This circuit-board assembly, in turn, should be secured to the wood base with small round-head woodscrews.

Wooden yokes are used for mounting phototransistors *Q1* and *Q4* and infrared emitters *LED1* and *LED2* directly in line with each other. The yokes must be fabricated so that they straddle the optical disc on each side of the motor's drive shaft and with the source and destination holes exactly aligned with the slots in the optical disc when it is finally mounted in place.

Referring first to Fig. 2(A), fabricate the two motor bearings as shown. Use 16-gauge or so steel, brass or aluminum stock for the bearings. Drill hole A just large enough to fit the shaft chosen for the motor. The shaft can be a *straight* 5-inch length of metal clothes hanger or brass or drill rod. It should not exceed 3/2 inch in diameter. Hence, the A holes drilled in the bearings should

be just the slightest bit larger than 3/2 inch to allow the shaft to rotate freely in them. Use a 1/8-inch bit to drill the holes labeled B.

Next, trim the perforated board on which the various driver and power transistors and their associated resistors are to be mounted and wired together to the dimensions shown in Fig. 2(B). Then drill 1/8-inch holes through the board as indicated at the lower-left and lower-right for mounting purposes.

For the base, you need 1/2-inch or so thick wood. This can be either pine lumber, particle board or plywood. After cutting the board to size, you can route a mortise on its top to accommodate the field-coil assembly, as detailed in Fig. 2(C). The mortise should be only about 1/16 inch deep and should be completely flat bottomed. The best way to make this is with a power router, squaring up the corners with a wood chisel. If you do not have a router, simply disregard the mortise.

If you decide to use the optional sub-base, use the same thickness material used for the base itself, cutting it to 4 1/2 inch square.

A flat thin piece of opaque material like Bakelite, phenolic board,

sheet aluminum or even heavy poster board can be used to make the optical disc. The material used should be about 1/16 inch thick. This is the most difficult item to fabricate. This is easiest to do with a power bandsaw or jig saw, which is essential if you are using aluminum for the optical wheel's material. With no access to these tools, you would be better off using easier-to-machine Bakelite, phenolic or poster board.

Whichever material you do use, start with a 4-inch square to allow sufficient excess for trimming. Locate the center of this square by drawing diagonal lines to opposite corners. Then, using a compass, scribe or draw a 3-inch-diameter circle on the material, centered at the point where the diagonal lines cross. Next, measure 1/6 in from the circumference of the circle and scribe or draw another concentric circle, referring to Fig. 3(A) for details.

Place a straight edge along one of the previously struck diagonal lines and strike lines that cross the inner circle against the straight edge. Then use a 30/60/90-degree triangle or a protractor to strike lines across the inner circle at 60 degrees from the just-drawn cross lines on the inner

# TAKE ANY ONE OF THESE HANDBOOKS FOR ONLY \$14.95 VALUES UP TO \$110.00

## — when you join the **ELECTRONICS AND CONTROL ENGINEERS' BOOK CLUB®**

- your one source for engineering books from over 100 different publishers
- the latest and best information in your field
- discounts of up to 40% off publishers' list prices



### STANDARD HANDBOOK FOR ELECTRICAL ENGINEERS, Twelfth Edition

Edited by D.G. Fink and H.W. Beaty  
• 2,248 pages, 1,863 illustrations and tables  
*Publisher's Price \$86.50*

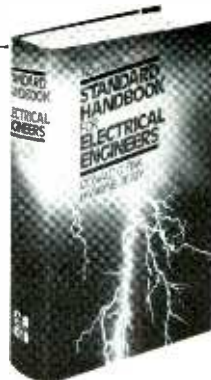

### MODERN ELECTRONIC CIRCUITS REFERENCE MANUAL

By J. T. Markus  
• 1,264 pages, 3,666 circuit diagrams  
*Publisher's Price \$82.50*



### ANTENNA ENGINEERING HANDBOOK, Second Edition

Edited by R. C. Johnson and H. Jasik  
• 1,408 pages, 946 illustrations  
*Publisher's Price \$110.00*



### 4 reasons to join today!

- 1. Best and newest books from ALL publishers!** Books are selected from a wide range of publishers by expert editors and consultants to give you continuing access to the best and latest books in your field.
- 2. Big savings!** Build your library and save money, too! Savings range up to 40% off publishers' list prices.
- 3. Bonus books!** You will immediately begin to participate in our Bonus Book Plan that allows you savings up to 70% off the publishers' prices of many professional and general interest books!
- 4. Convenience!** 14-16 times a year (about once every 3-4 weeks) you receive the Club Bulletin FREE. It fully describes the Main Selection and alternate selections. A dated Reply Card is included. If you want the Main Selection, you simply do nothing — it will be shipped automatically. If you want an alternate selection — or no book at all — you simply indicate it on the Reply Card and return it by the date specified. You will have at least 10 days to decide. If, because of late delivery of the Bulletin you receive a Main Selection you do not want, you may return it for credit at the Club's expense.

As a Club member you agree only to the purchase of three additional books during your first year of membership. Membership may be discontinued by either you or the Club at any time after you have purchased the three additional books.

**FOR FASTER SERVICE IN ENROLLING CALL TOLL FREE  
1-800-2-MCGRAW**

McGraw-Hill Book Clubs  
Electronics and Control Engineers' Book Club®  
P.O. Box 582  
Hightstown, NJ 08520-9959

Please enroll me as a member of the Electronics and Control Engineers' Book Club® and send me the book I have chosen for only \$14.95, plus local tax, postage, and handling. I agree to purchase a minimum of three additional books during my first year as outlined under the Club plan described in this ad. Membership in the club is cancellable by me or McGraw-Hill any time after the three book purchase requirement has been fulfilled. A shipping and handling charge is added to all shipments.

I wish to order the following book:

- STANDARD HANDBOOK FOR ELECTRICAL ENGINEERS (209/758)  
 MODERN ELECTRONIC CIRCUITS REFERENCE MANUAL (404/461)  
 ANTENNA ENGINEERING HANDBOOK (322/910)

Signature \_\_\_\_\_

Name \_\_\_\_\_

Address/Apt. # \_\_\_\_\_

City/State/Zip \_\_\_\_\_

This order subject to acceptance by McGraw-Hill. Offer good only to new members. Foreign member acceptance subject to special conditions.

E33966

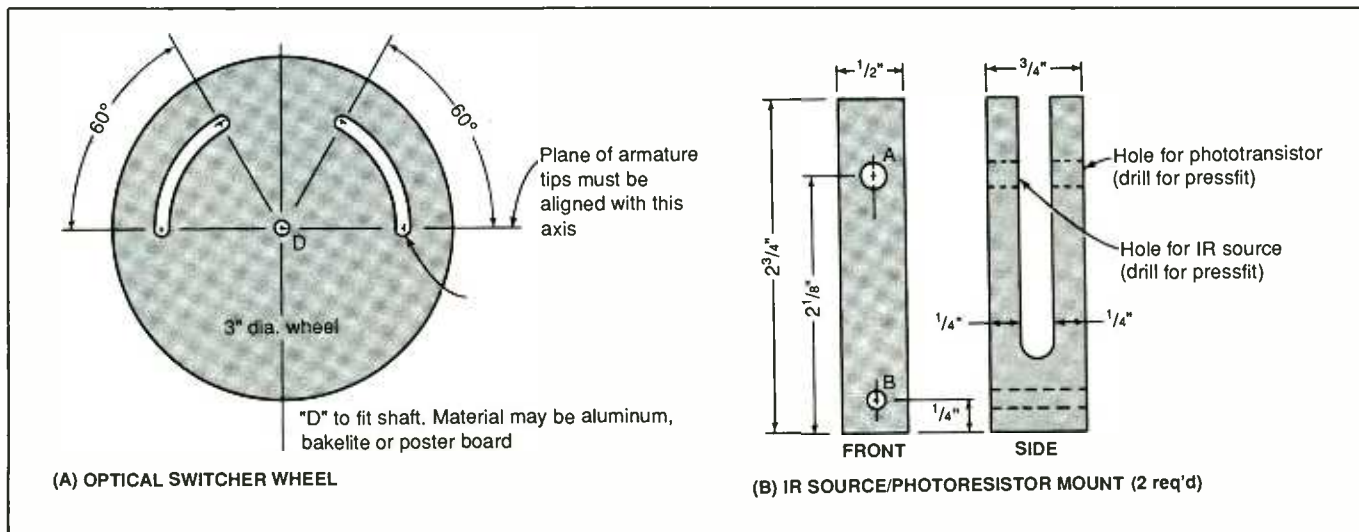

Fig. 3. Fabrication details for optical wheel (A) and IR source/receptor yoke mounts (B).

circle. The four cross points thus indicated are where  $\frac{1}{8}$ -inch-diameter holes must be drilled to start and end the slots in the optical disc. Drill these holes now. Then drill a hole in the center of the disc, sizing it for a press fit of the motor's shaft.

If you have access to a bandsaw, cut the disc out of the square. If not, use a coping saw to do the cutting of nonmetallic material. Then cut the slot. If the material being used is nonmetallic, you can use the coping saw or a jigsaw to cut the slots. You may even be able to use a jigsaw—not a coping saw—to cut the slots in aluminum if the material is very soft. Otherwise, drill a series of interconnecting holes and clean out unwanted material with a small round or curved file.

Referring to Fig. 3(B), fabricate the yokes from strips of  $\frac{3}{4} \times \frac{1}{2}$ -inch pieces of clear pine. After cutting them both to a length of  $2\frac{3}{4}$  inches, mark the locations for the holes to be drilled. For holes A, make center-point marks on both sides of the wood pieces since you may have to drill different-size holes through both arms of the yokes to accommodate LED and phototransistor cases that are different diameters. Holes B

should be  $\frac{1}{4}$ -inch in diameter and should go clear through both pieces.

With the yoke pieces laid  $\frac{1}{4}$ -inch-wide face up, strike a line down the center of each and measure  $\frac{1}{4}$  inch up from the ends through which the B holes have been drilled and strike a cross line. Drill a  $\frac{1}{4}$ -inch hole clear through both pieces of wood at the crossed lines.

If you have access to a bandsaw or jig saw, cut  $\frac{1}{4}$ -inch-wide slots whose rounded bottoms are the  $\frac{1}{4}$ -inch holes just drilled. Smooth the sides of the slots with a fine wood file or sandpaper. Temporarily slide a  $\frac{1}{4}$ -inch-thick piece of wood or Masonite into the yoke slots and drill holes A in both yokes. If the selected IR LEDs and phototransistors have cases with different diameters, size these holes accordingly to provide press fits. In this case, make sure that when you drill the hole on either side that you do not go clear through the central wood or Masonite. Remove the wood or Masonite pieces from the slots and discard them.

For the field-coil piece, you need a  $4\frac{3}{4}$  by  $\frac{1}{16}$ -inch piece of  $\frac{1}{16}$ - or  $\frac{1}{32}$ -inch-thick mild steel. As illustrated in Fig. 4, drill two  $\frac{1}{8}$ -inch holes, each 2 inches from the ends and centered in

the strip, to permit mounting. Then bend the steel strip into a U shape with  $\frac{1}{2}$ -inch legs.

You may want to fit onto the legs of the pole piece bobbin guides, as shown in the right illustration in Fig. 4. These optional guides can be fabricated from pieces of perforated board, Bakelite, phenolic board or heavy poster board measuring  $\frac{3}{4} \times \frac{5}{8} \times \frac{1}{16}$  inch. After cutting a  $\frac{3}{16} \times \frac{1}{16}$  or  $\frac{1}{32}$ -inch slot down the center of each guide. Punch or drill a small ( $\frac{1}{16}$ -inch or so) hole through each guide. Then slip one guide onto each leg of the field-coil piece. Then wrap a layer or two of plastic electrician's tape around the center of each leg to provide insulation, making the insulated areas  $\frac{3}{8}$  inch wide.

Push the bobbin guides up against the tape and secure in place with plastic cement. Slide the remaining two guides onto the legs as shown and cement these in place. Set the field-coil piece aside until the cement sets.

Meanwhile, prepare the pole pieces, as detailed in Fig. 5. For this, you must fabricate two paddle-shaped pieces of  $\frac{1}{32}$ -inch-thick mild steel as shown in detail (A). Once you have cut to size the steel pieces, drill a

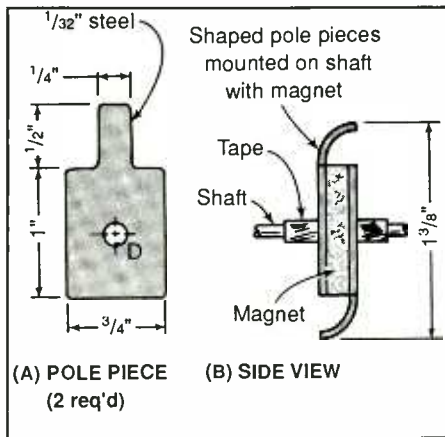

Fig. 4. Machining details for pole pieces (A) and "sandwich" made up of two pole pieces and a magnet.

hole the same size as that in the ceramic magnet chosen. Then bend the narrow tabs on both pieces in a smooth quarter-round arc as in detail (B). Use a drop or two of super glue to cement the steel pieces to opposite faces of the ceramic magnet, orienting the tabs so that they are at opposite ends of the magnet.

Cut to length four 24-foot No. 28 or 30 enameled (so-called "magnet") wires. Attach adhesive tags with the legends L1S and L1F to the start and finish of one wire, L2S and L2F for the start and finish of the second wire, L3S and L3F for the third wire, and L4S and L4F for the fourth wire. (The "S" and "F" in all cases refer to the start and finish ends, while the "L1" through "L4" refer to the individual field windings.)

Holding the L1S and L3S ends together and leaving a 4- to 5-inch starting "tail," wind both wires in parallel with each other around one leg of the field-coil piece. Continue winding until all but a 4- or 5-inch end tail is left. In the same manner, wind the other two wires onto the other leg, beginning with the ends labeled L2S and L4S and ending with the ends labeled L2F and L4F. It is extremely important that you wind both pairs of wires onto the pole

piece legs in the *same* direction. Otherwise, the motor will not operate but will simply hum as it consumes power from the dc source. Make the windings neat and even.

Depending on pole material thickness, each 27-foot length of wire should result in about 260 turns. If you have incorporated the bobbin guides, pass each start (labeled S) wire in turn through the small holes in the upper guides, reattaching its label immediately as it is passed through the hole. Do the same with the finish (labeled F) ends, passing each through the small holes in the lower bobbin guides.

You have now fabricated all the mechanical elements that make up the brushless dc motor. Now go back over them, checking them against the various figures to ascertain that each has been fabricated as specified. If so, smooth all cut edges and drilled hole edges to remove burrs and/or splinters. Lightly sand all wood members and, if desired, paint or seal them with clear or tinted urethane.

When everything is dry, use glue and 3/4-inch flat-head woodscrews to secure the base plate in the center of the sub-base plate (if you are using it). Then use 1/2-inch woodscrews to mount the field-coil assembly on the base plate, positioning it squarely in the mortise if you cut this. Then use 1/2-inch woodscrews to mount a bearing piece centered at one end of the

base plate (see lead photo). Slide onto one end of the shaft a friction-fit plastic bushing and position it about 1/2 inch from that end. If you cannot locate such a bushing, wrap a few layers of 1/2-inch-wide electrical tape around the shaft flush with the end. Pass the other end of the shaft through the hole in the bearing.

Next, slide onto the shaft the magnetic pole-piece assembly. It will be a loose fit, which will be taken care of later. Slide the other bearing onto the shaft and secure it in place, centered against the opposite end of the base plate, with 1/2-inch woodscrews (see Fig. 7). Once again, slide onto the free end of the shaft a press-fit plastic bushing or wrap a few turns of electrical tape around the shaft. When you are done with this, there should be just about 1/16 inch of play when you gently move the shaft back and forth.

Follow up with the optical disc. Remember that this is a press-fit operation; so be careful to avoid bending the motor's shaft as you press it into place.

Now mount the yokes in their respective locations to either side of the optical disc, with the LED holes facing away from the field-coil assembly. Carefully align the emitter/receptor holes of each with the slots in the disc, turning the motor's shaft as needed to bring the slots into alignment. Use a 1/4-inch woodscrew to

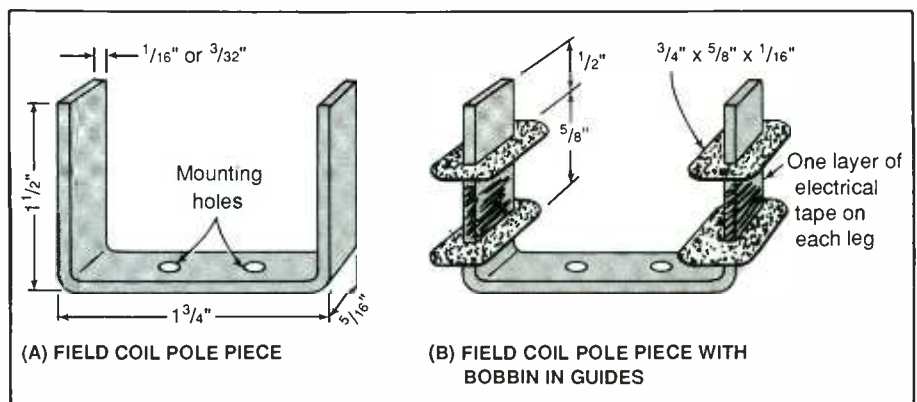

Fig. 5. Machining details for field-coil piece (A) and optional bobbin guides (B).

secure each yoke in place against the base plate.

Now align the shaft elements with the field-coil and yoke assemblies. The armature assembly must be centered over the field-coil assembly. To accomplish this, determine where on the motor's shaft this assembly must be located. Then wrap as many layers of tape over this location as needed to provide a relatively tight fit when the magnet assembly is pushed into place. It is not necessary—or desirable—to make the fit too tight because you will be cementing the magnet assembly into place. Be careful to avoid bending or distorting the shaft as you work.

Return to the optical disc. First, adjust the position of the disc on the motor's shaft so that the former sits centered in the slots in the yokes and is squared with the shaft. Rotate the shaft to make certain that no part of the disc touches the arms of the yoke. Use super glue or quick-set epoxy cement to secure the optical disc in place on the shaft, with square-cut bushings as shown in the lead photo, if you have them.

As you rotate the shaft, check for bearing binding. If you note binding, you may have to disassemble the motor to enlarge the holes in the bearings. Also check the clearance between the tabs on the magnetic pole piece and field-coil assembly. The two should not touch. Ideally, there should be about a  $\frac{1}{16}$ -inch separation between the two assemblies at their closest. If everything appears to be okay, place a drop of light machine oil or grease on each bearing to reduce friction.

Rotate the armature assembly on the motor shaft so that the tabs align equally with the bottoms of the slots in the optical disc. Do not glue this assembly in place just yet.

Now that the mechanical elements are assembled, install transistors *Q2*, *Q3*, *Q5* and *Q6* on the perforated board. Follow up with resistors *R3* through *R6*. Use appropriate solder-

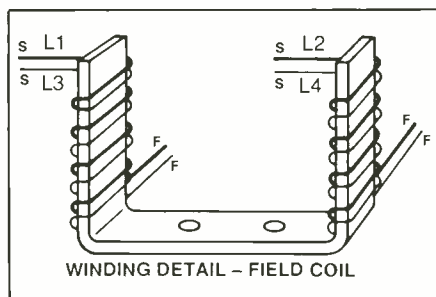

*Fig. 6. Winding details for field coils on pole piece. Both coil pairs must be wound in the same direction. Designations "S" and "F" refer to start and finish ends, respectively, of individual coil windings.*

ing or Wire Wrap hardware and include posts for soldering the +5-volt and ground cable into the circuit. Then, referring back to Fig. 1, wire together these components.

Power for the IR emitter circuit should be made from the circuit-board assembly. Therefore, mount *R1* and *R2* on this board. Install a wire that will connect from *R1* to the

anode lead of *LED1* and another wire that will connect from *R2* to the cathode lead of *LED2*. Also, include two more wires from the board's ground bus to connect to the cathode lead of *LED1* and the anode lead of *LED2*. Mount the circuit assembly against the wood base with wood-screws, as shown in the lead photo.

Referring to the lead photo, plug the domed cases of IR emitters *LED1* and *LED2* into their respective yoke holes. Do the same with phototransistors *Q1* and *Q4*. Then locate the two ground leads coming from the circuit-board assembly and connect and solder them to the cathode lead of *LED1* and the anode lead of *LED2*. Locate the wire connected to *R1* and solder its free end to the anode lead of *LED1*. Similarly solder the wire connected to *R2* to the cathode lead of *LED2*. Insulate the connections with plastic tubing or electrical tape. Then connect and solder the dc power cord (it should be color-coded red for +5 volts and black for ground or be a length of zip

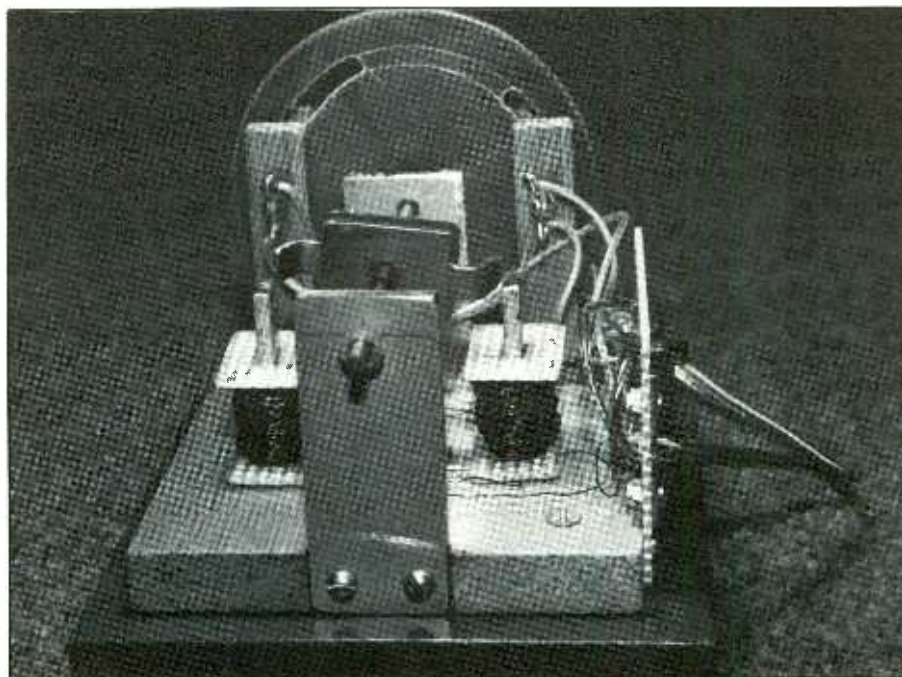

*Fig. 7. View of motor from rear shows orientation of pole-piece assembly with respect to optical disc's slots and bushing on end of motor shaft.*

cord with one readily identifiable conductor) to the power buses.

Finish up wiring by routing the leads from the field-coil assembly to the appropriate points in the circuit. Determine how long the lead labeled L1S should be to connect to the collector of Q3 and trim it to that length. Carefully scrape away about 3/8 inch of the insulating enamel coating and connect and solder this lead to Q3's collector. Do the same with the lead labeled L3S, connecting and soldering it to the collector of Q6.

Next, trim the leads labeled L1F and L2F, scrape away the enamel, twist the two together and solder. Do the same with the leads labeled L3F and L4F. Repeat with the leads labeled L2S and L4S. Insulate all three connections with electrical tape.

### Checkout & Use

Connect the motor to a 4.5- to 6-volt dc source, making certain that the connections are properly polarized. To get things started, turn by hand the shaft in either direction. The motor should take over and come up to speed in a few seconds. If it does not operate as it should, disconnect power and carefully readjust the angular position of the magnetic pole piece assembly with respect to the field-coil assembly while holding the shaft stationary until it does. Once you have the motor operating properly, super glue the pole piece into place.

Should the motor fail to operate altogether, power down and check for shaft binding. If this is not the problem, recheck all wiring against Fig. 1. Make certain that the IR LEDs and phototransistors are properly polarized and that connections to the leads of the driver and power transistor are correct. Also double check polarization of the power-source leads. This is a fairly simple circuit; so troubleshooting should not be too difficult.

You will find that it is best to operate the motor under subdued lighting

conditions, unless you provide a light shield for the infrared emitter/receptor arrangement.

Power for the motor can be any 4.5- to 6-volt dc source, including heavy-duty battery, though an ac-operated bench supply should be used if you plan on operating the mo-

tor for any extended period of time. You can adjust the motor's operating speed by varying the supply voltage. For demonstration purposes, you can also shine the beam of a small flashlight on the area of the IR source or phototransistors to reduce the speed. **ME**

## Do You Suffer From...

- High Prices
- Limited Selection
- Slow Delivery
- Unfriendly Service
- All of the above

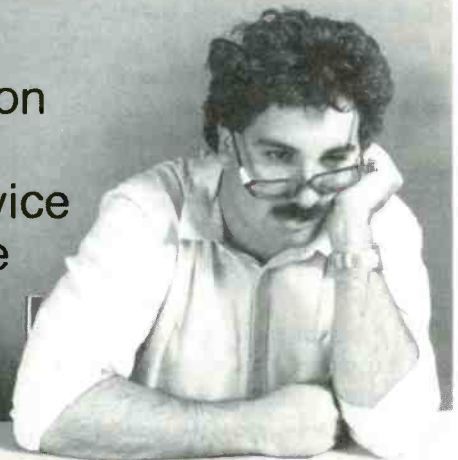

## MCM Electronics Brings **Relief!**

If you're tired of all the "headaches" that come from dealing with an electronics supplier that doesn't seem to understand your needs, it's time to pick up your phone and ask for a **FREE** copy of MCM's new catalog!

This 168-page "powerhouse" of electronic parts and components offers some of the best values in the industry on nearly 10,000 of the most commonly requested items.

You'll appreciate the friendly, personalized service provided by our courteous Sales Representatives and some of the most flexible payment terms in the industry. And you'll be pleased to learn that thanks to our huge inventory and state-of-the-art order entry system, your products can usually be on their way to you in 24 hours! So, get your copy today and get the relief you've been looking for. You won't be disappointed!

For your **FREE** copy, call **TOLL-FREE!**

**1-800-543-4330**

In Ohio, call 1-800-762-4315

In Alaska or Hawaii, call 1-800-858-1849



**MCM ELECTRONICS**  
858 E. CONGRESS PARK DR.  
CENTERVILLE, OH 45459-4072

A **PREMIER** Company

**SOURCE NO. ME-35**

CIRCLE 1 ON FREE INFORMATION CARD

# Converting Current to Voltage

By Duane M. Perkins

**E**lectronic circuit design frequently required conversion of a variable current to a voltage. The current source (or sink) is often the collector of a transistor, but it could be the output of an integrated circuit or any device whose output is a variable current. The conversion is usually accomplished by inserting a resistor in the circuit so that the current flows through the resistance. The voltage drop across the resistance varies linearly with the current.

The transistor circuit shown in Fig. 1 illustrates this method. Since the collector current is relatively unaffected by changes in the collector-to-emitter voltage, the output voltage varies linearly with the input voltage. Distortion occurs when  $V_{ce}$  drops below the linear portion of the operating characteristics curves. As a practical matter, this means that the supply voltage must be significantly greater than the maximum peak-to-peak output voltage swing.

Given a current source or sink that requires an essentially fixed voltage at its output, it is not feasible to insert a resistor into the circuit. A transducer that acts as a variable resistance will produce a current that varies linearly with its resistance only if supplied with a fixed voltage.

The problems of nonlinearity and source-voltage limitation can be overcome by using a very low value of resistance, since this means that the output voltage swing will be very small. The signal voltage can be amplified by as much as necessary. However, this approach introduces new problems. The required ampli-

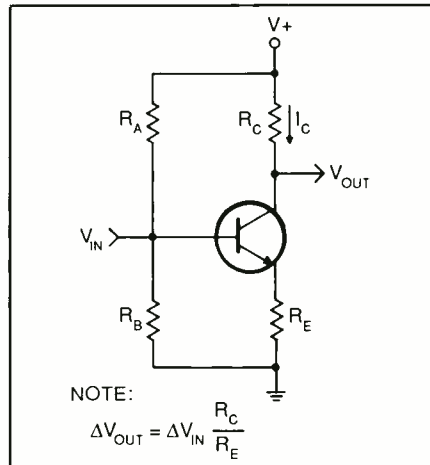

Fig. 1. An amplifier circuit that has a voltage input and a voltage output.

fier may add significantly to the complexity and cost of the device, particularly if dc amplification is required. There is also the potential for noise problems if much amplification is required.

## An Active Converter

The circuit in Fig. 2 shows an effective way to convert current to a dc voltage. If the input is a current source, use an npn transistor and reverse the supply voltage polarity. The  $V_{eb}$  drop is essentially fixed, thus providing a fixed voltage for the current source or sink. The relationships are shown as:

$$\begin{aligned} I_A R_A &= V_{eb} \\ (R_F/R_C) &\gg \beta \\ \Delta I_F &= -\Delta I_S \\ \Delta V_{out} &= \Delta I_S R_F \end{aligned}$$

## A Practical Application

Figure 3 shows a practical amplifier circuit that illustrates the advantages of an active current-to-voltage con-

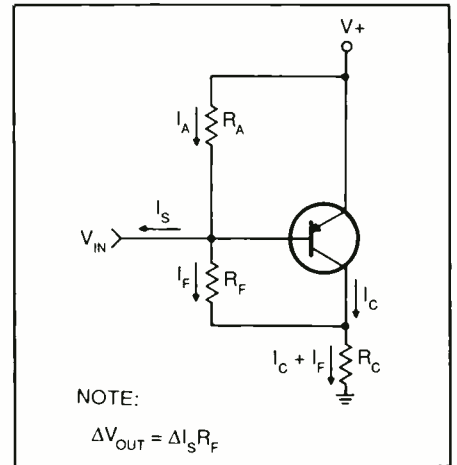

Fig. 2. An amplifier circuit that has a current input and a voltage output.

verter. It is a dc amplifier with provision for nulling the offset by adjustment of  $R_4$ . Input voltage  $V_{in}$  is converted to a current by  $Q1$ . The collector current of  $Q1$  is converted to a voltage by  $Q2$ . The offset is adjusted by adjusting  $R_4$  so that the dc potential at  $V_{out}$  is at ground level when  $V_{in}$  is grounded. Output is referenced to ground by using a split supply or simply by using a voltage divider consisting of two resistors of equal value.

The collector current of  $Q1$  will be about 2.3 milliamperes when the output is nulled. Accordingly,  $R_3 + R_4$  will be about 4,900 ohms. The calculated amplification factor is given by:

$$\frac{\Delta V_{out}}{\Delta V_{in}} = \frac{15 \Delta V_{in} \times 10^3}{4.9 \times 10^3} = 3.06$$

As actually measured, the voltage gain is closer to 2 because the voltage at the base of  $Q2$  is not absolutely fixed. The very small variation in the  $V_{eb}$  of  $Q2$  results in negative feed-



back that is amplified by the beta of transistor Q2.

With no reactive components in the circuit, other than the small capacitances inherent in the transistors and the conductors of the circuit itself, bandwidth is very large. High-frequency cutoff will depend largely on the transistors actually used, but it should be well above 1 MHz. An undistorted peak-to-peak output of about 15 volts is attainable.

### Other Applications

Certain integrated circuits source or sink a current that must be converted to a voltage. Usually, the output terminal is connected to one or more transistor collectors internally. Two examples are the DAC-801 digital-to-analog converter and the MC1350 i-f amplifier. The circuit in Fig. 2 can be used with these ICs. The MC1350 is a high-gain dc amplifier with a large bandwidth. Potential applications are much broader than the in-

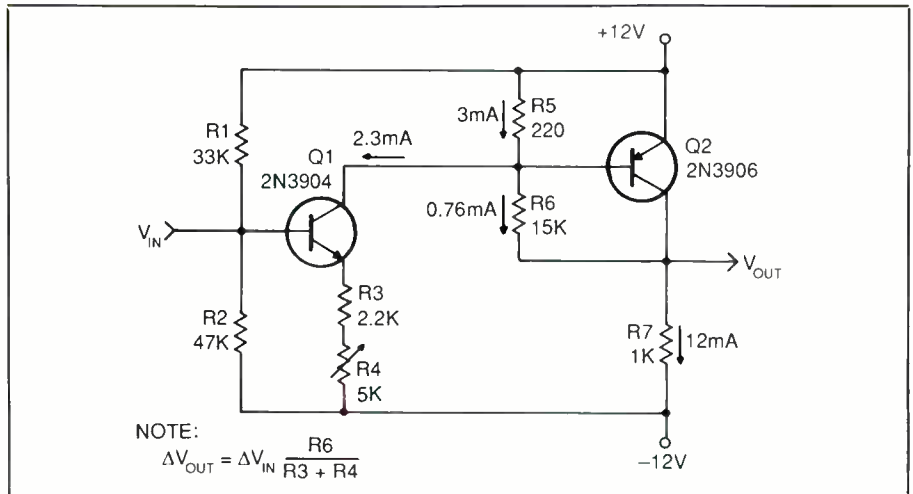

Fig. 3. A practical dc amplifier, with offset milling, for converting an input current to an output voltage.

tended use as an i-f amplifier.

Summing up, the circuit in Fig. 2 is an amplifier with a current input and a voltage output. It has negative current feedback that stabilizes the dc current, provides for linear amplification and reduces output impe-

dance. In many applications, it has advantages over the voltage-to-voltage amplifier illustrated in Fig. 1. We expect that readers whose interests include circuit design will find that these simple circuits can be effectively used to solve certain problems. **ME**

CALL FOR FREE CATALOG

### TEXT TO SPEECH BOARD!

PC/XT COMPATIBLE. MAKE YOUR COMPUTER TALK!

A VERY POWERFUL AND AMAZING SPEECH CARD. USES THE NEW GENERAL INSTRUMENTS SPO256-AL2 SPEECH CHIP AND THE CTS256A-AL2 TEXT TO SPEECH CONVERTER.

THIS BOARD USES ONE SLOT ON THE MOTHERBOARD AND REQUIRES A COM SERIAL PORT. BOARD MAY ALSO BE USED IN A STAND ALONE ENVIRONMENT WITH ALMOST ANY COMPUTER THAT HAS A RS232 SERIAL PORT. FEATURES ON BOARD AUDIO AMP OR MAY BE USED WITH EXTERNAL AMPS. DEMONSTRATION SOFTWARE AND A LIBRARY BUILDING PROGRAM ARE INCLUDED ON A 5 1/4 INCH PC/XT DISKETTE. FULL DOCUMENTATION AND SCHEMATICS ARE ALSO INCLUDED.



NEW!

PRICE CUT!

\$69.95  
ASSEMBLED & TESTED

### NEW! IC TESTER! \$149.00

SIMILAR TO BELOW EPROM PROGRAMMER. PLUGS IN TO YOUR PC OR XT. TESTS ALMOST ALL 14, 16, AND 20 PIN 74XX SERIES. INCLUDES STANDARD POWER, "S" AND "LS" DEVICES. ALSO TESTS CD4000 SERIES CMOS. SOFTWARE INCLUDED CAN EVEN DETERMINE PROGRAM NUMBERS OF MOST UNMARKED AND HOUSE NUMBERED DEVICES WITH SIMPLE MOD. THIS UNIT CAN ALSO TEST 6.4K AND 256K DRAMS! WITH MANUAL AND SOFTWARE: \$149. PERFECT FOR SCHOOLS.

### PC/XT EPROM PROGRAMMER \$169



ASK ABOUT OUR NEW PAL PROGRAMMER!

\* LATEST DESIGN \* PROGRAMS UP TO 4 DEVICES AT ONE TIME \* FEATURES EASY TO USE MENU DRIVEN SOFTWARE THAT RUNS UNDER PC OR MS-DOS. \* USES AN INTELLIGENT PROGRAMMING ALGORITHM FOR SUPER FAST (8X) EPROM BURNING. \* THIS PLUG-IN BOARD ATTACHES TO AN EXTERNAL MINI CHASSIS CONTAINING \* TEXT TOOL \* I.F. SOCKETS. \* NO PERSONALITY MODULES REQUIRED \* AUTOMATIC VPP SELECTION: 12.5V, 21V, OR 25V. \* EPROM DATA CAN ALSO BE LOADED FROM OR SAVED TO A DISKETTE. \* PROGRAMMING SOFTWARE SUPPORTS: 2716, 2732, 2732A, 2764, 2764A, 27128, 27128A, 27256, 27256A, 27512, AND 27512A. \* ASSEMBLED AND TESTED, BURNED. IN WITH MANUAL. \$169 WITH SOFTWARE.

JUST RECEIVED. SAME AS ABOVE PROGRAMMER, BUT PROGRAMS 8 UNITS AT ONE TIME - \$299.

### Digital Research Computers

P.O. BOX 381450 • DUNCANVILLE, TX 75138 • (214) 225-2309

TERMS: Add \$3.00 postage. We pay balance. Orders under \$15 add 75¢ handling. No C.O.D. We accept Visa and MasterCard. Texas Res. add 6-1/4% Tax. Foreign orders (except Canada) add 20% P & H. Orders over \$50 add 85¢ for insurance.

CIRCLE 48 ON FREE INFORMATION CARD

NEW

HEWLETT PACKARD

## The HP-28S Advanced Scientific Calculator

## The HP-27S for Science and Business

Brand New

\$84.95

NEW Calculators from Hewlett-Packard

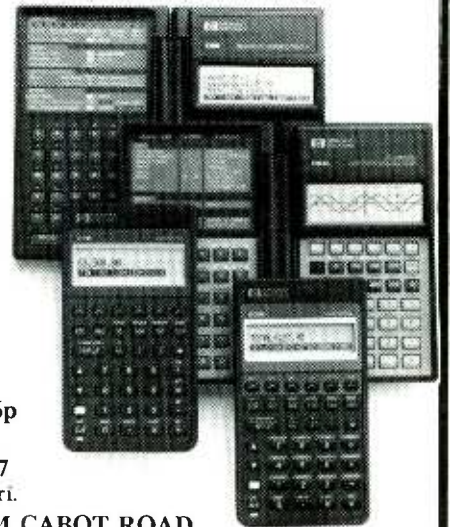

SEND FOR FREE CATALOG

If you like DISCOUNTS you'll want our H16p catalog!

(714)582-2637  
8-5 pm Mon.-Fri.

EduCALC, 27953-M CABOT ROAD  
LAGUNA NIGUEL, CA 92677 U.S.A.

CIRCLE 47 ON FREE INFORMATION CARD



## A Multi-Channel TTL Logic Tracer

*Digital test instrument incorporates six “logic-probe” channels and can be expanded as needed*

---

By Peter A. Lovelock

---

A simple logic probe that uses different-color visible indicators (usually LEDs) to tell you when a point under test in a circuit is high, low or pulsed is certainly a valuable tool in digital signal tracing. Its value, however, is limited because it is restricted to use on only one test point at a time. In many modern digital circuits, however, more than one point must be monitored simultaneously for meaningful tracing to be effected. To do this, of course, you could use multiple logic probes, but this is both cumbersome and expensive. My solution was to design a low-cost multiple logic

probe that I call a “Logic Tracer.” It is described in detail below.

Before designing the Multi-Channel TTL Logic Tracer discussed here, I examined a commercial logic probe. A look inside convinced me that the nine transistors and lots of other components it contained was not the way to go. What I ended up with was an elegantly simple circuit that gave me six test inputs and could be expanded as needed. The basic circuit contains only one hex-inverter IC, six bi-color LEDs and 12 resistors. It gives indications of high, low and pulsed conditions and operates reliably at frequencies up to about 1 MHz. Perhaps best of all, the entire project can be built for about the

cost of just one standard commercial single-point logic probe from components purchased locally.

---

### *About the Circuit*

---

The entire Multi-Channel TTL Logic Tracer schematic diagram is shown in Fig. 1, along with several Details that clarify circuit operation, powering options and IC pinouts and internal details. As the main schematic diagram shows, the project is built around a commonly available TTL hex inverter, *IC1*. Each channel's inverter also requires two resistors and a single bi-color (red/green) light-emitting diode. Six channels are possible with a single 7404 hex inverter.

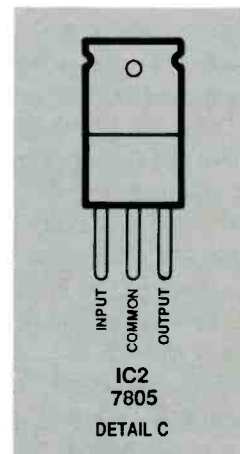
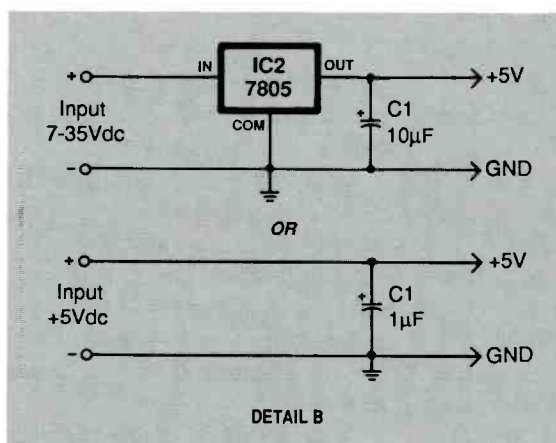
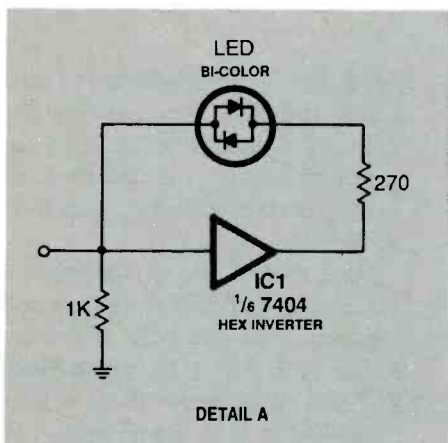
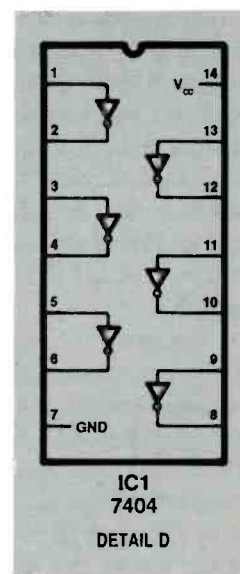
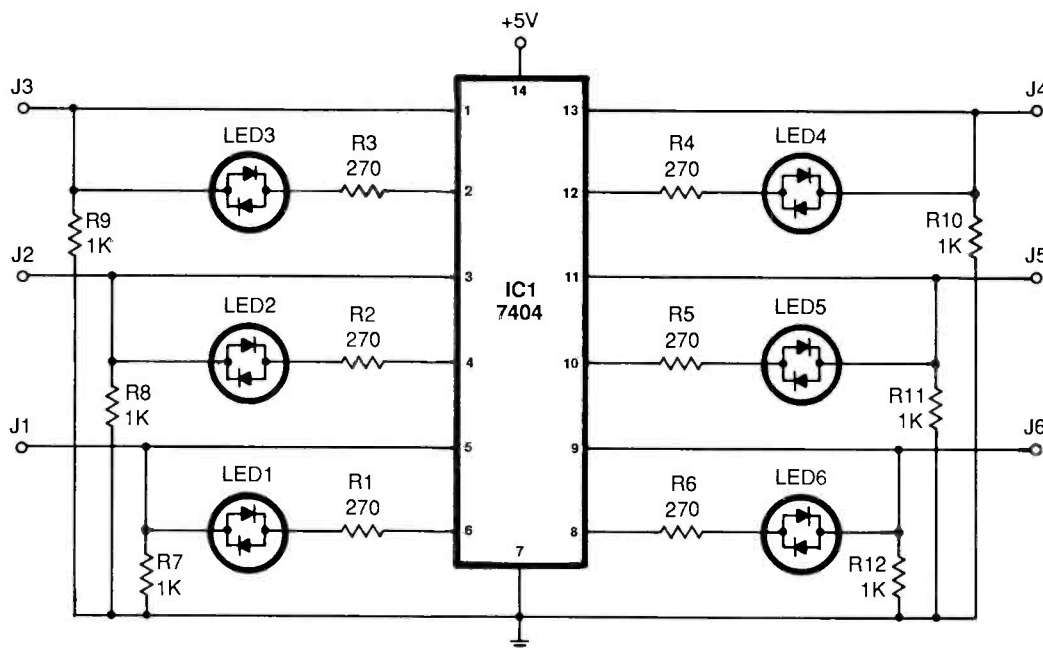

### PARTS LIST

#### Semiconductors

IC1—7404 TTL hex inverter  
 IC2—7805 + 5-volt regulator (optional—see text)  
 LED1 thru LED6—Bi-color (red/green) light-emitting diode (Radio Shack Cat. No. 276-035)

#### Capacitors

C1—10-µF, 10-volt tantalum

#### Resistors (¼-watt, 10% tolerance)

R1 thru R6—270 ohms  
 R7 thru R12—1,000 ohms

#### Miscellaneous

J1 thru J6 - Banana or pin jack

Double-sided printed-circuit board or perforated board and suitable soldering or Wire Wrap hardware; six banana or pin jacks; 14-pin DIP socket or Molex Soldercons® for IC1; project box (Radio Shack Cat. No. 270-231 or other 4" × 2½" × 1½" box with removable aluminum panel); six micro test clips (Radio Shack Cat. No. 270-355); 2 miniature alligator clips with insulating boots; small rubber grommets (see text); plug-in wall 7- to 35-volt dc power supply and mating jack (optional—

see text); dry-transfer labeling kit; clear spray acrylic; 4-40 × 1¼" machine screws, lockwashers and nuts (2 sets); ¼" spacers (2); red- and black-insulated test cable; hookup wire; solder; etc.

**Note:** The following items are available from R.&R. Associates, 3106 Glendon Ave., Los Angeles, CA 90024: Double-sided pc board with plated-through holes, \$4.50; Kit of parts for six-channel Tracer, including pc board, \$10.00 plus \$1.50 P&H. California residents, please add state sales tax.

Fig. 1. Complete schematic diagram of Multi-Channel TTL Logic Tracer and single stage (Detail A), dc powering options (Detail B) and internal details/pin-outs for ICs.

If additional channels are needed, you can simply add as many 7404 hex inverters, resistors and LEDs as are needed. For example, if you need an 8-channel Tracer, use two 7404s, 16 resistors and eight LEDs. A 16-channel Tracer requires three 7404s, 32 resistors and 16 LEDs, while a 32-channel Tracer requires six 7404s, 64 resistors and 32 LEDs. In these three examples, not all inverters in all 7404s are used. The unused ones can be disregarded, or they can be wired as extra channels that can be called into use as needed.

Since all channels in the Logic Tracer are identical, it is easier to refer to Detail A to examine how the project works. As you can see, each inverter is accompanied by a bi-color LED and 270-ohm current-limiting resistor connected between the inverter's input and output and a 1,000-ohm pull-down resistor from the input to circuit ground.

Depending on the polarity and frequency of the input signal to any given channel, the bi-color LED will give a different color indication. If a logic 1 of near +5 volts is applied to the input of the inverter, the output of the inverter will be at a logic 0 or near ground potential. With the LED connected as shown to both the input and output of the inverter, the low at the output will cause current to flow through only the red element inside the LED. On the other hand, if the input to the inverter is a logic 0, the output will be a logic 1, reversing the flow of current through the LED and causing the green element to light. Consequently, when the red element is on, the logic level at the point under test is high and if the green element is on, it is low.

In many cases, the signal at a point under test will not be a constant logic 1 or logic 0 but a pulse train. If the pulse train is very slow (less than about 10 Hz) you will see the red and green elements alternately coming on as the pulse train goes to high and then to low. On the other hand, if the

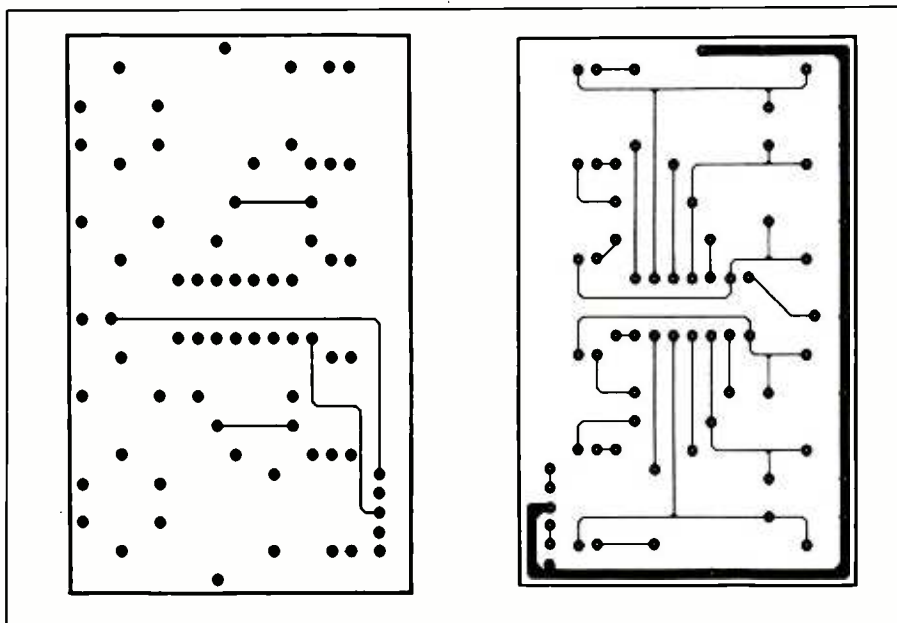

Fig. 2. Actual-size etching-and-drilling guides for top (left) and bottom (right) of double-sided printed-circuit board.

pulse train is faster than about 10 pulses per second, both LEDs will appear to be on simultaneously. Your eye's vision retentivity will then resolve the effective color to be anywhere between yellowish-green and reddish-orange, depending on the duty cycle of the pulse train. If the pulse train has a 50-percent duty cycle, the effective color will be nearly all yellow.

With no input applied to the inverter, no voltage difference will exist across the LED. In this case, neither element in the LED will light. A stable state is maintained by the 1,000-ohm pull-down resistor.

Since this Tracer deals with TTL levels, it requires a single +5-volt to ground power source. If only 12 or fewer inverter/LED stages are built, you can power the project directly from the power rails of the circuit under test as long as the current drain is limited to 100 milliamperes or less. If more channels are used, it is safer to power the project independently of the circuit under test. In this case, you can use a plug-in wall power supply and voltage regulator capable of

delivering sufficient current to safely handle the load. These powering options are shown in Detail B. In both cases, make sure to use the 10-microfarad, 10-volt tantalum capacitor for decoupling.

Note that Detail B indicates that you should use only one of the powering options—not both. If you wish to use both, however, make certain that you connect the direct +5-volt power input into the circuit on the *output* side of the 7805 IC2 regulator. With this arrangement, you need only one tantalum decoupling capacitor. This arrangement gives you a choice of powering options so that you can use the separate power supply if you are working on a very-low-power TTL circuit.

Detail C gives such information as the internal function information and pinouts of the 7404 hex inverter used for IC1 and the pinouts of the 7805 +5-volt regulator used for IC2.

### Construction

Owing to the basic simplicity of the project in terms of component count

and the fact that component layout is not critical, you can wire the Multi-Channel TTL Logic Tracer by any traditional means that suits you.

You can etch and drill your own double-sided printed-circuit board using the actual-size etching-and-drilling guides shown in Fig. 2 (or purchase a ready-to-wire board with plated-through holes from the source given in the note at the end of the Parts List). Alternatively, you can assemble and wire the project on a perforated board that has holes on 0.1-inch centers using suitable solder or Wire Wrap hardware. In either case, a socket is recommended for each 7404 hex inverter used.

If you etch and drill your own pc board, you will likely not be able to plate-through the holes. Therefore, you must make sure that you solder all wiring and component leads and pins to the copper pads on *both* sides of the board to assure that all connections are properly made. There are also four jumper points on the board, indicated by the letters A through D in Fig. 3, that require short lengths of solid bare wire or cut-off resistor lead to be inserted into each hole and be soldered to the pads on both sides of the board. Of course, if you prefer to avoid having to deal with the problems of a double-sided pc board that does not have plated-through holes, you can simply etch a single-sided board with just the bottom etching guide and replace the four solid conductors shown in Fig. 3 with physical insulated wire jumpers in the usual manner.

There is only one potential wiring difficulty with regard to using a home-made pc board that does not have plated-through holes. That is that you cannot use a conventional IC socket with molded plastic housing for IC1. However, the problem is easily solved simply by using strips of Molex Soldercons® in place of the socket. Simply cut or flex the Soldercons into two strips of seven socket pins each and plug one strip into one

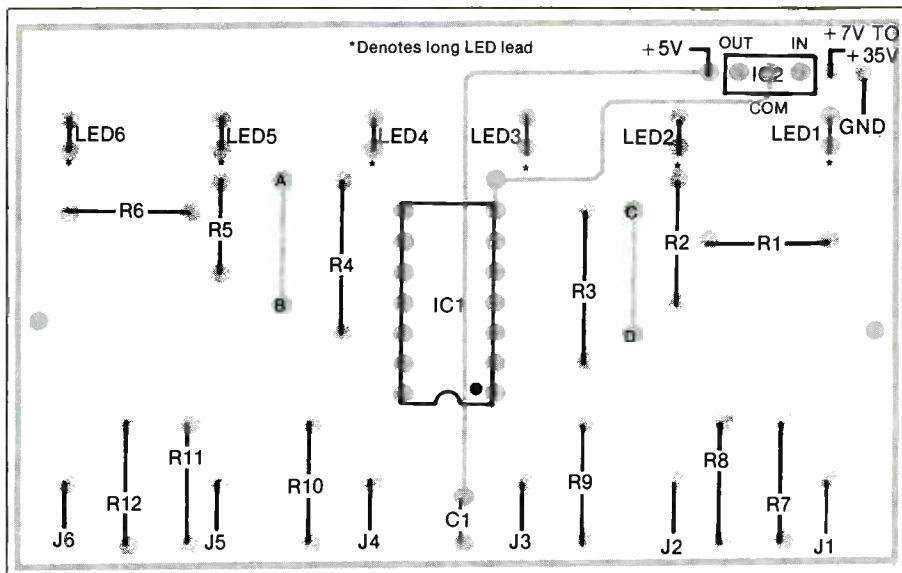

Fig. 3. Wiring guide for pc board. Use this as a rough guide to component locations and layout if project is assembled on perforated board.

set of IC1 holes in the board from the component side.

Turn over the board and solder the protruding pins to the copper pads, making sure to keep the Soldercon socket strip vertical on the component side of the board. Turn over the board and solder the sockets to the pads on the top of the board. Use solder sparingly to avoid clogging the socket pins as you solder them to the top of the board. Then flex the connecting strip free of the socket pins. Repeat for the other Soldercon strip.

From here on, we will be discussing assembly of the project on a printed-circuit board. If you opt for perforated board, lay out the circuit components as close as possible to that shown in the Fig. 3 pc wiring guide.

Start wiring the pc board by installing the IC socket (or Soldercons) and following with the resistors and the tantalum capacitor. If you are using a board with plated-through holes, simply solder each lead from the bottom of the board; capillary action will "wick" the solder into the holes and slightly mound it on the top pads and leads. If you are using a double-sided board that does not

have plated-through holes, make sure you solder each lead to the pads on *both* sides of the board to complete the circuit. Do *not* install the bi-color LEDs at this time.

Decide now if you are going to power the project directly from the supply rails of the circuits that will be tested, by its own separate power source or to give you a choice of either one or the other.

If you plan on powering the project directly from the supply rails of the circuits you will be testing, strip 3/8 inch of insulation from both ends of 36-inch lengths of red- and black-insulated test-lead wires. Tightly twist together the fine conductors at both ends of both wires and sparingly tin with solder.

Plug the one end of the red-insulated wire into the hole labeled +5V and solder into place on both sides of the board. Repeat with the black-insulated wire and the hole labeled GND. The other ends of these wires will be terminated after the circuit-board assembly has been installed inside its enclosure. (Note: regardless of which powering option you plan on using, you must make provisions for the black-insulated test lead to

serve as a ground reference for the project when making circuit tests.)

If you opt for a separate power supply or a choice of either, replace the 36-inch red-insulated wire with a 4- to 5-inch wire, and prepare a second same-length black-insulated wire in the same manner. Once again, solder just one end of each wire into the appropriate holes, leaving the other ends for connection later on.

Strip  $\frac{3}{8}$  inch of insulation from both ends of six 4-inch lengths of hookup wire. If you are using stranded hookup wire, tightly twist together the fine wires at both ends and sparingly tin with solder. Plug one end of each wire in turn into the holes labeled J1 through J6 on the circuit board and solder to the pads on both sides of the board. The other ends of these wires will be connected later. Temporarily set aside the circuit-board assembly.

A suitable enclosure in which to house the project is specified in the Parts List. This is a small plastic project box that has a removable aluminum panel. Unless you opt for a separate power supply or a choice between both powering options, all machining of the enclosure is performed by drilling holes in suitable locations through the aluminum panel of the project box.

Using the Fig. 4 template as a guide, machine the panel exactly as shown. There are separate holes for each LED and test-lead banana or pin jack, the +5-volt and ground power leads and the mounting holes for the circuit-board assembly. If you plan on using a separate power supply exclusively, do not drill the  $\frac{1}{4}$ -inch hole shown on the center axis at the left end of the panel. Once all the holes have been drilled, deburr them to remove sharp edges. (Note: You can save on the cost of the project by eliminating the banana or pin jacks, replacing them with small rubber grommets through which the test leads enter the enclosure and wire directly and permanently to the board.

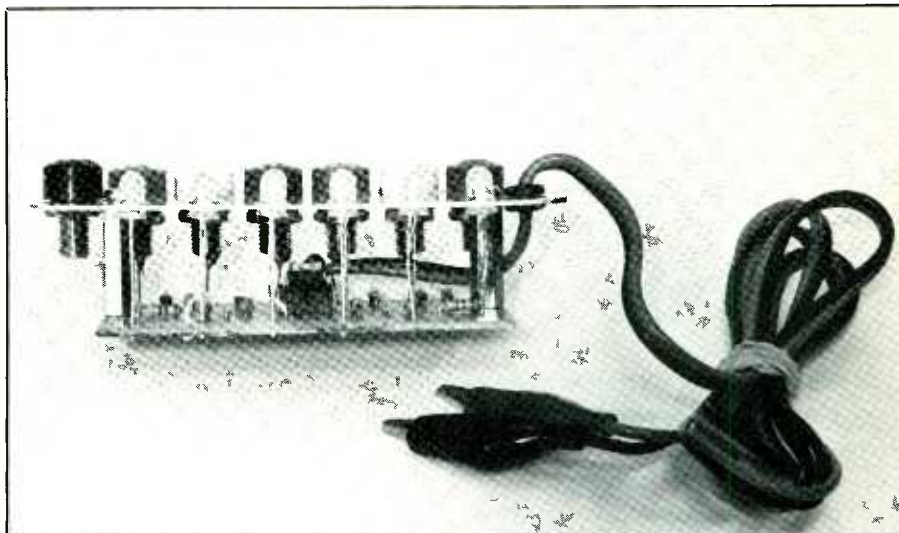

*Circuit-board assembly mounts with component side toward rear of front panel so that lenses of LEDs can drop into their respective holes.*

If you do this, make sure to tie strain-relieving knots in the test-lead wires inside the enclosure.)

Feed a No. 4-40  $\times$   $1\frac{1}{4}$ -inch machine screw into the small holes on the central axis and follow up with a  $\frac{3}{4}$ -inch spacer. Plug the leads of the bi-color LEDs into the holes in the circuit board, making sure that the long leads go into the holes near *IC1*. Plug the free ends of the screws into

the board's mounting holes and follow up with a machine nut on each. Make sure the component side of the board is facing toward the inside surface of the panel and that it is oriented so that the LEDs are on the side that matches up with their holes in the panel. Make the machine hardware finger tight.

Without allowing the LED leads to fall out of their holes in the board,

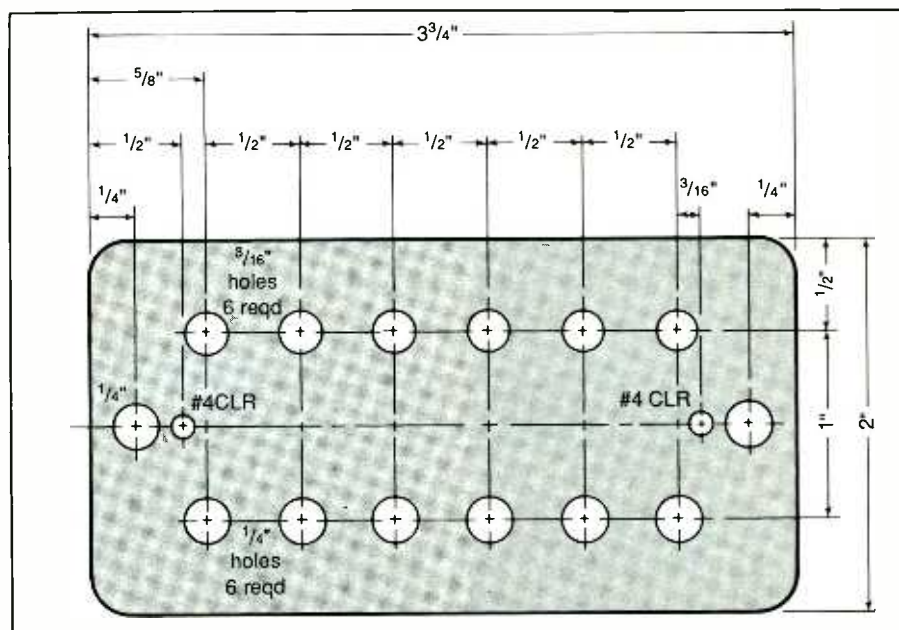

*Fig. 4. Front-panel machining details.*

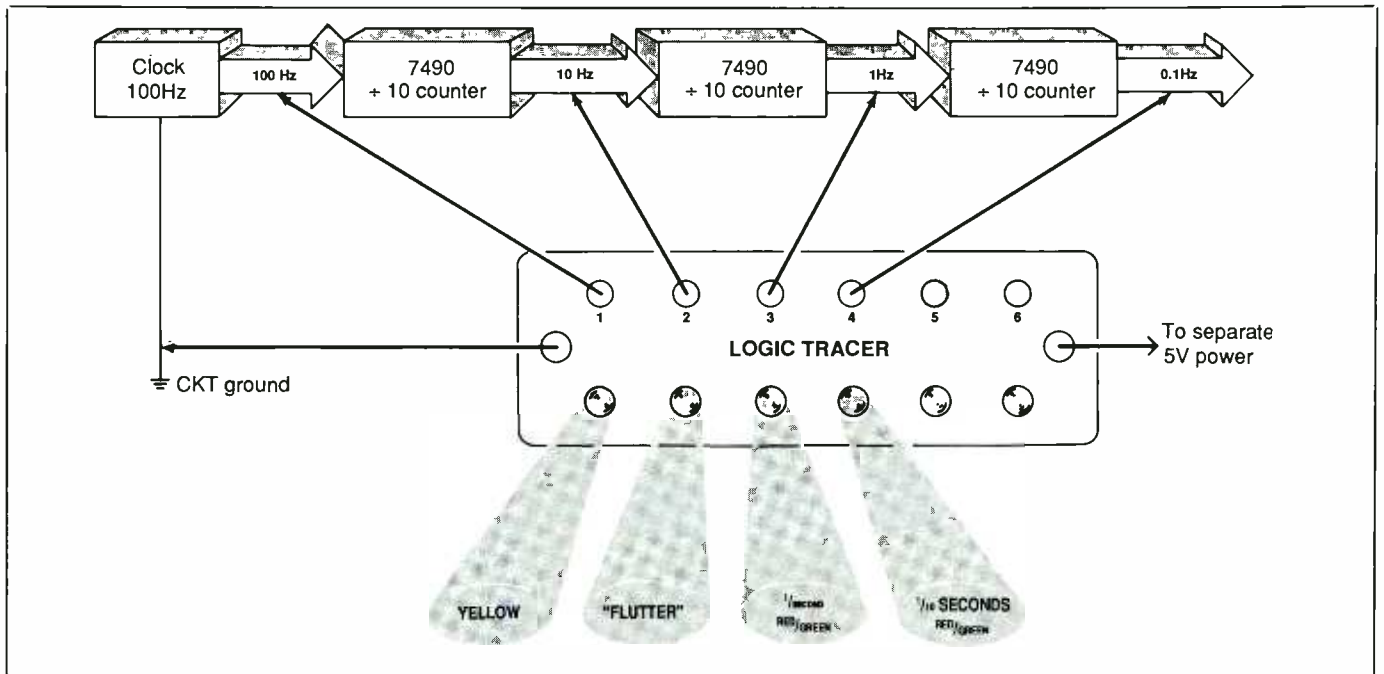

Fig. 5. Simple sequential logic application setup for using project.

invert the assembly so that the bottom side of the circuit board is facing up. Then gently push the lensed end of each LED into its respective hole in the panel. Holding the LEDs solidly against the panel, solder one lead of each to the pads on the bottom of the board. Turn over the assembly to check alignment from the front of the panel. If everything appears to be okay, solder the other lead of each LED to its bottom-of-the-board pad.

Remove the machine hardware and set it and the spacers aside. Gently remove the front panel from the circuit-board assembly, taking care to avoid displacing the LEDs from their current positions. Carefully solder the lead near *IC1* of one LED to its pad on the top of the board. Repeat for each LED in turn. Then do the same for the leads nearer the edge of the board. Make sure you do not move any of the LEDs as you do this. Lay aside the pc assembly.

Scrub the aluminum panel to remove all dirt, grease and other debris. When it is completely dry, label the panel with a dry-transfer letter-

ing kit. For example, you might center the legend INPUTS above the line of banana or pin jacks that will be used to plug in the test leads (or the grommets for the test leads). Just below them, you can label the jacks 1 through 6. Similarly, you can label the legend CHANNELS below the LED holes and label above each hole the numbers 1 through 6 in the same sequence used for the jacks. Finally, label the left central hole +5 VOLTS and the right central hole GND. Leave enough room between hole edges and labels to clear grommets and jacks.

When all labeling is done, apply two or three *light* coats of clear acrylic spray lacquer over the entire front panel to protect the labeling from damage. Wait until each coat is fully dry before spraying on the next. After the last coat has completely dried, mount the banana or pin jacks in their respective holes and gently force small rubber grommets into the power-lead holes.

Remount the circuit-board assembly on the front panel, using the 4-40 machine hardware and spacers you used before, but place a lockwasher

on each screw before screwing on the nuts. Make sure each LED aligns with and slides into its respective hole in the panel. Apply a drop of Krazy glue to each LED to secure it in its panel hole.

Locate the free ends of the short wires and connect and solder them to the lugs on their respective banana or pin jacks. Tie a double knot in the red and black test-lead wires about 5 inches from the ends connected to the circuit board and feed the free end of the red wire through the grommet in the hole labeled +5 VOLTS and the black wire through the grommet in the hole labeled GND.

If you do not plan on using the separate power supply option in the project, this completes construction but for terminating the power leads and preparing the test leads. If you are incorporating this option, install and solder into place on the circuit board the 7805 voltage regulator, making sure it is properly oriented before soldering its pins to the pads on both sides of the board.

(Continued on page 89)

# Troubleshooting Disk-Drive Power Supplies

*Cranky floppy-disk-drive write's and read's are sometimes caused by marginal power supplies*

By Ralph Tenny

**W**hat do you do when a stand-alone floppy-disk drive hasn't given up the ghost but occasionally drops a file or wipes out a directory. If, after cleaning heads and verifying with a test disk that alignment, *et al*, are fine, you might consider that this intermittent problem can be caused by a marginal power-supply design inside the drive's case.

The above scenario can occur even with add-in drives powered from the computer's power supply if the latter is marginally designed, though this is less likely to occur here. In this article, we'll discuss what to look for and, more importantly, how to go about solving the problem. If a poorly designed power supply is what's causing you grief, you'll be able to fix it yourself. If not, at least you'll know where not to look for a gremlin.

## Disk Power Supplies

Mini-floppy 5.25-inch and micro-floppy 3.5-inch drives are powered from two different-voltage power-supply rails. A +5-volt rail runs the electronics, while a +12-volt supply delivers driving power to the spindle assembly that revolves the disk inside its jacket or case as well as to the stepper motor that moves the read/write head.

The +5-volt supply that drives the read/write electronics must write da-

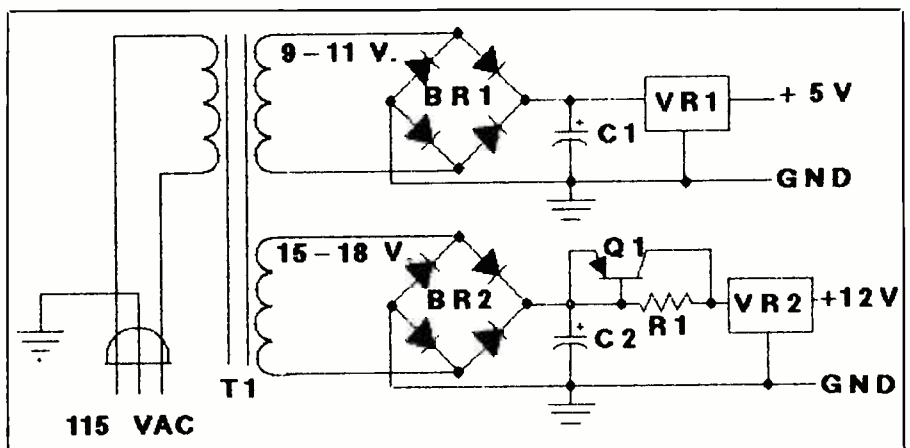

Fig. 1. Schematic diagram of an ideal +5/+12-volt power supply for a stand-alone floppy-disk drive unit. In this circuit, the two supply rails are derived from virtually independent supplies.

ta tracks that are both uniform in level and spacing. The motor supply must be designed to deliver a steady +12 volts so that the revolving speed of the disk is uniform and identical for both the read and the write operations. Of course, a very important factor to take into consideration with both power supplies is the demands placed upon them.

An essentially steady load is placed on the +5-volt supply. On the other hand, the +12-volt supply is subjected to a very heavy surge whenever the spindle motor starts up. Once the spindle motor has come up to speed, it settles down to a fairly steady drain on the power supply. Meanwhile, any attempt to access another track requires that the head stepper motor be switched on, placing an additional

load on the power supply. The most probable cause of power-supply-related random disk errors is interaction between the +5- and +12-volt supplies.

Properly designed floppy-disk power supplies have adequate isolation between the two voltage rails. In essence, the well-designed supply is actually two *separate* power supplies in one package. A few add-on disk drive power supplies, however, have been designed with what, for want of a better term, we'll call "short-cut engineering." Their performance can range from poor isolation to inadequate current capability and varying degrees of interaction between the two supply rails.

Shown in Fig. 1 is the schematic diagram of a typical well-designed



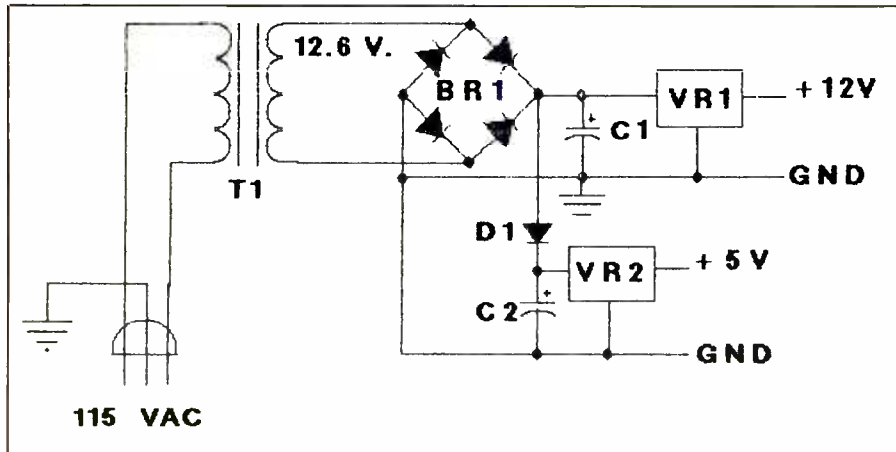

Fig. 2. An example of the circuit used in some shortcut power-supply designs. The only isolation—minimal at best—between the two supply rails is that provided by D1.

floppy-disk power supply. Note that the +5- and +12-volt rails are the result of separate transformer secondaries, rectifiers, filters and voltage regulators. The only element the both supplies share in common is the power transformer's primary winding. Hence, the two supplies are essentially independent of each other and minimal, if any, interaction between the two will occur under any loading conditions.

The ac output from each transformer secondary in the Fig. 1 circuit is well in excess of the desired dc voltage at the outputs of the supplies. The lower voltage indicated for each winding should be considered as the minimum usable for solid, reliable performance. That is, the transformer secondary potential in the +5-volt supply shouldn't be less than 9 volts, while the secondary potential in the +12-volt supply shouldn't be less than 15 volts. Additionally, the current ratings of both transformer secondary windings and the rectifier diodes (or bridge assemblies, as the case may be) should be conservatively rated. That is, each should be able to safely pass at least 20 percent more current than would ordinarily be demanded under the heaviest operating load placed on the supplies.

An "extra" feature is also illustrated in the Fig. 1 circuit. The *Q1/R1* network associated with voltage regulator *VR2* bypasses excess motor surge current around the regulator. The main benefit of this bypass network is prevention of *VR2*'s internal protection circuit from briefly current-limiting during the start-up surge placed on the supply by the motor. In turn, this allows the spindle motor to come up to speed as quickly as possible, which is typically about 0.5 second.

Figure 2 is the schematic diagram of a typical short-cut design power supply found in some stand-alone floppy-disk drive cabinets. Notice here that both supply rails are derived from a single power transformer secondary winding and rectifier system. The only components in this system that are separate for each supply are the filter capacitors and voltage regulators. With this particular arrangement some supply isolation is gained with the diode that feeds the filter capacitor for the +5-volt supply.

With a power supply built from the Fig. 2 circuit, the short-cuts used will have the following effects:

(1) The 12.6 volts ac available across the secondary winding of the

power transformer is so low that voltage regulator *VR1* can't always stay in regulation unless the ac line potential is at the "normal" 117-volt or greater level. That is, the potential across *C1* will become so low that *VR1* goes into current-limit mode. The result is that the spindle motor will come up to speed more slowly than normal.

(2) If the current ratings of the power transformer and bridge-rectifier assembly are also too low for the load placed on the power supply, the potential on *C2* may "sag" enough for *VR2* to also stop regulating. When this occurs, disruption of the disk read/write circuitry will cause random errors to be generated.

(3) In the event the ac line voltage is also low, the problems mentioned above will be compounded.

### Locating the Problem

The following assumes that you are troubleshooting a stand-alone floppy-disk drive unit. Unplug the drive from both the ac line and computer to which it is connected. Open the cabinet and locate the power transformer. Trace the circuitry revealed to identify the transformer leads that go to the 117-volt ac source, usually through a switch and fuse. Verify which leads go to the ac line cord with a continuity checker or ohmmeter from the power cord to the leads.

Having identified the primary leads of the power transformer, count the number of remaining leads. If there are only two leads, in addition to the two for the primary winding, the remaining power supply circuitry will likely be the same as or very similar to that shown in Fig. 2. In the unlikely event that there are three secondary leads on the transformer, the circuit design of the power supply is likely to be the same as in Fig. 3. If you find that there are four secondary transformer leads secondary leads, the schematic diagram of

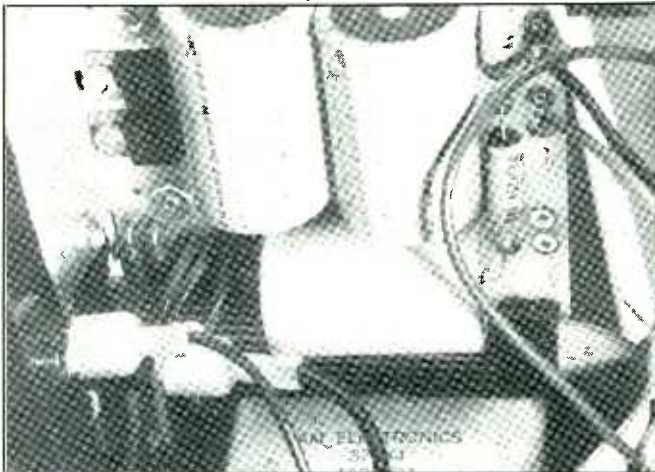

Fig. 3. An interior view of the power-supply section of a typical stand-alone disk-drive unit.

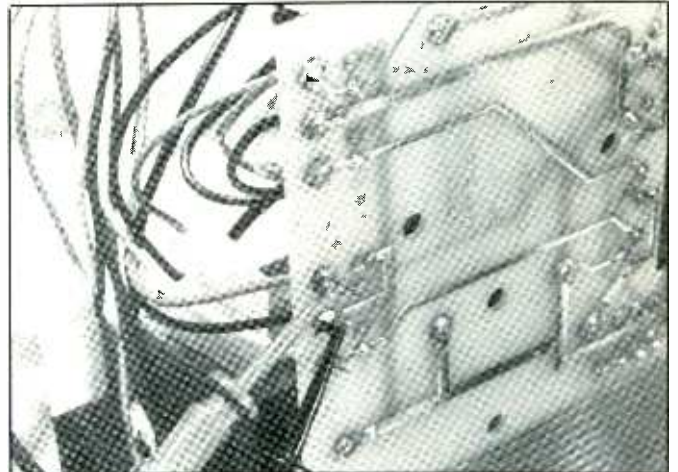

Fig. 4. The regulator output circuit board with test leads attached for taking voltage measurements.

the power supply is most likely to resemble Fig. 1.

Shown in Fig. 4 is a photographic view inside a typical floppy-disk drive. In the top-center, you can see two large filter capacitors. Check to see if they are *C1* and *C2* in the Fig. 1 circuit. To the left of *C1* are shown regulators *VR1* and *VR2*.

Power up the drive without the linking flat ribbon cable connected to the computer. Measure the potential across *C1* and *C2* with a dc voltmeter (observe proper polarity). With the drive not running, expect to read at least +12 volts across *C1* and perhaps as much as +20 volts across *C2*.

Next, locate the power cable that attaches to the drive and identify the conductors with the +5 and +12 volts on them. Figure 3 is a photo of a typical output card, this time on a dual-drive power supply. Use your voltmeter to verify that the outputs of the regulators are at the proper levels: +5 volts and +12 volts, both within  $\pm 10$  percent.

The final test for power-supply problems in your disk-drive system requires access to an oscilloscope and a test program to cycle the drive. The approach used is to set up a program loop that writes to the disk,

waits for the motor to turn off and then repeats this cycle endlessly until the program is interrupted by you.

When running the program, monitor the +5- and +12-volt regulated supply rails. Watch for dips in the required voltages when the spindle motor starts up. If neither supply rail's potential dips, you probably don't have a problem with your power supply, regardless of the design of the power supply circuit. The same is probably true if only the +12-volt rail's potential dips. The exception is if the dip slows the motor enough that the software starts read-

ing or writing before the motor is up to speed.

With your disk drive reconnected to the computer and the line cord plugged into an ac outlet, turn on both the computer and drive. Place a formatted disk in the drive, preferably one without any data on it you wish to save. Then key in the following BASIC program, which can easily be translated to any version BASIC interpreter:

After typing RUN followed by a RETURN (or ENTER if this is the designation on your keyboard), if the disk in the drive doesn't stop revolving as

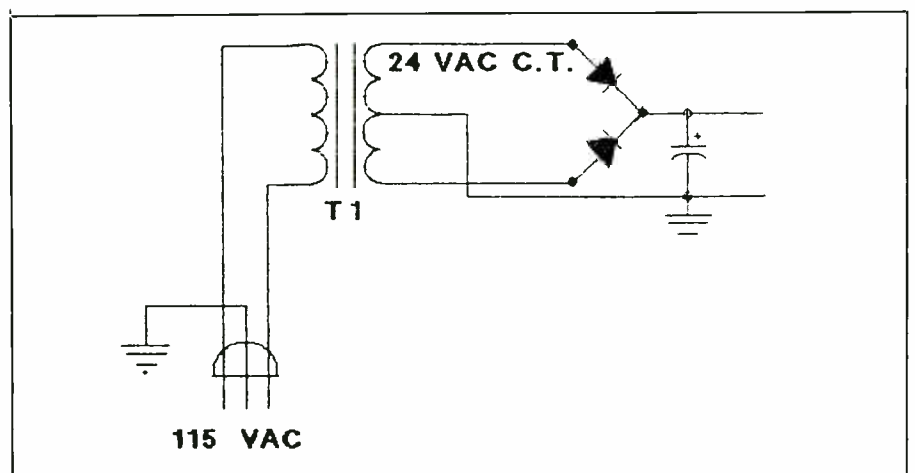

Fig. 5. An alternate rectifier/filter arrangement for the Fig. 2 circuit.

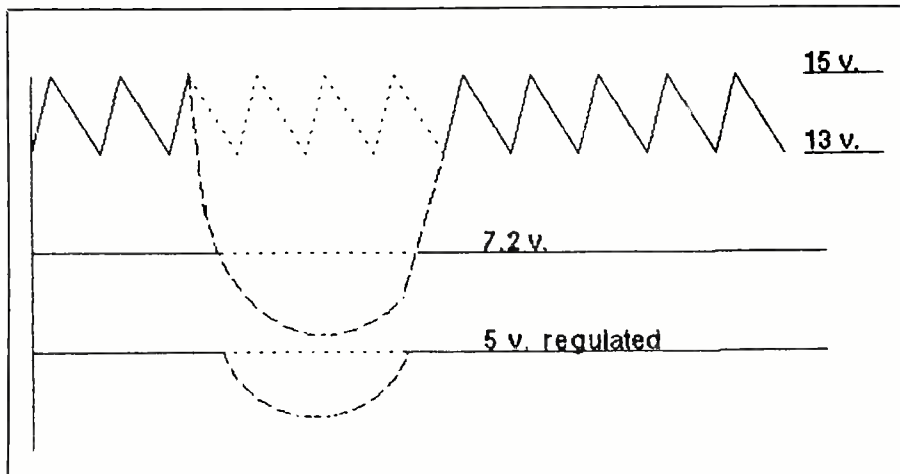

Fig. 6. Power supply waveforms observed on an oscilloscope screen, along with the sag, illustrated by the dashed lines, that can occur when a drive's spindle motor starts up.

the program executes, increase the delay in line 50. If the drive is idle for a relatively long time during each cycle, decrease the count in line 50. The optimum is for the motor to just coast to a stop before starting again for another run-through.

### Solving the Problem

There are two fixes for the motor-speed problem—fix the power supply or change the software so that it waits longer before beginning a read or write operation. Obviously, the preferable solution is to fix the power supply.

The quickest way to fix a supply that uses the circuit arrangement shown in Fig. 2 is to substitute a transformer that has slightly greater secondary voltage and adequate current capacity—if you can find a transformer with appropriate ratings. If the secondary voltage is only slightly low, you can replace the silicon rectifiers with Schottky rectifiers and double the microfarad rating of the filter capacitors. With regard to the latter, you can replace the existing capacitors altogether or simply connect an additional capacitor of the same value in parallel across each of the originals in the proper polari-

ty, assuming there is room in the supply to do so.

Figure 6 both sums up the problems and demonstrates the gains to be made by tweaking the existing power supply. The waveform at the top represents an estimated 2 volts of peak-to-peak ripple on a loaded disk supply built according to the design shown in Fig. 2. The 7.2-volt line represents the maximum drop across the standard three-terminal voltage regulator, and the last line represents the output from the regulator.

A dashed line in Fig. 6 represents a voltage sag caused by the starting surge of the spindle motor. As soon as this surge penetrates the 7.2-volt guard band, the regulator breaks regulation and will probably disrupt the disk electronics.

Schottky rectifiers have significantly lower voltage drop (about 40 percent) than do standard silicon rectifiers. Their use raises the peak charging voltage for the filter capacitor. The larger filter capacitance should reduce the ripple to about half of what it was before changing rectifiers.

The lower voltage drop of the Schottky rectifier further reduces ripple. With a higher voltage to start with and greater reserve, the voltage

sag may disappear altogether or be reduced enough to prevent disturbance in the +5-volt supply.

If you find that the rectifier/filter modifications detailed above aren't enough to solve the problem, you must use a beefed up power transformer to prevent sagging on the +5-volt rail. One other last-ditch measure can be taken here. If the disk drive in question is an older unit, you can replace it with a newer, thinner drive that uses a lot less power and works better. The thing to be on the alert for is that you don't inadvertently substitute a quad-density model for a double-density drive. AT-style quad-density disk drives require different diskettes and cannot read from or write to disks that are compatible with the lower-density XT and PC drives.

Except for the earliest models, the power supplies in MS-DOS computers generally have sufficient power to handle a full complement of add-in disk drives and expansion cards. If you encounter a problem with an MS-DOS disk drive, make the same tests detailed above for stand-alone drives, but take your voltage measurements on the drive board, as near as possible to the drive's power connector. If you note a dip in the +5-volt line, there are two possible causes for this: the computer's power supply is overloaded or defective, or there is a high-resistance connection in the power-supply cable.

Schottky rectifiers are fairly difficult to find. If you are having any difficulty here, one source of the 1N5822 Schottky rectifier is Digi-Key, 701 Brooks Ave. S., P.O. Box 677, Thief River Falls, MN 56701-0677. You might think that this rectifier is very expensive when compared to silicon rectifiers of similar rating, but the cost is well worth it considering the benefits obtained. It's much cheaper to buy the needed Schottky rectifiers than to have to replace or even build a new power supply to suit your needs!

ME

# An Automotive Air-Conditioning “Smart Box”

*Optimizes air conditioning to driving conditions so that fuel is saved and full engine power is available when it is needed most*

By Anthony J. Caristi

**H**igher-efficiency air-conditioning systems for vehicles reduce the fuel penalty of keeping cool. This is accomplished by having the A/C system's compressor cycle on and off in accordance with the cooling the system's demands. Previous designs required compressor operation 100 percent of the time during cooling periods.

Although newer A/C systems using the cycling clutch do provide a gain in fuel mileage, it is still only a half measure. No attention is paid to constantly varying driving conditions such as acceleration, coasting and braking. During acceleration, the A/C's compressor presents a load on the engine and increases fuel consumption. When decelerating or braking, the compressor load on the engine helps slow the vehicle, which uses virtually no fuel to do so.

If the A/C system could be synchronized so that it essentially kicks off during a quick acceleration or when the engine is straining to climb a steep hill, efficiency could be optimized. Our air-conditioning “Smart Box” does just that. This electronic device constantly monitors, via a miniature solid-state pressure sensor made by Nova Sensor of Fremont, CA, operation of a vehicle's engine.

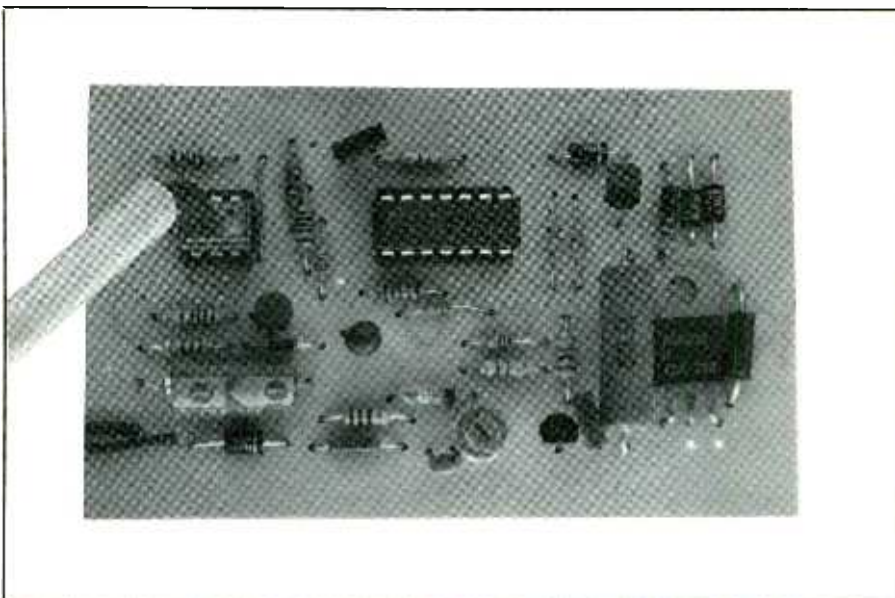

Using the sensor's output information, electronic circuitry enables the A/C compressor during coasting and braking, and inhibits it during acceleration and hill climbing. Your car's engine will provide more power when it's most needed and fuel economy will improve.

A light-emitting diode turns on when this fully automatic system is in operation. The project also has a control that lets you adjust compressor on/off threshold to suit different comfort needs and a disable switch that lets you bypass the Smart Box

when you want to return to uncontrolled A/C operation.

Engine vacuum is used by the Smart Box to control the A/C system. Hence, the project is suitable for use on only gasoline-powered vehicles.

## *About the Circuit*

As shown in Fig. 1, the heart of the Smart Box is pressure sensor *PSI*. The sensor is an integrated-circuit technology device that consists of four resistors, which are part of the chip's silicon wafer and are connected in a Wheatstone bridge configura-

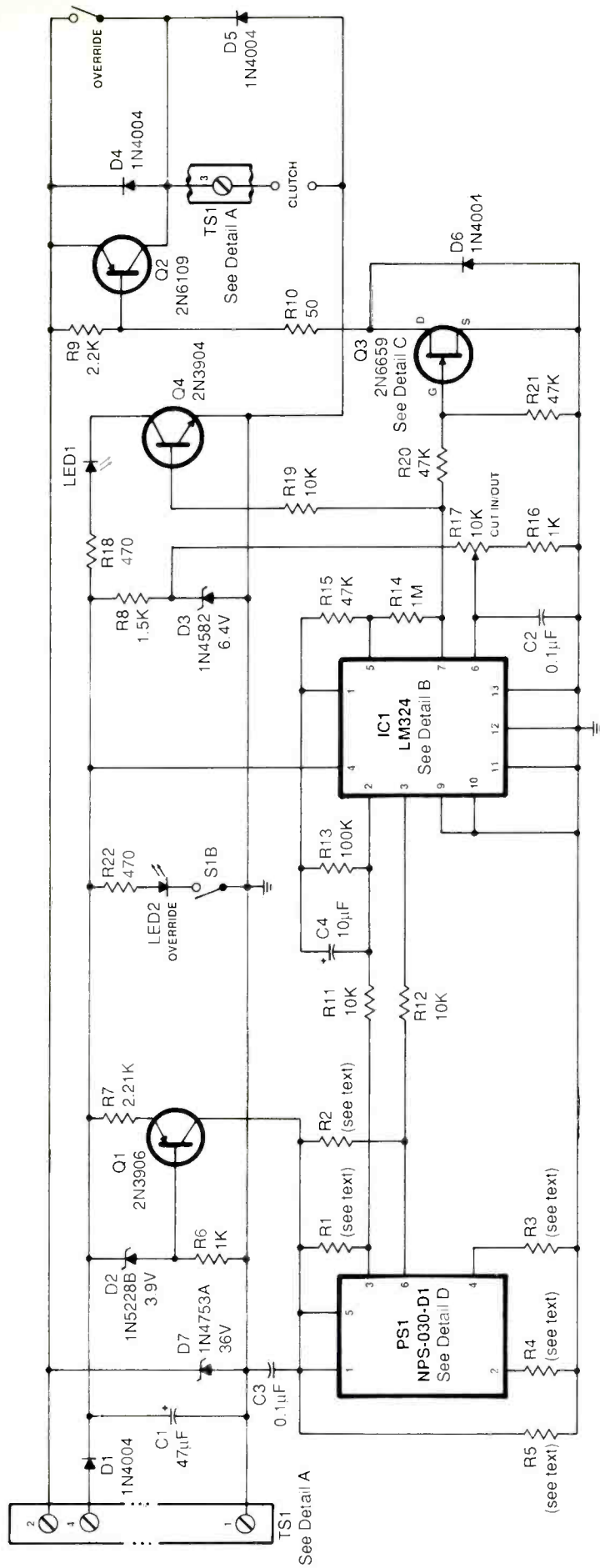

NOTE:  
Pin 1 and low-pressure port are adjacent to the "N" in NOVA on NPS-030-D1 pressure sensor device.

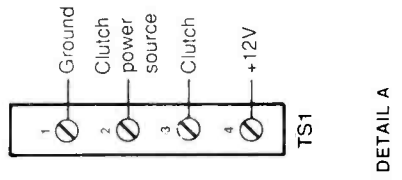
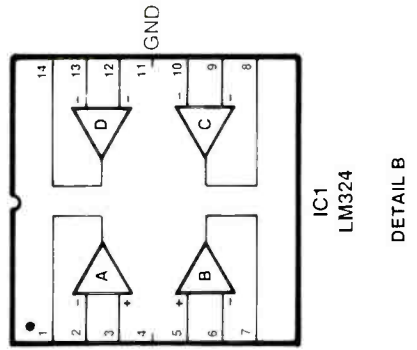
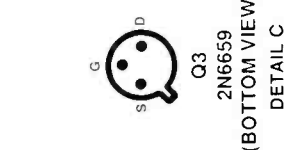
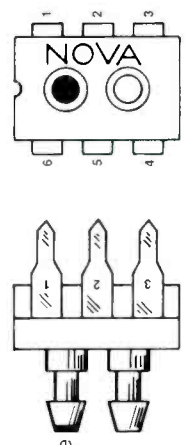

Fig. 1. Complete schematic of the automotive air-conditioning Smart Box and mechanical/electrical details of its pressure sensor and op-amp.

## PARTS LIST

### Semiconductors

D1, D4, D5, D6—1N4004 or similar silicon rectifier diode  
 D2—1N5228B or similar 3.9-volt zener diode  
 D3—1N4582 or similar 36-volt, 1-watt zener diode  
 D7—1N4753A or similar 36-volt, 1-watt zener diode  
 IC1—LM324 quad operational amplifier  
 LED1, LED2—2-volt, 20-mA red light-emitting diode  
 PS1—Pressure sensor (Nova No. NPS-30-D1)  
 Q1—2N3906 or equivalent npn silicon transistor  
 Q2—2N6109 or equivalent pnp silicon transistor  
 Q3—2N6659 or equivalent enhancement-mode n-channel field-effect transistor  
 Q4—2N3904 or equivalent npn silicon transistor

### Capacitors

C1—47- $\mu$ F, 35-volt electrolytic

C2, C3—0.1- $\mu$ F, 50-volt disc  
 C4—10- $\mu$ F, 25-volt tantalum

### Resistors ( $\frac{1}{4}$ -watt)

(1% tolerance metal-film)

R1 thru R5—Precision reference (see text)  
 R7—2,210 ohms  
 R11, R12—10,000 ohms  
 R13—100,000 ohms  
 R16—1,000 ohms  
 (10% tolerance carbon-composition)  
 R6—1,000 ohms  
 R8—1,500 ohms  
 R9—2,200 ohms  
 R14—1 megohm  
 R15, R20, R21—47,000 ohms  
 R18, R22—470 ohms  
 R19—10,000 ohms  
 R10—50 ohms (7-watt power type)  
 R17—10,000-ohm miniature pc-mount cermet trimmer potentiometer

### Miscellaneous

S1—Dpst toggle or slide switch with 5-ampere contacts

TS1—4-position screw-type terminal strip

Printed-circuit board; suitable enclosure (see text); sockets for IC1 and PS1 (see text); T adapter for vacuum connection; automotive vacuum hose (see text); 4 spade lugs (optional—see text); small-diameter plastic or heat-shrinkable tubing;  $\frac{1}{8}$ "-thick double-sided foam tape; hook-and-tape fastener or L brackets (see text); color-coded 16-gauge stranded wire; machine hardware; hookup wire; solder; etc.

**Note:** The following items are available from A. Caristi, 69 White Pond Rd., Waldwick, NJ 07463: Etched and drilled pc board, \$8.95; Nova NPS-030-D1 pressure sensor, \$29.95; set of five film resistors for PS1, \$2.50; set of five 1%-tolerance resistors for circuit, \$2.50; LM324 quad op amp, \$2.25; 1N4582 zener diode, \$5.00; 1N5228B zener diode, \$1.25; 1N4753A zener diode, \$3.75. Add \$1.50 per order for P&H. New Jersey residents, please add state sales tax.

tion. The sensor exhibits piezoresistive properties; that is, the value of each resistor in the bridge is a function of the mechanical stress impressed upon the silicon wafer as a result of positive or negative pressure.

The *PSI* bridge circuit is housed inside a 6-pin plastic DIP package similar to that used for integrated circuits. The sensor has two ports to which pressure can be applied. Output voltage from the bridge is a function of the current passing through it and the difference in pressure between the two ports, which is why this Nova device is known as a differential pressure sensor.

When the sensor is at rest (zero applied pressure), the bridge circuit is balanced and the output voltage, taken between pins 3 and 6 of *PSI*, is essentially zero.

The *QI* circuit that drives the bridge is a constant-current source that assures stability even under the

varying voltage conditions that normally occur in automotive electrical systems. In operation, *QI*'s base voltage, referenced to the +12-volt power-supply rail, is held to 3.9 volts below this rail's voltage by zener diode *D2*. Therefore, the emitter of *QI* must always be at a potential that is 3.2 volts lower than the supply potential because the emitter-to-base potential of a silicon junction is always 0.7 volt. Hence, the drop across *R7* is a constant 3.2 volts, and the current through *R7* is always about 1.5 milliamperes.

Because the transistor's emitter and collector currents are essentially equal, the current fed into the bridge circuit is a constant 1.5 milliamperes, regardless of any voltage changes that might occur on the +12-volt rail or changes in resistance of the bridge circuit.

When *PSI* is at rest such that there is zero pressure differential, the four

on-chip piezoresistor elements of which it consists are each equal in value. Hence, the output from the bridge, between pins 3 and 6 of the sensor device, is essentially zero volts. In actual use, the bridge circuit may have a very small offset in the output voltage, which for all practical purposes can be ignored in this circuit design.

The Nova pressure sensor comes factory calibrated with five individually selected values of resistance, identified in Fig. 1 as *R1* through *R5*. Each pressure sensor comes with resistors of the proper values. Since these values may vary from one sensor to another, no values are shown for *R1* through *R5* in Fig. 1 or are specified in the Parts List. In some cases, one or more resistors can be omitted entirely or be replaced by jumper wires.

The differential pressure sensor will respond to the difference in pres-

sures applied to its high and low pressure ports. In the Smart Box, the high pressure port is exposed to atmospheric pressure, which is considered here to be zero pressure (a pressure gauge always indicates zero when exposed to atmospheric pressure). The low pressure side of the sensor connects by means of a rubber vacuum hose to a source of engine vacuum, such as the power-brake vacuum connection. Consequently, the pressure sensor can respond to the variations in engine vacuum (and load) as you drive your car.

When the car's engine is idling, engine vacuum is approximately equal to 12 to 16 inches of mercury. This is equivalent to a negative pressure of about 8 to 10 pounds per square inch (psi). Under acceleration at full throttle, the negative pressure drops to near zero, while under cruising conditions the pressure settles down to about 3 or 4 psi. This means that engine vacuum, expressed as a negative pressure, will vary from more than 8 psi during idle and coasting to 3 psi or less when accelerating or climbing a hill. This variation in pressure enables the Smart Box to determine under what conditions your car is being driven.

Measured between pins 3 and 6 of *PS1*, the output of the pressure-sensitive bridge circuit will vary from about 0 volt at full throttle to more than 50 millivolts during coasting and deceleration. The greater the output from the sensor, the less power the engine is called upon to deliver. The bridge's output voltage is amplified by differential amplifier *IC1A* and then fed to *IC1B*, which is wired as a voltage comparator. (Refer to the details given in Fig. 1 for pinouts and internal/external details of *IC1* and *PS1*.)

The decision as to whether or not to allow the A/C compressor to operate is the responsibility of *IC1B*. This decision is based on a voltage that is set by CUT IN/OUT control *R17* and is determined empirically by

you. Since the output voltage from *IC1A* will decrease as engine load increases, *R17* can be set to a potential that represents the neutral point between cruising and accelerating.

Light-emitting diode *LED1*, driven by the output of comparator *IC1B* through transistor *Q4*, can be used as an aid in making the optimum adjustment setting for *R17*. Once this control is set to the optimum point, vehicle acceleration will cause the output of *IC1B* to drop to zero. This cuts off *Q4* and extinguishes *LED1*. At the same time, field-effect transistor *Q3* cuts off, since its gate-to-source voltage will be zero. Returning to cruise or during deceleration, engine vacuum will increase and forward-bias *Q3* and *Q4* and the latter will turn on *LED1*.

Two circuit enhancements have been included in the Smart Box to prevent the device from switching back and forth if you very rapidly change from acceleration to deceleration (and vice-versa). Capacitor *C3* introduces a time constant that prevents the output voltage from *IC1A* from changing suddenly, and resistor *R14* adds hysteresis to the comparator so that the input to pin 3 of *IC1* must change about 0.5 volt before any action takes place at pin 7.

Dc power that feeds the A/C compressor clutch must pass through power transistor *Q2* before the clutch can be energized and allow the compressor to turn on. When *Q3* is cut off during acceleration and hill climbing, *Q2*'s base current must be zero. Thus, *Q2* is switched off and no current flows through the clutch winding. When *Q3* is once again forward biased during cruising and deceleration, *Q2* is forward biased through *R10* and *Q3* and the energized clutch causes the compressor to turn on.

As you can see, the on time of the A/C compressor occurs only at those times when engine load is minimal, resulting in improved fuel mileage. Since the air-conditioning system

normally operates with a cycling clutch, synchronization is assured under engine loading conditions.

During sustained hill climbing or when starting your car after it has been parked in full sunlight during a very hot day, you may want to allow the A/C system to generate maximum cooling without regard to engine operating conditions. Inclusion of OVERRIDE switch *S1* permits you to bypass the Smart Box to regain uncontrolled A/C operation. Note that *S1A* performs the actual override function, while *S1B* simply switches in OVERRIDE *LED2* that, when turned on, alerts you to the fact that the Smart Box is not under control.

### Construction

Except for the switch, LEDs and terminal strip, all components that make up the Smart Box mount directly on a 3.25 × 2-inch printed-circuit or perforated board. You can etch and drill your own pc board using the actual-size artwork shown in Fig. 2 or purchase a ready-to-wire board from the source given in the Note at the end of the Parts List.

Bend the pins of the 2N6109 transistor used for *Q2* at a right angle toward the back of the device's case at the point where the pins widen near the body of the case. Temporarily plug the transistor's pins to the appropriate holes in the board and press down until the case is flush with the board's surface. Use a pencil to trace the mounting hole onto the top surface of the board. Remove the transistor and drill a 1/8-inch hole in the center of the marked location.

With the pc board oriented as shown in Fig. 3, begin wiring the board by installing sockets in the *PS1* and *IC1* locations. If you have any difficulty finding the 6-pin socket required by *PS1*, you can use a hacksaw to carefully cut down a socket with more pins or substitute two strips of three Molex Soldercons® for a socket for the molded socket. Do not install the pressure sensor or IC in their

respective sockets until after the board is fully wired.

Next, install and solder into place the diodes, followed by the capacitors and transistors. Make sure you properly polarize the diodes and electrolytic capacitors and properly base the transistors before soldering any leads or pins to the pads on the bottom of the board. Installing any one of these components in the incorrect orientation can result in damage to that component and perhaps others in the circuit.

Bear in mind that the Smart Box is essentially a high-quality instrumentation amplifier. To ensure proper operation under the varying temperature conditions normally encountered in the automotive environment, several temperature-stable components must be used. These are identified in the Parts List as 1-percent tolerance resistors and zener diode D3. It is essential that you use the specified components for these parts so that the cut-in/out setting of the project doesn't change as the temperature varies.

It is recommended that temperature-stable resistors, such as metal-film types of the same value, be substituted for the resistors supplied with the Nova pressure sensor.

Install the resistors in their respective locations on the board. Make certain that the proper values of resistance goes in each respective location.

Power transistor Q2 carries the relatively heavy clutch current. However, the transistor operates very cool and, therefore, requires no heat sinking. With its case flush against the top surface of the board, secure Q2 to the board with 4-40  $\times$   $\frac{1}{4}$ -inch machine hardware. If necessary, place an insulating fiber washer on the screw on the soldering side of the board before screwing on the nut to prevent the hardware from electrically contacting any of the board's nearby copper traces.

Now remove  $\frac{1}{4}$  inch of insulation from both ends of ten 4-inch lengths

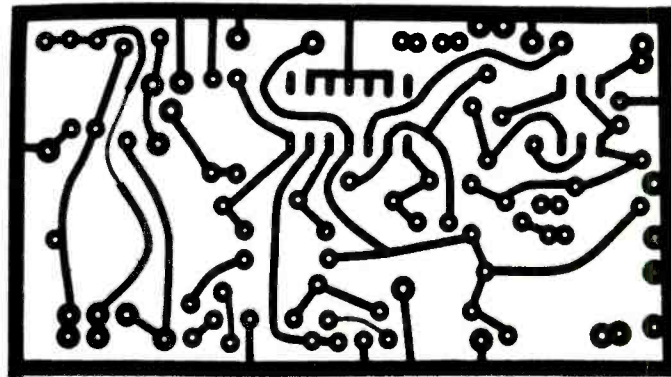

Fig. 2. Actual-size etching drilling guide for printed-circuit board.

of stranded hookup wire. If possible, use color-coded insulation for these wires with three of them in black, two in red and the remainder in any other colors, to avoid confusion during final wiring. Tightly twist together the fine conductors at both ends of all eight wires and sparingly tin with solder.

Plug one end of the black- and red-insulated wires into the holes labeled LED1, LED2 and TS1,1 and solder into place. Install the black-insulated wires in the *cathode* (labeled K) holes for the LEDs. Plug one end of the remaining wires into the holes labeled S1A, TS1,2, TS1,3, TS1,4, S1A and S1B and solder into place. The other ends of these wires will be connected after the circuit-board assembly has been mounted inside its enclosure.

The enclosure used for the Smart Box can be any metal or plastic utility box that is large enough to accommodate the circuit-board assembly and provides panel mounting space for the LEDs, switch and terminal strip used for making external connections to the automotive electrical system.

Machine the selected enclosure to permit mounting on one end a 4-position screw-type terminal strip and, on its top panel, the LEDs and switch. Place the circuit-board as-

sembly inside the box in the location where it will be mounted and determine and mark the location of the hole to be drilled to pass through the vacuum hose that will connect to the port on the pressure sensor. Drill a hole in that location, making it just large enough in diameter to comfortably pass the vacuum hose through. If you are using a metal utility box, deburr and smooth all holes. Mount the terminal strip, LEDs and switch in their respective locations.

Double check all components for proper locations and orientations on the circuit board. Then turn over the assembly and carefully inspect all soldering, checking for poorly soldered connections and possible solder bridges between closely spaced conductors and pads. Use solder wick or a vacuum-type desoldering tool to remove any bridges and reflow the solder on any connection that appears to be suspicious. Then use  $\frac{1}{8}$ -inch or thicker double-sided foam tape to secure the circuit-board assembly in place on the floor of the enclosure.

With the circuit-board assembly mounted in place, locate the wire coming from the TS1,1 hole and connect and solder it to lug 1 on the screw-type terminal strip. Then connect and solder the free ends of the



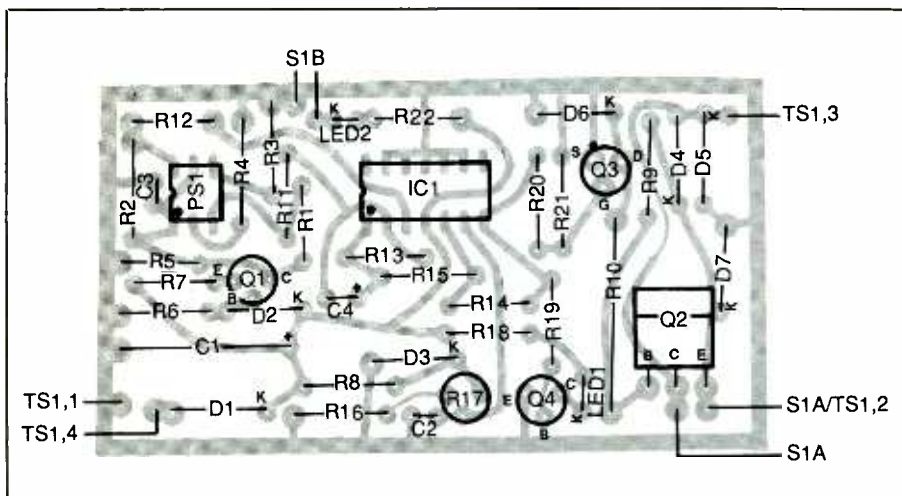

Fig. 3. Wiring guide for pc board.

wires coming from the holes labeled TS1,2, TS1,3 and TS1,4 to lugs 2, 3 and 4, respectively of the terminal strip.

Label the screw positions of the terminal strip, switch positions and LEDs with appropriate legends.

Cut the cathode leads of the LEDs to a length of  $\frac{1}{2}$  inch. Locate the LED cathode ( $\kappa$ ) wires coming from the board and slip over each a  $\frac{3}{4}$ -inch length of small-diameter heat-shrinkable or ordinary insulating plastic tubing. Crimp and solder together the LED cathode leads to the appropriate wires. Then slide the tubing over the joints until they are flush with the bottoms of the LED cases and shrink into place. Repeat with the LED anode leads and wires.

Crimp and solder the free ends of the remaining wires to the lugs of the switch. This done, refer to Figs. 1 and 3 for guidance and install the pressure sensor and LM324 quad op amp in the PS1 and IC1 sockets. Make sure you properly orient these devices and that no pins overhang the sockets or fold under between device bodies and sockets as you push these devices home.

Only one pneumatic connection from your vehicle's engine to the pressure sensor is needed. To make this connection, use a vacuum hose, available from any automotive parts

outlet. This hose plugs onto the low pressure port nipple of the sensor (see Fig. 1 for details in identifying the ports). For now, use only a 6-inch or so length of hose to make the connection to the port on the pressure sensor.

No connection to the pressure sensor's high pressure port is needed. This port is left open to atmospheric pressure. Locating it inside the enclosure in which the circuitry is located protects the sensor from dirt and other matter that could otherwise inhibit the circuit's operation.

### Preliminary Checkout

To perform preliminary checks on the Smart Box, you need a source of 12 volts dc at 300 or more milliamperes. If you use a bench-type power supply, make sure it is well filtered.

Apply dc power to the circuit between positions 1 (GND) and 4 (+12V) on the screw-type terminal strip at the end of the Smart Box's enclosure. With power applied, adjust the setting of *R17* over its entire range while observing *LED1*. The LED should turn on over part of the trimmer's range but be off for the remainder of the range. Set this control until *LED1* just turns on and then back off slightly but not enough to cause the LED to extinguish.

Now apply gentle, constant pressure to the open end of the vacuum hose with your mouth. Hold the pressure steady until the circuit reacts by *LED1* turning off and remaining that way when you remove the hose from your mouth. If you obtain this result, return the end of the hose to your mouth and gently suck in to create a steady vacuum condition. If all is well, *LED1* should come on and remain that way even after the vacuum condition is removed.

The above test checks operation of the pressure sensor, op-amp stage *IC1A* and comparator stage *IC1B* for proper operation. It also illustrates the hysteresis effect designed into voltage comparator *IC1B*.

To check the clutch circuit, apply +12 volts to the emitter of *Q2* with a dc voltmeter (or a multimeter set to the dc volts function) connected across *D5* in the proper polarity. With *S1* set to "off" (open), adjust the setting of *R17* so that *LED1* extinguishes, at which time, the reading on the meter should be 0 volt. Next, adjust *R17* so that the LED turns on; now the meter should indicate 12 volts. Placing *S1* in its alternate position should immediately turn on *LED2* to signal that the Smart Box has been bypassed.

If your project does not perform as detailed, rectify the problem before proceeding. Check the pressure sensor by measuring the dc voltage at pins 3 and 6 of *PS1*, both with respect to circuit ground. In both cases, the readings obtained should be 3.5 volts. Checking the voltage at pin 1 of *IC1* as *R17* is adjusted throughout its entire range should cause the meter reading to vary between 0.5 to 6.4 volts, and *LED1* should switch on and off as the control's setting crosses 3.5 volts. Finally, measuring the voltage at pin 7 of *IC1* as you adjust *R17* throughout its entire range should cause the meter reading to jump from 12 volts to 0 volt as the control's setting passes through the dc voltage at pin 1. If the

clutch does not perform as specified, carefully check the orientations of *Q2*, *D5*, *D6* and *Q3*. Also check the wiring to *SI*.

### ***Installation and Final Adjustment***

To keep it in a relatively temperature-stable environment and away from airborne hazards, the Smart Box should be mounted in the passenger compartment of your vehicle. Choose a location that is out of the way but still gives you unobstructed access to the switch and LEDs.

To power the project, use any electrical line that has +12 volts on it with the ignition turned on but has no power applied with the ignition off. Suitable pick-off points for the +12-volt connection are the radio, blower motor and windshield-wiper circuits. The Smart Box's current demand is a very low 0.3 ampere or less, so it will have no effect on any accessory to which it is connected. You can use any part of the vehicle's metal chassis to make the circuit ground connection. When making the ground connection to the vehicle's metal chassis, first clean the connection point with steel wool or fine emery cloth to obtain a bright shiny metal surface. Then drill a small hole in the center of the area and fasten down the ground wire with a No. 6 or No. 8 pan-head sheet-metal screw.

Make all connections between the vehicle's electrical system and the Smart Box with heavy-duty (at least 16-gauge) *stranded* wire. Strip  $\frac{3}{8}$  inch of insulation from both ends of all wires, tightly twist together the fine conductors at all ends and sparingly tin with solder. Terminate the project ends of the wires in crimp-on spade lugs.

Final electrical connections are to the clutch circuit. To determine where to make these connections in the vehicle's electrical system, locate the power wire that feeds the air conditioner's clutch. This will be a fairly

heavy wire that is usually terminated in a slip-on connector at or near the compressor. If in doubt about the location of this wire, consult your car dealer or any vehicle repair station.

You must cut the wire to the clutch and strip  $\frac{3}{8}$  inch of insulation from both cut ends tightly twist together the fine conductors at both stripped ends and sparingly tin with solder. Determine the lengths of the wires needed to route from the cut ends through the firewall to the location of the Smart Box in the passenger compartment and cut two 16-gauge stranded wires, preferably with color-coded insulation, to these lengths.

Solder one end of these wires to the cut ends of the clutch power-feed wire. Heavily insulate both connections with electrical tape and/or silicone sealant.

Route the free ends of the wires through your vehicle's firewall and to where the Smart Box will be installed. Being very careful to observe proper link-up, connect these wires to positions 2 and 3 on the screw-on terminal strip on the project's enclosure. The wire connected to the clutch must be go to the collector of *Q2* (position 3 of *TSI*), while the other wire goes to the emitter of *Q2* (position 2 of *TSI*).

The last connection to the Smart Box is the pneumatic one, made via the vacuum hose. Cut this hose to the length needed to go from the vacuum pick-off in the engine compartment to the project's pressure sensor device. Make the cuts at both ends as square as possible.

Pass one end of this hose through its hole in the project's utility box and then, referring to the appropriate detail in Fig. 1, plug it onto the low-pressure port nipple on *PSI*. Route the free end of the hose through the vehicle's firewall and into the engine compartment. This end must be connected to an *unported* or raw source of engine vacuum. Since today's vehicles have a multitude of vacuum-hose connections, it is mandatory

that you connect to the proper one.

The best place to make the vacuum connection is to the *input* side of the vacuum storage canister used to store vacuum for operating the air-conditioning and heating controls. A good second choice would be to the hose that feeds the vehicle's vacuum brake unit.

Cut through the appropriate vacuum line and insert into the cut ends the nipples on the crossbar of a common "T" connector. The hose from the project then plugs onto the "tail" of the T connector. You may have to obtain a hose adapter to allow you to connect together two different sizes of hose. If you have any doubt as to where the proper vacuum connection is to be made, ask your dealer for assistance.

Once all connections have been made to the Smart Box, mount it in the selected location. A good way to mount it is via a hook-and-loop fastener like Velcro®. For more rigid mounting, you might want to use small metal L brackets instead.

Final adjustment of trimmer potentiometer *R7* must be made under actual vehicle operating conditions. To do this, use *LED1* to indicate circuit status. For this adjustment, it does not matter if the air conditioner is in use or not, since the circuit responds only to engine vacuum. For obvious safety reasons, you should have someone else drive the vehicle as you adjust the setting of *R17*.

To start with, you need a stretch of highway that is straight and level and allows you to drive at 55 mph. While the driver is maintaining a steady 55 mph, adjust the setting of *R17* so that *LED1* just comes on. Now when you accelerate or encounter an upgrade, *LED1* should extinguish and when you take your foot off the gas pedal it should come on again. If you normally drive in areas where there are many upgrades, you may want to tailor *R17*'s adjustment to suit your driving needs.

*(Continued on page 89)*

# SELECT 5 BOOKS for only \$3.95

(values to \$130.70)  
and get a Free Gift!

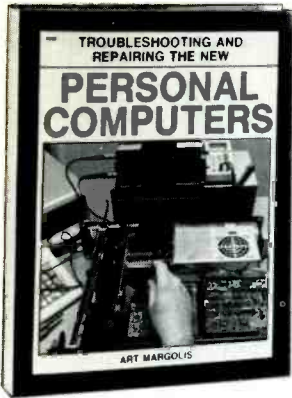
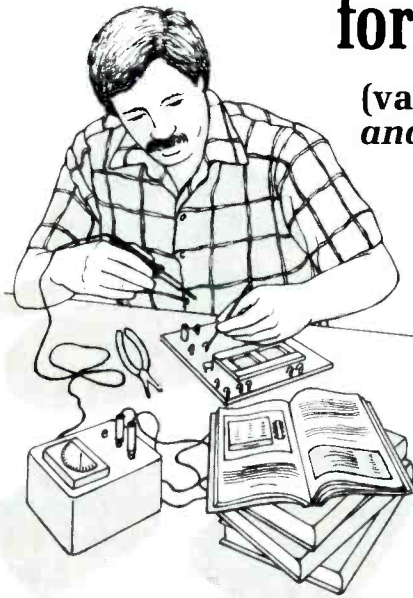

2809 \$26.95  
Count as 2

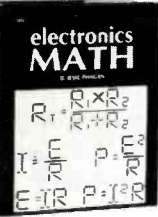

1962 \$22.95



1625P \$14.95



2905 \$19.95



2645P \$10.95



1536P \$8.95

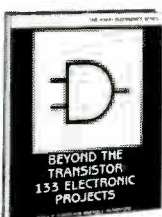

2887 \$16.95



1300P \$24.95  
Counts as 2



2613 \$23.95

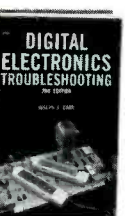

2750 \$25.95



1604 \$16.95



2861 \$14.95

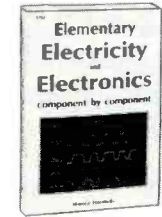

2753P \$16.95



2660P \$17.95



2617 \$17.95



1887P \$13.95



1999P \$14.95

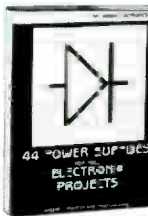

2522 \$4.95

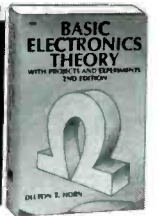

1775P \$18.95

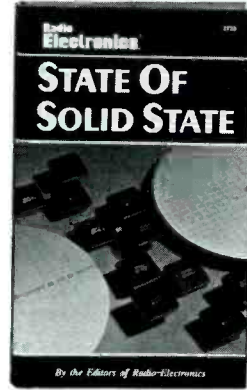

2733 \$14.95

Electronics projects . . . ideas . . . the latest technology  
all at up to 50% off publishers' prices!

**Membership Benefits** • **Big Savings.** In addition to this introductory offer, you keep saving substantially with members' prices of up to 50% off the publishers' prices. • **Bonus Books.** Starting immediately, you will be eligible for our Bonus Book Plan, with savings of up to 80% off publishers' prices. • **Club News Bulletins.** 14 times per year you will receive the Book Club News, describing all the current selections—mains, alternates, extras—plus bonus offers and special sales, with hundreds of titles to choose from. • **Automatic Order.** If you want the Main Selection, do nothing and it will be sent to you automatically. If you prefer another selection, or no book at all, simply indicate your choice on the reply form provided. As a member, you agree to purchase at least 3 books within the next 12 months and may resign at any time thereafter. • **Ironclad No-Risk Guarantee.** If not satisfied with your books, return them within 10 days without obligation! • **Exceptional Quality.** All books are quality publishers' editions especially selected by our Editorial Board.

All books are hardcover unless numbers are followed by a "P" for paperback. (Publishers' Prices Shown)  
© 1988 ELECTRONICS BOOK CLUB®, Blue Ridge Summit, PA 17294-0810

**FREE when you join!**

## 49 Easy-to-Build Electronic Projects

An exciting collection of practical projects that you can build simply, quickly, and from readily available and inexpensive parts!

(a \$6.95 value!)

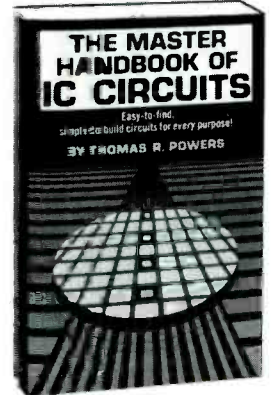

370P \$15.50



121EF \$14.95

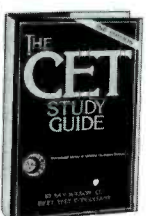

2941 \$21.95



**ELECTRONICS BOOK CLUB®**  
Blue Ridge Summit, PA 17294-0810

Please accept my membership in the Electronics Book Club® and send the 5 volumes listed below, plus my FREE copy of 49 Easy-to-Build Electronic Projects (1337P), billing me \$3.95 plus shipping and handling charges. If not satisfied, I may return the books within ten days without obligation and have my membership canceled. I agree to purchase at least 3 books at regular Club prices (plus shipping and handling) during the next 12 months and may resign any time thereafter.

Name \_\_\_\_\_  
Address \_\_\_\_\_  
City \_\_\_\_\_  
State/Zip \_\_\_\_\_ Phone \_\_\_\_\_  
Signature \_\_\_\_\_

Valid for new members only. Foreign applicants will receive special ordering instructions. Canada must remit in U.S. currency. This order subject to acceptance by the Electronics Book Club®. MDNE-588  
Signature of parent or guardian required for all new members under 18 years of age.



2867 \$24.95

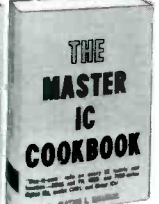

1199P \$14.95



1532P \$14.95



2731 \$21.95

# Dual Flashing Lights

*Attention-getting device uses LEDs for model railroad, toy and in-home signals, optional incandescent lamps for use as nighttime safety/hazard-warning device, etc.*

By Charles Shoemaker

A pair of lights that alternately flash to draw attention can be very useful to add realism to a model railroad layout as a crossing signal, to a toy ambulance or fire truck to keep a youngster absorbed in play, or to attract attention around the home. Adding a pair of high-brightness incandescent lamps to the device gives you a very practical alerter that can be seen a long way off on a dark night when changing a tire at roadside or to warn of a dangerous condition.

Our low-cost Dual Flashing Lights project offers the best of both worlds. In its most basic form, the project lets you use a pair of light-emitting diodes. To the basic circuit you can inexpensively add two each resistors, power transistors and high-brightness incandescent lamps. You can wire the project on a printed-circuit board you home fabricate or on perforated board. On-board facilities are provided for both versions of the circuit.

## About the Circuit

As shown in Fig. 1, the main element in the Dual Flashing Lights circuit is *IC1*, an LF351 JFET operational amplifier chip that is configured here as an astable multivibrator. I used the LF351 because I had it on hand; if you have a 741 or TL081 operational amplifier you can use it instead. With the values shown for *C1*

and *R1*, this circuit has a repetition rate of two flashes approximately every 1.6 seconds.

Pulse repetition rate of the *IC1* multivibrator is calculated with the formula  $T = 2 \times C1R1 \times 3.7$ , where *C1* is in microfarads and *R1* is in megohms. Therefore,  $T = 2 \times 0.47 \text{ microfarad} \times 0.47 \text{ megohm} \times 3.7 = 1.635 \text{ seconds}$ . You can increase repetition rate by increasing the value of either *C1* or *R1* or both, and vice-versa.

When power is first applied to the circuit, output pin 6 of *IC1* will be positive. Capacitor *C1* will begin to charge through resistors *R1* and *R4* to the pin 6 level. (Note: The value of *R4* is so small with respect to the value of *R1* that it can be disregarded in the pulse-repetition formula without significantly affecting the result of the calculation.)

Conditions at the junction of *R2* and *R3* set the voltage that appears on pin 3 of *IC1* to about 98 percent that of the voltage on pin 6. When *C1* charges to the pin 3 voltage, the output at pin 6 goes negative, at which point *C1* begins to discharge. The negative-going output at pin 6 is transmitted to the *R2/R3* network, further causing the output to swing quickly from positive to negative.

When the charge on *C1* falls below the potential on pin 3 of *IC1*, the output at pin 6 flips to positive to repeat the cycle. This sequence will recur for as long as power is applied.

Because the output waveform at pin 6 of *IC1* is a perfect square wave

(50-percent duty cycle), the off and on times are exactly the same in duration. Hence, we see here an operational amplifier serving the function of a switching comparator.

What is done with the output signal from pin 6 of *IC1* depends on the circuitry that follows. This output signal appears at the bases of *Q1* and *Q2*, a complementary (pnp/npn) pair of transistors that have the same characteristics.

Transistor *Q1* is reverse-biased and held in cutoff when the output signal at pin 6 of *IC1* is positive. Thus, with no emitter-to-collector current flowing, *LED1* is off as well. Under the same positive-signal condition, *Q2* is forward biased and conducts current to light *LED2*.

With a negative output signal on pin 6 of *IC1*, *Q1* becomes forward-biased and *Q2* becomes cut off. Now *LED1* lights and *LED2* extinguishes. Since the pin 6 output from *IC1* is normally a continuous train of pulses, the two transistors and their associated LEDs will alternately flash. Under existing circuit conditions, only one LED will be on at any given moment.

If you wish, you can add complementary power transistors to the basic circuit to drive automotive-type lamps that will alternately flash as described for the LEDs. The dashed lines in Fig. 1 indicate the connections that must be made to add this option, which consists of a complementary pair of power transistors (*Q3* and *Q4*) and two base resistors

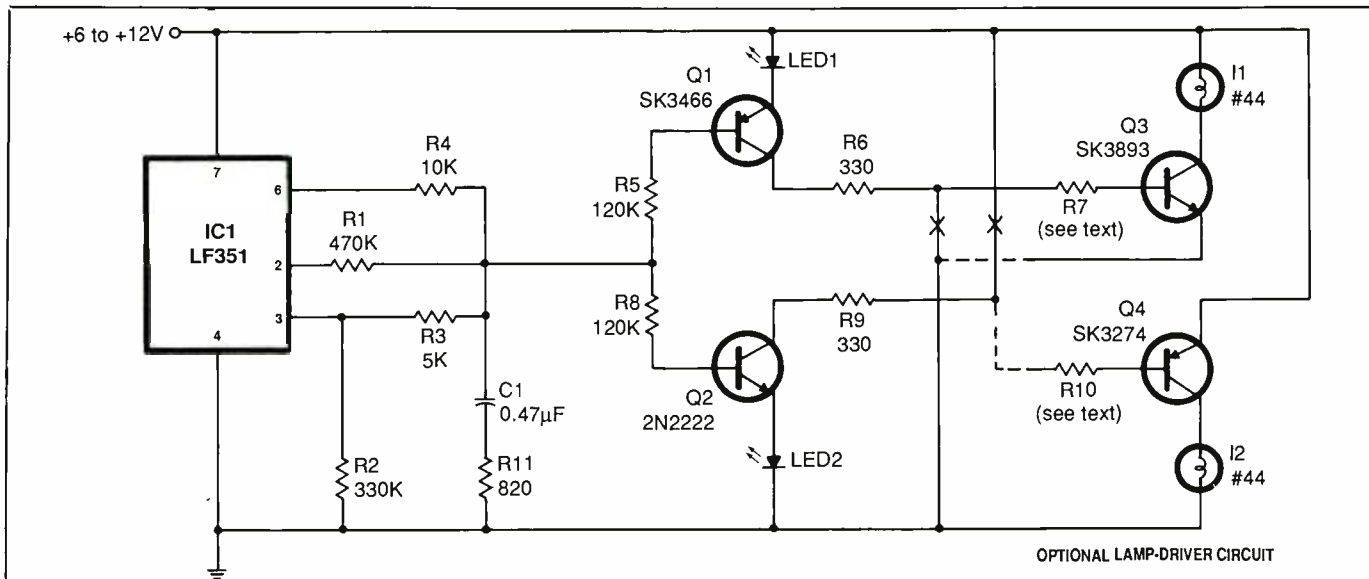

### PARTS LIST

#### Semiconductors

IC1—LF351 JFET operational amplifier (see text for alternative op-amp devices)

LED1, LED2—Red light-emitting diode

Q1—T1 593, SK3466 or equivalent silicon pnp signal transistor

Q2—2N2222, SK34444 or equivalent silicon npn signal transistor

Q3—SK3893 or equivalent silicon npn power transistor (optional—see text)

Q4—SK3274 or equivalent silicon pnp power transistor (optional—see text)

#### Capacitors

C1—0.047- $\mu$ F disc

#### Resistors (1/4-watt, 10% tolerance)

R1—470,000 ohms

R2—330,000 ohms

R3—5,000 ohms

R4—10,000 ohms

R5, R8—120,000 ohms

R6, R9—330 ohms

R7, R10—Optional; see text for value

R11—820 ohms

#### Miscellaneous

I1, I2—No. 44 or similar 6-volt incan-

descent lamp (optional—see text)

Printed-circuit board or perforated board with holes on 0.1-inch centers and suitable solder or Wire Wrap hardware; DIP socket for IC1; sockets for I1 and I2 (optional); suitable enclosure (see text); stranded hookup wire with color-coded insulation; small-diameter heat-shrinkable plastic tubing; double-sided foam tape; car cigarette lighter plug (optional); solder; etc.

Fig. 1. This complete schematic diagram of the Alternate Flashing Lamps project shows both the basic LED-only circuit and the optional high-power incandescent-lamp

system described in the text. The lamp circuit requires that the lines that have Xs through them to the +12-volt and ground rails must be cut.

(R7 and R10). A pair of "X" marks indicate where breaks in the basic circuit must be made when incorporating this option.

With the power-driver portions of the circuit added to the basic circuit, operation is as follows. When pin 6 of IC1 is at a positive potential, current flows through LED2, Q2's emitter-to-base junction and through R8 and R4 as before. This causes greater current to flow from the ground side of power supply through LED2, emitter-to-collector of Q2 and to the positive supply rail. In turn, this causes greater current (about 250 milliamperes) to flow through Q4

and incandescent lamp I2. This increased current turns on I2. Note that I2 and LED2 will both be on simultaneously.

When pin 6 of IC1 goes negative, the entire Q2/Q4 circuit turns off and the Q1/Q3 circuit turns on, this time lighting LED1 and I1 simultaneously. (The LEDs remain in the circuit when the incandescent-lamp option is incorporated to serve as indicators of circuit conditions in the event the filament in one or both lamps burn out.) As before, the entire sequence of events repeats indefinitely for as long as power is applied to the project.

Bias resistors R7 and R10 in the base circuits of Q3 and Q4 determine how bright will be the light from I1 and I2. The values of these resistors depend on the level of brightness you wish. Using 3,000-ohm resistors provides a current of about 280 milliamperes. Though this is beyond the capacity of a No. 44 incandescent lamp to handle under sustained conditions, it is safe for the same lamp to handle under 50-percent duty-cycle conditions.

The power transistors specified for Q3 and Q4 in the Parts List can handle a maximum of 1 ampere of current. This means that you can use

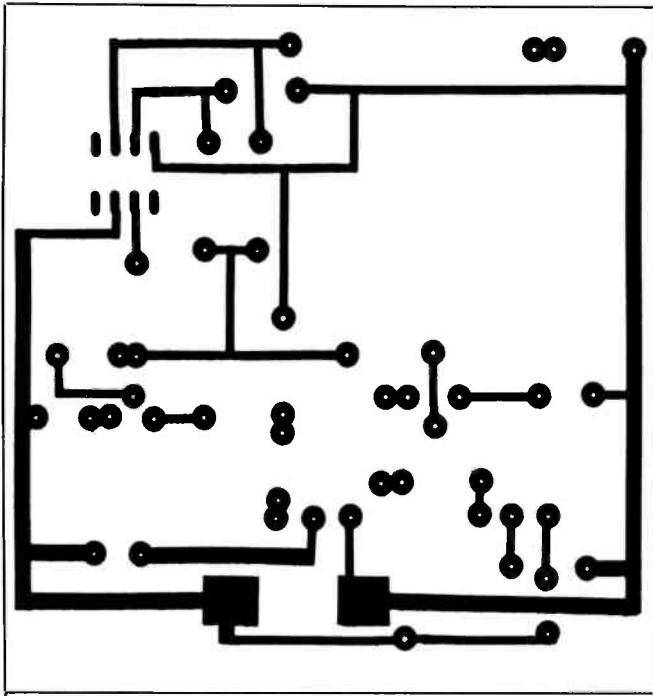

Fig. 2. This actual-size etching-and-drilling guide for the project's printed-circuit board incorporates facilities for both versions of the circuit to be installed.

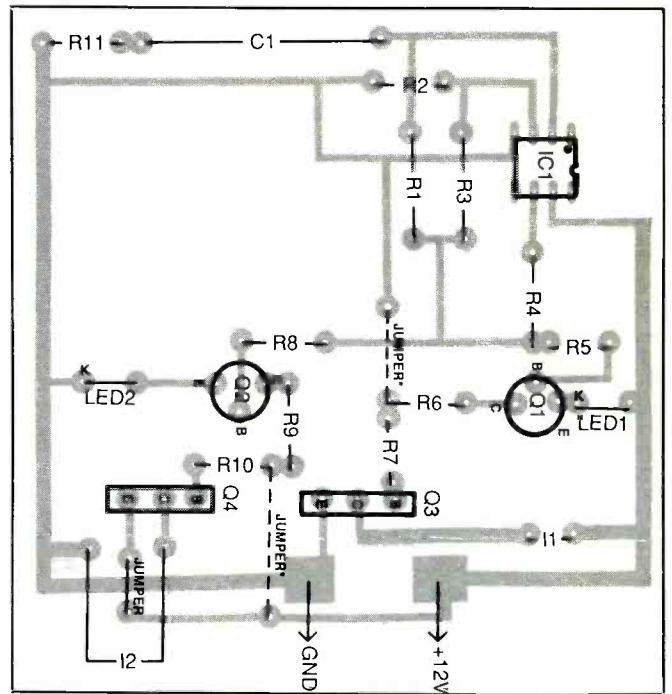

Fig. 3. This is the wiring diagram for the pc board illustrated in Fig. 2. Jumpers identified by dashed lines install on the board only if the incandescent-lamp option is not used.

other types of automotive incandescent lamps in this circuit, as long as their current draw does not exceed, say, 850 milliamperes (you need a margin of safety). For example, a 12-volt No. 67 CP automotive lamp will draw 500 milliamperes. To drive this lamp to any usable level of brightness, you'll have to change the value of *R7* and *R10* to a lower value of around 2,500 ohms.

With only the LEDs in the circuit, current drain on the power source is approximately 10 milliamperes. Adding the optional incandescent-lamp driver circuitry can increase this drain to 250 milliamperes or more. Therefore, if you incorporate the incandescent lamps into the project, make sure that the dc power source used to power this project can supply the required current.

Notice that incorporating the incandescent-lamp option in this project does not eliminate the two light-emitting diodes. These LEDs pro-

vide a means for monitoring circuit operation. If one or both incandescent lamps fail to turn on but both LEDs light alternately, you know that the circuit is operating up to par and that a dead lamp means that either the lamp's filament is blown or connections to the lamp are faulty.

You can power this project from any source that can deliver between 6 and 12 volts dc at the required current. If you use automotive lamps, make sure that the lamps have the proper voltage rating.

### Construction

The simplest and fastest way to build the Alternate Flashing Lights project is to wire its components on a printed-circuit board. You can fabricate the required single-sided board using the actual-size etching-and-drilling guide shown in Fig. 2. If you prefer not to make a pc board, you can substitute the same-size perforated board with holes on 0.1-inch centers

and suitable soldering or Wire Wrap hardware. Whichever you choose, use a socket for *IC1*.

Begin populating the board by installing and soldering into place the socket for *IC1* but do not install the IC in the socket at this time, as shown in the Fig. 3 wiring diagram. Then install and solder into place the resistors and capacitor. Next, taking care to properly base them, install and solder into place the appropriate transistors for each location.

If you are building the LED-only version of the circuit, omit resistors *R7* and *R10* and transistors *Q3* and *Q4*. Then complete the circuits to +12 volts and ground by installing and soldering into place the two jumper wires shown as dashed lines. Whichever version you are building, you must install the jumper wire shown as a solid line in the lower-right portion of Fig. 3. Use insulated solid hookup wire for the jumpers.

Assuming you are building the

high-power version of the project, omit the two jumpers shown as dashed lines and install and solder in to place *R7*, *R10*, *Q3* and *Q4*. Take care to properly base the transistors before soldering their pins to the copper pads on the bottom of the board.

You can install the LEDs directly on the board, properly polarized, if the project is to be used as a simple attention-getting device. This assumes that you will be housing the circuit-board assembly inside a clear-plastic enclosure. Otherwise, mount the LEDs off the board

Depending on your application for the circuit, you may or may not need a separate enclosure for the project. For example, if you are using the project on a toy, you can mount the circuit-board assembly inside the toy itself with double-sided foam tape to insulate it from the toy and keep it in place. Then run the hookup wires from the specified holes in the circuit board to the appropriate LED leads. If you are building the high-power incandescent-lamp version of the project, locate the LEDs on the enclosure where they will easily be seen. It helps if you use different colors of insulation for the hookup wires to avoid confusion. Use black for the cathode leads (K) and red for the anode leads (not identified).

Bear in mind that when making hookup-wire connections to the leads of the LEDs, you must make sure that no short circuits occur. To prevent short circuiting, first cut the cathode lead of the LED to a length of 1/2 inch. Slide a 1-inch length of small-diameter heat-shrinkable or insulated plastic tubing over the appropriate hookup wire end and crimp and solder the wire to the LED's lead stub. Do the same with the anode lead and wire. Then push the tubing over the connection until it is flush against the base of the LED's plastic case and shrink into place. Repeat with the other LED

If you are using an enclosure, machine it for mounting the LEDs side by side on one panel, assuming this is what you want. Also, drill any holes needed for exiting of the LED and/or incandescent-lamp wires and for entry of the power lines. This done, mount the circuit-board assembly inside the enclosure with 1/4-inch-thick double-sided foam tape or machine hardware and 1/4-inch spacers.

For the low-power LED-only version of the project, you need only 22-gauge stranded hookup wire for the power lines. Use wires with red insulation for the +12-volt line and black insulation for the circuit-ground line. Make these wires long enough to reach from the project box to the power source. Strip 1/4 inch of insulation from both ends of both wires. Tightly twist together the fine conductors at all ends and sparingly tin with solder. Install and solder one end of each wire in the appropriate holes in the board.

If you built the high-power incandescent-lamp version, increase the size of the wire used for both the power lines and interconnections to the lamps to, say, 16-gauge or light-duty lamp zip-cord size. Before installation, prepare their ends as described for the lighter-duty wire. Terminate the free end of the power cord in a standard automotive cigarette-lighter plug.

With *ICI* still not installed in its socket, plug the power cord into your car's cigarette-lighter socket (or connect it to another 12-volt dc source). Use a dc voltmeter (or a DMM set to the dc volts function) to measure the voltage between pins 4 (circuit ground) and 7 (+12 volts) of the IC socket. Your reading should be approximately +12 volts. If you obtain a negative reading, unplug the project and transpose the leads connected to the terminals on the cigarette-lighter plug. If you obtain a much lower reading or no reading at all, double check all wiring and rectify the problem before proceeding.

Once you are certain that the project has been wired correctly and that all soldering is good. Plug *ICI* into its socket (with no power applied to the circuit). Make sure you properly orient the IC.

As stated earlier, the basic project can be housed in any convenient enclosure. The same is true for the high-power version, except that you must make separate arrangements for housing the incandescent lamps external to the enclosure. A simple way to go for the lamps is to house them inside amber plastic pill containers that, in turn, fasten to opposite sides of the enclosure.

A much larger unit with greater reflection can be made from plastic freezer containers mounted back to back with the main circuit assembly sandwiched between the two. Alternatively, you can use a pair of disposable clear plastic drinking cups as domes for the lamps. **ME**

# ATTENTION! ELECTRONICS TECHNICIANS



**EARN YOUR  
B.S.E.E.  
DEGREE**

**THROUGH HOME STUDY**

Our New and Highly Effective Advanced-Placement Program for experienced Electronic Technicians grants credit for previous Schooling and Professional Experience, and can greatly reduce the time required to complete Program and reach graduation. No residence schooling required for qualified Electronic Technicians. Through this Special Program you can pull all of the loose ends of your electronics background together and earn your B.S.E.E. Degree. Upgrade your status and pay to the Engineering Level. Advance Rapidly! Many finish in 12 months or less. Students and graduates in all 50 States and throughout the World. Established Over 40 Years! Write for free Descriptive Literature

**COOK'S INSTITUTE  
OF ELECTRONICS ENGINEERING**

 4251 CYPRESS DRIVE  
JACKSON, MISSISSIPPI 39212

CIRCLE 49 ON FREE INFORMATION CARD

# The Semianalyzer

(Conclusion)

*Final assembly, checkout, calibration and use tips for this versatile benchtop troubleshooting instrument*

David Miga, CET

Last month in Part 1, we discussed operation of this time-saving instrument and gave details on wiring the main printed-circuit assembly. In this concluding part, we continue with construction details for the legend/numeric-display board and chassis machining and wiring; checkout and calibration; and some tips on using the Semianalyzer on your testbench.

## Wiring the Display Board

This single-sided board is easier to wire than the main board, both because much fewer components mount on it and the fact that no jumper wires that bridge between the conductors on both sides of the board are required.

• *Display Board.* This single-sided board is easier to wire than the main board, both because much fewer components mount on it and the fact that no jumpers that bridge between the conductors on both sides of the board are required.

Etch and drill the display board using the Fig. 6 artwork. Then carefully drill the 43 small holes through the traces along the bottom of the board as you did for the main board. Also, drill a 1/4-inch hole through the board, centered in the square in the center of the board below the lower-right string of three LEDs.

Before installing components, fashion a shield to contain the light



from each string of three LEDs in the area where its panel legend will be. This matrix shield will contain the light from the strings within their own display areas, eliminating spill-over to other areas.

Use thin strips of 1/8- or 1/16-inch-thick plastic or wood, or even heavy cardboard to make the shield. The best way to go about this is to cut 1/2-inch-wide strips to make the frame first. Cut two 3/4-inch and two 1 1/4-inch strips (this dimension may be larger or smaller, depending on the thickness of the material used). Plastic cement is ideal to glue the strips onto the component side of the board to form the frame. Note that there are four small square pads above and below the LED arrange-

ment (Fig. 8), which define the size of the frame. Cement the strips directly over these holes and let the cement set completely.

Measure the distance from left to right within the display area and cut two more strips to this length. Cement these strips midway between the holes between the LEDs and let set. Measure the distance between the top and middle horizontal strips and cut two strips to this length and repeat for the middle and bottom horizontal strips. Cement the strips between the middle and top strip and top of the frame, centering them between the three sets of horizontal LED holes and then repeat with the lower strips.

Let the cement completely set.



Then check to make sure that the top edges of the matrix shield are all even and flush with each other. Use a hobby or safety knife to trim any that are not flush.

With the display board oriented as shown, plug a line of three LEDs into the holes in the upper-left section of the matrix shield. Make sure the flat on the case of each LED that identifies the cathode lead goes into the lower hole in the matrix area. Push the LEDs down against the surface of the board and solder their leads to the pads on the bottom. Repeat for each string of three LEDs in all remaining matrix areas.

Install and solder into place the resistors below the matrix. Inspect your work to make sure that all 27 LEDs are properly oriented and that your connections are properly soldered, with no "cold" solder joints or solder bridges. Reflow the solder on any suspicious joint and use solder wick to remove any bridges.

You can install the LED numeric displays directly on the circuit board if you wish, after first clipping away pin 3 of each (there are no holes in the board for these pins). However, you might want to use low-profile DIP IC sockets instead. If you use sockets, clip away pin 3 of the sockets but not the displays. With pin 3 removed, there is no way to plug the displays into the board in the wrong direction.

Drop a straight pin into the right-most three holes along the bottom of the circuit-board assembly, so that the heads are flush against the component side of the board. Check to make sure that the heads do not touch each other; if they do, use pins with smaller heads. Then solder the right-most pin to the pad on the bottom of the board, making sure the pin remains perpendicular to the board's surface until the solder sets. Repeat for the remaining 42 holes. Use solder sparingly and watch out for solder bridging between the closely-spaced conductors.

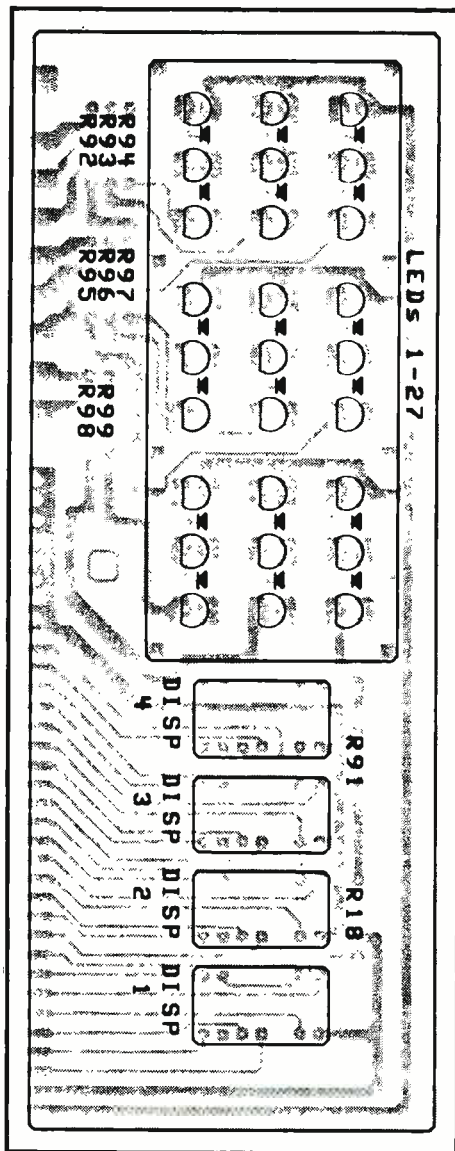

Fig. 8. Wiring guide for display pc board.

After soldering all 43 pins into place, bend them flat against and directly toward the edge of the board. Make sure the pins are parallel with each other. Plug the ends of the pins into the small holes in the main board, making sure that each pin end goes into its own hole. Tilt the display board so that it clears the plunger shaft on S2.

When the switch plunger has passed through the hole, push the display board all the way down on the main

board and, holding the two perpendicular to each other, solder each of the end pins to the pads on the bottom of the main board. Recheck to make sure the display assembly is perpendicular to the main circuit-board assembly. If it is not, gently bend it until it is perpendicular. It helps if you use a small triangle to "true up" the two boards during this operation. Then solder all remaining pins to the main board's traces. Be careful to avoid creating solder bridges, and clean your soldering tip frequently. Clip away all excess pin lengths.

Make a legend mask with the various legends in the display matrix shield. The most effective mask is one with transparent legends on a black background. You can obtain a suitable mask by having a photographer make a same-size film negative of Fig. 9. Otherwise, make the mask yourself using a clear plastic film and dry-transfer lettering to duplicate the Fig. 9 artwork and use this as a mask to expose the reversing film used in pc work.

Apply a very thin bead of plastic cement to all top surfaces of the display matrix shield and allow it to just "skin over." Then lower and very carefully position the mask over the matrix shield and gently press the mask into the cement. Place a flat weight on it until the cement sets.

Plug the 6.3-volt and 30-volt with center tap leads of power transformer T1 into the holes at the edge of the main board and solder into place. If you are using the transformer specified in the Parts List, follow the color coding of the plastic insulation indicated.

### Checkout & Calibration

Temporarily twist together one primary lead with one of the ac line cord's conductors and screw on a small wire nut. Do the same for the other primary and line-cord leads. Plug the line cord into an ac outlet

and place a fingertip on the case of the bridge rectifier and feel the main filter capacitors. If these components do not feel cool, power down the project and look for electrolytic capacitors and diodes that might be installed in the wrong polarity. Then use a voltmeter, set to a dc range that can measure 20 volts or so to perform the following tests, connecting the meter's common probe to any convenient circuit ground point and leaving it there until you are finished with initial checkout.

Touch the meter's "hot" probe to the positive leads of *C11* and *C13*. You should obtain readings of +5 and +12 volts, respectively. Change the meter's range to indicate up to, say, 200 volts dc and touch the meter's hot probe to the positive lead of *C20* and note that the reading should be +150 volts. Now touch the hot probe to the positive lead of *C8* and adjust trimmer *VR2* until the reading is exactly +9.00 volts. Similarly, connect the meter's hot probe to the negative lead of *C7* and adjust *VR1* for a reading of exactly -9.00 volts. Once *VR1* has been adjusted, connecting the hot probe to the positive lead of *C9* should yield a reading of approximately -5 volts. For precise readings at the +9.00- and -9.00-volt points, use a digital voltmeter for this.

If you do not obtain the proper meter readings or cannot adjust either trimmer potentiometer to obtain the proper readings, power down the project and rectify the problem before proceeding. Make sure the voltage-regulators are in the proper locations and that they are properly based, and check that the electrolytic capacitors are installed in proper polarization. Do the same for the rectifier diodes, zener diode and bridge rectifier assembly. Also check that the secondary leads of *T1* are plugged into the proper holes.

Once you are certain that the power supply is operating properly, install the ICs in their respective sock-

OPEN	SINGLE	JUNCT
LEAKY	DUAL	PNP
SHORT	TRIPLE	NPN

Fig. 9. Actual-size artwork for making legend display mask.

ets (the 2716 EPROM that plugs into the IC10 socket must be first programmed with the data given in the Program Listing table). Handle the CMOS devices with the same precautions you would use with any other MOS device to prevent damage to them from static electricity, and make sure that no pins overhang the socket or fold under between IC and socket.

Once again, plug the project's line cord into an ac outlet and recheck all voltages in the power supply. There should be no significant differences in measured voltages from those made earlier at the same points. If necessary, trim the settings of *VR1* and *VR2* until you obtain readings of exactly -9.00 and +9.00 volts, respectively.

### Final Assembly

You can house the Semianalyzer in any enclosure that will accommodate it. The enclosure pictured in the lead photo is ideal for this instrument because it has an easily machined front panel and a swivel carrying handle that doubles as a tilt stand on your testbench. If you cannot find this type, you use another type of instrument enclosure or even make an enclosure from lumber and a 1/8-inch-thick sheet of transparent red plastic for the front panel and 1/4-inch-thick Masonite for the rear panel.

If use lumber, make the enclosure in two pieces, one consisting of both sides and the top panels and the other

consisting of just the bottom panel so that you can easily disassemble the project if it ever needs servicing. Glue and nail the top "shell" pieces together but arrange things so that four screws and *no* glue secure the bottom panel to the side panels.

If your instrument case has a metal front panel, see if you can replace it with red transparent plastic to ease your machining task. Of course, you can use the metal panel, but you will have a lot more work machining it for the display areas, and you must still use thin clear red plastic panels in the display windows.

When using a plastic front panel, all you need do to prepare it is drill holes for the switches and input jacks and for the speaker's sound to be heard.

Once the front panel has been prepared, use a dry-transfer letting kit to label appropriate legends, as illustrated in the lead photo. If the panel is metal, spray two or three light coats of clear acrylic over it to protect the lettering. On the other hand, if the panel is plastic, you can place over it a sheet of transparent Mylar to protect the labeling.

You have a choice of a slide or miniature toggle switch or a push/push switch for POWER switch *S1*. If you use a push/push switch, fashion an L bracket from 1/8-inch-thick metal stock on which to mount it and then mount the assembly on the front of the main pc board to the right of the numeric display area with machine hardware fastened through the holes in the board. A

slide or toggle switch does not need a bracket; these switches can be mounted directly on the front panel.

Drill a hole in the rear of the enclosure to provide entry for the ac line cord. Only three or four more holes drilled through the floor of the enclosure are needed to mount *T1* and a 3-lug terminal strip (no lugs connected to the mounting tab or tabs). If you are not using the type of enclosure pictured in the lead photo, also drill two mounting holes for the circuit-board assembly through the floor of the enclosure. Mount the terminal strip in place with machine hardware.

Mount red and black banana jacks in the *J1* and *J2*, respectively, holes on the front panel. Strip  $\frac{1}{4}$  inch of insulation from a 6-inch-long hookup wire and crimp and solder one end of it and the free end of the wire coming from the GND hole on the main circuit board to the black banana jack's solder post. Then crimp and solder the free end of the wire coming from the RED JACK hole on the main circuit board to the solder post on the red banana jack.

Next, mount the circuit-board assembly in place and then *T1*. Remove the wire nuts from the line-cord/power-transformer primary leads and disconnect the leads. Tightly twist together the fine wires at the end of one line-cord conductor and tin with solder. If the rear panel is metal, place a rubber grommet in the line cord's hole and pass the free end of the line cord through the grommet and tie a knot in it about 8 inches from the prepared end inside the enclosure. Alternatively, use a plastic strain relief on the line cord as you install it in the hole, leaving about 8 inches of free cord inside the enclosure.

Separate the line cord's conductors to within about 1 inch of the knot or strain relief. Route and secure the tinned line cord conductor to one of the lugs on POWER switch *S1* and solder the connection. Deter-

mine the length needed for the other line cord conductor to reach the nearest end lug on the terminal strip and add 1 inch. Clip the remaining line cord conductor to this length and set aside the clipped-off conductor. Strip  $\frac{1}{4}$  inch of insulation from the conductor stub, twist together the fine wires and tin with solder. Crimp but do not solder the line cord conductor stub to the terminal-strip lug.

Crimp one lead of the fuse to the lug to which the line cord stub is connected and solder the connection. Crimp but do not solder the other fuse lead to the opposite end lug on the terminal strip. Crimp one primary lead of *T1* to this lug and solder the connection.

Strip  $\frac{1}{4}$  inch of insulation from both ends of the cut-off line cord conductor, twist together the wires at both ends and tin with solder. Crimp one end of this wire and the other primary lead of *T1* to the center lug on the terminal strip and solder the connection. Route the wire to the other lug on the POWER switch and solder the connection.

Mount the speaker on the front panel, centered over its holes, using silicone adhesive. Connect and solder the free end of the SPKR + wire from the main board to the appropriate lug on *S2*. Then wire "signal" lug on the speaker to the companion lug on *S2*. Connect and solder the free end of the wire coming from the black banana jack to the other lug on the speaker.

Prepare the test leads using red and black color-coded test-lead cable, banana plugs and test probes, the last preferably with sharp insulation-piercing tips.

---

### *Using the Semianalyzer*

---

With the Semianalyzer turned on and set to the junction mode, connect the black test probe to the base of a good npn transistor and touch the red probe to the transistor's col-

lector. The legends SINGLE, NPN and JUNCT should light up and a tone should be heard from the speaker. Moving the red probe to the emitter should light the same legends in the display and generate the same tone. Touching the probes between collector and emitter should light OPEN and JUNCT in the display. Shorting together the probes should now light SHORT and JUNCT in the display and the speaker should now be emitting a screeching sound.

Here are some things to keep in mind when using the Semianalyzer. The instrument will display DUAL and JUNCT and beep a tone that is slightly higher in frequency than is normal if the base-to-emitter junction of a Darlington transistor is tested. TRIPLE and JUNCT will be displayed when a bias diode of an amplifier is probed. LEAKY, NPN, PNP and JUNCT will be displayed if the Semianalyzer determines that no normal junction can be found. LEAKY, NPN and JUNCT does not necessarily mean that the semiconductor is defective, only that there may be a low-impedance component in the circuit.

Placing *S2* in the "voltage-breakdown" position turns on the numeric display, which will indicate the potential available for measuring voltage breakdown. Connecting the test leads of the instrument across a zener diode in this mode with red to cathode and black to anode should cause the displayed value to become the zener voltage and a small amount of white noise to be emitted by the speaker. If the zener diode is leaky, a lower voltage than its designed value will be displayed. If the emitter-to-collector junction of a noisy transistor is being tested, the displayed voltage will vary and you will hear a loud crackling sound from the speaker and the indicator lamp will light.

The voltage-breakdown mode can usually be used in-circuit to deter-

*(Continued on page 94)* 

## *A Video Tape Hard-Disk Backup*

The **VIDEOTRAX** hard-disk backup system from Alpha Micro is a sophisticated implementation of what is a basically simple idea: storing programs on magnetic tape. **VIDEOTRAX**, however, utilizes a video cassette recorder and standard video tape.

"Insurance" copies of valuable computer data are popularly made on floppy disks or on streaming tape. The former is inexpensive, often slow, and always cumbersome when dealing with lots of data that require multiple disks for storage. The latter is a quick, easy and reliable method. But a 20 MB tape backup system costs about \$500 and each cassette costs about \$30. In contrast, a **VIDEOTRAX** expansion board costs \$399 (before typical mail-order discount) plus the use of your home VCR, can store 240 MB of data on a single \$5 video tape, operates fast, and is simple to use. Consequently, the new half-length board is an interesting alternative. (A full-length board had been previously marketed.)

An SCSI interface version has been announced for use with an Apple Macintosh Plus, SE and MAC II, as well as any other computer using a "scuzzy" interface. Tandy sells a system for its IBM-compatible computers, too.

The **VIDEOTRAX** software and board convert hard-disk data, image, or program files into video signals that are sent to your VCR via the standard video in/out cables, then reconvert the data as it is read back to restore files.

Data reliability is ensured by adding a CRC (Cyclical Redundancy Count) number to each 512-byte block of data. When verifying the files, this CRC number is used to check the integrity of the recorded data. If there is ever a point in the entire backup where none of the four (or more) backup recordings of a single piece of data is readable, the tape is likely defective and you are notified about this on the screen display.

Actually, the verification pass shows a running count of the reliability of the recorded data and the number of soft errors (where the CRC check indicates



trouble with some, but not all, of the copies). This running count can help the operator spot dirty VCR heads or poor-quality tape before the system fails completely. If you have a low-quality tape but no hard errors, you can still use it by specifying additional copies of your data.

Installation is simple, with the only possible problem being an address conflict with other peripherals. This address is easy to change. Even choosing the American (NTSC) or European (PAL/SECAM) video tape standard is just a matter of moving one jumper on the board.

If you do not already have a VCR, the company sells a **VIDEOTRAX** VCR that incorporates HQ (high-quality video) and an IR remote control that has special features for computer data backup purposes. (The modified VHS record can also function as a standard VCR.) The special feature of this optional Alpha Micro VCR, which is priced at \$1,199, is a built-in servo controller that is connected by cable to the **VIDEOTRAX** expansion board.

The controller takes complete control

of the VCR, including rewind, record, and play functions. This lets the machine complete an automatic verify operation on any recording, something that would otherwise require an operator to push the rewind and play buttons in response to on-screen directions. Another feature available to those with the complete system is an automatic file location feature when using the file backup mode.

**VIDEOTRAX** either stores a complete image of your hard disk (image mode) or stores each file one by one. This file mode lets you specify (using ordinary \* and ? wildcards) which files to back up, including only those modified after a given date. When using the image mode you can only restore the entire hard disk, blank spaces and all, but it is much faster than the file mode backup when storing the entire disk full of files (about 1.3 minutes/megabyte at 4 copies).

When you store files using the file mode, you can play the tape and have the software just restore the files you specify (again by use of wildcards).

## Broadcast Potential

**One special** use of the AM-616 video controller (VIDEOTRAX) is the potential of working with satellite transmission of data at a very high 80Kbps, which is hundreds of times faster than transmission by microwave link or regular telephone lines.

There is no practical reason why data can't be transmitted by regular TV stations, perhaps after hours, to business and home subscribers. Since ordinary TV reception and any VCR provide sufficient quality for taping the data/programs, such 3 A.M. transmissions are entirely practical.

In fact, on May 30, 1985, the BBC (British Broadcasting Corporation) demonstrated the transmission of Alice in Wonderland at 40,000 cps.

In this country, the National Technological University, a video graduate school for engineers, daily transmits classroom handouts by VIDEOTRAX during their live video classes which are

carried by satellite to many locations throughout the U.S.

The signals are recorded on a VCR and processed by the standard VIDEOTRAX board in an IBM PC, after which the handouts are printed out during the lecture.

For those unfamiliar with TV broadcast standards, NTSC (National Television Standards Committee) is the designation for the U.S. standard 525 line by 60 field B&W TV picture having a 4.2-MHz video bandwidth and a color subcarrier at 3.58-MHz. This NTSC standard is used in the U.S., Japan, and the Philippines.

PAL (Phase Alteration by Line) and SECAM (Sequence a Memoire) both use a sharper black and white standard of 625 lines by 500 fields, but they treat color in differing ways. Most eastern European countries use SECAM (20 worldwide) and about 40 other countries use PAL.

If you think that the 21 minutes needed to make a complete file backup of a 10MB hard disk with 4 copies is a long time compared to the 5 minutes or less of some streaming tapes, you are right. However, it is far faster than formatting 30 or so floppy disks and spending another 25 minutes feeding them one at a time into your disk drive while you get writer's cramp making up labels.

A 44MB hard disk, fast becoming a popular size, takes about 130 disks, and I don't even like to think about the newer 70- and 115MB hard disks.

The backup time with VIDEOTRAX also looks much better when you remember that it operates entirely unattended, so you can easily back up a 40MB hard disk during your lunch hour or just leave it to run after you leave work for the day. If you also have the VIDEOTRAX VCR, you can even have the machine do an automatic verification pass after the backup.

Anyone who generates a lot of data or who requires many updates of data for security purposes, as is common for bookkeeping data, will find VIDEOTRAX a rewarding alternative to streaming tape backup. In any event, everyone should back up data, as onerous a task as it might be. It only takes one power outage, fire or other computer tragedy to make you wish you did. **ME**

—John McCormick

CIRCLE NO. 180 ON FREE INFORMATION CARD

## Comments

If you have made many multiple copies (for extra data security) and stored a large number of files (perhaps a 70 MB hard disk full), then it could take several hours to play through the entire tape.

Since VIDEOTRAX stores a complete directory at the beginning of each tape, the software can tell you (via screen prompts) to fast forward and play the tape until you reach the location of the desired file.

With the VIDEOTRAX VCR, this is all done automatically. A major advantage of VIDEOTRAX for business applications is that the backup information can be set up by the system operator and it will automatically take over and back up the hard disk at a preset time (usually every night), without further attention, and without the need to train other personnel to make proper backups.

For me, one big benefit provided by VIDEOTRAX is that by using the long-play mode I can store hundreds of megabytes of data on a single \$5 tape.

If it's difficult for you to imagine the advantage of this over floppy-disk backup, let me remind you that, at about \$1 each, 240MB worth of 360K floppy disks would cost more than \$660! They would also take about 6 hours to format.

VCR tapes are used as they come from the box. Although my largest hard disk is only 40MB, I have a great many programs and, by making note of the places on a videotape where I start storing the second or later files (using the tape counter found on almost every VCR), I can make dozens of file-mode backups on a single video tape.

## Addresses

**Manufacturer:** Alpha Micro, Inc.  
3501 Sunflower, Santa Ana, CA 92799  
(800) 253-3434 or (714) 957-8500.

**Mail order source:** Priority One  
21622 Plummer St.  
Chatsworth, CA 91311-4194  
(800) 423-5922 or (818) 709-5111.

**Retailer:** Radio Shack Stores  
(Ordered as an Express Order System item)

## A 16-Step Programmable Digital Controller

By Forrest M. Mims III

The subject of this column is a simple digital controller that can be programmed with up to 16 different 4-bit data words. Once programmed, the stored words can be sequentially accessed at a rate controlled by an adjustable clock. After each of the 16 stored words is sampled, the cycle repeats.

This simple digital sequencer or controller has many practical applications. The circuit's 4-bit output words can activate up to four LEDs, motors, solenoids or additional digital circuits. Alternatively, the 4-bit output can be decoded into 16 separate outputs, permitting the sequencer to control up to 16 different output devices—but only one at a time.

The 4-bit output can also control various analog circuits. All that is required to do this is a simple digital-to-analog conversion circuit.

In addition to these practical applications, the digital sequencer or controller described here nicely illustrates some of the basic principles behind the operation of more sophisticated controllers and even digital computers. Therefore, even if you choose not to assemble a working version of the controller, I hope you will still read the following. Let's start with a review of the basics of programmable sequencers and controllers.

### Programmable Sequencers & Controllers

Programmable sequencers and controllers have countless applications. One of the simplest programmable controllers is an electromechanical timer that can be programmed to switch on and off a light in one or more patterns during a 24-hour day.

Digital sequencers and controllers have far more versatility than their electromechanical counterparts. They can control individual lamps, motors and solenoids, or many different devices at the same time. Often, they can respond to external signals. And their programming can be quickly changed and revised.

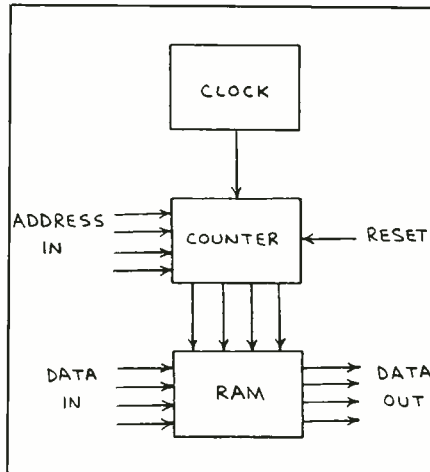

Fig. 1. Block diagram of basic 4-bit programmable controller/sequencer.

Advanced digital controllers have sophisticated instruction sets similar or identical to those for a microprocessor. Indeed, microprocessors are often used as programmable controllers. Advanced controllers can be programmed to alter a preprogrammed control sequence in response to external conditions.

### Selecting a Controller

Electromechanical timers are fine for very simple applications like controlling the lights of your house or apartment during your absence to create the impression that someone is home. Large-scale integrated microcontrollers or microprocessors are used for more sophisticated applications like controlling traffic lights and central air conditioners and outdoor sprinklers. For more specialized applications, advanced programmable controllers and interface modules are available.

For some applications, a low-cost home computer is the best choice. Programs can be easily changed, and a wide range of interface options is usually available.

### Do-It-Yourself Controllers

If I needed an advanced programmable controller for a one-of-a-kind applica-

tion, I would choose a cheap home computer. This approach would be much more economical and considerably more convenient than designing a custom microprocessor-based controller, writing the necessary software and loading the program into some kind of PROM.

If the application were relatively simple, however, I would consider building a controller from discrete components. The 16-step, 4-bit programmable controller or sequencer described below is one possible approach. Since its basic design is common to most sequencers and controllers, I will explain every aspect of its design and operation in detail. This should assist you if you decide to design your own sequencer or controller for a specific task. Even if you don't care to build this controller, if you read what follows, you will gain some basic insight into several rudimentary but essential principles of digital data processors.

### Hypothetical 16-Step, 4-Bit Controller

Figure 1 is a block diagram for a simple 4-bit programmable controller that can be assembled from inexpensive, readily available integrated circuits. The controller's single most important component is the random-access memory (RAM) chip, in which program instructions are stored. Therefore, the storage capacity of the RAM determines how many data words can be stored.

It's important to note that dedicated controllers—that is, those intended to be used for a single purpose—usually use some kind of ROM instead of RAM. This guarantees that the program data will not be lost should power to the system be interrupted. However, using ROM storage makes program modification impractical or impossible.

In the Fig. 1 arrangement, when the sequencer or controller is operating, the clock sends a series of pulses to the counter chip. The counter advances one count upon arrival of each clock pulse. The binary output from the clock is connected directly to the address inputs of

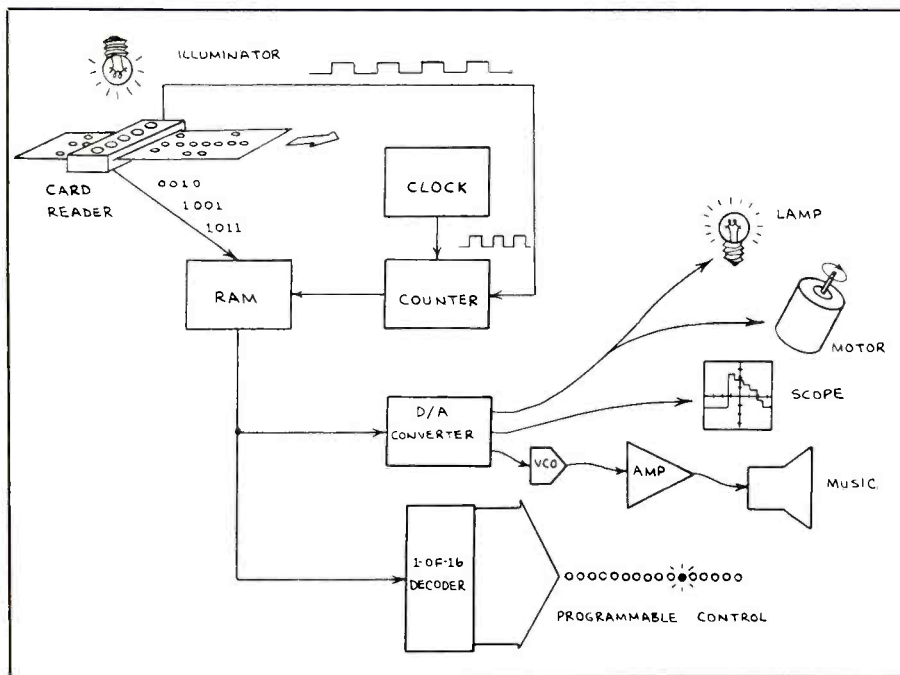

Fig. 2. Block diagram of programmer sequencer and output peripherals.

the RAM via a set of connections called the *address bus*. Therefore, the arrival of each clock pulse accesses the next sequential RAM address. For this reason, the counter is often referred to as the *address counter*.

Data can be stored in a controller's RAM by means of a keyboard or by entering each word in a row of toggle switches and then pressing a LOAD switch. A faster way is to encode the words in some kind of storage media that can be read into the controller by means of an input device.

Shown in Fig. 2 is a pictorial view of the 4-bit, 16-step sequencer or controller whose design and operation is described below. Data is loaded into this controller by means of an easily constructed optoelectronic card reader. The reader is made up of a row of five phototransistors and an illuminator. Four phototransistors read out the data words, while the fifth generates the clock pulses that advance the address counter when the card is pulled through the reader.

Data to be stored in the controller's RAM is first loaded into an opaque data card in the form of a pattern of punched holes. When the card is pulled through the reader, light from the illuminator stimulates a signal from the phototransistors installed in the base of the card-reader assembly under the holes in the card. No signal is generated by phototransistors that are under opaque sections of the card.

Individual data words are automatically loaded into RAM when the data card is pulled through the reader. A row of clock pulses running down the center of the data card automatically advances the address counter as the card is pulled through the reader.

Data stored in RAM can be sent directly to a decoder or various device control buffers. For example, a 4-bit RAM can control four separate light-emitting diodes or lamps. Alternatively, the RAM's output can be broken down into all 16 of its possible output states with a 4-line to 16-line decoder. Still another possibility

is to transform the RAM's binary output into an analog control signal by means of a digital-to-analog (D/A) converter.

In any case, the clock controls the rate at which individual words are read out of the RAM. In most sequencers, controllers and computers, clock speed is constant and is regulated by a crystal. In the circuit that follows, clock speed can be easily varied. This permits the circuit to perform operations that might otherwise require additional hardware and memory-consuming program instructions.

Note that using the RAM output directly provides only four control lines as opposed to the 16 lines made possible by addition of a decoder. This is not always a disadvantage, because when the outputs are fully decoded, one and only one can be active at any one time, but when the four outputs are not decoded, any or even all can be active simultaneously.

### Functional 16-Step, 4-Bit Controller

A fully functional 16-step, 4-bit controller is depicted schematically in Fig. 3. Most of the controller can be installed on a small perforated board. The optoelectronic card reader can be mounted on the controller board or be connected to it by a short cable. Let us analyze this controller in detail:

- *Optoelectronic Card Reader.* Data is entered into the controller's RAM by means of a simple do-it-yourself optoelectronic card reader. The reader consists of a row of five npn phototransistors and an illuminator.

Shown in Fig. 4 are the details of the prototype card reader that I fabricated from two  $2.5 \times 0.75 \times 0.25$ -inch strips of wood. You can make such a card reader in less than an hour. Proceed as follows.

First, clamp together the pieces of wood and drill a  $\frac{1}{16}$ -inch hole through the center of both. Then drill two additional  $\frac{1}{16}$ -inch holes on 0.3-inch centers on each side of the center hole. These five holes will provide a snug fit for TO-18 style phototransistors. If you use a phototransistor that has a different case style, ac-

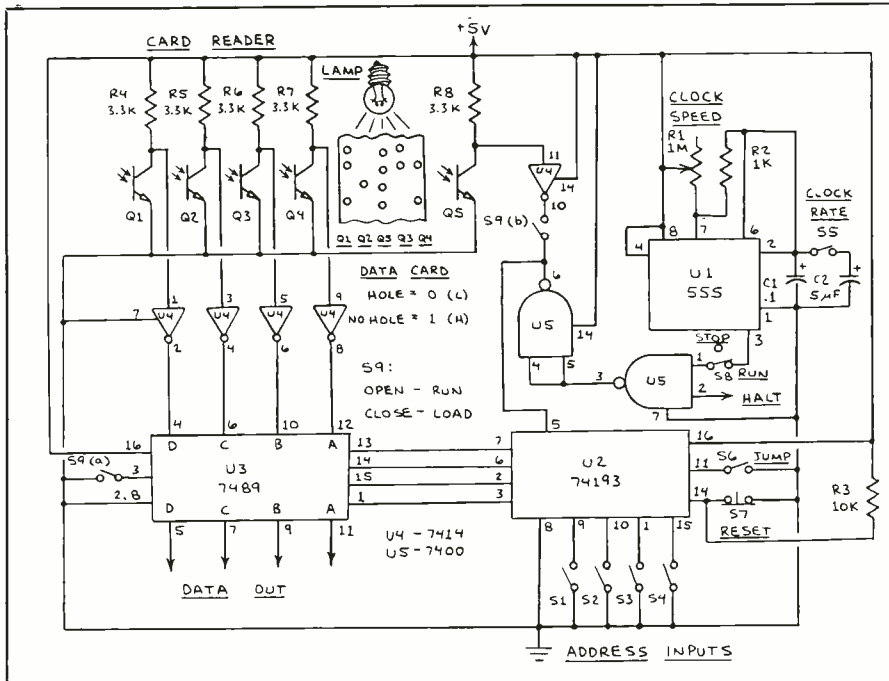

Fig. 3. A 16-step programmable digital sequencer.

cordingly modify the diameter of the holes drilled.

Drill a final pair of  $\frac{1}{4}$ -inch holes at each end of both strips of wood. The inside edges of these two pairs of holes should be spaced 1.75 inches apart, which is the width of the data cards you'll be using.

After drilling all holes, use 6-32 machine hardware to attach the two strips of wood together as illustrated. Be sure to place a washer over each of the screws and between the two strips to serve as spacers. This arrangement provides a slot through which a data card can be pulled.

After you've secured together the two wood strips, insert phototransistors Q1 through Q5 into the holes in the bottom of the reader assembly. Solder the emitter leads of all five phototransistors to a 1.5-inch-long bare copper wire. The collector leads of the phototransistors and the common emitter wire can now be connected to the controller circuit.

The phototransistors can be externally illuminated by a relatively bright light

source, such as a small desk lamp. For more consistent results, use an array of near-infrared LEDs inserted into the holes opposite the phototransistors. Figure 5 shows two ways to connect the LEDs. The forward currents listed here apply to the TIL32 LED. AlGaAs near-infrared or super-bright red LEDs can also be used, but the currents given in the tabular listing may be different from those in Fig. 5.

- **Card Reader Buffer.** The phototransistors can be connected directly to the data inputs of the RAM, though this arrangement is not always reliable. The Schmitt-trigger buffers (U4) provide a snap-action output that presents a true logical low or high to the RAM.

- **7489 RAM.** This is a 16-pin, 64-bit TTL random-access memory device that is organized into 16 4-bit words. It has open-collector outputs. Each memory location is accessed by applying a 4-bit pattern to four address lines. After a specific location has been addressed, a data word can be written into the location by plac-

ing both the MEMORY ENABLE (ME) and WRITE ENABLE (WE) inputs at pins 2 and 3, respectively, in the logical 0 state.

One side of dpst switch S9 controls whether the 7849 is in its read or its write state. When S9 is switched to RUN (is opened), the RAM is set to read. Setting S9 to LOAD (closed) places the RAM in its write state. Simultaneously, the other side of S9 connects the clock phototransistor from the card reader to the 74193, preparing the system to receive new data.

It's important to keep in mind that a data word is *inverted* when stored in the 7849. Therefore, the complement of the data word stored in a particular address or location will appear on the output lines when the ME input is placed in the logical 0 state and the WE input is placed in the logical 1 (high) state. When the ME input is placed in the logical 1 state, all the outputs assume the logical 1 state, regardless of the address accessed.

Incidentally, notice that the 7849's WE input and the four 74193 inputs are left floating when the switches connected to them are opened. This practice would not be acceptable if these were CMOS chips, whose inputs must *never* be left in a floating state. While a floating TTL input almost always assumes the high state, you can guarantee that a floating TTL input stays high by connecting it to the +5-volt positive rail via a 10,000-ohm pull-up resistor.

A method for adding a row of four readout LEDs to the data-output pins of the RAM is illustrated in Fig. 6. These LEDs will glow when the respective outputs from the RAM are low. Therefore, all four LEDs will be on when 1111 has been loaded into the RAM location being addressed. (Remember, the 7849 inverts data entered through its inputs; hence, 1111 is transformed to 0000.)

- **74193 Address Counter.** This is a 16-pin synchronous 4-bit up/down counter chip. In this circuit, the 74193 is referred to as an *address* counter because it determines which memory location in the 7849 is accessed. The counter is incremented (advanced) one count when a clock pulse is applied to the UP INPUT at pin 5. The



counter is decremented one count when a clock pulse is applied to the DOWN INPUT at pin 4. The current count in Fig. 5 appears at pins 3, 2, 6 and 7 of the 74193. The counter is reset to 0000 when the CLEAR INPUT at pin 14 is switched from low to high by momentarily opening S7.

An important feature of the 74193 is its programmability. Any desired count state can be placed on its four input lines at pins 15, 1, 10 and 9. When the LOAD INPUT at pin 11 is switched from high to low, the counter output assumes the count state on the input lines. This provides what computer programmers call a "jump" capability. In a microprocessor, a jump is implemented by means of a programmed instruction. Here, a manual jump can be implemented by momentarily closing S6.

Finally, the 74193 is equipped with a CARRY OUTPUT at pin 12 so that two or more counters can be cascaded to provide higher counts. For example, cascading two 4-bit 74193s, each having only 16

count states (0000 through 1111), provides an 8-bit counter that has a total of 256 count states (00000000 through 11111111).

• **555 Timer.** Clock pulses for the controller are provided by an ordinary 555 timer chip. The 555 is not required when the RAM is being loaded with data. Instead, the data cards are equipped with a row of clock holes that automatically advance the counter as the card is pulled through the reader.

Virtually all digital computers and advanced controllers use a crystal-controlled clock to assure stability at very high clock frequencies. However, this circuit shows that a crystal is not always necessary when a slow clock speed is used. The major exception is when it is necessary that the clock speed be correctly calibrated.

An important benefit of the simple 555 clock used here is that its speed can be easily varied by changing the values of R1 and C1/C2. When S5 is open, only C1 is

connected to the 555 and the clock operates over its fastest speed range. Closing S5 connects C2 in parallel with C1, causing the timer to operate over its slowest speed range.

• **NAND Gates.** The two NAND gates (U5) in Fig. 4 provide an interface between the 555 clock and the 74193 counter. When S8 is set to RUN, pulses from the clock are directed to the counter. The pin 5 HALT INPUT is normally left open or connected to +5 volts. However, if this input is made low, the clock pulses are prevented from reaching the counter and the controller circuit ceases to cycle through its memory.

This provides the opportunity for a programmed HALT instruction to be included in a list of data words stored in RAM. Suppose, for instance, that the HALT line is connected to the D output line from the RAM. If only logical 0s are stored in the D position of each word in RAM, clock pulses will reach the counter and the circuit will run because of the in-

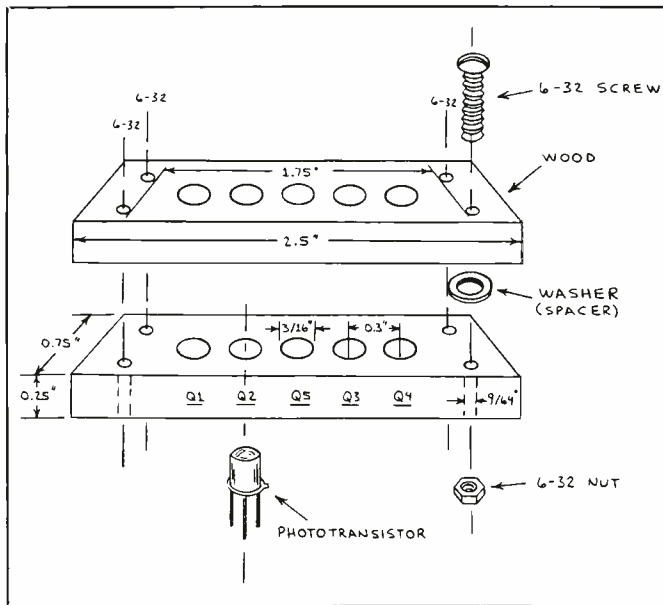

Fig. 4. Assembly details of an optoelectronic card reader.

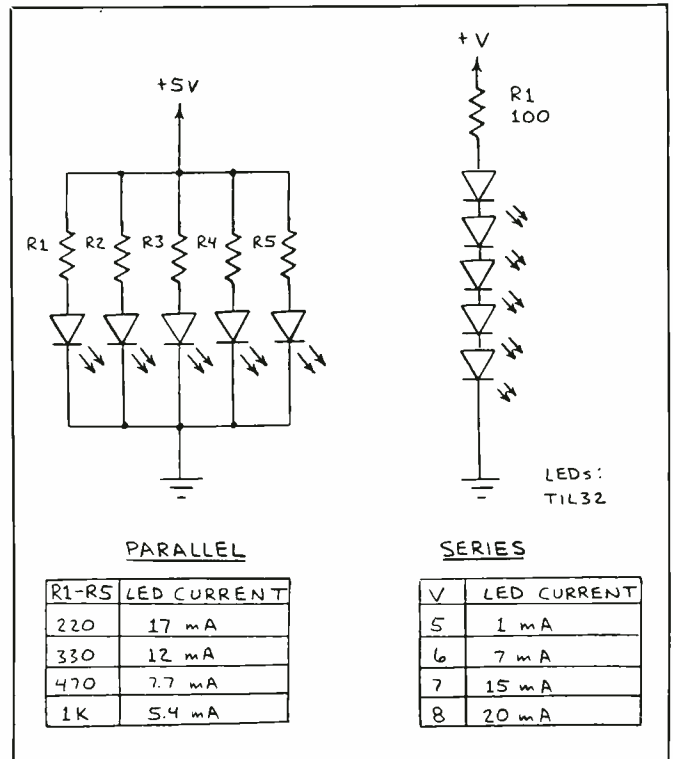

Fig. 5. LED illuminators for digital sequencer card reader.

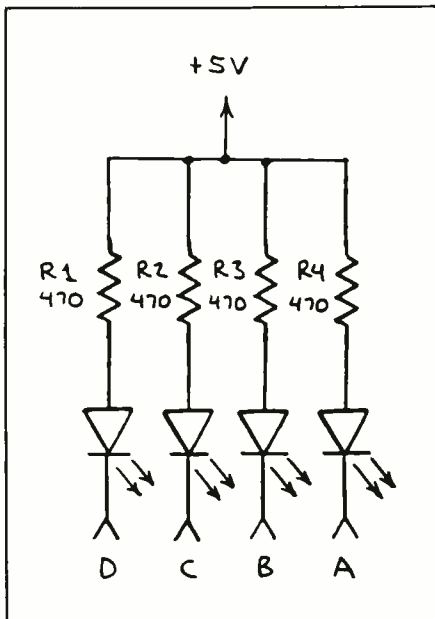

Fig. 6. LED readout for 4-bit programmable sequencer.

version that takes place inside the 7489.

Now, if the counter addresses a word containing a 1 in the D position, U5 will block the clock pulses and shut down the counter. If one bit of each word can be dedicated to the HALT instruction, this 16-step system can be programmed for automatic shutdown after 2 to 16 steps.

## Using the Controller

The format for a typical data card is illustrated in Fig. 7. For best results, make the cards from thin, opaque cardboard or plastic sheets. Black paper will work but only when inside a protective sleeve.

Use a 0.25-inch hole punch to form the data holes in the card. Be sure to punch the data holes a half hole width ahead of the clock holes and to extend the final clock hole into a slot as shown in Fig. 7. The presence of a hole loads a logical 0 into RAM, while the absence of a hole loads a logical 1.

Before loading a data card into the reader, set S8 to STOP and S9 to LOAD. Then switch on the card reader's illumina-

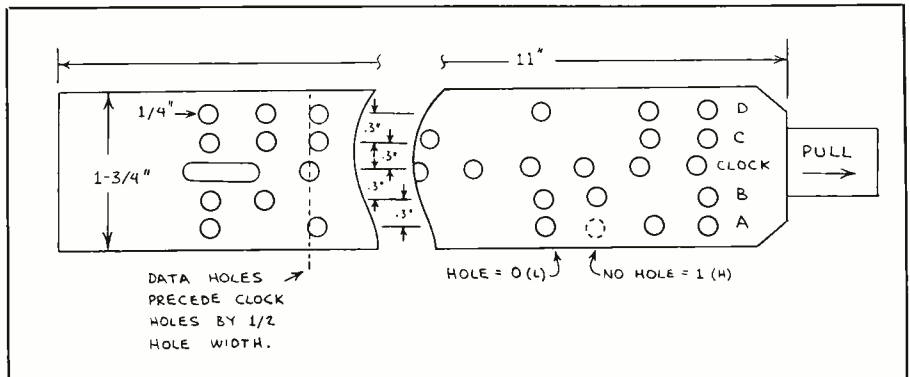

Fig. 7. Data card format used in prototype programmable controller.

tion source. Insert the first part of the card into the reader so that all five phototransistors are blocked from receiving light. Press S7 to reset the address counter to 0000. Next, pull the card through the reader, making sure to stop the card with the final clock slot still inside the reader assembly.

At this point, clock phototransistor Q5 should be illuminated but all four data phototransistors should be blocked. Now, with the card still in the reader, set S9 to RUN, remove the card and switch off the reader's light source.

If you pull the card completely through the reader without stopping at the final clock slot, the data to be loaded into address 0000 will be lost. To correct this, you must repeat the load procedure described above.

When an array of your LEDs is connected to the output of the 7489, this program will create a back-and-forth flasher:

0. 0001	8. 0100
1. 0010	9. 1000
2. 0100	10. 0100
3. 1000	11. 0010
4. 0100	12. 0001
5. 0010	13. 0010
6. 0001	14. 0100
7. 0010	15. 1000

When loaded and run, this sequence will continue to cycle indefinitely. Each time the sequence recycles from step 15

back to step 0, the two center LEDs will be skipped.

This program will count from 0 to 15 in binary and automatically recycle:

0. 1111	8. 0111
1. 1110	9. 0110
2. 1101	10. 0101
3. 1100	11. 0100
4. 1011	12. 0011
5. 1010	13. 0010
6. 1001	14. 0001
7. 1000	15. 0000

This program assumes that a glowing LED indicates a logical 0 and that an extinguished LED indicates a logical 1.

These two simple programs are merely examples of what the controller can do. Many other programs are possible.

## Adding Output Devices to the Controller

As noted above, the basic controller or sequencer circuit shown in Fig. 4 can control many different output circuits and devices. In an upcoming column, I will describe several suitable output circuits, including a 4-line to 16-line decoder, digital-to-analog converter and voltage-controlled oscillator. I will also show you how the basic 16-step controller shown in Fig. 4 can be expanded to 256 steps and give microinstructions for both a programmed JUMP and a HALT. **ME**

## Tone-ringer IC applications and an IBM PS/2-compatible Chip Set

Harry L. Helms

**Do you remember**—or do you still have—telephones with electromechanical ringing sections? The electromagnets in these sections were responsible for most of the weight in older telephones, and their shrill ringing action was guaranteed to catch your attention. By contrast, new phones today weigh but a fraction of their older counterparts, and the “ring” is actually more of a “warble.” You might suspect that the integrated devices have replaced mechanical ringers, and that’s exactly what’s happened. The new generation of “ringer ICs” can also be used in numerous applications where tone signaling or alerting is needed.

Figure 1 shows the package and pin connections for the MC34012 family of tone-ringer ICs from Motorola. (Before reading further, take a close look at Fig. 1. Notice anything unusual about this integrated circuit?)

The MC34012 family is designed to directly drive common piezoelectric transducers and meets all operational requirements for telephone ringer circuits specified by the FCC and EIA (Electronics Industries Association). These state that a ringer circuit *must* function when a ring signal is present yet *must not* function if another type of signal (voice, dialing signals, noise, etc.) is present on the line. The MC34012 also satisfies FCC and EIA requirements for input impedance when connected to a telephone network. There are three versions of the device, identified by a numerical suffix, each of which gives a different output tone (or “warble”). The suffix 1 denotes a 1,000-Hz output, 2 a 2,000-Hz output, and 3 results in 500 Hz.

The unusual aspect of the MC34012 hinted at above is that it is powered entirely by the input ringer signal applied to pins 2 and 3. There is no supply voltage ( $V_{cc}$  or  $V_{dd}$ ) input nor any ground pin. Moreover, for proper operation, the input ringer signal *must* be ac.

In effect, the MC34012 is an ac-powered IC! The ac input voltage range is substantial, ranging from 24 to 120 volts.

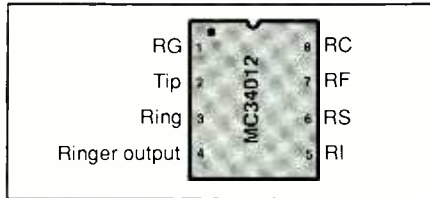

Fig. 1. Pinouts for Motorola's MC34012 family of tone-ringer ICs.

The output voltage at pin 4 is a healthy 20-volt peak-to-peak square wave. Note that the ac ringer input signal is identified as *tip* (pin 2) and *ring* (pin 3). This is carried over from landline telephone circuits and represents where the individual telephone is connected to the switching network. Normally, the ring side is negative with respect to the tip.

At this point, I must emphasize that extreme care is literally a matter of life and death when working with high ac voltages! The MC34012 is designed to operate with such voltages, and some of the application circuits this month will use them. Nevertheless, *don't* apply 120-volt ac tip and ring signals to any of these circuits unless you are thoroughly experienced in working with such voltages and observe proper safety precautions! Even 24 volts can have a nasty “bite” to it; so care is called for here as well.

When an ac voltage is applied to the tip and ring inputs of the MC34012, an internal full-wave diode-bridge circuit rectifies the input and uses it to power an internal 22-volt dc supply. Other internal

circuit are an oscillator/divider section, a two-input comparator, and a D flip-flop with reset. Output of the oscillator/divider section provides a clock input signal to the D flip-flop, and the frequency of the clock signal determines the ringer's output frequency. The oscillator/divider frequency is controlled by an external timing resistor and capacitor network.

The D input of the internal flip-flop is its Q output “looped back” to the D input. The D flip-flop is activated through its reset input, to which the comparator's output is applied. The rectified ac ringing input is applied to both inputs of the comparator. This input causes the comparator to be triggered, with the resulting signal to the reset input of the D flip-flop causing an output equal to the clock signal input frequency to be present at the Q output of the flip-flop. The Q output, in turn, is applied to an output buffer, which finally drives a piezoelectric sound transducer.

The “warbling”-tone output actually consists of two different tones that are rapidly alternated at the output. For example, a 1,000-Hz output consists of a low tone (about 900 Hz) and a high tone (typically 1,100 Hz) that alternate at the output at a frequency of 12 to 14 Hz.

Referring to Fig. 1, input RC (pin 8) is the one to which the external timing resistor and capacitor should be connected. Input RF (pin 7) is the terminal used for a filter capacitor utilized to detect input ringer signals. RG (pin 1) is the terminal for the negative output of the internal di-

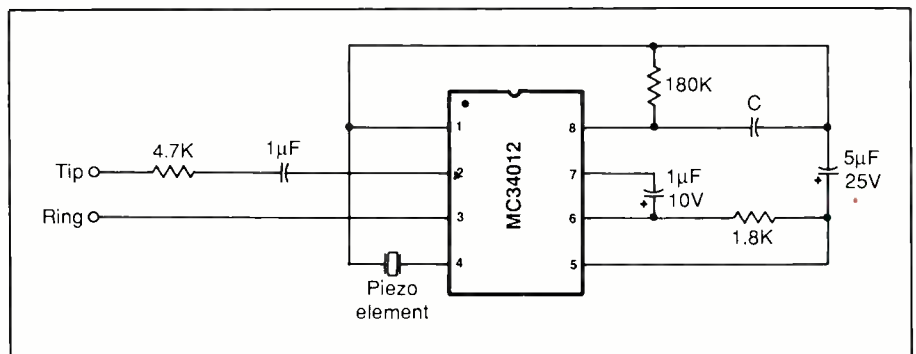

Fig. 2. The basic MC34012 circuit configuration used in telephone applications.

# SOLID-STATE DEVICES...

MC34012 Specifications	
Maximum ac input voltage	150 V rms
Output voltage	20 V p-p
Output duty cycle	50%
Output short-circuit current	50 mA

ode bridge and the negative supply of the tone-generating circuitry. R1 (pin 5) is the positive supply terminal for the oscillator/divider section and the output buffer stage. RS (pin 6) is the positive output of the internal diode bridge; an external current-sense resistor is connected here.

Fortunately, the MC34012 family is easy to use despite the complexity of its internal circuitry. Figure 2 shows the basic applications circuit for the MC34012 as a telephone tone ringer. The exact value of the capacitor labeled C will depend on which member of the MC34012 family is used. For the MC34012-1, a 1,000-pF capacitor should be to produce a 1,000-Hz tone. A 500-pF capacitor is employed with the MC34012-2 to give a 2,000-Hz output, while a 2,000-pF capacitor is used with the MC34012-3 to produce a 500-Hz output tone.

The Fig. 2 circuit will generate a "warbling" ringing sound whenever an ac signal of 24 volts or greater is present at the tip and ring inputs. Volume of the ringing sound can be controlled by placing a 10,000-ohm potentiometer in series between pin 4 and the piezoelectric element.

Operation of the Fig. 2 circuit can be altered so that a time interval will elapse between application of an ac voltage to the tip and ring inputs and the start of the ringing action. Figure 3 illustrates such an application circuit, where the delay interval is controlled by resistors R1 and R2 and capacitor C1.

Values of R1, R2 and C1 depend on the input voltage as well as the input delay desired. For example, if there is a 24-volt ac input, a 30-second delay can be obtained by an R1 value of 100 ohms, an R2 value of 1,600 ohms and a C1 value of 100 μF. If the input is 120 volts ac, then

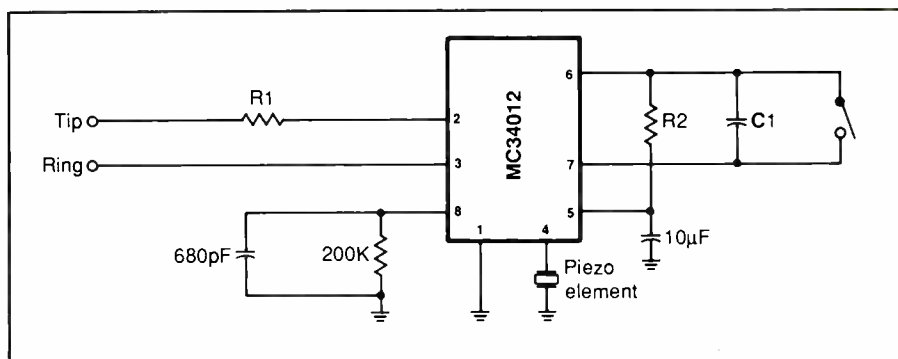

Fig. 3. A tone-ringer circuit with built-in delayed-on feature whose period is controlled by R1, R2 and C1.

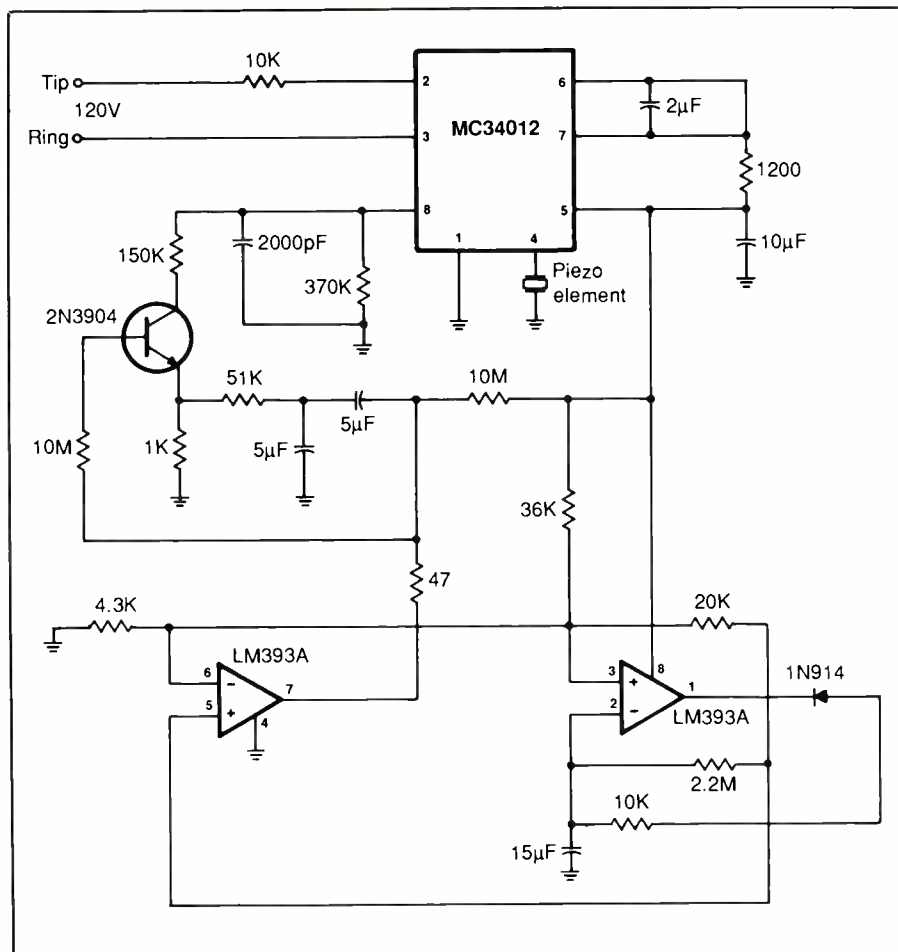

Fig. 4. An audio-frequency sweeper circuit in which an MC34012 is used to vary the frequency of a base oscillator.

the values of  $R1$  should be 16,000 ohms,  $R2$  should be 750 ohms and  $C1$  should be 1,000  $\mu\text{F}$  to produce the same 30-second delay. The switch across  $C1$  should be left open for a delay function; if closed, the ringer will operate normally.

The "warbling" output of the MC-34012 can also be used in music- and sound-effects circuits. Figure 4 is the schematic of an audio-frequency sweeper circuit in which the MC34012 varies the frequency of a base oscillator built around a 2N3904 transistor and an LM393A op amp. The 2N3904 is slowly turned on as the two 5- $\mu\text{F}$  capacitors charge, thus varying the equivalent resistance at pin 8 of the chip. This causes the frequency of the base oscillator to vary from low to high over a period of several seconds. Output of this circuit is similar to that heard in arcade video games, and the frequency range and sweep rate can be varied by altering values of the two 5- $\mu\text{F}$  capacitors and the 15- $\mu\text{F}$  capacitor connected between the inverting input (pin 2) and ground one LM393A section.

Complete specifications of the MC-34012 family can be obtained in the data sheet available from Motorola. Several applications circuits and supporting information are available in Applications Note AN933, "A Variety of Uses for the MC34012 and MC34017 Tone Ringers." There is also an AN937, "A Telephone Ringer which Complies With FCC and EIA Impedance Standards," that discusses using the MC34012 in conventional telephone ringer applications.

### PS/2-Compatible Chip Set

Chips & Technologies, a California-based custom IC company, has developed a custom chip set that is said to be a "logic replacement" for IBM PS/2 personal computer Models 50 and 60. When used with a microprocessor, appropriate support chips, and semiconductor memories, a compatible PS/2 "clone" can be constructed, according to the company.

This chip set is controversial since the PS/2 series makes use of IBM's patented Microchannel data bus. It is unclear at present whether it is permissible to build a truly compatible system to the PS/2 without licensing the Microchannel bus from IBM. In fact, some speculate that licenses for the use of IBM patents may be necessary even at the chip level. If patent licenses from IBM are indeed necessary, this would significantly cut down on "clone-maker" price advantages since the costs of such patents would have to be added to the clones; IBM would also make money off each "clone" sold through license fees.

What is clear is that the chip sets can significantly cut down on the number of ICs required for a PS/2 system. Instead of the 179 motherboard chips in an IBM PS/2 Model 80, a functional equivalent can be built using just 66 devices.

### Short Takes

Yet another proud name has vanished from the ranks of semiconductor companies. A decade ago, Mostek Corp. of Carrollton, TX was the world leader in semiconductor memories. Many early microcomputers were stuffed with their 4K and 16K RAMs. However, an inability to compete in the 256K-RAM market and failure to significantly diversify beyond memories has resulted in Mostek being sold by its corporate parent, United Technologies, to SGS-Thomson.

SGS-Thomson will use the old Mostek manufacturing facilities and incorporate a few of its devices into their own offerings, but the name "Mostek" will be used no more....Speaking of memories, participants at the recent International Solid State Circuits Conference in San Francisco heard predictions that, by the year 2000, RAM memories will go for about five cents per megabyte! By then, a one-megabyte RAM will be a "small" chip, with 16- and 64-megabyte devices being widely used. **ME**

## TELEPHONE SCRAMBLER

Installs on most phones including cellular



Easily installed between phones to scramble communication, including tone, wireless and cellular. Scrambler makes it impossible to intercept or decode. Solid state unit has 13000 selectable codes. Excellent sound quality allows immediate voice recognition. Fully self-contained and easy to use. Small, light weight and portable. Two units required. Only \$369.00 each plus \$4.00 shipping and handling.

**OTHER AMC PRODUCTS** 12 hr. modified Panasonic Recorder, Brief Case Recorder, Telephone Recording Adaptor, VOX Switch, Micro Recorder, Tie clip mike, VOX activated micros, Wired mikes, Transmitter detectors, etc. Send for FREE data. Mail order, VISA, M/C, C.O.D. ok., Cal. Res. add tax.

**AMC SALES INC.**, Dept. M • (213) 869-8519  
9335 Lubec St., Box 928, Downey, CA 90241

CIRCLE 43 ON FREE INFORMATION CARD

## Be an FCC LICENSED ELECTRONIC TECHNICIAN!



No costly school. No commuting to class. The Original Home-Study course prepares you for the "FCC Commercial Radiotelephone License". This valuable license is your "ticket" to thousands of exciting jobs in Communications. Radio-TV, Microwave. Computers. Radar. Avionics and more! You don't need a college degree to qualify, but you do need an FCC License.

**No Need to Quit Your Job or Go To School** This proven course is easy, fast and low cost! **GUARANTEED PASS** - You get your FCC License or money refunded. **Send for FREE facts now. MAIL COUPON TODAY!**

### COMMAND PRODUCTIONS

FCC LICENSE TRAINING, Dept. 220  
P.O. Box 2223, San Francisco, CA 94126  
Please rush FREE details immediately!

NAME \_\_\_\_\_  
ADDRESS \_\_\_\_\_  
CITY \_\_\_\_\_ STATE \_\_\_\_\_ ZIP \_\_\_\_\_

## *Compact-disc quality; lowdown on RLL controllers for hard-disk drives; safety precautions for electronics technicians*

By Curt Phillips

When compact-disc players first hit the market, the only CDs available were from the major record companies. Although the quality of LPs from these companies varied, you could count on these companies to provide an acceptable LP, and similarly an acceptable CD. Now, with CD players numbering in the millions, compact discs are coming out from a wide variety of sources, including compilations from telemarketers.

Records from telemarketers have a deservedly dubious reputation for quality. As a young fan of "oldies" rock-and-roll, I have ordered from these sources on several occasions to expand my collection of Fifties rock. The quality of these LPs has ranged from good to unlistenable, with some having so many pops and so much surface noise that even rock-and-roll couldn't blast through. Actually, the discount classical music records have been the worst offenders, perhaps because the numerous quiet passages emphasize the noise.

So it was with some trepidation that I ordered an oldies compilation on CD from a telemarketer. When it arrived, I was pleasantly surprised to find the quality comparable to CDs from the major labels. The big question: Was this a fluke or is compact-disc quality more uniform than LP quality?

First, there are three primary determinants of recorded music quality: quality of the source (the master tape), quality of the sound engineering and editing, and quality of the "pressing."

The quality of a master tape affects the music quality of both LPs and CDs. Much early rock-and-roll was recorded under crude conditions, often literally in a garage or basement. Many early classical and jazz recordings are characterized by distortion caused by the inability of old equipment to handle the wide dynamic range of these performances. On all types of music, background noises that were never before noticeable have been known to become painfully obvious on

compact disc. The ability of a compact disc to accurately reproduce all the sound from the tape master can cause flaws from the master tape to emerge that were covered over, or "masked," by the imperfections of the vinyl medium.

Some of these flaws can be ameliorated by the sound engineering and editing process, but many purists consider this to be tampering with an original work (like colorizing black-and-white movies) and it is sometimes avoided for this reason. Occasionally, a record company will put a different version of a song on a CD than the one that was popular because its master recording is considered to be better. But that can have repercussions as well. A minor uproar has arisen because the version of "Please, Please Me" on the Beatles CD release is different than the hit version.

There is a school of thought that contends that compact discs *must* be engineered differently than LPs. These people maintain that most master tapes are mixed with LPs and radio play in mind, resulting in restricted bass and dynamic range, and emphasized mid-bass and treble. They believe that "remastering" is the only way that the full potential of compact discs can be realized.

On the other hand, the engineering and editing process can create some audio flaws. This is most common in classical music, where long works joined together sloppily can be detected against the scrupulously quiet background of the compact disc.

It is the quality of the vinyl and the pressing that causes most of the problems with LPs, however, and this is where the CDs shine. All of the CD "pressing" equipment is of recent vintage, and although some may claim advantages, it appears that the quality of CD pressings is universally high. Compact disc pressing plants are licensed by the developers of the CD system (Philips and Sony) and must maintain minimum error rates to keep their licenses.

So, given good source material (admittedly a large given), you can expect high-quality compact discs from all sources.

Even better is the knowledge that, if you give the CD moderate care, the great sound will remain indefinitely without the deterioration experienced even with pampered LPs.

### *False Economy*

All of us in the great middle class look for ways to stretch our money, but we must always be aware of things that are "Penny wise, pound foolish."

Much publicity has been given to a class of hard-disk controllers known as RLL (Run-Length Limited). Most of the hard-disk controllers in use, especially on 10- and 20-megabyte drives, are MFM (Modified Frequency Modulation) types.

Replacing an MFM controller with an RLL controller is attractive because it will expand the storage capacity of the hard disk by 50 percent and provide an increase in operating speed. But although almost all hard-disk drives will initially work with an RLL controller, the life and reliability of some drives may be greatly diminished.

An RLL controller (RLL 2,7) has a data-transfer rate of 7.5 megabits per second and lays down 26 sectors per track compared to MFM's 5.0 megabits per second and 17 sectors per track. Since sectors in RLL hold the same amount of data as those in MFM, the miracle is achieved by the higher frequency writing data closer together. The RLL controller also writes to disk using a different bit configuration than that used by an MFM controller.

To reliably accomplish this, both the magnetic media of the hard drive and circuitry that interfaces the controller card to the drive must be rated appropriately. The media should have an Oersted rating of greater than 450 to handle the densely packed data. The interface circuitry, in turn, must have a processor capable of handling the RLL bit configuration and a filtering mechanism and amplifying system rated for the higher frequency of data transfer.

For example, the ubiquitous Seagate ST-225, which formats to 20 megabytes

### Ten Commandments for Technicians

1. Beware the lightning that lurketh in the undischarged capacitor, lest it cause thee to bounce upon thy buttocks in a most untechnician-like manner.

2. Cause thou the switch that supplieth large quantities of juice to be opened and thus tagged, that thy days in this earthly vale of tears be long.

3. Prove to thyself that all circuits that radiateth and upon which thou toil are grounded and thusly tagged lest they lift thee to radio heaven.

4. Tarry thou not amongst those fools that engage in intentional shocks, for they are surely non-believers and are not longeth for this world.

5. Take care that thou useth the proper method when thou takest the measure of a high-voltage circuit, lest thou incinerate both thyself and thy meter.

6. Take care thou tampereth not with interlocks and safety devices, for this incurreth the wrath of thy

supervisor and bringeth the fury of the safety inspector upon thy head and about thy shoulders.

7. Toil not thou on energized equipment, for if thou so dost, thy fellow workers will surely buy beers for thy widow and console her otherwise.

8. Service thou equipment not alone, for electrical cooking is a slothful process and thy might sizzle in thy own juices for hours upon a hot circuit before thy maker sees fit to end thy misery.

9. Trifle thou not with radioactive tubes and substances lest thou commence to glow in the dark like a lightning bug and thy wife hath no further use for thee except for thy wages.

10. Causest thou to be tagged all modifications made by thee upon equipment lest thy successor tear his hair and go slowly mad in his attempt to decide what manner of creature made a nest in the wiring of such equipment.

using MFM, uses the same media as the RLL-rated Seagate ST-238R, which yields 30 megabytes. It is the interface circuitry, mounted physically on the drive itself, that is different!

Some people have swapped the MFM controller for an RLL controller to use with the popular ST-225. This *will* work initially, but operation of the hard disk can become erratic. There have been reports of disk crashes soon thereafter, as well as data scrambled by programs that work perfectly on other drives.

To be safe, check with the manufacturer of your hard drive before you upgrade to an RLL controller. Usually, an "R" at the end of the model number indicates RLL rating, but be aware that some dealers have been appending "R" to the model numbers of drives not rated for RLL. So, check the number that is physi-

cally stamped on the drive itself.

Remember, just because a drive formats correctly under RLL initially does *not* mean that it will run reliably. Several tens of megabytes of data is a lot to risk; so be sure RLL is appropriate for your hard-disk drive before you convert.

Printer ribbons are another area where saving pennies can cost you dollars. There has been some widely disseminated advice to extend ribbon life on dot-matrix printers by spraying WD-40 in the ribbon case. What has not been so widely publicized is that this can cause the print-head to fail. It appears that WD-40 adversely affects lubrication in the print-head, and this causes it to fail.

Ribbon reinkers can also cause troubles, unless you use ink recommended for use with printers. The amount of money you save using improper ink or

WD-40 is small compared to that required to replace a printhead, so beware.

### Beginners Technical Texts

As I was browsing through the technical book section of a local used-book store, I ran across a copy of the first textbook I used to learn about electronics 20 years ago. The book had been recommended by the instructor of a ham radio course I was taking and was titled *Elements of Radio* by Marcus and Marcus.

As a thirteen-year-old, I couldn't afford to buy the book; so I obtained a copy from the library and studied it from cover to cover. Now coming across this old copy (priced insultingly at ten cents!), I *had* to buy it.

*Elements of Radio* is outdated now, of course, but even in retrospect it was a good text to learn from. But I don't know what book I could recommend today to a newcomer, other than the ARRL handbook, which some people find to be a bit too intimidating.

What book would you recommend to a newcomer, especially a youngster, to learn general electronics principles? If you have a favorite, let me know and I'll print the results.

### Ten Commandments

Perhaps more appropriate for the April issue than the May one, I recently obtained the *Ten Commandments for Technicians* accompanying this column from the "Rock'N Roll Party" BBS, a computer bulletin board run by an Atlanta radio station. Although written with broadcast technicians in mind, it humorously reminds us that the circuits we are working with can have deadly consequences if we don't take the proper precautions. As they used to say on TV's *Hill Street Blues*, "Let's be careful out there." **ME**

*Your comments and ideas are welcome. You can contact me at P.O. Box 678, Garner, NC 27529 or by computer on Delphi (CURTPHIL) or The Source (BDK887).*

**IF YOU BUY, SELL OR COLLECT  
OLD RADIOS, YOU NEED...  
ANTIQUA RADIO CLASSIFIED**



**Antique Radio's Largest-  
Circulation Monthly Magazine**

**FREE SAMPLE COPY!**

Classifieds - Ads for Parts & Services  
Articles - Flea Market Info.  
Early Radio, Wireless, TV, Ham Equip.,  
Books, Nostalgia, Art-Deco, Novelties,  
Telegraph, 40's & 50's Radios & more...  
200 Classified Ads, 32 Pages Monthly  
2000+ Subscribers

**Free 20-Word Ad Each Month**

6-Month Trial: \$10.

1 Year: \$18 (\$24 by 1st Class).

Canada & Mexico: \$24/yr. Other Foreign: \$33/yr.  
A.R.C., P.O. Box 2-L1, Carlisle, MA 01741

CIRCLE 18 ON FREE INFORMATION CARD.

**"Made in U.S.A."**



Since  
1965

We've been supplying quality  
crystals since 1965 —  
long before the flood of  
cheap imports.

We're still supplying quality  
crystals with

- Quick Turnaround
- Low Price
- High Quality

**TO SOLVE  
CRYSTAL  
PROBLEMS,  
GET THIS  
CATALOG**



**JAN CRYSTALS**

P.O. Box 06017

Ft. Myers, FL 33906

(813) 936-2397



**CALL 1-800-237-3063  
FREE (Except Florida)**

CIRCLE 19 ON FREE INFORMATION CARD

**BOOKS**

**Handbook of Practical I.C. Circuits by  
Harry L. Helms. (Prentice-Hall. Hard  
cover. 163 pages. \$34.95.)**

This book offers a bevy of different circuit "ingredients" that can be "stirred together" to produce a host of practical electronic devices and subsystems. Divided into six chapters, it begins with a brief, generalized discussion of IC technology, covering fabrication and packaging, the various types of ICs and families available and circuit building. It also discusses IC power requirements and gives complete schematic diagrams with component values given for the +9/ -9-volt and +12/ -12/ +5-volt power supplies commonly used in IC circuit designs. Next, a pair of chapters are devoted to linear (analog) circuits, one covering operational amplifiers and the other, popular linear ICs. Another two chapters deal separately with TTL and CMOS IC devices and the circuits that can be built using them.

Each of the four central "applications" chapters contain both general explanatory circuits and/or logic diagrams plus a range of practical circuit schematics that give component numbers and values. The latter have been debugged so that a reader can immediately build them as presented, connecting together whatever elements he needs to build circuits for specific applications. Where appropriate, important device information is given, such as pinouts and internal details for the various ICs used and tables of TTL and CMOS device numbers and descriptions.

A final chapter shows how to interface TTL and CMOS devices, interfacing with other components and devices, and debugging and troubleshooting procedures. It also gives a list of major IC manufacturers and their addresses from whom to obtain additional information.

If you experiment with and build IC-based electronic devices, whether digital, analog or a combination of both, you will like this book from the author of our "Solid-State Devices" column.

**The CET Study Guide, Second Edition,  
by Sam Wilson. (Tab Books. Soft cover.  
313 pages. \$14.95.)**

**The CET Exam Book, Second Edition,  
by Ron Crow & Dick Glass. (Tab Books.  
Soft cover. 272 pages. \$13.95.)**

Preparing to take a Certified Electron-

ics Technician (CET) exam can be made a good deal easier with these companion books at hand. The Study Guide provides fairly comprehensive coverage of a wide variety of topics to prepare the reader to take the Associate-level of the Certified Electronics Technician exam and the consumer Journeyman-level test (there are four Journeyman-level tests, depending on what area of specialization one wants). Its purpose is the filling of gaps in the reader's knowledge and to serve as an overall review guide. It is not meant to be a rigorous textbook. On the other hand, the companion Exam Book's main focus is on CET exam questions with very little explanatory text.

An introductory chapter in the Study Guide discusses the material one should know about the exam. The rest of the book deals with two-terminal components, three-terminal amplifying components and basic circuits, antennas and transmission lines, digital circuits in consumer products, linear circuits in consumer products, television, and test equipment and troubleshooting. The text serves as theory brush-up and to bring the reader up to date on new technology to prepare him to pass the Associate and a Journeyman level of the CET exam.

The Study Guide has review questions, followed by answers, at the end of each chapter, allowing the reader to gauge his progress and, if necessary, to re-study any material in which his knowledge is shown to be weak or deficient. Two complete 75-question exams and their answers are given at the end of the book.

The Exam Book is meant for readers who have already prepared for the exam with the Study Guide. Though not strictly a Q&A manual, it can be used in this manner. Early chapters deal with mathematics, electrical theory, series and parallel circuits and oscillators. Later on, the focus is on semiconductors, digital concepts, computer basics, communications electronics, and consumer-electronics basics. Specialty topics like test equipment and measurements, electronic component nomenclature, safety precautions and checks, block diagrams and troubleshooting are discussed in separate chapters sprinkled throughout the book. Each chapter begins with a brief quiz. (All answers to all quizzes are given in an answer key at the back of the book.) These sample questions are followed by brief expla-



nations of the principles involved. Asking questions before discussing the material in a chapter gives the reader a good idea of his weaknesses and suggests further preparation.

Used together, these two books should more than adequately prepare a reader to pass the CET exams. Both are well-written and generously illustrated with schematics, block diagrams and line art.

## NEW LITERATURE

**Electronic Parts/Equipment Catalog.** MCM Electronics' latest 168-page, colorful catalog features specifications and photos of electronic equipment, components, tools, accessory items and more. Among test equipment are: single- and dual-trace oscilloscopes; frequency counters, function generators and a combination counter/generator; handheld and benchtop digital multimeters, millivoltmeter, capacitance meter and audio signal generator; signal injector/tracer; analog multimeters; and power supplies. Specialty instruments include color-bar/dot, MTS TV stereo and NTSC signal generators and other TV servicing products.

Chemicals listed include coolants, solvents and cleaners, heat-sink compound, antistatic spray, oils, etc. Under technical aids are heat-shrinkable tubing, electronic symbols templates, work lights, cleaning swabs, among others, while under tools are wire strippers, IC test clips, soldering equipment and supplies, etc.

Category listings include: anti-static products, power centers, computer equipment, TV parts, antennas, wire and cable, CATV equipment, CATV and video accessories, VCR parts and accessories, phono cartridges, audio accessories, auto accessories, alarm systems, telephone accessories, etc. The parts sections are divided into device categories, such as resistors, capacitors, and so on, and semiconductor listings are divided into separate computer and general-purpose sections.

For a copy of Catalog No. 17, write to: MCM Electronics, 858 E. Congress Park Dr., Centerville, OH 45459-4072.

**PC Learning Aids Literature.** A new brochure from MicroVideo describes the company's complete line of Learning

Systems computer training programs. It details the company's tri-media approach to training via videocassette, data diskette and workbook. Among the training programs listed are: "The New PC Primer," "The R:Base Learning System," "dBase III Plus Learning System," "Running MS-DOS" and "Lotus 1-2-3 Learning System." For a copy, write to: MicroVideo, 119 W. 22 St., New York, NY 10011.

**Electronic Equipment Catalog.** Contact East's 1988 Catalog lists and describes thousands of products for testing, repairing and assembling electronic equipment. Included are listings for test instruments; hand tools; static protection devices; adhesives; soldering supplies; wire and cable aids; inspection aids; tool kits; and more. Color photos, technical details and prices are given for all products listed. For a free copy, write to: Contact East, 335 Willow St. S., P.O. Box 786, N. Andover, MA 01845.

**Opto Data Book/Selector Guide.** Motorola announced availability of its new optoelectronics Selector Guide No. SG87/D and Optoelectronics Data Book No. DL118/D. More than 65 new products are included in the data book and all applications information, including three new applications notes, has been grouped conveniently in a single section of the book. Both the data book and the selector guide are organized into specific sections for emitters/detectors, isolators, slotted switches and fiber-optic components. Both include an industry cross reference and reliability section. A new section has been added to the data book for optoelectronic chips or dies. For a copy of SG87/D (free) and/or DL118/D (\$2.50), write to: Motorola Literature Distribution Center, P.O. Box 20924, Phoenix, AZ 85063.

**Surface-Mount Component Catalog.** Detailed specifications and order guidelines are given in Bourns' "Surface Mount and Tape & Reel Components" catalog. In addition to listing a wide variety of surface-mount and components for automated assembly, the catalog gives detailed information on a variety of standard through-hole trimmer potentiometers in tape-and-reel packaging. For a free copy, write to: Bourns, Inc., 1200 Columbia Ave., Riverside, CA 92507.

## Put Professional Knowledge and a COLLEGE DEGREE in your Technical Career through HOME STUDY

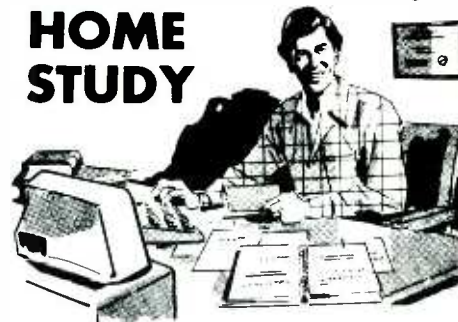

Add prestige and earning power to your technical career by earning your Associate or Bachelor degree through directed home study.

An important part of being prepared to *move up* is holding the right college degree, but the absolutely necessary part is *knowing your field*. Grantham can help you accomplish both objectives—to learn more *and* earn your degree, both of which together will prepare you for promotion in your present employment or for new better employment. Learn much more about

### ELECTRONICS and COMPUTERS,

as Grantham helps you *understand* your subjects and become a highly qualified expert, as you move thru the home study program and earn your accredited college degree.

No commuting to class. Study at your own pace, while continuing on your present job. Learn from easy-to-understand lessons, with help from your Grantham instructors when you need it.

*Write for our free catalog* (see address below) or telephone us at (213) 493-4421 (no collect calls) and ask for our "degree catalog."

Accredited by  
the Accrediting Commission of the  
National Home Study Council

**GRANTHAM**  
*College of Engineering*  
10570 Humbolt Street  
Los Alamitos, CA 90720

## Serial networking techniques; first looks at Hercules' InColor text/graphics card

By Ted Needleman

Let's take some quick looks at techniques for networking—tying together several PCs so that peripherals, such as large hard disks and printers, can be shared between them. Networks aren't all that new; they've been around in different forms for years. The most popular seem to be variants of the EtherNet system originally developed by Xerox. Hardware using this transmission scheme and the ArcNet scheme originally developed by DataPoint is available from more than 30 suppliers.

Network operating systems to utilize this hardware are primarily supplied by Novell and 3Com. Together with Apple Computer's AppleTalk network, these few companies dominate the network market. We'll talk about some of these networks in upcoming columns, but this first time around, we'll look at a simpler approach to networking—the serial network.

Serial networks connect computers together through each individual PC's serial port. Most PCs sold today have at least one built-in serial port (designated as COM1 by the operating system). By running the network connection through a COM port, serial networks eliminate both expensive network interface cards, and the expensive coax cable that is usually used to connect individual stations (called network NODES) together.

One of the better known serial networks is The Knowledge Network from Applied Knowledge Groups, Inc. For \$149.50 per machine (a starter kit for two systems is \$299) you get a special plug for each system. One end plugs into the DB25 serial port, while the other end has an RJ-11 modular phone connector. The individual PCs are connected with standard telephone cabling plugged into the RJ-11 side of the connectors. There is also a software disk supplied for each system. This disk is installed during the power-on boot to permit each system to communicate with the others in the network.

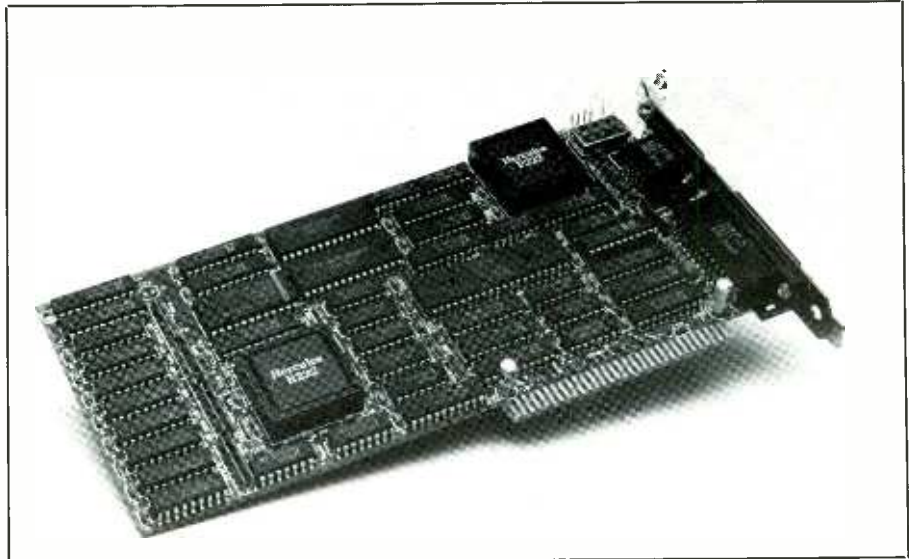

Hercules' InColor card for IBM PCs and compatibles features a hardware RamFont that permits display of 3,072 software-definable characters and color graphics.

Setting up The Knowledge Network is simple. A DEVICE statement is placed in your CONFIG.SYS file and a setup program is run. This program allows you to specify how the actual drives and printers physically connected to the systems on the network will be addressed by the network workstations. When this process is completed, and the computers are re-booted, the network is in place.

Once the network is set up, the disk drives on the other systems on the network appear as additional drives on your system. For example, if your system has floppy drive A: and hard disk C:, and a second system on the network has the same set-up, you might configure the network so that your system has floppy A:, and hard disk C:, while the other system has floppy B: and hard disk D: (regardless of the actual physical drive letters on the second system). To see what files are on the second system's hard disk, you'd simply issue the command DIR D: and the directory would scroll across your screen. The Knowledge Network also allows you to lock drives and/or files away from network access. This provides both

a degree of privacy and some protection of valuable files from inexperienced users on the network. Files can also be designated as "read only"—a user can view the file, but cannot alter it.

If this setup sounds pretty nifty, it is! And it works well at a reasonable price. But you get what you pay for. As networks go, this one, like all software-driven serial port LANs (Local Area Networks), is very slow. The maximum speed The Knowledge Network can squeeze out of a serial port is 115 kilobaud. This is very fast when you compare it to the average modem communication speed of 1200 or 2400 baud, but when contrasted to the average EtherNet network speed of 10 megabits per second, it's slow. An average 10-page Wordstar file can take over a minute to load from a remote network drive.

As a means of providing shared access to files, serial LANs such as The Knowledge Network provide a good compromise between complexity and cost. If you think of an EtherNet network as a first-class airline ticket between LA and New York, then a serial network might be the

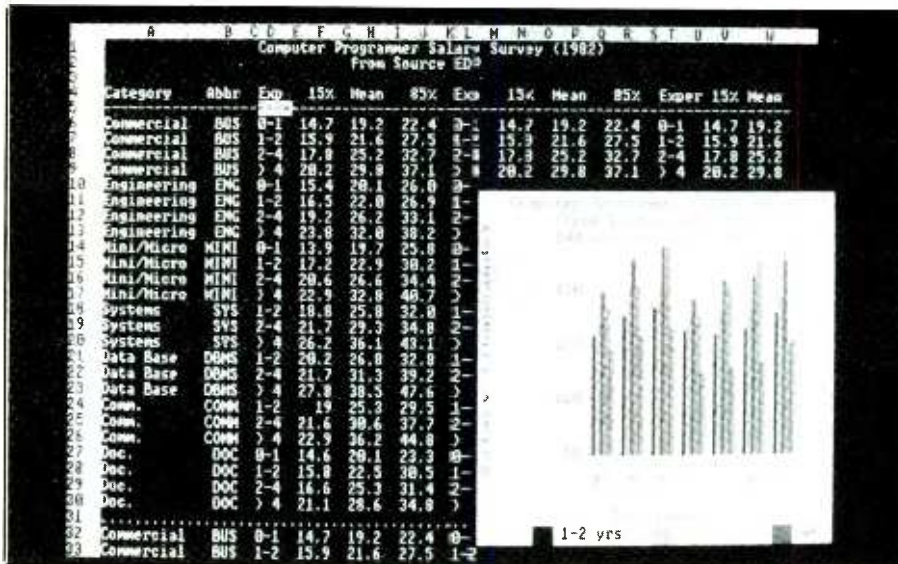

The InColor card expands the Lotus 1-2-3 spreadsheet to 90 columns by 38 rows and enables users to "window in" a 320 × 200 graph. The card displays 16 colors out of a palette of 64 in 720 × 348-pixel resolution.

equivalent of a bus ticket between the same two cities. Both will eventually get you there, but the jet will do so much quicker. Fortunately, it's not an either/or proposition. Future columns will present some of the in-between alternatives.

### The Hercules InColor Card

You really have to hand it to Hercules Computer Technology. It's not often that a small company can beat a big one at its own game. When the IBM PC was introduced in 1981, the "standard" display card was the monochrome display adapter (MDA), designed to display only text and a limited symbol set. If you wanted to produce graphics with the system, your other choice was an expensive (at that time) color graphics adapter (CGA) and color monitor. And even if you spent the extra money, resolution on the color graphics system was, at best, only fair.

Less than a year later, however, Hercules introduced a monochrome graphics display card that added excellent graphic resolution (720 × 348) on a standard TTL monitor at a cost substantially less

than IBM's CGA approach. The rest, as the cliché goes, is history. The "Hercules Graphics" standard is, at this time, supported by every major piece of software. Many other graphics-board manufacturers also emulate it.

Can Hercules pull it off again, almost six years later? It's trying with its new InColor board and RamFonts. Before we look at what the InColor card is, let's get straight on what it isn't. The InColor, though it requires an EGA compatible or multi-sync monitor for color, is not compatible with the EGA standard. Software that requires an EGA board will *not* run on the InColor. For that matter, software that requires a CGA board will also not run on the InColor card. This, however, is not as much of a limitation as it might seem.

The reason that these "limitations" are not really so limiting is that the InColor board *does* support the Hercules Graphic Standard. Therefore, if the developer of a particular software package decided to support the InColor card, it provides a Hercules Graphic Standard display in color. In either color or mono-

chrome, the resolution of this display is 720 × 348, a definite improvement over the EGA standard of 600 × 400, and quite a bit better than the CGA standard 600 × 200. It does this while providing a 16 color display (out of a palette of 64 colors).

If the software you're using does not support the InColor card, you can still get a color display. Only here, your choice of colors is limited to two—a background color, and a second color for the display matter. It produces this display in either standard IBM Text mode or in Hercules Standard Graphics mode, depending on what the software supports. The same driver is used for either color or monochrome displays, so swapping between such monitors or networking with both types is effortless.

Additionally, InColor has the ability to display a variety of alternate character sets. These are either those supplied by Hercules or, if you feel ambitious, developed by yourself. Hercules calls these alternate character sets RamFonts, and they are set with a font-manager utility that allows you to create 3,072 programmable characters (or 12,288 in two-color). Hercules supplies a simple word processing program with the board called Write On! This makes good use of the board's RamFont capabilities. Software drivers for specific programs, such as Lotus 1-2-3, AutoCAD, etc., are also supplied, and allow condensed fonts and color displays to be used with many popular programs. The board also incorporates a defeatable parallel port.

In RamFont mode, graphics can be run at text speed, and you can almost double the data you can satisfactorily read on a screen (Lotus 1-2-3 can be expanded to 90 columns by 38 rows, for example, as well as getting pop-up graphics windows).

The latest news, however, is that WordPerfect 5.0, the newest version of this most-popular word processing package, supports RamFonts. As the software is not yet available at the time I'm writing this, it's impossible to say how well the board and program will work to-

# They're Here!

## MODERN ELECTRONICS

### FUN PROJECT BOOKS

You'll want these two exciting project books, packed with complete plans for building a wide variety of useful electronic devices. The *First and Second Books of Modern Electronics Fun Projects*, both Howard W. Sams publications, are now available.

You'll find all the how-it-works information, schematics, photos, drawings, printed-circuit guides and parts sources to make it a snap to build almost 50 useful, unique electronic devices at modest cost.

Discover how these circuits and modern electronic devices perform their magic. Learn practical electronic technology the painless way and have fun doing it!

All projects are based on material published in *Modern Electronics*, with updates and revisions. They've been built and tested by the original authors. Chapters are divided into Intro To Electronic Projects, Home Electronics, Audio/Video Electronics, Security Electronics, Computers, Test Equipment, and Electronic Designing. There's something for everyone!

Look at what you can build & take pride in:

- \* Digital voltmeter accessories—high-frequency ac probe, true-rms adapter, temperature probe
- \* Car projects—anti-theft alarms, engine tachometer
- \* Life-saving detectors—gases & microwave leaks



- \* Computer system power controller
- \* Dual-pulse generator
- \* Surround-sound audio enhancer
- \* Security—telephoned status reporter, alarm control center
- \* Home convenience—selectable phone ringer musical tunes, touch-sensitive light controller.
- ... and so much more.

The Fun Projects are capped by introductory information on building projects and kits (tools needed, parts sources, etc.) and advanced design techniques that illustrate how a designer thinks and plans when putting together a practical end product.

From beginning to end, MODERN ELECTRONICS FUN PROJECT BOOKS are for you! Order them today for a fast start in the world of electronics.

MODERN ELECTRONICS  
76 N. Broadway, Hicksville, NY 11801

Name \_\_\_\_\_  
Address \_\_\_\_\_  
City \_\_\_\_\_  
State \_\_\_\_\_ Zip \_\_\_\_\_  
( ) Check ( ) MasterCard ( ) VISA  
Card No. \_\_\_\_\_  
Expires \_\_\_\_\_  
Signature \_\_\_\_\_

(Signature required on all charge orders)

Order Date: \_\_\_\_\_

QTY	Title	Price	Total
	First Book of Modern Electronics Fun Projects	\$12.95 ea.	
	Second Book of Modern Electronics Fun Projects	\$12.95 ea.	
		<b>Total</b>	
		*Shipping	
		<b>Grand Total</b>	

\*Shipping charges \$2 per order. Orders processed day received, but please allow 30 days for delivery.

## PC CAPERS...

gether. I expect, though, that the InColor card (or it's sibling-Hercules' Monochrome RamFont card) will provide a superior WYSIWYG (What You See Is What You Get) screen display.

Should you spend \$349 on an InColor card? Like most purchases, it depends on what you do with your system. If you are performing word processing, CAD, or desktop publishing, most software packages will support the InColor in Hercules graphic mode. This gives you superior resolution (and greater speed), though not always in full color. And Hercules has traditionally been very successful in getting software suppliers to support its graphics standard, however. Heavy Lotus 1-2-3 and Symphony spreadsheet users will welcome the ability to expand what they see and enjoy pop-up graphics.

On the other side of the question, though, is IBM's new VGA graphic standard. Introduced on its new PS/2 systems last year, most third party board manufacturers are already climbing on the VGA bandwagon. It's a sure bet, too, that most new software, especially that written for the new OS/2 operating system, will strive to be VGA compatible.

I like the InColor board. It provides an excellent crisp display on my EGA monitor. I think, however, I'd prefer to wait a few months for some of the dust to settle if I were contemplating buying the board to see if more software makers come on board. I'm impressed with the Hercules card, but my head is telling me that a VGA compatible graphics board might be a better investment. Unlike the first time around, IBM's new VGA might well be the end run around Hercules' newest board. **ME**

### Names & Addresses

**Applied Knowledge Groups, Inc.**  
1095 East Duane Ave., Suite 203  
Sunnyvale, CA 94086  
(408) 739-0300

**Hercules Computer Technology**  
921 Parker St.  
Berkeley, CA 94710  
(415) 540-6000

## *DESQview does windows, as well as multitasking, macro keys, DOS shells, and block copies with data translations between windows*

By John McCormick

Have you ever felt frustrated by the single-mindedness of your MS-DOS computer? By this I mean its inability to run more than one program at a time (multitask). How about the inordinate amount of time required to switch between two programs? Is that discouraging?

Amiga owners can switch between different programs in a split second, but MS-DOS owners have to save the data they're working on, unload the current program, and then locate and load the next application, sometimes needing to find a "key" disk in the process if the new program is copy-protected. Then, of course, you have to repeat the process to return to the original program.

DESQview from Quarterdeck, solves this and many other problems, allowing your MS-DOS computer to run many programs in small- or full-screen windows simultaneously, and it does it without making you buy a whole new set of programs.

For novice computer users, DESQview provides a very easy-to-use DOS shell that simplifies all those DOS commands, like BACKUP and COPY, reducing these and most common DOS services to a simple menu selection.

To use them, you just highlight the files you want to work with (DESQview sorts your directory using two levels of sorts, such as NT, for newest time, and extension or filename), then use arrow keys or mouse motion to locate the procedure you want, such as COPY, DELETE, or TYPE.

Power users won't be bothered by this because there are several very simple methods of going directly to DOS and keying in your commands, no matter what programs you may have running. For beginners and advanced users alike, however, DESQview provides two-key abbreviations for all programs, making it much simpler to start up programs without worrying about correct syntax or the hard-disk directory location for any program installed in DESQview's menu.

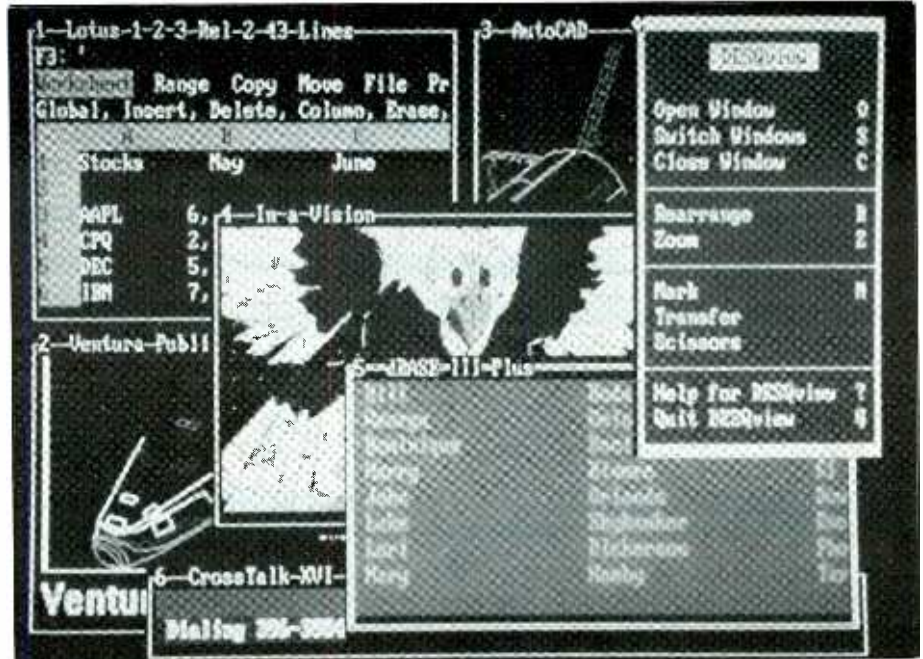

Although the software will run on an all-floppy system, it's really intended for hard-disk users, and the installation program actually searches a hard disk for programs it recognizes, automatically installing them.

### ***DESQview Power***

Once DESQview is installed (a nearly automatic operation), you can customize it in any way you want, but the default setup provided will get most people up and running in a few seconds, and it's simple to make any modification later.

Window characteristics (size, colors and such) are easily modified, either permanently (during setup) or temporarily while in a window.

With DESQview installed, you open a window by choosing some program, perhaps WordStar. DESQview opens this program in a window that can be moved around or zoomed to fill the screen.

Now open another window with the same or a different program! This gives you two programs running at the same

time and even makes windowless programs like WordStar into multi-window programs with no special programming of any sort (on your part, that is).

If this doesn't seem too exciting, how about this: load Hilgreave's HyperACCESS (or other well-behaved terminal software like CROSSTALK Mk.4) in a window, start a script running that will call MCI mail and retrieve your messages, then go back to word processing, programming, or working on a spreadsheet while your mail is located and downloaded. You could even have a program answer your phone and take or leave messages for other modem-equipped users, right while you are working on something else!

If you do any lengthy financial calculations using spreadsheets, massive database sorts, or any other time-consuming operations like compiling computer code into programs, you can start one or more of these operations in windows, then switch to current work like word processing.

Just how DESQview performs this

# SOFTWARE FOCUS...

**Change a Program**

Program Name.....:

Keys to Use on Open Menu:  Memory Size (in K):

---

Program...:

Parameters:

Directory.:

---

Options:

Writes directly to screen.....:  [Y]

Displays graphics information...:  [N]

Can be swapped out of memory...:  [Y]

Requires floppy diskette.....:  [N]

**Press F1 for advanced options** **Press ← when you are DONE**

A program's information file (.DVP) can be easily changed by displaying the "Change Program" menus as shown. The first screen covers basic information generally used, while the second gives the user the option of fine-tuning how a program runs.

**Change a Program Advanced Options**

System Memory (in K).....:  5 Maximum Program Memory Size (in K)...:

Script Buffer Size.....:  1000 Maximum Expanded Memory Size (in K):

Text Pages:  1 Graphics Pages:  0 Initial Mode:  Interrupts:  00 to  FF

---

Window Position:

Maximum Height:  25 Starting Height:  Starting Row...:

Maximum Width.:  80 Starting Width.:  Starting Column:

---

Shared Program

Pathname...:

Data.....:

---

Options:

Close on exit to DOS.....:  [N] Uses its own colors.....:  [N]

Allow Close Window command...:  [Y] Runs only in foreground.....:  [ ]

Uses math coprocessor.....:  [N] Keyboard conflict (0-4).....:  [0]

**Press F1 for standard options** **Press ← when you are DONE**

multitasking with ordinary programs you probably already own is a bit complex, although you do not need to know how it works to use it.

Basically, DESQview works best by placing a large amount of your program

into EMS or EEMS memory space and continuing to run the application with this split memory. If your system lacks this "expanded" memory, then your programs can only multitask (run simultaneously) if they fit along with DESQ-

view in your standard user RAM memory space (maximum of 640K on MS-DOS computers).

If a program is swapped to hard, floppy, or RAM disk (you should not swap communications programs while running), then nothing is lost and you'll go right back to the same place when you switch to that window again. The only disadvantages to disk swapping are that it slows down program access and the program(s) that are currently swapped to disk aren't able to run in the background.

- **Autodialer.** One especially nice built-in feature is the autodialer, which works with most autodial modems. Unlike similar programs, this one doesn't come with a small file to hold phone numbers—it isn't needed!

To use the autodialer, you merely open the DESQview window: hit and release the ALT key), push M (mark), P (phone), and DESQview highlights the first telephone # after the current cursor location. Then you press ENTER to dial this number or resume search for another number.

This means that you can autodial any number appearing in any database or word processor screen or file, as long as it's operating in the text rather than graphics mode.

- **Data Transfer.** Transferring data between windows running different programs is just as simple. If I want to make a table of numbers from one screen and insert it to another, I just block-copy the data; then use DESQview's filter to remove # and \$ symbols if necessary for a spreadsheet. After the first number is copied, I enter the command to move to the next cell (ENTER, TAB, or whatever) before copying the next number.

This is quicker done than described because it requires no special codes; you just copy one line, then perform the action you want taken next (even things like inserting commas or backspacing and erasing some part of the data), and strike a key to tell DESQview to complete the transfer using this method.

For a fast text transfer, just hit the ENTER key and you get the default that is

### DESQview Details

DESQview by Quarterdeck Office Systems, 150 Pico Blvd., Santa Monica, CA 90405; 213-392-9701.

Version 2.01 (\$129.95) has special features for 80386-based computers as well as takes advantage of the new VGA graphics mode on IBM PS/2 computers and uses both EMS and EEMS memory on older machines.

to transfer the data with a carriage return at the end of each line.

- *Mice.* DESQview's designers have recognized that, while some people find mice very useful, others won't let the little rodent near their computers. Thus, this program is just as easy to use with command keys, cursor keys, or mice.

- *Macros.* Macrokeys are just regular keyboard keys that have small (or large) programmed tasks attached to them, like loading a series of programs, or perhaps placing your name, address, and phone number at the close of every letter, using only a two-key command.

Macrokeys are very easy to create in DESQview, and you can have as many as desired because the same key combination can do something different for every program you load and still another task when you are working in the DESQview window.

Using macros, you can not only automate loading and setup of programs, you can also customize your regular programs by creating special command sequences that are easier for you to remember than the ones provided by the original programmer.

### Conclusions

One of the most amazing things about DESQview is that novice users will find it almost as useful as power users, and, with a hard disk (or RAMdisk) and DESQview, multitasking on any MS-DOS com-

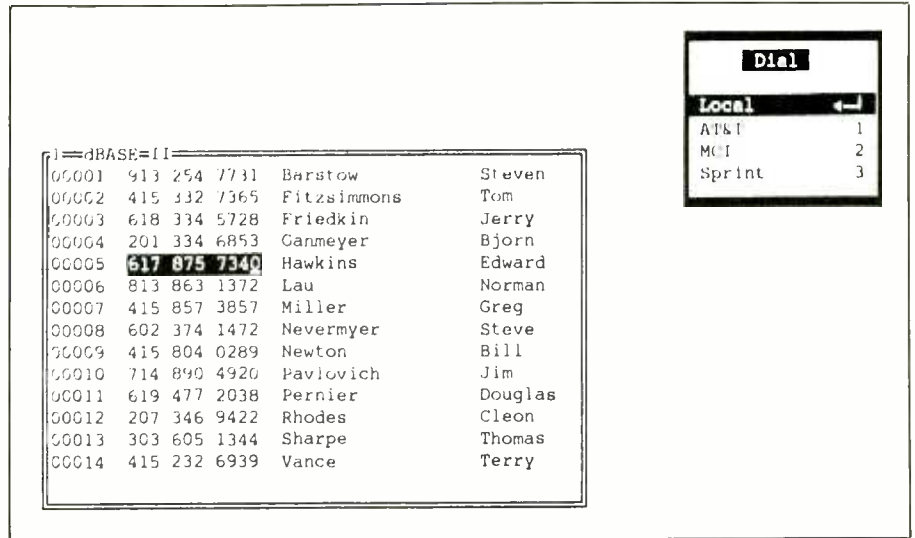

DESQview can be used with a modem to automatically dial a telephone number by an automatic search forward from the cursor or by manually marking a listed number.

puter is actually easier than single tasking on the same computer without DESQview.

Power users will find that running multiple programs simultaneously, having a different set of macros available in every window, and the ability to run powerful programs like Lotus, even in a tiny window, is very useful.

Just how much you can do with DESQview in your specific computer and how fast it will operate depends on how fast your hard disk is and how much memory you have.

You will need a minimum of 512K even to run DESQview with an applications program. But if you have EMS or EEMS memory (that memory over 1MB that's supplied by AST, Tecmar, Maynard, Zuckerboard or other add-on memory boards), then you can run several programs (each requiring more than 500K by itself), all at the same time without disk swapping.

Although fast computers like my IBM PS/2 Model 80 (16-MHz 80386) practically ignore the delays caused by disk swapping, I've also run DESQview for years on a Tandy 1200 (4.77-MHz XT

### Learn

#### Not Learning

Start Script	=
Finish Script	-
Cancel Learn	C

Fixed-Size Pause	F
Variable Pause	V
Time Delay	T

Display Scripts	D
Save Scripts	S
Load Scripts	L

One of DESQview's most powerful features is "Learn," which is a macro that tells the program to remember a sequence of keystrokes and to assign the keystrokes to a particular key on the keyboard. Thereafter, pressing the assigned key will recall those keystrokes.

## A Career Start in 21st Century Electronics



Since 1905, National Technical Schools has helped over 300,000 people just like you learn at their own pace and build successful careers. Enter the boom in electronics through home study courses in Microcomputer Technology & Servicing, TV & Radio Servicing, Video Technology, Industrial Controls (Micro-processing), Robotics or Basic Electronics.

To begin a new career or to sharpen your current skills, call 1-800-B-BETTER or write us today for complete details: NTS, Dept. ME-410, 456 West M.L. King Jr. Blvd., Los Angeles CA 90037.

Accredited by National Home Study Council

CIRCLE 46 ON FREE INFORMATION CARD

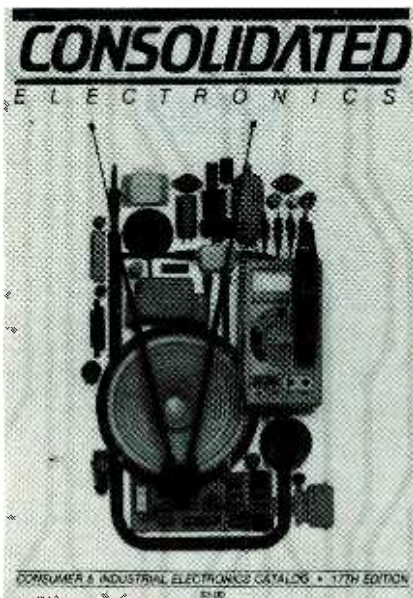

### GET THE ULTIMATE ELECTRONICS CATALOG.

Order your 260 page catalogue packed with over 10,000 money saving electronic parts and equipment. Send \$3.00 check or money order, or call 1-800-543-3568 today and use your Mastercard or Visa.  
Consolidated Electronics, Incorporated  
705 Watervliet Ave., Dayton, Ohio 45420-2599

NAME \_\_\_\_\_  
ADDRESS \_\_\_\_\_  
CITY \_\_\_\_\_  
STATE \_\_\_\_\_ ZIP \_\_\_\_\_

CIRCLE 45 ON FREE INFORMATION CARD

82 / MODERN ELECTRONICS / May 1988

## SOFTWARE FOCUS...

### Doing Windows

Windows are simply small-screen (or perhaps full-screen) segments of your monitor's screen where separate programs can be run. But they are also "windows" into your machine's memory.

If you have two windows, you can run two programs simultaneously (assuming you have enough memory to do so). If you have 50 windows (perfectly feasible with DESQview running on a machine like my PS/2 Model 80 computer with an 80386 CPU), you can have 50 programs running; either different one in each window, or perhaps several different copies of Lotus 1-2-3, dBASE, or your favorite word processor.

Where your applications program has windowing capability of its own, such as WordPerfect's two windows, these two windows run in each DESQview window where you install WordPerfect. The same holds true for programs like Microsoft's Word, which has eight windows available for each copy running.

All of this windowing can become difficult to follow. Except for very long programs, such as Lotus or other spreadsheet calculations, very long da-

tabase sorts, or compiling long code files, you would run only two or three windows most of the time, no matter how much memory you have available.

Although this program is claimed to be multitasking, meaning that it can not only load but actually run several programs at once, it is actually what is referred to as timesharing. Consequently, each window in effect runs for a short while; then the computer switches to the next window.

The amount of time (if any) you want allocated to background programs (those running while you are doing something else, like writing a letter, in the foreground) is easy to change.

Many programs can be run in the background, including DOS functions; so a long series of copies can take place in the background. You can even format disks in the background while doing something else.

Tasks will take longer, of course, because they receive only a portion of the computer's attention. But in many cases this is no problem, especially with today's 10-, 16- and even super-fast 20-MHz machines.

clone) and find it not only usable but indispensable. Without it, the delays encountered in closing and reloading programs are intolerable.

The documentation that accompanies DESQview is extensive and easy to understand. But really customizing this program for optimum performance will tax even advanced users because of the vast number of possibilities. To achieve true optimum performance will take a bit of experimenting, and you're bound to experience more than one system crash. Since I use automatic timed system backups for my WordPerfect files and know to expect trouble with those special in-

stallations, this has never really been a problem for me.

Just running DESQview as it comes from the box is very simple, however, and makes a vast improvement in the way your computer operates.

If you have a hard disk, EMS or EEMS memory, or even a floppy system with a RAMdisk and need to run a variety of programs during the day or perhaps have extensive processing to do that normally renders your computer useless for any other purpose for long periods of time (even 10 minutes is an eternity if you're waiting to get to the word processor while Lotus is still solving a problem), then

Say You Saw It In Modern Electronics



## Hands-On Power

To really get a feel for the power of DESQview, it is probably simplest if I describe how I use it and you can draw your own conclusions as to how its use might benefit you.

First, I like TSR (Terminate and Stay Resident) programs that provide calculators and notepads. Unfortunately, they can cause problems with other software; so I seldom load them.

After getting DESQview, I stopped using them altogether as TSRs, although I still use several of them in different DESQview windows as stand-alone programs (DESQview specifically supports Borland's SideKick).

Instead, I load Lotus 1-2-3 into one window for complex calculations, FORTYONE, a program that emulates an HP 41C pocket computer as my calculator, and several WordStar copies into other windows to serve as my "notebooks." Next, I load WordPerfect into two windows, giving me a total of four windows in WordPerfect (each program has two windows even without DESQview). Last, I load DESQview's DOS shell with a directory of word-processor files sorted to show which ones I worked on last, and a window for sim-

ple calculations gets a copy of the very neat ALS18C financial calculator from CloneWare.

I need all this because, as a writer and consultant, I am often working on several projects at a time. It might sound like this setup alone takes me most of the day to install. However, these programs are actually all loaded automatically, using a single DESQview macro!

If your programs are on a hard disk, you can do the same thing. Just set DESQview to macro mode and go through your favorite setup one time while your keystrokes are recorded. You can even load your favorite files into programs as part of the default setup.

Another example is the pair of macrokeys I programmed to load Reflex, a Borland database where I keep client files as well as my master mailing/phone list. Each macrokey loads Reflex, but one goes on to load the mail list while the other loads my client list. At least ten times a day, I pause a few seconds and use one of these keys to pop up Reflex to look something up or make a quick note, then close Reflex using the DESQview command if I did not add information, or automatically

re-sort the database and save to disk the new version using another single macrokey.

Having loaded all these programs and set each one to my desired color combinations, I am ready for anything. I can set Lotus to work on a long calculation, then with a tap of the ALT key go to WordPerfect to work on a computer article.

Say the phone rings and an editor wants to know something about an article I submitted last week. I switch to another window and call up that article, with my notes for the piece on yet another screen, *without* exiting and reloading the original article I was working on.

Back to the original job, I need to include a BASIC program in that article. So I open a BASIC window, block-copy the program, and move it to the correct place in the article. If things were the other way around, I could copy the BASIC code from the article to the BASIC window and then run the program without any changes!

As you can see, DESQview is a great productivity tool that I try to use to its fullest.

DESQview is more than a good idea; it's a necessity.

BBS operators should consider the possibilities of running their electronic bulletin boards as a background task.

If you're a beginning user (or are working with one) who is still confused about just how to start up programs and use the DOS commands, DESQview provides a simple, novice-ready, operating shell that has capabilities that go beyond those needed even by advanced users.

Just while writing this review, I've jumped to other programs a number of times to look up a phone number or take

a note or two, and several times to start up a file search that would locate various notes I already made on DESQview in some of my other articles.

I use both GOfer and WordPerfect's Word Search programs for different tasks, and even on a 16-MHz machine it sometimes takes those programs a minute or two to find the right file. But that doesn't slow me down because I just continue working until the search is done.

The only programs that won't run under DESQview are some games, notably those that don't run under DOS anyway (those that need to be in the disk drive

when the computer is re-booted).

Graphics-based programs will run perfectly well, but usually only in full-size windows. When they're loaded, the monitor is switched to graphics mode, which will give most text-based programs (like word processors) fits.

Accessing a graphics screen database like Borland's Reflex will cause your word processor screen to go all gray and useless, but only until you close the Reflex window, at which point everything will revert to normal with no data lost.

I personally wouldn't run an MS-DOS computer without DESQview. **ME**

CIRCLE NO. 178 ON FREE INFORMATION CARD

## A Sampling of Spring 1988 English-Language International Shortwave Broadcasts

By Gerry L. Dexter

Time	Country/Station	Frequencies
0000	Radio Austria Int'l.	9650
	BRT, Belgium (30)	5910, 9925
	Radio Portugal (30)	9689
	KUSW, Utah	11980
	HCJB, Ecuador (30)	9720
	Radio Berlin Int'l., E. Germany	6080, 9730
	REE, Spain	6125, 9630
	Radio Canada Int'l.	5960, 9755
	Radio Norway Int'l.(Mon)	9580, 9605
	Radio Havana Cuba	6090
	Vatican Radio (50)	6150, 9605, 11780
	Radio Beijing, China	9605, 9770, 11715
	Radio Sofia, Bulgaria	6070, 11720
	BBC, England (30)	5975, 6175, 7325, 9515
	Kol Israel	9435, 9855, 11610
0100	Radio Baghdad, Iraq	6110
	REE, Spain	9630, 6125
	Voice of Germany	6040, 6085, 6145, 9545, 9565, 9605, 11785
	RAI, Italy	9575, 11800
	Radio For Peace, Costa Rica	7375
	Radio Japan	15280, 17810, 17835, 17845
	Radio Moscow	5915, 5940, 6000, 6045, 6115, 7115, 7150, 7215, 7310, 9530, 11770, 12010, 12050, 13665, 15455
	WHRI, Indiana	7400, 9745
	Radio Austria Int'l.(30)	6000, 9550
	Radio Prague, Czechoslovakia	5930, 6055, 7345, 9540, 9630, 9740, 11990
	Kol Israel	9435, 9855, 11610
0200	RAE, Argentina	9690, 11710
	Radio Bucharest, Romania	5990, 6155, 9510, 9570, 11810, 11940
	Radio RSA, South Africa	9615, 9880, 11730
	Radio Cairo, Egypt	9475, 9675
	Radio Netherlands(30)	6020, 6195, 9590, 9895
	KUSW, Utah	9850
	Radio Sofia, Bulgaria	6025, 6110, 9520, 9585, 9835, 11910
	Radio New Zealand(30)	15150, 17705
	Radio Canada International	5960, 9755
	Radio Beijing, China	9645, 11790, 11980, 15455

Time	Country/Station	Frequencies
	Radio Kiev, Ukraine SSR	7185, 7205, 7260, 11790, 13645, 15180
	HCJB, Ecuador	6230
	Radio Sweden Int'l.(30)	9695
	RFI, France	3965, 5950, 6055, 9790
	Swiss Radio Int'l.	5965, 6135, 9725, 9885, 12035
	Voice of Free China	5985, 9765, 11740, 11745, 15345
	Radiobras, Brazil	11745
	Radio Polonia, Poland	6095, 6135, 7145, 7270, 9525, 11815, 15120
0300	Radio Austria Int'l.	6185
	Voice of Nicaragua	6100
	ZBS, Zambia(30)	3346, 4910
	Radio Budapest, Hungary	6025, 6110, 9520, 9585, 9835, 11910
	HCJB, Ecuador	9720
	Radio Berlin Int'l, East Germany	6080, 9560
	UAE Radio, United Arab Emirates	9640, 11940, 15435, 17890
	Voice of Germany	6010, 6045, 9700
	Capital Radio, Transkei, S. Africa	3930
	Radio France Int'l.(30)	3965, 6175, 7135, 9550, 9790
	Radio Japan	5960, 17810, 17845
	Trans World Radio, Netherlands Antilles	9535
	Radio Beijing, China	9645, 9770, 11715, 11980
	BBC, England(30)	5975, 6175, 7325
	Radio Prague, Czechoslovakia	5930, 6055, 7345, 9540, 9630, 9740, 11990
	HRVC, Honduras	4820
	Radio Polonia, Poland	6095, 6135, 7145, 7270, 9525, 11815, 15120
	Radio Tirana, Albania(30)	7065, 9755
0400	Radio Havana Cuba	5965, 6035, 6090, 6115, 6140
	Radio Botswana	4820, 7255
	Radio Lesotho	4800
	Radio Berlin Int'l.(30)	6080, 9560
	Voice of Turkey	9445
	Radio France Int'l.(40)	6045, 6055, 6175, 7135, 9550, 9800, 11700
	Swiss Radio International	6135, 9725, 9885, 12035
	Radio Budapest, Hungary	6025, 6110, 9520, 9585, 9835, 11910
	RAE, Argentina	9690, 11710

Times are in UTC. Numbers in parentheses are starting times for English that many minutes past the hour. For local time, subtract appropriate hours from UTC time given (example, deduct 5 hours for Eastern Standard Time).

Time	Country/Station	Frequencies	Time	Country/Station	Frequencies
0500	Radio Netherlands(30) KUSW, Utah REE, Spain Voice of Germany  Radio Japan Radio Moscow  Radio Havana Cuba Voice of Nigeria	6165, 9715 6175 6125 5960, 6120, 6130, 9635, 9700 5990, 15235, 17810 6095, 6150, 6190, 7260, 7345, 11790 5965, 6035, 6090, 6115 7255	1100	Radio Singapore Radio Finland Int'l. Radio Japan WHRI, Indiana Voice of Vietnam Radio Thailand(30) Radio France Int'l.(15)  Radio Pakistan Trans World Radio, Nether- lands Antilles(10) BBC, England Radio Pyongyang, North Korea	5052, 11940 11945, 15400 5990, 6120, 7210, 17810 5995 7430, 9730 9655, 11905 6175, 9590, 9805, 11670, 11700, 11790, 15195, 15425, 15435 15605, 17660  11815 5965, 6195, 9515, 11775 6576, 11735
0600	ELWA, Liberia HCJB, Ecuador Radio New Zealand Radio Korea, South Korea Radio Canada Int'l. WCSN, Mass. Voice of Nicaragua Radio Cook Islands	4760 9720 15150, 17705 6060, 9570 9740 7365 6100 11760	1200	Radio Austria Int'l. Radio Bangladesh(30) Radio Finland Int'l. VOPK, Kampuchea KUSW, Utah Radio Tashkent, Uzbek SSR  Radio France Int'l.(45) Radio Australia Radio Pyongyang, North Korea Radio Ulan Bator, Mongolia	15320 12030, 15525 11945, 15400 9695, 11938 9850 5945, 7275, 9600, 9715, 11785 15365, 17720 5995, 9580, 9770 9600, 9715, 9977 9615, 11990, 12015
0700	Radio Australia KUSW, Utah Solomon Islands Broadcasting Corp. Radio Japan  Radio Havana Cuba BBC, England(30) TWR, Monaco(25)	5995, 15160 6185  5020, 9545 5990, 15195, 15235, 17810 9525 5975 7160, 9495	1300	BRT, Belgium(30) Radio Finland Int'l. All India Radio(30) Voice of Vietnam(30) Radio Canada Int'l. Radio Norway Int'l.(Sun) Radio France Int'l.(05) Radio RSA, South Africa Radio Beijing, China	15590 15400 9545, 11810, 15335 9840, 15010 9625, 11855 6040, 9590, 15310 15365, 17720, 21645 9750, 15125, 17810 9530, 11600, 11755
0800	BRT, Belgium(25) KNLS, Alaska WHRI, Indiana Radio Beijing, China Radio Australia WRNO, Louisiana Radio Netherlands(30)	17600 6095 7365 9645, 11980 9580, 11720 6185 9630	1400	KVOH, California Radio Finland Int'l. Radio Korea, South Korea Radio Norway Int'l.(Sun)  Radio Sweden Int'l. Radio Japan KTWR, Guam(30) FEBC, Philippines	9495 15105, 15400 9750, 15575 9530, 15245, 15310, 15315 9695, 15345 5990, 7210, 9695, 11815 9870 9670
0900	Falkland Is. Broadcasting Serv. KUSW, Utah Radio New Zealand(30) Radio Canada Int'l.(30) Adventist World Radio, Portugal Radio Japan NBC, Papua New Guinea	3958 11980 9540, 11780 5960, 9755 9670 11840, 17810 4890	1500	WHRI, Indiana Radio Veritas Asia, Philippines Radio Beijing, China BBC, England Voice of Indonesia Radio Pyongyang, North Korea HCJB, Ecuador	15105 9770, 15215 11600, 15165 15260 11790, 15150 9940, 9977 11740, 15115, 17890
1000	Voice of Vietnam Radio Norway Int'l.(Sun) Radio Australia Kol Israel  Solomon Is. Broadcasting Corp. HCJB, Ecuador Radio Singapore WHRI, Indiana Radio Oman	9840, 15050 9590, 15180, 17780 5995, 9580, 9770 11585, 11605, 13750, 15095 5020 6130, 9745, 11925 5052, 11940 7355 9735, 11890	1600	KUSW, Utah	15225

# COMMUNICATIONS...

Time	Country/Station	Frequencies
	UAE Radio, UAE	11940, 15300, 15320, 17865
	Radio Nacional Angola	9335
	Radio Norway(Sun)	7290, 9590, 11850, 15310
	WCSN, Mass.	15280
	WRNO, Louisiana	15420
	BSKSA, Saudi Arabia	9705, 9720
	Radio France Int'l.	9860, 11700, 11705, 11995, 15315, 17620
	Radio Pakistan(15)	11610, 11625, 15125, 15605
1700	Radio Afghanistan(30)	11755
	WHRI, Indiana	15105
	Radio Surinam Int'l. (via Brazil)(30)	17835
	Radiobras, Brazil	15265
	Kol Israel	9460, 11585, 13750
	WRNO, Louisiana	15420
	Voice of Nigeria	11770

Time	Country/Station	Frequencies
1800	Radio Canada Int'l.	15260, 17820
	WCSN, Mass.	21515
	Radio Havana Cuba (30)	9670
	Radio Kuwait	11665
	Voice of Nigeria	15120
	BRT, Belgium(30)	11695
1900	KUSW, Utah	17715
	Radio Canada Int'l.(30)	5995, 7235, 11945, 15325, 17875
	VOIRI, Iran(30)	9022, 11930
	Kol Israel	11610, 12080, 13725, 17630
	Radio Kuwait	11665
2000	Radio Algiers, Algeria	15215
	All India Radio	9910, 11620
	WCSN, Mass.	9465
	Radio Kuwait	11665
	Radio Baghdad, Iraq	7295, 9875
	BSKSA, Saudi Arabia	9705, 9720
	Voice of Kenya	11740

2100	Radio Berlin Int'l., E. Germany	6125
	Radio Baghdad, Iraq	7295
	Radio Canada Int'l.(30)	11880, 15150, 17820
	Radio RSA, South Africa	7295, 9580, 11990
	Radiobras, Brazil	9760
	Voice of Nigeria	15120
	Radio Damascus, Syria(05)	9950, 12085
	Radio Yugoslavia(15)	6100, 7240, 9620

2200	BRT, Belgium	5910
	Radio Mediterranean, Malta(30)	6110
	KUSW, Utah	15580
	Radio New Zealand(45)	15150, 17705
	RAE, Argentina	9690, 11710
	All India Radio	9910, 11620, 11715
	Radio Sofia, Bulgaria	9700, 11720

2300	Radio Berlin Int'l. E. Germany	6070, 6125, 6165
	Radio Korea, South Korea(30)	15575
	Voice of Turkey	9445
	Radio Kiev, Ukraine SSR(30?)	7185, 7205, 7260, 11790, 13645, 15180
	Radio Sweden Int'l.	9695
	Radio Japan	7280, 11800, 15195, 15280
	Radio Moscow	5915, 5940, 6000, 6045, 6115, 7115, 7150, 7215, 7310, 11770, 12050, 13665, 15425, 15445, 17700
	Radio Pyongyang, North Korea	11735, 13650

**At KELVIN...  
Price, Service  
& Quality for  
over 42 years.**

**B & K · FLUKE · UNGAR  
HITACHI · WELLER  
BECKMAN · DREMEL  
STANLEY · MAKITA  
X-ACTO · KEPRO · XCELITE**



LISA HADAR  
EXECUTIVE VP, CPA

## METERS/OSCILLOSCOPES

B & K	2120	20Mhz Dual Trace	\$ 395*
Beckman	9020	20Mhz Dual Trace	425

Hitachi V212 20Mhz **\$365**

Fluke	73	3 1/2" Digit DMM	SPECIAL
Fluke	75	3 1/2" Digit DMM	
Fluke	77	3 1/2" Digit DMM	

\*PLUS Shipping & Insurance. Prices subject to change without notice.  
WE HAVE IT ALL.

• COMPONENTS • TOOLS • KITS • SECURITY • SEMI-CONDUCTORS • ELECTRICAL SUPPLIES • SOLDER EQUIPMENT • KELVIN KITS • TSM KITS • DRAFTING SUPPLIES

Volume Quotes, Industrial & School Bids Welcome.

ORDER TOLL FREE FOR INQUIRES & N.Y.S.  
**1-800-645-9212 516-349-7620**

**KELVIN  
ELECTRONICS**

NEW ADDRESS:

7 Fairchild Avenue • Plainview, NY 11803 • FAX: 516-349-7830

VISA/MASTER CARD ACCEPTED

CIRCLE 16 ON FREE INFORMATION CARD

Say You Saw It In Modern Electronics

Drill a hole in one wall of the plastic enclosure to mount the jack for the power supply in a location where it will not interfere with the circuitry. After mounting the jack, locate the free ends of the red- and black-insulated wires and solder them to the appropriate lugs on the jack.

If your project is to have both powering options, prepare red- and black-insulated test leads as described above. Tie double knots in each about 6 inches from one end. Connect and solder these leads *and* the shorter leads coming from the board to the appropriate lugs on the power jack. Be sure to observe color coding. Then feed the free ends through the appropriate grommet-lined holes in the front panel.

Terminate the +5-volt and GND leads in miniature alligator clips with insulating plastic boots. Finally, strip ¼ inch of insulation from both ends of six 36-inch-long miniature test lead wire. Tightly twist together the fine wires at each end and sparingly tin with solder. Connect and solder to one end of each lead a banana or pin plug, depending on the type of input jacks you are using. Terminate the other ends in plunger-type micro test clips.

### Checkout & Use

Once the project is completely assembled, check all soldered connections for poor soldering and solder bridges between closely spaced pads (especially around the ICs) and conductors. If you suspect any connection, reflow the solder on it. Then check all component locations and orientations.

If everything looks okay, connect the power leads to a 5-volt dc supply (or use the separate power supply if this was your option) to the project. If you are not taking power from the circuit under test, clip the GND test lead to the circuit's ground to provide a reference for the project.

Plug a test lead into INPUT jack 1

and touch its micro test clip to some point that is at ground potential in the circuit under test; the CHANNEL 1 LED should light and glow green in color. Now, touching the test clip to and +5-volt point in the circuit should cause the same LED to glow red. If the LED colors are opposite from what is expected, the device is installed backwards and must be removed from the circuit and be reinstalled in the proper polarity. Repeat this test for all channels.

If any of the LEDs glows slightly red when no input is applied to its channel, try adjusting the value of the 1,000-ohm pull-down resistor in that channel. If the LED will not completely extinguish no matter what value of pull-down resistance is used, replace it with a new one.

When everything checks out okay, disconnect and power down the project. Drop the panel/circuit-board assembly into the plastic enclosure and secure it in place with the screws provided with the project box.

### Application Example

Shown in Fig. 5 is a typical example of how the Multi-Channel TTL Logic Tracer is used. A 100-Hz clock is connected to three divide-by-10 counters in series with each other. With INPUT probe 1 connected directly to the clock's 100-Hz output, the CHANNEL 1 LED will glow yellow (assuming a 50-percent duty cycle for the clock pulses). With INPUT probe 2 connected to the output of the first 7490 decade counter, where the frequency is 10 Hz, the CHANNEL 2 LED will flicker between red and green at a fairly rapid 10 times per second. With INPUT probe 3 connected to the output of the second 7490 counter, where the frequency is 1 Hz, the CHANNEL 3 LED will alternate between red and green at the much more sedate pace of once each second. Finally, with INPUT probe 4 connected to the output of the last

counter, where the frequency is now 0.1 Hz, the CHANNEL 4 LED will alternate between red and green at an almost glacial rate of once every 10 seconds.

The arrangement depicted in Fig. 5 is an example of a sequential logic application. The Multi-Channel TTL Logic Tracer is also useful for keeping tabs on goings on in simultaneous logic situation, such as moment-by-moment events on a multi-line logic bus as in a computer or process-control system. It can even be used in systems where you want to monitor random events that are not synchronized either sequentially or simultaneously or in two or more unrelated logic circuits. Of course, at those times when you need only single-point tests, you can use the Tracer as an ordinary logic probe as well.

ME

### "Smart Box" (from page 48)

As you use the Smart Box, remember that when *LED1* is on, the compressor is enabled if the air-conditioning system is calling for cooling. After driving a few miles with the A/C on, you will be able to select the precise adjustment of *R17* that is just right for you.

When you park your vehicle in full sunlight on a very hot day, set *S1* to *BYPASS* until the passenger compartment becomes cool. The *BYPASS* mode allows your A/C to operate at maximum cooling and is indicated by *LED2* turning on. This *BYPASS* LED alerts you to the fact that your A/C is running without the economy and engine-strain-relief benefits of the Smart Box. So switch back to the alternate position of *S1* when the passenger compartment is at a comfortable temperature to reap the rewards of this project.

ME



**PICKS UP A WHISPER 50 FEET AWAY!**

The model WAT-50 miniature FM transmitter uses a 4-stage circuit NOT to be confused with a simple wireless microphone. Simply snap the unit on top of a 9V battery and you can hear every sound in an entire house up to 1 mile away! Use with any FM radio. Tunes to any frequency from 70mhz - 130mhz. Easy to assemble kit includes all parts and instructions. Only 29.98 tax incl.



The WIRELESS TELEPHONE TRANSMITTER model WTT-20 is only about the size of a dime, yet transmits both sides of a telephone conversation to any FM radio with crystal clarity. Completely automatic. Uses power from the telephone line itself - never needs a battery! Up to 1/4 mile range. Tunes from 70mhz - 130mhz. Easy to assemble kit includes all parts and instructions. Only \$29.98 tax incl.

Call or send MO, VISA, MC for immediate delivery. Single kit orders include \$1.50 S&H. FREE SHIPPING on orders of 2 or more. All orders shipped by U.S. Mail. COD add \$4.00. Personal checks allow 21 days.

**DECO INDUSTRIES**  
**BOX 607, BEDFORD HILLS, NY 10507**  
**914-232-3878**

CIRCLE 4 ON FREE INFORMATION CARD



The magazine for Computerist & Amateur Radio  
 Your #1 source of Packet info.

"... received my moneys worth with just one issue..."

—J. Trenbick

"... always stop to read CTM, even though most other magazines I receive (and write for) only get cursory examination..."

—Fred Blechman, K6UGT

U.S.A. \$18.00 for 1 year

Mexico, Canada \$32.00

Foreign \$43.00 (land) - \$68.00 (air)

(U.S. funds only)

Permanent (U.S. Subscription) \$150.00

Sample Copy \$3.50

**CHET LAMBERT, W4WDR**

1704 Sam Drive • Birmingham, AL 35235  
 (205) 854-0271

CIRCLE 5 ON FREE INFORMATION CARD

**SINGERS!**  
**REMOVE VOCALS**  
**FROM RECORDS AND CDs!**



**SING WITH THE WORLD'S BEST BANDS!**

An Unlimited supply of Backgrounds from standard stereo records! Record with your voice or perform live with the backgrounds. Used in Professional Performance yet connects easily to a home component stereo. This unique product is manufactured and sold Exclusively by LT Sound - Not sold through dealers. Call or write for a Free Brochure and Demo Record.

**LT Sound, Dept. ME-3, 7980 LT Parkway**  
**Lithonia, GA 30058 (404) 482-4724**  
 Manufactured and Sold Exclusively by LT Sound  
**24 HOUR PHONE DEMO LINE: (404) 482-2485**

**MODERN ELECTRONICS MART**

**Classified Commercial Rates:** \$1 per word, 15-word minimum (\$15.00) prepaid. (Word count includes name and address; ZIP code and abbreviation each count as one word; P.O. Box number and telephone number count as two words each.) Indicate free category heading (Computers, Communications, Electronics, Video or Miscellaneous). A special heading is available for a \$6 surcharge. First word only is set boldface caps at no charge. Add 20% for additional boldface words.

**Non-Commerical Rates:** FREE to subscribers, as space permits; maximum 15 words. A recent *Modern Electronics* mailing label must accompany ad.

**Mart Display Rates:** 1" x 1 col., \$120; 2" x 1 col., \$230. Prepayment discount 5% for 6 issues; 10% for 12 issues prepaid at once.

(All advertisers with P.O. Box addresses must supply permanent address and telephone number. Copy is subject to publisher approval.)

**Mailing Information:** Copy must be received by the publisher by the 25th of the third month preceding the cover date. Send Advertising material with check or money order to: Modern Electronics, Classified Department, 76 N. Broadway, Hicksville, NY 11801.

**VIDEO**

**PROJECTION TV . . .** Convert your TV to project 7 Foot picture . . . Results comparable to \$2,500 projectors . . . Total cost less than \$30.00 . . . **PLANS AND 8" LENS \$21.95 . . .** Illustrated information **FREE.** Macrocoma-MI, Washington Crossing, Pennsylvania 18977. Credit card orders 24 HRS. (215) 736-3979.

**ELECTRONICS**

**TUBES, Name Brands, New, 80% Off List,** Kerby, 298 West Carmel Drive, Carmel, IN 46032.

**SURVEILLANCE, Electronics, Debugging.** Latest High Tech Equipment - Kits. Catalog \$2.00. **TECHNOLOGY SERVICES, 829 Ginette Street, Gretna, LA 70056.**

**LASERS and OPTICAL COMPONENTS.** Write for free catalogue. M.J. Neal Co., 6672 Mallard Court, Orient, OH 43146. 614-877-3719.

**FIBER OPTIC CABLE .100" DIA. 10FT-8.50 100FT-69.95 JSDIST POB 361 PARCHMENT, MI 49004.**

**VOICE DISGUISEERS! FM Bugs! Telephone Transmitters! Phone Snoops! More! Catalog \$1.00 (Refundable): XANDI ELECTRONICS, Box 25647, "U", Tempe, AZ 85282.**

**WHO'S LISTENING? Telephone Tap Detector - red light, someone's listening - extension or tap; green light, talk safely. Telephone line power, no batteries, easy install. \$29.95 + \$3.50 S&H. THECO Logic, Box 25761, Portland, Oregon 97225-0761.**

**TESLA COILS - Kirlian Electrophotography - Plasma Bulbs. FREE 1988 Science Plan Catalog! SCIENTIFIC, Box 1054HMD, Duvall, WA 98019.**

**CANADIANS send for free price list. DQ ELECTRONICS, PO Box 312, NDG, PQ H4A 3P6.**

**AMPLIFIER 12V, 16WRMS, mono. Kit \$11.95, Assembled \$16.95. SASE for information. ERDA, 1016 Woodland Rd, Kohler, WI 53044.**

**TUBES - Sylvania receiving tubes huge discounts. Consumer and Industrial. Arlen Supply Co., 6026 Market St., Philadelphia, PA 19139, 215-472-3810.**

**TELEPHONE or room TAP. Range unlimited. \$88.00. CALL 1-800-633-8277. Catalog \$3.00. LISTEN, 603 Elgin, Muskogee, OK 74401.**

**1200 parts \$10.00. All new. Long leads. Resistors, diodes, etc. All good stuff. No junk. Bargain city. P.O. Box 121M, Glen, MS 38846.**

**Order Form**  
**Please print in block letters.**

**MODERN ELECTRONICS 76 North Broadway, Hicksville, NY 11801**

Name \_\_\_\_\_  
 Street \_\_\_\_\_  
 City \_\_\_\_\_  
 State \_\_\_\_\_ Zip \_\_\_\_\_

1	2	3	4	5
6	7	8	9	10
11	12	13	14	15

# CORPORATION

## 1-800-341-4300

AK, Puerto Rico - 218-681-6674 Telex - 62827914 FAX - 218-681-3380 TWX - 910350882 DIGI KEY CORP

**NATIONAL SEMICONDUCTOR • PANASONIC MACHINE • EAC, INC. • J. W. MILLER • AAVID ENGINEER • E. F. JOHNSON • ATLANTIC SEMICONDUCTOR**

**256K (262,144 x 1) DRAM 150NS \$5.70/1; \$39.95/9 Factory Firsts**

### INTEGRATED CIRCUITS

Part No.	Price	Part No.	Price
7400 TTL	1.95	74125N	1.95
7400N	1.95	74126N	1.95
7401N	1.95	74127N	1.95
7402N	1.95	74128N	1.95
7403N	1.95	74129N	1.95
7404N	1.95	74130N	1.95
7405N	1.95	74131N	1.95
7406N	1.95	74132N	1.95
7407N	1.95	74133N	1.95
7408N	1.95	74134N	1.95
7409N	1.95	74135N	1.95
7410N	1.95	74136N	1.95
7411N	1.95	74137N	1.95
7412N	1.95	74138N	1.95
7413N	1.95	74139N	1.95
7414N	1.95	74140N	1.95
7415N	1.95	74141N	1.95
7416N	1.95	74142N	1.95
7417N	1.95	74143N	1.95
7418N	1.95	74144N	1.95
7419N	1.95	74145N	1.95
7420N	1.95	74146N	1.95
7421N	1.95	74147N	1.95
7422N	1.95	74148N	1.95
7423N	1.95	74149N	1.95
7424N	1.95	74150N	1.95
7425N	1.95	74151N	1.95
7426N	1.95	74152N	1.95
7427N	1.95	74153N	1.95
7428N	1.95	74154N	1.95
7429N	1.95	74155N	1.95
7430N	1.95	74156N	1.95
7431N	1.95	74157N	1.95
7432N	1.95	74158N	1.95
7433N	1.95	74159N	1.95
7434N	1.95	74160N	1.95
7435N	1.95	74161N	1.95
7436N	1.95	74162N	1.95
7437N	1.95	74163N	1.95
7438N	1.95	74164N	1.95
7439N	1.95	74165N	1.95
7440N	1.95	74166N	1.95
7441N	1.95	74167N	1.95
7442N	1.95	74168N	1.95
7443N	1.95	74169N	1.95
7444N	1.95	74170N	1.95
7445N	1.95	74171N	1.95
7446N	1.95	74172N	1.95
7447N	1.95	74173N	1.95
7448N	1.95	74174N	1.95
7449N	1.95	74175N	1.95
7450N	1.95	74176N	1.95
7451N	1.95	74177N	1.95
7452N	1.95	74178N	1.95
7453N	1.95	74179N	1.95
7454N	1.95	74180N	1.95
7455N	1.95	74181N	1.95
7456N	1.95	74182N	1.95
7457N	1.95	74183N	1.95
7458N	1.95	74184N	1.95
7459N	1.95	74185N	1.95
7460N	1.95	74186N	1.95
7461N	1.95	74187N	1.95
7462N	1.95	74188N	1.95
7463N	1.95	74189N	1.95
7464N	1.95	74190N	1.95
7465N	1.95	74191N	1.95
7466N	1.95	74192N	1.95
7467N	1.95	74193N	1.95
7468N	1.95	74194N	1.95
7469N	1.95	74195N	1.95
7470N	1.95	74196N	1.95
7471N	1.95	74197N	1.95
7472N	1.95	74198N	1.95
7473N	1.95	74199N	1.95
7474N	1.95	74200N	1.95

### INTEGRATED CIRCUITS

Part No.	Price	Part No.	Price
4000 CMOS	1.95	74199N	1.95
4001N	1.95	74200N	1.95
4002N	1.95	74201N	1.95
4003N	1.95	74202N	1.95
4004N	1.95	74203N	1.95
4005N	1.95	74204N	1.95
4006N	1.95	74205N	1.95
4007N	1.95	74206N	1.95
4008N	1.95	74207N	1.95
4009N	1.95	74208N	1.95
4010N	1.95	74209N	1.95
4011N	1.95	74210N	1.95
4012N	1.95	74211N	1.95
4013N	1.95	74212N	1.95
4014N	1.95	74213N	1.95
4015N	1.95	74214N	1.95
4016N	1.95	74215N	1.95
4017N	1.95	74216N	1.95
4018N	1.95	74217N	1.95
4019N	1.95	74218N	1.95
4020N	1.95	74219N	1.95
4021N	1.95	74220N	1.95
4022N	1.95	74221N	1.95
4023N	1.95	74222N	1.95
4024N	1.95	74223N	1.95
4025N	1.95	74224N	1.95
4026N	1.95	74225N	1.95
4027N	1.95	74226N	1.95
4028N	1.95	74227N	1.95
4029N	1.95	74228N	1.95
4030N	1.95	74229N	1.95
4031N	1.95	74230N	1.95
4032N	1.95	74231N	1.95
4033N	1.95	74232N	1.95
4034N	1.95	74233N	1.95
4035N	1.95	74234N	1.95
4036N	1.95	74235N	1.95
4037N	1.95	74236N	1.95
4038N	1.95	74237N	1.95
4039N	1.95	74238N	1.95
4040N	1.95	74239N	1.95
4041N	1.95	74240N	1.95
4042N	1.95	74241N	1.95
4043N	1.95	74242N	1.95
4044N	1.95	74243N	1.95
4045N	1.95	74244N	1.95
4046N	1.95	74245N	1.95
4047N	1.95	74246N	1.95
4048N	1.95	74247N	1.95
4049N	1.95	74248N	1.95
4050N	1.95	74249N	1.95
4051N	1.95	74250N	1.95
4052N	1.95	74251N	1.95
4053N	1.95	74252N	1.95
4054N	1.95	74253N	1.95
4055N	1.95	74254N	1.95
4056N	1.95	74255N	1.95
4057N	1.95	74256N	1.95
4058N	1.95	74257N	1.95
4059N	1.95	74258N	1.95
4060N	1.95	74259N	1.95
4061N	1.95	74260N	1.95
4062N	1.95	74261N	1.95
4063N	1.95	74262N	1.95
4064N	1.95	74263N	1.95
4065N	1.95	74264N	1.95
4066N	1.95	74265N	1.95
4067N	1.95	74266N	1.95
4068N	1.95	74267N	1.95
4069N	1.95	74268N	1.95
4070N	1.95	74269N	1.95
4071N	1.95	74270N	1.95
4072N	1.95	74271N	1.95
4073N	1.95	74272N	1.95
4074N	1.95	74273N	1.95
4075N	1.95	74274N	1.95
4076N	1.95	74275N	1.95
4077N	1.95	74276N	1.95
4078N	1.95	74277N	1.95
4079N	1.95	74278N	1.95
4080N	1.95	74279N	1.95
4081N	1.95	74280N	1.95
4082N	1.95	74281N	1.95
4083N	1.95	74282N	1.95
4084N	1.95	74283N	1.95
4085N	1.95	74284N	1.95
4086N	1.95	74285N	1.95
4087N	1.95	74286N	1.95
4088N	1.95	74287N	1.95
4089N	1.95	74288N	1.95
4090N	1.95	74289N	1.95
4091N	1.95	74290N	1.95
4092N	1.95	74291N	1.95
4093N	1.95	74292N	1.95
4094N	1.95	74293N	1.95
4095N	1.95	74294N	1.95
4096N	1.95	74295N	1.95
4097N	1.95	74296N	1.95
4098N	1.95	74297N	1.95
4099N	1.95	74298N	1.95
4100N	1.95	74299N	1.95
4101N	1.95	74300N	1.95

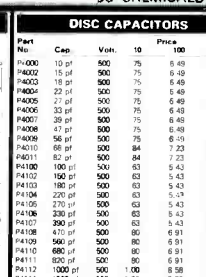
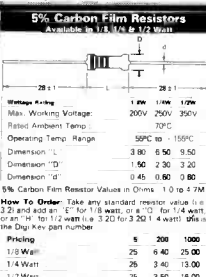

### DISC CAPACITORS

Part No.	Cap.	Vol.	Price
DC100	100pF	50V	1.95
DC200	200pF	50V	1.95
DC300	300pF	50V	1.95
DC400	400pF	50V	1.95
DC500	500pF	50V	1.95
DC600	600pF	50V	1.95
DC700	700pF	50V	1.95
DC800	800pF	50V	1.95
DC900	900pF	50V	1.95
DC1000	1000pF	50V	1.95

### TANTALUM CAPACITORS

Part No.	Cap.	Vol.	Price
TA100	100µF	10V	1.95
TA200	200µF	10V	1.95
TA300	300µF	10V	1.95
TA400	400µF	10V	1.95
TA500	500µF	10V	1.95
TA600	600µF	10V	1.95
TA700	700µF	10V	1.95
TA800	800µF	10V	1.95
TA900	900µF	10V	1.95
TA1000	1000µF	10V	1.95

### 7400 TTL

Part No.	Price	Part No.	Price
7400	1.95	7400	1.95
7401	1.95	7401	1.95
7402	1.95	7402	1.95
7403	1.95	7403	1.95
7404	1.95	7404	1.95
7405	1.95	7405	1.95
7406	1.95	7406	1.95
7407	1.95	7407	1.95
7408	1.95	7408	1.95
7409	1.95	7409	1.95
7410	1.95	7410	1.95
7411	1.95	7411	1.95
7412	1.95	7412	1.95
7413	1.95	7413	1.95
7414	1.95	7414	1.95
7415	1.95</		





**POLICE, Fire Scanning Radios.** Bearcat Regency Fanon. Harvey Park Radio, Box 19224ME, Denver, CO 80219.

**TRANSISTORS-TUBES:** MRF421 \$24.00, MRF454 \$14.50, MRF455-MRF477 \$11.75, MRF492 \$16.00, SRF2072 \$12.75, SRF3800 \$17.50, 2SC2290 \$16.75, 2SC2879 \$22.00, 6LF6, 6LQ6, 6JS6 8950, etc-call. New **RANGER AR3500** All Mode 10 Meter Transceiver \$319. Quantity Discounts! Best Prices on Hard-to-Find Parts, Antennas, Mics, Power Supplies, & Equipment! Catalog \$1.00 (refundable), or free with order. **RFPC**, Box 700, San Marcos, CA 92069. For information or Same Day Shipment—Call (619) 744-0728. VISA/MC/C.O.D.

**"BEARCAT, REGENCY"** Kenwood, Icom, Sony, NEW/USED, BUY/SELL/TRADE!! MORE!! 1988 Catalog \$1.00. **STAMP** For Used List!! **GALAXY**, Box 1202, Akron, Ohio 44309 (216) 376-2402.

**POLICE/FIRE SCANNER**

**"WANTED"** Good, Used Shortwave Receivers, Ham Gear, Police Scanners, CBs, Etc., Highest Prices Paid!! We Buy/Sell/Trade!! One Stamp For Our Huge Used List! **NEW** Catalog \$1.00. **GALAXY**, Box 1202, Akron, OH 44309 (216) 376-2402.

**INVENTORS**

**INVENTORS!** Can you profit from your idea? Call **AMERICAN INVENTORS CORPORATION** for free information. Over a decade of service, 1-800-338-5656. In Massachusetts or Canada call (413) 568-3753.

**INVENTORS**

**INVENTORS!** Have idea for product or invention, don't know what to do? Call **AIM** we present ideas to manufacturers - Toll Free US and Canada 1-800-225-5800.

**CB RADIO/10 METERS**

**WE specialize in technical information, parts, and services for CB radios. 10-Meter and FM Conversion kits, repair and modification books, plans, high-performance accessories. Over 12 years!** Catalog \$2. **CBCI**, Box 31500ME, Phoenix, AZ 85046.

**DIGITAL DASHBOARDS**

**COMPLETE** digital dashboard plans: \$14.45; free details. **Modern Labs**, dept. E2, 2900 Ruisseau, St. Elizabeth, QC, J0K2J0, Canada.

**TEST EQUIPMENT**

**PHILIPS "SBC"** line of service quality instruments: Scopes, Function Generators, Frequency Counters, Power Supplies, DMMs, Logic Probes and Pulsers, Scope Probes. Brand-new fully guaranteed low cost. Before you purchase any test equipment let us mail you our free illustrated flyer. **RUBYTRON INSTRUMENTS**, 117 North Ridge St., Port Chester, NY 10573, (914) 937-6376.

**CABLE EQUIPMENT**

**CABLE TV DECODERS AND CONVERTERS** get your free catalog or order toll free 1-800-624-1150. Information Call (402)-554-0417. **M.D. Electronics Inc.**, 5078 So. 108th Ste#115, Omaha, Nebraska 68137

**UNIVERSITIES**

**VILLARREAL NATIONAL UNIVERSITY.** Fully accredited state university, 45,000 students on campus. Offering non-residential Master's and Doctorate degrees. Inquire: International Program, c/o International Educational Consultants, 2175-B Highpoint Road, Suite 217-3, Snellville, GA 30278.

**TEST EQUIPMENT**

**TEKTRONIX** Scopes - Free list of reconditioned 500- series. **TEK 547** 50 MHz dual-timebase delayed-sweep 5-inch lab scope with type 1A2 dual-trace plug-in. Complete reconditioned & calibrated. Excellent condition. Shipped U.P.S. in 2 pkgs: \$395 ppd. 10-day money-back guarantee. **RUBYTRON Instruments**, 117 North Ridge Street, Port Chester, NY 10573 914-937-6376.

**MISCELLANEOUS**

**STRANGE STUFF COMPLETE ITEMS PLANS, KITS. LASER EAVESDROPPING, HIDDEN WEAPONS, BUGGING AND COUNTERMEASURE SOURCES, ADULT TOYS. INFORMATION PHOTO PACKAGE \$3.00 REFUNDABLE, DIRIJO CORPORATION, BOX 212-M, LOWELL, NC 28098. INFORMATION 704-868-3408.**









**HI-TECH** in your car. Complete plans: \$14.45; free details. **Modern Labs**, 2900A Ruisseau, St. Elizabeth, QC, J0K2J0, Canada.

**ASIAN LADIES** want correspondence for friendship, marriage, **SUNSHINE INTERNATIONAL**, Dept. TW, Box 5500, Kailua-Kona, HI 96745.

**SEND FOR FREE 1988 CATALOG... 52 PAGES!**

**QUALITY PARTS • DISCOUNT PRICES • FAST SHIPPING!**

**ALL ELECTRONICS CORP.**

<p><b>SWITCHING POWER SUPPLY</b></p>  <p>Compact well regulated switching power supply designed to power Texas Instruments computer equipment INPUT 14-25 Vac @ 1 amp OUTPUT +12 Vdc @ 350 ma +5 Vdc @ 1.2 amp 5 Vdc @ 200 ma SIZE 4 3/4" square CAT# PS-30 \$3.50 each</p>	<p><b>BLACKLIGHT ASSEMBLY</b></p>  <p>Complete functioning assembly includes ballast, on-off switch, power cord, sockets and F4T5 BL blacklight Mounted on a 7 1/8" X 3 1/8" metal plate Use for special effects lighting or erasing EPROMS CAT# BLTA \$10.00 each</p>	<p><b>MINI PUSH BUTTON</b></p>  <p>S P S T momentary Push to make CAT# MPB-1 35c each - 10 for \$3.25</p>	
<p><b>THIRD TAIL LIGHT</b></p>  <p>Sleek high tech lamp assembly Could be used as a third auto tail light emergency warning light or special effects lamp Red reflective lens is 2 3/4" X 5 1/2" is mounted on a 4" high pedestal with up-down swivel adjustment Includes 12 V replaceable bulb CAT# TLB \$3.95 each</p>	<p><b>VIC 20 MOTHERBOARD</b></p>  <p>26 IC's including 6520A and 6560 Not guaranteed but great for replacement parts or experimentation CAT# VIC-20 \$15.00 each</p>	<p><b>NICKEL-CAD CHARGER / TESTER</b></p>  <p>Will charge most nickel-cad batteries even button &amp; N CAT# UNCC-N \$15.00 each</p>	
<p><b>XENON FLASH TUBE</b></p>  <p>3/4" X 1 1/8" dia CAT# FLT-1 2 for \$1.00</p>	<p><b>LED'S</b></p>  <p>Jumbo T 1 3/4 (5mm) RED CAT# LED-1 10 for \$1.50 GREEN CAT# LED-2 10 for \$2.00 YELLOW CAT# LED-3 10 for \$2.00 TWO PIECE HOLDERS FOR ABOVE LED'S CAT# HLED 10 for 65c 100 for \$5.00</p>	<p><b>10 AMP SOLID STATE RELAY</b></p>  <p>Control 3-32 Vdc Load 10 amps 120 Vdc Size 2 1/2" X 3 1/4" X 7/8" CAT# SSRLY-10A \$9.50 each - 10 for \$85.00</p>	
<p><b>MAIL ORDERS TO</b></p> <p>ALL ELECTRONICS P.O. BOX 567 VAN NUYS CA 91408</p>	<p><b>TELEX 5101010163 (ALL ELECTRONIC) CUSTOMERS OUTSIDE OF THE U.S.A. SEND \$1.50 POSTAGE FOR CATALOG</b></p>	<p><b>TOLL FREE 800-826-5432</b> INFO: (818) 904-0524 FAX: (818) 781-2653</p>	<p><b>QUANTITIES LIMITED MINIMUM ORDER \$10.00 U.S.A. \$3.00 SHIPPING WORLDWIDE</b></p>

CIRCLE 3 ON FREE INFORMATION CARD

**You got it to work? Good!**



**MICROVOLTS** 100, 10, 1

**MILLIVOLTS** 1, 10, 100

**COARSE ADJUST**

**NOW MAKE IT LOOK GOOD**

Let **DATAK** be your designing partner. Use our dry transfer title sets to put that finishing touch to your custom project. Over 2200 titles plus alphabets and numbers insure that you'll have the words you need. Switch markings and dial plate arcs are in a companion set. Use **DATAKOAT** spray for complete protection. Sprays are not available.

- 948 Bk (949 Wht) 10 pt .105" Electronic Titles (24 sheets) . . . . . \$12.50
- 9581 Bk (9591 Wht) 12 pt .125" Electronic Titles (24 sheets) . . . . . \$12.95
- 968 Bk, Wht, Red asst. Meter dial & Switch Markings (12 sheets) . . . . . \$12.95
- 04177 **DATAKOAT** Gloss Spray (12 oz) . . . . . 5.75
- 04178 **DATAKOAT** Matte Spray (12 oz) . . . . . 5.75

Minimum order: \$20.00 (add 7% shipping. NJ and CA also add sales tax)

**WRITE FOR A FULL CATALOG AND SAMPLES TODAY**  
**DATAK Corp. • 3117 Paterson Plank Rd. • N. Bergen, NJ 07047**

CIRCLE 2 ON FREE INFORMATION CARD

# LETTERS...

(from page 7)

• Having come to the next-to-the-last paragraph in "Computer-Aided Troubleshooting" (February 1988), which states that some computers may not be able to run the program, I keyed it into my computer anyway. With a few modifications, the program appears to require about 5K of memory. If any readers are having difficulty getting it to run, the following may provide a solution:

(1) Some computers won't accept 3-character variables; so change them to 2- or 1-character variables (e.g. REE=RA, RBO=R1, etc.). Search through all lines and convert all 3-character variables.

(2) Change lines 65, 90, 105, 115, 130, 145, 160, 175, 190, 205, 220 to GOSUB 400 (these lines are all quite long and are the same).

(3) Add line 400, copying into it the statements that appear in line 65 and converting the 3-character variables as noted in (1) above, finishing with a RETURN.

(4) For the Tandy Color Computer, change all LPRINT statements to PRINT#2. (This works on both my TRS-80 Color Computer ECB 64 and Tandy Color Computer 3.)

(5) There are a few LPRINT statements that can be eliminated to save a bit of memory (and paper) as well.

Readers who wish to obtain a computer-derived hard copy of the converted program can do so by sending a SASE to me at the following address:

D.K.B.  
18509 Snohomish Ave.  
Snohomish, WA 98290

## Parts Availability

• Some readers may be finding it difficult to obtain the Teledyne 9400CJ F/V and V/F converter and Intersil ICL7660-CPA voltage inverter chips needed to build my "Frequency-Counter Adapter for DMMs" (November 1987). These (as well as the Pac-Tec enclosure and most other parts) are available from Active Electronics (1-800-343-8191) or by mail order (in the East at 133 Flanders Rd., Westboro, MA 01581, Tel. 617-336-8899; or in the West at 13107 Northrop Rd., Bellevue, WA 98001, Tel. 206-881-8191). Prices for the 9400CJ and ICL7660CPA are \$3.99 and \$1.69, respectively.

Crady VonPawlak

## Semianalyzer (from page 59)

### Kit Availability

A complete "Semianalyzer" Parts List was published last month in Part I. A kit or parts are available from the source noted, as follows:

The following items are available from Electronic Design Specialists, Inc., 951 SW 82 Ave., N. Lauderdale, FL 33068: Complete kit of all parts, including enclosure but not including sockets for displays, \$139.00 + \$7.50 P&H; double-sided main printed-circuit board with plated-through holes and single-sided display board, \$25.00; programmed EPROM, \$20.00; molded-plastic matrix display shield, \$5.00; cabinet kit, including hardware, \$29.00. Prices for other available components can be obtained by writing to the kit supplier. Add \$2.00 P&H for individual parts orders. Florida residents, please add state sales tax.

mine a zener diode's breakdown potential. It can also be used to test Mylar, ceramic and electrolytic capacitors out-of-circuit for their breakdown voltages and noise levels. Tantalum capacitors cannot be checked in this manner because their low leakage and non-healing properties will cause them to short-circuit. Neon lamps can be checked in-circuits, as can LEDs and individual segments of LED displays.

As you become familiar with it, you will find the Semianalyzer to be unlike any other test instrument you have used. It can save hours of troubleshooting time because it probes a circuit *statically*, rather than the usual dynamically, to locate defective components. Since the Semianalyzer does its own diagnosis of a circuit under test, you will automatically reach for it, rather than your DMM or transistor tester, whenever you have to troubleshoot a modern electronic circuit.

ME

## ADVERTISERS' INDEX

RS#		Page #
43	AMC Sales.....	69
135	ARRL.....	6
3	All Electronics.....	93
30	Antique Radio Classified.....	72
7	C&S Sales.....	17
5	CTM.....	90
50	Cleveland Institute of Elec.....	Cov. III
-	Command Productions.....	69
72	Communications Electronics.....	5
45	Consolidated Electronics.....	82
49	Cook's Institute.....	53
2	Datak.....	93
4	Deco Industries.....	90
76	Digi-Key Corp.....	91
48	Digital Research Computers.....	29
47	Edu-Calc.....	29
68	Electronics Book Club.....	49
-	Grantham College of Engineering.....	73
31	Jan Crystals.....	72
-	LT Sound.....	90
1	MCM Electronics.....	27
-	McGraw-Hill Books.....	21-23
-	Midwest Electronics.....	92
-	NRI Schools.....	10-13
46	National Technical Schools.....	82
8	OptoElectronics.....	Cov. H
-	Pacific Cable Co., Inc.....	7
-	Penn Research.....	92
63	RCA.....	3
12, 13	Simpson Electric Co.....	Cov. IV
-	Visitect Inc.....	92

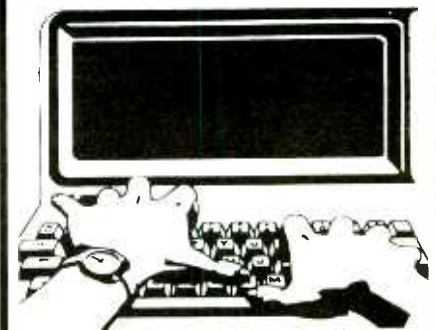

## Free Product Information

Readers can obtain free information on products advertised by the above companies, as well as for some editorially mentioned products. Simply circle the appropriate number printed below an advertisement onto the Modern Electronics "Free Information Service" card bound into this issue. After filling in your name and address, just mail the postpaid card. Your request will be forwarded directly to the advertiser with a mailing label prepared by our reader-service department to ensure speedy response.

# EXPAND YOUR CAREER HORIZONS...



*The CIE Microprocessor Trainer helps you to learn how circuits with microprocessors function in computers.*

## START WITH CIE.

Microprocessor Technology. Satellite Communications. Robotics. Wherever you want to go in electronics... start first with CIE.

Why CIE? Because we're the leader in teaching electronics through independent study. Consider this. We teach over 25,000 students from all over the United States and in over 70 foreign countries. And we've been doing it for over 50 years, helping thousands of men and women get started in electronics careers.

We offer flexible training to meet your needs. You can start at the beginner level or, if you already know something about electronics, you may want to start at a higher level. But wherever you start, you can go as far as you like. You can even earn your Associate in Applied Science Degree in Electronics.

Let us get you started today. Just call toll-free 1-800-321-2155 (in Ohio, 1-800-362-2105) or mail in

**CIRCLE 50 ON FREE INFORMATION CARD**

the handy reply coupon or card below to:  
Cleveland Institute of Electronics,  
1776 East 17th Street, Cleveland, Ohio 44114.

# CIE

**World Headquarters**

**Cleveland Institute of Electronics, Inc.**  
1776 East 17th Street • Cleveland, Ohio 44114

Please send your independent study catalog.  
For your convenience, CIE will try to have a representative contact you — there is no obligation.

Print Name \_\_\_\_\_

Address \_\_\_\_\_ Apt. \_\_\_\_\_

City \_\_\_\_\_ State \_\_\_\_\_ Zip \_\_\_\_\_

Age \_\_\_\_\_ Area Code/Phone No. \_\_\_\_\_

Check box for G.I. Bill bulletin on Educational Benefits

Veteran     Active Duty    **MAIL TODAY!**

Just call toll-free 1-800-321-2155 (in Ohio, 1-800-362-2105)

AMO-104

# Simpson® Professional Series

## ★ Quality and Reliability ★

The **Professional Series** of test instruments are characterized by the uncompromising quality and exceptional reliability that are synonymous with Simpson. The commitment to satisfy the needs of the professional began over 50 years ago with the world famous Simpson 260® and continues with the introduction of the **Professional Series**.

**CLASSIC SIMPSON —→ THE PROFESSIONAL SERIES**

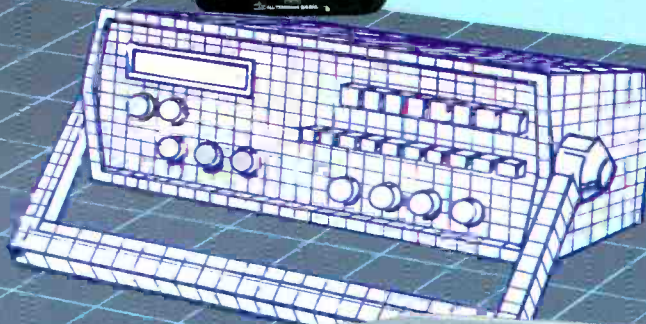

### SWEEP/FUNCTION GENERATORS

**5 MHz . . . . . Model 421**  
**5 MHz with 6-Digit Display . Model 422**

**Features**

- .05 Hz to 5 MHz in 7 ranges
- Linear and Log Sweeps
- Sine, Square and Triangle Waveforms
- Selectable Start/Stop Sweep Frequencies
- Internal/External Reading Frequency Counter — Model 422

### UNIVERSAL FREQUENCY COUNTERS

- 200 MHz Model 712**  
**520 MHz Model 713**

**Features**

- Period
- Frequency Ratio
- Time Interval
- 0.56" 8-Digit Orange LED Display
- Adjustable Triggering
- Totalize

- Model 712 . . . . . \$525.00  
 Model 713 . . . . . \$675.00  
 Model 421 . . . . . \$535.00  
 Model 422 . . . . . \$650.00

For information on:  
 712/713 circle 12      421/422 circle 13



**SIMPSON ELECTRIC COMPANY**  
 853 Dundee Avenue, Elgin, Illinois 60120-3090  
 (312) 697-2260 • Telex 72-24-6 • FAX (312) 697-2272

**A CHIPPEWA NATION TRIBAL ENTERPRISE**