

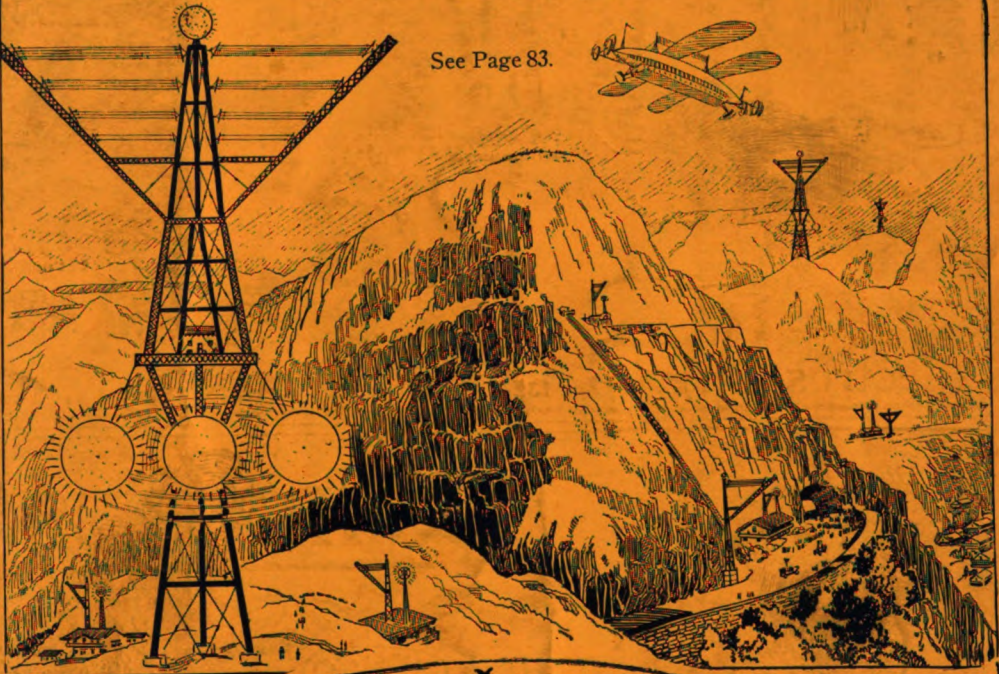

VOL. IV.

No. 2

# MODERN ELECTRICS



## Contents

THE PRACTICAL ELECTRICIAN  
By Prof. W. Weiler

RUHMER'S MULTIPLEX TELEPHONY  
By Dr. Alfred Gradenwitz

NEW STATION AT THE EIFFEL TOWER  
FIRE ALARMS BY AIR  
RALPH 124C 41 +  
By H. Gernsback

WIRELESS ACROSS THE U. S.  
By E. A. Mayne

MEASURING RESISTANCE BY AMMETER AND VOLT-  
METER  
By Leonard Work

WIRELESS REGISTRY

"THE ELECTRICAL MAGAZINE FOR EVERYBODY"

Copyright 1911, by MODERN ELECTRICS PUBLICATION

INSULATORS from 1,000 to 1,000,000 VOLTS

TRADE  
**ELECTROSE**  
MARK. INSULATION

**Standard of the World**

Adopted by U. S. NAVY  
and all Commercial Wireless Companies

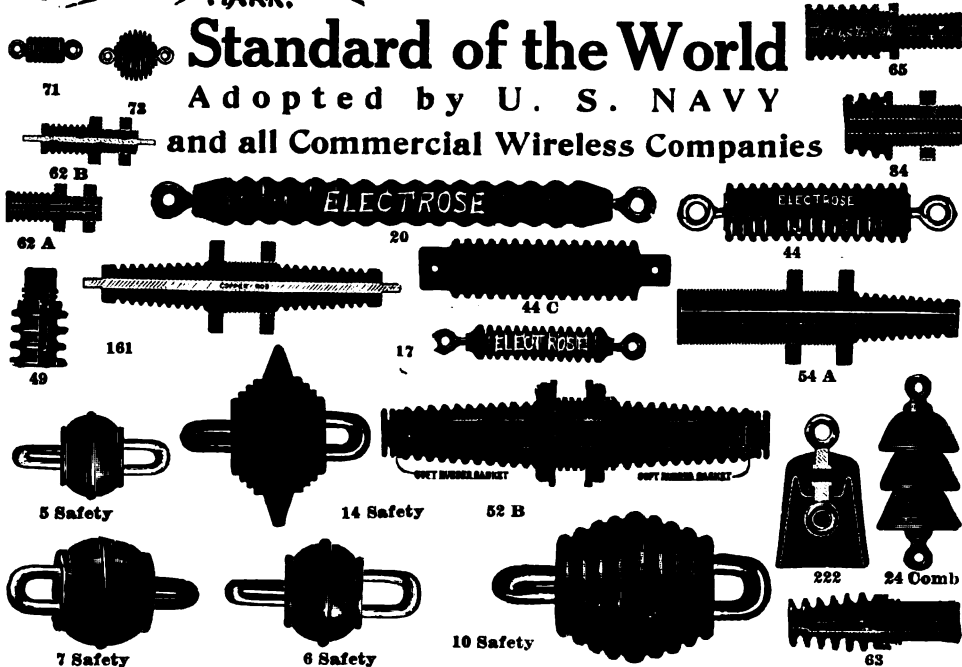

**Electrose Mfg. Co.,** 129-139 N. 10th St.  
132-242 N. 11th St. Brooklyn, N. Y.

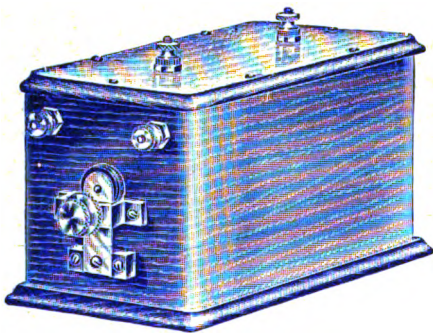

3/4-inch to 2-inch style

**WIRELESS**  
**SPARK**  
**COILS**



We make wireless spark coils which in efficiency, construction and finish are superior to all others. Our coils produce heavy, energetic sparks of greater than rated length and with less current consumption than all others.

A complete line of reliable wireless instruments are described in our 80-page Manual of Wireless Telegraphy and Catalog No. C 1, which will be mailed upon request.

**Manhattan Electrical Supply Co.**

17 PARK PLACE, NEW YORK :: :: 112-114 SOUTH FIFTH AVE., CHICAGO

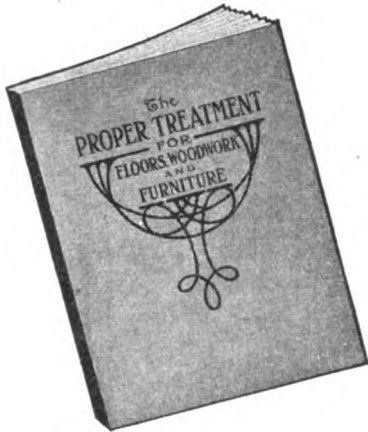

# Instruction Book AND Wood Finishing Samples FREE

HERE'S the best book ever published on artistic wood finishing, the work of famous experts, illustrated in five colors. For a limited time, we will mail it FREE, postage paid, together with samples of

**Yes!** You—yourself—can beautifully finish or refinish all furniture, woodwork or floors in the latest and most artistic shades—in little time—at small expense—with

## Johnson's Wood Dye and Prepared Wax

If you are interested in craftsmanship—if you want the correct finish on a new piece of furniture—if you are *building or remodeling*—if you want to brighten up or change the color of any piece of furniture or of woodwork or floors—either hard or soft wood—if you are interested in basketry—get this expert Instruction Book and **FREE SAMPLES AT YOUR LEADING PAINT DEALERS.**

Johnson's Wood Dye is made in many beautiful greens, browns, reds, etc. It is not a mere stain but a penetrating dye which colors the wood so deeply that if it becomes scratched or marred the natural color is not disclosed. It brings out the beauty of the grain without raising it, giving a soft, rich, permanent color. A coat of Johnson's Prepared Wax over the dye gives that beautiful, dull, artistic finish so much admired today. If you prefer a higher gloss than the wax gives apply a coat of UNDER-LAC over the dye and then one coat of Prepared Wax.

**Under-Lac** is a thin, elastic spirit finish very much superior to shellac or varnish. It dries hard in less than an hour. Under-Lac is just what you want for your linoleum and oilcloth; it brings out the pattern making it bright and glossy like new, protects it from wear and makes cleaning easy. It dries so the floors may be walked on in a hour.

Go to your leading paint dealer for Free Instruction Book, Edition No. ME-5, and Free Samples of Johnson's Wood Finishes, which we supply to him for his customers' use. If your dealer hasn't samples of our Wood Dye, Under-Lac and Prepared Wax, and the Books, we'll send them to you postpaid for the name of your dealer in paint. In writing mention shade of Dye wanted.

**S. C. Johnson & Son, "The Wood Finishing Authorities" Racine, Wis.**

When writing, please mention "Modern Electrics."



## Johnson's Wood Finishes

The Third Annual Official  
**Wireless Blue Book**  
 OF THE  
**Wireless Association of America**

Goes to press May 31st. See this month's editorial and grasp the importance of having your station registered in this great wireless book.

Become known to your fellow wireless experimenters by having your name and station printed in this issue.

**GUARANTEED EDITION 75,000.**

If you think anything of your station you cannot afford to stay out of the book. Fee of registration **TWENTY-FIVE CENTS.** This entitles you to one copy of the book.

**SPECIAL OFFER NO. 1.**

Join the Wireless Association of America, register your station and obtain besides the Blue Book the Association Button (price 20 cents).  
**ALL FOR FORTY CENTS.**

**SPECIAL OFFER NO. 2.**

Register your station, subscribe to Modern Electrics (1 year),  
**ALL FOR \$1.00.**

This is a net saving of 25 cents. (For Manhattan, Canada and foreign countries add usual postage.) No premiums are given with this offer.

The Wireless Blue Book will contain the following:

U. S. Land Stations (also Canadian Stations), government and commercial.

U. S. Ship Stations (including foreign ships touching U. S. ports), government and commercial.

U. S. Amateur Stations.

The book is arranged in such a manner that **ALL** calls are classified **ALPHABETICALLY.** Therefore, no matter from what part of the country or the sea, the wireless call comes, you will immediately locate the sender.

This book is the most complete one of wireless stations published and is warranted to be the most accurate one in print. No more guesswork.

In addition we furnish with each book a

**WIRELESS MAP OF THE U. S.**

in three colors, size 13 x 9½, which can be mounted or hung in your station. Gives location and distances for all Government and Commercial stations in the United States, and **ENABLES YOU TO COMPUTE QUICKLY DISTANCES, WHEN TRACING A CERTAIN CALL.**

**YOU CANNOT AFFORD TO BE WITHOUT THIS BOOK.**

**PRICE BY MAIL, 15c.**

When remitting send Money Order or Bank Draft, no stamps nor checks, please.

**MODERN ELECTRICS PUBLICATION :: :: 233 FULTON STREET, NEW YORK**

# Modern Electrics

VOL. IV.

MAY, 1911.

No. 2.

## The Practical Electrician

A Popular Course in Electricity on the Construction of Electrical Apparatus and Experiments to be Conducted with them

By PROFESSOR W. WEILER, of the University of Esslingen, (Germany)

Translation by H. GERNSBACK

### CHAPTER I.—Continued.

#### 22. CHEMICAL ACTIVITY IN COPPER SULPHATE BATTERIES.

**A**LL copper sulphate batteries have the great advantage that they furnish a very constant current. They do not give off any evil smelling vapors, besides, they use cheap materials. On the other hand, the voltage is very low and

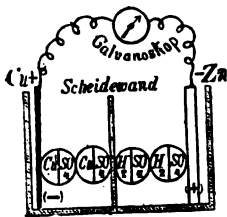
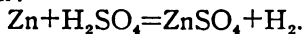

Fig. 20.

even if no current is used at all, the zinc is used up somewhat. These batteries generate current by decomposing the zinc plate and of which sulphate of zinc is formed while on the copper plate, metallic copper is deposited. Copper sulphate is composed of copper (Cu) and sulphuric acid. Fig. 20.

The weak sulphuric acid of the porous cup acts on the zinc after the following equation:



Through this, hydrogen is liberated. It passes through the porous cup and comes into contact with the copper sulphate. The hydrogen, however, has a greater affinity to the sulphuric acid (SO<sub>4</sub>) than copper, and therefore takes the place of the latter. Therefore, it is deposited on the copper plate, and as this deposit is rough, the action is enhanced, as the actual surface of the plate is thereby increased. The exchange between hydro-

gen and copper is effected after the equation:

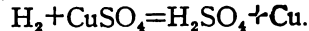

#### 23. LALANDE & CHAPERON CAUSTIC SODA BATTERY, 1882.

This battery is fairly easy to construct and gives great power and constancy, but the materials are somewhat expensive and it is not very easily handled. This battery may be made as follows: Fig. 21. Take a vessel about 4 inches wide and about 6 to 8 inches high. It is best made of iron or copper and the vessel itself serves as part of one element of the battery by soldering the wire to the vessel itself. On the bottom of the container, we place a layer of *red granulated copper oxide* about one-half inch thick. The negative electrode is an amalgamated

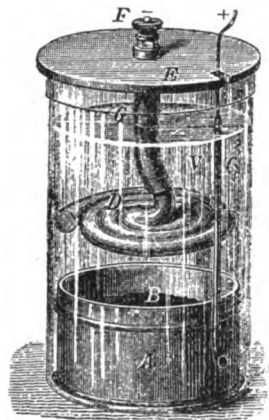

Fig. 21. (Glass Jar Type).

block of zinc or a spiral made of zinc sheet. This latter is suspended from a slate cover resting on the rim of the container. The electrolyte is a thirty to forty per cent. solution of caustic soda. It is

necessary that on top of this electrolyte a film of heavy mineral or paraffine oil is placed as else the carbonic acid of the air will shortly decompose the electrolyte.

The oxygen liberated by the copper oxide, with the zinc, forms oxide of zinc which, however, dissolves in the electrolyte. The hydrogen absorbs oxygen from the copper oxide and both unite and form water; copper therefore is deposited. The use of one ounce of zinc equals the use of three ounces of caustic soda and 1.25 copper oxide. This is of course theoretical and varies in different styles of batteries. While it is easy to get any amperage by increasing the size of this battery, the voltage is very low, being from .7 to .9 volts.

A fairly good quality of copper oxide may be made by the experimenter as follows: Take a quantity of copper filings or fine copper shavings and heat them in a cast iron container or in a crucible till they are red hot. While stirring them



Fig. 22.

with an iron rod, sprinkle a little water over the filings until they become ocker red. You will then have a fairly good quality of copper oxide. The explanation is that the oxygen of the air unites with the fine copper during the heat.

Fig. 22 shows the so called trow battery of this character. On the bottom is usually a layer of copper oxide and the zinc is separated by four porcelain blocks L. A large plate of zinc bent, as shown at D is used. The container A is made of sheet iron. This battery gives a current of about 20 amperes.

Fig. 23 shows another style whereby the copper oxide is formed into plates. These plates are held in the frame D. The zinc is shown at Z while the copper oxide plate may be seen at C. A soft rubber band K holds the elements together. The frame D is made of sheet iron, copper plated.

The experimenter wishing to make his own copper oxide plates may proceed as

follows: Mix the granulated or coarsely powdered copper oxide with 5 per cent. or 10 per cent. of magnesium chloride, and heat the heavy mass in forms, made of iron sheeting, the forms of course, being of the size of the wanted plate. The more chloride of magnesium used the more porous the plates will be.

In making these batteries, it is necessary to fully understand that not all kinds of copper oxide can be used. For instance, the black copper oxide in powder form cannot be used; there are also some brands of red copper oxide which are too finely divided (dust), and they are not of much use as this variety increases the resistance of the battery a great deal. The coarser the copper oxide, the better the results.

#### 24. CARBON ELECTRODES, ELECTRO-CHEMICAL SERIES, RITTER, 1798. CARBON-IRON BATTERY.

The electro-chemical series is a combination of solid bodies, which are arranged in such a manner that every one of the mentioned bodies, becomes positively electric with the one following directly after it, when making contact with same. If brought in contact with the body immediately preceding it, it will become negatively electric. This will be clear by studying the following:

+ zinc, lead, tin, bismuth, antimony, iron, copper, gold, platinum, graphite, oxide of manganese—.

The E.M.F. which is generated by contacting any two of the bodies shown in above chain; is greatest when the two bodies are separated the widest. Thus zinc and oxide of manganese will give the greatest E.M.F.

It was soon found that the copper in some of the existing batteries, when replaced with carbon would give much better results. At first coke was used but it could not be formed well nor could cylinders be made commercially. Coke is brittle and breaks easily when sawed.

Therefore the carbon as used today is made artificially. It may be made as follows:

1. Mix well 15 parts coke powder (or graphite in crystal form), 8 parts lamp-black and 8 parts molasses. Press the plastic mass in the desired form, dry in the open air and heat red hot in an iron container from which all air has been drawn.

2. A piece of wood is burned slowly to charcoal in a vacuum, by heating it in a container as above. Soak the piece of charcoal in molasses, or asphaltum or paraffine. Heat to a red heat, soak again and repeat this till the carbon so obtained is hard and conducts electricity well.

**Carbon—Iron Battery.**

Dissolve iron in muriatic acid which gives ferrous oxide.

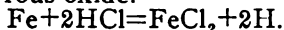

Iron+muriatic acid=ferrous oxide+hydrogen.

If now one passes into the solution chloruretted water, the formerly green liquid becomes yellow and is now chloride of iron:

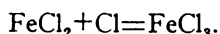

Ferrous water+chlorine=Chloride of iron.

Now make a battery by placing a car-

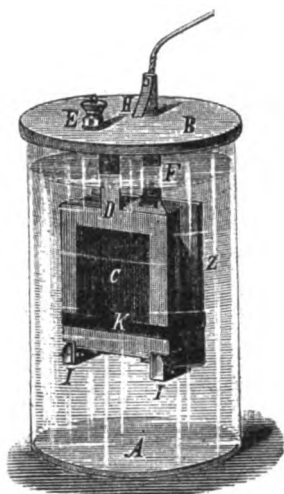

Fig. 23.

bon plate and an iron plate in a solution of chloride of iron. This is quite a cheap cell, but gives only 0.6 volts. The chemical reaction is as follows: A part of the chlorine in the solution combines with the iron when the current flows, and the solution becomes green after a while.

**25. CREEPING OF SALTS.**

If a carbon electrode is immersed for a longer period in a solution, the latter will tend to rise up through the carbon on account of the capillary action of the carbon. The solution or the salts formed by same soon reach the metal connection or binding post and destroy same due to electrolysis. To obviate this, the carbon electrodes should first be heated at their ends and then soaked in melted paraffine.

This closes the pores of the carbon and the solution or salts cannot rise beyond the paraffine. Glass jars also give rise to creeping salts, which have a tendency to creep over the edge of the jar. This can be overcome by smearing a film of vaseline inside and outside the top of the glass jar. (To be continued).

**UNIQUE AERIAL SWITCHES FOR HIGH POWERED SETS.**

By George F. Worts.

THE question of changing a wireless circuit from sending to receiving, and accomplishing it in a minimum time period, assumes large proportions to the experimenter who contemplates installing a high powered outfit.

Two illustrations given herewith show aerial switches which combine the two necessary requisites of good insulation and rapidity of action. They are both constructed principally of old lighting switch parts and may suggest helpful ideas even if their identical designs are not carried out.

The switch shown in the illustration, Fig. 1, embodies a wooden back for holding the high frequency aerial currents. When the blades are down it is in a position for sending. One of the blades, upon touching a contact, throws in the line current to the high potential

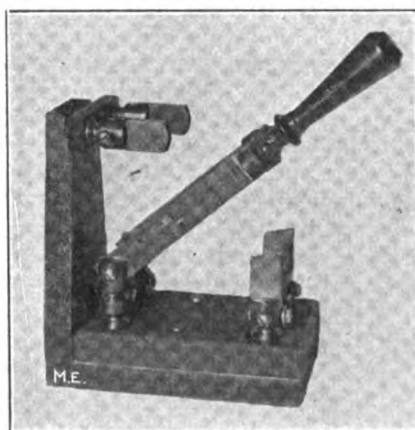

Fig. 1.

transformer, while the other effectively shunts the most vulnerable part of the receiving circuit. The blades being raised to an angle of 90 degrees interlock with the upper contacts. Only one side is used for receiving.

(Continued on Page 113)

### NOVEL THERMO-PENETRATION APPARATUS.

(By the Berlin Correspondent of *Modern Electrics*.)

**W**HILE being unable to act upon our nerves, high-frequency currents are known to exert on the tissues of the body a heating effect most beneficial from a curative point of view. In fact, the most painful affections are found to be relieved or cured nearly immediately, while tumors oth-

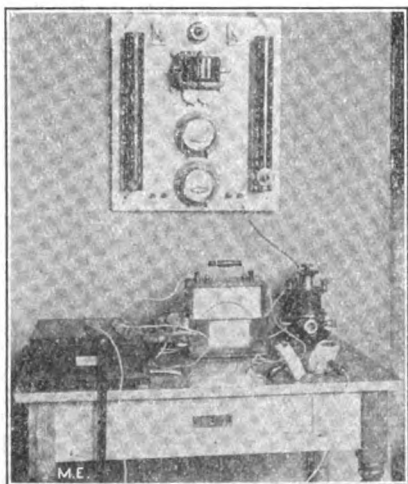

erwise inoperable will become scarred after a few minutes' application.

The various thermo-penetration (or diathermic) apparatus brought out of late years are mainly distinguished by the process used for the generating of high-frequency currents (or electric waves) and by the means of dosing their effects.

The apparatus designed by Mr. E. Ruhmer, of Berlin, is based on the use of electric arcs able to produce undamped electrical vibrations which obviously are far more efficient than intermittent groups of vibrations as produced by spark gaps. In order to augment the constancy, regularity and efficiency of these waves, the electric arc is arranged in parallel not only with the main vibratory circuit but with a damping circuit on the Ruhmer system, so that even sudden fluctuations in charge will be unable to interfere with the regular working of the apparatus.

The working circuit, protected by a cover, communicates through the in-

termediary of a hot-wire ammeter with the electrodes. A lever allows the circuit to be approached at will towards the main circuit, thus controlling with perfect safety, and in a manner as practical as possible, the heat effects of the apparatus.

This wave-generator is started by turning the switch arranged on the switchboard, carrying in addition to the terminals, choking coils and resistances, an ammeter and a volt-meter for controlling the intensity of the feeding current and the tension of the lamp.

This apparatus is of remarkable safety in working and easy superintendence, and supplies with about one million vibrations per second a vibratory energy of 250 watts as a maximum. The absence of any faradic effect shows the excellence of its design.

### RUHMER'S MULTIPLEX TELEPHONY.

By Dr. Alfred Gradenwitz.

**T**HE use of a given line for the simultaneous transmission of several conversations would obviously insure considerable saving, especially on trunk lines. While being inaccessible to ordinary telephone methods, this problem has recently been solved in a most elegant manner by the aid of the radio-telephonic principle, viz: by the agency of electric waves.

It frequently happens, in science as well as in industry, that two inventors living at far distant places will attempt and find simultaneously the solution of a given problem on practically

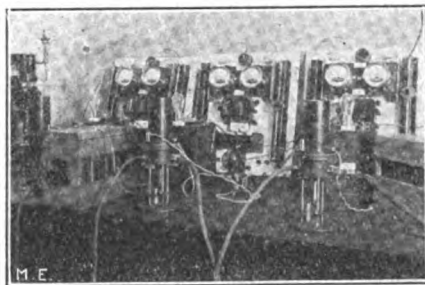

Ruhmer Multiplex Sender.

identical lines, independently of one another. This is the well-known duplication of great inventions and discoveries.



Thus it was that at the very moment that Major Squier in American electrical papers published a description of his multiplex telephony system (presented by him to the country), Mr. Ernst Ruhmer, the well-known inventor in the realm of applied electricity, was about to make public a system of his own which is mainly identical with the former. So far from settling the question of priority, we only wish to point out that the first tests of this system were made as far back as late in 1906. In fact, in his book on Wireless Telephony, (published in February, 1907), the inventor briefly refers to this work. After applying for letters patent in 1908, Ruhmer then commenced systematic experiments in the course of which up to six conversations were transmitted over the same line with perfect clearness and no mutual disturbance. The writer, about a year ago, had an opportunity of inspecting the apparatus just constructed for the Brussels Exhibition and which was eventually used in connection with satisfactory tests on cables of medium length.

In spite of recent improvements the principle of the system has remained unaltered. The same as in wireless telephony, there are used for transmission the high-frequency alternate currents (of variable frequency) set up by some generator, which after being superposed on the line are separated selectively at the receiving station, acting there on various vibratory circuits syntonized with those of the transmitting station, which communicate with the telephone receivers.

The coupling between the transmission line and the various receiving circuits, as well as among the latter, is relatively loose so as to effect a perfect separation of the various conversations, eliminating any possibility of undue perception of even the most feeble, which, especially in the case of numerous simultaneous transmissions, would give rise to troublesome disturbance.

The high-frequency currents are produced by any one of the known high-frequency generators, e. g. a wave generator comprising an electric arc with a vibratory circuit (Leyden jar and self-induction) in shunt. By

properly choosing the capacity and self-induction, the various vibratory circuits are adjusted to different numbers of oscillations.

The microphone currents are made to act either on the feeding current or the high-frequency current in the vibratory circuit. Any variation in the coupling between the transmitting circuit and the telephone line will be equivalent to a variation in the intensity of the high-frequency current traversing the circuit. The choice of the special method generally is limited only by the condition that the microphone of a given sending post should not influence in any way the alternating currents traversing the common transmission line from other sending posts.

Each of the sending posts corresponds with a similar receiving installation. In a plant comprising three

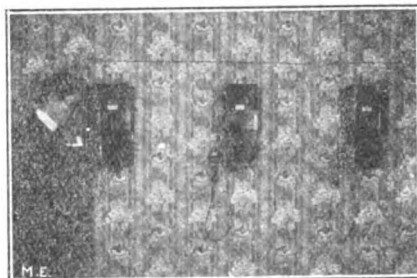

Ruhmer Multiplex Receiver.

telephones are arranged two vibratory circuits syntonized with the frequency of two vibratory circuits at the sending station which, the same as in radio-telephony, are made to act on the telephone receiver by the intermediary of a detector. In a third post, transformation is effected directly without any detector by an ordinary Foucault-current telephone.

The various microphone currents are transmitted over the common telephone line, which may be coupled relatively tightly with the vibratory circuits of the sender while being (according to the above) loosely coupled with the receiver circuits.

According to a simplified arrangement which dispenses with any special wave generator, a vibratory circuit comprising a capacity and self-induction is made immediately on talking into the microphone to give out a train

of damped waves, corresponding to the sound waves acting on the microphone.

A further improvement recently patented even allows the same vibratory circuit to be used alternately as sender and receiver so that the same apparatus may serve for speaking and listening as the case may be. This is made possible by a switch throwing into circuit alternately the microphone and battery, and the detector and telephone receiver, respectively. This switch can be designed so as to allow the coupling between the self-induction coil and the line to be altered at the same time, a tight coupling being more advantageous in speaking and a loose coupling in listening.

In connection with a recent demonstration four transmissions (German, French, song and gramophone music respectively) were effected simultaneously, but the number can obviously be increased considerably without any disturbance.

The first practical test of the system will shortly be made between the Bourses of Brussels and Antwerp.

### ATLANTA WIRELESS ASSOCIATION.

Claude Nealy writes us as follows:

Gaining practically all of their material pointers and general helpful information from *Modern Electrics* magazine, of which they are constant readers and ardent admirers, seven enterprising Atlanta young men have performed the remarkable feat of building and equipping wireless telegraph instruments in their own homes and are now daily sending and receiving messages.

In order that they may work out their plans with greater system and to further their studies, the "boy operators" on March 25, formed themselves into an organization, known as **The Atlanta Wireless Association**. That they may get the best information possible, they have started a library, to which they are adding all of the latest magazines and books treating of the "wireless" and electricity and in which *Modern Electrics* was the first to be

installed, the boys having developed their original ideas from this magazine.

Following are the members:—

Tye Sanders, 239 Woodward avenue, President of the Association; Charles E. Kruger, 509 South Pryor



Tye Sanders' Station.

street, vice-president; Howard Sawtell, 159 Capitol avenue, secretary; Roy Nichols, 534 Ponce de Leon avenue, treasurer; Mart Brooks, 49 Crew



street, chief operator; Roy Manning, 190 Greenwich street, West End, assistant operator, and Gates Dunn, 522 South Pryor street.

The boys are all enthusiastic and their achievement has attracted widespread interest.

### BRONX WIRELESS ASSOCIATION.

The Bronx Wireless Association of New York has been organized to bring into closer relationship and mutual help all those residing in the Borough of The Bronx interested in Wireless Telegraphy. Address all communications to Chas. F. White, 500 East 165th street, New York.

## New Station at the Eiffel Tower and Time Signals

**T**HE new station at the Eiffel Tower is now sending out time signals so that these can be received at any point lying within range of the plant. We present one of the most recent views of the station, and it will be remembered that it is placed entirely underground. From the top of the tower are stretched a number of aerial wires running to insulated points at the ground, and a set of wires runs down from the aerial system into the underground station. The high power apparatus has not been as yet installed so that the station can be used as it is intended to do in the future, but apparatus intended for the time signals are already in use, and these work to a distance of 1,800 miles.

Some time ago the idea of using the tower plant for sending time signals was advanced, and it was recognized that this would be of great usefulness for vessels at sea, so that they could regulate their chronometers once a day and thus be sure of finding their longitude. A government commission was appointed to consider the matter, and after a favorable report, the different departments such as war, navy, telegraph and others combined in order to carry out the work of installing the system. At the Paris Observatory, steps were taken to transmit the time signals by wire to the Eiffel Tower once a day. Two very accurate astronomical clocks were made for this purpose and they are combined with various electrical apparatus. The clocks, as well as others belonging to the observatory, are kept in a special chamber in which the temperature is very nearly constant. As the chamber is not opened for observations, these are taken through the glass doors by means of a small telescope which is used by the operator at another part of the building when he wishes to see the time. The clocks are regulated from a distance by an electromagnetic apparatus, and the adjustment is made every day, beginning at 11 P. M., in order to be ready to send the signals at midnight. When the clock has been adjusted, the operator calls up the Tower plant, so as to as-

sure that the wireless apparatus will be ready to receive the signals.

At midnight exactly, the clock makes a contact, and it makes a second contact two minutes, and a third contact four minutes later. Each of the contacts lasts about one-tenth second and produces three or four sparks at the wireless plant. These signals are received by the distant posts anywhere within the range of 1,800 miles. When the new high-power plant is working at the Tower, it is expected to send signals to at least 3,500 miles.

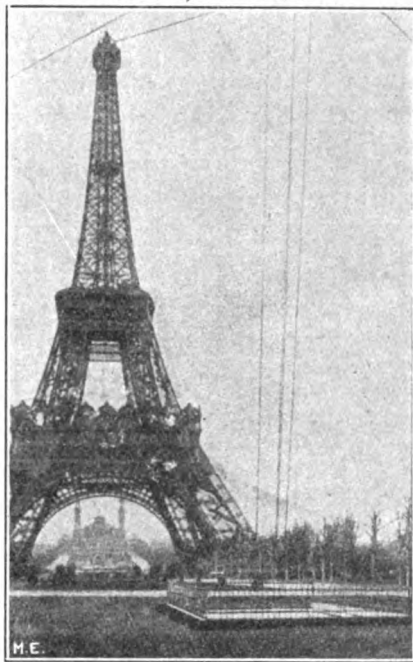

Eiffel Tower Plant. Sub-terranean Station on Right.

In order to bring the system into extensive use, especially upon the smaller vessels and also for clock-makers, so that they can receive the signals under the best conditions, it remained to design a receiving apparatus which should be of small size and readily handled even by inexperienced persons, also easy to install. A low cost was also one of the factors. Such an instrument would be likely to be used even on vessels of small tonnage and in all the large clockmaking establishments for regulating chronometers and clocks. We illustrate the new apparatus which has been quite recently de-

signed by the Ducretet firm and they have been able to make it in a very compact shape. A telephone is used in connection with a detector of the perikon type. The present detector had to answer to certain special conditions in order to adapt it for this kind of apparatus, and it now has a great sensitiveness as well as a regular action, being at the same time strong enough so as not to get out of order. It was desired to use a crystalline substance of a homogeneous composition which should give a regular sensitiveness over its whole surface, so as to avoid making trials and adjustments such as are needed with most of the crystals which are used for this purpose.

The substance which is found best is a selected variety of carbide of silicon which is obtained in the electric furnace. The other electrode is a point of suitable material. Such a detector is placed in a circuit of very high resis-

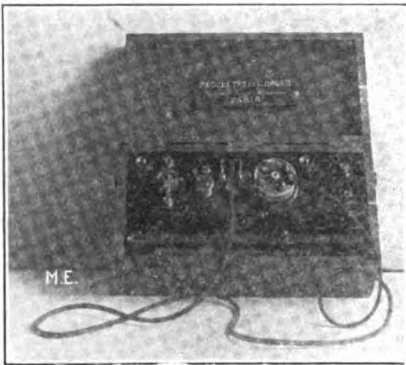

Portable Wireless Receiver.

tance which includes a small dry battery and a telephone receiver. A switch throws the battery out of circuit when the apparatus is not in use. Without modifying the apparatus, an electrolytic detector can be coupled in if such is desired. At the front of the box is the tuning coil with its slide contact. This circuit is designed so as to have a very small amount of damping, and it acts upon a circuit containing the detector and telephone whose resistances are very high and produce a great damping. This method has the advantage of not needing the use of a condenser, and a single slide is used for regulating. Experiments were made with the apparatus, and it was found to be all that was required.

## Correspondence

Editor *Modern Electrics* Publication,  
New York.

Dear Sir:—

Referring to Mr. Wm. E. Smith's letter published in the February issue of *Modern Electrics*, we beg to say that there are several points we would like to amend.

First of all: When we first heard from Mr. Smith, he wrote us on the stationery of the Signal Division N. M. N. Y., and signed the letter—"Wireless Quartermaster U. S. Naval Reserve." Hence we hastened to send him photos of our apparatus as he expressed the view that our apparatus would be of interest to the U. S. Navy. If Mr. Smith wanted to use the photos for his private publications, it was his duty to ask our permission, as it is a general rule—also in the U. S. A.—(we know this by personal experience in other cases), although the photos were not copyrighted.

Mr. Smith declares that the apparatus shown in Figures 6 and 7 are of American manufacture; we wish to protest against this as these photos were sent him by us, and show apparatus manufactured by us. We are enclosing prints for your personal inspection.

As to his remarks regarding Fig. 10—we do not find any difference between the expression *as used* and *used*; we regard this as a very poor reply.

We may add that the five photos published in No. 12 of Volume II of *Modern Electrics* are also photos of our apparatus, which we sent Mr. Smith under our old firm name—Kunsch & Jaeger (not Kuntz & Jaeger, Ltd.), now: Dr. Erich F. Huth, Ltd.

We are, dear sir,

Yours truly,

DR. ERICH F. HUTH, G. M.: B. H.  
Berlin, S. O., 26.

March 13th, 1911.

## COLLEGES PLAY CHESS BY WIRELESS.

The University of Pennsylvania has been sending challenges to various colleges for games of chess to be carried on by means of their wireless outfits.

## Fire Alarms by Air

**A**T this time when the "conservation of natural resources" has become a national issue, and from coast to coast the nation is taking steps to prevent unnecessary waste, it is inconceivable that so little has been done to lessen the annual waste of three hundred million dollars caused by fire. This loss shows an average of from \$2.19 to \$3.50 per capita, and when these figures are compared with the average per capita loss from fire in Europe of 25 cents, it will be recognized that there is something radically wrong. Since 1880 the population has increased 73 per cent. and during the same period fire losses have increased 134 per cent.

The records show that just as many fires in proportion occur in European cities, but the stone and brick construction of their buildings tends to confine these fires and the resultant losses are correspondingly small.

On the other hand, in this country the buildings are of the most inflammable character, and only a few minutes' headway is required to transform what should have been an insignificant fire into a conflagration entailing enormous losses.

Owing to their having constantly to combat these serious fires, the fire departments in the United States have reached a high state of perfection and the apparatus is of the most powerful character. It is recognized, however, that vast expenditures in this line are not the real solution of reducing the "Fire Waste." The figures prove that despite the universally increased fire departments the losses from the same cause are gaining to an alarming extent.

How then is the problem to be solved?

There is but one answer and that is: the extinguishing of the fire while it is in its incipient stage. And to accomplish this the departments must be notified within two minutes from the start of the blaze.

Ninety per cent. of the fires are not discovered until they have burned for a considerable time and thus gained great headway, so it will be seen that human agency cannot be relied

upon as a means for sending in quick alarms.

There remains, therefore, but one method for accomplishing the result and that is the extensive employment of an efficient automatic fire-alarm.

The ideas outlined above have, for the first time, been completely fulfilled in the new Automatic Fire-Alarm System known as the "Air-Alarm." These devices have been worked on absolutely new theories and the following

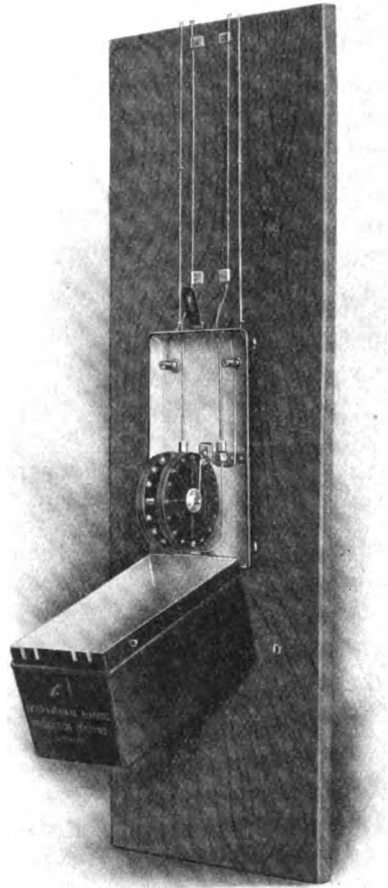

Detector Apparatus.

description will show that the extensive use of the "Air Alarm" will reduce our fire losses to their minimum.

The means for detecting the presence of the fire is the expansion of the atmosphere itself—the instantaneous result from exposed flames. This is accomplished as follows: A small continuous alloy tube is distributed on or near the ceilings of the building to be

protected. The diameter of this tubing (one-eighth inch), and the fact that in most cases it is only necessary to extend it once around the ceiling or moulding renders it in no way objectionable, and in fact, in most cases, entirely invisible. Each end of this tube terminates in a small case (4 inches square) containing an air chamber, a diaphragm, an electrical contact and a small vent for air leaks.

Several thousand feet of this continuous tubing may be attached to a single pair of these cases, and in most instances this amount of tubing will prove sufficient to give complete protection to one floor of the building.

The operation of the apparatus above described, is as follows: Any change of temperature, whether atmospheric or from natural means, such as steam pipes, stoves, etc., will cause the air in the room and consequently that in the tubing slowly to expand. The expanded air in the tubing is projected to the ends of same at which points it escapes through the vents in the air chambers. These vents, or air leaks, are so adjusted as to allow for the escape of any air expansion in the tubing which will result from natural heat sources.

In the event of a fire, however, the exposed flames cause a sudden rapid rise of temperature at the ceiling which is much more extreme than can be obtained in any other way. The

capacity to relieve the sudden and greatly increased pressure. This pressure is therefore exerted against the walls of the air chamber. As the diaphragm forms one of these walls and the only flexible one, it is forced outward by this additional pressure, and in so doing closes the electrical contact whose circuit operates the apparatus which sends in the alarm to the fire department.

From the above description it will be seen that the "Air-Alarm" does not rely for its operation on the old "fixed temperature" principle, which requires the melting of fusible metal, or expansion of metallic springs. To operate these old style devices it is necessary to have 150 to 200 degrees F., and nothing but a large fire will give this extreme temperature.

Another problem which has been solved by the "Air-Alarm" is that of instant notification of any accidental damage occurring to the system. This is accomplished by running a small insulated wire through the tubing and connecting the circuit thus formed to its suitable relay. If the tubing is cut or crushed, the wire inside it becomes severed or grounded against the wall of the tubing, causing the relay to fail and sending a signal at once to the "Air-Alarm" office notifying them that that particular section of the system has been damaged.

Nevertheless, the whole equipment is practically "Accident Proof" as any damage to its wires or tubing, while immediately sending a trouble signal, does not interfere with the subsequent transmission of fire signals. Damage to the transmission system automatically "throws in" a second path for the fire signals, while a cut or crush of the tubing does not prevent the subsequent immediate detection of an incipient blaze, owing to the fact that there is a diaphragm on each end of the tubing.

Marvellous as are the fire detecting qualities of the "Air-Alarm" they are no more wonderful than the system of transmitting the signals to both fire headquarters and the "Air-Alarm" office. The most modern telephone practice has been taken as the model in designing the transmission system, and the "spares" of the telephone com-

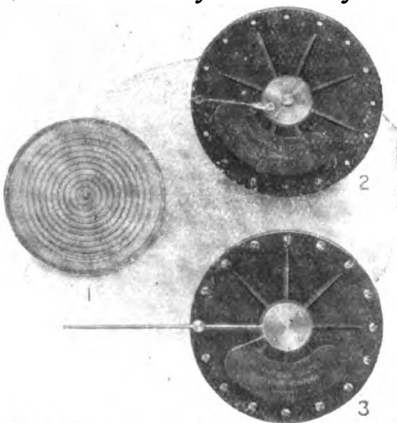

1. Diaphragm. 2. Back of Diaphragm.  
3. Front of Diaphragm.

resultant expansion of the air in the tubing is correspondingly great and when this expansion reaches the air chambers at the end of the tubing, the air vents in same have not sufficient

panies constitute "the lines." An ingenious instrument known as "The Automatic Operator" has been developed and one of these is placed in each of the telephone companies' "Centrals." Short lines of telephone spares

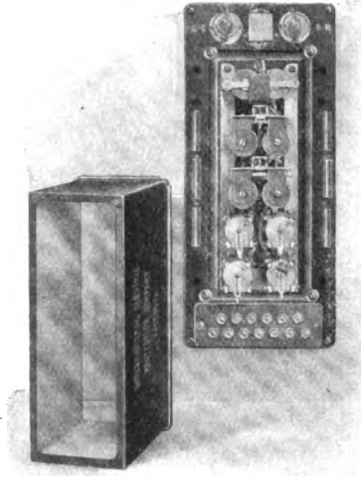

Automatic Operator.

connect all the risks in each district to the nearest automatic operator and two trunk lines run from this instrument to fire headquarters and the "Air Alarm" office.

An example of the working of this system would be as follows: A wastepaper basket accidentally catches fire. The tubing immediately operates as above described, and the signal number of that building is sent over the wires to the "automatic operator" of the telephone "central." This instrument instantaneously transmits the signal direct to both the fire department and the "Air Alarm" office, and within three minutes from the wastebasket's first blaze, the fire department is on its way to the building!

In addition, numerous gongs in the building itself have given to its occupants notice of the start of a fire, and it has been found in the majority of cases, that owing to the blaze still being in its incipient stage, the application of a bucket of water, or an extinguisher, has put out the fire before the department arrives!

As before stated, in the event of any damage to the system, the "automatic operator" sends a notification to the "Air-Alarm" office only. In this way all false alarms are eliminated and it will be seen that the system is abso-

lutely automatic in every phase of its operation.

### ANOTHER WIRELESS EFFICIENCY TEST.

On the evening of March 9, wireless telegraphy received another efficiency test in Chicago. A terrific powder explosion took place at Pleasant Prairie, a small hamlet about fifty-five miles north of Chicago, and caused such a disturbance of the earth's surface, that many thought it to be an earthquake.

But here is where the wireless operators showed their worth. In a short time messages were flying between Chicago, Milwaukee, and boats on the lake.

The operator of the United Wireless Telegraph Co. at the Congress Hotel Station, having heard of the explosion, sent out a bulletin, stating that a powder explosion had taken place at Pleasant Prairie.

The operators of the Chicago Telephone Company were then informed by the wireless operators, and they, in turn, informed the thousands of excited inquirers regarding the true state of affairs; and thus the excitement was allayed, and another victory gained for wireless.

### WIRELESS ASSOCIATION OF ALLEGHENY CO.

On Friday, March 24th, The Wireless Association of Allegheny County was organized. The object of the association is the furtherance of knowledge in the science of wireless telegraphy and telephony among amateurs. The officers elected at the meeting are as follows: President, George B. Richards, Jr.; vice-president, Lawrence Montgomery; secretary, Burton P. Williams, 2321 Perrysville avenue, N. S., Pittsburg; treasurer, Arthur O. Davis.

Any person wishing to become a member must be the owner and operator of a wireless station and must be within the limits of Allegheny County. There are as yet no dues or admission fees to be paid. Any person wishing to join should communicate with the secretary. There are twelve members enrolled.

# Measuring Resistance with Ammeter and Voltmeter

By Leonard Work.

**A**MATEUR workers in electricity, in addition to their studies of electrical phenomena, should not neglect the mathematical end of the science, but should learn to make ordinary electrical measurements, at least, and the study of this important part will in general be found quite fascinating.

The basis of electrical calculations, it may be said is Ohm's law, named after its discoverer, Dr. Ohm, a German physicist. It is expressed by the formula  $\frac{E}{R} = C$ ; where C is the current, E the electromotive force, and R the resistance. Other variations of the formula are  $C \times R = E$  and  $\frac{E}{C} = R$ .

For measuring resistance there are various instruments and each is useful in a certain field, but the simplest and perhaps most used by electrical manufacturing companies for measuring comparatively low resistance such as of machine and transformer windings, etc., is the ordinary portable ammeter and voltmeter.

As an illustration of the use of these instruments for the purpose in question, consider the measurement of resistance of the windings of a transformer as it is actually done in the factory.

To obtain the resistance of any circuit, it is only necessary to know the exact voltage required to force a definite current through it.

In the present case the terminals of one winding are connected to a source of direct current potential such as storage cells or a generator giving a steady voltage. Included in the circuit is an ammeter and a rheostat of convenient size for adjusting the current.

The maximum allowable current is indicated by the size of the wire on the transformer coil, however a current much below the maximum capacity must be used in order that the temperature of the coil may not be raised by the measuring current and the re-

sistance increased, as the resistance of copper wire varies with its temperature. Consequently the use of a large current is very likely to give conflicting results especially if the readings are not taken rapidly.

A voltmeter is connected directly across the resistance to be measured. Current is applied and raised until a good deflection on the ammeter is obtained when simultaneous readings are made of both instruments. At least three readings are taken each with slightly different current strengths.

The results may appear like the following:

Volts	76	66.5	55
Amps.	4	3.5	2.8

The first two readings agree precisely and indicate a resistance of 19 ohms; the third apparently shows 19.6 ohms, but considering that the first two values agree the latter is undoubtedly wrong and probably due to a wrong observation of the instruments, this not being at all unusual. Sometimes four or five readings will all differ very slightly. In such a case the average is taken.

For very precise results correction has to be made for temperature. A thermometer, attached to the windings prior to the test, indicates the temperature at which the wire was measured. If above 25 degrees Centigrade the measured ohms must be reduced by .0042 per cent. for each degree, or if below 25 degrees the resistance must be likewise increased in order to bring the results to the accepted standard of temperature for measurements.

In testing departments it is customary to work out all calculations on an ordinary pocket slide rule: this wonderful little instrument being an almost indispensable adjunct of the test room. All amateur workers in electricity would do well to obtain a slide rule as it is so easily learned and its use is so convenient that with it mathematical problems cease to be drudgery and become a pleasure.



# Paris Letter

## High Frequency Apparatus.

SOME very good results have been obtained in Italy by Dr. F. Jaciovello with his new method of producing high frequency waves. We have already mentioned the principle which he uses. He forms a high tension arc between metal electrodes and at the same time sends a very strong current of gas along the arc. At F and G are two metal tubes and the arc is made between them at L L. A current of gas is sent in the tubes in the direction of the arrows, and the blocks H H keep the gas stream in the region of the arc. We wish to illustrate the newest form of apparatus which he uses, based on this principle. The parts are held by the two metal plates D D and the containing cylinder M of insulating material. The lower tube A fits into the plate D by means of an insulating bushing O and at the top it carries the

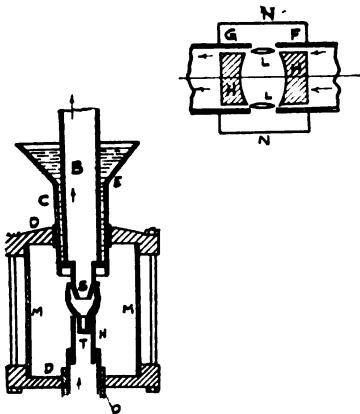

metal end piece H. Inside is a cylindrical piece T arranged so that when gas is sent up through the tube it escapes by a circular opening. The arc is formed between H and a corresponding end piece S carried on the end of the upper tube B. As the part S is conical, the arc takes the form which is shown here when driven by the gas. Means must be provided for cooling the upper tube. The lower tube is cooled very well by the incoming gas. Around the upper tube is mounted a water jacket C E for this purpose. The inventor has been very successful with this apparatus, using low tension al-

ternating current to start with, and obtains high frequency oscillations. It is claimed to secure much better results than usual for a given amount of current used in the arc.

## Solar Generator.

The question of utilizing the sun's heat as a source of energy is occupying inventors at present, and we wish to illustrate one of the newest methods, which is brought out in Germany by Joh and Wolf. They claim that the

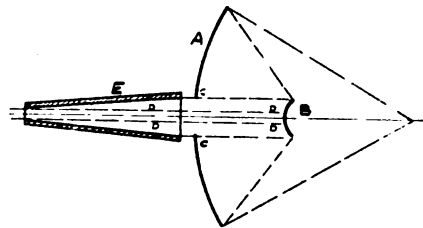

best effect of the sun's rays for a given surface can be obtained by using two mirrors so as to concentrate the rays upon a thermo-electric battery of special form. By using the large concave mirror A and the small convex mirror B mounted in front of it, the sun's rays are concentrated to a beam C C and this is sent through an opening in the large mirror so as to fall upon the thermo-electric battery E. This is made up of a number of cells disposed in rings and then built up so as to form a hollow cone. The inside of the cells is thus heated and the outside is kept cooled in order to have the difference of temperature which is needed to give the thermo-electric effect. A thin glass cover is used around the battery, and water is dropped on to it so as to give a cooling by evaporation. Owing to the fact that the middle opening in the large mirror does not act to reflect the light, there will be a dark part along the beam at A A, but owing to the present design most of the light acts upon the thermo-electric cells.

## High Frequency Apparatus.

The following method is used by a French inventor to obtain high frequency waves from the usual alternating current. It is designed to give a multiple break and the discharges of the condenser are made at certain ad-

justed points with relation to the wave of the alternating current. One discharge plate A is mounted on the shaft of the alternator and the fixed plate B lies opposite. The discharge points are placed on the plates so as to have a certain number of discharges per revolution. When we use A and B, for instance, we obtain two discharges per revolution, while using A<sup>1</sup> with B<sup>1</sup> we can have four discharges. It only remains to design these forms with the number of poles of the machine so as

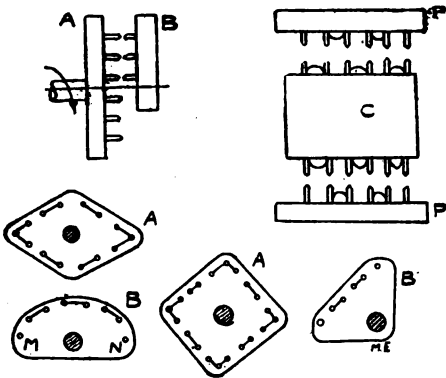

to have a determined number of discharges for each wave of the current. The rotating piece can be mounted on a synchronous motor instead of upon the alternator itself. We vary the angular position on the shaft so as to adjust the time of break with reference to the current wave. To obtain a greater number of breaks we can use a double form such as the revolving part C and

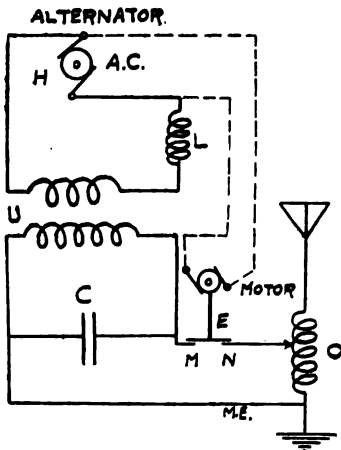

the fixed side plates P P, on the same principle.

The connections are shown in the diagram. On the motor shaft is the

rotating discharge plate E carrying its points. M and N represent the first and last discharge points of the fixed plate, corresponding to M and N on the preceding figure. The spark break is connected by M to one side of the condenser C and by N to the other side of the condenser through the coupler O. The condenser is mounted on the ends of the transformer U, which is connected to the alternator, using a properly adjusted choke coil L in series. It is stated that with the present method we can obtain five times the usual effect in producing high frequency waves. We obtain a regular succession of discharges which give a musical note, and also require less condenser capacity at the receiving end. More energy is given out for a given aerial.

**Ingenious Synchronizer.**

Most of the systems for transmitting images to a distance either by a pen or pencil recorder or by photographic methods require to have the transmitter and receiver cylinders or like parts rotated at exactly the same

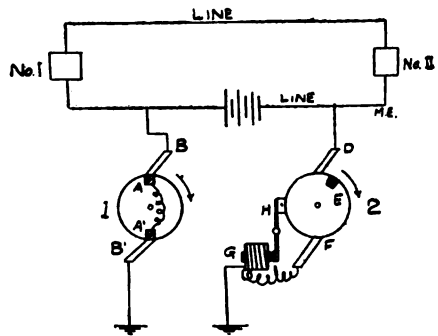

speed. However, it is not always easy to realize a good synchronizing method where we cannot allot a separate wire for controlling both motors, but must use the line wire to do this. M. De Vendeuil devises the following simple method for running the two shafts at the same speed, based on the use of a retarding brake. Using apparatus No. I and II on the line and battery as shown, the two rotating parts are seen at 1 and 2. Each shaft is driven by a separate electric motor at as near the same speed as possible. Disc 1 is of insulating material and carries the metal contacts A A<sup>1</sup> so that when the brushes are on them, current passes

across to ground. Disc 2 is of metal and has an insulating segment E. When brush D is not on E, current can pass through the disc and out by brush F. This is in series with an electromagnet G which works a brake H upon the disc. Suppose Disc 1 is in the present position and disc 2 has advanced beyond the proper point so that the brush D now bears on the metal. Current flows through the first disc and also through the second, putting on the retarding brake for a moment. This will slacken No. 2 so as to keep it in pace with No. 1. When both discs are at the same speed, brush B is on A, but brush D is at the same time on E or the insulated part, so that no current passes in the brake magnet and the brake is not thrown on.

**Rotary Spark Gaps.**

Among the new forms of rotary spark gaps, we mention one of French invention which uses a set of contact points mounted around a rotating wheel. On the motor shaft M is a fibre bushing N on which is mounted a disc F carrying a metal support for

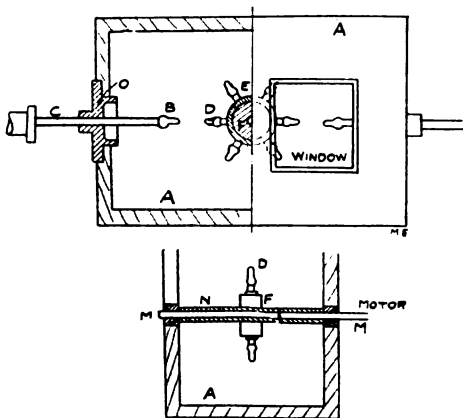

the contact pieces D. These are screwed in separately and are made of aluminium. Opposite them are like points carried on the sliding rod C, this being held in an insulating plate O. Windows placed opposite the gaps allow of observing them. In an English device, the spark points B are of curved shape and work between the sets of fixed points A A<sup>1</sup>. In the second diagram, the rotating wheel B works in connection with the fixed

points C placed around it in a circle, and the number of fixed points is one

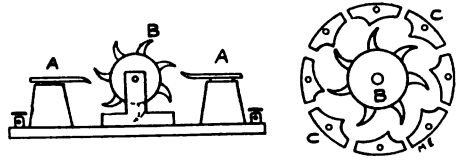

less than that of the rotating points. In this way a musical note is obtained.

**SOCIETY OF WIRELESS TELEGRAPH ENGINEERS.**

At the annual meeting and banquet of the society on February 27, at the Hotel Lenox, the following officers were elected for the coming year:—

President: Fritz Lowenstein, 115 Nassau street, New York City.

Vice-president: Dr. Louis Cohan, Washington, D. C.

Secretary: E. B. Moore, 39 Trinity place, Boston.

Treasurer: V. F. Greaves, 2 Avon street, Cambridge.

Directors: Samuel Cabot, 262 High street, Brookline; F. H. Knowlton, So. Framingham; and George Hill, 109 High street, Everett.

**"THE WIRELESS FIEND."**

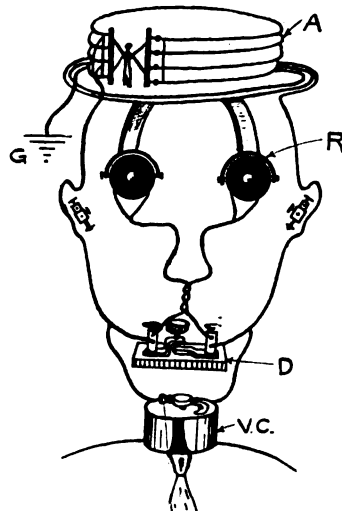

By Walden Fountain

# MODERN ELECTRICS

A Magazine devoted entirely to the  
Electrical Arts.

Published Monthly by

**Modern Electrics Publication**

NEW YORK CITY

**H. GERNSBACK, Editor**

**Subscription Price: For U. S. and Mexico  
\$1.00 per year, payable in advance.**

New York City and Canada, \$1.25.

Foreign Countries, \$1.50 in Gold.

Stamps in payment for subscriptions not accepted.

Checks on out of town Banks cannot be accepted unless the usual exchange is added.

**SINGLE COPY, 10 CENTS**

Forms close the 20th of the month preceding date of publication. Advertising rates on application.

The Editor will be pleased to receive original contributions of timely interest pertaining to the electrical and the affiliated arts. Articles with good drawings and clear photographs especially desired. If accepted, such articles will be paid for on publication, at regular rates.

**No manuscripts will be returned unless return postage is enclosed.**

Address all communications to:

**MODERN ELECTRICS PUBLICATION**

233 Fulton Street, New York, N. Y.

Chicago Office: 907 Manhattan Bldg.

Paris Office: 137 Rue d'Assas

Brussels Office: 23 Rue Henri Maus

Copyright, 1911, by MODERN ELECTRICS  
PUBLICATION.

Entered as second class matter March 31, 1908, at the New York Post Office, under the Act of Congress of March 3, 1879.

**Vol. IV                      MAY                      No. 2**

## EDITORIAL.

**T**HE 1911 issue of the *Wireless Blue Book* goes to press on May 31st. It will be much enlarged—almost twice the former size, and will contain a great many novel features. The book will be fully up-to-date and will contain all government

and commercial stations. The arrangement will be the same as the 1910 Blue Book, that is, the stations will be classified by their calls in alphabetical order so that a station can be found quickly, when receiving messages.

The amateur section will be about six times as large as formerly, as far as can be judged at the present time of writing.

If you have a station do not fail to register in the new Blue Book. For the small sum of 25 cents your station will be registered and for this you are entitled also to one copy of the Blue Book, which sells at 15 cents.

*We cannot urge you too much to register your station and to impress upon you the vital importance of this; please bear in mind that registering your station helps a great deal to prevent new wireless laws restraining the amateur. The Wireless Blue Book is well-known in Washington. As long as the Wireless Amateur is concealed and is not officially known, he does not act in good faith towards the Government.*

As long as the government does not exact registration, the Wireless Amateur should at least register in the only known book to show his good faith. This will help a great deal to make the now unpopular amateur popular.

Besides this, if every station were registered in the Blue Book, its owner would come more in contact with other amateurs in their neighborhood; they could form local associations of the *Wireless Association of America*, and could do much to further the art and restrain wireless legislation.

You cannot expect to become known to fellow wireless experimenters, if your name is not printed in the Blue Book.

*Register today. See our advertisement for further information.*

## Ralph 124C 41 +

(Continued.)

By H. Gernsback.

"**Y**OU must really think me very forward to keep on talking to you, a stranger, in this fashion," she resumed; "but you see the trouble is I have not spoken to any living being for the last five days, and I am just dying to talk."

"Why, how very extraordinary!" 124C 41 exclaimed, "I really cannot understand."

"It is simple enough, though," she smiled; "you see, father and I live in our villa half way up Mount Rosa, and for the last five days such a terrible blizzard has been raging that the house is entirely snowed in. The storm was so terrible that no aeroflyer could come near the house; I have never seen such a thing. Five days ago father and my brother left for Paris, intending to return the same afternoon, but they had a bad accident whereby my poor brother dislocated his knee-cap; both were therefore obliged to stay somewhere near Paris, where they landed, and in the meanwhile the blizzard set in. The Teleservice line became disconnected somewhere in the valley, and this is the first connection I have had for five days. How they came to connect me with New York, though, is a puzzle!"

"Most extraordinary—but how about the Wireless?"

"Both the Power mast and the Comunico mast were blown down the same day, and I was left without any means of communication whatever. However, I managed to put the light magnesium power mast into a temporary position again, and I had just called up the Teleservice Company, telling them again to direct the power, and getting some other information when they cut me in on you."

"Yes, I knew something was wrong when I saw the old-fashioned Radiolamp in your room, and I could not quite understand it. You had better try the power now; they probably have directed it by this time; anyhow, the Luminor will banish the darkness from you."

"You are probably right," and raising her voice, she called out sharply: "*Lux!*"

The delicate detectophone mechanism

of the Luminor responded instantly to her command; and the room was flooded at once with the beautiful cold pink-white Luminor-light, emanating from the thin wire running around the four sides of the room below the white ceiling.

The light, however, seemed too strong for her, and she sharply cried, "*Lux-dah!*" The faithful mechanism again responded; the cold light-radiation of the Luminor wire decreased at once in intensity, and the room appeared in an exquisite pink light.

"That's better now," she laughed. "The heater just begins to get warm, too. I am frozen stiff; just think, no heat for five days! I really sometimes envy our ancestors, who, I believe, heated their houses with stoves, burning strange black rocks or tree-chunks in them!"

"I am, so sorry for you! It must be a dreadful predicament to be cut off from the entire world, in these days of weather control; I believe it must be a novel experience. I cannot understand, however, what should have brought on a snow blizzard in midsummer."

"Why, you see, our governor had some trouble with the four weather-engineers of our district, some months ago, and they struck for better living. They claimed that the authorities did not furnish them with sufficient luxuries; and when their demands were refused, they simultaneously turned on the high-depression at the four Meteoro-Towers and then fled, leaving their towers with the high-tension currents escaping at a tremendous rate.

"This was done in the evening, and by midnight our entire district, bounded by the four Meteoro-Towers, was covered with two inches of snow. The four scoundrels, it seems, had erected especially for their nefarious work additional discharge arms, pointing downward from the towers, for the purpose of snowing-in the meteors completely.

"Their plans were well taken, for it became impossible to approach the towers for four days; and they finally had to be dismantled by directed energy

from forty other Meteor-Towers, which directed a tremendous amount of power against the four doomed towers, till the latter were fused and melted.

"The other Meteoros, I believe, will start in immediately to direct a low-pressure over our district; but, as they are not very near us, it will probably take them twenty-four hours to generate enough heat to melt the snow and ice. They will probably encounter considerable difficulty, because our snowed-under district naturally will give rise to some meteorological disturbances in their own districts, and therefore they will be obliged, I presume, to take care of the weather conditions in their districts as well as our own."

"What a remarkable case!" he ejaculated, and what a fine scientific understanding you have!"

"Oh that is nothing. I am somewhat of a scientist myself, and like nothing better than to dabble in papa's laboratory. That's why I was so interested when I saw yours," she added.

She opened her mouth as if to say something. But at that moment an electric gong began to ring furiously, so loud that it jarred even Ralph, four thousand miles away. She turned deathly pale, and he asked sharply:

"Heavens, what does that mean?"

"An avalanche has started at the top of the mountain! O God, what shall I do? It will be here in fifteen minutes, and I can't escape—I am snowed-in! What shall I do?" she cried hysterically.

For a few short seconds 124C 41 stood dumbfounded, while every drop of blood left his face. Then suddenly it came back with a rush, and he bellowed out, almost hysterical himself:

"Courage! I will save you! I'll show you how to deal with avalanches! You say your power-mast is up as yet?"

"Yes, but what good does . . . ?"

"Never mind! Speak quick! Your wave length?"

"620."

"Vibratory?"

"491,211."

"Can you direct it yourself?"

"Yes."

"Could you attach a six-foot piece of your blown-down Communico mast to the base of the Power aerial?"

"Certainly—it's of alomagnesium and it is very light."

"Good! Now act quick! Run to the roof and attach the Communico mast-piece to the very base of the power mast, and point the former towards the avalanche. Then move the directoscope exactly to West-by-South, and point the antenna of the power mast East-by-North. Now run—I'll do the rest!"

He saw her drop the receiver and rush away from the Telephot. Immediately he leaped up to the top of his building, and swung his big aerial around so that it pointed West-by-South.

He then adjusted his directoscope till a little bell began to ring. He knew then that the instrument was in perfect tune with the far-off instrument in Switzerland; he also noted that its pointer pointed exactly East-by-North.

"So far, so good," he whistled with satisfaction. "Now for the fireworks!"

He ran down to the laboratory, threw in one switch, while he threw in another one with his foot, clapping his ears tightly with his rubber-gloved hands. A terrible, yelling sound was heard, and the building shook. It was the warning siren on top of the house, which could be heard in a radius of sixty miles sounding its warning to all to keep away from tall steel or metal structures, or, if they could not do this, to insulate themselves.

He sounded the siren twice in succession for ten seconds, which meant that he would direct his ultra-power for at least twenty minutes, and everybody must be on his guard for this length of time.

No sooner had the siren blast stopped, while the sound echoed as yet fiercely, than he had seen Miss 212B 423 at the Telephot, beckoning him that everything was in readiness.

He yelled to her to insulate herself, and he could see her jump into a tall glass chair where she sat perfectly still, deathly white. He could see that she clasped her hands to her ears; and he knew that she must hear already the thunder of the death-bringing avalanche.

But already he had run up on his high glass ladder; and having reached the top, he began to turn the large glass wheel whose shaft was connected with the ultra-generator.

He began turning the wheel, and for the first time he looked at the clock.

He observed that it was just nine minutes after he first had heard the gong and he smiled, coldly. He knew he was in time.

A terrifying roar set in as soon as he had commenced to turn the wheel. It was as if a million devils had been let loose. Sparks were flying everywhere. Small metal parts, not encased in lead boxes, fused. All sharp objects emanated long streamers of blue flames, while ball-shaped objects glowed with a white aureole.

Large iron pieces became strongly magnetic, and small iron objects continually flew from one large iron piece to another. Ralph's watch chain became so hot that he had to throw it off, with his watch.

He kept on turning the wheel, and the roar changed to a scream so intense in its sharpness that Ralph had to pull out his rubber ear vacuum-caps so that he might not hear the terrible sound. As he turned the wheel farther around something remarkable happened. The tone of the ultra-generator had reached the note where it coincided with the fundamental note of the building, which was built of steelonium (the new substitute for steel).

Suddenly the whole building "sang," with a shriek so loud and piercing that it could be heard twenty miles off.

Another building whose fundamental note was the same as the one of the first building began to "sing" in its turn, just as one tuning fork produces sympathetic sounds in a similar distant one.

Ralph kept on turning, and the building stopped its sound. As he continued turning the wheel of the generator, the latter gave out sounds sharper and sharper, higher and higher, shriller and shriller, till the shrieking became unendurable. And then, all of a sudden, the sound stopped abruptly.

*The frequency had passed over twenty-thousand, and at this point the human ear ceases to hear sounds.*

Ralph turned the wheel a few more notches and then stopped. Except for the flying iron pieces, there was no sound. Even the myriads of sparks leaping around were strangely silent, except for the hissing noise of flames streaming from sharp metal points.

Ralph looked at the clock. It was exactly ten minutes after the first sounding

of the gong. He then turned the wheel one notch further and the room was plunged into a pitch-black darkness.

\* \* \* \* \*

An uninitiated stranger standing—well insulated—on a roof not very far off from Ralph's laboratory, would have witnessed the following remarkable phenomena:

As soon as Ralph threw the power of the Ultra-Generator on his aerial, the latter began to shoot out hissing flames in the direction of West-by-South.

As Ralph kept turning on more power, the flames become longer and the sound louder. The heavy iridium wires of the large aerial became red-hot, then yellow, then dazzling white, and the entire mass became white-hot. Just as the strange observer could hardly endure the shrill hissing sound of the outflowing flames any more, the sound stopped altogether, abruptly, and simultaneously the whole landscape was plunged into such a pitch-black darkness as he had never experienced before. He could not even see his hand before his eyes. The aerial could not be seen either, although he could hear the tremendous energy still flowing away.

What had happened? The aerial on top of Ralph's house had obtained such a tremendously high frequency, and had become so strongly etherized, that it acted toward the ether much the same as a vacuum pump acts on the air.

The aerial for a radius of some forty miles attracted the ether so fast that a new supply could not spread over this area with sufficient rapidity.

Inasmuch as light waves cannot pass through space without the medium of ether, *it necessarily follows that the entire area upon which the aerial acted was dark.*

Our uninitiated stranger who had never before been in an etherless hole, (the so-called negative whirlpool) experienced some remarkable sensations during the twenty minutes that followed.

It is a well known fact that heat waves cannot pass through space without their medium: ether, the same as an electric bell, working in a vacuum cannot be heard outside of the vacuum, because sound waves cannot pass through space without their medium, the air.

No sooner had the darkness set in,

then a peculiar feeling of numbness and passiveness came over our stranger.

As long as he was in the etherless space, *he absolutely stopped growing older*, as no combustion nor digestion can go on without ether. *He furthermore had lost all sense of heat or cold.* His pipe, hot previously, was neither hot nor cold to his touch. His own body could not grow cold as the heat of same could not be given off to the atmosphere, nor could his body grow cold, even if he had sat on a cake of ice, because there was no ether to permit the heat to pass from one atom to another.

He remembered how, one day, he had been in a tornado center, and how, when the storm center had created a partial vacuum around him, he all of a sudden had felt the very air drawn from his lungs. He remembered people talking about an air-less hole, in which there was no medium but ether (inasmuch as he could see the light). Now things were reversed. He could hear and breathe, because the ether has no effect on these functions; but he had been robbed of his visual senses, and heat or cold could not effect him, as there was no means by which the heat or cold could traverse the ether-hole.

\* \* \* \* \*

Miss 212B 423's father, who had heard of his daughter's distress in a round-about way, rushed back from Paris in his aeroflyer. He had speeded up his machine to the utmost, as if by instinct, he was scenting an impending disaster. When finally his villa came into sight, his blood froze in his veins and his heart stopped beating, because of what was revealed before his eyes.

He could see that an immense avalanche was sweeping down the mountain-side, with his house, harboring his daughter, directly in the path of it.

As he approached, he could hear the terrible roar and thunder of the avalanche as it swept away everything in its path. He knew he was helpless to do anything to aid his daughter, as he could not make the house in time, and it only meant the certain destruction of him also; and for that reason he could do well-nigh nothing but watch on hysterically the tragedy which would enact itself before his eyes in a few short minutes.

At this juncture a miracle, so it seemed to the distracted father, occurred.

His eye chanced to fall on the Power-mast on the top of his house. He could see, glistening in the sun, the iridium aerial wires which were pointing East-by-North; suddenly they became red-hot; then yellow, then white-hot, at the same time he felt that some enormous etheric disturbance had set up, as sparks were flying from all metallic parts of his machine. When he looked again at the aerial on his house, he saw that a piece of the Communico mast, which apparently had fallen at the base of the power mast, and which was pointing directly at the avalanche, was streaming gigantic flames which grew longer and longer, and gave forth shriller and shriller sounds. He had the impression, while looking on, that the flames which streamed from the end of the Communico-mast-piece looked much the same as a tremendously long jet of water leaving its nozzle under pressure.

For about five hundred yards from the tip of the Communico mast it was really only a single flame about fifteen feet in diameter. Beyond that it spread out fan-shape like. He could also see that the entire power mast, including the communico mast, was glowing in a white heat, showing that immense forces were directed upon it. By this time the avalanche had almost come in contact with the furthest end of the flames.

Here the remarkable happened. No more did the avalanche touch the flames, than it began turning to water. It seemed that the heat of those flames was so intense and powerful that had the avalanche been a block of solid ice it would not have made any marked difference. As it was, the entire avalanche had been reduced to hot water and steam even before it reached the main shaft of the flame.

A torrent of hot water rushing down the mountain was all that remained of the terrible avalanche; and while the water did some damage, it was insignificant compared to the damage the avalanche would have wrought, if it had continued on its original course unchecked.

For several minutes after the melting of the avalanche the flames continued to stream from the aerial, and then stopped gradually.

Ralph 124C 41, in New York, four thousand miles distant, had turned off the power of his ultra-generator.

He climbed down from his glass ladder, stepped over to the Telephot, and



found that Miss 212B 423 had already reached her instrument. Tears were flowing down her cheeks, and she was so hysterical from her miraculous escape from death that it took her a few minutes before she could find her voice.

"Oh, how can I ever thank you, sir, for having saved me from that terrible avalanche? I could see it sweep down—down—nearer and nearer—sweeping everything in its path—snapping trees like matches. I heard its terrifying thunder—I seemed to feel the wind that precedes it—it was actually on top of the house, big like a mountain—and in terror I closed my eyes —. When I opened them again I could hardly believe my eyesight—the avalanche had vanished! I could not believe I was alive till I chanced to look at the Telephot face-plate and saw you climbing down a glass ladder. I knew then that you had saved me, but I don't know yet what you have done, with the avalanche!"

"Melted it!", he said simply.

"Melted it!" she echoed, "how perfectly wonderful—and just think how many besides me you saved! There is a town down the valley" . . . she shuddered at the thought of it. "Oh, how can I ever thank you, noble sir—."

"By not mentioning the incident any more. I did what anybody would have done under the same circumstances."

Before she could answer, an old gentleman, highly excited, rushed into the young lady's room, and Ralph could see her fly into his arms, exclaiming: "Oh, father dear"—

Ralph 124C 41 with discretion hung up his receiver.

(To be continued.)

OUR SCIENTIFIC PRESS.

**W**E give herewith an illustration and the text-discussion of a "new" electric gambling device as described in the Sunday, April 23rd, issue of the otherwise well informed *New York Times*.

"The newest method in cheating in roulette is the platinum ball—a new invention. Mr. Flynn has secured two specimens of these. In the centre there are spindles of alternating zinc and copper; by means of fine wire brushes a strong current of electricity may be thrown to either the zinc or copper sections. As the positive or negative electric current attracts or rejects

platinum with great violence the ordinary ivory or composition roulette ball is substituted for this metal. The system of operation is easy. If a player bets on the red the croupier presses a button which is put under the table, thereby producing a negative current, and all the red pockets reject the ball. Next time, if the bets are placed heavily on the black, another button is touched and the ball flies from the black pockets as if possessed. Of course this system necessitates an elaborate device; the electric wires are passed through the table legs and under a carpet where the buttons are hidden, but placed conveniently to the feet of the operator."

It is really astonishing to see how many scientific untruths there are in the above single paragraph: "the current attracts or rejects platinum with great violence." is rather a new discov-

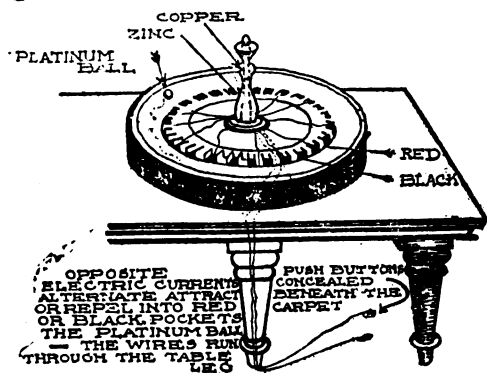

ery. The sentence "a strong current of electricity may be 'thrown' to either the zinc or copper sections," is also rather mysterious.

And still further: "thereby producing a negative current," is a few hundred years ahead of the times.

The real action is of course as follows: There are two sets of electromagnets; each pocket containing one electromagnet. One set of electromagnets (red pockets) is connected with a pushbutton and a battery. The other set (black pockets) connects with another pushbutton and the battery.

The ball is, of course, not platinum (which is un-magnetic), but is simply a soft iron hollow ball; to improve its appearance it is plated with platinum, or sometimes with gold.

(Continued on Page 118)



This department has been started with the idea to encourage the experimenter to bring out new ideas. Every reader is welcome to contribute to this department, and new ideas will be welcomed by the Editors. **WHEN SENDING IN CONTRIBUTIONS IT IS NECESSARY THAT ONLY ONE SIDE OF THE SHEET IS USED. SKETCH MUST INVARIABLY BE ON A SEPARATE SHEET NOT IN THE TEXT.** The description must be as short as possible. Good sketches are not required, as our art department will work out rough sketches submitted from contributors. **IT IS THEREFORE NOT NECESSARY FOR CONTRIBUTORS TO SPEND MUCH TIME IN SKETCHING VARIOUS IDEAS.** When sending contributions enclose return postage if manuscript is to be returned if not used. **ALL CONTRIBUTIONS APPEARING IN THIS DEPARTMENT ARE PAID FOR ON PUBLICATION.**

**FIRST PRIZE TWO DOLLARS.**

**A Silicon Ticker.**

**A**NY wireless operator living near one of the New Poulsen Wireless stations, doubtless has trouble in reading them, and perhaps he can not receive their signals at all.

If you live near such a station and have a detector known as a "Silicon Cat-whisker Detector," gently pull the

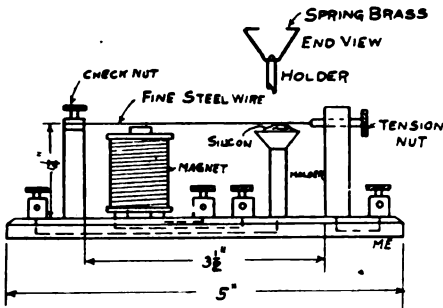

steel wire off and then let it fall back on the silicon; and as it vibrates it will give forth a beautiful, clear, humming sound; like picking a guitar string. This only lasts for an instant; as long as the wire vibrates against the silicon. From this experiment I worked out the following instrument which gives the result which the Poulsen people say can only be accomplished by their instruments, i. e., the Poulsen "Ticker."

The base is made of hard wood or rubber one-half inch in thickness, five inches long and 3 inches wide.

The small bell magnet can be taken from any electric bell of convenient size; generally they are one one-eighth

inches long; the dimensions on the diagram being for this size. If you have a different size the dimensions must be changed so the magnet will always be one-eighth inch away from the steel wire. This wire is the E string of a mandolin and must be steel. Make two brass standards one one-half inches long and drill holes in them one one-quarter inches from bottom, as in diagram, then thread in from the top for the check-nut on one of them, and on the side of the other for the tension nut. The tension nut can be taken from the spring of an old telegraph sounder; this is to keep the wire from breaking by twisting around.

Distance between standards is three and one-half inches. The electro-magnet is mounted exactly one-eighth inch under the wire. The holder is also mounted under the wire, so the wire will strike the top surface of the

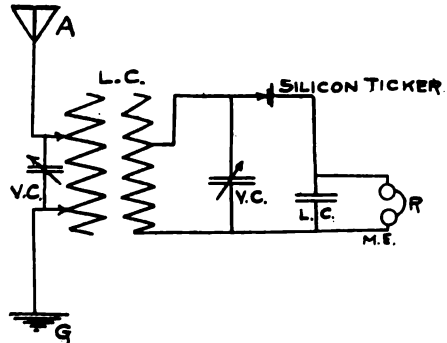

silicon. End view of holder is shown in Fig. 1.

Binding posts should be screwed on the ends of the ticker. One goes to the

standards and one to the silicon holder; also two in the middle for the magnet.

The magnet is connected to the alternating current supply, preferably 110 V. A. C. through a resistance which can be varied. Not more than four volts should pass through the magnet or it will heat up. A small water rheostat works very well in this connection. A small switch should be mounted near the ticker to open the circuit when you are not using it.

The ticker is connected up as in Fig. 2. The condenser which shunts the phones is three times as large as an ordinary condenser used in wireless work. The variable condenser should also be used to get good results.

Now adjust the tension nut and vary the current in the magnet, and tune very closely for what is known as the "Conversation Wave" and you will be a surprised person.

These stations send out two separate trains of waves. The arc sends out a sound which sounds like spilling milk, but you must tune for the waves which are generated in the closed oscillation circuit, arc, condenser and inductance. The station in question has an immense fan aerial composed of thirty-seven wires stretched between two 300-foot towers, 400 feet apart. They talk daily with a station in Texas.

Contributed by  
**STANLEY HYDE.**

**SECOND PRIZE ONE DOLLAR.  
THREE SLIDE TUNER.**

If one is making a three slide tuning coil and does not know how to operate it, or for some reason would like to

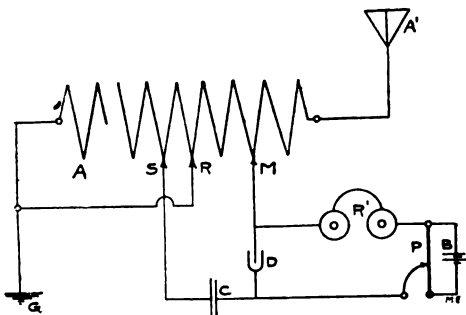

change from a three slide tuning coil to a one or two slide, one can do so by adding the following:

When your coil is almost finished winding cut the wire about one inch from the end, then add a separate winding, A, and ground as shown in drawing.

To operate as a two slide tuning coil move slider, S, to winding, A, and then only slider, R and M, are in use.

To operate as a single slide tuning coil, move sliders, S and R, to winding, A, thereby using only slider, M.

To operate as a three slide tuning coil move sliders off from winding, A, thereby putting them all in use.

This will help one to adjust a three slide tuning coil also to experiment with single and double slide coils.

Contributed by  
**WILLIAM S. WILDER.**

**FOOT-OPERATED AERIAL SWITCH.**

The accompanying is a diagram of an aerial switch of my own construction, which is placed under the table,

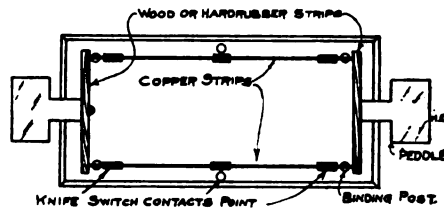

and is worked by the feet. The dimensions can be changed to suit. The copper strips are one inch wide and about one-eighth of an inch thick. A and B hold the large strips, and should be about an inch higher than the switch points. For a high power station, a box can be slipped over whole, leaving only insulated peddles exposed. Connections are made as with any D. P. D. T. switch. The diagram fully describes the switch.

Contributed by  
**CLIFT. R. RICHARDS, JR.**

**AERIAL MAST.**

Many persons who take up the study and operation of a wireless telegraph or telephone station find that there is no place, convenient to their station, high enough for an aerial. I raised my aerial about twenty-five feet in the manner described below. This, of course, necessitates a tree, which has

a thin butt. First saw a notch in the thick end (A in Fig 1). Now get a pulley which will take upward of one-half an inch rope, and rope to fit. Now fasten the pulley in the tree in which the mast is to be put. Tie one end

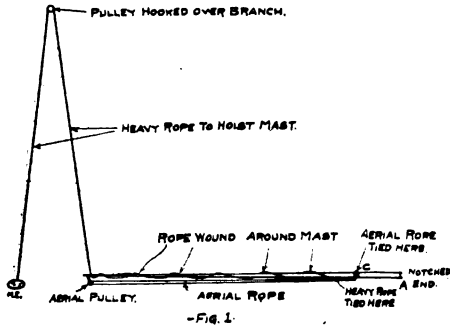

of this heavy rope near the (B, Fig. 1) heavy end and wind the rope all the way up the mast (shown in Fig 1).

Procure a small pulley by which to regulate the height of the aerial, and the right size rope to fit, about twice as long as the mast. Secure this pul-

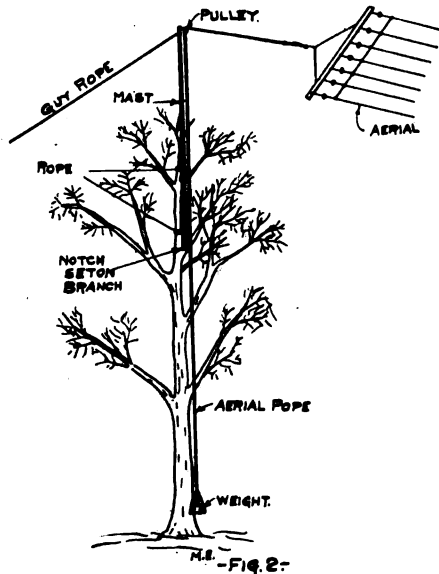

ley at the top end of the mast and pass the rope through. Tie both ends just below the large-sized rope on the mast (C, Fig. 1).

Fasten one guy wire just below the small pulley. Drive one or two nails about one inch long (to keep guy from slipping down) just below the guy wire. Leave the guy so it may be turned in any direction.

Now hoist the mast into the tree, untie the small aerial rope, untwist the

heavy rope from around the mast, and set the notched end on a branch so the branch fits into the notch. Then lash the mast securely to the tree and remove heavy rope and heavy pulley. Fasten the end of the small rope to the end of the aerial and hold tight to the other end when aerial end is released. Now fasten the guy wire on the opposite side from the aerial and then hoist aerial. Great care must be taken not to get the foot of the mast too high in the tree as the mast is apt to topple over.

Contributed by  
JOHN W. GUNDY.

### TURN BUCKLE SUBSTITUTE.

Considering the price of a good turn buckle, it is not unusual to see the guy wires of an aerial pole not equipped with them; so I built a cheap contrivance which I think will suit the pur-

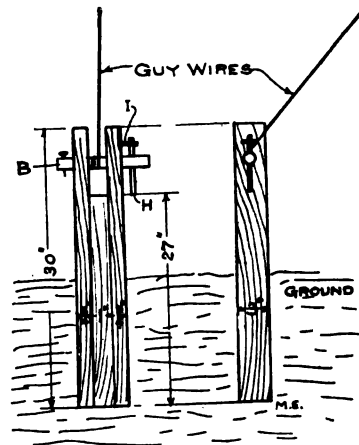

poses of one. I think the sketch is self-explanatory.

The whole thing is driven into the ground like a stake, winding the slack wire on (B), a six-inch length of broom stick, by turning the handle (H); it being held by the screw eye (i) when not in use.

Contributed by  
JOHN B. BRADY.

### A WELL-INSULATED HELIX.

Please find enclosed a contribution of a well insulated helix, which I use myself to comply with the laws of my city, which are now in effect.

First take your helix frame with flat upright; and take as many telephone

insulators as you need and place them one above each other, according to the number of wires on your helix.

Then take the upright in back of it and place the same number the same distance apart, only one-half the distance between one and the other lower. Then take a piece of large

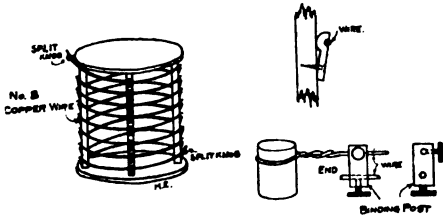

cord and wind it around the helix in these two grooves and place the others under the cord and screw them down. Then take the cord off and put on your wire; at the ends use split knobs so as to hold it tight.

Now take a couple of binding posts with two holes in them, and put one on the helix wire and your connecting wire to the other as in diagram.

I find this to work to perfection as far as insulation goes, and it makes a neat appearing helix.

Contributed by

ELMER LEGGE.

### IMPROVED BICHROMATE BATTERY.

I enclose a sketch of a battery which I have found to be satisfactory in a number of different ways.

The zinc element consists of a zinc strip one-half inch wide, riveted

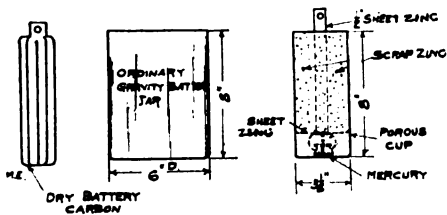

(zinc rivets) on to a disc of sheet zinc. To this is fastened a glass salt-cellar which contains mercury. Any old scrap zinc is placed in the porous cup. The solution for the porous cup consists of sulphuric acid one part, water, ten parts. The salt-cellar contains about one ounce of mercury. Outside, in the glass jar is a solution

composed of sodium or potassium bichromate one-half pound; sulphuric acid one pound; mixed with water, very slowly.

This battery is constant on medium resistances; and gives from ten to fifteen amperes on short circuit and an E. M. F. of two volts. Owing to the presence of mercury, there is no noticeable local action. Using four cells in series on a twelve c.p. Tungsten lamp, the approximate cost is one cent per hour.

Contributed by

F. HALL.

### A HOME-MADE THERMOSTAT.

I have a small hot-house situated some distance from dwelling, heated by an oil stove, and finding it inconvenient to go back and forth to note the temperature, I contrived the fol-

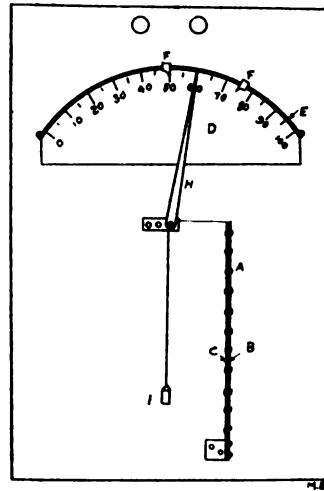

lowing alarm apparatus to ring a bell in my dwelling, should the temperature vary too much.

The base, which is fastened to the wall, is about 8x12 inches and must be made of a well seasoned and painted board. A is a compound bar made of a strip of brass, B, and a strip of steel, C, riveted together every half inch. Cut a strip of steel six inches long by one-quarter inch wide and not over one-sixteenth inch thick, (a piece of old saw blade is excellent), and punch a line of holes one-half inch apart its entire length. Now cut a strip of brass of the same dimensions and lay the steel strip over it and drill holes

to correspond to the end holes in the steel. Then put temporary rivets in them so that the rest of the holes can be bored exact by boring down through the steel. After being drilled, rivet them together with snug fitting rivets, leaving one hole at one end and two at other, without rivets. D is a thin piece of board  $6\frac{1}{2}$  inches long by  $2\frac{1}{2}$  inches wide, cut from a circle having a radius of four inches. Cut a strip of brass, E, a little wider than the board is thick, and bend around the curved side of the board, fastening at both ends with screws. Provide with brass sliders, F F, and mount board high enough above base so that sliders will work freely. G is a V-shaped piece with spindle running through its open end to which is soldered pointer H, made long enough to touch sliders.

Mount A as shown so that it will not touch the base; fasten thread to hole in top, take a turn around spindle and fasten a light weight to other end.

Carry wires from E and G through base to binding posts, J.

As the expansion and contraction of the strips composing A is different, it will cause A to warp and the needle to move accordingly. Now by calibrating E from a standard thermometer the dial may be spaced off and figured to correspond.

By putting this in circuit with a battery and bell, and moving sliders, it will be seen that an alarm will be given whenever the temperature goes above or below a certain point.

Contributed by

R. S. TRUE.

**A TUNING COIL OF FINE ADJUSTMENT.**

Enclosed please find a sketch and description of a tuning coil which can be cheaply constructed, and which is capable of fine adjustment.

Referring to the sketch, A represents a threaded wooden cylinder with about twelve (12) threads to the inch cut on it. B is a metal cylinder (the same size as the wooden one), which I made from a section of an old brass curtain pole with a wooden center. A copper band, C, which is five-eighths of an inch wide, is fastened around one end of the cylinder, A. Number 24

bare copper wire is wound in the thread of A. One end of the wire is soldered to C and the other end is soldered to one end of the metal cylinder, B. The copper brush, D, makes contact with the copper band, C. The other brush, E, makes contact with the metal cylinder. On both ends of each cylinder are fitted dowels which pass through holes in the wooden frame, F; which permits the cylinders to be revolved by the handles, G and H.

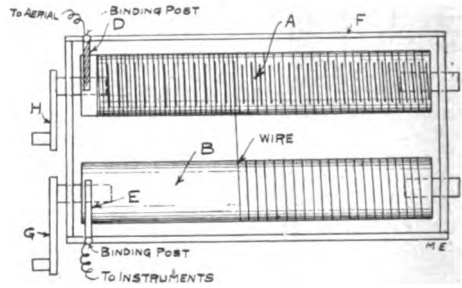

which permits the cylinders to be revolved by the handles, G and H.

The amount of wire in the aerial circuit is regulated by the amount of wire on A and the amount of wire on B is regulated by winding the wire from the one cylinder to the other.

Contributed by

HAROLD HERMANN.

**PLATE GLASS CONDENSER FOR RECEIVER.**

Procure a thin glass plate 20 inches long and fasten securely between suitable standards and with corresponding base board, glass being covered with tinfoil to within one-quarter inch of edge and suitable leads

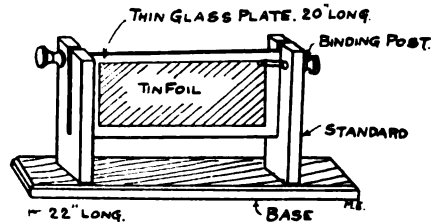

to two binding posts. This condenser has been used to great advantage by maker and can be used in many different hook-ups.

Contributed by

ETHAN CLARKE.

**SIMPLE ATTACHMENT PLUG.**

A plug that is made in the same way as Mr. Hans describes in the *March Modern Electrics*, can be made in a cheaper way by using a fuse plug, and after the wires are soldered in, it is filed up with plaster of paris and allowed to dry well.

Contributed by  
S. LEVENSTEIN.

**AN INTERESTING EXPERIMENT.**

Several days ago just for experimenting I devised an automatic transmitting outfit consisting of a large buzzer, ten dry batteries, helix, and an old clock.

The diagram is self-explanatory. Using the clock to break the circuit, I fastened two No. 28 bare copper wires to the back of the clock at A, A<sub>1</sub> with two small wood screws. Bending the ends around in such a manner that the swinging pendulum

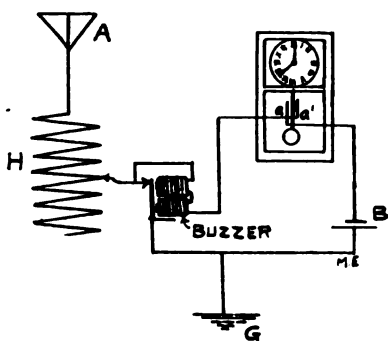

strikes one of the wires and pushes it against the other, thus making the circuit.

For ground connection, I drove a copper wire into the ground about two feet with a stick. For my aerial, I nailed a sixteen-foot pole on top of a sixteen-foot ladder and propped it up against the side of my barn. A four foot spreader was used with porcelain cleats as insulators, and two aluminum aerial wires.

I plainly heard the buzzer up to 500 feet, using a silicon detector and an ordinary telephone receiver; and by using a complete receiving outfit, I think it could be heard much farther.

By making the spring of the buzzer very tight, and screwing up the contact at the vibrator till the armature could just barely move, the tone

was very high pitched and when heard in the telephone receiver resembled the whizzing of a mosquito.

I am sure this experiment will be of interest to many amateur experimenters in wireless signalling.

Contributed by  
JAMES LEROY HODGES.

**HOT WIRE METER.**

For the pivot a double binding post, a battery binding post and nut is needed. Thread the nut extra large so it turns easily, and solder to one side a piece of No. 20 Copper wire as

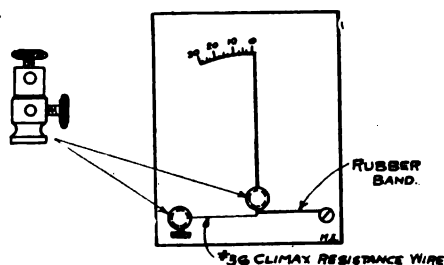

shown; and put the battery binding post through. Remove the thumb screw from the upper section of one double binding post, and in its place put the battery binding post, and secure the pivot and pointer to the base. Place a rubber band as shown, and secure one end to a wood screw so as to vary the tension on the pointer by turning same. Use the lower part of double binding post for lead wires.

Contributed by  
EDWARD HUTCHINSON.

**A GOOD HELIX CLIP.**

To make a good helix clip, take an ordinary, wooden clothes-pin and cover the inside part, as illustrated, with sheet tin, brass or copper. Then attach an insulated wire to metal and

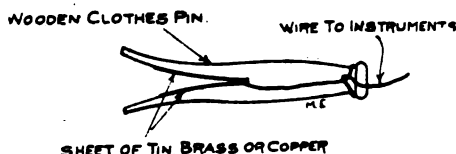

wind this wire around neck of pin once and fasten it there. The end of this wire is fastened to the instrument.

After completion push clothes-pin into heavy wire of helix as you would put pin on clothes line, and you have a good helix clip.

Contributed by

FRANK GREENFIELD.

**WIRELESS HINTS.**

(The following letter was received by us and we wish to call our reader's attention to the importance of proper connection of the detector in regards to direction of the local-battery current, and also of the insulation of the sending apparatus.)

I think many wireless experimenters fail to "get distance" as they have their detectors connected the wrong way. At the beginning of this winter I could not receive over 100 miles, although stations within 100 miles came in very loud; I connected my detector in the opposite direction to that which it had been connected, and that night I heard Tampa, Fla., which is 500 miles away. Since then I have received from over 1,300 miles.

While testing with a hot-wire ammeter, I found that by raising the spark gap on cleats, three times as much current is sent to the aerial.

Contributed by

EUGENE C. GRAVELEY.

**A SIMPLE LOOSE COUPLER FRAME.**

As a great many experimenters wish to build their apparatus as simply, cheaply, and with as few parts as possible, I will endeavor to outline a coupler that is simply a "fool killer."

We will start with the base: Procure a well seasoned cherry board 8 inches wide, 20 inches long, and three-quarter inch thick, and cut a slot one inch wide and 16 inches long in the middle as in Fig. 2 A. File this slot perfectly smooth and get two strips of aluminum or brass, 15 in long, one-half inch wide, and one-eighth inch thick as at B. Drill five holes in each and countersink for No. 6 screws. Fasten these strips, one on each side of base and about two inches from slot, and one-half inch from back end of board. After this is done, make two pieces of wood 8x½x1 inches and

screw them on the bottom of base at each end as at B, B, (Fig. 2 B). These will keep base from splitting or warping.

Make two pieces 7x7 inches and one-half inch thick, as at a Fig. 3; center them, and cut a hole five inches in diameter through each (or the diameter of your primary tube). Glue

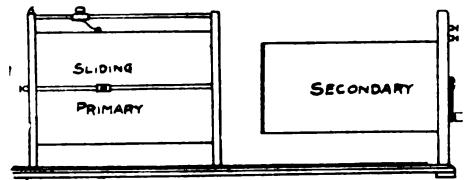

-FIG 1-

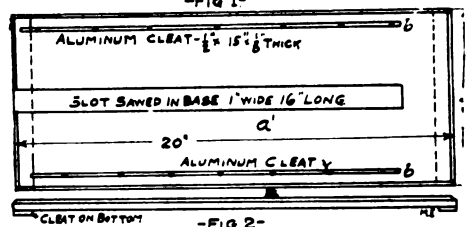

-FIG 2-

one of these boards on each end of tube, and wind on your wire.

After your winding is completed, fasten a cleat on bottom of primary heads, one inch wide, three-quarter inch deep, and eight inches long; this is to slide in groove of base.

For your secondary, make a board 7x7x½ inches, and then cut out a piece

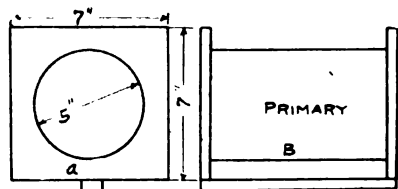

-FIG 3-

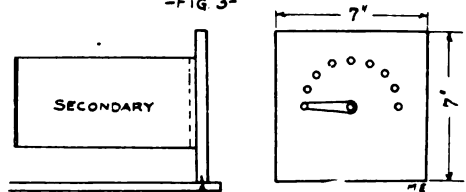

-FIG 4-

four inches in diameter, (or to fit inside secondary tube), and fasten with a screw and some glue in center of head board. Now glue the secondary tube to the head board and make windings, taking off taps so as to use a



switch on head of secondary. Fasten the secondary head with screws one-half inch from end of base, X. The instrument may be finished to taste. I think that Fig. 1 will make all other points clear.

Contributed by

F. W. DOTY.

**A SIMPLE ATTACHMENT PLUG.**

Take an old fuse plug and remove the mica cover. Then out of wood or

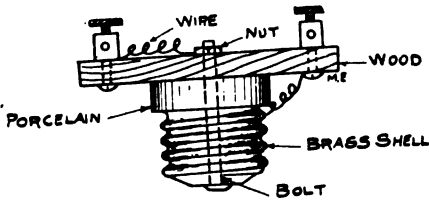

fiber, cut a circle about one-half inch larger than the plug.

Bore three holes in this for the binding posts and bolt. The connections are made as in the diagram, except that the wire that connects the brass with the binding post, goes inside of the porcelain shell.

Contributed by

G. K. BARNES.

**SIMPLE RHEOSTAT.**

I will endeavor to show my fellow-readers how to make a reducer to use on 110 volts A. C. or D. C.

First, procure a burnt-out Tungsten bulb and cut off the top, as shown in

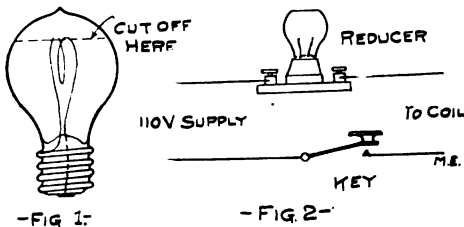

ing with a file and then tapping lightly. Take out all the filament, leaving the two lead-in wires. Fill with clean water about 1½ inches higher than the top of the two wires. Screw into top of the socket, as in Fig. 2, and connect with coil. If there isn't enough current flowing add a little salt to the water. Only a very little is necessary.

Contributed by

W. P. MORRIS.

**A TWO VOLT BATTERY.**

Many experimenters are in need of a good battery for experimenting purposes.

I will try to describe a battery which I think will be useful. This battery works on the plunge principle. When first set up it gives about two volts and a large current; excellent for motors, lamps, etc.

Procure a base of any suitable wood, (see below for all dimensions); then a standard S, and nail the upright one inch from one end of the base.

Now take a sal-ammoniac battery, and soak out all remaining crystals of sal-ammoniac from the carbon cylinder, in hot water.

Now procure what is known as a Fuller zinc, which is a conical shaped zinc cast on a copper rod. Proceed to place the cylinder in the jar, with the copper rod from the zinc extend-

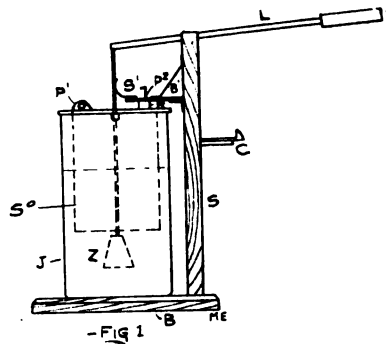

ing up through the porcelain insulator of the battery. Now set the battery on the base about 1½ inches from the standard. Next make a lever L from hardwood, and drill a hole through the end of the lever over the battery; also a hole must be drilled through the copper rod and a pin inserted. This joint must work very loosely. On the outside of the upright fasten a small piece of wood two inches long and on the end of this fasten a piece of metal strip with a notch cut in the upper end; this catch is to hold the lever down and keep the zinc out of the solution when necessary.

Now on the side of the upright and opposite to the top of the battery, fasten a piece of wood about one-quarter inch thick by three inches long. Brace it as shown by a metal strap.

Then bend a piece of spring brass as shown; which must press firmly against the copper rod. From the zinc place a binding post as shown on the brass strip, and it would be a good idea to have two brass strips one on each side of the rod. Beneath the wood strip, on which the spring is fastened, place a hard rubber pillar for an insulator. The battery is now ready for the solution. This is made as follows:

In a porcelain vessel, place 32 ounces of water, and into this dissolve four ounces of potassium bichromate. Pour into this mixture slowly in a fine stream, three ounces of sulphuric acid. Fill the battery with this until within three inches of the top. In use, lower the zinc into the solution, and when through elevate the zinc above the liquid. (Do not forget to amalgamate the zinc.) Following are the measurements, but they may be changed to suit anyone:

Contributed by

ALLEN A. GINN.

### VARIABLE CONDENSER.

The accompanying sketch represents a variable condenser of high capacity, which I recently built, and which gives fine results. I used thirteen glass

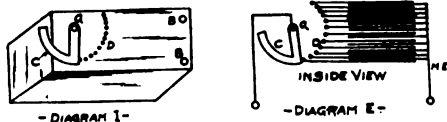

plates six inches by 3 inches, enclosing all in a varnished box, with switch and binding posts on top. The switch was made of an ordinary one except a circular extension of brass. The drawings I believe are self-explanatory.

Contributed by

LELAND A. REINHOLD.

### RECEIVING CONDENSER.

A cheap, yet neat and efficient, receiving condenser, can be made from the following:

Two pieces of wood (preferably hardwood),  $1\frac{3}{4} \times 1\frac{3}{4} \times \frac{1}{2}$  inches (Fig. 2); nickel-plated shaving-stick box,  $1\frac{3}{8}$  inch diameter, (Fig. 3); two screw-bottom binding posts, (Fig. 5);

section of broomstick  $2\frac{1}{2}$  inches long; five sheets of tinfoil,  $1\frac{3}{4} \times 12$  inches between six sheets of waxed paper that are free from flaws,  $2\frac{1}{4} \times 13\frac{1}{2}$  inches.

Cut out the wooden ends, centre them, and after having drilled a hole one-eighth inch diameter clear through and rounded the two upper corners, draw a circle with a diameter of  $1\frac{3}{8}$  inches on the inside of each end, and with a bit or a gauge cut away the wood inside the circle half way through

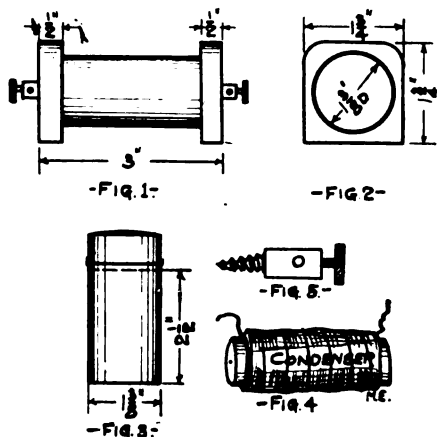

each of the ends; then give them a couple of coats of shellac or varnish (Fig. 2).

Cut the bottom out of the shaving stick box, and make another cut  $2\frac{1}{2}$  inches above, leaving a nickel-plated tube  $2\frac{1}{2}$  inches long; then from a broomstick cut a section  $2\frac{1}{2}$  inches long; center the ends and start a hole with a gimlet.

Heat the waxed papers containing the tinfoil and then wrap around the wooden core, securing with a few wraps of cotton, being sure that a terminal of the condenser is free at each end (Fig. 4). Insert the condenser into the nickel-plated tube, place the terminal that protrudes from each end into the small holes in the ends of the wooden core; then fit the wooden ends on the tube, and through the holes bored through these ends insert the binding posts and screw into the wooden core to hold the wooden ends in place and make contact with the condenser terminals. (Fig. 1).

Contributed by

HOLLY STARTZMAN.

**A GOOD LEARNER'S OUTFIT.**

In *Modern Electrics* for February I noticed an article on "A Novel Practising Set" by Mr. "H. W. D." This is a good outfit, but I think it is too much trouble to moisten the cloth each time; so I used the following plan.

Instead of laying the ends of the wire on a damp cloth I shellacked them

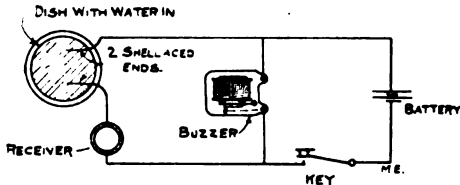

and then placed them about three or four inches apart in a dish of water. If the interrupter of the buzzer is tightened up so the vibrations are faster, the sound will be exactly like that of wireless. The ends must be shellacked or the sound in the receiver will be louder than a wireless message.

Contributed by

"S. G. T."

**ANOTHER "MONEY SAVER."**

I noticed an article in the April, 1911, issue of *Modern Electrics*, called "A Money Saver." It told how to connect a bell with the electric-lighting mains, by using a water rheostat.

Another way of accomplishing the same result without the water rheostat and with a silent call attached, is as follows:

Treat the bell in the same manner as in the previously mentioned article,

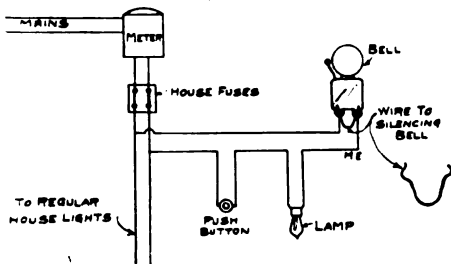

i. e., for alternating current disconnect the wire that runs to the vibrator or interrupter, and connect it straight to the second binding post.

Wire up as per diagram, putting an incandescent lamp in series in the circuit. The light may be placed in the room where you are accustomed to sit,

and of course will light up when the button is pressed.

Now, by bending a wire as per sketch, and snapping it over the binding posts, the bell may be easily cut out so that it will not ring, thus using only the light. This is sometimes very desirable if there are children in the house who are liable to wake up if the bell rings or if some one is sick.

Of course in using this system all wiring should be done as if for lighting.

Contributed by

H. W. BROWN.

**AN EFFICIENT GROUND FOR WIRELESS.**

A good, dead, ground may be obtained by taking a tin can, and, after punching holes in the bottom, so as to let the rain-water run out, pour melted lead over it to prevent it from rust. Then fill the can with small pieces of

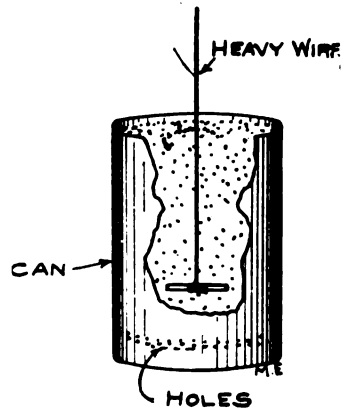

charcoal, leading a very heavy copper wire into the can. Attach the end of the wire to a large piece of carbon in the center of can. After this is finished, bury the can about five feet or more in the ground. It will be better if it is buried in moist earth. This ground will be excellent for wireless work.

The charcoal has the property to attract moisture.

Contributed by

FRANK GREENFIELD.

**UNIVERSAL DETECTOR.**

I have seen many designs of universal detectors, but this one is as efficient a detector as could be wished; as all one has to do to change the mineral is to move the slider either one

way or the other. First, a tin box is made about six inches long, one inch wide and one inch deep, in which to place the minerals. Then in the bottom, pour molten lead one-quarter inch deep and allow to cool. Take the desired crystals and grind one surface flat and smooth on an emery wheel, and grind the edges square. Now place the trough on a hot iron until the lead in the bottom can be worked like putty and place the crystals flat surface uppermost, in the trough, get-

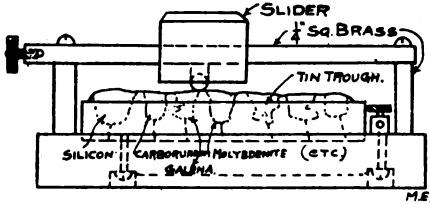

ting the surfaces even; when the lead has cooled and gripped the crystals sufficiently, fill the rest of the box with pure plaster-paris. An "E. I. Co." slider should be used, as the surface of the crystals may be slightly uneven and the finely tempered spring always keeps the ball in touch with the crystals, thereby insuring a good contact with the same. The base can be made of any material and to the owner's liking. It is also a good plan to cut a strip of paper, and glue it to the base with the names of the crystals on it as they come. The rest of the drawing is fairly plain.

Contributed by  
**EDWARD HUTCHINSON.**

**A BREAK KEY.**

This break key is nothing more

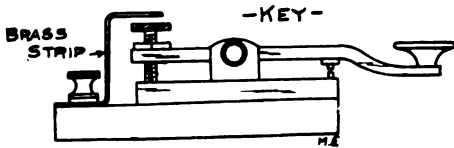

than an ordinary Morse sounder with the bridge inverted and a special con-

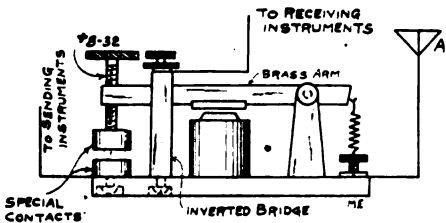

tact added; all of which is shown in diagrams.

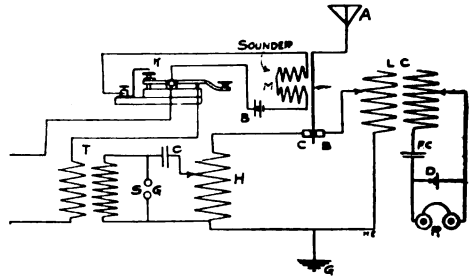

Contributed by  
**DICK CUTHBERT.**

**A FIXED RECEIVING CONDENSER.**

I have just received the March number of *Modern Electrics* and, among other things, I have noticed an article on a fixed receiving condenser. This is a very fine way to make one but I think I have one that works better.

For the covering I use the fuses having the lugs on each end, and also a

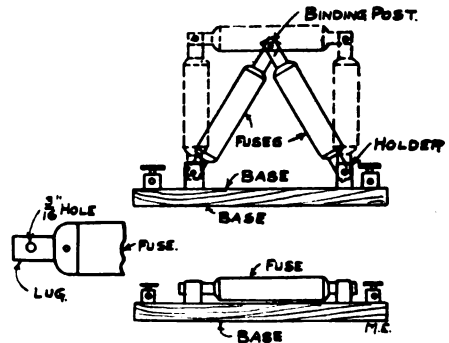

regular fuse holder for same, but if you have an old switch handy, one can be made out of this. In one of them I have tinfoil and paper same size, and two sheets of same as described by you. Then I have one with four sheets of paper and tinfoil; and also one with ten sheets of tinfoil and paper. In the end of each lug, I have drilled a hole large enough to pass a battery binding post screw, and when I need more condenser, as sometimes is the case, the apparatus can be easily connected as shown in sketch enclosed.

(To obtain larger capacity condensers must be connected in parallel.—*Editor.*)

Contributed by  
**PETER J. THEISEN.**

**HOW TO MAKE A WIRELESS FUSE AND SAFETY DETACHMENT.**

A good guard against atmospheric electricity, lightning, etc., is very easily made. Take a base 3x3 inches and four binding posts, A, B, C, and D, and place them, one in each corner. Then get two nails, a, b, and put them in posts A and B; heads in close together to form a spark gap. Then connect B and D together underneath the base. Put a lead wire, cd, between C and D to form a fuse. Connect the aerial with B and D, the ground with A, and the instruments with C. See

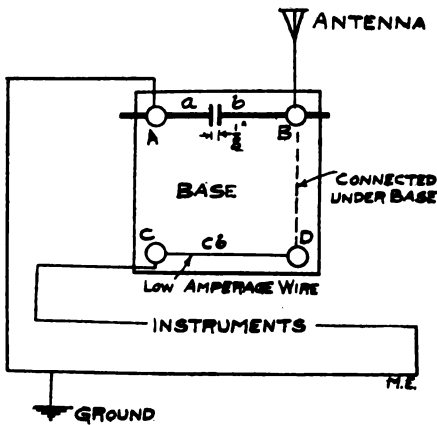

diagram. This is an absolute safeguard against heavy outside currents. When you are using your instruments, the current runs through C, cd, D and B. But when an outside current appears, it fuses cd, jumps across the gap from B to A and goes to the ground. The spark gap may be covered with friction tape to prevent fire, but it is not necessary. This guard we have used on our station with great success.

Contributed by  
C. T. SCHRAGE.

**MOUNTING CRYSTALS.**

When mounting crystals in a brass cup if a solid substance is melted and poured in, the heat sometimes ruins the crystal; when mercury alone is used it is easily spilled, so a better plan is to mix thin tinfoil and mercury until it is plastic; the crystal can be easily pressed into it.

Contributed by  
CHESTER W. SCHERF.

**AN ELECTRIC WATER ALARM.**

The accompanying diagram illustrates a simple electrical device for automatically sounding an alarm when the water in a boiler gets below a certain depth.

The two wires (one running up through the bottom of the gauge, and

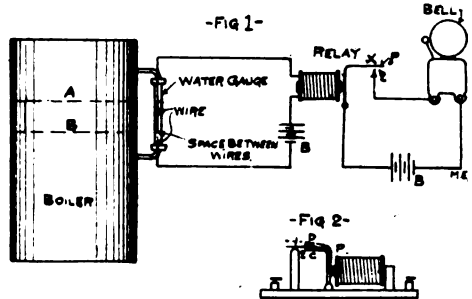

the one running down through the top), come within about one-half inch of each other. When the water fills the gap between the two wires it completes the relay circuit, closes the relay, and breaks the bell circuit. (As may be seen from diagram.)

When the water falls below the fixed depth, the circuit is automatically opened, which opens the relay, completing the bell circuit, sounding the alarm.

Figure 2 shows arrangement of contact points at X. D shows position of armature P, when relay circuit is closed; C shows its position open.

Any details omitted may be obtained from diagram.

Contributed by  
HARRY KING.

**AN ADDITION TO "BICYCLE LIGHT."**

In the April number of this magazine an article on "A Dynamo Bicycle

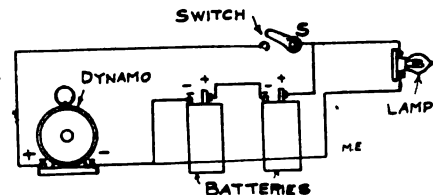

Light" appeared, which was certainly very ingenious, but the apparatus has a slight draw-back. Inasmuch as the bicycle does not run at a constant speed

all of the time the light will flicker considerably. To avoid this difficulty, the following plan may be used.

Two or even one dry cell may be connected in the circuit, as shown in the sketch, the only precaution being that the carbon or positive (+) pole of the battery be connected to the positive (+) wire of the dynamo and a switch, S, be opened when the dynamo is not running. The batteries will last indefinitely if this last precaution is taken. The batteries may be hung in any convenient manner, but one back of the other along the cross bar of the bicycle is a good place.

Contributed by

J. H. STEWART.

### A HOME-MADE ATTACHMENT PLUG.

Being in sudden need of an extension plug, and not having one handy, I devised one which I consider as handy as the manufactured article. It took me but a few minutes to make it, and the materials needed were but an old fuse plug, some solder and a copper wire, and a small piece of sealing wax or battery wax.

I first soldered the terminals of the wires to the points at which the fuse

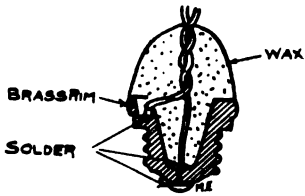

had been fastened and then filled the plug full of the melted wax. The brass rim was slipped over the other end of the wires (or slipped on before the wires are soldered, if necessary) and crimped in its position on the plug. A piece of wax just soft enough to mold, may be pressed under and above the cap in the shape of an ordinary plug, but this is not absolutely necessary. If the plug is not long enough to make connections in the socket, which is often the case, a small piece of solder may be fastened on the tip.

Contributed by

"A. D."

### A DETECTOR SWITCH.

Enclosed find a sketch of a detector switch, which I have made, and which gives very good results. The

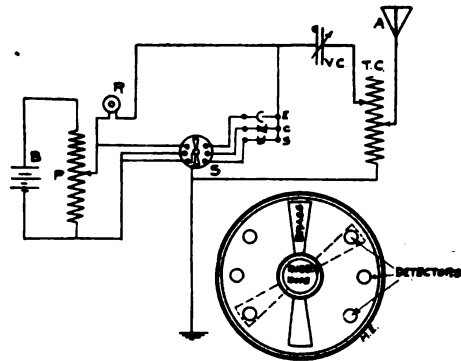

base of this switch is made of wood, two inches in diameter. The arm is made of brass, and a hard rubber nut fastened on it. As the sketch is plain and the switch is simple, I do not think that it needs to be explained. Diagram shows how I have this switch connected.

Contributed by

WALTER TROST.

### AN EFFECTIVE LEAD-IN INSULATOR.

One of the simplest and most effective lead-in insulators may be made by taking for example the lead-in of the high power transmission circuits. Drill a hole in the window pane slightly larger than your lead-in wire with a new steel twist drill. Keep drill and glass where you are drilling,

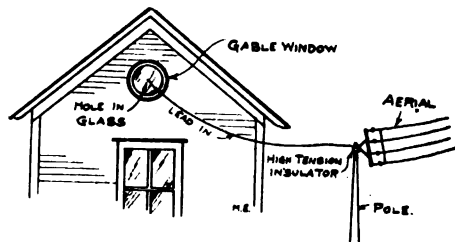

wet with turpentine to make it take hold. Thread the lead-in wire through and tie to a good insulator inside. This makes a very neat entrance through an attic window as seen in the sketch.

Contributed by

M. B. SHICKLEY.

**A GROUND BLOCK FOR WIRELESS.**

The following description is of a ground block which I made to use in connection with my wireless outfit.

Procure a tin box such as "ice wafers" come in, and punch four holes in the bottom. These holes are for the binding posts which may be taken from old dry cells.

Fasten them in with solder if possible, and be sure that all make per-

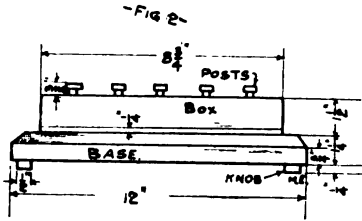

fect contact with the box. Next make a base out of hard wood with a half-inch bevel all the way around it. Now fasten the cover down on the center of the base with three-inch screws. Fit the box into it and solder. If the whole instrument is given a couple of coats of orange shellac it improves the appearance as well as the insulation. The instrument may be mounted on small porcelain knobs, or screwed directly on the wall or table. Connect a wire from a gas or water pipe to one of the end binding posts and connect the instruments to be grounded to the others. This block does away with a lot of "bug hunting" for defective ground connections.

Contributed by

R. S. CRAWFORD.

**AN EXPERIMENTAL WIRELESS TELEPHONE.**

Procure the wooden rims of two bicycle wheels. Wind these with about 2 1/2 pounds of No. 20 B. and S. gauge

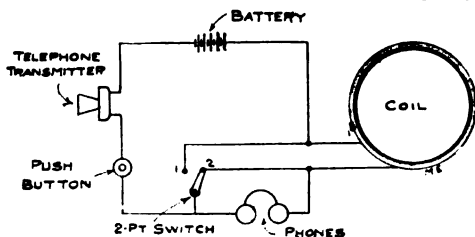

cotton-covered magnet wire. The wire should form at least 50 or 60 complete

turns. Two binding posts may be fastened to the rims, and the ends of the coils connected on these. Put the coil in series with about six good dry cells, a long distance telephone transmitter, and a telephone receiver. A double point switch and push button are connected as in diagram. These short-circuit the receivers when using the transmitter, and when receiving the transmitter circuit is broken. With coils three feet in diameter with about fifty or sixty turns of the above wire should send and receive about 50 or 60 feet. To talk, place switch on point 2 and press the push button. The person receiving must have his switch on point 1. To receive, place switch on point 1. A pair of high resistance 'phones will increase the range, but a 75-ohm 'phone will do.

Contributed by

H. W. H.

**A GOOD VARIABLE CONDENSER.**

First get seven plates of glass 3x5 inches, the thinner the better; then six sheets of tinfoil 2x4 inches. In sticking the glass and tinfoil together, con-

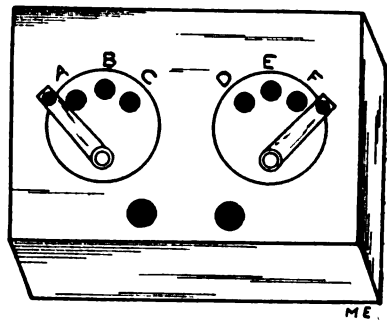

nect to the first sheet of tinfoil, on one side of the condenser, three covered wires about 8 or 9 inches long. To the second sheet on the same side, two wires, and to the third sheet, two wires. Now, on the other side to the fourth sheet, connect three wires; to the fifth sheet two wires, and to the sixth sheet, two wires.

Now put them in a box and paraffine it thoroughly; but in doing so be sure that you know which wires run to each sheet. Now get two three-point switches and screw them on the cover of the box. Now to point (a) connect one of the wires from the first

sheet; to point (b) connect one wire from the first sheet and one from the second; to point (c) connect one wire from the first sheet, one from the second and one from the third.

Now from the fourth sheet on the other side, connect one wire to point (d), to point (e), connect one wire from the fourth sheet and one from the fifth; to point (f) connect one wire from the fourth sheet, one from the fifth and one from the sixth. On the broad end of the cover screw two binding posts, and connect one wire from the lever of each switch to these. Now screw the cover on and connect from the binding posts to your instruments, as you would from any variable condenser. It is now ready for work, and use your switches as it suits you best.

Contributed by

FRANK SAMUELSON, JR.

### HOW TO PREVENT FLICKERING OF LIGHTS.

I think the following article will be of use to a great many amateurs who use an electrolytic interrupter, and find that it makes the lights in their house flicker.

I have been experimenting for some time, trying to find an effective way

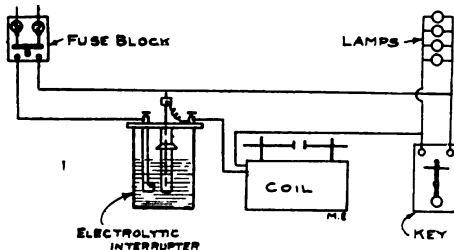

to stop this. I find that a choke coil simply cuts down the spark and sending range.

The accompanying sketch shows a simple, efficient way to prevent it without reducing the spark and sending range. The diagram, I think is self-explanatory. I only wish to say that as many lights as possible should be used in parallel with the key without setting the interrupter into action. The number of lights must be found by experiment, as all interrupters vary materially. Three, four or five 16 c.

p. lamps will in most cases be found sufficient. These lights should all go out as soon as the key is depressed, thus preventing a sudden drop in the voltage.

Contributed by

WALLACE C. HERMAN.

### SIMPLE STARTING BOX.

This instrument is used for starting small D. C. Motors, and, when correctly made, is not only efficient, but

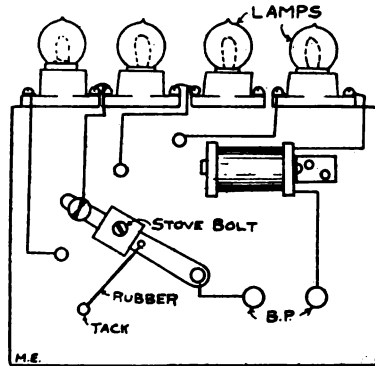

adds to the appearance of the experimenter's laboratory.

The drawing is plain, but a little explanation will not be out of place. The size and number of lamps will vary according to the size of the motor as well as the nature of the current to be used. The base should be of sufficient thickness to allow the lamp sockets plenty of room. With a little study the rest of the design will be plain.

Contributed by

EDWARD HUTCHINSON.

### ADJUSTABLE CONDENSER—FOR SENDING ONLY.

First, select six or eight thin table glasses, free from bubbles and cracks. It is best to wax the tops of each glass to prevent leakage. (See Fig. 1.)

Second, get a metal pan which will hold all of the glasses, and which is of the same height as the glasses.

The pan should be mounted on a base, provided with two binding posts. To one of the binding posts a wire is fastened, which, in turn, is soldered to the pan.

After the pan is fastened to the base, two uprights are provided, which are fastened to the base, about four inches



from the pan. Between the uprights, a metal rod is suspended, from which wires are dropped down into each glass; and which is connected to the other binding post. (See Fig. 2.)

The glasses are now filled with a solution of salt and water.

The capacity of this condenser is varied according to the amount of so-

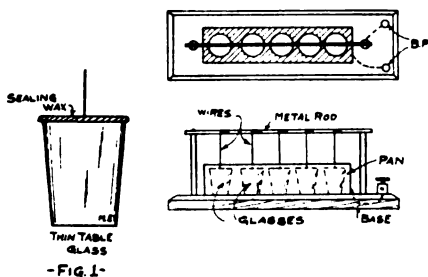

lution in the pan; or if a large capacity is required, the pan is filled with this solution up to the top. If a low capacity is required, the solution in the pan may be but a few inches. Thus the capacity of the condenser is varied according to the amount of solution in the pan.

Contributed by  
**JAY JAKOWSKY.**

### A HINT ON UMBRELLA-AERIAL CONSTRUCTION.

When an amateur lives in a flat he can take advantage of the air-shaft when raising the pole.

First, procure a two by four, a little longer than the width of the air-shaft or court way. Drive a ten-penny nail through the middle. Nail the board across the opening with the spike point upwards.

Drill a one-quarter inch hole in the bottom end of the pole, and then lower it bottom downwards into the opening.

After fastening the insulators, aerial and guy wires to the pole, have a number of boys each take one aerial wire and guide the pole, while another raises it and sets the end down over the nail.

After adjusting the guide wires and insulating the aerial wires, the aerial is finished so far as construction is concerned. All you have to do is to connect the wires.

Contributed by  
**NEILL E. DORRINGTON.**

### AN ACCURATELY ADJUSTED SPARK GAP.

A very neat spark gap can be made with little cost by the following plan: Procure a piece of one-quarter inch wood that measures 4x3½ inches. As shown in Fig. 1, holes are bored in the four corners to hold gap to table. Holes are also bored 1½ inches from each end to take binding posts. One inch from back and two inches from each side a hole is made and one zinc plug is put in place. From this plug two wires run to the two posts already made.

Now comes the most important part: Procure two-wire insulators such as are used to run wires up a building, two porcelain knobs (see Fig. 2), two double connecting binding posts, a strip of stiff brass, a long brass bolt with a lock nut, and the

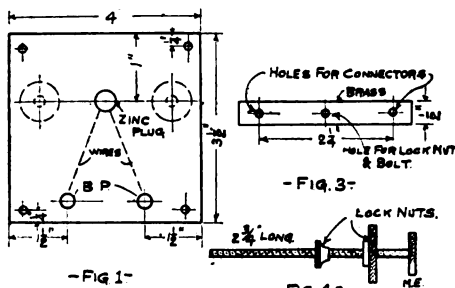

other zinc plug, also two long "cleatscrews." The lock nut and bolt are fastened in the hole in the middle of the strip, and then the zinc is put on. This may be done by boring a hole in the zinc, large enough to hold

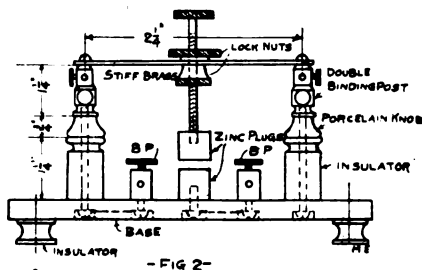

the bolt and then, with an iron punch, mash the zinc around it until it is solid. Or else it may be soldered. Now take the top thumbscrews of the double connectors off, and put them through the holes in the brass and screw them down tight. If they do

not set tightly, put some copper washers on; for they must fit snugly. Now run the long screws up through the wood insulators and into the connectors. If the thickness of wood, and height of insulators is observed, the screws will just be long enough to catch the thread of the connectors. By following the diagrams accurately, the gap will be found to be very easily and accurately adjusted. When the proper adjustment has been obtained, tighten the lock nut and it will remain so until changed. A gap of the above type will not cost more than 60c or 75c, and is well insulated throughout.

Contributed by

M. BRYANT

**MINERAL CLASP FOR DETECTORS.**

The accompanying sketch shows a

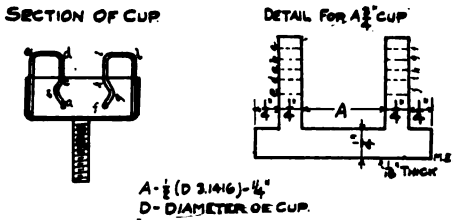

clasp to be used in connection with a wireless detector mineral cup.

Contributed by

HAROLD W. THOMPSON.

**A LOOSE COUPLER.**

First procure a piece of maple four feet long and seven inches wide. Work this until it is 7½ inches wide and three-quarter inch thick. From this piece cut one fourteen inches long. This is to be the base. Plane a three-eighth inch bevel on this piece. Now cut two pieces; one to be 6½ inches square, the other to be a little less than 6½ inches on two edges and 6½ inches on the other two sides. Now have a piece of white pine turned on a lathe until it is five inches long and five inches in diameter. Hollow this out for a distance of four inches and leave a rim one-quarter inch thick around it. Turn out another piece of pine four inches in diameter and five inches long. Glue these pieces to the ends which

are 6½ inches and 6½ by 6 7-16 inches respectively. Now get a steel rod 11¼ inches long and pass it through both cylinders until it reaches the end of the large cylinder. Now bore a one-quarter inch hole in the small piece "a" until it is one-half inch

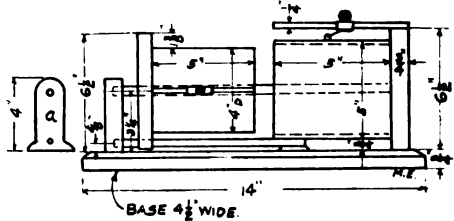

deep and 3¼ inches from the base. Fit the large rod into this. Now take a smaller piece of rod six inches long and bore a hole in the end of the small cylinder, five-eighth inch from the base. Bore another hole in the end "a," one-half inch deep. This rod is to keep the end of the small cylinder from sliding and rubbing the base.

Now screw the piece "a" to the base and assemble the parts. Then screw the end of the large cylinder also to the base. Now insert a small piece of wood under the smaller rod to hold it in place. Wind the large cylinder with No. 22 enameled wire and the small cylinder with No. 28 enameled wire. If a standard E. I. Co.'s slider and rod is used, the secondary slider and rod will clear the primary coil and allow adjustment while the secondary coil is in the primary. Procure two binding posts for both primary and secondary; each one being connected to a slider and the end of the wire which is nearest to the end of the core, respectively on both coils.

This instrument, when given a mahogany stain and polished, not only makes a useful piece of apparatus, but an ornament to any wireless experimenter's table.

Contributed by

WALTER LEAN.

**INSULATING COMPOUND.**

This is a good compound for exterior insulation: mineral pitch, ten parts; silica, six parts; tar, one part.

It is heated, thoroughly mixed, and applied with a brush.

**A HARD ACID-PROOF CEMENT**

Is made of litharge (yellow lead), and glycerine. The glycerine is added to the litharge to make a paste, or it can be mixed and kneaded like putty.

It should be used soon after it is made as it sets very rapidly.

Contributed by  
**RUSSELL BRANDT.**

**A VARIABLE SENDING CONDENSER.**

The base is made of a dry piece of wood about 10x8x1 inches. A piece of tinfoil about 6x6 inches is fastened on in the centre with mucilage, and connected to binding post. A small hole is drilled in each end, and a nut fastened over each one, threaded to take thumb screws as shown in drawing. A thin spring, about 1 1/4 inches long, is fastened at each corner. These serve to raise the glass and upper

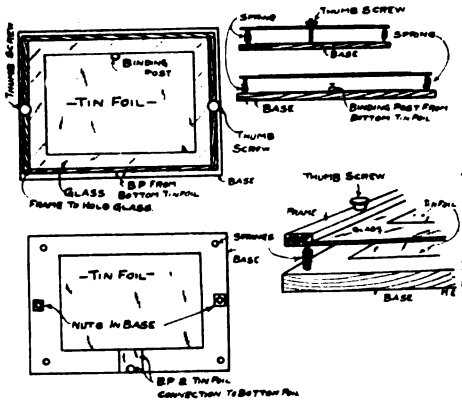

tinfoil when thumb screws are loosened. A frame is made to hold the glass, with room enough at each end to put thumb screws through, which must screw into nuts in base. A piece of tinfoil 6x6 inches is fastened on upper side of glass, and a binding post fastened to it. With this condenser you can get a very fine adjustment, and I have used it with great success.

Contributed by  
**WILLIAM MCGUIRE.**

**A SILICON DETECTOR.**

Silicon is generally a very hard substance to get into adjustment, and once there, is easy to get out of adjustment again. The following will give an idea of my own, how to get

rid of both of these troublesome faults of Silicon. This will make an efficient detector at a very low cost.

For the base, procure a piece of fibre 2 1/2 x 2 x 3/8 inches. Polish it with a file and sand paper and bevel the

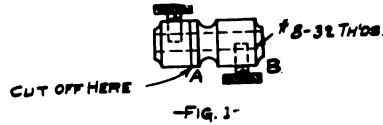

-FIG. 1-

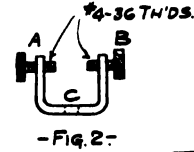

-FIG. 2-

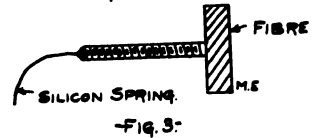

-FIG. 3-

edges, just for appearance's sake. Then drill two holes, 1 1/2 inches apart the long way of the base and in the center of the distance across.

Now get an old double connector (Fig. 1) and cut off about one-third of it at A (Fig. 1). Tap the hole in the center for 8-32 thread. Of course, one of the holes at the end, where the set screw was, (B Fig. 1), should be left.

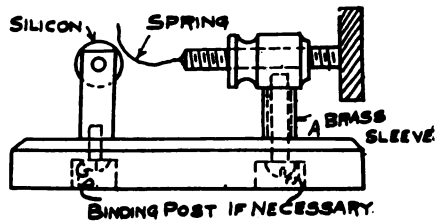

-FIG. 4-

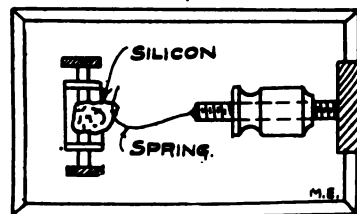

-FIG. 5-

Now take a brass sleeve that fits the 8-32 thread snugly and place it over an 8-32 screw which passes up through one of the holes in the base (A. Fig. 4). This is to hold part shown in Fig. 1, one-half inch off the base.

For the holder for the silicon, take a piece of brass and bend it into shape (Fig. 2) and thread it at A and B (Fig. 2) with 4-36 threads, to hold the silicon. It is held to the base by a screw through the bottom of the holder at C (Fig. 2).

Now get a brass machine screw 1½ inches long and make a suitable handle for the end of it. Then get a piece of silver or brass (silver preferred), and get a jeweller to roll it down to No. 33 and cut a piece 1-16x1½ inches and solder it on the end of the machine screw (Fig. 3). Then bend it as shown.

The silicon can be placed in the holder and this spring set up against the silicon so as to form a medium contact with it and thus get your adjustments. You should try to use a sharp or fairly sharp edge of the silicon to set your spring up against.

I have found that this beats all the kinds of detectors I have tried. This detector ranks even above the perikon or electrolytic, I think. And with it and suitable apparatus I have heard Honolulu, 2,100 miles away, as well as 1,000 miles over land every night.

Other minerals such as ferror, pyron, etc., can be used in it to good advantage.

Contributed by  
CLARENCE BALLARD.

**THE HUMAN BODY AS A DETECTOR.**

A short time ago as I was listening at my wireless instruments, my detector got out of adjustment, and, as I wished to get the whole message, I accidentally hit upon this method of connecting my instruments to the detector. I placed my finger on the silicon and another finger on the other contact. The other hand was placed upon the contact on the tuning coil to which the detector was connected. With this method of connection, I heard the party that was sending to me as clearly as before. Thus, with my aerial, which is very small, being only about 80 feet long and 30 feet at the highest end, I used the human body as a detector.

Contributed by  
I. G. WICHMAN.

**TUNING COIL SLIDER.**

The following is a description and sketch of a slider, that can be made in a short time at the operator's table. Take a rod from a tuning coil, either

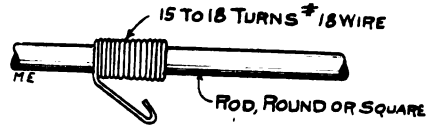

round, or square, and wind on it fifteen to eighteen turns of No. 18 bare copper wire, leaving one and a quarter inches project. Now bend the wire as in the diagram.

This slider works very easily, makes good contact, and touches only one wire at a time.

Contributed by  
BENJAMIN DRAPEAU.

**ELECTRICALLY OPERATED REVERSING SWITCH.**

The following is a method of reversing small motors at a distance by means of a polarized relay.

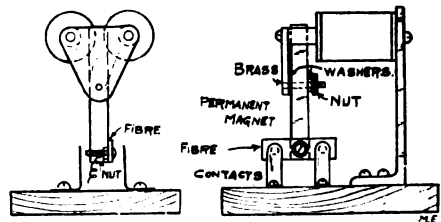

When the switch is reversed, the armature of the relay, which is a permanent magnet, is attracted to the other pole of the electro-magnet; thus

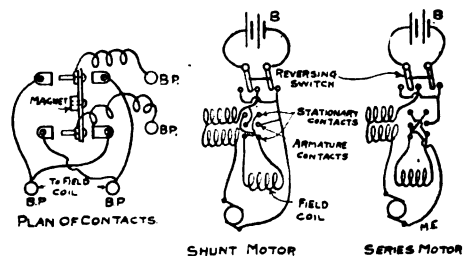

reversing again the current flowing through the field.

No dimensions are given as these would vary with the size of the motor. Contributed by

ERROL B. SHAND.

**HOW TO MAKE A STATIC MACHINE.**

Static electricity is produced by revolving glass plates, upon which a number of sectors are cemented. These sectors passing through neutralizing brushes distribute electrical discharges to collecting combs attached to discharging rods. The glass selected for the plates must be a clear white glass, free from wrinkles, and of a uniform thickness. Two plates are necessary to make this machine, and the glass should be of sufficient size to cut a circular plate (16) sixteen inches in diameter. A hole must be made exactly in the center of the plates, this being preferably done before cutting the circle. One of the best ways to make the hole is to drill it with a hard-tempered drill keeping it moistened with two parts of turpentine and one part of sweet oil. The hole is to be made three-fourths of an inch in diameter. The circle is then marked on each plate and cut with a glass

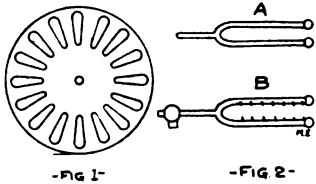

cutter. The plates are trued up after they are mounted by holding a piece of emery wheel on the edge when turning. Water should be applied to edges while doing this work.

The sectors are cut from tinfoil 1½ inches wide at one end, three-quarter inch at the other and four inches long. A thin coat of shellac varnish is applied to both sides of the plates and 16 sectors put on one side of each plate as shown in Fig. 1. The divisions can be marked on the opposite side of the plate and a circle drawn as a guide to place the sectors at proper intervals.

The collectors are made as shown in Fig. 2, from about one-quarter inch copper wire with two brass balls soldered to the ends. The fork part is six inches long and the shank four inches. Holes are drilled on the inside of the forks and pins inserted and soldered. These pins or teeth should be long enough to be very

close to the tinfoil sectors and yet not touch them when the plates are in motion.

The frame of the machine is made from any kind of finished wood with dimensions as shown in Fig 3, the side pieces being 24 inches long and the standards three inches wide. The

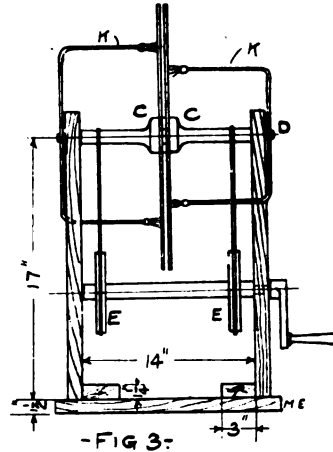

two pieces C C, Fig. 3, are made from solid, close grained wood, turned in the shape shown, with the face that rests against the plate four inches in diameter and the outer 1½ inches in diameter, the smaller end being turned with a groove for a round belt. Before turning the pieces a hole is bored through each piece for the center; and this hole must be of such a size as to take a brass tube that has an internal diameter of three-quarter

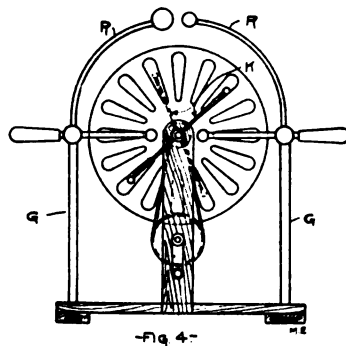

inch. The turned pieces are glued to the glass plates over the center holes and on the same side on which the sectors are fastened. Several hours' time will be required for the glue to set. A fiber washer is then

put between the plates and a brass tube placed through the hole. The plates, turned wood pieces, and brass axle turn on a stationary axle, D.

The drive wheels, E E, are made from seven-eighth inch material, seven inches in diameter; and are fastened on a round axle cut from a broom handle. This wood axle is centrally bored to admit a metal rod tightly, and extends through the standards with a crank attached to one end.

Two solid glass rods G, G, Fig 4, one inch in diameter and 15 inches long are fitted in holes bored into the end pieces of the frame. Two pieces of one inch brass tubing and the discharging rods, R, R, are soldered into two hollow brass balls, 2 or 2½ inches in diameter. The shanks of the collectors are fitted into these brass balls with the ends extending; to which insulated handles are attached. Brass balls are soldered to the upper ends of the discharging rods; one having a two-inch ball and the other one that is three-quarter inch in diameter.

Caps made from brass are fitted tightly from the ends of the stationary shaft, I, and drilled through their diameter to admit heavy copper rods, K, K, which are bent as shown. Tinsel or fine wire such as contained in flexible electric wire are soldered to the ends of these rods, and the brushes thus made must be adjusted so they will just touch the plates. The caps are fitted with screws for adjusting the brushes. These rods and brushes are called neutralizers. A little experimenting will enable one to locate the position of the neutralizers for the best results.

Contributed by

THOS. H. SMITH.

**WATCH-CASE WIRELESS OUT-FIT.**

Some time ago I wanted to make a small portable wireless receiving station which could be carried in the pocket and yet not be too heavy. An idea came to me that I could make a small wireless in a watch-case; so I decided to make same. The case I used was

an old Huntington make. In the side of the case I drilled four 1/64th inch holes as shown in Fig. 1.

I made a small detector as follows: For the base, a small piece of wood, one inch square by one-eighth inch thick was used, as shown in Fig. 2. A small piece of copper about three-quarter inch long by one-sixteenth inch

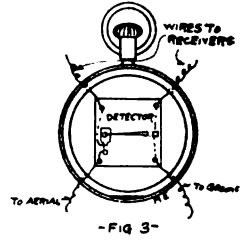
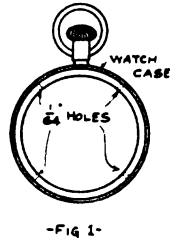

wide was cut as shown, and another piece, one-quarter inch square is cut and shaped into a small cup, as shown above. Let us turn our attention to the base again. Nearly in the middle of one side and about one-quarter inch from the end, drill two one-sixty-fourth inch holes, about one-eighth of an inch apart. Then take the piece of copper, three-quarter inches long by one-eighth of an inch wide, and put the one-eighth inch end in one of these holes, pull it through the other hole and bend it over. One end of this piece of copper should be cut to a point.

At the other side of the base, just opposite the other two holes make two more holes. In these two holes the

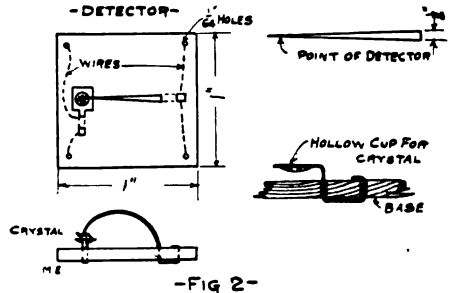

other piece of copper which is cut as shown in Fig. 2 is fastened the same as the first piece. Part of the second piece should be bent over so as to form a cup. Now at each of the four corners make a one-sixty-fourth of an

inch hole, these holes are for the connecting wires to go through. The wiring on the detector is shown in Fig. 3. The ends of these wires should go through the hole in the watch-case. The aerial used was an ordinary umbrella, and with this outfit I have heard Sound-steamers 15 miles away.

Contributed by

WILLIAM DETTMER.

**HOW TO MAKE A SENSITIVE GALVANOMETER.**

Finding the need of a good galvanometer, and one that would be very sensitive, without paying a high price for one, I succeeded in working out the following:

Make a base  $4 \times 4 \times \frac{5}{8}$  inches thick, of mahogany or walnut and bevel the edges as shown in Fig. 1. Make two standards or sides,  $2\frac{1}{4} \times 3\frac{1}{4} \times \frac{1}{2}$  inches.

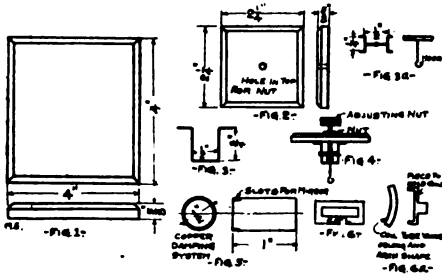

Fasten these to the base, with some good glue,  $2\frac{1}{4}$  inches apart (inside measurements).

Now make a top of the same material as the base, size  $2\frac{3}{4} \times 2\frac{1}{4} \times \frac{5}{8}$  inches, and bevel the top edges of this. Drill a hole in the center, large enough to admit a battery nut, see Fig. 2. Shape a piece of copper or brass as shown in Fig. 3. Make a cross piece to fit this, Fig. 3a. Fasten the support to the under side of the top, Fig. 4. This part of the apparatus works the same as the adjustment of the E. I. Co.'s electrolytic detector. Examine Fig. 4 carefully and all will be clear. Make a thumb screw as described in November, 1910, issue of *Modern Electrics*, page 452. The top may now be put in place with glue, and is shown complete in Fig. 4.

Next we must make a copper cylinder one inch long by one-half inch diameter. Prick or punch two small holes one-quarter of an inch from the

top, and diametrically opposite; also two one-sixteenth of an inch from the bottom. These are for the magnetic needles. Cut two slats in the top one-eighth of an inch deep and (wide enough to receive a small mirror, size  $\frac{3}{4} \times \frac{1}{2}$  inch), diametrically opposite.

Magnetize two needles or small bits of steel about one to three-quarters of an inch long. Place one of these in the top holes of the copper cylinder with its north pole to the left. Now place the other needle in the bottom holes, with the north pole to the right. This is to prevent the earth's magnetic field from affecting the readings, and is called the astatic system. The needles may now be fastened with a drop of glue or shellac. Now cut a mirror,  $\frac{3}{4} \times \frac{1}{2}$  inches, and fasten in the slots (on the top of the cylinder), with glue. Fasten a small silk thread to the center of the mirror with a drop of glue, and the other end of the thread must be fastened to the small hook on the plunger, Fig. 7. The spring on the bottom of Fig. 7 is made of No. 40 copper wire which has been annealed, one end being fastened to the copper cylinder and the other end to the base with a small tack.

Now make two coils, each two inches long by one inch wide by three-quarters of an inch thick. Wind them in the form of an arc as described by Fig. 6. They should be wound on pasteboard forms, and wound with fifty feet each of No. 36 wire. The resistance will then be approximately 100 ohms. They should be fastened to the sides of the box, with two pieces of wood as shown in 6a, and connected in series. The

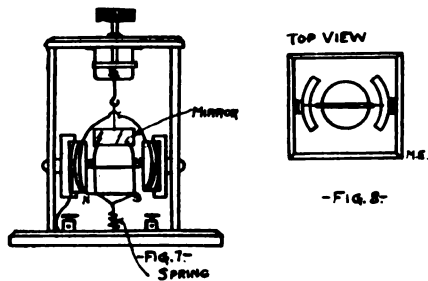

other ends are brought on the outside, to binding posts; see Fig. 7.

Now make a back and front from a piece of plain glass and fasten the front so that it will be removable. Fasten

a dial on two pieces of wire so that it will be adjustable and finish instrument with several coats of shellac.

Fig. 7 shows a side view of the instrument, and Fig. 8 shows a view from the top.

Contributed by  
FRANK L. BUNKER.

### HOW TO MAKE A GALVANOSCOPE.

A galvanoscope for detecting small currents of electricity can be made from a coil of wire, A; a glass tube, B, full of water; a core, C; and a base, D; with binding posts as shown. The core, C, which is made of iron and cork is a trifle lighter than the water it displaces, and will therefore remain in the tube normally; but as soon as a current of electricity passes through the coil, the core is drawn down out of sight. The current required is very small as the core is so nearly balanced that the least attraction will cause it to sink. The glass tube may be a test-tube as shown in Fig. 2, or any empty

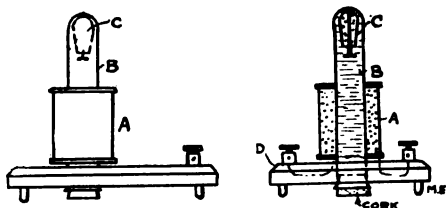

developer tube. If one has neither a test-tube nor a developer tube, an empty pill bottle may be used. The washers at the end of the tube may be fiber, hard rubber, or wood. The base is made of wood, or any other insulating material, and should have four legs on bottom. Make the coil of about No. 18 wire, and connect ends to binding posts as shown at Fig. 2. The core is made by pushing a small nail through a piece of cork. It should be made so as to rise slowly when placed under water. Some filing may be necessary to get the weight just right, but it should be remembered that the buoyancy of the core can be adjusted after the parts are assembled by pressing the cork in the bottom of the test-tube. This causes compression in the water space and especially of the upper cork, reducing its displacement and causing

it to sink. The lower cork is then slowly withdrawn, by twisting until the core slowly rises. The instrument is then ready for use.

Connect the binding posts to a single cell of battery—any kind will do, as a slight current will answer. On completing the circuit the core will descend; or put in a switch or push button on one of the battery wires. If the button be concealed where the operator can reach it, the core will obey his command to rise or fall, according to his control of the current. This is a mysterious-looking instrument, the core being moved without visible connection to any other part. If this instrument is connected up as per directions, one will have a very nice looking galvanoscope.

Contributed by  
LYLE BRITT.

### A SMALL VARIABLE CONDENSER.

Procure a chemist's test-tube six by seven-eighths of an inch in diameter. Coat the outside with shellac, and when nearly dry apply one turn of tinfoil. This forms one surface.

For the other surface take a wooden rod a trifle smaller than the inside of the test tube and about seven inches long. Cut a knob on one end to facilitate the sliding. Build this rod up with tinfoil until it barely slides into the test-tube.

For the clip use a piece of aluminum one-half inch wide and three and a half inches long. This will serve to hold the test-tube to the base, which is  $8 \times 2 \times \frac{1}{2}$  inches, and also to make connection to the tinfoil.

By referring to the diagram you can see how the other surface is connected

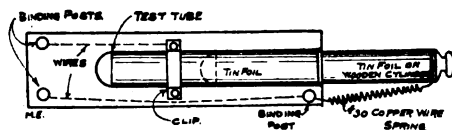

to the wires. The wire is scraped bare for eight inches and then wrapped around the tinfoil.

This makes a very efficient condenser and has a capacity of about .001 M. F.

Contributed by  
N. E. DORRINGTON.



**MULTIPLE DETECTOR STAND.**

While looking over June, 1910, issue of *Modern Electrics* I saw a detector designed by E. E. Ely.

I started to make one, but changed it so I could use it for more than one

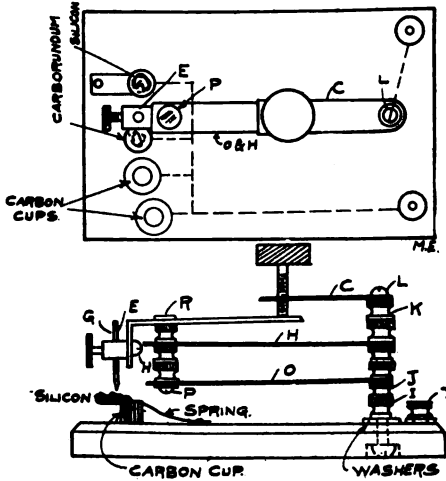

stand, by putting two carbon cups on two brass springs, an equal distance from the center bolt L (as in diagram). By this means you can bring either silicon, carborundum, tantalum or electrolytic into use without the aid of a detector switch.

This saves making a switch and more than one stand.

**REVERSING SWITCH.**

A battery motor can be made reversible

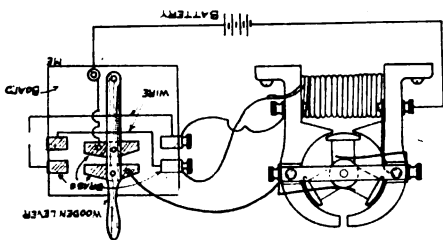

by following diagram closely.

Contributed by  
**ERVIN EPPLEY.**

**FREQUENCY INCREASER.**

Amateurs are often troubled with the frequency at the spark gap, especially those using A. C. transformers. I have found that by placing a glass or porcelain tube over the gap, the frequency is much higher and the sound at the receiving end has a higher pitch,

and is clearer. The tube should be about one inch longer than the gap and one-quarter inch larger in diameter. If glass is used red is preferable because the blue spark affects one's eyes.

Contributed by  
"M. A."

**HOOK-UP.**

The following is a hook-up, which I have never seen published. It is used

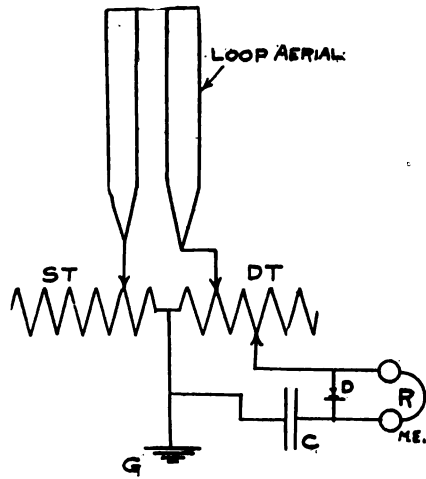

by nearly all boats and many land stations on the Pacific Coast.

Contributed by  
"M. A."

**MUSICAL SPARK GAP.**

Enclosed you will find a new diagram using a rotary spark gap. Two

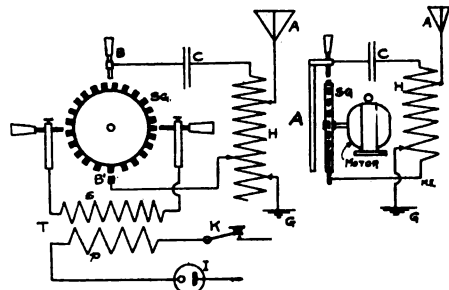

extra electrodes are used, as shown in B, B<sub>1</sub>. In A it is shown how these are supported. Heads from 8-penny nails can be used on the spark gap.

Contributed by  
**CLARENCE C. HESS.**

## Wireless Across the U. S.

By E. A. Mayne, Chief Operator, Poulsen Wireless Co.

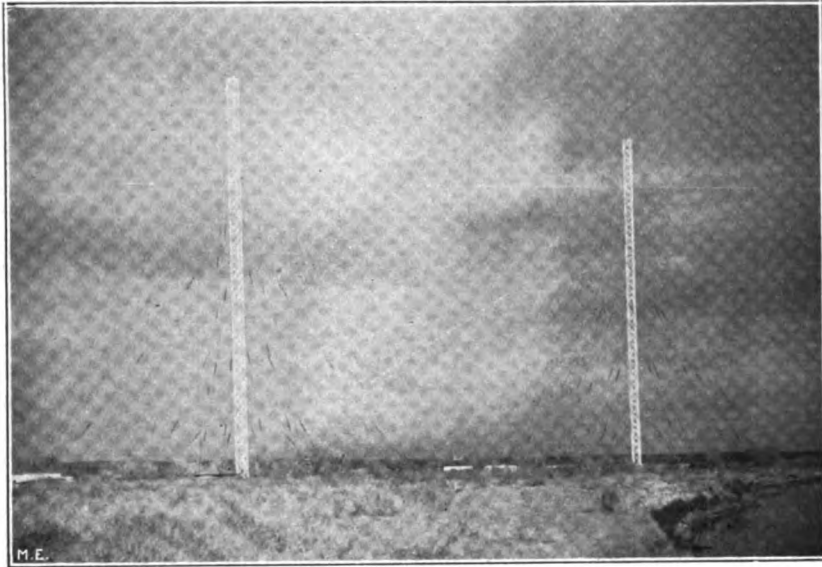

Poulsen Radiophone Station, El Paso, Tex.

**A**LTHOUGH wireless telegraphy on the undamped wave principle has been possible for several years, and communication by the employment of sustained oscillations was successfully demonstrated on the Poulsen system as far back as 1906 between Lyngby, Denmark, and Cullercoats, England, it has been only during the last few months that any determined efforts have been made to utilize the very evident advantages of the undamped wave for commercial purposes.

The Poulsen Wireless Telegraph and Telephone Company, with a capital of \$25,000,000, has been recently organized by a group of San Francisco millionaires under the laws of the State of Arizona, for the purpose of entering the commercial telegraph field in the United States. It is planned to establish a service from coast to coast, linking up all the principal cities of the country, and in view of the exorbitant rates charged by the wire telegraph monopoly the promoters are very sanguine of success.

At this writing the Poulsen Company have in regular operation stations at San Francisco and Los Angeles, Cal., and El Paso, Texas, and others are in course of erection at Honolulu,

T. H., and Fort Worth, Texas. The El Paso station has only within the last few days been completed and the results obtained have been most satisfactory to all concerned—communication being immediately established during broad daylight with San Francisco. This communication, covering as it does a distance of some 1,250 miles, some 800 of which are over desert, constitutes, it is believed, a world's record for daylight transmission under similar conditions and has been quite impossible of accomplishment under spark systems. The successful operation of the Poulsen system between these difficult points, from a wireless engineering point of view, across territory consisting mostly of dry, sandy desert as in Lower California and Arizona, speaks well for the success of the trans-continental service, and should also demonstrate the possibility of bridging vast spaces in other regions of the earth where communication has hitherto been considered impossible.

The power used at San Francisco and El Paso is 12 and 16 k.w. respectively, although further experimenting will undoubtedly lead to a considerable reduction in the energy required. At

both plants the antennae are supported by two 300 foot towers located 370 feet apart and consist of two sets of fans each of 22 wires suspended from a steel cable and guyed laterally. This double fan type of aerial has been found the most suitable by the Poulsen experts. The ground connections are in the form of radiating copper wires buried 4 feet in the sand and extending on one side of the lot into the Rio Grande River and on the other into an irrigation canal. The accompanying photo gives a very good idea of the El Paso station.

It will be observed that the towers are built in sections, each of six feet. The entire construction is of Oregon pine and is bolted to a foundation framework of 12 inch California red-wood embedded in the sand. The whole of the lumber arrived on the ground ready for erection, and both towers were erected by R. A. Beebee, construction engineer of the company, in seven weeks, at a labor cost of 87 cents per foot. Each tower is supported by five sets of guys consisting of three-inch steel cables, broken up by circuit breakers of hardwood on 10 feet in the lower and six feet in the upper guys. The towers are calculated to withstand a wind pressure of 100 miles per hour.

**UNIQUE AERIAL SWITCHES FOR HIGH POWERED SETS.**

(Continued from Page 69.)

The wooden back will be found quite efficient for holding the aerial voltage if it is well seasoned and treated with a varnish containing no chemicals.

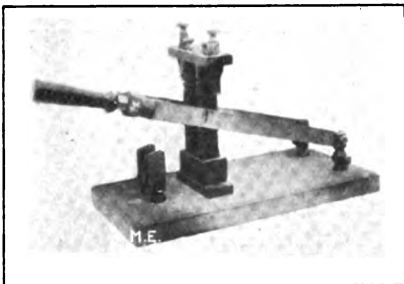

Fig. 2

This switch has been used satisfactorily on a 1 kw. 20,000 volt outfit.

The switch illustrated in Fig. 2 possesses practically the same operating

(Continued on Page 118.)

**Book Review.**

**E**LECTRIC Wiring: Fittings, Switches, and Lamp Circuits." By W. Perrin Maycock, M. I. E. E. The Macmillan Company, 66 Fifth avenue, New York City, 1911. Cloth; 628 pages. Price \$2.00.

A well written book, covering all phases of the subject in a clear, interesting way. It is worded in such a way that any one can easily understand it.

A complete list of good illustrations is added, explaining all the different connections, appliances, etc.

Full directions for wiring the simplest bell circuits up to the most complex diagrams are given.

The Wireless Operators' Pocketbook of Information and Diagrams. Leon W. Bishop. Bubier Publishing Company, Lynn, Mass.; 175 pages. Price \$1.50.

A very good reference book for the wireless operator, as a short discussion is given on all the different conditions of the art. Besides the regular text, an appendix is added containing many useful formulæ, tables and diagrams of wireless hook-ups.

Electric Wiring Diagrams. W. P. Maycock, M. I. E. E., Macmillan Company, 66 Fifth avenue, New York; 146 pages. Price \$.90.

A book which deals with all methods of wiring electrical instruments met with in ordinary practice.

The illustrations are very numerous and given in a clear manner, making the text easily understood. A new idea is also brought forth in distinguishing the positive wire from the negative wire, making the diagrams still more easily understood.

While there are many books on this subject on the market today, this book deals with it in a way completely its own.

**SPECIAL.**

**COMPLETE** unbound Volume No. 3, 12 numbers, will be sent to you at once on receipt of 75c money order, draft or express orders.

A chance that will never come again.

For \$2.00 we will send you one bound volume No. 2 and one unbound volume No. 3. Order today.

# Flying Sparks

## A FULFILLED DREAM.

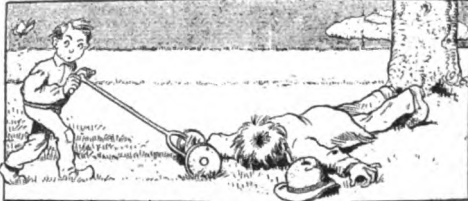

How Hooligan dreamed of a haircut—and how he got it.—Péle Mêle.

## INTERFERENCE PREVENTER.

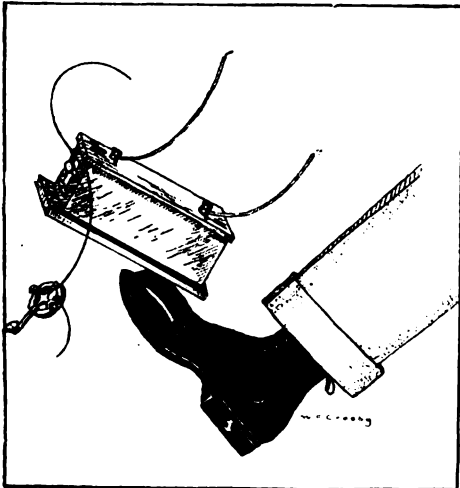

(Patent applied for.) By W. C. Crosby.

## WHO WILL KICK NEXT.



"This wireless business ought to be stopped. Just try and take a rest on these ether waves!"—Péle Mêle.

## THE DUCK, THE CAT AND THE DOG.

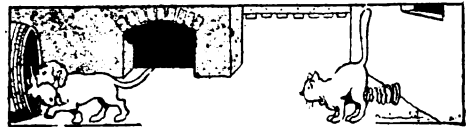
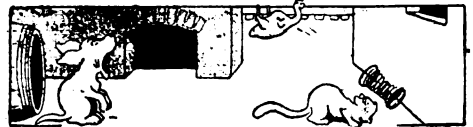
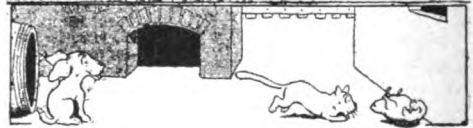
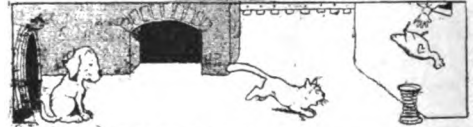

A SPRING story without words.—Péle Mêle.

## A SPARK GAP.



By W. C. Crosby.

# Wireless Telegraph Contest

Our Wireless Station and our Laboratory Contest will be continued every month until further notice. The best photograph for each contest is awarded a monthly prize of Three (3) Dollars. If you have a good, clear photograph send it at once; you are doing yourself an injustice if you don't. If you have a wireless station or laboratory (no matter how small) have a photograph taken of it by all means. Photographs not used will be returned in 30 days.

**PLEASE NOTE THAT THE DESCRIPTION OF THE STATION MUST NOT BE LONGER THAN 250 WORDS, AND THAT IT IS ESSENTIAL THAT ONLY ONE SIDE OF THE SHEET IS WRITTEN UPON. SHEET MUST BE TYPEWRITTEN OR WRITTEN BY PEN. DO NOT USE PENCIL. NO DESCRIPTION WILL BE ENTERED IN THE CONTEST UNLESS THESE RULES ARE CLOSELY ADHERED TO.**

It is also advisable to send two prints of the photograph (one toned dark and one light) so we can have the choice of the one best suited for reproduction.

This competition is open freely to all who may desire to compete, without charge or consideration of any kind. Prospective contestants need not be subscribers for (the publication) in order to be entitled to compete for the prizes offered.

## FIRST PRIZE THREE DOLLARS.

**E**NCLOSED please find photograph of my wireless telegraph station.

For sending, I have a five-inch Rhumkorff coil, electrolytic interrupter, helix, condenser, "Electro" zinc

sixty feet high at the house end.

My station is located in my room. Half of the instruments I have made myself following the instructions as given in your journal from time to time. My call is NE.

WILLIAM SHELLABARGER.  
Illinois.

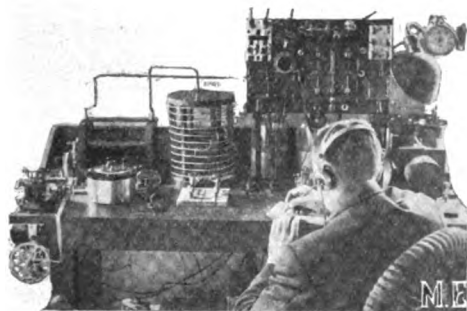

spark gap and megograph key. Coil runs off of one hundred and ten volts A. C.

For receiving, I have a two-thousand meter loose coupler, variable condenser, fixed condenser, electrolytic detector, two Ferron detectors, variometer, potentiometer, and "Electro" one thousand ohm receiver.

For the aerial system, I use a triple pole, double throw switch, two half-inch hard rubber tubes, each a foot long for my lead-in, aerial ground switch in a box outside of my window, which also contains a test buzzer. The aerial proper is one hundred feet long, seventy feet high at the far end and

## HONORABLE MENTION.

Enclosed you will find photo of my wireless station.

I will give a very brief description of it: Sending, E. I. Co.'s 2 inch glass plate condenser, spark gap, etc. Receiving: Single slide tuner, two detectors (silicon and electrolytic), fixed condenser, potentiometer, etc.

I will go a little out of the ordinary and tell of what we hear when listen-

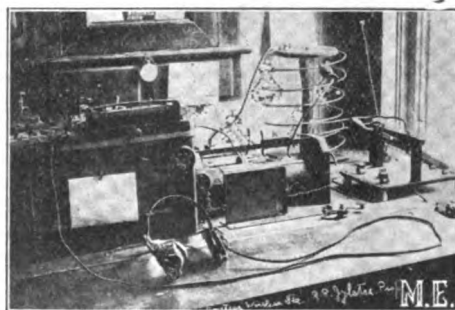

ing on here. I live on Whidby Island in the middle of Puget Sound, and, after the day's work is done, I put on my receiver and copy "mags" till bed-

time. I can hear all the steamers that pass in here from the Orient and many stations both Canadian and American within a radius of 100 miles; although at times, when there is not much interference, I can hear greater distances. I have heard both stations at San Francisco, U. W. Co.'s, and Mare Island Navy. Have also heard Cordova, Alaska. These stations are about 800 miles away.

I have been at it only two years, and have made most of my instruments in spare time; usually after supper, at night.

To those who believe in doing away with us amateur "wireless boys" will say: That if they knew how much we loved this form of "recreation" they would not think of disturbing us.

I can receive in Con. Code and can send in both M. & C. I get most of my receiving practice in the C. code as they use that mostly here in the West.

RICHARD R. ZYLSTRA.  
Washington.

#### HONORABLE MENTION.

Enclosed find a photograph of my wireless station. For receiving I use the jigger set, with which I can do very close tuning. It consists of a double slide tuning coil, ferron, perikon, and electrolytic detectors, which can be thrown in by means of a three-point switch. Potentiometer, two variable condensers, one rotary and one slide



type, two jiggers, and 2,000 ohm receivers. These are mounted on an oak box.

My sending consists of a two-inch coil, helix, oil immersed condensers, spark gap, and a six-volt storage battery. With this sending, I can trans-

mit within a radius of fifteen miles at all times.

Most of this set was made by myself with the help of "Modern Electrics," which I highly recommend to all amateurs. The wood-work is finished in highly polished oak, and the metal part in nickel plate. With this set I am able to pick up Cape Hatteras, Cape Cod, Brant Rock, Wilmington, and many other nearer stations.

JOHN F. McMAHON, JR.  
Conn.

#### HONORABLE MENTION.

Please find enclosed flashlight photo of my wireless station, which I have

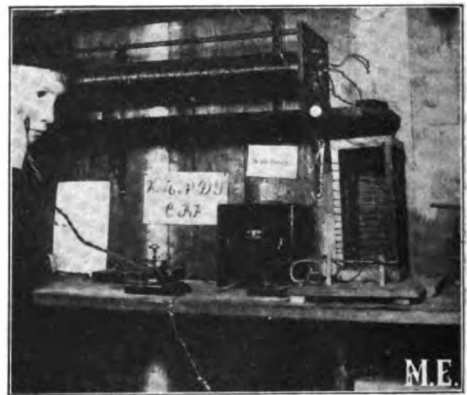

constructed myself. It consists of the following apparatus:

At the left of picture is my tuning coil, beneath which is a fixed condenser and silicon detector. Besides the detector is a medical induction coil, with which I am able to send one-quarter mile, using the key, spark gap and helix shown at right.

By short circuiting two of the binding posts on end of tuning coil, I am able to throw a loading coil, which is inside of large one, into the circuit. I use a 100 ohm 'phone, 40-foot 4 wire aerial, and a ground consisting of a strip of chicken wire and a copper plate buried in permanently moist ground. When not in use, the set is grounded by means of a knife switch fastened outside the door of the station.

Since this photo was taken I have added a larger helix, fixed sending condenser and a carborundum detector. I get Brant Rock, Wellsfleet, Boston

Navy Yard, and several amateurs with this outfit. Wishing success to *Modern Electrics*, I am respectfully yours,

RUSSELL COLLEY.

**HONORABLE MENTION.**

Enclosed please find flash-light of my set.

From left to right is an oscillation transformer, made of No. 8 copper wire, 8 turns outside and 30 turns inside. On top of it is high-tension variable condenser, made from a large tipless lamp globe, and water.

Next is step-up transformer, it has a closed core, made from stampings taken out of an old commercial transformer, primary has five taps, ranging from one-quarter to one kw., one end of secondary is grounded on core and



has two layers of empire-cloth between each layer.

Next is a spark gap with muffler, upper terminal of gap is a brass plug, and lower one is composed of a cup about two inches in diameter half filled with mercury, spark jumps from plug to surface of mercury; this I find gives a much better spark, and increases my range; it is placed on a piece of plank covered with cotton, with a one and two-gallon jar telescoped over it. On top is small tuner with glass jar core.

Next is a detector made from strip brass and mop-stick, the point rests on

silicon with molybdenite on top of it, —this gives sensitive lasting adjustment.

Last is large tuner with tile core and over 600 turns of No. 22 enameled wire on it. I use two S. & C. telephone receivers wound over with single silk covered copper wire one and one-half mil. in diameter, resistance is about 4,000 ohms per pair. Would be pleased to hear from any other amateurs in range.

ROSS B. AVERY.

South Bend, Ind.

**HONORABLE MENTION.**

Enclosed find a photo of my wireless receiving set, consisting of three mineral detectors, namely: Carborundum,

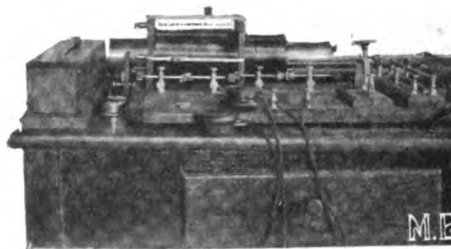

perikon and silicon. I can throw any of above detectors by means of a three point switch. I also have, as seen in the picture two variable condensers; one a plate one enclosed in box in left of photo, and another consisting of two brass tubes each 10 inches long. On the right, as you see, I have a potentiometer and a fixed condenser. In the center is my loose coupler wound with 28 and 22 enameled. My receivers are 1,000-ohm apiece. I have constructed most of these instruments myself, and have had good results.

WALTER TRÖST.

Chicago, Ill.

**HONORABLE MENTION.**

Please find enclosed a photograph of my wireless set.

Sending consists of small auto coil, telegraph key, M. E. S. Co. helix, small Leyden jar condenser and an 8-volt 80-ampere storage battery under table.

Receiving consists of home-made loose coupler, E. I. Co. variable con-

denser (not shown in picture), fixed condenser, pair of 1,000-ohm Murdock 'phones and silicon detector. Also E.

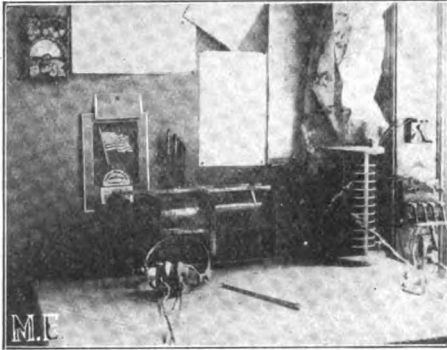

I. Co. mineral detector stand (not shown). I have tried many different kinds of detectors but class silicon above all others.

With the above outfit, and an aerial composed of 6 wires 60 feet long and 60 feet high, I have received about 300 miles and can send about two miles.

LOUIS I. PHILLIS.

Chicago, Ill.

#### HONORABLE MENTION.

Enclosed please find photo of my wireless station. The receiving consists of a loose coupler, 3-slide tuning coil, fixed condenser in back of coil;

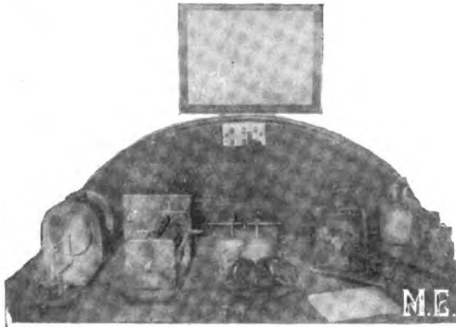

silicon detector, 2,000 ohm receivers. The sending set consists of one-inch spark coil, one-half pint Leyden jar, one key and 6 dry cells. My aerial is 30 feet long and in the attic.

CLARENCE THREEDY.

Chicago, Ill.

#### HONORABLE MENTION.

Enclosed please find a picture of my wireless.

Beginning at the right of the picture: Wireless key, E. I. Co. interrupter, E. I. Co. one-half kw. transformer, E. I. Co. spark gap, home-made glass plate condenser, E. I. Co. pancake helix, home-made tubular variable condenser, set of E. I. Co.'s "Saved the Republic" 'phones, E. I. Co. tuning coil, E. I. Co. graphite-rod potentiometer, E. I. Co. fixed condenser, E. I. Co. electrolytic detector, and universal detector. Since the photograph was taken I completed another glass plate condenser

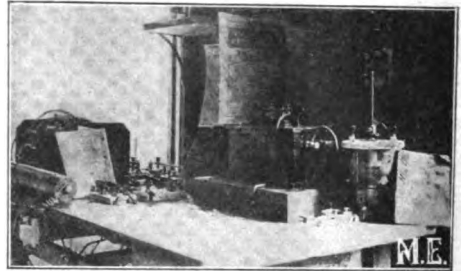

and I get a very powerful spark. For receiving, I find green carborundum to be very sensitive and easily adjusted.

HOWARD L. AUERBACH.

New York City.

#### WIRELESS ACROSS THE UNITED STATES.

(Continued from Page 113.)

principles as the one described above, but it has the advantage of being more rapid in action, with a throw of less than 30 degrees. Moreover, it may be used with a loop aerial having a double lead-in and is much more professional in appearance.

The upper contacts are secured to a fibre strip surmounting two corrugated rubber pillars. The corrugations effectively withstand surface leakage which is a serious drawback to rubber in high voltage insulation.

This switch is now in daily use in an experimental station with a  $1\frac{1}{2}$  kw. transformer developing about 30,000 volts on the high side.

#### OUR SCIENTIFIC PRESS.

(Continued from Page 87.)

Whichever set of electromagnets is energised attracts the ball when the roulette comes to rest, and by this simple method it is in the power of the operator to let the ball go to red or black as he may wish.



# Wireless Association of America

## WIRELESS REGISTRY

This department has been started with the idea to bring the wireless amateur in closer touch with commercial land and ship stations. From time to time a list of new members will be printed here and once each year an official BLUE BOOK will be issued by MODERN ELECTRICS giving a list of all the members who registered during the year. Each member will receive the Official Blue Book free of charge. The Blue Book will also contain a complete list of commercial and government stations, their call letters, wave length, etc.

To register a station requires: Total length of aerial (from top to spark gap), spark length, call letter, (if none is in existence M. E. will appoint one) name and address of owner.

Fee for Registry (including one Blue Book) 25 Cents.

NAME AND ADDRESS OF OWNER	CALL LETTER	APPROXIMATE WAVE LENGTH IN METERS	SPARK LENGTH OF INDUCTION COIL
M. D. Losey, Prin., Ravena High School, Ravena, N. Y.	R.L.S.	73	2 ins.
Stanley Patten, 172 W. 90th st., New York	S.P.M.	100	¼ "
Frank O'Rourke, 729 Amsterdam ave., New York	F.O.M.	55	¼ "
*R. J. LeBoeuf, Jr., 531 Western ave., Albany, N. Y.	R.L.B.	66	..
M. J. Quisenberry, Box 12, Conway, Ky.	M.F.M.	61	1½ "
Harry Baumer, 5036 Kenmore ave., Chicago, Ill.	H.B.M.	42	½ "
Lee Pumell, 3130 California st., S. Berkeley, Cal.	L.L.O.	375	2½ "
Ray E. Sage, 1011½ E. Terrace st., Seattle, Wash.	R.E.S.	2000	3 KW.
Arthur D'Romtra, Cape May Point, N. J.	A.D.R.	90	½ "
Wm. Osborn, 255 California st., San Francisco, Cal.	O.H.M.	100	¼ "
Wilmans Ballough, Daytona, Fla.	W.B.M.	51	½ ins.
Walter Paul, North River st., Hackensack, N. J.	W.P.M.	200	½ KW.
*J. S. Gerard, L. Box 332, Lodi, Cal.	W.D.M.	130	..
Edward Werner, 2313 9th st., W. Berkeley, Cal.	A.T.Z.	55	½ KW.
*Gerald F. Duryee, 900 Boulevarde, Bayonne, N. J.	G.D.M.	150	..
*L. W. Warner, Ashland, Wis.	L.W.M.	122	..
James King Hoyt, Jr., Sound Beach, Conn.	S.B.M.	4	¼ KW.
Daniel W. Smith, South st., Oyster Bay, N. Y.	L.D.M.	1500	¼-½ "
Chas. Balmer, 4615 N. Front st., Philadelphia, Pa.	B.A.M.	60	1 "
F. Crowther, 25 Linden st., Yonkers, N. Y.	B.G.M.	61	1¼ "
L. Howard Van Syckle, Central ave., Fort Lee, N. J.	L.H.S.	1000	1 "
*Fremont M. Hammond, 160 E. Main st., Patchogue, L. I., N. Y.	H.D.A.	53	..
R. A. Sturtevant, New Eng. Tel. & Tel. Co., Springfield, Mass.	R.A.S.	61	¼ KW.
Geo. Grainger, 23 Gerrard st., w., Toronto, Ont.	G.W.G.	650	½ "
Geo. B. Darby, Jr., Bala, Pa.	I.X.M.	50	½ "
C. W. Schwartz, Suffield, Conn.	S.B.M.	80	6 ins.
*Stanley S. Howe, Harris pl., Brattleboro, Vt.	Y.X.M.	55	..

NAME AND ADDRESS OF OWNER	CALL LETTER	APPROXIMATE WAVE LENGTH IN METERS	SPARK LENGTH OF INDUCTION COIL
Albert Carthous, 1319 State st., Milwaukee, Wis.	A.M.C.	..	4 "
E. M. Flaherty, 24 Lapidge st., San Francisco, Cal.	F.E.M.	52	1 "
P. H. Lattime, 78 Dexter st., Medford, Mass.	L.S.M.	..	2 "
Arthur Wilkinson, 1369 Haight st., San Francisco, Cal.	A.H.W.	61	2 "
Geo. Anston, 3205 Prairie ave., Chicago, Ill.	G-1	60	¼ KW.
M. D. Mosher, 325 West ave., Rochester, N. Y.	M.D.M.	110	½ "
Vernon Deal, 527 N. Front st., Hoopeston, Ill.	V.C.D.	..	1 ins.
Wm. C. Graf, 165 Sheridan ave., Paterson, N. J.	W.C.G.	52	¼ "
Max Alvin, 2446 Pensacola st., Chicago, Ill.	M.W.M.	..	..
H. Thomas, 3230 Indiana ave., Chicago, Ill.	H.T.M.	..	..
Vincent Flocker, 2647 Perrysville ave., Allegheny, Pa.	V.F.M.	..	1 KW.
Brooke Sawyer, Box 1526, Santa Barbara, Cal.	B.E.S.	121	2 ins.
Geo. T. Droste, 2132 Glebe ave., Unionport, N. Y.	G.T.D.	350	6 "
Darius Sylvester, R.V.C.	S.D.D.	500	1½ "
Tellesphore Peters, R.V.C.	S.D.L.	475	1½ "
Bernard Gasser, E. Rockaway, Harry Slegman, R.V.C.	S.D.M.	420	1½ "
S.D.N.	420	1½ "	
Mercer Bungart, R.V.C.	S.D.Y.	730	2 KW.
Harold DeWitt Smith, 75 W. 33rd st., Bayonne, N. J.	H.S.M.	42	½ ins.
W. B. Harper, Waitsburg, Wash.	W.B.H.	100	½ KW.
Frank Eaton, 43 Lexington ave., Jersey City, N. J.	E.A.T.	43	½ ins.
H. L. Haupt, 408 Young ave., Hoopeston, Ill.	G.W.M.	80	½ KW.
Bumer Hathaway, 591 Passaic ave., Nutley, N. J.	V.H.B.	106	4 ins.
Frank X. Kelling, Jr., 115 Market st., Newark, N. J.	W.K.M.	216	1 "
J. S. R. Nee, 1003 Watchung ave., Plainfield, N. J.	J.S.R.	366	3 "
Lynn G. E. Rhodes, 313 S. 2nd st., North Yakima, Wn.	L.E.M.	165	¾ KW.

Above Members will be listed in the 1911 BLUE BOOK, which will be issued June 15th. New members should register at once.

# Electrical Patents for the Month

989,145 COMBINED FISHING-FLOAT AND FLASH-LIGHT. ANDREW HAYNEMET, Louisville, Ky. Filed June 10, 1910. Serial No. 566,209

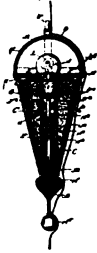

1 A fishing float having an electric lamp arranged thereon, a battery arranged in said float, and a circuit closing the circuit between said battery and lamp, said circuit closer being operated by the fishing line.

988,456 POTENTIOMETER. HENCO OBERMAYER, New York, N. Y. Filed Dec 7, 1910. Serial No. 506,088.



1 A potentiometer comprising a base having a disk under face, binding posts on said base, a scale indicated on said base, a sleeve embedded in the center of said base, a screw passing through said sleeve, a thumb piece and indicator on one end, a contact on the other end of said screw, electrical connections between said screw and one of said binding posts, a groove in the bottom face of the base, bars of high electrical resisting qualities embedded in said groove, said bars adapted to contact with the contact point on said screw, and electrical connections between the ends of said bars of high resisting materials and the other binding posts.

989,191 MULTIPLE TELEPHONE RECEIVER. WILLIAM B. RUTEN, Chicago, Ill. assignor of nine-tenths to Henry G. Copley, West Union, Nebr. Filed Aug 14 1905. Serial No. 274,207.

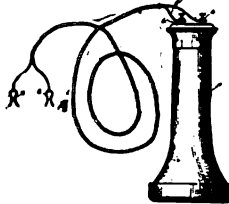

1 A telephone attachment comprising spring contact device for making contact with the terminals of the receiver of a telephone set and thereby temporarily occupying said attachment thereby said spring contact device being integral and so spaced apart that the two separate connections with the terminals of the receiver are made and broken simultaneously and a telephone receiver conductively connected with said contact device.

89,816 AUXILIARY TELEPHONE RECEIVER. WILLIAM B. RUTEN, Chicago, Germany. Filed June 15, 1910. Serial No. 567,092.



1 An auxiliary receiver for telephones comprising a reverterator, a tube leading thereinto, a tube connected to said tube and with a telephone receiver and having its end beveled and parallel with the diaphragm, and a reverterator connected with the second-named tube and serving as an auxiliary receiver.

930,134 ELECTROMAGNETIC COMPASS. DOMINIQUE JOSEPH ARMAND DONOTER, Versailles, France. Filed Mar 5 1907. Serial No. 180,770.

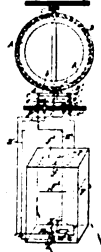

1 A compass for determining magnetic deviation, including in combination a coil adapted to be rotated in a magnetic field and in which induced currents are generated, a current collecting ring with caps at diametrically opposite points, electrical connections between said coil and ring, a galvanometer, and brushes connecting said coil through said ring to said galvanometer to cause the latter to indicate the intensity of said currents.

988,787 ELECTROLYTIC INTERRUPTER. HENCO OBERMAYER, New York, N. Y. Filed Feb. 12 1910. Serial No. 548,480.

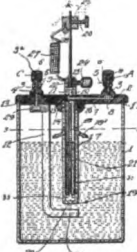

1. In a device of the character described, the combination with a receptacle, of an insulated cover thereon, said cover provided with a centrally arranged depending portion, said depending portion provided with a threaded socket, a tube of insulating material, said tube provided with an end threaded into said socket, said tube provided with an outlet formed near the upper end thereof, and with an aperture formed in the bottom thereof, an anode passing through said cover and having its lower end resting within said aperture and being adapted to normally close the same, and a cathode fixedly secured to said cover and provided with an angularly disposed lower end and positioned directly below said anode element.

986,856 TELEPHONE. WILLIAM C. LOCKWOOD, San Juan, Porto Rico. Filed Jan 29 1900. Serial No. 475,078. Renewed Apr. 22 1910. Serial No. 557,077.

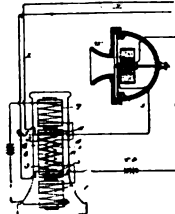

1 A telephone system comprising a transmitter, a circuit therefor, a receiver provided with an induction coil having a double primary winding and a single secondary winding, an electromagnet adjacent each end of the core of said induction coil, a closed loop circuit connected to the coils of the magnets and to two of the primary windings of the induction coil through the magnet coils, the magnet coils and the connected primary winding being also connected to the transmitter circuit, the second primary winding of the induction coil being also connected with the transmitter circuit, the line wire being connected to the secondary winding of the induction coil.

989,362 KNIFE SWITCH. CHAS H. HOOPER, Brownlee, Neb. Filed May 24 1910. Serial No. 563,190.

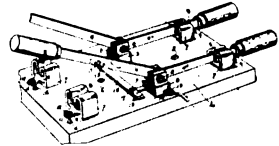

1 A switch of the class described comprising an insulating base with a posts mounted thereon, blades mounted on the posts, contacts on the base forming line terminals and with which the blades engage, lugs extending from the posts, a bridging strip engaging the lugs for electrically connecting the posts together, and headed fastenings extending through the lugs to clamp the said strip in place, said strip having recesses in one edge to receive the said fastenings and enter between the heads of the latter and the lugs.

990,266 FOOT-WARMING ATTACHMENT FOR ELECTROTHERMAL GARMENTS. FREDERICK E. CLAYSON, Portland, Oreg., Filed Oct. 12, 1910. Serial No. 565,723.

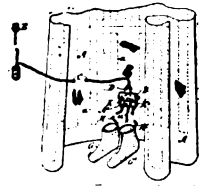

1 The combination with a source of electrical energy, and with a garment wired with a circuit for the diffusion thereof of electrical currents, of a contact block fixed to the fabric of said garment and receiving the terminals of its circuit wires,—a detachable contact strip or ring and flexible electrical connections therewith,—and separable foot-wraps or boots, wired also with circuits for the diffusion thereof of electrical currents, such circuits having their terminals in said detachable block, and whereby a common current may be directed through the body and feet of the user.

990,022 ELECTRICAL RELAY. EDWARD F. CLAYSON, Washington, D. C. assignor to The North Electric Company, Cleveland, Ohio, a Corporation of Ohio. Filed Dec 23 1905. Serial No. 293,149.

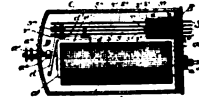

1 An electrical relay comprising a pair of electro-magnets having their cores united at their rear end, an L-shaped supporting yoke carried upon the front end of the cores, a bent armature pivoted on the angle of said supporting yoke and having a depending portion extending in front of and across the ends of the cores, and a substantially horizontal portion extending over the tops of the magnet spools, and a plurality of contact springs secured upon the rear yoke of the electro-magnets and extending forward with their ends resting over and adapted to be controlled by the horizontal portion of the armature, substantially as described.

990,021 CABLE OR TELEGRAPH CODE. MARY B. BURWER, Washington, D. C. Filed Feb 10 1910. Serial No. 543,047.

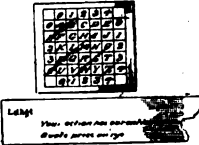

A code which consists of a series of numbers, each of which has a predetermined meaning, a table comprising a plurality of letters of the alphabet arranged in rows read vertically and horizontally, numerals arranged at two adjacent edges of the table, said numerals being composed of the same numerals as those appearing in the table, whereby two numbers having the desired meanings may be formed into a single code word by determining the letters of the table representing the first numeral of each number and then each of the other pairs of numerals, and arranging the letters so formed into a code word.

## Original Electrical Inventions for which Letters Patent Have Been Granted for Month Ending April 27, 1911

Copy of any of the above Patents will be mailed upon receipt of 10 cents

# WIRELESS CODES.

LETTERS	MORSE	CONTINENTAL	NAVY
A	••	••	••
B	••••	••••	••••
C	•••••	•••••	•••••
D	••••••	••••••	••••••
E	•••••••	•••••••	•••••••
F	••••••••	••••••••	••••••••
G	•••••••••	•••••••••	•••••••••
H	••••••••••	••••••••••	••••••••••
I	•••••••••••	•••••••••••	•••••••••••
J	••••••••••••	••••••••••••	••••••••••••
K	•••••••••••••	•••••••••••••	••••••~•••••••
L	••••••••••••••	••••••••••••••	••••••••••••••
M	•••••••••••••••	•••••••••••••••	•••••••••••••••
N	••••••••••••••••	••••••••••••••~	••••••••••••••~
O	•••••••••••••••••	••••••••••••••••	••••••••••••••••
P	••••••••••••••••••	•••••••••••••••••	•••••••••••••••••
Q	•••••••••••••••••••	••••••••••••••••••	••••••••••••••••••
R	••••••••••~••••••••	••••••••••~••••••••	••••••••••~••••••••
S	•••••••••••••••••••	••••••••••••••~•••	••••••••••~••••••••
T	••••••••••••••••••••	••••••••••~••••••••	••••••••••~••••••••
U	••••••••••~•••••••••	••••••••••~•••••••••	••••••••••~•••••••••
V	••••••••••~••••••••••	••••••••••~••••••••••	••••••~••••••••••
W	••••••••••~•••••••••••	••••••••••~•••••••••••	••••••~•••••••••••
X	••••••••••~••••••••••••	••••••••••~••••••••••••	••••••~••••••••••••
Y	••••••••••~•••••••••••••	••••••~•••••••••••••	••••••~••••••~•••••••
Z	••••••••••~••••••••••••••	••••••~••••••~••••••••	••••••~••••••~••••••~••
&	••••••••••~•••••••••••••••		
1	••••••••••~•••••••••••	••••••~••••••~••••••~••	••••••~••••••~••••••~••
2	••••••••••~••••••••••••	••••••~••••••~••••••~•••	••••••~••••••~••••••~•••
3	••••••••••~•••••••••••••	••••••~••••••~••••••~••••	••••••~••••••~••••••~••••
4	••••••~••••••~••••••~••••	••••••~••••••~••••••~•••••	••••••~••••••~••••••~•••••
5	••••••~••••••~••••••~•••••	••••••~••••••~••••••~••••••	••••••~••••••~••••••~••••••
6	••••••~••••••~••••••~••••••	••••••~••••••~••••••~••••••~	••••••~••••••~••••••~••••••~
7	••••••~••••••~••••••~••••••~	••••••~••••••~••••••~••••••~•	••••••~••••••~••••••~••••••~•
8	••••••~••••~••••••~••••••~••	••••••~••••~••••~••••~••••~••	••••~••••~••••~••••~••••~••
9	••••~••••~••••~••••~••••~•••	••••~••••~••••~••••~••••~••••	••••~••••~••••~••••~••••~••••
0	••••~••••~••••~••••~••••~••••~	••••~••••~••••~••••~••••~••••~•	••••~••••~••••~••••~••••~••••~••
.	••••~••••~••••~••••~••••~••••~•	••••~••••~••••~••••~••••~••••~••	
:	••••~••••~••••~••••~••••~••••~••	••••~••••~••••~••••~••••~••••~•••	
;	••••~••••~••••~••••~••••~••••~•••	••••~••••~••••~••••~••••~••••~•••~	
'	••••~••••~••••~••••~••••~••••~••••	••••~••••~••••~••••~••••~••••~••••~	
?	••••~••••~••••~••••~••••~••••~••••~	••••~••••~••••~••••~••••~••••~••••~•	

## ABBREVIATED NUMERALS USED BY CONTINENTAL OPERATORS.

1	••	2	••••	3	•••••	4	••••••	5	••
6	•••••	7	••••••	8	•••••••	9	••••••••	10	•••••

## WIRELESS ABBREVIATIONS.

- G. E. - GOOD EVENING
- G. N. - " NIGHT
- G. M. - " MORNING
- G. A. - GO AHEAD
- O. S. - SHIP REPORT
- D. H. - FREE MESSAGE
- M. S. Q. - MESSAGE
- O. P. R. - OPERATOR

- 4 - PLEASE START ME, WHERE
- 13 - UNDERSTAND
- 25 - AM BUSY NOW
- 30 - NO MORE
- 73 - BEST REGARDS
- 77 - MESSAGE FOR YOU
- 92 - DELIVERED
- 99 - KEEP OUT

## -DISTRESS SIGNALS+

S. O. S. MORSE                      C. Q. D. CONTINENTAL.

COPYRIGHT 1910 BY E. I. CO.





Queries and questions pertaining to the electrical arts, addressed to this department, will be published free of charge. Only answers to inquiries of general interest will be published here for the benefit of all readers.

On account of the large amount of inquiries received, it may not be possible to print all the answers in any one issue, as each has to take its turn. Correspondents should bear this in mind when writing.

Common questions will be promptly answered by mail if 10 cents to cover expenses have been enclosed. We can no longer undertake to furnish information by mail free of charge as in the past. There are as many as 150 letters a day now and it would be ruinous for us to continue acting as a free correspondence school.

If a quick reply is wanted by mail, a charge of 15 cents is made for each question. Special information requiring a large amount of calculation and labor cannot be furnished without remuneration. THE ORACLE has no fixed rate for such work, but will inform the correspondent promptly as to the charges involved.

NAME AND ADDRESS MUST ALWAYS BE GIVEN IN ALL LETTERS. WHEN WRITING ONLY ONE SIDE OF QUESTION SHEET MUST BE USED. DIAGRAMS AND DRAWINGS MUST INVARIABLY BE ON A SEPARATE SHEET. NOT MORE THAN THREE QUESTIONS MUST BE ASKED, NOR SHALL THE ORACLE ANSWER MORE THAN THIS NUMBER. NO ATTENTION PAID TO LETTERS NOT OBSERVING ABOVE RULES.

If you want anything electrical and don't know where to get it, THE ORACLE will give you such information free.

**AUDION DETECTOR.**

(936.) H. L. Damon, Ohio, asks:

Q. 1.—Is an Audion Detector as efficient in wireless telegraphy as a mineral?

A. 1.—While the audion detector is very sensitive, and gives good results when thoroughly understood, we do not advise its use for amateurs, as only the best results can be obtained by a thorough understanding of it. It is more sensitive than most detectors.

Q. 2.—I have the following instruments, and would like you to give me the correct diagram, and tell me how far I should receive with them: E. I. Co.'s large and small double-slide tuners, two fixed, and two variable condensers, silicon detector, 75 and 1,500-ohm receivers.

Aerial consists of 6 wires, two feet apart, 120 feet long, 85 feet high at top, and 30 at bottom.

I cannot hear Cleveland, which is only 52 miles; and they have a 2 k.w. station.

A. 2.—See diagram below.

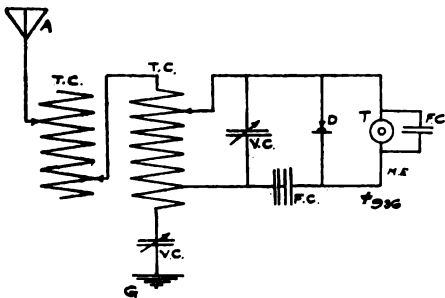

Q. 3.—Which is the better place for the station: in the barn, which is about ten feet below the bottom of aerial; or on the third floor of the house, which is about fifty feet below the top?

A. 3.—We advise you to put your instru-

ments in the house, as the greater distance below the aerial will give you a longer wave length, and therefore, a better outfit.

**INTERFERENCE PREVENTER.**

(937.) Archie L. Miller, Texas, asks:

Q. 1.—How far can I receive with the following instruments:

Interference preventer (see sketch); non-inductive potentiometer (like the one described in August issue of *Modern Electrics*); fixed zinc-plate condenser, having six 6x8 inch plates, separated with paraffined paper; variable condenser, containing 8 movable, and 9 stationary zinc-plates, 5x7 inches, separated with paraffined paper; electrolytic silicon, molybdenite, peroxide of lead detectors; 1,000 ohm phones; and umbrella type aerial, 80 feet high?

A. 1.—With this outfit you should be able to receive about 500 to 600 miles, under ordinary conditions.

Q. 2.—Please give diagram for connecting above instruments.

A. 2.—See diagram below.

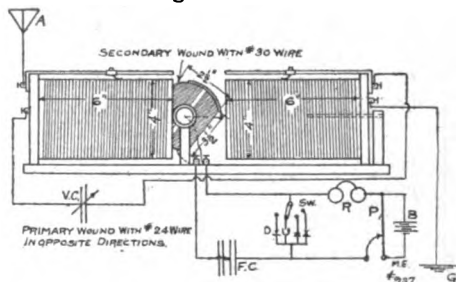

Q. 3.—Are zinc plates separated with paraffined paper as good for receiving condenser as glass plate condensers?

A. 3.—While a condenser made of glass has more capacity than one made of paraffine paper, the glass condenser requires more space, and so does not give satisfaction in



## On Which Side of the Desk Are YOU?

In every business there is a desk with two sides. The man on the one side thinks and makes money—the man on the other side works and draws "wages." On which side of the desk are *You*?

The man before the desk works with his *hands* and is paid for his *labor*. The man behind the desk works with his *head* and is paid for his *knowledge*. It is merely a question of "knowing how."

For 19 years the International Correspondence Schools, of Scranton, Pa., have been enabling people to advance in position and earn more money. Every month there are received at the I. C. S. over 400 voluntary letters telling of positions bettered and salaries increased through study of I. C. S. Courses. The writers of these letters are not men of genius—not the sort known as "gifted," "naturally bright," etc. They are plain men that have studied diligently the work of their choice. Spare-time study won their advancement.

Thousands that have doubled, tripled, or quadrupled their salaries made their start by marking and mailing an I. C. S. Coupon.

If you want to raise *your* salary, mark and mail the attached coupon. Mailing the coupon will cost you nothing but postage, but will bring to you a full explanation of the I. C. S. salary-raising plan.

**Mark and Mail the Coupon NOW.**

### International Correspondence Schools Box 992, Scranton, Pa.

Please explain, without further obligation on my part, how I can qualify for a larger salary and advancement to the position, trade, or profession before which I have marked X.

Electrical Engineering	Mechanical Engineer
Electric Lighting	Mechanical Draftsman
Electric Railways	R. R. Constructing
Electrician	Concrete Construction
Electric Car Running	Architect
Dynamo Foreman	Contracting and Building
Dynamo Tender	Architectural Draftsman
Wireman	Plumbing & Heating
Mining Engineer	Chemist
Telephone Expert	Bookkeeper
Civil Engineer	Advertising Man
Automobile Running	Civil Service Exams.

Name \_\_\_\_\_

St. & No. \_\_\_\_\_

City \_\_\_\_\_ State \_\_\_\_\_

When writing, please mention "Modern Electrics."

certain circumstances, where a condenser of a smaller size is wanted.

### 3-INCH SPARK COIL.

(938.) Joseph A. Corbalis, N. J., writes:

Q. 1.—Would you be kind enough to answer some questions in regard to the construction of this coil? Do you approve of the dimensions as per sketch? Of dividing the secondary into thirteen sections? Length of cone, etc.? How many pounds of wire will I need to get the best size spark obtainable from it (both primary and secondary)? How much (many pounds) of core wire to be used? Finally, what size spark can I draw from it?

A. 1.—Your design of the spark coil is not very practical; as the secondary windings will be too deep, and therefore will cause a loss of the magnetic lines of force. We advise the following dimensions, for a coil which will give a 3-inch spark: Core,  $12\frac{1}{2} \times 1\frac{3}{8}$  inches. Primary wire, No. 14 D. C. C., wound in two layers; and secondary, 8 pounds of No. 32 S. S. C., or enamelled wire, wound in 16 sections. The primary and secondary should be separated by a fibre tube, having a  $\frac{1}{4}$ -inch wall. For the core wire, you will require about  $3\frac{9}{10}$  pounds.

Q. 2.—My receiving range: Through seventy-five feet of aerial, forty feet at one end, fifteen at other, 1,000 ohm phone, silicon detector, "Deforest Instruments," double slide tuner.

A. 2.—With your outfit you should be able to receive about 50 to 75 miles, under ordinary conditions.

### TUNING COIL QUERIES.

(939.) Russell V. MacDonald, Minn., asks:

Q. 1.—Would you please tell me what size wire is best for tuning coil?

A. 1.—Wire for tuning coils may range from No. 14 to No. 28 according to the diameter of core. For ordinary work No. 20 is generally used, the core being about 5-inch diameter. For 2-inch diameter use No. 24.

Q. 2.—How many feet of wire will it take for a coil, 8 inches in diameter, and 14 inches long?

A. 2.—For coil of this size, you will require about 750 feet of No. 18 enamelled wire.

Q. 3.—What would be the wave length of this coil?

A. 3.—The wave length of this coil will be approximately 900 meters.

### WIRELESS HOOK-UP.

(940.) Bartow Koopman, New York, writes:

Q. 1.—Receiving: Murdock loose coupler, variable secondary; three-slide tuning coil; three variable condensers; one fixed condenser; Clapp-Eastham Ferron detector; 2,000 ohm head phones.

Transmitting: Two four-inch spark coils; nine one-quart Leyden jars; helix with spark gap enclosed; independent, magnetic vibrator; wireless key; five 6-volt storage batteries.

A. 1.—For hook-up, see diagram below. As you will notice, a 4 P. D. T. switch in the receiving circuit is used, as described in our April, 1911, issue, query No. 909.

Q. 2.—How far can I receive and send, using an aerial 125 feet high from street level, 200 feet long, of eight wires, two feet apart?

A. 2.—With this outfit you should be able to receive about 1,000 to 1,500 miles under or-

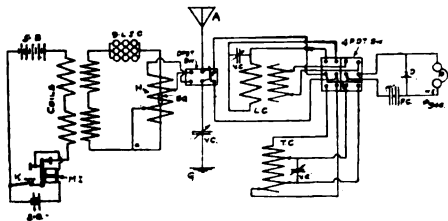

clinary conditions; and send about 75-90 miles.

**AMMETER FOR WIRELESS.**

(941.) E. J. Sortore, N. J., writes as follows:

Q. 1.—Please explain the manner in which ammeters are used in order to show how the clip on the helix is adjusted to put the station in the greatest resonance.

A. 1.—The accompanying diagram shows

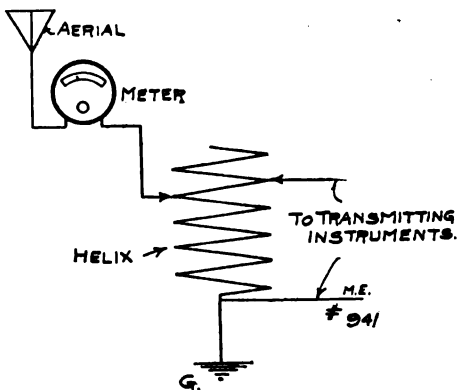

the method of connecting an ammeter in the aerial wire for determining the strength of the out-going waves. As you will notice, this ammeter is connected in series between the aerial and helix.

Q. 2.—Can ammeter No. 1039 of the Electro Importing Co. be used for this purpose?

A. 2.—As the ammeter in question measures currents from 1 to 25 amperes, it would not be satisfactory for wireless work in the above connection; as only currents of milli-amperes are generated in the aerial wire when sending. As you will no doubt have noticed, in previous issues of *Modern Electrics*, there have been many descriptions of hot-wire ammeters, and we advise you to construct one, or buy one of this type; as these only will give perfect satisfaction.

Q. 3.—Will the following set transmit signals 75 miles?

Aerial 55 feet high, 4 wire, in and out connection, heavily insulated.

E. I. Co.'s ½ k.w. transformer coil No. 8060; electrolytic interrupter No. 8,000; high tension condenser No. 531; wireless key No. 9212; adjustable spark gap No. 9220a; special sending helix No. 8770. Water-pipe ground.

Alternating current is used of 110 volts. The system includes all switches, fuses, etc.

A. 3.—If the above instruments are correctly connected and handled in an under-

**MURDOCK WIRELESS APPARATUS**



The final test of merit is fair comparison. The MURDOCK 'phones prove good on final tests. YOU neglect a vital factor in efficiency if you neglect MURDOCK 'phones. Satisfaction certain.

2,000 ohm ..... \$7.50  
3,000 ohm ..... 8.50

**WM. J. MURDOCK CO.**

40 Carter Street  
CHELSEA, MASS.  
162 Minna St. 221 S. Clinton St.  
SAN FRANCISCO CHICAGO

When writing, please mention "Modern Electrics."

**LUNA**

Batteries for bells, annunciators and burglar alarms, each.....15 Cts.

**CANNON**

Batteries for spark coils, gas engine ignition, etc. A battery that has the "juice," when let loose! Each 25 Cts.

Why not get next to our line of goods and let us show you that there is at least ONE concern that has attractive prices, that gives a square deal, and that makes prompt shipments.

**ALUMINUM WIRE FOR AERIALS**

If you have been using Copper or Galvanized Iron Wire for your Aerial, and the snow, sleet and strong winds of the winter has broken it down—why not construct a new Aerial with our extra strong Aluminum Wire—approximately 240 feet to the pound.

Price per pound .50c. Not Mailable.  
2000 ohm Double Head Receiver, complete .....\$4.50  
Loose Coupled Tuning Coils.....15.00



**WIRELESS APPARATUS. FLETCHER-STANLEY COMPANY**

Electric Supplies and Specialties  
32-34 FRANKFORD STREET  
NEW YORK

Attractive Prices  
A Square Deal  
Prompt Deliveries

When writing, please mention "Modern Electrics."

## EXPERIMENTER BARGAINS

We bought the entire stock of a dissolved Electrical Novelty concern and can sell very cheap:

MOTORS up to 1/2 H. P.,  
Electric Fire Alarm Apparatus.  
Telegraph Instruments, Re-  
lays, Sounders, Telephones,  
Magnetos, Bells, Arc Lamps,  
Jar Batteries, Nickel Parlor  
Battery Stands, Bell Electric  
Lamps, Clamond Telephone  
Receivers and Transmitters,  
Magnetic Grips, etc., etc.

**COSMOS ELECTRIC CO.**

132-136 Liberty St., New York

### BRANDES LONG DISTANCE WIRELESS RECEIVERS

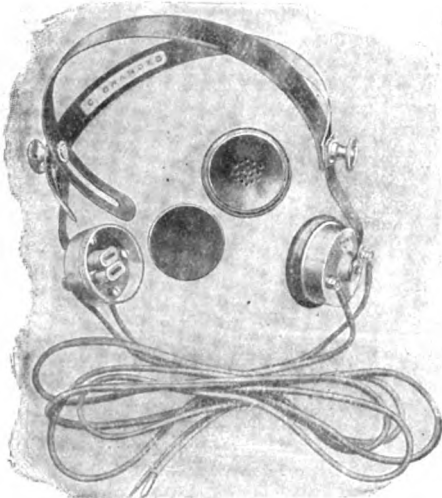

#### IMPORTANT ANNOUNCEMENT

We beg to announce our latest Model Improved Navy Receivers for professional use. These receivers are sold with a written guarantee that they are the best long distance reading receivers that money can buy. We send them on trial to those who wish to verify by test, the truth of this statement. Their price is \$13.00 complete set.

We also have other high-class wireless receivers for both amateurs and professionals, from \$1.50 each to \$9.00 a pair.

Send stamp for new literature to Dept. G.

C. BRANDES, The Wireless Receiver Specialist, 111 Broadway, N. Y.

FORD MING, 163 Belvedere Street, San Francisco, Cal.

When writing, please mention "Modern Electrica."

standing manner, they should easily cover a distance of 75 miles and more.

#### WIRELESS LEGISLATION.

(942.) Arthur Jennings, Cal., writes:

Q. 1.—I would like to know if a law was passed that amateur wireless operators could not use a transformer over one-half k.w. transformer? If so, what is the highest spark coil or transformer that I can use? I was going to get a one k.w., but I want to be sure before I do so.

A. 1.—There has been no law passed that restricts the power of a transmitting station for amateur use.

Q. 2.—I have a receiving set, and a large tuner of about No. 18, spaced about one-sixteenth of an inch; a silicon detector; a condenser, and a 500 ohm receiver. The detector is made from a design in *Modern Electrics*. How far can I receive?

A. 2.—With this set you should be able to receive about 250 to 300 miles.

Q. 3.—My sending set is a 1/2-inch coil; a helix of No. 8 copper wire; a Leyden jar; a heavy key; 8 batteries; a large aerial, about 120 feet high, and 3 wires. Would I send farther with a smaller aerial?

A. 3.—We judge, by your description, that the large aerial will give you very good satisfaction with the instruments you possess.

#### TUNING COIL QUERIES.

(943.) Hobart Sidler, Neb., asks:

Q. 1.—What would my transmitting and receiving range be with the following instruments: Key; 1-inch spark coil; zinc gap; variable condenser; helix, composed of thirteen and one-half turns of No. 8 aluminum wire, eight inches in diameter? These are connected to one side of a D. P. D. T. switch and then to an aerial 50 feet long, and 20 feet high at both ends; six strands of copper wire. Receiving: Silicon detector; pair of 75 ohm receivers, and a 1,000 ohm?

A. 1.—Your sending range should be about 5 to 8 miles; and receiving range about 75 to 100 miles, under ordinary conditions.

Q. 2.—What is the number of the enclosed wire and would it be possible to use it on a tuning coil? What would my wave length be and what would be some good dimensions for one to receive with in the above mentioned set to receive about 200 miles?

A. 2.—The enclosed wire is No. 16 B. & S. Gauge, S. C. C. wire. For a tuning coil using this wire, we advise you to make a core 7 inches in diameter, and 10 inches long.

Q. 3.—Would a 25-foot mast erected at one end improve it any, and what per cent.? How many sheets of tin foil 2x3 inches are needed to make a fixed condenser for the above coil?

A. 3.—Yes. About 25 per cent. For a condenser for the above coil you will need about 700 sheets of the size you mention.

#### CONDENSER CAPACITIES.

(944.) Neil Martin, Washington, D. C., asks:

Q. 1.—Will you please tell me where I can purchase climax wire No. 40 B. & S., as used in making a hot-wire ammeter as in the February 1911 number of *Modern Electrics*?

A. 1.—See any wire manufacturer's advertisement in our columns.



Q. 2.—When two condensers are connected in series is it one-half the capacity of either and when the same are shunted across each other is it the capacity of both combined?

A. 2.—When two equal-sized condensers are connected in series, the combined capacity is equal to *one* of the condensers; but when they are connected in parallel, the capacity is equal to the *sum* of the separate capacities of the condensers.

Q. 3.—Will you kindly state my receiving range, using a mica condenser of moderate capacity, galena, molybdenite, carborundum, silicon and zincite-iron pyrites detectors, switch for detectors, shunting condenser, tuner, double slide, having a core 4 inches diameter and 7½ inches of winding of No. 24 B. & S.?

My aerial is 68 feet long and at one end is 55 feet from my instruments while the other end is 35 feet from instruments.

A. 3.—With 2,000 ohm phones your range should be about 100 to 125 miles.

**AERIAL IN ATTIC.**

(945.) V. R. C. Fox, La., states:

Q. 1.—I have enclosed a sketch of my aerial, which is 20 feet high, 30 feet long, four wires, 1 foot apart at ends, and 6 inches at center. I have it nailed in the attic to the rafters, only touching two rafters at each end. Must it be insulated, and what instruments will it require, using this aerial, to receive 100, or 200 miles? Is it possible?

A. 1.—By using a loose-coupled tuning coil and 2,000 ohm phones and electrolytic detector, with instruments connected and operated in an understanding manner, you should be able to cover the required distance.

Q. 2.—There is a telegraph line running by the house, within 50 feet of the aerial. Is there any chance to get the inductance from this line?

A. 2.—In case the inductance from the telegraph line is noticeable in your phones, connect a variable condenser in series with the ground wire, or across the primary of the loose coupler.

**DOOR-BELL TRANSFORMER.**

(946.) Gifford N. Hartwell, N. Y., writes:

Q. 1.—Will you kindly give, through the "Oracle" of your paper, data for making a door-bell transformer, to be used on 110-volt A. C.; and of such a design and construction, that, when connected to the current supply, it will *not* cause the meter to register, except when the push button is pressed?

A. 1.—Construct your core with dimensions as given below. The tongues of the

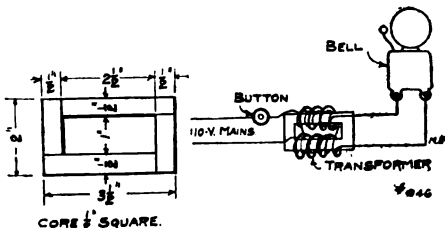

core should be one-half inch square. For the winding, you will require about 2,750 turns of No. 32 B. & S. Gauge, D. C. C. wire on each leg of the core, for primary; and 41 turns of No. 36 B. & S. Gauge, D. C. C. wire on each

## WIRELESS

Boys from Chicago and vicinity are invited to call at our store and look over our stock.

We carry **The Electro Importing Co.'s** complete lines.

Same Catalog—Same Prices.

---

**Detector as shown above, 55c.**

---

**Anderson Light & Specialty Co.**  
KNOWN AS  
**LA SALLE LIGHT STORE**  
 La Salle and Randolph Streets, Chicago  
 Opposite New City Hall

When writing, please mention "Modern Electrics."

## "NECO" WIRE GAUGE

FRONT

Cut is a 1/4 size illustration of our IMPROVED "NECO" POCKET WIRE GAUGE, for measuring wire from No. 18 to No. 000 B. & S. gauge. On the front is also given the carrying capacity of copper wire in amperes and on the reverse side the approx. decimal equivalent of the various size wires.

Mailed to any address in the United States or Canada upon receipt of 60 cents in cash or money order.

## Novelty Electric Co.

Manufacturers and Jobbers Electrical Merchandise

**50-52-54 North 4th St., PHILADELPHIA**

When writing, please mention "Modern Electrics."

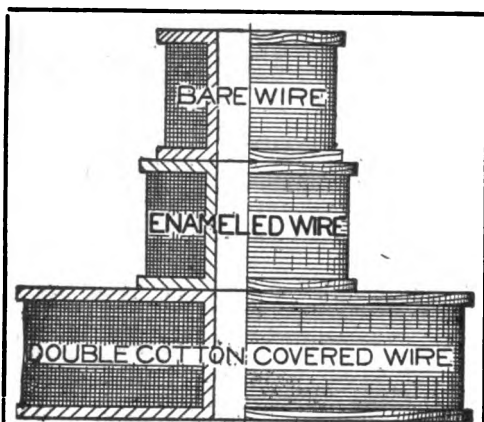

**IF YOU ARE NOT USING FEVAL ENAMELED WIRE**

on your instruments, you and your instruments suffer. Our strong, non-extravagant claim:

**"The Best Enameled Wire in America"**

**Feval Enameled Insulated Wire Co.**  
124a North Curtis Street  
CHICAGO, ILL.

When writing, please mention "Modern Electrica."

**TRY IT**



**COLUMBIA DRY CELL**

Only one trial is necessary to convince you that this cell will live longer, cost less and give better service than any other brand.

Its long life and strong current make it specially adapted to work on telephones, bells, buzzers, electric clocks and toys, wireless telegraph instruments, gas lighters, electric horns and many other similar devices.

Ask your dealer.

**NATIONAL CARBON CO.**  
CLEVELAND, OHIO

When writing, please mention "Modern Electrica."

leg for secondary. Connect as shown in diagram below. As you will notice, the transformer is not in the 110-volt circuit at all, until the button is pushed; thereby preventing registry on the power meter.

**COMPLETE LIST OF STATIONS OF U. S.**

- (947.) Chas. Daniels, Cal., asks:  
 Q. 1.—Will you please tell me where I can get a list of wireless calls of the Pacific Coast, besides the wireless Blue Book?  
 A. 1.—In the 1911 issue of the "Wireless Blue Book," out June 1st.  
 Q. 2.—Is there a station in Alaska that has a 20 k.w. transformer?  
 A. 2.—Yes; at Sitka; owned by the U. S. Navy. Call letters, N. P. B.

**AERIAL QUERIES.**

- (948.) W. Webb Troutman, Pa., writes:  
 Q. 1.—Which would be the best, a "T" or "L" shaped aerial?  
 A. 1.—"T" shaped aerial; as this type does not produce any directive effects.  
 Q. 2.—What method of wiring would you use in connecting the ends of the aerial wires together?  
 A. 2.—See diagram below.

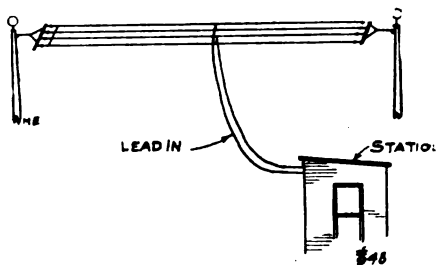

- Q. 3.—What would my wave length be?  
 A. 3.—Approximately 45 meters, if your instruments are located at the point where you bring your lead-in into the house. But if they are located on the ground level, your aerial will have a wave length of about 65 meters.

**HOW DO WIRELESS WAVES TRAVEL?**

- (949.) Digby Bell, Mich., asks:  
 Q. 1.—Do wireless waves, when meeting a mountain, go through, or up and down the other side?  
 A. 1.—According to the best authorities on this subject, the waves travel over the mountains instead of through them, as many formerly supposed.  
 Q. 2.—How many meters wave-length has a 3-slide tuner, 3 inches in diameter and 12 inches long? It is wound with No. 21 copper insulated wire.  
 A. 2.—Tuning coil in question will be about 70.5 meters.  
 Q. 3.—Does it do any harm to have the brushes on an A. C. motor lap over the edge of the commutator about one-sixteenth of an inch?  
 A. 3.—An A. C. dynamo has no commutator; but we suppose you mean the collecting rings. In this case, it makes no difference, so long as one brush does not touch two rings at the same time.

**LEARNING TO RECEIVE.**

- (950.) Norman E. Bucklin, La., asks:  
 Q. 1.—Will you kindly suggest some way

for an amateur to learn to receive? I have a buzzer, know the alphabet, and can send to a small extent; but the main trouble lies in the fact, that I have no one to send to me. I don't suppose I would recognize a letter if I were to hear it.

A. 1.—We advise you to invest in an Omnigraph outfit, as per our advertising columns. By this method you can learn to receive in a very practical manner.

**ADJUSTING SPARK GAP.**

(951.) J. A. Hybarger, Texas, writes:

Q. 1.—How far apart must the gap be set for the best results on a 1-inch coil?

A. 1.—It is impossible to give the exact distance for the spark gap for any station; as each one will vary to a certain extent. Adjust your spark gap until the maximum deflection of the meter, in the aerial wire, is noticed. If you have no such meter, adjust the gap until the spark is thick and white. The spark in no circumstances should be of a thin, thread-like appearance; or should not be of a reddish color; as this will soon heat up your spark gap, and will not produce any desirable effects.

Q. 2.—Can I operate a helix without ground connected to same?

A. 2.—Although it has occurred that amateurs have sent messages without ground connection to their helix, we advise the ordinary connection; and by this way you will be sure of sending out waves to the greatest extent of your coil.

Q. 3.—Have the wireless stations on board ships any special time to send or receive?

A. 3.—The ordinary sending of ships may occur at any time; as for instance: a danger call; or a call for pilot; or greetings from one captain to the other, etc. News dispatches are usually received about 11 P. M.

**1 K.W. CONDENSER.**

(952.) Harry E. Merrill, Kans., asks:

Q. 1.—Will you give me the plans of a condenser to be used on a 1 k.w. transformer; the size glass plates and tin foil; and also how many of each; and what will my sending range be with a 1 k.w. transformer and this condenser, key, helix and a 100-foot aerial?

A. 1.—A condenser for a 1 k.w. transformer should have the following dimensions: 19 tin foil sheets, 8x10 inches, between 20 glass plates, 10x12 inches. Range with this transformer should be about 200 to 250 miles, under ordinary conditions.

Q. 2.—And what will my receiving range be with a Murdock loose couple tuner and sliding variable condenser, and a pair of 2,000 Pro. receivers and fixed condenser?

A. 2.—One thousand to 2,000 miles, with an electrolytic detector and suitable aerial.

**A DETECTOR QUERY.**

(953.) S. Breese, N. J., asks:

Q. 1.—Which is the more sensitive, a peroxide of lead or an electrolytic detector?

A. 1.—The electrolytic detector is probably the most sensitive of all detectors, under ordinary conditions.

Q. 2.—How far can I receive with an aerial 150 feet long, about 35 feet high, with three strands of aluminum wire, 1½ feet apart; one double slide tuning coil; one electrolytic

**HOLTZER-CABOT  
Receivers**

**For Wireless Operator's Use.**

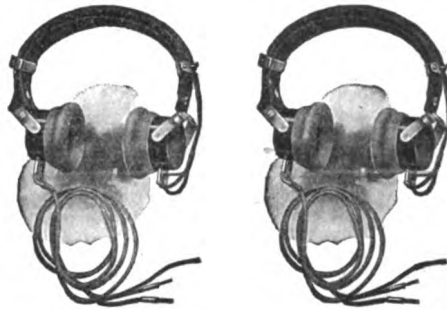

(Very Sensitive — Permanent Adjustment.)

500 Ohms to 4000 Ohms.

Adjustable Head Bands, (padded and pivoted.)

Pneumatic Ear Cushions.

SEND FOR BULLETIN 20 M 3.

**THE HOLTZER-CABOT ELEC. CO.**

BROOKLINE, MASS. and CHICAGO, ILL.

When writing, please mention "Modern Electrica."

**HOW TO RUN AN AUTO**

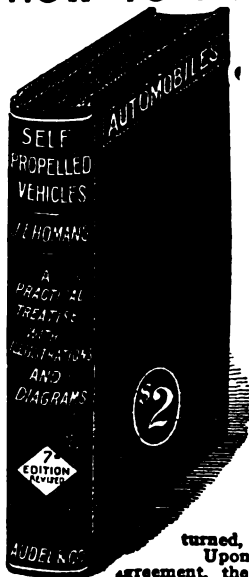

"Homans' Self Propelled Vehicles" gives full details on successful cars, handling and how to locate trouble.

Beginning at the first principles necessary to be known and then forward to the principles used in every part of a Motor Car.

It is a thorough 1911 course in the Science of Automobiles, highly approved by manufacturers, owners, operators and repairmen. Contains over 400 illustrations and diagrams, making every detail clear, written in plain language. Handsomely bound.

Price \$2.00 Postpaid

**APPROVAL OFFER**

The only way the practical merit of this MANUAL can be given is by an examination of the book itself, which we will submit for examination, to be paid for or returned, after looking over.

Upon receipt of the following agreement, the book will be forwarded.

**NO MONEY IN ADVANCE REQUIRED, SIGN AND RETURN**

Theo. Audel & Co., 63 Fifth Ave., New York  
Kindly mail me copy of Homans' Automobiles, and if found satisfactory, I will immediately remit you \$2.00, or return the book to you.

Name .....

Occupation .....

Address ..... Modern Electrica

# PATENTS

No attorney's fee until patent is allowed.  
Write for "Inventor's Guide."  
**FRANKLIN H. HOUGH,**  
Loan and Trust Bldg., Washington, D. C.

When writing, please mention "Modern Electrics."



**\$5**  
Will Start YOU  
Full Course \$15  
A Position Positively  
Guaranteed Paying  
**\$15 TO \$35**  
A WEEK IN NEW YORK CITY  
**Moving Picture Operating Taught**  
by correspondence or at our school  
Complete Moving Picture Machine furnished until  
you qualify. Over 1000 of my Students now employed  
Write for Catalogue B **TAYLOR'S SCHOOL** 50 W. 28th St.  
New York City

When writing, please mention "Modern Electrics."

## Faucet WATER MOTOR



Complete with emery wheel \$2.50  
buff wheel, pulley to run  
sewing and washing machine, pol-  
ish. In some cities where we have  
no agents, and where the water  
pressure is good, a sample motor will  
be given free; apply at once if  
you want to make some extra  
money, or if you can devote  
your whole time, liberal salary and  
commission will be paid.  
**ALCOHOL STOVES, LAMPS  
AND FLAT IRONS**  
ENGINEERS WANTED to send for catalog of in-  
dicators, Reducing Wheels Planimeters. Address,  
**LIPPINCOTT M. S. CO.**  
52 Columbia St.,  
Newark New Jersey

When writing, please mention "Modern Electrics."

## Typewriter Sacrifice Sale

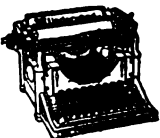

Greatest bargains ever offered.  
**Underwoods, Oliviers, Rem-  
ingtons, Smiths,** (All makes)  
rebuilt \$15 to \$38, worth  
double; sent subject to exam-  
ination and trial.

Send for "Bargain List"

(OLD RELIABLE)

**Consolidated Typewriter Exchange**  
245 Broadway, New York

Established 27 years on Broadway. Don't miss this  
chance to get a good typewriter at half price. Write  
immediately.

When writing, please mention "Modern Electrics."

detector; a potentiometer; a fixed condenser, and 75 ohm receivers?

A. 2.—About 40 to 50 miles.

### BATTERIES FOR 1/2 K.W. COIL.

(954.) Clydett Peter, Cal., asks:

Q. 1.—How many of E. I. Co.'s No. 555 storage batteries will it require to operate their 1/2 k.w. transformer coil to its full capacity? Electric light circuit not available.

A. 1.—We advise the use of two of these batteries, connected in series.

Q. 2.—Give the best hook-up for the following instruments: Receiving transformer; tubular fixed condenser; rotary variable condenser; electrolytic, ferron and silicon detectors; 2,000 ohm phones.

A. 2.—See diagram below.

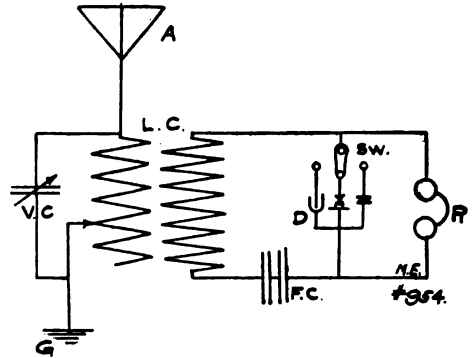

Q. 3.—What would be the receiving radius of the foregoing set with two poles, 100 feet high; aerial consists of a 6-wire spaced 4 feet apart; No. 14 copper wire; 100 feet span between the two poles; 6-wire lead-in ground, artesian well, 600 feet deep. Surrounding country very level?

A. 3.—About 1,000 to 1,500 miles, under ordinary conditions.

### CHARGING STORAGE BATTERIES.

(955.) Allen A. Gim, Tenn., asks:

Q. 1.—How many storage batteries (E. I. Co. type H. O.), would a 40-watt, 10-volt dynamo charge; and how long should current be on?

A. 1.—The dynamo will charge nine of this type of battery at once; if connected as in diagram below. The current should be

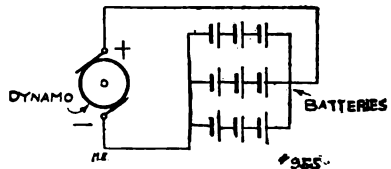

left on at least 8 to 10 hours without interruption, using 1 ampere.

Q. 2.—Can you give me the name and address of any company where I may obtain a one-eighth h.p. gasoline or steam engine?

A. 2.—For a small gasoline engine we advise you to apply to Detroit Engine Works, Detroit, Mich.

### WAVE LENGTH QUERIES.

(956.) F. M. Giffer, N. J., asks: .

Q. 1.—How can I find the wave-length of my station?

A. 1.—The *approximate* wave length of your station can be ascertained by multiplying the height of the aerial, above your instruments, in meters, times 4, added to the length of the wire on your tuning coil in meters, times 4.

Q. 2.—What size wave-lengths interfere with high-power stations?

A. 2.—Only sets having a wave length of 200 or 300 meters, or over, will interfere with the high-power stations.

Q. 3.—Can a No. 18 copper wire be used on a helix? If not, why not?

A. 3.—No. As the heating effects of this small wire would be too intense for this purpose. You should only use a wire not smaller than No. 12, for a helix.

**WIRELESS RANGE.**

(957.) M. M. McIntire, Cal., asks:

Q. 1.—What is the receiving range of my wireless set, consisting of: Aerial, 30 feet high at one end, and 20 at the other, composed of two strands of aluminium wire, two feet apart, and fifty feet long; a home-made tuning transformer, composed of a primary, wound with 100 feet of No. 18 D. C. C. wire, on a tube five inches in diameter, with two slides, and a secondary, three inches in diameter, wound with 231 feet of No. 36 D. C. C. wire; an "Electro"-lytic detector; potentiometer; 75 ohm receiver; and water-pipe ground?

A. 1.—You should be able to cover a distance of about 75 to 90 miles with the instruments mentioned above.

Q. 2.—Please tell me how to adjust an "Electro"-lytic detector when it is shunted with the secondary and batteries, according to the diagram given in the March, 1910, number of the *Modern Electrics*, under question No. 505.

A. 2.—Turn the adjusting screw, on the detector, down until the wire just touches the electrolyte. A faint click is then heard in the phones, and correct adjustment is accomplished when a faint hissing sound is heard after this click.

Q. 3.—What is the range of the following wireless set: Aerial 30 feet long, composed of three wires, one foot apart, thirty feet high; loose-coupled tuner; fused silicon detector; 75 ohm receiver; and water-pipe ground.

A. 3.—The receiving range with the above instruments should be about 50 to 60 miles.

**TUNGSTEN WIRE.**

(958.) J. H. Muth, Ohio, writes:

Q. 1.—Kindly inform me where I can buy Tungsten wire, please give names of firms, but not lamp makers. I want to buy the metal in large quantities; please give prices if possible.

A. 1.—Apply to Eimer & Amend, 18th Street and 3rd Avenue, N. Y. City; who will make you prices on Tungsten wire.

**TRANSFORMER QUERIES.**

(959.) Walter Phillips, Mont., writes:

Q. 1.—I have just completed a 2 k.w. transformer according to instructions in *Popular Electricity*, by Alfred P. Morgan; except that, where he says to use No. 32 on the secondary, I used No. 30. With all the primary in, the transformer gives the required voltage, but uses only five or six amperes; while it should take over eighteen. What could you suggest as a remedy?

**Something New in Insulators**



We present herewith our new departure antenna insulators which we are now offering in place of our regular antenna insulators, No. 10001.

They have the distinct advantage that there are no hooks to break out, and even if the insulator would be smashed, which is almost impossible, the aerial wires could not fall, because the loops of both antenna and support wires would hold each other.

These insulators are beautifully finished and have the highest insulating qualities. They will not leak any more than any good insulator, have a fine appearance, and are the lowest priced on the market.

No. 9461 is made of brown, TRIPLE glazed porcelain, size 1-4 x 3 1-2 in., weight 12 oz., for receiving only. Price 10 cents. Per doz. \$1.25.

No. 1166 is made of glass entirely, the most beautiful insulator ever made. Size 2 1-4 x 2 1-2 in., weight 11 oz., for receiving only. Price each 12 cts. Per doz. \$1.50.

No. 10341 (patent applied for). This insulator is made of the same material as No. 9461. It is longer and heavier. Its body is pierced by two round holes, through which the wire loops pass. For sending up to 2-in. spark length. Will not leak. By placing several of these insulators in series, large spark coils or transformers can be operated without fear of leakage. Size 3 x 2 1-4 in., weight 14 oz. Price each 16 cts. Per doz. \$1.95.

Send 2c. stamp for our new 128-page wireless cyclopedia No. 7, containing lots of information on wireless diagrams, etc.

**ELECTRO IMPORTING CO.**

"EVERYTHING FOR THE EXPERIMENTER"

233-2 Fulton Street  
New York

When writing, please mention "Modern Electrics."

Five expert mechanical engineers of the Du Pont Powder Company decided unanimously in favor of the

**L. C. Smith & Bros. Typewriter**



over all other makes. The Du Ponts immediately bought 521 machines to standardize equipment. Our Du Pont booklet telling about this will interest you. Send for it.

**L. C. SMITH & BROS. TYPEWRITER CO., Syracuse, N. Y.**

When writing, please mention "Modern Electrics."



**WE SHIP ON APPROVAL**

without a cent deposit, prepaid the freight and allow 10 DAYS FREE TRIAL.

IT ONLY COSTS one cent to learn our unheard of prices and marvelous offers on highest grade sport model bicycles.

**FACTORY PRICES** a bicycle or a pair of tires from anyone at any price until you write for our large Art Catalog and learn our wonderful proposition on first sample bicycle going to your town.

**RIDER AGENTS** everywhere are making big money exhibiting and selling our bicycles. We Sell cheaper than any other factory.

**TIRES, Coaster-Brake rear wheels, lamps, repairs and all sundries at half normal prices.** Do Not Wait! write today for our special offer.

MEAD CYCLE CO., Dept. T-244, CHICAGO

When writing, please mention "Modern Electrics."

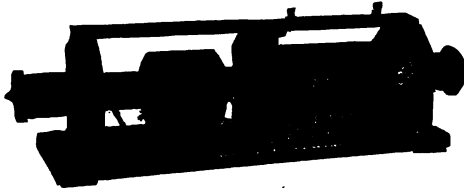
**Wireless Transformers and Induction Coils**

**½ K. W. Transformer complete \$30**  
**with Condenser and Spark Gap**  
 This is something new. Send for Catalog and Prices  
**E. S. RITCHIE & SONS**  
 115 Cypress St., Brookline, Mass.

When writing, please mention "Modern Electrics."

**CUTS OF SCREW MACHINE WORK**

Made to sample or Sketch

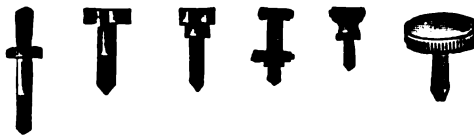

**BINDING POSTS, METAL PARTS AND OTHER SPECIALTIES. MAGNET WIRE.**  
 All kinds and sizes. Send for price list.

**S. M. COHN & CO.**  
 134 Liberty Street NEW YORK

When writing, please mention "Modern Electrics."

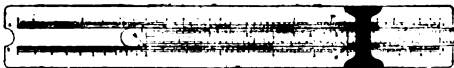

**DON'T CALCULATE.** Let the Slide Rule do it for you. Learn the use of this wonderful little instrument. You set the indexes and simply READ the result. Usually costs \$3 to \$4. Get one now for \$1.25 with complete instructions.  
**JOSEPH WORK, 108 N. 19th St., Philadelphia.**

When writing, please mention "Modern Electrics."

**"T. W. C." TRANSFORMERS AND CONDENSERS**  
 We are now manufacturing transformers and condensers up to 5 kw. and offer them for sale at reasonable prices. They are built for professional as well as amateur use and are designed to meet the requirements of a commercial station. Send for leaflet containing descriptions and prices.  
**TOLEDO WIRELESS CO.,**  
 2451 Collingwood Ave., Toledo, O.

When writing, please mention "Modern Electrics."

**Telegraphy-Big Outfit-50c.**  
 The original patented "Learner's Outfit." Key, Sounder, Wires and Book, postpaid, only 50c; extra loud, like railroad sets. To test this adv., we will include dry battery FREE if you mention "April Modern Electrics." Absolutely the best outfit ever offered by anyone anywhere for 50 cents. **THOMAS P. ST. JOHN, 848 9th Av., N. Y.**

When writing, please mention "Modern Electrics."

**HAVE YOU AN IDEA?**

Write for our books: "WHY PATENTS PAY," "100 MECHANICAL MOVEMENTS," "PERPETUAL MOTION"—50 Illustrations. MAILED FREE.

**F. C. DIETRICH & CO., Patent Lawyers, Washington, D. C.**

When writing, please mention "Modern Electrics."

The core is made of 28 gauge sheet iron, varnished on both sides; the legs of which are  $2\frac{1}{2} \times 2\frac{1}{2}$  inches. The other dimensions are given in the drawing. A movable tongue is also fitted. The total weight of core is between seventy and eighty pounds. The primary is wound with 250 turns of No. 8 B. & S. gauge, D. C. C. wire, with taps at 175, 200 and 225 turns. The secondary is wound with twenty-three pounds of No. 30 enameled wire, wound in fifteen pies of 3,500 turns each, and insulated by three blotting paper separators, soaked in paraffine.

The transformer is used on 60-cycle, 110-volt, A. C. By using from 100 to 125 turns of the primary, it takes the required amperage, but the voltage is objectionably high at the secondary terminals.

A. 1.—The only suggestion that we could make regarding your transformer, would be that your core is probably made out of an inferior quality of iron. This iron should be of very soft quality and also free from an excessive amount of impurities such as carbon, etc. We judge that by constructing your core of regular transformer iron the above fault will be remedied.

**SUBSTITUTE FOR AERIAL.**

(960.) H. S. Walker, N. Y., asks:

Q. 1.—If I connect one side of my bare-point detector with one side of house lighting circuit, and the other side of receiving circuit with water pipe, will the house circuit act as aerial?

As I am in no position to erect an aerial, and wish to receive from a distance of 25 miles, possibly you could recommend some means of substituting the aerial.

A. 1.—In the July, 1910, issue of *Modern Electrics*, page 207, Mr. Cropps writes that he has used the light circuit for an aerial and has been able to receive 100 and 150 miles with same, so by consulting this article and connecting as he mentions, you will probably get the same results.

**SHIP CODES.**

(961.) Arthur W. Clark, Conn., asks:

Q. 1.—What code do the Long Island Sound steamers use?

A. 1.—Morse Code.

**OPERATING RANGES.**

(962.) B. E. Kost, N. Y., writes:

Q. 1.—Please tell me the receiving distance of following: Aerial four wires, one foot apart and fifty long. One end, 38 feet from ground, other 25 feet; tuning coil; silicon detector; one 75 ohm receiver, and condenser of 25 sheets of tin foil, 7x4 inches.

A. 1.—You should be able to cover a distance of about 25 to 30 miles with the above-mentioned instruments.

Q. 2.—Is this aerial safe from lightning: lead-in wire of two No. 18 copper wire, grounded on porcelain switch; ground wire of four No. 18 twisted copper wires, grounded with common knife in damp ground?

A. 2.—Your lead-in wires should be constructed of at least No. 10 wire; and the ground wire should consist of No. 4, rubber covered copper wire. Also the knife

ground mentioned is altogether too small and does not serve for good protection. We advise you to bury at least a 4-foot copper plate in continuously damp ground. Also use a 100-ampere switch for grounding your aerial during storm.

**BANKRUPT SALE.**

The undersigned trustee will sell, at public auction on May 17, 1911, at eleven o'clock in the forenoon, the electrical supply business of the Electric Motor & Equipment Company, now being conducted by the trustee at No. 219 Market Street, Newark, N. J., at which place the sale will be held.

The property to be sold consists of a large stock of merchandise, store fixtures, office furniture and fixtures, the trustee's right, title and interest in a lease to the said premises expiring May 1st, 1913, with a privilege of renewal for an additional two years, together with the good will of the said business as a going concern.

The property may be inspected any business day. Further information, including catalogue, will be sent on application to the undersigned trustee, or his attorneys.

**HARRY V. OSBORNE, Trustee,**  
164 Market Street, Newark, N. J.  
**BILDER & BILDER, Attorneys of Trustee,**  
Offices: 164 Market St., Newark, N. J.  
Romaine Bldg., Paterson, N. J.

To introduce our carefully selected wireless goods, we will fill orders received before May 30th, for the following:—Spark Coils 30%; Rotary Variable No. 9, 10; off catalog prices.

Head Set 2000 Ohms, moulded receivers with enamel insulated copper winding, adjustable leather covered head band and five foot cord, \$4.50.

Just out: a new Rotary Condenser for portable sets, \$3.50. Write for particulars.

**J. ELLIOTT SHAW CO.**  
Wm. Gibson (Sole owner).  
632 Arch St. Phila., Pa.

A GREEN WRAPPER means that your subscription has expired. Subscribe to-day before you forget it.

**PATENTS**

**TRADEMARKS and COPYRIGHTS SECURED OR FEE RETURNED**

**Guide Book and What to Invent**

With valuable List of Inventions Wanted sent free. **ONE MILLION DOLLARS** offered for inventions; Electrical Cases a Specialty. Patents advertised free.

**VICTOR J. EVANS & CO., Washington, D. C.**

**\$5. HIGH GRADE RECEIVERS ONLY. \$5.**

We concentrate all our energies on Wireless Receivers that are guaranteed to give best results, or return your money without question.

**Positively no Risk. Write at once for Proof.** Price, complete, double receivers with double head-band and six-foot cord—**ONLY \$5**—all charges prepaid. Single set, \$3.

These receivers are equal or better than those sold by most houses at more than double this price.

**W. & A. RECEIVER CO.,**  
3523 North 18th St., Philadelphia, Pa.

When writing, please mention "Modern Electrics."

**WONDERFUL NEW DETECTOR**

The perfect detector found at last. **NO ADJUSTMENT** of minerals, no sloppy acids. 25 per cent. more sensitive and 50 per cent louder than **ANY OTHER.** The only detector that is always on the job. Price \$1.75, postage 16c extra. Send 3c in stamps for large illustrated catalogue of electrical specialties and **WIRELESS APPARATUS.**

**FRANKLIN ELECTRIC NOVELTY & MFG. CO.,**  
846 Ninth Avenue, New York, N. Y.  
**Levy Electric Co., San Francisco, Cal., Western Agents.**

When writing, please mention "Modern Electrics."

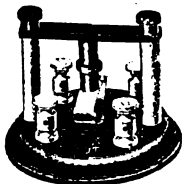

**TELEGRAPHY TAUGHT**

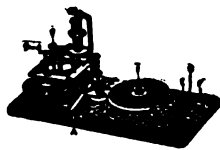

In the shortest possible time The Omnigraph Automatic Transmitter combined with standard key and sounder. Sends you telegraph messages at any speed just as an expert operator would. Five styles \$2 up. Circular free. Omnigraph Mfg. Co. 39% Cortlandt St., New York

When writing, please mention "Modern Electrics."

**SPECIAL COMBINATION OFFER OF WIRELESS STOCKS**

- One share MARCONI WIRELESS of America, par value .....\$25.00
- One share MARCONI WIRELESS of Canada Par value ..... 5.00
- One share MARCONI WIRELESS of England, Common, Par value ..... 5.00
- One share MARCONI WIRELESS of England, Pref. (dividend paying), Par value ..... 5.00
- Total four (4) shares (Par value \$40.00), cash with order, all for.....\$30.00

**P. C. KULLMAN & CO.**

Established 1889

The Wireless Brokers, 68 Wall St., New York.

**Patents 25 Years' Experience**  
**New Easy Plan of Payment**

BOOK MAILED FREE, telling all about Patents and how to obtain them. Illustrates 100 MECHANICAL MOVEMENTS, VALUABLE FOR INVENTORS.

**CHAS. E. BROCK, Patent Attorney**  
912 F Street, WASHINGTON, D. C.

**PATENTS**

**C. L. PARKER**

Ex-Examiner U. S. Patent Office  
**PATENT LAWYER**  
8 McGill Bldg., Washington, D. C.

PATENTS, TRADEMARKS, COPYRIGHTS, PATENT LITIGATION  
Handbook for Inventors. "Protecting, Exploiting and Selling Inventions" sent free upon request.

When writing, please mention "Modern Electrics."

**PATENTS**

**THAT PROTECT AND PAY**

Books, Advice, Search and List of Inventions Wanted **FREE.** Send Sketch or Model for Search. Highest References. Best Results. Promptness Assured.

**Watson E. Coleman, Patent Lawyer**  
622 F ST. N. W. WASHINGTON, D. C.

When writing, please mention "Modern Electrics."

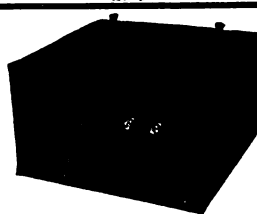

**90 MILES**

with 1-4 Kw.

"W-M"

**TRANSFORMER**

**WORTS-MCKISSON MFG Co., Toledo, O**—Gentlemen: Your 1-4 Kw transformer received, and must say it works to perfection. I have talked to the steamships 90 miles from shore in the Day Time. Can and will recommend your instruments whenever I have the opportunity. Yours truly, (Signed) J. J. WATERS, Port Richmond, N. Y.

Our new leaflet "C" lists 21 different sizes of transformers for any frequency or voltage. 1-4 Kw. 110 V., 60 cycles, \$16 00. 1-2 Kw. 110 V., 60 cycles, 20.00.

**Worts-McKisson Mfg. Co., Dept. D, Toledo, Ohio.**

When writing, please mention "Modern Electrics."

**CLASSIFIED ADVERTISEMENTS**

Advertisements in this column, 3 cents a word, no display of any kind. Payable in advance. Stamps not accepted. Count 7 words per line. Minimum, 2 lines. Heavy face type 4 cents a word. Minimum, 3 lines.

Advertisements under "Wireless" 5 cents a word. Minimum, 4 lines. Wireless books and blue prints not listed under "Wireless," 2 cents a word.

**ADVERTISEMENTS FOR THE JUNE ISSUE MUST BE IN OUR HANDS BY MAY 25.**

**ELECTRICAL APPARATUS**

1000 guaranteed pocket ammeters for testing batteries. Handsomely nickelplated. Each instrument in a chamomeli leather case, 25c postpaid. Stamps taken. Auto Repair Co., 521-23 West 144th St., New York.

**SPARK COILS** for sale; send for list. Wm. Canty, 7 Dane St., Somerville, Mass.

**ELECTRICAL BOOKS, BLUEPRINTS, ETC**

**SCIENTIFIC BOOKS** on Electricity, Mechanics, Trades, etc., for Skilled Tradesmen and Experimenters. Catalogue free. Clarence B. Hardage, Book-Monger, Syracuse, N. Y. (12)

**CHAUFFEUR'S BLUE BOOK**—40 illustrations, shows how to drive, adjust and maintain automobiles and pass examinations, 50c. License guaranteed. Chas. B. Milward, 1546 N. 60th St., Philadelphia, Pa.

**POCKET LAWYER**; invaluable treatise, 127 pages, now 10c. Interboro Book Co., New York.

**CHARACTER DICTIONARY**; learn to read faces; formerly \$1.00, now 25c. Interboro Book Co., New York.

**BLUE PRINTS**—Data on all sizes, transformers and coils, wireless hook-ups, construction model Bierlot Monoplane. Set 20 cents. Harcastle & Schultz, 1111 Travis St., Houston, Tex.

**FREE ILLUSTRATED BOOK** tells about over 360,000 protected positions in U. S. service. More than 40,000 vacancies every year. There is a big chance here for you, sure and generous pay, lifetime employment. Easy to get. Just ask for booklet A947. No obligation. Earl Hopkins, Washington, D. C.

**ELECTRICITY** in all branches and applications. Described in plain practical language. Including X-Rays, wireless, wiring and lighting of houses, with estimates of cost; 119 illustrations. 272 page cloth book, 25 cents. Allen Book Co., Dept. M., 818 E. 47th Place, Chicago.

**POSTAGE STAMPS**

**COLLECT POSTAGE STAMPS!** Write for free packet. E. Palmann, 76½ Nassau St., New York.

**WIRELESS WIRELESS FIENDS.**

Phosphor Bronze Aerial Wire as used by Government, the best yet. Just imported 25,000 feet. 1½ cts. per foot. Bornite and Zincite, the most sensitive combination, 50 cts. per set. Zincite and Copper Pyrites, 50 cts. per set. Silver plated brass cup for mounting crystals, 10 cts. each. Sliders (for square rod ¼-in. x ¼-in.) with ball and spring, 20 cts. complete. Black Asphaltum, Black and White Shellac, liquid ready for use, large bottle, 25 cts. Spool containing 1000 Ohms No. 50 Copper Wire, 60 cts. Silicon or Molybdenite, large piece, 15 cts. Send postage stamp for 196 page Catalog.

Electro Importing Co., 233-z Fulton St., N. Y.

Wireless fiends save freight and expressage. Why order from the East if you can secure ALL wireless goods on the Coast? We carry largest assortment of wireless apparatus in Frisco. Can make prompt shipments. Call or send postage for catalog. Paul Seller Electric Works, Market street, San Francisco, Cal.

When writing, please mention "Modern Electrics."

**COMPLETE LONG DISTANCE RECEIVING** set with 1000 receiver, \$5.95. Pair of guaranteed double-hole 1000 ohm receivers split head-band and six foot silk cord, \$5.25. Slider rod, 10c foot. Sliders, 23c. Reliable apparatus and supplies of all kinds. Send stamp for catalogue. Aiden Wireless Co., Dept. M., Campello, Mass.

**LARGE SUPPLY** wireless goods, taken in payment of debt. Will sell cheap. Send 2c for catalog or call. DeWitt, Room 926, Tribune Bldg., New York.

**WIRELESS APPARATUS** of all kinds for sale. If interested send stamps for prices to Evans, Grotz and Mertz, 1120 West St., Wilmington, Delaware.

**FERRO-SILICON: JUST OUT. TESTED CRYSTAL, 25 CENTS POSTPAID. LIMITED SUPPLY. ORDER TO-DAY. WIRELESS SUPPLY CO., P. O. BOX 727, NEW ORLEANS, LA.**

**NEW WIRELESS MINERAL.** To advertise it, will send it postpaid for 5c coin. Harold Hinckley, 23 Walnut St., Everett, Mass.

When writing, please mention "Modern Electrics."

**FOR SALE**

**FOR SALE:** 70 watt dynamo, wound for 15-20 volts; is new and in good condition; cost \$15, sell for \$7.50. Alvin W. Adams, Lowell, Wis.

**FOR SALE:** Large leading-in insulator, No. 6 rubber covered, leading-in wire 75 feet, full mechanical drawing outfit, six volumes electrical engineering course, spark gap, tuning coil, two thousand ohm navy type head phones, 2000 ohm amateur type head phones, quart gasoline torch, 20 ohm sounder key and resonator, 150 ohm relay. For prices, write H. Lang, care Western Union Telegraph Company, Tacoma, Washington.

**FOR SALE:** Complete E. I. Co.'s receiving outfit. Th. Hollman, 678 Marcy Ave., Brooklyn, N. Y.

**FOR SALE:** Two 1000 ohm receivers, \$1.00 each. One good one-inch coil, \$4.00. Myers, 402 West Rensselaer St., Bucyrus, Ohio.

**FOR SALE:** A 1 kw. open core transformer, wound with No. 30 enameled wire. Price \$12.50. Howard Rowan, Muskegon Heights, Mich.

**FOR SALE:** Brass moulds for casting storage battery plates. Home Mfg. Co., 5419 Windsor Ave., Jefferson Park, Chicago, Ill. (5)

When writing, please mention "Modern Electrics."

**WANTED**

**WANTED:** Manufacturer's agency for electric supplies and specialties—St. Louis, Missouri, and vicinity. Address Box 604, Albuquerque, New Mexico (temporarily).

**WANTED:** A 2 kw. rotary converter to give 110 volts A. C. from 110 volts D. C. Must be in good working condition. Send description and price. P. O. Box 60, Toledo, Ohio.

**WIRELESS ENGINEERS WANTED:** Our method enables you to master wireless at home. Absolutely the best and most up-to-date course ever given by mail. Don't fail to write for particulars today. Kenosha Wireless School, Kenosha, Wis.

**WANTED MEN** to sell our Modern Gasoline Lighting Systems, adapted for lighting stores, churches, residences, etc.; better light at 1-10th the expense of any other medium; reasonable in price, easily installed; exclusive territory; write today for FREE Illustrated Catalogue. Doud Lighting Co., 183 N. Sangamon St., Chicago, Ill. (3)

When writing, please mention "Modern Electrics."



**FREE TWO BOOKS:**  
61-Page "Inventor's Guide"  
AND  
64-Page "Proof of Fortunes in Patents—What and How to Invent."

**FREE**  
The above - entitled books will tell you How to Secure Money to "Patent" Your Invention, How to Sell Your Patent, and ALL about the  
**Great Success of My Clients**

Trade-Marks, Copyrights, Prints, Labels, Registered.

**ADVICE FREE.**  
Correspondence Solicited.

**PROTECT YOUR IDEA!**

# Patents THAT Pay

**"MY TRADE-MARK"**

"Your business will have my personal attention.—" E. E. V.

\$ 180,340.00 \$

MADE BY MY CLIENTS

**YOU SHOULD Have My FREE BOOKS Telling HOW OTHERS will do the same IN THE FUTURE "WHAT and HOW to INVENT" BOOK FREE**

**REFERENCES—**

- American National Bank Washington, D. C.
- Little Giant Hay Press Co. Dallas, Tex.
- Gray Lithograph Co. New York City, N.Y.
- Farmers Mfg. Co., Norfolk, Va.
- New Era Mfg. Co. Fairfield, Ia.
- The Parry Stationery Co. Oklahoma City, Okla.
- Bell Show Print Co. Bigourney, Ia.
- The Camp Conduit Co. Cleveland, O.
- The Iowa Mfg. Co. Oskaloosa, Ia.
- Sam'l Allen & Son Mfg. Co. Danville, N.Y.
- The Garl Electric Co. Akron, O.
- Superior Mfg. Co. Sidney, O.
- Tidnam Tel. Pole Co. Oklahoma City, Okla.
- Bernhard Furst Vienna I. Austria-Hungary
- Compound Motor Co. Brooklyn, N.Y.

I advertise my clients' patents free in a magazine having a two million circulation.

MY FEE RETURNED IF "PATENT" IS NOT ALLOWED

(SEE LIST OF REFERENCES—THEY TALK!)

HIGH CLASS WORK      EXCELLENT TESTIMONIALS

SUCCESSFUL CLIENTS IN EVERY SECTION OF THE U. S.

Expert-Prompt Services

Highest References

809 F. ST., N. W.

E. E. VROOMAN, Registered Patent Attorney  
Patent Litigation  
PATENT LAWYER Wash., D.C.

My offices are located across the street from the U. S. Patent Office.

When writing, please mention "Modern Electrica."

READY NOW

# "Wireless Hook-Ups"

96 PAGES      160 "HOOK-UPS"

This is No. 4 of our popular "ELECTRIC LIBRARY." This book, at the price we are selling it, is by far the greatest bargain we have ever offered.

The book contains nothing but wireless connection diagrams in a concise and clear manner, fully illustrated. Every conceivable diagram is here—none missing—from the simplest receiving diagram to the most complicated sending and receiving hook-up.

No matter what instrument you have, you will find a perfect hook-up, THAT WORKS, in our new book. Besides good directions, explanations, etc., are given wherever necessary.

If you are not familiar now to read diagrams, you will learn quickly, as a thorough course in how to read and study diagrams is given in the front part of the book.

This book will be the delight of every wireless "fiend" and will enable him to get far better results from his instruments and cover much greater ranges.

This book will, without doubt, bring real enjoyment in every up-to-date station, because it will enable the experimenter to change the connections of his apparatus to suit his wants.

Again we say, you are not getting full satisfaction from your set until you get this book.

Fourteen hundred books were ordered up to May 1st, before the book was even out, and orders are pouring in fast each day. Each order is filled in its turn, hence we urge you to order today—tomorrow you'll forget. Suppose before you turn this page, you sit down and mail us 25 cts., using the coupon, and you will surely not regret it.

PRICE 25 CENTS PREPAID

MODERN ELECTRICS PUBLICATION, 233 Fulton St., New York

—SEND US THIS COUPON—

Modern Electrics Publication,  
233 Fulton St., New York, U. S. A.,  
Please send me at once one copy of your new book "WIRELESS HOOK-UPS" for which I enclose 25c in

Name.....

St. and No.....

City..... State.....

# "Construction of Induction Coils and Transformers"

## CONTENTS

Compiled by H. W. SECOR

100 PAGES

72 ILLUSTRATIONS

The Induction Coil, its history and theory.  
 Coil Construction.  
 Secondary Coil impregnation.  
 Electric Stars  
 The Induction Coil as a means of amusement.  
 Interrupters.  
 How to build an efficient Spring Vibrator.  
 Construction of an Independent Vibrator.  
 Simple Wehnelt Interrupter.  
 An Adjustable Impedance Coil.  
 A Tesla Coil.  
 A Tesla Disruptive Coil.  
 Air Insulated Tesla Coils.  
 A large Demonstration Tesla Coil.  
 Experimenting with the Tesla Coil.  
 The High Tension Transformer.  
 How to build one-half to 3-kilowatt Closed Core Transformers.

### APPENDIX

Table of Spark Coil Dimensions one inch to twenty inch.  
 Table of Spark Coil Dimensions, one inch to twelve inch, heavy spark.  
 Table of Dimensions one-quarter inch to ten inch with enamel wire secondaries.  
 Table of open and closed Core Transformers 1/2 to 3 K. W.  
 Table of Glass Plate Condensers, for Transformers up to 5 kilowatt and spark coils 1 inch to 12 inch.  
 Table of Sparking Distances for various voltages. Inductivities of Dielectrics and method of finding condenser capacity.  
 Tables of turns per inch and feet per pound of insulated magnet wire.  
 Table of Soft Iron Core Weights. Tables giving the cost of wire, raw material, etc.

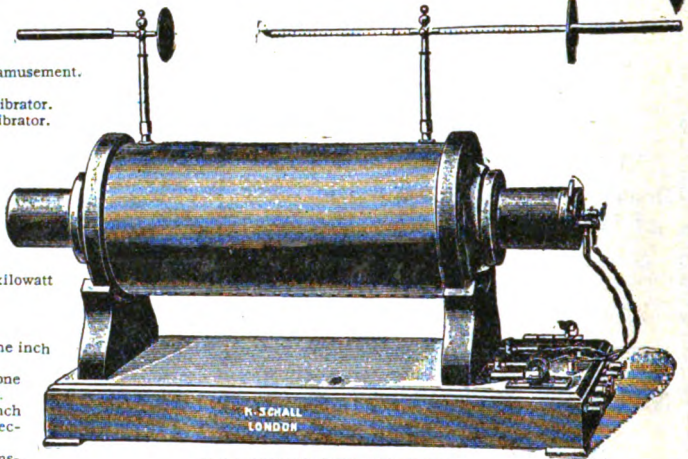

A 14 INCH SPARK COIL

You cannot afford to be without this book, the very latest on the construction of any size induction coil or high potential transformer for use in wireless telegraphy or X-ray work.

**PRICE, 25 CENTS, PREPAID**

# "HOW TO MAKE WIRELESS INSTRUMENTS" How to Make

BY 20 WIRELESS EXPERTS

96 PAGES

75 ILLUSTRATIONS

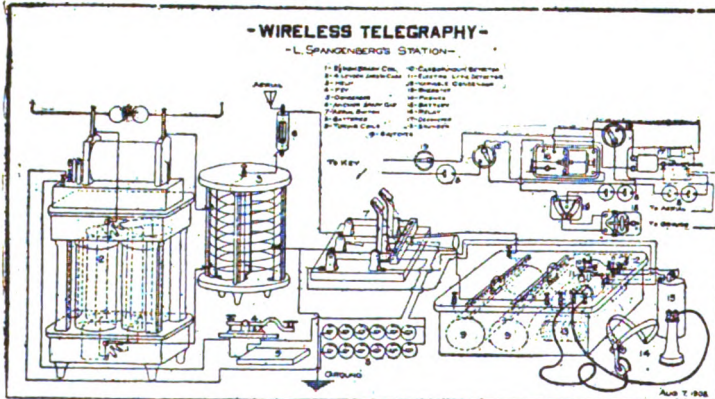

- a loose coupler.
- a microphone detector.
- a simple antenna.
- a spark gap muffler.
- a 1000-ohm relay.
- a carborundum detector.
- a bare point electrolytic detector.
- a selective tuner with weeding out circuit.
- a coil vibrator attachment.
- an electrolytic detector.
- suspend and insulate aerials.
- an iron pipe aerial.
- a tantalum detector.
- a transmitting helix.
- a potentiometer.
- an interrupter and detector combined.
- an electrical resonance apparatus.
- a wireless without aerial.
- a talking condenser.
- a two-mile wireless station.
- a tuning coil.
- a silicon detector.
- the simplest and most efficient wave detector.
- a wireless by speech only.

Our new book is the only one of its kind and contains more information on the construction of wireless instruments and apparatus than any book ever published — no matter what its price.

It contains descriptions of twenty-five different pieces of apparatus, each fully illustrated. Clear photographs of the actual apparatus, diagrams, dimensions and sketches of the necessary pieces will be found in great profusion.

A book that every experimenter and amateur in the wireless art must possess.

**PRICE, 25 CENTS, PREPAID**

**Modern Electrics Publication, 233 FULTON ST. NEW YORK**

# CASSELL'S CYCLOPÆDIA OF MECHANICS

## A GOLD MINE OF MECHANICAL REFERENCE

6,500 ILLUSTRATIONS 30,000 INDEXED ARTICLES  
FIVE HANDSOME VOLUMES



Edited by  
PAUL N. HASLUCK

A Practical  
"Mechanics' Bible"  
of Ready Reference

### Examine This Famous Mechanical Library in Your Home Free

Cassell's Cyclopaedia of Mechanics is an authoritative work, well printed and handsomely bound in five volumes. Written by a staff of skillful and talented mechanical and technical writers, under the direct editorship of Paul N. Hasluck, the foremost living writer on mechanical subjects—every paragraph the paid contribution of an expert. The work is practical from cover to cover, constituting a thoroughly trustworthy reference library and key to up-to-date workshop practice, full of plainly worded and well illustrated articles of interest to all who want a receipt, employ a mechanical process, or stand in need of an item of information concerning mechanical and practical matters. This great work fulfills a long felt want among practical mechanics as well as amateurs and beginners. Students who have previously found that there is nothing to be learned from the compilations of untried and possibly impracticable suggestions and receipts will find Cassell's Cyclopaedia of Mechanics thoroughly dependable and practicable. The work contains over 6,500 illustrations and 30,000 separately indexed articles; over 2,500,000 words. The five volumes number 1760 pages in all, each volume measuring 7½x10½ inches, strongly bound in stout extra durable cloth binding with lettering in gold. The type is large, clear and easy to read. So vast in fact is the scope of the work that only a leisurely examination can do it justice. That is why we make you this out-and-out offer to place it **free** in your home—we know you will find it the best and most valuable mechanical library for you.

### Examine This Great Set of Books at Our Expense

We want you to SEE this famous five volume work for we know you will be pleased with its binding, paper and printing and the wonderful fund of information it contains. We want you to EXAMINE it thoroughly, for we know you will be quickly impressed with its great practical value. We want you to ENJOY the finest mechanical library ever offered to discriminating professional or amateur mechanics. The price of this complete work in five volumes as above described is \$18. Just mail us the coupon opposite (send no money) and you will receive the set, carriage paid. Examine it five days. If, at the end of that time, you do not want it, notify us and hold subject to our order. If you keep it, pay us \$2.00 within five days and the balance \$2 a month until paid.

**Modern Electrics Publication**  
233 Fulton St., New York

5-11  
**M. E.**  
233 Fulton St.  
N. Y. C.

Gentlemen:—  
Kindly send me, carriage prepaid, for free examination, one complete set of Cassell's Cyclopaedia of Mechanics, in five volumes. It is understood that I may examine the work five days, and if I do not wish to keep it I agree to notify you and hold, subject to your order. If I keep it, I agree to pay you \$2 within five days and the balance of \$16 in monthly installments of \$2 until settled in full.

NAME.....  
ADDRESS.....  
REFERENCES.....  
Send this coupon or a copy of it.

Sign and mail this coupon today

When writing, please mention "Modern Electrics."

# THE WIRELESS TELEPHONE

By **H. GERNSBACK**

**80 Pages . . . . 57 Illustrations**

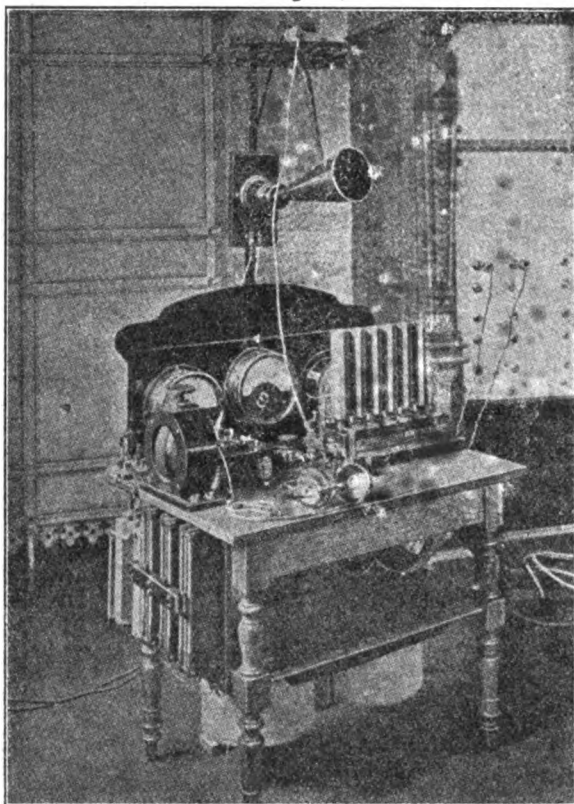

A WIRELESS TELEPHONE STATION

**T**HIS NEW BOOK, by Mr. Gernsback, stands in a class by itself.

It not alone describes the most important systems, but treats the subject from the experimenter's standpoint, in such a manner that even the less advanced student will have little trouble to clearly grasp the matter.

The book is the most up-to-date one and contains a digest of all the latest patents on wireless telephony, both in the United States and abroad.

This book is an absolute necessity to the rising wireless experimenter who desires to keep abreast with the progress of the new art, that will within five years, revolutionize telephone communication.

This book also contains directions for building small wireless telephone stations at a cost under five dollars for short distances up to one mile.

It had been our intention to sell this book for \$1.00 on account of its great value, but we believe that the demand will be so great for Mr. Gernsback's book that the low price at which it is sold, will repay us in time.

As we expect several thousand orders, it will be wise to order at once, so you will not be delayed.

**Price Twenty-five Cents Prepaid**

CLOTH BOUND, FIFTY CENTS

Send money or express order or coin, stamps or checks not accepted

---



---

**MODERN ELECTRICS PUBLICATION**

233 FULTON STREET, NEW YORK CITY

# The Greatest Magazine Bargains

We Save You As Much As 40 Per Cent. On Your Subscriptions

MODERN ELECTRICS.....	\$1.00	<b>OUR PRICE</b> <b>\$3.00</b>
COSMOPOLITAN (or American, or Good Housekeeping)	1.50	
REVIEW OF REVIEWS.....	3.00	
Regular Price, -		<b>\$5.50</b>

Modern Electrics.....	\$1.00	<b>Our Price</b> <b>\$4.05</b>
World's Work.....	3.00	
Everybody's.....	1.50	
Delineator.....	1.00	
Regular Price, -	<b>\$6.50</b>	

Modern Electrics.....	\$1.00	<b>Our Price</b> <b>\$5.40</b>
Pearson's.....	1.50	
Leslie's Weekly.....	5.00	
Regular Price, -	<b>\$7.50</b>	

Modern Electrics.....	\$1.00	<b>Our Price</b> <b>\$4.25</b>
Good Housekeeping.....	1.00	
The Outlook.....	3.00	
Regular Price, -	<b>\$5.00</b>	

Modern Electrics.....	\$1.00	<b>Our Price</b> <b>\$4.20</b>
Review of Reviews.....	3.00	
McClure's Magazine.....	1.50	
Woman's Home Companion.....	1.00	
Regular Price, -	<b>\$7.00</b>	

Modern Electrics.....	\$1.00	<b>Our Price</b> <b>\$2.15</b>
Pictorial Review.....	1.00	
Cosmopolitan, (or American or Good Housekeeping).....	1.50	
Regular Price, -	<b>\$3.50</b>	

Modern Electrics.....	\$1.00	<b>Our Price</b> <b>\$2.40</b>
The World Today.....	1.50	
Pearson's.....	1.50	
Regular Price, -	<b>\$4.00</b>	

## MODERN ELECTRICS IN CONNECTION

	REGULAR PRICE	OUR PRICE
With Ainslee's.....	\$2.80	<b>\$1.85</b>
" American Boy.....	2.00	1.45
" The Book-keeper.....	2.00	1.45
" Cosmopolitan.....	2.50	1.50
" Cycle & Automobile Trade Journal.....	3.00	2.30
" Farm Journal.....	2.00	1.45
" Fruit Grower.....	2.00	1.35
" Good Housekeeping.....	2.25	1.70
" Gunter's Magazine.....	2.50	2.00
" Harper's Magazine or Weekly.....	5.00	4.30
" Bazaar.....	2.00	1.50
" Judge's Weekly.....	6.00	5.90
" The Ladies World.....	1.50	1.10
" Leslie's Weekly.....	6.00	5.00
" Lippincott's.....	3.50	2.50
" McClure's Magazine.....	2.50	1.80
" Metropolitan.....	2.50	1.75
" Modern Priscilla.....	1.75	1.30

	REGULAR PRICE	OUR PRICE
With Motor Boat.....	\$3.00	<b>\$2.30</b>
" The Musician.....	2.50	1.80
" North American Review.....	5.00	4.30
" The Outlook.....	4.00	3.50
" Pacific.....	2.50	1.80
" Pearson's.....	2.50	1.50
" Pictorial Review.....	2.00	1.50
" Popular Magazine.....	4.00	3.00
" Recreation.....	4.00	3.00
" Review of Reviews.....	4.00	2.30
" Scientific American.....	4.00	3.30
" Telephony.....	4.00	3.10
" Suburban Life.....	4.00	3.05
" Success.....	2.00	1.50
" Sunset.....	2.50	1.30
" Travel.....	2.50	1.80
" Women's Home Companion.....	2.50	1.75
" The World Today.....	2.00	1.40

Canadian and Foreign Postage to be added to above prices.  
 We will gladly quote on any Magazine combination not listed above.  
 Prompt and careful service assured.  
 It is impossible to get the Magazines quoted in our list cheaper elsewhere.

MAIL ALL ORDERS TO

## Modern Electrics Publication

233 FULTON STREET NEW YORK

# YOU MUST BE MASTER of a Trade to be Master of a Business LEARN ELECTRICITY

**T**HE son of a Millionaire Englishman came to America recently to take a course in the New York Electrical School.

His father will soon turn over to him the full care and responsibility of a huge business that has an immense plant. The young man intends to manage the business himself. He wants to know whether the business is running right. To do this he must have a working knowledge of every line of work that enters into the conduct of the plant.

Electricity plays a large part in his plant. So he decided to learn the Electrical business.

The New York Electrical School was selected as the best school to give him a thoro knowledge of electricity in both theory and practice.

We taught him Electricity. He left New York for England prepared to handle every electrical problem that might arise, and to do the work himself if necessary.

You can learn Electricity and it will pay you to do so, whether you want to earn your daily bread or to rise to the head of some great business.

Electricity is the best paying industrial business in America say Government statistics.

## Learn the Electrical Business

WRITE FOR FULL INFORMATION

ADDRESS

**New York Electrical  
School**

26 W 17th St., New York, N. Y.

SEND THIS COUPON

NEW YORK ELECTRICAL SCHOOL,  
26 W. 17th St., New York, N. Y.

Please send me full information about your course  
in electricity.

NAME .....

ADDRESS .....

When writing, please mention "Modern Electrics."

# NEW PREMIUMS

We offer below a new assortment of premiums any one of which may be obtained by a little extra effort. You read Modern Electrics, which means it must be good, then show it to your friends. Help us, and help yourselves. You don't have to be a subscriber to take advantage of this chance to obtain a valuable instrument for nothing; it takes just a few minutes of your time. Get the subscription, send it to us and we will forward by return mail the premiums you select. Your own (new) subscription will count. Now get busy and get a practical present FREE.



Junior Fixed Condenser.

Used in all modern receiving sets. Special dielectric giving extra high capacity. Sealed in hard rubber base with binding posts, as shown. Sells for \$0.50.

(Add 6 cents for postage)

Given free for one subscription



Electric Scarf Pins. Many unique Styles. Fitted with cord and plug, and attachable to any flashlight by removing the lamp. Scarf Pin sells for \$0.45.

(Add 4 cents for postage)

Given free for one subscription



Zinc Spark Gap mounted on hard rubber base. Electrodes fitted with rubber handles. Pure zinc rods. Used in all of the best stations. Spark gap sells for \$0.60.

Add 7 cents for postage.

Given free for two subscriptions



Voltmeter or Ammeter. 1-1½ volts 1-15 amperes. 2½-inch face, heavily nickered and reliable. Dead beat, a first-class instrument. These meters sell for \$2.00.

(Add 7 cents for postage)

Given free for five subscriptions



Automatic Blow Torch.

The handiest torch made. Gives a solid blast of flame for soldering purposes, without any artificial blowing. The

very latest. Torch sells for \$0.50. (Add 10 cents for postage)

Given free for one subscription



"Electro" Rheostat. Rotary adjustment. Air cooled. Very useful to vary the speed of motors and small lamps.

with non-rusting wire.

Given free for one subscription

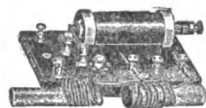

"Electro" Medical Coil. All quality. No end of fun with one of these coils, besides its therapeutic properties. Complete with cords and handles. Medical Coil sells for \$0.70. Add 12 cents for postage.

Given free for three subscriptions



"Electro" Amateur Phones, 2000 ohms resistance. Wound with No. 50 copper wire. Thin diaphragms. Leather covered adjustable headband. Weight 15 oz. 80 per cent. better than 75 ohm phones. Phones sell for \$4.50. Add 25 cents for postage.

Given free for ten subscriptions



The "Electro" Flaming Pocket Lighter. Lights your cigars anytime. Fits in the vest pocket. It sells for \$0.35.

Given free for one subscription



"Telim" Auto Coherer. HARD RUBBER BASE. Needs no decoherer.

Complete with two carbon plugs, one iron plug, graphite-carbon grains and bottle of mercury. Auto-Coherer sells for \$0.80. Add 15 cents for postage.

Given free for two subscriptions



"Electro" Lytic Bare Point Detector. Holds the world's record for long distance receiving. Mounted on hard rubber base. Finest adjustment. Increase your receiving range 30 to 40 per cent.

"Electro" Lytic Detector sells for \$1.25. Add 12 cents for postage.

Given free for three subscriptions



One Inch Spark Coil. This is the coil that has sent a message 90 miles with a suitable aerial. None better made. High speed French vibrator. One inch coil. Sells for \$4.50. Sent by express only.

Given free for 12 Subscriptions

We are sure you can get any of the above premiums, if you show this Magazine to your friends. They will want it right away. Then's your chance, nab 'em! before the other fellows get 'em. Strike while the iron is hot. Act now. Don't delay. You won't get this chance again.

Send money orders or N. Y. Drafts, no checks or stamps.

## Modern Electrics Publication

233 FULTON STREET - - - NEW YORK CITY

## ENAMELED WIRE BARGAINS

We still have left a few sizes of our "old formula" enameled wire. It's perfectly good especially for wireless windings, but we don't care to sell it as regular stock. We will close it out at the following **EXTRAORDINARILY LOW PRICES. CASH MUST ACCOMPANY ORDER.** No order accepted for less than \$1.00.



Size	Feet per lb.	Price per lb.
20	880	\$ .25
22	500	.30
24	810	.32
30	3240	.56
34	8098	.94
36	12818	\$1.76

**AMERICAN ELECTRIC FUSE CO.**  
Dept. M Muskegon, Mich.

## METAL STAMPING

When writing, please mention "Modern Electrics."



### MODEL AEROPLANE SUPPLIES

Engines, 1/4 H. P. Weight, 4 1/2 lbs.—1 H. P. 6 1/2 lbs. Very strong, powerful and efficient. Complete line of accessories, ball-bearing propeller shafts. Miniature pneumatic tire wheels, made in six sizes. Turn buckles, metal fittings, propellers, rattan, bamboo, all sizes of selected woods, finest grade English Rubber strand, etc.

CORRECT PRICES, COMPLETE CATALOGUE  
SENT ON REQUEST

### THE WHITE AEROPLANE COMPANY

Retail Store & Office, 1337 ADAMS ST.  
Factory, 15 Myrtle Ave. BROOKLYN, N. Y.

## FOUR EXTRAORDINARY OFFERS.

the 51,000 readers, who are now regular subscribers, and in order to do so, we are willing to go to an EXTRAORDINARY EXPENSE, never before attempted by any magazine.

To make May our banner subscription month, we are willing to make the following **FOUR WONDERFUL OFFERS.** Frankly, we would like to see your name appear among

### OFFER NO. 1.

Send us \$1.00 cash, stamps, or money order, and in return, we will send you:

- 1—Modern Electrics for one year (May issue free) ..... \$1.00
- 2—Book, How to Make Wireless Instruments, cost ..... .25
- 3—Book, The Wireless Telephone, by H. Gernsback, cost ..... .25
- 4—Book, Construction of Induction Coils and Transformers, by H. W. Secor, cost.. .25

Total..... \$1.75  
(If books are to be mailed add 6c. postage)  
**TOTAL NET SAVING..... .75**

### OFFER NO. 3.

Send us \$1.00 cash, stamps, or money order, and in return, we will send you:

- 1—Modern Electrics for one year (May issue free) ..... \$1.00
- 2—Linen Binder (automatic) holds 12 issues M. E., gold stamped..... .50
- 3—Any one of the 3 books shown in offer No. 1..... .25

Total..... \$1.75  
(Mail charges for Items 2 and 3, 15c. extra.)  
**TOTAL NET SAVING..... .75**

### GREAT WIRELESS OFFER NO. 2

Send us \$1.00 cash, stamps, or money order, and in return, we will send you:

- 1—Modern Electrics for one year (May issue free) ..... \$1.00
- 2—Wireless Code Chart, cardboard; size 9x12 in., Morse, Navy and Continental codes .10
- 3—Wireless chart with 20 Wireless Standard "Hook-ups" ..... .10
- 4—Join the Wireless Association of America, and Wireless Pin ..... .30
- 5—Official Wireless Blue Book, 32 pages, and 13x10 in. chart of U. S. stations..... .15
- 6—Any one of the 3 books shown in offer No. 1..... .25

Total..... \$1.90  
(Mail charges for Items 2, 3, 4, 5, 6, 8c. extra.)  
**TOTAL NET SAVING..... .80**

### OFFER NO. 4.

Send us \$1.00 cash, stamps, or money order, and in return, we will send you:

- 1—Modern Electrics for one year (May issue free) ..... \$1.00
- 2—12 back numbers of Modern Electrics, all consecutive numbers, all in good condition, each 10c. .... 1.20

Total..... \$2.20  
(No mail charges necessary.)  
**TOTAL NET SAVING..... \$1.20**

The offers as shown must not be changed nor can articles from any one offer be exchanged with any article of another offer. The selection is quite complete and we are positive that you will find a suitable offer among the four. **IMPORTANT:** For Manhattan and Canada, add 25c.; Foreign, 50c.

**MODERN ELECTRICS PUBLICATION, 233 Fulton St., NEW YORK, N. Y.**



# Bound Volume No. 3

**READY NOW**

The Greatest and Most Instructive Volume ever Issued by Us

**740 Pages. Over 1000 Illustrations. 300 Authors.  
650 Articles of Unusual Interest.**

Volume No. 3 should be in your Electrical Library, it is not complete without it. All new discoveries and inventions made during 1910 are fully described in this volume. If you have a workshop or laboratory, Volume No. 3 will be of invaluable aid to you in your experiments and researches. If you are a "How-to-make-it-yourself" man, Vol. No. 3 will be a veritable gold mine of interest for you.

## 1173 Questions and Answers

If you have read Vol. No. 3 you can truthfully say that your electrical knowledge is fully up-to-date.

As for the **Wireless Man**, he would no more think to be without Vol. No. 3 than to receive messages without his phones and detector. If you have any puzzling questions, you will surely find an answer in the **1173 Questions and**



**Answers** of the "Oracle." These 1173 answers are the most complete and accurate ones published anywhere in the world, and Vol. No. 3 is well worth having for the "Oracle" section alone.

If you think of developing a new idea or to bring out something new, Vol. No. 3 will be worth its weight in gold to you. The price is low now. it will be raised later, therefore order to-day, tomorrow never comes. Price of Complete Bound Volume No. 3, bound in rich black cloth, **gold stamped front and back.**

**\$1.25**

**By Mail extra anywhere U. S. and foreign, \$0.30  
No checks nor stamps accepted**

**GRAND SPECIAL**—Bound Volume No. 2 (612 pages) and Bound Volume No. 3, two volumes.  
Regular price, \$2.75, **NOW**

**\$2.50**

**By Mail extra anywhere U. S. and foreign, \$0.55  
No checks nor stamps accepted**

**MODERN ELECTRICS PUBLICATION, 233 Fulton St., New York**

When writing, please mention "Modern Electrics."

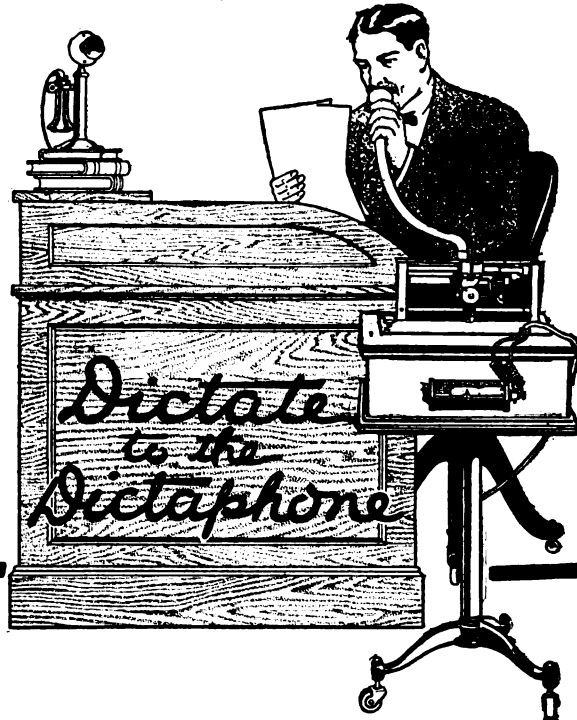

**Double your working efficiency by using the Dictaphone, the time and trouble saver.**

It's the direct method of dictation—no lost motions in between. You don't have to accommodate your thoughts to your stenographer's speed—you say what you want to say and she gets it—just that way.

Telephone or write to our nearest branch, or better yet call.

**BRANCHES :**

ATLANTA, 82-84 N. Broad Street	MINNEAPOLIS, 422-424 Nicolet Avenue	PITTSBURG, 101 Sixth Street
BOSTON, 178 Devonshire St.	NEW YORK, 89 Chambers Street	SANFRANCISCO, Phelan Bld.
CHICAGO, 94 Wabash Ave.	PHILADELPHIA, 1109 Chestnut Street	ST. LOUIS, 1008 Olive Street
DETROIT, 54-56 Lafayette Blvd.		TORONTO, CAN., 264 Yonge Street

And in all Large Cities.

Write for catalogues and full particulars, and a complete list of all branches, one of which may be nearer to you than any of the above, to

# “The Dictaphone”

**Box 121, Tribune Building, New York**

Columbia Phonograph Co., Gen'l, Sole Distributors

**Exclusive selling rights granted where we are not actively represented.**

When writing, please mention “Modern Electrica.”

# HIGHEST CLASS OF MOLDED ELECTRICAL INSULATION

## 1 Shellac Composition

—black—brown—Mica; substitute for hard rubber.

## 2 Sternoid

We are the **Pioneers** in this country of **Heat-proof Electrical Molded Insulation.**

### CLAIMS

500° F. without softening.  
A perfect insulator.  
Non-Hygroscopic.  
High mechanical resistance, can  
be tapped or drilled.  
Metal parts can be molded in.

## 3 Stern-BAKELITE

Heatproof—splendid for high tension, line and overhead insulation.

**PRACTICALLY UNBREAKABLE**

We solicit your correspondence—blue prints, models

**DICKINSON MANUFACTURING CO.**

KURT R. STERNBERG  
Treasurer and General Manager

**SPRINGFIELD, - MASSACHUSETTS**

J. H. PARKER, Sales Agent  
No. 6 Hawley Street, Boston, Mass.

When writing, please mention "Modern Electrics."

# E. I. CO.

## Look! Look!! Look!!!

### Odd Material Sale

Before taking inventory, we wish to dispose of the following material, ALL IN GOOD CONDITION. Look over our list and admit that you have never seen any such values before. This material is positively sold **BELOW COST**. Order quick—To-day—before somebody gets ahead of you.

**NO ORDER FOR LESS THAN 50 CENTS ACCEPTED.**

Only full spools, as shown, sold. Will not break up any spool. Especially suited for Spark

Colls.	S. C.—single cotton; D. C.—double cotton; S. S.—single silk covered.	Catalog Price	Now
No. 20 B. & S., S. C.	4 lbs.	\$2.32	\$1.40
No. 23 B. & S., S. S.	5 oz.	0.30	.18
No. 30 B. & S., D. C.	5 oz.	0.45	.27
No. 30 B. & S., S. S. Enamel	3 oz.	0.48	.30
No. 30 B. & S., S. S.	1 lb. 3 oz.	3.04	1.85
No. 32 B. & S., S. S. Enamel	2 lb. 12 oz.	9.45	5.70
No. 32 B. & S., S. S. Enamel	1 lb. 9 oz.	5.38	3.25
No. 32 B. & S., S. S. Enamel	1 lb. 4 oz.	4.30	2.60
No. 32 B. & S., S. S. Enamel	4 oz.	0.56	.55
No. 32 B. & S., S. S. Enamel	10 oz.	2.15	1.30
No. 32 B. & S., S. S. Enamel	13 oz.	2.50	1.68
No. 32 B. & S., S. S. Enamel	6 lbs.	20.40	12.25
No. 32 B. & S., S. S.	3 lb. 7 oz.	6.80	4.10
No. 32 B. & S., S. S. Enamel	2 lb. 4 oz.	7.65	4.60
No. 32 B. & S., S. S.	2 lb. 5 oz.	4.60	2.76
No. 32 B. & S., S. S.	2 lb. 6 oz.	4.72	2.85
No. 33 B. & S., S. S.	3 lb. 15 oz.	7.82	4.70
No. 34 B. & S., S. S.	11 oz.	1.76	1.06
No. 34 B. & S., S. S. Enamel	13 oz.	3.77	2.27
No. 34 B. & S., S. S. Enamel	1 lb 8 oz.	6.06	4.20
No. 34 B. & S., S. S.	14 oz.	4.06	2.45
No. 34 B. & S., S. S.	1 lb. 12 oz.	4.45	2.70
No. 34 B. & S., S. S.	1 lb. 4 oz.	3.18	1.90
No. 35 B. & S., S. S.	2 lb. 1 oz.	5.95	3.60
No. 36 B. & S., S. S.	5 oz.	1.00	0.60
No. 36 B. & S., S. S.	1 lb. 4 oz.	4.00	2.40
No. 36 B. & S., S. S.	1 lb. 10 oz.	5.20	3.12
No. 36 B. & S., S. S.	6 oz.	1.20	0.75
No. 36 B. & S., S. S.	12 oz.	2.40	1.45
No. 40 B. & S., S. S.	1 lb. 3 oz.	9.50	5.70

**NOTE.**—The enamel, single silk covered wire was made especially by the General Electric Company for spark coil work.

#### ALUMINUM MAGNET WIRE.

Something new for spark coils. On account of the higher resistance  $\frac{1}{4}$  less wire needed than for copper. One ounce of this replaces six of copper wire.

No. 35 B. & S., Aluminum S. S. 4 oz.	Catalog Price	\$2.90	Now	\$1.75
No. 36 B. & S., Aluminum S. S. 4 oz.	"	3.40	"	2.05
No. 36 B. & S., Aluminum S. S. 4 oz.	"	3.40	"	2.05

#### GERMAN SILVER WIRE.

No. 30 B. & S., G. S., S. S.	1 lb. 1 oz.	Catalog Price	\$2.20	Now	\$1.35
------------------------------	-------------	---------------	--------	-----	--------

**166 SOLID MAHOGANY CASES** (Took them in payment of old debt). Heavy nickel handle, especially suited for portable wireless sets. If you can have this box made for less than \$2.00, we will refund your money. Absolutely new; finest polish. Size 9x5 $\frac{1}{4}$ x7 $\frac{1}{2}$ . Price... \$1.00

**ONE LARGE WAVEMETER**, E. I. Co. make. Cost to build, \$22.00. Size 10x10x11. Price... \$12.50

**ONE RADIO TELEPHONE CO.** Wavemeter, never used. Cost, \$20.00. Now, Price... 15.00

**ONE RADIO TELEPHONE CO.** Variable rotary condenser, 19 plates. Size 7x7x3 $\frac{1}{2}$ . NOT ASSEMBLED. Cost originally \$15.00. Now, Price... 8.00

**ONE DEFOREST AUDION** in good condition. Cost originally, \$20.00. Now... 5.50

**ONE EXPERIMENTAL 2-INCH SPARK COIL**, with two vibrators (one on each end of core). Cost to build, \$11.00. Now... 9.00

**ONE IMPORTED FRENCH MILLIAMPEREMETER**. Cost originally, \$26.85. Now... 15.00

**THREE WESTERN ELECTRIC**, 300 Ohm commercial relays, hard rubber covered spools, adjustable. Size 8x4 $\frac{1}{2}$ x4 $\frac{1}{2}$  inches. Price originally (each), \$7.50. Now (each)... 4.00

**ONE SOLID "ELECTROSE" LEAD-IN**, 9x2 $\frac{1}{2}$  inches; 1-inch hole. Cost originally, \$2.75. Now... 1.25

**ONE THERMO-ELECTRIC CELL**. Works with gas; can be used to light a small lamp. Cost \$10.00. Now... 3.00

**ONE POTENTIOMETER, WOUND WITH GERMAN SILVER WIRE**. Mahogany ends; 12 inches long. Cost \$3.50. Now... 1.00

**36 FRENCH IMPORTED AUTOMATIC ARC LAMPS**. Fine regulation. For regular lighting work and for wireless telephone and singing arc light. Cost originally, each, \$8.00. Will refund money if not satisfactory. Resistance goes with each lamp. Now, each... 3.50

**ONE 1-5 H. P. 6-VOLT MOTOR**. Runs on 2 volts. An old type, but a generous built motor. Has surprising power. Cost originally, \$12.50. Weight, 8 lbs. Now... 4.00

**ONE HARD RUBBER TUBE**, 6-inch diameter, 8 $\frac{1}{2}$  inches long,  $\frac{1}{4}$  inch thick. Cost originally, \$4.00. Now... 2.00

**350 NEW MAHOGANY FINISHED** (our No. 9230) Detector Bases. Cost, each, 10c. Now... 6c

**175 NEW MAHOGANY FINISHED** (our No. 1098) Auto Coherer Bases. Cost, each, 10c. Now... 6c

**750 NEW MAHOGANY FINISHED** (our No. 3 $\frac{1}{4}$ x $\frac{1}{4}$  in.) "Tellicometer" Bases. Cost, each, 9c. Now... 5c

**109 NEW OAK** (our No. 9002), old model Electrolytic Detector Bases, 1 inch thick, 5 inch diameter. Cost, each, 15c. Now... 8c

**35 NEW OAK FINISHED** (our No. 12000 and 12001) Loose Coupler Frames (ends are slightly warped). Cost 55c. To clear out, each, now... 20c

# NEWS

## SLABY-ARCO VACUUM COHERER

This imported coherer, made by the German Telefunken Co. and used by the U. S. Government is the best coherer on the market today. It has solid silver plugs and with a fairly sensitive relay will work up to 300 miles. This coherer is "fool proof" and will stand a tremendous amount of abuse. Heavy nickel tubing for connections at each side. Sells usually for \$5.00.



Our Price **\$2.50**  
this month By Mail 5c Extra

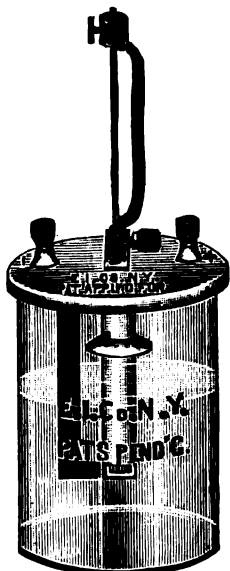

8000

New Orleans, La.,  
Jan. 11, 1911  
Electro Importing Co.  
Dear Sirs:  
It may be of interest to you to know that I communicate with a friend in Baton Rouge every night with my 1/2 K. W. Transformer coil, a distance of about 70 miles air line. My coil is working excellent, and anyone wishing to buy a coil cannot make a better move than by purchasing one like mine.  
Hoping this will be good news, I remain,  
Very truly yours,  
Bernard Oppenheim,  
1435 Henry Clay Ave.,  
New Orleans, La.

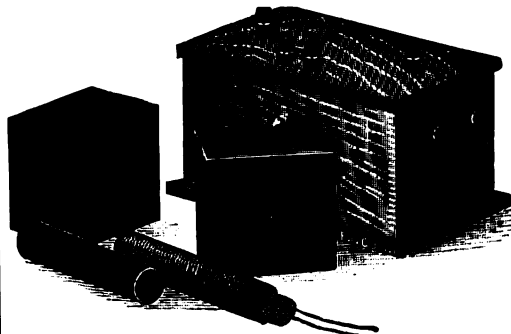

8050

Above letter came **UNSOLICITED**. It is one of the many we have in our files. It seems unbelievable that we can turn out goods that perform such extraordinary service at such low prices. The explanation is: quantity. Any one can possess our 1/2 K. W. 8050 transformer coil and we guarantee its range. This transformer is used in conjunction with our No. 8000 Gernsback Interrupter, on 110 volt circuit, either D. C. or A. C. Price of the transformer is **\$7.50**; price of Gernsback Electrolytic Interrupter, **\$2.25**. During this month we will send the transformer and the interrupter on receipt of **\$3.00**. The outfit will be sent by express with **privilege of inspection**. Balance to be paid after inspection. If goods are not as represented return them to us and we will refund money. This special offer ought to appeal to you. **ORDER TODAY.**

## COIL PART SALE

Each article listed below is fully guaranteed. If you ever wished to make your own coil, here is a chance that comes but few times during your life. Order now before it is too late.

Please note that we guarantee spark length of secondaries **ONLY** when proper primary, our vibrator and our own condenser is used in connection with same.

- 1/2 in. Secondary, guaranteed full spark, each..... **\$0.70**  
By mail extra 8c  
(Two of these used on one primary give 1 in. spark) price for the two... **2.00**
- 1 1/2 in. Secondaries (two are used for 1 1/2 in. spark) price for the two... **1.00**  
By mail extra, 16c
- One secondary (gives 3/4 in. spark), price each..... **1.00**  
By mail extra 9c
- Vibrators, French double spring style, for 1/2 in. or 1 in. spark..... **0.90**  
By mail extra 8c
- " " " " " for 1 1/2 in. or 2 in. spark..... **1.25**  
By mail extra 8c
- " " " " " for 3/4 in. spark, extra large..... **2.65**  
By mail extra 6c
- Condensers, rolled, best in the U. S., for 1 in. coils, each **\$0.35** by mail extra 6c
- Condensers, rolled, best in the U. S. for 1 1/2 in. coils, each..... **0.70**  
for 2 in. coils, each..... **1.00**



Secondary

Condenser

- 15 NEW OAK FINISHED (our No. 8050 and 8060), Transformer Coil Cases (slightly warped covers). Cost 80c. Each, now..... **30c**
- 2100 NEW OAK Coherer and Decoherer Bases (our No. 1097); edges finely finished. Size 7x3 1/2 x 1 1/2 in. Cost 16c. Now..... **9c**
- GERNSBACK RELAY ELECTROMAGNETS. Used on the Patent Gernsback Relay. Size 1 1/4 x 1/2 in. Finely finished. Silver contact on core. Three kinds (all same size). 20 Ohms, 50 Ohms, 75 Ohms. Bottom of core takes 8-32 screw. Cost 29c, 37c, 49c each, respectively. Will sell this month as follows: 20 Ohms, each, 20c; 50 Ohms, each, 30c; 75 Ohms, each, 40c. By mail extra, each 4c.

**H**AVE you a copy of our famous **196 Page Electrical Cyclopedia No. 9**, containing over **400 illustrations?** The most wonderful book ever printed, containing more information on all electrical and **Wireless** subjects than a \$3.00 text-book. Send 4c postage today and we will promptly mail it. Postal cards **NOT** answered.

**THE ELECTRO IMPORTING CO.** 233-Z FULTON ST., NEW YORK  
"EVERYTHING FOR THE EXPERIMENTER"  
Retail Store, 69 West Broadway  
for Chicago and the Middle West (WHOLESALE ONLY, no mail orders) ANDERSON LIGHT & SPECIALTY CO., 70 LaSalle Street, Chicago, Ill.



# The Trend of Sane American Accumulation

NEW  YORK

¶ The history of the Sterling Debenture Corporation confirms the belief that Americans are rapidly learning to distinguish intelligently between *True Investing* and *Speculating* in "Listed" Stocks.

¶ France has become a "Nation of Bankers" because the Frenchman, with true investment instinct, puts his money little by little into well-selected, permanent holdings. He never speculates, and his accumulation shows patience, prudence and determination.

¶ The policies and methods of this Corporation put a premium on conservative accumulation by placing before the American investing public the opportunity to become affiliated with worthy bank and industrial enterprises that have withstood the searching merit tests that characterize our investigation of all such enterprises.

¶ Our world-wide clientele of 45,000 satisfied customers, representing thoughtful and discriminating investors, in every walk of life, shows the trend of sane American accumulation.

¶ Through the United States mails, which is the only medium we employ for the dissemination of facts relative to the enterprises with which we are affiliated as Distributing Agents, we should like to acquaint you with some unusual investment opportunities. Write for pamphlet No. 359.

**STERLING DEBENTURE CORPORATION**  
**NEW YORK CITY**

When writing, please mention "Modern Electrics."