

In This  Number

WIRELESS ON AIRSHIPS.
By A. C. Marlowe

UNIVERSAL WIRELESS TESTING SET
By William Dubilier

GENERATOR OF RAPID ELECTRICAL VIBRATIONS
By Dr. Alfred Gravenwitz

EXPERIMENTS WITH GEISSLER TUBES
By J. H. Doran

CONSTRUCTION OF SENSITIVE WIRELESS DETECTOR
By W. H. Taber

MILITARY QUENCHED SPARK SET
By O. A. DeCelle

OSCILLATION TRANSFORMER
By Ralph Weddel

Geo. Westcott

THE SPIRIT OF WIRELESS

"THE ELECTRICAL MAGAZINE FOR EVERYBODY"

Patents Trade-Marks Designs Copyrights

YOUR ability to protect your patent from infringement depends largely on the presentation of the original application. The market value of your patent depends on the manner in which the invention is set forth in the claims. Let me tell you more about it.

Send for my booklet on Patents, Trade-Marks, Designs, Copyrights.

LANGDON MOORE

902a F STREET, WASHINGTON, D. C.

Ex. Asst. Examiner U. S. Pat. Off.

When writing, please mention "Modern Electrics."

Something New in Insulators



We present herewith our new departure antenna insulators which we are now offering in place of our regular antenna insulators, No. 10901.

They have the distinct advantage that there are no hooks to break out, and even if the insulator would be smashed, which is almost impossible, the aerial wires could not fall, because the loops of both antenna and support wires would hold each other.

These insulators are beautifully finished and have the highest insulating qualities. They will not leak any more than any good insulator, have a fine appearance, and are the lowest priced on the market.

No. 9461 is made of brown, TRIPLE glazed porcelain, size 2 1/4 x 2 1/2 in., weight 12 oz., for receiving only. Price 10 cents. Per doz., \$1.15.

No. 1166 is made of glass entirely, the most beautiful insulator ever made. Size 2 1/4 x 2 1/2 in., weight 11 oz., for receiving only. Price each 12 cts. Per doz. \$1.35.

No. 10341 (patent applied for). This insulator is made of the same material as No. 9461. It is longer and heavier. Its body is pierced by two round holes, through which the wire loops pass. **For sending up to 2-in. spark length.** Will not leak. By placing several of these insulators in series, large spark coils or transformers can be operated without fear of leakage. Size 3 x 2 1/4 in., weight 14 oz. Price each 16 cts. Per doz. \$1.85.

Send 2c. stamp for our new 128-page wireless encyclopedia No. 7, containing lots of information on wireless diagrams, etc.

ELECTRO IMPORTING CO.

"EVERYTHING FOR THE EXPERIMENTER"

233-2 Fulton Street
New York

When writing, please mention "Modern Electrics."



THE BEST

COLUMBIA DRY CELL

will last longer and give better results than any other dry cell known when used for general purposes.

Specially good for telephones, door bells, electric clocks, experimental work, wireless telegraph instruments, small motors and other similar devices.

Just the thing for the new stunts you are getting up or for your electrical toys. Buy them at your dealers.

National Carbon Co., Cleveland, O.

GOOD WIRELESS COIL



Correctly Designed,
Well Built,
Scientifically Wound,
Spark 1-4 to 8 in.

TYPE G WIRELESS COIL

Wound with AMERICAN ENAMELED MAGNET WIRE to secure exceptional efficiency
MUSKEGON COIL CO.

Dept. M
MUSKEGON, MICHIGAN

When writing, please mention "Modern Electrics."

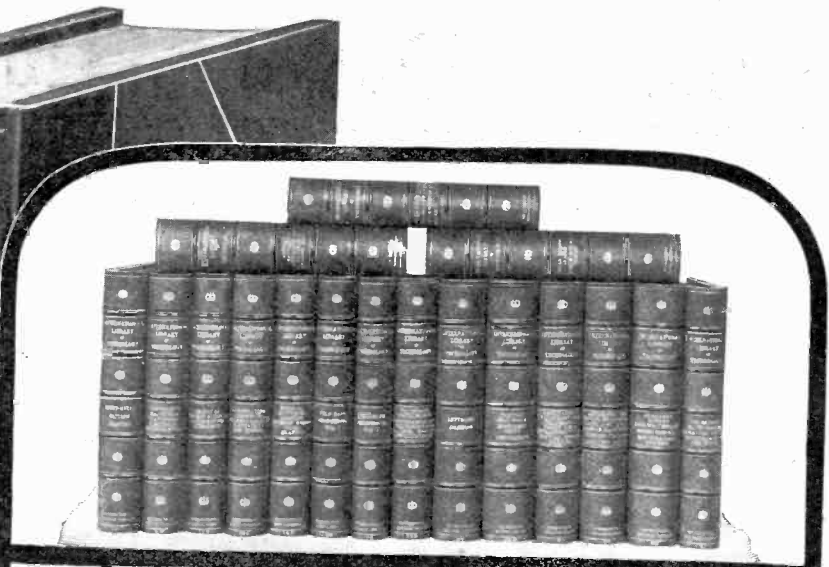
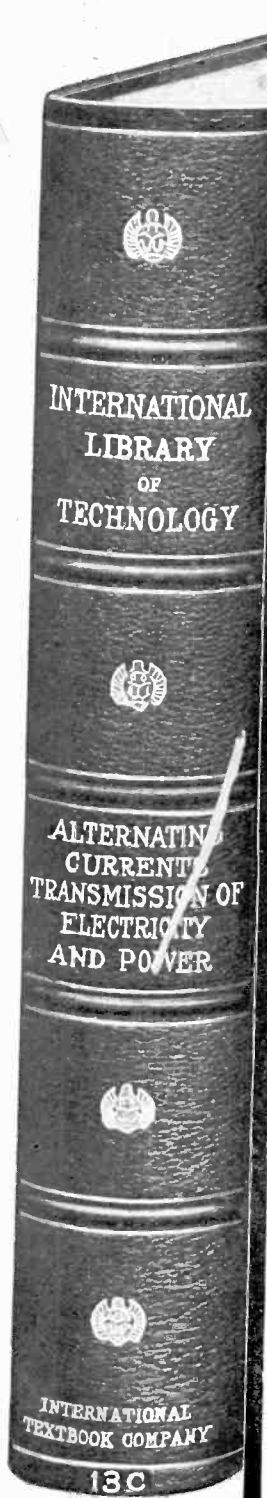

The Most Practical Electrical Library

The Electrical Engineering Library is part of the International Library of Technology that cost \$1,500,000 in its original preparation. It contains the knowledge given from the life experience of some of the best electrical engineering experts in the country, edited in a style that nineteen years of experience in publishing home-study textbooks has proved easiest to learn, to remember, and to apply. There is no other reference work in the world that so completely meets the needs of the electrician as the Electrical Engineering Library. The volumes are recommended by the highest authorities and are used in nearly all the leading universities and colleges. Not only can they be used to great advantage by superintendents, foremen, and engineers as an authoritative guide in their work, but since they can be so clearly understood, even by persons having no knowledge of higher mathematics, they can be used by all classes of electricians that are desirous of advancing to higher positions.

A few of the many subjects contained in the Electrical Engineering Library are as follows: Electricity and Magnetism; Electrodynamics; Electrical Resistance and Capacity; Magnetic Circuit; Electromagnetic Induction; Primary Batteries; Electrical Measurements; Dynamos and Dynamo Design; Direct-Current Motors; Alternating Currents; Alternators; Electric Transmission; Line Construction; Switchboards; Power Transformation and Measurement; Storage Batteries; Incandescent Lighting; Arc Lighting; Interior Wiring; Modern Electric Lighting Devices; Electric Signs; Electric Heating; Elements of Telegraph Operating; Principles of Telephony; Telephone Circuits, Receivers, Transmitters, Apparatus, Bells, Instruments, and Installation; Magneto-Switchboards; Electric-Railway Systems; Line and Track; Line Calculations; Motors and Controllers; Electric-Car Equipment; Multiple-Unit Systems; Efficiency Tests; Energy Regulation; Central Energy Systems, Main and Branch Exchanges; Common-Battery Signaling Systems; Bell-Energy System; Bell Trunk Circuits; Bell Toll and Testing Circuits; Exchange Wiring; Telephone Cables, etc.

The Electrical Library contains 17 volumes durably and handsomely bound in three-fourths red morocco. Each volume is 6x9 inches in size. They may be purchased in sets of five or more volumes. If you wish to know more about the most practical electrical library in the world, Send the coupon NOW.

International Textbook Co.

Box 992, SCRANTON, PA.

Please send, without further obligation to me, full particulars in regard to your Library of Technology, with special reference to the Electrical Library

Name _____

St. and No. _____

City _____

State _____

When writing, please mention "Modern Electrics."

Bound Volume No. 1

AFTER numerous requests by our readers, we have had a limited number (10 copies) of Volume 1 (April 1908 to March 1909) bound, and as this is a companion book to Vol. 2—you will surely want one. Below is a partial list of the many good things to be found, nowhere else but in this book.

If you would have a complete reference work on Wireless, you must have this book. It is impossible to obtain such a compendium of useful knowledge, **anywhere else at any price.**

Some of its Contents.

Aerophone Heard 200 Miles.	Harnessing the Ocean's Power.
Aerophone Station at Lyngby.	Bellini-Tosi Radio-Goniometer.
Aerials, Suspension and Insulation of.	The Production of Radium.
An Electric Sun Alarm.	How to Make Electrolytic Rectifiers for Alternating Current.
The Speaking Arc Lamp.	Relay Working on One-hundredth-billionth Ampere.
The Audion Detector.	Properties of Selenium.
An Ideal Battery.	Static Electricity as a Motive Power.
How to Make a Dry Storage Battery from a Wet One.	How to Make a Selective Tuner with Weeding-out Circuit.
A Simple Form of Wheatstone Bridge.	Typesetting by Wireless.
The Construction of Standard Cells.	The Electric Writing Machine.
Recharging Dry Cells.	Navigation by Wireless.
New Selenium Cell.	Poleless Wireless.
Experimenting with the Tesla Coil.	How to Make a Complete Two Mile Selective Wireless Set.
How to Make a Selenium Cell.	Walking Wireless Station.
How to Make a Tesla Coil.	The Collins Wireless Telephone.
A Talking Condenser.	Wireless Talk over 310 Miles.
Talking Dynamos and Transformers.	Wireless Telephony, Development.
How to Make an Extremely Sensitive Galvanoscope.	
The Production of Sustained High Frequency Oscillations.	

All of the articles named above, and many more, have been written by some of the best Wireless Engineers, Experts, and Inventors of the day, and you will find just the information you have looked for in vain.

Positively no other book like it in existence.

Remember, the supply is limited,—only 15 copies—and you must speak at once if you want to get a copy of the most wonderful book extant on Wireless. No more, when these are gone.

You have needed this book time and again, now is your last chance to get one. Opportunity knocks once at every man's door; Don't let her go away without answering the knock. Speak quick!

ORDER

PRICE, \$3.00

TO-DAY

Sent postpaid to any part of the World for \$3.26. Money Order, Draft or Cash, no stamps

Modern Electrics Publication,

233 FULTON STREET,

NEW YORK CITY.

NOTE:—Inasmuch as we have only 10 copies, we do not think that this ad will appear again.

Modern Electrics

VOL. III.

DECEMBER, 1910.

No. 9

Wireless On Airships

By A. C. MARLOWE.

WE are able at present to give some particulars about the wireless plant which was mounted upon the "Bayard-Clement" airship during the recent military maneuvers in France.

power is required, even at a range of 60 miles, this being less than 50 watts. The battery outfit need not be very heavy, and the above battery was amply sufficient.

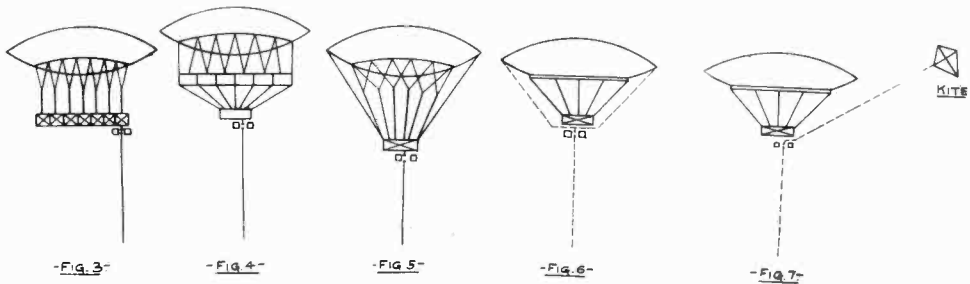

Signals were sent to the Eiffel Tower station by Capt. Ferrié, who had charge of the operations, and the results were very successful. Owing to the fact that the work is being carried on by the military department, there have not been published the full details, but the following will give an idea as to the airship post.

Capt. Ferrié finds that for airship work it is best to use sparks which are produced in rapid succession so as to give what is known as a "musical spark," having a high pitch. In the present instruments there is employed a pitch of 250 per second, using a vibrator which is designed by Messrs. Bethenod and Ferrié. It works on the electromagnetic tuning fork principle. Current is given by a battery of automobile storage cells, delivering 20 volts with a maximum output of about 20 amperes. Care is taken to shield the sparks so that they cannot ignite the gas of the balloon, by using wire-gauge covering on the apparatus. The total weight of the airship plant is 130 pounds. Some valuable data were here obtained as to power and range of signaling. To give a range of 40 miles or so, it was supposed that at least 2 kilowatts would be needed for the airship outfit, but in fact a much smaller

Capt. Ferrié lately read a paper at the

government telegraphic institution in which he brought out some new points as to the use of wireless plants upon airships. Such data he obtained after much experimenting, and it will be of interest to sum up some of the leading points. The usual connections for wireless are shown in Fig 1, where A is the aerial and T the ground. At E is the transmitting circuit and R the receiver, and connections can be made with the ends a, b, of the aerial circuit. For airships, where a ground cannot be used, we employ the connections shown in Fig. 2. An "artificial

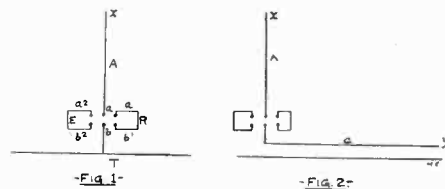

ground" is formed by running a wire C for some distance parallel to the ground, and this principle is applied by Capt. Ferrié as will be noticed below. He made some researches as to the brush discharges which are likely to occur in aerial circuits, and for airship work these must be avoided as much as possible, as they are likely to

set fire to any gas escaping from the balloon. We can use either ordinary sparks or a rapid succession of sparks which make a musical note. The latter are much preferred. When sending signals, the tension is not constant over the aerial circuit, but it is greater at the ends X and Y (Figs. 1 and 2). Brush discharges occur at these points, and these depend on the power used, being stronger during long-distance and high power work. We store up electrical energy in condensers to produce the sparks, and when the number of sparks is small, as in ordinary working, the energy of each spark is greater than where the whole energy is distributed among the frequent sparks of the musical system. The electric tension is less when we use a greater number of sparks, hence the musical system is preferred in order to cut down the brush discharges on the aerial. Such discharges thus depend not only upon the power but also upon the method of working. Capt. Ferrie finds that the brush discharges are much reduced by using musical sparks, and he adopts the latter in his airship plants.

He forms the aerial by hanging a single wire of 300 to 600 feet length from the airship. The artificial ground is made up in different ways, depending on the type of airship. In the present figures, the metal parts are shown in heavy lines. Fig. 3 shows the method which can be used for airships of the "Col. Renard" type. The apparatus E, R, are here represented outside of the balloon. The artificial ground is formed of the nacelle and the steel hanging wires, but these latter should not be less than 6 feet from the balloon body, as the brush discharges at the ends of the wire would give danger. Metal balls can be used in all cases to cover over the points, so as to lessen the discharge effect. For the "Gross" type, we use the metallic framing and the nacelle in the same way (Fig. 4), and in the "Parseval" type we can add the extra wires A A which are insulated from the balloon. Where the metal parts make up the body of the balloon, these should never be used, as we find in the "Zeppelin" or (Fig. 6) in the "Republique." Special wires shown by the dotted lines should be used, these being hung insulated and also away from the hanging wires to

avoid contact. In Fig. 7 the artificial ground wire is carried by a kite, and such could be used on any airship, provided it did not hinder the progress of the latter.

THE INJURIOUS AFFECTS OF WIRELESS UPON THE HUMAN EYE.

THOUGH the Roentgen or "X" ray soon after its practical application began to evince its harmful affects upon the virility of the operators, wireless, after a thorough test of nearly 20 years has proven to have but one injurious property and that of causing the practically harmless though troublesome irritation of the eye known as Conjunctivitis or Conjunctivitis.

The Conjunctiva is the mucous membrane that lines the inner surface of the eyelids and thence is reflected over the front of the eyeball, thus conjoining the lids and the globe of the eye. In Conjunctivitis (Pron. Kon-jungk-ti-vi-tis) the Conjunctiva is inflamed and the eyelid becomes swollen, red, partially shut and usually painful.

A cinder in the eye or a bruise may cause this. It may be interesting to note that the phrase "something in the eye" is not quite correct. Foreign substances do not lodge in the eye ball, as is usual thought, but in the Conjunctiva membrane lining the eyelid.

But to return to the subject. Ultra-violet rays and the sharp violet tone of an oscillator irritate the Conjunctiva and sometimes cause it to become inflamed. The cure is to wear smoked glasses when working with the spark and use the eyes as little as possible and to bathe them with an eye wash. Conjunctivitis, though usually acute, may become quite chronic unless cared for properly.

A game of chess was played by wireless between two vessels not long since. One vessel was the "Kaiserin Augusta" and the second the "Amazon." The two vessels were always at least 250 miles apart, and sometimes 400 miles while the game was being played.

A Generator of Rapid Electrical Vibrations

By DR. ALFRED GRADENWITZ.

(Berlin Correspondent MODERN ELECTRICS.)

THIS novel apparatus designed by Ernest Ruhmer is intended for keeping an electrical explosive distance (arc, spark gap) absolutely constant for any length of time. In connection with a vibratory circuit constituted by a capacity and self-induction, it is therefore well adapted for generating a series of regular and rapid electrical vibrations for the purposes of wireless telegraphy and telephony.

In connection with all previous arrangements, discharges were made to pass between the ends of electrode rods submitted to continual variations due to combustion, so that the regularity of wave generation was seriously interfered with. No automatic regulation of the explosive distances could so far be obtained with anything like the accuracy desirable.

The electrodes of the new generator are metal wires of square cross sections between the longitudinal edges of which the discharge is formed. These wires are located on two insulated storage rollers from which they are unwound by a small electro-motor (through a double worm gear) on two likewise insulated rollers, while passing at a moderate speed over two grooved rolls designed as cooling vessels, immediately beside one another. The discharge is formed at the point where the edges of the wires are nearest to one another, and after once having been adjusted for, with a micrometer screw, its length, owing to the continually renewed metal parts used as points of origin, is maintained absolutely constant. At the same time there is insured an excellent cooling of the discharge which greatly contributes to activating it; moreover, an electro-magnetical blower can be arranged in the case of high current intensities. Any irregularity is effectually prevented, the points of origin being always situated on the edges of the wire.

The wire contained in a couple of storage rollers suffices to keep the apparatus working continually for about a month. High-tension direct or alternate currents

can be used for feeding it. While a rapid succession of damped electrical vibrations is generally obtained, a series of continuous non-damped vibrations is generated with direct current of about 1,500 volts tension, derived, if possible, from a high-tension accumulator battery.

The generator above described has been used by its inventor in connection with a number of wireless telephony

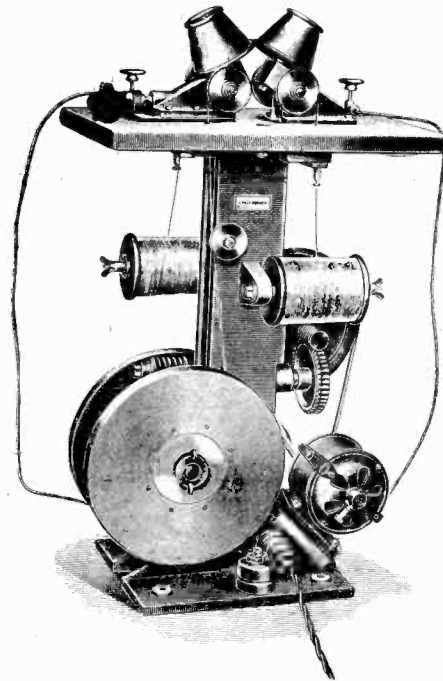

tests over considerable distances. The transmitting station was located in a small shed close to the Congo Museum at Tervueren, near Brussels; the high-tension direct-current being supplied from a set of several 500-volt dynamos connected up in series; the receiving station was situated in a cottage about 15 kilometers distant, at Uecle. After obtaining satisfactory results in this connection, Ruhmer extended his experiments to greater distances, the transmitting station being transferred to the Brussels Palace of Justice. The high-tension direct current was supplied by a high-tension accumulator battery and the receiving post was installed, at first, at Namur

(Continued on page 525)

Experiments with Geissler Tubes

By JAMES H. DORAN.

Geissler tubes are among the most interesting and beautiful apparatus used in electricity and as most amateurs have

show bright bands of light separated by dark spaces, Fig. 1. Figs. 2 and 3 shows a photograph of one of these tubes in

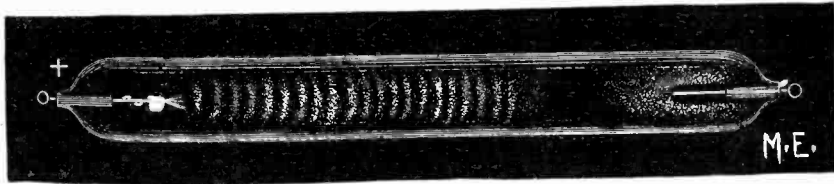

FIG. 1

spark coils, experiments with these tubes are always welcome.

Geissler or vacuum tubes are made by fusing platinum wires into small glass tubes, usually with bulbs at the ends as shown in Fig. 1. They are then exhausted by an air-pump to one, one-thousandth of an atmosphere, when the tube is sealed off. The color of the tube when working depends on the kind of gas left in the tube. Air gives a red color, hydrogen a light crimson, nitrogen a bluish, oxygen a dark purple, and carbon dioxide a pure white. The color of the glass depends on the kind used, ordinary glass gives a light yellow color, and the Uranium or Canary a beautiful bright green. The tubes are usually made

action. The dark space is always nearest the negative pole and this method is often used to distinguish the negative from the positive pole of an induction coil.

A 1 inch coil will light several ten or twelve inch tubes at once if connected in series. When two large tubes are connected to each terminal of the coil and the connections are made by grasping the ends of the tubes with the hands, the current passes directly through the body and lights the tubes up brightly. If the shock is too strong use more tubes in the circuit, when a point is found where the shock is not at all disagreeable. Lighting the tubes by passing the current through the body gives the appearance that a tremendous shock is received but the current is scarcely felt at all if enough tubes are used. A good way to tell is to place a spark-gap in the circuit and add tubes until only $\frac{1}{4}$ to a $\frac{1}{8}$ of an inch spark passes.

When a condenser is shunted across the secondary terminals of the coil the tubes light up brighter but not as many can be used.

Hold a tube near one terminal of a small coil, when it will light up faintly. Stop the coil and notice the after glow in the tube. The experiments are best performed in a dark room.

Tubes containing fluorescent liquids are especially beautiful and show many different colors.

Make a solution by dissolving 50 grs. of bisulphate of quinine in an ounce of water and adding 2 or 3 drops of pure sulphuric acid. Write or draw with this on white paper and hold it while still wet near a brightly lighted tube (a plain tube is best). The drawing will shine with a bright blue color. Make solutions

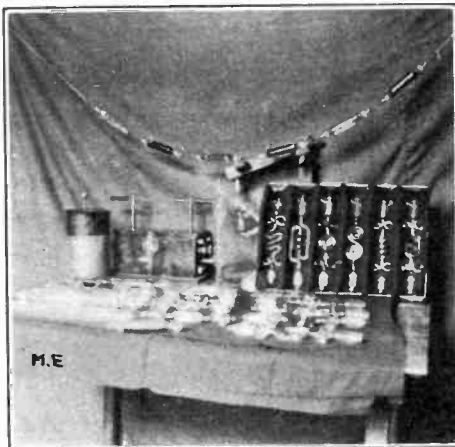

FIG. 4

into a variety of fancy shapes or designs and of different kinds of glass. A set of six of these tubes are shown in the right hand side of Fig. 4.

Straight tubes, known as Stratification Tubes, exhibit a flickering motion and

ly dissolving 2 or 3 grs. of uranine, rhodamine and eosin in an ounce of water. When viewed in the same way uranine gives a green color, rhodamine a crimson, and eosin an orange. These solutions may be used to fill the jackets of fluorescent tubes.

An interesting experiment is to light a string of tubes at a distance by wireless. This can be done by connecting the tubes to the secondary of a spark coil, the primary being connected in the usual way with batteries, etc., but instead of the switch or key the circuit is made by a relay operated by a coherer. The tubes can then be started at a distance by a transmitting outfit. In this way the writer has lighted several groups of tubes strung across the walls of a large hall. The coil and instruments being located on a lecture table at the front of the hall.

Vacuum tubes are especially interesting when used with Tesla Transformers or High Frequency apparatus.

Hold one end of a Geissler tube in the hand and with the other hand grasp one terminal of a Tesla Transformer or the terminal of an Oudin Resonator. The tube will light up and can be placed in

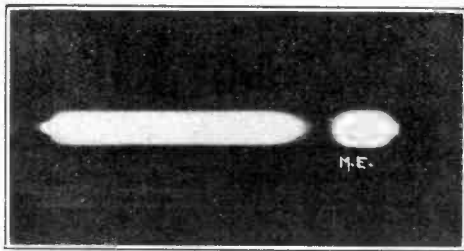

FIG. 2

any position or used as a wand and still remains lighted.

Connect a tube to each terminal of the transformer. The tubes light brightly with no connection between them.

Connect the terminal of the transformer to metal discs a foot or more in diameter, and place them three or four feet apart. A tube placed in the high electro-static field between the plates, glows brightly giving proof of the invisible discharge of the high frequency current.

Insulate a person from the ground and have him hold one terminal of the transformer. Start the apparatus, when a tube can be lit by holding it in any posi-

tion near him. A fairly large transformer is best for this experiment. This method is used by physicians for treating such diseases as rheumatism, hardening of the arteries and some diseases of the skin.

Geissler tubes when rotated by a motor (see Fig. 6) or other apparatus show a beautiful variety of designs and colors, depending on the speed of the rotator and the rate of interruption of the coil vibrator.

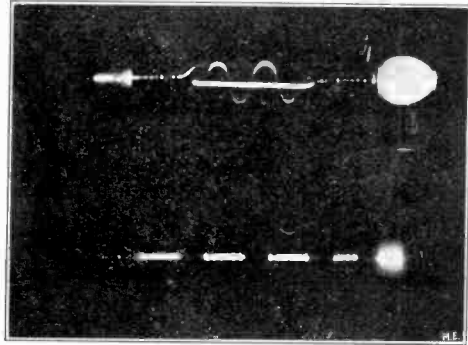

FIG. 3

Evening entertainments can be given with an induction coil or better still a Tesla Transformer and a few Geissler tubes, and people who see them in operation for the first time always remark on

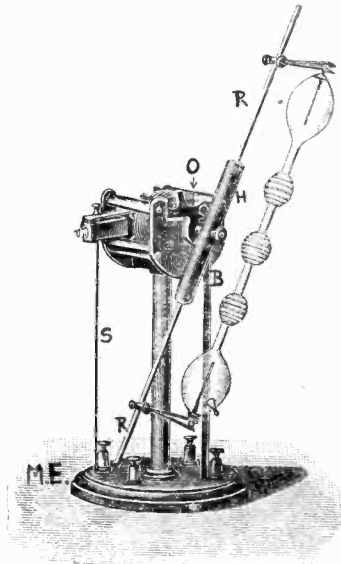

FIG. 6

their brilliancy and the great variety of beautiful colors displayed. Fig. 4 shows a good outfit for evening entertainments and for demonstration purposes.

Berlin Letter

A SELENIUM ALARM.

IT will be remembered that most tele-photographic apparatus is based on the photo-electric sensitiveness of selenium, a metal-like element related to sulphur. While being in the ordinary condition a perfect insulator, this substance under the influence of light, acquires the power of conducting the electric current, in a degree depending on the luminous intensity. Another ingenious use of this property has been recently made by a French engineer, Mr. E. Dafah at Jonzac, in connection with a burglar alarm, which without any material connection with its surroundings, is actuated at a distance, merely by the faint light of a dark lantern or even a match.

The apparatus comprises two parts, viz: the transmitter and receiver, situated at any distance from one another and connected by an electric wire. The

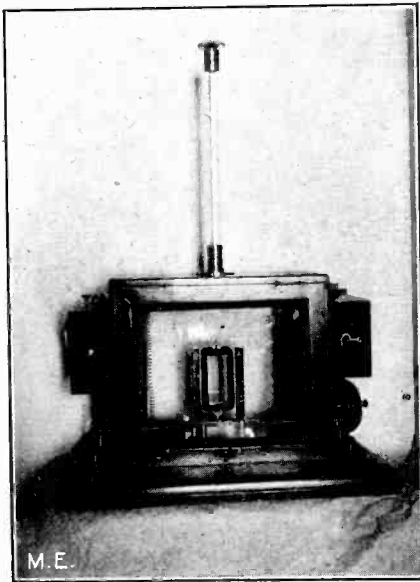

transmitter is merely a sensitive selenium cell in the shape of a small cylindrical box containing some selenium tape wound up in a coil. Any number of transmitters can be installed in connection with a given receiver.

The receiver mainly consists of a special electro-magnetic relay for actuat-

ing the alarm. This is a galvanometer, the frame of which, on the passage of current, is deflected about 90 degrees and by means of a milled knob, can be adjusted again in a parallel direction to the magnet field, after which a horizontal

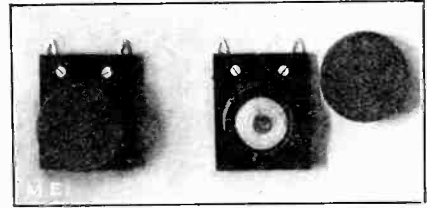

contact piece perpendicular to the magnet is inserted between the two terminals. As long as the transmitter is covered by its protective lid, the galvanometer remains at rest. As soon, however, as the lid has been withdrawn, and the selenium is struck by ever so faint an illumination, the resulting alteration in current intensity will produce a deflection of the galvanometer frame, so that the contact piece touching one or other of the terminals, will cause the alarm bell to be actuated.

The conductive wire connecting the transmitter with the receiver can be so arranged as to comprise in series connection, all the various objects (doors, drawers, locks, etc.) to be protected. After being once set working, the alarm bell cannot by any means be stopped from the transmitter room, not even by the tearing of conductors, which insures the inviolability of the apparatus.

The alarm above described can be utilized also as a fire alarm for signalling an incipient fire. If each of the rooms to be protected be equipped with a selenium cell the illumination produced even by the slightest fire, will set the receiver ringing, thus allowing the conflagration to be soon detected. The sensitiveness of the apparatus is controlled at will.

A PHANTOM SHIP.

An unusual sight was recently afforded by an unmanned motorboat moving about on a pond near Nuremberg; after swinging to and fro for some time in the midst of the water sheet, this on a shot signal

from the vessel, would start on its course, the propeller screw beginning swiftly to rotate. The rudder at the same time was controlled as though by invisible hands, and the boat in a daring curve, sailed round the lighthouse to the rear part of the pond, described a loop and returned to its point of departure. Whenever a rowing launch approached to a dangerous proximity, a bell signal was given, and the boat cleverly turned out of its way, to the right or left. These operations were continued for about an hour, the weird impression being enhanced, especially at night, by the variegated signalling lamps lighted from time to time. After another signalling shot, the boat would be stopped in order, after a few backward turns of the screw, again to lie quietly on the waves.

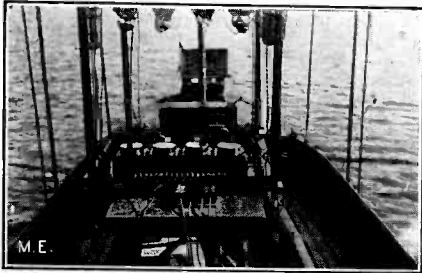

The apparatus used in operating this boat is the invention of Messrs. Wirth, Beck & Knauss of Nuremberg, who hope to have it adopted by the German Navy. On the bridge leading to the lighthouse was installed a transmitter of Hertzian waves in conjunction with an antenna. On the boat were set up a small receiving antenna, a wireless receiver, a wireless selector switch, the electrically operated rudder and other apparatus such as bells and signalling lamps. The electrical waves starting from the transmitter installed on the lighthouse were received by the antenna on board the motor boat, operating through the intermediary of the switch, all the various apparatus that serve to steer the course of a vessel.

NEW MERCURY INTERRUPTOR.

THE following is a new form of mercury interrupter which has been invented in France, and it is claimed to have certain advantages over the usual types. It is noticed that in such apparatus we usually have trouble with emulsion or powder which is produced

during the working, and the powder is likely to fill up the holes in the jet so as to hinder the action. Repeated cleaning is thus needed in order to keep the apparatus in proper shape. In the present type, special means have been taken to do away with this drawback and always have a clean apparatus.

A chamber or drum BB is mounted so as to rotate between the upper and lower supports AA of the apparatus. The lower part is filled with mercury and the upper part with the proper liquid. In the chamber is the annular groove CC which is designed so that it will contain the whole amount of the mercury which occupies this part when the drum is rotated. A horizontal tube D is held by an arm E to the upper fixed pivot F, and the tube has a small hole H lying opposite the disc L. This latter is of insulating material, and carries the metal plate J, which is connected by a wire to the collector ring N below. The disc L and the insulated part S are mounted in the metal tube M as shown, and this latter rotates along with the drum. Contact is made with the mercury by means of the ring N.¹

When the drum is rotated, we have the action which is shown in the second diagram. The mercury occupies the groove owing to centrifugal force, and it is taken up by the fixed tube D so that a jet R is formed against the rotating disc L. This makes contact with the

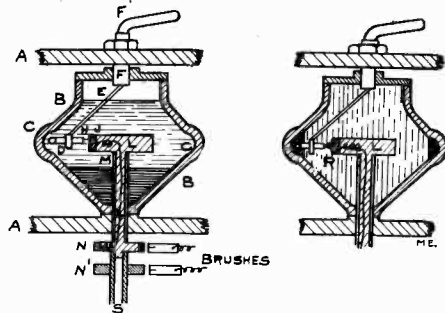

metal piece J at each revolution. Owing to the centrifugal effect, the rest of the matter (liquid, etc.), remains outside the groove and occupies a position according to its density. Any emulsion which tends to be produced is at once destroyed, and we have a phenomenon like that which occurs in a centrifugal machine used in separating mixed liquids. There is produced a separation or a sort of decantation of the emulsion, which the

(Continued on page 504)

A Universal Wireless Testing Set

BY WILLIAM DUBILIER.

THE TIME has come when the essential duties of the wireless companies is to seek to establish numerous wireless telegraph stations, and perhaps its most important task is now the manufacture of wireless appliances of various kinds.

An interesting class of such apparatus consists in the measuring devices which are put on the market for common practice and experimental work.

Among these we may note the multiple tuner, a device which can be used for a tuner, wave meter and distance measurer, the portable wave-meter, the direct reading portable decimeter, etc.

The Marconi multiple tuner is the outcome of many years experimental work and constant trials, both in regard to the scientific principles involved and in the manner in which they have been carried out.

The principal object is to tune the receiver or render it immune to interference from other stations, but it may be used for measuring the lengths of the transmitted and received waves

which A represents the aerial, E the earth, R the receiver or detector; the dotted line encloses the instrument

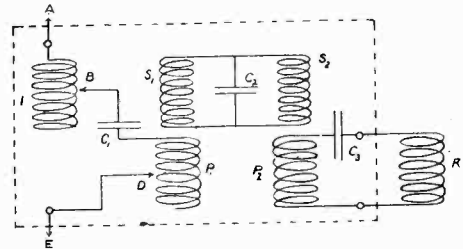

FIG. 1

proper. The latter contains three separate circuits called the aerial circuit, the intermediate circuit and the detector circuit. The aerial circuit passes from the aerial A through the aerial tuning inductance I, aerial tuning condenser C_1 , and aerial inducing inductance P_1 , to the earth at E.

The intermediate circuit consists of two equal inductances S_1 and S_2 connected in parallel to the intermediate tuning condenser C_2 . The detector circuit consists of an inductance P_2 in series with the detector tuning condenser C_3 and detector R. The inductance I and P_1 are adjustable at B and D respectively, and the condensers C_1 , C_2 and C_3 , are all adjustable and by means of these adjustments all the three circuits are tuned to the received wave length. The oscillations in the aerial circuit then (by means of P_1 and S_1) induce oscillations in the intermediate circuit which in turn induce (by means of S_2 and P_2) oscillations in the detector circuit. In addition to the above adjustments, the two coils S_1 and S_2 may be removed relatively to the coils P_1 and P_2 , so that the couplings between the three circuits may be varied.

The condensers C_1 , C_2 and C_3 , are rotating plate condensers and are continuously variable from zero to a maximum of 10 jars, a jar being of 1,000 centimeters capacity. The range of the instrument is increased by means of the condensers placed in parallel or in series by means of the tuning switch. The instrument is fitted, in addition to the parts shown in this dia-

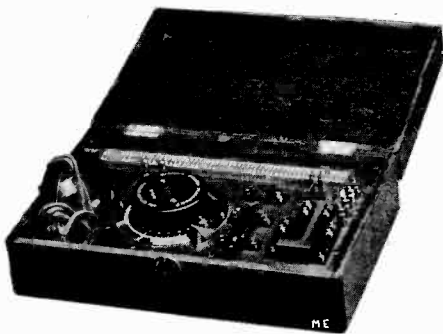

FIG. 3

and for estimating the distance of a known station. The essential parts fit into a plain wooden travelling case, beneath a board carrying the switches and contacts which are of the most substantial character and easily accessible for cleaning. The case measures 1 ft. 9 ins. by 9 ins. by 11 ins. high and weighs 32 lbs. complete; it is suitable for all wave lengths from 300 to 8,000 feet. The general principle of the instrument is shown in Fig. 1, in

gram, with a micrometer spark gap and shunt inductance, the latter of the order of 8,000 microhenries.

These instruments are connected between the aerial and earth terminals to prevent the accumulation of an electrostatic charge in the aerial, with a change switch by means of which the whole of the tuned circuits may be cut out and with a tuning switch by means of which the capacity in the intermediate and detector circuits may be increased to a maximum of 30 jars. The use of the multiple tuner for tuning, measuring the lengths of waves transmitted from the station, etc., offers no particular trouble. As for the measurements of distance between stations, this is done by comparing the strength of the received signals. The measurement is accordingly dependent on the hearing of the operator and upon conditions which are likely to vary from day to day, so that it is impossible to utilize it for the determination of the distance of the transmitting station, except if the same man on the same day makes relative measurements of the strength of the received signals.

The parallel wave-meter, of which a view is given Fig. 2 contains an oscillation circuit and a detector circuit with telephones, all enclosed in a box measuring 9¼ ins. by 6 ins. and weighing 6¼ lbs. complete. The oscillation circuit consists of a fixed inductance and a continuously variable condenser

justing it to resonance by varying its capacity until the loudest signals are heard in the telephone. The wave length may then be read off from the position of the condenser and the calibration curve or table supplied with each instrument.

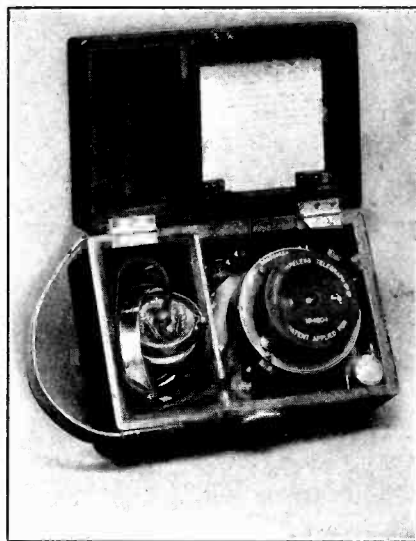

FIG. 2

A great accuracy is secured first by the whole of the oscillation circuit being fixed, second by varying of the condenser not affecting its dimensions in the slightest degree, second by the fact that the detector is not in the oscillation circuit but in a parallel circuit which has such high resistance that it practically does not affect the oscillation circuit, and third by the sensitiveness of the carborundum. Carborundum is very advantageous, owing to the constancy and simplicity of its manipulation and its great sensitiveness. A calibration table or curve giving the wave length in feet, or meters if required, corresponding to readings of the condenser is supplied with each instrument. The aim of the manufacturers in designing the portable decimeter has been the introduction of a practical instrument which will give the measurements of the quantities of energy radiated, capacities, etc., with a fair degree of accuracy and which can be used with rapidity and with a minimum amount of calculation. The instrument is furthermore extremely portable being fitted, as now made, in a box which measures 14 ins. by 9 ins.

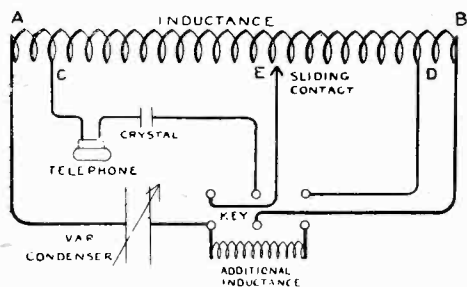

FIG. 4

forming a closed circuit with very small damping. The detector circuit is connected across the condenser in the oscillation circuit, and consists of a crystal of carborundum in series with a telephone. The wave length of the oscillations taking place in any circuit is measured by holding the wave-meter in the vicinity of the circuit and ad-

by 4½ ins. and weighs only 13 lbs. complete, Fig. 3. It consists of a coil of low resistance wire wound on an ebonite tube arranged in series with a condenser, variable within wide limits; across the condenser is arranged the detector circuit, consisting of a telephone receiver and a crystal of carborundum held between metallic clips. With each instrument is provided a table for rapid reading of wave lengths from the condenser readings and provided the waves being measured are very little damped, their length can be determined within 1 per cent.

The standard of wave length adopted was a parallel wire system consisting of two parallel wires spaced 5 ins. apart stretched horizontally 5 feet above the ground and sparked at one end one into the other, energy being supplied by an induction coil, four times the length of this system was called the absolute wave length. The measurement is based on the fact that if the circuit described above is brought into the field of an oscillator and the condenser varied, a sudden strengthening of sound will be heard in the telephone when the period of oscillating (T) is such that $T =$

$$2 \pi \sqrt{LC}$$

where L and C are the inductance and capacity of the receiving circuit.

The sensitiveness of the instrument is such that the presence of many waves, not previously noted by other instruments, has been observed, harmonics of the fundamental oscillation being noted down to the 1st, when the fundamental was 1,000 feet in length, during the determination of the absolute standards from the parallel wires.

In the operation so far described, the only variation involved is that of the condenser; however, if the coil AB Fig. 4 is made long and of small diameter, it can be assumed that the potential varies uniformly from one end of the coil to the other, and if not arrange the detector circuit so that one end of it is connected to the said coil at point C, and the other end of it at E, which is variable connection so we have a method of varying the strength of the signals without altering the oscillation part of the circuit. This will enable us to plot tuning curves for any wave length being received by adjusting the condenser to

different successive values and varying the position of the sliding contact E until just audible signals are being received.

In practice, however, such a process would be much too tedious and Bjerknæs' well-known formula for obtaining the decrement is used, the measurements being made by comparing signals in tune (the tap off being fixed to the sliding contact E) with those out of tune; the tap off being a permanent length C. D. A double pole two-way key performs the operation of throwing in and out of tune and altering the position of the tap off and a switch enables the throwing out of tune to be done by increase or decrease of inductance.

Finally, terminals are provided to enable capacities and inductances to be measured, inductances can be inserted in series with the circuit and from the table given their value obtained by taking two readings of one wave length with and without the inductances.

Small capacities can be measured by placing them in parallel with the decremeter condenser and noting the variation of the latter to bring it into tune again with the wave, the larger capacities are measured by inserting them in series with the circuit and reading off from the table or the formula supplied. The instrument is carefully standardized as to wave length, capacity and inductance; a Vernier is provided on the condenser to enable the tuning curves to be plotted accurately; the switch keys are arranged so that they can be quickly removed and the contacts cleaned if necessary. Fig. 3 shows decremeter complete.

WIRELESS ASSOCIATION OF MONTANA.

THE Wireless Association of Montana was organized Oct. 29, 1910, and the following officers were elected, President, C. E. Spitz; Vice-President, H. H. Mees; Secretary, K. I. Sparks.

The purpose of the club is to promote wireless throughout the State.

Anyone in Montana who owns or operates a station is eligible for membership.

For further particulars address the Secretary, 927 Utah Avenue, Butte, Montana.

How To Find The Required Capacity of Transmitting Condensers

By I. H. GLICKMAN.

IT is a well known fact that to secure the maximum efficiency from a transmitting set, the proper condenser capacity must be used.

When using an alternating current transformer, the amateur is very often puzzled to know how much condenser capacity is required to secure the best results.

There are several reputable firms in the market who sell transformers complete with a condenser of the necessary capacity. It is always best to purchase the condenser along with the transformer, as then one is positive he is using the right amount of capacity.

From the formula given below, (2) the capacity required for a transformer of any rated output, and working on any voltage and frequency can easily be obtained.

As will be seen, the higher the frequency, the less capacity will be needed for the same output. Consequently it is advantageous to use a frequency as high as convenient.

After finding how much capacity is required, the next thing will be to build a condenser. As several very excellent articles concerning the construction of these have appeared in this magazine, the author will not attempt to describe one. However, a few words would not be out of place. The most usual and generally adopted method is to use glass plates, about 8x10 inches, with heavy tinfoil or copper foil on both sides. One of the large commercial companies is using copper plated leyden jars in all its stations.

After deciding on one method or the other (the author prefers glass plates) the next thing will be to find how much foil will be needed to obtain the necessary capacity.

$$(2) A = \frac{36 \pi D C}{K \times 10^5}$$

A=Area of foil in square centimeters.

D=Thickness of dielectric in centimeters.

K=Dielectric Constant (see table at end of article).

C=Capacity in micro-farads.

$\pi = 3.1416$.

For example:—

How much capacity will be required for a 1/4 KW. transformer, primary voltage 110, frequency 60 cycles secondary voltage 20,000, condenser dielectric .2 centimeters thick, made of glass; dielectric constant 6.57.

It will be seen from the curve that a capacity of approximately .01041 mfs. will be necessary. Now substituting in formula (2) we have:—

$$A = \frac{36 \times 3.1416 \times .2 \times .01041}{6.57 \times 10^5}$$

$$6.57 \times 10^5$$

$$A = .2354692032 = 6.57 \times 10^5$$

$$A = .03584 \times 10^{-5}$$

$$A = 3584 \text{ sq. cent. of foil.}$$

From this we see that two sheets of tinfoil each approximately 60 cent. x 60 cent. separated by a dielectric made of

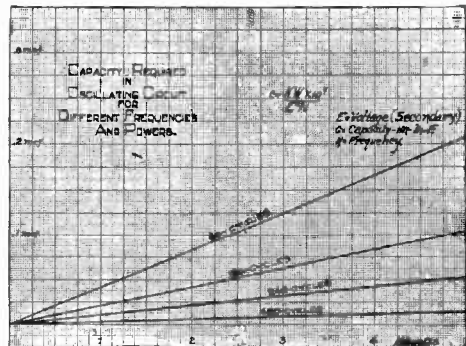

glass about .2 cent. thick will have the necessary capacity. However, it is hardly practical to use one plate so large. We can make a number of plates, their total area equaling 3584 sq. cent. 12 plates, each with a sheet of tinfoil on both sides measuring 15x20 cent. or 6x8 inches will when connected in parallel give a total capacity of approximately .01041 mfs +.

At first glance this may seem a trifle complicated, but on looking it over thoroughly you will be surprised to find how simple it all is.

Table of Dielectric Constants:

Air	1.
Parrafin	2.—2.3
Ebonite	2.05—3.15
Shellac	2.7 —3
Mica	6.64
Crown glass (hard)	6.96
Flint glass (light)	6.57
Flint glass (dense)	6.57—10.1
Water	81.07

Paris Letter

SIMPLE ARC LAMP.

Mr. F. Northrup, of London, has devised the following very simple arc lamp, which he finds to work very well, and is at the same time self-regulating. The upper carbon works in a brass or copper tube which should be brazed to the support, and the carbon is adjusted by a set screw. The main vertical arm can be made in any convenient manner, and is screwed down to the base-board. The lower carbon is

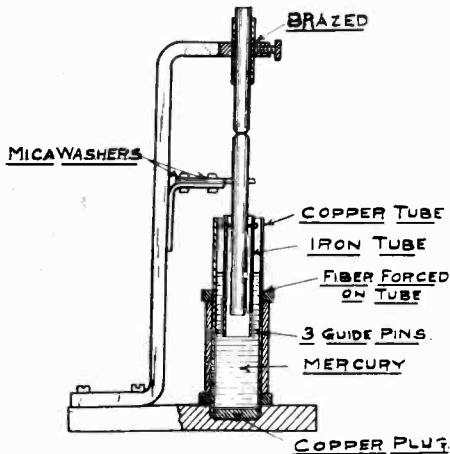

held in an iron tube by set screws and it floats in a large tube, the latter being filled with mercury. This tube is of copper and has a copper plug tightly fitted in the bottom, to prevent the mercury from leaking. Manganin alloy is much better than copper, however, as the mercury does not act upon it. Around the tube is a solenoid which is wound between two fibre washers. It should have 3 layers of 36 turns per layer, No. 13 B. & S. copper wire. The current comes in by the upper carbon and through the lower carbon to the solenoid and out. When the current flows, the solenoid draws the lower carbon down and we have an arc which is kept very steady. It is recommended to use a steel rod instead of the upper carbon when the light is used for photography, as this gives the best light for this purpose. We can use 100 volts on this lamp, with a resistance in circuit.

ROTARY SPARK GAP.

Capt. Ferrié, of Paris, has invented a rotary spark gap in which the wear upon the metal parts which is caused

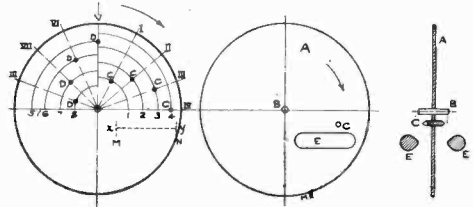

by the spark is much less than usual. A great number of sparks can thus be produced without undue wear or heating up at the sparking points, so that there is no hindrance to long working. On the shaft B is a rotating disc A which carries a contact piece C. The disc rotates between the two fixed cylindrical pieces E E so as to make the sparks occur between C and E. He uses a method which allows of utilizing a great number of pieces C upon the disc. Supposing the cylinder to occupy the position X Y and to extend from M to N. In the first quarter circle we space four contact points by drawing the circles 1, 2, 3, 4 and the radii 1 to IV. The intersections will give the four points C. In the quarter revolution of the disc there will thus be produced sparks at the corresponding four points. For the next quarter revolution we wish to mount the contact so that the sparks will lie between the former ones on the cylinder, so that the wear occurs at different places. We draw the four circles 5 to 8 which lie midway between the former circles, and thus obtain the four points D. Proceeding in the same way for the rest of the disc, we obtain 16 spark points which are distributed so that the wear on the cylinder is quite small in proportion to the number of sparks which are obtained.

A SPARKLESS MICROPHONE.

In a sparkless microphone it is the custom to use a liquid around the contacts so as to avoid sparking. The

present device has some advantages over the usual forms. Generally we find an upper fixed carbon and a lower carbon held on a float in mercury, the liquid resting directly above the mer-

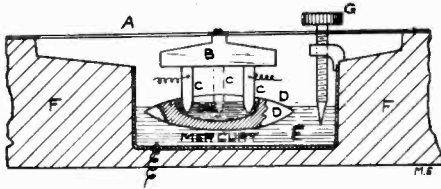

cury, and the contact pressure depends on the upward push of the mercury. This has a disadvantage, as there is a bad chemical effect when the liquid remains in contact with the mercury for a long time. The inventor separates the liquid entirely from the mercury in the following way. He uses the diaphragm A, the box F and the mercury trough E. To the diaphragm is fixed an insulating piece B, carrying two or more carbon pencils C, C, etc. The carbon's dip into a hollow float, also of carbon, which rests on the mercury. Liquid (oil, etc.,) is contained in the float so as to surround the con-

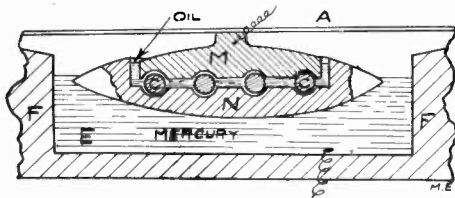

tacts. A screw G regulates the height of the mercury to give a sensitive adjustment of the contact pressure. Another form has the carbon block M and the carbon float, and between the two are placed the carbon balls C C, each in a separate socket and surrounded by oil.

NOVEL A. C. ELECTROMAGNET.

Where alternating current is used for electromagnets, the noise which is produced is often a drawback, especially when working at high frequency. Such noise is due mainly to the variation in the force of attraction of the magnet on its armature. The following device is intended to overcome the noise. The solenoid M carries the core C C, and upon the lower part of the core is mounted an iron piece which is bent up so as to come

near the top at D'. The armature is formed of the frame A A which is pivoted upon a cross-piece fixed to the core. Its upper part carries a tongue T which is bent into the position shown, so as to bridge over the air gap between the core and the adjoining piece. The

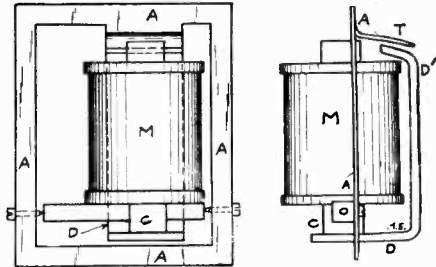

armature can be made so as to fall to one side by its own weight, or a spring can be used. When the current is put on, a strong pull is given, and at the same time the amount of vibration is much less than usual.

UNIQUE BURGLAR ALARM.

In the following burglar alarm apparatus, which is brought out at Paris, the wiring does not need to be concealed, as the bell will ring when the wires are cut and also when the door

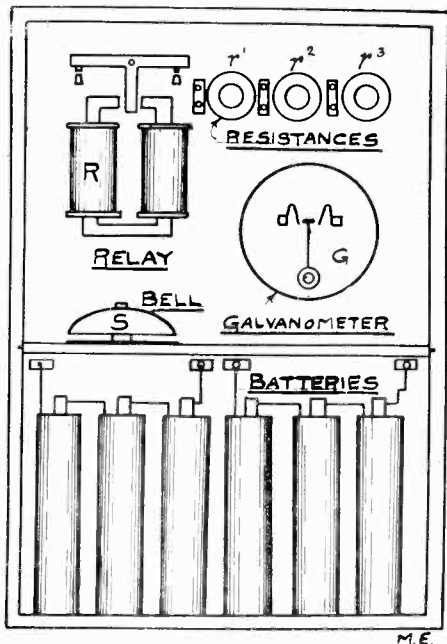

or window is opened. It works on the wheatstone bridge principle, and uses two resistances of 3,000 ohms balanced

with two others of 500 ohms. One of the 3,000 ohm resistances is distributed among all the contacts of the doors. The current passes in the two arms of the bridge, but not in the galvanometer, which is a sensitive milli-ampere meter G arranged to make a contact on either side, as will be observed. It is sensitive to 1/12,000 ampere at 4 volts. Should the alarm circuit be opened, the galvanometer receives current owing to the unbalancing of the bridge. Its contact works the relay R and this in turn makes the battery contact for the bell. Cutting the wire gives the same effect. On the other hand, the door contact cannot be shunted, as this will also unbalance the bridge and the galvanometer makes contact on the other side, ringing the bell. The whole is contained in a compact case and uses but four cells.

RESEARCHES ON SELENIUM.

H. Pelabon, in a paper presented to the French Academy of Sciences, finds some unusual results with selenium cells. He uses a cell formed of one electrode of an alloy of antimony and selenium and the other (negative pole) of pure antimony, the liquid being a solution of trichloride of antimony in hydrochloric acid. With the cell in the dark, we have a fixed electromotive force E_0 (at constant temperature). Letting light fall on the (+) electrode the e. m. f. at once rises to a point E_1 . It then drops to the original point, while the cell is still kept lighted, and keeps this value. Darkening the cell, we drop to a value E_2 and then rise slowly and reach E_0 in about 1 hour. In one test, $E_0 = 0.056$ volt; $E_1 = 0.079$ volt; $E_2 = 0.036$ volt, using open circuit. With closed circuit the values are different. The composite electrode works best when a very small percentage of selenium is used, say 1 per cent.

NEW FREQUENCY TRANSFORMER.

A GERMAN inventor, Goldschmidt, has invented a frequency transformer by which we can start from a low frequency and come up to a high frequency such as is used for wireless work. We use a gradual increase in the frequency of an alternating cur-

rent, and given a frequency of 1,000 cycles we convert to 2,000, and then from 2,000 to 3,000 and so on, finally reaching the frequency needed for wireless. Generally we start from zero, that is, direct current. A method already exists for doing this, using a fixed and a rotating winding so that the inductive action is varied, but as a

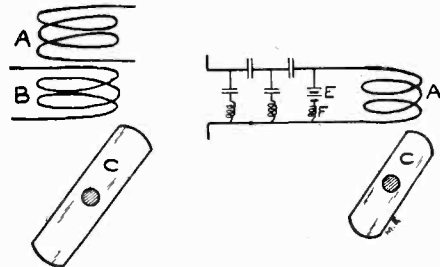

high speed is required, it is very difficult to rotate the winding owing to the well-known action of centrifugal force in such cases. M. Goldschmidt produces the result with two fixed windings and rotates the iron alone. The two inductive coils A B are provided with the rotating iron piece C (shown at a greater distance than ordinary) so that the inductive effect is varied. However, we can start by using direct current and need only one coil, as shown in the second diagram, provided we previously magnetize the iron by using a magnetizing coil or permanent magnet, and the system will then develop up like a dynamo. Here we use the battery E and coil A. At F is a choke coil to prevent the alternating current from reaching the battery.

(Continued from page 497)

mercury may have formed with the liquid, it is claimed. Such action keeps up as long as the drum is rotated. A black powder containing mercury is usually produced by the spark, and this is less dense than the mercury, so that the latter is separated from the powder which keeps on the outside. The tube dips into clean mercury, and no other matter comes into the jet. The mercury of the jet comes back into place at once. In this way the mercury which is used is always clean and there is no clogging up to be feared. The apparatus therefore will run for a long time without needing to be cleaned. The handle F¹ allows of adjusting the position of the jet.

MODERN ELECTRICS

A Magazine devoted entirely to the
Electrical Arts.

Published Monthly by

Modern Electrics Publication
NEW YORK CITY

H. GERNSBACK, EDITOR

A. C. AUSTIN, JR., ASSISTANT EDITOR

H. W. SECOR, ASSOCIATE EDITOR

Subscription Price For U. S. and Mexico
\$1.00 per year, payable in advance.

New York City and Canada, \$1.25.

Foreign Countries, \$1.50 in Gold.
Stamps in payment for subscriptions not accepted.

Checks on out of town Banks cannot be accepted unless the usual exchange is added.

SINGLE COPY, 10 CENTS

Forms close the 20th of the month preceding date of publication. Advertising rates on application.

The Editor will be pleased to receive original contributions of timely interest pertaining to the electrical and the affiliated arts. Articles with good drawings and clear photographs especially desired. If accepted, such articles will be paid for on publication, at regular rates. **No manuscripts will be returned unless return postage is enclosed.**

Address all communications to:

MODERN ELECTRICS PUBLICATION
233 Fulton Street, New York, N. Y.

Chicago Office: 45 La Salle St.

Paris Office: 137 Rue d'Assas

Brussels Office: 23 Rue Henri Maus

Copyright, 1910, by MODERN ELECTRICS PUBLICATION.

Entered as second Class matter March 31, 1908, at the New York Post Office, under the Act of Congress of March 3, 1879.

Vol. III DECEMBER No. 9

EDITORIAL.

This is a talk on advertising, and should be carefully read by every reader who has the welfare of MODERN ELECTRICS at heart.

Did it ever occur to you when you send your subscription to us, for which

you pay one dollar, that it costs us actually over \$1.25 to get up 12 single issues? In other words, on each subscription we sell, we lose 25 cents. The printing of each single number costs us over 6 cents. Then comes the expense of cuts, photographs, mailing expense, honorary of the many articles, salaries paid to foreign correspondents, office expenses and a hundred smaller items, each adding to the cost.

Our large news stands circulation is still more unprofitable, as we must sell each copy for 5 cents to the news company handling the magazine. We lose about 6 cents on each copy we sell.

We, therefore, must rely on our advertising pages to cover our expenses, the same as every magazine. There is not a paper printed which could exist without its advertising. No matter how good or how well gotten up a magazine is it must rely on its advertising pages or perish.

If you are a good observer the fact cannot escape your eyes that usually the magazines carrying a great amount of advertising present their readers with an abundance of text matter, as they can well afford to do so.

On the other hand, the large amount of advertising obtained was solely due to the reader's efforts to help the magazine, as the magazine has helped and instructed the reader.

We wish to impress the important fact on every reader that there is something equally as important about a magazine than merely perusing its text pages. There is such a thing as *duties of the reader* towards his magazine.

If you buy a wireless outfit you do not buy it for the sole purpose of looking at it, but you wish to bring out its best points. It is your duty to bring out its best points, and you knew this before you bought it. By buying the outfit you assumed a certain obligation towards same, as it were.

The same with your magazine. You wish to bring out its best points, naturally. You assume a certain obligation towards it, as soon as you start reading it. Like the wireless outfit, it will not "go" without your co-operation and without your assistance. You *must* help and co-operate if you wish to see this magazine to be the greatest of its kind.

Consider the advertiser for a second. He buys a page which is worth fifty dollars, or smaller space at a proportionate figure. Like yourself he has no money to throw away. *His advertising must pay him*, or else he is forced to seek a publication whose readers are known to take as much interest in the advertising section as in the text.

The reader should always bear in mind when perusing advertisements that the advertiser displaying only one or two articles, usually makes or handles probably a great many more, and while the reader will not always need the few advertised articles, he would unquestionably find what he really needed in the catalogue or literature, procured from the advertiser.

There are advertisements which very likely do not interest you at all. However, if you really knew what the advertiser had to say you would quite likely change your mind.

Most advertisements are like a theater curtain. You may not particularly like the curtain, but once it is raised you forget the curtain, and your interest is centred on the stage.

The same with the average "ad." It usually hides a good catalogue and a good proposition, and it is your duty to possess it.

As this magazine *absolutely guarantees* the reliability of its advertisers, every reader is fully protected. It is practically impossible for any one to lose money sent to advertisers, as MODERN ELECTRICS makes good every time.

There are several cases on record where this magazine has refunded money to readers who sent money to advertisers who became bankrupt or who went out of business.

Most readers would be astonished to know how much advertising is refused right along from unreliable persons or for "scheme ads." etc.

You never see in the advertising section patent medicine advertisements, "electrical" hair combs and other impossible schemes, which only serve to extract money from credulous readers.

If you see a doubtful advertisement in this magazine you may rest assured that it is not doubtful at all upon investigation. Each will stand the "acid

test." If you do not believe some of the statements made, do not discredit the advertisement, but let the advertiser "show you." He will be only too glad to do so.

And, before all, do not fail to get all the catalogs and literature you see advertised. You will need both when you least expect it, and before all you will save money.

And then, when sending your order maybe weeks or months later, do not fail to say that you became acquainted with the advertiser through MODERN ELECTRICS. It will pay you, him—and us.

AN INTERESTING EXPERIMENT.

TO show the choking effect of a coil on alternating current:—

Arrange two parallel wires, one having a high ohmic resistance of iron or german silver but perfectly straight. The other of low ohmic resistance, of a large size of copper but coiled up into a close spiral or solenoid. Put a red lamp in series with the straight but high resistance wire, and a green lamp in series with the low resistance solenoid or helix.

If we supply a continuous or direct current to the system the green lamp may be made to light up, but if we supply an alternating current the current will go through the resistance rather than through the large copper coil, thus showing the choking effect of a helix on alternating current. Note:—This will not work if the resistance wire is of too high resistance for the pressure used.

The diameter of the helix or solenoid used may also be varied, almost proportionally with the number of alternations used in the alternating current, thus, explaining the large diameter of "wireless" helices. It will be remembered the number of alternations in the wireless systems is sometimes exceedingly high.

Contributed by

MOORE STUART.

If you are keeping your copies for reference, it is necessary to obtain one of our beautiful binders, holding twelve issues. It is made of a rich, red vellum, stamped with gold lettering. Price prepaid, 50 cents.

New Military Quenched Spark Set

BY OLIVER A. DeCELLE.

CONSIDERABLE interest has been aroused among the wireless fiends of the United States this summer by the



FIG. 1

U. S. Signal Corps' exhibition of a new 2 K.W. portable military quenched spark outfit at the many tournaments and maneuvers extending from coast to coast.

The outfit, which was in charge of Sergeant J. C. Flicht, Master Signal Electrician, U. S. Signal Corps, is one of the latest products of the Telefunken Wireless Co., and is being thoroughly tested by the government.

The outfit is housed in two wagons, as is shown in Fig. 1, one containing the engine, dynamo, aerial poles, counterpoise, tools, etc., while the other contains the instruments.

The aerial is of the umbrella type and is made of stranded phosphor bronze wire. It is held in the air by an eighty-five foot, thin steel tubing pole which is in five foot sections. The bottom of this pole is thoroughly insulated from the ground by a stand made of five immense porcelain insulators.

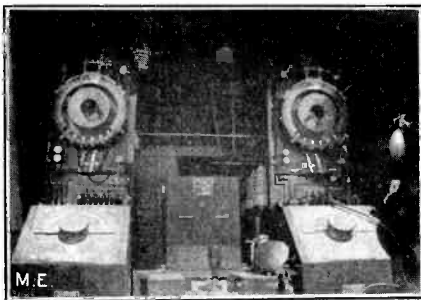

FIG. 2

Instead of having a ground, a counter-

poise, namely, another aerial is used. The regular counterpoise consists of a large area of wire netting, suspended twelve feet above the ground, over the wagons; but on account of the immense amount of trouble caused by putting up a counterpoise of this sort, a mass of heavy rubber covered wire, strewn over the ground, is usually substituted.

In the wagon to the right is the gasoline engine which is directly connected to a 500 cycle, 80 volt Dion induction alternator, which supplies the current for the transformer in the wagon on the left. This wagon also contains the tools, aerial and counterpoise wire, and upon it are strapped the aerial and counterpoise poles.

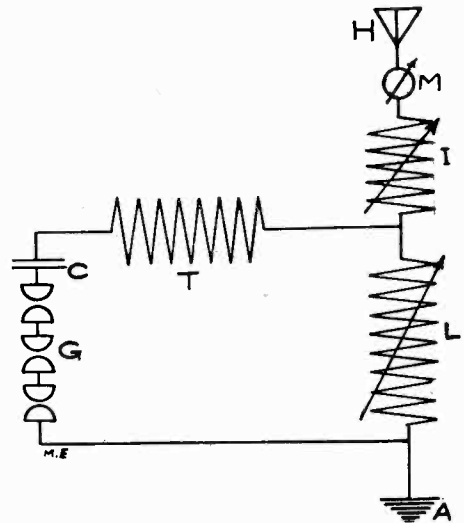

FIG. 3

In the wagon on the left are the wireless instruments. As can be clearly seen in Fig. 2, there are two complete receiving sets which are exactly alike. By having two sets, two different messages can be received at the same time, or two men can receive the same message at the same time.

These receiving sets consist of a tuning transformer, detector, fixed and variable condensers, and phones.

The tuning transformer (the highest instrument Fig. 2) is different from the ordinary type in which the secondary moves away from the primary, because in this case the primary (the outer disk)

moves away from the secondary (the inner disk) by means of a large hinge at the top of it. The secondary has three taps taken from its windings, while the primary has six.

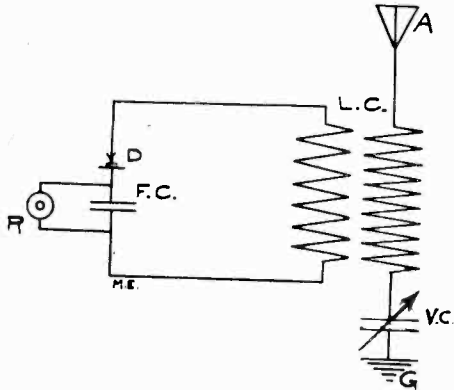

FIG. 4

The detector (the instrument under and to the left of the tuning transformer; it is not in place on the set of instruments to the left) is of a new design and the detecting materials are galena and carbon or tellurium.

The variable condenser (its knob and dial can easily be seen below the detector) is of the usual rotary type. Its plates, which are made of aluminum, are encased in the compartment beneath the dial.

As can be seen, there is but one phone to a headpiece, the other ear being padded by a cushion. The reason for this is taken from the fact that nearly every man has one ear better than the other, therefore it concentrates all the sound on the best ear.

Right below the tuning transformer can be seen a little two armed switch and to the sides can be seen the words, "Long Waves," "Short Waves." This switch changes the position of the variable condenser in the receiving circuit, as the condenser will receive long waves better in one position than in another; the same is true of short waves (see wiring diagram.)

The aerial switch (above and a little to the right of the variable condenser) is of a novel type, which with one throw cuts out the detector, turns on the current, throws in the aerial and ground, etc., and vice versa.

The fixed condenser, which is composed of alternate sheets of tinfoil and mica, has a very small capacity and is shunted around the phones.

The box between the two sets of instruments contains one of the most up-to-date wavemeters that can be had. With it, the wave length of any station can be accurately measured. The two boxes on either side of the key each contain three detectors, all adjusted and ready for use.

The sending instruments are in the rear of the receiving apparatus and are of the quenched spark type. The secondary terminals of the transformer can be seen behind the wavemeter (Fig. 2). This transformer delivers but 500 volts on the secondary side, but the amperage is something terrific compared to that of any other 2 KW. transformer; it is considered nothing to have the hot-wire ammeter in the aerial circuit registering four or five amperes.

The spark gap is of the same type as was described in the August, '09, issue of this magazine, namely, a number of circular shaped plates of copper, between which intermediary mica sheets maintain an accurately constant spark distance. This spark produces a musical note in the phones of the receiving set, and has marvellous carrying power.

The sending condenser was the hardest problem to solve in the portable set, such a large capacity being needed. This was

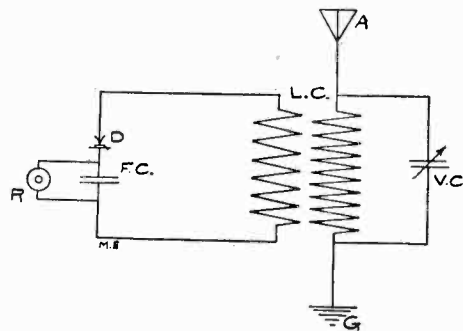

FIG. 4A.

solved finally, however, by the use of a condenser made of tinfoil and specially prepared paper.

The key, which is between the receiving instruments, is of the continental type, and has heavy copper contacts instead of the usual platinum contacts.

Instead of having the ordinary helix, a variometer system is employed. These variometers or inductances are all vari-

How to Make An Oscillation Transformer

By RALPH WEDDEL.

FINDING the need of a good oscillation transformer, and not seeing any article on how to make one, I designed one myself. Below find instructions for making same.

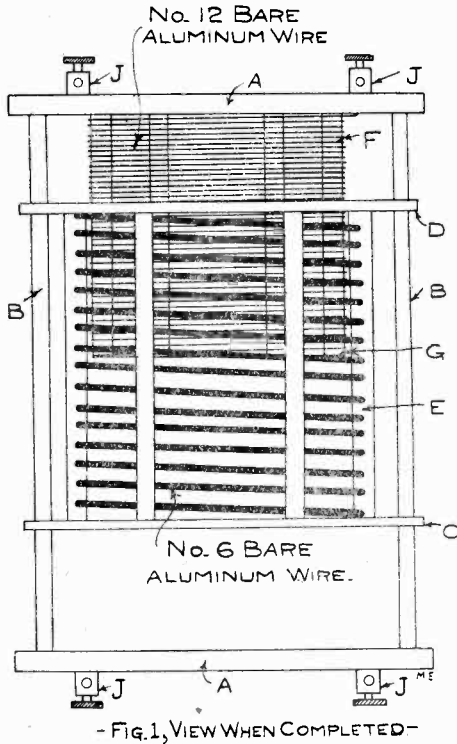

Next get 6 pieces of wood 1 inch square by 16 inches long as in Fig. 4 E. Number them 1, 2, 3, etc., up to 6. Take piece No. 1 and bore a $\frac{1}{4}$ inch hole, $\frac{1}{2}$ inch down from the top. Then bore 14 more holes 1 inch apart. Bore the holes exactly in the centre of the wood. Take piece No. 2 and bore a $\frac{1}{4}$ inch hole $\frac{7}{10}$ of an inch from the top and bore 14 more holes 1 inch apart. Take the other pieces in their respective order and bore $\frac{1}{4}$ inch holes $\frac{2}{10}$ of an inch farther from the top than the last one bored, and bore 14 more holes 1 inch apart, till the last piece, when the hole is $1\frac{1}{2}$ inches from the top.

This is made clearer by looking at Fig. 7. These holes are for the wire on the primary and are bored in this way so as to give the wire the proper pitch.

Next make 6 more pieces of wood 1 inch square and 12 inches long as shown in Fig. 5 F.

Then cut out a circle of wood 13 inches in diameter as in Fig. 6 G. Divide it into 6 equal parts and bore $\frac{1}{4}$ inch holes $\frac{1}{2}$ inch in from the edge.

We have now all the parts made and

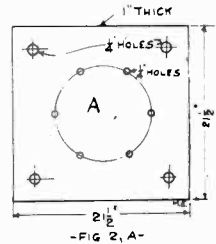
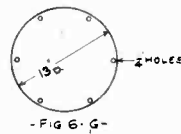
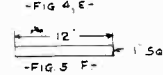
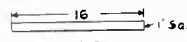
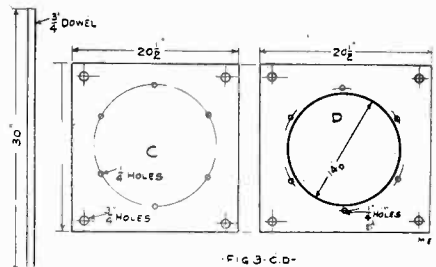

First cut out 2 squares of wood, $21\frac{1}{2}$ ins. square and 1 in. thick as shown in Fig. 2 A. Bore $\frac{1}{4}$ in. holes, $1\frac{1}{8}$ in. in from each side near the corners as shown in Fig. 8. Take one of them and finding the centre draw a circle 12 inches in diameter, and divide it into 6 equal parts and bore $6-\frac{1}{4}$ inch holes.

Next get 4 dowels, 30 inches long and $\frac{3}{4}$ inches in diameter, as shown in Fig. 3 B.

Then cut out 2 squares of wood $20\frac{1}{2}$ inches square and $\frac{1}{2}$ inch thick, as shown in Fig. 3 C-D. Take one of them, C, and draw a circle exactly in the centre, 15 inches in diameter. Divide it into 6 equals parts and bore $6-\frac{1}{4}$ inch holes. Take the other piece, D, and cut out a circle 14 inches in diameter. Divide the circle obtained into 6 equal parts and bore $6-\frac{1}{4}$ inch holes, $\frac{1}{2}$ inch out from the edge of the circle.

we need 1 pound of No. 12 bare aluminum wire and $1\frac{1}{2}$ pounds of No. 6 bare aluminum wire. Some brass screws, 10 of which are 2 to $2\frac{1}{2}$ inches

long and 12 of which are 1½ to 2 inches long. Also 4 binding posts and some high tension flexible cord and two helix clips, one of which is very small, so as to hold the No. 12 wire. I will not describe how to make a helix clip as there has been several good articles in this magazine lately on making them. We will now assemble the parts.

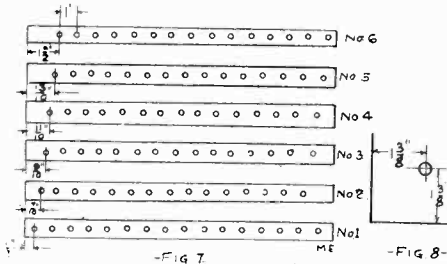

First take the piece A that has the 6¼ inch holes in it, and taking 6 pieces of wood, F, 1 inch x 1 inch x 12 inches and fasten them on to A by the long screws. Take the piece G and fasten it on to the other end of the stick 5 by means of the short screws. Then wind 40 to 50 turns of the No. 12 wire around

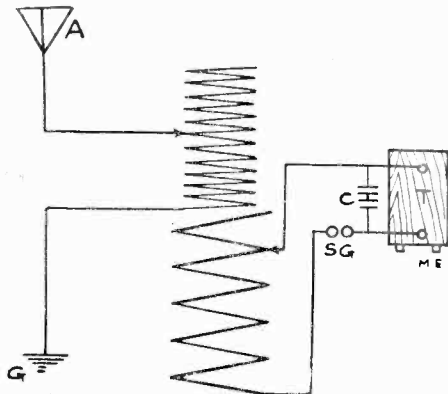

-FIG. 9-

the sticks. Wind it tight so it won't slip. We now have the secondary wound.

Take the pieces C and D and the pieces of wood E and make another core somewhat like the one made before, only put the sticks E in their respective order. First No. 1, then No. 2, etc. Take the No. 6 aluminum wire and put it through the top hole of No. 1 and continue to wind it around by putting it through the holes until you have 15 turns. This is the primary.

Then take the dowels and fasten them on to the other piece A. Then slip the primary through the dowels as the ends

of the primary has ¾ inch holes in the corner.

Then fasten the other ends of the dowels to the large piece A of the secondary. The primary wire should slip over the secondary wire by about an inch. Connect a flexible cord to the No. 6 wire and to the binding post J. Connect the biggest clip to another piece of the flexible cord and connect to the binding post. Do the same to the small clip only connect it to the binding post on the other end. Stain all the wood work with some good stain as walnut or oak. Connect it up as in the diagram Fig. 9. The transformer complete is shown in Fig. 1.

THE HAVERHILL WIRELESS ASSOCIATION.

THE "Haverhill Wireless Association" was organized Thursday, November 11, 1910, and the following officers were elected for a term of one year.

Wilfred Vigneault, President; Ridel G. Sprague, Vice-President; Leon R. Westbrook Secretary and Treasurer.

The aim of this Association is to advance the knowledge of the theory and practice of Wireless transmission among the amateurs.

The charter of this organization is open until December 1, and all persons in Haverhill and vicinity, who own or operate either a sending or receiving station, or both, are invited to communicate with Mr. Leon R. Westbrook, Secretary and Treasurer, 41 11th Avenue, Haverhill, Mass.

NEW MILITARY QUENCHED SPARK SET.

(Continued from page 509)

able, thereby permitting the wavelength to be changed to anything from 500 to 2000 meters.

Fig. 3 represents the arrangement of the sending apparatus. The secondary circuit is formed by the spark gap G, the condenser C, the coupling variometer L, extension variometer I, the counter-poise or counter-capacity A, transformer T, hot-wire ammeter M, and aerial H.

Note may be taken of the fact that nearly everything is electrically connected by means of square silver plated rods.

The receiving circuits are represented in Fig. 4 and 4 a.

The Construction of a Rotary Spark Gap

BY HALLAM ANDERSON.

FIRST take a piece of hard wood or hard rubber, about $\frac{3}{8}$ in. thick and $2\frac{1}{2}$ in. in diameter. (The end of a magnet wire spool will do very well.) Then take a bit about the size of No.

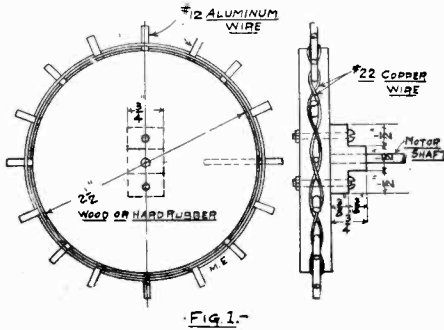

Fig. 1-

10 or No. 12 wire and drill 16 holes, about an inch deep, at equal distances around the circumference. Then cut from No. 10 or 12 aluminium wire 16 pieces about $1\frac{1}{2}$ in. long and force these pieces into the 16 holes. Then take some bare copper wire, about No. 22, and interwind it between the 16 pieces of wire about 4 times around. (See Fig. 1.)

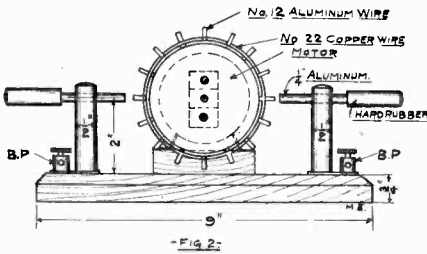

Fig. 2-

Now take a piece of hard rubber or fibre and cut it $\frac{3}{4}$ in. x $1\frac{1}{2}$ in. x $1\frac{1}{2}$ in., and then cut out two corners $\frac{3}{8}$ in. x $\frac{1}{2}$ in. (See Fig. 1.) then bore two holes in the fibre and wheel as shown and bolt together with 8-32 bolts and nuts. Then, in the exact centre of the wheel and fibre, bore a hole just large enough to fit axle of the motor to be used so it will go in very hard and the wheel will be tight on the axle.

From some hard wood, cut a base about $4\frac{1}{2}$ in. x 9 in. and $\frac{3}{4}$ in. thick. Bevel the edges to improve the appearance. Then take the battery motor with the gap wheel on the axle and find out how thick a block will have to be made to go under the base of the motor so as

to give the wheel about $\frac{1}{4}$ in. clearance above the base. Cut this block and screw it to the base and then screw the motor on the block so as to bring the wheel into the position shown in Figs. 2 and 3. (This will make the axle of the motor 2 inches above the base board.)

Then make two stationary electrodes as shown in Fig. 4.

Now mount the gaps as shown in

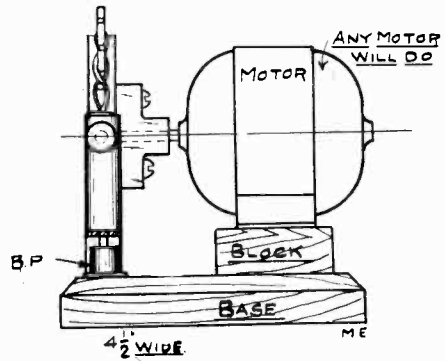

Fig. 3-

Figs. 2 and 3, and connect these to binding posts. Set the gaps as close to the wheel as possible (generally about $\frac{1}{8}$ in.) and see that when the wheel turns, the spokes do not hit the gaps.

Connect the two secondaries to the binding posts and connect the motor to about 4 dry cells and fix a suitable contact on the aerial switch to close the motor circuit when the switch is set for

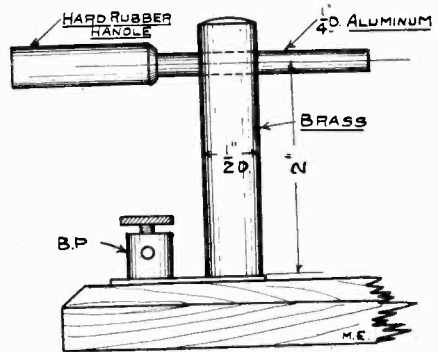
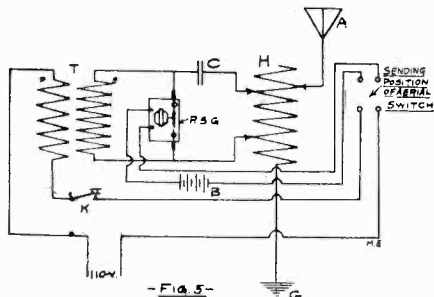

Fig. 4-

sending. If a break key is used, a separate knife switch may be used.

Start the motor up and send, and the result will be a very high frequency

spark. I have experimented with this gap for about three months and I find that it will put about 20% more amperes into the aerial than with a stationary gap, and that the high frequency spark is very easy to read through static or interference. *Caution.* Do not use 110



on the motor unless it is *belted* to the gap as the high tension secondary current will jump to the 110 which is connected to the primary of the transformer. These dimensions are only approximate and will have to be changed to suit different kinds of motors.

Book Review

La Télégraphie Sans Fil.
 La Télémécanique et la
 Téléphonie Sans Fil.
 E. Monier, Ingénieur Des Arts Et
 Manufactures
 Preface du Dr. E. Branly.
 Paris. (VI^e.)
 H. Dunod Et E. Pinat, Éditeurs.
 Price 75c.

A French treatise on the recent developments in Wireless Telegraphy and Telephony.

Dr. Branly's researches in this line are covered, also the Duddel Arc and its relation to Wireless Telephony. The book contains a good description of the Eiffel Tower Wireless plant.

A closing chapter deals with the possibility of television, and the International Wireless conference at Berlin.

WIRELESS MADE HIM THIEF.

The desire to build a wireless telegraph apparatus on the roof of his home, No. 188 Baltic Street, Brooklyn, was keen in the breast of seventeen-year-old William Allen. He was ar-

rested on complaint of his employer, Thomas Lamb, a druggist of No. 84 Court Street, who charged him with the larceny of \$55 from the safe. Allen admitted taking the money.

"I couldn't resist," he confessed. "I bought batteries, wires, and everything I needed, then Mr. Lamb discovered that the money was gone."

Lamb, who takes great interest in young Allen, despite the theft, said he had intended to send the boy to college as he saw Allen was bright and apt in the store. He pleaded with the police to deal gently with the boy, who is the sole support of a widowed mother.

Chief Magistrate Kempner held Allen in \$500 for examination.

CONSTRUCTION OF A SENSITIVE WIRELESS DETECTOR.

[Continued from page 505]

bronze strip S 1 may be soldered or riveted to SS. Purchase six machine screws, five of which are 1/2 in. long, the other being 5/8 in. with nut.

When all the parts are made and threaded, put them together as shown, and connect a wire through the groove from the machine screw in the bottom of P 2 to the binding-post. The other wire connecting the other binding post to M 2. It would be advisable to cut a piece of green felt and glue it onto the bottom of the base, so as not to scratch your table, or whatever you may have it on.

This detector is very efficient, especially when perikon is used. If you use perikon, solder the zincite crystals into the cup, without the spring movement, and the copper pyrites into the cup with the spring movement. The reason for having the cup, which contains the zincite crystals a little higher than the other, is so that the lump of copper pyrites will strike more in the centre of the zincite crystals. Of course, this detector will work excellently with silicon, molybdenite, iron pyrites, carborundum, etc., but in this case, a point must be fastened to S 1 instead of the cup. A platinum point is the best, silver next best, though brass or copper will do. If desired, all the parts may be nickel-plated, which will add a great deal to the detector's appearance.

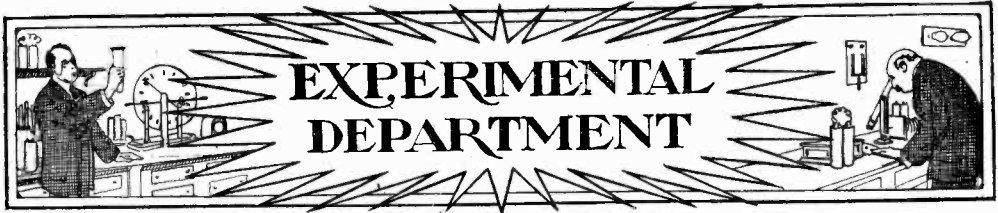

This department has been started with the idea to encourage the experimenter to bring out new ideas. Every reader is welcome to contribute to this department, and new ideas will be welcomed by the Editors. WHEN SENDING IN CONTRIBUTIONS IT IS NECESSARY THAT ONLY ONE SIDE OF THE SHEET IS USED. SKETCH MUST INVARIABLY BE ON A SEPARATE SHEET NOT IN THE TEXT. The description must be as short as possible. Good sketches are not required, as our art department will work out rough sketches submitted from contributors. IT IS THEREFORE NOT NECESSARY FOR CONTRIBUTORS TO SPEND MUCH TIME IN SKETCHING VARIOUS IDEAS. When sending contributions enclose return postage if manuscript is to be returned if not used. ALL CONTRIBUTIONS APPEARING IN THIS DEPARTMENT ARE PAID FOR ON PUBLICATION.

FIRST PRIZE \$2.00.

NEW BREAK KEY.

The diagram shows a break key which breaks the aerial, ground, and shorts the

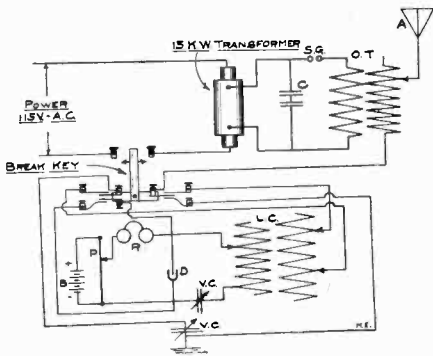

detector on the receiving set when the sending side is on.

The break key works perfectly with the most sensitive detectors, such as Electrolytic, Ferron, Carborundum, Perikon, etc.

The diagram explains itself pretty

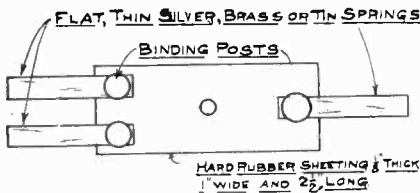

well, so there is no need of going into details.

This type of Break Key is used by nearly all the warships and navy stations on this coast, and most of the amateurs with high power have put them in.

You can use this break key diagram on closed or loose coupled receiving and sending. It does not matter how your station is arranged. The hard rubber sheeting goes between the key button and key lever.

Contributed by

NEAT M. TATE.

SECOND PRIZE \$1.00.

A SENSITIVE ELECTROSCOPE.

Procure a large-mouthed bottle, a brass ball, about eight inches of copper wire No. 9, a piece of gold foil

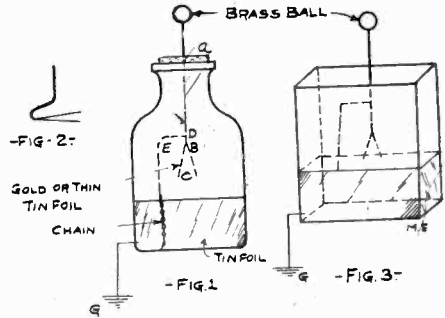

about 1/4 x 3 1/2 inches, a piece of brass chain 2 inches long and enough tin foil to construct a leyden jar 1 inch high around the bottom of the jar.

First place the brass ball on the piece of wire, then bend it as in Fig. 2. Flatten the end slightly, and with a sharp chisel split it about 1/4 inch. Carefully double the gold foil at the middle and place it in this slot and close it again, holding the foil in this vise-like slot. Now construct a leyden jar around the bottom of the jar, connect the inner coating with the

copper wire as in D and F so that it will not interfere with the foil leaves. The outer coating is connected to the ground. If desired, this can be made in a glass box as Fig. 3. This is very valuable in testing for static charges.

Contributed by

DANIEL GADDAS.

A CIRCULAR POTENTIOMETER.

Knowing the demand for instruments of the rotary type, the writer will endeavor to show the construc-

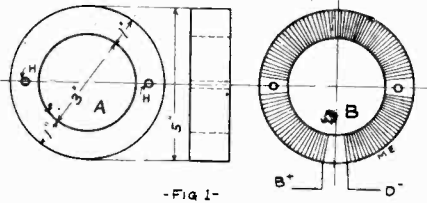

- Fig 1 -

tion of a potentiometer of the rotary type, which can be made at a low cost.

Materials:

- 1 piece of oak 6x6x1 inches.
- 2 pieces of oak 7x7x1/2 inches.
- 1 lb. of German silver wire No. 24.
- 3 binding posts.
- 3 screen door knobs and screws.
- A large hard rubber knob.
- 1 brass ball.
- Some small spring wire.

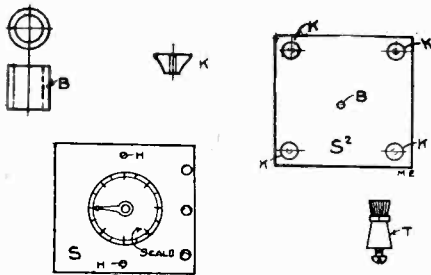

- Fig 2 -

Some brass tubing 3/16 inch outside diameter and about 5 inches long. Some brass tubing 3/16 inches inside diameter.

Take the piece of oak 6x6x1 inches and draw on it two circles, one 3 inches in diameter, and the other 5 inches in diameter, then cut with a scroll saw on these lines and the part cut should look like A in Fig. 1.

Sandpaper this ring until it is smooth. Then wind it with the wire

as shown in B, bringing out two long ends. Shellac this ring and put away to dry. Next get one of the 7x7x1/2

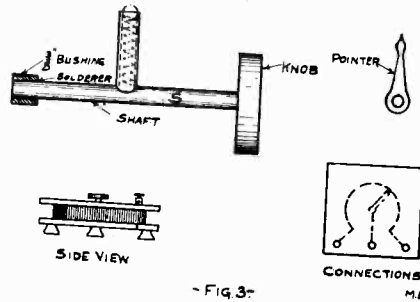

- Fig 3 -

inch pieces and screw the door knobs on one side, take 1/2 inch of the 3/16 tubing (inside diameter) and glue it in the center of this board in a hole drilled to take it; this is to be used as one bearing. The other 7x7 piece is fitted with a bearing of the same kind. Three binding posts are placed in the position shown in sketch. The slider is made like the drawing in Fig 3. The slider arm is 2 3/4 inches long soldered to S. The spring is put in position and then the knob. The bushing is fastened the last thing. Carefully scrape the insulation from the wire where the slider touches. Next put the instrument together as shown in Fig. 3, making connections as in Figure.

Contributed by

FANNON BEAUCHAMP.

INSULATED HANDLE.

Below please find diagram for a useful handle for sliders, detectors and binding posts.

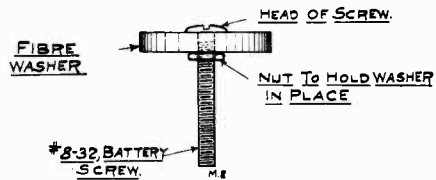

I find that the above arrangement makes a perfect insulated handle.

Contributed by

EDWIN MANVELL.

HOT WIRE METER.

In your October issue of Modern Electrics I saw a hot wire ammeter by D. R. Johnson, but as I did not quite understand it, I devised one myself.

In figure 1 is shown the general arrangement. (S) is a block of brass,

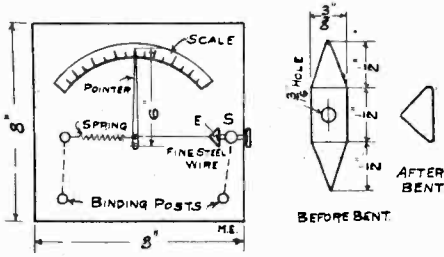

FIG 1-

tapped so as to take a battery binding post. The end of the post should have the threads filed off for a distance of one-eighth of an inch. Next procure a piece of copper 2 inches by three-eighths of an inch and cut on dotted lines as in Fig. 2. In the exact center bore a three-sixteenths inch hole to admit the binding post from which you filed the threads. After putting the binding post through the hole, batter so as not to let the copper slip off. The fine wire is next soldered to the copper. The binding post is allowed to extend outside of the box. This is used to adjust the pointer.

I would be very glad if some one would let me know how to calibrate the scale without using another meter in the circuit.

Contributed by

R. W. BURGER.

NEAT SENDING CONDENSER.

I give below description of a simple sending condenser which works very

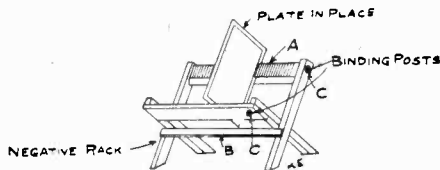

FIG 1-

good with my 1/2 K. W. Transformer Coil.

First, procure a negative rack which holds 24 negatives. Fig. 1.

Then get two strips of tinfoil the width and length of (A & B, Fig. 1) and glue it over the grooves in which the plate fits into.

Then bore two holes, one through A and one through B at one end, then insert binding post in each CC (See Fig. 1), then the rack is ready to receive the plates.

Cover 24 5x7 plates with tin foil on both sides, size 4x6, Fig. 2. Then make a tongue on both sides of the plates e, e (Fig. 2).

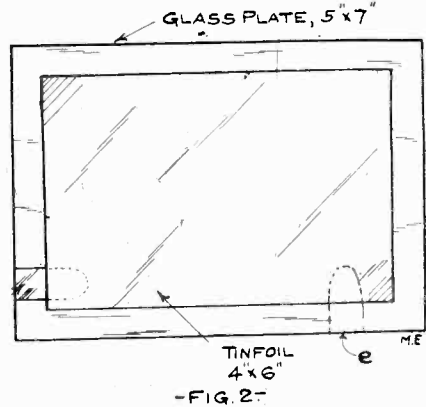

FIG. 2-

After the tin foil dries on the plate and sticks good, everything is ready for work.

Place plates in rack and add or take out the plates according to coil used.

Contributed by

JOHN C. RECTOR.

NEW CRYSTAL MOUNTING.

The usual way of mounting crystals in cups is to fill the cup with melted

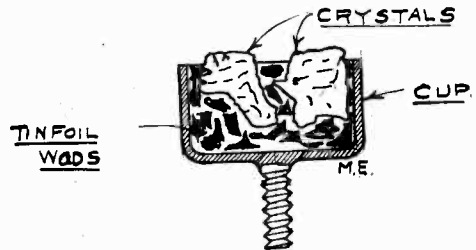

solder, or an alloy of low melting point, and while the metal is still melted, to insert the crystals into the cup. This method has the disadvantage of being permanent. Thus if the part of the crystal which was left exposed should be found not to be sensitive the cup, crystal and solder would be wasted. In practice it is

often found necessary to make up many before a good one is found. This is something which the experimenter can scarcely afford to do, at least when he pays the present prices for minerals and crystals.

A cheap and satisfactory way to mount crystals is as follows: Break off the cap from the carbon rod of a dry battery. This battery must be one which has a round carbon. Remove all the carbon from the cap and polish it with fine sandpaper.

Insert the crystal or mineral in this cap, and pack it in with little wads of crumpled tinfoil. The tinfoil can be packed in so tight that the crystals will not fall out. The cup may be assembled together with the other detector parts in any desired manner. If the crystal is found not to be sensitive at the parts left exposed, it is only necessary to pull out the tinfoil wads, turn the crystal or mineral over and pack again. In this way the sensitive part will soon be found.

Contributed by

PHILIP EDELMAN.

SPARKS FROM BUZZER.

As every one knows, a shock may be obtained from an electric bell or

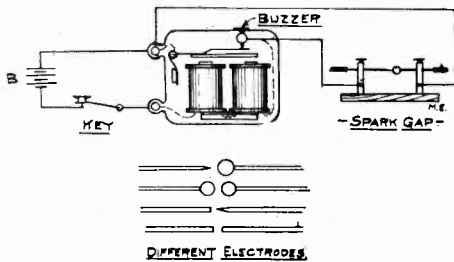

buzzer. if a pair of shocking handles be connected across the vibrator; thinking of this, I thought of trying to obtain a spark in a small spark gap connected across the contacts at CC. I accordingly did this, and with one wet battery, I obtained quite a large spark, considering its source. By adding more batteries, I got a larger spark. Different electrodes were tried, such as a set of pointed brass rods, two nickel plated brass balls, two zinc rods, one pointed graphite rod and one nickeled brass ball. The rods were of small diameter, about one-sixteenth of

an inch. This is an interesting experiment, and I thought I would give the readers of M. E. a chance to try it for themselves.

Contributed by

JOS. WURM.

SIMPLE SWITCH.

Enclosed you will find a description for a detector switch and also diagram.

Get a plug used for an electric lamp; take it apart and get the two catches like in diagram. Next take the middle

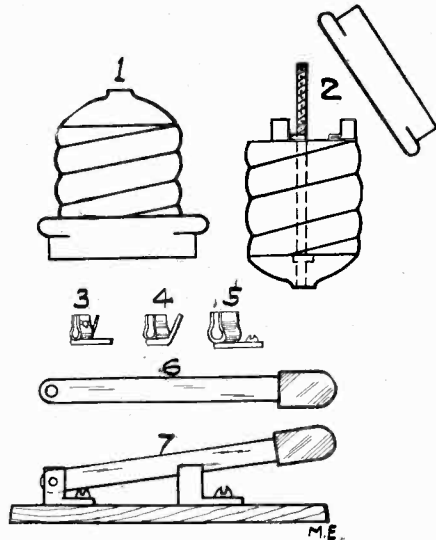

one and drill one hole in the middle and break side piece off, then take the other piece, bend it down and drill hole in bottom piece. Get a piece of brass $2\frac{1}{2} \times \frac{1}{4}$ in. and drill a hole in the one end and on the other end wrap tape and dip in sealing wax and shape handle. Take the middle piece and the brass piece and rivet it together with a pin and put it on a base and then fasten the other piece on the other end. For three detectors, use three plugs and put the three on one base about $\frac{1}{2}$ in. apart. This switch can be used for almost any work desired.

Contributed by

CHAS. NEIPOINT.

A UNIQUE CONDENSER.

Procure a strip of moving picture film about $2\frac{1}{2}$ feet long and take a strip of tin foil a little longer than the film, leav-

ing the one end of the foil extend over the end of the film and the other end of the foil should not come within 2 in. of the end of the film. Repeat the above until you have as many sheets as you think will serve the purpose.

The illustration below shows how the sheets should be laid.

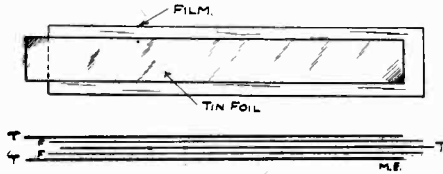

Now take the sheets and roll them up and fasten all the lugs together on each end, then put your condenser in melted paraffine for about 5 min. The condenser is now finished, and its appearance may be improved by setting it in a small box.

SIMPLE KEY.

Following is a key which can be made with little trouble and without any cost. Procure a piece of wood 3 by 3 inches and give this a good coat of shellac. Next get a spring clothespin and fasten this, at A, (about 1/2 in.) leaving 1 1/2 in. of the pin project from the board. Bore a hole in the upper and lower

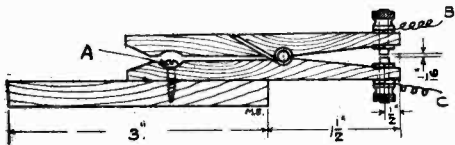

pieces, about 1/2 in. from the ends. Procure two binding posts off some old batteries and fasten these in the holes, having them about one-sixteenth of an inch distant at their meeting point. The wires can then be attached at B and C, as shown in the diagram.

Contributed by

IRVING GOLLOBER.

CHEAP VARIABLE CONDENSER.

First, get a piece of tin about 24 inches long and 12 inches wide, and cut it in two halves. Take the two pieces 12 inches wide and 12 inches long and make two cylinders so one

can slide inside the other; get some tissue paper and paraffine it and glue

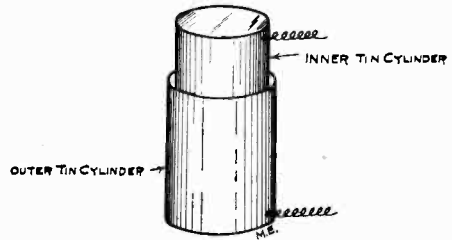

it to the outside of the smaller cylinder. Then get some wire and solder one piece to the small cylinder and another to the large cylinder. Your condenser is now complete.

Contributed by

BRUCE W. YOUNG.

NEW VARIABLE CONDENSER.

Having tried many times to make a variable condenser having high capacity, and yet, not containing an abnormal number of plates, I have struck one at last which fulfills these conditions. The difficulty in most cases was to space the plates closely enough. This is overcome, however, by letting the plates lie on each other, the separation—less than 1/64 inches—being obtained by means of a piece of empire cloth shellaced on one side of each of the plates. The plates were of zinc obtained from an engraver's store. The zinc is used exten-

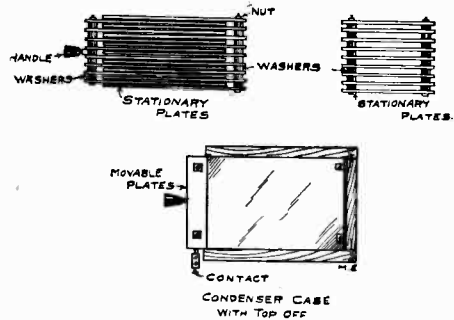

sively by them in their work and comes generally in sheets 2 feet x 2 feet, the surface of which is like a table top and the same time extremely solid and not liable to bend. Seventeen is generally about the correct number; nine stationary, and eight movable. The idea in

full is shown in the sketch and any energetic amateur could, I think, build this condenser, and obtain good results from it.

Contributed by

R. C. BODIE.

UNIQUE SENDING CONDENSER.

In the October issue I noticed that Mr. Weddell suggests how to make "An Emergency Sending Condenser." I would like to suggest a better and more compact way. Procure half a dozen or so test tubes and a small crock. Next get a board to cover the crock and cut just as many holes in it as you have test tubes and fit them in places. Now fill the crock almost

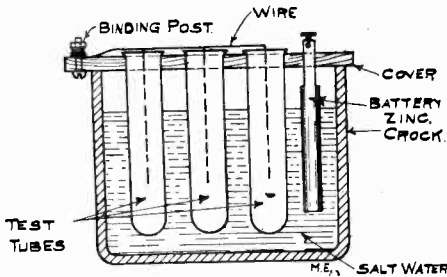

full of good salt water and fill the test tubes also with salt water, so that when they are put into the crock, the water in the test tubes and in the crock will be even. Then put a wire in every tube, letting the wire hang down in it, and fasten all the wires to a binding post. Next put a clean battery zinc into the water with the test tubes as in diagram.

Contributed by

JOHN P. HOBART, JR.

SIMPLE SPARK GAP.

The materials necessary are an old S. P. S. T. switch and two zincs which may be taken from wet cells. Remove the switch handle and bend the part which receives the blade of the switch

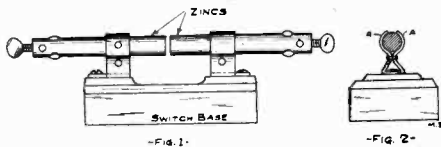

as in Fig. 2. Then cut both zincs off so as to leave about three inches for use in the gap. Now slide zincs in position, being sure that A.A. make

good contact with them. A couple of coats of lacquer on the metal parts will greatly improve its appearance.

Contributed by

A. ST. AUBIN.

UNIQUE POTENTIOMETER.

WHILE making a non-inductive potentiometer according to William Klaus's design in the October MODERN

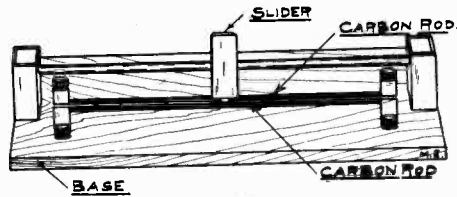

- FIG 1 -

ELECTRICS, I found that a rolling ball slider could be substituted for the spring type and higher efficiency secured without rendering the construction more difficult in the least. The method is as follows:

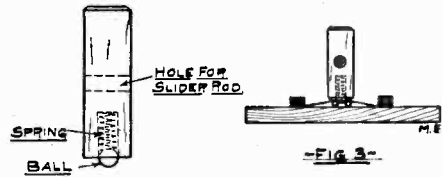

- FIG. 2 -

- FIG 3 -

The two resistance rods, instead of being three inches apart, are placed side by side directly beneath the slider rod and one-eighth inch apart between centers (Fig. 1). Of course neither they nor the clips holding them must touch.

The 3-16 inch holes in the supports for the slider rod, which is a 3-16 inch round

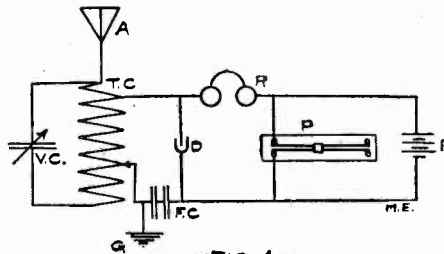

- FIG. 4 -

brass rod as before, are exactly 15-16 inches above the base, measuring from their centers. The slider is of hard wood 1/2x1/2x1 1/2 inches. A 3-16 inch hole for the slider rod is drilled through its center from side to side, and another hole of the same size one-half inch deep is made

in one end. In this is put a short spiral of spring brass wire, topped with a 3-16 inch steel ball bearing (Fig. 2).

The slider may now be put in place on its rod, the steel ball resting on the two resistance rods. When the height of the slider rod and the space between the resistance rods is properly adjusted the ball will roll easily along on the two rods, making connection with each and showing no tendency to jump out under ordinary handling. (See Fig. 3, a cross-section.)

The instrument may be connected as Mr. Klaus suggests, using two separate batteries, or it may be used as if it were a one-rod potentiometer, with only one battery (diagram, Fig. 4). Either method gives good results.

Contributed by

R. E. BAKER

A SPARKLESS SYSTEM.

A sparkless system—a diagram for connections of which is here given—met with fairly good results. The tun-

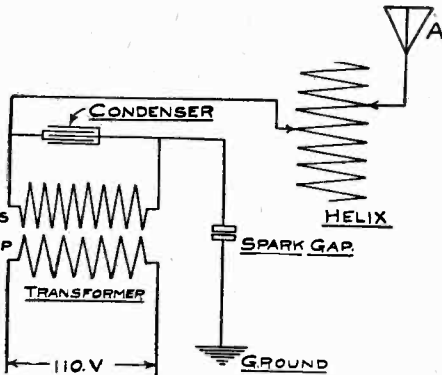

ing seemed to be much sharper and the spark—at the receiving end—was much clearer, although not quite as loud. The gap was cut down to about 1/32" long, and the tuning of the apparatus by helix and condensers was changed. This, however, may not be necessary in all outfits.

Contributed by

R. C. BODIE.

TUNING COIL SCRAPER.

In making a tuning coil some time ago, a strip of black enamel wire 1/4 inch wide and 12 inches long was needed for contact with the slider. Instead of using a knife to scrape away the insulation I used the following plan:

First, two laths were nailed on one side of the coil so as to make the space between them 1/4 inch wide and 12 inches long. Then I used a common ink eraser, rubbing up and down the groove made between the laths, until the wire was bare. The laths were removed and the result was very satisfactory.

You will note that the erasure does not scrape the wire, only the insulation, therefore no short circuits will occur.

Contributed by

E. M. RAHM.

A SIMPLE DETECTOR.

I made a very good electrolytic detector the other day from a burned-out

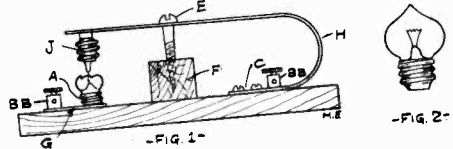

flashlight bulb with its tip broken off and the edges rounded in, as A in Figure 1. It is soldered to the strip of brass on which a binding post is soldered at G. H, is a strip of brass bent as shown. J is a small burned-out electric light, all the glass being broken away except K, as shown in Figure 2. All of the wires are broken off, K. The brass strip H is held in place by having a small block of wood nailed to the base and a round-headed screw going through H, as shown at E. The solution in A is one part nitric or sulphuric acid and four parts water. I found that this detector worked very well.

Contributed by

JOHN P. HOBART, JR.

A SIMPLE CORE FASTENER.

One of the main requirements for the successful working of a spark coil,

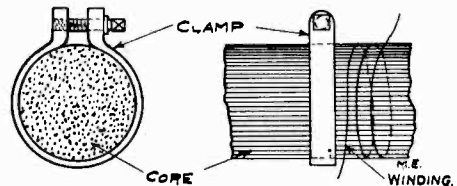

especially if a vibrator is to be used, is a solid core. If the following di-

rections are noted the core can be made as tight as necessary:

Procure an ordinary hose clamp, three-fourths or one-half inch, to fit core. Put the clamp firmly around the core and tighten the bolt. In case the clamp is a little loose, a few turns of paper can be put on the core before the clamp is put on. When the clamp is firmly on the core, put a couple of turns of wire around the core and twist it tight. When this is done the clamp may be removed.

Contributed by
WM. J. BUSCHMAN.

CRYSTAL MOUNTING.

While experimenting with crystal detectors I find that soldering takes a great deal of the sensitiveness out of the crystals. By using mercury in the cup instead of solder, I find it works fine; also crystals may be changed very readily.

Contributed by
ALEX. POLSON.

VARIABLE CONDENSER CONTACT.

Below find drawings for a contact for the movable plates of a variable condenser.

It is made of a ball-bearing slider and a strip of brass drilled and bent as shown in the diagram.

I think by the drawing the enthu-

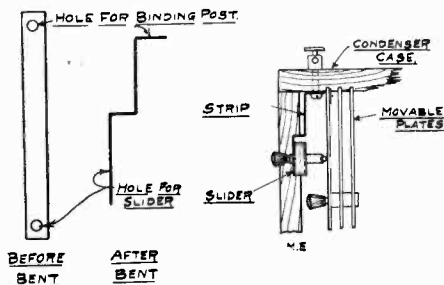

siastic amateur can see the principle, therefore other explanation is unnecessary.

Contributed by
HOWARD LUCAS.

EMERGENCY INTERRUPTER.

The interrupter on my coil broke down the other day and while it was

being fixed I made a makeshift one which is quite efficient. I took a common buzzer and made connections as per diagram with a 110 volt alternating light current. The lamp used was

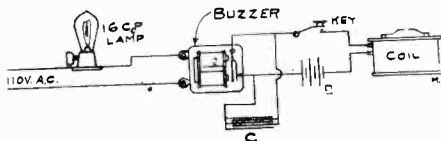

a 16 c. p. Then I connected a wire to the armature and one to the contact screw and connected these with the coil, key, and batteries as is shown in the diagram. The condenser is not needed, but it increases the efficiency.

Contributed by
J. DALLAS WISE.

SIMPLE WET BATTERY.

A fairly good form of wet battery may be made from an old worn-out dry cell by following the description below:

First cut the zinc covering off and bend it so it will fit snugly in a one

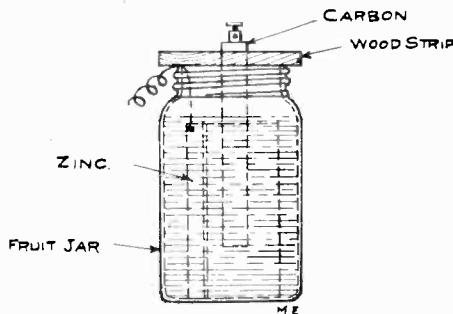

pint fruit jar. Then take the carbon stick and insert it in a strip of wood or heavy pasteboard three inches by one and one-half inches. Now put the parts in jar as per drawing.

Next fill the jar about one and one-half inches from the bottom with salammoniac, then add water until the solution comes within about two inches from the top of the jar.

Contributed by
E. S. COLLINS.

CONDENSERS.

I have found that if, after the tin-foil has been cut to size, a hot poker

or other iron be run around the edges to remove all the sharp, rough edges, there will be practically no brush discharge, as the edges are melted off round and smooth.

Contributed by

ALGY MACARTNEY.

A HANDY SPRING.

The amateur often has to affix to his table a piece of apparatus that is not provided with a base, such as a tuning coil. He must therefore fasten it by means of screws run up through the bottom of the table.

Such procedure will be found very troublesome and may be easily remedied. Heavy spring brass should be cut to the form shown in I and holes drilled in one end for screws and then

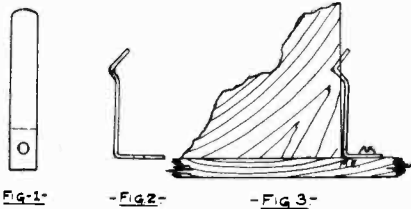

bent as in II. One spring should be provided for each corner of the instrument. The method of using these springs is clearly shown in III, the bend of the spring fitting into an angular niche in the wood. The reader should use his own discretion as to the size of these springs, varying them as to the size of the instruments. They will be found to facilitate quick removal for repairs or renewals.

Contributed by

T. McC.

A HANDY SWITCH.

First procure two battery binding posts, then insert them in a base (either a base made for the purpose or the instrument table) about two inches apart; insert them so that one will project about one-half inch more than the other. Then make a switch knife (like sketch 1.) The copper used in making the knife should be about $4\frac{1}{2}$ inches long and one thirty-second of an inch thick. The handle to this can be made of wood insulated with tape. Bend this and put it together like Fig. 2. You can

make this as many point switch as needed by inserting more binding post around the center one. This



-FIG. 1-

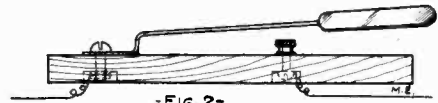

-FIG. 2-

switch comes in handy for switching of detectors and batteries. It is very easily made.

Contributed by

STANARD FUNSTEN.

A HELIX CLIP.

I have noticed a number of helix clips described in your magazine, but none have handles that are very good insulators.

This clip is made from a small glass medicine bottle, a screw, and a piece of brass $1\frac{1}{2}$ inches long and $\frac{1}{2}$ inch wide. A hole is drilled through the center of the brass, and it is then bent into the shape shown in the sketch. Make a small hole in the bottom of the bottle (this can be done with a common drill and turpen-

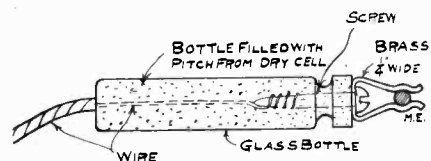

tine) through which the wire is put. The screw is put through the hole in the brass and the wire drawn through the bottle and soldered to it. The bottle is now filled with molten pitch from a dry battery (red pitch makes a neat appearance) and while it is still molten the wire is pulled so that the brass clip is drawn up against the mouth of the bottle. On cooling the screw and clip will be fastened firmly. This clip may be used while coil is working without fear of a shock.

Contributed by

ABNER B. SHAW.

CRYSTAL CUP.

The detector cup, of which a sketch is shown, permits any top point of the silicon or other mineral to be used and a new cup put on in a few seconds.

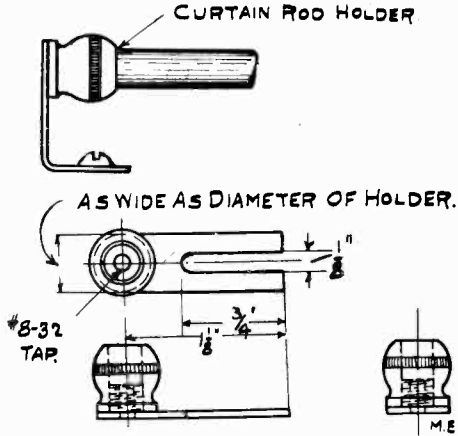

It is made from a curtain rod holder as per drawing. As the diameter

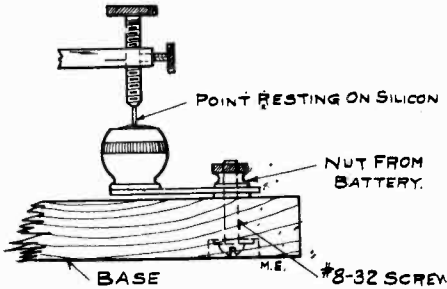

of the cups vary according to the diameter of curtain rod, the width of the brass piece on which the cup is attached, must also vary according to cup used. Drawing is self-explanatory. Contributed by

A. NEWMAN.

ROLLING WHEEL SLIDER.

To begin with, take a piece of square brass tubing one inch long

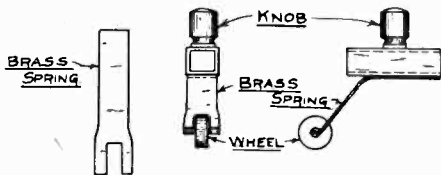

(size to fit rod). On the bottom solder the piece of spring brass shown in

Fig. 1. For the knob you have to solder on a flat head machine screw and on to this screw the knob. The other part is shown in diagram.

Contributed by

FRED BESSERER.

AN IMPROVED POTENTIOMETER.

When a potentiometer has been made, or is to be made, the one with a fine adjustment is most desired. A rotary one is hard to make, so I thought I would suggest a way by which one can be made almost as good as a rotary one with much less bother.

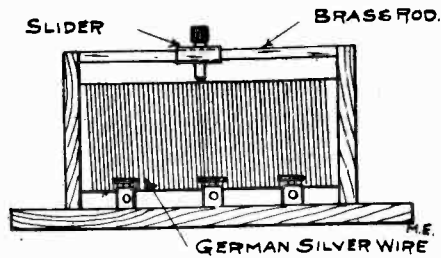

- FIG. 1 -

If one has a potentiometer like the one shown in Fig. 1, he can put the switch handles on the ends as shown (Fig. 2).

To make it, fasten a piece of wire on to each end as shown, which must be about three times as long as the diameter of the potentiometer's core or tube and of the same wire the potentiometer is wound with.

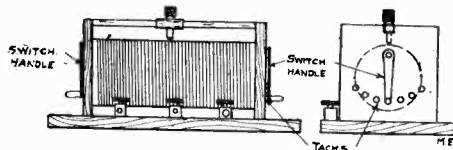

- FIG. 2 -

- FIG. 3 -

Next get two small switch handles and mount them on the ends as shown in Fig. 3; put as many points on the switch or end of potentiometer as you can.

Then divide the wire between each point equally, as shown in Fig. 3, so that the switch can regulate the amount of wire used to a nicety. This makes the potentiometer complete.

To operate slide the slider along and regulate as finely as possible.

Then move either handle to get finer adjustment.

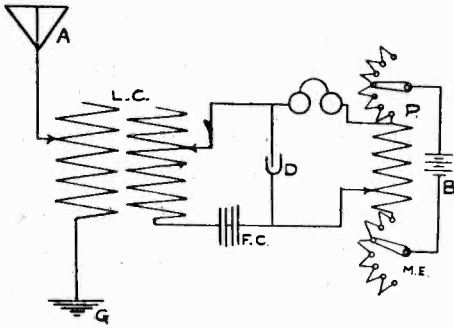

When made as described you will have a potentiometer that can be finely adjusted.

Contributed by

CARROLL M. PFLEEGOR.

WIRELESS HELPS.

By R. C. BODIE.

One side of the spark gap in most sending circuits is connected to ground, and it is advisable to have that side, the one which is insulated for the purpose of regulation of gap, so that no shock will be felt when so doing, even although the handle is not a very good non-conductor.

Silicon should never be touched more than possible by the fingers as the oil or grease on the hands is taken up by the metal and reduces its sensitiveness considerably.

If your interrupter does not give satisfaction, instead of sulphuric acid and water as the solution, try a mixture of salt and water which, I found, gives much better results as well as doing away with the fumes which is given off by the former. Obtain glass tubing and rod to fit fairly tight. Then fill the jar with water and add salt very slowly, trying the spark all the time, until the best results are obtained. When an interrupter is working at its best no noise should be heard from the jar. This can be helped along by using, instead of the carbon element largely used by amateurs, one made of a strip of zinc and keeping the tube well up in the water, only having perhaps one inch immersed in the solution. When the latter gets low in the jar it is only necessary to add a little more water, as the salt is not decreased in the solution by evaporation.

WIRELESS INSTITUTE.

At the regular monthly meeting of the Institute of Wireless Engineers, held in the Engineering Society's Building, New York City, on Wednesday, November 2nd, Prof. Alfred N. Goldsmith, of the College of the City of New York, lectured on High Frequency Phenomena and Wireless Telephony.

Several very interesting experiments with High Frequency Currents were performed, and the Poulsen Wireless Telephone System demonstrated. During the wireless telephone demonstration, a small receiving outfit was passed around the lecture hall enabling any one in the audience to listen to the wireless telephone in operation. The arc used was a genuine Poulsen arc, and the construction of same was observed by all present with a great deal of interest.

Mr. R. H. Marriot, President of the Society, gave a very interesting demonstration of the action of the selenium cell. The apparatus comprising a special selenium cell sealed in a glass tube, a Queen polarized relay of high resistance and a special relay equipped to handle 110 volts at the contacts, was loaned by Prof. Pickard, of Amesbury, Mass.

Mr. Marriot, in exhibiting the apparatus, demonstrated the possibility of lighting an incandescent bulb with a match. This was done by holding the match in front of the selenium cell. The lowering of the resistance allowed the current to pass through the contact of the relay; thus passing the current to the 110 volt lamp. By shielding the selenium cell from the light of the match, the incandescent bulb was extinguished.

At the close of the lecture Prof. Goldsmith, in talking to some of the people present, brought out the fact that the majority of the wireless instruments on the market to-day were made on the wrong principle; that is, built more for appearance than for actual working qualities, explaining that the nickel plating of the spark gaps, helices and antenna switches was very inefficient for the reason that high frequency currents travel on the surface of conductors only, and as the nickel coating is of higher resistance than copper, our

readers will readily understand that this creates a loss of energy in the instruments.

Prof. Goldsmith further stated that the spiral form of helix when wound with the inner coil .4 of the diameter of the outer coil produces less damping effect than the regular cylindrical helix, and as the present tendencies of wireless communication is toward the use of undamped waves, it will be readily understood that this latter point is of some importance.

On the whole, the meeting was enjoyed by all present and many points of general interest to the practical wireless man were brought out.

A. C. AUSTIN, JR.

WIRELESS TELEGRAPH AND TELEPHONE ASSOCIATION OF THE U. S.

OFFICERS are: Sidney Wein, president; Louis Weber, vice-president; Sam L. Wein, Chief Electrician; M. Levey, Assistant Chief; Jack Selacter, Secretary; M. Weber, Treasurer; H. Ocles, Sergeant-at-Arms.

The aim and object of this Society is to advance the art and science of Wireless Telegraphy, Telephony and Television among its members and all those who may be interested.

All those wishing to join this organization should communicate with the Secretary, care of the Boys' Club, 161 Avenue A, near 10th Street, New York City.

The dues of the club is 10c weekly, and 50c initiation fee.

NEW WIRELESS RECORD.

A new distance record was made for wireless transmission when the U. S. S. Tennessee, on the Pacific Ocean, recently sent and received messages 5,267 miles. A Fessenden 2 K. W transmitter was used for sending, and the navy standard receiving set, employing pyron and perikon detectors, for receiving.

MANY VESSELS CARRY WIRELESS.

According to a recent report of Lloyd's register of British and foreign shipping, there are now as many as 702 vessels which are equipped with wireless outfits.

WIRELESS ASSOCIATION OF SOUTHERN CALIFORNIA.

THE Wireless Association of Southern California has been organized about 2 months. Its object is to advance the art of Wireless Telegraphy among the amateurs of Southern California, and to protect its members from anything detrimental to the advancement of the art.

The following are its officers: President, Joe Stearn; Vice-President, Howard Lewis; Secretary, Hallam H. Anderson; Treasurer, J. F. Hopkinson.

The Club has at present a membership of about 40, and among its members are nearly all of the best known amateurs of Los Angeles and the vicinity.

The Club has rented a small cottage as a club house and are installing a fine set there. In the club house is a library and sleeping accommodations for members who reside out of the city, but who wish to spend the night in town.

The members wear a neat little button in the shape of a shield with an aerial on it, and a red band running across the front with W. A. of S. C. on it.

About half of its members belong to the W. A. O. A.

All amateur wireless experimenters who have at least a receiving set are invited to correspond with the Secretary, Hallam H. Anderson, 935 Denver Avenue, Los Angeles, Calif.

NEW PARIS-LONDON TELEPHONE LINE.

At the end of November there will be two new telephone lines opened up between Paris and London, and it is planned to have two other lines ready for service by next spring, so that 400 conversations per day can be handled.

A GENERATOR OF RAPID ELECTRICAL VIBRATIONS.

(Continued from page 493)

(50 kilometers distant) and afterwards at the Liège Observatory, distant about 110 kilometers. Another experimental station for wireless telegraphy, fed from a high-tension (6000 volts) accumulator battery comprising 3000 cells, has been fitted up at Ruhmer's Berlin Laboratory.

Wireless Telegraph Contest

Our Wireless Station and our Laboratory Contest will be continued every month until further notice. The best photograph for each contest is awarded a monthly prize of Three (3) Dollars. If you have a good, clear photograph send it at once; you are doing yourself an injustice if you don't. If you have a wireless station or laboratory (no matter how small) have a photograph taken of it by all means. Photographs not used will be returned in 30 days.

PLEASE NOTE THAT THE DESCRIPTION OF THE STATION MUST NOT BE LONGER THAN 250 WORDS, AND THAT IT IS ESSENTIAL THAT ONLY ONE SIDE OF THE SHEET IS WRITTEN UPON. SHEET MUST BE TYPEWRITTEN OR WRITTEN BY PEN. DO NOT USE PENCIL. NO DESCRIPTION WILL BE ENTERED IN THE CONTEST UNLESS THESE RULES ARE CLOSELY ADHERED TO.

It is also advisable to send two prints of the photograph (one toned dark and one light) so we can have the choice of the one best suited for reproduction.

This competition is open freely to all who may desire to compete, without charge or consideration of any kind. Prospective contestants need not be subscribers for (the publication) in order to be entitled to compete for the prizes offered.

FIRST PRIZE.

I enclose herewith prints of my station.
My outfit comprises the following:
Sending:

One-half kilowatt closed-core transformer (variable).

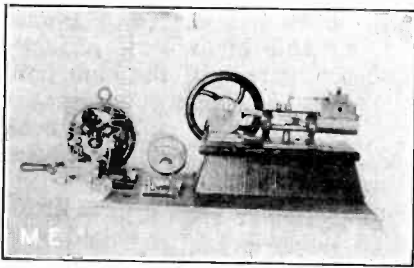

Plate condenser 60, 8x10 glass plates (variable).

Sending helix.

Muffled zinc spark gap.

Key with heavy contacts.

Receiving:

"Electro" loose coupled tuner.

"Electro" lytic detector.

"Electro" 1000-ohm head phones.

"Electro" potentiometer, (non-inductive).

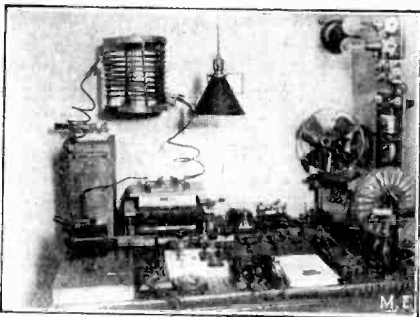

"Electro" rheostat regulator.

Variable plate condenser (rotary).

Silicon detector on large marble base.

Mineral detector stand.

"Western Union" plug-board for detectors.

Single-slide tuner.

Heavy slate base double-pole double-throw knife switch for sending and receiving.

Four-pole double-throw knife switch.

Single-pole single-throw knife switch for grounding circuit.

Besides the wireless I have the following electrical appliances:

One-fourth H. P. steam engine.

"Electro" Wimshurst static machine.

Type "S" dynamo-motor.

"Midget" dynamo-motor.

"Albert" duplex motor.

"Manhattan" fan motor, No. 3.

"Omnigraph" with motor attachment and 30 discs.

Three sounders.

Four keys.

"Mecograph" sending apparatus.

"Wireless Operator's Telegraph and Telephone Handbook."

MODERN ELECTRICS Standard Wireless diagrams, and Wireless blue book, and MODERN ELECTRICS magazine completes my hobby, in fact wouldn't be half so interested without MODERN ELECTRICS.

JOS. LESMEISTER, N.D.

HONORABLE MENTION.

Enclosed please find photograph of my wireless station.

The aerial is one hundred feet long and sixty-five feet high, made of four phosphor bronze wires.

The station consists of a demonstrating set and long distance outfit.

The demonstrating set consists of a one inch spark coil, and a coherer, electric bell, and one thousand ohm relay. This can be used for ringing bells, running motors, lighting lights, firing a cannon on a miniature battleship, etc., from one room to another.

The tuned receiving set is mounted in one case with cover for carrying and consists of a pair of two thousand ohm receivers, variable coupling tuning coil, two different kinds of potentiometers,

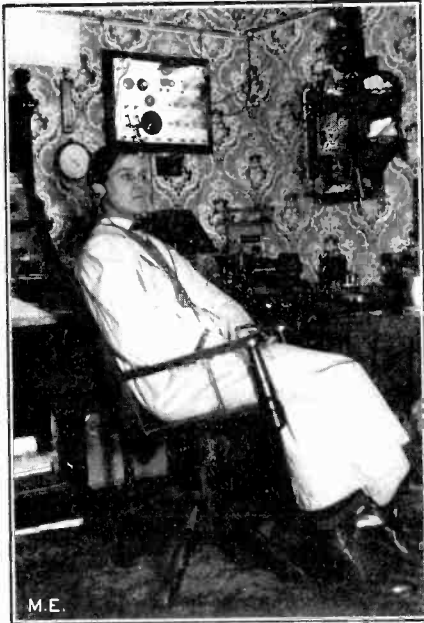

two electrolytic, perikon, silicon and carbon detectors, three variable condensers, viz.: variable slide plate, tube and plug, two fixed condensers, and buzzer test. For controlling this set there are three D. P. D. T. switches, four plugs and two S. P. switches.

For sending I am using a small spark coil. I have a one-half K. W. under construction.

I also have an inductive wireless telephone set, mercury lamp flasher, four drop annunciator, automatic aerial switch, automatic alarm clock switch for opening or closing a circuit, pocket telegraph sounder made from an old watch case, medical coil, rotary aerial switch, arc light, telegraph circuit, etc. The switch board consists of lightning arrester, lamp rheostat, pole changer, etc.

All instruments are of my own make.
G. A. HIGBEE.

Michigan.

HONORABLE MENTION.

Please find inclosed a photo of my wireless station. The aerial is composed of eight strands of No. 14 aluminum wire on a twelve foot spreader. The aerial is forty-five feet high.

My sending consists of an electrolytic interrupter, one inch spark coil, two quart leyden jars, Morse key, E. I. Co's.



zinc spark gap, helix composed of twelve turns No. 4 aluminum wire.

My receiving consists of E. I. Co's. transformer tuner, E. I. Co's. junior tuner, also one silicon detector and one pair of 150 ohm receivers, one single slide tuner, twelve inches long, four inches diameter.

R. G. WRIGHT.

Montana.

HONORABLE MENTION.

Enclosed you will find photo of my wireless station. The photo was taken by myself.

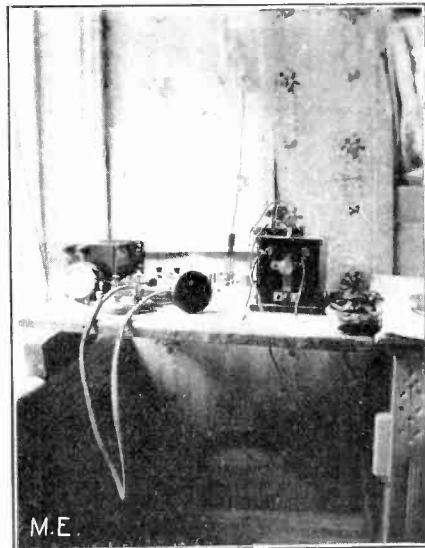

The instruments are as follows: Reading from left to right, tuning coil; this is of E. I. Co's. make and has 140 feet enameled wire wound on the core and has a striking appearance, although small; it has two slides, then comes the

condenser with which I get very good results. Next is a universal detector stand with which I can use any substance, but I find silicon the best of any. I also have another detector the same make and an auto coherer, not shown in the photo; beside the detector is my phone. I have another of these phones, but when the photo was taken I had lent it to a friend.

In the center is the D. P. D. T. switch to change from receiving to sending, then comes my spark coil giving a spark from one and three-fourths to two inches; on top of it is the gap; then comes a Morse telegraph key. You will also notice lamp of three and one-fourth c. p. in the background and voltmeter in the left hand corner.

My aerial is suspended from pole on the roof 50 feet from the ground to a pole 12 feet high and has four wires two feet apart and 60 feet long. With this receiving and sending set I can receive 100 miles and send about ten miles.

I am making a tuning coil, fixed condenser and glass plate condenser now.
Toronto, Canada. C. E. TIPPING.

HONORABLE MENTION.

Below is a photo of my wireless station.

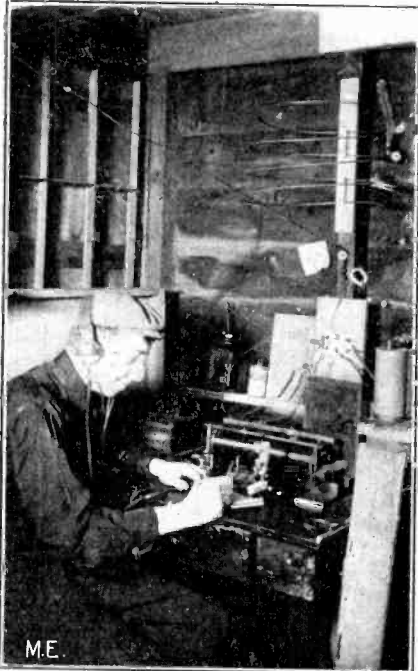

This outfit comprises the following:

Receiving set on the right, E. I. Co's. 1000 ohm receiver, double slide tuning coil, two detectors, silicon and electrolytic connected by two point switch, one variable condenser and one fixed condenser.

One T. P. D. T. switch for connecting ground and antenna with the instruments.

Transmitting set on the left.

Transformer of my own make and strap key, helix and adjustable test tube condenser also of my own make. Using 110 volts with my interrupter supplies the transformer.

I have an aerial 45 feet high consisting of four wires 65 feet long on bamboo spreaders.

I made the instruments from designs received from January to September MODERN ELECTRICS, which gives some very helpful hints.

RAYMOND RUFFING.

Ohio.

HONORABLE MENTION.

The accompanying photograph shows my complete wireless outfit.

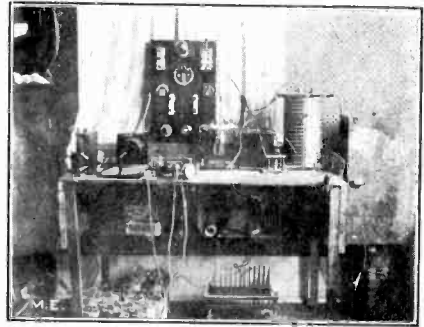

I think the photograph speaks for itself as to the instruments I have. 110 V. A. C. is used as power.

This outfit is perfect in every detail. They are all E. I. Company's goods.

It is surprising how far these instruments can send and receive.

Anybody near my neighborhood will please write or call. My call is J. R. M.

JOHN C. RECTOR.

Illinois.

HONORABLE MENTION.

The inclosed is a photograph of my portable wireless receiving station as set up, out of doors, in the town of Gardiner, Maine. The entire apparatus in-

cluding the aerial wire, was packed in a box just large enough to take the inductive tuner and so was easily carried from Portland to Gardiner, where the apparatus was put in working order in only three hours. The aerial was formed by two No. 24 B. & S. copper wires,



125 feet long and separated three feet. From its center, two leads were brought down to the instruments. A ground, easily made to a water pipe, completed the station.

Referring to the photograph, the inductive tuner is at the extreme left, a little to its right is the perikon detector and farther to the right is the little condenser on the top of which is the connecting plug for the telephones. Every piece of this apparatus was designed and constructed by myself, except the telephone receivers.

With this hastily put up apparatus, the ships in Portland harbor 56 miles away were heard and the weather reports from Cape Elizabeth, about 75 miles from Gardiner, were read. I also heard the station at Wellsfleet, Cape Cod, very loud, although it was over 175 miles away. I consider this a good performance as the aerial was only 36 feet above ground at one end and about 25 feet at the other.

ALAN S. DANA.

Portland, Maine.

HONORABLE MENTION.

Following is a photograph and a description of my wireless telegraph station.

At the right is the switchboard. Under it are the rotary variable condenser and the variometer. To the left of these is the key, partly hidden in the shadow of the receiving-box. The latter is made of magogany, and holds

the following instruments: A loose coupler with two slides on the primary and a five point switch to vary the inductance on the secondary, an electrolytic detector, a Murdock professional silicon detector, an E. I. Co's. circular potentiometer, a selective switch for throwing in either detector and for short-circuiting the receivers when sending, and a fixed condenser of the telephone type. To the left of the box is a pair of 3000 ohm Murdock head receivers. Back of these may be seen the helix with spark-gap mounted on top, and to the left of the helix is the condenser rack with ten plates, twenty-two inches square.

Underneath the table may be seen my 1 KW. open core transformer, to the right of this the foot operated arial switch and under the extreme right end of the table is the letter file in which I keep all the messages received.

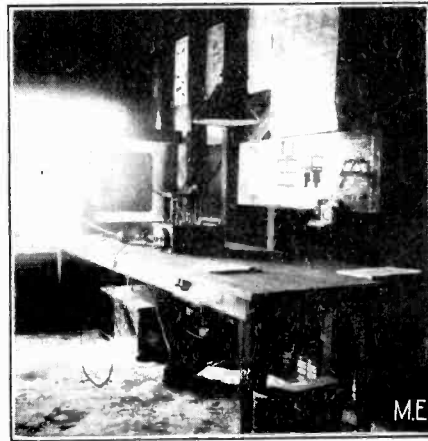

The station has given excellent results. The instruments were, for the most part, made by myself.

I intend to add a hot-wire ammeter to my equipment within a couple of months.

ELLERY STONE.

Oakland, Cal.

COMPULSORY AEROGRAPHY.

Austria is the first European nation to make aerography compulsory on passenger ships.

The Government has ordered that all steamers voyaging beyond Gibraltar or Aden must be equipped with wireless apparatus.

Wireless Patents for the Month

974,762. WIRELESS TELEGRAPHY. REGINALD A. FAY. Herndon, Washington, D. C. Filed Jan. 14, 1907. Serial No. 352,212.

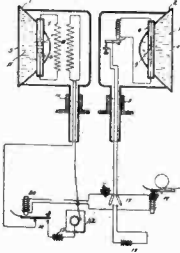

1. In wireless signaling the combination of a receiving apparatus and a transmitting apparatus, means for shielding the receiving apparatus from the action of the sending apparatus during the simultaneous operation of the sending and receiving apparatus, said means comprising a focusing device for receiving the waves and a focusing device for emitting the waves, both focusing devices being filled with a medium having a higher dielectric constant than air, so that the waves are emitted and received over a much shorter wave length than when traversing the space between the stations.

974,985. RECEIVING APPARATUS. FREDERICK W. MIDGLEY, Jersey City, N. J., assignor to International Telegraph Construction Company, a Corporation of New York. Original application filed Jan. 28, 1906, Serial No. 297,887. Divided and this application filed Feb. 25, 1909, Serial No. 479,918. Renewed Sept. 30, 1910, Serial No. 584,764.

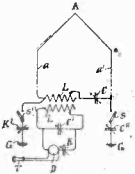

1. In a wireless signaling system, a looped aerial conductor, capacity and inductance connected in said loop to form a closed circuit, said closed circuit forming a single path through all the inductance in series, a circuit in inductive relation with said loop, and a wave-responsive device and a condenser serially connected to said associated circuit.
2. In a wireless signaling system, a looped aerial conductor, frequency determining elements of different kinds connected in said loop to form a closed circuit, a circuit in inductive relation with said loop, a wave-responsive device and a condenser serially connected in said associated circuit, and a connection from said looped aerial conductor to earth through another condenser.
3. In a wireless signaling system, a looped aerial conductor, frequency determining elements of different kinds connected in said loop to form a closed circuit, a circuit in inductive relation with said loop, a condenser in said inductively related circuit, a wave-responsive device and a condenser serially connected in said associated circuit, and a connection from said looped aerial conductor to earth through another condenser.
4. In a wireless signaling system, a looped aerial conductor, frequency determining elements of different kinds connected in said loop to form a closed circuit, a circuit in inductive relation with said loop, a condenser in said inductively related circuit, and a wave-responsive device and a condenser serially connected in shunt to said condenser.

976,000. WIRELESS TELEGRAPHY. FREDERICK G. SARGENT, Grantville, Mass. Filed Aug. 26, 1905. Serial No. 275,877.

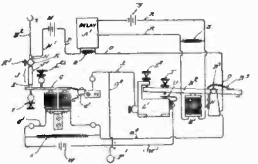

1. In a coherer, in combination, the tube composed of extensible material, the rods entering opposite ends of such tube and having said ends connected therewith, and the cohering material between the proximate ends of such rods.

974,160. TRANSMITTING APPARATUS. FREDERICK W. MIDGLEY, Jersey City, N. J., assignor to International Telegraph Construction Company, a Corporation of New York. Filed Feb. 1, 1906. Serial No. 296,897.

1. In a wireless signaling system, transmitting apparatus comprising the combination of an aerial conductor connected at one end to earth, means for impressing electrical energy upon said conductor, and a conductor connecting the top of said aerial conductor non-inductively to earth, and a condenser connected in said last named conductor approximate its earth end.

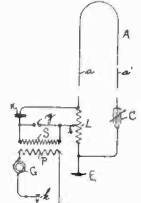

2. In a wireless signaling system, transmitting apparatus comprising the combination of a looped aerial conductor, means associated with one leg of said loop for impressing high frequency electrical energy thereon, a second leg of said loop non-inductively connected at its top to said first leg and non-inductively connected to earth, said a condenser connected in the second leg approximate its earth connection.

974,191. WIRELESS APPARATUS. FREDERICK G. SARGENT, Westford, Mass. Filed Apr. 3, 1909. Serial No. 487,669.

1. In a device of the character described, the combination of a metallic conductor supported at its ends and free to vibrate, and a vibratory carbon contact point adapted to engage said conductor, said contact point and conductor being adapted to vibrate under the influence of Hertzian waves.

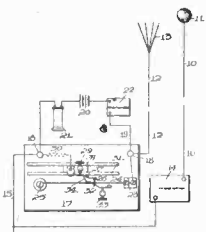

974,927. RECEIVING APPARATUS. HARRY SHORMAN, Jersey City, N. J., assignor to International Telegraph Construction Company, a Corporation of New York. Filed Dec. 11, 1904, Serial No. 347,272. Renewed Sept. 30, 1910. Serial No. 584,763.

1. In a signaling system, receiving apparatus comprising a wave-responsive device of normal sensitiveness associated with means for reproducing a signal, in combination with a local producer of high frequency impulses for rendering said wave-responsive device over-sensitive.
2. In a signaling system, receiving apparatus comprising a self-restoring wave-responsive device of normal sensitiveness associated with means for reproducing a signal, in combination with a local producer of high frequency oscillations for rendering said wave-responsive device over-sensitive.

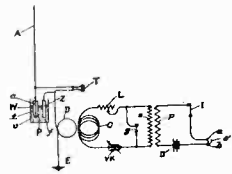

3. In a signaling system, receiving apparatus comprising a receiving conductor or circuit, a wave-responsive device of normal sensitiveness associated with means for reproducing a signal, and means for producing locally high frequency oscillations to render said wave-responsive device over-sensitive.

974,638. RECEIVING APPARATUS FOR ELECTRO-MAGNETIC WAVES. EDWIN H. BURTRICK, Chicago, Ill. Filed July 24, 1906. Serial No. 327,485.



1. An electromagnetic wave detector comprising an electrolyte, and a cathode and an anode having a very small area and a relatively large area, respectively, exposed to said electrolyte.
 2. An electromagnetic wave detector comprising an electrolyte, a cathode consisting of a minute wire having an area approximately the area of the cross section of said wire exposed to said electrolyte, and an anode having a relatively large area exposed to the electrolyte.
 3. An electromagnetic wave detector comprising an electrolyte free from deleterious electro-depositable substances, a cathode having a very small area exposed to said electrolyte, and an anode of non-depositable material having a relatively large area exposed to the electrolyte.
 4. An electromagnetic wave detector comprising a minute metallic cathode, a relatively large carbon anode, and an interposed electrolyte.
 5. An electromagnetic wave detector comprising a minute platinum cathode and a relatively large carbon anode, and an interposed electrolyte free from deleterious electro-depositable substances.
- 976,778. APPARATUS FOR PRODUCING AND UTILIZING ELECTRIC CURRENTS OF HIGH PERIODICITY. SIDNEY GEORGE BROWN, London, England. Filed Dec. 17, 1906. Serial No. 348,309.

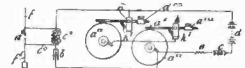

1. In an apparatus for producing and utilizing electric currents of high periodicity, the combination of a spark gap formed between electrodes lying in contact with and adapted for movement relatively to each other, a source of continuous current in series with said spark gap, an oscillatory circuit shunting said spark gap, and means for varying the periodicity of the oscillating circuit consisting in inducting therein a microphone capable of varying the resistance of said circuit.
2. In an apparatus for producing and utilizing electric currents of high periodicity, the combination of a spark gap formed between a balanced metal pole and a revolving disk on which said metal pole lightly rests, a source of continuous current in series with said gap, an oscillatory circuit shunting said gap, and a microphone for varying the periodicity of said oscillatory circuit by varying the resistance.
3. In an apparatus for producing and utilizing electric currents of high periodicity, the combination of a spark gap formed between a balanced metal pole and a revolving disk on which said metal pole lightly rests.

974,171. RECTIFYING ELECTRIC CURRENTS. JAMES J. MONTGOMERY, Santa Clara, Cal. Filed Aug. 28, 1909. Serial No. 616,107.

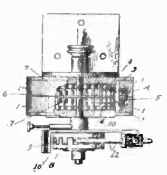

1. In the art of reorganizing alternating electric current the herein described process of rectification which consists in the following operations: (1) In imparting to the moving element through the agency of a fixed element and the utilization of a derived portion of the current under rectification, a succession of positive and negative accelerations, the resultant effect of which is a step-by-step progression of the moving element undulatory in its character, the successive undulations being in response to the successive variations of the electrical force of the current under rectification, and in synchronism with and contemporaneous as regards time with, such variations, whether such variations occur in successively equal times or not; and (2) In imparting the said step-by-step progression to an element of a pole changing device having its other elements connected to the circuit carrying the current under rectification, and when said element receiving said step-by-step motion cooperates with the other elements of the pole changing device to successively reverse the order of the terminal connections of the circuit carrying the current under rectification to a utilization circuit, substantially as described.

Original Electrical Inventions for which Letters Patent Have Been Granted for Month Ending Nov. 30

Copy of any of the above Patents will be mailed upon receipt of 10 cents.



Queries and questions pertaining to the electrical arts addressed to this department will be published free of charge. Only answers to inquiries of general interest will be published here for the benefit of all readers. Common questions will be promptly answered by mail.

On account of the large amount of inquiries received, it may not be possible to print all the answers in any one issue, as each has to take its turn. Correspondents should bear this in mind when writing, as all questions will be answered either by mail or in this department.

If a quick reply is wanted by mail, a charge of 15 cents is made for each question. Special information requiring a large amount of calculation and labor cannot be furnished without remuneration. THE ORACLE has no fixed rate for such work, but will inform the correspondent promptly as to the charges involved.

NAME AND ADDRESS MUST ALWAYS BE GIVEN IN ALL LETTERS. WHEN WRITING ONLY ONE SIDE OF QUESTION SHEET MUST BE USED; DIAGRAMS AND DRAWINGS MUST INVARIABLY BE ON A SEPARATE SHEET. NOT MORE THAN THREE QUESTIONS MUST BE ASKED, NOR SHALL THE ORACLE ANSWER MORE THAN THIS NUMBER. NO ATTENTION PAID TO LETTERS NOT OBSERVING ABOVE RULES.

If you want anything electrical and don't know where to get it, THE ORACLE will give you such information free.

NOTICE.

It becomes necessary to call attention to those who make use of this department, to the fact that 99% of the questions asked are, "How far can I send? and How far can I receive?" In the past two months the amount of questions received of this tenor has been simply astounding.

The Editor of the "Oracle," wished to say that MODERN ELECTRIC is not a strictly "Wireless" magazine, and the question and answer department is for the purpose of giving information within its power on general electrical subjects, including wireless.

Now one of the first points to be observed is this. Think twice before you write your questions, and see if you cannot find the answer to them in back numbers of MODERN ELECTRICS or in text books on your library shelf.

Another point is; use one side of the stationery only, and express the problem in as direct and concise a manner as possible; not failing, however, to give all the necessary facts and figures, and last but not least be BRIEF.

HIGH FREQUENCY WAVES.

(785.) N. POLASKI, Del., asks:

Q. 1. I have a variometer, 2 slide loose coupler, one rotary variable condenser, one

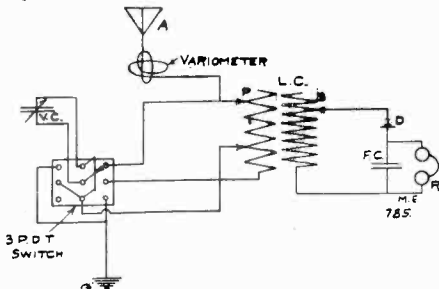

fixed condenser, galena detector, 2,000 ohm head phones. Please give diagram showing

necessary switches so that the variable condenser may be shunted around the loose coupler primary for short waves or put in the ground circuit for receiving long waves?

A. 1. Diagram below. Use a 3-pole, double-throw switch to change the condenser connections.

Q. 2. What is the highest frequency ever obtained from an arc such as the Poulsen arc.

A. 2. With an arc comprising a water-cooled copper cathode and a silver pointed anode. N. Stschodro, has obtained a frequency of 300,000,000 Oscillations per second.

LAMP CHIMNEY CONDENSER.

(786.) L. A. BELKNAP, Ohio, says:

Q. 1. Do Welbach gas light burner chimneys make good sending condensers, if covered with tin foil, leaving 1½ inches space at each end?

A. 1. Yes.

Q. 2. What is a good solution for an electrolytic detector?

A. 2. 4 parts water to 1 nitric acid.

Q. 3. In a variable condenser is it necessary to have one more stationery plate than there are movable ones?

A. 3. Yes.

TOOL KIT.

(787.) H. D. NICHOLS, Mechanicville, N. Y.:

Q. 1. Would you please publish in MODERN ELECTRICS a complete list of tools to be used by an all-round electrician?

A. 1. Blow torch; 6" side cutting pliers; small pair long nose pliers; 6", 9", 12" and 16", screwdrivers; ratchet screwdriver; brace and set of bits, with several long bits; hand drill and machine drills; gas pliers; level; plumb bob; tape measure; 6' rule; steel rule; 8" and 12" monkey and stillson wrenches; ball pein hammer; wood chisels; cold chisel; hack saw; compass saw, square; several different shaped files; small pocket compass; pair of dividers; scriber; leather bag to carry same.

Practical Model Aeroplane AND THEY FLIE

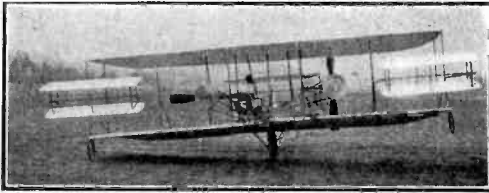

A Lot of Fun for a Dollar

We will send, postpaid, upon receipt of **One Dollar**, an exact model of any of the following well-known types of aeroplanes:

Curtis	Bleriot
Wright	Demoiselle
Santos Dumont	Antionette

measuring two feet across, all ready to be put together.

This is no plaything, but a practical, interesting and instructive miniature of the machines used by the foremost aviators.

All necessary parts furnished, packed securely. Write at once.

**FOR TWO DOLLARS WE WILL SEND YOU CURTIS OR FARMAN
American Aeroplane Manufacturing Co.
Singer Building, New York.**

The History of The Telephone

By HERBERT N. CASSON

Author of "The Romance of Steel," etc.

WHO can deny that a history of the rise of the telephone, through untold vicissitudes to its present commercial importance, and the financial support of over a billion dollars in the United States, alone, to say nothing of the rest of the world, is interesting.

Yet in spite of our familiarity with this indispensable instrument, and our absolute dependence on it in many ways, how few of us know anything of its remarkable story.

Mr. Casson has a unique faculty of describing the evolution of commercial enterprises in such a way as to make his writing decidedly entertaining, and in "THE HISTORY OF THE TELEPHONE," he has produced a work that every one interested in electricity will find highly instructive as well.

*Profusely illustrated. Cloth Bound
299 Pages. Indexed. \$1.50 net*

At All Bookstores

or from

A. C. McCLURG & CO., Publishers
NEW YORK CHICAGO SAN FRANCISCO

EDISON STORAGE BATTERY.

(788.) R. E. TERHUNE, Paterson, N. J.:

Q. 1. Will the new Edison battery run a thirty (30) H.P. 220 volt A. C. motor? If not, what horse power motor will it run?

A. 1. No; not without a rotary converter; Any H.P.

Q. 2. Will the Edison battery run any A. C. motor, of 110 volts, or is there any special motor to be used with this battery.

A. 2. The Edison battery will not run any A. C. motor but sufficient cell's of same may be used to run any D. C. motor.

AERIAL DESIGN.

(789.) P. MURAWSKI, Brooklyn, N. Y., writes:

Q. 1. Please state whether it is better to place the insulators on the aluminum aerial wire as shown in Fig. 1, or is it better to place them as in Fig. 2 on the spreading supports?

A. 1. On the aerial wires.

Q. 2. Give diagram of wires on aerial and show where wires should be connected onto aerial that lead to the instruments?

A. 2. See diagram below.

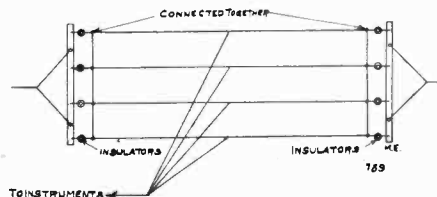

RECEIVERS IN SERIES.

(790.) ALFRED KRUMHOLZ, Chicago, Ill.:

Q. 1. I have two wireless phones; one is 500 ohm and the other is 1,500 ohm; could I get better results by using the 1,500 ohm phone alone or by using both of them on a head band?

A. 1. Use the 1,500 ohm phone alone, to get best results.

Q. 2. How far ought I be able to receive with a 55-ft. aerial, composed of 4 strands of No. 14 aluminum wire, placed 16 inches apart; height of aerial 50 feet, one silicon detector, tuning coil, fixed condenser and best of above phones?

A. 2. 200-300 miles.

Q. 3. How far would I be able to send with a 1 inch spark coil?

A. 3. 3 to 5 miles.

½ K. W. TRANSFORMER COIL.

(791.) A. G. BAKER, Zanesville, O., states:

Q. 1. I recently purchased the E. I. Co's ½ K. W. transformer and their Gernsback electrolytic interrupter which is to be used on 110 volts A. C. or D. C.; how far could I use the same transformer on 8 to 10 volts battery current, and where could I purchase such an interrupter?

A. 1. Attach a vibrator to it. Write to the Electro Importing Co., 233 Fulton St., New York.

OPERATOR'S SALARY.

(792.) CHAS. ADAMS, Brooklyn, N. Y., writes:

Q. 1. What is the salary paid to Wireless Operators on land and sea stations, for beginners as well as experts?

A. 1. It varies from \$50.00 to \$75.00 per month.

Q. 2. What qualifications must he have for such a position?

A. 2. An operator should have a well grounded knowledge of electricity in general, be a rapid penman, have good hearing and be able to operate in the Morse or Continental code at 30 to 40 words per minute.

WHAT IS A ROTARY CONVERTER?

(793.) E. K. WESBECHER, St. Louis, Mo., says:

Please answer the following questions in the Oracle.

Q. 1. What is a Rotary Converter of Electricity? Its advantage, use, and does it change current frequency?

A. 1. A rotary converter is a dynamo and motor combined into one unit, having a common field magnet excited by direct current, and an armature with two windings one for A. C., and one for D. C., or its equivalent. The converter usually takes its power from A. C. mains and operates as a synchronous motor, supplying D. C. from a commutator on one end of the machine.

The D. C. for exciting the field magnets is taken from the commutator of the machine or is supplied separately.

If the machine takes its power from D. C. mains, and supplies A. C., it is known as an inverted rotary.

The frequency, or number of phases, may be changed by having two separate machines, and having the requisite number of field poles, and windings in each. In this case the machine would take A. C. power and deliver A. C. power and would be called a frequency changer.

Q. 2. An Interurban System entering my city runs on 1,200 volts D. C. I have noticed that it crosses our city car system which operates on 550 volts. Does not this crossing of the two trolley wires act in favor of the city car company by acting as a feeder? If so there is a great loss to the High Power Line. Please explain this?

A. 2. Your question is not clear and we do not know whether the trolley wires actually touch one another or just pass each other. To be connected together, they would both have to have the same voltage, or the 1,200 volts flowing along the 500 volt circuit, would put out of commission every car on the 500 volt line, before you knew what had happened.

Q. 3. How far could I send with the following set: Receiving at one end; consists of 75 ohm receiver, silicon detector, and single slide tuner. Sending (if possible) Buzzer on 6 volts?

A. 3. $\frac{1}{2}$ mile.

MECOGRAPH

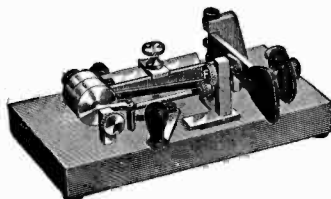

SUPERB FOR WIRELESS

The Best Telegraphic Transmitter in the World. More MECOGRAPHS are in

use than all other automatic transmitters combined.

BECAUSE: Over 60 per cent. more movements required to send on a Morse key than on a MECOGRAPH.

Holds best records for speed and long distance sending. All expert telegraphers and all bonus men use sending machines.

Operators everywhere are improving their efficiency by adopting the use of the Mecograph. Fall in line now Eliminates glass arm.

PRICE \$7.50

After Nov. 1, 1910, price goes up to \$8.00. Carrying Case, \$1.00 extra. Sign and mail us Coupon or our Free Catalogue.

MECOGRAPH CO.

321 Frankfort Ave.
Cleveland
Ohio

COUPON
MECOGRAPH CO., 321 Frankfort Ave.,
Cleveland, O. Please send me descriptive literature of the Mecograph.
Name _____
Address _____

When writing, please mention "Modern Electrics."

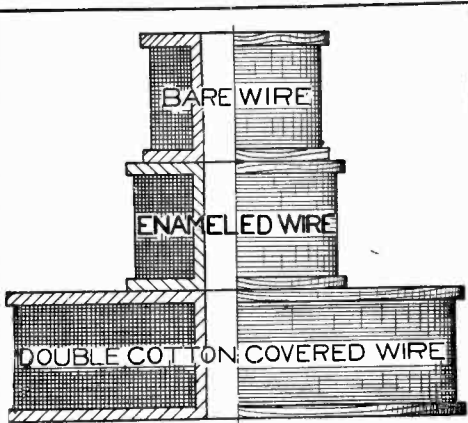

IF YOU ARE NOT USING FÉVAL ENAMELED WIRE

on your instruments, you and your instruments suffer. Our strong, non-extravagant claim:

"The Best Fnameled Wire in America"

FÉVAL ENAMELED INSULATED WIRE CO.
124A N. CURTIS STREET
CHICAGO, ILL.

When writing, please mention "Modern Electrics."

MURDOCK Wireless Apparatus

SPARK GAP No. 441

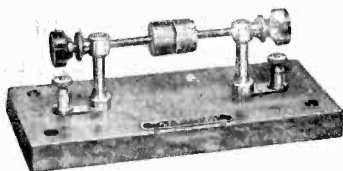

$\frac{1}{4}$ and $\frac{1}{2}$ k. w. - - - - \$5.00
1 and 2 k. w. - - - - 10.00

Mounted on polished marble base, $8\frac{1}{2}$ in. x 4 in. x $\frac{3}{4}$ in. Gap of special durable alloy. Adjustment simple and accurate. Each arm fitted with radiation plates. Efficient and lasting. Other instruments separate and combined, manufactured and guaranteed by MURDOCK will be found in the best stations. Why not in yours? Full information on request. State your needs.

WM. J. MURDOCK CO.

40 CARTER ST., CHELSEA, MASS.

162 Minna Street
San Francisco

221 So. Clinton St.
Chicago

PATENTS

TRADEMARKS AND COPYRIGHTS
SECURED OR FEE RETURNED

Send model or sketch and description of your invention for free search of the U. S. Patent office records. Our **Four Books** mailed Free to any address. Send for these books: the finest publications ever issued for free distribution.

HOW TO OBTAIN A PATENT

Our illustrated eighty page Guide Book is an invaluable book of reference for inventors, and contains 100 mechanical movements illustrated and described.

FORTUNES IN PATENTS

Tells how to invent for profit and gives history of successful inventions. Also list of Patent Buyers.

WHAT TO INVENT

Contains a valuable list of Inventions Wanted and suggestions concerning profitable fields of inventions. Also information regarding prizes offered for inventions, among which is a

PRIZE OF ONE MILLION DOLLARS

offered for one invention and \$10,000 for others.

PATENTS THAT PAY

Contains fac-similes of unsolicited letters from our clients who have built up profitable enterprises founded upon patents procured by us. Also endorsements from prominent inventors, manufacturers, Senators, Congressmen, Governors, etc.

WE ADVERTISE OUR CLIENT'S INVENTIONS FREE in a list of Sunday Newspapers with two million circulation and in the **WORLD'S PROGRESS**. Sample Copy Free. Electrical Case a Specialty.

VICTOR J. EVANS & CO.

(Formerly EVANS, WILKENS & Co.)

Main Offices, 200 "F" Street, N. W.

WASHINGTON, D. C.

When writing, please mention "Modern Electrics."

WRITING MESSAGES.

(794.) H. W. DAWSON, Port Hope, Ont., Can., inquires:

Q. 1. When receiving a message is it best to take down each individual letter immediately as it sounds in the receivers, or to pause 'till the end of each word or perhaps sentences, before writing it down?

A. 1. The best method is to wait every two or three words and then write them down, although some operators write after every sentence.

Q. 2. In the later developments of wireless do you think that there is any possibility of automatic receiving altogether doing away with the necessity of an expert operator?

A. 2. Yes. This is very desirable especially for Government or Official business.

Q. 3. Is the frequency of the oscillating circuit in a transmitting station independent of the length of the spark gap?

A. 3. No.

Q. 3. (b) If not does the frequency decrease with increase in spark lengths?

A. 3. (b) Yes.

SILVER ON VIBRATOR.

(795.) LOREN GAY, Wyoming, N. Y., writes:

Please answer these questions in the Oracle.

Q. 1. Will silver do for contact points on a one inch coil vibrator?

A. 1. Yes, but not satisfactorily.

Q. 2. How much would enough platinum cost to make a one inch coil vibrator?

A. 2. About 50 cents.

OPERATING RADII.

(796.) W. H. SMITH, Denver, Colo., says:

Q. 1. What will be the receiving and sending range of the following outfit. Aerial 70 feet high at both ends, 100 feet long. 6 No. 12 aluminum wire (3 feet apart) open at both ends with six 35 foot leads from center of aerial to single copper lead-in, and water pipe ground: Instruments consist of a 6 inch spark coil, adjustable glass plate condenser, helix, and electrolytic interrupter with 110 volt A. C. Receiving; Etheric Electric Co's., loose coupler, 2 slide tuning coil, tubular variable condenser, fixed condenser, Ferron and silicon detectors, 2,000 ohm phones?

A. 1. Sending 50-75 miles. Receiving 500-600 miles.

Q. 2. Is connection in enclosed diagram as good as looped aerial? If not, please give diagram or most efficient connection of this set using looped aerial?

A. 2. Diagram given very good.

BATTERY.

(797.) ALLEN GIMM, Knoxville, Tenn., writes:

Q. 1. Which is the best for general work, experimenting, lighting lamps, ringing bells, etc., the dry battery, or Sal-Ammoniac battery, and which will last the longest?

A. 1. Dry cells.

Q. 2. Will you please tell me how to make a mica condenser for wireless receiving?

A. 2. See the November, 1909 issue.

LOADING COIL.

(798.) GEORGE DAVIS, Pa., asks:

Q. 1. Please show diagram for the connection of the following: Five step loading coil, 3 variable condensers, 2 fixed, pyron detector, 3,000 ohm phones, Murdock loose coupler, with switch on secondary, single slide tuning coil, Radio variometer?

A. 1. Diagram given below.

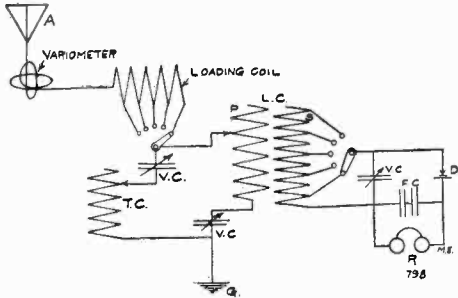

Q. 2. Is the use of a loading coil standard practice, and is it generally placed in the aerial lead?

A. 2. Yes.

Q. 3. Does a Radio Wave Meter give the reading direct?

A. 3. No; the variable condenser is adjusted, until the sounds in the receivers are a maximum, and the degrees read off the graduated dial. The wave length is found from calibration curves supplied with the instruments; the wave length corresponding to any condenser reading being readily ascertained.

CONDENSER CAPACITY.

(799.) H. M. TERRY, Wis., says:

Q. 1. What should be the capacity in M. F. of the variable condensers used in the primary circuit of the Fessenden interference preventer?

A. 1. It is .005 M. F.

Q. 2. Tell me how to tune my transmitting oscillating circuit to the desired wavelength it being loose coupled; show diagram?

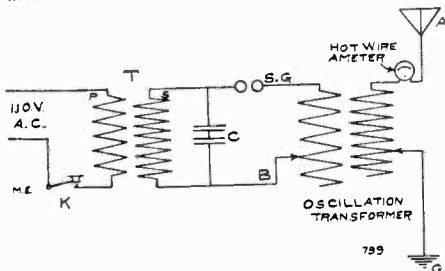

A. 2. Referring to diagram adjust clip A on secondary until sufficient inductance has been inserted in the aerial circuit to give the desired wave-length. Now adjust the primary clip B, to get the two circuits in resonance; which will be evidenced by the fact that the hot wire ammeter will register a maximum deflection, or a geissler tube in the aerial lead will glow the brightest.

YOUR WIRELESS PROBLEM!

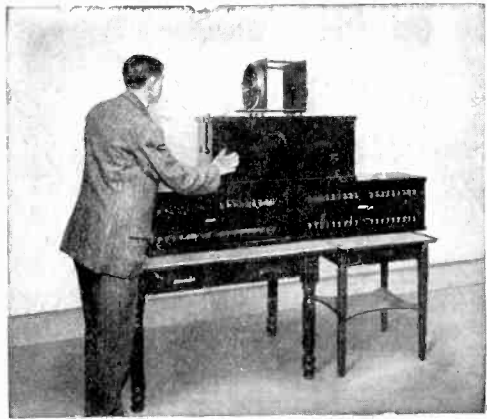

"BEACON" 3 K. W. Transmitting Set

PERHAPS you contemplate the installation of a wireless telegraph equipment for business, pleasure, or convenience.

Perhaps you have apparatus which is unsatisfactory. Perhaps you want to improve your present equipment.

In any event you will want apparatus of absolute reliability.

Our catalog G will be mailed for a stamp and is full of facts describing apparatus in use in many hundred private, marine, commercial and United States Government Stations.

Clapp-Eastham Company

139 Main Street

Cambridge, Mass.

IF you have a broken article made of Cast Iron, don't throw it away! Clean and fasten together with binding wire, then put in fire till cherry red—throw some brass on the place to be brazed together with a little

C. R. U. Brazing Salt

and your Cast Iron will be brazed and mended just the same as had it been Steel or brass.

\$1.00 per pound 12 pounds \$10.00

JOBBERS WANTED

Chas. R. Uebelmesser Co.

BAY SIDE, N. Y., L. I.

When writing, please mention "Modern Electrics."

If I Will Agree

To Get You A Position Paying Good Wages

When You Graduate From My School of

Telegraphy

Will You Come?

The demand for telegraph operators far exceeds the supply. My graduates are given immediate employment by Railroads, Telegraph and Wireless Companies, because my school is recognized as the only one graduating thoroughly practical operators. If you are looking for

Good Wages, Easy Work and a Bright Future

write me today. I offer you advantages unequalled anywhere. A few of them are:

1. Oldest, Largest and most Successful Telegraph School in the World. 2. Expert Instructors. 3. Best Equipment—we occupy exclusively a large modern building with R. R. train wire and complete wireless station installed. 4. Low Rates. 5. Easy Payments. 6. Living expenses earned while learning. Correspondence courses if desired. Write me today for illustrated descriptive catalog and interesting testimonials.

GEO. M. DODGE, Pres.

Dodge Institute of Telegraphy
6th Street, VALPARAISO, IND.

When writing, please mention "Modern Electrics."

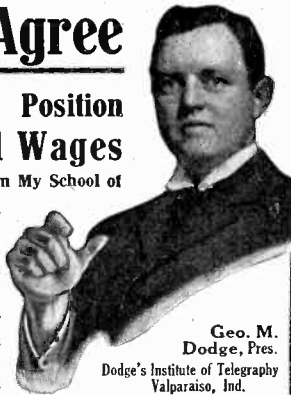

Geo. M.
Dodge, Pres.
Dodge's Institute of Telegraphy
Valparaiso, Ind.

FREE

WITH EVERY
ORDER

A 48-PAGE HANDY
TELEPHONE INDEX

OUR SPECIAL OFFER

1000 Envelopes . . .	\$1.50
1000 Bond Letter-heads	2.00
1000 Business Cards . . .	1.75
1000 Bill-heads . . .	1.75
1000 Statements . . .	1.75

Money Order
Draft or CASH
No Stamps

Special prices for
large quantities
Shipped in 24
hours. No delays

GEO. I. WILSON & SON

60 JOHN STREET NEW YORK

Q. 3. Is it possible for 3 distinct wave lengths to exist at one time on an antenna?

A. 3. Yes.

POULSEN ARC.

(800.) A. P. PHARES, N. J., writes:

Q. 1. In the Poulsen arc used for Wireless Telephony, why is it that explosions do not occur when too much alcohol is fed into the arc chamber?

A. 1. They would, were it not that spring safety valves are fitted into it, to prevent excessive pressures being formed therein. . . Q. 2. How is the alcohol feed regulated?

A. 2. By means of a standard glass lubricating cup with needle feed, which allows of regulating the flow to a nicety.

Q. 3. Is the oscillating circuit connected directly across the arc?

A. 3. Yes.

1/10 MICRO-FARAD CONDENSER.

(801.) H. H. ALSEN, Salt Lake City, Utah, requests:

Q. 1. The area of tin-foil required to make a 1/10 micro-farad glass condenser?

A. 1. It will require 7,118 square inches of active dielectric (glass .05" thick), covered on both sides with tin-foil.

Q. 2. How much No. 36 S. S. C. wire required on the secondary of a coil with a core 9 inches long by one inch in diameter, with primary of two layers of D. C. C. wire (I do not know the size so am inclosing a sample) to make the coil give a 3 inch spark?

A. 2. 3½ pounds.

Q. 3. How to make a glass plate condenser for above coil?

A. 3. Use 18—8" x 10" glass plates with foil on both sides 6" x 8".

500 MILE RECEIVING SET.

(802.) A. H. WOLFE, Preston Hollow, N. Y., asks:

Q. 1. With a 40 foot aerial, 100 feet long, using 4 strands aluminum wire, how far apart should the strands be placed?

A. 1. 3 or 4 feet.

Q. 2. What instruments are needed with the above aerial, to receive 100 miles; 500 miles?

A. 2. For 100 miles; 1,000 ohm phones, perikon detector, 2 slide tuning coil or loose coupler, fixed and variable condensers, for 500 miles use 2,000 ohm phones.

Q. 3. Does the wave length vary directly with height of aerial, or the length of it?

A. 3. With the length.

RECEIVING RANGE.

(803.) F. J. SUCHANEK, New York, inquires:

Q. 1. How far can I receive with the following instruments: Electrolytic detector, double slide tuning coil, 16 inches long, 4 inches in diameter, wound with 2 pounds No. 20 enameled wire, Electro Fixed condenser, Electro potentiometer, 2,000 ohm, Electro amateur phones, aerial 6 aluminum wires No. 14, 1 foot apart, 70 feet high, Water pipe ground?

A. 1. 800-1,000 miles.

Q. 2. What can I do to make this set a better one.

A. 2. Add a variable condenser.

Q. 3. Can I use a 850 ohm rheostat for potentiometer?

A. 3. Yes, if connected properly.

5 K. W. TRANSFORMER.

(804.) W. C. THOMPSON, San Antonio, Tex., requests:

Q. 1. Please give size wire and core for a 5 K. W. transformer of the closed core type to be used on 110 volt A. C.?

A. 1. Core of soft laminated sheet iron 1/32" thick, 20" long by 10 1/2" wide, size of leg 3" x 3"; Primary of 139 turns of No. 4 or two No. 7 B. & S. D. C. C. wires weight 26 pounds. Secondary of 33 pounds No. 25 B. & S. D. C. C. wire, wound in 32 pies of 583 turns each. Primary volts 110 A. C. 60 cycle. Current 45.5 amperes.

Q. 2. What is the secondary voltage and amperage?

A. 2. 15,478 volts and .338 amperes.

Q. 3. What is the weight of the iron core in pounds?

A. 3. 118 pounds.

TRANSFORMER TROUBLES.

(805.) S. R. LOWE, Oakland, Cal., says:

Q. 1. Kindly give diagram of connecting up a break key so as not to have any trouble of burning out detector when sending?

A. 1. See April, 1910, MODERN ELECTRICS, article by H. Anderson.

Q. 2. I have a 1/4 K. W. close core transformer which worked fine before I put it in oil, but when I had it in transformer oil it sparked very badly and failed to get even 15 miles. Can you tell me what was the trouble?

A. 2. Inferior oil or presence of air bubbles. Remedy, cook secondary in vacuum, before placing in oil.

Q. 3. Please give detail dimensions of a three K. W. close core transformer A. C. 220 volts, 60 cycles?

A. 3. Laminated iron core 18" x 9 1/2"; cross-section core leg 2.5" x 2.5". Primary coil of 392 turns No. 9 B. & S. D. D. C. wire. Secondary of 27 lbs. No. 26 B. & S. D. D. C. wire wound in 30 sections of 708 turns each. Amperes in primary 13.65.

GUY WIRE INSULATORS.

(806.) B. F. DODGE, Ohio, says:

Q. 1. Can an ordinary one inch spark coil be run from the 110 volt alternating current by using a suitable rheostat and screwing down the interrupter and thus running it as a transformer?

A. 1. Yes, but not very well, as the windings are not right.

Q. 2. Is steel, copper covered wire, suitable for a wireless aerial?

A. 2. No, owing to the choking effect of the iron.

Q. 3. Is it necessary for guy wires on the aerial to be insulated?

A. 3. Yes.



**HOLTZER-CABOT
Receivers**

For Wireless Operator's Use.

(Very Sensitive—Permanent Adjustment.)

**Adjustable Head Bands, (padded and pivoted.)
Pneumatic Ear Cushions.**

SEND FOR BULLETIN 20 M 3.

**THE HOLTZER-CABOT ELEC. CO.
BROOKLINE, MASS. and CHICAGO, ILL.**

When writing, please mention "Modern Electrics."

Bubier's Ten Cent Electrical Books

- How to Make a Dynamo
- How to Make a Telephone
- How to Make an Electric Motor
- How to Make a Storage Battery
- How to Make a Wimshurst Electric Machine
- How to Make a Magneto Machine
- How to Make a Medical Induction Coil
- How to Make a Pocket Accumulator
- How to Make a Plunge Battery
- How to Make a Galvanometer
- How to Make a Hand Dynamo
- How to Make a Talking Machine
- How to Make a One-Eighth Horse Power Motor or Dynamo
- How to Make a Small Transformer
- How to Make a Condenser and a Leyden Jar

- How to Make a Telegraph Key and Sounder
- How to Make a Toy Motor
- How to Make an Electric Bell
- How to Wind Armatures
- How to Make an Ammeter
- How to Make a Thermostat
- Motor Rotation
- How to Make an Electric Soldering Iron
- How to Make a Small Electric Heater
- How to Make an Electric Furnace
- How to Make a Hand-Feed Arc Lamp
- How to Make a Jump Spark Coil
- How to Make a Rheostat
- Telephone Troubles and How To Find Them
- The Manual of Telegraphy.
- How to Make an Automobile

BOOKS ON WIRELESS TELEGRAPHY and TELEPHONY.

Books on DYNAMO AND MOTOR BUILDING and the Castings and All Parts to Build Your Own Dynamo or Motor. Telegraph Supplies; Wireless Supplies.

M. Bubier Publishing Company, Lynn, Mass. U. S. A.

When writing, please mention "Modern Electrics."

HAVE YOU AN IDEA?

Write for our books: "WHY PATENTS PAY," "100 MECHANICAL MOVEMENTS," "PERPETUAL MOTION"—50 Illustrations. Mailed free. F. C. DIETRICH & CO., Patent Lawyers, WASHINGTON, D. C.

When writing, please mention "Modern Electrics."

PATENTS

No attorney's fee until patent is allowed.
Write for "Inventor's Guide."
FRANKLIN H. HOUGH,
Loan and Trust Bldg., Washington, D. C.

When writing, please mention "Modern Electrics."

Faucet WATER MOTOR



Complete with emery wheel \$2.50 buff wheel, pulley to run sewing and washing machine, polish. In some cities where we have no agents, and where the water pressure is good, a sample motor will be given free; apply at once if you want to make some extra money, or if you can devote your whole time, liberal salary and commission will be paid.

ALCOHOL STOVES, LAMPS AND FLAT IRONS

ENGINEERS WANTED to send for catalog of indicators. Reducing Wheels Planimeters. Address,
LIPPINCOTT M. S. CO.

52 Columbia St.,

Newark

New Jersey

When writing, please mention "Modern Electrics."

XMAS SPECIAL



Our T. A. T. 2800 ohm set, complete with gold plated diaphragms, sterling plated bobbins, only

\$8.75

Our 3200 ohm Navy. The famous receivers for long distance work, complete,

\$12.00

Send for Catalog. We guarantee our receivers. Let us prove it.

C. BRANDES, 111 Broadway, New York

C. F. KING, 163 Belvedere St., San Francisco, Cal.

When writing, please mention "Modern Electrics"

Wireless Transformers and Induction Coils

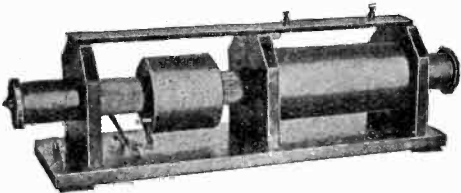

½ K. W. Transformer complete with Condenser and Spark Gap \$30

This is something new. Send for Catalog and Prices

E. S. RITCHIE & SONS

115 Cypress St., Brookline, Mass.

When writing, please mention "Modern Electrics."

BELT WIDTHS.

(807.) T. H. WADE, New York, says:

Q. 1. Please give the comparative conductivity of aluminum and copper for equal sizes?

A. 1. Aluminum .54— .63; Copper 1.

Q. 2. What is the method of finding the width of belt for a given H. P.?

A. 2. For single belts the formula is
H.P. x 2520

$$W = \frac{\quad}{D \times R}$$

Where W=Width of belt in inches.

D=Diameter of pulley in inches.

R=Revolutions per minute.

For double belts it is:—

$$W = \frac{\quad}{H.P. \times 1575}$$

$$D \times R$$

Q. 3. Which are the best; fibre or iron pulleys?

A. 3. Fibre pulleys, by actual tests.

TUNGSTEN LAMPS.

(808.) C. MCHENRY, Pa., writes:

Q. 1. How many watts do Tungsten lamps consume per candlepower?

A. 1. 1.25 watts per C. P.

Q. 2. What is the watt per candlepower rating of carbon filament lamps?

A. 2. 3.5 watts per C. P.

Q. 3. How many watts on 110 volts will a 16 C. P. carbon filament lamp take; a 50 C. P.?

A. 3. 56 watts; 175 watts.

SPARK VOLTAGE.

(809.) A. DONALD, — Tenn., says:

Q. 1. I have 2 spark balls 2 C. M. in diameter and when a spark 5 centimeters long jumps between them, what is the voltage?

A. 1. 64,200 volts as given by Heydweiller.

Q. 2. When it is 2 centimeters long?

A. 2. 47,400 volts.

Q. 3. What is the voltage of a 2 C. M. spark between needle points?

A. 3. 16,000 volts.

DYNAMO DESIGN.

(810.) R. E. SMITH, New Jersey, asks:

Q. 1. In designing a dynamo how is the requisite size of armature wire found?

A. 1. Allow 600 circular mils for every ampere of armature current and the diameter of the wire is found by extracting the square root of the total circular mil area.

Q. 2. What are the advantages of Rope Driving for Dynamos?

A. 2. Little slippage and quiet running.

Q. 3. What size manila rope will be required to drive a 30 H. P. dynamo, the velocity being 4,200 feet per minute.

A. 3. A 1½" rope will be the correct size.

VELOCITY OF SOUND.

(811.) A. NAGLE, Montana, inquires:

Q. 1. What is the velocity of sound?

A. 1. 1,090 feet per second.

Q. 2. The velocity of light?

A. 2. 186,000 miles per second.

Q. 3. Why is it during electric storms that the lightning is seen first and the thunder comes rolling in several seconds later?

A. 3. Owing to the low velocity of sound and high velocity of light, you see the spark or lightning discharge before you hear the thunder, which is the noise caused by the vast discharge breaking down the air dielectric in its path.

INDUCTION MOTOR.

(812.) H. REED, Nevada, writes:

Q. 1. Having a single phase induction motor of the squirrel cage type, 110 volts 60 cycle, with 4 stator poles, I would like to know how the synchronous speed is figured?

A. 1. The synchronous speed is found from the formula.

$$S = \frac{2 \times f \times 60}{P}$$

Where S=Speed of motor in R. P. M.

F=Frequency in cycles per second.

P=Number of field poles.

Hence the above motor should have a theoretical speed of 1,800 R. P. M.

Q. 2. What is meant by the slip of induction motors.

A. 2. The slip, generally represented as a per cent. of the synchronous speed is that difference between the synchronous or theoretical speed and the actual working speed of the motor; due to the mechanical load and partly to the inherent lag in the rotor itself. The per cent. slip is given by the formula.

$$\frac{(S - S_1)}{S} \times 100$$

Where S₁ is the actual working speed and S is the synchronous speed.

Q. 3. What size transformers are necessary to carry a 20 H. P. 3 phase induction motor, using 3 transformers?

A. 3. Three 7.5 K. W. transformers.

AUTO COILS.

(813.) H. H. HALWORTH, New Bedford, Mass.:

Q. 1. I have two single unit jump spark coils and wish to make them up into one box to operate a two cylinder gasoline engine for automobile use: will you kindly give me a drawing showing connections for putting same together?

A. 1. Sketch shown below.

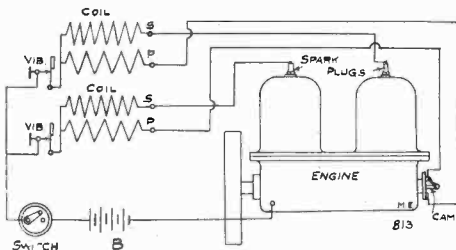

WANTED-IDEAS

The demand for good, patentable ideas is greater than ever before. Am constantly in receipt of letters from parties desiring to buy patents procured through me. Electrical devices, tools of all kinds, advertising novelties, agents' supplies, mail-order articles, and many other inventions are sought after. Protect your idea! Write for "Stepping Stones" (containing over 200 inventions wanted) and new guide book "Successful Patents". Clients' patents sold free. My personal services. Highest references.

RICHARD B. OWEN

Dept. 7 WASHINGTON, D. C.

CAPITALIZE YOUR BRAINS

TYPEWRITER SACRIFICE SALE



Greatest bargains ever offered, Underwoods, Oliviers, Remingtons, Smit's (all makes) rebuilt \$15 to \$38, worth double; sent subject to examination and trial.

Send for "Bargain List"

(OLD RELIABLE)

Consolidated Typewriter Exchange, 245 Broadway, New York.

Established 27 years on Broadway. Don't miss this chance to get a good typewriter at half price. Write immediately.

Special! Special!! Special!!!

- 2000 ohm Double Head Type Receivers with Leather Covered Head Band Complete... \$ 4.50
- Aluminum Wire for Aerial (240 Feet to the pound) per lb. .50
- Loose Coupled Tuning Coils (Warranted Best Made) 15.00
- Variable Condensers, (Aluminum Plates) Very efficient 8.00
- Wireless Apparatus of every description. Every instrument guaranteed.

FLETCHER-STANLEY COMPANY

Electrical Supplies and Specialties

32-34 FRANKFORT ST., NEW YORK

When writing, please mention "Modern Electrics."

NEED A SWITCH OR A COIL?



The ACME switch is just the thing for WIRELESS work. The lever is removable, so that no one can tamper with your outfit. We can also make you ROCK BOTTOM prices on COILS. Write TO-DAY. SWITCH sells at 50c.; COILS \$2.50 up.

ACME PARTS CO. Lafayette, Ind.

A-B-C-CODE
WHITE PLANE

TELEPHONE
 1040 MAIN

THE
WHITE AEROPLANE CO.



Send for our
 "1911" 16-page
 catalogue of
 "model supplies"
FREE

**THE WHITE
 AEROPLANE CO.**
 15 Myrtle Ave.
 Brooklyn, N.Y.

When writing, please mention "Modern Electrics."

Closed Core Wireless Transformers

To be operated on 110 V. A. C. 60 cycles, without interrupter or resistance of any kind. Laminated annealed iron used. Maximum power factor.

Size	Spark length with condensers	Price
1/4 Kw.	3/8-inch	\$12
1/2 Kw.	7/8-inch	16
3/4 Kw.	1 1/4-inch	24
1 Kw.	1 3/4-inch	30

Send stamp for descriptive leaflet.

WORTS-MCKISSON MFG. CO., Grand Avenue, Toledo

When writing, please mention "Modern Electrics."

PATENTS

THAT PROTECT AND PAY
 BOOKS, ADVICE, SEARCH AND } **FREE**
 LIST OF INVENTIONS WANTED }

Send sketch or model for search. Highest References
 Best Results, Promptness Assured.

Watson E. Coleman, Patent Lawyer
 622 F Street N. W. Washington, D. C.

When writing, please mention "Modern Electrics."

**LEARN WATCHMAKING
 AT HOME**



You can learn by our modern and original system of instruction every part of the Watchmaker's Trade at home as good or better than at a shop. You can earn money while learning and secure a well paying position or start in business after completing our course of instruction. Good watchmakers are always in demand and can earn from \$20 to \$35 per week. For particulars apply to the **WISCONSIN SCHOOL OF WATCHMAKING**, Enterprise Bldg., MILWAUKEE, WIS.

When writing, please mention "Modern Electrics."

NEW WIRELESS WONDER
 AERO-FIELD RECEIVING OUTFIT RECEIVES 75 MILES

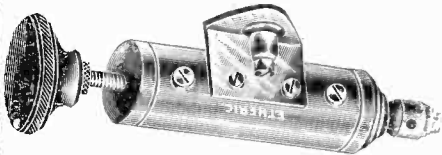

Send 2c. for Catalogue. **PRICE, \$4.00**
ETHERIC ELECTRIC CO., 278 Lenox Avenue, New York

When writing, please mention "Modern Electrics."

Sensible Christmas Gifts for MEN

"YANKEE" TOOLS

Pocket Screw Driver-N. 60



Steel-Nickel-plated and polished -very attractive. Four blades, carried in handle-Fits the hand-Fits the pocket-Fits the screws-Fits the purse. **65c. postpaid**

An Acceptable Little Gift-Fit for any Man

"YANKEE" TOOLS make sensible and very acceptable gifts for all men who ever have occasion to use tools of any kind. They last for years and the giver is remembered whenever they are used. Send for book of new ideas in time-and-labor-saving tools, full of interesting suggestions for Christmas.

A postal brings it if you mention "Modern Electrics." Ask your dealer for "YANKEE" TOOLS

NORTH BROS. MFG. CO., Dept. M., PHILADELPHIA, PA.

When writing, please mention "Modern Electrics."

METAL E. KONIG'S SLOW STAMPING & TOOL WORKS. **STAMPING**
 CLEVELAND, O.
 DIE MAKERS. HARDWARE SPECIALTIES.

When writing, please mention "Modern Electrics."

NEW PREMIUMS

We offer below a new assortment of premiums any one of which may be obtained by a little extra effort. You read Modern Electrics, which means it must be good, then show it to your friends. Help us, and help yourselves. You don't have to be a subscriber to take advantage of this chance to obtain a (valuable instrument for nothing; it takes just a few minutes of your time. Get the subscription, send it to us and we will forward by return mail the premiums you select. Your own (new) subscription will count. Now get busy and get a practical present FREE.



Junior Fixed Condenser. Used in all modern receiving sets. Special dielectric giving extra high capacity. Sealed in hard rubber base with binding posts, as shown. Sells for \$0.50. (Add 6 cents for postage)

Given free for one subscription



Automatic Blow Torch. The handiest torch made. Gives a solid blast of flame for soldering purposes, without any artificial blowing. The very latest. Torch sells for \$0.55. (Add 10 cents for postage)

Given free for one subscription.

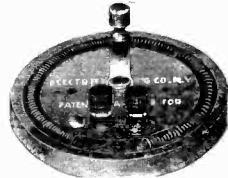

"Electro" Rheostat. Rotary adjustment. Air cooled. Very useful to vary the speed of motors and small lamps. Wound with non-rusting wire.

Given free for one subscription.



Electric Scarf Pins. Many unique styles. Fitted with cord and plug, and attachable to any flashlight by removing the lamp. Scarf pin sells for \$0.45.

Given free for one subscription.



The "Electro" Flaming Pocket Lighter. Lights your cigars anytime. Fits in the vest pocket. It sells for \$0.35.

Given free for one subscription.

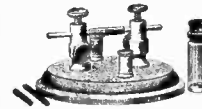

"Tellm" Auto Coherer. HARD RUBBER BASE. Needs no de-coherer. Complete with two carbon plugs, one iron plug, graphite-carbon grains and bottle of mercury. Auto-Coherer sells for \$0.80. Add 15 cents for postage.

Given free for two subscriptions.



Zinc Spark Gap mounted on hard rubber base. Electrodes fitted with rubber handles. Pure zinc rods. Used in all of the best stations. Spark gap sells for \$0.60. Add 7 cents for postage.

Given free for two subscriptions.



"Electro" Medical Coil. All quality. No end of fun with one of these coils, besides its therapeutic properties. Complete with cords and handles. Medical Coil sells for \$0.70. Add 12 cents for postage.

Given free for three subscriptions.



"Electro" Lytic Bare Point Detector. Holds the world's record for long distance receiving. Mounted on hard rubber base. Finest adjustment. Increases your receiving range 30 to 40 per cent. "Electro" Lytic Detector sells for \$1.25. Add 12 cents for postage.

Given free for three subscriptions.



Voltmeter or Ammeter. 1-12 volts, 1-15 amperes, 2 1/2 inch face, heavily nickelled and reliable. Dead beat, a first-class instrument. These meters sell for \$2.00.

Given free for five subscriptions.



"Electro" Amateur Phones. 2000 ohms resistance. Wound with No. 50 copper wire. Thin diaphragms. Leather covered adjustable headband. Weight 15 oz. 80 per cent. better than 75 ohm phones. Phones sell for \$4.50. Add 25 cents for postage.

Given free for ten subscriptions.



One Inch Spark Coil. This is the coil that has sent a message 90 miles with a suitable aerial. None better made. High speed French vibrator. One inch coil. Sells for \$4.50.

Sent by express only.

Given free for twelve subscriptions.

We are sure you can get any of the above premiums, if you show this Magazine to your friends. They will want it right away. Then's your chance, nab 'em! before the other fellows get 'em. Strike while the iron is hot. Act now. Don't delay. You won't get this chance again. Send money orders or N. Y. Drafts, no checks or stamps.

MODERN ELECTRICS PUBLICATION
233 FULTON STREET - - - NEW YORK CITY

The Greatest Magazine Bargains

We Save You As Much As 40 Per Cent. On Your Subscriptions

MODERN ELECTRICS.....	\$1.00	OUR PRICE \$3.00
COSMOPOLITAN, (or American, or Good Housekeeping)	1.50	
REVIEW OF REVIEWS.....	3.00	
Regular Price -		\$5.50

Modern Electrics.....	\$1.00	Our Price \$4.05
World's Work.....	3.00	
Everybody's.....	1.50	
Delineator.....	1.00	
Regular Price -		\$6.50

Modern Electrics.....	\$1.00	Our Price \$5.40
Pearson's.....	1.50	
Leslie's Weekly.....	5.00	
Regular Price -		\$7.50

Modern Electrics.....	\$1.00	Our Price \$4.25
Good Housekeeping.....	1.00	
The Outlook.....	3.00	
Regular Price -		

Modern Electrics.....	\$1.00	Our Price \$4.20
Review of Reviews.....	3.00	
McClure's Magazine.....	1.50	
Woman's Home Companion.....	1.50	
Regular Price -		\$7.00

Modern Electrics.....	\$1.00	Our Price \$2.15
Pictorial Review.....	1.00	
Cosmopolitan, (or American or Good Housekeeping)	1.50	
Regular Price -		

Modern Electrics.....	\$1.00	Our Price \$2.40
The World Today.....	1.50	
Pearson's.....	1.50	
Regular Price -		\$4.00

MODERN ELECTRICS IN CONNECTION

	REGULAR PRICE	OUR PRICE	REGULAR PRICE	OUR PRICE
With Ainslee's.....	\$2.80	\$1.80	With Motor Boat.....	3.00
" American Boy.....	2.00	1.45	" The Musician.....	2.50
" The Book-keeper.....	2.00	1.45	" North American Review.....	5.00
" Cosmopolitan.....	2.50	1.50	" The Outlook.....	4.00
" Cycle & Automobile Trade Journal.....	3.00	1.80	" Pacific.....	2.50
" Farm Journal.....	2.00	1.45	" Pearson's.....	2.50
" Fruit Grower.....	2.00	1.35	" Pictorial Review.....	2.00
" Good Housekeeping.....	2.25	1.70	" Popular Magazine.....	4.00
" Gunter's Magazine.....	2.50	2.00	" Recreation.....	4.00
" Harper's Magazine or Weekly.....	5.00	4.30	" Review of Reviews.....	4.00
" " Bazar.....	2.00	1.50	" Scientific American.....	4.00
" Judge's Weekly.....	6.00	5.00	" Telephony.....	4.00
" The Ladies World.....	1.50	1.10	" Suburban Life.....	4.00
" Leslie's Weekly.....	6.00	5.00	" Success.....	2.00
" Lippincott's.....	3.50	2.50	" Sunset.....	2.50
" McClure's Magazine.....	2.50	1.80	" Travel.....	2.50
" Metropolitan.....	2.50	1.75	" Women's Home Companion.....	1.50
" Modern Priscilla.....	1.75	1.30	" The World Today.....	2.00

Canadian and Foreign Postage to be added to above prices.
 We will gladly quote on any Magazine combination not listed above
 Prompt and careful service assured.
 It is impossible to get the Magazines quoted in our list cheaper elsewhere.

MAIL ALL ORDERS TO

Modern Electrics Publication

233 FULTON STREET

NEW YORK

INVENTORS UNIVERSAL EDUCATOR

600 CONTAINS MECHANICAL MOVEMENTS ALSO SUPERPERPETUAL MOTIONS HOW TO OBTAIN PATENTS

EVERY INVENTOR SHOULD HAVE A COPY

FRED DIETRICH \$1.00
OURAY BLOCK. WASH. D.C. BY MAIL

When writing, please mention "Modern Electrics"



MASTER YOUR MOTOR CAR, MOTOR BOAT, Motorcycle or Aircraft.

Automobile Troubles and How to Remedy Them. Automobile Driving Self-Taught. Automobile Motors and Mechanism. Ignition, Timing and Valve Setting. Motor Boats: Construction and Operation. ABC of The Motorcycle. Flying Machines.

Flexible leather and cloth bindings, round corners, DATE, RELIABLE, 1910 EDITIONS. Price, \$1.50 Leather, \$1.00 Cloth, postpaid. Sold and guaranteed by Book-sellers, Auto and Marine Supply Houses, or direct.

THE CHARLES C. THOMPSON COMPANY
Publishers, 545-549 Wabash Ave., CHICAGO

TELEGRAPHY TAUGHT



in the shortest possible time The Omnigraph Automatic Transmitter combined with standard key and sounder. Sends you telegraph messages at any speed just as an expert operator would. Five styles \$2 up. Circular free.

Omnigraph Mfg. Co.
39 1/2 Cortlandt St., New York

When writing, please mention "Modern Electrics."

Patents 25 Years' Experience
New Easy Plan of Payments

BOOK MAILED FREE, telling all about Patents and how to obtain them. Illustrates 100 MECHANICAL MOVEMENTS, VALUABLE FOR INVENTORS.

CHAS. E. BROCK, Patent Attorney
912 F Street, WASHINGTON, D. C.

WIRELESS APPARATUS

Our Wireless goods are the best on the market, and are guaranteed to work. Our instruments are made of the finest materials, and are sold at present at a price within the reach of every experimenter. Send a 2c. stamp for our large catalogue which contains a full list of Wireless instruments, Novelties and Electrical goods, and also a great deal of Wireless information for the Wireless experimenter.

THE W. T. WIRELESS CO.,
728a Broadway, Brooklyn, N. Y.

VENTRILOQUISM

Taught Any Man or Boy

by Mail at Home. This is no special gift as you have supposed, but an art. I have taught thousands in all parts of the world. Cost small. Send today, 2-cent stamp for particulars and proofs.

O. A. SMITH, Room 1415-823 Bigelow St., PEORIA, ILL.



LEARN CHIROPRACTIC
The new method of drugless healing
EARN \$50 TO \$100 PER WEEK

Our free book tells how you can learn to detect disease and remove the cause by Howard's method of Spinal Adjustment. Potency the most simple, direct, advanced and scientific method of "cure's" healing. Based on unerring natural laws. Anyone can understand, learned in spare time. Improve your social prominence and financial standing. Start now on the road to honor and success. Write for free book and special scholarship offer.

NATIONAL SCHOOL OF CHIROPRACTIC
800 Wendell Bank Bldg., Chicago, Ill.

LEARN TO BE A WATCHMAKER



Bradley Polytechnic Institute
Horological Department A
Peoria, Illinois
FORMERLY PARSONS HOROLOGICAL INST
Largest and Best Watch School in America

We teach Watch Work, Jewellery, Engraving, Clock Work, Optics. Tuition reasonable. Board and rooms near school at moderate rates. Send for Catalog of information.

When writing please mention "Modern Electrics."

METAL PARTS For All Electrical Instruments
SCREW MACHINE PRODUCTS
MAGNET WIRE All Styles and Sizes

S. M. COHN & CO

136 LIBERTY ST. NEW YORK

WONDERFUL WIRELESS TELEGRAPH



With our little outfit you can send messages across a large room or from one room to another; complete with Morse Alphabet and full instructions to cts.

G. CO. DEPT., 11 Norwalk, Conn.

When writing, please mention "Modern Electrics."

PATENTS C. L. PARKER
Ex-Examiner U. S. Patent Office
PATENT LAWYER
8 MCGILL BLDG
WASHINGTON, D. C.

Patents, Trade Marks, Copyrights, Patent Litigation
Handbook for Inventors "PROTECTING, EXPLOITING AND SELLING INVENTIONS" sent free upon request.

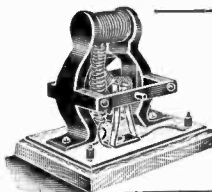

The White Eagle Electric Motor

Postpaid, 75c.

We make working models of inventions. Send for illustrated catalogue of Modern Supplies.

The Pierce Model Works

Industry B'g., 855th Ave., Chicago

Maver's Wireless Telegraphy and Telephony

By **WILLIAM MAVER, Jr.**

366 pages; 258 diagrams, including Amateur Department

Until further notice this valuable book will be sent to members of the Wireless Association of America and to readers of "Modern Electrics," for \$1.25, postage paid (Price heretofore \$3.) "An exceedingly well pleased with Maver's Wireless Telegraphy and Telephony, just received."—Owen L. Grubb 76 Maryland Ave., Columbia, Mo. Send orders direct to

MAVER PUBLISHING CO.

136 LIBERTY STREET, NEW YORK

When writing, please mention "Modern Electrics."

CLASSIFIED ADVERTISEMENTS.

Advertisements in this column 2 cents a word, no display of any kind. Payable in advance. stamps not accepted. Count 7 words per line. Minimum, 2 lines. Heavy face type 4 cents a word. Minimum, 3 lines.

Advertisements under "Wireless" 5 cents a word. Minimum, 4 lines. Wireless books and blue prints not listed under "Wireless," 2 cents a word.

Advertisements for the Jan. issue must be in our hands by Dec. 30.

ELECTRICAL APPARATUS.

HOW TO RENEW dry batteries; absolutely guaranteed, 25c (no stamps). Blue prints for wireless telephone and telegraph outfits. Long distance sets, 25c. or two for 40c. Voltmeters (12 volts) and polarity indicators combined, \$3.00. Arlington Wireless Co., Arlington, Cal.

EXPERIMENTERS—I build all kinds of wood bases for Wireless Instruments, after your designs. Detector bases, 10c. Send drawing of base wanted, for estimates. F. W. Doty, Mehoopany, Pa.

AGENTS WANTED for electrical specialties. Burt Mfg. Co., Wollaston, Mass.

STUDY ELECTRICITY AT HOME. A complete electrical course at home, containing 30-page detail book, 220-page text-book, 200-page experiments and over 100 pieces of apparatus. Price, complete, only \$5.60. Catalogue "M. E. S." explains this and other remarkable offers. Thomas M. St. John, 848 Ninth ave., New York.

When writing, please mention "Modern Electrics."

ELECTRICAL BOOKS, BLUE PRINTS, Etc.

WIRELESS CODES AND DIAGRAMS, Blueprint of Morse, Continental and Navy Codes, 10c. Twenty Standard Wireless Circuits, 5c. A. C. AUSTIN, Jr., Hasbrouck Heights, N. J.

HAND CUFF KINGS! MAGICIANS! our 1911 Trick catalogue is just off the press. Send for a copy. Misto Trick Mfg. Co., 751 6th Ave., New York.

MR. WIRELESS OPERATOR: What Wave length are you using? Do you know? Are you interfering with government or commercial stations. To avoid any trouble, get my complete Formulae and tables showing how to find the correct Wave Length of any tuned station. Special 20c. Send 10c for a new hook-up used by the U. S. Navy and guaranteed to eliminate 98% of all static and interference. H. Winfield Secor, Electrical Expert, 206 W. 23rd St., New York City.

**WIRELESS
WIRELESS FIENDS.**

Phosphor Bronze Aerial Wire as used by Government, the best yet. Just imported 25,000 feet. 1½ cts. per foot. Bornite and Zincite, the most sensitive combination, 50 cts. per set. Zincite and Copper Pyrites, 50 cts. per set. Silver plated brass cup for mounting crystals, 10 cts. each. Sliders (for square rod ¼-in. x ¼-in.) with ball and spring, 20 cts. complete. Black Asphaltum, Black and White Shellac, liquid ready to use, large bottle, 25 cts. Spool containing 1000 Ohms No. 50 Copper Wire, 60 cts. Silicon or Molybdenite, large piece, 15 cts. Send postage stamp for 128 page Catalog.

FREE WIRELESS CRYSTAL with every formula. Formulae for calculating Wave Length, Inductance, Capacity, Frequencies and for any other wireless calculation, 25c each. Will make calculation, 50c each. T. J. M. Daly, 133 Ianham Place, Memphis, Tenn.

Attention Wireless Experimenters. We have the best assortment of wireless instruments in Detroit. We keep everything in stock, no delay. Send 2 ct. stamp for catalog. Seidler, Miner Electric Co., Detroit, Mich.

Wireless fiends save freight and expressage. Why order from the East if you can secure ALL wireless goods on the Coast? We carry largest assortment of wireless apparatus in Frisco. Can make prompt shipments. Call or send postage for catalog. Paul Seiler Electric Works, Market street, San Francisco, Cal.

All wireless goods and supplies carried in stock. Most complete assortment in St. Louis. You save money by dealing with us, and you get the most up-to-date instruments. A call will convince you. Stamp for catalog. Hance Electric Co., Olive street, St. Louis, Mo.

FOR SALE.

FOR SALE—A Wireless Specialty Co. ½ K.W. closed core transformer. Clapp-Eastham ½ K.W. glass plate condenser. Clapp-Eastham ½ K.W. spark gap. Chicago Wireless Specialty Co. ½ K.W. helix and a J. H. Bunnell Wireless sending key, making a complete set for the transmission of wireless signals over a distance of between twenty and forty miles. This set was used slightly for four months and is in perfect condition. Price, \$25.00. Address, J. H. Michener, MacKenzie School, Dobbs Ferry, N. Y.

FOR SALE—Complete Receiving set, also Experimental Outfit; will sell whole or in parts. Chester R. Davis, 258 Madison St., Passaic, N. J.

FOR SALE—Static machine. 3 inches, \$2.75. Electric street car, \$1.00; \$3.00 Telegraph set. \$1.25. All new. 1,500 varied stamp collection, \$4.00, or trade for electrical apparatus. D. Lay, Kewanee, Ill.

FOR SALE—Two complete wireless receiving outfits. Address L. C. Gildersleeve, Nattituck, N. Y.

FOR SALE—Two thousand ohm navy type headphones and band, \$8.00. Two thousand ohm United Wireless headphone, \$7.00. Amateur type, two thousand ohm phones, \$4.00. Hundred thousand volt insulator, \$3.00. Two one-inch spark coils, \$2.00. Twenty ohm sounder key, and hundred fifty ohm relay, \$3.50. Ten inch Electroose insulator, 50c. Five pounds number 14 aluminum antenna wire, \$2.00. Two tuning coils, \$1.50 each. De Forest model Electro-lytic detector, \$5.00. Large reactance for sending transformer, \$2.00. Large sending key, commercial type, \$4.00. One-fourth K.W. transformer, \$10.00. H. Lang, Tacoma, Wash., care W. U. Telegraph Co.

FOR SALE—Wireless Receiving Outfit. Instruments sold separately at low cost. Best of reasons for selling. In use only one week. All Electro Importing Co.'s goods. Address R. W. Duckwitz, 4627 Cedar Ave., W. Philadelphia, Pa.

LONG DISTANCE WIRELESS CRYSTAL, used with silicon, with or without battery. Unaffected by vibration or heavy spark discharge. Users hear stations clearly after silicon has ceased to emit a sound. Money refunded if unsatisfactory. Postpaid with complete instructions, 20c. Robert Muns, 105 Hudson St., New York.

NEW 5-inch swing lathe, motor driven. \$15. Particulars for stamp. Walter W. Hartman, Box 1084, Clay Center, Kans.

When writing please mention "Modern Electrics."

WATCH THIS PAGE!

Dickinson Manufacturing Co.

SPRINGFIELD, MASS.

100 MECHANIC STREET

PIONEERS

OF

MOULDED INSULATING MATERIAL

ESPECIALLY FOR

Wireless

and all other ELECTRICAL INSULATION PURPOSES

SUBSTITUTES FOR HARD RUBBER
INSULATION

“STERNOID”

(Heat-proof, High Electrical Resistance)

“STERN-BAKELITE”

(High Mechanical and Electric Resistance,
also Heat-proof up to 500 Fh.)

Shellac Composition

Quantities Only.

NO RETAIL.

KURT R. STERNBERG

Treas. and Gen'l Manager

“Construction of Induction Coils and Transformers.”

Compiled and arranged by H. Winfield Secor.

100 Pages. 72 Illustrations.

A New Hand-Book Giving Detailed Instructions and Data on the Construction of Induction Coils and Wireless Transformers.

CONTENTS

The Induction Coil, its history and theory.
 Coil Construction.
 Secondary Coil impregnation.
 The Induction Coil as a means of amusement.
 Electrical Stars.
 Interrupters.
 How to build an efficient Spring Vibrator.
 Construction of an Independent Vibrator.
 Simple Wehnet Interrupter.
 An Adjustable Impedence Coil.
 A Tesla Coil.
 A Tesla Disruptive Coil.
 Air Insulated Tesla Coils.
 A large Demonstration Tesla Coil.
 Experimenting with the Tesla Coil.
 The High Tension Transformer
 How to build one-half to 3-kilowatt Closed Core Transformers.

APPENDIX

Table of Spark Coil Dimensions one inch to twenty inch.
 Table of Spark Coil Dimensions one inch to twelve inch, heavy spark.
 Table of Spark Coil Dimensions one-quarter inch to ten inch with enamel wire secondaries.
 Table of Dimensions of open and closed Core Transformers $\frac{1}{2}$ to 3 K. W.
 Table of Glass Plate Condensers, for Transformers up to 5 kilowatt and spark coils 1 inch to 12 inch.
 Table of Sparking Distances for various voltages.
 Inductivities of Dielectrics and method of finding condenser capacity.
 Tables of turns per inch and feet per pound of insulated magnet wire.
 Table of Soft Iron Core Weights
 Tables giving the cost of wire, raw material, etc.

Price, Twenty-five Cents, Prepaid.

You cannot afford to be without this book, the very latest on the construction of any size induction coil or high potential transformer for use in wireless telegraphy or X-ray work.

Its 96 pages are brim full of live, useful, up-to-the-minute information that you have been wanting for a long time; profusely illustrated with 72 clear drawings especially made for this work, and an APPENDIX of valuable tables which are alone worth the price we ask for the book.

As we expect an exceptional demand for this very timely book, by a writer whose ability is already well known to MODERN ELECTRIC'S readers, it will be wise to order now, so that you don't get left. Order at once, to-day, before you forget it; to-morrow never comes.

READY FOR DELIVERY NOW.

Send money or express order, or coin. Stamps or checks not accepted.

Modern Electrics Publication, 233 FULTON STREET
 NEW YORK CITY

Wireless Supplies and Electrical Novelties

FOR HOLIDAY GIFTS

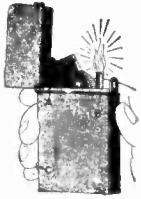

Combination pocket light and cigar lighter. The best metallic friction spark lighter on the market. Will last a life-time. Press the button, the lid springs up, and the sparks from the "Ceric Iron" pill ignite the wick. Unscrew valve and fill with 40 drops benzine, gasoline or alcohol which will last 8 days. Benzine preferred. Regular price, \$1.50.

Our price. By mail, postpaid, . 95c
Extra "Ceric Iron" rellii pill, . 10c

(new process) Merchlor Battery, and enameled Tungsten Bulb.
Price by mail postpaid 95c
In silver finish \$1.35
In gold finish 1.50
Extra Battery [Merklor] 25c
Extra Tungsten Bulb (Flat) 35c

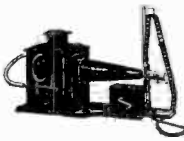

Acetylene Moving Picture Machine. Throws a 5x5 picture 20 feet. 500 candle power. Safer than kerosene oil. Regular price, \$10.

Our price, with 5-ft. film. \$4 35
Electric 9.60

Electric Engine Outfit. Red Sea battery, engine and water bucket.
By Express 95c
With extra piece of shafting and wind mill added . . . \$1.35



Complete Wireless Outfit. Will receive 50 miles, and send two miles. Consisting of Auto Coherer, Receiver, Fixed Condenser, Double Slide Tuning Coil, 1-inch Spark Coil, Rheostat, Regulator, Key, Spark Gap, and 1 pound aluminum wire. Will operate on from 4 to 6 dry cells, and can be tuned perfectly. Regular price \$11.50.
Special, by express \$9.35

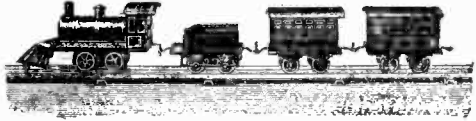

Classic Train Outfit, consisting of Locomotive, Tender, 2 trailers and a set of third rail track (2 straight and 4 curved). Will operate on 1 or 2 dry cells.

Holiday price, complete, by express \$1.65

No. 9. Larger Locomotive, with headlight, large trailers, and 4 sections straight and 4 sections curved track.
Price, complete. \$3 90
Extra sections, 1 foot, third rail track, 15c

Send 4c stamp for our Wireless Booklet and General Catalog of Electrical Novelties.
PRICES: Wireless Booklet, Net; Large Catalog; 20 per cent Discount.

ANDERSON LIGHT & SPECIALTY CO.
Known as LA SALLE LIGHT STORE
70 La Salle Street Opposite the New City Hall, CHICAGO

When writing, please mention "Modern Electrics."

FREE TWO BOOKS:
61-Page "Inventor's Guide" AND 64-Page "Proof of Fortunes in Patents—What and How to Invent."

FREE
The above - entitled books will tell you How to Secure Money to "Patent" Your Invention, How to Sell Your Patent, and ALL about the **Great Success of My Clients**

Trade-Marks, Copyrights, Prints, Labels, Registered.
ADVICE FREE.
Correspondence Solicited.

PROTECT YOUR IDEA!

Patents THAT Pay

"MY TRADE-MARK"

"Your business will have my personal attention."—E. E. V.

\$ 180,340.00 \$
MADE BY MY CLIENTS

YOU SHOULD Have My FREE BOOKS
Telling HOW OTHERS will do the same IN THE FUTURE "WHAT and HOW to INVENT" BOOK FREE

REFERENCES

- American National Bank Washington, D. C.
- Little Giant Hay Press Co. Dallas, Tex.
- Gray Lithograph Co. New York City, N.Y.
- Farmers Mfg. Co., Norfolk, Va.
- New Era Mfg. Co. Fairfield, Ia.
- The Parry Stationery Co. Oklahoma City, Okla.
- Bell Show Print Co. Sigourney, Ia.
- The Camp Conduit Co. Cleveland, O.
- The Iowa Mfg. Co. Oskaloosa, Ia.
- Sam'l Allen & Son Mfg. Co. Danville, N.Y.
- The Gari Electric Co. Akron, O.
- Superior Mfg. Co. Sidney, O.
- Tidnam Tel. Pole Co. Oklahoma City, Okla.
- Bernhard Furst Vienna Austria-Hungary
- Compound Motor Co. Brooklyn, N.Y.

I advertise my clients' patents free in a magazine having a two million circulation.

MY FEE RETURNED IF "PATENT" IS NOT ALLOWED

HIGH CLASS WORK EXCELLENT TESTIMONIALS

Expert-Prompt Services Highest References 809 F. ST., N. W.
E. E. VROOMAN, Registered Patent Attorney Patent Litigation Wash., D.C.
PATENT LAWYER

My offices are located across the street from the U. S. Patent Office.

When writing, please mention "Modern Electrics"

THIS CHRISTMAS OUTFIT FOR \$5

Fifty-Piece Experimental Set

CONTAINS :

Complete Magneto-Generator, Weight 5 pounds, has brass gear drive, silk wound armature, handle, bronze bearings and oil cups.

Polorized Interrupter Set

Three Bar Magnetic Set and Compass

Ten Brass Binding Posts

Polorized Ringer Set

Complete Set Electro-Magnets

Telephone Induction Coil

200 Ohm. Relay, complete

Three Push Buttons.

Six Blue Prints of fifty electrical diagrams.

One 110 Volt Lamp and Socket for Generator.

Complete parts for the construction of a signal system, including green and red incandescent lamp with sockets, wood base, posts, bottle of Shellac, tape, empire cloth, sleeving, brass tubing, mica, spool of magnet wire, solenoid signal balls, contacts, spring wire, fibre for rings, and switch.

Complete parts for the construction of a spark coil for gas lighting, including wire, insulating materials, blue print, iron core wire and instructions.

MONEY REFUNDED IF NOT SATISFACTORY

We buy the salvage of the largest electrical houses in the world—and sell quickly at a small profit. The materials that make up this outfit have been selected by Edgar P. Hazazer, formerly Electrical Instructor at the Coyne Trade School, Chicago, Ill., so that you get the benefit of close buying as well as practical instruction.

FREE CHRISTMAS OFFER

Send in your order and remittance of five dollars, and we will send you FREE, and in addition to the above list all of the following materials.

250 Page Electrical Instruction Book.

1 Key brass wall socket

1 Set fuses and cut out.

1 Keyless wall socket

1 W. p. socket.

1 Drop brass socket

1 Porcelain Socket

1 Attachment plug

1 Combination socket and holder

and for one dollar extra

A STANDARD LONG DISTANCE TELEPHONE, with receiver, transmitter, induction coil, hanger cradle—all complete in a mahogany telephone box, \$7, value for \$1.

USE THE COUPON

This coupon and \$5 entitles the sender to the 8 additional fittings, and the 250 page book

WESTERN ELECTRIC SALVAGE CO.

1224 So. Washtenaw Avenue,

Chicago, Ill.

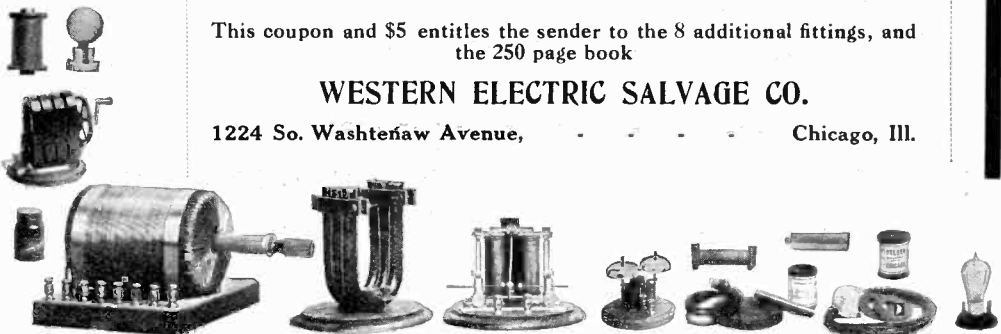

The Second Annual Official
Wireless Blue Book

READY NOW

- The only book of this kind in existence. In three parts:
- U. S. Land Stations (also Canadian Stations).
- U. S. Ship Stations (including foreign ships touching U. S. ports).
- U. S. Amateur Stations.

The book is arranged in such a manner that ALL calls are classified ALPHABETICALLY. Therefore, no matter from what part of the country or the sea, the wireless call comes, you will immediately locate the sender.

This book is the most complete one of wireless stations published and is warranted to be the most accurate one in print. No more guesswork.

In addition we furnish a

WIRELESS MAP OF THE U. S.

in three colors, size 13 x 9½, which can be mounted or hung in your station. Gives location and distances for all Government and Commercial stations in the United States, and ENABLES YOU TO COMPUTE QUICKLY DISTANCES, WHEN TRACING A CERTAIN CALL.

YOU CANNOT AFFORD TO BE WITHOUT THIS BOOK.

PRICE BY MAIL, 15c.

Cash or Stamps (only U. S.—no foreign ones) taken

MODERN ELECTRICS PUBLICATION :: 233 Fulton St., New York



HIGH GRADE WIRELESS APPARATUS

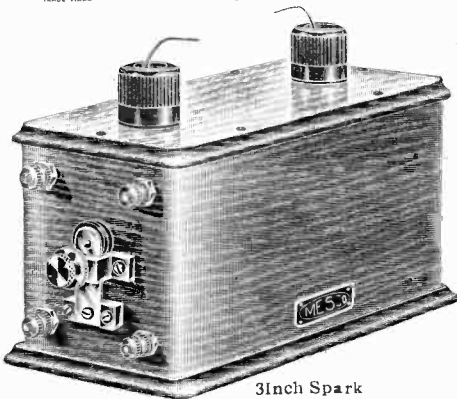

3 Inch Spark

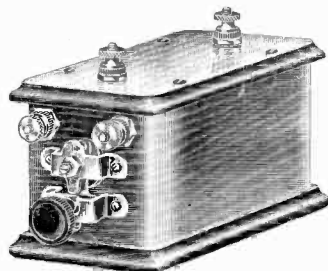

¾ Inch Spark

The above cuts show two of our high grade wireless spark coils. The secondaries never break down on their rated voltage, and the current consumption is about half of other coils.

A complete line of high grade wireless instruments is described in our new 80 page MANUAL OF WIRELESS TELEGRAPHY, No. C1, which also gives detailed instructions for the latest known methods of installation, mailed on request. SEND FOR IT.

Catalog No. 24C illustrating a full line of General Electrical Supplies mailed on application.

ASK YOUR DEALER FOR **MESCO** APPARATUS.

MANHATTAN ELECTRICAL SUPPLY CO.

NEW YORK: 17 Park Place

CHICAGO: 188 Fifth Avenue

When writing please mention "Modern Electrics."

THE WIRELESS TELEPHONE

By H. GERNSBACK

80 PAGES. . . . 57 ILLUSTRATIONS

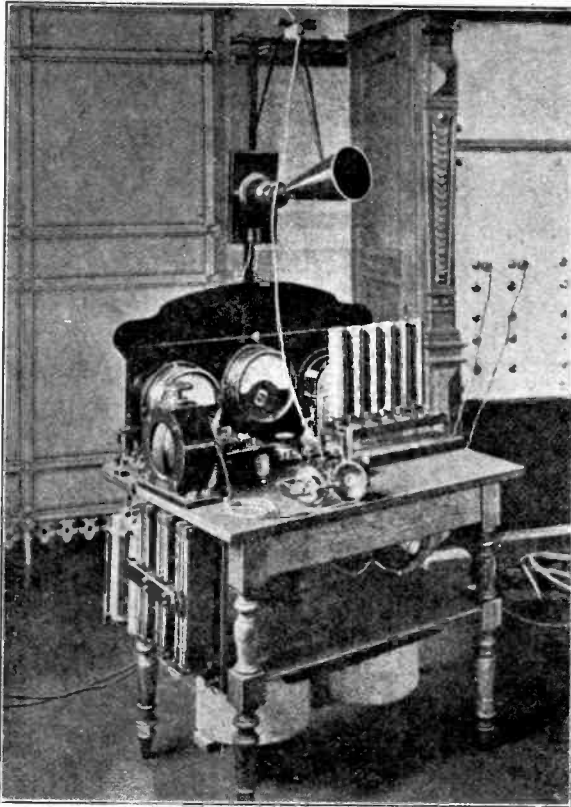

A WIRELESS TELEPHONE STATION

THIS NEW BOOK, by Mr. Gernsback, stands in a class by itself.

It not alone describes the most important systems, but treats the subject from the experimenter's standpoint, in such a manner that even the less advanced student will have little trouble to clearly grasp the matter.

The book is the most up-to-date one and contains a digest of all the latest patterns on wireless telephony, both in the United States and abroad.

This book is an absolute necessity to the rising wireless experimenter, who desires to keep abreast with the progress of the new art, that will within five years, revolutionize telephone communication.

This book also contains directions for building small wireless telephone stations at a cost under five dollars for short distances up to one mile.

It had been our intention to sell this book for \$1.00 on account of its great value, but we believe that the demand will be so great for Mr. Gernsback's book that the low price at which it is sold, will repay us in time.

As we expect several thousand orders, it will be wise to order at once, so you will not be delayed

Price Twenty-five Cents Prepaid

CLOTH BOUND, FIFTY CENTS

Send money or express order or coin, stamps or checks not accepted

MODERN ELECTRICS PUBLICATION

233 Fulton Street, NEW YORK CITY

INSULATORS from 1,000 to 1,000,000 VOLTS

TRADE MARK
ELECTROSE INSULATION
REG. U.S. PAT. OFF. & FOREIGN COUNTRIES.

Standard of the World
Adopted by  U. S. NAVY

and all Commercial Wireless Companies

No Retail. Wholesale Only

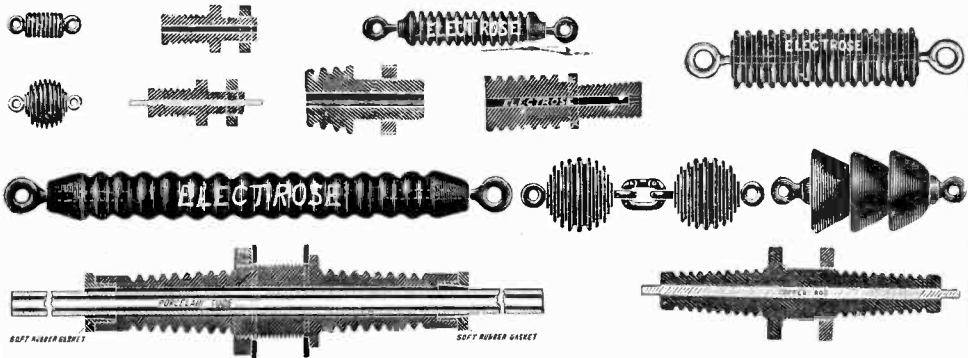

Electrose Mfg. Co., 127-137 N. 10th St., Brooklyn, N. Y.
130-140 N. 11th St.,

Anything Electrical or Wireless

Our New Big 200 Page Catalog, Unquestionably the Most Elaborate Wireless and Electrical Catalog Published,—May be had for a 4c. Stamp to cover Postage.

Twice the size of our last catalog, which was as large as any published.

Twenty large sections of Wireless and Electrical Goods. Get this Catalog before making Christmas purchases.

This Catalog contains sixty pages of Wireless Instruments, for commercial and marine installation; Transmitting Sets ranging from 1/4 K. W. to 5 K. W. The Experimental Wireless Outfits embrace over 25 pages.

Our \$19.00 Receiving Set has a demonstrated proven range exceeding 700 miles from only a 2 K. W. station. The exceeding delicacy and admirable adjustment of our Ferron Detector; the fine selectivity and accurate tuning, obtainable only with a tuning coil wound with bare copper wire, and by an exclusive method protected by patent, and the unquestioned superiority of our 1000 Ohm Western Electric double head sets, render ordinary what would be considered extraordinary with any other receiving set of equal price.

J. J. DUCK, 432 St. Clair St., TOLEDO, OHIO

Christmas

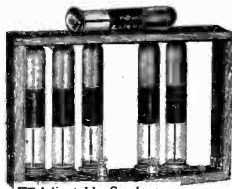

Adjustable Condenser.
Now \$2.00

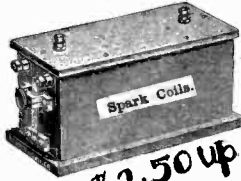

Spark Coils.
\$2.50 up



Flaming Pocket Lighter.
Now 35¢

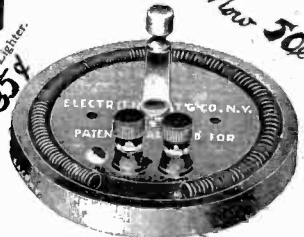

Variable Condenser. Now 50¢
ELECTRIC CO. N.Y.
PATENT

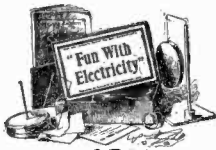

50¢



Telephone Receiver.
Now 35¢



1205 Head Receiver.
Now 63¢



40¢

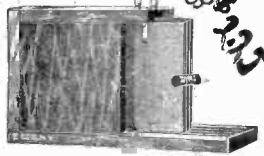

Now \$2.25



Flash Light.
40¢ UP

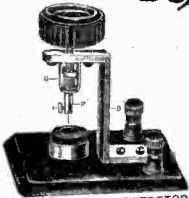

"ELECTROLYTIC DETECTOR."
Now \$1.25



1/2 K. W. Transformer.
Now \$2.00



45¢



10¢

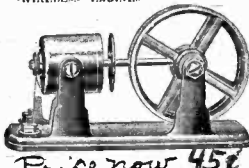

Price now 45¢



THE "ELECTRO" 1/2 K. W. TRANSFORMER-COIL.
(100 MILE WIRELESS COIL)



Now 80¢

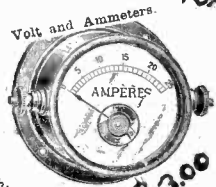

Volt and Ammeters.
Now \$3.00

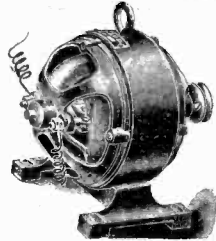

"Electroport" Dynamo.
Price now \$3.70

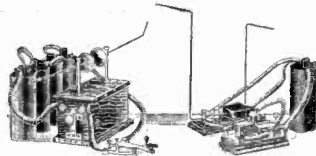

The "TELEMO" Wireless Telegraph.
Now \$7.70



Now \$1.50
Telimco.

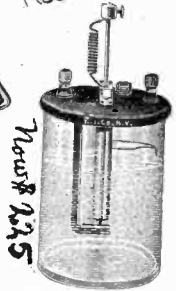

Now \$2.25
ELECTROLYTIC INTERRUPTER.
PATENTS PENDING.

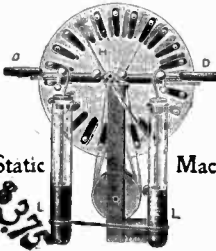

Static Machine.
\$3.75

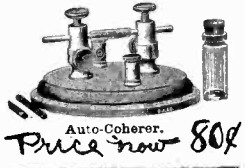

Auto-Coherer.
Price now 80¢



Geissler Tubes.
20¢ UP



35¢

Now \$3.00
with one of our Batteries.
\$3.25 with one of our Batteries.

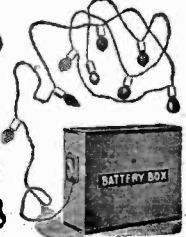

Christmas Tree Outfit.

IMPORTANT NOTE—For the convenience of our New York City and Suburban Patrons, our Retail Store at 69 West Broadway (near Chambers Street), will be open until 10 P.M., beginning December 15th up to December 24th.

MAY WE Send You Free Samples

*To Prove That You Can Artistically Color and
Finish Any Kind of Wood About the Home*

YOU can produce any desired shade and effect. The expense is slight—the work easy and simple. First apply Johnson's Wood Dye—made in 14 shades as listed below. Over the Dye lightly apply Johnson's Prepared Wax—and you have a beautiful, rich, subdued finish that will not mar or show scratches.

Johnson's Wood Dye must not be confused with colored varnishes or stains, which merely coat the surface of the wood hiding the grain beauty. Johnson's Wood Dye is not a mere stain—not merely a surface dressing—it is a deep-seated dye which goes to the very heart of the wood and stays there, fixing a rich and permanent color.

JOHNSON'S WOOD DYE

is made in 14 attractive shades, as follows:

No. 126 Light Oak	No. 140 Manilla Oak	No. 130 Weathered Oak	No. 122 Forest Green
No. 123 Dark Oak	No. 110 Bog Oak	No. 131 Brown Weathered Oak	No. 172 Flemish Oak
No. 125 Mission Oak	No. 128 Light Mahogany	No. 132 Green Weathered Oak	No. 178 Brown Flemish Oak
	No. 129 Dark Mahogany	No. 121 Moss Green	

Pints, 50 Cents Each

JOHNSON'S PREPARED WAX

dries quickly over dye or any other finish so that it may be brought to a beautiful, dull, artistic finish. It should be used for all woodwork, floors and furniture including pianos and is just the preparation for Mission furniture.

JOHNSON'S UNDER-LAC

is not a common varnish, but a thin, plastic spirit preparation superior to shellac or ordinary varnish, and is to be used over Wood Dye where a higher gloss than a wax finish is desired, drying hard in half an hour. Best preparation for linoleum and oilcloth, bringing out the pattern as glossy as new. Gallons, \$2.50—smaller sizes down to half pints.

Fill out the coupon for free samples and booklet

S. C. JOHNSON & SON

"The Wood Finishing Authorities"

RACINE, WISCONSIN



FREE SAMPLE COUPON

Please send me free samples of Wood Dye, Shade No. Prepared Wax and Under-Lac—also Booklet. If samples are found satisfactory will ask my dealer to supply me

Name.....

Address.....

M. E. 12.....