

D.R.S.G. FOOD

# ELECTRICAL COMMUNICATION

*Technical Journal of the  
International Telephone and Telegraph Corporation  
and Associate Companies*

•

INTELEX RESERVATIONS FOR PENNSYLVANIA RAILROAD  
RADIO PROVIDES COMMUNICATION TO ERIE RAILROAD TRAINS  
TELEGRAPH SYSTEM PLANNING  
CARRIER TELEGRAPH SYSTEM USING FREQUENCY MODULATION  
MULTICATHODE GAS-TUBE COUNTERS  
DESIGN OF SINGLE-FREQUENCY PHASE-SHIFTING NETWORKS  
2n-TERMINAL NETWORKS FOR CONFERENCE TELEPHONY



Volume 27

SEPTEMBER, 1950

Number 3



# ELECTRICAL COMMUNICATION

Technical Journal of the  
INTERNATIONAL TELEPHONE AND TELEGRAPH CORPORATION  
and Associate Companies

H. P. WESTMAN, Editor

F. J. MANN, Managing Editor

J. E. SCHLAIKJER, Editorial Assistant

## REGIONAL EDITORS

E. G. PORTS, Federal Telephone and Radio Corporation, Clifton, New Jersey  
B. C. HOLDING, Standard Telephones and Cables, Limited, London, England  
P. F. BOURGET, Laboratoire Central de Télécommunications, Paris, France  
H. B. WOOD, Standard Telephones and Cables Pty. Limited, Sydney, Australia

## EDITORIAL BOARD

H. Busignies	H. H. Buttner	G. Deakin	E. M. Deloraine	W. T. Gibson	Sir Frank Gill
W. Hatton	E. Labin	A. W. Montgomery	Haraden Pratt		G. Rabuteau
T. R. Scott	C. E. Strong	A. E. Thompson	E. N. Wendell		W. K. Weston

Published Quarterly by the

## INTERNATIONAL TELEPHONE AND TELEGRAPH CORPORATION

67 BROAD STREET, NEW YORK 4, NEW YORK, U.S.A.

Sosthenes Behn, Chairman

William H. Harrison, President

Charles D. Hilles, Jr., Vice President and Secretary

Subscription, \$2.00 per year; single copies, 50 cents

Electrical Communication is indexed in Industrial Arts Index

Copyrighted 1950 by International Telephone and Telegraph Corporation

Volume 27

September, 1950

Number 3

## CONTENTS

INTELEX IMPROVES RESERVATION SYSTEM OF PENNSYLVANIA RAILROAD .....	171
RADIO PROVIDES DIRECT COMMUNICATION TO ERIE RAILROAD TRAINS .....	173
TELEGRAPH SYSTEM PLANNING .....	175
<i>By E. P. Bancroft</i>	
CARRIER TELEGRAPH SYSTEM USING FREQUENCY MODULATION .....	205
<i>By J. L. Jaitlow and B. B. Mahler</i>	
MULTICATHODE GAS-TUBE COUNTERS .....	214
<i>By G. H. Hough and D. S. Ridler</i>	
DESIGN OF SINGLE-FREQUENCY PHASE-SHIFTING NETWORKS .....	227
<i>By L. G. Fischer</i>	
THEORY OF $2n$ -TERMINAL NETWORKS WITH APPLICATIONS TO CONFERENCE TELEPHONY .....	231
<i>By Vitold Belevitch</i>	
IN MEMORIAM	
GEORGE H. NASH .....	245
KENNETH E. STOCKTON .....	246
RECENT TELECOMMUNICATION DEVELOPMENTS	
DUBLIN-CORK TELEPHONE CABLE .....	204
ANTENNA FOR OMNIDIRECTIONAL RADIO RANGE .....	230
CONTRIBUTORS TO THIS ISSUE .....	247







*Courtesy of Copperweld Steel Company*

**Outside plant for a long-distance telegraph or telephone system is typified by the cross-country pole line.  
A paper on the over-all planning of telegraph systems will be found on page 175.**

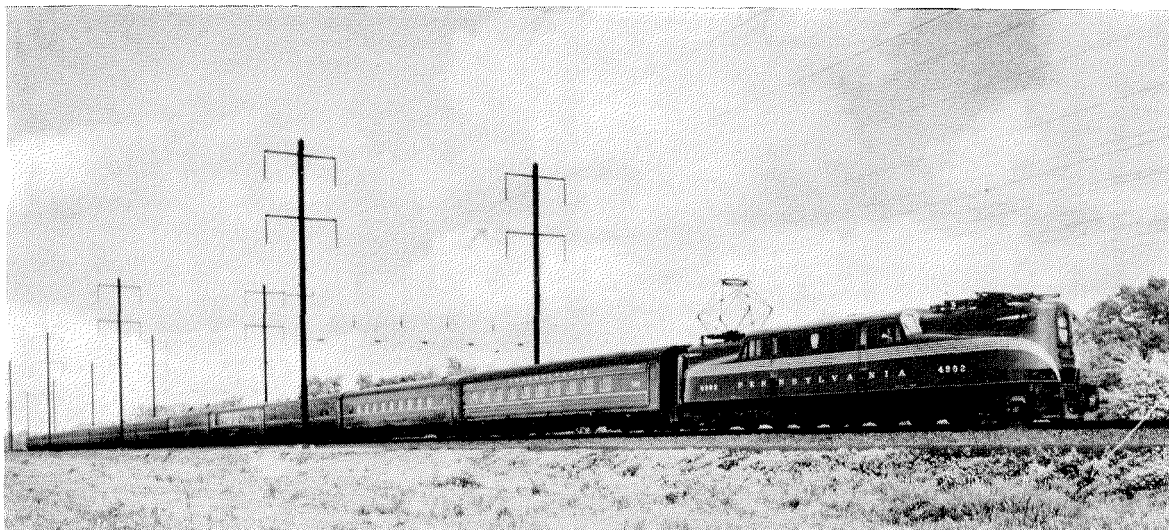

## Intelix Improves Reservation System of Pennsylvania Railroad

**R**ESERVATION of space on trains can be a time-consuming and, hence, expensive process to both the traveler and the railroad. A great deal of thought has been given to making it a quick, reliable, and simple procedure, and there has recently been installed for the Pennsylvania Railroad a new system based on Intelix<sup>1</sup> equipment, modified to meet the particular requirements of railroading. This initial installation in Pennsylvania Terminal in New York City, the largest reservation bureau in the world, now handles all reservations for the seven daily trains to Chicago from New York City and Newark, New Jersey.

Getting information to the ticket clerk on what space is still available on each train is one of the most serious problems. At the present time, this is done by having the ticket clerk telephone the reservation bureau where the diagram cards for each car in the train are checked for the desired space.

With Intelix, the ticket clerk dials a code number and listens to a voice, magnetically recorded, that informs him of all the space available on the train in which he is interested.

Whenever the last unit of a given type of accommodation has been reserved or if a cancellation opens a previously filled type, a new "availability" broadcast record is prepared to replace the current one. Any number of ticket clerks can listen to the broadcast simultaneously and information on any train for 60 days ahead can be checked by dialing the appropriate code number.

To make a reservation, the ticket clerk sends a short coded message by teleprinter to the space-control unit of the reservation bureau. The code directs the message automatically to the proper file cabinet and slides out onto a counter a tray holding the diagram cards for the designated train so that the operator may record the reservation. After making the reservation, the space-control operator adds to the teleprinted request message the space and car numbers and the entire message is retransmitted to the ticket clerk as a confirmation that the reservation has been made. As both the request and confirmation are in the form of printed messages, the probability of errors will be small.

If the request for space was telephoned directly to the reservation bureau, the space-control operator will send a confirmation message to any

<sup>1</sup> J. D. Mountain and E. M. S. McWhirter, "Intelix—Automatic Reservations," *Electrical Communication*, v. 25, pp. 220–231; September, 1948.

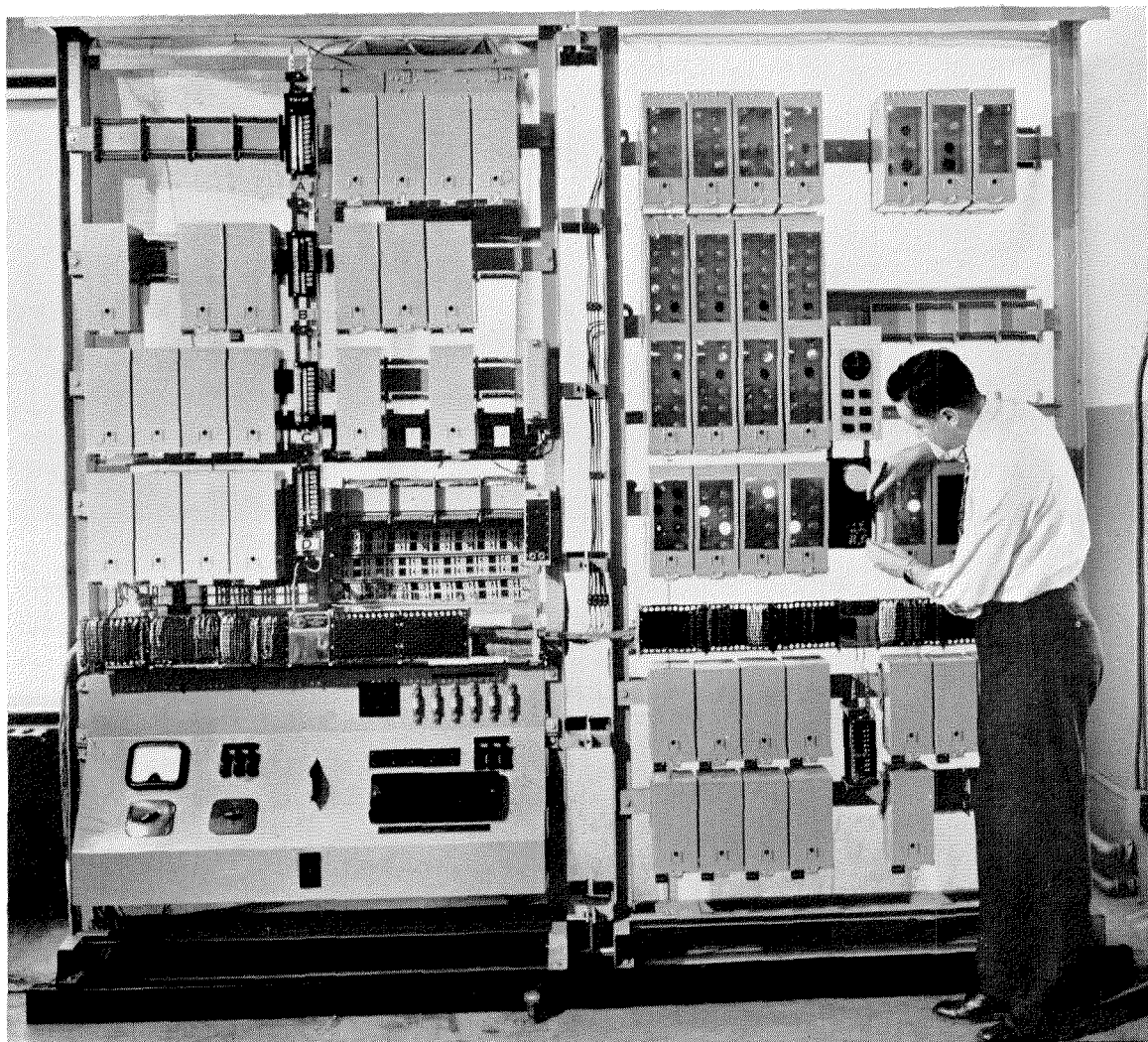

Utilizing principles and elements of machine telephone switching, magnetic recording, printing telegraph, and automatic bookkeeping, this equipment comprises about a sixth of the present Intelix installation used by the Pennsylvania Railroad for making reservations on its New York-Chicago passenger trains.

ticket office selected by the patron, where it will provide all the necessary information to permit the ticket to be issued. Formerly, the ticket clerk had to call the reservation bureau to confirm the reservation before making out the ticket.

Developed and installed by the International Standard Trading Corporation, an associate of

the International Telephone and Telegraph Corporation, this Intelix system will be extended progressively to the principal cities served by the Pennsylvania Railroad. It is estimated that with Intelix the time required on the average for making a reservation will be only a third of that now needed.



## Radio Provides Direct Communication to Erie Railroad Trains

OVER the past several years, the Erie Railroad, which provides freight and passenger service between New York City and Chicago, has been actively engaged in extending its wire-line communication network to moving trains through the use of mobile radio equipment.

There are four types of service encompassed by its recently installed radio system. First, is a communication path between the locomotive and the caboose of a train. Formerly, the conductor in the caboose had to depend on hand or lantern signals to notify the engineer of any undesirable condition.

A curving right-of-way, fog, or similar condition could disable this signaling system and the conductor would be compelled to open an air-brake valve if it were necessary to halt the train. The interest of the engineer in keeping the train in motion and that of the conductor in stopping it frequently resulted in broken knuckles and drawbars.

A second service is communication between trains. This enables crews to inform each other of any unusual conditions noted when their trains pass on parallel tracks.

The third provision is for direct communication between a moving train and the dispatcher. The dispatcher has charge of a division, which is approximately 100 miles of route, and transmits his orders over a "party-line" wire telephone circuit connecting all important way stations and signal towers. With radio, his circuits are extended to the moving train itself through the way station nearest the train.

A fourth use is effective in emergencies when, due to weather or other conditions, the party line fails. Radio will bridge gaps in the wire-line system and will provide service until repairs have been completed.

Over a route of almost 900 miles, which is about 85 percent of the Erie system, there are 50 wayside transmitting stations spaced between 6 and 30 miles apart. The topography being quite

varied, the specific location of each transmitter was determined by testing between a portable equipment set up along the way and a locomotive. The strength of the signal from the locomotive was noted as it passed each milepost so that the point at which two-way communication became unsatisfactory was readily established. Wayside transmitters

The diesel-locomotive engineer uses a telephone handset with a push-to-talk switch to communicate by radio with the conductor of the train, with the nearest way station, or with the crew of another train.

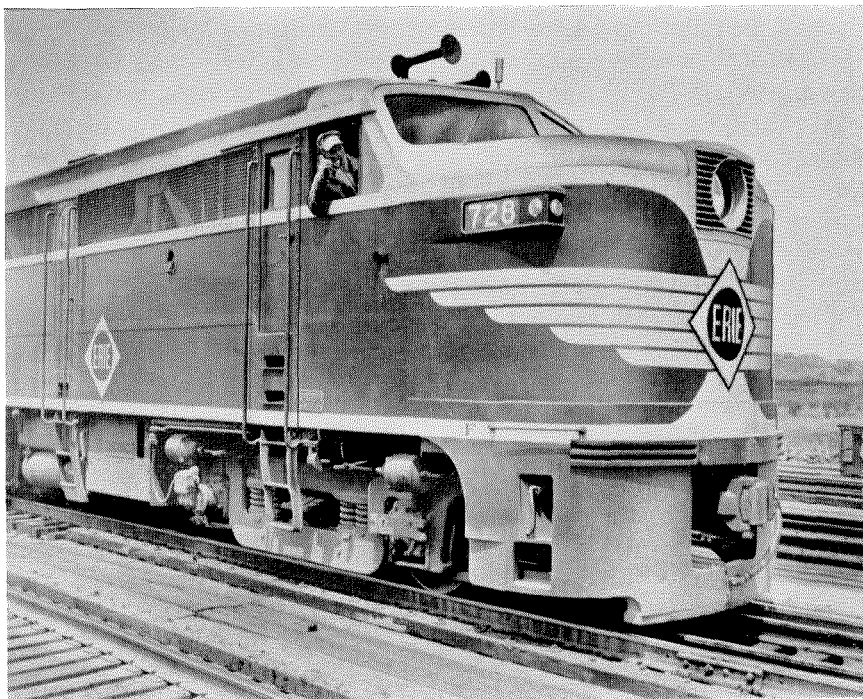

were then arranged to have adequate overlap of their radiated fields.

These base-station transmitters develop about 20 watts of power at 160.05 megacycles. They are controlled from the 24-hour wayside offices and some are connected to these offices by 175-kilocycle inductive systems using existing wayside wires for propagation.

There are 161 mobile units that normally operate on the same frequency as the base stations but which may be shifted to an adjacent channel to provide a second communication path. They are automatically retuned to the regular channel when the handset is hung up, thus insuring that all receivers will

normally monitor the main channel. Installations in diesel locomotives account for 119 of the mobile units and the remaining 42 are in cabooses.

Frequency modulation is used to insure a satisfactory signal-to-noise level under conditions that often produce high noise fields. All radio equipment is made up of plug-in units to permit immediate replacement in the field; the defective unit is sent to a central radio shop for repair. Power for the caboose installations is derived from axle-driven generators and converters.

Early in 1947, the Erie Railroad invited Cape-



A freight-train conductor, while sitting in the cupola of his caboose, may speak by radiotelephone directly to the engineer of his train, to the crew of a passing train, or to the division dispatcher through the nearest way station.

hart-Farnsworth Corporation, associate company of the International Telephone and Telegraph Corporation, to assist it in making the extensive tests required for the planning of a practical radio system and to develop and manufacture equipment capable of meeting the severe and exacting conditions encountered in railroading. This venture in cooperation has produced a communication system that fulfills all the requirements of the railroad and is based on equipment that is economical to manufacture and service.

# Telegraph System Planning

By E. P. BANCROFT

*International Telephone and Telegraph Corporation, New York, New York*

**E**SSENTIAL information is given to enable field engineers to make sound fundamental plans for modern national and private-line telegraph systems and to select equipment best suited for each specific application.

. . .

Historically, telegraph systems were, and in many cases still are, based on single-wire ground-return circuits. Where long circuits were involved, economy dictated the use of apparatus and operating methods that would permit maximum traffic to be moved over each circuit. Multiplex systems, such as the Baudot and Murray, operated duplex, produced economies over earlier methods but still left the circuit and associated equipment costs as a substantial portion of the total message-handling costs. Increasing labor and material costs in recent years have emphasized the need for further improvement of efficiency. It is, therefore, of utmost importance that changes and improvements in telegraph systems be undertaken only after sound fundamental plans have been made.

## 1. Basic Considerations

The telegraph, as contrasted with the mail, may be classed as an emergency service and has for its principal stocks in trade speed, accuracy, and convenience. Systems may be classified generally under three main headings.

- A. Public message systems.
- B. Private-line systems.
- C. Intercommunicating systems.

### 1.1 PUBLIC MESSAGE SYSTEMS

Public message systems are generally national in scope and frequently include international connections. With dispatch and efficiency, messages in record form are collected from and delivered to members of the general public

located in any two places in the system. To perform such a function well, circuits must extend to practically every place in the nation.

### 1.2 PRIVATE-LINE SYSTEMS

Private-line telegraph systems are used to interconnect main and branch offices, factories, and similar elements of a business. The customer operates the terminal equipment and is responsible for all phases of traffic handling. The circuit facilities are normally leased from the national system although in special cases they might be privately owned.

### 1.3 INTERCOMMUNICATING SYSTEMS

Intercommunicating systems may be confined to a single locality such as hotels, manufacturing plants, or government offices or they may be nationwide wherein any subscriber to the service may communicate directly with any other subscriber. In the smaller private systems, the user commonly owns and operates the system. A nationwide service, however, is usually furnished in much the same manner as telephone service. A national company furnishes the facilities and does the switching while the customer does the operating.

## 2. Quality of Service

Telegraph traffic, as is well known, does not originate uniformly. The volume varies widely from hour to hour, day to day, and season to season. Since this traffic deals largely with commercial affairs, the volume naturally reflects business activity primarily. The facilities needed will be governed largely by the average volume in messages per time unit and the degree to which delays may be introduced during peak traffic periods.

The quality of service desired by customers varies. Most commercial and social traffic may be considered as being handled satisfactorily if



messages are delivered in not more than 30 minutes from the time they are received from the customer. Deferred low-rate traffic may be delayed for much longer periods. On the other hand, messages dealing with buying or selling of commodities, stocks, and bonds on exchanges or

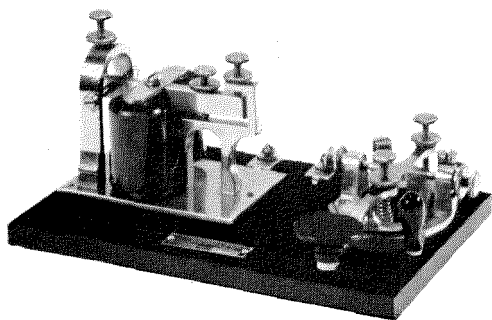

The hand key and sounder have symbolized manual operation over the years.

boards of trade usually require fast handling. Delays in delivery of only a very few minutes frequently give rise to complaints of poor service. Accordingly, in planning a public message system, one of the early decisions that must be taken concerns the quality of service to be rendered.

The classes of traffic the system will be designed to handle must be determined so that a standard of service quality or "speed of service" for each class may be set.

Two other standards must be considered, namely, accuracy and reliability. Accuracy standards are extremely important in public message telegraph systems and determine to a large extent the amount and kind of training and supervision of operating personnel. Reliability, on the other hand, is reflected largely in the type of equipment and outside plant construction and to the extent spare equipment and alternative facilities are provided. This standard will naturally be flexible since the degree to which failure of a piece of equipment or a circuit will influence operation of the entire system is not the same in all cases.

### 3. Traffic Studies

A thorough knowledge of the traffic to be handled is a prerequisite to making sound

fundamental plans for any telegraph system. The basic information is frequently not available and must be gathered through traffic studies. These studies should cover a sufficient period of properly selected time to insure that the data obtained cover representative conditions. Further, the data collected for all stations should cover the same period of time. Studies for this purpose involve considerable work but are not difficult if it is kept in mind that the information sought is the amount of traffic originating at each place in the system and destined for each other place and the rate at which the business originates.

In existing public message systems, this origin and destination study usually can be made by selecting from the files for each office all messages originating at that office for the period covered by the study. These messages are sorted according to destination and arranged by time of filing. A tabulation is then made showing for each time period and for each destination the number of messages and of words filed. At stations where messages are retransmitted, all messages received from another station for retransmission to a third station must be excluded from this tabulation. If different classes of messages such as urgent, ordinary, and deferred are handled, then the tabulation should be further divided to show this information.

This basic traffic information should be collected and collated for ready reference since it is these data that serve as the starting point for determining facilities requirements and general plant arrangements.

When private-line systems are being planned, actual traffic data may not be obtainable. In such cases, estimates will have to be made of the probable traffic originating at each location. It may even be necessary to indicate types of traffic that could be handled advantageously by the proposed system to develop a complete estimate of probable traffic loads.

The establishment of a nationwide switched telegraph system for private-customer use requires reliable estimates of the number of potential customers in each place and the extent of use of such a service. Here, it is the number of calls and the length of time for each call that is of particular significance. In this connection, experience indicates that teleprinter calls follow

very closely the pattern of toll telephone traffic, particularly as to holding time or length of call. Thus, in collating and evaluating traffic statistics in terms of facility requirements, the same procedures are followed as are in common use in the toll telephone field.

It should be obvious that the final analysis of the traffic data should be based on a knowledge of the type of equipment and methods of operation that are contemplated in the final system. However, before deciding on the equipment and system to be adopted, preliminary studies of traffic statistics should be made to obtain an over-all picture of the problem. For example, it is desirable to know the principal offices at which traffic originates, their relative location, and the volume of traffic between each pair of them. This can be easily done by indicating on an outline map the location of the main traffic centers and either directly on the map or in tabular form the daily volume of traffic between each pair of them, using as a preliminary figure only the originating traffic at each center. The secondary traffic, originating at offices contiguous to these main centers and which would normally pass through them, can be determined and added to the principal traffic when the system layout takes a more complete form.

#### 4. System Selection

##### 4.1 GENERAL

Having analyzed the basic traffic data to the extent of determining the probable major centers of the system, it is next necessary to select the method of operation through which the required quality of service can be given most economically. However, before proceeding with the selection of operating methods, it is considered pertinent to discuss in general terms some of the tools that are available for incorporation in the modernized system as well as some cost factors that may well determine the final selection.

##### 4.2 PRINTER DEVELOPMENT

The first important advancement in automatic operation was the introduction of the Hughes printing telegraph system. This system employed a piano-type keyboard with a key for

each letter and a recorder that printed the message on a narrow paper strip that could be glued to the message blank for delivery. This was followed by the Baudot multiplex system (and later the Murray multiplex), which permitted operation on a time-sharing basis of a number of printers over a single circuit.

Experience with multiplex systems brought to light one of the basic principles in economic telegraph operation, namely, that maximum personnel efficiency is obtained when individual traffic channels are operated at a speed that does not exceed that of a single transmitting operator or a single receiving operator.

Experience has shown that the maximum sustained speed for experienced top-grade operators using modern typewriter-like keyboards ranges between 70 and 75 words per minute. Multiplex equipment using 4 channels in each direction (duplex) and operating at 75 words per minute is thus capable of handling traffic over a single artery at 600 words per minute or, roughly, 1200 messages of 30 words each per hour.

Probably the most important step in telegraph-equipment development was the perfection of the modern teleprinter, which combines in a single unit a typewriter-like keyboard transmitter and

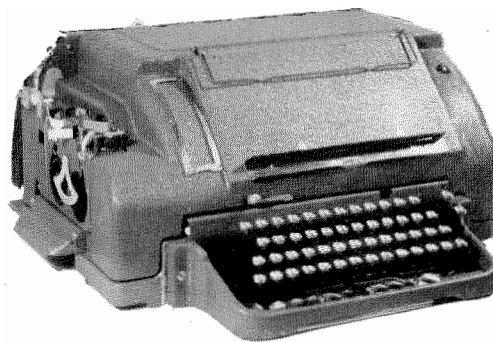

Automatic telegraph operation is based on the modern teleprinter.

either a tape or a page printing recorder. Present-day units are capable of sustained operation at speeds of 100 words per minute although the common operating range is from 60 to 75 words per minute. These machines can be connected so as to provide a home record or the connections may be split to provide independent transmitting and recording operation.

### 4.3 TRANSMISSION DEVELOPMENTS

#### 4.3.1 General

Paralleling advances in transmitting and receiving apparatus for telegraph systems has been an equally important development in transmission facilities, namely, the multichannel voice-frequency carrier telegraph system. With single-wire ground-return circuits, it was possible to utilize only a small portion of the available frequency spectrum for the transmission of telegraph signals because of external interference (power induction and cross talk from adjacent circuits, particularly at higher frequencies) and wide transmission variations under changing weather conditions. Voice-frequency carrier telegraph systems, on the other hand, operate over metallic circuits, which are more stable and can be rendered substantially free from external interference.

Voice-frequency carrier telegraph systems can be operated over any stable circuit suitable for high-grade telephone service. Thus, this system can be applied to physical voice circuits or voice circuits derived through the application of single or multichannel carrier telephone systems. Standard voice-frequency carrier telegraph systems provide up to 18 full-duplex telegraph channels over a single 4-wire telephone circuit. Carrier telegraph systems can be extended to 24 channels if the telephone circuit is of sufficiently high quality.

Single-channel, 3-channel, and 12-channel carrier telephone systems are available and in combination will provide up to 16 telephone circuits over a single open wire pair. By applying a 3-channel and a 12-channel carrier telephone system to a single pair of wires and superimposing voice-frequency carrier telegraph on the physical telephone circuit as well as on all 15 carrier telephone circuits, as many as 350 duplex telegraph circuits can be obtained.

Operation of voice-frequency carrier telegraph on 2-wire physical telephone circuits requires the use of different frequencies for the two directions of transmission. For this reason, only 8 duplex carrier telegraph channels are normally obtainable over a physical telephone circuit passing frequencies up to about 2750 cycles per second. If the frequency band extends to 5000 cycles, then by employing special modulating equip-

ment the full 18 channels of a normal voice-frequency system may be obtained.

Open-wire carrier telephone systems employ different frequency bands for voice transmission in opposite directions thereby providing the equivalent of 4-wire voice circuits. For this reason, a full 18-channel voice-frequency telegraph system can be operated over each carrier telephone channel. In the standard 12-channel open-wire or cable carrier telephone systems, the voice band transmitted is sufficiently wide to permit up to 24 voice-frequency telegraph channels to be operated on each of the 12 telephone channels.

#### 4.3.2 Radio for Telegraph Circuits

##### 4.3.2.1 General

Radio has long been used for telegraph communication between places so situated that the construction of lines is either impossible or impracticable. Recent advances in radio techniques have greatly increased the field of application and materially improved the reliability of radio circuits. Modern radio links may be used in much the same manner as other types of circuit links in a coordinated communication system. However, account must be taken of the susceptibility of some radio circuits to fading, noise, and, in certain cases, total failure during severe magnetic storms.

The problem from a system-planning point of view may be considered from two angles, namely:

- A. Provision of service to isolated places where one or several circuits may be required to handle the traffic.
- B. Provision of main trunk circuits.

##### 4.3.2.2 Service to Isolated Places (*Point to Point*)

For service to isolated places, radio circuits in the high-frequency band (3 to 30 megacycles) are usually employed and normally provide a single transmission channel varying in bandwidth according to the intended service.

The radiotelegraph transmitters, particularly when intended for printer operation, should employ frequency-shift modulation as this provides essential protection against noise interference as well as greatly improved performance under fading conditions. Such circuits can handle a single teleprinter channel, or by the application



of time-division multiplex (Baudot) up to 4 teleprinter channels.

Where more than 4 traffic channels are needed, requirements can be met by using radiotelephone transmitters and modulating with up to 24 channels of voice-frequency carrier telegraph.

#### 4.3.2.3. *Main Trunk Circuits*

Main trunk-line circuits can be provided by radio systems operating in the ultra- and super-high-frequency bands (300 to 30,000 megacycles). These systems are essentially broad band and, when necessary, employ repeaters located at

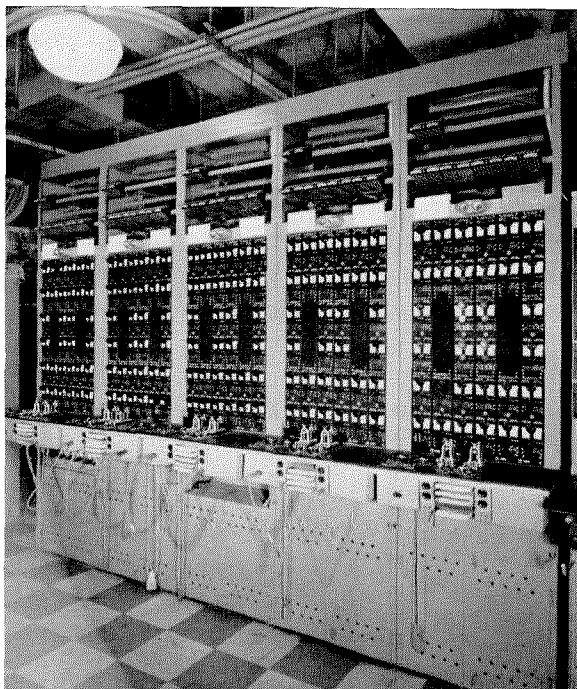

Voice-frequency carrier telegraph installation in a modern Western Union Telegraph Company office. Each vertical rack of carrier equipment (left) mounts 8 channels. The test board is at the right.

For this purpose, single-sideband transmission provides important advantages from the standpoint of bandwidth and signal-to-noise ratio at the expense of some increase in equipment costs.

These types of equipment are adapted for point-to-point operation and can be expected to give reliable service under most conditions. The type and power of the equipment, radiating system, and choice of transmission frequencies will depend on the distance between stations and the intervening topography. For line-of-sight or slightly greater distances, equipment operating in the very-high-frequency band (30 to 300 megacycles) may be employed and as many telegraph channels as may be required can be provided by superimposing voice-frequency carrier telegraph on radiotelephone links.

line-of-sight intervals between terminals. Highly directive antennas result in little, or no, interference between systems even where the same frequencies are used. Multichannel operation is obtained by dividing the broad band on a time or frequency basis.

There are a number of systems employing time division, the two most prominent being referred to as pulse-time modulation and pulse-code modulation. A pulse-time-modulation system has been developed to provide up to 23 telephone channels, each suitable for carrying up to 24 voice-frequency carrier telegraph channels or a total capacity of 552 telegraph channels. It is relatively economical to drop one or more telephone channels at a repeater point. Pulse-code-modulation systems are still in the development

stage and, while promising results have been obtained, are not yet available for general application.

Systems employing frequency division use much the same technique as is used to obtain multichannel operation on coaxial cables. The frequencies from a basic group of channels, say 12, are combined by modulation with other basic groups to form supergroups and these supergroups are again combined to form the broad band of frequencies transmitted over the radio link. Dropping individual telephone channels at intermediate repeater points is not a simple matter so this type of system is not well adapted to obtaining telegraph channels except at terminals. Each of the telephone channels is suitable for superimposing thereon up to 24 voice-frequency carrier telegraph channels. Thus the total telegraph circuit capacity of such a system is 24 times the number of telephone channels provided.

#### 4.4 CIRCUIT COSTS

##### 4.4.1 General

Individual circuit costs in any comprehensive telegraph network will vary greatly depending to a large extent on the circuit density on any given route. On routes having but a single circuit, or at most two or three, circuits will be relatively costly while on routes having many circuits the cost per circuit will be much lower. Method of operation, i.e., ordinary duplex on physical wires, multiplex, voice-frequency carrier, and radio, also will materially influence costs.

##### 4.4.2 Wire-Plant Costs

In the curves that follow, relative costs are given rather than actual costs since the latter may vary considerably with labor and material costs, in difficulties of construction, taxes, and in other

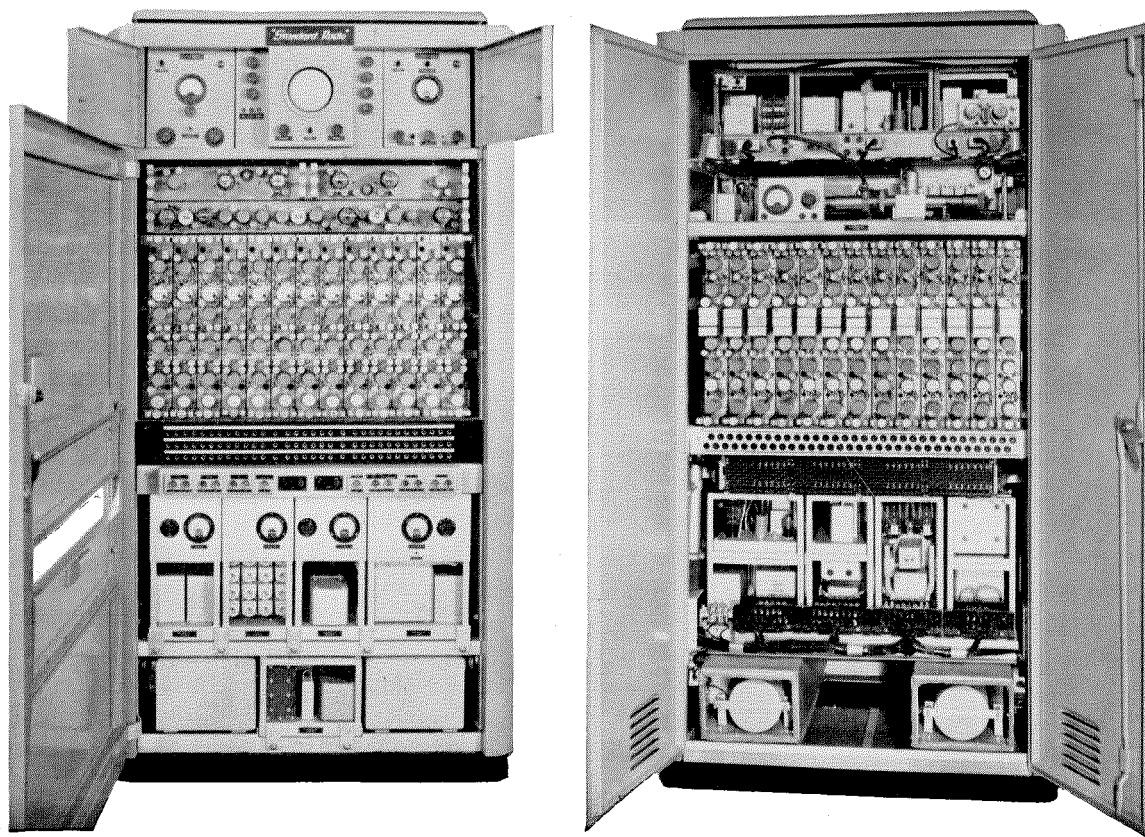

Transmitter and receiver cabinets of an ultra-high-frequency time-division-multiplex radio link supplying 24 telephone channels. This equipment may be set up to give over 500 teleprinter circuits.

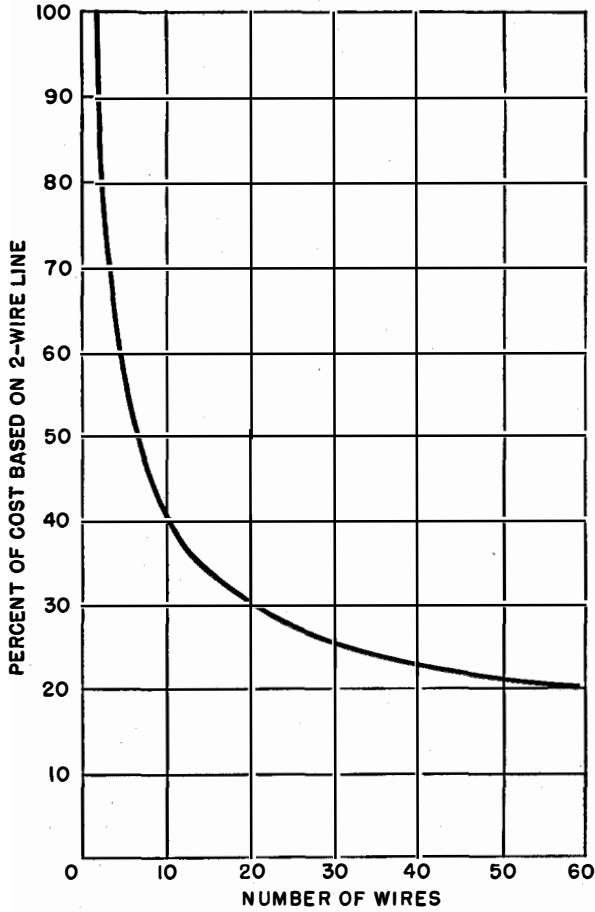

Figure 1—Relative cost per wire for a line having between 2 and 60 conductors of 0.104-inch copper based on the cost per wire of a 2-wire line.

ways. Right-of-way and real-estate costs are not included. However, for any given territory the relations shown should hold with sufficient accuracy to permit selection of the most economical arrangement.

4.4.2.1 Line Costs

Figure 1 shows the effect of the number of conductors on the cost per unit length of line using the cost per wire of a 2-wire line as the basis of comparison. All costs for labor and materials for the various sizes of line constructed under average conditions have been included. The cost of construction is for new high-grade lines suitable for carrier operation and built to withstand a load of 0.25 inch of ice and an 8-pound wind (medium loading). This curve shows clearly the economies to be realized in cost per unit length of wire as the number of wires is increased.

4.4.2.2. Line and Equipment Costs

The curves of Figure 2 show the effect on the cost per unit length of telegraph circuit of increasing the number of circuits on the same route for three methods of operation and for circuit lengths between 125 miles (201 kilometers) and 1000 miles (1610 kilometers). The cost of 2 duplex circuits operated on physical

Figure 2—Comparative initial cost per circuit-mile using three types of transmission equipment over distances between 125 and 1000 miles. Two-circuit duplex operation over physical wires is the basis of the comparison. The curves are - · - · duplex on physical wires; - - - - multiplex (with extension arms) on physical wires; and — voice-frequency carrier telegraph plus carrier telephone.

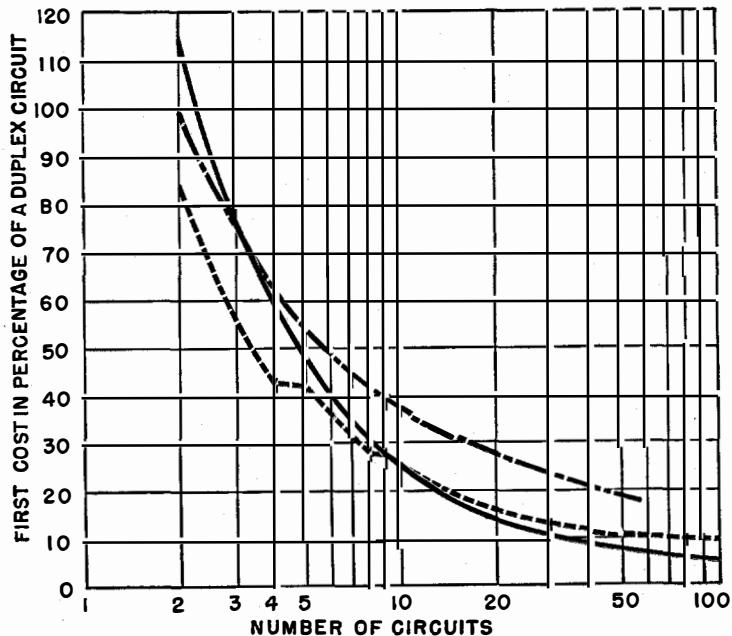



wires 125 miles long has been used as the basis of comparison. The plant is assumed to be used solely for telegraphy and the three methods of operation are

- A. Ordinary duplex on physical wires.
- B. Duplex multiplex (Baudot) on physical wires.
- C. Voice-frequency carrier telegraph on physical or carrier-derived telephone circuits.

These curves represent practical conditions and include a minimum of 5 percent of spare wire facilities to meet possible failures, as well as transmission, test, and power equipment, plus the cost of the wire lines. Where few circuits are required, the percentage of spare wire facilities exceeds 5 percent as a minimum of one spare wire, or one spare pair of wires, is provided in all cases. This procedure has naturally raised the cost for small groups considerably but is justified as insurance against possible circuit failures.

The cost of floor space and associated operating equipment has not been included, as these requirements may be taken as substantially the same for all three methods of operation. In the case of multiplex operation, it has been assumed all multiplex channels will be operated with teleprinters through the use of extension arm equipment. Floor space requirements will probably favor carrier telegraph operation.

Figure 3 shows the comparative first cost per telegraph circuit mile on a slightly different basis from the curves of Figure 2. In Figure 3, only the costs of the actual working transmission equipment and circuit facilities have been considered; the costs of the pole line and all spare equipment and circuit facilities have been excluded. The sawtooth appearance of the multiplex curves results from the fact that multiplex transmission equipment for one channel costs almost as much as for four channels and an additional line circuit is needed for each additional four channels or fraction thereof. Voice-frequency carrier, on the other hand, because a large number of channels can be provided over a single pair of wires, shows a decreasing cost as the number of channels is increased. For one circuit, an ordinary duplex circuit will cost least. For 2 to 4 circuits, multiplex will be least expensive. Above 4 circuits, voice-frequency

carrier telegraph has an advantage that increases with the number of circuits. These comparisons are of particular interest where a pole line is already in service and additional circuits are required but cannot be obtained from existing wires.

These curves show clearly the substantial savings that can be realized through the use of modern equipment, particularly where large numbers of circuits are required. When first costs are equal or nearly so, carrier systems should be preferred because of their greater flexibility, ease of later expansion, better stability of operation, higher-quality transmission, and markedly lower costs of operation and supervision.

It should be pointed out, however, that both the multiplex and the carrier telegraph systems are suitable principally for through circuits as it is neither easy, nor economical, to have access to individual channels at intermediate points. This means that for circuits to intermediate traffic points along routes connecting principal traffic centers, physical wire circuits will usually meet requirements best although in some cases combinations of short-haul carrier systems and physical circuits may prove economically sound.

Other factors being equal, the cost of maintaining open wire lines will increase with the number of conductors. Conversely then, the system that requires the fewest wires for a given number of telegraph channels will have the smallest charges for line maintenance. Viewed from this angle, the general methods of operation referred to in Figure 2 are to be preferred in the same order as shown on the initial-cost curves. Thus, up to 8 circuits, multiplex requires fewer wires than physical duplex or voice-frequency carrier and should therefore be cheaper than either from a line-maintenance standpoint. Between 8 and 12 circuits, multiplex and voice-frequency carrier require the same number of conductors (including spares). Above 12 circuits, voice-frequency carrier has the advantage since only 4 wires are needed to provide as many as 350 circuits.

Experience has shown that, channel for channel, voice-frequency carrier telegraph equipment is least costly to maintain and multiplex most costly. For this reason, carrier operation is generally preferred even when first costs may be slightly greater.

Both physical duplex and multiplex circuits operate in the band of frequencies where transmission is most affected by changing line conditions. In both cases, circuits are operated with ground return and such circuits are seriously affected by induction from other telegraph circuits, by adjacent power lines, and by variations

methods for as few as 3 or 4 circuits and distances as short as 50 or 60 miles.

#### 4.4.3 Radio Plant Costs

Cost comparisons for radio depend on so many variables peculiar to each installation that it is difficult to arrive at general figures similar to

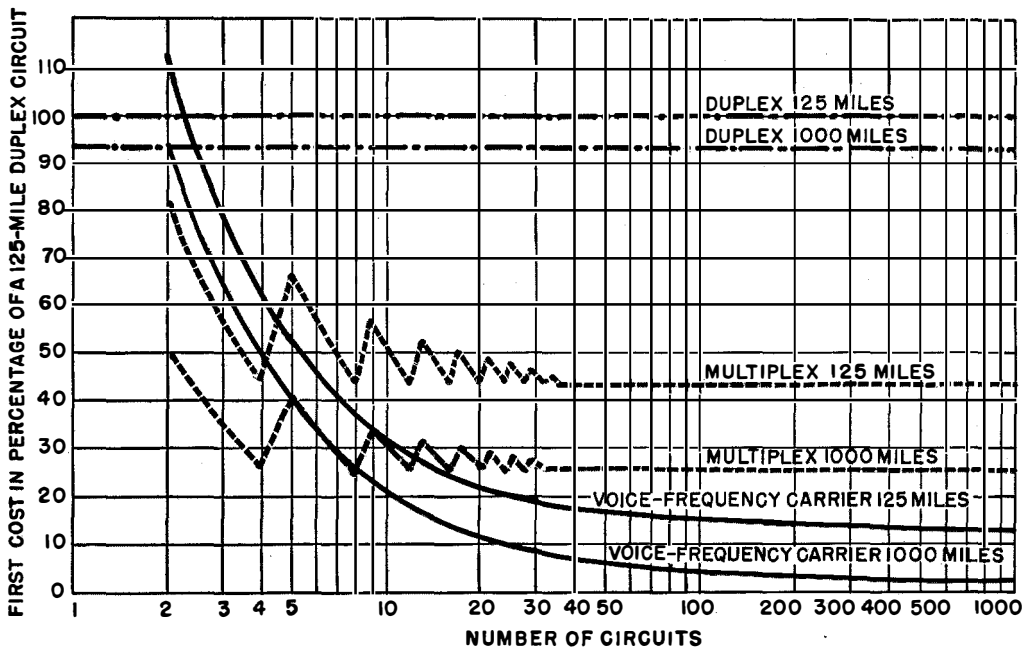

Figure 3—Comparative initial cost per circuit-mile for adding terminal equipment and conductors to an existing pole line, using duplex, multiplex, and voice-frequency carrier systems.

in the earth's magnetism. Close supervision is needed if duplex balances and other essential operating conditions are to be maintained and serious circuit failures avoided. This requires substantial staffs for testing and regulating.

Carrier telegraph circuits, on the other hand, operate on a metallic basis and in the range of frequencies where lines are far more stable under varying weather conditions. The carrier equipment itself is extremely stable. As a result, voice-frequency carrier telegraph circuits operate for long periods of time without attention or failure. Thus, from an operating point of view, carrier operation is both more satisfactory and more economical. In fact, the economies are sufficient to justify carrier operation even when initial installed costs are substantially higher than for other methods. All factors considered, carrier telegraph operation should prove in over other

those presented for wire plant. This is particularly true of the type of service referred to in section 4.3.2. Even for trunk-line circuits, the variables are too great to permit generalization.

Some factors that must be taken into account in determining radio circuit costs are listed below; some of them may vary widely according to local conditions.

- A. Cost of transmitting equipment including housing.
- B. Cost of receiving equipment including housing.
- C. Cost of land for transmitting and receiving stations.
- D. Cost of transmitting and receiving antennas.
- E. Cost of lines connecting transmitting and receiving stations with operating rooms.
- F. Cost of terminal operating equipment.
- G. In the case of microwave trunk-line systems, the cost of repeater stations, including land and buildings; access roads; power, including stand-by power supplies; towers for antennas; and equipment.

It is necessary to determine for each location the cost of these various items as well as the length of the link before the cost per unit circuit length can be ascertained.

#### 4.5 JOINT USE OF FACILITIES FOR TELEGRAPH AND TELEPHONE SERVICES

The curves of Figure 2 show that maximum economies will be realized where large groups of circuits (100 or more) are used. On the other hand, relatively few routes will require so many circuits and the answer is to combine the use of the line with other services such as telephone and broadcasting. As an example, let it be assumed that between two traffic centers 125 miles apart there is need for 18 telegraph channels and 15 telephone circuits. If the telegraph requirements only are to be considered, then the initial cost per channel mile using voice-frequency carrier would be about 15 percent of the initial cost for a physical duplex channel. Now, if the requirements are combined, there would be a total need for 16 telephone channels, 15 for telephone service and 1 to provide 18 channels of carrier telegraph. Only 1/16th of the cost of the line and carrier telephone equipment need be charged against the telegraph circuits. Thus, in effect, the cost of the telegraph circuits would be at the same rate as if the requirement were for 286 telegraph circuits ( $16 \times 18$ ) or 3.0 percent. This is only 1/5th as much as if telegraph requirements alone are considered.

Figure 4 gives curves for circuits of 125 miles (201 kilometers) and 1000 miles (1610 kilometers) in length comparing the initial cost of telephone channels in varying numbers up to 64 when obtained by different methods and using the cost of a physical telephone circuit on a 125-mile 4-circuit line as a basis of comparison. No spare wire facilities are included for the physical telephone circuits, but a minimum of 5-percent spare wire facilities are included for the carrier circuits. Curve C has been carried down to 12 channels to show the effect when only the 12-channel system is utilized. As the number of channels increases, there is a rapid decrease in the cost per channel, particularly when multichannel carrier telephone equipment is employed.

The advantages of combining telephone and telegraph services over common facilities are

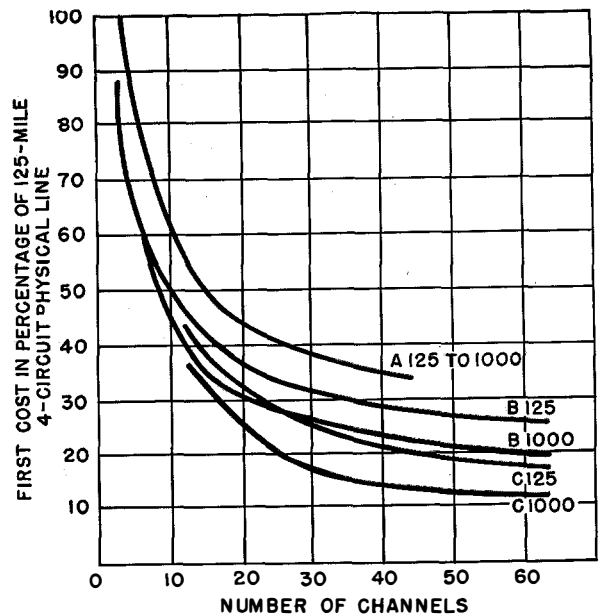

Figure 4—Comparative initial cost per telephone channel-mile for: A, physical and phantom circuits; B, physical plus 3-channel carrier; and C, physical plus 3- and 12-channel carrier, for distances indicated on curves in miles and based on 1 circuit of a 125-mile physical line.

equally apparent in the cases of traffic points contiguous to principal traffic centers. Usually, relatively few telegraph circuits are needed in these cases and can be obtained by simplexing the telephone circuits, the number of which will normally exceed the requirements for telegraph circuits. Where composite or simplex dialing prevents the use of simplex telegraph, it is frequently more economical to employ a short-haul carrier telephone channel and voice-frequency carrier telegraph superimposed thereon than to place additional wires for telegraph purposes only. For distances over about 50 miles, even one telegraph circuit usually can be obtained economically in this manner. If as many as 5 circuits are required, distances as short as 30 miles may justify this method. In cases where duplex telegraph service is necessary, the distances may be as short as 20 miles.

Another alternative sometimes used to provide 1 or 2 telegraph circuits is a special voice-frequency telegraph equipment designed to operate in the upper portion of the voice range on a normal telephone circuit. This equipment is known as speech-plus-duplex and utilizes a frequency range above approximately 2100



cycles for carrier telegraph purposes. The application of this equipment to a telephone circuit deteriorates the speech quality only slightly. It is possible to obtain up to 2 voice-frequency carrier telegraph circuits over each telephone circuit by this method.

The preceding discussion has been directed primarily at first costs of providing entirely new plant. Where an operating plant exists, other considerations enter the picture and may change the final arrangement to some extent, depending largely on the nature of the existing outside and inside plant.

To an overwhelming extent, telegraph systems were developed on the basis of using single-wire ground-return circuits. Only relatively recently has copper begun to replace iron as the conductor. Iron circuits are not suitable for carrier operation and in any modernization program must be replaced by properly transposed conductors of suitable materials such as copper, bronze, or Copperweld. Copper conductors already existing and in good condition can be paired and transposed to fit satisfactorily into the modernized plant. When modernizing a line previously used for nonpaired telegraph circuits, it is frequently necessary to reconstruct portions of the line to obtain pole locations and spacings suitable for properly transposing the line for carrier operation. It is well to keep in mind that a large number of carrier circuits are transmitted over very few wires and these lines must be well built to insure reliable uninterrupted service.

The re-use of inside-plant equipment and layouts will be governed largely by the character of the existing plant and by the basic method of operation adopted. However, unless modern teleprinters, rack-mounted duplex equipment and switchboards, and modern power supplies are already being used, it is safe to say that a very large portion of the existing inside-plant equipment will be found inadequate to meet the requirements of the modernized system.

## 4.6 CHOICE OF OPERATING METHOD

### 4.6.1 *General*

The underlying principle in all telegraph systems is to have each message reach its destination as quickly as possible commensurate with

allowable costs. If all messages could be transmitted over direct circuits from origin to destination and enough circuits were available to handle the heaviest volumes of traffic, very fast service could be given. Obviously it would not be economical in any large network to have direct circuits interconnecting all traffic points. As a result, certain centers, usually main traffic origin and destination points, are established through which messages are relayed or retransmitted.

The number and location of relay centers for the fundamental plan depends significantly on the general method of operation. Three basic methods of operation are available, namely, manual relay, tape relay, and automatic switching.

### 4.6.2 *Manual Relay*

Manual relay refers to the transfer of messages in record form from one circuit to another. In other words, each message is received by an operator and after being checked (words counted to tally with the indicated number) is transferred manually or by conveyor in written or printed message form to the second circuit where it is again transmitted by an operator. Each manual relay, thus, involves the services of two operators as well as means for physically transporting the message from one operating position to the other. This is generally referred to as two handlings.

Operating space requirements are large as an operating position must be provided for each transmitting operator, each receiving operator, and each combined transmitting and receiving operator. In larger offices, belt conveyors, pneumatic tubes, or other means must be provided for transporting messages from one operating position to another through distributing or routing centers.

Operating personnel is likewise large as an operator must be provided for each active position and there must be messengers and numerous supervisors. The number of personnel influences not only operating space but cloak and rest rooms as well. Equipment requirements are heavy as each position must be provided with transmitting or receiving apparatus.

Delays are inherent in the manual system because of the number of operations involved in



Manual teleprinter switchroom at Manchester, England.

each relay. In larger offices, this delay may normally range anywhere up to as much as 20 minutes and in heavy-traffic periods may be longer. Thus, if several relays are involved in getting a message from its point of origin to its destination, the office drag, as it is commonly called, becomes important and generally will prevent really fast service.

Operating costs are high but line costs can be kept at a minimum as circuits can be fully utilized and only sufficient circuits need be provided to handle busy-period traffic.

Another disadvantage of this method of operation is that each manual handling, whether it be receiving the message or transmitting it, is a source of possible error. Thus, where many such handlings are necessary, very careful checking and supervision are required if a satisfactory high standard of accuracy is to be maintained.

#### 4.6.3 Tape Relay

In the tape relay system, incoming messages are recorded on a perforated tape and this tape controls the transmission of the message over the outgoing circuit. As messages are manually transcribed only once, the chance of operator errors is substantially reduced. Several types of tape relay systems have been developed; they differ primarily in the degree to which automatic operation has been incorporated.

##### 4.6.3.1 Torn-Tape System

In perhaps the simplest tape relay system, messages are received on typing reperforators arranged in banks in such a way that one operator has access to several machines. When a message is completed, the operator tears off the incoming message tape, reads the destination printed on it, and inserts the tape in a transmitter associated with the proper outgoing circuit. Several transmitters may be connected to one outgoing circuit as automatic means are

provided for activating these transmitters for transmission of any message held therein. If no message is in any particular instrument, then the automatic switching equipment causes the circuit to be connected to the next one and so on until each in turn has had access to the outgoing circuit.

This arrangement greatly reduces the amount of labor at the relay center as all the operator has to do is to determine the message destination and place the perforated tape in the correct transmitter. Likewise, the amount of equipment required is not excessive. It has the disadvantage of handling numerous small lengths of perforated tape and requires careful supervision to avoid loss of messages.

#### 4.6.3.2 Push-Button Switching

The second type of tape relay system, known as push-button switching, eliminates the handling of loose pieces of perforated tape. In this system, the receiving positions are connected to the outgoing positions through high-speed intra-office circuits. There is a transoffice transmitter associated with each receiving typing reperforator and a transoffice reperforator with each outgoing transmitter. By operating a key, the transmitter at the receiving position may be switched to circuits leading to any of the reperforators associated with the line transmitters. To avoid congestion, the transoffice circuits operate at speeds approximating twice those of the line circuits. Safeguards are provided to prevent one switching operator interfering with another in case both attempt to use the same transoffice reperforator. When the key switching the transmitter is operated, the circuit is checked and, if not busy, transmission proceeds; if that circuit is busy, however, the transmitter is held inoperative until the circuit becomes idle. End of message signals perforated in the tape stop the transoffice transmitters at the end of each message thus minimizing the danger of messages being directed to the wrong outgoing circuit due to failure to stop the transmitter.

This system requires extensive central-office equipment both of the printing-telegraph type such as reperforators and transmitters and of the automatic switching variety. However, because of the small amount of work required of the

operator, the reduction in operating personnel more than offsets increased charges for additional equipment. The handling of loose perforated tapes is avoided and relaying is expedited.

#### 4.6.3.3 Automatic Tape Relay

A third tape relay system, similar to the one just described but going a step further, uses signals in the perforated tape to select automatically the proper outgoing circuit, thus eliminating almost completely the requirements for operating personnel at relay points. Some increase in equipment over push-button switching is required but not enough to offset savings resulting from reductions in operating staff. In reality, this is a fully automatic switching system but is classed under tape relay systems mainly because it uses perforated tapes as the relaying medium and does not provide direct origin-to-destination communication without intermediate retransmission.

#### 4.6.3.4 Traffic Procedures

Any telegraph system must provide for service messages for correcting mutilated messages. In manual systems, it is necessary usually only to query the last office from which the mutilated message was sent. In tape relay systems, experience has shown that such requests should be directed to the office at which the message originated. This frequently requires passing through intermediate relay offices both for the request and the answer, thereby introducing a delay that may be long enough to cause repeat requests to be sent. All this has a tendency to increase unduly the number of service messages as well as delay delivery of messages that have been mutilated. It is thus highly important, where tape relay systems are employed, to have a plant that will give continuous, reliable, error-free transmission and to provide well-trained accurate operators.

#### 4.6.4 Automatic Switching

Under this heading are classed those systems that provide direct intercommunication between calling and called teleprinter stations. Although

systems may vary as to details, there are two general classifications under which the principal automatic switching systems fall, namely, dial signaling and permutation-code signaling. The actual switching equipment utilizes standard automatic telephone switching apparatus and techniques modified, where necessary, because of the differences between telegraph- and telephone-circuit requirements.

circuits and director circuits may be used in the same way and for the same purposes as in a multiple-exchange telephone system.

#### 4.6.4.2 *Permutation-Code Signaling*

In permutation-code signaling systems, the teleprinter keyboard is used to send the calling signals to the exchange and very little special



Push-button switching aisle in Philadelphia, Pennsylvania, office of Western Union Telegraph Company.

#### 4.6.4.1 *Dial Signaling*

Systems employing dial signaling have at each teleprinter station a special unit including a dial (like the dial on an automatic telephone) and the necessary control circuits for changing from the calling to the transmitting condition and from the call-receiving to the telegraph-receiving conditions. At the automatic exchange, the dial signals are used in the normal manner to complete the call and to connect and signal the called line. In multiple-exchange areas, register

equipment is required at the teleprinter station. At the exchange, the permutation-code signals are received and translated in register or similar circuits into signals suitable for operating the automatic switching equipment. From the standpoint of operations, this system appears to have advantages over the dial systems in its flexibility, particularly with respect to tape storage and retransmission at switching centers and the fact that little special apparatus is required at the teleprinter station.

#### 4.6.4.3 Circuit Requirements

In automatic switching systems, the telegraph circuits are operated on a half-duplex basis, i.e., telegraph transmission in only one direction at a time. Likewise, circuits must be provided on a basis that will avoid frequent busy conditions, particularly during heavy-traffic periods. This naturally results in rather inefficient use of the telegraph circuit capacity and in requirements for large numbers of circuits between principal traffic and switching centers. This increase in circuit requirements is offset by reductions in central-office equipment costs and in operating personnel, which are usually sufficient to justify the use of automatic switching.

#### 4.6.4.4 Overload Provisions

Automatic switching systems designed to handle public message traffic must provide means for dealing with peak traffic loads. This is usually accomplished at switching centers by providing reperforators to which calling lines are switched when a call encounters a busy condition. The message, thus stored in perforated tape, can be forwarded either automatically or manually as soon as the outgoing circuit becomes free.

The tape relay systems automatically provide storage at relay points both between the receiving reperforator and the transoffice transmitter and between the transoffice reperforator and the line transmitter and are thus capable of handling large overloads at some sacrifice in speed of service.

A certain amount of delay will occur during these peak periods because of the tape storage

and it is the system-planning engineer who must assure that sufficient facilities and equipment are provided to keep these delays at an economical minimum.

#### 4.6.4.5 Private-Customer Automatic Switching

Automatic switching systems designed to serve individual customers on a station-to-station basis must be provided with facilities that will keep delays in completing calls at a reasonable minimum. Tape storage at switching points will rarely be found satisfactory for absorbing peak traffic loads in this type of service. Calls encountering busy conditions tie up equipment without corresponding movement of traffic thus tending toward service breakdown if the overload is severe as well as causing irritation to the customer. Trunk-circuit facilities should be provided, therefore, on a more liberal basis than in switching networks in which tape storage can be used to relieve conditions during peak traffic periods.

#### 4.6.5 Traffic Capacity

An economic comparison for any territory can be made only after basic layouts have been made and the number of circuits and the kind and quantity of equipment required for each method of operation has been determined. To make such a determination, the engineer must know, in addition to the busy-hour and total traffic involved, the capacity of the circuits and equipment to handle such traffic under the method of operation assumed. Since the volume of traffic that can be handled over a circuit or with given

TABLE 1  
MANUAL RELAY

Kind of Circuit	Number of Transmission Paths	Type of Transmission	Practical Operator Busy-Hour Message Capacity for Each Transmission Path
Single	1	Keyboard	45
Single	1	Tape	60
Duplex	2	Keyboard	60
Duplex	2	Tape	100
Multiplex 2 channel	4	Keyboard	60
3 channel	6	Keyboard	60
4 channel	8	Keyboard	60
Multiplex 2 channel	4	Tape	100
3 channel	6	Tape	100
4 channel	8	Tape	100



equipment varies widely with the several operating methods, data on the traffic capacity of circuits and equipment under a number of conditions is covered in the following discussion.

#### *4.6.5.1 Circuit Traffic Capacity*

Telegraph systems using manual or tape relay methods permit full circuit utilization since each circuit terminates in recording equipment and no problem exists of finding an idle circuit for switching purposes. For system design purposes, the recommended traffic-carrying capacity of various types of high-grade telegraph circuits used in manual relay systems is given in Table 1. It is assumed that 75-word-per-minute teleprinters are used and that transmission may be either directly by keyboard or by automatic tape. It is further assumed that the average message is 25 words.

#### *4.6.5.2 Traffic Capacity Using Tape Relay*

In tape relay systems, all trunk channels are operated on a tape transmission basis and such channels, when fully loaded, can be expected to carry as many as 140 messages per hour. Other circuits in the tape relay system can be expected to handle traffic at the rates shown in Table 1.

#### *4.6.5.3 Traffic Capacity Using Automatic Switching*

From a traffic point of view, systems using automatic switching employ circuits on a single or half-duplex basis because of the necessity for revertive signals to control the switching equipment. The traffic-handling capacity per circuit is thus reduced to half that of full-duplex circuits. It is still further reduced by the need of providing circuits in sufficient quantity to meet random switching requirements and avoid too-frequent busy-circuit conditions. Also, it is necessary to take into account the time consumed in calling, switching, acknowledging, and clearing. Experience has shown that the total time per message of 25 or 30 words is roughly one minute. This is usually referred to as holding time. The grade of service is usually referred to as the ratio of the number of calls per busy condition encountered.

#### *4.6.5.3.1 Local Exchanges*

In teleprinter local-exchange networks, only a single switching operation is required and completion of a call depends on finding the called circuit idle. Relatively high circuit loads may be used in the interest of circuit economy. For most single-exchange systems, a grade of service of 0.05 (1 busy call in 20) during the busy period is considered to be satisfactory.

#### *4.6.5.3.2 Multiple Exchanges*

In multiple-exchange systems, tandem switching occurs and it is at once apparent that a high grade of service must be provided if excessive busy conditions on multiswitch calls are to be avoided. Experience has shown that on inter-exchange trunks the design should be on the basis of a service grade of 0.002 (1 busy call in 500). For local connections to such exchanges, a service grade of 0.005 (1 busy call in 200) is usually considered allowable. Even with these liberal allowances, an over-all service grade better than 0.01 (1 busy call in 100) cannot be expected on calls involving one or more trunks in addition to the terminal connections.

Table 2 shows on the basis of experience and the laws of probability the number of circuits required to handle various amounts of traffic for several grades of service. The advantages in circuit message capacity through use of large groups of trunks are evident. For a service grade of 0.002, each trunk in a group of 20 has a capacity of 30.2 messages per hour as compared to a capacity of only 8 messages per hour for each trunk in a group of 4. When this increased capacity is considered in conjunction with the lower cost per unit circuit length for the larger groups, the importance of layouts that result in heavy trunk groupings is doubly emphasized.

#### *4.6.5.3.3 Increased Efficiency on Small Trunk Groups*

When light-traffic conditions are encountered, as for example, between terminal switching offices and terminal printer stations, and only one or at most a few trunks can be justified by the volume of traffic, consideration should be given to one of two alternatives available for increasing

the traffic-handling capacity of such trunks. The first alternative consists in using tape storage for transferring messages from the switching system to the small offices. In this way, at the cost of some delay, trunks to the smaller offices may be more efficiently loaded and their number reduced. The second alternative is to provide for repeated hunting, which can be continued for a prescribed time before a busy condition is signaled. If hunting is continued for a period equal to the normal setting-up time for a call, a substantial increase in traffic capacity of the final trunk can be realized without appreciable increase in holding time over the main trunks beyond what it would be when repeat tries are necessary because of immediately sending back the busy condition.

5. Fundamental Plans

5.1 GENERAL

In the preceding pages, the basic information on which to build a sound fundamental plan for a modern telegraph system has been discussed. The possibilities of major economies while maintaining high-grade service have been clearly indicated. With this information as a background and having set the standards of service that the system will be designed to provide, and further having tentatively selected the methods of operation to be considered, the engineer is prepared to proceed with fundamental planning. It should be realized that several basic plans will probably have to be tried before a thoroughly

TABLE 2

EQUATED BUSY-HOUR MESSAGES THAT CAN BE HANDLED ON GROUPS OF 1 TO 50 CIRCUITS FOR VARIOUS GRADES OF SERVICE

Number of Circuits	Busy-Hour Messages for Probability of Loss of				Number of Circuits	Busy-Hour Messages for Probability of Loss of			
	0.002	0.005	0.01	0.05		0.002	0.005	0.01	0.05
1	—	—	—	3	26	871	948	1017	1256
2	4	7	9	23	27	917	996	1068	1314
3	15	21	27	54	28	963	1044	1118	1372
4	32	42	52	91	29	1010	1093	1169	1430
5	54	68	82	133	30	1056	1142	1220	1488
6	79	97	114	178	31	1103	1191	1271	1546
7	108	129	150	224	32	1151	1240	1323	1605
8	138	164	187	272	33	1198	1290	1374	1663
9	171	200	227	322	34	1245	1339	1426	1722
10	206	238	268	373	35	1293	1390	1478	1780
11	241	277	310	424	36	1341	1440	1530	1839
12	278	316	352	477	37	1389	1490	1582	1898
13	316	358	396	529	38	1438	1541	1635	1957
14	355	400	441	584	39	1486	1592	1687	2016
15	395	442	486	639	40	1535	1642	1740	2075
16	436	486	533	692	41	1584	1693	1793	2134
17	476	530	579	748	42	1633	1745	1845	2194
18	519	575	626	804	43	1683	1796	1898	2253
19	561	620	675	859	44	1732	1846	1951	2313
20	604	666	722	915	45	1782	1897	2004	2372
21	648	712	770	971	46	1829	1949	2058	2432
22	693	758	819	1028	47	1879	2001	2112	2492
23	736	805	868	1085	48	1930	2053	2166	2552
24	780	852	918	1142	49	1982	2106	2220	2612
25	826	900	967	1199	50	2031	2159	2273	2671

- NOTES:
1. The probability of loss is expressed in terms of busy-hour attempts when busy-hour messages carried on the circuit group are as shown, e.g., if a 30-circuit group carries 1220 completed messages, the most probable number of attempts will be  $1220 \times 1.01 = 1232$ , and the number of "lost" attempts will be  $1232 - 1220 = 12$ .
  2. The calculation of message capacities are based on the following assumptions:
    - A. Holding times per message are distributed at random about an average of one minute.
    - B. Attempts are distributed over the busy hour at random with respect to time.
    - C. Attempts made when all circuits are busy will return a busy signal to the caller and will have zero holding time on the circuit group.
    - D. The number of traffic sources is large compared to the number of circuits. It is to be noted that this is a "liberal" assumption, that is, when the number of sources is small compared to the number of circuits, the capacities are slightly greater than shown in the table.

satisfactory one for each method of operation is found. However, the task can be minimized if the work is systematized and a logical sequence of steps is followed. The suggested steps in order of precedence are:

- A. Complete analysis of traffic data and determination of circuit requirements.
- B. Preliminary circuit layouts.
- C. Final circuit layouts.

## 5.2 TRAFFIC ANALYSIS

The first step in arriving at a suitable plan is an analysis of the traffic data obtained from the origin and destination studies made as directed in Section 3. From these statistics, all places between which there is sufficient traffic to justify direct circuits should be selected and listed, together with the actual average daily and peak-hour traffic between them. To these traffic figures should be added the traffic that would be relayed through these direct circuits from places near the terminal cities. It is desirable to list the traffic between two places separately in each direction. For this preliminary selection, the amount of traffic required to justify a direct circuit should be about 200 messages per 24-hour day (both directions) for circuits up to 200 miles in length, 400 messages for 500 miles and, roughly, 600 messages for circuits over 700 or 800 miles long.

In analyzing traffic data, it is essential to take into account not only existing traffic but also probable future traffic. For estimating probable future traffic, the history of traffic volume should be used as a guide. In addition, improved service may generate increases in traffic that in cases of major service improvement might run as high as 50 percent or more. Each main traffic center and the area it serves should be carefully examined, taking into account all known factors such as industrial or other developments that may produce changes in traffic volume or character, and an estimate should be made of the expected traffic volume at stated future dates. Preferably two 5-year intervals followed by one 10-year interval—20 years in all—should be covered. These estimates should be reviewed from time to time in order that significant changes in traffic may be taken into account in future planning in

time to avoid serious and expensive rearrangements in plant layout.

## 5.3 PRELIMINARY CIRCUIT LAYOUTS

The places between which direct circuits are indicated should next be spotted on an outline map of the territory of the proposed system, together with a list of the circuits leading away from each place. This should show circuit requirements for existing as well as expected future traffic. A study of this map should indicate the probable main trunk-line routes, which should then be drawn in on the map.

In selecting main trunk routes, it should be kept in mind that large groups of telegraph channels are not only far cheaper per channel than small groups but are generally more efficient in the movement of traffic, particularly in automatic switching systems. Thus, in many cases, it will prove more economical to utilize a longer route having a substantial group of circuits between two places than a direct route with a very small group or a single circuit. In some territories, a single main route may be indicated while in others a ring-type arrangement may be preferable. It is highly desirable to provide alternative routings to prevent complete service breakdown in case of a total line failure in any section of the main trunk. The number of telegraph circuits required over each section of the routes indicated should be computed and shown on the map.

In addition to the traffic originating in or near each place having a direct circuit outlet, there is a considerable volume of traffic that will require relaying over 2 or more direct circuits in tandem. This traffic should now be assigned to the selected direct-circuit routes in such a manner as to minimize the number of retransmissions required in getting it to its destination. This will increase the volume of traffic over the direct circuits and may increase the number of circuits required. A careful study of this traffic may show a need for direct circuits to other places and these additional circuits should be indicated on the map. This preliminary layout should be made without regard to existing pole-line routes or circuit layouts to obtain a clear picture of the ideal arrangement.

## 5.4 FINAL CIRCUIT LAYOUTS

### 5.4.1 General

The final circuit layouts and assignments are developed from the preliminary plan and method of operation. Here, existing line routes must be taken into consideration but need not necessarily be controlling. Since the preferred circuit layout may differ for manual relay, tape relay, or automatic switching, each will be discussed separately.

### 5.4.2 Manual Relay

In a system based on manual relaying, the number of times each message is handled should be reduced to a minimum to obtain the lowest cost of handling, speed up service, and minimize error probability. This means direct circuits wherever practical. As an example, if each message handling costs \$0.035 and there is a traffic of 60,000 messages per year between two points, the relaying of this traffic at an intermediate point will cost  $60,000 \times 2$  (indicating 2 handlings per relay)  $\times 0.035$ , or \$4200 per year. This cost plus the annual charges on the equipment that would be saved could provide a through circuit.

For a manual relay system, the preliminary layout arrived at as described in 5.3 should be very close to the final plan. Such modifications as may take into account existing outside and inside plant facilities and desirable alternate routings, should be sketched in as a basis for the cost study. This cost study should include new lines, reconstruction of existing lines, new buildings, modifications to existing buildings, new transmission equipment, testing equipment, switchboards, office rearrangements, as well as a valuation of the existing plant that will be part of the modernized system.

### 5.4.3 Tape Relay

Tape relay systems derive their advantage from four main factors: reduction in operating personnel, more rapid transit of messages through relay centers, efficient use of trunk and tributary circuits, and an improvement in accuracy because of fewer manual retransmissions. At relay points, one operator can handle the switching of

messages from 3 to 5 high-speed telegraph channels, taking the place of from 6 to 10 in the manual system. Some extra labor is required for messages originating at switching centers, so the actual personnel reduction should amount to roughly 80 percent. More-rapid transit through relay centers results from the direct transfer of incoming messages to outgoing circuit transmitters through high-speed transoffice circuits. Efficient circuit utilization is realized through full-duplex operation where required and through 100-percent storage at switching centers.

Tape relay systems require substantial increases in central-office equipment, the cost of which must be balanced against the operator savings. In the over-all picture, experience has shown that the cost of passing a message through a tape relay office is from 30 to 40 percent of the cost for manual relay. Thus, in the example used under manual relay, the cost for tape relay would be roughly \$1500 instead of \$4200. This reduction plus the greater traffic capacity of trunk circuits in tape relay systems makes it practical to relay messages more frequently and thus reduce to some extent the number of lightly loaded direct circuits. More-frequent relaying may increase slightly the number of circuits over the main trunk routes but will reduce the over-all circuit costs.

Locations for tape relay offices should be chosen so that each serves a well-defined territory; these locations need not necessarily be major traffic centers. In the United States, Western Union plans to have 15 major relay offices each serving a definite zone. Such major traffic centers as New York and Chicago will be terminal offices and not tape relay centers. All interzone traffic will pass through the switching offices except in cases where direct intercity circuits will be maintained because of the heavy direct traffic. The relay offices should be chosen primarily from the point of view of network economy, all relay centers being interconnected by groups of trunk circuits adequate to meet the traffic needs.

### 5.4.4 Automatic Teleprinter Switching

The selection of a fundamental plan for an automatic switching system on a national scale requires careful consideration if satisfactory

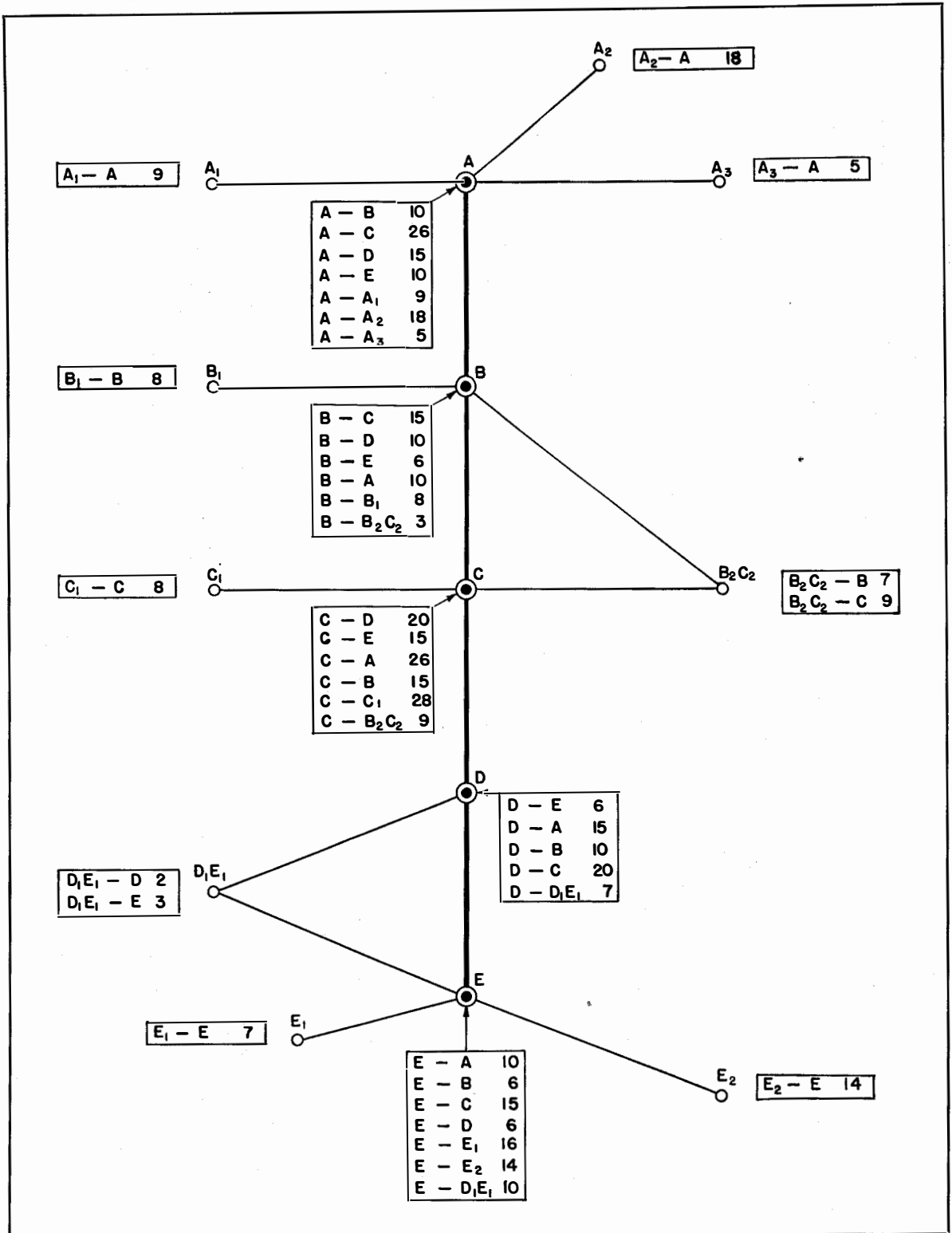

Figure 5—Typical multiexchange teleprinter switching system having a single main route. Zone switching centers are indicated by dots in circles and district switching centers by circles. The figures in boxes give the number of trunks between the centers noted.



results are to be realized. Since such a system provides direct connection between the calling and the called station, the problem of intermediate handling of traffic does not arise except for overflow traffic. Experience indicates that territories to be provided with an automatic teleprinter switching system generally can be served best by dividing the territory into a limited number of major zones with groups of trunks interconnecting zone centers. These major zones usually are divided into subzones, or districts, with groups of trunks connecting the district centers to their zone center. Terminal offices in turn are connected to the district center. In some cases, district centers may be connected directly to more than one zone center, or even to other district centers, if the traffic is sufficient to justify a reasonably sized group of trunks. Two such arrangements are shown in Figures 5 and 6. Figure 5 is a layout for one

principal trunk route while Figure 6 is of the ring type, which is preferred since failures must occur at two points in the ring to isolate any part of the system. For sake of simplicity, circuits for district centers to teleprinter stations are not shown nor are future circuit requirements, although such information should be indicated on any actual layout.

Figure 5 represents final circuit requirements. Zone centers are first selected and zone boundaries established. District centers are chosen to permit all terminal offices to be reached over reasonably short extensions from the district centers. Once the zone and district centers have been tentatively selected, a layout of the channels of communication should be made in diagrammatic form as illustrated in Figure 7. In this figure, the lines indicate the channels of direct communication. In general, it is desirable to arrange them in such fashion that not more than 1

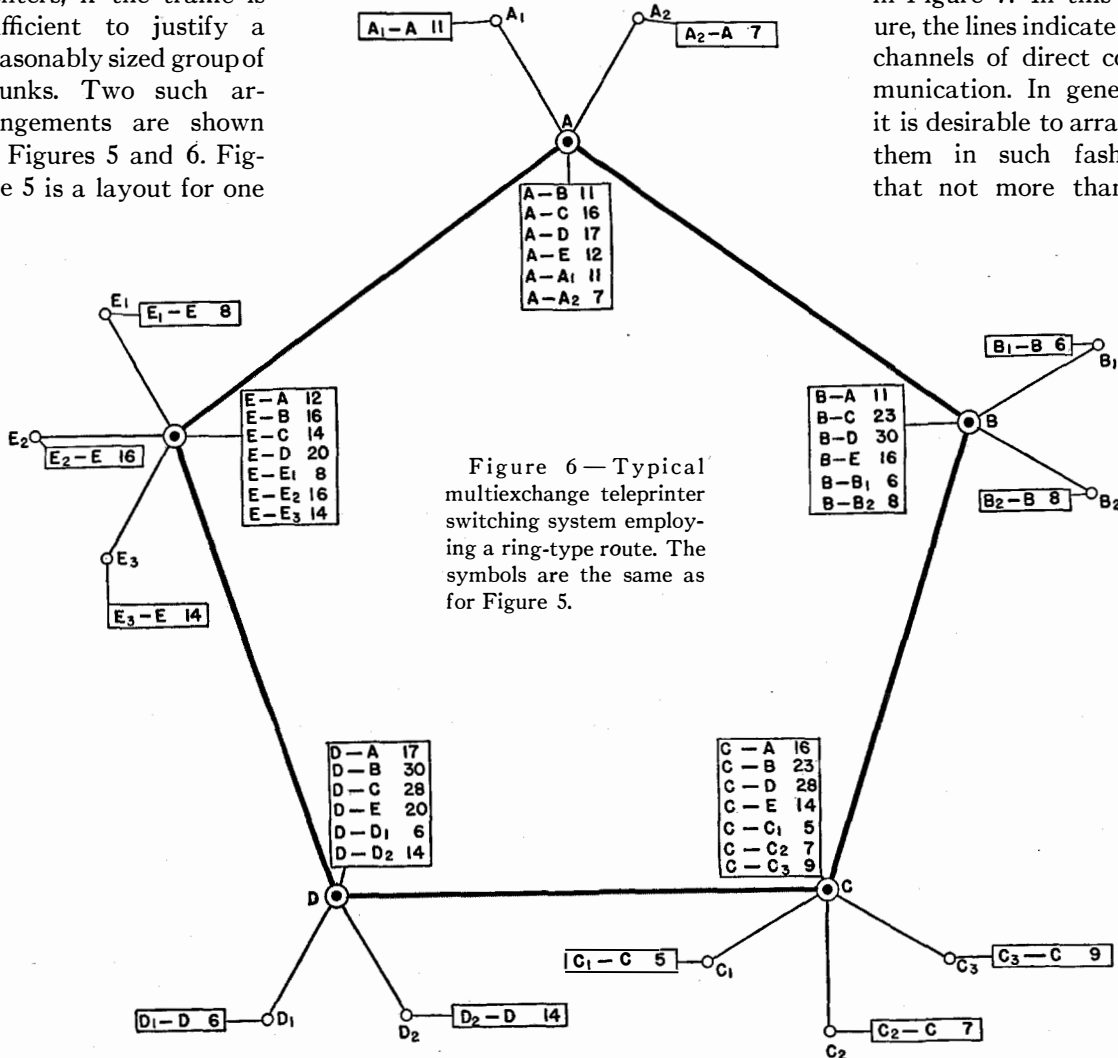

interzone trunk, 2 zone-to-district trunks, and 2 terminating trunks (5 links in all) are required to complete any call using regularly assigned routes. Alternate routes to meet emergency conditions may use up to 3 interzone trunks.

The traffic data should now be re-examined and collated to show the total busy-hour traffic on each communication link. For example, to the direct traffic between A and C, must be added all traffic originating in the districts connected to A that is destined for C or any of the districts connected thereto, as well as traffic in the reverse direction. For the zone-to-district links, the traffic load will consist of all messages originating within the district destined for places outside the district plus all traffic reaching the zone center from the remainder of

the system and destined for stations connected to the district center.

These busy-hour traffic-load figures should be tabulated in convenient form such as is illustrated in Table 3, where up and down refer to traffic in opposite directions over any link.

In estimating future growth, it must be remembered that telegraph traffic has a tendency to reach a saturation level and growth beyond this point will follow closely population and industrial growth. Likewise, it is better to consider traffic between individual places rather than use an over-all percentage growth factor since growth is not likely to be uniform in all cases and increased traffic between certain stations will not necessarily increase traffic on all trunks in the same manner.

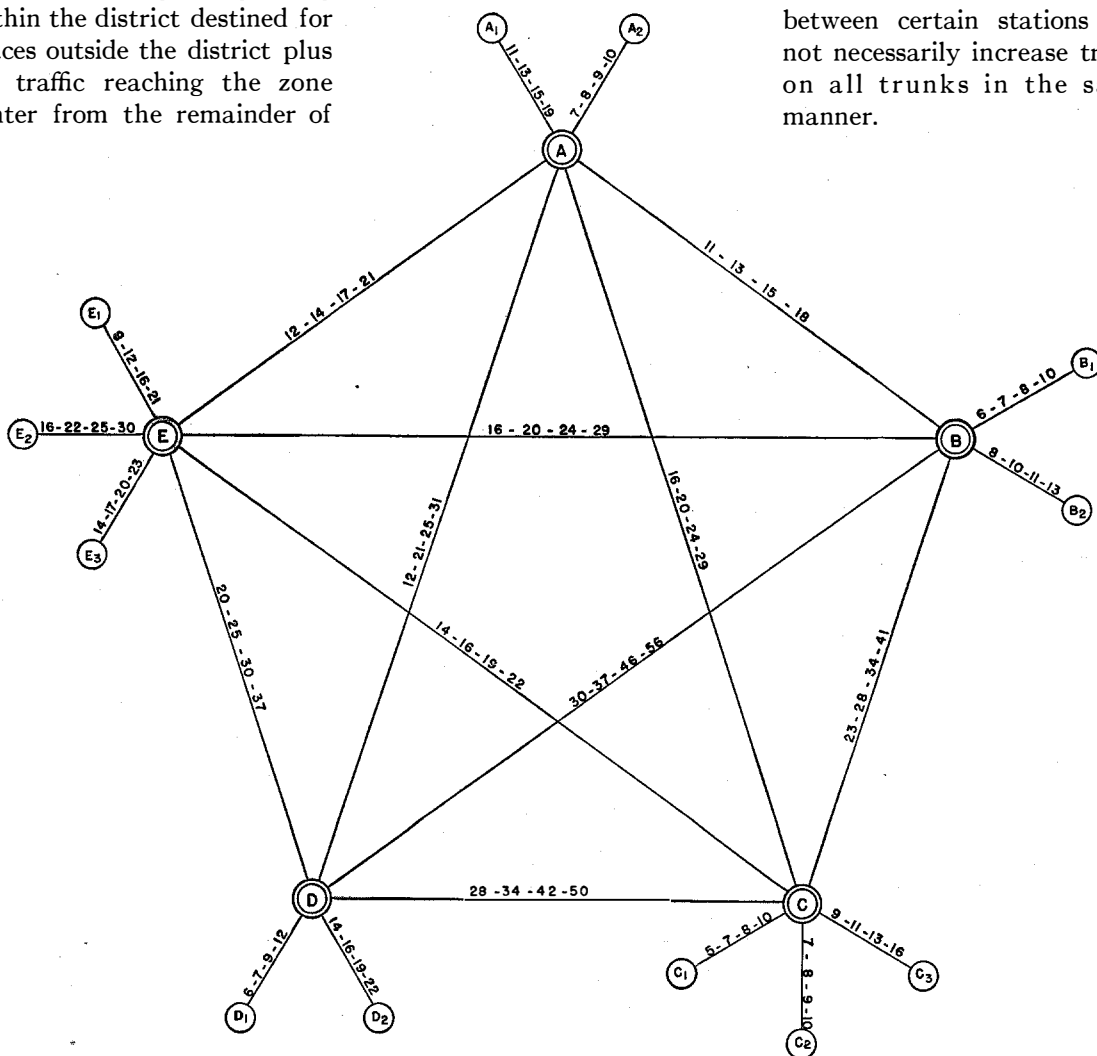

Figure 7—Traffic-channel requirements for the present and for 5, 10, and 20 years later. The zone centers are double circles and the district centers, single circles. The numbers of channels for the four time intervals indicated above are given in that order along the traffic channel lines.

By referring now to Table 2 and using the total busy-hour traffic figures of Table 3, the number of circuits required for each link can be determined. This has been recorded in Table 3. These circuit requirements are now transferred to the diagram, Figure 7, where the numbers alongside each direct communication channel show the number of channels required to handle the traffic at present, and at the end of 5, 10, and 20 years, respectively. From these data, plans corresponding to Figures 5 and 6 can be constructed, taking into account the selected routes for the trunk circuits. Likewise, it is now practical to determine the number of voice-frequency systems that will be required at present as well as at future periods. For this purpose, a maximum of 18 channels per system should be used and intermediate repetition of signals at telegraph frequencies should be avoided on interzone trunks as far as possible. From this information, the number of telephone channels required over each part of the system is determined, giving the size of the wire plant needed to handle present and estimated future traffic.

Having determined the number of telegraph channels entering each zone and district switching center, the sizes of the switching centers are

established and their costs can be estimated. Two factors remain, namely, the number and method of providing district-to-terminal-station circuits and the method of handling overflow traffic in cases of excessive loads such as on special holidays or due to other causes that produce traffic volumes greatly in excess of normal.

District-to-terminal-station circuits are normally engineered on a service grade of 0.005 to insure an over-all grade of service of 0.01 in all cases. Where traffic on these links requires more than three circuits on the basis of Table 2 with a service grade of 0.005, some economy in the number of circuits required can be realized by using separate groups of circuits for traffic with the terminal station. As there is no question of traffic availability on each outgoing circuit, the maximum amount of traffic the operator is capable of sending can be handled. With an over-all holding time of one minute, including calling, transmission of the message, and clearing, a theoretical maximum of 60 messages per hour could be handled. A practical maximum for engineering purposes is 50 messages per busy hour. Thus, if the busy-hour traffic is 84 messages equally divided between incoming and outgoing,

TABLE 3  
TRAFFIC STATISTICS AND CIRCUIT REQUIREMENTS  
Service Grade 0.002

Between	Present Busy-Hour Traffic			Estimated Busy-Hour Traffic at End of Years Indicated			Circuits Required at End of Years Indicated			
	Up	Down	Total	5	10	20	Now	5	10	20
A-A <sub>1</sub>	120	120	240	310	385	540	11	13	15	19
A-A <sub>2</sub>	50	54	104	135	168	200	7	8	9	10
A-B	120	115	235	310	380	515	11	13	15	18
A-C	215	210	425	595	775	975	16	20	24	29
A-D	230	240	470	620	806	1080	17	21	25	31
A-E	135	140	275	347	470	640	12	14	17	21
B-B <sub>1</sub>	36	42	78	105	135	210	6	7	8	10
B-B <sub>2</sub>	68	65	133	200	240	305	8	10	11	13
B-C	340	365	705	935	1215	1555	23	28	34	41
B-D	510	530	1040	1360	1810	2315	30	37	46	56
B-E	220	210	430	585	755	975	16	20	24	29
C-C <sub>1</sub>	27	25	52	105	135	205	5	7	8	10
C-C <sub>2</sub>	55	53	108	130	170	200	7	8	9	10
C-C <sub>3</sub>	82	84	166	236	316	425	9	11	13	16
C-D	460	470	930	1210	1605	1990	28	34	42	50
C-E	170	175	345	435	540	690	14	16	19	22
D-D <sub>1</sub>	40	37	77	106	170	270	6	7	9	12
D-D <sub>2</sub>	170	178	348	430	550	670	14	16	19	22
D-E	300	300	600	790	1030	1350	20	25	30	37
E-E <sub>1</sub>	70	65	135	270	420	630	8	12	16	21
E-E <sub>2</sub>	210	220	430	660	825	1030	16	22	25	30
E-E <sub>3</sub>	180	170	350	470	590	730	14	17	20	23

4+1 circuits would be required on a split-group basis as against 6 circuits on a purely random basis. If the traffic were 388 messages, the requirement would be 9+4 as compared with 14. If tape transmission is employed at the terminal station, expert operators may actually reach 60 messages per busy hour without difficulty. Another advantage of split operation arises from the fact that for received traffic one operator can readily take care of two and usually three incoming circuits, thus saving in operating personnel.

To provide these district-to-terminal-station circuits, a number of alternatives are available. The first is to use single-wire ground-return circuits. This is satisfactory for local circuits within a municipality, particularly where such circuits can be leased from the telephone entity. For circuits to outlying centers, single-wire telegraph circuits will usually be found expensive and every effort should be made to obtain such circuits by operating simplex on existing telephone circuits or by applying carrier and voice-frequency carrier telegraph or speech-plus-duplex to such telephone circuits. Distances as short as 20 miles should be considered for voice-frequency telegraph operation.

Certain holidays, a local event of national importance, or a disaster may produce excessive peaks of traffic often double, or more, the normal or seasonal peak. Obviously, it is uneconomical to provide sufficient facilities to handle these occasional peaks in the normal manner. However, unless special provisions are made to handle them, a complete breakdown in service through excessive busy conditions being encountered may occur, thus tying up equipment without compensating movement of traffic. To overcome these deleterious effects, it is common practice in teleprinter switching systems, particularly in public message service, to introduce tape storage at switching points. Reperforators (either typing or nontyping) are cut in automatically when busy-circuit conditions are encountered. The calling station is notified when this occurs and the message can then be transmitted and stored until such time as the previously busy circuit becomes idle. The transmission of the message forward can be controlled automatically or manually as desired. When controlled automatically, signals indicating the destination office

are perforated in the tape ahead of the message so that automatic sensing equipment may control the forward-switching signals. Normally, messages for only one destination are stored in the tape from one reperforator to avoid having one message for transmission over a busy route hold up subsequent messages that might be forwarded over other nonbusy circuits. Also, where automatic retransmission is employed, it is usually desirable to arrange the equipment so that the forward circuit is seized for transmission of stored messages only after more than one forward trunk becomes idle. Unless such a plan is followed, practically all traffic during these extra peak periods would be stored and an excessive number of reperforators and transmitters would be required.

When retransmission of stored messages is to be under manual control, the operator can check the condition of the forwarding circuits and, at the price of some delay, overloading of the busiest circuits can be avoided. Typing reperforators are a convenience to the control operator in ascertaining the destination address.

Whether automatic or manual control of retransmission of stored messages is used, circuit facilities should be such that only a limited amount of traffic will be stored during normal busy periods and sufficient reperforators and transmitters should be available for abnormal peaks.

For customer-to-customer automatic switching systems, storage of messages at switching points will rarely provide a satisfactory service and, accordingly, other facilities must be provided to meet all traffic needs.

#### 5.4.5 Combined Systems

The discussion of the various operating methods so far presented has assumed that the entire system would be operated in accordance with one or the other of the methods described. In actual practice, however, more than one method of operation may be desirable. Thus, as already discussed, a certain amount of tape relay operation is normally incorporated in a fully automatic switching system to provide for overflow traffic during extra-heavy-traffic periods. Likewise, in a basically tape relay system, automatic switching may be used to connect terminal stations in a

limited area over a few trunks to a tape relay switching center with a resultant saving in circuit requirements. Also, within the tape relay office, automatic switching may be used to provide for switching messages through the office without the intervention of an operator. Accordingly, it is advisable to consider carefully each portion of a proposed system with a view to selecting methods of operation that will produce the best and most-economical results.

## 5.5 EQUIPMENT

Up to this point, emphasis has been placed on obtaining for several methods of operation sound basic circuit layouts that meet present traffic requirements and can be augmented without extensive and costly rearrangements to fulfill later demands as traffic grows. It is next necessary to consider the equipment that will be required to enable each system to function efficiently.

### 5.5.1 *Transmission Equipment*

From Sections 4.3 and 4.4, it is apparent that for trunk routes requiring sizable groups of circuits voice-frequency carrier telegraph offers greatest economy. Its advantages over other methods are striking, particularly where joint use can be made of circuits for both telephone and telegraph purposes. An examination of the circuit layouts will enable the engineer to determine the number of telegraph circuits required over each portion of the system, the number of carrier systems required to furnish these circuits, and the terminals between which such systems should be operated. If the number of carrier telegraph systems over any link is such that multichannel carrier telephone systems are required, it should be remembered that the telephone channels can be connected through, either at carrier frequencies or at voice frequencies, to provide through circuits. It is thus practical to combine voice circuits, single- and multichannel carrier telephone circuits, and voice-frequency carrier telegraph circuits operated over wire lines or radio links to meet a wide variety of circuit requirements.

At voice-frequency carrier system terminals, the channels of one system can be connected

through at telegraph frequencies to channels of another system either permanently or by patching cords. It is desirable to limit such through connections as each one introduces a small amount of distortion. Another method of obtaining through channels is to connect a channel of one system to a corresponding channel of another system so that signals pass through at the channel carrier frequencies rather than at telegraph frequencies. Such intermediate through connections should be limited in any one link to a maximum of two and not more than one should be used as a general rule.

Two general types of voice-frequency carrier telegraph systems are available, namely, amplitude-modulation and frequency-modulation systems. Each type will produce satisfactory high-grade telegraph circuits. When applied to voice channels that have good transmission-level stability, amplitude modulation may be slightly cheaper for multiple installations. For physical voice circuits or where transmission levels are subject to considerable variation, frequency modulation should be preferred as this system will accept substantial level variations without introducing appreciable bias or distortion. Where frequency-modulation systems are operated over single- or multichannel carrier telephone systems, particular attention must be paid to the frequency stability of the telephone systems as variations of even a few cycles in the telephone carrier frequencies will produce bias in the telegraph channels. It is fortunate, however, that most modern multichannel carrier telephone systems are or may be made sufficiently frequency stable to insure satisfactory operation of frequency-modulation carrier telegraph systems superimposed thereon.

Terminating equipment for direct-current telegraph circuits, operated either as single or duplex circuits, should be rack mounted and separated from the operating positions. It is much more satisfactory to have personnel assigned specifically to the testing and regulating of circuits than to permit the operating personnel to perform such tasks.

Proper testing facilities are an essential part of any modern communication plant. It is, therefore, necessary to provide adequate test-board and patching facilities at all principal terminal and repeater stations. These facilities



should permit testing lines for grounds, crosses, leakage, etc., radio links for proper circuit performance, and telegraph circuits for lining up, operation, and for measuring telegraph-signal distortion.

### *5.5.2 Operating Layouts and Equipment*

#### *5.5.2.1 Manual Relay Operation*

In manual relay operation, a transmitting and a receiving position or a combined transmitting and receiving operating position must be available for each working telegraph channel terminating in an office. Trunk-line and other heavy-traffic circuits normally have operating positions individual to each circuit. Local and other lightly loaded circuits, such as way wires (omnibus circuits), usually terminate in concentrators, either manual or automatic, where a few operating positions may serve a much larger number of circuits. In the larger offices, operating positions are grouped into those serving trunk lines and other main circuits and those serving local and way-wire circuits. The trunk-line positions may be further subdivided according to geographical areas. To expedite handling messages through such large offices, belt or other conveyor systems are usually employed. Associated with these conveyors are distribution and routing centers to transfer messages rapidly from one part of the operating room to another. Belts normally pick up messages from each receiving position and deliver them automatically to the distribution center. Messages for transmission are deposited in drops located in the area of the office from which the message is to be transmitted and distributed manually from these drops to the transmitting operators.

Perforated-tape transmission is usually employed on main trunk channels and other heavily loaded circuits, and the perforated tape provides the only home records that are usually kept. For local circuits and way wires, transmission direct from the keyboard of the teleprinters is satisfactory.

#### *5.5.2.2 Tape Relay Operation*

Equipment layouts for tape relay offices vary widely depending primarily on office size. In the larger offices, it is common practice to mount the

equipment in frameworks or cabinets arranged in receiving and transmitting aisles. Each operator normally handles from 3 to 5 incoming circuits. All messages are transmitted from perforated tapes. Originating messages are prepared in a perforator pool and go to the receiving positions, where they are handled in the same manner as messages arriving over trunk circuits. Perforator operators are required for originating traffic only. Messages for delivery from a reperforator switching office pass over the intra-office circuits to local positions where the tapes are used to transmit the messages over delivery circuits to branch offices and customers.

As has already been pointed out, each incoming circuit is equipped with a typing reperforator and an associated cross-office transmitter and each sending position with a nontyping cross-office reperforator and a line transmitter. In addition, switching means are needed to connect the cross-office transmitters to the proper cross-office reperforator. Substantial amounts of automatic switching equipment, normally located outside the operating room, are required to control all the switching operations. Since messages are transmitted from point of reception to point of transmission electrically, little or no conveyor equipment is required.

For the same volume of traffic, floor space requirements are substantially less for tape relay than for manual relay offices. This applies also to space requirements for operating-personnel rest and locker rooms because of the substantial reduction in operating staff with tape relay.

#### *5.5.2.3 Automatic Switching*

Automatic switching centers consist primarily of equipment rooms with a very small operating section devoted to the handling of stored traffic. Transmitting and receiving teleprinter equipment is located in branch offices and other terminals at which messages are received for transmission and delivery. Space requirements are similar to those for comparable automatic telephone exchanges.

#### *5.5.2.4 Power Supply*

Each office should be provided with a reliable source of power. If reliable commercial power is

available, it is preferable to use it as the primary source. Most modern equipment is designed to operate directly from alternating-current power mains so that, generally, reserve storage batteries may be omitted. It is desirable, however, to have a gasoline- or diesel-engine-driven alternator for emergencies. These machines should be of sufficient size to provide full power for operating the office, including emergency lighting. Also, this emergency power supply should start and take the load automatically in case of power failure and should be capable of operation over extended periods.

## 6. Economic Selection

### 6.1 GENERAL

Having arrived at final fundamental plans for particular methods of operation, it is time to make economic and service comparisons. In these comparisons, it is essential to keep in mind that the ultimate object is to provide the fastest practicable service at the least possible cost. To determine the most economical arrangement capable of giving the required speed of service, it is necessary to take into account all factors entering into the cost of doing business, namely:

- A. Annual charges including interest, insurance, taxes, and depreciation on first cost or capital investment in lines, radio stations, right of way, equipment, and buildings.
- B. Maintenance charges, including materials, labor, supervision, and administration on lines, radio stations, equipment, and buildings.
- C. Operating costs, including direct wages, supervision, administration, and supplies.
- D. Social security or other taxes not otherwise included.
- E. Cost of leased lines, radio channels, equipment, and buildings.

After first costs of the systems under consideration are determined, annual charges, maintenance costs, operating costs, and other costs should be computed. Estimates should also be made for the 5-, 10-, and 20-year intervals. With these figures available, the various methods of operation should be compared and the method that fully meets requirements and promises to produce the best results economically should be adopted as the basic fundamental plan.

### 6.2 COST ESTIMATES

Since the cost comparisons referred to in 6.1 are to be made during the planning period, most, if not all, of the costs will be on an estimated basis. Line costs in general are well stabilized and can usually be estimated with considerable accuracy. Radio-station costs can be determined once the type of installation is known. Apparatus and transmission equipment costs are easily obtainable and, once quantities are determined and general office layouts visualized, over-all equipment costs can be estimated. Depreciation rates and maintenance costs for lines, equipment, buildings, etc. are well established. Considerable care, however, must be exercised in visualizing personnel requirements for the various operating arrangements, if reasonably accurate estimates of operating costs are to be realized. Consideration must be given to the adaptability of existing personnel to learn new operating methods and techniques. Training of new personnel may be required. It is thus important that engineers and others making these cost comparisons of different fundamental plans have broad experience in such work and that use be made of all available reliable information relating to the various systems and methods of operation.

## 7. Facsimile in Telegraph Service

Facsimile has long been thought of as a desirable method of transmitting recorded information. However, for long-distance operation, circuit costs have proved too high for trunk-line service. On the other hand, in local areas where a pair of wires is normally provided for telegraph service between outlying local points and a central telegraph office, the circuit cost ceases to be controlling and facsimile provides some attractive operating features. One of the most important is that operators with a high degree of training are not required. Recently developed units, which are simple, relatively inexpensive, and reliable, now offer a satisfactory means for message pick-up and delivery, particularly between main telegraph offices and smaller branch offices or important customers. In the United States, trials are being made with facsimile recorders mounted in motor cars for delivering telegrams to the public, particularly in

residential areas. Results have been encouraging both as to cost and improvement in service. It is still too early for definite conclusions but results indicate that facsimile may soon play an important role in local telegraph service.

## **8. Terminal Services**

### **8.1 PICK-UP AND DELIVERY**

The pick-up and delivery of messages has always been a difficult problem in public message systems. Three common methods employed for this purpose are:

- A. Messenger service.
- B. Telephone service.
- C. Direct circuits to customer's offices.

Of these three methods, the oldest and most common is messenger service. Many telegraph administrations do not pick up messages for transmission but require that they be filed in telegraph commercial offices; delivery is by messenger in most cases.

In business districts located near telegraph offices, messengers provide reasonably satisfactory service. In residential areas, this method is expensive if rapid delivery is maintained or unsatisfactory if a messenger is to carry a number of messages on each trip.

Many administrations now permit filing and delivery of messages by telephone, providing quick service at a reasonable cost. However, many customers object to delivery by telephone, particularly business messages.

In some countries, telegraph administrations provide circuits to and telegraph equipment (teleprinters, principally) in offices of customers having a large telegraph business. Sometimes this service is provided free on the basis that the savings in delivery costs offset the cost of circuits and equipment. In other cases, rental charges are made.

### **8.2 BRANCH OFFICES**

In metropolitan areas, it is common practice to establish branch offices for public filing of telegrams and to speed up delivery. Careful study of branch-office location is required if maxi-

imum benefits are to be obtained. Generally speaking, railway and air terminals, major hotels, and centers of major business activity are good locations. These branch offices should be connected to the central telegraph office either by pneumatic tubes if distances are short, or by teleprinter or facsimile circuits.

## **9. Implementation of Fundamental Plan**

### **9.1 GENERAL**

The principal emphasis up to this point has been on formulating a sound fundamental plan primarily because a clear picture of the ultimate setup is essential if a fully successful, modern, efficient telegraph service is to be realized. However, the establishment of a fundamental plan is only a first step and there remains the major problem of converting existing plant, equipment, and operating setup into the new system. To accomplish this, it is essential to determine those portions of the existing system that can be retained in the new system, those that can be modified, and those that must be scrapped.

### **9.2 STANDARDS**

One of the first problems in modernization work is the establishment of standards. This involves providing standards for outside plant construction, for performance of both transmission and operation equipment, for maintenance of both outside and inside plant, standard operating methods and procedures, office arrangements, and a multitude of minor details too numerous to enumerate. To accomplish this task, the planning engineer must be thoroughly conversant with modern practices, equipment, and operating methods. Fortunately, literature dealing with present-day construction practices, modern equipment, and operating methods is available from many sources.

### **9.3 SCHEDULING**

A second and equally important consideration is the timing of the various operations so as to obtain maximum benefit from each step while causing the least disturbance to normal operations.

### 9.3.1 Outside Plant

No telegraph system can be expected to function reliably and efficiently without adequate and highly stable circuits. This is especially true where tape relay or automatic teleprinter switching are employed. Thus, the first approach is a careful review of outside plant and a determination of the changes that must be made. This should be followed by a schedule of when changes are to be made since, obviously, the whole job cannot be done at one time. Here again, an attempt should be made to obtain maximum benefits at the earliest possible moment. In addition to major scheduled changes, all normal routine rebuilding and maintenance work should meet the new standards. It may also be necessary very early in the project to set up courses of instruction for teaching proper construction and maintenance methods to produce high-quality results.

### 9.3.2 Inside Plant

What is true of outside plant is likewise true of inside plant. Changes should be carefully engineered and scheduled to obtain maximum early benefit. Where carrier operation is to be introduced into a plant, it is essential that those responsible for its installation, operation, and maintenance be thoroughly trained for their work. Schools for such training are highly desirable if not absolutely essential. Since teleprinters and similar equipment form the principal operating-room apparatus, training of both operating and maintenance personnel must be given careful attention.

### 9.3.3 Operating Rooms

Special consideration must be given to equipment- and operating-room layouts. Different methods of operation require radically different arrangements of operating and equipment rooms. Layouts should be made with the final requirements in view, allowing adequate space for growth. Special attention should be given to the flow of traffic through the office to minimize handling and other time-consuming operations. Special rooms should be provided for filing and delivery of telegrams by telephone. These rooms

should be carefully planned to eliminate unnecessary delays and confusion. Sound-proofing treatment is desirable. For incoming calls, special allotter equipment will insure calls being answered in the order in which they are received. In larger offices, in particular, adequate provision should be made for rest rooms, locker rooms, and in many cases for restaurant or cafeteria service.

## 9.4 SUMMARY

To summarize, every modernization project should be not only carefully planned but each step should be properly engineered and scheduled so that, as each part is completed, it will fit into a coordinated whole without expensive and disturbing changes and with little or no disruption to normal operations. So planned and executed, such projects can produce a thoroughly modern, efficient, and satisfactory telegraph system.

## 10. Bibliography

The following list of descriptive literature and technical articles is given with a view to providing a source of information covering many phases of modern telegraph practices and equipment.

1. R. F. Blanchard and W. B. Blanton, "Push Button Switching in Telegraph Systems," *American Institute of Electrical Engineers Technical Papers*, TP 48-317; 1948.
2. R. F. Blanchard and W. B. Blanton, "The Development of Western Union Switching Systems," *Western Union Technical Review*, v. 2, pp. 75-92; April, 1948.
3. W. B. Blanton and F. L. Currie, "Push Button Switching," *Western Union Technical Review*, v. 2, pp. 119-127; July, 1948.
4. F. B. Bramhall, "High-Speed Voice-Frequency Carrier Telegraph System," *Transactions of the A.I.E.E.*, v. 59, pp. 873-878; 1940.
5. W. A. Brandt, R. G. Maddox, and A. C. Phillips, "9-A-1 Single-Channel Carrier Telephone System," *Electrical Communication*, v. 23, pp. 278-290; September, 1946.
6. P. J. Clemens, "Some Recent Developments in Teleprinter Switching Systems," *Electrical Communication*, v. 16, pp. 263-275; January, 1938.
7. F. E. D'Humy and H. L. Browne, "Recent Developments in Telegraph Switching," *Transactions of the A.I.E.E.*, v. 59, pp. 71-78; 1940.
8. F. E. D'Humy and P. J. Howe, "American Telegraphy After 100 Years," *Transactions of the A.I.E.E.*, v. 63, pp. 1014-1032; 1944.

9. R. F. Dirkes, "A Modern Reperforator Switching System for Patron Telegraph Service," *Western Union Technical Review*, v. 2, pp. 138-149; October, 1948.
10. J. A. Duncan, R. D. Parker, and R. E. Pierce, "Telegraphy in the Bell System," *Transactions of the A.I.E.E.*, v. 63, pp. 1032-1044; 1944.
11. E. V. D. Glazier, "Problems Involved in the Design of Radio Links for Teletypewriter Operation," *Proceedings of the I.R.E. (Australia)*, v. 9, pp. 16-20; June, 1948.
12. L. H. Harris, "Automatic Teletypewriter Switching," *Post Office Electrical Engineers' Journal*, v. 29, pp. 217-219; October, 1936.
13. L. H. Harris, E. H. Jolley, and F. O. Morrell, "Recent Developments in Telegraph Transmission, and Their Application to the British Telegraph Services," *Journal of the Institution of Electrical Engineers*, v. 80, pp. 237-268; discussion, pp. 268-285; March, 1937.
14. P. Machanik and E. H. Harwood, "The Cape Town-Johannesburg Carrier Telephone and Associated Voice Frequency Telegraph System," *Electrical Communication*, v. 15, pp. 52-57; July, 1936.
15. A. L. Matte, "Advances in Carrier Telegraph Transmission," *Bell System Technical Journal*, v. 19, pp. 161-208; April, 1940.
16. R. E. Page and J. L. Skerrett, "Developments in Carrier Telegraph Transmission in Australia," *Electrical Communication*, v. 22, n. 3, pp. 226-245; 1945.
17. W. T. Perkins, "Modern Telegraph Systems and Equipment," Newnes, London, 1946.
18. G. H. Ridings, "Facsimile Transmission for Pickup and Delivery of Telegrams," *American Institute of Electrical Engineers Technical Papers TP 48-233*; 1948: *Western Union Technical Review*, v. 3, pp. 17-25; January, 1949: *Electrical Communication*, v. 26, pp. 129-137; June, 1949.
19. J. D. M. Robinson and E. V. D. Glazier, "International Automatic Telegraph Networks," *Journal of the British Institution of Radio Engineers*, v. 7, pp. 266-297; November-December, 1947.
20. F. Schmidl, "Subscriber Dialing and the Public Telegraph (in German)," *O.T.F.*, v. 1, pp. 92-98; November-December, 1947.
21. F. J. Singer, "Military Teletypewriter Systems," *American Institute of Electrical Engineers Technical Papers, TP 48-251*; 1948.
22. R. B. Shanck, F. A. Cowan, and S. I. Cory, "Recent Developments in the Measurement of Telegraph Transmission," *Bell System Technical Journal*, v. 18, pp. 143-189; January, 1939.
23. F. J. Tickner, "Telegraph Switching," *Post Office Telecommunications Journal*, v. 1, pp. 4-7; November, 1948.
24. G. S. Vernam, "An Automatic Concentration Unit for Printing Telegraph Circuits," *Electrical Communication*, v. 10, pp. 200-209; April, 1932.

### Recent Telecommunication Development

#### Dublin-Cork Telephone Cable

**A**N UNDERGROUND CABLE is being laid in Eire between Dublin and Cork as the overhead lines now in use are loaded to capacity. This cable will contain two coaxial tubes, which with repeaters at 6-mile intervals are capable of handling 600 telephone channels. Regular wires are also included to provide circuits between intermediate places.

The cable will go from Dublin through Port Laoighise and Limerick to Cork. Later, branches will be added from Port Laoighise to Athlone to serve Galway and the west and to Waterford via

Kilkenny. The circuits passing through Mallow on the Limerick-Cork section will also be extended from there to Killarne and Tralee. A no-delay service over the greater part of the internal trunk system will result. Provision has been made for broadcast program circuits.

The various sections will be placed in service as they are completed; the entire project will require about two years. The cable and associated equipment are being installed under the supervision of Post Office engineers by Standard Telephones and Cables, Limited.



# Carrier Telegraph System Using Frequency Modulation

By J. L. JATLOW and B. B. MAHLER

*Federal Telephone and Radio Corporation, Clifton, New Jersey*

**E**LECTRICAL and mechanical characteristics of the *9-E-1* carrier telegraph system, employing frequency-shift modulation, are discussed. Sending and receiving channels may be stacked to provide up to 19 two-way high-quality teleprinter circuits in the spectrum width of a single voice-frequency telephone channel (300–2750 cycles per second).

• • •

## 1. General Description

A voice-frequency carrier telegraph system has been designed to answer the need for a high-quality teleprinter communication system providing up to 19 channels of full-duplex telegraphy. It is suitable for application to physical lines, radio links, or carrier communication circuits from which a 4-wire or 2-wire telephone circuit can be derived.

By the use of specially designed separation and directional filters, up to 6 duplex telegraph channels may be added to a speech channel (speech-plus-duplex system). This is accomplished by separating the upper part of the speech channel by means of filters and using this portion for telegraphy. The greater the number of telegraph channels to be added, the more the speech band must be reduced.

A multichannel telemetering system is obtained by the elimination of the loop-control panels and the telegraph power supplies. The signaling relays may be mounted on the carrier channel-terminal panel or on a separate panel, depending on the type of relay used.

Frequency modulation is employed, which results in a system practically immune to sudden or slow changes in received signal level within its entire range of sensitivity, and also gives a greatly improved signal-to-noise ratio over existing amplitude-modulation systems.

Table 1 shows the frequency allocations of the various channels. The space frequency is 30

cycles below, and the mark frequency 30 cycles above the nominal channel mid-frequency.

The system is flexible in that it is assembled on a unit basis. Separate transmitter and receiver panels are used for each channel. Loop-control panels and power supplies are also arranged for maximum flexibility, permitting the installation of only the equipment needed for the initial demand, and the later acquisition of additional units to meet growing traffic.

A complete 18-channel telegraph terminal may be mounted either on two 11-foot 6-inch (3.51-meter), or on three 8-foot 8-inch (2.64-meter) standard 19-inch (48.26-centimeter) relay racks. Optional bay arrangements are provided to conform to different heights of racks or to accommodate different numbers of channels. A 6-channel bay is shown in Figure 1.

Ease of maintenance is achieved by making all wiring and active components, such as tubes, controls, and relays, that may require service during operation, accessible from the front, with all inert parts such as transformers and filters

TABLE 1  
CHANNEL FREQUENCY ALLOCATIONS

Channel	Mid-Frequency in Cycles	Channel	Mid-Frequency in Cycles
1	420	11	1620
2	540	12	1740
3	660	13	1860
4	780	14	1980
5	900	15	2100
6	1020	16	2220
7	1140	17	2340
8	1260	18	2460
9	1380	19	2580
10	1500		

mounted on the rear of the panels. Hermetically sealed components are used throughout.

A complete installation includes the equipment listed in Table 2. A rack of test equipment developed for the maintenance of the system is illustrated in Figure 2.

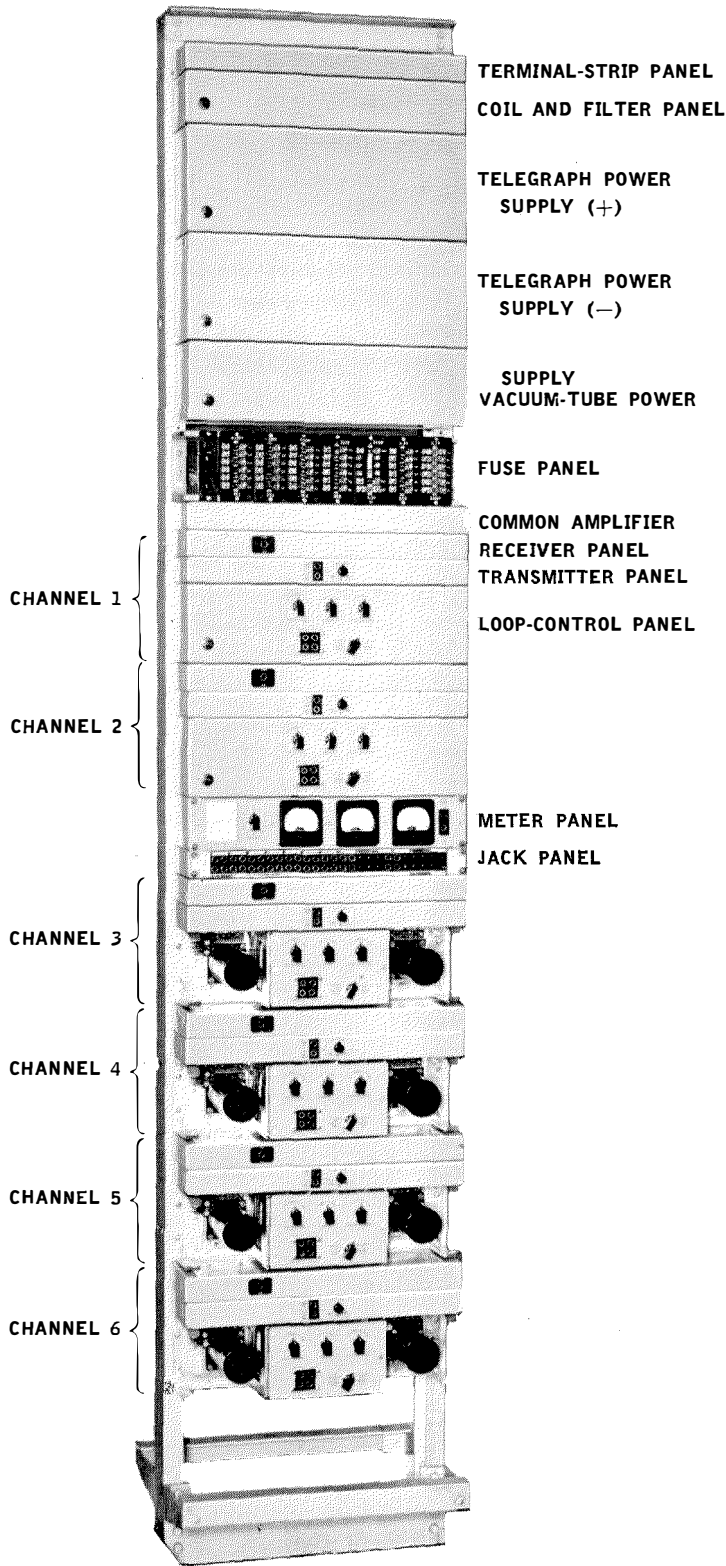

Figure 1—6-channel carrier telegraph system on 8-foot 8-inch rack.

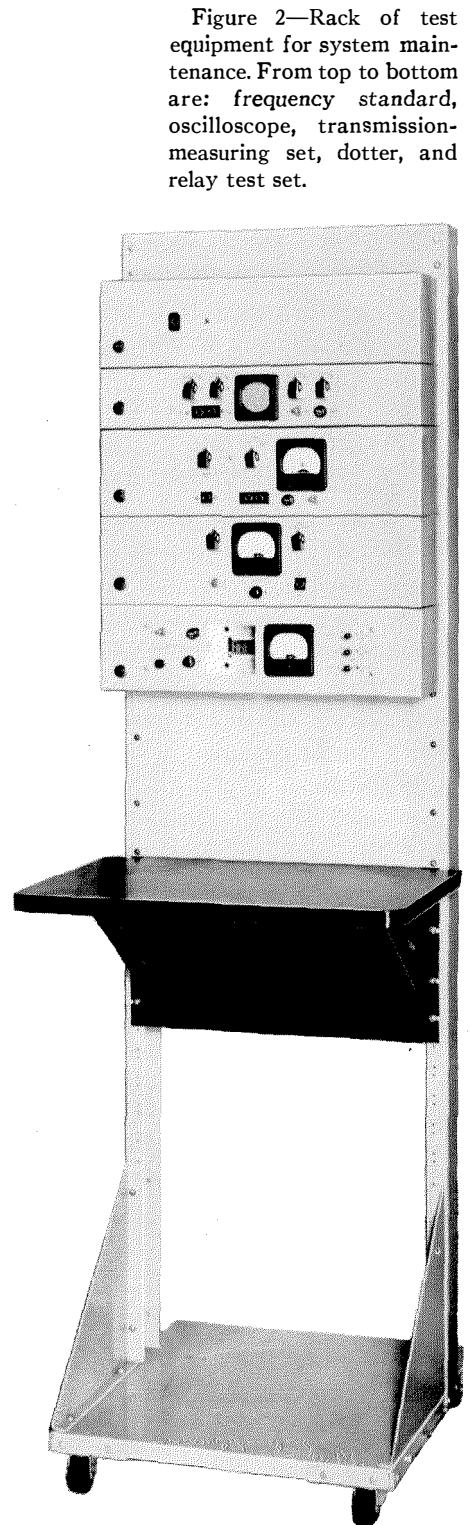

Figure 2—Rack of test equipment for system maintenance. From top to bottom are: frequency standard, oscilloscope, transmission-measuring set, dotter, and relay test set.

2. Channel Equipment

A transmitter panel, receiver panel, and loop-control panel are required for each channel terminal. These are discussed below.

2.1 TRANSMITTING CIRCUIT

Figure 3 shows a simplified schematic diagram of the transmitting circuit, including a portion of the telegraph loop-control circuit for full-

frequency-determining elements in the oscillator circuit and the pass band of the sending filter.

Electrically, the circuit includes a 6SN7 dual triode, one section of which is operated as a resistance-stabilized Hartley oscillator, and the other section as a cathode-follower buffer-amplifier at the transmitter output. Positive or negative 130-volt direct-current bias, corresponding to the mark or space telegraph signal, is applied through a pulse-shaping network to a

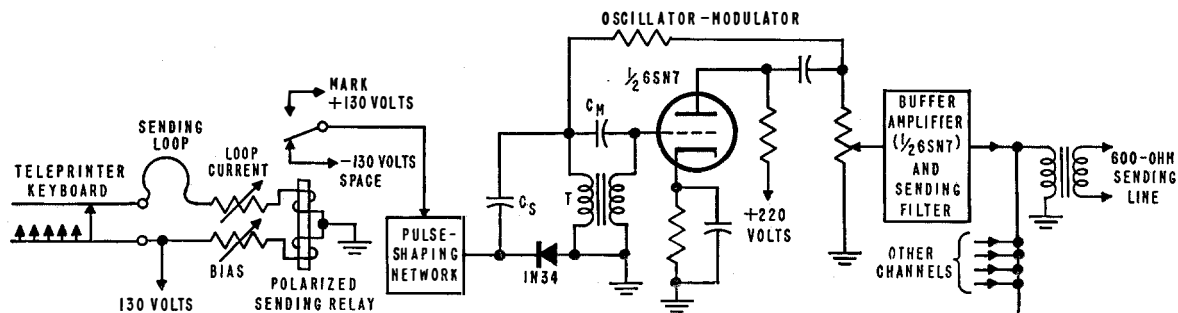

Figure 3—Transmitting circuit of a single channel.

duplex transmission. As mentioned above, one such circuit is used at each channel terminal, and all are alike, except for the values of the fre-

quency-determining elements in the oscillator circuit and the pass band of the sending filter. When the negative signal corresponding to the space condition is applied, the diode conducts, and capacitor  $C_s$  is effectively connected across the primary of transformer  $T$ , causing the oscillator frequency to drop to 30 cycles below the mid-band frequency. When the diode is cut off by the positive mark signal, the oscillator frequency is determined by the inductance of  $T$  and the capacitance of  $C_m$ , and is 30 cycles above the mid-band frequency.

TABLE 2

CARRIER TELEGRAPH EQUIPMENT ON RELAY RACK

Equipment	Vertical Mounting Spaces*	Number Required for 18-Channel System
Channel Equipment		
Transmitter Panel	1	18
Receiver Panel	1	18
Common Amplifier	1	1
Telegraph-Loop Control	3	18
Power Supplies		
For Telegraph Loops	4	4
For Vacuum-Tube Circuits	3	2
Miscellaneous Equipment		
Terminal-Strip Panel	1	2 or 3
Fuse Panel with Alarms	3	2 or 3
Coil and Filter Panel	1 or 2	1
Jack Panel	1	2 or 3
Meter Panel	2	1
Test Equipment		
Transmission-Measuring Set	3	One set of test equipment per office is recommended.
60-Cycle Frequency Standard	3	
2-Inch Oscilloscope	2	
Dotter	3	
Relay Test Set	3	

The level of the transmitter output is adjusted by the voltage divider in the oscillator plate circuit. The oscillator signal is amplified by the buffer-amplifier stage and is then applied through the sending filter to the line. A characteristic curve of a typical sending filter is given in Figure 4.

2.2 RECEIVING CIRCUIT

Each receiver uses a filter to select its proper band of frequencies from the combined signal on the line. A characteristic curve of such a filter is given in Figure 4. Figure 5 illustrates the circuit of a receiver, including a portion of the telegraph loop-control circuit for full-duplex reception.

\* One mounting space on a standard 19-inch relay rack is 1 3/4 inches (4.45 centimeters).

The output from the filter is amplified and limited in a circuit using a *6SL7* dual triode. The output of the limiter is constant for all input levels above 25 decibels below 1 milliwatt ( $-25$  dbm), the nominal sensitivity of the receiver, and hence no input level control is necessary. Instantaneous limiting occurs over the entire range of sensitivity.

The discriminator circuit comprises two transformers, one tuned to the mark and the other to the space frequency, connected at the limiter output. The outputs of the tuned circuits are rectified to produce negative voltages at the grids of the *6SN7* flip-flop circuit. A mark signal causes a higher negative voltage at point *A* than at point *B* (Figure 5), thus cutting tube *S* off and

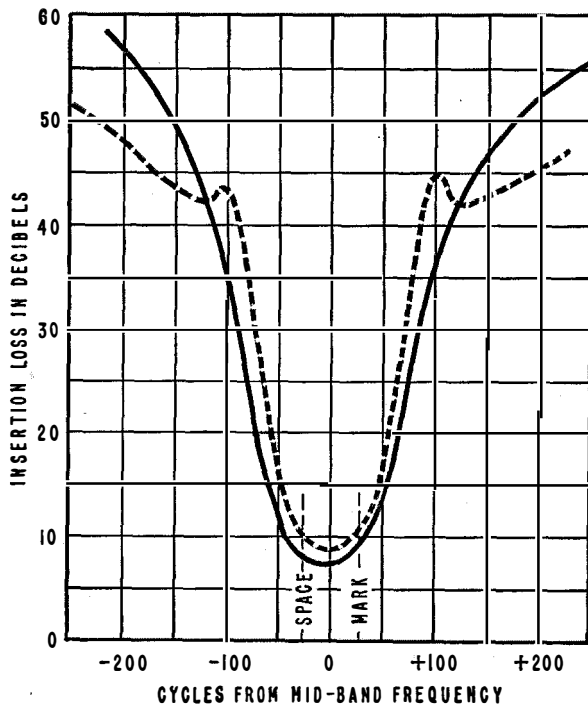

Figure 4—Band-pass characteristics of the sending filter (solid) and receiving filter (dotted) for a typical channel.

making tube *M* conduct. This action reverses with a space signal.

The receiving relay is connected in the plate circuit of the *6SN7*, and operates on a differential current of approximately 10 milliamperes. The action of the flip-flop circuit is extremely rapid, and thereby restores the square shape of the telegraph signals.

### 2.3 COMMON AMPLIFIER

The nominal receiving-terminal sensitivity of 25 decibels below 1 milliwatt is sufficient in all cases where a carrier telephone channel is used as a transmission medium. Where physical lines are used, a greater sensitivity is often desirable. For this purpose, rather than penalize each telegraph-channel receiver with an additional stage of amplification, a common amplifier was designed for installation ahead of the receivers. It is of conventional design with 600-ohm input and output impedances, and employs a *6SN7* dual triode in a resistance-coupled circuit with approximately 20 decibels of negative feedback. Maximum gain is 20 decibels, continuously variable.

### 2.4 LOOP CONTROL

The direct-current telegraph loop-control panel is arranged to provide a choice of any of the following loop-operating conditions:

- Option 1—Neutral to negative battery at station.  
Half or full duplex.
- Option 2—Neutral to positive battery at station.  
Half or full duplex.
- Option 3—Neutral to ground, negative marking battery.  
Half or full duplex.
- Option 4—Neutral to ground, positive marking battery.  
Half or full duplex.
- Option 5—Differential polar duplex.
- Option 6—Two-path polar.

One panel is used for each channel and includes the sending and receiving relays, the loop-current controls, and the sending-bias-adjustment rheostat. A strapping board is provided for the selection of any of the above options. A toggle switch changes operation from full duplex to half duplex as required.

## 3. Power Supplies

### 3.1 TELEGRAPH-LOOP SUPPLY

In installations where no office batteries are available, two regulated power supplies are required to furnish positive and negative 130-volt potentials for operation of the direct-current loops of up to 9 channels. Each of these operates

from a 115/230 volt, 60-cycle source, and delivers up to 1.5 amperes at 130 volts,  $\pm 1$  percent. A simplified schematic diagram is given in Figure 6.

To prevent distortion of the direct-current telegraph signals due to the rapidly changing

such a direction as to shift the firing angle of the thyratrons and return the output to the correct value.

Strapping arrangements are provided at the power-supply terminals to change the polarity

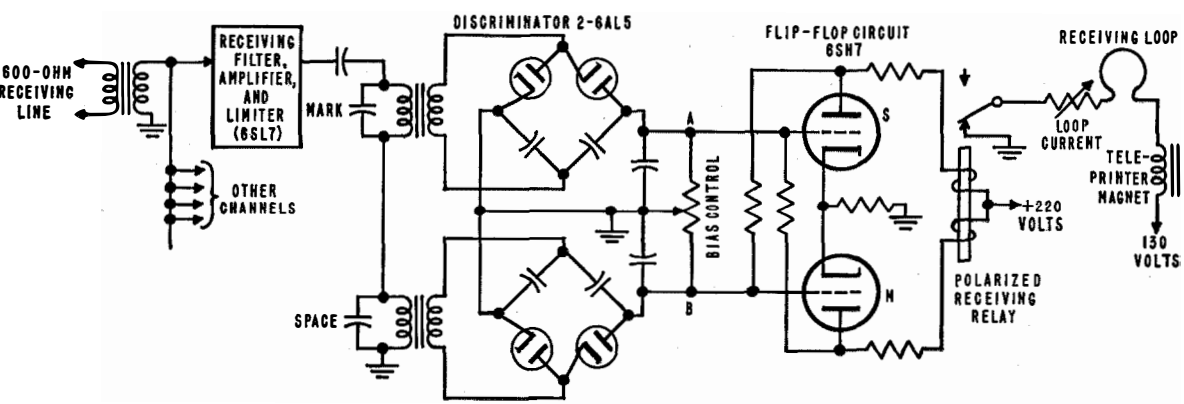

Figure 5—Circuit of a channel receiver. A multivibrator-type circuit operates the polar relay.

load, particularly where several direct-current telegraph loops are operated from the same supply, good regulation and dynamic characteristics of the telegraph power supplies are of great importance.

A good dynamic characteristic of the output is obtained with the use of *ELC3J* thyratrons followed by a high-capacitance resistance-capacitance filter in the output circuit. Regulation is obtained by (A) the use of a 90-degree phase-shifting network that changes the phase of the grid voltage with respect to the plate voltage of the thyratrons, (B) a constant reference voltage obtained across the *VR-105* regulator tube, and (C) a portion of the direct current output applied in series with the phase-shifted grid voltage. Any voltage change at the power-supply output acts in

of the output voltage with respect to ground. A single design of power supply thus suffices for both positive and negative supplies.

3.2 SUPPLY FOR VACUUM-TUBE CIRCUITS

This power supply is of conventional design and furnishes plate and filament power for up to

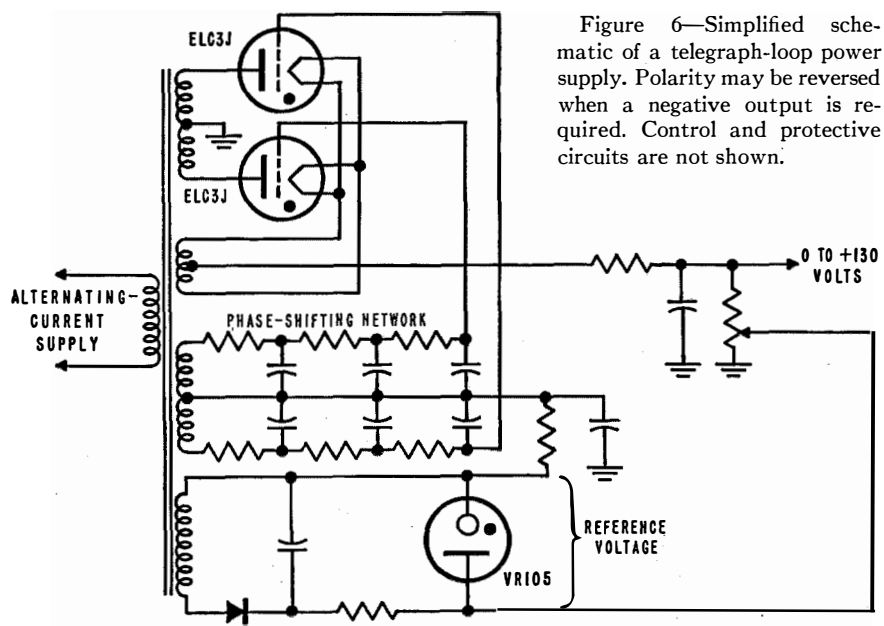

Figure 6—Simplified schematic of a telegraph-loop power supply. Polarity may be reversed when a negative output is required. Control and protective circuits are not shown.

9 channels of equipment. It operates from a 115/230-volt, 50/60-cycle supply, and delivers 210 milliamperes at 220 volts, and up to 24 amperes at 6.3 volts alternating current.

#### 4. Test Equipment

A photograph of a rack of test equipment is given in Figure 2. The rack is mounted on casters to make it movable, so that only one set of test equipment is required for an office.

To operate a direct-current telegraph system with consistently good results, it is necessary that the telegraph relays, bias controls, and loop currents be maintained in proper adjustment. Voice-frequency carrier-telegraph systems require additional adjustment for proper operation of the electronic circuits.

While the *9-E-1* is a frequency-modulation system, and is independent of level changes on the lines, it is advisable to line it up for operation at a point in the middle of its sensitivity range. This permits line fluctuations over the entire sensitivity range to occur without affecting good operation.

#### 4.1 TRANSMISSION-MEASURING SET

A vacuum-tube voltmeter is provided for lining up the system as well as for voltage measurements on the electronic circuits of the system. The meter is calibrated in decibels (0 decibels=1 milliwatt in 600 ohms) as well as in root-mean-square volts.

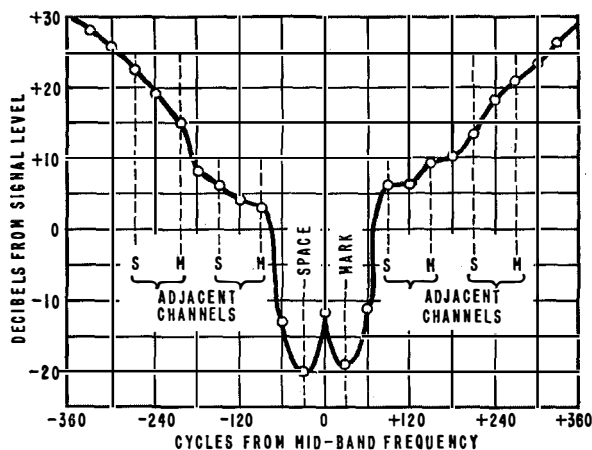

Figure 7—Curve showing level of single-frequency interference producing 4-percent distortion in a telegraph circuit at 75 words per minute.

#### 4.2 FREQUENCY STANDARD AND OSCILLOSCOPE

The crystal-controlled 60-cycle frequency standard (accurate to within  $\pm 0.01$  percent) and the 2-inch oscilloscope are used together to provide a convenient method for accurately setting each channel on its proper frequency. The mark and space frequencies of each of the 19 channels of the system are integral multiples of 60 cycles. By applying the 60-cycle standard frequency to one pair of the oscilloscope deflection plates, and the output of a channel transmitter to the other pair, the correct mark and space frequencies can be determined by two criteria:

A. The Lissajou figure is stationary, or almost stationary, and shows a single crossover indicating that the transmitter output is a multiple of 30 cycles.

B. The amplitudes of the mark and space signals are approximately the same. This indicates that the two frequencies are symmetrically located in the center of the sending band-pass filter.

If, by some error, a stationary pattern is obtained that is 30 or 60 cycles off the correct frequency, this error will be indicated by a large difference between mark- and space-signal amplitudes because one of the two frequencies will be outside the sending-filter pass band.

#### 4.3 DOTTER SET

The dotter test set uses a vacuum-tube oscillator to operate a polar relay that produces neutral or polar reversals for lining up direct-current telegraph loop circuits. Reversals are available at 23, 28, and 37 cycles, corresponding to teleprinter speeds of 60, 75, and 100 words per minute.

#### 4.4 RELAY TEST SET

A test set is provided for testing the electrical bias and the sensitivity of the Western Electric 255A polar relays used in the transmitting and receiving circuits.

### 5. Performance Data

Tests made on the system showed that at 60 words per minute the peak distortion ranged between 1.5 and 4 percent; at 75 words per

minute, the distortion was between 2 and 5 percent; and at 100 words per minute, between 4 and 9 percent.

Tandem operation of 6 random channels at 60 words per minute produced a total distortion of 20 percent.

The advantages and disadvantages of frequency-modulation versus amplitude-modulation telegraphy have been covered to a great extent in previous literature. The main points of consideration, when comparing the two methods, have been:

- A. Effects of slow and sudden variations in signal amplitude.
- B. Effects of noise interference (including effects of lightning and other disturbances).
- C. Effects of variation of the signal frequency.

The performance data of the present system with respect to these 3 criteria follows.

### 5.1 AMPLITUDE VARIATIONS

The amplifier-limiter circuit of the receiver panel presents a constant output to the discriminator for all levels above 25 decibels. The action of the limiter is instantaneous, and the system, therefore, withstands sudden or slow level changes over its entire range of sensitivity without noticeable effect on distortion.

### 5.2 INTERFERENCE FROM NOISE

The curve of Figure 7 was obtained by determining the single-frequency interference level that introduces approximately 4-percent distortion in a telegraph circuit sending a miscellaneous signal ("Quick brown fox") at 75 words per minute (28 cycles), and adjusted to a 1-milliwatt level.

It can be seen from the curve that at the space and mark frequencies of a channel, i.e., in the pass band of the channel receiving filter, a single interfering frequency must be 20 decibels below the signal level to introduce 4-percent distortion. Outside the pass band of the filter, the signal-to-noise ratio improves very rapidly. At the adjacent channel, the interfering frequency may be 3 decibels, and at the next removed channel, 15 decibels above the signaling level without introducing objectionable distortion. It may be

concluded, therefore, that noise peaks as high as 20 decibels below signaling level, as well as the disturbance from adjacent channels, have negligible effect on the quality of transmission.

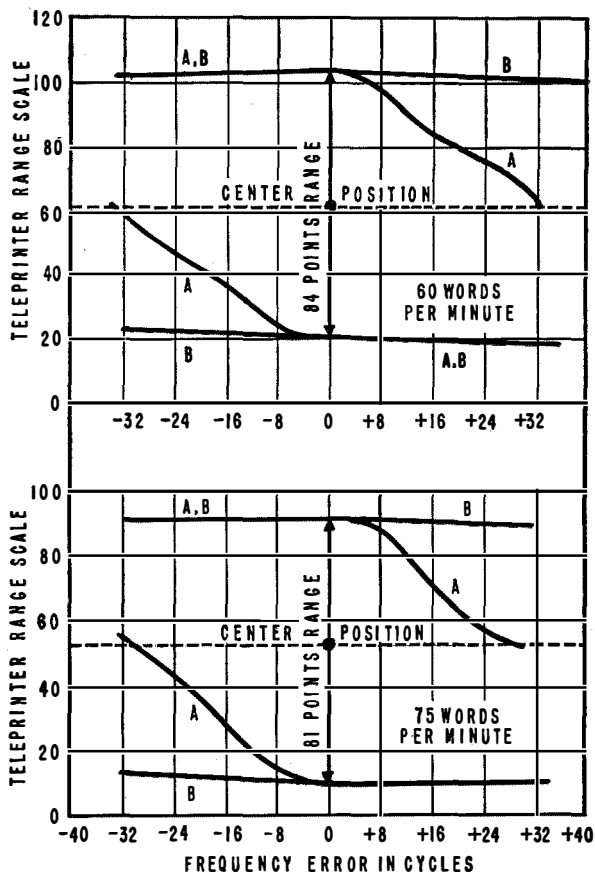

Figure 8—Curves showing effect of variation in center frequency of a telegraph channel. A—no adjustment of receive-bias control, and B—bias control readjusted for zero bias.

### 5.3 VARIATION OF SIGNAL FREQUENCY

The curves of Figure 8 were obtained by varying both space and mark frequencies with respect to the channel mid-band frequency without disturbing the frequency interval (60 cycles) between them. Such a condition can be caused by variation of the carrier frequency of the telephone channel over which the telegraph system is operating. In both figures, curve A represents the condition when no adjustment whatever was made, and curve B the condition when the receive-bias control on the channel



receiver was adjusted to indicate zero bias on reversals.

The curves of Figure 8 indicate the change of teleprinter orientation range with frequency error. The useful orientation range of any particular teleprinter may be between 75 and 90 points depending on the mechanical condition of the machine. The 60-word-per-minute teleprinter used in the test to obtain the upper curves of Figure 8 would print without error over a local loop when the range scale was set from 20 to 106 points, resulting in a range of 86 points.

When printing over a channel of the 9-E-1 system that was lined up for zero bias and zero frequency error, the range obtained was 20 to 104, or 84 points. Introducing a frequency error of, say, +16 cycles, the range can be read from the curves to be 19 to 84, or 65 points. Readjusting the receive-bias control for zero bias, the full

range of 84 points was restored. Furthermore, it can be seen that when the system is originally lined up for zero bias and zero frequency error and (after determining the extreme settings of the range) when the adjustment is set to the center position of 62 points, the frequency may change as much as 32 cycles in either direction

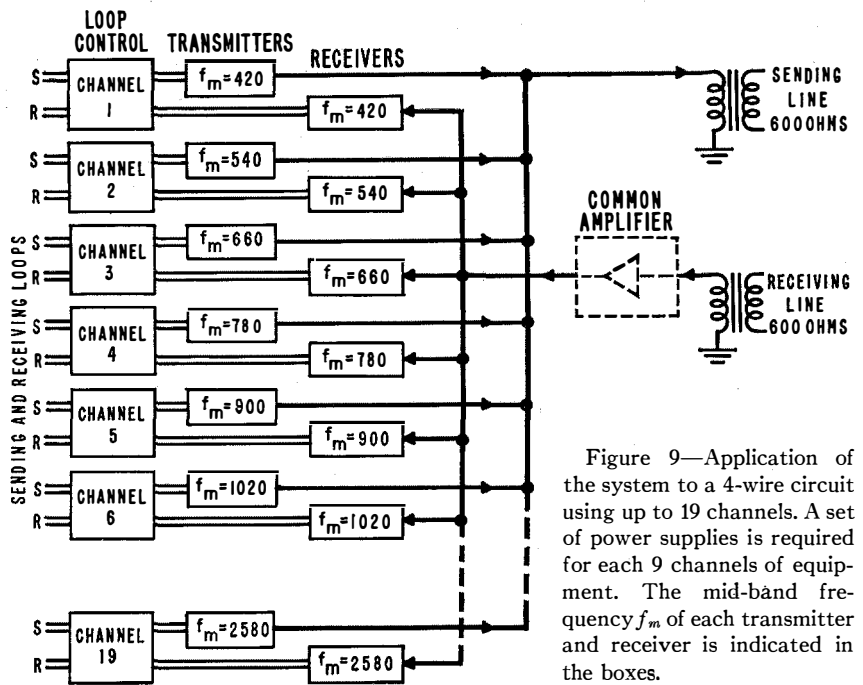

Figure 9—Application of the system to a 4-wire circuit using up to 19 channels. A set of power supplies is required for each 9 channels of equipment. The mid-band frequency  $f_m$  of each transmitter and receiver is indicated in the boxes.

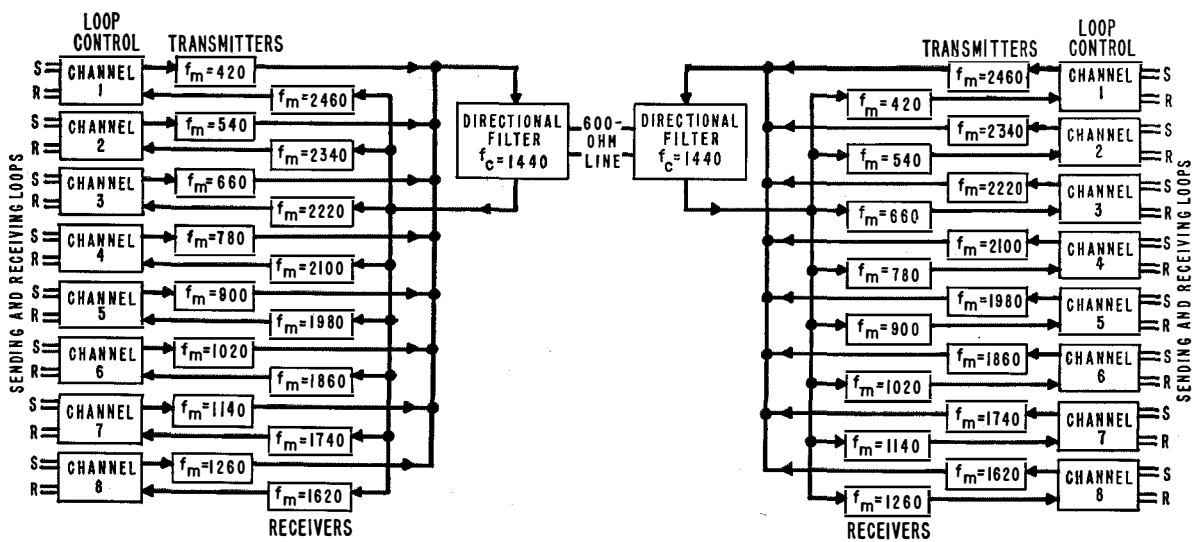

Figure 10—Up to 8 channels may be arranged in a 2-wire circuit as above. The crossover frequency  $f_c$  of the directional filters is 1400 cycles in each case.

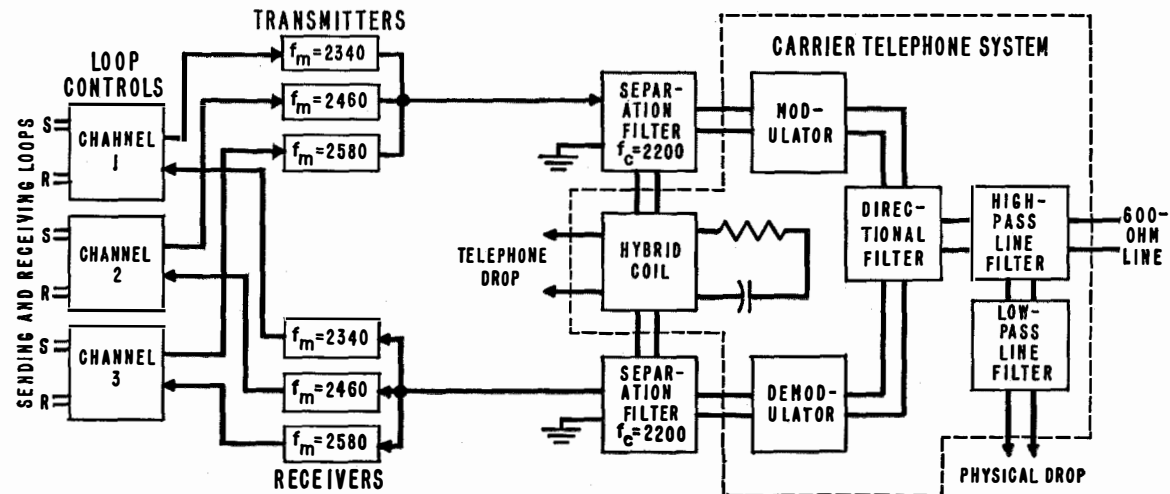

Figure 11—Speech-plus-3-duplex carrier telephone system applied to a carrier telephone system. The crossover frequency  $f_c$  of the separation filters is 2200 cycles.

before service fails. The lower curves of Figure 8 for 75 words per minute may be interpreted in a similar manner.

**6. Applications**

Typical applications of the 9-E-1 system are shown in Figures 9, 10, and 11. In Figures 10 and 11, a common receiving amplifier (shown in Figure 9 only) may be used to increase the

receiver sensitivity of each channel to 45 decibels below 1 milliwatt.

Figure 11 shows a typical speech-plus-3-duplex system. Speech-plus-6-duplex may be obtained by using channels 14 ( $f_m = 1980$ ), 15 ( $f_m = 2100$ ), 16 ( $f_m = 2220$ ), 17 ( $f_m = 2340$ ), 18 ( $f_m = 2460$ ), and 19 ( $f_m = 2580$ ), and separation filters with a crossover frequency near 1700 cycles.

# Multicathode Gas-Tube Counters

By G. H. HOUGH

*Standard Telephones and Cables, Limited, London, England*

and D. S. RIDLER

*Standard Telecommunication Laboratories, Limited, London, England*

A SHORT HISTORY is given of gas-tube counters, together with comments on their performance. A new principle of priming is described together with some types of counter that result from different electrode combinations. A practical decade uni-directional counter is introduced and performance details are given with typical circuits to illustrate its operation.

. . .

The suitability of the gas-discharge gap as a two-position device for use in counting chains was first recognised by Wynn-Williams, who presented a paper<sup>1</sup> to the Royal Society in 1931 disclosing some basic circuit arrangements using hot-cathode thyratrons. Much of his technique proved to be fundamental and is still in use at the present time. Later, circuit designers recognised advantages of the cold-cathode discharge, which are the absence of heater supplies and the visibility of the glow. A paper<sup>2</sup> on cold-cathode tubes as circuit elements in 1939 showed counter circuits based on the original Wynn-Williams techniques, and in 1942 a counter<sup>3</sup> was designed that is representative of modern counter-design trends using individual cold-cathode tubes; it will now be described as a background to more recent work.

Figure 1 shows a number of cold-cathode trigger tubes *CTA* . . . *CTN* arranged as an *N*-stage counter. Assume that any one tube, say *CTA*, is conducting and that current is flowing from the positive supply through the common anode load resistance *R1*, the main gap of *CTA*, resistances *R2* and *R3* to earth. Capacitor *C1* will

have charged to the potential across *R2* and *R3* and in addition *C2* will have charged to the potential across *R3* to raise the potential of the trigger electrode of *CTB*. If, now, a positive pulse is applied to lead *CL* of insufficient amplitude to break down a trigger-cathode gap except when added to the potential across *R3*, only tube *CTB* will trigger and conduct. Current will flow through the common load *R1* and depress the anode voltage. As initially *C1* is charged and *C3* not, the potential drop across *CTA* is reduced below its maintaining potential and, with proper choice of constants, *CTA* can be extinguished. *C3* will charge with a time constant of

$$\frac{R1 \cdot (R4 + R5) \cdot C3}{R1 + R4 + R5}$$

while *C1* discharges through *R2* and *R3* in series. Capacitor *C4* charges through *R6* and prepares or primes tube *CTC* so that it is triggered by a further pulse to extend bias to *CTD* and so on. The ring is completed by tube *CTN* priming the first tube *CTA*.

In view of later developments it is of interest to note here that double-trigger gas tubes have been used to make so-called reversible counters.<sup>4</sup> The potential from each tube primes both the preceding and the following tube, each priming direction being associated with a pulse lead, so that the position of the discharging tube is moved forward by a pulse on one lead and backward by a pulse on the other.

An alternative to this pulse-and-bias method is the use of a simple rectifier gate circuit between stages, which gives an advantage in speed of operation at some slight increase in complexity. It should be realized, however, that all these depend ultimately for their operation upon a potential from a conducting tube which, when

<sup>1</sup> C. E. Wynn-Williams, "The Use of Thyratrons for High Speed Automatic Counting of Physical Phenomena," *Proceedings of the Royal Society*, v. 132; July, 1931.

<sup>2</sup> S. B. Ingram, "Cold-Cathode Gas-Filled Tubes as Circuit Elements," *Electrical Engineering*, v. 58, pp. 342-346; July, 1939.

<sup>3</sup> F. H. Bray and L. R. Brown, British Patent 566,156.

<sup>4</sup> A. J. Mullerkey, British Patent Application 15,812/48.

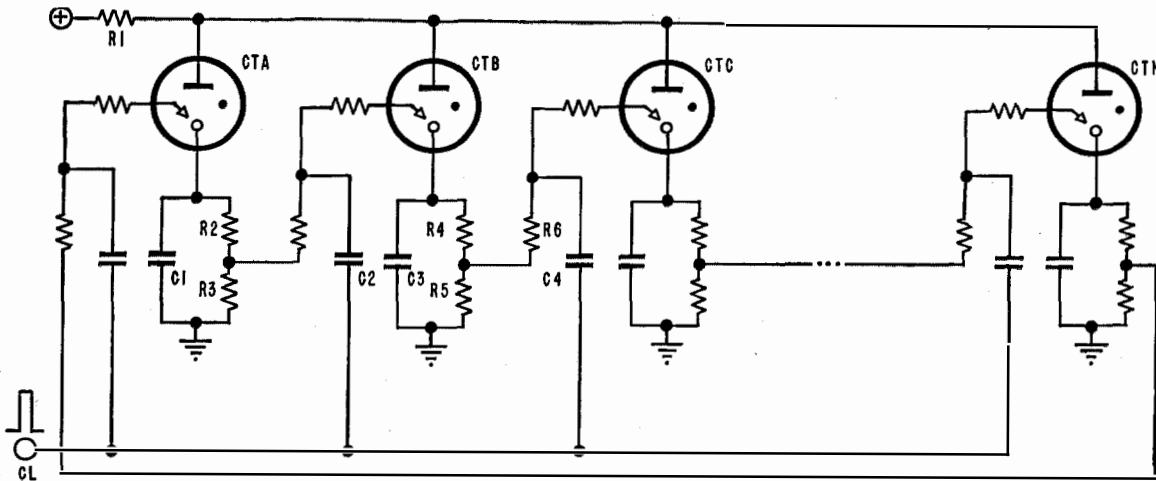

Figure 1—Counting chain using cold-cathode trigger tubes.

combined with a pulse, causes a following tube to fire.

Despite the flexibility of the individual tube counter, designers felt the requirement for a design that combined the known advantages of the cold-cathode counters with higher speed and greater simplicity. The inclusion within a single envelope of a number of counting gaps could be practical only if the mechanism of count was simple and flexible. It is interesting that one multipoint tube was made on the general principle of the individual-tube counter but was not considered a serious competitor to its parent types.

### 1. Introduction to the Multicathode Tube

In 1946 the potentialities of the use of a priming discharge to influence the breakdown voltage of an adjacent gap were appreciated<sup>5</sup> by A. H. Reeves and an investigation of the physical processes involved was initiated. It was known that a priming discharge could be used to stabilize the breakdown voltage of a gap, and it was in the extension of this effect that the major effort was expended. It was immediately appreciated that the priming gap need not be completely physically separate from the primed gap since a common anode electrode could be used. The type of assembly used in the study of these effects is shown in Figure 2. The cathodes consisted of flat-ended nickel wires that were either painted

with an insulator, or projected through an insulator such as mica, to restrict the glow of the discharge to the top portion. The anode was constructed of either a bar or a metal sheet formed in such a way as to produce the effect of a bar,

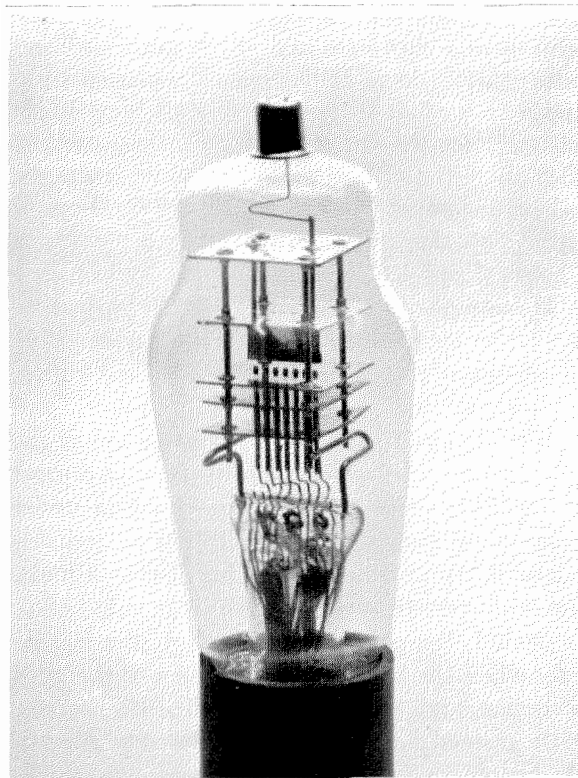

Figure 2—Early tube using a priming discharge to influence the breakdown voltage of an adjacent gap.

<sup>5</sup> A. H. Reeves, British Patent Application 22,140/46.

and the complete assembly was mounted in a mica tier construction to ensure accurate reproduction of important dimensions.

The speed limitations in a gas-discharge device are set to a large extent by the deionization

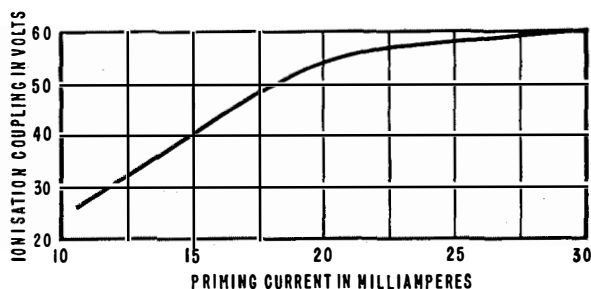

Figure 3—Variation of ionization coupling with priming current.

properties of the gaseous filling. To reduce the deionization time of a neon-argon mixture to a suitable value a deionizing gas was added, and all tubes described have been filled with such a mixture. The term "ionization coupling" was used to define the difference in breakdown potentials of a gap measured in the unprimed and primed conditions. It has been designated by  $\phi$  and measured in volts. Experiments were made to determine the variation of ionization coupling with all the important parameters in a geometrical arrangement similar to Figure 2. Typical curves of the results obtained are shown in Figures 3 and 4.

Measurements were made of the values of ionization coupling under pulse conditions, using pulses down to 1 microsecond wide, and curves similarly shaped to those shown in Figures 3 and 4 were obtained. A detailed investigation of the time factors involved in the rate of establishment of the final value of ionization coupling under pulse conditions showed that photons and diffusing electrons from the priming discharge make the major contribution to the final value of  $\phi$ . It should, however, be noted that this is true only when the horizontal separation of the gaps is great enough to prevent the field at the cathode of the primed gap from being distorted by the discharge at the priming gap. In some designs of multielectrode gas tubes it may be desirable to take advantage of what is described as field

coupling, in which case the horizontal separation between the cathodes is reduced to the same order as the length of the cathode dark space of the priming discharge.

In the limit, when field coupling is used, it is possible to reduce the breakdown potential of a primed gap to its maintaining potential, since immediately the voltage across the gap reaches that value a discharge is set up, the space-charge distortion at the cathode already being in existence.

If the effect described as ionization coupling is to be of practical use, it is necessary that stable and repeatable values shall be obtained. This implies that the priming discharge glow will be correspondingly stable and necessitates the introduction of some method of glow control. In view of the requirement of long life, the method referred to in the above description of the tube of Figure 2 is unsatisfactory, since sputtered particles extend the cathode area, making it necessary to increase the discharge current to re-stabilize the glow. Consequently shield electrodes are introduced to perform the stabilizing function. They are separated from areas of the cathode, from which the discharge should be inhibited, by a distance less than the cathode dark space and restrict the glow by field distortion. In the tube of Figure 2, this shielding function is performed by the middle one of the

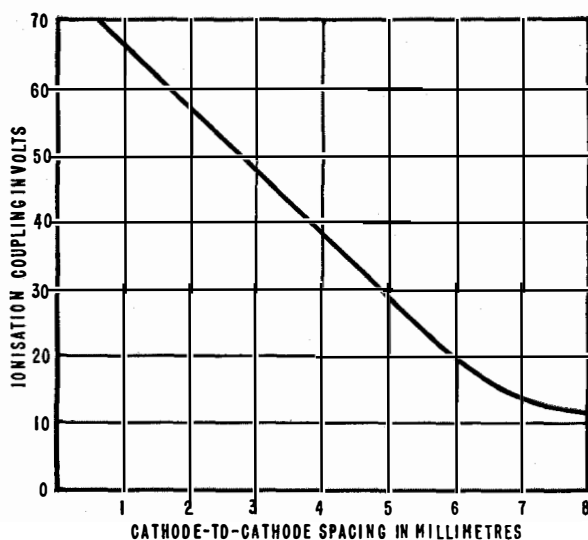

Figure 4—Variation of ionization coupling with cathode-to-cathode spacing for constant priming current of 1.5 milliamperes.

transverse mica sheets visible in the photograph.

The actual effect of a priming discharge is measurable in terms of volts, and an obvious parallel exists between the use of this method of priming and that used in the counter shown in Figure 1. In this counting circuit, however, the priming is in the forward direction only, whereas the ionization coupling is symmetrical about a priming discharge. To produce the corresponding forward priming feature it is necessary to introduce some type of asymmetry into the design of the priming gap. This can be achieved by the use of a suitably designed cathode, which will be described later, but which in the meantime shall be referred to as a "directional" cathode.

## 2. Various Electrode Combinations

The use of ionization priming in combination with directional and non-directional cathodes gives rise to a number of possible configurations within one envelope. Each has a set of properties and limitations that suit it for a particular field of application, and it is therefore proposed to discuss some of the possibilities.

The first arrangement of the multielectrode counter is similar to that shown in Figure 2. In this case there is a row of symmetrically situated cathodes protruding through a closely fitted aperture plate and equally spaced from the anode. Figure 5 shows a typical circuit arrangement for such a tube used as a counter. The anode *A* is connected through the secondary of a pulse transformer *T1* to a positive potential that is greater than the maintaining potential of the gaps but less than their normal, or primed, breakdown potential. Cathodes *K2*, *K3*, *K4*, and *K5* are earthed through series limiting resistances *R2*, *R3*, *R4*, and *R5*, and *K1* is connected through *R1* to negative bias which raises the *AK1* voltage above the normal gap breakdown voltage. This gap then fires and remains as a permanent priming discharge whenever the tube is in use. The resistance *R1* limits the current through the gap to some small convenient value, similar in magnitude to that taken by the other gaps when they have been fired.

Because of the decay of  $\phi$  with horizontal separation, it is possible to supply a positive pulse of a particular amplitude and width to the

anode, which breaks down the *AK2* gap only. The *AK2* gap then takes over the priming function and primes the *AK3* gap to the same level to which it was itself originally primed by *AK1*. The application of a further pulse to the anode will then initiate a second additional discharge in *AK3* and so on until all the gaps are fired. The voltage developed across the resistance in the last cathode can then be taken to indicate a count of 4 in this case, and to trigger some device for generating a suitable negative pulse to

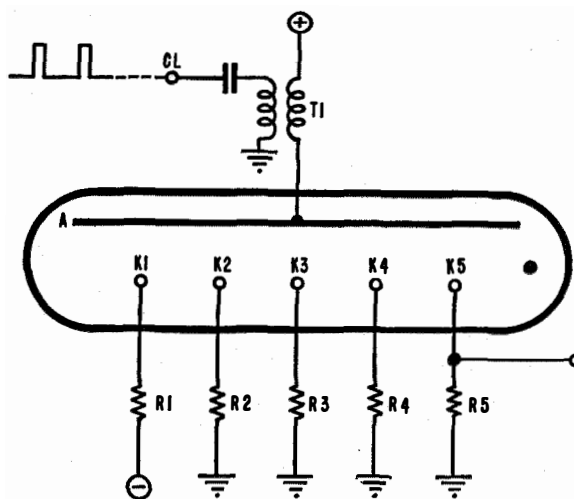

Figure 5—Circuit arrangement for a counter using the tube shown in Figure 2.

the anode to extinguish all gaps and reset the tube to a condition where it is ready to start a second cycle.

This is essentially a high-speed device, which has been used at pulse repetition frequencies up to 200 kilocycles per second. It requires pulses that are of the order of a microsecond wide and of about 60 volts amplitude.

The limitations to the speed and circuit tolerances are, in general, associated with the registering and extinguishing circuit. Another limitation is that the position of the count is indicated by a number of cathode glows, as opposed to the single discharging gap obtained in the low-speed counter of Figure 1.

The next arrangements<sup>6</sup> use one or a number of auxiliary cathodes to transfer a discharge between two main cathodes. The principle of

<sup>6</sup> D. S. Ridler, British Patent Application 15,875/48.

such a transfer cathode is illustrated with waveforms in Figure 6, which shows a simple tube in which  $K1$  and  $K3$  are main cathodes and  $K2$  is the transfer cathode. The geometry and gas pressure are such that a discharge in any one gap has a major effect only on the breakdown potential of an adjacent gap. For this reason, if current initially flows through gap  $AK1$  the third gap will not break down. The second gap is biased so that the potential across  $AK2$  is less than its maintaining potential and does not break down until a negative-going pulse is applied to provide the additional potential to cause breakdown. Since the anode tends to follow the pulse and capacitor  $C2$  holds cathode  $K1$  positive, the potential across  $AK1$  is reduced causing it to extinguish. The discharge has now transferred to cathode  $K2$  on the leading edge of the pulse and gaps  $AK1$  and  $AK3$  will, therefore, be primed for the duration of the pulse. On the trailing edge, the anode potential rises until  $AK3$  breaks down. It should be noted that the potential across the first gap also increases but does not reach a value high enough to cause breakdown, since capacitor  $C2$  will not have discharged through  $R2$ . Furthermore, the anode potential is held down by the discharge on  $K3$  by capacitor  $C3$  charging. The discharge from  $K2$  is extinguished because the potential across the gap is reduced below its maintaining level at the end of the pulse. In this way a pulse on the transfer cathode  $K2$  has resulted in a transfer of discharge from cathode  $K1$  to  $K3$ . Since the circuit is symmetrical, a second pulse will transfer the discharge back to  $K1$  and so on.

Figure 7 shows in schematic form six configurations in which transfer electrodes are used, together with the pulse waveforms required for their operation. Scale-of-5 counters are shown, but it will be understood that any number of points could be included within practical limits.

Figure 7A shows a combination using one non-directional main cathode and two non-directional transfer cathodes for each stage of count. If current is initially flowing through the common load  $R1$ , gap  $AK1$  and resistance  $R2$  to earth, it is apparent that gap  $AK2$  is primed so that a negative pulse on the counting lead  $CL1$  will transfer the discharge to that gap in the manner previously explained. A second pulse on lead  $CL2$  immediately following will bring the dis-

charge to  $K3$  and so to  $K4$  on its trailing edge. The discharge has thus transferred from the first main gap  $AK1$  to the second main gap  $AK4$ . Since alternate transfer cathodes  $K2$ ,  $K5$ ,  $K8$ , and  $K11$  are commoned together, as are  $K3$ ,  $K6$ ,

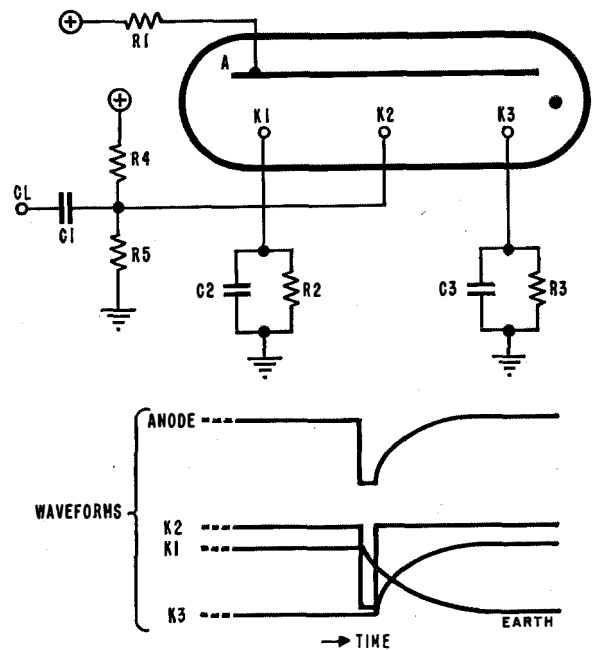

Figure 6—In this tube,  $K1$  and  $K3$  are the main cathodes and  $K2$  is pulsed to transfer the discharge from one main cathode to the other. The waveforms in transferring from  $K1$  to  $K3$  are shown.

$K9$ , and  $K12$ , a second pulse on  $CL1$  and  $CL2$  can only move the discharge forward to  $K7$  and so on for further pulses. It is thus the order in which pulses appear on leads  $CL1$  and  $CL2$  that gives a sense of direction; a pulse occurring on lead  $CL2$  before lead  $CL1$  would, therefore, move the discharge towards cathodes having a suffix of a lower order.

The parallel capacitance-resistance networks may be alternately commoned if individual outputs are not required, in which case the capacitors charge and discharge on alternate counting pulses. Furthermore, it will be appreciated that the natural waveforms produced by these latter networks could be replaced by those from an external pulse source. A counter of this type has been described.<sup>7</sup>

<sup>7</sup> J. J. Lamb and J. A. Brustman, "Polycathode Glow Tube for Counters and Calculators," *Electronics*, v. 22, pp. 92-96; November, 1949.



A simplification of this split-input pulse system is shown in Figure 7B in which there is only one transfer cathode between each main cathode. The transfer cathodes are alternately common and the input pulses are fed alternately to each input. Again it is the relation of these pulse trains that provides the sense of direction.

These counters are complicated by the twin input pulse systems, and result in rather complicated tube structures and external tube circuitry. The next two types illustrate the simplification that results from the use of directional cathodes.

Figure 7C shows a tube<sup>8</sup> with directional main cathodes interspaced by non-directional transfer cathodes. A discharge on *K1* can be transferred to *K2* and so to *K3* by a first pulse on *CL*. A second pulse on the common transfer cathodes can only move the discharge via *K4* to *K5* due to the directional property of *K3*. As in the simple case of transfer, it is the charge on the cathode capacitor of *K3* that prevents the discharge retreating from *K4* to *K3* on the trailing edge of the pulse.

A related tube is shown in Figure 7D in which both transfer and main cathodes are directional. The capacitors are now no longer necessary to prevent a retreat to previous cathodes, and the tube becomes independent of external time-constant circuits. Such a tube is inherently faster than the previous type, which is necessarily slowed down by the

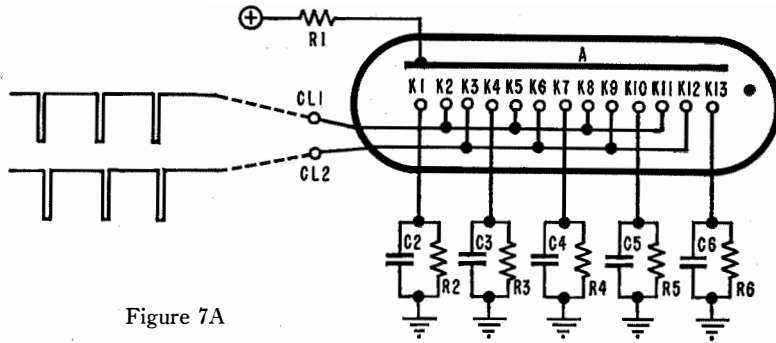

Figure 7A

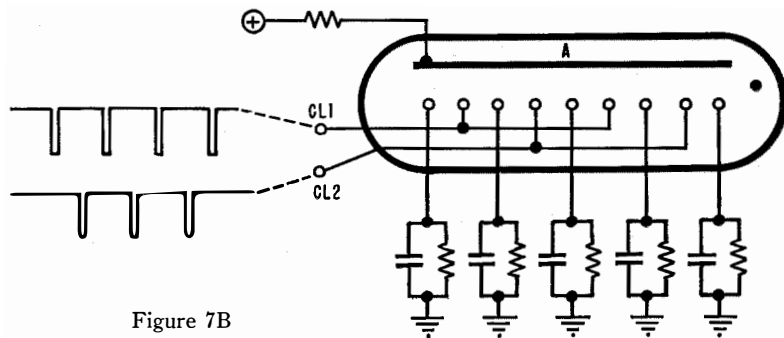

Figure 7B

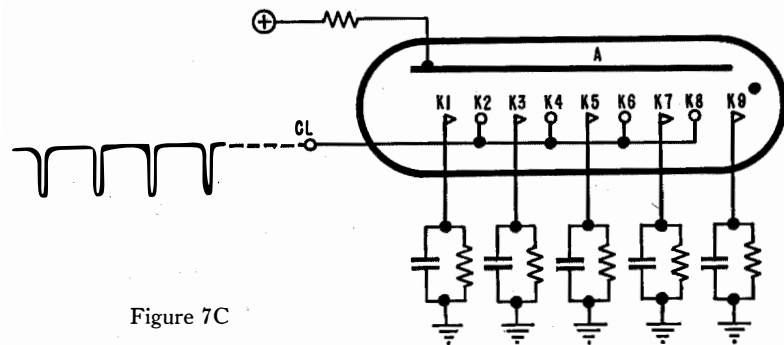

Figure 7C

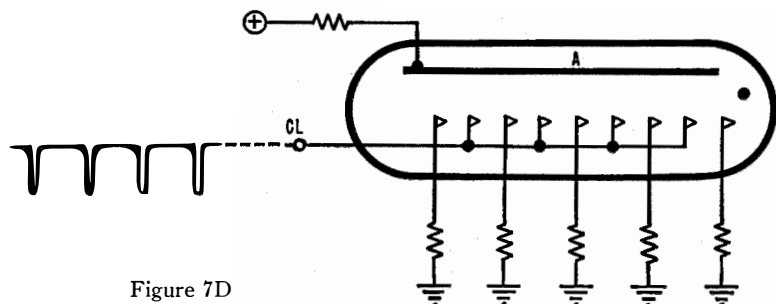

Figure 7D

<sup>8</sup>G. H. Hough, British Patent Application 25,487/48.

nature of the exponential cathode waveform. The speed becomes dependent upon the rate at which the discharge becomes directionally effective on each cathode and also the rate at which the previous gap can recover.

Although these two latter types can be operated in only one direction, Figure 7E shows that the use of a main cathode that is directional with respect to a forward and reverse set of transfer cathodes retains the flexibility of the previous types without the complicated input systems. The direction of the discharge movement is dependent upon the pulse supply being connected to the forward or reverse transfer cathodes.

A further possible combination is shown in Figure 7F in which the discharge may travel from a home cathode to two main cathodes each giving access to two further cathodes. In the simple tube shown, the discharge may be stepped to any one of the 4 final cathodes *K10* to *K13* by a suitable combination of two pulses on the leads *CL1* and *CL2*. It will be seen that this arrangement may act as a binary-code selector.

### 3. Decade Counter *G10/240E*

#### 3.1 OPERATION AND DESIGN

Having briefly described some combinations of electrodes possible in a multielectrode tube, a more detailed account will be given of the tube that has resulted from the combination of a directional cathode and a plain transfer cathode as shown in Figure 7C. This combination was selected for development because it was considered most suitable for general application. The *G10/240E* is shown in Figure 8 together with trigger tubes, which are used as associated circuit elements. Some of the parts used in the *G10/240E* are shown in Figure 9.

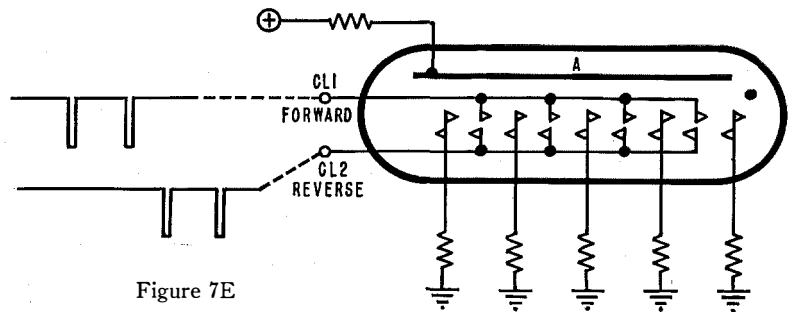

Figure 7E

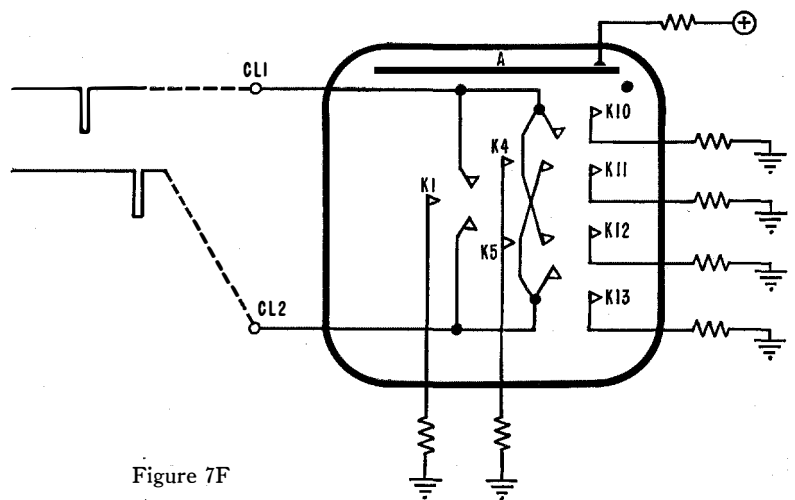

Figure 7F

There are in this tube 10 main cathodes arranged in a circle so that the 10th cathode is adjacent to the first. The 10 transfer cathodes are joined internally and externally biased to a suitable potential. The shield electrode is taken to a positive potential derived from a potential divider across the high-tension supply. The cathodes are so designed that the transfer electrode in the forward direction is primed to a much greater extent than that in the backward direction in a manner to be explained later.

The principal feature of the design is the achievement of an effective directional coupling from the main cathodes to the two adjacent transfer cathodes. This is produced by making the main cathode consist of two sections. The first section is adjacent to the previous transfer cathode, under the influence of which its breakdown voltage can be reduced to a figure approaching its maintaining potential. This section

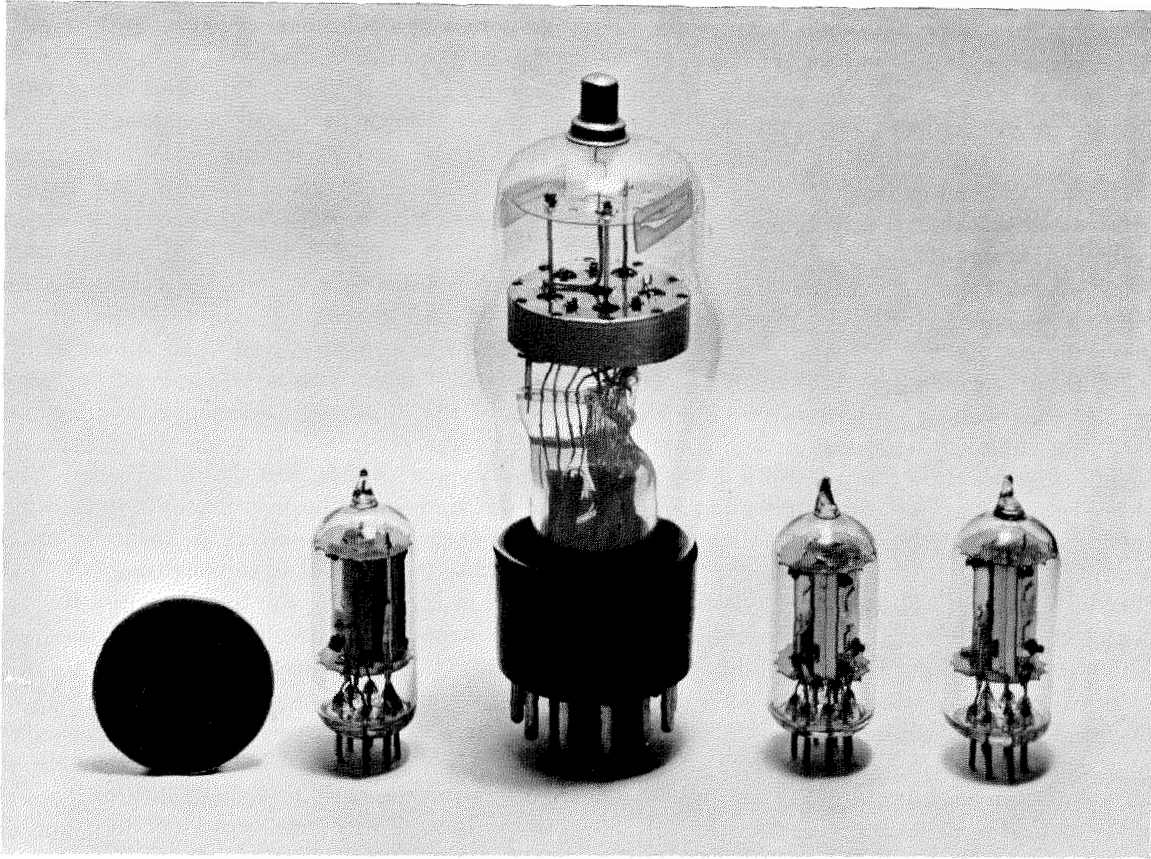

Figure 8—The *G10/240E* tube employs directional cathodes and plain transfer cathodes. The smaller units are trigger tubes. The coin is a British penny.

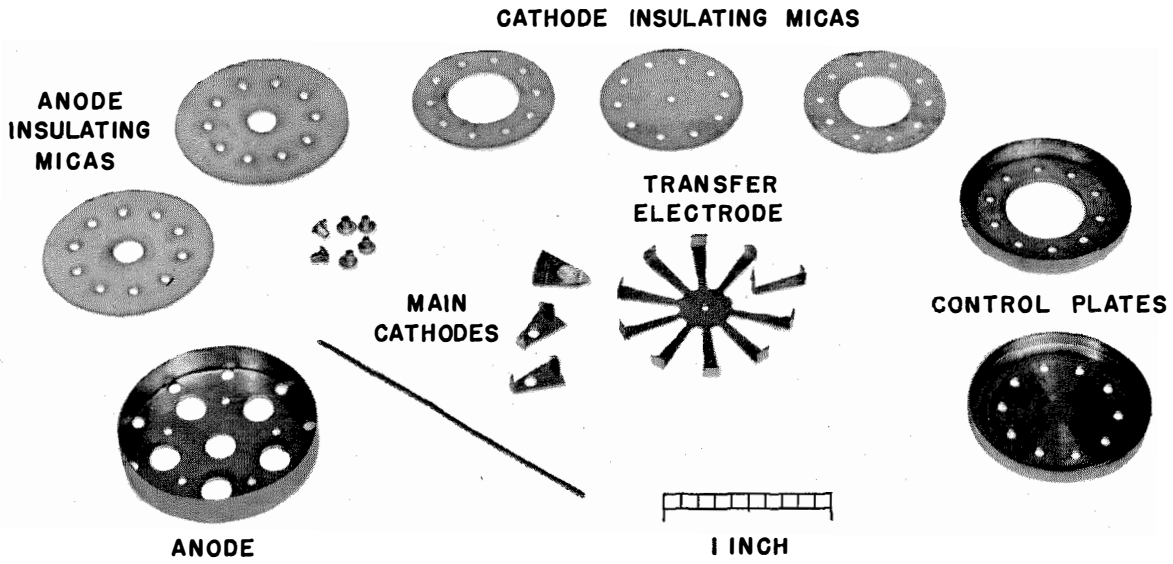

Figure 9—Some of the components of the *G10/240E*.

is arranged to have a high maintaining potential and to saturate on a low value of current. It is physically joined to the second part of the cathode, which has a lower maintaining potential, and will not saturate until a higher current is conducted. The sequence of operation is that the cathode starts to conduct current on the first section and then rapidly transfers the glow to the second section, from which the forward transfer electrode is more effectively primed than the preceding one.

The mechanical design of the tube is such that the electrode system consists of two sub-assemblies. The main and transfer cathodes and the shield electrodes form one assembly, and the anode and its locating and insulating micas form the second. They are designed so that the one can be accurately located with respect to the other and locked in position. The complete assembly can be placed in a closely fitting glass envelope without deleterious effects being introduced by the proximity of the glass. This has been achieved by completely surrounding the cathode assembly by the anode, which is in the form of a cup. Suitable holes have been cut in the top of the anode so that a visual inspection of the cathode glow can be made. In addition, the glow is visible from beneath the assembly.

Due to the circular construction, the glow can be made to rotate continuously if the transfer cathode is fed with a continuous train of pulses. In a 10-point tube, any one cathode thus provides a single pulse out for every 10 impressed on the tube.

### 3.2 THE TRANSFER MECHANISM

To determine the exact mechanism of the transfer of the glow from one main cathode to another via a transfer cathode, a detailed examination was made in which the currents flowing in the various electrodes in the tube were measured at different points in time. From this examination, it was shown that there are three modes in which the transfer can be effected.

*Mode 1* is that previously described and is the normal mode of operation. A negative counting pulse fires the transfer cathode, and its amplitude should be sufficient to extinguish the first cathode and to reduce the potential across all other anode-cathode gaps to below the maintain-

ing potential of all other cathodes. At the trailing edge of the negative pulse the anode potential rises, and on reaching the maintaining potential of the next cathode is caught and held at that level, at the same time extinguishing the transfer-cathode discharge. This condition requires the transfer cathode to take a current that is in excess of the current conducted by the gap that is being extinguished, and thus demands a relatively large transfer current.

*Mode 2* is a modification of the previous one, and is associated with a reduction of the amplitude of the pulse supplied to the transfer cathode. Firing the transfer cathode now extinguishes the previous cathode, but the total current taken by the transfer cathode is insufficient to reduce the voltage on the anode to a point below the maintaining potential of the next cathode in the array, so that during the transfer pulse the next cathode starts to conduct. Here again, the transfer cathode takes current that is equal to, or in excess of, the main-gap current.

*Mode 3.* In this case the transfer cathode is fired by a small pulse, which reduces the current flowing in the previous cathode but does not extinguish it. The anode potential does not fall more than about 15 volts, so that when the next cathode is primed by the transfer cathode, there is a high enough potential across the gap to fire it. When it fires, the initial peak current taken to charge the capacitor in its resistance-capacitance circuit extinguishes the previous cathode by dropping the anode voltage. Therefore, the transfer cathode conducts a small amount of current, which may be less than that taken by the main cathodes but which has to be large enough to cover the transfer cathodes with glow, and thus primes the forward adjacent cathode.

To summarize the three modes in terms of pulse amplitude and high-tension supply voltage, the following very general conditions exist:—

*Mode 1.* High pulse amplitude (125 volts) and medium and low high-tension supply.

*Mode 2.* Medium pulse amplitude (80–125 volts) and medium and low high-tension supply.

*Mode 3.* Minimum pulse amplitude (80 volts) and high and medium high-tension supply.

Assuming an operating range of 60 volts on the high-tension supply, the terms low, medium, and high might correspond to 20-volt steps of high tension.

### 3.3 OPERATING LIMITS

The minimum high-tension supply is determined by the minimum current necessary to establish a stable forward-priming discharge. The maximum high-tension potential is fixed by the maximum current a cathode can take before a second cathode breaks down in the absence of a pulse. This range is generally in the region of 300 to 360 volts, but is determined partly by the choice of circuit components.

The following are typical operating conditions for the type of tube described for a frequency range of 0 to 5 kilocycles, over which the pulse output from the cathode approximates to a square:—

High-Tension Supply Voltage	330 ± 30 Volts
Transfer-Electrode Bias	75 Volts
Shield-Electrode Bias	100 Volts
Anode Load	27 000 Ohms
Cathode Time Constant	15 000 Ohms and 0.005 Microfarad
Pulse Amplitude	120 Volts
Pulse Width	16 Microseconds

Typical direct-current characteristics are:

Breakdown Voltage	
Anode-Cathode	250 Volts
Anode-Transfer Cathode	250 Volts
Maintaining Potential	165 Volts
Maximum Current	5.0 Milliampères

The maximum operating frequency in the present design is approximately 25 kilocycles, although under special conditions frequencies of 40 kilocycles have been used.

### 4. Circuit Application

It is the essence of any practical tube that it should be flexible in its application to circuitry and it will be seen that the *G10/240E* tube is convenient to use either as a divider or as a distributor. If successive division is required, the tubes may be coupled together in decades by interposing cold-cathode trigger tubes acting as gates. A similar technique can be used to increase the number of points on a distributor.

In Figure 10 is shown a panel mounting three multicathode tubes with gating triggers in a scale-of-1000 counter.

Figure 11 shows this circuit of three tubes arranged to operate in decade. The first multicathode tube *MTA* is supplied with negative-going pulses through *C1*. Since only one cathode is used for an external function, the first 9 main cathodes use only two resistance-capacitance networks and the 10th is connected to the trigger of the gate tube *CTA*. Sufficient potential to break down the trigger-cathode gap of this tube only occurs with a combination on the trigger of a positive pulse from the counting tube and a

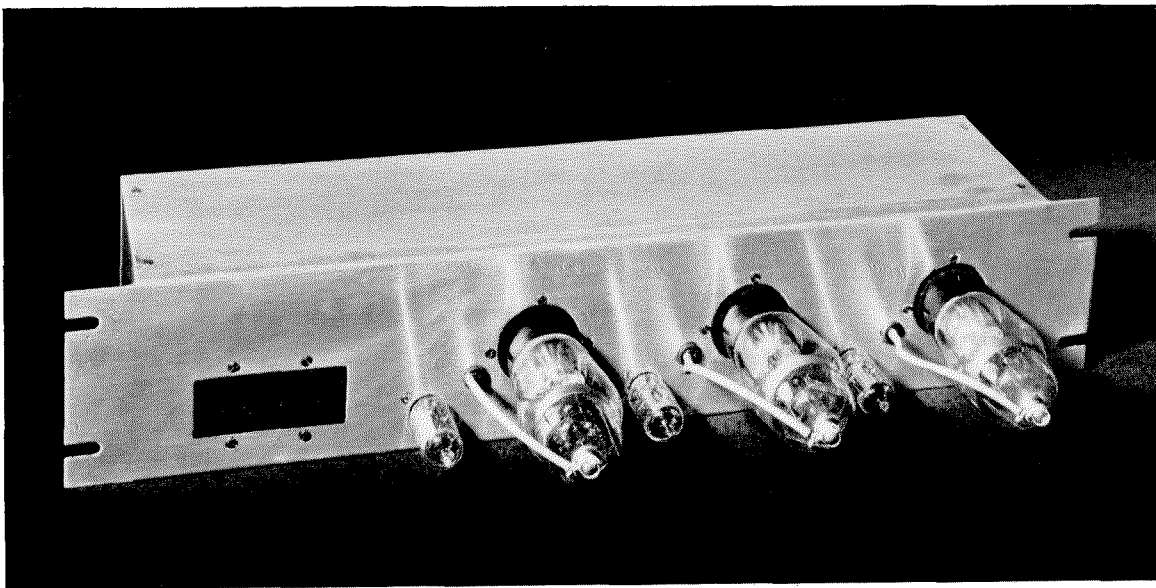

Figure 10—These three multicathode tubes and their associated trigger tubes will count to 1000.

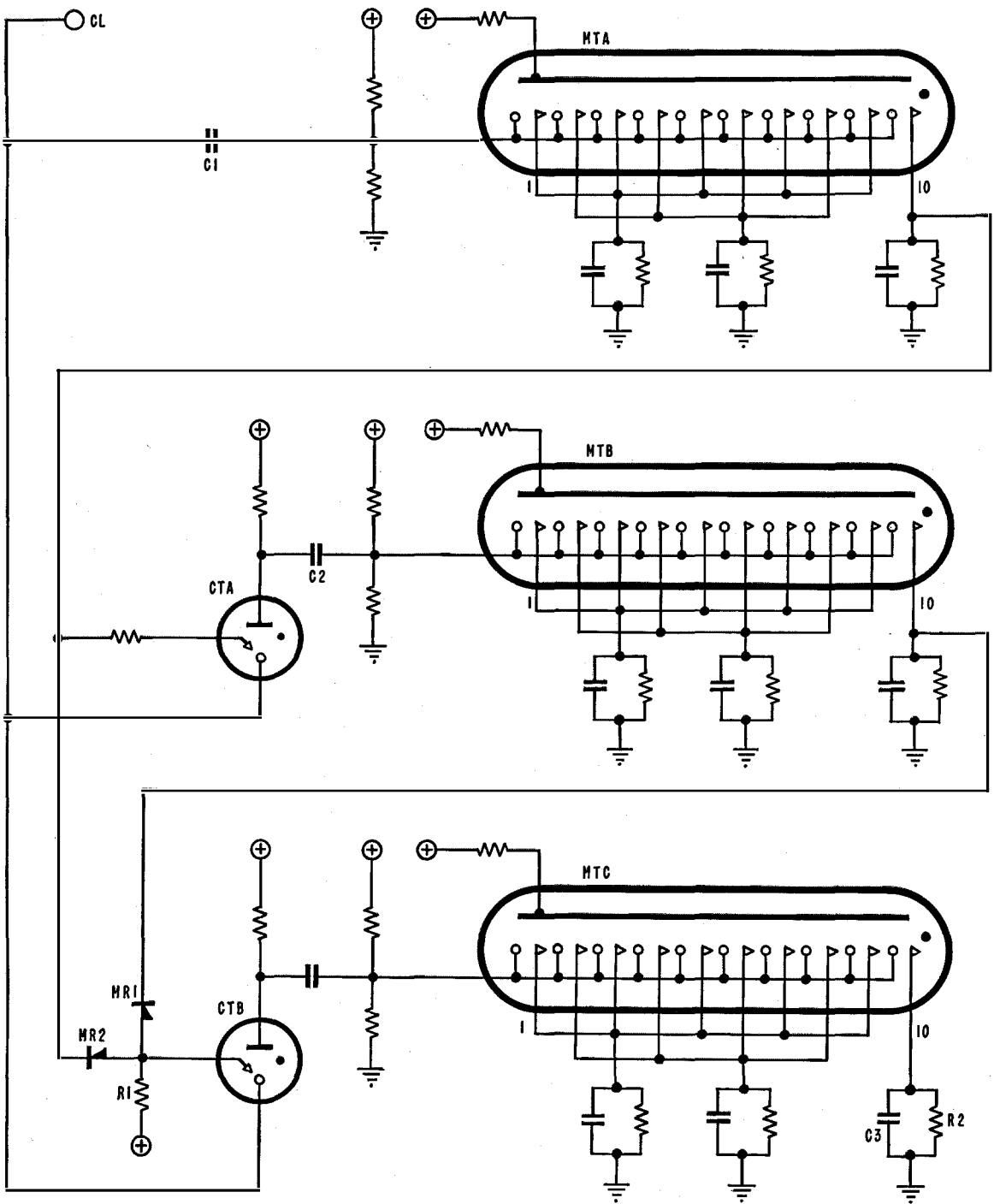

Figure 11—(Above) Three scale-of-10 counters arranged to count to 1000.

Figure 12—(At Right) Operation of tubes in series to increase the number of distribution points.





negative pulse from the supply lead on the cathode. Hence every 10th pulse is passed through *CTA* and *C2* to tube *MTB*, which operates in response. Every hundredth pulse is gated to the third tube *MTC* through gate tube *CTB*, which is controlled by the last cathodes of *MTA* and *MTB* by means of the simple rectifier coincidence network<sup>9,10</sup> comprising *R1*, *MR1*, and *MR2*. The output from the network *R2-C3* represents a division by 1000 of the original pulse supply. Further stages can be added to give higher orders of division, the limiting factor being the rectifier coincidence networks.

Figure 12 shows the general method of operating the tubes in series to increase the number of distribution points. The effective number of cathodes on each tube is reduced from 10 to 9, since it is necessary to use one cathode as a rest position. The circuit represents a 27-point distributor. To follow the sequence of operation, assume that tubes *MTB* and *MTC* are initially discharging on their 10th or rest cathodes and that tube *MTA* is discharging on its first cathode which represents the first outlet of the 27-point distributor. Rectifiers *MR1* and *MR2* are blocked by the discharge potentials from tubes *MTB* and *MTC* and the trigger of gate tube *CTA* is therefore held positive. Before this gating potential is removed, 8 successive counting pulses will move

the discharge to cathode 9 on *MTA* priming the trigger of the second gate tube *CTB* so that the 9th pulse steps both counter tubes *MTA* and *MTB*. The blocking potential to *MR1* is removed, but the 10th-cathode discharge potentials on *MTA* and *MTC* block *MR3* and *MR4* so that now tube *MTB* responds to the next 9 impulses gated through tube *CTB*. In a similar manner tube *CTC* gates a following set of 9 pulses and so on to tube *CTA* to start the cycle a second time. Again any number of tubes may be operated in series dependent only upon the characteristics of the rectifier networks.

### 5. Conclusions

The combination of the directional cathode and non-directional transfer electrode has proved to be one that is flexible in circuit design and has many applications. Although a number of individual tubes would appear to be equivalent to a multicathode tube there are in fact considerable practical advantages in economy of components, wiring, and space. Preproduction problems have been few and further development of the valve is anticipated.

### 6. Acknowledgments

The authors would like to thank their colleagues in Standard Telecommunication Laboratories and in Standard Telephones and Cables for their assistance in the preparation of this paper.

<sup>9</sup> E. M. S. McWhirter, R. H. Dunn, and R. W. Lennox, British Patent Application 24,096/47.

<sup>10</sup> D. S. Ridler and A. B. Odell, British Patent Application 24,481/49.

# Design of Single-Frequency Phase-Shifting Networks

By LAURIN G. FISCHER

*Federal Telecommunication Laboratories, Incorporated, Nulley, New Jersey*

**Q**UITE FREQUENTLY applications are found for resistance-capacitance or resistance-inductance phase-shifting networks consisting of several sections. Reliance is normally placed on the rule of thumb that "each successive section shall have an impedance 10 times the previous section." By this assumption, loading is considered to be negligible and the phase shift per section may be calculated readily.

The difficulty encountered with such a network, however, is in the very high impedance of the last section, making coupling to it a serious problem. An investigation was, therefore, made of the optimum characteristics of such circuits with full allowance for loading and resulted in the design curves of this paper.

Assuming the ratio of reactance to resistance to be the same for each section and equal to  $k$ , and the impedance of each section being  $\alpha$  times the impedance of the previous section, then the network of Figure 1 results.

The attenuation characteristic of this configuration as a function of the number of meshes  $N$  required for a 180-degree phase shift, is also shown in the figure. The  $\alpha = \infty$  curve is the ideal case, where each section is not shunted by the succeeding group. Obviously, the attenuation is a direct function of the phase shift per section, the output decreasing as fewer meshes are used for the desired 180-degree phase shift. In the limiting case, no output is obtained when the phase change per section is 90 degrees ( $N = 2$ ).

## 1. Over-All Design

An immediate consequence of applying the information embodied in Figure 1 can be illustrated in the following examples.

A. In the usual rule-of-thumb case, for a 180-degree phase shift, 3 sections are chosen with  $\alpha = 10$ ,  $k = 0.577$  ( $\tan^{-1} k = 60$  degrees). The output voltage ratio will then be 0.125.

Reference to Figure 1 shows that by merely adding one more section ( $k = 1.0$ ,  $\tan^{-1} k = 45$

degrees) the output is just doubled, while adding two more sections nearly triples the output!

B. For  $\alpha = 10$ ,  $N = 3$ , the output-to-input voltage ratio is 0.125. However, the impedance of the last section is 100 times that of the first.

By going to five sections of the  $\alpha = 2$  network, the output-to-input ratio goes up to 0.17, while the impedance of the last section is only 16 times that of the first!

Having chosen the  $\alpha$  and  $N$  values, the required  $k$  can be obtained from Figure 2. Then, by merely choosing the impedance of any one element, the value of every element in the network is determined. It is understood that  $k$  can be positive or negative (inductive or capacitive) without affecting the results. Furthermore, a circuit of the form shown in Figure 3 may be

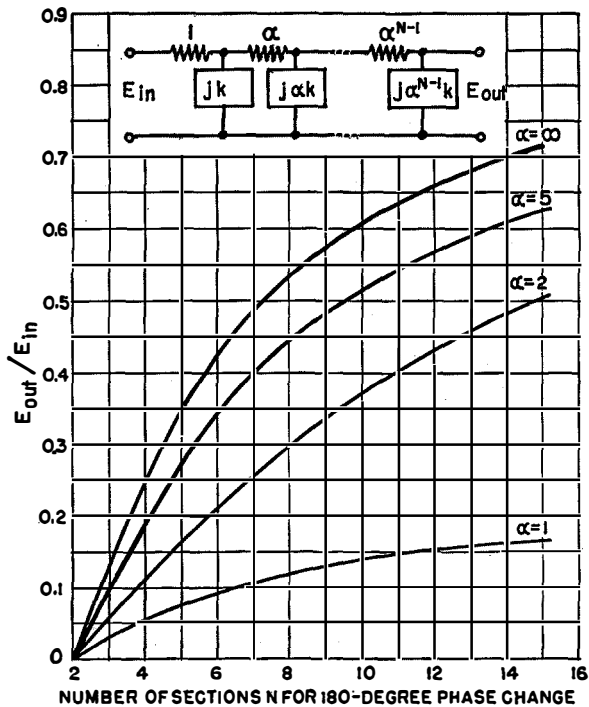

Figure 1—Attenuation characteristic as a function of the number of meshes required for a 180-degree phase change.

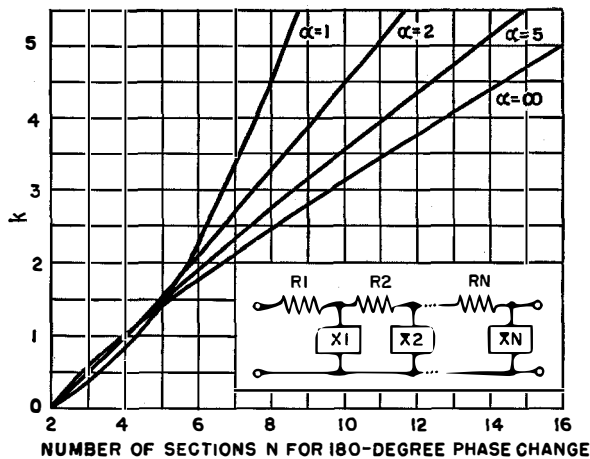

Figure 2—Values of  $k$  plotted as a function of the number of sections when  $\alpha$  and  $N$  have been chosen. With reference to the circuit diagram, the individual elements for the 4 values of  $\alpha$  are as follows.

$\alpha$	$R1$	$R2$	$R_N$	$X1$	$X2$	$X_N$
1	1	1	1	$jk$	$jk$	$jk$
2	1	2	$2^{N-1}$	$jk$	$j2k$	$j2^{N-1}k$
5	1	5	$5^{N-1}$	$jk$	$j5k$	$j5^{N-1}k$
$\infty$	1	$\infty$	$\infty^{N-1}$	$jk$	$j\infty k$	$j\infty^{N-1}k$

employed by replacing  $k$  by its reciprocal, as shown in the figure.

**2. Numerical Example**

It is desired to have a 180-degree phase-shifting network of the series-resistance-shunt-capacitance type. The attenuation must not be greater than 12 decibels. The circuit will be energized from a constant-voltage source and will be shunted by a 2.5-megohm resistive load.

- A. From Figure 1, for  $\alpha=5$  and  $N=5$ ,  $E_{out}/E_{in}=0.27$ , equivalent to a loss of 11.4 decibels.
- B. From Figure 2, for  $\alpha=5$  and  $N=5$ ,  $k=1.43$ .
- C. Select a final-section capacitance having a reactance of  $X_c=250,000$  ohms.
- D. The entire network then is given in Table 1

TABLE 1  
VALUES FOR NETWORK ELEMENTS

Section	Series Resistance in Ohms	Shunt Reactance (Capacitive) in Ohms
1	280	400
2	1,400	2,000
3	7,000	10,000
4	35,000	50,000
5	175,000	250,000

When it is desired to have a constant-impedance network, where the actual impedance of each section is the same as the preceding or succeeding section, the curves of Figures 4 and 5 apply. It can be seen from Figure 4 that the output voltage ratio increases rapidly with the

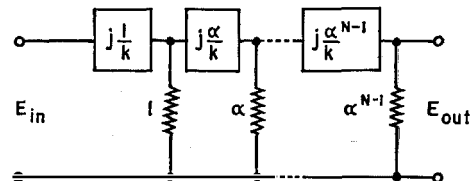

Figure 3—Circuit obtained by replacing  $k$  by its reciprocal.

number of sections  $N$ , until four or five sections are employed, and then increases at a much slower rate, indicating that these are the optimum conditions. Having chosen  $N$ , the characteristic phase angle  $\phi_c$  is found from the same figure. The  $X/R$  ratio  $k$  is of course equal to  $\tan \phi_c$ . It is evident from Figure 4 that  $k$  can never be greater than 1 for the series-resistance-shunt-reactance network, nor can it be less than 1 for the series-reactance-shunt-resistance case.

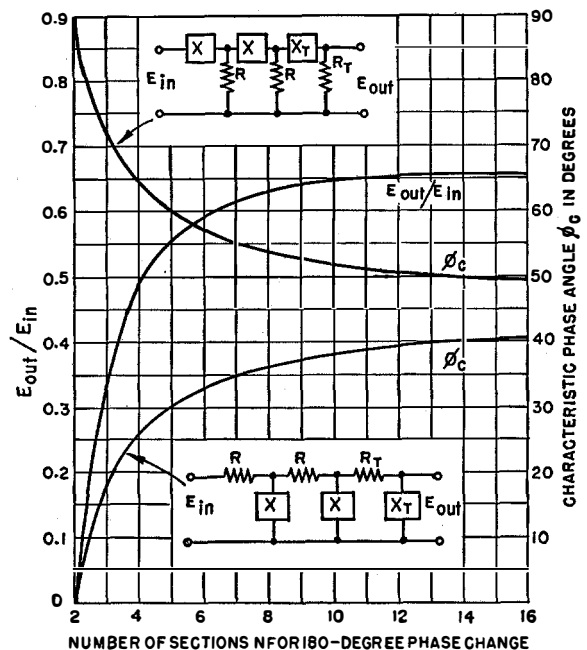

Figure 4—For a constant-impedance network producing a 180-degree phase change, the output voltage ratio  $E_{out}/E_{in}$  and the phase characteristic  $\phi_c$  are plotted as a function of the number of sections.

In either event,  $R$  or  $R_T$  would go negative to preserve the constant-impedance characteristic.

The complete design data are obtained from Figure 5. All sections preceding the last section are identical, while the  $N$ th section consists of the characteristic impedance  $R_T + jX_T$ . For the previously chosen value of  $\phi_c$ , the  $X_T/X$ ,  $R/R_T$ , and  $X_T/R_T$  ratios are found, and selecting the value of any one of these immediately determines the others. The individual-section data appear in Figure 6.

**3. Conclusion**

Design data are listed for obtaining the most suitable phase-shifting network for any specific application. When output-impedance values and voltage attenuation are important factors, the desirable trend is toward a network with more sections and a smaller impedance-multiplication ratio.

**4. Appendix**

The curves of Figures 2 and 3 were derived from the following relation.

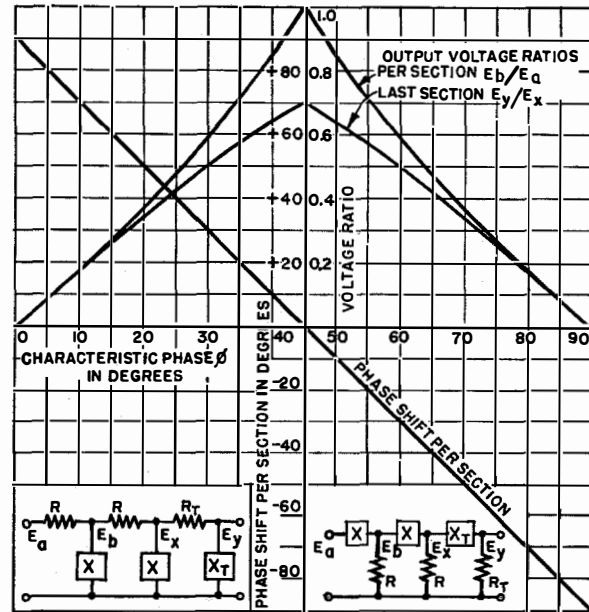

Figure 6—Individual-section data.

$$\frac{E_{out}}{E_{in}} = \frac{jk(Z_2)}{jk + Z_2} \times \frac{j\alpha k(Z_3)}{j\alpha k + Z_3} \times \dots \times \frac{j\alpha^{N-1}k}{\alpha^{N-1} + j\alpha^{N-1}k} = \rho e^{i\theta}$$

when  $\theta = 180$  degrees,  $\rho$  is plotted as a function of  $N$  for Figure 1, and  $k$  is plotted as a function of  $N$  for Figure 2.

For the constant-impedance network, the solution is much neater. The input impedance  $Z_T = R_T + jX_T$  is also the shunting impedance. Hence

$$R_T + jX_T = R + \frac{jX(R_T + jX_T)}{R_T + j(X + X_T)} \tag{1}$$

From which, equating reals,

$$R_T^2 - RR - X_T^2 = 0, \tag{2}$$

and equating imaginaries,

$$2R_T X_T - XR - X_T R = 0. \tag{3}$$

Since  $k = X_T/R_T$ , from (2)

$$R = R_T(1 - k^2), \tag{4}$$

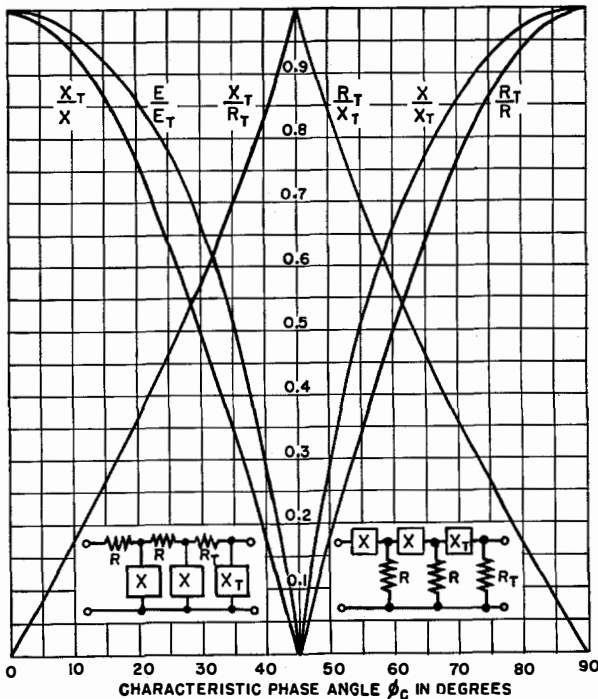

Figure 5—Complete design data.

and from (3)

$$R = \frac{2kR_T^2}{X + kR_T} \tag{5}$$

From (4) and (5)

$$\frac{R_T}{X} = \frac{(1 - k^2)}{k(1 + k^2)}, \tag{6}$$

or, since  $X_T/R_T = k$ ,

$$\frac{X_T}{X} = \frac{(1 - k^2)}{(1 + k^2)}. \tag{7}$$

Now, since

$$X_T/R_T = k = \tan \phi_c, \tag{8}$$

from (4)

$$\frac{R}{R_T} = \frac{\cos 2\phi_c}{\cos^2 \phi_c}, \tag{9}$$

and from (7)

$$\frac{X_T}{X} = \cos 2\phi_c. \tag{10}$$

Relations (8), (9), and (10) are plotted in Figure 5.

The complex-output-to-input-voltage ratio of the sections preceding the final section is

$$\begin{aligned} \frac{E_2}{E_1} = \frac{Z_2}{Z_1} &= \frac{R_T - R + jX_T}{R_T + jX_T} \\ &= \frac{R_T k^2 + jX_T}{R_T + jX_T} \\ &= k \left( \frac{k + j1}{1 + jk} \right) \\ &= k \mathcal{E}^{j(90 \text{ degrees} - 2\phi_c)}, \end{aligned} \tag{11}$$

and of the last section is

$$\frac{E_{out}}{E_{N-1}} = \frac{jk}{1 + jk} = \sin \phi_c \mathcal{E}^{j(90 \text{ degrees} - \phi_c)}. \tag{12}$$

If the total phase shift is 180 degrees,

$$180 = (N - 1)(90 - 2\phi_c) + (90 - \phi_c)$$

and

$$\phi_c = 90 \frac{(N - 2)}{(2N - 1)}. \tag{13}$$

Then, the total output voltage ratio, from (11) and (12),

$$\frac{E_{out}}{E_{in}} = (\tan \phi_c)^{N-1} (\sin \phi_c). \tag{14}$$

Relations (13) and (14) are plotted in Figure 4 while (11) and (12) appear in Figure 6.

**Recent Telecommunication Development**

**Antenna for Omnidirectional Radio Range**

UNDER TEST at the Civil Aeronautics Administration Technical Development and Evaluation Center, Indianapolis, Indiana, is a new type of antenna for 112-118-megacycle omnidirectional radio ranges. This unit, developed by Federal Telecommunication Laboratories, provides a very pure source of horizontal polarization; rotation of the pattern is accomplished by turning of a radiating element situated inside the center of the structure.

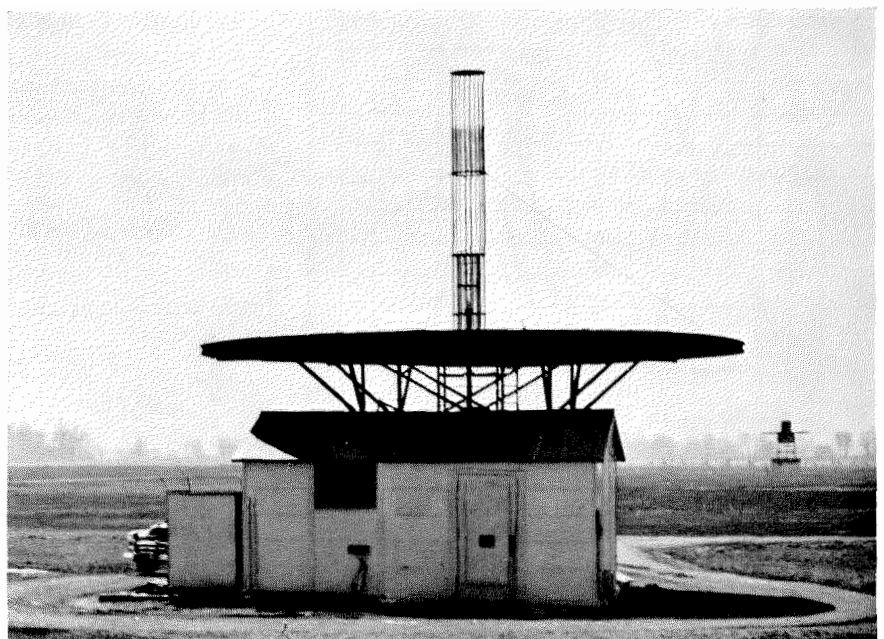

# Theory of $2n$ -Terminal Networks with Applications to Conference Telephony

By VITOLD BELEVITCH

*Bell Telephone Manufacturing Company, Antwerp, Belgium*

NETWORKS composed of resistances and ideal transformers, simultaneously matched at all their terminal pairs to a given set of resistances and having prescribed losses between the various pairs of terminals, are treated. A method of design based on the efficiency matrix is applied to 6-terminal and some important classes of 8-terminal networks. Results in the theory of transformer networks are applied to the design of new networks of practical importance for conference telephony. Matched nondissipative networks interconnecting  $n$  telephone circuits and giving a loss of  $10 \log_{10}(n-1)$  decibels between all their terminal pairs are constructed for various values of  $n$ . Transformer networks suitable for interconnecting 4-wire circuits are also discussed.

• • •

The restrictions imposed by physical realizability on the attenuations between the various terminal pairs of a passive network have been discussed in a preceding paper.<sup>1</sup> In the present paper, matched networks with prescribed attenuations that are independent of frequency are studied in greater detail.

Section 1 is devoted to general theoretical relations in  $2n$ -terminal resistance and transformer networks. The synthesis of nondegenerate networks is based on a relation between the *efficiency matrix* (also called *scattering matrix*<sup>2</sup>) and the impedance (or admittance) matrix already proved in the preceding paper. A different approach is needed in degenerate cases. This is described for ideal transformer networks in Section 1.2.

<sup>1</sup> V. Belevitch, "Transmission Losses in  $2n$ -Terminal Networks," *Journal of Applied Physics*, v. 19, pp. 636-638; July, 1948.

<sup>2</sup> C. G. Montgomery, R. H. Dicke, and E. M. Purcell, "Principles of Microwave Circuits," McGraw-Hill Book Company, New York; 1948: p. 146.

In Section 2, the method of Section 1.1 is applied to the design of matched 6-terminal and symmetrical 8-terminal networks. Various bi-conjugate 8-pole networks, including the so-called "resistance hybrid," are discussed.

Section 3 deals with conference networks, i.e., with matched networks having the same attenuation between all couples of terminal pairs. The minimum attenuation is shown to be 6 decibels for  $n=3$  and 7 decibels for  $n=4, 5$ , and 6. The networks for  $n=3$  and 4 are described in Section 2 and an immediate extension of the latter yields networks for  $n=5$  and 6. The case for  $n=6$  is of particular interest since the network is non-dissipative and the loss 7 decibels =  $10 \log_{10} 5$  merely results from the division of power. This raises the question of what values of  $n$  produce such an ideal conference network. A complete answer has not yet been obtained but important steps toward the solution are described. The last part of Section 3 is devoted to a class of biconjugate ideal  $2n$ -pole networks.

## 1. Theory of Resistance and Transformer Networks

### 1.1 SYNTHESIS OF NONDEGENERATE NETWORKS

Let  $\theta_{pq} = A_{pq} + jB_{pq}$  be the prescribed transfer constant between terminal pairs  $p$  and  $q$ , where  $A_{pq}$  is expressed in nepers and  $B_{pq}$  (0 or  $\pi$  for a resistive network) in radians. Define a square matrix  $S$  of order  $n$  by

$$\left. \begin{aligned} S_{pq} &= e^{-\theta_{pq}} & \text{for } p \neq q \\ &= 0 & \text{for } p = q. \end{aligned} \right\} \quad (1)$$

According to reference 1,  $S$  is the *efficiency matrix* of the network operating between its image impedances and is related to the normalized impedance matrix  $Z$  of the network by

$$S = (Z - E)(Z + E)^{-1}, \quad (2)$$

where  $E$  is the unit matrix.<sup>3</sup> Solving (2) for  $Z$ , the normalized impedance matrix is

$$Z = \frac{(E+S)(E-S)^{-1}}{2(E-S)^{-1}-E} \quad (3)$$

and the actual impedance matrix is obtained by multiplying  $Z_{pq}$  by  $(R_p R_q)^{\frac{1}{2}}$ , where  $R_p$  denotes the prescribed image impedance at the  $p$ th terminal pair. The problem is now reduced to the synthesis of a  $2n$ -terminal resistive network from its impedance matrix, and this has been solved by Cauer,<sup>4</sup> who indicated a canonic construction by means of resistances and ideal transformers for any network having a positive or semipositive resistance matrix. The last condition characterizes a passive network and results in various restrictions between the transfer constants, which have been discussed in reference 1 and are obtained by stating that  $E+S$  and  $E-S$  are non-negative definite matrices.

If the prescribed losses are such that  $\det(E-S) = 0$ , (3) shows that the network has no impedance matrix. An alternative design based on the admittance matrix can still be used if  $\det(E+S) \neq 0$ : the normalized admittance matrix is

$$Y = \frac{(E-S)(E+S)^{-1}}{2(E+S)^{-1}-E} \quad (4)$$

and the actual admittance matrix is obtained by dividing  $Y_{pq}$  by  $(R_p R_q)^{\frac{1}{2}}$ . If both  $\det(E \pm S)$  vanish, neither method is applicable. This occurs, for instance, in the case of networks composed of ideal transformers alone. A similar difficulty in conventional 4-pole theory is avoided by using a mixed matrix. A perfectly general discussion of  $2n$ -terminal networks based on mixed matrices would be tedious, but the case of ideal transformers yields simple results of practical interest. These are described in Section 1.2.

In practical problems, complete transfer constants between various terminal pairs are seldom

<sup>3</sup> Equation (2) of this paper is (17) of reference 1, but with  $-S$  replacing  $S$ . This results from a change of definition of  $S$  in the present paper, which merely increases by  $\pi$  all phase constants. Although the sign of  $S$  is somewhat arbitrary, the definition adopted in (1) of reference 1 is inconvenient practically because it leads to attributing a phase shift of  $\pi$  to a 4-terminal network reduced to a short circuit between its input and output. In accordance with this change of notation,  $S$  should be replaced by  $-S$  in all quotations of reference 1 used in the present paper.

<sup>4</sup> W. Cauer, "Theorie der Linearen Wechselstromschaltungen," I, Akademische Verlagsgesellschaft Becker & Erler, Leipzig; 1941: pp. 190-194.

prescribed, the phase shifts (0 or 180 degrees for resistive networks) often being unimportant. This corresponds to prescribing only the moduli of the elements of  $S$ : each  $S_{pq}$  can be taken arbitrarily as  $\pm e \exp(-A_{pq})$ . By the reciprocity theorem,  $S$  must be symmetrical and the number of distinct matrices corresponding to the same attenuation requirements is  $2^{n(n-1)/2}$ . On the other hand, a simultaneous multiplication of the  $p$ th row and the  $p$ th column by  $-1$  merely reverses the polarity of the  $p$ th terminal pair and the number of really distinct matrices is reduced to  $2^{(n-1)(n-2)/2}$  if such trivial modifications are disregarded.

For  $n=2$  (4 poles), only one network is obtained. The case  $n=3$  yields two distinct networks, corresponding to matrices  $S$  and  $-S$ , dual to each other. The conditions of physical realizability are expressed in terms of  $E \pm S$  and are identical for dual networks, so that, in the case of  $n=3$ , only one network needs to be discussed in detail. On the contrary, for  $n \geq 4$ , several solutions, neither equivalent nor dual to each other, can be obtained, and the conditions of physical realizability will lead to essentially different results for each solution. It will actually

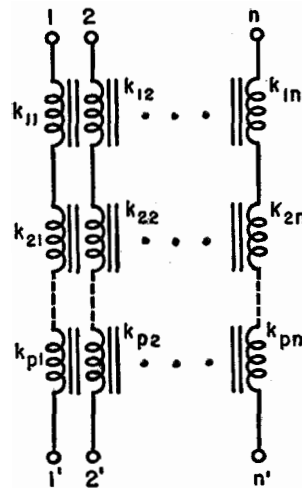

Figure 1—General  $2n$ -terminal transformer network.

be shown that a set of attenuations may or may not be realized depending on the set of phase shifts with which it is associated, and the synthesis of a network with prescribed attenuation must be preceded by a discussion of the phase shifts.



1.2 TRANSFORMER NETWORKS

The most general 2n-terminal transformer network is represented in Figure 1. The circuits of the n terminal pairs are coupled by means of a number p of n-winding transformers in series. Such a network without physical connection between the n circuits is perfectly general, since any connection can be simulated by transformers with unit ratios.

Call  $k_{ij}$  the number of turns on that winding of the  $i$ th transformer that is in the circuit of the  $j$ th terminal pair. If the  $(p, n)$  matrix<sup>5</sup>  $K = \|k_{ij}\|$  is of rank p, the transformers introduce p linearly independent relations between the currents. If K is of rank  $r < p$ , the relations are not linearly independent and  $p - r$  transformers are superfluous. In the following, only the case of independent transformers will be considered. The largest number of independent transformers that can be incorporated in a 2n-terminal network is n, and the network is equivalent to n separate open-terminal pairs. The other extreme case  $p = 0$  corresponds to n separate short circuits.

It will now be shown that in the general case of p independent transformers ( $0 < p < n$ ), it is

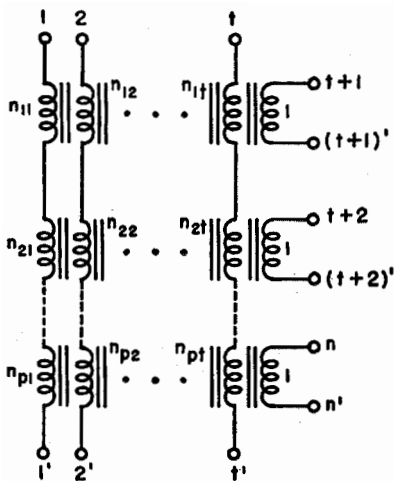

Figure 2—Canonic 2n-terminal network, where  $t = n - p$ .

possible to reduce to zero  $p - 1$  windings on each transformer without altering the external properties of the network. The network of Figure 1 is then replaced by the *canonic transformer network*

<sup>5</sup> A rectangular matrix having p rows and n columns is called a  $(p, n)$  matrix.

of Figure 2, where each transformer has  $n - p + 1 = t + 1$  windings. This transformation requires a suitable change in the turns ratios that will now form a  $(p, t)$  matrix  $N = \|n_{ij}\|$ , the last winding on each transformer being assumed to have a number of turns equal to one. As only ratios are of interest, an arbitrary number of turns may be imposed on one winding of each transformer.

To prove the equivalence, the original matrix K is split into two submatrices, a  $(p, t)$  matrix  $K_1$  composed of the first t lines of K, and the remaining  $(p, p)$  matrix  $K_2$ . Similarly, the first t currents are separated to form a  $(t, 1)$  matrix  $I_1$ , and the p latter form a  $(p, 1)$  matrix  $I_2$ . In the same way, the voltage matrices are  $V_1$  and  $V_2$ . In addition, call  $U_i$  the voltage per turn on the  $i$ th transformer. The  $U_i$  form a  $(p, 1)$  matrix U. The network equations are, denoting a transposed matrix by a prime,

$$K_1 I_1 + K_2 I_2 = 0. \tag{5}$$

$$\left. \begin{aligned} V_1 &= K_1' U; \\ V_2 &= K_2' U. \end{aligned} \right\} \tag{6}$$

Since  $K_2$  is a square matrix,  $K_2^{-1}$  exists if  $\det K_2 \neq 0$ ; since K is of rank p, at least one minor of order p does not vanish and can be identified with  $\det K_2$ , possibly after a renumbering of terminal pairs. With this assumption, (5) can be solved in  $I_2$ , and U eliminated in (6). Defining N by  $K_2^{-1} K_1$ , (5) and (6) become

$$\left. \begin{aligned} I_2 &= -N I_1 \\ V_1 &= N' V_2 \end{aligned} \right\} \tag{7}$$

and obviously correspond to the canonic configuration of Figure 2. They extend to matrices the usual scalar equations of a two-winding transformer.

To obtain the efficiency matrix S in terms of N, all voltages and currents will be normalized or, equivalently, all terminal resistances will be made equal to 1 ohm. For other values of resistance, it is sufficient to replace  $n_{ij}$  by  $n_{ij}(R_{t+i}/R_j)^{1/2}$  in all subsequent equations. The matrix S is obtained as in reference 1 by solving the network equations combined with the terminal conditions. The calculation is made in terms of submatrices of S defined, with their order, by

$$S = \begin{vmatrix} S_{11} & S_{12} \\ S_{21} & S_{22} \end{vmatrix} \begin{matrix} (t) & (p) \\ (t) & (p) \end{matrix} \tag{8}$$

The diagonal submatrices are of order  $t$  and  $p$ , respectively, and two distinct unit matrices  $E_t$  and  $E_p$  of corresponding orders must be used. The following values are obtained for the submatrices

$$\left. \begin{aligned} S_{11} &= E_t - 2(E_t + N'N)^{-1} \\ S_{12} &= 2(E_t + N'N)^{-1}N' \\ S_{21} &= 2(E_p + NN')^{-1}N \\ S_{22} &= 2(E_p + NN')^{-1} - E_p \end{aligned} \right\} \quad (9)$$

and the conditions of symmetry and orthogonality proved in reference 1 are automatically satisfied.

An orthogonal symmetrical matrix has eigenvalues<sup>6</sup> equal only to  $\pm 1$ . The sum of the eigenvalues is equal to the *trace* or *spur* of the matrix, i.e., to the sum of the elements of its leading diagonal. This sum is thus an integer between  $-n$  and  $n$ , and odd or even with  $n$ , zero being

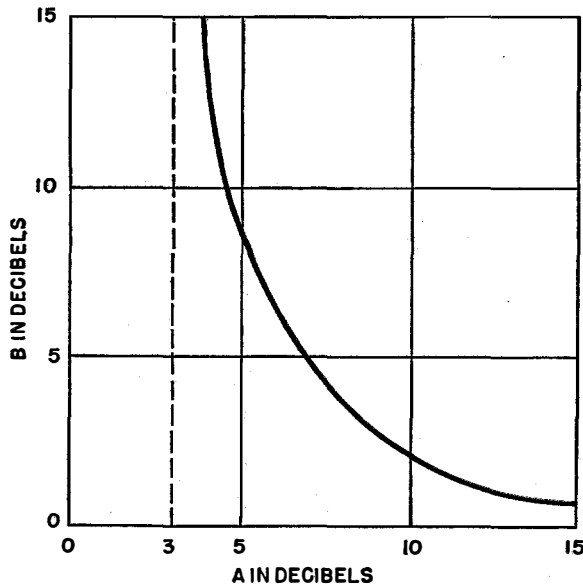

Figure 3—Relations between the minimum attenuations  $A = A_{13} = A_{23}$  and  $B = A_{12}$  of a symmetrical 6-pole network.

considered an even integer. The trace of the efficiency matrix is the sum of the reflection coefficients at all the terminal pairs and will be called the *total reflection coefficient*. The following theorem will now be proved:

<sup>6</sup> The values of  $\lambda$  for which the linear system  $SX = \lambda X$  admits a nontrivial solution are called *eigenvalues* of  $S$  and the corresponding single-rowed matrices  $X$  are the *eigenvectors* of  $S$ . The eigenvalues are the roots of the equation  $\det(S - \lambda E) = 0$ .

The total reflection coefficient of a transformer network is  $2p - n$ , where  $p$  is the number of independent transformers composing the network and  $n$  is the number of terminal pairs.

The theorem is consistent with the preceding remarks: the trace  $2p - n$  is indeed odd or even with  $n$  and is between  $-n$  and  $n$ , since  $p$  can only vary from 0 to  $n$ . The proof is equivalent to

$$\text{tr}(E_p + NN')^{-1} - \text{tr}(E_t + N'N)^{-1} = p - t, \quad (10)$$

$N$  is a  $(p, t)$  matrix,  $N'N$  is a square of order  $t$ , and  $NN'$  is a square of order  $p$ . If  $p > t$ , any eigenvalue  $\lambda$  of  $N'N$  is also an eigenvalue of  $NN'$ ; after multiplying by  $N$ , the matrix equation  $N'NX = \lambda X$ , where  $X$  is an eigenvector of  $N'N$ , it appears that  $NX$  is an eigenvector of  $NN'$  with the same eigenvalue  $\lambda$ . In addition, the remaining  $p - t$  eigenvalues of  $NN'$ , which are not eigenvalues of  $N'N$ , are necessarily zero. This results from the fact that  $NN'$  and  $N'N$ , though of different order, are of same rank and thus have the same number of nonzero eigenvalues. The equality of rank is obvious, since any minor of  $NN'$  and of  $N'N$  is the square of a minor of a matrix  $\hat{N}$  obtained by supplementing  $N$  by  $p - t$  columns of zero elements. As a consequence, the eigenvalues of  $(E_p + NN')^{-1}$  include those of  $(E_t + N'N)^{-1}$  and, in addition,  $p - t$  supplementary eigenvalues equal to 1. This proves (10). A similar proof holds for  $p < t$ . Equation (9) and the trace theorem permit  $N$  to be calculated from a prescribed  $S$  matrix.

Since networks having a total reflection coefficient different from zero cannot be simultaneously matched, networks with zero total reflection deserve special consideration. For such networks,  $2p = n$  and the number of terminal pairs is necessarily even. In addition,  $t = p$  and the ratio matrix  $N$  is square. The efficiency matrix (8) is then automatically partitioned into 4 square submatrices of order  $p$ :

$$\left. \begin{aligned} S_{11} &= E - 2(E + N'N)^{-1} \\ &= (N'N + E)(N'N - E)^{-1} \\ S_{12} &= S_{21}' \\ &= 2(E + N'N)^{-1}N' \\ S_{22} &= 2(E + NN')^{-1} - E \\ &= (E - NN')(E + NN')^{-1}, \end{aligned} \right\} \quad (11)$$

where  $E$  is the unit matrix of order  $p$ . Conversely, if  $S_{11}$  and  $S_{12}$  are known and satisfy the orthogonality relation

$$S_{11}^2 + S_{12}S_{12}' = E, \quad (12)$$

the ratio matrix is calculated by

$$N = S'_{12}(E - S_{11})^{-1} = (E + S_{11})S^{-1}_{12} \tag{13}$$

and the network can be constructed according to the scheme of Figure 2.

An important particular case arises when  $N$  is orthogonal, thus  $N'N = NN' = E$ . The efficiency matrix is then reduced to

$$S = \begin{vmatrix} 0 & N' \\ N & 0 \end{vmatrix} \tag{14}$$

and simultaneous matching automatically results. The corresponding networks are of practical importance for the interconnection of 4-wire circuits and will be discussed in Section 3.4.

## 2. 6- and 8-Terminal Networks

### 2.1 6-TERMINAL NETWORKS

It has been mentioned that for 6-terminal networks only one of the dual solutions needs to be discussed and the phase shifts may thus all be taken as zero. This is equivalent to assuming that all the elements of the prescribed efficiency matrix are nonnegative. The only nontrivial restriction imposed by physical realizability is

$$\det(E - S) = 1 - 2S_{12}S_{23}S_{13} - S^2_{23} - S^2_{12} - S^2_{13} \geq 0. \tag{15}$$

Before attempting to construct the network, the particular case where two attenuations are equal will be discussed. Assuming, for instance,  $S_{13} = S_{23}$ , condition (26) becomes

$$1 - 2S_{12}S^2_{13} - 2S^2_{13} - S^2_{12} = (1 + S_{12})(1 - S_{12} - 2S^2_{13}) \geq 0; \tag{16}$$

dropping the first factor, which is always positive, and for the sake of brevity setting  $A_{13} = A_{23} = A$  and  $A_{12} = B$ , the final form of the condition is

$$1 - e^{-B} - 2e^{-2A} \geq 0. \tag{17}$$

It will be sufficient to discuss the network corresponding to the limiting case of equality in (17), for networks with larger attenuations can always be realized by adding appropriate 4-terminal pads. The limiting case is represented graphically in Figure 3. The values  $B = \infty$  and  $A = 3$  decibels correspond to a hybrid coil, and

the case  $A = B = 6$  decibels corresponds to the completely symmetrical pad of Figure 4 with  $R_a = R_b = R_c = R/3$ , where  $R$  is the prescribed image impedance. If  $R_a$  is allowed to take a value different from  $R_b = R_c$ , the network of Figure 4 is an appropriate solution for the case  $A \neq B$ , but the resulting image impedance  $R_1$  is also different from  $R_2 = R_3$  and, if identical image impedances

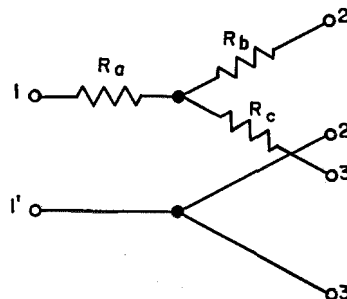

Figure 4—Six-terminal resistance network.

are prescribed at all terminal pairs, a transformer must be inserted at terminals 1,1'. The following design formulas for the elements are obtained by elementary network analysis.

$$\left. \begin{aligned} e^{2A} &= 4R_1/R_2 \\ R_a &= R_1(e^{2A} - 3)(e^{2A} - 1)^{-1} \\ R_b &= R_c = R_2(e^{2A} - 1)^{-1} \end{aligned} \right\} \tag{18}$$

This shows that the configuration of Figure 4 is only possible for  $e^{2A} \geq 3$ , i.e., for  $A \geq 4.8$  decibels. For the limiting value  $A = 4.8$  decibels; which corresponds to  $B = 2A = 9.6$  decibels,  $R_a$  vanishes and for smaller values of  $A$  becomes negative. The equivalent circuit of a hybrid coil shown in Figure 5, which is easily proved by Norton's impedance transformation, will be applied to eliminate the negative resistance. Replacing the negative resistance  $R_a$  of Figure 4 and a part of the positive resistances  $R_b$  and  $R_c$  by a hybrid coil, by means of the particular case of equivalence of Figure 5 corresponding to  $n = 1$ , the hybrid network of Figure 6 is obtained and the design formulas are deduced from (18) with

$$R'_a = -R_a; R'_b = R'_c = R_b + 2R_a = 2R_1 - R_2. \tag{19}$$

The image impedances of the network of Figure 6 are still related by the first equation (18) but can be modified by changing the ratio of the hybrid

coil. In the limiting case  $A = \infty$ ,  $R'_b$  vanishes and the network is reduced to a conventional hybrid coil.

In the construction of the general 6-terminal network with 3 different attenuations, the limit-

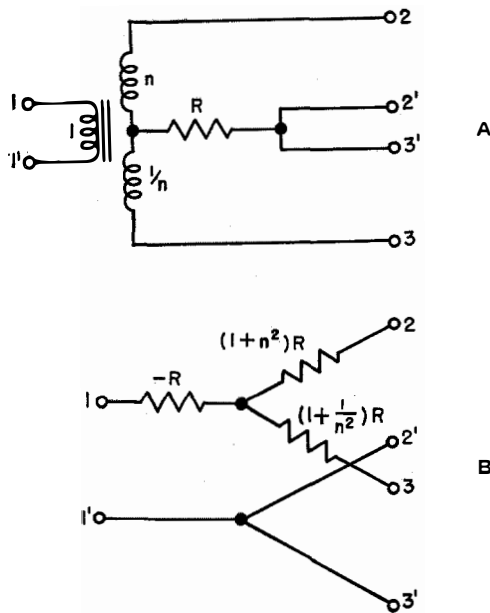

Figure 5—A—Hybrid coil. B—Equivalent circuit of A.

ing case of equality in (15) will again be assumed. As this makes  $\det(E - S) = 0$ , the design must be based on the admittance matrix. By the method described in Section 1.1, the short-circuit admittances are obtained, and the synthesis of the network of Figure 4 is then obvious.

The following design formulas containing an arbitrary common factor  $R$  are obtained.

$$\left. \begin{aligned} R_a &= (S_{23}^2 - S_{12}^2 S_{13}^2) R \\ R_b &= (S_{13}^2 - S_{23}^2 S_{12}^2) R \\ R_c &= (S_{12}^2 - S_{13}^2 S_{23}^2) R \\ R_1 &= (S_{23} + S_{12} S_{13})^2 R \\ R_2 &= (S_{13} + S_{23} S_{12})^2 R \\ R_3 &= (S_{12} + S_{13} S_{23})^2 R. \end{aligned} \right\} \quad (20)$$

This generally results in 3 different image impedances  $R_1, R_2, R_3$  and, if other terminal resistances are prescribed, simultaneous matching will require 2 additional transformers. The network resistances are all positive if  $(S_{23} - S_{12} S_{13})$  and the two similar expressions are positive.

Since this is equivalent to

$$A_{23} \leq A_{12} + A_{13} \quad (21)$$

together with the similar inequalities deduced by cyclic permutation from (21), the condition for the realizability of a resistance network is that the 3 attenuations can be the sides of a triangle. When equality holds in (21), one of the resistances vanishes; the condition  $B = 2A$  obtained in the symmetrical case is an instance of this rule. It is easily seen that only one of the network resistances given by (20) can be negative. The network can then be transformed into the configuration of Figure 6 with the help of the equivalence of Figure 5.

### 2.2 SYMMETRICAL 8-TERMINAL NETWORKS

The general case of an 8-pole network is quite complicated, so that the following discussion is limited to a symmetrical case. An entirely different method of network synthesis will be used and this will first be explained.

The network of Figure 7 has been studied by Cauer.<sup>7</sup> Its admittance matrix  $Y$  can be expressed in terms of the elements of the admittance matrices  $2P$  and  $2Q$  of the 4-pole pads composing the network. It appears then that the network

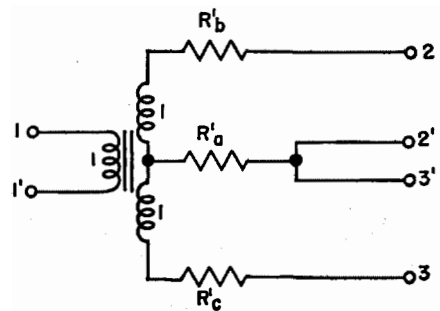

Figure 6—Six-terminal hybrid network.

has the particular type of symmetry characterized by the relations

$$\left. \begin{aligned} Y_{11} &= Y_{33} \\ Y_{22} &= Y_{44} \\ Y_{12} &= Y_{34} \\ Y_{14} &= Y_{23}, \end{aligned} \right\} \quad (22)$$

which indicates that terminal pairs 1 and 3 and

<sup>7</sup> Reference 4, p. 450.

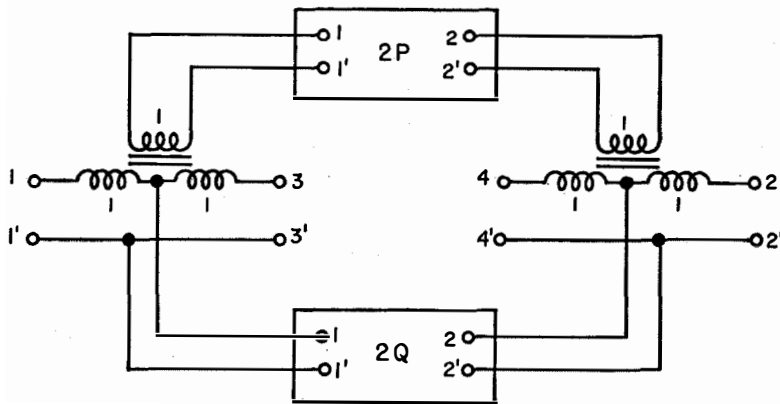

Figure 7—Symmetrical 8-pole network.

containing transformers. As an alternative to the network of Figure 7, a generalised lattice (*double-bridge*), also discussed by Cauer, can be used, but the insertion of 1:1 transformers in some of the component 4-pole networks will normally be required to prevent the circulation of longitudinal currents. The question of interconnection of 4-pole networks is discussed by Guillemin.<sup>8</sup>

pairs 2 and 4 are electrically indistinguishable from each other. When the admittance matrix is explicitly written, taking into account relations (22), thus

$$Y = \begin{vmatrix} Y_{11} & Y_{12} & Y_{13} & Y_{14} \\ Y_{12} & Y_{22} & Y_{14} & Y_{24} \\ \hline Y_{13} & Y_{14} & Y_{11} & Y_{12} \\ Y_{14} & Y_{24} & Y_{12} & Y_{22} \end{vmatrix}, \quad (23)$$

a partition in 4 submatrices appears, involving only 2 distinct submatrices of the second order. This partition is suggested by the dotted lines in (23) and Cauer has shown that the partial submatrices, which will be denoted here by  $Y_a$  and  $Y_b$ , are equal to  $(Q \pm P)/2$ , so that the complete admittance matrix is

$$Y = \begin{vmatrix} Y_a & Y_b \\ Y_b & Y_a \end{vmatrix} = \frac{1}{2} \begin{vmatrix} (Q+P) & (Q-P) \\ (Q-P) & (Q+P) \end{vmatrix}. \quad (24)$$

Conversely, any 8-pole network having the type of symmetry defined by (22) has a matrix of the form (23) and can be constructed according to the scheme of Figure 7. This is easily proved by showing that the matrices

$$\begin{aligned} P &= Y_a - Y_b \\ Q &= Y_a + Y_b \end{aligned} \quad (25)$$

resulting from (24), satisfy the conditions of physical realizability for 4-pole networks, if  $Y$  satisfies similar conditions for an 8-pole network.

The preceding results for symmetrical 8-pole networks are the exact counterpart of the canonic construction of symmetrical 4-pole networks as lattice structures or equivalent configurations

The efficiency matrix of an 8-pole network having the admittance matrix (24) and working between terminal impedances satisfying the symmetry conditions  $R_1 = R_3$  and  $R_2 = R_4$  can also be symmetrically partitioned in submatrices

$$S = \begin{vmatrix} S_a & S_b \\ S_b & S_a \end{vmatrix}. \quad (26)$$

If, in addition, simultaneous matching is assumed, the submatrices are of the form

$$\begin{aligned} S_a &= \begin{vmatrix} 0 & S_{12} \\ S_{12} & 0 \end{vmatrix} \\ S_b &= \begin{vmatrix} S_{13} & S_{14} \\ S_{14} & S_{24} \end{vmatrix} \end{aligned} \quad (27)$$

so that the symmetry conditions (22), expressed in terms of image parameters, give

$$\left. \begin{aligned} R_1 &= R_3 \\ R_2 &= R_4 \\ S_{12} &= S_{34} \\ S_{14} &= S_{23} \end{aligned} \right\} \quad (28)$$

By the method of Section 1.1, the admittance matrix of the 8-pole network is calculated and the normalized admittance matrices of the component 4-pole networks are expressed in terms of  $S_a$  and  $S_b$ . To avoid a special notation for normalized matrices, all image impedances are assumed to be equal to unity. The component admittance matrices are then

$$\begin{aligned} P &= 2(E + S_a - S_b)^{-1} - E \\ Q &= 2(E + S_a + S_b)^{-1} - E \end{aligned} \quad (29)$$

and the synthesis of the 8-pole network is

<sup>8</sup> E. A. Guillemin, "Communication Networks," Volume 2, J. Wiley & Sons, New York; 1935: p. 147.

achieved by constructing the component 4-pole networks by known methods. The conditions of realizability are obtained from (29), which immediately show that the four matrices  $E \pm S_a \pm S_b$  must be nonnegative. This gives the four conditions

$$\left. \begin{aligned} \alpha &= (1 - S_{13})(1 - S_{24}) - (S_{12} + S_{14})^2 \geq 0 \\ \beta &= (1 - S_{13})(1 - S_{24}) - (S_{12} - S_{14})^2 \geq 0 \\ \gamma &= (1 + S_{13})(1 + S_{24}) - (S_{12} + S_{14})^2 \geq 0 \\ \delta &= (1 + S_{13})(1 + S_{24}) - (S_{12} - S_{14})^2 \geq 0 \end{aligned} \right\} \quad (30)$$

2.3 DISCUSSION AND EXAMPLES

As for 6-terminal networks, important results are obtained by considering the particular case of equality in some or all of the conditions (30). The case

$$\alpha = \beta = \gamma = \delta = 0 \quad (31)$$

corresponds to a hybrid coil. The equation

$$\beta - \alpha = 4 S_{12} S_{14} = 0 \quad (32)$$

associated with conditions (26), requires either

$$S_{12} = S_{34} = 0 \quad (33)$$

or

$$S_{14} = S_{23} = 0 \quad (34)$$

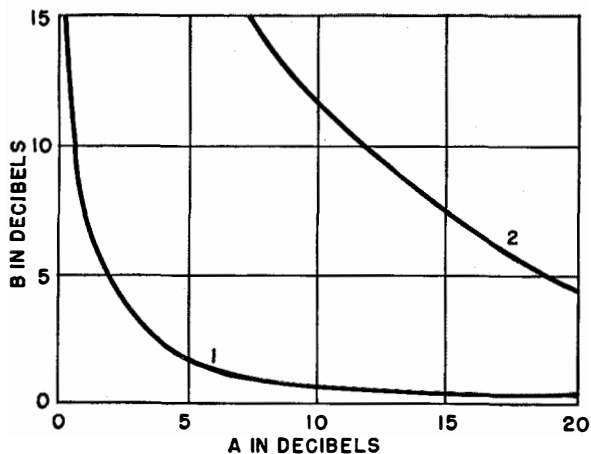

Figure 8—Relation between the attenuations of a biconjugate network. 1—Hybrid coil. 2—Resistance hybrid.

so that in both cases the network is *biconjugate*, i.e., gives no transmission between two mutually excluding couples of terminal pairs. Conditions (33) give  $S_a = 0$  and (27) then give

$$Q = P^{-1} = 2(E + S_b)^{-1} - E \quad (35)$$

so that the component 4-pole networks are dual to each other. On the other hand, the network of case (34) simply results from the network of case (33) by including a supplementary phase reversal in the 4-pole network of matrix  $P$ , and only one of these cases needs to be discussed in detail. Accepting thus (34), the remaining conditions give

$$S_{24} = -S_{13} \quad (36)$$

$$1 - S_{13}^2 - S_{12}^2 = 0, \quad (37)$$

which are the familiar relations between the attenuations and phases of a hybrid coil. Only two distinct attenuations  $A = -\log S_{12}$  and  $B = -\log S_{13}$  are obtained, and (37) or

$$e^{-2A} + e^{-2B} = 1 \quad (38)$$

is represented in curve 1 of Figure 8 using decibel scales.

By dropping some of the preceding conditions, biconjugate networks more general than the hybrid coil are obtained. As an example, the practically important case of the so-called *resistance hybrid* will be discussed. Keeping conditions (34) and (36) but dropping (37), networks are obtained that have a behavior similar to that of a hybrid coil but with larger attenuations. If such a network is realized as a generalized lattice, it can be made purely resistive if the component 4-pole networks are realizable without using transformers. This leads for both 4-pole networks to the common condition:

$$(1 - S_{12})^2 + (1 - S_{13})^2 = 1 \quad (39)$$

or

$$(1 - e^{-A})^2 + (1 - e^{-B})^2 = 1 \quad (40)$$

represented in curve 2 of Figure 8. The resulting network is shown in Figure 9 with

$$R_a/R = (2e^A - 1)^{\frac{1}{2}} - 1 = R/R_b, \quad (41)$$

where  $R$  is the image impedance of the 8-pole network. The particular case

$$A = B = 20 \log_{10} (2 + 2^{\frac{1}{2}}) = 10.7 \text{ decibels}$$

gives  $R_a/2 = R_b = R2^{\frac{1}{2}}/2$ . This symmetrical resistance hybrid is sometimes used in connection with 2-wire repeaters.<sup>9</sup>

The general discussion of 8-pole networks will now be continued, excluding biconjugate net-

<sup>9</sup> P. G. Edwards, "V.1 Telephone Repeater Arrangements," *Bell Laboratories Record*, v. 20, pp. 20-23; September, 1941.

works. Since the four expressions  $\alpha$ ,  $\beta$ ,  $\gamma$ , and  $\delta$  are related by the identity

$$\alpha + \delta = \beta + \gamma, \tag{42}$$

it cannot be assumed that three of them vanish. The next hypothesis will be to dispose of two

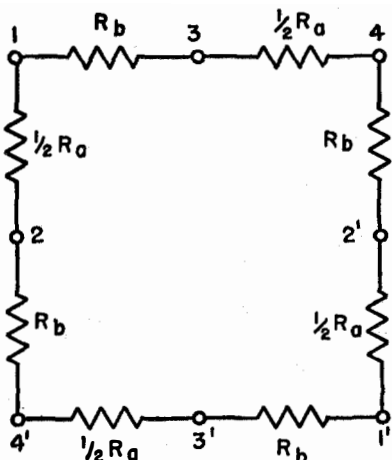

Figure 9—Resistance hybrid.

of these quantities. This has a simple physical meaning: conditions (26) reduce the number of independent attenuations to two, and by extracting pads from a symmetrical 8-pole network, it will in general be possible to reduce to zero only two of the four expressions of (30). Furthermore, identity (42) shows that the two vanishing quantities must be chosen one in each member of (42), for the remaining quantities must remain positive. Except for a permutation of terminal pairs, the only new combination is  $\alpha = \gamma = 0$ . Conditions (30) in this case become

$$S_{24} = -S_{13} \tag{43}$$

$$\left. \begin{aligned} 1 - S_{13}^2 - (S_{12} + S_{14})^2 &= 0 \\ S_{12}S_{14} &\geq 0. \end{aligned} \right\} \tag{44}$$

The 4-pole network of matrix  $Q$  is reduced to an ideal transformer of ratio

$$n = \left( \frac{1 - S_{13}}{1 + S_{13}} \right)^{\frac{1}{2}} \tag{45}$$

and the components of the matrix  $P$  are

$$\begin{aligned} P_{11} &= (2 S_{12}S_{14})^{-1}(1 + S_{13}) - 1 \\ P_{12} &= (2 S_{12}S_{14})^{-1}(S_{14} - S_{12}) \\ P_{22} &= (2 S_{12}S_{14})^{-1}(1 - S_{13}) - 1. \end{aligned}$$

In the particular case

$$S_{12} = S_{14}, \tag{46}$$

$P_{12}$  vanishes and the 4-pole network of matrix  $P$  degenerates into two separate resistances  $R_a$  and  $R_b$  given by

$$\frac{R_a}{R} = \frac{1 - S_{13}}{1 + S_{13}} = \frac{R}{R_b}. \tag{47}$$

The network has only two distinct attenuations related by

$$1 - S_{13}^2 - 4S_{12}^2 = 0. \tag{48}$$

As an example, the solution  $S_{13} = S_{12} = 1/5^{\frac{1}{2}}$  will be examined. This gives

$$\begin{aligned} n &= (5^{\frac{1}{2}} - 1)/2 \\ R_a/R &= (3 - 5^{\frac{1}{2}})/2 = R/R_b. \end{aligned} \tag{49}$$

An economical form of network is represented in Figure 10 and has been obtained by interchanging the terminal pairs of one of the hybrid coils and by combining it with the 2-winding transformer. The network of Figure 10 has an image impedance equal to  $R$  at all its terminal pairs and has an attenuation of  $10 \log 5 = 7$  decibels between all couples of terminal pairs.

### 3. Conference Networks

#### 3.1 GENERAL

The network of Figure 10 is characterised by the three following properties.

- A. Simultaneous matching to equal resistances is possible at all terminal pairs.
- B. Attenuations between all couples of terminal pairs have the same value.
- C. Attenuation is the smallest possible for a passive network.

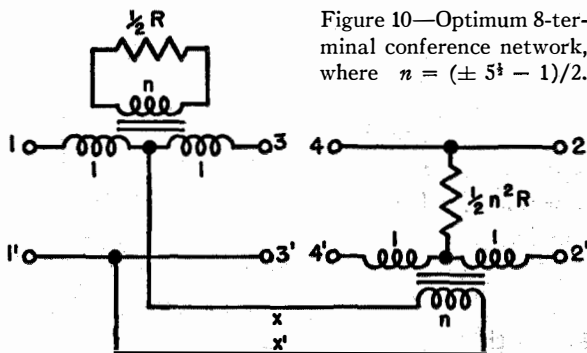

Figure 10—Optimum 8-terminal conference network, where  $n = (\pm 5^{\frac{1}{2}} - 1)/2$ .

Networks satisfying the above conditions give the optimum solution to the problem of interconnecting several transmission lines, when communication is desired between any pair of lines with the same efficiency. Such networks are of practical interest for conference telephone systems, train-dispatching transmission circuits, and other similar applications. Condition *C* is usually less essential than the first two since a larger loss can often be tolerated if the resulting network is simpler or cheaper. For convenience, networks satisfying conditions *A* and *B* will be called *conference networks*; when, in addition, condition *C* is fulfilled the term *optimum conference network* will be used.

The optimum 6-terminal conference network has been mentioned in Section 2.1 and corresponds to Figure 4 with three equal resistances. A similar configuration is well known for the  $2n$ -terminal case: the network consists of  $n$  resistances each equal to  $(n-2)R/n$ , where  $R$  stands for the image impedance, the attenuation between any two terminal pairs being

$$A = 20 \log_{10} (n-1) \text{ decibels.} \quad (50)$$

For  $n > 3$ , this does not yield the optimum conference networks. Indeed, for  $n=4$ , (50) gives a loss of 9.6 decibels whereas the network of Figure 10 has a loss of only 7 decibels.

Optimum conference networks for the cases  $n=5$  and  $n=6$  are easily obtained by a modification of Figure 10. Since  $\frac{2}{3}$  of the input power is dissipated in the internal resistances of this network, two more terminal pairs may be energized if the resistances are replaced by a third hybrid coil as shown in Figure 11. Since no power is consumed in the network, this actually gives the optimum conference network for  $n=6$ . The same network with one dummy load is also the optimum network for  $n=5$ , for a 10-terminal network with a loss smaller than 7 decibels would yield an 8-terminal network with the same attenuation if a second dummy load is incorporated; but 7 decibels has been shown to be the minimum loss in that case.

### 3.2 IDEAL CONFERENCE NETWORKS

The conference network for the case  $n=6$  is quite remarkable since it contains no resistances and it is clear from the preceding discussion that a conference network composed of ideal transformers alone is impossible for  $n < 6$  except for the unimportant case of  $n=2$ . It is the purpose of the following sections to show that such networks, which will be termed *ideal conference networks*, exist for some other numbers of terminal pairs larger than 6. Since no power is either consumed or reflected in an ideal network, the attenuation merely results from the division of power equally among  $n-1$  outputs and is

$$A_0 = 10 \log_{10}(n-1) \text{ decibels.} \quad (51)$$

This is half of the attenuation of the conventional resistance pad given by (50).

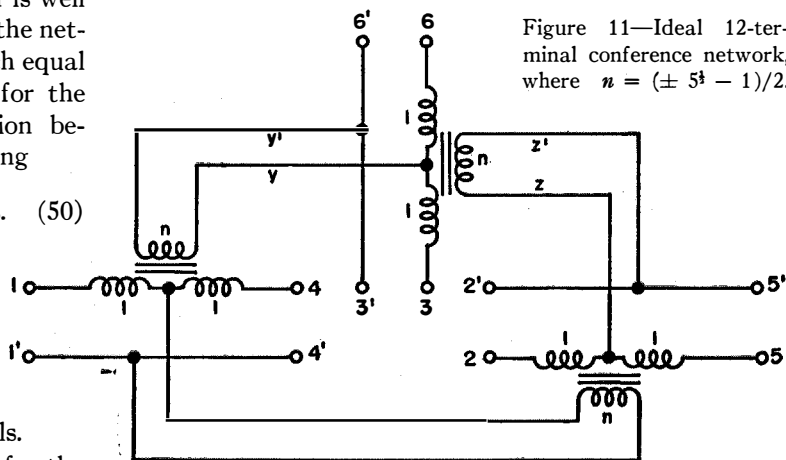

Figure 11—Ideal 12-terminal conference network, where  $n = (\pm 5^{\frac{1}{2}} - 1)/2$ .

It results from (51) that the nondiagonal elements of the efficiency matrix of an ideal conference network are all equal to  $\pm s$ , where

$$s = (n-1)^{-\frac{1}{2}}, \quad (52)$$

so that the matrix is of the form

$$S = s \begin{vmatrix} 0 & \pm 1 & \pm 1 & \dots \\ \pm 1 & 0 & \pm 1 & \dots \\ \dots & \dots & \dots & \dots \end{vmatrix}, \quad (53)$$

the distribution of the signs being restricted only by the conditions of symmetry and orthogonality. In Section 1.2, matched  $2n$ -terminal transformer networks with  $n$  odd have already been excluded



and we can write  $n=2p$ . In addition, it can be shown by writing the orthogonality condition for any set of three rows of (53), that for an ideal conference network  $p$  must be odd. Setting  $p=2k+1$ , the number of terminal pairs is

$$n=2p=4k+2 \tag{54}$$

and ideal conference networks can only exist for  $n=2, 6, 10, \dots$ .

Networks for  $n=2$  and  $6$  have already been mentioned and more complicated cases will now be investigated. From Section 1.2, it is known that the network for  $n=2p$  will be composed of  $p$  transformers. By analogy with the solution for  $n=6$  (Figure 11), it will be heuristically assumed that the  $p$  transformers are identical and cyclically interconnected. This corresponds to a circulant ratio matrix of the form

$$N = \begin{pmatrix} n_0 & n_1 & n_2 & \dots & n_{p-1} \\ n_{p-1} & n_0 & n_1 & \dots & n_{p-2} \\ n_{p-2} & n_{p-1} & n_0 & \dots & n_{p-3} \\ \dots & \dots & \dots & \dots & \dots \\ n_1 & n_2 & n_3 & \dots & n_0 \end{pmatrix}, \tag{55}$$

where each row is the preceding one shifted by one step to the right. In the following, a circulant matrix will be simply denoted by its first row, thus

$$N = (n_0, n_1, n_2, \dots, n_{p-1}).$$

A circulant and symmetrical matrix is further characterized by the relations

$$n_{p-1} = n_1, n_{p-2} = n_2, \dots$$

As a consequence of (11), if  $N$  is circulant,  $S_{12} = S'_{21}$  is circulant and  $S_{11} = -S_{22}$  is circulant and symmetrical. In the case of conference networks, the common factor (52) will be extracted:

$$\begin{aligned} S_{11} &= -S_{22} = sA \\ S_{12} &= S'_{21} = sB. \end{aligned} \tag{56}$$

This defines  $A$  and  $B$ ;  $B$  is circulant and composed of elements equal to  $\pm 1$ :

$$B = (b_0 b_1 b_2 \dots b_{p-1}); \tag{57}$$

and  $A$  is circulant and symmetrical and has elements equal to  $\pm 1$  except for the leading diagonal, which is composed of zeros:

$$A = (0, a_1, a_2, \dots, a_k, a_k, \dots, a_2, a_1); \tag{58}$$

the index  $k$  is defined by (54) or  $p=2k+1$ . Relations (12) and (13) become

$$A^2 + BB' = (n-1)E \tag{59}$$

$$N = B'[(n-1)^{\frac{1}{2}}E - A]^{-1} = [(n-1)^{\frac{1}{2}}E + A]B^{-1}. \tag{60}$$

Consider the identity

$$\sum_{j=1}^p (\sum_{i=1}^p a_{ij})^2 + (\sum_{i=1}^p b_{ij})^2 = \sum_{i=1}^p \sum_{k=1}^p \sum_{j=1}^p (a_{ij}a_{kj} + b_{ij}b_{kj}), \tag{61}$$

where both members differ only by the order of summation and the designation of dummy indices. By (59), the right-hand member becomes, using Kronecker's symbol,

$$(n-1) \sum_{i=1}^p \sum_{k=1}^p \delta_{ik} = (n-1)p;$$

in the left-hand member,

$$\sum_{i=1}^p b_{ij} = b_0 + b_1 + \dots + b_{p-1} = \beta \tag{62}$$

is independent of  $j$  and similarly

$$\sum_{i=1}^p a_{ij} = 2(a_1 + a_2 + \dots + a_k) = \alpha. \tag{63}$$

The left-hand member is thus reduced to  $p(\alpha^2 + \beta^2)$  and (61) finally becomes

$$\alpha^2 + \beta^2 + 1 = n; \tag{64}$$

since  $p$  is odd and all  $b$ 's equal to  $\pm 1$ ,  $\beta$  is odd and (63) shows that  $\alpha$  is even.

As a conclusion, the hypothesis of a circulant ratio matrix leads to (64), which is more restrictive than (54). The first values of  $n$  according to (64) are

$$\left. \begin{aligned} 2 &= 0^2 + 1^2 + 1 \\ 6 &= 2^2 + 1^2 + 1 \\ 10 &= 0^2 + 3^2 + 1 \\ 14 &= 2^2 + 3^2 + 1 \\ 18 &= 4^2 + 1^2 + 1 \\ 26 &= 4^2 + 3^2 + 1 \\ &= 0^2 + 5^2 + 1 \\ 30 &= 2^2 + 5^2 + 1 \\ 38 &= 6^2 + 1^2 + 1 \dots \end{aligned} \right\} \tag{65}$$

and 22, 34,  $\dots$  do not satisfy (64).

Although condition (64) is necessary, it was not proved sufficient, but cyclic networks have actually been constructed for all values of  $n$  listed in (65). The method of construction is discussed in the next section and the networks are described. When, as it happens for 26, 66, ... several expansions in sums of two squares can be found, several *essentially distinct* networks exist.<sup>10</sup> The networks are particularly simple when  $n-1$  is a square.

### 3.3 DESIGN OF CYCLIC NETWORKS

The method of designing cyclic ideal conference networks having a number of terminal pairs satisfying (64) will first be summarized. By (62) and (63), the integers  $\alpha$  and  $\beta$  determine the number of negative elements in matrices  $A$  and  $B$ . To find their distribution, it is necessary to write the relations (59) explicitly, but due to the cyclic symmetry only  $k$  relations are distinct and it is sufficient to consider the products of the first row by the  $k-1$  next rows. Although no systematic method has been found to locate the negative elements without trial and error, the discussion is relatively simple when the number of terminal pairs is not too large. It is simplified on the one hand because of the special symmetry structure of  $A^2$  and on the other hand because  $B^2$  is not altered by a cyclic permutation of the elements of  $B$  nor by a complete reversal of their order. Once matrices  $A$  and  $B$  are determined, the ratio matrix is calculated by (60) and the canonic

network is immediately deduced. The complete solutions up to  $n=38$  have been obtained and their symmetry structure investigated in detail. Limitation of space forbids further comments and only typical results are listed.

#### 3.3.1 Case $n=6$

Negative element:  $b_0$ .

Ratios:  $n_0=1, n_1=n_2=(1\pm 5^{\frac{1}{2}})/2$ .

The resulting canonic network is equivalent to the hybrid-coil network of Figure 11, as can be checked by a linear transformation.

#### 3.3.2 Case $n=10$

Negative elements:  $a_2, b_0$ .

Ratios:  $n_0=-1, n_1=n_4=0, n_2=n_3=1$ .

Two windings are reduced to zero on each transformer. Rearranging the canonic configuration to show cyclic symmetry, Figure 12 is ob-

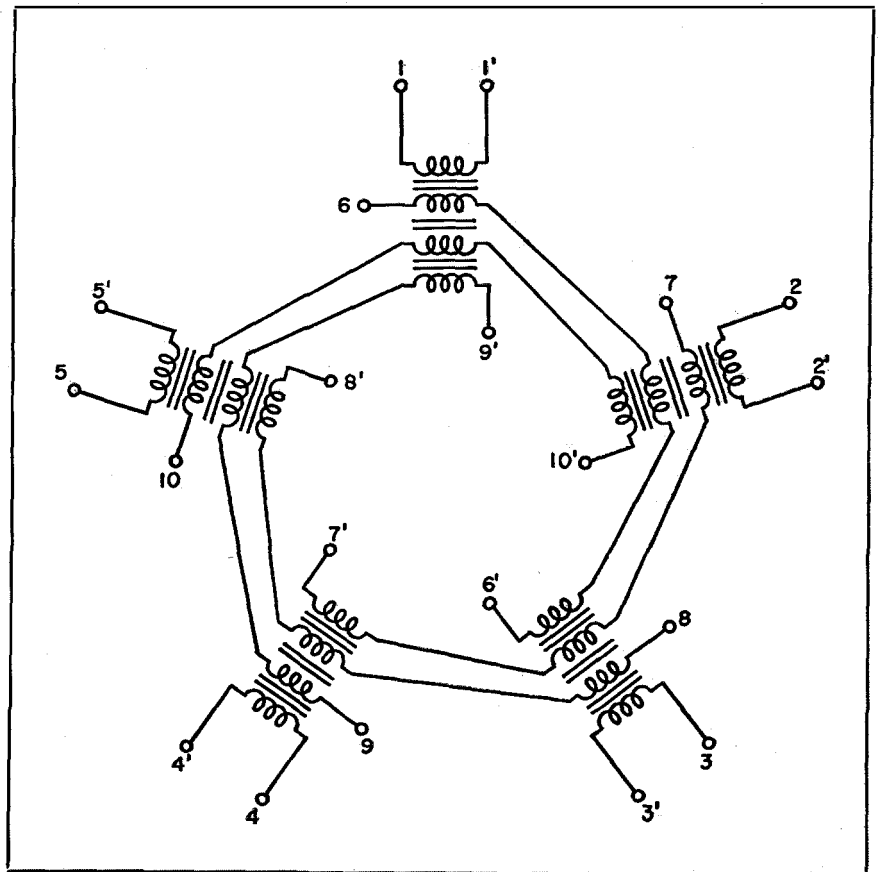

Figure 12—Ideal 20-terminal conference network. The turns ratio of each transformer are 1:1:−1:1 from center outwards.

<sup>10</sup> The number of different expansions may be very large. See M. Kraitchik, "Théorie des Nombres," Gauthier - Villars, Paris, 1922: p. 100.

tained. A network according to Figure 12 has been tested and its performance was in complete agreement with the theory.

**3.3.3 Case  $n = 14$**

Negative elements:  $a_1, b_3, b_4$ .

Ratios:  $n_0 = (\pm 13^{\frac{1}{2}} - 4)/3$   
 $n_1 = n_6 = (\pm 13^{\frac{1}{2}} - 1)/3$   
 $n_2 = n_5 = (1 \mp 13^{\frac{1}{2}})/6$   
 $n_3 = n_4 = (7 \mp 13^{\frac{1}{2}})/6$ .

**3.3.4 Case  $n = 18$**

Negative elements:  $a_1, b_1, b_4, b_5, b_8$ .

Ratios:  $n_0 = (\pm 17^{\frac{1}{2}} - 1)/2$   
 $n_1 = n_8 = (\pm 17^{\frac{1}{2}} - 3)/4$   
 $n_2 = n_7 = (\pm 17^{\frac{1}{2}} + 1)/4$   
 $n_3 = n_6 = 1$   
 $n_4 = n_5 = (7 \mp 17^{\frac{1}{2}})/4$ .

**3.3.5 Case  $n = 26$**

This case is specially interesting because of the two expansions mentioned in (65). In addition, each solution leads to two essentially distinct networks corresponding to opposite signs in  $(n-1)^{\frac{1}{2}} = \pm 5$ . Although this occurred equally in all the preceding cases, the fact that the square root is rational leads here to different simplifications, according to the sign chosen. A total of four distinct networks is thus obtained, and the results are listed here below.

**3.3.5.1 Solutions based on  $26 = 0^2 + 5^2 + 1$**

Negative elements:  $a_1, a_3, a_4, b_0, b_1, b_3, b_9$ .

Ratios	1st Solution	2nd Solution
$n_0$	0	1
$n_1 = n_3 = n_9$	$\frac{2}{3}$	0
$n_2 = n_8 = n_6$	0	$-\frac{2}{3}$
$n_4 = n_{10} = n_{12}$	$-\frac{2}{3}$	$\frac{1}{3}$
$n_7 = n_5 = n_{11}$	$\frac{1}{3}$	$-\frac{1}{3}$

**3.3.5.2 Solutions based on  $26 = 4^2 + 3^2 + 1$**

Negative elements:  $a_1, a_5, b_0, b_2, b_3, b_{10}, b_{11}$ .

Ratios	1st Solution	2nd Solution
$n_0$	$-\frac{1}{3}$	-1
$n_1 = n_5 = n_8 = n_{12}$	$-\frac{1}{3}$	1
$n_4 = n_6 = n_7 = n_9$	$-\frac{1}{3}$	0
$n_2 = n_3 = n_{10} = n_{11}$	$\frac{1}{3}$	0

Obviously, the last solution is the most practical; observe that it is a natural extension of the case  $n = 10$  and that a similar network with a large

number of vanishing windings could not have the required properties.

**3.3.6 Case  $n = 30$**

Negative elements:  $a_1, a_2, a_5, b_0, b_1, b_4, b_{11}, b_{14}$ .

**3.3.7 Case  $n = 38$**

Negative elements:  $a_1, a_3, a_8, b_0, b_1, b_3, b_4, b_9, b_{10}, b_{15}, b_{16}, b_{18}$ .

We conclude this section with a few remarks on the theory of conference networks. This theory seems quite difficult and the only general result obtained is the systematic construction of an orthogonal matrix for all values of  $n = 4k + 2$ , for which  $n - 1$  is a prime. As any prime of the form  $4k + 1$  is the sum of two squares, this does not contradict (64). The proof is too long and will not be given. Lack of time prevented further investigation but it is hoped that the attack initiated on this problem of matrix arithmetic will stimulate further research.

**3.4 4-WIRE NETWORKS**

We will now briefly examine a new class of ideal conference networks suitable for interconnecting 4-wire transmission circuits. The discussion may be started by an example corresponding to  $p = 4$  and  $n = 8$ .

Consider the orthogonal ratio matrix

$$N = \frac{1}{3^{\frac{1}{2}}} \begin{vmatrix} 0 & 1 & 1 & -1 \\ 1 & 0 & 1 & 1 \\ -1 & 1 & 0 & 1 \\ -1 & -1 & 1 & 0 \end{vmatrix}$$

The efficiency matrix of the corresponding 16-terminal network is immediately obtained from (14) and the terminal pairs are separated in two biconjugate groups (1, 2, 3, 4) and (5, 6, 7, 8), respectively. The network is appropriate for connecting four 4-wire lines as shown in the schematic diagram of Figure 13, where the direction of transmission in each circuit has been symbolized by 4-wire repeaters. From terminal pair 1 for instance, signals are transmitted to 6, 7, and 8 with an attenuation of 4.8 decibels; no power is wasted in the outputs 2, 3, and 4 of the incoming amplifiers; there is no transmission from 1 to 5 (side tone); and the network is matched at all its terminal pairs.

When the turns ratios or the terminal impedances differ from their design values, the

infinite attenuations are replaced by finite values, and it is of practical importance to calculate this effect. If the external impedance of the  $i$ th terminal pair is  $R'_i$  instead of the nominal value  $R_i$ , the deviation will be expressed in terms of the reflection coefficient

$$P_i = \frac{R'_i - R_i}{R'_i + R_i},$$

deviations from the design values of the turns ratios being immediately related to impedance deviations. A unit voltage applied on terminal pair  $i$  produces a voltage  $S_{ik}$  at output  $k$ ; a part  $S_{ik}P_k$  of this voltage is reflected and the fraction  $S_{ik}P_kS_{kj}$  of this reflected voltage reaches terminal pair  $j$ . The total voltage transmitted from  $i$  to  $j$  will consist of a number of contributions  $P_kS_{ik}S_{kj}$

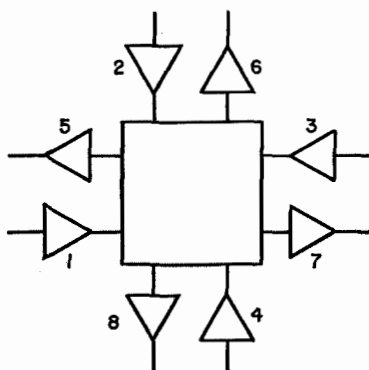

Figure 13—A 4-wire conference network.

from all other terminal pairs  $k$ , and this is superimposed on the direct transmission  $S_{ij}$ . In addition to this direct wave and to the indirect waves with a single intermediate reflection, multiple-reflection waves have to be considered. Successive reflections at two intermediate terminal pairs  $a$  and  $b$  give a contribution of the form  $S_{ia}P_aS_{ab}P_bS_{bj}$ . In conclusion, if reflections of higher order than the second are neglected, the modified efficiency is

$$S'_{ij} = S_{ij} + \sum_k P_k S_{ik} S_{kj} + \sum_a \sum_b P_a P_b S_{ia} S_{ab} S_{bj}.$$

Applying this to a coefficient such as  $S'_{15}$  relating pairs that belong to the same 4-wire circuit, the direct wave and the first-order reflections give no contribution and the equation is reduced to

$$S'_{15} = 3^{-3}(P_2P_8 + P_3P_6 + P_4P_7 - P_6P_4 - P_7P_2 - P_8P_3).$$

The balance is thus much less sensitive to impedance deviations than in the case of conventional hybrid coils, where first-order reflections occur.

A whole series of 4-wire conference networks has been designed, but their systematic theory seems difficult. The networks have  $n = 2p$  terminal pairs,  $p$  being the number of interconnected 4-wire circuits and also the number of independent transformers. The network synthesis is reduced to the design of an orthogonal ratio matrix with elements equal to  $\pm 1/(p-1)^{1/2}$  and zeros on the leading diagonal. Such a matrix is similar to the efficiency matrix of a 2-wire conference network and the cases  $p = 2, 6, 10, \dots$  are thus immediately solved. But the ratio matrix need not be symmetrical, and dissymmetrical solutions can be obtained for other numbers of terminal pairs. Obviously,  $p$  must be even for an orthogonal matrix. The case  $p = 4$  has already been discussed and solutions for  $p = 8$  and 12 will now be described. It has been found that a number of solutions are easily obtained if the matrix is assumed to be of the form

$$N = \begin{pmatrix} 0 & n_1 & n_2 & n_3 & \cdots & n_{p-1} \\ -n_{p-1} & 0 & n_1 & n_2 & \cdots & n_{p-2} \\ -n_{p-2} & -n_{p-1} & 0 & n_1 & \cdots & n_{p-3} \\ -n_{p-3} & -n_{p-2} & -n_{p-1} & 0 & \cdots & n_{p-4} \\ \cdots & \cdots & \cdots & \cdots & \cdots & \cdots \\ -n_1 & -n_2 & -n_3 & -n_4 & \cdots & 0 \end{pmatrix},$$

which is deduced from a circulant matrix by changing the sign of half the elements. Such a matrix is also characterized by its first row. As an example, the following solutions have been found.

### 3.4.1 Case $p = 8$

$$n_1 = n_2 = n_3 = n_6 = 1/7^{1/2} \\ n_4 = n_5 = n_7 = -1/7^{1/2}.$$

### 3.4.2. Case $p = 12$

$$n_1 = n_2 = n_3 = n_4 = n_7 = n_8 = n_{10} = 1/11^{1/2} \\ n_5 = n_6 = n_9 = n_{11} = -1/11^{1/2}.$$

## 4. Acknowledgment

The author wishes to express his indebtedness to his colleague, M. Karlin, for his continuous collaboration and particularly for several suggestions and results incorporated in Sections 3.2 and 3.3.

## In Memoriam

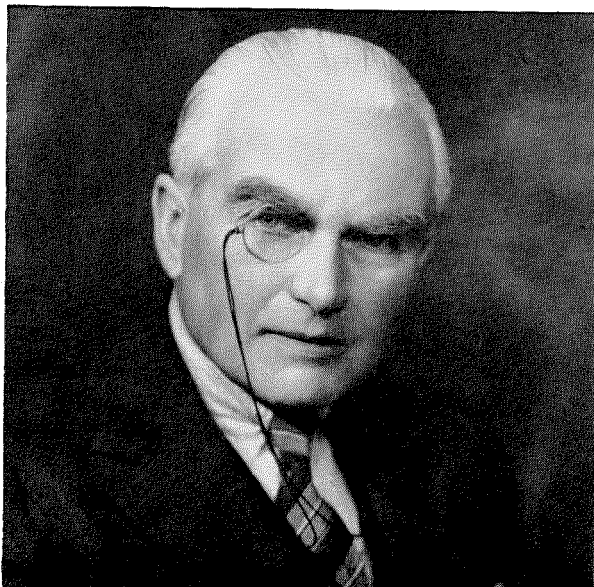

*Copyright Lafayette Limited*

GEORGE HOWARD NASH

**G**EORGE HOWARD NASH was born in 1881 and died on April 7, 1950 in London. He was educated at Grocers School, the Northampton Polytechnic, and London University.

He served first as a junior technician with the old National Telephone Company, and in 1905 joined the Western Electric Company, which later became part of the International Telephone and Telegraph Corporation. His activities in the International System and its predecessor companies were widespread.

He was chief engineer of Standard Telephones and Cables, Limited, from 1911 to 1928 and a director from 1927 to 1938. With International Standard Electric Corporation, he served as assistant European chief engineer for 1928 and 1929, as vice president from 1930 to 1933, and as technical consultant for the following five years. From 1929 to 1932, he was executive vice president of International Telephone and Telegraph Laboratories, Incorporated, and was also vice president of the Mexican Telephone and Telegraph Company. He served as chairman of International Marine Radio Company, Limited, from 1930 to 1934. He was a director of Inter-

national Telephone and Telegraph Company, Limited, from 1928 to 1933.

During the first World War, he was prominently identified with the Western Electric Mining Detector and the Nash Fish Hydrophone. Based on the principle of the seismograph, the mining detector was used to locate enemy mining operations in trench warfare. The fish hydrophone was towed by a ship to locate enemy submarines. For his work in this development, the training of hydrophone officers, and the equipping of a considerable number of vessels with this device, he received the C.B.E. award.

He had a way of reducing most complicated problems to simple terms and during the second World War, as deputy director of the Ministry of Aircraft Production, he did valuable work on the standardization of screw threads and aircraft parts.

Despite his manifold professional activities, Mr. Nash found time to indulge his hobby of designing, building, and sailing model yachts, in which fields he was an acknowledged authority. He collaborated with Admiral Turner in developing the theory of the metacentric shelf and was one of its most able exponents.

## In Memoriam

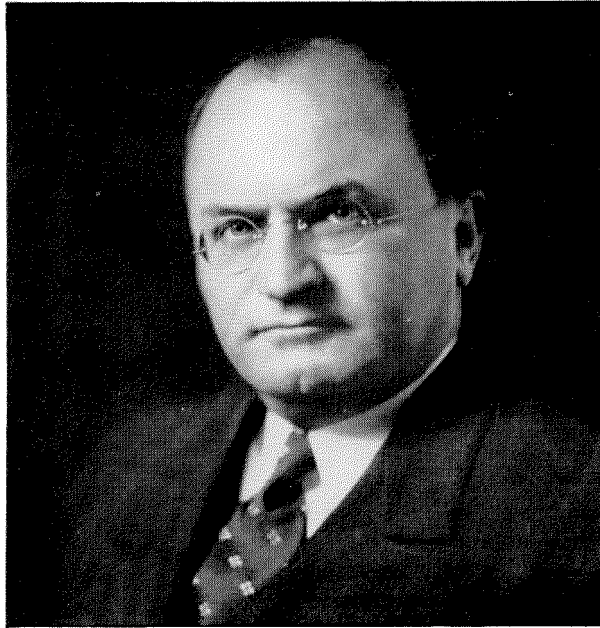

KENNETH E. STOCKTON

**K**ENNETH E. STOCKTON was born in Kansas City, Missouri, on January 25, 1893 and died on May 11, 1950. He was graduated from Princeton University in 1914 and from Columbia University Law School in 1917.

He joined the legal department of International Telephone and Telegraph Corporation in 1925, becoming assistant general attorney in 1928. In 1935, he was elected a vice president and in 1939 became a member of the Board of Directors. From 1940 to 1945, he served as chairman of the executive committee of American Cable and Radio Corporation. During the next

three years, he was divisional vice president for all Europe of International Telephone and Telegraph Corporation.

In 1948, Mr. Stockton became president of American Cable and Radio Corporation and of its operating subsidiary, All America Cables and Radio, Incorporated; positions he held at the time of his death. He also served as a director of American Cable and Radio, Incorporated; All America Cable and Radio, Incorporated; Compañía Radio Aérea Marítima Española; and the International Telephone Building Corporation.

## Contributors to This Issue



EDWIN P. BANCROFT

activities in the System include service with International Telecommunication Laboratories, Postal Telegraph Company, Federal Telephone and Radio Corporation, and International Standard Electric Corporation. He retired recently after serving as record-communications engineer and a member of the general engineering department of International Standard Electric Corporation.

Mr. Bancroft is a member of the American Institute of Electrical Engineers and the Association of American Railroads. He received a Citation for Meritorious Service from the Chief Signal Officer, American Expeditionary Forces.

• • •

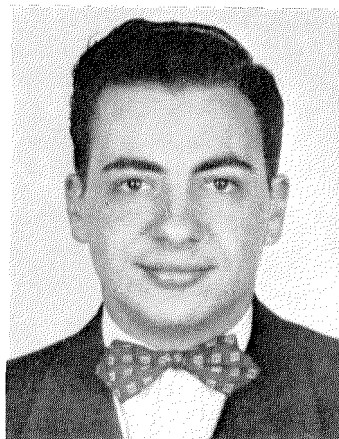

LAURIN G. FISCHER

VITOLD BELEVITCH was born at Helsingfors, Finland, on March 2, 1921. He studied until July, 1936, at the Notre-Dame de la Paix College at Namur. He then followed an engineering course at the University of Louvain and graduated in 1942 with an engineering degree.

Employed by the Bell Telephone Manufacturing Company at Antwerp in October, 1942, in the transmission department, he undertook various studies relating in particular to special transmission problems. In October, 1945, he received a doctor's degree in applied science from the University of Louvain.

• • •

LAURIN G. FISCHER was born on August 25, 1922, in New York City. He received the B.S. degree in electrical engineering from the Cooper Union in 1942.

Mr. Fischer has been with Federal Telecommunication Laboratories since 1942 except for service with the United States Marine Corps from 1944 to 1946. He is now a senior engineer in the development of radio aids to aerial navigation.

Mr. Fischer is an Associate Member of the Institute of Radio Engineers.

• • •

GEORGE HUBERT HOUGH was born in Cuddington, Cheshire, England on

October 21, 1921. He obtained an honours degree in physics in 1939 at Kings College in London.

During the war, he worked in the Admiralty Signal Establishment at Haslemere. In 1946, he joined Standard Telecommunication Laboratories and is now in the valve research division of Standard Telephones and Cables, where he is engaged in research on the basic properties of cold-cathode glow discharges and tubes utilizing this phenomenon.

• • •

JACK L. JATLOW was born on April 7, 1902. He received an electrical engineering degree from Rensselaer Polytechnic Institute in 1924.

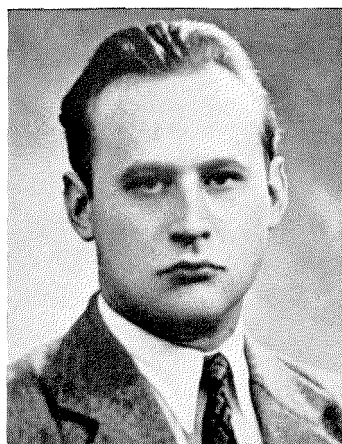

VITOLD BELEVITCH

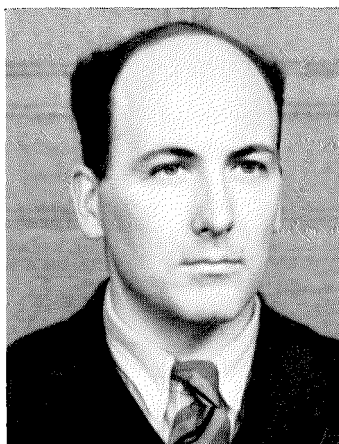

GEORGE H. HOUGH

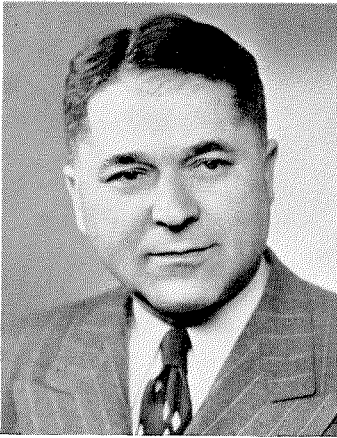

JACK L. JATLOW

From 1924 to 1931, he was associated with the Conner Crouse Corporation. During 1931 and 1932, he was with Wired Radio Corporation, and for the following four years served as assistant chief engineer of F.A.D. Andrea Radio Corporation. From 1936 to 1940, he was employed by Pose Print Corporation for research on photographic emulsions. He was chief engineer of Republic Engineering Products from 1940 to 1942. In 1942, he joined Federal Telephone and Radio Corporation and is now engineering section head of the wire transmission division.

Mr. Jatlow is a Member of the American Institute of Electrical En-

gineers and an Associate Member of the Institute of Radio Engineers.

• • •

BENJAMIN B. MAHLER was born on January 31, 1918, in Austria. He attended the Physical Institute of Vienna for two years and in 1945 received a B.S. degree in electrical engineering from Newark College of Engineering.

On graduation, he joined the wire transmission division of Federal Telephone and Radio Corporation. At present, he is a project engineer in the development of frequency-modulation carrier telegraph systems.

Mr. Mahler is an Associate Member of the American Institute of Electrical

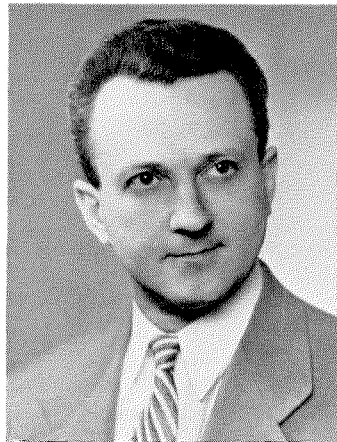

BENJAMIN B. MAHLER

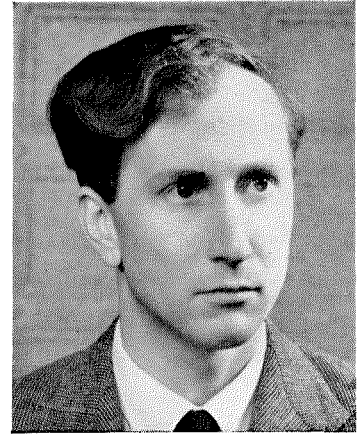

D. S. RIDLER

Engineers and a member of Tau Beta Pi.

• • •

D. S. RIDLER was born in London in 1921. He joined Standard Telephones and Cables in 1939, and completed a 3-year apprenticeship course as a laboratory assistant, obtaining the Higher National Certificate with an endorsement giving exemption from the entrance examination of the Institution of Electrical Engineers. Mr. Ridler has been actively engaged in laboratory work and, more particularly, with the application of gas-filled tubes. He is now located at Standard Telecommunication Laboratories at Enfield.



# INTERNATIONAL TELEPHONE AND TELEGRAPH CORPORATION

## Associate Manufacturing and Sales Companies

### United States of America

International Standard Electric Corporation, New York, New York  
Federal Telephone and Radio Corporation, Clifton, New Jersey  
International Standard Trading Corporation, New York, New York  
Capelhart-Farnsworth Corporation, Fort Wayne, Indiana

### Great Britain and Dominions

Standard Telephones and Cables, Limited, London, England  
Creed and Company, Limited, Croydon, England  
International Marine Radio Company Limited, Croydon, England  
Kolster-Brandes Limited, Sidcup, England  
Standard Telephones and Cables Pty. Limited, Sydney, Australia  
Silovac Electrical Products Pty. Limited, Sydney, Australia  
Austral Standard Cables Pty. Limited, Melbourne, Australia  
New Zealand Electric Totalisators Limited, Wellington, New Zealand  
Federal Electric Manufacturing Company, Ltd., Montreal, Canada

### South America

Compañía Standard Electric Argentina, Sociedad Anónima, Industrial y Comercial, Buenos Aires, Argentina  
Standard Eléctrica, S.A., Rio de Janeiro, Brazil  
Compañía Standard Electric, S.A.C., Santiago, Chile

### Europe and Far East

Vereinigte Telephon- und Telegraphenfabriks Aktiengesellschaft Czeija, Nissl & Co., Vienna, Austria  
Bell Telephone Manufacturing Company, Antwerp, Belgium  
China Electric Company, Limited, Shanghai, China  
Standard Electric Aktieselskab, Copenhagen, Denmark  
Compagnie Générale de Constructions Téléphoniques, Paris, France  
Le Matériel Téléphonique, Paris, France  
Les Téléimprimeurs, Paris, France  
C. Lorenz, A.G. and Subsidiaries, Stuttgart, Germany  
Mix & Genest Aktiengesellschaft and Subsidiaries, Stuttgart, Germany  
Süddeutsche Apparatefabrik Gesellschaft m.b.H., Nuremberg, Germany  
Nederlandsche Standard Electric Maatschappij N.V., The Hague, Netherlands  
Fabbrica Apparecchiature per Comunicazioni Elettriche, Milan, Italy  
Standard Telefon og Kabelfabrik A/S, Oslo, Norway  
Standard Eléctrica, Lisbon, Portugal  
Compañía Radio Aérea Marítima Española, Madrid, Spain  
Standard Eléctrica, S.A., Madrid, Spain  
Aktiebolaget Standard Radiofabrik, Stockholm, Sweden  
Standard Telephone et Radio S.A., Zurich, Switzerland

## Telephone Operating Systems

Compañía Telefónica Argentina, Buenos Aires, Argentina  
Compañía Telefónico-Telefónica Comercial, Buenos Aires, Argentina  
Compañía Telefónico-Telefónica del Plata, Buenos Aires, Argentina  
Companhia Telefónica Nacional, Porto Alegre, Brazil  
Companhia Telefónica Paranaense S. A., Curitiba, Brazil  
Compañía de Teléfonos de Chile, Santiago, Chile

Compañía Telefónica de Magallanes S.A., Punta Arenas, Chile  
Cuban American Telephone and Telegraph Company, Havana, Cuba  
Cuban Telephone Company, Havana, Cuba  
Compañía Peruana de Teléfonos Limitada, Lima, Peru  
Porto Rico Telephone Company, San Juan, Puerto Rico  
Shanghai Telephone Company, Federal Inc. U.S.A., Shanghai, China

## Radiotelephone and Radiotelegraph Operating Companies

Compañía Internacional de Radio, Buenos Aires, Argentina  
Compañía Internacional de Radio Boliviana, La Paz, Bolivia  
Companhia Radio Internacional do Brasil, Rio de Janeiro, Brazil

Compañía Internacional de Radio, S.A., Santiago, Chile  
Radio Corporation of Cuba, Havana, Cuba  
Radio Corporation of Porto Rico, San Juan, Puerto Rico

## Cable and Radiotelegraph Operating Companies

(Controlled by American Cable & Radio Corporation, New York, New York)

The Commercial Cable Company, New York, New York<sup>1</sup>  
Mackay Radio and Telegraph Company, New York, New York<sup>2</sup>

All America Cables and Radio, Inc., New York, New York<sup>3</sup>  
Sociedad Anónima Radio Argentina, Buenos Aires, Argentina<sup>4</sup>

<sup>1</sup> Cable service. <sup>2</sup> International and marine radiotelegraph services.  
<sup>3</sup> Cable and radiotelegraph services. <sup>4</sup> Radiotelegraph service.

## Laboratories

Federal Telecommunication Laboratories, Inc., Nutley, New Jersey

Standard Telecommunication Laboratories, Limited, London England

Laboratoire Central de Télécommunications, Paris, France