

# ELECTRICAL COMMUNICATION

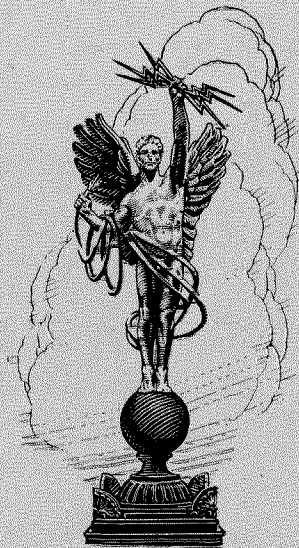

APRIL  
1923

No. 4  
VOL. 1

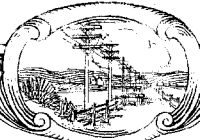

# ELECTRICAL COMMUNICATION

A Journal of Progress in the  
Telephone, Telegraph and Radio Art

Published Quarterly by the  
INTERNATIONAL WESTERN ELECTRIC COMPANY  
INCORPORATED

195 BROADWAY, NEW YORK, N. Y., U. S. A.

Charles G. DuBois, President

George C. Pratt, Secretary

J. W. Johnston, Treasurer

Subscription \$1.50 per year; single copies 50 cents

Volume I

APRIL, 1923

Number 4

## CONTENTS

FRANK GILL, O. B. E. ....	3
THE NEW SIMPLON CABLE. ....	4
<i>By R. A. Mack</i>	
PRACTICAL APPLICATION OF CARRIER TELEPHONE AND TELEGRAPH IN THE BELL SYSTEM. ....	16
<i>By Arthur F. Rose</i>	
THE WESTERN ELECTRIC EXHIBIT AT THE RIO DE JANEIRO EXPOSITION. ....	24
<i>By Col. N. H. Slaughter</i>	
PUBLIC ADDRESS SYSTEMS. ....	27
<i>By I. W. Green and J. P. Maxfield</i>	
USE OF PUBLIC ADDRESS SYSTEM WITH TELEPHONE LINES. .	46
<i>By W. H. Martin and A. B. Clark</i>	
MOBILE PUBLIC ADDRESS SYSTEM. ....	57
<i>By E. S. McLarn</i>	
THE BUDGET PLAN OF THE BELL SYSTEM. ....	64
<i>By C. A. Heiss</i>	

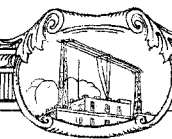



Photograph by Bachrach

FRANK GILL, O. B. E.

European Chief Engineer, International Western Electric Company

# Frank Gill, O. B. E.

*European Chief Engineer, International Western Electric Company*

**I**N the Inaugural Address delivered before the British Institution of Electrical Engineers on November 2, 1922, the President, Mr. Frank Gill, in outlining the conditions necessary for the establishment of an adequate long-distance telephone service for Europe, suggested the holding, at an early date, of a conference of all the interested telephone authorities, companies and municipalities, as well as Government departments, to study this problem in detail and endeavor to find a solution. The high esteem in which Mr. Gill is held as a telephone engineer is illustrated by the favorable reception given to this suggestion, resulting in the formation of an International Technical Committee on Long-Distance Telephony. The first meeting of this Committee was held on March 12, 1923, in Paris, preliminary to a general European conference to be held later.

Mr. Gill's telephone experience began in 1882, when at the age of sixteen he started his career with the United Telephone Company in London. In 1896 he became responsible for the management of the entire Irish system, and in 1902 was selected to fill the position of Engineer-in-Chief of the National Telephone Company. Ten years later, with his assistant engineer, Mr. Cook, he established the firm of Gill and Cook, consulting telephone engineers, in which capacity he was jointly responsible for work in Argentina, Brazil, China, Egypt, India, Malay States, Portugal and Turkey.

At the outbreak of the war, he was called upon to organize a department of the Ministry of Munitions, which he undertook in a voluntary capacity, later organizing and taking charge of another department which occupied his time from 1917 until he relinquished the office of Comp-

troller of Stores in the Ministry of Munitions, on June 30, 1919, to enter the services of the International Western Electric Company as its European Chief Engineer. Mr. Gill, in recognition of his services during the war, has been awarded the Order of the British Empire.

As European Chief Engineer of the International Western Electric Company he has been actively engaged in extending the Engineering Department to permit of a more detailed study of the particular telephone problems existing in Europe. This Department is modeled along the lines of the Engineering Department of the Western Electric Company at New York, with which it is closely in touch.

Among the recent activities of the European Engineering Department to which Mr. Gill has given considerable personal attention, are the extensive tests which were required prior to the transatlantic radio telephone demonstration on the evening of January 14, 1923, the application of repeaters, engineering and installation of automatic telephone installations and the study of transmission and development of long-distance cables for certain of the European countries. One of the most interesting of recent installations of this nature is the new telephone cable through the Simplon Tunnel, a description of which appears in this number of "Electrical Communication."

Mr. Gill has an extended knowledge of the telephone practices prevailing throughout the world and a broad vision of the ultimate extensive adoption of telephone service, not only as a working medium, but also as a means of promoting better cooperation and fellowship between the peoples of the various nations.



# The New Simplon Cable

By R. A. MACK

*European Engineering Department, International Western Electric Company*

OF the new telephone cables recently laid in Europe, one of striking interest is the Simplon Cable, the installation of which was completed in the Autumn of 1922. In view of the continued development of railway electrification, one of the most important problems which face the telephone engineer is that of interference between electrified railways and communication circuits. There is at present every indication that during the next few years railway electrification will make important strides in practically every country in Western Europe, and accordingly it is necessary for the communication engineer to plan against conditions which he knows are likely to cause him some anxiety and concern. This is one of the reasons that the Simplon Cable is of particular interest.

The electrified traction system of the Simplon Tunnel is 3-phase and operates with a trolley voltage of 3,200 volts at  $16\frac{2}{3}$  cycles per second. Two of the phases are connected to the overhead trolley conductors, while the 3rd phase is connected to the rails. The tunnel has, since its inception, been used also as a route for both telephone and telegraph cables connecting Switzerland and Italy, and on account of the confined space within the tunnel, the conditions are particularly favorable for interference between the power system and the telephone and telegraph circuits. Although the length of the tunnel is but 20 km., which is small when compared with the distances covered by modern communication circuits, the close proximity of the traction and communication systems, makes the problem of constructing quiet telephone circuits one of some difficulty.

Until 1922 the tunnel contained but one gallery, between Brigue on the Swiss side and Iselle on the Italian side, but in that year, the completion of a second gallery running parallel to the first was taken advantage of to carry out repairs and reconstruction in the old gallery. It was decided by the Swiss and Italian Telegraph Administrations to install at this time a new telephone cable along the route and this was laid side by side with the existing power, telegraph and telephone cables in the old gallery. Until

the new cable was installed, telephone facilities between Switzerland and Italy over this route were provided by means of a 7-pair continuously loaded cable which was put into service in 1906.<sup>1</sup> As the new cable is of the coil loaded type, it affords interesting comparison with the older type of cable, not only from the point of view of economy of material for a given number of circuits and a given attenuation, but also as regards freedom from inductive interference.

The contract for the cable was given in May, 1922, to two firms:

Société D'Exploitation des Câbles Électriques Système Berthoud Borel & Cie of Cortaillod, Switzerland, for that portion of the cable which would be upon Swiss territory, that is between Brigue and the frontier, which occurs at a point approximately half-way through the tunnel.

Societa Italiana Reti Telefoniche Interurbane of Milan for the portion between the frontier and the Italian end of the tunnel at Iselle.

The above firms are licensees for the exploitation of the Western Electric loaded cable system in Switzerland and Italy, respectively.

The Western Electric Company supplied the loading equipment and were responsible for testing and jointing arrangements and for the over-all results.

The important role which the new cable will play in future international telephony, made it necessary that every care be taken in design, manufacture and installation, to ensure that the standard of performance obtained should satisfy not only the immediate requirements, but, in addition, the requirements which could reasonably be expected to develop in the future. These considerations were of particular importance where they had a bearing upon the operation of repeaters subsequently to be connected to circuits passing through the new cable, or upon the elimination of interference from the electrified traction system.

For this reason the contractors concerned spared no pains in an endeavor to make the

<sup>1</sup> See *Journal Télégraphique*, Jan. 25 and Feb. 25, 1907, "Le Cable Télégraphique et Téléphonique du Simplon," by Prof. G. di Pirro.

finished cable in accordance with the very highest standards of telephone engineering practice.

The numerous precautions to this end involved considerable cost and much special effort, but this was deemed justified by the special nature of the case and the necessity of obtaining the very best service possible from a cable, the installation of which was a matter of great difficulty.

The following notes give a general picture of the technical features of the new cable including a brief reference to the method of installation. These are followed by the details of the transmission characteristics of the finished cable, as measured by the Western Electric Company.

Fig. 1 indicates the relation of the Simplon Cable to the telephone systems of Northern Italy and Switzerland. The following important

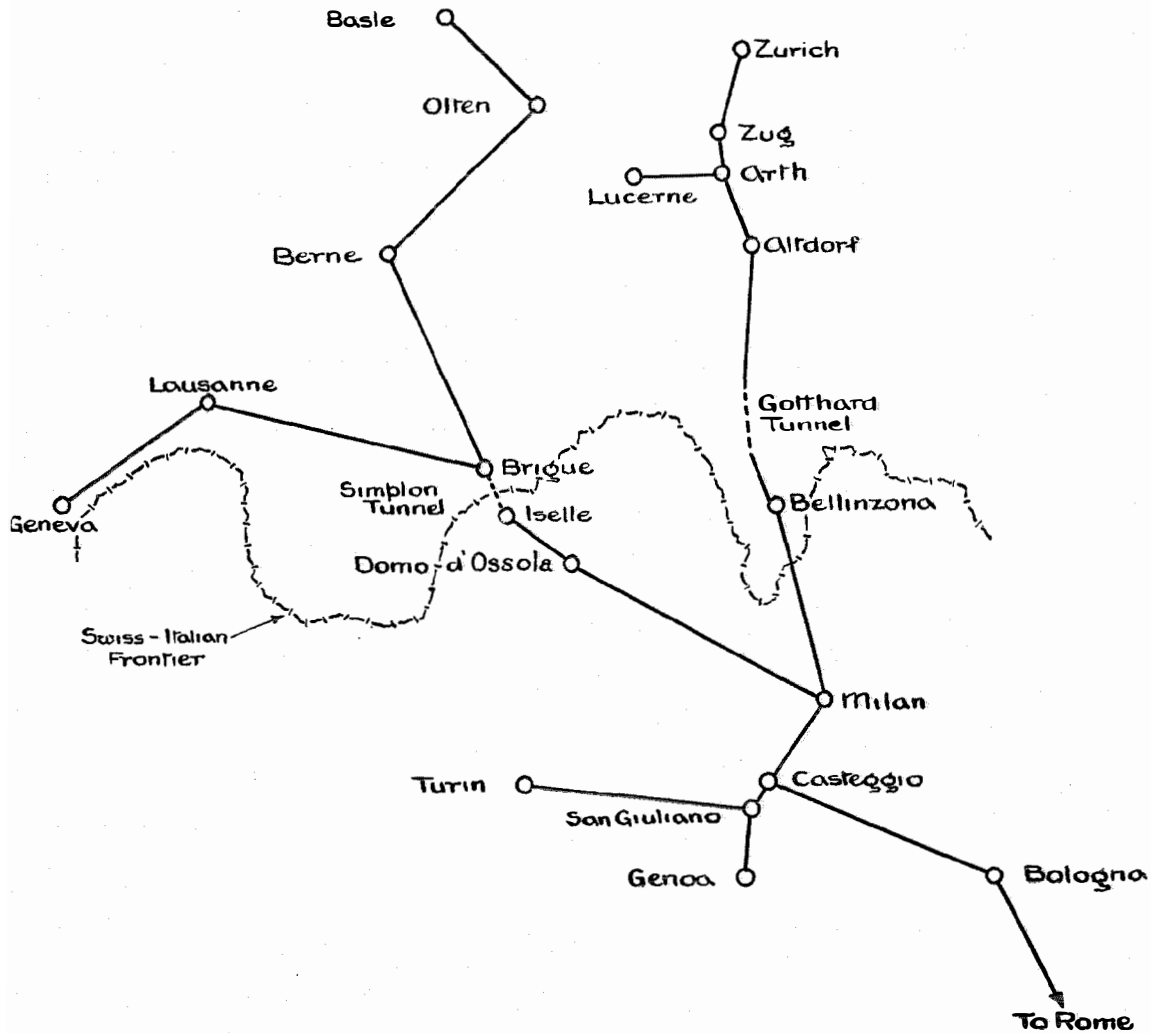

FIGURE 1

There can be little doubt that the additional costs involved in this way were warranted on economic grounds. Also, that except in similar circumstances the cost of attaining so high a standard of performance would not, at any rate at the present time, be justified in the case of commercial telephone cable systems when the conditions of installation are more normal.

circuits pass over this route at present: Milan-Berne, Milan-Geneva, Milan-Basle, Milan-Frankfort and Milan-Berlin.

The new cable extends from the telephone exchange at Brigue through the old gallery of the tunnel to the cable hut at Iselle, where it is joined to open wire circuits passing into Italy. The total length of the cable is 22.2 km. of

which but 19.8 km. are in the tunnel, there being a distance of 1.8 km. between the telephone exchange and the tunnel entrance at Brigue and .4 km. between the tunnel entrance at Iselle and the cable hut.

The cable is of standard Western Electric quadded type, designed for phantom circuits and contains 10 quads (20 pairs) of 1.0 mm. conductors. The general make-up and dimensions of the cable can be seen from Fig. 2. On account

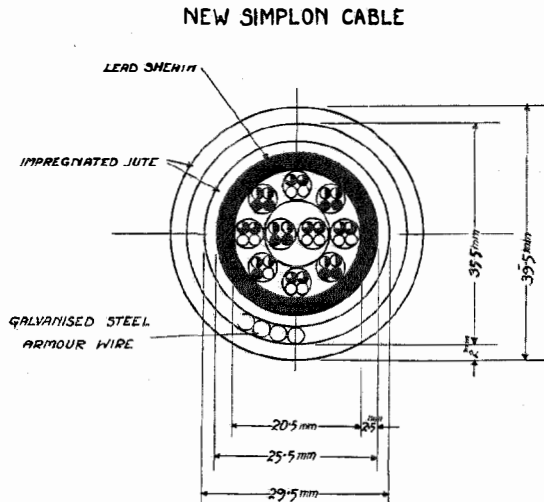

of the close proximity to the electrified traction system and the consequent risk of induced voltage, the cable was designed to meet a guaranteed breakdown voltage of 2,000 volts at 50 cycles for 1 minute between the complete core of conductors and the lead sheath.

Over the portions of the route external to the tunnel, the cable is laid in split iron duct, whereas in the tunnel the cable is placed in a bed of sand, which also accommodates the various other cables passing through the tunnel.

Fig. 3 gives a cross-section of the old gallery from which can be seen the relative location of the cable and the railway track. The joints within the tunnel were placed in small brick chambers filled with sand and covered with stone slabs. This figure also indicates the large niches which occur in the walls of the gallery every 1,000 meters. These niches (4 meters x 4 meters x 5 meters deep) were utilized for locating the loading coil cases which were spaced every 2,000 meters along the route. Unfortu-

nately, the niches in the wall nearest the cable were occupied with railway material so that the niches on the opposite wall had to be used and the cable made to cross under the track to make connection to the loading coil case installed at each loading point. Although at one point within the tunnel, the distance between alternate niches was less than 2,000 meters, the full loading section length of cable was laid between the two loading points, the excess length being coiled upon the ground adjacent to the loading coil. The lead covered stub cables leading to the loading coils were encased in cast iron protection covers.

Fig. 4 gives a plan of the cable route and indicates the distribution of the loading points.

The *electrical constants of the cable proper* are as follows:

Average loop resistance of all side circuits throughout the cable	43.2 ohms per km. at 15°C.
Average A.C. mutual capacity of all side circuits throughout the cable	.0345 mfd. per km.
Average A.C. mutual capacity of all phantom circuits throughout the cable	.0570 mfd. per km.

The above values of capacity are approximately 10% less than would normally have been used for such a cable when the loading coils are spaced every 1,800 meters. These lower capacities were deliberately chosen so that the impedance of the circuits would be the same as that of cables of normal construction with loading coils every 1,800 meters. This feature will allow direct connection between the Simphon circuits and other cable circuits in the system with a minimum of impedance irregularity.

In order that repeaters could be operated satisfactorily over the cable, it was of great importance that the capacity in every circuit be uniform throughout the cable from loading section to loading section. Although the cable was manufactured partially in Switzerland and partially in Italy, the close co-operation between the manufacturers was such that the variations in capacity were not greater than would have happened had the whole of the cable been made in one factory.

The well-known Western Electric system of 3-coil loading was used. The over-all electrical constants of the loading coils, as meas-

ured in a 3-coil loading unit at 800 cycles and 1 mil-ampere are as follows:

Inductance of side circuit coils.....	.177 henry	$\pm 2\%$
Inductance of phantom circuit coils....	.107 "	$\pm 2\%$
Average effective resistance of side circuit	13.7 ohms	
Average effective resistance of phantom circuit.....	7.0 ohms	

between September 2-9, 1922. The tests referred to below were not completed until November 13, 1922. Through the courtesy of the two Administrations concerned the Western Electric Company was able to make such exhaustive tests.

The results of the various transmission tests

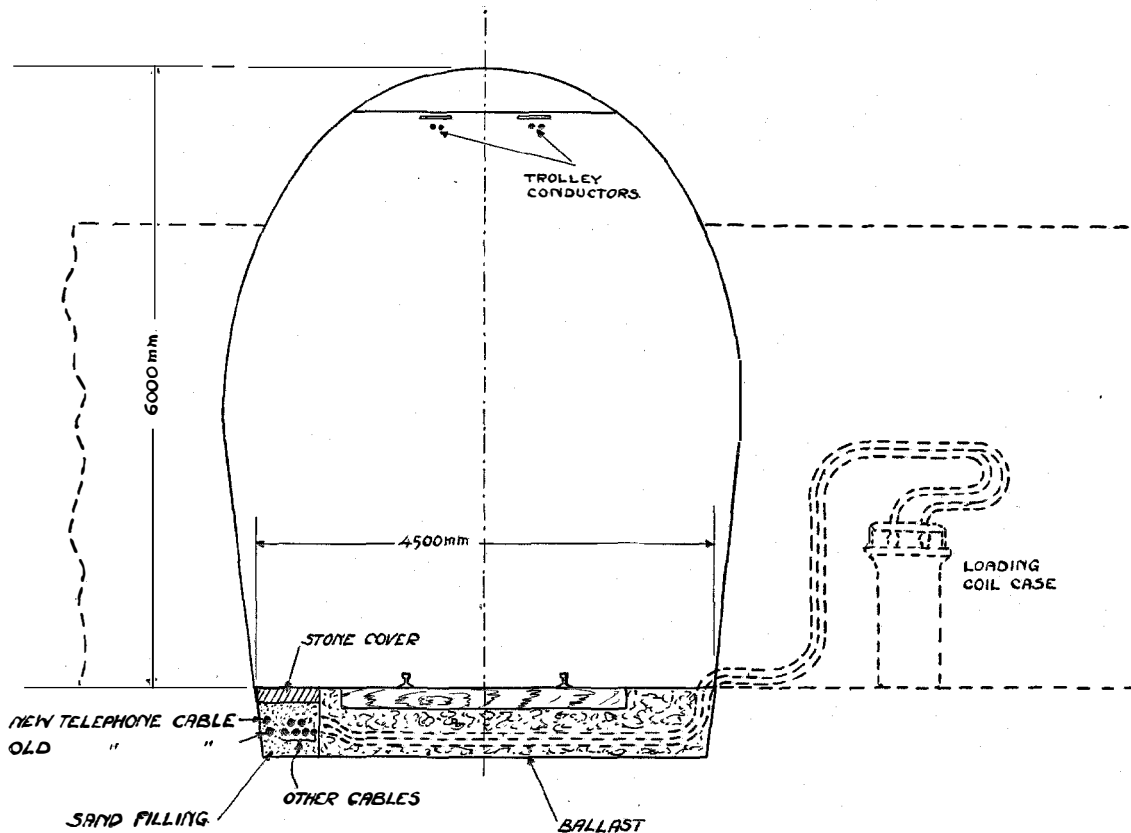

FIGURE 3

All the coils were of the patented dust core type and are guaranteed by the Western Electric Company not to change by more than 5% in inductance after the passage of 2 amperes direct current through a line winding.

Upon completion of installation, exhaustive tests were made from Brigue to determine the transmission characteristics of the finished cable. The Swiss and Italian Telegraph Administrations were anxious that the cable should be put into commercial service as soon as possible and on this account these tests were not completed before the cable was officially handed over to the Administrations. The Administrations concerned carried out final acceptance tests

are recorded below. Where precautions of a special nature, taken during installation, have a bearing upon the results, these have been referred to under the various tests.

*Copper Resistance* measurements were made upon all pairs, using a Wheatstone Bridge. The following values were observed:

Maximum loop resistance per km. of any circuit including coils.....	48.02 ohms
Mean loop resistance of all circuits per km. including coils.....	47.96 ohms

The mean ohmic resistance difference between two wires of a pair for the whole length of cable was .17 ohm, that is, 0.032% of the resistance of one wire.



The maximum difference observed was .45 ohm. The temperature within the tunnel at the time of the resistance measurements varied from 20° to 26° C.

The insulation resistance of one conductor measured against all other conductors and the

work. The values have been corrected to allow for the end section at Brigue being more than an exact half section and have been reduced to  $\beta$  per km. The values at 800 cycles per second have also been reduced to miles of standard cable (M.S.C.) per mile of circuit, the

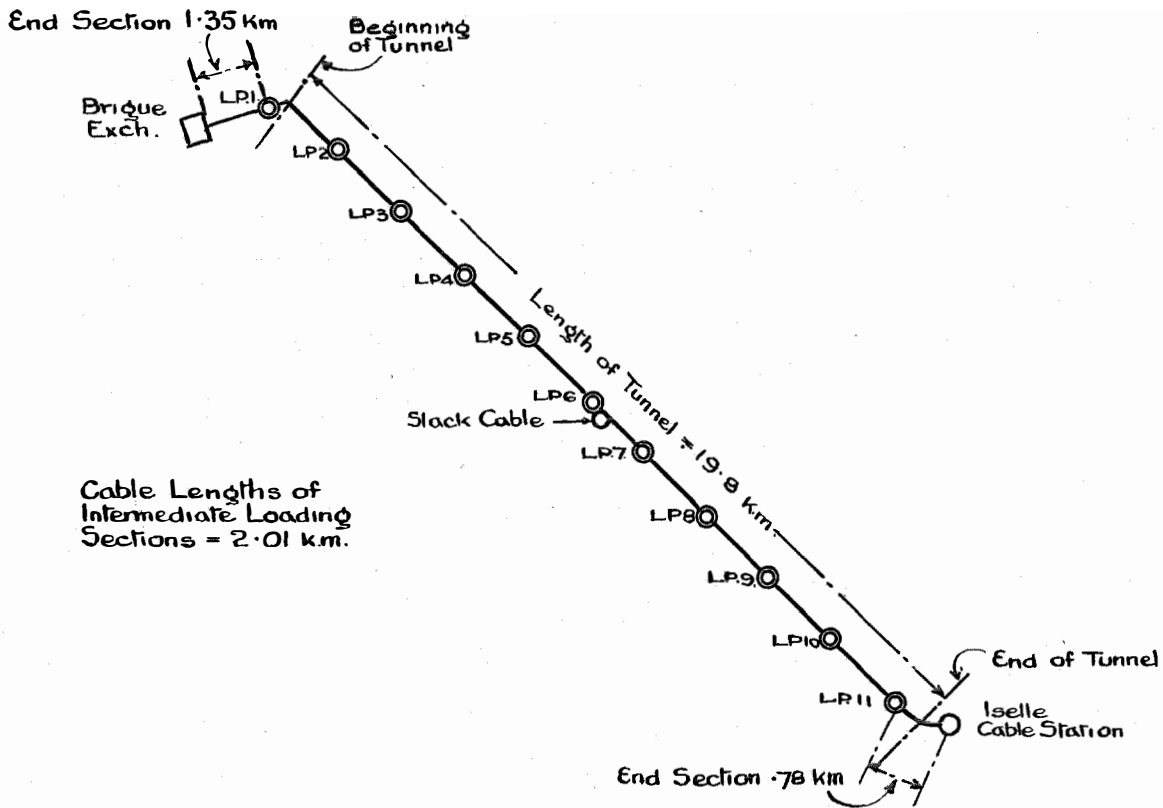

FIGURE 4

lead sheath was measured for each of the conductors, using a direct current of 300 volts and observing after an interval of 30 seconds. The average value observed was 33,100 megohms per km.

The attenuation constant of each of the circuits, both side and phantom, was measured from readings of open and closed circuit impedance. The values obtained were checked by means of a transmission measuring set.

On account of the fact that the transmission loss upon the circuits is comparatively small, the first method gives more accurate results. The values given below have been computed from impedance measurements made from Brigue when the partial section at Iselle was built out to a half section by means of an artificial net-

attenuation of one mile of standard cable at 800 c.p.s. being taken at 0.109.

Frequency. Cycles per Second	Mean Value of Attenuation Constant per km.	
	Side	Phantom
500.....	.0162	.0131
800.....	.0166	.0135
1,200.....	.0172	.0141
1,500.....	.0178	.0146

M.S.C. per mile of circuit at 800 cycles—

Sides..... 0.245  
Phantoms..... 0.200

The values of  $\beta$  given above have been plotted against frequency on Fig. 5, together with the

values which were guaranteed by the contractors to the Administration. It will be noticed that there is a margin of approximately 5% between the values observed and those guaranteed.

CROSSTALK

The crosstalk between various circuits within the cable was measured by means of a crosstalk

current was connected to and the crosstalk measured at the Brigue end of the cable.

These measurements have been corrected for differences in impedance between the phantom and the side circuits and are given below expressed in units of crosstalk:

(1 unit of crosstalk corresponds to the current in the receiving circuit being one millionth of

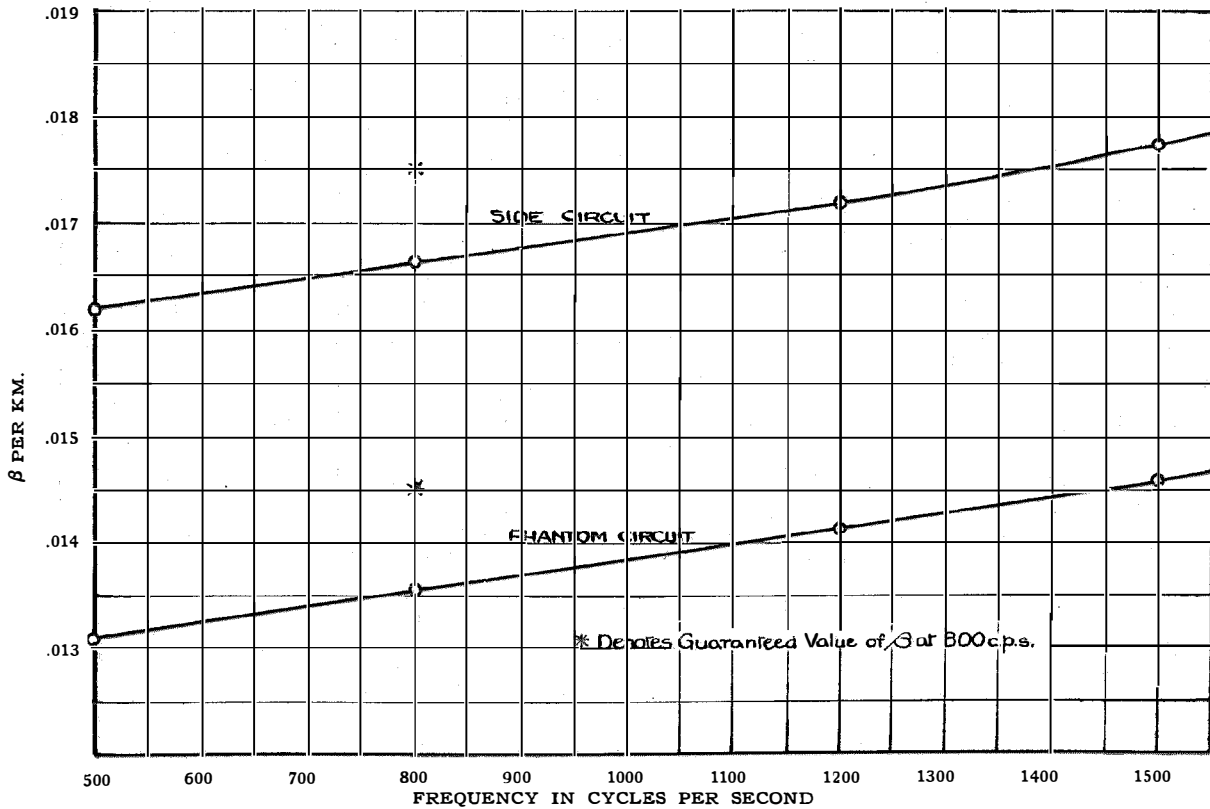

FIGURE 5

meter of the standard type. The circuits under test were in all cases terminated with resistance approximately equal to the characteristic impedance of the circuits.

Measurements of phantom-to-side and side-to-side crosstalk within quads were made upon every quad in the cable at 800 cycles per second. Similar measurements between circuits in different quads were made from two phantom circuits to all the side circuits in the remaining quads and from one side circuit to all the remaining side circuits. In addition, the crosstalk between each phantom circuit and every other phantom circuit was measured. In all cases the source of

the current in the sending circuit when both circuits are of the same impedance.)

CROSSTALK WITHIN QUADS

	Maximum	Mean	Minimum	Guaranteed Value
Ph.—S.....	220	127	15	550
S.—S.....	175	103	20	340

CROSSTALK BETWEEN CIRCUITS IN DIFFERENT QUADS

	Maximum	Mean	Minimum	Guaranteed Values
Ph.—S.....	115	50	0	...
S.—S.....	140	66	35	...
Ph.—Ph.....	210	83	15	550

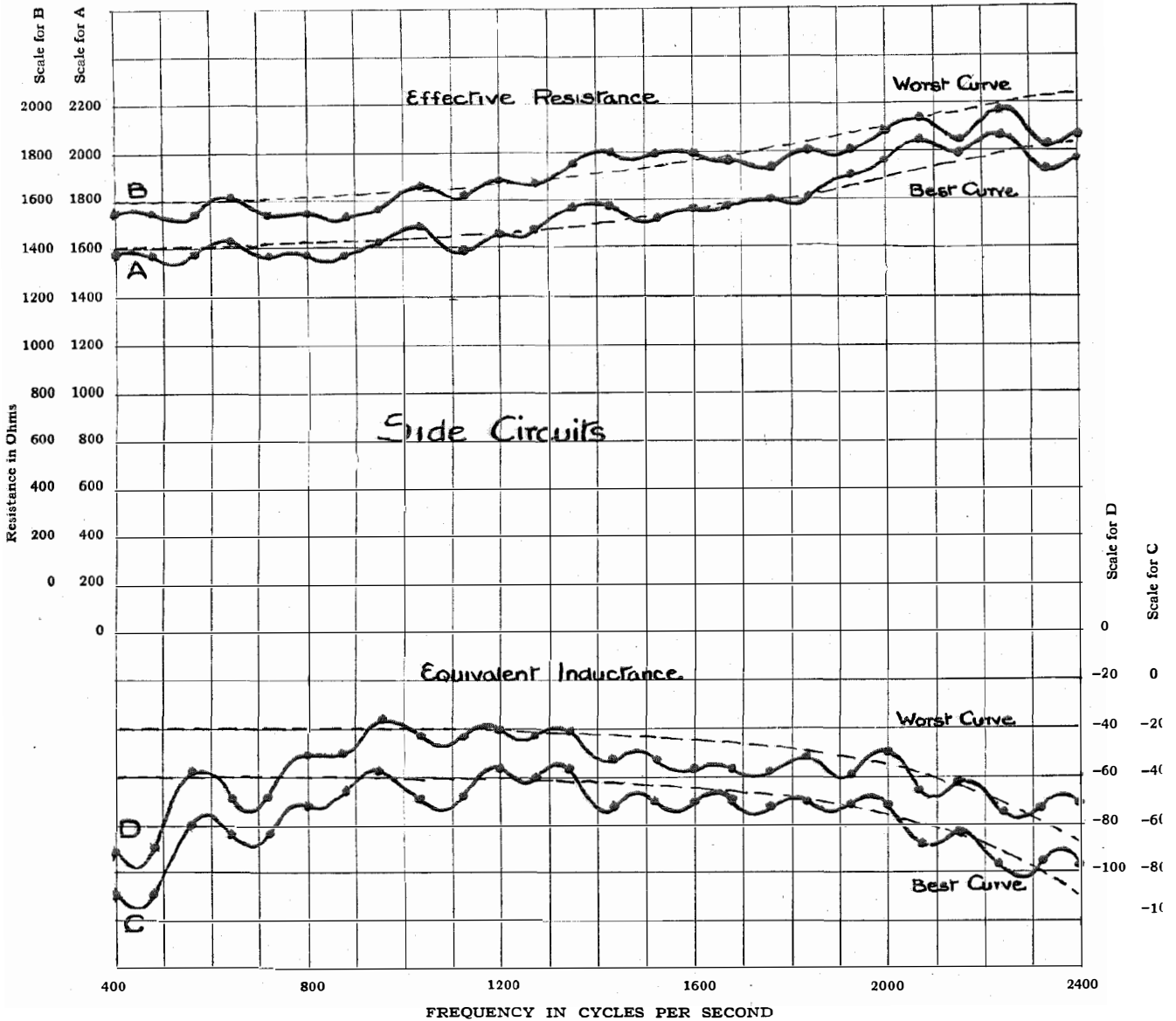

FIGURE 6

The crosstalk values guaranteed to the Administrations were quoted in terms of  $\beta l$ . 550 units of crosstalk correspond to  $\beta l = 7.5$  and 340 correspond to  $\beta l = 8.0$ .

On account of the Simplon Cable containing only 10 quads, it was necessary, during installation, to arrange for the jointing to be carried out in such a way that the crosstalk between circuits in different quads could be kept reasonably low. The test figures show that in spite of

the small number of quads involved, the crosstalk is remarkably low.

The *characteristic impedances* of all the circuits, both sides and phantom, were calculated from measurements of open and closed circuit impedance made at Brigue, the end section at Iselle having been built out to half section.

The values given below have been corrected to compensate for the end section at Brigue being longer than a true half section:

Frequency. Cycles per Second	Mean Value of Characteristic Impedance	
	Side	Phantom
500.....	$1,593\sqrt{4^{\circ} 25'}$	$989\sqrt{3^{\circ} 48'}$
800.....	$1,631\sqrt{5^{\circ} 25'}$	$1,026\sqrt{5^{\circ} 24'}$
1,200.....	$1,719\sqrt{2^{\circ} 12'}$	$1,074\sqrt{2^{\circ} 8'}$
1,500.....	$1,902\sqrt{2^{\circ} 17'}$	$1,167\sqrt{1^{\circ} 42'}$

looped section at Iselle equivalent to a full loading section were computed from the average constants for the whole cable and were left constant from test to test upon the side circuits, also upon the tests with the phantom circuits.

The same remark applies to the artificial networks (Hoyt type) used to terminate the far end of the circuits at Brigue.

Figs. 6 and 7 are graphs of effective resistance and equivalent inductance obtained in this manner. These graphs are, of course, of great importance in considering the future operation of repeaters at Brigue. These figures show also

In addition to the above tests of characteristic impedance at various frequencies, measurements of impedance were made upon all circuits, both,

Scale for A

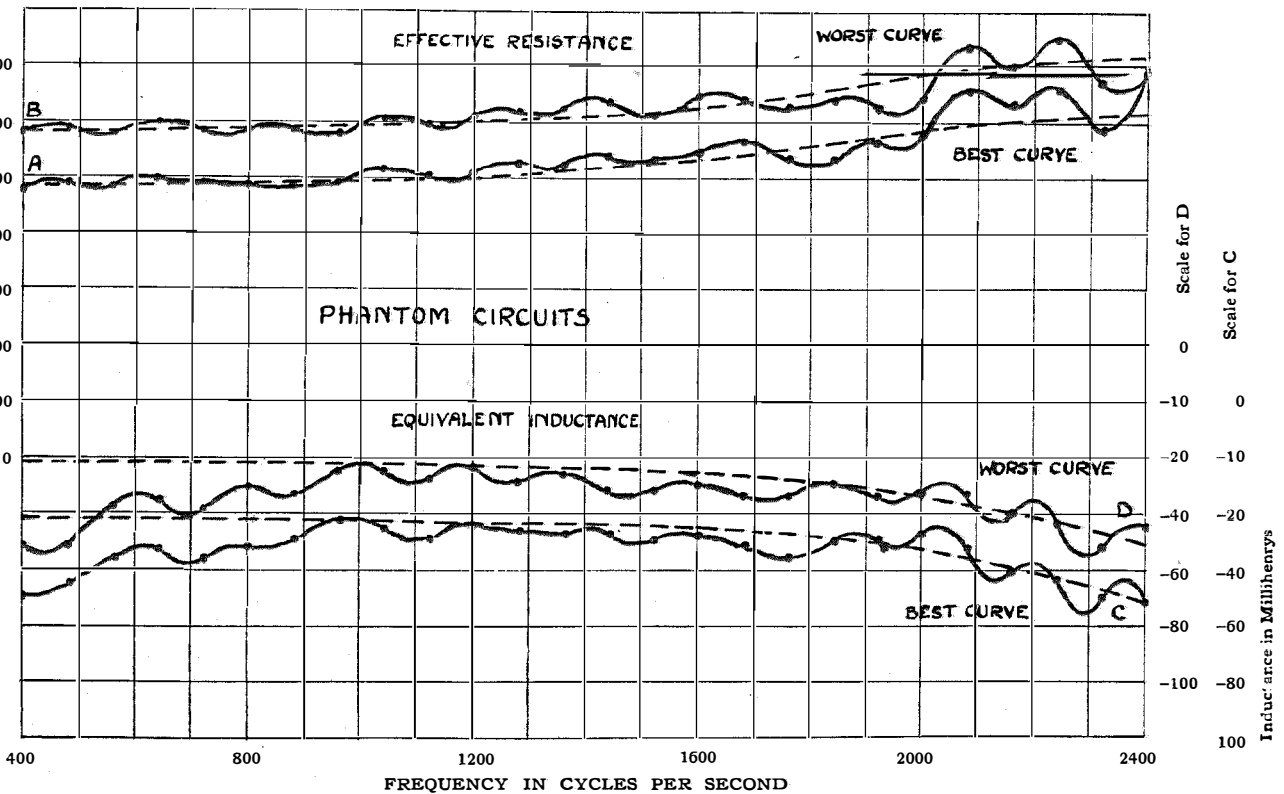

FIGURES 7

side and phantom at intervals of 40 cycles over a frequency range of 400 to 2,400 cycles per second.

An A.C. Impedance Bridge, using a vacuum tube oscillator as a source of current was employed in these tests. The circuits were tested in twos, the two circuits under test being joined together at Iselle through an artificial network comprising capacity and resistance. The values of capacity and resistance used to make up the

the effective resistance and equivalent inductance curves for line balancing networks of the Western Electric patented type such as would be used at the Brigue repeater station. The constants of these networks have been computed from the average constants for the whole cable and not from the constants for the particular circuits, whose curves are shown. Fig. 6 shows the curves for the side circuit test giving the greatest and also the least variation from the balancing



network curves. Fig. 7 gives similar information for the phantom circuits.

From the point of view of the operation of two wire repeaters at Brigue, it is, of course, desirable that the impedances of the lines are simulated by their respective networks for all frequencies at which the repeater is giving gain to the circuit. The degree to which the impedance of a line departs from that of its balancing network determines the gain at which the repeater can be satisfactorily operated.

Comparing the line curves with the network curves, it will be noticed that at the lower frequencies the equivalent inductance of the line in all cases departs appreciably from that of

All the curves show slight, more or less regular ripples. These are chiefly due to the artificial networks at Iselle and Brigue not simulating exactly the characteristics of the line under test.

A more practical method of determining the suitability of a line for 2-wire repeater operation is the "Singing Point" test, in which a repeater of the 21 type (2-way, 1 tube) is connected between the line (properly terminated at the far end) and the balancing network which would be used to balance the line.

The maximum amplification at which the repeater can function when so connected without singing occurring is called the Singing Point of the circuit against the network, and this has

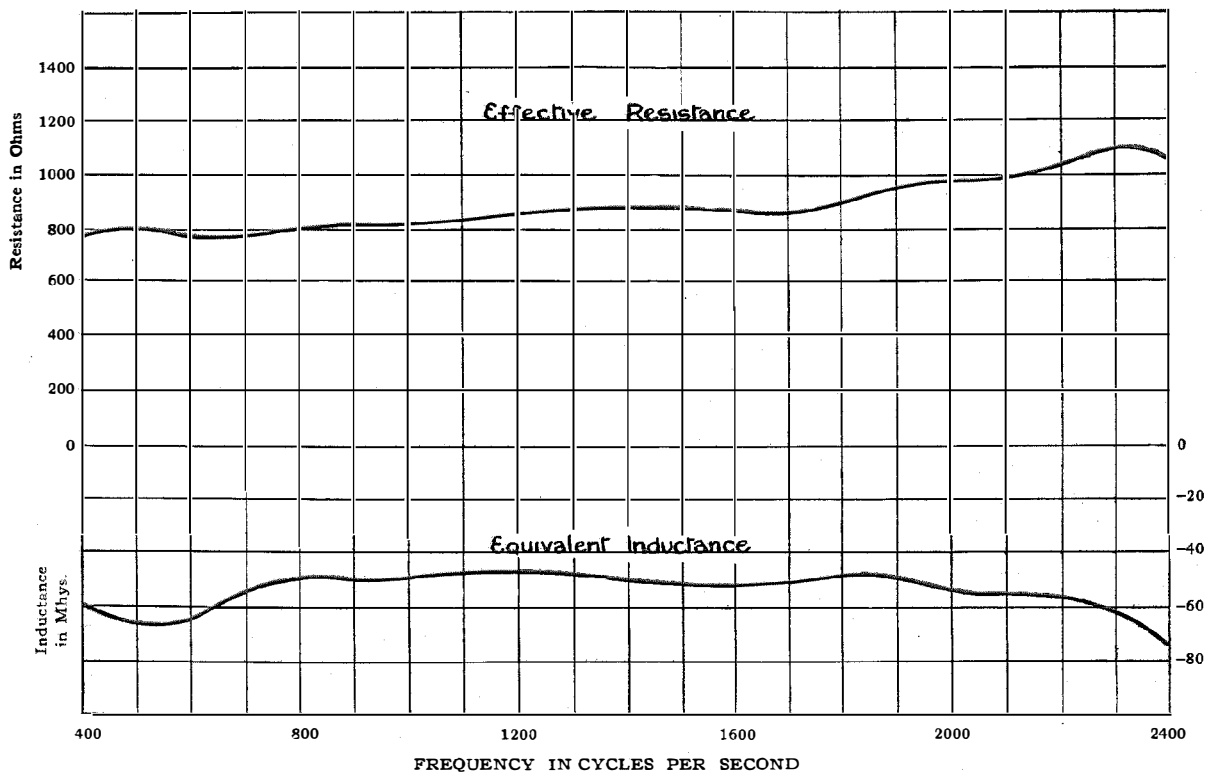

FIGURE 8

the network. This is, however, of small importance, since at the low frequencies the equivalent inductance contributes inappreciably to the magnitude of the line impedance. Even at the higher frequencies, irregularities in the curve of equivalent inductance are of less importance than those in the effective resistance curve.

been adopted as a measure of the degree of impedance balance between the two.

Tests of this kind were not made upon the Simplon Cable, but the various impedance curves obtained have been used to predict the Singing Points of the circuits.

For this purpose it has been assumed that the

repeater used would give uniform amplification over the frequency range 400–1,900 cycles per second. The summarized results are:

*Singing Points against fixed networks*

	Maximum		Mean		Minimum	
	Stand- ard Miles	$\beta l$	Stand- ard Miles	$\beta l$	Stand- ard Miles	$\beta l$
Side Circuits . . .	32	3.5	30	3.3	28	3.05
Phantom Circuits	30	3.3	28	3.05	26	2.84

The excellence of the above values can be appreciated when it is remembered that in commercial practice the gain at which 2-wire repeaters operate, seldom exceeds 15 or 16 standard miles ( $\beta l = 1.63$  to  $1.75$ ).

When operating at a gain approaching the singing point, the gain frequency characteristic of a repeater becomes distorted and for this reason it is not good practice to operate a repeater at a gain within 5 standard miles ( $\beta l = .55$ ) of the singing point. Allowing for this, it will be seen that on the average the Simplon circuits could be used in conjunction with two wire repeaters at Brigue, giving a gain of 24 standard miles ( $\beta l = 2.62$ ). Other conditions such as crosstalk and echo effects will, however, render such high gains impracticable.

It has been assumed above that only one type of balancing network would be used for all the side circuits and only one type for the phantom circuits. This is, of course, the requirement in practice.

Fig. 8 shows the effective resistance and inductance curves for a circuit in the cable, when the terminating network, specially adjusted, was located at Iselle, the circuit in this case not being looped back at Brigue.

The smoothness of the curve for effective resistance (which on account of its relatively large contribution to the magnitude of the impedance is much more important than the curve for inductance) indicates the very high degree of regularity in construction, which has been achieved upon the Simplon Cable.

The cable having been made in two different factories makes this the more remarkable and is a tribute to the very close co-operation of the contractors concerned.

Many tests, bearing upon the *interference* of the electrified railway with the cable were carried out. A Recording Voltmeter connected between conductors in the cable and earth at Brigue, while the other ends of the conductors were earthed at Iselle, showed that voltages in the order of 150 volts sometimes occur under normal condition of railway traffic.

A Western Electric I.A. Noise Measuring Set was used to make measurements of noise on the side and phantom circuits which previous tests had shown to be most liable to interference. The following results were obtained under the worst conditions of railway traffic within the tunnel:

Side Circuit		Phantom Circuit	
Far End Open	Far End Short Circuited	Far End Open	Far End Short Circuited
5 units	20 units	30 units	40 units

These values are very low and prove that when in commercial service the circuits of the new cable will be practically free from noise due to the electric traction. Experience has shown that 150 noise units is easily tolerable under commercial conditions.

The circuit conditions for the noise tests are given in Fig. 9.

The 8 ohm variable shunt resistance shown in this figure allows for measurements up to 2,000 noise units. In practice this shunt resistance is calibrated directly in noise units.

Measurements of noise between the circuits and earth were also made, simultaneously, with values of voltages to ground.

As the noise upon the circuits is due wholly to harmonics present in the wave form of the traction power, and as the voltage to ground is produced almost entirely by the fundamental of this, the ratio between noise to ground and voltage to ground gives a measure of the extent to which the traction system will cause interference.

This ratio was found to have a mean value of 6.5.

In a similar manner the ratio of noise to ground and circuit noise can be used as a measure of freedom from interference of the cable circuits.

This noise ratio, measured upon the worst

circuits of the cable, was found to have a mean value of 10.

The last mentioned tests were made as a matter of interest, and it is believed that this is the first time that these ratios have been deduced for cable circuits.

ulated and connected through a resistance to earth. In the latter case a uniform current of 30 mil-amperes was used throughout the tests. The test was made with the distant ends of the circuit both open and short circuited. The figures given below refer to "noise units":

MEASUREMENT OF NOISE BETWEEN WIRES

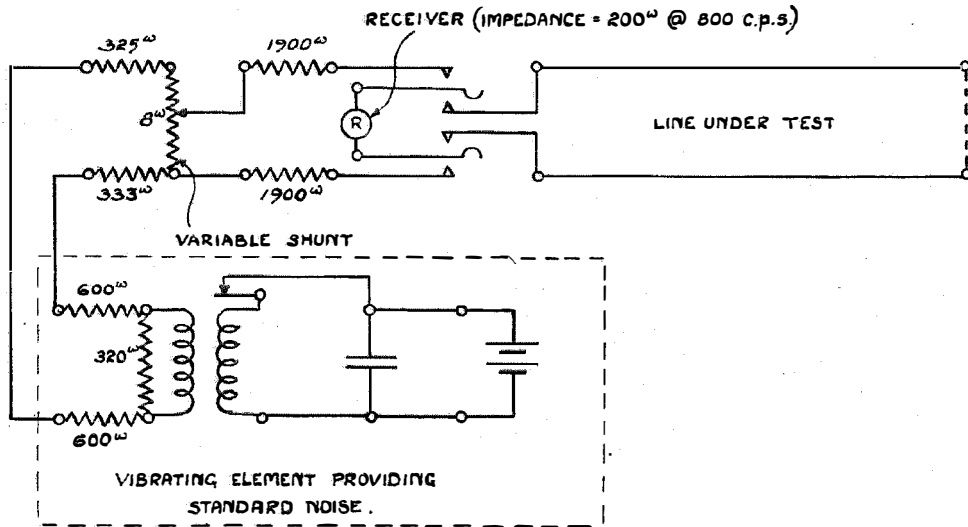

MEASUREMENT OF NOISE TO GROUND

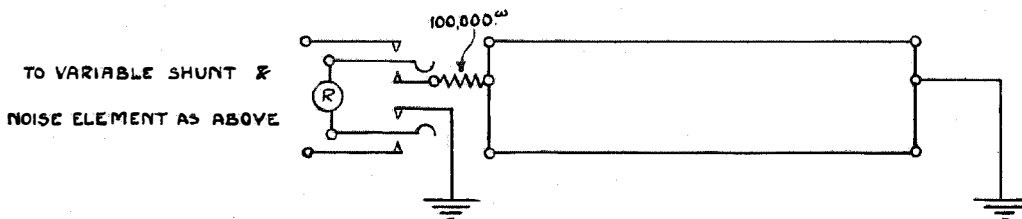

DIAGRAM OF CONNECTIONS FOR NOISE MEASURING SET

FIGURE 9

As the contractors had guaranteed that the new cable should be at least as free from inductive interference as the existing 7 pair continuously loaded telephone cable, it was necessary that comparative noise tests be made upon both cables. For this purpose the least perfect circuits of both cables were first chosen and comparative "circuit noise" measurements made when one pole of the 125 volt lighting circuit at Brigue being used as a source of disturbing current or potential, was connected to a conductor in the cable under test, the other end of the conductor at Iselle being alternately in-

Disturbing Circuit	Old Cable		New Cable			
	Pair Circuit		Side Circuits		Phantom Cts.	
	Open	Sht. Ct.	Open	Sht. Ct.	Open	Sht. Ct.
Insulated . . . (Electrostatic Interference)	300	200	20	15	25	15
30-Mil-amps. to earth . . . (Electromagnetic Interference)	300	450	10	4	15	15

From the point of view of induction from external power circuits, the test with current from the power circuit is, of course, the more vital, as the lead sheath of the cable effectively screens the circuits from direct electrostatic induction. Throughout these tests the electric traction in the tunnel was in operation. From the results obtained, it can be said that the noise upon the new cable is appreciably less than one twentieth that upon the old cable.

In conclusion, it is interesting to compare certain other characteristics of the two cables. The data given below applies to the pair circuits and side circuits respectively:

	Old Cable— Continuous	New Cable— Coil
Direct Current Resistance per km. . . . .	16.23 ohms	47.9 ohms (inclg. coils)
Mutual Capacity per km. . .	.042 mfd.	.0345 mfd.
Inductance per km. . . . .	.008 henry	.0885 henry
Attenuation Constant per km. at 800 c.p.s. . . . .	.0177	.0166
Weight of copper per km. of wire. . . . .	21 kg.	7 kg.
Weight of Copper per Cir- cuit-Kilometer. . . . .	42 kg.	9.3 kg.

This comparison indicates in a striking manner the progress which has been made in the art of telephone cable engineering during the last two decades. It leaves no doubt that loading coils, where properly applied, can be made to give circuits of the very highest standard, operating under the most exacting conditions.

It is believed that the Simplon Cable, thanks to the close co-operation of the Engineering Staffs of the Administrations and Contractors concerned, represents one of the highest achievements yet made in telephone cable construction. It will not be until the circuits connecting to it at Brigue and Iselle are carried by cables of a similar type that its good qualities will be fully realized.

This article deals, in a somewhat broad manner, with the more interesting features of the new cable.

For a more detailed account, particularly as regards the cable proper and the loading equipment, the reader is referred to the excellent article by Mr. A. Muri, Chief Engineer of the Swiss Telegraph and Telephone Administration, which appeared in the *Tech. Mitteilungen* (Bern) issue No. 1, February, 1923.



# Practical Application of Carrier Telephone and Telegraph in the Bell System

By **ARTHUR F. ROSE**

*Department of Operation and Engineering, American Telephone and Telegraph Company*

**I**N 1918 it was announced that the engineers of the Bell System had perfected carrier current telephone apparatus to such a point that four talking circuits had been added to one pair of wires already in use for telephone and telegraph communication and were being used commercially between Pittsburgh and Baltimore for providing needed telephone facilities. Since that time the growth of carrier application in the Bell System has been quite rapid. The purpose of this paper is to summarize the applications of carrier up to the present time and give a few typical examples where it has been found economical to provide circuits by means of carrier rather than by other types of facilities.

## PRINCIPLES OF OPERATION

The theory of carrier current systems, together with a historical sketch, was presented by Messrs. Colpitts and Blackwell before the American Institute of Electrical Engineers in February, 1921, and was published in Volume XL of the Transactions of the Institute. For those who do not wish to go into the detailed theory given in that paper, it may suffice to say that in a carrier current system a number of telephone or telegraph messages are simultaneously superposed on a single pair of wires by means of high frequency currents of different frequencies on which the individual messages are impressed. It is from this principle that the carrier current systems get their name, as the individual high frequency currents may be said to "carry" the telegraph or telephone messages. By using different frequencies for the carrier currents, the individual messages retain distinctive features which enable them to be separated one from another at the receiving end of the circuit.

On account of the much higher frequencies that are used in carrier operation, the carrier currents are attenuated more rapidly than the ordinary low frequency voice currents. This

requires that repeaters be located at frequent intervals in a carrier system. In these repeaters all the carrier channels are amplified together although the ordinary voice frequency channel is separated out and amplified in its own repeater.

The telephone and telegraph carrier systems although alike in their essentials differ very materially in the details of their operation. With the present equipment the frequencies employed in carrier telephony are much higher than in carrier telegraphy, thereby requiring more frequent repeater stations. In both telephone and telegraph systems it is necessary to provide for two way operation. This may be accomplished by using different carrier frequencies in the two directions or by using the same frequency in each direction with directional selectivity obtained by the three-winding coil (hybrid coil) used in repeater work. In this latter case it is necessary to provide networks to balance the lines over which the carrier system is operated. In the past both of these methods have been used but the tendency is now in the direction of eliminating balance entirely on account of its attendant maintenance difficulties and of providing for directional selectivity entirely by means of different frequencies in the two directions.

In order to show the variations in equipment arrangements which have been used in carrier systems, Figs. 1, 2 and 3 have been included. Fig. 1 shows one terminal of the original Pittsburgh-Baltimore carrier telephone system. In this picture it will be noted that the apparatus is mounted on racks about 6 feet high and occupying about one square foot of floor space, which are lined up in rows as space permits. Fig. 2 shows a terminal of a later type of carrier telephone equipment which was installed between Harrisburg and Detroit. In this case the apparatus for a complete terminal (4 channels) is mounted on four relay bays as shown. The

*Copyright, 1923, by American Telephone and Telegraph Company*

carrier telegraph equipment shown in Fig. 3 is a typical installation of the latest apparatus. Here rack construction is used although the individual panels are considerably larger than the older telephone equipment.

#### PRESENT DEVELOPMENT

As pointed out by Mr. Vail in his original announcement of the successful development of

permissible distance between these repeaters depends on the gauge of wire employed in the circuits on which the carrier circuits are superposed. For this reason the large gauge circuits of the Bell System have been equipped first with the result that practically all the existing carrier installations are installed on the 165 mil wires which are the largest generally in use throughout the Bell plant. This wire is largely used on

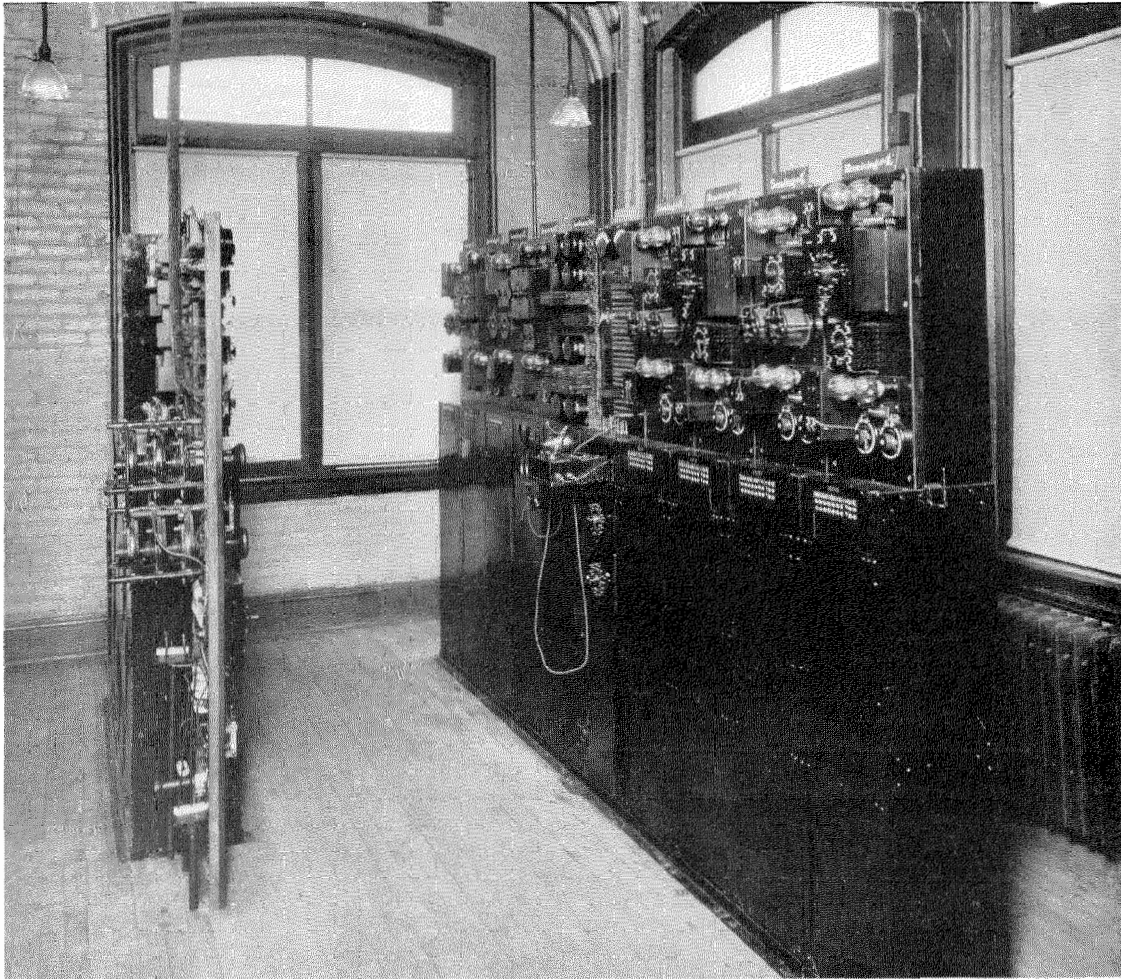

FIGURE 1

the carrier equipment, carrier systems are economical only for the longer circuits in the plant. The cost of the terminal equipment is so great that short circuits cannot economically be provided by carrier apparatus. Repeaters for amplifying the high frequency currents must also be installed at frequent intervals. The

the important backbone routes of the country and it is on these that the existing carrier circuits are superposed. In looking over the map of Fig. 4, which shows all the existing carrier installations, this fact will be noted and also that the carrier systems in most cases provide circuits over 250 miles in length.

It is of interest to note that the application of carrier very completely covers the important cross country routes. In the west the circuits from Portland to Los Angeles are equipped, the transcontinental line from San Francisco east to Harrisburg, and the eastern coast route from Bangor to Atlanta with the exception of the all cable sections between Boston and Washington. As each line on the map represents several channels the number of circuits obtained by carrier does not appear as large as is actually the case. In order to give a better idea of the extent of the carrier application the following table has been prepared which lists all the systems shown on the map and totals the channel miles obtained by each system. The telegraph channels if placed end to end would circle the globe 3 times and the telephone channels would extend somewhat more than half way round.

Carrier Telephone System	Channels	Miles	Channel Miles
Harrisburg-Chicago	4	742	2,968
Boston-Bangor	4	250	1,000
San Francisco-Los Angeles	4	446	1,784
Harrisburg-Detroit	3	605	1,815
Boston-Burlington	1	284	284
Oakland-Portland	3	735	2,205
Pittsburgh-Chicago	6	552	3,312
Chicago-Detroit	4	327	1,308
Total	29	3,941	14,676

Carrier Telegraph System	Channels	Miles	Channel Miles
Washington-Atlanta	8	647	5,176
Harrisburg-Chicago	18	749	13,482
Oakland-Portland	10	735	7,350
Chicago-Omaha	20	495	9,900
Chicago-Pittsburgh (Via Terre Haute)	20	634	12,680
Chicago-Pittsburgh (Via Indianapolis)	8	588	4,704
Key West-Havana	3	115	345
Chicago-Minneapolis	10	424	4,240
Chicago-St. Louis	10	333	3,330
St. Louis-Kansas City	10	294	2,940
Omaha-Denver	10	584	5,840
Denver-Salt Lake	8	580	4,640
Salt Lake-Oakland	6	771	4,626
San Francisco-Los Angeles	10	446	4,460
Total	151	7,395	83,713

#### TYPICAL CASES—TELEGRAPH

It will perhaps be of interest to consider several typical cases of carrier installations in order to see the economies involved in providing circuits by carrier rather than by other methods. Taking first the carrier telegraph systems as the considerations involved there are usually very simple, we shall consider the Pittsburgh-Chicago section. There are at present three carrier telegraph systems actually in operation

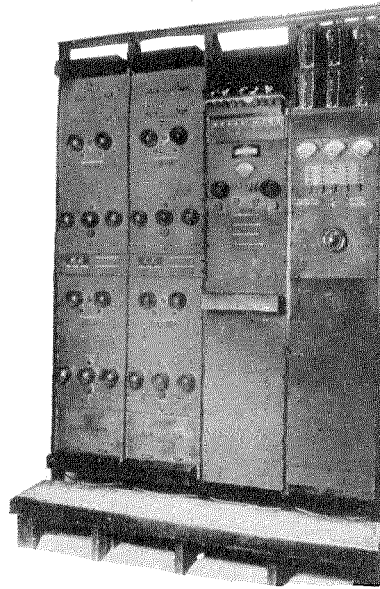

FIGURE 2

between Pittsburgh and Chicago. They provide a total of twenty-eight full duplex channels. These give service which could not be given otherwise as all the open-wire facilities between Pittsburgh and Chicago are completely equipped with direct current composited telegraph sets (to give all possible telegraph channels). The layout of the carrier telegraph systems between these points is shown in Fig. 5.

The above example is representative of the conditions under which carrier telegraph will be installed. In cases where open wire or cable facilities are available which can be composited with the ordinary direct current methods, the telegraph facilities can be obtained as a by-product most cheaply in this way. As soon as these facilities are all in use or an insufficient number of spare circuits remains, carrier tele-

graph can properly be used provided the returns from the special contract telegraph service are sufficient to meet the annual charges on the apparatus itself.

graph apparatus used in our ordinary land installation. Without the carrier equipment it would have been possible to obtain only one telegraph channel on each of the three sub-

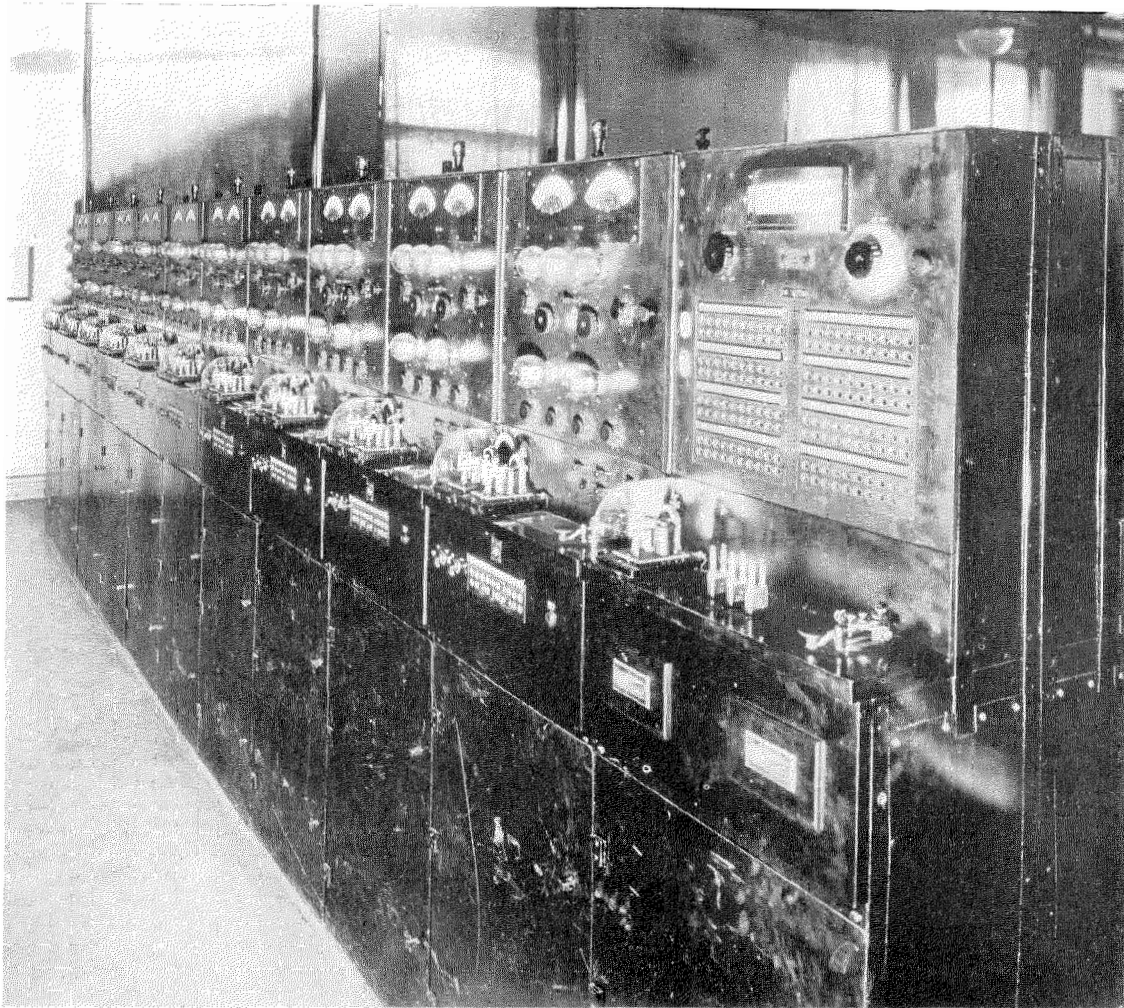

FIGURE 3

One of the carrier systems listed in the above tables is the Key West-Havana carrier system. The details of the telephone and telegraph channels obtained for the submarine cables were described in detail in the paper on the "Key West-Havana Submarine Telephone and Cable System" published in the journal of the A. I. E. E., dated March, 1922. On account of the considerable length of this cable and its high attenuation, the carrier equipment is special although resembling in principle the carrier tele-

marine cables by means of direct current composite sets. With the carrier apparatus it is possible to obtain 4 telegraph channels in addition to the single telephone channel.

#### TYPICAL CASES—TELEPHONE

The most important application at the present time of carrier telephone apparatus is probably between Pittsburgh and Chicago where the existing open-wire leads are so congested that the additions of further circuits would require ex-



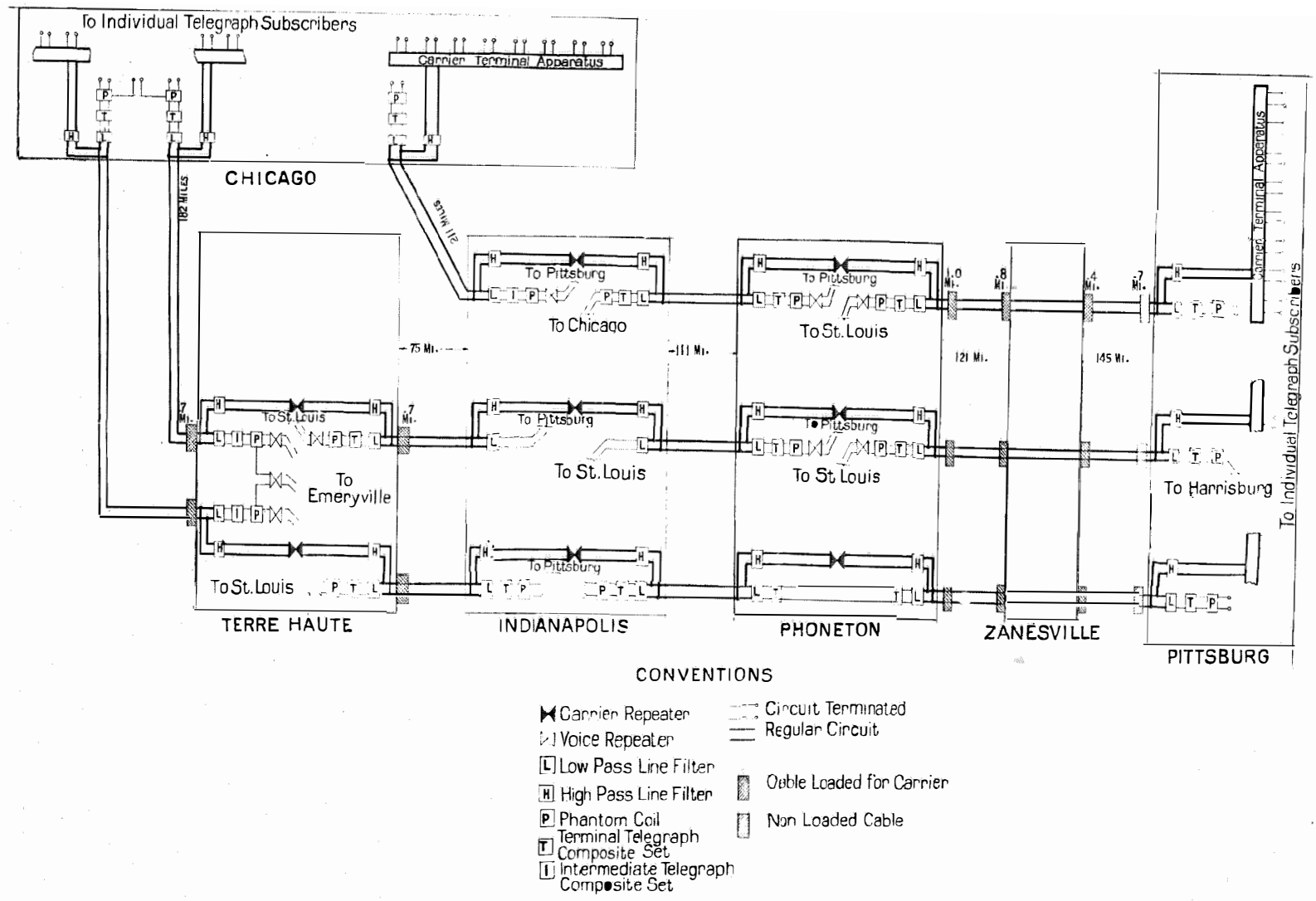

Fig. 5—Chicago-Pittsburgh Carrier Telegraph Systems

tensive construction work and possibly an entirely new pole line. An engineering study of this situation resulted in the drawing up of plans for an aerial toll cable which will largely replace the open wire. Work is already well advanced on the installation of this cable and it will be

carrier telephone channels. These will be supplemented by at least two additional systems before the cable is completed. As soon as the cable is installed the carrier systems will probably be removed from service here and reinstalled in other locations.

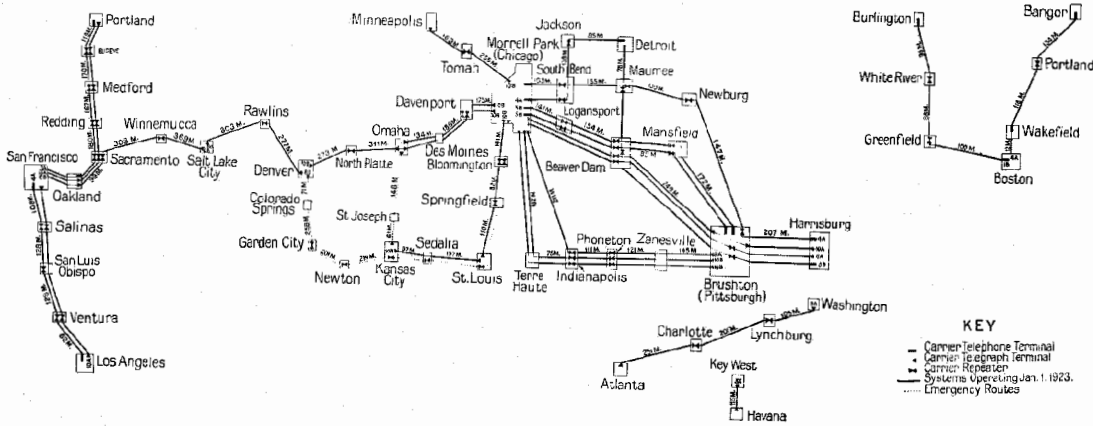

Fig. 4—Carrier System Installations

completed within the next few years but in the meantime, the use of carrier apparatus enables the traffic growth to be taken care of without stringing wire which, under the circumstances, would be very expensive.

In most cases the problem of providing additional circuits is not as difficult as in the section between Pittsburgh and Chicago. For this reason the relative economies of providing circuits by carrier and by the other methods

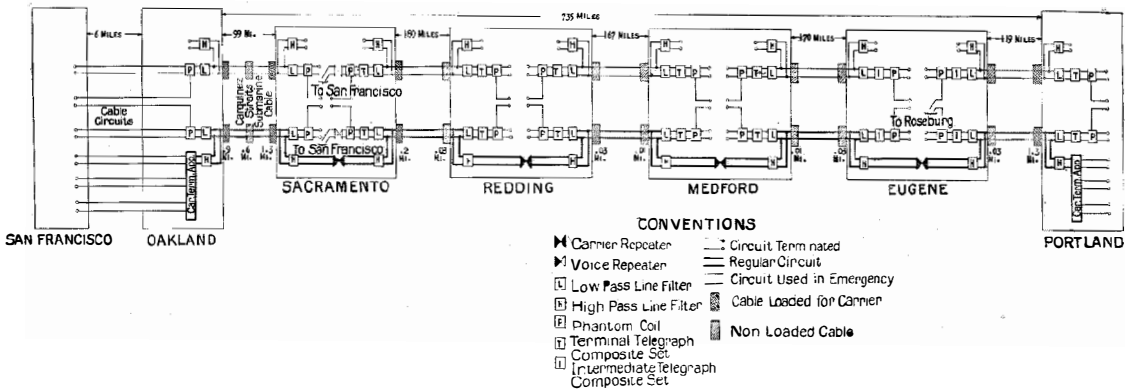

Fig. 6—Oakland-Portland Carrier Telephone System

There are, at present, operating between Harrisburg and Chicago, one 4-channel telephone system and between Pittsburgh and Chicago two 3-channel systems, providing a total of 10

must be more carefully considered. Even where no congestion exists, however, it will be found that where the circuits are long enough the carrier circuits will be cheaper than any other

method of providing the facilities. The circuits to be provided must usually be several hundred miles in length before this is the case; also, since the cost of a carrier channel goes down as the number of channels installed at one time is increased it will usually be found that an installation of 3 channels will prove in for considerably shorter distances than would be necessary if a lesser number of channels are installed. In the practical case a complete system consisting of either three or four channels is usually installed at one time.

A typical case of a carrier telephone installation where the existing open wire lead is not already full but where the circuits required are long, is the Oakland-Portland system which in conjunction with a short cable between Oakland and San Francisco provides San Francisco-Portland circuits. The detailed layout is shown on Fig. 6. Here the cost study showed a considerable saving in annual charges in favor of the carrier although there was room for stringing open wire on the existing pole line. This system was put in service by the Pacific Telephone and Telegraph Company in 1921 and has since given very satisfactory service.

Another type of carrier installation is one installed to defer a proposed cable project. A long toll cable project involves the investment of such large sums of money that deferring the annual charge on the cable circuit for one year will frequently be sufficient to pay for and maintain a carrier system over the same period. Additional carrier systems may then be added to further defer the cable if this appears economical. The addition of a second system to a lead usually involves some considerable line expense for transposition work, however, and this may prove out the further addition of carrier. Even if it appears economical to install additional carrier systems, a point will soon be reached where the cumulative annual charges of the carrier systems will exceed that of the cable. The first few systems prove in over the cable because the carrier provides only for the immediate circuit requirements while the cable must take care of growth and therefore includes many idle facilities when first installed. Where carrier is used to provide facilities in place of a toll cable it should always be considered an intermediate and temporary step between open wire and cable plant.

The use of carrier as outlined above may effect further economies after the apparatus has been removed as the equipment may be reused at some other point to advantage. A typical example of the use of carrier apparatus to defer a cable is the Boston-Bangor carrier system which was put in to defer the installation of the first section of the Boston-Portland cable. The layout of this system is given in Fig. 7. It will be seen that this system is fairly short but the first year's annual charge on the first 50 miles of the Boston-Portland cable would have been sufficient to pay the entire first cost of this carrier project. It is possible that further carrier may be installed on this route before the cable is finally installed. The present system has deferred the cable somewhat longer than was originally expected as the growth of traffic has not been quite as rapid as was expected at the time of the war emergency.

Another example of line congestion enabling the carrier to be proved in on somewhat shorter than the ordinary economical length is in case a considerable amount of line reconstruction is involved if open-wire circuits are added to an existing lead. A case of this kind was the Boston-Burlington system where a very considerable amount of line reconstruction work would have been involved if an effort had been made to add a phantom group to the existing lead. The use of the carrier system on the existing 104 mil circuits enabled this work to be eliminated from consideration and it is possible that the work will not need to be done until this section of the line is relieved by cable or other means.

There are many cases in which the use of carrier can be considered a stop-gap to take care of the transient period between open wire and cable facilities. This has been true in the case of the former Baltimore-Pittsburgh system where the original apparatus has been removed from service as cable facilities are now available between these points via Philadelphia, Reading and Harrisburg. This does not mean that the equipment is no longer of value, since it usually can be used again on some other location. Even the experimental panels which were used in the Pittsburgh-Baltimore system will probably be reinstalled within the next year. It is now thought that this apparatus will be used between Chicago and Minneapolis in connection with some additional panels to provide for new telephone circuits there.

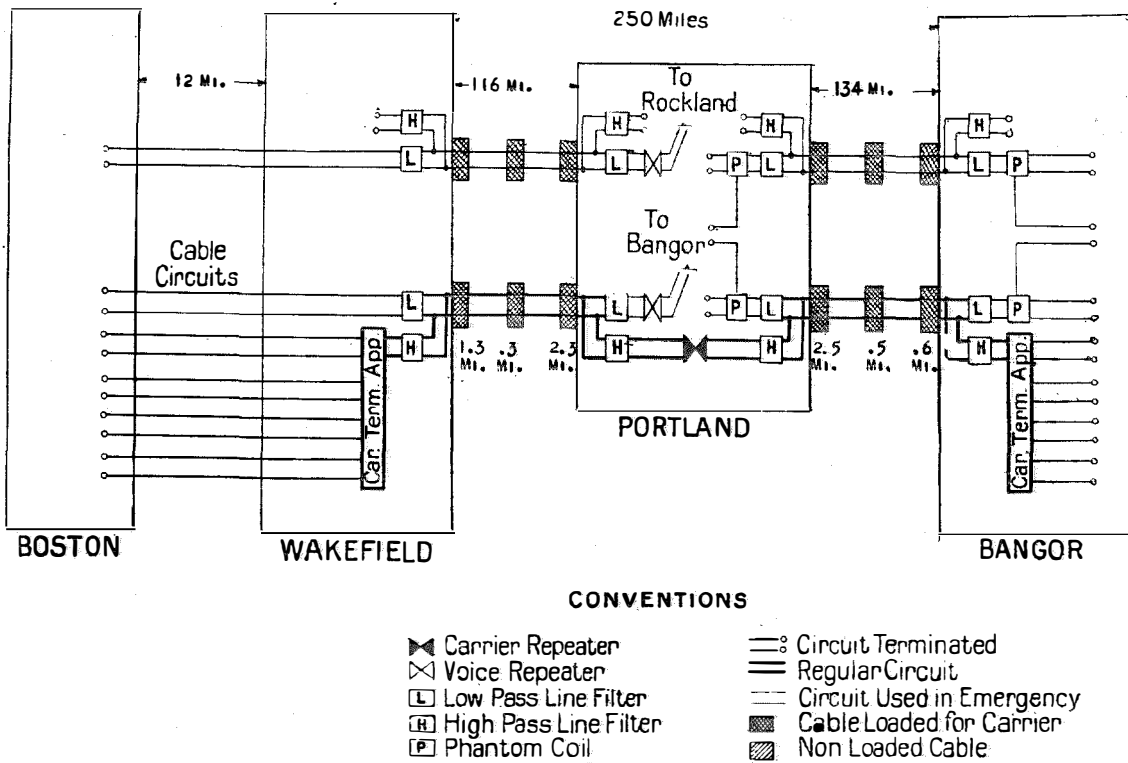

Fig. 7 Boston-Bangor Carrier Telephone System

**EXPECTED DEVELOPMENT**

Looking forward for the next ten years, it is expected that carrier telephone facilities will be installed at the rate of about 5,000 to 10,000 channel miles and telegraph facilities at the rate of from 20,000 to 30,000 channel miles per year. In the meantime development work may produce cheaper systems which will prove

in on shorter circuits, thereby extending the field of use so that the rate of application may possibly be doubled or trebled. Even now the number of channel miles in service constitutes an important part of the total facilities of the Bell System and present a very interesting picture of rapid growth when compared with the beginning between Baltimore and Pittsburgh in 1918.

# The Western Electric Exhibit at the Rio de Janeiro Exposition

By COL. N. H. SLAUGHTER

*Engineering Department, Western Electric Company*

**C**ELEBRATING the One Hundredth Anniversary of the independence of Brazil, there was inaugurated at Rio de Janeiro on September 7, 1922, the Brazilian Centennial Exposition. The official opening ceremonies took place at four P. M. in the Palacio dos Festas, where a few of the many

to the Palacio dos Festas, in fact more clearly than in the rear of the auditorium where the speaking took place.

Thus was introduced to the Brazilian public the latest development in the Telephone Art, the Western Electric Public Address System. This system is intended to reinforce a speaker's voice



Fig. 1. Rio de Janeiro Exposition—Looking Toward the Market

thousands of visitors were gathered. To the amazement of those congregated throughout the grounds, the addresses delivered by the President of the Republic and the French Ambassador, and the National Anthem as rendered by Brazil's finest Military Band, were heard clearly throughout the open areas adjacent

and enable his words to be clearly heard over much larger areas than is possible with the unaided voice. The system comprises essentially a microphone placed in proximity to the speaker, amplifiers for strengthening the currents produced by this microphone, and sound projectors for converting the electrical currents into

sound and distributing the sound over the desired area. Sufficiently powerful amplifiers and projectors are used so that an outdoor audience of a million people is well within the capabilities of the system.

In planning the installation of the Public Address System at the Rio Centennial Exposition, consideration was given to making the system available for a great variety of uses, and at the same time accessible for inspection by visitors. Working in conjunction with the Rio de Janeiro and Sao Paulo Telephone Company, the control center was established in the heart of the Exposition grounds (in the same room as the telephone pay station booths of the Exposition), while sound projectors were located at various points covering practically the entire outdoor area of the grounds. A portable amplifier for use with the "pick-up" microphones, together with a network of telephone cables running to various points within and outside the Exposition, made it possible to pick up speeches and music at any desired point, transmit it to the control room, amplify it there and distribute the output to sound projectors at any desired point.

The following partial summary of the uses to which the Public Address System has been put will indicate the flexibility of the equipment:

(a) Weather reports broadcast through the grounds by telephone operator in control room.

(b) Symphony Orchestra (conducted by Mascagni) playing an open air concert in the grounds, reinforced by sound projectors placed above the orchestra, so that ten times as many people heard as with an unaided orchestra.

(c) Speeches by Mayor of Rio de Janeiro and French Ambassador, at banquet to Exposition delegates, heard by entire gathering due to reinforcement by Public Address System, whereas without the reinforcement only those immediately adjacent to the speakers could hear. (For this occasion the microphones were installed on the speakers' table, wired to an amplifier in a room nearby, transmitted by telephone cable one mile to the control room, amplified further and transmitted back to the banquet hall over another telephone cable, and reproduced in sound projectors in the balcony just over the speakers' table.)

(d) Addresses on matters of public interest by speakers in various auditoriums, reproduced

and distributed to outdoor areas through the grounds.

(e) Speeches and music at the meetings of the International Eucharistic Congress held in the Sao Francisco Cathedral, several miles from the Exposition, and reproduced for the crowds in the park outside the Cathedral.

(f) Musical concerts consisting of selected phonograph records, amplified through the Public Address System and reproduced throughout the grounds.

(g) Musical concerts broadcast from the Western Electric Radiophone station, picked up

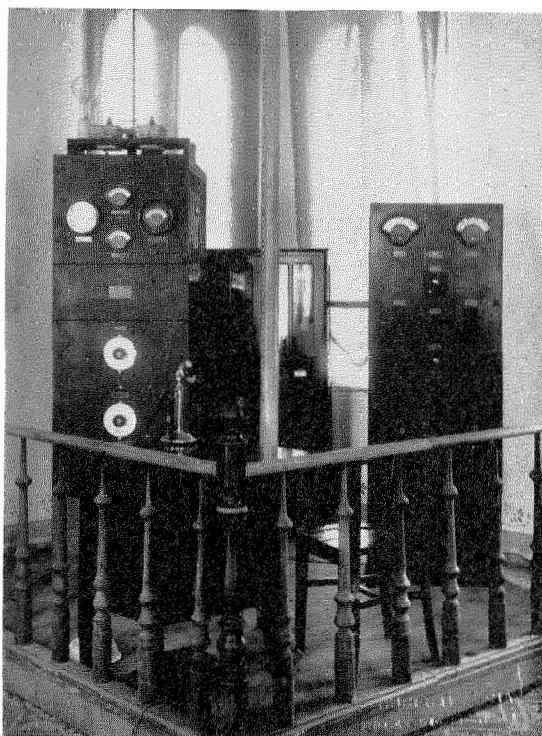

Fig. 2. Rio de Janeiro Exposition—Western Electric Radio Sending Station

by a radio receiver in the Control Room and reproduced on the Public Address System.

(h) Football returns of games at Rio, transmitted by telephone lines to Sao Paulo 300 miles distant, and reproduced there for an open air crowd of twenty thousand people.

In these and other ways the Public Address System has added greatly to the success of the Exposition and has been one of the most popular exhibits of the Exposition.

In addition to the Public Address System the International Western Electric Company has installed a standard 500-watt Radiophone transmitter in the Exposition.

This station is being operated in conjunction with the National Telegraphs of Brazil, and has been in frequent use for broadcasting and for transmitting speech and music to other cities, such as Sao Paulo, Juiz de Fora, and Bello Horizonte. This installation gave satisfactory transmission even in the Summer forenoon, day

five hundred feet high, supported by a steel cable strung between two neighboring mountains.

The latest type of Western Electric Duplex Printing Telegraph has also been installed and demonstrated for the National Telegraphs with entirely successful results.

Although not a feature of the Exposition, it is of interest to note that a Western Electric Type "B" Carrier Telephone System has been installed and is in successful operation between

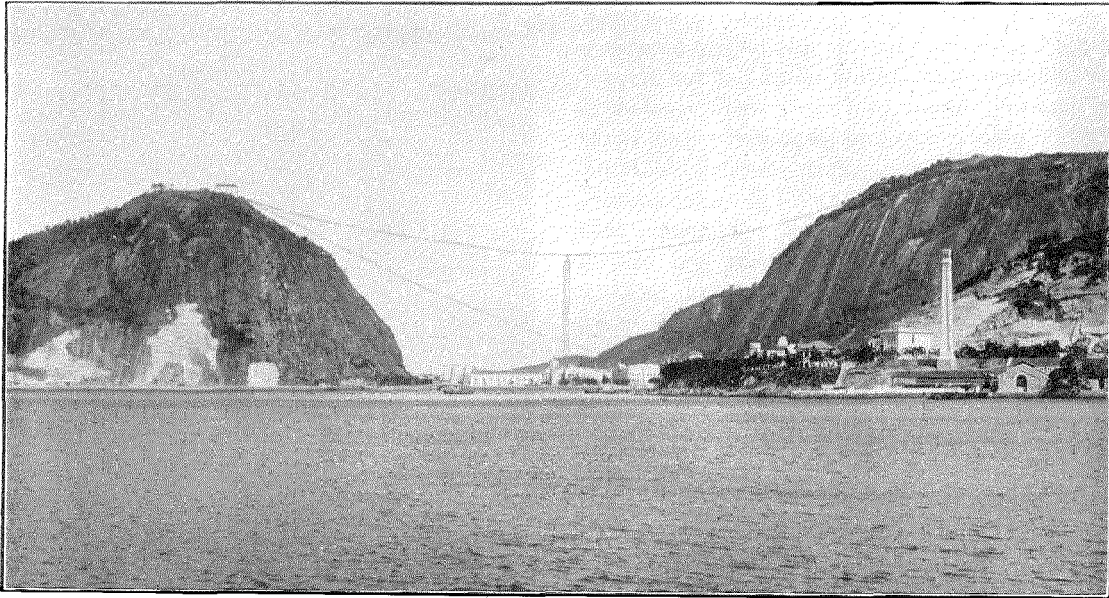

Fig. 3. Rio de Janeiro Exposition—Antennae of Western Electric Radio Station

by day, over a period of several weeks, transmitting speech from Rio to Sao Paulo, air line distant 220 miles. An extreme record of 8000 miles was established when speech from this station was received in Honolulu.

Among the interesting demonstrations may be mentioned one in which an address by the Minister of Agriculture and music by the National Marine Band were transmitted by radio to Sao Paulo, and reproduced by a Public Address System for a distinguished audience in a theatre in Sao Paulo. Two-way telephone conversations have been held with the Western Electric Radiophone Station in Buenos Aires, 1000 miles distant. The Rio station has a novel form of antennae, consisting of a vertical cage

Rio and Sao Paulo, adding three channels to the existing toll facilities. The Rio-Sao Paulo toll line is about 300 miles long, using No. 12 N.B.S. copper open wire circuits, with several miles of No. 13 gauge toll cable at each terminal. One carrier repeater is employed, approximately midway between terminals.

The equipments above described, namely, Public Address, Radio Telephone, Printing Telegraph and Carrier Telephone, represent the latest developments in the communication art; and since better communication facilities are among the most important needs of the rapidly developing South American republics, the Western Electric exhibit has an unusual importance and significance at this time.

# Public Address Systems<sup>1</sup>

By I. W. GREEN

*Department of Development and Research, American Telephone and Telegraph Company.*

and J. P. MAXFIELD

*Engineering Department, Western Electric Company*

**SYNOPSIS:** *A public address system comprises electrical equipment to greatly amplify a speaker's voice so it will reach a much larger assemblage than he could speak to unaided. Beginning with the presidential conventions of the two major parties in 1920 and the inaugural address of President Harding in March 1921, when a special address system installed by the telephone engineers enabled him to address an audience estimated at 125,000, there followed in rapid succession, many public events demonstrating the value of such systems. One of the most notable of these occurred on Armistice Day 1921, when the speeches, prayers and music at Arlington, Virginia, were heard, not only by 100,000 persons gathered there at the National Cemetery, but by some 35,000 in New York City and 20,000 in San Francisco. On this occasion the three public address systems, one for each of these cities, were joined by long distance telephone circuits.*

*The fundamental requirements of a satisfactory public address system are naturalness of reproduction and wide range of output volume. The meeting of these two requirements for music proves more difficult than for speech.*

*The public address system here described is most readily considered in three sections—"pick-up" apparatus which is placed in the neighborhood of the speaker and converts his words into undulatory electric currents; a vacuum tube amplifier for amplifying these currents; and a "receiver-projector" for reconverting the current into sound waves and distributing the sound over all of the audience. In the present system each of these three parts of the equipment has been designed with the intention of making it as nearly distortionless as possible, so that the various parts might be adaptable for audiences ranging in size from possibly one thousand to several hundred thousand, and might also be used in connection with the long distance telephone lines and with either radio broadcasting or receiving stations. One of the larger public address systems is easily capable of magnifying a speaker's voice as many as 10,000 times.*

*The pick-up device whether of the carbon microphone variety or a condenser transmitter need not be placed close to the speaker's lips but will operate satisfactorily when four or five feet away. The loud-speaking receiver mechanism is so designed that it will carry a power of several watts with small distortion. Under normal conditions, 40 watts distributed among a number of receiver-projectors arranged in a circle is ample to reach an audience of 700,000 persons.*

**T**HIS paper aims to present the problems encountered in the development of electrical systems for amplifying the voices of public speakers and music; and to describe the equipment as brought to a commercial state and now in use in the United States and various other countries.

The two main requirements of a successful public address or loud speaking system are, first, that it shall reproduce the sounds, such as speech or music, faithfully; and second, that this faith-

ful reproduction shall be loud enough and sufficiently well distributed for all of the audience to hear it comfortably. Most of the development work has been directed toward obtaining these two results under the various conditions which surround the operation of these systems.

The faithful and natural reproduction of sound depends upon many factors, of which the following are some of the more important: The acoustics of the space in which the sound originates, the characteristic of the loud speaking system itself and the acoustics of the space in which the sound is reproduced. Where the sound is picked up and reproduced in the same space, as is the case when the speaker is using one of these systems to address a large audience locally, there is a reaction between the horns and the transmitter or pick-up mechanism which is controlled by the acoustic conditions under which the system is operated.

## ACOUSTICS OF THE SPACE

In connection with the acoustics of the space in which the sound originates, or in which it is reproduced, four factors stand out. These concern the effects of reverberation, of echo, of resonance, and of diffraction. In the specific cases where the sound is reproduced in the same space or room in which it originates, another effect is encountered, which has generally been termed "singing," and is evidenced if sufficiently great by the emission of a continuous note from the equipment.

Reverberation is caused by reflection and is evidenced by the persistence of the sound after its source has ceased emitting. When the reverberation in the space in which the initial sound is being picked up is sufficient to cause one sound to hang over and become mingled with succeeding sounds, in other words, so that the sound from one syllable interferes with that of the succeeding syllable, it is practically impossible to improve the acoustic conditions

<sup>1</sup> Presented at the Midwinter Convention of the A. I. E. E., New York, N. Y., February 14-17, 1923. Published in the Journal of the A. I. E. E. for April, 1923.



solely by the use of the public address system. In such a case, the first procedure is to place material which absorbs sound in the space. The purpose of this absorbing material is to lower the time required for the sound to die away after the source ceases to emit. The amount which any given material lowers the time of reverberation depends not only upon the amount of material introduced, but also upon its disposition within the space.

The term "echo" applies to a similar phenomenon, but is generally used where there is sufficient time lag between the reflected sound and that originally emitted, so that two distinct impressions reach the ear.<sup>2</sup>

The troubles encountered from echoes usually occur only in large buildings or large open spaces surrounded by buildings, trees, or other obstacles and are generally associated with interferences with the reproduced sound rather than with the original sound. There are cases, however, particularly in auditoriums, where some of the walls or ceiling are large curved surfaces, in which case localized echoes may result. The speaker's voice or extraneous sounds from the audience may be reflected from one or more of these surfaces to focus spots where the volume of sound is consequently abnormally great. It is important, therefore, that the transmitter which is picking up the sound shall not be located at one of these spots. These points of localized echo are particularly troublesome also when they occur in the space occupied by the audience. Under these conditions not only is the sound intensity too great, but the character of the sound is altered and very often badly confused. The avoidance of such difficulties is a matter of test and the proper arrangement of the reproducing mechanism, as will be seen later in some detail.

The effect of resonance seldom occurs in connection with the amplified and reproduced sound, inasmuch as the spaces dealt with are large and their natural frequencies are too low to be troublesome. Resonance usually becomes of importance in connection with mounting the pick-up apparatus or transmitter. It generally results from attempts to conceal the transmitter by placing it in some form of small enclosure. The best form of housing from an acoustic standpoint consists of a screen cover which protects

the instrument from being struck or injured but in no way affects the sound reaching it.

Resonance produces a distortion which it has been customary to consider as of two varieties. First, there is an unequal amplification of sounds of various frequencies and second, there is the introduction of transients. These transients occur whenever the sound changes but are most easily recognized audibly by their continuation after the source has ceased emitting. They also have frequency characteristics which depend not only on the sound which started them but also upon the character of the resonant portion of the system.

The troubles introduced by diffraction are seldom of very great importance except where the sound is reflected from regularly spaced reflectors or passed through regularly spaced openings. Quite serious diffraction troubles have been encountered when operating a loud speaker in a large field, surrounded by an open work board fence, the trouble being evidenced by very distinct areas, particularly at the outskirts of the audience, where the sounds were badly distorted.

The difficulties encountered as a result of "singing" form one of the most troublesome problems connected with the actual operation of these systems. When a portion of the sound emitted by the projectors reaches the transmitter with sufficient intensity, that its reproduction is as great as the originally emitted sound from the projectors, and with such phase relation that it tends to aid the original sound, the system will emit a continuous note. Moreover, when the portion of the sound from the projectors which reaches the transmitter is not sufficient to cause a continuous note, it may be sufficient to cause considerable distortion of the speech or music. In excessively reverberant halls these conditions are often fulfilled when the actual amplification is so small that the people at the distant points are scarcely able to hear the speaker. In all cases in our experience the difficulty has been sufficiently overcome by properly placing the transmitter with respect to the projectors. The situation is very much helped by the presence of the audience, which adds considerably to the acoustic damping of the room.

It will be seen, therefore, that the acoustic conditions of the space in which loud speakers are used are of considerable importance.

<sup>2</sup> Collected Papers on Acoustics, Wallace Clement Sabine, Harvard University Press, 1922.

## CHARACTERISTICS OF THE SYSTEM

The first requirement of the system itself is that it shall reproduce speech or music faithfully. A system is said to do this, or in other words, its quality is called perfect, when the reproduced sound contains all of the frequencies, but no others, contained in the original sound striking the "pick-up" mechanism, and when these frequencies have the same relative intensities that they had in the original.

An imperfect or distorting system is one which fails to fulfill this requirement. There are two main types of distortion which had to be considered; the first being the unequal amplification of the system for the various frequencies constituting the sound and the second being the introduction of frequencies not present in the original sound. For simplicity of discussion, this last class will be divided in three parts, namely: the effect of transients, the effect of asymmetric distortion and the effect of disturbing noises.

The effect of transients has already been mentioned in connection with acoustics and they, of course, produce the same type of distortion whether they occur in the acoustic or the electrical system. Transients occur whenever the sound changes either in pitch or intensity and are introduced at the beginning and ending of each speech sound. This modification of the characteristics of the speech sounds acts to lower the intelligibility. It probably causes more trouble in speech transmission than the fact that the sound continues after the source ceases.

Asymmetric distortion affects one half of the wave differently from its other half. This causes the introduction of frequencies which, in some cases, produce very serious disturbances in the transmission of music and speech. The most noticeable troubles are from the formation of sum and difference tones.<sup>3</sup> Such tones are likely to give rise to dissonances with the other sounds occurring in the music. In the case of speech asymmetric distortion manifests itself by a lower intelligibility.

The effect of foreign noises sometimes encountered is twofold. First, they influence the ability of the listener to hear the characteristics of the speech sounds and hence tend to lower the intelligibility. Secondly, the constant at-

tempt of the hearer to sort out the speech sounds or music through the disturbing noises tires him appreciably. In order that this strain shall be inappreciable, it is desirable that the sound delivered by the system shall be at a power level approximately 10,000 times that of the noise.

The second general requirement which is placed on a successful system is that it shall deliver its faithful reproduction loud enough for all the audience to hear it comfortably and enough above noise for good intelligibility. In this connection there have arisen one or two interesting points bearing on the psychology of hearing. One of the most striking of these is concerned with the coordination between hearing and seeing. Although the projectors are usually mounted twenty or more feet above the speaker's head, and in some exceptional cases, slightly to one side of him, the majority of the audience is conscious of only one source of sound, and that appears to be the speaker himself.

This phenomenon is so marked that in several cases the question has been raised in the minds of the listeners as to whether the system was functioning. They could only be convinced that it was by having it shut down for a few seconds when their inability to hear made them realize how successfully the system could operate.

Another of these psychological phenomena deals with the apparent distortion of the voice when its intensity at the ears of the listener is too great or too small. If the speaker is talking in a normal conversational tone, his voice contains a larger percentage of low frequencies than is the case when he is raising his voice to a considerable volume. If the loud speaker so amplifies his voice that it reaches the audience with such volume that their instinct tells them that the speaker should be shouting, the system appears to make his voice sound quite heavy and somewhat unnatural. It has been found necessary, therefore, to so regulate the amount of amplification that the people at the farthest portion of the hall can hear comfortably and the volume of sound shall not be permitted to become any louder than necessary to meet this condition. On the other hand, if the volume is insufficiently loud, certain of the weaker speech sounds are entirely lost, and it becomes difficult to understand.<sup>4</sup>

<sup>3</sup>Origin of Combination Tones in Microphone-Telephone Circuits. E. Waetzmann, *Annalen der Physik*, Vol. 42, 1913.

<sup>4</sup>Physical Examination of Hearing, R. L. Wegel, *Proceedings of the National Academy of Sciences*, Volume 8, Number 7, July, 1922.

## SOLUTION OF THE PROBLEM

With these considerations in mind it may be interesting to take a brief survey of the whole problem and the method by which the solution was reached. Two general methods of attack

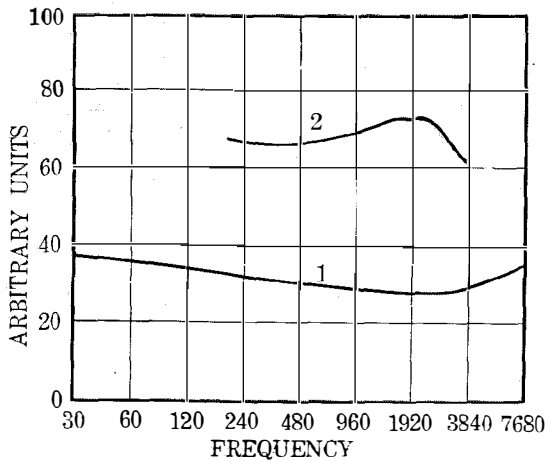

Fig. 1—1-Condenser Transmitter with Associated Amplifier.  
2-Carbon Transmitter without Amplifier.

were considered. The first was to attempt to make each unit of the system faithfully reproduce its input, while the second was to make any distortions of one part of the system, cancel those of another portion, so that the complete system would operate satisfactorily. In either case, it was desirable to keep each unit free from asymmetric distortion, as this type of distortion cannot be easily compensated for.

While it would probably have been simpler to follow the second line of attack, the greatly increased flexibility of a system in which each part is correct in itself was of sufficient value to cause the attempt to be made that way. When it is realized that these systems, to be commercially successful, must be capable of operating for various sized audiences, ranging possibly from one thousand to several hundred thousand, that they must be used in connection with long distance telephone lines, as well as with either radio broadcasting or receiving stations, the desire for flexibility can be understood.<sup>5</sup>

As a result of attempting the development in the manner already described, there has resulted a system which involves four functional units;

<sup>5</sup> Use of Public Address Systems with Telephone Lines, W. H. Martin and A. B. Clark. Presented before A. I. E. E., Feb. 14, 1923.

a "pick-up" mechanism or transmitter unit, a preliminary amplifier unit, commonly called the speech input equipment, a second amplifier unit commonly called the power amplifier, and a receiver-projector unit for transforming the amplified currents back into sound, and properly distributing it throughout the space to be covered.

It may be interesting at this place to determine how successfully these various units and the system as a whole fulfill the requirements of equal sensitivity to all frequencies within the important speech or music range. Fig. 1 shows the relative sensitiveness of the transmitter as a function of frequency. The ordinates are proportional to the logarithm of the power delivered for constant sound pressure at the diaphragm and the abscissae to the logarithm of the frequencies employed. The lower of the two figures refers to the condenser transmitter with its associated input amplifier.<sup>6</sup> The upper refers to the push-pull carbon-type transmitter. These transmitters will be described in detail later.

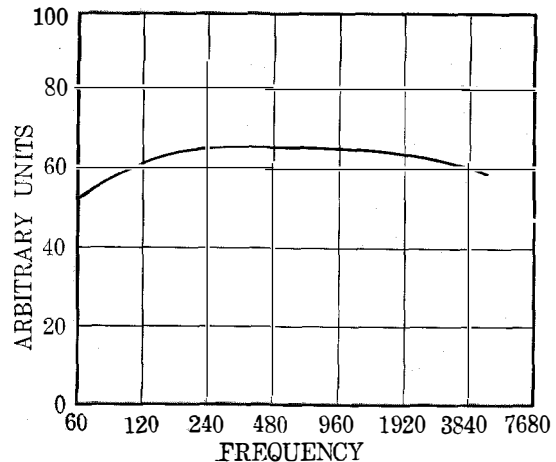

Fig. 2—Public Address System Amplifiers.

Fig. 2 shows a similar curve for the complete amplifier system, comprising a three-stage speech input amplifier, and a power stage capable of delivering approximately 40 watts of speech frequency electrical power without distortion. In connection with these amplifiers a sharp distinction should be made between their gain rating, or amplification, and their overload or

<sup>6</sup> The Sensitivity and Precision of the Electrostatic Transmitter for Measurement of Sound Intensities. E. C. Wente, *Physical Review*, N. S. Vol. 19, No. 5, May, 1922.

power rating. Gain measures the power amplification which can be obtained provided the input is small enough so that the equipment at the output end is not overloaded. Overload or power rating refers to the maximum power which can be supplied by the amplifier without causing distortion of the currents being amplified. Although the power rating of power equipment is usually determined by the heat which can be dissipated, a marked distortion of wave form takes place when the iron in any of the apparatus is worked beyond the straight line portion of the magnetization curve. In the case of amplifiers, the maximum power obtainable is limited by the power output at which distortion occurs rather than by the heat which can be dissipated.

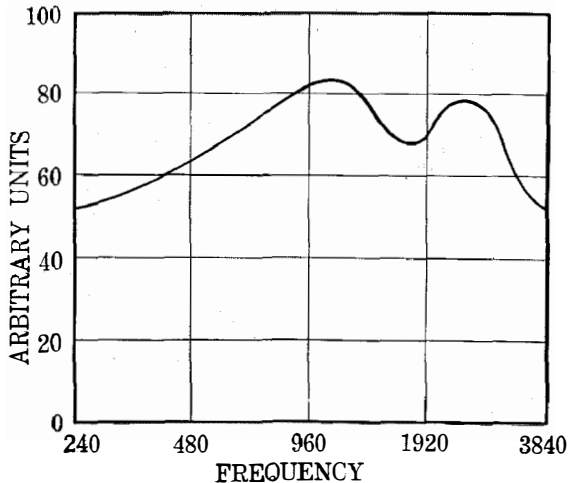

Fig. 3—Complete Public Address System with Carbon Transmitter.

Fig. 3 shows a chart for the characteristics of the complete system, including the carbon transmitter, the speech input and power amplifiers and the receiver projector unit.

In connection with the requirements for equal amplification of all frequencies, it is interesting to note that a system, which does not fail to reproduce equally all frequencies in the speech range by more than a ratio of 10 to 1 in reproduced power, is indistinguishable from a perfect system or from the speaker, himself. It seems probable that this effect is, in some way, connected with variations in the frequency sensitiveness curve of normal ears. Normal ears show a sensitiveness variation with frequency as great as 10 to 1 and the frequencies of max-

imum sensitiveness vary materially from one individual to another.<sup>7</sup>

It has been found that in order to transmit speech with entire satisfaction for loud speaker purposes, that is, sufficiently well so that the audience is not aware of the contribution of the mechanical equipment, it is necessary for the system to operate with essentially uniform amplification over a range of frequencies from 200 to 4000 cycles. While there are, in speech, frequencies slightly outside of this range, the loss in naturalness and intelligibility by the system's failure to reproduce them, is slight.<sup>8</sup>

While no such frequency range is required for intelligibility only, it has been found that systems not covering substantially this frequency range, sound unnatural. When the lower frequencies are missing, the reproduction sounds "tinny." When the higher frequencies are missing it sounds heavy and muffled. The requirements for thoroughly natural reproduction of music are probably more severe, particularly in the low-frequency region, than are the similar requirements for speech, but, at the present time, complete data are not available to indicate the contribution of these frequencies to naturalness.

In connection with the flexibility of the system, it is interesting to note that the speech input equipment has been designed to raise the power delivered by the transmitter to such an extent that it is sufficient for long distance telephone transmission or for the operation of a radio transmitting set. The power amplifier is designed to receive power at approximately this level and deliver it to the projector units sufficiently amplified to operate them satisfactorily.

#### FUTURE DEVELOPMENT

In viewing the loud speaker field from the point of view of future development there are two lines of attack along which work is being done, and which give promise of success. These are the improvements in frequency characteristics and increase in the range of loudness which the system can accommodate satisfactorily.

The improvement to be expected from a more uniform frequency characteristic is mainly an increase in naturalness, especially where music is

<sup>7</sup> Frequency Sensitiveness of Normal Ears, by H. Fletcher and R. L. Wegel, *Physical Review*, July 1922.

<sup>8</sup> The Nature of Speech and Its Interpretation. Harvey Fletcher, *Journal of the Franklin Institute*, Vol. 193, No. 6, June, 1922.

being reproduced. A slight increase in intelligibility may be hoped for, although this factor is of little importance, as the present system is satisfactory in this respect.

The other improvement mentioned, namely, volume range, is probably the more difficult, but is necessary before music can be reproduced in a perfect manner. Rough experimental data indicate that the loudness in an orchestra selection may vary from one part of the selection to another by a ratio as great as 50,000 to 1. While the present equipment does not operate with entire satisfaction over this range of loudness, it has been found relatively easy to obtain good results by manual adjustment of the amplification during the rendering of the selection. If the gain is varied in small enough steps, the change is not noticeable to the listeners.

An increase in the loudness range would render the manual adjustment unnecessary and would make the reproduction a faithful duplicate of the music as actually played.

#### TECHNICAL DESCRIPTION OF THE SYSTEM

The foregoing discussion having described the requirements which must be met in order that the public address system shall successfully transmit speech and music, the system in its commercial form will now be described. In order to make clear the arrangement of the equipment, a typical installation is shown in Fig. 4, this being an installation where the audience and speaker are in the open air, and where no connection is made with the long distance lines. It might be well to state here that with the equipment shown an audience of 700,000 can be adequately covered.

Some of the sound leaving the speaker's mouth is picked up by the transmitter, on a reading-desk type of pedestal, which is normally mounted at the front of the platform.

The feeble currents from the transmitter are led by carefully shielded leads to the amplifiers in the control room, which is usually located directly beneath or to one side of the speaker's stand. A floor space of not more than 125 square feet is required for this room, even in the case where it is desirable to transmit phonograph music to the audience between speeches.

The amplifier and power supply equipment is shown on the two panels in the center of the control room. The amplified speech currents

are led from these amplifiers to the receiver projector units, which, in this case, are arranged on the super-structure above the speaker's platform. This position is most desirable, as the illusion produced is such that the voice appears to come from the speaker rather than

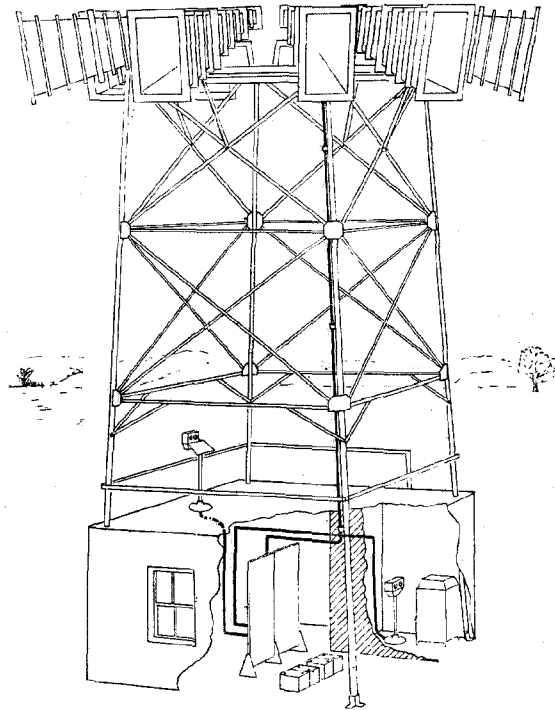

Fig. 4.

from the projectors, a factor, the importance of which has already been mentioned. Moreover in this position the acoustic coupling between the transmitter and the projectors is a minimum, permitting the operation of the system at a satisfactory degree of amplification with an ample margin below the point where singing troubles are encountered.

A public address equipment, similar to that just described, but with a somewhat lower power output, has been developed for use at the smaller open air meetings, and in all but the largest indoor auditoriums. Fig. No. 5 shows one of these equipments, mounted on an automobile truck, which has been employed at a number of points in the eastern part of the United States. This smaller system has characteristics as good as the larger system in regard to faithful reproduction of speech and music, with a power



Fig. 5.

output in the order of one-tenth as great. An audience of 50,000 can be adequately covered at an outdoor meeting with this system.

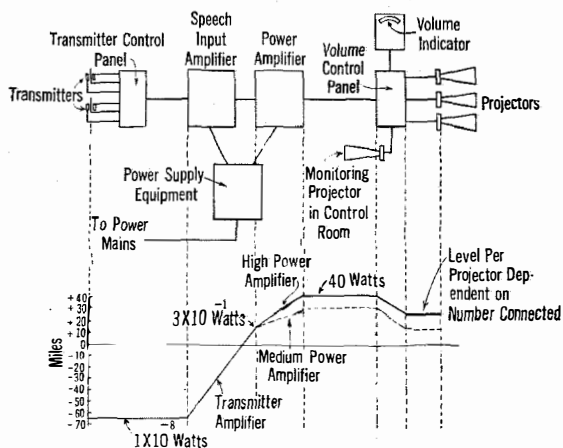

Fig. 6.

Fig. 6 is a schematic arrangement of the equipment at an installation of the type shown in Fig. 4. At the extreme left are the transmitters where the sound waves are picked up. The output from these transmitters is taken to

a switching panel where means are provided for cutting in the various transmitters. From this panel the transmitter currents are taken to the transmitter amplifier, which is capable of amplifying them to a power level suitable for input to the power amplifier, or for connection to the long distance lines, in those cases where the speeches are transmitted to distant audiences. It is also suitable where connection is to be made to a radio station for broadcasting the speeches. The power amplifier is shown just to the right of the transmitter amplifier. Below it is indicated the power supply equipment by which the commercial power is converted to a form suitable for the vacuum tubes in both amplifiers. The output from the power amplifier is taken through a panel where switches and a multi-step auto-transformer are provided for the regulation of several projector circuits. Just above this panel is an indicating instrument, known as the volume indicator, provided in order that the operator may know what volume output is being delivered to the projectors.

The projectors, at the extreme right of the figure, consist of the motor or receiver unit transforming the speech currents into sound waves, and a horn to provide the proper distribution of the sound.

It is interesting to note the power amplification which is obtained in the larger of the two systems from the transmitter to the projectors. Referring to Fig. No. 6, a chart will be seen which indicates the power levels through the system drawn to a scale based on miles of standard telephone cable, our usual reference unit. The output of the high quality transmitter is of the order of 65 miles below zero level, this latter being the output from a standard telephone set connected to a common battery central office by a line of zero resistance. Expressed in watts the output of this transmitter under average conditions of use with the public address system is of the order of  $10^{-8}$  watts. Incidentally, this is of the same order as the speech power picked up by the transmitter, or in other words, the transmitter does not amplify the speech power received by it as is the case with the transmitter used for regular telephone service.

This very minute amount of power in passing through the transmitter amplifier may be amplified about 120,000,000 times. Expressed in terms of telephone power levels, this is 17 miles above the zero level previously mentioned, or a few tenths of a watt.

The power amplifier serves to increase this power from a level of 17 miles to about 40 miles, the latter corresponding to about 40 watts. This power is then distributed to the projectors, the amount consumed by each projector, of course, depending upon the number connected.

An idea of what this amount of power at speech frequencies means may be given by the statement that it is sufficient to operate at about the level considered commercial all of the 14,000,000 telephone receivers in use in the Bell system if these were directly connected to the amplifier.

In describing the various pieces of equipment which together make up the system, we will follow the order in which the power is carried through the system from the transmitter to the receiver-projector units where the amplified sound waves are propagated.

## TRANSMITTERS

In the early work on the public address system, an air-damped, stretched diaphragm condenser transmitter was employed, having a thin steel diaphragm about 2 inches in diameter, constituting one plate of the condenser. The other plate was a rigid disk, the dielectric being an air film  $1/1000$  of an inch in thickness. Due to the stretching of the diaphragm and the stiffness of the air film, the diaphragm of this transmitter had a natural period of approximately 8000 cycles per second which is well above the important frequencies in the voice range. This high natural period, in conjunction with the damping due to the thin film of air, resulted in a transmitter of very high quality of reproduction. However, its extremely small capacity (in the order of 400 micro-microfarads) made it necessary to use leads of very low capacity between the transmitter and the first amplifier, and due to the high impedance of the transmitter and its associated input circuit to voice frequency currents, these leads were very susceptible to electrostatic and electromagnetic induction. It was necessary to limit them to a length of 25 feet, and to provide complete shielding. Moreover the output of this transmitter was less than one five-thousandth of that of the transmitter now used, and for the early installations of the system, it was necessary to provide a preliminary amplifier beneath or to one side of the speaker's stand in order to keep the transmitter leads short and to provide sufficient power to properly operate the main amplifiers. Work was therefore undertaken to provide a transmitter having quality practically as good as the condenser transmitter, volume output sufficient to operate the main amplifiers, and not requiring the elaborate precautions as to shielding the leads.

The high quality transmitter which was the result of this development work is of the granular carbon type with two variable resistance elements, one on each side of the diaphragm, and is commonly known as a push-pull transmitter. It has nearly the same high quality reproduction characteristics as the condenser transmitter, due to the use of the same stretched diaphragm and air damping structure. It introduces no appreciable distortion over the range of frequencies required for good reproduction of speech, but it must be understood that this quality was

obtained only at the sacrifice of sensitiveness, the latter being in the order of 1-1000th that of the transmitter used at telephone stations in

at the opposite end where the electrical power is transformed into sound waves and propagated, as the device at this point must be capable of handling large amounts of power with minimum distortion.

Referring to Fig. No. 7 which is a cut-away view of this push-pull high quality carbon transmitter, the granular carbon chambers will be seen. The electrical path through each of these variable resistance elements is from the rear carbon electrode through the carbon granules to a gold-plated area on the diaphragm

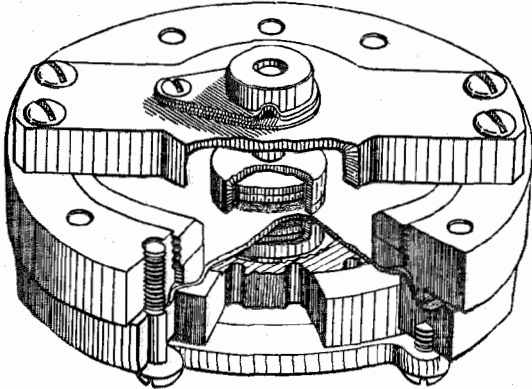

Fig. 7.

the Bell system. With the multi-stage vacuum tube amplifiers available this low volume efficiency is not serious, and in fact we are using this transmitter for what is known as distant talking, *i.e.*, the speaker may be at a distance of

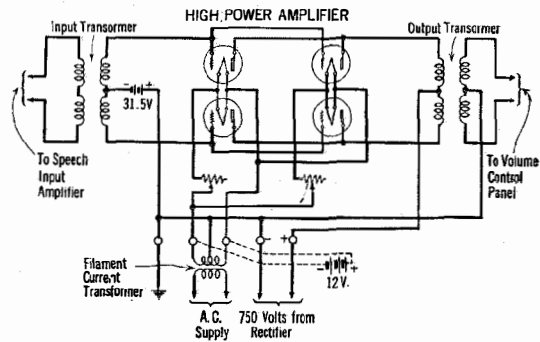
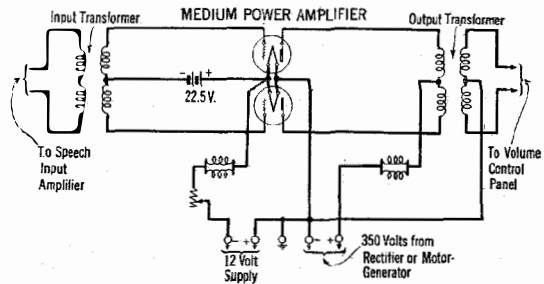

Fig. 9.

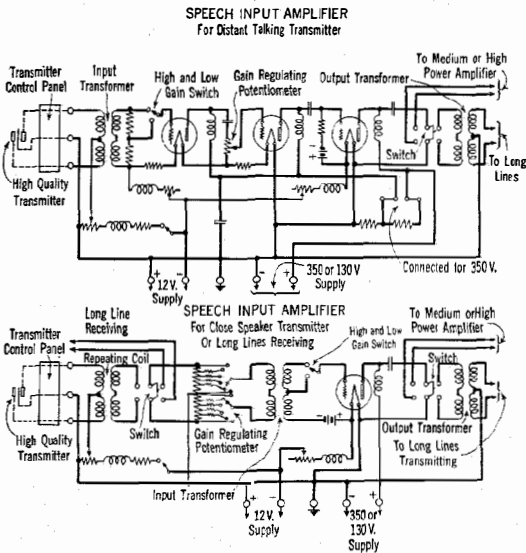

Fig. 8.

five or six feet from the transmitter. This is, of course, necessary in any transmitter suitable for public address work as it is not possible to greatly limit the movement of the speakers, nor can they be required to use a hand transmitter. It might be well to point out that this sacrifice in volume efficiency in order to gain high quality is possible at the transmitting end of the system, but not

itself. The resistance of this path is about 100 ohms and as the two buttons are in series for the telephone currents, the transmitter is designed to work into an impedance of 200 ohms. The double button construction almost completely eliminates the distortion caused by the non-linear nature of the pressure-resistance characteristics of granular carbon.

As this instrument has a practically flat frequency characteristic no collecting horn or mouth piece is used with it as resonance is introduced by such chambers, with accompanying distortion. To insure the insulation of the transmitter from building vibrations, a simple spring suspension has been provided. To protect the transmitter from injury, two types of



transmitter mountings have been used, both arranged for the suspension of the transmitter in a screen-enclosed space—the first adapted to take a single transmitter for indoor use only, while the second for outdoor use, mounts two

mitter to another, as with some public functions, the speeches are made at different points during the ceremonies. This switch is arranged to short-circuit the output of the power amplifier when passing from one transmitter to another, to pre-

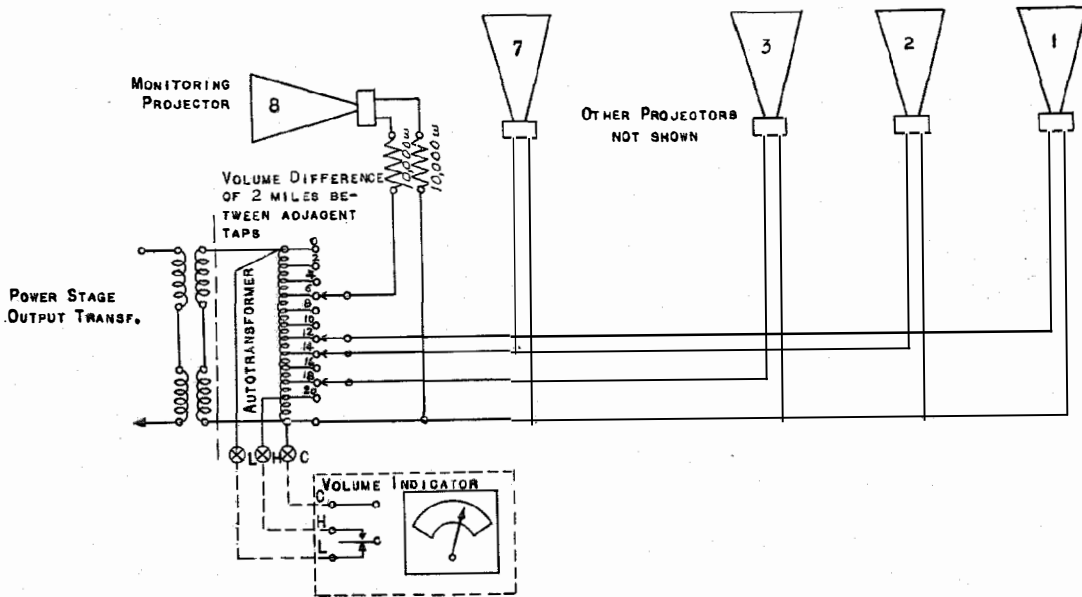

Fig. 10.

transmitters within a double screen enclosure to prevent any noise effects due to winds. This second type is arranged to attach to a simple pedestal-type of reading desk, which it has been found desirable to provide as there is a slight tendency for the speaker to remain fairly close to the desk. In this connection it is interesting to note that we have found a small rug, so placed as to cover the area which the speaker should occupy during the delivery of his speech, is of great assistance in this regard, as he unconsciously confines himself to the area of this rug. Both of these measures to insure the speaker remaining in proper relation to the transmitter, are supplemented, wherever possible, by an explanation of the system to all the speakers previous to the actual performance.

#### TRANSMITTER SWITCHING PANEL

Resuming the path of the speech currents through the system, the output from the transmitters is taken to a panel designed to enable the operator to switch quickly from one trans-

mitter to another. In certain cases, the equipment is arranged to permit two or more transmitters to be connected to the amplifiers at one time, as is desirable when solo singers and an orchestra are to be picked up in a theatre, with proper adjustment of their respective volumes.

The amplifier equipment has been built in four units which may be grouped as necessary under the various conditions encountered in commercial installations. The proper amplifiers are determined, first, by the source of the voice frequency current to be amplified, that is whether a distance talking or a close talking transmitter is to be used, or whether the speeches are brought in over a telephone line, and secondly, the size of the space in which the amplified sounds are to be delivered to the audience. It was found that four units would provide for all the conditions occurring in practise, two of these being speech input or transmitter amplifiers with different gains and two being power amplifiers of different power ratings. These units and other equip-

ment used with the system, are made up in panels, of uniform width, in order that the proper equipment for any installation may be assembled on two vertical angle iron racks arranged to be fastened to the control room floor.

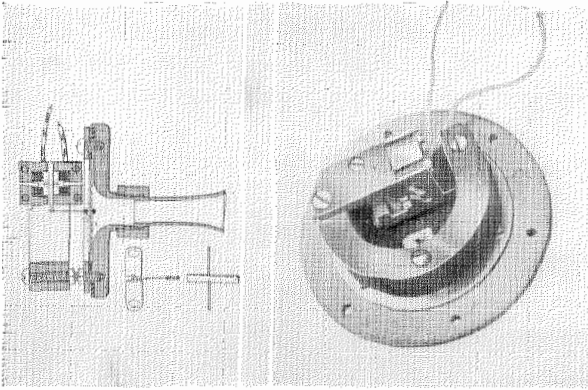

Fig. 11.

#### SPEECH INPUT AMPLIFIER—FIRST TYPE

The first of the speech input amplifiers is shown schematically in the upper part of Fig. 8. It is a three-stage amplifier. Two potentiometers provide adjustment of the gain over a

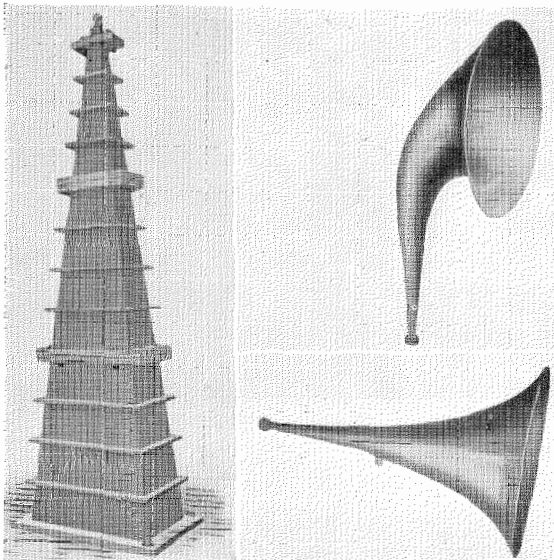

Fig. 12.

large range, and switching arrangements allow the output to be connected directly to the input of the power amplifier, when the program is to be transmitted to a local audience; or to be connected, through a transformer of proper

impedance, to the long distance lines when the program is to be transmitted to a distant audience, or to a radio-broadcasting station. The filaments of the tubes are supplied from a 12-volt storage battery, while the plate circuits obtain direct current at 350 volts from the power supply equipment mentioned later. Arrangements are also provided for using 130 volts instead of 350 volts under certain conditions. The proper grid potentials are obtained by utilizing the drop over a resistance in the filament circuits of the first two tubes, and for the third tube small dry cells furnish the grid potential. The maximum gain with this ampli-

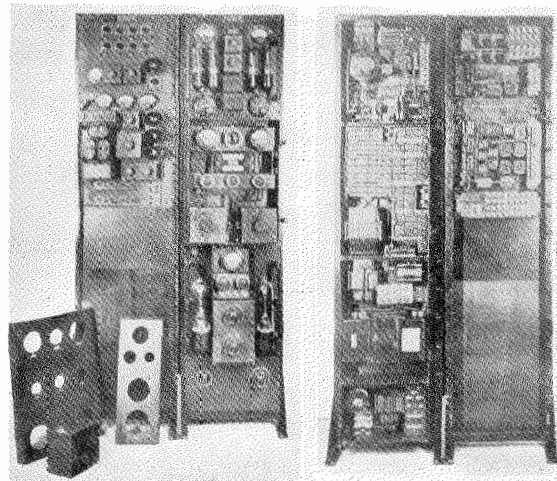

Fig. 13.

fier is 85 miles, which expressed as a power ratio is  $1.2 \times 10^8$ . Under this condition the output is approximately  $3/10$  of a watt. The front and rear views of this amplifier, mounted on the supporting rack, as shown in Fig. 13, where the gain regulating potentiometers, the rheostats for controlling the filament and transmitter currents, the three tube mountings with protective gratings and the jacks which permit the connection of instruments for determining the current flow in the filament, plate and transmitter circuits, will be noted. Great care was taken in the design of this amplifier to obtain as nearly as possible equal amplification of all the important frequencies in the voice range. The transformers, and the retardation coils in the plate circuits were chosen with this consideration in mind.

## POWER AMPLIFIERS

For practically all of the larger installations the maximum power possible with the system is required and the output from the transmitter-amplifier is taken directly to the high power amplifier. Referring to Fig. 9 it will be seen that this a four-tube amplifier so connected that but one stage of amplification is obtained. Usually alternating current at 12 to 14 volts is

since the tubes may be worked beyond the straight part of their characteristic. The grid potential is chosen to permit the largest variation of current without distortion and is obtained from a group of small flashlight batteries.

The output transformer at the right of the figure is designed to match accurately the impedance of the tubes to that of the number of receiver-projector units which has been found to



Fig. 14a.

used for heating the filaments of these tubes, the latter being connected in what we know as a push-pull arrangement. It will be seen that each side of the push-pull arrangement consists of two power tubes in multiple. It is interesting to note that this push-pull arrangement of the tubes will deliver somewhat more power for equal quality than the same number of tubes connected in the ordinary multiple arrangement,

give the greatest flexibility under the varying conditions of commercial operation. This amplifier, speaking in telephone terms, is worked at a gain of 23 miles, a power amplification ratio of about 200, the maximum output being about 40 watts. The plate circuits of the tubes are supplied at a d-c. potential of 750 volts. As has been pointed out previously, this amplifier gives a practically uniform gain for all the important

frequencies in the voice range. This high-power amplifier is shown mounted on the supporting rack, in Fig. 13. The apparatus on the rear of the panel is protected with a sheet metal cover and integral with this cover is a disconnecting switch, which, when the cover is removed, cuts

The schematic of this amplifier is shown in Fig. 9. The input coil is the same as is used in the high-power amplifier. The push-pull connection of the tubes is also used in this amplifier, although but two power tubes are used. The filaments of these tubes are supplied from a



Fig. 14b.

off the high potential from all the exposed parts on the set.

For indoor installations where the audience is small the power output given by the high-power amplifier is not required and a medium-power amplifier has been developed for this use. It is arranged to connect directly to the transmitter amplifier and the output is taken to the projectors through the volume control panel. It has a gain of 17 miles or a power amplification ratio of about 33. The maximum output is about 4 watts, or about one-tenth of the power obtainable from the high-power amplifier.

12-volt storage battery while the plate circuits are supplied at 350 volts direct current from a motor generator set which will be described later.

#### SPEECH INPUT AMPLIFIER—SECOND TYPE

A speaker using the system may read his speech from his home or office and in such cases it is unnecessary to use the push-pull carbon transmitter in the distant-talking manner. For use when this transmitter is spoken into from a distance of a few inches, a second form of speech input amplifier has been made available having a gain of the proper value to supply either of the

power amplifiers, or a long distance line if desired. This gain is relatively small as the output of the transmitter when used for close talking is about 10,000 times that when it is used for distant talking.

Fig. 8 shows the schematic of this amplifier which is a single-stage one, employing one tube

The switching means provided on this amplifier allow it to be used in a number of ways. Announcements from a close talking transmitter may be made from the projectors through a power amplifier or may be sent out on the telephone lines to a distant public address system installation or a radio-broadcasting station. In

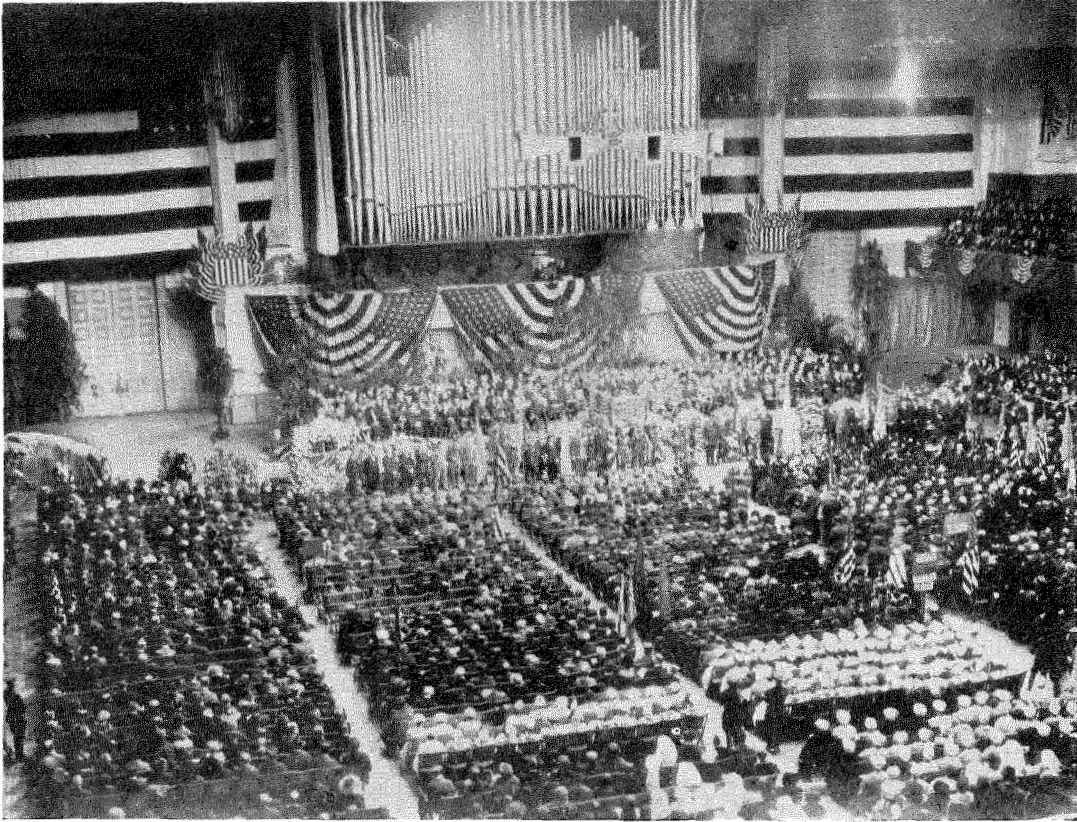

Fig. 15.

and having the same over-load characteristic as the first form of speech-input amplifier. A two-way switch permits the connection of the transmitter or an incoming long distance line to the amplifier. To the right of this switch is a potentiometer for regulation of the gain. To the right of the tube is a second two-way switch for connecting the output either to the power amplifier or through an output transformer to an outgoing long distance line. The power supply for the tubes and transmitters, is the same as was described under the first form of speech input amplifier.

In addition to these uses, incoming speech over the long distance lines may be put out on the projectors through the power amplifier or may be sent out on the long distance lines to a distant installation.

#### VOLUME CONTROL

As discussed heretofore, it is necessary to give the operator control of the volume put out by each projector or group of projectors. The equipment provided for this purpose is mounted on a panel uniform with the others and consists essentially of an auto-transformer connected



across the output of the power amplifier with 11 taps multiplied to the contacts of eight dial switches, the arrangement being shown schematically in Fig. 10. Seven of the dials control projector circuits on each of which one or more projectors may be grouped, the eighth dial being reserved for controlling the volume of the operator's monitoring projector in the control room. A key is associated with each dial for opening the circuit and a master key is provided for cutting off all of the projectors simultaneously.

The deflections of the meter therefore serve as a basis for determining the adjustment required on the transmitter-amplifier to give the required output when switching from one transmitter to another or for different speakers.

#### RECEIVER—PROJECTORS

From the control panel the power is taken to the projectors, each of these consisting of a loud-speaking receiver mechanism to transform the speech-currents into sound waves, and a horn to

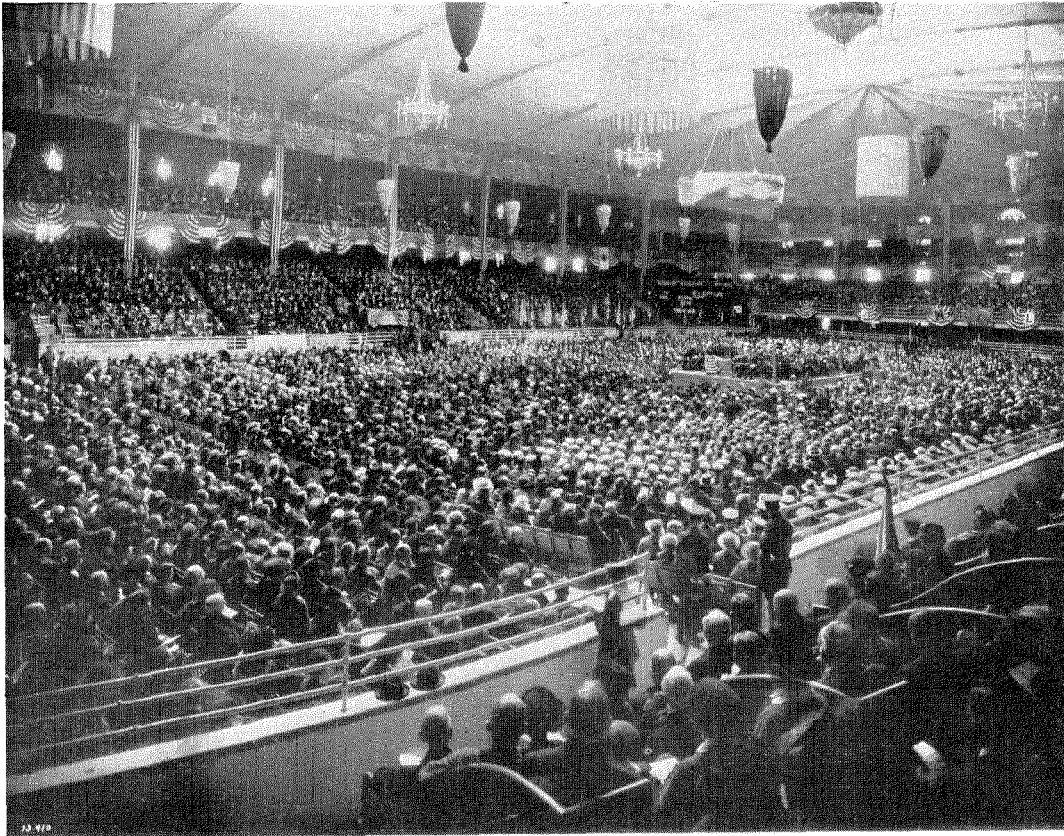

Fig. 16a.

The device shown as "Volume Indicator" in this figure consists of a vacuum tube detector bridged across the output terminals of the power amplifier. The rectified current is taken to a sensitive direct-current meter of the moving coil type, the degree of deflection of this meter measuring the output from the power amplifier when connected at a proper place in the circuit.

distribute the sound. The receiver is so designed that it will carry several watts with small distortion. It is shown in Fig. 11 where it will be seen that a light spring-supported iron armature is mounted between the poles of a permanent magnet and passes through the center of the coils carrying the voice currents. A light connecting link ties one end of this armature to

the diaphragm which is of impregnated cloth, corrugated to permit vibrations of large amplitude. A stamped metal cover protects the parts from mechanical injury, and a cast iron case, in which the whole assembly mounts, is provided for protection against moisture.

and two types of fibre horns are used. One of these is straight in the body, with a flaring open end, while the other used in the control room, is bent.

The grouping of projector units on the volume control switches differs with the type of in-



Fig. 16b.

One of these receivers equipped with the largest projector provided, will carry without serious distortion or overheating, power which is about 27 miles above the zero level. With this output, it is possible to project speech a distance of 1000 feet under ordinary weather conditions and this has been done at several installations.

On account of the different conditions encountered in installations three types of horns have been used, shown in Fig. 12. Where it is necessary to project the sound to great distances, a tapering wooden horn is used, of rectangular cross section,  $10\frac{1}{2}$  feet long, the walls being stiffened to prevent lateral vibration. For most installations these large horns are not required,

stallation. In outdoor performances, the necessity of correcting the volume in certain directions due to varying winds makes it advisable to group adjacent projectors on a single switch. This is not the case with indoor performances, as no wind effects are possible. Instead, symmetrically placed projectors which will always require equal volume are grouped on a single switch.

#### POWER SUPPLY EQUIPMENT

In order to convert the commercial electric power supply to forms suitable for supplying the filament and plate current for the vacuum tubes in the amplifiers, two types of power

equipment have been made available. When the installation is of a size requiring the high-power amplifier, a vacuum tube rectifier taking its supply at 110 or 220 volts, 60 cycles, and delivering 750 volts direct current for the plate circuits is employed. A potentiometer arrangement provides a direct-current supply at

volt d-c. generator driven by a suitable motor, the total power drawn from the supply mains being about 500 watts. A low-voltage generator for supplying direct current at 12 volts for the operation of the amplifier tubes is incorporated in this motor generator set. A filter is necessary and a reactance coil and a 12-volt storage

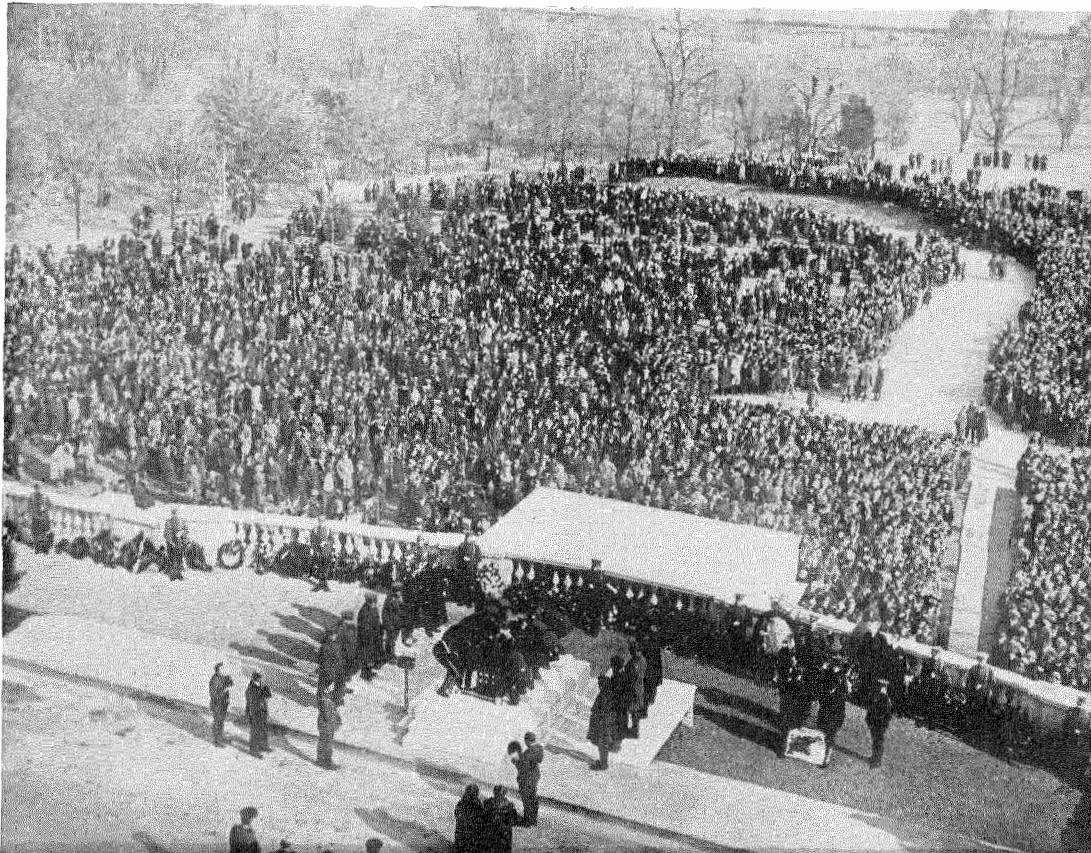

Fig. 17a.

350 volts for the speech-input amplifier tubes. Full wave rectification is obtained and a filter consisting of a large series reactance coil and bridged condensers is used to render the direct-current output suitable for this use. Included in the power equipment is a step-down transformer for supplying the filaments of the power amplifier. For the larger installations, employing the rectifier, the total power drawn from the commercial supply is 1500 watts.

For installations of a size not requiring the use of the high-power amplifier, a compact motor generator set is provided consisting of a 350-

battery is floated across its output. This supplies the transmitters and the tube filaments. The necessary indicating meters are provided on a meter panel for observing the voltages and currents of all the items of equipment which do not have individual meters associated with them.

#### OBSERVING SYSTEM

In addition to the monitoring projector provided in the control room for the guidance of the operator, it has been found necessary in all but the simplest installations to provide observing stations at various points in the audience. The



observers stationed at these points are equipped with portable telephone sets, by which they may immediately communicate with the operator, who is provided with a telephone set consisting of a head receiver and a breast transmitter. The value of these observation stations for regulation of output volume during a program will be apparent.

In the case of an open air performance a variable wind may make it necessary to increase



Fig. 17b.

the volume of certain projectors and decrease the volume of others in order to cover the audience uniformly. Without the observers, the control operator would be unable to take care of these changes.

Considerable preparation is required where the equipment is being used for the first time, in order that the performance of the public address system installation will be of the highest order. Where the acoustic conditions are unfavorable it is necessary to make tests with various arrangements of the projectors, in order to determine the most satisfactory one. It has been found advisable to carry out the entire program previous to the performance in order that the oper-

ating force may become familiar with the sequence.

#### CONCLUSION

The usefulness of such systems is very well illustrated by a few of the results which have actually been obtained. Fig. 14 shows a crowd of approximately 125,000 people, every one of whom was able to hear clearly and distinctly all of the words spoken in President Harding's inaugural address in March, 1921. This crowd was relatively small, compared with the crowd which could be accommodated by one of the larger type systems. Some insight into the number of people which could be accommodated can be gained from the fact that such a system will cover comfortably a complete circle whose diameter is 2000 feet when the projector units are placed at the center.

One of the largest and most successful uses to which this equipment has been put took place on Armistice Day in 1921 when 20,000 people in San Francisco, 35,000 people at Madison Square Garden, New York City, and approximately 100,000 people at Arlington Cemetery near Washington joined in the impressive ceremonies which took place at the burial of the Unknown Soldier. Figs. 15, 16 and 17 are views at the three cities, during the ceremonies.

Some of the other uses which have been made of the public address system are the Republican and Democratic Conventions prior to the last presidential election, after-dinner speaking in large ballrooms and in halls where speakers have to address large audiences. There is one more application of this type of equipment which is gaining rapidly in its use. This last is the application of the speech input equipment to radio broadcasting. The broadcasting of the opera, "Aida," from the Kingsbridge Armory, and of the Philharmonic Concerts from the Great Hall of the College of the City of New York are two of the successful uses where music and speech were concerned, while broadcasting of the results of the football games from the various distant cities indicates possibilities for the dissemination of interesting information.<sup>9</sup>

The social and economic possibilities of the system are scarcely realized by the public as a whole at the present time, when the method

<sup>9</sup> Use of Public Address Systems with Telephone Lines. W. H. Martin and A. B. Clark.

resorted to for reaching large numbers of people is usually the printed word. While this method is effective, it leaves much to be desired in that the personal touch between the man with ideas and the people to receive them is entirely lost. The difficulty for any but those possessing the strongest voices to reach an appreciable number of people at one time has led to a decline in oratory as a means of conveying public messages to large numbers, for it is not always the man with the best ideas or the best ability of presenting them, who is blessed with a powerful voice. A system such as the one which has just been described enables the speaker, even though his voice be relatively weak, to address at one

time and in one gathering, several hundred thousand persons, and if the system be used in connection with long distance telephone lines or radio broadcasting, the number which may be reached is increased almost indefinitely. The value of such a situation can hardly be over-rated in times of national emergency or stress when it is necessary for those in responsible positions in the Government to get their message to the people directly.

The development of the apparatus just described has been the result of the efforts of such a large number of investigators working co-operatively that no attempt has been made to acknowledge the individual contributions.

# Use of Public Address System with Telephone Lines<sup>1</sup>

By W. H. MARTIN and A. B. CLARK

*Department of Development and Research, American Telephone and Telegraph Company.*

**SYNOPSIS:** *The combination of the public address system and the telephone lines makes it possible for a speaker to address, simultaneously, audiences located at a number of different places. Such a combination has been used in connection with several public events and a description is given of the system as used on Armistice Day, 1921, when large audiences at Arlington, New York and San Francisco joined in the ceremonies attending the burial of the Unknown Soldier, at the National Cemetery, Arlington, Virginia.*

*More recently the public address system has been used in conjunction with telephone lines to attain two-way loud-speaker service. This arrangement permits the holding of joint meetings between audiences in two or more locations, separated by perhaps thousands of miles, in such a manner that speakers before each of the audiences can be heard simultaneously by the other audiences. A demonstration of two-way operation was given at the mid-winter convention of the American Institute of Electrical Engineers in February, 1923, and took the form of a joint meeting between 1,000 members in New York and 500 in Chicago.*

*The electrical characteristics of any telephone line which is to be used in conjunction with loud-speaker equipment must receive special attention. In commercial telephone service the main requirement is understandability, while with the loud-speaker naturalness of reproduced speech is very important. People are accustomed to hearing through the air with very little distortion and naturally expect the same result with loud speakers. A satisfactory line for this purpose must show freedom from transients, echo effects, etc., as well as good uniformity of transmission over the proper frequency range.—EDITOR.*

**T**HE public address system which is described in the preceding paper by I. W. Green and J. P. Maxfield, was developed and first used for the purpose of extending the range of the voice of a speaker addressing an audience. With the aid of this system enormous crowds extending from the speaker's stand to points a thousand feet and more distant have in reality become an audience and have easily understood the speaker whose unaided voice covered only that portion of the crowd within a hundred feet or so from him.

When this system, consisting of a high quality telephone transmitter, distortionless multi-stage vacuum tube amplifiers, powerful loud speaking receivers and projectors, had so shown its capabilities in reproducing speech sounds, a logical extension of its application was to use it with telephone lines. By connecting the transmitting and receiving elements of the public address system through a suitable telephone line a system is provided whereby a speaker can address

an audience at a distant point. Also with a complete public address system at the point where the speaker is located, connected by lines to receiving elements of the public address system located at one or more distant points, the speaker is enabled to address a large local audience and to be heard simultaneously by audiences at one or more remote points. This last arrangement was first used on Armistice Day, 1921, when audiences at Arlington, New York and San Francisco joined together in the ceremonies attending the burial of the Unknown Soldier at the National Cemetery at Arlington, Virginia.

By means of the public address system, the meeting of this Institute at New York, at which this paper is presented is attended and participated in by Institute members at a meeting in Chicago. This is the first occasion on which complete public address systems installed at meetings in two cities have been connected together by telephone lines so that speakers at each meeting address the local and distant audiences simultaneously.

With the transmitting element of the public address system working into the radio transmitter of a broadcasting station and with the receiving elements of the system connected to the output of radio receiving sets, a system is provided whereby a number of people can be reached by each radio receiver.

The combination of these wire and radio communication channels with the elements of the public address system is, therefore, without limit in the number of persons who may be reached simultaneously by one speaker. Such combinations may prove extremely serviceable for occasions of nation-wide interest and importance.

The public address system apparatus has been used not only for transmitting speech sounds but also for music, both vocal and instrumental. The paper<sup>2</sup> describing the public address system has pointed out that the requirements for such a system are that for a wide frequency range it

<sup>1</sup> Presented at the Midwinter Convention of the A. I. E. E., New York, N. Y., February 14-17, 1923. Published in the *Journal of the A. I. E. E.* for April, 1923.

<sup>2</sup> Green and Maxfield, "Public Address System."

be practically distortionless, that is, transmit and reproduce with equal efficiency all frequencies in that range. This requirement must apply likewise to lines which are used with the loud speaker system. It has been found that a circuit which transmits without material distortion the frequency range from about 400 to 2000 cycles, can be used with the public address system to reproduce speech sounds which are fairly understandable under favorable conditions, although sounding unnatural. In general it is important to extend this range at both ends in order to improve the intelligibility of the sounds and increase the naturalness. For vocal and for some types of instrumental music the melody can be reproduced with the above frequency range, but these tones also are lacking in naturalness. Since some of the musical instruments are used to produce tones three and even four octaves below middle C, it is evident that the proper reproduction of music requires a further extension of the lower limit of the transmitted band than does speech. While the fundamentals of the higher musical tones lie in general in the range mentioned above, it is the harmonics in musical tones which distinguish those produced by different instruments and which give what musicians term "brilliance." The true reproduction of many musical selections requires the distortionless transmission of a frequency band of from about 16 cycles to above 5000 cycles. Many musical selections, however, employ only a part of this range and accordingly can be satisfactorily reproduced by systems not transmitting the whole range. Also, even with slight distortion obtained with somewhat narrower ranges, reproductions may be given which are agreeable to many popular audiences.

#### LINE REQUIREMENTS

In general the same line requirements which make for satisfactory transmission of speech over commercial telephone circuits also make for satisfactory transmission when telephone circuits are associated with loud speakers. There is this difference however. The loud speakers tend to make the line distortion much more noticeable and serious. Speech transmitted over a particular telephone line is, in general, more difficult to understand when listening to loud speakers than when listening to telephone receivers.

In commercial telephone service the main

requirement is intelligibility while, with the loud speaker, the naturalness of the reproduced speech sounds is very important. People are accustomed to hearing transmission through the air with very little distortion and naturally expect the same result with loud speakers.

The above constitute the reasons why, for transmitting voice currents over telephone lines with loud speakers, it is necessary to pay unusual attention to the electrical characteristics of the lines. Evidently when music is to be transmitted, particularly music of a fairly high grade, it is necessary to place even more severe electrical requirements on the lines.

An analysis of what constitutes the electrical requirements of a telephone line which make for good transmission, particularly when loud speakers are employed, will now be given.

In the first place, as explained above, it is essential that a sufficiently broad frequency range be transmitted. As explained in another paper<sup>3</sup> it is not sufficient that a telephone circuit transmit sustained alternating currents within a given frequency range. It must also transmit short pulses of alternating currents within the proper frequency range without introducing oscillations of its own or "transient effects." This requires that loaded circuits for loud speaker use have a high cut-off frequency and hence have the frequencies of the predominant natural oscillations high. It has been found that when the cut-off frequency of loaded circuits is about 5000 cycles, good results are secured with loud speakers.

The two types of telephone circuit which best meet the requirements of transmitting a broad band of frequencies, both when sustained and when applied in short pulses, are non-loaded open-wire lines and extra-light loaded cable circuits. These are suitable for transmission over very long distances. For transmission over short distances, say from one point in a city to another point in the same city, non-loaded cable circuits equipped with distortion networks or attenuation equalizers for equalizing the attenuation, give good results.

A good idea of the range of frequencies which can be transmitted over high grade telephone circuits can be secured from Fig. 1, which shows

<sup>3</sup> Clark, Telephone Transmission Over Long Cable Circuits, *Journal of A. I. E. E.*, January, 1923. Also February, 1923, issue of *Electrical Communication*.

the transmission efficiency at different frequencies for the New York-San Francisco circuit. This circuit is a non-loaded No. 8 B. W. G. open wire line equipped with twelve telephone re-

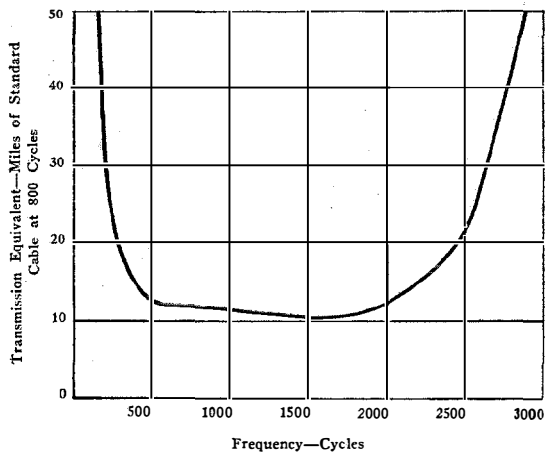

Fig. 1—Transmission Characteristic of Transcontinental Circuit—New York to San Francisco.

peaters and is 3400 miles long. Its frequency characteristic meets very well the requirements for easy understanding of voice transmission although it causes some loss of naturalness.

The frequency range which can be transmitted with approximately constant efficiency is limited at the lower end by the fact that composite sets are employed in order to make it possible to superpose direct current telegraph circuits. The elimination of these composite sets would make it possible to improve the transmission of low frequencies and thus improve the operation of the circuit in connection with loud speakers. The resulting improvement, however, would not be of importance for commercial telephone service and would render it more difficult to avoid noise on circuits exposed to induction from paralleling power or telegraph circuits.

At high frequencies the range is limited because these same wires are equipped with apparatus to permit super-position of multiplex carrier telegraph circuits above the voice range. This limitation also is not important for commercial telephone service although it is of importance for loud speaker use. To raise the upper limit of the voice transmission range would require giving up some of these facilities.

Fig. 2 will give an idea of how the distortion introduced by a length of non-loaded cable can

be corrected by employing distortion networks or attenuation equalizers. This figure shows the transmission frequency characteristic of about 10 miles of non-loaded No. 19 A. W. G. cable.

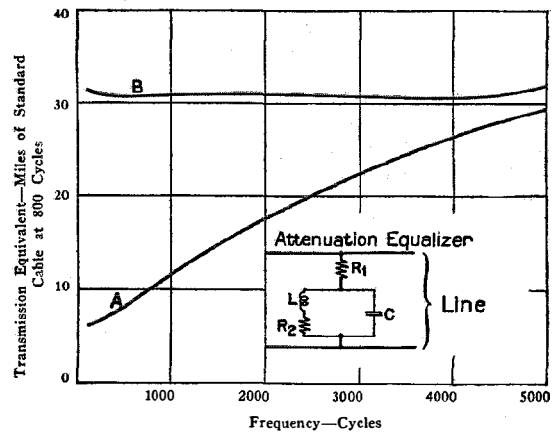

Fig. 2—Transmission Characteristic of No. 19 Gage Non-Loaded Cable Circuit.

A—Without Attenuation Equalizer.  
B—With Attenuation Equalizer.

Curve A, in the figure, shows the characteristic when uncorrected, while Curve B shows the characteristic for the circuit when equipped with an attenuation equalizer.

After choosing the proper types of telephone circuits for use in connection with loud speakers, there remains to be considered a number of other important matters.

The maintaining of the telephone power within proper limits at different points in the circuit is very important. The power must not be allowed to become too weak, otherwise the extraneous power induced from paralleling circuits would tend to obliterate the telephone transmission. On the other hand, the telephone power must not be amplified to such an extent that the telephone repeaters will be overloaded or severe cross talk be induced into paralleling circuits.

To keep the telephone power throughout the circuit between the above limits, requires careful study and adjustment. For handling regular telephone connections, the circuits are laid out and equipped with repeaters at proper points so that each circuit will be able to handle the varying volumes applied at the terminals when different subscribers are connected without getting into serious difficulties. When loud speakers are employed it is necessary to maintain the

volume at the terminals of the toll lines at least within these limits and it is preferable to do somewhat better than this.

With the public address system, the high quality transmitter which picks up the sound at the sending end is usually associated with an amplifier whose adjustment is varied, depending on the output of voice currents from the transmitter. In order to obtain the proper adjustment of this amplifier, it is necessary to have some means for quickly indicating the volume of transmission. For this purpose, there has been developed a device which is called a "volume indicator." This consists of an amplifier detector working into a direct-current meter. With this volume indicator connected across the output of the transmitter amplifier, the volume of transmission delivered to the line is indicated by the deflections on the meter. By adjusting the amplifier, therefore, to keep the deflections of this meter reasonably constant at some deflection determined by previous calibration, it is practicable to keep the telephone power within the required limits. Obviously, this same device may also be employed to keep the telephone power constant at any other point in the system.

While the necessity for keeping the power applied to the toll lines within proper limits cannot be over-emphasized, it should also be noted that this is not sufficient. It is also essential that all parts of the toll circuit, including the repeaters, be maintained at prescribed efficiency so that the power levels at all intermediate points in the circuit will also be kept within proper limits. Long telephone lines are designed with special emphasis on this matter of constant efficiency so that, in general, no special precautions are required when using these circuits in connection with loud speakers.

In another paper,<sup>4</sup> the "echo" effects which may occur on long telephone circuits are explained. When setting up two-way circuits for loud speaker use, it is necessary to pay particular attention to effects of this sort. Furthermore, there is another source tending to produce echoes in circuits arranged for two-way use with loud speakers. This is the tendency for the sound delivered from the loud speaker projectors to enter the sensitive transmitter and be returned to the distant end of the circuit as an echo. Owing to the relatively slow velocity of

transmission of sound through air the lag in such an echo may be great enough to be serious, although the line is a short one with high transmission velocity. It is, therefore, evident that this coupling through the air between the loud speaker projector and the transmitter must be kept small. If a very sensitive transmitter arranged so that a speaker may stand several feet away from it is employed, this problem becomes even more difficult.

There is one thing more that remains to be considered: the necessity for special operation. When a large number of people are assembled at some point to hear an address delivered at a distant point, it is evident that delay in establishing the connections cannot be tolerated. It is, therefore, necessary to establish such connections ahead of time and it is usually also necessary to set up spare circuits for use in case of failure of the regular circuits. A special operating force is required for checking up the circuits, establishing the connections when required, and making the necessary adjustments. Rehearsals are necessary on important occasions to insure proper functioning of the circuits and proper co-ordination of the handling of the circuits with the programs at different points.

#### TYPICAL CIRCUIT COMBINATIONS OF PUBLIC ADDRESS SYSTEM AND LINES

Following are a number of typical combinations of the public address system and telephone lines. The combinations by means of which one-way service may be rendered, are given first, following which certain combinations for giving two-way service are discussed.

By one-way service is meant service in which no provision is made for anyone in the distant audience to talk to the place where the speaker is located. Two-way service provides for speakers at either of two or more points addressing all of the other points. This is similar to the two-way service rendered by regular telephone circuits.

Fig. 3 shows the circuit arrangement which would be used when a speaker at one point in a city, for example, at his office, is to address an audience at another point in the same city. A high quality close talking transmitter *T*, together with a fixed gain single-stage amplifier *A*, are provided at the point where the speaker is located. This combination is designed to deliver to the line the same amount of power as

<sup>4</sup> Clark, *loc. cit.*

a commercial type substation set. Connecting this point with the point at which the audience is gathered is a non-loaded cable circuit. To

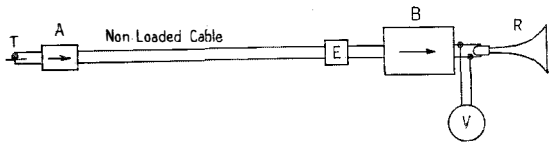

Fig. 3—One-Way Connection to Point in Same City.

correct for the distortion in this cable circuit, an attenuation equalizer *E* is provided. The apparatus at the point where the audience is

located is similar to that shown in Fig. 3. of this amplifier as shown by the dotted lines in Fig. 4. When the volume indicator is employed at this point it is necessary to take into account the loss introduced by the non-loaded cable and the equalizer *E*<sub>1</sub>, together with the gain of the repeater *C*<sub>1</sub>, in order to deliver volume within proper limits to the toll line. The toll line, shown equipped with repeaters *D*<sub>1</sub>, *D*<sub>2</sub>, etc., extends to the toll office in the distant city. At this point the amplifier *C*<sub>2</sub> is located, together with another equalizer *E*<sub>2</sub>, for correcting the distortion in the local non-loaded cable circuit. The apparatus at the point where the audience is located is similar to that shown in Fig. 3.

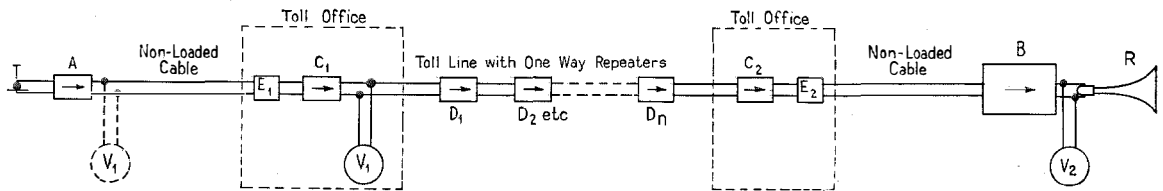

Fig. 4—One-Way Connection to Point in Distant City.

located is the equipment of the public address system without the transmitter and its associated amplifier. In Fig. 3, *B* is the amplifier for delivering sufficient power to the group of loud speaker projectors indicated by *R*. A volume indicator *V* associated with the amplifier *B* is used in maintaining constant the volume of sound delivered from the projectors.

Fig. 4 shows the circuit combination required when a connection is to be established to a distant city where the loud speaking receivers are located. In the city where the speaker is located, connection is made to the toll office by means of a non-loaded cable circuit equipped with an equalizer similar to Fig. 3. A volume indicator *V*<sub>1</sub> is associated with the amplifier *C*<sub>1</sub> at the toll office to enable proper adjustment of amplifier *C*<sub>1</sub> to be made so that the power delivered to the toll line will be within the proper limits. As explained above if the volume at the toll office is allowed to become too great, the telephone repeaters on the toll line will be overloaded and serious distortion will result, while if the volume is allowed to become too weak, extraneous noise and crosstalk will tend to obliterate the direct transmission. If a distant talking transmitter is used for the speaker, a multi-stage adjustable amplifier is associated with it. In this case the volume indicator is located at the output

Fig. 5 shows the circuit combination employed when a local address is to be given, while at the same time the same address is delivered to one or more distant points. In order to allow the local audience to hear the address by means of the loud speakers, the power amplifier *B* sup-

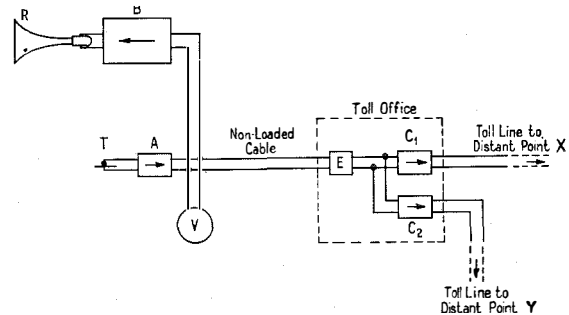

Fig. 5—One-Way Connection for Addressing Local and Distant Audiences Simultaneously.

plying energy to these is bridged across the output of the amplifier *A* associated with the transmitter *T*. A volume indicator *V*, connected across the circuit at the point where the bridge is made, makes it possible to maintain constant volume both for the local loud speakers and for the transmission applied to the toll lines by suitable adjustment of amplifier *A*. At the toll office means are indicated for connection to two distant points *X* and *Y*. Owing

to the fact that amplifiers  $C_1$  and  $C_2$  are one-way devices, no inter-actions can occur between lines  $X$  and  $Y$  or between these lines and the local loud speaking system. The arrangements for reaching the distant points  $X$  and  $Y$  are similar to the one illustrated in Fig. 4.

nections are so arranged that transmission can pass only in the proper direction. Two volume indicators are provided at each end. Referring to the left-hand terminal, volume indicator  $V_1$  is provided to insure that power is supplied to the toll line within the proper limits of volume,

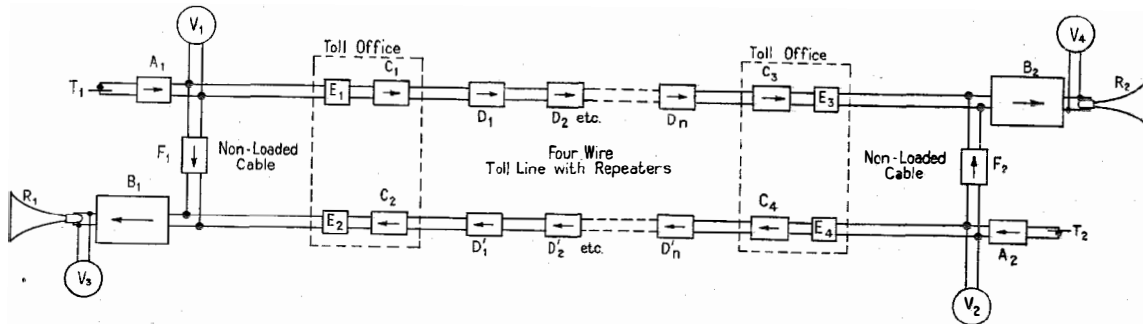

Fig. 6—Two-Way Four-Wire Connection for Addressing Local and Distant Audiences.

All of the circuit arrangements which have so far been described are arranged simply so that a speaker may address one or more local or distant points. When it is desired that the speaker and the audience at the sending end also be able to hear a speaker at the distant point, more complicated arrangements are required.

as explained above.  $V_3$  is provided to facilitate adjustment of the by-pass circuit  $F_1$  and of amplifier  $B_1$  so as to deliver proper volume from  $R_1$  both for the local talking and for the reception of the addresses from the distant end of the circuit. The volume indicators  $V_2$  and  $V_1$  at the right-hand end of the circuit have functions similar to those of  $V_1$  and  $V_3$  respectively.

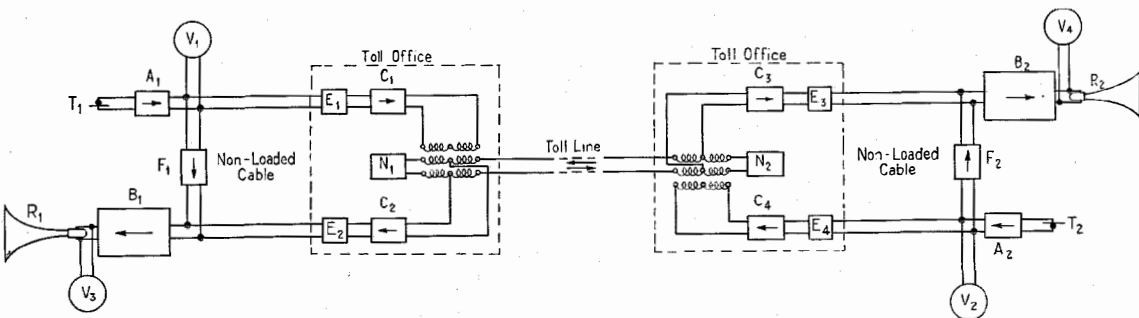

Fig. 7—Two-Way Two-Wire Connection for Addressing Local and Distant Audiences.

Fig. 6 shows a circuit arranged for such two-way service, the line being operated on the four-wire principle, *i. e.*, two separate transmission paths are provided, one for transmission in each direction. The circuits connecting transmitter  $T_1$  with the projector group  $R_2$  and transmitter  $T_2$  with the projector group  $R_1$  are similar to the circuit in Fig. 4. By-pass connections  $F_1$  and  $F_2$  are added at the two ends which allow part of the output of each transmitter to pass into the local loud speakers. These by-pass con-

Fig. 7 is similar to Fig. 6 with the exception that the toll line is of the two-wire type. At each end of the toll line, which may, or may not, contain two-way repeaters, transformers and networks  $N_1$  and  $N_2$  are placed for converting the two-wire circuit into a four-wire circuit. The equalized cable circuits at the two ends thus form two sides of short four-wire circuits. The conditions of balance between the networks and the toll lines prevent more than a very small amount of the direct transmission



from each local transmitter from entering the local loud speaking receiver circuit at the points where the local circuits connect to the toll line. Practically all of the transmission from transmitter  $T_1$  to projector group  $R_1$  and from transmitter  $T_2$  to projector group  $R_2$  is delivered through the adjustable by-pass circuits  $F_1$  and  $F_2$ , respectively.

For connections requiring to and fro conversations between three or more points, all of which may be equipped with loud speakers, intermediate points may be connected to a two-wire telephone circuit by employing the arrangement shown in Fig. 8. A three-winding transformer is inserted in the toll line which is so constructed that the impedance which it introduces into the circuit is small enough to avoid a serious irregularity. Talking currents are put out on the toll line through this transformer. The received transmission is obtained from a high impedance bridge across the mid-points of two of the windings of the three-winding transformer. Amplifiers  $C_1$  and  $C_2$  introduce sufficient gain to overcome the losses due to the inefficient coupling with the telephone line. The rest of the circuit at the intermediate point is the same as Figs. 6 and 7, the local speaker

100,000 people at Arlington, 35,000 people at New York and 20,000 people at San Francisco,

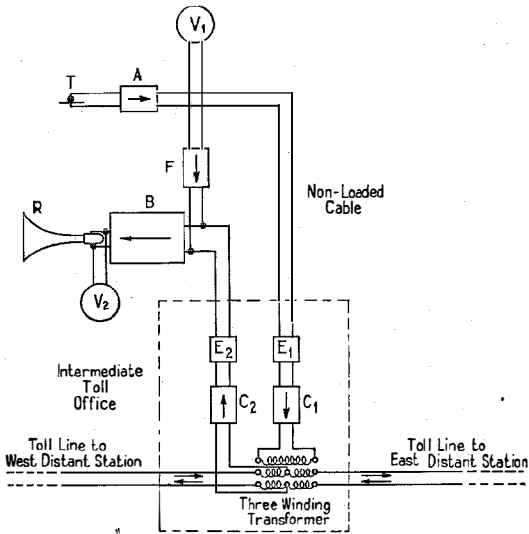

Fig. 8—Arrangement for Connecting Third Point to Circuit of Fig. 7.

joined in the services at the burial of the Unknown Soldier. This was the first time that audiences at more than one distant point were

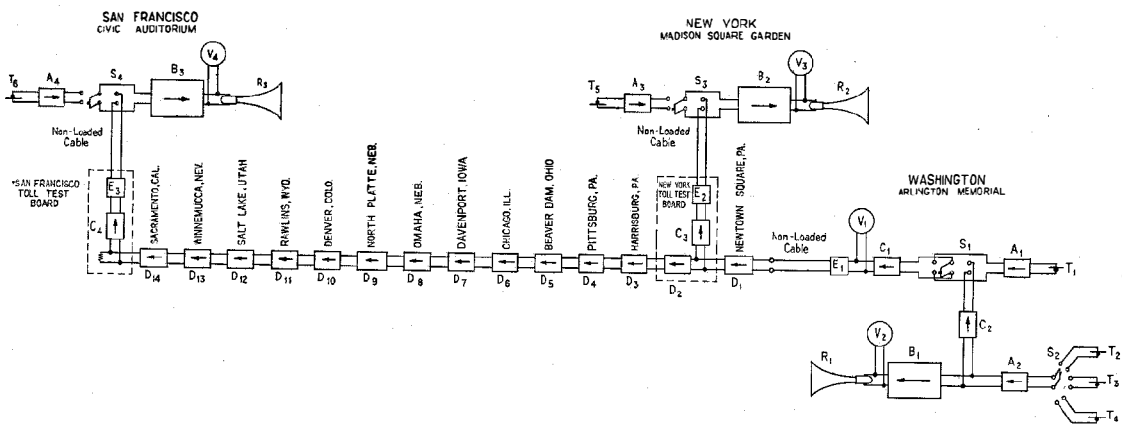

Fig. 9—Circuit Used for Ceremonies on Armistice Day, 1921.

being heard by his own audience by means of transmission delivered through by-pass  $F$ . A modification of the arrangement of Fig. 8 can, of course, be used with a four-wire toll circuit.

ARRANGEMENTS FOR ARMISTICE DAY, 1921

Fig. 9 shows the circuit which was employed on Armistice Day, 1921, when audiences of

simultaneously addressed from one point by means of the public address system.

At Arlington three different transmitters  $T_2$ ,  $T_3$  and  $T_4$  were used for the different parts of the ceremonies.  $T_2$  was used for the musical selections,  $T_3$  for the speeches made in the amphitheatre, and  $T_4$  for the speeches at the grave of the Unknown Soldier. Another trans-

mitter  $T_1$  was provided for the use of an announcer who kept the audiences at New York and San Francisco advised of the proceedings. The speech currents leaving these transmitters were brought up to moderate volume by means of amplifiers  $A_2$  and  $A_1$ , the former taking care in turn of the three different transmitters employed during the ceremonies.

The voice currents from the transmitters which were employed for the ceremonies, after passing through amplifier  $A_2$ , separated into two branches, one branch going to the local amplifier  $B_1$ , which supplied the local loud speakers  $R_1$ , the other going to the telephone circuit through amplifier  $C_2$ , switch  $S_1$  and amplifier  $C_1$ . The switch  $S_1$  was provided for connecting either the announcing transmitter  $T_1$  or one of the transmitters for picking up the ceremonies to the end of the toll line.  $V_1$  and  $V_2$  are volume indicators,  $V_1$  being employed to

telephone circuit, the volume indicator  $V_1$  making it possible to keep the volume applied to the toll line within close limits. At the same time independent adjustments were made of the amplifier  $B_1$  to take care of the varying conditions introduced by the different talking conditions as well as the varying conditions introduced by shifting of the crowds listening to the ceremonies.

After leaving the amplifier  $C_1$  at Arlington, the voice currents first passed through a non-loaded section of cable whose distortion was corrected by equalizer  $E_1$ . A non-loaded 8-gauge open-wire circuit carried the voice currents to New York City. At this point, the circuit again branched, one branch delivering a part of the voice currents to the apparatus at Madison Square Garden, the other branch going to San Francisco over one of the non-loaded No. 8-gauge transcontinental circuits. The arrange-

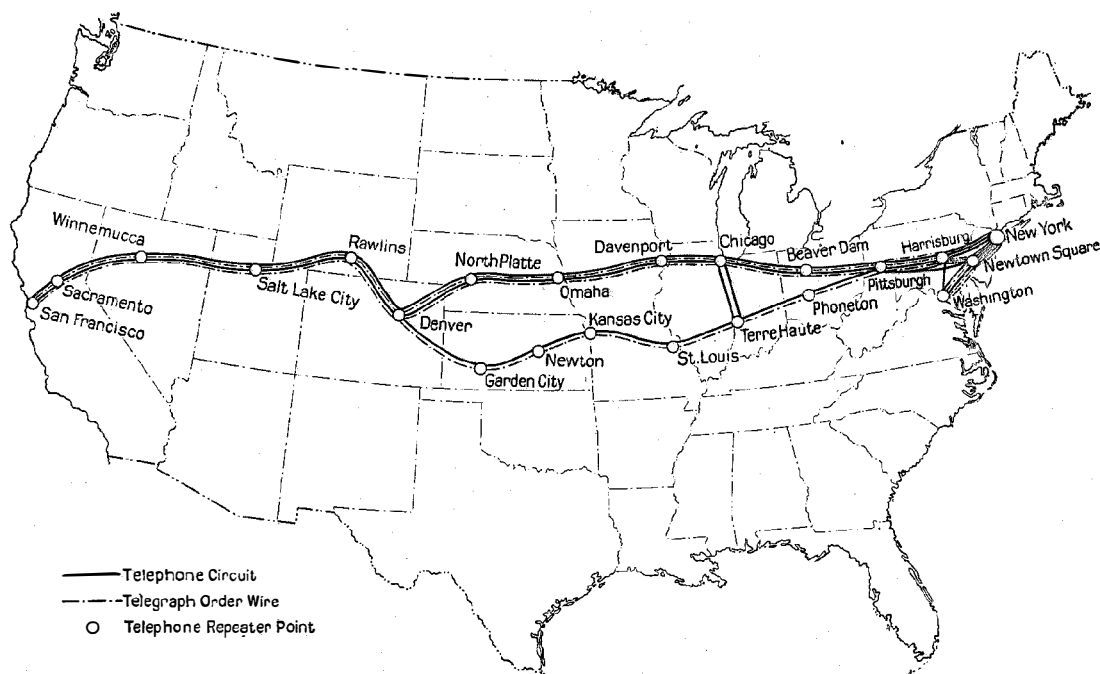

Fig. 10—Telephone and Telegraph Lines Used on Armistice Day, 1921.

indicate that the proper power was being put into the toll line, while  $V_2$  furnished an indication of the volume which was being delivered by the projector group  $R_1$ . During the ceremonies the amplifier  $C_2$  was continuously adjusted so as to deliver proper volume to the long distance

ments employed at Madison Square Garden and at the Civic Auditorium in San Francisco were similar, switches being provided at each point to connect to the projector groups the circuit from Arlington or from the local transmitter.

The difficulties involved in transmitting voice

currents for the first time to loud speaker installations at distant points, as well as the great importance of the occasion, made it necessary to take elaborate precautions in order to insure the success of the undertaking. The long distance telephone circuits were carefully inspected ahead of time and all of the amplifiers and other apparatus employed were subjected to numerous careful tests. For checking the complete circuit, alternating currents of different frequency were applied at Arlington and measured simultaneously at New York and San Francisco. The curve on Fig. 1 was obtained from the results of one of the measurements made on this occasion.

To guard against possibility of failure of the circuits, emergency circuits were provided, these emergency circuits taking different routes wherever possible. Fig. 10 shows the network of long distance circuits which was set up for this occasion. The solid lines in this figure indicate telephone circuits while the broken lines indicate telegraph circuits. The latter were for the purpose of transmitting orders between different units of the operating organization at different points.

At Arlington the nature of the ceremonies and the place in which they were held presented many difficulties from the acoustic standpoint. The main addresses were made in an open amphitheatre surrounded by a double colonnade of marble. The platform on which the speakers were located was partially covered by a marble arch. The floor of the amphitheatre is of cement on which are arranged marble benches. Temporary seats also were placed on top of the colonnade. During the ceremonies large crowds surrounded the amphitheatre on all sides. The arrangement of the amphitheatre and the surroundings is shown by Fig. 11.

In order that the crowds outside of the amphitheatre might hear the speakers, loud speaking receivers and their associated projectors were placed on top of the colonnade. They were arranged in four groups as shown on Fig. 11, the projectors referred to being numbered from 1 to 21 inclusive. Those in the east group were on top of the structure forming the main entrance to the amphitheatre. The projectors were carefully directed to cover uniformly the area around the amphitheatre and were supplied with sufficient power so that the speaker could

be heard for at least a thousand feet from the outside of the amphitheatre. It was found, however, that while these projectors are highly directive, some of the sound from them could be heard inside the amphitheatre. This sound leakage at the western side was particularly serious because of the fact that it reached the rear seats inside of the amphitheatre sufficiently far enough ahead of the corresponding sounds directly from the speaker to be noticeable. To overcome this, the small projectors 29, 31, 32 and 34, placed on top of the arch over the platform, were directed at the rear seats and given sufficient volume output to overcome the sound reaching these seats from the loud speakers on the colonnade.

The adjustment of the power to these small projectors required great care because if given too great volume, bad reflections would be set up in the amphitheatre. On the other hand if this volume were not great enough, the outside projectors would cause serious interference. The small projectors 27 and 28 were used to overcome the sound leakage effects on the top of the west side of the colonnade. The projectors 35 and 36 covered the top of the colonnade on the east side.

Fig. 11 shows also the location of the three transmitters used during the ceremonies, *a*, on the platform for the speakers, *b*, in front of one of the boxes in which were placed the singers and behind which was located the band, and *c*, at the grave. When the transmitter at the grave was tested it was found that serious interference was obtained between the speaker's voice and the sound from the projectors 16 to 19 inclusive. For the ceremonies at the grave, therefore, these loud speakers were disconnected and those numbered 22 to 26 used instead. Also in order to properly cover the inside of the amphitheatre during the ceremonies at the grave, the small projectors 30 and 33 were used. These were located on the arch over the platform and were directed at the front seats in the amphitheatre.

The projectors were divided up into a number of small groups and so connected that the volume of sound delivered by each group could be varied without affecting the other groups. This was necessary in arriving at the power to be delivered by each projector to give uniform

distribution and to avoid interference between different groups.

By means of these arrangements all parts of the ceremonies were carried to all parts of the audience at the National Cemetery and were also delivered by means of the lines to the audiences in the distant cities.

developed for the public address system were applied to this new field as it also demands high quality reproduction for speech and music. The transmitters and amplifiers associated with them in the public address system are used in radio broadcasting studios for delivering speech frequency electrical power to the radio transmitter.

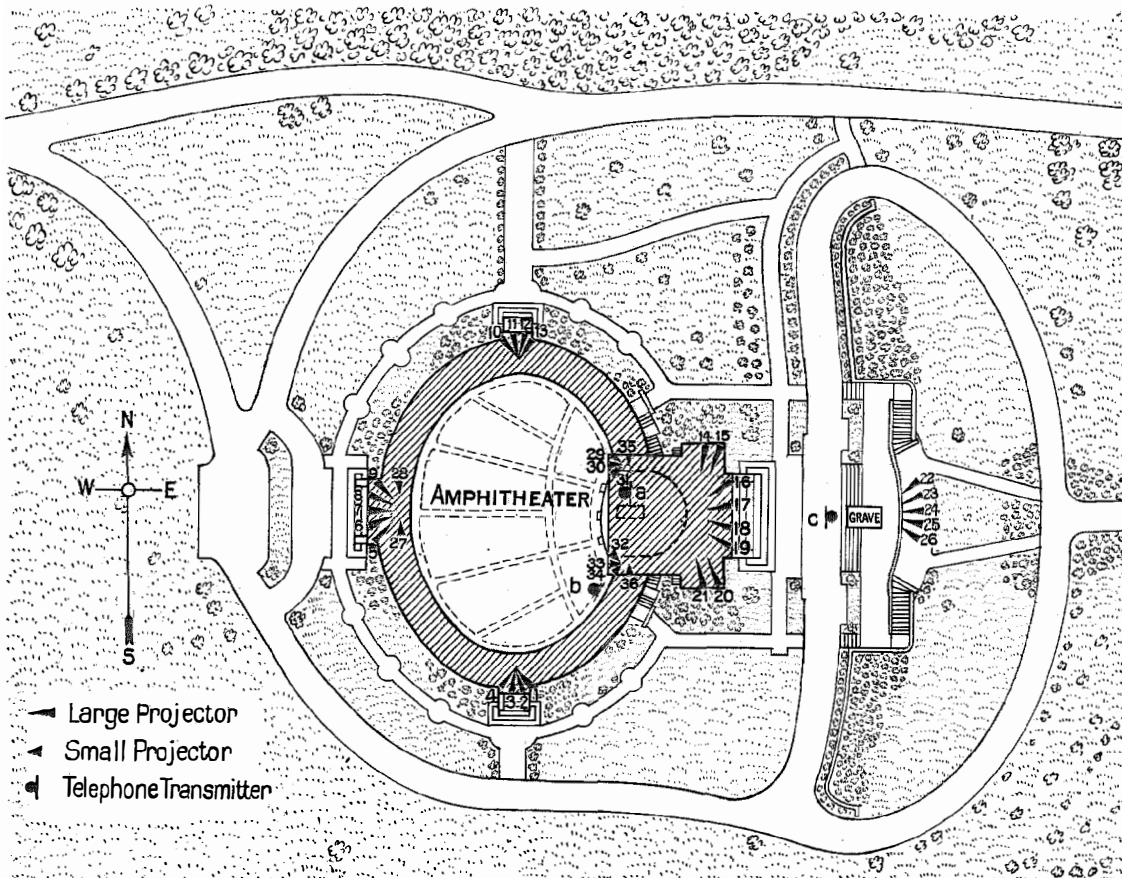

Fig. 11—Arrangement of Projectors at Arlington Amphitheater.

At New York, a group of fifteen loud speakers was used in Madison Square Garden to satisfactorily reach all parts of the audience and a group of twenty-one loud speakers was suspended outside the building for the outside audience. At San Francisco, ten loud speakers were used in the Civic Auditorium and seven outside.

#### USE OF PUBLIC ADDRESS SYSTEM APPARATUS WITH RADIO

When radio broadcasting came into general use, the apparatus and methods which had been

Loud speaking receivers and amplifiers for delivering sufficient power to operate them are used with many of the radio receiving sets.

The methods which have been employed to connect public address system transmitters with toll lines are being used for the broadcasting by radio of speeches and music given at points remote from the radio station. In such cases the transmitter and its associated amplifier are operated and controlled in the same way as described above for toll lines. In some cases the radio station is in the same city as the place

where the speech or music is given and in other cases the two have been in different cities. In the first case the output of the transmitter amplifier is carried to the radio station over non-loaded cable circuits which are equalized by means of distortion correction networks to have uniform efficiency over a wide frequency range, in some cases up to 5000 cycles. Where the two points are in different cities, the non-loaded cable circuit goes to the toll office and there is connected to the toll lines which are operated in the same manner as described above for loud speaker use.

For some of the higher grade music, such as that given by symphony orchestras, the less efficient, but slightly higher quality condenser type transmitter has been used instead of the double button carbon type. This requires the use of an additional two stage amplifier in front of the regular three stage transmitter amplifier.

The output of the transmitter amplifiers is controlled with the aid of a volume indicator bridged across the output terminals of the amplifier. For best results, particularly in reproducing music, it is necessary to adjust the gain of these amplifiers to compensate partially for the large range in the volume of the music. If the amplifiers are set high enough in gain to send through the low passages of the music with sufficient volume so that it will override the static and the interference from other sending stations, the loud parts of the music will seriously overload the radio transmitter system, unless it is of very large capacity, and will in general overload the receiving sets. Furthermore putting out these loud parts at the same relative level with respect to the low passages as they

are given by the orchestra, makes the interference between radio stations more serious. In some orchestral concerts the power amplification of the transmitter amplifier has been adjusted over a range of more than a hundred to one, these changes being made, however, so that they were not noticed by those listening to the concert by radio.

Proper volume control is very important in picking up such music for radio broadcasting. The lack of such control is responsible for many of the poor results that are being obtained. In this connection, the location of the transmitter with respect to the various instruments in the orchestra or smaller combination of instruments, so as to maintain in the reproduced music the proper balance between the several parts is, of course, of great importance.

An interesting illustration of the combination of the public address system, telephone lines and radio broadcasting was used in connection with reporting a football game played in Chicago in the fall of 1922. By means of high quality transmitters and amplifiers located at the football field, announcements of the plays and the applause of the spectators were delivered to a circuit extending to the toll office in Chicago. This circuit was connected there to a toll line to New York where it delivered the telephonic currents to a radio broadcasting transmitter. In Park Row, in New York City, was located a truck on which was mounted a radio receiving set arranged to operate a public address system. By this means the reports of the plays of the football game in Chicago were delivered to a large crowd in the streets of New York.

# Mobile Public Address System

By E. S. McLARN

*Engineering Department, Western Electric Company*

**H**OW far from the point of delivery can a public speaker be heard? Stating the question in another way, how many people can hear a public speaker? The acoustic properties of the auditory area, be it indoors or out, the speaker's enunciation and strength of voice are controlling factors and under ideal conditions the outskirts of the audience may be as much as 80 feet from the speaker and approximately 5000 people may be crowded within hearing distance. The preceding statement is true when the speaker uses no artificial means of increasing his voice range.

Until recently the only practical method of increasing the range of a public speaker's voice was by means of a megaphone, the limitations of which are well known. Today it is possible for a speaker to address with perfect comfort to himself a gathering of 1,000,000 people and more, every one of whom hear clearly and naturally his every word.

This seemingly miraculous result became a fact only after many years of painstaking effort on the part of the Bell System engineers which resulted in the development of the system now known as the Western Electric Company's "Public Address System". That marvel of never ending wonders, the audion or vacuum tube; a specially constructed microphone sensitive to the voice of a speaker 6 feet from the instrument and so designed that every gradation of tone is faithfully reproduced; a loud speaking projector of great sensitiveness, capable of handling comparatively large amounts of voice current energy without distortion;—these are the three principal elements that make the system possible.

The Public Address System came into national prominence in 1919 when it was used in the "Victory Way" celebration in New York City. During this celebration, the system enabled all those on "Victory Way" within several hundred feet of the speaker's stand to hear the speaker's message. Not only this but they could hear the addresses of speakers flying in aeroplanes in the

vicinity and also those of the nation's leaders in Washington speaking over the telephone wires between the two cities.

The Public Address System has since served many novel and useful purposes culminating in a joint meeting of the American Institute of Electrical Engineers in New York and Chicago in February of this year. On this occasion two meetings, widely separated, were made as one. The president of the Institute occupying the chair at New York presided over both the New York and Chicago meetings. Papers presented and discussed in either city were heard equally well in both. The results were precisely the same as though the two meetings were conducted in the same auditorium, except that vision between the two gatherings was lacking. Science does not as yet permit us to exercise the sense of vision over so great a distance.

In addition to the gatherings which were at New York and Chicago, there were the countless thousands in the radio audience who, while invisible, were none the less "present" since the transactions were also transmitted to station WEAJ, broadcasting station, New York City, and broadcasted to all those who could and cared to listen. To one with imagination this achievement will conjure up pictures of the future with myriad possibilities.

In our commercial, social and political life there are many occasions when a Public Address System is badly needed. Lack of time may not permit of engineering and installing the system and in such a case a mobile system—one on wheels capable of rapid transit under its own power—would provide the required service with the least possible lapse of time.

The Western Electric Company prepared to meet such emergencies by mounting Public Address Systems on motor trucks, as illustrated in Figs. 1, 2 and 3. One light and one heavy truck were fitted out, the equipment on each being for the most part the same with the notable exception that the heavier one carries a complete power plant which makes it entirely independent of external sources of current supply.

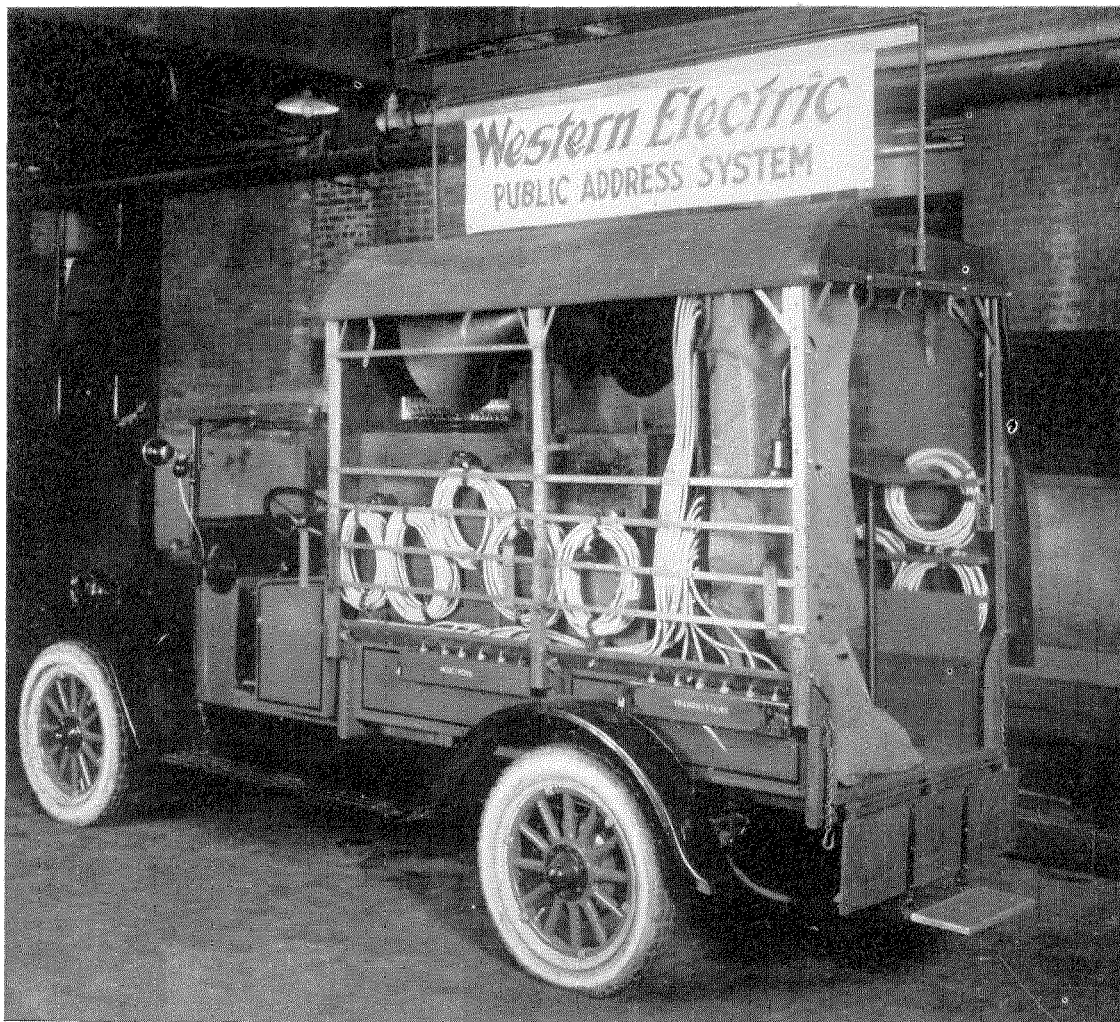

Fig. 1. Mobile Public Address System—Interior View of Truck

The No. 2 Public Address system is used on the trucks. It is made up of one or more microphones, two amplifiers and six or more loud speaking projectors, together with the control and current supply equipment. One of the amplifiers provides three stages of amplification. It receives and amplifies the weak voice currents obtained from the microphone circuit. The other amplifier which receives its current direct from the three stage amplifier is a single stage two-tube amplifier operating on the "push-pull" principle. This form of connection makes it possible to deliver a comparatively large amount of power at voice frequencies without distorting the complex wave form of the voice currents.

The potentials and current required for the operation of the various elements of the system are as follows:

- For microphones—12-volt storage battery, current approximately 0.1 ampere.
- Filament circuit—3-stage amplifier, 12 volts D. C. 3.3 amperes.
- Filament circuit—"push-pull" amplifier, 12 volts D. C. 2.7 amperes.
- Filament circuit—volume indicator, 12 volts D. C. 1 ampere.
- Plate circuit—3-stage amplifier, 350 volts D. C. 40 milliamperes.
- Plate circuit—"push-pull" amplifier, 350 volts D. C. 70 milliamperes.
- Plate circuit—volume indicator, 120 volts D. C. 1 milliampere.

The current and potentials required for the various units are supplied by storage batteries having sufficient capacity to operate the system



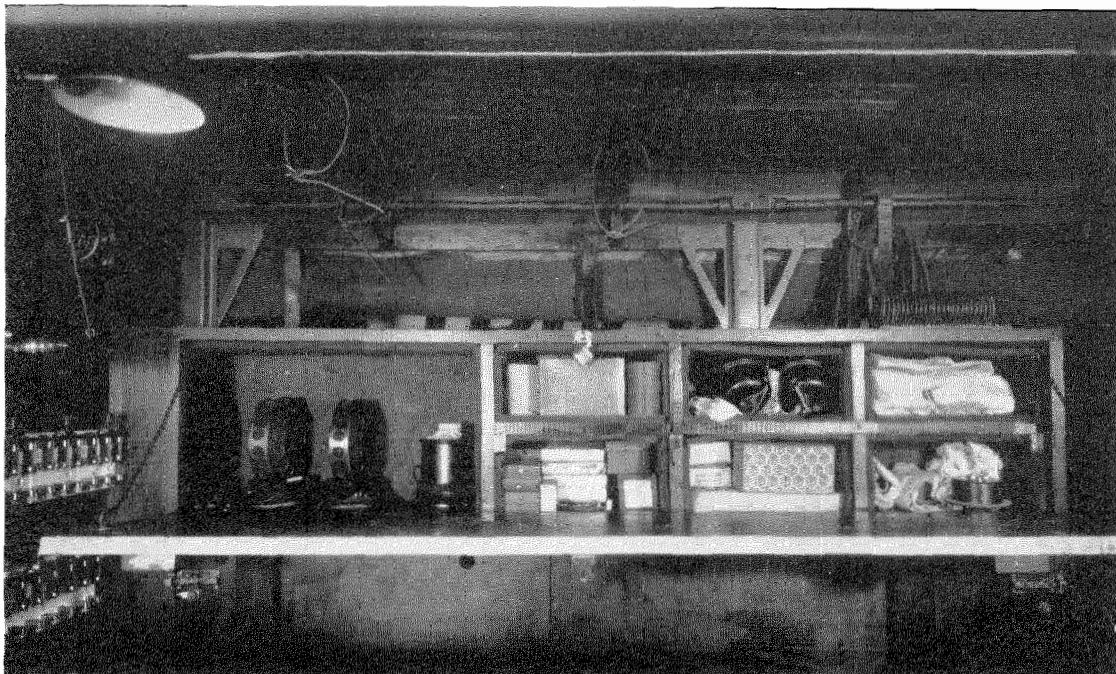

Fig. 2. Mobile Public Address System—Storage Facilities

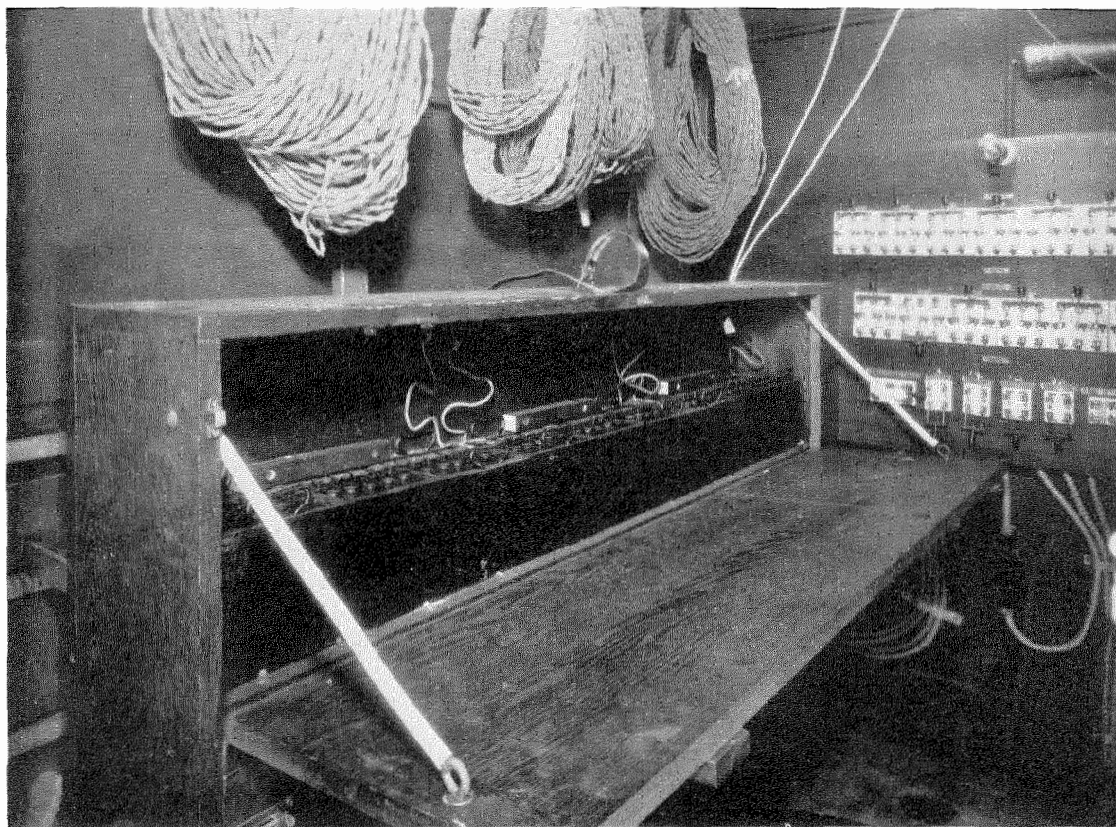

Fig. 3. Mobile Public Address System—Storage Battery Equipment



for at least 15 hours. Performances are rarely over 3 hours duration and it will be apparent that the batteries need only be charged after 4 or 5 performances.

While the self-contained feature of the heavy truck is one that would be appreciated in some parts of the world, experience in this country has shown that the charging set is not necessary. Nearly every town and village throughout the United States has battery-charging facilities where the charging job can be done at little expense and practically no inconvenience. Owing to its lower first cost, greater economy of operation and ability to cover ground, the light truck has proven the more practical and useful and stress will be laid on it rather than the heavy one.

The light truck is a Reo model "F" canopy top "Speed Wagon". In its canopy body, the top of which was raised 17 inches, are mounted all the permanent elements of the system. Accessories, spares and those elements that are portable are stowed away in convenient places at the top and along the sides. The accompanying photographs show clearly the arrangement of the equipment and the provisions made for stowing away loose material.

The storage batteries which are of the vehicle type are carried in two special cabinets placed longitudinally near the front of the truck body. One cabinet is placed on each side of the body, leaving a 2 ft. aisle to the switchboard which is placed on the panel separating the driver's seat from the body of the truck. The filament current is supplied by two 6 volt 120 ampere hour batteries. The plate battery current is supplied by thirteen 30 volt 11 ampere hour batteries. Twelve of these batteries in series are used in normal operation with a tap taken off the fourth battery for the 120 volt volume indicator plate circuit. The other one is a spare and can be switched in series if necessary to raise the voltage. Triple pole double throw switches make it possible to throw these batteries in parallel for charging and any one or more of the 30 volt batteries may be disconnected from the line and put on charge without opening the line circuit from the rest of the batteries. Four 8 volt 120 ampere hour batteries in series supply current for lighting the interior of the truck body. In the light line are placed two outlets for plugging in an extension cord and a 32 volt electric soldering iron, in case repairs

are needed upon the apparatus while the truck is en route. All batteries are charged through three charging jacks which are placed on the outside of the body underneath the flare boards on the right hand side.

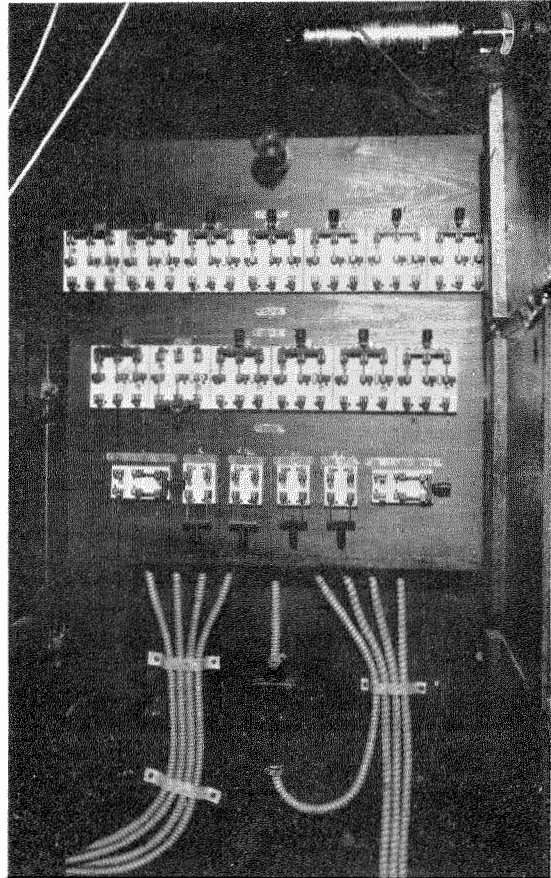

Fig. 4. Mobile Public Address System—  
Switchboard

The amplifiers and control panels are carried on an iron framework plainly seen in the rear view, Fig. 5. To eliminate jarring and vibration of the delicate apparatus while in transit the framework is cushioned from the floor by several inches of soft rubber pads. Excessive swaying is eliminated by the use of guy wires to the top of the framework in which are inserted turn buckles and strong helical springs.

The carrying case seen in the foreground is for vacuum tubes and other delicate apparatus and is heavily padded with felt to resist shocks.

All internal wiring except the battery charging leads is in iron armored cable for two reasons:

1. The microphone circuit must be carefully shielded at every point to prevent inductive noises which if present in the slightest degree would be ruinous.
2. To prevent mechanical injury to the wiring.



Fig. 5. Mobile Public Address System—Amplifiers and Control Panels

The external wiring to the microphone is, for the first reason stated above, through iron armored cable. This cable which is 3 conductor is furnished in seven 50 ft. lengths with a connecting block and junction box on each length. There is carried for the projector lines, 2000 ft. of twisted pair braided rubber covered wire and 600 ft. of 2 conductor armored cable for use where there is danger of mechanical injury. This cable is also in 50 ft. lengths with connecting block and junction box on each length.

Connections between the internal and external wiring is made at the connecting boxes—Fig. 6—marked “transmitters” and “receivers” on the outside of the truck just beneath the flare board.

The projectors when in use are mounted on special collapsible tripod, Fig. 7, built of castings and iron pipe. When extended the projectors are approximately 22 ft. from the ground. The tripod collapses into a convenient length for

carrying on brackets on the left side of the truck.

A reading stand shown in Fig. 7 is a part of the truck equipment and is used both for the speaker's notes and as a support for the microphone.

The conditions under which the mobile Public Address System is operated may require the truck to be several hundred feet removed from the speaker and his audience. The operator of the system standing at the control apparatus at the rear of the truck must at all times be in touch with the audience to enable him to keep the quality of the performance at par. This is arranged by placing at advantageous places in the audience, observers with telephone sets connected to a line which terminates at the control panel. The operator is equipped with a head receiver and chest transmitter and by plugging into a jack he may communicate with the observers. In addition a loud speaking receiver for monitoring purposes is constantly in operation in the truck during a performance enabling the operator at all times to judge of the volume of sound produced by the projectors.

In public performances, however well arranged, there are unavoidable delays between numbers that are apt to be wearisome. Then, too, some of the audience gather early and a little entertainment during the waiting period

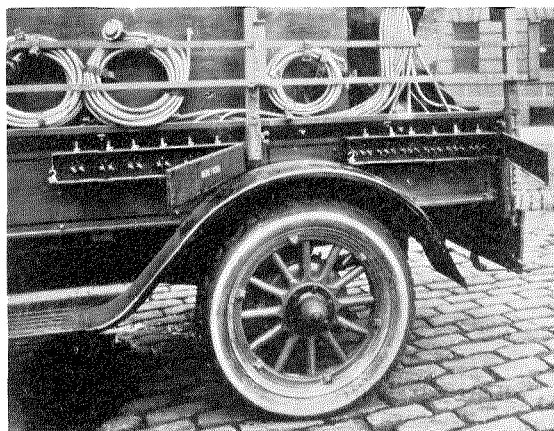

Fig. 6. Mobile Public Address System—Connecting Boxes

is often found useful in increasing the enjoyment. The Public Address System admits of filling in such gaps by transmitting to the audience phonograph selections or the programs from radio broadcasting stations within range.



Fig. 7. Mobile Public Address System—Tripod and Reading Stand

An idea of the ability of the light truck to fill engagements in widely separated places with short time intervals may be had from a consideration of the following itinerary between the dates of Sept. 12th and Oct. 31st, 1922:

Sept. 12th—New York, N. Y.

Sept. 15th—Chicago, Ill. (Auditorium Hotel)

Sept. 16th—Hawthorne, Ill. (Western Electric Company)

Sept. 17 and 18th—Chicago, Ill. (Auditorium Hotel)

Sept. 20th—Chicago, Ill. (Stock Yards)

Sept. 27th—Columbus, Ohio

Sept. 28th—Buffalo, N. Y.

Sept. 29th—Buffalo, N. Y.

Oct. 5th to 8th (incl.)—Williams College, Williamstown, Mass.

Oct. 11th and 12th—Fort Hamilton, N. Y.

Oct. 16th—Camden, N. J.

Oct. 17th—Philadelphia, Pa.

Oct. 18th—Atlantic City, N. J.

Oct. 28th—Newark, N. J.

Oct. 30th—Schenectady, N. Y. (Chamber of Commerce)

Oct. 31st—Schenectady, N. Y. (Proctors Theater)

From Sept. 12th to Dec. 20th, inclusive, the truck covered under its own power, 4346 miles and filled 25 engagements. Its crew was made up of a driver, operator and one or two observers. It would be possible to combine the function of the driver with one of the others as the truck is at rest during a performance.

# The Budget Plan of the Bell System

By C. A. HEISS

*Comptroller, American Telephone and Telegraph Company.*

THE pages of history tell us of many ways by which mankind has sought to foresee and appraise the future. Soothsayers and astrologers, sibyls and oracles, all were held in high esteem in the life of their times. The bases for prophesies were many and varied; the position of the stars, the bones of lambs, nature's marking on stones, and many other things quite as irrelevant were all used. Great significance was attached to the interpretation of dreams, and we have a familiar example in the story of Joseph, who, from Pharaoh's dream of seven lean kine devouring seven fat kine, was able to anticipate the seven years of famine and, from the abundance of seven fat years, laid by stores for the lean years which followed.

With the advance of knowledge and lessons from experience, men have discarded these methods of appraising the future. They have learned that guesses, auguries, or "hunches" are unreliable guides and that the best assurance toward a prosperous future lies in careful planning for it—by studying what has happened in the past and, in the light of experience, surveying the problems and possibilities of the future so far as they may reasonably be foreseen. The wisdom of this course is universally recognized; by following it Governments hope to realize a partial solution of their present-day fiscal problems; modern business enterprises find in it a more scientific and safe way of directing their affairs, and even the twentieth century housewife finds it an excellent way to insure an abundance of "pin money" and to promote domestic happiness. Manifestly, other things being equal, the greater success and satisfaction will be realized by those who intelligently follow this program of planning carefully their future course.

Modern business in particular, when conducted on a large scale, has, by experience, come to realize the value of recording, classifying and analyzing its problems, performance and potentialities in order to learn, if possible, what it may expect for the years which are to come. To this end carefully adapted methods of accounting and statistics have been developed to

record the past and point to the future. By analysis of these the executive finds an indispensable aid in forming his judgments and directing intelligently his undertakings.

The Bell System with its immense problem—continually increasing in complexity—of performing a national telephone service for more than one hundred and ten million people, has not failed to appreciate the importance of utilizing this valuable and logical aid in conducting its affairs. For many years it has prepared a Budget Plan, or what is more familiarly known as the "Provisional Estimate." From simple beginnings, this Budget Plan has been developed along with the growth of the business, until it has become one of the indispensable adjuncts to successful administration and operation of the national system. In fact, without it, the administration of an organization so large and complex as the Bell System would be exceedingly difficult, if not impossible.

## THE NEED FOR A BUDGET PLAN

The Budget Plan or "Provisional Estimate" in the Bell System is a complete statistical summary of construction, operating and financial facts, both as they are presented by a pertinent period of past performance and as they may be forecast for a reasonable future period. It begins with an analysis of past experience and, in the light of that, searches the future and makes orderly preparation to move upon it. Those who administer the business have available a comprehensive picture of the growing and changing character of the business for the purpose of reaching well balanced judgments as to the lines of development necessary to meet the public needs and as to the best administrative policies and practices to be followed.

In the past, this Budget has been confined principally to a survey of the situation for one year in advance, set up in comparison with the realized performance of the present and past. However, the continually increasing demand for telephone service; the greater dependence upon

the telephone as a means of simplifying and expediting the conduct of business and social life; the more highly technical character of the facilities required; and the increasing complexity of the entire undertaking, all require from those who furnish this service an ever increasing foresight. The most careful planning for future years is now essential. It demands, moreover, (to meet successfully this evolution in business and social life) the wise provision of great quantities of additional and improved facilities, many of which require several years for engineering, manufacture and installation; the preparation of the most economical programs for obtaining and expending the large amounts of money required; and the solution of numerous and complex construction, operating and management problems.

A few facts may be cited to illustrate this expansion in the Bell Telephone System and the size of its problem. At the end of 1900, there were 37,000 employees, 800,000 company owned stations, a plant investment of \$180,000,000, and net plant additions for that year of \$35,000,000. At the close of 1921, there were 224,000 employees, nearly 9,000,000 company owned stations, a plant investment of \$1,550,000,000 and net plant additions for the year of \$180,000,000. (It is interesting to note that the net additions to plant in the Bell System for 1921 alone were as large as the entire telephone plant investment in 1900, accumulated during the 25 years after the telephone was invented.)

The future does not promise any slackening in the demand for additional service. New facilities must be added, equipment must be replaced, in brief the telephone structure must keep pace with our national development. Obviously, the many complicated problems presented by this widespread telephone structure, with its rapid growth, require most careful study of what has happened and most comprehensive analysis of the needs and possibilities of the future. To meet this situation, and to obtain a better appreciation of the effects of general industrial and economic conditions upon the demand for telephone service and the requirements involved in these demands, it is necessary to look further into the future than we have in the past so that the task of rendering telephone service may be better visualized, and its problems anticipated and provided for intel-

ligently in advance. To this end, the Bell System, during the past year, has substituted for its one-year plan a five-year Budget, by means of which it aims to obtain as comprehensive a picture as possible of the task ahead of it for at least that period. This five-year program, stepped up annually by adding one year and by correcting for previously unforeseen situations, provides a continuous and dynamic forecast of the problem before the Bell System.

#### THE CHARACTER OF THE BUDGET PLAN

This fundamental and continuous five-year Budget Plan aims to provide data which is truly comprehensive and well balanced from all points of view. The facts brought together are intended to show why and how certain things should be done, and what may be expected, particularly in development, capital costs, revenues, expenses and net return, as the result of the action proposed. Accordingly, past performance is tabulated and the reasonable assumptions for the future are set up in comparison. In the preparation of this picture, practically every department of the company is in some way or another concerned.

As a preliminary step the Executives must make available a tentative program of general policies in respect of the business and its future development, so that the several departments may have a basis upon which to proceed in bringing together the material for that part of the picture for which they are immediately responsible.

The Statistician must give his picture of economic and financial conditions, as these may be anticipated, with their probable effect on development; he must analyze business and labor conditions and the probable trend of interest rates and the money market. The telephone business, it is true, continues to increase with remarkable evenness year by year, in spite of wars, business depressions, and other disturbing factors and, in general, is by no means as much affected by external influences as manufacturing, mercantile, and other business; nevertheless, economic influences cannot be disregarded and no estimate of the future of the telephone problem will be fully significant which does not incorporate the result of careful study of economic factors such as the increase in national

wealth, the tides of immigration, the increase or decrease in population, distribution of income, and housing conditions.

The Commercial forces must estimate as carefully as possible the increase in population in the territory to be served, the growth of cities and other communities, the extent to which these changes will influence the increase in stations, and the prospective use of telephone facilities by patrons. Possible new forms of service must be studied and their effect on the business ascertained; estimates must be made of the probable revenues which may be expected from each class of service which is or may be offered.

The Traffic forces must survey the requirements for handling the service demanded, in the way of both equipment and personnel. Related labor supply and costs must be studied. Various methods of handling traffic must be considered to find the most efficient and economical practices and types of equipment. All of these must be resolved into expected capital expenditures and operating costs for the period.

The Engineering and Plant forces must consider the traffic and service requirements as forecast for the future, and determine the amount of additional facilities required, the types of plant best adapted to meet efficiently and economically the demands for service as they are foreseen. They must also give consideration to spare facilities, and their fundamental plans must be such as to lay the foundation for meeting still greater service demands in the future in an orderly step by step progression along sound and carefully worked out economic lines. Replacement and rebuilding of plant and equipment must be considered and proper provision made for the maintenance of the property. All of these and many other factors must be resolved into plant, labor and material requirements, capital expenditures and operating expenses.

The Accounting forces must provide from their records data as to past performance of every phase of the business. They must also estimate and summarize future requirements as to taxes, fixed charges, dividends, and general and miscellaneous expenditures. Items of revenue must be estimated and tabulated.

In fact, every function of the business must outline its program of activities for the period, justify their value to the business and appraise

the cost and results thereof, and all of these judgments and estimates brought together, coordinated and summarized, comprise, for the Executives, a Provisional Estimate of the task and its probable results immediately ahead of the Bell Telephone System. The picture is by no means complete, for many unforeseen situations and contingencies will arise to modify the work as planned and the results expected. Estimates also are sometimes influenced by hope of accomplishment rather than by an analysis of the cold facts, but nevertheless a valuable fund of data has been made available.

#### THE USE MADE OF THE BUDGET PLAN

This fund of information regarding the future of the business enables the administrative and executive officials to consider the soundness and wisdom of their policies and programs for the future. They must review the possibilities in respect of general business conditions, price changes, labor conditions and wages, the demands for service, the requirements for plant additions, improvements and replacements, the requirements for maintenance, operating and general expenses, depreciation, and taxes. They must give due consideration to unforeseen contingencies and make due allowance for estimates of the future based on scanty data. They must eliminate the non-essential in the plans as proposed. The adequacy of the present rate structures must be studied, the revenues expected from new developments must be carefully scrutinized, and a conservative appraisal made of the possibilities of increased revenues. The prospects of obtaining the new capital required must be considered and the probable cost thereof ascertained.

In brief, those who administer the business must obtain a full knowledge of what is involved in their responsibility for furnishing adequate and efficient telephone service for the future, whether their policies and the programs as proposed by the several functions can be executed, or whether they should be revised, modified or discarded. However, beyond this they must satisfy themselves that the program which is finally adopted will yield a proper and reasonable amount of net earnings on the investment required, otherwise that program, no matter how splendidly planned, must fail, for investors



will not long supply the additional capital required unless they are assured of the protection of their investment and an adequate return thereon.

In meeting these two major responsibilities, namely, adequate and efficient telephone service to the public and an adequate return to those who invest their labor and money in the business, the data provided by the Budget Plan furnishes the executives with a continuing basis for action. With its aid they can lay plans for the future and arrange for the conduct of operations in an orderly and economical manner from every viewpoint. A few of the advantages made possible may be mentioned.

From the viewpoint of future material requirements, when one stops to consider that the purchases of equipment and construction and other materials required by the Bell System now exceed \$150,000,000 annually and that these for the most part are highly fabricated and specially manufactured for its purposes, it becomes evident that construction and service programs must be anticipated and requirements furnished to the suppliers at least several years in advance, in order that equipment and supplies may be manufactured and delivered under normal schedules. Time should also be available for reasonable foresight as to price changes, to enable a more liberal purchasing of materials during periods when prices are at relatively favorable levels. The supply of raw materials now used may become limited and it may be necessary to find new sources or substitutes if delay and inconvenience are to be avoided. Deliveries of material can be scheduled and made available by the supplier in an orderly manner so that no delay will result when work on a project is started. At the same time, the manufacture and delivery of equipment can proceed in such a way as to limit to the minimum the preliminary non-earning period of capital tied up therein.

From the viewpoint of construction and maintenance work for the future, large and important developments and projects can be studied and possible alternative plans considered to find the best and most economical way to meet the desired result. Switchboards and installations must be engineered, and construction activities co-ordinated. Replacement and maintenance programs may be prepared. The necessary workmen can be trained in advance so as to be skilled

and experienced in their work. The general demand for and supply of available labor can be analyzed and a continuous program of work arranged so that skilled labor may be continually employed. In brief, plans may be made to conduct the necessary operations year after year on an even keel without undesirable changes in working forces and labor turnover.

From the viewpoint of operation, there is afforded an opportunity to study increased service demands, and if these require that methods of handling traffic be revised, or that new and better facilities be provided or new methods designed to meet the requirements, this can be done. The necessary operators may be trained and the source of supply analyzed to ascertain whether the needs of the System can be met or whether other methods of handling the traffic must be employed. Anticipated operating expenses of every type may be scrutinized and plans laid to ensure the latest and most economical methods.

From the viewpoint of revenues which are required to make possible the success of any program adopted, the Budget Plan provides an opportunity to plan carefully in advance for rate schedules which will be adequate and consistent with the quality of service rendered, yet reasonable in cost and adapted to develop traffic. New sources of revenue may be arranged by more effective and intensive uses of the service. Rate situations may be systematically studied and equitably adjusted so that expensive rate litigation may become necessary only as a last resort.

From the viewpoint of supervision, the data so made available affords an excellent means of checking actual performance. If the estimates take full account of all of the conditions under which the proposed work must be done, and its actual performance presents higher costs or other unfavorable conditions, an opportunity is afforded to check whether the work was done efficiently and economically, or whether it is properly organized and supervised; in brief, whether the desired result is being obtained at the lowest possible cost.

Finally, one of the major functions performed by the Budget Plan is to lay a sound foundation for financing. After the entire program for the immediate future has been summarized, checked and revised to a sound basis, consistent with the



expected demands for service and conservative as to cost, the problem presented is that of financing the undertaking. All proposed activities must be resolved finally to capital costs and net earnings. If net earnings are not adequate to yield a proper return, one of two courses of action must obviously be taken—either more revenues must be made available or the program must be modified. The large army of investors in Bell System stocks and bonds—numbering upwards a half million—must realize as much on their funds in this business as from other forms of investment, otherwise their funds will be withheld. The Budget makes it possible to so plan the future of the business as to retain these investors and to interest others, while rendering service at a reasonable price.

The capital cost of any program approved must be obtained by new investments from those who are already investors and by developing new sources of capital, and to this end, the Budget permits a continuous forward-looking financial program in respect of the large amounts of new capital required. During the past few years, these capital requirements have averaged upwards of \$100,000,000 annually. To make available at the minimum cost to the Bell System, these immense amounts of new capital and to have funds on hand as needed is indeed a task of no small proportions. Consideration must be given to the best form of security to be issued—whether stocks, bonds or notes—and the most favorable time for issuing these must be determined. The conditions of the investment money market and the trend of and possible changes in interest rates must be critically considered. New sources of capital must be tapped and confidence must be established and maintained in the securities issued. The foundation must also be laid for future issues, since the business is a continuing one and the demand for telephone service shows no signs of slackening.

But the task of financing can be carried to successful completion only if net earnings are and continue to be such as attract and hold capital in the business, and in this connection, the Budget Plan appraises anticipated earnings and gives a basis for making every possible effort by sound planning and economies to make them adequate now and for the future.

The American Telephone and Telegraph Company and its Associated Companies comprising the Bell System have as their responsibility to society the task of furnishing a national telephone service. In performing this task the development of a well organized and intelligent force of men and women has been necessary and an investment aggregating over two billion dollars is now involved. The size of this undertaking has not come about by the personal desire of any one individual or group of individuals in the Bell System that the organization and structure which provides this essential service should be the largest of its kind, or that an enormous volume of service should be rendered as a business venture; rather, this structure has been made necessary by and created out of the demands of society that it be supplied with this indispensable instrument in the conduct of its business and social life. For the same reason, the business will assume even greater proportions, more complex service and operating problems will be encountered and much additional capital must be obtained.

This responsibility for the future can and will be met, but to that end a careful study of past performance is required, and careful and logical planning for the future must be in evidence, to assure that development and growth will proceed in an orderly, economical and stable manner. On this account, a continuous scientific Budget Plan, which lives and grows with the business and is always adapted to the needs of the time is indispensable.

---

---

# *International Western Electric Company*

INCORPORATED

*Head Offices*

195 BROADWAY  
NEW YORK, U. S. A.

*European General Offices*

CONNAUGHT HOUSE  
ALDWYCH, LONDON, ENGLAND

## *Affiliated Companies*

- Western Electric Company, Limited . . . . . *Aldwych, London, England*  
Branches: Birmingham, Cardiff, Glasgow, Leeds, Manchester, Newcastle-on-Tyne, Cairo, Johannesburg, Simla, Singapore.
- Bell Telephone Manufacturing Company . . . . . *Antwerp, Belgium*  
Branches: Berne, The Hague.
- Le Materiel Telephonique . . . . . *Paris, France*
- Telefonos Bell, S. A. . . . . *Madrid, Spain*
- Western Electric Italiana . . . . . *Milan, Italy*
- Western Electric Norsk Aktieselskap . . . . . *Christiania, Norway*
- Vereinigte Telephon und Telegraphen Fabrik . . . . . *Vienna, Austria*
- United Incandescent Lamps and Electrical Company, Limited  
*Budapest (Ujpest), Hungary*
- Western Electric Company (Australia) Limited . . . . . *Sydney, Australia*
- Nippon Denki Kabushiki Kaisha . . . . . *Tokyo, Japan*  
Branches: Osaka, Dalny (Manchuria), Seoul (Chosen)
- Sumitomo Electric Wire & Cable Works, Ltd. . . . . *Osaka, Japan*
- China Electric Company, Limited . . . . . *Peking, China*  
Branches: Shanghai, Tientsin
- Northern Electric Company, Limited . . . . . *Montreal, Canada*  
Branches: Quebec, Halifax, Toronto, London (Ontario), Hamilton, Windsor, Winnipeg, Calgary, Regina, Vancouver
- Compania Western Electric Argentina . . . . . *Buenos Aires, Argentina*
- International Western Electric Company . . . . . *Rio de Janeiro, Brazil*

Sales Offices and Agencies Throughout the World

To those interested in better communication the International Western Electric Company and its Affiliated Companies offer the facilities of their consulting engineering departments to aid in the solution of problems in Telephony, Telegraphy and Radio.