

PROCEEDINGS OF THE I.R.E.

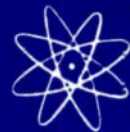

AND



WAVES AND ELECTRONS

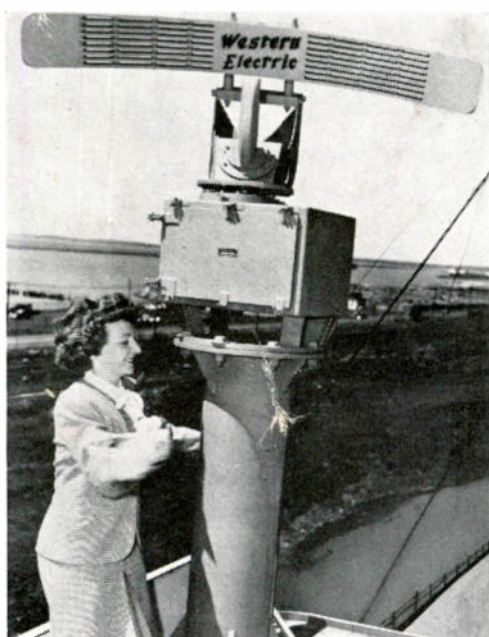

Photographs Courtesy of Western Electric

RADAR SWORD BEATEN INTO PLOUGHSHARE

Radar: Powerful Implement of War Finds Peacetime Use as Navigational Guide on the American Great Lakes.

August, 1946

Volume 34

Number 8

PROCEEDINGS OF THE I.R.E.

Radar

Waves and Electrons

Section

Magnetic-Wire Record Response

Abstracts and References



The Institute of Radio Engineers



VARITRAN

(VARIABLE VOLTAGE TRANSFORMER)

EXCELLENT REGULATION
 HIGH EFFICIENCY
 SMOOTH CONTROL
 LOW TEMPERATURE RISE
 NO DISTORTION
 RUGGED DESIGN

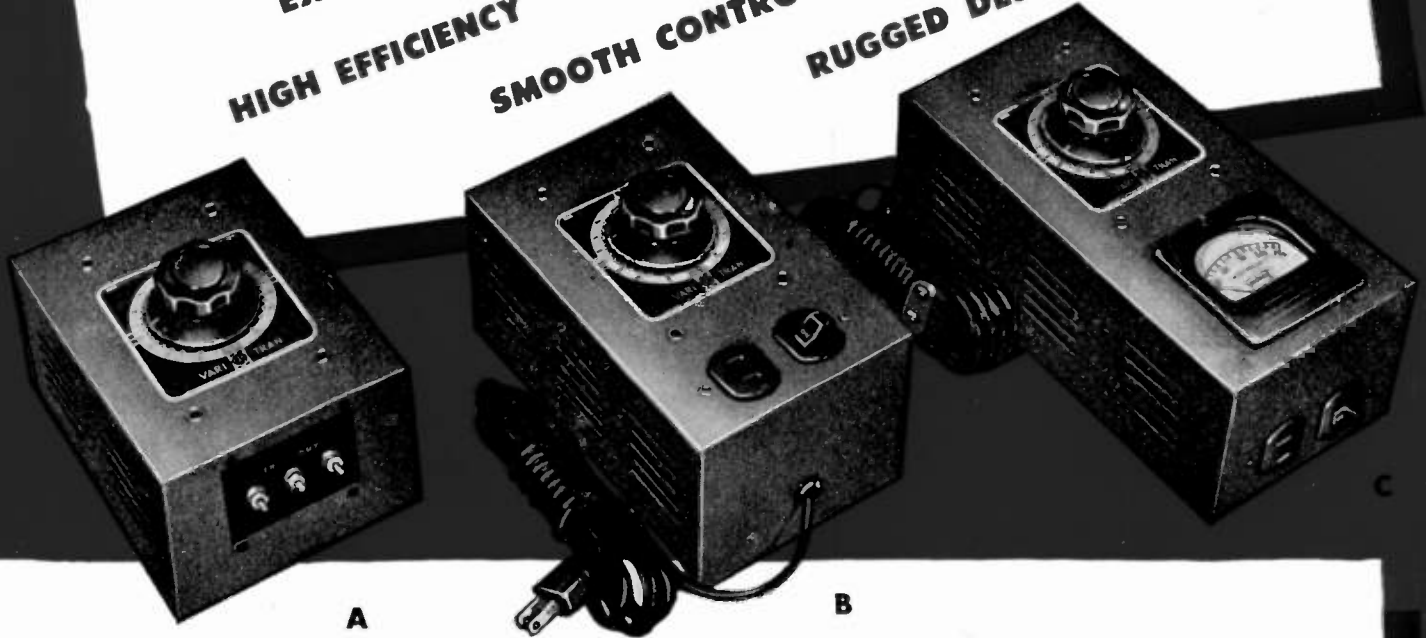

The UTC Varitran is a simple autotransformer whose turns are arranged on one layer with the insulation removed so that every exposed turn may be used as a tap of the winding. A special non-fusing contact, having resistance to minimize circulating currents, is mechanically arranged so that it can be moved to any position on the winding, permitting the exact voltage desired to be obtained.

STANDARD VARITRANS

Standard Varitrans are designed for 115 or 230 volt service. The respective output voltages are 0-130 and 0-260 volts.

Type	Input Voltage	Output Voltage	Watts	Maximum Amps.	Figure	Net Price
V-0	115 volts	0-130	230	2	A	\$10.10
V-0-B	230 volts	0-260	230	1	A	12.45
V-1	115 volts	0-130	570	5	B	14.25
V-1-M	115 volts	0-130	570	5	C	23.80
V-2	115 volts	0-130	570	5	A	11.90
V-2-B	230 volts	0-260	570	2.5	A	14.85
V-3	115 volts	0-130	850	7.5	A	17.85
V-3-B	230 volts	0-260	850	3.75	A	23.80
V-4	115 volts	0-130	1,250	11	A	26.15
V-4-B	230 volts	0-260	1,250	5.5	A	33.30

UNIVERSAL VARITRANS

Universal Varitrans have two 110 volt Primary windings (110 or 220V connection) and a 28 volt variable secondary winding. This winding can be used as a 0-28 volt low voltage source. It can also be used in autotransformer connection with the primaries to effect . . . 115 in/87 to 143 out, 220 in/192 to 248 out, 220 in/82 to 138 out, 115 in/202 to 258 out.

Type	Max. Amps. Output	Approx. Dimensions	Approx. Weight, Lbs.	Figure	Net Price
VL-0	1.5	4 1/2 x 6 1/2 x 2 1/2	5	A	\$ 8.30
VL-1	3.5	4 1/2 x 6 1/2 x 3	7	A	9.50
VL-2	6	4 1/2 x 6 1/2 x 4	10	A	11.90
VL-3	11	5x7x5	15	A	19.00

PRICES ARE SUBJECT TO CHANGE

United Transformer Corp.

150 VARICK STREET

NEW YORK 13, N. Y.

EXPORT DIVISION: 13 EAST 40th STREET, NEW YORK 16, N. Y.

CABLES: "ARLAB"

NEW DESIGN POSSIBILITIES

... WITH THIS NEW LINE OF
SMALLER, LIGHTER, ENERGY—
STORAGE CAPACITORS

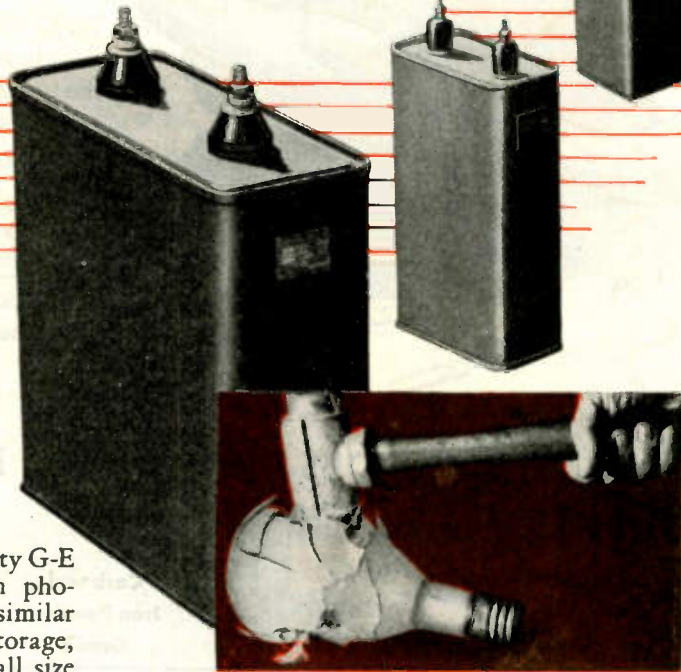
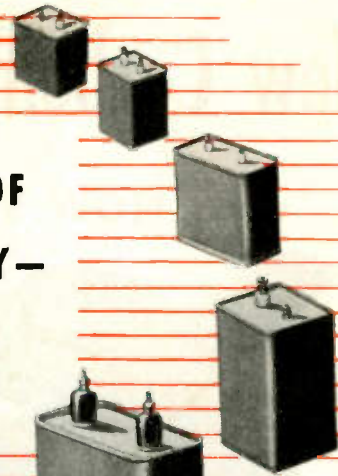

For

High-speed flash photography,
Light-metal welding,
Electronic-timing
devices, etc.

A complete new line of light-duty G-E Pyranol* capacitors is now available for flash photography apparatus, light-metal welding, and similar applications requiring economical energy storage, fast discharge and service reliability. Their small size and light weight will help designers reduce the size of such equipment.

The high dielectric constant of Pyranol and its high dielectric strength provide outstanding electrical characteristics. Ambient temperature operating limits, at rated voltage, range from 0 to 50 C and the capacitance tolerances, measured at 25 C, are ± 10 per cent. The performance of these compact units has been thoroughly proved by several years of laboratory tests and actual operating experience in the field.

G-E light-duty energy storage capacitors are made in a wide range of ratings to fit practically every requirement of high-speed flash photography as well as

This flash photo was made possible by G-E capacitors.

home and industrial welders of light metals. Careful construction, quality materials, and skillful design contribute to long life and efficient operation.

The accompanying table lists preferred ratings which can be promptly shipped. For further information on these ratings or on designs for special operating conditions, advise us of your problem through *Apparatus Dept., General Electric Company, Schenectady 5, N. Y.*

*Pyranol is G.E.'s trade name for askarel, a noninflammable liquid dielectric.



PREFERRED RATINGS

Max. D-C Volts	Muf	Watt/Sec	Cat. No.	Base	Case Height in In.	Height Over Terminals in In.	Na. of Terminals	Net Wt. Lb.
2000	25	50	25F903	A	4 19/32	5 7/64	2	5.2
2000	40	80	25F910	A	7	8 1/4	1	7.8
2500	25.5	80	25F911	A	7	8 1/4	1	7.8
3000	60	270	14F312	B	13 1/8	15 1/8	2	26
3350	17.8	100	25F912	A	7	8 1/4	1	7.8
4000	25/50	200/400	14F309	B	13 1/8	15 1/8	3	26
4000	100	800	14F311	C	12 7/8	15 1/8	2	56
4500	10	100	26F872	A	5 1/2	6 3/4	1	6
5000	25/50	313/625	14F305	D	13 1/8	15 1/8	3	46
6600	55	1200	14F313	C	12 7/8	16 5/16	2	56
7000	25	613	14F314	B	13 1/8	16 5/16	2	26

BASE DIMENSIONS (IN.)

A 3 3/4 by 4 9/16

B 4 by 8

C 5 1/8 by 13 1/2

D 4 1/8 by 13 1/2

GENERAL ELECTRIC

407-101-5700

PROCEEDINGS OF THE I.R.E. AND WAVES AND ELECTRONS, August, 1946, Vol. 34, No. 8. Published monthly in two sections by The Institute of Radio Engineers, Inc., at 330 West 42nd Street, New York 18, N.Y. Price \$1.00 per copy. Subscriptions: United States and Canada, \$10.00 a year; foreign countries \$11.00 a year. Entered as second class matter, October 26, 1927, at the post office at Menasha, Wisconsin, under the act of March 3, 1879. Acceptance for mailing at a special rate of postage is provided for in the act of February 28, 1925, embodied in Paragraph 4, Section 412, P. L. and R., authorized October 26, 1927.

Table of contents will be found following page 32A

A New Carbonyl Iron Powder... "HP"

...NOW RELEASED FOR CIVILIAN APPLICATIONS



CARBONYL Iron Powder "HP" made it possible to bring bomber loop antennas inboard.

Why? Because an *extra* step in the carbonyl process greatly reduces the size of the particles and minimizes the impurities. At frequencies up to several megacycles —magnetic coils from "HP" powder combine *high* permeability with *low* losses.

High "Q" values and high permeability offered by Carbonyl Iron Powder "HP" make its application to *permeability tuning* outstanding.

Check your requirements against these basic features of Carbonyl Iron Powder "HP."

HOW DOES "HP" DIFFER PHYSICALLY?

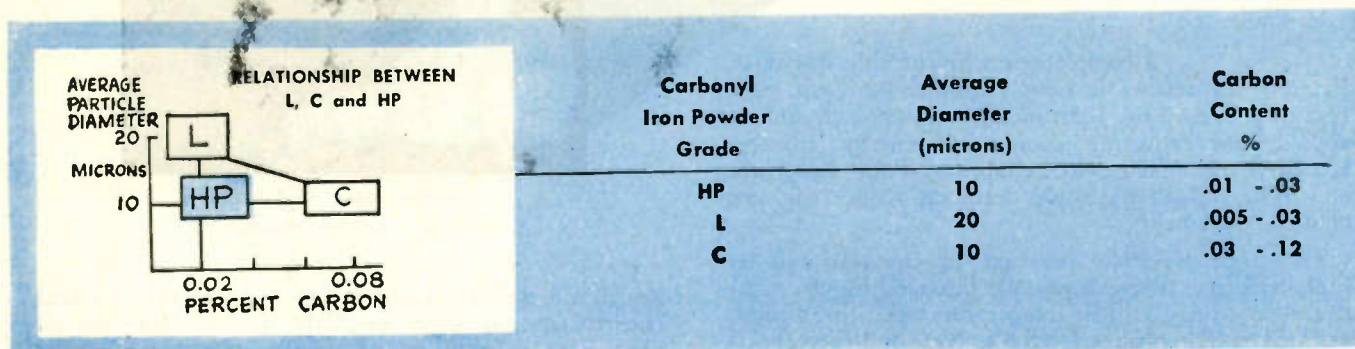

1. "HP" powder has a smaller particle size than Carbonyl Iron Powder "L"—a higher degree of purity than Carbonyl Iron Powder "C." (Note, however, that possibly "HP" will

show no superiority over a "C" powder core in many cores of high dilution or insulation content.)

HOW DOES "HP" DIFFER ELECTROMAGNETICALLY?

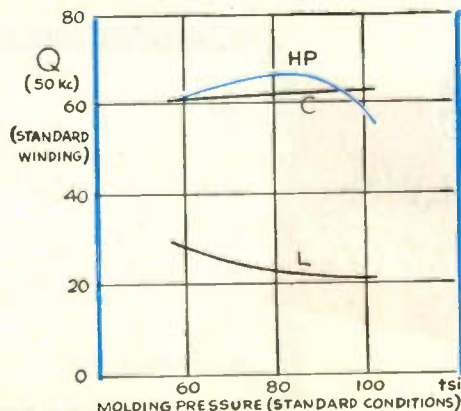
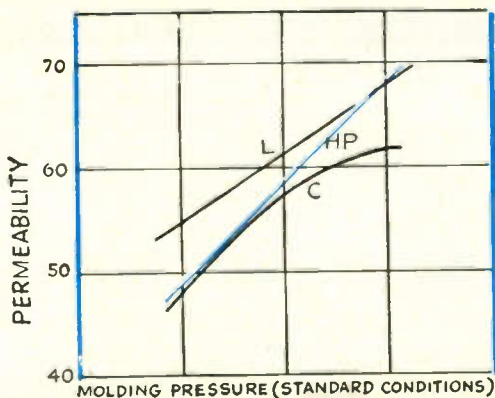

2. "HP" powder has distinct advantages in permeability and "Q" value (plotted against molding pressure). For com-

parative purposes, toroid core curves for Carbonyl Iron Powders "L" and "C" are shown against "HP."

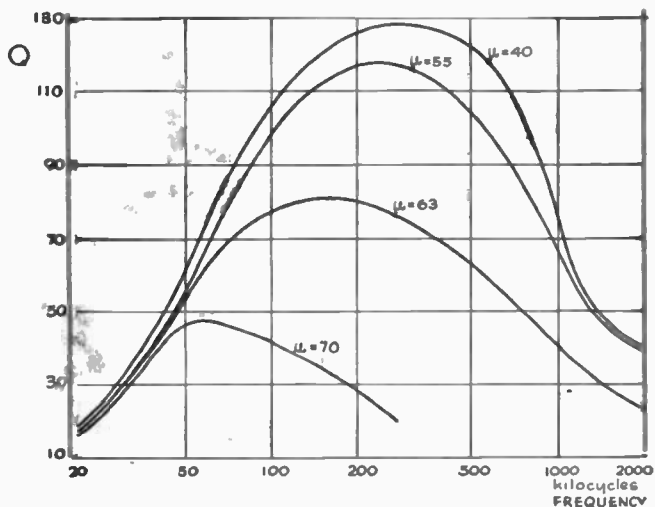

3. These curves show "Q" values versus frequency for several "HP" and comparison toroid cores. Even at relatively

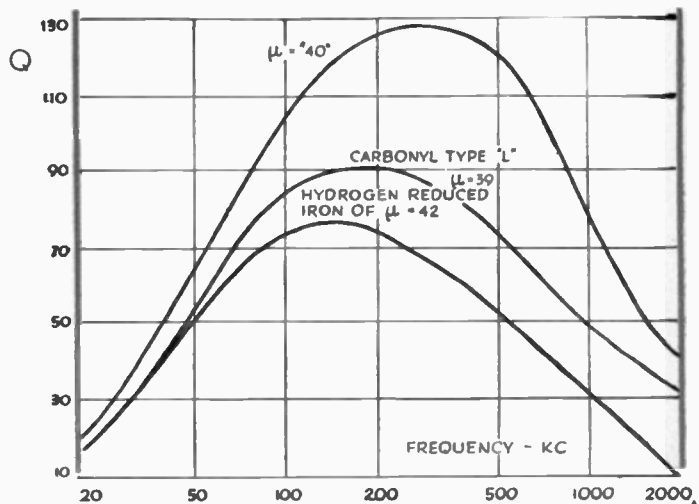

high frequencies, working permeabilities up to 70 can be obtained with reasonable "Q" values.

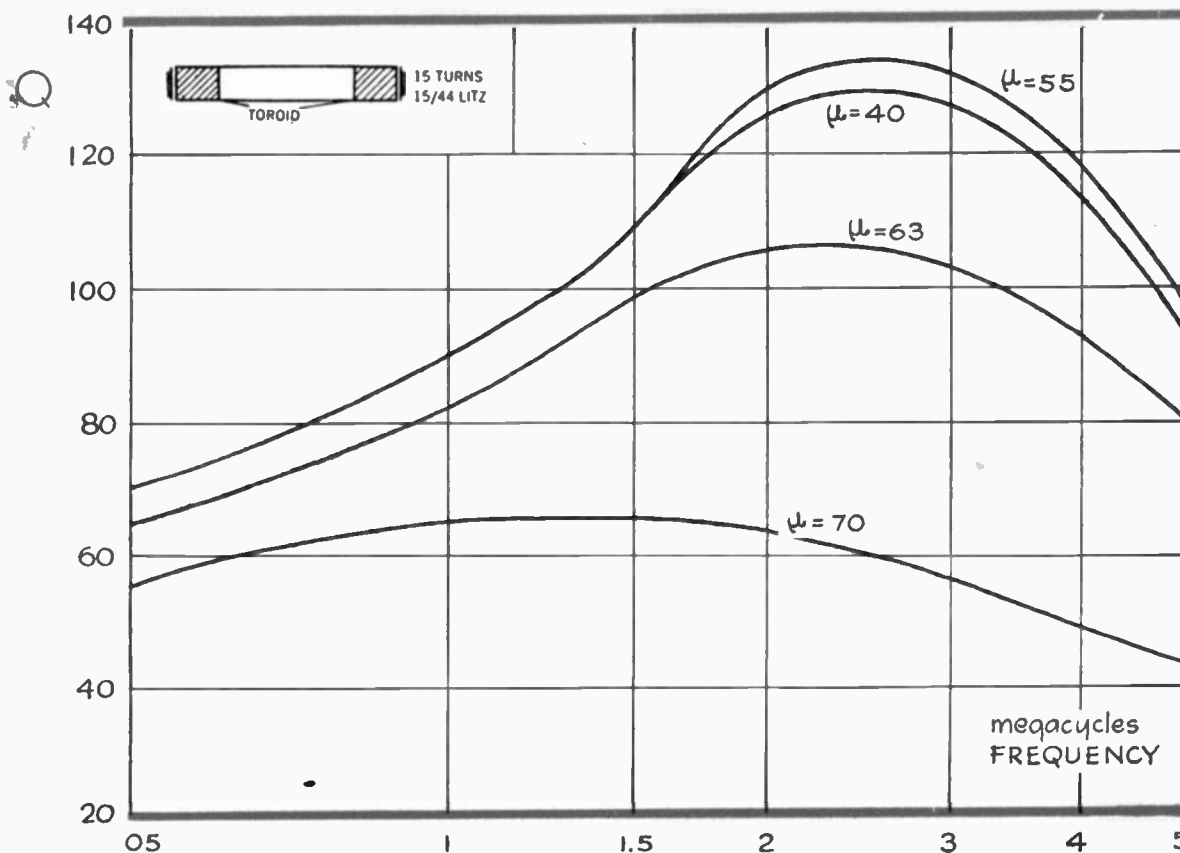

4. "HP" powder has superiority in cylindrical winding, as illustrated by this curve.

Particular requirements can be met by applications of Carbonyl Iron Powder "HP." Additional specific informa-

tion and technical data are available without obligation.

Write or wire collect: Special Products Sales Division, General Aniline & Film Corporation, 270 Park Avenue, New York 17, N. Y.



G.A.F. CARBONYL IRON POWDERS



Super **NON-INDUCTIVE RESISTORS**

FOR HIGH R-F USES

Sprague Koolohm type SIF super non-inductive resistors have solved many serious problems in high-frequency radar and communications work involving dummy loads and dummy antennae, line terminations, rhombic antenna phasing resistors, and others—wherever there is need for power wire-wound resistors having extremely small phase angles.

These SIF units are made in seven

types, with power rating from 15 to 150 watts. Typical maximum phase angle values, measured at 3MC are as follows:

5 ohms to 26 ohms . . . 20°
27 ohms to 99 ohms . . . 12°
100 ohms and higher . . . 6°

For complete details write for the new catalog of Sprague Koolohm wire-wound resistors for every requirement.

A Large Government Laboratory Reports :

"Preliminary measurements on the Sample No. 878, Type 120SIF resistors have indicated that these resistors should fulfill the requirements of the intended service. Over a frequency range from 6 to 15 Mc and with six units connected in parallel the impedance ($R \pm jX$) varied from $49 + j4.3$

to $51 + j6.3$. At a frequency of 10 Mc and with each unit measured singly, the resistance of six units varied from 295 to 306.5 ohms and the reactance varied from 0 to -4.2 ohms. The higher reactance obtained for the parallel arrangement is partially due to the necessary connecting buss bars."

SPRAGUE ELECTRIC COMPANY

RESISTOR DIVISION

NORTH ADAMS, MASS.

SPRAGUE KOOLOHM RESISTORS

Reg. U. S. Pat. Off.

WIRE-WOUND POWER TYPES • BOBBIN TYPES • METER MULTIPLIERS • MEGOMAX, ETC.

**NEW... an
ELECTRONIC STOPWATCH
for microsecond timing
and high-speed counting**

**2 models
2 ranges**

TYPE WF-99A measures time intervals up to 0.1 second in one-microsecond steps. Counts at speeds up to 1,000,000 per second.

TYPE WF-98A measures time intervals up to one second in five-microseconds steps. Counts at speeds up to 200,000 per second.

- Extreme accuracy maintained by temperature-controlled, crystal oscillator
- Silent operation—no moving parts to wear out
- Direct reading—figures in columns light up

THIS *electronic* time-interval counter makes it easy for you to accurately time or count operations too fast for mechanical counters. There are no moving parts to wear out prematurely under the strain of high-speed, continuous service.

Counting or measuring is started and stopped by means of electrical impulses. Results are read directly each time the stopping action is triggered.

Here are a few of the many ways you can use this new instrument profitably:

For Measuring: Velocities and accelerations of projectiles, etc.; opening and closing time of circuit breakers

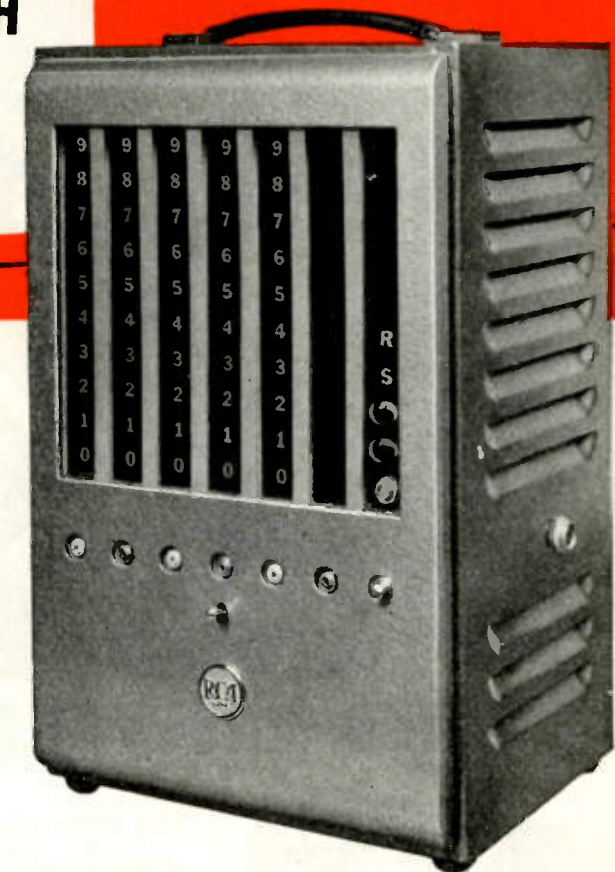

and relays; electric impulses from generators, switches, and amplifiers.

For Counting (when used with phototube equipment): Items on rapid conveyors; drops falling from viscosity testing apparatus; rpm.

For Built-in Applications: As part of electronic calculators; with industrial control devices for control based on a preselected number of items. Counts pills, packages, etc.

Size: 17 inches high, 11 inches wide, 9 inches deep.
Use the coupon below for additional information on how this instrument can help you.



**TEST AND MEASURING EQUIPMENT
RADIO CORPORATION
of AMERICA**

**ENGINEERING PRODUCTS DEPARTMENT
CAMDEN, N. J.**

In Canada: RCA VICTOR Company Limited, Montreal

**Radio Corporation of America
Dept. 67-H, Test and Measuring Equipment Section
Camden, New Jersey**

Please send me the complete story on the new RCA Time-Interval Counters for microsecond timing and high-speed counting.

Name _____

Company _____

Street _____

City _____ Zone _____ State _____



STACKPOLE

FIXED AND VARIABLE RESISTORS



DEPENDABLE LOW-COST SWITCHES

Line, Slide, Rotary Action Types
Ideal for radios, toys and all electrical equipment where high-grade but inexpensive switching is required. Available in standard types to meet almost any requirement. Write for Catalog RC6.

One of the nation's largest producers. Stackpole offers a dependable source of supply for both fixed and variable resistors for a wide variety of applications. Fixed types include $\frac{1}{2}$ - and 1-watt insulated units in smallest sizes consistent with modern performance demands. Variables include standard-size units, midgets, sealed designs and numerous special types. Write today for Stackpole Electronic Components Catalog RC6.

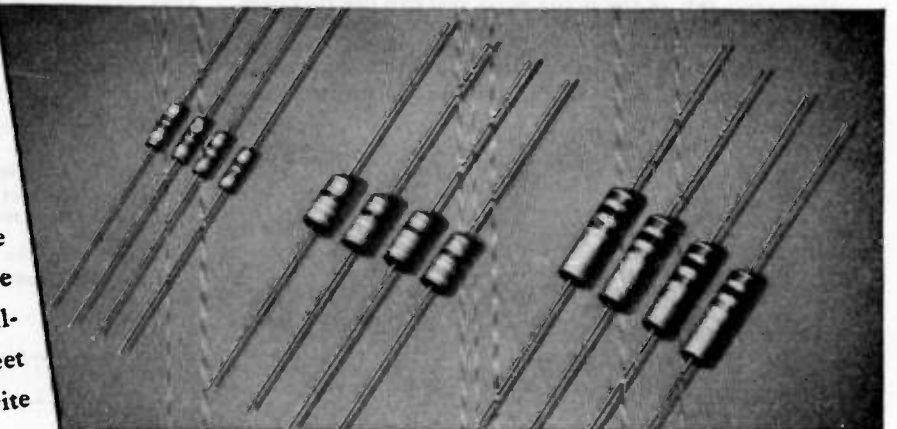

STACKPOLE CARBON COMPANY
(Electronic Components Division)
ST. MARY'S, PA.

VITAL DEVELOPMENTS IN NEW 889R-A

these bring impressive improvements in:

1 — MECHANICAL STRENGTH

2 — HIGH FREQUENCY OPERATION AT PEAK VOLTAGE LEVELS

REPORT....

Summary of Developments

Both filament and grid structures are mounted from one piece, oxygen free, high conductivity copper supports (A) making possible the use of heavy shoulder sections (B). The older, outmoded structure necessitated both the internal brazing of thimble and the external brazing of a small reinforcing disk. Complete elimination of the brazing procedure eliminates not only a weaker mechanical area but also its detrimental effects on the copper and the glass seal. A strong conical form (C) replaces the less desirable cylindrical form at the seals (D). The anode and grid shields (E) have been relocated and redesigned.

Summary of Tests

Distortion: Equal forces were applied to the old and new structures (Fig. 1). The old structure was heavily distorted; the new structure showed no change. Force on the new structure was increased in the endeavor to distort it, but the glass dish invariably failed first (Fig. 2).

Thermal Fatigue: At the end of 200 cycles no apparent fatigue fail-



ure was discernible, thus assuring freedom from grid-filament shorts caused by stresses on the terminals.

Copper Seals: Copper seals were chosen for this tube because the pure metal is non-magnetic, has very low rf resistance and high conductivity. The seals were not heated by rf during operation. Terminals ran much cooler.

Electric Field: Relocation and redesigning of the anode and grid shields reduced the high concentration of the electric field in the glass envelope. Glass heating and resultant punctures were traced to this concentration in the out-moded design.

Conclusion: The redesigning has resulted in an impressive increase in mechanical strength and improvement in high frequency operation at peak voltage levels.

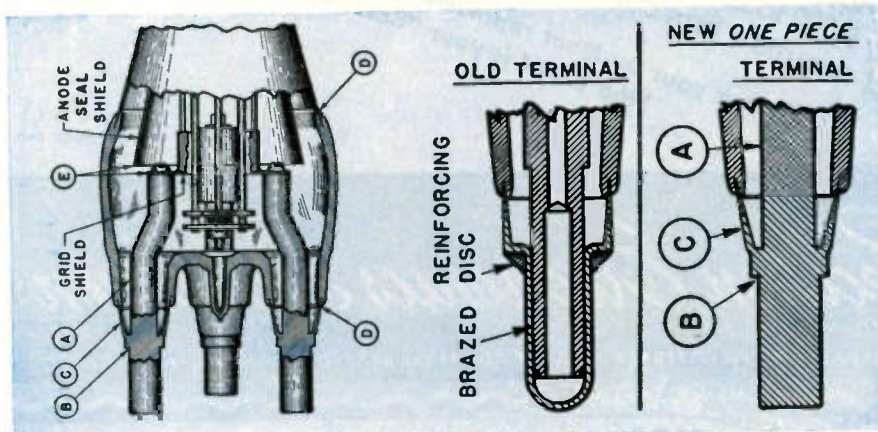

WRITE FOR technical rating and data sheets.

**AMPEREX
ELECTRONIC
CORPORATION**



25 WASHINGTON STREET, BROOKLYN 1, N. Y.
In Canada and Newfoundland: Rogers Majestic Limited
622 Fleet Street West, Toronto 28, Canada

CHOOSE

DUMONT

FOR THE BEST IN TELEVISION

FROM ANY ANGLE

IT'S YOUR "BEST BUY"



IT'S DU MONT'S

TYPE 12JP4 TELETRON

**for
ECONOMY
PERFORMANCE
DEPENDABILITY**

▶ Du Mont's Type 12JP4, using magnetic deflection and focus, is a "natural" for installation in television receivers in which cabinet depth is a major consideration. The Type 12JP4 has an over-all length of 17 1/2 inches—slightly less than that of a standard 10-inch tube; yet it provides a picture which is one-third larger, or approximately 7 3/4 by 10 1/4 inches. The short physical length and the standard duodecal base keep your production cost down. Optimum performance calls for a power supply of only 8,000 to 10,000 volts. The standard flush terminal ball contact assures a firm connection of the anode.

▶ Ask your Du Mont representative to prove that the 12JP4 is your "Best Buy."

© ALLEN B. DUMONT LABORATORIES, INC.

DUMONT

Precision Electronics & Television

ALLEN B. DUMONT LABORATORIES, INC., PASSAIC, NEW JERSEY • CABLE ADDRESS: ALBEEDU, PASSAIC, N. J., U. S. A.



FOR
vhf
uhf
shf

UNRIVALED MECHANICAL CHARACTERISTICS

LOW LOSS COAXIAL LINE SPACERS CUSTOM MADE OF ALSIMAG 243

The mechanical properties of AlSiMag 243, coupled with excellent dielectric characteristics, make this material highly desirable for vhf, uhf and shf coaxial line insulators. This permanently rigid, mechanically strong material does not leave conducting paths after flashover. It does not warp or distort with age.

Coaxial line spacers of AlSiMag 243 are custom made to your design and to

the tolerances you specify. Extremely close tolerances involve commensurate cost. The material is non-hygroscopic. Glazed finish available if desired.

A coaxial line is expensive. Electric power at high frequencies is expensive. Repairs to a coaxial line are expensive. Thus it is economy to use permanently stable, mechanically strong, low loss insulation . . . AlSiMag 243.

ABBREVIATED PROPERTY CHART ALSIMAG 243

(Complete chart on request)

Softening Temperature	2624° F
Resistance to Heat (Safe limit for constant temperature)	1832° F
Tensile Strength—lbs. per sq. in.	10,000
Compressive Strength—lbs. per sq. in.	85,000
Flexural Strength—lbs. per sq. in.	20,000
Dielectric Constant	1 MC.....	6.2
	10 MC.....	6.2
	100 MC.....	6.1
Power Factor	1 MC.....	.0004
	10 MC.....	.0003
	100 MC.....	.0003
Loss Factor	1 MC.....	.0025
	10 MC.....	.0019
	100 MC.....	.0018

ALSiMAG
TRADE MARK REGISTERED U. S. PATENT OFFICE



Original Award July 27, 1942
 Second Award February 13, 1943
 Third Award September 25, 1943
 Fourth Award May 27, 1944
 Fifth Award December 2, 1944

AMERICAN LAVA CORPORATION

CHATTANOOGA 5, TENNESSEE
 43RD YEAR OF CERAMIC LEADERSHIP

ENGINEERING SERVICE OFFICES:

ST. LOUIS, Mo., 1123 Washington Ave., Tel: Garfield 4959 • NEWARK, N. J., 671 Broad Street, Tel: Mitchell 2-8159
 CAMBRIDGE, Mass., 38-B Brattle St., Tel: Kirkland 4498 • CHICAGO, 9 S. Clinton St., Tel: Central 1721
 SAN FRANCISCO, 163 Second St., Tel: Douglas 2464 • LOS ANGELES, 324 N. San Pedro St., Tel: Mutual 9076

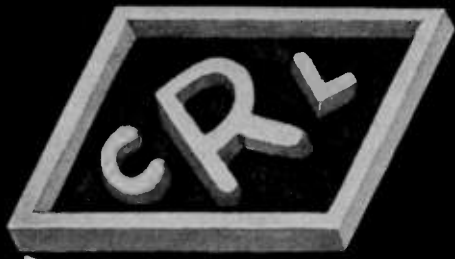

$CQ (bsmc) + ed + \frac{73c}{7s(8at)} + 4(ii) = (Tfp + eoi)(iyUHFe) *$



* CENTRALAB Quality button silver mica capacitors + early delivery + 73 combinations made up of 7 styles with 8 available terminals + 4 individual inspections (capacitance, power factor, voltage breakdown and leakage resistance) = Trouble free performance and ease of installation in your Ultra High Frequency equipment.

Send for Bulletin 586

Centralab

Division of GLOBE-UNION INC., Milwaukee

PRODUCERS OF



Silver Mica Capacitors
Bulletin 630

Ceramics
Bulletin 720

Ceramic High Voltage Capacitors
Bulletin 630

Ceramic Trimmers
Bulletin 630

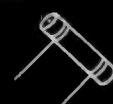
Radiohms
Bulletin 697

Tubular Ceramic
Capacitors
Bulletin 630

Selector Switches
Bulletin 722

Ceramic Plate Capacitors
Bulletin 630

MAKING TUBES IS EASY

If **YOU**
KNOW HOW!

HYTRON KNOW-HOW

IS MODERN

SUPPOSE you were given the job of making certain that micas for Hytron tubes were punched exactly to specifications. How would you go about it? You might use a gage or a precise rule. For a modern, faster, more accurate method, however, you would probably choose the illustrated J & L comparator.

The light beam of the comparator would project optically the magnified image of the mica. By adjusting precision controls, you could then compare visually to .0001 inch the dimensions and orientations of the mica's holes with allowable tolerances in the factory specification book.

That is the way this Hytron inspector is doing the job. Note the tiny mica just below the circular screen. Observe the image magnified 20 times. Many other Hytron tube parts are checked in this manner: plates, shields, leads, cathode sleeves, radiators, grids, ceramic insulators, filament springs.

The comparator is only one of numerous modern inspection tools employed by Hytron's Materials In-

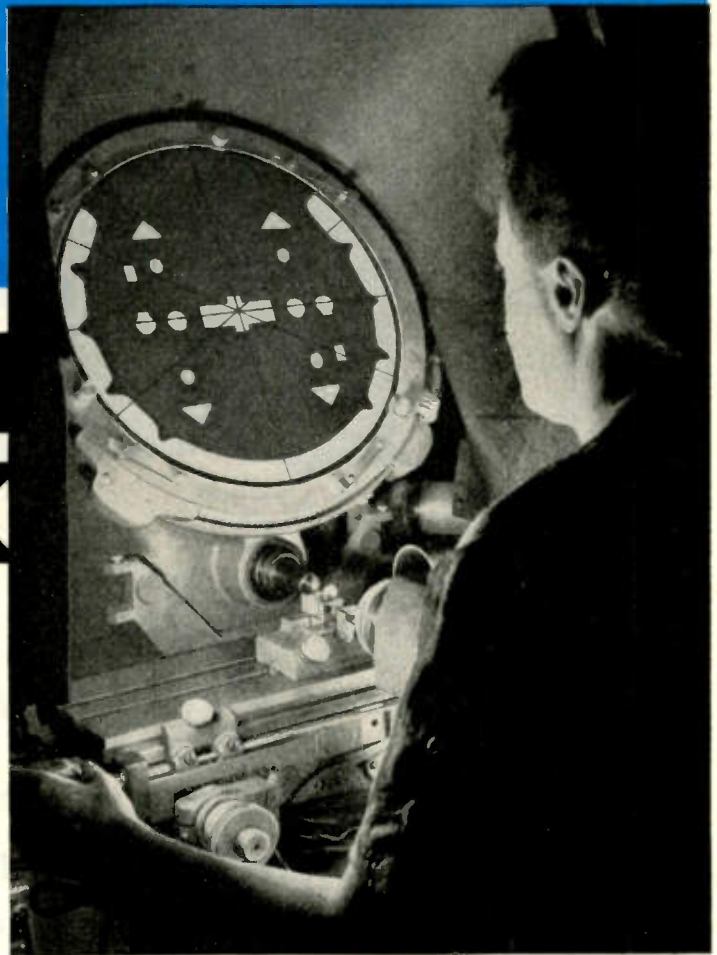

spection Department. For example, a Scott wire tester records graphically elongation, yield point, and breaking load of heater, filament, and grid wire. An amazing variety of precision balances, gages, and micrometers checks parts to .01 milligram or .0001 inch. Qualitative and quantitative chemical and metallurgical analyses assure adherence to specifications of coatings and alloys.

Every modern method is used to maintain exacting control over every part that goes into every Hytron tube you buy. If there is a newer way to do the job better — easier — Hytron is alert to expand the know-how which means the best in tubes for you.



SPECIALISTS IN RADIO RECEIVING TUBES SINCE 1921

HYTRON
RADIO AND ELECTRONICS CORP.

MAIN OFFICE: SALEM, MASSACHUSETTS



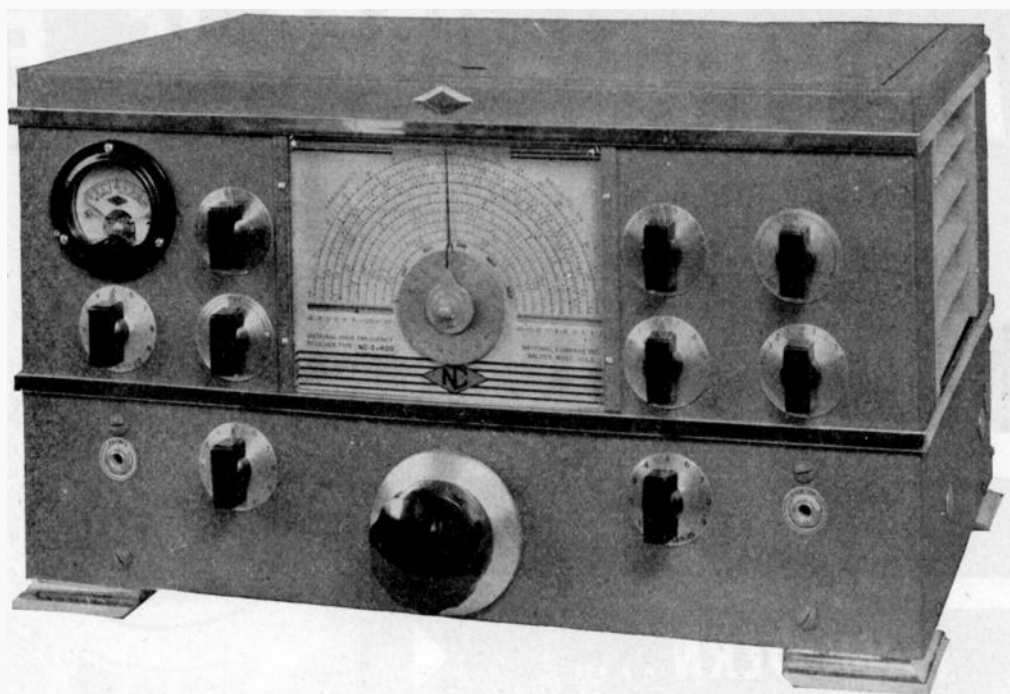

THE NC-2-40D

with amateur band coverage

Every feature the amateur needs is found in the superb NC-2-40D receiver. Special expanded coil ranges for the 10, 20, 40 and 80 meter bands are included in addition to general coverage from 490 Kc. to 30 Mc. Each amateur band is spread over 80% of the dial range and the full vision dial shows your location in the band at a glance. Stability and sensitivity are outstanding. A wide range crystal filter gives optimum selectivity under all conditions. The series-valve noise limiter, the AVC, beat oscillator, tone control and S-meter are among the many auxiliary circuits that contribute toward the all-around excellence of the NC-2-40D.

See it at your dealer's.



NATIONAL COMPANY, INC., MALDEN, MASSACHUSETTS

New!

Series 200

A RELAY BY GUARDIAN with Interchangeable Coils

BUILT IN TWO PARTS

A. C. Coil Assemblies available for 6 v., 12 v., 24 v., 115 v.
D. C. Coil Assemblies available for 6 v., 12 v., 24 v., 32 v., 110 v.

★ Two basic parts—a coil assembly and a contact assembly—comprise this simple, yet versatile relay. The coil assembly consists of the coil and field piece. The contact assembly consists of switch blades, armature, return spring, and mounting bracket. The coil and contact assembly are easily aligned by two locator pins on the back end of the contact assembly which fit into two holes on the coil assembly. They are then rigidly held together with the two screws and lock washers. Assembly takes only a few seconds and requires no adjustment on factory built units.

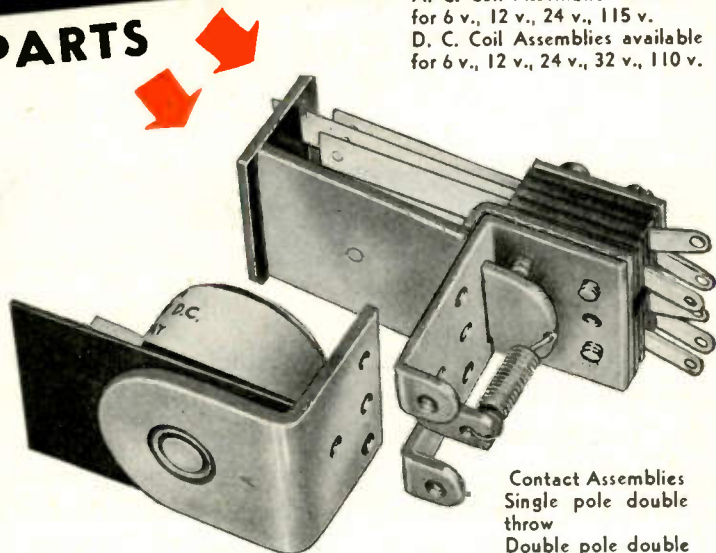

Series 200 Relay

Contact Assemblies
Single pole double throw
Double pole double throw

On Sale at Your nearest jobber NOW!

See it today! . . . this amazing new relay with interchangeable coils. See how you can operate it on any of nine different a-c or d-c voltages—simply by changing the coil. Ideal for experimenters, inventors, engineers.

TWO CONTACT ASSEMBLIES

The Series 200 is available with a single pole double throw, or a double pole double throw contact assembly. In addition, a set of Series 200 Contact Switch Parts, which you can buy separately, enables you to build dozens of other combinations. Instructions in each box.

NINE COIL ASSEMBLIES

Four a-c coils and five d-c coils are available. Interchangeability of coils enables you to operate the Series 200 relay on one voltage or current and change it over to operate on another type simply by changing coils.



Your jobber has this sensational new relay on sale now.
Ask him about it. Or write for descriptive bulletin.

GUARDIAN ELECTRIC

J 8261 W. WALNUT STREET

CHICAGO 12, ILLINOIS

A COMPLETE LINE OF RELAYS SERVING AMERICAN INDUSTRY



LABORATORY INSTRUMENTS FOR SPEED AND ACCURACY

A New Versatile -hp- Power Supply Unit

- Portable
 - Compact
 - Light Weight
 - 1% Regulation
 - Low Cost:
- \$75.00**

New -hp- Model 710A

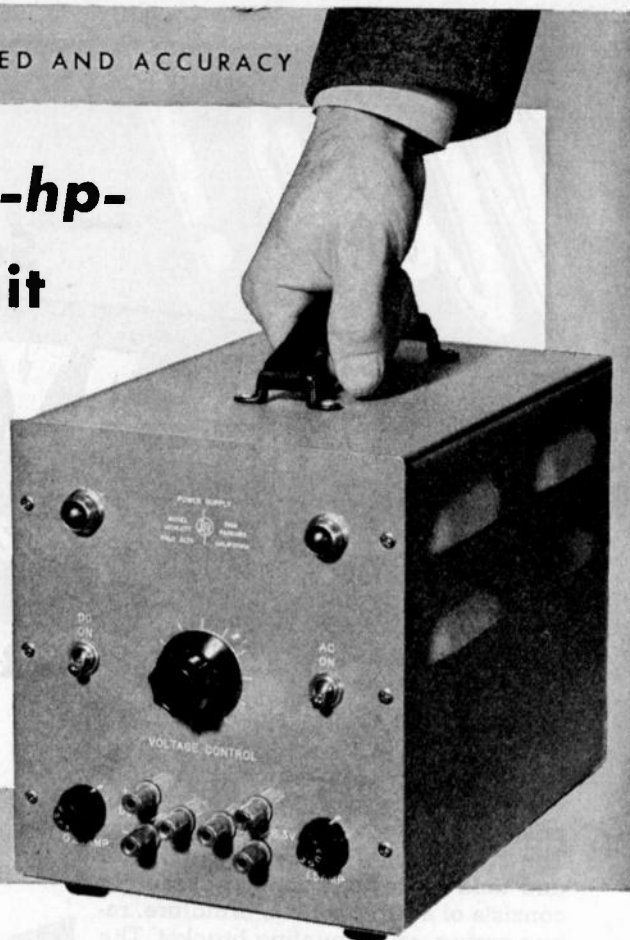

With good regulation, light weight and small physical size, the new -hp- Model 710A Power Supply is now available at the exceptionally low price of \$75.00. Every laboratory and production department will find hundreds of uses for this versatile power source. The low cost makes it practical and economical to utilize several of them.

RANGE 180-360 VOLTS

The -hp- Model 710A Power Supply will deliver any required voltage between 180 and 360 volts, with less than 1% variation for output currents of from 0 to 75 ma. (Maximum current is 100 ma).

Line voltage variations of $\pm 10\%$ cause less than 1% change in output voltage.

Since total noise and hum output is less than .005 volts for any condition of operation, the -hp- Model 710A may be used to supply low-level, high-gain amplifier stages without the necessity of additional filtering.

6.3 FILAMENT VOLTS

Either positive or negative terminal may be grounded to provide maximum flexibility. To increase its usefulness even more, the -hp- Model 710A supplies up to 5 amps at 6.3 volts AC for heating fila-

ments. Either terminals or center-tap may be grounded.

These features, combined with its compact portability, make the -hp- Model 710A the ideal power supply for general use. It can simplify your equipment problem tremendously. Get your order in early for immediate delivery.

SPECIFICATIONS

Supplies any DC voltage between 180 and 360

Either positive or negative terminal may be grounded

Small size, consumes a minimum of bench space

Holds DC voltage constant from 0 to 75 ma load

Holds DC voltage constant with $\pm 10\%$ change in line voltage

Low AC ripple output

Low cost . . . \$75.00

HEWLETT-PACKARD COMPANY

1198 D • PAGE MILL ROAD • PALO ALTO, CALIFORNIA

Audio Frequency Oscillators

Signal Generators

Vacuum Tube Voltmeters

Noise and Distortion Analyzers

Wave Analyzers

Frequency Meters

Square Wave Generators

Frequency Standards

Attenuators

Electronic Testmeters





SYMBOL OF FIDELITY...

Fidelity to the world's most critical employer . . . the international press . . . Fidelity to the task of engineering, developing and fabricating communication equipment and systems to stand the gaff of delivering tens of thousands of words of vital, high speed, radio communications traffic each day as demanded by the press of the world.

Back of this Press Wireless Symbol of Fidelity is an organization of men who for years have been charged with the responsibility of planning, installing and operating the vast array of equipment which makes up the Press Wireless international radio press circuits.

The communication equipment, designed and fabricated to serve the international press, is now available to all who require dependable radio communication equipment and systems.



PRESS WIRELESS MANUFACTURING
CORPORATION

Executive Offices: 38-01 35th AVENUE, LONG ISLAND CITY 1, NEW YORK

Introducing... the new Aerovox Series 83

PLASTIC-CASE PAPER TUBULAR

that withstands

HEAT and HUMIDITY



Combination of special plastic casing and special sealing compounds for ends, insures immunity to moisture.

Already rated for operation at maximum temperature of 95° C. (203° F.).

Will not deteriorate under normal storage conditions.

Overall dimensions identical with those of Aerovox paper tubulars of corresponding voltages and capacitance values.

Somewhat higher in cost than corresponding paper tubulars.



"Slick as a Seal"

● Forget about that melting and dripping wax when it comes to tubular capacitors operating at elevated temperatures. Especially in auto radios. Also forget about humidity; capacitors sticking together and picking up dirt; premature breakdown.

The new Aerovox plastic-case bonded-seal tubulars (Series -83) now protect your good name with performance insurance. Slick as a seal, these clean, bright, handy tubulars are immune to temperatures ranging from sub-zero cold up to sizzling heat, and

impervious to moisture penetration.

This latest Aerovox development (patents pending) overcomes usual objections to paper tubulars for the *more critical* applications. The rigid plastic case with bonded-seal ends, provides real protection for the capacitor section. Overall wax dip becomes a thing of the past, while rigid humidity tests are readily met.

Simply install them—forget them—and be insured!

● Write for further details...

FOR RADIO-ELECTRONIC AND INDUSTRIAL APPLICATIONS



AEROVOX CORPORATION, NEW BEDFORD, MASS., U.S.A.

SALES OFFICES IN ALL PRINCIPAL CITIES • Export: 13 E. 40th St., New York 16, N. Y.

Cable: 'ARLAB' • In Canada: AEROVOX CANADA LTD., HAMILTON, ONT.

There's an "Eveready" Radio Battery for any receiver you design!



For Pocket Radio Receivers: 1/2-ounce, 1.5-volt No. 915 "A" Battery (left) and 1 1/2-ounce, 22 1/2-volt No. 412 "B" Battery (right) comprise complete power complement.



For Home Radios: New No. 754 "A-B" Pack gives same voltages, same capacity, as older, larger No. 748 — permits smaller, lighter radios.



For Portable Receivers: "Eveready" No. 754 is the first "Mini-Max" "A-B" portable battery pack. Delivers 90 volts plate; 7 1/2-9 volts filament supply.

TYPES	VOLTAGE	LENGTH	WIDTH	HEIGHT	TERMINALS	SUGGESTED CURRENT RANGE	WEIGHT BATTERY
"A-B" PACK FOR HOME RECEIVERS							
754	7.5 & 9 A	10 1/2"	3 1/4"	4"	Socket —, +7.5 & 9	A: 50 m.a.	6 lb. 8 oz.
	90 B				Socket —, +90	B: 5.0 to 15.0 m.a.	
"A-B" PACK FOR PORTABLE RECEIVERS							
758	1.5 A	10 1/8"	4 1/8"	6 1/8"	Socket —, +1.5	A: 200-300 m.a.	14 lb. 8 oz.
	90 B				Socket —, +90	B: 7.0-12.0 m.a.	
"A" BATTERIES FOR HOME RECEIVERS							
A-1300*	1.25	5 1/8"	4 1/2"	8 5/8"	Socket —, +1.25	100-600 m.a.	5 lb. 13 1/2 oz.
#6 Ignitor	1.5	2 5/8" D		6 5/8"	Screw —, +1.5	100-250 m.a.	2 lb. 2 oz.
"B" BATTERY FOR HOME RECEIVERS							
487	45	5 3/8"	2 3/8"	7 1/4"	Socket —, +22.5, +45	7.0-12.0 m.a.	4 lb. 4 oz.
"A" BATTERIES FOR PORTABLE RECEIVERS							
718	6	3 1/8"	2 3/4"	5 1/2"	Socket —, +6	50 m.a.	2 lb. 13 oz.
741	1.5	3 7/8"	2 1/8"	5 3/8"	Socket —, +1.5	100-350 m.a.	2 lb. 13 oz.
742	1.5	2 3/8"	2 3/8"	4"	Socket —, +1.5	100-250 m.a.	1 lb. 6 oz.
743	1.5	3 1/8"	2 3/8"	4 3/8"	Socket —, +1.5	100-300 m.a.	2 lb. 1 oz.
745	1.5	3 3/8"	1 7/8"	10 3/8"	Socket —, +1.5	100-350 m.a.	2 lb. 13 oz.
746	4.5	3 1/8"	1 7/8"	4 3/8"	Socket —, +4.5	50 m.a.	1 lb. 4 oz.
747	6	3 7/8"	1 7/8"	10 3/8"	Socket —, +6	50 m.a.	2 lb. 13 oz.
"B" BATTERIES FOR PORTABLE RECEIVERS							
482	45	3 1/8"	1 3/8"	5 1/2"	Socket —, +45	5.0-15.0 m.a.	1 lb. 14 oz.
"A" BATTERY FOR PERSONAL RECEIVERS							
950	1.5	1 23/64" D		2 3/4"	Flat Contact —, +1.5	25-250 m.a.	3 1/2 oz.
"B" BATTERIES FOR PERSONAL RECEIVERS							
455	45	2 5/8"	1"	3 1/8"	Snap Type —, +45	1.0-10.0 m.a.	8 oz.
467	67.5	2 1/8"	1 3/8"	3 1/8"	Snap Type —, +67.5	1.0-10.0 m.a.	12 oz.
"A" BATTERIES FOR POCKET RECEIVERS							
915	1.5	35/64" D		1 3/8"	Flat Contact —, +1.5	25-100 m.a.	1/2 oz.
1016	1.5	1 5/64" D		2 1/64"	Flat Contact —, +1.5	25-100 m.a.	1.1 oz.
"B" BATTERIES FOR POCKET RECEIVERS							
412	22.5	1 3/2"	5/8"	2"	Flat Contact —, +22.5	0.3-1.0 m.a.	1 1/2 oz.
413	30	1 3/2"	5/8"	2 1/8"	Flat Contact —, +30	0.3-1.0 m.a.	1 2/3 oz.
420	22.5	1 1/8"	3/8"	2 1/8"	Flat Contact —, +22.5	0.5-2.0 m.a.	2 1/2 oz.
430	30	1 1/8"	1"	2 1/8"	Flat Contact —, +30	0.5-2.0 m.a.	3 oz.

*"Air-Cell" Battery

Write for your copy of Battery Engineering Bulletins Nos. 1 and 2

The registered trade-marks "Eveready," "Mini-Max" and "Air-Cell" distinguish products of National Carbon Company, Inc.



NATIONAL CARBON COMPANY, INC.
30 East 42nd Street, New York 17, N.Y.
Unit of Union Carbide and Carbon Corporation



Field Strength Measurements from 88mc to 400mc

Obtain dependable field strength patterns. The new Stoddart Model NMA-5 Field Strength Meter is an instrument designed to acceptable government specifications and standards. The Stoddart Field Strength Meter is a highly sensitive precision type receiver of extreme stability with sufficient amplification to operate a Vacuum Tube Voltmeter as the Indicating Meter.

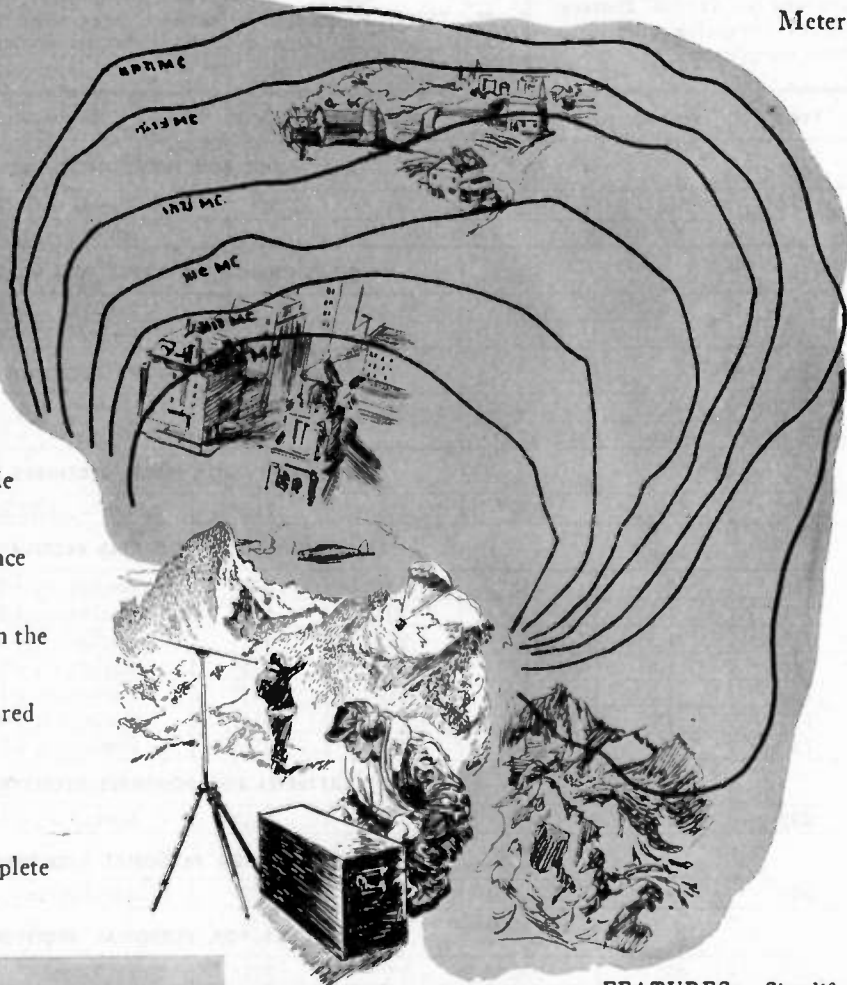

The single band, wide range R.F. Unit offers noiseless tuning from 88 MC to 400 MC. This is made possible by the use of "Butterfly" circuit elements which vary capacitance and inductance simultaneously without the use of sliding contacts. By means of compensator controls on the R.F. and mixer "Butterfly" circuit elements, maximum resonance and sensitivity are assured over the entire frequency range. It is ruggedly constructed and suitably protected to meet the rigid requirements for Laboratory and Field Service. Write for complete specifications and technical data.



MODEL NMA-5

FEATURES: Simplified calibration control, External outlet for recording. Dipole antenna tunable over entire range. Power source 110 Volts A.C., 60 Cycles. Rotary converter for 12- or 24-Volt storage battery operation. Sensitivity — 5 MV to 100,000 MV per meter.

STODDART AIRCRAFT RADIO CO.

GENERAL OFFICE AND FACTORY • HILLSIDE 9294
6644 Santa Monica Boulevard • Hollywood 38, California
 2-159 G. M. Bldg. 2718 Grand Central Terminal Bldg. 110 W. Broadway
 Detroit 2, Mich. New York 17, N.Y. Glendale 4, Calif.
 TRInity 1-9260 MURray Hill 4-2558 CITrus 1-0871



... Impromptu Discussions about Miniature Tubes



"I'm planning to use a Tung-Sol miniature rectifier in it... it's an indirectly heated cathode type. And it has an ample overload safety factor. I've found that their small size not only makes them easily adaptable to both large and small sets, but they're also mechanically superior.

"Take Tung-Sol's 117Z3 for instance. It's a half wave, high vacuum rectifier. Just the tube for a 3-way portable where a battery powered set has to do double duty as a home AC or DC power receiver. For plate and filament power, it more than satisfies the demands of a normal 4, 5, or even 6 tube portable receiver. That's because it supplies 100 ma. continuous current.

It'll deliver 110 volts at full load rating, or 125 volts at half load rating across the input filter condenser. That's with 117 volts rms. supply to the plate. Furthermore, its heater is reliable and consumes less than five watts. It can be placed directly across the normal house lighting system. Its generous cathode structure permits full use of the 6 to 1 peak to average current ratio with a source impedance of 30 ohms and as much as 70 uf input condenser. That's important in simplifying the design for minimum ripple. And the ability of the 117Z3 to withstand

momentary plate current surges of 2 amperes without damage is of particular value in many designs.

"Besides the 117Z3, Tung-Sol makes the 35W4 and 6X4 miniature rectifiers as well as complete super-het kits of miniature tubes. They all provide 'big tube' performance. When I'm designing new circuits and considering the selection of tubes, I always get in touch with the Tung-Sol engineers. You see, they're tube manufacturers, not set builders, so I know I can talk to them in confidence."



TUNG-SOL
vibration-tested
ELECTRON TUBES

TUNG-SOL LAMP WORKS INC., NEWARK 4, NEW JERSEY
Sales Offices: Atlanta • Chicago • Dallas • Denver • Detroit • Los Angeles • New York
Also Manufacturers of Miniature Incandescent Lamps, All-Glass Sealed Beam Headlight Lamps and Current Intermittors

AVAILABLE NOW!

REVERE MAGNESIUM SHEET CAN HELP PUT YOUR
PRODUCT IN A PROFITABLE CLASS BY ITSELF



If sheet metal deliveries are all that is holding up your production, you can quickly give your plant the green light. Revere magnesium alloy sheet can be shipped to you in short order. It comes in a variety of standard sizes and gauges or it will be produced to your specifications—in either of two qualities: Commercial or Aircraft.

This means not only that you can start producing without further delay, but also that you can market a new, improved product without extensive redesign. For Revere magnesium alloys, with nearly the strength of steel, are so feather-light that they often eliminate from a product one-third to one-half of its weight.

Such products offer new values to the user, tend to rise above competition and command more attractive selling prices. That is why Revere magnesium alloy sheet can help you produce *now* at a profit!

Revere magnesium products include sheet, plate and strip, rod and bar, pipe and tube, extruded shapes, and forgings. Revere aluminum alloy products include pipe and tube, extruded shapes, and forgings. A Revere Technical Advisor will gladly consult with you about the application of these metals to your business. For prompt service on magnesium sheet call Revere today.

Like other metals, magnesium is priced by the pound. But a pound of magnesium is so much greater in volume and goes so much further that a price comparison on a cents-per-pound basis is misleading. Always compare magnesium's cost with that of another metal after first finding how many pounds you will save with magnesium. You will likely discover that Revere magnesium alloy is entirely within your reach.

REVERE

COPPER AND BRASS INCORPORATED

Founded by Paul Revere in 1801

230 Park Avenue, New York 17, New York
Mills: Baltimore, Md.; Chicago, Ill.; Detroit, Mich.; New
Bedford, Mass.; Rome, N. Y.—Sales Offices in Principal Cities,
Distributors Everywhere.



many a tough
 spring engineering problem
 has been solved
 by Accurate engineers...

what's yours?



Manufacturers of hundreds of different things have brought their spring design problems to Accurate engineers. And, Accurate engineers have been able to design springs that were exactly right for the jobs. Often, their suggestions have improved product performance, reduced spring costs and even speeded up assembly time. Could you use practical help on your spring engineering problems? Would you benefit by the services of a specialized engineering department... one with millions of springs of experience? Ask an Accurate representative to call.

ACCURATE SPRING MFG. CO.
 3835 W. Lake Street
 Chicago 24, Illinois

Write for
 the
 Accurate
 Handbook
 on
 Springs

Springs

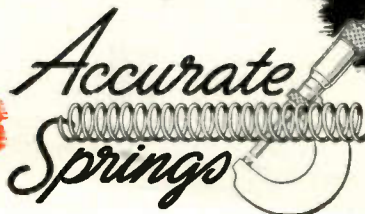

Wire Forms • Stampings

NEW

FM TRANSMITTERS

Unexcelled Performance of Western Electric FM Transmitters

Audio Frequency Response	± 0.25 DB from 30 to 15,000 cycles.
Harmonic distortion—for ± 75 KC swing	Less than 0.5% from 30 to 15,000 cycles.
	—for ± 100 KC swing Less than 0.75% from 30 to 15,000 cycles.
Intermodulation—for ± 75 KC swing	Less than 0.5% for 80% 50 cycles and 20% 1000 cycles; less than 1.0% for 80% 50 cycles and 20% 7000 cycles.
FM noise level	65 DB below ± 75 KC swing.
AM noise level	50 DB below 100% amplitude modulation.
Carrier frequency stability	Less than 2000 cycles deviation (no crystal heater).

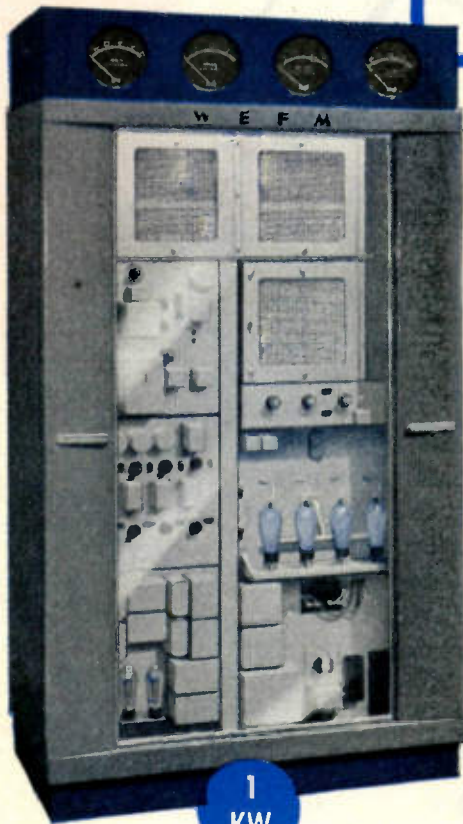

1
KW

Not only a transmitter in itself, this unit serves as the basic driver for all higher powered transmitters.

Has its own rectifier and power components, with completely shielded air-cooled triode in broad-band circuit.



3
KW

BY *Western Electric*

NEW Line is Keynoted by 1, 3 and 10 KW Units

New in appearance, new in performance, these FM transmitters, specially designed for operation on the higher frequencies, incorporate Synchronized Frequency Control, developed by Bell Telephone Laboratories and Western Electric.

Outstanding new cabinet designs keep pace with circuit improvements. For the first time in FM broadcasting, all tubes are visible to the operator at a glance.

For your convenience, all units are standard width, make use of identical door assemblies and

use the same top and side panels. Where more than one unit is used, a common base and meter panel provide single unit appearance.

In addition to the 1, 3 and 10 KW transmitters, Western Electric's full line will include 250 watt, 25 KW and 50 KW units.

For complete information, see your nearest Graybar Broadcast Equipment Representative, or write Graybar Electric Co., 420 Lexington Avenue, New York 17, N. Y.



— QUALITY COUNTS —

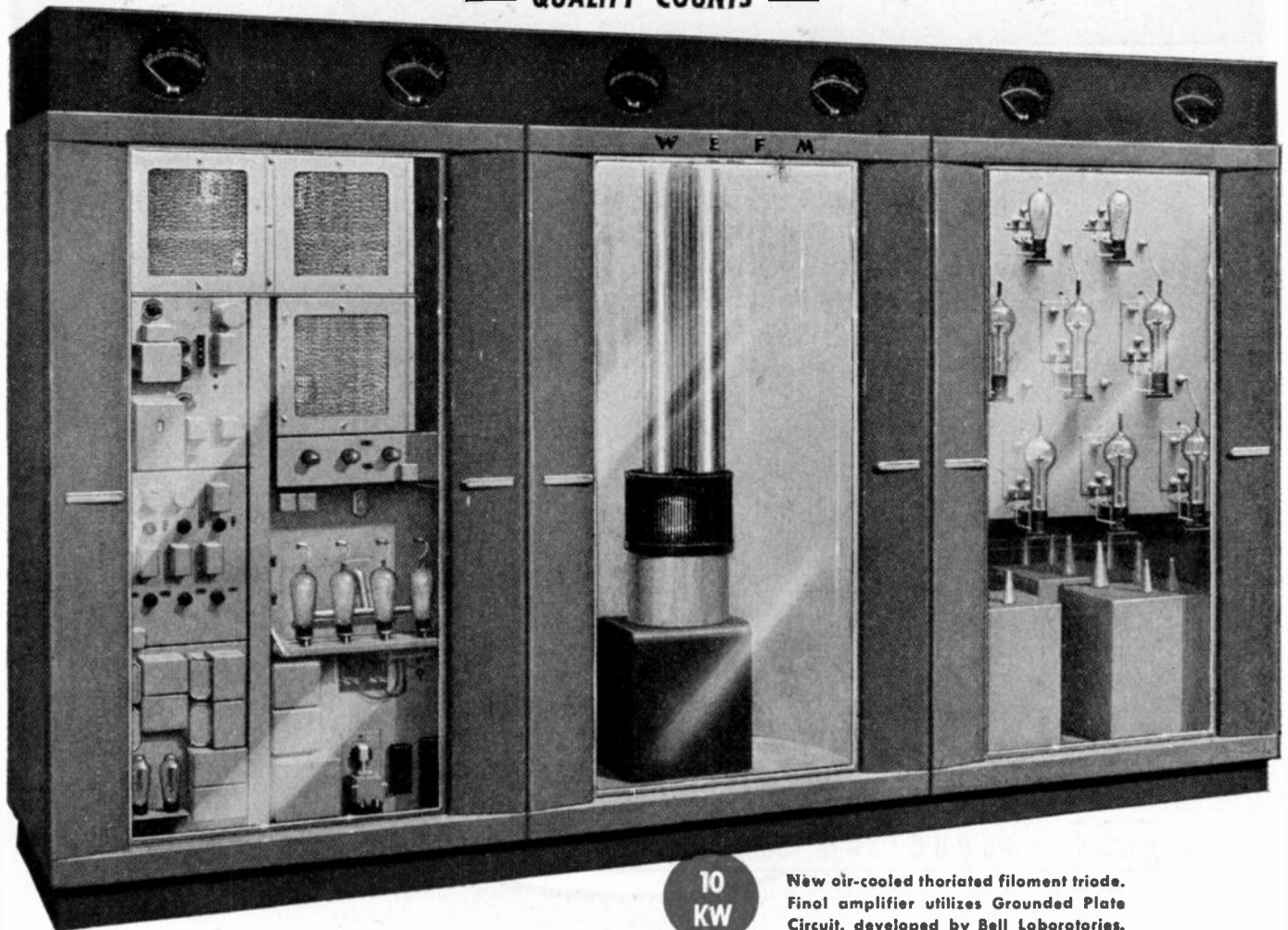

10
KW

New air-cooled thoria filament triode. Final amplifier utilizes Grounded Plate Circuit, developed by Bell Laboratories.

K-TRAN

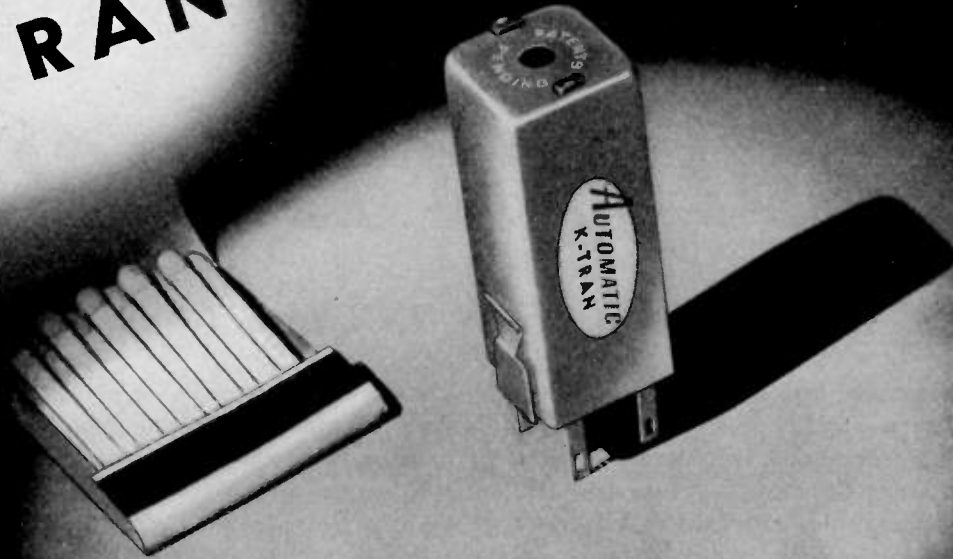

The post-war K-TRAN is an outstanding development in the standardization of I. F. transformer design.

Its ability to reproduce large transformer performance in a small space eliminates the need for large and expensive stocks of many different numbers.

Data sheets on initial types will be ready shortly.



MASS PRODUCTION COILS & MICA TRIMMER CONDENSERS

900 PASSAIC AVE.

EAST NEWARK, N. J.

HERE'S WHY YOU SHOULD USE
THE NEW 
Ceramic Insulated
**MULTI-CONTACT
 CONNECTOR**

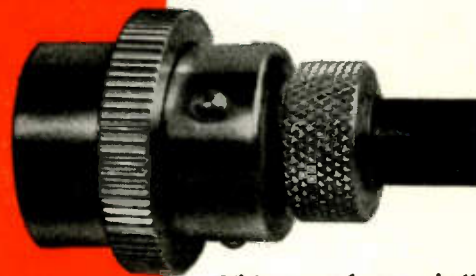
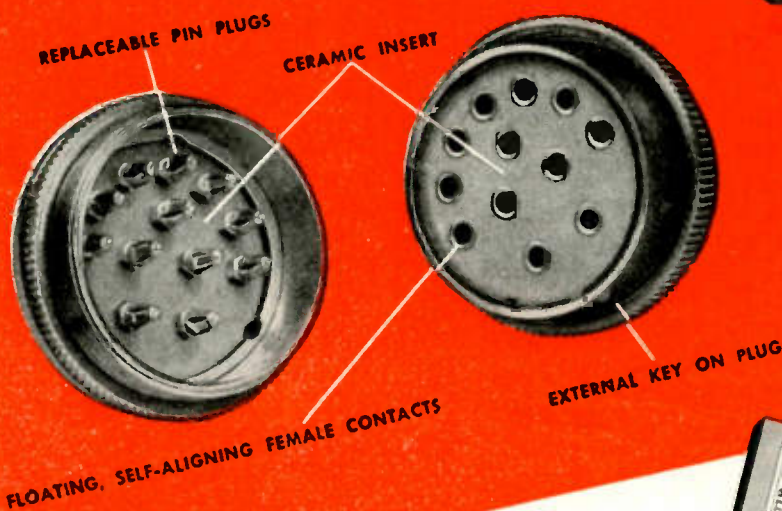

This type of outer shell construction is suitable for multi-conductor cable or open wiring. Shell construction for use with shielded cabling is also available on request.



ALSO AVAILABLE: Free, illustrated catalog of A.R.C. components, including

- Variable and Adjustable Air Condensers
- Sealed Condensers, Chokes and Transformers
- Miniaturized D. C. Relays
- Precision-Built Switches
- Snap-slide Fasteners
- Mica Base Terminal Boards
- Microwave Plumbing and Accessories

Ceramic insulation, the latest development in multi-contact plug and receptacle design, is now brought to you by A.R.C.

The ceramic type of insulation combats the common problem of carbon-tracking due to flashover, thus eliminating the possibility of sustained short circuits and permanent damage to connectors or equipment from this cause.

Other features of the Ceramic-insulated connector include the use of replaceable pin plugs and floating, self-aligning female contacts. Similar in general appearance and dimensions to A.R.C. Bakelite-Insulated Plugs and Receptacles, the Ceramic Type are completely interchangeable with them, and are available in 4, 6, 8, 12, and 19-pin combinations.

Your inquiries are invited. For complete information, write

AIRCRAFT RADIO CORPORATION

708 MAIN ST., BOONTON, NEW JERSEY



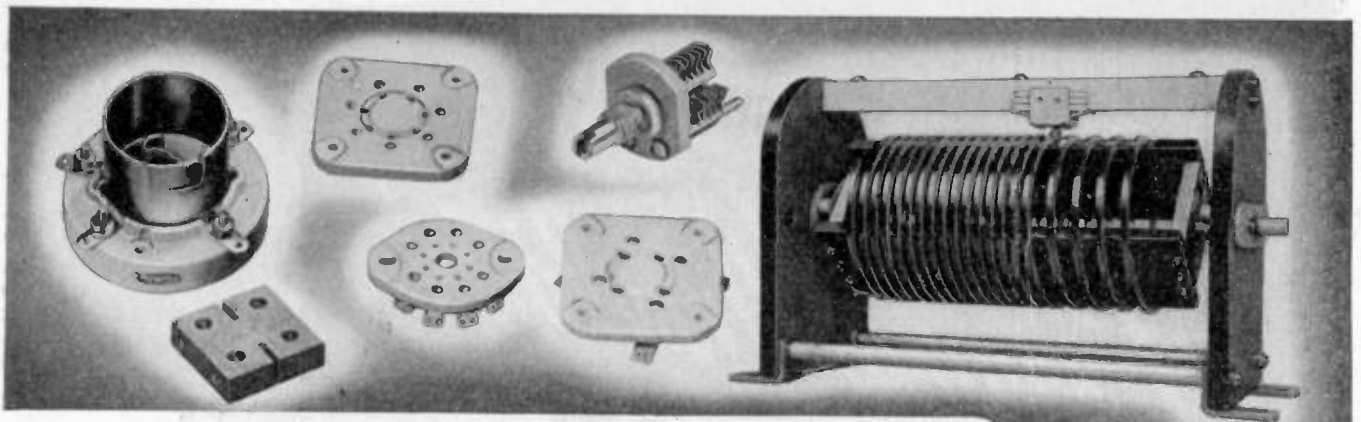

JOHNSON components are widely used and have proven their dependability through outstanding performance in industrial electronic, commercial transmitting and amateur radio applications.

CAPACITORS--Variable and fixed, Air and Pressurized Gas dielectrics. From thimble size miniatures to man-size cast plate models.

INDUCTORS--Wire wound, edgewise-wound copper strip, copper ribbon and copper tubing, plated to meet requirements. Fixed, tapped, continuously variable and variable pitch types.

TUBE SOCKETS--Bayonet, Wafer, Miniature, Acorn and Special Types. Designed to meet the rigid requirements of present day electronic circuits.

INSULATORS--Stand-Off, Thru-Panel, Cone and Antenna. Engineered for maximum mechanical strength and breakdown voltages.

CONNECTORS--Spring Sleeve and Banana Spring type Plugs and Jacks, Tip Plugs and Jacks, Multi-Wire Cable Connectors, Inductor Clips, Soldering Terminals and Tube Cap Connectors.

SHAFT COUPLINGS, R. F. CHOKES, PANEL and **PILOT LIGHTS** and machined **GLASS BONDED MICA PARTS** are among the other outstanding **JOHNSON** components engineered for flexible, trouble-free service.

JOHNSON standard components, only a few of which are shown here, are highly adaptable to special applications. The result to **JOHNSON** customers is time and money saved!

All standard products stocked by leading radio-electronic parts jobbers.

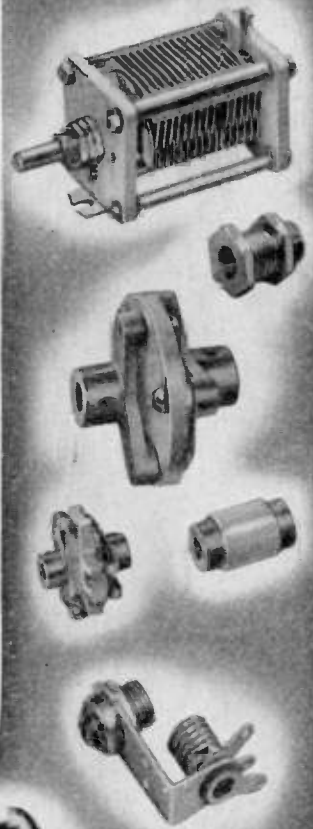

JOHNSON

a famous name in Radio

E. F. JOHNSON CO. • WASECA • MINNESOTA



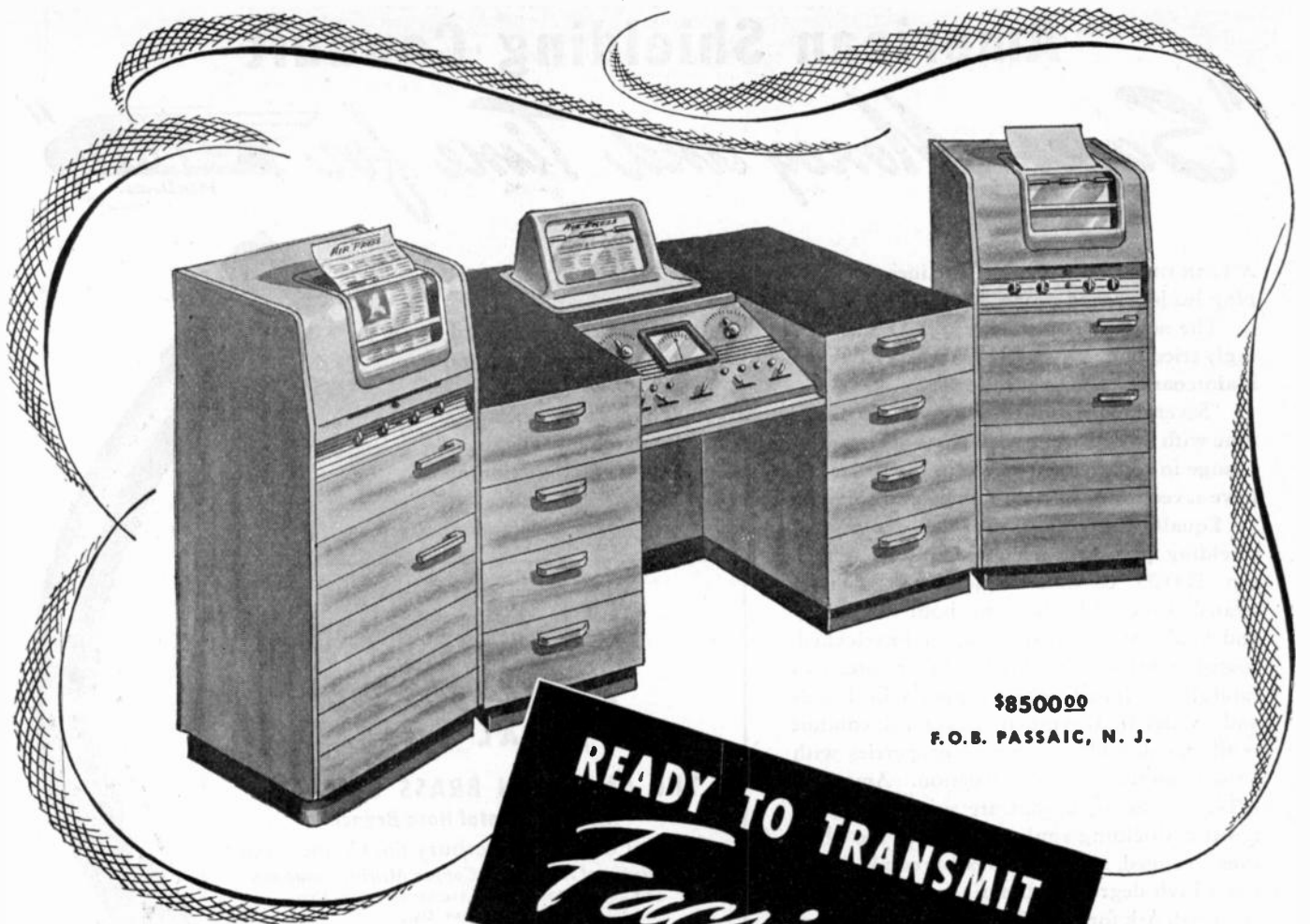

\$8500⁰⁰

F.O.B. PASSAIC, N. J.

READY TO TRANSMIT
Facsimile

HERE COMES

PRINTED-AND-ILLUSTRATED RADIO

The new Finch Telefax Facsimile Broadcasting Equipment embraces every new development of Finch experience and research — backed by more than 100 issued patents and many others pending.

Assembly shown above consists of a monitor control desk flanked by two transmitting scanners, which assure a continuous flow of program material through the transmitter.

Operation is simple, reliable, time-saving, with automatic copy loading controlled by push

button, and automatic return of scanner carriage at end of each page. The extra recorder on the control desk provides a file copy of the program.

The Finch sales contract carries with it complete license benefit and rights under the more than 100 facsimile patents and applications owned by Finch for the use of Finch Facsimile equipment. Orders are now being accepted for fall deliveries. And the cost is much less than some estimates have been. Write for full particulars.

 self-synchronizing
finch facsimile

FINCH TELECOMMUNICATIONS, INC.
10 EAST 40th STREET, NEW YORK 16, NEW YORK
Also manufacturers of Finch ROCKET Antennas for FM Stations.

American Shielding Conduit

"Saves Money and Time for



A YEAR OR SO AGO, Capital Airlines—PCA found that the replacement of spark plug leads reached nearly 50% at 750 hours.

The new American Type HTCD Shielding Conduit assemblies were accordingly tried out, and Luther Harris, Vice President in Charge of Engineering and Maintenance, reports as follows:

"Several American Brass assemblies have reached 3000 hours total operating time with no replacement of parts necessary in the field or at overhaul. The sharp change in replacement rate plus the fewer delays due to harness malfunctioning have saved much of both money and time for Capital Airlines."

Equally important are the exceptional shielding properties characteristic of American HTCD conduit—conclusively demonstrated, time and again, by both laboratory and field tests. Consisting of an interlocked, coated stainless steel flexible inner-core, two carefully designed tinned copper wire braids and a water-tight synthetic jacket, this conduit combines desirable electrical properties with *proven* mechanical construction. American HTCD types of conduit are suitable for any ignition shielding application or for use wherever a rugged, long-lived flexible conduit having a high degree of shielding effectiveness is required. Ask for our "Data Book for Electronics Industries."

48351



American
METAL HOSE

THE AMERICAN BRASS COMPANY
American Metal Hose Branch

General Offices: Waterbury 88, Connecticut
Subsidiary of Anaconda Copper Mining Company
In Canada: ANACONDA AMERICAN BRASS LTD.,
New Toronto, Ont.

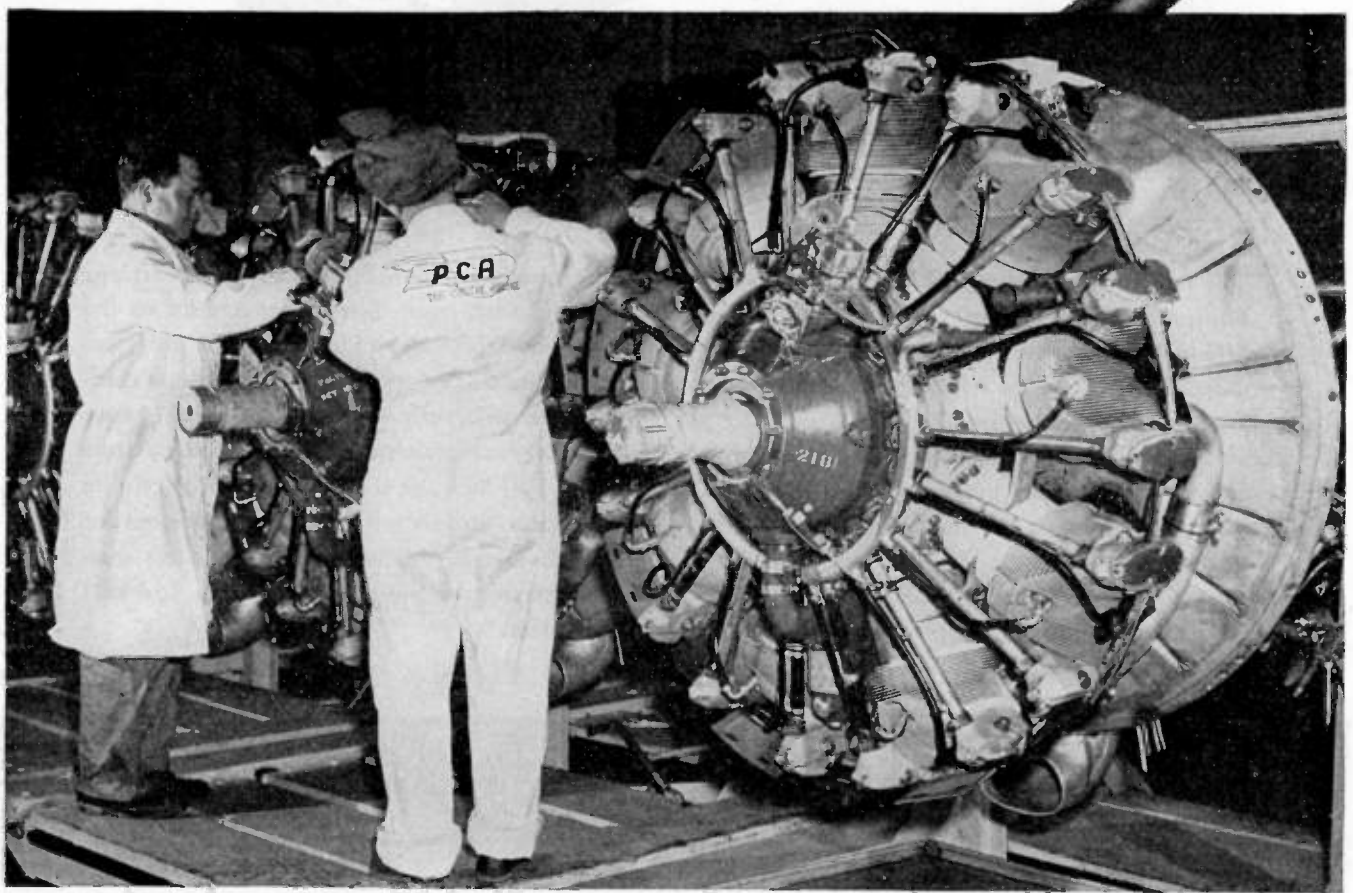

MACHLETT ELECTRON TUBES FOR ALL RADIO TRANSMITTING AND INDUSTRIAL PURPOSES



2C-39



ML-891R



ML-893A



ML-E39RA



ML-889A

MACHLETT LABORATORIES, Incorporated, one of the country's earliest producers of electron tubes, and today the world's largest supplier of tubes for X-ray purposes, brings to the radio and industrial fields its half century of electron tube experience. The tubes illustrated are typical examples of the Machlett line of radio transmitting and industrial tubes.

Machlett's comprehensive background of leadership in the design and production of X-ray tubes places it in a most effective position to meet the increasingly stringent requirements of modern electron tube manufacture. The production methods used in the manufacture of quality X-ray tubes are, more than ever before, essential to meet the constantly increasing requirements for higher power, higher frequencies and higher voltages in practically all fields of electron tube application. Processes essential to assure quality, performance and long useful life at voltages of 50 KV and higher, precision assembly of parts for the accurate control of electron stream, complete and permanent outgassing of the assembled tube and its individual parts have long been characteristic of X-ray tube manufacture and inherent in Machlett's design and productive operation. These skills and techniques developed for, and long used in its X-ray activities, now find unique additional value in their application to electron tubes for radio and industrial purposes.

The Machlett background of almost 50 years of continuous electron tube production, modern, laboratory-like manufacturing facilities, and up-to-the-minute experience assures the user that he will receive tubes engineered and processed for a long life of trouble-free operation.

For complete information write our nearest representative, or the factory at Springdale, Connecticut.

MACHLETT LABORATORIES, INC., Springdale, Connecticut



ML-392



ML-207



ML-830



APPLIES TO RADIO AND INDUSTRIAL USES
ITS **49** YEARS OF ELECTRON TUBE EXPERIENCE

TRUSCON RADIO TOWERS COVER NEBRASKA

For the Nebraska State Safety Patrol!

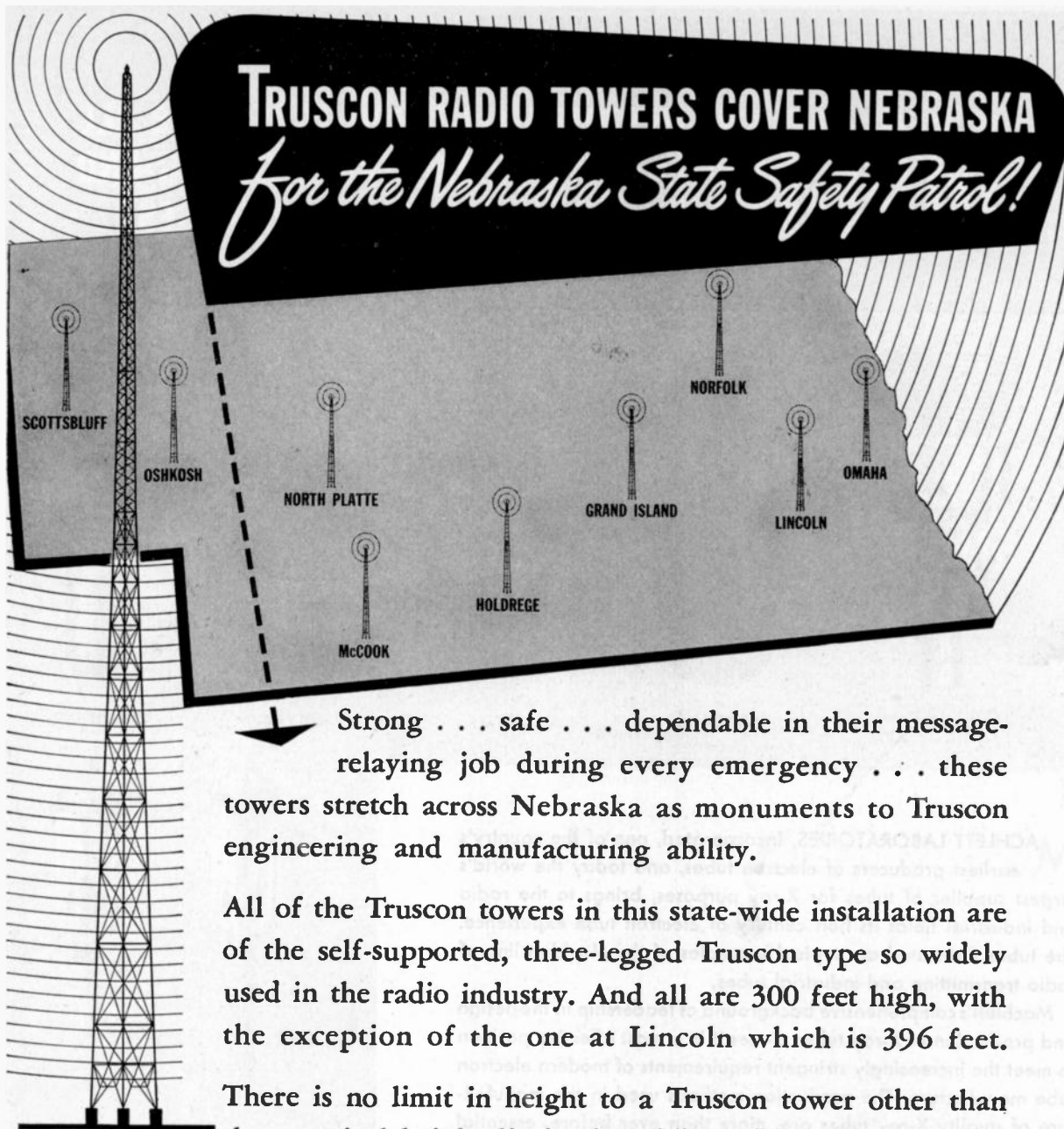

Strong . . . safe . . . dependable in their message-relaying job during every emergency . . . these towers stretch across Nebraska as monuments to Truscon engineering and manufacturing ability.

All of the Truscon towers in this state-wide installation are of the self-supported, three-legged Truscon type so widely used in the radio industry. And all are 300 feet high, with the exception of the one at Lincoln which is 396 feet.

There is no limit in height to a Truscon tower other than the practical height limitation. The tallest towers in the United States today are Truscon built; ie., WNAX at Yankton, South Dakota (912 feet above base insulator) and WKY at Oklahoma City, Okla. (900 feet above base insulator, and designed to support additionally a 50 ft. 6-bay FM antenna).

Experienced Truscon engineers will be glad to help solve your tower problems of today and tomorrow.

TRUSCON STEEL COMPANY

YOUNGSTOWN 1, OHIO • Subsidiary of Republic Steel Corporation

Manufacturers of a Complete Line of
Self-Supporting Radio Towers . . .
Uniform Cross-Section Guyed Radio
Towers . . . Copper Mesh Ground
Screen . . . Steel Building Products.

RAYTHEON

STANDARDIZED SUB-MINIATURE TUBES for Pocket Receivers

Since 1938 Raytheon has pioneered in the design, development and production of small, low drain, long life tubes. These have helped to make possible the modern extremely compact hearing aid.

NOW FOR RADIO RECEIVERS—Now Raytheon announces a kit of flat style, sub-miniature tubes for radio receiver applications. Included are a shielded RF-pentode amplifier, a triode-heptode converter, a diode-pentode detector-amplifier and an output pentode for earphone operation.

MUCH SMALLER RADIOS POSSIBLE—These tubes make it possible to construct radios a fraction the size of conventional "personals," with sensitivity rivaling much larger sets. The tube size is approximately 1 9/16" long and 0.3" by 0.4" in cross section.

SPACE SAVING SOCKETS AVAILABLE—Each tube is available either with long flexible leads for wiring directly into the circuit or with terminal pins for use with small sockets as illustrated. These sockets are available from principal socket manufacturers.

All progressive radio manufacturers anticipate the tremendous possibilities inherent in the small pocket receiver built around Raytheon standard sub-miniature tubes.

Call on Raytheon for every electronic tube need—large or small—for excellence in tube engineering, production and performance.

ELECTRICAL CHARACTERISTICS

(Illustrations Actual Size)

	RAYTHEON 2E32 5AX2	RAYTHEON 2G22 7AX2	RAYTHEON 2E42 6AX2	RAYTHEON 2E36 5AX2
	2E31† 2E32‡ Shielded RF Pentode	2G21† 2G22‡ Triode- Heptode	2E41† 2E42‡ Diode- Pentode	2E35† 2E36‡ Output Pentode
Filament Voltage	1.25 V	1.25 V	1.25 V	1.25 V
Filament Current	50 ma	50 ma	30 ma	30 ma
Max. Grid-Plate Capacitance	0.018 uuf	0.065 uuf‡	0.10 uuf	0.2 uuf
Plate Voltage**	22.5 V	22.5 V	22.5 V	22.5 V
Screen Voltage	22.5 V	22.5 V	22.5 V	22.5 V
Control Grid Voltage*	0	0	0	0
Osc. Plate Voltage	—	22.5 V	—	—
Plate Current	0.35 ma	0.2 ma	0.4 ma	0.27 ma
Screen Current	0.3 ma	0.3 ma	0.15 ma	0.07 ma
Osc. Plate Current	—	1.0 ma	—	—
Transconductance	500 umhos	60 umhos (Gc)	400 umhos	385 umhos
Plate Resistance	0.35 meg	0.5 meg‡‡	0.25 meg	0.22 meg

*With 5 megohm grid resistance connected to F—.

**Higher voltage operation is possible as shown on engineering characteristics sheet available by request.

†Flexible Lead Types.

‡Plug-in Types.

‡‡Approximate conversion Rp.

‡Signal grid to mixer plate Capacitance.



Excellence in Electronics
RAYTHEON MANUFACTURING COMPANY
 RADIO RECEIVING TUBE DIVISION
 NEWTON, MASS. • CHICAGO • LOS ANGELES.

How to select RCA Phototubes

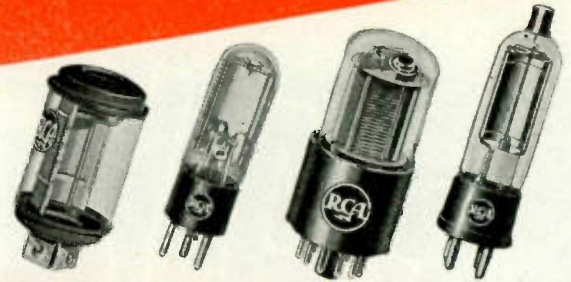

PHOTOTUBES have found such a wide variety of applications that many types have been developed to meet special needs. The complete RCA line includes both gas and vacuum phototubes, with various spectral responses and a variety of sizes and shapes. And for applications requiring extreme sensitivity, RCA supplies multiplier phototubes with various spectral responses within the red to ultra-violet region.

Color Sensitivity: The cathode coating material and the envelope glass determine color sensitivity. RCA phototubes fall into four "color groups":

Use	Tube Types	Maximum Color Sensitivity
With incandescent lamps —and for infra-red application	Vacuum: <u>917, 919, 922, 925</u> Gas: <u>IP40, IP41, 868, 918, 920, 921, 923, 927, 928, 930</u>	Red and infra-red
With incandescent lamps —and for infra-red application	Vacuum: <u>IP22, 926</u> Gas: <u>IP29</u>	Blue light. Approximates the human eye
With light source for calorimetry application	Vacuum: <u>IP39, 929, 934</u> . Gas: <u>IP21, IP37, 931-A</u>	Blue light. Very sensitive to incandescent light at a color temperature above 2700° K.
Far ultra-violet measurement	Vacuum: <u>IP28, 935</u> .	Same as above, but special glass envelope permits high ultra-violet sensitivity

Vacuum-or-Gas or Multiplier-Type: Several important factors to be considered in selecting the general type of phototube for a service are given in the following table. Specific values should be considered in selecting a specific tube type.

Characteristic	High-Vacuum Type	Gas-filled Type	Multiplier Type
Sensitivity	Low	Medium	Very High
Current Output	Low	Medium	Very High
Amplification	1	Up to 10	Up to 2,000,000
Relative signal-to-noise ratio (including amplifier stage)	Low	Intermediate	High
Anode Voids Distortion (audio)	Up to 500 Negligible	Not over 90 Appreciable in same cases	Up to 1250 Negligible
Frequency Range	Limited by capacitance effects	Limited by gas amplification effect	Limited by capacitance effects

Gas phototubes are, at present, extensively used for sound-on-film reproduction and for relay work. Vacuum types are widely used where high sensitivity is not needed; for precision measurements where stability of calibration is essential; and for high-speed work.

Sensitivity: The sensitivity of a phototube may vary according to whether the light change is abrupt or continuous. *Static sensitivity* is the quotient of anode direct current divided by constant light input. *Dynamic sensitivity* is the quotient of the variation

of anode current divided by the variation of light input. The sensitivity of gas phototubes drops off at high audio frequencies.

Optical Systems: The performance of phototubes can be greatly improved by the judicious choice of a suitable optical system.

Mechanical Features: As illustrated above, several types of tubes are available. Space, vibration, directional requirements, insulation, etc., all may affect phototube selection.

Phototube Life: RCA phototubes are inherently sturdy, long-lived tubes and, when operated under recommended conditions, give very reliable service.

Application Hints: Here are a few general suggestions for applying phototubes:

1. In general, for measurement work, a vacuum phototube is required because of its high stability of performance; for relay work the high sensitivity of a gas tube often determines its choice, since high stability is of minor importance.
2. In sensitive relay and measurement circuits where tubes must respond to very small amounts of light, avoid external leakage currents. Keep tube terminals and sockets clean. Erratic leakage currents will affect results.
3. In amplifiers where low leakage is important, select top cap types such as the RCA 917, 919, or 935.
4. Shield phototube and leads to amplifier or relay tubes when amplifier gain or phototube load resistance is high.
5. Where high-frequency response is important, keep phototube leads short to minimize capacitance shunting of output.
6. For constant calibration of high-precision vacuum phototube devices, keep anode potential at or below 20 volts. Keep incident light spread over wide cathode area. Keep current density below 10 uamp. per sq. in.
7. Choice of circuit constants should be based on tests with the equipment operating over the expected range of line-voltage variation, and should provide sufficient circuit adjustment or safety factor to allow for normal characteristic variations between tubes.
8. RCA voltage-regulator tubes can improve phototube circuit performance.
9. Anode characteristic curves on phototubes can be used to predict average performance under given operating conditions.
10. The phototube types underlined in the color tabulation are recommended as RCA Preferred Types for design considerations.

WHAT PHOTOTUBE DO YOU NEED?

If you have a specific application problem or wish further published information on RCA Phototubes and how to use them, write RCA, Commercial Engineering Department, Section D-18H, Harrison, N.J.

THE FOUNTAINHEAD OF
MODERN TUBE DEVELOPMENT IS RCA

RCA PRINCETON LABORATORIES



TUBE DEPARTMENT

RADIO CORPORATION of AMERICA

HARRISON, N. J.

PROCEEDINGS OF THE I.R.E.

AND

WAVES AND ELECTRONS

Published Monthly by

The Institute of Radio Engineers, Inc.

BOARD OF DIRECTORS, 1946

Frederick B. Llewellyn
President

Edmond M. Deloraine
Vice-President

William C. White
Treasurer

Haraden Pratt
Secretary

Alfred N. Goldsmith
Editor

Hubert M. Turner
Senior Past President

William L. Everitt
Junior Past President

1944-1946

Raymond F. Guy
Lawrence C. F. Horle

1945-1947

Stuart L. Bailey
Keith Henney
Benjamin E. Shackelford

1946-1948

Walter R. G. Baker
Virgil M. Graham
Donald B. Sinclair

1946

Ralph A. Hackbusch
Frederick R. Lack
George T. Royden
William O. Swinyard
Wilbur L. Webb
Edward M. Webster

●
Harold R. Zeamans
General Counsel

●
George W. Bailey
Executive Secretary

William H. Crew
Assistant Secretary
Robert B. Jacques
Technical Secretary

●
BOARD OF EDITORS

Alfred N. Goldsmith
Chairman

●
PAPERS REVIEW COMMITTEE

Murray G. Crosby
Chairman

●
PAPERS PROCUREMENT COMMITTEE

Dorman D. Israel
General Chairman
Edward T. Dickey
Vice General Chairman

VOLUME 34

August, 1946

NUMBER 8

PROCEEDINGS OF THE I.R.E.

The Real Economy in Engineering . . . Harold A. Wheeler	526
Harold E. Ellithorn, Chairman, South Bend Subsection, 1946	527
Radar Edwin G. Schneider	528
Discussion on "The Steady-State Operational Calculus," by D. L. Waidelich	
. Nelson F. Riordan and D. L. Waidelich	579
Discussion on "The Image Formation in Cathode-Ray Tubes and the Relation of Fluorescent Spot Size and Final Anode Voltage," by G. Liebmann	
. G. Liebmann and Hilary Moss	580

INSTITUTE NEWS AND RADIO NOTES

I.R.E. People	587
Sections	592
Books:	
"Fundamentals of Alternating-Current Machines," by A. Pen-Tung Sah	
. Reviewed by Frederick W. Grover	594

WAVES AND ELECTRONS

SECTION

Electronics and the Research Physicist . . Stanley V. Forgue	595
Palmer McFadden Craig, Past Secretary-Treasurer, Philadelphia Section	596
Theoretical Response from a Magnetic-Wire Record	
. Marvin Camras	597
Abstracts and References	603
Section Meetings 34A	Positions Open 50A
Membership 36A	Positions Wanted 56A
Advertising Index	70A

Copyright, 1946, by The Institute of Radio Engineers, Inc.

EDITORIAL DEPARTMENT

Alfred N. Goldsmith
Editor

Helen M. Stote
Publications Manager

Clinton B. DeSoto
Technical Editor

William C. Copp
Advertising Manager

Lillian Petranek
Assistant Advertising Manager

Responsibility for the contents of papers published in the PROCEEDINGS OF THE I.R.E. AND WAVES AND ELECTRONS rests upon the authors. Statements made in papers are not binding on the Institute or its members.

Changes of address (with advance notice of fifteen days) and communications regarding subscriptions and payments should be mailed to the Secretary of the Institute, at 450 Ahnaip St., Menasha, Wisconsin, or 330 West 42nd Street, New York 18, N. Y. All rights of republication, including translation into foreign languages, are reserved by the Institute. Abstracts of papers, with mention of their source, may be printed. Requests for republication privileges should be addressed to The Institute of Radio Engineers.



Through long and constructive experience in engineering, certain of the pioneer workers are in a position to present useful and constructive suggestions to the radio-and-electronic engineering fraternity. It is accordingly helpful to present the following editorial by a prominent Fellow of The Institute of Radio Engineers, the Chairman of the I.R.E. Handbook Committee, and a radio physicist of recognized standing. *The Editor.*

The Real Economy in Engineering

HAROLD A. WHEELER

The successful engineer is the one who does more than solve just the problem at hand. He is the one who sees the problem as an example of many problems which have something in common. He seeks and finds the solution for this class of problems, then the example becomes easy.

It is recognized that expediency often must govern a particular job. Too often, however, expediency is taken for granted as the antidote for perfectionism. The engineer must realize that expediency, as a rule, is a luxury he cannot afford. It is a poison which destroys his constructive initiative built on years of training and experience. It is permissible only with this realization, and then only as a minor part of his work. Taken in excess, it reduces him to the level of a tinkerer.

Expediency means solving an easy problem the hard way. The engineer's training and his working time are too valuable to be dissipated in solving a problem the hard way. It is false economy. His job is to find the easy way. Since an exact solution to a practical problem is never possible, the engineer indulges in approximations which make the problem simple enough for an exact solution. While the selection of permissible approximations may require much study, it is the kind of thoughtful analysis and originality which develops the engineer rather than wasting his time and poisoning his initiative.

The real economy in engineering is the best use of every available aid in arriving at an understanding of the problem and an expeditious solution. Understanding a problem does not require a leisurely period of study and research. It requires concentration, enlisting the aid of the best references and charts, practicing on examples, developing new and simpler formulas and charts, outlining the limitations. Once having arrived at a real understanding, the solution of a few examples becomes almost routine.

The pioneering in science will always leave in its wake a great demand for reference material which will aid in the solution of engineering problems by reducing the labor of computation and especially by doing this in such a way as to contribute to the understanding of the solution and its limitations. General principles and graphic viewpoints are the most valuable. The great help already afforded by a few inspired handbooks and textbooks offers the best incentive for unending further effort to present our subject in the most concise form, with every possible short cut to relieve the engineer of unproductive nuisance in thinking, computing, and testing.

The engineer who will advance furthest in his profession, who will contribute the most to science and industry, and who will derive the greatest satisfaction in his work, is the one who works hard to find the easy way.



Harold E. Ellithorn

Chairman, South Bend Subsection, 1946

Harold E. Ellithorn was born on October 11, 1911, at Detroit, Michigan. He received the B.S. degree in electrical engineering in 1934 from Union College, Schenectady, New York. From 1934 to 1935, he held a scholarship at Harvard University and received the M.S. degree in communication engineering. In June, 1935, he joined the engineering staff of the radio tube division of the Sylvania Corporation at Salem, Mass., and in November, 1936, he was appointed supervisor of the engineering laboratory of the tube division at Salem. During the next two years, Dr. Ellithorn was concerned with test equipment and test methods for radio tubes and the study of tube performance in radio and special circuits. In 1938, he left Sylvania to pursue graduate studies in physics at the University of Notre Dame and was a graduate assistant in electrical engineering from 1938 to 1940. In 1940, he became an instructor in the Electrical Engineering Department and in 1943, was

advanced to rank of assistant professor, a post he has held to date. Since 1944, Dr. Ellithorn has also served as special project engineer and consultant for Electro-voicè, Inc., in South Bend. In 1945, he received his doctor's degree in physics from the University of Notre Dame.

Dr. Ellithorn joined The Institute of Radio Engineers as an Associate in 1936, was transferred to Member grade in 1944, and became a Senior Member in 1946. He was one of the charter members of the South Bend Subsection, of which he is at present chairman.

He is the author of articles which have appeared in the PROCEEDINGS and other technical magazines.

Dr. Ellithorn is also a member of the Acoustical Society of America, Eta Kappa Nu, the Society for Promotion of Engineering Education, an Associate member of the American Institute of Electrical Engineering, and Sigma Xi.

Radar*

EDWIN G. SCHNEIDER†

I. INTRODUCTION

SINCE a fairly large percentage of the effort of physicists and electrical engineers in this country and in England was expended on radar development during the war, techniques in electronics have advanced at possibly ten times the normal peacetime rate. The purpose of this paper is to give a brief survey of the wartime developments in electronics and to show how these were used in a few radar sets. Because the applications of radar to civilian activities will probably be of minor importance when compared with the sum total of other electronic applications, this survey makes no attempt to give a complete description of any particular radar set. Those readers who are interested in a detailed description of a radar installation will find complete information on the SCR-268 in the literature.^{1,2} On the other hand, for those readers who are interested in further details of the electronic devices mentioned here, a set of treatises is being prepared. These are to be published by McGraw-Hill during the next year, the royalties to go to the Federal Government.

II. BASIC PRINCIPLES OF RADAR ELECTRONIC TECHNIQUES OF RADAR

1. General

Basically, radar determines the existence of an object by observation of reflected radio energy. In the case of tail-warning radar and one type of air-search equipment mounted on submarines, the prime use is to give warning of the presence of aircraft in the neighborhood, the exact location being a secondary consideration. However, most radar sets are designed to give reasonably accurate information on the position of the objects which are reflecting energy. Bearing or azimuth with respect to north is normally determined by rotating a directional antenna to the position of maximum echo, a process similar to locating an object by use of a searchlight beam. Similarly, one method of measuring angle of elevation is to tilt the antenna to center the beam on the target. In contrast with the optical case, in which range must be measured by difficult triangulation methods, radar simply measures the time for a short pulse of radio energy to travel to the target and return. Although a great deal of work has gone into development of timing circuits, range measurement is opera-

tionally an extremely simple process compared with optical measurements. Furthermore, the range accuracy with properly designed equipment is such that secondary bench marks may be located for topographical surveys by measuring the range to primary points. An interesting example of the discovery of a map error by radar occurred in northern Italy. During the operations, a blind-bombing system called shoran was very successfully used for bombing pin-point targets such as bridges. This system consists of an airborne radar which triggers two coded radio beacons at known points on the ground. The signals from the two beacons, which merely serve to give signals which cannot be mistaken for other objects, are displayed on a cathode-ray tube in the aircraft. By suitable timing circuits the range to each of these beacons is measured with an accuracy of a few yards, and the position of the plane is located by triangulation, using the beacons as reference points. With one beacon set up in Corsica and the other in Italy, the positions being accurately located from maps, a bombing mission was run. Strike photographs showed a miss of almost a thousand yards. Since this was about 50 to 100 times the error expected, a recheck of the calculation of target position was made but no error was discovered. The suggestion was then made that the position of Corsica as shown on the map might be wrong. The problem was therefore worked backward to correct the position of Corsica. A correction of very nearly 1000 yards in the map position of Corsica was used on the next bombing run with strike results indistinguishable from optical bombing. That this result was not fortuitous was borne out by several months of successful bombing using the corrected position for Corsica.

Since the pulse energy travels the distance to the target twice, once on the way out and again on the return trip, the time required to receive an echo from an object a mile away is that necessary for a radio wave to travel two miles. With radio waves traveling at a speed of 186,000 miles a second, 10.7 microseconds elapse between the time the pulse is sent out and the time it is received from a target one mile away. It is apparent, therefore, that time measurements must be made in terms of millionths of a second. Furthermore, the transmitted pulse may be a large fraction of a mile or even several miles in length. For this reason the range must be measured by determining the time interval between the start of the transmitted pulse and the beginning of the received pulse. Methods for measuring range and displaying target positions will be discussed in detail later.

2. Maximum Range of a Radar Set

Before discussing details of actual equipments, let us examine some of the factors which determine whether

* Decimal classification: R537. Original manuscript received by the Institute, February 20, 1946; revised manuscript received, May 7, 1946.

† Formerly, Radiation Laboratory, Massachusetts Institute of Technology, Cambridge, Mass.; now, Stevens Institute of Technology, Hoboken, N. J. This paper is based on work done for the Office of Scientific Research and Development under Contract OEMsr-262 with the Massachusetts Institute of Technology.

¹ "The SCR-268 radar," *Electronics*, vol. 18, pp. 100-109; September, 1945.

² "The SCR-584 radar," *Electronics*, vol. 18, pp. 104-109; November, 1945.

or not a measurable reflection of energy can be obtained from an object. To be detectable, the received power P_r must obviously be greater than the minimum power sensitivity of the receiver. The problem of determining the maximum range of the set is, therefore, one of calculating the range at which the received power is just measurable. The relationship between the major factors which affect the received power may be derived as follows.

The power per unit area at the "target" will be proportional to the instantaneous peak power transmitted by the radar P_T , and will be proportional to the gain G of the transmitting antenna, where the gain in a given direction represents the increase in power resulting from focusing of the radio energy by the antenna as compared with that which would have been present if the energy had been radiated equally in all directions. For example, placing a dipole at the focus of a searchlight type of reflector may result in an increase of a factor of 1000 in the amount of power sent in one direction. The reflector has, therefore, resulted in a gain of 1000 in the direction of the focused beam as compared with the dipole, while in other directions the amount of power has been correspondingly greatly reduced. Unless otherwise specified, the gain is understood to mean the ratio of power increase in the strongest part of the beam. A so-called "isotropic radiator," one which radiates equally in all directions, is usually considered as the source for measuring gain. On this basis a dipole in its strongest directions of radiation has a gain of $3/2$; hence, the antenna in the above example has a gain $G=1500$. Using the above facts, we may write for a target a distance R from an isotropic radiator

$$\text{power per unit area} = P_T/4\pi R^2 \quad (1)$$

and for an actual antenna with a gain G ,

$$\text{power per unit area} = P_T G/4\pi R^2. \quad (2)$$

This energy is intercepted by the target and scattered in many directions, a portion being reflected to the receiving antenna which may or may not be the same as the transmitting antenna. Since most targets are of a very complicated form, it is customary to use an effective scattering cross section for the target which is defined as the cross section of a perfectly reflecting sphere which would give the same strength of reflection in the direction of the radar as does the actual object. (The scattering by such a sphere can be shown to be isotropic.) If this cross section is denoted by S , the total power received by the equivalent sphere is

$$\frac{P_T G S}{4\pi R^2}.$$

This power will be reradiated equally in all directions, and the amount intercepted by the receiving antenna and thence transmitted to the receiver will be

$$P_r = \frac{P_T G S}{4\pi R^2} \frac{A}{4\pi R^2} \quad (3)$$

where A is the area of the receiving antenna.

A rather complex calculation shows that the gain of an antenna is given by

$$G = K \frac{A_T}{\lambda^2} \quad (4)$$

where A_T is the area of the antenna, λ is the wavelength, and K is a constant which varies with the type and efficiency of the antenna but is, in general, between 3 and 10 in magnitude.

Since most radars use the same antenna for transmitting and receiving, we may take the antenna areas in (3) and (4) as being equal for simplicity of discussion. Substituting (4) in (3) and rearranging we obtain

$$R = \sqrt[4]{\frac{P_T S K A^2}{16\pi^2 P_r \lambda^2}} = \sqrt[4]{\frac{C P_T S A^2}{P_r \lambda^2}} \quad (5)$$

where

$$C = K/16\pi^2.$$

If P_r is considered to be the minimum energy detectable by the receiver, (5) shows that the maximum range at which an object can be detected is proportional to the fourth root of the power, the square root of the antenna area, and the square root of the frequency since frequency bears a reciprocal relationship to the wavelength. We see, therefore, that changing the power output or the receiver sensitivity does not alter the maximum range as rapidly as a change in antenna area or wavelength. Before making a sample substitution in (5), let us see what values may be considered reasonable for the above factors.

If a more accurate value for K is not known from experimentally measured gains on antennas of the type to be used, a value of 5 will serve as a fairly representative number for range calculations.

The effective cross-section area of the target is usually not under the control of the radar set designer. For detection of aircraft, for example, the set must be built with due regard to the effective reflection from standard planes. In a few cases, such as the use of radar to locate a rubber life raft carrying a metal reflector, the size of the reflecting surface can be varied within reasonable limits to obtain the desired performance. For objects such as aircraft or ships, the effective cross section S will obviously vary with the size, being larger for the larger craft. On the other hand, because of the complicated shape of such objects the reflection will vary considerably with the orientation. This is especially true where there are flat surfaces which may give an intense directional reflection for a very specific orientation. The flash of the sun from the windshield of an approaching car when it is in just the right position is a common example of such a highly directional reflection. This variation in reflection results in a radar signal which varies considerably in strength as a plane is deflected slightly from its course by rough air or by small changes in steering by the pilot. In the case of a ship,

the rolling caused by the waves may easily be seen in the changing signal strength. The net result is that the maximum range of a set is not a definite quantity. It not only varies with the size of the object, but will vary from one trial to another with the same object. For example, a plane flying away from a radar set will show a continuous but fluctuating signal when near the set. As it gets farther away the signal will at times drop below the minimum detectable value, causing the tracking to become intermittent. As the distance increases still more, the intervals during which the signal is lost become longer because only the peaks are seen. Eventually even the strongest peaks are too weak to see. The range at which the last signal is seen will, therefore, depend on just how the plane happened to be bounced around by rough air. For radar-set design, it is customary to consider the range of a set for a particular target as that distance for which the signal is visible half of the time. It has also been customary to use the effective cross section of a medium-sized plane such as an A-20 or B-25 for computing ranges on planes. Fighters will then give ranges about 25 per cent less, small planes such as "Cubs" will be about 35 per cent less, while large bombers and transports may be followed 20 to 30 per cent farther, depending on the size. Experimentally, it has been determined that a value of $S=2\pi^2$ will give a reasonable prediction of the range on a medium bomber when used in (5) for frequencies between 100 and 9000 megacycles. This value is only approximate, and the π^2 is used not for theoretical reasons but in order to simplify the numerical calculation.

In general, the value of S for a given object is very small when the dimensions are small compared with the wavelength. As the wavelength is decreased, S rises rapidly as half-wave resonance is approached, and then falls very gradually with further decrease in wavelength. The exact shape of the curve is dependent on the shape of the object, the maximum at resonance being much more pronounced for a properly oriented wire than for a wide object.

The maximum transmitter power available will vary with the frequency chosen for the set. For example, at extremely short wavelengths, say in the neighborhood of 1 centimeter, the antenna dipoles and transmission lines may impose the eventual limit to the power which can be handled, whereas at 1 meter the transmitter tube may always remain the limiting factor. At present, in all frequency regions used for radar, the power output of existing transmitters is the limiting factor. For wavelengths longer than about 7 centimeters, present, techniques will permit a peak pulse-power output greater than 1,000,000 watts, provided the spacing between pulses is great enough to keep the average power within the ratings of the tubes. In the neighborhood of 3 centimeters, peak powers of about 250 kilowatts are available, while near 1 centimeter only about 50-kilowatt output may be realized with present tubes. Where

weight and size of the transmitter are not considerations and it is desired to obtain as great a range as possible, a radar system should be designed to use the maximum power available with existing techniques at the chosen frequency. Frequently weight and size are important and may set the limit on the practical power for the application. For example, in an aircraft it may not be feasible to carry a sufficiently large transmitter unit nor to supply the power to operate a set with an output of 1 megawatt. In such cases, consideration of the proper allotment of weight between the transmitter and antenna must be made to obtain the optimum-range performance.

In computing the maximum range to be expected from a radar, P_r is the minimum power which the receiver can detect. For the frequency range commonly used in radar, receivers can detect signals as small as 1 to 0.1 microwatt. Since the cost in weight, size, and complexity of a good receiver is at most only slightly greater than that of a poor one, the receiver is always designed to have the greatest possible sensitivity.

Antenna sizes are usually determined by considerations of mechanical design, space, or weight. It is at present considered impractical to build antennas much over 30 feet wide for transportable field equipment, although larger sizes might be quite practical for permanent fixed installations. For ship or airborne sets and for many ground purposes even this size of antenna is impractical. Furthermore, in many applications the maximum possible range is unnecessary; hence, a small antenna is adequate. The aspects of antenna design will be more fully covered in later sections on antennas and radar systems.

The factors controlling the choice of frequency are wave-propagation effects and antenna beamwidth. These will be discussed in detail in later chapters. Let us now use (5) to compute the range of a large microwave set which might have the following values:

$$A = 200 \text{ square feet}$$

$$\lambda = 4 \text{ inches} = 1/3 \text{ foot}$$

$$P_T = 750 \text{ kilowatts} = 750,000 \text{ watts}$$

$$P_r = 5 \times 10^{-13} \text{ watt}$$

$$R = \sqrt[4]{\frac{5}{16\pi^2} \frac{7.5 \times 10^5 \times 2\pi^2}{5 \times 10^{-13}} \times \frac{(200)^2}{(1/3)^2}}$$

$$= 760,000 \text{ feet} = 144 \text{ miles}$$

or roughly 150 miles on a medium bomber.

III. WAVE PROPAGATION AND ATMOSPHERIC EFFECTS

1. Horizon Limitation

Because the effective scattering cross section of an object decreases very rapidly for wavelengths greater than the maximum dimension of the object, wavelengths longer than a few meters are not practical for detection of aircraft and small ships. This fact is unfortunate, because at high frequencies very little energy

reaches the region below the horizon. Hence, the maximum range of detection of ships and of very low-flying aircraft is usually determined by the horizon rather than by the performance of the radar. A very easily remembered formula which takes into account a small penetration of the radio energy below the optical horizon can be used to calculate the horizon ranges. The formula is

$$R = \sqrt{2H} \quad (6)$$

where the range R is in land miles and the height H is in feet. As may be seen from Fig. 1, the range to the target from the antenna is the sum of the target horizon



Fig. 1—Maximum pick-up range on target.



(a)



(b)

Fig. 2—Anomalous propagation effects.

range R_T and the antenna horizon range R_A . Hence the maximum pickup range (if the set performance is not the limiting factor) will be

$$R = R_T + R_A = \sqrt{2H_T} + \sqrt{2H_A} \quad (7)$$

where H_T is the target height and H_A is the antenna height. As an example, a plane at 50-foot elevation will first be seen by a radar at 200 feet when it approaches to

$$R = \sqrt{2 \times 50} + \sqrt{2 \times 200} = \sqrt{100} + \sqrt{400} \doteq 30 \text{ miles.}$$

Note that R is slant range to the target rather than ground range, because the radio waves travel in straight lines rather than following the surface of the earth.

For large vessels which have an appreciable superstructure, the maximum pickup range will be determined by the antenna height and the height of the superstructure of the target. On the other hand, very small boats will not be seen appreciably beyond the distance from the antenna to the horizon.

2. Anomalous Propagation

Since the atmosphere is not uniform in either density or moisture content, it is possible for local conditions to exist under which the radio beam is appreciably bent by inhomogeneities. Conditions under which the beam does not follow the normal straight-line path are called conditions of "anomalous propagation." Bending of the beam is most apt to occur on days when there is little wind and in places where the air temperature is different from the surface temperature. Anomalous propagation is most prevalent over water, where a pronounced temperature gradient may be established by heat inter-

change between the water and the air immediately above it. Over-water conditions are also favorable for formation of a moisture gradient by evaporation from the water surface. Since the velocity of the radio wave is slightly less in dense or moist air than in less dense or dry air, the beam will be bent in the direction of the optically dense layer. Fig. 2(a) shows one condition which will cause downward bending, while Fig. 2(b) shows a condition which will cause upward bending. Under the conditions indicated in Fig. 2(a), surface targets may be seen far beyond the horizon. Perhaps

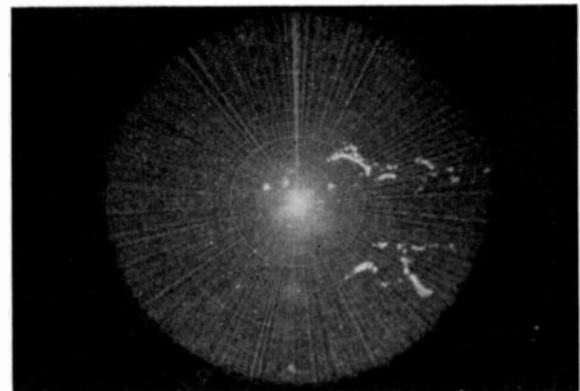

(a) Note echoes corresponding to map position of Cherbourg

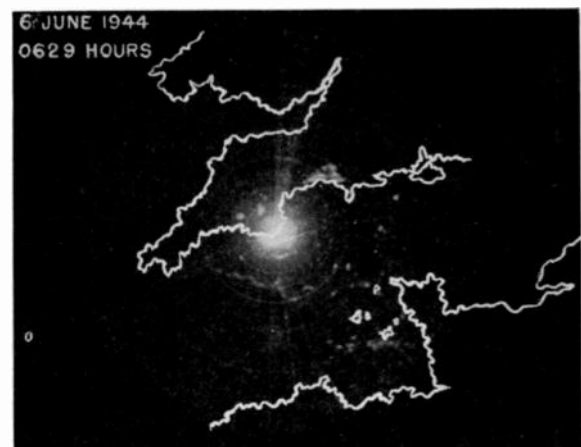

(b) The map outline traced on the photograph does not appear on radar.

Fig. 3—Radar photographs of Cherbourg Peninsula

the most extreme case of this type of anomalous propagation has occurred over the Indian Ocean where the coast of Arabia has been seen by a station on the west coast of India, a distance of 1200 miles. Less spectacular examples of this type of anomalous propagation are quite frequent. Fig. 3(a) shows the outline of the Cherbourg Peninsula as seen from Start Point, in England, on the evening of June 7, 1944. In addition to the echoes from the land, some of the invasion shipping and air activity can be seen. The concentric circles are centered at the radar station and are separated by ten-mile

intervals. Fig. 3(b) shows the appearance of the same indicator a few hours earlier when the atmosphere was behaving normally. From this station during the spring and summer, part of the French coast was visible several evenings a week. As a rule, near land the conditions for anomalous propagation are more favorable in some directions than others. For example, at this site the Cherbourg Peninsula was much more frequently observed than the Brest Peninsula, although the distances and heights of the land masses were not appreciably different.

Anomalous propagation of the type shown in Fig. 2(a) favors long-range detection of ships and low-flying aircraft, while that shown in Fig. 2(b) prevents seeing objects on the surface until they are very close to the radar. Although the condition of Fig. 2(b) is less common than that in Fig. 2(a), it has been observed a number of times. For example, a station on the coast of Rhode Island normally saw Block Island as an extremely strong signal at a distance of 19 miles, but on several days no trace of this signal could be observed for several hours at a time. During these same periods, echoes from hills beyond Providence were of normal strength indicating both that the set was operating normally and that the unusual atmospheric conditions existed only over the water. On these days visibility was good near the surface of the water but graded into a dense fog at a few hundred feet, giving visible evidence of a moisture gradient.

Since many complex conditions may exist, such as the partial trapping of the energy in a layer which is well above the surface of the earth, this discussion by no means covers the subject of atmospheric conditions leading to anomalous propagation. These propagation effects are dependent on frequency and are usually more pronounced at high frequency but, in the case of trapping layers, may show rather large changes in behavior near critical frequencies which are related to the thickness of the layer. In order to get trapping or to show a pronounced bending, it is necessary for the antenna to be at about the same height as the layer in which the gradient exists. For example, a radar set on Saipan was sited at 1500 feet above sea level, where an almost continuous condition favorable to trapping of energy exists. This resulted in unusually long range pickup of aircraft at altitudes of 1000 to 2000 feet. However, on the days when this condition moved up to 2500 feet, no effect could be observed on the pickup range of aircraft at any altitude.

So far, nothing has been said about the magnitude of these bending effects. The amount of bending of the radio beam is rarely more than one or two degrees because change in the index of refraction of the atmosphere with moisture content and density is actually very small. Furthermore, only the energy traveling within the layer and within one or two degrees of the direction of the layer is appreciably affected by the refractive gradients.

3. Ground Reflection

A quite different phenomenon of nature still further limits our ability to place the radio energy exactly where we desire it. Land and water are good reflecting surfaces for radio waves, particularly at grazing incidence. Consequently, if a part of the wave from the transmitter strikes the earth's surface, it will be reflected into the beam above the surface. If this reflected wave is in phase with the direct wave, it will reinforce, and if out of phase, it will cancel. Furthermore, if the reflected wave is equal to the directly transmitted wave in amplitude, there will be places where the cancellation is complete and others where the amplitude is doubled. If the earth is assumed to be flat, the directions of maximum reinforcement and cancellation can be computed easily. Many readers will recognize this as the well-known optical problem of the Lloyd's mirror. Calculation of the exact distribution of the wave, especially for a curved earth, is beyond the scope of this paper.

The direct wave from the antenna, Fig. 4, makes an angle β with the reflecting plane, while the reflected

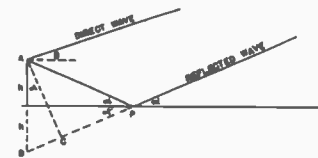

Fig 4—Reflection of radar beam.

wave which reaches the same point in space starts downward striking the earth at an angle α . Since the angle of reflection is equal to the angle of incidence, the reflected wave will leave the earth at an angle α and will appear to have come from the mirror image B of the antenna at A . If the line AC is drawn perpendicular to BP , the distance BC will very nearly equal the difference in path between the direct and reflected waves from the antenna to the point of intersection of these two lines in space. The more nearly the direct and reflected waves parallel each other, the more accurate is this approximation. The approximate path difference is then

$$BC = 2h \sin \alpha. \quad (8)$$

The condition for reinforcement is that the direct and reflected waves be in step. This condition will obviously be met when BC is a whole number of wavelengths if there is no phase shift upon reflection. (This condition of no phase shift holds for vertical polarization only.) Mathematically

$$BC = n\lambda \quad (9)$$

where n is an integer. Hence,

$$\sin \alpha = n\lambda/2h. \quad (10)$$

Equation (10) may be written as

$$\alpha = n\lambda/2h = \text{direction of maximum reinforcement} \quad (11)$$

if α is small and only the first few maxima above the horizon are considered. It must be remembered that this equation was derived with the use of several approximations and does not apply for large values of n nor for conditions where the antenna is only a few wavelengths high.

For horizontal polarization there is a 180-degree phase shift on reflection so that (10) and (11) become the conditions for cancellation.

Cancellation for vertical polarization and reinforcement for horizontal polarization will occur at angles halfway between those determined by (11).

The result of reflection from the earth's surface is a series of lobes in the vertical plane of the antenna pattern. The spacing between these lobes decreases linearly with antenna height and increases linearly with wavelength.

Fig. 5 shows the lobe pattern for two different antenna heights for the SCR-270 Army radar which operates at 106 megacycles. The energy striking the ground is essentially equal to the direct radiation, with the result that virtually complete cancellation takes place in the "nulls." In the directions of the lobe maxima the range is twice what it would have been without ground reflection, because the amplitude of the wave has been doubled by reinforcement. The power at the target is thereby increased by a factor of 4, and another factor of 4 in power occurs by reinforcement of the received radiation.

Although the range has been doubled in certain directions by ground reflection, this has been accomplished at the expense of causing blind regions. If the curves of Fig. 5 are interpreted as the lines along which the signal from a given-sized aircraft is just measurable, it is apparent that between the lobes the plane will not be seen, while well within the lobes the signal will be strong. The fading of the signal from an approaching plane on account of this lobe pattern can be very troublesome operationally. For example, at 30,000 feet, under the conditions of Fig. 5(a), between 115 and 145 miles the whereabouts of a plane cannot be determined. This presents a very serious difficulty when the set is being used to intercept hostile aircraft or to avoid possible collision between friendly planes.

A further disadvantage of designing a set which depends on ground reflection arises from the fact that reinforcement in the desired directions can be obtained only over relatively flat ground. Sets such as the SCR-270 were not successful in the mountainous country of Burma because in many places there was no surface flat enough to give reflection. Moreover, in other places the surface was far from horizontal, with the result that the vertical pattern was unpredictable and differed radically with the compass direction. On the other hand, these sets were extremely successful on the Pacific islands where they were used for air search over water. At wavelengths of 20 centimeters or less, tree tops and bushes absorb so much of the energy that very little

reflection can be expected. However, at these short wavelengths a flat surface, such as an air field or a water surface, acts as an excellent mirror.

Fig. 6 shows the coverage diagram of a large set operating at a wavelength of about 10 centimeters. Fig. 6(a) shows the calculated coverage over water

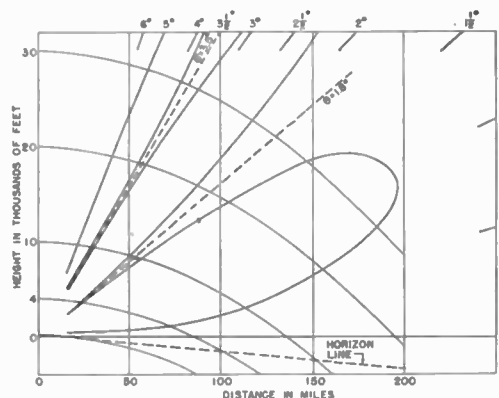

(a) Antenna height = 125 feet.

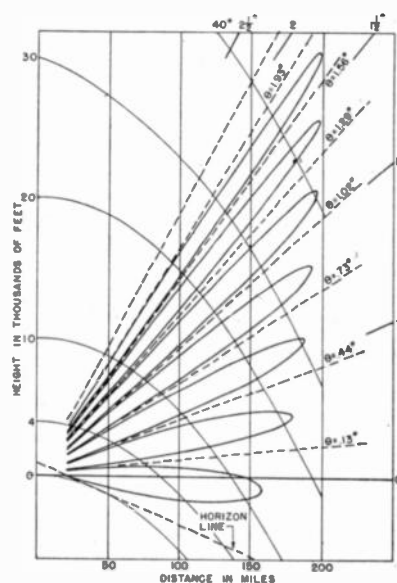

(b) Antenna height = 1000 feet.

Fig. 5—Vertical-coverage diagram for 106 megacycles.

when the center of the beam is pointed 1 degree above the horizon. The nulls do not go to zero because the power striking the water is considerably less than the direct wave. The dotted curve labeled *A* shows the coverage of this set with the same antenna angle, but when no ground or water reflection occurs. Fig. 6(b) shows the calculated coverage with the antenna pointed so that the center line of the antenna beam lies along the water. It might be argued that these lobes are so close together that the nulls would not be troublesome. Tracking results taken with somewhat reduced performance but under conditions corresponding to Fig. 6(b) are shown in Fig. 7. The main difference attributable to the reduced performance is that the whole pattern is proportionately reduced in slant range so that the aircraft

flights do not have to be as long to pass out of the coverage of the set. The intermittent tracking is due to the lobe structure, but with lobes this closely spaced, variations in aircraft altitude and unsteadiness in the atmosphere make it impossible to repeat observations on the exact positions of the nulls. When the lobes are as large as those in Fig. 5, flight tests show consistent results on the null positions.

parent regions between these bands. Because of this absorption it will probably never be practical to use wavelengths below 2 centimeters for long-range operation.

At 3 centimeters the absorption and scattering of radiation by the water droplets may cause a serious decrease in signal strength of a target beyond a heavy tropical shower 10 miles across.

(a) Antenna pointed 1 degree above horizon. Curve A is for no ground reflection and is adjusted to match the SCR-270 performance.

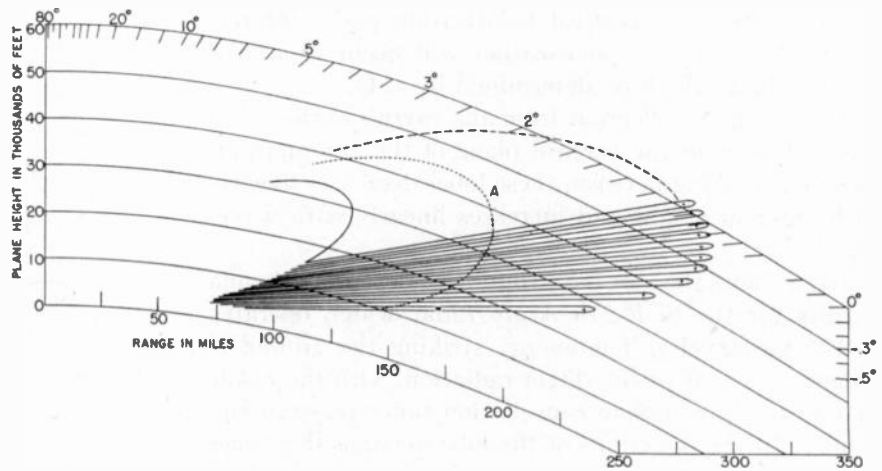

(b) Antenna pointed at horizon.

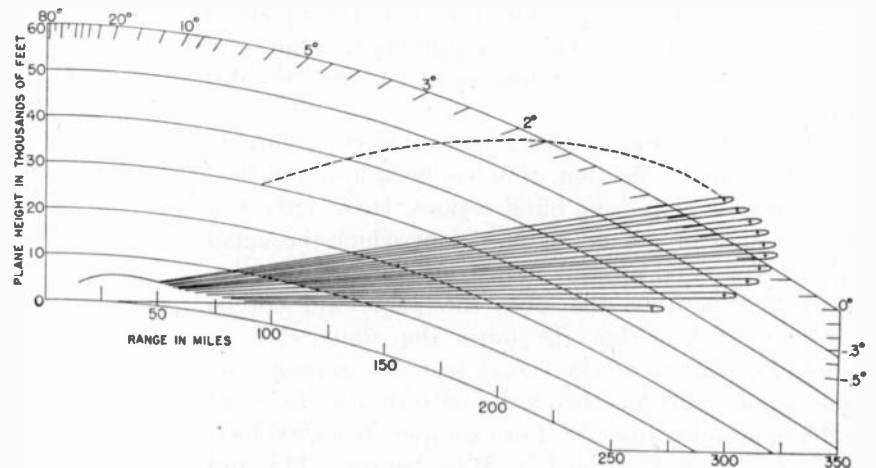

Fig. 6—Vertical coverage diagram for 3000 megacycles. Antenna height, 100 feet.

The only advantage in designing a set to use ground reflection is to avoid building a tall reflector or radiating surface. The same range without the nulls can always be obtained by making the vertical aperture of the antenna four times as great and tilting the center of the beam to prevent a large amount of the radiation from striking the ground.

4. Atmospheric Absorption

Absorption of energy by the atmosphere may limit the use of certain frequencies for radar. For wavelengths greater than 2 centimeters, the absorption of moist air is not likely to impose a serious limitation. At shorter wavelengths there are strong absorption bands caused by water vapor and oxygen, with some narrow trans-

Obviously, this loss in performance is a serious handicap in certain long-range applications such as warning of approaching hostile aircraft. At 10 centimeters, 50 miles of heavy rain between the radar and the target causes no serious decrease in performance, while at longer wavelengths the loss is not readily measurable.

A part of the loss in a heavy shower is due to absorption of energy and a part is due to scattering by the droplets. The scattering not only weakens the beam beyond the shower but also returns energy to the receiver, with the result that an echo is observed. At 1200 megacycles, only the very heaviest tropical showers give an appreciable echo. At 3000 megacycles, a moderate rain will give a return, while at 9000 megacycles, very light rain can be seen. However, even at frequencies

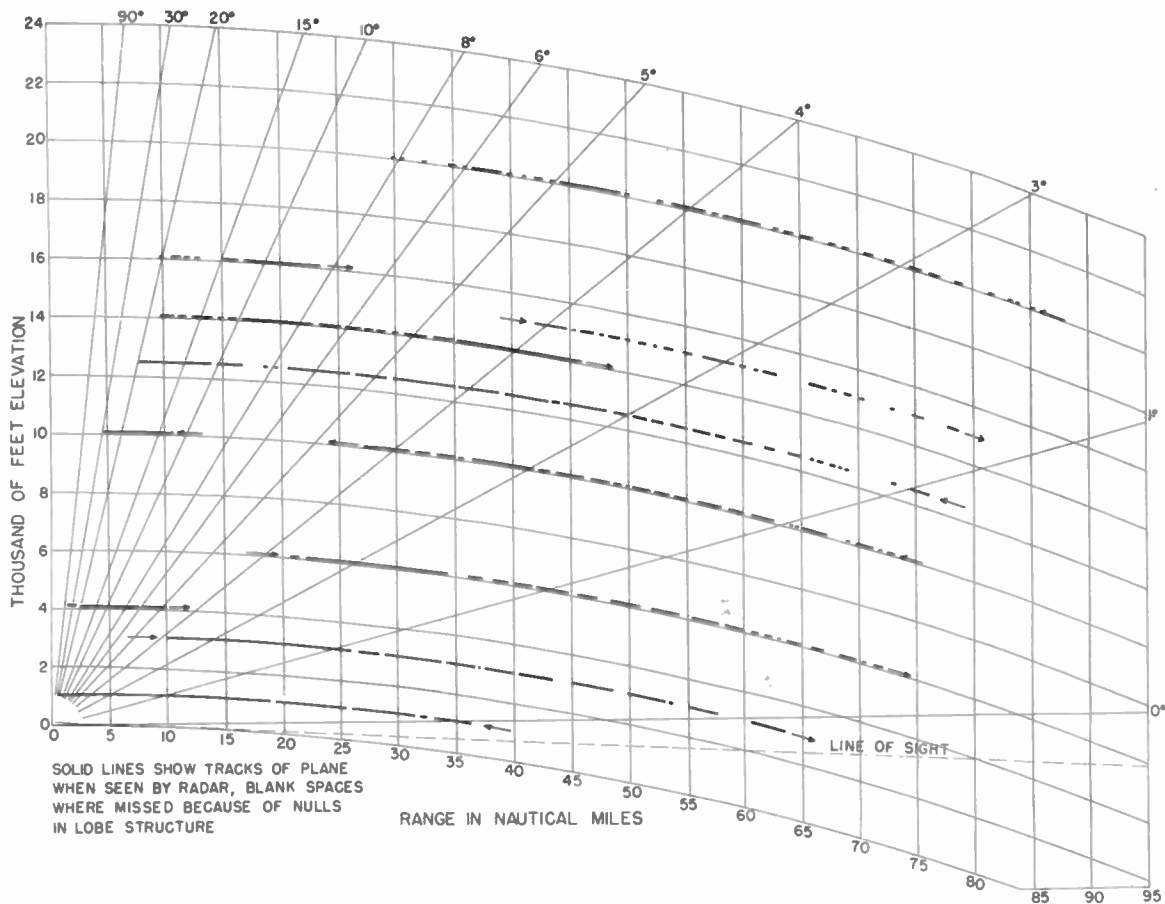

Fig. 7—Coverage on TBM plane over water.

as high as 9000 megacycles, fog particles which make up the ordinary cumulus clouds cannot be seen; drops large enough to be considered rain rather than a heavy fog are necessary to give an echo.

Since the rain echo is the sum of the reflections from a large number of drops spread over a volume of space, the relative echo strength compared with some object such as an aircraft will depend on the beamwidth and pulse length of the radar as well as the frequency. If the rain storm is wider than the beam, changing the beamwidth with all other factors constant will not affect the strength of the returned signal, because a fixed fraction of the energy will be reflected. A plane, on the other hand, is usually much smaller than the beam; therefore, any concentration of the energy into a narrower pencil will result in a greater amount being intercepted by the plane and also in an increased signal. Again, if the storm is longer than the wave train in one pulse, energy will be received simultaneously from drops along the length of this wave train, while the aircraft will be returning energy from only a short length of the wave. Hence, decreasing the pulse length will increase the plane signal relative to the storm. Investigations in Florida by the Army Air Forces indicate that at 3000 megacycles a 1-degree beamwidth and a 1-microsecond pulse length will give plane signals larger than storm signals where it is safe to fly.

In the tropical thunderstorms prevalent in that part of the world, turbulent centers of much greater echo strength are present. In none of the cases investigated were the pilots willing to risk entering the regions of very strong storm echoes. Thus the possibility exists of guiding planes through gaps in bad weather where the presence of dangerous local storms would make it unsafe to fly unaided. At 9000 megacycles, most rain storms give echoes stronger than small planes, while at 1200 megacycles, only the most intense regions in a storm are visible. Fig. 8 shows the appearance of thunder storms on a 10-centimeter radar set. The set was located on the west coast of Florida.

IV. THE BASIC RADAR SET

So far, this discussion has involved the general behavior of the radiation in space. Let us now see what is needed to build a radar set. Fig. 9 shows the basic components which must be used in all sets.

The modulator, otherwise known as a keyer or pulser, is a pulse generator. Its output consists of a series of short square-topped voltage pulses separated by time intervals much greater than the pulse duration. These pulses drive the transmitter, which in turn generates short wave trains of high-frequency radiation. These are piped to the transmitting antenna through coaxial cable or wave guide in most sets. Since reception takes place

in the time intervals between the transmitted pulses, it is more economical to use the same antenna for transmitting and receiving, although this is not necessary. Where a common antenna is used, the receiver must be isolated by a very fast-acting switch to prevent damage

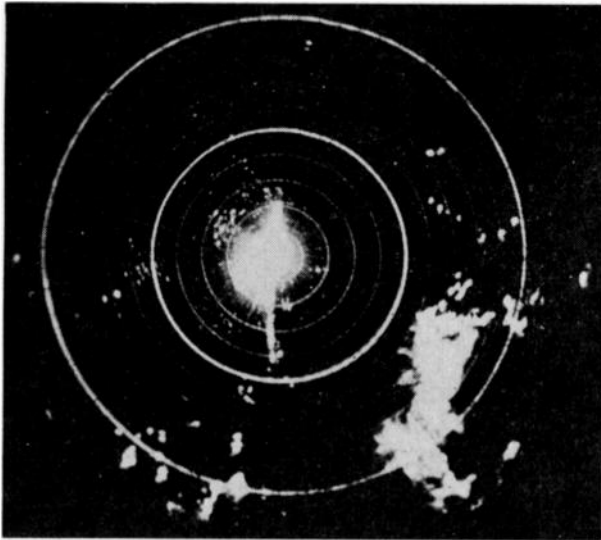

Fig. 8—Echoes from dense clouds on 10-centimeter radar.

by the outgoing power. Since mechanical switches are not fast enough, a gas discharge device is normally used. The term "TR box" (transmit-receive box) has become the generally accepted designation for this switch. During reception the radio-frequency energy is channeled to the receiver, where it is amplified and converted into

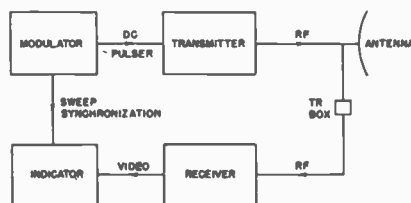

Fig. 9—Block diagram of basic radar set.

video signals. These are then displayed on an indicator which is usually some form of cathode-ray tube. In a few cases, the display is in the form of a meter or an audio tone. Since range is measured by timing the pulse to the target and back, the indicator must have timing circuits which are synchronized with the out-going pulse. Hence, a sweep synchronizing voltage is needed. If the set also determines azimuth position of the target by the directional properties of the antenna, some means must be used to indicate the antenna position.

Although all radars have these basic components (with the exception that the TR box may be replaced by a separate receiving antenna), there is considerable variation in the construction, and refinements. Specialized components are frequently added to accomplish some particular purpose. In general, once the frequency of a new set is chosen, the antenna together with its

mount, the indication, and the special-purpose components require the most development.

V. MODULATOR DESIGN

1. General Problem

The major problems consist of controlling the pulse-repetition frequency (PRF), and of generating a high-voltage pulse suitable for driving the transmitter. Since the voltage applied to the transmitter may be as high as 50 kilovolts with peak power of 5 megawatts there are also problems of insulation and suitable control, and safety circuits must be provided. Although there has been considerable improvement in high-voltage cable and connector design and in control-relay construction during the war, these techniques are essentially those used in standard radio transmitters and need no special discussion.

2. Sine-Wave Control of Pulse Rate

In most of the earlier radar systems, and in systems where extremely accurate range measurements must be made, a sine-wave oscillator is used to control the pulse-repetition frequency. The oscillator frequency will then be the same as the pulse-repetition frequency or some multiple of it. If the exact spacing between the pulses is not critical, a simple tuned-circuit oscillator or the alternating-current power line may be used to obtain the sine wave. Where the spacing between pulses must be held very constant, a crystal-controlled oscillator is used.

A number of methods can then be used to convert this sine wave into a series of pulses suitable for driving the transmitter.

a. Overamplification and "differentiation": By the use of several stages of amplification in which the tubes are driven beyond cutoff, the sine wave can be converted into a series of almost square waves, as shown in Fig. 10(b). If this square wave is fed into a small capacitor-and-resistor combination, as shown in Fig. 10(e), the output will appear as in Fig. 10(c). During the time the voltage applied to the left-hand side of the capacitor is rising, the voltage applied to the grid of the following amplifier will rise because of the action of the capacitor. Because of this rise in voltage, current will also flow through the resistor and partially discharge the capacitor, thereby preventing the voltage from rising to the full value of the input. As soon as the applied voltage becomes constant, the current through the resistor starts discharging the capacitor. Since the capacitor will discharge to about one third of its original voltage in a time $R \times C$ seconds (R =resistance in ohms and C =the capacitance in farads), the width of the pulses in Fig. 10(c) can be adjusted accordingly. Since these pulses are saw-tooth in shape, further amplification and clipping by driving tubes beyond cutoff is necessary to obtain square-topped pulses as shown in Fig. 10(d). Proper adjustment of the amplifier-bias points will determine the section of the saw tooth which is finally

used. This method of obtaining square pulses is apt to be expensive in tubes and power, because of the total amplification involved. Furthermore, unless the amplification is extremely great, the sides of the pulses will not be steep.

b. Triggering a square-wave generator: Rather than using the brute-force method outlined above, the sine

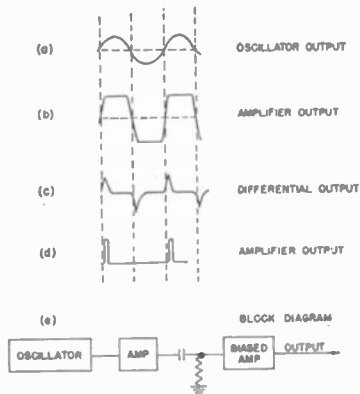

Fig. 10—Square-wave generation from sine wave.

wave with a moderate amount of amplification can be made to trip a square-wave generator such as a “multivibrator.” One type of multivibrator is shown in Fig. 11(a). Other types will be discussed in the section on indicators.

Before the input is turned on, tube 1 is running at zero bias and tube 2 is biased beyond cutoff. When a wave form such as that in Fig. 11(b) is applied to the grid of T_1 , the grid is driven negative to cutoff. This voltage change is then amplified by the two tubes and is fed back onto the grid of T_1 by the capacitor C_1 . T_1 is thereby held beyond cutoff until the charge on C_1 leaks off through R_1 . When T_1 again becomes conducting, the multivibrator rapidly returns to its original condition. The wave forms in Fig. 11(b) show the voltage changes on the various electrodes.

The values of R_2 and C_2 are not critical. If they are so small that the grid of T_2 drops back to cutoff before T_1 begins to draw current, the width of the square pulse will be determined by this circuit rather than by the grid circuit of T_1 as discussed above. On the other hand, if R_2 and C_2 are very large, the excess negative overshoot (see Fig. 11(d)) caused by the drop in voltage of plate 1 may not have time to leak back to approximately the bias point. When this happens, the next cycle turns T_1 off, but the impulse on the grid of T_2 may not be great enough to cause T_2 to draw current. Under this condition, the multivibrator fails to catch and nothing happens in the output. Although large values of R_2 and C_2 may be chosen purposely to make the multivibrator go only alternate times or even less frequently, for the purpose under discussion the value is chosen to insure recovery within one cycle. It is advantageous to have the grid circuit of T_2 recover only shortly before the next cycle because this prevents triggering by stray pickup before the desired time.

By replacing C_2 with a resistor of the proper value to give the correct negative bias on the grid of T_2 , it is possible to avoid the problems introduced by the recovery time of T_2 . This form of multivibrator is particularly advantageous where the trigger spacing is not uniform.

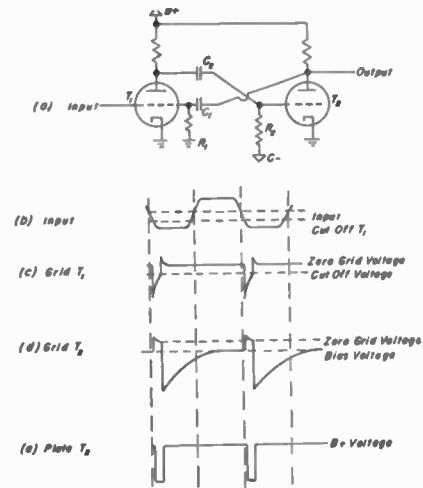

Fig. 11—Multivibrator and wave forms.

Fig. 12 shows the block diagram of a modulator using a multivibrator for producing pulses.

3. Generation of a Trigger to Operate Switching Devices

In a later section, networks will be described which give a square wave when discharged. To operate these, some form of electronic switch such as a thyratron or spark gap is used. These switches are activated by a sharp voltage impulse which may be obtained from a sine wave by either of the methods described above or by use of a blocking oscillator which is tripped by a sine wave.

Where very accurate pulse spacing is not required, it is not necessary to use a sine wave as the starting point



Fig. 12—Block diagram of modulator employing multivibrator.

for pulse generation. A saw-tooth generator similar to those used in cathode-ray oscilloscopes has been employed to set the pulse-repetition frequency using techniques similar to those described above. Another method is to start with a multivibrator similar to that shown in Fig. 11(a) in which the grid of T_2 is returned to ground rather than to a negative bias. Such a multivibrator will operate without an input trigger and will have a pulse-repetition frequency which is determined by the slowest grid-recovery time. A third method is to use a rotary spark-gap.

4. Modulator Types

Radar modulators fall into two general categories: (a) those in which the pulse is formed at low level and is amplified for application to the transmitter; and (b)

those in which the pulse is generated at high level by means of a special network which is discharged into a transmitter through a switching device.

5. Hard-tube Modulators

Modulators which operate by amplifying a small pulse require the use of high-power vacuum tubes together with the necessary direct-current power supply to operate them. For experimental purposes they have the advantage that the amplification is easily controlled by adjustment of the voltages, but for field use they have the disadvantage of being heavy and complex. Although the amplification could be obtained by several stages of conventional amplification, this would be extremely expensive in power because some of the tubes would be carrying full current for the long intervals between the transmitted pulses. In order to keep the average current as small as possible it is desirable to operate all tubes near cutoff and have them turned

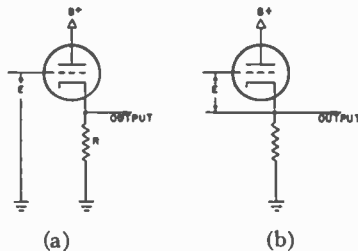

Fig. 13—(a) Cathode follower. (b) Bootstrap amplifier.

on only during the transmitting period. This requires that all tubes operate on positive input pulse. In the conventional amplifier, a positive grid input causes a negative plate output which is coupled to the next tube. If the load resistor is placed in the cathode circuit, this phase inversion can be avoided. Fig. 13 shows two circuits in which the load resistor is placed in the cathode circuit.

When the voltage E is applied to the grid of the "cathode follower" (see Fig. 13(a)), the voltage between the grid and cathode will be $E - I_p R$ where I_p is the plate current. A study of the output voltage using the curves for any triode will show that the output voltage may be nearly equal to the input voltage but can never be appreciably greater. Hence, no practical voltage amplification occurs. On the other hand, the voltage E may be supplied from a low-current source and still control a large current through the resistance R . The cathode follower is, therefore, useful in obtaining current amplification. Expressed in another way, the cathode follower is a useful device for matching a high-impedance circuit to a low-impedance load.

In the case of the "bootstrap amplifier," the input voltage is the actual voltage between the cathode and grid and is not altered by the voltage drop across the cathode resistor. This means that the output voltage will be $I_p R$, and will be determined from the tube characteristics in the same way as the plate output of a conventional amplifier with the cathode at ground and the

load connected between the plate and $B+$. The one disadvantage of the bootstrap amplifier is that the whole circuit supplying the input voltage is at a voltage $I_p R$ above the ground. This means that the chassis must be insulated for this voltage and that the filament and plate transformers must be insulated to withstand this voltage. Furthermore, at high frequencies the capacitance between this unit and ground may be equivalent to an appreciable by-pass capacitor across R .

Fig. 14 shows the essential parts of a modulator making use of two stages of bootstrap amplification.

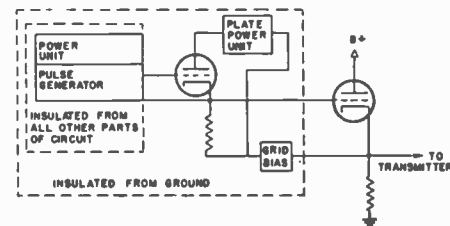

Fig. 14—Hard-tube modulator.

Each of the units enclosed within the dotted lines, including filaments, must be direct-current insulated from ground either by the use of batteries or with transformers built to stand the voltage labeled $B+$ between primary and secondary. If the pulse from the pulse generator is positive, all output pulses will be positive. The tubes will carry appreciable current only during the time of transmission and the current during the dead interval will be determined by the bias voltages.

A modulator of this type giving an output pulse voltage of 30 kilovolts and a 1-megawatt direct-current output pulse of 1-microsecond duration is used in the SCR-584. The direct-current power supply to furnish the voltage for the output stage weighs about 1800 pounds and fills a cabinet about $24 \times 30 \times 60$ inches. The modulator unit is about the same size and weighs approximately 1500 pounds.

6. Pulse-Network Modulators

Much lighter-weight modulators can be built by using a "pulse-forming network" which is discharged directly into the transmitter by means of a suitable switch. The disadvantage of this type of modulator over the type described above is that the pulse width is not readily altered. The pulse-forming network is based on the principle that a charged transmission line will maintain a constant current through a short-circuiting resistor which is suddenly placed across the line until the whole length of line is discharged, and then the current will suddenly drop to zero. If the line is terminated at the far end by a resistor equal to the impedance of the line, no further current will flow. The time for this discharge to take place is equal to the time required for an electrical impulse to travel the length of the transmission line. If the far end of the line is not properly terminated, this initial pulse will be followed by a number of oscillations which rapidly die out.

Instead of an actual transmission line, an artificial line made up of chokes and capacitors may be used. Fig. 15(a) shows one method for making such an artificial line, where all chokes L have the same inductance, and all capacitors C are of the same capacitance. This combination of inductances and capacitances will behave more and more like an actual transmission line as the number of elements is increased. At least ten elements are necessary to obtain a reasonably good approximation to a transmission line. Only a few circuit elements are necessary to give the desired wave form, if the values of L and C are properly chosen to have critical values not all equal. A very complex calculation is required to work back from a given wave shape to the values of the capacitors and chokes necessary to obtain this desired wave shape. This calculation has been carried out for a number of cases, and networks which give a square voltage and current pulse when discharged through the proper impedance are now commercially built. Fig. 15(b) shows a circuit used to obtain a pulse 1-microsecond wide at the base. The output pulse is as shown in Fig. 15(c).

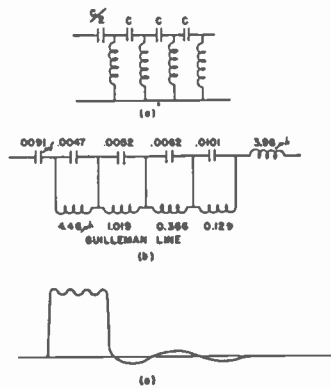

Fig. 15—Pulse-forming network.
(a) Artificial line
(b) Pulse network
(c) Pulse output

A network of this type can drive a transmitter directly, provided the transmitter impedance is correct; or, the impedance may be matched by use of a pulse transformer which has been developed to pass the high-frequency components in the pulse without serious amplitude or phase distortion. Although these transformers are iron-cored, they pass video pulses of less than 1 microsecond in width. Fig. 16 shows the basic circuit for a modulator of the pulse-network type.

The pulse-forming network is charged by the high-voltage power supply in the interval between transmitted pulses. At the proper time the switching device closes and allows this charge to be dissipated in the transmitter. The current limiter is placed in the circuit to prevent overload of the power supply while the switch is in the closed position. The current obviously must be kept within the rating of the power supply but must be great enough to permit charging of the pulse line during the time the transmitter is off. As mentioned

above, the output may go to a pulse transformer between the modulator and transmitter. When the impedance of the modulator is less than that of the transmitter the pulse transformer used for impedance matching will also step up the pulse voltage, thereby

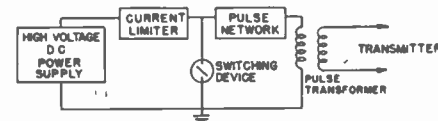

Fig. 16—Modulator using pulse-forming network.

permitting a low-voltage modulator to drive a tube at high voltage. For example, if 30 kilovolts are needed at the transmitter and the pulse transformer gives a voltage step-up of 3 to 1, only 10 kilovolts need be handled in the modulator, thus simplifying insulation problems. Since the transmitter may be some distance from the modulator, it is customary to make the modulator impedance 50 ohms. The modulator will then be matched to a 50-ohm cable, a type which is readily available and is suitable for handling high-voltage pulses.

The switching device in Fig. 16 may take a number of different forms. Gas tubes such as thyratrons or ignitrons may be used. These must be tripped by a trigger, which may be obtained by the methods discussed in the first part of this chapter but need not necessarily be a square wave, provided the leading edge is steep. One interesting development in thyratrons for this purpose is a hydrogen-filled tube which will operate a modulator with a peak power output of over 1 megawatt. This tube is only slightly larger than a glass 6L6. Higher powers can be handled by using these tubes in parallel. The firing time with a suitably fast trigger is reliable enough that two tubes may be fired simultaneously to within 1/50th of a microsecond, provided the time delays in the transmission of the pulse to the grids are equalized.

Another switching device which has been successfully used is a triggered spark gap. The pulse-repetition frequency is set at the desired value by applying a voltage impulse to the gap. Since this voltage is merely used to initiate the spark, the main power and voltage coming from the pulse-forming network, a simple low-powered trigger unit can be used.

Probably the simplest type of switching device which can be used is the rotary spark gap in which the pulse-repetition frequency is determined by the rotor speed and the number of points in the gap. This type of switch has the one serious disadvantage that it cannot be used in applications where the spacing between pulses must be held constant. The time interval between pulses may vary as much as 100 microseconds because of motor-speed variations and irregularity in the distance that successive sparks jump as the gap closes. For many applications this is no handicap.

Modulators built around the basic circuit shown in Fig. 16 will weigh about one quarter to one eighth as

much as the type described first and will occupy less than half the space for the same power output.

One other trick which can be used to simplify modulators where the pulse-repetition frequency can be tied to the frequency of the modulator power supply is to allow the switching device to act as the rectifier. If the direct-current power supply in Fig. 16 is replaced by an alternating-current source, the pulse network will alternately be charged positively and negatively. If a positive charge on the network is the desired condition at the time of closing the switch, the modulator will operate if the switching device is made to close at the peak of the charging cycle. This can be done by generating a trigger from the alternating-current which is then applied to a thyatron or fixed spark gap. A phase shift may be required to adjust the timing trigger for optimum performance, but this presents no great difficulty. An alternate method is to operate a rotary gap with a synchronous motor, again adjusting the phase properly.

Since the pulse-forming network acts as a capacitance in the circuit and the current limiter may be an inductance, the values may be chosen to obtain resonance at the alternating-current frequency. This results in a voltage higher than the output of the transformer, thereby decreasing the size of the transformer needed. Resonant charging by the same method will also take place with a direct-current source of power as shown in Fig. 16 if the circuit is resonant at the pulse-repetition frequency.

An early experimental modulator furnishes a good example of a rotary-gap type using alternating-current charging. The circuit is essentially that shown in Fig. 16. Since the set operates on 60-cycle power and a pulse-repetition frequency of about 400 pulses per second is desired, a motor generator is used to obtain 400-cycle single-phase power from the main 60-cycle power. This power is applied to the pulse network through a step-up transformer without being rectified. The current limiter does not appear as a separate choke because of the special design of the transformer to obtain resonance with the pulse network. The switching device is a rotary gap mounted on the same shaft as the motor generator, the phasing being adjusted by moving the fixed spark-gap points. This modulator, including control box, weighs only 600 pounds and has a power output of 3 megawatts. The over-all dimensions are approximately 20×30×40 inches.

VI. TRANSMITTERS

1. Frequency Bands

The wartime trend in radar has been steadily toward higher frequencies, but the eventual limit imposed by the absorption of air is rapidly being approached. It is interesting to note that the wavelengths of about 1 centimeter, at which Hertz carried out his studies of electromagnetic radiation, are again becoming the subject of investigation.

The early work on radar was carried out in the fre-

quency region between 30 and 100 megacycles, largely because the techniques were more advanced than at the higher frequencies. As techniques improved, the higher frequencies offered the advantages of higher antenna gains with smaller antennas and also provided better resolution because the energy can be focused into a sharper beam with a moderate-sized antenna.

It now appears that the best frequencies for long-range search are between 600 and 6000 megacycles, and those for most airborne applications lie between 3000 and 60,000 megacycles, the air being too opaque for satisfactory operation at higher frequencies.

2. Conventional-Tube Transmitters

Up to 1000 megacycles, transmitter techniques are largely extensions of the use of the conventional circuits using triodes, tetrodes, etc. Two factors which limit the use of conventional types of tubes and circuits at high frequency are (1) the time of flight of the electrons between the cathode and plate; and (2) stray inductance and capacitance of lead wires and tube elements. If the frequency is so high that the plate or grid alternating voltage reverses during the time of flight of the electrons from the cathode to these electrodes, the tube will fail to oscillate, or at best will put out only small power. Within limits, the time of flight may be reduced by decreasing the electrode spacing and by increasing the direct-current potentials; but manufacturing difficulties, low power dissipation of small electrodes, and voltage breakdown make these solutions of the problem less practical as the frequency is increased.

3. Cavity Resonators

The problems of stray capacitance due to lead wires, of internal capacitance in coils, and of internal inductance in capacitors may be easily eliminated by using metallic cavities as electrical resonators. Although great improvements in tuned-cavity techniques have been worked out during the war, the fundamentals were well known prior to 1940. Basically, a hollow metallic cavity will act as a tuned circuit if electrical energy is coupled into the interior of the cavity by some means such as a dipole, probe, or loop. The resonant frequency of such a cavity will be determined by its size, its shape, and the method of coupling. Fig. 17 shows a cross section through a cavity, the connections being made through coaxial cable.

On the left, the power is coupled by means of a loop, while on the right, a probe type of coupling is shown. Tuning may be accomplished by screwing a plunger in or out. The choice of coupling method and the position of the coupling devices will depend on the orientation of electric field to be established. In most cavities it is possible to set up several different "modes" or ways in which the cavity will oscillate. A common mechanical example of this behavior is a metal rod which may vibrate with bending or with a twisting motion or may

have a compression wave traveling in it. Each of these general types of vibration may also have harmonics. Since the electric fields will be quite different for the different modes, the position and type of input coupling used will frequently decide which mode is excited. Most or all of the energy will go into those modes of oscillation which have electric and magnetic fields most nearly like those of the coupling device at the position of the input. For example, if a mode of the cavity requires a voltage zero at the input and the input sets up a high voltage at this point, that mode will not be set into oscillation. If the frequency of the input power is not determined by the cavity itself, only the modes for which the natural frequency of vibration is very close to that of the input will be excited. For most applications, the shape and size of the cavity are chosen to give the cavity a single mode in the desired operating frequency region. The inputs and outputs are then chosen and are placed to couple with this mode.

The loop type of coupling is desirable where a direct-current return path is needed, while a probe or dipole is useful where direct-current insulation between the

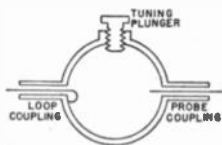

Fig. 17—Resonant cavity.

cavity and feed line is required. The coupling efficiency of a loop will increase with size and may also be varied by changing the orientation of the loop, provided the rotation does not cause excitation of a new mode. The coupling efficiency of a probe will depend on its penetration into the cavity. In both of these cases, altering the coupling may change the tuning of the cavity.

4. Lighthouse Tube

The "lighthouse tube" offers the best example of the successful stretching of triode oscillator techniques into the region above 1000 megacycles. As may be seen from Fig. 18, the name is derived from the appearance of the tube. The cathode, grid, and plate are parallel planes with extremely small spacing between them and are held in place by copper disks which extend through the glass envelope of the tube. Because of the small spacing between tube elements it has not been possible to build tubes with an average power output of more than a few watts, but it has been possible to obtain a peak-pulse output of over 1 kilowatt. The tube is "wired" to its circuit by placing metal cylinders against the discs, as shown in Fig. 18. These cylinders must be direct-current insulated from each other to permit the application of direct-current voltage as in normal triode applications. The cavities formed by the spaces between these cylinders are the tuned circuits, and feedback from plate to grid is accomplished by using a coupling loop or a small hole between the cavities. This

oscillator has both tuned grid and tuned plate circuits, and the tuning is accomplished by sliding the tube in the cylinders to change their lengths. Conventional methods may be used for modulating the radio-frequency output of these tubes.

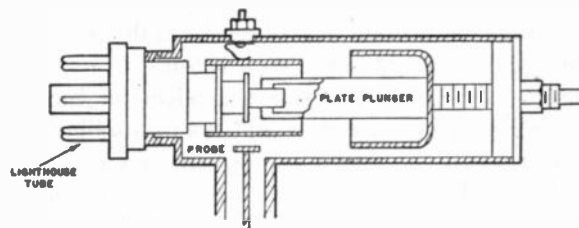

Fig. 18—Lighthouse tube in re-entrant cavity.

5. The Klystron

A quite different type of high-frequency oscillator for low-power applications is the klystron. Although klystrons were discussed in the literature before the war, a brief discussion will help in understanding the more recent developments. The present designs use cavity-type circuits; but at frequencies below 1000 megacycles, where cavities become too large to be convenient, it should be possible to use coils and capacitors for the tuned circuits. As shown in Fig. 19, a steady stream of electrons is focused into a beam by an electron gun similar to that used in a cathode-ray tube. Since the electron velocity is already appreciable by the time these electrons strike the working part of the tube, the distance traveled in one cycle will be much greater than in a triode where the electrons start with low velocity within the working region; hence, the difficulties due to time of flight become troublesome only at much higher frequencies than in a triode with the same spacing.

The stream of electrons from the gun in Fig. 19 is directed through two toroidal cavities and finally reaches a collector. The cavities, which are normally of similar construction, are designed to oscillate in a mode which causes an alternating electric field to exist between the entrance and exit holes for the electron beam, as indicated in Fig. 19 (b) and (c). Now, assuming cavity 1 to have been set in oscillation by some means such as the turning-on of the tube (this assumption of already existent oscillations is necessary to visualize the behavior of any oscillator), let us see what happens to the electrons passing through it. Electrons passing through the cavity while the far side is positive, as in Fig. 19(b), will be speeded up, while those passing through a half-cycle later will find the far side negative, as in Fig. 19 (c), and will be slowed down. Thus, for alternate half cycles the electrons are speeded up and slowed down. After the electron stream has gone beyond cavity 1 the faster electrons will begin to overtake the slower ones, thereby causing a bunching in much the same way a group of fast cars which has been held up by a traffic light overtakes a group of slower cars held up by the previous turning of the light. This traffic

concentration obviously occurs some distance beyond the light. The region at which the electron traffic jam occurs is fairly sharp; and because the amount of speeding-up or slowing-down of the electrons varies with the phase of the oscillation, it can be shown that the electrons which passed through the cavity between the extreme voltage conditions will all tend to pile up at about the same place along the electron beam.

If cavity 2 is placed where this electron bunching occurs, this group of electrons will set up oscillations as it passes through the cavity by inducing charges on the walls. When the two cavities are tuned to identical frequencies the oscillations in cavity 2 will maintain a constant phase relationship with those in cavity 1, the phase having been established by the time the first group of electrons entered cavity 2. If we now return

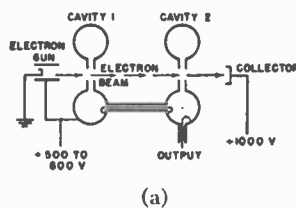

(a)

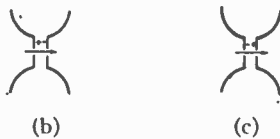

(b) (c)

Fig. 19—Klystron.

our attention to cavity 1, we see that a steady stream of electrons is still entering and the oscillations in cavity 1 are continuing. Therefore, 1 cycle after the first group of electrons has passed, conditions are duplicated and are proper for forming a second bunch which will arrive at cavity 2 at the proper time to feed more energy to it. By drawing a few sketches of the bunched electrons crossing the cavity and remembering that the wall nearest the electron group will have positive charges induced on it, the reader may verify this statement and may also satisfy himself that the maximum power will be extracted from the electrons if their time within the cavity is a half cycle. It may also be seen that the field will be in a direction to slow down the electrons. The energy going into the electric oscillations has been obtained, therefore, by robbing the electrons of some of their kinetic energy.

The tube described so far will operate only so long as the accidental oscillations in cavity 1 continue. In order to insure that these oscillations continue, a small amount of energy from cavity 2 is fed back into cavity 1 by means of a short length of coaxial transmission line coupled by loops in the two cavities. The length of this line must obviously be chosen to maintain the proper phase relationship between the two cavities. Another effect of this coupling system is to tie the two circuits together so that they act as a double-tuned

circuit similar to that shown in Fig. 20. As long as the two coupled cavities are each tuned for approximately the same frequency they will oscillate as a unit with a single-frequency output; and over small ranges the tuning of one cavity will then shift the resonant frequency of the system as a whole.

The collector beyond the second cavity in Fig. 19(a) is used to dispose of the electrons after they have served their purpose.

When the frequency of operation of the klystron is chosen, the design of the cavities and the separation between them can be fixed. In order to provide a reasonable tuning range the cavities may be made adjustable in size by making the walls of airtight metal bellows. After the two cavities have been adjusted to resonate at approximately the same frequency, the voltage used to accelerate the electrons from the gun is adjusted for maximum power output. Frequently, sev-

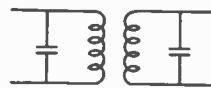

Fig. 20—Double-tuned circuit.

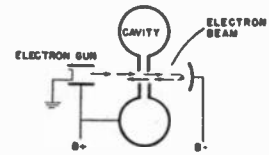

Fig. 21—Reflex klystron.

eral resettings of the controls are required to obtain optimum performance and to make the tube oscillate over a reasonable range of frequencies.

Much of the difficulty in adjusting this type of klystron arises from the fact that there are two cavities which must be matched. A great simplification in operation can be made by eliminating one cavity. The "reflex klystron" uses the same cavity for bunching the electrons and for extracting power by reflecting the bunched electrons back through the cavity, as shown in Fig. 21.

In this device the electrons, on their way through the cavity from the gun, are speeded up or slowed down as in the two-cavity klystron. This process on the average requires no power, because half of the time electrons absorb power by being speeded up and the other half of the time give power to the cavity by being slowed down. After the electrons have passed through the cavity they are reflected by a negative voltage on the reflector, so that they return through the exit hole into the cavity. The reflector must be properly shaped to keep the electrons focused into a beam. The point at which these electrons turn around will depend on the voltage applied to the reflector; hence, the distance traversed outside of the cavity may be adjusted by changing this voltage. During the time these electrons are outside of the cavity the faster ones are catching up on the slower ones, as was previously discussed. Now, if the dimensions and voltages are properly adjusted, the electron bunches will start back through the cavity in the proper phase to increase the oscillations. When this condition occurs, the cavity will oscillate and power can be extracted. Since only one cavity is involved,

oscillation will occur at the resonant frequency of the cavity when the voltage on the reflector is properly set. Hence, the frequency is primarily set by the cavity and the power output can be adjusted by the reflector voltage. If the exit hole of the cavity is large, a change in the reflector voltage will also cause a shift in frequency and may be used for tuning over a small range. Likewise, altering the cavity size will cause a change in power output. Reflex tubes are available in two types; one with a built-in cavity and the other with copper-disk seals similar to those in a lighthouse tube, to which an external cavity may be attached.

All klystron transmitters can be amplitude modulated by varying the current from the electron gun. Although the average power output is limited to a few watts, pulse peak power of a few kilowatts may be obtained from the larger tubes. It is interesting to note that the reflex klystrons which may be tuned by varying the voltage of the reflector are readily frequency modulated by applying the signal to the reflector.

6. Magnetrons

For high-power radar sets at frequencies above 1000 megacycles, the most successful tube is the magnetron. For the same frequencies at which a few kilowatts of pulse power may be obtained from a triode or klystron, a magnetron will give 2 or 3 megawatts. For example, at 3000 megacycles, tubes capable of giving over 1000 kilowatts have been in large-scale production for some time and tubes giving 2500 kilowatts are now being produced. The former will operate with an average power input of about 1200 watts and the latter at about twice this level. Since these tubes will not operate well as continuous-wave oscillators and cannot be modulated readily except by a square pulse of less than 5 microseconds duration, their use is largely limited to radar, pulse-communication systems, and other applications using pulse techniques. A somewhat different design of magnetron is built for continuous-wave use. The maximum output is about 10 kilowatts at 3000 megacycles, but here again modulation is difficult.

Although the magnetron was invented by Hull in 1921, it was not put to much practical use until early in the war when the British first investigated it as a pulsed transmitter. The "cavity magnetron" as used during the war is a split-anode type with resonant circuits built into the tube. Most of the British and American tubes have had eight or more anode segments with a resonant cavity between each segment. The Japanese used four-segment tubes in their 10-centimeter radar. Fig. 22 shows the internal construction of an 8-cavity magnetron. The anode is the solid metal block into which the resonators are cut as slots and holes. The natural frequency is determined largely by the width and radial depth of these slots and to some extent by the axial length and the position of the ends of the tube. The space which is left between each end or lid of the tube and the block in which the slots are cut serves

to act as a coupling cavity between the separate oscillators, and also provides space for the cathode and heater leads. The cathode lies along the axis at the center of the block and is usually an oxide-coated nickel tube enclosing a heater winding. The radio-frequency power is extracted by a coupling loop in one of the cavities and is brought out through a short coaxial line. The tube is normally operated with the anode at ground potential since this simplifies the problem of connecting the output to the remainder of the system.

For operation, the magnetron is placed between the poles of a magnet so that the field is parallel to the axis of the cathode. An electron leaving the cathode thus finds itself in a radial electric field produced by the cathode-anode potential and also in an axial magnetic

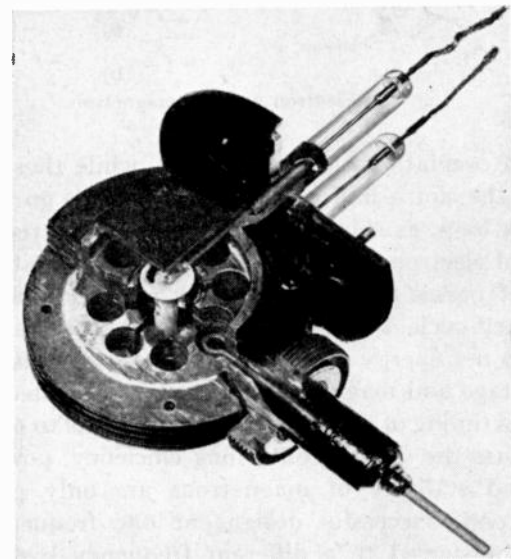

Fig. 22—Cutaway view of magnetron.

field. The electric field tries to accelerate the electron toward the anode, while the magnetic field acts to make the electron circle back to the cathode. When the magnetic field and anode voltages are adjusted to make the tube oscillate these two counteracting effects are balanced, so that most of the electrons come close to the anode but do not quite strike it. Because of the complicated geometry and the effects of space charge on the electron paths, it has not been possible to work out a complete analysis of the operation of the magnetron. It is certain, however, that the presence of the oscillating fields across the openings of the resonators causes the electron cloud to become bunched in the region close to the anode. It is also certain that this electron cloud rotates around the cathode at the correct rate for these electron groups to feed power into the circuit as they pass the resonator openings. The probable mechanism for the electron bunching is as follows: the magnetic field causes the electrons which miss the anode to return to the vicinity of the cathode. Since the sharpness of curvature of the path of an electron moving in a magnetic field is greater for slow than for fast electrons,

those electrons which have been slowed down by giving power to the oscillators will be bent around sharply and will miss the cathode, as shown in Fig. 23(a). Those which have neither gained nor lost energy should just touch the cathode, while those which have increased speed by gaining energy should strike the cathode, as in Fig. 23(b), and be captured. (That the latter action occurs is proved by the large amount of secondary electron emission from the cathode and by heating which may be sufficient to permit turning-off of the filament power in some tubes after oscillations start.) The net result of these changes in electron velocity is to remove those which passed a slot during one half



Fig. 23—Electron paths in magnetron.

cycle of oscillation of the resonator, while those which passed the slot a half cycle later remain to go through another loop, as shown in Fig. 23(a). This remaining group of electrons will feed energy into the next oscillator if it passes during the proper phase in the radio-frequency cycle. Since the first passage of the electrons gave no net energy to the resonator, it is obvious that the voltage and magnetic field must be adjusted to obtain this timing of the electrons if the tube is to oscillate.

Because the factors controlling efficiency, power output, and stability of magnetrons are only partially understood, successful designs at one frequency are often transferred to a different frequency by scaling. If all dimensions are scaled in proportion to the wavelength, the tube will have similar characteristics. The operating voltage and average power output will remain constant, but the magnetic field will vary inversely with the wavelength.

Some idea of the operating conditions may be obtained from Table I.

TABLE I

Wave-length in Centimeters	Power		Per Cent Efficiency	Anode Voltage in Kilovolts	Gauss Magnetic Field
	Peak Pulse Output in Kilowatts	Average Input in Watts			
23	1000	2000	50	28	1800
10	1000	1200	50	28	2800
3	250	700	40	21	5000
1	50	100	22	14	7600

These values are near maximum output for particular tube types but may vary with the design of the tube and must be taken merely as an indication of what may be expected for the different frequency regions.

Most of the magnetrons now in use are "fixed tuned," i.e., the frequency is determined by the construction at the factory and is not controllable in the set. These

tubes are tested and labeled to show the frequency region of operation, but individual tubes of a particular marking may differ by several megacycles. A definite preassigned frequency for each station cannot be made, therefore, without laborious tube selection. Recently, tunable tube designs have been worked out, one method being a movable diaphragm which changes the size of the space between the resonator block and the lid. Thermal expansion of the resonant cavities makes exact frequency control difficult, even with tunable tubes.

Another factor which makes operation on an exact frequency difficult is the frequency "pulling" which occurs when standing waves exist in the transmitting system. A change in phase and amplitude of a wave reflected back into the magnetron may cause a shift in frequency of the output. Under certain conditions this frequency change may alter the reflected-wave phase in the proper direction to change the frequency still further. When this happens there may be a frequency region in which the magnetron will not operate unless the reflected wave is changed by altering some other part of the radio-frequency system. The pulling may cause considerable trouble in systems where the reflected wave changes with antenna position. For example, in aircraft radar installations where the antenna must be housed in a streamlined plastic dome, the reflection from the plastic may vary with the direction of the antenna. When this happens the frequency of the transmitter varies with antenna orientation, making it difficult to keep the receiver tuned. The best cure is to reshape the antenna housing.

The frequency pulling can, however, be used as a method of frequency modulating a magnetron. If a resonant cavity is placed in the transmission line near the magnetron, the frequency of the transmitter may be varied by tuning this cavity. Voice modulation, for example, may be applied by making one side of the cavity a thin diaphragm which vibrates under the impact of sound waves, thereby changing the cavity dimensions and hence its resonant frequency. When a magnetron is tuned by this means, care must be taken to see that the standing waves do not cause voltage breakdown in the transmission line.

VII. RADIO-FREQUENCY TECHNIQUES

1. Transmission-Line Types

In the radio-frequency region below a few hundred megacycles, parallel-wire transmission lines may be used. Since the spacing between the two wires must be kept small compared with the wavelength in order to prevent radiation, such lines become mechanically impractical at higher frequencies.

Coaxial transmission lines consist of a wire or rod along the axis of a cylinder. The electric field is applied between the wire and cylinder, the wave being completely enclosed so radiation cannot occur. Such lines may be conveniently used at low as well as high

frequencies, but at frequencies above 3000 megacycles the losses become rather high. Another difficulty at microwave frequencies arises from the fact that, when the circumference of the outer conductor becomes comparable with the wavelength, the electric fields need not be radial, much of the energy being carried as a space wave which has different velocity from the simple radial wave. Hence, at wavelengths of around 1 centimeter, coaxial lines are too small to carry appreciable power. Even at 10 centimeters, the maximum allowable size of a coaxial line is too small to carry the now-available pulsed powers without arcing.

For microwave frequencies the most practical transmission line is a wave guide. This consists of a hollow pipe in which the energy is carried as a confined space wave. Because wave guides were not in common use before the war, a more detailed discussion of their properties will be given after a brief review of the behavior of the more familiar types of transmission lines.

2. Properties of Transmission Lines

The ratio of the voltage to the current in a transmission line carrying a single wave is a constant which depends on the wire size and spacing. This ratio is called the "characteristic impedance" and is expressed in ohms. When a resistance equal to the characteristic impedance is placed across one end of a transmission line and a transmitter is used to drive the other end, no reflection of the wave will occur at the resistance. If, on the other hand, the line is not terminated by a resistor equal to its characteristic impedance, a part of the power in the wave will be reflected back to the transmitter. The reflected wave will then combine with the original wave to form "standing waves." Where the reflected and original waves are equal in amplitude, the wave pattern will appear to be stationary along the line but will still vary in instantaneous value with time; hence the term "standing waves." A vibrating string is a mechanical example of a standing wave. Whenever standing waves appear on a transmission line, the line is said to be "mismatched," the standing wave being evidence of a reflection due to a discontinuity in impedance along the line. Obviously, the efficiency of the transmission line is decreased under these conditions because part of the power is returned to the source. Therefore, it is desirable to reduce the standing waves to a minimum.

When standing waves exist, points of maximum and minimum voltage may be located by sliding an alternating-current voltage-measuring device along the line. For example, a small probe may be inserted in a slot cut lengthwise in the outer conductor of a coaxial line. If the probe is connected to a vacuum-tube voltmeter or to a calibrated crystal detector, the voltage developed by the wave along the line may be measured by placing the probe at various points along the slot. In order to avoid the introduction of spurious standing

waves, the probe should not penetrate an appreciable distance into the coaxial line. The "voltage-standing-wave ratio" is then the ratio of the maximum voltage to the minimum voltage. When no reflected wave is present this ratio will be unity, while with a reflected wave equal in amplitude to the transmitted wave the ratio becomes infinite, because there are points at which the voltage is always zero. The distance between adjacent maximum and minimum voltage points will be a quarter wavelength.

Let us now examine the standing-wave conditions on a transmission line which ends in an open circuit. When the wave reaches the open end of the line the current I must be zero, because there is no conductor to carry it. The impedance Z at this point will then be

$$Z = E/I = \infty \quad (12)$$

because the voltage E will not be zero at an open circuit. The power must all be reflected, since there is nothing to dissipate the power at the open circuit. The reflected wave will then add to the transmitted wave in a proper phase to keep the current zero at the open end. This will result in a current standing wave, as shown in Fig. 24(a), and the current will be found to vary in time

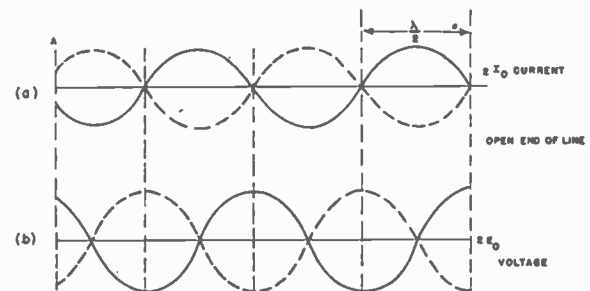

Fig. 24—Standing waves.

between the limits indicated, the dotted line occurring a half cycle later than the solid line. Fig. 24(b) shows the voltage accompanying this current wave, the voltage being a maximum at the open end. Since the instantaneous maximum current or voltage occurs when the incident and reflected waves are adding momentarily in phase, the value will obviously be twice that of the incident wave. The separation between the nodes or points where the wave is zero is a half wavelength ($\lambda/2$). A quarter wavelength from the open end of the line the voltage is zero but the current is finite. Therefore,

$$Z = E/I = 0. \quad (13)$$

Zero impedance denotes a short circuit; the line will, therefore, appear to be short-circuited here. Placing a short-circuiting bar across the line at this point will not alter conditions in the part of the circuit to the left of this short circuit. Between these two conditions of infinite and zero impedance the voltage-current ratio will be finite and may be either positive or negative. A positive value of the impedance corresponds to an inductance and a negative value to a capacitance.

Therefore, if the line were cut and terminated in the proper value of inductance or capacitance, conditions to the left of this point would remain unaltered. From another point of view, at some point *A* the apparent impedance due to the remainder of the line can be altered by changing the position of an open circuit along the line.

In practice it is easier to change the position of a short circuit than to adjust the line length. Therefore, a brief summary of the properties of a short-circuited line is in order. At a short circuit the voltage must be zero and the current a maximum; hence, the impedance is zero. As in the case of the open line, the wave must be reflected without loss in amplitude because there is no dissipation of energy in an ideal short circuit. Thus a standing wave is established. A simple analysis of this standing-wave pattern shows that the voltage is always

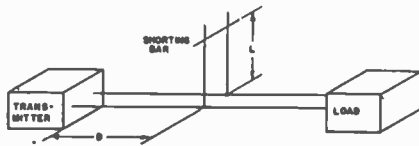

Fig. 25—Transmission line with T junction.

zero at points an integral number of half wavelengths from the short circuit. Hence, these points appear to be short circuited when seen from the source of the original wave. At points an odd number of quarter wavelengths from the short circuit, the line appears to be open or infinite in impedance because the current is always zero. At distances between the points just discussed, the impedance appears inductive or capacitive. A comparison with the open-circuit line shows that a short circuit is equivalent to an open circuit placed a quarter wavelength from the position of the short circuit.

3. Properties of Stubs

If we have a T junction in a transmission line, either parallel wire or coaxial cylinder, as shown in Fig. 25, the side branch will form a parallel circuit because the current divides at the T. When the branch line is short-circuited, there will be a reaction back on the main line and hence on the transmitter. Let us consider several cases. If L is a quarter wavelength, the impedance of the side arm at the junction will appear infinite. Then, since this side arm is a parallel circuit with infinite impedance, it will have no effect on the main line. On the other hand, if the short-circuiting bar is placed at $L=0$ or $L=1/2$ wavelength or any multiple of a half wavelength, the line will appear to be short-circuited at the T; and the load will be cut off from the transmitter. This short circuit at the T will, in turn, appear as an impedance at the transmitter.

If D is some integral number of half wavelengths, the transmitter will see a short circuit on the line; while if it is an odd number of quarter wavelengths, the line

will appear to be disconnected from the transmitter. At intermediate values of D the line will act as an inductance or capacitance.

This property of a T junction may be used to modulate the transmitter. If the load is the antenna and a tube placed electrically an integral number of half wavelengths from the T is used as a short-circuiting bar, the power reaching the load may be controlled by turning this tube on and off. The length D should be adjusted to some number of half wavelengths to prevent overload of the transmitter during the short-circuited condition of the side arm. Further discussion of the use of this arrangement for switching purposes will be given later.

This property may also be used to provide supports for the inner conductor of a coaxial line. Side arms a quarter wavelength long and short-circuited at the end are used, as shown in Fig. 26. The successful operation of this "stub-supported line" depends on the fact that the short circuit is a quarter wavelength from the line.

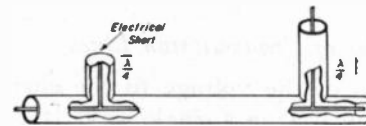

Fig. 26—Stub-supported line.

Therefore, the band of frequencies which may be passed without setting up serious standing waves is limited. A right-angle stub-supported bend is shown at the end of this line.

Still another application of these principles is the "choke joint" for coupling two coaxial lines together, particularly where rotation between the two sections of line is required. In Fig. 27(a), energy leaking out through the gap A goes out past B to C , where it is reflected by the short circuit. If BC is a quarter wavelength, the circuit at B will appear to be open. This open circuit will in turn appear to be a short circuit across the gap at A if AB is a quarter wavelength. Now, since the crack at B is in series with the path ABC , and the impedance is infinite at B due to the short circuit at C , it will be immaterial whether the contact at B is good or bad. No energy will leak as long as the gap at B is small compared with a quarter wavelength.

The inner conductor may be coupled by maintaining a good electrical contact or by an arrangement as shown in Fig. 27(b). If there is no contact or contact only at the center of the hole, this coupling will act in the same manner as the choke in Fig. 27(a) if the distances AB and BC are again a quarter wavelength.

4. Impedance Matching

Now let us consider the case of a circuit shown in Fig. 25, in which the load is not matched to the transmission line. The relative impedances of the load and of the side arm as seen at the T can be adjusted by changing L . Since these circuits are in parallel, the division of the transmitted power at the T will be

determined by these impedances. Part of the power from the load is reflected, while all of that from the side arm is returned. Therefore, if the length L is adjusted to present the proper impedance at T , the reflected wave from the short circuit will be just equal in amplitude to that from the load. These two reflected waves will not be in the proper phase to cancel, however, unless the T is at the proper place on the line. If the T can be moved along the line or the length of line between the T and the load can be varied by using a telescoping section, the two reflected waves can be made to cancel in the line D . Changing the length of the line between the load and the T will change the apparent load impedance at the T , thereby necessitating a change in the short-circuiting-bar position. Hence, the final adjustment must be made in a series of steps during which both variables are changed to reduce the standing waves in the line D . Thus a variable-length stub may be used to match the load to the transmitter. Where the power to the load is high, a telescoping section in the line is undesirable because arcing corrodes the sliding contacts causing power losses. For matching such a load two tuning stubs placed

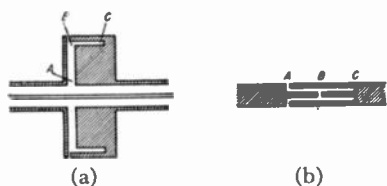

Fig. 27—Choke joint.

a quarter wavelength apart along the line will match many loads into the transmitter. Three stubs placed at quarter-wave intervals will match any load to the transmitter but are almost impossible to adjust properly if the shorting bars are moved independently. By ganging the two outer short-circuiting devices so that they move together, only two independent adjustments are needed, thereby making the manipulation reasonably simple. Although tuning stubs and variable-length lines were used in earlier radar systems, there has been a continued and successful attempt to make the radio-frequency system sufficiently broad-band to make such variable matching devices unnecessary. A system perfectly tuned by an expert may perform a few per cent better than a well-designed fixed-tuned set, but it has been thoroughly demonstrated that the average performance over a period of time will be better if the number of necessary adjustments is made as small as possible.

5. Broad-Band Systems

The problem of making a radio-frequency system with a broad bandpass is, to a large extent, a matter of designing individual components whose impedances are not frequency sensitive, and are nearly equal. It is usually impossible to have all components in the system perfectly matched; hence, it is necessary to make use of

stubs and other tuning devices. In many cases, however, these tuning devices may be adjusted on the basis of bench tests and permanently set. One rule where a broad bandpass is desired is to place the matching device as close to the point of origin of unwanted reflections as possible. Consider the case of Fig. 25, where the load is not matched to the line. If the distance between the T and the load is many wavelengths, it is obvious that a slight change in wavelength will cause a large shift in phase of the reflected wave at the T . The reflection from the stub will no longer cancel that from the load when this occurs. On the other hand, if the T is only a fraction of a wavelength from the load, a small change in wavelength will not appreciably alter the phase. A second practice in broad banding is to use several matching devices rather than a single one. This practice is based on the principle that the matching devices act as resonant circuits which are coupled together by the transmission line. As in the case of standard tuned circuits, the bandpass of a single circuit will appear as in Fig. 28(a), while multiple-coupled resonant circuits will give a bandpass as shown in

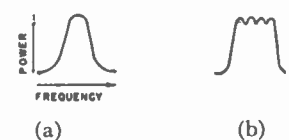

Fig. 28—Frequency response.
(a) Single circuit
(b) Coupled circuits



Fig. 29—Radio-frequency impedance-matching transformer.

Fig. 28(b). The flat frequency characteristic over the desired region is obtained at the expense of poor frequency response outside this region. A bandpass, as shown in Fig. 28(b), may be obtained by using several matching stubs properly adjusted rather than a single one.

Since the impedance of a coaxial transmission line depends on the ratio of the diameter of the inner and outer cylindrical conductors, a change in this ratio may be used in place of a stub as a matching device. Fig. 29 shows such a transformer. The change in diameter of the inner conductor, the length of the raised portion, and its position along the line must be properly chosen to accomplish the desired matching. In general, any device which alters the line impedance may be used as a matching device if it can be adjusted to cancel the standing waves.

6. Waveguides³⁻⁵

Most of the discussion of the properties of parallel-wire and coaxial transmission lines applies to wave guides, but there are some differences which will be

³ J. C. Slater, "Microwave Transmission," McGraw-Hill Book Company, New York, N. Y., 1942.

⁴ S. Ramo and J. R. Whinnery, "Fields and Waves in Modern Radio," John Wiley and Sons, New York, N. Y., 1944.

⁵ R. I. Sarbacher and W. A. Edson, "Hyper and Ultrahigh Frequency Engineering," John Wiley and Sons, New York, N. Y., 1944.

pointed out in the following sections. Since a complete discussion of wave-guide properties is beyond the scope of this paper, only those items which have direct application to radar techniques will be considered. Although any hollow pipe of the proper size may be used as a transmission line for a range of frequencies, rectangular pipes are most frequently used. Fig. 30 shows the distribution of electric and magnetic fields for two "modes" of propagation in a rectangular pipe. The electric field is perpendicular to the wide dimension and runs straight across the pipe. The electric-field distribution is shown by the curves sketched beside the pipe. The magnetic field surrounds the strong electric-field regions and lies in a plane parallel with the wide pipe dimension. In the TE_{01} mode, which is the most widely used, the currents flow lengthwise at the center of the broad face and on

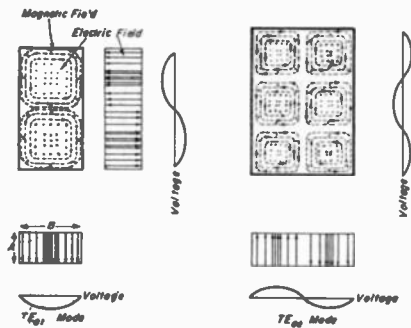

Fig. 30—Modes in rectangular wave guide.

the sides flow parallel to the electric field inside the pipe. This means that a lengthwise slot can be cut in the center of the broad face without disturbing the currents. Such a slot is used for a probe entrance to measure standing waves.

The TE_{02} mode is effectively two TE_{01} modes side by side in the same pipe. Higher modes in this series are designated by increasing the last subscript and correspond to more TE_{01} modes running side by side. The velocity of propagation of waves in these modes is higher than that in free space and is given by

$$V = v_0 \frac{1}{\sqrt{1 - (n\lambda_0/2B)^2}} \quad (14)$$

where V_0 and λ_0 are the normal wave velocity and wavelength in the medium with which the pipe is filled. B is the width of the pipe perpendicular to the electric field, and n is a whole number designating the mode. When the quantity inside the parenthesis is greater than unity, the velocity becomes imaginary and the wave will be highly attenuated. The condition for propagation of a wave is, therefore, that B must be larger than $n\lambda_0/2$. For pipe of a given size and $n=1$ there will be a maximum wavelength which can be transmitted. For the $n=2$ mode this maximum wavelength will be half as large. Hence, there will be a band of wavelengths for which the pipe will transmit only the TE_{01} mode. At longer wavelengths the guide acts as an attenuator,

while at shorter wavelengths more than one mode may exist simultaneously. When two or more modes exist in the pipe it is difficult to control the distribution of energy between them, and it is usually impossible to match both modes into the load. Therefore, the pipe size is normally chosen to transmit only the TE_{01} mode.

So far, nothing has been said about the dimension A , as in Fig. 30. This dimension can be made as small as one pleases without altering the wave-transmission properties, but since a strong electric field exists in this direction, electrical breakdown may occur if this distance is too small. This dimension can theoretically be increased indefinitely, but from a practical point of view it should be kept smaller than the cut-off guide width to prevent formation of a TE_{01} wave at right angles to that shown.

Many more complex modes can be excited in rectangular guides, but they will not be discussed because they are not commonly used.

In round guide the TE_{11} mode is similar to that in rectangular guide, the only difference in field distribution being that shown in the end view in Fig. 31(b). Because there is no preferred direction across a circular pipe, the polarization of this wave in a long line is likely to rotate by an amount determined by irregularities in the pipe. Although this can be prevented by stretching a wire across the pipe diameter at intervals, the further difficulty exists that the difference between the cut-off diameter and that which will allow the next higher mode to exist is rather small. On straight runs this causes no trouble, but at bends and T joints higher modes may be excited. In the case of a given-sized rectangular pipe, the two longest wavelengths λ_m which can be transmitted are carried in the TE_{01} and TE_{02} modes with values $\lambda_m = 2B$ and $\lambda_m = B$ respectively. For circular pipe, the two longest wavelength modes are the TE_{11} and TM_{10} modes with $\lambda_m = 3.412R$ and $\lambda_m = 2.62R$, respectively, where R is the pipe radius.

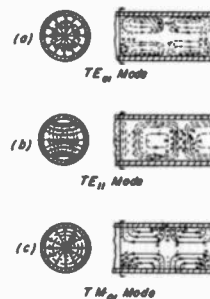

Fig. 31—Modes in circular wave guide.

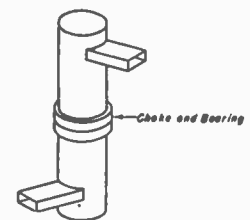

Fig. 32—Rotating wave-guide joint.

The TM_{01} mode shown in Fig. 31 has the property of having axial symmetry and is, therefore, a useful mode for rotating joints. Fig. 32 shows a section of circular guide fed by rectangular guides. If the rectangular guides enter about a quarter wavelength from the closed ends of the circular pipe, the TM_{01} mode will be excited. The circular guide is cut in the middle so that one half can rotate with respect to the other, and a choke

joint similar to Fig. 27(a) is used to keep the power from leaking out. Because the TM_{01} mode is symmetrical, the power passing through this system will be independent of the angle between the two rectangular guides.

Since the TE_{01} mode for rectangular pipe is the most important, let us see how this mode can be driven by a transmitter such as a magnetron or klystron. These tubes are the main sources of energy in the frequency region where wave guides are used and are usually built to feed directly into a coaxial line. The problem is, therefore, largely one of transition from coaxial to guide. Because the electric field is transverse in the guide, one method is to terminate the coaxial in a probe as shown in Fig. 33. This results in an intense field between the tip of the probe and the top of the guide. A suitable matching transformer must be used and may be of the type shown. The closed-end stub is placed a half wavelength from the probe so that the reflected power is in phase with the incoming power. The probe will be broader in its frequency characteristics and less apt to arc if it is large in diameter. This same device can be used to transmit energy from the guide to the coaxial line.

A second and better method is to establish the magnetic field by a current, as shown in Fig. 34. In this case, large oscillating currents flow from the coaxial to the top of the guide through the metal "doorknob." This establishes a magnetic field in the plane perpendicular to the paper. Since this is the proper direction for the magnetic field in the TE_{01} mode, a wave of this type is generated. The coupling may be just a wire crossing the guide, but the door-knob shape makes the system broad band and helps in matching. Again the position of the closed end is chosen to make the reflected wave add to the input wave.

Two of the transition sections shown in Fig. 34, with the coaxial lines meeting in a choke, make an excellent rotating joint.

Unlike parallel-wire and coaxial transmission lines, a wave guide does not have a definite characteristic impedance. Although the line can be terminated in a matched load which will give no reflection, the proper resistance value of the load will depend on the method of termination. Nevertheless, the behavior of mismatched lines is similar to that described earlier in the chapter. In a rectangular guide there are two possible ways of attaching a T. When fastened on the narrow side, as shown in Fig. 35(a), the behavior is as described previously. On the other hand, when the stub or T is fastened on the wide side, as shown in Fig. 35(b), the currents are interrupted. This effectively puts the side arm in series with the line, thereby reversing the effects of a short circuit and open circuit in cutting off the load. Another important fact in this so-called E plane T is that the phase of the wave is shifted a quarter wavelength in turning the corner. The T and bend shown in Fig. 35(a) are called H plane because the plumbing lies

in the plane of the magnetic field, while those in Fig. 35(b) are called E plane.

Tuning stubs are made by mounting a rectangular piston in the side arm. Care must be taken to insure good electrical contact of the plunger at the center of the wide sides of the guide because the current is large at these points.

Another method of matching loads in a guide is to insert a screw or diaphragm. A metallic projection into the guide from the wide side adds capacitance, while one from the narrow side adds inductance. Therefore, a load which appears inductive can be matched by inserting capacitive diaphragms, as shown in Fig. 36(a). Figure 36(b) shows added inductance.

7. Transmit-Receive Boxes

By proper addition of inductance and capacitance it is possible to keep the impedance of the opening in a diaphragm matched to the guide. Since this diaphragm

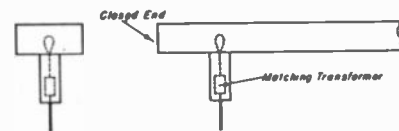

Fig. 33—Probe transition section.

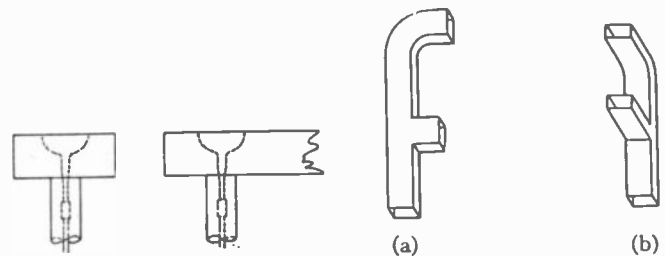

Fig. 34—"Doorknob" transition section.

Fig. 35—T's and bends in wave guide.
(a) H -plane bend and T.
(b) E -plane bend and T.

acts as a lumped resonant circuit, it does not have the cut-off limitation on the width of the hole. The diaphragm must, however, be thin compared with the wavelength. Holes of complicated shape, such as that in Fig. 36(c), may be matched to the guide so that a low-power wave will pass the diaphragm as though it were not there. On the other hand, a high-power wave will create a high field across the gap in Fig. 36(c), causing electrical breakdown. When this happens the impedance changes by a large amount, thereby reflecting most of the energy. This principle is used in one type of gas switch used to cut off the receiver during transmission when a common transmitting and receiving antenna is used (see Fig. 37). Tubes for this purpose are called "TR boxes" (transmit-receive boxes). The most successful of the types built to fit directly into a waveguide line is a section of wave guide with resonant windows on the two ends and several resonant diaphragms similar to Fig. 36(c) placed at quarter-wave intervals. The chamber thus formed is filled with low-pressure

gas. The high power of the transmitter causes a discharge to flash across the window and some of the resonant diaphragms, thereby preventing the transmitted energy from passing through the TR. The received voltage, however, is too low to cause a gas discharge and, therefore, passes through the TR as though it were a piece of wave guide. By using several resonant diaphragms which act as coupled resonant circuits, broad bandpass is obtained.

Another type of TR box which may be used with either coaxial or wave-guide lines is shown in Fig. 38. This tube consists of two metal cones which nearly touch and are sealed into a glass envelope containing gas

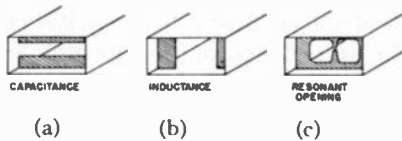

Fig. 36—Wave-guide matching diaphragms.

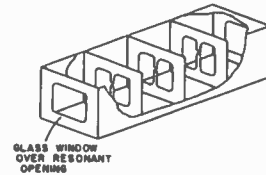

Fig. 37—Wave-guide broadband transmit-receive box.

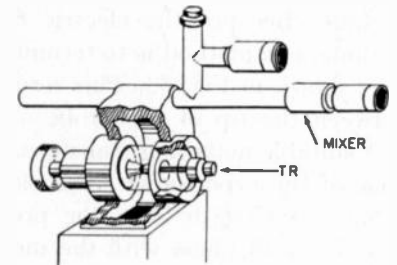

Fig. 38—Tuned transmit-receive box.

at low pressure. The metal disks holding these cones are clamped in an external cavity to form a resonant chamber. In a coaxial system power is coupled in and out of this cavity by coupling loops, while on a wave-guide system the side of the cavity may be cut away to form a resonant window through which the power may pass. The cavity is tuned for maximum received signal by means of screw plugs. During transmission the high voltage developed between the cones causes an arc which detunes the cavity, thereby preventing power from passing to the receiving system.

8. Duplexers

Fig. 39(a) shows the schematic of a "duplexing system" for a radar which uses a common transmitting and receiving antenna, while Fig. 39(b) shows a photograph of a 10-centimeter duplexer. The transmitter must be matched to the characteristic line impedance for maximum efficiency. For a long-wave transmitter this may be a transformer of conventional coupled coils, while for microwaves the matching devices described previously may be used. The TR box and anti-TR box are special gas tubes which flash over to form a short circuit when the transmitter operates. During transmission both T's, which act as parallel circuits, should present an infinite impedance at the line so that all of the power goes to the antenna. This means that the gas tubes should be an odd number of electrical quarter wavelengths from the line. Because of the capacitance and inductance of the gas tubes, the actual side-branch transmission lines will, in general, not be of exactly this length. When the TR box flashes it also short-circuits the line going to the receiver, thereby preventing the high power from burning out the input circuits. The gas discharges go out when the transmitter is off. The received signal then finds the TR box

matched to the line and, consequently, goes through it to the receiver. In order to prevent loss of energy by reflection at the receiver, the receiver input must be matched to absorb all of the incident power. However, the received energy can also go down the main line to the transmitter. The function of the anti-TR is to prevent this energy loss by cutting off this part of the line. If the side line ends at the anti-TR, the circuit will be open when the gas discharge is out. This open circuit will appear as a short circuit at the T because of the quarter-wave spacing. This short circuit will, in turn,

appear as an open circuit at the TR-box T if the spacing between the two T's is chosen as a quarter wavelength. The net result is, therefore, to disconnect the transmitter, thereby forcing all of the received energy through the TR box. If the anti-TR, because of its capacitance, does not sufficiently approximate an open circuit during reception, the line may be extended beyond it by an

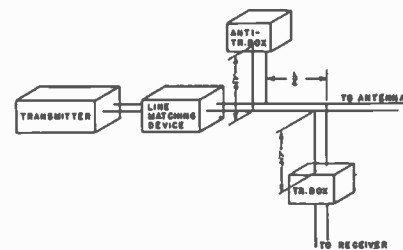

(a) Block diagram

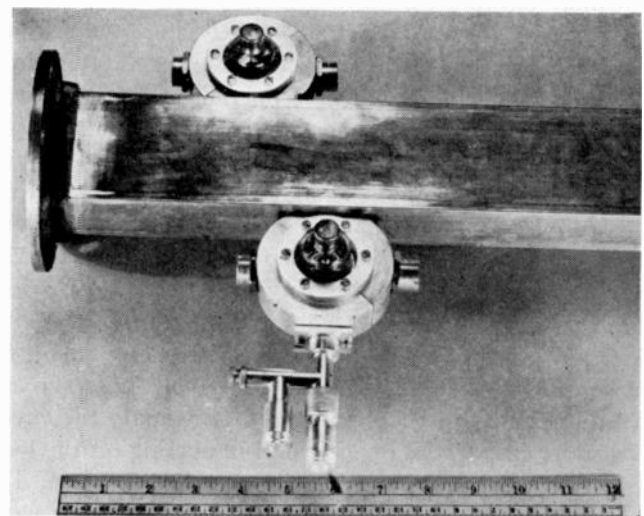

(b) 10-centimeter duplexer.
Fig. 39—Duplexing system.

electrical quarter wavelength and there be permanently short-circuited.

Although the duplexers in a parallel-wire system or a coaxial system look quite different from Fig. 39(b), the principle of operation is identical.

9. Radio-Frequency Bridge Duplexers

Another quite different principle, which may be used to prevent the transmitter power from reaching the receiver, employs a class of devices which are built so that power entering a junction can leave only on certain paths. One example of this type of device is the "rat race" sketched in Fig. 40. This system is built with waveguides having negligible loss; therefore, the phase balance is the important factor.

In Fig. 40, all of the T's are in the *E* plane, the narrow side of the guide being parallel to the paper. Power from the transmitter divides at *A* when it enters the guide, which is bent into a circle; but being an *E*-plane T there is a half-wave phase difference between the waves going in opposite directions because of the electric field

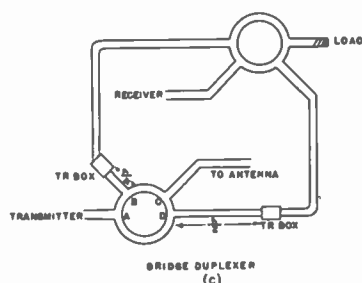
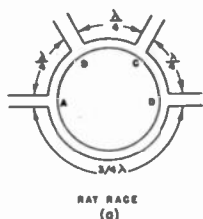
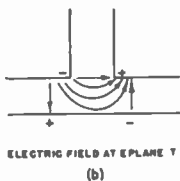

Fig. 40—"Rat-race" bridge duplexer.



distribution indicated in Fig. 40(b). Upon meeting at the entrance of another side pipe these two waves must be a half wave out of phase to send energy into it. If they meet in phase both sides of the branch become positive at the same time, with the result that a TE_0 mode is not excited; and all other modes are beyond cut-off. With this in mind, let us see which paths power can take through the device. For simplicity of argument, let us use the clockwise wave at *A* as the reference. Then the counterclockwise wave is a half wavelength different in phase. At *B* the counterclockwise wave has traveled one wavelength farther than the clockwise wave so the two waves are a half-wave different in phase, the condition for transmission of power into arm *B*. At *D* the two waves have traveled the same distance and, therefore, send power into arm *D*, while at *C* the two waves meet in phase with the result that no power enters arm

C. Continuing this analysis, we find that power cannot be transferred between line *A* and line *C* nor between line *B* and *D*.

Now let us consider the circuit shown in Fig. 40(c). If the two TR boxes are identical and the arms between the two circles are of equal length, power from the antenna goes only to the receiver. Also, if the shorting action of the TR's is neglected for the moment, the transmitter power goes only to the load and not to the receiver nor to the antenna. When the TR boxes are allowed to fire, there is a small amount of transmitter power passing through them because the gas discharge is not a perfect short circuit; and this power is still absorbed in the load rather than reaching the receiver, thereby giving better protection than the TR alone. The short-circuiting action of the TR boxes is also used to allow the transmitter power to reach the antenna. The TR box in line *B* is placed a quarter wavelength from the junction. This is an *E*-plane T; therefore, a short circuit in this TR box reflects as an open circuit in the path *ABC* and cuts off the clockwise wave from *A*. In line *D*, which is effectively in series with the path *ADC*, the TR box is a half wavelength from the junction, so that the reflected short circuit completes this path and permits the counterclockwise wave from *A* to pass out through arm *C*.

The "magic T," which is illustrated in Fig. 41, is

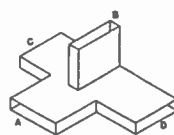

Fig. 41—"Magic T."

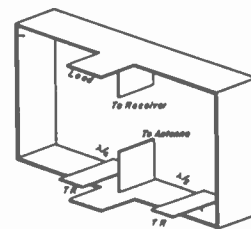

Fig. 42—"Magic-T" bridge duplexer.

another device in which power from one arm cannot transfer to another arm entering the same junction. A wave entering *A* can divide and go out *C* and *D* but, because the polarization is wrong, cannot enter *B*. Likewise, energy entering *B* can go out *C* and *D* but not *A*. On the other hand, a wave entering *C* or *D* can go out all of the other arms.

Fig. 42 shows a method of using the magic T. Remembering that the two waves leaving or entering an *H*-plane T are in phase while those leaving or entering an *E*-plane T are out of phase, it may be seen that the antenna will feed power only to the receiver and the transmitter only to the load when the TR's do not fire. On the other hand, when the TR's place short circuits across the lines, these reflected waves meet at the T with a 180-degree phase shift, thereby allowing the power to transfer from the transmitter to the antenna.

VIII. RECEIVERS

1. Microwave Receivers

Since the receiver input in systems operating at

wavelengths shorter than 15 centimeters is very frequently an integral part of the duplexing system, let us begin by discussing the techniques for these wavelengths. So far, radio-frequency amplifiers have not been as sensitive as crystals. Therefore, the usual receiver is of the superheterodyne type, with an intermediate frequency of the order of 30 to 100 megacycles. The local oscillator and the incoming radio-frequency signal without amplification are mixed in a crystal detector to develop the intermediate frequency. The intermediate frequency is then amplified by standard receiving-type tubes such as the 6AC7, or by miniature tubes such as the 6AK5 if space and weight are important.

The local oscillator is normally a klystron of the type which may be voltage tuned, although at the long-wave end of this region triode oscillators such as the light-house tube may be used.

2. Crystal Mixers

The early crystal mixer was of a tuned-cavity type, one example being illustrated in Fig. 43. Where the

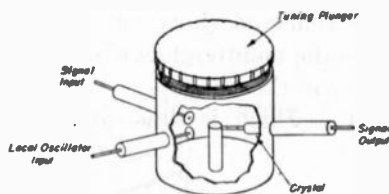

Fig. 43—Tuned mixer.

main function of the resonant cavity was to obtain an electrical match between the crystal and the radio-frequency system, careful control of the crystal manufacturing made it possible to build mixers which use a fixed-tuned matching device, thereby simplifying the operation of the receiver. For experimental work on crystals where their radio-frequency impedances may vary over wide ranges, the tuned mixer is still in common use.

Fig. 44 shows one type of fixed-tuned mixer which

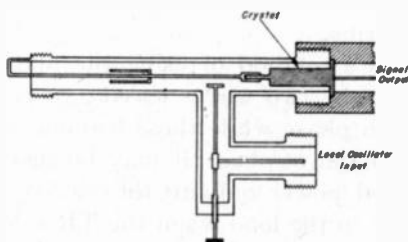

Fig. 44—Crystal mixer.

is in common use in radar systems operating in the 10-centimeter region. The matching is carried out by adjusting the size of the coupling loop. This mixer is not entirely untuned because the TR tuning for maximum signal results in some improvement in matching of the crystal to the TR box. In this mixer the direct-current

path for the crystal current is completed through the coupling loop. The local oscillator power is adjusted by changing the capacitance between the crystal feed line and the local oscillator probe. The cup on the radio-frequency line is a quarter wavelength deep for the third harmonic of the transmitter and, therefore, reflects as open circuit onto the line for this frequency. This third harmonic, which is not stopped by the type of TR shown in Fig. 38, may be present in amounts up to several watts peak power, while the crystal may be burned out by 0.2 watt.

For broad-band 10-centimeter systems where a waveguide TR is used, the mixer may take the form shown in Fig. 45. The position of the crossbar, which also acts

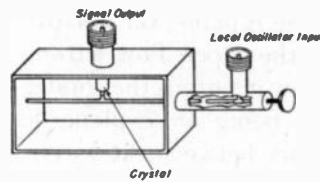

Fig. 45—Wave-guide mixer.

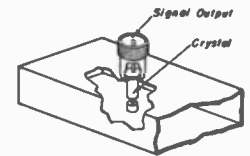

Fig. 46—X-band mixer.

as a local oscillator input, is adjusted to obtain proper crystal matching.

Three-centimeter waveguide mixers may take the form shown in Fig. 46. However, at these frequencies a considerable amount of noise is introduced into the receiver input circuit from the local oscillator. In order to eliminate this noise, a balanced mixer, as shown in Fig. 47, has been developed. The output from the two

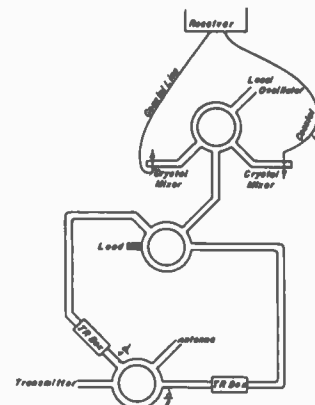

Fig. 47—Full-wave balanced mixer.

crystals, which have the added advantage of giving full-wave rectification, is combined so that the received signals add but the local oscillator noise is canceled. This circuit also has the advantage that the received signal does not enter the local oscillator and the local-oscillator output cannot go out to the antenna. The latter is particularly important where a receiver used to monitor enemy installations should not radiate.

3. Radio-Frequency Amplifiers

At wavelengths longer than 15 centimeters, good radio-frequency amplifiers exist and are commonly

used. In addition to providing more sensitivity to receivers at these frequencies, they are not so easily burned out by the transmitter power as crystals. Since radio-frequency amplifiers are harder to build than intermediate-frequency amplifiers, it is customary to use only enough radio-frequency stages to amplify the signal voltage well above the noise level of the first detector. Beyond this point the amplification is at intermediate and video frequencies. Lighthouse tubes are used for frequencies between 2000 and 600 megacycles, while "high-frequency" tubes which have been on the market for a number of years may be used at frequencies below 800 megacycles.

4. Receiver Sensitivity

The ultimate sensitivity of a receiver, regardless of its construction and number of stages of amplification, is limited by the random voltages produced by thermal agitation of the electrons in the conductors and resistors of the circuit. It can be shown that the average noise power P introduced into the input circuit of a receiver by these fluctuations is

$$P = cKT\Delta f \text{ watts} \tag{15}$$

where c is a small number which depends on the exact form of the input circuit, K is Boltzmann's constant having the value 1.371×10^{-23} joules per degree absolute, and Δf is the bandwidth of the receiver. Since a signal of the same magnitude as this noise will be indistinguishable from a random noise pulse, P may be considered the theoretical limit of sensitivity for the receiver. It is customary to express the actual receiver sensitivity as being so many decibels worse than a theoretically perfect receiver for which $c=1$. This quantity, called the noise figure, is

noise figure

$$= 10 \log_{10} \frac{\text{average noise power in receiver}}{KT\Delta f} \text{ decibels.} \tag{16}$$

At frequencies below 100 megacycles, receiver-noise figures of 2 to 6 decibels are possible with present techniques; between 100 and 1500 megacycles noise figures of 4 to 8 decibels may be expected, while at frequencies between 1500 and 30,000 megacycles the values should be around 8 to 12 decibels including losses in the TR system. Substitution in (16) shows that signals of the order of 10^{-13} watts should be detected by a good receiver.

The difference between an actual receiver and a theoretically perfect one arises from the fact that the amplifier tubes and first detector introduce noise into the circuit which is greater than that caused by the resistances. Furthermore, these devices may not be perfectly efficient amplifiers or detectors. If part of the signal is wasted, the noise figure is increased.

At any point in the circuit there will be a certain amount of noise due to the adjacent circuit elements

and also due to the noise coming to this point from the input. These two noise powers will add to give the noise level passed on. Now suppose the noise power at the receiver input is P_i and that this is amplified by a factor of 5 by the first stage. This noise will then be $5 P_i$ at the input of the second stage. Also, suppose that the first stage itself adds a noise power of P_1 . Then the noise power in the grid circuit of the second stage will be $5P_i + P_1$. We see that the first stage has added an amount of noise power to the circuit which is equivalent to increasing the initial input noise by $P_1/5$. Hence the noise figure is

$$\text{noise figure} = 10 \log \frac{P_i + P_1/5}{KT\Delta f} \tag{17}$$

instead of

$$10 \log \frac{P_i}{KT\Delta f}$$

This argument can be extended to a multistage amplifier where P_i is the input-circuit noise including the detector noise if no radio-frequency amplifier is used, P_1 is the noise of the first amplifier and G_1 is its gain, P_2 and G_2 are the corresponding quantities for the second amplifier, and so on. Then

$$\text{noise figure} = 10 \log_{10} \frac{P_i + P_1/G_1 + P_2/G_1G_2 + \dots}{KT\Delta f} \tag{18}$$

From this formula it may be seen that, if the amplifier gain is high, only the first one or two stages add appreciable noise to the circuit. The reason radio-frequency amplifiers are only moderately successful at 10 centimeters is that P_1 is large and G_1 small for the tubes which have been built. Where radio-frequency amplifiers are used, the first detector is inserted at the stage where its noise power divided by the gains is negligible in the above formula. If the noise figure with and without a term in (18) differ by less than one-quarter decibel, that term is considered negligible.

The arguments advanced to derive (18) essentially assumed perfect efficiency in utilizing the incoming signal. Since this is very rarely the case, let us see what effect a partial loss of the signal will have on the noise figure. As was stated previously, the signal should be at least equal to the average noise power to be detected. Therefore, if only, say, a quarter of the incoming signal power is utilized by the receiver, the signal must be four times stronger than if all of the power were used. The same effect would be achieved if we had a receiver which utilized all of the signal power but was four times as noisy. Therefore, if the reciprocal of the fraction of the power actually used by the receiver is denoted by F , the noise of the receiver will be

$$\text{noise} = 10 \log_{10} F \left(\frac{P_i + P_1/G_1 + P_2/G_1G_2 + \dots}{KT\Delta f} \right) \tag{19}$$

For radio-frequency amplifiers, F is likely to be near

unity, which means most of the incoming signal is utilized, but P_1 is apt to be several times $KT\Delta f$. On the other hand, the present silicon or germanium crystals together with their mounts have values of F averaging in the neighborhood of 4 to 6, while P_1 is very near the theoretical value of $KT\Delta f$.

As may be seen from (19), the receiver sensitivity may be increased by decreasing the Δf . However, a certain band of frequencies is required to obtain a reasonably undistorted signal output from a modulated signal. It is obvious that if the signal is so distorted that it is unrecognizable, the receiver cannot be considered sensitive to that signal. This means that Δf cannot be given an arbitrary value, but the receiver bandwidth should be no wider than is necessary to pass the required signal. In a radar system where a pulse length of t seconds is used, the optimum receiver sensitivity occurs when $\Delta f = 1.5(1/t)$, approximately. The sensitivity drops off very rapidly when Δf is much less than $1/t$ but is still good when Δf is $S(1/t)$. For applications in which extremely accurate range measurements are required the importance of an undistorted signal may make it desirable to sacrifice some receiver sensitivity by using a wide bandwidth.

5. Intermediate-Frequency and Video Amplifiers

Fig. 48 shows one of the best input circuits for use with a crystal detector and also shows a typical stage

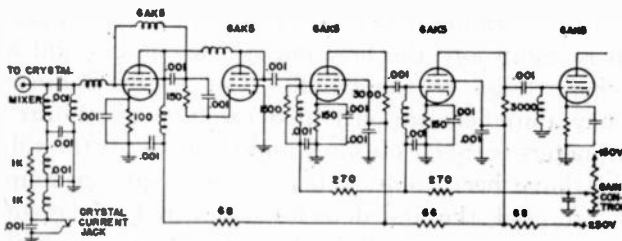

Fig. 48—Receiver input.

of an intermediate-frequency amplifier. The coupling coils between the intermediate-frequency stages may be tunable or, by holding the components to close specifications, receivers may be built which require no intermediate-frequency alignment. Once the intermediate-frequency amplifier is properly aligned, the only receiver tuning required is in the radio-frequency stages (if a radio-frequency amplifier is used) and in the adjustment of the local oscillator frequency.

Pulsating direct current required for the operation of cathode-ray tubes and other devices used to display the signal is obtained by passing the intermediate-frequency output through a second detector. The signal level entering the detector, as shown in Fig. 49, is of the order of a 1 volt. The detector is followed by one or more stages of video amplification, and a cathode follower may be used to drive a transmission line leading to the indicators. If, as in the case of some applications, it is desired to limit the level of strong signals, the video amplifier may be driven to cutoff.

6. Automatic Gain Controls

The strength of radar signals from distant and nearby objects may vary by a factor of more than 1,000,000; hence, a receiver which is adjusted to the proper output voltage for a weak signal may be greatly overloaded by strong signals. Although this overload, (which occurs in the last few intermediate-frequency stages) may be prevented by decreasing the gain of the intermediate-frequency amplifiers, it is usually undesirable to use the manual gain control for this purpose. For example, in a search-radar set it may be necessary to observe weak and strong signals at essentially the same time. Under

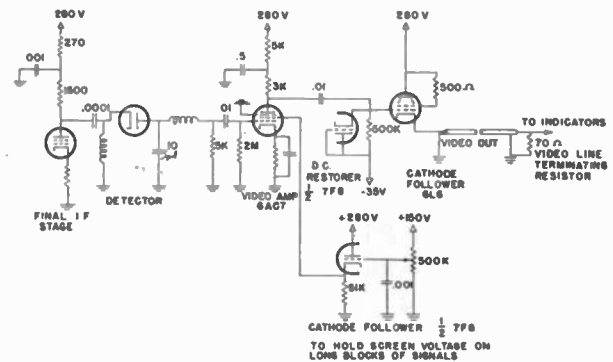

Fig. 49—Detector and video amplifier.

these conditions the receiver gain should be set to a different value for each signal, an impossible manipulation for the operator. On the other hand, the receiver gain can be electronically adjusted with great rapidity. Fig. 50 shows a "back-bias" circuit which uses the signal

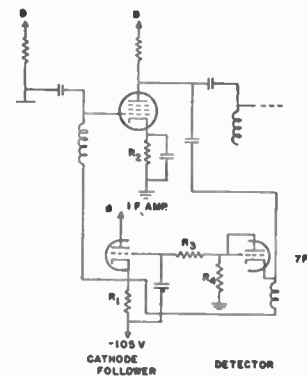

Fig. 50—Back-bias circuit.

strength to control the gain at an intermediate-frequency-amplifier stage. For simplicity the intermediate-frequency-amplifier circuit is only partially shown. The detector is cut off when there is no signal output from the intermediate-frequency amplifier, because the cathode voltage in a cathode follower is always more positive than the grid by an amount dependent on the value of the load resistor. When a signal appears on the output of the intermediate-frequency amplifier, it causes the detector to draw current provided the signal amplitude is greater than the cutoff voltage on the

detector. Hence, the signal level at which the back bias circuit begins to act may be adjusted by varying R_1 . When the signal is strong enough to operate the detector the capacitor C_1 becomes negatively charged, thereby making the follower grid and thence the intermediate-frequency-amplifier grid more negative. Since this results in a decrease in the amplifier gain the tendency to overload is reduced; but there may be some signal distortion because the operation is moved to a more curved part of the tube characteristics. The recovery time after a strong signal is adjusted by the values of C_1 , R_1 , and R_4 . R_3 is a small resistor which prevents the intermediate frequency from appearing on the grid of the follower. This type of circuit is most useful where the desired signal is obscured by overloading from certain types of jamming or from the signal return from a storm or waves on the sea. For such applications, the recovery time should not be much longer than the pulse length. Where control of one intermediate-frequency stage does not cover an adequate range, similar circuits may be applied to, say, the last three stages. In this case, medium signals cause the back bias to operate only on the last stage, strong signals on the last two stages, while very strong signals cause the back bias to operate on all three stages.

Another method of controlling overloading is to amplify the output of the second detector of the receiver and use this voltage to control the bias on one or more of the early stages in the receiver. This type of circuit has been used as an automatic volume control on broadcast receivers. Because this type of circuit operates on all signals above a certain level, tending to make the output constant, the contrast between strong and weak signals is not as great as with the back-bias circuits when the recovery time is short. On the other hand, where the average amplitude is to be controlled without observing short-time fluctuations in the signal, automatic volume control with a long recovery time is useful. This is particularly true where a single signal is selected to operate an automatic-tracking circuit.

7. Gated Receivers

A single signal may be selected by "gating," or turning on the receiver only at the time the desired signal is being received. This may be accomplished by applying a square positive pulse to the grids of two or three intermediate-frequency-amplifier stages which are biased beyond cutoff. Fig. 51(a) shows a block diagram of a "short-gate" circuit for selecting a single signal. P in Fig. 51(b) is the transmitted pulse and S the desired signal. The trigger from the transmitter may be used to trip a multivibrator as a delay mechanism, the duration of its output square wave being adjusted to be just less than the time between P and S . The back edge of this square wave may in turn trip a second multivibrator which puts out a square pulse just a little wider than the signal. S is the only signal reaching the output, since the receiver is turned on only during this time. Several

other types of circuits suitable for delaying the triggering of the short gate will be discussed in the section on indicators.

8. Automatic Frequency Control

The local oscillator is the only item which needs tuning in a broad-band system; therefore, completely

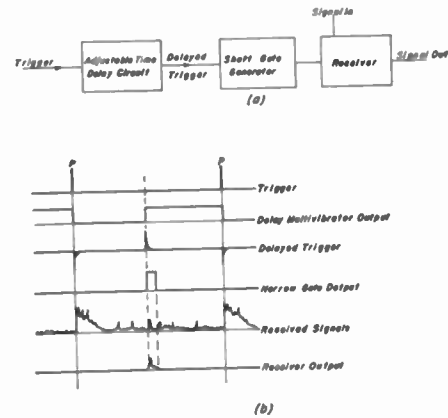

Fig. 51—"Short-gated" receiver.

automatic operation of the transmitting and receiving system can be achieved by using automatic frequency control (AFC). For this purpose a voltage-tuned klystron may be used as a local oscillator, the voltage being controlled by the transmitted signal. Since the receiver input is cut off during transmission, the power to operate the automatic frequency control must be tapped from the transmission line through a suitable attenuator and fed into a separate mixer from the normal receiver mixer. The same local oscillator must, however, feed the two mixers. Fig. 52 shows the circuit (above), and

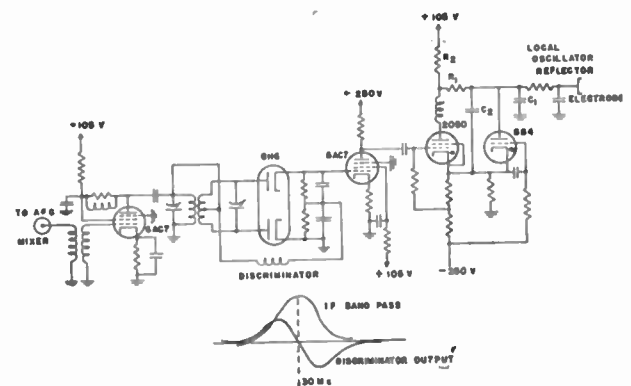

Fig. 52—Automatic frequency control.

the intermediate-frequency and discriminator-output voltages as a function of frequency (below). The intermediate frequency is chosen as 30 megacycles for the sake of discussion.

The 884 works as a relaxation oscillator and provides voltage to sweep the local oscillator over its complete tuning range of 20 megacycles. It is so biased that when its plate reaches -50 volts from ground the tube fires or becomes conducting, and capacitor C_1 is charged to about -230 volts which is close to the potential of the 884 cathode. The characteristics of the 884 are such

that, once conduction starts, the grid loses control; and conduction continues until the plate potential drops to or near the cathode voltage. Conduction then ceases, and the grid resumes control.

The capacitor C_1 and the local-oscillator reflector are connected by R_1 and R_2 to +105 volts, thus sweeping the reflector voltage in the positive direction and tuning the local oscillator from a higher to a lower frequency. When C_1 reaches -50 volts the 884 again fires and starts the cycle over again. Thus a saw-tooth sweep is put on the reflector of the klystron tube.

The 2050 operates the control or holding circuit. Its function is to stop the sweep and hold it when the sweep voltage reaches the point which corresponds to a difference of 30 megacycles between the local oscillator and the transmitter frequencies. It is so biased that it does not conduct at any time unless a positive pulse is applied to the grid. The sweep circuit causes the local oscillator to go from higher to lower frequency; and if the local oscillator is properly tuned to the high-frequency side of the transmitter, the intermediate frequency, which is the difference between the local oscillator and transmitter frequencies, will go from a higher to a lower value.

From Fig. 52 it may be seen that at first the intermediate frequency, which is much too high, produces a positive pulse output from the discriminator and hence a negative pulse on the grid of the 2050. This negative pulse on the 2050 produces no effect, even though the intermediate frequency continues to become lower. When the intermediate frequency reaches 30 megacycles it is at the crossover in the discriminator pattern; just a little later, it is lower than 30 megacycles. It then produces a negative pulse from the discriminator which becomes a positive pulse on the 2050 grid, thereby firing the tube and charging C_2 to -230 volts.

The grid of the 2050, as in the case of the 884, loses control when the tube fires. Thus the tube conducts until the plate is near cathode potential. When the 2050 ceases to conduct, C_2 swiftly recharges to its former voltage. During the interval that C_2 is more negative than C_1 , C_1 , which has been charging in the positive direction through R_1 , changes its direction of charge and starts to go in the negative direction.

This change of direction of charge also reverses the direction of change in the intermediate frequency, making it higher than 30 megacycles, a condition in which no positive pulse reaches the 2050 grid. After C_2 returns to its former voltage, C_1 resumes its charging in the positive direction, making the intermediate frequency again become lower than 30 megacycles by a small amount; the 2050 again receives a positive voltage on the grid, fires, and the process is repeated.

Thus it can be seen that the intermediate frequency shifts slightly from above to below 30 megacycles, the 2050 firing often enough to keep the average voltage at C_1 and hence on the reflector at the value required for an intermediate frequency very close to 30 megacycles.

The 884 cannot operate at this time, or at any other time, unless the voltage at the reflector reaches -50 volts. As long as the transmitter is tuned in and operating the 2050, the reflector voltage is more negative than -50 volts and is held closely at or near the voltage necessary to maintain the proper intermediate frequency of 30 megacycles.

9. Crystal Video Receivers

The receivers discussed so far have been of fairly narrow bandwidth and are the type used for radar sets where it is undesirable to receive signal frequencies different from the transmitter frequency. There are, however, applications for a very broad-band receiver—for example, radar beacons—which must be tripped by a wide range of transmitter frequencies.

Receivers having very wide bandwidths of the order of 20 per cent of the carrier frequency can be made by converting the radio-frequency signals directly into video pulses and obtaining the desired output voltage by video amplification. The main factor which limits the bandpass in these receivers is the radio-frequency and antenna system. Because of large conversion loss in the detector, the noise figure of these receivers is poor.

IX. ANTENNAS

1. Beam Width

For most radar applications, directional antennas are used to determine the azimuth position of the target and to concentrate the energy in the desired direction. The gain of a directional antenna and the way in which it affects the range performance were discussed in Section II. For direction finding, the angular width of the antenna pattern is also an important item. It is customary to define arbitrarily the width of the antenna pattern W as the angle between the two half-power points, as indicated on Fig. 53. In this diagram the

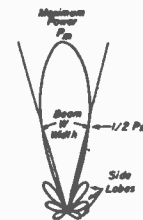

Fig. 53—Antenna pattern.

radial distance from the origin represents the power radiated in that direction. In addition to the main lobe there are a number of side lobes indicated. Where the beam is formed by some type of reflector or by an area covered with properly phased radiators, the approximate beamwidth is given by

$$W = 2.1 (\lambda/D) \quad (20)$$

where W is the angular beamwidth in degrees, λ is the wavelength in centimeters, and D is the distance across the effective part of the antenna in feet. Thus a high-

frequency transmitter and a wide antenna will give the narrowest beam. The intensity of the side lobes is very sensitive to details of the geometry of the antenna, but the angular position of these lobes with respect to the main lobe will be found to vary directly with the beamwidth of the main lobe when λ or D is changed.

2. Parabolic Reflector

At high frequencies, the most common method for obtaining a focused beam is to place a radiating dipole at the focus of a paraboloid of revolution. This will form a radio beam in the same way that a searchlight reflector forms a beam of light. Paraboloids as large as 60 feet in diameter have been built for this purpose, but none larger than 30 feet were used for operations during the war.

3. Dipole Arrays

Another commonly used method for concentrating radio power is based on wave reinforcement. If we have a row of radiators spaced a distance d apart, as shown in Fig. 54, and all are radiating in phase, the radiations

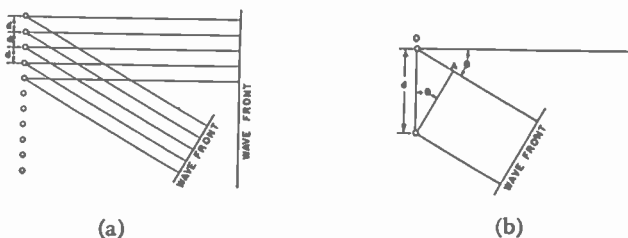

Fig. 54—Diffraction antenna.

from them obviously will be in phase on a line in space parallel to the source because the paths are all equal in length. As in an optical grating, the radiation may also be in phase at an angle θ from the normal. In Fig. 54(b), the path difference OA between adjacent dipoles is given by

$$OA = d \sin \theta.$$

When OA is any whole number of wavelengths, the energies from each source will again be in phase, thereby forming another wave front. Hence the energy will be concentrated in directions given by

$$\sin \theta = n\lambda/d \quad (21)$$

where n is a whole number and λ is the wavelength. Between the angles given by (21) there will be some small lobes caused by reinforcement between, say, every third or every fifth source; but these will be small because the intermediate sources will largely cancel each other. If $n\lambda/d$ is greater than unity, only one wave front can exist. Therefore, if d is chosen so that λ/d is greater than one, only the lobe for $n=0$ will exist and the energy will go out perpendicular to the array of sources. The beamwidth will be given by (20) when D is the length of the array.

The 10-centimeter ultraportable beacon known as

“Bups” uses an antenna of this type. Since this beacon is used to mark points on the ground, it is built to be nondirectional in azimuth; but a reasonable antenna gain is achieved by concentrating the energy at low angles. Fig. 55 shows the construction and a section through the lobe pattern.

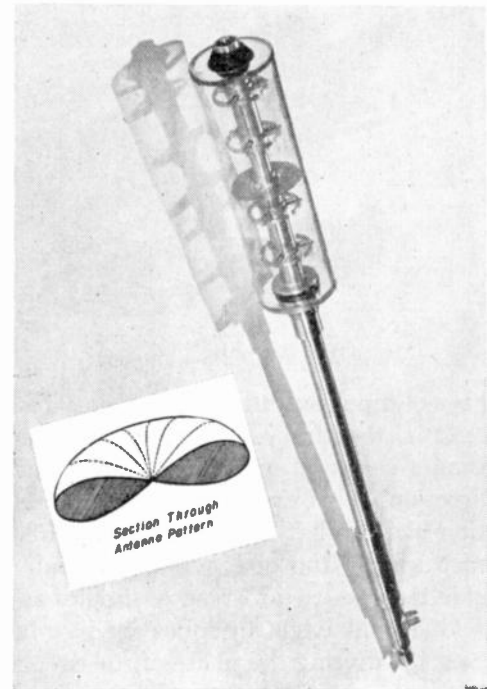

Fig. 55—“Bups” antenna.

Where it is desired to concentrate the energy in one direction, several of these arrays can be placed side by side to obtain reinforcement in both the vertical and horizontal directions. Fig. 56 shows the construction of the SCR-270 antenna for which the radiators are dipoles. In order to keep the spacing d at the desired value and

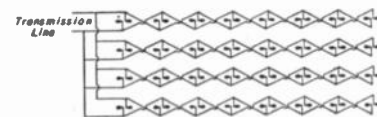

Fig. 56—Dipole array, SCR-270 antenna.

still preserve the phase relationship without unnecessary lengths of transmission line, it is advantageous to reverse the polarity of the line between the dipoles as shown. The line lengths are chosen to place the dipoles a half wavelength apart along the transmission line, but the dipoles themselves are driven in phase by reversing connections on alternate dipoles. Back radiation is prevented by placing a wire screen a half wavelength behind this dipole array. The reflected energy is then in phase with transmitted energy at the dipole. All of the early search-radar sets used this type of antenna.

4. Cylindrical Reflectors

Another method of concentrating the power from a line of sources is to use a parabolic cylinder for a reflector,

as shown in Fig. 57. The array causes concentration of the energy in the direction of the axis of the cylinder, while the reflector focuses the energy in the direction at right angles. This type of antenna is used on the MEW(AN/CPS-1), GCA(AN/MPN-1), and Eagle (AN/APQ-7). At the high frequencies used by these sets

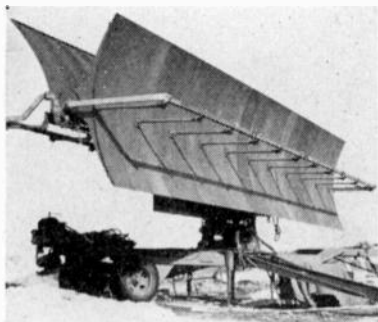

Fig. 57—AN/CPS-1 antenna.

the number of dipoles along the array may be a hundred or more. It is, therefore, more economical to use a reflector than a series of arrays to obtain focusing in the other direction. This type of antenna finds its main application where a flat thin beam is required. Slots of the proper length and size across the wide face of a wave guide may be used instead of dipoles as radiators.

In the GCA and Eagle antennas the beam is changed in direction by altering the phase of the energy reaching the dipoles. If a variable-frequency transmitter were available, the phase of the dipoles placed along the line would vary with the frequency. This phase change would then alter the direction of the beam of Fig. 54(b), because the condition of reinforcement would require the phase difference S plus $d \sin \theta$ to be a whole wavelength. This variation of beam position with frequency may be a disadvantage in an array used for accurate angle measurements.

Since variable-frequency transmitters are not available in the microwave region, the variation of wavelength in a wave guide with the dimension B in Fig. 30

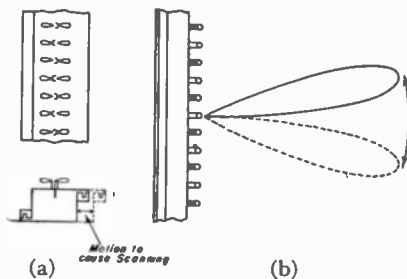

Fig. 58—"Eagle" antenna.

may be used to shift the phase. When the two sections of guide shown in Fig. 58(a) are moved back and forth with the sides kept parallel, the beam scans back and forth as indicated in Fig. 58(b). The dipoles are driven through short lengths of coaxial line, and the energy is coupled from the guide by using the proper length of wire conductor protruding into the guide as a probe.

As in the case of the SCR-270, the dipoles are about a half wave apart but are fed in phase by turning alternate dipoles 180 degrees to interchange the positions of the wings fed by the inner and outer conductors of the coaxial line.

5. Horns

Another method of forming a radio beam is to use a horn which is properly shaped so that the radiation which reaches the mouth of the horn is in phase at all points on the wave front. Horns are likely to be bulky, compared with other antenna types, so are seldom used for forming the final beam. For example, a Japanese 10-centimeter set uses a horn about 5 feet long to obtain an effective antenna aperture of 30 inches. The same result could be obtained with a 30-inch-diameter paraboloid about 10 inches deep. Horns are, however, very commonly used in place of dipoles to illuminate a reflector. Horn feeds are best adapted to wave-guide lines while dipoles are more easily adapted to coaxial and parallel-wire transmission lines.

6. Lenses

Presumably, radio energy could also be focused by means of lenses made of a material such as plastic or glass which is transparent at the transmitter frequency. However, it is usually impractical to handle large blocks of such materials. The property which makes a lens or prism change the direction of a light beam is a difference in wave velocity from that in the surrounding medium. In a prism the part of the wave which has traveled the farthest in glass will lag the most, thereby bending the light beam toward the thick part

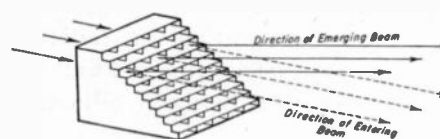

Fig. 59—Wave-guide prism.

of the prism. Since the velocity of a wave in a wave guide is greater than that in free space, it is possible to bend a radio beam by a prism made of a stack of guides, as shown in Fig. 59. Here the beam will be bent toward the narrow part of the prism because the wave gets ahead in traveling through the guide. By proper choice of the lengths of equal-area wave guides, a lens action may be obtained. To form a converging beam, such a lens will be thicker on the rim than at the center. Another method is to make the lengths of guide constant but to vary the width of the guide to alter the velocity over the face of the lens. Lens antennas are most useful in applications where the feed mechanism is large and would block out a large fraction of a reflector.

7. Rapid-Scan Devices

When radar is used to locate objects whose position is unknown, it is necessary to scan or sweep out an area.

This may obviously be done by turning the whole antenna system to look in the desired direction, but may not be practical if rapid scanning is desired. Therefore, a number of rapid-scan devices have been developed. Although these are frequently called "electrical scans," most of them depend on moving mechanical parts.

One type of rapid-scan mechanism is that used in the GCA and Eagle sets as described earlier.

Another type is used in the SCR-598 and operates with a "Schmidt-camera" type of focusing system. Since a complete description of this set has been given,¹ it will not be described here.

A number of scanning devices have been built on the principle that moving the feed off the axis of a lens or paraboloid will cause the beam to swing off axis on the opposite side. Since the gain of the antenna decreases rapidly when the feed is far off axis, the angle of scan obtainable by this method is usually limited to a few beamwidths on either side of center. The obvious method is to oscillate the feed about the axis. Although one large radar set used an oscillating feed at several oscillations per second, vibration presents a serious mechanical problem which can be avoided by rotary motion. The "Robinson feed" offers one solution. If the antenna is fed by a thin horn in which the feed is moved up and down along the opening, as indicated in Fig. 60(a), the beam will oscillate as just described, the horn having little effect. The input end of the horn is now rolled into a circle without bending the other end, as indicated in Fig. 60(b), and the feed is moved in a circular path. The antenna scan remains the same as for that in Fig. 60(a), but the mechanism for driving the feed will be much simpler.

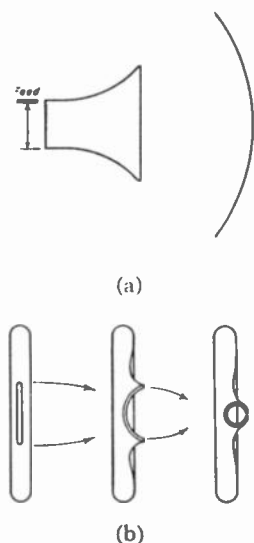

Fig. 60—Robinson feed.

The "Foster scanner" uses a line source of radiation obtained by feeding a parabolic "pillbox," as shown in Fig. 61(a). The polarization is across the thin dimension so that the opening acts as a very wide wave guide. When this pillbox is placed in front of a cylindrical reflector, as shown in Fig. 61(a), a beam will be formed,

the pillbox focusing in the vertical and the reflector in the horizontal direction. Rocking the pillbox up and down causes the reflected beam from the cylinder to scan up and down. In order to scan with a purely rotary motion the pillbox is bent to fit inside a cone the large end of which is shown in Fig. 61(b). The power is reflected to the outside of this cone by two mirrors at 45 degrees to the tangent line as shown. A second cone is placed outside this cone and carries another mirror which reflects the power trapped between the two cones

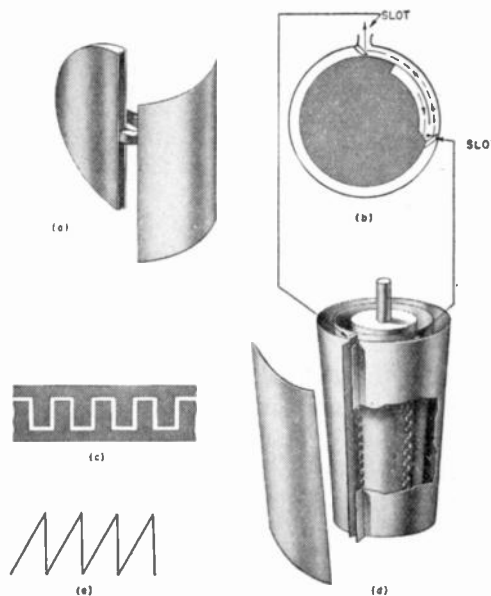

Fig. 61—Foster scanner.

out through a slot. The space between the two cones acts as a very wide wave guide, so that the wave velocity is essentially that of free space. As may be seen from Fig. 61(d), the power in leaving the pillbox will have to travel farther to reach the slot at the large end of the cone than at the small end. This is equivalent to tipping the top of the pillbox away from the reflector in Fig. 61(a). Now if the inner cone is rotated, the difference in distance traveled by the power at the two ends of the cone will change, thereby simulating a rocking of the pillbox in Fig. 61(a). In order to allow the inner and outer cone mirrors to pass, they are built as teeth (see Fig. 61(c)) spaced close enough to prevent leakage of power. Since the difference at the two ends approaches zero as the teeth meet and suddenly jumps to a maximum after they pass, the scan will be as shown in Fig. 61(e).

8. Scan Procedures

Because effective search for a target can be made only when the whole area of interest is scanned without gaps, the search must be carried out in some methodical manner. When the target is a ship, the problem is simply one of sweeping a horizontal beam over the surface of the water; but when the target is an aircraft, the search must also cover the vertical dimension.

For limited solid-angle search the spiral scan, as in

Fig. 62(a), and the saw-tooth scan, as in Fig. 62(b), may be used to cover the volume of space by a beam which does not fill either dimension of the solid angle. In order to insure solid coverage, the separation between turns of the spiral or sweeps of the saw tooth should be no more than half a beamwidth. This means that the rate of radial motion of the spiral scan must have a fixed relationship to the circular rate, and that the horizontal motion of the saw tooth as shown must be related to the vertical-scan speed. Because it is simpler to visualize the

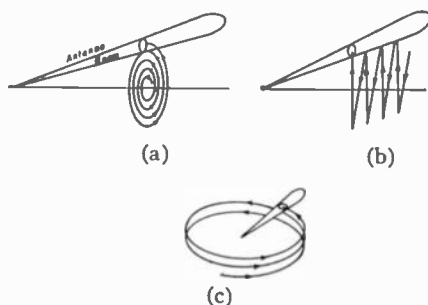

Fig. 62—Types of scans.

mechanical system, let us confine our attention to the saw tooth for the moment. Let us assume vertical motion is generated by rocking the antenna in elevation and horizontal motion by rotating it in azimuth. Also let us take the radar beamwidth as 4 degrees. Then the antenna can move only 2 degrees in azimuth for one complete vertical oscillation if the coverage requirement of an overlap of at least half a beamwidth is to be met at all points. Now if the antenna is to search once over a 90-degree azimuth sector in 30 seconds, 45 complete vertical oscillations will be required in this time, or 1.5 oscillations per second. Although this azimuth scan rate is low for aircraft search, the vertical-scan rate is high enough to present a considerable mechanical problem if the whole antenna is rocked; hence the requirement for rapid-scan devices.

Where the azimuth search angle is 360 degrees, the saw-tooth scan may be used; but the spiral scan is impracticable. In its place a helical scan is used. In the helical scan the antenna tilts one-half beamwidth in elevation for each complete revolution in azimuth. Normally, on 360-degree search, the scan is not carried above 30 degrees in the vertical direction because a large fraction of the search time would be spent in this region which represents an extremely small fraction of the volume of space in which aircraft might be found. Where search at high angle is required, a separate low-powered set is more economical.

9. Shaped Beams

Another method of obtaining solid search from the horizon to a given elevation angle is to use a beam which fills this angle and to scan only in azimuth by rotating the antenna structure. The beamwidth in the vertical direction depends on the vertical aperture of the antenna and the wavelength (see (20)). From (5) we see that,

where the same antenna is used for transmitting and receiving, the performance of the set for a given vertical beamwidth will be independent of frequency if all other factors are held constant. However, at the higher frequencies the azimuth beamwidth will be narrower and the resolution will be better. Also, the antenna will be smaller in the vertical dimension. If both sets make use of ground reflection to obtain increased range, these conclusions still hold; but the coverage will have gaps due to the lobes. As was discussed in Section III, these gaps may be a serious handicap in tracking aircraft.

Since aircraft at present do not often fly above 40,000 feet, obtaining high-angle coverage, as indicated by the dotted line in Fig. 63, would be expensive because the power in the beam is much greater than is required to insure coverage up to 40,000 feet. The antenna pattern indicated by the solid line would be much more economical because only a small extra coverage is provided to insure tracking at 40,000 feet. Antennas which give a constant-altitude top coverage are called "cosecant-squared antennas" because the power in the antenna pattern on one-way transmission must fall off as the square of the cosecant of the elevation angle. This same type of pattern is needed to give constant illumination on the ground over a large vertical angle measured

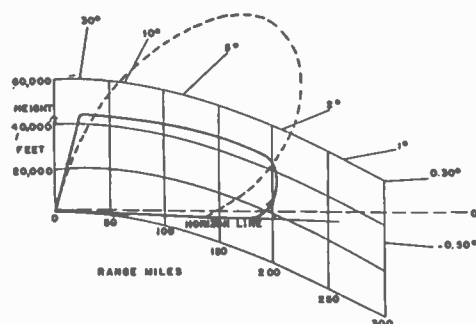

Fig. 63—Cosecant-squared beam.

downward from an aircraft. Shaping of the beam can be accomplished by shaping the reflector or lens to throw the energy in the proper directions. To a reasonably good first approximation, the reflector shape may be visualized by imagining sections of a parabolic reflector properly tilted to give a series of beams which overlap to form the desired beam. After these are chosen with due regard to the gain and the beamwidth needed for each section and are pieced together, the reflector will be made up of several parabolic sections which do not join smoothly. A smooth curve joining the centers of these sections will be very nearly the shape required for the final beam. A second method is to use a paraboloidal reflector with several radiators arranged in a line perpendicular to the axis. A fairly good approximation to the desired result will be obtained if these dipoles or horns are placed so that the beams which they produce independently will add to make the final beam and the relative power distribution is properly adjusted. Some adjustment of phase and amplitude may be necessary to

smooth out the pattern. These sources can be fed from the same transmitter and may be placed in parallel along a transmission line. On the other hand, if insufficient power is available to obtain the coverage with one transmitter, the sources can be fed on separate frequencies.

Since the radiation pattern from an antenna is too wide to determine accurately the angular position of the target, lobe switching is commonly used for precise angle measurements. If the phase between dipoles in an array or the position of the feed in a reflector is alternated between two values, the antenna lobe will oscillate between two positions, as shown in Fig. 64. A target on the line OA will give equal signals from the two lobes, while one on the line OB will give a much stronger signal from the right lobe. The target angle is read from the antenna position when the two signals are matched. An angular accuracy of a tenth of a degree is obtainable by this method.

A conical scan is convenient where lobe matching is required in both azimuth and elevation. If the antenna feed is placed slightly off axis and is rotated in a circle about the axis of a paraboloid, the antenna-beam center will rotate on a cone centered about the axis. Equalizing the signals for all positions of this feed establishes the line of sight to the target.

X. INDICATORS

1. Types of Indication

The presentation of the radar signal must be interpreted readily by the operator, and a great many types of signal indicators have been developed in an effort to improve the speed, accuracy, and ease of data interpretation. However, only the types most commonly used will be discussed here.



Fig. 64—Lobe switching.

The standard cathode-ray oscilloscope in which the signal appears as a deflection on a time-base sweep is called an "A-scan." In cases where the range scale or time-base sweep is too compressed, a small portion of the A-scan may be expanded by starting the sweep some time after the transmitter has fired. Although this expanded sweep is essentially an A-scan, it has been named an "R-scan." Another method of obtaining a long trace on a small tube is to bend the A-sweep into a circle to form a "J-scan." Examples of these presentations are shown in Fig. 65. The general fuzz which causes

the time base to appear broad is the noise from the receiver input.

These indicators usually employ electrostatically deflected cathode-ray tubes with a nonpersistent fluorescent screen.

In another group of indicators the signal is presented as an intensity brightening. The "B-scan" displays range against azimuth angle in rectangular co-ordinates, as shown in Fig. 65(c). The "C-scan" presents azimuth against elevation. In the PPI (plan-position-indicator), azimuth angle and range appear in their true relationship as polar co-ordinates. Hence, this indicator presents a map picture with only a small distortion introduced by the use of slant range instead of ground range. For height finders, a variety of indicators presenting range against height have been built. This type of indicator is known as RHI (range-height indicator). Most of the intensity-modulated indicators use magnetically deflected cathode-ray tubes with a persistent screen which glows for several seconds after the beam passes over the target.

2. Range Circuits

The basic range-sweep circuit is shown in Fig. 66(a). A square-wave generator synchronized with the transmitter operates an electronic switch which controls a saw-tooth generator as indicated by the wave forms in Fig. 66(c). This square wave is also applied to the cathode-ray tube as a blanking voltage to cut off the electron beam during the return trace. The blanking voltage may be applied to the cathode, grid, or first anode of the indicator tube, provided the amplitude and sign of the voltage wave are properly chosen. Although the square wave may be generated by any of the methods described in Section V, the multivibrator is the most commonly used in the newer types of radar.

a. Saw-tooth generators: The timing or range sweep is a saw-tooth wave form generated by charging or discharging a capacitor. If the capacitor is charged through a resistor, the saw tooth is nonlinear and results in a range scale which is compressed at the long-range end. If, as in the usual cathode-ray oscilloscope, only a small fraction of the charging curve is used, the nonlinearity is not particularly noticeable. Still further improvement may be made in the wave form by using a nonlinear amplifier which produces distortion in the proper direction to straighten the saw tooth. Another method for obtaining a linear saw tooth is to charge or discharge a capacitor at constant current. Since the plate current of a pentode is very nearly constant over a wide range of plate voltage, the circuit shown in Fig. 66(b) will give an excellent range sweep.

Constant-current charging can be even more closely approximated by using the circuit in Fig. 66(d). When the switch tube is turned off, the capacitor C_1 begins to charge through the resistor R . This rise in voltage carries the grid of the cathode follower in a positive direction, thereby raising the voltage at A by very nearly the

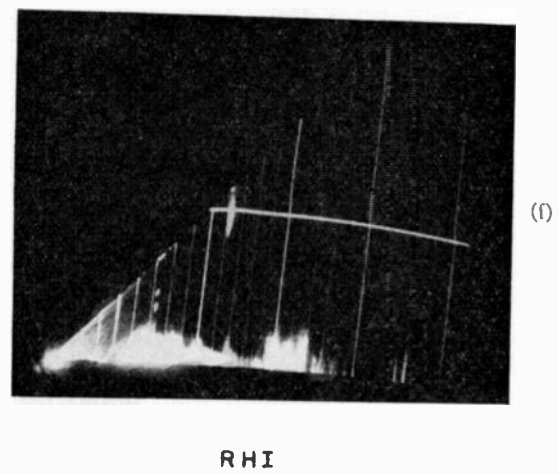
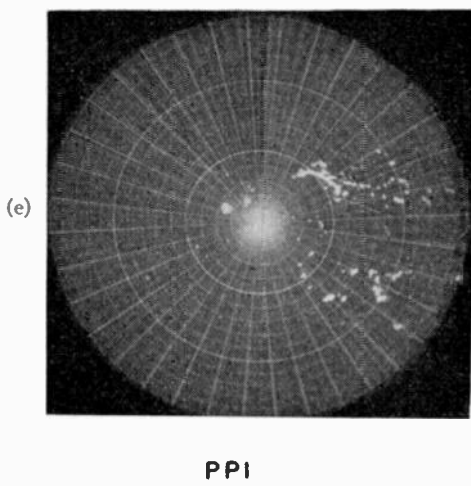
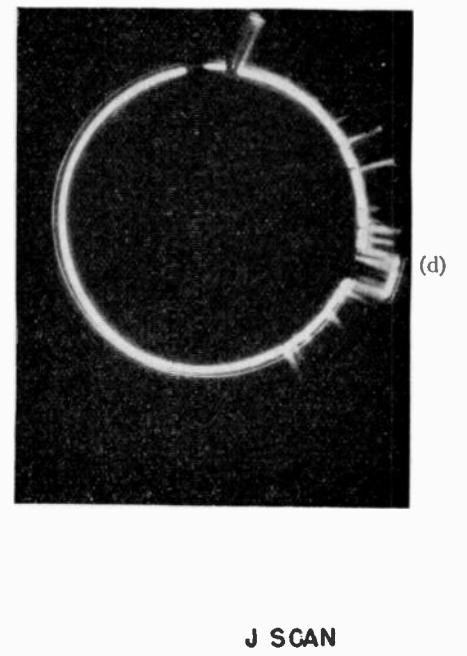
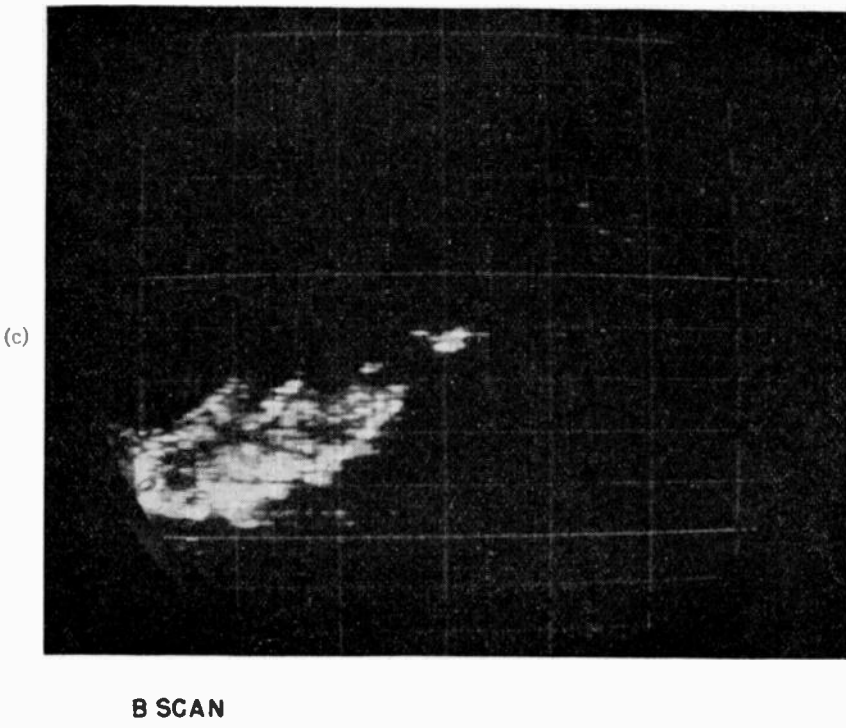
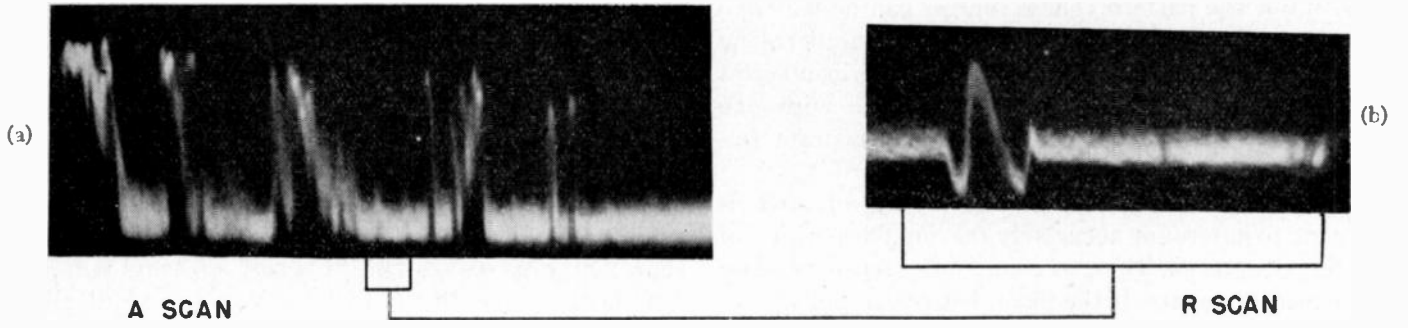

Fig. 65—Types of indicators.

same amount. If the capacitor C_2 is very much larger than C_1 , C_2 will not become appreciably discharged during the charging of C_1 . Hence the voltage across C_2 may be considered to remain constant. Then, as the voltage of point A rises, the voltage at point B is carried positive by the same amount, thus maintaining essentially constant current through R . During this process C_2 is acting as the source of current, and the diode is cut off by the rise in voltage at point B .

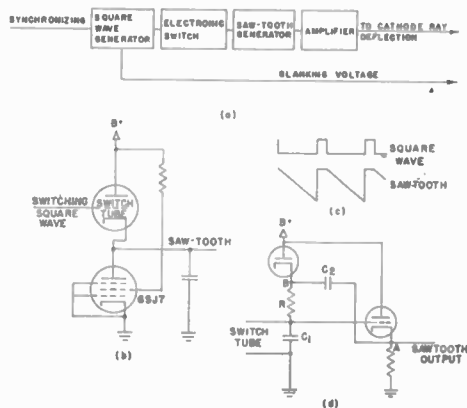

Fig. 66—Range-sweep circuit.

b. Sweep-delay circuits: Where a section of the range scale is to be enlarged as in an R-scope or a “delayed B-scan,” a time-delay circuit is placed between the source of synchronizing voltage and the square-wave generator. The remainder of the circuit is as shown in Fig. 66(a), in which the circuit constants are adjusted to produce a faster sweep than in an indicator which is to present a long-range scale. Several adjustable range-delay devices have been used for this purpose.

(1) *Multivibrators:* The back edge of a multivibrator square pulse may be used to trigger the circuit of Fig. 66(a). If this multivibrator is triggered by the transmitter, the time delay will be equal to the “flop-over time,”

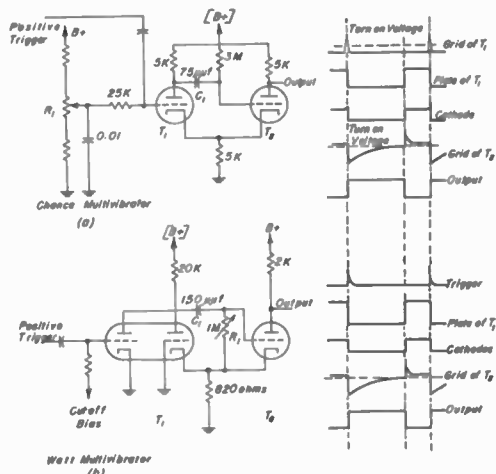

Fig. 67—Cathode-coupled multivibrators.

as determined by R_1 and C_1 in Fig. 11, and may be readily adjusted by making R_1 a variable resistance. The width of the square wave does not vary linearly with the

value of R_1 in this type of multivibrator; therefore, a “cathode-coupled multivibrator” is preferable for this purpose. Fig. 67 shows two types of cathode-coupled multivibrators for which the width of the square wave varies linearly with the value of R_1 .

In both of these circuits, tube T_1 is initially biased to cutoff by the voltage across the cathode resistor, this voltage being maintained by the current through T_2 . The mechanism of operation of these circuits is illustrated by the wave-form diagrams. If the voltage ($B+$) is very well filtered, the time “jitter” in the sweep circuit due to variations in the width of the multivibrator output can be reduced to less than 0.1 microsecond. When the width of the multivibrator output used for the time delay varies by more than the transmitter pulse length, signals on successive sweeps will not coincide on the tube face; and a loss in definition of the radar picture will result. It is, therefore, important to provide additional filtering for the ($B+$) voltage and is desirable to use a VR tube to aid in holding this voltage constant.

(2) *Saw-tooth delay:* A second method of delaying a sweep is illustrated in Fig. 68. A linear saw tooth is

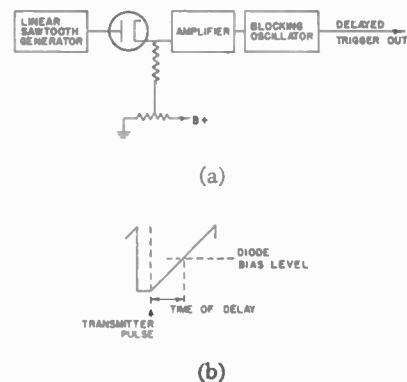

Fig. 68—Saw-tooth delay circuit.

started at the instant the transmitter pulse is sent out. When this saw tooth reaches the bias voltage on the diode, current will flow, thereby raising the grid voltage in the amplifier. This voltage change may then be developed into a trigger by tripping a blocking oscillator or may be amplified to the point where it is sufficient to start the multivibrator used to generate the delayed sweep. The time delay between the transmitter pulse and the trigger generated by this circuit may be adjusted by the setting of a linear bias potentiometer.

(3) *Phantastron:* The “phantastron” shown in Fig. 69 offers a third method for obtaining the required time delay. The second control grid G_2 is biased to cutoff, a process which forces all of the current to go to the first screen grid G_3 . If the cathode is about 40 volts above ground, G_3 should be at about 25 volts. Neglecting the diode for the moment, one sees that a positive pulse applied to G_3 allows the plate to draw current and, consequently pulls the first control grid to a lower voltage because of the coupling capacitor C . This action drops the cathode voltage to near zero so that G_3 no longer

cuts off the plate current. As the charge leaks from the capacitor C , the current through the tube increases because the first grid becomes more positive. The plate voltage then drops below the initial turn-on value and tends to prevent the grid voltage from rising. The net result is a downward drift of the plate voltage and an upward drift of the first grid, as indicated in Fig. 69(b).

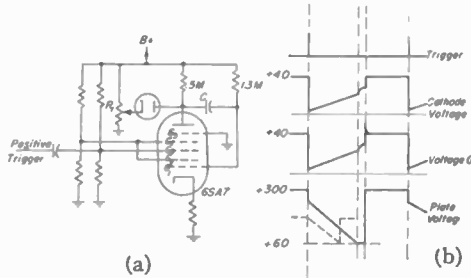

Fig. 69—Phantastron.

Eventually the plate voltage is so low that most of the further increase in cathode current goes to the screen. At this point the first grid voltage rises at the discharge rate of C and carries the cathode with it until G_2 again cuts off the current to the plate. The plate immediately rises to $B+$ carrying the first grid with it, and after a short transient period the tube returns to its original state.

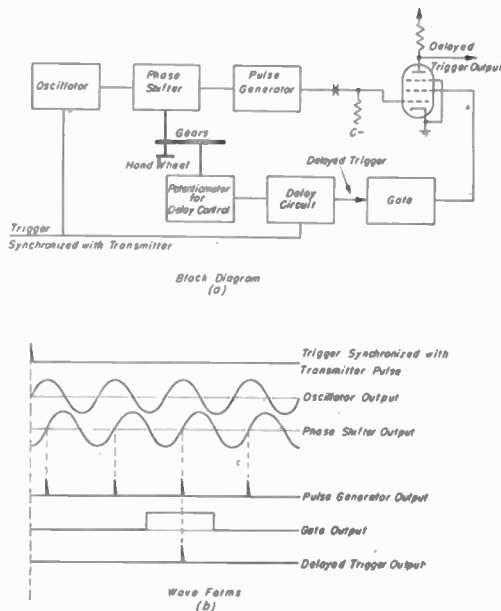

Fig. 70—Accurate range delay circuit.

Placing the diode in the circuit prevents the plate from reaching the $B+$ voltage. Its action is to move the plate-voltage curve to a lower value, as shown by the dotted line in Fig. 69(b). Since the plate-voltage curve is very linear on the down slope, the length of time required for recovery is decreased in proportion to the voltage applied to the diode. Thus R_1 may be used to control the time delay between the trigger and the rapid plate rise. This plate rise is used as the output from which a delayed trigger is developed.

(4) *Phase-shift delay*: Where very accurate control of the time delay is desired, the method illustrated in Fig. 70 may be used. A sine-wave oscillator with stable frequency characteristics having a frequency considerably greater than the pulse-repetition rate is used as an accurate timing device. This oscillator may be used to generate the radar-pulse frequency by some counting-down device, or may be turned on in synchronism with the transmitter by methods to be described later.

The output of this oscillator is passed through a phase shifter in which the phase change may be varied continuously and accurately by turning a hand crank. The sine-wave output from the phase shifter is then formed into a series of "pips" by one of the methods described in Section V. As the hand crank is turned, any given pulse will appear to move along the time base and can be moved to any chosen point. If we watch a particular pip, we may mark the phase shifter when this pip coincides with the transmitted pulse and then, by observing the number of turns on the hand crank, determine the number of oscillator cycles required to move this pip to a given point. From this observation and the oscillator frequency the range may be computed. Considerable effort will be saved if a calibrated dial is geared to the hand wheel, and still further simplification will result if the oscillator frequency is chosen to make one cycle correspond to, for example, 1000 yards when the range is to be read in yards.

We must now find some method of eliminating all but the desired pulse if we wish to use it as a delayed trigger. This may be done by using a cathode-coupled multivibrator or phantastron to trigger a second multivibrator whose output acts as a gate to select the desired pip, as indicated in Fig. 70. The potentiometer which controls the delay is geared to the phase shifter so that the gate moves with the pip. Because there is considerable space between pips, the gate need not be moved with a high degree of accuracy; however, it must track accurately enough to let through only the desired pip.

c. Range marks: Although range to the target can be measured by a scale placed on the face of the tube, it is preferable to use electronic methods which are independent of the linearity and centering of the trace. One of the most commonly used methods, which is particularly suitable for timing the very short intervals involved, is to develop range-marking "pips" from the sine-wave output of an oscillator. The oscillator frequency is usually chosen to correspond to the desired spacing between marker pips. For example, to obtain markers one mile apart the frequency should be $1/T = 186000/2 = 93$ kilocycles, where T is the time for the pulse to travel to a target one mile distant and return. However, by the use of counting-down circuits this same oscillator can be made to give, for example, 5-, 10-, or 100-mile markers.

Fig. 71(a) shows the basic method for obtaining electronic range marks. In systems in which an oscillator is used to control the pulse-repetition frequency, a continuously running oscillator may be used to generate

the range marks, the pulse-repetition frequency being obtained by counting down. In systems in which the repetition frequency is determined by some other method, such as a rotary spark gap, the oscillator cannot be run continuously because then it will not be synchronized with the transmitter. For such systems the oscillator must be started from a completely stopped condition and synchronized with the transmitter each time a pulse is sent out. The oscillator, if still running when the transmitter operates, may be imperfectly synchronized. Where a tuned circuit is used to control the frequency the oscillations may be stopped in two or three cycles by short-circuiting the resonant circuit with a tube, as shown in Fig. 71(b). The oscillations will always start in the same phase when this tube is turned off by a multivibrator triggered by the transmitter. On the other hand, if a crystal oscillator is used, the crystal will vibrate for a considerable time after being short circuited. Its oscillations, however, can be stopped rapidly by applying an out-of-phase voltage, as indicated in Fig. 71(c). Here, again, the impulse caused by turning off the switching tube will start the crystal in a definite phase. A crystal operated in this manner is not as stable as a steadily running crystal. Therefore, a good temperature-compensated coil-and-capacitor combination is almost as good as a crystal, since it is about as constant in frequency.

Fig. 71(e) shows the sequence of wave forms for a range-mark circuit which is turned on by the transmitter, as indicated in Fig. 71(b). The range marks shown on the PPI photograph in Fig. 65 were generated by a circuit of this type. The oscillator frequency was set to

negative voltage of the input wave starts the tube conducting. The plate current drives the grid positive through the coupling transformer, thereby causing the grid to draw current and charging the capacitor. As soon as the plate current reaches a steady value the voltage applied to the grid through the transformer falls to zero, because a transformer develops a voltage in its secondary only when the current in the primary winding is changing. This condition allows the grid to be carried negative by the charge on the capacitor. The plate, therefore, returns to B+, since the current is cut off, and remains there until the tube again becomes conducting, either because of the input or because the charge leaks off the capacitor through the resistor. If the resistor is so large that the grid is still too negative to permit the next negative input swing to turn the tube on, the blocking oscillator will not operate and will therefore count down.

3. Precise Ranging

Where very accurate range measurements are to be made, estimating the distance between range marks is inadequate. It then becomes necessary to bring a marker into coincidence with the signal. If the phase shifting device in the circuit sketched in Fig. 70 is accurately calibrated, the output pulse can be used as an electronic marker which may be moved to coincide with the signal, the range then being indicated on dials.

(a) *J-scan*: The J-scan offers another simple method of making very accurate range measurements. The tube used for the J-scan has two pairs of deflecting plates mounted at right angles, as in an ordinary cathode-ray tube. The sine wave from an oscillator is fed directly (or through a linear amplifier) to one pair of plates, and the same oscillator output, after passing through a 90-degree phase shifter, is fed to the other pair of plates. The resultant voltage from these two sine waves causes the beam spot to travel in a circle on the face of the tube. One complete circle is described for each cycle of range sweep. The radius of the circle is determined by the amplitude of the sine waves. The path will be an ellipse if the two waves are not equal in amplitude or if the phase shift is not exactly 90 degrees. In order to make the signal show as a deflection from this circle, the signal voltage must be applied radially between an electrode sealed in the center of the tube face and a conducting coating on the side wall of the tube. When the J-scan oscillator frequency is equal to the pulse-repetition frequency, the same signals on successive pulses will appear at the same points on the tube, and the range can be measured by a dial placed around the tube carrying a radial marker which is placed over the signal. If the oscillator frequency is some multiple of the pulse-repetition frequency the signals on successive pulses will still land at the same points on the tube, but there will be confusion as to the particular revolution of the sweep on which a given signal appeared. For example, if the pulse-repetition

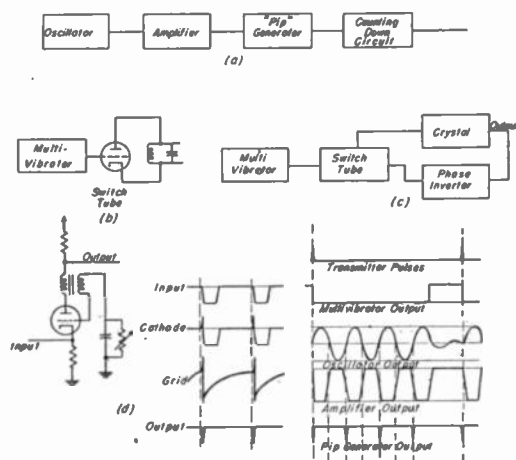

Fig. 71—Range-mark circuit.

give 10-mile pip intervals. The 50-mile marks were brightened by counting down by a factor of 5 to 1 and then superposing the 50-mile marks thus obtained on the original 10-mile marks.

(1) *Blocking oscillator*: A blocking oscillator such as that shown in Fig. 71(d) is used to convert the sine wave into these sharp range marks, and also as the counting-down circuit to obtain the 50-mile marks. The tube is biased off by a charge on the grid capacitor, but the

frequency is 9.3 kilocycles and the J-scan oscillator frequency is 93 kilocycles, there will be ten superposed sweeps, each expanded by a scale factor of 10 over a J-scan operating at 9.3 kilocycles. In order to know whether the signal appeared at 5.6 miles rather than at, say, 1.6 or 7.6 miles, it is necessary to blank all but one revolution on the tube. A blanking gate operated by any of the delay circuits described earlier in this section may be employed; it need not be positioned with a high degree of accuracy because it is used merely to indicate which mile is involved. The accurate range is measured by positioning a pointer over the signal as previously described; but, since this scale has been expanded by a factor of 10 in this example, the range measurements can be made with greater accuracy. For convenience of operation, the blanking gate is geared to the range dial.

The ability to present range on a dial means an ability to turn a mechanical shaft in accurate correspondence with the range. This ability is extremely important because it provides a means of feeding range data to gun directors, bomb-release-point computers, automatic-plotting tables, and other computing or plotting devices.

4. B-scan

Indicators such as the B-scan, RHI, and PPI require, in addition to a range sweep, a voltage which is a

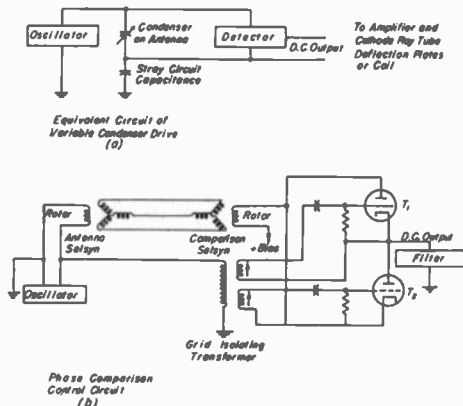

Fig. 72—B-scan azimuth sweep-control circuits.

function of the antenna position. Let us begin the discussion with the B-scan since it is the simplest case, and one which requires a voltage proportional to the azimuth angle of the antenna.

The simplest method of obtaining this voltage is to attach a potentiometer to the shaft in the antenna pedestal. For presentation of the full 360 degrees on the B-scan the potentiometer will have to be wound to cover a complete circle, except for a small space to separate the two ends of the winding. All potentiometers are apt to give trouble because of dirt, which causes poor contact between the sliding arm and the windings. A potentiometer gives an excellent solution to the problem in applications where this dirt can be kept out.

The second method is to attach a linear variable capacitor to the azimuth shaft. A high-frequency alternating current which is subsequently rectified is used, and

the variable capacitor together with the cable and circuit capacitance is used as a voltage divider. The equivalent circuit is shown in Fig. 72(a). Because of the geometry of a variable capacitor, a B-scan built on this principle can cover only 180 degrees; and unless the stator plates can be rotated by the operator, the 180-degree coverage cannot readily be shifted to a different sector.

A third method is based on the use of a phase-shifting device which is rotated by the antenna mount. In Fig. 72(b) a pair of selsyn transformers is used. When the two rotor coils are in the same position with respect to the stators, the phase shift is zero. The phase shift changes from this point in proportion to the angle of rotation of the rotor. A brief consideration of this circuit shows that tube T_1 conducts only when the grid voltage and plate voltage are positive, and that T_2 conducts only when the grid voltage is positive and the cathode voltage negative. Thus, both tubes act as half-wave rectifiers with T_1 rectifying only the in-phase components, thereby driving the output positive from a voltage point which is determined by the bias applied to the output selsyn rotors. When the selsyn output is out of phase with the oscillator, T_2 drives the direct-current output negative with respect to the equilibrium point. Since the comparator output is essentially sinusoidal with respect to the angle of rotation of the antenna, a B-scan operated in this manner will be reasonably linear only over a 90-degree sector. Therefore, a single B-scan of this type is not adequate for 360-degree search. One advantage of this circuit lies in the fact that the comparison selsyn may be placed within easy reach of the operator, so that he can select the 90-degree sector to be viewed by adjusting the selsyn rotor position.

Both the capacitor-driven 180-degree B-scan and the selsyn-driven 90-degree unit require blanking of the return azimuth sweep.

5. C-scan

A C-scan can obviously be built by using these types of sweep controls, one unit being operated by the azimuth antenna position and the second by the elevation.

6. Range-Height Indicator (RHI)

In an ideal RHI, the constant height lines should be straight and perpendicular to the constant-range lines. The height H of the target is given by

$$H = R \sin \theta$$

where R is the slant range and θ is the elevation angle of the antenna when pointed directly at the target. This equation may be solved electrically by feeding the range saw-tooth sweep through a device whose output is equal to the sine of the elevation angle. The output sweep from the sine computer is then applied to the cathode-ray tube to give a vertical deflection, and the range sweep provides a horizontal deflection. The resultant path of the spot on the cathode-ray tube will be along a diagonal.

A potentiometer wound so that the resistance varies as the sine of the angle of the contact arm may be used, but a simpler method is to wind a uniform resistance on a flat card. If the voltage is picked off by an arm pivoted as shown in Fig. 73(a), the output voltage will vary as the sine of the angle θ . The only electrical contact between this arm and the card is at the sliding contact. Fig. 73(a) also shows the basic RHI circuit. The height scale may be expanded by amplification of the sine-potentiometer output.

A capacitor voltage divider may also be used as height computer if the plates are properly shaped.

Fig. 73(b) shows another method of obtaining a voltage proportional to the sine of the angle. The "resolver" in principle consists of two sets of coils. The stator establishes a uniform field in which a rotor coil is placed. The coupling between the stator and rotor will vary with the sine of the angle as indicated. This resolver may be substituted for the sine potentiometer in the circuit in Fig. 73(a).

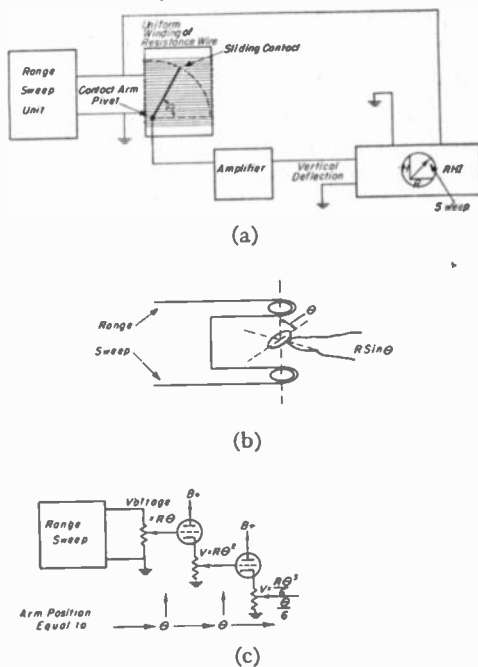

Fig. 73—Range-height-indicator sweep circuits.

Another method which gives an approximate solution is to make use of the equation

$$\sin \theta = \theta - \frac{\theta^3}{3!} + \frac{\theta^5}{5!} - \frac{\theta^7}{7!} + \dots$$

The series, which must have an infinite number of terms to be exact, is cut off at the term which is smaller than the permissible error. Each term is then separately produced by suitably designed electrical and mechanical systems, and the voltages are added. For example, the term $\theta^3/3! = \theta^3/6$ may be produced by three linear potentiometers, as shown in Fig. 73(c). The cathode followers are used to prevent loading of one potentiometer by the next, but play no other role in the circuit since their voltage-amplification factor is essentially unity.

7. PPI

If two arms of equal length at right angles to each other are used to make contact on the resistance card shown in Fig. 73(a), one contact point will give a voltage proportional to the sine of the angle and the other a voltage proportional to the cosine. Obviously, the pivot must be moved to the center of the card if 360-degree rotation is required. The cathode-ray spot will sweep radially from a point on the tube face, if the horizontal sweep connection in Fig. 73(a) is removed from the range-sweep unit and connected to the second arm through an amplifier identical with that in the vertical sweep circuit. The position of this point will be determined by the direct-current and voltage conditions in the circuit when no range-sweep saw tooth is present. This point will be at zero range, thereby corresponding to the map position of the antenna. The angular direction of the radial sweep will follow the angular direction of the antenna and the range mark will trace out a circle on the tube face as the antenna rotates. These statements may be verified by plotting the spot position for constant angle with the range varying, and for constant range with the angle varying, remembering that the sine and cosine voltages are applied at right angles to each other.

As in the case of the RHI, the potentiometer may be replaced by a resolver having two rotor coils placed at right angles. One coil will give a sine function and the other a cosine function.

These PPI sweep drives can be used with either electrostatically deflected or magnetically deflected tubes.

A very simple PPI sweep mechanism can be made with a magnetic deflection coil. If the coil is placed to give a magnetic field at right angles to the electron beam, the cathode-ray spot will move at right angles to both the magnetic field and the electron beam when the current is changed through the coil. If the coil is rotated about the electron beam as an axis, a range sweep fed into the coil will cause the spot to move radially. The angular direction of the sweep will correspond to the azimuth angle of the antenna if the coil is rotated in one-to-one correspondence with the antenna. In order that a true map picture may be presented, the zero range or starting point of all range sweeps, regardless of direction, must be at the same point on the tube face. This condition requires the current in the coil to be zero at the beginning of each range sweep. The position of the zero range point may be altered by adjusting the angular position of and current through another deflection coil which remains stationary as the antenna rotates. Fig. 74(b) shows an "off-center PPI" in which the zero range point has been moved to one edge of the tube. Actually, the center may be moved completely off the tube face.

8. Servo Controls

The coil in the "rotating-coil PPI" may be driven directly from the antenna by a flexible shaft or through

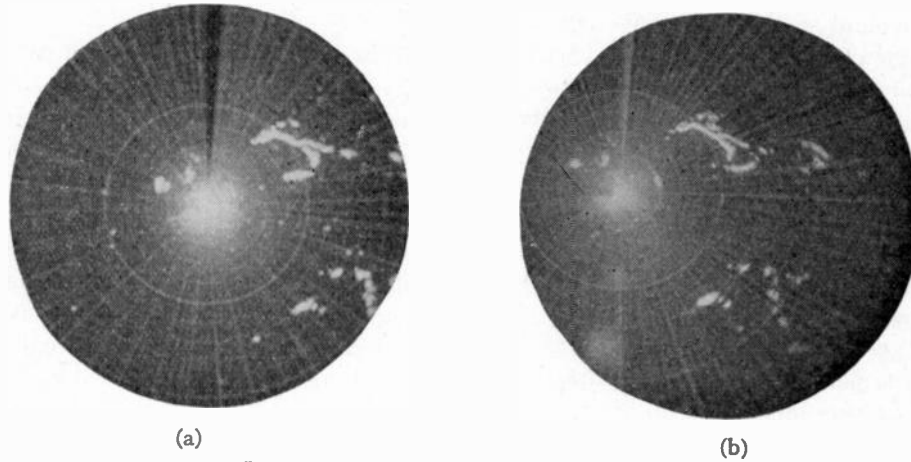

Fig. 74—Off-center plan-position indicator.

gears, but this method may be extremely inconvenient if the antenna is several hundred feet from the PPI.

If the torque required to turn the PPI coil is very small, the coil may be driven by a pair of selsyns connected as shown in Fig. 75. When the two rotors are lined up electrically, the induced voltages in the stators are canceled and there is no torque on the shafts. The voltages will no longer be canceled if one rotor is turned from this position. This unbalanced voltage will produce torques on the two rotor shafts in the proper directions to make them realign in the no-torque position. The torque increases as the displacement between the rotors

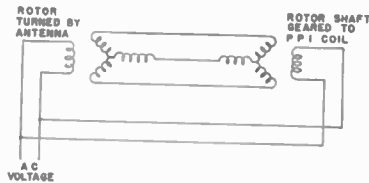

Fig. 75—Selsyn drive.

increases. Thus, if one rotor is turned and the other is free to rotate, the latter will follow the former, attempting to remain in the no-torque position. Frictional drag in the following selsyn will cause some lag in angle; hence its position will be uncertain by a few degrees. If the antenna selsyn is geared up by a ratio of 10 to 1 and the PPI is geared down 10 to 1 from its selsyn, the PPI coil will still make one revolution for each revolution of the antenna; but the selsyns will make ten revolutions. A lag of 5 degrees between the selsyns will then cause only 0.5-degree lag of the PPI coil from the antenna because of the gear reduction. Introduction of this gear system also results in ten stable positions (separated by 36-degree intervals) of the PPI coil with respect to the antenna, because the follower selsyn locks in 1-to-1 correspondence with the antenna selsyn and not with the antenna.

In applications where large torques are required it is not feasible to use a selsyn drive, but the phase difference between two selsyns may be converted to a voltage which may be used to drive a motor. If the motor turns

both the follower selsyn and the system which is being driven, the rotation will continue until the selsyns are again lined up. The motor must obviously be capable of reversing when the follower selsyn gets ahead of the transmitter selsyn in angle. Since there are a great many types of "servo-control" systems, a complete survey would require a highly technical discussion of the reasons for the different factors involved in selecting a particular type for a given job. Therefore, only two simple systems will be discussed to illustrate the general problem.

Fig. 76 shows a circuit used to control a two-phase alternating-current motor. The amplified selsyn output is fed to one coil of the two-phase motor, while the alternating current from the power line is connected to the other coil. When these two waves are in phase, no torque is developed. Displacement of one of the selsyns

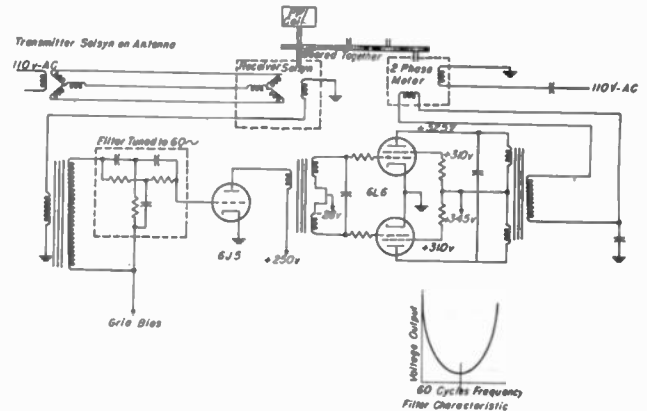

Fig. 76—Alternating-current servo system.

creates a phase shift which results in a torque on the motor. In order to have a stable system, this torque obviously must act in the proper direction to decrease the phase shift. In order to reduce the time lag of the motor system in following the transmitter selsyn, a signal proportional to the rate of change of the receiver-selsyn output is also fed through the amplifier. Thus, when the transmitter selsyn is suddenly turned, the torque on the motor is greater than that caused by the

selsyn output alone by an amount proportional to the rate at which the two selsyns become out of step. The selection of the proper type of rate signal is greatly dependent on the mechanical system to be controlled and is one of the most important and most involved items in servo design.

The "parallel-T" filter in Fig. 76 has the band-pass characteristic shown. Therefore, the voltage applied to the 6J5 grid increases as the frequency departs from 60 cycles. A change in error signal from the receiver selsyn may be considered as made up of a pure 60-cycle sine wave plus a modulating wave whose frequency is the rate of rotational displacement between the two selsyns. This modulation then results in output frequencies of 60 cycles plus and minus the rotation frequency. Since the grid swing is greater for these sum and difference frequencies than for the steady 60-cycle signal after passing through the filter, the power applied to the motor is increased by an amount dependent on the rate of change of the selsyn error signal. If the filter response curve is too broad, the servo does not follow quickly and accurately; while if it is too sharp, the servo oscillates about its stable equilibrium point.

A circuit of the type illustrated in Fig. 77 may be used to drive a split-field direct-current motor. The pulsating direct-current output of a phase comparison circuit, such as that shown in Fig. 72, is passed through

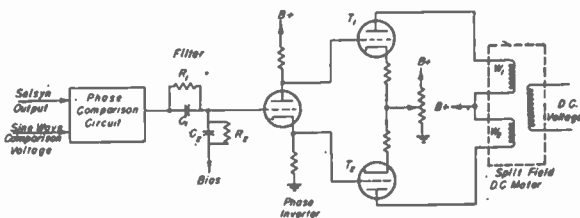

Fig. 77—Direct-current servomotor drive.

a filter network and is applied to a phase inverter. When the direct-current voltage on the grid of the phase inverter rises above the equilibrium voltage, the phase inverter draws more currents. This action raises the voltage of the grid of T_2 and lowers that of T_1 , thereby causing the current in the winding W_2 to increase and that in W_1 to decrease. If these currents are originally adjusted to produce canceling torques in the motor, this change in current balance causes the motor to run in one direction. On the other hand, if the phase-inverter grid swings below the equilibrium point, the current unbalance in the motor causes rotation in the opposite direction.

The filter R_2 and C_2 is adjusted to smooth the output of the phase comparison circuit, while R_1 and C_1 are adjusted to give a voltage which depends on the rate of change of the selsyn output. In other words, R_1 and C_1 perform the function of the "parallel-T" filter in the case previously discussed.

The servo-control mechanisms used in radar may vary from small units, such as are used for driving PPI coils, to units of many horsepower for turning antennas. As a

rule, some power-control device other than a vacuum tube is used to supply the final power to the motor in large servo systems. Nevertheless, the basic principle is as sketched here.

9. Angle Marks

Angle marks may be put on indicators by the simple expedient of a slotted disk, turned by the antenna. Light from a bulb actuates a photoelectric cell when the slots are in the correct position. The photocell output is then amplified and is used to change the intensity of the cathode-ray spot.

10. Map Presentation

When a "television picture" of a map is combined with the video from the radar, the picture of the map will appear on the indicator along with the signals. Since the radar picture is scanned rapidly in range at the pulse-repetition frequency and slowly in angle with the rotation of the antenna, the "television" picture of the map must be scanned in the same manner if it is to combine properly with the radar video. The spot on a PPI will scan a map in the proper manner if the map is of the correct scale and is placed on the tube face. Therefore, a PPI adjusted to give a bright spot may be used as a light source to scan a transparency placed on the tube face. No signals are applied to this PPI, of course. The light which passes through the clear space on the film is picked up by a photoelectric cell whose output is amplified and mixed with the radar signals for presentation on another PPI or on a B-scan. This device may be useful in directing aircraft to landing fields in bad weather since the position of the plane and field may then be clearly seen together on the radar tube.

XI. RADAR SYSTEMS

1. General Design Considerations

The first step in the design of a radar system is to study the requirements of the particular application. Some of the major items to be considered are the range, vertical coverage, accuracy of determination of target position, weight and size limitations, radio frequency, and presentation of data. Since several different methods may be used to accomplish practically the same end result, the final choice is usually made on the basis of compromises between these factors. The following discussion of radar systems will be far from a complete survey of all existing sets and, furthermore, will not attempt to describe any one system in full detail. The emphasis will be on the reasons for the choice of design rather than on detailed description.

2. Aircraft Search Systems

The AN/TPS-3, as shown in Fig. 78, is a "light-weight" radar set used to give air-raid protection to troops on a beachhead. This set was designed to guide fighter planes to intercept raiding aircraft; therefore, a

range of at least 60 miles on a single fighter was considered necessary, and coverage to 30,000 feet was desired. The maximum allowable weight including two gasoline-engine-driven generators was set at 2000 pounds. In order to save transformer weight, a prime-power frequency of 400 cycles was used. The indicators were placed directly under the antenna so that minimum lengths of cable

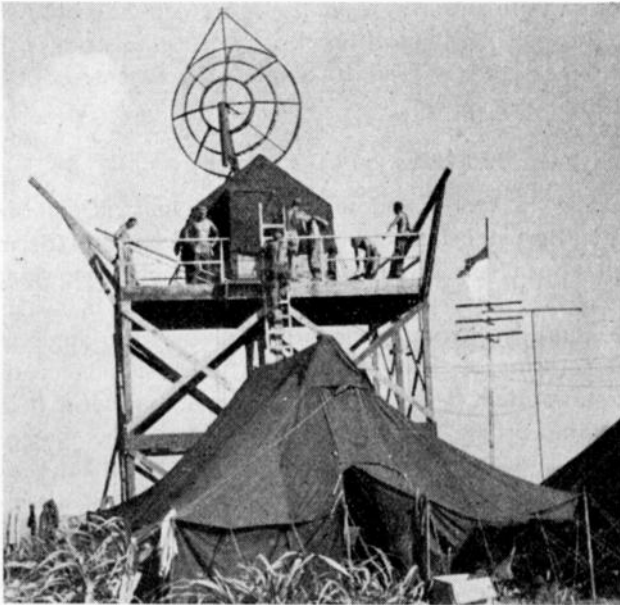

Fig. 78—AN/TPS-3 set placed on tower to clear surrounding obstacles.

are needed and so that the operator may turn the antenna by a simple hand crank. A frequency of 600 megacycles was chosen because calculations showed that the desired coverage could be obtained by a 10-foot paraboloid with its center 12 feet above the ground. Weight and windage are reduced by using wire screen to form the paraboloid. By using ground reinforcement, the lowest lobe gives good coverage up to the desired altitude at the cost of blind regions at higher angle; but because a 20-foot-diameter antenna would be needed to obtain the range performance without using ground reflection, the lobes are a necessary evil. This use of ground reflection also makes the set unsatisfactory in mountainous country where a flat reflecting surface cannot be found. Echoes from the mountains would make the set practically useless in rough terrain, so this lack of a flat surface is not considered a serious drawback. A rotary spark-gap modulator was chosen as the lightest available type, the gap being mounted on the generator shaft. The pulse-repetition frequency was selected as 200 cycles in order to utilize alternating-current resonant charging of the pulse-forming network, the discharge taking place on alternate cycles. A PPI was selected for the main presentation because an undistorted map picture is required to direct fighter planes. An A-scope was also incorporated but is more often used as a test instrument than as a radar search presentation. Under heavy

air traffic conditions, a single PPI is often inadequate to handle the traffic; but, since minimum weight of the set and size of the operating crew were the prime considerations, the components were designed to be as light and simple as possible and yet meet the essential military requirements.

The opposite extreme in air-search sets is the AN/CPS-1, which is commonly called MEW (microwave early warning). A solid search range of 150 miles on heavy bombers above the horizon and below 40,000 feet was requested. No limitation was placed on weight and size; but, since the antenna was required to withstand a 125-mile-an-hour wind, a maximum length of 25 feet was set as a practical limit by the mechanical designers. The radio frequency was chosen as 2800 megacycles, because this was the highest frequency allocated to ground equipment on which very high power could be obtained. As discussed in Section IX, both the beam width and the vertical aperture of an antenna for a given coverage decrease as the frequency is increased. Small vertical aperture was considered desirable to reduce wind loading, and the narrow azimuth beam width was needed to locate aircraft to better than 1 degree in azimuth. Since solid tracking was required, no use could be made of ground reflection; and calculations showed that the desired coverage could not be obtained with a single radar system. It was decided, therefore, that two sets should be built on a single antenna mount. An 8-foot vertical aperture was required for the long-range antenna, and a 5-foot aperture for the high-angle coverage. Because of the long, narrow aperture a line feed in a cylindrical reflector was chosen, a parabolic cylinder being used for the main beam and a "cosecant-squared" reflector to spread the energy to high angles for the upper beam. These two antennas were placed back to back, as shown in Fig. 57, to reduce windage. (It would have been better from an operational point of view if the two beams had been pointed in the same direction so that the video outputs of the two sets could have been combined on a single indicator.)

In order to simplify the radio-frequency system, the modulator, transmitter, and receiver were placed on the antenna and rotated with it. This avoided the necessity for radio-frequency rotating joints, which may introduce power loss, and allowed slip rings to be used to carry all voltages through the antenna axis. A rotary gap modulator was chosen because of light weight and simplicity of maintenance, since it was to be mounted on the antenna. Wave guide was chosen because of the high power (1000 kilowatts) and frequency.

A large number of indicators was provided because the set was to be used for reporting positions of large numbers of aircraft to an air-warning center as well as to control aircraft in flight. The B-scans, which display a limited section of the range scale and of the azimuth angle, are used to divide the area covered by the set, as indicated in Fig. 79. Since these indicators are of the type sketched in Fig. 72(b), the area covered by a given

tube can be changed quickly. A PPI may be used as shown to cover a low traffic area. The division of area among the scopes is made on the basis of traffic, so that no one operator has more planes to report than he can handle. For control of aircraft, to intercept enemy planes, or to bring aircraft over a point on the ground, PPI tubes are provided. In this set every attempt has been made to provide maximum flexibility.

The cost of the performance and flexibility of the MEW is about 30 tons in weight and an operating crew of about 300 men, as compared with the AN/TPS-3, which weighs 1300 pounds and requires a crew of about 20 men. On the other hand, considerable advantage is gained by having all of these functions in a centralized spot. Since several AN/TPS-3 sets require a central coordinating organization to maintain an over-all air traffic picture and to assign raids to a given set, the apparent ratio of 15 to 1 (based on manpower required) does not give a true picture of the relative costs and values of the two sets. Furthermore, the solid coverage

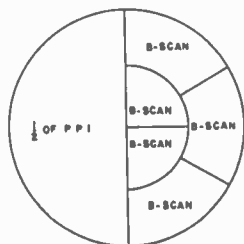

Fig. 79—Possible scope coverage.

and the greater angular accuracy of the MEW makes the manpower basis of comparison a minor factor. These two sets were chosen as representing extremes. Many other sets have been built and used which fill intermediate requirements. On the other hand, these two extremes have their faults, and should not be considered as perfect answers, even for the purposes for which they were designed.

3. Height Finders

The class of set discussed in the section on general design considerations shows only the range and bearing of the target and must, therefore, be supplemented by a height-finding radar.

The simplest height finder, from a technical point of view, is illustrated by the AN/TPS-10, as shown in Fig. 80. The antenna, which is continuously rocked in elevation by a motor, is turned by hand to point in the direction of a target discovered on a search set such as the AN/TPS-3. As the beam sweeps vertically across the target the echo appears on a range-height indicator, the height being read by noting the position of the center of the signal on a calibrated scale.

The antenna is 10 feet high and 3 feet wide, and is fed by a horn on the end of a wave guide. Since the set operates at 3 centimeters, the beam is about 0.7 degree high and 2 degrees wide. The 3-centimeter wavelength was

chosen so that a very narrow vertical beam could be obtained with a reasonable size of antenna. The horizontal beamwidth had to be wide enough to make the target easy to find, and yet the antenna gain had to be great enough to give the desired range of 50 miles on a medium bomber. Since the horizontal aperture affects these two antenna characteristics in opposite directions, the 3-foot antenna width or 2-degree beamwidth represents a compromise.

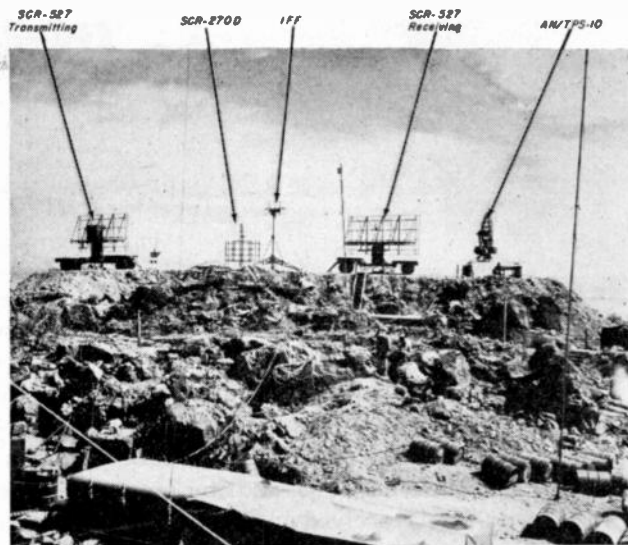

Fig. 80—Radar on Iwo Jima.

This set may also be used for aircraft search if the azimuth rotation is controlled by the elevation rate to give a saw-tooth scan, as discussed in paragraph 8 of Section IX. Since the elevation-scan rate is low, less than 2 cycles per second, a PPI presentation of the signals is very unsatisfactory because of the flash which occurs when the beam crosses and recrosses the target in elevation. On a search set, aircraft may be lost because the echo from the target and a hill at the same range are received simultaneously, the target echo being buried in the signal returned by the ground. Therefore, if a PPI is used with the AN/TPS-10, the echo may be masked by the afterglow of the ground return on the PPI. On the RHI this masking does not occur because an aircraft appears above the mountain on the tube. Therefore, the AN/TPS-10 offers one method of locating aircraft in mountainous country. It would be improved for this purpose, however, if the elevation-scan rate were increased.

A second method of height-finding is used in the SCR-527 (see Fig. 80). This set operates at 200 megacycles and uses ground reflection to obtain the range performance. When the set is perfectly sited, the vertical lobe pattern is the same at all azimuth angles. Since the ground must be level to within one foot for a radius of one-half mile around the antenna, it is not often that this uniformity of lobe pattern with azimuth angle is achieved. The antennas are arrays of dipoles, 8 wide and



Fig. 81—SCR-584 with gun battery.

4 high, mounted just a few feet above the ground. Separate transmitting and receiving antennas are used. By a switching device, the height of the center of the radiating area of the antenna can be changed by alternately feeding the top and bottom rows of dipoles. This effective change in antenna height shifts the lobe positions. Height is then measured by estimating on an A-scope the ratio of the signals received on the alternate antenna lobe positions. The square wave which switches the antenna is applied to the horizontal deflection of the A-scope to make the signals on alternate positions appear side by side. The signal ratio is converted to height by use of a calibration chart. If the radar site is not perfect, the calibration will vary with the azimuth angle.

A PPI is used to obtain range and azimuth. The SCR-527, therefore, gives complete co-ordinates of the target if properly sited to read height.

The SCR-584 shown in Fig. 81 also uses lobe switching to determine height but does not depend on estimation of signal ratios. Since this set was designed to aim anti-aircraft guns at a target which could not be seen visually, the whole design of this set was guided by the need for accuracy in measuring the target position. For the operating frequency, 2800 megacycles was chosen because a narrow beam was required, and at the time of the design this was the highest frequency at which appreciable transmitter power was available. A stub-supported coaxial transmission line was used largely because wave-guide techniques were not well developed. A 6-foot paraboloid was chosen as a convenient antenna reflector for truck mounting. This gave considerably more gain than was needed to meet the required range performance and gave a sufficiently narrow beam, 4 degrees, to obtain the required average angular accuracy of 0.1 degree when used with a conical scan.

The antenna turns in both azimuth and elevation so that search may be carried out by using a helical scan. The signals are presented on a PPI as well as on a J-scan which covers the full range of the set; another

J-scan covers any desired 2000-yard interval of range. When a target is located, the helical scan is stopped; and the antenna is pointed at the aircraft by using hand controls which operate servo drives to position the reflector.

The cross hair for measuring range on the full-scale J-scan is then put in position over the signal. This automatically sets the blanking gate to the proper range to allow the same signal to appear on the expanded J-scan, as described in paragraph 3 of Section X. Further adjustment of the hand crank places another crosshair over the front edge of the signal on the expanded J-scan. The target range can then be read from dials with an accuracy of better than 50 yards. In order to achieve this accuracy, the range circuit and transmitter pulse rate are controlled by a crystal oscillator.

By means of a phase-shift delay circuit a narrow gate is also positioned by the range handwheel. This gate is applied to a channel in the receiver different from that feeding the signals to the scopes and permits only the signal under the range cross hair to pass through the gated channel. This selected signal is used to automatically center the conical scan on the target. A reference generator attached to the rotating dipole feed gives a voltage in phase with the motion of the beam on the conical scan. This voltage is used to switch the signal from the narrow-gated receiver into four channels corresponding to the up, down, right, and left positions of the beam during a revolution of the conical scan. If the elevation angle of the antenna is wrong, the average direct-current output voltages of the "up" and "down" channels will not be equal because at one position of the conical scan the beam will be pointed more directly at the target. When the antenna is turned to equalize these two voltages, the elevation angle is correct. A similar equalizing of the "right" and "left" voltages brings the target to the center of the conical scan. These voltage differences may be displayed on meters with the antenna adjustment made manually by the operators; or may,

as in the normal use of the SCR-584, be fed into the servo-control system as an "error voltage" to keep the antenna pointed automatically at the target.

With the antenna accurately pointed at the target in elevation, the height of the target may be computed from the elevation angle and the slant range. Automatic height computers operating on principles similar to those used in producing RHI sweeps are in use in the SCR-584.

4. Shipborne Sets

Radar sets for shipboard differ from ground radar sets in only one major respect. Since the ship changes course and also rolls and pitches, the antenna must be stabilized.

Azimuth angles should be measured with respect to north in order to correlate readily the radar echoes with a map. There are two methods of north stabilization which may be illustrated by imagining a ground set placed on shipboard with the zero azimuth angle corresponding to the antenna pointing directly forward. When the ship is headed north, a PPI on this set will have north at the top of the tube, the normal orientation for reading a map. Now if the ship swings to a course due east, the top of the PPI will be east since the signals from straight ahead of the ship will appear at the top of the tube. If the whole PPI chassis is rotated through 90 degrees in a clockwise direction, north may again be brought to the top of the tube. The same effect can be obtained by rotating the PPI azimuth-sweep coils or the data take-off device on the mount. This general method of correction is known as "data stabilization" since only the data are corrected, the antenna still swinging with the ship.

Although data stabilization could be carried out by a man watching a compass, it is more satisfactory to use a gyrocompass which turns a selsyn as the ship's course changes. The output of this selsyn is then used to operate a servo unit which either mechanically rotates the azimuth data take-off or operates a phase-shifting device in the electrical circuit controlling the data output, thereby introducing the proper correction. For example, if the PPI is selsyn or servo driven, introducing a 90-degree phase shift between the two selsyns will cause the follower to rotate 90 degrees.

If the antenna of this data-stabilized system is stopped and pointed at some target, the azimuth data will always be correct; but the operator will be kept busy turning the hand control to keep the antenna on target as the ship changes course. This turning of the hand wheel can again be done by a servo drive operated from a gyrocompass. In order to avoid having the hand control continually whipping around and to allow the operator to change the antenna position, the ship's motion is normally put into the antenna-drive hand control by a differential. This enables the ship's motion and the hand drive to be added without interfering with each other. The differential may be a mechanical gear system

or an electrical circuit, depending on the means used to control the antenna. With this "north-stabilized antenna" the ship turns without rotating the antenna with it. Therefore, the data stabilization previously inserted must be removed to give a correct presentation. A ship system should have either data or antenna stabilization, but not both.

Another stabilization problem arises from the roll and pitch of the ship. For a long-wave set in the 200-megacycle region which uses water reflection to obtain its vertical-coverage pattern, the roll and pitch of the ship has little effect other than causing a slight change in antenna height. On the other hand, when the vertical beamwidth of a radar set is narrow, the rolling of the ship may swing the beam off the target in the vertical direction. Stabilization in elevation is controlled by a "stable-vertical" gyro which introduces corrections in the antenna-elevation-control system for the roll and pitch of the ship. In order to obtain complete correction, two elevation axes at right angles must be provided. Sufficient stabilization for many purposes may, however, be obtained by a single elevation axis.

Since ship navigation is certain to be an important peacetime use of radar, a brief discussion of the probable form of such a set is in order. Only a small antenna gain is required, because the range at which other vessels and land may be seen is usually limited by the horizon rather than by the radar performance. On the other hand, since high resolution and accurate bearing measurements are needed, the beamwidth should be very narrow. In order to obtain a narrow beam with a small antenna, say 2 by 3 feet, the set should operate at 9000 megacycles or higher. Stabilization will also be required. Another advantage of this high frequency arises from the fact that the lobes caused by water reflection lie much closer to the surface than do those of a longer wavelength set at the same height. This improves the signal strength from buoys and small boats. The signals should be presented on a PPI so that a true map picture of the position of objects which cause echoes may be obtained.

5. Airborne Radar

Although weight and size, particularly of the antenna, must always be kept in mind when designing sets for ship use, in an aircraft virtually all other considerations play a role secondary to these factors. Light-weight, compact construction is required throughout. This requires the use of light-weight metals such as aluminum and magnesium and a frequency of 400 cycles or higher for the prime power source. Since power costs weight in the form of generators and transformers, every effort must be expended to keep the over-all power consumption to a minimum even to the extent of sacrificing items which would be helpful but are not essential. Furthermore, any safety factor in components costs weight; for example, a transformer or capacitor operated below the maximum rating is less apt to burn out but is larger

and heavier than one built for this smaller operating current and voltage.

Because the antenna must be mounted inside the fuselage or in a streamlined housing, the maximum size of the antenna is seriously limited. The antenna may be mounted in the nose or in a nacelle on the wing when it is not necessary for the radar to see behind the plane. From these positions it is possible to scan the forward 180 degrees. To obtain 360-degree coverage the antenna must be put in a blister on the belly. In many cases, provision must be made for retracting this blister when the plane lands.

With the radar competing with other items for allowance of weight and space and for power from the plane's generator, a great deal of consideration must be given to the choice of antenna size, the transmitter power output, and the packaging of the components. As a rule, the installation is more satisfactory if the set is designed to fit the plane because the radar components may then be built to take full advantage of existing space. Even when the set is built for a particular aircraft, extensive modification of the plane may be necessary to make the installation.

The problems of airborne-radar design may be illustrated by two navigational sets. The AN/APS-10, as shown in Fig. 82, was designed as a navigational set. Since installation in fighter planes was anticipated, the total weight limit was set at 100 pounds. In order to be useful for navigation, a range on land masses of at least 50 miles is needed. This is equivalent to a range of 3 to 5 miles on an aircraft. Furthermore, the beam must be narrow to allow rivers and other prominent landmarks to be seen. On the other hand, the largest antenna which may be fitted into a fighter is about 18 inches. At the time this set was designed, 3 centimeters was the highest usable frequency and was, therefore, used. The final design uses a peak output power of only 8 kilowatts, although the magnetron is capable of giving 50 kilowatts with a heavier

modulator. The signals are displayed on a 5-inch PPI placed in front of the pilot. The total power consumption of the set is 500 watts. Although this set meets the requirements for which it was built, the pilots of the Fighter Commands were unwilling to sacrifice 100 pounds of ammunition or gasoline for a simplification of the problem of navigation. Even on the long flights from Iwo Jima to Japan, where navigation was a serious problem, 100 pounds more of gasoline was considered a better safety insurance than 100 pounds of radar.

Radar blind bombing, the application which has received the most publicity, is largely a navigational problem, and therefore requires the best possible radar navigation equipment. This factor has led to a continued improvement in resolution by going from 200 to 3000 megacycles, and then to as short a wavelength as possible with antennas as large as practical. Best results in picking out landmarks are obtained when the illumination of the ground is the same at all ranges; therefore, a "cosecant-squared" antenna pattern is used. Because the pattern of landmarks must be readily recognizable and therefore should correspond as closely as possible with the appearance of the map, a PPI presentation is used. The center of the PPI is rather badly distorted at the shorter ranges on account of the fact that slant range rather than ground range is used. Particularly noticeable is the "altitude circle," as in Fig. 83, which is formed by the nearest signal, the ground directly under the plane. Thus, the range of the first echo is the altitude of the plane. This fact is used as the basis for one type of radio altimeter.

In addition to the radar, a bomb-release computer is needed. In one form, this device may mark electronically the proper course and release point on the PPI tube, or in another form the signal on the tube may be tracked to feed data to the computer.

It is obvious from Fig. 83 that aircraft beyond the range of the altitude signal would be overlooked in the ground return. Therefore, a navigational set would be

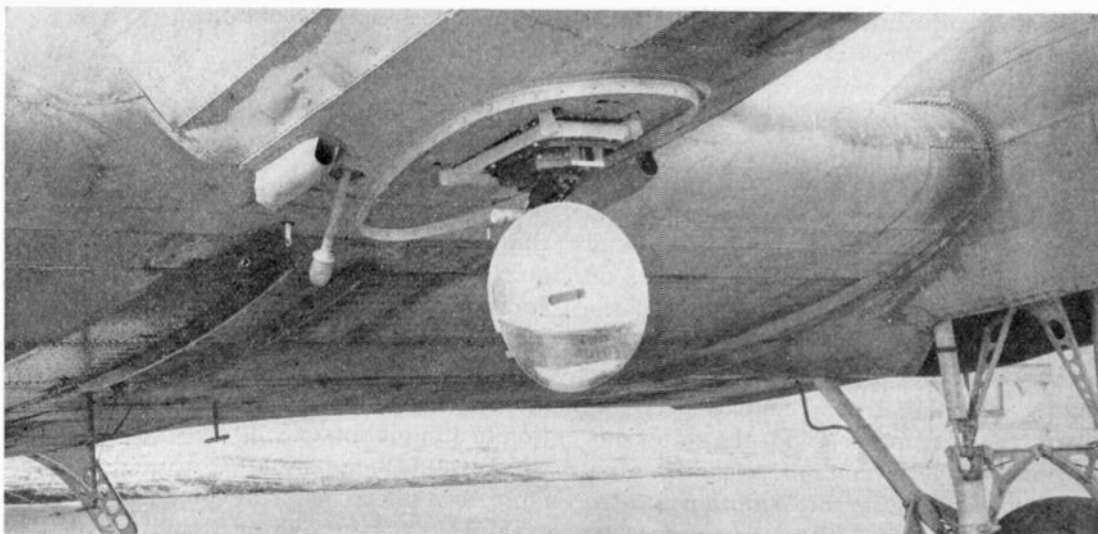

Fig. 82—AN/APS-10 antenna on C-47, antenna housing removed.

of relatively little value for collision avoidance. In air-to-air search applications, such as a night fighter after a bomber, the beam should be narrow enough so that it does not strike the ground. For example, the SCR-720 used in Army night fighters has a pencil beam which is used with a rapid helical scan. The azimuth scan rate is 360 revolutions per minute, and the vertical rate is 30 degrees per second. The signals are presented on a B-scan to determine range and direction of the target, and on a C-scan to determine altitude.

The AN/APS-13, which was designed to provide warning of a plane closing in from the rear, offers a possible solution to collision avoidance. This set, which weighs 20 pounds, operates at 415 megacycles and requires only 90 watts at 27 volts direct current. The antenna, which consists of two folded dipoles, is mounted in a fixed position and covers 60 degrees horizontally and 90 degrees vertically. When another aircraft enters this cone and is within 800 yards, a red light shows in front of the pilot and a bell rings. A modification, which

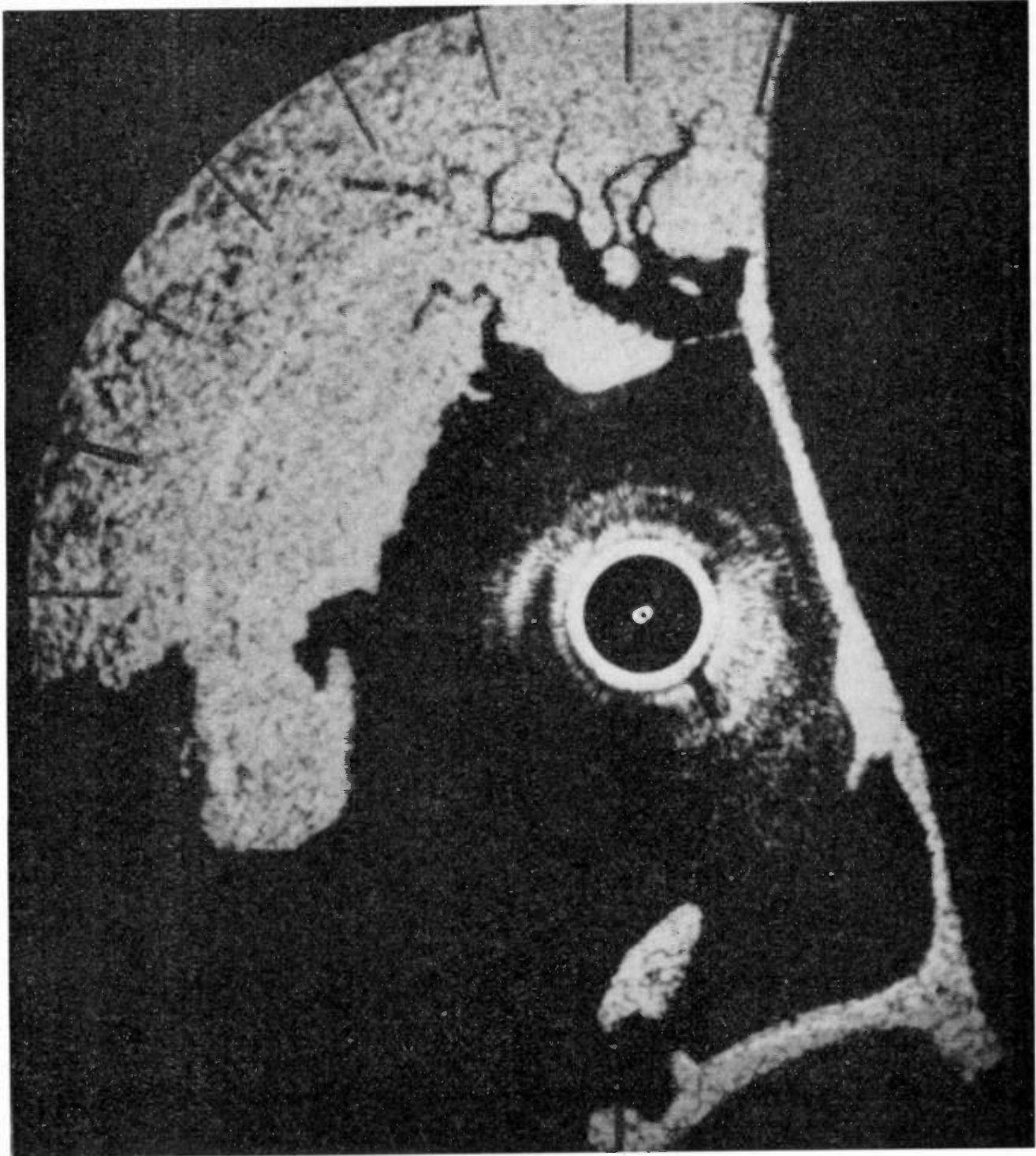

Fig. 83—Airborne radar photograph taken at low altitude over Duxbury Bay, Mass.

uses the return signal from an object closer than 800 yards to trip the transmitter, can provide an audio tone which rises in pitch as the distance decreases. This gives the pilot a rough indication of range.

XII. BEACONS AND RADAR NAVIGATIONAL SYSTEMS

1. Radar Beacons

Radar beacons, unlike the radio beacons now commonly in use, do not transmit continuously. The radar beacon is triggered or "interrogated" by the radar in order to show position rather than just direction. The beacon consists of an antenna, a receiver, a transmitter, and, usually, a coder. The radar transmitter pulse, if of the correct frequency and pulse length, is received and amplified so that it may be used to trip the beacon transmitter. The transmitter then sends out a pulse or series of pulses as determined by the coder. Since the time delay between the reception of the signal and the firing of the transmitter is extremely small, the beacon signal reaches the radar at essentially the same time as the echo from an object placed at the beacon. Thus, the beacon response may, in effect, be used to strengthen the echo from the target.

A wide-band crystal-video receiver may be used on the beacon where the band of frequencies of the interrogating sets is not too great. However, since the radar set has a narrow receiving band, the beacon response frequency cannot readily be spread sufficiently to be received on all of these sets. Two solutions to this problem exist. One is to make the frequency of the beacon transmitter sweep with time. This solution is adequate where a few seconds may be spent in interrogating the beacon, the time being spent in waiting for the beacon response frequency to sweep through the receiving band of the interrogating system.

The other solution to this beacon response problem is to have all beacons transmit on a particular frequency. The radar sets must then have a receiver for the beacon replies which is tuned to the beacon frequency. The video output of this receiver can then be mixed with the radar video for presentation on the scopes. Having the beacon respond on a separate frequency from the radar makes possible the presentation of beacon signals only. The major advantage of this lies in the fact that no ground echoes appear under these conditions.

Beacons have been used for extending the range of tracking, since the beacon response essentially is a radar signal "reinforcer." They have also been used for the obvious purpose of marking airfields for aircraft equipped with radar. Because beacons must receive radar pulses from any direction, beacon antennas are nondirectional. Therefore, the beacon antenna gain is quite low. This factor is more than compensated for, however, by the fact that the power in going from the source to the receiver need not make a round trip. Hence, the signal strength falls off as the inverse square rather than the inverse fourth power of the distance. Therefore, if the beacon receiver is reasonably sensitive and its transmit-

ter power is of the order of a few watts, the range at which it may be seen is usually limited only by the horizon. When the beacon receiver is not sufficiently sensitive, the beacon may stop responding when the radar signal becomes too weak. When this happens, the beacon response will either be strong at the radar or will not appear. On the other hand, where the beacon power output limits the range, the beacon signal will become very faint before it is lost.

In some aircraft, the P-38 for example, two beacon antennas are required to achieve a nondirectional antenna pattern because in certain directions parts of the plane obstruct the radiation from a single antenna. Even on planes where a single antenna can be employed, considerable care must be used in selecting a satisfactory location.

The customary beacon antenna on an aircraft is a dipole, while on ground beacons the antenna may be a dipole or a short array similar to that shown in Fig. 55.

2. Beacon Navigation System

Beacon markers may obviously be used as known reference points for aircraft equipped with radar and have been used as runway markers for instrument landing.

Because radar range measurements may be made with an accuracy of 50 feet with suitably designed equipment, very precise position fixes may be made by triangulation, as indicated in Fig. 84. The ranges R_1 and R_2 from two beacons at accurately known ground points are measured. The plane is then known to be at the intersection of circles of radius R_1 and R_2 drawn about beacons 1 and 2, respectively. Since there are two intersections, the proper one is determined by a rough knowledge of position obtained by some other means.

In the "oboe" system two ground stations are used. The master station is a normal radar, while the other is merely a receiving station with its range circuits synchronized by a pulse from the master station. The aircraft carries a beacon which is interrogated by the master station. The beacon response is received on both stations, and the two ranges are accurately measured. Instructions are given to the pilot by suitable modulation of the radar beam. One pair of ground stations can handle only a single flight at a time.

In the gee-H, shoran, and micro-H systems, two ground beacons are used. These are interrogated by a radar set in the plane and reply on different frequencies or with different codes to enable the operator in the plane to determine which signal belongs to a given beacon. Where precise navigation is not required, the plane's position may be determined by drawing circles on a map about the beacon position. However, where the position must be known as accurately as possible, such as in bombing, special indicators and computers must be used. An elaborate calculation making corrections for slant range and curvature of the earth must also be made. Since this requires considerable time, the calculations are made before the flight and the plane is

kept on a predetermined path. For aerial mapping the calculations may be made after the flight if a record is kept of the range readings at the time a photograph was taken.

3. Gee and Loran

Although these navigational systems are not strictly radar, they do use pulse-transmission techniques. Both of these systems are based on the principle that a hyperbola is generated by keeping the difference in distance from two fixed points constant. If stations *A* and *B*, (see Fig. 85(a)), send out pulses simultaneously, a measurement of the difference in time of arrival of the signal from *A* and from *B* will determine the difference in distance of the two stations from the receiver. The plane or ship is then known to lie on a given hyperbola corresponding to this difference in distance. Another such pair of stations will give a second line of position, the fix being determined by their intersection.

In the gee system, *A* is the master station which transmits at fixed repetition rate and alternately triggers two slave stations *B* and *C*. These stations all operate on the same frequency and are displayed on an A-scope, as indicated in Fig. 85(b), the trace from the pair *AC* being displaced vertically from that on which *AB* appears. The pulse from *B* or *C* may be coded to show which pair of stations corresponds to the lower trace. The two range intervals *AB* and *AC* are used to locate the position from a map on which families of hyperbolas have been drawn. Interpolation between these calculated hyperbolas is usually necessary. Navigation can be accurate to a fraction of a mile where the curves for the two pairs of stations cross steeply, but is poorer where these curves are nearly parallel on crossing. The

radio frequency is high enough that the range is limited by the horizon.

Loran operates on the same principle but uses stations in pairs, each pair consisting of a master and a slave station. It also operates on a much lower frequency; hence the range is not limited by the horizon. The use of

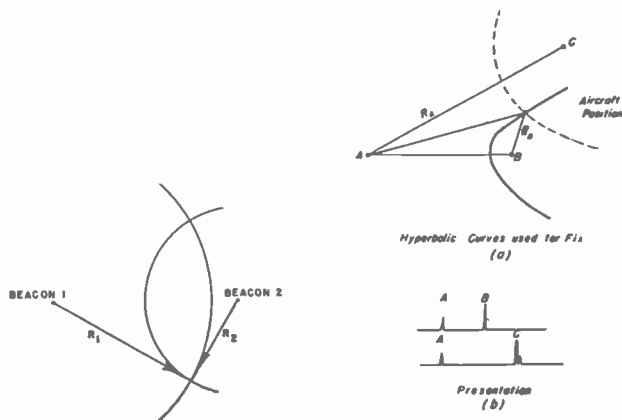

Fig. 84—Range triangulation. Fig. 85—"Gee" system for navigation.

pairs of stations, rather than a triplet as in gee, makes it possible to place the stations in positions better for getting steeply crossing hyperbolas at long range. The pairs operate on different repetition rates and are identified by the synchronizing-control setting. Because of multiple reflections from the ionosphere, the alternate presentation of stations as in the gee system is not practical. Fixes are made, therefore, by taking a reading on one pair and then resetting the oscilloscope to obtain a reading on a second pair of stations. Map charts are again used to locate the position of the plane or ship. Loran will give a fix to better than 5 miles at a distance of 600 or 700 miles from the stations.

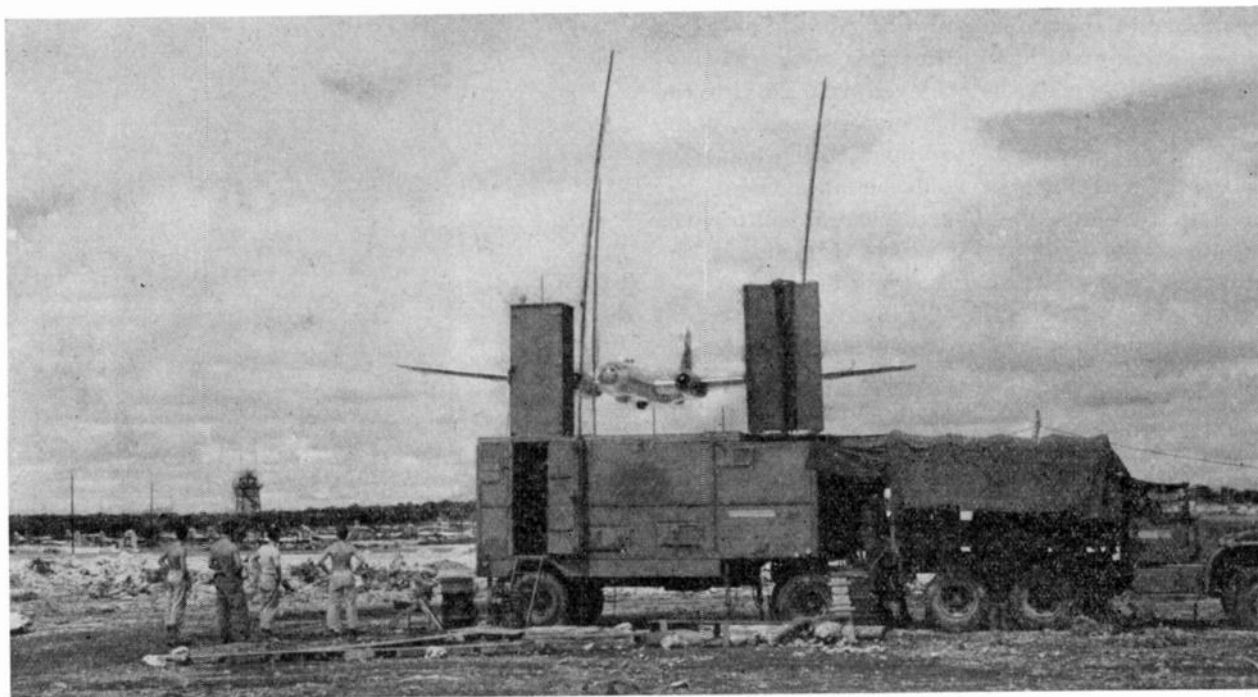

Fig. 86—AN/MPN-1 on Guam.

4. Radar Aids to Air Navigation and Traffic Control

Although airborne radar may be used as a navigational aid, several serious difficulties exist. As was mentioned previously, the ground echoes obscure signals from planes. However, navigation entirely by beacons and the use of airborne beacons would eliminate this difficulty. On the other hand, since it costs about 500 dollars a year to replace a pound of cargo by a pound of equipment in a commercial plane, the installation of both radar and beacon would be quite expensive. Furthermore, this installation will not greatly help the control tower in handling congested traffic at an airport because the controller does not have direct access to the information presented on the airborne set.

An alternate proposal which has many interesting possibilities is the use of a network of long-range high-resolution ground stations to watch the air traffic. This network provides complete information on aircraft position to the control tower, thereby eliminating the dependence of the controller on the pilot for information as to the location of his plane. The present method of depending on the pilot to supply this information breaks down when most needed; namely, when the pilot is lost. If the signals from these ground radars are mixed with a "video map" on which air routes and fields are marked, the controller can see on his PPI when a plane is off course. Although controllers on the ground could continually direct the pilots in course, altitude, and speed, a much more satisfactory solution would be to use a radio link to relay the radar picture to the plane where the pilot or co-pilot could keep a continual check on the course and on the presence of other aircraft. Such a relay system has been operated on the ground very successfully, but the receiving system needs re-engineering for aircraft use. Only a receiver and PPI are needed in the plane; the weight, therefore, would be considerably less than for an airborne radar, and the radar coverage would be far greater than could be achieved with an airborne set. Where positive identification of a particular plane is required, the plane may be equipped with a beacon.

Since a system of this type would be more useful near an airport than on long flights across open country, the installations might be limited to heavy traffic areas, the present types of navigational systems being used between these areas. A program of comparative tests and further development is needed to work out the proper solution to the airway problems which are already serious when visibility is poor and will increase with the volume of air traffic. At present the problem of navigation is fairly well solved, but the problem of traffic control requires considerable research.

Radar has made a contribution to the instrument-landing problem. Although the AN/MPN-1, shown in Fig. 86, is by no means a complete solution to this problem, it has already safely landed a number of aircraft which would otherwise have been abandoned by parachute. This set is most suitable for use where there is a low ceiling with fair visibility at low altitude, so that the

pilot may make the final touchdown visually. It has, therefore, been nicknamed GCA (ground control of approach). It is a high-resolution search set which is used to locate the plane. The proper approach line and the runway are drawn on a large PPI. There is also a rapid-scan height finder which displays the height of the plane on an RHI. The desired glide path is marked on this tube. A controller verbally tells the pilot how to turn to get on and stay on the proper course, and at the same time gives directions to keep the plane on the desired glide path. When the plane breaks through the overcast, it should be in the proper position for the pilot to take over and land visually. The advantage of this system lies in the fact that no special equipment is needed in the plane. The chief disadvantage is the number of human links in the chain, any one of which may make an error in judgment. A system operating on this principle may become standard airport equipment to take over in the event of failure of a more elaborate system and to handle planes which are not equipped for instrument flying.

Since navigation and aircraft control will be the greatest peacetime uses of radar, a considerable effort will be expended in the next few years in adapting the techniques used on war equipment to the design of suitable sets for these purposes. Military sets were designed for specific purposes and were often rushed into service prematurely; hence, most of them are not immediately adaptable to civilian uses. Suitable radars for ship navigation and collision avoidance are probably more nearly ready for use than those required for the aircraft field where the problem is three-dimensional and speeds are high. Radar for air navigation and traffic control will require considerable development and operational test before commercial use is satisfactory.



EDWIN G. SCHNEIDER

Edwin G. Schneider received the Ph.D. degree in physics from Harvard University in 1934. From 1941 to 1945 he was associated with Radiation Laboratory, Massachusetts Institute of Technology, as systems engineer on SCR-615; leader of a systems group on microwave ground radar; with the Far East Allied Expeditionary Forces in Manila for the Radiation Laboratory; at the British branch of Radiation Laboratory; and connected with the office of the Secretary of War, as a consultant on radar.

Dr. Schneider is now executive vice-president of Stevens Research Foundation, at Hoboken, New Jersey.

Discussion on

“The Steady-State Operational Calculus”*

D. L. WAIDELICH

Nelson F. Riordan:¹ The February, 1946, issue of the PROCEEDINGS contains a paper by D. L. Waidelich, outlining an alleged extension of the complex Fourier transform. He shows that the steady-state response is obtainable by taking the path of integration in the complex frequency plane so as to enclose only the poles on the imaginary axis. It is implied that this method constitutes a new operational calculus.

I should like to point out that Mr. Waidelich's procedure is nothing more than the application of the complex Fourier transform with the path of integration chosen so as to prevent the transient part of the solution from appearing. He goes a long way around to limit the solution to contain only the steady-state terms.

A fundamental theorem of analysis states that any function of a complex variable, whose singularities in the finite plane are no worse than poles, can be expressed as a sum of partial fractions, each term of which places a pole of the function in evidence. Since the inverse transform may be obtained by integrating the partial-fraction expansion term by term, the time response consists of a sum of terms, each of which depends on the location and residue of a pole in the frequency plane. Thus it is possible to suppress any term of the solution by ignoring the pole on which it depends. By distorting the path of integration, any or all terms of the general solution can be suppressed. But to do this deliberately to suppress the transient terms in the solution, without some compensating advantage, is hardly a new operational method.

Any of the operational methods permit determination of the steady-state response alone. We simply ignore the poles in the left half plane, which is to say that we do not bother to evaluate the exponentially decaying terms when we take the inverse transform. This is accomplished by inspection of the function, with no unnecessary labor. Mr. Waidelich does this same thing by distorting the integration path to exclude the unwanted poles; we simply pretend they are not there, and then integrate around the entire half plane in the usual way. The mathematical justification of either method follows directly from Cauchy's theorem.

Inasmuch as Mr. Waidelich disregards the transient portion of the solution, it is not surprising that his direct transform is not unique. Obviously, any functions with the same imaginary axis poles have the same steady-state response, no matter what differences exist between their poles in the left half plane. The elaborate analysis by which Mr. Waidelich demonstrates this in his appendix is scarcely justified.

D. L. Waidelich:² The letter of Mr. Riordan was very interesting to me, and in replying to it I am glad that I have the opportunity at the same time to clarify several points concerning the steady-state operational calculus.

It is a well-known fact of the ordinary operational calculus that if the inverse transform of the operational expression for the current in a circuit is evaluated at certain selected poles, the steady-state current of the circuit results. For any linear-circuit solution involving sinusoidal waves, there are two poles located on the imaginary axis symmetrically placed with respect to the origin that must be used to obtain this steady-state current. For any linear circuit involving nonsinusoidal waves with discontinuities, there is an infinite number of poles on the imaginary axis extending from minus infinity to plus infinity that must be used to obtain the steady-state current. The result in the latter case is always an infinite Fourier series. These facts have been brought out in one of the references³ cited in the paper under discussion. Since the method of this paragraph is the same as that suggested by Mr. Riordan, the Fourier series for the current will always be obtained, but it might be pointed out that there are simpler methods of obtaining the Fourier series for the steady-state current of a circuit.

In applications which require the current wave form rather than the values of the harmonic currents, the Fourier series for the current is often almost useless, and in its place the expression for the sum of the Fourier series is needed. The problem of obtaining the sum function of the Fourier series for the circuit current is the reason for the development of the steady-state operational calculus. There are a number of other methods of obtaining this sum function of the series, and these are covered in the references given in the paper under discussion. The steady-state operational calculus is as general in application as any of these methods, and with the aid of tables of transforms will probably be easier to use than the other methods.

In attempting to apply the ordinary operational calculus to the solution of this problem, it was found that an extension³ of this calculus would give the circuit current as the desired sum function of the Fourier series. This extension was limited in its application to the solution of circuits, for among other reasons there were no general direct and inverse transforms that had been defined. These transforms were defined subsequently as the basic ideas of the steady-state operational calculus.

¹ Iowa State College, Ames, Iowa.

² D. L. Waidelich, "Steady-state currents of electrical networks," *Jour. Appl. Phys.*, vol. 13, pp. 706-712; November, 1942.

* *Proc. I.R.E.*, vol. 34, pp. 78P-83P; February, 1946.
¹ Submarine Signal Company, Boston, Mass.

The inversion theorem presented in the appendix of the paper was used to show that the inverse transform actually erased the work of the direct transform, and vice versa. This may be obvious for a finite number of poles, but it certainly is not obvious if an infinite number of poles is involved. Since the great majority of the applications of this calculus will probably involve functions with an infinite number of poles, it was decided to present the outline of the inversion theorem.

One other point should be made. It was found that the sum function for the current always contained terms which derived from the poles in the left-hand plane; i.e., the poles which normally contribute the transient terms. It is necessary, then, to obtain part of the sum-function expression for the steady-state current from these poles. If Mr. Riordan's suggestion were followed and the poles were ignored, erroneous expressions would result.

Nelson F. Riordan: It is true that evaluation of the function at the poles on the imaginary axis leads to an infinite series, and that expression of the response in closed form may be difficult, but I am not convinced that, in the general case, Mr. Waidelich would not have the same amount of difficulty. The examples given in his article are not of sufficient complexity to demonstrate the advantage of his method.

In the last paragraph of Mr. Waidelich's reply to my criticism, he states that the poles in the left half plane cannot be ignored. I am not quite sure what he means. The periodicity of the function introduces poles at $p=jn\omega$ (the roots of $1-e^{-pT}$), and only these poles contribute to the steady state. Mr. Waidelich makes this

clear in the first page of his paper in defining the path of integration. Since his method depends on subtracting out that part of the function that depends on the poles in the left half plane, he clearly cannot disregard them; but this does not mean that they contribute to the steady state.

But, on the whole, I believe we are in agreement; and, in view of Mr. Waidelich's considerable experience with the steady-state problem, and my own lack of it, I tentatively accept the statement that his method is more direct in obtaining the sum function, and withdraw my objection.

D. L. Waidelich: It is true that the poles $p=jn\omega$ are the only ones that contribute directly to the expressions for the steady-state currents and voltages, but it should be remembered that the poles in the left half plane modify the sizes of the residues at the poles $p=jn\omega$. This fact also affects the sum function in several ways, and one of these ways is that, if there is an infinite number of poles $p=jn\omega$, terms derived from the poles in the left half plane are always present in the expression for the sum function. If for example, there is a pole $p=-a$ in the left half plane, the sum function for the steady-state current or voltage will always contain one term involving the quantity a .

The steady-state operational calculus has been used to good advantage to obtain the sum function (closed form) of the steady-state currents and voltages in circuits involving repeated pulses, saw-tooth, and square wave forms. In the near future it is hoped to present a paper showing how this method may be applied to the solution of rectifier-circuit problems.

Discussion on

“The Image Formation in Cathode-Ray Tubes and the Relation of Fluorescent Spot Size and Final Anode Voltage”*

G. LIEBMANN

Hilary Moss:¹ My attention has recently been directed to a paper by Dr. Liebmann dealing with the above subject. Space hardly permits me to do justice to this contribution, and I hope to publish a detailed reply later. However, in view of the importance of the subject, I feel it desirable to make a brief reply here.

Dr. Liebmann assails the generally accepted view that the spot size of a cathode-ray tube is inversely proportional to the square root of the final anode potential. He reaches the astonishing conclusion that the

spot size is almost entirely independent of the final anode potential.

I feel bound to disagree with this opinion on the following main grounds:

(a) He appears to forget the effect of the final lens (lens No. 3 in his Fig. 2) when he applies the conclusions of his theory based on optical analogy. Thus in his Fig. 3 he refers to B_2 as the virtual cathode image produced by lens No. 2, but he then neglects the action of lens No. 3 in imaging B_2 on the screen. A direct application of the Helmholtz-Lagrange law to lens No. 3 would appear to show that the diameter of the spot focused on the cathode-ray-tube screen varies as $1/\sqrt{V}$

* Proc. I.R.E., vol. 33, pp. 381-389; June, 1945.

¹ Valve Research Laboratory, A. C. Cossor, Ltd., Highbury, England.

where V is the final anode (and therefore screen) voltage. This follows because Dr. Liebmann admits that "the position of the virtual cathode image which is, in turn, imaged on to the screen by lens No. 3, changes only very slightly by comparison with the object and image distances of lens No. 3 if the accelerating voltage is changed."

(b) Dr. Liebmann is indeed skating on thin ice, when he bases his experimental conclusions regarding spot size on *photographs* of traces. The width of the spot or line depends on how one chooses to define it, since it has a Gaussian distribution, and has no sharp edge. When we assert that the spot diameter is inversely proportional to the final anode potential, the "diameter" is being defined as that ring on which the *current* density has fallen to some assigned fraction of the peak density on the axis. But this is far from meaning that the light output from the screen, still less the density of the photographic image, follows the same law.

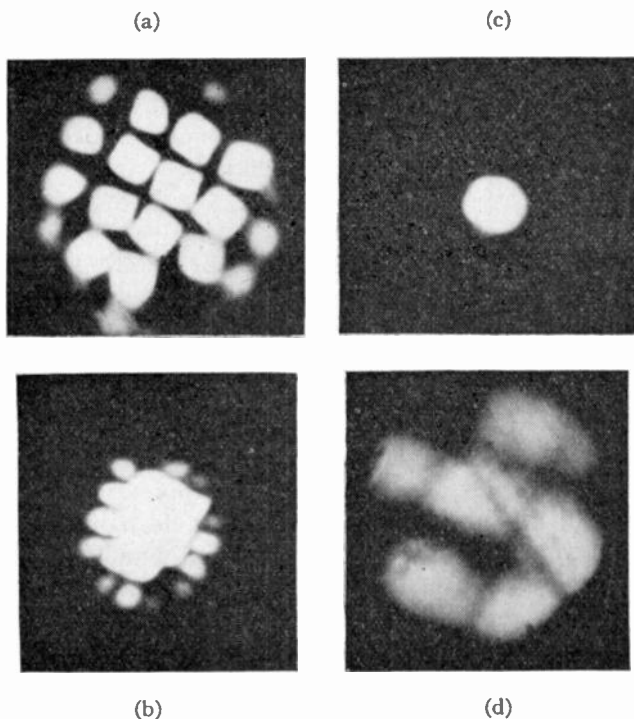

Fig. 1—(a) $VA_2 = 800$
 (b) $VA_2 = 885$
 (c) $VA_2 = 960$
 (d) $VA_2 = 1170$.

Experiments made in these laboratories, to be published elsewhere, have shown excellent agreement with the accepted relationship. The spot diameter in this work was measured by the precise method of "slit scanning" first described by Jacob.³

I find myself in disagreement with many other statements in this paper, but space permits a discussion of only one other point; namely, the question of what it is being focused on the screen of the cathode-ray tube when the spot size is smallest. Dr. Liebmann considers

³ L. Jacob, "Electron distribution in electron-optically focused electron beams," *Phil. Mag.*, vol. 28, pp. 81-98; July, 1939.

that the "object" is really a virtual image of the cathode, whereas conventional belief asserts that it is the "crossover." Dr. Liebmann bases his support for the "virtual-image" theory on the fact that "many cathode-ray-tube spots, when focused for smallest spot diameter, show a greater or smaller amount of structure, which would be impossible if they were images of structureless crossovers, but which is quite consistent with the assumption that the spot on the tube screen is an image of the cathode."

In an endeavor to detect the "greater or smaller" amount of structure in the image, we constructed an entirely conventional electron gun (of the type belonging to system 2 of Dr. Liebmann's Table I). In this gun the cathode surface was covered with a very fine-mesh nickel gauze, the latter being in electrical contact with the cathode. In effect, this device merely divides the cathode surface into a series of emitting "pockets" between the meshes of the gauze, and so gives a definite and characteristic cathode structure. The first and final (third) anodes were joined together and excited at 5 kilovolts. The grid was operated at -3 volts. These figures were held constant while only the second-(focusing-) anode voltage was changed. Fig. 1 shows the resulting patterns visible on the fluorescent screen for four different values of focusing-anode voltage. The optical magnification was held constant.

In Fig. 1(a) the focusing-anode voltage is such as to give too high a voltage ratio for best focus; i.e., the final lens is imaging a plane *nearer* to it than the plane in which the smallest object lies. It is therefore imaging a *real* image of the cathode produced by the triode portion of the electron gun. The effect of the gauze is clearly visible, and the photograph proves that the cathode possesses a characteristic and recognizable structure. In Fig. 1(b) the lens power is somewhat lower and the object plane lies nearer to the crossover. It will be noted that the center of the image is losing its characteristic structure. Presumably, the presence of some residual structure round the edge is due to field-curvature effects. In Fig. 1(c) the second anode voltage is adjusted to give the best focus condition. It will be noted that no structure is now visible. Finally, in Fig. 1(d), there is shown the effect of further raising the second anode potential so as to weaken the lens and focus a plane nearer still to the cathode itself. A rather indistinct image of the cathode face is now beginning to appear, and this becomes more sharply defined as the voltage is raised further.

These experiments, it is submitted, admit of only one interpretation—namely, that the "object" which is being focused when the spot size on the screen is at a minimum lies between the plane of the cathode image (which actually is *very* ill-defined) and the cathode surface. Furthermore, the "object" is structureless. In fact, everything is here consistent with the accepted crossover theory.

Towards the end of his paper Dr. Liebmann states:

"Under certain conditions the fluorescent spot may, therefore, be an image of a structureless space-charge disk, although such high cathode-current densities are not frequently met in practice." The conditions referred to are those of very high emission densities. However, in the experiments illustrated in Fig. 1, the total cathode current was only about 5 microamperes, so that the absence of structure in 1(c) can hardly be ascribed to excessive cathode-current densities.

Finally, I should add that, even if Dr. Liebmann were right in supposing that the spot is an image of the cathode, it appears to me that the accepted spot-size versus anode-voltage law would still hold. Surely the question as to what is the object does not affect the validity of the Helmholtz-Lagrange law?

G. Liebmann:³ In his observations on my recent paper, Dr. Moss appears to make the following criticisms:

- (1) that I forgot the effect of the final lens;
- (2) that the Helmholtz-Lagrange law should be applied, in his opinion, to the final lens (No. 3 in my notation);
- (3) that the photographic method of measuring spot size is inaccurate and that my results do not agree with his own observations;
- (4) that he has not been able to detect a deliberately introduced cathode "structure" in the focused spot of an experimental tube although this could be observed if the spot were defocused; and that, therefore, the focused spot must be an image of the "crossover."

Referring to his first point, I think that I gave as much weight as is appropriate to the effect of the final lens. I stated in my paper with reference to Fig. 4 (which unfortunately is not as clear as desirable owing to the quality of the wartime paper) "the position of the virtual cathode image which is, in turn, imaged onto the tube screen by lens No. 3, changes only very slightly by comparison with the object and image distances of lens No. 3 if the accelerating voltage is changed." The experimental evidence is that this change is of the order of 0.1 centimeter, whereas the object distance of the final lens is of the order of 3 to 5 centimeters in most cathode-ray tubes, and the effect of this change of position of the imaged object on the final spot size should therefore be practically negligible. I cannot think of any other effect of the final lens, except of introducing aberrations, as the focusing *voltage ratio* of the electrodes forming an electrostatic final lens remains unchanged if the final anode voltage is altered, and hence the properties of the final lens (No. 3) remain fixed. If the final lens is a magnetic one, it is found that the expected square-root law for the focusing current is well obeyed, indicating again that the optical

properties of the final lens remain almost unchanged.

The effect of aberrations in the final lens may be considerable, and would account, in my opinion, for the frequently observed dependence of the spot size on the final anode voltage; this point was discussed briefly in my paper, on page 385, bottom of right column, and also on page 388, lower part of right column. It may be of interest to discuss the effect of spherical aberration in greater detail.

The diameter d_s of the smallest disk of confusion due to spherical aberration is about⁴

$$d_s = SpM\alpha^3 \quad (1)$$

where S is a dimensionless constant determined by the lens construction and lens power, p the lens-object distance, M the magnification produced by the lens and α the semiangle of the cone of electrons traveling towards the final lens. According to the theory proposed in my paper, a change in final accelerating voltage E_a leaves S , p , and M almost constant, but changes α approximately in proportion to $E_a^{1/2}$. Hence

$$d_s = \text{constant} \times E_a^{-3/2}. \quad (2)$$

If we call, in the absence of spherical aberration in lens No. 3, the diameter of the focused spot d_o , the actually observed diameter would be

$$d = d_o(1 + cE_a^{-3/2}). \quad (3)$$

The constant S has been calculated by Ramberg⁴ for several lens types,⁵ and measurements which I carried out on various types of lenses confirm Ramberg's values. As S , p , M , and α for a given value of E_a , can be measured for each tube, we can determine the constant c in our equation (3) by experiment. Its value is near 0.3 for most average tubes for *small beam currents*, if $E_a = 1$ kilovolt, varying between approximately 0.1 and 1.0, depending on the design of the electron gun, the physical dimensions of the tube and final lens, and whether electrostatic or magnetic focusing is employed. c depends also rather strongly on the beam current, although its increase with beam current is a function of the gun design. It may also be noted that this increase of the constant c with beam current appears to be a major factor contributing to the defocusing of tubes at high beam currents (or "blooming," as Dr. Bachman called this effect in a recent paper).^{6,7} To give a quantitative example, tube No. 1 of my paper, which was developed in this laboratory in 1938 with a view to reducing the angle α for a given spot size, and so obtaining a higher beam current before defocusing occurs, has a value of $c = 0.10$ at 10 microamperes and

⁴ E. G. Ramberg, "Variation of the axial aberrations of electron lenses with lens strength," *Jour. Appl. Phys.*, vol. 13, pp. 582-594, September, 1942.

⁵ Ramberg calculated a parameter ξ/M which is linked with S by the relation $\xi/M = S(D/f_o)^2$, D being the diameter of the lens, f_o its focal length.

⁶ C. H. Bachman, "Image contrast in television," *Gen. Elec. Rev.*, vol. 48, pp. 13; 1945.

⁷ C. H. Bachman and S. Ramo, "Electrostatic electron microscopy," *Jour. Appl. Phys.*, vol. 14, pp. 8; 1943.

³ Vacuum Research Laboratory, Cathodeon, Ltd., Cambridge, England.

$c=1.0$ at the "defocusing point" with a beam current of 200 microamperes. It was on account of the complication introduced into comparative spot size measurements by spherical aberration that the measurements described in the paper were carried out at low beam currents where its effect is marked only at low accelerating voltages. The influence of spherical aberration is shown in Fig. 2 as function of E_a and c . The same representation is chosen as in Fig. 6 of my paper, the definition (proportional to reciprocal spot size) being chosen as 100 lines for $E_a=1$ kilovolt. With the assumption that d_0 , the spot size determined with disregard of spherical aberration, should be practically independent of E_a , this graph demonstrates the following interesting facts: if spherical aberration is small ($c \leq 0.1$), the spot size increases below approximately 1 kilovolt, but remains practically constant above this voltage. With moderately great spherical aberration ($0.1 \leq c \leq 1.0$) the spot size decreases to some extent with increasing final anode voltage, but reaches eventually a constant value; this is well confirmed by experiment. For large aberration values ($c > 1.0$), the decrease of spot size with increase of anode voltage is very pronounced. One can also see that, for moderately large aberration values, over a fairly wide range of voltages, say 5:1, the decrease in spot size may be within approximately 10 per cent of that predicted by the "crossover" theory under quite different premises. The graph, Fig. 2, refers to the simple case of a gun without a beam

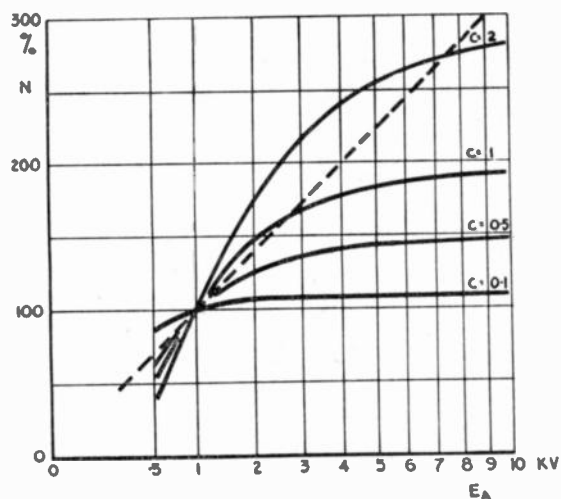

Fig. 2.—Definition (reciprocal spot size) as function of final anode voltage E_a in the presence of spherical aberration for constant primary spot size d_0 , as predicted by new theory. Dashed line represents square-root law as predicted by "crossover" theory.

stop. If a stop is employed, matters become rather more complicated, and the radial current distribution in the electron beam has to be taken into consideration.

Returning now to the other points raised by Dr. Moss, the final lens is not at all concerned in the operation of Helmholtz-Lagrange's law as $E_{a2}/E_{a1} = \text{constant}$. It is the lens No. 2, formed by the field between the first and second anodes, where Helmholtz-Lagrange's law

applies. This assumption forms the basis of my theory, and is discussed in detail in the paper (pp. 382-384).

Dr. Moss's criticism of the use of the photographic method seems unjustified. The photographic method was chosen because the equipment was available and because it allows the taking of comparative measurements on tubes of different origin. (The experiments at first were intended as investigation of how far the new theory was applicable to tubes of less common design.) As stated in my paper, the spot-size measurements are based on *brightness* values, not on density values. The brightness-density relationship was checked several times during the progress of the investigation, and the required precautions, as the same batch of plates, the same developer, the same developing time, the same developing temperature, and approximately equal maximum density, were scrupulously observed. This leaves the beam current brightness relationship. From numerous measurements of screen characteristics carried out in this laboratory, this relationship was well known for all tubes concerned in this investigation. This relationship is for most tubes nearly linear up to the peak brightness used in these experiments, the deviation owing to current saturation amounting to approximately -10 per cent. In an investigation of a *change* of spot size with a change of anode voltage we should obtain only a falsification of results if this small amount of current saturation should change appreciably with the accelerating voltage; however, this variation amounts only to approximately 2 to 3 per cent. I consider, therefore, that the error in my determination of the spot size is not greater than ± 10 per cent, as stated in the paper. This is certainly quite small compared with the change of 300 per cent predicted by the old theory. No considerable difference should be found with results obtained by other methods. Dr. Moss's claim of having confirmed experimentally the square-root law is rather surprising to me, and contrary to results obtained on many different tubes in this laboratory (including tubes made by the Cossor company). Or should spherical aberration as shown in the graph, Fig. 1, have played a part in Dr. Moss's investigation?

The experiment demonstrated by Fig. 1 of Dr. Moss's letter is interesting, but I was acquainted with results of this kind. Indeed, it was such observations which made me suppose that the object imaged onto the tube screen is an intermediate image of the cathode, although a very poor one. The image projected onto the tube screen in the under-focused position (lens voltage too high) is inverted, as can be shown easily by using an asymmetrical test object; e.g., a letter scratched into the cathode surface, as was done in my own experiments. If the lens voltage is lowered beyond the focusing value, the final image reappears upright, which means that the imaged object is the *same as before*; change of orientation is due to the fact that the imaging pencils cross each other at the focal point now in front of the tube screen. Similar experiments have been made using

magnetic lenses, and if the final anode voltage is low enough, one can obtain a focused spot twice, or more often, changing the coil current monotonically. It would be difficult to understand why we should in this case first have an image of the intermediate cathode image (starting with a low coil current), then of a crossover, then of the cathode image again, then again of the crossover, then again of the intermediate cathode image, etc. The problem is, then, why does the "structure" of the cathode image disappear at the point of best focus? It seems to me that, except in very special circumstances, the effects of chromatic and spherical aberrations in lens No. 1 (where they are very strong owing to the large aperture used), of spherical aberration in lenses No. 2 and No. 3, of light scattered in the crystals of the fluorescent screen, and of space charge in the beam taken together may very well account for the observed fact, even if other lens aberrations as coma or astigmatism are absent. It was noticed that in a few cases of tubes with very uneven cathode emission some trace of structure appeared to be still there at the point of best focus, although I feel that my remark that "many tubes show structure" may have been too rash.

The radial current distribution in a "crossover" should be described by the law $i = i_0 e^{-E_0^2}$. But Dr. Moss himself demonstrates remarkably well with Fig. 1(c) that the best focused spot cannot be an image of a crossover as his photograph shows the same clear cut edge as Fig. 7 of my paper.

Hilary Moss:¹ Dr. Liebmann's attempt by appeal to aberration theory to explain my objection to his views on final-anode voltage versus spot size relation is interesting, but I am afraid that I must return to my original attack, and in more detail.

In Fig. 3 we see a sketch of the electron trajectory in

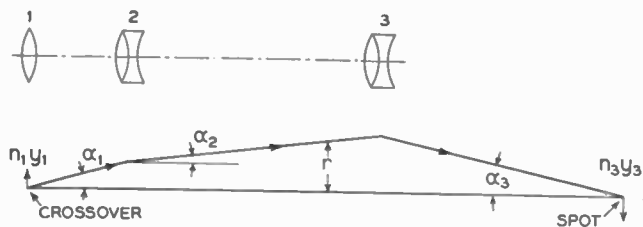

Fig. 3—Application of Helmholtz-Lagrange law.

the lens system he suggests. The Helmholtz-Lagrange law states (for small α)

$$n_1 y_1 \alpha_1 = n_2 y_2 \alpha_2 = n_3 y_3 \alpha_3$$

whence

$$y_3 = \frac{n_1 y_1 \alpha_1}{n_3 \alpha_3} \quad (4)$$

Now we are considering the case when conditions on the triode (i.e., cathode, grid, and first anode) are constant. Hence n_1 , y_1 , and α_1 are constant and so from (4)

$$y_3 = \frac{K}{n_3 \alpha_3} \quad (5)$$

From Fig. 3 we see that α_3 is proportional to α_2 .

In brief, Dr. Liebmann now asserts that α_2 is proportional to $1/n_3$, so that from (5) the spot size y_3 is constant. As it appears to me, there is no more *a priori* justification for this view than there is for the substitution $\alpha_3 = \text{constant}$, which makes y_3 proportional to $1/n_3$.

Everything will depend on the nature of the n_3/α_2 relationship, and this, in turn, depends on the electrode geometry in the A_1/A_2 lens region. I fail entirely to see how Dr. Liebmann justifies his equation (10), for in his derivation this lens geometry appears to be ignored.

I assume that in applying his (10) the first anode voltage is constant. Let it be E_{a1} . Then according to (10), $E_a \rightarrow 0$, $r \rightarrow \infty$ which is impossible and contrary to observation. For as E_a steadily decreases, the second anode voltage (say E_a/k) becomes less than E_{a1} and the action of the A_1/A_2 lens (his No. 2) again becomes convergent and hence r decreases. In fact r is a maximum when $E_a/k = E_{a1}$, for then the lens No. 2 disappears. But Dr. Liebmann's (10) is quite at variance with these facts.

A typical experimental plot of the variation of r with E_a/k is shown in Fig. 4. This clearly shows the *quite general principle* that r is a maximum when $E_a/k = E_{a1}$ and also shows that r does not vary very much with E_a/k provided the ratio kE_{a1}/E_a lies between about 1/3 and 3. It is this last fact which provides justification

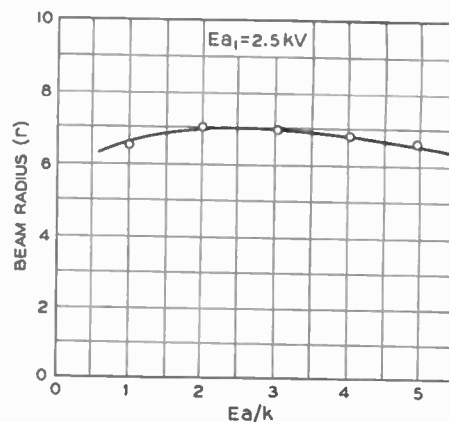

Fig. 4—Experimental plot of the variation of r with E_a/k .

for the classical assertion that α_2 is constant so that $y_3 \propto 1/n_3$, but, of course, the relation is only an approximation. The fact that Dr. Liebmann finds his (10) verified in the experiment illustrated in his Fig. 8 would appear to be coincidental and there is no justification for generalization.

I hope he will not interpret my own contribution as a suggestion that the spot size is *always* proportional to $1/\sqrt{E_a}$. Again, that is true only when the A_1/A_2 lens is weak and I merely suggest that this condition is fairly general in cathode-ray tubes.

(2) *Marked-Cathode Experiment*

With regard to Dr. Liebmann's views on my experiment with the marked cathode, I can only reiterate that everything is there consistent with the accepted theory. His "interpretation" is admittedly quite permissible, but nevertheless remains an interpretation and requires additional postulates for which there is no direct evidence.

(3) *Photography*

The weight of my objection to Dr. Leibmann's deductions based on photographic investigation of spot "size" could hardly have been better demonstrated than by his closing paragraph. My photograph (Fig. 1(c)) has a remarkably "clear-cut edge" but is nevertheless a photographic reproduction of a spot having a current-density distribution illustrated by the photograph in Fig. 5. The latter was obtained directly from the "slit-scanning" experiments referred to in my first letter, and is for an identical gun run under identical conditions to that used to obtain Fig. 1(c)

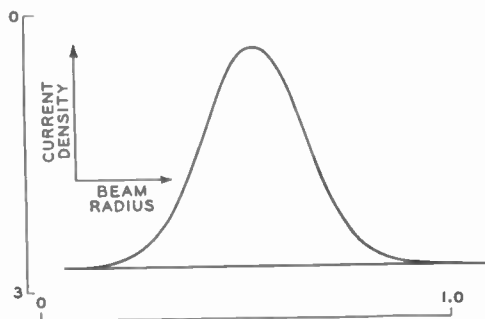

Fig. 5—Current-density distribution obtained by "slit-scanning" experiments.

It shows the almost perfect Gaussian distribution which the crossover theory requires.

Incidentally, Dr. Liebmann's comparison with his

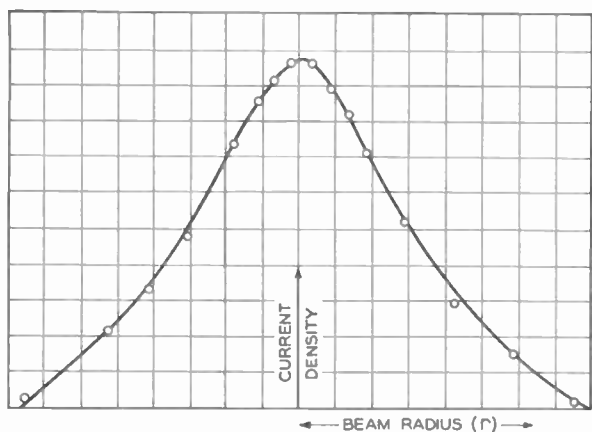

Fig. 6—Experimental plot of current distribution obtained by "hole-scanning" method.

Fig. 7 seems irrelevant. The current distribution in Fig. 7 is that which obtains at the cathode image and has a much sharper edge. An experimental plot is shown in

Fig. 6. Again this was obtained with a "hole-scanning" method. I am unable to understand why he should identify the shape of the current-density distribution at the crossover with that which obtains at other sections of the beam.

G. Liebmann:⁸ I entirely agree with most of Dr. Moss's remarks on the application of the Helmholtz-Lagrange law as given in his second letter. Equation (10) of my paper was derived under the clearly stated assumption $|(n_2/n_1 - 1)p_1| \ll \rho$, and the subsequent discussion of the equivalent optical system of the cathode-ray tube showed that there is good reason to assume that this condition is usually fulfilled there, but no claim to an "a priori" justification was made. The experiments described in my paper certainly prove that a wide range of cathode-ray-tube designs appear to meet the required condition. It may be noted that in all these tubes Ea_1 was of the order of 100 to 250 volts (as prescribed by the makers), much lower than the lowest value of Ea_2 used, whereas the tube with which Dr. Moss obtained his curve, Fig. 4, employed a high value of Ea_1 , of the same order as his values of Ea_2 . If the condition $|(n_2/n_1 - 1)p_1| \ll \rho$ is fulfilled, the beam angle will depend only on n_2/n_1 , and equation (10) and $r^2 Ea_2 = \text{constant}$ will be replaced by $r^2/Ea_2 = \text{constant}$ if⁸ $Ea_2 \ll Ea_1$, the transition region between these two equations being properly described by Dr. Moss's Fig. 4. A three-anode tube with $Ea_1 = Ea_3$ and $Ea_2 < Ea_1$ would require a four-lens optical analogy, as lens No. 2 (in the notation of the paper) splits up into two lenses owing to the appearance of a potential saddle within or near the first anode.

In reply to Dr. Moss's further remarks on "photography," his apparent own disregard of the precautions required to obtain correct results with densitometric photographic methods did not apply to the measurements reported in the paper (this technique is a recognized method of quantitative spectrographic analysis).

Referring to Dr. Moss' last paragraph, he might have seen from my paper that I consider the "crossover" to be identical with the first cathode image produced by the immersion lens in front of the cathode, this cathode image being situated between grid and first anode. Owing to the great depth of focus, I should therefore expect the radial-current distribution *anywhere* in the beam to be closely related to the cathode-current distribution although modified by aberrations. Obviously, the relative influence of aberrations, producing "disks of confusion" around each image point, will be the more marked the smaller the beam cross section, and it will be strongest in the focused spot itself.

As a help in forming an opinion on this matter, I have drawn, in Fig. 7, four radial-current-distribution curves which were brought to the same scale by placing for each curve the point $i_r = 0.5 i_o$ at $r/r_o = 0.6$, the

⁸ Unless Ea_2 is so small that the decelerating lens thus formed focuses the beam near the cross section under consideration.

value of the calculated curve. Curve 1 is the *calculated* cathode-current density⁹ for the electron gun of tube No. 1 ($Ea_0 = 250$ volts, $Eg = -2$ volts, $r_0 = 0.03$ centi-

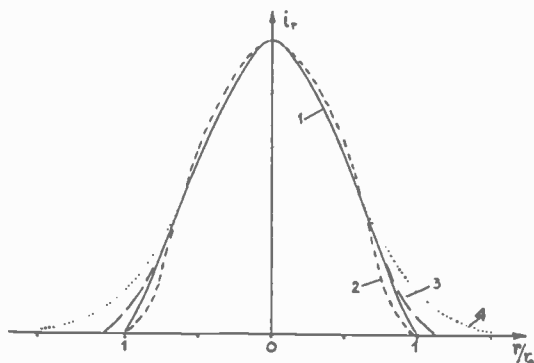

Fig. 7—Radial-current distribution in electron beam. Curve 1: At cathode (calculated). Curve 2: at position of final lens (measured). Curve 3: Same as 1, but corresponding to “slit scanning.” Curve 4: Gaussian distribution.

⁹ Details of the computing method used will be published later.

meter. Curve 2 is the *measured* radial-current-density distribution of the beam at the position of the midplane of the final lens ($Ea_1 = 250$ volts, $Eg = -2$ volts, $i_{a2} = 200$ microamperes, $Ea_2 = 1000$ volts, $r_0 = 0.80$ centimeter). Curve 3 would be obtained from curve 1 if “slit-scanning” were substituted for “spot scanning,” and curve 4 represents the corresponding Gaussian distribution. The current distribution of the *ideal cathode image* is fairly similar to a Gaussian curve except for the sharp cutoff, and the always present aberrations will make it resemble the Gaussian curve to a still greater extent. It is easily possible to “synthesize” a Gaussian current distribution in this way, and it is not permissible to deduce from an experimentally found “Gaussian distribution” in the focused spot that the current distribution in the original object is truly Gaussian.

In conclusion, the experimental evidence would appear to me rather heavily weighted against the “crossover” theory, but further investigations may, perhaps, lead to a more direct way of deciding the issue.

Correspondence

Correspondence on both technical and nontechnical subjects from readers of the PROCEEDINGS OF THE I.R.E. and WAVES AND ELECTRONS is invited, subject to the following conditions: All rights are reserved by the Institute. Statements in letters are expressly understood to be the individual opinion of the writer, and endorsement or recognition by the I.R.E. is not implied by publication. All letters are to be submitted as typewritten, double-spaced, original copies. Any illustrations are to be submitted as inked drawings. Captions are to be supplied for all illustrations.

Who Invented the Butterfly Circuit?

I read with much interest Mr. Landman's letter regarding the “Butterfly Circuit” in the February, 1946, issue of PROCEEDINGS. A large number of patents have been issued in the past which remind us of this circuit (patent No. 2367681), or at least of the underlying principles for this circuit. It occurred to me that I should write you about some butterfly-type circuits which I made as early as 1936. I am not able to prove this statement with a patent, but I described some of my tuners, which had simultaneously variable inductive and capacitive elements and no sliding contacts, to Professor Erik Loefgren, head of the radio engineering department of the Royal Institute of Technology in Stockholm, who may recall them if he happens to read these lines. Also, some of the tuners were described in notes and drawings, but at present I am unable to say if this material has been preserved.

One of my tuners was shaped as a cylindrical spring with rectangular cross section which spring could be contracted axially by means of a tuning dial gear. This ultra-high-frequency tuner gave reasonably good frequency range and Q value. Another tuner utilized the cylindrical spring but had, in addition, a moving vane of a variable capacitor applied at the end so as to give maximum capacitance to the flat surface of the last turn in one position, and minimum capacitance and inductance (damping of the electromagnetic field) in the other position; the reduction of inductance being caused by the restriction of magnetic flux area. A third circuit represented a different solution to the problem, which solution I prefer not to reveal at present. A fourth circuit was the one described below with reference to Fig. 1. In this symmetrical circuit the rotor is adjustable through an angle of 180 degrees to a position in which the rotor is interleaved to the maximum extent with the stator elements. The farthest stator

element (shown dotted in reduced size) is separated a short distance, the approximate thickness of the moving vane, from the front one. It should be noted that my tuner provides a continuous capacitance variation over the tuning range 0 to 180 degrees.

While collecting available notes about my ultra-high-frequency tuners, I have found some sketchy records dated August 3 and December 29, 1940, and January 10, January 14, and February 29, 1941, as well as later ones. The notes of January 10 and 14, 1941, show the invention conceived by myself in 1936 (see Fig. 1). This circuit corresponds to the semibutterfly circuit shown by Figs. 1 and 2, in patent 2,367,681. My practical designs never extended to true “butterflies,” but such extension is indicated in my notes dated February 29, 1941, and is made possible by using the design in the patent, Fig. 1, as an intermediate step. I gave to the director of Cruft Laboratory, for their file, a description with drawing similar to the one shown in Fig. 1.

The General Radio patent was filed December 10, 1941, but independent work must have been done by the General Radio engineers much earlier. I submit this letter merely as a document of academic interest. In 1936 I was not foresighted enough to see the importance of these inventions, while the skill and knowledge of the General Radio engineers permitted them to proceed directly to the valuable “butterfly” patent. I think my friends Karplus and Peterson of the General Radio Company, who are responsible for the original work presented by patent No. 2,367,681, made an excellent high-class engineering job out of it.

HARRY STOCKMAN
Chief, Communications Laboratory
Air Matériel Command, Army Air Forces,
Cambridge 39, Mass.

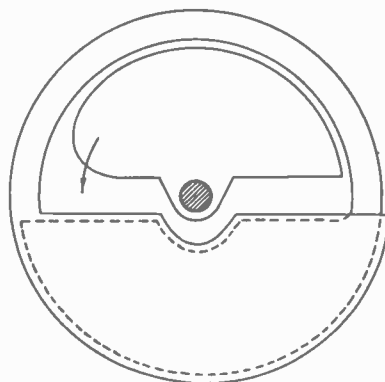

Fig. 1.

I.R.E. People



FREDERICK W. GROVER

FREDERICK W. GROVER

Frederick W. Grover (M'17-SM'43), professor of electrical engineering at Union College, Schenectady, New York, retired on July 1 after serving on the faculty for twenty-six years, first as associate professor and, since 1932, as professor.

From 1899 to 1901, Dr. Grover was assistant in physics and astronomy at Wesleyan University and, during 1901 and 1902, was instructor in electrical engineering at Lafayette College. Thereafter, he served as laboratory assistant, assistant physicist, and associate physicist at the National Bureau of Standards until 1911, when he became head of the physics department at Colby College.

Dr. Grover was affiliated with the Bureau of Standards as consulting physicist from 1918 to 1933 and, during World War I, performed educational work for the Signal Corps. He is one of the authors of the Signal Corps textbook, "Principles Underlying Radio Communication" published in 1918, and the author of *Inductance Calculations*, published in 1946. He is an authority on electrical measurements and electrical-circuit theory, and he has published numerous articles on this subject. Dr. Grover is a Fellow of the American Physical Society and the American Association for the Advancement of Science, a member of Sigma Xi, the American Institute of Electrical Engineers, the Board of Editors and Papers Review Committee of The Institute of Radio Engineers, and a trustee of Dudley Observatory in Albany, New York.



HUGO A. BONDY

Hugo A. Bondy (A'29), formerly assistant chief engineer of WNEW, has been named sales engineer for Altec Lansing Corporation. Mr. Bondy has recently returned from three years overseas with the Office of War Information where he had charge of planning and installing a number of radio stations.

R. A. MONFORT

R. A. Monfort (A'36-SM'45) has become chief television and radio engineer for the Los Angeles *Times*, and presently supervises color-television experimental work in conjunction with the California Institute of Technology.

In 1927, Mr. Monfort served as broadcast station operator for WREN and for WDAF in 1928. The following year, he became equipment engineer for the Western Electric Company, and in 1932, he joined the National Broadcasting Company as broadcast equipment maintenance engineer. Transferred to NBC's development laboratory in 1936 to engage in television development, Mr. Monfort became television-maintenance supervisor in charge of all television-studio plant equipment in 1940. In 1944, he assumed over-all supervision of the NBC television department's personnel and studio facilities.

Mr. Monfort's television work with NBC covered the development, design, construction, test, maintenance, and operation of the New York television plant and also included color television experiments. Specialization in synchronizing generator work and video switching led to several patents, and he designed and built the lap-dissolve and superimposition equipment presently used by NBC. During the war, he performed classified work for the National Defense Research Council which included Project Ring (military airborne television). He was certified by the Committee on Scientific Research Personnel of the War Manpower Commission and acted as instructor for industrial electronics engineers under the Education, Science, and Management War Training program. Mr. Monfort is a member of the Society of Motion Picture Engineers.

DELAYS MAY OCCUR—PLEASE WAIT!

It is intended that the PROCEEDINGS OF THE I.R.E. AND WAVES AND ELECTRONS shall reach its readers approximately at the middle of the month of issue. However, present-day printing and transportation conditions are exceptionally difficult. Shortages of labor and materials give rise to corresponding delays. Accordingly, we request the patience of our PROCEEDINGS readers. We suggest further that, in cases of delay in delivery, no query be sent to the Institute unless the issue is at least several weeks late. If numerous premature statements of nondelivery of the PROCEEDINGS were received, the Institute's policy of immediately acknowledging all queries or complaints would lead to severe congestion of correspondence in the office of the Institute.



L. GRANT HECTOR

L. GRANT HECTOR

L. Grant Hector (A'26-SM'43) has recently been appointed director of research and engineering for the Sonotone Corporation, Elmsford, New York. Author of several textbooks in the field of physics, Dr. Hector was professor of physics at the University of Buffalo. He subsequently became a consulting engineer and, later, director of engineering of the National Union Radio Corporation. Dr. Hector begins his new duties after a period of service with the Office of Scientific Research and Development as engineer in charge of the group responsible for developing the subminiature radio tubes used in the radio proximity fuze.



R. F. SHEA

The appointment of R. F. Shea (A'29-M'32-SM'43) as engineering consultant to advise on technical and engineering problems in the specialty division of General Electric Company's electronics department, Syracuse, New York, has been announced by R. C. Longfellow (A'40), engineer of the division. Mr. Shea joined the company's receiver division in 1937 where he served as section leader on small receivers, and he designed the first line of General Electric Musaphonic receivers.



ROLLIN H. MAYER

Rollin H. Mayer (A'43) has been elected vice-president and general manager of the newly organized St. Louis Microphone Company. From 1937 to 1944, he was a radio engineer with various Government activities, and during the last year of the war, Mr. Mayer served as civilian colonel with the Army Air Forces Operations Analysis division, and as communication consultant to the commanding general, Eleventh Air Force, in the Aleutian Islands.

I.R.E. People

WALTER A. RUSH

The retirement of Walter A. Rush (F'36), controller of the radio division, Department of Transport, Ottawa, Canada, after thirty-four years of Governmental radio work has been announced.

First associated with British firms in the construction of electrical works, Mr. Rush came to Canada in 1905 to join the Marconi Wireless Telegraph Company. He engaged in the construction and operation of the wireless stations at Cape Ray and Cape Race, Newfoundland, which he also supervised. In 1912, he was appointed chief inspector of the Canadian Government Wireless Service of the Department of Naval Services, and throughout World War I, he was responsible for setting up direction-finding stations for detection and location of enemy submarines. In 1922, the Wireless Service was transferred to the then Department of Marine and Fisheries, and Mr. Rush was named division superintendent of radio-telegraph service and later, superintendent. When the Department of Transport was created in 1936, the Government radio service was transferred to it, and Mr. Rush became controller of radio in the air-services branch.

During the war, Mr. Rush attended the the Transatlantic Air-Services Safety Organization Conference in 1942. In 1944 and 1945, he attended the Commonwealth and Empire Conferences on Radio for Civil Aviation, the Commonwealth Communications Council, the Third Inter-American Telecommunications Conference, the Commonwealth Telecommunications Conference, and the Bermuda Telecommunications Conference. Under Mr. Rush's direction, the facilities available for intercepting short-wave radio transmissions from German surface and undersea raiders were provided by the Department of Transport monitoring stations, and the Vancouver monitoring station performed outstanding work in intercepting Japanese transmissions. He was responsible for the construction and development of facilities which provided radio aids to air navigation to meet the requirements of Canada's expanded air force, the British Commonwealth Air Training Plan, the Ferry Command, and the United States Army Air Forces; also for the assignment of frequencies in the radio spectrum required by the Armed Forces and the co-ordination of research to eliminate radio interference in service aircraft, aboard navy ships, and in army vehicles extension of the coastal radio-telephone network of departmental stations in the St. Lawrence River and Gulf for the control of convoy movements was extended. Mr. Rush also served as liaison officer to co-ordinate frequency allocations with the United States, United Kingdom, and Newfoundland authorities.

Formerly vice-president of The Institute of Radio Engineers in 1942, Mr. Rush is a member of the Engineering Institute of Canada, the Professional Engineers of Ontario, and the Professional Institute of the



WALTER A. RUSH

Civil Service of Canada. Early this year, Mr. Rush received the Professional Institute's medal for outstanding contributions to international or world well-being in fields of endeavor other than pure and applied science. In awarding the medal, it was stated that Mr. Rush was the person "responsible for organizing and planning the means of



INSTITUTE MEDAL AWARDED WALTER A. RUSH BY THE PROFESSIONAL INSTITUTE OF THE CIVIL SERVICE OF CANADA

carrying into practical effect the work of the scientists especially in the field of radio and the monitoring of enemy messages and signals."

PAUL D. ZOTTU

Paul D. Zottu (A'31-M'38-SM'43-F'44), consulting electronics engineer of Newton, Massachusetts, recently received the John Wesley Hyatt Award, consisting of a gold medal and half of a one-thousand dollar prize, for outstanding achievement in the plastics industry. The Hyatt Award, sponsored by the Hercules Powder Company, was presented at a dinner given by the Society of the Plastics Industry at the Hotel Commodore in New York City.

JAMES W. MCRAE

James W. McRae (A'37) has been appointed director of radio projects and television research for the Bell Telephone Laboratories, Inc., in New York City.

Associated with the Laboratories since 1937, Dr. McRae undertook research on transoceanic radio transmitters at the Deal, New Jersey, plant. In 1940 he turned to a study of microwave techniques, their use in radio-relay systems, and to the construction of a microwave communications transmitter for the National Defense Research Committee. This was followed by a general study of radar possibilities and subsequent investigation of microwave radar components.

Commissioned a major in the Army Signal Corps in 1942, Dr. McRae was assigned duty in the engineering and technical service of the office of the Chief Signal Officer in Washington, D. C., where he served for two years and was instrumental in initiating and expediting programs for airborne jammers and countermeasures. He was responsible for liaison activities on technical matters with the Navy and British services and was later transferred to headquarters of the Signal Corps Engineering Laboratories at Bradley Beach, New Jersey, to become chief of the engineering staff.

Dr. McRae has recently been released from active duty as a colonel where his last assignment was as deputy director of the engineering division of the Signal Corps Engineering Laboratories. In recognition of his services, the Legion of Merit medal was awarded to him.

CYRUS T. READ

Cyrus T. Read (A'43) has been appointed supervising buyer of electronic equipment for Montgomery Ward and Company, Chicago, Illinois. During World War II, he served as radio engineer and administrative officer with the Army Signal Corps; supervisor of the Burr, Bancroft, and Spry Signal School; Signal Corps representative at the University of Chicago; and assistant director of the Chicago Radar School. Well known for his articles on amateur radio, Mr. Read begins his new duties after resigning his position on the engineering staff of the Hallicrafters Company.

J. ALBERT WOOD

J. Albert Wood (A'35-SM'45) has joined the Thayer School faculty of Dartmouth College as assistant professor of electrical engineering. He will supervise the installation of new electrical laboratory equipment at Thayer and will direct the electronics work in the school's new electrical engineering course. Formerly assistant director of the Radar School at the Massachusetts Institute of Technology, Dr. Wood joined the MIT faculty in 1935.

I.R.E. People



Blackstone Studios

GEORGE W. BAILEY

GEORGE W. BAILEY

George W. Bailey (A'38-SM'46), executive secretary of The Institute of Radio Engineers, recently was re-elected president of the American Radio Relay League and of the International Amateur Radio Union at the annual meeting of the Board of Directors of ARRL. Mr. Bailey formerly held the position of chief of the Scientific Personnel Office of the Office of Scientific Research and Development.



VIRGIL M. GRAHAM

The appointment of Virgil M. Graham (A'24-M'27-F'35) as manager of technical relations for Sylvania Electric Products, Inc., New York City, was announced by E. Finley Carter (A'23-F'36), vice-president in charge of engineering. Formerly manager of the industrial apparatus plant in Williamsport, Pennsylvania, Mr. Graham will be responsible for maintaining close liaison with advertising and public relations, and he will direct the company's activities with professional and technical associations and gather information on engineering develop-



VIRGIL M. GRAHAM

ments for use on a company-wide basis. Mr. Graham joined Sylvania's engineering staff eleven years ago.

Active in the Radio Manufacturers Association from its inception, Mr. Graham has been an associate director of the engineering department since 1942. He is a director of The Institute of Radio Engineers and has served as chairman of its Rochester Fall Meeting Committee since 1929. Mr. Graham is a member of the Institute of Radio Engineers of Australia, the Acoustical Society of America, the Society of Illuminating Engineers, the Société des Radioélectriciens, and the Rochester Engineering Society.



LEO L. BERANEK

On June 3, Leo L. Beranek (S'36-A'41-SM'45) was awarded the honorary degree of



LEO L. BERANEK

Doctor of Science by Cornell College, Iowa, in recognition of his achievements in theoretical and applied acoustical science and contributions to the literature of acoustics.

During World War II, Dr. Beranek directed the electroacoustic and systems research laboratories at Harvard University where a staff engaged in the quieting of combat vehicles, the study of voice-communication systems, the development of sound-locating devices, and the improvement of radar, radio, and telephone communication systems. In 1944, he received the biennial award of the Acoustical Society of America in this connection, and since February 1, has held a Guggenheim Fellowship jointly at the Massachusetts Institute of Technology and Harvard University.

Dr. Beranek is a member of the American Institute of Physics and Sigma Xi, a Fellow of the Acoustical Society of America, and a member of its executive council. Chairman of the American Standards Association subgroup in fundamental acoustical measurements, Dr. Beranek is co-author of "Principles of Sound Control in Airplanes" published by the National Defense Research Committee.



HARRY H. SCHWARTZ

HARRY H. SCHWARTZ

Harry H. Schwartz (S'38-A'39-VA'39-M'45) has joined the engineering department staff of Dee Electronics, Ltd., Montreal, Canada, as chief engineer. He will engage in the development of audio-frequency transformers, audio amplifiers, and other electronic equipment.

A graduate of McGill University in 1938 with a degree of B.E.E., Mr. Schwartz received his S.M. degree in communications from Massachusetts Institute of Technology in 1942. He first served the Canadian Marconi Company as radio design engineer, engaged in radio-receiver work and the design of all iron-core components. In 1942, he joined the Northern Electric Company's engineering department, electronics division, to work on general radio design, including frequency-modulation communicating systems and traffic-signal equipment. Later, he became affiliated with the audio-frequency group developing amplifiers, and for the past two years he has lectured at McGill University on the design and construction of communication transformers.



RALPH BOWN

Ralph Bown (M'22-F'25) has been



RALPH BOWN

I.R.E. People

named director of research for the Bell Telephone Laboratories, succeeding M. J. Kelly (M'25-F'38) who will serve as executive vice-president. Dr. Bown, associated with the Bell System since 1919, will have charge of the several hundred scientists, engineers, and technicians engaged in fundamental research covering physics, chemistry, wire transmission, radio, and television.

During World War I, Dr. Bown served as officer in charge of radio development work at the Army Signal Corps Radio Laboratories at Camp Vail, New Jersey, where he participated in communications experiments between aircraft and ground by radiotelephone. He then joined the department of development and research of the American Telephone and Telegraph Company where he investigated various aspects of radio broadcasting and ship-to-shore and overseas telephony. In 1934, he was appointed associate director of radio research for the Bell Telephone Laboratories and three years later was named director of radio and television research. Dr. Bown has served as assistant director of research at the Laboratories since 1944.

Recognized for pioneer research and development work in the field of communication engineering, Dr. Bown recently has had charge of the engineering group at the Laboratories which developed the overseas long- and short-wave radiotelephone services of the Bell System, single-side band radiotelephony, the rhombic antenna, the multiple-unit steerable antenna, wave guides, and ultra-high-frequency apparatus. He was president of The Institute of Radio Engineers in 1927, in which year the Institute also honored him with its Morris Liebmann prize in recognition of his distinguished researches into wave-transmission phenomena. A division member and consultant of the National Defense Research Council specializing in radar, Dr. Bown was sent to England in 1941 by the Government to study radar operation under combat conditions. He has also served as expert consultant to the Secretary of War.

PAUL M. GUNZBOURG

Paul M. Gunzbourg (M'43-SM'43), consulting engineer and president of Mac-



PAUL M. GUNZBOURG

Donald International, Inc., was recently presented with a Certificate of Appreciation by the United States War Department. The award was given for Mr. Gunzbourg's "patriotic services in a position of trust and responsibility" during the war in his capacity as consultant to the director of intelligence of the Army Service Forces and "whose advice on matters pertaining to French electrical, chemical, and mineral assets, as well as on problems encountered in connection with occupation, relief, and rehabilitation was of invaluable assistance to the department."

A graduate electrical engineer of the Polytechnical Institute of St. Petersburg, Russia, Mr. Gunzbourg served in World War I as a member of the Supreme Council and Defense of the Imperial Territory and of the Evacuation of War-Menaced Russian Industries three-man board. Until the Russian revolution, he was chief engineer and manager of the Russian Siemens Company under government sequester, and he also worked under the Soviets in the Electrical Trust as publisher and consulting engineer. From 1926 to 1940, Mr. Gunzbourg was executive vice-president and president and general manager of the Belgian and French Siemens Companies. At the beginning of the European war, he served the British government as representative of His Majesty's Office of Works in France.

Mr. Gunzbourg arrived in the United States in 1940 and, in 1941, became president of the Consultant and Suppliers Company of South America, located in New York City. From 1943 to 1945, he served on the Board of Directors of the General Ceramics and Steatite Corporation in New Jersey; was a managing partner of the affiliated Ceracap Associates; and acted as consulting engineer for firms in the communications field.

A licensed professional engineer in New York State, Mr. Gunzbourg numbers among his affiliations membership in the American Institute of Electrical Engineers; the French Society of Electrical Engineers; the Belgian Society of Electrical Engineers; the Inter-

national Conference of Power Grids in Paris, France; and the National Society of Professional Engineers, New York Chapter.

HUGH E. ALLEN

Commander Hugh E. Allen (A'23-M'31-SM'43) has joined the Telephonics Corporation in New York City as manager of electronics engineering and sales.

In 1923, Commander Allen became associated with the General Electric Company working with radio transmitters, carrier-current control, and telephony, and in 1930, he joined the Radio Corporation of America, later having charge of electronic-equipment design in the aviation radio-engineering department. Before entering the Navy, Commander Allen was chief engineer in charge of production for Harvey-Wells, Inc. Since 1943, he has been with the Bureau of Aeronautics, assigned to the radio-electronics branch of the engineering division, where he was in charge of planning the electronic and equipment of all naval aircraft.

Commander Allen is a member of Sigma Tau and an Associate Fellow of the Institute of Aeronautical Sciences.

ROBERT B. ALBRIGHT

The appointment of Robert B. Albright (A'31-SM'45) as principal engineer heading those laboratory operations of the Bendix Radio division of the Bendix Aviation Corporation, Baltimore, Maryland, concentrating on the electrical design of broadcast radio receivers, has been announced by W. L. Webb (A'35-SM'44), director of engineering and research. Mr. Albright will assist D. C. Hierath (A'40-M'45), acting chief engineer of radio and television.

First associated with the Radio Corporation of America, Mr. Albright later joined the Philco Corporation to engage in export set design and domestic broadcast radio and radio-phonograph development. His fifteen years experience in broadcast radio-receiver design and frequency modulation includes his war activities devoted to radar and ultra-high-frequency transmission and reception

Collective Bargaining for Engineers

A list of references dealing with analyses of, and procedures in, collective bargaining by engineering groups has been prepared. A copy of this list is available to members, on request to the headquarters office of the Institute at 330 West 42nd Street, New York 18, N. Y. and without charge. The subject is of such complexity legally, professionally, and organization-wise that members interested in this topic may find the cited references of assistance to them.

Prospective Authors

The Institute of Radio Engineers has a supply of reprints on hand of the article "Preparation and Publication of I.R.E. Papers" which appeared in the January, 1946, issue of the PROCEEDINGS OF THE I.R.E. AND WAVES AND ELECTRONS. If you wish copies, will you please send your requests to the Editorial Department, The Institute of Radio Engineers, Inc., 26 West 58th Street, New York 19, New York, and they will be sent to you with the compliments of the Institute. It would be greatly appreciated if your requests were accompanied by a stamped, self-addressed envelope.

I.R.E. People



JOHN B. TREVOR, JR.

JOHN B. TREVOR, JR.

John B. Trevor, Jr. (A'42-M'45) has recently received the Navy's Meritorious Civilian Service Award for "outstanding service to the Navy." The citation reads: "For devising methods required to analyze X-ray radiations from radar equipment so that means could be provided for preventing injury to operating personnel." During the war, Mr. Trevor served as civilian engineer on the Naval Research Laboratory staff attached to the fire control division at the Laboratory's Anacostia, D. T., station.



ALLYN W. JANES

Allyn W. Janes (A'43) is now associated with Gawler-Knoop, Inc., Newark, New Jersey, as sales engineer. Formerly test engineer for General Electric Company and a member of the Radio Corporation of America's tube-application laboratory, Mr. Janes served as ensign in the United States Naval Reserve attached to the New York Navy Yard.



ARTHUR W. MELLOH

Arthur W. Melloh (A'33-SM'45) has been appointed to the telephone transmission group of Stromberg-Carlson Company and will be responsible for the development of carrier-current equipment. Formerly an instructor at the University of Minnesota and a member of the Automatic Electric Company's development laboratory, Mr. Melloh trained officers and enlisted personnel in the operation and maintenance of underwater sound equipment at the Navy's San Diego radio and sound laboratory during the war.



NAVY COMMENDATIONS

Commendations by the Secretary of the Navy have been presented to Lieutenant Commander H. C. I. Knutson (A'30), United States Naval Reserve, for outstand-

January, 1946, copies of The PROCEEDINGS OF THE I.R.E. and WAVES AND ELECTRONS, in good condition, will be purchased by The INSTITUTE OF RADIO ENGINEERS at 50 cents a copy.

ing performance of duty during the war in the special-devices division of the Office of Research and Inventions, Washington, D. C., and to Lieutenant Commander Ethelbert A. Hungerford, Jr. (A'43), United States Naval Reserve, in the radar section.

Now co-ordinator of engineering of the special devices division, Commander Knutson formerly was associate professor of electrical engineering at Lehigh University. His citation reads: "For outstanding performance of duty as head of the radar section of the special devices division, Bureau of Aeronautics, from August, 1942, to May, 1945. Responsible for organizing and developing the facilities of this activity to meet the needs of the Navy's rapidly expanding airborne electronics program, Lieutenant Commander Knutson originated numerous radar-training devices which have been incorporated in the syllabi in all activities using radar equipment and throughout all stages of the program for training pilots and aircrewmembers in maintenance and operation of radar, including the night-fighter training of pilots. By his initiative, leadership, and expert technical and professional skill in a new field, Lieutenant Commander Knutson contributed materially to the successful prosecution of the war and upheld the highest traditions of the United States Naval Service."

Commander Hungerford serves as chief engineer, radar section, of the special-devices division; prior to his entry into the Navy, he was television broadcast executive with the National Broadcasting Company. The citation presented to him reads: "For outstanding performance of duty as chief engineer and subsequently as assistant head of the radar section, special-devices division, from August, 1942, to May, 1945. Displaying superior technical and professional skill in the unprecedented radar-training program, Lieutenant Commander Hungerford rendered invaluable service in the development and production of numerous devices which have been incorporated in all phases of radar training to meet the needs of the Navy in this program, and in the design and development of a number of devices which include such outstanding equipment as the ground-control interception trainers and constitute an important contribution to the Naval aviation program. His initiative, ingenuity, and conscientious devotion to an important assignment were essential factors in the successful prosecution of the war and reflect the highest credit upon himself and the United States Naval Service."



RECENT DEVELOPMENTS FAVOR EARLY TELEVISION EXPANSION

E. W. Engstrom (A'25-M'38-F'40), vice-president in charge of research of the RCA

Laboratories Division, Princeton, New Jersey, spoke before a meeting of the New York Electrical Society on February 6 in New York City. Mr. Engstrom told his audience that the solution of technical obstacles enables the American radio industry to proceed in establishing unexcelled television broadcast service to the public. He asserted that demonstration of his company's black-and-white, all-electronic television system showed it to be ready for the home.

It was pointed out that color television's stage of advancement lacks too much to be acceptable to the public at present and that a correct aim is to create an all-electronic color system equal in clarity to its black-and-white television system. Mr. Engstrom stated the "musts" that exist before color can be incorporated into a complete television system for the home: the design and development of transmitters and receivers capable of meeting radically new problems in broadcast service; adequate field-testing time; analysis and solution of transmission, reception, and studio-operations problems; industry agreement on technical standards; and final approval by the Federal Communications Commission.

Mr. Engstrom described television's wartime advances since V-J Day. Improved transmitters now are capable of delivering all power necessary on all thirteen channels assigned by the Federal Communication Commission for commercial black-and-white television; new cathode-ray tubes in RCA receivers have gained 50 per cent in light efficiency, thereby increasing brilliance and contrast; a new television camera employing his company's image orthicon is 100 times more sensitive to light than prewar cameras, can "see" by candlelight, and can pick up any event or scene that the human eye can see comfortably. In addition, Mr. Engstrom added, steps are being taken by his company for the use of higher frequencies in television, with an experimental 5000-watt transmitter scheduled to go on the air in New York early this year.



STANDARDIZATION OF SCHOOL SOUND FACILITIES

The Radio Manufacturers Association announces a program for standardizing radio and sound-amplifying equipment in the nation's schools. Tentative specifications were drawn and approved at a recent meeting in Cleveland, Ohio, of the RMA School Equipment Committee, representatives of the National Education Association, the Association for Education by Radio, and the United States Office of Education. The specifications cover central program distributions systems, classroom receiving sets, portable transcription players, speech-input units, and recorders.

The purpose of establishing minimum standards for school radio facilities is to provide a guide in the selection and purchase of sound equipment and to protect the institutions from inferior equipment; the purchase of equipment not designed to meet the kinds of instructional applications in which schools are interested; and the difficulties arising from use of equipment

for applications other than those for which it was intended. RMA officials stated that standardization will encourage exchange of material between various organizations and school groups, thus reducing the costs of radio educational programs.



**Meetings of
Technical Committees
I.R.E.**

ANTENNAS

Date..... June 6, 1946
Place..... McGraw-Hill Building
New York, N. Y.
Chairman..... P. S. Carter

Present

P. S. Carter, *Chairman*
W. S. Duttera D. C. Ports
J. E. Eaton S. A. Schelkunoff
R. B. Jacques J. Schelleng
W. E. Kock G. Sinclair

Work on revision of definitions on Antennas was continued from the last meeting. New ideas and usages developed during the past decade have caused great need for a complete revision of most existing definitions. This was caused especially by the development of the microwave region of the frequency spectrum. A special effort is being made to co-ordinate the definitions with the laws of both radio frequency and optics. The work on Definitions is gradually reaching completion and the efforts of the committee will then be concentrated on Test Methods for Antennas.

ELECTROACOUSTICS

Date..... June 7, 1946
Place..... McGraw-Hill Building
New York, N. Y.
Chairman..... E. Dietze

Present

E. Dietze, *Chairman*
P. N. Arnold A. C. Keller
S. J. Begun H. F. Olson
R. B. Jacques H. H. Scott
E. S. Seeley

Since this was the first meeting of the Committee on Electroacoustics since shortly before the war, a great amount of discussion was necessary in order to outline the aims and program of the committee. The question of duplication of effort was discussed in connection with the work being carried on by American Standards Association, Radio Manufacturers Association, and the Acoustical Society of America. It is felt that there is a need for The Institute of Radio Engineers to fill in the gaps left by the other groups, especially in conjunction with Standards of interest to radio engineers. The following fields of interest will be covered by this committee: Microphones, Loudspeakers and Telephone Receivers, Studio and Livingroom Acoustics, Recording and Reproducing, Underwater Sound, and Super-sonics. It is planned to start by revising and making additions to the existing Standards on Electroacoustics, 1938.

SECTIONS

Chairman

Secretary

	ATLANTA September 20	M. S. Alexander 2289 Memorial Dr., S.E. Atlanta, Ga.
H. L. Spencer Associated Consultants 18 E. Lexington Baltimore 2, Md.	BALTIMORE	G. P. Houston 3000 Manhattan Ave. Baltimore 15, Md.
Glenn Browning Browning Laboratories 750 Main St. Winchester, Mass.	BOSTON	A. G. Bousquet General Radio Co. 275 Massachusetts Ave. Cambridge 39, Mass.
	BUENOS AIRES	Raymond Hastings San Martin 379 Buenos Aires, Argentina
H. W. Staderman 264 Loring Ave. Buffalo, N. Y.	BUFFALO-NIAGARA September 18	J. F. Myers Colonial Radio Corp. 1280 Main St. Buffalo 9, N. Y.
T. A. Hunter Collins Radio Co. 855—35 St., N.E. Cedar Rapids, Iowa	CEDAR RAPIDS	R. S. Conrad Collins Radio Co. 855—35 St., N.E. Cedar Rapids, Iowa
Cullen Moore 327 Potomac Ave. Lombard, Ill.	CHICAGO September 20	D. G. Haines 4000 W. North Ave. Chicago 39, Ill.
J. D. Reid Box 67 Cincinnati 31, Ohio	CINCINNATI September 17	P. J. Konkle 5524 Hamilton Ave. Cincinnati 24, Ohio
R. A. Fox 2478 Queenston Rd. Cleveland Heights 18, Ohio	CLEVELAND September 26	Walter Widlar 1299 Bonnieview Ave. Lakewood 7, Ohio
E. M. Boone Ohio State University Columbus, Ohio	COLUMBUS September 13	C. J. Emmons 158 E. Como Ave. Columbus 2, Ohio
Dale Pollack Templeton Radio Corp. New London, Conn.	CONNECTICUT VALLEY September 19	R. F. Blackburn 2022 Albany Ave. West Hartford, Conn.
R. M. Flynn KRLD Dallas 1, Texas	DALLAS-Ft. WORTH	J. G. Rountree 4333 Southwestern Blvd. Dallas 5, Texas
J. E. Keto Aircraft Radio Laboratory Wright Field Dayton, Ohio	DAYTON September 19	Joseph General 411 E. Bruce Ave. Dayton 5, Ohio
H. E. Kranz International Detrola Corp. 1501 Beard Ave. Detroit 9, Mich.	DETROIT September 20	A. Friedenthal 5396 Oregon Detroit 4, Mich.
N. L. Kiser Sylvania Electric Products, Inc. Emporium, Pa.	EMPORIUM	D. J. Knowles Sylvania Electric Products, Inc. Emporium, Pa.
E. M. Dupree 1702 Main Houston, Texas	HOUSTON	L. G. Cowles Box 425 Bellaire, Texas
H. I. Metz Civil Aeronautics Authority Experimental Station Indianapolis, Ind.	INDIANAPOLIS	V. A. Bernier 5211 E. 10 Indianapolis, Ind.
R. N. White 4800 Jefferson St. Kansas City, Mo.	KANSAS CITY	Mrs. G. L. Curtis 6003 El Monte Mission, Kansas
B. S. Graham Sparton of Canada, Ltd. London, Ont., Canada	LONDON, ONTARIO	C. H. Langford Langford Radio Co. 246 Dundas St. London, Ont., Canada
Frederick Ireland 950 N. Highland Ave. Hollywood 38, Calif.	LOS ANGELES September 17	Walter Kenworth 1427 Lafayette St. San Gabriel, Calif.

Chairman

L. W. Butler
3019 N. 90 St.
Milwaukee 13, Wis.
J. C. R. Punched
Northern Electric Co.
1261 Shearer St.
Montreal 22, Que., Canada
J. T. Cimorelli
RCA Victor Division
415 S. Fifth St.
Harrison, N. J.
W. A. Steel
298 Sherwood Dr.
Ottawa, Ont., Canada
Samuel Gubin
4417 Pine St.
Philadelphia 4, Pa.

W. E. Shoupp
911 S. Braddock Ave.
Wilkesburg
C. W. Lund
Rt. 4, Box 858
Portland, Ore.
A. E. Newlon
Stromberg-Carlson Co.
Rochester 3, N. Y.
S. H. Van Wambeek
Washington University
St. Louis 5, Mo.

David Kalbfell
941 Rosecrans Blvd.
San Diego 6, Calif.

R. V. Howard
Mark Hopkins Hotel
San Francisco, Calif.
E. H. Smith
823 E. 78 St.
Seattle 5, Wash.

H. S. Dawson
Canadian Association of
Broadcasters
80 Richmond St., W.
Toronto, Ont., Canada

M. E. Knox
43-44 Ave., S.
Minneapolis, Minn.

F. W. Albertson
Room 1111, Munsey Bldg.
Washington 4, D. C.

W. C. Freeman, Jr.
2018 Reed St.
Williamsport 39, Pa.

K. G. Jansky
Bell Telephone Laboratories,
Inc.
Box 107
Red Bank, N. J.
C. W. Mueller
RCA Laboratories
Princeton, N. J.

H. E. Ellithorn
417 Parkovash Ave.
South Bend 17, Ind.

W. A. Cole
323 Broadway Ave.
Winnipeg, Manit., Canada

MILWAUKEE

MONTREAL, QUEBEC
October 9

NEW YORK
October 2

OTTAWA, ONTARIO
September 19

PHILADELPHIA
October 3

PITTSBURGH
September 9

PORTLAND

ROCHESTER
October 17

St. LOUIS
Vice Chairman
R. L. Coe
KSD
Post Dispatch Bldg.
St. Louis 1, Mo.

SAN DIEGO
September 3

SAN FRANCISCO

SEATTLE
September 12

TORONTO, ONTARIO

TWIN CITIES

WASHINGTON
September 9

WILLIAMSPORT
September 4

SUBSECTIONS

MONMOUTH
(New York Subsection)

PRINCETON
(Philadelphia Subsection)

SOUTH BEND
(Chicago Subsection)
October 17

WINNIPEG

Secretary

E. T. Sherwood
9157 N. Tennyson Dr.
Milwaukee, Wis.
E. S. Watters
Canadian Broadcasting Corp.
1440 St. Catherine St., W.
Montreal 25, Que., Canada

J. R. Ragazzini
Columbia University
New York 27, N. Y.

A. N. Curtiss
RCA Victor Division
Bldg. 8-9
Camden, N. J.

C. W. Gilbert
52 Hathaway Ct.
Pittsburgh 21, Pa.

L. C. White
3236 N.E. 63 Ave.
Portland 13, Ore.

K. J. Gardner
111 East Ave.
Rochester 4, N. Y.

N. J. Zehr
1538 Bradford Ave.
St. Louis 14, Mo.

Clyde Tirrell
U. S. Navy Electronics Labo-
ratory
San Diego 52, Calif.

Lester Reukema
2319 Oregon St.
Berkeley, Calif.

W. R. Hill
University of Washington
Seattle 5, Wash.

C. J. Bridgland
Canadian National Telegraph
347 Bay
Toronto, Ont., Canada

Paul Thompson
Telex Incorporated
1633 Eustis Ave.
St. Paul, Minn.

G. P. Adair
Federal Communications
Commission
Washington 4, D. C.

S. R. Bennett
Sylvania Electric Products,
Inc.
Plant No. 1
Williamsport, Pa.

A. V. Bedford
RCA Laboratories
Princeton, N. J.

J. E. Willson
WHOT
St. Joseph and Monroe Sts.
South Bend, Ind.

C. E. Trembley
CJOB
Lindsay Building
Winnipeg, Manit., Canada

ELECTRON TUBES

Date..... May 14, 1946
Place..... McGraw-Hill Building
New York, N. Y.
Chairman..... R. S. Burnap

Present

R. S. Burnap, *Chairman*
J. W. Greer I. E. Mourontseff
E. C. Homer L. M. Price
S. B. Ingram H. J. Reich
R. B. Jacques A. C. Rockwood
D. E. Marshall C. M. Wheeler

The existing subcommittees were asked to continue their work in 1946 until the present job is completed. The resignations of R. L. Freeman and T. T. Goldsmith, Jr., from this committee were accepted with regrets and thanks extended for the work accomplished by these two members. A general reorganization of the subcommittees and the main committee is contemplated as the nature of the work changes. Material submitted by the subcommittee on Gas Tubes was examined and corrected. It was decided that the subcommittee should revise most of the Methods of Testing before submitting it again to the main committee.

Advanced Developments

Date..... May 10, 1946
Place..... McGraw-Hill Building
New York, N. Y.
Chairman..... A. L. Samuel

Present

A. L. Samuel, *Chairman*
A. E. Harrison E. D. McArthur
G. Hok P. H. Miller
E. M. Houghton T. Moreno
W. H. Huggins L. S. Nergaard
R. B. Jacques E. C. Okress
W. E. Kirkpatrick H. T. Pekin
L. B. Linford R. M. Ryder
W. G. Shepherd

W. G. Shepherd was delegated the responsibility of making some final changes and possible rearrangements of the subject matter to be submitted to the Electron-Tube Committee for issuance as standards on Ultra-High-Frequency Definitions.

The procedure was outlined by which the subcommittee as a whole will proceed on the development of test standards for ultra-high-frequency techniques. The necessary subgroups were organized with the understanding that as much work as they were able to carry out during the summer months would be prepared prior to the next scheduled meeting, tentatively set as September 27, 1946.

ELECTRON-TUBE CONFERENCE

Date..... June 10, 1946
Place..... McGraw-Hill Building
New York, N. Y.
Chairman..... A. L. Samuel
Acting Chairman.... H. J. Reich

Present

H. J. Reich, *Acting Chairman*
J. W. Greer I. E. Mourontseff
R. B. Jacques L. S. Nergaard
G. D. O'Neill

Final plans for the Electron-Tube Conference were completed at this meeting.

NAVY CIVILIAN SERVICE AWARDS

Peter Waterman (S'42-A'45), James J. Fleming (A'42), and Prescott N. Arnold (A'29) have recently received Meritorious Civilian Service Awards for outstanding service to the Navy.

Mr. Waterman, a member of the American Physical Society, is section head in equipment research, missile-control division, of the Naval Research Laboratory, Anacostia, D. C. His citation reads: "For exceptional skill and accomplishments in directing a servomechanisms group which made important contributions to the improvement of Navy gun-fire-control equipment."

A member of the American Physical Society and an Associate Member of Sigma Xi, Mr. Fleming heads the operational research section, missile-control division, of the Laboratory. The citation presented to him reads: "For unusual skill and exceptional perseverance in directing the work of a research section in a comprehensive analysis and evaluation of all types of naval anti-aircraft fire-control systems, thereby insuring the Navy that it was procuring the best possible fire-control equipment."

Mr. Arnold heads the Laboratory's research section I, sound division, and is a member of the American Physical Society, the Acoustical Society of America, and the Philosophical Society of Washington, D. C. Before entering the Naval civilian service, he was a physics and communication engineering instructor at Cruft Laboratory, Harvard University. Mr. Arnold's citation reads: "For pioneering work in the development of techniques for underwater acoustic measurements leading to the standardization and superior performance of naval equipment."

◆

WESTON ENGINEERING NOTES

A new bimonthly publication, *Weston Engineering Notes*, has been inaugurated by the engineering laboratories of the Weston Electrical Instrument Corporation. Distributed gratis, the publication will provide application engineering information for users of electrical indicating instruments. Those whose interests include instrumentation problems, will be placed on the mailing list if a request is sent to John Parker, Editor, Weston Electrical Instrument Corporation, Newark 5, New Jersey.

◆

RAYMOND BRAILLARD

Raymond Brailard (F'35) died at his home, 9 rue des Gâte-Ceps, Saint-Cloud, France, on Saturday, October 27, 1945. Mr. Brailard, a Chevalier of the Legion of Honor, was awarded the Croix de Guerre for the period 1914 to 1918.

POLL ON PUBLIC RESPONSE TO
COLOR TELEVISION

Peter C. Goldmark (A'36-M'38-F'42) has expressed confidence in the future public acceptance of color television. He has based his viewpoint in part on the following statement which he has issued:

"Color television, as developed and broadcast daily by the Columbia Broadcasting System, found enthusiastic acceptance by the public as shown by a scientific poll taken by the CBS Television Research Institute. As a test, color television was shown to about 90 owners of black-and-white television sets, picked at random. None of the people chosen were CBS employees.

"The average price the viewers were willing to pay for the color television shown over the black-and-white as they know it, was 34 per cent. They were willing to pay 28 per cent more for color on projection receivers. Only 12 per cent were completely satisfied with black-and-white television. Only one person out of 90 expressed disappointment with color television.

"The demonstrations, of which almost 100 have taken place, were carried out with a commercial ultra-high-frequency television transmitter, with receivers designed to stand up under long use and studio equipment, prototypes of which are now being manufactured.

"Regarding electronic color, one must bear in mind that color television as known today is already 90 per cent electronic. The only nonelectronic components of color television are the means for introducing color filters in the pickup camera and at the receiver. It is important to realize that when electronic color is accomplished, the resulting images can be no better than the color-television pictures of today. The chief reason is that colorimetrically the combination of phosphor and color filters at the receiver have already reached such a high degree of perfection that any further improvement in that direction would be asymptotic.

"Naturally, means for electronic color selection would be desirable. Such an electronic color selector could operate on the standards currently proposed for color television. The considerations which led CBS to the choice of its color standards, took into account all feasible electronic or non-electronic color-selection methods."

◆

AMERICAN STANDARDS ASSOCIATION

The motion that President Llewellyn be authorized officially to invite the American Standards Association to proceed along the lines of establishing a Communication and Electronics Standards Committee (CESC) was unanimously approved at the June 5, 1946, meeting of the Board of Directors. This Committee would assume a role parallel to the Electrical Standards Committee (ESC) with cognizance of those projects dealing with radio communication and electronics; leaving the ESC free to deal with the remaining projects in the electrical field.

Books

Fundamentals of Alternating-
Current Machines, by A.
Pen-Tung Sah

Published (1946) by McGraw-Hill Book Co., Inc., 330 West 42 St., New York 18, N. Y. 460 pages+6-page index+xi pages. 218 illustrations, 5 $\frac{7}{8}$ ×9 inches. Price, \$5.00.

This book is intended primarily as a college textbook but will be found generally useful by other students who have a knowledge of fundamental alternating-current theory and an elementary acquaintance with the complex quantity for the representation of vectors. It is written from the standpoint of the operating engineer rather than the designer, and in recognition of this fact sufficient attention is paid to the usual methods of measuring machine constants to make clear the essential unity of testing methods for alternating-current machinery. The use of per unit quantities is introduced early in the book and used freely thereafter. The theoretical analysis of each type of machine is based on fundamental circuit theory.

The transformer is chosen for treatment first with the idea of tying in with the earlier course in alternating currents. Then follow, in logical order, polyphase induction motors, synchronous generators, synchronous motors, single-phase induction motors, and single-phase commutator motors.

The treatment of each type of machine is introduced by a chapter dealing with physical principles and general descriptive matter. Special chapters are also devoted to methods of starting induction motors and their speed control and to the operation of alternators in parallel. In the theoretical analysis examples are freely introduced in the text to illustrate the use of the fundamental equations, and an ample collection of problems is appended to the book.

As an indication of the thoroughness of the treatment, special mention should be made of the very complete and readable treatment of the subject of the calculation of alternator regulation. Final chapters also give a good coverage of the more advanced topics of unsymmetrical operation by the use of symmetrical components, and the essentials of the theory of transients in alternating-current machines.

In fact, practically everything of essential importance in the modern theory of alternating-current machinery is treated in the moderate compass of this book. The author is to be congratulated on his success in presenting an up-to-date treatment of his subject in such a clear, concise, and readable form.

FREDERICK W. GROVER
Union College
Schenectady, N. Y.

◆

NORTH CAROLINA-VIRGINIA
SECTION

The recommendation of the Executive Committee that the petition for the establishment of a North Carolina-Virginia Section be granted was unanimously approved by the Board of Directors at its June 5, 1946, meeting.

Waves and Electrons Section

Electronics and the Research Physicist

STANLEY V. FORGUE

The techniques of electrical communication are finding an increasing number of novel and useful applications and some of these applications are in fields far removed from radio and wire operations. Their significance is analytically appraised in the following guest editorial, which is based on a more extensive article which appeared in December, 1945, issue of *Engineer Experiment Station News*, published by The Ohio State University.—*The Editor*.

Long before the word "radar" could be mentioned by name publicly, it had become a major factor in bringing about favorable decisions for the Allies in their battles with the enemy. How had a weapon, so potent that military commanders would hesitate to do battle without it, quietly arisen to a place of such importance in so short a time? This had come about principally as a product of the work of trained research and development men in leading industrial radio corporations and in certain industries.

It was indeed fortunate that such men with a sound basic training in physics and mathematics were available; without them the theoretical work guiding the various research programs would have been lacking, while the laboratory work would have been reduced almost to a blind cut-and-try process. Had such a condition obtained, the problems presented by the military forces for investigation would have largely remained unsolved, at least in time to be effective. It may be remarked that not all of the benefits were on the part of the military, for during the war the research man himself has gained experience in producing results of immediate practical use.

A few examples of the more recent scientific developments are illustrative of the diversity of fields of application for the talents of the research man in electronics. The new electron microanalyzer supplements the electron microscope and permits the rapid and accurate identification of atoms in ultra-microscopic particles of matter no larger than 10^{-116} inch in diameter. High-frequency heating has become increasingly important to industry for a wide range of applications. An all-electronic drying system for the bulk reduction of penicillin solutions completes in thirty minutes a vital operation requiring twenty-four hours by previous methods. A new electron-emitting surface promises to have special fields of usefulness not covered by the conventional oxide-coated or thoriated-tungsten cathodes. Both facsimile transmission and frequency modulation have been developed to a commercially usable state of perfection. The introduction of the electron multiplier to the phototube has multiplied its output more than a million times, greatly increasing the usefulness of this important element of electronic control devices.

But the field offering perhaps the greatest challenge is that of television. Black-and-white pictures of high entertainment value are being received regularly in many homes today and with the advent of peace shortly will be available for homes on a mass-production basis. However, many interesting problems in the over-all television field still remain. To cite only one example: mechanical systems of color transmission have demonstrated the usefulness of color in television, but the problem of the development of an all-electronic color system still remains to be solved.

In the field of electronics the research man has ample opportunity to apply his knowledge of electrical, mathematical, and mechanical principles. Here is an area of research in which a thorough understanding of electron optics, of field theory, and of circuit theory is of everyday value to the investigator.



Wanamaker—Underwood and Underwood

Palmer McFadden Craig

Past Secretary-Treasurer, Philadelphia Section, 1946

Palmer McFadden Craig was born on January 29, 1904, in Cherry Hill, Maryland. He was awarded his B.S. in E.E. degree from the University of Delaware in 1927, and was an honors student active in campus affairs.

After graduation, he was first connected with the engineering department of Westinghouse Electric and Manufacturing Company in Pittsburgh, Pa., East Springfield, Mass., and Newark, N. J. Later he was associated with the RCA-Victor Division of the Radio Corporation of America in Camden, N. J., as a radio engineer, and did extensive development work on home radio receivers.

Joining Philco in 1933, Mr. Craig became a senior engineer responsible for many phases of radio receiver design. Until the outbreak of war, he played an important part in numerous important developments in radio, including the design of high-fidelity broadcast and short-wave receivers; development of 1.5-volt tubes for farm and portable radio receivers; improvements in tone controls, automatic volume control and automatic tuning; standardization on glass tubes as against metal; development of loktal and multimu tubes; and the design of built-in aerial systems and antenna selectors.

From 1941 until the end of the war, Mr. Craig's major duties involved the design and development of ultra-high-frequency and microwave radar and radio equipments for the United States Army and Navy, as well as our Allies. Promoted to the position of chief

engineer of the radio division of Philco in 1943, he assumed responsibility for the engineering required in designing for production many of the most important airborne search radar systems, including several for antisubmarine and precision bombing at both high and low altitudes. The famous "Mickey" radar bombsight, for example, was engineered for production under Mr. Craig's direction. He also was in charge of the development of aircraft information-friend-or-foe, radar and loran equipments, the VT proximity fuze, aircraft and tank radio communications equipment, and many other vital wartime projects.

In recent months, Mr. Craig's duties as chief engineer of the Philco radio division have been successfully "reconverted," and his department has designed for production nearly 60 new radio receivers and radio-phonographs in the company's 1946 lines for domestic and export sales. Beyond this major responsibility, moreover, he is continuing to supervise a number of postwar engineering developments in radar and microwave electronics for the War and Navy Departments.

Mr. Craig joined The Institute of Radio Engineers as an Associate Member in 1935 and transferred to Senior Member in 1945. He is now serving as secretary-treasurer of the Philadelphia Section and he is also chairman of the Radio Manufacturers Association engineering committee on broadcast and international short-wave receivers.

Theoretical Response from a Magnetic-Wire Record*

MARVIN CAMRAS†, ASSOCIATE, I.R.E.

Summary—This paper considers the effect of magnetic properties of a record wire on the output level and frequency response of a magnetic recording system. The amount of magnetic energy that can be stored at each wavelength determines the voltage output to be expected from a given translating head. Frequency response for a typical record wire is calculated according to derived relations, and compared with experimental data.

INTRODUCTION

IN RECENT years there has been a revival of interest in magnetic-wire recording. Although machines using wire were tried soon after Poulsen's first experiments in 1898, these recorders did not prove successful because they were clumsy and because of inherent difficulties in recording on round wire. Modern wire recorders have overcome these difficulties.¹ Their portability, ruggedness, and ability to operate under conditions of shock and vibration have made them useful to the armed forces during World War II.

The over-all performance of a magnetic recording system is influenced by a number of variables. In general, the output will be a function of

- (1) linear velocity of the wire,
- (2) diameter of the wire,
- (3) magnetic properties of the wire,
- (4) frequency,
- (5) method of recording (record head),
- (6) method of pickup (pickup head),
- (7) recording-amplifier response characteristic,
- (8) playback-amplifier response characteristic.

While the reproduced wave depends on many factors, it is interesting to study the inherent capabilities and limitations of the record medium. Accordingly, this paper will concern itself with properties of a magnetic wire. It will indicate how the wire is magnetized, and derive equations for determining the magnetism retained at various wavelengths. These will determine final output and frequency response. Only the record is considered, and for the assumptions made the derivations are true regardless of how the magnetism is put on during recording, or picked up for playback.

VOLTAGE OUTPUT

Longitudinal magnetization is used on round wire because transverse records would be affected if the wire rotated on its axis between the time of recording and of playback. A longitudinally magnetized wire is rather convenient for theoretical analysis, and while this paper

limits itself to this type of medium, the derivations could be modified to apply to transverse-recording or flat-record media.

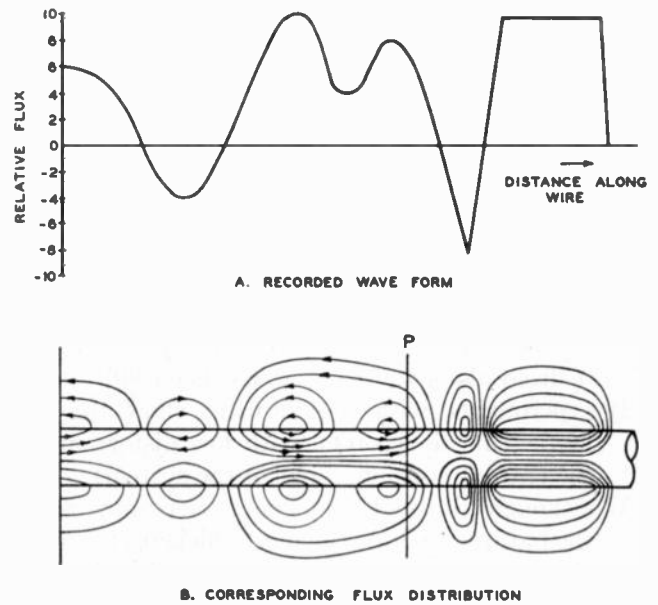

Fig. 1—Flux distribution around a wire record.

Flux distribution around a wire record is pictured in Fig. 1. Several fundamental theoretical relations are apparent from this figure.

- (1) Any complex wave (such as the one in Fig. 1A) can be represented by a corresponding flux distribution.
- (2) The external flux passing through a plane perpendicular to the wire axis at any point P is equal and opposite to the internal flux.
- (3) If the external flux is considered to originate at poles on the wire surface, then the pole strength at any element of surface is proportional to the space rate of change of internal (or external) flux through the corresponding perpendicular plane.

Theoretically, at least, an internal and external space distribution of flux in a wire can be pictured that will represent any arbitrarily selected function. Can such a distribution exist in an actual wire, and how can it be produced? If no limitation is set on the distance scale, a magnetic record corresponding to the wave form of Fig. 1A could be synthesized by taking separate magnets of appropriate strength and placing them end for end over a distance totaling perhaps a hundred feet. Where changes in magnetization take place slowly with respect to distance, the interaction of the magnets with each other to cause demagnetization would be small; and if spread out over a sufficiently great length, such a series of magnets could be made to represent a function to any required degree of accuracy.

* Decimal classification: R365.35. Original manuscript received by the Institute, July 25, 1945; revised manuscript received, March 7, 1946.

† Armour Research Foundation, Illinois Institute of Technology, Chicago, Ill.

¹ M. Camras, "A new magnetic wire recorder," *Radio News*, vol. 30, Radionics Section, vol. 1, pp. 3-5, 39; November, 1943.

When the distance for a recorded wave form is decreased, interaction is no longer negligible. Magnetic poles form where flux enters and leaves the magnets. These poles set up a field which tends to weaken the magnets, and prevents them from retaining their maximum theoretical flux density. The extent to which the magnets are weakened depends upon the material from which they are made, and upon the length and shape of the magnets. The demagnetization is not a simple function of the magnet length, magnet material, or field strength. For this reason, an analysis which attempted to show directly the effects of interaction on a complex wave would become extremely complicated.

The analysis may be simplified considerably by choosing a sine function for the flux distribution along a wire. The justifications for choosing a sinusoidal flux distribution are:

- (1) for very long wavelengths, at least, a sine wave (or any more complicated wave form) can be realized along the wire, as has been indicated;
- (2) experiments with actual wires show that sine waves can be recorded with low distortion over the entire frequency range of the system;
- (3) although sinusoidal magnetization may not be the natural mode or the most efficient one, we can obtain figures for the maximum possible sinusoidal magnetization, and establish a theoretical upper limit for the output at each frequency.

Results of such an analysis are useful in checking against frequency-response measurements made in the laboratory with a sine-wave signal generator for a source of recording signal.

If a magnetized wire is "scanned" by a pickup which is sensitive to the flux at any section, then the output voltage is proportional to the rate of change of flux. On first thought, it might appear that for long wavelengths the output would be decreased by reducing the scanning-gap length. However, with a sinusoidal flux distribution the rate of flux change depends only on the maximum flux, the wavelength, and the wire speed; and is independent of the scanning-gap length.

The output voltage of a pickup device operated by the wire flux can be derived by assuming a sinusoidal distribution of flux as pictured in Fig. 2. The external flux through any section is

$$\phi_E = \phi_M \sin \frac{2\pi}{\lambda} x \quad (1)$$

where ϕ_E = external flux density
 ϕ_M = maximum flux density
 λ = recorded wavelength
 x = distance along wire.

When the wire moves past the pickup aperture with a velocity v , then $x = vt$ and

$$\phi_E = \phi_M \sin \frac{2\pi v}{\lambda} t, \quad (2)$$

$$\phi_E = \phi_M \sin 2\pi ft. \quad (3)$$

where t = time

$f = v/\lambda$ = frequency of the reproduced wave.

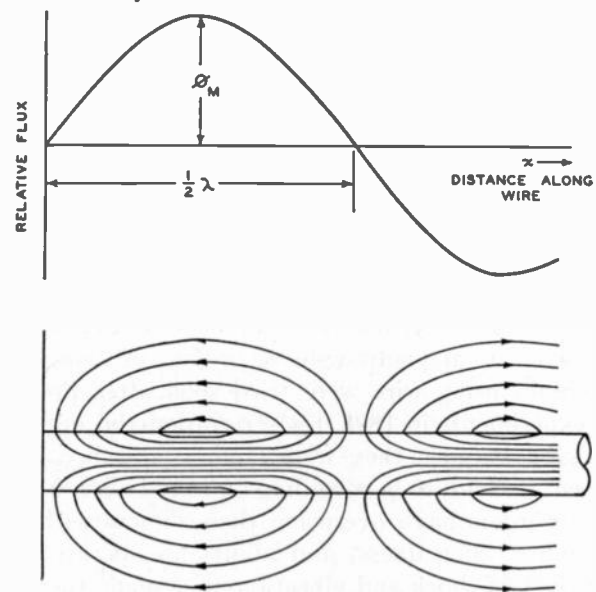

Fig. 2—Sinusoidal flux distribution.

When ϕ_E is caused to link a pickup coil of N turns, the instantaneous value of the induced electromotive force will be

$$E = N \frac{d\phi_E}{dt} = N(2\pi f \phi_M \cos 2\pi ft) \text{ abvolts} \quad (4)$$

and the root-mean-square value will be

$$E_{RMS} = \sqrt{2} \pi N f \phi_M (10^{-8}) \text{ volts.} \quad (5)$$

This is a familiar expression for induced electromotive force, except that the factors have particular meaning described for the case of a magnetized wire. It is interesting to note that this expression shows the output voltage at a given frequency to be independent of wire velocity. It is understood, of course, that the record is recorded and reproduced at the same wire velocity in each case. For higher wire velocities the wavelength is longer for the same frequency, but the flux change is no greater, since ϕ_M defines the maximum flux that the wire can retain at any wavelength.

Suppose each of the variables is considered separately. The output electromotive force is directly proportional to the number of turns N , as would be expected. Mechanical considerations and cost set an upper limit on the number of turns that can be used profitably on a pick-up coil. The use of a relatively low-impedance winding together with a step-up transformer will increase the effective N somewhat, but eventually the distributed capacitance of the windings and shunt capacitance of the vacuum-tube input circuits will put an upper limit to the number of turns.

As long as ϕ_M remains independent of frequency the output voltage is directly proportional to frequency, and the signal will rise 6 decibels per octave.

SELF-DEMAGNETIZATION

The most interesting as well as the most important factor in the expression for electromotive force is ϕ_M . The upper limit for ϕ_M is determined by the residual magnetization value for the wire material. This upper limit is realized only at long wavelengths. As the wavelength is decreased, surface poles along the wire exert a demagnetizing influence, so that the ultimate ϕ_M is a lower value than corresponds to B_R . Fig. 3 is a hysteresis loop typical of a permanent-magnet steel suitable for magnetic recording, with saturation value B_S , residual

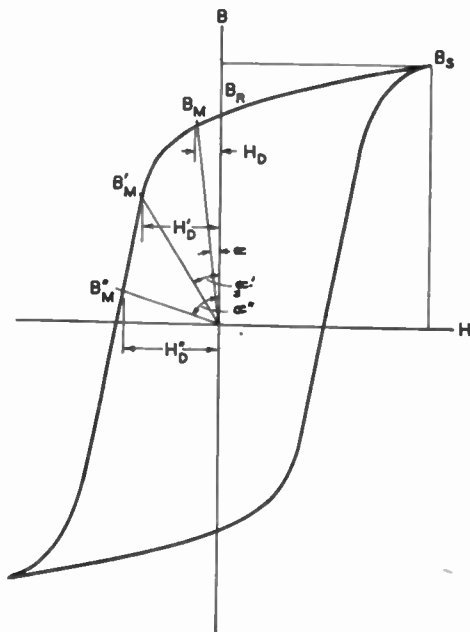

Fig. 3—Magnetization retained by a wire.

magnetization B_R , and demagnetizing field due to surface poles H_D . For a very long bar magnet, the poles are so far away that H_D at the center section is practically zero, and B_M , the magnetization retained at the center of the bar, is substantially B_R . As the magnet is shortened, the demagnetizing field H'_D reduces the magnetization to B'_M . Very short magnets are almost completely demagnetized by a field H''_D which allows a maximum retained flux density of only B''_M . It is obvious that a magnet cannot completely demagnetize itself, since it is the retained flux that causes H_D in the first place.

Since B_M produces H_D , which in turn lowers B_M , the equilibrium point is really the solution of a pair of simultaneous equations. A graphical solution is given in Fig. 3, where one of the equations is the hysteresis loop and the other equation is a straight line through the origin

$$H_D = -DB_M. \tag{6}$$

D is a constant depending on length of the magnet. This constant has been calculated for long ellipsoids by

Thompson,^{2,3} but his results do not apply to a continuously magnetized wire.

DEMAGNETIZING COEFFICIENTS

For the case of a magnetic record, let us assume a sinusoidal flux distribution along an infinitely long wire. (A complex wave could be represented by a Fourier

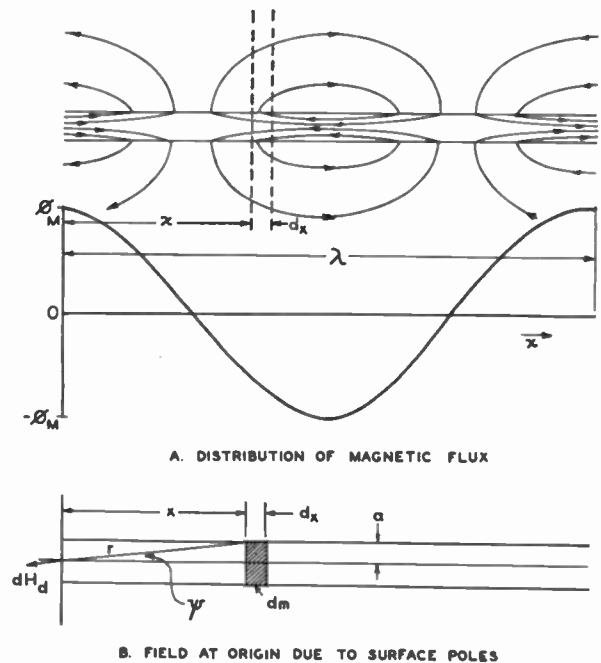

Fig. 4—Demagnetizing effect of surface poles.

series of sine waves, and the same theory applied.) In Fig. 4 let

- a = radius of the wire
- λ = wavelength of the sinusoidal record
- ϕ_M = maximum flux retained in wire section
- B_M = maximum flux density retained in wire section
- ϕ_E = external flux
- ϕ_I = internal flux
- x = distance along wire from origin
- dm = magnetic pole strength at element of surface
- dH_D = demagnetizing field at origin due to an element of surface pole
- ψ = angle made by dH_D with wire axis
- $D = -H_D/B_M$ = demagnetizing coefficient = demagnetizing field per unit of retained flux density.

Choosing the origin at a point of maximum flux,

$$\phi_E = -\phi_I = -\phi_M \cos \frac{2\pi x}{\lambda}. \tag{7}$$

ϕ_E is the external flux through a plane perpendicular to the wire at x . If the plane is moved an infinitesimal distance dx , then according to Gauss's law ϕ_E will change by 4π times the change in surface poles.

$$\frac{d\phi_E}{dx} = 4\pi \frac{dm}{dx}. \tag{8}$$

² S. P. Thompson, "The magnetism of permanent magnets," *Jour. I. E. E.* (London), vol. 50, p. 92; 1913.

³ H. du Bois, "The magnetic circuit in theory and practice," Longmans, Green and Co., London, 1896, p. 41.

Substituting (7) for ϕ_E and solving for dm ,

$$dm = \frac{1}{4\pi} \frac{d\phi_E}{dx} dx = \frac{\phi_M}{2\lambda} \sin \frac{2\pi x}{\lambda} dx. \quad (9)$$

In Fig. 4B the poles on a ring-shaped surface at dx will set up a field at the origin whose axial component is

$$dH_D = \frac{dm}{r^2} \cos \psi = \frac{dm}{r^2} \frac{x}{r}. \quad (10)$$

Since $r = \sqrt{x^2 + a^2}$,

$$dH_D = \frac{xdm}{(x^2 + a^2)^{3/2}}. \quad (11)$$

Substituting (9) for dm ,

$$dH_D = \frac{\phi_M x \sin \frac{2\pi x}{\lambda}}{2\lambda(x^2 + a^2)^{3/2}} dx. \quad (12)$$

Equation (12) gives the demagnetizing field at the origin due to magnetic poles at dx . Elements of this kind from $-\infty$ to $+\infty$ are taken into account to get the total demagnetizing field.

$$H_D = \frac{\phi_M}{2\lambda} \int_{-\infty}^{+\infty} \frac{x \sin \frac{2\pi x}{\lambda}}{(x^2 + a^2)^{3/2}} dx. \quad (13)$$

The demagnetizing field per unit of retained flux density is defined by the equation $D = -H_D/B_M$, so that in terms of (13) the demagnetizing coefficient is

$$D = \frac{-\phi_M}{B_M} \frac{1}{2\lambda} \int_{-\infty}^{+\infty} \frac{x \sin \frac{2\pi x}{\lambda}}{(x^2 + a^2)^{3/2}} dx. \quad (14)$$

But ϕ_M/B_M is the cross-sectional area of the wire, which, in terms of the radius, is πa^2 .

$$D = -\frac{\pi a^2}{2\lambda} \int_{-\infty}^{+\infty} \frac{x \sin \frac{2\pi x}{\lambda}}{(x^2 + a^2)^{3/2}} dx. \quad (15)$$

This integral may be reduced to the form

$$D = -\frac{2\pi^2 a^2}{\lambda^2} \int_0^{+\infty} \frac{\cos \frac{2\pi ax}{\lambda}}{\sqrt{x^2 + 1}} dx. \quad (16)$$

Letting $n = 2\pi a/\lambda$,

$$D = -\frac{n^2}{2} \int_0^{+\infty} \frac{\cos nxdx}{\sqrt{x^2 + 1}}. \quad (17)$$

No simple analytical solution could be found for this integral, and graphical methods were used for its evaluation. The final results are plotted in Fig. 5.

Demagnetizing coefficients calculated in this way are about 40 per cent higher for the sinusoidal distribution than if each half wavelength had been considered a magnetized rod. This result seems reasonable in view of the additional demagnetizing effect of adjacent magnets.

For short wavelengths, where λ/a is 10 or less, the above analysis is strictly true only for the center of the wire. The flux distribution and demagnetizing field is not uniform throughout the sectional area, however.

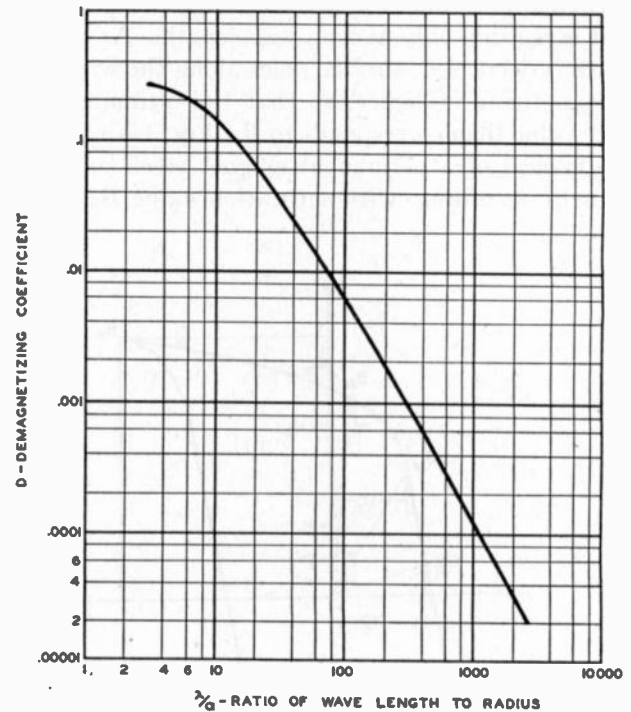

Fig. 5—Demagnetizing coefficients for sinusoidally magnetized wire.

For this reason the D 's for λ/a less than 10 should be greater than indicated by Fig. 5. Also, at short wavelengths the resolving power of the pickup gap is important. Both these factors tend to reduce the output voltage.

The maximum residual flux density that a wire can retain at any wavelength may be found from Fig. 6. Lines having a slope $1/D$ corresponding to each wavelength are drawn from the origin to intersect the demagnetization curve. Solutions for various frequencies are shown, assuming a wire velocity of $2\frac{1}{2}$ feet per second and a 0.004 inch-diameter wire.

It will be noticed that for frequencies below about 200 cycles the retained magnetism (B_M) is very nearly the same as the remanent magnetism (B_R). An increase in B_R would bring a proportionate increase in output at these frequencies; a change in coercive force would have little effect.

On the other hand, at frequencies above 1000 cycles B_M is practically equal to the height of the demagnetization curve intercepted by the D line drawn from the origin. ($B_M \cong H_C/D$, where H_C is the coercive force.) If H_C were doubled, the intercepted portion would be doubled. In general the high-frequency output is proportional to coercive force, and is not affected by changes in B_R .

It is interesting to note that a decrease in wire diameter increases the λ/a ratio, reduces the demagnetizing

coefficient, and improves the relative high-frequency response.

$$k = \frac{B_M}{B_R}, \tag{18}$$

which is the ratio of actual flux density to the maximum possible residual flux density.

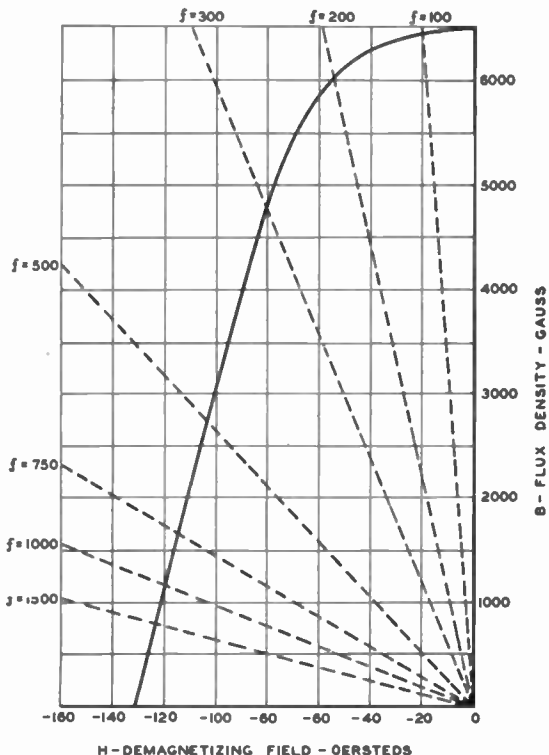

Fig. 6—Graphical solution for B_M at various frequencies. Wire diameter = 0.004 inch. Wire velocity = $2\frac{1}{2}$ feet per second.

MODIFICATION OF FIELD BY PICKUP HEAD

The demagnetizing effect of adjacent poles may be eliminated partially or completely under some conditions; for example, when the wire passes through certain designs of playback heads, or when it is coiled against itself on a spool. However, the magnetization under these conditions may be found from $B-H$ curves such as in Fig. 7, which indicates what would take place for a recorded frequency of 1000 cycles. Initially the residual magnetization of point 1 is brought down to point 2 by the self-demagnetizing field after the wire passes the recording head. When the demagnetizing field is removed (as is very nearly the case when the wire is in the scanning gap, and the wavelength is long) the magnetization is represented by point 3, having gone up from 1170 to 1700 gauss.

Depending on the pickup head and other physical conditions, the retained flux density will lie somewhere between the lower values given by Fig. 6 and the higher values found by tracing a $B-H$ path as in Fig. 7. A family of curves such as in Fig. 7 is used to obtain the B'_M values corresponding to B_M at different frequencies. Only the case for 1000 cycles was shown in Fig. 7 for purposes of clarity.

FREQUENCY RESPONSE

Values of B_M or B'_M taken from Fig. 6 or Fig. 7 can be used directly in (5) for calculating the output voltage at each frequency. It is more convenient to define a coefficient of retained flux density

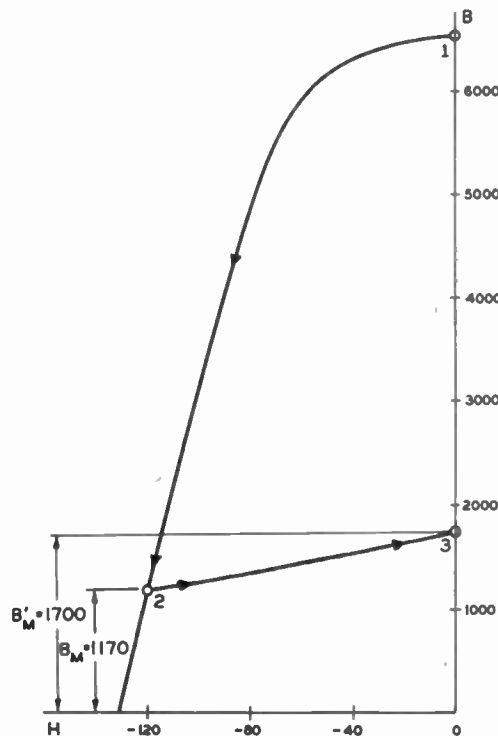

Fig. 7—Increase in magnetization of 1000-cycle signal upon removal of demagnetizing field.

In Fig. 8 the k values are plotted for different frequencies. The solid line represents the coefficients with

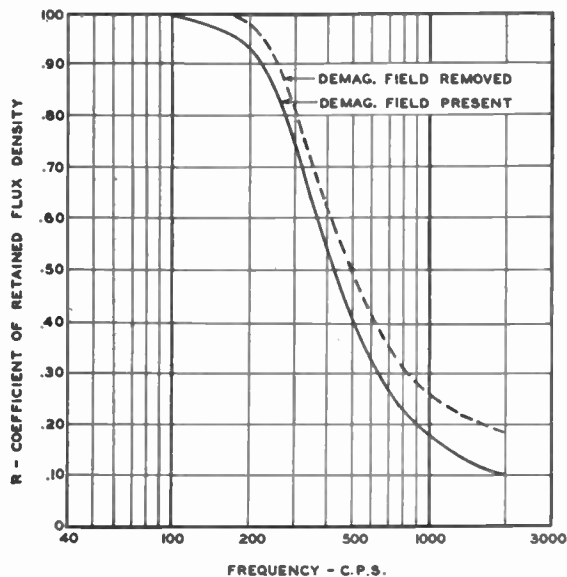

Fig. 8—Coefficient of retained flux density — k for 0.004-inch wire at $2\frac{1}{2}$ feet per second.

demagnetizing field present, as calculated from the B_M s of Fig. 6. The dashed line gives the coefficients when the field is removed as calculated from B'_M s as in Fig. 7. As given by these graphs, k would change with wire

speed. If k were plotted against λ , it would be independent of speed, although not as convenient to use.

Equation (5) may now be rewritten

$$E_{\text{RMS}} = k\sqrt{2} \pi f N B_R A (10^{-8}), \quad (19)$$

where k = coefficient of retained flux density
 f = recorded frequency = wire velocity/wave-length
 N = number of turns on pickup coil
 B_R = residual flux density of wire sample
 A = area of wire.

From (19) an ideal frequency-response curve for the wire may be calculated. Such a graph is drawn in Fig. 9, and represents the output obtainable at each frequency if the pickup device had perfect resolution and no losses; i.e., the only limitation is in the record medium itself, and in the ability of the recording magnet to produce the sinusoidal flux distribution. The solid-line and the dashed-line curves correspond to respective values of k from Fig. 8. The points shown on Fig. 9 are experimental data to check the calculated response. These average about 2 decibels lower than the calculated values, indicating losses of about 20 per cent from all factors combined.

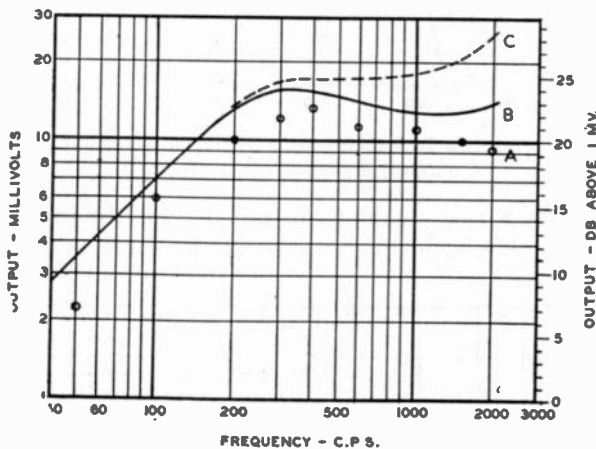

Fig. 9—Calculated and measured output versus frequency for a magnetic record.

A measured
 B calculated, demagnetizing field present
 C calculated, demagnetizing field removed.

The agreement between calculated and measured results is excellent at low frequencies. At higher audio frequencies the effect of pickup-gap resolution becomes increasingly important, and the output voltage will be considerably below the value predicted by considering demagnetization alone. Core loss also acts to decrease the output. Fig. 9 indicates that at 2000 cycles the measured output is 4 decibels below the amount predicted with demagnetizing field present, or 10 decibels below the amount predicted with demagnetizing field removed.

In actual use, the frequency response of Fig. 9 would be flattened by the use of equalizers. As an example, pre-equalization could be adjusted so that with typical speech or music spectra all frequencies would be equally likely to reach overload. Postequalization would then

be adjusted to complement the pre-equalization and recording characteristic in such a way as to make the over-all response flat.

CONCLUSIONS

Several important relations in magnetic recording are apparent from the foregoing discussion.

- (1) Voltage output is independent of scanning-gap length in the pickup head at low frequencies.
- (2) Voltage output is independent of wire speed for a given low frequency (when recorded and reproduced at the same speed).
- (3) Voltage output at low frequencies is directly proportional to B_R of the wire.
- (4) Voltage output at low frequencies is directly proportional to the cross-sectional area of the wire.
- (5) Voltage output is directly proportional to frequency at low frequencies (where the maximum flux density is independent of frequency).
- (6) Voltage output at high frequencies is proportional to H_C of the wire.
- (7) The relative high-frequency response is improved by decreasing the wire diameter.
- (8) Theoretical sine-wave frequency response of a wire record can be predicted if its diameter, speed, and magnetic properties are given.

Experimental verification of theoretical calculations shows these to hold with good accuracy. The difference between calculated and observed results gives a test of how closely the actual recording system meets the ideally assumed conditions, and can also be used as a basis for judging other effects, such as loss of resolution in the scanning aperture.



MARVIN CAMRAS

Marvin Camras (A '40) was born at Chicago, Illinois, in 1916. He received the B.Sc. degree in electrical engineering from Armour Institute of Technology in 1940, and the M.Sc. degree from Illinois Institute of Technology in 1942. Since 1940 he has been on the staff of Armour Research Foundation, where he has done considerable work in the field of magnetic recording.

Mr. Camras has also worked on a variety of other projects in the electronics department: remote control, high-speed photography, magnetostriction oscillators, and static electricity. He is a member of the Acoustical Society of America, the American Institute of Electrical Engineers, Tau Beta Pi, and Eta Kappa Nu.

Abstracts and References

Prepared by the National Physical Laboratory, Teddington, England, Published by Arrangement with the Department of Scientific and Industrial Research, England and *Wireless Engineer*, London, England.

The number at the upper left of each Abstract is its Universal Decimal Classification number and is not to be confused with the Decimal Classification used by the United States National Bureau of Standards. The number in heavy type at the top right is the serial number of the Abstract.

The Institute of Radio Engineers has made arrangements to have these Abstracts and References reprinted on suitable paper, on one side of the sheet only. This makes it possible for subscribers to this special service to cut and mount the individual Abstracts for cataloging or otherwise to file and refer to them. Subscriptions to this special edition will be accepted only from members of the I.R.E. and subscribers to the Proceedings of the I.R.E. and Waves and Electrons at \$15.00 per year. Subscribers to this special edition will also receive an Annual Index to Abstracts and References as part of their subscription service. All others, who are not subscribers to this service, but who are either members of the Institute or subscribers to the Proceedings of the I.R.E. and Waves and Electrons may purchase the Annual Index for \$5.00. Subscriptions to the Index only must be received by the Institute not later than March 1, 1947. All subscriptions for the Abstract service and its Annual Index should be sent to

Mr. George W. Bailey
Executive Secretary
The Institute of Radio Engineers, Inc.
330 West 42nd Street
New York 18, N. Y.

	PAGE
Acoustics and Audio Frequencies . . .	603
Aerials and Transmission Lines	604
Circuits	605
General Physics	606
Geophysical and Extraterrestrial Phenomena	607
Location and Aids to Navigation	608
Materials and Subsidiary Techniques . .	609
Mathematics	611
Measurements and Test Gear	612
Other Applications of Radio and Electronics	612
Propagation of Waves	614
Reception	614
Stations and Communication Systems . .	616
Subsidiary Apparatus	616
Television and Phototelegraphy	618
Transmission	618
Vacuum Tubes and Thermionics	619
Miscellaneous	620

ACOUSTICS AND AUDIO FREQUENCIES

534.21 1744
Sound Radiation from a Source Placed in Water at a Small Depth—L. M. Brekhovskikh. (*Compt. Rend. Acad. Sci. U.R.S.S.*, vol. 47, pp. 396-399; May 30, 1945. In English.) If the depth of the water is large compared with the distance from source to

receiver, the sound pressure at the receiver varies as the inverse square of the distance; for water of small depth compared with the sender-receiver distance, and with a perfectly reflecting bottom, the pressure varies as the inverse square root of the distance. In both cases, the pressure increases with depths of source or receiver to a distance approximately equal to a quarter of a wavelength. The case of a source attached to a solid submerged hemisphere is discussed briefly. For description of confirmatory experiments, see 1745 below.

534.21 1745
Radiation of a Sound in Water as Affected by Depth of Submersion—N. N. Andreyev, L. M. Brekhovskikh, and L. D. Rosenberg. (*Compt. Rend. Acad. Sci. U.R.S.S.*, vol. 47, pp. 400-402; May 30, 1945. In English.) Description of experiments carried out to confirm the theory put forward by Brekhovskikh (see 1744 above). The experimental curves follow the theoretical curves well, and variations about them can be explained by interference owing to multiple reflections between bottom and surface. The maximum sound pressure is attained at a depth of a quarter of a wavelength, as predicted by theory.

534.24 1746
Acoustic Reflection from Triplanes, Spheres, and Disks—C. J. Burbank. (*Phys. Rev.*, vol. 69, p. 136; February 1-15, 1946.) "... reflection from a triplane (an object made of three mutually perpendicular square plates with coinciding centers) is compared [experimentally] with the back reflection from a sphere and a disk." Abstract of an American Physical Society paper.

534.26 1747
On Diffraction of Elastic Waves—Scherman. (*See* 1906.)

534.321.9 1748
Ultrasonic Generator—F. W. Smith, Jr., and P. K. Stumpf. (*Electronics*, vol. 19, pp. 116-119; April, 1946.) The basic piezoelectric transducer is an X-cut quartz crystal excited in the thickness mode and loaded (usually) with transformer oil, which has high acoustic resistance and good dielectric properties. The design of a crystal holder with an airpocket which makes the radiation unidirectional is described. The crystal, which may be 10 centimeters in diameter, is silver plated and clamped at its edge.

The input impedance is equivalent to about 10,000 to 250,000 Ω shunted by about 100 micromicrofarads. Methods of matching this to the usual class-C amplifier are discussed, and a π -matching network is favored. The radio-frequency generator may be crystal-controlled but the radiating crystal may not be used, as its frequency varies with loading. Frequencies used are usually 150 to 1000 kilocycles, but frequencies up to 500 megacycles have been used.

534.321.9: 534.2 1749
A Variable Path Ultrasonic Interferometer for the Four-Megacycle Region with Some Measurements on Air, CO₂, and H₂—J. L. Stewart. (*Rev. Sci. Instr.*, vol. 17, pp. 59-65; February, 1946.) Alignment of the piston and crystal to the order of 10⁻⁶ inch in this interferometer gave an accuracy of 0.1 per cent in the measurement of velocity in gases, and of 50 per cent in the measurement of absorption and reflection coefficients. Preliminary measurements on H₂ gave evidence of molecular dispersion in the range 4 to 8 megacycles.

534.417: 534.88 1750
Sonar for Submarines—R. S. Lanier and C. R. Sawyer. (*Electronics*, vol. 19, pp. 99-103; April, 1946.) Description of an underwater sonic and supersonic listening system. The pickup, a magnetostriction hydrophone, incorporates a magnetized nickel tube 3 feet long and 2 inches in diameter. The hydrophone output is taken to a 5-stage resistance-coupled amplifier supplying a loudspeaker or headphones. The amplifier has five frequency-response characteristics, any one of which may be selected. The sensitivity is about 20 decibels above that required to raise the water noise to audibility. A frequency converter may be switched into the circuit to reduce the frequencies of supersonic signals to below 5 kilocycles.

534.417: 621.396.9: 355.326.4 1751
The Sonobuoy—K. H. (*See* 1855.)

534.43: 621.395.61: 621.396.619.018.41 1752
An FM Phono Pickup—A. Badmaieff. (*Radio Craft*, vol. 17, p. 106; November, 1945.) An application of 1144 of May.

534.833.1 1753
Demountable Soundproof Rooms—W. S. Gorton. (*Communications*, vol. 26, pp. 30, 33; March, 1946.) *See* 825 of April.

621.395 [.61+ .625] 1754
A.I.E.E. Winter Convention, January, 1946—(*Elec. Eng.*, vol. 65, pp. 29-35; January, 1946.) Abstracts are given of the following papers presented at the convention: "Inertia Throat Microphones," by E. H. Greibach and L. G. Pacent; "Laboratory Method for Objective Testing of Bone Receiving and Throat Microphones," by E. H. Greibach; "A New Wire-Recorder-Head Design," by T. H. Long; "A B-H Curve Tracer for Magnetic-Recording Wire," by T. H. Long and G. D. McMullen; "Signal and Noise Levels in Magnetic Tape Recording," by D. E. Wooldridge; "Phonograph Reproducer Design," by W. S. Bachman; "Recently Developed Tools for the Study of Disk-Recording Performance," by H. E. Roys; "Sound Recording in Business," by L. D. Norton.

Titles of other papers are given in other sections. For other abstracts, see *Electronics*, vol. 19, pp. 230-266; April, 1946.

- 621.395.61 1755
Microphones: Parts 1 & 2—S. W. Amos and F. C. Brooker. (*Electronic Eng.*, vol. 18, pp. 109-111, 136-141; April and May, 1946.)
1. It is shown that the basic differential equations for the oscillations in electrical, mechanical, and acoustic systems are similar in form. The electrical equivalents of various acoustic networks consisting of combinations of cavities, tubes, and slits are given, with indication of how they may be applied to microphone design.
2. The mechanisms of pressure-operated and velocity-operated (differential) microphones are analyzed, and typical response curves given.
- 621.395.61: 621.395.623.8 1756
Microphone Design in Electric Megaphones [To Reduce Acoustic Feedback]—A. J. Sanial. (*Communications* vol. 26, pp. 30-61; February; 1946.) See also 17 of January.
- 621.395.645.3: 621.385.4 1757
Intermodulation Tests for Comparison of Beam and Triode Tubes Used to Drive Loudspeakers—Hilliard. (See 2043.)
- 621.395.665 1758
Contrast Expansion—Parnum. (See 1793.)
- 621.395.665 1759
Contrast Expansion—White. (See 1792.)
- 621.395.667 1760
Paraphase Bass-Treble Tone Control—D. L. Jaffe. (*Radio*, vol. 30, pp. 17, 51; March, 1946.) A detailed account of a single resistance-capacitance network, giving an independent variation in bass and treble response about an arbitrary crossover frequency in the audio-frequency spectrum.
- 621.395.667 1761
Improved [Tone] Compensator—F. C. Davis. (*Radio Craft*, vol. 17, p. 425; March, 1946.) Independent bass and treble control are achieved by splitting the signal between two channels in which these controls are respectively situated, and afterwards recombining the two outputs.
- 621.395.667: 534.43: 621.395.61 1762
High Fidelity Bass Compensation for Moving Coil Pick-Ups—F. M. Haines. (*Electronic Eng.*, vol. 18, p. 121; April, 1946.) Correction to a circuit diagram in 833 of April. For an illustrated summary of original article, see *Radio*, vol. 30, p. 4; March 1946. (Note correction of wrong UDC number applied to 833 of April.)
- 621.395.92+621.396.62 1763
Radio Hearing Aid—A. Montani. (*Radio Craft*, vol. 17, pp. 392, 438; March, 1946.) Description and circuit diagram of a combined hearing aid and pocket radio.
- AERIALS AND TRANSMISSION LINES**
- 621.315.21.029.6: 621.396.9 1764
Radar Cables—Recent Developments in Conductors for Very High Frequencies—E. W. Smith. (*Wireless World*, vol. 52, pp. 129-131; April, 1946.) The chief objective, in development was reduction in the power factor of the dielectric. This was achieved first by making air-dielectric cables and later by the use of polythene. With polythene, much progress has been made in manufacturing methods, especially in the avoidance of air inclusion, and in attaining the accurate uniformity of diameter necessary to reduce standing waves. Some special types of cable (e.g., delay and low-impedance types) are mentioned, and methods of mechanical and electrical testing briefly described.
- 621.315.211.2.029.5/6 1765
Applications of High-Frequency Solid-Dielectric Flexible Lines to Radio Equipment—H. Busignies. (*Elec. Commun.*, vol. 22, pp. 295-301; 1945.) A review of the present and past needs for flexible moisture-proof radio-frequency lines. The polystyrene dielectric formerly used has largely been replaced by polyethylene. The mechanical and electrical requirements are detailed, together with the corresponding methods of test. The importance of electrical balance and stability of electrical length is emphasized, particularly in relation to directional systems used for navigation and aircraft landing.
- 621.315.212.1 1766
Flexible Coaxial Cable—R. M. Krueger. (*QST*, vol. 30, pp. 51-53; April, 1946.) A survey of solid-dielectric concentric and unscreened twin cables using polyethylene as dielectric. A list of abridged specifications of United States Army-Navy standard coaxial cables is given.
- 621.315.213.14.017.2 1767
Determination of the Temperature Rise and the Maximum Safe Current Through Multiconductor Electric Cables—H. P. Iskenderian and W. J. Horvath. (*Jour. Appl. Phys.*, vol. 17, pp. 255-262; April, 1946.) The temperature rise in rubber-insulated cables is calculated using the thermal constants of the cable. The theory has been confirmed experimentally and the thermal resistivity constants obtained as a function of size and composition. The maximum safe current to limit the temperature rise at the center to 25 degrees centigrade is predicted.
- 621.396.611.029.63/.64: 621.392 1768
Semi-Transparent Oscillating Electromagnetic Cavities—Kahan. (See 1795.)
- 621.396.67+621.396.11 1769
The Ratio Between the Horizontal and the Vertical Electric Field of a Vertical Antenna of Infinitesimal Length Situated Above a Plane Earth—K. F. Niessen. (*Philips Res. Rep.*, vol. 1, pp. 51-62; October, 1945.) The Hertzian vector function is simplified (for the case of a radio landing beacon) by considering the observer to be a large number of wavelengths away from the emitting aerial and relatively close to the reflecting earth. The reflection formula so derived is only applicable under certain conditions of height and angle of elevation which are deduced. The resulting horizontal-to-vertical field ratio is obtained and is shown to be reduced when the aerial is raised a little above the ground.
- 621.396.67 1770
The General Reciprocity Theorem in the Theory of Receiving and Transmitting Antennae—J. N. Feld. (*Compt. Rend. Acad. Sci. U.R.S.S.*, vol. 48, pp. 476-478; September 10, 1945. In English.) "The reciprocity theorem for two arbitrary antennas in the case of harmonic oscillations of one and the same frequency f is written $\dots I^{(1)}E_1 = I^{(2)}E_2$, where $I^{(1)}$ and $I^{(2)}$ are the currents passing through the terminals of the first and second antennae when operating as receiving aeriels and E_1 and E_2 are the total electromotive forces of the generators connected to the terminals of the antennas when the latter are operating as transmitting aeriels. \dots [This theorem] holds, however, only under the condition that the internal (complex) resistances of the generators z_1 and z_2 corresponding to the resistances of the receivers $Z^{(1)}$ and $Z^{(2)}$ \dots are equal." The more general case, when the condition is not fulfilled, is considered in this paper.
- 621.396.67 1771
The Thin Cylindrical Antenna: A Comparison of Theories—D. Middleton and R. King. (*Jour. Appl. Phys.*, vol. 17, pp. 273-284; April, 1946.) The solutions of Hallén's integral equation given by Hallén (2763 of 1939), Bouwkamp (2197 of 1944), Gray (1931 of 1944), King and Middleton (1453 of June) are compared together and with Schelkunoff's transmission-line theory (1049 of 1942 and 1930 of 1944) and with experiment. The King-Middleton second-order theory agrees best with experimental results. It is concluded that the integral-equation method of Hallén leads to a satisfactory theory of the thin cylindrical aerial.
- 621.396.67 1772
I.R.E. 1946 Winter Technical Meeting—(*Communications*, vol. 26, pp. 22-66; February, 1946.) Abstracts of some of the papers read. For titles, see 1448 of June.
- 621.396.676: 621.396.932.029.54 1773
Radiation of Ship Stations on 500 Kc/s—Marique. (See 2071.)
- 621.396.677 1774
A Theory for Three-Element Broadside Arrays—C. W. Harrison, Jr. (*PROC. I.R.E. AND WAVES AND ELECTRONS*, vol. 34, pp. 204-209; April, 1946.) "The vector relationship between the voltages that must be applied across the terminals of a three-element array, to maintain input currents of the same amplitude and phase, is determined. Each antenna is of half-length h , and of radius a . The spacing between antennas is b . Two broadside arrays having the following dimensions are analyzed numerically: (a) $h=\lambda/2$, $b=\lambda/2$, and $\Omega=2 \ln(2h/a)=20$; (b) $h=\lambda/4$, $b=\lambda/2$, and $\Omega=20$. The results of these calculations are supplies in the form of vector diagrams."
- 621.396.677.029.62 1775
A V.H.F. Directive Antenna System—A. Niutta. (*Communications*, vol. 26, pp. 18-20; February, 1946.) A simple unidirectional aerial system for 100 megacycles is obtained by using a pair of horizontal centered full-wave dipoles, side by side, spaced a quarter of a wavelength apart. Transformer connections are such that there is a $\pi/2$ phase difference between the two dipoles. The theory of the design is given, and alternative means of obtaining the required phasing are discussed.

- 621.396.677.029.64: 564.566 **1776**
Laguerre Functions in the Mathematical Foundations of the Electromagnetic Theory of the Paraboloidal Reflector—Pinney. (See 1909.)

CIRCUITS

- 621.3.011.2: 621.385.2 **1777**
Radio Design Worksheet: No. 46—Non-Linear Resistance—(Radio, vol. 30, pp. 31–32; March, 1946.) Consideration of the relationships between current, potential drop, and power in a diode for direct-current and alternating-current excitation.
- 621.3.012.8: 512.831 **1778**
Tensors and Equivalent Circuits—Hoffman. (See 1898.)
- 621.318.572 **1779**
Signaling System—R. F. Massoneau. (Radio, vol. 30, p. 28; March, 1946.) A method of counting the number of cycles in a pulse of electrical energy, suitable for use in transmission of numerical data. Summary of U. S. Patent 2,379,093.
- 621.318.572: 621.317.755 **1780**
Four-Channel Electronic Switch—N. A. Moerman. (Electronics, vol. 19, pp. 150–153; April, 1946.) To enable four signals, whose frequencies need not be related, to be viewed simultaneously on a single-beam tube, the inputs are applied to gate amplifiers which are switched at 25 kilocycles by a crystal-controlled ring counter. The latter allows accurate measurement of short time intervals. Useful resolution is obtainable well above commercial power frequencies.
- 621.385.38: 621.396 **1781**
Thyratrons and Their Applications to Radio Engineering—Maddock. (See 2099.)
- 621.392+621.396.622+621.396.64 **1782**
I.R.E. 1946 Winter Technical Meeting—(Communications, vol. 26, pp. 22–66; February, 1946.) Abstracts of some of the papers read. For titles, see 1462 of June.
- 621.392.4.012 **1783**
Graphical Solution of Series Circuits—P. K. Hudson. (Communications, vol. 26, pp. 48–49; March, 1946.) It is shown that a simple chart for converting polar co-ordinates into rectangular co-ordinates can be applied to circuit problems concerning series resistances and reactances.
- 621.392.43 **1784**
Conjugate-Image Impedances—S. Roberts. (Proc. I.R.E. and Waves and Electrons, vol. 34, pp. 198–204; April, 1946.) An analysis of the power in a load connected to a signal generator by a four-terminal network, in relation to the matching of generator and load to the conjugate impedance of the network terminals. The power gain (i.e., ratio of power in the load to power available from the generator) is calculated, with discrimination between ultimate, available, and actual gains, corresponding respectively to the cases of conjugate-impedance match at both output and input of the network, at the output only, and at neither output nor input. The analysis is applied to an oscillator problem.
- 621.392.5 **1785**
Transient Delay Line—J. M. Lester. (Electronics, vol. 19, pp. 147–149; April, 1946.) Design criteria for a pulse-delay network. If the highest frequency component of the transient is known, a simple graphical solution is possible for the values of inductance and capacitance.
- 621.392.5 **1786**
Solving 4-Terminal Network Problems Graphically—R. Baum. (Communications, vol. 26, pp. 50–53; March, 1946.) The networks contain either lumped or distributed constants. The use of the Smith diagram (1372 of 1939) and of inversion diagrams is explained in detail.
- 621.392.52 **1787**
A.I.E.E. Winter Convention, January, 1946—(Elec. Eng., vol. 65, pp. 29–35; January, 1946.) Abstracts are given of the following papers presented at the convention:—"A Tunable Rejection Filter," by R. C. Taylor; "A New Crystal Channel Filter for Broad-Band Carrier Systems," by E. S. Willis.
- Titles of other papers are given in other sections. For other abstracts, see *Electronics*, vol. 19, pp. 230–266; April, 1946.
- 621.394/.395].645.34 **1788**
Graphical Analysis of Degenerative Amplifiers—R. G. Middleton. (Radio, vol. 30, pp. 23–24, 50; March, 1946.) A current-feedback amplifier is analyzed by making certain algebraic transformations on the characteristic curves of the vacuum tubes. The technique can also be applied to voltage feedback.
- 621.394/.397].645.2 **1789**
Wide-Band Amplifiers: Part 2—(Wireless World, vol. 52, pp. 125–126; April, 1946.) Broadening the bandwidth by critical mistuning or stagger gives a higher gain per stage than does increase of damping in coincidence-tuned stages. For part 1, see 1190 of May.
- 621.394/.397].645.3 **1790**
Shifting Concepts—"Cathode Ray"—(Radio, vol. 30, pp. 6–12; March, 1936.) Illustrated summary of 1192 of May ("Cathode Ray") on negative feedback.
- 621.395.645.3: 621.385.4 **1791**
Intermodulation Tests for Comparison of Beam and Triode Tubes Used to Drive Loudspeakers—Hilliard. (See 2043.)
- 621.395.665 **1792**
Contrast Expansion—J. G. White. (Wireless World, vol. 52, pp. 120–123, April, 1946.) Circuits described in 3489 and 3929 of 1945 (White) use variable negative feedback to produce contrast expansion; a slight modification of these eliminates unwanted current-feedback and can lead to an 8-decibel increase in expansion. The effect of control bias on reproduction distortion is discussed at some length. An error in one of the earlier papers (3489 of 1945) is pointed out. See also 1793.
- 621.395.665 **1793**
Contrast Expansion—D. H. Parnum. (Wireless World, vol. 52, p. 136; April, 1946.) Discussion of 3489 and 3929 of 1945 (White). See also 1792.
- 621.396.6.018.1 **1794**
Phase Relationships—C. E. Cooper. (Wireless World, vol. 52, pp. 127–128; April, 1946.) When considering the difference between grid and anode signals it is better to use the term "reversed polarity" than "180 degrees out of phase."
- 621.396.611.029.63/.64]: 621.392 **1795**
Semi-Transparent Oscillating Electromagnetic Cavities—T. Kahan. (Compt. Rend. Acad. Sci., Paris, vol. 220, pp. 496–497; April 4, 1945.) A cavity is said to be semitransparent if part of its wall is made of a partly reflecting film, e.g., a very thin metal film on a low-loss dielectric base. A cavity consisting of a metal cylinder closed at one end by a thin film and at the other by a reflecting piston can be made, by proper choice of the film density and piston position, to be a nonreflecting termination to a wave guide. Other applications of partly reflecting films for matching discontinuities in wave-guide circuits are briefly mentioned.
- 621.396.615 **1796**
Three-Phase R-C Oscillator for Radio and Audio Frequencies—H. Rakshit and K. K. Bhattacharyya. (Sci. Culture, vol. 9, pp. 509–510; March, 1946.) A three-stage resistance-capacitance coupled amplifier with regenerative feedback made with suitable component vacuum tubes is shown to have two possible stable modes of oscillation. The normally favored mode generates a radio frequency; on suppressing this, by means of a simple adjustment, the audio frequency is obtained. In the example quoted, the two frequencies were about 2 megacycles and 250 cycles.
- 621.396.615.14.029.63 **1797**
Coaxial Butterfly Circuits—E. E. Gross, Jr. (Electronics, vol. 19, pp. 156–160; April, 1946.) Wide-frequency-range circuits for use with the 2C43 lighthouse vacuum tube are described and illustrated. A theoretical chart showing the resonant frequency as a function of the loading capacitance for various Z_0 is given, and is useful for design. A typical circuit gave 1000 to 1300 megacycles and a power of 0.3 to 0.7 W at 250 volts for use in a beat-frequency oscillator for obtaining low-frequency pulses with rapid build-up. A wide-range oscillator covering 620 to 1340 megacycles is also described. The arrangements for the output coupling loop and the possibility of extending the circuits to higher frequencies are discussed. See also 3260 of 1945 (Karplus). Abstracts noted in 884 of April and 1209 of May.
- 621.396.615.17 **1798**
Multivibrator Theory—S. C. Snowdon. (Phys. Rev., vol. 69, p. 134; February 1–15, 1946.) "The transient response of a symmetrical multivibrator has been analyzed neglecting the effect of shunt capacities and grid current." Abstract of an American Physical Society paper.
- 621.396.615.17: 621.317.755 **1799**
Time-Base Converter and Frequency-Divider—Moss. (See 2103.)
- 621.396.619.16 **1800**
Pulse [width] Modulation—A. T. Hickman. (R. S. G. B. Bull., vol. 21, pp. 150–153; April, 1946.) A typical modulation circuit is described and the frequency spectrum analyzed.

621.396.645.3.029.5 1801
Station Design and Planning: Part 2—The Power Amplifier—W. H. Allen. (*R. S. G. B. Bull.*, vol. 21, pp. 103–105; January, 1946.) An elementary account of the design of a low-power transmitter, including considerations of valve type, biasing, and anode circuit. For part 1, see 1058 of April; for parts 3, 4, and 5, see 2067 and 1980.

621.396.66: 621.385.2 1802
Limiting Circuits—J. McQuay. (*Radio Craft*, vol. 17, pp. 396–427; March, 1946.) An explanation of the principles, using a diode as a limiter, and description of various forms of limiting actions.

621.396.662 1803
The Design of Band-Spread Tuned Circuits for Broadcast Receivers—D. H. Hughes. (*Jour. I. E. E.* (London) vol. 93, pp. 87–96; March, 1946.) The design of pre-selector and oscillator circuits is discussed. The basic circuit for band-spread tuning by variable capacitance is analyzed, formulas are developed for calculating the elements of the capacitance network, and graphical methods of solution are developed and illustrated. The use of temperature-compensated capacitors, and methods of circuit trimming are discussed.

621.396.662.34 1804
H.F. Band-Pass Filters: Part 4—H. P. Williams. (*Electronic Eng.*, vol. 18, pp. 158–162; May, 1946.) Gives a practical example of band-pass design. For previous parts, see 1498 of June and back references.

621.396.69 1805
Printed Electronic Circuits—Brunetti and Khouri. (See 1887.)

621.318.7 1806
An Introduction to the Theory and Design of Electric Wave Filters. [Book Review]—F. Scowen. Chapman & Hall Ltd., London, 1945, 164 pp., 15s. (*Engineering, Lond.*, vol. 161, p. 171; February 22, 1946. *Elec. Rev., Lond.*, vol. 138, p. 146; January 25, 1946. *Electronic Eng.*, vol. 18, p. 164; May, 1946.)

GENERAL PHYSICS

535.312/.313 1807
Fresnel's Formulae for the Reflection of Light and the Misunderstandings in Their Application—T. Kravetz. (*Jour. Phys., U.S.S.R.*, vol. 9, p. 59; 1945.) Abstract of a paper of the Academy of Science, U.S.S.R.

535.37 1808
The Phosphorescence of Various Solids—J. T. Randall and M. H. F. Wilkins. **Phosphorescence and Electron Traps: I & II.**—J. T. Randall and M. H. F. Wilkins. **Short Period Phosphorescence and Electron Traps**—G. F. J. Garlick and M. H. F. Wilkins. (*Proc. Roy. Soc. A*, vol. 184, pp. 347–364, 365–389, 390–407, 408–433; November 6, 1945.)

535.43 1809
On the Problem of the Diffuse Reflection of Light—V. Ambarzumian. (*Jour. Phys., U.S.S.R.*, vol. 8, pp. 65–75; 1944.) Previous solutions ignore the effect of multiple scattering which is included in the present analysis for the case of a medium in plane-

parallel layers. The indicatrix (the angular distribution of the scattered rays in the elementary process) is assumed to be spherical. The reflection coefficient r , and $R(=4\pi r/\lambda)$ are calculated in terms of functions of $\eta(=\cos\theta)$ and $\eta_0(=\cos\theta_0)$ where θ and θ_0 are the angles between the normal and the reflected and incident rays respectively, (λ =coefficient of pure scattering versus sum of coefficients of absorption and pure scattering).

Lambert's empirical law that the coefficient of brightness ($\rho=r/\eta$) is constant for white bodies ($\lambda\approx 1$) is found theoretically to hold when ρ is averaged over all azimuths and for angles of incidence and reflection not too large ($\theta, \theta_0 > 70$ degrees).

537.525 1810
On the Kinetic Theory of an Assembly of Particles with Collective Interaction—A. Vlasov. (*Jour. Phys., U.S.S.R.*, vol. 9, pp. 25–40; 1945.) Usually, in the collision theory of the many-body problem, the long range forces (operating at distances greater than the mean particle spacing) are neglected. By taking account of these forces it is shown that new dynamic properties of polyatomic systems are revealed, such as eigenfrequencies, a quasi-crystal structure in gases, and the presence of currents in a medium due to collective interaction of the particles. There is previous work on the subject by Vlasov in *Zh. eksp. teor. Fiz.*, vol. 8, p. 291; 1938.

537.525 1811
Oscillation and Relaxation Processes in the Electron Plasma of the Discharge—E. Adirovich. (*Compt. Rend. Acad. Sci. U.R.S.S.*, vol. 48, pp. 551–554; September 20, 1945. In English.) A theoretical consideration of the processes of propagation of small disturbances in the plasma leads to conclusions that longitudinal density oscillations on a frequency higher than that deduced by Langmuir are possible. The theory also deals with the development of relaxation processes in the plasma.

537.525 1812
Disintegration of the Plasma of a Low-Pressure Electrical Discharge—V. L. Granovsky. (*Jour. Phys., U.S.S.R.*, vol. 8, pp. 76–88; 1944.) An investigation of the deionization of gas in a discharge tube after the electric field is removed. Expressions are derived theoretically for the rates of decrease of the temperature and concentration of the electrons which are initially exponential. The decrease of the velocities of the ions is much more rapid than that of the electrons, and the ambipolar diffusion coefficient D_{am} decreases relatively slowly. The effect of fresh ionization during the process is practically negligible.

The plasma disintegration of Hg vapour in cylindrical tubes of 65- and 105-millimeter diameter at various pressures from 2.3 to 65 μ Hg was investigated experimentally. A 50-cycle recurrent technique with oscillographic display was used and the potential-drop across a low resistance in the probe circuit was passed to the cathode-ray oscilloscope through a direct-current amplifier. The ionization decreased in the predicted manner, and the time constant τ_0 of the initial process was computed and found to be in good agreement with the value derived

from D_{am} in stationary processes. Thirty-seven references are given.

537.525 1813
Propagation of Waves and Retardation of Electron Beams in Plasma—E. Adirovich. (*Compt. Rend. Acad. U.R.S.S.*, vol. 48, pp. 630–632; September 30, 1945. In English.) Sequel to 1811 above.

537.525: 621.3.015.532 1814
Variation of the Mobility of Negative Ions in Strong Fields and the Influence of this Variation on the Characteristics of the Corona Discharge—A. Kaptzov. (*Jour. Phys., U.S.S.R.*, vol. 9, pp. 62–63; 1945.) Abstract of a paper of the Academy of Sciences, U.S.S.R.

537.525.8 1815
Cathode Dark Space and Negative Glow of a Mercury Arc—C. G. Smith. (*Phys. Rev.*, vol. 69, pp. 96–100; February 1–15, 1946.) Discussion of an experimental attempt to distinguish between field and emission theories of electron liberation. The voltage gradient at the cathode surface is deduced from accurate measurements of the thickness of the cathode dark space. "The inferred voltage gradient at the cathode is entirely too small for the field theory of electron liberation, and . . . [furthermore] a powerful ionizing agent must be operative . . . [cathode] surface."

537.591 1816
On the Existence of Highly Ionizing Particles in the Soft Component [of Cosmic Rays]—A. Alichanian, A. Alichanow, and S. Nikitin. (*Jour. Phys., U.S.S.R.*, vol. 9, pp. 56–58; 1945.)

541.14 1817
Some Observations on the Inner Photo-effect in Crystals of Alkali-Halide Salts—N. Kalabuchov. (*Jour. Phys., U.S.S.R.*, vol. 9, pp. 41–44; 1945.) It is suggested that light may induce the formation of colloid particles in crystals at low temperatures, a phenomenon already known to exist at high temperatures. Measurements of the saturation current due to photoconductivity in crystals of alkali-halide salts seem to indicate an effect similar to the Ramsauer effect which occurs in gases.

621.315.61+537.226]: 536.2 1818
On the Thermal Conductivity of Dielectrics at Temperatures Lower than that of Debye—I. Pomeranchuk. (*Jour. Phys., U.S.S.R.*, vol. 6, pp. 237–250; 1942.) Theoretical analysis extending the previous work of Debye and Peierls and including the effect of the scattering of elastic waves (phonons) at impurities (e.g., chemical, lattice defects, isotopes). The results are shown graphically where the conductivity K is given as a function of the absolute temperature T and of the relative concentration of the impurities ϵ . For values of ϵ greater than a critical concentration ϵ_0 , the conductivity is proportional to $L^{\frac{1}{2}}/T^{\frac{1}{2}}$ where L is the linear dimension of the crystal. Over a certain range of low temperatures K is proportional to $L^{\frac{1}{2}}$ but independent of T , an effect observed experimentally for diamond for $T=24$ to 343 degrees kelvin. This temperature range is wide for dielectrics with high Debye temperatures,

but may be absent when the Debye temperature is low and ϵ is small. At very low temperatures, where the free path of the phonons is of the order of L , the conductivity varies as LT^3 (e.g., diamond below 10 degrees kelvin). The effect of crystal twinning is discussed briefly and found to be unimportant in the case of sodium chloride.

621.383.2+535.215.1 1819
Complex Photoelectric Cathodes—N. Khlebnikov. (*Jour. Phys., U.S.S.R.*, vol. 9, p. 63; 1945.) A new conception of complex cathode emitters, in which the emission is considered as the external photoelectric effect of semiconductors possessing unusually low values of the work function. Abstract of a paper of the Academy of Science, U.S.S.R.

621.385.833: 537.533 1820
Field-Emission of Electrons—Lukirsky. (See 1947.)

GEOPHYSICAL AND EXTRA-TERRESTRIAL PHENOMENA

523.7+550.38]“1945.10/.12” 1821
Solar and Magnetic Data, October to December, 1945, Mount Wilson Observatory—S. B. Nicholson and E. S. Mulders. (*Terr. Magn. Atmos. Elec.*, vol. 51, pp. 55-56; March, 1946.)

523.7: [525.23+525.24 1822
A Possible Atmospheric Solar Effect in Both Geomagnetism and Atmospheric Electricity—O. R. Wulf. (*Terr. Magn. Atmos. Elec.*, vol. 51, pp. 85-87; March, 1946.) “In the average behaviour of the daily variation of the horizontal magnetic force there appears in the summer months a recognizable effect [a maximum] which occurs at closely the same universal time [2000 GMT] at Cheltenham (Maryland), Tucson (Arizona) and Honolulu (Hawaii) . . .” which suggests “. . . something unusual in the reaction of the Earth to solar radiation when the Sun is over the longitude . . . 105 degrees to 120 degrees west.”

523.72: 621.396.822 1823
Radio-Frequency Energy from the Sun—J. L. Pawsey, R. Payne-Scott, and L. L. McCready. (*Nature, Lond.*, vol. 157, pp. 158-159; February 9, 1946.) An account of observations of radiation from the sun on a wavelength of 1.5 meters during October, 1945. The mean intensity is correlated with the total sunspot area. It is suggested that “cosmic static” originating in the region of the “milky way” may be attributed to similar bursts of radiation from stars, caused by gross electrical disturbances analogous to terrestrial thunderstorms. See also 1824 through 1826 below, and 323 of February (Appleton).

523.72: 621.396.822 1824
Noise Observed During Radio Fade-Out, August 17, 1945—J. M. Watts. (*Terr. Magn. Atmos. Elec.*, vol. 51, pp. 122-125; March, 1946.) Observations made at ionospheric station at Maui, Hawaii.

523.72: 621.396.822 1825
Solar Radiations in the 4-6 Metre Radio Wave-Length Band—J. S. Hey and F. J. M. Stratton. (*Nature, Lond.*, vol. 157, pp. 47-48; January 12, 1946.) Radiation of the or-

der of 10^6 times the power expected, assuming the sun to behave as a black-body radiator, was observed on Army radar equipments on February 27-28, 1942, and appeared to be associated with a big solar flare occurring at that time.

523.72: 621.396.822 1826
Short-Wave Radio Emission from the Sun—(*Engineering, Lond.*, vol. 161, p. 164; February 15, 1946.) A brief account.

523.72: [550.38+551.51.053.5 1827
Variation of the Sun's Ultra-Violet Radiation as Revealed by Ionospheric and Geomagnetic Observations—C. W. Allen. (*Terr. Magn. Atmos. Elec.*, vol. 51, pp. 1-18; March, 1946.) From a study of critical frequency variations (E , F_1 and F_2) at Washington, Huancayo, Watheroo, and Mount Stromlo (1937-44) and of variations in the S_q magnetic field at Apia, Watheroo, and Cape Town (1937-43) it is concluded that: (a) The variable part of the Sun's ultra-violet illumination comes mainly from active regions characterized by the appearance of sunspots, flocculi, and faculae. (b) The sources of ultra-violet have a longer life than sunspots, and possibly a longer life than faculae. (c) The three ionospheric layers E , F_1 and F_2 , and the S_q -field are influenced by the same sources of ultra-violet light. (d) The sources emit considerable ultra-violet radiation when at the centre of the Sun and probably emit some radiation when near the limb. (e) F_2 electrons take periods of one or two days to reach equilibrium concentration; at the level of S_q -currents recombination is much more rapid. (f) The variable part of the ultra-violet flux is proportional to sunspot-number, and is about equal to the steady part at sunspot-maximum. This applies to radiation exciting the E -, F_1 -, and F_2 -regions. (g) There is a linear relation between f^oF_2 and sunspot-number. (h) Faculae could produce continuous ultra-violet radiation that might account for ionospheric and geomagnetic variations.”

523.74: 550.38 1828
Distribution of Solar Eruptions in Relation to Magnetic Storms—P. Bernard. (*Compt. Rend. Acad. Sci., Paris*, vol. 220, pp. 506-508; April 4, 1945.) Eruptions in the central zone of the solar disk have a preponderating influence on terrestrial magnetism because they are apparently more frequent and greater in extent. It seems that apart from this effect of geometrical position, no part of the sun is more effective than another in regard to eruptions and related geomagnetic disturbances.

523.746“1945.10/.12” 1829
Provisional Sunspot-Numbers for October to December, 1945—M. Waldmeier. (*Terr. Magn. Atmos. Elec.*, vol. 51, p. 36; March, 1946.)

523.746.5 1830
An Addition to the Table of Secular Variations of the Solar Cycle—W. Gleissberg. (*Terr. Magn. Atmos. Elec.*, vol. 51, p. 121; March, 1946.) Addition to the table given in 1388 of 1945. The epoch of the last sunspot minimum is taken as 1944.2, and the smallest relative sunspot number is 7.7, giving 1923.5 for the epoch of the secularly

smoothed minimum of 1923. This confirms the existence of a long period (about 80-year) cyclical variation of the 11-year cycle.

523.78: [551.51.053.5+621.396.11 1831
The Solar Eclipse of 1945 and Radio Wave Propagation—R. L. Smith-Rose. (*Nature, Lond.*, vol. 157, pp. 40-42; January 12, 1946.) A preliminary summary of observations made in Britain. Ionospheric soundings showed a reduction in ionization before the optical eclipse, which may be associated with a corpuscular eclipse, though the main reduction of 30 to 45 degrees occurred during the optical eclipse. Similar effects were also observed in the U.S.S.R. Ionospheric absorption at vertical incidence at 2 megacycles was reduced by roughly 10 decibels. Long-distance communications showed a small but definite decrease in absorption in the band of 60 kilocycles to 1 megacycle. Long-distance direction-finding observations and very-high-frequency propagation measurements showed no appreciable change.

523.78: 551.51.053.5 1832
Scientists' Study of Last Solar Eclipse—S. P. Chakravarti. (*Curr. Sci.*, vol. 14, p. 283; November, 1945.) Brief account of the radio investigations on the ionosphere during the eclipse of July, 1945.

525+526+55+91: 001.4 1833
Some Thoughts on Nomenclature—S. Chapman. (*Nature, Lond.*, vol. 157, p. 405; March 30, 1946.) “Geonomy,” analogous to “astronomy,” is suggested as a comprehensive word covering all the studies of the earth such as geography, geophysics, etc. “Aeronomy” is suggested to replace meteorology.

550.38 1834
Induction Effects in Terrestrial Magnetism: Part 1.—Theory—W. M. Elsasser. (*Phys. Rev.*, vol. 69, pp. 106-116; February 1-15, 1946.) A mathematical paper dealing with the electromagnetic effect of motions in the earth's core, considered as a fluid metallic sphere. “The secular variation of the [terrestrial magnetic] field is interpreted as a modification of the current system caused by inductive interaction between mechanical motions of the fluid and the magnetic field.”

550.38“1941/1944” 1835
Three-Hour-Range Indices, K , of Geomagnetic Activity at the Magnetic Observatory, Hermanus, Comparison with K -Indices at American-Operated Observatories, and Mean K -Indices, K_A , for the Years 1941-44—A. Ogg. (*Terr. Magn. Atmos. Elec.*, vol. 51, pp. 75-83; March, 1946.)

550.38“1945” 1836
American Magnetic Character-Figure C_A , Three-Hour-Range Indices, K , and Mean K -Indices, K_A , for October to December, 1945, and Summary for Year 1945—W. E. Scott. (*Terr. Magn. Atmos. Elec.*, vol. 51, pp. 57-66; March, 1946.)

550.38“1945” 1837
The Spherical Harmonic Analysis of the Earth's Magnetic Field for the Epoch 1945—V. I. Afanasieva. (*Terr. Magn. Atmos. Elec.*, vol. 51, pp. 19-30; March, 1946.)

- 551.51.052 **1838**
Radiative Equilibrium of the Atmosphere and the Thermal Structure of the Troposphere—R. Ananthakrishnan. (*Curr. Sci.*, vol. 14, pp. 298–299; November, 1945.) An analysis of records from sounding balloons released at Agra over a number of years shows a thermal structure of the upper troposphere with marked lapse-rates and inversions; this can be explained by the existence of a heat-emission layer, as postulated by Albrecht (1931 Abstracts, p. 493).
- 551.51.053.5 **1839**
Cause and Effect in Region F_2 of the Ionosphere—J. Bannon and F. W. Wood. (*Terr. Magn. Atmos. Elec.*, vol. 51, pp. 89–102; March, 1946.) From an analysis of f^oF_2 values for ionosphere stations in the neighborhood of latitude 35 degrees it is concluded that: (a) There is a variation, in the composition of region F_2 , from place to place over the Earth's surface. (b) The annual effect found by Berkner and Wells may be due to the variation in composition of region F_2 , and to the differences in $\bar{s} \cos \frac{1}{2}$ in the two hemispheres. (c) The annual effect has not a sidereal cause. (d) As far as annual mean values of maximum electron-density are concerned, the transition from noon to midnight is not influenced by the number of sunspots. (e) If the thermal-expansion hypothesis is correct, midnight temperatures are probably low, and do not vary much throughout the year. Summer-noon temperatures are very much higher than temperatures at midnight.
- 551.51.053.5: 621.396.11 **1840**
Intense Scatter in E_s -Region at Christmas Island—R. C. Peavey. (*Terr. Magn. Atmos. Elec.*, vol. 51, pp. 126–127; March, 1946.) Very marked scattering of sporadic- E echoes has been observed. It occurs mainly in the frequency band of 3.7 to 4.4 megacycles and occasionally at higher frequencies. It occurs regularly during daylight hours but only infrequently at night.
- 551.51.053.5: 621.396.11 **1841**
Low-Level Reflections Observed at Christmas Island—R. C. Peavey. (*Terr. Magn. Atmos. Elec.*, vol. 51, pp. 125–126; March, 1946.) A report on weak echo signals from apparent heights of 40 to 70 kilometers on frequencies between 1.0 and 2.0 megacycles, observed during daytime in June, 1945. Signals cannot have been reflected from terrestrial objects, because of the isolation of the island. The possibility of reflections from heavy cloud formation is mentioned.
- 621.396.11: 551.53.051.5 **1842**
Short-Period Fluctuations in the Characteristics of Wireless Echoes from the Ionosphere—Eckersley and Farmer. (*See* 1968.)
- 621.396.91.087.5: 551.51.053.5 **1843**
A Simple Kerr Modulator for Ionospheric Recording—Rydbeck. (*See* 2049.)
- 551.57: 621.396.82 **1844**
Precipitation Static—(*See* 1991 through 1993.)
- LOCATION AND AIDS TO NAVIGATION**
- 534.417: 534.88 **1845**
Sonar for Submarines—Lanier and Sawyer. (*See* 1750.)
- 621.383: 551.576 **1846**
The Cloud Range Meter—Moles. (*See* 1943.)
- 621.396.9 **1847**
A.I.E.E. Winter Convention, January, 1946—(*Elec. Eng.*, vol. 65, pp. 29–35; January, 1946.) Abstracts are given of the following papers presented at the convention:—"Techniques and Facilities for Microwave Radar Testing," by E. I. Green, H. J. Fisher, and J. G. Ferguson; "Radar Systems Considerations," by D. A. Quarles; "Marine Radar for Peacetime Use," by L. H. Lynn and O. G. Winn; "Air-Borne Radar for Navigation and Obstacle Detection," by R. C. Jensen and R. A. Arnett; "Shoran Precision Radar," by S. W. Seeley; "The SCR-584 and SCR-784 Equipments," by M. R. Briggs.
- Titles of other papers are given in other sections. For other abstracts, see *Electronics*, vol. 19, pp. 230–266; April, 1946.
- 621.396.9 **1848**
The Decca Navigator—M. G. Scroggie. (*Communications*, vol. 26, pp. 21–24; March, 1946.) For another account, see 1242 of May.
- 621.396.9 **1849**
Radar Navigation—(*Electrician*, vol. 136, pp. 1245–1246; May 10, 1946.) A short account of the reading before the radio section of the Institute of Electrical Engineers of papers on radar navigation, gee, oboe (ground-controlled precision bombing aid), H_2S (airborne navigation and bombing aid), and radar interrogator-beacon systems. The respective authors were R. A. Smith, R. J. Dippy, F. E. Jones, C. J. Carter, and K. A. Wood.
- 621.396.9 **1850**
I.E.E. Radiolocation Convention—(*Electrician*, vol. 136, pp. 798–810, 887–892; March 29, and April 5, 1946.) A summary of the proceedings. The main contributions dealt with developments of aeriels and wave guides; importance of meteorological factors in propagation; applications and developments of cathode-ray tubes, discussion of trace visibility and use for display; difficulties in precision radar, and range and azimuth measurement; development of ultra-high-frequency vacuum tubes, and the outstanding value of the magnetron; ultra-high-frequency measurements and test gear; decimeter- and meter-wave transmitters and receivers; applications of radar to navigation and gunnery.
- 621.396.9 **1851**
Radar Technique—H. Stoelzel. (*Schweiz. Bauztg.*, vol. 126, pp. 249–252; December 1, 1945. In German.) A short and elementary account of the basic principles of radar sets and of their applications in war and peace.
- 621.396.9 **1852**
Radiolocation or Radar—R. L. Smith-Rose. (*R. S.G.B. Bull.*, vol. 21, pp. 119–125; February, 1946.) Optical methods are used to illustrate the underlying principles. Historical development is traced from early ionosphere experiments to centimeter radar. Reference is also made to location by sound.
- 621.396.9 **1853**
Radar Countermeasures—(*Engineer, Lond.*, vol. 180, pp. 460–461; December 7, 1945.) Outline account of ground-based and air-borne operations which were successful in reducing the efficiency of German radio communication and radar systems. "Hoaxing" operations connected with D-day are described in some detail.
- 621.396.9(091) **1854**
The Historical Development of Radar—E. G. Bowen. (*Proc. I.R.E., Aust.*, vol. 7, pp. 3–9; March, 1946.) Abstract of lecture and discussion before the Institution. Radar developments in England and the United States during the war are outlined. Radar was in early use in Germany, but research ceased in 1941. Japanese radar and its operational use were very backward.
- 621.396.9: 355.326.4: 534.417 **1855**
The Sonobuoy—K. H. (*Electronics*, vol. 19, pp. 154–155; April, 1946.) Description of an expendable radio transmitter, modulated by signals from an underwater magnetostriiction hydrophone, for revealing the presence of submerged submarines to patrol ships and aircraft.
- 621.396.9: 523.3 **1856**
Radar Echoes from the Moon—J. Mofenson. (*Electronics*, vol. 19, pp. 92–98; April, 1946.) Experiments by the United States Signal Corps using considerably modified radar equipment. The crystal-controlled transmitter was operated at 111.5 megacycles with a pulse recurrence period of 4 seconds and pulse lengths of 0.02 to 0.25 second at 3-kilowatt power. The crystal-controlled receiver had a noise factor of 7 decibels (using 2 grounded-grid radio-frequency stages) and a bandwidth of 50 cycles for maximum sensitivity. The aerial system 8×8 horizontal dipoles in a vertical plane gave a beam width of 15 degrees, and was only suitable for use at times near moonrise and moonset. Assuming no attenuation in space the calculated signal-to-noise ratio was 20 decibels, which checked closely with experiment. The anticipated delay time of 2.4 seconds and Doppler frequency shift due to the moon's radial velocity were observed.
- 621.396.9: 621.385.832 **1857**
Cathode-Ray Tube Displays—J. G. Bartlett, D. S. Watson, and G. Bradfield. (*Electronic Eng.*, vol. 18, pp. 143–150; May, 1946.) The displays are classified as conventional, pictorial, realistic, or instructional, and are further classified as general or precision. The principles of all displays are given, with more detailed descriptions of operational displays developed in the period 1936 to 1945. Methods of improving the visibility of the tube traces are discussed. Long summary of a paper read at the Institution of Electrical Engineers Radiolocation Convention.
- 621.396.9: 621.385.832: 778 **1858**
Use of Film in Radar Training—(*Elec-*

photographs and of divergent X-ray beam photographs.

Progress is noted in the application of the technique of X-ray scattering and in the interpretation of the complex phenomena observed. In the case of Rochelle salt, the change in crystalline structure associated with the very marked changes in dielectric and piezoelectric properties is accomplished by a change of axial angle of only 2 minutes of arc. The anomalies appear to be caused by changes in the length of the hydrogen bonds, combined with changes in the mobility of the hydrogen atoms.

549.514.1: 537.228.1 1874

Control of Electrical Twinning in Quartz—W. A. Wooster and N. Wooster: L. A. Thomas, J. L. Rycroft, and E. A. Fielding. (*Nature, Lond.*, vol. 157, pp. 405-406; March 30, 1946.) The electrical twinning of quartz can be eliminated by suitable combinations of stress and temperature. The method can be applied to most of the rotated Y-cut plates, including the BT-cut (but not the Y-cut itself or the Z-cut), with so high a proportion of successes that the large-scale processing of quartz plates is practicable.

549.514.1: 621.396.611.21 1875

Crystal Grinding Without Tears—F. R. Cowles. (*QST*, vol. 30, pp. 48-50; April, 1946.) Hints on how to grind and clean AT- and BT-cut crystals. Activity can be increased by edge-grinding or by changing electrodes.

621.3(213) 1876

Tropical Moisture and Fungi: Problems and Solutions—E. S. McLarn, H. Oster, H. Kolin, and A. Neumann. (*Elec. Commun.*, vol. 22, pp. 303-313; 1945.) A comprehensive and detailed review of the effects of tropical conditions on radio and electrical components and materials, and the means of protection against them. The protective measures include initial design, selection of suitable materials, and the use of fungicidal coatings. Moisture proofing is the prime necessity and requires hermetic sealing in many cases. Recommended materials at the present time include ceramics having a glazed finish, porcelain, glass, and glass-bonded mica. Plastic sleeving of the polyvinyl-chloride type has proved preferable to fabric and cellulose-acetate sleeving.

Details are given of the nature, characteristics, and limitations of the three main types of fungicidal agents: phenyl mercurials, chlorinated phenols, and salicylanilides.

The advances made in this technique during the war open up new possibilities of development in regions where climatic conditions had previously prevented the use of modern technical equipment.

See also 1561 (Prentice) and 1562 (Leutritz and Hermann) of June.

621.3.011.2: 546.49-1 1877

The Temperature Dependence of the Resistance of Liquid Metals at Constant Volume—S. Gubar and J. Kikoin. (*Jour. Phys., U.S.S.R.*, vol. 9, pp. 52-53; 1945.) Experiments on the resistance of a column of mercury completely filling a closed stout-walled glass capillary tube are briefly described, from which it is concluded "... it may be regarded as directly proved that for

mercury the increase of resistance normally observed with temperature rise is associated exclusively with the effect of its thermal expansion . . . It should be noted that . . . with an appropriate selection of the glass used it is possible to make the resistance of the specimen entirely independent of temperature."

621.3.011.2: 546.87 1878

Negative Resistance-Temperature Coefficient of Thin Evaporated Films of Bismuth—T. J. Tulley. (*Nature, Lond.*, vol. 157, p. 372; March 23, 1946.) A letter briefly describing observations. Films of bismuth were evaporated on microscope slides at a pressure of about 10^{-3} millimeters of mercury using a mercury diffusion pump without a trap. Values of the resistance-temperature coefficient for various thicknesses of film are tabulated, giving a peak value of -31.2×10^{-4} per degree centigrade for an estimated film thickness of 1.5 microns, which falls to -20.8×10^{-4} for a thickness of about 0.03 microns, and to -16.8×10^{-4} for a thickness of 6.5 microns. Some values of the (positive) coefficient for other metals are added for comparison.

621.315.551: 621.396.823: 621.365 1879

Interference with Broadcast Reception by Electrical Heating Apparatus—Gerber and Werthmüller. (*See* 1996.)

621.315.58.029.54/.64 1880

The Electrical Properties of Salt-Water Solutions Over the Frequency Range 1-4000 Mc/s—R. Cooper. (*Jour. I.E.E.* (London), vol. 93, pp. 69-75; March, 1946.) Stationary-wave measurements with a parallel-wire transmission line have been used to determine the refractive index and absorption coefficient of solutions of salt in concentration up to 4 per cent, in the frequency band 690 to 4320 megacycles. The conductivities were obtained in the range 0.95 to 13 megacycles by measuring the change in Q of a resonant circuit shunted by a column of the solution in a capillary tube. Comparison is made with existing data on sea water at the lower frequencies. The results are examined in relation to the Debye-Falkenhagen electrolyte theory and to the theory of anomalous dispersion in dipolar liquids, and it is shown that the ionic and dipolar conductivities can be added arithmetically.

621.315.611.011.5 1881

Dependence of the Dielectric Constant of Barium Titanate upon the Pressure—B. M. Wul and L. F. Vereschagin. (*Compt. Rend. Acad. Sci. U.R.S.S.*, vol. 48, pp. 634-636; September 30, 1945. In English.) A brief description of the apparatus used to measure the pressure variation is given. It was found that over the range of 300 to 2000 atmospheres, the dielectric constant increased at a steadily diminishing rate. The work is being extended to include higher pressures and different temperatures.

621.315.615.017.143 1882

The Effect of High-Frequency Alternating Currents on Liquid Semiconductors—J. Granier and G. Granier. (*Compt. Rend. Acad. Sci., Paris*, vol. 220, pp. 555-557; April 16, 1945.) Figures for resistivity (ρ) and loss angle (α) are given for hexane, ether, and vaseline oil at frequencies of 0.10^8 , 10^4 , 10^5 , and 10^6 cycles.

621.315.617.3: 519.283 1883

Quality Control of Insulating Varnishes—L. P. Hart, Jr. (*Gen. Elec. Rev.*, vol. 49, pp. 8-15; April, 1946.) The need for systematic checking of the composition and physical properties of the varnishes is pointed out, and a routine proved to be satisfactory in practice is described.

621.315.618.011.5 1884

The Dielectric Constants of Eight Gases—L. G. Hector and D. L. Woernley. (*Phys. Rev.*, vol. 69, pp. 101-105; February 1-15, 1946.) The constants for the He, Ne, Ar, H₂, O₂, N₂, CO₂ and dry air at STP have been measured to a few parts in 10^{-7} by a heterodyne method of observing the change in frequency of a tuned circuit on introducing the gas to a previously evacuated capacitor. The results are discussed in relation to previous work.

621.316.86: 546.281.26 1885

[Silicon-carbide] Non-Ohmic Resistors—F. Ashworth, W. Needham, and R. W. Sillars. (*Electrician*, vol. 136, pp. 817-818; March 29, 1946.) Summary and discussion of an Institution of Electrical Engineers paper.

621.319.51: 546.78 1886

Electrical Properties of Tungsten Oxide Films—F. L. Jones. (*Nature, Lond.*, vol. 157, pp. 371-372; March 23, 1946.) Letter briefly describing experiments on the intensity of cold-cathode electronic emission from tungsten electrodes on which were formed films of tungsten oxides, carried out with a view to devising a self-triggering two-electrode spark gap. The electrodes were used in a short spark gap with an applied impulsive electric field, the potential drop across the gap at breakdown being taken as a measure of the concentration of the initial electrons. Properties of rough and oxidized surfaces of tungsten were investigated with gaps in air and nitrogen at atmospheric pressure. Considerable emission was indicated for a surface coating of a mixture of the yellow and blue oxides of tungsten, and a polarity effect was observed when one of the electrodes was smooth clean tungsten. Roughened electrodes show emission without polarization. It is suggested that, in the case of oxide films, emission of electrons is due to intense microscopic electric fields set up by positive charges on the upper surface of the film, while with roughened electrodes photo-ionization takes place throughout the gap due to photons emitted from minute discharges at the microscopic points on the electrode. Normally the oxide surfaces show some degree of roughness and both causes probably operate.

621.396.69 1887

Printed Electronic Circuits—C. Brunetti and A. S. Khouri. (*Electronics*, vol. 19, pp. 104-108; April, 1946.) Details of a technique for preparing compact radio apparatus. The "chassis" is a block of ceramic material such as steatite, upon which the circuit is built in the following stages: (a) the wiring, consisting of silver in the form of a paint or paste, is applied to the base through a silk or metal stencil, and subsequently bonded by heat treatment; (b) resistors in the form of a carbon or resin mixture are sprayed through masks in the appropriate positions in the

circuit; (c) small disk-type ceramic capacitors, and (d) any other components such as vacuum tubes, are soldered directly to the silver wiring, using a 2 per cent silver solder. Performance of these printed circuits and component stability are similar to those of ordinary equipment.

621.791.75: 621.362 1888
Welding Fine Thermocouple Wires—E. D. Hart and W. H. Elkin. (*Jour. Sci. Instr.*, vol. 23, pp. 17-18; January, 1946.) Simple method for wires of size 40 to 50 standard wire gauge.

621.791.76: 546.621 1889
The Development of the Spot-Welding of Aluminum—A. von Zeerleder. (*Schweiz. Arch. angew. Wiss. Tech.*, vol. 10, pp. 218-226; July, 1944. Discussion, vol. 10, pp. 335-362; November, 1944. In German.) A brief historical survey and very detailed metallurgical study of present practice, with a bibliography of about twenty-five items. The discussion is mainly on the mitigation of the effects of spot-welding machines on the supply network.

621.791.76: 621.3.011.2 1890
Measurement and Effect of Contact Resistance in Spot Welding—R. A. Wyant. (*Trans. A.I.E.E. (Elec. Eng.*, January, 1946), vol. 65, pp. 26-33; January, 1946.) Static measurements using bridge circuits and dynamic measurements using oscillograph records were made on aluminium, magnesium and nickel alloys, and steel, with surfaces chemically and mechanically cleaned. Results are shown graphically, and remaining research problems are reviewed.

666.189.4: 621.385 1891
Sintered Glass—E. G. Dorgelo. (*Philips Tech. Rev.*, vol. 8, pp. 2-7; January, 1946.) The technique is particularly useful in the construction of lamps and tubes for experimental purposes. The main features and applications are described.

679.5 1892
Plastics for the Amateur: Part 2—A. G. Chambers. (*R.S.G.B. Bull.*, vol. 21, pp. 106-107; January, 1946.) A practical article describing recommended methods of working plastic materials with particular reference to the thermosetting (Bakelite, Paxolin, Tufnol) and thermo-plastic (Perspex, Distrene, Alkathene) groups. For part 1, see 956 of April.

679.5 1893
Plastics and Chemicals—(*Gen. Elec. Rev.*, vol. 49, pp. 60-61; January 1946.) Annual review of developments.

549.211: 62 1894
Diamonds Tools [Book Review]—P. Grodzinski. N. A. G. Press, London, 1945, 20s. (*Engineering, Lond.*, vol. 160, p. 441; November 30, 1945.) Applications of diamonds described include hardness testing, crystal cutting, and jewel bearings. "An invaluable work of reference for all who make use of diamonds in production."

621.315.6(083.75) 1895
A.S.T.M. Standards on Electrical Insulating Materials (With Related Information) [Book Review]—A.S.T.M. Committee D-9. American Society for Testing Materials, Philadelphia, 1945, 545 pp., \$3.25.

(*PROC. I.R.E. AND WAVES AND ELECTRONS*, vol. 34, p. 210; April, 1946.) "This book contains all of the essential data which normally would be of interest to engineers engaged in the design or testing of electrical insulating materials, and is presented in clear and easily readable form." See also 1274 of May.

679.5: 621.3 1896
Plastics for Electrical and Radio Engineers [Book Review]—Tucker and Roberts. Technical Press, Kingston, Surrey, 1946, 12s. (*Electrician*, vol. 136, p. 1037; April 19, 1946.) "... explains sufficient about the manufacture and properties... and describes their methods of application..."

778: 62 1897
Photography in Engineering [Book Review]—C. H. S. Tupholme, Faber and Faber, London, 1945, 276 pp., 188 plates, 42s. (*Engineering, Lond.*, vol. 160, pp. 440-441; November 30, 1945. *Nature, Lond.*, vol. 157, pp. 32-33; January 12, 1946.) "... forms a greatly needed and compact source of information on the subject." Applications of photography to workshop and drawing-office practice are included.

MATHEMATICS

512.831: 621.3.012.8 1898
Tensors and Equivalent Circuits—B. Hoffmann. (*Jour. Math. Phys.*, vol. 25, pp. 21-25; February, 1946.) Criticism of Kron's work on equivalent circuits (2905 of 1943 and 2838 of 1944) for mechanical, electro-dynamical, and other systems.

517.3 1899
An Extension of Schuster's Integral—H. Bateman. (*Proc. Nat. Acad. Sci., Wash.*, vol. 32, pp. 70-72; March, 1946.) The integral occurs in the theory of total reflection of light.

517.564.3 1900
A Note on Bessel Functions of Purely Imaginary Argument—E. W. Montroll. (*Jour. Math. Phys.*, vol. 25, pp. 37-48; February, 1946.)

517.947.44 1901
On the Near-Periodicity of Solutions of the Wave Equation: Part 1—S. L. Soboleff. (*Compt. Rend. Acad. Sci. U.R.S.S.*, vol. 48 pp. 542-545; September 20, 1945. In French.) Mathematical analysis of the wave equation for the general case of a space of n , variables leading to the conclusion that, subject to the continuity of certain derivatives of the solution to the wave equation, the latter can be shown to be periodic or nearly periodic.

517.947.44 1902
On the Near Periodicity of Solutions of the Wave Equation: Part 2—S. L. Soboleff. (*Compt. Rend. Acad. Sci. U.R.S.S.*, vol. 48, pp. 618-620; September 30, 1945. In French.) "In an earlier note [see 1901 above] it was shown that the solutions of the wave equation with constant coefficients were nearly periodic... In the present note, a generalization of the earlier results for the case of a wave equation with variable coefficients is given."

518.5 1903
A Computer for Solving Linear Simultaneous Equations—Berry, Wilcox, Rock, and Washburn. (*See* 1927.)

518.5 1904
Integrating Machine for Ordinary Differential Equations—R. Sauer and H. Pösch. (*Zeit. Ver. d. Ing.*, vol. 87, pp. 221-224; April 17, 1943.) Brief description of the design and testing of a mechanical integrator.

518.5: 621.38 1905
U. S. War Department Unveils 18,000-Tube Robot Calculator—U. S. Army Ordnance Dept. (*See* 1928.)

534.26 1906
On Diffraction of Elastic Waves—D. I. Scherman. (*Compt. Rend. Acad. Sci. U.R.-S.S.*, vol. 48, pp. 626-629; September 30, 1945. In English.) A short mathematical paper on the calculation of the vector components of a steady vibration propagated in an elastic medium.

621-526 1907
On the Method of van der Pol and its Application to Non-Linear Control Problems [Servo Mechanisms]—B. V. Bulgakov. (*Jour. Frank. Inst.*, vol. 241, pp. 31-54; January, 1946.) "The construction of approximate differential equations of a mechanical or electrical pseudo-linear oscillatory system with many degrees of freedom... applicable to the study of the transitory or quasi-periodic processes and not only of the periodic vibrations" as previously investigated.

The analysis is applied to an automatically controlled system with inertia (servo mechanism) in which feedbacks proportional to the departure from the preselected state and the first and second time derivatives of this quantity are present. It is shown that in the absence of continuous external perturbations the effect of the acceleration control is equivalent to the alteration of the constants in a system without such control.

Periodic vibrations of the system are studied by an "approximate linearization" of the equation expressing the behavior of the servo motor, and the conditions for stability are investigated.

621.395.4 1908
The Probability Distributions of Sinusoidal Oscillations Combined in Random Phase—M. Slack. (*Jour. I.E.E. (London)* vol. 93, pp. 76-86; March, 1946.) A theoretical discussion of "the probabilities associated with the instantaneous value and the length of the resultant vector obtained by combining n cosine oscillations of equal amplitude and random phase relationship. It is mainly concerned with very small values of n ($=2, 3, 4 \dots 12$), and gives, for the first time, a complete set of curves showing the probabilities of the instantaneous value and the length of the resultant vector exceeding any given limits." The problem is fundamental to multichannel transmission through a common amplifier, the operational loading of which depends on whether there can be simultaneous occurrence of peak values in all the speech channels.

538.566: 621.396.677.029.64 1909
Laguerre Functions in the Mathematical Foundations of the Electromagnetic Theory of the Paraboloidal Reflector—E. Pinney. (*Jour. Math. Phys.*, vol. 25, pp. 49-79; February, 1946.) The laws of geometrical optics are not rigorously applicable for

microwave radiation within a paraboloidal reflector; differences from experimental results are considerable, even for reflector diameters as great as 10 to 15 wavelengths. The paper establishes "a beginning point for this practical development of a more rigorous paraboloidal theory." Extensive bibliographies are given for the polynomials $L_n(z)$ and $L_n^a(z)$.

MEASUREMENTS AND TEST GEAR

621.3.011.2: 546.77 1910
Negative Resistance-Temperature Coefficient of Thin Evaporated Films of Bismuth—Tulley. (See 1878.)

621.317 1911
A.I.E.E. Winter Convention, January, 1946—(Elec. Eng., vol. 65, pp. 29-35; January, 1946.) Abstracts are given of the following papers presented at the convention: "Electronically Balanced [Potentiometer-] Recorder for Flight Testing and Spectroscopy," by A. J. Williams, Jr., W. R. Clark, and R. E. Tarpley; "Techniques and Facilities for Microwave Radar Testing," by E. I. Green, H. J. Fisher, and J. G. Ferguson.

Titles of other papers are given in other sections. For other abstracts, see *Electronics*, vol. 19, pp. 230-266; April, 1946.

621.317 1912
A Braille Analyzer—W. S. Wartenberg. (*Radio Craft*, vol. 17, pp. 387-388; March, 1946.) An instrument for use by the blind for measuring direct current, potential drop, and impedance. The unknown quantity is balanced against a standard, essentially by the use of potentiometer circuits. The out-of-balance current is passed through ear-phones, and is interrupted by a vibrator switch so as to produce an audible note that vanishes in amplitude when balance is reached. The potentiometer control and circuit switches have Braille markings.

621.317.3.029.58/.62]: 621.315.213.12 1913
Apparatus for Measurements on Balanced-Pair High-Frequency Cables in the Range 10-200 Mc/s—J. S. Simmonds. (*Jour. I.E.E. (London)*, vol. 93, pp. 148-149; March, 1946.) Summary of 667 of March.

621.317.3.029.63/.64 1914
Radio Measurements in the Decimetre and Centimetre Wavebands—R. J. Clayton, J. E. Houldin, H. R. L. Lamont, and W. E. Willshaw. (*Jour. I.E.E. (London)*, vol. 93, pp. 97-117; discussion pp. 117-125; March, 1946.) A survey of apparatus and methods used in the research laboratory of the (British) General Electric Company. A large number of subjects are briefly discussed under the headings of circuit theory, signal sources, the measurement of frequency, power, impedance, and field strength, and measurements on receivers and aeri-als. The paper is followed by a long discussion.

621.317.3.029.63/.64]: 621.315.611 1915
Resonance Methods of Dielectric Measurement at Centimetre Wavelengths—F. Horner, T. A. Taylor, R. Dunsmuir, J. Lamb, and W. Jackson. (*Jour. I.E.E. (London)*, vol. 93, pp. 149-150; March, 1946.) Summary of 966 of April.

621.317.33.029.63 1916

The Measurement of Impedances Particularly on Decimetre Waves—J. M. van Hofweegen. (*Philips Tech. Rev.*, vol. 8, pp. 16-24; January, 1946.) At wavelengths greater than 1 meter the detuning and damping of a tuned circuit by the impedance is measured, using a diode voltmeter. At shorter wavelengths, e.g., 50 centimeters, a screened twofold Lecher system is used.

621.317.35 1917
Complex Waveforms: The Harmonic Synthesiser—H. Moss. (*Electronic Eng.*, vol. 18, pp. 113-116; April, 1946.) Part 4 of a series on cathode-ray tube traces. Three types of wave symmetry (alternance, normal, and skew symmetry) are illustrated and their application to wave-form analysis discussed. For part 3, see 3988 of 1945.

621.317.361+621.396.611.21 1918
Low-Frequency Quartz Crystals—C. E. Lane. (*Radio*, vol. 30, pp. 12, 14; March, 1946.) Illustrated summary of 1582 of June.

621.317.7: 621.319.4 1919
Capacitors for Measurement—C. G. Garton. (*Electrician*, vol. 136, pp. 543-544; March 1, 1946.) An account of the reading and discussion of an Institution of Electrical Engineers paper on the characteristics and errors of capacitors used for measurement purposes.

621.317.7: 621.396.62 1920
Sensitive [Signal] Tracer—C. Zwicker. (*Radio Craft*, vol. 17, pp. 393-394; March, 1946.) Description and circuit diagram of a tracer for use in servicing receivers.

621.317.7: 621.396.82 551.57: 629.135 1921
[U. S.] Army-Navy Precipitation-Static Project: Part 2—Aircraft Instrumentation for Precipitation-Static Research—Waddell, Drutowski, and Blatt. (See 1992.)

621.317.725: 621.385 1922
Converting D. C. [Volt] Meter to A.C. V.T.V. Use—W. M. Breazeale. (*Communications*, vol. 26, pp. 38-39; March, 1946.) A circuit comprising a triode cathode follower that rectifies the signal, and a pentode cathode follower that operates the direct-current meter. Diode overload protection is included.

621.317.761.029.62/.64 1923
The Measurement of Frequencies in the Range 100 Mc/s to 10,000 Mc/s—L. Es- sen and A. C. Gordon-Smith. (*Jour. I.E.E. (London)*, vol. 93, p. 147; March, 1946.) Summary of 679 of March.

621.317.763.029.62/.64]: 621.396.611 1924
Cavity-Resonator Wavemeters—L. Es- sen. (*Wireless Eng.*, vol. 23, pp. 126-132; May, 1946.) A detailed description of "four simply constructed cavity-resonator wavemeters covering the frequency ranges 10,000 Mc/s-4000 Mc/s, 5600 Mc/s-2000 Mc/s, 2700 Mc/s-1000 Mc/s and 1000 Mc/s-200 Mc/s. The mode of resonance employed is the hybrid between the cylindrical TM_{010} mode and the coaxial TM_{00g} mode, and the frequency variation is effected by the axial movement of a plunger attached to a micrometer head. For the first three wavemeters the plunger is of a noncontact design, thus obviating the necessity for a good electrical

contact which has hitherto caused considerable manufacturing difficulties. The setting accuracy of the instruments is shown to be better than 1 part in 10^4 of frequency throughout the greater part of the range."

621.317.79: 621.39 1925
New Test Equipment Circuits—(*Radio*, vol. 30, p. 30; March, 1946.) Circuit diagrams of an intermodulation analyzer and a dual resistance-capacitance sine-wave signal generator.

621.396.611.21: 621.396.615.14 1926
Frequency Stabilization at 450 Mc/s—P. B. Myers. (*Electronics*, vol. 19, pp. 214-216; April, 1946.) Generator using the fifth harmonic of a 10-megacycle crystal with two electronic triplers. The output at 450 megacycles is as stable (2.5 parts in 10^6) as the crystal's fundamental frequency.

OTHER APPLICATIONS OF RADIO AND ELECTRONICS

518.5 1927
A Computer for Solving Linear Simultaneous Equations—C. E. Berry, D. E. Wilcox, S. M. Rock, and H. W. Washburn. (*Jour. Appl. Phys.*, vol. 17, pp. 262-272; April, 1946.) Basic electrical circuits for representing the mathematical relations are given, and a commercial model of a 12-equation computer described. This may be applied to any problem involving simultaneous linear equations, and it is found that solving 12 equations requires only $\frac{1}{4}$ to $\frac{1}{2}$ of the time required by conventional methods.

518.5: 621.38 1928
[U. S.] War Department Unveils 18,000-Tube Robot Calculator—U. S. Army Ordnance Dept. (*Electronics*, vol. 19, pp. 308-314; April, 1946.) Description of the Electronic Numerical Integrator and Computer (Eniac) designed for aiding ordnance calculations. It is a digital machine, performs a single addition in 1/5000 second, and can carry out more than 10^7 additions or subtractions of 10-figure numbers in 5 minutes. The arithmetic, memory, and control elements are described, and the use of punched cards for external memory is noted.

53+6(73) 1929
American Trends of Development in the Physical Sciences—Overbeck. (See 2073.)

621.3: 629.13 1930
Air Forces' Needs in Electric Equipment—G. C. Crom, Jr. (*Elec. Eng.*, vol. 65, pp. 17-22; January, 1946.) The substance of a lecture reviewing control, communications, and navigation.

621.317.39 1931
Electrical Non-Destructive Testing of Materials—G. R. Polgreen and G. M. Tomlin. (*Electronic Eng.*, vol. 18, pp. 100-105; April, 1946.) The correct correlation between the electrical and magnetic properties of the materials and the corresponding physical properties, which the instruments are required to measure, is dealt with in general. Details are given of a magnetic sorting bridge for testing the chemical composition, hardness and tempering of springs, valves, and gudgeon pins for internal combustion engines. Also described are a radio-frequency method for detecting and measuring longi-

tudinal cracks, laps, or seams in uniform-cross-section conductors of any length and diameters ranging from $\frac{1}{4}$ inch to 6 inches, the Tait layer-thickness meter for measuring nonmagnetic coatings on a magnetic base, and an electronic micrometer for the continuous measurement of metal foil thickness.

621.318.572: 778 1932
Spectrograph Exposure Control—J. R. Cosby. (*Electronics*, vol. 19, pp. 123–125; April, 1946.) A semiautomatic device for obtaining duplicate exposures of spectrographic plates despite variation of source intensity. The current through a photocell exposed to the light source charges the grid of a cold-cathode tube which ultimately fires, operates a ratchet counter, and re-establishes its initial operating condition. The exposure is ended after a predetermined number of impulses.

621.365.5+621.317.39 1933
A.I.E.E. Winter Convention, January, 1946—(*Elec. Eng.*, vol. 65, pp. 29–35; January, 1946.) Abstracts are given of the following papers presented at the convention: "Induction Heating of Long Cylindrical Charges," by H. F. Storm; "Stress Measurement by Electrical Means," by S. B. Williams and R. E. Kern.

Titles of other papers are given in other sections. For other abstracts, see *Electronics*, vol. 19, pp. 230–266; April, 1946.

621.365].5+.92 1934
Role of Automatic Rematching in H.F. Heating—E. Mittelman. (*Elec. World*, p. 98; August 4, 1945.) Abstract in *Electronic Eng.*, vol. 18, p. 155; May, 1946.

621.365].5+.92 1935
High-Frequency Electric Heating—(*Electrician*, vol. pp. 351–354; February 8, 1946.) A number of industrial applications are discussed.

621.365.5+621.365.92]: 621.396.662 1936
A.F.C. for R.F. Heating—S. I. Rambo. (*Electronics*, vol. 19, pp. 120–122; April, 1946.) The changing load during a heat cycle makes some form of frequency control essential to avoid interference with communication services. Crystal oscillators with power amplifiers may be suitable for low powers. Mechanical variation of the tuning circuit is cheaper and simpler for powers over about 10 kilowatts. A practical system using a reversible motor is outlined, and a method of regaining control when the frequency is outside the bandwidth of the discriminator is described.

621.365.52 1937
Steel Furnaces: Coreless Induction Type—M. J. Marchbanks. (*Elec. Rev.*, Lond., vol. 138, pp. 603, 641; April 19–26, 1946.) Summary and discussion of an Institution of Electrical Engineers paper.

621.365.52 1938
H.F. Inductor Heating—(*Elec. Rev.*, Lond., vol. 138, pp. 399–403; March 15, 1946.) Special attention is given to cases where only part of the object requires heat treatment. The equipment described (Birlec Ltd.) includes a spark-gap type for uncritical operations, frequency up to 100 kilocycles,

and high-frequency alternator, frequency up to 12 kilocycles for heating more than 200 pounds of metal per hour, and a vacuum tube generator, frequency above 12 kilocycles, for heating less than 200 pounds per hour.

621.365.92: 664.6 1939
R.F. Heating in Bakery Industry—V. W. Sherman. (*Electronics*, vol. 19, pp. 166–186; April, 1946.) A survey of applications and costs. Report of lecture.

621.38+621.395/.396](43): 06.064 1940
Exhibition of German Electronic Equipment—P. I. Nicholson. (*Electronic Eng.*, vol. 18, pp. 156–157; May, 1946.) An account of the exhibition at Earls Court, which included radio components, vacuum tubes, relays, communications equipment, acoustic instruments, infrared equipment, radio navigational aids, and control units for rockets and other missiles.

621.38+621.396 1941
Electronics—(*Gen. Elec. Rev.*, vol. 49, pp. 54–58; January, 1946.) Annual review of developments.

621.38: 62 1942
Electronics in Engineering—(*Engineer*, Lond., vol. 181, pp. 82–83; January 25, 1946.) Description of some instruments designed by the (British) General Electric Company, including magnetic sorting bridge, radio-frequency crack detector, film thickness meter, and metal thickness meter.

621.383: 551.576 1943
The Cloud Range Meter—F. J. Moles. (*Gen. Elec. Rev.*, vol. 49, pp. 46–48; April, 1946.) An optical device analogous with radar. Very intense light flashes of one microsecond duration are produced by a high-voltage spark gap at the focus of a paraboloidal reflector. The beam is aimed at the cloud and the flashes are reflected back to a receiving paraboloidal mirror with a photocell at its focus. Both mirrors are mounted on the same support, point in the same direction, and move together. The pulses from the photocell are amplified in a high-gain Video amplifier and displayed on a cathode-ray oscillograph. The timebase sweep is started in synchronism with the transmitted pulse, so the position of the reflected pulse along the sweep is a measure of the cloud distance; a calibrated scale on the mirror support gives the cloud elevation. The whole apparatus is compact and transportable.

621.385.833 1944
The Measured Characteristics of Some Electrostatic Electron Lenses—Discussion—K. Spangenberg. (*Elec. Commun.*, vol. 22, pp. 379–380; 1945.) Discussion of 1294 of 1944 (Spangenberg and Field) explaining an apparent discrepancy, and correcting a typographical error.

621.385.833 1945
Calculation of Fields of the Simplest Electrostatic Lenses—A. Vlasov. (*Jour. Phys.*, U.S.S.R., vol. 9, p. 60; 1945.) Abstract of a paper of the Academy of Science, U.S.S.R.

621.385.833 1946
A Short Magnetic Lens with a Minimum

Spherical Aberration—A. Vlasov. (*Jour. Phys.*, U.S.S.R., vol. 9, p. 60; 1945.) Abstract of a paper of the Academy of Science, U.S.S.R.

621.385.833 1947
Further Improvement in the Resolving Power of the Electron Microscope—J. Hillier. (*Jour. Appl. Phys.*, vol. 17, pp. 307–309; April, 1946.)

621.385.833 1948
Electron Microscope of the State Optical Institute—V. Vertzner. (*Jour. Phys.*, U.S.S.R., vol. 9, p. 60; 1945.) The instrument gives a magnification up to 25,000 with a resolving power of 75 to 100 angstroms providing two microphotographs per charge of the camera. In an investigation of the evaporation of silver on a celluloid film, particle dimensions of 75 to 300 angstroms with separations of 200 angstroms were noted, corresponding to 13 micrograms per square centimeter. Abstract of a paper of the Academy of Science, U.S.S.R.

621.385.833 1949
A Shadow-Casting Adaptor for the Electron Microscope—T. F. Anderson. (*Rev. Sci. Instr.*, vol. 17, pp. 71–72; February, 1946.)

621.385.833 1950
Preparation of Electron Microscope Specimens for Determination of Particle Size Distribution in Aqueous Suspensions—A. M. Cravath, A. E. Smith, J. R. Vinograd, and J. N. Wilson. (*Jour. Appl. Phys.*, vol. 17, pp. 309–310; April, 1946.)

621.385.833 1951
Electron Microscope and Investigation of the Structure of Ceramic Materials—I. I. Kitaigorodsky. (*Compt. Rend. Acad. Sci. U.R.S.S.*, vol. 48, pp. 563–564; September 20, 1945. In English.)

621.385.833: 537.533 1952
Field-Emission of Electrons—P. Lukirsky. (*Jour. Phys.*, U.S.S.R., vol. 9, pp. 59–60; 1945.) The field-emission current from a metal usually takes place at lower fields, than is required by the Fowler-Nordheim theory because of surface roughness. With smooth spheres, theoretical values of the current agree with experiment. Complex cathodes were investigated and current resulted at field strengths of 10^6 volts per centimeter. The energy spectrum of the emitted electrons and field emission from single crystals was examined in relation to the field-emission electron microscope. Abstract of a paper of the Academy of Science, U.S.S.R.

621.386.1: 6 1953
Prague Conference on the Use of X-Rays in the Metal Industries—V. Vand. (*Nature*, Lond., vol. 157, pp. 415–416; March 30, 1946.)

621.396.9: 529.781 1954
Pocket Radio Watch—E. A. Witten. (*Radio Craft*, vol. 17, p. 389; March, 1946.) Nontechnical description of proposed broadcast time-signal service that would operate with pocket receivers.

621.396.91: 550.37 1955
Radio-Sonde Recording of Potential Gradients—K. Kreielsheimer and R. Belin.

(*Nature*, Lond., vol. 157, pp. 227-228; February 23, 1946.) The modulation frequency of the balloon transmitter is varied by changes in the modulator grid potential caused by passing the current due to a point discharge through a resistor. The discharge is initiated by a field of 3 volts per centimeter with a 64-foot collector wire. A sample record of a balloon flight through an isolated CuNb cloud is shown.

621.396.933.2: 621.396.91 1956

The Application of Ultra-Short-Wave Direction Finding to Radio Sounding Balloons—Smith-Rose and Hopkins. (See 1864.)

621.398+621.396.932 1957

The Engineering Work of the Clyde Lighthouses Trust—Stevenson. (See 1862.)

621.3.078: 54 1958

Principles of Industrial Process Control [Book Review]—D. P. Eckman. J. Wiley & Sons, New York, N. Y., 1945, 237 pp., \$3.50. (*Jour. Sci. Instr.*, vol. 23, p. 18; January, 1946. *Elec. Ind.*, vol. 5, pp. 161-162; February, 1946.) "... deals essentially with the design and operation of controllers and control instruments which are used in the chemical industry."

621.365.92 1959

Capacity Current Heating [Book Review]—T. H. Messenger and D. V. Onslow. British Electrical & Allied Industries Research Assn., London, 1945, 9s. (*Engineering*, Lond., vol. 160, p. 474; December 7, 1945.) Summarizes available information on existing applications. The report is in three sections dealing with theory, applications, and equipment costs, and contains a bibliography of 241 items.

621.388.833 1960

Electron Optics and the Electron Microscope [Book Review]—V. K. Zworykin, G. A. Morton, E. G. Ramberg, J. Hillier, and W. A. Vance. John Wiley & Sons, New York, N. Y., 754 pp., \$10.00. (PROC. I.R.E. AND WAVES AND ELECTRONS, vol. 34, p. 212; April, 1946.)

PROPAGATION OF WAVES

621.396.11+621.396.67 1961

The Ratio Between the Horizontal and the Vertical Electric Field of a Vertical Antenna of Infinitesimal Length Situated Above a Plane Earth—Niessen. (See 1769.)

621.396.11 1962

On the Propagation of Radio Waves Along an Imperfect Surface: Part 3—E. Feinberg. (*Jour. Phys.*, U.S.S.R., vol. 9, pp. 1-6; 1945.) This part deals with the effective path of the ground ray. It is suggested that the earth regions immediately surrounding the transmitter and receiver are of much greater importance than the rest of the intervening path. The analysis is based on Sommerfeld's theory, but has limited application as it applies only for large numerical distances where the integrals involved may be approximated by asymptotic formulas. The parameters characterizing an imperfect intermediate region of the path are negligible only in so far as the assumed perfect initial and final regions have the dimensions for which the numerical distances, calculated with respect to the properties of the intermediate region, are large compared to unity.

For previous work, see 2529 through 2531 of 1945.

621.396.11: 061.6 1963

Interservice Radio Propagation Laboratory—(*Jour. Frank. Inst.*, vol. 241, pp. 62-63; January, 1946.) An account of the laboratory set up at the National Bureau of Standards during the war to supply radio propagation information to the Armed Forces.

621.396.11: 551.51.053.5 1964

Forecasting for Radio—M. G. Morrow. (*Sci. News Lett.*, Wash., vol. 49, pp. 234-235; April 13, 1946.) Simple account of the predictions based on ionospheric and solar observations.

621.396.11: 551.51.053.5 1965

Short-Wave Conditions—T. W. Bennington. (*Wireless World*, vol. 52, p. 124; April, 1946.) Propagation conditions are forecast for April, 1946, with tables of maximum usable frequencies. Conditions occurring in February are described, including the effect of a large sunspot group.

621.396.11: 551.51.053.5 1966

Low-Level Reflections Observed at Christmas Island—Peavey. (See 1841.)

621.396.11: 551.51.053.5 1967

Intense Scatter in E_s -Region at Christmas Island—Peavey. (See 1840.)

621.396.11: 551.53.051.5 1968

Short Period Fluctuations in the Characteristics of Wireless Echoes from the Ionosphere—T. L. Eckersley and F. T. Farmer. (*Proc. Roy. Soc. A*, vol. 184, pp. 196-217; August 21, 1945.) A spaced-frame direction-finder system is used with a twin-channel amplifier and cathode-ray tube display. The phases and amplitudes of the electromotive forces in the aerial system can be determined from the elliptical trace, by using appropriate aerial connections. Pulsed transmissions can be examined by means of an adjustable gating device that densitizes the receiver for all but about 15 microseconds of the time-base cycle. Rapid changes in polarization and direction can be studied.

F-layer echoes show little change in characteristics over a period of about 20 seconds; abnormal-E and scatter reflections change in one second or less; but a continuity of phase was noticed even during the most rapid changes. The scatter echoes show remarkable variability of phase and direction. Skellett's suggestion (1752 of 1938) of meteoric origin of these echoes seems unlikely, as meteoric velocities of 100 kilometers would be required.

621.396.11: 523.76: 551.51.053.5 1969

The Solar Eclipse of 1945 and Radio Wave Propagation—Smith-Rose. (See 1831.)

621.396.11.029.56/.58 1970

The NBS-ARRL Radio Observing Projects—T. N. Gautier, Jr. (*QST*, vol. 30, pp. 18-23; April, 1946.) Since 1941, members of American Radio Relay League observed signal strengths and the highest frequencies received in the band 1.5 to 30 megacycles. In 1943, similar observations were started using transmitter WWV (2.5, 5, 10, and 15 megacycles). Charts show how the observations agreed with the maximum usable frequencies and the lowest useful high frequencies fore-

cast by the National Bureau of Standards. See also *Jour. Frank. Inst.*, vol. 241, pp. 243-244; March, 1946.

621.396.11.029.64+621.396.24+621.385.1 1971

Simultaneous Uses of Centimeter Waves and Frequency Modulation—A. G. Clavier and V. Altovsky. (*Elec. Commun.*, vol. 22, pp. 326-338; 1945.) English translation of 402 of February.

621.396.11.029.64: 551.577 1972

The Effect of Rain upon the Propagation of Waves in the 1- and 3-Centimeter Regions—S. D. Robertson and A. P. King. (PROC. I.R.E. AND WAVES AND ELECTRONS, vol. 34, pp. 178-180; April, 1946.) Observations were made on wavelengths of 1.09 centimeters and 3.2 centimeters over sufficiently short paths (1260 feet and 900 feet) to obtain uniformity of rainfall. There was a definite correspondence between heaviness of rainfall and attenuation of the radio signal on both wavelengths, the effect being greater on the shorter wavelength. Results were obtained mainly from two heavy storms, and mean values deduced from them were 0.05 decibel-per-mile path loss per millimeter-per-hour rainfall for $\lambda=3.2$ centimeters and 0.3 decibel-per-mile per millimeters per hour for $\lambda=1.09$ centimeters. During extremely heavy rain the attenuation was roughly 5 and 30 decibels per mile respectively, for the two wavelengths.

621.396.11.029.64: 551.577 1973

Propagation of 6-Millimeter Waves—G. E. Mueller. (PROC. I.R.E. AND WAVES AND ELECTRONS, vol. 34, pp. 181-183; April, 1946.) Observations on the effect of rainfall on waves of length 0.62 centimeter were made over a 1200-foot path. The method used was similar to that of Robertson and King (see 1972 above) and gave a mean value of 0.6 decibel-per-mile attenuation per millimeter-per-hour rainfall. The nonlinearity of the attenuation-per-wavelength curve found in a comparison with the results of Robertson and King is explained qualitatively in terms of the relative influence of scattering and absorption by the drop. Atmospheric absorption was found to be small (perhaps 0.2 decibel per mile) compared with loss due to rain.

RECEPTION

621.396.1 1974

CAA Alaskan Diversity Receiving System: Part 2—Ivers. (See 2002.)

621.396.11.029.64+621.396.24+621.385.1 1975

Simultaneous Use of Centimeter Waves and Frequency Modulation—Clavier and Altovsky. (See 1971.)

621.396.61.029.62 1976

The "Tiny Tim" Handie-Talkie—Haist (See 2063.)

621.396.62+621.395.92 1977

Radio Hearing Aid—Montani. (See 1763.)

621.396.62 1978

Radio Design Data Presented in Chicago—(*Electronics*, vol. 19, pp. 216-224; April, 1946.) Abstracts of papers on frequency-modulation receiver design, trends in receiver response, and intermodulation effects

in audio amplifiers presented at the Conference of the Chicago Section of the Institute of Radio Engineers.

621.396.621 1979
I.R.E. Winter Technical Meeting, January, 1946—(*Communications*, vol. 26, pp. 22-66; February, 1946.) Abstracts of some of the papers read. For titles, see 1649 of June.

621.396.621 1980
Station Design and Planning: Parts 4 and 5. The Amateur Bands Receiver—W. H. Allen. (*R.S.G.B. Bull.*, vol. 21, pp. 138-141; March, 1946; vol. 21, pp. 154-156; April, 1946.) A general account of the desirable features with elementary hints and suggestions for obtaining good performance, and notes on the design of audio-frequency stages. For previous parts, see 1801, 2067, and 1058 of April.

621.396.621 1981
Super-Reflex Radio—W. T. Connater. (*Radio Craft*, vol. 17, pp. 403-424; March, 1946.) Description and circuit of a three-tube superheterodyne broadcast-receiver.

621.396.621 1982
Hi-Fi T.R.F. Tuner—W. F. Frankart. (*Radio Craft*, vol. 17, pp. 401, 415, March, 1946.) Circuit diagram and constructional details of a three-stage tuner for amplitude-modulation broadcast reception.

621.396.621 1983
Radio Data Sheet 333—(*Radio Craft*, vol. 17, p. 395; March, 1946.) Servicing data for (U. S.) General Electric receivers 100, 101, 103, and 105.

621.396.621: 621.396.619.018.41 1984
F.M. Radio Service—J. King. (*Radio Craft*, vol. 17, pp. 391, 443-444; March, 1946.) Some instructions for servicing frequency-modulation receivers, indicating the main differences between amplitude-modulation and frequency-modulation receivers.

621.396.621.53 1985
Superheterodyne Frequency Conversion Using Phase-Reversal Modulation—E. W. Herold. (*Proc. I.R.E. AND WAVES AND ELECTRONS*, vol. 34, pp. 184-198; April, 1946.) "The principle of conversion herein described is to reverse the phase of the signal output periodically at a rate which differs from the signal frequency by the intermediate frequency. This may be done either by continuous variation of phase or by continuous variation of tube transconductance from positive to negative. The result is a conversion transconductance which is twice as high as had heretofore been believed ideal. Furthermore, if the phase-reversal rate is made by any integral multiple of an applied local-oscillator frequency, equally good conversion is obtained at a harmonic of the local oscillator without spurious responses at any other harmonic than the one chosen. An electron tube with a multihumped characteristic has been devised as a means to this end since the transconductance characteristic will then vary from positive to negative as the control voltage is varied. An analysis of such a tube is carried out in detail, including the effect of fluctuation noise.

"The analysis shows that the new conversion method doubles the conversion gain possible in a tube with a given maximum

transconductance. In an ideal case with no second-stage noise, the signal-to-noise ratio is as good as with the same tube used as amplifier; even in practical cases, the mixer is only 10 per cent to 20 per cent poorer than the amplifier. This is in contrast with conventional mixer methods in which the signal-to-noise ratio is from two to three times poorer than when the same tube is used as an amplifier.

"Conversion at a harmonic may also be achieved with high gain but it is found that the signal-to-noise ratio is not as favorable as with fundamental operation."

621.396.621.53 1986
Non-Linear Analysis—H. Stockman. (*Radio*, vol. 30, pp. 14, 47; March, 1946.) Illustrated summary of 1492 of June.

621.396.621.53.029.58 1987
A Band Pass 28-mc/s Converter—B. Goodman. (*QST*, vol. 30, pp. 44-120; April, 1946.) The construction of a fixed-tune, two-stage amplifier using staggered, single-tuned, low-*Q* circuits to obtain a pass-band ± 1.25 megacycles at 29 megacycles. A triode oscillator and a pentode mixer convert the signal frequency to 7.3 ± 1.25 megacycles. A conventional communication receiver follows the converter.

621.396.622.71 1988
A Low-Distortion Diode Detector—R. Knowles. (*R.S.G.B. Bull.*, vol. 21, p. 108; January, 1946.) An arrangement of a double-diode-triode (HL41/DD) to provide an efficient detector free from peak-clipping. A capacitor connected in the cathode circuit ensures that the input conductance, and therefore the damping of the tuned circuit is small.

621.396.622.71 1989
Low Distortion Diode Detector—R. G. Kitchenn: F. A. Ruddle. (*R.S.G.B. Bull.*, vol. 21, p. 161; April, 1946.) Correspondence on 1988 above.

621.396.82 1990
Beat-Frequency Interference Chart—D. Barton. (*Electronics*, vol. 19, p. 162; April, 1946.) Chart showing possible interfering signal frequencies when using a receiver with an intermediate frequency of 445 kilocycles, tuned within the range 550 to 1600 kilocycles. The curves are computed from formulas in 1879 of 1941 (Adams).

621.396.82: 551.57: 629.135 1991
[U. S.] Army-Navy Precipitation-Static Interference Problem and Methods for Its Investigation—R. Gunn, W. C. Hall, and G. D. Kinzer. (*Proc. I.R.E. AND WAVES AND ELECTRONS*, vol. 34, pp. 156-161; April, 1946.) The general nature of the project is reviewed, and the main lines of investigation discussed. One of the most important causes of precipitation static is the corona discharge which follows charging either by thunderstorms or by frictional electrification of the plane in flying through normal precipitation. Details of investigations on the various types of charging and discharging are given in ensuing papers. See 1992, 1993, and three other papers to be published later.

621.396.82: 551.57: 627.135: 621.317.7 1992
[U. S.] Army-Navy Precipitation-Static Project: Part 2—Aircraft Instrumentation

for **Precipitation-Static Research**—R. C. Waddel, R. C. Drutowski, and W. N. Blatt. (*Proc. I.R.E. AND WAVES AND ELECTRONS*, vol. 34, pp. 161-166; April, 1946.) Electric-field meters and wick dischargers measure the intensity and direction of the electric field, and an artificial charger simulates autogenous charging conditions. "A radio-noise meter is used to measure the interference level associated with precipitation static. Search electrodes, termed patches and probes, provide both integrated and detailed information on the charging processes concerned when precipitation strikes solid surfaces. An air-conductivity meter is provided for measuring the conductivity and ion content of the atmosphere. An accelerometer utilizing a telegauge tube measures turbulence. Data from the above and other instruments are brought to a central meter panel and intermittently photographed in flight. This photo-observer is supplemented by a disk voice recorder."

Some details are given of the various instruments used.

621.396.82: 551.57: 629.135 1993
[U. S.] Army-Navy Precipitation-Static Project: Part 3—Electrification of Aircraft Flying in Precipitation Areas—R. G. Stimmel, E. H. Rogers, F. E. Waterfall and R. Gunn. (*Proc. I.R.E. AND WAVES AND ELECTRONS*, vol. 34, pp. 167-177; April, 1946.) The main cause of electrification causing precipitation static is friction between the aircraft and particles of snow and ice. The charging characteristics of typical aircraft flying through dry snow are given and correlated with reliable data obtained on the ground under controlled conditions. It is shown that the charging depends both in rate and sign on the material of the surface of the aircraft. It was possible to make a noncharging aircraft by coating part of the surface with colloidal silica, so that the charging of the coated and uncoated parts balanced, but the contamination of the surface after ordinary servicing of the aircraft destroyed the noncharging property.

The charging current is a maximum at about -5 to -10 degrees centigrade under otherwise similar conditions. Under most conditions the charging current increases as the cube of the air speed.

Discharge first occurs by thermal ionization of the exhaust gases, and then, at higher voltage gradients (e.g., ~ 200 volts per centimeter), corona from aerials, wing and propeller tips, etc., carries the main discharge. Discharge by convection and atmospheric conductivity are unimportant.

Charging due to thunder conditions are discussed briefly. The fields at the aircraft surfaces due to this cause vary rapidly and can be very high (e.g., ~ 3000 volts per centimeter) for short periods.

621.396.82: 621.396.619.018.41 1994
Interference in Frequency Modulation—N. Marchand. (*Communications*, vol. 26, pp. 38-40, 42; February, 1946.) A theoretical comparison of frequency-modulation and amplitude-modulation receiver responses to adjacent-carrier, random-noise, and impulse-noise types of interference. The signal-to-noise ratio is in each case greater for frequency-modulation, particularly if de-emphasis is used. This paper is a sequel to 1675 of June.

- 621.396.82: 621.396.619.018.41 1995
Effect of Common-Channel Interference on Frequency-Modulation Broadcasting—A. L. Durkee. (*Proc. I.R.E., Aust.*, vol. 7, pp. 10–11; March, 1946.) Reprint of 2591 of 1945.
- 621.396.823: 621.365: 621.315.551. 1996
Interference with Broadcast Reception by Electrical Heating Apparatus—W. Gerber and A. Werthmüller. (*Tech. Mitt. Schweiz. Telegr. Verw.*, vol. 23, pp. 241–247; December, 1945. In German.) Domestic receivers usually take a considerable part of their high-frequency power from the house power-supply wiring system. Consequently, interference can be caused by variations in the high-frequency currents in the house wiring, resulting from periodic variation of the high-frequency impedance of the wiring. Hum interference due to this cause is estimated to affect 20 per cent of broadcast receivers. The hum tunes in with a received signal, and is sometimes thought by the listener to be due to modulation of the transmitter. It has previously been shown by the writer's department (evidently the Swiss Post Office; no reference is given to previous publications) that such interference is almost entirely associated with domestic heating appliances, and is a result of the use of ferromagnetic alloys for the heating elements. The high-frequency impedance of these elements varies with permeability, the permeability depends on the temperature of the heater, and the temperature varies at double the frequency of the alternating heating current. The ferromagnetic properties of the nickel-chromium-iron heater-wire alloys are discussed, and recommendations made for the selection of nonmagnetic types. The nature of the interference modulation is discussed in some detail. The shunting of heating devices with by-pass capacitors is an effective method of reducing the interference.
- STATIONS AND COMMUNICATION SYSTEMS**
- 621.39: 623.6 1997
Infantry Combat Communications—R. E. Willey. (*Elec. Eng.*, vol. 65, pp. 1–7; January, 1946.) A description of the radio and line, telephone and telegraph equipment used by the U. S. Infantry. The range, frequency, and power output of various radio sets are given, with their uses in combat. Examples are quoted of communication problems encountered in action and unorthodox methods used in overcoming them.
- 621.395.1 1998
Communication System—T. W. W. Holden. (*Radio*, vol. 30, pp. 29, 48; March, 1946.) A device for securing voice transmission, using a frequency band much narrower than that usually required, by leaving "repetitious" waves out of the transmission and reintroducing them at the receiver. Summary of U. S. Patent 2,387,906.
- 621.395.4 1999
The Probability Distributions of Sinusoidal Oscillations Combined in Random Phase—Slack. (*See* 1908.)
- 621.395.44 2000
The Unit Bay 1B Coaxial Cable Transmission System: Part 3—R. A. Brockbank and C. F. Floyd. (*Post Office Elec. Eng. Jour.*, vol. 39, pp. 14–17; April, 1946.) Continuation of 184 of January, describing the terminal repeater station equipment.
- 621.396.1 2001
Frequency Service Allocations—P. D. Miles. (*PROC. I.R.E. AND WAVES AND ELECTRONS*, vol. 34, pp. 188–192; April, 1946.) An account of the principles underlying the (U. S.) Federal Communications Commission's plan for frequency allocation announced in May, 1945.
- 621.396.1 2002
CAA Alaskan Diversity Receiving System: Part 2—J. Ivers. (*Communications*, vol. 26, pp. 56–58, 61; February, 1946.) The rectified outputs from the eight diversity receivers are combined and used to key the output from an audio-frequency oscillator. The outputs from a number of diversity systems may be transmitted over one telephone line, using highly stable Wien-bridge oscillators on different audio frequencies. For part 1, see 1669 of June.
- 621.396.11.029.64+621.396.24+621.385.1 2003
Simultaneous Use of Centimeter Waves and Frequency Modulation—Clavier and Altovsky. (*See* 1971.)
- 621.396.61.029.58 2004
200-Kilowatt High-Frequency Broadcast Transmitters—Romander. (*See* 2061.)
- 621.396.619.16 2005
Pulse [Width] Modulation—A. T. Hickman. (*R.S.G.B. Bull.*, vol. 21, pp. 150–153; April, 1946.) A typical modulation circuit is described and the frequency spectrum analyzed.
- 621.396.619.16 2006
Pulse Modulation—"Cathode Ray"—(*Wireless World*, vol. 52, pp. 113–117; April, 1946.) A discussion of the various types of modulation explaining the advantages of pulse modulation at very high frequencies.
- 621.396.721 2007
Mobile 2 to 18 Mc/s Radioteletype for Long-Range Operation—H. L. Landau. (*Communications*, vol. 26, pp. 36–74; February, 1946.) The AN/MRC-2, designed for tactical army use, has been installed in a railway coach and in an aircraft. A 2-kilowatt transmitter, with frequency-shift keying, and dual space-diversity receivers are used. The transmitter is remotely controlled, and can be converted for hand keying.
- 621.396.82: 621.396.619.018.41 2008
Interference in Frequency Modulation—Marchand. (*See* 1994.)
- 621.396.97(73) 2009
Broadcasting in U.S.A.—Report on Post-War Trends—A. Dinsdale. (*Wireless World*, vol. 52, pp. 132–135; April, 1946.) The economic position of American broadcasting, with its great dependence on advertising rents, is such that rapid development in television and in frequency-modulation transmission is unlikely.
- SUBSIDIARY APPARATUS**
- 53+6(73) 2010
American Trends of Development in the Physical Sciences—Overbeck. (*See* 2073)
- 531.788: 539.164.92 2011
Radium-Type Vacuum Gauge—Mellen. (*See* 1867.)
- 621–526 2012
On the Method of van der Pol and its Application to Non-Linear Control Problems [Servo Mechanisms]—Bulgakov. (*See* 1907.)
- 621–526 2013
Theory of Servo Systems—A. L. Whiteley. (*Electrician*, vol. 136, pp. 823–824; March 29, 1946.) Summary and discussion of an Institution of Electrical Engineers paper.
- 621.3 2014
A.I.E.E. Winter Convention, January, 1946—(*Elec. Eng.*, vol. 65, pp. 29–35; January, 1946.) Abstracts are given of the following papers presented at the convention: "Applications of Thin Permalloy Tape in Wide-Band Telephone and Pulse Transformers," by A. G. Ganz; "A B-H Curve Tracer for Magnetic-Recording Wire," by T. H. Long and G. D. McMullen; "An Automatic Oscillograph with a Memory," by A. M. Zarem; "Electronic Generator Voltage Regulator," by J. E. Reilly and C. E. Valentine.
- Titles of other papers are given in other sections. For other abstracts, see *Electronics*, vol. 19, pp. 230–266; April, 1946.
- 621.314.2.017 2015
Thermal Characteristics of Transformers: Part 1—V. M. Montsinger. (*Gen. Elec. Rev.*, vol. 49, pp. 31–35, 38–42; April, 1946.) Power transformer loadings approved by the A.I.E.E. Standards are governed by the "eight-degree" rule, which states that the rate of mechanical deterioration of class-A insulation is doubled for each eight degrees centigrade increase in temperature.
- In determining the effect of high operating temperatures on the life of a transformer, measurement of the dielectric strength of the insulation is not a safe guide, since the determining factor is the ability of the materials involved to withstand abnormal mechanical stresses.
- It has been found that the eight-degree rule is fairly reliable in the range 115 degrees to 200 degrees centigrade; it decreases from eight degrees at 115 degrees centigrade, gradually, down to about three degrees at 75 degrees centigrade.
- Practical temperature standards and other factors governing the design of transformer cooling systems are considered.
- 621.314.2.017 2016
Temperature Rise of Water-Cooled Power Transformers—J. R. Meador. (*Gen. Elec. Rev.*, vol. 49, pp. 55–59; April, 1946.)
- 621.314.22/23 2017
The Impedances of Multiple-Winding Transformers: Part 2—S. A. Stigant. (*Beama Jour.*, vol. 53, pp. 109–114; March, 1946.) The derivation of the impedance tensor Z_{ab} and the construction of equivalent impedance network diagrams for m -winding transformers. For part 1, see 1685 of June. To be continued.
- 621.314.632.029.6: 546.28 2018
H.F. Crystal Diodes—LeDuc. (*See* 2077.)
- 621.314.65: 621.396.71 2019
The Application of High-Voltage Steel-

Tank Mercury-Arc Rectifiers to Broadcast Transmitters—P. A. T. Bevan. (*Jour. I.E.E.* (London), vol. 93, pp. 131-136; March, 1946.) Long abstract of 206 of January.

621.314.65: 621.396.71 2020
High-Voltage Steel-Tank Mercury-Arc Rectifier Equipments for Radio Transmitters—J. C. Read. (*Jour. I.E.E.* (London), vol. 93, pp. 128-130, March, 1946.) Long abstract of 205 of January.

621.316.54 2021
Fundamental Properties of the Vacuum Switch—R. Koller. (*Phys. Rev.*, vol. 69, p. 134; February 1-15, 1946.) "An exhaustive study of the basic mechanism affecting the direct-current operation of the vacuum switch." Abstract of an American Physical Society paper.

621.316.86: 546.281.26 2022
[Silicon-carbide] Non-Ohmic Resistors—Ashworth, Needham, and Sillars. (*See* 1885.)

621.317.35 2023
Complex Waveforms: The Harmonic Synthesiser—Moss. (*See* 1917.)

621.317.755 2024
High Speed Oscillograph—N. Rohats. (*Electronics*, vol. 19, pp. 135-137; April, 1946.) An oscillograph for transient measurements at writing speeds greater than 50 centimeters per microsecond using a sealed hot-cathode tube described in 3117 of 1937. A balanced thyatron sweep generator that can trigger or be triggered by the transient under observation is also described. Speeds up to several meters per microsecond may be used with a camera lens of aperture $f/1.5$.

621.318.572 2025
Electronic Contactors for Control Applications—W. D. MacGeorge. (*Electronics*, vol. 19, pp. 186-206; April, 1946.) A survey of switch circuits using hard tubes and hot- and cold-cathode relay tubes. Typical trigger requirements and power handling capacity are quoted.

621.318.572: 531.76: 539.16.08 2026
Experimental Arrangement for the Measurement of Small Time Intervals between the Discharges of Geiger-Müller Counters—B. Rossi and N. Nereson. (*Rev. Sci. Instr.*, vol. 17, pp. 65-71; February, 1946.) A circuit is designed to give a voltage pulse of which the magnitude is a function of the time interval. The recovery time is sufficiently long to allow either visual observations or photographic recording with a cathode-ray tube. Details are also given of an arrangement using a pen recorder.

621.319.4: 621.317 2027
Capacitors for Measurement—Garton. (*See* 1919.)

621.383 2028
[Photoelectric] Electron Multipliers—E. Kormakova. (*Jour. Phys.*, U.S.S.R., vol. 9, p. 62; 1945.) The multipliers described have semicircular emitters located on a cylindrical surface. Caesium-oxide surfaces, prepared on glass or nickel, are used as emitters and cathode. The cylindrical type with 10 or 12 emitters and a grid, has a

sensitivity of 0.5 to 5 amperes per lumen, with "dark" current 0.52 microamperes. Abstract of a paper of the Academy of Science, U.S.S.R.

621.383 2029
Some Results of the Application of Principle of Secondary-Electron Transformation—L. Kubetzky. (*Jour. Phys.*, U.S.S.R., vol. 9, p. 62; 1945.) A highly sensitive photocell has been derived from a secondary electron mechanism. An efficient emitter of high stability has been discovered, being a combination of copper, sulphur, and caesium. A new photocathode with improved spectral characteristics is also mentioned. Abstract of a paper of the Academy of Science, U.S.S.R.

621.383.2+535.215.1 2030
Complex Photoelectric Cathode—Khlebnikov. (*See* 1819.)

621.383.2 2031
New SB-Cs Photocells—N. Khlebnikov and A. Melamid. (*Jour. Phys.*, U.S.S.R., vol. 9, p. 64; 1945.) Two new types, one for use down to 1900 angstroms and the other a highly sensitive (50 microamperes per lumen) model showing no fatigue even at high cathode illumination (10 Lx.) Abstract of a paper of the Academy of Science, U.S.S.R.

621.383.2 2032
Energy Distribution of the Electrons and Dependence of Photocurrent for Caesium-Oxide Cathodes on the Angle of the Incidence of Light—A. Pyatnitsky. (*Jour. Phys.*, U.S.S.R., vol. 9, p. 64; 1945.) Semi-transparent photocathodes on a glass surface were used, and the emission found to depend on the angle of incidence, wavelength, and cathode structure. The largest increase was found for an angle of incidence of 70 degrees, when illuminated by blue light. Abstract of a paper of the Academy of Science, U.S.S.R.

621.383.2 2033
Physical Properties of Silver-Caesium-Oxide Cathodes—P. Morozov and M. But-slov. (*Jour. Phys.*, U.S.S.R., vol. 9, pp. 63-64; 1945.) The spectral distribution of the sensitivity of a caesium-oxide photocathode of variable thickness has been investigated, and found to be directly connected with the thickness. The structural peculiarity of the cathode leads to a spectral absorption and scattering of the incident light. The work function was found to be 0.87 to 0.90 volts. Abstract of a paper of the Academy of Science, U.S.S.R.

621.383.4 2034
A New Electrolytic Selenium Photo-Cell—A. von Hippel, J. H. Schulman, and E. S. Rittner. (*Jour. Appl. Phys.*, vol. 17, pp. 215-224; April, 1946.) "... consists of a metal electrode [cathode] completely coated with metallic selenium, immersed in an aqueous solution of an electrolyte, preferably selenium dioxide, together with an auxiliary electrode of a noble metal. ..." "Our cell differs from . . . earlier electrolytic selenium cells chiefly in that directly electro-deposited metallic selenium gives rise to a higher sensitivity and that the selenious acid permits a higher lifetime as well as hermetic sealing of the cell. . . ." A full description of the cell construction is given, with its

characteristics as a function of operating voltage, temperature, external resistance, and time, and an account of its response to unmodulated, modulated, and monochromatic light. A feedback circuit is described, which greatly improves the voltage output of the photoelement and which "is generally applicable to photoconductive and photovoltaic cells."

621.383.5 2035
Photometric Equipment for Blocking-Layer Light-Sensitive Cells—H. T. Wrobel and H. H. Chamberlain. (*Gen. Elec. Rev.*, vol. 49, pp. 25-29; April, 1946.) A compact laboratory equipment for the quick and accurate testing of the temperature characteristics of barrier-layer selenium cells.

621.384.6 2036
Acceleration of Charged Particles—(*Nature, London*, vol. 157, pp. 381-382; March 23, 1946.) A brief review of 439 of February (McMillan) and of *Phys. Rev.*, vol. 68, p. 233 (Kerst); 1945.

621.384.6 2037
A Proposed High Energy Particle Accelerator—The Cavitron—R. F. Post. (*Phys. Rev.*, vol. 69, pp. 126-127; February 1-15, 1946.) A proposal for obtaining high intensity electron accelerating fields by replacing the usual "dee" assembly and acceleration chamber by an electromagnetic cavity resonator.

621.384.6 2038
Combination of Betatron and Synchrotron for Electron Acceleration—H. C. Pollock. (*Phys. Rev.*, vol. 69, p. 125; February 1-15, 1946.) Comment on 439 of February (McMillan).

621.384.6.017.6 2039
Radiation Losses in the Induction Electron Accelerator—J. P. Blewett. (*Phys. Rev.*, vol. 69, pp. 87-95; February 1-15, 1946.) A discussion of the possibility that, because of the high radial accelerations experienced by the electrons in an induction electron accelerator, the radiation losses may introduce limitations in the design of accelerators for energies above 100 million electron volts. Radiation effects consistent with theoretical predictions have been observed. The radiation itself has not yet been detected.

621.385.832: 621.396.9 2040
Cathode-Ray Tube Displays—Bartlett, Watson, and Bradfield. (*See* 1857.)

621.394.64: 621.394.3 2041
Electronic Regeneration of Teletprinter Signal—H. F. Wilder. (*Trans. A.I.E.E. (Elec. Eng., January, 1946)*, vol. 65, pp. 34-40; January, 1946.) A description of an electronic device for receiving weak and distorted teletprinter signals and retransmitting them in correct sequence. The received signal is corrected for time of duration by means of a timing delay network controlling balanced trigger circuits. Starting and stopping is performed by electronic bridge relays.

621.394.652: 621.394.141 2042
An Electrical Keying Device—F. Dearlove. (*R.S.G.B. Bull.*, vol. 21, pp. 136-137; March, 1946.) An arrangement of a polarized relay to provide an automatic morse key. The device is simple, easy to adjust, uses no

vacuum tubes, is noiseless in operation, and is capable of very high speeds.

621.395.645.3: 621.385.4 **2043**

Intermodulation Tests for Comparison of Beam and Triode Tubes Used to drive Loudspeakers—J. K. Hilliard. (*Communications*, vol. 26, pp. 15–17, 54; February, 1946.) The usual high distortion of the beam-power tube is overcome by careful amplifier design with little negative feedback. The main requirement is for an output transformer with high self-impedance, high coupling coefficient, low distributed capacity, and carrying capacity such that the output power shall be uniform over a wide frequency range. Intermodulation tests, which compare favorably with listening tests, showed that beam-power amplifiers gave the same or less distortion than triodes, and have advantages of less hum and greater efficiency.

621.396.664. **2044**

An Interlocked Line-Switching System—H. E. Adams. (*Communications*, vol. 26, pp. 34–36; March, 1946.) For feeding programs to any of four lines from either of two control rooms, with interlocking to prevent both control rooms from feeding the same line together. Description of the design, construction, and operation.

621.396.682: 621.397.62 **2045**

Television Receiver R-F Power Supply Design—H. C. Baumann. (*Communications*, vol. 26, pp. 26, 70; March, 1946.) The advantage of using a radio-frequency (50 to 300 kilocycles) oscillator, step-up transformer and rectifier to supply 10 to 50 kilovolts at 1 milliamperes are outlined, and the design and construction of such equipment are described. See also 2169 of 1943 (Schade.)

621.396.69 **2046**

The Design of a Screened Room—C. C. Eaglesfield. (*Electronic Eng.*, vol. 18, pp. 106–108, 112; April, 1946.) Detailed description of a room 10 ft. X 8 ft. X 8 ft. high, made with copper sheet, giving an attenuation of outside interference of 100 decibels at frequencies 1 to 550 megacycles. A fan outside provides forced ventilation, the air inlet and outlet apertures being covered with perforated zinc. Power supplies are introduced through low- and high-frequency filters designed to give the same attenuation as the screening.

621.396.69 **2047**

Post-War Components—(*Wireless World*, vol. 52, pp. 106–112; April, 1946.) A review of an exhibition by the Radio Component Manufacturers' Federation (February, 1946) which illustrates modern trends in design. A list of manufacturers and products is given.

621.396.69: 06.064 **2048**

Reports on Exhibitions—(*Electronic Eng.*, vol. 18, pp. 122–128; April, 1946.) Brief notes on some of the electronic equipment exhibited at the Institution of Electronics, Manchester, at the Radio Component Manufacturers' Federation Exhibition, and at the North-East Coast Exhibition.

621.396.91.087.5: 551.51.053.5 **2049**

A Simple Kerr Modulator for Ionospheric Recording—O. E. H. Rydbeck. (*Chalmers tekn. Högsk. Handl.*, 13 pp.; 1945. In English.) Detailed description of the design

and construction of a Kerr cell suitable for replacing the point glow lamp used in certain types of ionosphere recording equipment.

771.448.1: 778.39 **2050**

An Apparatus for Stroboscopic Observation—S. L. de Bruin. (*Philips Tech. Rev.*, vol. 8, pp. 25–32; January, 1946.) A capacitor discharge is used to provide repeated current impulses in a high-pressure argon tube, with time intervals of between 2 and 0.004 second. Light flashes of about 10^{-8} seconds duration are obtained.

TELEVISION AND PHOTOTELEGRAPHY

621.397 **2051**

Color Television on Ultra High Frequencies—D. G. F. (*Electronics*, vol. 19, pp. 109–112; April, 1946.) The present CBS system uses 525 lines, interlaced 2:1, the interlaced fields being scanned at 120 per second. Improved definition is obtained with a 10-megacycle bandwidth in the band 480 to 920 megacycles, and single-side-band operation is eventually contemplated. The transmitter used a disk-seal triode (6C22) giving a 1-kilowatt peak or 600-watt average; a slotted waveguide radiator gives a concentration in the horizontal direction with a power gain of 20. The use of the vision flyback period for sound permits transmission up to 10,500 cycles. Of two receivers demonstrated, one gives direct vision of a 10-inch cathode-ray tube and the other an optical system giving a 17 by 22-inch picture. A tunable crystal mixer and 105-megacycle intermediate-frequency amplifier with a bandwidth of 12 megacycles gives an equivalent input noise level of 8 microvolts. The color wheel uses standardized green, blue, and red filters, giving an average transmission of 14 per cent. The required bright phosphor image is obtained with an accelerating voltage of 8000. Details of the camera and pickup equipment are given.

621.397 **2032**

"Videoesonic" Sound—D. I. Lawson. (*Radio Craft*, vol. 17, pp. 385–422; March, 1946.) For other descriptions of this system of transmitting sound and vision on one carrier, see 459 of February and back references. See also *Electronics*, vol. 19, pp. 208–212; April, 1946.

621.397 **2053**

Improved Phototelegraphy—(*Electrician*, vol. 136, pp. 734–736; March 22, 1946.) A description and block diagram of a new phototelegraphic equipment designed at the (British) Post Office Research Station for overseas transmissions by Cable & Wireless Ltd.

621.397 **2054**

I.R.E. Winter Technical Meeting, January, 1946—(*Communications*, vol. 26, pp. 22–66; February, 1946.) Abstracts of some of the papers read. For titles, see 1704 of June.

TRANSMISSION

621.314.65: 621.396.71 **2055**

The Application of High-Voltage Steel-Tank Mercury-Arc Rectifiers to Broadcast Transmitters—Bevan. (See 2019.)

621.385.3 **2056**

Grounded-Grid Power Amplifiers—Spitzer. (See 2085.)

621.394.652: 621.394.141 **2057**

An Electrical Keying Device—Dearlove (See 2042.)

621.396.11.029.64+621.396.24+621.385.1 **2058**

Simultaneous Use of Centimeter Waves and Frequency Modulation—Clavier and Altovsky. (See 1971.)

621.396.61 **2059**

I.R.E. Winter Technical Meeting, January, 1946—(*Communications*, vol. 26, pp. 22–66; February 1946.) Abstracts of some of the papers read. For titles, see 1715 of June.

621.396.61.029.56 **2060**

A Self-Contained 60-Watt C. W. Transmitter—D. Mix. (*QST*, vol. 30, pp. 13–17, 114; April, 1946.) The construction and adjustment of a set comprising a Tri-tet crystal oscillator driving an 807 output stage, for use in the 3.5-, 7-, and 14-megacycle bands.

621.396.61.029.58 **2061**

200-Kilowatt High-Frequency Broadcast Transmitters—H. Romander. (*Elec. Commun.*, vol. 22, pp. 253–261; 1945.) A technical description of two transmitters recently installed at Delano and Dixon (California). For a previous description of the circuit, see 787 of March.

The beam aeriels are arranged in groups of three for each sector to be covered, the aeriels of each group being graded so that a wide range of frequencies can be covered with uniform gain. The description is illustrated by photographs and circuit diagrams.

621.396.61.029.62 **2062**

Stabilizing the 144-Mc/s Transmitter—G. Grammer. (*QST*, vol. 30, pp. 24–30; April, 1946.) Unwanted frequency modulation can be reduced by the use of a buffer amplifier between the master oscillator and the power amplifier. Constructional details are given for a 40-watt three-stage (buffered) transmitter, and its performance is compared with that of two-stage and single-stage transmitters.

621.396.61.029.62 **2063**

The "Tiny Tim" Handie-Talkie—C. T. Haist, Jr. (*QST*, vol. 30, pp. 58–59; April, 1946.) A pocket-size 144-megacycle band transceiver using two midget triodes as detector-oscillator and audio amplifier and modulator. Range, about one mile.

621.396.61.029.62: 621.396.619.018.41 **2064**

250-Watt F.M. Transmitter for 88 to 108 Mc/s—M. B. Kahn and S. L. Sack. (*Communications*, vol. 26, pp. 44–53; February, 1946.) The use of balanced reactance-modulators and push-pull oscillator provides twice the frequency swing of a single modulator, so that only three doubler stages are necessary. Stabilization of center frequency is obtained by mixing the output with the signal from a standard crystal oscillator, and passing the resulting amplitude-modulation and frequency-modulation audio output to a phase detector. The direct-current voltage so obtained controls thyatrons which operate a motor that tunes the master oscillator. Frequency stability is better than ± 1500 cycles.

621.396.61.029.63 **2065**

Oscillators and Amplifiers at 1000 Mc/s—P. S. Rand. (*QST*, vol. 30, pp. 34–40; April, 1946.) Detailed description

(with diagrams and photographs) of the use of "Lighthouse" tubes and cavity resonators in a U. S. Navy 25-watt 900-megacycle transmitter. The modifications necessary for operation on 1215 megacycles are described.

621.396.611.21: 621.396.615.14 **2066**
Frequency Stabilization at 450 Mc/s—
 Myers. (See 1926.)

621.396.615.17+621.396.619 **2067**
Station Design and Planning: Part 3—
Frequency Multiplication and Keying—
 H. Allen. (*R.S.G.B. Bull.*, vol. 21, pp. 126-127; February, 1946.) Frequency-doubling circuit resembles power amplifier. Keying is best performed by grid-blocking of the oscillator. Necessary precautions are outlined. For part 1, see 1058 of April; for parts 2, 4, and 5, see 1801 and 1980.

621.396.619: 621.396.619.018.41 **2068**
Reactance Tube Modulators—
 N. Marchand. (*Communications*, vol. 26, pp. 42-45; March, 1946.) Circuit equations for a frequency-modulation source are derived, including cases of effective capacitive and inductive inputs. Distortion can be minimized by using balanced reactance tubes. A deviation of ± 3.75 kilocycles is easily obtainable with a source frequency of 5 megacycles and gives ± 75 megacycles at a radiated frequency of 100 megacycles. For previous parts in this series, see 1675 of June and 1994.

621.396.645.3.029.5 **2069**
Station Design and Planning: Part 2—
The Power Amplifier—Allen. (See 1801.)

621.396.664 **2070**
Radio-Frequency Transmitter—
 J. N. Whitaker. (*Radio*, vol. 30, p. 29; March, 1946.) A method of switching the tank circuits of a high-frequency oscillator, without using metallic contactors. Summary of U. S. Patent 2,388,233.

621.396.676: 621.396.932.029.54 **2071**
Radiation of Ship Stations on 500 Kc/s—
 J. Marique. (*Wireless Eng.*, vol. 23, pp. 146-151; May, 1946.) A summary of the results of measurements made on the polar diagrams and range (in terms of meter-amperes) of a number of ship stations on about 500 kilocycles—the frequency used for distress traffic. It was found that the horizontal polar diagram of typical ship aeriels may show 2 to 1 variations of effective height with directions relative to the fore-and-aft line, and that the radiated power W_r can be represented by $W_r = (\text{meter-amperes } K)^2$, where $K^2 = \lambda^2 / 160\pi^2 \alpha^2$, α being the "form factor" of the aerial. K lies between 25 and 50 at 454 kilocycles.

The paper includes a graph showing the relation between field strength and distance for daytime conditions over sea as functions of aerial power and aerial height.

621.396.721 **2072**
Radio Amateur's Examination—
 (R.S.G.B. *Bull.*, vol. 21, pp. 117-119; February, 1946.) The syllabus of the new [British] Radio Amateur's Examination of the City and Guilds Institute, the passing of which qualifies for a Government Post Office amateur transmitting licence.

VACUUM TUBES AND THERMIONICS
 53+6](73) **2073**
American Trends of Development in the

Physical Sciences—O. J. Overbeck. (*Jour. Sci. Instr.*, vol. 23, pp. 1-10; January 1946.) Includes disk-seal, radial-beam, and photo-multiplier tubes, and many other devices.

537.533 **2074**
On the Secondary Electron Emission of
Solid Bodies—S. Lukianov. (*Jour. Phys., U.S.S.R.*, vol. 9, p. 62; 1945.) The emission is affected by: (a) the total energy loss per unit length suffered by the primary particle, and (b) the range of the secondary electron in the given substance. The mean energy of formation of secondary electrons is estimated (in aluminium $E=15\text{eV}$). The small emission of pure metals and the high emission of certain nonmetals are discussed. Abstract of a paper of the Academy of Science, U.S.S.R.

537.533 **2075**
On the Influence of Strong Electric
Fields on the Secondary Electronic Emission of Dielectric Films—
 D. Zernov. (*Jour. Phys., U.S.S.R.*, vol. 9, pp. 61-62; 1945.) The characteristics of emission from aluminum, cesium and magnesium oxides are discussed, and the emission shown to depend on the primary current, collector potential, and velocity of the primary electrons. The secondary current practically ceases to follow primary-current variations at audio frequencies. Abstract of a paper of the Academy of Science, U.S.S.R.

537.583 **2076**
The Emission of Oxide-Coated Cathode
Under Impulse Excitation—
 A. Andrianov. (*Jour. Phys., U.S.S.R.*, vol. 9, p. 60, 1945.) Experiments were made using diodes with concentric cylindrical electrodes. The current impulse was of 3 to 4 microseconds duration and the repetition frequency 50 cycles. The saturation current at different temperatures was measured. The volt-per-ampere characteristic given by this method for small values of average current differs from that given by large values. Abstract of a paper of the Academy of Science, U.S.S.R.

621.314.632.029.6: 546.28 **2077**
H.F. Crystal Diodes—
 H. A. LeDuc. (*Radio Craft*, vol. 17, pp. 386, 428; March, 1946.) A short description of the theory, construction, and main uses in ultra-high-frequency equipment, of stable cartridge-mounted germanium and silicon rectifiers. A table of the properties of eighteen types is added. See also 1728 of June.

621.38 **2078**
I.R.E. Winter Technical Meeting, January, 1946—
 (*Communications*, vol. 26, pp. 22-66; February, 1946.) Abstracts of some of the papers read. For titles, see 1730 of June.

621.383 **2079**
[Photoelectric] Electron Multipliers—
 Kormakova. (See 2028.)

621.385.1 **2080**
Reflex-Klystron Oscillators—
 E. L. Ginzton and A. E. Harrison. (*PROC. I.R.E. AND WAVES AND ELECTRONS*, vol. 34, p. 209; April, 1946.) Correction to 1734 of June.

621.385.1 **2081**
What are the Klystron and the Rhumbatron?—
 J. Baltá Elias. (*Euclides, Madrid*, vol. 5, pp. 287-297; May, June 1945.) A simple account of the limitations of triode oscillators at ultra-high frequency and of the development of velocity-modulated oscillators.

621.385.1+621.385.16 **2082**
The Magnetron and the Klystron—
 T. F. Wall. (*Engineering, Lond.*, vol. 161, pp. 125-127, 148, 184-185; February 8, 15, 22, 1946.) Description of the mode of operation, including a simplified mathematical treatment. The discussion of the magnetron oscillator is limited to the split-anode type with external tuned circuit. Two-cavity klystron amplifiers and oscillators are considered.

621.385.1.029.63/.64 **2083**
The Klystron and Other Micro-Wave
Oscillators—
 A. C. Ramm. (*Proc. I.R.E. Aust.*, vol. 6, pp. 3-4; November, 1945.) Summary of a talk on the development of Barkhausen-Kurz, magnetron, and klystron oscillators.

621.385.16 **2084**
Development of the Magnetron—
 J. T. Randall. (*Electrician*, vol. 136, pp. 537-538; March, 1946.) A summary of a paper read before the Royal Society of Arts describing the practical and theoretical development during the war.

621.385.3 **2085**
Grounded-Grid Power Amplifiers—
 E. Spitzer. (*Electronics* vol. 19, pp. 138-141; April, 1946.) The lower capacitance of this amplifier permits wider-bandwidth operation than the conventional capacitance-neutralized triode, with reduced possibility of self-oscillation. Some 3 to 10 times greater driving power is needed, but this is transferred to the anode circuit. The 9C21 type (a 100-kilowatt triode) is described; its use in an amplifier and its modulation characteristics are considered.

621.385.3/.5].012 **2086**
Pentodes and Tetrodes Operating as
Triodes—
 C. C. McCallum. (*Electronic Eng.*, vol. 18, pp. 82-83; March, 1946.) Chart showing, on a log-log plot, the root-mean-square input voltage and the audio-frequency output power for various triodes and triode-connected pentodes and tetrodes. A maximum second-harmonic distortion of 5 per cent and the use of optimum load resistance is assumed. British and American types are included.

621.385.3/.5].032.24 **2087**
The Current to a Positive Grid in Elec-
tron Tubes: I. The Current Resulting from
Electrons Flowing Directly from the Cathode
to the Grid—
 J. L. H. Jonker and B. D. H. Tellegen. II. **The Current Resulting from**
Returning Electrons—
 J. L. H. Jonker. (*Philips Res. Rep.*, vol. 1, pp. 13-32; October, 1945.) 1. Electron paths are calculated for the case of a planar triode by taking into account an extra velocity moment gained by electrons in passing close to the grid wires. This gives a second approximation to the expression for the direct electron current that agrees well with observed data. 2. The angular deflections suffered by electrons in passage through one or more grids are investigated, and the electron current that returns to the positive grid is calculated from the proportion deflected through more than a certain critical angle. The effect of relative pitch in two grids is discussed in some detail.

621.385.3(091) **2088**
Saga of the Vacuum Tube: Parts 21 &
22—
 G. F. J. Tyne. (*Radio News*, vol. 35, pp. 54-56, 130, 52-133; February and April,

1946.) Concludes a survey of development in France and Germany during the first world war. For part 20, see 489 of February.

621.385.38: 537.56 **2089**

Note on the Ionization and Deionization Times of Gas-Filled Thyratrons—J. C. R. Cance. (*Jour. Sci. Instr.*, vol. 23, pp. 50-52; March, 1946.) The ionization time of G.T.1C Thyratrons determined at currents ranging from 5 to 25 milliamperes is shown to be independent of (a) anode current, (b) anode voltage, (c) rate of change of grid potential, and is sensibly constant at 1.4 ± 0.4 microseconds. The relation between deionization time and negative grid voltage is illustrated graphically for different values of anode volts and current. At constant grid volts and anode current, the deionization time is shown to be independent of the magnitude of anode-cathode potential change used to effect extinction.

621.385.38: 621.396 **2090**

Thyratrons and Their Applications to Radio-Engineering—A. J. Maddock. (*Elec. Commun.*, vol. 22, pp. 339-378; 1945.) A review of the nature, mechanism, and characteristics of thyratrons, of the range of existing types, and of the main types of controlling circuits in which they are used, illustrated by application to operation timing, peak voltmeters, overload relays, over-modulation indicators, frequency meters, direct-current amplification, transmitter keying, pulse generation, cathode-ray-tube switching and time bases, harmonic generators, frequency dividing, power-supply regulation and control, rectification, and inversion. The paper is illustrated by numerous typical circuit diagrams and has a bibliography of 66 items.

621.385.4 **2091**

Beam Tetrode Characteristics—S. Rodda. (*Wireless Eng.* vol. 23, pp. 140-145; May, 1946.) The anode-current versus anode-voltage characteristic is deduced on the assumption that the electrons entering the screen/anode space have a distribution in angle given by a continuous function of the sine of the angle of entry. (Previous treatments have assumed a discontinuous function.) Even with the continuous distribution in angle, the action of space charge produces "regions of instability" with "sharp knees." See also 1807, 2222, and 2635 of 1945 (Walker).

621.385.5: 621.396.619 **2092**

New Modulation Tube for Frequency Modulation—(*Electronics*, vol. 19, pp. 204-212; February, 1946.) An illustrated account of the "phasitron" described in 1405 of May,

621.396.615.17: 621.317.755 **2093**

Time-Base Converter and Frequency-Divider—H. Moss. (*Wireless Eng.*, vol. 23, p. 152; May, 1946.) A letter supporting the writer's previous contention that the introduction of new types of components is only justified by a substantial technical advantage to be gained, and that the case for such technical advantage is not valid in the case of the deflexion-modulated tubes ("signal-converters") proposed by Nagy and Goddard in their original paper. See 3891 of 1945 and 3393 of 1943.

MISCELLANEOUS

003.6: 621.392.5 **2094**

Graphical Symbols for Filters and Cor-

recting Networks—G. H. Foot. (*Wireless Eng.*, vol. 23, pp. 103-106; April, 1946.) Suggested new symbols based on the shape of the performance graph of attenuation against frequency.

519.283: 621.315.617.3 **2095**

Quality Control of Insulating Varnishes—Hart (See 1883.)

62 "1945" **2096**

Progress in Engineering Knowledge during 1945: Design Engineering—P. L. Alger, J. Stokley, C. F. Scott, H. B. Marvin, J. L. Tugman, and K. W. Given. (*Gen. Elec. Rev.*, vol. 49, pp. 9-19; February, 1946.) A review, with an extensive bibliography, of many fields, including the solution of partial differential equations by equivalent electrical circuits, the measurement and recommended field-strength limits for interference from electrical apparatus, improvements in television fluorescent-screen construction, and a combined triode-cavity resonator for radar applications.

621.316.96: [621.38/39] **2097**

Vibration and Shock Testing of Mobile Equipment—J. H. Best. (*Electronics*, vol. 19, pp. 126-129; April, 1946.) Testing techniques for newly developed anti-vibration mountings for electronic equipment. In addition to a test on the unmounted unit for over a range of frequencies, data are obtained on the vibration-isolation efficiency of the mount itself. Vibration tests in three mutually perpendicular directions are made, and account taken of any tendency for torsional oscillation.

621.396.6 **2098**

Naval Wartime Communication Problems—J. O. Kinert. (*PROC. I.R.E. AND WAVES AND ELECTRONS*, vol. 34, pp. 193-195; April, 1946.) As a result of experience gained during the war, the following recommendations are urged for the design of military equipment: (a) the greatest simplification consistent with satisfactory performance; (b) the maximum practicable reduction in weight and size; (c) standardization of parts and components; and (d) maximum use of automatic features.

621.396(73) **2099**

Those New Frontiers—P. A. Porter. (*PROC. I.R.E. AND WAVES AND ELECTRONS*, vol. 34, pp. 185-188; April, 1946.) A general discussion of the future of radio engineering in America.

621.396 "1945" **2100**

Radio Progress During 1945—(*PROC. I.R.E. AND WAVES AND ELECTRONS*, vol. 34, pp. 164-184; April, 1946.) Survey of world progress, based on a bibliography of over 400 references.

621.396.6(083.75) **2101**

Proposed Standards of the [U. S.] Radio Manufacturers Association—(*PROC. I.R.E. AND WAVES AND ELECTRONS*, vol. 34, pp. 198-200; April, 1946.) Summaries of proposals 163 through 169, concerned with details of receivers, gramophone records, and vacuum-tube type designations.

621.396.712 **2102**

From Studio to Master Control—H. J. Seitz. (*Radio News*, vol. 35, pp. 47-158; January, 1946.) Description of the various duties of the broadcast engineer, including

field broadcasting maintenance, master control, and studio operation, the latter being concerned with acoustics and realistic reproduction.

621.396.721 **2103**

Radio Amateur's Examination—(See 2072.)

621.798 **2104**

Protective Packaging—O. C. Rutledge. (*Gen. Elect. Rev.*, vol. 48, pp. 16-19; December, 1945.) A review of new methods for protecting equipment against corrosion and shock while in storage or in transit.

621.798 **2105**

Dynamics of Package Cushioning—R. D. Mindlin. (*Bell Syst. Tech. J.*, vol. 24, pp. 353-461; July, October, 1945.) A comprehensive analysis of the protective cushioning necessary in the transportation of packaged articles. The four parts of the paper are concerned with (a) methods for predicting the maximum acceleration that the cushioning permits the packaged item to reach, (b) the form of the acceleration/time relation, (c) the effect of acceleration on the packaged article with methods for determining whether or not the strength of the packaged article will be exceeded, (d) the influence of distributed mass and elasticity in both the packaged article and cushioning medium. The results of the analysis have been applied to the packaging of large vacuum tubes.

621.798: 621.396.69 **2106**

Hermetic Sealing—A. L. Anderson. (*Radio*, vol. 30, pp. 25-27, 46; March, 1946.) Describes the technique of filling the enclosure with inert gas under a pressure of 5 to 10 pounds per square inch above atmospheric. See also 811 of March (Herbert).

654.19 **2107**

1946 Radio Statistics—(*Electronic Ind.*, vol. 5, p. 63; January, 1946.) Figures for the production of broadcast receivers in the years 1922-1945.

016: [621.38/39] **2108**

The Electronic Engineering Master Index [Book Review]—F. A. Petraglia (Editor). Electronics Research Publishing Co., New York, N. Y., 1945, 318 pp. \$17.50. (*Elec. Ind.*, vol. 5, p. 128; January, 1946.) "A comprehensive and painstaking subject index of electronic engineering periodicals covering, in separate sections, the two decades from 1925 to June, 1945."

5(082.2) **2109**

The Autobiography of Science [Book Review]—F. R. Moulton & J. J. Schifferes (Editors). Doubleday, Doran & Co., New York, 1945, 666 pp. \$4.00. (*Sci. Mon.*, N. Y., vol. 61, pp. 489-491; December, 1945.) Selections from original scientific writings of historical interest. "... an excellent effort to offer the best in scientific literature. ..."

519.283 **2110**

Statistical Analysis, Quality Control, etc. [Book Reviews]—(*Bull. Amer. Soc. Test. Mat.*, pp. 60-62; January, 1946.) Reviews for 13 books and pamphlets condensed from *Jour. Amer. Statistical Assoc.*, September, 1945.

moistureproof

because it's

sealdtite*

★EXCLUSIVELY SOLAR

Modern, "Reliable in Every Climate"

Sealdtite paper tubular capacitors are securely sealed against any changes in atmospheric conditions.

Solar's original wax-molding process actually eliminates all possibility of any atmospheric moisture getting in to attack the capacitor element.

The squeezeproof solid housing is your assurance of long service at low cost.

"Sealdtites" and other popular

Solar paper, electrolytic and mica capacitors for service, industrial and ham use

are fully described in the new easy-to-read 36 page catalog SC-1, which is yours for the asking.

See your Solar distributor or drop us a postal card today.



SOLAR MANUFACTURING CORPORATION

285 MADISON AVENUE • NEW YORK 17, N. Y.

Ⓢ 1302

ELECTROLYTIC, PAPER AND MICA CAPACITORS

Proceedings of the I.R.E. and Waves and Electrons

August, 1946





ATLANTA

"Railroad Radio Systems," by Leo G. Sands, Bendix Radio, Bendix Aviation Corporation; May 26, 1946.

BOSTON

"Electronics in Medicine," by K. S. Lion, Massachusetts Institute of Technology; May 24, 1946.

Election of Officers; May 24, 1946.

CEDAR RAPIDS

"Radar Countermeasures," by F. E. Terman, Stanford University; June 18, 1946.

CHICAGO

"Pulse-Time Modulation Multiplex Radio Relay," by D. D. Grieg and N. J. Gottfried, Federal Telecommunications Laboratories; June 7, 1946.

Election of Officers; June 7, 1946.

COLUMBUS

"Use of Models in Measuring Patterns of Aircraft Antennas," by G. Sinclair, Ohio State University; May 10, 1946.

"Communications In The 37th Division," by Major Roger Lindley; June 6, 1946.

Election of Officers; June 6, 1946.

DALLAS-Ft. WORTH

"Radar Countermeasures," by A. E. Cullum, Jr., Consulting Radio Engineer; June 3, 1946.

DAYTON

"Stratovision," by L. S. McLeod, Westinghouse Electric Corporation; June 11, 1946.

"Railroad Radio Communication Systems," by G. H. Phelps, Westinghouse Electric Corporation; June 20, 1946.

EMPORIUM

"Electronics as an Aid to Railroads," by H. Richards, Airplane and Marine Instruments Inc., June 14, 1946.

HOUSTON

"Infrared Receivers and Their Amplifiers," by C. B. Aiken, Electro-Mechanical Research, Incorporated; June 11, 1946.

INDIANAPOLIS

"Amplitude-Modulation—Very-High-Frequency Broadcasting Including the new Five Dollar Converter," by Sarkes Tarzian; May 17, 1946.

"The Amplitude-Modulation—Very-High-Frequency Transmitter," by Mr. Weigel an associate of Sarkes Tarzian; May 17, 1946.

"Mechanical Details of Antenna and Tower," by Mr. Sonneborn an associate of Sarkes Tarzian; May 17, 1946.

"The Five-Dollar Converter," by A. Valdetaro, an associate of Sarkes Tarzian; May 17, 1946.

"Very-High-Frequency Antenna Systems," by A. G. Kandoian, Federal Telecommunication Laboratories; May 24, 1946.

(Continued on page 36A)

Transformers

designed with

STANDARDIZED *basic mountings*

to fit the customer's

SPECIALIZED *requirements*

To achieve economy and speed of production in meeting customers' transformer requirements, Chicago Transformer manufactures and stocks a wide range of sizes in vertical shields and drawn steel cases, which are standardized in construction and appearance, yet are readily adaptable to a variety of special applications. For details on how transformers using these mounting parts will benefit your new product plans, consult Chicago Transformer's sales and engineering staffs.



CHICAGO TRANSFORMER

DIVISION OF ESSEX WIRE CORPORATION

3501 ADDISON STREET · CHICAGO, 18

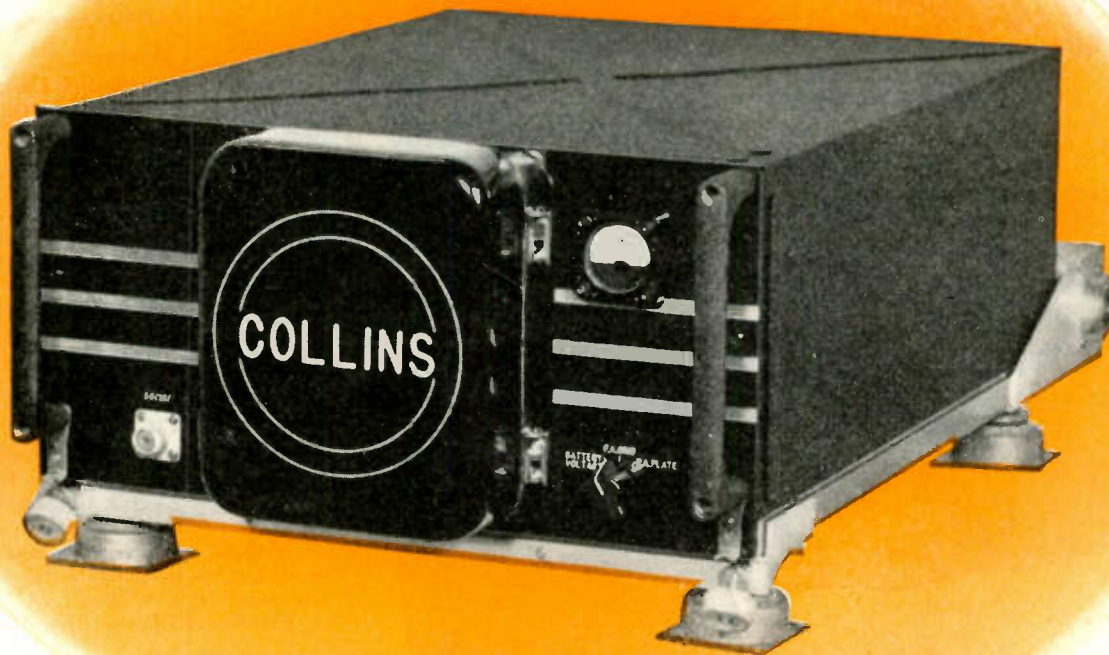

Aircraft communication at its best

THE COLLINS 18S-1 transmitter-receiver is engineered for highest performance in aviation communications. It is specifically designed for commercial airlines and executive aircraft. Reflecting years of experience and proved dependability in the field of aircraft radio, the 18S-1 is new in every respect, and has performed superbly under flight tests.

Ten channels, with twenty crystal controlled frequencies are available for transmission between 2.5—10.0 mc. Power output from the transmitter is more than 100 watts. The receiver is controlled by a separate group of 20 crystals, and does not necessarily operate on the transmitting frequency. Quick, automatic frequency selection is provided, with all circuits tuned and ready to operate. Remote control encourages locating the unit with respect to proper weight distribution within the plane. The 18S-1 works into a 50 ohm transmission line.

A single 1½ ATR unit cabinet contains transmitter, receiver, and dynamotor power supply for the transmitter. The receiver operates directly from the 26.5 volt d-c source. The entire weight, including shock mount, is 60 lbs.

The first group of these equipments is scheduled for delivery to airlines in September of this year. Write today for further information.

Collins Radio Company, Cedar Rapids, Iowa

11 West 42nd Street
New York 18, N.Y.

458 South Spring Street
Los Angeles 13, California

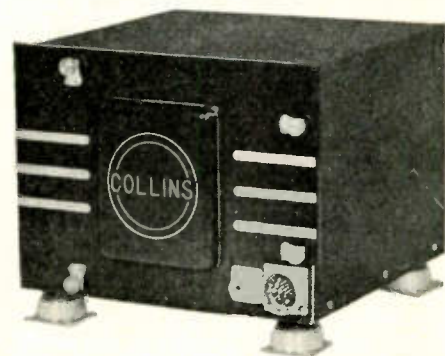

THE 180K-1 antenna loading unit efficiently transfers the power output from the 18S-1 to any standard commercial fixed antenna. Remote controlled, pretuned operation for ten channels is provided. The nominal input impedance is 50 ohms. Weight, 10 lbs. Size, 7½" h, 10½" d, 12" l.

— IN RADIO COMMUNICATIONS, IT'S... —



THE

Individual TOUCH

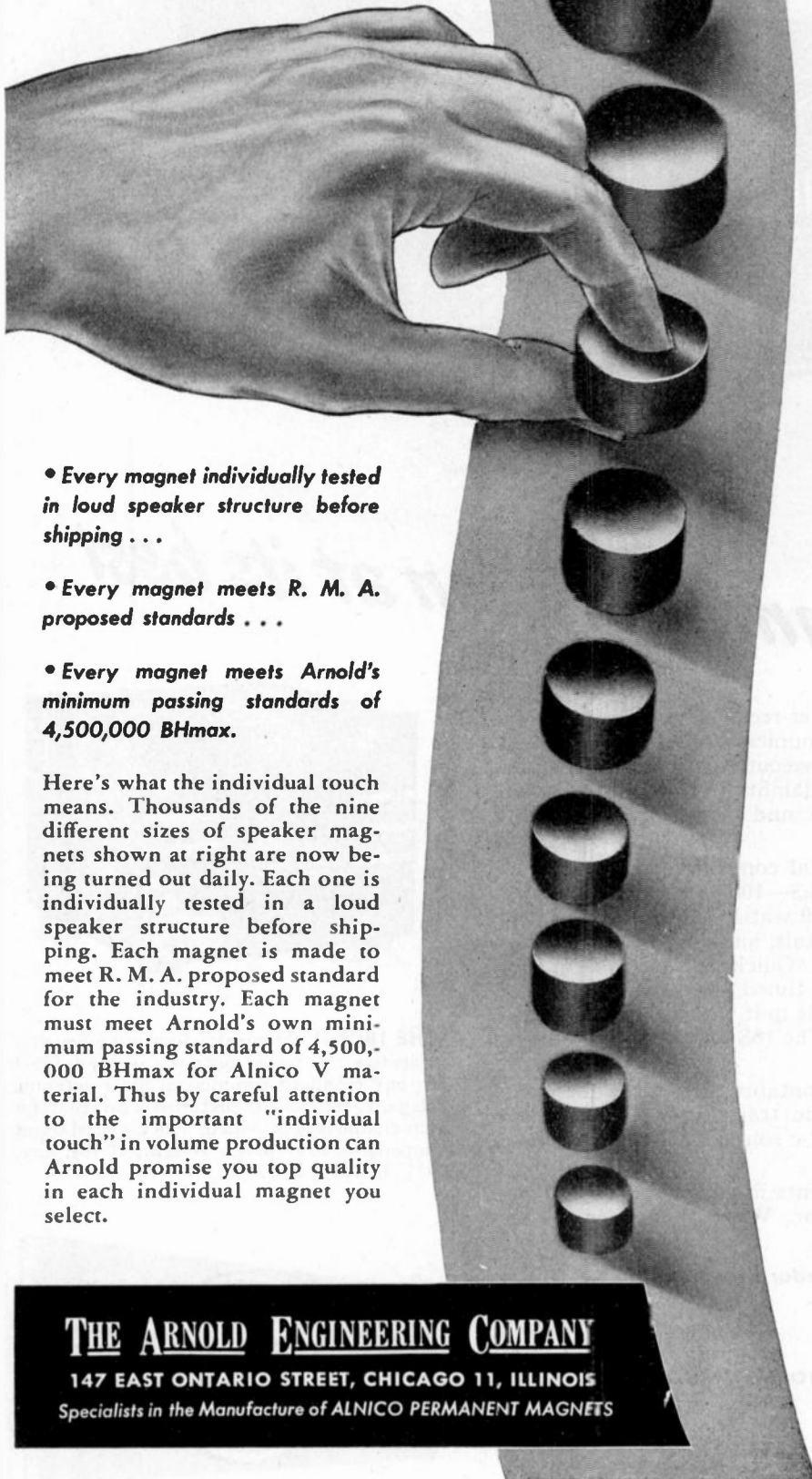

• Every magnet individually tested in loud speaker structure before shipping . . .

• Every magnet meets R. M. A. proposed standards . . .

• Every magnet meets Arnold's minimum passing standards of 4,500,000 BHmax.

Here's what the individual touch means. Thousands of the nine different sizes of speaker magnets shown at right are now being turned out daily. Each one is individually tested in a loud speaker structure before shipping. Each magnet is made to meet R. M. A. proposed standard for the industry. Each magnet must meet Arnold's own minimum passing standard of 4,500,000 BHmax for Alnico V material. Thus by careful attention to the important "individual touch" in volume production can Arnold promise you top quality in each individual magnet you select.

THE ARNOLD ENGINEERING COMPANY

147 EAST ONTARIO STREET, CHICAGO 11, ILLINOIS
Specialists in the Manufacture of ALNICO PERMANENT MAGNETS



(Continued from page 34A)

MONTREAL

Inspection Trip through Canadair Aircraft Factory, Cartierville, P. Q.; May 15, 1946.

NEW YORK

"Charting the Course of the Institute of Radio Engineers," by F. B. Llewellyn, President, The Institute of Radio Engineers; June 5, 1946.

"Technical Co-ordination on an International Basis in Communication and Allied Fields," by E. M. Deloraine, Vice-President, The Institute of Radio Engineers; June 5, 1946.

PITTSBURGH

"Radar Symposium," by J. A. Hutcheson, W. E. Shoupp and M. R. Briggs, Westinghouse Electric Corporation; May 13, 1946.

"Guided Missiles—Azon and Razon," by R. K. Crooks, Union Switch and Signal Company; June 10, 1946.

Election of Officers; June 10, 1946.

PORTLAND

"The Phasitron Modulator Tube for Frequency Modulation," by J. E. Hogg, General Electric Company; May 27, 1946.

ST. LOUIS

"Developments in Microwave Electronics," by A. L. Samuel, Bell Telephone Laboratories; May 29, 1946.

SAN DIEGO

"Some Considerations of the Formation of Radiation Patterns," by C. J. Burbank, United States Navy Electronics Laboratory; June 4, 1946.



The following transfers and admissions were approved on July 2, 1946:

Transfer to Senior Member

- Barney, H. L., 5 Pine Ave., Madison, N. J.
Beck, A. C., Box 107, Red Bank, N. J.
Bloom, J. D., Jr., 5718 St. Charles Ave., New Orleans 15, La.
Boerner, T. J., 721 Linwood Ave., Collingswood, N. J.
Boone, E. M., Department of Electrical Engineering, Ohio State University, Columbus 10, Ohio
Deerhake, F. M., 600 Oakwood St., Fayetteville, N. Y.
Evans, H. W., Bell Telephone Laboratories, 180 Varick St., New York 14, N. Y.
Fritschel, E. H., Tube Division, General Electric Co., Schenectady, N. Y.

(Continued on page 38A)



AMPHENOL

COMPONENTS FOR

FM and

TV

FREQUENCIES



Now that the emphasis in communications is turning more and more toward the FM and Television frequencies, there is a great demand for quality components made to increasingly critical specifications. Amphenol products have kept abreast of developments and are available now—in quantity—to manufacturers of equipment operating in these frequencies and to amateurs.

In addition to the long line of standard parts, Amphenol engineers announce the following new products particularly adaptable to FM and Television:

Radio Frequency Cable and Connectors and a new line of low-capacitance microphone cables. Also, new cables especially developed for Television color cameras and for Facsimile work.

Hi-Q Tube Sockets. Standard, miniature and sub-miniature. Also new sockets for cathode ray viewing tubes and similar applications.

Twin-Lead. This Amphenol-developed parallel transmission line is widely used as antenna lead-in and, in addition, has become standard for built-in folded dipole antenna construction.

FM Antennas. New Amphenol designs for standard reception that deliver the greatest gain, particularly in low signal areas. Write for complete information.

Plastic Components, in a wide variety, adaptable where this superb dielectric is an integral part of the engineering of critical circuits.

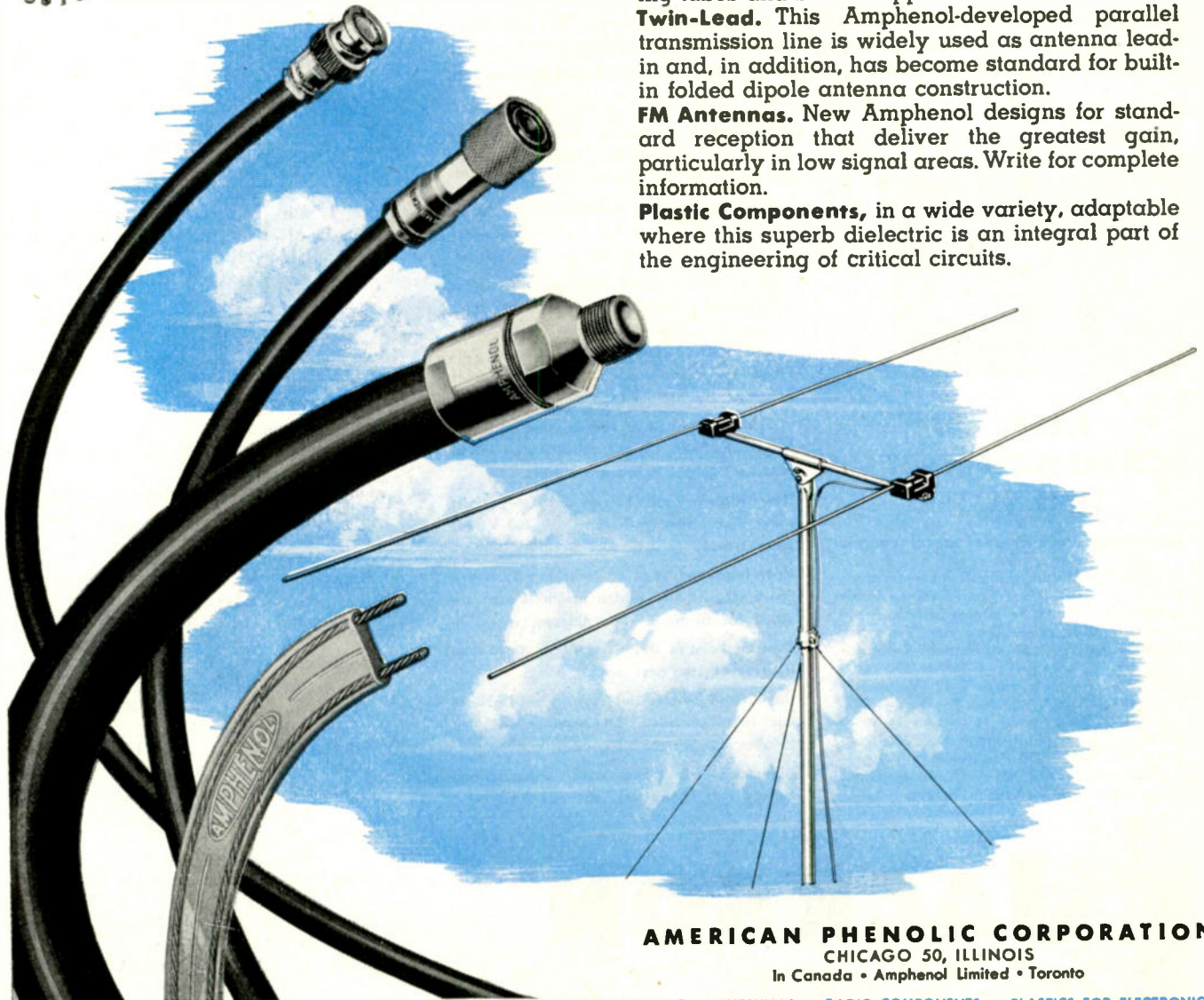

AMERICAN PHENOLIC CORPORATION

CHICAGO 50, ILLINOIS

In Canada • Amphenol Limited • Toronto

COAXIAL CABLES AND CONNECTORS • INDUSTRIAL CONNECTORS FITTINGS AND CONDUIT • ANTENNAS • RADIO COMPONENTS • PLASTICS FOR ELECTRONICS

ALL IN ONE PACKAGE



You've got a lot of "sharp" Instruments in a small space when you buy the Jackson Model 637. In addition to complete tube testing, it combines 9 functions and 27 ranges, readily selected by push buttons that save time and guesswork.

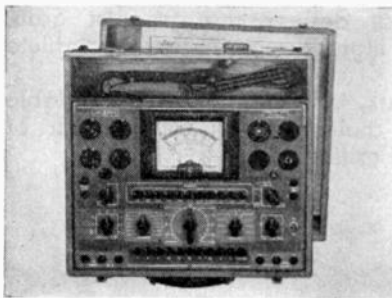

MODEL 637 DYNAMIC OUTPUT TUBE TESTER

with complete universal meter ranges

1—Dynamic Output Tube Tester—accurate, thorough. 2—Ballast Tube Tester—finds shorts or burn-outs. 3—High-sensitivity Neon Continuity Tester. 4—Condenser Tester for finding shorted or leaky condensers. 5—Multi-range A.C. Voltmeter: 0-10/100/250/500/1000/2500. 6—Multi-range D.C. Voltmeter: 0-10/100/250/500/1000/2500. 7—Decibel Meter—Ranges from minus 10 to plus 14/10 to 34/30 to 54. 8—Multi-range D.C. Milliammeter 0-1/10/100/250. 9—Ammeter Range—0 to 10 amperes D.C. 10—Triple Range Ohmmeter 0-3000/300,000/0-30 megohms.

Automatic Push Button Selector—permits instant use of any range. Remarkably fast; reduces chance of mistakes.

Full Range Filament Selection—from $\frac{3}{4}$ V. up to and including 115 V . . . Filament selector marked directly in volts at each position.

Tests All Tubes—all of the popular receiving types and television amplifiers, including Bantams — Miniatures — Loctals — Single Ended — and High-Voltage Filament Types. Provision for many more. Two spare socket positions are provided on panel.

"Dynamic" Method of Test is more accurate, frequently finds "poor" tubes which might pass for "good" in ordinary testers.

New High-Voltage Power Supply—permits using higher plate voltages (over 200 V. for some types), giving more accurate results.

Most Improved Type of Switching System—Spare circuits and switch positions are provided for future use on different tubes.

Controls Easy to Use—You don't waste time figuring out the next move.

Illuminated Meter Dial easy to read. Noise test jacks provided. Dimensions: $14\frac{3}{4}$ " x $13\frac{3}{4}$ " x 6". Weight 14 pounds.

Accessories—Complete with self-contained battery (for ohmmeter), and test prods.

JACKSON

Fine Electrical Testing Instruments

JACKSON ELECTRICAL INSTRUMENT COMPANY, DAYTON, OHIO



(Continued from page 36A)

- Giet, G. R., U. S. Navy Postgraduate School, Annapolis, Md.
 Hall, E. L., National Bureau of Standards, Radio Bldg., Washington 25, D. C.
 Hausz, W., 232 Jackson Ave., Schenectady 4, N. Y.
 Heaton, V. E., National Bureau of Standards, Radio Section, Washington 25, D. C.
 Hromada, J. C., 164 Blue Ridge Rd., Indianapolis, Ind.
 Iversen, R. J., The New York Times, Times Square, New York 18, N. Y.
 Jones, J. L., 2051 McClellan St., Schenectady 8, N. Y.
 Kelsey, E. S., 279—34 Ave., Lachine, P. Q., Canada
 King, L. A., RCA Victor Division, Bldg. 53-C-1, Camden, N. J.
 Kurth, H. H., Fox Woods, RFD 8, North Kansas City 16, Mo.
 Larrick, C. V., 1454 Lowell Rd., Schenectady 8, N. Y.
 Longfellow, R. C., 146 Westminster Ave., Syracuse 10, N. Y.
 Lovejoy, R. E., 712 Yuma St., S.E., Washington 20, D. C.
 Mitchell, J. K., 187 Greenwood Ave., East Orange, N. J.
 Moe, R. E., General Electric Co., Thompson Road Plant, Syracuse, N. Y.
 Mroz, M., 214 N. Lincoln Ave., Park Ridge, Ill.
 Mumford, W. W., Box 107, Red Bank, N. J.
 Nace, A. S. 5210 Ira Ave., Cleveland 9, Ohio
 Nielsen, J. J., Jr., 370 Oak Vista Dr., Glendale 6, Calif.
 Norris, C. A., 95 Atlas Ave., Toronto, Ont., Canada
 Offner, F. F., 5320 N. Kedzie Ave., Chicago 25, Ill.
 Ong, F. C., Bell Telephone Laboratories, Box E, Whippany, N. J.
 Pennoyer, R. T., 302 Perry St., Schenectady, N. Y.
 Rappaport, G., 132 East Ct., Harshman Homes, Dayton 3, Ohio
 Reukema, L. E., 2319 Oregon St., Berkeley 5, Calif.
 Robinson, A. L., Bell Telephone Laboratories, Whippany, N. J.
 Rosser, T. N., Sr., 26 S. Gladstone Ave., Indianapolis 1, Ind.
 Salinger, H. W. G., 2527 Hoagland Ave., Fort Wayne 6, Ind.
 Sandorf, I. J., U. S. Naval Academy, Postgraduate School, Annapolis, Md.
 Sands, W. F., RCA Victor Division, Bldg. 5, Camden, N. J.
 Schock, R. E., 141 Riverside Dr., Riverhead, N. Y.
 Schulz, E. H., 5947 W. Ohio St., Chicago 44, Ill.
 Soucy, C. I., 304 Milverton Blvd., Toronto, Ont., Canada
 Stewart, W. E., 2 Lincoln Terrace, Moorestown, N. J.

(Continued on page 40A)

Just published!



Electronic

MANUAL OF TRANSMITTING TUBES



OVER 600 LARGE PAGES \$2

COMPLETE — UP-TO-THE-MINUTE — packed with application data!

NEW AND AUTHORITATIVE, G. E.'s transmitting tube manual contains photographs, outline drawings, ratings, performance curves, and application data on 94 different tube types, covering the full scope of AM-Television-FM broadcasting and communications. It is a modern and complete reference work.

DESIGNERS OF EQUIPMENT for broadcasting and communications, and owners and engineers of broadcast stations, need General Electric's comprehensive new manual so they can be fully posted on transmitting tubes and their electrical and other characteristics.

PHASITRON AND LIGHTHOUSE TUBES are included, along with other new developments in the high and ultra-high-frequency fields. Throughout the range of tube types, exhaustive application data is given in the form of definitions, classes of operation, examples of tube operating conditions, and typical circuits.

TABBED DIVIDERS AND INDEXED PAGE CORNERS make it easy to locate information. The loose-leaf format and new sheets mailed to you whenever changes occur, mean that G. E.'s transmitting tube manual is kept constantly up-to-date. Order direct from *Electronics Department, General Electric Company, Schenectady 5, N. Y.*

"Electronic Tubes, Transmitting Types" comes to you for \$2. Also, for an annual service charge of \$1 new and revised pages will be sent to you regularly as issued. . . . ORDER TODAY, enclosing payment, or giving authority on your company letterhead to invoice you.

GENERAL ELECTRIC

161-E11-0880

FIRST AND GREATEST NAME IN ELECTRONICS

new...
improved
portable

Radiotone

HOLLYWOOD



(Continued from page 38A)



"America's
Finest Portable Recorder"
illustrated—Model RA-116

Here's the answer to your recording problems in a single, compact, portable unit! Radiotone, a pioneer in instantaneous recording, with over 10-years experience backed by thousands of units in service is now manufactured by Ellinwood Industries, famous for Design Simplicity—Dependability. Check these features—note the improvements—then send for name of local representative and complete, illustrated catalog describing the RA-116 and other portable models.

FEATURES

THE RA-116—Produces acetate recordings of professional quality from 6" up to 16". Accommodates 17½" masters for 16" pressings.

DUAL SPEED—78 or 33½ rpm. Instantly selected by an improved lever shift which locks into position.

LEAD SCREW—Positive feed overhead lead screw insures perfect grooves and dependable operation. Direction of cut can be changed instantly from outside-in to inside-out. Run-in grooves may be made when desired.

VARIABLE LINES—The number of lines per inch on the disc may be varied from 90 to 130.

DEPTH OF CUT ADJUSTMENT—Accurate regulation of pressure at the cutting stylus is obtained by turning a calibrated knob.

DRIVE SYSTEM—Radiotone has perfected a positive silent drive insuring perfect motion, correct pitch, and stability. Moving parts have been reduced to a minimum. Speed accuracy is maintained within .3% at 78 rpm, and .4% at 33½ rpm. Single revolution accuracy is maintained within .1%.

TURNTABLE—A 16" dynamically balanced cast aluminum turntable is used. The hardened steel driving shaft revolves on a single steel ball at the bottom of a 6" cast bearing well which contains two bronze "oilite type" bearings.

DUO-CHROMATIC EQUALIZERS—Two controls allow continuously variable response over both high and low registers.

MULTIPLE INPUT CHANNELS—Two high impedance input channels are provided. (Low impedance also available.) Two jacks are for

microphone use and have an overall gain of 130 DB. The other two have an overall gain of 80 DB, which is suitable for most any crystal, magnetic or dynamic pickup as well as a zero level line.

MIXERS—Two independent volume controls are provided and may be operated simultaneously.

VOLUME INDICATOR—A volume indicator meter is provided for accurate monitoring of recording level.

OUTPUTS—All output impedances are 8 ohms.

AMPLIFICATION STAGES—The amplifier has four stages. The first one is a dual pre-amplifier utilizing one 7F7 tube which provides the two microphone inputs. The second is the duoharmonic equalizer stage also utilizing one 7F7 tube. The third uses two 7F7 tubes in push-pull as phase inverted degenerative resistance coupled drivers. The fourth is the power output stage using two 7C5 tubes in push-pull class "A" feeding an extra heavy duty output transformer. Inverse feedback is employed to insure stability. Power output is 14 Watts. Harmonic distortion at cutting level is less than 1%.

RADIO—A radio receiver designed for recording is available as an accessory to the RA-116 and space is provided by removing the panel at the left side of the amplifier.

POWER REQUIREMENTS—110-120 Volts. 50 or 60 cycles AC. 150 Watts. May be used on DC by addition of converter.

SPEAKER—Heavy duty 12-inch high fidelity, permanent magnet dynamic type.

FINISH—Handsome leatherette case with chromium hardware. Exterior metal parts finished in baked crackle lacquer with chrome trim.

ELECTRONICS DIVISION
Ellinwood
INDUSTRIES

170 WEST SLAUSON AVE., Los ANGELES 3, CALIF.

Stott, H. T., 17 Slyvan Ave., Mill Hill, London, N. W. 7, England
Strohschneider, W., Neuhausstrasse 6, Zollikon/Zurich, Switzerland
Trafton, D. C., 7103 Gloster Rd., Washington 16, D. C.
Van Wambeek, S. H., c/o Washington University, St. Louis 5, Mo.
Willis, F. C., Passaic Ave., Caldwell, N. J.
Wissel, F. A., 3444 Oakview Pl., Cincinnati 9, Ohio

Admission to Senior Member

Allen, W. S., Ministry of Works, Government Bldgs., Broadway West, Gosforth, Newcastle 3, England
Bohren, A. K., Bell Telephone Laboratories, 463 West St., New York 14, N. Y.
Bryant, N. W., Bell Telephone Laboratories, Whippany, N. J.
Burnell, L. G., 1188 E. 12 St., Brooklyn 30, N. Y.
Hamilton, D. R., 35 Jefferson Rd., Princeton, N. J.
Houghton, E. W., 195 Hillside Ave., Chatham, N. J.
Leach, E. A., Box 1044, Chappaqua, N. Y.
MacGregor, E. I. R., 1785 Massachusetts Ave., N.W., Washington 6, D. C.
McPetrie, J. S., Signals Research & Development Establishment, Ministry of Supply, Christchurch, England
Perkins, E. H., 463 West St., Bell Telephone Laboratories, New York, N. Y.
Seeley, E. S., 542 Linwood Ave., Ridge-wood, N. J.
Wilson, H. M., 27 Taft Ave., Lexington 73, Mass.
Ziegler, G. E., Midwest Research Institute, 4049 Pennsylvania Ave., Kansas City 2, Mo.

Transfer to Member

Behringer, D. S., 72 Sycamore Ave., Mill Valley, Calif.
Berman, G., 5297 California St., San Francisco, Calif.
Blatterman, H. L., 141 N. Vermont St., Los Angeles 4, Calif.
Brociner, V., 310 E. 75 St., New York 21, N. Y.
Buggy, R. V., 5934 N. 7 St., Philadelphia 12, Pa.
Burns, H. S., Box 392, Islington, Mass.
Clark, H. L., 141—25 Northern Blvd., Flushing, N. Y.
Coffman, B. C., 25 Park St., Montclair, N. J.
Conner, R. W., 17 Spring Garden St., Palmyra, N. J.
Deeter, E. L., Naval Ordnance Laboratory, Bldg. 210, Navy Yard, Washington, D. C.
Dickens, W. D., c/o Standard Bank of S. A., Eloff Street Branch, Johannesburg, South Africa

(Continued on page 42A)

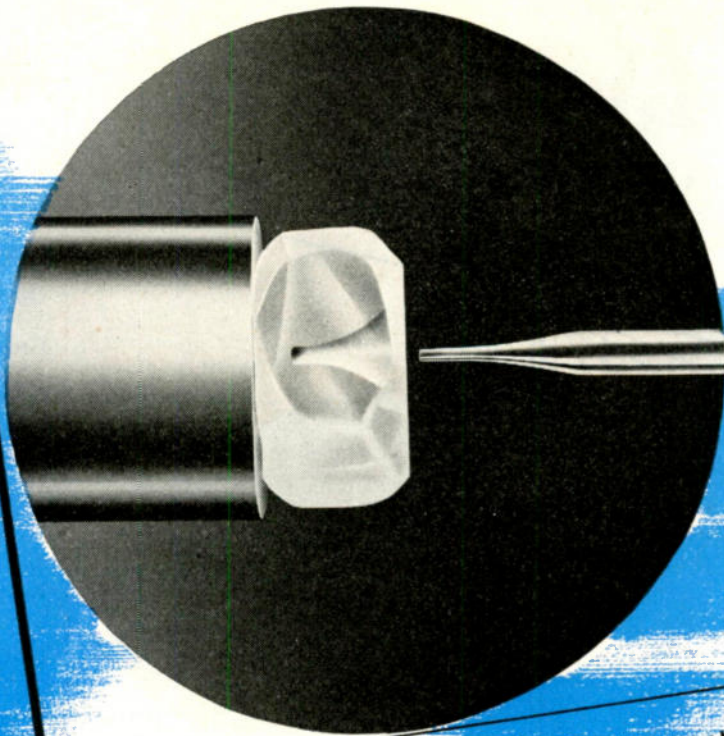

Shown here is microphotograph of a diamond being drilled. It shows the precise Philips workmanship.

Tolerances so close they must be weighed

That's right—the tolerances of the fine wire made by North American Philips cannot be measured by micrometers—the wire must be weighed on delicate balances.

That kind of precision craftsmanship—which goes back to and beyond even the smallest component—has made possible the production of wire so fine that 2,000 pieces laid side by side measure but an inch.

To draw wire this fine—with tolerances and characteristics maintained—Philips developed its own methods of drilling precision diamond dies. These dies are in daily use in Philips and other factories, insuring fine wire users of a more precise product.



Such fine wire—drawn through Philips precision diamond dies—is a vital component of electronic tubes manufactured by Philips and others.

Thus the skill of an organization, known for over fifty years for its devotion to *precision craftsmanship* down to the smallest *component*, is evidenced in the increasing acceptance and use of Philips products.

In addition to fine wire and diamond dies, North American Philips also manufactures quartz crystals, cathode ray tubes, industrial and medical X-ray tubes and equipment, tungsten and molybdenum products.

Norelco
Reg. U. S. Pat. Off.



ELECTRONIC PRODUCTS



NORTH AMERICAN PHILIPS COMPANY, INC.

DEPT. F-8, 100 EAST 42nd STREET
NEW YORK 17, N.Y.

NEW DI-FAN RECEIVING ANTENNA



...covers ALL
television and
FM frequencies

THE Andrew Co., pioneer specialist in the manufacture of a complete line of antenna equipment, continues its forward pace with the introduction of this new DI-FAN receiving antenna.

The DI-FAN antenna provides excellent reception on *all* television and FM channels. It thus supersedes ordinary dipole antennas or dipole-reflector arrays which work well over only one or two television channels.

In addition, the following advanced features will recommend the DI-FAN to dealers and receiver manufacturers who want the best possible antenna for use with their FM and TV receivers:

- Impedance of DI-FAN matched to impedance of transmission line, preventing ghost images.
- Designed for use with 300 ohm transmission lines, conforming to RMA standards for FM and TV receivers.
- DI-FAN has a graceful, attractive shape—looks well on any building.
- Light in weight but strong and durable. High strength aluminum alloy elements. Supporting members of heavily plated steel.
- All insulators are high grade glazed stearite.
- Mounting supports available for either chimney or roof installations.

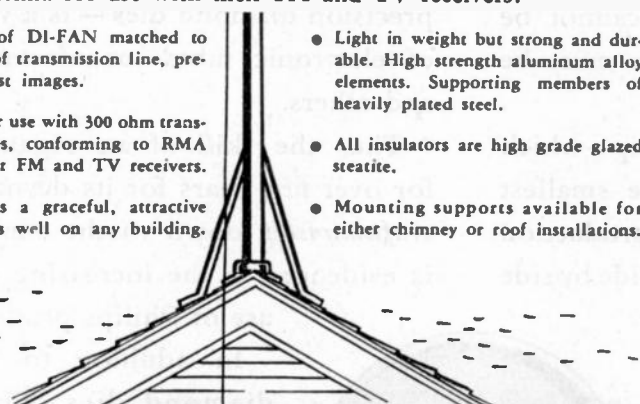

ANDREW
CO.
363 E. 75th St.
Chicago 19, Ill.

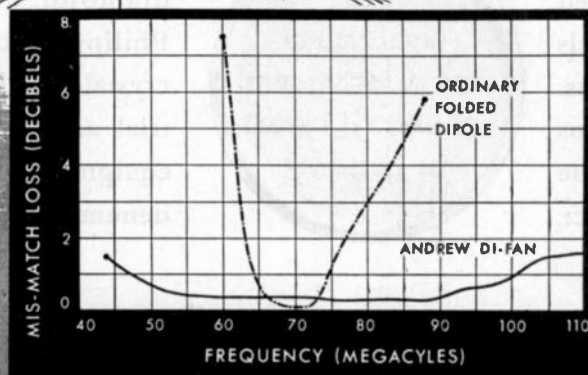

This graph illustrates the superiority of the Andrew DI-FAN over an ordinary folded dipole.



(Continued from page 40A)

- Dorschug, H. A., 707 Longfellow St., N.W., Washington 11, D. C.
- Fong, A., 1673 Commonwealth Ave., Brighton 35, Mass.
- Gorham, J. E., 503 Morris Ave., Spring Lake, N. J.
- Gregory, A. H., 2705 W. 30 Ave., Vancouver, B. C., Canada
- Harvey, N. L., 46-49—157 St., Flushing, N. Y.
- Hayes, A. E., Jr., Bendix Radio Corp., Baltimore 4, Md.
- Holaday, D. F., Box 1252, Galveston, Tex.
- Hopkins, J. J., 10122 Greenock Rd., Silver Spring, Md.
- Jones, B. R., Coral Hotel, Key West, Fla.
- Kearney, J. W., Airborne Instruments Laboratory, Inc., 160 Old Country Rd., Mineola, N. Y.
- Kelley, E. K., 318 E. Cowan Dr., Houston 7, Texas
- Kennedy, R. C., Greenbush Apts., Orangeburg Rd., Orangeburg, N. Y.
- Kirkpatrick, E. L., 3947 Nichols Ave., S.W., Washington 20, D. C.
- Kleinkauf, J. D., 463 West St., New York 14, N. Y.
- Krevsky, S., 704 Ferguson Ave., Dayton, 7, Ohio
- Krieger, H., 4193 West Park Station, Bremerton, Wash.
- Logemann, H., Jr., 43 Museum St., Cambridge, Mass.
- Mathews, G. D., 1114 N. Main St., Wheaton, Ill.
- Mathews, W. I., 119 Hallock St., Riverhead, N. Y.
- McCaffrey, F. K., 1155 Orizaba Ave., Long Beach, Calif.
- McGuigan, W. D., 420 Memorial Dr., Cambridge, 39, Mass.
- McKee, L. H., 214-32—43 Ave., Bayside, N. Y.
- Mollman, L. A., Union Electric Bldg., St. Louis 1, Mo.
- Moncton, H. S., 27-03—200 St., Bayside, N. Y.
- Myers, J. F., 249 Linwood Ave., Buffalo 9, N. Y.
- Nicholas, J. C., RFD 2, Box 228-A, San Diego 10, Calif.
- Orth, J. T., 4101 Fort Ave., Lynchburg, Va.
- Parker, B. E., 338 S. 12 St., Quincy, Ill.
- Patterson, M. C., 2520 Bloor St., W., Toronto 9, Ont., Canada
- Pilling, T., P. O. Radio Branch, P. O. Research Station, Dollis Hill, London, N. W. 2, England
- Relis, M. J., 1428 Saratoga Ave., Washington 18, D. C.
- Richardson, G. A., 203 Electrical Engineering Laboratory, University of Kansas, Lawrence, Kansas
- Stansfield, S. J., 7425 Kenneth Ave., Skokie, Ill.
- Towne, A. E., RFD 1, Box 194, San Mateo, Calif.
- Webster, H. C., University of Queensland, Brisbane, Australia

(Continued on page 44A)

*One of a new line of
Du Mont De Luxe
Television Receivers,
incorporating the
finest in video and
audio entertainment.*

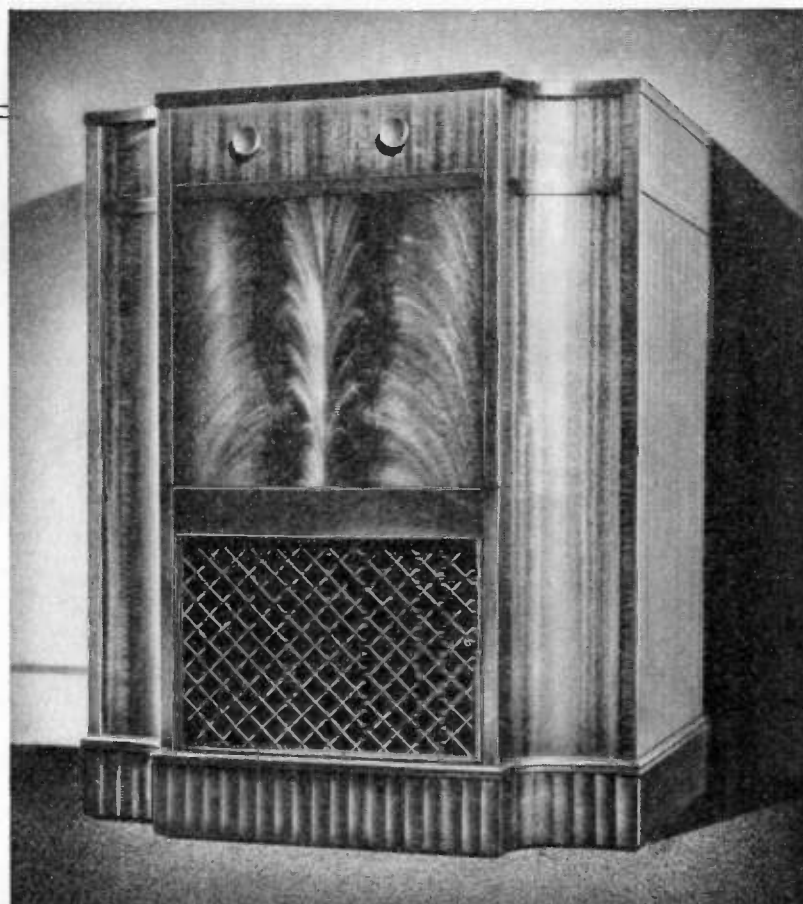

"20-20 teleVISION" by DU MONT



We at AmerTran are pleased that cooperation between Du Mont engineers and those of our staff have resulted in the choice of AmerTran Transformers in important circuits of these television receivers.



AMERICAN TRANSFORMER COMPANY
178 Emmet St., Newark 5, N. J.

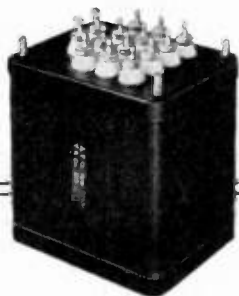

AmerTran Transformers and Reactors are component parts in the best-known communications, broadcast and electronic equipment now produced.

AMERTRAN

REG. U. S. PAT. OFF.
MANUFACTURING SINCE 1901 AT NEWARK, N. J.

*Transformer Suppliers
to the Electronics Industry*



THIS IS THE TRANSFORMER DESIGN . . .



(Continued from page 42A)

Williams, F. B., 6900 Knox Ave., Lincolnwood, Ill.

Admission to Member

- Ansperger, W. B., 3937 Pennsylvania Ave., S.E., Washington, D. C.
 Bell, P. R., Jr., 25 A Shaler Lane, Cambridge 38, Mass.
 Blount, R., 1801—25 St., S.E., Washington 20, D. C.
 Boehmer, H. W., Department of Physics, Cornell University, Ithaca, N. Y.
 Cammen, M. M., 129 Pritchard Ave., Corning, N. Y.
 Cartwright, L. A., 7214 Fay Ave., La Jolla, Calif.
 Cobb, W. A., 304 N. Maple Ave., East Orange, N. J.
 Combella, E. M., 630 Raritan Ave., Camden, N. J.
 Crandell, C. F., 810 Telephone Bldg., Dallas 2, Texas
 Dean, J. E., Dept. of Electrical Engineering, Iowa State College, Ames, Iowa
 DeSoto, C. B., 26 W. 58 St., New York 19, N. Y.
 Eichhorn, C. W., 27 Golden Ball Rd., Weston 93, Mass.
 Emmons, C. J., 158 E. Como Ave., Columbus 2, Ohio
 Fattig, W. L., Box 788, Emory University, Georgia
 Gardner, H. A., 25 Hillside Ave., Stoneham 80, Mass.
 Graber, R. E., Ordnance Research Laboratory, State College, Pa.
 Greene, T. A., 658 W. First St., Elmira, N. Y.
 Grob, B., 4500 Broadway, New York 33, N. Y.
 Gunn, M. E., 3515 N. Wallace St., Indianapolis 1, Ind.
 Heintz, K. O., 209 Humble Bldg., Houston, Texas
 Hemingway, F. S., Det. D, T-4009, P. G. Troops, Aberdeen Proving Ground, Md.
 Hiestand, N. T., 200 Mt. Pleasant Ave., Newark 4, N. J.
 Hooper, G. A., 604 Meadow Lane, Oreland, Pa.
 Hope, C. R., General Engineering Department, Box 2211, Atlanta 1, Ga.
 Hughes, V. W., 439 Marlborough St., Boston, Mass.
 Johnson, J. C., 202 Humble Bldg., Houston 1, Texas
 LaHue, P. M., 1112 King Ave., Pittsburgh 6, Pa.
 Lippitt, K. H., 125 Spring Valley Rd., Darby, Pa.
 McDonald, A. J., Canadian Broadcasting Corp., Keefer Bldg., St. Catherine St., Montreal, P. Q., Canada
 Mack, J. L., 142 Clinton St., Greenville, Pa.
 Massa, E. A., 305 William St., Osborn, Ohio
 Mofenson, J., 407½ Monmouth Ave., Bradley Beach, N. J.

(Continued on page 48A)



. . . THAT GUARANTEES FINEST PERFORMANCE

This is one of the basic Acme Electric transformer designs that has the mechanical features and basic physical appearance to provide for better than average performance. End bells protect coils from accidental damage. Leads may be brought out through bottom, front, sides or top to meet the requirements of the installation. Available in ratings from 35 VA to 500 VA. Send specifications to Acme Electric transformer engineers and enjoy the cooperation that has enabled manufacturers of electronic and radio products to improve performance through better transformer design. Bulletin 168 gives all details.

ACME ELECTRIC CORPORATION
TRANSFORMER ENGINEERS

44 Water St.

CUBA, N.Y.

Acme  **Electric**

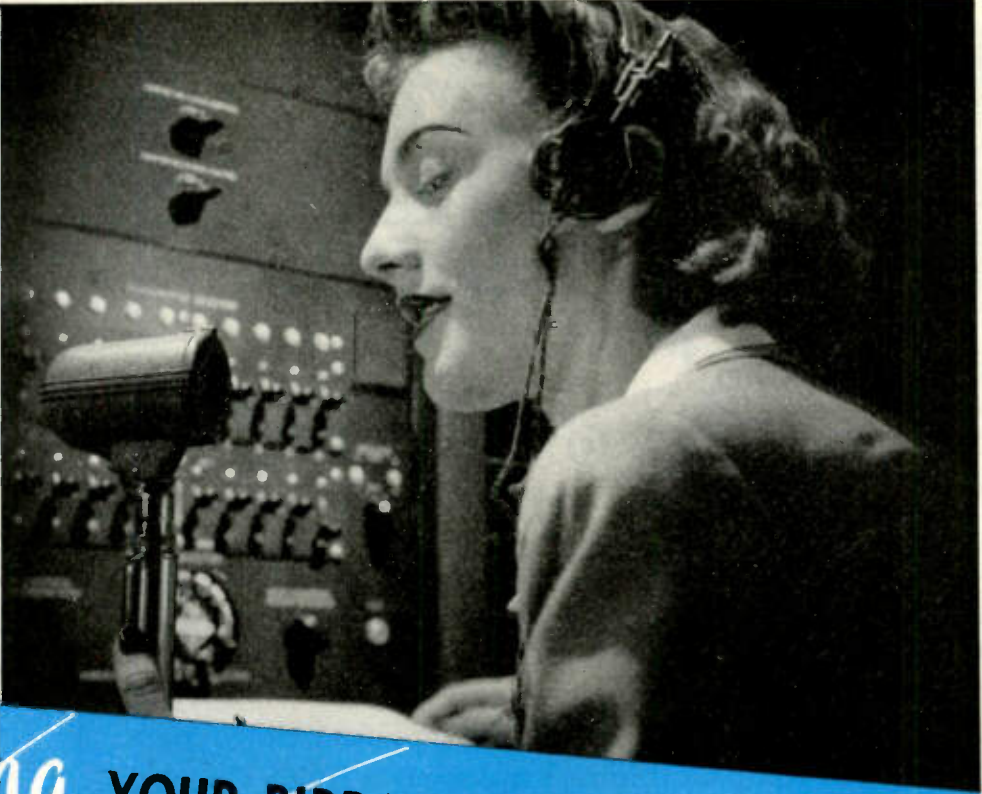

Bringing YOUR BIRDS HOME TO ROOST

Dependable communication between planes and airports is yours with Wilcox radio equipment. Its high performance is but one of many virtues. Economy, convenience, easy maintenance, and protection against frequency obsolescence are provided through extensive research, careful assembly, and thorough testing. Check the features of the Wilcox Type 99A Transmitter and see what they mean to you.

★ Four transmitting channels, in the following frequency ranges:

- 125-525 Kc. Low Frequency
- 2-20 Mc. High Frequency
- 100-160 Mc. Very High Frequency
- Other frequencies by special order

★ Simultaneous channel operation, in following maximum combinations:

- 3 Channels telegraph
- 2 Channels telephone
- 1 Channel telephone, 2 Channels telegraph

★ Complete remote control by a single telephone pair per operator

★ 400 Watts plus corner power

★ REMOVABLE R.F. HEADS are protection against frequency obsolescence. All connections to the transmitter are by means of plugs and receptacles. Instant removability means quick and easy maintenance.

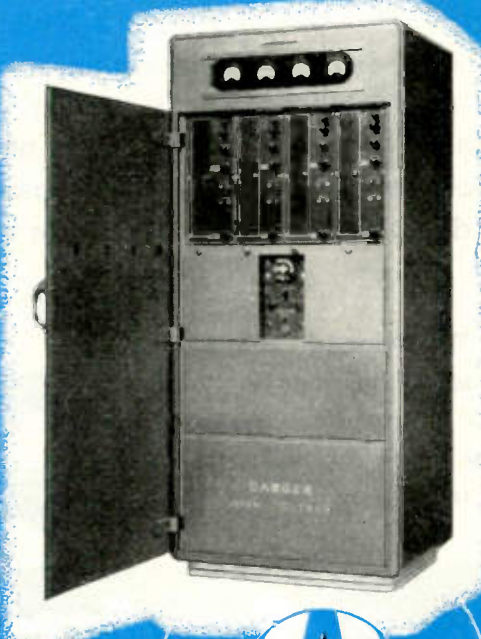

WRITE FOR COMPLETE INFORMATION

WILCOX ELECTRIC COMPANY, INC.
KANSAS CITY, MISSOURI



X-RAY VIEW

Astatic Nylon 1-J

**PICKUP
CARTRIDGE**

- A. 2-64 Ejection Screw
- B. Crystal
- C. Needle Guard
- D. Taper Nylon Chuck
- E. Taper Nylon Needle Knee
- F. Sapphire Playing Tip
- G. Needle Locating Fin

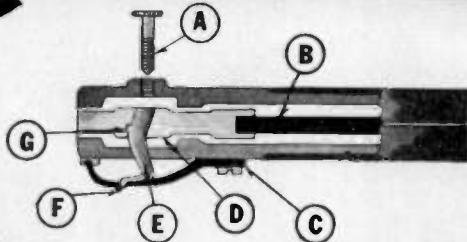

**GIVES AND MAINTAINS
IMPROVED PERFORMANCE**



THIS important, new-type Crystal Pickup Cartridge, employing a Nylon Chuck and matched, replaceable, sapphire-tipped Nylon Needle, contributes immeasurably to improved phonograph reproduction. Among its many advantages are: suppression of mechanical resonances of crystal element, improved tracking at low needle pressure, reduced record wear, and permanent needle reproduction with needle replacement advantages. The use of Astatic's Nylon 1-J Cartridge assures phonograph manufacturers and ultimate users or owners alike that the quality of reproduction will remain constant regardless of needle replacements because the Nylon needle is matched to the cartridge and **NO OTHER** type of needle may be used.

The Nylon 1-J Cartridge is furnished with Astatic Studio Master 400 Transcription Pickups and new Model 508 Pickups for 10" and 12" records.

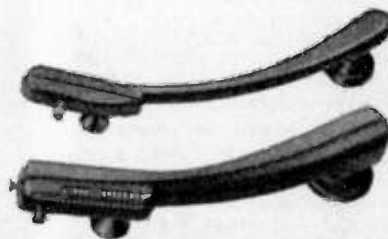

THE Astatic CORPORATION
 ASTATIC CORPORATION
 CONNEAUT, OHIO
 IN CANADA: CANADIAN ASTATIC LTD., TORONTO, ONTARIO

Astatic Crystal Devices manufactured under Brush Development Co. patents.

MICRO-DIMENSIONAL

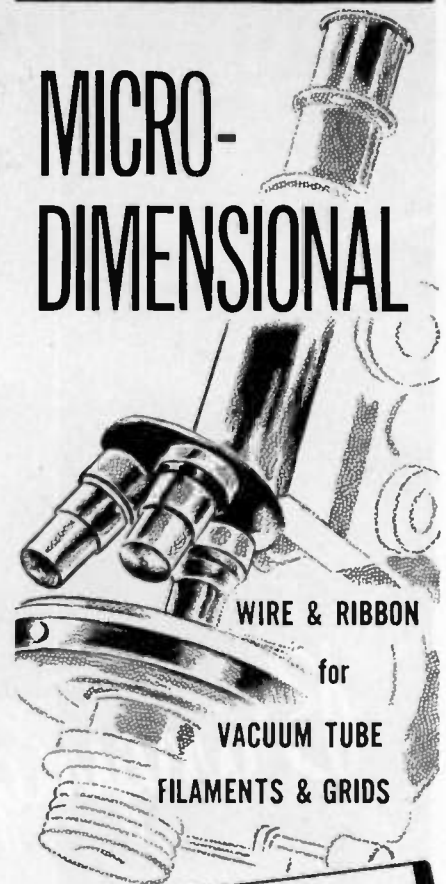

● Many sizes and alloys for a range of applications such as miniature tubes, hearing aid tubes, low-current-drain battery tubes, receiving tubes . . .

● Melted and worked to assure maximum uniformity and strength. WIRES drawn to .0004" diameter; RIBBON rolled to .0001" thickness . . .

● Wollaston Process Wire drawn as small as .000010"; made to your specifications for diameter and resistance.

● SPECIAL ALLOYS made to meet individual requirements. Write for list of stock alloys.

SIGMUND COHN & CO.
 44 GOLD ST. NEW YORK
 SINCE 1901

Largest MYCALEX

Part Ever Molded

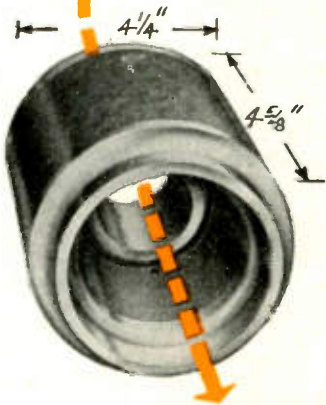
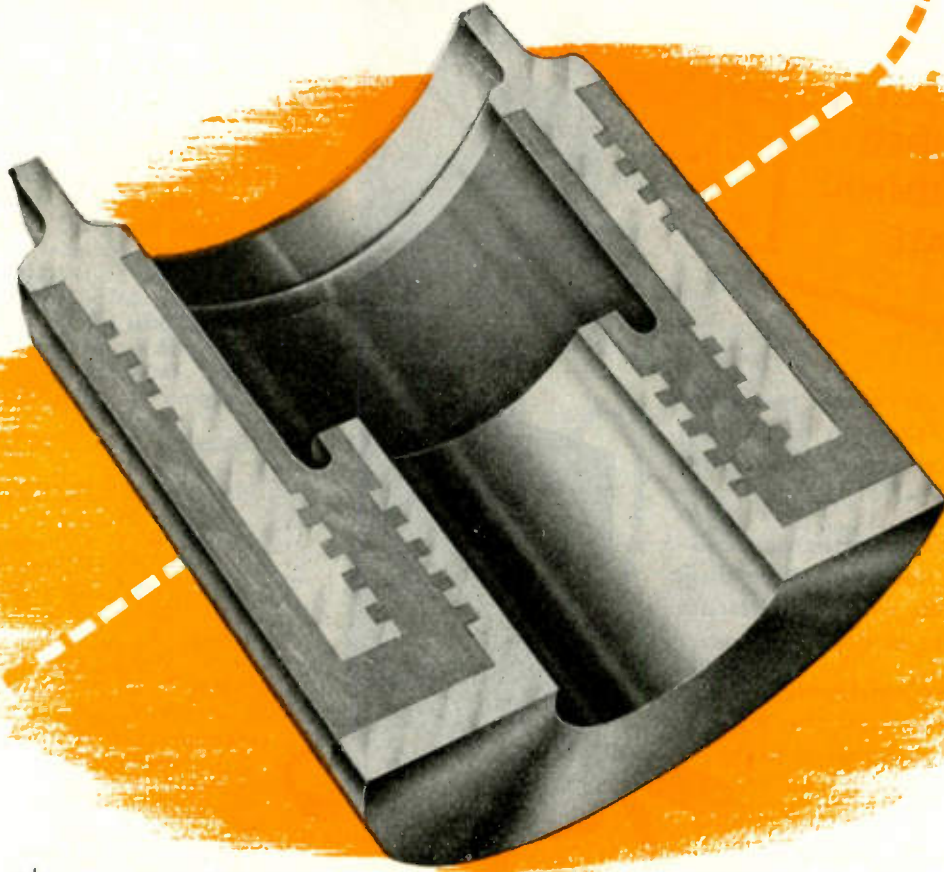

This cross section of a MYCALEX-to-metal molded component part was made for one of the country's leading manufacturers, and is the result of close cooperation between the customer's and our own engineering staffs. It exemplifies a new development in the molding of MYCALEX 410 with metal to form a hermetic seal.

The objective was to take advantage of the low loss factor and other desirable properties of MYCALEX 410 to produce a rugged bushing assembly in a single molding operation.

A difficulty was presented by the extremely long and branched path which the MYCALEX 410 had to follow. Total charge of MYCALEX 410 was 7 pounds, while the metal weighed 6 pounds to make a total weight of 13 pounds.

The MYCALEX and metal were sealed into one closely-bonded integral part, held to extremely close dimensional tolerances.

For more than 27 years MYCALEX has met and surpassed the most exacting needs engineers have been able to devise from year to year. MYCALEX 410, together with our highly perfected methods of molding it, is the greatest advancement in this high frequency low loss insulation to date.

Our technical staff is at your service. What is your problem in low loss insulation?

MYCALEX CORPORATION OF AMERICA

"Owners of 'MYCALEX' Patents"

Plant and General Offices, CLIFTON, N. J.

Executive Offices, 30 ROCKEFELLER PLAZA, NEW YORK 20, N. Y.

A Ballantine ELECTRONIC VOLTMETER

For every requirement

ALL MODELS HAVE THE
SIMPLIFIED
LOGARITHMIC
SCALE

STANDARD
Model 300



Ideal for the *Accurate* measurement of AC voltages in the Audio, Supersonic, Carrier Current and Television ranges.

Use of Logarithmic voltage scale assures uniform accuracy of reading over whole scale while permitting range switching in decade steps.

Each Voltmeter equipped with an output jack so that the instruments can be used as a high-gain stable amplifier.

SPECIFICATIONS

MODEL 300

RANGE—.001 to 100 volts.
FREQUENCY—10 to 150,000 cycles.
ACCURACY—2% at any point on scale.
AC OPERATION—110-120 volts.

MODEL 304

RANGE—.001 to 100 volts.
FREQUENCY—30 c.p.s. to 5.5 megacycles
ACCURACY—0.5 DB.
AC OPERATION—110-120 volts.

MODEL 302

RANGE—.001 to 100 volts
FREQUENCY—5 to 150,000 cycles.
ACCURACY—2% at any point on scale.
DC OPERATION—self-contained batteries.

Send for Bulletin for further description

Model 302
BATTERY
OPERATED

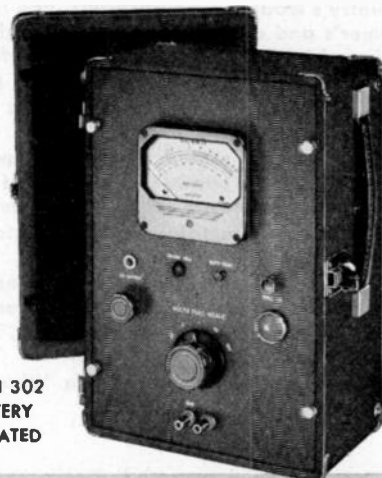

BALLANTINE LABORATORIES, INC.

BOONTON, NEW JERSEY, U. S. A.



(Continued from page 44A)

- Munzer, E. N., 469 Oakwood St., S.E., Washington 20, D. C.
Oldfield, H. R., Jr., 109 Rugby Rd., Syracuse 6, N. Y.
Paledes, T. P., 47 W. Green St., Mascoutah, Ill.
Parker, M. J., 2147 O St., N.W., Washington 7, D. C.
Polisse, L. F., 421 Woodbine Ave., Syracuse 6, N. Y.
Pollard, J. R., 83 Sevington Rd., London N. W. 4, England
Portmann, P. A., 146-19-58 Rd., Flushing, N. Y.
Pringle, F. V., 108 Donlea Dr., Leaside, Ont., Canada
Rudenauer, F., Box 100, Webster, Mass.
Shank, W. M. 3543 Robson St., Indianapolis 1, Ind.
Sidhu, H. S., 26, Darya Ganj (Faiz Bazar) Delhi, India
Simpson, M., 21 McLellan St., Dorchester, Mass.
Skinrood, D. A., 2720 Lincoln St., Evanston, Ill.
Smith, C. V. L., 9 Hillside Ave., Winchester, Mass.
Snyder, S. J., Wilmette Laboratory, 236 W. 55 St., New York 19, N. Y.
Stowell, N. J., 400 S. Austin St., Dallas 1, Texas
Thron, B. K., 119 N. Clermont Ave., Margate City, N. J.
Veith, F. S., 29 Spruce St., Great Neck, N. Y.
Wentzel, A. B., 1232 Blair Mill Rd., Silver Spring, Md.
Wiley, T. N., Box 2451, Anchorage, Alaska
Wyckoff, P. H., 4151 AAF BU, Watson Laboratories, Red Bank, N. J.
Zurakov, S. D., 647 Sheridan Rd., Chicago, Ill.

Admission to Associate

- Alexander, W. G., 5 Manor Ave., Baltimore 6, Md.
Alter, J., 1243 Dean St., Brooklyn, N. Y.
Anderson, V. A., 2611 Fair Ave., Bexley 9, Ohio
Andrews, A. G., Box 55, Lucknow, Ont., Canada
Arnold, R. F., 1280 Main St., Buffalo 9, N. Y.
Aronoff, M., 3117 Broadway, New York 27, N. Y.
Bargman, M., 182 Commonwealth Ave., Buffalo 16, N. Y.
Beatty, T. L., 409 School St., Watertown, Mass.
Bentall, C. R., 5923 Pennswood Ave., Bellflower, Calif.
Berry, N. F., Colonial Radio Corp., 1280 Main St., Buffalo 9, N. Y.
Bieda, W. C., 771 Starin Ave., Kenmore 17, N. Y.
Blutman, E., 107 Belshaw Ave., Eatontown, N. J.
Box, R. J., Engineering Associates, St. Charles, Ill.
Boyle, H., 89c, Nithdale Rd., Plumstead, London S. E. 18, England

(Continued on page 62A)

NEW **EBY** MINIATURE SOCKETS

FLAT SADDLE

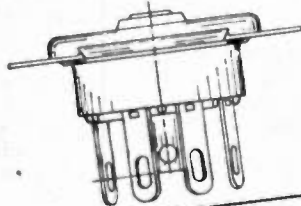
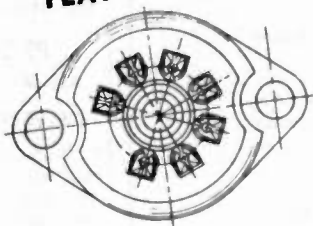

INSULATOR PART NO.	CONTACTS	
	Phos. Bronze	Beryl. Copper
General Purpose	8323	8100
Ceramic	8326	8083
Mica-filled Phenolic	8327	8082

SHOCK SHIELD

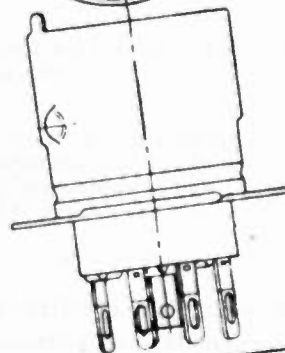
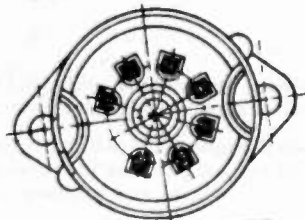

INSULATOR PART NO.	CONTACTS	
	Phos. Bronze	Beryl. Copper
General Purpose	8322	
Ceramic	8328	7676
Mica-filled Phenolic	8329	7670

NON-MICROPHONIC

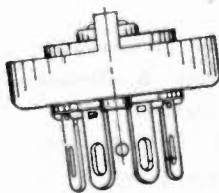
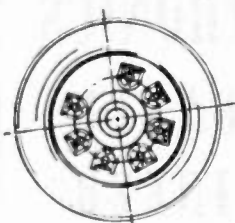

PART NO. 8341

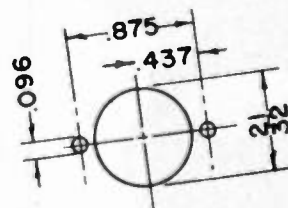

MOUNTING LAYOUT

Flat Saddle
Shock Shield
Non-Microphonic

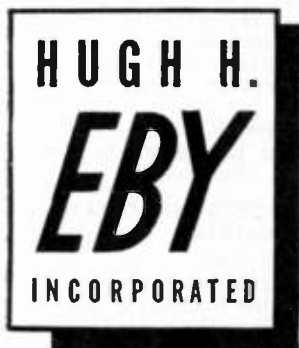

WRITE TODAY for complete details —

HUGH H. EBY, INC.

18 W. Cheltenham Ave.

Phila. 44, Pa.

WANTED...

6 EXPERIENCED ENGINEERS

The following positions are in the East and are with one of the country's largest producers of electronic equipment.

* * *

Chemical Engineer or Physicist with Ph.D. degree, 2 or more years of industrial experience or equivalent in research.

Mica Capacitor Designers (2) with at least 3 years' experience in the design of mica capacitors for power and high-frequency applications; to investigate and evaluate new materials for use in this field.

Design Engineers (2) with at least 3 years' experience in the design of RF coils and/or RF circuits, to undertake development of new types.

Transformer Engineer—5 years' experience in design of laminated iron core coils and transformers—capable of original development work and designing of power and special application transformers such as filters and special audio types.

* * *

In applying please give details of education, experience, special achievements and personal history. Box 427

The Institute of Radio Engineers, 330 West 42nd St., N.Y. 18, N.Y.



The following positions of interest to I.R.E. members have been reported as open. Apply in writing, addressing reply to company mentioned or to Box No.

The Institute reserves the right to refuse any announcement without giving a reason for the refusal.

PROCEEDINGS of the I.R.E.

330 West 42nd Street, New York 18, N.Y.

ELECTRONICS RESEARCH ENGINEER

Experienced in research, development and design, special devices, servo, electronic controls, etc. Top man required by a nationally known manufacturing company. State complete résumé of experience and background. Box 425.

INSTRUCTIONAL STAFF

Electrical Engineering Department in large Middle Western University has staff opening in grades of Instructor to Associate Professor depending upon training and experience. For details write Box 426.

ACOUSTIC ENGINEERS, PHYSICISTS, RESEARCH ASSISTANTS

To do research in the field of acoustics full or part-time while carrying graduate work in allied subjects at Washington University. Stipend commensurate with proven ability and past earnings. St. Louis Microphone Company, Box 3440, Maplewood 17, Mo.

MICROWAVE DEVELOPMENT ENGINEERS

Experience desirable on antenna, waveguide component and general system design. Permanent. Write giving full details regarding education and experience to Personnel Department, Raytheon Manufacturing Company, Waltham 54, Mass.

ENGINEER OR PHYSICIST

Small research and development company in New York City has opening for a graduate engineer or physicist with an electronic or communications background. Work affords great opportunity for exploration and ingenuity in servos, optics, and radiation. Salary open. Box 420.

PHYSICISTS AND ELECTRICAL ENGINEERS

Research project leaders for work combining electronics and general applied physics. Bachelor's degree in physics or engineering plus graduate work and two to four years practical experience.

Junior research engineers for work in electronics. Bachelor's degree in electrical engineering or physics plus one or two years of graduate work or practical experience.

Communicate with R. F. Simons, Airborne Instruments Laboratory, Inc., 160 Old Country Rd., Mineola, N.Y.

APPLIED PHYSICISTS—MICROWAVE ENGINEERS

Organization with long term research and development program in microwaves, electronics and other branches of applied physics has openings for several senior and junior staff members. Seniors should

(Continued on page 52A)

RAWSON MULTIMETERS



Types 501A, 501B, 501C
Accuracy $\frac{1}{2}$ of 1%

Readings from 2 microamperes to 1 ampere on 5 ranges, and 20 microvolts to 1000 volts on 9 ranges.

The word MULTIMETER is our copyrighted trade mark.

Write for bulletins

We can also supply

Single range meters and other combinations of ranges

THERMAL MULTIMETERS for A. C.

ELECTROSTATIC VOLTMETERS FLUXMETERS

Special apparatus built to order

RAWSON ELECTRICAL INSTRUMENT CO.
118 POTTER ST. CAMBRIDGE 42, MASS.

Representatives
CHICAGO LOS ANGELES NEW YORK CITY

ELECTRONICS RESEARCH ENGINEER

experienced in Research, Development & Design Special Devices, Servo, Electronic Controls, etc. Top man required by a Nationally known manufacturing company. State complete resume of experience and background.

Box #425.

The Institute of Radio Engineers

330 West 42nd St.
New York 18, N.Y.

SEALED

**to stop air, oil, water
and current leaks
in h-f circuits**

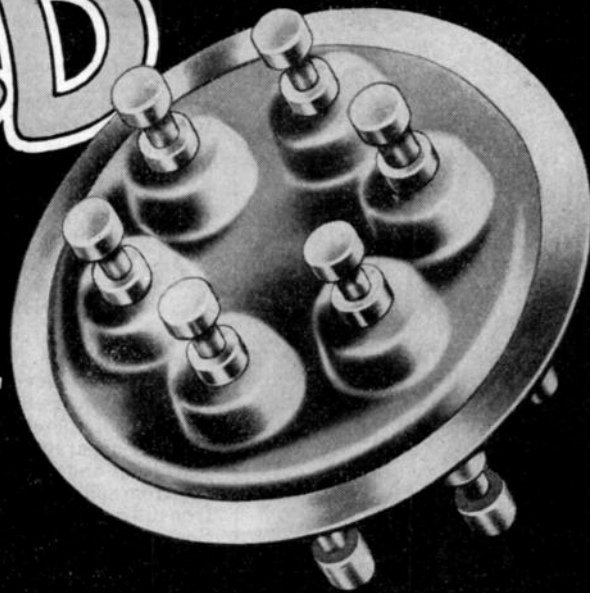

In high-frequency, high-voltage circuits, current arcs right through ordinary insulation or seeps away in high losses.

Specially-developed dielectrics are needed. One of these is Mycalex, a glass-bonded mica product made by the Mycalex Corporation of America, Clifton, N. J., and widely used for more than twenty-five years.

But even with Mycalex there still remains a difficulty when building units in which the insulation must be combined with metal conducting elements—as, for example, lead-ins or terminals.

For such units you need a current-carrying metal that will match the thermal expansion characteristics of Mycalex. Otherwise, unequal expansion and contraction rates will separate the metal inserts from the insulating material, letting oil, air and

moisture into the electrical system.

The metal also must offer adequate electrical conductivity... must suffer no corrosion that would reduce surface conductivity... must be workable into the small sizes and intricate shapes needed.

To get all these properties, Mycalex engineers always recommend Monel—one of the versatile INCO Nickel Alloys—to ensure the dependable hermetic seals they need.

MORE AND MORE ENGINEERS ARE "DISCOVERING" THE INCO NICKEL ALLOYS

Investigate the INCO Nickel Alloys whenever you have a tricky metal problem. Strong, tough, and corrosion-resisting as a group, each also offers the individual properties so frequently needed in electric and electronic applications.

★ ★ ★

Write for your copy of "INCO NICKEL ALLOYS for ELECTRONIC USES"—a summary of properties and recommended applications.



"EXTREMELY SATISFACTORY"

Six Monel terminals are molded into this Mycalex assembly for a transformer. After testing it for leakage, United Transformer Corporation reported it to be "extremely satisfactory for hermetic sealing purpose."

Because the coefficients of thermal expansion of Monel and Mycalex are so compatible, and because the surface conductivity of Monel cannot be reduced by corrosion, Mycalex engineers recommend Monel above all other metals for use with Mycalex. 3

THE INTERNATIONAL NICKEL COMPANY, INC., 67 Wall St., New York 5, N. Y.

NICKEL  ALLOYS

MONEL • "K" MONEL • "S" MONEL • "R" MONEL • "KR" MONEL • INCONEL • NICKEL • "L" NICKEL • "Z" NICKEL
*Reg. U. S. Pat. Off.

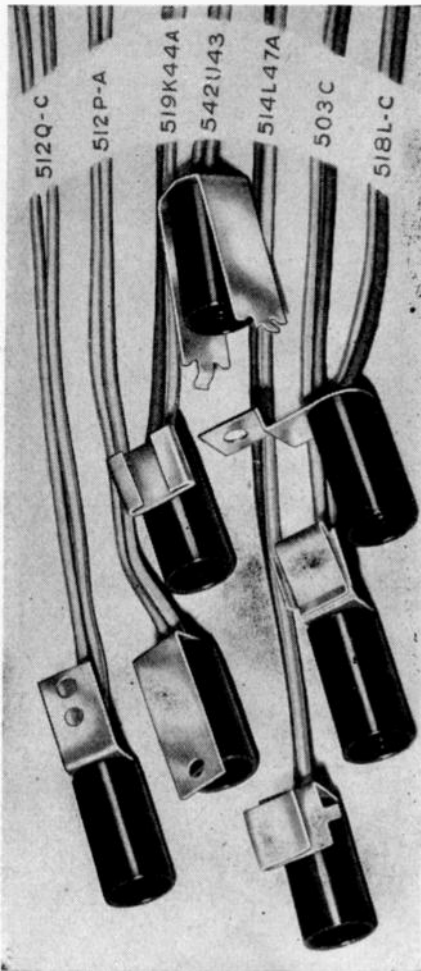

TOP QUALITY AT LOW COST!

DRAKE patents plus modern high speed methods and machinery go a long way toward achieving the traditional excellence and economy of our products. It should pay you in better performance and *lower costs* to specify DRAKE for all of the Socket and Jewel Light Assemblies you need. Ask for prices and the newest Drake Catalog.



DRAKE MANUFACTURING CO.

1713 W. HUBBARD ST., CHICAGO 22, ILL.



(Continued from page 50A)

have advanced degrees in physics or electrical engineering and be capable of taking complete charge of project. Juniors require B.S. degree and preferably two or more years experience in development of electronic or microwave equipment. Salaries commensurate with abilities. Location N.Y.C. Give all details in first letter. Box 421.

PHYSICIST

Wanted by a large Mid-West petroleum company for the Physics Section of the Research and Development Laboratories. A man well versed in the design and construction of the electronic components of physical apparatus used in the testing of petroleum and its products, for example, spectrographs, mass spectrometers, electron diffraction and recording instruments. Some knowledge of and experience with high frequency oscillators would be desirable. This position is permanent and offers unusual and interesting opportunities for the right man. Give complete details as to personal history, education, experience and salary required in first letter. Box 422.

PHYSICISTS

Two Physicists, M.S. or Ph.D. (experience preferred) for long term project in microwave research and development. For details write Box 417.

ENGINEERS AND PHYSICISTS

With experience in radar and/or microwave research, development and design, interested in working along these lines. Write full details as to education and experience to Box 424.

RADIO INSTRUCTORS

Receiver servicing experience. Degree preferred. \$3600 to start; \$4200 after 4 months. Work in the heart of the radio industry. Write Raleigh G. Dougherty, c/o New York Technical Institute of New Jersey, 158 Market St., Newark 2, N.J.

PRODUCTION EXECUTIVES

Two executives: Production Manager also Head Production Control Department with several years experience in electronic equipment manufacturing and assembly. Salary \$5000 to \$8000. Write for interview describing background and experience especially peacetime production responsibilities before the war. Box 418.

FACTORY ENGINEER

We have openings in our Factory Engineering Division for two outstanding men. Experienced background of at least five years engineering work on factory problems relating to receiving tube manufacture required. Engineering degree would be helpful, but primary requirements of the positions are the experience and ability to successfully solve the everyday problems encountered in the manufacture of receiving tubes. Apply by letter to Personnel Department, National Union Radio Corporation, Lansdale, Pa.

ENGINEERS

TELEVISION. Experienced television receiver senior engineer.

RADIO. Experienced home set senior engineer.

(Continued on page 54A)

ENGINEERING PERSONNEL WANTED FOR PERMANENT EMPLOYMENT BY HAZELTINE ELECTRONICS CORPORATION

A total of 13 engineers, experienced in radio design, are required for work on home receivers, television receivers, and radar equipment. Minimum design experience of one year required. Of these positions, 12 are located in the New York area and 1 in the Chicago area. Salary commensurate with age and experience.

Apply by mail to

HAZELTINE ELECTRONICS CORPORATION
58-25 Little Neck Parkway
Little Neck, N.Y.

Attention: Personnel Manager
giving age, education, previous experience, and salary expected.

"RCA Victor Division,
Radio Corporation of
America, Camden, New
Jersey, has openings for
experienced capable en-
gineers for the design and
development of special
radio, radar and elec-
tronics equipment."

PRESTO made the on-the-spot recordings at Bikini!

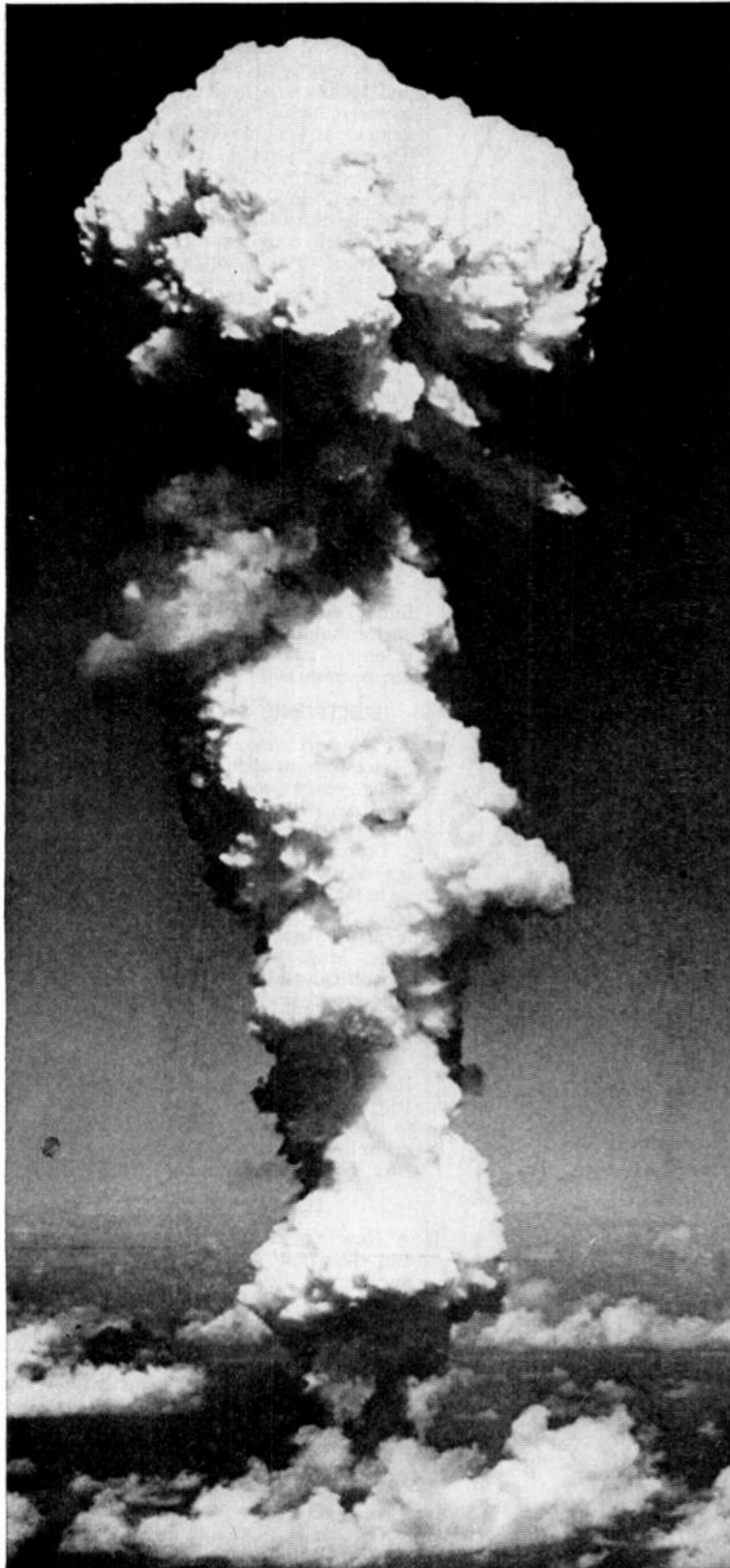

Acme Photo
Proceedings of the I.R.E. and Waves and Electrons August, 1946

WHEN the special events men of KSFO and the Universal Broadcasting Co. of San Francisco went to Bikini to record an on-the-spot word picture of the preparation for the atom bomb test, they selected PRESTO recording equipment to do the job.

This PRESTO equipment recorded the interviews with the natives of Bikini in their new home on the island of Rongerik. It recorded the on-the-spot report of an air trip over Bikini in an Army plane open to the winds and weather at 10,000 feet altitude.

This PRESTO equipment traveled to Kwajalein where the B-29 that dropped the bomb was being readied for the flight . . . it went from target ship to target ship in Bikini Lagoon . . . and it made a practice run in a pilotless plane at Eniwetok.

In hot, damp, salt air that rusted metal parts overnight if they were not protected, through surf so rough only rubber lifeboats could live in it, and in the scorching heat of these South Seas atolls, PRESTO equipment of standard design recorded this once-in-a-lifetime story for listeners of a hundred American radio stations to hear.

Thus, the atom bomb test was also a rigorous test of PRESTO equipment. And PRESTO passed that test with flying colors!



RECORDING CORPORATION
242 West 55th Street, New York 19, N.Y.
WALTER P. DOWNS, LTD., in Canada

**WORLD'S LARGEST MANUFACTURER OF
INSTANTANEOUS SOUND RECORDING EQUIPMENT**

Announcing

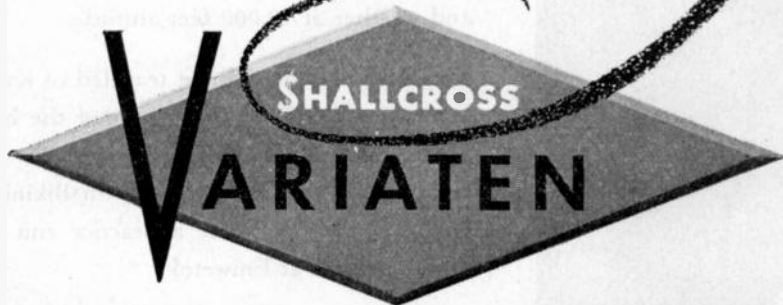
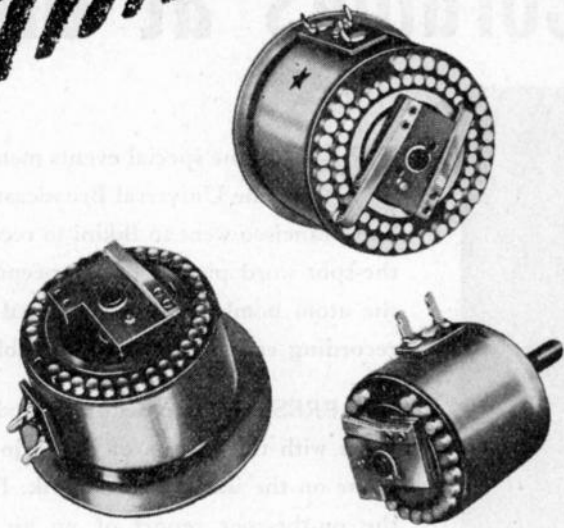

VARIABLE ATTENUATORS

Quality-proved on the world's most exacting applications

Now . . . the foremost Attenuator line . . . Variaten . . . is being engineered and produced by a national leader in precision electronic equipment . . . SHALLCROSS.

To a line already popular with broadcast, communication, recording and movie-sound equipment studios, has been added the complete facilities of this leading producer of fine electrical measuring instruments, selector switches and precision wire-wound resistors.

SHALLCROSS VARIATEN ATTENUATORS employ wire-wound resistors. Stone-lapped brush and contact surfaces assure complete overall contact for minimum noise level and lengthened service life. Types include ladder mixers, bridged and straight "T" attenuators, bridged and straight "H" attenuators, grid control potentiometers, loud speaker volume controls, turn-table faders, D.B. and V.U. meter range-extend-ers, and fixed pads for every purpose. Special designs made to specifications. Write for catalog.

Shallcross Manufacturing Co.
DEPT. IR-86, COLLINGDALE, PA.

POSITIONS OPEN

(Continued from page 52A)

Both positions are permanent and offer excellent opportunity and pay. United States Television Manufacturing Corp., 3 West 61st Street, New York 23, N.Y.

TUBE DESIGN DEPARTMENT HEADS

Electron Tube General Development and Magnetron Section Heads (2). Completely equipped laboratory; 10 scientists and technicians now in each group; extremely broad, going research and development programs; salary above \$5000. Thorough physics background, varied tube experience, creative ability, administrative ability required. State education, experience, salary expected. Replies will be treated confidentially. Present groups informed of this notice. Box No. 428.

EXPERIENCED TEACHERS

A well-known New York City Educational Organization is contemplating expanding its present Radio Courses to include engineering and technical courses in Radio.

Personnel who can assist with the work entailed in planning and setting up such a school, that would be on a college level, would be offered positions that would probably lead to supervisory work at this school. The proper persons would be excellently remunerated.

Kindly respond in a detailed letter, outlining educational, teaching and radio background. Please enclose a photograph, if one is available. The photograph cannot be returned. Write Box No. 429.

ELECTRONIC RESEARCH ENGINEER

An Eastern manufacturer of electronic devices has an opening for a man with five to ten years experience in electronics and familiar with blind landings systems or airport traffic control.

This is essentially a liaison job, requiring contact with companies and government agencies engaged in electronic systems work, to evaluate their work in terms of its applicability to specific problems. Must be able to carry on some theoretical and experimental work in addition to laying the technical ground work for possible formation of a group to engage in advanced development.

Prefer B.S. or M.S. in Physics, E.E., Radio Engineering, or Communications. Please send sufficient information relative to age, education, experience and salary desired to warrant an early interview. Box No. 431.

ELECTRONIC PHYSICIST

A New York manufacturer of electrical and electronic devices has an interesting opening for an M.S. or Ph.D. with five to fifteen years background in teaching, research, or advanced development in physics.

Requirements are: 1. Ability to devise and develop unusual systems which are fundamentally electronic in nature, but may include also other physical operations.

2. The evaluation of system possibilities, and theoretical predictions of performance.

3. Organization and utilization of the technical assistance of skilled consultants,

(Continued on page 56A)

**PRECISION MEASUREMENTS IN
MICROWAVE FREQUENCY BANDS . . .
PROVIDED BY THE NEW**

Sperry *Microline*^{*}

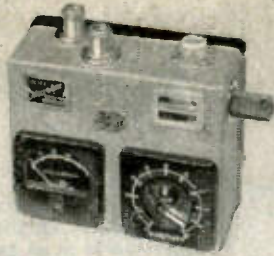

522—DETECTOR WAVEMETER

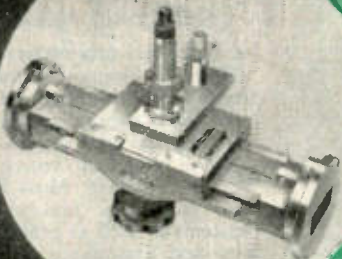

103—PRECISION IMPEDANCE METER

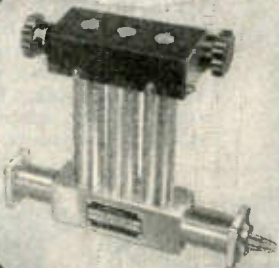

34A—TRIPLE STUB TRANSFORMER



322—WATTMETER BRIDGE

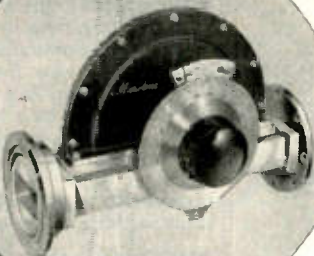

102—SPIRAL CARD ATTENUATOR

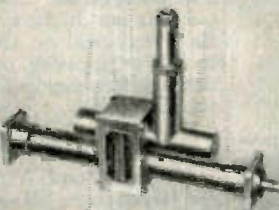

710—DIRECTIONAL COUPLER

Adequate microwave test and measurement equipment is of vital importance both in laboratory and field. Sperry provides it in its comprehensive MICROLINE. Virtually every type of instrument, essential to precision microwave measurements, is represented in this new Sperry line. The instruments shown in the illustrations but partly suggest the wide range of Sperry Microline instruments, among which are included many new designs and developments for obtaining quick, accurate measurements in the microwave frequency bands. For more complete information regarding these Sperry instruments, and their applications to your individual problems and requirements, write our Special Electronics Department.

^{*}Trade Mark



Sperry Gyroscope Company, Inc.

EXECUTIVE OFFICES: GREAT NECK, N. Y. • DIVISION OF THE SPERRY CORPORATION
LOS ANGELES • SAN FRANCISCO • SEATTLE • NEW ORLEANS • CLEVELAND • HONOLULU
Aircraft: Gyropilots • Gyrosyn Compasses • Altitude Gyros • Directional Gyros • Gyro-Horizons • Detonation Indicators • Automatic Radio Direction Finders • Instrument Landing Systems • Traffic Control Systems • Marine: Gyro-Compasses • Gyro-Pilots • Gyro-Magnetic Compasses • Incandescent Searchlights Steering Systems • Radar • Loran • Industrial: Railroad Radio • Microwave Relays Microline-Test Equipment • Klystron Tubes • Strobodine • Knockometer

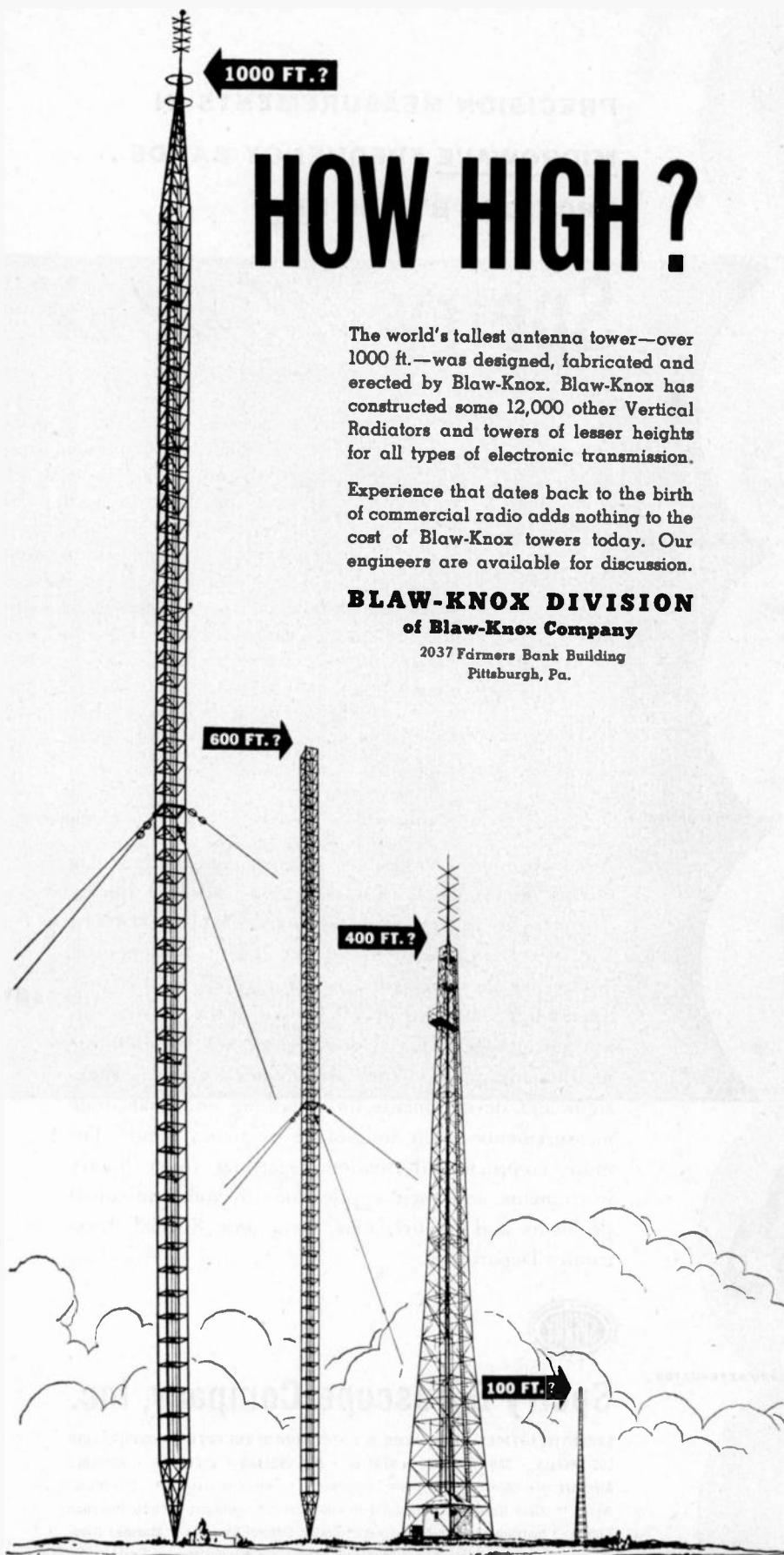

HOW HIGH?

The world's tallest antenna tower—over 1000 ft.—was designed, fabricated and erected by Blaw-Knox. Blaw-Knox has constructed some 12,000 other Vertical Radiators and towers of lesser heights for all types of electronic transmission.

Experience that dates back to the birth of commercial radio adds nothing to the cost of Blaw-Knox towers today. Our engineers are available for discussion.

BLAW-KNOX DIVISION of Blaw-Knox Company

2037 Farmers Bank Building
Pittsburgh, Pa.

**BLAW-KNOX ANTENNA
TOWERS**



(Continued from page 54A)

and the experimental verification of theoretical work. Qualified applicants will be interviewed at an early date in New York City. Please send particulars outlining age, education, experience, and salary expectation. Box No. 430.

ELECTRONIC RESEARCH ENGINEER

A large and progressive manufacturer of electronic equipment has an opening in the New York area for a man with five to ten years experience in radar, loran, or aircraft navigation aids. This experience should cover an entire system and be broad in nature. Must be able to devise and plan new and complex electronic systems as well as evaluate their possibilities and limitations. Must also supervise and carry out the design and development of the circuits required by the system.

B.S. or M.S. in Physics, Electrical Engineering, Radio Engineering or Communications preferred.

Early interviews will be arranged for qualified applicants furnishing full details regarding age, education, experience, and salary requirements. Box No. 432.



Positions Wanted By Armed Forces Veterans

In order to give a reasonably equal opportunity to all applicants, and to avoid overcrowding of the corresponding column, the following rules have been adopted:

The Institute publishes free of charge notices of positions wanted by I.R.E. members who are now in the Service or have received an honorable discharge within a period of one year. Such notices should not have more than five lines. They may be inserted only after a lapse of one month or more following a previous insertion, and the maximum number of insertions is three per year. The Institute necessarily reserves the right to decline any announcement without assignment of reason.

TWO-WAY RADIO AND MICROWAVES

Well-known highly experienced engineer, investor and author on two-way radio and microwaves. Long successful record pre-war and in Navy. Available for top-flight technical or administrative position in field engineering, sales, research or production. Minimum salary \$7200. Any location. Box 28W.

ENGINEER

Living in South Africa, diploma Professor Barkhausen (Dresden); A.M. (S.A.) I.E.E. seeks position with American manufacturing concern. Box 29W.

(Continued on page 58A)

YOU CAN PROFIT

from War Surplus
**ELECTRONIC EQUIPMENT
and COMPONENT PARTS**



Maybe you've wondered how YOU could get into the war surplus disposal business...on a profitable basis. Maybe you've been discouraged by red tape, by distant, inaccessible depots, or by the difficulty of choosing and quickly obtaining the kind of goods YOU can sell, in the quantities you can handle.

Here's YOUR Opportunity

Whether you're a retailer, wholesaler or manufacturer, this Raytheon catalog answers your questions—makes it *easy and convenient* to select, order and get delivery on the merchandise you want. It's just like ordering regular commercial merchandise from a wholesaler or manufacturer.

And make no mistake about this: all the material offered by Raytheon is *salable merchandise*—carefully segregated from scrap-and-salvage items of war surplus. It's all electronic gear made for the Army and Navy by America's finest electronic manufacturers. And it's all in the catalog—described—indexed—priced—easy to find and easy to order.

It's the most complete, most usable, most informative catalog of war surplus electronic equipment yet offered! Send for it at once—that's the first step. Then get in touch with Raytheon for technical advice and merchandising plans for speedy action.

RAYTHEON MANUFACTURING COMPANY

Acting as Agent of the
War Assets Administrator under Contract No. S1A-3-46
60 East 42nd St., New York 17, N. Y.

West Coast Office:
2802 N. Figueroa St., Los Angeles, Cal.



Excellence in Electronics

RAYTHEON MANUFACTURING COMPANY
Surplus Property Division
60 East 42nd Street, New York 17, N. Y. P.I.R.E. 8

GENTLEMEN: Send your new Catalog of salable and immediately-available war surplus electronic equipment to

Name.....
Company.....
Street Address.....
City..... Zone..... State.....

Case Histories from the RICHARDSON files

PRODUCT RE-DESIGN

Problem: To re-design bearings in bottle vending machine. Must be non-corrosive to withstand moist atmosphere. Bore of finished part must serve as a non-lubricated bearing, while the outer periphery must resist abrasive action.

Solution: Using Laminated INSUROK, Grade CG, Richardson Plastics furnished precision plastic bearings having the required characteristics. For Grade CG INSUROK contains a high percentage of natural graphite, has excellent strength qualities, resists abrasion and the action of moisture.

The versatility of The Richardson Company is at your service no matter what the plastics application may be. Through the correct use of INSUROK, both molded and laminated, Richardson Plastics have shared in the rapid growth of many industries. Tell us your plastics problems . . . and let us help you solve them!

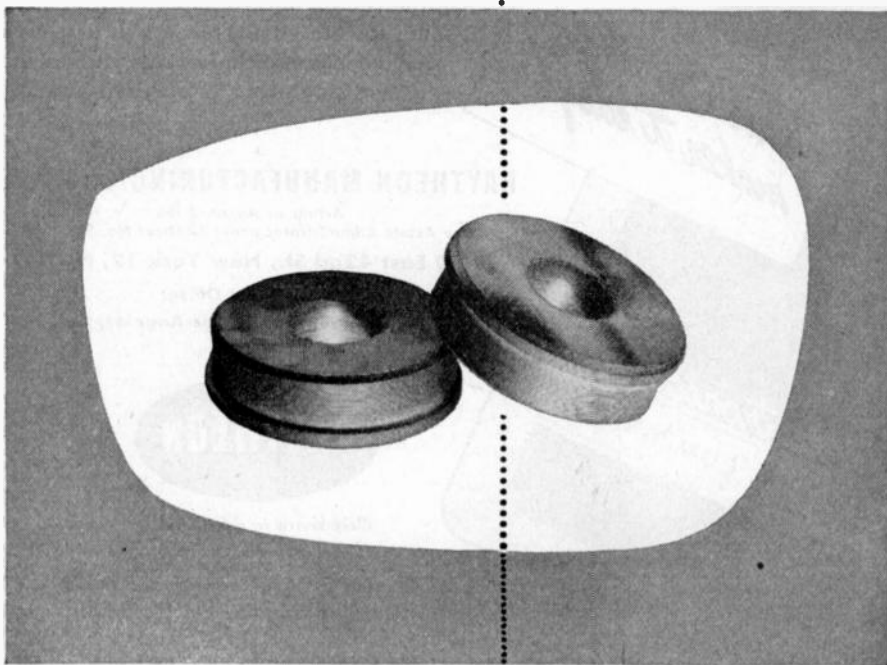

INSUROK *Precision Plastics*

The RICHARDSON COMPANY

LOCKLAND, CINCINNATI 15, OHIO FOUNDED 1858 Sales Headquarters: MELROSE PARK, ILL.

Sales Offices: NEW YORK 6 • CLEVELAND 15 • DETROIT 2

Factories: MELROSE PARK, ILL. NEW BRUNSWICK, N. J. INDIANAPOLIS, IND.

Positions Wanted

(Continued from page 56A)

NAVAL OFFICER

Age 28, married. Three years Naval radar, Chief Petty Officer. First class radiotelephone and telegraph since 1939. Experienced in transmitter maintenance both FM and AM. Box 30W.

ELECTRONIC DEVELOPMENT-CONSULTING

B.S. Physics, Chemistry, 2½ years Navy Radio-Radar Officer. Three years civilian teaching, radio theory-design. Class A license. High fidelity amplifier experience. Charles J. Fuchs, 160 E. Third St., New York 9, N.Y.

ELECTRONICS ENGINEER

B.E.E. 1944, Rensselaer, Tau Beta Pi, Sigma Xi. Age 23, Navy trained radar officer. Good mathematics background. Desire position concerned with development work in UHF. Box 31W.

SALES OR SALES ENGINEER

Coast Guard electronics officer, age 27, five years military experience, pre-war electronic sales. Excellent sales record in industrial field since discharge. Will go anywhere in United States or foreign. Box 32W.

ELECTRICAL ENGINEER

B.S. in E.E., graduate work at University of Pennsylvania. Three and one-half years civilian experience in design, development, and production of radio, radar, and electronic equipment. Radio engineering or production engineering position desired. A. F. Driesman, 2169 Pacific St., Brooklyn 33, N.Y.

ENGINEER

B.E.E. 1943, some postgraduate work. 1½ years civilian experience in design and construction of electronic instruments for ballistic measurements. U. S. Army Ordnance; 1½ years abstracting German technical documents. Available October. Box 33W.

JUNIOR ENGINEER

BS in EE, broadcast license since 1940, technician. Desire position with station or as assistant in design or manufacture. Age 24. J. M. McClamrock, 7515 E. Burnside St., Portland, Ore.

AAF ELECTRONIC OFFICER

AAF Electronic Officer with good experience in installation and operation of Loran transmitters or receivers. Experienced with all types of control circuits. Box 15W.

ENGINEER

BEE. UHF. Age 22. Some experience in research and design of test equipment. Navy work in radar and communication. Desires research or engineering in electronics near NYC. Available August. Box 16W.

RADIO ENGINEER

BS 1941. Courses at C.C.N.Y., N.Y.U., L.I.U., B'klyn Polytech., Yale, Harvard, and M.I.T. Experience testing, research and teaching. Former Radar countermeasures officer. Desiring position New York area. Box 17W.

ENGINEER

M.I.T. trained radar officer, BS physical chemistry Rutgers 1941, photochemical research, electronic teaching, vacuum tube manufacturing experience. Seeks development work electronics or physical chemistry. Box 18W.

(Continued on page 60A)



ANY RESISTANCE-ROTATION CURVE IS AVAILABLE

The resistor of the Type J Bradleyometer is a solid molded ring. During manufacture the resistor material is varied throughout the circumference of the molded ring to provide any desired resistance-rotation curve. (See chart below.)

The resistor unit is molded as a one-piece casting with terminals, face plate, and threaded bushing imbedded in the ring. The contact between brush and resistor unit improves with age.

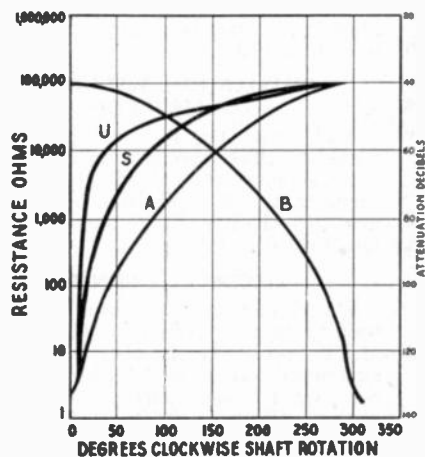

These A-B Adjustable Resistors are solid-molded for permanence

The resistor is a thick ring of solid-molded material, heat-treated under pressure to produce a unit that is unaffected by heat, cold, moisture, or length of service.

Since it is not a film or paint-type resistor, its resistance-rotation characteristic remains permanent. Moreover, the Type J Bradleyometer is the only continuously adjustable composition resistor having a 2-watt rating with a good safety factor. Bradleyometers are available in single-, dual-, and triple-unit type, with or without line switch. Complete specifications on application.

Allen-Bradley Company, 114 W. Greenfield Ave.
Milwaukee 4, Wis.



ALLEN-BRADLEY

FIXED & ADJUSTABLE RADIO RESISTORS

QUALITY

The Most Indispensable Reference in Radio-Electronics
Electronic Engineering Master Index

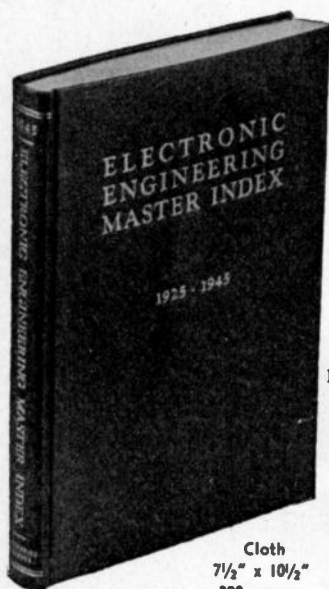

A master compilation of over 15,000 titles of texts and articles selected for their value to the research engineer, this INDEX covers the years 1925-1945 and enables you to survey twenty years of research literature on any subject in a matter of minutes!

Vitaly Needed in Every Laboratory and Library

COMPLETE IN ONE VOLUME

PART I	PART II
January 1925 to December 1934	January 1935 to June 1945



PARTIAL LIST FROM 65 PERIODICALS INDEXED

Bell Laboratories Record	General Electric Review
Bell System Technical Journal	Journal of Applied Physics
Communications	Proceedings of I.R.E.
Electrical Communication	Transactions of A.I.E.E.
Electronics	Radio News
Electronic Industries	R.C.A. Review
Journal of I.E.E.	Wireless Engineer

Cloth
7 1/2" x 10 1/2"
320 pages

A \$500 Reference Library in One Volume for \$17.50

Descriptive circular on request.

ELECTRONICS RESEARCH PUBLISHING COMPANY

2 W. 46th Street

New York 19, N.Y.

Positions Wanted

(Continued from page 58A)

RADIO ENGINEER

BS in EE. Three years development electronic equipment and systems. Four years research and development in RF and antenna field both VHF and microwave. Now holding responsible technical position. Available July. Box 19W.

RADAR-COMMUNICATIONS ENGINEER

EE graduate, 25, with Navy officer training at Princeton and M.I.T. in electronics plus duty at NRL. 1 1/2 years experience as radar instructor. First class radio telephone license held. Desires position in June. Box 20W.

BEGINNING ENGINEER

Ensign, USNR, being discharged August. BS in EE The Rice Institute. Tau Beta Pi. Age 22. 8 years radio sales and service. Navy radar training. Desire position in southwest U.S. Box 526, Manitou Springs, Colo.

NAVAL ELECTRONICS OFFICER

BEE, age 23, married. First class phone license; broadcast and industrial experience. Desire radio design or broadcast engineer position. Prefer middle west. Available July 1. Box 22W.

ELECTRICAL ENGINEER

BEE, age 24. Instrument research experience. Studied Navy electronic equipment. Commercial operator's license. Prefer east. Box 24W.

SALES ENGINEER

BE Yale 1940, project engineer Naval Research Lab. and Radiation Lab., M.I.T., aeronautical and marine radar, Loran, UHF radio experience. Résumé of experience on request. Box 25W.

ELECTRICAL ENGINEER

BEE, age 27. 1 year civilian development experience, 3 1/2 years Naval officer, specializing in radar, radio maintenance aboard ship. Interested in development, field, or sales position. Consider west coast. Box 23W.

POSITION WITH STATION

Age 25, single. Two years Signal Corps. First class license with 3 1/2 years commercial indorsement. Experienced in studio and transmitter maintenance. Also audio and equipment design. Box 9W.

ELECTRICAL ENGINEER

BS in EE, University of California. Age 25, married. 4 years executive experience in research, development, test, and maintenance of electronic and elect-mech devices. Now Naval electronics officer. Available May 1 for manufacturing or consulting firm. Box 10W.

INSTALLATION, TESTING OR CONSTRUCTION

NYU graduate, 1 year experience in telephone office, specification writing and DC machinery test, plus 3 years in field engineering and supervision of construction of Airways radio and navigation facilities. Box 11W.

ELECTRICAL ENGINEER

Electrical engineering plus electronics training as Army officer at Harvard and M.I.T. specializing in radar. Two years experience on ground radar overseas. Supervised maintenance and repair of radar. I. Ginsberg, 20 Gilmer St., Mattapan, Mass.

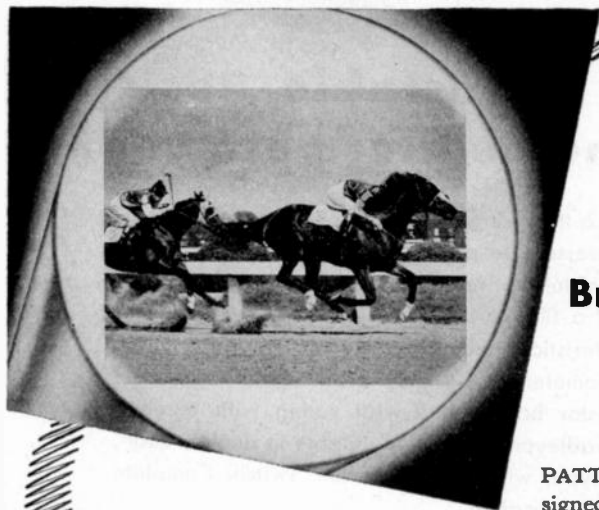

**Patterson
Phosphors
for Contrast...
Brilliance...Detail
in Television
Images**

PATTERSON PHOSPHORS are designed for maximum luminescence with minimum input energy. Quality phosphors for television, radar, oscilloscopes and other electronic instruments are available from Patterson Screen Division of E. I. du Pont de Nemours & Co. (Inc.), Towanda, Pa. Manufacturers, experimental laboratories and schools are invited to write us outlining their requirements.

PATTERSON PHOSPHORS ARE AVAILABLE
IN A WIDE RANGE OF

- | | |
|---------------|------------------------|
| 1. Colors | 4. Types of Excitation |
| 2. Grain Size | 5. Afterglow |
| 3. Brilliance | 6. Special Blends |

**PATTERSON
LUMINESCENT CHEMICALS**

BETTER THINGS FOR BETTER LIVING . . . THROUGH CHEMISTRY



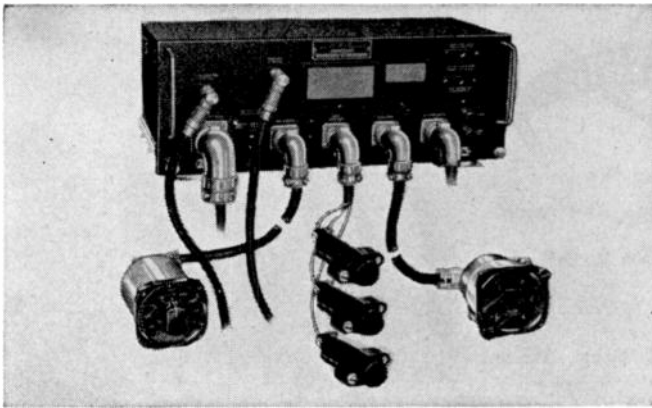

MODEL AVQ-6
CAATC 449

—Low-Altitude Altimeter is a ruggedly constructed, lightweight (28.4 pounds) transmitter-receiver unit, with a panel mounting dual-indicator meter, which registers absolute altitude in the range of 0 to 400 feet and 400 to 4,000 feet. Low battery drain is less than 3 amperes at 24 volts. Warning-indicator switch and warning lights shown are optional.

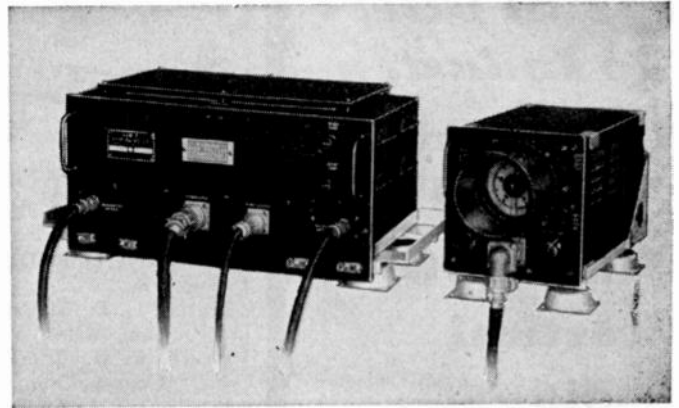

MODEL AVQ-9
CAATC 447

—High-Altitude Altimeter is built to the same high standards as all RCA Aviation Products. Nominal operating range of the equipment is 0 to 40,000 feet, with one complete revolution of the scale for every 5,000 feet. Easy on the pay load, installation less cable weight only 34.4 pounds, with total power consumption 135 watts at 115 volts (400 to 2,400 cycles).

RADAR ALTIMETERS by RCA

type certificated for scheduled airline service

RCA, designer, perfecter, and largest producer of radar altimeters, is proud to offer commercially two CAA-certificated models of this important new aid to flight—the RCA AVQ-6 Low-Altitude Altimeter and the RCA AVQ-9 High-Altitude Altimeter.

These advanced altimeters provide direct measurement of absolute altitude (terrain clearance) during flight. Their basic characteristics, inherent in the radar design, insure readings at all levels, independent of barometric altimeter, and have solidly established themselves as "musts" for modern flying safety.

Both the AVQ-6 and AVQ-9 provide the pilot or navigator with accurate readings in feet by measuring electrically the time interval required for a transmitted radar signal to travel from aircraft to earth or sea and return.

Available now for commercial and private aircraft.

For further information write: Aviation Section, Dept. 67-H, Radio Corporation of America, Camden, New Jersey.

**Leading Airlines Use
RCA
RADAR ALTIMETERS**

Here are a few of them:

- American Airlines
- American Overseas Airlines
- KLM (Royal Dutch Airlines)
- Pan American World Airways
- Swedish Intercontinental
Airlines (SILA)
- Trans World Airline



AVIATION SECTION

RADIO CORPORATION of AMERICA

ENGINEERING PRODUCTS DEPARTMENT, CAMDEN, N.J.

★ CREI Offers To Industry A Planned Program of **GROUP** **TRAINING IN** **Practical** **Radio** **Engineering**

To modernize the technical knowledge of your staff through a proved program of high calibre home study

If your organization is engaged in any phase of radio-electronics, your technical personnel must know FM—television — Ultra High Frequency Techniques, and all other phases of war-developed electronics technology; and, of course, a thorough and complete knowledge of the fundamentals of practical radio-electronics engineering.

The CREI "Employers' Plan" for group training will:

1. Increase the technical abilities of your radio-electronics personnel.
2. Enable them to perform their duties more efficiently and in less time.
3. Increase the value of their services to your organization.

No company time is required for this training . . . it is accomplished by spare-time home study to meet each individual organization's requirements.

The CREI "Employers' Plan" is useful for the up-grading of technical personnel in manufacturing, AM, FM, and television broadcasting, communications, industrial electronics, including the following:

Engineers
Engineering Aides
Laboratory
Assistants
Inspectors

Testers
Technicians
Field Servicemen
Installers
Maintenance Men

Your request will promptly bring an outline of the plan, as now in use with other organizations, and complete details will follow when your particular needs are known. No obligation or cost, of course.

**CAPITOL RADIO
ENGINEERING INSTITUTE**
E. H. RIETZKE, President
Dept. PR-8, 3224—16th St., N.W.
WASHINGTON 10, D.C.



(Continued from page 48A)

- Bozoian, M., 702 Fifth St., Ann Arbor, Mich.
 Bratcher, A. L., RFD 20, Box 26, Orlando, Fla.
 Broster, G. S., 53 Lafayette Ave., Hingham, Mass.
 Brown, R. H., Jr., Black Point, Marin County, Calif.
 Brugliera, F. J., 444 Sullivan St., Chicago, 10, Ill.
 Bulger, W. L., Jr., 129 Danbury St., Washington 20, D. C.
 Carlson, H. D., 1763 Columbia Rd., N.W., Washington 9, D. C.
 Carnine, R. L., 1339 Newton St., N.W., Washington 10, D. C.
 Chandler, J. F., 242 Delaware Rd., Kenmore 17, N. Y.
 Chapin, E. H., 21 Custer St., Buffalo 14, N. Y.
 Chattopadhyaya, R., 12 E. 10 St., New York 3, N. Y.
 Child, D. K., 6310 Patterson St., Riverdale, Md.
 Christensen, C. L., International House, 500 Riverside Dr., New York 27, N. Y.
 Chu, M., 500 Riverside Dr., New York 27, N. Y.
 Clements, R. P., 2615 Juan St., San Diego 10, Calif.
 Conant, R. J., 2908 Lafayette St., Houston, Texas
 Conn, R. A., 6932 Lowe Ave., Chicago 21, Ill.
 Cooper, C. W., 47-48—48 St., Woodside, N. Y.
 Couldwell, H., "Lyndair," 52 Fraser St., Shaw, Nr. Oldham, Lancashire, England
 Cowperthwait, F. N., Jr., 126 Newbury St., Boston 16, Mass.
 Crandall, W. R., 1118 S. Alameda St., Corpus Christi, Texas
 Daniel, J., Georgia Power Co., Electric Bldg., Atlanta, Ga.
 Dewey, D. L., 2136 Branch Ave., S.E., Washington 20, D. C.
 Dwork, B. M., 3120 Bainbridge Ave., New York 67, N. Y.
 Elliott, R. M., 110 Ford Ave., Syracuse, 7, N. Y.
 Field, B. W., 218 Fourth Ave., S.E., Aberdeen, S. D.
 Forsman, M. E., 5943 Gardenia Ave., Long Beach 5, Calif.
 Foster, J. C., 4001 N.E. 77 Ave., Portland 13, Ore.
 Fournier, C. E., Iroquois, Madawaska County, N. B., Canada
 Freres, C. E., 2075 Bacon St., San Diego 7, Calif.
 German, A. M., 1812 E. Republican St., Seattle 2, Wash.
 Gilliam, C. E., 7602 State St., Huntington Park, Calif.
 Grandizio, L. A., 2175 Washington Ave., New York 57, N. Y.
 Graul, T. A., 564 Austin Ave., Pittsburgh 16, Pa.

(Continued on page 64A)

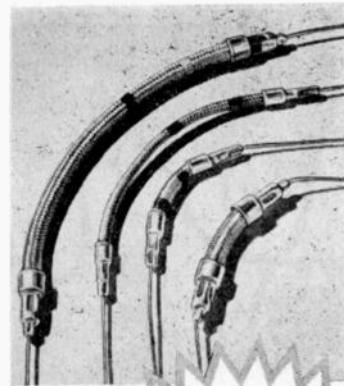

GLASOHM
flexible
resistors

★ Exclusively Clarostat! These flexible glass-insulated wire-wound resistors spell tougher components for tighter spots. Fibre-glass core and fibre-glass braided covering. Nothing to char or burn. Self-supporting when soldered in place. Especially handy for point-to-point wiring. Ideal for attenuators or step-by-step controls. Truly midget power resistors.

In two ratings: Series FXG, 1 watt per winding inch; Series FYG, 2 watt.

Maximum resistance per winding inch: Series FXG, 750 ohms; FYG, 1500 ohms.

Minimum resistance per winding inch: Series FXG, 1/4 ohm; Series FYG, 1/2 ohm.

Both types supplied to any reasonable length.

Patented "Clinch-Grip" ferrules and 2" pigtail leads, standard.

★ DATA on request . . .

Postwar Engineering Bulletin No. 105 gives complete specifications. Copy on request. Meanwhile, submit your problems or requirements for our collaboration.



CLAROSTAT MFG. CO., Inc. • 285-7 N. 6th St., Brooklyn, N. Y.

"
Alive
"
Response



Unit 524
Transcription
Turntable



without telltale rumble, noise or wows!

When we say 'alive' response we mean uncannily 'alive'. You won't hear any signs of artificiality when you listen to the new Unit 524 Fairchild Transcription Turntable. It's completely new. The drive and turntable were designed especially for cabinet installation. They're not portable units set in a console. Study their heavy construction and you'll see why.

Turntable noise, rumble and vibration are practically non-existent because of the unique method of mounting the drive — at the bottom of the cabinet!

A specially designed rubber coupling connects the synchronous motor and drive which are spring-mounted and precision-aligned in a single heavy casting. Special mechanical filters on the hollow drive shaft reduce the transmission of vibration from the drive mechanism to the turntable which is mounted in a heavily webbed cast aluminum panel at the top of the cabinet.

'WOW'—free operation is assured by a carefully maintained evenness of speed. The motor has excellent starting and operating characteristics. The turn-

table is perfectly balanced with extra weight in the rim. The turntable clutch permits shifting from 33.3 to 78 rpm in operation and aids in smooth stopping, starting and exact cueing of the record. And the standard broadcast height, solidly built cabinet permits easy operation, easy servicing.

Arrange to see the new Unit 524 Fairchild Transcription Turntable. Examine it closely. Listen to its 'alive' response critically. Address: 88-06 Van Wyck Boulevard, Jamaica 1, New York.

**SOUND
EQUIPMENT**



Fairchild

CAMERA AND INSTRUMENT CORPORATION

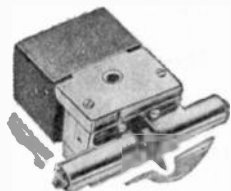

UNIT 541
MAGNETIC CUTTERHEAD

FOR IMPROVED PERFORMANCE

Earlier FAIRCHILD portable models and many other types of recorder-playbacks will give vastly improved performance if equipped with an adapter and an improved Fairchild Pickup and Cutterhead.

Write for complete information.

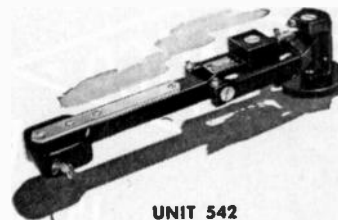

UNIT 542
LATERAL DYNAMIC PICKUP



there
is

NO SUBSTITUTE

for good, honest WIRE, unwinding itself
cross-country, through mighty public buildings and
humble cottages, in and out of America's radio sets and
legion other communications units. You are getting some
CORWICO Wire now . . . and more is on the way . . .

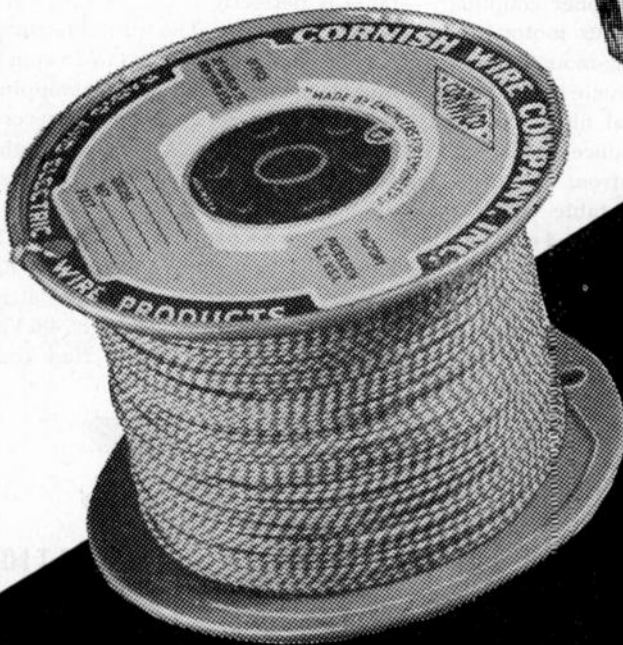

cornish
WIRE COMPANY, INC.

15 Park Row, New York 7, N. Y.

"Made by Engineers for Engineers"



(Continued from page 62A)

- Greenbaum, J. R., 601 W. 112 St., New York 25, N. Y.
- Grinnell, A. L., 122 1/2 S. Oxford Ave., Los Angeles 4, Calif.
- Haines, A. B., 463 West St., New York 14, N. Y.
- Hart, G. W., 871 Dorian Rd., Westfield, N. J.
- Hartman, G. R., 1150A N. 10 St., Reading, Pa.
- Haywood, W. J., Jr., 321 Minnesota St., Corpus Christi, Texas
- Higgs, H. P., 320 Woodcrest Blvd., Kenmore 17, N. Y.
- Hinman, W. H., 19 E. Wren Circle, Dayton 10, Ohio
- Hoffman, W. C., Mine Brook Rd., Bernardsville, N. J.
- Huggler, L. R., 3934 Dalewood Ave., Pittsburgh 27, Pa.
- Hyatt, W. R., Jr., 5123 N. Eighth St., Philadelphia 20, Pa.
- Ingalls, D., 2 Greenwood Rd., Mountain-side, N. J.
- Irelan, H. F., Box 223, Elgin, Ill.
- Jackson, J. H., Jr., Radio Electronics Institute, 1321 Arch St., Philadelphia, Pa.
- Juanillo, J. F., 487 W. 135 St., New York, N. Y.
- Junkins, A. H., 112 School St., Geneva, Ill.
- Karakash, J. J., Lehigh University, School of Electrical Engineering, Bethlehem, Pa.
- Kenkel, H. H., 319 W. Wilson Ave., Glendale 3, Calif.
- Kent, R. A., 48 E. 62 St., New York 21, N. Y.
- Kezer, J., 417 N. Stone Ave., LaGrange, Ill.
- Khan, A. U., 4, Jamaica St., Edinburgh 3, Scotland
- Kiver, M. S., 426 Briar Pl., Chicago 14, Ill.
- Koprowski, E. M., 8 Lomasney Ave., Schenectady, N. Y.
- Kowal, L. J., 316 Esser Ave., Buffalo 7, N. Y.
- Krus, G. D., Station WBKB, 190 N. State St., Chicago 1, Ill.
- Kubelnick, J., Federal Telecommunication Laboratories, Rye Lake Airport, White Plains, N. Y.
- Krenzer, B. A., 4637 N. Dixie Dr., Dayton 5, Ohio
- Lamparero, F. T., APO 834, c/o Postmaster, New Orleans, La.
- Lapping, A. M., 2402 Benson Ave., Brooklyn 14, N. Y.
- Leahy, E. F., 1317 McNeilly Ave., Pittsburgh 16, Pa.
- Lockhart, H. H., 37 Orient Ct., Swampscott, Mass.
- Lord, G. C., c/o Elmer & Amend, 635 Greenwich St., New York 8, N. Y.
- Lowers, C. E., 625 Elaine Rd., Columbus 9, Ohio
- Magee, H. A., 1109 Tennessee Ave., Cincinnati 29, Ohio
- McGarvey, H. J., 190 Springville Ave., Buffalo 14, N. Y.
- McKinney, A., Superior Oil Co., 538 Mission St., South Pasadena, Calif.

IS YOURS
IN LINE?

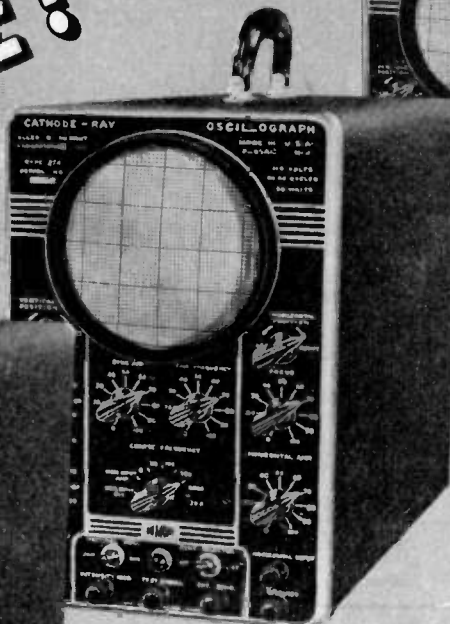
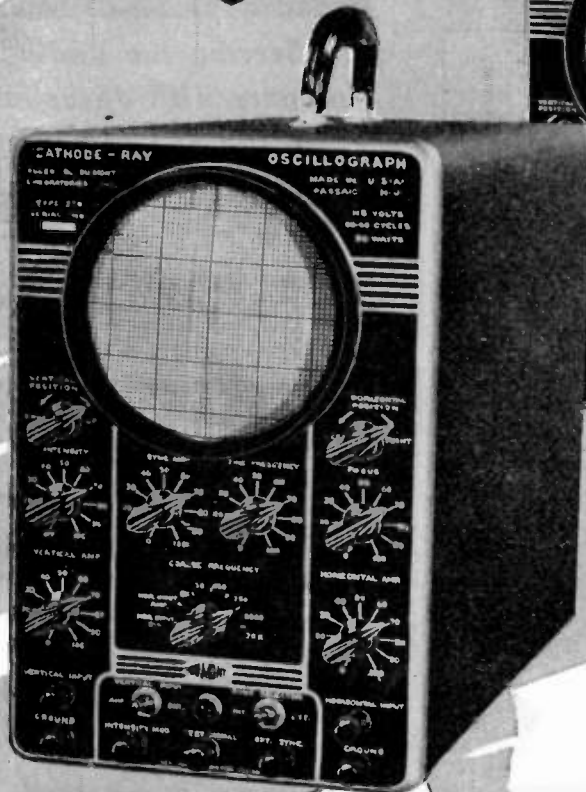

DU MONT'S *new*

TYPE **274**

5" CATHODE-RAY OSCILLOGRAPH

◆ It's handsome... it's accurate... it's Du Mont quality throughout! Among the many fine features of the Type 274 are: 5BP cathode-ray tube; identical vertical and horizontal amplifiers uniform within 20% from 20 to 50,000 c.p.s.; linear time base, 8 to 30,000 c.p.s. with synchronization from vertical amplifier or external signal; provision for intensity modulation.

◆ Send for descriptive literature!

© ALLEN B. DU MONT LABORATORIES INC.

MEMO:
at \$99.50
it's your
"best buy"

DU MONT

Precision Electronics & Television

ALLEN B. DUMONT LABORATORIES, INC., PASSAIC, NEW JERSEY • CABLE ADDRESS: ALBEEDU, PASSAIC, N. J., U. S. A.

Don't Overlook C.T.C.'s New I-F Slug Tuned INDUCTOR

This compact, easy-to-mount LS-3 coil is available in four windings (see below). Total possible frequency span is from 1/2 mc. to better than 150 mc. You'll find them ideal for many applications.

The chart gives the individual characteristics:

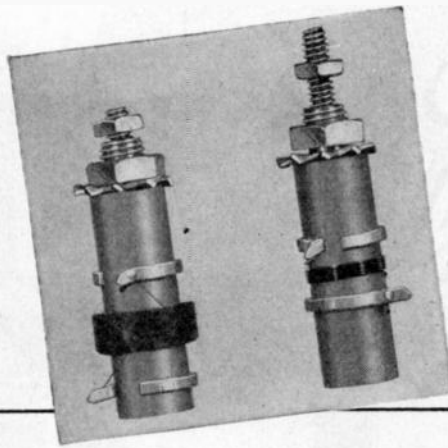

	Q	DC RESISTANCE	INDUCTANCE	VARIATION OF INDUCTANCE	TYPE & SIZE OF WIRE	NO. OF TURNS	TYPE OF WINDING
1 meg. unit	56	18.14 ohm @23°C.	420 micro-henries ± 5%	325 to 750 microhenries	#38 SCE	198	Multiple
10 meg. unit	44	1.90 ohm @19.5°C.	8.4 micro-henries ± 5%	4.75 to 14.25 microhenries	#38 SCE	24.5	Multiple
30 meg. unit	46	.126 ohm @20°C.	0.7 micro-henries ± 5%	.350 to 1.0 microhenries	#28 E	7	Single layer
60 meg. unit	46-50	.126 ohm @20°C.	.061 .102 micro-henries ± 5%	.065 to .095 microhenries	#28 E	2	Single layer

If these standard LS-3 don't meet your requirements, we'll be pleased to submit quotations on coils built to your specifications. Write for C.T.C. Catalog No. 100.



CAMBRIDGE THERMIONIC CORPORATION
456 Concord Avenue · Cambridge 38, Mass.

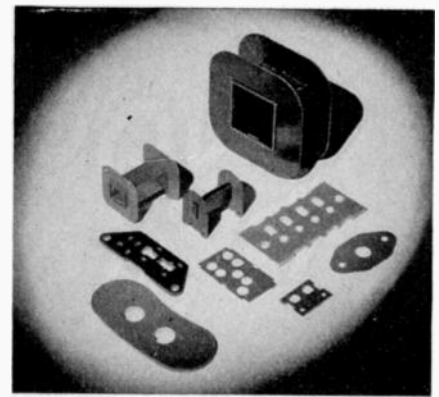

Serving the Radio Industry with dependable laminated plastics

NATIONAL VULCANIZED FIBRE

PHENOLITE
Laminated PLASTIC

—because of their lightness in weight, high dielectric strength, ready machinability, exceptional wearing and other qualities—are playing a vital part.

NATIONAL VULCANIZED FIBRE CO.
WILMINGTON, DELAWARE

Offices In  Principal Cities

In Canada: National Fibre Co. of Canada, Ltd.
Toronto · Montreal



NOW AVAILABLE for immediate delivery

A ruggedly constructed direct reading laboratory instrument specially designed to measure Q, inductance, and capacitance values quickly and accurately. Invaluable in selecting proper low loss components for high frequency applications.

SPECIFICATIONS:—FREQUENCY RANGE: 30-200 mc, accuracy 1%
RANGE OF Q MEASUREMENT: 80 to 1200
Q CAPACITOR RANGE: 11-60 mmf; accuracy ±1% or 0.5 mmf, whichever is greater

WRITE FOR CATALOG "C"

BOONTON RADIO Corporation
BOONTON · N.J. · U.S.A. 

Remler Appointed Agent for WAR ASSETS ADMINISTRATION

(Under Contract No. 59A-3-48)

... to handle and sell a wide variety of

ELECTRONIC EQUIPMENT

released for civilian use

Write for Bulletin Z-1A

Remler Company Ltd.
2113 Bryant St.
San Francisco 10, Calif.

REMLER

SINCE 1918

Radio · Communications Electronics

MICROPHONE NEWS
The NEW St. Louis OUTDOOR RUGGED MICROPHONE



One of the "Finest Line of Modern Dynamic Microphones." Each engineered to fit your specific applications. Modern design—Rugged construction.

Range: 40-9000 Cycles. Built to take the toughest treatment under the worst operating and climatic conditions. Alnico-V Magnet. Variable impedance output adjustable to low, 200, 500 or high. Gunmetal Gray, Black Lacquer or Olive Drab Finishes.

Write today for further information on the Complete St. Louis Line.

Licensed under Patents of the American Tel. & Tel. Co. and Western Electric Company, Inc.

ST. LOUIS MICROPHONE CO.
 2726-28 Brentwood Blvd.
 St. Louis 17, Missouri

ATTENUATORS

by
TECH LABS

STANDARD TYPE 700

MIDGET TYPE 600

"Midget" model is especially designed for crowded apparatus or portable equipment.

- Solid silver contacts and stainless silver alloy wiper arms.
- Rotor hub pinned to shaft prevents unauthorized tampering and keeps wiper arms in perfect adjustment.
- Can be furnished in any practical impedance and db. loss per step upon request.
- TECH LABS can furnish a unit for every purpose.
- Write for bulletin No. 431.

TECH LABORATORIES

Manufacturers of Precision Electrical Resistance Instruments
 337 CENTRAL AVE. • JERSEY CITY 7, N. J.

for every photo tube application

there is a High Sensitivity

RAULAND VISITRON

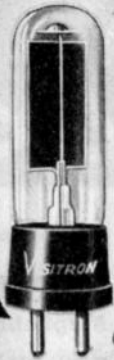

There is a Rauland VISITRON available for every phototube application . . . for industrial electronic control devices, sound-on-film, research and development. For high sensitivity, uniformity and dependability, Rauland VISITRONS are the preferred phototubes.

Specify VISITRON . . . and be sure!

Send for valuable Rauland VISITRON Catalog—it's yours for the asking.

THE RAULAND CORPORATION
 CHICAGO 41, ILLINOIS

RADIO **Rauland** RADAR
 SOUND • COMMUNICATIONS • TELEVISION



FREE

Have You Seen The Solar System?

It's a bi-monthly magazine of authoritative information on new developments in the capacitor field. Simply fill in the coupon below if you'd like to receive this easy-to-read

technical publication regularly at your home or at your office.



Ⓢ 1689

Solar Manufacturing Corporation
 285 Madison Avenue, New York 17, N. Y.

Gentlemen: Please send me the SOLAR SYSTEM regularly, starting with the current issue.

Name.....

Address.....

City.....Zone No.....State.....

*Laboratory
Standards*

By
**MEASUREMENTS
CORPORATION**

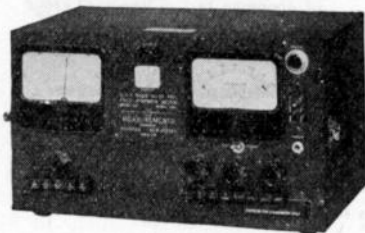

**U. H. F. RADIO NOISE and
FIELD STRENGTH METER
Model 58**

FREQUENCY RANGE: 15 to 150 mc. Push-button switching for rapid, accurate measurement of noise levels or field strength.



**SQUARE WAVE
GENERATOR Model 71**

FREQUENCY RANGE: 5 to 100,000 cycles.
WAVE SHAPE: Rise time less than 0.2 microseconds.

OUTPUT VOLTAGE: 75, 50, 25, 15, 10, 5 peak volts fixed; 0-2.5 volts continuously variable.

MANUFACTURERS OF
Standard Signal Generators
Pulse Generators
FM Signal Generators
Square Wave Generators
Vacuum Tube Voltmeters
UHF Radio Noise & Field Strength Meters
Capacity Bridges
Megohm Meters
Phase Sequence Indicators
Television and FM Test Equipment

Catalog
on
request

**MEASUREMENTS
CORPORATION**
BOONTON NEW JERSEY



Professional Cards

W. J. BROWN

Electronic & Radio Engineering Consultant
Electronic Industrial Applications, Commercial and Broadcasting Transmitter and Receiver Design, Test Equipment, etc.

23 years experience in electronic development
1420 East 25th St., Cleveland 14, Ohio
Superior 1241

EDWARD J. CONTENT

Acoustical Consultant

and

Audio Systems Engineering, FM Standard Broadcast and Television Studio Design.

Roxbury Road Stamford 3-7459
Stamford, Conn.

R. A. DINZL

Electronic Consultant

Ultra High Frequency Transmitters and Receivers, Pulse Modulation, Broadcast Studio Circuits and Equipment Selection.

648 Nottingham Place
Westfield, N.J. Telephone 2-4539

STANLEY D. EILENBERGER

Consulting Engineer

INDUSTRIAL ELECTRONICS

Design—Development—Models
Complete Laboratory and Shop Facilities
6309-13—27th Ave.

Kenosha, Wis. Telephone 2-4213

F. T. Fisher's Sons Limited

Consulting Engineers

Broadcast Transmitters, Antenna Systems, Studio Equipment, Mobile and Fixed Communication Systems.

6202 Somerled Ave., Montreal 29, Quebec

DAVID C. KALBFELL, Ph.D.

Engineer — Physicist

Complete laboratory facilities
Industrial instrumentation and control
Broadcast engineering and measurements
941 Rosecrans St. Bayview 7303
San Diego 6, California

FRANK MASSA

Electro-Acoustic Consultant

DEVELOPMENT PRODUCTION DESIGN
PATENT ADVISOR
ELECTRO-ACOUSTIC & ELECTRO-MECHANICAL
VIBRATING SYSTEMS
SUPERSONIC GENERATORS & RECEIVERS
3393 Dellwood Rd., Cleveland Heights 18, Ohio

M. F. M. Osborne Associates
Consulting Physicists

Fluid Dynamics, Mechanics, Electronic Design, Electromagnetic and Acoustic Wave Propagation, Mathematical Analysis.

703 Albee Bldg., Washington 5, D.C.
Atlantic 9084

ALBERT PREISMAN

Consulting Engineer

Television, Pulse Techniques, Video Amplifiers, Phasing Networks, Industrial Applications

Affiliated with
MANAGEMENT TRAINING ASSOCIATES
3308-14th St., N.W. Washington 10, D.C.

HAROLD A. WHEELER

Consulting Radio Physicist

Radio - Frequency Measurements
Special Antenna Problems

Wideband Amplifiers and Filters
259-09 Northern Boulevard
Great Neck, New York Imperial 645

Paul D. Zottu
Consulting Engineer
Industrial Electronics

High Frequency Dielectric and Induction Heating Applications, Equipment Selection, Equipment and Component Design, Development, Models.

272 Centre St., Newton, Mass. BIG-9240

**YOU GET MANY
Extras!**

**Rowe No. 7
Permanent
Magnetic
Driver Unit**

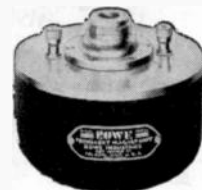

Extra power, extra long life, extra freedom from break-downs, extra ease of replacement . . . these are but a few of the many extras you get in the ROWE No. 7 PERMANENT MAGNET . . . first choice of sound engineers who investigate thoroughly and analyze carefully.

The 3 lb., 4 oz. ALNICO Magnet gives power and permanency; combined voice coil and diaphragm assembly heads off trouble, provides for quick replacement if necessary. Write for circular giving complete details.

ELECTRONICS DIVISION

ROWE Industries
3120 MONROE ST., TOLEDO 6, OHIO

IMPORTANT ANNOUNCEMENT

from the
McGraw-Hill Book Company

In preparation—First volumes ready in 1947

Massachusetts Institute of Technology RADIATION LABORATORY SERIES

This series of 27 titles and a general index were written and edited principally by members of the Radiation Laboratory, maintained during the war at the Massachusetts Institute of Technology under contract with the National Defense Research Committee of the Office of Scientific Research and Development. The Laboratory was the foremost U. S. research and development institution in the field of microwave radar.

LOUIS N. RIDENOUR
Editor in Chief

GEORGE B. COLLINS
Deputy Editor in Chief

role of these advances as the basis for the new electronics, rather than to treat each part of the work in terms of its contributions to radar. The usefulness of the Series will thus extend over all the fields—communication, television, industrial instrumentation and control, research in the biological and physical sciences, and radar itself—in which electronic techniques are of great and increasing applicability and importance.

It is the aim of the Series to treat the advances arising from radar work in a fashion which will emphasize the

The volumes in the Series will be priced and sold separately. They will be published in early 1947.

Volumes in the Series

- | | | |
|--|---|--|
| <ol style="list-style-type: none"> 1. Radar System Engineering 2. Radar Aids to Navigation 3. Radar Beacons 4. Loran 5. Pulse Generators 6. Microwave Transmission Circuits 7. Klystrons and Microwave Triodes 8. Principles of Microwave Circuits 9. Microwave Transmission Circuits | <ol style="list-style-type: none"> 10. Waveguide Handbook 11. Technique of Microwave Measurements 12. Microwave Antenna Theory and Design 13. Propagation of Short Radio Waves 14. Microwave Duplexers 15. Crystal Rectifiers 16. Microwave Mixers 17. Components Handbook 18. Vacuum Tube Amplifiers 19. Waveforms | <ol style="list-style-type: none"> 20. Electronic Time Measurements 21. Electronic Instruments 22. Cathode Ray Tube Displays 23. Microwave Receivers 24. Threshold Signals 25. Theory of Servomechanisms 26. Radar Scanners and Radomes 27. Computing Mechanisms and Linkages 28. Index |
|--|---|--|

FOR FURTHER INFORMATION

We invite you to place your name on file, without obligation, to receive notification and further details when specific volumes in this series are about to be published. Just send the coupon, checking the volume or volumes in which you are interested.

McGraw-Hill Book Company, 330 West 42nd Street, New York 18, N.Y.

Send me descriptive information and notice of publication date on the books in the M.I.T. Radiation Laboratory Series which I have checked below. I understand that this obligates me in no way whatever.

ALL 1 2 3 4 5 6 7 8 9 10 11 12 13 14 15 16
 17 18 19 20 21 22 23 24 25 26 27 28

Name

Address

City and State

Company

Position IRE 8-46

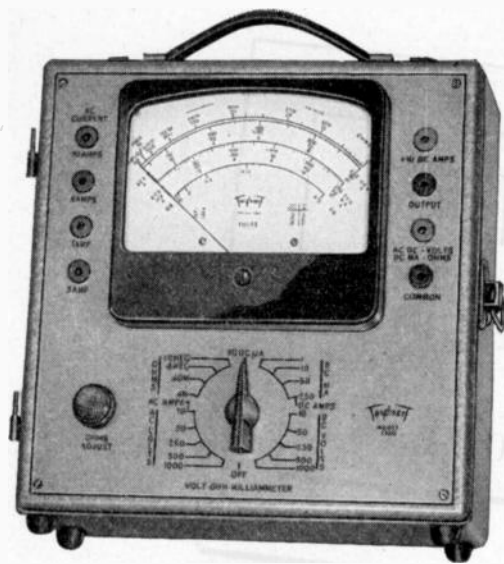

MODEL 2405 Volt • Ohm Milliammeter

25,000 OHMS PER VOLT D. C.



SPECIFICATIONS

NEW "SQUARE LINE" metal case, attractive tan "hammered" baked-on enamel, brown trim.

■ **PLUG-IN RECTIFIER**—replacement in case of overloading is as simple as changing radio tube.

■ **READABILITY**—the most readable of all Volt-Ohm-Milliammeter scales—5.6 inches long at top arc.

Model 2400 is similar but has D. C. volts Ranges at 5000 ohms per volt.

Write for complete description

Triplet

ELECTRICAL INSTRUMENT CO.

BLUFFTON OHIO

NEW ENGINEERING NEW DESIGN • NEW RANGES

30 RANGES

- Voltage: 5 D.C. 0-10-50-250-500-1000 at 25000 ohms per volt.
- 5 A.C. 0-10-50-250-500-1000 at 1000 ohms per volt.
- Current: 4 A.C. 0-.5-1-5-10 amp.
- 6 D.C. 0-50 microamperes—0-1-10-50-250 milliamperes—0-10 amperes.
- 4 Resistance 0-4000-40,000 ohms—4-40 megohms
- 6 Decibel -10 to +15, +29, +43, +49, +55
- Output Condenser in series with A.C. volt ranges

Worthy of an Engineer's Careful Consideration

THE 201 SERIES RECTIFIERS

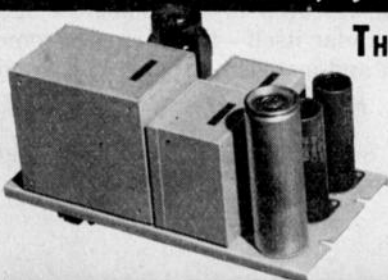

The 201 Series consists of the 201-A which has a single filter stage and 201-B which has a dual filter stage. The latter type is designed to supply filament and plate power for pre-amplifiers, such as Types 106 and 111. The 201 Series also supplies power for associated line amplifiers such as the Langevin 102 Series. Both units of the 201 Series possess excellent regulation and low ripple content.

The Langevin Company

INCORPORATED
SOUND REINFORCEMENT AND REPRODUCTION ENGINEERING
NEW YORK SAN FRANCISCO LOS ANGELES
37 W. 65 St., 23 1050 Howard St., 3 1000 N. Seward St., 3B

A NEW KILOVOLT METER 0-30 KV, DC, LOW DRAIN

For use in:

- Television
- Electrostatic Precipitation
- Geiger-Mueller counters

and all circuits requiring a low drain, high voltage meter.

SAFE: 10" handle permits measurements on live circuits
SENSITIVE: 20 μ a full scale. Less than 1 μ a/KV
STABLE: Resistor encased in newly developed non-hygroscopic compound
RUGGED: Switch shorts meter in transit
COMPACT: 11" x 5" x 7"
LOW COST: \$59.00

Write for descriptive literature

BETA ELECTRONICS COMPANY

1762 Third Avenue New York 29, N.Y.
Manufacturers of KV meters; 0-30KV Portable Power Supplies;
Electronic Microammeters



Model 101

INDEX

Section Meetings	34A
Membership	36A
Positions Open	50A
Positions Wanted	56A

DISPLAY ADVERTISERS

Accurate Spring Mfg. Co.	21A
Acme Electric Corporation	44A
Aerovox Corporation	16A
Aircraft Radio Corp.	25A
Allen-Bradley Company	59A
American Brass Company (Metal Hose Branch)	28A
American Lava Corp.	9A
American Phenolic Corp.	37A
American Transformer Co.	43A
Amperex Electronic Corp.	7A
Andrew Co.	42A
Arnold Engineering Co.	36A
Astatic Corp.	46A
Automatic Mfg. Corp.	24A
Ballantine Labs., Inc.	48A
Beta Electronics Co.	70A
Blaw Knox Co.	56A
Boonton Radio Corporation	66A
W. J. Brown	68A
Cambridge Thermionic Corp.	66A
Capitol Radio Engineering Institute	62A
Centralab	10A
Chicago Transformer	34A
Clarostat Mfg. Co., Inc.	62A
Sigmund Cohn & Co.	46A
Collins Radio Co.	35A
Edward J. Content	68A
Cornell Dubilier Electric Corp.	Cover III
Cornish Wire Co.	64A
R. A. Dinzl	68A
Drake Mfg. Co.	52A
Allen B. DuMont Labs., Inc.	8A & 65A
E. I. DuPont de Nemours & Co., Inc.	60A
Hugh H. Eby Inc.	49A
Stanley D. Eilenberger	68A
Eitel-McCullough, Inc.	72A
Electronics Research Publishing Co.	60A
Ellinwood Industries	40A
Fairchild Camera & Inst. Corp.	63A
Finch Telecommunications, Inc.	27A
F. T. Fisher's Sons	68A
General Aniline & Film Corp.	2A & 3A
General Electric Co.	1A & 39A
General Radio Co.	Cover IV
Guardian Electric	13A
Hazeltine Electronics Corp.	52A
Hewlett-Packard Company	14A
Hytron Radio & Electronics Corp.	11A
International Nickel Co., Inc.	51A
Jackson Electrical Inst. Co.	38A
E. F. Johnson Co.	26A
David C. Kalbfell	68A
Langevin Co.	70A
Machlett Laboratories, Inc.	29A
Frank Massa	68A
McGraw Hill Book Co.	69A
Measurements Corp.	68A
Mycalex Corp. of America	47A
National Carbon Co., Inc.	17A
National Company, Inc.	12A
National Vulcanized Fibre Co.	66A
North American Philips Co., Inc.	41A
M. F. M. Osborne	68A
Albert Preisman	68A
Press Wireless Manufacturing Corp.	15A
Presto Recording Corp.	53A
Radio Corporation of America	5A, 32A, 52A, 61A, 71A
Rauland Corp.	67A
Rawson Electrical Inst. Co.	50A
Raytheon Mfg. Co.	31A, 57A
Remler Co. Ltd.	66A
Revere Copper & Brass, Inc.	20A
Richardson Company	58A
Rowe Industries	68A
St. Louis Microphone Co.	67A
Shallcross Mfg. Company	54A
Solar Mfg. Corp.	33A & 67A
Sprague Electric Company	4A
Stackpole Carbon Co.	6A
Stoddart Aircraft Radio Co.	18A
Sperry Gyroscope Co., Inc.	55A
Tech Labs.	67A
Triplet Electrical Instrument Co.	70A
Truscon Steel Co.	30A
Tung-Sol Lamp Works, Inc.	19A
United Transformer Company	Cover II
Western Electric Company	22A & 23A
Harold A. Wheeler	68A
Wilcox Electric Company, Inc.	45A
Paul D. Zottu	68A

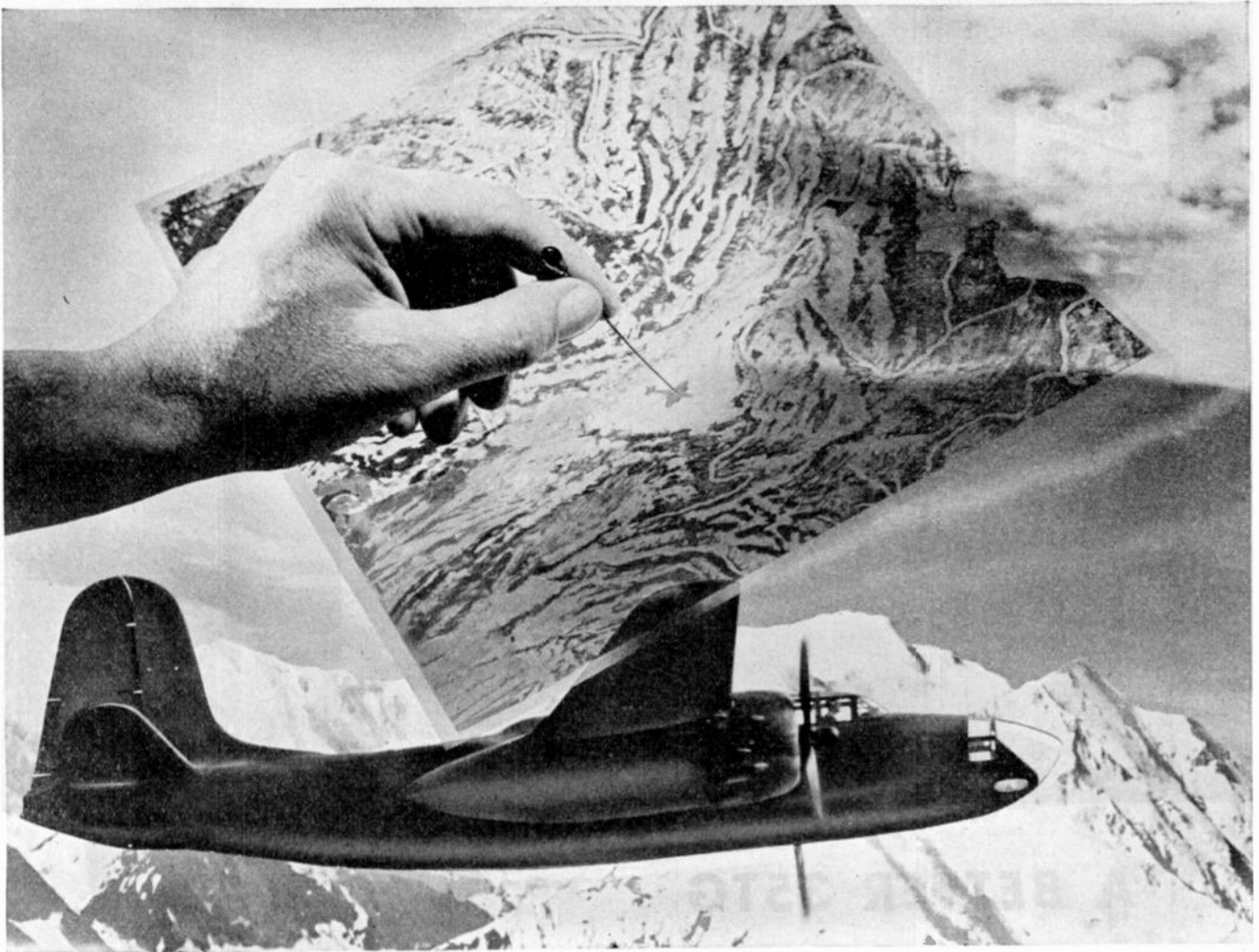

Developed by RCA as an aid to blind bombing in wartime, Shoran is a new radar yardstick for world mapping

SHORAN—a surveying system

with pin-point accuracy!

One small error in a map can be costly in the location of an oil well or mining property. But with Shoran, vast areas can now be charted by plane with an error of less than twelve inches in five miles—and in a matter of minutes or hours as opposed to weeks or months that would be required by laborious surveys made on the ground. Shoran is called one of the most important geographic inventions since the compass.

Shoran can also direct a plane flying in a blackout or heavy overcast with such accuracy that during the war it

was possible to drop bombs only a few hundred feet ahead of completely invisible advancing troops below with unerring precision.

Just as Shoran is a revolutionary stride forward in map-making, so do all RCA products represent the farthest point of progress in their fields.

And when you buy anything made by RCA or RCA Victor, you are sure of getting one of the finest instruments of its kind science has achieved.

Radio Corporation of America, RCA Building, Radio City, New York 20. Listen to The RCA Victor Show, Sundays, 2:00 P. M., Eastern Daylight Time, over NBC Network.



Until recently a closely guarded military secret, Shoran was developed at RCA Laboratories—a world center of radio and electronic research. Here, in this vast community of scientists, the same imagination and skills that developed Shoran keep RCA and RCA Victor the outstanding names in radio, television and recorded entertainment.



RADIO CORPORATION of AMERICA



THE COUNTERSIGN OF DEPENDABILITY IN ANY ELECTRONIC EQUIPMENT



A BETTER 35TG

The famous Eimac 35TG VHF tube, with its low inter-electrode capacitances, its logical terminal arrangement, its lack of internal hardware, *is further improved*. It now has a non-emitting grid, an improved filament, and a cooler operating plate. These improved elements, the result of wartime developments in manufacturing technique, are being incorporated in many Eimac tubes and are consistently resulting in vastly increased life.

The 35TG is a power triode of wide applicability. It will function as a Class-C oscillator or amplifier, or as a Class-B audio or supersonic amplifier, and in such service will give excellent performance, due to its stability and low driving-power requirements.

Longer operating life is but one of the many advantages afforded by Eimac tubes. It will pay you to keep informed... see your nearest Eimac representative today, or write direct.

Follow the leaders to



EITEL-McCULLOUGH, INC.
1229 J, San Mateo Ave., San Bruno, Calif.
Plant located at: San Bruno, California

Export Agents: Frazar and Hansen, 301 Clay Street, San Francisco 11, California, U. S. A.

EIMAC
35TG
POWER
TRIODE

ELECTRICAL CHARACTERISTICS

Filament: Thoriated tungsten	
Voltage	5.0 volts
Current	4.0 amperes
Amplification Factor (Average)	39
Direct Interelectrode Capacitances (Average)	
Grid-Plate	1.8 uuf
Grid-Filament	2.5 uuf
Plate-Filament	0.4 uuf
Transconductance ($i_b = 100 \text{ ma.}, E_b = 2000 \text{ V.}, E_c = -30 \text{ V.}$)	2850 umhos
Frequency for Maximum Ratings	100 mc

CALL IN AN EIMAC REPRESENTATIVE FOR INFORMATION

ROYAL J. HIGGINS (W9AIO), 600 S. Michigan Ave., Room 818, Chicago 5, Illinois. Phone: Harrison 5948.	ADOLPH SCHWARTZ (W2CN), 220 Broadway, Room 2210, New York 7, N. Y. Phone: Cortland 7-0011.
VERNER O. JENSEN, CO., 2616 Second Ave., Seattle 1, Washington. Phone: Elliott 6871.	HERB BECKER (W6QD), 1406 S. Grand Ave., Los Angeles 15, California. Phone: Richmond 6191.
M. B. PATTERSON (W5CI), 1124 Irwin-Keasler Bldg., Dallas 1, Texas. Phone: Central 5764.	TIM COAKLEY (WIKKP), 11 Beacon Street, Boston 8, Massachusetts. Phone: Capitol 0050.



*She may
take a derby,
some day...*

TAKE THIS FILLY. She's a blueprint of a winner. But it's where she pastures . . . who trains her . . . and a hundred incidents that happen before she ever tickles track dirt that decide if she's headed for the 'big money'.

Whether you've a mind for horses, or not, you know it works the same way with your own blueprints. They can be pretty perfect. But the twenty-one or a hundred-and-one components that make up the final product really tell the story.

Here at Cornell-Dubilier we build capacitors. We have devoted much time and money to make our-

elves proficient at the job. If we can't build them better than anyone else, we'd rather not build them for you.

That's the kind of thinking we do at C-D. And today, C-D capacitors are widely imitated, but seldom equaled in quality. For no one else can build into capacitors the years of study, the extensive engineering and design experience that are exclusively C-D's.

Keep that in mind when your plans call for the "unheard of" in capacitor design.

Perhaps our engineers can help you with some special capacitor problem. Cornell-Dubilier Electric Corporation, South Plainfield, New Jersey. Other plants in New Bedford, Providence, Worcester, Brookline.



CORNELL - DUBILIER

world's largest manufacturer of

CAPACITORS

MICA • DYKANOL • PAPER • ELECTROLYTICS

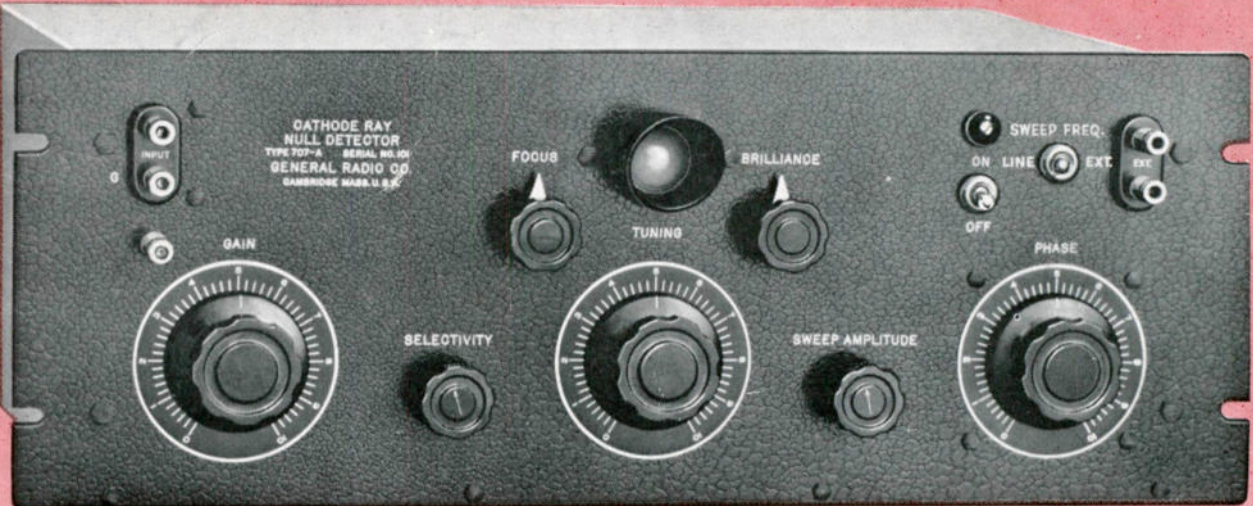

IMPROVED NULL DETECTOR

for a-c Impedance Bridges

SENSITIVE • RUGGED • CONVENIENT TO OPERATE

THE G-R Type 707-A Null Detector, temporarily withdrawn from production during the war, is now available again. It uses a one-inch cathode-ray tube in a non-inductive degenerative amplifier circuit, with tuning and phasing networks and sweep and sensitivity controls. As a null detector on any a-c impedance bridge its advantages over former types of detectors are numerous, and include:

- | | |
|--|--|
| <p>1 Operation in noisy locations</p> <p>2 Not affected by strong fields</p> <p>3 May be used at all frequencies up to 2 kilocycles, and higher as an untuned amplifier</p> <p>4 Separately indicates balance of the resistive and reactive components</p> <p>5 Makes possible precise balancing of either component with only moderately close balance of the other</p> <p>6 Precise measurement of the steady component can be made while the other varies erratically</p> | <p>7 Shows immediately any drift of either or both components</p> <p>8 Provides positive indication of the direction of off-balance for either component, as selected</p> <p>9 Can be calibrated to show the degree of unbalance</p> <p>10 Can be used at all times at maximum sensitivity, even with the bridge far off-balance</p> <p>11 Supplies instantaneous response</p> <p>12 Will withstand any overload caused by marked off-balance and is instantaneous in recovery</p> |
|--|--|

The input impedance of the detector is one megohm. Its sensitivity is 100 microvolts at 60 cycles and 200 to 300 microvolts at 1,000 cycles. Its selectivity is 40 db against the second harmonic. Plug-in units tune the amplifier to any operating frequency desired between 20 and 2,000 cycles with a continuous tuning range of $\pm 5\%$ for each unit.

TYPE 707-A CATHODE-RAY NULL DETECTOR \$250.00

NOTE! We have a few in stock. ORDER NOW!

GENERAL RADIO COMPANY

Cambridge 39,
Massachusetts

90 West St., New York 6

920 S. Michigan Ave., Chicago 5

950 N. Highland Ave., Los Angeles 38