

# PROCEEDINGS AND WAVES of the I·R·E<sup>AND</sup> and ELECTRONS



The Institute of Radio Engineers

INCORPORATED



Westinghouse

RADAR ANTENNA

FORTABLE RADAR EQUIPMENT DESIGNED FOR BEACHHEAD OPERATIONS BY U. S. MARINE CORPS.

## FEBRUARY, 1946

Proceedings of the I.R.E.

Volume 34

Number 2

Television-Sound Transmission  
R-F Resistors as Transmission Lines  
Self-Balancing Phase Inverters  
Thyratron Grid-Control Circuits  
Steady-State Operational Calculus  
Differential-Microphone  
Characteristics

## Waves and Electrons

Volume 1

Number 2

Canadian Council of I.R.E.  
Plea for Scientific Method  
R-F Dehydration of Penicillin  
Vacuum-Contained Triode  
Transmitter  
New Antenna Types  
Decibel Conversion Chart

## REPORTS of the Theory, Practice, and Applications of Electronics and Electrical Communication

- Radio Communication • Sound Broadcasting • Television • Marine and Aerial Guidance • Tubes • Radio-Frequency Measurements • Engineering Education • Electron Optics • Sound and Picture Electrical Recording and Reproduction • Power and Manufacturing Applications of Radio-and-Electronic Technique • Industrial Electronic Control and Processes • Medical Electrical Research and Applications

TUBE SPECIALISTS SINCE 1925 - AMPEREX \*

COMMUNICATION  
RECTIFICATION  
INDUSTRIAL  
ELECTRO-MEDICAL  
SPECIAL PURPOSE

ONE SOURCE FOR ALL TYPES. AMPEREX

WHETHER IT BE A "STANDARD" TUBE OR A SPECIAL DEVELOPMENT TO VITALIZE THE PLANS OF EQUIPMENT MANUFACTURERS, AMPEREX IS THE SOURCE TO WHICH ENGINEERS TURN WITH CONFIDENCE. TWO DECADES OF CREATIVE RESEARCH, PRECISION MANUFACTURE AND HELPFUL SERVICE HAVE GIVEN AMPEREX A UNIQUE POSITION IN THE POWER TUBE FIELD. THIS MEANS A BACKLOG OF EXPERIENCE AND A FORWARD-LOOKING VIEWPOINT WHICH NATURALLY TRANSLATES ITSELF INTO TUBE ORIGINALITY, PERFORMANCE, RELIABILITY AND ECONOMY.



S O N E D

POWER TUBES IN ALL THEIR APPLICATIONS  
**AMPEREX ELECTRONIC CORPORATION**

25 WASHINGTON STREET, BROOKLYN 1, N. Y., CABLES: "ARLAB"

In Canada and Newfoundland: ROGERS MAJESTIC LIMITED, 622 Fleet Street West, Toronto 2B, Canada



# OVER AND OVER AGAIN THE IMPOSSIBLE BECOMES POSSIBLE

Over and over again, Hytron has licked the problem of making smaller and smaller radio tubes. Its BANTAM GT, which other tube engineers said was impossible, telescoped glass receiving tubes to the T-9 bulb (bantam and loktal), and has since become the most popular receiving tube.

Next Hytron sweated out development of the BANTAM JR.—the first subminiature. The HY155 was soon superseded by the even tinier HY255.

It was only natural that the Navy and OSRD should turn to Hytron in 1940, to design diminutive, rugged tubes for the VT or variable time fuse. Fired from a gun, such tubes, despite their size, must withstand 20,000 G's and 475 rps.

Months of research at Hytron resulted in the smallest tube which has ever been mass-produced. The tube's internal cubic volume is approximately half that of the smallest competitive tube. Again new horizons were explored by Hytron. New techniques and production equipment solved fabrication, assembly, glass, and exhaust problems.

The same skills which created the BANTAM GT, the BANTAM JR., and the smallest VT-fuse subminiature are now concentrated primarily on production of Hytron GT's and T-5½ miniatures for home receivers. You can count, however, on Hytron's continuing leadership in vacuum tube development.

ALL TUBES ACTUAL SIZE

OLDEST MANUFACTURER SPECIALIZING IN RADIO RECEIVING TUBES



# HYTRON

RADIO AND ELECTRONICS CORP.



MAIN OFFICE: SALEM, MASSACHUSETTS

PROCEEDINGS OF THE I.R.E., February, 1946, Vol. 34, No. 2, and WAVES AND ELECTRONS, February, 1946, Vol. 1, No. 2. Published monthly by The Institute of Radio Engineers, Inc., at 450 Ahnaip St., Menasha, Wis. Price, \$1.00 per copy. Subscriptions: United States and Canada, \$10.00 a year; foreign countries, \$11.00 a year. Entered as second-class matter, October 26, 1927 at the post office at Menasha, Wisconsin, under the act of February 28, 1925. Acceptance for mailing at a special rate of postage is provided for in the act of February 28, 1925, embodied in Paragraph 4, Section 412, P. L. and R., authorized October 26, 1927.

Table of Contents will be found on page 32 B

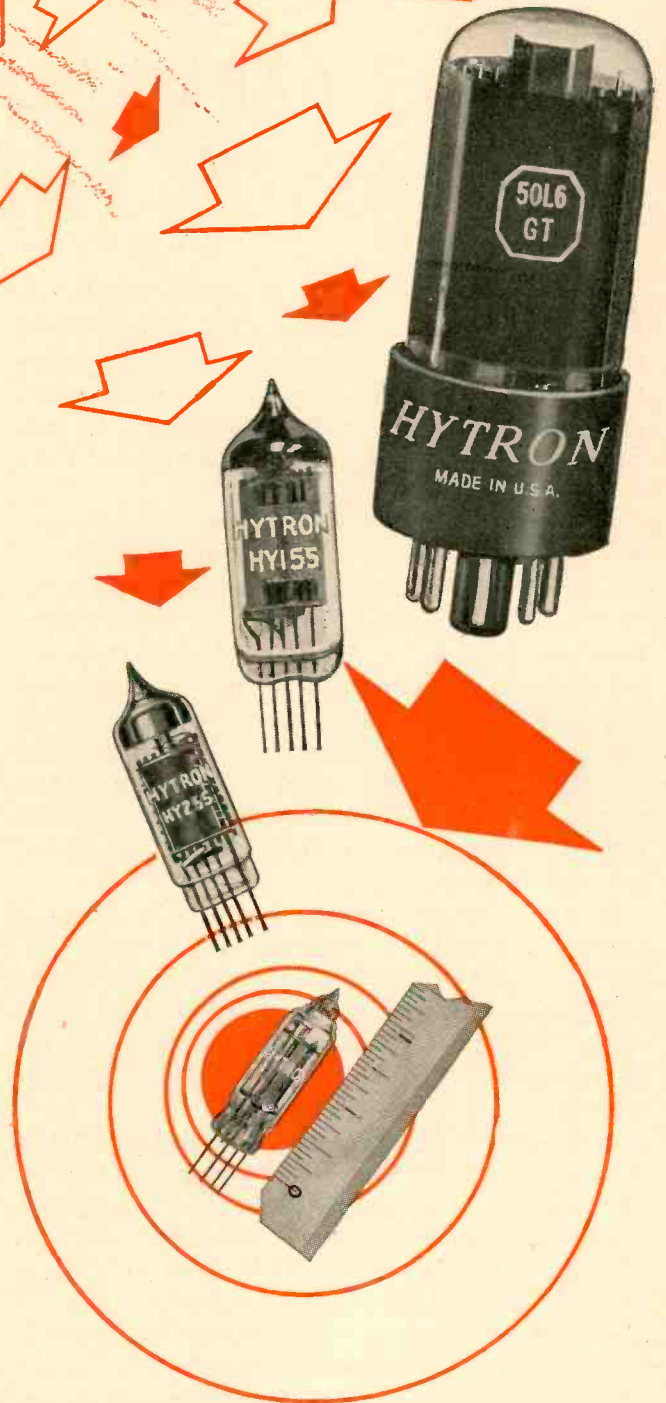

HERE 3 CAPACITORS

DO TWICE THE WORK OF 25

A MANUFACTURER of induction heaters replaced 25 mica capacitors in his resonant (tank) circuit with three General Electric HFP parallel-plate, water-cooled capacitors. He saved nearly half the cost and space, and more than doubled the kva. Result: a more compact, more powerful, and more efficient heater.

Class HFP capacitors, with their two sets of heavy, sheet-aluminum plates, are specifically designed for use in resonant circuits of high-frequency oscillators, such as those employed in electronic heaters. Outstanding features of Class HFP capacitors are compact construction, and ability to operate at high voltages and to carry heavy continuous currents at frequencies from 50 kilocycles up into the megacycles. The special dielectric is a new, stable, synthetic liquid which combines the desirable characteristics of low loss, high dielectric constant, and high dielectric strength.

A coil of copper tubing, for water-cooling the capacitor, is installed inside the case in direct contact with the grounded pair of capacitor plates. Couplings are provided for connection to 3/8-in. copper tubing. The cooling feature permits a compact assembly and high current rating per unit volume.

The cases are of nonmagnetic metal, hermetically sealed, and flexible enough to take care of thermal expansion of the liquid dielectric. Capacitance tolerance is from plus 5 per cent to minus 5 per cent of the rated capacitance at 25 C; Q factor is above 2000 for full load operation at frequencies from 50 kilocycles to one megacycle. Internal inductance is low, which gives resonant frequencies from 3 to 9 megacycles, depending upon the capacitance rating. Write for Bulletin GEA-4365. Apparatus Dept., General Electric Company, Schenectady 5, N. Y.

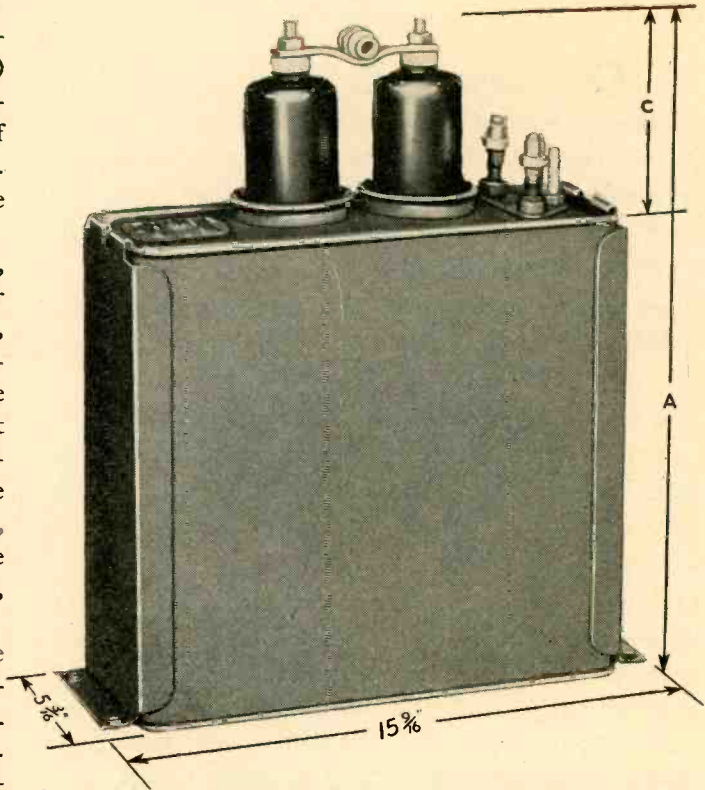

CLASS HFP HIGH-FREQUENCY, PARALLEL-PLATE, WATER-COOLED CAPACITORS.

Maximum Permissible Rms Working Voltage	Microfarad Rating	Maximum Permissible Rms Working Current in Amp at 540 Kilocycles	Approximate Dimensions in Inches	
			A	C
2000	0.025	170	16 7/32	2 1/2
	0.030	204		
	0.034	230		
3000	0.0165	168	16 7/32	2 1/2
	0.0075	153		
6000	0.01	204	18 7/16	4 7/16
	0.009	202		
9000	0.0029	88	18 7/16	4 7/16
	0.005	153		
	0.0056	171		



# DIGEST

## Timely Highlights on G-E Components

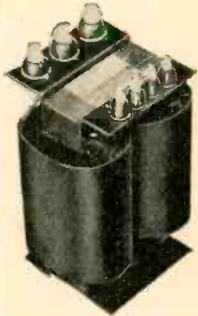

### LIGHT-WEIGHT TRANSFORMERS

*for tight spots*

When size and weight are important and weather resistance isn't, G-E core-and-coil transformers solve a lot of electronic-design problems. Uniform coils, automatically wound over the finest-grade core laminations, are of the same high quality and give the same reliable performance as G-E cased transformers.

Standard core and coil units include 60 types and ratings of plate transformers, 106 filament transformers, 34 plate-and-filament transformers, and 61 reactors. Ratings up to 50 kva (physical size) are wound on standard laminated cores; larger units can be built from special parts. Write for Bulletin GEA-4280.

### Small ONLY IN Size

Inside these G-E small panel instruments are packed accuracy and reliability usually associated with larger G-E instruments. They have space-saving internal-pivot construction. They respond quickly. Accurate readings are easily made. The instrument weighs a mere 3 ounces and is just 1½ inches wide and less than 1 inch deep. Either watertight or conventional construction is available for direct-current, audio-frequency and radio frequency applications. Write for Bulletin GEA-4380.

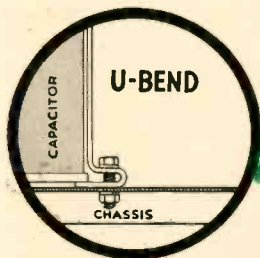

### BRACKETS

*that hold their own*

A distinct advance in bracket design simplifies the mounting of rectangular-cased G-E capacitors. A U-bend replaces the conventional L-shape and provides a spring-washer effect for secure capacitor mounting. At the same time, it reduces strain on both capacitor and chassis, and compensates for tolerances in capacitor case heights.

For either base or inverted mounting, U-bend brackets are available for most G-E rectangular-case a-c and d-c capacitors. Write for Bulletin GEA-4357.

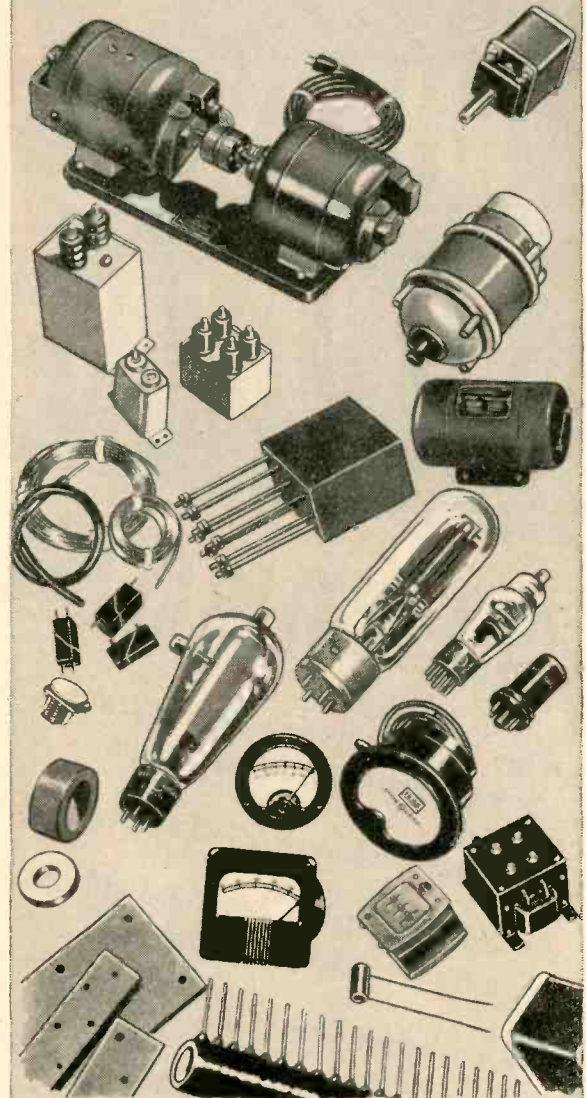

Capacitors • Sensitive control and time-delay relays • Limit switches • Motors, dynamotors, amplidyne • Motor-generator sets • Alnico magnets • Small panel instruments • Formex\* magnet wire • Radio transformers • Switchettes • Selsyns • Chokes • also tubes, crystals, plastics products, insulation materials, and many others

General Electric Company  
Apparatus Dept., Sec. 642-10  
Schenectady 5, N. Y.

Please send me the bulletins checked:

..... GEA-4365

..... GEA-4380

..... GEA-4280

..... GEA-4357

NAME .....

COMPANY .....

ADDRESS .....

CITY .....

STATE .....



# DUAL DIVERSITY RECEIVERS

by **PRESS WIRELESS**

- Two identical superheterodyne receivers with isolating antenna matching network
  - Five pre-tuned bands 2.4-23 megacycles
  - Common crystal or self-excited HFO and BFO in thermostatically controlled oven
  - Interlocking diversity AVC action
  - Four diversity antenna combinations
  - Electronic "eye" tuning indication
  - Local and remote dial control
  - Self contained power supply
  - Cabinet rack and 19" panel construction
- ENGINEERING BULLETIN SENT ON REQUEST

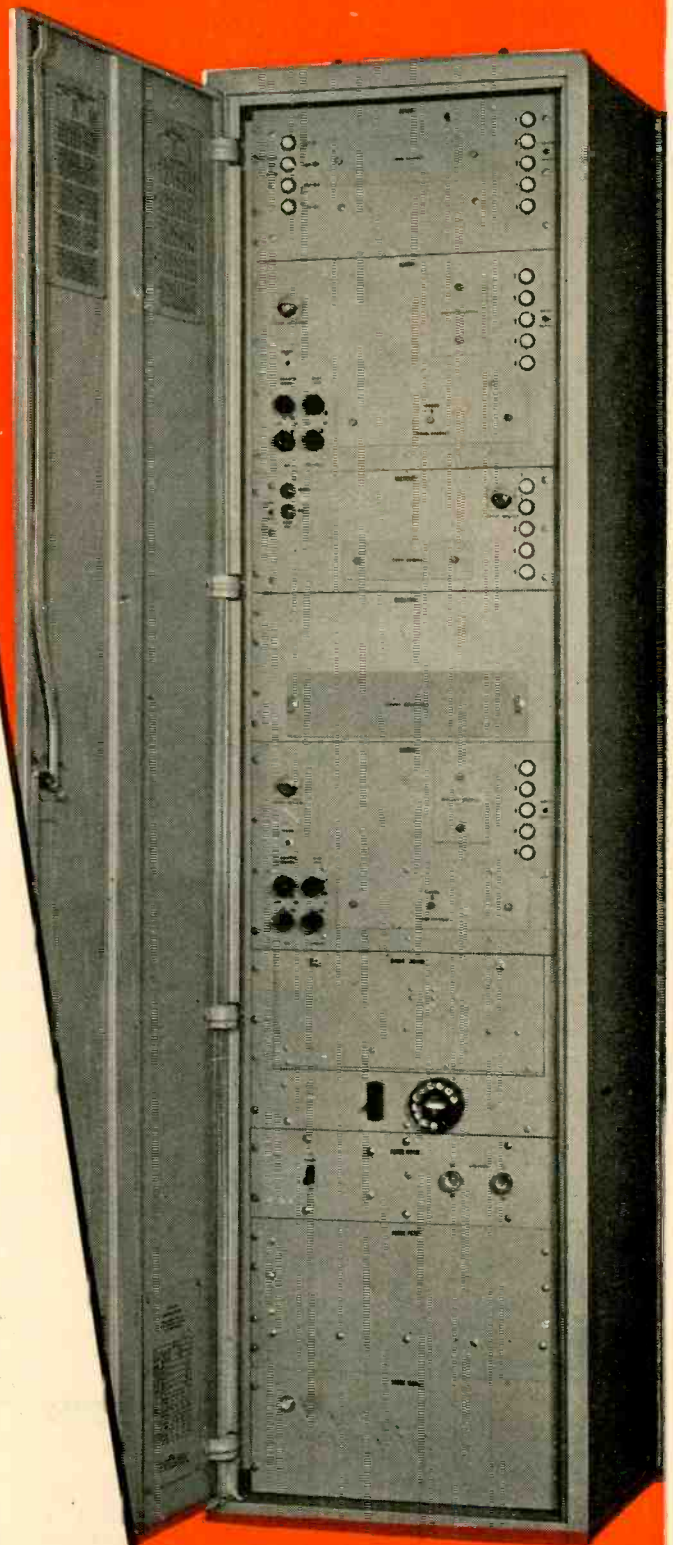

DUAL DIVERSITY RECEIVER  
Press Wireless Model 6019A

## PRESS WIRELESS MANUFACTURING

C O R P O R A T I O N

Executive and Sales Office, 1475 BROADWAY, NEW YORK CITY 18



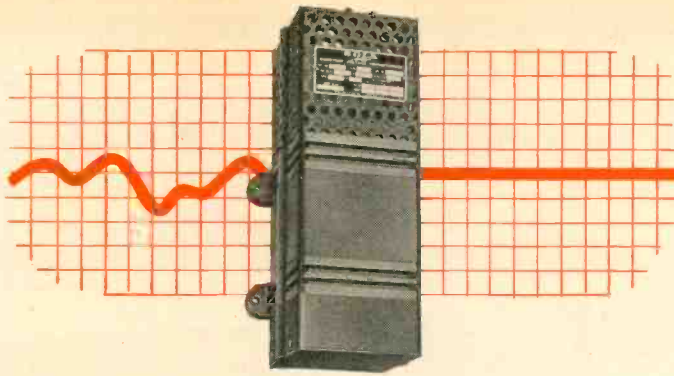

# Constant Voltage

... is always available to equipment protected by a  
**SOLA CONSTANT VOLTAGE TRANSFORMER**

Are you looking for new ways to—

1. Increase the efficiency of your product?
2. Lower its cost to the user?
3. Reduce maintenance expense?

Much of this can be accomplished with a SOLA Constant Voltage Transformer built into your product. Now, more than ever before, electrical equipment needs line-voltage protection.

Stable voltage, direct from supply lines, is *not* available to the users of your equipment. Voltage may vary as much as 15-20% from the rating on your label. *Your* equipment will be blamed for the inefficient operation that results.

Build a SOLA Constant Voltage Transformer into your equipment and operating voltages will always be within  $\pm 1\%$  of rated requirements

regardless of line fluctuation as great as 30%.

There is a wide range of sizes and capacities in SOLA Constant Voltage Transformers which can be built specifically for your product. The savings you can make through the elimination of other components and anticipated service calls, plus greater operating efficiency and satisfaction to your users, merit your consideration of SOLA Constant Voltage Transformers as a component in your equipment design.

SOLA Constant Voltage Transformers are fully automatic with no tubes, or moving parts. They require no supervision or manual adjustments.

There's a new SOLA handbook that describes fully the theory, operation and use of SOLA Constant Voltage Transformers. Write for your copy.

Ask for Bulletin CV-102

## SOLA Constant Voltage Transformers

**Transformers for:** Constant Voltage • Cold Cathode Lighting • Mercury Lamps • Series Lighting • Fluorescent Lighting • X-Ray Equipment • Luminous Tube Signs  
Oil Burner Ignition • Radio • Power • Controls • Signal Systems • etc. **SOLA ELECTRIC COMPANY, 2525 Clybourn Avenue, Chicago 14, Illinois**

# KEEP PRODUCTION MOVING with **PIERCE** → SERVICE

**FAST DELIVERY**  
 at  
**REASONABLE PRICES!**

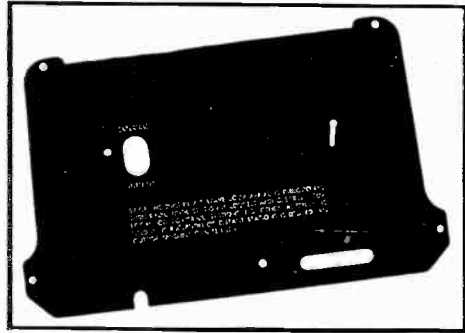
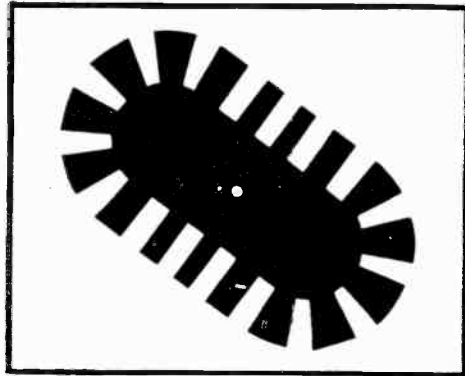
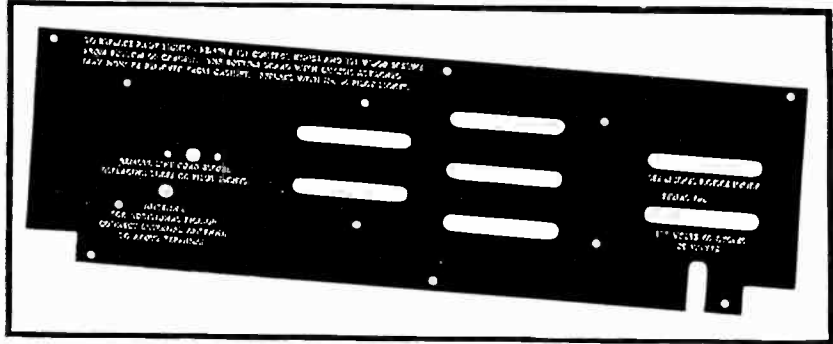

**LOOP ANTENNA FRAMES • CABINET BACKS**  
 (complete with envelope protector)

**BAFFLES • LOUD SPEAKER GASKETS**

Die cut and printed complete  
 to your specifications from

**NON-METALLIC PULPBOARD, FIBRE BOARD  
 BINDERS BOARD, NEWS OR CHIPBOARD**  
 paraffine treated or plain.

*Tested for non-conductive properties.*

*Manufacturing processes include lining  
 of board for special papers.*

Don't let shortages of the above items bottleneck your production. For ON-TIME-DELIVERY, call on PIERCE. Years of experience, plus accelerated War Production, has given us the "KNOW-HOW" and trained personnel to expedite your job and produce accurate, superior work.

The modern PIERCE factory is amply equipped with up-to-date machinery for Die cutting by Rotary, Platen and Punch Press or Hollow Die Methods. **A complete die-making department and an adequate supply of board insure prompt delivery!**

**SUBMIT SAMPLE OR SPECIFICATIONS FOR  
 IMMEDIATE QUOTATIONS—NO OBLIGATION**



**PAPER PRODUCTS COMPANY**

**2711 AUBURN STREET    ROCKFORD, ILLINOIS**

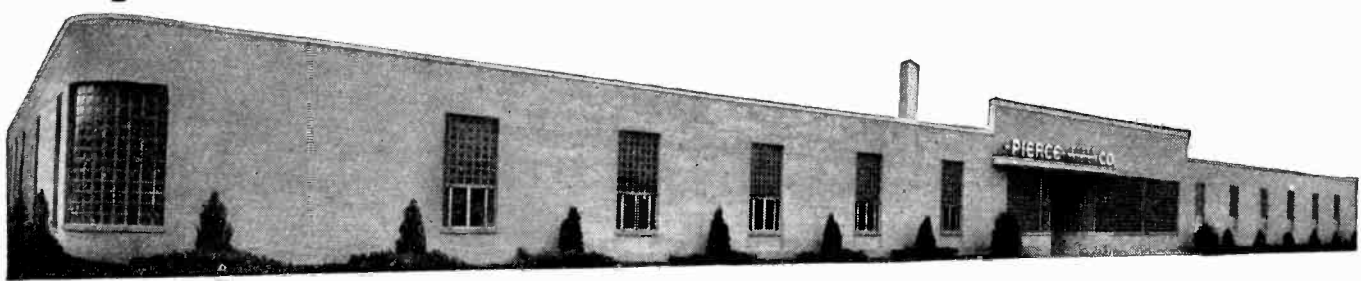

**SUBSIDIARIES**

**Charles H. Luck Envelope Company, Chicago.    Capital Envelope Company, St. Paul.**



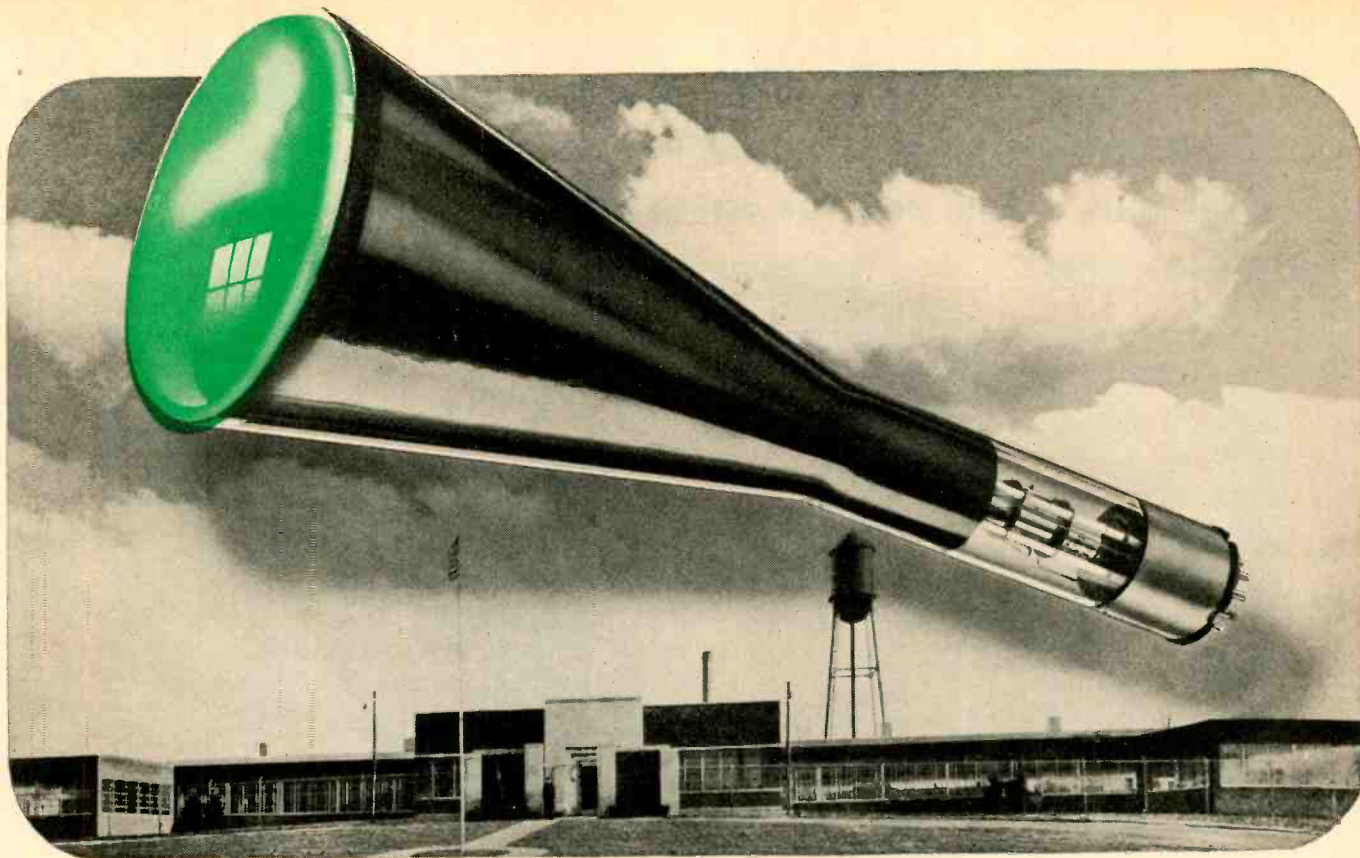

## A Bright Spot in the Television Picture

Now ready at National Union is a group of new cathode-ray tubes capable of picture reproduction superior to anything television has yet offered. Here are tubes whose ultra fine grain screens\* catch the most subtle gradations of light and shadow. Pictures are far more detailed, clearer, more brilliant. When enlarged by projection, they hold their distinct, high-definition quality and depth of tone. Here, too, ion burn, as a major television problem, is a thing of the past!

National Union enters the "Age of Television," ideally equipped to supply high-grade C-R Tubes at mass market prices. Here, is a large modern plant . . . an ultra-efficient pro-

duction line . . . equipment designed for the most advanced manufacturing techniques . . . the highest standards of quality control . . . skilled workers . . . able engineers. All backed by one of this Industry's most extensive and fruitful Electronic Tube Research programs —assurance that N. U. will contribute its full share to future C-R Tube progress.

---

*\*So fine is the texture of the special florescent material developed by National Union Research Laboratories, it is calculated that a 10-inch picture on the screen of a National Union cathode-ray tube is reproduced on 10 billion crystals!*

**NATIONAL UNION**  
**RADIO AND ELECTRON TUBES**  
NATIONAL UNION RADIO CORPORATION • NEWARK 2, N. J.

# NOW...MORE COMPACT PORTABLE RECEIVERS!

NEW "EVEREADY" COMBINATION "A-B" 90-VOLT  
BATTERY UNIT PACKS MORE POWER  
INTO LESS SPACE



## SPECIFICATIONS

of new "Eveready" "A-B" pack

### VOLTAGE:

"A"—9 tapped at 7½

"B"—90

### SIZE:

10<sup>9</sup>/<sub>16</sub>" x 3<sup>1</sup>/<sub>4</sub>" x 4<sup>1</sup>/<sub>4</sub>"

### NET WEIGHT:

6½ lbs.

**T**HIS new "Eveready" "A-B" battery for portable receivers is no ordinary pack. Size for size, it actually contains more energy — actually lasts far longer — than any other pack!

Reason for this is that for the first time the "B" section is constructed on the famous "flat-cell" principle used exclusively in the "Mini-Max" battery. See in the box at right how this revolutionary construction packs more power into less space.

Imagine what this "Eveready" pack can do for your portable receivers: It means simplified construction. It also means more powerful receivers can be built without increasing the size.

Engineers at National Carbon Company, Inc., will be glad to provide you with more information on this compact "Eveready" "A-B" pack.

### NATIONAL CARBON COMPANY, INC.

Unit of Union Carbide and Carbon Corporation



General Offices: New York, N. Y.

Division Sales Offices: Atlanta, Chicago, Dallas, Kansas City,  
New York, Pittsburgh, San Francisco



**ORDINARY "B" BATTERY** is made of many round cells, which cannot be packed together without wasted space. Nearly one-third of the volume inside an ordinary "B" battery, is cardboard, pitch—and air!

**"MINI-MAX" "B" BATTERY** is a solid mass of flat cells! No space is wasted. A "Mini-Max" "B" Battery is actually much more battery than other brands of identical size ... contains more of the active materials — lasts much longer in use!



The registered trade-marks "Eveready" and "Mini-Max" distinguish products of National Carbon Company, Inc.



*Only with Westinghouse  
can you gain the full benefit of  
this mark of greater dependability*

**more supervisory controls  
than any other type of  
transmitter . . .**

Your job is easier because Westinghouse AM transmitter controls include everything from one master switch to a complete indicator lamp system. And the soundness of Westinghouse design is backed by more experience in actual station operation than any other manufacturer. Write today for the full story. Westinghouse Electric Corporation, P. O. Box 868, Pittsburgh 30, Pennsylvania.

J-08149

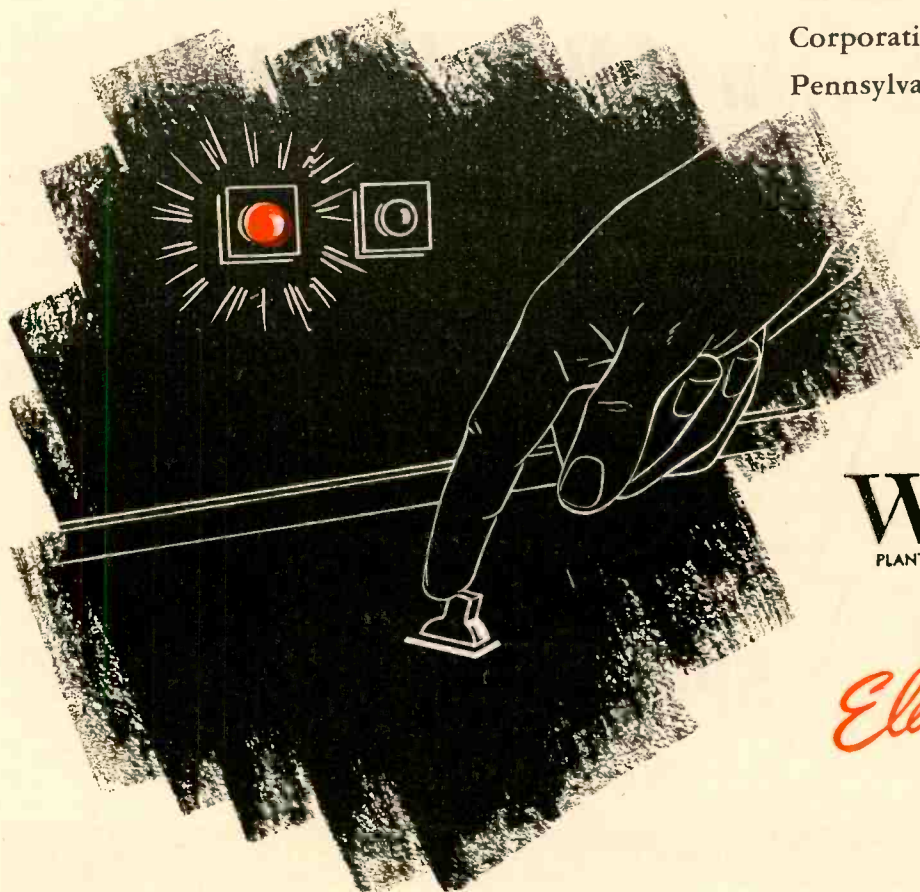

**Westinghouse**  
PLANTS IN 25 CITIES . . . OFFICES EVERYWHERE

*Electronics at Work*



# ONE STANDARD TYPE

does the job...

**NEW** type end seal for extra humidity protection.

WOUND WITH  
CERAMIC  
INSULATED  
WIRE  
1000°C.  
HEAT-PROOF!

**NEW** glazed ceramic shell to withstand thermal shock, humidity and corrosive conditions.

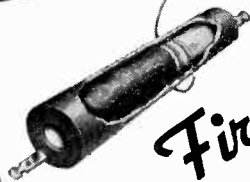

*First*

with resistors wound with ceramic-insulated wire.



*First*

with glass-to-metal sealed resistors.

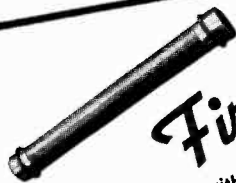

*First*

and still exclusive with MEGOMAX, the high-resistance, high-voltage resistors.

*and First*

with the EXTRA humidity protection features for STANDARD resistors described above.

## ..in ANY climate!

No more "special orders" to obtain suitable resistors to withstand the extreme thermal and humidity conditions to which your product may be subjected in many parts of the world! STANDARD Sprague Koolohm Wire-Wound Resistors now incorporate these extra protection features — and this means that you can count on STANDARD Sprague Koolohms for maximum dependability in ANY climate, ANYwhere on the face of the globe. Write for new catalog of Sprague Koolohm wire-wound types for every requirement.



# SPRAGUE KOOLOHM

TRADEMARK REGISTERED U.S. PAT. OFF.

## WIRE-WOUND RESISTORS

SPRAGUE ELECTRIC COMPANY, Resistor Division, North Adams, Mass.





# Sherron

## STUDIO CONTROL

### DESK MODEL SE-300 FOR VIDEO

This unit is especially designed to afford exclusive control to the program or technical director in charge of telecasting.

Three video pictures are included for ease in selection of camera pick-ups and in viewing the final transmitted picture. In addition, this Model SE-300 is equipped with inter-communication for contact with master control and studio camera men.

A loudspeaker in the end-unit gives the director his aural pick-up. . . .

The kinescopes are 7" direct viewing tubes, which facilitate the duties of the individual in charge of detail and contrast.

Should more camera pick-ups be needed, the Sherron Studio Control Desk can be enlarged by increasing the number of kinescope panels. Furthermore, a turntable can be included in one of the end-units.

As is characteristic of all Sherron broadcast equipment, maintenance and safety are primary considerations. Each chassis is removable without soldering of wires.

Plugs offer ease of removal and quickness of change.



# SHERRON ELECTRONICS CO.

Subsidiary of Sherron Metallic Corp.

1201 Flushing Avenue • Brooklyn 6, N. Y.

*"Where the Ideal is the Standard, Sherron Units are Standard Equipment."*

# BETTER "Q"

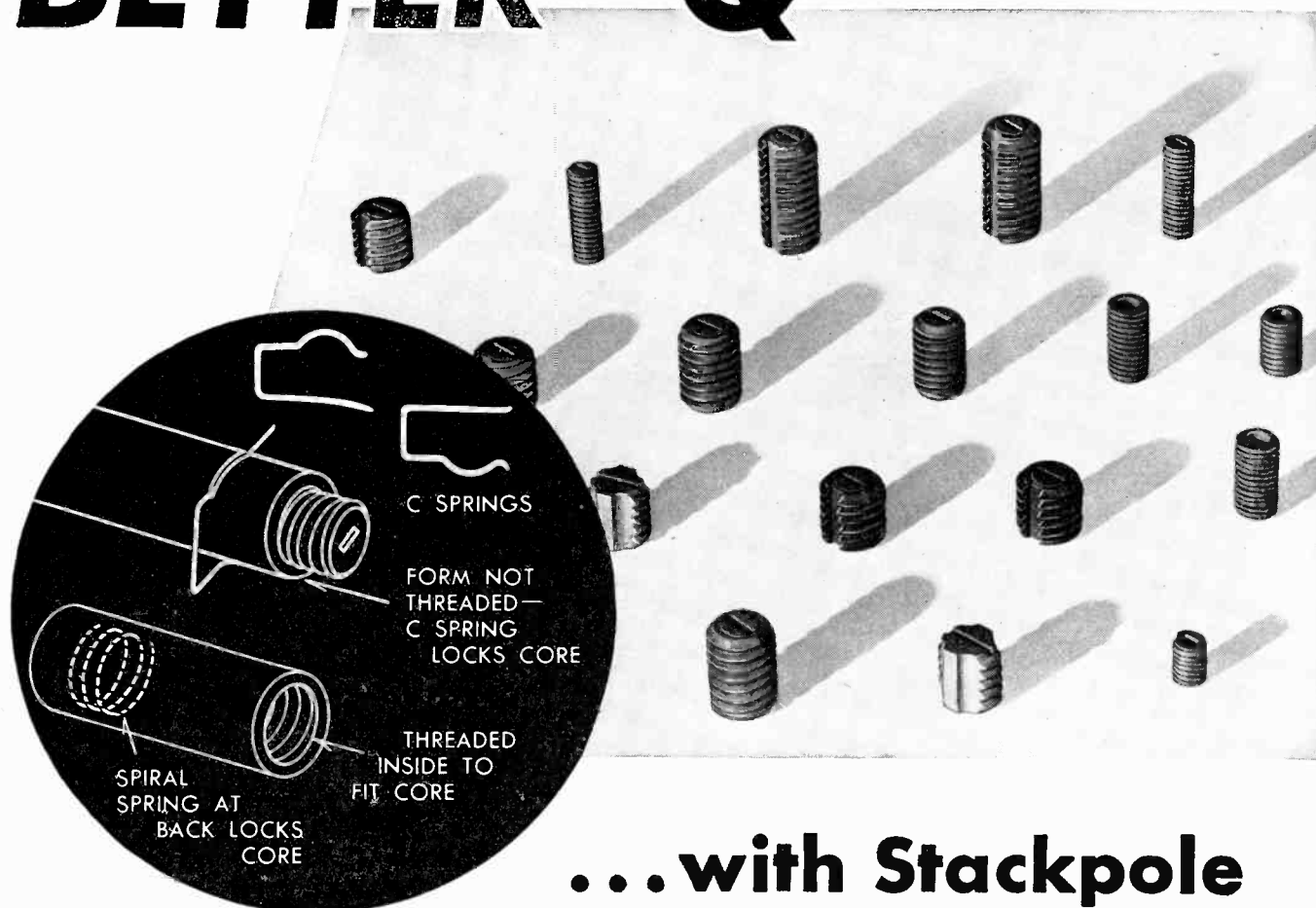

## ... with Stackpole Screw-type Molded Iron Cores

**HIGHER "Q"**—Since there is no brass core screw in field of coil and the core is not grounded.

**SMALLER ASSEMBLIES**—Overall length of coil and screw type core is less than that of conventional core, machine screw and bushing, thus permitting smaller coil assemblies and smaller cans.

**FACILITATE DESIGN OF I-F TRANSFORMERS AND DUAL I-F** transformers for AM and FM

since all cores may be tuned from one end of the I-F transformer can by placing coils side by side.

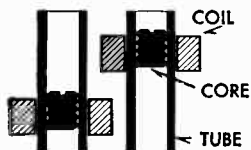

Antenna, R-F and Oscillator coils for each band of a multi-band set become small and compact and may be mounted in groups for each band.

**HIGHLY ECONOMICAL**—Threaded coil forms unnecessary. See accompanying sketch for suggested use of wire clip in form slot. If desired, the tube can be threaded to fit core as illustrated.

### Electronic Components Catalog!

Write for Stackpole Electronic Components Catalog RC6 covering switches, fixed and variable resistors and iron cores.

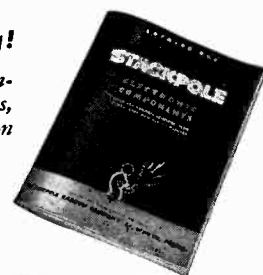

*Samples and Engineering Data gladly sent on request*

STACKPOLE CARBON COMPANY, St. Marys, Pa.

# STACKPOLE

"EVERYTHING IN CARBON BUT DIAMONDS"





FOR  
HEARING AIDS  
VEST POCKET RADIOS  
AIR BORNE DEVICES

## UTC SUB-OUNCER SERIES

UTC Sub-Ouncer units are 9/15" x 5/8" x 7/8" and weigh only 1/3 ounce. Through unique construction, however, these miniature units have performance and dependability characteristics far superior to any other comparable items. The coil is enamel layer wound of Formex wire . . . On a molded nylon bobbin . . . insulation is of cellulose acetate . . . leads mechanically anchored (no tape) . . . core material Hipermalloy . . . entire unit triple (waterproof) sealed. The frequency response of these standard items is  $\pm 3$  dB from 200 to 5,000 cycles.

Type	Application	Level	Pri. Imp.	D.C. in Pri.	Sec. Imp.	List Price
SO-1	Input	+ 4 V.U.	200		250,000	\$5.00
			50	0	62,500	
SO-2	Intersape 3:1	+ 4 V.U.	10,000	0	90,000	5.00
SO-3	Plate to Line	+ 23 V.U.	10,000		200	5.00
			25,000	3/1.5 mil.	500	
SO-4	Output	+ 20 V.U.	30,000	1.0 mil.	50	5.00
SO-5	Reader 50 HY at 1 mil. D.C.					4.50
	3000 ohms D.C. Res.					

## UTC OUNCER SERIES

The standard of the industry for seven years. The overall dimensions are 7/8" diameter by 1-3/15" height including lugs. Mounting is effected by two screws, opposite the terminal board side, spaced 11/16". Weight approximately one ounce. Units not carrying D.C. have high fidelity characteristics being uniform from 40 to 15,000 cycles. Items with D.C. in pri. are for voice frequencies from 150 to 8000 cycles.

Type	Application	Pri. Imp.	Sec. Imp.	List Price
0-1	Mike pickup or line to 1 grid	50, 200, 500	50,000	\$11.60
0-4	Single plate to 1 grid	8,000 to 15,000	60,000	\$ 9.25
0-5	Single plate to 1 grid, D.C. in Pri.	8,000 to 15,000	60,000	\$ 9.25
0-6	Single plate to 2 grids	8,000 to 15,000	95,000	\$10.45
0-8	Single plate to line	8,000 to 15,000	50, 200, 500	\$11.60
0-9	Single plate to line, D.C. in Pri.	8,000 to 15,000	50, 200, 500	\$11.60
0-12	Mixing and matching	50, 200	50, 200, 500	\$10.45
0-13	Reactor, 200 Hys-no D.C., 50 Hys-2MA, D.C., 6,000 ohms			\$ 8.10

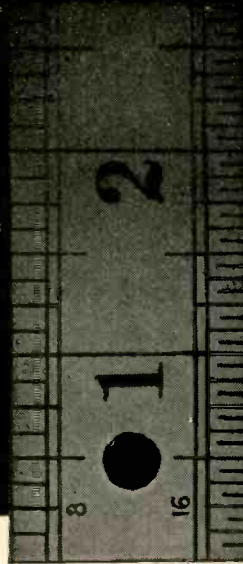
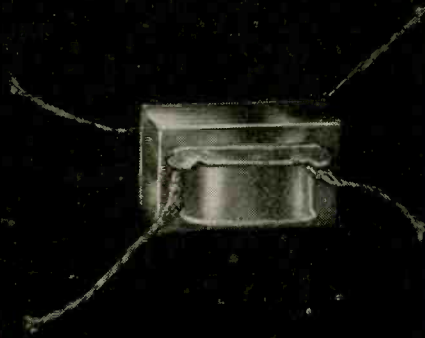

Manufacturers: Our experience in building hundreds of thousands of ouncers and sub-ouncers is yours for the asking. Special types, and mountings are readily available. U.T.C. engineers can help you save weight and space in the design of miniature equipment.



*United Transformer Corp.*

150 VARICK STREET

NEW YORK 13, N. Y.

EXPORT DIVISION: 13 EAST 40th STREET, NEW YORK 16, N. Y., CABLES: "ARLAB"

# Introducing the Most Efficient Method of By-Passing Tube Pins to Ground



ERIE CERAMICON BY-PASS CONDENSERS



CINCH LOCK-IN, OCTAL and MINIATURE TYPE TUBE SOCKETS

## CINCH-ERIE "Plexicon" TUBE SOCKET \* with Built-in Ceramicons

Now for the first time it is possible to increase the efficiency of high frequency circuits by providing the shortest possible electrical path to ground when by-passing tube pins. This is accomplished in the new Plexicon Tube Socket, with silvered ceramic condensers built into the socket, immediately around the tube prongs.

The joint development of the leading manufacturers in their respective fields, Erie Resistor Corporation and Cinch Manufacturing Corporation, this revolutionary socket eliminates all leads which are necessary with conventional by-pass condensers. Not only does this design save space, but it also permits the moving of other components closer to the tube socket.

The Plexicon Tube Socket will be available in Lock-in, Octal and Miniature type sockets, with either center or periphery ground connection. The design is such that any desired combination of tube pins can be by-passed. The maximum capacity of the condenser is 1,000 MMF. The plan view and mounting dimensions of Cinch-Erie Plexicon Tube Sockets are identical with those of standard Cinch sockets.

Samples of the Plexicon Tube Socket will be available shortly in the Lock-in type. Octal and Miniature types will be available later. Contact your nearest Erie Resistor or Cinch representative for further information and samples of this outstanding contribution to VHF and UHF design.

\* Patent Applied For

*A Joint Advertisement of*  
**CINCH MANUFACTURING CORP.**  
CHICAGO, ILLINOIS



**A Joint Development  
of ERIE  
RESISTOR CORP.  
and CINCH  
MANUFACTURING  
CORP.**

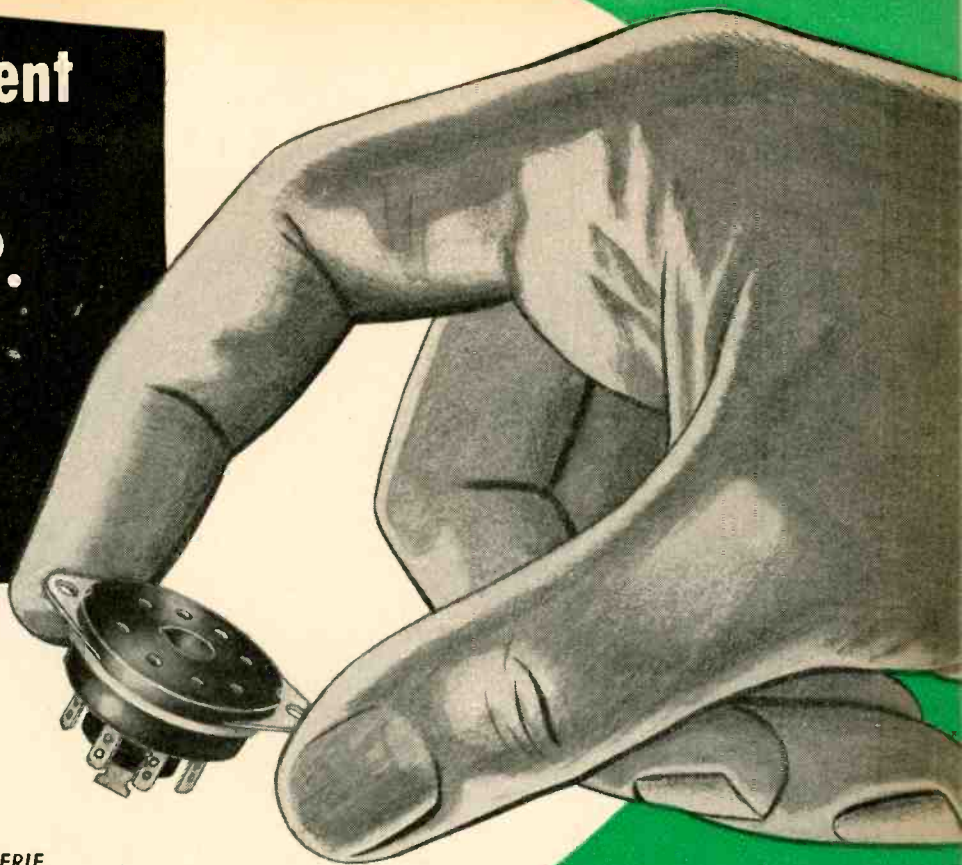

CINCH - ERIE  
Plexicon Tube Socket

*Puts the By-Pass Condensers  
where they belong . . .  
Around the Tube Pins*

- 1 *Provides shortest possible electrical path to ground.*
- 2 *Saves space—permits moving other components closer to tube socket.*
- 3 *Reduces set assembly costs.*
- 4 *Capacitive coupling effect between by-passed tube pin and adjacent pins is reduced by shielding effect of outer electrode of condenser.*
- 5 *Plexicon sockets are installed exactly the same as standard Cinch Lock-in, Octal, and Miniature type sockets.*
- 6 *Top of Cinch-Erie Plexicon Lock-in type socket matches tube base.*

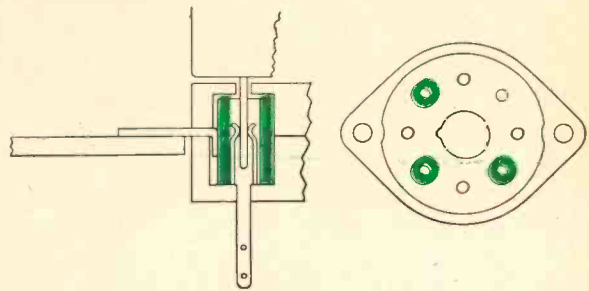

The above two schematic diagrams show the basic design principles of Cinch-Erie Plexicon Tube Sockets.

In the plan view, the socket is shown with condensers for by-passing three tube pins. The silvered-ceramic condensers are shown in green.

Note in the side view that standard tube prong clips are used, and that the condenser completely surrounds the tube pin.

Mounting dimensions of the Lock-in type are: 1.312" between center line of mounting holes; chassis hole 1.125" diameter.

*Electronics Division*  
**and ERIE RESISTOR CORP.**

ERIE, PENNSYLVANIA





# WHY ARE THESE BUSHINGS



**CORNING**  
— means —  
Research in Glass



# LIKE A TIN CAN . . .

**T**HE answer to that is easy! They're like a tin can because they also form permanent hermetic seals when soldered in place. By means of the famous Corning metallizing process, metal is attached to glass so firmly it can't be removed without taking glass with it. This means that there is no possibility of leakage and assembly parts and operations are cut in half.

These bushings have high voltage rating, high volume and surface resistivity and high dielectric strength. They're strong, too, and being glass, resist chemical action and weathering. And the Pyrex Brand low-expansion glass makes them able to withstand great thermal

shock. As you can see they come in both tubular and skirted form. Many standard items are available for immediate shipment. Or special items can be quickly made in any quantity desired.

If metallized glass can improve your product through hermetic seals or faster assembly, Corning can help you. Look at the Corning Electronic products below. If something like these is what you've been looking for, write, wire or phone The Electronic Sales Department, P-2, Technical Products Division, Corning Glass Works, Corning, New York. There'll be a Corning engineer working on your problem as soon as he can get there.

**NOTE**—The metallized Tubes and Bushings, Headers and Coil Forms below are all made by the famous Corning Metallizing Process. Can be soldered into place to form true and permanent hermetic seals. Impervious to dust, moisture and corrosion.



**Metallized Tubes** for resistors, capacitors, etc. 20 standard sizes  $\frac{1}{8}$ " x 2" to  $1\frac{1}{4}$ " x 10". Mass-produced for immediate shipment.

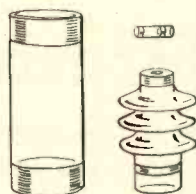

**Metallized Bushings.** Tubes in 10 standard sizes,  $\frac{3}{16}$ " x  $\frac{25}{32}$ " to 1" x  $4\frac{1}{2}$ " in mass production for immediate shipment.

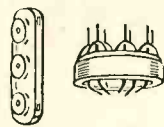

**Headers**—The best way to get a large number of leads in a small space for assembly in one operation.

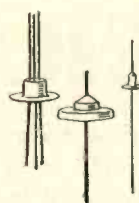

**Eyelet Terminals**—Single or multiple eyelets permit design flexibility. Standard items readily available in quantity.

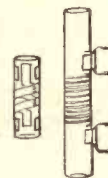

**Coil Forms**—Grooved for ordinary frequencies—metallized for high frequencies. In various designs and mountings.



**VYCOR Brand cylinders**—very low loss characteristics. Stands thermal shock up to 900°C. Can be metallized.

"VYCOR", "CORNING" and "PYREX" are registered trade-marks and indicate manufacture by Corning Glass Works, Corning, N. Y.

## Electronic Glassware





Looms Large on the  
**CERAMIC Firmament**

Your search for a "hard-as-diamond" versatile material ends when you discover the myriad possibilities of Steatite.

Let us tell you more about STEATITE . . . a material that may solve your production problems.

**Centralab**

Division of GLOBE-UNION INC., Milwaukee

PRODUCERS OF



Ceramic Trimmers  
 Bulletin 695



Variable Resistors  
 Bulletin 697

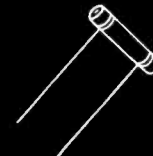

Tubular Ceramic Capacitors  
 Bulletins 630 and 586

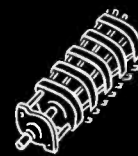

Selector Switches  
 Bulletin 722



Ceramic High Voltage Capacitors  
 Bulletin 814



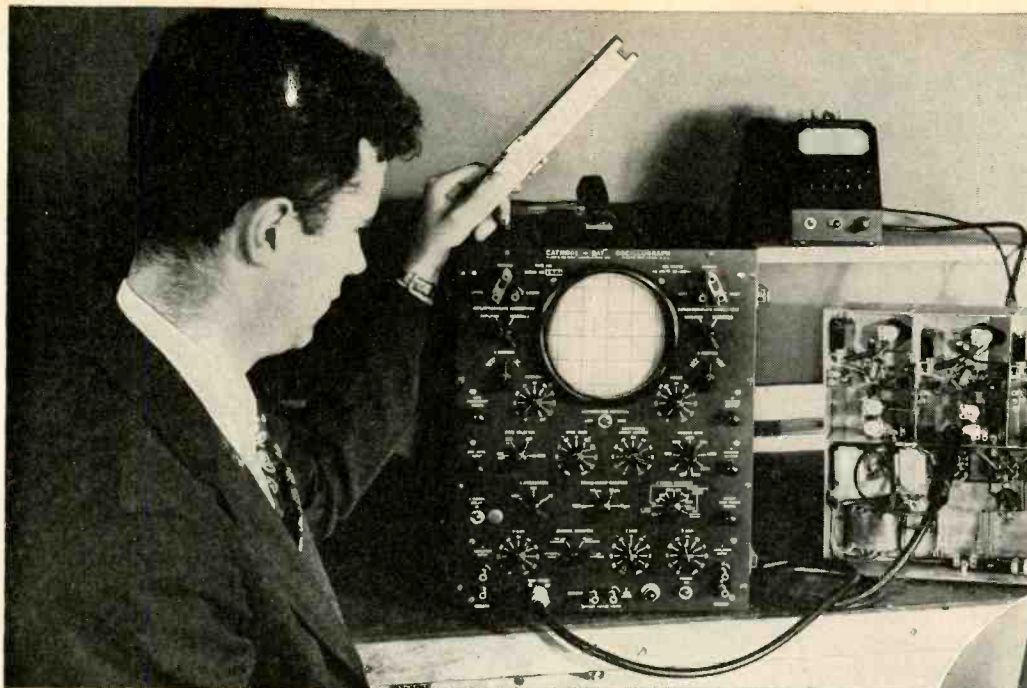

Left—Indicator Unit of Type 248 Oscillograph

Below—Power Supply Unit of Type 248 Oscillograph

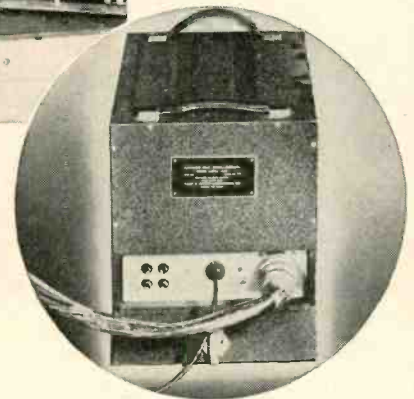

## PRECISION ACCURACY to the

# Microsecond!

▶ The Du Mont Type 248 Cathode-Ray Oscillograph was developed to meet the need for a precision-measurement instrument of laboratory-standard accuracy . . . an instrument of such outstanding performance and dependability that it has no rival in the commercial field.

If your immediate or long-range program involves pulses, transient response, waveshaping circuits, video amplifiers or any problems which require the unusual combination of a cathode-ray synchroscope and oscillograph, you'll find the Type 248 the perfect answer to all your requirements . . . with accuracy to the MICROSECOND!

**THE DU MONT TYPE 248 CATHODE-RAY OSCILLOGRAPH IS NOW AVAILABLE FOR IMMEDIATE DELIVERY! FURTHER INFORMATION IS YOURS FOR THE ASKING.**

© ALLEN B. DUMONT LABORATORIES, INC.

### NOTE THESE UNUSUAL FEATURES

1. Driven or "slave" sweep speeds which exceed one inch per microsecond.
2. Visual display of non-repetitive transients which produce writing rates as fast as three or more inches per microsecond.
3. Better than one-half microsecond signal delay which permits observation of the initial part of a transient or pulse.
4. Self-contained trigger pulse oscillator for synchroscope applications.
5. Internally provided timing markers at 1, 10, and 100 microsecond intervals which may be superimposed upon the observed wave.
6. Separate indicator and power supply units which add to its utility as a portable instrument.

# DUMONT

## Precision Electronics & Television

ALLEN B. DUMONT LABORATORIES, INC., PASSAIC, NEW JERSEY • CABLE ADDRESS: ALBEEDU, PASSAIC, N. J., U. S. A.



**FIXED INSULATED RESISTORS**

**1/2-WATT**

Length 3/8 in. Diam. 9/64 in.



**1-WATT**

Length 9/16 in. Diam. 7/32 in.



**2-WATT**

Length 11/16 in. Diam. 5/16 in.



Length of all leads—1 1/2 inches

**"A-B Fixed Resistors will not break down under the Cold Test"**

During wartime, a high official made this significant statement: "Allen-Bradley now is the only known source for a resistor that will not break down under the Cold Test requirements."

War service, of course, called for top dependability in resistor performance. Hence, in every war zone, Allen-Bradley fixed and adjustable resistors were the choice of the men who required resistors that held up under all extremes of temperature, pressure, and humidity.

Allen-Bradley insulated fixed resistors are available in 1/2-watt, 1-watt, and 2-watt ratings with 1 1/2-inch leads and tolerances of 5, 10, and 20 per cent. Specifications furnished on request.

Allen-Bradley Company  
114 W. Greenfield Ave., Milwaukee 4, Wis.

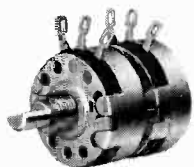

Type J Bradleyometers are furnished in single, dual, and triple construction, to be used as rheostats or potentiometers.



The molded resistor element has substantial thickness... approximately 1/32 inch. Any resistance-rotation curve is available.

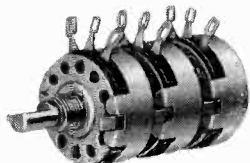

Bradleyometers have no rivets, no soldered or welded connections, and no conducting paints in the electrical circuits.



**ALLEN-BRADLEY**  
**FIXED & ADJUSTABLE RADIO RESISTORS**

QUALITY



Not jet propelled...

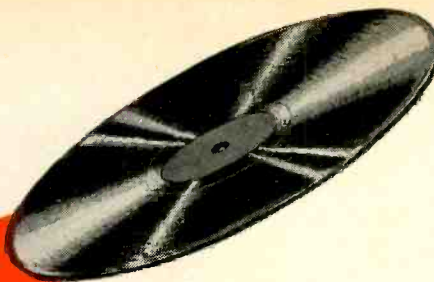

**PRESTO 8-D**

but just as **NEW!**

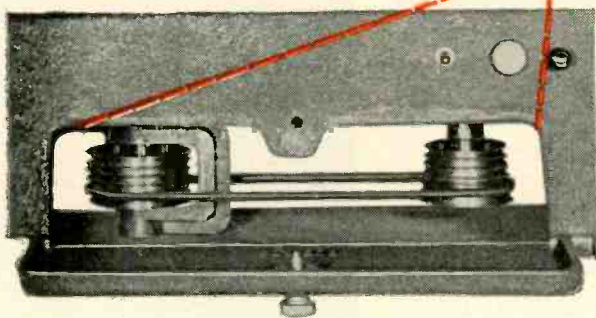
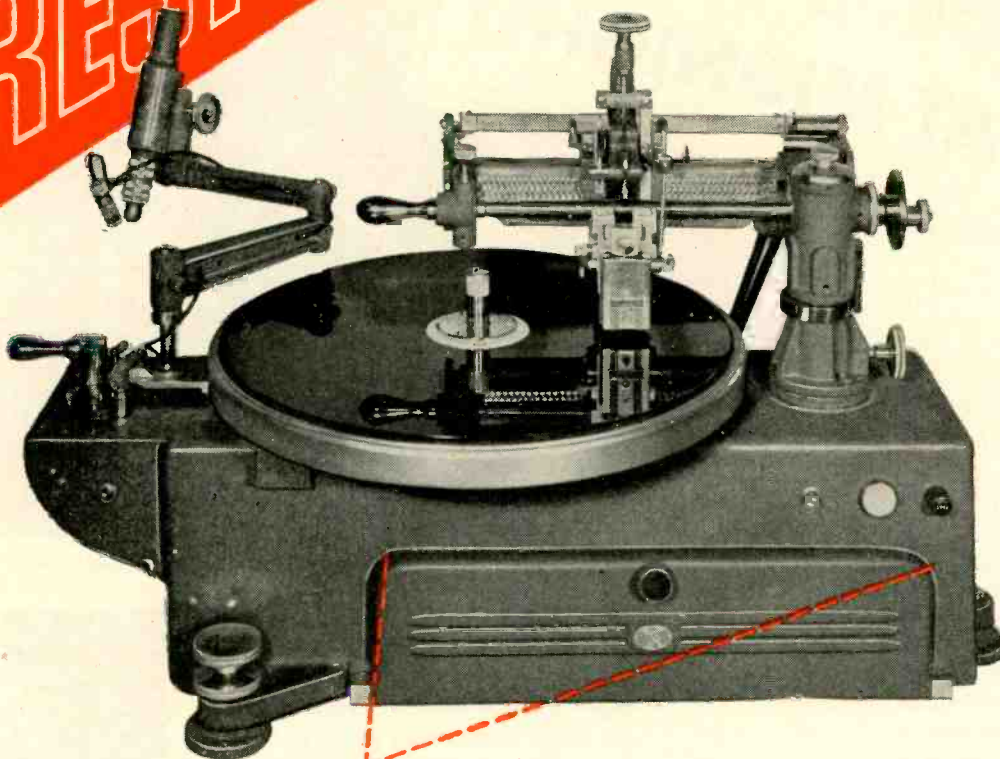

The belt on step pulleys slips instantly to any position to set cutting pitch at 96-104-112-120-128 or 136 lines per inch. Other pitches available on special order.

PRESTO'S newest *turntable*... for highest quality master or instantaneous recordings. The 8-D features instantaneous change of cutting pitch. An improved cutting head provides higher modulation level, more uniform frequency response and retains its calibration under all normal temperature conditions.

The heavy cast-iron turntable and mounting base insure exceptionally low background noise. Adjustable feet permit accurate leveling on bench or stand at a height to suit the operator.

**PRESTO**



**RECORDING CORPORATION**  
242 West 55th Street, New York 19, N. Y.  
Walter P. Downs, Ltd., in Canada

**WORLD'S LARGEST MANUFACTURER OF INSTANTANEOUS SOUND RECORDING EQUIPMENT AND DISCS**

They wanted  
**MIDDAY VIEWS**  
**...AT MIDNIGHT!**



Night aerial photo of St. Lo in Normandy on D-Day. Taken with the new "super" flash tube!

During the closing stages of the war, many a lone plane, traveling fast at medium altitudes, would roar over enemy territory in the dead of night.

As it winged over certain areas, an intermittent series of blindingly brilliant flashes would dart like lightning from its belly.

Then, the plane would speed away.

Such planes were on photo reconnaissance. Each was equipped with a "super" flash tube a thousandfold brighter than a news photographer's strongest flash bulb. In its split-second bursts of dazzling light, nocturnal troop movements were easily filmed from altitudes as high as 10,000 feet.

**How the "Super" Flash Tube Works**

The source of light is a 4,000-volt discharge between two electrodes in a coiled quartz tube filled with a rare gas. The outer container is a cylinder of Pyrex.

A single discharge gives plenty of light

...and plenty of heat. It is this intense heat that has made Inconel the choice for the springs, clips and wire used to support the quartz coil within the Pyrex cylinder.

No other metal could stand up under such extreme temperatures. Before Inconel was used, previous supporting metals either lost their springiness or became distorted.

With Inconel on the job, there has been no trouble. This high-Nickel alloy retains its properties at elevated temperatures... doesn't scale away... never rusts.

Thermally durable Inconel is used on many jobs where high heat is a problem. Perhaps in your product, too, you can use Inconel in some form "to build-in the performance you plan."

Detailed information on this INCO Nickel Alloy is given in Technical Bulletin T-7, "Engineering Properties of Inconel." For your copy, write:

**The International Nickel Company, Inc.**  
**67 Wall Street New York 5, N. Y.**

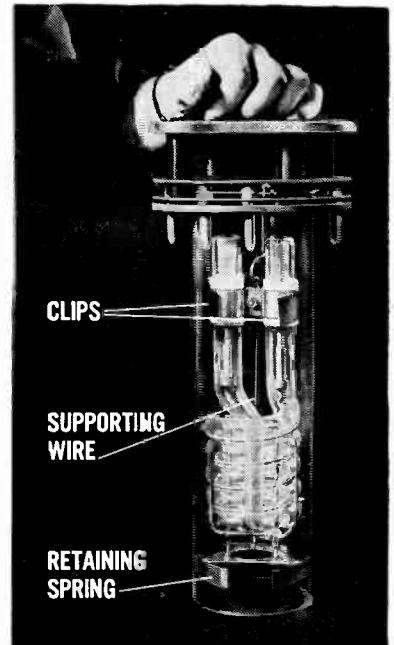

The "super" repeating flash tube built by General Electric's Lamp Department, Nela Park, Cleveland, Ohio. Arrows indicate the metal supporting parts. Possible peacetime uses for the flash tube's sudden bolts of sun-like radiance include aerial beacons, marine lighthouses, and scientific photography.

**NICKEL**  **ALLOYS**

MONEL • "K" MONEL • "R" MONEL • "KR" MONEL • "S" MONEL • INCONEL • NICKEL • "L" NICKEL • "Z" NICKEL • Sheet... Strip... Rod... Tubing... Wire... Castings... Welding Rods (Gas and Electric)



# A rugged performer with a big voice and keen ear!



Collins AN/ARC-2 Autotune transmitter-receiver

The AN/ARC-2 Autotune transmitter-receiver was designed and is built by Collins for two place and larger military aircraft. It is an example of the experience, design ingenuity and manufacturing skill also available, in the Collins organization, to commercial users of communication equipment.

Transmitter, receiver and dynamotor are all contained in the same case. The weight and space requirement of the AN/ARC-2 is considerably less than that of the equipment it replaces. Any one of eight pre-tuned channels is immediately and automatically available by means of the Collins Autotune, operated either at the main panel or by remote control. The transmitter and receiver operate on the same frequency and are tuned simultaneously by a single set of controls.

This equipment, including its Autotune mechanism, functions reliably at all temperatures from  $-58^{\circ}$  to  $+140^{\circ}$  F, all altitudes from sea level to 40,000 feet, and all conditions of humidity up to saturation.

The Collins organization specializes in fulfilling exacting requirements. We will welcome an opportunity to make recommendations regarding your needs in the field of radio communication equipment. Collins Radio Company, Cedar Rapids, Iowa; 11 West 42nd Street, New York 18, N. Y.

Remote  
Control  
Box



IN RADIO COMMUNICATIONS, IT'S . . .

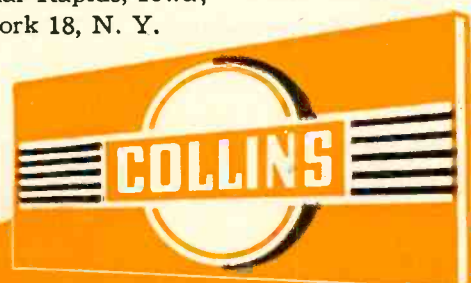



# Announcing a NEW FM Phase-Modulation Tube

## Revolutionary in design and performance

Achieves modulation by providing a rotating "wheel" of electrons, which is advanced or retarded in speed by magnetic fields produced by audio-frequency currents.

**DIRECT CRYSTAL FREQUENCY CONTROL  
WITH ONLY ONE CRYSTAL. NO MOTORS  
OR REACTANCE-TUBE TUNING.**



Type GL-2H21  
**PHASITRON**

### Ratings for Typical Operation

Heater voltage	6.3 v	d-c
Heater current	300 ma	d-c
Voltage, solid anode	250 v	d-c
Voltage, perforated anode	200 v	d-c
Voltage, 1st focus electrode	10 v	d-c
Voltage, 2nd focus electrode	25 v	d-c
Voltage, 3-phase deflectors	85 v	d-c
Voltage, neutral deflector	30 v	d-c
Driving voltage, r-f	35 v rms	
Audio driving power	50 mw	

**P**ioneered by Zenith—developed, designed, and built by General Electric—the new PHASITRON tube offers sensational advantages to manufacturers and users of FM transmitters.

Several tuned circuits, with their tubes and other components, are eliminated by Type GL-2H21. Greater frequency stability—less distortion—a lower noise level—these are important improvements

in FM transmitters made possible by the PHASITRON.

Use of Type GL-2H21 produces a straightforward FM transmitter design, one which is easier to tune—also it means less maintenance for the transmitter operator, as well as a simpler, more reliable product in the 88 to 106-megacycle band.

Fast service by G-E tube engineers is available to manufacturers who wish to consider the PHASITRON

for their new FM transmitter circuits. Phone your nearest G-E office, or communicate direct with *Electronics Department, General Electric Company, Schenectady 5, N. Y.*

# GENERAL ELECTRIC

161-E3-0850

TRANSMITTING, RECEIVING, INDUSTRIAL, SPECIAL PURPOSE TUBES • VACUUM SWITCHES AND CAPACITORS



*Just what does Accurate offer  
a company like yours . . .*  
**if springs are important  
to you?**

THE advantages of millions of springs of experience are yours, here at Accurate. This experience is as broad as it is long . . . covers a multitude of precision spring types and sizes, various wireforms and light metal stampings.

IT takes people to make springs, and Accurate offers you a specialized, highly trained personnel . . . experts at their jobs, well qualified to give you the finest in spring-making craftsmanship.

ANOTHER advantage Accurate offers is the latest in modern, efficient springmaking machinery and equipment. Much of our equipment is of our own design . . . another reason why you can expect every Accurate spring to perform dependably and well.

EXPERIENCED spring engineers are here for consultation. They can help you obtain efficient spring performance at the lowest possible cost. This service is in confidence of course.

*... we'd like to talk over your spring problems with you*



**Accurate Spring Manufacturing Co.**

3835 W. Lake Street, Chicago 24, Illinois

SPRINGS • WIRE FORMS • STAMPINGS

Send for your copy of the new Accurate Spring Handbook. It's full of data and formulae which you will find useful. No obligation of course.



**POST WAR SERIES-400**

*"Super-Pro"*



**FULL COVERAGE  
.54 — 30 MC.**

**1—FULL COVERAGE**

**2—VARIABLE CRYSTAL SELECTIVITY**

**3—VARIABLE I.F. SELECTIVITY**

**4—FULL BAND SPREAD**

**5—IMPROVED NOISE LIMITER 6—ADJUSTABLE S METER**

### *Greatly Improved Performance*

This is the greatest "Super-Pro" ever offered to the professional or amateur operator. Your new 400 Series "Super-Pro" covers the broadcast band as well as the 10 meter amateur band and its performance is greatly stepped-up through war-time developments.



# HAMMARLUND

THE HAMMARLUND MFG. CO., INC., 460 W. 34TH ST., NEW YORK 1, N.Y.  
MANUFACTURERS OF PRECISION COMMUNICATIONS EQUIPMENT



# TRANSTATS

used by The International Nickel Co., Inc.  
for "...close electrical  
temperature control"

In this research laboratory at Bayonne, N.J., Transtats are used to control elevated temperatures in "creep testing" of alloys for high temperature applications. Since these tests are continuous over long periods, a high degree of reliability and accurate control are essential. The Transtats in conjunction with automatic controllers, connected to resistance heaters, keep the temperature at the required degree within close limits.

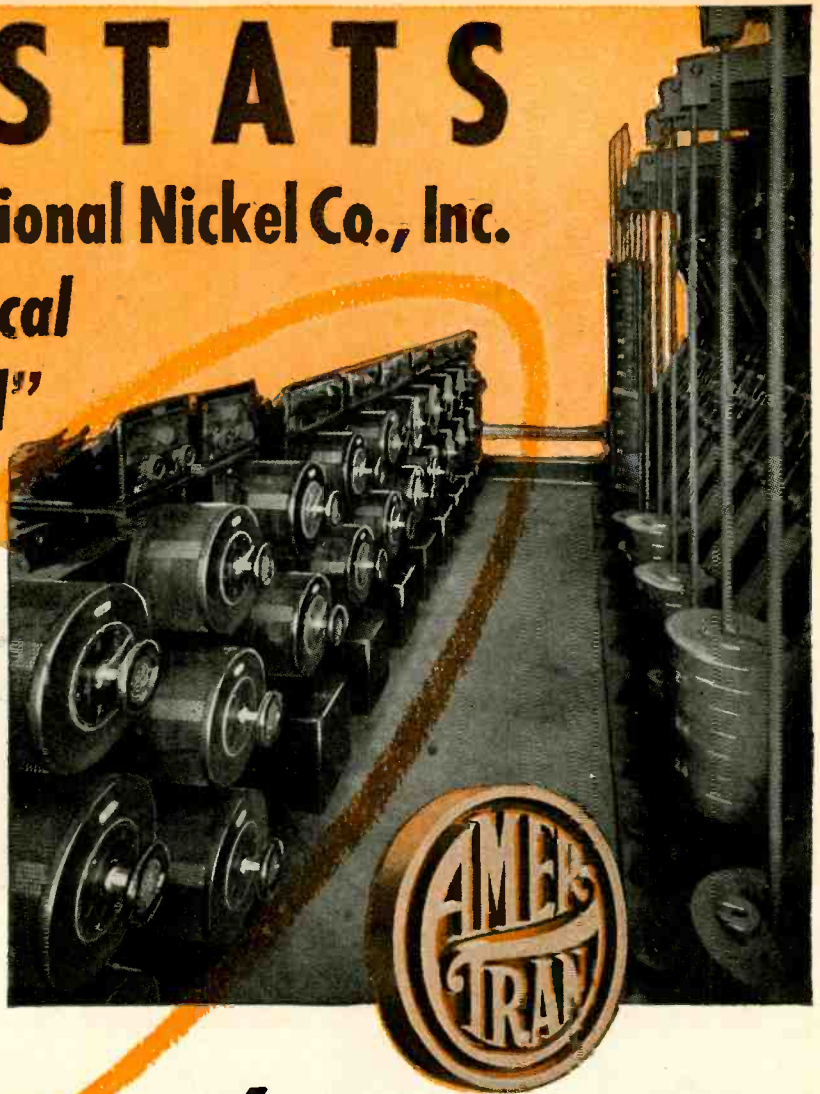

## 6 TRANSTAT "EXTRAS"

1. **Potentiometer smoothness** with transformer efficiency (93-99%)
2. **High turn-to-turn insulation** and solid insulating material between commutator bars—a combination of extra wire insulation and varnish impregnation of core and coil.
3. **Broad, Uniform Commutating Surface** ground from the evenly spaced outer wires of the coil.
4. **Smooth Commutating Surface.** Velvety action—no arcing—every turn a perfect contact.
5. **Longer Brush—more contact area,** reducing current density and providing greater arc for heat dissipation.
6. **Balanced Collector Arm** maintains brush setting at any degree of mounting.



For a continuously adjustable voltage or a constant voltage from a fluctuating source, specify Transtats.

**AMERICAN TRANSFORMER COMPANY**  
178 Emmet Street • Newark 5, New Jersey

Proceedings of the I.R.E.

February, 1946

# AMERTRAN

MANUFACTURING SINCE 1901 AT NEWARK, N. J.

Pioneer Manufacturers of Transformers, Reactors and  
Rectifiers for Electronics and Power Transmission



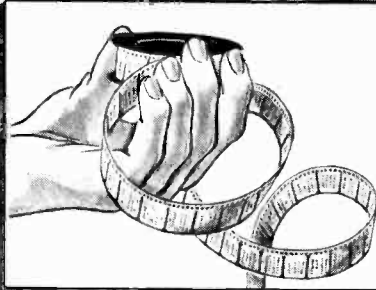

more efficient  
... in miniature

A roll of microfilm about the size of a typewriter ribbon is the equivalent of the many cubic feet of filing space necessary to store records in the original paper form. Filing for record in miniature is the same trend toward efficiency as the controlling of electronic circuits with miniature tubes.

Tung-Sol Miniature Tubes and smaller component radio parts mean a reduction in the over-all size of radio equipment. Miniature Tubes are characterized by short leads, making for low lead inductance; low inter-element capacities and high mutual conductance. These factors make Tung-Sol Miniature Tubes distinctly superior in performance when used in high frequency circuits. Miniatures are constructed with smaller and lighter parts. This

makes possible a more rigid construction that is more impervious to the effects of vibration and shock.

The experience of Tung-Sol engineers in designing circuits and selecting tubes is offered to manufacturers wishing to improve their present electronic equipment or to create new. All plans disclosed in consultation will, of course, be held in strictest confidence.



ACTUAL SIZE

# TUNG - SOL

*vibration-tested*

## ELECTRONIC TUBES

**TUNG-SOL LAMP WORKS, INC., NEWARK 4, NEW JERSEY**  
 Sales Offices: Atlanta • Chicago • Dallas • Denver • Detroit • Los Angeles • New York  
 Also Manufacturers of Miniature Incandescent Lamps, All-Glass Sealed Beam Headlight Lamps and Current Intermittors



# Which one is yours?

ROLLING OFF THE PRODUCTION LINE . . .

## The New 1000 Watt Frequency-Modulation Broadcast Transmitters

Using the Armstrong Dual Channel Direct Crystal Controlled Modulator

Wire for Bulletin No. 5006 for Complete Engineering Information on this transmitter

Other REL FM Broadcast Equipment Available for Ordering

Cat. No.

250 Watt FM Broadcast Transmitter . . . . . 549 A-DL  
3000 Watt FM Broadcast Transmitter . . . . . 519 A-DL  
10,000 Watt FM Broadcast Transmitter . . . . . 520 A-DL

### Speech Equipment

Cat. 603—Studio Speech Console, Table Type, 6 position.

Cat. 604—Station Speech Console, Table Type, combined with Cat. 600. Monitor and transmitter desk control.

### Monitoring Equipment

Cat. 600—FM Station Frequency and Modulation Monitor.

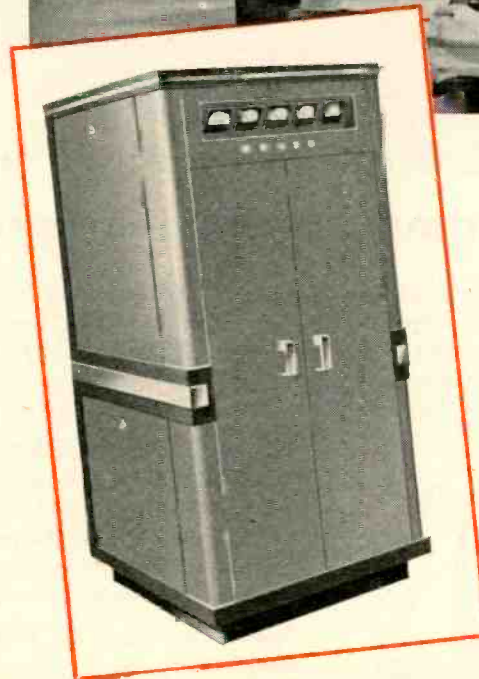
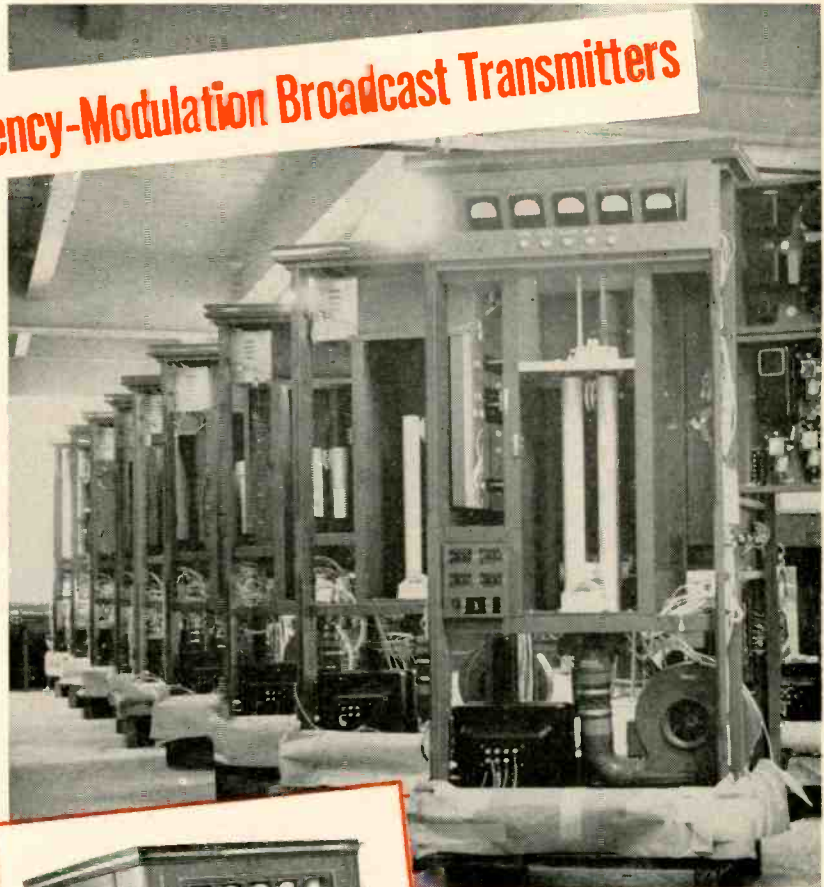

**SIMPLE,  
STABLE,  
EFFICIENT  
PERFORMANCE**

PIONEER MANUFACTURER  
OF FM TRANSMITTERS  
EMPLOYING ARMSTRONG  
PHASE-SHIFT MODULATION

**REL**

### Sales Representatives

• SOUTHEAST •  
JOHN F. BIVINS  
1008 Wellington Road  
Highpoint, North Carolina

ELECTRONIC SUPPLY CO.  
112 North Maine  
Anderson, South Carolina

• MICHIGAN •  
M. N. DUFFY & CO., INC.  
2040 Grand River Avenue, W.  
Detroit, Michigan

• MIDWEST •  
REL EQUIPMENT SALES, INC.  
612 North Michigan Boulevard  
Chicago, Illinois

• PACIFIC COAST •  
NORMAN B. NEELY ENTERPRISES  
7422 Melrose Avenue  
Hollywood 46, California

**RADIO ENGINEERING LABS., INC.**

*Long Island City, N.Y.*

# hallicrafters *new Model S-40*

New beauty and perfect ventilation in the perforated steel top

Separate electrical bandspread with inertia flywheel tuning.

Tuning range from 540 kc to 42 Mc continuous in four bands

Self-contained, shock mounted, permanent magnet dynamic speaker

All controls logically grouped for easiest operation. Normal position for broadcast reception marked in red, making possible general use by whole family.

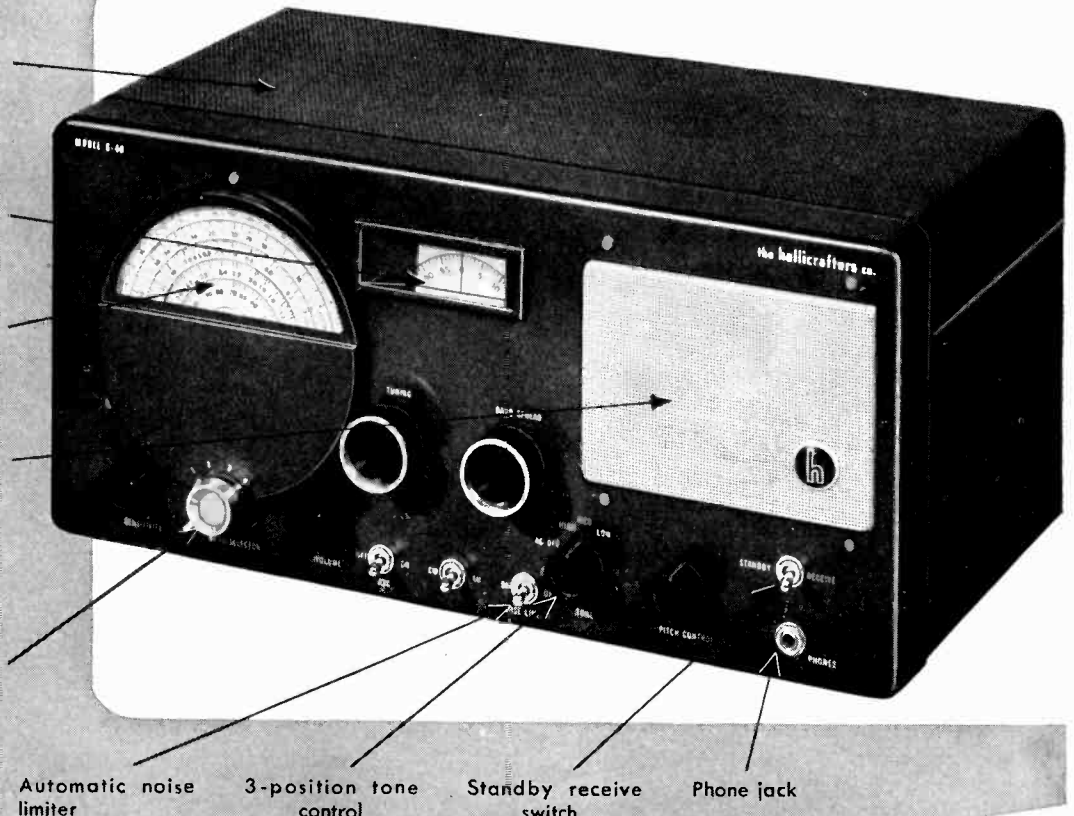

Automatic noise limiter

3-position tone control

Standby receive switch

Phone jack

(APPROXIMATELY)

**New design, new utility in a great \$79<sup>50</sup>  
new communications receiver . . .**

Here is Hallicrafters new Model S-40. With this great communications receiver, handsomely designed, expertly engineered, Hallicrafters points the way to exciting new developments in amateur radio. Read those specifications . . . it's tailor-made for hams. Look at the sheer beauty of the S-40 . . . nothing like it to be seen in the communications field. Listen to the amazing performance . . . excels anything in its price class. See your local distributor about when you can get an S-40.

**INSIDE STUFF:** Beneath the sleek exterior of the S-40 is a beautifully engineered chassis. One stage of tuned radio frequency amplification, the S-40 uses a type 6SA7 tube as converter mixer for best signal to noise ratio. RF coils are of the permeability adjusted "micro-set" type identical with those used in the most expensive Hallicrafters receivers. The high frequency oscillator is temperature compensated for maximum stability.

*From every angle the S-40 is an ideal receiver for all high frequency applications.*

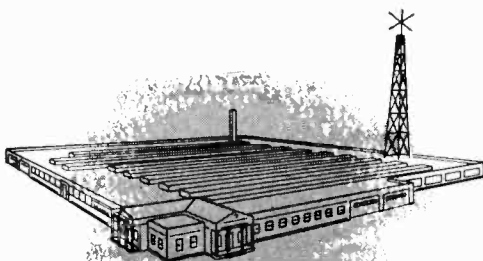

COPYRIGHT 1945 THE HALLICRAFTERS CO.

## hallicrafters RADIO

THE HALLICRAFTERS CO., MANUFACTURERS OF RADIO AND ELECTRONIC EQUIPMENT, CHICAGO 16, U. S. A.

Sole Hallicrafters Representatives in Canada: Rogers Majestic Limited, Toronto - Montreal



Proceedings of the I.R.E. February, 1946



# VARIABLE INDUCTORS

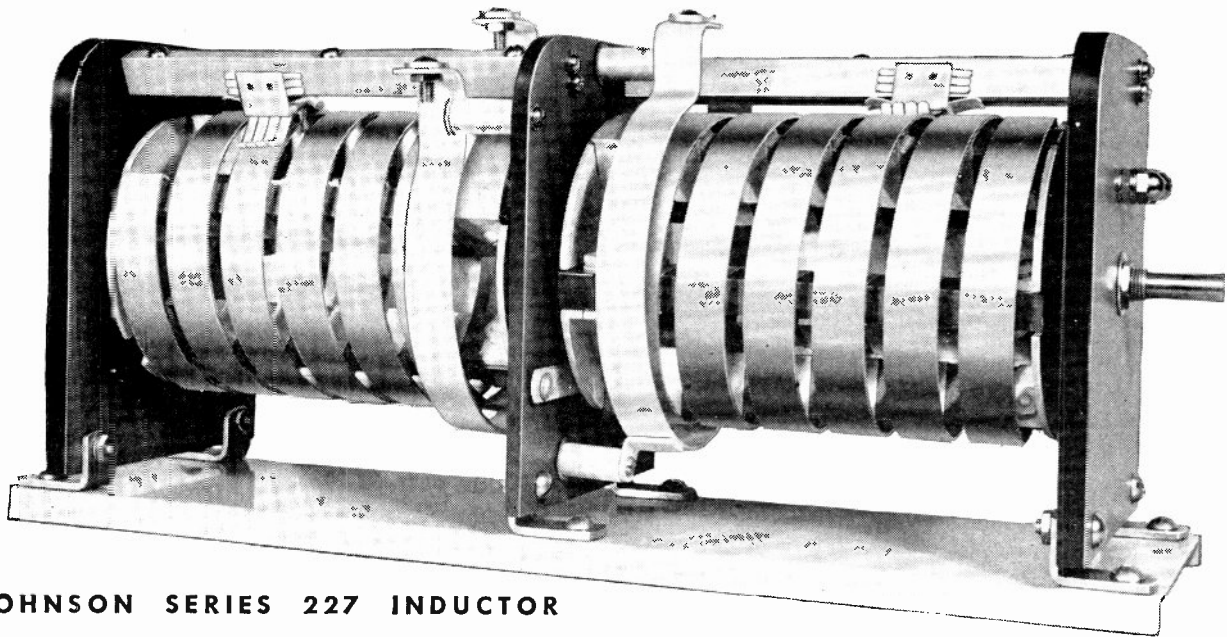

**JOHNSON SERIES 227 INDUCTOR**

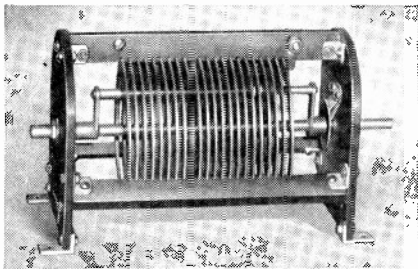

**SERIES 212**

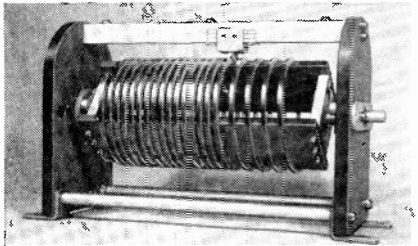

**SERIES 226**

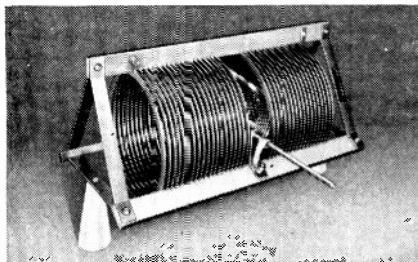

**SERIES 204**

**ELECTRONIC HEATING**—Designed for high current, the variable inductor shown above is especially adaptable for electronic heating installations. Available in single and dual models, with or without coupling links, the series 227 inductors are engineered to meet the rigid requirements of electronic heating circuits. Wound with heavy copper ribbon, conductor and contact surfaces may be heavily silver plated for minimum R.F. resistance. The dual model features counter-rotating coils, providing automatic balancing for push-pull circuits. Machined Mycalex is used for end frames and supporting bars. For lower power electronic heating applications the Johnson series 212 variable inductor, shown at left, is designed to give maximum efficiency. Conductor surfaces are of edge-wound copper strip, frames and supporting bars are of machined Mycalex.

**TRANSMITTERS**—The series 227 variable inductor shown above, is also engineered to meet demands of high-power transmitter tank designs, while the series 212 is recommended for applications at lower frequencies in medium power transmitters. The Johnson series 226 variable inductor is applicable for high-frequencies and for a wide frequency range by means of its variable pitch design. The Johnson series 204 inductor is widely used for tank coupling and other transmitter applications and can be supplied with either a variable coupling rotor or as a variometer.

**VARIABLE INDUCTORS**—Offer many important advantages to the electronic engineer and manufacturer. They provide close control and adjustment of fixed and limited frequency range circuits and allow the use of smaller, lower-cost, fixed capacitors. In series filters or networks where it is desired to simulate high-capacity, low-impedance conditions variable inductors again serve as desirable means of control.

Whether you need inductors for electronic heating equipment or transmitters, you will find Johnson's engineering and production facilities ready to meet your needs. Johnson fixed and variable inductors range in size from small, wire-wound units for oscillator and low-power stages to the large, high-power models where copper tubing acts as the conductor for both radio-frequency current and liquid for cooling.

**TUBE SOCKETS • VARIABLE CAPACITORS • INSULATORS • BROADCAST COMPONENTS**

*Write for Specific Information*

**JOHNSON**  
*a famous name in Radio*

**E. F. JOHNSON COMPANY • WASECA • MINNESOTA**

*Proceedings of the I.R.E. February, 1946*

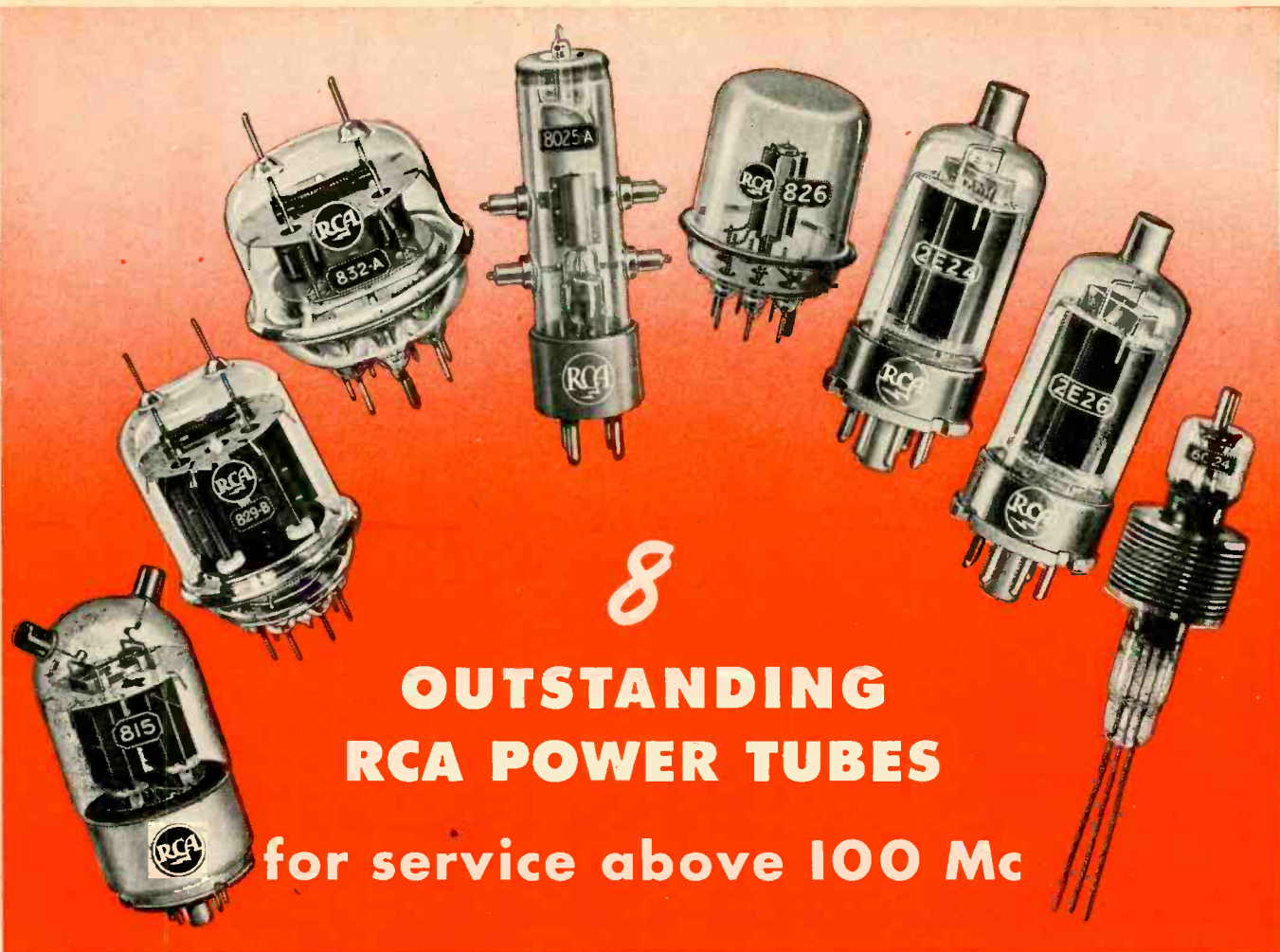

# 8 OUTSTANDING RCA POWER TUBES

for service above 100 Mc

Ideally suited to compact transmitter designs for emergency, aeronautical, and other upper-frequency applications

**TWIN BEAM-POWER TYPES:** The RCA 815, 829-B and 832-A push-pull beam-power tubes offer unusual compactness, combining high-power sensitivity with low plate-voltage requirements. Neutralization is seldom necessary.

**SINGLE BEAM-POWER TYPES:** The new RCA 2E24 is a quick-heating type for emergency stand-by service. Its sturdy *coated-type* filament reaches operating temperature in less than two seconds. The new RCA 2E26 is a slow-heating type particularly adaptable to FM transmitter designs.

**POWER TRIODES:** The RCA 826 and 8025-A triodes can be operated with unusual plate efficiency at frequencies as high as 250 and 500 Mc, respectively. Both tubes have a double-helical, center-tapped filament to minimize the effect of filament-lead

inductance. The 8025-A has double grid and plate connections that can be paralleled to reduce lead inductance. The new RCA-6C24 high-power triode employs forced-air cooling. Its relatively small size, center-tapped filament, and low inter-electrode capacitances account for its exceptional high-frequency performance.

RCA tube application engineers are ready to consult with you on any design problems you may have involving these or other RCA Electron Tubes. If you wish their services, or additional technical data on these tube types, write to RCA, Commercial Engineering Department, Section D-18E, Harrison, N. J.

COMPARATIVE TECHNICAL DATA (Plate-Modulated Class C Telephony)					
Tube Type No.	Plate Input Watts	Driving Power at Tube	Max. Rating Freq. Mc.	Plate Volts	List Price
2E24	ICAS 27	0.2	125	500	\$3.50
2E26	ICAS 27	0.2	125	500	3.20
6C24	CCS 1000	75.0	160	2500	45.00
815	ICAS 60	0.2	125	400	4.50
826	CCS 75	6.5	250	800	12.00
829-B	CCS 90	1.0	200	425	17.00
832-A	CCS 22	0.2	200	425	13.00
8025-A	ICAS 33	1.5	500	800	11.00

The Fountainhead of Modern Tube Development is RCA



**TUBE DIVISION**  
**RADIO CORPORATION of AMERICA**  
HARRISON, N. J.



BOARD OF DIRECTORS, 1946

Frederick B. Llewellyn  
*President*

Edmond M. Deloraine  
*Vice-President*

William C. White  
*Treasurer*

Haraden Pratt  
*Secretary*

Alfred N. Goldsmith  
*Editor*

Hubert M. Turner  
*Senior Past President*

William L. Everitt  
*Junior Past President*

1944-1946

Raymond F. Guy  
Lawrence C. F. Horle

1945-1947

Stuart L. Bailey  
Keith Henney  
Benjamin E. Shackelford

1946-1948

Walter R. G. Baker  
Virgil M. Graham  
Donald B. Sinclair

1946

Ralph A. Hackbusch  
Frederick R. Lack  
George T. Royden  
William O. Swinyard  
Wilbur L. Webb  
Edward M. Webster

Harold R. Zeamans  
*General Counsel*

George W. Bailey  
*Executive Secretary*

William H. Crew  
*Assistant Secretary*

BOARD OF EDITORS

Alfred N. Goldsmith  
*Editor*

PAPERS COMMITTEE

Frederick B. Llewellyn  
*Chairman*

PAPERS PROCUREMENT COMMITTEE

Dorman D. Israel  
*General Chairman*

Edward T. Dickey  
*Vice General Chairman*

# Proceedings

## of the I·R·E

*Published Monthly by*

The Institute of Radio Engineers, Inc.

VOLUME 34

February, 1946

NUMBER 2

Society's Hopes for the Engineer.....	Haraden Pratt	48 P
Transmission of Television Sound on the Picture Carrier.....	Gordon L. Fredendall, Kurt Schlesinger, and A. C. Schroeder	49 P
Radio-Frequency Resistors as Uniform Transmission Lines.....	D. Rogers Crosby and Carol H. Pennypacker	62 P
An Analysis of Three Self-Balancing Phase Inverters.....	Myron S. Wheeler	67 P
Pulse Response of Thyatron Grid-Control Circuits.....	C. Herbert Gleason and Carl Beckman	71 P
The Steady-State Operational Calculus.....	D. L. Waidelich	78 P
Antinoise Characteristics of Differential Microphones.....	Harold E. Ellithorn and A. M. Wiggins	84 P
Discussion on "Exalted-Carrier Amplitude- and Phase-Modulation Reception," by Murray G. Crosby.....	A. H. Taylor and Murray G. Crosby	90 P
Correspondence:		
" 'Historic First' Electronic Lecture".....	Lloyd Espenschied	91 P
"Phase-Inverter Circuit," by D. L. Drukey..	C. B. Fisher and D. L. Drukey	92 P
" Asymmetrical Butterfly Circuit".....	A. Landman	92 P
Contributors to the PROCEEDINGS.....		93 P
Advertising Index.....		86 A

WAVES AND ELECTRONS follows after page 94 P.

EDITORIAL DEPARTMENT

Helen M. Stote  
*Publications Manager*

Ray D. Rettenmeyer  
*Technical Editor*

Winifred Carrière  
*Assistant Editor*

William C. Copp  
*Advertising Manager*

Lillian Petranek  
*Assistant Advertising Manager*

Responsibility for the contents of papers published in the PROCEEDINGS rests upon the authors. Statements made in papers are not binding on the Institute or its members.



Changes of address (with advance notice of fifteen days) and communications regarding subscriptions and payments should be mailed to the Secretary of the Institute, at 450 Ahnaip St., Menasha, Wisconsin or 330 West 42nd Street, New York 18, N. Y. All rights of republication, including translation into foreign languages, are reserved by the Institute. Abstracts of papers, with mention of their source, may be printed. Requests for republication privileges should be addressed to The Institute of Radio Engineers.

Copyright, 1946, by The Institute of Radio Engineers, Inc.

Like other human institutions, engineering is in a process of continuous evolution. One fundamentally important broadening of the scope, opportunities, and obligations of the engineer is forcefully presented in the following editorial by the Secretary of the Institute (who, it may be mentioned, is himself an outstanding instance of the successful blending and performance in an individual of the functions of the technologist and the industrialist).—*The Editor*.

## Society's Hopes for the Engineer

HARADEN PRATT

Never before have business and industry been so alerted to the importance of technical research and development. This consciousness now even extends into the body politic generally. The daily papers and most popular magazines found in every home have taken up the theme and dwell upon the wondrous achievements recently made in weapons, machines, and basic science applications. We read about the coming industrial revolution and the effects that it will have on the methods of living with its new materials, advanced manufacturing processes, easy communications, and spectacular means of transport.

All of this rehearsing and speculation is conditioning the people to the realization that we must advance technically or be left behind in the future world. They are being taught that a nation not adequately sponsoring basic research and technical development will become a back number and eventually be at the mercy of the others. But to be successful such a nation must maintain an adequate educational system whereby it can produce the trained people required, a free and encouraging atmosphere in which they can work, a universal exchange of technical information, suitable incentives without which best effort cannot be achieved, and a broadened point of view, both by and towards the engineer.

An industry, just as a nation, can no longer blunder ahead successfully leaving the technological aspects to chance. It must plan carefully. It cannot proceed far with such plans without expert technical guidance. Forward-looking business administrators will be driven to seek out technically informed persons to become active if not leading elements of their directing organizations.

The new awareness of the indispensability of the technical man featuring this postwar era and the now generally prevalent public enthusiasm of expectation create a serious challenge to our engineering profession because it will be the engineer who must become acquainted with the reservoir of scientific knowledge, appraise it in the light of the needs of the life of the people, and then, by judicious interpretation, develop the useful applications. The engineer must better fit himself to meet this obligation and it is to this new opportunity and its problems that I wish to call particular attention.

The experience of the technically trained man gained in the molding together of the tangible and intangible provides him with a unique point of view which is urgently needed to complement the thinking of legislators and the pioneers of enterprises. Too few engineers realize this broadened role into which they must expand. They must themselves take advantage of the occasion to reorient their objectives and recognize that the highest attainment in their profession is to become masters of the fundamentals and facts of science and at the same time to discern the cry of the people and minister to their wants. They must themselves take the lead in enlarging the engineer's scope and educate themselves to fit it, thereby not only contributing to their own success but ensuring the better fulfillment of their proper function in the society of today and tomorrow.



# Transmission of Television Sound on the Picture Carrier\*

GORDON L. FREDENDALL†, ASSOCIATE, I.R.E., KURT SCHLESINGER‡, ASSOCIATE, I.R.E.,  
AND A. C. SCHROEDER‡, ASSOCIATE, I.R.E.

*Summary*—Several pulse methods for the transmission of television sound on the picture carrier during the line-blanking intervals are analyzed from the points of view of signal-to-noise ratio, audio fidelity, and transmitter and receiver design.

The advantages of duplex transmission are: (1) elimination of a separate sound transmitter; (2) elimination of the ambiguity and difficulty which may occur when a standard frequency-modulated sound signal is tuned in; (3) freedom of the audio output from the type of distortion which occurs in frequency-modulated receivers as a consequence of excessive drift of the frequency of the local oscillator; and (4) improvement of the phase characteristic of the picture intermediate-frequency amplifier resulting from elimination of trap circuits.

The highest audio-modulation frequency in duplex systems must not exceed one half of the line-scanning frequency. This is a disadvantage under the present television standards which specify a line frequency of 15,750 cycles per second.

With the exception of pulsed frequency modulation, the signal-to-noise ratios of sound in duplex systems are not so great as the ratio offered by the transmission of a standard frequency-modulated carrier. The comparison is subject to the condition that the amplitude of the frequency-modulated carrier is 0.7 of the peak amplitude of the duplex carrier. The signal-to-noise ratio of a pulsed frequency-modulated signal may equal the ratio of a standard frequency-modulated signal up to a critical distance from the transmitter, but is less at greater distance.

## INTRODUCTION

FROM TIME to time, proposals have been made that the sound accompaniment for television may be transmitted by a modulation of the picture carrier during the line-blanking intervals when no picture detail is transmitted. Improved reception of picture and sound, decreased investment in receivers and transmitters, and greater channel width for the picture signal are mentioned as possibilities of a "duplex" transmission of picture and sound. The purpose of this paper is to assist engineers in their evaluation of duplex transmission as a practicable system by offering an analysis of several methods of duplexing.

A review of the method of sound transmission and reception in use is helpful as a setting for the discussion. In the present arrangement, sound is transmitted by a frequency-modulated sound transmitter operating on a carrier frequency which is 4.5 megacycles above the picture carrier. At the position of the sound carrier, the recommended standards<sup>1</sup> state that the field strength of

the picture sidebands shall not exceed 0.0005 of the picture carrier. There is essentially nothing at the transmitting point to distinguish a television sound transmitter from a conventional frequency-modulation transmitter designed for operation in the frequency-modulation band. The sound receiver is likewise conventional and may share only the same heterodyne oscillator with the picture receiver.<sup>2</sup>

The picture transmitter is amplitude-modulated and radiates a wave form illustrated by Fig. 1. Picture content is transmitted during about 85 per cent of the total "time on the air." No picture detail is transmitted during the blanking intervals of the scanning tubes in the transmitter and receiver. Such "idle" intervals amount to about 15 per cent of the total time.

Proposals<sup>3,4</sup> for duplexing have been directed, therefore, toward the utilization of some part of the blanking interval for sound transmission. Thus the television transmitter would be converted into a picture-sound duplex transmitter which radiates picture intelligence during 85 per cent of the time and sound intelligence during some part of the remaining 15 per cent, using only one antenna and one radio-frequency power amplifier. There would be a synchronized electronic switch in the receiver for the opening of the sound channel to the video signal sometime during the blanking interval.

Factors which are involved in a comparison of duplex methods and the present method of continuous transmission of sound are the following: (1) audio fidelity; (2) signal-to-noise ratio; (3) amount of interaction between video and audio signals; (4) permanency of receiver alignment; (5) picture quality; (6) ease of receiver tuning; (7) cost of receiver; (8) cost of transmitter.

Certain advantages and disadvantages of a duplex system may be predicted in advance of a theoretical and experimental analysis. First, there is no separate sound transmitter and antenna. This economic advantage can not be accorded much weight unless there is a resultant economy in the television receiver because the ratio of receivers to transmitters is so great that the economics

<sup>2</sup> In some designs, the sound and picture signals are amplified at intermediate frequency in one or more common stages before branching off into separate intermediate-frequency amplifiers occurs.

<sup>3</sup> H. E. Kallman, "Audio and video on a single carrier," *Electronics*, vol. 14, pp. 39-42; May, 1941.

<sup>4</sup> Numerous patents including: U. S. patents, No. 1,655,543, R. A. Heising; No. 1,887,237, J. L. Finch; No. 2,061,734, R. D. Kell; No. 2,083,245, H. Shore and J. N. Whittaker; No. 2,086,918, D. G. C. Luck; No. 2,089,639, A. V. Bedford; No. 2,227,108, H. A. Rosenstein; No. 2,257,562, H. Branson; No. 20,153, E. F. W. Alexanderson (reissue).

\* Decimal classification: R583. Original manuscript received by the Institute, July 3, 1945.

† RCA Laboratories, Princeton, N. J.

‡ Columbia Broadcasting System, New York, N. Y. Work covered in this paper was done while the author was a member of RCA Laboratories, Purdue University, Lafayette, Ind.

<sup>1</sup> Final report of the Radio Technical Planning Board.

of the receiver is the controlling factor.

A significant advantage of a duplex receiver is the freedom of the audio output from the type of distortion which occurs in frequency-modulation receivers as a consequence of excessive drift of the frequency of the local oscillator. Audio modulation is conveyed in a

(It may be anticipated that the signal-to-noise ratio with duplex sound would be unfavorable as a consequence of the reduced time for transmission of sound. This is a serious obstacle in some duplex systems. A further limitation is the imposition of a maximum audio frequency that may be transmitted without the intro-

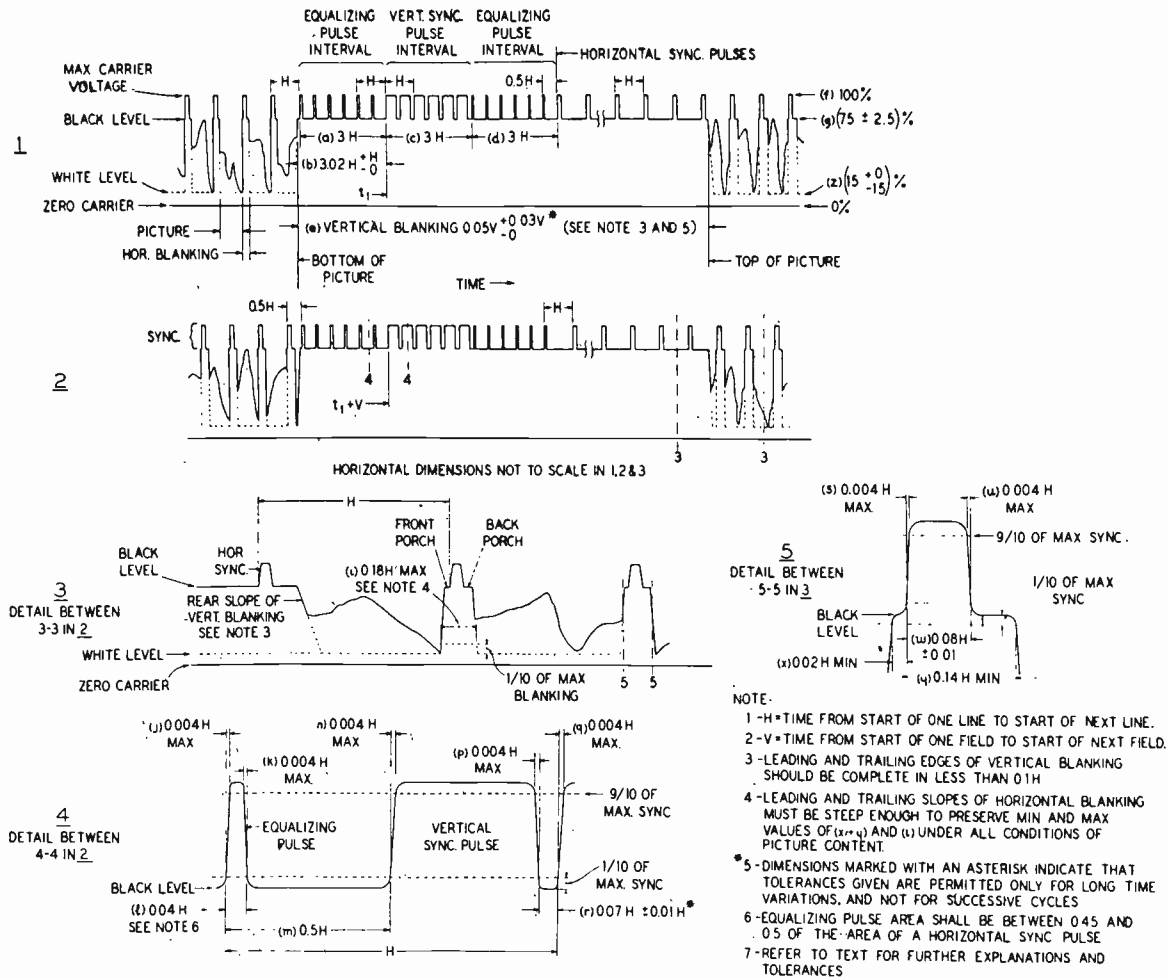

Fig. 1—Television synchronizing wave form.

duplex system by the envelope of a radio-frequency carrier and is relatively unaffected by instability of the local oscillator.

Sound-rejector circuits in the picture intermediate-frequency amplifier can be removed with a resulting reduction in phase distortion and some improvement in picture quality.

The ambiguity involved in tuning-in a conventional frequency-modulation signal is removed. In the present system a choice must be made of tuning for minimum interference in the picture or minimum noise in the sound in receivers which are somewhat misaligned.

There is also available a small extension of the video band into the space now assigned as a guard band for the sound; this amounts to about one quarter of a mega-

duction of spurious frequencies into the audio spectrum. This restriction has been noted before in pulse transmission of sound. Finally, there is the complication of synchronizing the electronic sound selector in the receiver with the line-scanning frequency.

### DUPLEX METHODS

#### 1. Amplitude-Modulated Pulses

One of the most obvious duplex systems is the modulation of the amplitude of a rectangular pulse wave in accordance with the audio signal and the insertion of the modulated pulses in the line-blanking interval of the video signal. Fig. 2 illustrates the successive steps at the transmitter. The pulse wave form shown in (A) of Fig. 2 is amplitude modulated by the audio signal  $M(t)$ , as



illustrated in (B). In (C) the modulated pulses have been inserted in the part of the blanking interval following the synchronizing pulse. Such a composite wave would be applied as modulation of the picture carrier.

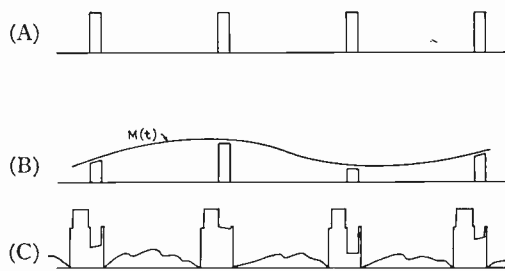

Fig. 2—Amplitude-modulated duplex wave forms.

(A) pulse carrier  
(B) audio wave form  $M(t)$  and amplitude-modulated pulse carrier  
(C) amplitude-modulated pulses combined with television wave form

If it is granted that the synchronized electronic switch in the receiver is able to select the pulses from blanking so that the pulse wave in Fig. 2(B) is recovered, the audio fidelity of the duplex system can be found from the solution for the frequency components of (B). An analysis shows that the spectrum consists of the applied audio-modulation frequency  $f_0$  and a large number of sidebands  $(f_c \pm f_0)$ ,  $(2f_c \pm f_0)$ ,  $(3f_c \pm f_0) \dots (nf_c \pm f_0)$  in which  $f_c$  is the fundamental frequency (line frequency) of the pulse wave.<sup>5</sup> The amplitude of each group obeys the damped sine-wave law  $\sin n\pi r/n$  where  $n$  is the order of the sideband and  $r$  is the ratio of the width of the pulse to the fundamental period. In a television application,  $r$  could not exceed about 0.06 and hence the amplitude factor,  $\sin n\pi r/n$  changes slowly. When  $f_0$  exceeds  $1/2 f_c$ , there is overlapping of the first-order lower sideband and the audio-frequency component, as well as general overlapping of adjacent sidebands of higher order. We do not have knowledge of any detector whereby an undistorted audio signal can be recovered from this multiplicity of overlapping sidebands. However, if the frequency of the audio modulation is restricted by a low-pass filter at the transmitter to less than one half the fundamental pulse frequency, this confusion is avoided. A similar filter must be installed in the receiver for the rejection of frequencies above  $f_c/2$ . Such a low-pass filter in the receiver functions as a distortionless detector of the audio modulation. Therefore, the theoretical upper limit of the audio bandwidth is equal to one half of line frequency, or 7875 cycles with the present standards.

Vertically scanned pictures would allow a greater maximum audio frequency of  $4/3 \times 7875$ , or 10,500 cycles.<sup>6</sup> However, it has been observed in laboratory tests that moving subjects scanned vertically with an interlaced pattern do not, in general, reproduce with as

much detail as horizontally scanned subjects. This is due, probably, to the predominance of horizontal motion in average subject matter. Hence, it appears that vertical scanning must be rejected as a means of increasing the maximum audio frequency.

The most promising way of increasing the upper audio limit in a monochrome system is an increase in the video bandwidth. The two quantities are related by the formula<sup>7</sup>

$$f_a = K_1 \sqrt{f_v} \quad (1)$$

in which

$f_a$  = maximum audio frequency

$f_v$  = video bandwidth

$K_1$  = a constant.

Fig. 3 shows the correlation between sound band, video band, and number of lines for monochrome and color transmissions. The latter is assumed to be a sequential tricolor system with an interlace ratio of 2:1 and a color-field frequency of 120 cycles.<sup>8</sup> For a given video bandwidth, the quality of duplex sound in terms

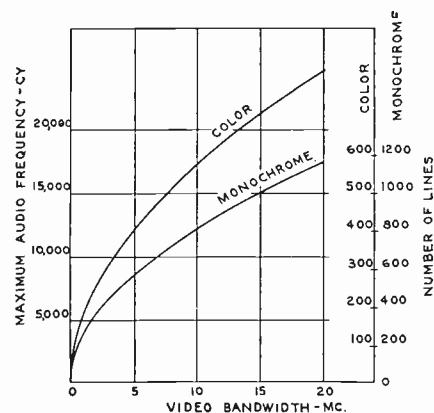

Fig. 3—Maximum audio frequency versus video bandwidth and number of lines.

of audio bandwidth may be made 1.4 times better for color than for monochrome television. Thus, high-fidelity sound (11,000 cycles) may be duplexed along with a color picture of about 360 lines over a video channel of 4 megacycles, while a monochrome picture of 525 lines, which occupies the same video band, accommodates only about 7800 cycles. A maximum audio frequency of 11,000 cycles would require over 700 lines in a monochrome system.

The corresponding radio-frequency channel in all cases is approximately 30 per cent greater than the video bandwidth as a consequence of the additional space required by the vestigial sideband.

A proposal for sound transmission has been disclosed which removes the limitation on the maximum audio frequency of one-half line frequency.<sup>9</sup> In effect, the

<sup>5</sup> Appendix I.

<sup>6</sup> The line frequency in a vertical scanning system is  $4/3$  the line frequency of the standard horizontal scanning system with an aspect ratio of 4 to 3.

<sup>7</sup> Appendix II.

<sup>8</sup> P. C. Goldmark, J. N. Dyer, E. R. Piore, and J. M. Hollywood, "Color television," Proc. I.R.E., vol. 30, pp. 162-182; April, 1942.

<sup>9</sup> A. V. Bedford, U. S. Patent No. 2,089,639.

system provides for the modulation of a rectangular pulse carrier of two times line frequency and the subsequent delay of alternate pulses to a time position which permits transmission of pairs of pulses during horizontal blanking time. At the receiving point, the previously undelayed pulses are delayed before detection, thus restoring the modulated pulse signal to its original form as a wave of double line frequency. The maximum audio frequency has thereby been increased to line frequency. This system, however, does not appear to be economically feasible from the point of view of receiver design at the present time.

Success or failure of a method of transmission often rests on the degree of immunity to noise. The signal-to-noise ratios appearing in Table I provide a direct com-

parison of signal-to-noise ratio, is a constant-amplitude pulse system wherein the width of a pulse is proportional to the amplitude of the audio signal. Two examples of width-modulated signals are illustrated in Fig. 4(B) and (C). In type (1), a dissymmetrical modulation, the leading edges of the pulses occur periodically, but the widths are proportional to the instantaneous

TABLE I  
SIGNAL-TO-NOISE RATIOS (root-mean-square)

Method of Transmission	(1) Signal-to-Noise	(2) Signal-to-Noise (Critical)	(3) Signal-to-Noise $P/N = K/d^2$	(4) Signal-to-Noise $P/N = K/d^2$	(5) Signal-to-Noise (Critical)
Standard Amplitude Modulation	$\frac{2P}{\sqrt{f_a} N}$	None	$\frac{2}{\sqrt{f_a}} \frac{K}{d^2}$	$0.023 \frac{K}{d^2}$	None
Standard Frequency Modulation	$\frac{\sqrt{3} f_d P}{f_a^{3/2} N}$	$\sqrt{b} \left(\frac{f_d}{f_a}\right)^{3/2}$	$\frac{\sqrt{3} f_d K}{f_a^{3/2} d^2}$	$\frac{f_d = 150 \text{ kilocycles}}{0.417} \frac{K}{d^2}$	$\frac{f_d = 150 \text{ kilocycles}}{217}$
Amplitude-Modulated Pulses	$\frac{3 \sqrt{2} \sqrt{r} P}{4 \sqrt{f_a} N}$	None	$\frac{3 \sqrt{2} \sqrt{r} K}{4 \sqrt{f_a} d^2}$	$0.003 \frac{K}{d^2}$	None
Symmetrical Width-Modulated Pulses	$\frac{3w P}{2t_s \sqrt{f_v} N}$	$\frac{4w}{t_s}$	$\frac{3w K}{2t_s \sqrt{f_v} d^2}$	$0.012 \frac{K}{d^2}$	62
Dissymmetrical Width-Modulated Pulses	$\frac{3w P}{2 t_s \sqrt{f_v} N}$	$\frac{4 \sqrt{2} w}{t_s}$	$\frac{3w K}{\sqrt{2} t_s \sqrt{f_v} d^2}$	$0.016 \frac{K}{d^2}$	87
Pulses of Frequency Modulation	$\frac{3 \sqrt{6} \sqrt{r} f_d P}{8f_a^{3/2} N}$	$\sqrt{6} \sqrt{r} \left(\frac{f_d}{f_a}\right)^{3/2}$	$\frac{3 \sqrt{6} \sqrt{r} f_d K}{8f_a^{3/2} d^2}$	$\frac{f_d = 150 \text{ kilocycles}}{0.052} \frac{K}{d^2}$	$\frac{f_d = 150 \text{ kilocycles}}{107}$
Pulses of Frequency Modulation	$\frac{3 \sqrt{6} \sqrt{r} f_d P}{8f_a^{3/2} N}$	$\sqrt{6} \sqrt{r} \left(\frac{f_d}{f_a}\right)^{3/2}$	$\frac{3 \sqrt{6} \sqrt{r} f_d K}{8f_a^{3/2} d^2}$	$\frac{f_d = 1200 \text{ kilocycles}}{0.417} \frac{K}{d^2}$	$\frac{f_d = 1200 \text{ kilocycles}}{2420}$

The signal-to-noise formulas in columns (1), (3), and (4) of the table for standard frequency modulation, width-modulated pulses, and pulses of frequency modulation during postblanking, are valid only for ratios higher than the critical ratio since the formulas are derived with the assumption that noise limiting is effective. Thus it may appear, with only a casual reading of the table, that the ratio is always the same for standard frequency modulation and pulses of frequency modulation  $f_d = 1200$  kilocycles. The fact is that the two types of transmission yield equal signal-to-noise ratios only when the critical ratio for pulses of frequency modulation is exceeded. At greater distances from the transmitter standard frequency modulation is superior.

Values of constants:  $f_a = 7500$  cycles per second;  $r = 0.06$ ;  $w/t_s = 15.4$ ;  $f_v = 4 \times 10^6$  cycles per second.

parison of amplitude-modulation pulse transmission and other systems. Comments on the significance of the ratios, and the bearing on modulated pulses as an audio service for television are made later. It is clear that the amplitude-modulation pulses suffer a disadvantage in that superimposed noise cannot be reduced by amplitude limiting to the extent possible in certain other systems.

2. Width-Modulated Rectangular Pulses

A more promising form of pulse modulation, from the

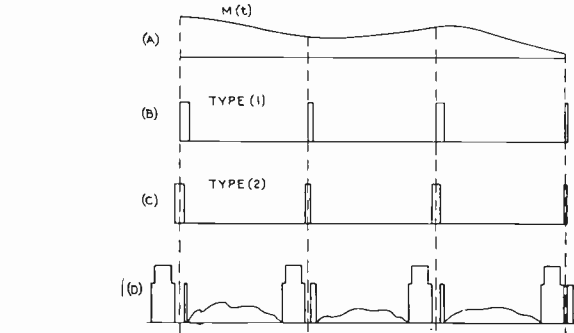

Fig. 4—Width-modulated duplex wave forms.

- (A) audio modulation  $M(t)$
- (B) pulse carrier dissymmetrically width-modulated by  $M(t)$ —type (1)
- (C) pulse carrier symmetrically width-modulated by  $M(t)$ —type (2)
- (D) combination of type (2) and television wave form

amplitude of the audio signal  $M(t)$  at the instant of the leading edge; that is, only the trailing edge is "modulated." Type (2) is a symmetrical modulation, the width of a pulse being proportional to the instantaneous amplitude at the instant corresponding to the center line of the unmodulated pulse. The center lines are periodically spaced; thus, both leading and trailing edges of type (2) are modulated. Such pulse waves may be inverted in polarity and combined with the standard television wave form as shown in Fig. 4(D) for type (2) modulation. Any amplitude variation of the pulse due to noise may be removed by limiting in the receiver following separation of the pulse from the video signal if the peak noise does not exceed one half of the pulse amplitude.

Equation (28) in Appendix III is the expression for a pulse wave width-modulated in the symmetrical manner (type 2) by a sine wave. The similarity to standard frequency modulation is noticeable in the sequence of sidebands which are generated. Thus when a pulse carrier of fundamental frequency  $f_c$  is width-modulated at a rate of  $f_0$  cycles per second, the resultant wave contains component frequencies  $f_c, (f_c + f_0), (f_c - f_0), (f_c + 2f_0), (f_c - 2f_0),$  etc., as well as corresponding sidebands for each harmonic of the fundamental  $f_c$ ; namely  $2f_c, (2f_c + f_0), (2f_c - f_0), (2f_c + 2f_0), (2f_c - 2f_0),$  etc. In addition, the frequency terms containing only the modulating frequency  $f_0$  and its harmonics  $2f_0, 3f_0,$  etc. appear. The general term is  $(Mf_c \pm Nf_0)$  where  $M$  and  $N$  are positive integers or zero.

Since overlapping of  $f_0$  and the sideband  $(f_c - f_0)$  must be prevented, the modulating frequency should not exceed  $f_c/2$ . At the receiving end, the modulated pulse-signal may be applied to a low-pass filter which rejects all sidebands and harmonics exceeding one half the



frequency of the fundamental  $f_c$ . However, all distortion terms are not thereby excluded; harmonics of  $f_0$  and the sidebands of higher order  $(f_c - 2f_0)$ ,  $(f_c - 3f_0)$ , may fall within the pass band. The magnitudes of the most important distortion terms in (28) have been plotted in Fig. 5. The modulation constant  $\alpha$  was taken equal to 1, the value corresponding to maximum modulation. A value of 3 per cent was assigned to  $w$ , the unmodulated pulse width. Therefore, the widths of the pulses in the modulated wave vary from 0 to 6 per cent of the period of the carrier. This is substantially the maximum varia-

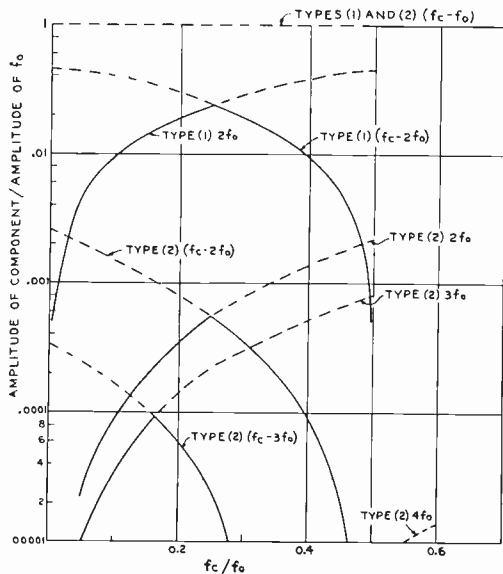

Fig 5—Frequency components resulting from width modulation of a pulse carrier wave by a sine wave.

Type (1) = dissymmetrical modulation  
 Type (2) = symmetrical modulation  
 $f_c$  = pulse frequency  
 $f_0$  = modulating frequency

tion under the specifications given for the television synchronizing wave form (Fig. 1). The broken-line portion of a curve indicates the range of the component which is suppressed by the low-pass filter in the receiver. Thus the component  $(f_c - 2f_0)$  is suppressed for the range  $f_0 < f_c/4$  but is transmitted when  $f_0 > f_c/4$ . In a reverse manner the component  $2f_0$  is transmitted when  $f_0 < f_c/4$  and suppressed when  $f_0 > f_c/4$ . The maximum value attained by either component is approximately 0.05 per cent of the amplitude of the audio component  $f_0$ .

An analysis of a dissymmetrical width-modulated pulse wave (Appendix III, equation (31)) displays the same general characteristics as the symmetrical modulation. Harmonics of the audio frequency, as well as numerous sidebands, are present, but the magnitudes shown in Fig. 5 are greater than in type (2) modulation. The largest contribution of any distortion term is 2.5 per cent.

Signal-to-noise ratios calculated according to the derivations in Appendix IV appear in Table I and Fig. 15.

Fig. 6(A) illustrates one method for the production of dissymmetrical width-modulated pulses. The starting

point is a wave of narrow triangular pulses (Fig. 6(B)) which is derived from driving pulses at line frequency normally generated by the synchronizing generator. To the triangular pulses is added the audio signal from which the frequency components higher than one half the line frequency have been removed by a low-pass filter. Limiter No. 1 removes the audio wave below the base line as shown in Fig. 6(B). The residue is greatly amplified and then acted upon by limiter No. 2, with the result that width-modulated pulses of substantially rectangular shape are produced. These are inserted in the line-blanking interval following the synchronizing pulse (postblanking). The standard field synchronizing pulse must be slotted down to black level during the

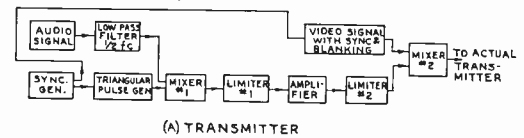

(A) TRANSMITTER

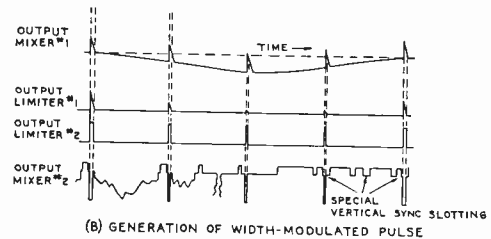

(B) GENERATION OF WIDTH-MODULATED PULSE

Fig 6—Width-modulated duplex-system transmitter.

line pulses, as shown in Fig. 6(B), in order that the width-modulated pulses when applied may extend to white level. The combined video signal is applied to the picture transmitter in the customary manner.

Fig. 7(A) illustrates the functional arrangement of the receiver. The selection of the width-modulated pulses

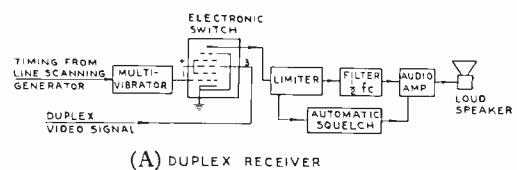

(A) DUPLEX RECEIVER

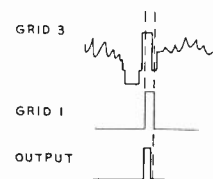

(B) OPERATION OF ELECTRONIC SWITCH

Fig 7—Width-modulated duplex system. Type (1) receiver.

from the video signal and rejection of picture components is performed by an electronic switch, usually a vacuum tube having two control grids. A keying pulse originating in a multivibrator which is synchronized by

the line-scanning circuit is impressed on grid 1 of the switch. The width and timing of the pulse is critical for the most favorable signal-to-noise ratio. The duplex video applied to grid 3 causes plate current to flow only when the tube is keyed on. In this way the width-modulated pulses are isolated.

Amplitude noise is removed by limiting if the peak noise does not exceed one half of the pulse amplitude but the variation of the pulse width due to noise is not removable. Such variation constitutes a width modulation and is reproduced as audible noise. When the synchronization of the receiver is impaired by noise, the timing of the switch is likewise affected, and parts of blanking and picture may be admitted into the audio amplifier and appear as noise in the loud speaker. There is a marked increase in the immunity of the system to noise if the receiver is synchronized by automatic frequency control.<sup>10</sup>

Audio components in excess of one-half line frequency are removed by a low-pass filter.

Additional kinescope blanking must be provided in the receiver since the duplex signal extends to white level during the sound pulse. In Fig. 7(A) blanking is derived from the multivibrator simultaneously with the keying pulses.

Means for excluding signal from the audio circuits when the receiver is not in synchronism is very desirable. Without such a device, video components are admitted to the audio system with an annoying audible result. A circuit may be devised which is sensitive to the changed character of the signal passed by the electronic switch during intervals of missynchronization and applies a bias beyond cutoff to the audio amplifier.

In September, 1943, television signals containing width-modulated pulses of the dissymmetrical type were transmitted by television station WNBT, and successfully received in Princeton, New Jersey, using the system outlined above.

### 3. Pulse Time Modulation

Another form of modulation known as "pulse time modulation" is related to width modulation.<sup>11</sup> In pulse time modulation the pulse amplitude and width remain constant, but the time interval between successive pulses is varied in accordance with the instantaneous amplitude of the audio signal and the rate of this variation corresponds to the instantaneous frequency of the signal. Such a pulse wave may be regarded as the sum of two width-modulated pulse waves of the dissymmetrical type of opposite polarities as illustrated in Fig. 17. The frequency components of the pulse time wave are therefore solvable from (31).

<sup>10</sup> K. R. Wendt and G. L. Fredendall, "Automatic frequency and phase control of synchronization in television receivers," *PROC. I.R.E.*, vol. 31, pp. 7-15; January, 1943.

<sup>11</sup> E. M. Deloraine and Emil Labin, "Pulse time modulation," *Elec. Commun.*, vol. 22, pp. 91-98; 1944.

### 4. Pulsed Frequency Modulation

In contrast with the foregoing duplex methods involving rectangular pulses for the transmission of sound during the line-blanking interval, there is a method which may be called "pulsed frequency modulation," that employs wave bursts of a frequency-modulated subcarrier for the same purpose. The bursts are generated at the transmitter by a sine-wave oscillator which is operative only during line blanking and is frequency modulated by the audio signal during this interval. The center frequency and deviation are chosen so that the essential sidebands lie within the video band. These subcarrier bursts are combined with the video wave form as modulation of either the line synchronizing pulses or the post-blanking (Fig. 8). From the point of view of signal-to-noise ratio, Fig. 8(B) is preferable. In either case, the composite signal is applied as amplitude modulation of the radio-frequency carrier.

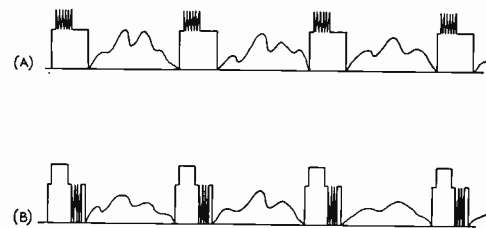

Fig. 8—Pulsed frequency-modulation duplex wave forms.

(A) in synchronizing pulse  
(B) in post blanking

In the receiver, the bursts are first isolated at the video level from the picture part of the composite wave, then amplitude limited for removal of noise, and finally applied to a conventional balanced frequency-modulation discriminator centered at the frequency of the subcarrier. The output of the discriminator is an amplitude-modulated pulse wave. The audio signal is derived from the pulse output of the discriminator by removing all components in excess of one-half line frequency with a low-pass filter.

As the result of experimental and theoretical work with pulsed frequency modulation, certain features of the technique were discovered which could escape a casual study. Such matters are treated in the following discussion.

*A. Transient response of pulsed frequency-modulated circuits:* If a pulsed frequency-modulated system is to function properly, the peak value of the detected pulses should depend solely on the instantaneous frequency of the subcarrier. This means that the various tuned circuits involved should complete their transients in a time which is short compared with the total duration of the wave burst. Fig. 9 shows the response of a simple tuned circuit to a wave burst of constant amplitude that starts and stops with zero phase and lasts  $T_p$  seconds. The circuit has a build-up time  $\tau$ , which may be adjusted by the damping resistor  $R$  and is correlated with the



bandwidth  $b$  in the form

$$\tau = 2RC = 1/\pi b. \tag{2}$$

The minimum bandwidth is determined by the time allowed for the transients. If these are to be complete within  $p$  percent of the pulse time,

$$b \geq \frac{100}{\pi p T_p}. \tag{3}$$

The total number  $n$  of cycles per pulse, as well as the number  $\Delta n$  occurring before the steady state is attained, are

$$n = T_p f_s \tag{4}$$

$$\Delta n = \tau f_s. \tag{5}$$

Equation (5) holds regardless of the subcarrier frequency  $f_s$ . The following set of constants is representative of a typical circuit designed for pulsed frequency-modulation operation:

Pulse time $T$	5 microseconds
Time of build-up $\tau$	0.5 microsecond
Circuit capacitance $C$	25 micromicrofarads
Circuit resistance $R$	10,000 ohms
Bandwidth $b$	400 kilocycles
Subcarrier frequency $f_s$	4 megacycles
$Q$ factor	10
Cycles per pulse $n$	20
$\Delta n$	2 cycles

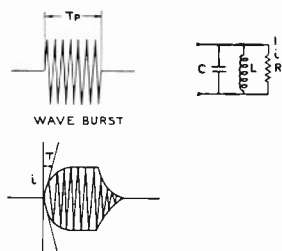

Fig. 9—Response of a tuned circuit to a pulse of frequency modulation.

*B. Generation of phasing of the subcarrier at the transmitter:* According to the calculation above, a total variation of no more than 2 subcarrier cycles is sufficient to produce peak modulation in the receiver. Hence it follows that the instantaneous wave forms of the subcarrier bursts must be closely similar at the beginning. Unless the initial phase of each burst is repeated with extreme accuracy, the otherwise random initial phases may introduce audible beat notes and noise in the detected signal.

In this connection, the keying of the subcarrier for part-time modulation presents a major problem. If an independent subcarrier oscillator supplying a continuous frequency-modulated wave is used, an electronic on-off switch controlled by the main synchronizing generator must be provided. This switch cuts into the

subcarrier and admits sections of its wave train for modulation of the synchronizing pulses (or blanking). It is obvious that the timing of this switch would have to be accurate within small fractions of one subcarrier cycle, or about 0.1 microsecond, in order that the initial phases of all pulses be substantially equal. The noise susceptibility of this method is high, because the subcarrier modulation is keyed on and off at full amplitude.

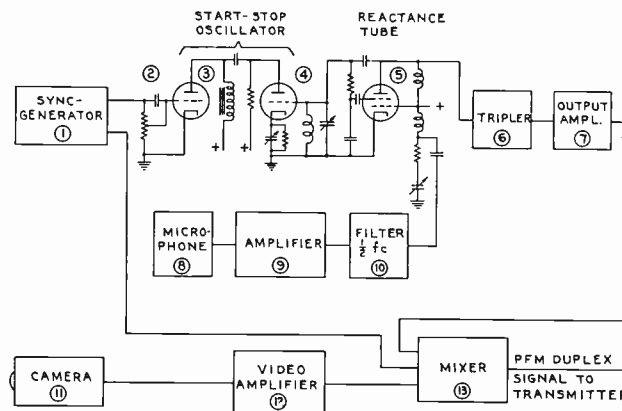

Fig. 10—Transmitter for pulsed frequency modulation.

The problem of precise keying is further aggravated by the fact that the repetition frequency of television pulses is not constant. In all practical television synchronizing generators, the line frequency is subjected to continuous frequency control so that it constitutes, at any instant, a definite multiple of the field frequency. The field frequency is synchronized with a 60-cycle power supply which is inherently variable around a well-defined average. As a result, beat notes of variable pitch are bound to occur if a subcarrier source with continuous frequency modulation and constant center frequency is subjected to keying from a synchronizing generator unless special precautions are taken.

In the system described below, such spurious signals have been effectively eliminated. A continuous subcarrier generator is not used; instead, the bursts are supplied from a start-stop oscillator which is switched on and off by the line blanking pulses. The start-stop subcarrier oscillator shown at (4) in Fig. 10 is active only when plate voltage is applied in the form of a pulse from the control tube (3). Pulses of appropriate wave shape at line frequency are derived directly from the synchronizing generator and impressed on the grid of the control tube. Hence throughout the line-scanning interval the subcarrier oscillator is inoperative, but at the end of each line it receives a plate-voltage pulse. As a result, subcarrier oscillations are built up with exactly the same initial phase conditions each time. Since the plate-power pulse is derived from the line-blanking pulse, it participates automatically in any variations of the line frequency. The power pulses may also be preshaped in such a manner that the plate supply ceases in time to allow

the subcarrier oscillations to decay within the allotted duration of sound transmission.

Fig. 11 illustrates the subcarrier burst without and with frequency modulation.

In Fig. 11(B), which shows a large number of frequency-modulated pulses in superposition, the first half of the wave burst is sharp while the wave trace appears increasingly blurred toward the end. This verifies the fact that the initial phase is substantially identical for all bursts regardless of the frequency modulation: that is, the pulse fronts are "coherent."

*C. Pulsed frequency-modulation transmitter:* Fig. 10 shows a possible arrangement of components in a pulsed frequency-modulation transmitter. The start-stop oscillator is coupled to a reactance tube (5) which is controlled continuously by the audio signal. A low-pass filter (10) with a cutoff at one half of the line frequency prevents the generation of overlapping sidebands of the

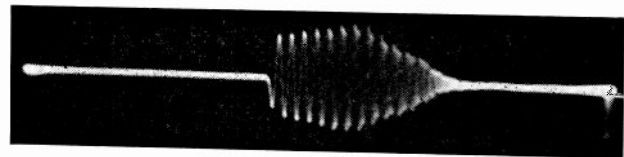

(A)

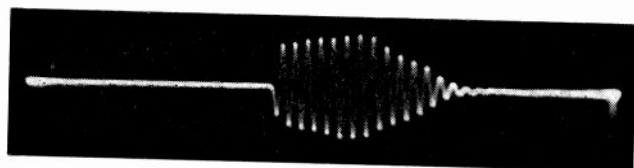

(B)

Fig. 11—(A) subcarrier burst  
(B) subcarrier burst, frequency-modulated

subcarrier that would interfere with audio fidelity. In an experimental transmitter, the master oscillator generated about 10 cycles at a frequency of 2 megacycles during each burst with a deviation of  $\pm 100$  kilocycles. At the output of the doubler stage (6) the center frequency becomes 4 megacycles and the deviation  $\pm 200$  kilocycles. The subcarrier burst is amplified and combined with the video signal at (13).

From the point of view of pulsed frequency modulation the field synchronizing pulse and the equalizing pulses interfere with the regular sequence of horizontal synchronizing pulses. Some modification of the standard television wave form (Fig. 1) is necessary to allow the transmission of wave bursts of constant duration. Interruptions in the sequence result in the generation of a narrow 60-cycle pulse that contains harmonics of 60 cycles extending throughout the audible spectrum.

If the bursts occur during postblanking (Fig. 8(B)) the field-synchronizing pulse may be slotted as in Fig. 6(B), but if the line-synchronizing pulses are modulated by the bursts, the modification shown in Fig. 12 is desirable. Here the slots  $S_1$  isolate the subcarrier bursts

from the field signal so that separation of the sound may take place in the receiver. The slots  $S_2$  act as equalizers for maintenance of interlacing. Fig. 13 shows the modified television wave form carrying pulsed frequency-modulation duplex on the line synchronizing.

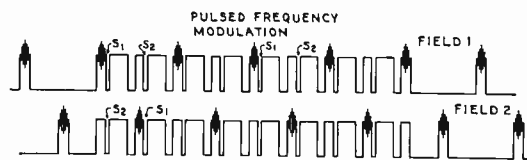

Fig. 12—Modification of television wave form for pulsed frequency modulation on line-synchronizing pulses.

*D. Pulsed frequency-modulation receiver:* A complete pulsed frequency-modulation receiver is shown in Fig. 14. Isolation of the frequency-modulation bursts (whether

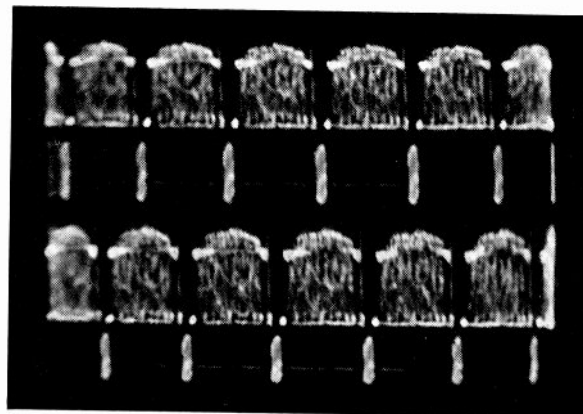

Fig. 13—Combined video signal and pulsed frequency modulation of line-synchronizing pulses.

in line-synchronizing pulses as in Fig. 8(A) or in post-blanking, as in Fig. 8(B)) is performed by a selector such as a tube with two control grids. The selector is biased off by a suitable pulse signal generated by a multivibrator which is synchronized from the line-

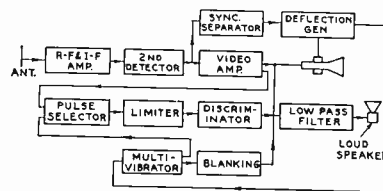

Fig. 14—Pulsed frequency-modulation receiver.

deflection generator or the line-synchronizing circuits of the video receiver. A limiter removes the amplitude noise to substantially the same extent as in conventional frequency-modulation systems. Demodulation of the bursts is accomplished in a conventional discriminator circuit centered at the subcarrier frequency. All audio components above a frequency of one-half line frequency are removed by a low-pass filter as in the other duplex

systems mentioned above. A locally generated blanking signal is required for biasing off the kinescope when the wave form of Fig. 8(B) is used.

#### SIGNAL-TO-NOISE RATIOS OF DUPLEX AND STANDARD SYSTEMS

Formulas for the signal-to-noise ratios of duplex and standard systems are derived in Appendix IV. A comparison of the various ratios requires the assumption of a numerical relationship between the amplitudes of the respective carriers.

The usual practice in television installations is to establish the amplitude  $S$  of the standard frequency-modulated sound carrier at about 0.7 of the peak amplitude  $P$  of the picture carrier. For convenience the ratio  $S/P$  will be taken as  $1/\sqrt{2}$ . When amplitude modulation was standard for sound transmission prior to the adoption of frequency modulation, the same ratio  $1/\sqrt{2}$  was customary.

The amplitudes in duplex transmission are fixed by the amplitude of the picture carrier.

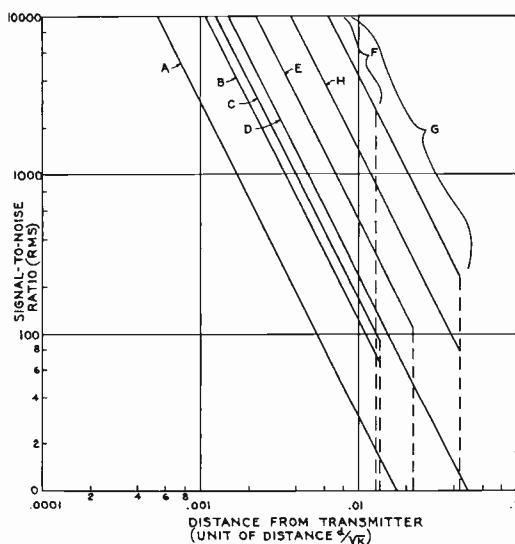

Fig. 15—Signal-to-noise ratios for sound transmission.  
 A = amplitude-modulated pulses  
 B = width-modulated pulses (symmetrical)  
 C = width-modulated pulses (dissymmetrical)  
 D = standard amplitude modulation  
 E = pulsed frequency modulation ( $f_d = 150$  kilocycles)  
 F = pulsed frequency modulation ( $f_d = 1200$  kilocycles)  
 G = standard frequency modulation ( $f_d = 150$  kilocycles)  
 H = standard frequency modulation ( $f_d = 50$  kilocycles; bandwidth = 150 kilocycles).

The unmodulated amplitude  $h$  of the amplitude-modulated pulse carrier is one half the amplitude of blanking. In the standard wave form (Fig. 1) blanking is three fourths of the peak amplitude of the picture carrier. Hence  $h$  may be taken as  $3P/8$ . The amplitude of the pulsed frequency-modulation signal during post-blanking is also  $3P/8$ . The amplitude  $H$  of width-modulated pulses is equal to the full amplitude of blanking or  $3P/4$ .

Column (1) of Table I lists the audio signal-to-noise

ratios for the various methods of transmission of sound in terms of  $P/N$  and other dimensions which are associated with a particular method.  $P$  is the amplitude of the picture carrier and  $N$  is the noise factor.

Column (2) lists the critical signal-to-noise ratios below which the formulas are no longer valid. This limit exists in the case of width-modulated pulses when the peak noise is higher than one half the pulse amplitude. There is no limit in standard amplitude modulation and amplitude-modulated pulses since limiting is not applied. The limit occurs in standard frequency modulation and pulsed frequency modulation when the peak amplitudes of noise and signal are equal.

If the noise is assumed to remain constant, the signal, and therefore the signal-to-noise ratio, varies with distance from the transmitter according to the law for the propagation of television signals. Hence  $P/N$  may be replaced by  $K/d^2$  as shown in column (3) where  $d$  is the distance from the transmitter and  $K$  is a proportionality constant. If the distance  $d$  exceeds the line-of-sight distance, a somewhat higher power of  $d$  would be appropriate.

Columns (4) and (5) show the forms taken by (2) and (3) when values are substituted.

Fig. 15 illustrates the variation of the signal-to-noise ratios with distance from the transmitter. Comparisons made of the various methods of sound transmission from Fig. 15 are necessarily on a relative basis since the unit of distance is  $d/\sqrt{K}$ .

Standard frequency modulation with a deviation of 150 kilocycles yields the most favorable signal-to-noise ratio within 0.044 units of distance. An equal ratio may be obtained over a more limited distance of 0.013 units with pulsed frequency modulation during postblanking if the maximum deviation is of the order of 1.2 megacycles. A greater deviation is required in pulsed frequency modulation for equality, because the audio signal which may be recovered from a pulsed-frequency-modulation wave is proportional to the pulse width, whereas the audio noise is proportional to the square root of the width.<sup>12</sup> The maximum distance from the transmitter at which limiting of a pulsed frequency-modulation signal is effective in removing noise (that is, the critical distance) is necessarily less because the noise voltage admitted to the receiver is greater as a consequence of the greater deviation.

Pulsed frequency modulation during postblanking with the customary deviation of 150 kilocycles is intermediate between standard amplitude modulation and standard frequency modulation.

Width-modulated pulses are intermediate between amplitude-modulation pulses and standard amplitude modulation.

Amplitude-modulated pulses rank lowest, largely as a consequence of not being susceptible to limiting.

<sup>12</sup> Appendix IV, equation (43).



## OTHER RECEIVER CONSIDERATIONS

A duplex receiver is "no better" than its sound pulse selector. Audible noise can be introduced into the audio system of a duplex receiver when portions of the video signal, representing picture, are selected along with the desired sound signal. This occurs when the accuracy of synchronization of the selector is reduced sufficiently by noise and interference. In this respect, the automatic frequency control of synchronization was found to be definitely superior to conventional triggered synchronization.<sup>10</sup> The flywheel effect of the automatic-frequency-control circuit tends to minimize the disturbing effect of noise on synchronization.

It appears that with automatic-frequency-control synchronization the major part of the total audible noise in a well-designed duplex system may be attributed to the inherent noise characteristics discussed in Appendix IV rather than to inaccurate selection of the sound signal.

The stability of duplex circuits was not studied, but it is clear that drifts in the values of circuit elements that affect the accuracy of sound selection would be detrimental.

An exhaustive study of the relative costs of a television receiver designed for duplex sound on a conventional receiver intended for reception of standard frequency modulation was not included in the scope of this project. However, an analysis of two experimental receivers constructed according to the arrangements in Figs. 7(A) and 14 indicates that the cost of a commercial duplex receiver is not likely to exceed that of a standard receiver.

## APPENDIX I

A rectangular-pulse wave of unit amplitude may be expressed as a cosine series

$$e(t) = r + \frac{2}{\pi} \left\{ \sin \pi r \cos \omega_c t + \frac{\sin 2\pi r}{2} \cos 2\omega_c t + \dots \right. \\ \left. + \frac{\sin n\pi r}{n} \cos n\omega_c t + \dots \right\} \\ \left\{ \begin{array}{l} \omega_c = 2\pi f_c \\ r = \text{pulse width per pulse period.} \end{array} \right. \quad (6)$$

Modulation of  $e(t)$  by an audio signal  $M(t)$  has the result

$$f(t) = [1 + M(t)]e(t)$$

$$\begin{array}{c} \left( \begin{array}{c} \text{original} \\ \text{unmodulated} \\ \text{pulse wave} \end{array} \right) \left( \begin{array}{c} \text{audio signal} \\ \text{diminished} \\ \text{by } r \end{array} \right) \left( \begin{array}{c} \text{sidebands of carrier} \\ \text{and its harmonics} \end{array} \right) \\ \downarrow \quad \downarrow \quad \downarrow \\ = e(t) + rM(t) + \sum_{n=1}^{\infty} \frac{2}{\pi} M(t) \frac{\sin n\pi r}{n} \cos n\omega_c t. \quad (7) \end{array}$$

## APPENDIX II

A well-known formula<sup>13</sup> expressing the video bandwidth required for equal horizontal and vertical resolution is

$$f_v = \frac{1}{2} KL^2 Na \quad (8)$$

in which

$f_v$  = video bandwidth

$L$  = number of scanning lines

$N$  = frame repetition rate

$a$  = aspect ratio

$K$  = experimental factor often taken equal to 0.6.

Since the maximum audio frequency  $f_a$  which may be transmitted by a pulse carrier is  $LN/2$ , the combination of this formula and (8) gives

$$f_a = \sqrt{\frac{f_v N}{2K_a}} = K_1 \sqrt{f_v} \quad (9)$$

Equation (9) should be regarded chiefly as an expression of proportionality between the quantities because the value of  $K$  depends upon the criterion for equal resolutions, which is not a precise concept.

## APPENDIX III

## FREQUENCY COMPONENTS RESULTING FROM SYMMETRICAL WIDTH MODULATION OF A RECTANGULAR-PULSE CARRIER BY A SINE WAVE

The problem is the calculation of the amplitude and frequency of each component in a rectangular-pulse carrier which is width-modulated in a symmetrical manner by a sine wave. The width of a pulse is proportional to the amplitude of the modulating wave at the instant corresponding to the center line of the pulse. Hence, the width  $a_p$  of the  $p$ th pulse is

$$a_p = w \left( 1 - \alpha \cos 2\pi p \frac{T_c}{T_o} \right) \quad (10)$$

in which

$w$  = width of unmodulated pulse

$T_c = 1/f_c$  = period of pulse wave

$T_o = 1/f_o$  = period of modulating wave

$\alpha$  = modulation factor.

In the general case, the modulated carrier wave will not repeat precisely at the end of each audio cycle, but after some time greater than the period  $T_o$  there will be repetition. Let this time be called  $T$  and the corresponding frequency,  $f$ . The equation of the modulated pulse wave may be deduced by regarding the wave as the summation of a large number of pulse waves of equal period  $T$ . Each component wave will be characterized by a certain pulse width which is constant for the particular component. Thus there is a wave starting at the origin and characterized by a pulse width  $a_0$ , a wave of

<sup>13</sup> R. D. Kell, A. V. Bedford, and M. A. Trainer, "An experimental television system, Part II. The transmitter," PROC. I.R.E., vol. 22, pp. 1246-1266; November, 1934.

width  $a_1$  and phase  $T_c$ , a wave of width  $a_2$  and phase  $2T_c$ , etc.

The  $p$ th wave has a width  $a_p$  and phase  $pT_c$ . There are  $(f_c T - 1)$  waves to sum. The equation of the  $p$ th wave is

$$e_p = \left[ \frac{a_p}{T} + \frac{2}{\pi} \sum_{n=1}^{\infty} \frac{\sin n\pi a_p f}{n} \cos 2\pi n f(t - pT_c) \right]. \quad (11)$$

A summation over  $p$  yields the equation of the modulated pulse wave.

$$e' = \sum_{p=0}^{f_c T - 1} \frac{a_p}{T} + \frac{2}{\pi} \sum_{p=0}^{f_c T - 1} \sum_{n=1}^{\infty} \frac{\sin n\pi a_p f}{n} \cos 2\pi n f(t - pT_c) \\ = e_{d.c.} + e. \quad (12)$$

Since the direct-current component is not of interest, it need not be considered further. If a certain frequency component of  $e$  is sought, the contributions of each of the  $p$  waves must be summed in the form

$$\frac{2}{\pi} \sum_{p=0}^{f_c T - 1} \frac{\sin n\pi a_p f}{n} \cos 2\pi n f(t - pT_c). \quad (13)$$

The amplitude of the component ( $fn$ ) is  $\sqrt{A_1^2 + B_1^2}$  in which

$$A_1 = \frac{2}{\pi} \sum_{p=0}^{f_c T - 1} \frac{\sin (n\pi a_p f)}{n} \cos 2\pi n p T_c \quad (14)$$

$$B_1 = \frac{2}{\pi} \sum_{p=0}^{f_c T - 1} \frac{\sin (n\pi a_p f)}{n} \sin 2\pi n p T_c. \quad (15)$$

The remainder of the derivation is devoted to an examination of  $A_1$  and  $B_1$ . It is expected that only certain values of  $n$  will lead to nonzero values for  $A_1$  and  $B_1$ . Before summation, the expression for  $a_p$  is inserted in  $A_1$  and  $B_1$ . There results

$$A_1 = \frac{2}{\pi} \sum_{p=0}^{f_c T - 1} \frac{1}{n} \sin [2n\pi f\epsilon(1 - \alpha \cos 2\pi T_c f_0 p)] \\ \cos 2\pi n p T_c \quad (16)$$

$$B_1 = \frac{2}{\pi} \sum_{p=0}^{f_c T - 1} \frac{1}{n} \sin [2n\pi f\epsilon(1 - \alpha \cos 2\pi T_c f_0 p)] \\ \sin 2\pi n p T_c. \quad (17)$$

Expansion of  $A_1$ , in terms of Bessel functions, yields

$$A_1 = \frac{2}{\pi} \sum_{p=0}^{f_c T - 1} \frac{1}{n} \left[ \cos R p \sin A \sum_{s(\text{even})=2}^{\infty} 2(-1)^{s/2} J_s(B) \cos sC_p \right. \\ \left. + J_0(B) + \cos R p \cos A \sum_{v(\text{odd})=1}^{\infty} 2(-1)^{(v+1)/2} J_v(B) \cos vC_p \right] \quad (18)$$

and

$$B_1 = \frac{2}{\pi} \sum_{p=0}^{f_c T - 1} \frac{1}{n} \left[ \sin R p \sin A \sum_{s(\text{even})=2}^{\infty} 2(-1)^{s/2} J_s(B) \cos sC_p + \sin R p \cos A \sum_{v(\text{odd})=1}^{\infty} 2(-1)^{(v+1)/2} J_v(B) \cos vC_p \right] \quad (19)$$

in which

$$\pi n f w = A \quad 2\pi T_c f_c = C \\ n\pi w \propto f = B \quad 2\pi f n T_c = R. \quad (20)$$

A typical term in  $A_1$  involving the summation over  $s$  is

$$\frac{4(-1)^{s/2}}{\pi n} J_s \sin A \sum_{p=0}^{f_c T - 1} \cos R p \cos sC p. \quad (21)$$

The expression

$$\sum_{p=0}^{f_c T - 1} \cos R p \cos sC p \quad (22)$$

is a finite trigonometric sum which is known to have the value

$$\frac{1}{2} \frac{\cos [(f_c T - 1)(R - sC)/2] \sin [f_c T(R - sC)/2]}{\sin [(R - sC)/2]} \\ + \frac{1}{2} \frac{\cos [(f_c T - 1)(R + sC)/2] \sin [f_c T(R + sC)/2]}{\sin [(R + sC)/2]}. \quad (23)$$

The above sum may be abbreviated

$$S = \frac{S_1}{2} + \frac{S_2}{2}. \quad (24)$$

If the expressions for  $R$  and  $C$  in (20) are introduced,  $S_1$  in (24) becomes

$$S_1 = \frac{\cos \pi [sT_c f_0 - nT_c f + n - sT f_0] \sin \pi [n - sT f_0]}{n \sin \pi (nT_c f - sT_c f_0)}. \quad (25)$$

If  $S_1$  is to have a nonzero solution, the denominator must be zero at least for some values of  $n$ . This follows from the observation that  $\sin \pi (n - sT f_0)$  is always zero. From inspection, it is seen that the denominator of (25) is zero when

$$n = \pm MT f_c + sT f_0 \quad (26)$$

in which  $M$  is the positive integer. When (26) is inserted in (25), the indeterminacy may be reduced to

$$S_1 = \frac{1}{sT_c f_0 \pm M}. \quad (27)$$

Similar reasoning leads to explicit forms for  $A_1$  and  $B_1$  in

(14) and (15). Finally, (12), for the modulated wave, may be written in the form

$N\sqrt{f_a}$  = peak amplitude of noise  
(= 4 × root-mean-square noise)<sup>14</sup>

$$e = \frac{2}{\pi} \sum_{M=0}^{\infty} \left[ \sum_{\nu=-\infty}^{\infty} \{J_{|\nu|}[\pi w \alpha (Mf_c + \nu f_0)]\} \frac{\sin [\pi w (Mf_c + \nu f_0) - |\nu| \pi/2]}{M + \nu f_0/f_c} \cos 2\pi (Mf_c + \nu f_0)t \right]. \quad (28)$$

FREQUENCY COMPONENTS RESULTING FROM  
DISSYMMETRICAL WIDTH MODULATION  
OF A RECTANGULAR-PULSE CARRIER  
BY A SINE WAVE

Crosby<sup>15</sup> and others have shown that

$$\left( \frac{\text{signal}}{\text{noise}} \right)_{\text{FM}} = \frac{\sqrt{3} f_d}{2f_a} \left( \frac{\text{signal}}{\text{noise}} \right)_{\text{AM}} \quad (33)$$

When each pulse of a symmetrically-modulated pulse carrier is translated to the right (or left) on the time axis by an amount equal to one half the width of the modulated pulse, the carrier becomes unsymmetrically modulated. Therefore (12) may be modified to read

in which  $f_d$  is 2 times frequency deviation. The amplitude of noise is assumed to be below the threshold value. From (32) and (33),

$$e' = \sum_{p=0}^{f_c T-1} \frac{a_p}{T} + \frac{2}{\pi} \sum_{p=0}^{f_c T-1} \sum_{n=1}^{\infty} \frac{\sin n\pi a_p f}{n} \cos 2\pi n f \left[ t - pT_c - \frac{a_p}{2} \right] \quad (29)$$

in which

$$a_p = w(1 - \alpha \cos 2\pi p T_c f_0). \quad (30)$$

A mathematical process similar to that outlined in Appendix II yields the result

$$\begin{aligned} e = & \sum_{v(\text{odd})=1}^{\infty} \frac{1}{\pi} (-1)^{(v+1)/2} \frac{J_v[2\pi w \alpha (Mf_c + \nu f_0)]}{M + \nu f_0/f_c} \cos 2\pi [(Mf_c + \nu f_0)(t - w)] \\ & + \sum_{v(\text{odd})=1}^{\infty} \frac{1}{\pi} (-1)^{(v+1)/2} \frac{J_v[2\pi w \alpha (Mf_c - \nu f_0)]}{M - \nu f_0/f_c} \cos 2\pi [(Mf_c - \nu f_0)(t - w)] \\ & + \frac{2}{\pi} \sum_{\xi} (-1)^{(p+\beta-2)/2} \frac{J_p[\pi w \alpha (Mf_c + \xi f_0)] J_{\beta}[2\pi \epsilon \alpha (M + \xi f_0)]}{M + \xi f_0/f_c} \sin 2\pi [(Mf_c + \xi f_0)(t - w)] \\ & + \frac{2}{M\pi} \sin (\pi M f_c w) \cos 2\pi f_c M (t - w/2) \end{aligned} \quad (31)$$

$$\xi = (\rho + \beta), (\rho - \beta), (-\rho + \beta), (-\rho - \beta)$$

$$\left( \frac{\text{signal}}{\text{noise}} \right)_{\text{FM}} = \frac{\sqrt{6} S \sqrt{f_a}}{N f_a} \sqrt{\frac{f_d}{f_a}}. \quad (34)$$

$\rho$  and  $\beta$  are odd positive integers.

Other symbols have the same significance previously assigned.

APPENDIX IV

SIGNAL-TO-NOISE RATIOS

1. Standard Amplitude Modulation and Standard Frequency Modulation

The root-mean-square signal-to-noise ratio for 100 per cent amplitude modulation is

$$\frac{S}{\sqrt{2}} \bigg/ \frac{N\sqrt{f_a}}{4} = 2\sqrt{2} \frac{S}{N\sqrt{f_a}} \quad (32)$$

in which

$S$  = unmodulated amplitude of carrier  
 $f_a$  = highest audio frequency

2. Amplitude-Modulated Pulses

In a 100 per cent amplitude-modulated pulse system the root-mean-square value of the audio signal detected by means of a low-pass filter in the receiver (see Appendix I) is

$$\frac{rh}{\sqrt{2}} \quad (35)$$

in which

$h$  = unmodulated height of the pulse

$r$  = ratio of pulse width to period of pulse carrier.

If the assumption is made that the pulse wave is applied to the detector (low-pass filter) only during the time of

<sup>14</sup> Vernon D. Landon, "The distribution of amplitude with time in fluctuation noise," PROC. I.R.E., vol. 29, pp. 50-55; February, 1941.

<sup>15</sup> Murray G. Crosby, "Frequency-modulation noise characteristics," PROC. I.R.E., vol. 25, pp. 472-517; April, 1937.



the pulses, the root-mean-square noise is

$$\sqrt{r} \frac{N\sqrt{f_a}}{4} \tag{36}$$

Hence

$$\left( \frac{\text{signal}}{\text{noise}} \right)_{\text{AM pulses}} = 2\sqrt{2} \frac{h\sqrt{r}}{N\sqrt{f_a}}$$

3. Width-Modulated Pulses

Before detection, the noisy signal is clipped, or limited, top and bottom so that only a comparatively narrow section near the center of each pulse is selected. Hence, it is assumed that noise effects are introduced into width-modulated pulses chiefly by the random displacement of the sides of the pulses.

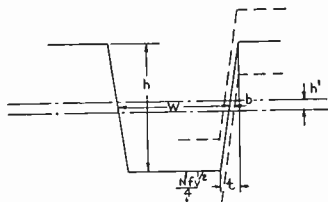

Fig. 16—Width-modulated pulses.

The following derivation applies when the peak noise is less than one half of the amplitude of the pulses. In Fig. 16, let

- $w$  = unmodulated width of pulse
- $H$  = height of pulse
- $t_s$  = time of rise of pulse side
- $b$  = displacement of side in seconds due to a root-mean-square noise voltage
- $f_v$  = video-frequency bandwidth.

Then the slope of the side of a pulse is

$$\frac{H}{t_s} = \frac{N\sqrt{f_v}}{4} / b \tag{37}$$

from which

$$b = \frac{N\sqrt{f_v}}{4} \frac{t_s}{H} \tag{38}$$

The audio signal recovered from the pulse wave, whether symmetrically or dissymmetrically modulated, is

$$\frac{CwH'}{\sqrt{2}} \tag{39}$$

In this expression,  $C$  is a proportional constant.  $H'$  is the new height of the pulse after the center section of the pulse has been selected out and the remainder rejected (as shown in Fig. 16). Amplitude due to the random displacement of one side of a pulse in dissymmetrical modulation is

$$CbH' \tag{40}$$

Hence the signal-to-noise ratio is

$$\frac{CwH'}{\sqrt{2}} / CbH' = \frac{2\sqrt{2} wH}{t_s N\sqrt{f_v}} \tag{41}$$

In symmetrical modulation, both sides of a pulse are subject to random displacement due to noise. The noise voltage given in (40) must therefore be multiplied by  $\sqrt{2}$ . The signal-to-noise ratio for symmetrical modulation is therefore

$$\frac{2wH}{t_s N\sqrt{f_v}} \tag{42}$$

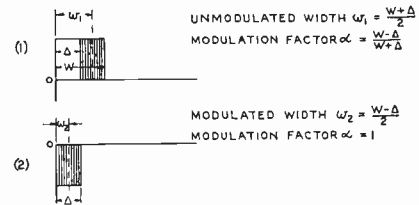

Fig. 17—Decomposition of a pulse time wave into width-modulated pulses (1) and (2) of the dissymmetrical type. Shaded lines intended to simulate an oscillogram.

4. Pulses of Frequency Modulation

The audio signal which may be recovered from a keyed frequency-modulated wave by means of a discriminator followed by a low-pass filter (Fig. 14) is proportional to the pulse width. However, the noise appearing in the audio output is proportional to the square root of the width. Hence

$$\left( \frac{\text{signal}}{\text{noise}} \right)_{\text{P-F-M}} = \sqrt{r} \left( \frac{\text{signal}}{\text{noise}} \right)_{\text{standard F-M}} \tag{43}$$

# Radio-Frequency Resistors as Uniform Transmission Lines\*

D. ROGERS CROSBY†, ASSOCIATE, I.R.E., AND CAROL H. PENNYPACKER‡

**Summary**—A theoretical study is made of the behavior of resistors, particularly the type where the resistance element is in the form of a film so there is negligible skin effect. When the electrical length of the resistor is a small fraction of a wavelength, it is shown that certain optimum proportions of the resistor exist in order best to terminate a radio-frequency transmission line.

## INTRODUCTION

THE THEORETICAL and experimental behavior of resistors employed as transmission lines has been discussed frequently.<sup>1,2</sup> The material presented here is largely in the form of curves intended to give an easily grasped perspective of the subject. These curves are also suitable for design purposes. The dimensionless parameters used in plotting these curves are thought to be particularly convenient for engineering use. The existence of certain optimum values of the parameters is shown.

This paper is an analysis of the classical transmission-line equations. We thus assume that the resistors employed as transmission lines are long compared to the diameter of the shields surrounding them, so that the current flowing in the short circuit at the far end has an electromagnetic field which is small compared to the total electromagnetic field surrounding the resistor. It is further assumed that the resistance per unit length is independent of frequency. This is substantially true in the film-type resistors used at radio frequencies, since the current penetration through the film is substantially complete for the usual resistance values. Particular attention has been given to the case where the resistor is intended to terminate or "match" a coaxial transmission line. A family of curves showing standing-wave ratio for various values of line resistance, as a function of frequency, has been plotted.

Consider the most common radio-frequency transmission line, made of copper. As the frequency of such a short-circuited line is raised from zero, the input resistance rises, reaching a maximum when the line is about a quarter wave long. For higher frequencies, the resistance

oscillates with maxima slowly decreasing in amplitude. When the transmission-line conductor consists of a resistance that is not negligible compared to the characteristic impedance of the transmission line, the above impedance function is not obtained, since, as the frequency increases from zero, the input resistance may increase or decrease from the direct-current value. For frequencies a few times greater than the first resonant frequency, the input resistance may have a negligible amount of oscillation.

Consider a resistance employed as a transmission line and short-circuited at the far end (Fig. 1).

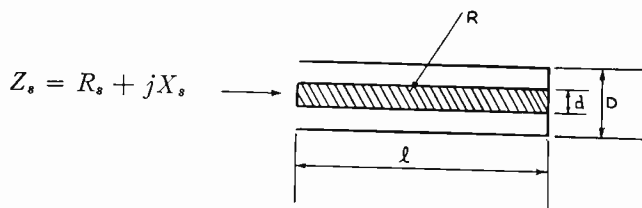

Fig. 1—Resistance employed as a transmission line. Far end is short-circuited.

$l$  = length of line in inches

$D$  = diameter of inside of outer conductor in inches

$d$  = diameter of resistor in inches

$Z_s$  = input impedance to line in ohms

$Z_0$  = characteristic impedance of line in ohms when  $R$  is zero

$R$  = total value of series resistance of line in ohms

$L$  = inductance of line in henries

$C$  = capacitance of line in farads

$f_{mc}$  = operating frequency in megacycles

$\lambda$  = free-space wavelength in inches

$\omega = 2\pi f = 2\pi f_{mc} \times 10^6$

From the classical theory

$$Z_0 = 138 \log_{10} \frac{D}{d} \quad (1)$$

$$Z_0 = \sqrt{\frac{L}{C}} \quad (2)$$

$$C = \frac{l}{\lambda} \times \frac{1}{Z_0 \times f} \quad (3)$$

$$L = \frac{l}{\lambda} \times \frac{Z_0}{f} \quad (4)$$

\* Decimal classification: R383×R144. Original manuscript received by the Institute, May 1, 1945; revised manuscript received, August 10, 1945.

† RCA Victor Division, Radio Corporation of America, Camden, N. J.

<sup>1</sup> G. H. Brown and J. W. Conklin, "Water-cooled resistors for ultra-high frequencies," *Electronics*, vol. 14, pp. 24-28; April, 1941.

<sup>2</sup> J. A. Fleming, "The Propagation of Electric Currents in Telephone and Telegraph Conductors," D. Van Nostrand Co., Inc., New York, N. Y., 1911 Chap. III, Eq. (51).

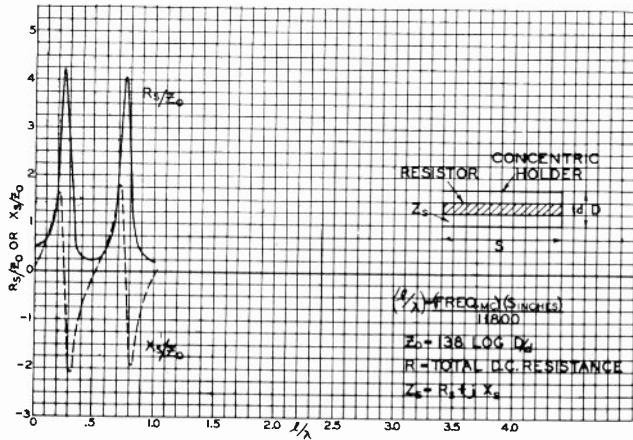

Fig. 2—Impedance of short-circuited transmission line.  $R/Z_0 = 0.5$ .

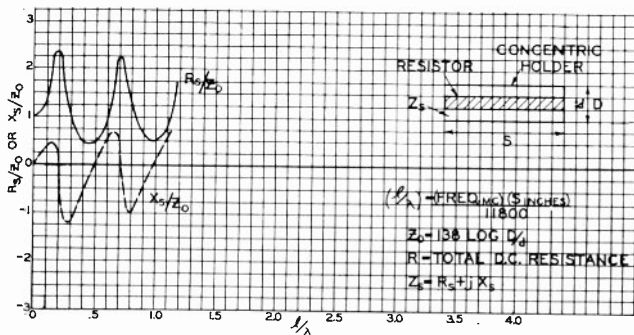

Fig. 3—Impedance of short-circuited transmission line.  $R/Z_0 = 1.0$ .

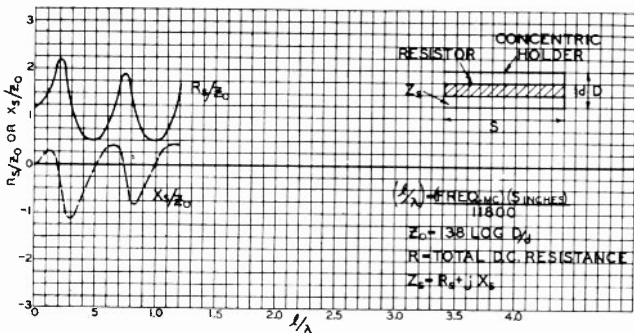

Fig. 4—Impedance of short-circuited transmission line.  $R/Z_0 = 1.2$ .

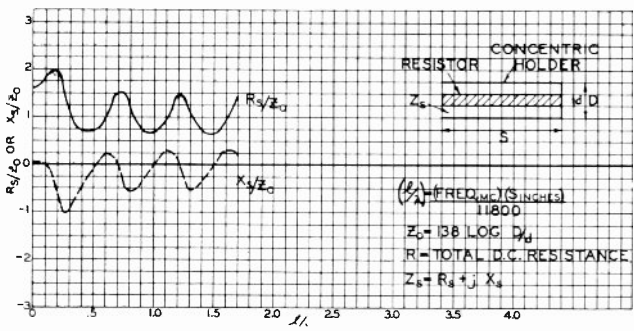

Fig. 5—Impedance of short-circuited transmission line.  $R/Z_0 = 1.6$ .

$$\frac{l}{\lambda} = \frac{l \times f_{mc}}{11,800} \quad (5)$$

$$Z_s = \sqrt{\frac{R + j\omega L}{G + j\omega C}} \tanh \sqrt{(R + j\omega L)(G + j\omega C)}. \quad (6)$$

We consider only the case where  $G$  is negligibly small. From the above equations, we obtain

$$\frac{Z_s}{Z_0} = \sqrt{1 - j \frac{R}{Z_0} \frac{1}{2\pi(l/\lambda)}} \cdot \tanh \sqrt{-4\pi^2 \left(\frac{l}{\lambda}\right)^2 + j2\pi \frac{l}{\lambda} \frac{R}{Z_0}} \quad (7)$$

Two independent parameters are now involved,  $R/Z_0$  and  $l/\lambda$ . The term  $R/Z_0$  is independent of frequency, and is fixed by the proportion of the resistor to the jacket diameter. The term  $l/\lambda$  is proportional to frequency, so the plot of the impedance versus this term gives the frequency characteristic of the resistor.

The plot of (7) is given in Figs. 2, 3, 4, 5, 6, 7, 8, 9, and 10, and shows:

1. For values of  $R/Z_0$  appreciably less than unity, both the resistance and reactance oscillate over a wide range of values.

2. For values of  $R/Z_0$  much greater than unity, the oscillations are of minor amplitude.

3. For large values of  $R/Z_0$ , the reactance is always negative. For some short resistors, the reactance is positive, and for others it is negative.

Three special values of  $l/\lambda$  are of interest:

- $l/\lambda$  very small
- $l/\lambda$  very large
- $l/\lambda = 1/4$ .

#### SMALL VALUES OF $l/\lambda$

Expanding (7) in powers of  $2\pi l/\lambda$  we obtain

$$\frac{R_s}{Z_0} = \frac{R}{Z_0} + (2\pi l/\lambda)^2 \left( \left(\frac{R}{Z_0}\right) \frac{2}{3} - \frac{2}{15} \left(\frac{R}{Z_0}\right)^3 \right) + (2\pi l/\lambda)^4 ( ) + \dots \quad (8)$$

$$\frac{X_s}{Z_0} = (2\pi l/\lambda) \left( 1 - \left(\frac{R}{Z_0}\right) \frac{2}{3} \right) + (2\pi l/\lambda)^3 ( ) + \dots$$

If the  $n$ th derivative of a function expressed in a power series is zero when the variable is zero, the coefficient of the  $n$ th term in the series must be zero.

Since in the expression for  $R_s/Z_0$ , the term involving  $(l/\lambda)$  to the first power is missing, we conclude that the slope of all the resistance curves will be zero at  $l/\lambda = 0$ . Figs. 2, 3, 4, 5, 6, 7, 8, 9, 10, and 11 illustrate this. For  $R/Z_0 = \sqrt{5}$ , the coefficient of the second term in the



expression for  $R_s/Z_0$  vanishes. Thus for this value the curvature of the resistance characteristic will be zero at  $l/\lambda = 0$ .

Since in the expression for  $X_s/Z_0$ , the term involving  $l/\lambda$  to the second power is missing, we conclude that the curvature of all the reactance curves (Fig. 12) will be zero at  $l/\lambda = 0$ . For  $R/Z_0 = \sqrt{3}$ , the coefficient of the first term in the expression for  $R_s/Z_0$  vanishes. Thus, for this value, the slope of the reactance curve will be zero at  $l/\lambda = 0$ .

When resistors are used for terminating transmission lines, the principal cause of standing waves is the presence of reactance. Thus the derived relation  $R/Z_0 = \sqrt{3}$  gives the widest frequency response for a fixed minimum standing-wave ratio. The RCA patent office called to our attention U. S. patent No. 2,273,547 filed in 1939 by Radinger of Berlin, Germany, which also gives the  $\sqrt{3}$  ratio as being optimum. Radinger refers to German patent No. 618,678 filed in 1932 by Roosenstein. Roosenstein discloses the method of finding the optimum value. Due to an error in an expansion, he arrived at  $\sqrt{2}$  instead of  $\sqrt{3}$ .

A plot has been made in Fig. 13 to show how the standing-wave ratio varies with frequency when a coaxial line is terminated with a resistor. The value of  $R$  is taken equal to the characteristic impedance of the line to be terminated. This insures that the line will be matched at low frequencies.

The value of  $R/Z_0$  is determined by the ratio of the resistor diameter to the diameter of the transmission-line jacket in which the resistor is mounted. Thus the value of  $Z_0$  is independent of the characteristic impedance of the line to be terminated. From Fig. 13 it can

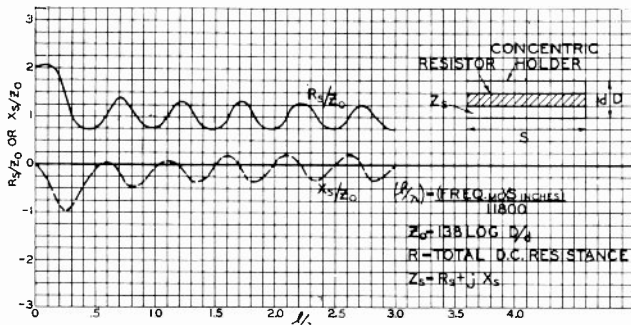

Fig. 6—Impedance of short-circuited transmission line.  $R/Z_0 = 2.0$ .

be seen that the standing-wave ratio nearest unity occurs for  $R/Z_0 = \sqrt{3}$ .

Suppose we have a resistor 12 inches long and plan to use it up to 100 megacycles. Using (5) we obtain

$$l/\lambda = 0.1.$$

From the curves of Fig. 13, we see that if the jacket is chosen so  $R/Z_0 = \sqrt{3}$ , the standing-wave ratio at 100 megacycles will be 0.9.

From this plot, we see that with the proper jacket, the

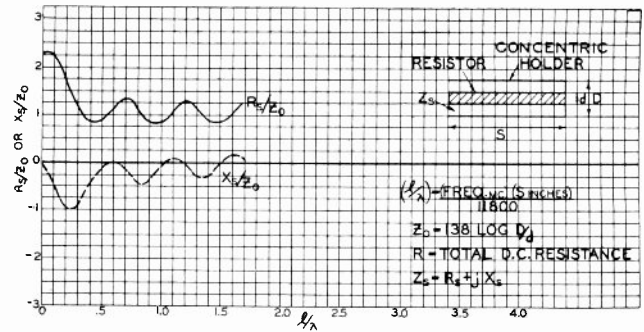

Fig. 7—Impedance of short-circuited transmission line.  $R/Z_0 = 2.25$ .

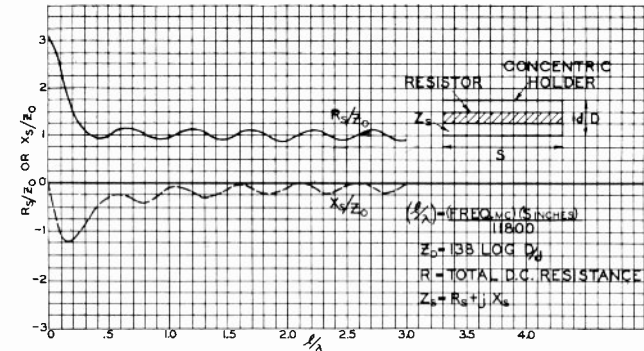

Fig. 8—Impedance of short-circuited transmission line.  $R/Z_0 = 3.0$ .

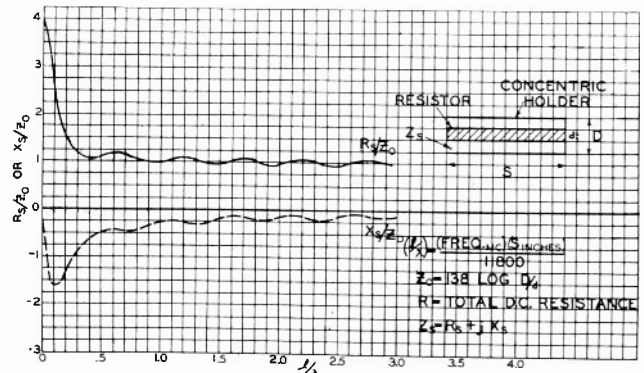

Fig. 9—Impedance of short-circuited transmission line.  $R/Z_0 = 4.0$ .

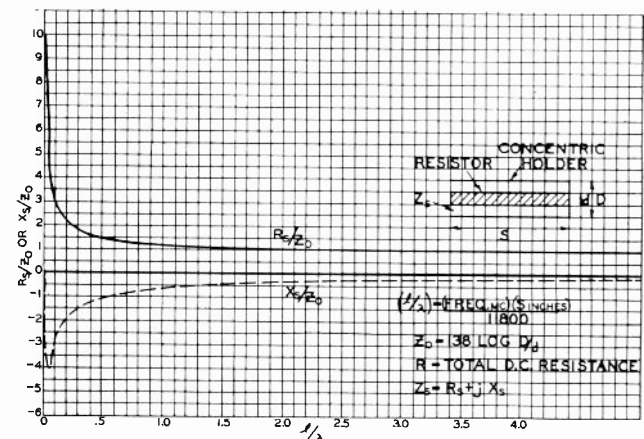

Fig. 10—Impedance of short-circuited transmission line.  $R/Z_0 = 10.0$ .

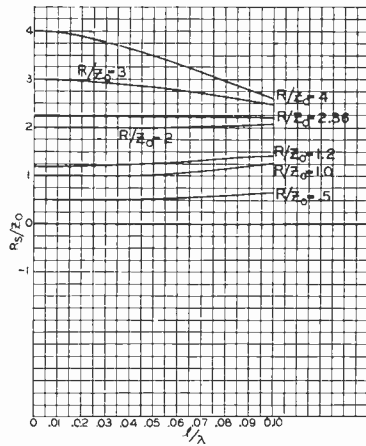

Fig. 11—Resistance of short-circuited transmission line. All slopes are zero at  $l/\lambda=0$ . For  $R/Z_0 = \sqrt{3}$ , curvature is zero at  $l/\lambda=0$ .

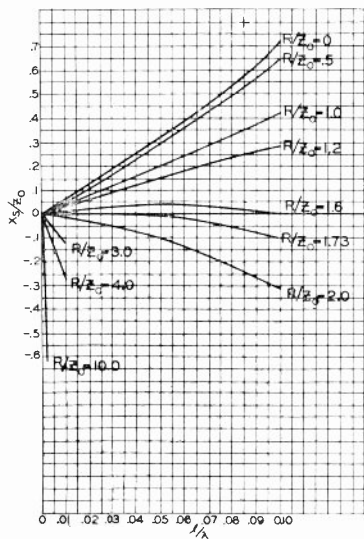

Fig. 12—Reactance of short-circuited transmission line. For  $R/Z_0 = \sqrt{3}$ , slope is zero at  $l/\lambda=0$ .

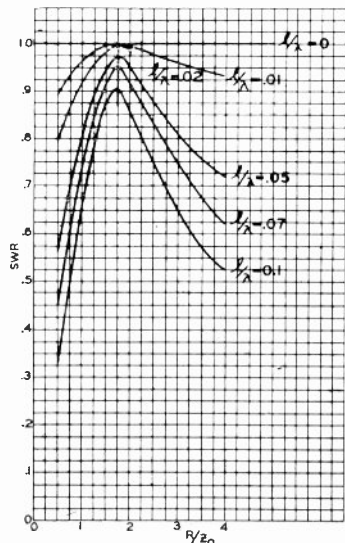

Fig. 13—Standing-wave ratio versus  $R/Z_0$  for constant  $l/\lambda$ . Note as  $l/\lambda$  increases, the standing-wave ratio is minimum for  $R/Z_0 = \sqrt{3}$ .

standing-wave ratio will be 0.97 for  $l/\lambda = 0.05$ . Putting this value in (5)

$$0.05 = \frac{l \times f_{mc}}{11,800} \tag{9}$$

or approximately

$$f_{mc} = \frac{600}{l}$$

This rounded constant 600 is convenient for quick design. Thus a resistor 1 inch long can have good characteristics up to 600 megacycles, and a resistor 12 inches long up to 50 megacycles.

The curves of Fig. 13 were computed using the formulas

$$\text{standing-wave ratio} = \frac{1 - |K|}{1 + |K|} \quad K = \frac{1 - \frac{Z_s}{R_0}}{1 + \frac{Z_s}{R_0}} \tag{10}$$

where  $K$  is the reflection coefficient.

That the resistance may either increase or decrease as the frequency is raised from zero can also be shown from an equivalent lumped circuit of the resistor.<sup>3,4</sup> The equivalent circuit of the resistor is shown in Fig. 14, where  $Z_0 = \sqrt{L/C}$  and  $Q = Z_0/R$ .

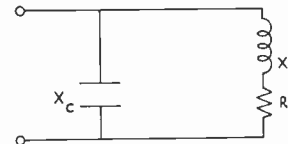

Fig. 14—Equivalent lumped circuit of resistor.

It can be shown that the reactance slope for the above circuit is zero at zero frequency for

$$\frac{R}{Z_0} = 1.$$

The condition at which the resistance begins to decrease as the frequency is raised is

$$\frac{R}{Z_0} = \sqrt{2}.$$

The corresponding two values from the transmission-line analysis are  $\sqrt{3}$  and  $\sqrt{5}$ . Thus the lumped-circuit analysis gives only an approximate answer.

When resistors of the order of 10,000 ohms or higher

<sup>3</sup> D. B. Sinclair, "The type 663 resistor—a standard for use at high frequencies," *Gen. Rad. Exper.*, vol. 13, pp. 6-11; January, 1939.

<sup>4</sup> R. G. Anthes, "Behavior of resistors at radio frequencies," *Electronic Industries*, vol. 3, pp. 86-88; September, 1944.

are employed, it is not practical to mount them so that the  $Z_0$  of the circuit is near the optimum value of

$$\frac{R}{Z_0} = \sqrt{3}.$$

When such resistors are mounted near a ground plane,  $R/Z_0$  is usually several hundred. When such resistors are mounted well above a ground plane, the connecting leads to the resistor violate the assumption of this analysis.

#### LARGE VALUES OF $l/\lambda$

To study the impedance characteristic for large values of  $l/\lambda$ , it is convenient to consider separately the two terms in our exact equation (7). The first term approaches a limit as  $l/\lambda$  becomes large.

$$\sqrt{1 - j \frac{R}{Z_0} \frac{1}{2\pi(l/\lambda)}} = \left[ 1 - j \left( \frac{R}{Z_0} \right) \frac{1}{4\pi(l/\lambda)} + \dots \right]. \quad (11)$$

This term gives the normalized characteristic impedance of the line, and approaches unity in the limit as  $l/\lambda$  increases. Since the total resistance of the line is held constant, we should expect from physical reasoning that the impedance angle of the characteristic impedance would approach zero as the line length increases.

The second term of (7) does not approach a limit as  $l/\lambda$  increases, but oscillates between values dependent on  $R/Z_0$ . For  $l/\lambda$  large,

$$\begin{aligned} \tanh \sqrt{-4\pi^2(l/\lambda)^2 + j2\pi \frac{l}{\lambda} \frac{R}{Z_0}} \\ = \frac{\tanh \frac{R}{2Z_0} + j \tan 2\pi \frac{l}{\lambda}}{1 + j \tanh \frac{R}{2Z_0} \tan 2\pi \frac{l}{\lambda}}. \quad (12) \end{aligned}$$

As  $l/\lambda$  increases, the real part of this expression oscillates between  $\tanh R/2Z_0$  and the reciprocal,

$$\frac{1}{\tanh \frac{R}{2Z_0}}.$$

The amplitude of the oscillation of the  $j$  part is much smaller, being

$$\frac{1}{2} \left[ \tanh \frac{R}{2Z_0} - \frac{1}{\tanh \frac{R}{2Z_0}} \right].$$

This behavior is in contrast to the common case in which the frequency is held constant and the line length is increased. The total line resistance then increases indefinitely, and the input impedance of the line approaches a limit, which is the characteristic impedance of the line.

Consider the example plotted in Fig. 6.

$$\frac{R}{Z_0} = 2 \quad \tanh \frac{R}{2Z_0} = 0.762.$$

The normalized resistance oscillates for large  $l/\lambda$  between 0.76 and 1.31 while the reactance oscillates between  $\pm 0.28$ . These values are obtained by substituting in the above expressions. The plot in Fig. 6 shows how the oscillation approaches a finite limit for its amplitude.

The oscillations of the plot of Fig. 10 are negligible since  $R/Z_0=10$  and  $\tanh R/2Z_0=0.9999$ .

#### DISCUSSION OF $l/\lambda = 1/4$

For small value of  $R/Z_0$ , the resistance maximizes near  $l/\lambda=1/4$ .

The value of this maximum resistance is approximately

$$\left( \frac{R}{Z_0} \right)_{\max} = \frac{2Z_0}{R}.$$

In Fig. 2,  $R/Z_0=0.5$  and the first maximum is approximately 4, as the plot shows. This situation has been discussed by Terman.<sup>5</sup>

<sup>5</sup> F. E. Terman, "Resonant lines in radio circuits," *Elec. Eng.*, vol. 53, pp. 1046-1053; July, 1934.



# An Analysis of Three Self-Balancing Phase Inverters\*

MYRON S. WHEELER†, ASSOCIATE, I.R.E.

**Summary**—A self-balancing phase inverter is a circuit converting one driving voltage to two output voltages of opposite phase but of essentially equal magnitude by an inherent characteristic of the device and not by virtue of any critical adjustment. The algebraic solution of three self-balancing phase inverters is given, assuming all circuit elements are linear. Included in the solution are the conditions for self-balance, the balance ratio, and the voltage gain. From this information, the type of inverter for a particular service may be selected and designed.

## INTRODUCTION

THE DESIGN of audio and video amplifiers frequently requires the conversion from a single-ended to a double-ended (or push-pull) channel. Two familiar examples of this type of amplifier are the driving of cathode-ray-tube plates in push-pull from an amplifier that must be, for convenience, single ended at its input; and the driving of audio power amplifiers in push-pull where it is again convenient to use single-ended voltage-amplifier stages and input.

This conversion requires a network with two output voltages, equal in magnitude but opposite in phase, and proportional to its driving voltage. While a transformer fulfills these requirements, it is frequently more economical and more uniform in frequency response to use a tube to invert the phase in a circuit that automatically equalizes the two output signals.<sup>1,2</sup>

Three self-balancing phase-inverting circuits will be analyzed: the common-plate-impedance inverter, the common-cathode-impedance inverter, and the cathode and plate-loaded inverter. The only assumption made in the analysis is that all circuit elements (and in particular, the tube parameters) are linear. This assumption is well justified, as this type of amplifier is generally designed for linear operation. And, although the solutions are given for such a frequency range that the load impedances are resistive, the solution could be extended to any frequency by the substitution of their complex impedances. The circuits in Figs. 1, 2, 3, 4, 5, and 6 are all equivalent signal-voltage circuits, as there is no loss in generality by omitting the direct-current components.

## COMMON-PLATE-IMPEDANCE SELF-BALANCING INVERTER

Referring to Figs. 1 and 2, the following tube parameters are defined as:

\* Decimal classification: R139. Original manuscript received by the Institute, July 6, 1945; revised manuscript received, October 2, 1945.

† Westinghouse Electric Corporation, Bloomfield, N. J.

<sup>1</sup> J. G. Brainerd, "Ultra-High-Frequency Techniques," D. Van Nostrand Co., Inc., New York, N. Y., 1942, pp. 100-101.

<sup>2</sup> M.I.T. Staff, "Applied Electronics," John Wiley and Sons, New York, N. Y., 1943, pp. 489-490.

$$r_{p1} = \frac{\partial E_{p1}}{\partial i_1} \quad \mu_1 = \frac{\partial E_{p1}}{\partial e_0}$$

$$r_{p2} = \frac{\partial E_{p2}}{\partial i_2} \quad \mu_2 = \frac{\partial E_{p2}}{\partial e_0}$$

Then, adding the voltages around three closed circuits,

$$\mu_1 e_0 - i_1 r_{p1} - i_1 r_1 - (i_1 - i_2) R_0 = 0$$

$$\mu_2 e_0 - i_2 r_{p2} - i_2 r_2 + (i_1 - i_2) R_0 = 0$$

$$e_0 - (i_1 - i_2) R_0 = 0$$

and as

$$E_2 = i_2 r_2 - e_0$$

and

$$E_1 = i_1 r_1 + e_0$$

Solving for  $E_2/E_1$

$$\frac{E_2}{E_1} = \frac{\mu_2 R_0 r_2 - r_{p2} R_0}{\mu_2 R_0 r_1 + r_1 r_2 + r_1 r_{p2} + R_0 r_1 + R_0 r_2 + R_0 r_{p2}} \quad (1)$$

In (1) the terms  $\mu_2 R_0 r_2$  and  $\mu_2 R_0 r_1$  are much greater than the rest, and it can be seen that, if the others were

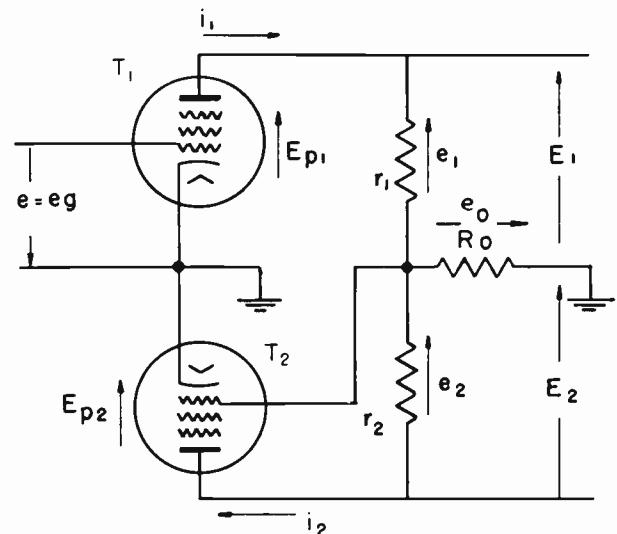

Fig. 1—Equivalent signal-voltage circuit of common-plate-impedance self-balancing inverter.

negligible compared with these two, the condition for balance (equal output voltages) would be

$$\mu_2 R_0 r_2 = \mu_2 R_0 r_1 \quad \text{or} \quad r_2 = r_1$$

The circuit could be brought to balance, however, in

any event by adjusting  $r_1$  and  $r_2$  so that

$$\frac{E_2}{E_1} = 1$$

but we are more interested in the degree of unbalance resulting when  $r_2 = r_1$ , which we shall call  $r$ ; then

$$\frac{E_2}{E_1} = \frac{\mu_2 R_0 r - r_{p2} R_0}{\mu_2 R_0 r + r^2 + r r_{p2} + 2R_0 r + R_0 r_{p2}} \quad (2)$$

In order to minimize the unbalance,  $R_0$  should be selected as great as possible, as it can be seen from (2) that

$$\frac{E_2}{E_1} \rightarrow \frac{\mu_2 r - r_{p2}}{\mu_2 r + 2r + r_{p2}} \quad (3)$$

$$\lim_{R_0 \rightarrow \infty}$$

which is the closest  $E_2/E_1$  comes to 1 as  $R_0$  varies from 0 to  $\infty$ . Practical limits, however, set the maximum

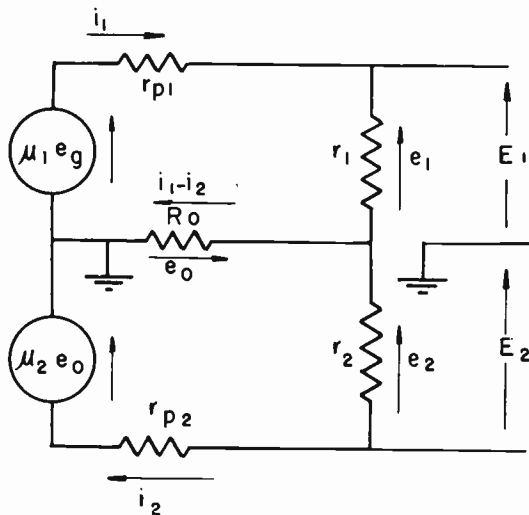

Fig. 2—Equivalent linear-tube-parameter circuit of common-plate-impedance self-balancing inverter.

value of  $R_0$  near  $r$ . As a basis of comparison of this type of phase inverter with some others, let  $R_0 = r$ . Then

$$\frac{E_2}{E_1} = \frac{\mu_2 r - r_{p2}}{\mu_2 r + 3r + 2r_{p2}} \quad (4)$$

To simplify this expression further, if we define the gain of the inverter tube  $T_2$  as  $N$ , and omit intermediate algebraic steps

$$N = \frac{E_2}{e_0} = \frac{\mu_2 r_2 - r_{p2}}{r_{p2} + r_2} \quad (5)$$

then with  $r_1 = r_2 = r$  as above from (2)

$$\frac{E_2}{E_1} = \frac{NR_0}{r + R_0(N + 2)} \quad (6)$$

and with  $R_0 = r$  as in (4)

$$\frac{E_2}{E_1} = \frac{N}{N + 3} \text{ (exactly)} \quad (7)$$

where  $N$ , the gain of the inverter tube  $T_2$ , is defined exactly by (5). It is essentially, however, the gain of  $T_2$  as a normal plate-loaded voltage amplifier.

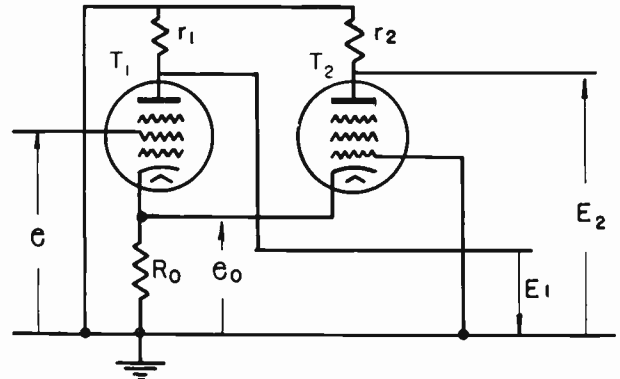

Fig. 3—Equivalent signal-voltage circuit of common-cathode-impedance self-balancing inverter.

That is

$$N \cong \text{normal plate-loaded gain} = \frac{\mu_2 r_2}{r_{p2} + r_2}$$

as can be seen from (5), because generally

$$\mu_2 r_2 \gg r_{p2}$$

Let us stop to interpret these equations. We find from (7) that the balance of the inverter depends upon the gain of  $T_2$ , provided  $R_0$  is sufficiently great as shown in (3), where the gain of  $T_2$  is defined by (5). The balance also requires that the plate-load resistors of the two stages be equal as seen in (1), but the two tubes need not be the same. The tube  $T_1$ , then, acting only as a voltage amplifier has a gain

$$\frac{E_1}{e} = \frac{\mu_1 \mu_2 R_0 r_1 + \mu_1 (r_1 r_2 + r_1 r_{p2} + r_1 R_0 + R_0 r_2 + R_0 r_{p2})}{(r_1 + r_{p1})(r_2 + r_{p2}) + R_0 (r_1 + r_{p1})(1 + \mu_2) + R_0 (r_2 + r_{p2})} \quad (8)$$

The only purpose of writing (8) was to show approximately that the gain of  $T_1$  is the same as a normal plate-loaded amplifier with a load resistance of  $r_1$ , if

$$\gg 1$$

for then

$$\frac{E_1}{e_0} \cong \frac{\mu_1 \mu_2 R_0 r_1}{(\mu_2 + 1)(r_1 + r_{p1})R_0} \cong \frac{\mu_1 r_1}{(r_1 + r_{p1})} \quad (9)$$

#### COMMON-CATHODE-IMPEDANCE SELF-BALANCING INVERTER

Using the same symbols as in the previous analysis, it can be seen from Fig. 3 that

$$e_{p1} = e - (i_1 + i_2)R_0$$

$$e_{p2} = (i_1 - i_2)R_0.$$

Adding the voltages around two closed paths in Fig. 4

$$(i_1 - i_2)R_0 - \mu_1[e - (i_1 - i_2)R_0] + i_1(r_1 + r_{p1}) = 0$$

$$(i_1 - i_2)R_0 + \mu_2(i_1 - i_2)R_0 - i_2(r_{p2} + r_2) = 0.$$

Then solving for  $E_2/E_1$

$$\frac{E_2}{E_1} = \frac{R_0(\mu_2 + 1)r_2}{R_0(\mu_2 + 1)r_1 + (r_{p2} + r_2)r_1}. \quad (10)$$

As in the previous solution, let

$$r_1 = r_2 = r.$$

$R_0$  should again be as great as practical limitations permit to obtain the best balance. In general this is near the value of  $r$ , and to compare this inverter with the previous type, let

$$R_0 = r_1 = r_2 = r.$$

Then

$$\frac{E_2}{E_1} = \frac{\mu_2 r + r}{\mu_2 r + 2r + r_{p2}}. \quad (11)$$

This expression may also be simplified in the same manner as the previous case.

$$\frac{E_1}{e} = \frac{\mu_1(1 + \mu_2)R_0r_1 + \mu_1(r_{p2} + r_2)r_1}{(\mu_2 + 1)(r_1 + r_{p1})R_0 + (\mu_1 + 1)(r_2 + r_{p2})R_0 + (r_1 + r_{p1})(r_2 + r_{p2})}. \quad (15)$$

Define the gain of  $T_2$  as

$$N = \frac{E_2}{e_0} = \frac{(\mu_2 + 1)r_2}{r_{p2} + r_2}. \quad (12)$$

Then

$$\frac{E_2}{E_1} = \frac{R_0 N}{R_0 N + r} \quad (13)$$

and with

$$R_0 = r$$

$$\frac{E_2}{E_1} = \frac{N}{N + 1} \text{ (exactly)} \quad (14)$$

where  $N$  is again essentially the gain of  $T_2$  as a normal plate-loaded voltage amplifier.

That is,

$$N \cong \text{normal plate-loaded gain} = \frac{\mu_2 r_2}{r_{p2} + r_2}$$

as it can be seen from (10), because generally

$$\mu_2 \gg 1.$$

The common-cathode-impedance phase inverter, it has been seen, is quite analogous to the common-plate-

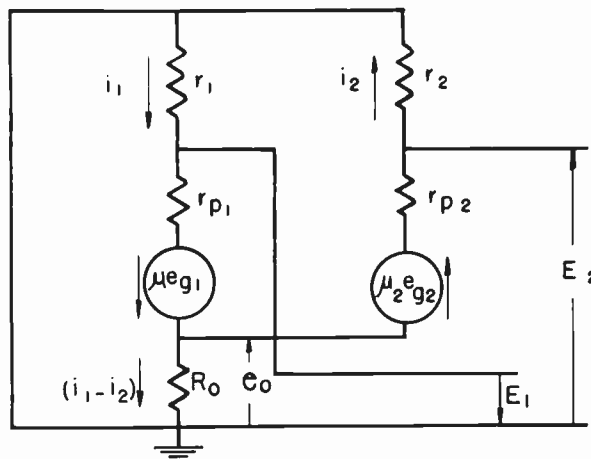

Fig. 4—Equivalent linear-tube-parameter circuit of common-cathode-impedance self-balancing inverter.

impedance phase inverter. Good balance depends upon equal load resistors, high gain in  $T_2$ , and a common cathode resistor as large as practicable. The degree of balance is a little better than the common-plate-impedance type, but the voltage amplification of  $T_1$  is found to be about half, for

To simplify the equation consider

$$r_1 + r_{p2} = r_2 + r_{p2}$$

and

$$\mu_1 = \mu_2$$

where

$$\mu_2 \gg 1.$$

Then

$$\frac{E_1}{e} = \frac{\mu_1 r_1}{2(r_1 + r_{p1})}. \quad (16)$$

Again the only purpose of writing (15) was to show approximately the gain of  $T_1$ , which is roughly one half of the gain of the normal plate-loaded amplifier with a load resistance of  $r_1$ .

#### CATHODE- AND PLATE-LOADED INVERTER

Again using the same tube parameters, it can be seen from Fig. 5 that

$$e_0 = e - E_2$$



and from Fig. 6

$$i_p = \frac{\mu e_g}{r_p + r_1 + r_2}$$

Then solving for  $E_2/E_1$

$$\frac{E_2}{E_1} = \frac{r_2}{r_1}$$

and perfect balance is obtained when

$$r_2 = r_1.$$

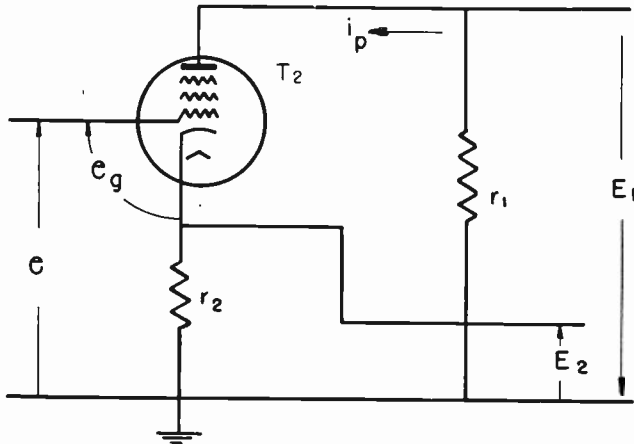

Fig. 5—Equivalent signal-voltage circuit of cathode- and plate-loaded inverter.

Define

$$N = \frac{E_2}{e}$$

and making

$$r_2 = r_1 = r$$

$$N = \frac{\mu r}{r_p + 2r + \mu r} \tag{17}$$

The gain is essentially unity as seen from (17) since generally

$$\mu r \gg r_p + 2r.$$

The conditions for balance are less rigid in this type of inverter, the only requirement being that the load resistors be equal. To compare the voltage gain of this single-tube circuit with the previous types, let us con-

sider a voltage amplifier before the inverter as part of the voltage gain. This tube would have a gain

$$\frac{E}{e} = \frac{\mu r}{r_p + r} \tag{18}$$

The inverter, having an approximate gain of unity per phase, will give an over-all gain, to a first approximation, equal to the gain of the first tube. This is also approximately the gain obtainable with the common-plate-loaded inverter, the exact ratios of the gains being easily obtainable but of little interest.

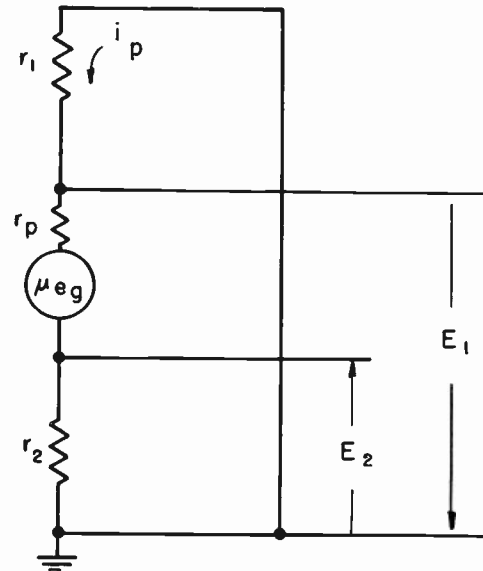

Fig. 6—Equivalent linear-tube-parameter circuit of cathode- and plate-loaded inverter.

Table I summarizes this data so that the three phase inverters may be compared.

TABLE I

Type	Balance Depends Upon	Exact Degree of Balance	Exact Inverter Gain	Approximate Inverter Gain	Approximate Relative Over-All Voltage Gain
Common Plate Load	$r_1 = r_2 = r$ $R_0 \approx r$ $N \gg 3$	$N$ $N + 3$	$N = \frac{\mu r_2 - r_{p2}}{r_{p2} + r_2}$	$N \approx \frac{\mu r_2}{r_{p2} + r_2}$	1
Common Cathode Load	$r_1 = r_2 = r$ $R_0 \approx r$ $N \gg 1$	$N$ $N + 1$	$N = \frac{(\mu_2 + 1)r_2}{r_{p2} + r_2}$	$N \approx \frac{\mu_2 r_2}{r_{p2} + r}$	$\frac{1}{2}$
Plate-Loaded Cathode-Loaded	$r_1 = r_2 = r$	1	$N = \frac{\mu r}{r_p + 2r + \mu r}$	$N \approx 1$	1

# Pulse Response of Thyatron Grid-Control Circuits\*

C. HERBERT GLEASON†, ASSOCIATE, I.R.E., AND CARL BECKMAN†, ASSOCIATE, I.R.E.

**Summary**—For applications in which a thyatron must function as an accurately controlling device, rather precise grid control is required. Frequently, the desired precision of firing is obtained by applying peaked voltage pulses to the grid of the thyatron. Satisfactory operation of the thyatron and its associated grid-control circuit usually requires an external grid-cathode capacitance and a current-limiting grid resistance. For a given pulse shape supplied by the grid signal generator, the grid resistance and capacitance can alter materially the wave form of the voltage which appears on the grid. This paper presents, in the form of curves, an analysis of the influence of the grid-circuit components upon the grid response for several commonly used grid signal pulses. Advantages of peaked wave-form grid control are discussed, and an example is worked out to illustrate the use of the curves in evaluating the grid response to a typical signal pulse.

## I. INTRODUCTION

THE LAST FEW years have seen a gradual increase in the use of peaked wave-form grid signals for thyatron control. Several of the advantages of peaked-grid-signal control can be seen by reference to Figs. 1 and 2. The various grid-control curves shown in Fig. 1 may differ from each other for several reasons: (1) the control characteristics corresponding to different condensed-mercury temperatures for a mercury-vapor tube; (2) random variation in control characteristic from tube to tube of the same type; (3) control curves corresponding to different types of tubes, interchangeable, except for grid characteristics. In Fig. 2 the control curves of Fig. 1 have been trans-

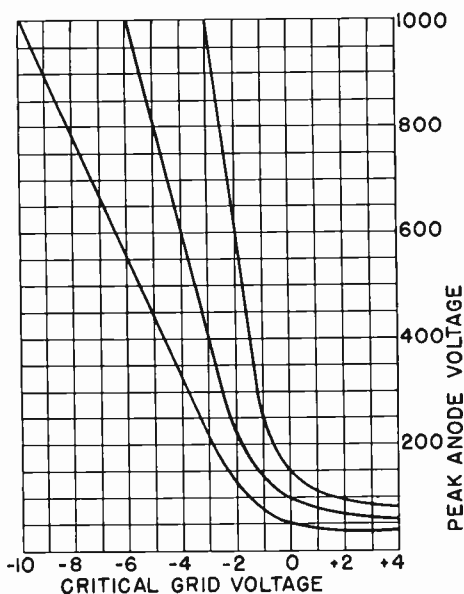

Fig. 1—Typical grid-control curves for a thyatron.

lated in the conventional manner for a sinusoidal anode voltage applied to the tube. Thus, for the positive half cycle of anode voltage shown in Fig. 2, the correspond-

\* Decimal classification: 621.375.1. Original manuscript received by the Institute, May 14, 1945.

† Westinghouse Electric Corporation, Bloomfield, N. J.

ing time variation of the critical grid potential is determined by the various curves of Fig. 1.

Now, by applying a grid signal with a very high rate of rise we can "sweep" through the various grid-control

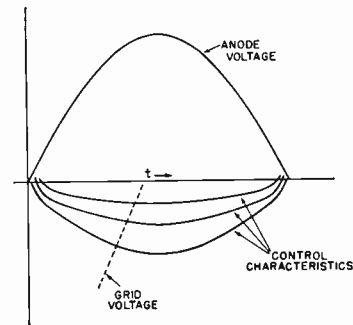

Fig. 2—Grid-control curves of Fig. 1 for a sinusoidal anode voltage.

characteristics very rapidly. The intersections of this steep-wave-front signal with the characteristic curves determine the instants of time at which the thyatron might fire, depending, of course, upon the particular grid characteristic the tube might have. By increasing the grid-signal rate of rise, it is possible to confine these intersections, or firing points, to a very narrow time interval. In this manner very precise firing can be obtained in spite of considerable variations in control characteristic.

To obtain a comparable rate of rise (and hence the same precision of firing) by means of an ordinary alternating-current grid signal would require an extremely large amplitude, which in most cases would be considerably in excess of the maximum allowable grid voltage specified by the tube manufacturer. Furthermore, over a portion of the range of phase control, an alternating-current signal will drive the grid positive during the inverse cycle of anode voltage. Such a condition of positive grid potential while the anode is negative is thought to increase materially the probability of an arc back; that is, failure of the tube to stand inverse voltage. There is also some evidence to indicate that this condition may increase the rate of "cleanup" in tubes filled with inert gases. These difficulties are easily avoided by the use of a narrow peaked wave for the grid signal.

A general discussion of peaked-wave-form grid control, including several other advantages such as short ionization and deionization times, has been given by Morack.<sup>1</sup>

A considerable amount of material on pulse-forming circuits may be found in the literature.<sup>2,3</sup> Several of these have been adapted to thyatron-control applications by incorporating with them a phase-shifting

<sup>1</sup> M. M. Morack, "Voltage impulses for thyatron grid control," *Gen. Elec. Rev.*, vol. 37, pp. 288-295; June, 1934.

<sup>2</sup> O. Kiltie, "Transformers with peaked waves," *Elec. Eng.*, vol. 51, pp. 802-804; November, 1932.

<sup>3</sup> J. G. Brainerd, Glenn Koehler, Herbert J. Reich, and L. F. Woodruff, "Ultra-High-Frequency Techniques," D. Van Nostrand Co., Inc. New York, N. Y., 1942, Chapter 4.

network, enabling the peak of the grid pulse to be shifted in time with respect to the thyatron's anode voltage.

## II. GRID-CIRCUIT RESPONSE TO PEAKED-WAVE-FORM GRID SIGNALS

The grid-control circuits used in the majority of thyatron applications can be simplified for this analysis into the circuit of Fig. 3. The bias battery prevents firing of the thyatron until a definite grid signal is applied. In practical circuits, the bias battery is usually

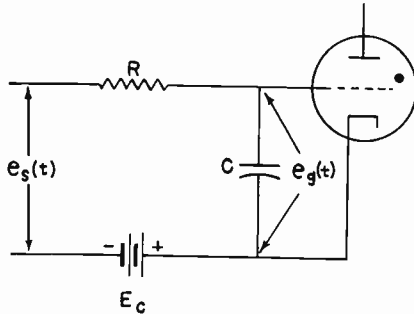

Fig. 3—Typical grid-control circuit for a thyatron.

replaced by a dry-type rectifier, tube rectifier, or an alternating-current voltage. The grid resistance limits the current which may be drawn from the grid-voltage supply. The grid capacitance  $C$  is the equivalent capacitance of the grid-cathode tube capacitance, combined with the external capacitance. This external capacitance is usually added in conjunction with the grid resistance to minimize undesirable fluctuations in grid potential resulting from disturbances coming in from the anode through the electrostatic coupling between grid and anode, or disturbances coming in through the grid circuit itself.

For most applications, the grid resistance  $R$  varies from 1000 ohms to several megohms and the capacitance  $C$  ranges from a few micromicrofarads to several hundredths of a microfarad. The grid-cathode capacitance of the thyatron is almost always very much less than the capacitance added externally, so it can usually be neglected. If pre-conduction grid currents are ignored, the influence of the tube on its grid potential is negligible until the initiation of the discharge between cathode and anode. (This assumption will be discussed later.)

However, the grid resistance and capacitance can affect very materially the wave form and magnitude of the potential which appears on the grid for a given wave form from the grid signal generator. The alteration in the grid-potential wave form is, of course, more serious the steeper the wave front of the signal applied to the circuit. Since this distortion in wave form can be very appreciable, it seems of interest to examine the response of the grid circuit for several types of signal impulses commonly used. For simplicity it will be assumed that the internal impedance of the signal generator is small compared to the impedance of the grid circuit, so that the generator's wave form is not influenced appreciably by the loading imposed by  $R$  and  $C$ . This assumption is a fairly reasonable one for the signal generators usually employed in this type of application and

for the ranges of  $R$  and  $C$  required for satisfactory tube operation.

The response to three types of pulses has been analyzed. These are the triangular, square, and exponential pulses shown in Fig. 4. Only the results are presented in the main body of the paper. The essential details of the analysis for each type of pulse may be

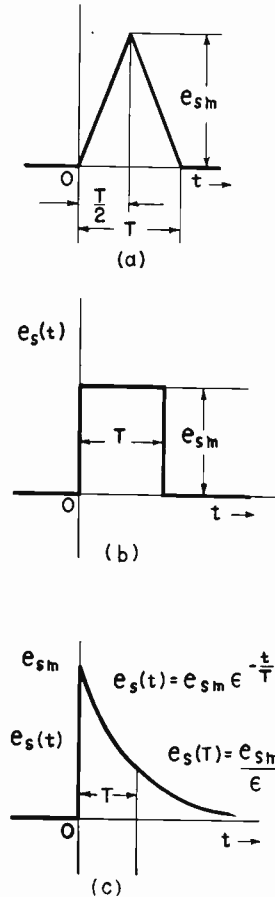

Fig. 4—Grid-signal pulses.

found in the mathematical appendix. For generality the analytical results are presented in the form of curves. These curves, showing the response characteristics of the grid circuit, involve dimensionless quantities representing the parameters of the grid circuit and the signal pulses.

*a. Response to a triangular pulse:* The analysis of the response to a triangular pulse of duration  $T$  is quite simple if the pulse is regarded as being formed by the addition of three functions as shown in (a) in Fig. 5. Resolving the pulse into these three components leads to three expressions for the response, each valid for the respective time intervals  $0 \leq t \leq T/2$ ,  $T/2 \leq t \leq T$ ,  $t \geq T$ .

### NOMENCLATURE

- $t$  = time
- $e_o(t)$  = instantaneous voltage between grid and cathode
- $e_{gm}$  = maximum value of the grid-to-cathode voltage
- $e_s(t)$  = instantaneous electromotive force of the grid-signal generator
- $e_{sm}$  = maximum value of the signal pulse
- $i(t)$  = instantaneous current in the grid circuit
- $E_c$  = grid-bias-supply voltage
- $T$  = time of duration of the grid-signal pulse
- $R$  = grid resistance
- $C$  = grid-cathode capacitance
- $\beta = RC/T$
- $\Delta t$  = time interval between instant of maximum signal-pulse voltage and the instant of maximum grid-to-cathode voltage



$\tau$  = time required for the grid-potential wave form to pass through two critical values of grid potential  
 $\ln$  = logarithm to the base  $e$   
 $p$  = parameter of the Laplace transform  
 $E_g(p)$  = Laplace transform of  $e_g(t)$   
 $E_s(p)$  = Laplace transform of  $e_s(t)$   
 $I(p)$  = Laplace transform of  $i(t)$

For no initial charge on the capacitance  $C$ , the ratio of the instantaneous grid potential to the maximum value

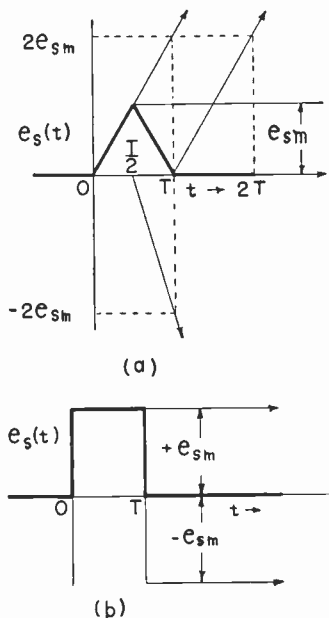

Fig. 5—Components of the triangular and square pulses.

of the signal pulse ( $e_g(t)/e_{sm}$ ) is found to be

$$\begin{aligned} \frac{e_g(t)}{e_{sm}} &= 2 \left\{ \frac{t}{T} - \beta(1 - e^{-(1/2)(t/T)}) \right\} \text{ for } 0 \leq t \leq T/2 \\ &= 2 \left\{ \left(1 - \frac{t}{T}\right) + \beta \left[ 1 + e^{-(1/\beta)(t/T)}(1 - 2\epsilon^{1/2\beta}) \right] \right\} \\ &\quad \text{for } T/2 \leq t \leq T \\ &= 2\beta e^{-(1/\beta)(t/T)} \{ 1 - 2\epsilon^{1/2\beta} + \epsilon^{1/\beta} \} \text{ for } t \geq T \end{aligned} \quad (1)$$

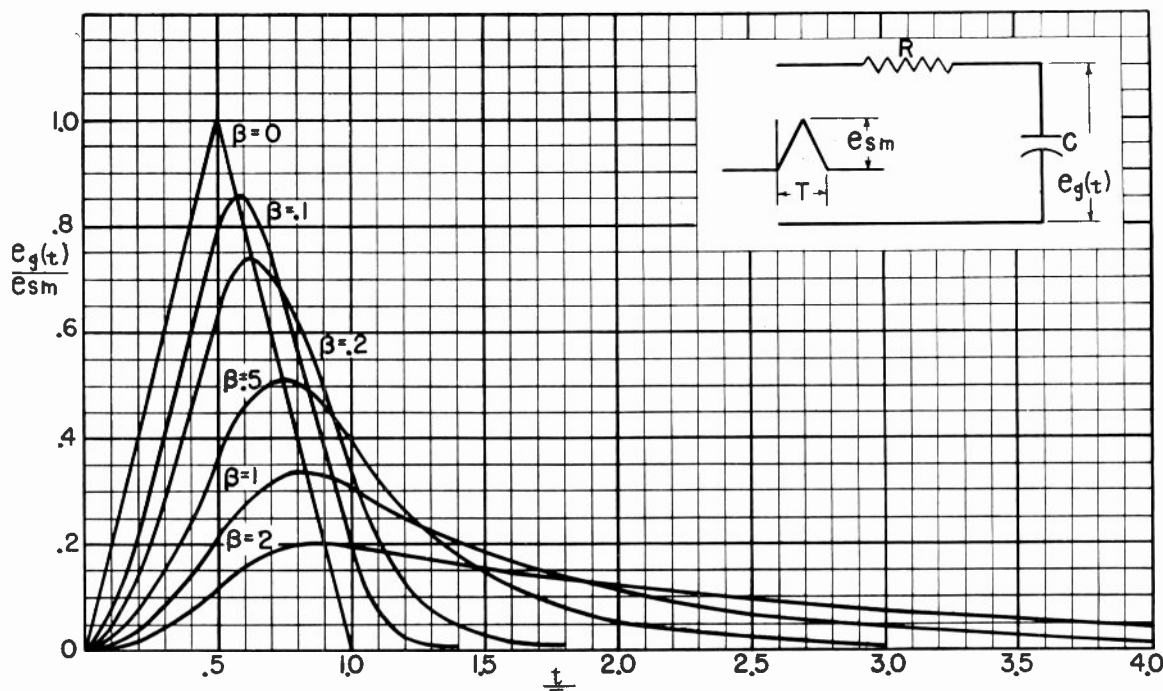

Fig. 6—The ratio ( $e_g(t)/e_{sm}$ ) as a function of ( $t/T$ ) for a triangular pulse with  $\beta = RC/T$  as a parameter.

where  $\beta = RC/T$ . In Fig. 6 the response of (1) is shown as a family of curves in terms of the parameter  $\beta$  and the variable  $t/T$ . Examination of the time derivatives of (1) shows that the maximum value of the ratio  $e_g(t)/e_{sm}$  always occurs during the interval  $T/2 \leq t \leq T$  at an instant  $t_m$  obtainable from

$$t_m/T = \beta \ln(2\epsilon^{1/2\beta} - 1). \quad (2)$$

The time interval  $\Delta t$  between the peak of the signal pulse and the peak grid voltage can then be expressed in terms of a ratio to the pulse width  $T$  as

$$\Delta t/T = \frac{t_m - T/2}{T} = \beta \ln(2\epsilon^{1/2\beta} - 1) - 1/2. \quad (3)$$

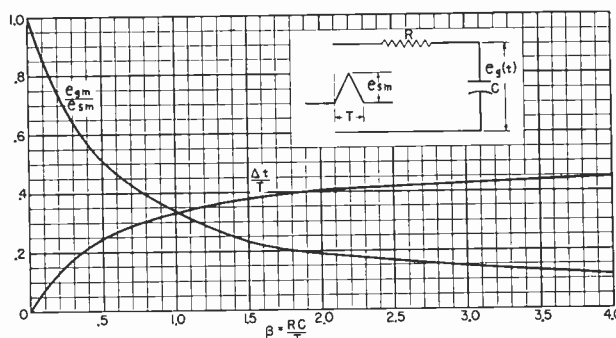

Fig. 7—The ratios ( $e_{gm}/e_{sm}$ ) and ( $\Delta t/T$ ) as functions of  $\beta = RC/T$  for a triangular pulse.

This ratio  $\Delta t/T$  is shown as a function of  $\beta$  in Fig. 7. Note that the curve approaches the value 0.5 as a limit for very large values of  $\beta$  as  $t_m$  must occur in the range  $T/2 \leq t_m \leq T$ . Substitution of the value  $t_m$  from (2) into (1) gives as the maximum value of ( $e_g(t)/e_{sm}$ )

$$e_{gm}/e_{sm} = 2[1 - \beta \ln(2\epsilon^{1/2\beta} - 1)], \quad (4)$$

and from (3) this ratio is also

$$e_{gm}/e_{sm} = 1 - 2 \left( \frac{\Delta t}{T} \right). \quad (5)$$

This ratio is shown as a function of  $\beta$  in Fig. 7 and in terms of  $(\Delta t/T)$  in Fig. 8.

*b. Response to a square pulse:* The square pulse of Fig. 4 (b) is often regarded as being formed by two step functions as shown by (b) in Fig. 5. Correspondingly, the response is found to consist of two expressions, each valid over different time intervals. For the grid capacitor initially uncharged, the ratio of the grid voltage to the height of the square pulse is

$$\begin{aligned} e_g(t)/e_{sm} &= 1 - \epsilon^{-(1/\beta)(t/T)} && \text{for } 0 \leq t \leq T \\ &= \epsilon^{-(1/\beta)(t/T)}(\epsilon^{1/\beta} - 1) && \text{for } t \geq T. \end{aligned} \quad (6)$$

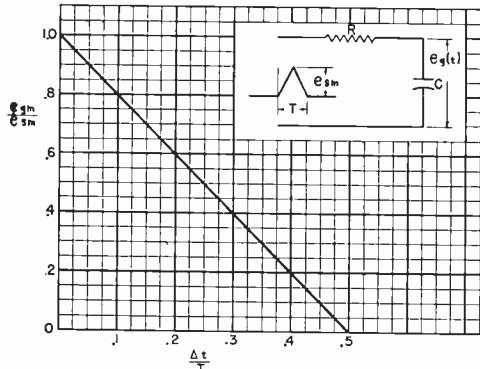

Fig. 8—The ratio  $(e_{gm}/e_{sm})$  as a function of  $(\Delta t/T)$  for a triangular pulse.

This function is presented in Fig. 9 as a family of curves with  $\beta$  as the parameter and  $t/T$  as the independent variable where, as before,  $\beta = RC/T$ . By examination it is evident that the grid voltage is a maximum at the end of the pulse, so

$$t_m = T. \quad (7)$$

The ratio of the maximum grid voltage to the height of the square pulse is, by (6) and (7)

$$e_{gm}/e_{sm} = 1 - \epsilon^{-1/\beta}. \quad (8)$$

This ratio is shown as a function of  $\beta$  in Fig. 10.

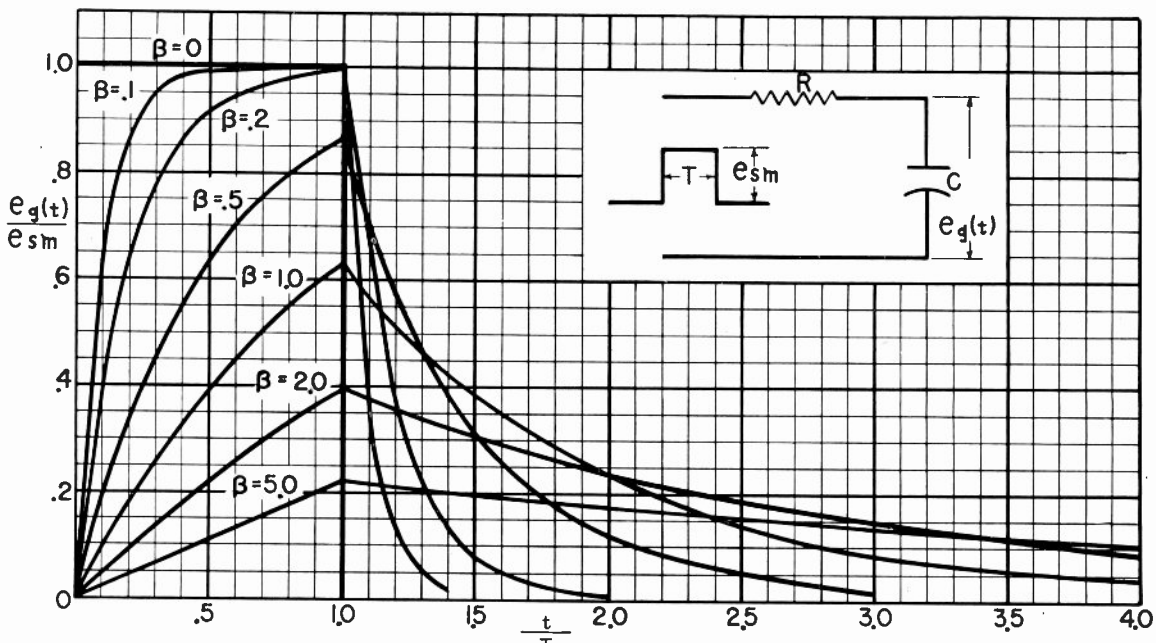

Fig. 9—The ratio  $(e_g(t)/e_{sm})$  as a function of  $(t/T)$  for a square pulse with  $\beta = RC/T$  as a parameter.

*c. Response to an exponential pulse:* The exponential pulse of Fig. 4 (c) has a maximum value of  $e_{sm}$  at  $t=0$  and a time constant  $T$ . In a sense,  $T$  may be regarded as the pulse width, in that it represents the width of the pulse at the instant for which  $e_s(t) = e_{sm}/\epsilon$ . The response of the grid circuit to an exponential pulse falls into two cases: the general case  $RC \neq T$ , and the special case  $RC = T$ . For the grid capacitor initially uncharged, the

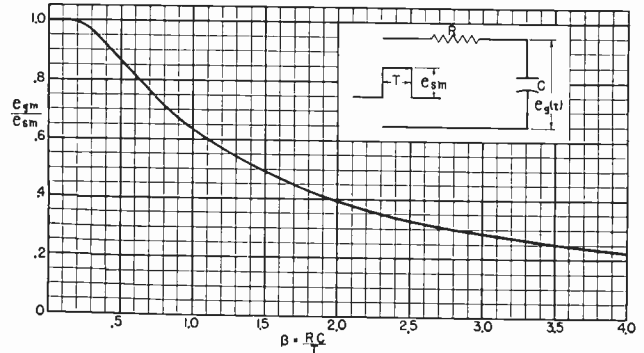

Fig. 10—The ratio  $(e_{gm}/e_{sm})$  as a function of  $\beta = RC/T$  for a square pulse.

ratio of the grid-capacitor voltage to the maximum value of the exponential pulse is, in terms of  $\beta = RC/T$ ,

$$\begin{aligned} e_g(t)/e_{sm} &= \epsilon^{-t/T} - \epsilon^{-(1/\beta)(t/T)} && \text{for } RC \neq T \\ &= \frac{t}{T} \epsilon^{-t/T} && \text{for } RC = T. \end{aligned} \quad (9)$$

This ratio  $(e_g(t)/e_{sm})$  is shown as a function of  $\beta$  and  $t/T$  in Fig. 11. The time derivatives of (9) show that

$$\frac{t_m}{T} = \frac{\Delta t}{T} = \frac{\beta}{\beta - 1} \ln \beta \quad \text{for } RC \neq T$$

and

$$t_m = \Delta t = T \quad \text{for } RC = T. \quad (10)$$

A curve of  $(t_m/T)$  as a function of  $\beta$  is shown in Fig. 12. From the relations of (9) and (10) the ratio of the

maximum grid voltage to the peak of the exponential pulse is

$$e_{gm}/e_{sm} = \frac{1}{1 - \beta} [\beta^{(\beta/1-\beta)} - \beta^{(1/1-\beta)}] \text{ for } RC \neq T$$

$$= 1/\epsilon = 0.367 \text{ for } RC = T. \quad (11)$$

This ratio ( $e_{gm}/e_{sm}$ ) is shown as a function of  $\beta$  in Fig. 12.

draws a current ranging from a few hundredths of a microampere up to several microamperes, or even higher for some of the larger, high-power thyratrons. Unless the grid resistance  $R$  is of the order of a megohm or more, the influence of this pre-conduction grid current for small, low-power thyratrons is small. However, if a large grid resistance is used, or if the tube has an exces-

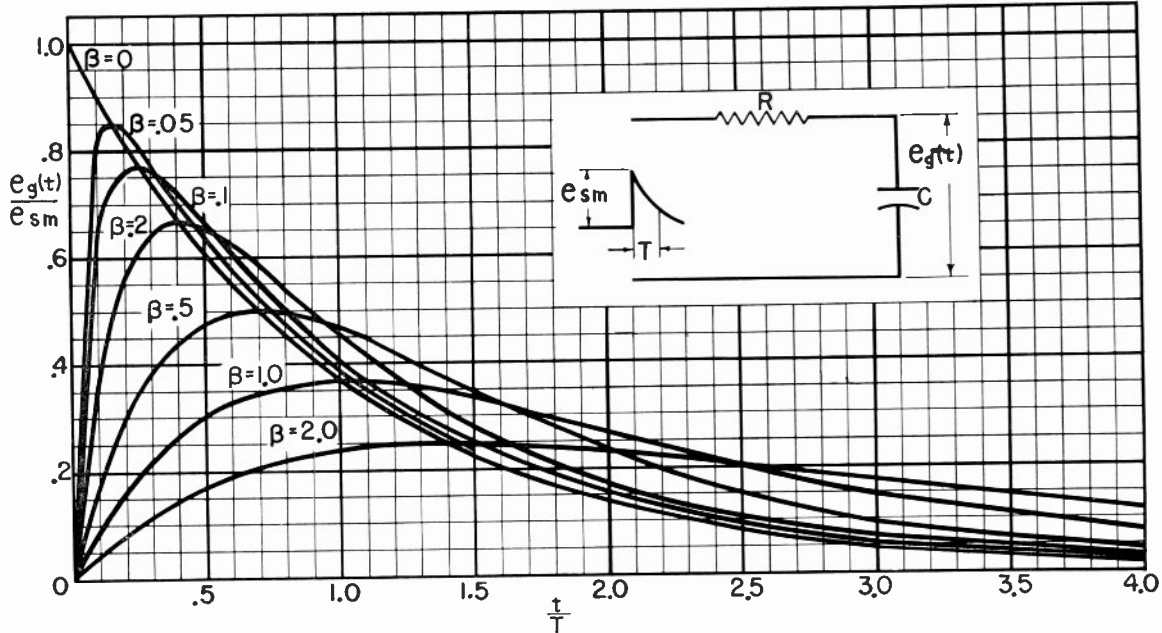

Fig. 11—The ratio ( $e_g(t)/e_{sm}$ ) as a function of ( $t/T$ ) for an exponential pulse with  $\beta = RC/T$  as a parameter.

### III. APPLICATION OF THE ANALYSIS

#### General Discussion

The purpose of this paper is to present information from which the influence of the grid circuit on the grid-potential wave form can be predicted for several standard-signal wave forms. The validity of the foregoing analysis is based on the assumption that the thyatron presents a relatively high impedance to the grid circuit. Although the grid-cathode capacitance of the tube itself offers no particular difficulty, as it can be combined with the capacitance added externally to form the equivalent capacitance  $C$  used in the analysis,

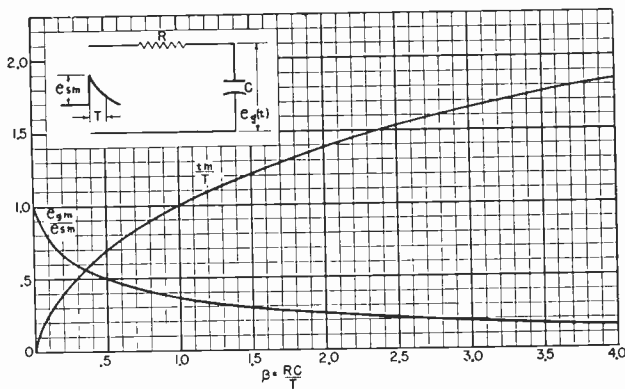

Fig. 12—The ratios ( $t_m/T$ ) and ( $e_{gm}/e_{sm}$ ) as functions of  $\beta = RC/T$  for an exponential pulse.

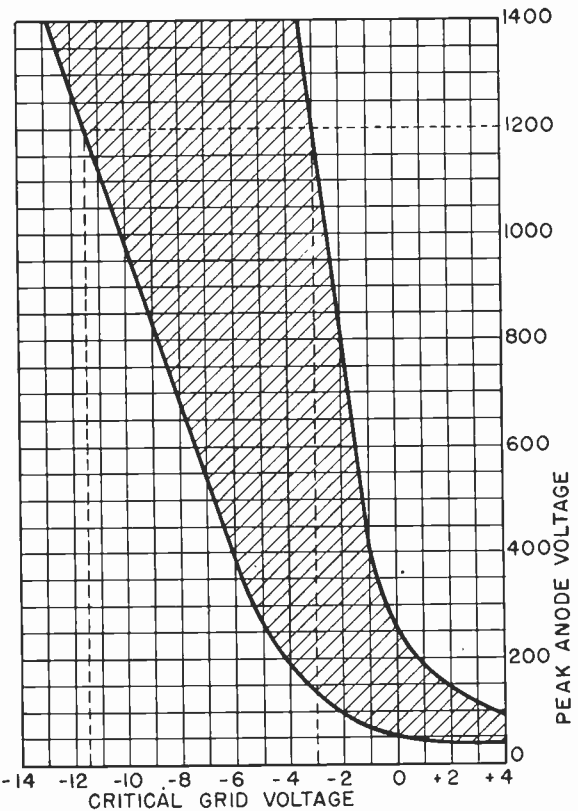

Fig. 13—Control band showing a possible range of variation of control characteristic for a thyatron.

the volt-ampere characteristic of the grid electrode does require consideration. It has been found that during the period prior to the initiation of the discharge, the grid

sive pre-conduction grid current, an elaboration of the analysis must be made to correct for the  $IR$  drop in the grid resistance. In many cases this grid current is



reasonably constant over a considerable range of negative grid voltage and the correction amounts to a shift in the direct-current bias value.

It is usually assumed that the thyratron fires at the instant the grid potential intersects the static grid-control characteristic. For simplicity we shall do likewise. This assumption, while quite satisfactory in most cases, is not strictly correct because of the time required to ionize the tube. Measurements indicate that this ionization time can range from a few microseconds down to very small fractions of a microsecond, depending upon the amount of grid over-voltage, the anode voltage, gas density, and circuit parameters. This complex dependence of the ionization time upon so many factors discourages its introduction into an analysis. Although this paper is concerned primarily with the influence of the grid-circuit parameters on the grid wave form during the pre-conduction period, a word should be said about the influence of tube conduction on the grid circuit. After initiation of the discharge, the grid input impedance decreases to an extremely small fraction of its pre-conduction value. During the period of tube conduction, the grid assumes a potential of a few volts positive with respect to the cathode (if the grid-circuit resistance is more than a few hundred ohms). This makes it possible to approximate the effect of tube conduction on the grid circuit by replacing the grid input impedance by a small positive grid-cathode potential of about 5 volts.

#### Relation of the Pulse Response to the Bias Voltage

The grid response has been given for only the signal pulse, whereas the presence of a grid bias voltage has not been considered. If the circuit elements are linear, the principle of superposition may be employed to combine the responses to the signal pulse and to the bias voltage. Thus, in the case of a direct-current bias, the pulse response may be added directly to the direct-current bias value. For an alternating-current bias, the response to this bias may be evaluated and added to the pulse response. In many cases the alternating-current bias voltage remains sensibly constant during the pulse width  $T$ , hence the pulse response may be added to the grid potential existing just prior to the application of the pulse.

#### Illustrative Example

A typical problem may best illustrate the use of the response curves for various pulse shapes and grid-circuit parameters. The following example indicates how these response curves may be used to estimate the degree of precision of firing for a specific application.

Most manufacturers of thyratrons present their grid-control information in the form of a control "band," as in Fig. 13. This band indicates the variation in control characteristics to be expected from such things as (1) variation in condensed-mercury temperature; (2) manufacturing variations from tube to tube; and (3) variations throughout the life of the tube.

Suppose a triangular signal pulse is applied to the circuit of Fig. 3 at an instant for which the anode voltage is 1200 volts. Reference to Fig. 13 shows that for

an anode potential of 1200 volts, the critical grid potential may range from  $-3.0$  to  $-11.5$  volts. The application of the triangular pulse will cause the grid potential to sweep through this critical range in a time  $\tau$ . This time interval  $\tau$  may be regarded as a measure of the firing precision. Suppose the parameters of the grid circuit and the triangular pulse are as follows:

$$R = 50,000 \text{ ohms}$$

$$C = 0.004 \text{ microfarad}$$

$$e_{sm} = 150 \text{ volts}$$

$$T = 200 \text{ microseconds}$$

$$E_c = 50 \text{ volts.}$$

From this information  $\beta = (RC/T) = 1$ . The response

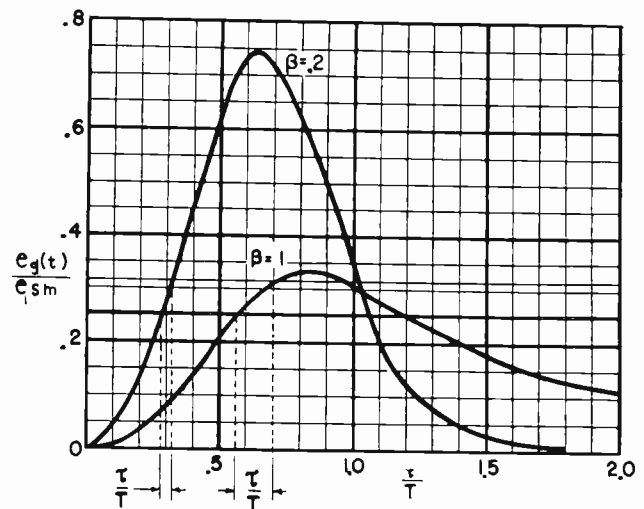

Fig. 14—Graphical determination of the precision of firing.

curve for a triangular pulse with  $\beta = 1$  is selected from Fig. 6 and repeated in Fig. 14. The critical grid voltages and the bias voltage are introduced in the following manner: assuming that the change in anode voltage is inappreciable during the time of the pulse duration  $T$ , the critical grid potentials are also constant over the interval of interest. Now, in order for the tube to fire, the grid potential must rise from a potential ( $-E_c = -50$  volts) to the critical potential (ranging from  $-11.5$  to  $-3.0$  volts). Hence the pulse must raise the grid voltage by 47 volts to assure firing. To evaluate  $\tau$  with the aid of the response curve it is necessary to "normalize" these voltage increments (38.5 and 47 volts) by dividing by the peak of the triangular pulse  $e_{sm}$ . These values of  $(e_c/e_{sm})$ , 0.313 and 0.258, are then laid out on the curve for  $\beta = 1$  in Fig. 14. From the resulting intersections the value of  $\tau/T$  is found to be 0.13. For a 200-microsecond pulse, the value of  $\tau$  is 26 microseconds. It should be noted that one intersection is only slightly below the peak of the response curve. Such a condition should be avoided as it would not insure dependable firing. The situation can be improved by decreasing the grid resistance to 10,000 ohms. The response curve for  $\beta = 0.2$  is then taken from Fig. 6 and laid out in Fig. 14. The intersections with this new curve result in a much better precision of firing,  $\tau = 9$  microseconds. In addition, the

response curve for  $\beta=0.2$  rises considerably above  $(e_g(t)/e_{sm})=0.313$  thus assuring an ample safety factor for dependable firing.

#### MATHEMATICAL APPENDIX

##### I. RESPONSE TO A TRIANGULAR PULSE

The integrodifferential equation for a resistance-capacitance circuit is

$$Ri(t) + \frac{1}{C} \int_0^t i(t)dt + e_g(0) = e_s(t) \quad (12)$$

where  $e_g(0)$  is the grid-capacitor voltage at  $t=0$ . For  $e_g(0)=0$ , the corresponding Laplace transform equation is

$$RI(p) + \frac{1}{Cp} T(p) = E_s(p), \quad (13)$$

from which

$$I(p) = \frac{1}{R} \frac{p}{p + 1/RC} E_s(p) \quad (14)$$

and, since

$$E_g(p) = \frac{1}{CP} I(p) \quad (15)$$

the  $L$  transform of the capacitor voltage is

$$E_g(p) = \frac{1}{RC} \frac{1}{p + 1/RC} E_s(p). \quad (16)$$

The  $L$  transform of the triangular signal pulse of Fig. 4 (a) is

$$E_s(p) = \frac{2e_{sm}}{p^2T} [1 - 2\epsilon^{-p(T/2)} + \epsilon^{-pT}]. \quad (17)$$

The three terms within brackets will be recognized as corresponding to the three time functions into which the triangular pulse may be divided. The two exponential terms are "shift" operators which shift the time response corresponding to  $(2e_{sm}/p^2T)$  by  $T/2$  and  $T$ , respectively. Substitution of (17) in (16) results in

$$E_g(p) = \frac{2e_{sm}}{RCT} \frac{1}{p^2(p + 1/RC)} (1 - 2\epsilon^{-p(T/2)} + \epsilon^{-pT}). \quad (18)$$

The grid voltage as a time function,  $e_g(t)$ , is found by evaluating the inverse  $L$  transform of  $E_g(p)$ . This leads to the three expressions of (1) for  $e_g(t)$ .

##### II. RESPONSE TO A SQUARE PULSE

With no initial charge on the capacitor, the  $L$  transform of the grid voltage is again

$$E_g(p) = \frac{1}{RC} \frac{1}{p + 1/RC} E_s(p). \quad (16)$$

The  $L$  transform for a square pulse of height  $e_{sm}$  and duration  $T$  is

$$E_s(p) = \frac{e_{sm}}{p} (1 - \epsilon^{-pT}), \quad (19)$$

where the two terms in brackets correspond to the two step-functions which combine to form the square pulse. Upon substitution of (19) in (16), the  $L$  transform of the grid voltage becomes

$$E_g(p) = \frac{e_{sm}}{RC} \frac{1}{p(p + 1/RC)} (1 - \epsilon^{-pT}). \quad (20)$$

As before, the exponential term is a "shift" operator which shifts the response to a unit step-function by the time  $T$ . The inverse  $L$  transform,  $e_g(t)$ , is given by (6).

##### III. RESPONSE TO AN EXPONENTIAL PULSE

As in the preceding cases, the  $L$  transform of the grid voltage is

$$E_g(p) = \frac{1}{RC} \frac{1}{(p + 1/RC)} E_s(p), \quad (16)$$

where the  $L$  transform of an exponential pulse of initial height  $e_{sm}$  and time constant  $T$  is

$$E_s(p) = \frac{e_{sm}}{p + 1/T}. \quad (21)$$

With the substitution of (21) in (16), the  $L$  transform of the grid voltage is

$$E_g(p) = \frac{e_{sm}}{RC} \frac{1}{(p + 1/RC)(p + 1/T)}. \quad (22)$$

This  $L$  transform leads to two time functions: one for the general case  $RC \neq T$ , and one for the special case  $RC = T$ . The corresponding time functions for  $e_g(t)$  are given by (9).

#### ACKNOWLEDGMENT

We wish to thank Mr. D. E. Marshall, of the Industrial Tube Section of this company, for his encouragement and helpful comments during the preparation of this paper.

# The Steady-State Operational Calculus\*

D. L. WAIDELICH†, SENIOR MEMBER, I.R.E.

**Summary**—The direct and inverse transforms of the steady-state operational calculus are presented, together with two methods of evaluating the inverse transform, the first resulting in a Fourier series and the second giving a sum function. A proof of the inversion theorem connecting the two transforms is outlined in the Appendix. Two examples are presented illustrating the application of this operational calculus to circuit problems, and a comparison is made between the ordinary and the steady-state operational calculuses.

## INTRODUCTION

THE USE of nonsinusoidal wave forms in electric circuits has increased greatly in the past few years, particularly with the advent of new and improved electronic devices. Fourier series may be used in the solution of the circuit problems that arise in these applications if the harmonic voltages and currents with appreciable amplitude are few in number. If, however, the harmonics with large amplitudes are great in number, other methods of circuit solution must be utilized. These methods of steady-state solution of circuits with nonsinusoidal wave forms recently have been the object of increased study, as evidenced by the number of investigations that have been made.<sup>1</sup> It appears that many of the results obtained in these scattered investigations may be integrated into a steady-state operational calculus which will present a more consistent method of solving for the steady state of nonsinusoidal circuit problems. It is the purpose of this paper to present such a steady-state operational calculus; an operational calculus in many ways quite similar to and yet in other ways quite different from the ordinary operational calculus. The method will also be applied to several examples.

An operational calculus is a method of solving differential equations in which the process of integration and differentiation is replaced by an operator which is manipulated as an algebraic quantity. The resulting operational equation is solved, and the operational solution is then transformed into the actual solution of the differential equation. As a result of this method, the ordinary operational calculus produces a solution of a differential equation of, for example, a current, which is composed of a transient part and a steady-state part. These two parts are difficult to identify and separate in many cases, and the steady-state part is sometimes in the form of a Fourier series which is hard to use and interpret. As a result of the steady-state operational calculus, the steady-state current is obtained by itself, and the current may be expressed either as a Fourier series or as a sum function. In a given circuit with a non-

sinusoidal periodic voltage applied, the current may be obtained by changing the voltage into a Fourier series, calculating the current for the fundamental and each harmonic, and adding the results to obtain the Fourier series of the current. To obtain the wave form of the current from this series is very tedious, particularly if the voltage has any sharp discontinuities in it. The current, on the other hand, may be expressed as a sum function of the series by the use of the steady-state operational calculus, and the current wave form is easily plotted from this sum function.

The operational method, in brief, consists of operating on the impressed voltage by means of the direct transform. The transformed voltage is divided by the operational impedance to obtain the transformed current. The transformed current is then operated upon by the inverse transform to obtain the resulting current. The two most important concepts of any operational calculus are the direct and the inverse transforms, and these will be introduced first.

## TRANSFORMS

The direct transform was introduced by McLachlan<sup>2</sup> in 1937. If the periodic time function  $f(t)$  has a period of  $T$  seconds, then the direct transform is

$$S[f(t)] = \int_0^T e^{-pt} f(t) dt \quad (1)$$

where  $p$  is a complex number. The inverse transform has been introduced<sup>3</sup> recently, and was used to obtain the steady-state solution of circuits. It is

$$S^{-1}[F(p)] = \frac{1}{2\pi j} \int_W \frac{e^{pt} F(p)}{(1 - e^{-pT})} dp \quad (2)$$

where  $F(p)$  is a function of  $p$  with properties as outlined in the Appendix. It is possible to extend this inverse transform to include the case of functions with branch points such as those encountered in transmission-line theory, but discussion of this more difficult integral will be deferred for the present. The type of function considered here will contain practically all of the cases encountered in ordinary linear-circuit theory using concentrated parameters. For the inverse transform, the path of integration  $W$  in the complex plane is composed of two parts,  $W_1$  and  $W_2$  as shown in Fig. 1. All of the poles of  $F(p)$  must be to the left of  $W_2$ , except for the points,  $p = (jn2\pi/T) = jn\omega$  where  $n$  is a positive or negative integer, which must lie between  $W_1$  and  $W_2$ . The

\* Decimal classification: 510×R140. Original manuscript received by the Institute, April 23, 1945. This paper contains material from a thesis to be submitted for a doctoral degree at Iowa State College.

† University of Missouri, Columbia, Missouri.

<sup>1</sup> See List of Additional References and footnotes 2, 3, and 4.

<sup>2</sup> N. W. McLachlan, "Fourier expansions obtained operationally," *Phil. Mag.*, vol. 24, pp. 1055-1058; December, 1937.

<sup>3</sup> D. L. Waidelich, "Steady-state currents of electrical networks," *Jour. Appl. Phys.*, vol. 13, pp. 706-712; November, 1942.

path  $W_3$  to be used later is the same as  $W_2$  except that the direction is reversed.

It is explained in the outline of the inversion-theorem proof as given in the Appendix that the inverse transform is unique; i.e., it has one and only one value for a given value of  $t$ , whereas the direct transform is not unique. This is one of the points of difference between the ordinary operational calculus and the operational method outlined in this paper. There is one value of the direct transform that is unique, however, and that is the transform  $F(p)$  which has no poles anywhere in the finite part of the complex plane. It is also the transform obtained always from (1) and will henceforth be called the primitive direct transform.

The evaluation of the direct transform may be accomplished readily by treating the operator  $p$  as a constant, and by using an ordinary table of integrals. To evaluate the inverse transform, on the other hand, requires a working knowledge of the theory of residues for functions of a complex variable.<sup>4</sup> The evaluation of the inverse transform has been treated in detail,<sup>3</sup> so only a summary of the method will be given here.

1. *Evaluation as a Fourier series:* The residues of the integral at the poles  $p = (jn2\pi/T)$  within the path of integration  $W$  are calculated and summed to give the Fourier series.

2. *Evaluation as a sum function:* In many cases, the inverse transform may be evaluated as the sum function of the Fourier series. The transform may be expressed as two separate integrals

$$\begin{aligned} S^{-1}[F(p)] &= \frac{1}{2\pi j} \int_W \frac{\epsilon^{pt}F(p)}{(1 - \epsilon^{-pT})} dp \\ &= \frac{1}{2\pi j} \int_{W_1} \frac{\epsilon^{pt}F(p)}{(1 - \epsilon^{-pT})} dp \\ &\quad - \frac{1}{2\pi j} \int_{W_2} \frac{\epsilon^{pt}F(p)}{(1 - \epsilon^{-pT})} dp. \end{aligned} \quad (3)$$

The path of integration  $W_1$  of the first integral of (3) is the same as that of the inverse transform of the ordinary operational calculus and may be evaluated in the same manner.<sup>3</sup> Thus

$$\begin{aligned} &\frac{1}{2\pi j} \int_{W_1} \frac{\epsilon^{pt}F(p)}{(1 - \epsilon^{-pT})} dp \\ &= \frac{1}{2\pi j} \int_{W_1} \epsilon^{pt}F(p) dp + \frac{1}{2\pi j} \int_{W_1} \epsilon^{p(t-T)}F(p) dp + \dots, \end{aligned} \quad (4)$$

and when  $0 < t < T$ ,

$$\frac{1}{2\pi j} \int_{W_1} \frac{\epsilon^{pt}F(p)}{(1 - \epsilon^{-pT})} dp = \frac{1}{2\pi j} \int_{W_1} \epsilon^{pt}F(p) dp \quad (5)$$

which may be evaluated by calculating the residues at

<sup>4</sup> N. W. McLachlan, "Complex Variable and Operational Calculus," Cambridge University Press, New York, N. Y., 1939.

all poles to the left of  $W_1$ . The second integral of (3) may be evaluated by calculating the residues at the poles to the left of  $W_2$  since the contribution of the integral around a large semicircle to the left of  $W_2$  can be shown

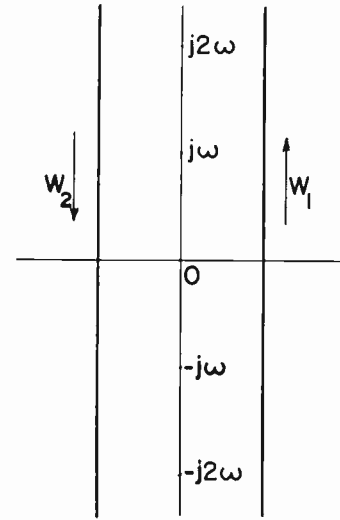

Fig. 1—One path of integration employed in the inverse transform.

to approach zero as the radius of the semicircle approaches infinity. Difficulty is sometimes encountered when some of the poles of  $F(p)$  lie on the imaginary axis or to the right of the imaginary axis. In these cases, the paths of integration  $W_2$  or  $W_3$  must be bent around these poles so that the poles are to the left of the paths. This will be illustrated in the examples of the next paragraph.

The first example will be that of a sine wave  $e(t) = E_m \sin(\omega t + \phi)$ . From (1) the direct transform is

$$\begin{aligned} S[e(t)] &= \int_0^T \epsilon^{-pt} E_m \sin(\omega t + \phi) dt \\ &= \frac{E_m(p \sin \phi + \omega \cos \phi)(1 - \epsilon^{-pT})}{p^2 + \omega^2}. \end{aligned} \quad (6)$$

The inverse transform is obtained by substituting (6) into (2)

$$\begin{aligned} S^{-1} &= \frac{1}{2\pi j} \int_W \frac{\epsilon^{pt} E_m(p \sin \phi + \omega \cos \phi)}{p^2 + \omega^2} dp \\ &= \frac{1}{2\pi j} \int_W \frac{\epsilon^{pt} E_m(p \sin \phi + \omega \cos \phi)}{(p - j\omega)(p + j\omega)} dp. \end{aligned} \quad (7)$$

The integral (7) has two poles  $p = \pm j\omega$ , both of which lie within the path of integration  $W$  and hence the residue must be found at both poles. When this is done it will be found that

$$S^{-1} = E_m \sin(\omega t + \phi). \quad (8)$$

Fig. 2 is an illustration of the full-wave rectified sine wave to be used as the second example.

$$S = \int_0^T \epsilon^{-pt} E_m \sin(\pi t/T) dt = \frac{E_m(\pi/T)(1 + \epsilon^{-pT})}{p^2 + (\pi^2/T^2)}. \quad (9)$$

The inverse transform



$$S^{-1} = \frac{1}{2\pi j} \int_W \frac{\epsilon^{pt} E_m (\pi/T) (1 + \epsilon^{-pT})}{[p^2 + (\pi^2/T^2)] (1 - \epsilon^{-pT})} dp \quad (10)$$

is evaluated as a Fourier series by calculating the residues at the poles  $p = (jn2\pi/T)$  where  $n$  is any positive or negative integer.

$$\begin{aligned} S^{-1} &= \frac{2E_m}{\pi} \sum_{n=-\infty}^{+\infty} \frac{\epsilon^{(j2\pi n t/T)}}{1 - 4n^2} \\ &= \frac{2E_m}{\pi} - \frac{4E_m}{\pi} \sum_{n=1}^{\infty} \frac{\cos(2\pi n t/T)}{4n^2 - 1}. \end{aligned} \quad (11)$$

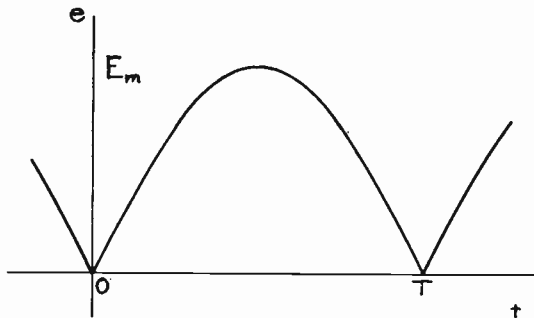

Fig. 2—The full-wave rectified sine-wave voltage.

Equation (10) may also be evaluated as the sum function of the Fourier series

$$\begin{aligned} S^{-1} &= \frac{1}{2\pi j} \int_{W_1} \frac{\epsilon^{pt} E_m (\pi/T) (1 + \epsilon^{-pT}) (1 + \epsilon^{-pT} + \epsilon^{-p2T} + \dots)}{p^2 + (\pi^2/T^2)} dp \\ &\quad - \frac{1}{2\pi j} \int_{W_3} \frac{\epsilon^{pt} E_m (\pi/T) (1 + \epsilon^{-pT})}{[p^2 + (\pi^2/T^2)] (1 - \epsilon^{-pT})} dp. \end{aligned}$$

When  $0 < t < T$

$$\begin{aligned} S^{-1} &= \frac{1}{2\pi j} \int_{W_1} \frac{\epsilon^{pt} E_m (\pi/T)}{p^2 + (\pi^2/T^2)} dp \\ &\quad - \frac{1}{2\pi j} \int_{W_3} \frac{\epsilon^{pt} E_m (\pi/T) (1 + \epsilon^{-pT})}{[p^2 + (\pi^2/T^2)] (1 - \epsilon^{-pT})} dp. \end{aligned} \quad (12)$$

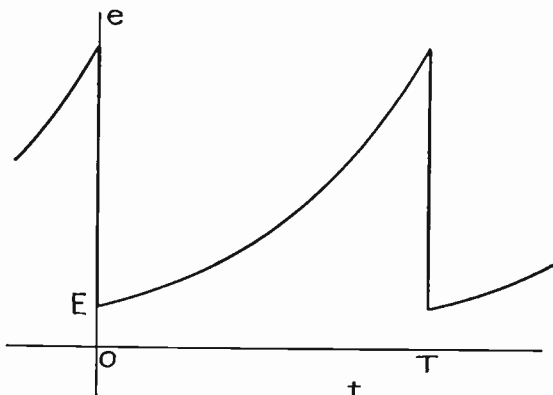

Fig. 3—Exponential wave form.

The first integral of (12) has two poles  $p = \pm j(\pi/T)$ , while the second has no poles; hence

$$S^{-1} = E_m \sin(\pi t/T). \quad (13)$$

The third example is that of the exponential wave form shown in Fig. 3 whose equation for  $0 < t < T$  is  $e = E\epsilon^{at}$  where  $a > 0$ .

$$S = \int_0^T \epsilon^{-pt} E \epsilon^{at} dt = \frac{E}{p - a} [1 - \epsilon^{-(p-a)T}]. \quad (14)$$

The inverse transform as the sum function is

$$\begin{aligned} S^{-1} &= \frac{1}{2\pi j} \int_W \frac{\epsilon^{pt} E [1 - \epsilon^{-(p-a)T}]}{(p - a)(1 - \epsilon^{-pT})} dp \\ &= \frac{1}{2\pi j} \int_{W_1} \frac{\epsilon^{pt} E}{p - a} dp \\ &\quad - \frac{1}{2\pi j} \int_{W_3} \frac{\epsilon^{pt} E [1 - \epsilon^{-(p-a)T}]}{(p - a)(1 - \epsilon^{-pT})} dp \\ &= E \epsilon^{at}. \end{aligned} \quad (15)$$

The first integral of (15) has one pole  $p = a$ , but the second integral has no poles. Determine now for the direct transform

$$S = \frac{E(1 - \epsilon^{aT})}{p - a} \quad (16)$$

the corresponding inverse transform

$$\begin{aligned} S^{-1} &= \frac{1}{2\pi j} \int_W \frac{\epsilon^{pt} E (1 - \epsilon^{aT})}{(p - a)(1 - \epsilon^{-pT})} dp \\ &= \frac{1}{2\pi j} \int_{W_1} \frac{\epsilon^{pt} E (1 - \epsilon^{aT})}{p - a} dp \\ &\quad - \frac{1}{2\pi j} \int_{W_3} \frac{\epsilon^{pt} E (1 - \epsilon^{aT})}{(p - a)(1 - \epsilon^{-pT})} dp. \end{aligned} \quad (17)$$

The path  $W_3$  has to be bent as shown in Fig. 4 because the pole  $p = a$  must be to the left of  $W_3$ . Both integrals

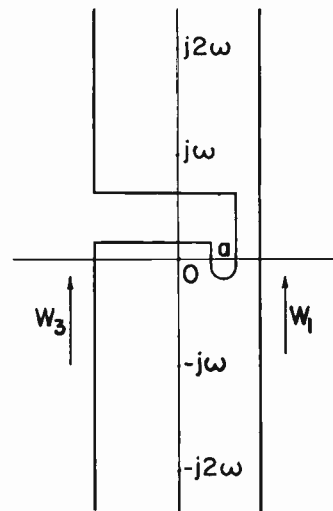

Fig. 4—An alternate path of integration employed in the inverse transform.

of (17) have the pole  $p = a$ , and when evaluated at this

pole, the inverse transform becomes

$$S^{-1} = E\epsilon^{at}. \quad (18)$$

It will be noticed that two different direct transforms, those of (14) and (16), both have the same inverse transform, indicating again that the direct transform is not unique. The primitive direct transform for this example is that of (14), since first, it has no singularities in the finite part of the complex plane, and second, it is obtained from (1). Equation (16) is one of the infinite number of nonprimitive transforms for this example, and was obtained from the primitive transform by subtracting the quantity

$$\frac{E\epsilon^{aT}(1 - \epsilon^{-pT})}{p - a} \quad (19)$$

which, when substituted in the inverse transform, will be found to be zero. Just as there are two forms of the inverse transform; i.e., the Fourier series and the sum function, there are also two forms of the direct transform, the series form and the sum-function form. From the second part of the inversion theorem of the Appendix, if  $F(p)$  is a primitive direct transform, then

$$F(p) = \sum_{n=-\infty}^{+\infty} \frac{(1 - \epsilon^{-pT})F(j2\pi n/T)}{T(p - j2\pi n/T)}. \quad (20)$$

As an illustration, the primitive transform (14) of example 3 may be expanded into the series

$$S = \frac{E}{p - a} [1 - \epsilon^{-(p-a)T}] \\ = \sum_{n=-\infty}^{+\infty} \frac{(1 - \epsilon^{-pT})E(\epsilon^{aT} - 1)}{T(p - j2\pi n/T)(a - j2\pi n/T)}. \quad (21)$$

#### CIRCUIT ANALYSIS

Three simple theorems are necessary before this method may be applied to the solution of steady-state circuit problems. These are

1. If  $f_n(t) = S^{-1}[F_n(p)]$ ,  $f(t) = S^{-1}[F(p)]$ , and  $F(p) = \sum_{n=1}^{\infty} F_n(p)$ , then  $f(t) = \sum_{n=1}^{\infty} f_n(t)$ . This theorem may be inverted if  $F(p)$  and  $F_n(p)$  are primitive transforms.

2. If  $g(t) = g(0) + \int_0^t f(t)dt$  and  $g(t)$  is continuous, then

$$S[g(t)] = (1/p)(1 - \epsilon^{-pT})g(0) + (1/p)S[f(t)]. \quad (22)$$

The proof of this particular theorem will be carried through.

$$S[g(t)] = \int_0^T \epsilon^{-pT} g(0)dt + \int_0^T \epsilon^{-pt} \left[ \int_0^t f(t)dt \right] dt \\ = (1/p)(1 - \epsilon^{-pT})g(0) + (1/p) \int_0^T \epsilon^{-pt} f(t)dt \\ = (1/p)(1 - \epsilon^{-pT})g(0) + (1/p)S[f(t)].$$

3. If  $g(t) = d[f(t)]/dt$  and  $f(t)$  is continuous, then

$$S[g(t)] = - (1 - \epsilon^{-pT})f(0) + pS[f(t)]. \quad (23)$$

Both the second and third theorems may be applied as many times as is necessary. A number of other interesting but less essential theorems may be derived in a similar manner, but these are not included here.

Two examples of the application of this steady-state operational calculus to the solution of circuit problems will be given.

1. The first example is that of the sinusoidal voltage  $e(t) = E_m \sin(\omega t + \phi)$  applied to a series resistance  $R$ , inductance  $L$ , and capacitance  $C$  circuit, whose voltage equation is

$$e(t) = Ri + L \frac{di}{dt} + \frac{q}{c}. \quad (24)$$

Let  $I = S[i(t)]$ , and by the use of the three preceding theorems, (24) becomes

$$S[e(t)] = RI - (1 - \epsilon^{-pT})Li(0) + LpI \\ + (1/p)(1 - \epsilon^{-pT})[q(0)/c] + (I/pC). \quad (25)$$

Solving for  $I$ ,

$$I = \frac{pS[e(t)]}{L(p^2 + pR/L + 1/LC)} + \frac{p(1 - \epsilon^{-pT})i(0)}{p^2 + pR/L + 1/LC} \\ - \frac{(1 - \epsilon^{-pT})q(0)}{LC(p^2 + pR/L + 1/LC)}. \quad (26)$$

The expression for  $I$  in (26) is the primitive transform of the steady-state current  $i(t)$ . The last two terms of (26), when substituted into the inverse transform, will be zero, and hence the first term is the only one that need be used. This first term is a nonprimitive transform of  $i(t)$ , and in effect its use means that (22) and (23) become

$$S \left[ g(0) + \int_0^t f(t)dt \right] = (1/p)S[f(t)] \quad (27)$$

and

$$S[df(t)/dt] = pS[f(t)]. \quad (28)$$

These two equations can be used for almost all circuit problems, but if there is any doubt, (22) and (23) should be used. Using the first term of (26) and with the aid of (2) and (6),

$$i = \frac{1}{2\pi j} \int_w \frac{\epsilon^{pt} E_m p (p \sin \phi + \omega \cos \phi)}{L(p^2 + \omega^2)(p^2 + pR/L + 1/LC)} dp \\ = (E_m/Z) \sin(\omega t + \phi - \theta) \quad (29)$$

where

$$Z = \sqrt{R^2 + (\omega L - 1/\omega C)^2} \quad \text{and} \quad \theta = \tan^{-1} [(\omega L - 1/\omega C)/R].$$

This is the familiar expression for the steady-state current of this circuit.

2. The square-wave voltage used in communications work is shown in Fig. 5 and has the direct transform

$$S[e(t)] = (E_m p)(1 - \epsilon^{-pT/2}). \quad (30)$$

The voltage is applied to the circuit of Fig. 6, and the voltage  $e_c$  across the capacitance  $C$  is required. The

transform of this voltage is

$$E_c = \frac{pLS[e(t)]}{p^2CRL + pL + R}, \tag{31}$$

and the inverse transform of (31), for  $0 < t < T/2$ , is

$$e_c = 4E_m \left(\frac{m}{n}\right) \epsilon^{-nt} \left[ \frac{\sin nt + \epsilon^{-mT/2} \sin n(t - T/2)}{1 + 2\epsilon^{-mT/2} \cos(nT/2) + \epsilon^{-mT}} \right] \tag{32}$$

where  $m = (1/2CR)$ ,  $n = \sqrt{(1/LC) - m^2}$ , and  $LC < (2CR)^2$ . The voltage  $e_c$  is shown in Fig. 7 for the values

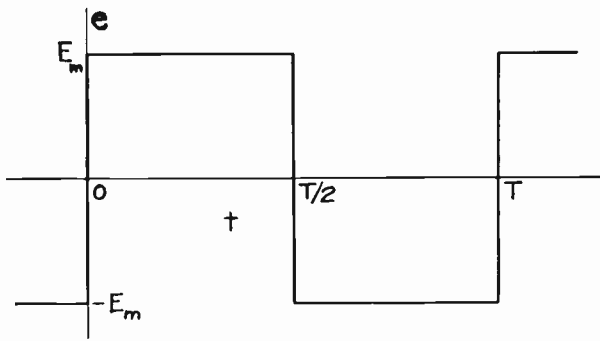

Fig. 5—The square-wave voltage applied to the circuit of Fig. 6.

$\omega^2LC = 0.236$  and  $\omega CR = 1.0$  where  $\omega = (2\pi/T)$ . When  $LC > (2CR)^2$ ,

$$e_c = 2E_m \left(\frac{a + b}{a - b}\right) \left[ \frac{\epsilon^{-bt}}{1 + \epsilon^{-bT/2}} - \frac{\epsilon^{-at}}{1 + \epsilon^{-aT/2}} \right] \tag{33}$$

where  $a = m + jn$  and  $b = m - jn$ . The wave form of Fig. 6 may also be observed experimentally.

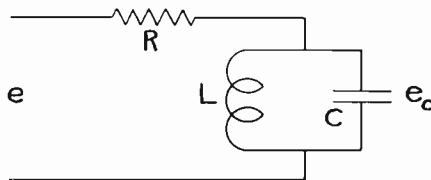

Fig. 6—Resistance-inductance-capacitance circuit.

A table of corresponding direct and inverse transforms would be very useful in solving for the steady-state currents of circuits, but such a table would have to be very lengthy because of the many different types of voltages that are encountered in this work, and also because of the many direct transforms, both the primitive one and nonprimitive ones, that correspond to a given inverse transform. For this reason, a compilation of a transform table was not attempted here, but it is hoped to present one later.

A succinct comparison of the ordinary operational calculus and the steady-state operational calculus is presented in Table I. It will be noticed that in both operational calculuses, the derivative sign is replaced by  $p$  and the integral sign by  $(1/p)$ .

CONCLUSIONS

The direct and inverse transforms of the steady-state

operational calculus have been presented, together with an inversion theorem that shows that the two transforms are actually inverses of each other. With the aid of several theorems involving the derivative of a function and the integral of a function, it was demonstrated that the inverse transform, when evaluated, yields the steady-state currents and voltages of the circuit under study. This method was then applied to two examples,

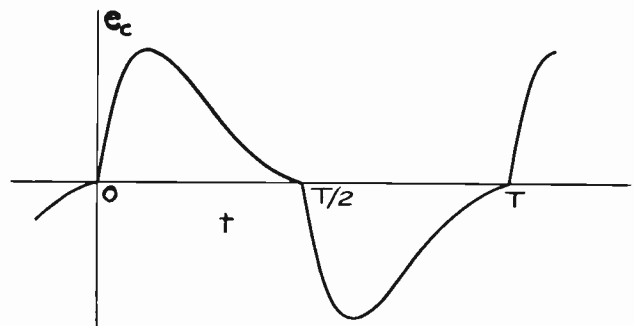

Fig. 7—Resulting voltage  $e_c$  across the capacitance.

and the solutions were obtained as sum functions which are very convenient in plotting the wave forms involved. On the other hand, the solutions may be obtained as a Fourier series if the values of the harmonics are desired.

TABLE I

	Ordinary Operational Calculus	Steady-State Operational Calculus
Direct Transform	$L[f(t)] = \int_0^\infty \epsilon^{-pt} f(t) dt$	$S[f(t)] = \int_0^T \epsilon^{-pt} f(t) dt$
Inverse Transform	$L^{-1}[F(p)] = \frac{1}{2\pi j} \int_{c-j\infty}^{c+j\infty} \epsilon^{pt} F(p) dp$ where $c$ is greater than the real parts of the poles of $F(p)$ .	$S^{-1}[F(p)] = \frac{1}{2\pi j} \int_W \frac{\epsilon^{pt} F(p)}{(1 - \epsilon^{-pT})} dp$
Transform of a Derivative	$L \left[ \frac{df(t)}{dt} \right] = pL[f(t)]$ if $f(0) = 0$	$S \left[ \frac{df(t)}{dt} \right] = pS[f(t)]$
Transform of an Integral	$L \left[ \int_0^t f(t) dt \right] = (1/p)L[f(t)]$	$S[g(t)] = (1/p)S[f(t)]$ where $g(t) = g(0) + \int_0^t f(t) dt$

APPENDIX

OUTLINE OF INVERSION-THEOREM PROOF

Part 1: It will be assumed here, as is true in almost all practical problems, that  $f(t)$  is bounded and has at most a finite number of discontinuities.

If  $F(p) = \int_0^T \epsilon^{-pt} f(t) dt$ , then

$$f(t) = \frac{1}{2\pi j} \int_W \frac{\epsilon^{pt} F(p)}{(1 - \epsilon^{-pT})} dp.$$

For if  $\alpha > 0$  and  $y > 0$ , let

$$\begin{aligned} A_1 &= \frac{1}{2\pi j} \int_{\alpha-jy}^{\alpha+jy} \frac{\epsilon^{pt} F(p)}{(1 - \epsilon^{-pT})} dp \\ &= \frac{1}{2\pi j} \int_{\alpha-jy}^{\alpha+jy} dp \int_0^T \frac{\epsilon^{p(t-x)} f(x)}{1 - \epsilon^{-pT}} dx \\ &= \frac{1}{2\pi j} \int_0^T dx \int_{\alpha-jy}^{\alpha+jy} \frac{\epsilon^{p(t-x)} f(x)}{1 - \epsilon^{-pT}} dp \end{aligned}$$

$$\begin{aligned} &= \frac{1}{2\pi j} \int_0^T dx \int_{\alpha-jy}^{\alpha+iy} f(x) \epsilon^{p(t-x)} \left[ \sum_{n=0}^{\infty} \epsilon^{-n\pi T} \right] dp \\ &= \frac{1}{2\pi j} \int_0^T f(x) \left\{ \sum_{n=0}^{\infty} \int_{\alpha-jy}^{\alpha+iy} \epsilon^{p(t-x-nT)} dp \right\} dx \\ &= \frac{1}{\pi} \int_0^T f(x) \left\{ \sum_{n=0}^{\infty} \frac{\epsilon^{\alpha(t-x-nT)} \sin y(t-x-nT)}{t-x-nT} \right\} dx \\ &= \sum_{n=0}^{\infty} \frac{1}{\pi} \int_{t-(n+1)T}^{t-nT} f(t-nT-u) \left( \frac{\epsilon^{\alpha u} \sin yu}{u} \right) du. \end{aligned}$$

Similarly, if  $\beta > 0$  and  $y > 0$ , let

$$\begin{aligned} A_2 &= \frac{1}{2\pi j} \int_{-\beta-jy}^{-\beta+iy} \frac{\epsilon^{p t} F(p)}{1 - \epsilon^{-pT}} dp \\ &= - \sum_{n=0}^{\infty} \frac{1}{\pi} \int_{t+nT}^{t+(n+1)T} f[t+(n+1)T-u] \frac{\epsilon^{-\beta u} \sin yu}{u} du. \end{aligned}$$

Then

$$\begin{aligned} &\frac{1}{2\pi j} \int_W \frac{\epsilon^{p t} F(p)}{(1 - \epsilon^{-pT})} dp \\ &= \lim_{y \rightarrow \infty} (A_1 - A_2) \\ &= (1/2) [f(t+0) + f(t-0)] \text{ if there is a discontinuity at } t. \end{aligned}$$

Or

$$\frac{1}{2\pi j} \int_W \frac{\epsilon^{p t} F(p)}{(1 - \epsilon^{-pT})} dp = f(t) \text{ if there is no discontinuity.}$$

It is also possible to show that the inverse transform is unique.

*Part 2.* It will be assumed here that  $F(p)$  is a meromorphic function of  $p$ ; i.e., a function analytic everywhere in the finite part of the complex plane except for a finite number of poles as singularities in each finite part of the complex plane. The function  $F(p)$  must not have any essential singularities or branch points in any finite portion of the plane.

If

$$f(t) = \frac{1}{2\pi j} \int_W \frac{\epsilon^{p t} F(p)}{(1 - \epsilon^{-pT})} dp$$

and

$$\left| \frac{F(z)}{1 - \epsilon^{-zT}} \right| \rightarrow 0 \text{ as } r \rightarrow \infty \text{ where } z = \frac{(2r+1)\pi}{T} \epsilon^{i\theta}$$

and  $r$  is an integer,

$$\text{then } F(p) = \int_0^T \epsilon^{-p t} f(t) dt.$$

For if  $\alpha > 0$  and  $y > 0$ , let

$$B_1 = \int_0^T \epsilon^{-p t} \left\{ \frac{1}{2\pi j} \int_{\alpha-jy}^{\alpha+iy} \frac{\epsilon^{z t} F(z)}{(1 - \epsilon^{-zT})} dz \right\} dt$$

where all the singularities of  $F(z)$  lie to the left of the line  $z = \alpha$ .

$$B_1 = \frac{1}{2\pi j} \int_{\alpha-jy}^{\alpha+iy} \frac{F(z)}{(1 - \epsilon^{-zT})} \left\{ \int_0^T \epsilon^{(z-p)t} dt \right\} dz$$

$$= \frac{1}{2\pi j} \int_{\alpha-jy}^{\alpha+iy} \frac{F(z) [1 - \epsilon^{-(p-z)T}]}{(p-z)(1 - \epsilon^{-zT})} dz.$$

Similarly, if  $\beta > 0$  and  $y > 0$ , let

$$\begin{aligned} B_2 &= \int_0^T \epsilon^{-p t} \left\{ \frac{1}{2\pi j} \int_{-\beta-jy}^{-\beta+iy} \frac{\epsilon^{z t} F(z)}{(1 - \epsilon^{zT})} dz \right\} dt \\ &= \frac{1}{2\pi j} \int_{-\beta-jy}^{-\beta+iy} \frac{F(z) [1 - \epsilon^{-(p-z)T}]}{(p-z)(1 - \epsilon^{-zT})} dz \end{aligned}$$

where all the singularities of  $F(p)$  are to the left of the line  $p = -\beta$  except for the poles  $p = j2\pi m/T$ . Consider the integral

$$D_m = \frac{1}{2\pi j} \int_{C_m} \frac{F(z) [1 - \epsilon^{-(p-z)T}]}{(p-z)(1 - \epsilon^{-zT})} dz$$

where  $m$  is a positive integer and  $C_m$  is a rectangular curve traversed counterclockwise and with straight-line sides, whose equations are  $p = \alpha$ ,  $p = j(2m+1)\pi/T$ ,  $p = -\beta$ , and  $p = -j(2m+1)\pi/T$ . Then

$$D_m = \sum_{m=-m}^{+m} G_m \left( \frac{1}{p - j \frac{2\pi m}{T}} \right)$$

where  $G_m$  is the principal part at the pole  $p = j2\pi m/T$ . The contribution to  $D_m$  of the integrals along the lines  $p = \pm j(2m+1)\pi/T$  approaches zero as  $m \rightarrow \infty$ . Hence

$$\begin{aligned} \int_0^T \epsilon^{-p t} f(t) dt &= \lim_{y \rightarrow \infty} (B_1 - B_2) = \lim_{m \rightarrow \infty} D_m \\ &= \sum_{m=-\infty}^{+\infty} G_m \left( \frac{1}{p - j \frac{2\pi m}{T}} \right) \\ &= F(p) + II(p) \end{aligned}$$

where  $II(p)$  is a function of  $p$  which, when substituted in the inverse transform, will turn out to be zero. Hence the direct transform is not unique but may have any number of values.

**Additional References**

- (1) C. W. Carnahan, "The steady-state response of a network to a periodic driving force of arbitrary shape, and applications to television circuits," Proc. I.R.E., vol. 23, pp. 1393-1404; November, 1935.
- (2) H. W. Droste, "Ein Satz der Laplaceschen Funktionentransformation über die Aufteilung in Dauer- und Ausgleichvorgang bei Gleich- und Wechselstrom und der Ausgleichssatz der Komplexen Umwandlung," Elek. Nach. Tech., vol. 16, pp. 253-257; October, 1939.
- (3) Nathan Marchand, "The response of electrical networks to nonsinusoidal periodic waves," Proc. I.R.E., vol. 29, pp. 330-333; June, 1941.
- (4) Edwin W. Hamlin, "The response of a network to an arbitrary periodic driving force," Jour. Frank. Inst., vol. 233, pp. 257-270; March, 1942.
- (5) D. L. Waidelich, "The steady-state response of circuits," Communications, vol. 22, pp. 14-18; October, 1942.
- (6) S. Frankel, "Closed-form steady-state response of networks," Communications, vol. 23, pp. 30-36; April, 1943.
- (7) D. L. Waidelich, "Steady-state testing with saw-tooth waves," Proc. I.R.E., vol. 32, pp. 339-348; June, 1944.
- (8) P. T. Chin, "Circuit response to nonsinusoidal wave forms," Electronics, vol. 17, pp. 138-141; October, 1944.



# Antinoise Characteristics of Differential Microphones\*

HAROLD E. ELLITHORN†, MEMBER, I.R.E., AND A. M. WIGGINS‡, ASSOCIATE, I.R.E.

**Summary**—The operation of the differential<sup>1,2</sup> microphone is described, and the noise discrimination of differential microphones operating on various orders of pressure gradients is obtained. Equations of the discrimination against random sounds are developed for both theoretical and practical microphones. Curves are drawn, showing discrimination versus frequency. The noise discrimination of the *n*th-order pressure gradient is obtained as the ultimate in differential-type microphones.

## I. INTRODUCTION

AMONG the many refinements in the technique of electrical transmission of sound, a substantial number has been concerned with exclusion from the transmitter of unwanted, ambient noise arising from extraneous sources and of reflections of the desired sound. The problem has been met satisfactorily in cases where acoustic conditions at the transmitting location can be controlled by suitable insulation against undesired sounds and by treatment of the enclosing walls to reduce or diffuse reflections. These methods, however, give no relief to the difficulties encountered when a communication microphone must be located in a zone of high ambient noise. While baffles, shields, directional microphones, weighted response curves, throat microphones,<sup>3</sup> etc., are sometimes helpful, none provides sufficiently complete noise rejection to outweigh their various inherent disadvantages, such as loss of articulation and intelligibility, large, awkward, or uncomfortable microphones, or limitations on movement of the speaker. This problem became really serious when the communication needs of modern, mechanized warfare required direct-speech communication from such locations as the inside of a tank, where ambient noise commonly runs to levels beyond any peacetime precedent. The United States Army Type T-45 lip microphone, developed by Burroughs and Kahn from the original conception of Beekley,<sup>2</sup> has proven a thoroughly satisfactory solution of the military problem; and other versions of the same microphone, adapted to hand-held, handset, and switchboard-operator types, promise important improvement in many peacetime telephone and radiophone communication services.

Considering the differential<sup>1</sup> microphone as a variety

\* Decimal classification: R385.5. Original manuscript received by the Institute, March 12, 1945; revised manuscript received, July 29, 1945.

† University of Notre Dame, Notre Dame, Indiana; and Electro-Voice, Inc., South Bend, Indiana.

‡ Electro-Voice, Inc., South Bend, Indiana.

<sup>1</sup> The following definition has been used for "differential microphone" in this paper: "A differential microphone is a pressure-gradient microphone which has two or more entrances which are separated by an acoustic distance which is small compared to the wavelength for the sound which may impinge on opposite sides of the same diaphragm or on separate diaphragms, so that the resultant force actuating the microphone for a distant sound source is attenuated, while the resultant force for a close sound source is preponderantly that resulting from the sound pressure at the openings nearer the sound source."

<sup>2</sup> F. C. Beekley, United States Patent No. 2,350,010.

<sup>3</sup> J. Shawn, "Application of the throat microphone," *Communications*, vol. 23, p. 11; January, 1943.

of pressure-gradient microphone, the characteristics of it may be examined mathematically by methods similar to those that have been applied to other pressure-gradient microphones of heretofore familiar varieties.<sup>4-7</sup>

One of the characteristics of a differential microphone is the difference in frequency response and level when actuated by a sound wave from a close source, over that of a distant source. The response of a pressure-gradient microphone to a spherical wave is a function of the distance to the sound source. Most users of velocity microphones are familiar with this phenomenon, as the microphone accentuates the low frequencies when the microphone is brought nearer the sound source. Another characteristic of the pressure-gradient microphone is its polar response curve which is a function of the cosine of the angle which the incident sound wave makes with the microphone. This polar characteristic reduces the response of the microphone for random sounds. The difference in response and level due to the proximity of the sound source combined with its polar characteristics makes the pressure-gradient microphone ideally suited for an antinoise microphone.

It is the purpose of this paper to show how this proximity effect and polar response may be utilized to produce an antinoise and antifeedback microphone.

## II. THEORETICAL FIRST-ORDER DIFFERENTIAL MICROPHONE

The basic principle of the differential microphone may be clearly represented by plotting pressure versus distance in a spherical wave as the wave progresses from a point source. Since the pressure in a spherical wave varies inversely as the distance from the source, a differential microphone operates on a rapidly decreasing portion of the pressure curve if the microphone is close to the sound source, while if the microphone is a considerable distance from the sound source the change in pressure, in a distance equal to the spacing between the sound entrances, is small as shown in Fig. 1.

While Fig. 1 shows that the difference of sound pressures at the two sound entrances is large for short distances from the source and practically zero for large distances, this figure is altered by the fact that phase change of the pressure wave as a function of distance has been ignored. There will be a change in phase caused by any difference in acoustic distance from the sound

<sup>4</sup> H. F. Olson, "Mass controlled electrodynamic microphones: the ribbon microphone," *Jour. Acous. Soc. Amer.*, vol. 3, pp. 56-68; July, 1931.

<sup>5</sup> B. F. Miessner, United States Patent No. 1,507,081, describes a pressure-gradient microphone used as an antinoise microphone.

<sup>6</sup> B. Baumzweiger, United States Patent No. 2,237,298, describes a higher-order gradient microphone using two ribbons for increasing the directivity over that of a first-order gradient.

<sup>7</sup> H. F. Olson, United States Patent No. 2,301,744, describes several higher-order gradient microphones used for increased directivity over that of a first-order gradient microphone. The effect of a spherical wave on the response is also described.

source of the two sound entrances. Consequently, in developing equations for the differential microphone the change in magnitude and phase must be considered.

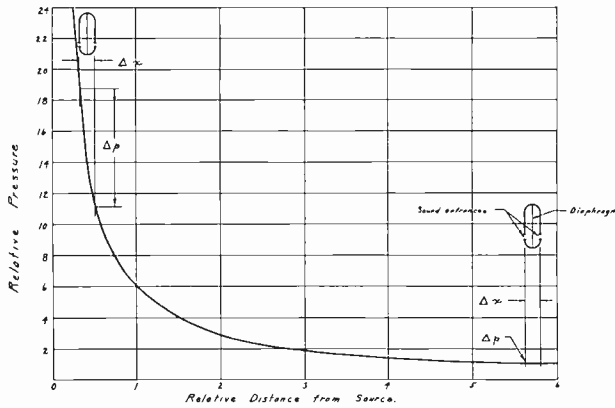

Fig. 1—Variation of pressure with distance from a point source.

In the discussion of differential microphones, there are two distinct cases that could be considered. The first is the comparison of the response of an ideal gradient microphone, which has infinitesimal thickness, to a sound source at a small distance from the microphone with the response to the same sound source when it is at a large distance from the microphone. The second and more general case, which includes the first case, is the response of the microphone to a source close to the microphone compared with the response to a sound source which is a large distance away but is producing the same pressure, at one surface of the microphone as the close sound source. It is the second case which will be analyzed, considering the sound sources as being on the axis of the microphone. Fig. 2 shows the physical setup for such a case.

$P_1$  = maximum pressure of sound source  $S_1$  at unit distance from source.

$P_2$  = maximum pressure of sound source  $S_2$  at unit distance from source.

$r_1$  = distance of sound source  $S_1$  from microphone.

$r_2$  = distance of sound source  $S_2$  from microphone.

$p$  = instantaneous pressure at one side of microphone.

$x$  = variable distance.

$k = 2\pi/\lambda$ .

$\lambda$  = wavelength.

$c$  = velocity of sound.

$A$  = maximum pressure  $P_1$  or  $P_2$ , as the case may be.

$dx$  = infinitesimal distance between sound entrances of theoretical microphone.

Under these conditions, the instantaneous pressure  $p$  at the microphone may be written<sup>8</sup> as

$$p = \frac{A}{x} \cos k(ct - x). \quad (1)$$

Although (1) pertains to a point source of sound for the theoretical analysis, it must be emphasized that, in practice, the actual microphone is used close to the mouth and the effects of mouth-cavity resonances,

<sup>8</sup> H. F. Olson, "Elements of Acoustical Engineering," D. Van Nostrand and Co., New York, N. Y., 1939, p. 11.

directivity of source, and body reflections will be present, causing the sound wave to deviate from a true spherical wave. Differentiating (1) with respect to  $x$ , there results

$$\frac{\partial p}{\partial x} = \frac{Ak}{x} \sin k(ct - x) - \frac{A}{x^2} \cos k(ct - x). \quad (2)$$

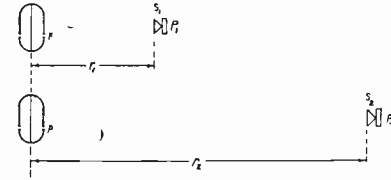

Fig. 2—Relative source and microphone locations used in calculating discriminations.

Obtaining the root-mean-square value of the pressure variation, we have

$$\begin{aligned} \left[ \frac{\partial p}{\partial x} \right]^2 &= \frac{A^2 k^2}{x^2} \sin^2 k(ct - x) \\ &\quad - 2 \frac{A^2 k}{x^3} \sin k(ct - x) \cos k(ct - x) \\ &\quad + \frac{A^2}{x^4} \cos^2 k(ct - x). \end{aligned}$$

Now averaging over a half cycle we have since

$$\frac{1}{\pi} \int_0^\pi \sin^2 \theta d\theta = \frac{1}{2},$$

$$\frac{1}{\pi} \int_0^\pi \cos^2 \theta d\theta = \frac{1}{2}$$

$$\frac{1}{\pi} \int_0^\pi \sin \theta \cos \theta d\theta = 0$$

and substituting  $\theta = k(ct - x)$  and  $d\theta = kcdx$

$$\left[ \frac{\partial p}{\partial x} \right]^2 = \frac{A^2 k^2}{x^2} \frac{1}{2kc} + \frac{A^2}{x^4 2kc}$$

so

$$\left[ \frac{\partial p}{\partial x} \right]_{r-m-s} = \frac{Ak}{x\sqrt{2kc}} \sqrt{1 + \frac{1}{k^2 x^2}}. \quad (3)$$

If, however, the root-mean-square value is found from (3) under the condition that  $x$  is large so that  $1/x^2$  may be neglected, we see that

$$\left[ \frac{\partial p}{\partial x} \right]_{x \text{ large}} = \frac{Ak}{x\sqrt{2kc}} \quad (4)$$

the ratio of (3) to (4) is then the ratio of the action of the microphone under the two conditions and is thus the discrimination against the more distant source.

$$\begin{aligned} \frac{\left[ \frac{\partial p}{\partial x} \right]_{r-m-s, x=r_1}}{\left[ \frac{\partial p}{\partial x} \right]_{r-m-s, x=r_2}} &= \frac{\frac{P_1 k}{r_1 \sqrt{2kc}} \sqrt{1 + \frac{1}{k^2 r_1^2}}}{\frac{P_2 k}{r_2 \sqrt{2kc}}} \\ &= \frac{P_1 r_2}{P_2 r_1} \sqrt{1 + \frac{1}{k^2 r_1^2}}. \end{aligned} \quad (5)$$

Since, for equal amplitudes of pressure at the microphone,

$$\frac{P_1}{r_1} = \frac{P_2}{r_2} \quad (6)$$

the noise discrimination, which is given as a ratio of the absolute magnitudes, may be written as

$$\text{first-order average discrimination} = \sqrt{1 + \frac{1}{k^2 r_1^2}} \quad (7)$$

on the axis. Equation (7) predicts the average discrimination on the axis as a function of  $(kr_1)$ . The average discrimination due to polar response characteristics or directional efficiency<sup>9-11</sup> is that given by (7) multiplied by the  $\sqrt{3}$ .

First-order average random discrimination

$$= \sqrt{3} \sqrt{1 + \frac{1}{k^2 r_1^2}} \text{ for point sources.} \quad (8)$$

This equation is plotted as a function of  $kr_1$  in Fig. 10 (see Section IV) in which the ordinate is  $20 \log_{10}$  (average random discrimination).

### III. PRACTICAL MICROPHONE OF THE FIRST ORDER

Equation (8) gives the discrimination of a first-order gradient microphone where the acoustic distance between the openings to the two sides of the diaphragm is infinitesimal, and consequently very small compared to the distances from the sound sources. In a practical microphone, the acoustic distance between the sound

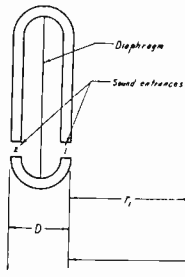

Fig. 3—Relative source and microphone locations used in calculation of discrimination of microphone with distance  $D$  between sound entrances.

entrances to the two sides of the diaphragm is comparable to the distance to the sound source. The effect of this finite spacing of the sound entrances is to decrease the discrimination from that predicted by (8) for distant sounds, and to limit the frequency range over which cancellation or discrimination is obtained. The smaller the spacing between the sound entrances, the higher the frequency at which discrimination is obtained and the better is the discrimination, because of smaller phase displacement.

The above statements are proved in the following manner. If the practical microphone has a spacing between sound entrances of  $D$  and is at distances of  $r_1$  from the nearer sound source and  $r_2$  from the distant sound source, the practical arrangement is as shown in Fig. 3.

<sup>9</sup> See p. 222 of footnote reference 8.

<sup>10</sup> B. B. Bauer, "Super-cardioid directional microphone," *Electronics*, vol. 15, p. 31; January, 1942.

<sup>11</sup> J. Weinberger, H. F. Olson, and F. Massa, *Jour. Acous. Soc. Amer.*, vol. 5, pp. 139-147; October, 1933.

Assuming, as for the theoretical case, that each source is producing equal pressure at the nearer sound entrance and that the wave form is spherical, then  $p_1 = (P_1/r_1) \cos k(ct - r_1)$  is the pressure at the nearer sound entrance and  $p_2 = (P_1/r_1 + D) \cos k[ct - (r_1 + D)]$  is the pressure at the second sound entrance when the nearer source  $S_1$  is considered. Since  $D$  is comparable to  $r_1$ , there is a change in the magnitude of the pressure as well as a change in the phase of the pressure wave by an angular amount of  $kD$ . These results are shown in the vector diagram in Fig. 4.

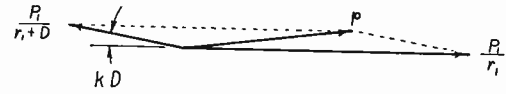

Fig. 4—Vector representation of pressure actuating microphone diaphragm. Close point source.

Finding the resultant pressure  $p$  on the diaphragm

$$\Delta p = \sqrt{\left[ \frac{P_1}{r_1} - \frac{P_1}{r_1 + D} \cos kD \right]^2 + \left[ \frac{P_1}{r_1 + D} \sin kD \right]^2}$$

or

$$\Delta p = \frac{P_1}{r_1} \sqrt{1 + \left[ \frac{r_1}{r_1 + D} \right]^2 - \frac{2r_1}{r_1 + D} \cos kD}. \quad (9)$$

By similar reasoning, the pressure at the two sound entrances due to the distant sound source is  $p_1' = (P_2/r_2) \cos k(ct - r_2)$  and  $p_2' = (P_2/r_2 + D) \cos k[ct - (r_2 + D)]$ . In this case, however, since  $r_2$  is very much larger than  $D$ , it may be assumed that  $P_2/r_2 + D = P_2/r_2$ . There is, however, the same phase shift of  $kD$ , and the vector diagram becomes as shown in Fig. 5.

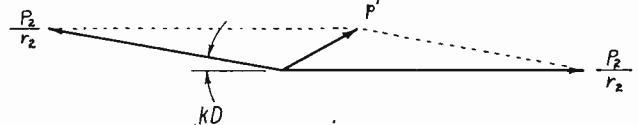

Fig. 5—Vector representation of pressure actuating microphone diaphragm. Distant point source.

Finding the resulting pressure  $p'$  on the diaphragm

$$\Delta p' = \sqrt{\left[ \frac{P_2}{r_2} - \frac{P_2}{r_2} \cos kD \right]^2 + \left[ \frac{P_2}{r_2} \sin kD \right]^2}$$

or

$$\Delta p' = \frac{P_2}{r_2} \sqrt{2 - 2 \cos kD}. \quad (10)$$

The ratio of (9) to (10) then gives the discrimination

$$\frac{\Delta p}{\Delta p'} = \frac{\frac{P_1}{r_1} \sqrt{1 + \left[ \frac{r_1}{r_1 + D} \right]^2 - \frac{2r_1}{r_1 + D} \cos kD}}{\frac{P_2}{r_2} \sqrt{2 - 2 \cos kD}} \quad (11)$$

However, by the conditions postulated for the problem  $P_1/r_1 = P_2/r_2$  or equation (11) becomes

discrimination

$$= \sqrt{\frac{1 + \left[ \frac{r}{r + D} \right]^2 - \frac{2r}{r + D} \cos kD}{2(1 - \cos kD)}} \quad (12)$$

where  $D$  is the acoustic distance between the sound entrances and  $r$  the distance from the sound source to the nearest sound entrance. Equation (12) gives the discrimination against sounds originating on the axis of the sound entrances. For random sounds, the discrimination is increased by about 5 decibels. Fig. 6 shows the effect of the sound-entrance spacing on the discrimination against random sounds for  $D$  equal to various fractions of  $r$ .

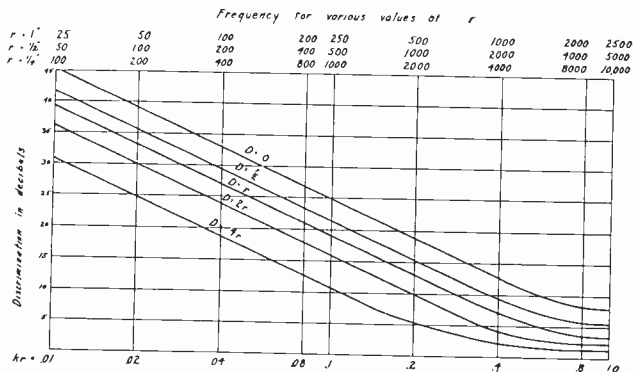

Fig. 6—Theoretical discrimination against random sounds for various spacings  $D$  of openings to front and back of diaphragm, and for various distances  $r$  from point source.

Equation (2) shows that the response of a gradient microphone is a function of the distance from the microphone to the source. From (3) it may be seen that the force available for actuating the diaphragm for sound waves of equal pressures is proportional to

$$\sqrt{k^2 + \frac{1}{r^2}} \tag{13}$$

For very large values of  $r$  the force may be considered proportional to  $k$ , or in other words, the force is proportional to frequency. For low frequencies and small distances  $r$ , the force is proportional to  $1/r$ . The force available for actuating the diaphragm at various distances from the source versus frequency is plotted in Fig. 7, where the ordinate is  $20 \log_{10}$  (relative force). The frequency response of a microphone which is designed to have a flat response curve at a distance of one-quarter

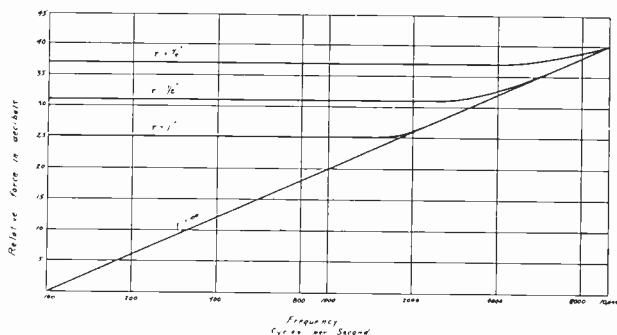

Fig. 7—Force available for actuating diaphragm.

inch from the source will no longer have a flat response curve at some other distance from the source. The frequency-response curves at various distances from the sound source, for a microphone designed to have a flat response curve at a distance of one-quarter inch, are shown in Fig. 8.

Fig. 9 shows a drawing of the T-45 lip microphone and its equivalent acoustic-mechanical circuit. Any

unbalance in the impedances on the two sides of the microphone will cause the discrimination to suffer. The

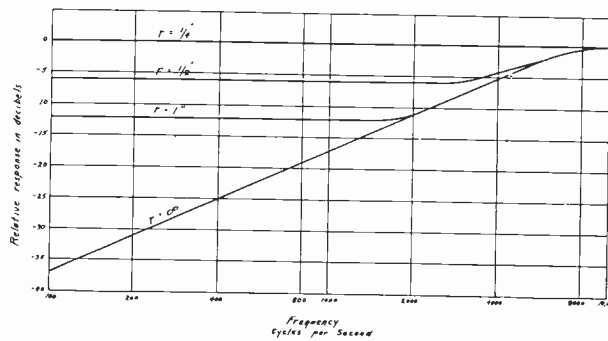

Fig. 8—Theoretical response at various distances  $r$  from source for microphones having a flat response  $1/4$  inch from source.

head and mouth of the speaker will upset the impedance balance, causing the discrimination to suffer somewhat at the higher frequencies.<sup>12</sup>

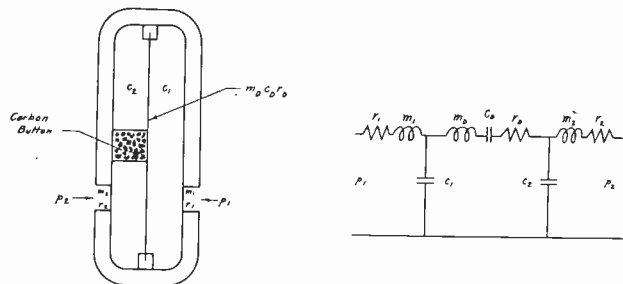

Fig. 9—Diagram of differential microphone and its equivalent acoustic-mechanical circuit.

#### IV. THEORETICAL SECOND- AND HIGHER-ORDER DIFFERENTIAL MICROPHONES

It is of interest to see how the discrimination of the differential microphone changes as it changes from a first-order gradient to a second-, third-, fourth-, etc., order gradient microphone. In order to obtain the characteristics of a second-order differential, it is necessary to differentiate (2) again, which gives the following results:

$$\frac{\partial^2 p}{\partial x^2} = \frac{-k^2 A}{x} \cos k(ct - x) - \frac{2kA}{x^2} \sin k(ct - x) + \frac{2A}{x^3} \cos k(ct - x) \tag{14}$$

performing the averaging process on (14) as for the first-order differential case

$$\left[ \frac{\partial^2 p}{\partial x^2} \right]_{r-m-s} = \frac{k^2 A}{x\sqrt{2kc}} \sqrt{1 + \frac{4}{k^4 x^4}} \tag{15}$$

Again forming the ratio for the close to distant conditions

$$\frac{\left[ \frac{\partial^2 p}{\partial x^2} \right]_{r-m-s, x=r_1}}{\left[ \frac{\partial^2 p}{\partial x^2} \right]_{r-m-s, x=r_2}} = \frac{\frac{k^2 P_1}{r_1 \sqrt{2kc}} \sqrt{1 + \frac{4}{k^4 r_1^4}}}{\frac{k^2 P_2}{r_2 \sqrt{2kc}}} = \frac{P_1 r_2}{P_2 r_1} \sqrt{1 + \frac{4}{k^4 r_1^4}}$$

<sup>12</sup> G. G. Muller, R. Black, and T. E. Davis, *Jour. Acous. Soc. Amer.*, vol. 10, pp. 6-14; July, 1938.



Substituting as previously for  $P_1$  and using the average discrimination the following results:

$$\text{second-order average discrimination} = \sqrt{1 + \frac{4}{k^4 r_1^4}} \quad (16)$$

on the axis.

To find the average random discrimination, (16) must be corrected for the polar characteristic<sup>9</sup> which results in second-order average random discrimination

$$= \sqrt{5} \sqrt{1 + \frac{4}{k^4 r_1^4}} \quad (17)$$

The third-order differential is obtained similarly by differentiating (14) again resulting in the following equation:

$$\begin{aligned} \frac{\partial^3 p}{\partial x^3} &= \frac{-k^3 A}{x} \sin k(ct - x) + 3 \frac{k^2 A}{x^2} \cos k(ct - x) \\ &+ \frac{6Ak}{x^3} \sin k(ct - x) - \frac{6A}{x^4} \cos k(ct - x). \end{aligned} \quad (18)$$

Performing the averaging process on (18) there results the following equation:

$$\left[ \frac{\partial^3 p}{\partial x^3} \right]_{r-m-s} = \frac{k^3 A}{x\sqrt{2kc}} \sqrt{1 - \frac{3}{k^2 x^2} + \frac{36}{k^6 x^6}} \quad (19)$$

Evaluating this for the boundary values assumed and forming the ratio for discrimination there results:

$$\begin{aligned} \frac{\left[ \frac{\partial^3 p}{\partial x^3} \right]_{x=r_1}}{\left[ \frac{\partial^3 p}{\partial x^3} \right]_{x=r_2}} &= \frac{\frac{k^3 P_1}{r_1 \sqrt{2kc}} \sqrt{1 - \frac{3}{k^2 r_1^2} + \frac{36}{k^6 r_1^6}}}{\frac{k^3 P_2}{r_2 \sqrt{2kc}}} \\ &= \frac{P_1 r_2}{P_2 r_1} \sqrt{1 - \frac{3}{k^2 r_1^2} + \frac{36}{k^6 r_1^6}} \end{aligned}$$

Average discrimination of a third-order microphone becomes

$$\text{third-order average discrimination} = \sqrt{1 - \frac{3}{k^2 r_1^2} + \frac{36}{k^6 r_1^6}} \quad (20)$$

on the axis.

For random noise and effect of polar characteristic,<sup>9</sup> (20) becomes

$$\text{third-order average random discrimination} = \sqrt{7} \sqrt{1 - \frac{3}{k^2 r_1^2} + \frac{36}{k^6 r_1^6}} \quad (21)$$

The fourth, fifth, and higher orders are obtained in a similar manner, giving the following results:

$$\text{fourth-order average random discrimination} = \sqrt{9} \sqrt{1 - \frac{8}{k^2 r_1^2} + \frac{576}{k^8 r_1^8}} \quad (22)$$

fifth-order average random discrimination

$$= \sqrt{11} \sqrt{1 - \frac{15}{k^2 r_1^2} + \frac{40}{k^4 r_1^4} + \frac{14400}{k^{10} r_1^{10}}} \quad (23)$$

Equations (17), (21), (22), and (23) are plotted in Fig. 10.

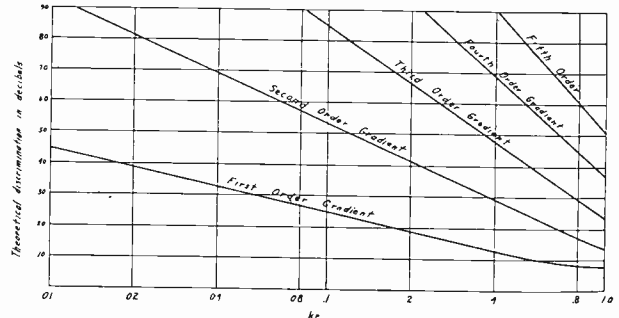

Fig. 10—Theoretical discrimination of pressure gradient microphones of various orders.

### V. THEORETICAL $n$ TH-ORDER DIFFERENTIAL MICROPHONE

The discrimination of the  $n$ th-order differential microphone may be arrived at as follows: Using Leibnitz's rule for the  $n$ th derivative of a product,

$$\begin{aligned} \frac{\partial^n (\mu v)}{\partial x^n} &= \frac{v \partial^n \mu}{\partial x^n} + n \frac{\partial v \partial^{n-1} \mu}{\partial x \partial x^{n-1}} + \frac{n(n-1)}{2!} \frac{\partial^2 v}{\partial x^2} \frac{\partial^{n-2} \mu}{\partial x^{n-2}} \\ &+ \frac{n(n-1)(n-2)}{3!} \frac{\partial^3 v}{\partial x^3} \frac{\partial^{n-3} \mu}{\partial x^{n-3}} + \dots + \frac{\mu \partial^n v}{\partial x^n} \end{aligned} \quad (24)$$

where in the case at hand, since  $p = (A/x) \cos k(ct - x)$ , the function  $\mu = x^{-1}$  and the function  $v$  is  $\cos k(ct - x)$ .

Using (24), it is possible to find the discrimination for any order differential microphone. It is of special interest to find the discrimination of the  $n$ th order. From (4), (15), and (19) it is seen that the  $n$ th gradient of pressure, when the source is a large distance away, is given in general by

$$\left[ \frac{\partial^n p}{\partial x^n} \right]_{x=r_1} = \frac{k^n P_2}{r_2 \sqrt{2kc}} \quad (25)$$

If the  $n$ th-order differential is obtained using (24), the following equation results:

$$\begin{aligned} \frac{1}{n!} \left[ \frac{\partial^n p}{\partial x^n} \right] &= \frac{A}{x^{n+1}} \left\{ (-1)^n \cos k(ct - x) \left[ 1 - \frac{(kx)^2}{n(n-1)} \right. \right. \\ &+ \left. \left. \frac{(kx)^4}{n(n-1)(n-2)(n-3)} \dots \right] \right. \\ &+ (-1)^{n-1} \sin k(ct - x) \left[ \frac{kx}{n} - \frac{(kx)^3}{n(n-1)(n-2)} \right. \\ &+ \left. \left. \frac{(kx)^5}{n(n-1)(n-2)(n-3)(n-4)} \dots \right] \right\} \end{aligned} \quad (26)$$

as  $n$  approaches infinity the coefficient of the cosine term in (26) approaches unity, while the coefficient of the sine term vanishes; hence, in the limit, (26) becomes

$$\frac{1}{n!} \left[ \frac{\partial^n p}{\partial x^n} \right] = \frac{A(-1)^n}{x^{n+1}} \cos k(ct - x).$$

Performing the averaging operation on this expression and rewriting,

$$\left[ \frac{\partial^n p}{\partial x^n} \right]_{x=r_1}^{r-m-s} = \frac{n!P_1}{r_1^{(n+1)}} \left[ \frac{1}{\sqrt{2kc}} \right]. \quad (27)$$

Dividing (27) by (25), the discrimination becomes

$$\frac{\left[ \frac{\partial^n p}{\partial x^n} \right]_{x=r_1}^{r-m-s}}{\left[ \frac{\partial^n p}{\partial x^n} \right]_{x=r_2}^{r-m-s}} = \frac{\frac{n!P_1}{r_1^{(n+1)}} \left[ \frac{1}{\sqrt{2kc}} \right]}{\frac{k^n P_2}{r_2 \sqrt{2kc}}} = \frac{n!P_1}{k^n P_2} \left[ \frac{r_2}{r_1^{(n+1)}} \right]$$

or again finding the average discrimination

$$nth\text{-order average discrimination} = \frac{n!}{k^n r_1^n} \text{ on the axis.} \quad (28)$$

It is clear that as  $n$  becomes infinite the discrimination of an  $n$ th-order differential microphone becomes infinite.

As the order of the gradient becomes larger, the directional efficiency increases as the multiplying factor in (8), (17), (21), (22), and (23) show. The increased discrimination due to polar response may be written in

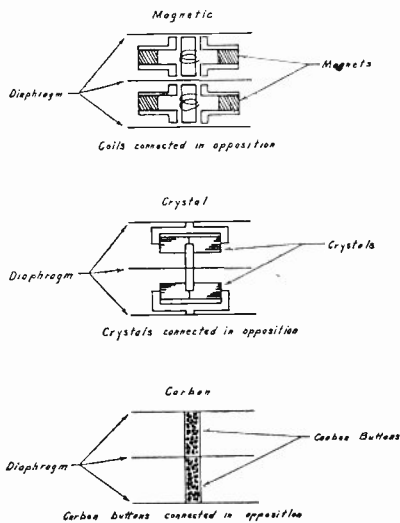

Fig. 11—Higher-order gradient microphones.

general as  $\sqrt{2n+1}$ . As  $n$  approaches infinity, the increased noise discrimination due to polar response is increased by an infinite amount. This corresponds to a decreasing solid angle over which pickup of noise is obtained. The response of the microphone is now limited to that produced by sound sources lying on the axis of the sound entrances. Consequently the average random discrimination is increased over that predicted by (28).

## VI. DIFFERENTIAL MICROPHONES OF A HIGHER ORDER

There are many ways in which a higher-order differential microphone may be designed. Two closely spaced first-order differential dynamic microphones with their voice coils connected in opposition will be a second-order differential microphone. Two of these combinations connected differentially will give a third-order differential microphone, etc. Diagrammatic representations of other types of higher-order differential microphones are shown in Fig. 11. There are certain practical limitations to the construction of higher-order differential microphones. Each first-order differential unit used in a higher-order differential microphone must have very nearly identical sensitivity and response. This problem of balancing limits the practical use of higher-order differential microphones. The signal-to-noise ratio of the higher-order series is, of course, considerably better than that for a first-order differential; but the first-order differential gives sufficient discrimination against noise for practically all applications. The response of a higher-order differential microphone also varies more with the distance from the source than does a first order.

The discrimination curves of higher-order differential microphones indicate that they would be much better for use, under severe feedback conditions, than a first order. This is not true in practice, however, as the mouth acting as a Helmholtz resonator upsets the balance causing the system to oscillate before the full discrimination, against unwanted sounds originating at a distance, can be realized.

## VII. CONCLUSION

From the equations developed and the curves plotted for the differential microphone, irrespective of the order of pressure gradient which operates it, it is clearly seen that the differential microphone is ideally suited for noise cancellation in the usual noise fields. The frequencies encountered in the noise of aircraft, tanks, gun fire, trains, etc., are predominantly in the lower frequency range and the differential microphone produces more noise discrimination at the lower frequencies for a fixed position of the microphone.

It has been shown that the noise discrimination of differential microphones increases rapidly with the order of pressure gradient upon which they operate and that the  $n$ th-order gradient would give the most desirable results theoretically. In practice, however, the construction of higher-order gradient microphones presents difficulties due to balancing of the individual first-order gradient units used in the higher-order gradient series.

## "Exalted-Carrier Amplitude- and Phase-Modulation Reception"\*

MURRAY G. CROSBY

**A. H. Taylor:**<sup>1</sup> I here read with particular interest the paper by Crosby on "Exalted Carrier Reception."\* When I was a student with Professor Barkhausen at the Sächsische Technische Hochschule, Dresden, in 1937-38, Professor Barkhausen's chief assistant, H. Oltze, demonstrated a broadcast receiver embodying the same principles of carrier reinforcement. Herr Oltze used one mixer only, with two separate intermediate-frequency amplifiers at the same intermediate frequency, for program and supplementary carrier. There was no automatic frequency control. Automatic frequency control was not necessary because there was no crystal filter or limiter; modulation was eliminated from the carrier channel by sharp inductance-capacitance tuning plus a fast automatic volume control having a time constant of 1/20,000 second. Like Mr. Crosby, Herr Oltze fed his supplementary carrier to the second (recombining) detector via a phase-adjusting network; however, the relative phases of normal and supplementary carriers seemed unimportant provided the latter was large enough.

The receiver was demonstrated by tuning in an out-of-town station (Praha, Č.S.R.) and then setting beside the receiver a laboratory oscillator tuned to give a loud audio whistle with the distant transmitter, with no carrier reinforcement. When the reinforcement was brought up, the whistle all but vanished and the program could be enjoyed. This seems to disagree with the experience of Mr. Crosby, who states that intercarrier heterodyne notes are not reduced by carrier reinforcement.

Herr Oltze did this work in his spare time, more or less as a stunt. He did not know of the work of Polkinghorn and Schlaack, and asked me whether I thought he could get a U. S. Patent. I think he should get whatever credit is due him, particularly since he was a perfect gentleman and no Nazi.

**Murray G. Crosby:**<sup>2</sup> Mr. Taylor's interesting letter has brought to the fore a possible misunderstanding that I am happy to have this opportunity to clarify.

I have reference to the apparent disagreement as to the reduction of intercarrier heterodyne. As I see it, there is no disagreement as to results. I believe the results described by Mr. Taylor would be duplicated on the exalted-carrier receivers with which I have worked.

\* Murray G. Crosby, "Exalted-Carrier Amplitude- and Phase-Modulation Reception," *PROC. I.R.E.*, vol. 33, pp. 581-591; September, 1945.

<sup>1</sup> Naval Research Laboratory, Washington 20, D. C.

<sup>2</sup> Paul Godley Company, Upper Montclair, N. J.

The apparent disagreement is brought about by a difference in interpretation of results, which in turn, was brought about by a difference in test conditions.

The statement that intercarrier heterodynes were not suppressed was based on the use of carriers which were both modulated. Under these test conditions, the introduction of carrier exaltation prevents the modulation from the stronger, undesired carrier from masking the modulation on the weaker, desired carrier. Switching to the exalted-carrier condition then converts the receiver output from undesired to desired modulation, without change in the amplitude of the intercarrier whistle.

In the conditions of Herr Oltze's experiments, the strong, undesired carrier was unmodulated. In the absence of exaltation this condition would leave a predominance of intercarrier heterodyne, with weak, desired modulation in the background. The introduction of carrier exaltation would bring up the level of the desired modulation, but the level of the whistle would remain the same. Where the confusion in interpreting the results arises is in the fact that the output amplitude of the heterodyne remains constant while the desired-modulation output is increased by the exaltation. Perhaps a more accurate and descriptive term is "desired-modulation-to-whistle ratio." We would both agree that this ratio is improved by the use of carrier exaltation, regardless of whether the undesired carrier is modulated or not. Such a term eliminates the necessity of having to choose between the two test conditions which involve absence, or presence, of modulation on the interfering carrier.

With regard to credit to Herr Oltze, I would not be willing to concede priority on the basis of the dates mentioned in Mr. Taylor's letter. Receivers of the type mentioned were demonstrated at the Riverhead RCA Laboratories considerably earlier than 1937. In this respect reference is made to my U. S. Patent No. 2,065,565 filed June 13, 1932, and patented December 29, 1936, which describes a working model of a receiver of this type.

**A. H. Taylor:** Mr. Crosby's reply to my comments answers all questions which I had in mind.

This is apparently another of the many instances where the first inventor of a device does not immediately publish, and subsequently someone else invents the same thing quite independently, without knowing of the original inventor's work.

## Correspondence

Correspondence on both technical and nontechnical subjects from readers of the PROCEEDINGS OF THE I.R.E. and WAVES AND ELECTRONS is invited, subject to the following conditions: All rights are reserved by the Institute. Statements in letters are expressly understood to be the individual opinion of the writer, and endorsement or recognition by the I.R.E. is not implied by publication. All letters are to be submitted as typewritten, double-spaced, original copies. Any illustrations are to be submitted as inked drawings. Captions are to be supplied for all illustrations.

### “Historic First” Electronic Lecture

To the Editor:

In the February, 1945, issue of the PROCEEDINGS, in the editorial captioned “Electronic Papers,” Past President H. M. Turner reminds us that The Institute of Radio Engineers has been actively interested in electronics from the early days.

This is indeed true, as witness the first public demonstration of the vacuum tube as an amplifier, the first such in this country at least, made before the Institute in the late fall of 1913 by Dr. Lee de Forest himself.

The report of this “historic first” electronic lecture is published as a paper on pages 15–30 of the March, 1914, issue of the PROCEEDINGS. I believe it was you, Mr. Editor, in your youthful enterprise, who drafted that paper after the lecture and then had it passed upon by de Forest. For as I remember it, upon this occasion de Forest with his usual enthusiasm launched into the subject, talked and demonstrated to his heart’s content, without confining himself to a text. Incidentally I think the Editor is to be congratulated upon his enterprise and reporting ability, whereby we do have an appropriate record of this important meeting. For certainly “Doc” himself was too impatient to have prepared the paper and probably would not have remembered just what he did say! Incidentally the *discussion* of the paper as published is especially interesting, touching as it did on feedback and what not.

It happened that the present writer and a boyhood amateur pal of his with whom he is still associated here in the Bell Telephone Laboratories, namely Austen M. Curtis, were among those who attended this meeting. I wonder how many other old-timers recall it. Fortunately what de Forest disclosed and said so impressed me at the time that I sent a memorandum on the meeting to my departmental head who was then Elam Miller, transmission and protection engineer of the American Telephone and Telegraph Company. Since this little report brings out some additional aspects of the meeting, as seen by one who was then a sort of hybrid radio-wire-telephone engineer, a verbatim copy of the memorandum is attached.

Incidentally, de Forest’s paper, as pub-

lished in the PROCEEDINGS, is given in a footnote as having been delivered on December 3, 1913. The date appears to be in error. The memorandum which I wrote on the day following the meeting is dated November 6. A second memorandum which I wrote on the same day, on the subject of the vacuum tube used as a power limiting device, helps to confirm the date of de Forest’s lecture as that of November 5. The *New York Herald* for Friday, November 7, 1913, carried a little news item of de Forest’s lecture, pertaining to the possible use of the vacuum tube on the then projected transcontinental telephone line, and referred to the meeting as having been held at Columbia University “last Tuesday night.” This would have been November 4. Probably the meeting was on the usual Wednesday night, which would make the date November 5.

Sincerely,

LLOYD ESPENSCHIED  
Bell Telephone Laboratories  
New York, N. Y.

The Audion as an Amplifier—Paper by Dr.  
Lee de Forest.

November 6, 1913.

Memorandum for Mr. Miller,  
Transmission and Protection Engineer.

At a meeting of the Institute of Radio Engineers held at Columbia University November 5, Dr. Lee de Forest gave a paper accompanied by demonstrations on the Audion as an amplifying device. Following are the principal points of interest which were discussed.

The use of the Audion as a detector and as an amplifier in radio communication was first considered. Emphasis was laid upon the distinct difference between the Audion and Fleming’s vacuum rectifier detector; that there is a difference is made evident by the fact that the maximum possible converter efficiency of the Fleming valve is 50 per cent, while that of the Audion may easily be several hundred per cent. As evidence of the sensibility of the Audion in radio receiving, mention was made of instances of receiving long-distance messages. It was claimed that signals which were practically inaudible when using the Audion simply as a detector may be converted into signals of commercial volume by means of the Audion amplifier. He stated that the Audion was used as an amplifier in the San Francisco-Los Angeles Poulsen wireless transmission. The signals were transmitted at about 60 words per minute and at the receiving end were amplified by means of the Audion and recorded on the telegraphone. The telegraphone, running at a low speed, then repeated the signals to a receiving operator who transcribed them on a typewriter.

Referring to the use of an Audion as a telephone amplifier mention was made of the difficulty met in obtaining lines sufficiently well balanced to be efficiently used in connection with a repeater. Proper circuits are now being worked out and it was thought probable that the Audion would be very successfully applied in telephone transmission. A demonstration of the amplification of the telephone currents was made using an ordinary telephone receiver as a magneto transmitter and three Audions connected in tandem as the receiving amplifier. Speech was transmitted from an adjacent

room, amplified by means of the Audion, and transmitted to the audience through loudspeaking receivers. In a similar way, wireless signals which had previously been recorded on the telegraphone were made audible to the entire audience. In connection with the use of the Audion in telephone transmission, Dr. de Forest mentioned a possible telephone system organized as follows:

Use a magneto transmitter at the subscriber’s station instead of the microphone transmitter for the purpose of more faithfully reproducing the voice.

Transmit the currents so generated (without any battery) to the central office, possibly over subscriber loop conductors much smaller than those now used.

At the central office pass the transmitted currents through an Audion amplifier which directly feeds the trunk.

At the distant central office possibly again amplify the telephone currents by means of an Audion and pass them to the subscriber loop and receive in the ordinary way.

A discussion was taken part in by Mr. John Stone Stone. He considered the Audion the most promising device he knew of for detecting radio signals and for amplification purposes. He recalled that the most objectionable feature to a system of high-frequency wire transmission, such as has recently been brought forward by Major Squier, is the very high attenuation. He thought it quite probable that this objectionable feature may be entirely eliminated by the use of the Audion amplifier and that high-frequency telephone transmission may thus be placed on an economical basis at least comparable with that of the present system of telephone transmission. He pointed out that high-frequency transmission was practically void of distortion and that the multiplexing of such a line, for either telephone or telegraph purposes, is a valuable feature.

(Initialed) L.E.

NEW YORK HERALD  
FRIDAY, NOVEMBER 7, 1913

(Article appearing on the Editorial Page,  
page 12)

MAY TALK TO THE PACIFIC  
Telephone Service Across Continent  
Believed Near By The Use Of  
Audion Amplifier

That direct telephone service between this city and San Francisco will begin soon was the assertion of many who attended the monthly meeting of the Institute of Radio Engineers at Columbia University last Tuesday night.

Dr. Lee de Forest, inventor of the new Audion amplifier, or relay, demonstrated the possibilities of his invention, and declared that through the amplification of minute electric currents results will be accomplished heretofore considered impossible.

Representatives of the United States Navy who were present showed much interest in the invention as a possible aid in wireless operation.

A true transcription made today in the Old-Newspaper Room of the New York Library, 137 West 25 Street, New York City, by Lloyd Espenschied, July 6, 1944.



### Phase-Inverter Circuit

A brief description of a so-called "phase-inverter" circuit written by D. L. Drukey from a very famous locale, recently appeared in the PROCEEDINGS.<sup>1</sup> An interesting application of this circuit was used in a radio receiver designed for the Northern Electric Company, Limited, in 1936.

A schematic diagram of the pertinent part of the circuit is shown in Fig. 1. A type 6C5 tube was used to drive a pair of type 6V6G tubes connected in push-pull, with circuit-component values as shown. It is seen that the grid of one output tube was driven from a 10,000-ohm resistor in the plate circuit of the type 6C5 tube, and the other output-

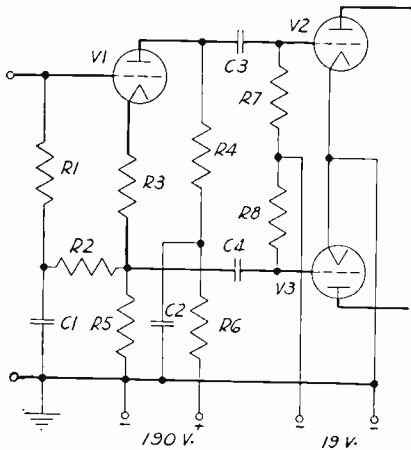

Fig. 1—Detailed circuit of unbalanced-to-balanced impedance conversion stage. Circuit values as follows:

Microfarads	Ohms	Tube
C1 = 0.05	R1 = 500,000	V1 = 6C5
C2 = 8	R2 = 500,000	V2 = 6V6G
C3 = 0.02	R3 = 1500	V3 = 6V6G
C4 = 0.02	R4 = 10,000	
	R5 = 10,000	
	R6 = 5000	
	R7 = 100,000	
	R8 = 100,000	

tube grid was driven from a 10,000-ohm resistor in the cathode circuit. Grid bias for the driver tube was secured from an additional unbypassed resistor in its cathode circuit. While this resulted in some loss of gain, it was undesirable for standardization reasons to secure bias from a division of the 10,000-ohm cathode resistor. As the type 6C5 tube followed a high-impedance stage it was necessary to introduce a resistance-capacitance filter to eliminate alternating

<sup>1</sup> Proc. I.R.E., vol. 33, p. 722; October, 1945.

voltage from the cathode coupling resistor from the grid circuit of the type 6C5 tube. Under the circuit conditions shown the type 6C5 tube operates with the following constants: plate current, 2.7 milliamperes; amplification factor, 17.5; plate resistance 10,300 ohms; mutual conductance, 1700 micromhos; undistorted output, 40 volts peak, grid-to-grid.

The stage gain is 3 decibels and there is 17 decibels of negative feedback. This circuit therefore not only achieves the high degree of balance and the independence of tube characteristics mentioned by Drukey, but also suppresses by a large factor any hum, tube noise, or distortion generated in the driver stage. It also results in an equivalent alternating-current impedance across the grids of the push-pull tubes of only about 3200 ohms, which is of great practical importance with many types of tubes. If R3 is adequately bypassed or otherwise removed from the feedback path, the gain of the stage increases to 5 decibels and the grid-to-grid impedance is reduced to less than 1000 ohms.

C. B. FISHER,  
F. T. Fisher's Sons, Ltd.,  
Montreal, Que., Canada

My thanks to Mr. C. B. Fisher for his comment on my letter on the phase inverter. This was not presented as an original idea, although to my knowledge it was, but rather as a circuit which warranted further use in the electronic art.

D. L. DRUKEY  
17 Outer Dr.  
Oak Ridge, Tenn.

### Asymmetrical Butterfly Circuit

I have read the excellent paper by Mr. E. Karplus on "wide-range tuned circuit and oscillators for high frequencies" in the July issue of the PROCEEDINGS of the I.R.E. It may be of interest to your readers to know that late in 1941, while working in the laboratories of the Electric and Musical Industries, Ltd., Hayes, England, on a radar equipment, I developed an asymmetrical butterfly circuit which performed exceedingly well. It is described in detail in the British Patent No. 563,468. A considerable amount of work on lumped tuned circuits has been done by W. S. Percival of the abovementioned laboratories, of whose ideas my invention was a further development.

The mechanical build-up and schematic diagram are shown in the accompanying

illustrations. The tube used was a Mullard RL.16 and the frequency range of the oscillator circuit was restricted deliberately

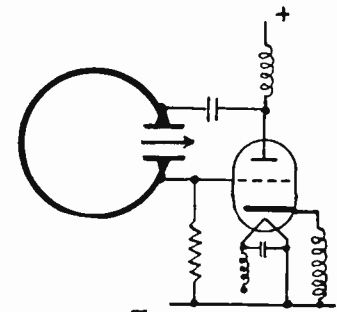
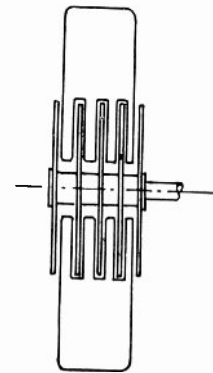
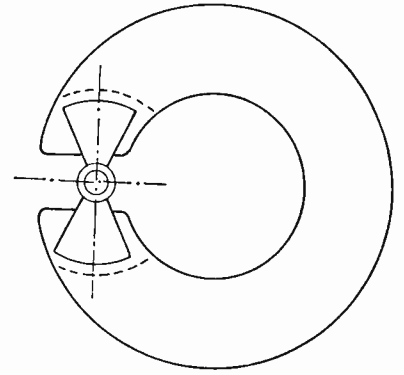

to cover 290 to 350 megacycles per second. The stability of the circuit proved to be excellent.

A. LANDMAN  
2 Monkswood Gardens  
Ilford, Essex  
England

# Contributors

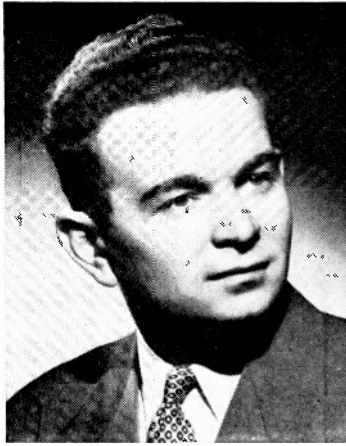

CARL BECKMAN

Carl Beckman (A'42) was born on August 27, 1915, in Philadelphia, Pennsylvania. He received the B.A. degree in physics from Temple University in 1937, the B.S. degree in electrical engineering from the University of Pennsylvania in 1940, and the M. S. degree in electrical engineering from Stevens Institute of Technology in 1943. Mr. Beckman has been an electronics engineer with the Westinghouse Electric Corporation, Bloomfield, New Jersey, since 1940. He is a member of Eta Kappa Nu, the American Institute of Electrical Engineers, the American Physical Society, the Franklin Institute, and the Montclair Society of Engineers.



D. Rogers Crosby (A'36) was born on October 12, 1911, at Lockport, New York. He received the E.E. degree from Rensselaer Polytechnic Institute in 1934, and the M.S. degree in communication engineering from Harvard University, in 1935.



GORDON L. FREDENDALL

From 1935 to 1941, Mr. Crosby was employed by the Federal Telephone and Telegraph Company, at Newark, New Jersey, engaged in experimental work on radio printer circuits and very-high-frequency link circuits for control of communication transmitters. Since 1941 he has been associated with the Radio Corporation of America at Camden, New Jersey. He is engaged in development work on problems associated with high-powered transmitters, particularly methods and means for measuring high voltage and high power.

Mr. Crosby is an Associate of the American Institute of Electrical Engineers, and a member of Sigma Xi.



HAROLD E. ELLITHORN

Harold E. Ellithorn (A'36-M'44) was born on October 11, 1911, at Detroit, Michigan. He received the B.S. degree in electrical engineering from Union College in 1934, and the M.S. degree in communication engineering from Harvard University in 1935.

From 1935 to 1936 Mr. Ellithorn was employed in the engineering department of Sylvania Corporation, in Salem, Massachusetts, and in 1936 he became supervisor of the engineering laboratory of the radio-tube division. From 1938 to 1940 he was a graduate student in physics at the University of Notre Dame, and in 1940 he was appointed an instructor in electrical engineering at that institution. He became an assistant professor in 1943, a post which he has held to date, and since 1944 Mr. Ellithorn has also served as special project engineer and consultant for the Electro-Voice, Inc., in South Bend, Indiana.

He is a member of Eta Kappa Nu and the Acoustical Society of America, and an Associate Member of Sigma Xi and the American Institute of Electrical Engineering.

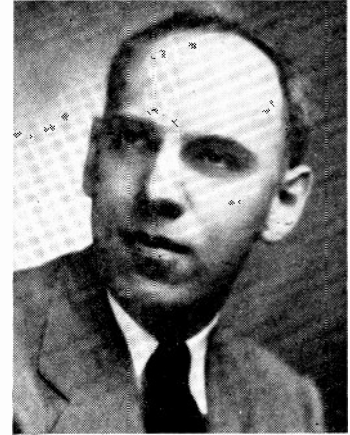

D. ROGERS CROSBY



Gordon L. Fredendall (A'41) received the Ph.D. degree from the University of Wisconsin. From 1931 to 1936 he taught electrical engineering and mathematics, and engaged in research work in mercury-arc phenomena at the University of Wisconsin. Since 1936 he has been with the Radio Corporation of America, working on television research. He is at present located in Princeton, New Jersey, at the RCA Laboratories.



C. Herbert Gleason (A'42) was born at Halstead, Kansas, on October 1, 1918. He received the B.S. degree in electrical engineering from the University of Kansas in 1940, and the M.S. degree in electrical engineering from the University of Missouri in 1942. He was a teaching assistant at the University of Missouri during 1940 and 1941 and an instructor at that University in 1941 and 1942. Since 1942 Mr. Gleason has been with the electronics engineering division of the Westinghouse Electric Corporation, Bloomfield, New Jersey. He is a member of Sigma Xi and Tau Beta Pi.

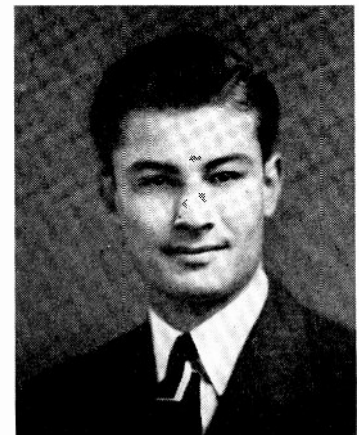

C. HERBERT GLEASON



A. C. SCHROEDER

A. C. Schroeder (A'38) was born at West New Brighton, Staten Island, N. Y., on February 28, 1915. He received the B.S. degree in electrical engineering from the Massachusetts Institute of Technology in 1937, and the M.S. degree from the same institution in the same year. He joined the Radio Corporation of America in 1937, and is now engaged in television research at the RCA Laboratories in Princeton, New Jersey. He is a member of the American Association for the Advancement of Science.



Kurt Schlesinger (A'41) was born on April 20, 1906, at Berlin, Germany. In 1928 he received the engineer's diploma, and in 1929 the degree of Doctor of Applied Physics, both from Technische Hochschule in Berlin. From 1929 to 1930 he was research physicist in Ardenne Research Laboratory, Berlin, and from 1931 to 1937 was chief engineer in the television department of Loewe Radio Company, also in Berlin. In 1938 Dr. Schlesinger became affiliated with the Radio and Cables-Grammont in Paris, France, where he devoted his time to television development. From 1941 to 1944 he was a research engineer for the Radio Corporation of America, attached to the laboratory at Purdue University. He is now associated with the Columbia Broadcasting System in New York City.



D. L. WAIDELICH



CAROL H. PENNYPACKER

Carol H. Pennypacker was born on March 1, 1922, at Haddonfield, New Jersey. She received the A.B. degree in mathematics from Smith College in 1943, and, since graduation, has been employed in a research division of the Radio Corporation of America, at Camden, New Jersey.



D. L. Waidelich (S'37-A'39-SM'44) was born on May 3, 1915, at Allentown, Pa. He received the B.S. degree in electrical engineering in 1936, and the M.S. degree in 1938, from Lehigh University. He was teaching assistant at Lehigh University from 1936 to 1938, and instructor and assistant professor of electrical engineering at the University of Missouri from 1938 to 1944. In the summer of 1937 he worked with Bell Laboratories, Inc., in the field of electronics research and in the summer of 1941 was a member of the electronic research staff of the Westinghouse Electric and Manufacturing Company, at Bloomfield, New Jersey.

During 1944 and 1945, Mr. Waidelich was with the Naval Ordnance Laboratory in Washington, D. C., as an electrical engineer and has now returned to the University of Missouri. He is a member of the American Institute of Electrical Engineers, the Society for the Promotion of Engineering Education, Sigma Xi, Tau Beta Pi, and Eta Kappa Nu.

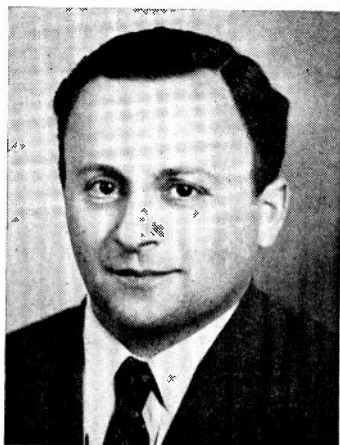

KURT SCHLESINGER

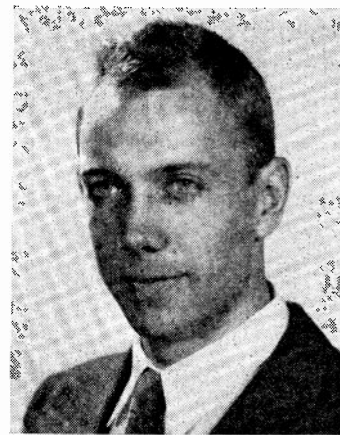

MYRON S. WHEELER

Myron S. Wheeler (A'43) was born at Pittsburgh, Pennsylvania, on January 15, 1920. He received the B.S. degree in electrical engineering in 1942 from the Pennsylvania State College. Since that time he has been doing graduate work at Stevens Institute of Technology and working with the Westinghouse Electric Corporation in a development section on radar. He is a member of Eta Kappa Nu and Sigma Tau.



A. M. Wiggins (A'42) was born on January 8, 1911, at Plainview, Texas. He received the B.S. degree in electrical engineering from Texas Technological College in 1933, and the M.S. degree in electrical engineering in 1936, from the University of Texas. From 1936 to 1941 he was employed by Seismic Explorations, Inc., of Houston, Texas. In 1941 he became associated with the RCA Manufacturing Company, in Camden, New Jersey, working in the research department until 1942, when he was transferred to RCA Laboratories, in Princeton, New Jersey, doing acoustical research. From 1944 to the present, Mr. Wiggins has been a research engineer for the Electro-Voice, Inc., South Bend, Indiana.

He is a member of Sigma Xi and the Acoustical Society of America.



A. M. WIGGINS

# WAVES

AND

# ELECTRONS

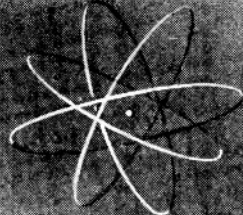
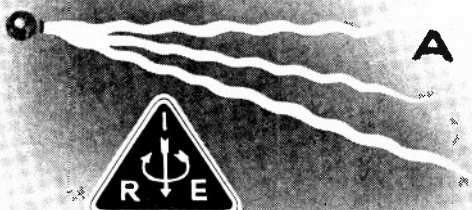

*Published Monthly  
by*

The Institute of Radio Engineers, Inc.

VOLUME I

*February, 1946*

NUMBER 2

Donald B. Sinclair—Board of Directors—1946.....	52 W
Army and Navy Letters of Recognition.....H. C. Ingles and Joseph R. Redman	53 W
The Historical Background of the Canadian Council of The Institute of Radio Engineers.....Ralph A. Hackbusch	54 W
A Plea for the Scientific Method.....Louis Hoffer	56 W
Radio-Frequency Dehydration of Penicillin Solution.....George H. Brown, R. A. Bierwirth, and Cyril N. Hoyler	58 W
A Vacuum-Contained Push-Pull Triode Transmitter.....Harold A. Zahl, John E. Gorham, and Glenn F. Rouse	66 W
Three New Antenna Types and Their Applications.....Armig G. Kandoian	70 W
Decibel Conversion Chart.....Robert C. Miedke	76 W

### **Institute News and Radio Notes**

Our New Home.....	78 W	Executive Committee.....	96 W
Winter Technical Meeting Summaries.....	80 W	Sixth Annual Broadcast Engineering Conference.....	96 W
Awards.....	94 W	Radio Pioneers' Dinner.....	97 W
Board of Directors.....	96 W	I.R.E. People.....	98 W
Sections.....	102 W		

### **Books**

"Electronics Laboratory Manual," by Ralph R. Wright.....	103 W
.....Reviewed by E. D. McArthur	
"Lehrbuch der Funktionentheorie—Volumes I and II," by Ludwig Bieberbach..	104 W
.....Reviewed by Frederick W. Grover	
"Electromagnetic Engineering, Vol. 1—Fundamentals," by Ronold W. P. King..	104 W
.....Reviewed by J. R. Whinnery	
Contributors to WAVES AND ELECTRONS.....	105 W
Section Meetings.....	38 A
Membership.....	42 A
Positions Open.....	50 A
Positions Wanted.....	54 A
Advertising Index.....	86 A

PROCEEDINGS contents on page 47 P.

#### **EDITORIAL DEPARTMENT**

Alfred N. Goldsmith  
*Editor*

Helen M. Stote  
*Publications Manager*

Ray D. Rettenmeyer  
*Technical Editor*

Winifred Carrière  
*Assistant Editor*

William C. Copp  
*Advertising Manager*

Lillian Petranek  
*Assistant Advertising Manager*

Responsibility for the contents of papers published in WAVES AND ELECTRONS rests upon the authors. Statements made in papers are not binding on the Institute or its members.

Changes of address (with advance notice of fifteen days) and communications regarding subscriptions and payments should be mailed to the Secretary of the Institute, at 450 Ahnaip St., Menasha, Wisconsin or 330 West 42nd Street, New York 18, N. Y. All rights of republication, including translation into foreign languages, are reserved by the Institute. Abstracts of papers, with mention of their source, may be printed. Requests for republication privileges should be addressed to The Institute of Radio Engineers.

*Copyright, 1946, by The Institute of Radio Engineers, Inc.*





## Donald B. Sinclair

Board of Directors—1946

Donald B. Sinclair was born at Winnipeg, Manitoba, Canada, on May 23, 1910. He attended the University of Manitoba from 1926 to 1929, and from 1929 to 1932 was enrolled in a co-operative course in electrical engineering at the Massachusetts Institute of Technology, from which he received the S.B. degree in 1931, the S.M. degree in 1932, and the Sc.D. degree in 1935.

During 1930 and 1931, Dr. Sinclair was associated with the Bell Telephone Laboratories and the New York Telephone Company, in New York City, and with the Western Electric Company, in Hawthorne, New Jersey. As a research assistant, from 1932 to 1935, and research associate during 1935 and 1936, he worked with the Massachusetts Institute of Technology on the electrocardiograph, electromechanical computing machines (differential analyzer and cinema integrator), and high-frequency measurements. Under co-operative arrangement with the General Radio Company, his doctorate research work on high-frequency impedance measurements was sponsored by that organization and done in its laboratories during 1934 and 1935.

In 1936 Dr. Sinclair became an engineer with the General Radio Company, and was appointed chief engineer in 1944. His work in this connection has dealt

with general development and design of measuring instruments, with emphasis on high-frequency impedance-measuring equipment.

Dr. Sinclair was a radio amateur in Winnipeg from 1926 to 1929, under call VE4FV, and from 1928 to 1929 he was a part-time radio operator for the Western Canada Airways. His wartime activities include work as research associate and consultant with the radio research laboratory of Harvard University, and as a section member on the National Defense Research Committee. He served in North Africa at the Allied Force Headquarters in 1943, as technical observer with the United States Army Airforces.

Dr. Sinclair became a Junior member of The Institute of Radio Engineers in 1930, an Associate in 1933, a Member in 1938, and a Senior Member in 1943. He was awarded the grade of Fellow in 1944, "for the development and application of various types of networks for high-frequency measurement of impedance." He was elected a member of the Board of Directors of the Institute in 1945, and is active on the Papers, Papers Procurement, Television, and the Antenna Committees. He also served on the Transmitters and Antennas Committee from 1941 to 1944.

The New York Section of the Institute held its fourth Radio Pioneers' Dinner on November 8, 1945. Two of the honored guests, Rear Admiral Joseph R. Redman, U. S. Navy, Chief of Naval Communications, and Major General H. C. Ingles, Chief Signal Officer, War Department, addressed to Louis G. Pacent, Chairman of the General Committee for the dinner, the tributes to all radio and electronic engineers and workers which are presented below.

## Army and Navy Letters of Recognition

On the occasion of your Radio Pioneers' Party, I welcome the opportunity to express the gratitude of the Signal Corps to the many radio-and-electronic engineers whose notable contributions to victory are now part of an imperishable historical record.

Demands, undreamed of by the founders of radio, were made by the Signal Corps upon those engineers and upon the entire electronics industry.

These demands were met even though it was necessary to create what virtually amounted to a new industry. Organizations and individuals placed the war needs of the nation above all other considerations and in the quality and quantity of their production and by their unselfish public service earned the acclaim of their country.

It is the earnest desire and confident hope of the Signal Corps that this close relationship and co-operation will not now be relaxed but will continue long into the future in order that our Army may be assured of unparalleled communications equipment.

Sincerely yours,  
H. C. INGLES  
Major General  
Chief Signal Officer

Whenever a group of old-timers meet at a gathering such as this Radio Pioneers' Party it is customary to think back over the years and to reminisce about the progress that has been made within our field. It is doubtful that the most imaginative old-timer could predict the remarkable development which was to take place in radio. Both World Wars I and II proved to be a tremendous stimulus to the radio industry. The great strides we have made in electronics during the past few years are now beginning to be made known to the public. The result will be that the electronic industry will step up in importance to one of the front-rank fields of our daily life and will find outlets for its devices in every branch of human endeavor.

Our national defense will depend to a still greater extent upon the electronic devices in the near future. It is an important element in all our planning. Our position in world affairs is dependent upon the progress which we have made and hope to make in the future. The progress we make will be the result of the brain power and human efforts which lie behind all development work. The past history is remarkable but we may be certain that the future will be even more so. The Navy appreciates the good work which has been done and will co-operate in every way in order to assist in making future developments as fantastic to the present-day conceptions as is the present state compared with the crude wireless you pioneers experimented with in the early days.

The Navy extends its congratulations to the Pioneers who laid the ground work for the achievements of the present day. 73.

JOSEPH R. REDMAN  
Rear Admiral, U.S. Navy  
Chief of Naval Communications

# The Historical Background of the Canadian Council of The Institute of Radio Engineers\*

RALPH A. HACKBUSCH†, FELLOW, I.R.E.

WHILE the actual inception of the Canadian Council of The Institute of Radio Engineers is relatively recent, the events leading up to the formation of the Council date back to the year 1925.

During that year, a group of radio engineers in Toronto decided that they should set up a group representative of the radio engineers in Canada, and after mature discussion, petitioned the Board of Directors of The Institute of Radio Engineers for a charter setting up a Canadian Section on October 2, 1925.

This charter was granted on July 10, 1926, and the Canadian Section, as such, made considerable progress, partially due to the energetic leadership of the various executive committees, partially to the fact that Toronto became the center of the bulk of receiving-set manufacture in Canada prior to 1931, and partially to the fact that the University of Toronto offered a communications option in the electrical-engineering course of the School of Practical Science, dating back to 1922.

The fact that the Dean of the department of electrical engineering, several of the professors, and many of the lecturers at the university were interested in the work of the Institute, and the fact that the meetings have always taken place in the Electrical Building of the university, have contributed to the progress of the Institute in the Toronto area.

In August, 1930, due to the energetic work of the Toronto group, the Fifth Annual and First International Convention of the Institute took place in Toronto, during which convention joint meetings with the engineering committee of the Radio Manufacturers Association were featured, following a pattern instituted in the United States of America at the Radio Manufacturers Association Annual Meeting at Atlantic City the previous year.

The Canadian Section co-operated with the Rochester, Buffalo, Niagara Falls, and Cleveland Sections in establishing the successful I.R.E. Eastern Great Lakes District Convention, held in Rochester in the fall of 1929, which was the forerunner of the now annual Rochester Fall Meeting of members of the I.R.E. and of the Radio Manufacturers Association engineering department.

\* Decimal classification: R060. Original manuscript received by the Institute, October 3, 1945.

† Stromberg-Carlson Company, Toronto, Ontario, Canada.

After the depression of 1930, many of the receiving-set manufacturers in the Toronto Area ceased to function, and many of the engineers who had been charter members of the Canadian Section of The Institute of Radio Engineers moved to Montreal, which was the center of the commercial activities of three large companies.

It was natural that this group should petition the Institute's Board of Directors for a charter for a Montreal section. This charter was granted on December 2, 1936, and formally presented to the Section on January 20, 1937.

Due to the close co-ordination of the members of the Montreal Section and the Toronto Section through close association in the activities of the Radio Manufacturers Association of Canada engineering committee over a period of years, the Canadian members of the Institute were kept informed of the activities of the two Sections.

With the advent of the war, Canada having declared war on Germany in September, 1939, there started a displacement of personnel from former centers and an increased interest in the field of radio and electronics. Naturally, there followed an increase in the Canadian membership of the Institute and a specific localization of interest in those areas where the war effort had established centers of activity.

There followed in rapid succession the formation of a Section in Ottawa, Canada, chartered September 5, 1944, and a Section in London, Ontario, chartered on November 24, 1944.

During this period the Canadian Government had passed certain labor laws dealing with collective bargaining, which affected professional engineers and those members of the Institute resident in Canada, who held a professional status and/or held membership in one or more of the Provincial associations of professional engineers, which had been established by Provincial law—Quebec, 1909; Ontario, 1922.

In order to meet this situation, a committee representative of the four major technical societies or bodies in Canada, set up a Committee of Fourteen to meet with the Government to discuss the professional phases of the Federal labor laws. However, prior to this, a representative of the Montreal Section had proposed that the Toronto and Montreal Sections should set up a Council to deal with such problems. Such councils or regional representation having been proposed by ballot to the

membership during 1941, but unfortunately defeated.

In view of the fact that the situation in Canada was unique and because of the fact that the writer was the vice-president of the Institute, and a member of its Board of Directors at the time when these problems became apparent, a request was made to the Board to permit the writer to act for the members of the Institute during this interim period, in collaboration with other engineering societies, in protecting the rights of our members in Canada, in connection with government acts and regulations.

At the same time, recognizing the fact that the members of the Institute resident in Canada were subject to the laws of the Government of Canada and various Provincial acts, the writer placed a motion before the Board of Directors to permit the functioning of national councils on an interim plan of action, which would not involve the Institute financially or legally, to deal with national matters within any one country until such a time as the Board of Directors decide on a final policy, and suggested that the chairmen of the Sections involved should act to give effect to this motion.

The I.R.E. Board of Directors unanimously passed this motion September 6, 1944, but it was not until April 7, 1945, at London, Ontario, that the chairmen met formally to set up a Canadian Council of The Institute of Radio Engineers.

At this meeting, it was agreed that the Council should consist of the chairman of each Section, the immediate past chairman of each Section (as ex-officio members), and to ensure close contact with Headquarters in New York, any Canadian Director of the I.R.E. who is resident in Canada. In the event that no Canadian, resident in Canada, be elected or appointed to the Board, it is further moved that a quorum of the Council be empowered to nominate for membership on the Council a representative for the Canadian membership at large.

It was agreed that the Secretary of the Council should be the chairman or the immediate past chairman of the Section from which the elected chairman of the Council had come, thus ensuring an effective working relationship between these two officers of the Council. The objects of the Council are those set forth in the constitution of The Institute of Radio Engineers, Article 1, Section 2; namely,

(a) Its object shall be the advancement of the theory and practice of radio and allied branches of engineering and of the related arts and sciences, their application to

human needs, and the maintenance of a high professional standing among its members.

(b) The Council shall act for the Canadian membership of the Institute on Canadian matters which are the common concern of the Canadian members, but it shall not involve The Institute of Radio Engineers either financially or legally.

(c) The Council shall endeavour to correlate the thoughts and actions of the Canadian membership of the Institute so that it may express the opinions of all Canadian members.

(d) The Council shall consider and take appropriate action in the following: (1) legislative matters affecting the Canadian membership and which are peculiar to Canada; (2) matters which require joint action with other engineering and professional associations in Canada; (3) matters associated with the education of professional workers in the fields of radio, communications and electronics; (4) matters associated with the professional status of workers in these fields; (5) matters associated with the public recognition of the contribution made by the radio and electronic industries in Canada during the war years; (6) such other matters as shall be added by a majority vote of the Council.

(e) The Council shall, at the request of the Sections, serve as a clearinghouse for speakers and papers and in a like capacity in other matters which may arise from time to time.

At the first meeting Dr. F. S. Howes, of the Montreal Section, was named chairman, while E. O. Swan was named vice-chairman. Since this date, L. A. W. East, the chairman of the Montreal Section, was named the secretary, and various committees were established under instructions from Chairman Howes, covering professional status, education committee, and a Canadian charter committee.

The Canadian Council of The Institute of Radio Engineers is a contributing sponsor to the work of the Canadian Radio Technical Planning Board, and maintains membership in the Canadian Council of Professional Engineers and Scientists.

At the present time, the expenses of the Council are defrayed by special vote of the Board of Directors.

It is felt that the work of the Canadian Council will establish a pattern for other groups within the Institute residing outside of the United States, to perform similar functions for their members, and thus further the usefulness and standing of a truly international Institute of Radio Engineers.



# A Plea for the Scientific Method\*

LOUIS HOFFER†

**Summary**—The rapid growth and development of the radio industry accelerated by the impetus of war, the new technical advancements, and the increased complexity of electronic application have indicated the need for more intensive training and a revision of the educational approach in this field.

Too much emphasis cannot be given to the inculcation of the "scientific habit of thought" and the development of the "scientific research" method in engineering thinking.

## WHAT IS SCIENTIFIC RESEARCH

SCIENTIFIC research is a method of finding out what we want to know, a technique which has survived because of its utility. The test of the validity of any method lies in its results. Whatever technique achieves that result is necessarily a valid technique. These techniques may vary from the "trial-and-error" method of the simple technician to the rigorous solution of a highly complicated abstract mathematical problem by a professional. The method to be adopted should be the one which is direct, simple, accurate, and reliable.

It is understood that all methods are tentative. Everyone works out something for his own use. Even in the highly formalized sciences, new methods supplant old. Methods in vogue in any field are the residues of techniques used by men to find out what they wanted to know.

However, one method man has used has enabled him to attain an understanding and control of the physical world far beyond the fondest dream of the ancients. In view of the success of this method, the scientific technique, we should be interested in its application to radio engineering. Conscious effort should be made to train the engineer in the common characteristics of this technique.

## CRITICAL DISCRIMINATION

The first requisite of this method of scientific analysis is the determination and ability to get at the basic facts and not be influenced by mere appearance, prevalent notions, and one's own wishes. Such a mental attitude is the core of the scientific frame of mind. It is the "be all" of all science.

Perhaps the best account of a scientific frame of mind is to be found in Francis Bacon's flattering description of *himself* in one of his famous works: "A mind nimble and versatile enough to catch the similarity between

facts, and at the same time, steady enough to fix and distinguish their subtle differences, . . . endowed by nature with the desire to seek, the patience to doubt, fondness to meditate, slowness to assert, readiness to consider, carefulness to dispose and set in order, neither affecting what is new nor admiring what is old . . ."

Critical discrimination is indispensable in all fields and is really a prime requisite in the field of engineering research. The radio industry would profit immeasurably from the scientific frame of mind on the part of every investigation in the laboratory.

## CLASSIFICATION

A second requirement of the scientific method is proper classification. Once the data have been collected by observation and experimentation, it is necessary to recognize the relationships that exist between these collected facts. Electrical phenomena should be classified on the basis of the similarity of the character of things, processes, and results achieved.

These classifications may be natural ones, such as the classifications of chemical elements based on atomic weights; or special-purpose classifications for specific objectives. The point is that, in order to arrive at proper conclusions, data must be arranged in some orderly array which naturally leads to such conclusions.

Of course, there is always the danger of improper classification for special purpose. The story is told of that lady who went on a railroad journey with a menagerie of pets. The conductor informed her of the fare for her dogs but didn't know the charge for her other pets. After inquiry of the railroad office, the conductor told the lady that according to the office, "as cats are dogs and rabbits are dogs and so are parrots, the fare would be the same but this here tortoise is an insect so there isn't any charge for it." So far as the railroad was concerned dogs, cats, and parrots belong to the same class, but it would be dangerous to use that type of special-purpose classification in the field of engineering research.

## FAIR SAMPLE AND VERIFICATION

Our scientific method starting from observed fact and experimentation usually ends in generalizations of some kind concerning large classes and groups of facts. The right we have to apply the results of our observations of a very limited number of facts to a large number of others which have not been observed depends on the principle of fair sample and verification, which means

\* Decimal classification: R070. Original manuscript received by the Institute, October 9, 1945.

† Emerson Radio and Phonograph Corporation, 111 Eighth Avenue, New York 11, N. Y.

that, with reasonable care, it is possible to judge the character of a large group by the aid of a sample selection from it.

Science, in this, as in other respects, follows the lead of the practical man. In business, it is often impossible to examine each item in a large shipment of goods. Hence, businessmen are content to estimate the character of the whole shipment by the aid of a sample. On the whole, experience shows that, provided the sample is selected with some care, it fairly represents the whole, but is itself only a small fraction of the whole. The actual number of samples is less important than the range of selection, and the accuracy of the generalization depends not only on the proper selection but on the degree of accuracy achieved in verifying the conclusion.

#### IMPORTANCE OF SCIENTIFIC TECHNIQUE

Too often only lip service has been paid to the "scientific habit of thought" summarized in the preceding paragraphs. Little effort is made to define the problem and determine the most fruitful line of attack. The game of prodigal waste called "tinkeritis" seems to have a tremendous appeal as an occupational technique, even though the dangers of illusion, fallacy, and "wish fulfillment" are common and serious enough to warn any sensible person who uses the critical approach against excessive confidence in his own conclusions without verification. As a matter of fact, there appears to be a large number of workers in the radio-engineering field who take pride in their ignorance of scientific techniques of logic, and of the value of the faculty of critical discrimination. To them, scientific technique and logical analysis are a kind of refined intellectual game played according to certain rules in selected academic circles.

In reality, however, the scientific method is as important and serious as life itself. Pursued in the right spirit, it will not only lead to the enrichment of engineering research, but will also be an invaluable training in the art of self-criticism which is so necessary to the peace and welfare of humanity.

#### NEED FOR PURE RESEARCH

Scientific research and the scientific frame of mind are handmaidens of pure science. Not only is there a need for the scientific technique in radio engineering, but also a need for fundamental inquiry into basic principles. If only the practical and useful aspects of radio engineering are considered, the radio industry will soon find itself "intellectually handcuffed" and in exactly the same position as that of the manufacturer who suddenly finds himself cut off from his supply of raw materials from which he fabricates his finished product.

As one writer has said, "Everyone recognizes that applied science rests on pure science—that, to cite a single illustration, radio communication would have remained not only impossible but inconceivable save for the fundamental experiments of Faraday, the mathematical formulation of wave theory by Maxwell, the experimental realization of Maxwell's predictions by Hertz—all being advances in knowledge made without thought of practical application or financial return."

"All the ingenuity in the world could not have produced an automobile until science had brought to light the electrical, metallurgical, and mechanical principles involved in its construction."

However, there appears to be a lack of appreciation of the importance and the possibilities of pure research. If insufficient attention and inadequate financing of pure research continues, the stream of creative thought in the field of radio engineering will eventually dry up.

If the Radiation Laboratory at The Massachusetts Institute of Technology (Office of Scientific Research and Development) had such admirable success in war, intelligent industry should see to it that its research role is continued in peace. Industry could certainly develop "a moral-equivalent-of-war spirit" to subsidize a permanent "radiation laboratory" or other research body, devoted to pure science and beneficial to both industry and society.

As Admiral S. C. Hooper said in the June, 1943, issue of the *PROCEEDINGS OF THE I.R.E.*, "The progress and prosperity of our Nation, as well as the readiness of its forces of war, are in no small measure dependent upon keeping peacetime research going full speed."

# Radio-Frequency Dehydration of Penicillin Solution\*

GEORGE H. BROWN†, FELLOW, I.R.E., R. A. BIERWIRTH‡, MEMBER, I.R.E., AND  
CYRIL N. HOYLER†, SENIOR MEMBER, I.R.E.

**Summary**—Many pharmaceutical materials, such as penicillin and antitoxins, lose their desirable properties when the material is in liquid solution for a period of time. In general, these solutions suffer from the application of heat. In the dry state, the same materials retain their properties over long periods of time, even at elevated temperatures. Drying of penicillin is generally carried out by freezing and then applying a high vacuum so that the material is dried by sublimation. This paper describes certain experiments and developments made by the authors to bring about the drying of penicillin by the application of radio-frequency power in a very moderate vacuum.

The system presented in this paper has been divided into three parts: (1) bulk concentrating of the solution; (2) drying the concentrate in the final containers to a moisture content of a few per cent; and (3) completing the drying in auxiliary chambers. The equipment is capable of producing 2000 dry bottles per hour, using inexpensive vacuum pumps and simple condensers. The whole system operates with a minimum of maintenance.

A few experiments have been made concerning the drying of other pharmaceuticals with promising results.

## I. INTRODUCTION

LATE IN 1943, many newspaper and magazine articles were published which told the story of the manufacture of penicillin. Particular emphasis was given to the problem of drying the product for packaging. Two points were stressed. First, penicillin in a water solution soon lost its bactericidal properties so it was necessary to dry the product thoroughly before storage or shipment. Second, penicillin solution was so sensitive to heat that it was necessary to keep the solution in a frozen condition before drying and even to dry in the frozen state. This freeze-drying process was expensive and took a long time. Our previous work in dehydration of materials by means of radio-frequency power, particularly the drying of rayon cakes in a vacuum, led us to speculate about the possibilities of contributing something to the penicillin production program by the application of radio-frequency power. The writers then suggested to the late Dr. George A. Harrop, Director of Squibb Biological Laboratories, that it might be possible to evaporate the water from the liquid state if the vacuum were such that the boiling point remained at about 50 degrees Fahrenheit and the energy necessary for vaporization were supplied by a radio-frequency generator. Dr. Harrop expressed great interest in the possibilities and offered to co-operate in tests to determine whether such a procedure would harm the product. Before such tests could be made, other producers of penicillin heard of our ideas and

\* Decimal classification: R590. Original manuscript received by the Institute, September 18, 1945.

† RCA Laboratories, Princeton, N. J.

‡ Formerly RCA Laboratories, Princeton, N. J., now Sound, Inc., Chicago, Ill.

wished to discuss the proposal. Some of these producers provided samples for test purposes. A description of the pertinent tests will be included in this paper. In order to orient the reader, it seems desirable to say a few words concerning the methods of testing for bactericidal properties and the means of expressing these properties, since the purpose of our early experiments was to determine how our radio-frequency methods affected these properties.

## II. PENICILLIN ACTIVITY OR POTENCY

Pure crystals of penicillin salt are believed to be very stable and to have constant bacteria-destroying properties for a given weight. Pure crystals are difficult to obtain. However, in limited amounts, these crystals are useful in testing solutions of penicillin which contain impurities and are of unknown activity. The Oxford unit of activity was selected shortly after the discovery of penicillin, so the unit is smaller than necessary for convenient use.<sup>1</sup> Pure crystals of penicillin possess 1667 Oxford units of activity per milligram.

In testing a solution of unknown potency, various dilutions of the substance are placed on a bacteria culture. At other spots on the same plate, a penicillin solution of known activity is placed. After incubation for a fixed period of time, observations are made of the dimensions of the zones of inhibition.

Another test makes use of observations of turbidity of various dilutions of penicillin in cultures of bacteria. Again the observations are correlated with a known solution.

The accuracy or consistency of these bacteriological determinations is not very great. A number of measurements of potency taken on the same sample may show deviations as high as plus or minus fifteen per cent from the average.

In our experiments, control samples were kept so that any deterioration of the solution with time could be sorted out from the effect of radio frequency.

## III. INITIAL EXPERIMENTS WITH RADIO-FREQUENCY HEATING

With a few exceptions, the people connected with penicillin production assured us that it was extremely important to keep the solution frozen throughout the drying cycle. They warned that if this were not done the potency would be lost. The statements did not appear to be based on experience related to the method of

<sup>1</sup> One Oxford unit is that amount of penicillin which, when dissolved in 50 milliliters of meat-extract broth, just inhibits completely the growth of the test strain of *Staphylococcus aureus*.

drying which we proposed. Therefore, it seemed desirable to determine by experiment just what the effect would be.

To dry by conventional freeze-drying methods,<sup>2</sup> it is necessary to maintain a vacuum of between 100 and 300 microns (0.1 to 0.3 millimeters of mercury). We were not interested in freeze-drying with radio-frequency power, for a number of reasons. In the first place, if we were to contribute to the penicillin program by furnishing a faster and simpler system, the elimination of the expensive high-vacuum systems, complicated condensers, and elaborate refrigeration seemed to be the most important step. Second, for the same voltage or electric intensity, the residual atmosphere ionizes much more readily with a vacuum of 100 microns than it does at a vacuum of about 20 millimeters, which is the order of vacuum that we had in mind for our purpose. In addition to the fact that the air ionizes easier at 100 microns, the solution is frozen when under this vacuum. The electrical conductivity of frozen penicillin is so much lower than that of the liquid that much higher voltages must be used to generate the same power. This effect is very pronounced. When attempts were made to dry in the frozen state with radio-frequency power, it was necessary to reduce the radio-frequency voltages to such an extent that it became apparent that most of the heat of vaporization was being supplied by heat conduction from the warm air of the laboratory through the glass walls of the container.

A number of samples of a weak solution of penicillin were submitted by the representatives of a penicillin producer. They were anxious that the tests be made in the frozen state, so only one sample was subjected to the test which we wished to make. Each sample was a frozen solution weighing 1000 milligrams. The results of the experiments are given in Table I.

TABLE I

Sample	Final Weight (Milligrams)	Units of Activity Per Milligram	Total Units In Sample	Treatment
Control	58.7	67.0	3933.0	Control dried by conventional freeze-drying.
1	59.1	47.0	2780.0	Shelled <sup>1</sup> and dried for 80 minutes with radio frequency, vacuum of 80 microns.
2	68.4	55.0	3760.0	Shelled <sup>1</sup> and dried for 60 minutes with radio frequency, vacuum of 100 microns.
3	57.5	76.0	4370.0	Not shelled. Radio frequency applied for 10 minutes, but vacuum of 100 microns for 90 minutes.
4	55.5	82.0	4550.0	Frozen when placed on pump, and vacuum of 10 millimeters applied. Radio-frequency power used. Melted immediately. Appeared dry in five minutes. Heating continued for total of 30 minutes.

<sup>1</sup> Shelling is the procedure of freezing the liquid in a thin layer on the sides of the bottle, accomplished by holding the bottle on its side and slowly rotating the bottle while submerged in a refrigerant until the contents are completely frozen.

The tests shown in Table I indicated that the best results were achieved by boiling out the water at the rela-

<sup>2</sup> Earl W. Flosdorf, Lewis W. Hull, and Stuart Mudd, "Drying by sublimation," *Jour. Immunology*, vol. 50, pp. 21-54; January, 1945.

tively high pressure of 10 millimeters. Since this was not in accordance with the opinion of experts, it seemed desirable to verify this conclusion by further tests. Accordingly, four samples obtained from E. R. Squibb and Sons were treated. These samples were all frozen when placed in the drying apparatus. However, the pressures were high enough so that the material quickly melted. The following conditions prevailed for these samples:

Sample 1: Vacuum of 10 millimeters. Drying time 52 minutes.

Sample 2: Vacuum of 18 millimeters. Drying time 103 minutes.

Sample 3: Vacuum of 6 millimeters. Drying time 75 minutes.

Sample 4: Vacuum of 3 millimeters. Drying time 35 minutes.

The activity tests reported by Squibb Laboratories were as shown in Tables II and III.

TABLE II

	Control No. 1	Control No. 2
First dilution	73,100 units	82,400 units
Second dilution	70,900 units	82,500 units
Average	72,000 units	82,450 units
Average of controls	77,225 units	

TABLE III

Sample	First Dilution	Second Dilution	Average
1	82,400	76,200	79,300
2	83,560	82,100	82,830
3	76,100	77,500	76,800
4	75,000	72,700	73,850
Average of radio-frequency samples			78,195

Four more samples were later dried under the following conditions and tested for activity by Squibb Laboratories (Table IV).

TABLE IV

Sample	Activity	Treatment
5	88,644	Vacuum of 150 microns, with radio frequency. Sample frozen throughout treatment. Drying time 5 hours.
6	87,316	Vacuum of 10 millimeters. Drying time 70 minutes. No loss of weight after 40 minutes. Sample melted quickly and had dried appearance after six minutes.
7	83,664	Vacuum of 10 millimeters. Drying time 60 minutes. No loss of weight after 45 minutes. Sample melted quickly and had dried appearance after six minutes.
8	75,862	Vacuum of 30 millimeters. Drying time 60 minutes.
Control	70,625	

The people at the Squibb Laboratories attributed the lower activity of sample 8 and the control to the fact that both specimens had been kept in solution in a frozen state for several days after samples 5, 6, and 7 were dried.

In any event, we felt that the test results showed that no harmful effects appeared when the dehydration took place with vacuums of the order of 10 millimeters. These initial tests have been repeated many times, always with the same result—no loss in potency.

In the above tests, it may appear that it is possible to freeze-dry with high vacuum in times varying from one



to five hours. In our laboratory tests, the sample was in a thin-walled glass bottle which was connected to a manifold. Here the entire bottle was exposed to the warm air of the laboratory. In practice, where thousands of these bottles are placed in large vacuum tanks, no circulation of warm air takes place. The drying time by this method may take from eight to twenty hours.<sup>3</sup>

#### IV. A RADIO-FREQUENCY BULK REDUCER FOR PENICILLIN

As a result of these initial successes, much interest was exhibited by a number of penicillin producers. It seemed extremely desirable to review the work and consider how best to fit radio-frequency power into the picture.

After the penicillin mold is grown and the penicillin harvested, the material goes through a number of complex chemical processes from which it finally emerges as a weak water solution of a sodium or calcium salt of penicillin, with varying amounts of impurities. At the time that we were interested in considering the situation, it was the practice to freeze or shell this solution on the walls of a number of large glass bottles which were then attached to a manifold of a vacuum system. The vacuum was maintained at about 100 microns. The only heat supplied was by conduction through the walls of the bottles. After many hours, the material was considered to be dry and was then scraped from the bottles and pulverized. A measurement of potency, in Oxford units per milligram, was then made to determine the amount by weight that would be placed in the final ampoule or bottle. Since it was necessary to maintain a high degree of sterility, this operation was done in an air-conditioned box containing an analytical balance, a tray of penicillin powder, a rack of bottles, and the necessary loading tools. The operator manipulated the apparatus by inserting his arms into a pair of rubber gloves that were anchored to two openings in the box and by peeping through a small glass window in the wall of the box. This process was slow and expensive, as well as tedious and inaccurate.

We were told that most processors were considering a modification in which freeze-drying in the large bottles would be halted at a point where the activity of residue would be between 10,000 and 100,000 units per cubic centimeter. The material would then be allowed to melt and the liquid would be assayed for potency. Depending on the activity attained, between one and ten cubic centimeters of material could be accurately measured into each final container. Then a rack of final containers would be frozen and inserted in a large vacuum chamber and the pressure reduced to about 100 microns, for the final drying. Because of this change of procedure, it was decided that a radio-frequency bulk reducer was first in order of importance. The bulk reducer could then be

<sup>3</sup> See p. 38 of footnote reference 2.

used to remove sufficient water to concentrate to a potency of 100,000 units per cubic centimeter, after which one cubic centimeter of the material would be measured into each of the final containers and taken down to complete dryness by the freeze-drying high-vacuum chambers. The twofold advantage of the radio-frequency bulk reducer is that the expensive high-vacuum bulk reducer and refrigeration system is eliminated and the output of the final freeze-drying cabinets is increased because only one cubic centimeter of water is removed from each final container.

The first experiments in bulk reduction were conducted with a laboratory oscillator which could be changed readily to a number of frequencies. The frequencies investigated particularly corresponded to the frequencies of commercially available oscillators.

The experimental arrangement is shown in Fig. 1. The penicillin was contained in the large bottle shown at the

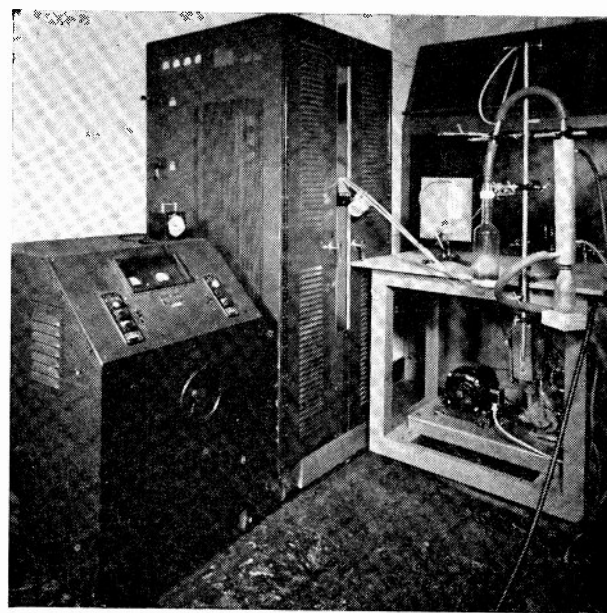

Fig. 1—First experimental bulk reducer.

table's edge. The tall chimney was necessary to prevent losses of material due to splashing. The electrodes were simply thin sheets of metal taped to the outside surface of the bottle. The bottom of the bottle was made concave so the load presented to the oscillator would remain fairly constant throughout the concentration cycle. This enabled us to use wider electrodes and still preserve this constancy of load. With a flat bottom, the liquid was sometimes concentrated below the level of the electrodes so that there was danger of ionization in the air space and sometimes arcing from the electrodes.

Attempts were made to operate at a frequency of 10 megacycles, but we were not able to overcome sparking at the electrodes. Further experiment showed that, at a frequency of 28 megacycles, there was little danger of electrode trouble, provided the concave bottom was used.

A Beach-Russ vacuum pump, of the wet type, with a capacity of six cubic feet per minute, was used through-

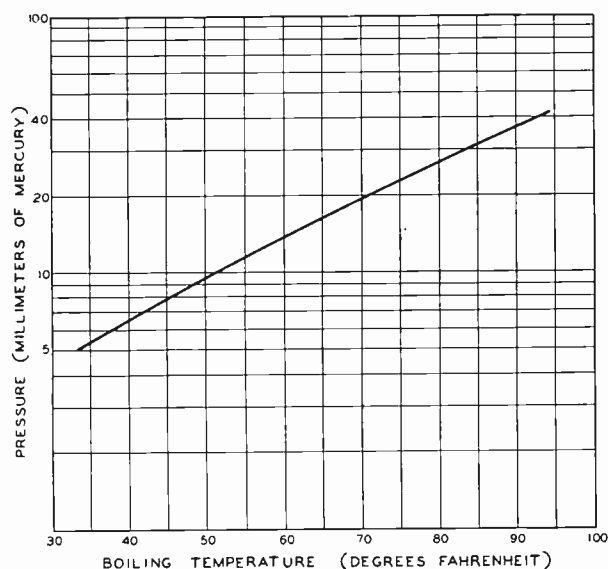

Fig. 2—Boiling temperature versus pressure.

out the experiments with the bulk reducer and in the final model. The water vapor was passed into a water-

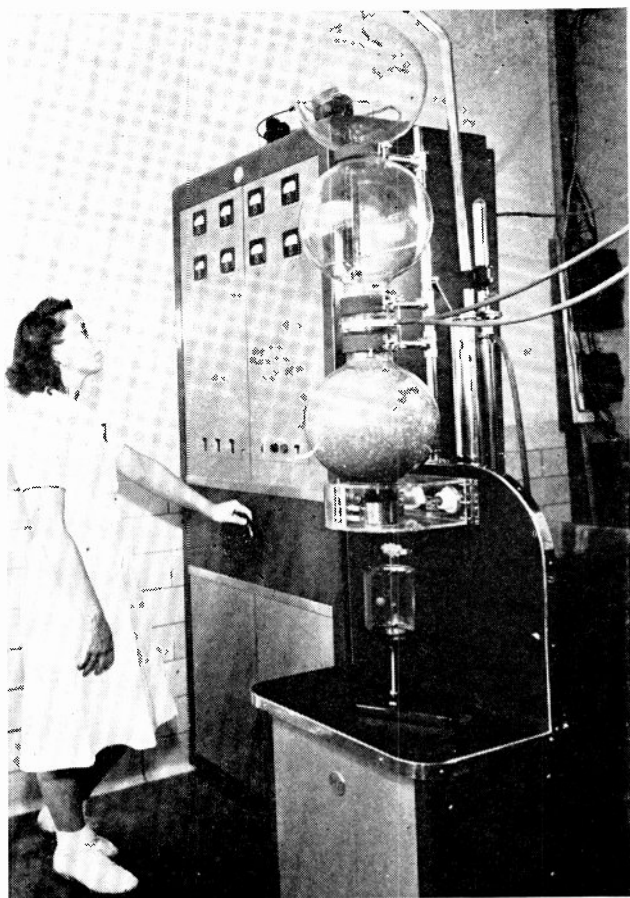

Fig. 3—Pilot bulk reducer in operation at Squibb Laboratory

cooled condenser so the pump was not forced to handle large quantities of vapor.

A large number of experiments was carried out to learn the necessary technique for a practical system. Further tests were necessary to determine the safe range of temperatures and pressures which could be used without harming the penicillin. The temperature at which water boils as a function of pressure is shown in Fig. 2. While much of our operation took place at a pressure

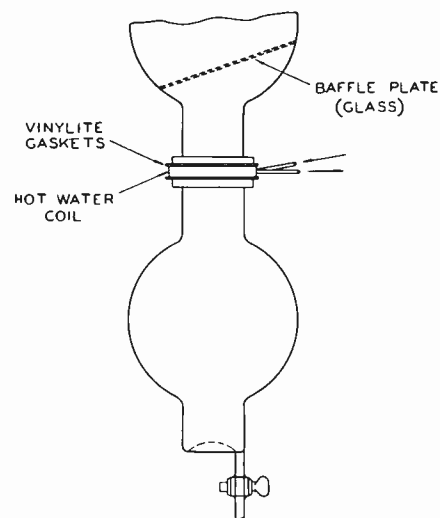

Fig. 4—Diagram of bottles with baffle plate and water coil in place.

between 10 and 20 millimeters of mercury, we have run the equipment at pressures up to 40 millimeters without loss in potency of the penicillin.

A pilot unit was next constructed. The oscillator consisted of two RCA-833A vacuum tubes acting as a conventional oscillator at 28 megacycles, with a power output of two kilowatts. Fig. 3 shows the equipment in operation at Squibb's plant. The three large glass bottles provide room for foaming of the liquid when the vacuum is applied. Penicillin solution is extremely foamy so that our efforts in suppressing the foam were extensive. A baffle plate was inserted in the middle bottle. Also, a coil made of silver-plated copper tubing was inserted between the bottom and the middle bottles. The arrangement is shown in Fig. 4. Warm water (125 degrees Fahrenheit) was passed through this coil. When the foam and bubbles rise and contact the warm coil, the part of the bubble in contact with the coil evaporates and the bubbles collapse. This arrangement has been extremely successful in the operation at the Squibb laboratory.

In connection with the foaming problem, it might be mentioned that the excessive foaming difficulties were encountered at a time when most penicillin solution carried a large amount of impurities. Observations made recently show that the penicillin solution now being produced by most manufacturers has improved in characteristics to such an extent that neither the baffle plate

nor the hot-water coil need be used. Actually, the most violent foaming only fills the lower half of the bottom flask.

In using the bulk reducer, the sequence of operations is as follows: The hot-water supply for the bubble-breaking coil and the cold-water supply for the condenser are turned on and the vacuum pump started. When a liter of material is ready for treatment, a flask containing the solution is placed beneath the bottom bottle and the pet cock is opened. The penicillin solution is thus sucked up into the bottle. The pet cock is then closed and the oscillator turned on. With full power applied, 1000 cubic centimeters of liquid will be reduced to 100 cubic centimeters in eighteen minutes.

After turning off the oscillator, the vacuum pump is stopped and the relief valve is opened. Then the pet cock below the bottom bottle is opened and the penicillin solution drained from the bottle. After this operation, the pump is started and a new supply of penicillin is drawn into the bottle.

#### V. DRYING IN THE FINAL CONTAINER

In Section III, the results of early experiments were reported. Here the drying was carried out in large test

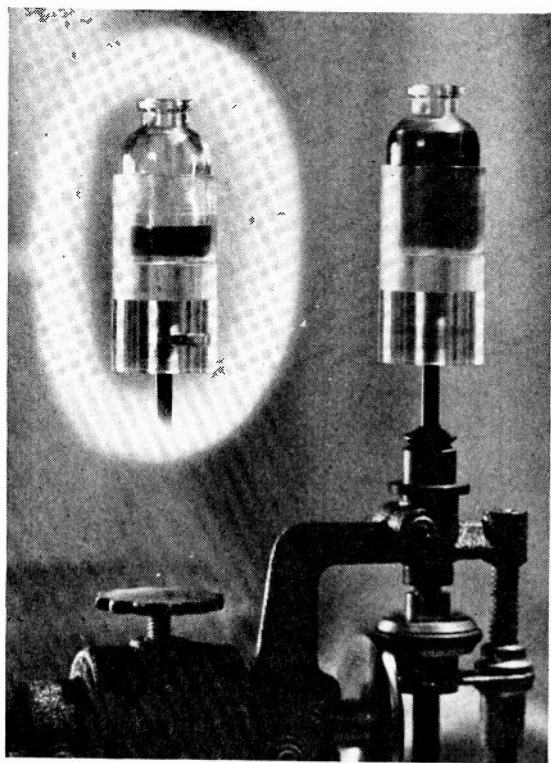

Fig. 5—The bottle is placed in a plastic cup. The bottle at the right is rotating at a speed of 3000 revolutions per minute. The liquid forms a thin film on the wall of the bottle.

tubes or ampoules. The material splattered up on the walls of the container when the vacuum was applied and splattered again when the radio-frequency power was

turned on. This resulted in a messy appearance when finally dried. However, we were interested in the effect on the activity and for the moment were not concerned with appearance. When later attempts were made to



Fig. 6—Samples of penicillin dried by spinning in a radio-frequency field. Each bottle contains 100,000 units of penicillin, with varying amounts of impurities.

dry in the final bottle, it became apparent that it was almost impossible to keep all the material in the bottle. Initial application of the vacuum usually resulted in loss of a certain amount of solution due to splattering. After the application of power, severe bumping sometimes entirely emptied the bottle. Numerous expedients were resorted to in an attempt to solve this problem. Rotating the bottle at high speed during the evacuating and drying period revealed that this was a way to eliminate these difficulties. Fig. 5 illustrates this action. The bottle on the left contains about one cubic centimeter of penicillin solution. The same bottle is shown on the right, rotating at a rate of 3000 revolutions per minute. The liquid and solids in the liquid are then formed in a thin layer on the walls of the bottle. The force on the solids at this rotational speed is estimated to be at least one hundred times the force of gravity. When vacuum is applied, no material is lost. Then, as radio-frequency power is applied, the material dries in a thin film on the side of the bottle with a rather pleasing appearance. Dried samples may be seen in Fig. 6. A single-unit drier consisting of a plastic cup driven at a speed of 3000 revolutions per minute and a set of electrodes is shown in Fig. 7. This unit was found to be very useful in the laboratory, and several hundred samples of penicillin solution have been dried under various conditions with this equipment. With approximately 20 watts of power at 30 megacycles, it is possible to remove most of the moisture from one cubic centimeter of solution in three minutes. Typical data taken during a drying cycle is shown in Fig. 8. It may be seen that most of the water is removed in the first 60 seconds. The rate of drying

progressively decreases as time passes. Measurements of the  $Q$  factor of the circuit taken during the drying

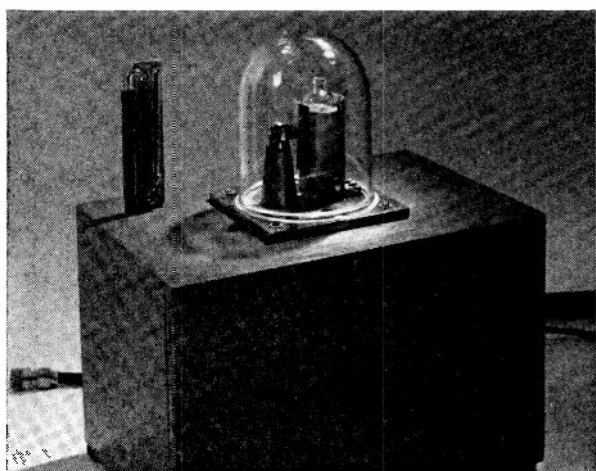

Fig. 7—A laboratory arrangement for drying one bottle at a time.

cycle are also shown in Fig. 8. As the material dries out, the  $Q$  becomes high so that there is quite a change in loading of the oscillator during the drying period. At the

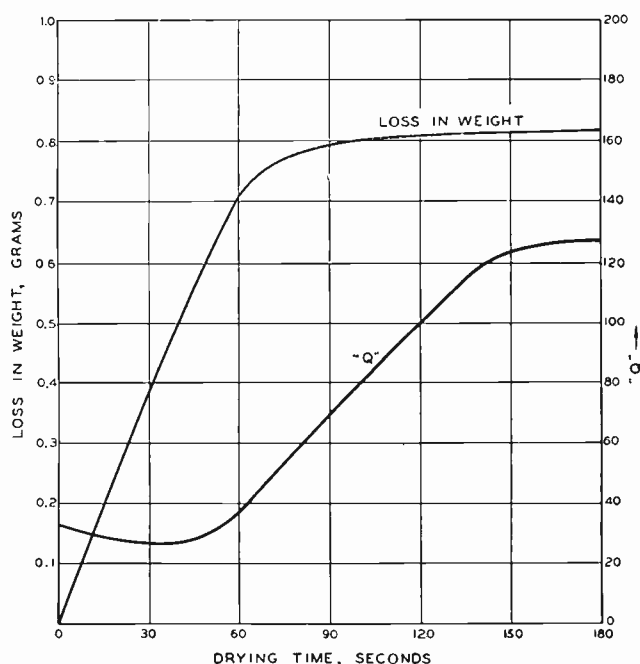

Fig. 8—Drying rate and  $Q$  of a single bottle as a function of time.

end of three minutes, the moisture content is reduced to about 4 per cent. Application of radio-frequency power for longer periods will reduce the moisture content still further. However, by the time the moisture content has been reduced to 4 per cent, the material is very stable and will stand much higher temperatures than it does when in the liquid condition. This allows us to introduce another step which is important in the construction of final equipment, since it permits the use

of a minimum number of rotating cups. The bottles are transferred to metal plates which are heated by ordinary electric heaters. A bell jar is then placed over the heater plate and the system evacuated. Since the ma-

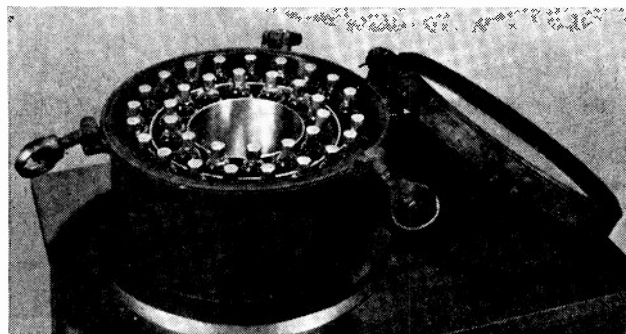

Fig. 9—An experimental drying chamber which holds thirty-four bottles.

terial is dried on the sides of the bottle in a thin film, heat conduction through the glass bottle to remove the last traces of moisture is efficient.

Early in the investigation, several samples of penicillin solution were dried and tested for activity and moisture content. In each case the bottle was rotated for three minutes in a radio-frequency field, with a vacuum of 50 millimeters of mercury. Then the bottles were removed from the radio-frequency field and placed in a metal box which in turn was placed in a bell jar, with a vacuum of 8 millimeters of mercury. An electric heater, thermostatically controlled, heated the metal plate which supported the bell jar to a temperature of 65 degrees centigrade. At the end of the run, the bottles reached a temperature of 50 to 55 degrees centigrade. The conditions of test as well as activity measurements are shown in Table V.

TABLE V

Sample	Time in Bell Jar	Activity Oxford Units	Number of Activity Tests
Control	—	95,954	8
Control	—	103,441	6
204	2 hours	115,233	4
205	2 hours	101,853	4
206	2 hours	101,561	4
212	1 hour	108,265	4
214	1 hour	110,349	4

The moisture determinations were as shown in Table VI.

TABLE VI

Time in Bell Jar	Per Cent Moisture (Average of Three Samples)
2 hours	0.43
1 hour	0.60
Zero	4.13

With these and similar data at hand, the construction of a system which would handle large numbers of bottles was started. A unit of the system is shown in Fig. 9. A port-hole frame is used as a vacuum chamber. Thirty-four plastic cups are mounted on the peripheries of two



circles. An electrode, insulated from ground may be seen between the two rings of bottles. An inner metal ring and the wall of the port form the two ground electrodes. Radio-frequency power is fed in through a vacuum-tight insulating bushing. Each of the plastic cups is individually gear driven at a speed of 3000 revolutions per minute.

Fig. 10 shows a circular table which supports six of these chambers. Each chamber is subjected to radio-

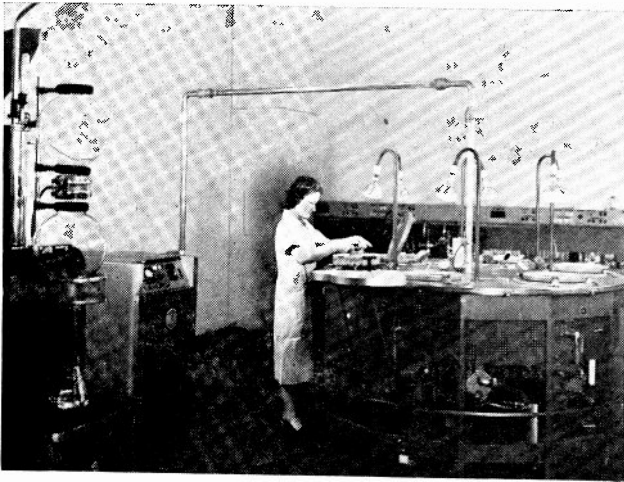

Fig. 10—A circular table with six drying chambers. This equipment dries 2000 bottles per hour. The infrared lamps prevent condensation on the cold lids of the vacuum chambers.

frequency power for three minutes. A rotary switch is used so that three chambers are connected to the oscillator at one time. One chamber is in the wet stage; that is, it is in the first third of its drying cycle. Another chamber is in the second third of its drying cycle, while a third chamber is in the last stage of the drying cycle. At the end of one minute, the chamber containing dry bottles is switched from the oscillator and a fresh chamber is connected in the group. Thus the oscillator remains essentially fully loaded at all times. An examination of Fig. 8 reveals the reasoning behind this procedure. In addition, the automatic load-tuning circuit incorporated in the RCA-2B oscillator insures complete stability with respect to power output. While three chambers are being dried, the fourth is in the process of unloading, the fifth is being loaded, and the sixth is in the initial stages of evacuation. Since one chamber of thirty-four bottles is unloaded every minute, over two thousand bottles are processed each hour.

The bottles are next loaded into aluminum trays and the trays are placed on the electrically heated bases shown in Fig. 11. The metal domes are then closed and evacuated to about 5 millimeters of mercury. After one-half hour in these auxiliary domes, the bottles are removed for capping.

The equipment shown in Fig. 10 is largely automatic. The operator's duties consist of operating the vacuum

applicator valves and vacuum release valves on the side of the table, as well as opening the lids of the chambers, removing the processed bottles, and inserting new bottles to be dried. When the operator closes the lid to a chamber, a microswitch is actuated and the bottles begin rotating. A green pilot light at each chamber indicates that the chamber may be opened. A red pilot light shows that radio-frequency power is being applied to the chamber. At the end of each minute, a timer turns off the oscillator, operates the rotary switch so that one



Fig. 11—The auxiliary drying chambers.

chamber is dropped out and a fresh chamber connected, and then turns on the oscillator. If the operator has not yet processed this fresh chamber and thrown the vacuum-applicator valve to the final position, the oscillator will not turn on, and an amber pilot light will indicate the chamber that is delaying the proceedings. When the vacuum-applicator valve is finally thrown, the one-minute cycles will then be resumed.

## VI. ELECTRICAL CONDUCTIVITY OF PENICILLIN

It has been suggested many times that we reconsider the situation and attempt to dry in the frozen state. Since we have shown that our method of drying produces a dry product with no loss in activity, there seems to be no point to the introduction of greater complications of higher vacuums and colder condensers. In addition, the high voltage required in the presence of the more perfect vacuum seems to be an obstacle which will not be solved easily. Early in this paper, it was stated that the voltages necessary to develop power in the frozen material were markedly higher than for the liquid solution. This point may be illustrated by a specific example.

The power generated in a one-centimeter cube of material is

$$P(\text{watts}) = E^2\sigma$$

where  $\sigma$  = conductivity of the material in mhos for a centimeter cube

$E$  = electric intensity in the cube in volts per centimeter.

Then for one watt generated in the cube, the electric intensity is

$$E = \frac{1}{\sqrt{\sigma}}$$

This electric intensity may be regarded as the voltage required between opposing faces of the cube.

Murphy and Morgan<sup>4</sup> show that the conductivity of ice increases as a function of frequency but flattens off completely when the frequency is greater than 10,000 cycles. For ice at  $-0.8$  degrees centigrade, they show a conductivity of  $4.15 \times 10^{-7}$  mhos for a centimeter cube. When substituted into the above equation, it is seen that the voltage across the one-centimeter cube for one watt is 1550 volts. However, this temperature is very close to the melting point of ice at atmospheric pressure. A few degrees drop in temperature reduces the conductivity appreciably. At  $-45.8$  degrees centigrade, a temperature where freeze-drying is usually carried out, the conductivity has dropped to  $10^{-8}$  mhos for a centimeter cube, with a resultant field intensity of 10,000 volts per centimeter.

Measurements on typical penicillin solution in the liquid state (20 degrees centigrade) show that the conductivity may be expressed as

$$\sigma = 10^{-6}A$$

where  $A$  is the activity measured in Oxford units per cubic centimeter. Thus when the activity is 100,000 units per cubic centimeter, the conductivity is 0.1 mhos for a centimeter cube, and the field intensity necessary to generate one watt in a centimeter cube reaches the remarkably low value of 3.16 volts per centimeter.

In addition to these quantitative relations, the difficulties of coupling radio-frequency energy to ice may be realized by means of a simple experiment. A set of electrodes which will hold a penicillin bottle is mounted on the capacitor terminals of a conventional  $Q$  meter. Then if a bottle containing several cubic centimeters of frozen penicillin solution and an empty bottle are successively plugged into the electrodes, it is impossible to detect a difference in the reading of the  $Q$  meter.

<sup>4</sup> E. J. Murphy and S. O. Morgan, "The dielectric properties of insulating materials," *Bell Sys. Tech. Jour.*, vol. 18, p. 512; July, 1939.

## VII. CONCLUSION

Experiments leading to the development of a successful method of dehydrating penicillin solution by means of radio-frequency heat have been presented. The process has been divided into three parts: (1) bulk reducing of the solution to achieve an activity of 100,000 units per cubic centimeter; (2) drying one cubic centimeter of the concentrate in the final bottles until the moisture content is reduced to four per cent; and (3) completing the drying in auxiliary chambers. The equipment described is capable of producing 2000 dry bottles each hour, using inexpensive vacuum pumps and simple condensers. The whole system operates with a minimum of maintenance.

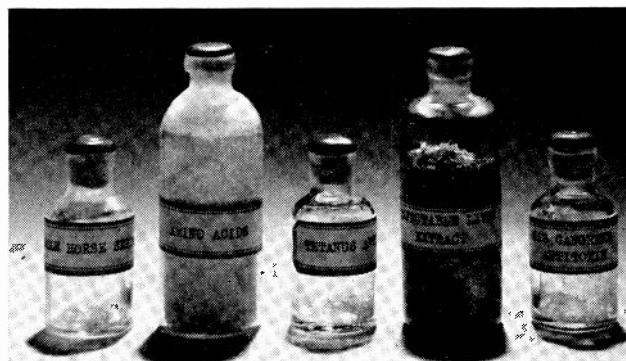

Fig. 12—Representative pharmaceuticals dried by the radio-frequency method. From left to right: whole horse serum, amino acids, tetanus antitoxin, injectable liver extract, gas gangrene antitoxin.

When the bottles are removed from the auxiliary heaters, they are closed with rubber stoppers, and aluminum caps are pressed on to hold the stoppers in place. The bottles may then be stored for long periods of time until needed. At that time, sterile water is injected through the rubber stopper with a hypodermic syringe, the penicillin readily dissolves in the water, and the solution is withdrawn into the syringe.

Because the techniques described in this paper are so different from conventional methods of drying of pharmaceuticals and biologicals, it is difficult to predict what will happen to the many products which might be dried by these methods. Until a broad experience has been built up, it is necessary to submit each product to experiment. The authors have dried a limited number of products with results which show great promise. Representative samples are shown in Fig. 12.

# A Vacuum-Contained Push-Pull Triode Transmitter\*

HAROLD A. ZAHL†, ASSOCIATE, I.R.E., JOHN E. GORHAM†, ASSOCIATE, I.R.E., AND  
GLENN F. ROUSE†

*Summary*—A 600-megacycle transmitter is described which varies from the usual triode design in that the resonating grid and plate circuits are contained in vacuum and form an integral part of the grid and plate structures. The design described, while applicable for continuous-wave operation, covers particularly United States Army-type tube VT-158 constructed only for pulse operation. Peak powers of 200 to 300 kilowatts can be obtained under proper conditions of operation.

## I. INTRODUCTION

**A** FEW YEARS ago Major-General Roger B. Colton, then Director of the Signal Corps Laboratories, Fort Monmouth, N. J., noticed how much difficulty was being experienced with radio-frequency sparking and loading of more or less conventional ultra-high-frequency high-power, triode oscillator circuits. He suggested that most of the troubles would be eliminated if the oscillators were constructed with the circuits contained in a vacuum. This paper will describe a transmitter which was subsequently built so as to incorporate most of the radio-frequency circuits inside the vacuum envelope.

## II. DESIGN DESCRIPTION

The illustration represents a tube constructed by the authors which can be made to oscillate in a narrow frequency band between 200 and 700 megacycles. Although satisfactory continuous-wave oscillators of this type have been built, the main application has been in the field of high-power pulse oscillators capable of furnishing about two- or three-hundred kilowatts of radio-frequency power.

Fig. 1 shows a general view of one model of this type of tube. The two vertical, parallel rods at the top of the tube form a balanced-line output circuit which is coupled directly to the plate circuit. The parallel transmission line serves in a rough way as a matching circuit to connect the tube to a 50-ohm concentric line, such as is often used to transmit power in this frequency band.

The uppermost loop, or plate loop, is connected directly to the anodes in such a way as simultaneously to reduce the problem of connecting the oscillating circuit to the plates, and by virtue of the flat surface of the loop, increase the effective radiating surface and power dissipation of the plates. The plate loop, made up of

two U sections, serves to maintain the symmetry of the circuit, and of course each of the two U sections, in effect, resonates with half of the interelement capacitances. Thus for a given half-loop length and set of interelement capacitances, the tube may be made to oscillate at a higher frequency than if only one half loop was used.

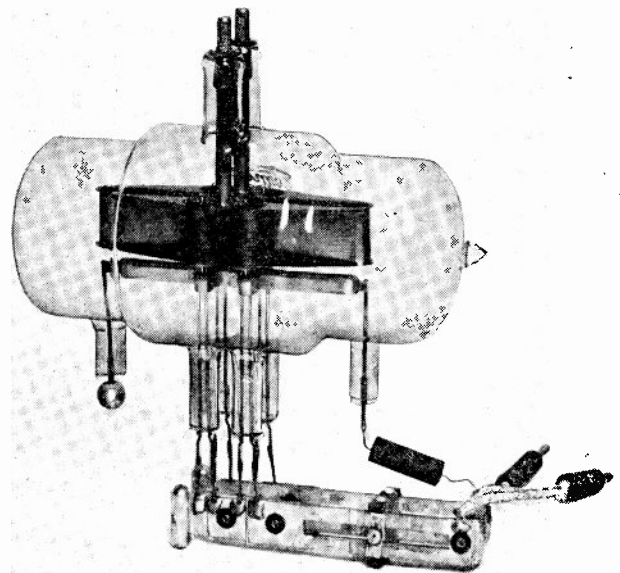

Fig. 1—Front view of transmitting tube.

It has been found advantageous to make both the upper and lower loops of tantalum, since this metal is relatively easy to work and is well known as a good getter. Production models of this general design depend entirely on the tantalum for getter action.

A word should be said about the two anodes in parallel, which in turn operate in push pull with two more anodes in parallel. Several successful continuous-wave oscillators were built with single anodes on each side, but when the tube was pulsed to obtain peak powers several thousand times larger than the average power, it was found that the main limitation in tube output was determined by the amount of available peak emission. The parallel-anode type of construction thus doubled the available peak emission for a given type of element configuration.

The lower loop is the grid loop. Its primary purpose is to obtain grid driving power from the plate circuit. It has been found that relatively little of the power dissipated in the grid cages is conducted along the grid

\* Decimal classification: R355.5×R561×R339. Original manuscript received by the Institute, June 5, 1945; revised manuscript received, October 11, 1945. Presented, 1945 Winter Technical Meeting, New York, N. Y., January 25, 1945.

† Signal Corps Engineering Laboratories, Bradley Beach, N. J.

wires to the external loop, and therefore it can have less radiating surface than the plate loop. In normal operation, the anodes are run at a red heat, and the filaments are run at a somewhat higher temperature than is usually used. This results in having the grid cages located between two very hot elements, and they are therefore very sensitive to grid contamination and subsequent blocking during oscillation. Under such conditions when plain tantalum wire is used in the cages, the tube becomes sufficiently contaminated to be inoperative in about 24 hours. This difficulty has been overcome completely by the use of Eimac "X" grid cages,<sup>1</sup> and without exception the end of tube life is determined by loss of emission, as it should be, after many hundreds of hours.

high voltage applied to the filaments. The filament line is tuned so that the filaments are effectively points of zero radio-frequency voltage. It has been found that this external line may be either parallel or at right angles to the axis of the tube. While it is usually preferable to have the filament line at right angles, since radio-frequency corona is less troublesome, where space is important it is mounted parallel with the axis of the tube.

Four filaments, instead of two larger ones, were used since several advantages were thus obtained. The filament spirals could be made more compactly and therefore less susceptible to sagging, and the filament power could be dissipated in two anodes instead of one, with attendant lower element temperatures. This construc-

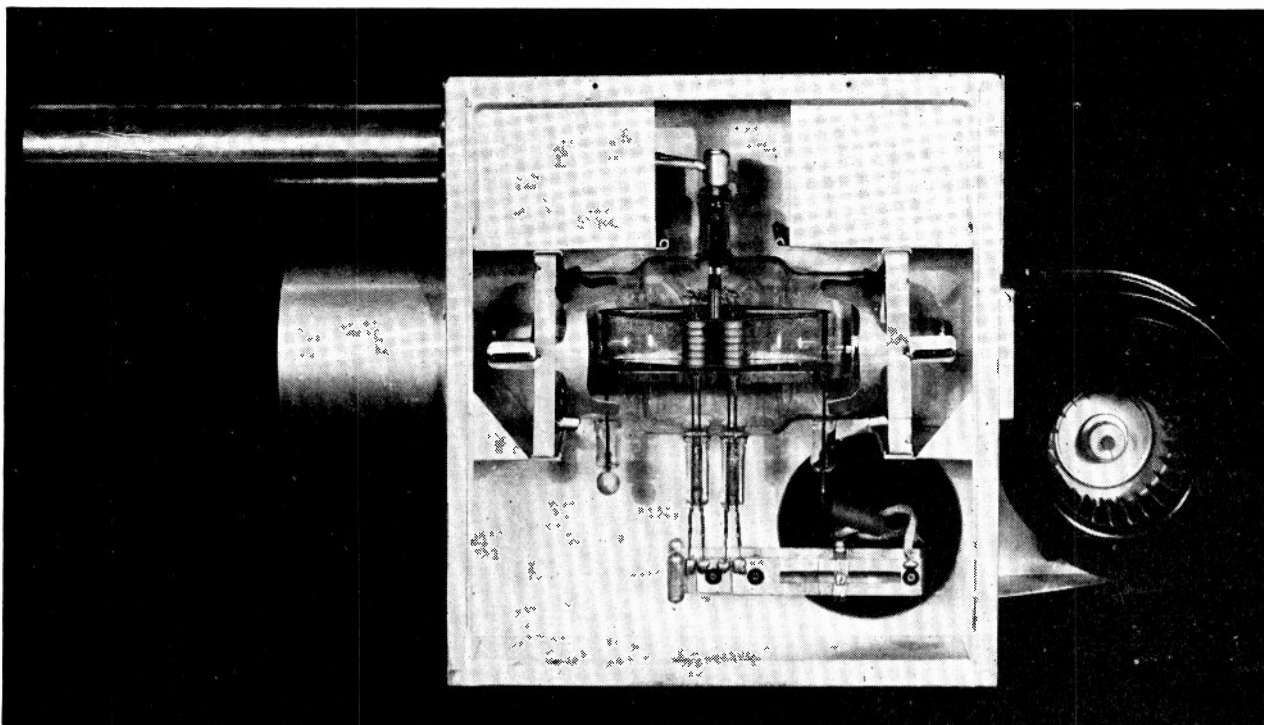

Fig. 2—Front view of transmitting tube and shield.

The filaments are made of carbonized, thoriated tungsten wire and run at a temperature which gives an emission of about 200 milliamperes per watt. In order to obtain satisfactory operation, an external, parallel transmission line is attached so that the two filaments on the same side of the tube are tied together for radio-frequency considerations. Several such transmission lines have been designed with which it is possible to run all four filaments in series if a higher voltage, lower current source is to be used. Since it is most convenient to connect the plate output directly to the output transmission line, the tube is usually run with the plate circuit at direct-current ground potential, and a negative

<sup>1</sup> H. E. Sorg and G. A. Becker, "Grid emission in vacuum tubes," *Electronics*, vol. 7, pp. 104-109; July, 1945.

tion also allows closer spacing of the elements, an important advantage at these frequencies where transit time must be considered. The obvious disadvantage of this multiple-filament design is its complexity, and it must be said that the highest tribute is due the several tube manufacturers for their ingenuity in overcoming the production difficulties by the development of very clever techniques, tools and jigs, and particularly to Mr. W. Eitel and Mr. J. A. McCullough of Eitel McCullough, Inc., for early assistance in establishing the mechanical design of the production-type tube.

### III. SHIELDING

If the oscillator is used without a shield, about 80 per cent of the power output obtainable with a shield is



realized. In general, the shielding found most successful is shown in Fig. 2 and consists of a rectangular metal box with two central transverse shelves which serve to hold the tube, and to separate the cavity containing the tube from the cavities containing the output and filament circuits. The output cavity has been designed to act as a "bazooka" or radio-frequency choke at the end of the concentric line, and thus accomplish the transition from the balanced output of the tube to the unbalanced, concentric transmission line. The filament-line cavity serves primarily to contain the radiation, but its shape also determines the magnitude of standing waves at the point where the filament pins are sealed through the glass envelope.

In contrast with the situation at the plate output seals, the filament leads inside the envelope act as a rough transformer to produce a high radio-frequency voltage at the filament seals. At extremely high voltages and powers, this causes corona and subsequent detuning of the oscillator in an erratic manner. This can be avoided for peak powers greater than 300 kilowatts by use of a vertical, external filament line and proper design of the cavity. The frequency of the oscillator does not seem to be especially sensitive to the type of shield used.

#### IV. OPERATING CHARACTERISTICS

A typical set of characteristics is shown in Table I. (Joint Army-Navy terminology is used.)

TABLE I  
DESCRIPTION: ULTRA-HIGH-FREQUENCY PULSED OSCILLATOR VT-158.

Ratings:	$E_f$	$I_f$	$E_b$	$E_c$	$I_b$	$I_c$	$P_p$	$\phi_i$	Modulation
Absolute:	volts	amperes	kilovolts direct current		amperes	—	watts	kilowatts	
Maximum:	10.5	10.5	30	—	70	—	400	1500	Plate
Test conditions:	(Note 1)	(Note 2)	—	—	—	—	(Note 3)	—	—
Reference	Test	Test	Conditions	—	—	—	—	—	—
						Minimum	Acceptance Limits	Maximum	
F-6b(3)	*Bump: Angle = 10 degrees (Note 4)								
F-6b(4)	*Bump: Angle = 3½ degrees (Note 4)								
—	Filament voltage (Note 1)		$E_f$ :	9.8	10.2	volts			
—	†Emission: $e_b = e_c = 3000$ volts		$i_s$ :	70	—	amperes			
—	†Pulse operation		$P_o$ :	150	—	kilowatts			
	$E_b = 20$ kilovolts direct; current pulse repetition rate = 240 pulses per second								
	$f = 595$ to 600 megacycles, pulse width = 1 microsecond								
F-6p	*Capacitance:			$C_{gp}$ :	11.8	16.0	micromicrofarads		
				$C_{gf}$ :	11.9	16.1	micromicrofarads		
				$C_{pf}$ :	1.25	1.69	micromicrofarads		
—	*Gas Test: pulse operation: (Note 5)								
F-4	Life Test: pulse operation:				$P_o$ :	500	—	hours	
F-4B	Life-Test end point:					135	—	kilowatts	

Note 1: Measured for each filament separately.

Note 2: The tube is self-biased (80 ohms 5W, grid resistor).

Note 3: A minimum of 60 cubic feet of free air per minute is required across the tube for a plate dissipation of 400 watts.

Note 4: The hammer arm shall be allowed to strike the glass envelope at an angle of 90 degrees to the plane of grid leads.

Note 5: The tube shall be subjected to the pulse-operation test three times for two minutes at two-minute intervals applying all voltages including filament voltage and cooling devices, simultaneously. The temperature of the bulb of the tube shall not exceed 50 degrees centigrade at start of this test. There shall be no indications of gas or seal failure during or at the conclusion of this test.

Although the optimum output is obtained at a definite frequency, determined by the geometry of the elements inside the envelope, it has been observed that the ex-

ternal filament line may be used to shift the operating frequency over a bandwidth of 30 megacycles between half-power points. This feature is of considerable importance in allowing some tolerance in manufacturing, and in adapting the tube to several different types of radio-frequency circuits. It may be said that ordinary vacuum-tube production tolerances may be used to obtain tubes (from several different manufacturers) which all peak within a few megacycles of the same frequency.

The tube may be pulsed by biasing the grid beyond cutoff and applying suitable pulses to drive the grid positive several hundred volts for the required pulse interval. In another method of pulsing, the grid may be connected to the common radio-frequency point of the filament circuit through an appropriate resistor, and the filaments pulsed negatively with respect to the plate by as much as 30 kilovolts. Although efficiencies as high as 40 per cent have been observed for experimental tubes, the oscillator efficiency for production tubes is about 25 per cent under optimum conditions, and is constant for applied voltages greater than several kilovolts. This is interpreted as meaning that transit-time effects are negligible above this voltage, and rough calculations show that this should be the case. Frequency stability has been checked only during pulse operation, and within the uncertainty due to the Fourier components of the pulse, no instability could be found, nor could any frequency modulation be detected. An interesting feature of the tube characteristics is that the anode high-voltage filament power and blower can all be simultaneously turned on and off without any previous warm-up. No bad effects due to this practice have been observed.

#### V. THEORY

Theoretical investigation of the properties of this type of design has proved to be difficult, primarily because of uncertainty about the current distribution in the closely spaced plate and grid loops at the frequencies mentioned. The general type of circuit is not new; similar circuits having been treated in papers by Holburn,<sup>2</sup> Mesny,<sup>3</sup> Gutton and Pierret,<sup>4</sup> and Denhardt,<sup>5</sup> and summarized in a paper by Wenstrom.<sup>6</sup> All of these treatments are concerned essentially with an experimental determination of the circuit characteristics.

Since in pulse operation the electron transit time is not appreciable, the tube probably should be capable of running with an efficiency of at least 50 per cent. Accordingly, the conventional-oscillator-design principles advanced by Prince about 1923 were applied to this tube by Lewis Greenwald, of this laboratory.

<sup>2</sup> F. Holborn, *Zeit. für Phys.*, vol. 6, pp. 328, 1921.

<sup>3</sup> Mesny, *L'Onde Electrique*, vol. 3, pp. 25-37; January, 1924.

<sup>4</sup> C. Gutton and E. Pierret, *L'Onde Electrique*, vol. 4, p. 387; 1925.

<sup>5</sup> A. Denhardt, *Zeits. für Hochfrequenz.*, vol. 35, pp. 212-223; June, 1930.

<sup>6</sup> W. H. Wenstrom, "An experimental study of regenerative ultra-short-wave oscillators," *Proc. I.R.E.*, vol. 20, pp. 113-131; January, 1932.

These principles have been found to be quite adequate for ultra-high-frequency tubes so long as the transit time is small. The interloop coupling problem was avoided by considering the two loops and external load as a four-terminal network connected to the grids and plates, as shown in Fig. 3. It was assumed that this network maintained approximately 180 degrees phase difference between grid and plate and insured push-pull operation. On this basis, approximate explanations of many observed phenomena were made possible, and some improvement in efficiency was effected by increasing the plate-filament capacitance. However, the efficiency was not made to approach the value of 50 per cent. This may be due to use of incorrect effective values of interelement capacitances or to lack of sufficient information about the operation of the loops.

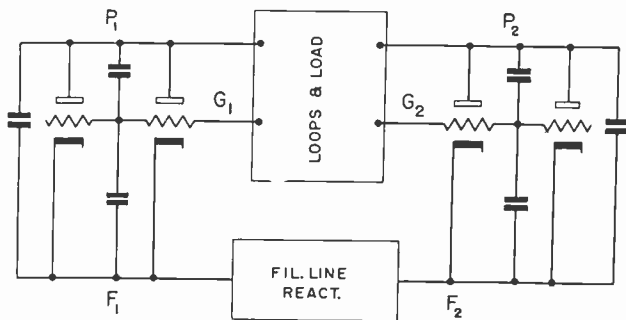

Fig. 3—Equivalent circuit of transmitting tube.

## VI. GROUNDED-PLATE, -GRID, AND -CATHODE DESIGNS

It occurred to the authors, and to McCullough and Eitel in an unpublished communication, that the design herein described might be simplified by altering the internal construction so that the two anodes were tied together to have zero radio-frequency voltage difference (grounded plate). This would eliminate one internal tuned circuit, and would necessitate taking the power out at the filament line. Such a tube was built and it was found that almost exactly half the normal radio-frequency power could be obtained in this way. Subsequent tests on tuned-plate, tuned-grid tubes also showed that only half the power could be obtained from the

filament lines, and work on grounded-plate tubes was then dropped without further investigation.

The authors attempted further designs involving grounded-grid and grounded-cathode construction, and the results were uniformly most unsuccessful, in that these types of tubes were never observed to oscillate. The grounded-grid construction was carried so far as to involve slits in the anodes to allow direct connection of the four grid cages by the shortest possible leads. The grounded-cathode tube was built around a rectangular box-type oxide cathode mounted between the two sides of the plate loop. In all cases, the element geometry was such as to have about the same amplification factor and transit time as for the tuned-plate, tuned-grid type of tube.

## VII. CONCLUSION

This tuned-plate tuned-grid type of vacuum tube and circuit was developed a few years ago when low radio-frequency-impedance glass-metal seals had not been widely applied to tubes of this power and frequency. The subsequent development of such seals and corresponding tube improvement, especially in development of tubes which could be connected intimately with many different types of radio-frequency circuits which jointly covered a much wider band of frequencies, has been of great practical importance both in the war effort and in postwar applications. However, it is desired to point out one advantage of the tube of special importance for military use. Those who have seen extremely high-power pulse-transmitter circuits using the new low-impedance glass-metal-seal tubes are invariably impressed with the large size, weight, and complexity of concentric-line plumbing, a most descriptive term. Also, high-power pulse magnetrons for these frequencies are extremely large and heavy. Compared with these, the present tube is shipped from the tube manufacturer as a complete transmitter. The combined tube and shield weigh only about two pounds, occupy a much smaller volume, and are much simpler to make and assemble than are the newer type tubes and external oscillating circuits.

Tube type VT-158 was used principally in the light weight, early warning radar set AN/TPS-3, in both the European and Pacific theaters of operation.<sup>7</sup>

<sup>7</sup> H. A. Zahl and J. W. Marchetti, "Radar on 50 centimeters," *Electronics*, vol. 19, pp. 98-104; January, 1946.

# Three New Antenna Types and Their Applications\*

ARMIG G. KANDOIAN†, SENIOR MEMBER, I.R.E.

**Summary**—Three newly developed types of antennas are described. The radiation pattern of each is substantially omnidirectional in the horizontal plane. The first has vertical polarization, the second has horizontal polarization, and the third is elliptically or circularly polarized.

Variations of the above types, bandwidth considerations, tuning range, advantages, and limitations of each type are discussed, as well as the use of these antennas singly or in directive arrays for high power gain. Application to very-high-frequency and ultra-high-frequency broadcast, television, and link communication is briefly considered.

Photographs of experimental models giving construction details are shown, as well as measured characteristics of the type of antennas under consideration. Installation schematic of a typical array for frequency-modulation broadcasting is also shown.

## INTRODUCTION

THREE new types of antennas have been developed for use primarily in the very-high-frequency and ultra-high-frequency spectrums. The radiation pattern of each antenna is essentially equivalent to that of a dipole; that is, it may be represented by a solid of revolution determined by a rotating figure of eight.

Type I, the Discone antenna, is intended primarily for vertical polarization, and, like a vertical dipole, gives an omnidirectional pattern in the horizontal plane. A distinctive feature of this antenna is its simplicity of construction and feeding. Its most important characteristic is satisfactory operation over a very wide band of frequencies (several octaves) without a substantial change of either input impedance or radiation pattern.

This type of antenna has wide applications wherever extremely wide frequency ranges are encountered and simplicity of mechanical design and installation are required.

Type II, a coaxially fed loop antenna, is intended primarily for horizontal polarization. The radiation pattern is omnidirectional in the plane of the loop. The radiators forming the loop are metallicly supported from the mast or other supporting structure. Further, both supports and radiators form part of the coaxial feeding circuit. No balanced lines are used anywhere in the circuit. The bandwidth is controllable, though in general much narrower than with the type I antenna. No stubs are necessary to obtain a match to any common type of coaxial feeder of 50, 70, or 100 ohms.

The most important feature of this antenna is its simplicity of mechanical design and construction, and the ease with which a larger number of antennas may be "stacked" for high-degree directivity in the vertical plane while retaining omnidirectional radiation in the horizontal plane.

Typical applications of this type of antenna are fre-

quency-modulation broadcasting, television, and general communication.

Type III antenna is similar to type II, except that at the center of the loop and perpendicular to it a vertical radiator has been added. The radiation pattern of type III is essentially the same as that of types I or II; the free-space field intensity at all points has both horizontal and vertical components in equal amounts. The type III, being a combination of an "electric" dipole (vertical radiator) and a "magnetic" dipole (horizontal loop), might, therefore, be called an "electric-magnetic" dipole.

Equality of amplitude of the two polarization components is not necessary as any desired ratio of amplitude as well as phase relationship between the horizontally and vertically polarized fields may be obtained.

The most interesting application of this type of radiator is in high-directivity arrays or in illuminating a highly directive parabolic reflector or horn for general communication application. The presence of both vertical and horizontal components, it is felt, will be helpful in reducing fading. There is also a possible application of this type of antenna to very-high-frequency and ultra-high-frequency broadcasting, where the receiving dipole could then be oriented for optimum signal-to-noise ratio.

## TYPE I—THE DISCONE ANTENNA

The Discone antenna, as the name suggests, consists of a disk and a cone whose apex approaches and becomes common with the outer conductor of the coaxial feeder at its extremity. The center conductor terminates at the center of the disk which is perpendicular to the axis of the cone and the feeding transmission line. Fig. 1 is a schematic of the Discone antenna with a tabulation of typical dimensions. Fig. 2 shows a Discone antenna.

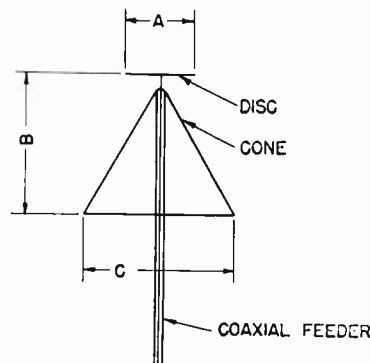

Fig. 1—Schematic diagram of the Discone antenna.

Cutoff Frequency	A	B	C
90 megacycles	18 inches	24 inches	20 inches
200 megacycles	9 inches	12½ inches	14 inches

The Discone antenna in its radiation behaves essentially as a vertical dipole. However, its change of impedance versus frequency is very much less than any

\* Decimal classification: R329. Original manuscript received by the Institute, April 2, 1945; revised manuscript received, August 6, 1945. Presented, Winter Technical Meeting, New York, N. Y., January 27, 1945.

† Federal Telephone and Radio Laboratories, New York, N. Y.

ordinary dipole of fixed length. The same is true of its radiation pattern.

From the circuit standpoint the Discone antenna is essentially a high-pass filter. It has an effective cutoff

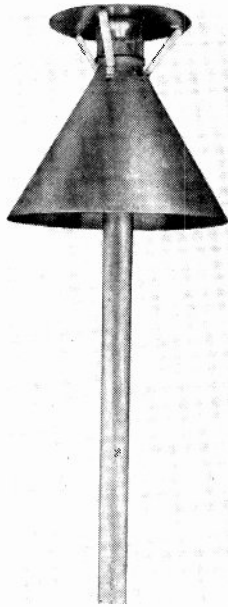

Fig. 2—Discone antenna for cutoff frequency of 200 megacycles.

frequency below which it becomes very inefficient, causing severe standing waves on the feeding coaxial line. Above the cutoff frequency, however, little mismatch exists and the radiation pattern remains substantially the same over a wide range of frequencies. The slant height of the cone is approximately equal to a quarter wavelength at the cutoff frequency.

Fig. 3 illustrates a typical mismatch versus frequency of a Discone antenna measured on a 50-ohm coaxial feeder.

Fig. 4 shows a typical measured radiation pattern of a Discone antenna, cut off at approximately 200 megacycles, measured every 50 megacycles up to 650. It is evident that, from cutoff (200 megacycles) all the way up to 650 megacycles, no drastic change in the radiation pattern has taken place. At the high-frequency end, however, the pattern does begin to turn upward. Investigation is now in progress to determine its characteristics at much higher frequencies.

The radiation patterns shown in Fig. 4 are measured patterns of the Discone antenna proper. As in most antennas with vertically polarized radiation, the supporting structure, in the present case the coaxial feeder, participates somewhat in the over-all radiation. This is due to currents induced in the supporting structure by the antenna. The amplitude of the induced currents in the present case is of the order of 5 per cent of the main antenna current and, hence, cause "scalloping" of the radiation pattern of approximately  $\pm 5$  per cent. For applications where it is required, a suppressing means, such as, for example, radial rods clamped on the supporting structure below the open end of the cone, may be used to prevent coupling between the antenna and the supporting structure.

An interesting application of the Discone antenna occurs when the cone of the antenna serves as the complete housing for the transmitting or receiving equipment.

A variation of the Discone antenna which has some useful applications is where the lower end of the cone is "grounded"; that is, made common with a large conducting surface.

Fig. 5 shows another experimental Discone antenna with a cutoff frequency of approximately 90 megacycles. Its performance is in general quite analogous to the small unit just described.

The Discone antenna may be visualized as a radiator intermediate between a conventional dipole and an electromagnetic horn. At the low end of its operating band, it behaves very much as a dipole; at much higher frequencies, it becomes essentially a horn radiator.

For information on antennas related to but not entirely equivalent to the Discone, the reader is referred to several investigators.<sup>1-3</sup>

#### TYPE II—COAXIALLY FED LOOP

Type II antenna is a loop radiator. This type is sometimes referred to as a "magnetic" dipole. An experimental model of the present type for approximately 550 megacycles is shown in Fig. 6.

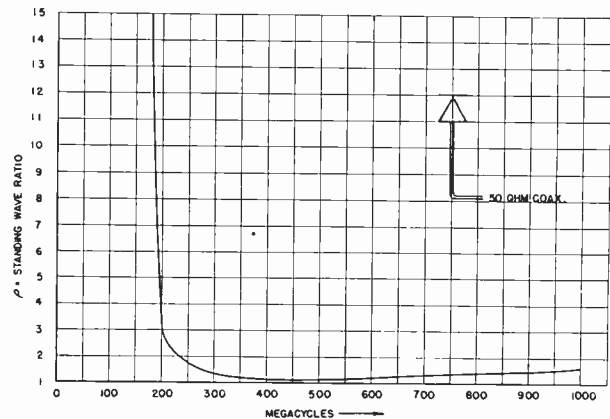

Fig. 3—Mismatch versus frequency of Discone antenna for a cutoff of 200 megacycles.

Loop antennas for very-high-frequency and ultra-high-frequency application have been described by several investigators.<sup>4-7</sup> While the present type of loop has the same radiation characteristic as an equivalent-size loop antenna previously described, its mechanical and electrical design is considerably different and offers some advantages and new possibilities in the application of the loop antennas.

<sup>1</sup> S. A. Schelkunoff, "Electromagnetic Waves," D. Van Nostrand Company, New York, N. Y., 1943, pp. 441-459.

<sup>2</sup> G. C. Southworth, United States Patent Nos. 2,231,602 and 2,369,808.

<sup>3</sup> W. L. Barrow, L. J. Chu, and J. J. Jansen, "Biconical electromagnetic horns," *PROC. I.R.E.*, vol. 27, pp. 769-780; December, 1939.

<sup>4</sup> Andrew Alford and A. G. Kandoian, "Ultra-high-frequency loop antennae," *Trans. A.I.E.E., (Elec. Eng., 1940)*, vol. 59, pp. 843-848; 1940, and *Elec. Commun.*, vol. 18, pp. 255-265; April, 1940.

<sup>5</sup> M. W. Scheldorf, "FM circular antenna," *Gen. Elec. Rev.*, vol. 46, pp. 163-170; March, 1943.

<sup>6</sup> Jesse B. Sherman, "Circular loop antennas at ultra-high frequencies," *PROC. I.R.E.*, vol. 32, pp. 534-538; September, 1944.

<sup>7</sup> Donald Foster, "Loop antennas with uniform current," *PROC. I.R.E.*, vol. 32, pp. 603-607; October, 1944.



Figs. 7, 8, and 9 show schematic diagrams of the type of loop under consideration. The metallic supporting structure as well as the radiators themselves form part

mission line. Fig. 7 shows a single-element design in which the circumference of the loop is in the neighborhood of one-half wavelength or less. Figs. 8 and 9

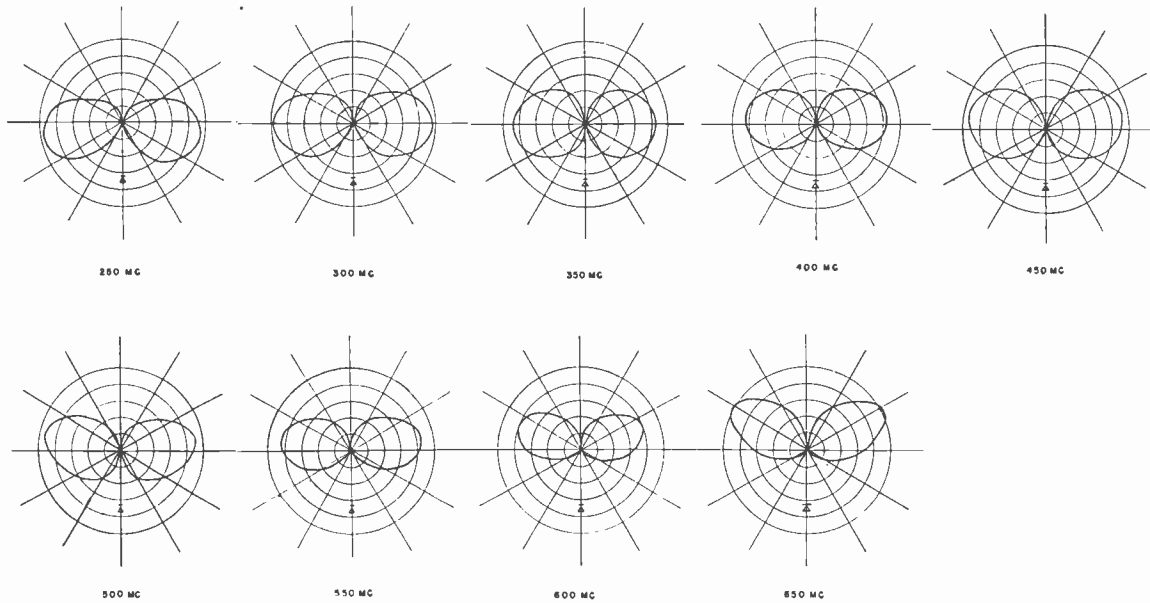

Fig. 4—Vertical radiation patterns of a Discone antenna for a cutoff frequency of 200 megacycles. Radiation patterns measured every 50 megacycles from 250 to 650 megacycles.

of the coaxial feeding system. By proper choice of surge impedance of these two short lengths of line, in the sup-

illustrate multiple-element designs. No limitations, other than practical, exist for the number of elements

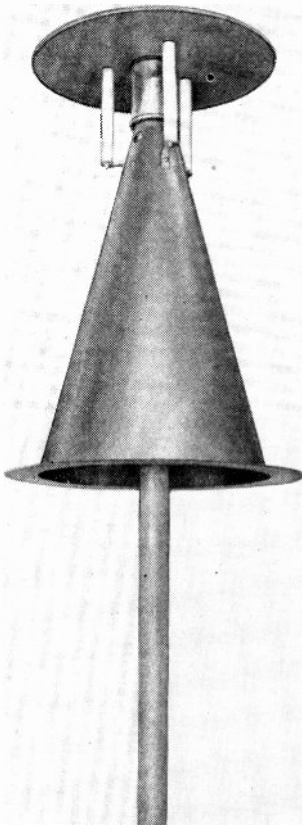

Fig. 5—Discone antenna for cutoff frequency of 90 megacycles.

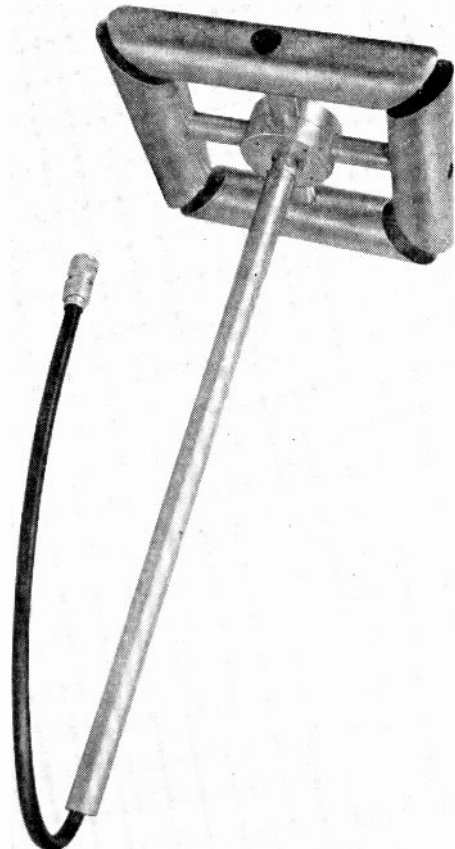

Fig. 6—Coaxially fed loop antenna for 550 megacycles.

porting arm and the radiator itself, the desired impedance of 50, 70, or 100 ohms pure resistance may be obtained to match any common type of coaxial trans-

mission line. Thus, a loop antenna of any diameter may be constructed and the current distribution maintained essentially uniform. The limitation of

diameter, small compared to a wavelength, need not be observed.

The radiation pattern of a loop with substantially uniform current distribution, and with a diameter small compared to a wavelength, is well known. In the plane of the loop the radiation is nondirective. In the plane perpendicular to the loop the radiation varies approximately as  $\cos \beta$ ,  $\beta$  being the angle measured from the plane of the loop.

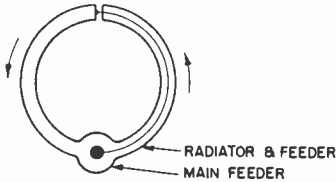

Fig. 7—Schematic diagram of single-element coaxially fed loop. Circumference approximately  $\lambda/2$  or less.

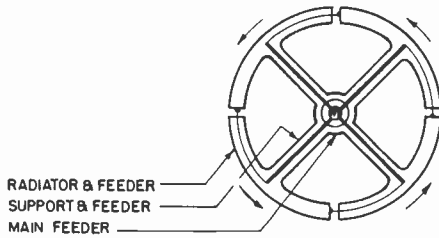

Fig. 8—Schematic diagram of 4-element coaxially fed loop. Circumference approximately  $2\lambda$  or less.

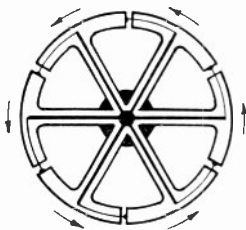

Fig. 9—Schematic diagram of 6-element coaxially fed loop. Circumference approximately  $3\lambda$  or less.

For loop antennas of any diameter and uniform current distribution, the radiation in the plane of the loop is still nondirective. In the plane perpendicular to the loop, Foster<sup>7</sup> has shown that the pattern is of the form  $J_1(\pi d/\lambda \cos \beta)$  where  $d$  is the loop diameter to wavelength ratio and  $J_1$  represents the Bessel function of the order unity.

An important consideration in any antenna is the input impedance. At very-high frequencies and ultra-high frequencies, the most practical way of expressing this information is in terms of standing waves on the line feeding the antenna. A typical measurement is shown in Fig. 10. The impedance at the center feed point is inductive below and capacitive above the midoperating frequency of 550 megacycles. The feeding line is a 50-ohm coaxial. Other experimental loops have been constructed giving both more and less bandwidth. In general, however, the bandwidth of a loop antenna cannot be made nearly so wide as a Discone type of antenna.

The loop type of antenna is particularly useful when high-degree directivity is desired in the vertical plane while retaining the omnidirectional pattern in the horizontal plane. This is accomplished by vertical stacking of any desired number of loops.

Fig. 11 depicts two experimental loops built as a pair and spaced approximately one wavelength. The input impedance to the pair is 50 ohms.

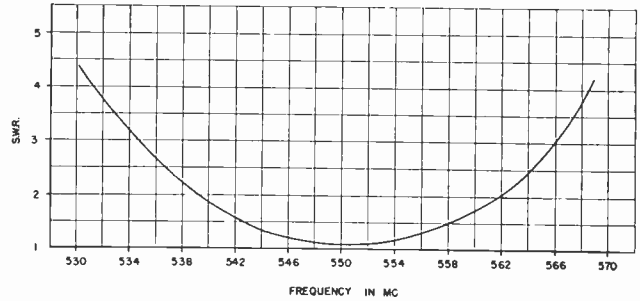

Fig. 10—Characteristic curve of frequency versus standing-wave ratio for a square loop. Four elements of 2-inch cross section; loop diameter,  $8\frac{1}{2}$  inches.

Any number of such pairs may be stacked to give a desired amount of power gain. At the junction of the transmission line of any two pairs, however, a 2-to-1

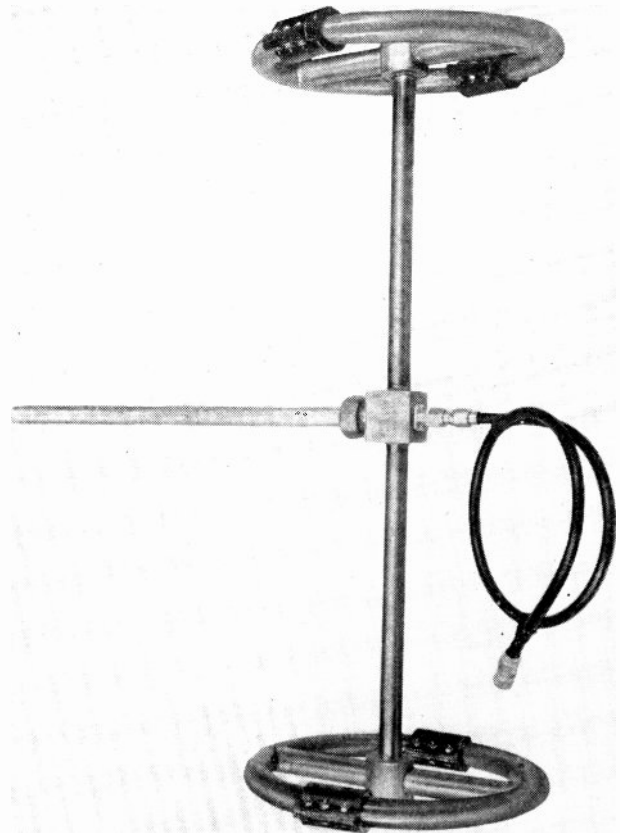

Fig. 11—Vertical stack of two loops with tuning stub.

impedance-correcting network is required to raise the impedance to the line impedance of 50 ohms (or any other desired level). A quarter-wave transformer probably is the most convenient network for this purpose. Fig. 12 shows the schematic of a feeding system for a stack of four loops for frequency-modulation broadcasting

Fig. 13 gives the necessary theoretical data to show what spacings to use between loops and what gains may be expected due to vertical stacking when equal currents are fed to successive loops.

A directive vertical pattern essentially free from minor lobes may be obtained by proper distribution of current between successive stacked loops.<sup>8</sup> However, under these conditions the over-all power gain from a fixed number of loops is reduced.

The characteristics and relative merits of the type of loop under consideration may be summarized as follows:

- No balanced feeders are used.
- No stubs are needed for matching; hence, the full bandwidth capability of the loop may be realized. A

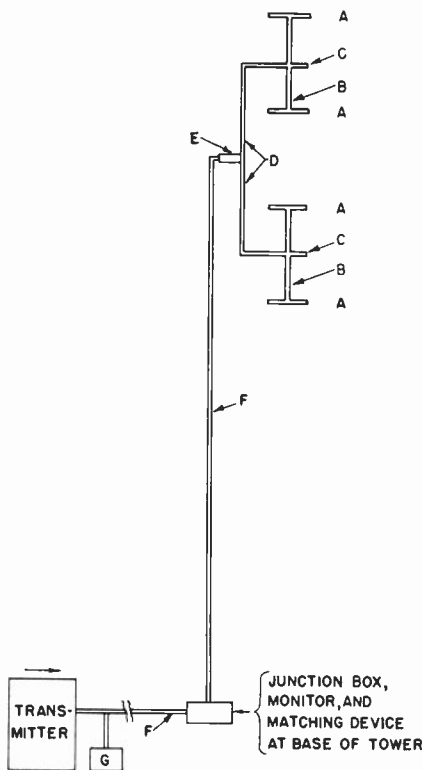

Fig. 12—Transmission line and feeding system for frequency-modulation broadcast antenna.

- A = loop antennas
- B = 100-ohm coaxial line
- C = matching stub to be for operating frequency
- D = 50-ohm line
- E = quarter-wave 35-ohm line
- F = 50-ohm coaxial line
- G = pressurizing and air-drying equipment

stub may be found desirable, however, to tune the loop, or a group of loops, over a wide frequency range.

(c) No insulator mechanical supports are necessary. Metallic supports are used, rigidly fastened to the mast and radiating members.

(d) Any size loop may be built, with essentially uniform clockwise or counterclockwise current distribution. Loop diameters of several wavelengths are feasible, and for certain applications desirable.

<sup>8</sup> A. G. Kandoian, "Ultra-high-frequency technique; radiating systems and wave propagation," *Electronics*, vol. 15, pp. 39-44; April, 1942.

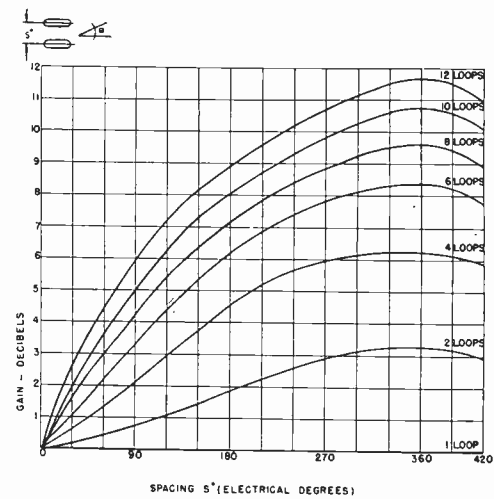

Fig. 13—Gain of linear array of loops vertically stacked.

$$(\beta) = \frac{\sin\left(\frac{ns^\circ}{2} \sin\beta\right)}{\sin\left(\frac{s^\circ}{2} \sin\beta\right)} \cos\beta$$

$n$  = number of loops

$$\text{gain (db)} = 10 \log_{10} \frac{1}{\frac{1}{h} + \frac{3}{n^2} \sum_{k=1}^{n-1} (n-k) \left[ -\frac{2 \cos ks^\circ}{(ks^\circ)^2} + \frac{2 \sin ks^\circ}{(ks^\circ)^3} \right]}$$

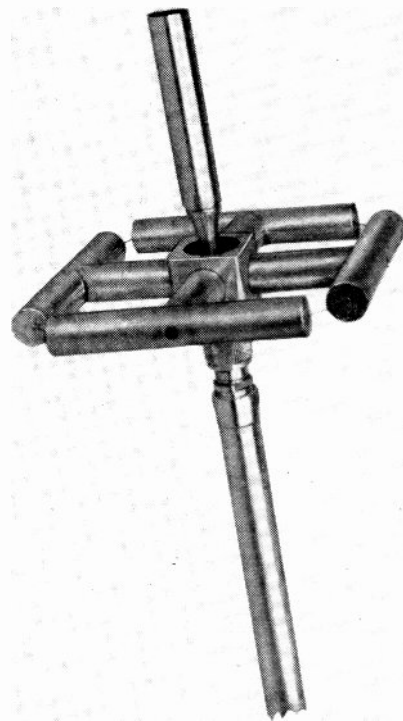

Fig. 14—Type III antenna for an operating frequency of 1200 megacycles.

#### TYPE III—"ELECTRIC-MAGNETIC" DIPOLE

An experimental model of this type of antenna is illustrated in Fig. 14. This particular unit was built for use in the neighborhood of 1200 megacycles.

The "electric-magnetic" dipole consists essentially of a loop radiator of the type previously described, except

that at the transmission-line junction at the center of the loop, and perpendicular to the plane of the loop, a vertical radiator is added. In effect, it is a combination of an "electric" and a "magnetic" dipole.

The radiation pattern of a horizontal loop, with a diameter of the order of  $\lambda/2$  or less, is substantially the same as that of a vertical dipole. The only difference in the radiated field is in polarization. Thus, at every point in space equal amounts of horizontal and vertical polarization will be obtained, if the available power is equally divided between the loop and the dipole.

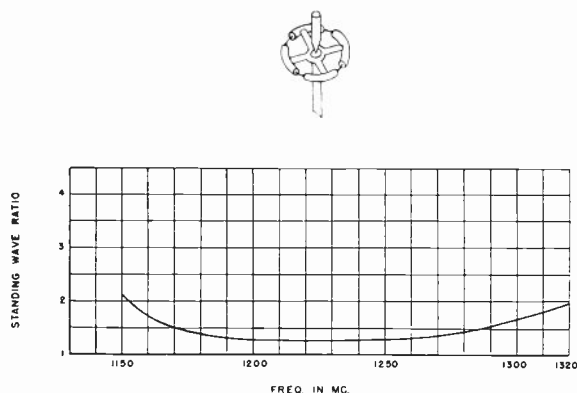

Fig. 15—Curve showing the standing-wave ratio versus frequency for the loop-dipole combination shown at top.

Control of the relative phase and amplitude of currents in the dipole and the loop is, of course, possible; and hence, any type of polarization desired can be produced; i.e., horizontal, vertical, circular, or the most general case, elliptical.

It is not difficult to demonstrate experimentally that at any point around such a transmitting antenna one can achieve a field strength independent of the orientation of the receiving dipole, provided that the receiving dipole is kept perpendicular to the direction of propagation.

In Fig. 15 is shown the mismatch-versus-frequency characteristic of an antenna of this type for operation in the neighborhood of 1200 megacycles. Fig. 16 shows another such experimental antenna for use around 350 megacycles.

In ultra-high-frequency communication networks where considerable fading may exist due to changes in the medium of propagation, this type of antenna will probably prove very useful. In cases of severe fading the probabilities are that both horizontal and vertical components of the electric field will not vary at the same rate and at the same time, since they are affected differently by the reflecting medium between the transmitter and receiver. Considerable improvement, therefore,

should be experienced in reducing the over-all fading by the use of such a radiator, or a combination of such radiators in an array.

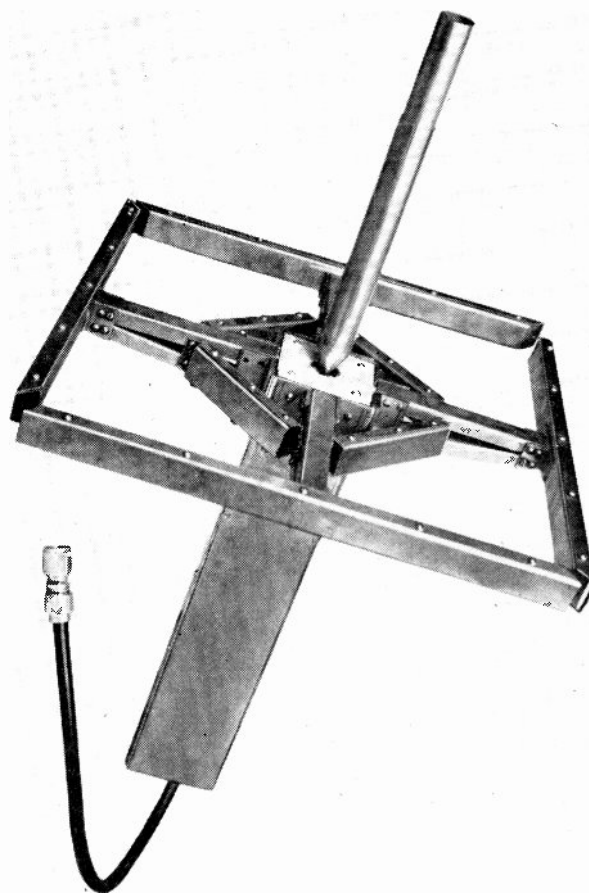

Fig. 16—Type III antenna for an operating frequency of 350 megacycles.

In addition, this type of radiator is particularly well suited for illuminating a large reflecting surface such as a paraboloid in a highly directive antenna system.

A possible important application of the "electric-magnetic" dipole is in the field of very-high-frequency and ultra-high-frequency broadcasting where the relative merits of horizontal as against vertical polarization have been under discussion for some years. If circular polarization were used at the transmitting end, it would permit the use of either a vertical or horizontal dipole at the receiving end, depending on convenience or architectural acceptability. The more particular listener would, of course, tend to orient his dipole to obtain the best signal-to-interference ratio, if there is any interference.

Whether any substantial improvement of performance would result in over-all reception can be determined only after field tests.



# Decibel Conversion Chart\*

ROBERT C. MIEDKE†, ASSOCIATE, I.R.E.

*Summary*—A decibel conversion chart has been designed for versatility and simplicity of use. This chart gives decibels directly from any two values of voltage, current, or power. It has two ranges; the lower range (scales *A*, *C*, and *E* of Fig. 1) are for voltage, current, or power ratios up to 10 to 1 and the extended range (scales *B*, *D* and *F*) are for voltage, current, or power ratios up to  $10^6$  to 1.

SEVERAL examples explaining the use of the decibel conversion chart are as follows:

(1) Assume a voltage ratio of 2.4 to 1.2. This voltage ratio in decibels is found by drawing a line from 1.2 on scale *A* to 2.4 on scale *E* passing through the

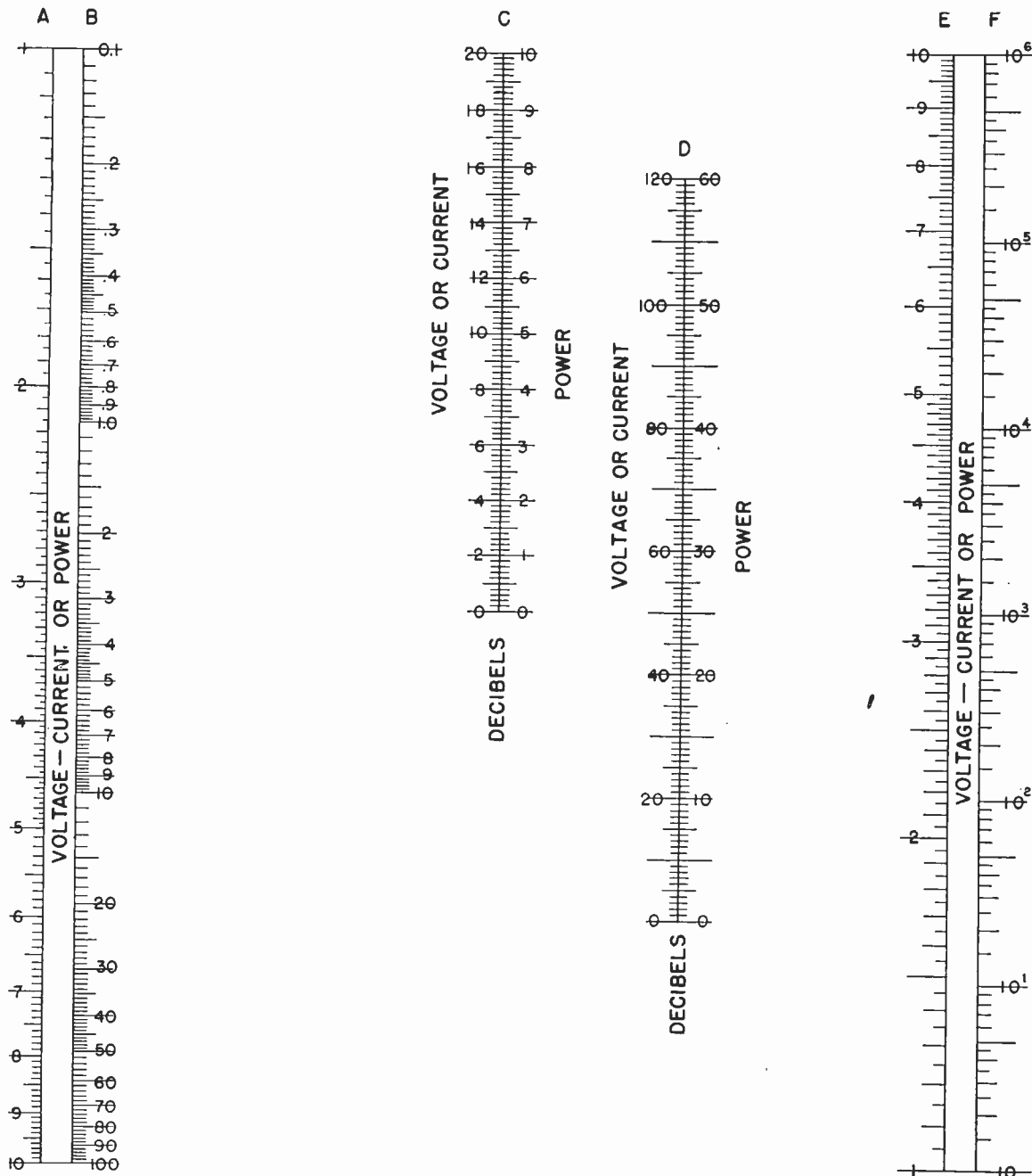

Fig. 1—Chart for converting current or power ratios to decibels.

\* Decimal classification: R084. Original manuscript received by the Institute, September 24, 1945; revised manuscript received, November 5, 1945.

decibel voltage scale *C* at 6 decibels. This can also be

† Naval Research Laboratory, Washington, D. C.

found on scales *B*, *D*, and *F*; however, the decibel scale *D* is not expanded so much as the decibel scale *C* and cannot be read as accurately.

(2) Assume a voltage ratio of 1200 to 1.2. This voltage ratio in decibels is found by drawing a line from 1.2 on scale *B* to 1200 on scale *F* passing through the decibel scale *D* at 60 decibels.

(3) Assume a power ratio of 580 to 320. This power ratio in decibels is found by drawing a line from 3.2 on scale *A* to 5.8 on scale *E* (the ratio of 580 to 320 is the

same as 5.8 to 3.2) passing through the decibel scale *D* at 2.6 decibels.

From the above examples it will be noted that the smaller value of any ratio will always be located on scale *A* or *B* and the larger value will always be located on the respective scale *E* or *F*. Also, the decibels corresponding to ratios of less than 10 to 1 can be found on either set of scales; however, it is preferable to use scales *A*, *C*, and *E* as the decibel scale *C* is expanded and can be read with greater accuracy.

#### ALLIED MILITARY GOVERNMENT AND ALLIED COMMISSION IN ITALY

An interesting 125-page report entitled: "Review of Allied Military Government and of the Allied Commission in Italy" has reached the Institute from Italy through the courtesy of Rear Admiral Ellery W. Stone, U. S. Naval Reserve (A'14-M'16-F'24), Deputy President and Chief Commissioner of the Allied Commission since June 22, 1944. The magnitude of the tasks assumed in the temporary control of Italian affairs by the Allied Forces is clearly set forth in historical fashion in the report. The Institute is gratified that one of its leading members has played so constructive a part in a project of such magnitude.

Admiral Stone received the Award of Commander of the British Empire in March, 1945, and in December, 1945, he received the appointment as Knight Commander of the British Empire, the K. B. E.



#### NONTECHNICAL RADAR BROADCAST

One of the first network broadcasts intended to explain for nontechnical listeners the principles and objectives of radar was given on September 6, 1945, in New York City when E. W. Engstrom (A'25, M'38, F'40) Irving Wolff (A'27-F'42), and J. E. Evans of RCA Laboratories and Stanley

Parker of the U. S. Navy were interviewed by Miss Mary Margaret McBride. The fundamental principles, underlying the operation of radar and early experiments dating back to 1932, were covered by the RCA Laboratories representatives while Stanley Parker told about some of the actual experiences that he had had at sea with the operation of radar equipment. A short demonstration was given to show how a received radio wave when used in conjunction with a sharp microwave transmitting beam, could be used to show the direction of a reflecting object.



#### CLEVELAND SECTION

In *Cleveland Engineering*, published weekly by The Cleveland Technical Societies Council, the columns devoted to news of The Institute of Radio Engineers contain two items which are of interest to the entire membership of the I.R.E. Alfred J. Kres (A'39), secretary of the Cleveland Section, reported that a very small percentage of the questionnaire postcards, regarding proposed changes in the name of the Institute, had been returned.

The Cleveland Section subscribed 258 per cent over their quota in contributions to the Building Fund. A book containing the names of all contributors, intended to be kept in the lobby of the new building, went to press about December first.

#### ELECTRONICS IN WAR AND PEACE

C. N. Kimball (A'34-M'40-SM'43), vice-president in charge of sales engineering for Aireon Manufacturing Corporation, recently spoke before the Advertising and Sales Executive Club of Kansas City on the use of early warning radar, ground control of fighter aircraft, blind bombing, and radar countermeasures in World War II. He directed his audience's attention to the proximity fuze and the recent acceleration of electronic research. The latter part of the speech was devoted to the carry-over value of these devices for peacetime functions, covering the navigational uses of radar and the part the absolute altimeter and terrain indicator will play in the safety of flight. Dr. Kimball mentioned the increase in speed of railway travel due to research in radio applications to railroad communication; industrial heating of plastics; uses of high-frequency radiation for cooking and heating applications; development of instruments to be used in the meat industry for determining humidity, frosting, and defrosting; and electronic instruments used in sorting, counting, measuring, oil prospecting, and color comparison.

It was pointed out that there exists an electronic solution or electronic aid for nearly every operation encountered in the course of manufacturing, packaging, or distributing, with the resultant increased safety, comfort, and leisure for the public.





## Our New Home

**B**Y AUTHORIZATION of the Board of Directors, The Institute of Radio Engineers has now purchased a building for its home. The Institute has acquired the Brokaw mansion on the northeast corner of Fifth Avenue and 79th Street in New York City. This building faces 79th Street, and is located in an extremely attractive residential neighborhood. It is only a block from the Metropolitan Museum of Art, which is diagonally across Fifth Avenue from the building.

The building is of chateau design, faced with gray granite and with steeply sloping tile roofs. It was constructed in 1889 for Mr. Brokaw, by Rose and Stone, architects. It has four stories, attic, basement, and cellar. The main body of the building is about 47×81 feet. It stands on a lot 51 feet 2 inches on Fifth Avenue and 110 feet along 79th Street. It faces south, and has a spacious yard on the easterly side of the building and open courtyards in front and on the Fifth Avenue sides, which spaces are in lawn. Since it does not occupy the

whole lot, it is accessible to sunlight on three sides.

The building was purchased for \$200,000 which is believed to be comparable with, or even less than, the value of the land. The mansions of the nineties and nineteen hundreds are being gradually sold. They are then torn down or converted to other uses, because of changes in living habits of the people who could afford to live in them. The property acquired by the Institute could be purchased for what is considered a justified amount because of a complicated ownership situation of a type which does not inspire real estate agents to devote much effort toward its sale, nor attract the speculator who is interested in acquiring property quickly at an opportune moment. Negotiations with three parties and court approval were necessary to complete the transaction.

The Board of Directors at its April, 1945, meeting instructed the Office Quarters Committee to begin negotiations toward the purchase of the property. The deeds were signed and the property

became ours on December 28, 1945.

The building from the exterior is one of the most attractive structures in that part of the city. It is well constructed throughout. Naturally, it will require some changes and alterations to suit it to the purposes of the Institute. However, these changes and alterations are materially less than would be necessary for many other buildings which the Committee seriously considered.

The Office Quarters Committee spent a year and a half searching for a structure considered suitable as a home for the Institute. At the start of this search there was available only a relatively small amount of money in surplus funds of the Institute, and the buildings available then within that limit were few and far between. None was considered a suitable permanent home for the Institute. Serious consideration was given to purchasing one as a temporary home because of the extremely pressing need for more space and the difficulty of finding rentable space in the city.

The Office Quarters Committee in its search inspected dozens of buildings of all kinds including ex-clubs, small office buildings, and many old mansions, and the members picked up on their faces, hands, and clothing considerable dust that may not have been disturbed since the eighteen nineties. After this search had progressed for well over six months, the Office Quarters Committee recommended that the Board approve a campaign to raise a building fund without waiting to have in mind a particular building that they desired to purchase. To have bound themselves to purchase a building before starting the drive for the fund would have involved risking a considerable portion of the Institute's reserves, and the Board wisely would not proceed on this basis. No "superbargain" was found that justified such a plan. It was believed that possible donors would be as willing to donate funds toward the purchase of a building to be selected later as to give funds to buy a particular building picked beforehand. In the latter half of 1944, therefore, the intensive search for a building was temporarily abated while plans were gotten under way to start the building-fund drive. Early in 1945 when the donations being received indicated that the goal desired likely would be reached, the Committee invited the Board to inspect the most promising buildings at prices falling within the range of the expected building fund. The Board was unhesitatingly in favor of the building which has just been purchased.

The Board and the Committee gave much attention and thought to the matter of acquiring a home which would be nearer the center of New York City, that is, nearer the railway stations, large hotels, and the three subway lines that tend to serve the center of Manhattan so thoroughly. Suitable and appropriate buildings, however, were very scarce and their price was very high. It would cost the Institute \$100,000 to \$200,000 more to acquire an equivalent home convenient to all the transportation centers than to purchase the building it has acquired. Neither the Committee nor the Board was persuaded that this extra expense was justified. The Institute staff will be the persons who are traveling to and from the building every working day. Such groups of long-term employees

usually adjust their home locations to the site of their work. Committee Members in holding Committee meetings will travel to and from the building occasionally, and the Board will do so once each month or less frequently. Inquiry as to whether institutions located somewhat outside of the central business district find themselves handicapped by such locations led to the reply that they did not. People from outside of the city coming into the city usually do not find it any more difficult to reach a moderately outlying building by a taxicab than a more near-by one. Local commuting members who develop the habit of catching certain trains home are the ones who prefer always to be within a short distance of their railway terminal, and who particularly stressed their wish for what would be for them a more convenient location. The Committee and the Board, therefore, after considering all factors, felt they could not justify the purchase of a home in the highly expensive central business part of the city but that the location which they have secured will be satisfactory.

The building is a six-minute walk from the 77th Street stop on the Lexington Avenue subway and only about two more minutes' walk from the 86th Street stop, which is an express station. Fifth Avenue buses pass by the building on Fifth Avenue and there is a bus line running completely across 79th Street and passing the building. There seems to be a goodly supply of taxicabs passing up and down Fifth Avenue all the time.

The building has ample room for Committee meetings, Board meetings, and other normal activities. No attempt was made to find a building which could serve as a meeting place for a large group of members. The cost of such a building would not be justified as such meeting rooms would be used by the Institute only one or two days per month. Meetings of the New York Section will continue to be held either in the Engineering Societies Building on 39th Street or in other auditoriums in the city.

The Committee now is making detailed plans for alterations and decoration of the building for Institute purposes and to meet present safety regulations. It is not known when these alterations will be completed due to the difficult building-construction situation in the city. Every effort will be made to have the remodeling done as soon as possible in order that the staff, which is now divided between two locations, can be brought together again.

A photograph of the exterior of the building is to be found in this issue of the PROCEEDINGS. It is planned to publish in later issues the plans of the building, and photographs of parts of the interior. It is thought that the new headquarters of the Institute will be exceptionally attractive in appearance, and that particularly efficient operation of the work of the Institute can be carried out by the staff in the carefully planned new quarters. It is expected that the new building will have a home-like and welcoming atmosphere so that the visiting members will at last find commodious and cheerful I.R.E. quarters in which they can meet the staff and their fellow members and comfortably conduct whatever activities they have planned.

R. A. Heising, *Chairman*  
Office Quarters Committee

# Winter Technical Meeting

January 23, 24, 25, and 26, 1946

## SUMMARIES OF TECHNICAL PAPERS

No papers are available in preprint or reprint form nor is there any assurance that any of them will be published in the *PROCEEDINGS OF THE I.R.E. AND WAVES AND ELECTRONS*, although it is hoped that many of them will appear in their pages.

### CONSIDERATION OF FREQUENCY, POWER, AND MODULATION FOR A LONG-RANGE RADIO NAVIGATION SYSTEM

P. R. ADAMS

(Federal Telecommunication Laboratories, Inc., New York, N.Y.)

The general suitability of various types of radio transmission are examined with respect to the requirements of a long-range aerial-navigation system. By long-range navigation is meant, primarily, transoceanic navigation over distances of the order of 1500 miles.

The characteristics of short waves and long waves are separately and thoroughly analyzed with the help of considerable data which have been tabulated for this purpose. Data on other important factors are also considered, such as on signal field strength, in particular, for transmission below 300 kilocycles, also on atmospheric noise intensities, and on antenna radiating efficiency. A certain number of conclusions are obtained from these discussions. Modulation and other problems such as corona effect are also considered.

### PHASE AND FREQUENCY MODULATION— A NEW METHOD

ROBERT ADLER

(Zenith Radio Corporation, Chicago, Ill.)

AND

F. M. BAILEY AND H. P. THOMAS

(General Electric Company, Syracuse, N. Y.)

The design of frequency-modulation transmitters has been simplified and their performance improved by the development of a new phase-modulator tube. In a concentric structure of conventional dimensions, a radial electron stream is shaped into a wave-like pattern which progresses continuously around the cathode. The development of the tube is reviewed. A description is also given of a commercial frequency-modulation broadcast transmitter making use of this tube together with a discussion of the design features involved.

### ANTENNA FOR FREQUENCY-MODULATION STATION WGHF

ANDREW ALFORD

(Consulting Engineer, Cambridge, Mass.; formerly, Antenna and Direction-Finder Division, Radio Research Laboratory, Harvard University, Cambridge, Mass.)

An antenna of a new type is described. The radiation is horizontally polarized and essentially omnidirectional. One radiating element gives considerable gain over a dipole in the vertical plane. Design data and test results are discussed.

### BROAD-BAND ANTENNAS AND DIRECTION- FINDING SYSTEMS FOR VERY HIGH FREQUENCIES

ANDREW ALFORD

(Consulting Engineer, Cambridge, Mass.; formerly, Antenna and Direction-Finder Division, Radio Research Laboratory, Harvard University, Cambridge, Mass.)

AND

J. D. KRAUS, A. DORNE, AND J. CHRISTENSEN

(Formerly, Antenna and Direction-Finder Division, Radio Research Laboratory, Harvard University, Cambridge, Mass.)

Methods have been developed to obtain broad-band antenna operation with low standing-wave ratio for frequency ranges employed in radar. The description of these methods includes directional antennas, antennas with circular polarization, slot antennas, nondirectional antennas, and also direction finders giving instantaneous visual presentation of direction for the same frequencies. These direction finders are usable over wide frequency ranges without any antenna adjustments and have a pickup sensitivity comparable to or exceeding that of a half-wave dipole. Examples of homing devices for use on airplanes are given.

### DESIGN OF A SMALL SIZE HIGH-VOLTAGE RECTIFIER, TYPE 1Z2

GEORGE BAKER

(National Union Radio Corporation, Newark, N. J.)

The new factors in the design of a small-size, low-current rectifier tube for operation at several kilovolts are considered. The filament must withstand large mechanical forces produced by the electric field. The anode is shaped and processed to minimize cold field emission which, if uncontrolled, would result in large reverse current and high-velocity electrons striking the glass. The dielectric losses and leakage currents in the glass must be kept within limits.



## MAGNETIC RECORDER AS AN ADJUNCT TO THE HOME RECEIVER

S. J. BEGUN

(Brush Development Company, Cleveland, Ohio)

## BASIC PRINCIPLES OF UNDERWATER SOUND-EQUIPMENT DESIGN

CAPTAIN R. BENNETT

(U. S. Navy, Bureau of Ships, Navy Department, Washington, D. C.)

The general subject of sound navigation and ranging is discussed in outline with some emphasis on the historical side of this little-known field.

The use of sonic and supersonic echo ranging and detection equipment for location of submarines is discussed briefly with special emphasis on the general principles of systems. Some of the special problems in this field of general interest are presented for information and possible study.

## ELECTRONICS IN NAVAL WARFARE

CAPTAIN R. BENNETT

(U. S. Navy, Bureau of Ships, Navy Department, Washington, D. C.)

A general survey of the use of electronic equipment in naval warfare is given with special emphasis on the progress made during the war. An attempt is made to show the interrelation of military uses of equipment with commercial uses. The effects of standardization and lack of it are indicated as they apply to the military and commercial fields. In this connection, some of the circuit developments made during the war are discussed briefly. This paper is nonmathematical.

## NAVAL AIRBORNE RADAR

CAPTAIN L. V. BERKNER

(U. S. Navy, Bureau of Aeronautics, Navy Department, Washington, D. C.)

Development of airborne microwave radar with improved indication gave enormous impetus to aircraft applications and produced advanced types of air to air interception, high- and low-altitude bombing, reconnaissance, submarine search, and many specialized applications. Several types of airborne radar and auxiliary devices are discussed and illustrated, including considerations of design and utilization problems. Limitations of advantages of airborne radar as a solution to future aircraft problems are briefly considered.

## TEST EQUIPMENT AND TECHNIQUES FOR AIRBORNE RADAR FIELD MAINTENANCE

CAPTAIN E. A. BLASI AND G. C. SCHUTZ

(Radar Laboratory, Air Technical Service Command, Dayton, Ohio)

This paper discusses the various testing methods, techniques, and equipment that are used for the field maintenance of airborne radar systems. Techniques used in the measurement of frequency, power, and receiver sensitivity are outlined, as well as measurements of performance characteristics peculiar to airborne radar equipment. The specially designed instruments required for field maintenance and unique procedures devised to accomplish the measurement of radar performance are described.

## FIELD INTENSITIES BEYOND LINE OF SIGHT AT 45.5 AND 91 MEGACYCLES

C. W. CARNAHAN, N. W. ARAM, AND E. F. CLASSEN

(Zenith Radio Corporation, Chicago, Ill.)

This paper presents the results of a field-intensity monitoring project initiated by the Federal Communications Commission during the summer of 1945. Signal strengths from WMFM, a frequency-modulation broadcast transmitter at 45.5 megacycles, and an experimental 91-megacycle transmitter, both located at Richfield, Wisconsin, were continuously monitored for a period of two months at Deerfield, Illinois, a distance of about 80 miles. The data are analyzed in terms of the average field strengths at the two frequencies, and individual characteristics, such as the range and prevalence of fading and diurnal variation of average field strength. Comparison is made with field strengths predicted from Federal Communications Commission curves, and the ratio of the 91-megacycle field strength to that at 45.5 megacycles is found to be considerably lower than expected.

## TWO NEW MINIATURE TUBES FOR FREQUENCY-MODULATION CONVERSION

R. M. COHEN, R. C. FORTIN, AND C. M. MORRIS

(RCA Victor Division, Harrison, N. J.)

The use of a new miniature converter tube and a new miniature radio-frequency amplifier tube in the headend unit of a frequency-modulation receiver covering the 88- to 108-megacycle band is described. The unit employs a radio-frequency stage, a converter stage, and two intermediate-frequency stages. Pertinent data covering construction and performance including circuit constants, stage gain, over-all gain, signal-to-noise ratios, image rejection, and oscillator-frequency drift are presented.

## MICROWAVE MAGNETRONS

GEORGE COLLINS

(Radiation Laboratory, Massachusetts Institute of Technology,  
Cambridge, Mass.)

A brief historical introduction reviews the wartime development and applications of microwave magnetrons. A review of the principles of operation and basic theories, as far as they are known, is presented, and a consideration of design principles, such as voltage and wavelength scaling and cathode problems, follows. Slides illustrating the construction of magnetrons designed for specific purposes are shown and actual operating conditions and characteristics given. A review of certain important characteristics of microwave magnetrons, both advantageous and otherwise, proceed some concluding remarks on special continuous-wave magnetrons suitable for communication purposes.

## DESIGN OF COMMUNICATION RECEIVERS FOR THE NAVAL SERVICE WITH PARTICULAR CONSIDERATION TO THE VERY-HIGH-FREQUENCY AND ULTRA-HIGH-FREQUENCY RANGES

T. McL. DAVIS

(Naval Research Laboratory, Washington, D. C.)

Consideration is given to the unusual conditions under which naval communication receivers must function, the ideal receiver to meet these conditions, and the compromises which have been accepted in the interest of economy of space and weight, simplicity of operation and maintenance, and others which must be accepted due to limitations imposed by tube and circuit characteristics at the present state of developmental progress. The influence upon design as dictated by allocated channel spacing is discussed. The consideration is directed chiefly to the 100- to 400-megacycle band.

## DEVELOPMENT IN RADIO SKY-WAVE PROPAGATION RESEARCH AND APPLICATIONS DURING THE WAR

J. H. DELLINGER AND NEWBERN SMITH

(National Bureau of Standards, Washington, D. C.)

During the war, there were both a great and continuing improvement in world-wide coverage of ionospheric observing stations and development of rapid, simplified techniques for applying ionospheric data to military operational problems. The major aspects of the world-wide radio-propagation program, developed during the war, are described in this paper, some of which are geomagnetic "longitude effect" in the ionosphere, world-wide study of atmospheric radio noise, methods for calculating sky-wave field intensities, ionospheric-storm forecasting, effects of ionosphere on direction-finder indication, new frequency-allocation and -selection methods, and rapid dissemination of predictions and forecasts to the Allied Armed Services.

## NAVY RADIO AND ELECTRONICS DURING WORLD WAR II

COMMODORE JENNINGS B. DOW

(U. S. Navy, Bureau of Ships, Navy Department,  
Washington, D. C.)

A decisive factor in our victories over the Axis Powers in World War II was the superiority of our radio-communication systems and the electronic equipment used in radar, sonar, loran, fire control, countermeasures, and ordnance. The paper deals with the vast expansion of the electronic industry to supply needed equipment, the organization of the Navy for research and development, procurement, installation and maintenance of the equipment. Statistical data are introduced to show the magnitude of the electronic-material problem, and the effort required to equip our vast fleet and its air arm with modern electronic apparatus in all categories.

## GENERATION OF CONTINUOUS-WAVE POWER AT VERY HIGH FREQUENCIES

W. G. DOW, J. N. DYER, W. W. SALISBURY, AND  
E. A. YUNKER

(Radio Research Laboratory, Harvard University,  
Cambridge, Mass.)

Techniques for the generation of continuous-wave power at high frequencies have advanced greatly in recent years, both with respect to the amount of power that can be generated and the frequencies that can be reached. This paper describes a number of oscillator and amplifier techniques for the generation of continuous-wave power in the range of frequencies used by radar. These power sources are tunable over considerable frequency ranges such as 1.5 to 1, and can be modulated over relatively wide frequency bands. Arrangements employed include open-wire resonant lines with conventional tubes, concentric oscillators employing parallel-plane triodes, resonatrons, and magnetrons. Powers range from 10 watts upward, depending on the tubes employed, and the frequencies. The art has been advanced sufficiently to permit generation of at least 1 kilowatt of continuous-wave power up to the lower frequencies used in microwave radar, and powers as great as 30 kilowatts can be obtained at somewhat lower frequencies.

## MICROWAVE CONVERTERS

C. F. EDWARDS

(Bell Telephone Laboratories, Inc., New York, N. Y.)

Microwave converters using point-contact silicon rectifiers as the nonlinear element are discussed with particular emphasis on the design of the networks connecting the rectifier to the input and output terminals.

Several converters which have been developed during recent years for use at wavelength between 3 and 30 centimeters are described. Some of the effects of the impedance-frequency characteristic of the networks on the converter performance are discussed.

### IMPROVED CATHODE-RAY TUBES WITH METAL-BACKED LUMINESCENT SCREENS

D. W. EPSTEIN AND L. PENSACK  
(RCA Laboratories, Princeton, N. J.)

Considerably improved cathode-ray tubes result from the application of a thin metallic layer on the beam side of the luminescent screen. Observations and measurements of such tubes show the advantages of increased light output, improved contrast, elimination of secondary-emission difficulties, and, under appropriate conditions, the elimination of ion spot.

### SOME TECHNICAL DEVELOPMENTS IN LIGHT-WAVE COMMUNICATIONS

COMMANDER J. M. FLUKE AND LIEUTENANT (j.g.)  
N. E. PORTER  
(U. S. Naval Reserve, Bureau of Ships, Navy Department,  
Washington, D. C.)

The purpose of this paper is to present and describe some of the recent technical advances in methods and components utilized in light-wave-communication devices. Reasons for exploitation of communication possibilities in the so-called light-wave portion of the spectrum are initially discussed, and some comparison is made with other communication methods. Included in this discussion, also, are the features of some of the new types of light-energy radiators, filter developments, converter tubes, highly sensitive receiving elements, and the associated electronic power supply and amplifying equipment.

### A MEDIUM-POWER TRIODE FOR FREQUENCIES ABOUT 600 MEGACYCLES

S. FRANKEL AND J. J. GLAUBER  
(Federal Telecommunication Laboratories, Inc., New York, N. Y.)  
AND  
J. WALLENSTEIN  
(Federal Telephone and Radio Corporation, Newark, N. J.)

A tube is described which was originally designed for pulse operation to deliver approximately 50 kilowatts peak power output at 600 megacycles with good efficiency.

Design considerations are discussed which include, as

the most important factor, problems of transit time, peak emission, cooling, and circuit properties of the internal tube structure.

A detailed description of this tube structure is given which includes design considerations of the electrodes, operating conditions, and static characteristics. Uniformity of characteristics is also discussed.

Methods of testing and using the tube as an oscillator, amplifier and frequency multiplier are described and the results obtained are given. These results include data and curves of power output versus frequency; efficiency versus frequency; power gain as an amplifier and multiplier; and life-test results.

### THE ROLE OF ATMOSPHERIC DUCTS IN THE PROPAGATION OF SHORT RADIO WAVES

J. E. FREEHAFFER  
(Radiation Laboratory, Massachusetts Institute of Technology,  
Cambridge, Mass.)

Experience gained during the war has shown that strong fields, at frequencies greatly exceeding the penetration frequency of the ionosphere, are often observed at several times the horizon distance. Experimental and theoretical investigations in this country and in England indicate that these effects are associated with the presence of layers in the troposphere in which the vertical gradient of refractive index exceeds numerically the reciprocal of the earth's radius. Under these conditions a duct is formed which for sufficiently high frequencies both reduces the rate at which the field is attenuated with range and also disturbs the normal height-gain effect.

### A SPECTRUM ANALYZER FOR MICROWAVE PULSED OSCILLATORS

F. J. GAFFNEY  
(PIB Products Company, Brooklyn, N. Y.; formerly  
Radiation Laboratory, Massachusetts Institute of Technology,  
Cambridge, Mass.)

A spectrum analyzer is described which utilizes a sharply tuned receiver whose response frequency is swept across the frequency spectrum to be analyzed at a rate slow compared to the pulse recurrence rate. The receiver output pulses are displayed on the screen of a cathode-ray oscilloscope whose horizontal sweep is synchronized with the variation of receiver response frequency. The envelope of these pulses represents the Fourier transform of the pulsed oscillator output. The distortion produced by the finite bandwidth of the receiver is analyzed. Design details of the radio-frequency input plumbing are discussed.

## ELECTRICAL CHARACTERISTICS OF QUARTZ-CRYSTAL UNITS AND THEIR MEASUREMENT

W. D. GEORGE, M. C. SELBY, AND R. SCOLNIK  
(National Bureau of Standards, Washington, D. C.)

An investigation of methods of accurately measuring the performance characteristics of two-terminal quartz-crystal units is presented. Relative merits and limitations of these methods are listed and forms of presentation of performance characteristics are indicated. Some observations of crystal-unit behavior, most useful to the radio-and-electronic engineer, are given. These may be interpreted and predicted on the basis of the performance characteristic curves suggested. It is believed that a practical approach is described whereby relatively simple measuring apparatus may be used in studying and standardizing those constants and characteristics that specify the quartz-crystal unit in itself apart from any external circuits with which it may be applied.

## TELEVISION IN THE ULTRA-HIGH FREQUENCIES

PETER C. GOLDMARK  
(Columbia Broadcasting System, New York, N. Y.)

The Columbia Broadcasting System ultra-high-frequency television system and results of recent tests are described and considerations of color in television discussed.

## MICROWAVE TRIODES ADAPTED TO MODERN USAGE

EVERETT M. GOODELL  
(Sylvania Electric Products, Inc., Emporium, Pa.)

A new series of planar-grid triodes has been developed which is adaptable both to pulse and continuous operation at microwave and lower frequencies. Special features incorporated into the mechanical design permit quick changes and adaptability to a wide variety of usage.

## A NEW SYSTEM OF ANGULAR VELOCITY MODULATION EMPLOYING PULSE TECHNIQUES

JAMES F. GORDON  
(Bendix Radio Division, Baltimore, Md.)

A frequency-modulation system is described in which a crystal-controlled pulse triggers a multivibrator. This pulse establishes a reference time for the system. The

asymmetry of the multivibrator cycle varies with modulation. Clipping the reference pulse and differentiating the intelligence pulse which is generated at the cross-over point of the multivibrator cycle produces a source of time-modulated intelligence. These pulses are used to control the phase of a continuous-wave carrier.

## LINEAR SERVO THEORY

R. E. GRAHAM  
(Bell Telephone Laboratories, Inc., New York, N. Y.)

The servo system is presented as a feedback circuit. Typical components of electromechanical circuits are described in homogeneous terms by means of a conventional analogy. The nomenclature of frequency analysis is used to describe the servo circuit as a transmission system.

The problems of linear servo design are discussed in the language of electrical-circuit feedback theory. A simple logarithmic frequency plot is found adequate for most design considerations. Exact and approximate methods for calculating dynamic errors in follow-up systems are described, and a discussion is given of the interrelations between input signal, dynamic error, transient response, and noise vulnerability.

Linearization of motor-drive systems by use of local velocity feedback and pre-equalization of the input signal to reduce over-all error are described.

## AIRBORNE RADAR EQUIPMENT FOR AIRCRAFT INTERCEPTION

MAJOR F. L. HOLLOWAY, CAPTAIN R. P. BURROWS,  
AND J. E. KETO  
(Radar Laboratory, Air Technical Service Command, Dayton, Ohio)

This paper describes some of the outstanding airborne radar equipments and systems developed during the war for the radar-bombing operations of the Army Air Forces. Technical characteristics and requirements of such equipment are presented. Problems introduced by the technical and operational aspects of radar bombing are discussed as well as the effect of such problems on the design of the subject equipment.

## TUNABLE RECEIVERS FOR VERY HIGH FREQUENCIES

G. E. HULSTED, J. M. PETTIT, H. E. OVERACKER,  
K. SPANGENBERG, AND R. R. BUSS  
(Radio Research Laboratory, Harvard University,  
Cambridge, Mass.)

Developments have greatly advanced receiver techniques in the direction of obtaining tunability, good

sensitivity, and wide frequency coverage at increasing high frequencies. This paper describes techniques that have been employed in a line of receivers that give continuous coverage of 10,000 megacycles. The most advanced of these equipments have high image rejection even at microwave frequencies, have single-dial control, a sensitivity reasonably close to the theoretical ultimate, and are tunable over frequency ranges of approximately 2 to 1 or more.

### THE THEORY AND APPLICATION OF THE RADAR BEACON

CAPTAIN R. D. HULTGREN AND L. B. HALLMAN, JR.  
(Watson Laboratories, Red Bank, N. J.)

Part I discusses the general theory underlying the operation of radar beacons. The various components of a typical beacon, such as the receiver, discriminator, modulator, coder, and transmitter, are discussed in some detail. System considerations such as factors governing choice of operating frequencies, required receiver sensitivity and transmitter power, choice of pulse duration, the cause and effect of delay in the beacon, and type of coding, are discussed. Part II discusses the application of radar beacons to aircraft homing, landing, rendezvous, identification, and airport surveillance. Special types of radar beacon applications such as the Beacon Blind Approach System (BABS), sea rescue devices, and communication aids are discussed in some detail.

### THREE- AND NINE-CENTIMETER PROPAGA- TION MEASUREMENTS IN LOW-LEVEL OCEAN DUCTS

M. KATZIN AND R. W. BAUCHMAN  
(Naval Research Laboratory, Washington, D. C.)

In order to check the effect on three- and nine-centimeter transmissions of low-level ducts formed in oceanic air, one-way measurements between a ship and a shore station were made with antenna combinations of various heights. The experimental setup and techniques are described. Meteorological measurements taken from both shore and ship are described, and the variations in duct height and strength discussed. Meteorological and radio measurements inland were made, and the effect of distance back from the shore on meteorological conditions and radio transmission are described. Three-centimeter radar observations were made during the latter part of the project, and the variation of echo amplitude with range of ship target was measured. Analysis of radio and radar measurements is given.

### NAVAL WARFARE COMMUNICATIONS PROBLEMS

COMMANDER J. O. KINERT  
(U. S. Navy, Naval Operations, Navy Department,  
Washington, D. C.)

A brief review of problems encountered during the development and growth of amphibious assault techniques is given. How problems were met from point of view of electronic material with an evaluation of available types is discussed. Recommendation for future design is also given.

### METAL-LENS ANTENNAS (With Demonstration)

W. E. KOCK  
(Bell Telephone Laboratories, Inc., New York, N. Y.)

A new type of antenna is described which utilizes the optical properties of radio waves. It consists of a number of conducting plates of proper shape and spacing and is, in effect, a lens whose focusing action is due to the high-phase velocity of a wave passing between the plates. Its field of usefulness extends from the very short waves up to wavelengths of perhaps five meters or more. The paper discusses the properties of this antenna, methods of construction, and applications.

### TWO MULTICHANNEL MICROWAVE RADIO- RELAY EQUIPMENTS FOR THE U. S. ARMY COMMUNICATION NETWORK

RAYMOND E. LACY  
(Coles Signal Laboratory, Red Bank, N. J.)

Radio set AN/TRC-5 and radio set AN/TRC-6 are described whereby the U. S. Army Signal Corps has pioneered in applying the art of microwave techniques to communication equipments in order to provide transportable multichannel radio-relay sets for interconnection with high-grade voice circuits. An explanation is given of radar-type pulse-time-division methods of modulation which eliminate the relatively cumbersome carrier-frequency terminal equipment usually associated with a multiplex system. Audio performance and radiation characteristics are shown which presage a microwave epoch for long-lines communication.

### CAPACITANCE-COUPLED WIDE-BAND INTER- MEDIATE-FREQUENCY AMPLIFIERS

MERWIN J. LARSEN AND LYNN L. MERRILL  
(Stromberg-Carlson Company, Rochester, N. Y.)

The design and performance of capacitance-coupled intermediate-frequency amplifiers is discussed, with



particular emphasis on applications to television receivers. Experimentally obtained curves are presented as an aid in selecting the circuit parameters necessary to produce flat-top frequency response for various operating ranges. The design of capacitance-coupled traps is treated theoretically, and experimental evidence is presented to show the validity of the theoretically predicted results.

### A THREE-BEAM OSCILLOGRAPH FOR RECORDING AT FREQUENCIES UP TO 10,000 MEGACYCLES

GORDON M. LEE

(Central Research Laboratories, Red Wing, Minn.)

Transit-time distortion is a fundamental limiting factor in the application of high-speed cathode-ray oscillographs to the recording of high-frequency voltages or fast transients. A three-beam, high-speed, micro-oscillograph is described in which the transit-time reduction in deflection sensitivity is calculated to be but 4 per cent at 3000 megacycles and 40 per cent at 10,000 megacycles. Single-sweep oscillograms of 3000 and 10,000 megacycle oscillations and  $10^{-9}$ -second transients are shown.

### CASCADE AMPLIFIER KLYSTRONS

E. C. LEVINTHAL

(Sperry Gyroscope Company, Inc., Garden City, L. I., N. Y.)

The theory of operation of a three-resonator klystron amplifier is discussed for the case of small-signal operation. An analogy between the operation of a cascade amplifier and velocity modulation by a saw-tooth voltage is demonstrated. Some calculated values of tube parameters are given which yield theoretical efficiencies in the neighborhood of 74 per cent. Data are presented which verify the production of greater efficiency for large-signal operation.

### ENEMY RADIO AND RADAR EQUIPMENT

LIEUTENANT COMMANDER E. L. LUKE  
AND JOHN C. LINK

(Naval Research Laboratory, Washington, D. C.)

### ULTRA-HIGH-FREQUENCY TELEVISION RECEIVERS

HAROLD T. LYMAN

(Columbia Broadcasting System, New York, N. Y.)

Combined black-and-white and color television receivers, both in direct-view and projection types, have been developed in the Columbia Broadcasting System laboratories. These receivers operate in the television band between 480 and 920 megacycles with sight and sound on one carrier. Details of circuit design, mechanical layout, and performance data are presented.

### APPLICATION OF RADAR TECHNIQUES TO AIRCRAFT FIRE-CONTROL SYSTEMS

MAJOR E. A. MASSA, CAPTAIN I. PAGANELLI, AND  
CAPTAIN FRED A. BEST, JR.

(Radar Laboratory, Air Technical Service Command, Dayton, Ohio)

This paper will discuss the basic problems involved in aircraft fire-control systems and the three basic types of radar systems which have been developed to solve these problems. A more detailed description of several of these equipments, including equipments which depart from conventional radar design, will be presented. The advantages which have been gained by the use of radar in this field will be listed and analyzed. A short discussion of future radar fire-control systems concludes the paper.

### THE ROLE OF ELECTRONICS IN ANTI-AIRCRAFT GUN-FIRE CONTROL

CAPTAIN F. B. MACLAREN

(Ordnance Department, Frankford Arsenal, Philadelphia, Pa.)

During the war, our major caliber anti-aircraft equipment advanced from an essentially mechanical system to one employing electronics as a vital part. A detailed description of the circuits involved in associated radar, computer, servomechanism, and proximity-fuze components, compared with equivalent enemy material, will explain the high degree of effectiveness obtained in combat. However, many improvements are still needed in electronic systems to supplement the defense against weapons such as the German V-2 rocket, especially if augmented with atomic power.

### SECONDARY-EMISSION CATHODES FOR MAGNETRONS

J. W. McNALL, H. L. STEELE, JR.,  
AND C. L. SHACKELFORD

(Westinghouse Electric Corporation, Bloomfield, N. J.)

A few weeks before Pearl Harbor, an investigation was begun at the Massachusetts Institute of Technology Radiation Laboratory on cathodes for microwave multicavity magnetrons. The cathode used for such tubes was an indirectly heated oxide-coated cathode. It was known that the cathode temperature increased considerably due to back-bombardment by electrons when the magnetron was operated, and, in fact, it was believed that most of the emission current was not of thermionic but rather of secondary origin. Realizing that the electron back-bombardment of the cathode would impose undesirable limitations on the duty cycle and maximum average power at which magnetrons could be operated, it was decided to investigate the feasibility of using a cold secondary-emitting cathode in place of the thermionic one generally used. Since bombardment of the cathode can occur if the magnetron is oscillating, and since the magnetron will oscillate only

if there are electrons available in the cathode-anode space, it is obvious that an auxiliary primary emitter must be provided. This emitter is required to supply, however, only enough current to initiate oscillations in the magnetron. At the Radiation Laboratory, many different materials were used as secondary emitters, including beryllium, aluminum, nickel-barium alloy, thorium, and silver-magnesium alloy.

At the beginning of 1943, this project was discontinued at the Radiation Laboratory and was taken up in the Westinghouse Lamp Division Research Department. The work was directed along several lines including investigations of activation processes, methods of cooling the secondary-emitting cathode, investigations of several more materials, testing at higher duty cycles, studies of the effects of heating, measurements of the secondary emission yield of the surface, and correlations of these yield measurements with the maximum peak emission currents obtainable for various voltages and states of activation.

### FREQUENCY ALLOCATIONS

COMMANDER PAUL D. MILES

(Federal Communications Commission, Washington, D. C.)

A brief review of international and domestic frequency-allocation regulation is given, followed by a description of the steps taken in the past two years by the United States to prepare for the next international telecommunications conference. Consideration is given to new radio services which must be anticipated, their probable effect upon future allocation tables, and improved techniques which must be exploited to insure the accommodation of these services in the spectrum.

### PROBLEMS ASSOCIATED WITH THE STANDARDIZATION OF QUARTZ-CRYSTAL UNITS FOR MILITARY EQUIPMENT

CAPTAIN CHARLES J. MILLER, JR.

(Squier Signal Laboratory, Fort Monmouth, Red Bank, N. J.)

Some of the technical problems which must be solved before a series of ultimate standard quartz-crystal units for use in military signal equipment can be established are discussed, and progress to date in the solution of these problems is indicated. The crystal impedance meter, a new instrument for measuring the impedance of a crystal unit, is introduced and described. A brief review of the fundamental electrical properties of crystal units and associated oscillator circuits is included to furnish a technical background upon which to discuss these problems. A review of the three principal applications of crystal units in frequency-control circuits, calibrator circuits, and filter circuits, and a review of the various types of crystal holders and methods of mounting are included.

### GLASS PROBLEMS IN THE MANUFACTURE OF MINIATURE TUBES

HENRY J. MILLER

(RCA Victor Division, Harrison, N. J.)

The use of miniature tubes in military equipment made it necessary to develop stem making and stem-to-bulb sealing techniques to provide tubes which would withstand without glass failure severe mechanical and thermal loading and shock as well as vibration. The three factors which govern the mechanical stability of the stem are buffer gas, depth of insertion, and strain. Methods of controlling these factors are described. The stem-to-bulb sealing technique required to obtain a seal of maximum mechanical rigidity is outlined. It is shown that the resulting procedures for the mass production of tubes were successful in withstanding the severe mechanical stress of wartime use without any epidemic glass failure in the field.

### NOISE SPECTRUM OF CRYSTAL MIXERS

P. H. MILLER

(University of Pennsylvania, Philadelphia, Pa.)

Studies of the noise spectrum of crystal mixers were made over the frequency range of 50 to 1,000,000 cycles per second. In the audio range a band-pass filter employing a three-terminal Wien bridge was used to perform the analysis. For analysis at higher frequencies 7 megacycles were added to the noise spectrum and a communications receiver employed. It was found that regardless of the type of power applied to the crystal the noise temperature varies inversely with the frequency. The noise in the audio range is always large, a noise temperature ratio of  $10^6$  being typical. A mechanism responsible for the observed noise has not yet been suggested.

### A NEW SYSTEM OF RADIO TELEMETERING

DAVID W. MOORE, JR., AND FRANK G. WILLEY

(Fairchild Camera and Instrument Corporation, Jamaica, L. I., N. Y.)

The Fairchild system of radio telemetering was designed to transmit indication of aircraft instruments from plane to ground over a conventional aircraft radio transmitting and receiving equipment. Ground indication is made by an indicator which closely simulates the standard aircraft instrument in appearance and modification to the aircraft instrument in the plane in flight. Instrument indication is transferred into electrical phase angle which may be transmitted by radio equipment. This phase angle is then compared with a reference signal in the receiving station and converted to a dial indication. Provision may be made for sending a number of instrument indications over a single carrier,

enabling transmission of indications of a flight group of instruments from, for example, a radio-controlled plane or missile to a distant operating point, either on the ground or in another plane.

### MICROWAVE POWER MEASUREMENT

T. MORENO AND O. C. LUNDSTRUM

(Sperry Gyroscope Company, Inc., Garden City, L. I., N. Y.)

Possible methods of microwave power measurement are reviewed. The design requirements for bolometric wattmeters are outlined, and examples are given of bolometer elements that have been developed to meet these requirements. A recently developed bolometer element that may be used over an exceedingly wide band of frequencies is included. The results of experiments to determine the accuracy of these wattmeters are summarized; these experiments indicate that errors may be held to within a few per cent.

### DIRECTIONAL COUPLERS

W. W. MUMFORD

(Bell Telephone Laboratories, New York, N. Y.)

The directional coupler is a device which samples separately the direct and the reflected waves in a transmission line. A simple theory of its operation is derived. Design data and operating characteristics for a typical unit are presented. Several applications which utilize the directional coupler are discussed.

### AIRCRAFT AUTOMATIC POSITION PLOTTER

A. C. OMBERG AND W. L. WEBB

(Bendix Radio Division, Baltimore, Md.)

The development of a device for feeding information from two automatic direction finders and a magnetic heading device into a computer, which changes polar co-ordinates into rectangular co-ordinates, is described.

The rectangular co-ordinates give the position of an aircraft with respect to two ground transmitters automatically controlling a "crab" which continuously plots the position of the aircraft on a chart. The method of developing the computer and a model of the device is described.

### RADAR MODEL XAF

R. M. PAGE

(Naval Research Laboratory, Washington, D. C.)

This paper gives the story of the technical development of the U. S. Navy's first operational radar equipment, the XAF. Theoretical considerations and design parameters are given for pulse-modulation transmission and reception equipment, and exemplified in the XAF

circuits. Of particular interest are the six-tube, high-frequency oscillator and the coupling circuits permitting efficient operation of both transmitter and receiver on the same antenna.

### A NEW HIGH-SPEED RECORDING POTENTIOMETER

V. L. PARSEGIAN

(Portable Products Corporation, C. J. Tagliabue Division, Brooklyn, N. Y.)

A new high-speed recording potentiometer is described, having a carriage travel of 10 inches in one second and balancing to within an accuracy of 0.1 per cent of full range. The instrument is of the photoelectric type, using a new sturdy, short-period, low-inertia-error galvanometer, a photocell, and a phase-reversing amplifier which drives a split-phase carriage motor when the photocell illumination exceeds, or is less than, an intermediate "balance" value. Means for canceling the galvanometer lag is described, as well as a new thyatron circuit for printing records.

### AN INTRODUCTION TO HYPERBOLIC NAVIGATION

J. A. PIERCE

(Radiation Laboratory, Massachusetts Institute of Technology, Cambridge, Mass.)

In less than five years, loran, the American embodiment of the new method of navigation, has grown from a concept into a service used by tens of thousand of navigators over three tenths of the surface of the earth. The first part of the present paper describes the history of this program. A second section deals with the fundamental concepts of hyperbolic navigation and gives some details regarding the kinds of equipment now employed for transmission, reception, and interpretation of pulse signals for this service.

### JOINT ELECTRON TUBE ENGINEERING COUNCIL

O. W. PIKE

(Joint Electron Tube Engineering Council)

This paper outlines the conditions leading up to the formation of the Joint Electron Tube Engineering Council as the joint body responsible for the technical aspects of tube standardization in the National Electrical Manufacturers Association and the Radio Manufacturers Association. The basic organization of JETEC is described, and its relation to the parent organizations and other agencies such as the Joint Army-Navy Committees is outlined. The activities of JETEC during the past year are summarized and its program for the future indicated.

## MAGNETRON CATHODES

M. A. POMERANTZ

(Bartol Research Foundation of the Franklin Institute,  
Swarthmore, Pa.)

This paper will include a description of the spectacular high-pulsed emissions from oxide cathodes which were initially responsible for the success of magnetrons. Other matters which will be touched upon are decay of emission with time, cathode and anode sparking, the role of back-bombardment and secondary emission, and thoriated cathodes.

## ELECTRONIC FREQUENCY STABILIZATION OF MICROWAVE OSCILLATORS

R. V. POUND

(Radiation Laboratory, Massachusetts Institute of Technology,  
Cambridge, Mass.)

For many purposes, microwave signal generators of very-high-frequency stability are desirable. Two methods of electronic frequency control relative to the resonant frequency of an isolated microwave cavity resonator are discussed. The relative frequency can be maintained to better than one part in  $10^8$  and the absolute frequency stability is that of the cavity. High-fidelity frequency modulation with deviations of the order of  $f/14Q$  about the stabilized frequency is possible. Several uses are mentioned.

## FROM WIRING TO PLUMBING

E. M. PURCELL

(Radiation Laboratory, Massachusetts Institute of  
Technology, Cambridge, Mass.)

At microwave frequencies circuit components are needed which, although comparable to a wavelength in size, provide the functional flexibility of ordinary radio-frequency circuit elements. Connectors, rotating joints, T-junctions, transformers, filters, variable reactors, attenuators, etc., must be manufacturable, durable, and in electrical behavior accurately predictable. In some respects microwave circuits are simpler than their low-frequency counterparts. Line-length transformations are conveniently and freely employed. Also, the symmetry properties of wave-guide transmission modes permit the realization, in simple form, of networks with interesting and useful properties. With a few notable exceptions microwave circuit design has been reduced to an engineering science.

## TELEVISION-STUDIO EQUIPMENT

JAMES J. REEVES

(Columbia Broadcasting System, New York, N. Y.)

The design of camera and studio control-room equipment, recently built and used by the Columbia Broad-

casting System for the transmission of high-definition color television and 1029-line black-and-white images is described in detail.

## MICROWAVE PROPAGATION

### Part I

#### The Effect of Rain Upon the Propagation of Waves in the One- and Three-Centimeter Region

S. D. ROBERTSON AND A. P. KING

(Bell Telephone Laboratories, Inc., New York, N. Y.)

The effects of rainfall and atmospheric absorption on the propagation of microwaves and the methods employed for measuring them are described. The attenuation of 3.2-centimeter waves is slight for moderate and light rainfall. During a cloudburst, the attenuation may approach a value of 5 decibels per mile. At 1.09 centimeters, the waves are appreciably attenuated even by a moderate rain.

### Part II

#### Propagation of Six-Millimeter Waves

G. E. MUELLER

(Bell Telephone Laboratories, Inc., New York, N. Y.)

Attenuations in excess of 25 decibels per mile have been observed during a cloudburst. The losses are still higher at 0.62 centimeter reaching a value of 42 decibels per mile for a cloudburst. The gas attenuation at this wavelength is probably less than 0.2 decibel per mile.

## THE IMAGE ORTHICON, A SENSITIVE TELEVISION PICKUP TUBE

ALBERT ROSE, P. K. WEIMER, AND H. B. LAW

(RCA Laboratories, Princeton, N. J.)

The image orthicon is a new television pickup tube of high sensitivity. It operates stably at all light levels and the picture transmitted is substantially independent of the illumination over a wide range. Scenes have been transmitted successfully with one hundredth of the illumination previously required by commercial pickup tubes.

The advantageous features of the image orthicon have been attained by incorporating with the orthicon an electron multiplier, an electron-image section and a two-sided target. This new development is described in detail.

## DUPLEX OPERATION OF INDEPENDENT HIGH-POWER OSCILLATORS FOR INDUCTION HEATING

W. C. RUDD

(Induction Heating Corporation, New York, N. Y.)

In the production of high-frequency power for induction heating, it has been found advantageous to use

multiple oscillators for the production of powers beyond that of a single unit. The problem involves the interconnection of two independent tank circuits in a manner such that the output frequency of the two units is the same and in synchronism. In addition, the total load must be shared equally by the two power supplies. The paper describes the electrical problems involved, together with their practical solution for the production of powers of 40 and 50 kilowatts, using two 20- or two 25-kilowatt oscillators.

### DESIGN CONSIDERATIONS IN BROADSIDE ARRAYS

JOHN RUZE

(Evans Signal Laboratory, Belmar, N. J.)

The various factors considered in the design of broadside arrays are discussed and their effect on antenna bandwidth as determined by pattern deterioration are mentioned. Mutual impedance between antenna elements and means of establishing a desired current and phase distribution are detailed. Various methods of lobing a broadside array with magnitude of secondary lobes and bandwidth are discussed. Several designs will be detailed, such as the antenna system used on the SCR-270 and the AN/CPX-1.

### A FREQUENCY-MODULATION ALTIMETER FOR METER AND LIGHT INDICATION AND THE AUTOMATIC ALTITUDE CONTROL OF AIRCRAFT

R. C. SANDERS, JR., AND W. R. MERCER  
(Raytheon Manufacturing Company, Watham, Mass.)

AND

IRVING WOLFF AND J. C. SMITH  
(RCA Laboratories, Princeton, N. J.)

### AN AUTOMATIC VISUAL-INDICATING RADIO DIRECTION FINDER

ALDO SCANDURRA AND SAMUEL STIBER  
(Signal Corps Engineering Laboratory, Belmar, N. J.)

Radio set AN/TRD-2 is a Signal Corps development designed to provide a portable and mobile direction finder giving instantaneous indications and automatic sense. This direction finder is unique in that the instantaneous indication on the oscilloscope is a single line generated from the center of the screen with a length proportional to the signal strength and the angular position of which indicates the direction of arrival of the signal without sense ambiguity. An additional feature is that noise and modulation are almost completely eliminated from the visual indication.

### ELECTROOPTICAL CHARACTERISTICS OF TELEVISION SYSTEMS

O. H. SCHADE

(RCA Victor Division, Harrison, N. J.)

Optical and psychological capabilities of the human eye determine the performance standards for television systems.

Significant values for image detail and contrast, the electrical channel width, and signal-to-noise ratios are derived from the threshold visibility of picture detail and random brightness fluctuations.

Optical requirements and processes of developing electrical signals in television cameras for monochrome or color transmission are examined to establish relations and comparative values for obtainable signal-to-noise ratios and the required light flux.

### SIGHT AND SOUND ON ONE CARRIER

KURT SCHLESINGER

(Columbia Broadcasting System, New York, N. Y.)

The fundamental aspects of audio and video multiplex operation are outlined, and a description of the various forms of multiplex modulation is given. Theoretical and experimental considerations of performance characteristics are considered. There is a detailed discussion of transmitter and receiver circuits and a discussion of results of recent tests.

### EQUIVALENT CIRCUITS FOR WAVE-GUIDE STRUCTURES

JULIAN SCHWINGER

(Radiation Laboratory, Massachusetts Institute of Technology, Cambridge, Mass.)

Wave-guide structures can be completely and rigorously described by equivalent lumped-constant circuits. It is the purpose of the lecture to show how typical equivalent circuits are constructed by employing the special symmetry of the situation, to demonstrate that much qualitative information can be obtained from the form of the circuit even without knowledge of the values of the circuit constants, to discuss how the values of the circuit constants can be directly measured, and to indicate the procedure of the theory in calculating the values of the circuit parameters in their complete dependence on frequency and geometry.

### DISCRIMINATORS FOR FREQUENCY- MODULATION RECEIVERS

S. W. SEELEY

(RCA Laboratories, New York, N. Y.)

Many of the aspects of frequency-modulation detection, including the new amplitude insensitive discriminators, are discussed.



## ULTRA-HIGH-FREQUENCY TELEVISION TRANSMITTERS AND ANTENNAS

ROBERT SERRELL

(Columbia Broadcasting System, New York, N. Y.)

Ultra-high-frequency television transmitters of several types have been developed and built in the Columbia Broadcasting System laboratories. These transmitters embodying tubes developed during the war, utilize a 10-megacycle modulation bandwidth. The design and performance of these transmitters and of wide-band antennas used will be described in detail. Also, some results of experimental ultra-high-frequency broadcasts are discussed.

## MEASUREMENT OF THE ANGLE OF ARRIVAL OF MICROWAVES

W. M. SHARPLESS

(Bell Telephone Laboratories, Inc., New York, N. Y.)

This paper describes a method of measuring the direction from which microwaves arrive at a given receiving site. Data which have been collected on two short optical paths using a wavelength of  $3\frac{1}{4}$  centimeters are presented to illustrate the use of the method. Angles of arrival as large as  $\frac{1}{2}$  degree above the true angle of elevation have been observed in the vertical plane while no variations greater than  $\pm 1/10$  degree have been found in the horizontal plane. More recent work, using a lens-type scanning antenna operated at a wavelength of  $1\frac{1}{4}$  centimeters revealed that, at times, as many as four distinct transmission paths were present simultaneously on a 12.6-mile circuit. Simultaneous meteorological soundings were made near both terminals of the circuit.

## MODEL AIRCRAFT-ANTENNA MEASUREMENTS

GEORGE SINCLAIR, E. W. VAUGHAN, AND  
EDWARD C. JORDAN

(Ohio State University Foundation, Columbus, Ohio)

Although antenna models have been used for many years in studying antenna patterns, the measurements were severely limited as to frequency and type of antenna. It is shown how the techniques may be extended to cover a very wide frequency range and a wide variety of antennas. Particular application to the study of aircraft antenna patterns are cited. The utility of models in studying special properties of antennas, such as polarization errors of direction finders, propeller-modulation effects, ellipticity of polarization, etc., are discussed.

## ONE-MILLIONTH-OF-A-SECOND RADIOGRAPHY AND ITS APPLICATIONS

C. M. SLACK AND D. C. DICKSON

(Westinghouse Electric Corporation, Bloomfield, N. J.)

The making of ultra-speed radiographs, using exposure times of the order of one millionth of a second, requires the passage of electron currents of 1000–2000 amperes. Such currents can be supplied by an electron source utilizing field emission from a cold-cathode electrode which degenerates into a metallic arc in a high vacuum. The recording of such high-speed transients are briefly discussed. The development of this equipment has been greatly accelerated because of the war. Slides showing its applications to various radiographic problems requiring short exposure times which have just been released by the War Department are shown; among these are radiographs taken at Frankford Arsenal and Aberdeen Proving Grounds of exploding shells and bombs, and at Princeton University, showing the wounding mechanism of high-velocity fragments. Future applications also are discussed.

## THEORY OF IMPULSE NOISE IN IDEAL FREQUENCY-MODULATION RECEIVERS

DAVID B. SMITH AND W. E. BRADLEY

(Philco Corporation, Philadelphia, Pa.)

An analytical treatment of noise in frequency-modulation receivers is given for the case when a mixture of noise and useful signals is applied to the receiver input. Methods of measuring the performance of receivers with respect to frequency-modulation noise are discussed.

## GROUND-CONTROLLED APPROACH

ERNEST STORRS, W. DEVITT, AND BEN GREEN

(Watson Laboratories, Red Bank, N. J.)

Out of the development race for military supremacy in World War II has come one of the most outstanding navigational aids yet known. It is known as ground-controlled approach or, more popularly termed, GCA. The military designation has been the nomenclature AN/MPN-1. Its purpose is to talk the pilot down the glide path under conditions approaching zero visibility to a safe landing by means of the normal communications equipment already installed in the aircraft.

## A KINESCOPE FOR HOME PROJECTION-TYPE TELEVISION RECEIVERS

L. E. SWEDLUND

(RCA Victor Division, Harrison, N. J.)

The development of a small high-voltage cathode-ray tube for home projection-type television receivers,

soon to be available commercially, is described. Several new insulation and fluorescent screen problems had to be solved because of the need for operating at relatively high voltage. An outstanding gain in light output and performance was attained by applying an electron-transparent, light-reflecting aluminum film to the back of the fluorescent screen.

### HIGH-FREQUENCY PLATED QUARTZ-CRYSTAL UNITS FOR CONTROL OF COMMUNICATIONS EQUIPMENT

R. A. SYKES

(Bell Telephone Laboratories, Inc., New York, N. Y.)

A description is given of the general problems relating to the development of high-frequency plated-crystal units, the methods employed for supporting the crystal blank, adjustment to final frequency by means of vaporized or evaporated films, and the various problems associated with the aging of such units. The general problems of devising simplified procedures for the large-scale manufacture of such crystal units are also described.

### CRYSTAL RECTIFIERS IN HETERODYNE RECEIVERS

H. C. TORREY

(Radiation Laboratory, Massachusetts Institute of Technology, Cambridge, Mass.)

Crystal rectifiers as frequency converters are superior to other detectors of microwave signals as measured by the noise figure—a quantity dependent on conversion loss and noise temperature of the mixer. Linear-network theory can be applied to microwave converters, a mixer being represented as a three-terminal pair device with terminals at signal, image sideband, and intermediate frequency. Such a representation is helpful in estimating the effect on conversion loss of image-sideband termination and of parasitic impedances. Other factors of importance are resistance to burnout and stability. Representative microwave mixers designed by Radiation Laboratory are described.

### RADAR ASPECTS OF NAVAL FIRE CONTROL

CAPTAIN DUNDAS P. TUCKER

(U. S. Navy, Bureau of Ordnance, Navy Department, Washington, D. C.)

Application of radar to fire control required the development of many new designs and techniques for the purpose of providing high precision in measuring target position and high resolution against multiple targets and interfering objects. A special circuit for measuring time intervals to 0.05 microsecond, and angles to 0.05 degree

were developed. American possession of radar-controlled gunfire was a decisive factor in many naval engagements with Japanese ships and aircraft.

### BEAM-SHAPING METHODS IN ANTENNA DESIGN

L. C. VAN ATTA

(Radiation Laboratory, Massachusetts Institute of Technology, Cambridge, Mass.)

The angular width of an optical searchlight beam is determined by the extended light source placed at the focal point of the paraboloid reflector and by inaccuracies in the reflector shape. The beam width of a microwave paraboloid antenna, however, is due to diffraction of the radiation at the aperture. For sharp beams, it is desirable, frequently, to distribute the radiation in some manner other than that determined by diffraction. The focusing property of the antenna system can be modified either by providing an extended antenna feed or distorting the paraboloid shape. Straightforward experimental and theoretical approaches are available to the antenna designer in achieving a wide variety of beam shapes for special application.

### STAGGER-TUNED WIDE-BAND AMPLIFIERS

H. WALLMAN

(Radiation Laboratory, Massachusetts Institute of Technology, Cambridge, Mass.)

In radar and television receivers, the simplicity of single-tuned circuits strongly commends itself to the designer of wide-band, band-pass amplifiers. Unfortunately, with present tubes, one cannot make a high-gain amplifier wider than about 4 megacycles; the principal reason is the rapidity with which bandwidth decreases as identical single-tuned stages are cascaded. This paper describes the scheme of stagger-tuning, the individual single-tuned circuits, which essentially eliminates the shrinking of over-all bandwidth and thus makes possible very simple 10- and 15-megacycle wide amplifiers. Stagger-tuning appears to be much less well known than it deserves. Graphs are presented condensing the whole basic design of a wideband amplifier into the work of a few minutes; actual examples of amplifiers are shown.

### METALLIZED-GLASS ATTENUATORS FOR RADIO-FREQUENCY APPLICATIONS

ERNST WEBER

(Polytechnic Institute of Brooklyn, Brooklyn, N. Y.)

Based on special techniques of precision metallizing of glass plates and tubes, power-absorbing elements have been developed suitable for use in calibrated attenuators in coaxial as well as wave-guide radio-

frequency power transmission systems of moderate power level. Particular attention had to be given to proper matching of the attenuating sections to the practically lossless transmission lines by means of impedance transformers which themselves are part of the metallized-glass elements. Several models with precision measuring drives were developed for use as reference standards.

### THE NEW "SPEEDOMAX" POWER-LEVEL RECORDER

A. J. WILLIAMS, JR., AND W. R. CLARK  
(Leeds and Northrup Company, Philadelphia, Pa.)

The new "Speedomax" power-level recorder is an instrument that faithfully records rapid or slow variations in power level with time, and is independent of variations in frequency within its frequency range (25 to 150,000 cycles). The recorder scale is linear in decibels. A 20-decibel change in power input can be recorded in about one second. The new circuits used in this new recorder are described in detail, and its performance characteristics are given.

### A PULSE ALTIMETER OF HIGH ACCURACY AT HIGH ALTITUDES

IRVING WOLFF, W. D. HERSHBERGER,  
G. W. LECK AND R. R. WELSH  
(RCA Laboratories, Princeton, N. J.)

### COLOR-TELEVISION TRANSMITTER

N. H. YOUNG  
(Federal Telecommunication Laboratories, Inc., New York, N. Y.)

On December 21, 1945, Federal Telecommunication Laboratories delivered to the Columbia Broadcasting

System a color-television transmitter. It operates on a carrier frequency of 490 megacycles with a peak power output of 1 kilowatt and can be modulated uniformly at all frequencies from direct current to 10 megacycles. It is the most powerful transmitter of this frequency and bandwidth ever used in television service.

The transmitter is made possible by the development of a new ultra-high-frequency triode, type 6C22. This tube is used in the four final stages of the radio-frequency section and in the two final stages of the video-frequency section.

A conventional sequence of crystal oscillators and frequency multipliers is used in the radio-frequency section. The video-frequency section is unusual chiefly in the use of direct-current coupling between amplifier stages, thus making the use of direct-current restoring circuits unnecessary. The final radio-frequency amplifier is grid-modulated, and the low plate resistance of the tube aids greatly in securing adequate bandwidth in the output radio-frequency circuit.

### HERMETICALLY SEALED METAL HOLDER FOR CRYSTAL UNITS

A. W. ZEIGLER  
(Bell Telephone Laboratories, Murray Hill, N. J.)

A metal-type holder has been developed to replace the phenolic-type for hermetically sealing low- and high-frequency crystal units for use by the various branches of the Armed Forces. The holder comprises an assembly of a drawn-metal cover fluxless soldered by induction heating to a base carrying glass-to-base seal terminals. The techniques developed follow closely those used in miniature vacuum-tube assemblies. Similar holders are being developed for peacetime applications in the communication field.

## Awards

W. C. White, chairman of the Awards Committee, presented to the Board of Directors on November 7, 1945, the list of nominees selected for the 1946 Awards. These recommendations were unanimously approved by the Board, and the Awards were presented at the Banquet of the Winter Technical Meeting held on Thursday, January 24, 1946.



Medal of Honor—1946

RALPH VINTON LYON HARTLEY

"For his early work on oscillating circuits employing triode tubes and likewise for his early recognition and clear exposition of the fundamental relationships between the total amount of information which may be transmitted over a transmission system of limited bandwidth and the time required."



Fellow Award—1945

THOMAS LYDWELL ECKERSLEY

"For his outstanding contributions to the theory and practice of radio-wave-propagation research. Both his approach to the problem from the standpoint of practical communications and his invention of mathematical tools useful in the computation of radiated fields are achievements of lasting value acclaimed by the whole radio world, and form a monument of which he may be justly proud."



Fellow Award—1945

CLARENCE W. HANSELL

"For his pioneer work in the development and application of equipment for the ever higher frequencies employed for radio communication."



Fellow Award—1945

GREGORY BREIT

"For pioneering in the experimental probing of the ionosphere and giving to the world the first publication of the experimental proof of the existence of the ionosphere; and for having initiated at an early date the pulse method of probing by reflection which is the basis of modern radar."



Fellow Award—1945

HENRI G. BUSIGNIES

"For his accomplishments in the field of radio direction finders, particularly pioneering work on instruments having automatic indicating features."



Morris Liebmann Memorial Prize—1945

PETER C. GOLDMARK

"For his contributions to the development of television systems, particularly in the field of color."



Fellow Award—1945

HAROLD LESTER KIRKE

"For his services to broadcasting in the British Isles and in particular for his leadership in the research activities of the British Broadcasting Corporation."



Fellow Award—1945

JOSEPH SLEPIAN

"In recognition of his contributions as scientist, engineer, and inventor to the field of electronics."



Conway Studios, Inc.

Fellow Award—1945

HAROLD S. OSBORNE

"For his contributions in the electrical communication field including outstanding leadership and direction in the application of new techniques to telephony."



Fellow Award—1945

HOWARD A. CHINN

"For his contributions to improved broadcasting."

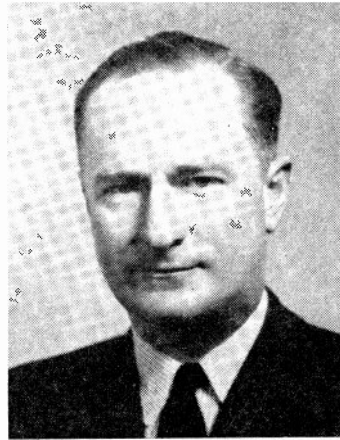

Fellow Award—1945

WALTER C. EVANS

"In recognition of his past contributions to radio and his present active participation in the affairs of the Institute."



JULIUS A. STRATTON

"In recognition of his contributions as a teacher and author, adept in the field of fundamental research who has applied his knowledge to improve radio communications."



MERLE ANTHONY TUVE

"For pioneering in the experimental probing of the ionosphere and giving to the world the first publication of the experimental proof of the existence of the ionosphere; and for having initiated at an early date the pulse method of probing by reflection which is the basis of modern radar."



Fellow Award—1945

ELMER D. McARTHUR

"For his developments in the field of ultra-high-frequency electron tubes."



Fellow Award—1945

JULIUS A. STRATTON

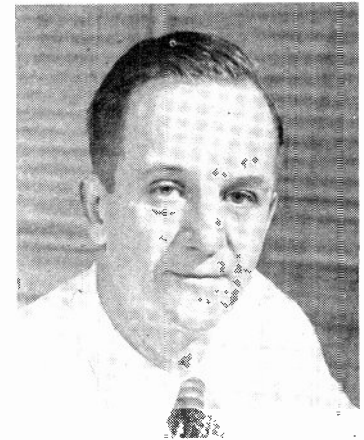

Fellow Award—1945

MERLE ANTHONY TUVE



Fellow Award—1945

ARTHUR L. SAMUEL

"For his fundamental work in the field of electronic research and for development of electronic devices of particular value at very high frequencies."

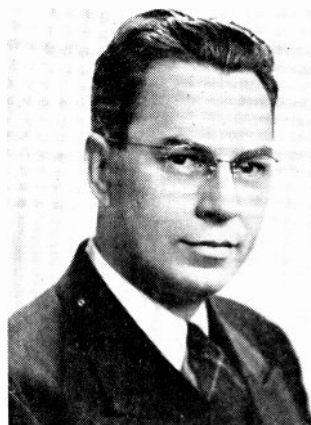

Fellow Award—1945

WILLIAM O. SWINYARD

"In recognition of his work in promoting electronics and the affairs of the Institute, particularly in his district."



*K. Rarick*

Fellow Award—1945

RONALD J. ROCKWELL

"For active work in the affairs of the Institute and in the engineering of high-power international broadcast transmitters."



# Institute News and Radio Notes

## Board of Directors

**December 5 Meeting:** At the regular meeting of the Board of Directors, which was held on December 5, 1945, the following were present: W. L. Everitt, president; G. W. Bailey, executive secretary; S. L. Bailey, W. L. Barrow, L. M. Clement, W. H. Crew, assistant secretary; R. F. Guy, R. A. Hackbusch, R. A. Heising, treasurer; Keith Henney, F. B. Llewellyn, B. E. Shackelford, D. B. Sinclair, H. M. Turner, H. A. Wheeler, and W. C. White.

**Executive Committee Actions:** It was unanimously approved that the actions of the Executive Committee taken at its November 7, 1945, meeting, be ratified.

### Committees

**Building-Fund:** Dr. Shackelford, chairman of the I.R.E. Building-Fund Committee, reported that the Fund had passed \$623,000, and that the final report of the Building-Fund Committee would be submitted at the January meeting.

**Tellers:** The report of the Tellers Committee, dated November 15, 1945, was unanimously approved.

### Constitution and Bylaws

**Executive Committee:** It was unanimously approved to adopt, as of December 3, 1945, the following amended Bylaw, Sec. 27:

"Sec. 27—The Executive Committee shall be responsible for the management of the office of the Institute, which shall include special activities, technical activities, office operations, accounting, advertising, and publications, and the setting of salaries (with the exception of Officers' salaries) in all instances in the limits of the budget. Such activities as the Executive Committee shall direct shall be administered by Executive Secretary. The salary of the Executive Secretary shall be determined by the Executive Committee."

**Price of PROCEEDINGS in Annual Dues:** It was unanimously approved to adopt, as of December 3, 1945, the following amended Bylaw Sec. 57:

"Sec. 57—The price of a single annual subscription to the PROCEEDINGS for a Fellow, Senior Member, Member, or Associate shall be \$6.00, to be included in his annual dues as specified in Article IV of the Constitution."

**Regional Representation Plan:** The Board considered the proposed Constitutional Amendments for the Regional Representation Plan and made suggestions for minor changes which will be made in the final draft by the Constitution and Laws Committee. The following actions were taken:

a. The term "Regional Committee" was adopted.

b. The entire group of proposed Constitutional Amendments for Regional Representation will be submitted to the membership as the only option, and modifications in the Constitution which are desirable, but

not essential, to the Plan may also be included in the group.

**Student Status:** It was unanimously approved that the Board rescind the previous motion of October 3, 1945, approving two and one-half years in Student status.

**Postponement of Dues:** It was unanimously approved that the Board approve the recommendation of the Executive Committee that the final date of payment of 1946 dues outside of United States and Canada be extended from April 30 to June 30, 1946.

**Appointment:** Dr. Alfred N. Goldsmith was reappointed as I.R.E. representative on the Standards Council, and Mr. Raymond F. Guy as alternate, for the three-year period, 1946-1948.

## Executive Committee

**December 5 Meeting:** The Executive Committee meeting, held on December 5, 1945, was attended by W. L. Everitt, president; G. W. Bailey, executive secretary; S. L. Bailey, W. L. Barrow, E. F. Carter, W. H. Crew, assistant secretary; R. A. Heising, treasurer; and F. B. Llewellyn (guest).

**Membership:** Approval was given to the 390 applications for membership in the Institute listed on page 46 A of the January, 1946, issue of the PROCEEDINGS of the I.R.E. and WAVES and ELECTRONS. These applications are as follows:

For Transfer to Senior Member grade	15
For Admission to Senior Member grade	7
For Transfer to Member grade	52
For Admission to Member grade	53
For Admission to Associate grade	169
For Admission to Student grade	94
Total	390

### Committees

The following appointments were approved:

EDUCATION	
R. W. Jones	Elmer H. Schulz
Glenn Koehler	Robert P. Siskind
Jack D. Ryder	Karl Spangenberg
Alexander H. Wing, Jr.	

FACSIMILE	
E. F. Watson	

PIEZOELECTRIC CRYSTALS	
Paul L. Smith	

TELEVISION	
W. F. Bailey	S. Maulner
M. E. Strieby	

RADIO RECEIVERS	
J. M. Pettit	

RADIO WAVE PROPAGATION	
Earl Cullum	

**URSI:** It was unanimously approved that the Institute of Radio Engineers cooperate with the International Radio and Scientific Union in the Spring Meeting.

## Sixth Annual Broadcast Engineering Conference

Under the joint sponsorship of The Ohio State University and the University of Illinois and with the continued co-operation of the National Association of Broadcasters and The Institute of Radio Engineers, the Broadcast Engineering Conference will be resumed this year. This is a continuation of the annual conferences held during the years from 1938-1942, inclusive. Dr. W. L. Everitt, now head of the department of electrical engineering at the University of Illinois, Urbana, Illinois, will continue to act as the director with Professor E. M. Boone of The Ohio State University as associate director.

The 1946 conference will be held at The Ohio State University in Columbus, Ohio, during the week of March 18-23. The conference will be held annually, and the place of meeting will alternate between the campus of The Ohio State University and that of the University of Illinois. Emphasis in the program will be placed on the impact of developments since 1942 on operating problems in broadcast engineering, including frequency modulation and television.

As a result of the war, many engineers have moved or changed their affiliations, and many new men have entered the field. The mailing list accumulated during previous conferences is obviously out of date. The director requests that those interested notify him of their present address so that they can be informed of the details of the program as soon as available. Communications to Dr. Everitt should be addressed c/o University of Illinois, Urbana, Illinois.

### PROGRAM

All meetings to be held in Campbell Hall Auditorium, The Ohio State University

#### Monday, March 18

9:00 A.M. to 1:00 P.M.

"Contributions of War Developments to Broadcasting" by A. B. Chamberlain, Chief Engineer, Columbia Broadcasting System

"Symposium on Broadcast Maintenance Problems," by A. J. Ebel, Chief Engineer, University of Illinois Radio Service, Chairman

2:30 P.M. to 4:30 P.M.

"Design of Broadcast Studios with Irregular Boundary Surfaces," by K. C. Morrical and J. E. Volkman, Radio Corporation of America

#### Tuesday, March 19

9:00 A.M. to 1:00 P.M.

"Antenna Patterns and the Antennalyzer," by George H. Brown, Research Engineer, Radio Corporation of America

"Symposium on Recording Techniques," by Lynn Smeby, Associate Director, Operational Research Staff, Office of the Chief Signal Officer, U. S. War Department

2:30 P.M. to 4:30 P.M.

General Acoustical Problems in Broadcasting," by E. J. Content, Station WOR

**Wednesday, March 20**

9:00 A.M. to 1:00 P.M.

"Symposium on Very-High-Frequency Antenna and Coupling Circuits," by E. C. Jordan, Department of Electrical Engineering, University of Illinois, *Chairman*

"Symposium on Television-Station Operation," by Robert E. Shelby, National Broadcasting Company, *Chairman*

2:30 P.M. to 4:30 P.M.

"Radio Relays for Frequency Modulation and Television"

**Thursday, March 21**

9:00 A.M. to 1:00 P.M.

"Stratovision," by Ralph Harmon, Westinghouse Electric Corporation, and representatives from Glenn L. Martin Aircraft Co.  
"Round Table and Question Box," by A. D. Ring, Consulting Engineer, *Chairman*; John Willoughby, Assistant Chief Engineer, Federal Communications Commission, in charge of Broadcasting; also representative chief engineers from broadcasting stations.

2:30 P.M. to 4:30 P.M.

"Interconnecting Facilities for Frequency Modulation and Television Broadcasting," by H. I. Romnes and W. E. Bloecker, American Telephone and Telegraph Company

**Friday, March 22**

9:00 A.M. to 1:00 P.M.

"High-Powered Tubes for Very-High-Frequency Operation," by W. W. Salisbury, Collins Radio Company

"Symposium on Frequency-Modulation Operating Problems," by Philip B. Laeser, *Milwaukee Journal* Company, *Chairman*

2:30 P.M. to 4:30 P.M.

"Symposium on Frequency-Modulation Monitors," by R. C. Higgy, Director WOSU, Ohio State University, *Chairman*; D. B. Sinclair, General Radio Company; Frank Gunther, Radio Engineering Laboratories; H. R. Summerhayes, Jr., General Electric Company

**Saturday, March 23**

9:00 A.M. to 1:00 P.M.

"Symposium on Frequency-Modulation Methods," by W. L. Everitt, Head, Department of Electrical Engineering, University of Illinois, *Chairman*

"Symposium on Field Experiences in Very-High-Frequency Propagation," by Raymond M. Wilmotte, Consulting Engineer, *Chairman*

**Tuesday, March 19**

8:00 P.M.

Popular Scientific Lecture, University Hall, The Ohio State University

**Thursday, March 21**

6:30 P.M.

Banquet, Fort Hayes Hotel

## Radio Pioneers' Dinner

The New York Section of the Institute of Radio Engineers held its fourth Radio Pioneers' Dinner at the Hotel Commodore in New York City on the evening of November 8, 1945. The General Committee, under the chairmanship of Louis Gerard Pacent, planned ambitiously and effectively; the attendance of over 800 eclipsed by far any other dinner meeting of the Section and has been exceeded only seldom at national convention banquets of the Institute.

The American Radio Relay League, Radio Club of America, and Veteran Wireless Operators Association were guests of the Section and were represented by their presidents: George Bailey, also executive secretary of the Institute; Fred Klingenschmitt; and William J. McGonigle, respectively. President Everitt of the Institute was master of ceremonies.

Although the keynote of the evening was fun, John V. L. Hogan, who together with Robert H. Marriott and Alfred N. Goldsmith was responsible for the merging of the Wireless Institute and the Society of Wireless Telegraph Engineers into the Institute, read excerpts of a brief address he prepared for the occasion. His theme, "radio will be developed faster if those engaged in it will work together more," was taken from a letter sent by Mr. Marriott in 1909 to some 200 wireless people who, it was hoped, would be interested in founding a radio society, the Wireless Institute.

Mr. Marriott, first president of both the Wireless Institute and the Institute of Radio Engineers, and Dr. Goldsmith, indefatigable worker and supporter of the Institute and editor of its publications, were unable to be present. Their messages, read by President Everitt, did much to soften the reality of their absence.

Held during the week commemorating the twenty-fifth anniversary of the initiation

of radio broadcasting, it was fitting for The American Broadcasting Company to arrange for Deric Leighton to direct a skit depicting some of the early trials of "Wireless Pioneering," for Ed East to entertain at the piano, and for Ray Knight to tell of the "Early Days and Late Nights."

Some twenty gifts were contributed as door prizes. Included among them was an unannounced surprise which was won by General Van Deusen—a week-old bull calf—pointfree! As the prizes were drawn, they were augmented by others put up by those present. Among the "upsets" were the winning of a General Electric receiver by Louis Pacent, Jr., presented by the chairman of the Prize Committee, his boss, Dorman Israel, vice-president of Emerson, and the selection of E. M. Deloraine, vice-president-elect of the Institute and president of the International Telephone and Telegraph International Telecommunication Laboratories, as the recipient of a National communications receiver.

Sergeant Irving Strobog, who transmitted the last message from Bataan before it was overrun by the Japanese, was introduced and expressed his desire to continue his radio studies. Jack Poppele, chairman of the Scholarship Committee of the Veteran Wireless Operators Association, presented him with a scholarship in the Capital Radio Engineering Institute, an on-the-spot decision of the officers of that organization.

Reproduced on the editorial page of this issue, are messages from two of the honored guests who were present, Admiral Redman and General Ingles, heads of communications of the Navy and Army. The significance and scope of their tributes to all radio-and-electronic engineers for outstanding accomplishments in the war efforts, place their statements far beyond the confines of any "old-timers dinner."

Jack Binns, famed radio operator of the



Louis G. Pacent, general chairman of the Radio Pioneers' Dinner of the New York Section presenting the gavel of master of ceremonies to Dr. Everitt, president of the Institute.

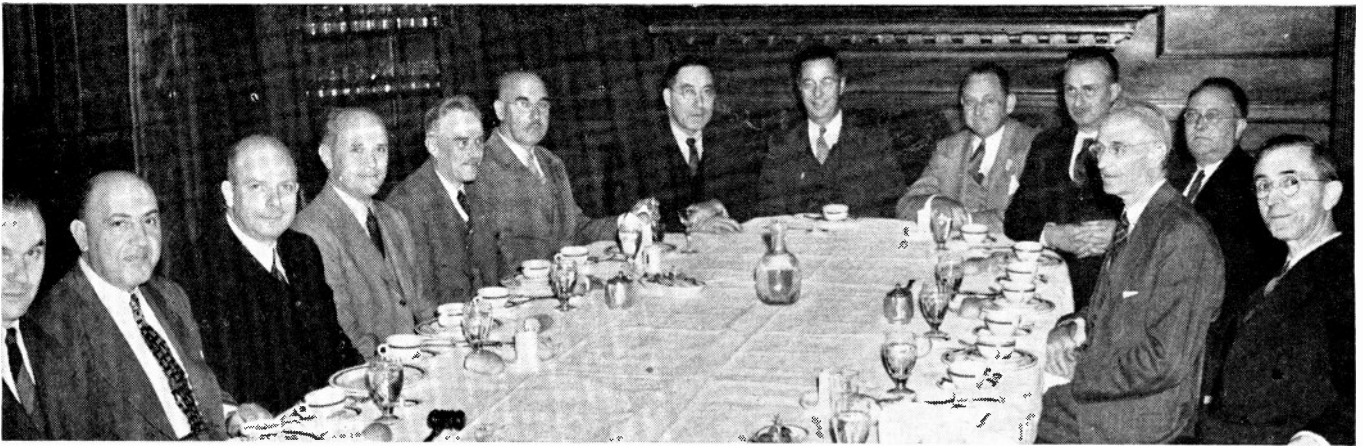

The group responsible for the Radio Pioneers' Dinner is shown above. Around the table from left to right are George B. Hoadley, chairman of the New York Section; Louis G. Pacent, general chairman of the Dinner Committee; W. L. Everitt, president of the Institute and master of ceremonies; Roger M. Wise; Glen Payne; Raymond Guy; Ralph R. Batcher, secretary; Edward J. Content, treasurer; D. W. May; P. R. Morton; J. C. Stroebel; H. C. Gawler; and E. L. Bragdon. Missing were vice-chairman George Lewis, O. H. Caldwell, George H. Clark, George C. Connor, John Di Blasi, Hugo Gernsback, O. B. Hanson, J. Q. A. Holloway, Robert H. Marriott, Dorman D. Israel, Harry Sadenwater, and Harold P. Westman.

*S.S. Republic* disaster, tried his fist, not too successfully, on the first radio set offered for sale to the general public. Built by the Electro Importing Company in 1909, its spark-coil transmitter and coherer-and-electric-bell detector were too slow for Binns' still-modern fist. The presence of various representatives of the Federal Communications Commission was evidence of the wisdom of Hugo Gernsback in obtaining a special license for the operation of the transmitter at the dinner.

A souvenir booklet, unique perhaps in that it carried no advertising, was devoted to a seriously presented history of wireless from its early beginnings through 1925. Designed to stimulate the memories of all old-timers, it contained numerous pictures of equipment and personalities inextricably associated with the "good old days."

Miniature replicas of volume I, number 1, of *Modern Electrics*, published in April, 1908, were also distributed through the courtesy of Hugo Gernsback. This was the

first regular magazine in America devoted to wireless.

Twenty-seven commercial organizations made financial contributions to the success of the meeting. The General Committee planned so well that not only was the deficit from the cocktail party, dinner, and souvenir booklet covered, but the New York Section was enabled to make a substantial contribution to the Building Fund of the Institute.

## I.R.E. People

### CANADIAN SHORT-WAVE BROADCASTING

A new short-wave international broadcast station has been established by the Canadian Broadcasting Corporation near Sackville, New Brunswick. The equipment

includes two 50-kilowatt short-wave transmitters. Space is available for an additional 7.5-kilowatt short-wave transmitter.

Installation of the equipment was supervised by Joseph M. Conroy (A'23) and Fred R. Quance (A'42), engineers of the RCA Victor Division at Camden, New Jer-

sey. The layout of the building housing the equipment was carried out by a group of engineers under the direction of G. W. Olive (A'29) of the same organization. Numerous technical problems of interest were encountered and solved in the design and installation of this new Canadian Station CHTA.

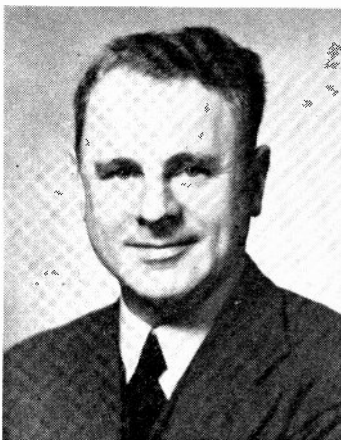

G. W. OLIVE



FRED R. QUANCE

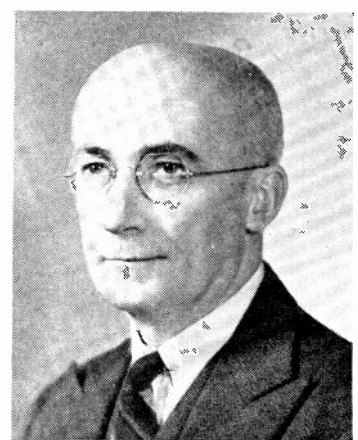

JOSEPH M. CONROY



Harris and Ewing

RAYMOND M. WILMOTTE



PAUL H. CRAGO



G. CURTIS ENGEL

NEW WILMOTTE LABORATORY

Raymond M. Wilmotte (M'29-F'38), director of Wilmotte Laboratory, Inc., of Washington, D. C., recently announced the opening of a branch laboratory at 236 West 55 Street, New York 19, N. Y., offering engineering services in the application of electronics to industrial uses.

During the war, Wilmotte Laboratory devoted its activities largely to research and development for the Army, Navy, and Office of Scientific Research and Development. Much of this work was on radar, fire control, and other special devices. In the course of this work, the Wilmotte Manufacturing Company was organized to produce special electronic devices.

It is Mr. Wilmotte's intention to expand this combination of facilities in order to provide industrialists with complete engineering services applying the full potentialities of electronics to their processes.

The New York laboratory will be under the supervision of Paul H. Crago (A'44), who was section engineer with the Union Switch and Signal Company, in charge of design and application of electromagnetic signaling devices for railroads. He was more recently with Specialties, Inc., as executive

engineer in charge of research and development of ordnance instruments for the Armed Forces, and the Federal Telephone and Radio Corporation.

G. Curtis Engel (A'45), formerly production manager of General Electronics, Inc., and manager of the laboratory of General Time Instruments Corporation, will head a group specializing in electronic controls and inspection methods. Another group will do consulting work in the application of dielectric heating.

JACK KAUFMAN

Jack Kaufman (A'30-SM'44) has been appointed a vice-president of the Aireon Manufacturing Corporation. He recently joined the organization to head the new San Francisco office which serves the transportation and communications industries on the Pacific Coast.

A graduate of the University of California in 1917, Mr. Kaufman has been engaged for a number of years in electronics in San Francisco. He was formerly president of Heintz and Kaufman, Limited, and executive vice-president of Globe Wireless, Ltd.

Mr. Kaufman formerly was president of the West Coast Electronic Manufacturers' Association, San Francisco Council, and vice-president of the coast-wide group of the same Association. Until recently, he was a member of the Industry Advisory Committee with the Board of War Communications.

E. C. PAGE AND J. WESLEY KOCH

Lieutenant Colonel E. C. Page (M'42-SM'43), director of engineering of the Mutual Broadcasting System, has announced that Captain J. Wesley Koch (J'29-S'33-A'36-M'45) joined the engineering staff of the network on October 15 when he was released from the Army.

While in the Army, Captain Koch served as technical adviser of the Radio Propagation Unit and was concerned with radio propagation conditions throughout the world. He was a staff radio officer at Allied Force Headquarters in North Africa and Italy, and until October, 1945, he was with the office of the Chief Signal Officer at Baltimore, Maryland.

Captain Koch is a native of Nebraska and received his B.S. degree in electrical engineering at the University of Nebraska in 1934. It was while he was at the University that he designed and constructed special equipment for a wired-radio program distributing system operated by the Program Service of Lincoln, Nebraska. He later accepted a position with KFEQ, St. Louis, Mo., in 1934, as chief engineer. It was here that he designed and constructed most of the transmitting equipment at this station. After installing a complete new transmitting plant at KFEQ in 1942, Captain Koch resigned to accept a commission with the Signal Corps.



E. C. PAGE

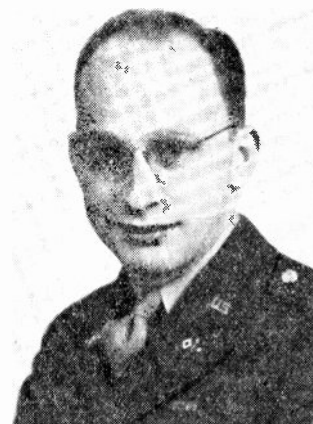

J. WESLEY KOCH





Fabian Bachrach

HUGH S. KNOWLES

## HUGH S. KNOWLES

Hugh S. Knowles (A'25-F'41), vice-president and chief engineer of the Jensen Radio Manufacturing Company, recently was elected president of the Acoustical Society of America.

Before graduating from Columbia University, Mr. Knowles was an editor of *Popular Radio*; technical columnist for the *New York Herald Tribune*; manager of Columbia University's experimental radio station; and president of the University's Radio Club. After receiving his Bachelor's degree, he undertook further work at Columbia and extensive graduate work at the University of Chicago. As a guest lecturer at Chicago University, he prepared and gave a graduate course on sound and vibrating systems. Mr. Knowles then served as radio engineer for Hammarlund Manufacturing Company and as manager of the parts division of Silver-Marshall. In 1931, he joined the staff of the Jensen Radio Manufacturing Company as chief engineer and was elected to the position of vice-president in charge of product research and development in 1940.

Mr. Knowles was chairman of the Committee on National Defense, the Electroacoustics Standards Committee of The Institute of Radio Engineers, and Sound Equipment Standards Committee of the Radio Manufacturers Association. He has also represented the IRE and the RMA on various electroacoustical committees of the American Standards Association, and he served as chairman of the Chicago Section of the IRE. Mr. Knowles received the Fellowship Award of the IRE for "engineering leadership in the field of acoustics and its radio applications."

## NORMAN B. NEELY

Norman B. Neely (A'39), West Coast manufacturers' representative for several electronic firms, has resumed active management of his firm, Norman B. Neely Enterprises of Hollywood, California. During the war, Mr. Neely was associated with Western Electric Company as special field engineer engaged in confidential work on Army Air Force equipment contracts.

## PAUL D. ZOTTU

Paul D. Zottu (A'31-M'38-SM'43-F'44), formerly chief engineer, Thermex Division, the Girdler Corporation, Louisville, Kentucky, has announced his entrance into the field of consulting industrial electronic engineering. He offers to industrial users and equipment manufacturers a consulting service in the field of high-frequency induction and dielectric heating, specializing in applications, equipment and component design, and equipment selection.

Mr. Zottu has an extensive background in the radio field covering a wide range of activities. The last seven years, outside of the part time spent at the Radiation Laboratory at Massachusetts Institute of Technology, have been devoted entirely to industrial high-frequency heating problems. In this field, he pioneered the design and application of many industrial installations. Mr. Zottu is chairman of the Technical Committee on Industrial Electronics of the I.R.E., a member of the committee on Industrial Heating Applications of the Radio Technical Planning Board, Induction and Dielectric Heating Committee of the American Institute of Electrical Engineers, chairman of the committee on Frequency Allocations of the Society of the Plastics Industry, member of the American Physical Society, American Association for the Advancement of Science, and Society of the Plastics Industry.



PAUL D. ZOTTU

## ALLAN R. OGILVIE

Allan R. Ogilvie (A'43) has been named a vice-president of Maguire Industries, Inc., in charge of its Bridgeport, Connecticut plant.

A native of Boston, Mr. Ogilvie studied at the Massachusetts Institute of Technology and Temple University. His first position was with the Wireless Specialty Company, after which he became affiliated with Western Electric Company. Later, Mr. Ogilvie joined the Radio Corporation of America where he was an engineer for fourteen years. He became a member of the staff of Maguire Industries, Inc., in 1944, and was chief engineer of the Company's electronics division.



D. L. JAFFE

## D. L. JAFFE

D. L. Jaffe (A'37) has joined the Polarad Electronics Company of New York as a partner and general manager.

From 1937 to 1939, Dr. Jaffe performed research in frequency modulation at Columbia University, and in 1939, he joined the Columbia Broadcasting system as television engineer engaged in studio-equipment development. Dr. Jaffe was appointed development engineer in the microwave radar division of the Raytheon Manufacturing Corporation in 1942, during which time he acted as liaison engineer between that Corporation and the Radiation Laboratory at the Massachusetts Institute of Technology. He then joined the staff of the Templetone Radio Manufacturing Corporation as chief research engineer.

Dr. Jaffe is an Associate member of the American Institute of Electrical Engineers and a member of Sigma Xi.

## CLAUDE LYONS

Claude Lyons (M'27-SM'43) joint managing director of Messrs. Claude Lyons, Ltd., Liverpool and London, England, was appointed on July 5, 1945, as the first Chairman of the Federation of Anglo-American Importers, the headquarters of which are at 180 Tottenham Court Road, London, W.1, England. The Federation is a nonprofit organization open to importers into England of radio, electronic, and allied equipment; manufacturers of such equipment in the United States of America; and persons interested in the promotion of and the continued welfare of the radio, electrical, and allied industries, as well as good relationships in international commerce.

## F. C. McMULLEN

F. C. McMullen (A'42) has been appointed chairman of the aviation section of the Radio Manufacturers Association's transmitter division, and is in charge of aviation radio sales for Western Electric Company. He succeeds J. W. Hammond (A'44-SM'45) of Bendix Radio, Baltimore, Maryland.





#### PEACETIME RADIO PRODUCTION

I. J. Kaar (right) (J'22-A'24-M'29-F'41), manager of General Electric's receiver division, discusses first peacetime radio off production lines at the company's Bridgeport, Connecticut, plant, with Paul L. Chamberlain (A'43), manager of sales for the division. In background is radar console.

#### HENRY GROSSMAN

Progress in the various phases of television research of the Columbia Broadcasting System, under the direction of Peter C. Goldmark (A'36-M'38-F'42), has made possible an integration of technical operations in the television field with the network's other New York broadcast operations. Accordingly, Henry Grossman (M'34-SM'43) will share in the responsibility for television technical operation routines, personnel, and routine maintenance of equipment, supplementing his previous broadcast commitments. The responsibility for equipment design and installation, engineering standards, and development tests will remain under Dr. Goldmark's direction, the latter working directly with Mr. Grossman and the technical supervisors to facilitate the application of new knowledge and new techniques.



CBS Photo

HENRY GROSSMAN



developed various types of microphones, noise-measuring apparatus, methods for quieting equipment, and the development of methods of noiseless recording. In 1936, Mr. Hanna devised a gyroscopic regulator for steel-mill-roll motors, which assures that all the rolls run at the same speed, thus maintaining even tension in the steel sheet as it runs through them. Two years later, he designed an automatic voltage regulator first used for the control of generators.

He was born in Indianapolis in 1899 and was graduated from Purdue University in 1922 with the degree of Bachelor of Science in electrical engineering. He enrolled immediately in the Westinghouse Graduate Student Training Course in the East Pittsburgh, Pennsylvania Works, became a research engineer for the company the following year, and received the professional degree of electrical engineer from Purdue in 1926. Four years later, he was made manager of the electromechanical department of the laboratories, and was appointed an associate director last year.

Mr. Hanna has reported on his technical experiences in numerous scientific journals. He is a Fellow of the American Institute of Electrical Engineers and of the Acoustical Society of America and a member of the Institute of Aeronautical Sciences.

#### MANUEL FERNANDEZ

Major Manuel Fernandez (A'42-M'44), Division Communications Officer, was awarded the Bronze Star Award, it was recently announced by Brigadier General William H. Tunner, commanding general of the India China Division, Air Transport Command. The award was made for distinguishing himself by meritorious service in connection with military operations against the enemy during the period October 26, 1944 to September 2, 1945.

The citation accompanying the award adds:

"For distinguishing himself by meritorious service as Division Communications officer, India China Division, ATC, Major Fernandez was responsible for the co-ordination of all communication facilities and activities of the India China Division. His close liaison with all those whose work showed a direct relationship to Communications and his co-ordination of all Division activities in this respect were fundamental factors in the harmonious and efficient functioning of communication matters throughout the ICD. In discharging his duties with a measure of efficiency conspicuously above the ordinary, and by his ability, aggressiveness, and perseverance in successfully coping with all problems and phases of communications under his jurisdiction, he rendered services of very great value to the India China Division, Air Transport Command."

In civilian life Major Fernandez worked in communications for Pan American Airways. He is a member of the Veteran Wireless Operators Association, Inc.

#### CLINTON R. HANNA

Clinton R. Hanna (M'28-SM'43), inventor of the gyroscopic tank gun stabilizer which played so vital a role in the effectiveness of America's tank warfare, recently was presented for the degree of Doctor of Engineering at the eighty-first commencement exercises of Purdue University in Lafayette, Indiana.

Mr. Hanna won a Presidential Citation in 1942 for his work in the development of the tank gun stabilizer—the instrument which enabled Allied tanks to fire accurately while in motion. He has long been associated with Westinghouse engaging in and directing advanced development work on new apparatus, and has patented many of his inventions. Mr. Hanna has been engaged in research on loudspeaker equipment, on power tubes for radio receiving sets, and has

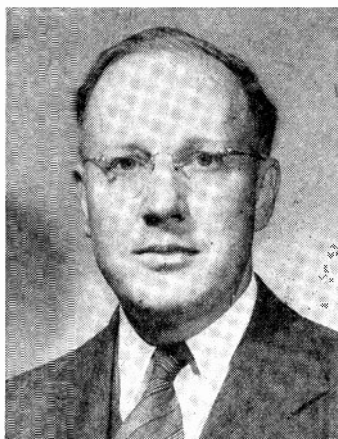

CLINTON R. HANNA

## SECTIONS

## Chairman

R. A. Holbrook  
146 Lawrenceville Rd.  
Decatur, Ga.

R. N. Harmon  
1920 South Rd.  
Mt. Washington, Baltimore 9,  
Md.

C. C. Harris  
Tropical Radio Telegraph Co  
Box 584, Hingham, Mass.

A. DiMarco  
Carabobo 105  
Buenos Aires, Argentina

J. M. Van Baalen  
282 Orchard Dr.  
Buffalo 17, N. Y.

T. A. Hunter  
Collins Radio Co.  
855—35 St., N.E.  
Cedar Rapids, Iowa

Cullen Moore  
327 Potomac Ave.  
Lombard, Ill.

J. D. Reid  
Box 67  
Cincinnati 31, Ohio

R. A. Fox  
2478 Queenston Rd.  
Cleveland Heights 18, Ohio

H. W. Sundius  
Southern New England Tele-  
phone Co.  
New Haven, Conn.

R. M. Flynn  
Station KRLD  
Dallas 1, Texas

L. B. Hallman  
3 Crescent Blvd.  
Southern Hills  
Dayton, Ohio

H. E. Kranz  
International Detrola Corp.  
1501 Beard Ave.  
Detroit 9, Mich.

N. L. Kiser  
Sylvania Electric Products,  
Inc.  
Emporium, Pa.

H. I. Metz  
Civil Aeronautics Authority  
Experimental Station  
Indianapolis, Ind.

R. N. White  
4800 Jefferson St.  
Kansas City, Mo.

B. S. Graham  
Sparton of Canada, Ltd.  
London, Ont., Canada

Frederick Ireland  
General Radio Co.  
1000 N. Seward St.  
Hollywood, Calif.

ATLANTA  
March 15

BALTIMORE

BOSTON

BUENOS AIRES

BUFFALO-NIAGARA  
February 20

CEDAR RAPIDS

CHICAGO  
March 15

CINCINNATI  
March 12

CLEVELAND  
February 28

CONNECTICUT VALLEY  
February 21  
New Haven  
"Color Television"  
L. Grew

DALLAS-FT. WORTH

DAYTON  
March 5  
Dayton Engineers' Club  
(Joint Meeting)  
"Engineering Education"  
W. L. Everitt

DETROIT  
February 21

EMPORIUM

INDIANAPOLIS

KANSAS CITY

LONDON, ONTARIO  
March 19

LOS ANGELES  
March 15

## Secretary

I. M. Miles  
554—14 St., N.W.  
Atlanta, Ga.

F. W. Fischer  
714 S. Beechfield Ave.  
Baltimore, Md.

A. G. Bousquet  
General Radio Co.  
275 Massachusetts Ave.  
Cambridge 39, Mass.

H. Krahenbuhl  
Transradio Internacional  
San Martin 379  
Buenos Aires, Argentina

H. W. Staderman  
264 Loring Ave.  
Buffalo, N. Y.

R. S. Conrad  
Collins Radio Co.  
855—35 St., N.E.  
Cedar Rapids, Iowa

D. G. Haines  
4000 W. North Ave.  
Chicago 39, Ill.

P. J. Konkle  
5524 Hamilton Ave.  
Cincinnati 24, Ohio

Walter Widlar  
1299 Bonnieview Ave.  
Lakewood 7, Ohio

L. A. Reilly  
989 Roosevelt Ave.  
Springfield, Mass.

J. G. Rountree  
Box 5238  
Dallas 2, Texas

Joseph General  
411 E. Bruce Ave.  
Dayton 5, Ohio

A. Friedenthal  
WJR  
Fisher Building  
Detroit 2, Mich.

D. J. Knowles  
Sylvania Electric Products,  
Inc.  
Emporium, Pa.

V. A. Bernier  
5211 E. 10  
Indianapolis, Ind.

Mrs. G. L. Curtis  
6003 El Monte  
Mission, Kansas

C. H. Langford  
Langford Radio Co.  
246 Dundas St.  
London, Ont., Canada

Walter Kenworth  
1427 Lafayette St.  
San Gabriel, Calif.



PAUL J. GOLLHOFER

## PAUL J. GOLLHOFER

Paul J. Gollhofer (A'44) has been appointed director of television of the Sherron Electronics Company of Brooklyn, New York. In this capacity he will be engaged in the technical phases of the work of that company and will co-operate with all persons and agencies concerned with the engineering, design, and operation of a new experimental television station W2XDK.



## J. KELLY JOHNSON

J. Kelly Johnson (A'25-M'35-SM'43) has opened an office for radio and electronic engineering consulting services at 55 West 42 Street, New York, N. Y.

Mr. Johnson, who received the graduate degree in electrical engineering from Columbia University in 1927, was an instructor in physics at the Mechanics Institute, New York, from 1925 to 1929, and an instructor in electrical engineering at Columbia from 1928 to 1929. During this latter period, he also held the position of chief research engineer at the Pacent Electrical Corporation, New York, and for the period 1929 to 1930, was assistant chief engineer at Silver-Marshall, Chicago, Illinois. Mr. Johnson then returned to New York to become an engineer with the Hazeltine Corporation. From 1934 to 1943, he was again located in Chicago, serving as chief engineer with Wells Gardner Company, and later as engineer in charge of the Chicago Laboratory of Hazeltine Service Corporation. In 1943, at the Office of the Secretary of the Navy, Washington, D. C., Mr. Johnson became chief of production section, electronics division, until 1944, when the Hammerlund Manufacturing Company, New York, named him executive engineer.

Mr. Johnson was a director of The Institute of Radio Engineers in 1942, and chairman of the Chicago Section in 1936. He is a member of the Receivers and Sections Committees of the Institute, and holds the chairmanship of the I.R.E. Papers Procurement Committee on Radio Communications. Mr. Johnson is a Fellow of the Radio Club of America, a member of the American

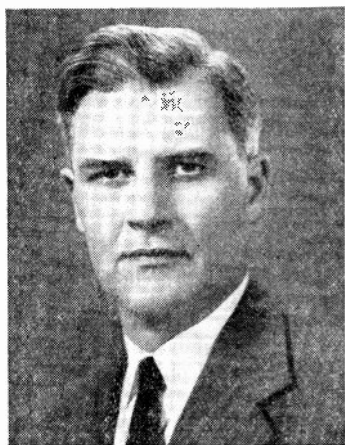

J. KELLY JOHNSON

Institute of Electrical Engineers and of the Radio Engineers Club of Chicago. He is also a member of the Export Receivers, Very-High-Frequency, and Receivers Executive Committees of the RMA, and of Tau Beta Pi, Sigma Xi, and Epsilon Chi.



## Books

### Electronics Laboratory Manual, by Ralph R. Wright

Published (1945) by McGraw-Hill Book Co., 330 West 42 St., New York, N. Y. 77 pages+viii pages. 78 illustrations. 5½×8 inches. Price, \$1.00.

This manual is designed to present 12 basic experiments "intended to acquaint the student with the characteristics, principle of operation, and applications of electron tubes."

Since the attainment of this objective is nearly impossible in 12 experiments, it becomes necessary to choose illustrative examples. The choice seems unfortunate in some instances when, for example, one finds that three of the 12 experiments are devoted to vacuum-tube amplifiers but oscillators are not mentioned at all.

Although the avowed purpose of the text is explanatory, many paragraphs seem hurried and superficial. For example, one cannot do much more than suggest the existence of a Thyatron inverter in the 11 lines of text devoted to that subject. Unfortunately, also some of the statements in the text are either inaccurate or have erroneous implications.

The inclusion of exercises and references at the end of each experiment is excellent, but the omission of precautions to be observed, circuit constants, advice on the selection of appropriate circuit elements, etc., will force the student to use the manual merely as an outline and seek much additional information from other sources.

E. D. MCARTHUR  
General Electric Co.  
Schenectady 5, N.Y.

### Chairman

L. A. W. East  
Canadian Pacific Railway  
204 Hospital St.  
Montreal, Que., Canada

G. B. Hoadley  
85 Livingston St.  
Brooklyn, N. Y.

W. A. Steel  
298 Sherwood Dr.  
Ottawa, Ont., Canada

D. B. Smith  
Philco Corporation  
Philadelphia 34, Pa.

J. A. Hutcheson  
852 N. Meadowcroft Ave.  
Pittsburgh 16, Pa.

C. W. Lund  
Rt. 4, Box 858  
Portland, Ore.

G. R. Town  
Stromberg-Carlson Co.  
Rochester 3, N. Y.

B. B. Miller  
2356A Lawrence St.  
St. Louis 10, Mo.

David Kalbfell  
941 Rosecrans  
San Diego, Calif.

R. V. Howard  
Mark Hopkins Hotel  
San Francisco, Calif.

E. H. Smith  
823 E. 78 St.  
Seattle 5, Wash.

F. H. R. Pounsett  
Research Enterprises, Ltd.  
Leaside, Ont., Canada

H. E. Hartig  
University of Minnesota  
Minneapolis, Minn.

F. W. Albertson  
Room 1111, Munsey Bldg.  
Washington 4, D. C.

Harry Smithgall  
Sylvania Electric Products,  
Inc.  
Plant No. 1  
Williamsport, Pa.

R. C. Higgy  
2032 Indianola Ave.  
Columbus, Ohio

P. B. Laeser  
9410 Harding Rd.  
Milwaukee, Wis.

L. J. Giacometto  
9 Villa Pl.  
Eatontown, N. J.

W. C. Johnson  
Princeton University  
Princeton, N. J.

H. E. Ellithorn  
417 Parkovash Ave.  
South Bend 17, Ind.

MONTREAL, QUEBEC  
March 13

NEW YORK  
March 6

OTTAWA, ONTARIO  
February 21

PHILADELPHIA  
March 7

PITTSBURGH  
March 11  
Mellon Institute, 8 P.M.  
"Pulse-Time Modulation—  
Its Application to Multichan-  
nel Radiotelephone Systems  
and Multichannel Broad-  
casting"  
D. D. Grieg

PORTLAND

ROCHESTER  
February 21

ST. LOUIS  
February 28

SAN DIEGO

SAN FRANCISCO

SEATTLE  
March 14

TORONTO, ONTARIO

TWIN CITIES

WASHINGTON  
March 11

WILLIAMSPORT  
March 6

### SUBSECTIONS

COLUMBUS  
March 8

MILWAUKEE

MONMOUTH

PRINCETON

SOUTH BEND  
February 21

### Secretary

R. R. Desaulniers  
Canadian Marconi Co.  
Box 1690 (Place D'Armes)  
Montreal 1, Que., Canada

J. T. Cimorelli  
RCA Victor Div.  
415 S. Fifth St.  
Harrison, N. J.

L. F. Millett  
33 Regent St.  
Ottawa, Ont., Canada

P. M. Craig  
Philco Corporation  
Philadelphia 34, Pa.

C. W. Gilbert  
52 Hathaway Ct.  
Pittsburgh 21, Pa.

L. C. White  
3236 N.E. 63 Ave.  
Portland 13, Ore.

A. E. Newlon  
Stromberg-Carlson Co.  
Rochester 3, N. Y.

N. J. Zehr  
1538 Bradford Ave.  
St. Louis 14, Mo.

Clyde Tirrell  
U. S. Navy Radio and Sound  
Laboratory  
San Diego 52, Calif.

Lester Reukema  
2319 Oregon St.  
Berkeley, Calif.

W. R. Hill  
University of Washington  
Seattle 5, Wash.

Alexander Bow  
137 Oxford St.  
Guelph, Ont., Canada

M. R. Ludwig  
315 E. 24 St.  
Minneapolis, Minn.

G. P. Adair  
Federal Communications  
Commission  
Washington 4, D. C.

F. L. Burroughs  
2030 Reed St.  
Williamsport 39, Pa.

Warren Bauer  
376 Crestview Rd.  
Columbus 2, Ohio

E. L. Cordes  
3304 N. Oakland Ave.  
Milwaukee, Wis.

C. D. Samuelson  
5 Russel Ave.  
Fort Monmouth, N. J.

J. G. Barry  
Princeton University  
Princeton, N. J.

J. E. Willson  
WHOT, St. Joseph and Mon-  
roe Sts.  
South Bend, Ind.

## Lehrbuch der Funktionen- theorie—Volumes I and II, by Ludwig Bieberbach

Vol. I (Fourth Edition)—Published (1945) by Chelsea Publishing Co., 231 W. 29 Street, New York 1, N. Y. 320 pages + 2-page index + xiv pages. 77 illustrations.  $5\frac{1}{2} \times 8\frac{1}{2}$  inches. Price, \$3.25.

Vol. II (Second Edition)—Published (1945) by Chelsea Publishing Co., 231 W. 29 Street, New York 1, N. Y. 368 pages + 2-page index + vi pages. 47 illustrations.  $5\frac{1}{2} \times 8\frac{1}{2}$  inches. Price, \$3.25.

This is a new edition, brought out under the authority of the Alien Property Custodian, of the fourth (1934) edition of volume I, and the second (1931) edition of volume II of Bieberbach's textbook on the theory of functions of a complex variable.

The preface of the first volume states that it was written to give the student a knowledge of the fundamental concepts and theorems of the subject, and not alone from one standpoint but also the different historical methods of development. The work was intended for students of college grade with some knowledge of analytic geometry and the calculus.

In the first volume are included the subjects usual in a textbook on this subject, that is, definitions, theorems of convergence, differentiable functions, conformal mapping, integration in the complex domain, development in series, and a study of the more important types of functions individually. The treatment is restricted to analytic functions of a complex variable.

The scope of the work is wide and the treatment is thorough. However, from the standpoint of the engineer, the book suffers from a paucity of examples. This, it should be stated, is characteristic of books on this subject in general, and this book is rather better than most.

The second volume is more advanced in tone, since it has for its goal an exposition of the more recent developments of function theory. In general, the engineer will find it harder going than the first volume.

In the production of these books the publishers have succeeded in bringing out volumes well printed and of attractive size and appearance.

FREDERICK W. GROVER  
University College  
Schenectady, N. Y.

## Electromagnetic Engineering, Vol. 1—Fundamentals, by Ronold W. P. King

Published (1945) by the McGraw-Hill Publishing Company, 330 W. 42 Street, New York 18, New York. 568 pages + 12-page index + xiv pages. 76 illustrations.  $8\frac{1}{2} \times 5\frac{1}{2}$  inches. Price, \$6.00.

This book, subtitled Fundamentals, is the first of three volumes under the general title, "Electromagnetic Engineering." The second and third volumes are to be concerned with "Antennas" and "Transmission

Circuits and Wave Guides," respectively. The purpose of the present volume is to present the laws, definitions, basic equations, and some general solutions necessary for an understanding of the succeeding volumes.

There are six chapters in the present volume. The first, entitled "The Mathematical Description of Matter," is concerned with definitions of surface and volume densities of charge, convection current, polarization, and magnetization. An essential volume characteristic is defined for both the static state and the steady state. The extension of these definitions to the nonstationary state is discussed.

In Chapter II, Maxwell's field equations are presented as fundamental postulates for the mathematical model of space and simple media. The integral forms (Gauss's, Ampere's, and Faraday's laws) are derived from the fundamental equations, and the force equations are treated.

In Chapter III, the fundamental equations are transformed into a number of forms, including the forms in terms of potential functions, the complex forms for periodic time dependence, and the energy equations.

Chapter IV is concerned with waves in unbounded media and discusses wave solutions both in terms of the potentials and the electric and magnetic fields. Special attention is given the separation into near-zone or induction fields and far-zone or radiation fields, and several basic radiation problems are treated.

Chapter V discusses skin effect and internal impedance.

Chapter VI, entitled "Electric Circuits," presents the foundations of circuit theory as based upon the field equations and includes a number of articles on miscellaneous problems in mutual impedance, self-impedance, two-wire and four-wire lines. There are five appendixes and seventy-eight problems for the student.

The book is authoritative and very complete within the author's planned scope. Its most significant feature is the careful attention to detailed rigor, not only in the mathematics, but especially in the discussions of the philosophy of many aspects of electromagnetic theory. This feature will make the book attractive to a certain group of readers; it will also make difficult reading for others, for most passages require careful study and reflection and usually a certain maturity in point of view. The author states that the book is intended for graduate students and advanced seniors, but has been used for large groups of undergraduates in war-training programs. For the reasons mentioned above, the book seems more suitable for graduate students.

There are some differences between the conventions and notation of the book and those most often used in engineering literature up to this time. For example,  $E$  and  $B$  are grouped together as the fundamental field vectors with  $D$  and  $H$  as the auxiliary vectors.  $H$  is then written as  $\nu B$  rather than  $B = \mu H$ . If, as the reviewer believes, this is an arbitrary choice subject to personal preference, many will prefer the older con-

vention, especially since the very useful transmission-line analogies of wave propagation with  $\mu$  corresponding to an inductance per unit length then follow with direct correspondence. Dr. King's point is that it is not a matter of preference but of correctness or incorrectness. The vector notation used employs parentheses and brackets to distinguish between scalar and vector products in place of the dot and cross of Gibb's notation. The author is to be commended on his use of rational mks units and the engineering convention  $e^{j\omega t}$  for complex sinusoids.

The use of symbols in the book will also cause differences of opinion. It is very specific so that there is a difference in notation between real scalars, complex scalars, real vectors, and complex vectors, internal and external quantities. However, this requires the use of Gothic letters as well as italics with both in ordinary and bold type. It is sometimes difficult to distinguish between certain of these, especially between ordinary and bold-face Gothic when both are not present on the same page for comparison purposes. This is also important in teaching from the book, for it is difficult to distinguish in blackboard writing between four kinds of a given letter (eight, counting lower case). Superscripts are also used as well as subscripts. The use of an asterisk both to denote conjugates of complex quantities and for certain footnote references should be noted.

"Electromagnetic Engineering," more than many books on an old subject, is characterized by an individuality both in approach and detail, and for this reason will find both supporters and critics among its readers.

J. R. WHINNERY  
General Electric Co.  
Schenectady, N. Y.

---

## BERNARD A. ENGHOLM

Bernard A. Engholm (A'22-M'27-SM-'43), former president of The Rola Company, Inc., of Cleveland, Ohio, died on October 20, 1945. He was born in Ouray, Colorado, in 1899.

Mr. Engholm entered the field of radio in 1924 after developing a loudspeaker in a barn in Seattle. He took his device to a radio store in that city, and a demonstration of it resulted in a partnership in loudspeaker manufacturing. The business begun in Seattle was later moved to Oakland, California, and then to Cleveland. Mr. Engholm subsequently established The British Rola Company and The Australian Rola Company. He later relinquished his control over the Australian firm but retained an equal interest in the British company.

During World War II, Mr. Engholm developed and produced many war items and during his lifetime secured more than forty patents, all of which were assigned to his company. His interest in The Rola Company was sold by him about a month prior to his death.

---

# Contributors



R. A. BIERWIRTH

R. A. Bierwirth (M'45) was born at Anthon, Iowa, in 1901. He received the B.S. degree in electrical engineering from Iowa State College in 1925, and the M.S. degree in electrical engineering from Union College in 1928. Mr. Bierwirth was employed in the radio-engineering department of the General Electric Company at Schenectady from 1925 to 1930 and in the engineering department of RCA Manufacturing Company at Camden from 1930 to 1941. He was engaged in research work on industrial applications of radio frequency at the RCA Laboratories at Princeton, New Jersey, until the end of 1945, when he became affiliated with Sound, Inc., Chicago, Illinois. He is a member of Sigma Xi.

George H. Brown (A'30-F'42) was born on October 14, 1908, at North Milwaukee, Wisconsin. He received the B.S. degree at the University of Wisconsin in 1930; the degree of M.S. in 1931; the Ph.D. degree in 1933; and his professional degree of E.E. in 1942. From 1930 until 1933 he was a Research Fellow in the electrical-engineering department at the University of Wisconsin, and from 1933 to 1942 he was in the research division of the RCA Manu-

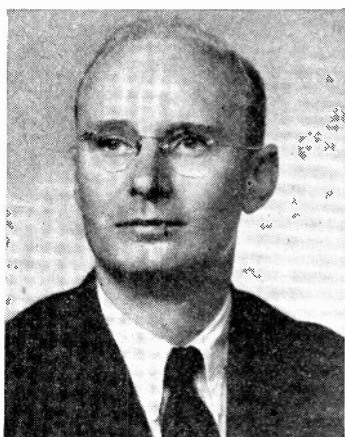

JOHN E. GORHAM

facturing Company at Camden, New Jersey. Since 1942, he has been at the RCA Laboratories at Princeton, New Jersey. He is a Member of Sigma Xi and the American Institute of Electrical Engineers.

John E. Gorham (A'42) was born in 1911 at Moline, Illinois. He received the B.S. and M.S. degrees in physics at Iowa State College in 1933 and 1934, respectively, and the Ph.D. degree in physics from Columbia University in 1938. While at Columbia he was a teaching assistant, and a postdoctorate research assistant for one year.

In 1939 he was associated with the Belmont Radio Company as production test equipment engineer, and in early 1940 with the Continental X-Ray Corporation as electrical design engineer. Since 1940 Dr. Gorham has been associated with the Signal Corps Engineering Laboratories, and at various times has been engineer in charge of radar transmitter and modulator development and vacuum tube development. At



RALPH A. HACKBUSCH

present he is a principal physicist and recently has been appointed chief of the thermionics branch, Evans Signal Laboratory.

He is a member of the American Physical Society, Sigma Xi, Phi Kappa Phi, and Pi Mu Epsilon.

Ralph A. Hackbusch (A'26-M'30-F'37) was born at Hamilton, Ontario, Canada, on September 18, 1900. He was educated at Hamilton Collegiate Institute and later specialized in electrical engineering. For thirteen years, Mr. Hackbusch was associated with the Canadian Westinghouse Company, Ltd., and later with the Canadian Brandes Company (Kolster Radio). In 1930 he became chief engineer and factory manager of the Stromberg-Carlson Telephone Manufacturing Company at Toronto, and in 1940 was appointed vice-president and general manager. In the same year. Mr.



GEORGE H. BROWN

Hackbusch was requisitioned by the Canadian government and placed in charge of the radio division of the government-controlled Research Enterprises, Ltd., at Toronto, a post from which he resigned in 1943 to return to Stromberg-Carlson as managing director. He has continued in this capacity to date.

Mr. Hackbusch is a member of the Canadian Electrical Code Committee, the Canadian Standards Association, the Radio Manufacturers Association, and is a registered professional engineer in the Province of Ontario. He has been vice-president of the Canadian Radio Technical Planning Board since 1944. Mr. Hackbusch is a member of the Board of Directors of the Institute and served as its vice-president during 1944. He is also chairman of the Canadian Building-Fund Committee.

Louis Hoffer was born at New York City on March 17, 1907. He received the M.A. degree from Columbia University in 1932, and the Ph.D. in social sciences from New York University in 1936. From 1936 to 1943 he was employed by the State of New York as a research analyst, and has been



LOUIS HOFFER





CYRIL N. HOYLER

associated with Emerson Radio and Phonograph Corporation, in New York City, since 1943.

Mr. Hoffer is a member of Phi Beta Kappa, the American Economic Society, and the American Academy of Political and Social Science.

Cyril N. Hoyler (A'35-SM'45) was born on August 8, 1905, at Edmonton, Alberta, Canada. He received the B.S. degree from Moravian College in 1928 and the M.S. degree in physics from Lehigh University in 1935. After teaching mathematics and German for one year in the public schools of Irvington, New Jersey, he was invited to join the faculty of Moravian College in 1929 to develop a department of physics at that institution. Mr. Hoyler held that position until 1941, when he joined the research laboratories of the RCA Manufacturing Company, Inc., and is now located in the RCA Laboratories at Princeton, New Jersey. He has held an amateur operator's license



ROBERT C. MIEDKE

since 1930 and a broadcast operator's license since 1940. He is a member of Sigma Xi.

Robert C. Miedke (A'39) was born in Moline, Illinois, on February 12, 1918. From 1936 to 1938 he was engaged in radio servicing. After completing the radio operators course at the RCA Institutes in March, 1939, he joined the Illinois State Police Radio Division doing radio operating and maintenance work at station WQPG in Sterling, Illinois. In 1940 he accepted a position with the Pan American Airways Radio Division in Miami, Florida, engaged in aircraft radio maintenance and installation. Since March, 1942, Mr. Miedke has been conducting engineering tests on aircraft radio-communications and electronic equipment at the Naval Research Laboratory in Washington, D. C.

Glenn F. Rouse was born at Milan, Illinois, on July 20, 1895. After receiving his B.A. degree from Cornell College (Iowa) in 1920, he attended the University of Wisconsin where he received his Ph.D. degree in physics in 1925. From 1925 to 1940 he taught physics; for two years, 1925 to 1927, in the physics department at Lehigh University, Bethlehem, Pennsylvania, and for thirteen years at American University, Washington, D. C. During two summer periods he worked at the United States Bureau of Standards, in Washington, D. C.

Since June, 1940, he has worked at the Signal Corps Engineering Laboratories, Bradley Beach, New Jersey, on problems involved in the construction and operation of electronic tubes.

He is a member of the American Physical Society, Sigma Xi, and Phi Beta Kappa.

Harold A. Zahl (A'39) was born in Chatsworth, Illinois, on August 24, 1904. He received the B.A. degree in physics and mathematics from North Central College in 1927, and the M.S. and Ph.D. degrees in physics and mathematics from the State University of Iowa in 1929 and 1931, respectively.

In 1931, Dr. Zahl accepted appointment as physicist with the Signal Corps Laboratories at Fort Monmouth, New Jersey, and from 1931 to 1942, he participated in many Signal Corps research and development projects including work on sound, infrared, vacuum tubes, radar, etc. He has been intimately connected with the Army program on radar since its inception, and was civilian engineer in charge of the first service tests on Army radar. Dr. Zahl has been particularly active in connection with the general Army program on vacuum tubes, being responsible for the development of a number



GLENN F. ROUSE

of types used in United States Army equipment.

In 1942 he entered active military duty as Major, and was promoted to the rank of Lieutenant Colonel in 1945. As an Army officer he continued to serve with the Signal Corps Engineering Laboratories, dividing his time between technical and administrative matters pertaining to the development of electronic equipment and vacuum tubes for use by the Armed Forces. He is at present deputy director of the engineering division, Signal Corps Engineering Laboratories, Bradley Beach, New Jersey.

Lieutenant Colonel Zahl is a member of Sigma Xi, American Physical Society, Gamma Alpha, and the New York Academy of Sciences.

For a photograph and biographical sketch of Armig G. Kandoian, see the January, 1946, issue of WAVES AND ELECTRONS.

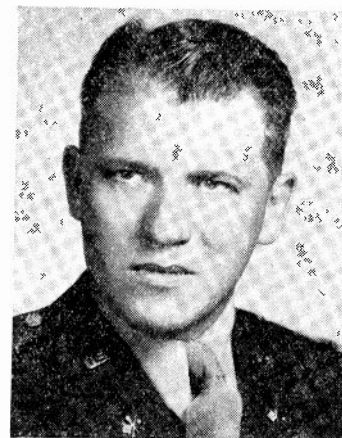

HAROLD A. ZAHL

# You can't put the **squeeze** on "Sealdtite" Capacitors

**T**ake a genuine "Sealdtite" capacitor and try to squeeze it. No "soft spots."  
Why? Because this Solar capacitor has its high purity paper-and-foil-winding ingeniously molded into a cylinder of solid wax.

No atmospheric moisture can penetrate this protective housing to attack the capacitor element. In genuine wax-molded "Sealdtite" capacitors, there just is no possibility of those twin omens of trouble — soggy cardboard tubes and moisture-filled hollows.

For real reliability, specify Solar "Sealdtites" for your new designs.



**SOLAR MANUFACTURING CORPORATION**

285 Madison Avenue • New York 17, N. Y.

Ⓢ 1009





# W. K. **this team could do**

There are three reasons why the team of Bell Telephone Laboratories and Western Electric was able to handle big war jobs fast and well.

(1) It had the men—an integrated organization of scientists, engineers and shop workers, long trained to work together in designing and producing complex electronic equipment.

(2) It had unequalled physical facilities.

(3) Perhaps most important of all, it had a long-established and thoroughly tested method of attack on new problems.

### *What is this method of attack?*

In simple terms, it is this. Observe some phenomenon for which no explanation is known—wonder about its relationship to known phenomena—measure everything you can—fit the data together—and find in the answer how to make new and better equipment.

In the realm of *pure research*, Bell Laboratories have carried on continuing studies in all branches of science, with particular emphasis on physics, chemistry and mathematics. Often they have set out to gain new knowledge

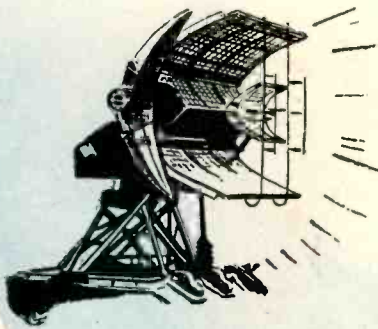

Bell Laboratories and Western Electric teamed up to supply more than 56,000 radars of 64 types—approximately 50% of the nation's radar production on a dollar volume basis.

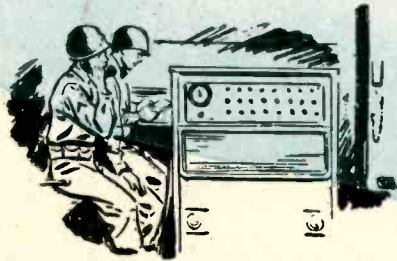

Bell Laboratories designed and Western Electric produced more than 1600 electronic gun directors and gun data computers which greatly increased the accuracy of anti-aircraft and coast defense guns.



More than 1,000,000 airborne radio receivers and transmitters were furnished by Western Electric to help coordinate attack and defense in the air.



Bell Laboratories designed and Western Electric furnished more than 139,000 multi-channel FM receivers and 74,000 multi-channel FM transmitters for use by the Armored Forces and Artillery.



Bell Laboratories and Western Electric furnished revolutionary carrier telephone terminal equipment in great quantities—all "packaged" for quick installation in the field.

# war jobs like these

with no immediate prospect of an application in the communications field. Time after time, their discoveries have eventually brought about fundamental scientific advances.

## *Applying new discoveries*

As new discoveries have reached the stage of application, Western Electric manufacturing engineers have always worked closely with Bell Laboratories men to assure a final design suited to quantity production of highest quality equipment.

During the war, the capabilities of this unique research-production team expanded rapidly. New techniques were explored—new methods were developed—new ideas were born, rich with possibilities for the future.

## *What this means to YOU*

Today Bell Laboratories and Western Electric are once more applying their facilities and their philosophy to the development and production of electronic and communications equipment for a world at peace. Depend on this team for continued leadership in AM, FM, and Television broadcasting equipment and commercial radar.

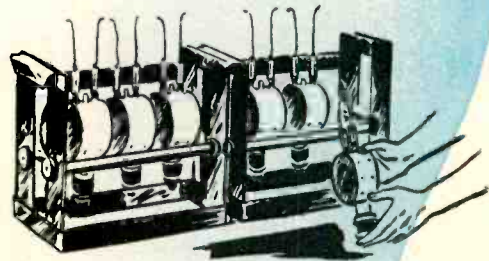

Bell Laboratories and Western Electric played outstanding roles in the design and production of magnetrons and other essential vacuum tubes for use in radar and communications.



## BELL TELEPHONE LABORATORIES

World's largest organization devoted exclusively to research and development in all phases of electrical communication.

# Western Electric

Manufacturing unit of the Bell System and nation's largest producer of communications and electronic equipment.





## It's a mark of quality in any equipment when the frequency source is a **BLILEY CRYSTAL**

Anyone familiar with radio frequency applications knows that the name Bliley on a crystal means original engineering for a specific job. True—Bliley builds crystals by the million—but Bliley craftsmanship was never gained through mass production.

Fifteen years of interpreting the needs of communications engineers, personalized attention to their individual problems, has provided the engineering background and experience that has

made possible consistent quality production.

In the current line of Bliley Crystals all that proved good in wartime models has been retained, with important refinements for peacetime applications. New types have been added—more are on the way.

Make it a habit to consult Bliley engineers on all of your frequency control problems. You will benefit from this mark of quality in your equipment.



**TYPE TC91**—This new Temperature Stabilizer is just one of many products described in a new Bliley bulletin. Write for your copy.

Ask for bulletin **P-27**

# Bliley CRYSTALS

**BLILEY ELECTRIC COMPANY • UNION STATION BUILDING, ERIE, PENNSYLVANIA**



For *greater* brilliance and *greater* DEFLECTION SENSITIVITY—

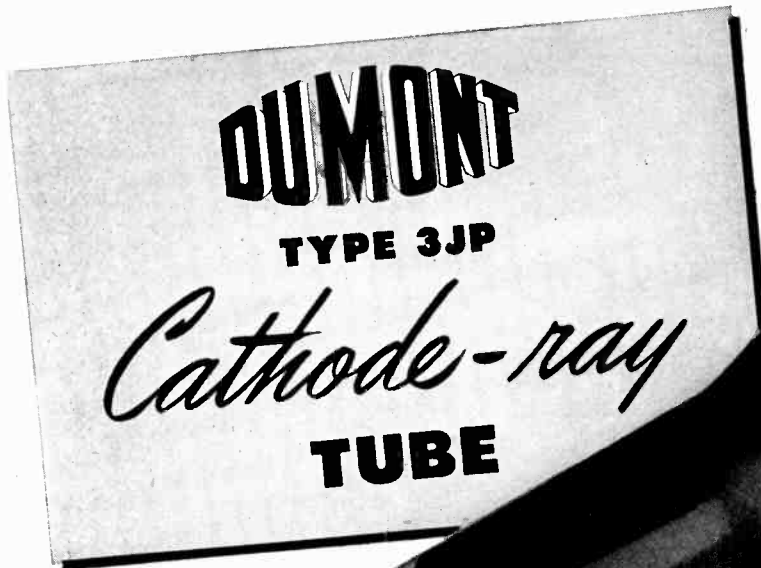

Here's the logical successor to the wartime Types 3BP and 3FP, combining the high deflection sensitivity of the 3BP with the higher operating voltage and brightness of the 3FP. Thus, it is the ideal tube for test equipment which is operated under high ambient light.

The new DuMont Type 3JP is designed for oscillographic and other applications requiring a small, short tube with very high light output and high deflection sensitivity. The focusing electrode current under operating conditions is negligible, thereby simplifying bleeder design. The 2" dia. neck and dihepal base provide adequate insulation between electrode leads for high-altitude insulation.

For applications where deflecting voltages are under suitable control, the 3JP is directly interchangeable with the 3FP. Equipment using the 3BP may be readily adapted to use the 3JP by providing for connecting the intensifier electrode of the 3JP either to the second anode potential or to a higher potential than the second anode. Due to the higher deflection sensitivity, the 3JP can be utilized with intensifier potential equal to twice the second anode potential without reduction in sensitivity, as compared with the 3BP operating with the same second anode potential.

TECHNICAL DATA ON REQUEST.

**CHARACTERISTICS . . .**

Deflection and Focus ..... Electrostatic  
Screen: Choice of P1, P2, P4, P7  
and P11 Screens

**RATINGS:**

Heater Voltage ..... 6.3 a.c. or d.c.  
Current ..... 0.6 ampere  
Anode #3 (Intensifier) ..... 4400 volts max.  
Anode #2 (Accelerating) ..... 2200 volts max.  
Anode #1 (Focusing) ..... 1100 volts max.  
Grid (Control Voltage) ..... Never Positive  
Peak Voltage between Accelerating  
Electrode and Any Deflecting  
Electrode ..... 550 volts max.  
Grid Circuit Resistance ..... 1.5 meg. max.  
Impedance of Any Deflecting  
Electrode Circuit at Heater Supply  
Frequency ..... 1.0 meg. max.  
Eb3/Eb2 Ratio ..... 2.3 max.

**MECHANICAL CHARACTERISTICS:**

Overall Length ..... 10"  
Maximum Diameter ..... 3"  
Base ..... Med. 12-pin dihepal

© ALLEN B. DUMONT LABORATORIES, INC.

DUMONT

Precision Electronics & Television

ALLEN B. DUMONT LABORATORIES, INC., PASSAIC, NEW JERSEY • CABLE ADDRESS: ALBEEDU, PASSAIC, N. J., U. S. A.

# INSTRUMENTS YOU CAN AFFORD TO USE

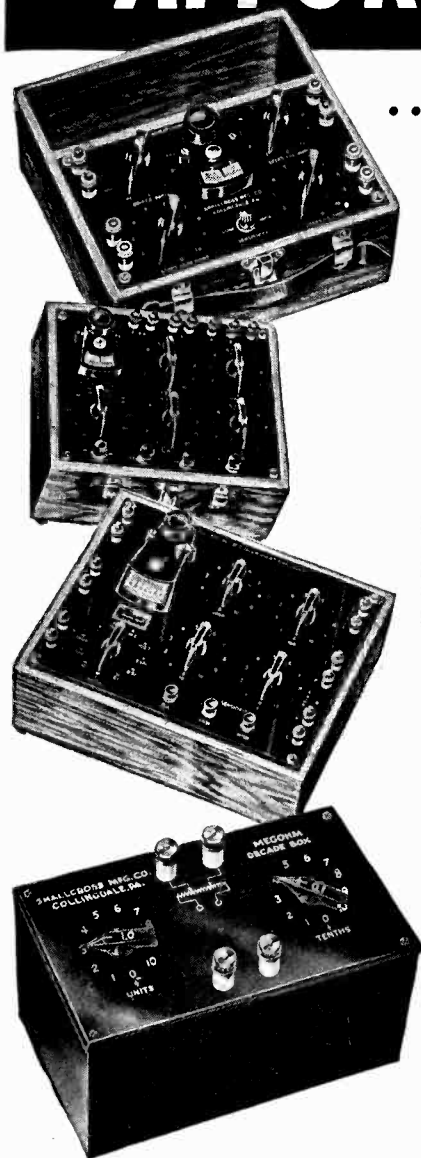

... on everyday jobs

**INEXPENSIVE**

**ACCURATE**

**RUGGED**

**EASILY REPAIRED  
IN CASE OF MISUSE**

Hundreds of production line testing jobs and field investigations, in addition to laboratory tests require dependable instruments of a type that don't have to be kept under lock and key because of their extreme delicacy and high cost. Shallcross answers this need with many types of

**BRIDGES — DECADE BOXES  
RESISTANCE STANDARDS  
DECADE POTENTIOMETERS  
HIGH-VOLTAGE TEST EQUIPMENT, etc.**

These instruments are accurate for every commercial and laboratory need up to the point of the most exacting research in pure physics. They are rugged, easy to operate and decidedly moderate in price. In case of misuse, they can quickly be repaired to full efficiency by any reasonably competent individual without the expense and delay of returning them to the factory.

## WRITE FOR BULLETINS

- Bulletin 810*, Shallcross Resistance Standards
- Bulletin 825*, Resistance Decades
- Bulletin D-1*, Bridges
- Bulletin LRT*, Low Resistance Test Sets
- Bulletin G*, Electrical Measuring Apparatus for schools and colleges

**SHALLCROSS MFG. CO., DEPT. IR-26 Collingdale, Pa.**

# SHALLCROSS

Electrical Measuring Apparatus • AKRA-OHM Resistors • Precision Switches • Electronic Engineering



### BALTIMORE

"Generation and Transmission of Microwaves," by E. U. Condon, National Bureau of Standards; November 27, 1945.

"Technical Description and Discussion of AN/MPG-1," by A. E. Abel, M. Taylor, J. H. Taylor, and J. T. McNaney, Bendix Radio Division; December 18, 1945.

### BOSTON

"The Future of Radar," by L. A. DuBridge, Massachusetts Institute of Technology; December 14, 1945.

### CEDAR RAPIDS

"Practical Considerations in the Design of Very-High-Frequency Components," by W. W. Salisbury, Collins Radio Company; November 15, 1945.

### CINCINNATI

"High-Frequency Measurements," by Arnold Peterson, General Radio Corporation; November 20, 1945.

### CLEVELAND

"Romance of Clips," by Ralph Mueller, Mueller Electric Company; December 27, 1945.

Election of Officers; December 27, 1945

### DALLAS-FT. WORTH

Cafeteria Supper and Inspection Tour of Telephone Building; November 27, 1945.

"Practical Problems of Frequency-Modulation Broadcasting," by M. W. Woodward, Commercial Radio Equipment Company, December 10, 1945.

### DAYTON

"Atomic Energy," by M. L. Pool, Ohio State University; December 13, 1945.

### DETROIT

"Squelch Circuits in Amplitude-Modulation and Frequency-Modulation Receivers," by F. M. Hartz, Detroit Edison Company; October 19, 1945.

"Improved Frequency-Modulation Circuits," by J. R. Boykin, Westinghouse Electric Corporation; November 16, 1945.

"The Sonic Bomb Scoring Recorder," by L. H. Larime, Technical Service, Inc.; December 21, 1945.

Election of Officers; December 21, 1945.

### EMPORIUM

"Review of War Electronics," by D. G. Fink, *Electronics*; December 13, 1945.

Election of Officers; December 13, 1945

### LONDON

"Some Factors Involved in Sound Reproduction," by H. Goldin, Dominion Sound Equipments, Ltd.; December 14, 1945.

### LOS ANGELES

"New Analytical Viewpoints in Ultra-High-Frequency Engineering," by Simon

(Continued on page 40)

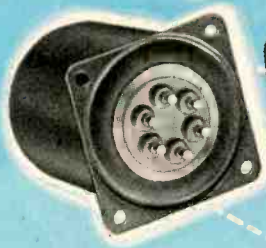

# MYCALEX 410

(Molded)

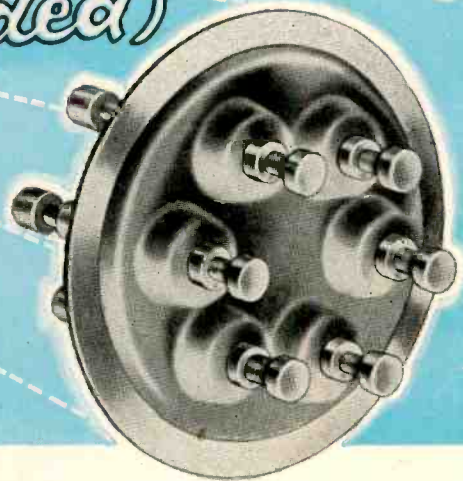

UNITED TRANSFORMER CORPORATION  
NEW YORK 13, N. Y.

150 VARICK STREET



November 3, 1945



Mycalex Corp. of America  
30 Rockefeller Plaza  
New York 20, N. Y.

Attention: Mr. Jerome Taishoff

Gentlemen:

We have conducted the following test on the two-six terminal molded mycalex assemblies you submitted:

- 1 - Meg test - 500 megohms
- 2 - Place in oven at 40°C for 8 hours
- 3 - Place in hot sodium chloride at 65°C for 1 hour
- 4 - Place in cold sodium chloride at 0°C for 1 hour
- 5 - Leave overnight in salt water at room temperature 20°C
- 6 - Meg test - infinity test

This test was repeated three times. At the end of the test the unit was tested for leakage and showed a small amount. This amount was within the limitations imposed by the Army Signal Corps. After the assemblies had dried for about 15 minutes they indicated no leakage. We consider these terminals to be extremely satisfactory for hermetic sealing purposes.

We wonder what would happen if these same 6 terminals were compressed into a smaller diameter assembly? We would greatly appreciate receiving samples of your single terminal assemblies.

Yours very truly,

*S. W. Levy*  
S. W. Levy  
Chief Production  
Engineer

## MAKES "EXTREMELY SATISFACTORY HERMETIC SEAL"

REPORTS

*United Transformer Corp.*

Are you seeking a hermetic seal for transformer terminals? Do you want a low loss, high frequency insulating material that will bond to metal and give positive assurance against oil leakage and the damaging effects of moisture?

Then read the United Transformer Corporation report made after tests of MOLDED MYCALEX in conjunction with Monel Metal in this application. The results speak for themselves.

For 25 years MYCALEX has been known to engineers the world over as the "most nearly perfect high frequency low loss insulation." Now, in highly perfected form, MYCALEX offers new opportunities for product improvement.

Specify MYCALEX where low loss factor and high dielectric strength are required. Our engineers are at your service.



# MYCALEX CORPORATION OF AMERICA

"Owners of 'MYCALEX' Patents"

Plant and General Offices, CLIFTON, N. J.

Executive Offices, 30 ROCKEFELLER PLAZA, NEW YORK 20, N. Y.

# Stancor Delivers Specified Performance



**FEATURING PRECISION PRODUCTION  
WITH TRUE ECONOMY...**

**S**TANCOR is justly proud of its ability to meet all specialized transformer needs. At STANCOR, the combination of superior engineering skill and a long record of difficult and complex manufacturing problems successfully solved, unite to guarantee the production of transformers unexcelled in durability, service and economy.

Every individual specification that comes to STANCOR receives individualized attention and study . . . persistently and practically devoted to the ideal of "more performance per dollar."

Competent laboratory and sales engineering facilities are available NOW to meet your most exacting transformer specifications.



## STANCOR

STANDARD TRANSFORMER CORPORATION  
1500 NORTH HALSTED STREET CHICAGO 22, ILLINOIS



(Continued from page 38A)

Ramo, General Electric Company; November 27, 1945.

"The Engineer in Business for Himself," by Frank Pettit, Harvill Corporation, M. J. Brown, L. A. Chamber of Commerce; Douglas Sellers, Patent Attorney, H. J. Barnicoat, ERPI, M. Marquardt, World Broadcasting System; December 18, 1945.

Election of Officers; December 18, 1945.

### OTTAWA

"Design Principles and History of Radar in Canada," by Fred Sanders, National Research Council; November 22, 1945.

Visit to the Montreal Road Laboratories of the National Research Council, and the Communications Building of the Royal Canadian Corps of Signals; December 13, 1945.

### PHILADELPHIA

"Proximity Fuse for Gun-Fired Missiles," by R. H. Thayer; Johns Hopkins University; December 6, 1945.

"Proximity Fuze for Rockets, Bombs, and Mortars," by W. F. Hindman, National Bureau of Standards; December 6, 1945.

### PITTSBURGH

"The History and Future of Radio Broadcasting," by L. W. Chubb, Westinghouse Research Laboratories; November 13, 1945.

"The Development of Atomic Energy," by J. R. Dunning, Columbia University; December 10, 1945.

### PORTLAND

"Magnetic Sound Recording on Wire," by Henry Sturtevant, KALE; November 29, 1945.

### ST. LOUIS

"Pulse Transmission and Pulse Modulation," by R. S. Glasgow, Washington University; December 20, 1945.

### SAN DIEGO

"High-Fidelity Sound Reproduction," by W. G. Collins; Don Lee Broadcasting System; December 4, 1945.

### SAN FRANCISCO

"Some Aspects of Intermediate-Frequency Amplifier Design," by Karl Spangenberg; Stanford University; December 19, 1945.

Election of Officers; December 19, 1945.

### TORONTO

"High-Quality Sound Recording on Magnetic Wire," by L. C. Holmes, Stromberg Carlson Company; October 15, 1945.

Motion Picture: "A Record of Flight," October 15, 1945.

"Cathode-Ray Tubes for Television," by G. T. Waugh, General Electric Company; October 29, 1945.

(Continued on page 42A)



**IT'S YOURS AGAIN... WITH NEW LAURELS!**

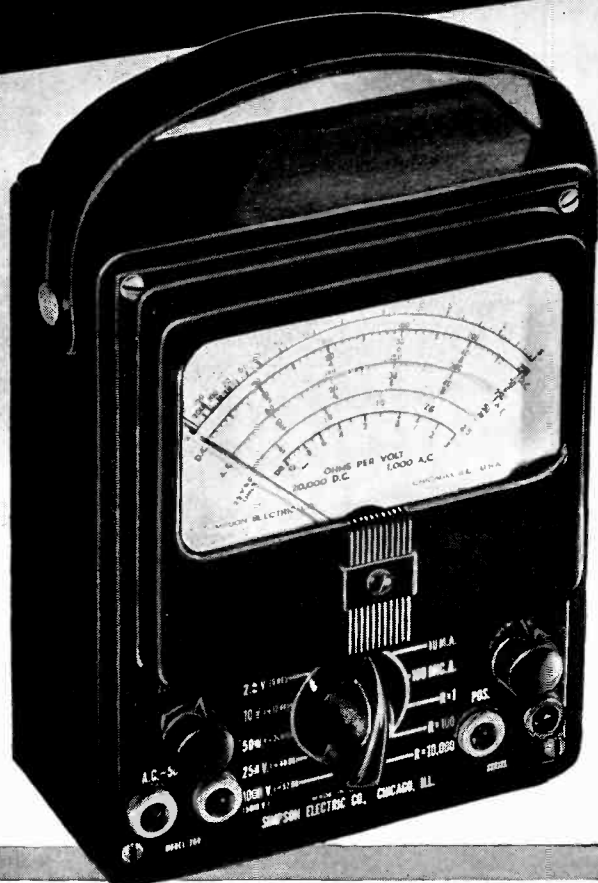

• Originally designed as a radio serviceman's test unit, the Simpson 260, because of its sensitivity and wide range was found adaptable during the war to general service duties in the entire electronics and electrical fields. It was given thousands of essential war jobs in the production and servicing of communications equipment.

Over 300 government agencies and university laboratories of the United States and Canada procured every one of these test instruments Simpson could deliver on an expanded war production schedule. They were turned out by the thousands. Every branch of the armed services — Army, Navy, Marines, Coast Guard—carried them to the far ends of the earth.

Chosen on its merits, the 260 became uniquely *the* test instrument of the war.

**AVAILABLE NOW TO YOU**

Now the Model 260, always the preferred instrument of radio servicemen, is available again to a widened field of peacetime services. We ask you to remember its record as an example of the quality and advanced engineering that goes into all Simpson instruments, as evidence that other new Simpson developments during 1946 are well worth waiting for. They are being released as soon as Simpson standards for their manufacture are satisfied. They will continue the leadership that has given Simpson a world-wide reputation for "instruments that stay accurate" with ideas that stay ahead.

**SIMPSON 260, HIGH SENSITIVITY SET TESTER FOR TELEVISION AND RADIO SERVICING**

Ranges to 5000 Volts—Both A.C. and D.C.  
20,000 Ohms per Volt D.C.—1000 Ohms per Volt A.C.

At 20,000 ohms per volt, this instrument is far more sensitive than any other instrument even approaching its price and quality. The practically negligible current consumption assures remarkably accurate full scale voltage readings. Current readings as low as 1 microampere and up to 500 milliamperes are available.

Resistance readings are equally dependable. Tests up to 10 megohms and as low as 1/2 ohm can be made. With this super sensitive instrument you can measure automatic frequency control diode balancing circuits, grid currents of oscillator tubes and power tube, bias of power detectors, automatic volume control diode currents, rectified radio frequency current, high-mu triode plate voltage and a wide range of unusual conditions which cannot be checked by ordinary servicing instruments. Ranges of Model 260 are shown below.

Price, complete with test leads.....\$33.25  
Carrying case ..... 4.75

Volts D.C. (At 20,000' ohms per volt)	Volts A.C. (At 1,000 ohms per volt)	Output
2.5	2.5	2.5 V.
10	10	10 V.
50	50	50 V.
250	250	250 V.
1000	1000	1000 V.
5000	5000	5000 V.

Milliamperes D.C.	Microamperes	Ohms
10	100	0-1000 (12 ohms center)
100		0-100,000 (1200 ohms center)
500		0-10 Megohms (120,000 ohms center)

(5 Decibel ranges: -10 to +52 DB)

**ASK YOUR JOBBER**

**SIMPSON ELECTRIC COMPANY**  
5200-5218 W. Kinzie St., Chicago 44, Ill.

**Simpson**  
INSTRUMENTS THAT STAY ACCURATE



*Case Histories from the RICHARDSON files*

## LAMINATED OR MOLDED PLASTICS

**Problem:** Produce quickly and economically an intricate yet sturdy control instrument part for use in aircraft.

**Solution:** To insure immediate delivery, Richardson fabricated this intricate part of Laminated INSUROK. At the same time, molds were being made. When these were finished, production of the part was shifted to Molded INSUROK. Thus, production continued without interruption, costly delays were avoided—another example of Richardson versatility!

The Richardson Company—to our knowledge—is the only plastics manufacturer fully equipped to do both laminating and molding of plastics . . . the molding of rubber and bituminous plastics . . . and the manufacturing of rubber-plastic combinations. These complete facilities enable us to meet your needs efficiently and economically! Find out how *Richardson Plasticians* can help you improve both the appearance and performance of your products. Write today for information.

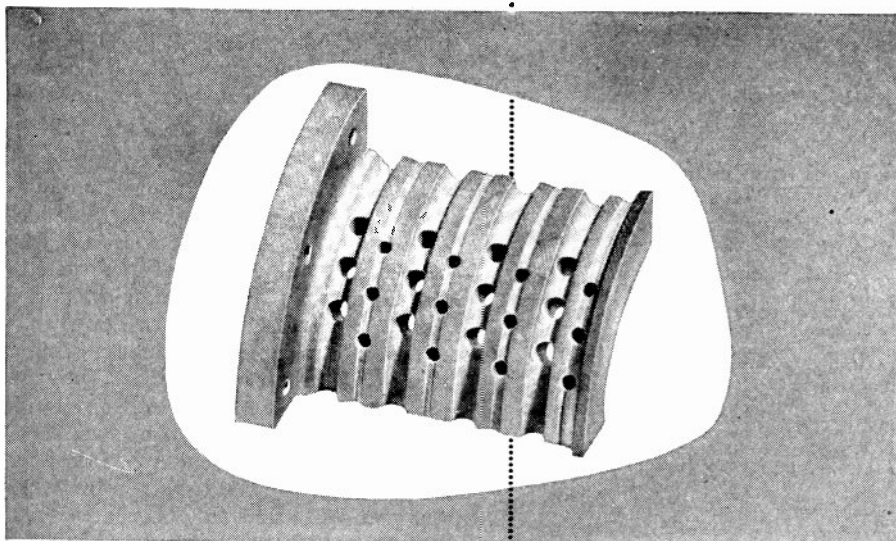

# INSUROK *Precision Plastics*

*The* RICHARDSON COMPANY

LOCKLAND, CINCINNATI 15, OHIO FOUNDED 1858 Sales Headquarters: MELROSE PARK, ILL.

Sales Offices: NEW YORK 6 • CLEVELAND 15 • DETROIT 2

Factories: MELROSE PARK, ILL. NEW BRUNSWICK, N. J. INDIANAPOLIS, IND.



(Continued from page 40A)

Motion Picture: "R For Rubber,"; October 29, 1945.

"Frequency Modulation for Domestic Receivers," by R. A. Hackbusch, Stromberg Carlson Telephone Company; H. S. Dawson, Canadian Association of Broadcasters; and C. J. Irwin, Canadian General Electric Company; November 19, 1945.

TWIN CITIES

"Atomic Energy and the Engineer," by J. W. Buchta, University of Minnesota; December 5, 1945.



The following transfers and admissions were approved on January 9, 1946:

### Transfer to Senior Member

- Conte, T. M., 21 Forsyth St., Boston, Mass.
- Craib, J. F., Hazeltine Electronics Corp., 58—25 Little Neck Pkwy., Little Neck, L. I., N. Y.
- Cummings, K. M., United Air Lines, 5959 S. Cicero Ave., Chicago 38, Ill.
- Hallmark, C. E., Farnsworth Television and Radio Corp., 3700 E. Pontiac, Fort Wayne, Ind.
- Holloway, J., 150 Broadway, New York 7, N. Y.
- Jorgensen, C. M., 1637 Balmoral Ave., Chicago 40, Ill.
- Keto, J. E., Radar Laboratory, A.T.S.C., Wright Field, Dayton, Ohio
- Metz, H. I., CAA Experimental Station, Indianapolis 44, Ind.
- Moldawsky, B. W., 68—38 Yellowstone Blvd., Forest Hills, L. I., N. Y.
- Okrent, J. J., 21 Barstow Rd., Great Neck, L. I., N. Y.
- Salati, O. M., Hazeltine Electronics Corp., 58—25 Little Neck Pkwy., Little Neck, L. I., N. Y.
- Seeley, W. J., Duke University, Durham, N. C.
- Tuttle, W. N., Lowell Rd., Concord, Mass.
- Walsh, A. A., 1403 Milford Terrace, West Englewood, N. J.

### Admission to Senior Member

- Austrian, R. B., RKO Television Corp., 1270-6 Ave., New York 20, N. Y.
- Balasundaram, N., 29 Mahila College Rd., Lahore, India
- Chase, C. T., 56 Carleton Rd., Belmont 78, Mass.
- Crew, W. H., 11 Bolton Gardens, Bronxville 8, N. Y.
- Duncan, R. C., Naval Ordnance Laboratory, Navy Yard, Washington, D. C.
- Lamm, R. A., 3941 Newdale Rd., Chevy Chase 15, Md.

(Continued on page 44A)

Proceedings of the I.R.E. February, 1946

# FM

# by Federal

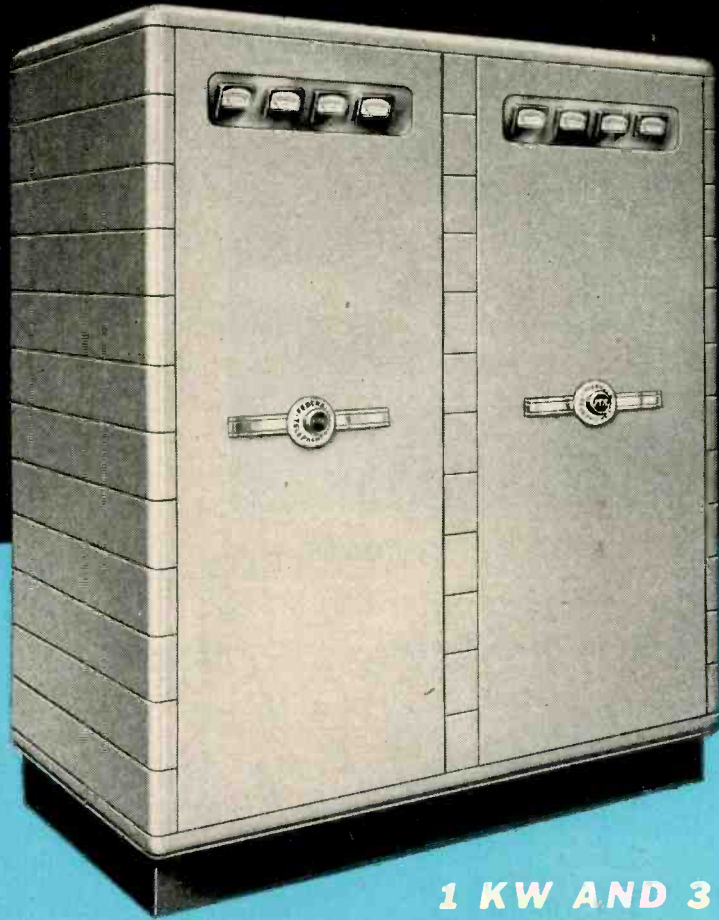

**1 KW AND 3 KW  
FEDERAL FM BROADCAST  
TRANSMITTERS**



**A Complete FM Package by Federal  
— from Microphone to Antenna.**

Write for brochure "Complete FM. by Federal" descriptive of Federal's complete FM Radio Broadcast Equipment from microphone to antenna.

*Federal Telephone and Radio Corporation*

Export Distributors:  
International Standard Electric Corporation<sup>®</sup>



Newark 1, N. J.

Because of the bakelite-insulated metal-clad resistance element, these **CLAROSTAT SERIES MMR RESISTORS** in actual operation are . . .

# Definitely COOLER

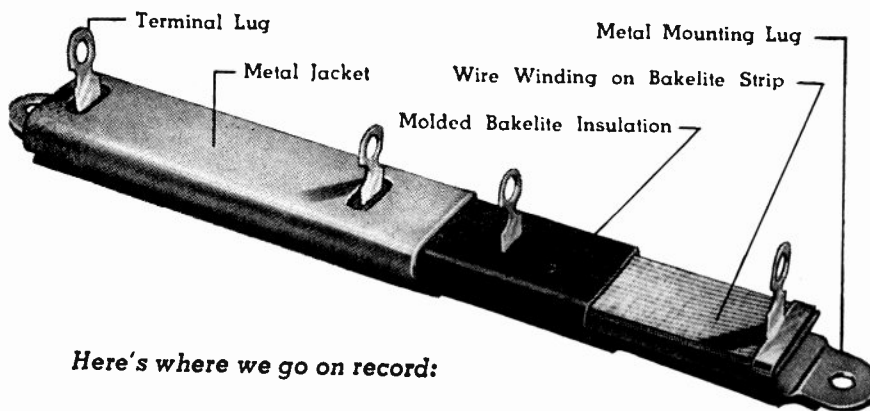
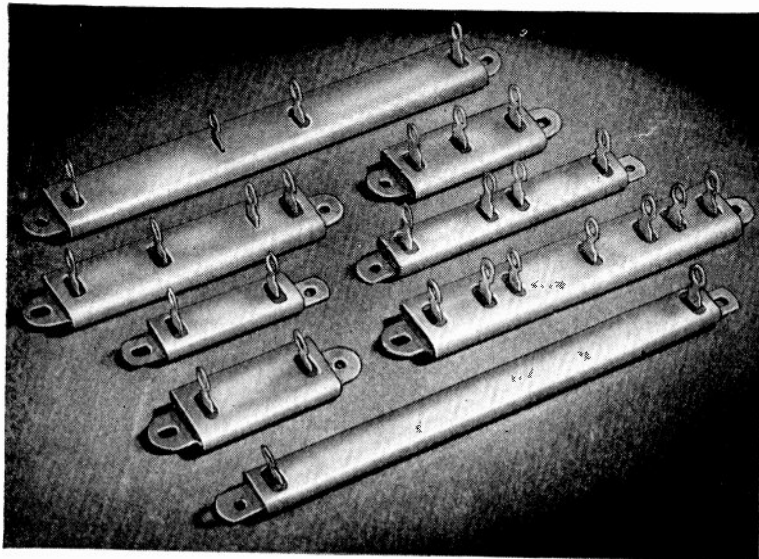

Here's where we go on record:

★Clarostat Series MMR bakelite-insulated metal-clad resistors are definitely **COOLER** than any other similar types, **SIZE FOR SIZE**; or putting it another way, these resistors will **DISSIPATE MORE POWER** for the same temperature rise, **SIZE FOR SIZE**.

That's our statement. We invite your own tests. Sample on request if you write on your business letterhead. Also detailed literature.



**CLAROSTAT**

## Controls and Resistors

CLAROSTAT MFG. CO., Inc. · 285-7 N. 6th St., Brooklyn, N. Y.



(Continued from page 42A)

- Moore, J. H., 141 Haddon Pl., Upper Montclair, N. J.
- Nicholson, F. H., 11319 Frankstown Rd., Wilkensburg, Pa.
- Scott, N. R., Special Projects Laboratory, TSELP, A.T.S.C., Wright Field, Dayton, Ohio
- Van Voorhis, S. N., 314 Beacon St., Boston 16, Mass.

### Transfer to Member

- Apple, H. L., Box 57, Stamford, Conn.
- Becker, H. W., 1426 Amador, Vallejo, Calif.
- Bemis, E. W., 195 Broadway, New York 7, N. Y.
- Berger, M., 303 N.E. 8 Ave., Fort Lauderdale, Fla.
- Black, E., Jr., Box 2, Southbridge, Mass.
- Brent, L. L., 1330 N. Newstead Ave., St. Louis 13, Mo.
- Caskey, H. B., National Broadcasting Co., NBC Bldg., 815 Superior Ave., Cleveland, Ohio
- Cater, C. E., 4 Ashford Ave., Ashford, Middlesex, England
- Caywood, W. P., Jr., 23 Sandy Creek Rd., Pittsburgh 21, Pa.
- Chatterjee, S. K., 91, Ballygunge Pl., Calcutta, India
- Clark, C. B., 3 Sacramento St., Cambridge 38, Mass.
- Cohn, S. B., 1737 Cambridge St., Cambridge 38, Mass.
- Collins, W. G., 4684 Saratoga Ave., San Diego 7, Calif.
- Crispell, H. L., 19 Everett St., Cambridge 38, Mass.
- Dennis, F. R., 463 West St., New York 14, N. Y.
- Desnoyers, H. B., 52 Maple St., Newton 58, Mass.
- Dutt, N. L., 33/2, Beadon St., Calcutta, Bengal, India
- Epstein, D. J., General Electric Co., Wolf St., Plant, Syracuse, N. Y.
- Everett, J. E., 52-21 Browvale Lane, Little Neck, L. I., N. Y.
- Farr, K. E., 14-3 St., Great Neck, L. I., N. Y.
- Finch, H. D., 10851 Jefferson Blvd., Culver City, Calif.
- Fischer, R. E., 63 Arcadia Ave., Lakeside Park, Covington, Ky.
- Flynn, F. J., 217 W. 64 Pl., Inglewood, Calif.
- Forman, N. J., RFD 1, Box 18, Emporium, Pa.
- Frey, S. C., 3900-14 St., N.W., Washington 11, D. C.
- Friedberg, M. R., 2804 E. 132 St., Cleveland, Ohio
- Gostyn, E., 409 Maple Rd., Longmeadow 6, Mass.
- Grelck, H. L., 528-81 St., Brooklyn 9, N. Y.
- Guenther, J. H., 162 Naples Rd., Brookline 46, Mass.
- Hannahs, W. H., 315 Market St., Williamsport, Pa.

(Continued on page 46A)



# MACHINED STEATITE

## FOR INTRICATE CERAMIC DESIGNS



**TURNING**



**DRILLING**



**THREADING**



**SLOTING**

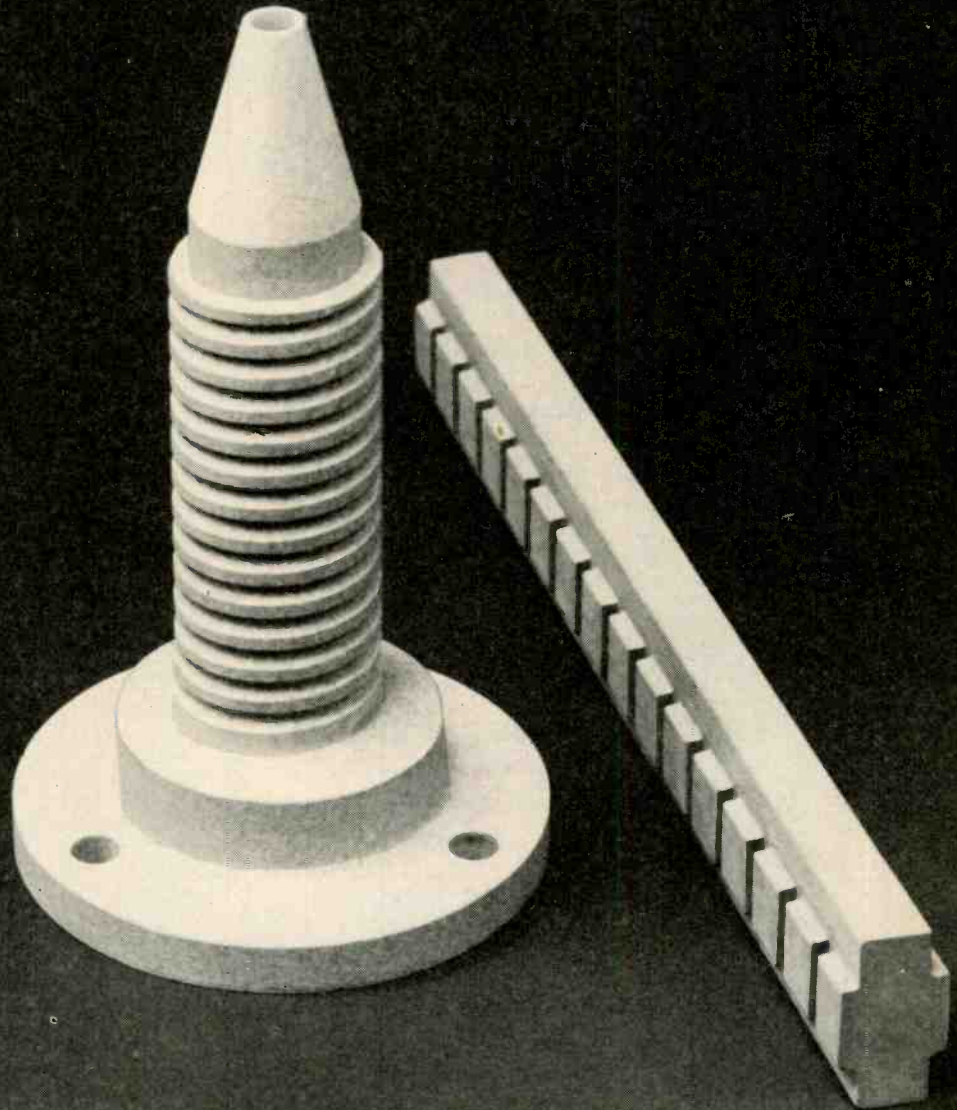

*Original Award July 27, 1942  
Second Award February 13, 1943  
Third Award September 25, 1943  
Fourth Award May 27, 1944  
Fifth Award December 2, 1944*

# ALSiMAG

TRADE MARK REGISTERED U. S. PATENT OFFICE

**I**F your equipment requires intricate or unusual Ceramic designs, we can furnish machined ALSiMAG Steatite parts. Highly specialized equipment of our own design, as well as conventional machine tools, is used for turning, threading, drilling, slotting and other machine operations. Send us a sample or blueprint of your design.

**AMERICAN LAVA CORPORATION**  
**CHATTANOOGA 5, TENNESSEE**

43RD YEAR OF CERAMIC LEADERSHIP

## CERAMICS

FOR ELECTRONIC AND ELECTRICAL USES

**Quality to Highest  
Known Standards**

**Large Production  
Facilities**

**Research and  
Engineering  
Collaboration**

**HIGHER PERFORMANCE**

**LOWER MAINTENANCE**

Those are not claims,  
but facts — attested to  
by many hundreds of  
Blaw-Knox Vertical  
Radiators now boost-  
ing the coverage and  
clarity of America's  
major stations.

**BLAW-KNOX DIVISION**

of Blaw-Knox Company  
2037 Farmers Bank Bldg.  
Pittsburgh, Pa.

**BLAW-KNOX  
VERTICAL RADIATORS**



*(Continued from page 44A)*

- Harrell, B. F., 9006 Fauntleroy Ave.,  
Seattle, Wash.
- Hoffstetter, G. E., 938 Washington Blvd.,  
Oak Park, Ill.
- Johnson, M. L., Bureau of Ships, Code  
925, Navy Dept., Washington,  
D. C.
- Kihchel, O. D., 3224—16 St., N.W., Wash-  
ington, D. C.
- Kitty, F. J., 1617 Missula Rd., Towson,  
Md.
- Knudson, L. I., 34 Overlook Dr., Sidney,  
N. Y.
- Lamb, W. X., Jr., Sperry Gyroscope Co.  
Inc., Garden City, L. I., N. Y.
- LeVay, T. C., 58—25 Little Neck Pkwy.,  
Little Neck, L. I., N. Y.
- Lindsay, G. A., 520 Grosvenor Ave., West-  
mount 6, P. Q., Canada
- Linton, R. L., Jr., 2532 Ridge Rd.,  
Berkeley 4, Calif.
- Lott, A. L., Tait Rd., Old Greenwich,  
Conn.
- Magnusson, P. C., 3612 Newark St., N.W.,  
Washington 16, D. C.
- Mao, Y. A., 521 W. 112 St., New York 25,  
N. Y.
- Masin, G. F., 290 Monrovia Ave., Long  
Beach 3, Calif.
- Miles, J. G., Sylvania Electric Products,  
Inc., Williamsport, Pa.
- Miller, D. M., 160 Old Country Rd.,  
Mineola, L. I., N. Y.
- Murphy, E. J., 102 The Narrows, East  
Hempstead, L. I., N. Y.
- Naschke, E. S., 1073—57 St., Sacramento  
16, Calif.
- Neumann, A. J., Box 363, Princeton, N. J.
- Packard, A. C., 507 Virginia Ave., Alex-  
andria, Va.
- Prache, P. M., 5 bis, Ave. des Etats Unis,  
Versailles, Seine et Oise, France
- Price, H. W., Jr., 2816 Hemlock Ave.,  
Baltimore 14, Md.
- Pride, E. W., 35 Burke Ave., Towson, Md.
- Sarault, G. E., Universite Laval, Dept. de  
Genie Electrique, Quebec, P. Q.,  
Canada
- Schuchard, E. A., 1700—29 St., S.E.,  
Washington 20, D. C.
- Seshadri, T. N., Presidency College,  
Madras, South India
- Sinnett, R. J., 3201—25 St., Rock Island,  
Ill.
- Smith, C. McR., Jr., 440 Newbury St.,  
Boston 15, Mass.
- Stanbery, J. F., 129B Hillcrest Ave.,  
Collingswood, N. J.
- Tittle, C. W., Massachusetts Institute of  
Technology, 470 Atlantic Ave.,  
Boston 10, Mass.
- Trautman, D. L., Jr., Carnegie Institute of  
Technology, Pittsburgh 13, Pa.
- Turczyn, W. A., 578 E. 37 St., Brooklyn 3,  
N. Y.
- Walker, M. C., c/o Mr. Roy B. Walker,  
Royse City, Tex.
- Whitby, O., 20 Prescott St., Cambridge 38,  
Mass.
- Winer, J. T., 74 Dayton St., Elizabeth 2,  
N. J.

*(Continued on page 48A)*



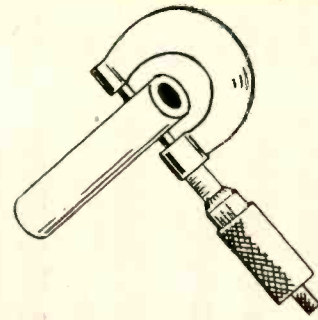
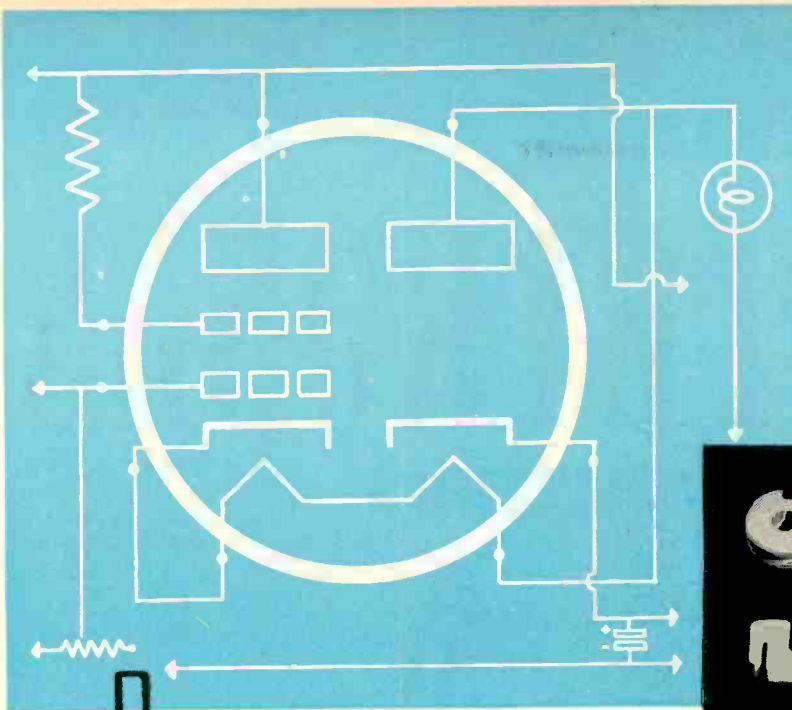

Precision quality control makes  
**STUPAKOFF**  
**CERAMICS**  
 . . . . your best choice

Stupakoff quality control means . . .

1. Strict adherence to your specifications—
2. Uniform, dimensionally-accurate ceramic insulators that minimize production losses—
3. Maximum mechanical strength—
4. Maximum electrical protection.

These advantages of Stupakoff Ceramics are gained through carefully selected and laboratory controlled materials . . . competent engineering, backed by years of experience and research . . . plus modern manufacturing facilities and constant inspection. For the finest ceramic insulators . . . specify Stupakoff.



Write for Bulletin 245 describing Stupakoff Ceramic Products and Hermetic Seals.

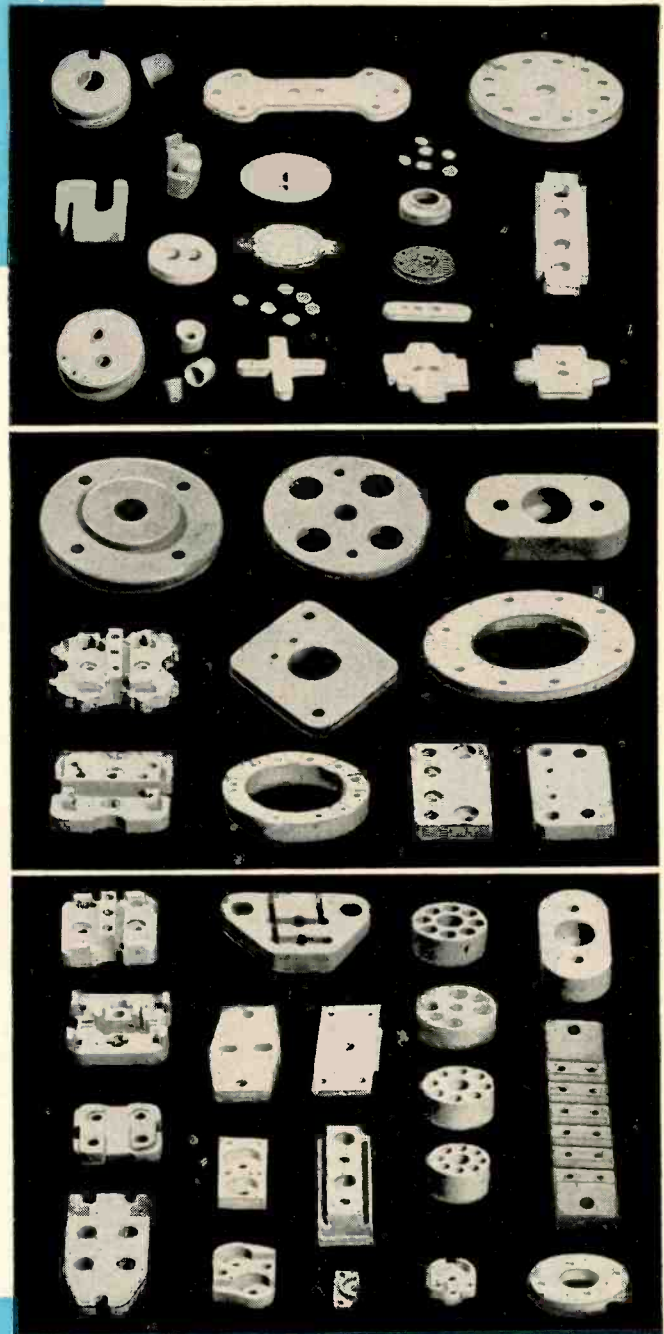

**STUPAKOFF** CERAMIC and MANUFACTURING CO.  
 LATROBE, PENNSYLVANIA

# HERE IS THE NEW WESTINGHOUSE FAMILY OF POWER TETRODES FOR FM TRANSMITTERS

Designed specifically for FM . . . Full power input at 120 mc . . . Low driving power . . . Low grid-to-plate capacitance . . . Simplified neutralization . . . Forced air cooling . . . Concentric terminal construction.

Two WL-477R tubes are used in the output stage of a 1-KW transmitter; two WL-478R tubes in a 3-KW transmitter; and two WL-479R tubes in a 10-KW transmitter.

For descriptive data write your nearest Westinghouse office or Electronic Tube Sales Department, Westinghouse Electric Corporation, Bloomfield, N. J.



**Forced Air Cooled Tetrode**  
 Filament: Thoriated Tungsten . . . 5 Volts  
 Voltage . . . 23 Amperes  
 Current . . . 240  
 Amplification Factor . . .  $E_c = -5V$   
 Transconductance ( $I_b = 300$  ma.,  $E_c = -5V$ ,  
 $E_{c2} = 500$  V.) 13000 umhos  
 Max. Screen Voltage . . . 750 Volts  
 Max. Anode Voltage . . . 3000 Volts  
 Anode Dissipation (Max.) . . . 700 Watts  
 Approximate Anode Power  
 Output (Class C) . . . 1000 Watts

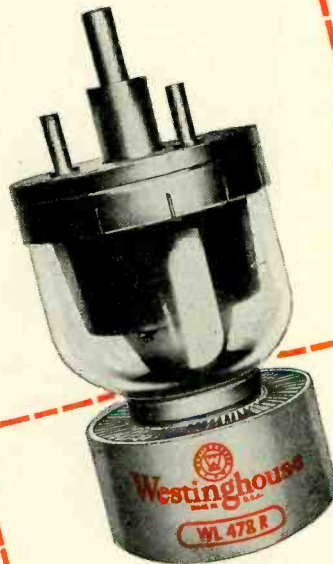

**Forced Air Cooled Tetrode**  
 Filament: Thoriated Tungsten . . . 5 Volts  
 Voltage . . . 70 Amperes  
 Current . . . 240  
 Amplification Factor . . .  $E_c = -5V$   
 Transconductance ( $I_b = 330$  ma.,  $E_c = -5V$ ,  
 $E_{c2} = 500$  V.) 14800 umhos  
 Max. Screen Voltage . . . 1000 Volts  
 Max. Anode Voltage . . . 5000 Volts  
 Anode Dissipation (Max.) . . . 2500 Watts  
 Approximate Anode Power  
 Output (Class C) . . . 3000 Watts

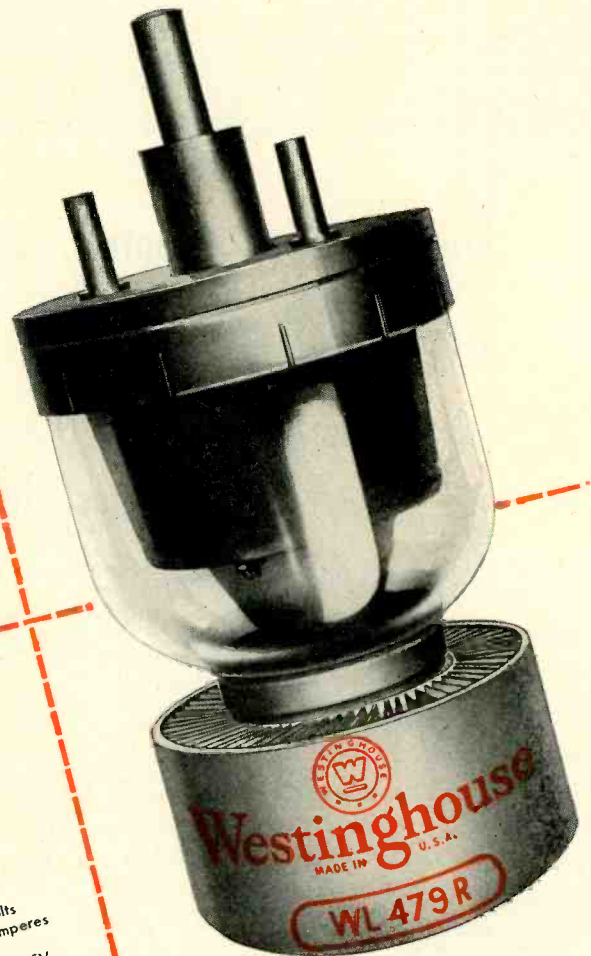

**Forced Air Cooled Tetrode**  
 Filament: Thoriated Tungsten . . . 5 Volts  
 Voltage . . . 206 Amperes  
 Current . . . 140  
 Amplification Factor . . .  $E_c = -5V$   
 Transconductance ( $I_b = 914$  ma.,  $E_c = -5V$ ,  
 $E_{c2} = 750$  V.) 33200 umhos  
 Max. Screen Voltage . . . 1000 Volts  
 Max. Anode Voltage . . . 6000 Volts  
 Anode Dissipation (Max.) . . . 6000 Watts  
 Approximate Anode Power  
 Output (Class C) . . . 7500 Watts

# Westinghouse *Electronic Tubes at Work*

# The famous Electron Microscope by Radio Corporation of America

ITS MAIN

*Capacitor by*

**INDUSTRIAL  
CONDENSER CORPORATION**



Enormously widening man's capacity to see and photograph the "invisible," RCA's new Electron Microscope is an outstanding asset to scientific progress. Following the necessarily rigid standards such a device demands, the 30,000 volt main capacitor is made by Industrial Condenser Corporation.

Skilled Industrial Condenser Corporation engineers, in the world's most modern condenser plant, design and build capacitors for every application. If your products require Electrolytic, Paper, Oil, or Motor capacitors, call your nearest Industrial Condenser Corporation district office today.

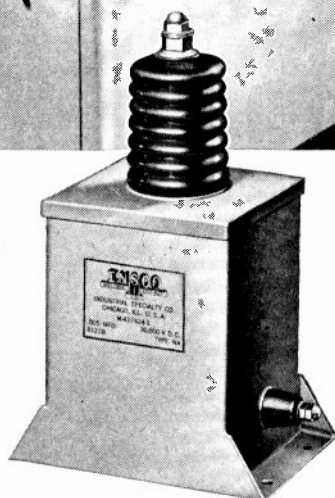

**INDUSTRIAL CONDENSER CORPORATION**

3243-65 NORTH CALIFORNIA AVENUE, CHICAGO 18, U. S. A.

District Offices in Principal Cities

**PAPER, OIL AND ELECTROLYTIC MOTOR CAPACITORS**



(Continued from page 46A)

- Williams, E. A., Box 1005, Fort Lauderdale, Fla.
- Williams, H. C., 2636 Milton Rd., Cleveland 21, Ohio
- Williams, J. R., 142 Wilmington Pl., S.E., Washington 20, D. C.
- Wise, J. W., 2326—25 St., S.E., Washington 20, D. C.
- Woodhead, R. C., 241 Ballantyne Ave. N., Montreal West, P. Q., Canada
- Yaffee, P., 317—3 St., S.E., Washington 3, D. C.

#### Admission to Member

- Aldredge, L. R., 3133 Jennings Rd., Kensington, Md.
- Bartelt, A. D., 605 Bashford Lane, Alexandria, Va.
- Bloomsburgh, R. A., Jr., 123 S. Pine Ave., Albany 3, N. Y.
- Bower, G. G., 225 Atlantic Ave., Long Branch, N. J.
- Bright, W. E., Rm. 461, Bldg. 5, General Electric Co., 1 River Rd., Schenectady 5, N. Y.
- de Britto Pereira, M. P., Standard Electrica S.A., Ave. Almirante, Borroso 91, Caixa Postal 430, Rio de Janeiro, Brazil
- Buchanan, D. B., 805 Highland Terrace, N.E., Atlanta, Ga.
- Carlson, K. J., 2717 Branch Ave., S.E., Washington 20, D. C.
- Chorpening, C. M., Box 120, Conneaut, Ohio
- Cleveland, A. W., 275 Massachusetts Ave., Cambridge 39, Mass.
- Copisarow, A. C., 145 Alexandra Rd., Manchester 16, England
- Crippa, E. R., 6 Forrester S., S.E., Washington 20, D. C.
- Cronin, W. M., 329 W. Grand Ave., Springfield, Ohio
- Cruikshank, J. E., 8440—170 St. Jamaica, L. I., N. Y.
- Cutrona, L. J., Rm. 722, Graybar-Varick Bldg., 180 Varick St., New York 14, N. Y.
- Dixon, R. K., 86 Wilson Rd., Nahant, Mass.
- Eppenstein, H. F., 18 Dewey Dr., Dayton 10, Ohio
- Epstein, J., 410 Central Park West, New York, N. Y.
- Finch, T. R., 463 West St., Rm. 677A., New York 14, N. Y.
- Flewelling, J. D., Plant Engineering Agency, Architect Bldg., 17 and Sansom Sts., Philadelphia 3, Pa.
- Forbes, G. D., Wayland Rd., Sudbury, Mass.
- Franke, F. A., 919 Ridge Court, Evanston, Ill.
- Garing, H. R., Bell Telephone Laboratories, Inc., 463 West St., New York 14, N. Y.
- Garrison, K. K., 552 Park Ave., East Orange, N. J.
- Goverman, A. B., 3900 Connecticut Ave., N.W., Washington 8, D. C.

(Continued on page 58A)





The following positions of interest to I.R.E. members have been reported as open. Apply in writing, addressing reply to company mentioned or to Box No. ....

The Institute reserves the right to refuse any announcement without giving a reason for the refusal.

#### PROCEEDINGS of the I.R.E.

330 West 42nd Street, New York 18, N.Y.

#### SENIOR ENGINEER

Newly formed organization for manufacture of radio receiver sets requires experienced man to assume charge of production and general development. Must be able to lay out, set up, and properly equip modern assembly line. New plant in New York area. Excellent opportunity for permanent connection. All inquiries treated confidential. Box 409.

#### RADIO AND ELECTRONICS ENGINEER

Manufacturer established since 1921 has permanent opening for engineer capable of designing circuits and thoroughly familiar with designing of condensers, sockets, jacks, plugs, etc. more from electrical than mechanical angle. Box 410.

#### RADIO SPEAKER ENGINEER

Position for a present chief engineer or assistant with confidence backed by experience in design and economical production of radio speakers. Outstanding opportunity to establish yourself as important member of our company. Salary and bonus. Eventual participation in company stock after proof of performance. Massachusetts location. Interview arranged at our expense. Write full details of experience, past and present positions, earnings etc. to enable us to accurately judge you. Replies held confidential. Our men know of this ad. Box 411.

#### DESIGN ENGINEER

To design and develop production test equipment and fixtures used to check R.F. coils and condensers. Knowledge and experience on design of electronic test equipment essential and some radar experience desirable. Salary open. Location Newark. Box 412.

#### ASSISTANT CHIEF ENGINEER

Prominent Eastern radio set manufacturer requires assistant chief engineer to take complete charge of laboratory. Must be thoroughly competent in AM and FM receiver design; also television; and possess executive ability. Excellent salary and good future. Write complete qualifications and background. Box 408.

#### TECHNICAL EDITOR

Skilled in servicing electronic equipment, to assist in writing and editing articles about radio repairing. Radio Maintenance Magazine, 295 Broadway, New York 7, N.Y.

*(Continued on page 54A)*

## WANTED Chief Engineer

A leading manufacturer of high frequency equipment needs a capable graduate electrical engineer between the ages of 35 and 45 with experience in radio transmitter or high frequency equipment, to assume full responsibility of managing complete engineering staff. Knowledge of high frequency heating will be valuable. Apply with letter giving full information. Education, commercial and industrial experience, age, salary expected and personal qualifications should be included. A recent photo will be welcome. This is a big, important and permanent position.

P.O. Box 413

The Institute of  
Radio Engineers  
330 West 42nd Street  
New York 18, N.Y.

## RADIO ENGINEER

Preferably with training in physics for interesting work in magnetron development. Tube experience not essential. Personnel Division, RCA Victor Division, Camden, New Jersey.

## Draftsman Wanted

Also

### Designer

### Detailer

### Tracer and

### Engineer

We are one of the largest manufacturers of a wide variety of communication and electronic equipment in the world, fully prepared and ready to go ahead with a very ambitious, expansion program as quickly as we are permitted. There will be unlimited possibilities for creative, ambitious men to advance to key positions both in research development and production field.

At present, we are producing vital equipment for our fighting forces.

Good Starting Salaries  
Exceptionally fine working conditions.

Apply Personnel Office  
8 A.M. to 5 P.M.

FEDERAL TELEPHONE &  
RADIO CORP.  
the Mfg. unit of the International  
Tel. & Tel. Corp.  
591 Broad St., Newark, N.J.  
WMC Rules Observed

... it's New!



**FOR  
TELEVISION  
RADAR AND  
FAC-SIMILE**

## *Wide Band* **VIDEO AMPLIFIER**

Designed primarily for use in amplifying complex waves to be viewed on an oscilloscope, this instrument is also extremely useful in laboratory work as an audio amplifier for tracing and measuring small R. F. Voltages, (as in the early stages of radio receivers.) and many similar applications.

### *Specifications*

**BAND WIDTH:** Frequency response is flat within 1.5 DB of the 10 KC response from 15 cycles, to 4 megacycles and 3 DB from 10 cycles to 4.5 megacycles. Phase shift is controlled to provide satisfactory reproduction of pulses on the order of one micro-second, and square waves at repetition rates as low as 100 per second.

**GAIN:** The gain is approximately 1000 when direct input is used. Use of probe input introduces an attenuation of approximately 10:1.

**INPUT** is normally through a probe (furnished with the equipment), which has an input circuit consisting of a 1.1 megohm resistance in parallel with approximately 18 mmfd. The amplifier direct input (without probe) is approximately 2.2 megohms of resistance in parallel with 40 mmfd.

**OUTPUT** voltage can be adjusted from zero to 50 volts R.M.S. with a sine wave signal.

**LOAD IMPEDANCE:** Designed to work into a load of not more than 22 mmfd.

**RIPPLE OUTPUT** is less than 0.5 volt for all operating conditions and all positions of gain control.

**CIRCUIT FEATURES:** A cathode follower input stage provides circuit isolation and is equipped with a 3-position attenuator.

Attenuator ratios are 1:1, 10:1 and 100:1 (This is in addition to probe attenuation). A gain control conveniently varies the video output. A "Signal Polarity" switch is provided which carries the cathode bias on the output stage in such a manner that the amplifier may be adjusted for optimum performance, regardless of the polarity of the input signal.

**OPERATING VOLTAGE:** 110 to 120 volts, 60 cycles.

**POWER CONSUMPTION:** 100 watts.

**WEIGHT:** 35 pounds (Complete with tubes and probe).

**WIDTH:** 7 $\frac{3}{4}$ "      **HEIGHT:** 9"      **LENGTH:** 20 $\frac{3}{4}$ "

INQUIRE EARLY TO INSURE PROMPT DELIVERY

# **UNITED CINEPHONE CORPORATION**

*Designers, Engineers and Manufacturers of Electronic Products*

**18 NEW LITCHFIELD STREET**

**TORRINGTON, CONNECTICUT**



# NEW

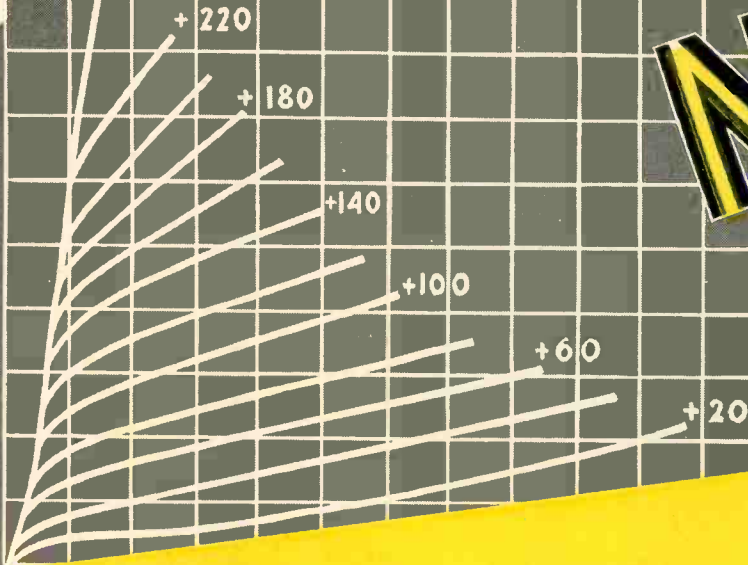

## 4C32—a work horse for industrial heating and diathermy use

- No more loose terminals from excessive heating in service.
- Pure copper terminals for grid and plate connections welded directly to the glass bulb. A technique formerly employed only on tubes of many times the cost of 4C32.
- More filament watts, giving longer life and ability to withstand harder usage.
- The LEWIS process of treating graphite plates insures long, gas-free life.

Filament Voltage	10.0 volts ac	Maximum Power Output	600 watts
Filament Current	4.5 amps	Approximate Driving	
Amplification Factor	30	Power	10 watts
Plate Dissipation	200 watts	Mutual Conductance	3500 micromhos

### Inter-electrode Capacitances

Grid-Plate	5.8 mmf	Input, Grid-Filament	5.3 mmf
		Output, Plate-Filament	1.1 mmf

Frequency Limit for Maximum Ratings—60 mc. Base 4 pin Jumbo.

*Catalog Sheet and Tubes Ready for Distribution*

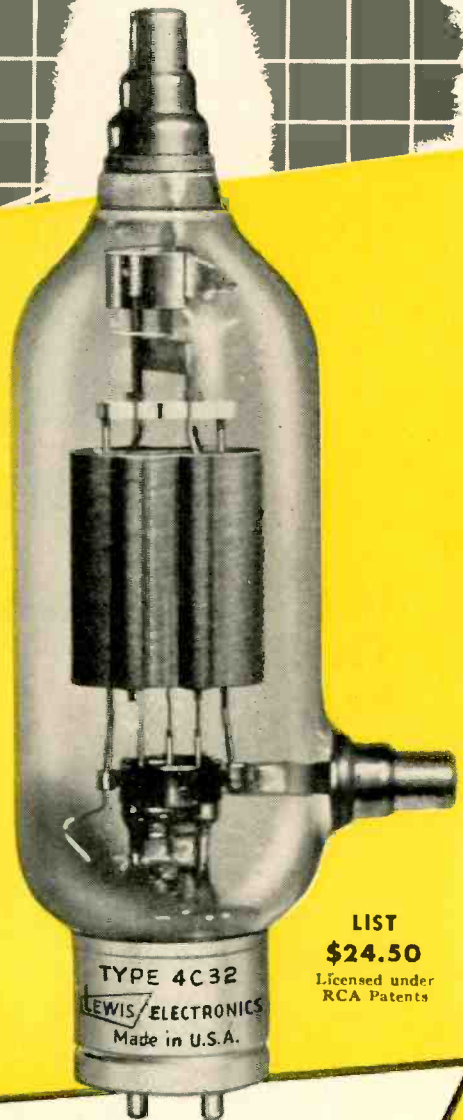

LIST  
\$24.50  
Licensed under  
RCA Patents

Manufacturers of all types of transmitting tubes—from 35 watt West Coast type triodes to 35 kilowatt external anode, multi-grid tubes—a new member of the Aireon family.

# Lewis

Subsidiary of **Aireon**  
MANUFACTURING CORPORATION

## ELECTRONICS

LOS GATOS • CALIFORNIA

# Aireon

## Cinaudagraph Speaker

... Engineered For High Fidelity

True High Fidelity, long-lasting and trouble-free, is built into the design, construction and materials of every Aireon Cinaudagraph Speaker. The result of exacting research and precision workmanship, the Aireon Cinaudagraph Speaker incorporates many electronic and acoustical developments for stamina and tone. The design of the special polyfibrous cones . . . the Acim voice-coil form, impervious to moisture or temperature variations . . . the use of Alnico 5 "the miracle metal" in the magnet structures . . . ribbon wire voice coils . . . are only a few of the plus factors which give Aireon Cinaudagraph Speakers the more efficient performance you require.

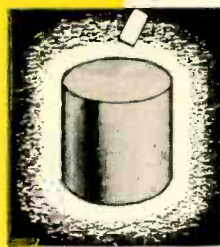
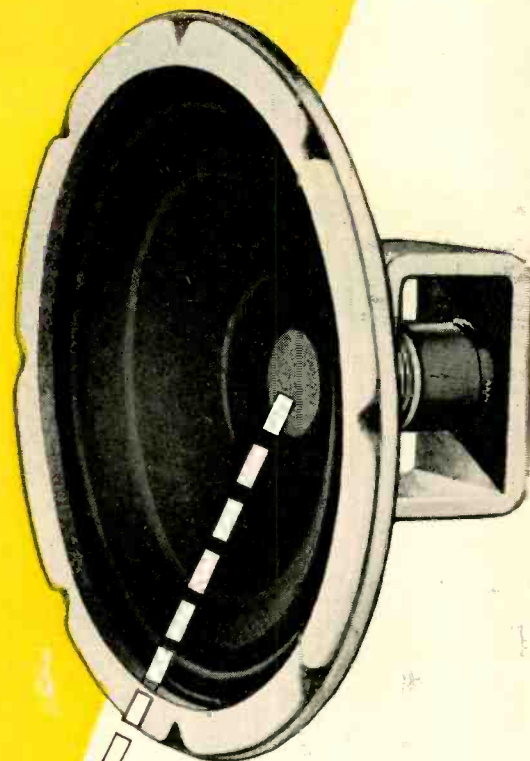

Alnico 5

All P.M. Models of Aireon Cinaudagraph Speakers use Alnico 5, the miracle metal that gives you 4 times the performance without size or weight increase.

**Cinaudagraph Speakers, Inc.**

Subsidiary of **Aireon** Manufacturing Corporation

3911 SOUTH MICHIGAN AVENUE, CHICAGO





**MOTOR DATA**  
No. 130

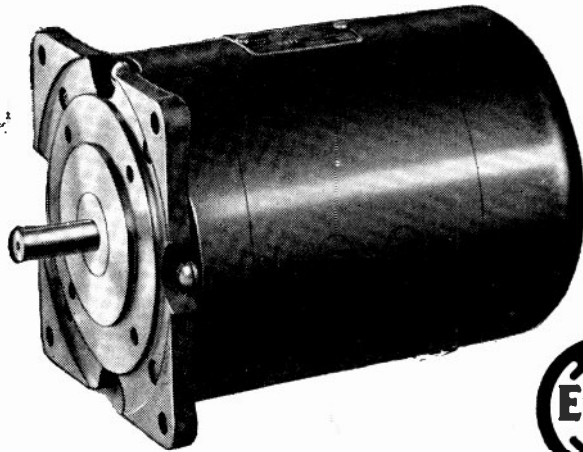

**5200 FRAME MOTOR**  
1/4 HP at 1625 RPM

This motor was the answer to a customer's question . . .  
"Will you design a totally enclosed dual motor unit to drive our warehouse trucks?" Today Type 5230 motors, thousands of them, are wheeling industrial loads. Such engineering service, instantly available, may also solve a difficult motor problem for you.

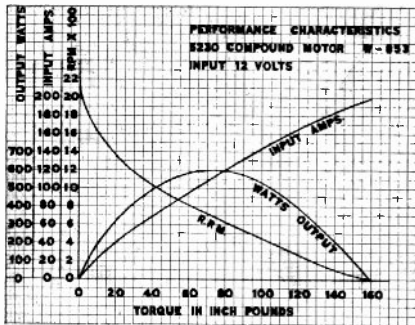

**FEATURES**

**ELECTRICAL**

- Series, shunt, or compound-wound
- Unidirectional or reversible
- Optional torque
- Optional speed
- Optimum efficiency
- For control circuits
- Electric braking optional

**MECHANICAL**

- Ventilated or enclosed types
- Base or flange mounting
- Operation in any position
- Low space factor
- Ball bearing equipped
- Optional shaft details
- Rugged construction

5200 FRAME MOTORS		5220 Shunt	5230 Compound
Output, Con. (H.P.)		1/4	1/4
Torque at 3900 RPM	(in. lbs.)	4.5	10
Torque at 1625 RPM	(in. lbs.)	45	160
Lock Torque	(in. lbs.)	6	6
Volts input	(min.)	110	110
Volts input	(max.)	5 1/4"	5 1/4"
Diameter		8"	9"
Length less shaft		1/2"	1/2"
Shaft Dia.	(max.)	18	24
Weight	(lbs.)		

**EICOR, INC.** 1501 W. Congress St., Chicago, U. S. A.  
DYNAMOTORS • D. C. MOTORS • POWER PLANTS • CONVERTERS  
Export: Ad Auriema, 89 Broad St., New York, U. S. A. Cable: Auriema, New York

★ ★ ★  
**Positions Wanted  
By Armed Forces  
Veterans**

In order to give a reasonably equal opportunity to all applicants, and to avoid overcrowding of the corresponding column, the following rules have been adopted:

The Institute publishes free of charge notices of positions wanted by I.R.E. members who are now in the Service or have received an honorable discharge within a period of one year. Such notices must not have more than five lines. They may be inserted only after a lapse of one month or more following a previous insertion, and the maximum number of insertions is three per year. The Institute necessarily reserves the right to decline any announcement without assignment of reason.

**ENGINEER**

Caltech graduate, with development, test, installation, and administrative experience on instrument landing equipment, radio, and radar, consisting of 1 year industry, 2 1/2 years Signal Corps officer and 10 years practical radio, desires engineering position with promise of real future. Box 2W.

**ENGINEER**

Engineering graduate, 38 years old, desires permanent position involving executive or administrative responsibilities. 11 years commercial engineering experience on radio and television receivers, signal generators, etc. 5 years military experience on airborne radio and radar. Box 3W.

**ELECTRONICS ENGINEER AND ANALYST**

Electronics Engineer and Analyst—B.S.; Electronics and VHF Techniques—Harvard University, M.I.T.; 3 years experience ground, airborne radio, radar systems—desire research, design analysis, technical editing position. Box 4W.

**RADIO ENGINEER**

Skilled radio engineer located in South Africa desires to join staff of radio factory planned for establishment in that country. Address Box 5W.



(Continued from page 50A)

**SALES ENGINEER**

Graduate electrical engineer to apply and sell small fractional horsepower motors to industry. Work direct from sales office of established manufacturer in Rochester, N.Y. Manufacturer's representatives not considered. State fully education, experience, age, and salary expected. Box 322, Rochester 2, N.Y.

**RADIO ENGINEERS**

For design and development of home radio receivers. Can use men with experience in design laboratories on communications and entertainment receiving sets. Call or write Mr. Frank A. Hinners, Vice President in Charge of Engineering, Air King Products, 1523 63rd St., Brooklyn 19, N.Y.

(Continued on page 70A)

# This is the time...

## TO CONTACT THE N-Y-T SAMPLE DEPT. FOR TRANSFORMER DESIGNS

Equipped with two complete sample shops, N-Y-T offers experienced collaboration in working out all details—engineering and production—of sample components for your peacetime requirements.

While actual transformer, choke and filter production schedules are still sub-normal, due to material shortages, N-Y-T engineering design service is prompt and efficient. Backed by more than 9,500 separate and distinct transformer, choke and filter developments for critical wartime applications, N-Y-T Sample Department offers all the name implies . . . thorough and complete collaboration with your own engineering department.

*Address inquiries to Dept. P*

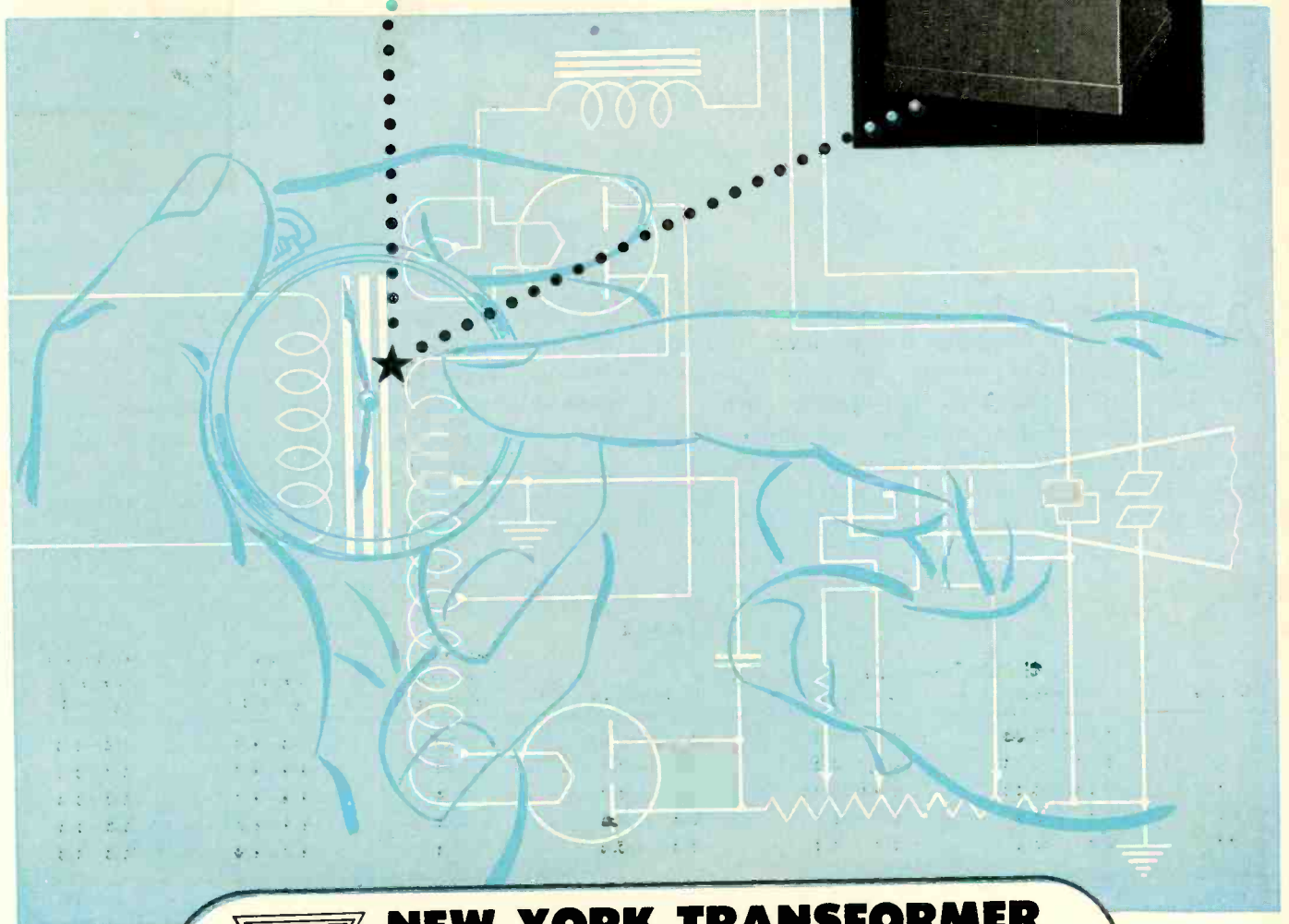

### NEW YORK TRANSFORMER COMPANY

62 WILLIAM STREET, NEW YORK 5, N.Y.

# What are Carbonyl Iron Powders?



**A**BOVE you see the fundamental characteristics found only in G.A.F. Carbonyl Iron Powders. The text below outlines kinds of powders, chemical and physical analysis, including "Q" value, and suggested uses.

G.A.F. Carbonyl Iron Powders are obtained by thermal decomposition of iron penta-carbonyl. There are five different grades in production, which are designated as "L," "C," "E," "TH," and "SF" Powder.

The particles making up the powders "E," "TH," and "SF" are spherical with a characteristic structure of increasingly larger shells. The particles of "L" and "C" are made up of homogenous spheres and agglomerates.

The chemical analysis, the weight-average particle size, the "tap density," and the apparent density as determined in a Scott Volumeter are given in the following table for the five different grades:

Grade	Chemical Analysis		% Nitrogen	Wt. Ave. diameter microns	Tap Density g/cm <sup>3</sup>	Apparent Density g/cm <sup>3</sup>
	% Carbon	% Oxygen				
L	0.005—0.03	0.1 —0.2	0.005—0.05	20	3.5—4.0	1.8—3.0
C	0.03 —0.12	0.1 —0.3	0.01 —0.1	10	4.4—4.7	2.5—3.0
E	0.65 —0.80	0.45—0.60	0.6 —0.7	8	4.4—4.7	2.5—3.5
TH	0.5 —0.6	0.6 —0.7	0.5 —0.6	5	4.4—4.7	2.5—3.5
SF	0.5 —0.6	0.7 —0.8	0.5 —0.6	3	4.7—4.8	2.5—3.5

With reference to the chemical analysis shown above, it should be noted that spectroscopic analysis shows the rest to be iron with other elements present in traces only.

Carbonyl Iron Powders are primarily useful as elec-

tromagnetic material over the entire communication frequency spectrum.

Table 2 at right gives relative Q values (quality factors) and effective permeabilities for the different grades



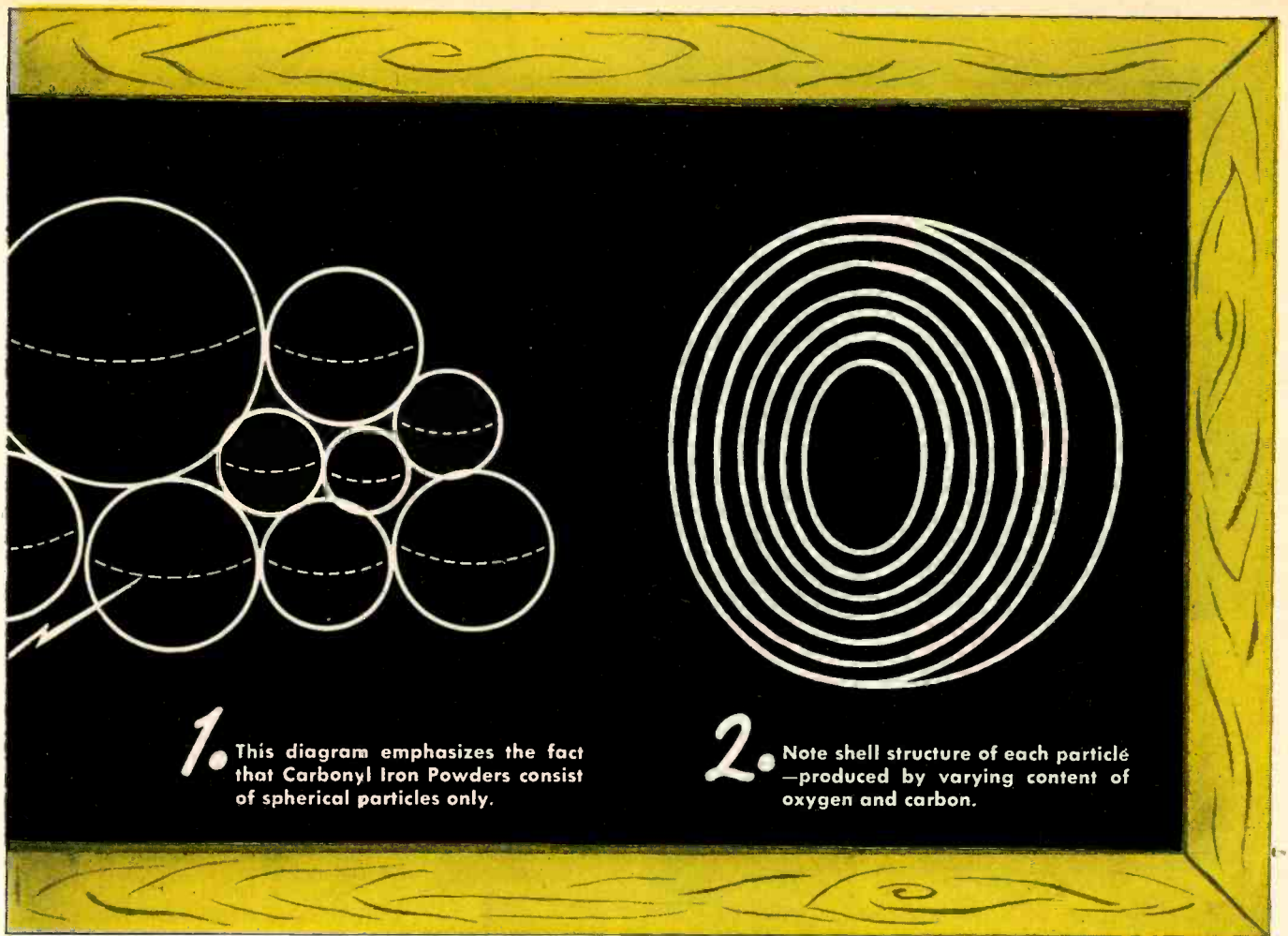

of carbonyl iron powder. The values given in the table are derived from measurements on straight cylindrical cores placed in simple solenoidal coils. Although the data were not obtained at optimum conditions, the Q

values as expressed in percentage of the best core give an indication of the useful frequency ranges for the different powder grades.

TABLE 2

Carbonyl Iron Grade	Effective Permeability at 1 kc	Relative Quality Factor at				
		10 kc	150 kc	200 kc	1 Mc	100 Mc
L	4.16	100	96	90	43	1
C	3.65	94	100	98	72	3
E	3.09	81	94	100	97	30
TH	2.97	81	93	98	100	54
SF	2.17	62	71	78	84	100

(Note: The actually measured Q values can be obtained by multiplying the rows respectively with: 0.78, 1.09, 1.25, 2.05, and 1.62.)

“L” and “C” powders are also used as powder metallurgical material because of their low sintering temperatures, high tensile strengths, and other very desirable qualities. (Sintering begins below 500°C and tensile

strengths reach 150,000 psi.)

Further information can be obtained from the Special Products Sales Dept., General Aniline and Film Corporation, 270 Park Ave., New York 17, N. Y.

**G.A.F. CARBONYL IRON POWDERS**

# Permanent Magnets

## FOR LOUD SPEAKERS

From 1/2 oz. to over 30 lbs. . . and from start to finish . . . Arnold manufactures better Alnico permanent magnets for loud speakers. They are now available for all civilian applications, and include the proposed Radio Manufacturers Association standard speaker magnets in Alnico V.



The speaker magnets illustrated above are representative, yet are just one type of permanent magnets described in the new 24-page Arnold bulletin, "Permanent Magnets for Industry."

WRITE TODAY on your company letterhead  
FOR THIS NEW BULLETIN

**THE ARNOLD ENGINEERING COMPANY**

147 EAST ONTARIO STREET, CHICAGO 11, ILLINOIS

Specialists in the manufacture of  
ALNICO PERMANENT MAGNETS

## Membership

(Continued from page 49A)

- Halford, J. H., Jr., Holt Rd., Andover, Mass.  
Harben, L. A., 217 W. Vesta Ave., College Park, Ga.  
Hart, G. F., 10 Brimmer St., Brewer, Me.  
Hegar, E. A., 802 Telephone Bldg., Dallas 2, Tex.  
Henry, E. G., 148 Westminster Rd., West Hempstead, L. I., N. Y.  
Hoffman, G. R., Submarine Signal Co., 160 State St., Boston 9, Mass.  
Huntington, A., 20 Durant Rd., Wellesley 81, Mass.  
Ivey, H. F., Research Laboratory, National Union Radio Corp., 251 Plane St., Newark 2, N. J.  
Izenour, G. C., 240 Sea Cliff Ave., Sea Cliff, L. I., N. Y.  
Jackson, K. R., 2046 Fort Davis St., S.E., Washington 20, D. C.  
Kane, E. W., 1515 W. Wisconsin Ave., Milwaukee 3, Wisc.  
Keithley, J. F., 500 Parkside Dr., Peoria 5, Ill.  
Kiefer, J. C., 2204 Winona Ave., Chicago 25, Ill.  
Kuehne, W., 700 E. 11 St., Austin 22, Tex.  
Kyte, W. O., General Electric Co., 212 N. Vignes, Los Angeles, Calif.  
Larkin, K. T., 3434 Shenandoah Ave., Dallas 5, Tex.  
Lichterman, G., 2616 N. Spaulding St., Chicago 47, Ill.  
Llewellyn-Thomas, E. R. C., British Army Staff, Washington, D. C.  
Loes, P. A., Electronics Laboratory, Navy Yard, Philadelphia 12, Pa.  
Love, E. R., 903 Palmerston Ave., Winnipeg, Manitoba, Canada  
Lubin, S., 106 Addington Rd., Brookline 46, Mass.  
McCombs, R. K., University of Colorado, Boulder, Colo.  
McDavitt, M. B., 463 West St., New York, N. Y.  
McGaughan, H. S., 3800 W St., S.E., Washington 20, D. C.  
Meyer, R. V., 165 Brattle St., Arlington 74, Mass.  
Nail, J. J., 243 Morris Ave., Summit, N. J.  
O'Donnell, A. J., Jr., 3 Stodder Pl., Salem, Mass.  
Parton, J. E., 18 Westbourne Ave., Cannock, Staffs, England  
Peters, G. O., 222 Greenwood Rd., Sharon Hill, Pa.  
Plotkin, G. N., 261 Kentucky Ave., S.E., Washington 3, D. C.  
Prior, T. C. J., 160 Centre St., Rumford, R. I.  
Riley, O. V., 224 E. Beechwood Ave., Dayton 5, Ohio  
Rockwell, H. P., Thomas and Skinner Steel Products Co., 1120 E. 23 St., Indianapolis 5, Ind.  
Rulison, J. P., 109 New York Ave., Baldwin, L. I., N. Y.  
Ryerson, C. M., 1510-41 St., S.E., Washington 20, D. C.  
Scharmman, R. F., 1 Kenwood St., Pittsfield, Mass.  
Sharon, J. L., Bell Telephone Laboratories, 250 Hudson St., New York 13, N. Y.

(Continued on page 60A)



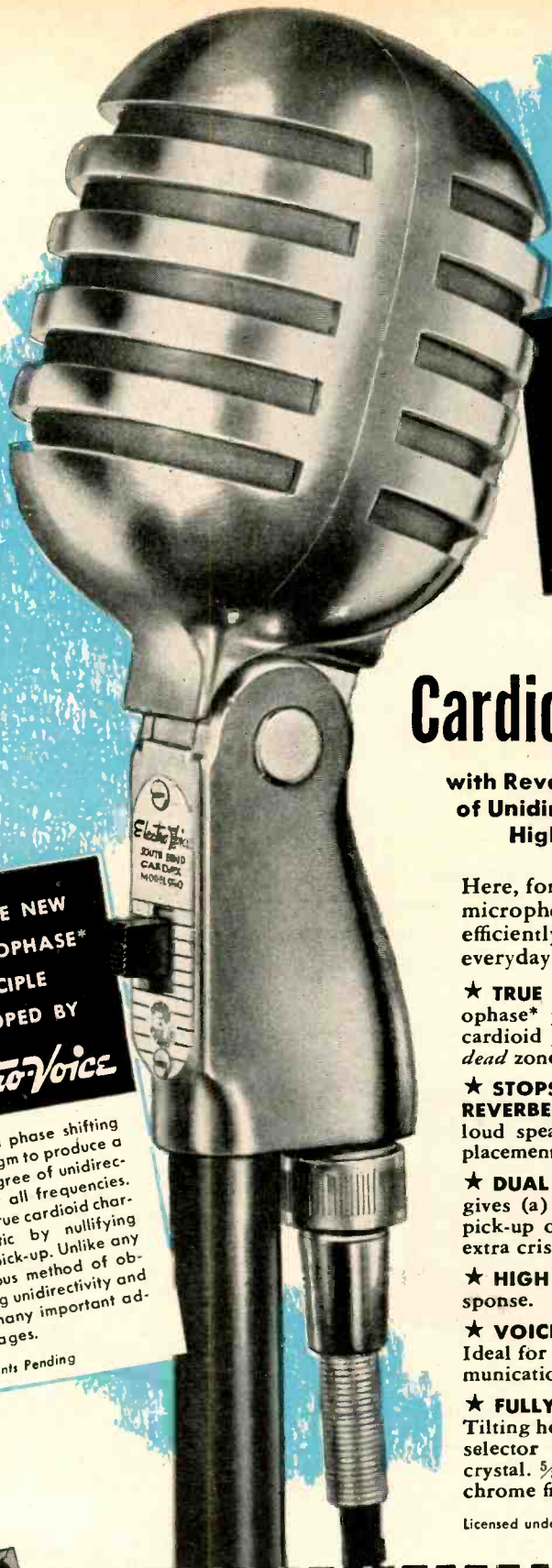

**Electro-Voice**  
ANNOUNCES THE  
**CARDAX**

**A NEW**  
**Cardioid Crystal Microphone**

with Revolutionary New **MECHANOPHASE\*** Principle of Unidirectivity . . . Dual Frequency Response . . . High Output . . . and other big features!

Here, for the first time, you get *all* these features in *one* microphone! With amazing flexibility, new **CARDAX** efficiently serves many applications . . . easily solves everyday problems of sound pick-up and reproduction!

★ **TRUE CARDIOID POLAR PATTERN** New E-V Mechanophase\* principle gives wide-angle front pick-up in true cardioid pattern over wide frequency range. Sound at rear dead zone cancels out and is not reproduced.

★ **STOPS FEEDBACK—CUTS BACKGROUND NOISE AND REVERBERATION PICK-UP** Permits nearly double usable loud speaker volume. Simplifies microphone and speaker placement. Assures finer reproduction of just the sound wanted.

★ **DUAL FREQUENCY RESPONSE** Screw control on back gives (a) Wide range flat response for high fidelity sound pick-up or (b) Wide range with rising characteristic for extra crispness of speech or high frequency emphasis.

★ **HIGH OUTPUT LEVEL** —57 db for flat frequency response. —48 db for rising frequency response.

★ **VOICE AND MUSIC PICK-UP EXACTLY AS DESIRED** Ideal for public address, recording, remote broadcast, communications . . . indoors and outdoors.

★ **FULLY EQUIPPED FOR CONVENIENT OPERATION** Tilting head. Built-in "On-Off" switch. Dual frequency range selector switch. Cable connector. 20 ft. cable. Bimorph crystal.  $\frac{5}{8}$ "-27 thread. New modern functional design. Satin chrome finish. **CARDAX Model 950, List Price . . . . . \$37.00**

Licensed under Brush Patents, Electro-Voice Patents Pending.

**EXCLUSIVE NEW**  
**MECHANOPHASE\***  
PRINCIPLE  
DEVELOPED BY

**Electro-Voice**

Utilizes a phase shifting diaphragm to produce a high degree of unidirectivity at all frequencies. Gives true cardioid characteristic by nullifying back pick-up. Unlike any previous method of obtaining unidirectivity and has many important advantages.

\*Patents Pending



**SEND FOR BULLETIN NOW**  
Get full facts about amazing new **CARDAX!** Describes **Mechanophase**. Shows how dual frequency response selector works. Includes diagrams and response curves.

No Finer  
Choice Than

**Electro-Voice**

**MICROPHONES**

**ELECTRO-VOICE, INC.**, 1239 South Bend Ave., South Bend 24, Indiana  
Export Division: 13 East 40th St., New York 16, N. Y., U.S.A.—Cables: Arlab

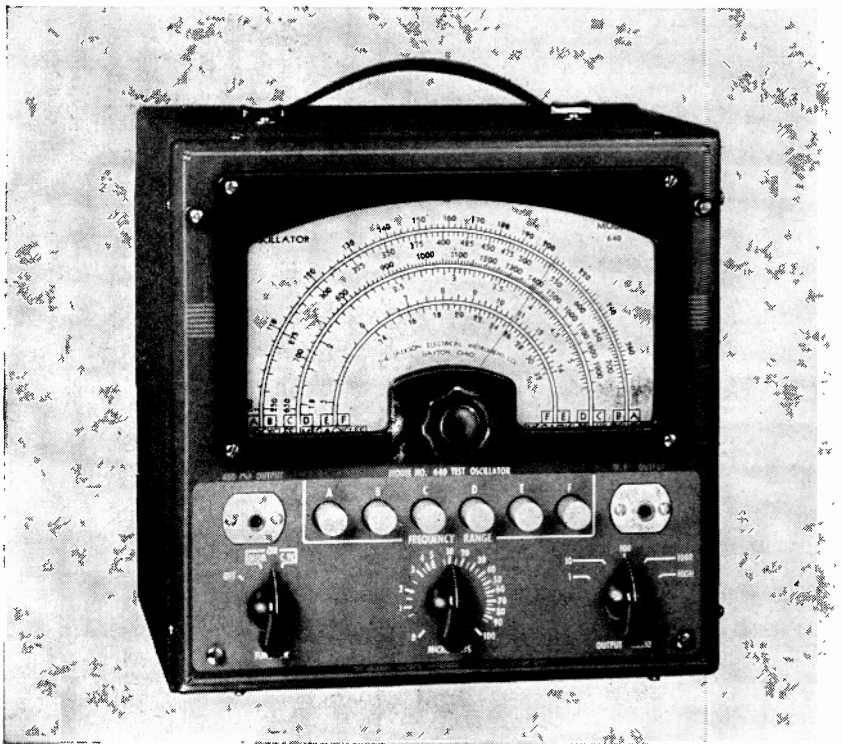

## TEST OSCILLATOR Model 640

A COMPLETE "standard type" oscillator for all general purpose work. Has full range direct reading dial from 100 KC up to 30 megacycles. No skips or harmonics calibrated. All ranges are fundamental frequencies.

**Push Button** selection of all ranges makes speedy and accurate operation possible.

**Glass Enclosed Dial**—prevents dust and avoids possibility of damage to pointer.

**Two Circuit Attenuator** provides variable ratio and also vernier control.

**Has Powerful Signal** output which may be used either as pure R.F. or Modulated R.F. The A.F. voltage is available for external use. Carrier is modulated at approximately 30%.

**Accuracy Guaranteed** to  $\frac{1}{2}$  of 1% on all ranges. Operates from 110 volt 60 cycles. Uses three tubes (rectifier, oscillator and modulator).

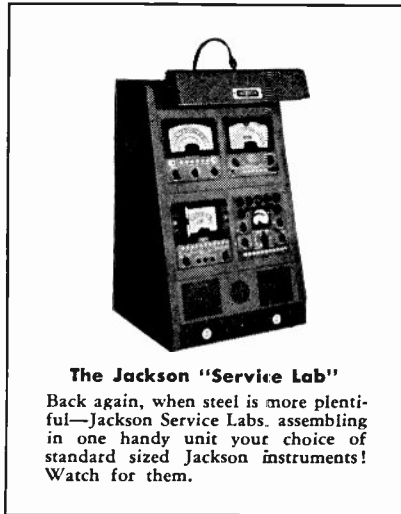

**The Jackson "Service Lab"**

Back again, when steel is more plentiful—Jackson Service Labs. assembling in one handy unit your choice of standard sized Jackson instruments! Watch for them.

# JACKSON

*Fine Electrical Testing Instruments*

JACKSON ELECTRICAL INSTRUMENT COMPANY, DAYTON, OHIO

## Membership

(Continued from page 58A)

- Snyder, R. L., Jr., Nassau Club, Princeton, N. J.  
 Starks, J. C., Box 307, Sunbury, Pa.  
 Stewart, S. W., 11 Ash St., Garden City, L. I., N. Y.  
 Strohm, W. E., Lacey Field, MD 14, Newburgh, N. Y.  
 Stutz, S. L., 5 Nimitz Dr., Dayton, Ohio  
 Sullivan, M. C., 522 Bailey Ave., San Antonio 3, Tex.  
 Syrdal, R. R., 2000 Irving Ave., S., Minneapolis 5, Minn.  
 Tate, J. B., 3926 Southern Ave., S.E., Washington 20, D. C.  
 Thornton, T. W., 5000 Yorktown Rd., Washington 16, D. C.  
 Tolles, W. E., Airborne Instruments Laboratory, Inc., 160 Old Country Rd., Mineola, L. I., N. Y.  
 Tower, W. R., 325 Newport Ave., Webster Groves 19, Mo.  
 Trimble, R. F., 18 Buena Vista Park, Cambridge 40, Mass.  
 Ulm, E. H., Sylvania Electric Products Inc., 500—5 Ave., New York 18, N. Y.  
 Ward, R. A., 157 S. Virgil Ave., Los Angeles 4, Calif.  
 Weichbrod, J., 2525—14 St., N.E., Washington 18, D. C.  
 Weis, J. L., 4713—3 Pl., N.W., Washington 11, D. C.  
 Wennersten, D. L., 1304 $\frac{1}{2}$ —36 St., N.W., Washington 7, D. C.  
 Wilson, D. W., 1406 Downing St., N.E., Washington, D. C.  
 Wilson, L. D., 25 Evans St., Watertown 72, Mass.

### Admission to Associates

- Adams, M. F., Jr., 142 Poplar Circle, Decatur, Ga.  
 Altmann, H., c/o Mrs. J. Brown, House Tarsha, Jerusalem-Talbie, Palestine  
 Anderson, C. L., 1 Elton St., Brooklyn, N. Y.  
 Aronow, S., 5969 W. Ohio St., Chicago 44, Ill.  
 Balcom, H. A., 4136 Shenandoah St., Dallas 5, Tex.  
 Baltzer, O. J., 500 E. 24 St., Defense Research Laboratory, University of Texas, Austin, Tex.  
 Banta, H. E., Box 6007, Houston 6, Tex.  
 Barnes, R. S., Sperry Gyroscope Co., Garden City, L. I., N. Y.  
 Bartle, O. E., 64 Otho St., Inverell, N.S.W., Australia  
 Beecher, W. C., 1301 N. Troy St., Arlington, Va.  
 Beretzki, D., 33 Ave. Amiral Courbet, Eaubonne-Seine et Oise, France  
 Berger, L. L., c/o Postmaster, New York, N. Y.  
 Bernard, P., 1425 Grand Concourse, New York 52, N. Y.  
 Brennan, J. E., 55 Armory St., Quincy 69, Mass.  
 Bruno, D., 95 Hillman Dr. N., East Paterson, N. J.  
 Butler, W. R., 1604 Central Ave., Sandusky, Ohio  
 Carter, W. L., Jr., 75 Whitman Ave., West Hartford 7, Conn.

(Continued on page 62A)



**avoid damage  
from "in-the-package"  
moisture**



**no rust  
no corrosion  
in this container**

**SHIPPER!** Your product can be seriously damaged by rust, corrosion, or mildew . . . because of "in-the-package" moisture. Avoid such damage. Include Jay Cee Silica Gel, the ideal drying agent, in the packages with your product.

Your container may be sealed "tight as a drum" against outside moisture. Yet, the vapor within can cause untold harm. Particularly, a slight drop in temperature can release dangerous moisture.

Jay Cee Silica Gel keeps the air in the package dry . . . adsorbs the vapor . . . prevents moisture damage. Jay Cee Silica Gel is a crystalline substance resembling rock salt in general appearance . . . chemically inert. Has amazing power to take up moisture without its particles changing in size or shape. Packed in 1, 2, 4, 8 oz. and 1 and 5 lb. bags. Used widely with shipments of metal parts, precision instruments, electronic equipment, dehydrated foods, fabrics, and chemicals.

The illustration shows Mr. Otto Mueller, packaging foreman, inspecting one of his Ampro Sound-On-Film Projectors sealed tightly within a representative moisture vapor-proof barrier, ready to be placed in a shipping carton. Packed within the barrier, with the Projector, are three small bags of Jay Cee Silica Gel . . . which adsorb "in-the-package" moisture and prevent damage from rust or corrosion.

(Cellophane packaging was used in this illustration as a substitute for the actual wrapping).



**JOLIET CHEMICALS, LTD.**

116 INDUSTRY AVENUE  
JOLIET, ILLINOIS

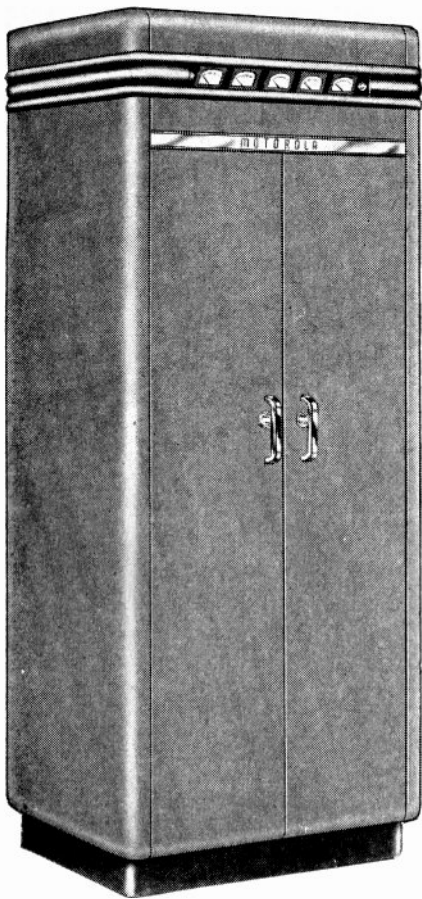

Illustrated is Motorola's newest contribution to this field—the Model FSTRU-250-BR 250-watt Central Station Transmitter-Receiver Unit, designed for the newly-established 152-162 mc. band.



That all Motorola Police and Public Utility equipment uses ANDREW Coaxial Cable is indicative of Motorola's confidence in ANDREW engineering and manufacturing skill. The ANDREW Company is a pioneer in the manufacture of coaxial cable and accessories.

## POLICE USE *Motorola*

Eighty percent of all FM Police radio equipment in use today is Motorola. This includes a roster of 35 state police systems and many thousands of city and county systems throughout the United States.



WRITE FOR  
ANDREW CATALOGUE  
TODAY

## Membership

(Continued from page 60A)

- Chan, W. W., Sperry Gyroscope Co. Inc., Research Laboratories 1R25, Garden City, L. I., N. Y.
- Charlton, G., Bridgetown, N.S., Canada
- Cohen, E., 10 Rutgers Pl., New York 2, N. Y.
- Colfax, L. J., 1503-17 St., Santa Monica, Calif.
- Collins, J. S., 227 Church St., New Haven 6, Conn.
- Coombs, G. F., 4635 Bermuda Ave., San Diego 7, Calif.
- Cunningham, R. D., 329 S. Wilson St., Casper, Wyo.
- Crompton, M. J., 25 Wickham Grove, Nth Essendon W. 5, Melbourne, Australia
- Dexter, G. W., 2250 Carleton, Berkeley 4, Calif.
- Dick, T. M., 38-25 Bell Blvd., Bayside, L. I., N. Y.
- Dickon, A. J., 11 Squire St., Hartford, Conn.
- Doronin, V. P., 1351 Park Rd., N.W., Washington 10, D. C.
- Downs, E. E., 8 Rogers Ave., London, Ont., Canada
- Dunlap, G. S., 2608 W. Haddon Ave., Chicago 22, Ill.
- Dustman, H. C., 1431 S. 73 St., West Allis, Wisc.
- Dyberg, T., Vastergatan 33, Eslov, Sweden
- Edmunds, J. J., Jr., RFD, Bridgewater, Me.
- Fair, R. G., U. S. Coast Guard Air Station, San Diego 50, Calif.
- Fallon, M. W., 117 Lake Ave., Newton Centre 59, Mass.
- Fay, H. W., 450 N. Walnut St., East Orange 1, N. J.
- Foschi, E. J., 322 Beach 74 St., Arverne, L. I., N. Y.
- Friedrich, W. J., 515 (Rear) Lebanon Ave., Belleville, Ill.
- Fukuda, F., 2920 Cass St., Detroit 1, Mich.
- Gardner, D. R., 19308 Beacons Field, Detroit 24, Mich.
- Geery, P. W., 2507 Shakespeare, Houston 5, Tex.
- Gerber, I. B., 94 Portland St., Boston, Mass.
- Gong, W. A., R.M.S. Staff, Treasure Island, San Francisco, Calif.
- Grad, H., 743 Kelly St., New York 55, N. Y.
- Greenwald, M. H., 5203 Arbor St., Philadelphia 20, Pa.
- Gresslin, C. H., 1237 Hathaway, Lakewood 7, Ohio
- Gulden, E. V., 14 W. Mayo Ave., Dayton 9, Ohio
- Hance, L. V., RFD 1, Box 484, Michigan City, Ind.
- Hannurker, L. G., c/o S.T.C. Mhow, Mhow, Central India
- Harris, H. H., 514 Atlanta Ave., St. Louis 19, Mo.
- Heaton, R. G., 8 Prescott St., Cambridge, Mass.
- Henroteau, F. C., Farnsworth Television and Radio Corp., Fort Wayne 1, Ind.
- Hicklin, W. H., Jr., Capitol Radio Engineering Institute, 16 and Park Rd., N.W., Washington 10, D. C.

(Continued on page 64A)

**Start RIGHT  
AND YOU End  
RIGHT!**



**with WESTONS ON ALL PRODUCTION  
TEST-STANDS AND INSPECTION EQUIPMENT!**

With the race for markets in full swing, electrical manufacturers are eliminating costly production bottlenecks by providing *uniform dependability* in testing procedure all along the line. From the inspection of purchased components right through to final product inspection, they insure accurate testing by using instruments they can trust.

And it's easy to insure *measurement dependability* at every step, because there are WESTONS for every testing need . . . including types for all special test-stand requirements, as well as a broad line of multi-range, multi-purpose test instruments. These compact, multi-purpose testers often afford new simplicity and economies in testing procedure, while assuring the dependability for which WESTONS are renowned.

Literature describing the complete line of WESTON panel and test instruments is freely offered . . . Weston Electrical Instrument Corporation, 578 Frelinghuysen Avenue, Newark 5, New Jersey.

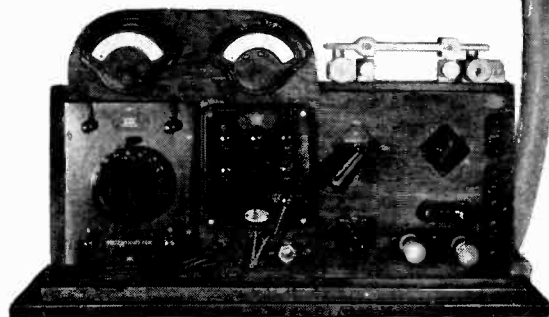
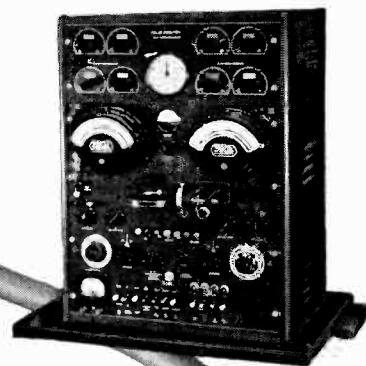

**Weston Instruments**

ALBANY • ATLANTA • BOSTON • BUFFALO • CHICAGO • CINCINNATI • CLEVELAND • DALLAS • DENVER • DETROIT • JACKSONVILLE • KNOXVILLE • LOS ANGELES • MERIDEN  
MINNEAPOLIS • NEWARK • NEW ORLEANS • NEW YORK • PHILADELPHIA • PHOENIX • PITTSBURGH • ROCHESTER • SAN FRANCISCO • SEATTLE • ST. LOUIS • SYRACUSE  
In Canada, Northern Electric Co., Ltd., Powerlite Devices, Ltd.



## Patterson Phosphors for Contrast... Brilliance...Detail in Television Images

PATTERSON PHOSPHORS are designed for maximum luminescence with minimum input energy. Quality phosphors for television, radar, oscilloscopes and other electronic instruments are available from Patterson Screen Division of E. I. du Pont de Nemours & Co. (Inc.), Towanda, Pa. Manufacturers, experimental laboratories and schools are invited to write us outlining their requirements.

PATTERSON PHOSPHORS ARE AVAILABLE  
IN A WIDE RANGE OF

1. Colors
2. Grain Size
3. Brilliance
4. Type of Excitation
5. Afterglow
6. Special Blends

**PATTERSON  
LUMINESCENT CHEMICALS**



BETTER THINGS FOR BETTER LIVING . . . THROUGH CHEMISTRY

## ATTENUATORS by TECH LABS



"Midget" model is especially designed for crowded apparatus or portable equipment.

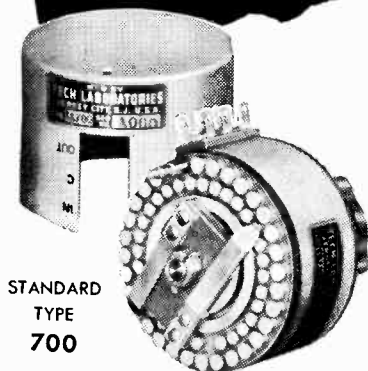

STANDARD  
TYPE  
700

- Solid silver contacts and stainless silver alloy wiper arms.
- Rotor hub pinned to shaft prevents unauthorized tampering and keeps wiper arms in perfect adjustment.
- Can be furnished in any practical impedance and db. loss per step upon request.
- TECH LABS can furnish a unit for every purpose.
- Write for bulletin No. 431.



Manufacturers of Precision Electrical Resistance Instruments  
337 CENTRAL AVE. • JERSEY CITY 7, N. J.

## Membership

(Continued from page 62A)

- Hildyard, J. M., 2869 S. Buchanan, Fairlington, Arlington, Va.
- Hodges, E. B., 37 Ellenwood Ave. Los Gatos, Calif.
- Hogan, J. J., 6600 N. 8 St., Philadelphia 26, Pa.
- Hogg, C. B., Box 116, Allegan, Mich.
- Hosmer, D. W., 12 Garland Rd., Newton Centre 59, Mass.
- Hovey, I. C., 6206 Taggart St., Houston 7, Tex.
- Huang, G. T. C., c/o Apt. 5L, 790 Riverside Dr., New York 32, N. Y.
- Humphreys, R. V., 218 Havelock St., Toronto 4, Ont., Canada
- Jeffery, J., c/o Jeffery and Jeffery, 7 Market Lane, London, Ont., Canada
- Johnson, J. B., 207 Chenery St., San Francisco 12, Calif.
- Jones, R., 35 Hiawatha Rd., Toronto, Ont., Canada
- Judd, A. N., 52, Bushey Grove Rd., Watford, Herts., England
- Kilby, P., Pattonville, Mo.
- Klein, L. F., 1604 N. 60 St., Milwaukee 8, Wisc.
- Koombs, I., 1442 Nelson St., Vancouver, B. C., Canada
- Krasnican, M. J., 11 Madison Ave., Irvington 11, N. J.
- Krulikowski, S. J., Jr., Research Corp., c/o Dr. H. J. White, Bound Brook, N. J.
- Lane, C. C., 39-34 Glenwood St., Little Neck, L. I., N. Y.
- Large, R. F., 57 Euston St., Charlotte-town, P. E. I.
- Lee, J. A., 97 Murray St., St. Mary's Park, San Francisco 12, Calif.
- Leonard, L. J., 40 Prince Arthur Ave., Toronto 5, Ont., Canada
- Levy, J. P., 1402 Varnum St., N.W., Washington 11, D. C.
- Loewenstein, C. N., 47 Northview Ave., Upper Montclair, N. J.
- Lubiancki, M., 4422 DeReimer Ave., New York, N. Y.
- MacKenzie, J. M., 961 W. Genesee St., Syracuse 4, N. Y.
- MacNichol, E. F., Jr., Hamilton, Mass.
- Maxwell, R. S., 1312 E. Washington Blvd., Fort Wayne 4, Ind.
- McKendry, J. K., 235 Payson Rd., Belmont 78, Mass.
- McMenomey, J. M., 2061 S. Mountain Ave., Monrovia, Calif.
- McMichael, J. T., 6624 W. Wells St., Milwaukee 13, Wisc.
- Membery, A. H., 171 Earlsdale Ave., Toronto 10, Ont., Canada
- Merrill, R. P., Clinton, Ont., Canada
- Miller, A. G., 211 Hendren St., Staunton, Va.
- Miller, C. M., 954 Geary St., San Francisco 9, Calif.
- Mitchell, G. A., 52 King St. W., Cobourg, Ont., Canada
- Mroz, M., 214 N. Lincoln Ave., Park Ridge, Ill.
- Nakagawa, S., Jr., 29 Macon St., Brooklyn 16, N. Y.
- Ochwatt, P., 2448 S. California Ave., Chicago, Ill.
- O'Neil, A. R., 218 N. St. Louis Blvd., South Bend 17, Ind.

(Continued on page 66A)



# SPACE SAVERS



**OY4G**  
ACTUAL SIZE



**OY4**  
ACTUAL SIZE

SPACE SAVERS

# RAYTHEON

## IONICALLY HEATED LOW VOLTAGE GAS RECTIFIERS

A major deterrent to the further size reduction of radio receivers and other equipment designed for universal operation from a standard 117 volt AC or DC line or internal batteries, has been the size and power dissipation associated with the rectifier tube. The advantages of an ionically heated tube for low voltage applications were recognized early by the Raytheon engineers, who have long pioneered in the field of gas tube development. However, considerable research has produced the OY4 and OY4G which start cold from no more than 95 volts DC. High rectification efficiency is realized from the low internal drop and high peak current ratings. Physically these types have the same dimensions as the familiar OZ4G and OZ4.

Where size is an important factor, use of the OY4G in place of the 117Z6GT, as extensively employed in the three way receivers, will result in a substantial reduction of the space requirements.

Even more important is the differential of approximately eight watts in favor of the OY4 and OY4G because of the ionic heating feature. This saving cuts the input power down by more than 50% for a normal receiver. Consequently, cabinet size can be decreased without danger of excessive heating. Furthermore, the time required for the set to become operative is the same whether on DC, AC or battery — that is, almost instantaneous.

These tubes have been engineered to produce a minimum of the radio frequency disturbances associated with a gaseous discharge. The simple filter circuit indicated below will generally reduce such interference to a negligible value.

If your product does not call for the ionically heated low voltage gas rectifier, there is a Raytheon type designed for your need. And all Raytheon tubes follow the same rigid pattern of advanced engineering with precision manufacture. To get continuing best results, specify Raytheon High-Fidelity Tubes.

### OY4G AND OY4 RATINGS

Half Wave Rectifier—Condenser Input to Filter\*

Maximum Inverse Peak Voltage . . . . .	300 volts
Maximum Peak Current . . . . .	500 ma
Maximum DC Output Current . . . . .	75 ma
Minimum DC Output Current . . . . .	40 ma
Minimum Series Anode Resistance (117V line operation) . . . . .	50 ohms
Approximate Tube Drop . . . . .	12 volts
Maximum DC starting Voltage** . . . . .	95 volts

\*Pins 7 and 8 must be connected together. Rapid intermittent operation is undesirable.  
\*\*With starter anode network as shown in circuit.

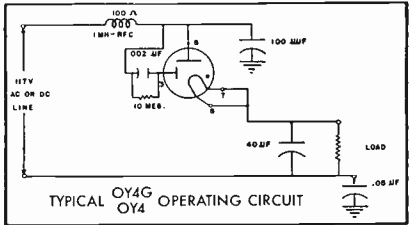

*Excellence in Electronics*

*Radio Receiving Tube Division*

NEWTON, MASSACHUSETTS  
NEW YORK • CHICAGO

## Membership

(Continued from 64A)

- Osborn, M. W., 2428 E. Bellevue Pl., Milwaukee 11, Wisc.
- Pearson, J. L., Port McNicoll, Ont., Canada
- Potts, L. T., 101 Terrace Ave., Hasbrouck Heights, N. J.
- Rawcliffe, A. S., 1416 W. Hunting Park Ave., Philadelphia 40, Pa.
- Reiffin, J. L., 2704 Kingsbridge Terrace, Bronx 63, N. Y.
- Reynolds, R. C., 7608 Bradford, Houston 12, Texas
- Rockwood, C. H., 1003 S. 76 St., West Allis 14, Wisc.
- Rosenberg, B. G., 1029 S. Citrus Ave., Los Angeles, Calif.
- Russell, W. J., Jr., 9463 TSU Radio Propagation Unit, Holabird Signal Depot, Baltimore, Md.
- Sangster, L. M., 705—9 Ave. S.E., Cedar Rapids, Iowa
- Schlegel, C. J., EE and RM, N.T.C., Gulfport, Miss.
- Schmidt, H., 311 E. Cowan Dr., Houston 7, Tex.
- Schneider, S. A., 1357 Estes Ave., Chicago 26, Ill.
- Schwab, D., 32-37—42 St., Astoria, L. I., N. Y.
- Sears, C. B., 2416 Pennsylvania Ave. N.W., Washington 7, D. C.
- Segel, H. P., 143 Newbury St., Boston 16, Mass.
- Sheridan, W. F., 20 Muzzey St., Lexington 73, Mass.
- Shirk, A. B., Box 185, Hilliards, Ohio
- Skiba, R. R., 2876 N. 36 St., Milwaukee 10, Wisc.
- Skirrow, J. E., 36 Manor Ave., Hempstead, L. I., N. Y.
- Skirving, A. E., "Kenmuir," Berwick, Victoria, Australia
- Smith, A., W. National Ave. 4911, Milwaukee 14, Wisc.
- Smith, D. H., 33 Ferncliff Rd., Scarsdale, N. Y.
- Soules, W. F., 1239 South Bend Ave., South Bend 24, Ind.
- Stewart, J. L., 2976 Neil Ave., Columbus 2, Ohio
- Stouse, L. E., Jr., 1320 Octavia St., New Orleans 15, La.
- Sullivan, A. D., 9385 Parkside, Brentwood 17, Mo.
- Sulzer, P. G., RFD 112, Cheney, Pa.
- Van Haaren, R. H. Ch., c/o Royal Dutch Airlines Curacao, Netherlands West Indies
- Vermillion, R. K., 633½—2 St. N., St. Petersburg, Fla.
- Walsh, L. R., Physics Dept., University of Illinois, Champaign, Ill.
- Waterman, A. T., Jr., Box F, University Station, Austin, Tex.
- Weill, A. E., 2440 N. Kedzie Blvd., Chicago 47, Ill.
- Weirich, E. M., 5424 Byron St., Chicago 41, Ill.
- Welch, R. C., Box 42, Tisdale, Saskatchewan, Canada
- Welz, W. C., 2712 Leeland, Houston, Tex.
- Wiechmann, R. S., Calle Papudo No. 407, Valparaiso, Chile
- Yerger, L. K., 93 Dewey Ave., Buffalo 14, N. Y.

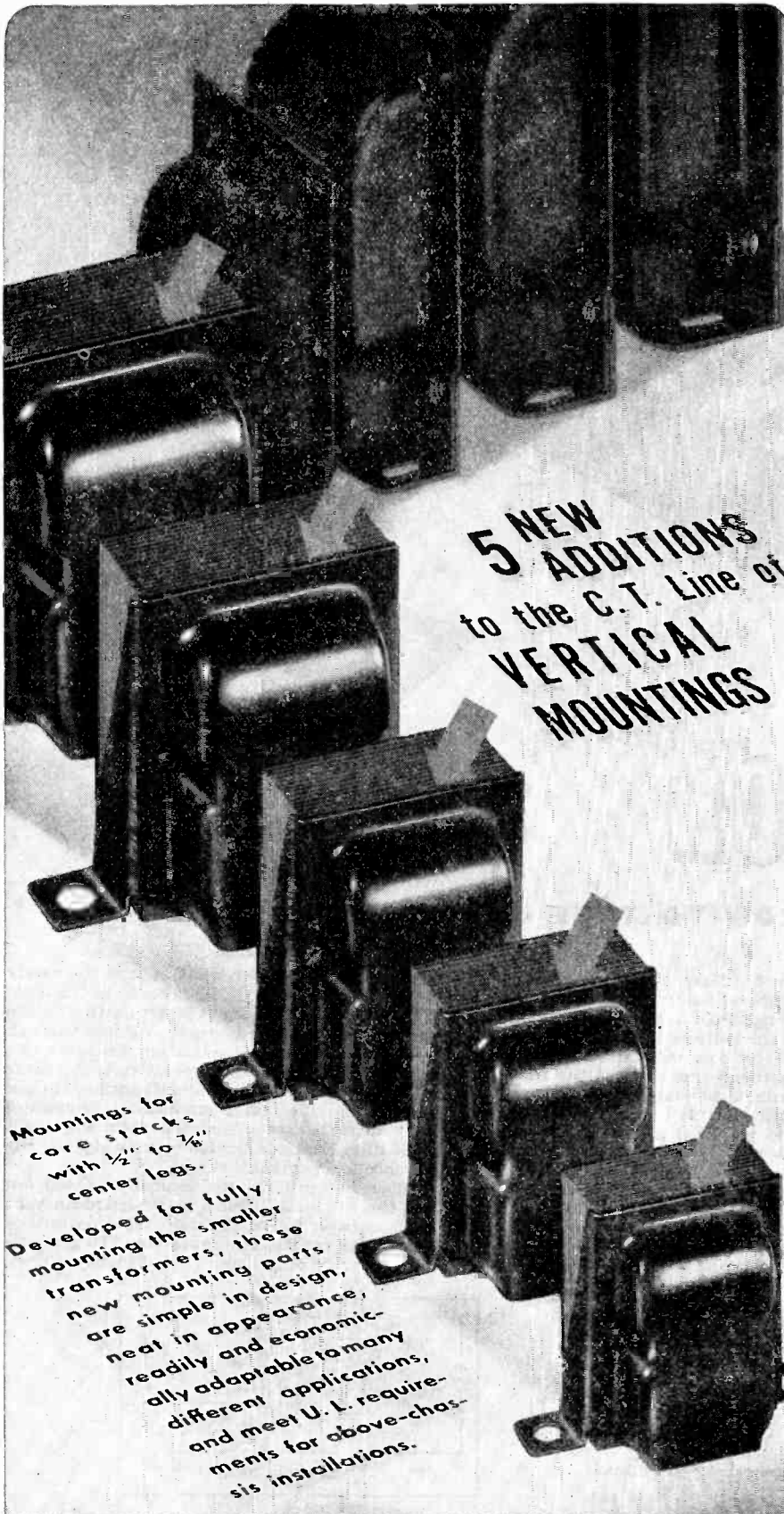

**5 NEW  
ADDITIONS  
to the C.T. Line of  
VERTICAL  
MOUNTINGS**

Mountings for  
core stacks  
with  $\frac{1}{2}$ " to  $\frac{3}{8}$ "  
center legs.

Developed for fully  
mounting the smaller  
transformers, these  
new mounting parts  
are simple in design,  
neat in appearance,  
readily and economic-  
ally adaptable to many  
different applications,  
and meet U. L. require-  
ments for above-chas-  
sis installations.

# CHICAGO TRANSFORMER



DIVISION OF ESSEX WIRE CORPORATION

3501 WEST ADDISON STREET

CHICAGO, ILL.



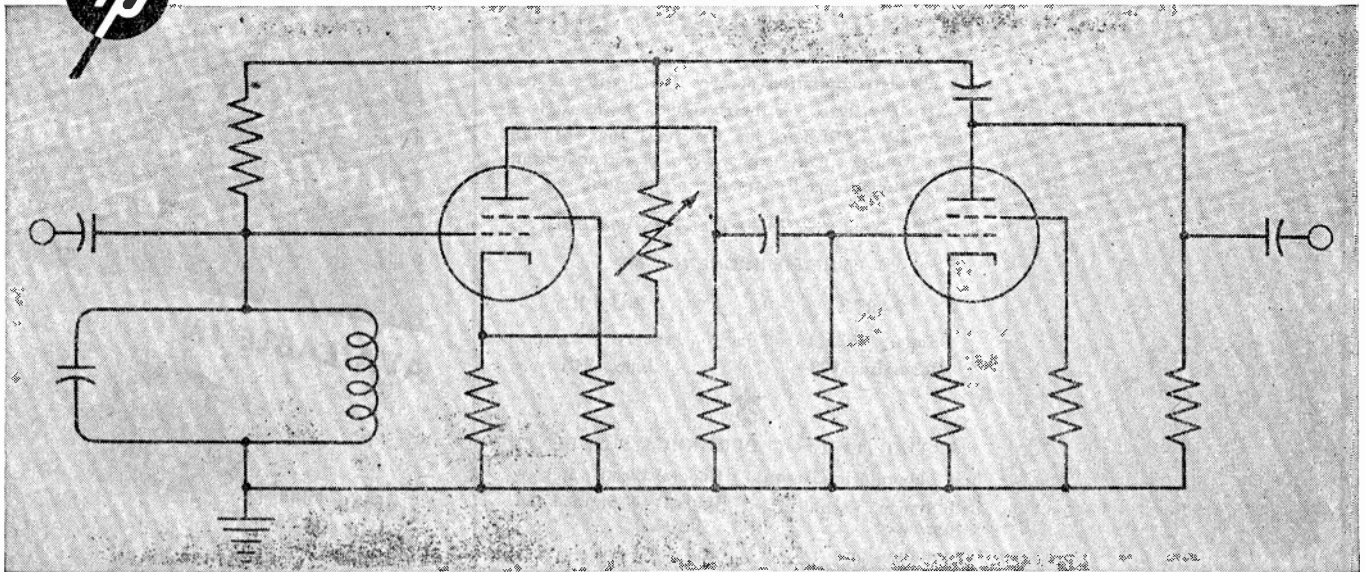

## The High – and Variable “Q” of This Circuit Means Rapid, Accurate Wave Analysis

This *-hp-* Harmonic Wave Analyzer measures the individual components of complex waves with speed and surety, because of the highly efficient composite circuit shown above. The variable selectivity of the amplifier is the factor which makes it especially useful for measurements at higher frequencies. Regeneration is used to give the amplifier a high effective “Q,” and a degeneration control provides variable selectivity. The resulting performance of this circuit is shown in accompanying graph.

harmonics to be measured. Yet the fingertip control is easy to manage. This characteristic makes the *-hp-* Harmonic Wave Analyzer useful for many applications where constant selectivity would be unsuitable. Variable selectivity is required in measuring distortion of sound on recorded film, disks and other cases where there may be a small amount of frequency modulation. It is also used in integrating the noise spectrum in acoustic measurements and elsewhere when a wider pass band gives a more representative integration.

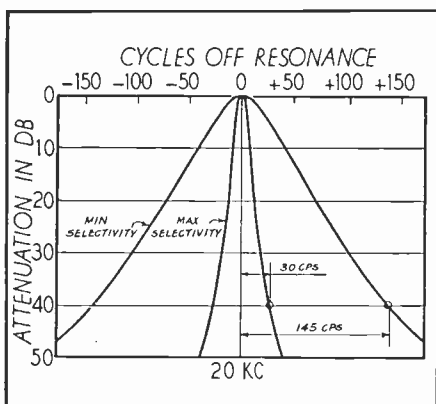
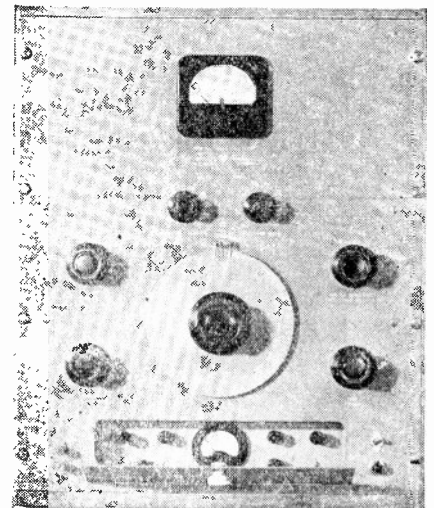

In practical terms, variable selectivity means no tedious “searching out” of the

The *-hp-* Harmonic Wave Analyzer covers the audio spectrum from 30 to 16,000 cps. There is likewise a wide voltage range; full scale voltmeter readings may be obtained with inputs of .001 to 500 volts. Thus the 300A may be used with equal success with low output recording devices and high power modulating amplifiers. Other features which make it unexcelled for both laboratory and production testing are the linear meter scale, fully protected against overloads, and the built-in calibrating system to standardize voltage measurements. With the stability, accuracy, flexibility and ease of operation of the Harmonic Wave Analyzer, Hewlett-Packard continues to set a new standard.

### These *-hp-* Representatives Are at Your Service

**Eastern Representative:**

Burlingame Associates, Ltd.  
11 Park Place  
New York 7, N. Y.—Worth 2-2171

**Midwestern Representative:**

Alfred Crossley  
549 West Randolph Street  
Chicago 6, Illinois—State 7444

**Western Representative:**

Norman B. Neely Enterprises  
7422 Melrose Avenue  
Hollywood 46, California—Whitney 1147

**Canadian Representative:**

Atlas Radio Corporation  
560 King Street West  
Toronto 2, Canada—Wa 4761

## HEWLETT-PACKARD COMPANY

BOX 1119 D . STATION A . PALO ALTO, CALIFORNIA

Audio Frequency Oscillators    Signal Generators    Vacuum Tube Voltmeters  
Noise and Distortion Analyzers    Wave Analyzers    Frequency Meters

Square Wave Generators    Frequency Standards    Attenuators    Electronic Tachometers

Proceedings of the I.R.E.    February, 1946

JUST PUBLISHED!

The Most Indispensable Reference in Radio-Electronics!

# Electronic Engineering Master Index

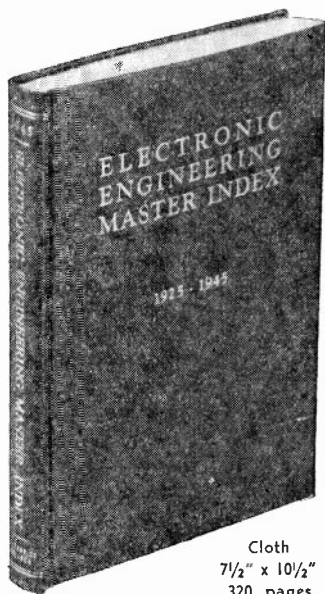

Cloth  
7 1/2" x 10 1/2"  
320 pages

A master compilation of over 15,000 titles of texts and articles selected for their value to the research engineer, this INDEX covers the years 1925-1945 and enables you to survey twenty years of research literature on any subject in a matter of minutes!

Vitally Needed in Every Laboratory and Library

COMPLETE IN ONE VOLUME

**PART I**  
January 1925 to  
December 1934

**PART II**  
January 1935 to  
June 1945



### PARTIAL LIST OF PERIODICALS INDEXED

Bell Laboratories Record	General Electric Review
Bell System Technical Journal	Journal of Applied Physics
Communications	Proceedings I.R.E.
Electrical Communication	Transactions of A.I.E.E.
Electronics	Radio News
Electronic Industries	R.C.A. Review
Journal of I.E.E.	Wireless Engineer

A \$500 Reference Library in One Volume for \$17.50

Descriptive circular on request.

**ELECTRONICS RESEARCH PUBLISHING COMPANY**

2 West 46th Street

New York 19, N.Y.

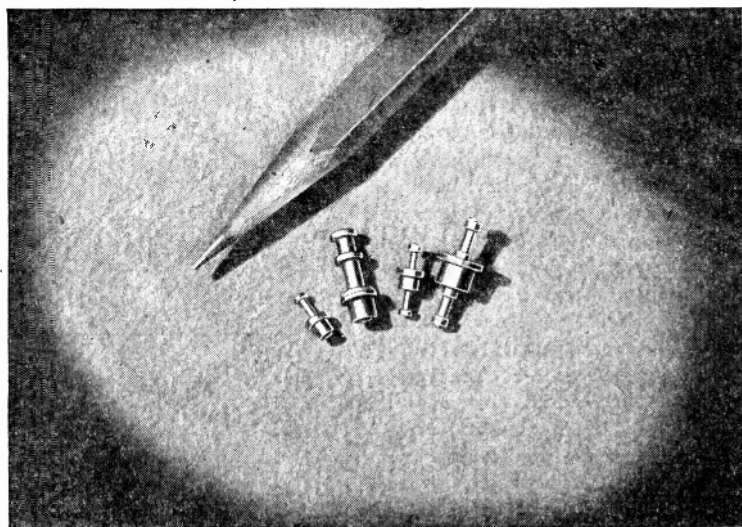

## Now C.T.C. MIDGET TERMINAL LUGS Are In The Spotlight

This newest C.T.C. addition to their quick-anchoring, swift-soldering line of Terminal Lugs incorporates all the advantages of the standard sizes plus the additional advantage of their midget size.

Pictured above, actual size with standard C.T.C. lugs, you can readily see how their size

and construction make them perfect for use where space is limited.

C.T.C. Midget Terminal Lugs are available in two types — Midget Turret Terminal Lugs to fit 1/32", 1/16" and 3/32" board thicknesses and Midget Double End Lugs to fit 1/32" and 1/16" board thicknesses.

For complete information on C.T.C. Midget Terminal Lugs write for C.T.C. Catalog No. 100 or drawings No. 1463 and 1457.



**CAMBRIDGE THERMIONIC CORPORATION**

456 Concord Avenue

Cambridge 38, Mass.

# EBY SADDLE TYPE MINIATURE TUBE SOCKETS

AVAILABLE IN

GENERAL PURPOSE  
PHENOLIC (EBY #8100) →

LOW LOSS PHENOLIC  
(EBY #8082) →

STEATITE  
(EBY #8083) →

The castings and beryllium copper contacts are identical with JAN S-28 Types SO 10M and SO 10C except that the shield base is replaced with a saddle. These EBY sockets meet the need for quality replacement of sockets of the saddle type. Write today for prices and samples.

### LONG LIFE CONTACTS

The self-aligning beryllium copper contacts have been especially designed and Micro-processed to assure constant, even pressure on all parts of the socket pin without fatigue in contacts after continuous use.

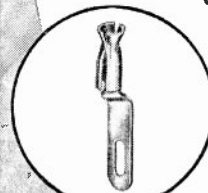

IF IT'S IN A CIRCUIT  
... EBY COMPONENTS  
AND SERVICES WILL  
HELP YOU DO IT BETTER

HUGH H.  
**EBY**  
INCORPORATED  
18 W. CHELTON AVE.  
PHILADELPHIA, PA.



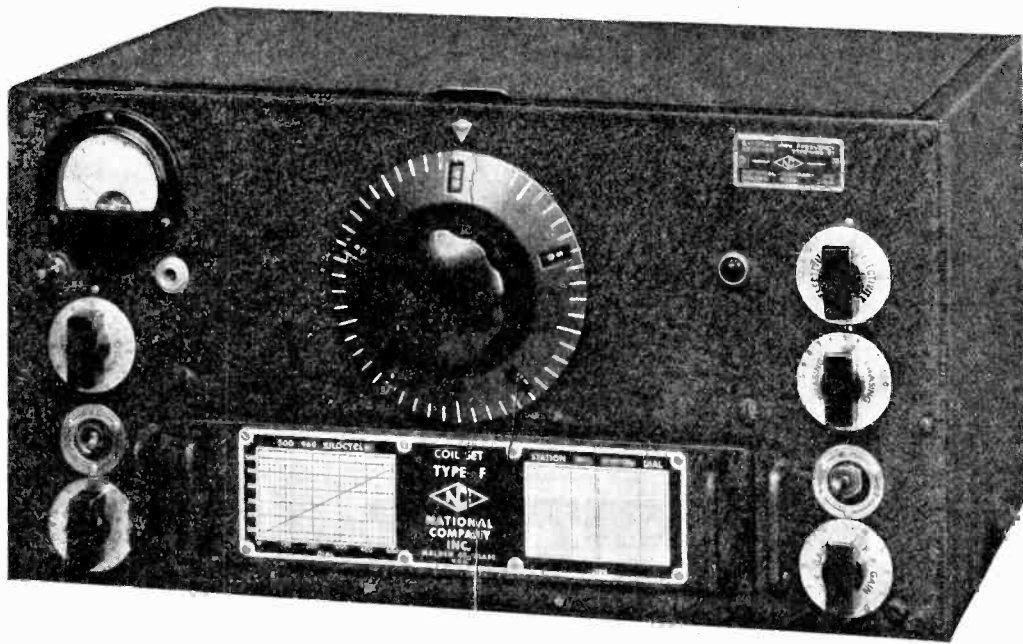

## THE HRO-5TA

Your old friend, the HRO, has seen active service all over the world with the armed forces of the United States and our allies. Much has been learned, and the HRO has emerged from its trial by fire an even better receiver than the superb receiver you knew before the war.

The HRO-5TA (table model) and the HRO-5RA (rack mounting) are new receivers incorporating design improvements based on field reports from all over the world. They are superb performers of extreme reliability.

The new National catalogue lists the new HRO-5A receivers and their accessories together with a versatile group of parts you will need in your new rig. Ask your dealer for a copy.



**NATIONAL COMPANY, INC.**  
MALDEN, MASSACHUSETTS, U.S.A.

MALDEN  
MELROSE  
★★★★

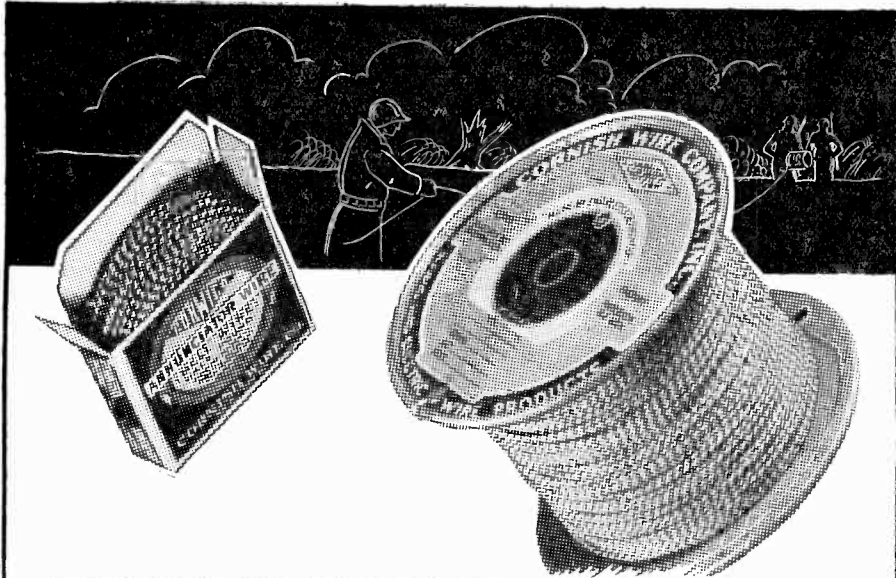

# ESSENTIAL

*in War and*  
**PEACE**

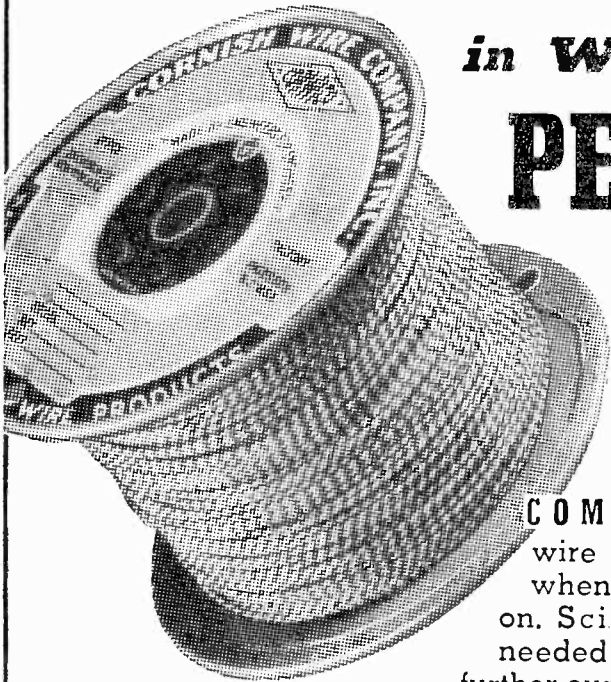

**COMMUNICATION**  
wire is as vital now as when there was a war on. Scientific wires are needed by the carload to further our national program of reconversion. CORWICO is

doing its best to deliver such wire for civilian use. There's a tremendous job to be done, and you and we will do that job.

**cornish**

**WIRE COMPANY, INC.**

**15 Park Row, New York City, New York**

*"Made by Engineers for Engineers"*



(Continued from 54A)

## ENGINEERS

A large midwest manufacturer has immediate openings for the following engineers:

**Senior Development Engineers.** Openings in domestic radio and television receiver development for two Senior Radio Project Engineers and one Mechanical Engineer.

**Assistant Chief Engineer.** To assume complete supervision of household and auto radio receiver development. Extensive prewar experience in above lines imperative. Television receivers will be in our line.

**Research Engineers.** Two research men with prewar development experience in the radio receiver or television field.

All inquiries will be treated as confidential. Reply to Box 406.

**Seleton**

**SELENIUM RECTIFIERS**

25 milliamperes to 1000's of amperes output  
MADE ON ALUMINUM



**LIGHT  
RUGGED  
COMPACT**

• Their light weight characteristic, compactness, long life, and efficiency assure a service unit to the electrical field—WHERE QUALITY IS THE TEST. The absence of fragile or moving parts reduces maintenance costs to a minimum.

• Seleton rectifiers are produced in seven standard sizes from 1" to 4 3/8" diameter and a 5" x 6" rectangular plate, and can be hermetically sealed, if desired.

• Excellent delivery schedules. Write for brochure, "Seleton," giving complete technical information.

**RADIO RECEPTOR COMPANY, Inc.**  
Since 1922 in Radio and Electronics  
251 WEST 19th STREET • NEW YORK 11, N. Y.

*Use Standard Parts • Save Time And Money*

*Automatic Manufacturing Corp.*  
*900 Passaic Avenue*  
*East Newark, N. J.*

---

*Manufacturers of*  
*Intermediate Frequency Transformers*  
*Mica Trimmer Condensers*



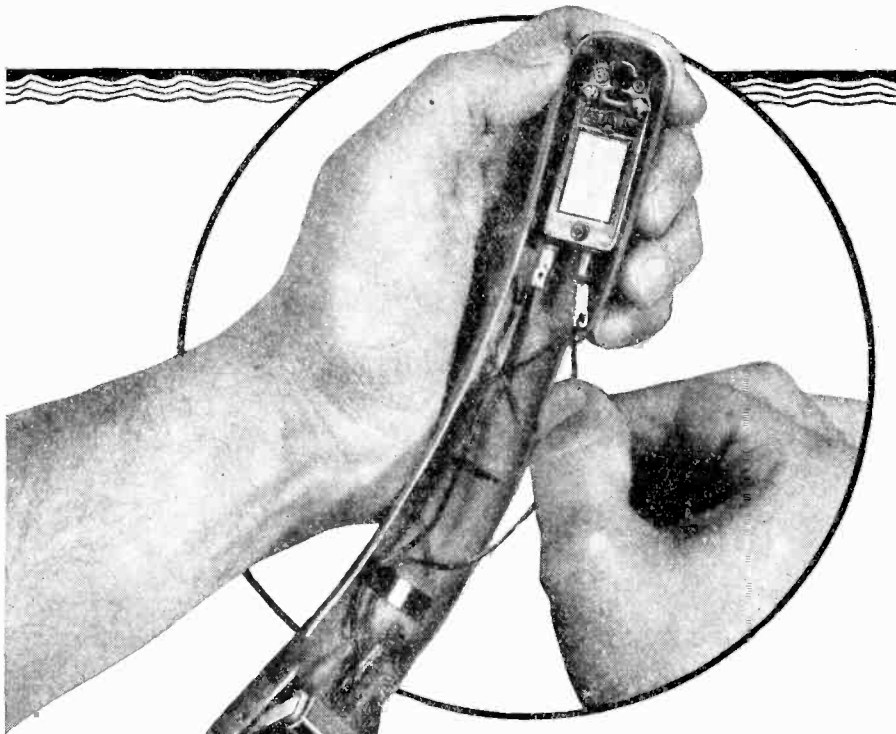

## QUICK DISCONNECT

Among other improvements in the design of new Astatic Phonograph Pickups is a QUICK-DISCONNECT feature for instant removal or insertion of Crystal Pickup Cartridges. Wire leads on the pickup tone arm are now equipped with special terminal connections which may be slipped on or off the cartridge pins without tools, soldering or unsoldering. Originally, these wire terminals were permanently attached to the cartridge. This new QUICK-DISCONNECT feature, used with both permanent and removable needle type cartridges in newly designed Astatic Pickups, eliminates messy soldering and saves valuable time in service work. Small details, such as this, coupled with the high operating efficiency of Astatic Pickups, contribute to their ever-increasing popularity and usage.

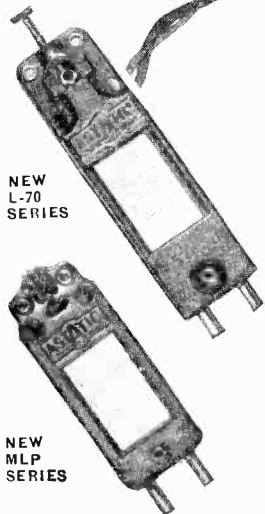

*Astatic Crystal Devices manufactured under Brush Development Co. patents.*

**THE Astatic CORPORATION**  
**ASTATIC** CONNEAUT, OHIO  
 IN CANADA. CANADIAN ASTATIC LTD. TORONTO, ONTARIO

# CML SERVES THE ELECTRONIC INDUSTRY

Designed to meet the most rigorous specifications for precision, every CML unit is equipment of accredited performance.

- 1** ROTORIDGE . . . This automatic inspector checks for proper wiring, correct resistance, capacity and inductance values in all types of electronic equipment.
- 2** MODEL 1100, MODEL 1110 . . . Voltage regulated power supply units; with extremely low noise level and excellent regulation.
- 3** MODEL 1420 GENERATOR . . . Furnishes test power over a wide frequency range; may also be employed in 3-phase circuits.
- 4** MODEL 1200 STROBOSCOPE . . . Stops motion within range of 600 to 600,000 R.P.M.

WRITE FOR DESCRIPTIVE BULLETINS

**COMMUNICATION MEASUREMENTS LABORATORY**  
 120 GREENWICH ST., NEW YORK 6, N. Y.

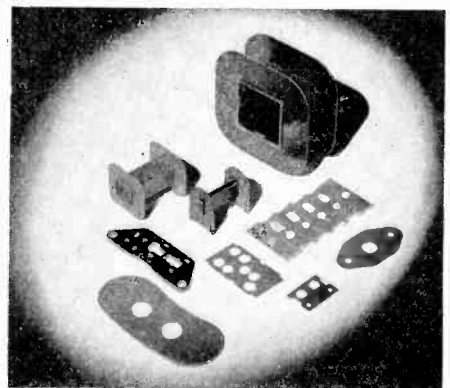

**Serving the Radio Industry with dependable laminated plastics**

**NATIONAL VULCANIZED FIBRE**

**PHENOLITE**  
 Laminated PLASTIC

—because of their lightness in weight, high dielectric strength, ready machinability, exceptional wearing and other qualities—are playing a vital part.

**NATIONAL VULCANIZED FIBRE CO.**

Offices in Principal Cities  
 WILMINGTON, DELAWARE



✓✓✓✓ from **START** to **FINISH** insures **AEROVOX**  
**PAPER-CAPACITOR** *Craftsmanship*



To determine suitability of aluminum foil for capacitor use, every lot is tested for thickness, unit weight and electrochemical characteristics.

Uncased paper sections are checked prior to impregnation. Completed units are tested for capacitance, power factor, insulation resistance, terminal-to-terminal and terminal-to-can, as well as for dielectric strength and tightness of seal.



The porosity of paper dielectric is important. This porosity test is made on each roll of paper.

● A paper capacitor can be no better than its several layers of paper dielectric, the quality of the impregnant, and the thoroughness of the impregnation and sealing.

That is why there are so many routine check-ups in Aerovox paper capacitor production. Paper tissues, metal foils, oils and sealing compounds, are critically checked. Sections are checked before impregnation and casing. Completed units are subjected to a final check-up and inspection.



"Individually-tested" is no idle boast as applied to Aerovox capacitors. It means precisely what it says. And to the capacitor user, it is a guarantee of dependable and long-lasting and economical service for the smallest and cheapest quite as well as the largest and costliest of types that bear the Aerovox label.

Production control of impregnating materials. Electrical test is preceded by careful checking of temperature of oils.



**FOR RADIO-ELECTRONIC AND INDUSTRIAL APPLICATIONS**

**AEROVOX CORPORATION, NEW BEDFORD, MASS., U.S.A.**

SALES OFFICES IN ALL PRINCIPAL CITIES • Export: 13 E. 40th St., NEW YORK 16, N. Y.

Radio: 'ARLAB' • In Canada: AEROVOX CANADA LTD., HAMILTON, ONT.

# ★ CREI Offers A Planned Program of Group TECHNICAL TRAINING

To Modernize the Technical Knowledge of Your Employees Through Modern Training for Professional Self-Improvement

If your organization is engaged in any phase of radio-electronics, your technical personnel must know FM—television — Ultra High Frequency Techniques, and all other phases of war-developed electronics technology; and, of course, a thorough and complete knowledge of the fundamentals of practical radio-electronics engineering.

### The CREI "Employers' Plan" for group training will:

1. Increase the technical abilities of your radio-electronics personnel.
2. Enable them to perform their duties more efficiently and in less time.
3. Increase the value of their services to your organization.

No company time is required for this training . . . it is accomplished by spare-time, home study, to meet each individual organizations requirements.

The CREI "Employers' Plan" is useful for the up-grading of technical personnel in manufacturing, AM, FM, and television broadcasting, communications, industrial electronics, including the following:

Engineers	Testers
Engineering Aides	Technicians
Laboratory Assistants	Field Servicemen
Inspectors	Installers
	Maintenance Men

Your request will promptly bring an outline of the plan, as now in use with other organizations, and intimate details will follow when your particular needs are known. No obligation or cost, of course.

## CAPITOL RADIO ENGINEERING INSTITUTE

E. H. RIETZKE, President

Home Study Courses in Practical Radio-Electronics Engineering for Professional Self-Improvement

Dept. PR-2, 3224—16th St., N.W.  
WASHINGTON 10, D.C.

Contractors to the U. S. Navy—U. S. Coast Guard — Canadian Broadcasting Corp. Producers of Well-trained Technical Radiomen for Industry.

## Binders

for the Proceedings

Protect your file of copies against damage and loss

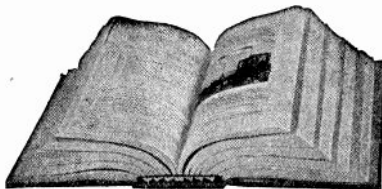

Binders are available for those who desire to protect their copies of the PROCEEDINGS with stiff covers. Each binder will accommodate the twelve monthly issues published during the year. These binders are of blue Spanish grain fabricoid with gold lettering and will serve either as temporary transfers or as permanent binders. They are so constructed that each individual copy of the PROCEEDINGS will lie flat when the pages are turned. Copies can be removed from the binder in a few seconds and are not damaged by their insertion.

Available for both the old, small size PROCEEDINGS or the new, large size (1939 to date).

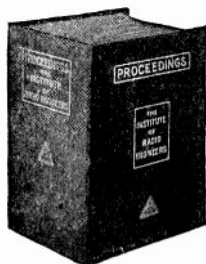

Price: \$1.50

either size (specify which)  
Postpaid to all countries

You may have a volume number or your name stamped in gold for 50 cents additional.

Remittance should accompany your order

THE INSTITUTE OF  
RADIO ENGINEERS, INC.  
330 West 42nd Street,  
New York, N.Y.

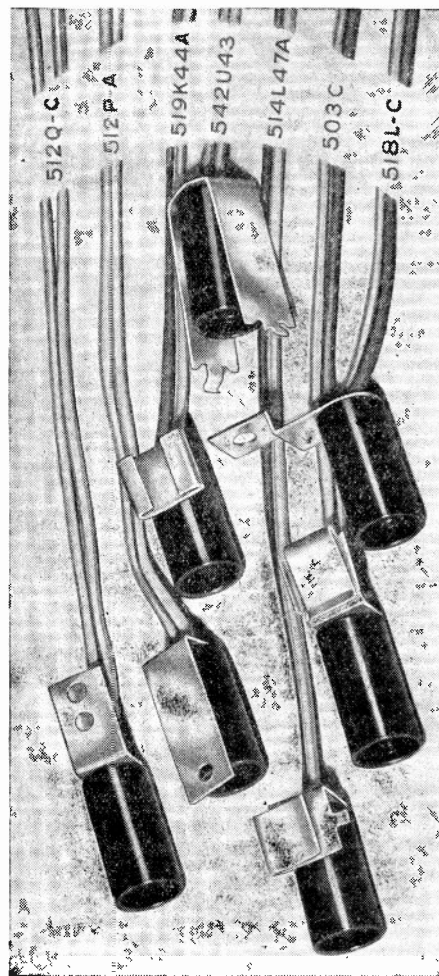

## TOP QUALITY AT LOW COST!

DRAKE patents plus modern high speed methods and machinery go a long way toward achieving the traditional excellence and economy of our products. It should pay you in better performance and lower costs to specify DRAKE for all of the Socket and Jewel Light Assemblies you need. Ask for prices and the newest Drake Catalog.



DRAKE MANUFACTURING CO.

1713 W. HUBBARD ST. CHICAGO 22, ILL.

## REVERE COPPER IN FEDERAL 200 KW TUBE

THE 200 KW vacuum tube made by Federal Telephone and Radio Corporation is the most powerful h-f tube yet built in this country. It has been used in short-wave transmitters and has demonstrated its capabilities as to power output and dependability.

Revere OFHC (Oxygen-Free High Conductivity) Copper is one of the principal materials used in the tube. The anode is machined from a large tube of this material, which is also employed in the form of heavy sheet for making the cup that closes the anode at the bottom, in the form of strip for drawing the terminal cups. All copper used in the tube is from Revere, which thus again demonstrates its ability to meet the most rigid requirements as to electrical and thermal conductivity, workability and uniformity. For high-quality copper and brass for radio purposes, see Revere.

# REVERE

**COPPER AND BRASS INCORPORATED**  
*Founded by Paul Revere in 1801*

230 Park Avenue, New York 17, New York  
Mills: Baltimore, Md.; Chicago, Ill.; Detroit, Mich.;  
New Bedford, Mass.; Rome, N. Y.

Sales Offices in principal cities, distributors everywhere  
Listen to Exploring the Unknown on the Mutual Network every  
Sunday evening, 9 to 9:30 p. m., EST.

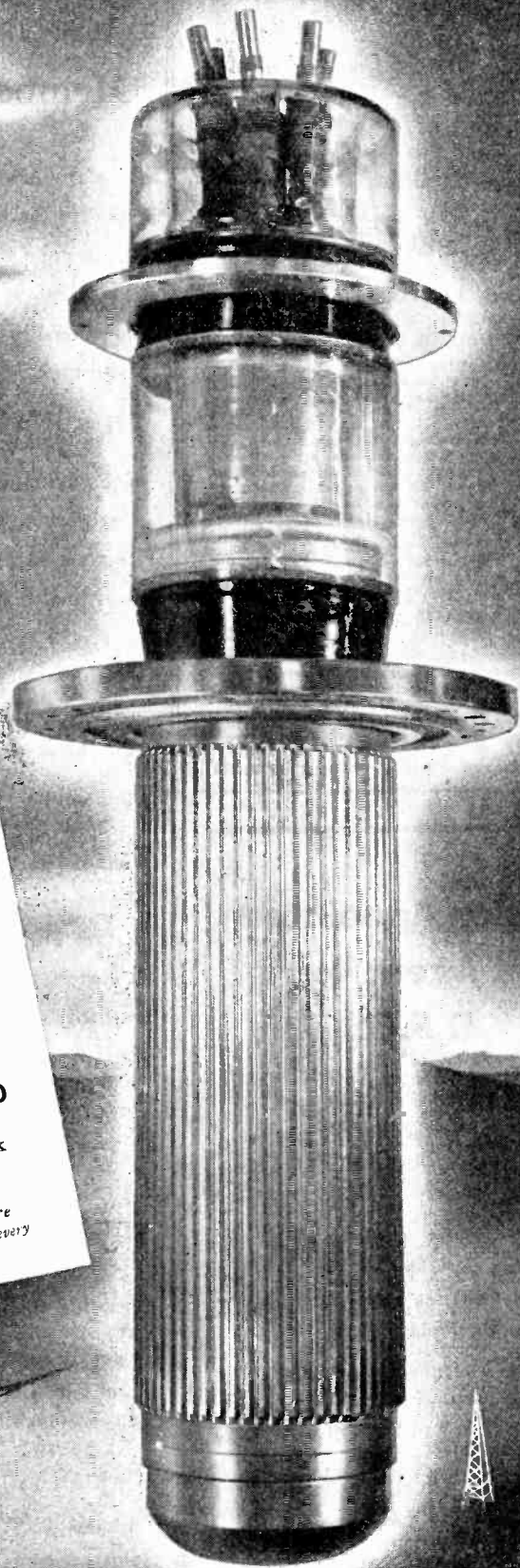

Federal 134 Transmitting Tube, 200 KW oscillator and amplifier; length, 34- $\frac{1}{8}$ ".

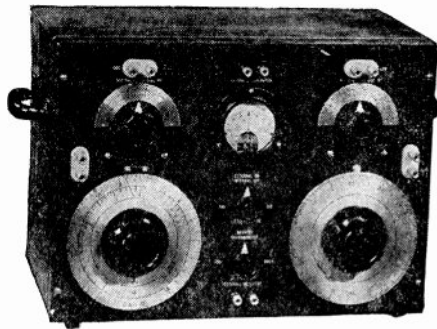

## High Accuracy

In Measuring:

- \* CAPACITANCE—RESISTANCE—INDUCTANCE
- \* STORAGE FACTOR (Q) OF COILS
- \* DISSIPATION FACTOR OF CONDENSERS

● MODEL 200-A IMPEDANCE BRIDGE is a portable, self contained instrument of highest quality used extensively by the Army, Navy, and many manufacturers.

The range of measurement for capacitance is 1 micro microfarad to 100 microfarads; for resistance, 1 milliohm to 1 megohm; for inductance, 1 microhenry to 100 henrys. The accuracy on the main decade is 1% for capacitance or resistance measurements and 2% for inductance tests.

Reading obtained from 6 inch direct reading dials. All controls and connections plainly marked and conveniently located on the panel. 35-page book gives methods for many types of measurements.

### IMMEDIATE DELIVERIES

Our factory is in a position to make fast deliveries on Model 200-A and other products including precision mica condensers, binding posts, several types of AWS rheostat-potentiometers and decade and low capacity switches.

## Brown Engineering Co.

4635 S. E. Hawthorne Blvd. Portland 15, Oregon

## Remler Appointed as Agent for R.F.C.

... to handle and sell government owned electronic equipment released for civilian use.

Write for Bulletin Z-1 listing a wide variety of equipment covering entire electronic field.

Remler Co., Ltd. · 2101 Bryant St.  
San Francisco 11, Calif.

# REMLER

SINCE 1918

Communications · Electronics

## Attention Associate Members!

Many Associate Members can qualify for higher membership grades and should certainly do so. Members are urged to keep membership grade up in pace with their present development.

An Associate over 24 years of age who is occupied as a radio engineer or scientist, and is in this active practice three years may qualify for Member Grade.

An Associate who has taught college radio or allied subjects for three years may qualify.

Some may possibly qualify for Senior Grade. But transfers can be made only upon your application. For fuller details request transfer application-form in writing or by using the coupon below.



### Coupon

Institute of Radio Engineers  
330 W. 42nd St.  
New York 18, N.Y.

2-46

Please send me the Transfer  
Application Membership-Form.

Name .....

Address .....

Place .....

State .....

Present Grade .....

## EXAMPLE OF ENGINEERING FLEXIBILITY to meet a specific need

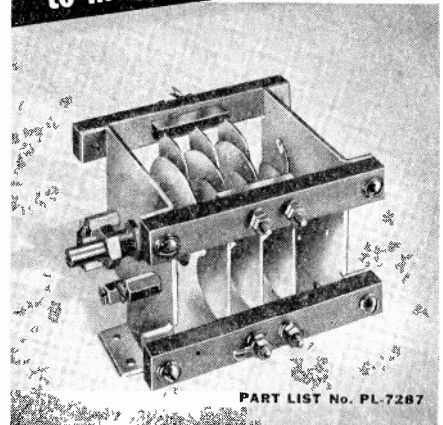

PART LIST No. PL-7287

### GENERAL CHARACTERISTICS

Capacity Range: 12-6 mmfds. per section.

Airgap: .218"

Insulation: MYCROY (glass bonded mica).

Size: Approximately 3" H x 3 1/2" W x 3/4" L.

Material: All aluminum except steel shaft, brass bearings, stator blocks, studs and screws.

Bearings: Ball thrust rear—straight shoulder bearing in front.

Mounting: Foot mounting to chassis or three point to panel.

THIS grid balancing condenser was specially designed for 5 or 10 K.W. Frequency Modulation Radio Transmitters operating in the 100 M. C. range. This is just one of many examples of how Cardwell has developed condensers to meet specific problems. If you have a tough condenser problem, consult Cardwell engineers.



THE ALLEN D. CARDWELL MFG. CORP.

Main Office: 81 Prospect Street,  
Brooklyn 1, N. Y.

Factories: Plainville, Conn.—Brooklyn, N. Y.



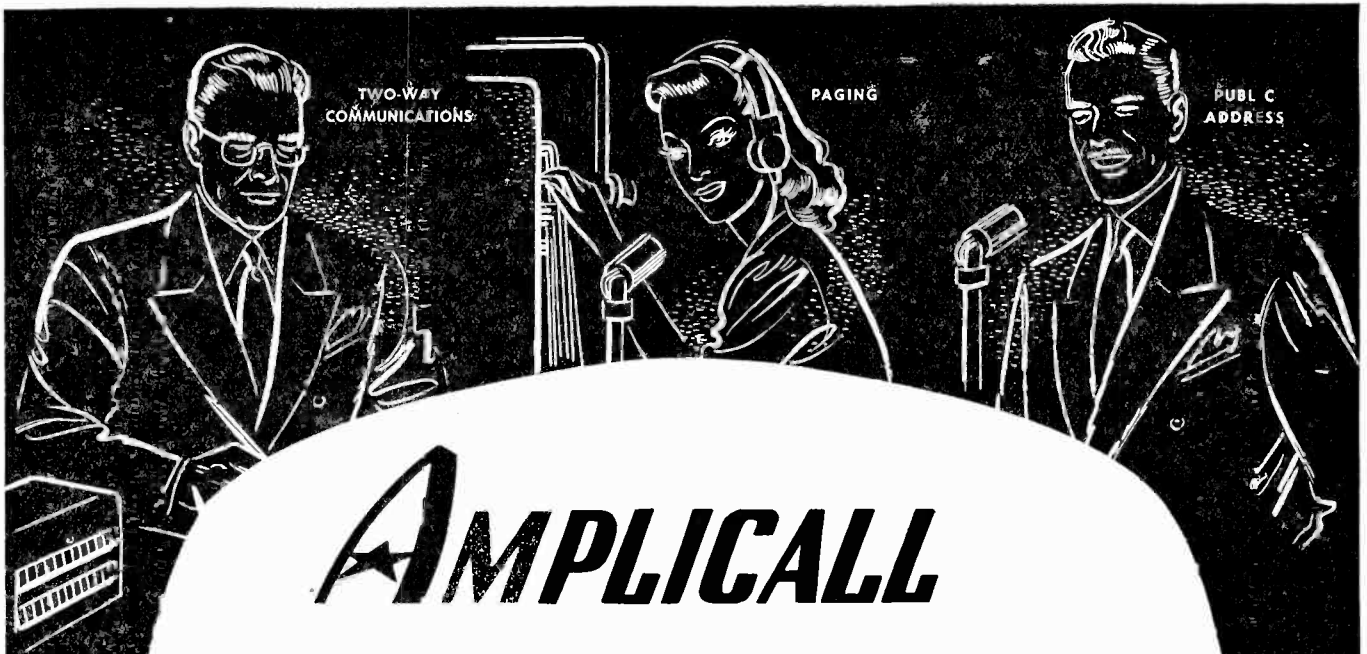

# AMPLICALL

**Two-Way Communication,  
Paging and Public Address Systems**

**... Proved during the war!**

When it was necessary to save not only hours but minutes and even seconds, *AMPLICALL* "came through." Its complete day-in-and-day-out dependability, multiple uses, flexible design, trouble-free operation and tone quality make it the preferred communications system. "*AMPLICALL*" is another way of saying "efficiency"... learn how it can bring about a greater efficiency for your business.

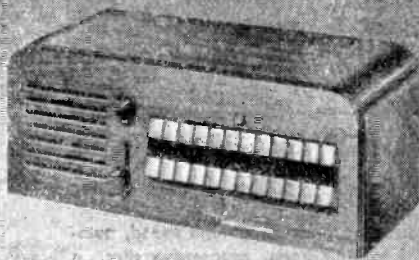

AMPLICALL  
Intercommunication unit, available for two-way communication between multiple stations.

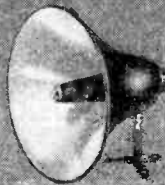

AMPLICALL  
Weatherproof Speaker



AMPLICALL  
Paging Control Unit

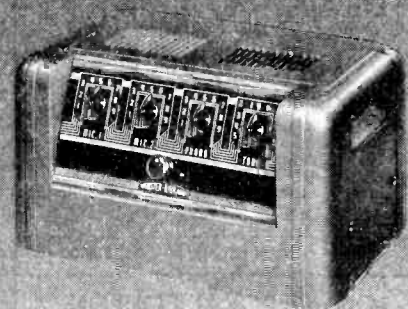

AMPLICALL  
Audio Amplifier unit for laboratory, test equipment and general applications.

RADIO • RADAR • SOUND

# Rauland

COMMUNICATIONS • TELEVISION

*Electroneering is our business*

THE RAULAND CORPORATION • CHICAGO 41, ILLINOIS

NOW IN BOOK FORM—

a practical guide to

# ELECTRON OPTICS and the ELECTRON MICROSCOPE



By  
V. K. ZWORYKIN,  
G. A. MORTON,  
E. G. RAMBERG,  
J. HILLIER, A. W.  
VANCE; all at RCA  
Laboratories, Prince-  
ton, N.J.

A comprehensive treat-  
ment of the electron  
microscope in all its  
phases. ELECTRON OPTICS AND THE  
ELECTRON MICROSCOPE is designed:

- (1) to aid the electron microscopist in understanding his instrument and in using it to greatest advantage, and
- (2) to present the practical and theoretical knowledge which must form the basis for further progress in electron microscope design.

To fulfill this twofold purpose, the book has been divided into two parts. The first part contains descriptions of various types of electron microscope, together with a non-mathematical discussion of the electron optical theories on which the electron microscope is based. The second part presents a methodical development of theoretical electron optics. This section is intended to supplement the practical information of the first part and to serve as a guide in electron optical design of improved instruments.

## CONTENTS

**PART I—PRACTICAL ELECTRON OPTICS AND ELECTRON MICROSCOPY.** Electron Optics. Applications of Electron Optics. Electron Microscopes. Electron Optics of High Magnification. The Magnetic Electron Microscope. Aberrations and Tolerances in the Electron Microscope. Electron Microscope Power Supplies. Manipulation of the Electron Microscope. The Electron Microscope as a Research Instrument.

**PART II—THEORETICAL BASIS OF ELECTRON OPTICS AND THE ELECTRON MICROSCOPE.** Theoretical Basis of Electron Optics. Determination of Potential Distribution. Electron Trajectory Tracing. Gaussian Dioptrics of Electrostatic Lenses. Magnetic Fields. Electron Motion in Magnetic Fields and Magnetic Lenses. Aberrations of Electron Lenses. Magnitude and Correction of Electron Lens Defects. High-Voltage Electron Optics—Ion Optics. Image Formation in the Electron Microscope.

APPENDIX

(1946) 747 Pages \$10.00

## ON APPROVAL COUPON

JOHN WILEY & SONS, Inc.  
440 Fourth Ave., New York 16, N.Y.

Please send me a copy of Zworykin's ELECTRON OPTICS on ten days' approval. At the end of that time, if I decide to keep the book, I will remit \$10.00 plus postage; otherwise I will return the book postpaid. IRE-2-46

Name .....  
Address .....  
City and State .....  
Employed by .....  
Approval offer not valid outside U. S. and Canada

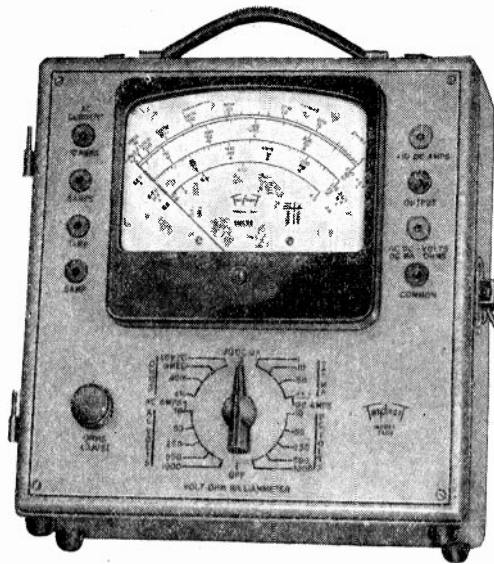

## NEW ENGINEERING NEW DESIGN • NEW RANGES 50 RANGES

Voltage: 5 D.C. 0-10-50-250-500-1000 at 25000 ohms per volt.  
5 A.C. 0-10-50-250-500-1000 at 1000 ohms per volt.  
Current: 4 A.C. 0-.5-1-5-10 amp.  
6 D.C. 0-50 microamperes—0-1-10-50-250 milliamperes—0-10 amperes.  
4 Resistance 0-4000-40,000 ohms—4-40 megohms  
6 Decibel -10 to +15, +29, +43, +49, +55  
Output Condenser in series with A.C. volt ranges

MODEL 2405.

# Volt • Ohm Milliammeter

25,000 OHMS PER VOLT D. C.

STANDARDS ARE SET BY



## SPECIFICATIONS

NEW "SQUARE LINE" metal case, attractive tan "hammered" baked-on enamel, brown trim.

■ PLUG-IN RECTIFIER—replacement in case of overloading is as simple as changing radio tube.

■ READABILITY—the most readable of all Volt-Ohm-Milliammeter scales—5.6 inches long at top arc.

Model 2400 is similar but has D. C. volts Ranges at 5000 ohms per volt.

Write for complete description

# Triplet

ELECTRICAL INSTRUMENT CO.

BLUFFTON OHIO



How PROGRESSIVE DIES Cut Costs

## GOAT PRECISE-FORMED STAMPINGS

Save Money in quantity production

New techniques in construction and use of high speed, automatic, single operation, multiple-stage, progressive dies, in conjunction with the GOAT Precision Feed (U. S. Pat. No. 2,250,520), make possible: higher production speeds, lower scrap losses, less tool maintenance, overall lower costs, and closer tolerances than ever before possible. On lots of 500,000 or more the savings are indeed worthwhile.

Submit samples or drawings  
for cost estimates

LET US  
REDESIGN  
FOR  
STAMPING



GOAT METAL STAMPINGS, INC.  
Affiliate of The Fred Goat Co., Inc.  
314 DEAN STREET BROOKLYN, N. Y.



# TALL OR SMALL AM or FM

**Truscon service  
can fill your radio  
tower needs!**

Again available—Truscon Radio Towers in guyed or self-supporting types, either tapered or uniform cross section!

Truscon Radio Towers are triangular in cross section and are built entirely of heavy steel members with all shop assembled connections made by means of electric arc-welding.

There is no limit in height to a Truscon tower other than the practical height limitation. The tallest towers in the United States today are Truscon built; i.e., WNAX at Yankton, South Dakota (912 feet above base insulator) and WKY at Oklahoma City, Oklahoma (900 feet above base insulator, and designed to support additionally a 50 foot 6-bay FM antenna).

If you contemplate FM broadcasting, your radio tower facilities will undoubtedly have to be modified. Perhaps you will require a new and higher tower to adequately serve your needs.

Experienced Truscon radio tower engineers will be glad to help solve your radio tower problems of today and tomorrow.

**TRUSCON STEEL COMPANY • YOUNGSTOWN 1, OHIO**  
*Subsidiary of Republic Steel Corporation*



**WNAX**  
YANKTON, S. D.  
927 Ft.



**WKBN**  
YOUNGSTOWN, OHIO  
352 Feet

# TRUSCON

Self-Supporting  
and Uniform  
Cross Section Guyed

# TOWERS



## How Would You Like it IF APPLES WERE PRICED LIKE SCREWS?

Inconvenient—to say the least! Why should you have to figure out a complicated string of discounts to arrive at your Net price for fasteners?



### QUOTES NET PRICES!

You can tell at a glance *exactly* what you pay when you order STRONGHOLD Screw Products. Send for copy of our "Net Price Catalog." It is an up-to-date fastener encyclopedia, reference guide, specification chart, and NET price list of precision-made STRONGHOLD products. Every purchasing agent and every engineer who specifies fasteners should have a copy.



**MANUFACTURERS  
SCREW PRODUCTS**  
283 W. Hubbard St.,  
Chicago 10, Ill.

It's Faster to Phone—  
Whitehall 4680  
Standardize on  
STRONGHOLD

Paste This Coupon on Your Letterhead and Mail!

**MANUFACTURERS SCREW PRODUCTS**  
283 W. Hubbard St., Chicago 10, Ill.  
Please send me a copy of the new STRONGHOLD "Net Price Catalog."  
NAME .....  
POSITION .....  
COMPANY .....  
ADDRESS .....  
CITY, ZONE, STATE .....

- Check here if you would also like a free copy of our "Pocket Library of Engineering Data," a handy, fingertip reference to technical information every user of fastener products should have.
- Please send a few samples of your products.
- Please quote prices as per attached request.

## Complete Your Files of the Proceedings of the I.R.E.

Some back issues available

Each issue is priced at \$1.00 but members of I.R.E. are given a 25% discount and accredited public and college libraries a 50% discount. The following issues are offered subject to prior sale.

- 1913-1915 Volumes 1-3  
Quarterly**  
1913 Vol. 1 January (a reprint)
- 1916-1926 Volumes 4-14  
Bimonthly**  
1917 Vol. 5 April, June, August, October  
1918 Vol. 6 None  
1919 Vol. 7 December  
1920 Vol. 8 April, June, August, October, December  
1921 Vol. 9 All 6 issues  
1922 Vol. 10 All 6 issues  
1923 Vol. 11 February, April, June, August, December  
1924 Vol. 12 August, October, December  
1925 Vol. 13 April, June, August, October, December  
1926 Vol. 14 All 6 issues

- 1927-1938 Volumes 15-26  
Monthly**  
1927 Vol. 15 April, May, June, October, December  
1928 Vol. 16 February to December, inc.  
1929 Vol. 17 April, May, June, November  
1930 Vol. 18 January, April to December, inc.  
1931 Vol. 19 All 12 issues  
1932 Vol. 20 January, March to December, inc.  
1933 Vol. 21 All 12 issues  
1934 Vol. 22 All 12 issues  
1935 Vol. 23 All 12 issues  
1936 Vol. 24 January to April, inc., June  
1937 Vol. 25 February to December, inc.  
1938 Vol. 26 All 12 issues

- 1939-1945 Volumes 27-33  
Monthly**  
New Format—Large Size  
1939 Vol. 27 All 12 issues  
1940 Vol. 28 All 12 issues  
1941 Vol. 29 All 12 issues  
1942 Vol. 30 January, February, April, October to Dec., inc.  
1943 Vol. 31 February to December, inc.  
1944 Vol. 32 January, February, July to December, inc.  
1945 Vol. 33 All issues

*Remittance should accompany  
your order.*

*Please do not send cash except by  
registered mail*

**THE INSTITUTE OF  
RADIO ENGINEERS, INC.**  
330 West 42nd Street,  
New York 18, N.Y.

# Long and Satisfying Service

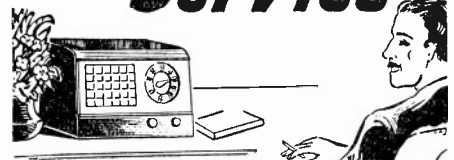

IT'S  
ENGINEERED WITH  
**HI-Q**  
COMPONENTS

Ask any service man with years of radio set repair experience and he'll tell you most sets "go bad" because of the failure of some insignificant component. That's why it's important to give more than ordinary consideration to the selection of capacitors. Engineer a unit with Hi-Q components and you have strengthened every link in the chain of satisfying performance. Hi-Q ceramic capacitors are individually tested at every step of their manufacture. They'll stand up under the severest conditions of temperature, humidity, vibration and shock. Send for samples and complete data.

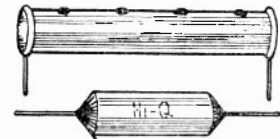

### CERAMIC CAPACITORS

CN type with parallel leads  
CI type with axial leads



### WIRE WOUND RESISTORS

Sizes and quantities available promptly to required specifications.



### CHOKE COILS

Uniform in quality — rugged construction tested for performance.

**ELECTRICAL REACTANCE  
CORPORATION**  
FRANKLINVILLE, N.Y.



*Scenes from*  
The Radio Engineering Show



7021 visitors and members registered, but about ten thousand visited the first great post-war convention and Radio Engineering Show of the Institute of Radio Engineers, at the Hotel Astor, January 23, 24, and 25.

The pictures above show the crowds visiting the exhibits furnished by 135 firms serving the radio-and-electronic industry. Note the keen interest shown in these beautiful displays. Photos by A. G. Michaelson, New York and courtesy of exhibitors.

*Built for the*  
**PRODUCTION LINE**

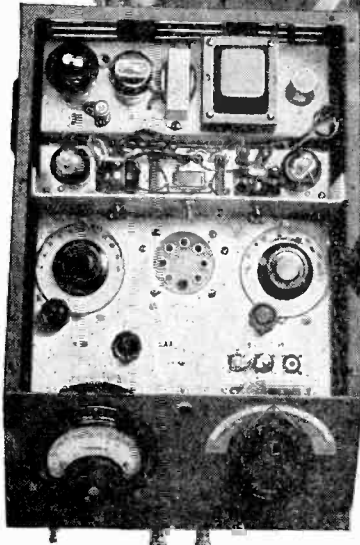

**Preset controls enclosed for fool-proof, simple operation**

Factory personnel cannot of course make measurements. They can compare production parts with approved standard parts — and with the QX-Checker these comparisons can be made quickly, simply and accurately.

**QX-CHECKER TYPE 110-A**

The QX-Checker is specifically designed for production use to check both the reactance and resistance of any R.F. component. These properties are simultaneously indicated when a component is resonated in a tuned circuit. The two factors, reactance and resistance, are separately indicated, one on the condenser dial, the other on the meter so that the deviation of either from established tolerances is immediately shown. Insures uniform parts held within close tolerances. Frequency range 100 kc. to 25 mc.

*For further information, write for catalog "C"*



**BOONTON RADIO Corporation**  
BOONTON, N. J.



DESIGNERS AND MANUFACTURERS OF THE "Q" METER, QX-CHECKER, FREQUENCY MODULATED SIGMA GENERATOR, BEAT FREQUENCY GENERATOR, AND OTHER DIRECT READING TEST INSTRUMENTS

**WOLLASTON Process**  
*Wire... So Fine it can be seen only under high Magnification*

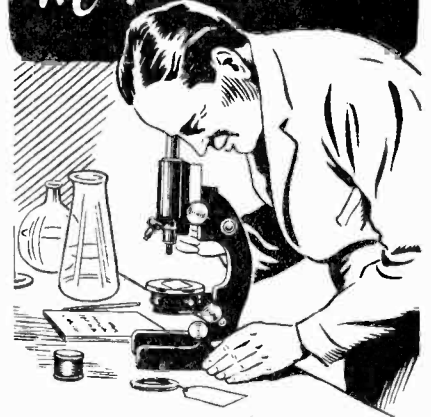

We can draw wire as small as

$$\frac{1}{100,000} \left\{ \begin{array}{l} \text{of an inch} \\ \text{in diameter} \end{array} \right.$$

*... available in Platinum and some other Metals*

.00001" is less than 1/30 the diameter of the smallest wire die commercially available. Yet our Wollaston Process wire (drawn in a silver jacket) closely meets your specifications for diameter, resistance and other characteristics.

This organization specializes in wire and ribbon of smaller than commercial sizes and closer than commercial tolerances. Write for List of Products.

**SIGMUND COHN & CO.**



**44 GOLD STREET NEW YORK 7**

# Scenes from The Radio Engineering Show

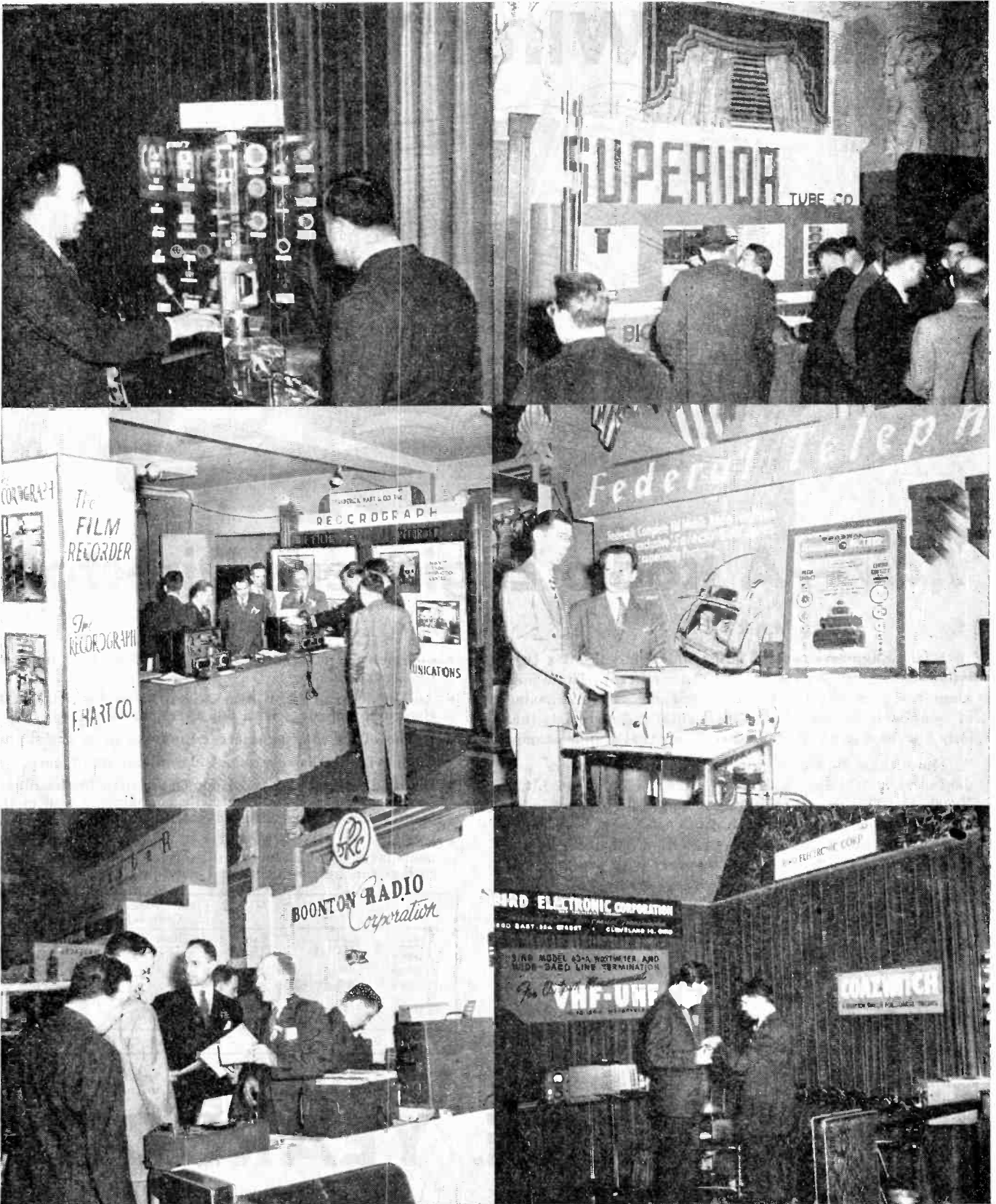

Radio-and-Electronic engineers met with manufacturers at the I.R.E. Radio Engineering Show, a part of the 1946 Winter Technical Meeting, the Institutes first great post-war convention. An estimated 10,000 visited 135 excellent exhibits.

These pictures by A. G. Michaelson show the educational and promotional value of this kind of display, which gives manufacturer and engineer an opportunity to discuss products—bringing production and market closer together.



# Do Radio Engineers Know What You Make?



## Now—A Radio Engineer's Directory

### MARKET

Radio Engineers control the technical buying of a two-billion-dollar radio-electronic and radar market. These men alone are competent to do the specifying and purchasing of complicated radio tubes, components, and materials that only a trained and experienced engineer really understands.

More than 15,000 radio-and-electronic engineers and engineers in training, will receive and use the 1946 I.R.E. Yearbook. This membership roster and radio product index has a close personal relationship to each engineer because it lists the reader himself and his fellow members in the radio profession. It is his own property with a permanent place on his desk — at his fingertips, a reference to both friends and radio-product data he needs and wants.

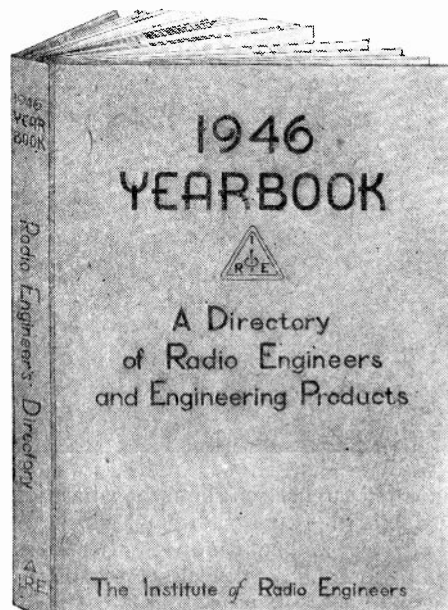

### FEATURES

- Complete membership list of The Institute of Radio Engineers.
- An alphabetical list of over 2000 firms serving the radio-electronic industry, with addresses, and —
- Names of the chief engineers of most of these firms, plus,
- Coding for 25 basic product classifications of each.
- Detailed product classifications (more than 100 headings) for all kinds of radio-electronic components and equipment listed for the firms advertising in the Yearbook.
- **PRODUCT ADVERTISING** of equipment and component-parts manufacturers, displaying and giving specifications for their products and providing engineering data.

RATES			For "Proceedings of I.R.E. Contract Advertisers"	
Space	Rate	Size	6 Times	12 Times
1 page	\$250.	7" x 10"	\$225.	\$200.
3/4 page	180.	4 5/8" x 10"	160.	140.
1/2 page	100.	{ 2 1/4" x 10" { 4 5/8" x 4 7/8" { 2 1/4" x 4 7/8" { 4 5/8" x 2 3/8"	90.	80.
1/4 page	60.		55.	50.

Agency Discount 15%. Cash Discount 2% 10 days.

# 1946 I.R.E. YEARBOOK

THE INSTITUTE OF RADIO ENGINEERS

303 West 42nd Street, New York 18, N. Y.

ME. 3-5661

WILLIAM C. COPP — National Advertising Manager

SCOTT KINGWILL

DUNCAN A. SCOTT & COMPANY

Central States Representative

Pacific Coast Representative

35 E. Wacker Drive  
Chicago 1

Mills Building  
San Francisco 4

448 So. Hill Street  
Los Angeles 13



## FILTER CONDENSER Bargains!



Thousands of rugged, oil-filled, oil-impregnated condensers at ridiculously low prices. Write for list! New Time Payment Plan if desired.

### BIG NEW CATALOG!

By mailing us your name and address, you will be among the first to get a copy of our own big new catalog, plus latest announcements of new and bargain components and equipment. Write today! Address Dept. 1R of nearest Newark branch.



CHICAGO  
Newark **ELECTRIC** Company  
NEW YORK  
115-117 W. 45th St. NEW YORK 19  
323 W. Madison St. CHICAGO 6

# THE FEATHEROAK?

THERE'S NO SUCH THING . . . BUT

## Skydyne SANDWICH CONSTRUCTION

IS

LIGHT AS A FEATHER...  
STRONG AS AN OAK...



. . . a long-sought combination correctly engineered into "SKYPLY"—the miracle material now available for your electronics cabinet needs.

Rigidly tested on fighting fronts throughout the world, where "SKYPLY" radar and radio cabinets proved their resistance to heat, cold, moisture, vibration and sound—this modern Skydyne Sandwich Construction is the perfect

answer to your product housing requirements.

Results of the "Drop Test" show that "SKYPLY" is twice as strong with half the weight, thereby reducing dead weight and lowering shipping costs.

Adaptable to all types of designs because "SKYPLY" is form-moulded, this Skydyne Sandwich Construction offers a beautiful, smooth surface, with curvatures easily attained.

Get the full story of this and many other "SKYPLY" uses.

WRITE TODAY FOR OUR FREE BROCHURE

## Skydyne Inc.

PORT JERVIS, NEW YORK

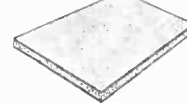

"SKYPLY"

Immediate Delivery!  
**WIDE RANGE  
VACUUM TUBE  
VOLTMETERS**

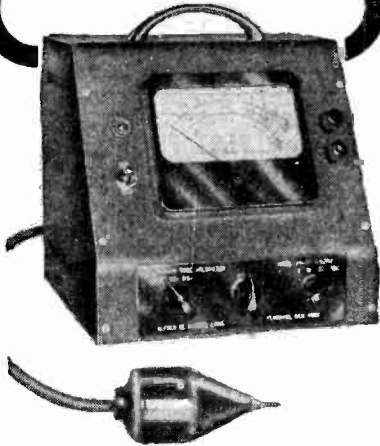

- High input impedance for both AC and DC measurements.
- Convenient, low capacity "Probe" especially adapted to high frequency radio use—100 megacycles and over.
- Self-regulating operation from power line; no batteries.
- Multiple voltage ranges — accurate and stable.

BULLETIN ON REQUEST

**ALFRED W. BARBER  
LABORATORIES**

34-04 Francis Lewis Blvd. Flushing, N.Y.



Absolute thoroughness in design and manufacture is one part of Electronic Engineering Company policy. The other part is detailed inspection at every manufacturing phase. This is your assurance of dependable performance—because every Electronic Engineering transformer gets this Inspection Plus.

"SPECIALIZED

Transformer

ENGINEERS"



3223-9 WEST ARMITAGE AVENUE

CHICAGO 47, ILLINOIS

# ADVERTISER'S INDEX

Scenes from the Radio Engineering Show ..... 81A, 83A  
 Sections Meetings ..... 38A  
 Membership ..... 42A  
 Positions Open ..... 50A  
 Positions Wanted ..... 54A

Accurate Spring Mfg. Co. .... 25A  
 Aerovox Corp. .... 73A  
 Aireon Mfg. Corp. .... 52A, 53A  
 Allen-Bradley Company ..... 20A  
 American Lava Corp. .... 45A  
 Amer. Tel. & Tel. Co. .... 34A, 35A  
 American Transformer Co. .... 27A  
 Amperex Electronic Corporation ..... Cover II  
 Andrew Co. .... 62A  
 Arnold Engineering Co. .... 58A  
 The Astatic Corp. .... 72A  
 Automatic Mfg., Corp. .... 71A  
 Alfred W. Barber Laboratories ..... 85A

Blaw Knox Co. .... 46A  
 Bliley Electric Company ..... 36A  
 Boonton Radio Corp. .... 82A  
 W. J. Brown ..... 86A  
 Brown Engineering ..... 76A

Cambridge Thermionic Corp. .... 68A  
 Capitol Radio Engineering Institute ..... 74A  
 The Allen D. Cardwell Mfg. Corp. .... 76A  
 Centralab ..... 18A  
 Chicago Transformer Corp. .... 66A  
 Cinaudagraph Speakers, Inc. .... 53A  
 Cinch Manufacturing Corp. .... 14A  
 Clarostat Mfg., Co., Inc. .... 44A  
 Sigmund Cohn & Co. .... 82A  
 Collins Radio Co. .... 23A  
 Communication Measurements Lab. .... 72A  
 Cornell-Dubilier Electric Corp. .... Cover III  
 Corning Glass Works ..... 16A, 17A  
 Cornish Wire Co. .... 70A

Drake Manufacturing Company ..... 74A  
 Allen B. DuMont Labs., Inc. .... 19A, 37A  
 E. I. DuPont de Nemours & Co., Inc. .... 64A

Hugh E. Eby, Inc. .... 68A  
 Eicor, Inc. .... 54A  
 Stanley D. Eilenberger ..... 86A  
 Eitel-McCullough, Inc. .... 88A  
 Electrical Reactance Corp. .... 80A  
 Electronic Engineering Co. .... 85A  
 Electronics Research Publishing Co. .... 68A  
 Electro-Voice, Inc. .... 59A  
 Erie Resistor Corp. .... 14A, 15A

Federal Tel. & Radio Corp. .... 43A, 50A  
 F. T. Fisher's Sons Limited ..... 86A

General Aniline & Film Corp. .... 56A, 57A  
 General Electric Co. .... 2A, 3A, 24A  
 General Radio Co. .... Cover IV  
 Goat Metal Stampings, Inc. .... 78A

Hallicrafters Company ..... 30A  
 Hammarlund Mfg. Company, Inc. .... 26A  
 Hewlett-Packard Company ..... 67A  
 Hytron Radio & Electronics Corp. .... 1A

Industrial Condenser Corp. .... 49A  
 International Tel. & Tel. Corp. .... 43A, 50A  
 International Nickel Co., Inc. .... 22A  
 I.R.E. Yearbook ..... 84A

Jackson Electrical Inst. Co. .... 60A  
 E. F. Johnson Co. .... 31A  
 Joliet Chemicals, Ltd. .... 61A

The Langevin Company, Inc. .... 86A  
 Lewis Electronics ..... 52A

Manufacturers Screw Products ..... 80A  
 Frank Massa ..... 86A  
 Mycalex Corp. of America ..... 39A

National Carbon Company, Inc. .... 8A  
 National Company, Inc. .... 69A  
 National Union Radio Corp. .... 7A  
 National Vulcanized Fibre Co. .... 72A  
 Newark Electric Co., Inc. .... 85A  
 New York Transformer Company ..... 55A

M. F. M. Osborne Associates ..... 86A

Pierce Paper Products Company ..... 6A  
 Albert Preisman ..... 86A  
 Press Wireless Mfg. Corp. .... 4A  
 Presto Recording Corp. .... 21A

Radio Corp. of America ..... 32A, 50A, 87A  
 Radio Engineering Labs., Inc. .... 29A  
 Radio Receptor Co., Inc. .... 70A  
 The Rauland Corp. .... 77A  
 Raytheon Mfg., Co. .... 65A  
 Remler Co., Ltd. .... 76A  
 Revere Copper and Brass Inc. .... 75A  
 The Richardson Company ..... 42A

Shallcross Mfg. Company ..... 38A  
 Sherron Electronics Co. .... 11A  
 Simpson Electric Company ..... 41A  
 Skydyne, Inc. .... 85A  
 Sola Electric Company ..... 5A  
 Solar Mfg. Corp. .... 33A  
 Sprague Electric Company ..... 10A  
 Stackpole Carbon Co. .... 12A  
 Standard Transformer Corp. .... 40A  
 Stupakoff Ceramic & Mfg. Co. .... 47A

Tech Labs ..... 64A  
 Triplett Electrical Instrument Co. .... 78A  
 Truscon Steel Co. .... 79A  
 Tung-Sol Lamp Works, Inc. .... 28A

United Cinephone Corp. .... 51A  
 United Transformer Company ..... 13A

Western Electric Company ..... 34A, 35A  
 Westinghouse Electric Corp. .... 9A, 48A  
 Weston Electrical Inst. Corp. .... 63A  
 John Wiley & Sons, Inc. .... 78A

Paul D. Zottu ..... 86A

## Professional Service

**M. F. M. Osborne Associates**  
 Consulting Physicists

Fluid Dynamics, Mechanics, Electronic Design, Electromagnetic and Acoustic Wave Propagation, Mathematical Analysis.

703 Albee Bldg., Washington 5, D.C.  
 Atlantic 9084

**FRANK MASSA**

*Electro-Acoustic Consultant*

DEVELOPMENT PRODUCTION DESIGN  
 PATENT ADVISOR

ELECTRO-ACOUSTIC & ELECTRO-MECHANICAL  
 VIBRATING SYSTEMS

SUPERSONIC GENERATORS & RECEIVERS  
 3393 Dellwood Rd., Cleveland Heights 18, Ohio

**W. J. BROWN**

*Electronic & Radio Engineering Consultant*

Electronic Industrial Applications, Commercial and Broadcasting Transmitter and Receiver Design, Test Equipment, etc.

23 years experience in electronic development

1420 East 25th St., Cleveland 14, Ohio  
 Superior 1241

**STANLEY D. EILENBERGER**

*Consulting Engineer*

**INDUSTRIAL ELECTRONICS**

Design—Development—Models

Complete Laboratory and Shop Facilities  
 6309-13—27th Ave.

Kenosha, Wis. Telephone 2-4213

**ALBERT PREISMAN**

*Consulting Engineer*

Specializing in Television and Pulse Techniques, Video Amplifiers, Industrial Applications.

616 St. Andrews Lane Silver Spring, Md.

**Paul D. Zottu**

*Consulting Engineer*

**Industrial Electronics**

High Frequency Dielectric and Induction Heating Applications, Equipment Selection, Equipment and Component Design, Development, Models.

314 Washington St., Newton, Mass. BIG-9240

**F. T. Fisher's Sons Limited**

*Consulting Engineers*

Broadcast Transmitters, Antenna Systems, Studio Equipment, Mobile and Fixed Communication Systems.

1425 Dorchester Street W., Montreal

*Worthy of an Engineer's Careful Consideration*

## TYPE 102 - A LINE AMPLIFIER

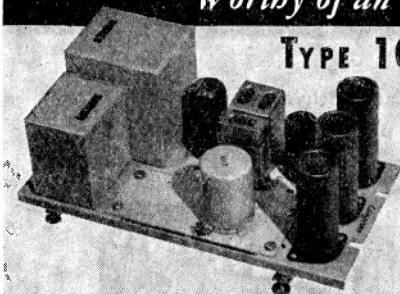

TYPE 102A Amplifier is one of the 102 Series Line Amplifiers of which four different types are available. The "A" is mostly used to drive the line after the master gain control. It is quiet, has excellent frequency characteristic and ample power output with low distortion products.

**The Langevin Company**

INCORPORATED  
 SOUND REINFORCEMENT AND REPRODUCTION ENGINEERING

NEW YORK  
 37 W. 65 St., 23

SAN FRANCISCO  
 1050 Howard St., 3

LOS ANGELES  
 1000 N. Seward St., 38

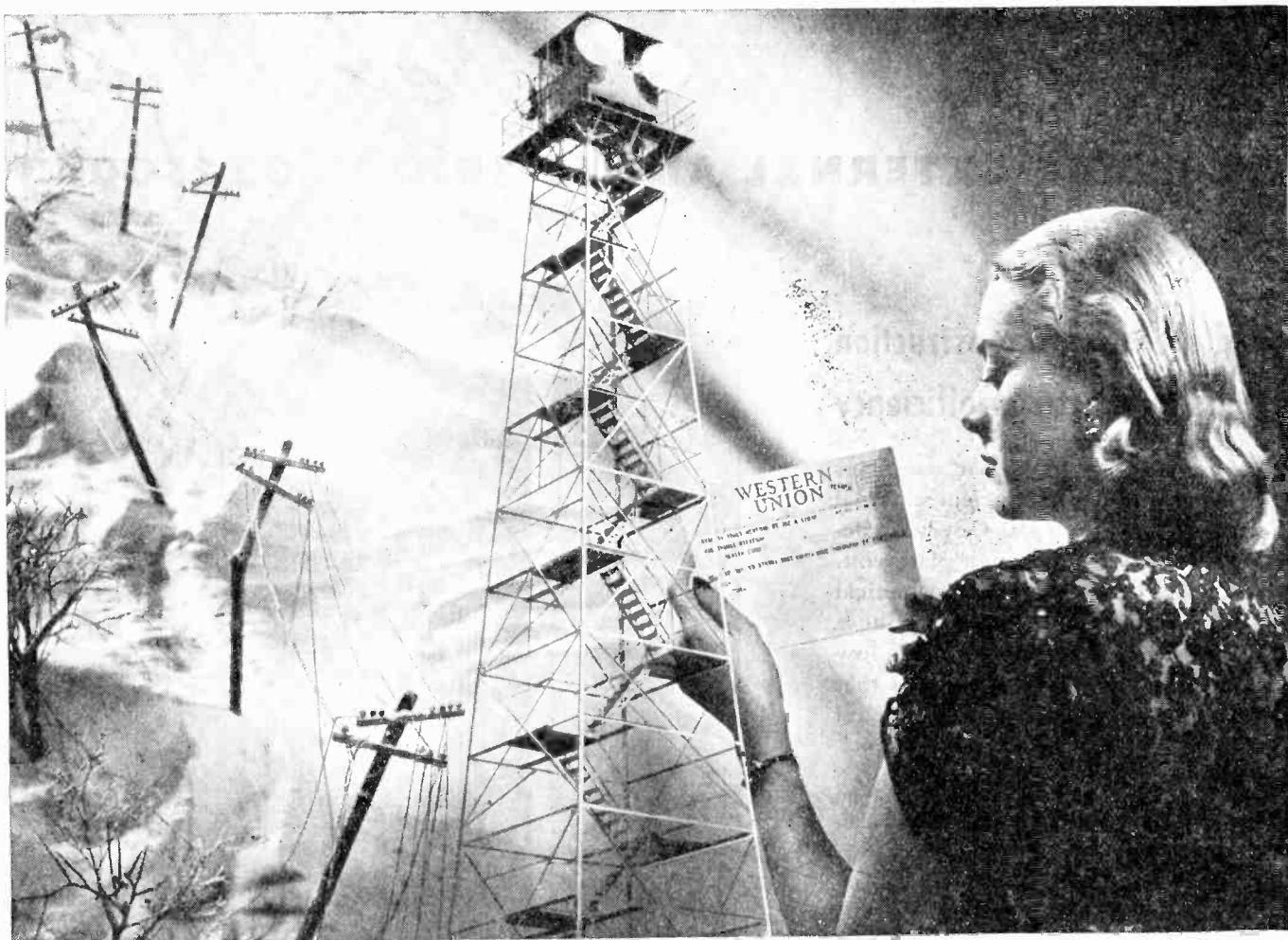

Radio relay towers, about 50 miles apart, will gradually replace thousands of miles of telegraph poles and wires.

## Now, telegrams "leapfrog" storms through RCA Radio Relay

With the radio relay system, developed by RCA, Western Union will be able to send telegraph messages between principal cities without poles and wires.

"Wires down due to storm" will no longer disrupt communications. For this new system can transmit telegrams and radiophotos by invisible electric microwaves. These beams span distances up to fifty miles between towers and are completely unaffected by even the angriest storms.

When large numbers of communications circuits are required, these automatic radio relay systems are more efficient than the pole and wire system . . . are less costly to build and maintain. They'll be particularly useful, too, in areas such as

China and South America where distances are great and long-line services have not been developed.

This revolutionary stride in communications was made possible by research in RCA Laboratories—the same "make it better" research that goes into *all* RCA products.

And when you buy an RCA Victor radio or television set or a Victrola\* radiophonograph, you enjoy a unique pride of ownership. For you know, if it's an RCA it is one of the finest instruments of its kind that science has achieved.

Radio Corporation of America, RCA Building, Radio City, New York 20, N. Y. . . Listen to *The RCA Victor Show, Sundays, 4:30 P.M., Eastern Time, over the NBC Network.*

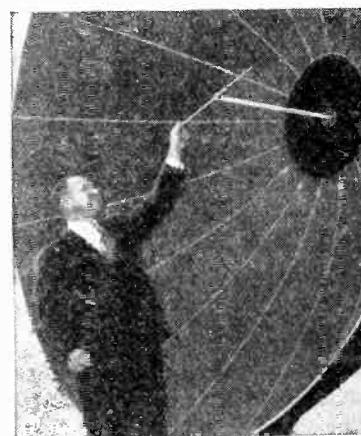

Research in microwaves and electron tubes at RCA Laboratories led to the development by the RCA Victor Division of this automatic radio relay system. Here is a close-up view of a microwave reflector. This system holds great promise of linking television stations into networks, as well as relaying other forms of electric communications.



**RADIO CORPORATION of AMERICA**

\*Victrola, T. M. Reg. U. S. Pat. Off.

# NEW EIMAC EXTERNAL ANODE TRIODE 3X2500A3

**Rugged mechanical construction**  
**Outstanding electrical efficiency**

In the new 3X2500A3, Eimac engineers have developed a highly efficient external anode triode which, in Class C service, delivers up to 5 KW output at a plate voltage of only 3,500 volts. The mechanical design is radically simple, incorporating a "clean construction" which gives short, low inductance heavy current connections that become an integral part of the external circuits at the higher frequencies.

The external anode, conservatively rated at 2500 watts dissipation, has enclosed fins so as to facilitate the required forced air cooling.

Non-emitting vertical bar grid does not cause anode shadows ordinarily created by heavy supports in the grid structure.

Thoriated tungsten filament. Note unusually large filament area, and close spacing.

Filament alignment is maintained throughout life of the tube by special Eimac tensioning method.

New glass-to-metal seals do not have the RF resistance common to iron alloy seals, nor the mechanical weaknesses of the feather-edged types.

Grid ring terminal mounts a cone grid support which acts as a shield between plate and filament.

A coaxial filament stem structure forms the base of the tube. This makes possible proper connections to the filament lines.

Grid and filament terminal arrangements make it possible to install or remove the 3X2500A3 without the aid of tools.

The new mechanical and electrical features of the Eimac 3X2500A3 external anode triode make it valuable for use on the VHF as well as low frequencies. More complete data and information yours for the asking.

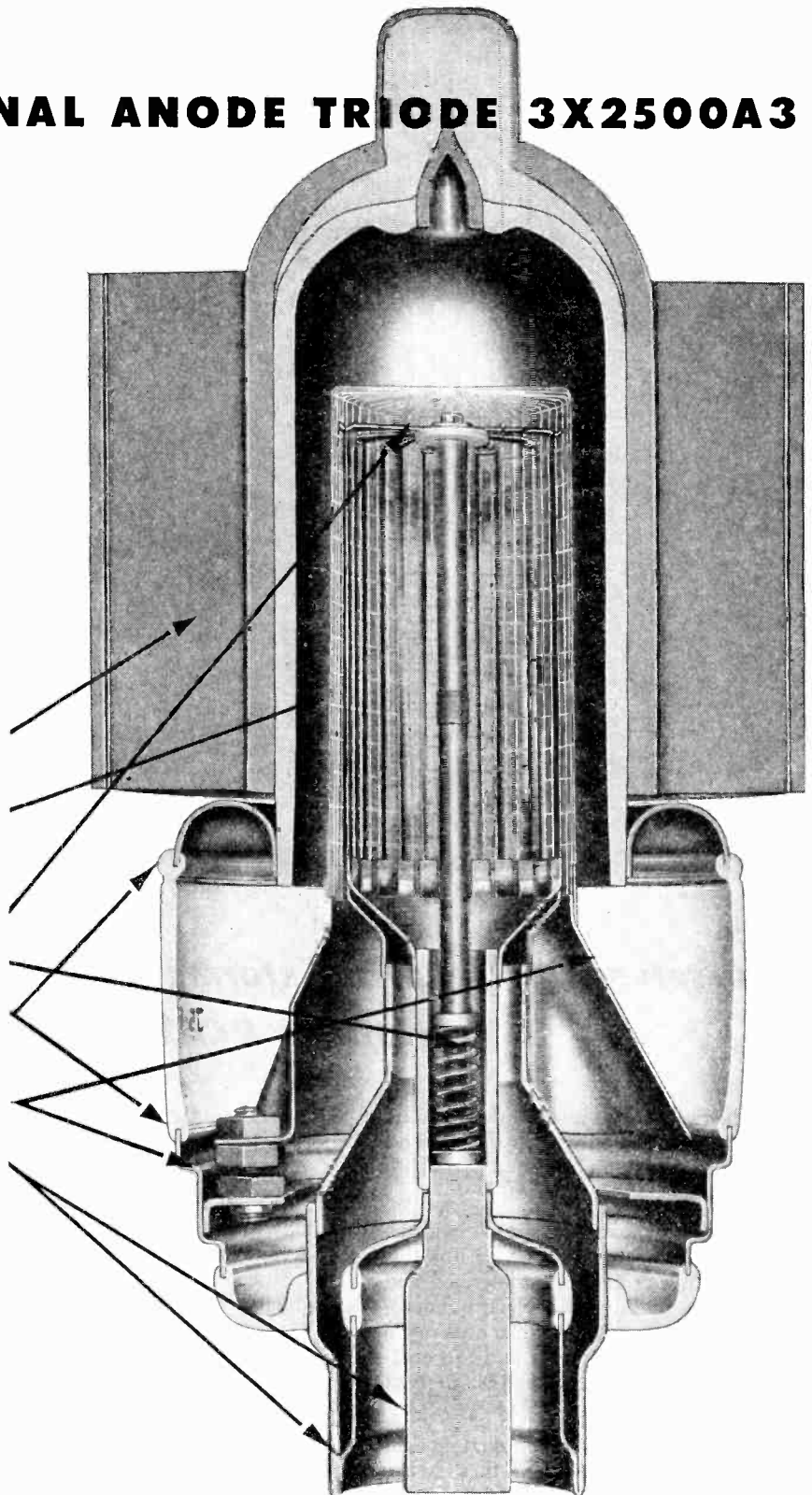

FOLLOW THE LEADERS TO



EITEL-McCULLOUGH, INC., 1123 J San Mateo Ave., San Bruno, Calif.

Plants located at: San Bruno, Calif.  and Salt Lake City, Utah

Export Agents: Frazar and Hansen, 301 Clay St., San Francisco 11, Calif., U.S.A.

## TYPE 3X2500A3 - MEDIUM MU TRIODE

### ELECTRICAL CHARACTERISTICS

Filament: Thoriated Tungsten	
Voltage . . . . .	7.5 volts
Current . . . . .	48 amperes
Amplification Factor (Average) 20	
Direct Interelectrode Capacitances (Average):	
Grid Plate . . . . .	20 <i>u</i> fd.
Grid Filament . . . . .	48 <i>u</i> fd.
Plate Filament . . . . .	1.2 <i>u</i> fd.
Transconductance ( <i>i</i> <sub>B</sub> =830 ma., <i>E</i> <sub>B</sub> =3000 v.)	20,000 <i>u</i> mhos





## DOING ONE THING WELL

Thirty-six years ago, in one small plant, we set out to do just one job—and do it well. Today, in six large plants—we're still at it—doing one thing well.

We like to feel that it is for this reason that more engineers specify C-D Capacitors. And for this reason too, that there are more C-D's in use today, than any other make.

This accumulative engineering and manufacturing "know-how" has enabled us to design over one hundred thousand different types of capacitors in the past year. Actually, these designs encompassed every conceivable type of capacitor from the tiny tubulars used in the "Proximity Fuze" to the giant tank units used in the world's most powerful transmitters.

C-D Capacitors—of whatever type you may require—will add quality and dependability to *your* products. Creative, far-sighted engineering, extensive plant facilities—plus the knowledge and techniques of over thirty-six years of specialization—are yours to command. Catalog or request. Cornell-Dubilier Electric Corporation, South Plainfield, New Jersey. Other plants at New Bedford, Worcester, Brookline, Mass.; and Providence, R. I.



**Cornell-Dubilier** World's Largest Manufacturer of **Capacitors**





# **DIRECT-READING** **Capacitance Bridge**

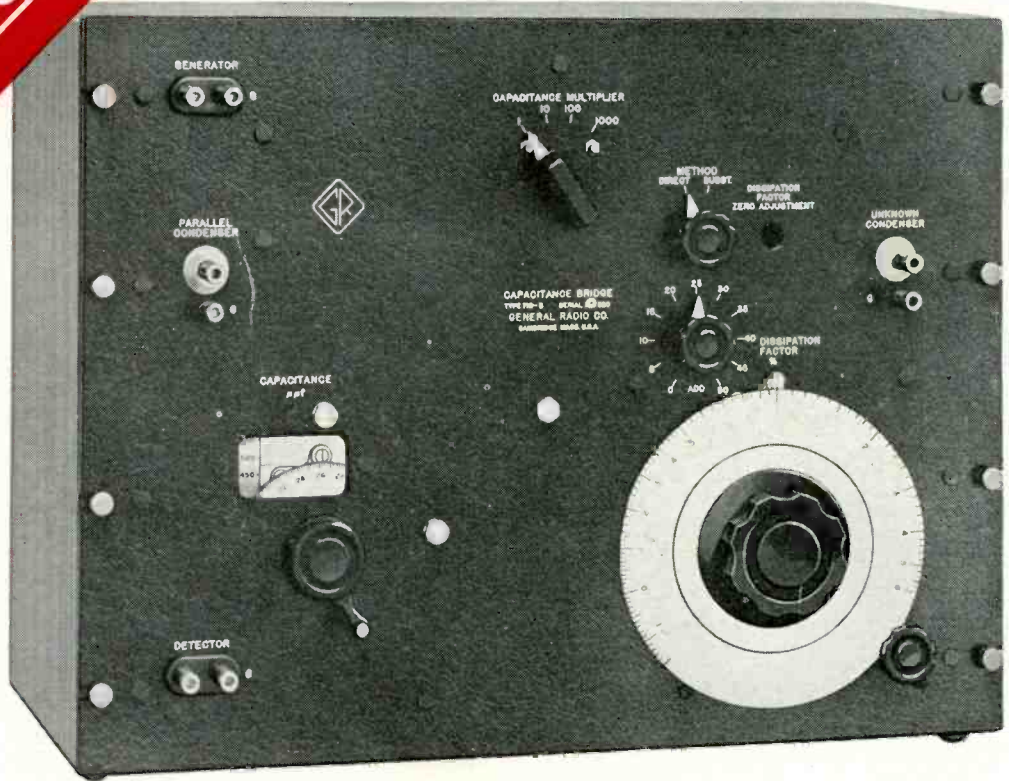

FOR THE MEASUREMENT of capacitance and dissipation factor this direct-reading bridge is finding wide application for such determinations as dielectric constant, phase angle, power factor, loss factors and other dielectric properties of insulating materials and changes in these properties with factors such as temperature and humidity. For the production adjustment and testing of fixed and variable condensers it is particularly effective.

This instrument is a modified Schering bridge, direct-reading in both capacitance and power factor at 1,000 cycles. By adding an external decade resistance box, it can be converted into a series- or parallel-resistance bridge.

**WIDE RANGES** Direct-reading in capacitance from 100 micro-microfarads to 1 microfarad; in dissipation factor from 0.002% to 56%. Substitution method for capacitance the range is 0.1 micromicrofarad to 1,000 micromicrofarads with internal standard, and to 1 microfarad with external standard.

**HIGH ACCURACY** Direct-reading accuracy for capacitance is 0.2% of full scale for each range; substitution method accuracy for capacitance is  $\pm 0.2\%$  or  $\pm 2$  micro-microfarads.

**WIDE FREQUENCY RANGE** All calibration adjustments are for the 1 kc direct-reading settings; any frequency between 60 cycles and 10 kc can be used, in which case the dissipation-factor readings are corrected by multiplying the dial readings by the frequency in kilocycles.

This bridge is suitable for practically any type of capacitance measurement. Because of its design, the readily accessible terminals and the simplified controls it is a very flexible and simple-to-operate instrument.

TYPE 716-BR Relay Rack Mounting \$335

TYPE 716-BM Cabinet Model \$360

**Write for complete specifications**

# **GENERAL RADIO COMPANY**

**Cambridge 39,  
Massachusetts**

90 West St., New York 6

920 S. Michigan Ave., Chicago 5

1000 N. Seward St., Los Angeles 38