

# Proceedings



*of the*

# I·R·E

OCTOBER 1942

VOLUME 30 NUMBER 10

Electronic Potentiometer  
New Magnetic Materials  
Transient Response of Television  
Apparatus  
Oscillograph for Television  
Crystal Control for Ultra-Short Waves  
Radio-Noise-Meter Performance  
Radio Manufacturing in the War Effort  
Radio Broadcasting in the War Effort  
Radio Engineering in the War Effort

Institute of Radio Engineers

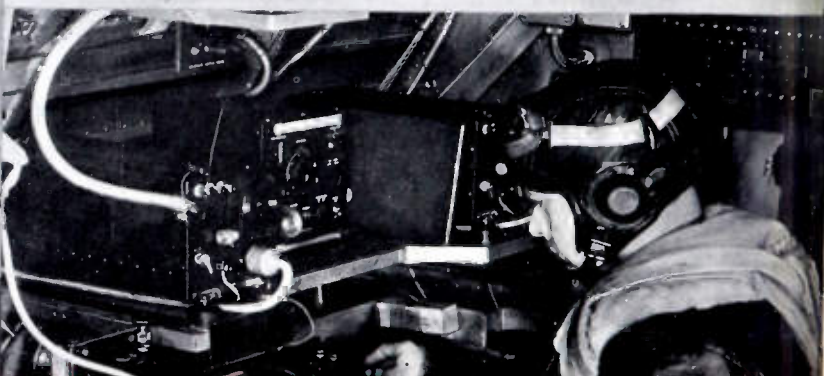
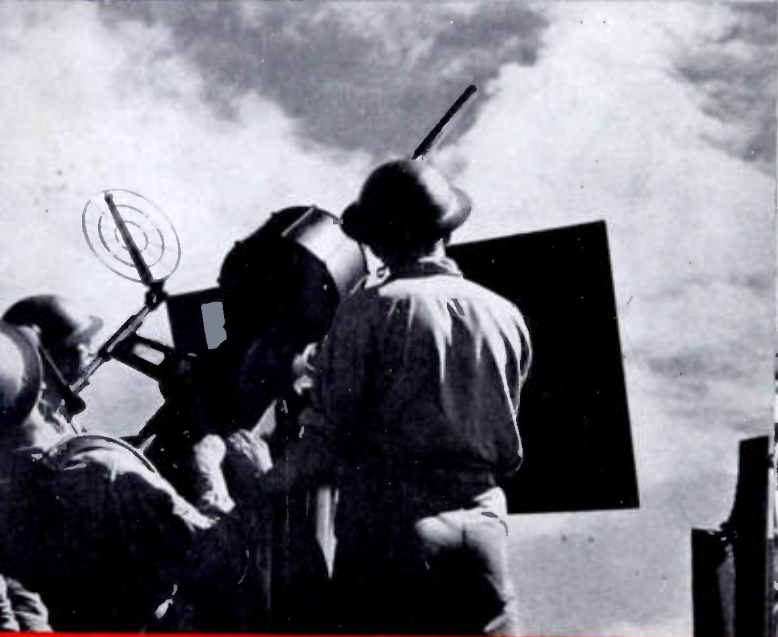

U. S. NAVY OFFICIAL PHOTOS

# UTC CASE HISTORIES

Laboratory File No. S14-S23



This unit helps "keep them flying." A UTC redesign combined two units in one . . . reduced quantity of critical materials 50% . . . reduced weight and size 40% . . . reduced installation time 60% . . . reduced possible trouble points 50%.

Laboratory File No. S14-312



This unit maintains ground communications at a more efficient level. Now plastic housed. Critical materials reduced 50%. UTC design reduced possible trouble points 50% . . . reduced difficulty of operation 50%.

Laboratory File No. T16-399



This unit is used at a number of points in aircraft communication. A UTC design reduced quantity of critical materials used 20% . . . reduced weight and size 20% . . . reduced possible trouble points 50%.

Laboratory File No. S9-474

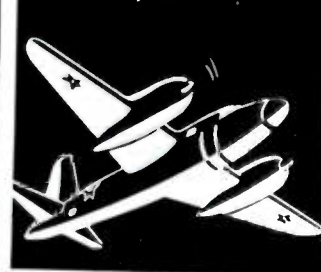

This unit is a component in a piece of aircraft equipment. A UTC design reduced quantity of critical materials 60% . . . reduced weight and size 60% . . . made possible a similar reduction of size and weight in the complete equipment of which it is a component.

**WHAT CAN WE DO FOR YOU?**

# UNITED TRANSFORMER CO.

150 VARICK STREET



NEW YORK, N. Y.

EXPORT DIVISION: 160 VARICK STREET NEW YORK, N. Y. CABLES: "ARLAP"

BOARD OF DIRECTORS

- Arthur F. Van Dyck, *President*
- Walter A. Rush, *Vice President*
- Haraden Pratt, *Treasurer*
- Harold P. Westman, *Secretary*
- Alfred N. Goldsmith, *Editor*
- Austin Bailey
- Adolph B. Chamberlain
- Carl C. Chambers
- Ivan S. Coggeshall
- William L. Everitt
- Harold T. Friis
- O. B. Hanson
- Lawrence C. F. Horle
- C. M. Jansky, Jr.
- J. Kelly Johnson
- Frederick B. Llewellyn
- Frederick E. Terman
- Browder J. Thompson
- Hubert M. Turner
- Harold A. Wheeler
- Lynde P. Wheeler

Harold R. Zeamans,  
*General Counsel*

BOARD OF EDITORS

- Alfred N. Goldsmith, *Editor*
- Ralph R. Batcher
- Lloyd V. Berkner
- Philip S. Carter
- Lewis M. Clement
- Elmer W. Engstrom
- William L. Everitt
- Peter C. Goldmark
- Frederick W. Grover
- C. M. Jansky, Jr.
- John D. Kraus
- Frederick B. Llewellyn
- Samuel S. Mackeown
- Edward L. Nelson
- Harry F. Olson
- Greenleaf W. Pickard
- Haraden Pratt
- Conan A. Priest
- Leon J. Sivian
- Lynne C. Smeby
- Browder J. Thompson
- Harold A. Wheeler
- Lynde P. Wheeler
- Laurens E. Whittemore
- Gerald W. Willard
- William Wilson
- Charles J. Young

Helen M. Store, *Assistant Editor*  
William C. Copp,  
*Advertising Manager*  
William B. Cowilich,  
*Assistant Secretary*

# Proceedings

## of the I·R·E

*Published Monthly by*

The Institute of Radio Engineers, Inc.

VOLUME 30

October, 1942

NUMBER 10

An Electronic Potentiometer.....	M. A. Honnell	433
New Magnetic Materials.....	W. E. Ruder	437
Analysis, Synthesis, and Evaluation of the Transient Response of Television Apparatus.....	A. V. Bedford and G. L. Fredendall	440
A Portable High-Frequency Square-Wave Oscillograph for Television....	R. D. Kell, A. V. Bedford, and H. N. Kozanowski	458
A New Direct Crystal-Controlled Oscillator for Ultra- Short-Wave Frequencies.....	W. P. Mason and I. E. Fair	464
An Evaluation of Radio-Noise-Meter Performance in Terms of Listening Experience.....	Charles M. Burrill	473
War Contributions of Radio Manufacturing.....	Paul V. Galvin	479
What Radio Broadcasting Means in the War Effort.....	Neville Miller	482
Radio Engineering in the War Effort.....	Arthur Van Dyck	482
Correspondence on "The Engineer in Modern Society," by Arthur Van Dyck.....	L. T. Bird	485
Institute News and Radio Notes.....		486
To Be or Not To Be—In Uniform.....	Arthur Van Dyck	486
Board of Directors.....		486
Executive Committee.....		486
Roy Alexander Weagant.....		487
Malcolm P. Hanson.....		487
Summer Convention.....		488
Institute Committees—1942.....		489
Institute Representatives in Colleges.....		491
Institute Representatives on Other Bodies.....		492
Contributors.....		493
Section Meetings.....		xiv
Membership.....		xiv
"E" Honor Roll.....		xxvi
Positions Open.....		xxviii
Advertising Index.....		xxxii

The contents of papers published in the PROCEEDINGS are the responsibilities of the authors and are not binding on the Institute or its members.



Entered as second-class matter October 26, 1927, at the post office at Menasha, Wisconsin, under the Act of February 28, 1925, embodied in Paragraph 4, Section 538 of the Postal Laws and Regulations. Publication office, 450 Ahnalt Street, Menasha, Wisconsin. Editorial and advertising offices, 330 West 42nd St., New York, N. Y. Subscription \$10.00 per year; foreign, \$11.00.

# THE INSTITUTE OF RADIO ENGINEERS

INCORPORATED



New York Meeting—November 4, 1942

## SECTION MEETINGS

**ATLANTA**  
October 16

**CLEVELAND**  
October 22

**DETROIT**  
October 16

**LOS ANGELES**  
October 20

**PHILADELPHIA**  
November 5

**PITTSBURGH**  
November 9

**WASHINGTON**  
November 9

## SECTIONS

- ATLANTA**—Chairman, J. M. Comer; Secretary, G. V. Waldo, 3166 Peachtree Dr., N. E., Atlanta, Ga.
- BALTIMORE**—Chairman, G. J. Gross; Secretary, G. J. Gross, Pa. Water & Power Co., 1611 Lexington Bldg., Baltimore, Md.
- BOSTON**—Chairman, J. M. Henry; Secretary, R. O. Oberg, Northeastern Univ., Boston, Mass.
- BUENOS AIRES**—Chairman, J. P. Arnaud; Secretary, Alexander Nadosy, Florida St. 1065, Dept. C-6, Buenos Aires, Argentina.
- BUFFALO-NIAGARA**—Chairman, F. H. Scheer; Secretary, A. J. Dybowski, Dymac Radio, Inc., 1531 Main St., Buffalo, N. Y.
- CHICAGO**—Chairman, R. A. Kay; Secretary, Walter Kenworth, 5505 Potomac Ave., Chicago, Ill.
- CINCINNATI**—Chairman, W. I. Schwesinger; Secretary, Howard Leppele, 4432 Raceview Ave., Cincinnati, Ohio.
- CLEVELAND**—Chairman, P. L. Hoover; Secretary, A. S. Nace, 3209 Archwood Ave., Cleveland, Ohio.
- CONNECTICUT VALLEY**—Chairman, F. G. Webber; Secretary, C. I. Bradford, 187 Glenarden Dr., Fairfield, Conn.
- DALLAS-FORT WORTH**—Chairman, Truett Kimzey; Secretary, P. C. Barnes, Radio Station WFAA-WBAP, Grapevine, Texas.
- DETROIT**—Chairman, H. F. Tank; Secretary, Paul Frincke, 219 S. Kenwood Ave., Royal Oak, Michigan.
- EMPORIUM**—Chairman, R. K. Gessford; Secretary, H. D. Johnson, Hygrade Sylvania Corp., Emporium, Pa.
- INDIANAPOLIS**—Chairman, S. E. Benson; Secretary, B. H. Rinehart, 1920 Park Ave., Indianapolis, Ind.
- KANSAS CITY**—Chairman, H. K. Morgan; Secretary G. L. Taylor, Midland Radio School Power and Light Building, Kansas City, Mo.
- LOS ANGELES**—Chairman, C. F. Wolcott; Secretary, E. S. Sievers, Room 567, 417 S. Hill St., Los Angeles, Calif.
- MONTREAL**—Chairman, J. A. Ouimet; Secretary, J. R. Bain, Dept. 912, Northern Electric Co., 1231 Shearer St., Montreal, Que., Canada.
- PHILADELPHIA**—Chairman, C. C. Chambers; Secretary, R. L. Snyder, 103 Franklin Rd., Glassboro, N. J.
- PITTSBURGH**—Chairman, D. A. Myer; Secretary, A. P. Sunnergren, West Penn Power Co., 14 Wood St., Pittsburgh, Pa.
- PORTLAND**—Chairman, R. W. Deardorff; Secretary, B. R. Paul, 5960 S. W. 41st. Ave., Portland, Ore.
- ROCHESTER**—Chairman, O. L. Angevine, Jr.; Secretary, G. R. Town, Stromberg-Carlson Tel. Mfg. Co., Rochester, N. Y.
- ST. LOUIS**—Chairman, O. S. McDaniel; Secretary, H. D. Seielstad, 1017 S. Berry Rd., St. Louis, Mo.
- SAN FRANCISCO**—Chairman, H. E. Held; Secretary, W. G. Wagener, Heintz and Kaufman, South San Francisco, Calif.
- SEATTLE**—Chairman, K. H. Ellerbeck; Secretary, H. E. Renfro, 4311 Thackeray Pl., Seattle, Wash.
- TORONTO**—Chairman, T. S. Farley; Secretary, L. C. Simmonds, A. C. Simmonds and Sons, 301 King St., E., Toronto, Ont., Canada.
- TWIN CITIES**—Chairman, R. E. Allison; Secretary, A. G. Peck, Twin-Cities Studios, Columbia Broadcasting System, 625 Second Ave., S., Minneapolis, Minn.
- WASHINGTON**—Chairman, E. M. Webster; Secretary, J. D. Wallace, Radio Division U. S. Naval Research Laboratory, Anacostia Station, D. C.

# An Electronic Potentiometer\*

M. A. HONNELL,† ASSOCIATE, I.R.E.

**Summary**—A direct-current, degenerative, slide-back, vacuum-tube voltmeter employing standard potentiometer design principles is described. The voltmeter is completely self-calibrated upon construction. By adjusting the voltmeter to the same reference balance condition for all voltage measurements, the grid current is readily reduced to less than  $10^{-9}$  ampere. Voltages in the range from 1 to 100 volts are read to four significant figures in the experimental model of the voltmeter.

## INTRODUCTION

THE most accurate voltage standard available to the independent investigator is a standard cell employed with an accurate potentiometer. That is, a known voltage and standard resistances are utilized to establish definitely known voltages. This idea is incorporated in a direct-current vacuum-tube voltmeter which employs an accurate potentiometer and a known current, or a known voltage, as an integral part. It is a degenerative, slide-back, triode voltmeter designed to utilize the advantages of both the direct-current slide-back<sup>1</sup> and degenerative voltmeters.<sup>2</sup> A direct-current vacuum-tube voltmeter of this type is the nucleus of an accurate all-purpose instrument which may be used as a direct-current ammeter when provided with shunts, or as a radio-frequency voltmeter<sup>2</sup> and ammeter<sup>3</sup> when used in conjunction with a diode voltmeter.

## THEORY OF OPERATION

Fig. 1 is the fundamental functional circuit of the voltmeter. Initially, the push-button switch PB is pressed to the position marked "set," and the cathode resistor  $R_k$  is adjusted so that the milliammeter reads exactly 0.001 ampere. Assume, then, that the voltage to be measured  $E_i$  is precisely 40 volts, and that this voltage is applied to the voltmeter with positive polarity on the grid of the tube. When the push button is released to the position marked "read," the cathode current, as indicated by the milliammeter, will change. It is apparent that the meter reading may be returned to 0.001 ampere at one particular setting of the 100,000-ohm potentiometer marked  $P$ . At this setting,  $R_1$  is precisely 40,000 ohms, and the voltage drop across  $R_1$  is 40 volts.

With the circuit constants shown in Fig. 1, and a reference current of 0.001 ampere, direct voltages up to 100 volts may be measured. For example, if the unknown voltage is 95 volts, the meter reading will be returned to 0.001 ampere when  $R_1$  is 95,000 ohms. The voltage drop across  $R_1$  is then 95 volts. For

any particular adjustment of the potentiometer,  $R_1 + R_2 = 100,000$  ohms. It is evident that if the meter is accurately calibrated at the single point of 0.001 ampere, the unknown voltage is read in terms of the resistance of the section of the potentiometer marked  $R_1$  in Fig. 1. Furthermore, the circuit is adjusted to identical values of element potentials and currents for all voltage measurements.

With a plate-supply voltage of 250 volts, the total voltage drop across the potentiometer is 100 volts, when the cathode current is adjusted to the reference value of 0.001 ampere. The remaining voltage drop is

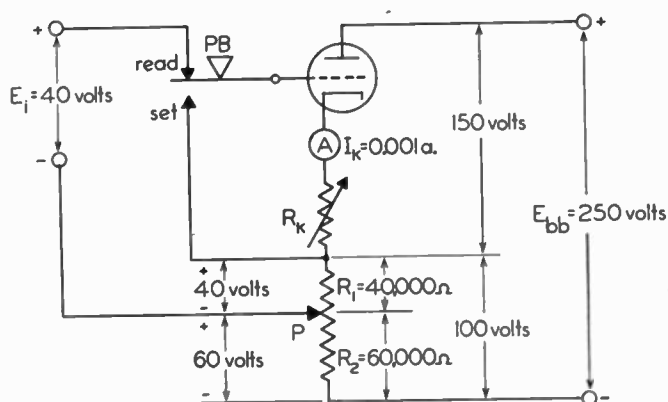

Fig. 1—Fundamental functional diagram.

across the tube and  $R_k$ . The value of the plate-supply voltage is dictated by the range of voltages to be measured and by the circuit constants employed. However, it need be only high enough to permit adjustment of the cathode current to 0.001 ampere.

One of the principal factors governing the accuracy of the voltmeter is the precision with which the cathode current may be adjusted to the reference value of 0.001 ampere. It is evident that the total resistance included in the cathode circuit has the predominating effect on the value of the plate, or cathode, current. The effect of the various circuit parameters on the sensitivity of adjustment of the plate current to the nominal value may be determined to a first approximation through a mathematical investigation of the circuit by use of the equivalent plate-circuit theorem. Referring to the basic circuit of Fig. 2, the voltage increment  $\Delta E_g$ , acting from the grid to the cathode, causes an incremental change in plate current

$$\Delta I_p = \frac{\mu \Delta E_g}{r_p + R_t} \quad (1)$$

where

$\mu$  = the amplification factor of the tube,  
 $r_p$  = the dynamic plate resistance of the tube, and  
 $R_t$  = the total resistance in the external plate-to-cathode circuit.

The change in plate current  $\Delta I_p$  flowing through  $R_1$  produces the voltage drop  $\Delta I_p R_1$  with a polarity

\* Decimal classification: R243.1. Original manuscript received by the Institute, September 9, 1940; revised manuscript received, June 17, 1942.

† Georgia School of Technology, Atlanta, Georgia.

<sup>1</sup> H. J. Reich, "Theory and Application of Electron Tubes," McGraw-Hill Book Company, New York, N. Y., 1939, pp. 571-574.

<sup>2</sup> W. N. Tuttle, "Type 726-A vacuum-tube voltmeter," *Gen. Rad. Exp.*, vol. 11, pp. 1-6; May, 1937.

<sup>3</sup> D. B. Sinclair, "The type 726-A vacuum-tube voltmeter as a radio-frequency ammeter," *Gen. Rad. Exp.*, vol. 13, pp. 1-4, August-September, 1938.

opposite to  $\Delta E_i$ , the incremental change in input voltage. The net incremental grid voltage acting from the grid to the cathode of the tube is defined by

$$\Delta E_g = \Delta E_i - \Delta I_p R_f. \quad (2)$$

Substitute (2) in (1) and solve for  $\Delta I_p$  to obtain

$$\Delta I_p = \frac{\Delta E_i}{\frac{r_p + R_t}{\mu} + R_f}. \quad (3)$$

Since both  $\mu$  and  $r_p$  may be considered constant when the point of operation is in the vicinity of the nominal

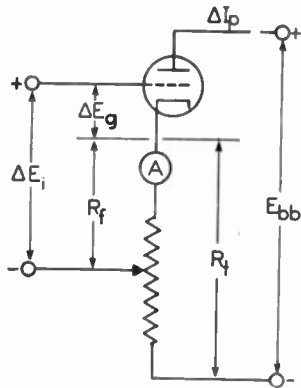

Fig. 2—Basic circuit.

plate current, or as the balance point is approached, (3) may be written in the form

$$\Delta I_p = \frac{\Delta E_i}{k + R_f} \quad (4)$$

where

$$k = \frac{r_p + R_t}{\mu}.$$

Equation (4) gives the incremental change in plate current about the balance point to a good degree of accuracy. For a given change in input voltage, the change in plate current approaches a maximum as the resistance of  $R_f$  approaches zero. Therefore, as  $R_f$  is increased, the least perceptible change in plate current is decreased for a given change in input voltage. However, the resistance of  $R_f$  is small when low voltages are measured, and it is large when relatively high voltages are measured. The effect of this is to render the per cent accuracy of adjustment of the voltmeter reasonably constant over most of its range.

Wide changes in plate voltage have no effect on the accuracy of the voltmeter so long as the plate-supply voltage remains constant during the interval between the initial and the final adjustments of the potentiometer. The degeneration present with any particular adjustment of the potentiometer aids in providing good stability of setting.

Vacuum tubes with far-different characteristics may be interchanged in the voltmeter without affecting the calibration, since the calibration of the voltmeter is dependent solely upon the calibration of the potentiometer and of a single point on the milliamme-

ter. It is to be noted that this voltmeter differs from the usual self-calibrating slide-back vacuum-tube voltmeter in that it employs a single meter, or indicating device.

### THE PRACTICAL VOLTMETER

In order to reduce to a minimum the manual operations necessary in making a voltage measurement, the basic circuit of the vacuum-tube voltmeter is rearranged as in Fig. 3. The push button  $PB$  is pressed, and  $R_k - R_k'$  is adjusted so that the meter in the cathode lead reads exactly 1 milliampere. Then the push-button is released and the voltmeter is ready for use. The cathode resistor  $R_k - R_k'$  consists of a fine and a coarse adjustment in order that the initial cathode-current adjustment may be precisely made.

A vacuum-tube voltmeter utilizing the circuit of Fig. 3 with a range of 0 to 100 volts is illustrated in Fig. 4. The tube employed in the voltmeter is a 6F5GT, a high- $\mu$  triode with a small glass envelope. The grid lead of the 6F5GT is brought through the top of the glass envelope, thus insuring a high-resistance path between the grid and the other elements in the tube.

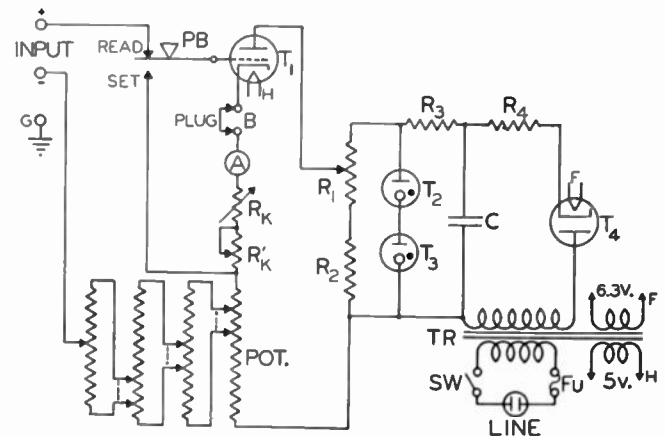

Fig. 3—The practical vacuum-tube voltmeter circuit.

- $R_1$  = 5000-ohm potentiometer
- $R_2$  = 25,000-ohm bleeder resistor
- $R_3$  = 5000-ohm resistor
- $R_4$  = 5000-ohm adjustable resistor
- $R_k$  = 250-ohm variable resistor
- $R_k'$  = resistor adjustable in ten 200-ohm steps
- POT. = 100,000-ohm Thomson-Varley potentiometer
- $C$  = 16-microfarad electrolytic condenser
- TR = small power transformer
- $T_1$  = 6F5GT triode
- $T_2$  and  $T_3$  = VR150-30 glow-discharge tubes
- $T_4$  = 1-V rectifier

In order that the setting of the potentiometer, and hence the unknown voltage, may be read to four significant figures, a 4-dial, 100,000-ohm potentiometer, or calibrated voltage divider, of the Thomson-Varley<sup>4</sup> type composed of resistors of 0.1 per cent accuracy is employed. The total resistance of this type of potentiometer remains constant irrespective of the position of the individual dials. Fig. 5 is a schematic diagram of this potentiometer. Any potentiometer having a constant total resistance independent of the setting is suitable.

<sup>4</sup> C. L. Dawes, "A Course in Electrical Engineering," vol. 1, McGraw-Hill Book Company, New York, N. Y., 1937, p. 184.

As the normal plate current drawn by the voltmeter is only 0.001 ampere, a simple power supply using a 1-V rectifier tube suffices. Two glow-discharge voltage-regulator tubes connected in series maintain the plate-supply voltage constant at 300 volts. The heater of the 6F5GT has enough "thermal inertia" to eliminate fluctuations of plate current due to rapid variations of heater voltage. It is desirable, however, to connect the vacuum-tube voltmeter to a small voltage-regulated transformer for maximum stability, where frequent variations of line voltage are encountered.

The meter is a 5-inch diameter, 0 to 1.5 millimeter accurately calibrated at the 1-milliamper point. Two terminals connected in series with the milliammeter are provided on the panel of the vacuum-tube voltmeter in order that a highly accurate external meter, or other calibration device may be conveniently employed. It is to be noted that the use of an external meter has no effect on the calibration of the voltmeter. The saturation value of the plate current with the

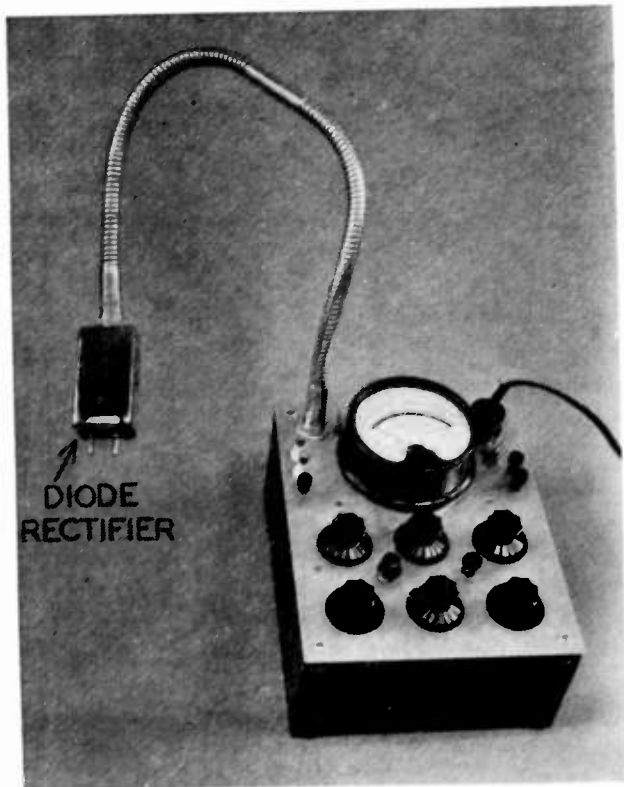

Fig. 4—Experimental model of the vacuum-tube voltmeter.

circuit constants and the plate-supply voltage employed is less than 3.0 milliamperes. This value of current is insufficient to cause severe damage to the meter on overload. If the grid becomes positive on large overloads, the milliammeter will read the sum of the plate and the grid currents. The resistance in the cathode circuit provides some degree of protection. If the normal grid current at the balance condition is negligible, the meter may be placed directly in the plate circuit. The milliammeter may be completely protected by connecting a 1-megohm resistance in series with the grid of the tube.

When this vacuum-tube voltmeter is used to measure the output voltage of a diode voltmeter connected to a resonant circuit, it will give a direct qualitative indication of resonance in the circuit. Resonance is indicated by a maximum increase in the cathode current for any particular setting of the Thomson-Varley

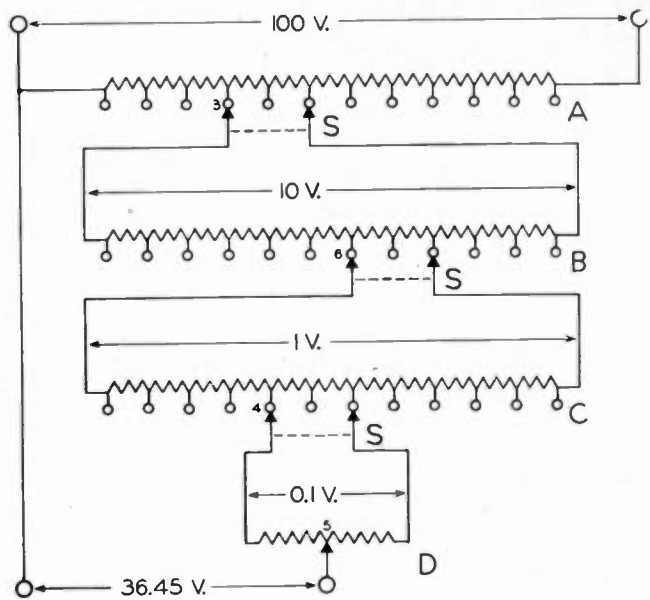

Fig. 5—100,000-ohm Thomson-Varley potentiometer.

A = eleven 10,000-ohm resistors

B = eleven 2000-ohm resistors

C = eleven 400-ohm resistors

D = calibrated 800-ohm potentiometer

S = two-gang, ten-position switches connected so as to bridge over two resistors in series as indicated.

With 100 volts applied to the potentiometer, the output is 36.45 volts for the switch positions indicated in the figure.

potentiometer. After resonance has been established, it is an easy matter to read the exact value of the voltage developed at the diode voltmeter output terminals by using the slide-back feature.

The stray voltage developed at the diode voltmeter output terminals with no input voltage is balanced out by an equivalent voltage developed across the variable cathode resistance  $R_k - R_k'$ . In order to effect this balance, the diode input terminals are shorted, the Thomson-Varley potentiometer is set at zero, and the cathode resistance  $R_k - R_k'$  is adjusted for the reference cathode current of 0.001 ampere. The voltmeter is then ready for alternating-voltage measurements.

#### GRID CURRENT

In a self-biasing circuit of the type used in the voltmeter, the grid is always negative with respect to the cathode at the reference balance condition. With this mode of operation, the input resistance of the tube is extremely high, as normally there is only a minute grid-circuit current<sup>6,6</sup> due to (1) electrons emitted by the cathode, (2) positive gas ions, (3) insulation leakage, (4) electrons emitted by the grid, and (5) positive metallic ions emitted by the cathode. The first three of these contribute most to the grid current.

<sup>6</sup> Institute of Radio Engineers, "Standards on Electronics," 1938, Section III-D, pp. 34-38.

<sup>6</sup> R. M. Bowie, "This matter of contact potential," *Proc. I.R.E.*, vol. 24, pp. 1501-1513; November, 1936.

The grid emission current (4) is reduced in the practical voltmeter by operating the 6F5GT at a heater voltage of 5 volts instead of at the rated value of 6.3 volts. The insulation leakage current (3) is reduced by coating the glass envelope of the tube with ceresin wax and by carefully insulating the external grid circuit. The positive-ion current (2) will vary considerably from tube to tube. It may be reduced by employing a low plate-to-cathode potential. Variations in the net grid current are much more objectionable than the fact that a grid current flows. For this reason, it is important that all insulation in the grid-cathode circuit of the voltmeter be nonhygroscopic.

Grid current causes an appreciable voltage drop in the voltage read across the terminals of a high-resistance voltage source, and is, therefore, undesirable. The grid current is particularly objectionable if the internal resistance of the voltage source and the magnitude of the grid current are unknown.

In the vacuum-tube voltmeter of Fig. 3, the grid current is reduced to less than  $10^{-9}$  ampere by adjusting the grid bias to the "floating-grid" potential<sup>7</sup> of the tube in the following manner: A resistance of 100 megohms shunted by a push-button short-circuiting switch is connected to the input terminals of the voltmeter. Then with the calibrated potentiometer set at zero, the cathode resistor  $R_k - R_k'$  is adjusted for the reference value of plate current of 1 milliampere. If the plate current changes when the high resistance is short-circuited, a new value of plate-supply voltage is selected by means of the resistance  $R_1$  in Fig. 3, and the plate current is again adjusted to 1 milliampere. A combination of plate and bias voltages is readily found which gives no change, or a minimum change, of plate current when the 100-megohm resistance is short-circuited. In the event that there is a change in plate current when this resistance is short-circuited, the voltage drop developed across it is measured by readjusting the plate current to 1 milliampere by means of the calibrated potentiometer. The grid current is then calculated from the known value of the 100-megohm resistance and the voltage drop as read from the potentiometer setting. It is understood that these extreme precautions to reduce, or to calculate, the grid current are necessary only when a minute grid current may not be tolerated.

#### CALIBRATION AND ACCURACY

The inherent over-all accuracy of the voltmeter is determined by the precision of design of the potentiometer, the accuracy of the calibration of the meter at a single point, and the stability of all circuit parameters during a measurement interval. It is important that the resistors comprising the potentiometer have a low temperature coefficient of resistance, and are free from aging effects. These resistors need dissipate a

<sup>7</sup> R. H. Cherry, "The Measurement of Direct Potentials Originating in Circuits of High Resistance," Bulletin printed by Leeds and Northrup Company, Philadelphia, Pennsylvania, 1938, Reprint E-96R(1) 180-738.

total of only one tenth of a watt when the voltmeter is balanced, and less than a watt under extremely unbalanced conditions. The temperature rise of the resistors is, therefore, negligibly small.

The vacuum-tube voltmeter is completely calibrated upon construction, if the 1-milliampere point is accurately marked on the milliammeter. This point may be checked at any time by connecting an accurate laboratory milliammeter to the calibration terminals marked *B* in Fig. 3. The completed vacuum-tube voltmeter may be precisely calibrated by checking it against a standard cell.

In using the vacuum-tube voltmeter for direct-voltage measurements, no difficulty is encountered in repeating readings to four significant figures for voltages in excess of 1 volt. As fewer dials of the potentiometer are brought into use when voltages lower than 1 volt are read, the number of significant figures obtainable is necessarily reduced. It must be remembered, however, that the ultimate per cent accuracy of the experimental model of the vacuum-tube voltmeter is limited by the accuracy of the resistors comprising the potentiometer.

#### CONCLUSIONS

Standard design procedure may be employed to construct a low-voltage, battery-operated, vacuum-tube voltmeter using the circuit described in this paper with reduced element potentials to insure a low grid current. Long battery life is insured by the low plate current required. If great accuracy of voltage measurement is desired, it is necessary only to match the individual resistor units composing the calibrated potentiometer to a good degree of precision. The absolute resistance of the potentiometer is then of secondary importance, since the voltage drop across the potentiometer is readily standardized by comparison with a standard cell. In this case, the milliammeter is calibrated at a point determined by the voltage range to be covered by the voltmeter.

Although the vacuum-tube voltmeter described in this paper is not direct reading, this disadvantage is offset by the fact that great accuracy is obtained over the complete range of the instrument from 0 to 100 volts without employing a range-changing arrangement. It must be remembered that the accuracy of many vacuum-tube voltmeters is dependent on the calibration of a d'Arsonval-type meter with an accuracy specified in per cent of full scale. The accuracy of these meters at one-fourth scale, or lower, may be quite poor.

In addition to its utility as a general-purpose meter, the practical model of the voltmeter has proved particularly useful as a reference standard in calibrating direct-current voltmeters and milliammeters. Not only is there little danger of injuring the meter on overload, but it also provides a precision of reading which is obtainable only in the more expensive types of laboratory standard instruments.



# New Magnetic Materials\*

W. E. RUDER†, NONMEMBER, I.R.E.

**Summary**—With the rapid growth of the radio and communication industry, a need for magnetic materials having special properties for this particular application has developed. A number of nickel-iron alloys, such as permalloy, nicaloi, Mu Metal, and variations of these have found wide application as they all have the common property of high permeability at relatively low inductions. Where high resistivity also is desired, additional alloying elements, such as chromium and molybdenum, have been added. Complete freedom from strain, either mechanical or chemical, is necessary for good magnetic quality, and the strain set up by magnetization can be compensated for in many cases by heat treatment in a magnetic field. Silicon-iron alloys and some of the nickel-iron alloys can be very much improved by a combination of cold-rolling and heat treatment which induces a high degree of preferred orientation. This cold-rolled strip has found wide application in various types of electrical apparatus.

Permanent-magnet alloys of the alnico type have been very greatly improved recently so that the external energy factor ( $BH_{max}$ ) is now about three times what it was in the best alnico heretofore available. Comparative data on the different types of permanent-magnet steels and alloys are given, and the new material should find wide application in the radio field. Considerable saving in material and size and weight of apparatus can be made by the application of these outstanding recent developments in magnetic materials provided suitable changes in design are made to allow for the most economical use.

WE ARE living in an age of custom-built alloys where every mechanical device has some metal or alloy which is best suited to each of its parts and formed or treated to give optimum service. Parts for magnetic circuits are no exception. Since Stanley built his first transformer of "tintype" steel, probably because it was thin and had a varnished surface, the metallurgists have been kept busy to find the materials and treatments to meet the rapidly expanding and increasingly exacting requirements of the electrical engineer.

For some years the development of magnetic materials centered around low losses and high permeability at relatively high densities, for the engineer was concerned with increased efficiency and the decrease in size of his apparatus. To this end silicon-iron alloys were developed to a high degree and losses have been reduced from 1.20 to 0.35 watt per pound, 60 cycles, at 10,000 lines of force, through careful control of composition, structure, and heat treatment. Although many another has been tried, no completely satisfactory substitute for silicon as an alloying element has been found. The study of the nickel-iron alloys developed a most interesting range of magnetic and electrical properties, but the most interesting of these had a very high alloy content and relatively low magnetic saturation, so that they found only limited application for economic reasons.

With the rapid growth of the radio and communication industry, however, greater interest was shown in materials having high permeability in the low induction range, and the nickel-iron alloys came into their own. Permalloy, developed by the Bell Telephone Laboratories; the 50 per cent nickel-iron alloy now

\* Decimal classification: R282.3. Original manuscript received by the Institute, December 17, 1941. Presented, Rochester Fall Meeting, Rochester, New York, November 11, 1941.

† Research Laboratory, General Electric Company, Schenectady, New York.

being made under a number of trade names; Mu Metal; and a number of other variations are now standard products, and permeabilities of a magnitude unheard of some years ago are readily obtainable. The number of magnetic alloys proposed to serve such special ends as high initial permeability, high resistivity, constant permeability, low loss at very high frequencies, and combinations of these are legion. For other than power applications, most of these are nickel-base alloys. The function of other alloying elements is principally to increase resistivity. There are certain underlying principles which govern the magnetic quality of all soft magnetic materials, most of which have to do with the control of internal strain.

The practice of careful annealing to remove mechanical strain is of long standing. There are, however, other sources of strain which are not relieved by temperature alone. Impurities, the presence of

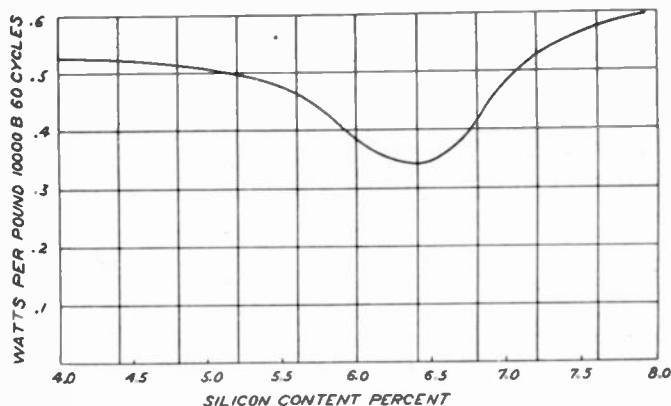

Fig. 1—Effect of silicon content on watt loss.

which disrupt the orderly arrangement of the atoms, set up strain, so freedom from dissolved impurities, usually nonmetallic, is of first importance. There are also strains set up by magnetization itself, the change in length called magnetostriction. The effect of grain size is probably also a manifestation of strain due to grain-boundary discontinuities, but the effect of crystal orientation is another matter.

In manufacturing high-grade transformer sheet these principles are applied to the greatest degree found to be commercially practicable. Silicon has the effect of increasing resistivity and reducing the solubility of the alloy for carbon, thereby increasing the magnetic quality at medium and low density, but it has the limiting effect of reducing the saturation induction. The highest quality that has been obtained in commercial silicon alloys is in a 6½ per cent silicon sheet (see Figs. 1, 2, and 3), where high permeability and low loss (under 0.35 watt per pound, 60 cycles, 10,000 lines of force) result from the use of an alloy having practically zero magnetostriction. (78 per cent nickel permalloy is another example of such an

alloy.) The alloy is quite brittle, although it can be rolled, punched, and sheared without difficulty.

For many years engineers have known that there is a preferred direction in magnetic sheets and that the properties are distinctly better in the rolling direction. Careful study of the magnetic properties of single crystals shows this to be due to the fact that the rolling develops a certain degree of preferred orientation of the crystals. The measurements made in this labo-

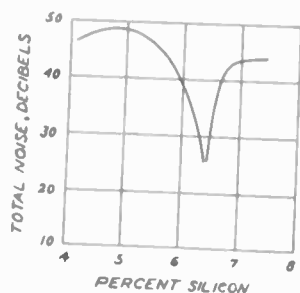

Fig. 2—Effect of silicon on noise.

ratory in 1917-1918 showed that silicon ferrite crystals oriented so that they presented a cube face perpendicular to the direction of magnetization were much more easily magnetized than crystals in which the face was oriented at an angle; and when the magnetization was in the direction of a cube diagonal, the crystal was most difficult to magnetize.<sup>1</sup> Smith, Garnett, and Randall<sup>2</sup> found that ferromagnetic materials subjected to drastic cold reduction followed by suitable heat treatment had a structure in which most of the crystal grains were oriented in a direction most favorable to easy magnetization and so found a practical process

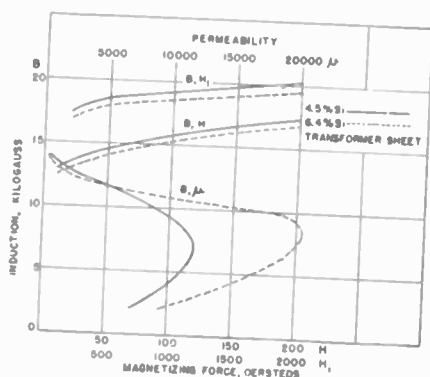

Fig. 3—Magnetization and permeability of normal and high silicon transformer sheets.

for producing a ferromagnetic material approaching in properties those of a single crystal. N. P. Goss,<sup>3,4</sup> working with the Allegheny Ludlum Steel Corporation on silicon iron alloys alone, found that the same general principle of cold reduction and suitable heat

<sup>1</sup> W. E. Ruder, "Magnetization and crystal orientation," *Trans. Amer. Soc. for Steel Treating*, vol. 8, pp. 23-29; July, 1925.

<sup>2</sup> W. S. Smith, H. J. Garnett, and W. F. Randall, United States Patent No. 1,915,766.

<sup>3</sup> N. P. Goss, "Written discussion," *Trans. Amer. Soc. Metals*, vol. 22, pp. 1133-1139; December, 1934.

<sup>4</sup> N. P. Goss, "New development in electrical strip steels characterized by fine grain structure approaching the properties of a single crystal," *Trans. Amer. Soc. Metals*, vol. 23, pp. 511-531; June, 1935.

treatment produced a low-loss high-permeability strip and obtained patents on such a process.

The commercial development of these processes has made available a high-grade silicon-alloy strip which, when applied so that it is magnetized in the direction of rolling, can be used at much higher densities than usually used with hot-rolled sheets. Fig. 4 shows a comparison of magnetization curves in the

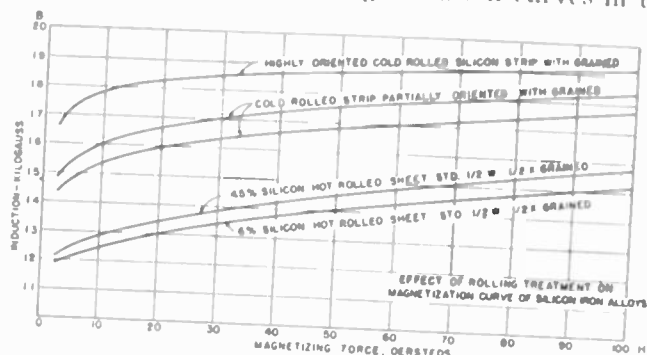

Fig. 4

medium to high-induction range for hot-rolled sheet and cold-rolled strip with various degrees of preferred orientation. This new material has made possible radical changes in design<sup>5</sup> and improvements in efficiency of distribution and power transformers.

In the low-density range, cold rolling and magnetic annealing may also be applied to advantage. The degree of improvement obtained varies with the alloy. An idea of the magnitude of these changes at low induction may be obtained from the figures given in Table I.

TABLE I

	$\mu_{max}$	$B$ at $H=0.05$	$\mu$ at $B=1000$	$\mu$ at $B=100$
Silicon sheets—transformer grade	13200	165	5800	2950
Silicon sheets—magnetic anneal	20000	240	7950	4100
6 per cent silicon sheet	18000	140	5700	2500
6 per cent silicon—magnetic anneal	32100	220	8600	3450
Cold-rolled silicon strip	30500	700	6700	1600
Cold-rolled—magnetic anneal	42800	700	7150	1700
Nicaloi—hot-rolled	45500	1545	—	7400
Nicaloi—cold-rolled	94500	4600	44000	13100
Cold rolled + magnetic anneal	161000	7800	81800	29000
Allegheny Mu Metal	100500	3413	100000	74250
"65" permalloy—cold rolled	8500	160	6890	2830
"65" plus magnetic anneal	490000	9650	337500	105000

There has been a great advance in the field of permanent-magnet materials in the last ten years. This advance has opened many new applications as well as simplified many of the older applications of permanent magnets. Table II lists a number of these and their properties.

The best of the quench-hardening types have a maximum external energy value ( $BH_{max}$ ) of about 1,000,000. Carbon-free magnet alloys were first developed along about 1930.<sup>6-9</sup> Alloys of this type

<sup>5</sup> E. D. Treanor, "The wound-core distribution transformer," *Elec. Eng.*, vol. 57, pp. 622-625; November, 1938.

<sup>6</sup> W. Kroll, French Patent No. 669,551, 1929.

<sup>7</sup> R. S. Dean, United States Patent No. 1,904,859, 1933.

<sup>8</sup> W. Köster, "Permanent magnets of the precipitation hardening type," *Stahl und Eisen*, vol. 53, pp. 849-856; August, 1933.

<sup>9</sup> W. Köster, "Mechanical and magnetic precipitation hardening of iron-cobalt-tungsten and iron-cobalt-molybdenum alloys," *Archiv. für Eisenh.*, vol. 6, pp. 17-23; July, 1932.

TABLE II  
TYPICAL VALUES OF SOME PERMANENT-MAGNET ALLOYS

Composition (approximate)	$H_c$	$B_r$	External Energy $B_d H_d \max \times 10^6$
Quench Hardening			
1% carbon steel	48	8600	0.18
6% tungsten steel	72	10000	0.32
36% cobalt, 4% tungsten, 5% chromium	240	9600	0.98
Dispersion Hardening			
12% cobalt, 17% molybdenum, 0.1% carbon	250	10500	1.20
Alnico I	440	7300	1.40
Alnico II	560	7350	1.65
Alnico III	475	6900	1.38
Alnico IV	730	5300	1.30
Alnico V	550	12500	4.5
New "KS"	785	7150	2.03
Superlattice			
76.7% platinum, 23.3% cobalt	2650	4530	3.77
78% platinum, 22% iron	1750	5380	3.07
86% silver, 9% manganese, 5% aluminum	6980	5550	1.56
Oxide Magnets			
16 CoO, 34 Fe <sub>2</sub> O <sub>3</sub> , 50 Fe <sub>3</sub> O <sub>4</sub>	580	4050	1.34
16 CoO, 34 Fe <sub>2</sub> O <sub>3</sub> , 50 Fe <sub>3</sub> O <sub>4</sub>	915	2170	—
Cold-Worked			
60% copper, 20% nickel, 20% iron	513	5350	1.26
41% copper, 24% nickel, 35% cobalt	444	5325	0.99

According to Legg,<sup>12</sup> the theoretical limit for  $H_r$  is about 23,000. The closest approach to this was reported by Nesbitt and Kelsall.<sup>13</sup> They found a  $B_r$  value of 15,000 gauss in an iron-vanadium-cobalt alloy.

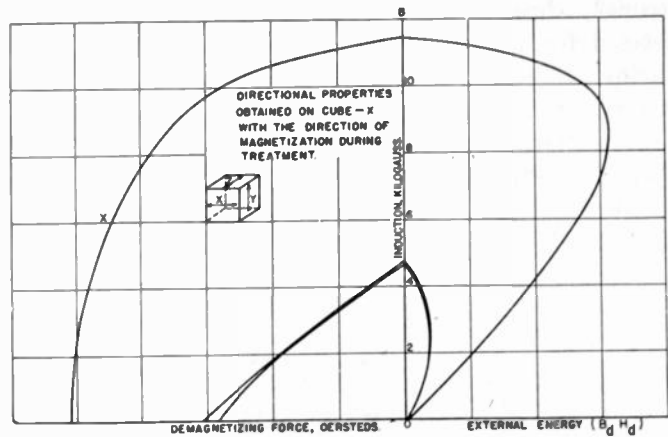

Fig. 6—Directional properties of alnico V.

which have found the widest application are in the nickel-aluminum-iron group, which is now known in this country and England as alnico.<sup>10,11</sup>

The general requirement for a good permanent-

Legg also places the theoretical limit for  $H_c$  at 23,000 oersteds. The nearest approach to this is a value of about 7000 oersteds for aluminum-manganese-silver.<sup>14</sup> It has now become customary to designate the quality

TABLE III

Composition in per cent					Usual thermal treatment			Same treatment but cooled in a magnetic field			Cooling rate 1200 degrees to 600 degrees centigrade
Nickel	Aluminum	Cobalt	Copper	Titanium	$BH_{max} \times 10^6$	$H_c$	$B_r$	$BH_{max} \times 10^6$	$H_c$	$B_r$	°C/second
16	8.5	23	—	—	1.22	348	9050	3.45	492	126500	1
13.5	8.0	24	1.5	—	1.32	370	9450	3.77	505	13100	2.6
13.5	8.0	24	3.0	—	1.68	535	8300	4.78	600	13350	1.8
16	7.8	25	—	2.8	1.60	604	7600	3.06	640	10000	4
14	7.1	24	3.0	2.4	1.72	594	7900	3.78	660	11050	4
14	7.5	20	6.5	1.8	1.65	620	7350	3.25	676	9825	4.3
16.5	8.1	20	1.1	2.3	1.82	640	8150	3.12	685	10200	4

magnet material is a hysteresis loop of large area. The area of this loop is largely determined by the value of the residual ( $B_r$ ) and the coercive force ( $H_c$ ). The shape

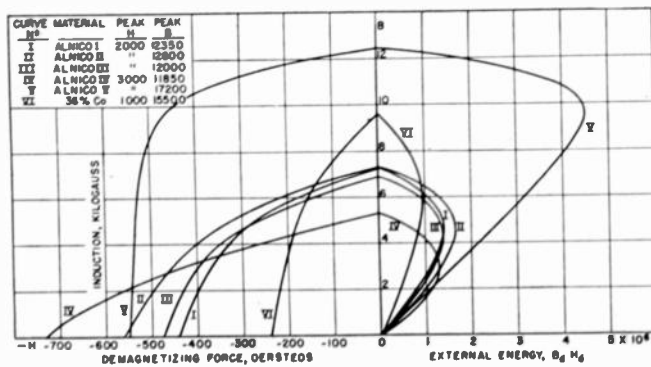

Fig. 5—Demagnetization and energy curves of alnico type of permanent magnets.

of the demagnetization curve, however, is also important as it determines the density at which a permanent magnet can be used with greatest efficiency.

<sup>10</sup> W. E. Ruder, United States Patent No. 1,947,274; February, 1934.

<sup>11</sup> T. Mishima, United States Patent No. 2,027,994, 1936.

of the magnet in terms of its maximum external energy, or  $BH_{max}$  value. As shown in the table, this has been increased from 1,000,000 in Honda's cobalt magnet steel to 1,800,000 in alnico II, to 2,000,000 in the "new KS," and to 3,770,000 in the platinum-cobalt alloy. Oliver and Shedden<sup>16</sup> improved the  $B_r$  value and the  $BH_{max}$  some 20 per cent by subjecting a nickel-aluminum-cobalt-copper permanent-magnet alloy to a strong magnetic field at high temperature. Jonas and van Embden,<sup>16</sup> working with this type of alloy, but with considerably higher cobalt content and in some cases with small copper and titanium additions, produced a remarkable increase in  $BH_{max}$ .

<sup>12</sup> V. E. Legg, "Survey of magnetic materials and applications in the telephone system," *Bell Sys. Tech. Jour.*, vol. 18, pp. 438-464; July, 1939.

<sup>13</sup> E. A. Nesbitt and G. A. Kelsall, "Vicalloy, a new permanent magnet material," *Phys. Rev.*, vol. 58, p. 203; July 15, 1940.

<sup>14</sup> H. H. Potter, "Some magnetic alloys and their properties," *Phil. Mag.*, vol. 12, pp. 255-264; August, 1931.

<sup>15</sup> D. A. Oliver and J. W. Shedden, "Cooling of permanent magnet alloys in a constant magnetic field," *Nature*, vol. 142, p. 209; July 30, 1938.

<sup>16</sup> B. Jonas and H. J. Meerkamp van Embden, "New kinds of steel of high magnetic power," *Philips Tech. Rev.*, vol. 6, pp. 8-11; January, 1941.

Details of this process and composition of the high-cobalt alloys are given in the British patent specification No. 522,731, from which Table III on page 439 is taken.

The product, shown in Fig. 5 as alnico V, has strongly directional properties, i.e., it must be magnetized for use in the direction of the field applied during the heat treatment. Fig. 6 shows the difference in properties in different directions.

Like all magnetic materials, optimum properties are obtained only with the most careful control of composition and heat treatment. It is possible with the right conditions to obtain values of  $BH_{\max}$  as high as

6,000,000, with  $B_r$  up to 13,500, and  $H_c$  up to 700. The high cobalt content makes the cost per pound relatively high, but the high energy content with the resultant saving in size brings the cost per unit of available energy to a figure quite comparable with the other alnico compositions.

The application of these two outstanding recent developments in magnetic materials calls for radical changes in design in each case if their use is to be justified, but in all applications where such changes are made, considerable savings in material and reductions in size and weight of apparatus can be made.

## Analysis, Synthesis, and Evaluation of the Transient Response of Television Apparatus\*

A. V. BEDFORD†, ASSOCIATE, I.R.E., AND G. L. FREDENDALL‡, ASSOCIATE, I.R.E.

*Summary*—The sharpness of detail in a television picture is directly dependent upon the capability of the transmitter for the transmission of abrupt changes in picture half tone. A suitable test signal is a square wave of sufficiently long period.

Rules are deduced for the evaluation of the subjective sharpness, to be expected in transmitted pictures and may be applied when the square-wave response of the transmitting apparatus is known.

Rapid chart methods have been devised for (1) the analysis of a square-wave output into sine-wave amplitude and phase response and (2) the synthesis of a square-wave response from a given set of amplitude and phase characteristics. Analysis furnishes an immediate solution to the familiar but troublesome problem of finding the sine-wave characteristics of television apparatus.

The four aspects of the application of square waves to television, i.e., measurement, analysis, synthesis, and evaluation, are presented as a basis for a unified and complete technique.

The authors hope that this paper will be a contribution to the general problem of working out electrical specifications for television transmitters and other television apparatus, giving information regarding the steepness of rise and the amplitude of overswing of the square-wave response.

### I. INTRODUCTION

AS a result of the scanning process, the sharpness of detail in a television picture is directly dependent on the capability of the transmitter and receiver for the faithful transmission of signals arising from abrupt changes in picture half tone along the scanning line. Recognition of the validity of the Heaviside unit voltage, the electrical equivalent of an abrupt change in half tone, as a test signal, was accorded early in the art. Notwithstanding, the preponderance of emphasis has been placed upon the sine-wave characteristics of television apparatus, that is, upon the amplitude- and phase-versus-frequency characteristics.

It has long been known that the response of a linear signal-transmitting system to a Heaviside unit voltage contains all the information necessary to determine both the phase-frequency and the amplitude-frequency characteristics. Conversely, the two frequency characteristics determine uniquely the response to a unit

voltage (and incidentally the response to any other transient input wave). It is also known that the response to a single abrupt rise in a repeating square wave of sufficiently long period is essentially the same as the response to a Heaviside unit voltage insofar as that part of the transient response due to high frequencies is concerned.

In view of this implicit relationship between the sine-wave and the transient-response<sup>1</sup> characteristics of electrical circuits, it is surprising that the testing and specifying of high-frequency fidelity of both audio and video apparatus by the response to a square-wave has not become more common.<sup>2</sup>

Several circumstances have impeded rapid growth in the use of square waves to determine the high-frequency response. In the first place, the well-established sine-wave methods, which were developed for audio work, have the advantages of precedence and well-developed techniques for measurement, recording and plotting data, diagnosing imperfection, and comparing performances. Second, the lack of suitable oscillographic apparatus for accurately indicating the instantaneous response as a function of time has been a large contributing factor. A recently developed square-wave oscillograph<sup>3</sup> and square-wave generator provide a solution to this problem.

<sup>1</sup> In this paper, the term *transient response* will be used as the equivalent of the expression *response to a Heaviside unit voltage*.

<sup>2</sup> The use of a 60-cycle square-wave generator and an oscillograph for investigation of the behavior of a television system at low frequencies of the order of the field scanning rate is well established. In these measurements, performance is judged by inspection of the "tilted" output wave and harmonic analysis of the wave is usually not desired. In general, a television system will have uniform response over a frequency range of many octaves in the region between the so-called "low-frequency" end and the "high-frequency" end, so that fidelity measurements at the two ends of the spectrum may be considered separately. This paper will be concerned only with the high-frequency end.

<sup>3</sup> R. D. Bell, A. V. Bedford, and H. N. Kozanowski, "A portable high-frequency square-wave oscillograph for television," *Proc. I.R.E.*, this issue, pp. 458-464.

\* Decimal classification: R583. Original manuscript received by the Institute, February 19, 1942. Presented, Summer Convention, Detroit, Michigan, June 25, 1941.

† RCA Manufacturing Company, Inc., Camden, N. J.

The laboriousness of classical methods for translating the results of sine-wave measurements into transient response and vice versa, has tended improperly to make the two test methods seem unrelated and competitive instead of complementary. Furthermore, there has been no satisfactory means for evaluating numeri-

sharpness for a wave having nonuniform steepness during the time of rise. The presence of overshoot in the transient response makes evaluation even more difficult because of the effect on the visual sharpness of the picture and because of the introduction of spurious effects in the picture.

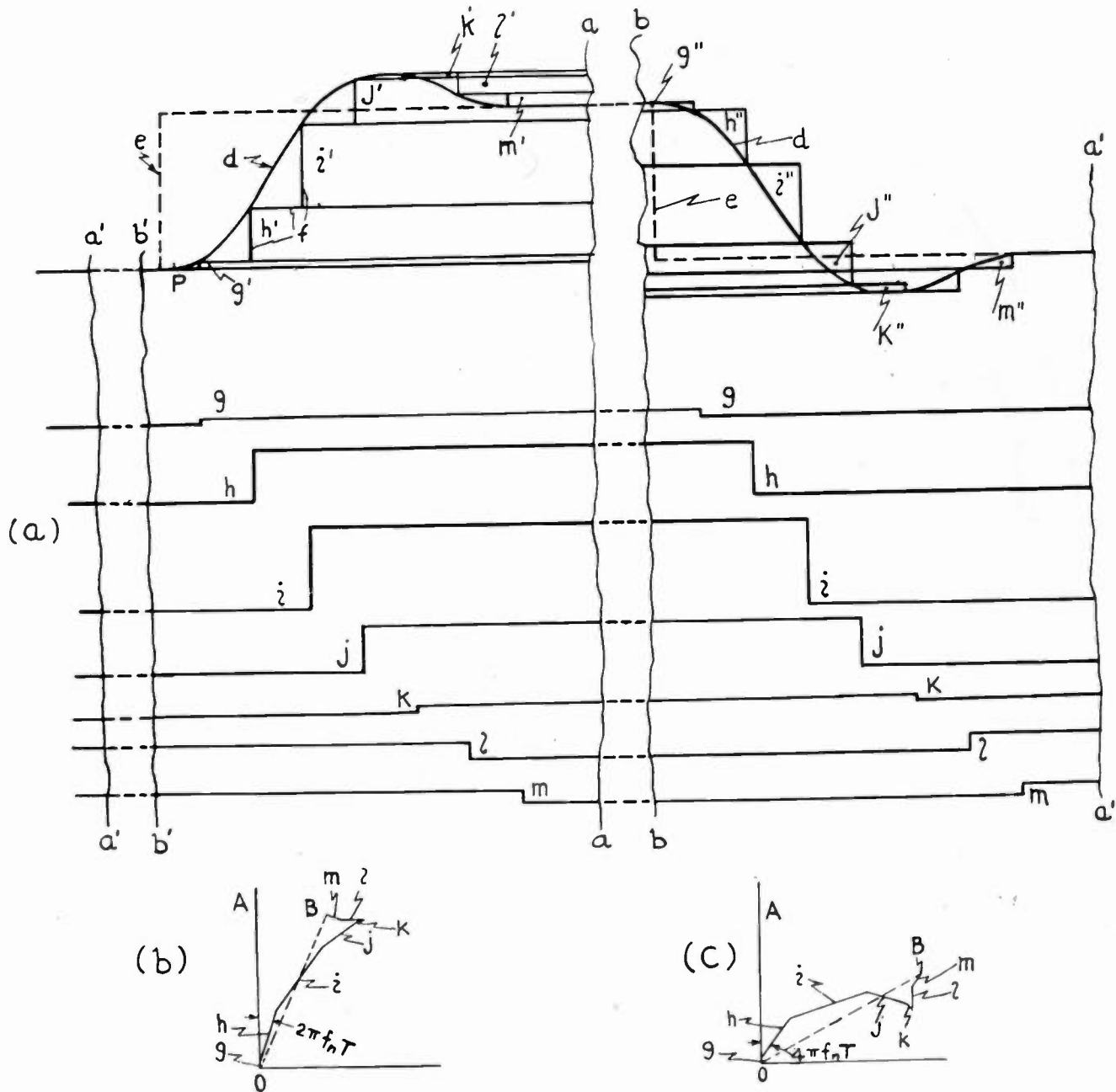

Fig. 1—(a) Approximation of a square-wave response  $d$  by a stepped wave  $f$ .  
 (b) Vector addition of components of frequency  $f_n$  in waves  $g, h, i$ , etc.  
 (c) Vector addition of components of frequency  $2f_n$  in waves  $g, h, i$ , etc.

cally the fidelity of a particular piece of apparatus or transmitting system from the transient response. In television applications it has been recognized that the "mean" steepness of rise of the transient-response wave is a measure of the sharpness of the picture which the system could transmit. Still there is no general agreement on a method of measurement and calculation of a mean value of steepness which is a consistent and an accurate indication of the picture

Accordingly, for the purpose of simplifying the passage between sine-wave response and transient response and interpreting the latter, we present below: (1) a graphical chart method for analyzing the response of a system to a square-wave input signal to obtain the sine-wave phase and amplitude characteristics; (2) a graphical chart method for synthesizing the response to a square wave from the sine-wave phase and amplitude characteristics; (3) a method for

evaluating the mean steepness of a transient-response wave in terms of the *width of blur* produced in a television image by a wave which is similar in its visual effect and which has a *linear* change from one level to another; and (4) suggestions for the supplementing of sine-wave measurements by transient measurements.

period of  $e$  is not critical but must be taken long enough to insure that wave  $d$  has subsided to a substantially constant level during the latter part of each half cycle. Also the true time relation between waves  $d$  and  $e$  under test conditions has no significance in the present analysis and need not be known.

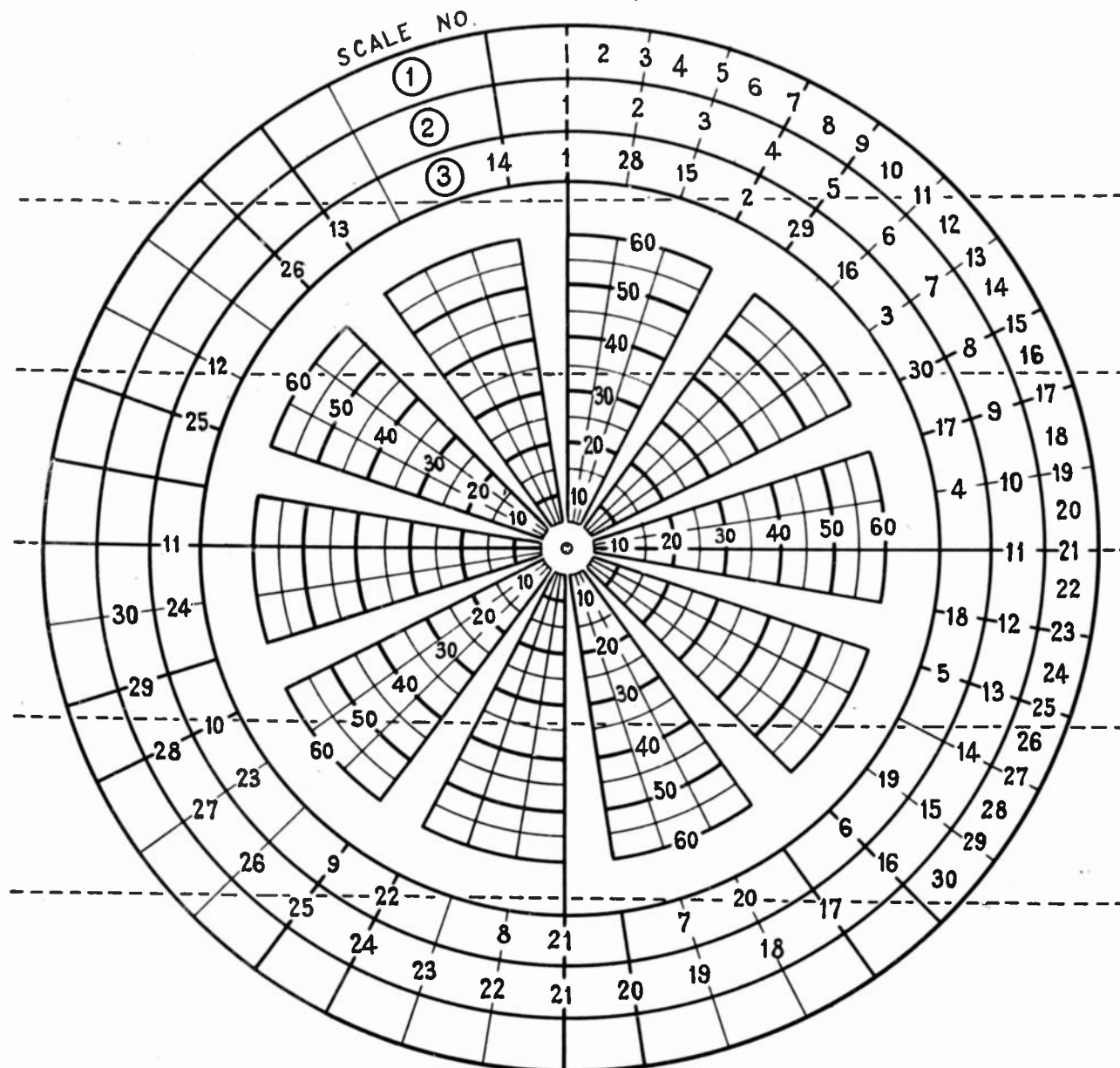

Fig. 2—Chart for square-wave analysis.

Scale	20-Mc Dots	30-Mc Dots
①	0.25 Mc	0.375 Mc
②	0.5 Mc	0.75 Mc
③	1.5 Mc	2.25 Mc

## II. ANALYSIS OF SQUARE-WAVE RESPONSE INTO PHASE-FREQUENCY AND AMPLITUDE-FREQUENCY CHARACTERISTICS

The analysis employs several permanent charts, (Figs. 2 to 5), the construction and use of which may be simply explained by reference to Fig. 1.

Fig. 1 (a) shows the repeating square wave  $e$  applied to the apparatus under test. Wave  $d$  is the response measured at the output terminals. The fundamental

A basic hypothesis upon which the analysis of wave  $d$  rests is that a stepped wave  $f$  may be drawn which approximates in harmonic content that of wave  $d$ . It is clear from inspection that the waveform of  $f$  may be caused to approach that of  $e$  as closely as desired by taking the steps sufficiently small. Since wave  $f$  in the regions  $a$  to  $b$  and  $a'$  to  $b'$  is of uniform amplitude, the lengths of the time intervals from  $a$  to  $b$  and  $a'$  to  $b'$  have no bearing on the shape of the transient portion

of the waves. Hence, the fundamental period of wave  $f$  is unimportant provided that the value is great enough so that a part of  $f$  is uniform after each transition. The upward transition of wave  $f$  is the same as the downward transition except for inversion. Hence, the rectangles  $g''$ ,  $h''$ ,  $i''$ , etc., may be considered as

relative to the same harmonic in the input wave  $e$ , is indicated by the sum of a group of vectors having amplitudes proportional to the steps  $g'$ ,  $h'$ ,  $i'$ , etc., and angular positions corresponding to the different delays of the square waves  $g$ ,  $h$ ,  $i$ , etc. No cognizance need be taken of the fact that the harmonics of a square wave

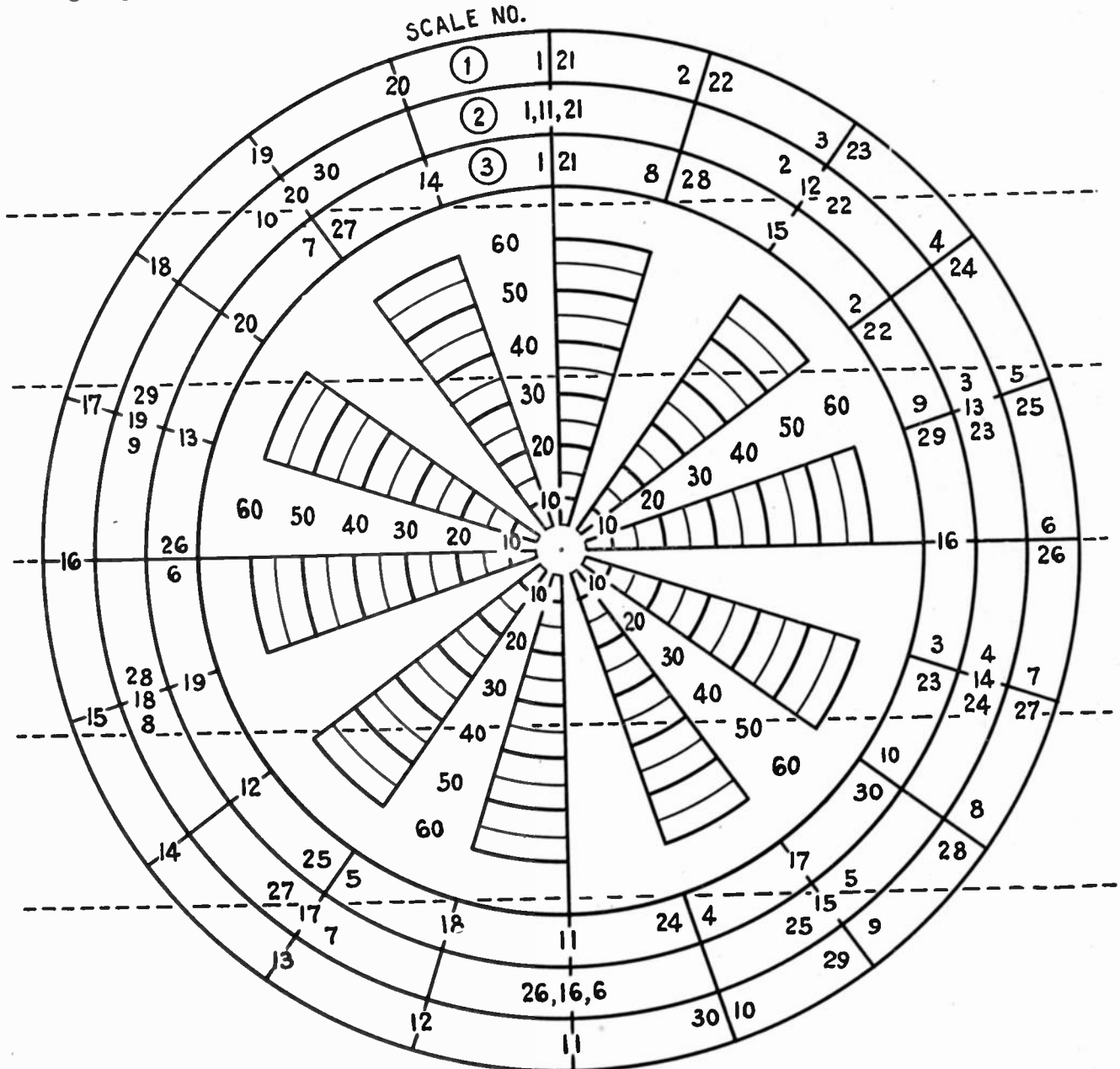

Fig. 3—Chart of square-wave analysis.

Scale	20-Mc Dots	30-Mc Dots
①	1 Mc	1.5 Mc
②	2 Mc	3 Mc
③	3 Mc	4.5 Mc

continuations of rectangles  $g'$ ,  $h'$ ,  $i'$ , etc. It follows that wave  $f$  has the components  $g$ ,  $h$ ,  $i$ , etc.

Each of these square-wave components is identical in shape to the input wave  $e$  and hence contains all harmonics in the same proportion as the input wave. Each of the square waves, however, has a different delay and hence, the harmonics of the various square waves occur in different phase relations. Therefore, the magnitude of each harmonic in the stepped wave,

vary in amplitude inversely as their frequencies. Inasmuch as the fundamental frequency of the input wave may be allowed to approach zero (such that wave  $e$  becomes a Heaviside unit voltage), any reference to discrete harmonics may be dropped and the response of the apparatus approximated at any frequency to a degree of accuracy which depends on the fineness of the steps in wave  $f$ .

Fig. 1(b) shows the vector addition involved in

finding the response for the frequency  $f_n$ . Each vector component has the same angular position, namely,  $2\pi f_n T$ , with respect to the preceding component since the waves  $g, h, i$ , etc. correspond to points on the real response curve taken at equal time intervals  $T$ . Waves  $l$  and  $m$  are negative; hence, the vectors  $l$  and  $m$  are

A set of analysis charts, Figs. 2, 3, 4, and 5, were designed in order to reduce to a minimum the labor involved in performing the vectorial additions in Figs. 1(b) and (c). Essentially, each chart serves as a protractor and a linear radial scale for use in locating the end points of the vectors. Two sets of time intervals,

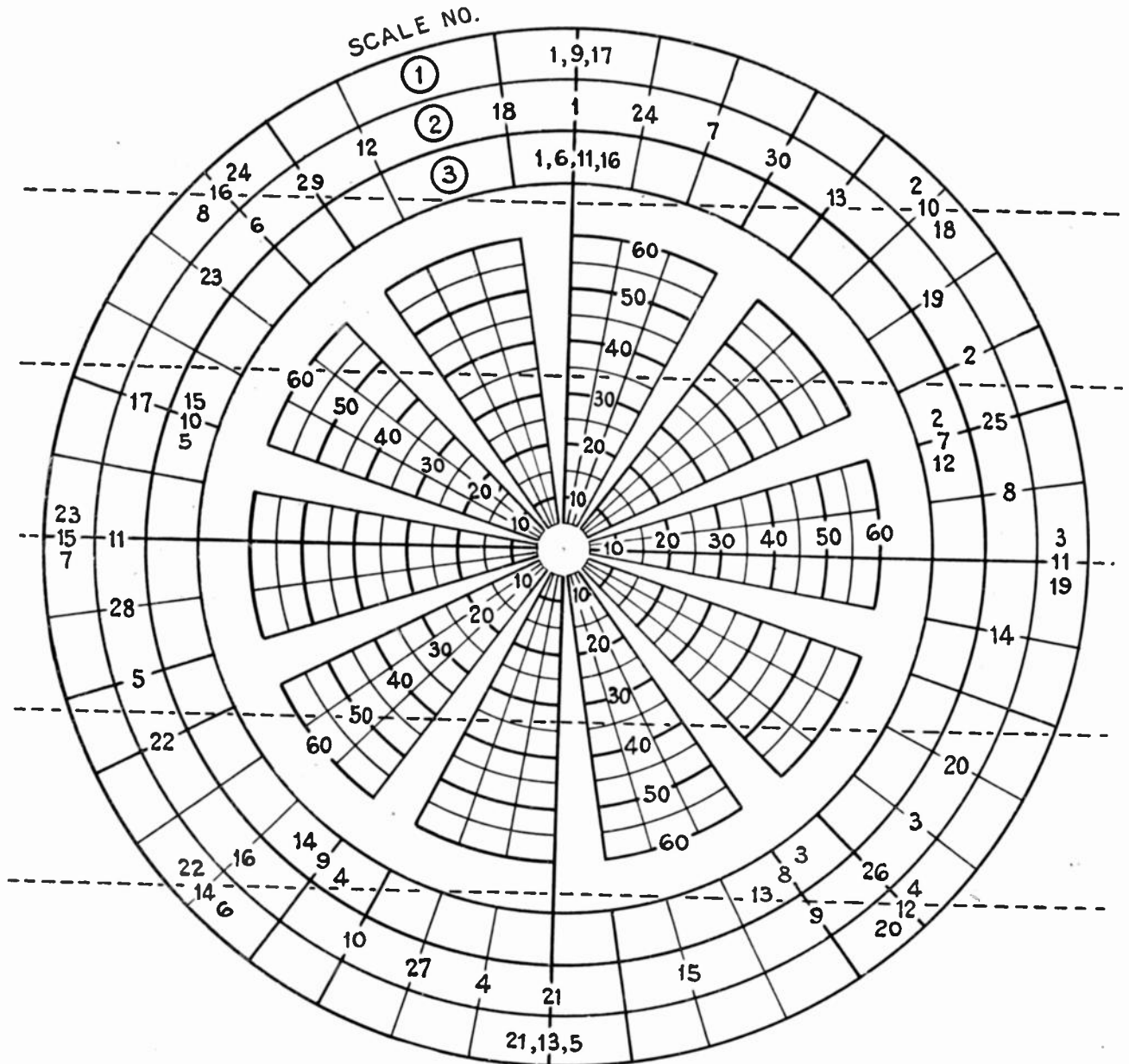

Fig. 4—Chart for square-wave analysis.

Scale	20-Mc Dots	30-Mc Dots
①	2.5 Mc	3.75 Mc
②	3.5 Mc	5.25 Mc
③	4.0 Mc	6.0 Mc

negative. The length of the vectorial sum  $OB$  gives the relative amplitude response of the apparatus tested and the angle  $AOB$  is the relative phase shift for the sine wave  $f_n$ . Fig. 1(c) is drawn for a frequency equal to  $2f_n$ . The angle between successive vectors is  $2\pi 2f_n T$ . As in Fig. 1(b),  $OB$  is the amplitude response at the frequency  $2f_n$  and the angle  $AOB$  is the relative phase shift.

$1/20$  and  $1/30$  microsecond, (referred to as 20- and 30-megacycle dots) between successive components  $g, h, i$ , etc., appear to be adequate for television applications. The basis for a choice of one of the two sets depends upon the degree of accuracy desired. This aspect is discussed later. Components (i.e. readings from the transient-response wave  $d$ ), are numbered to correspond to radial lines on the charts. The angle between



consecutively numbered radial lines is the angle used in the construction of Figs. 1(b) and (c) (e.g., on Fig. 3, the angle in scale 1 for the solution of the response at 1 megacycle is 18 degrees.) The component vectors  $g, h,$

*A. Instructions for Using Figs. 2, 3, 4 and 5 for Analysis of Square-Wave Response*

Using a square-wave generator and an oscillograph or other means, obtain per cent voltage readings at

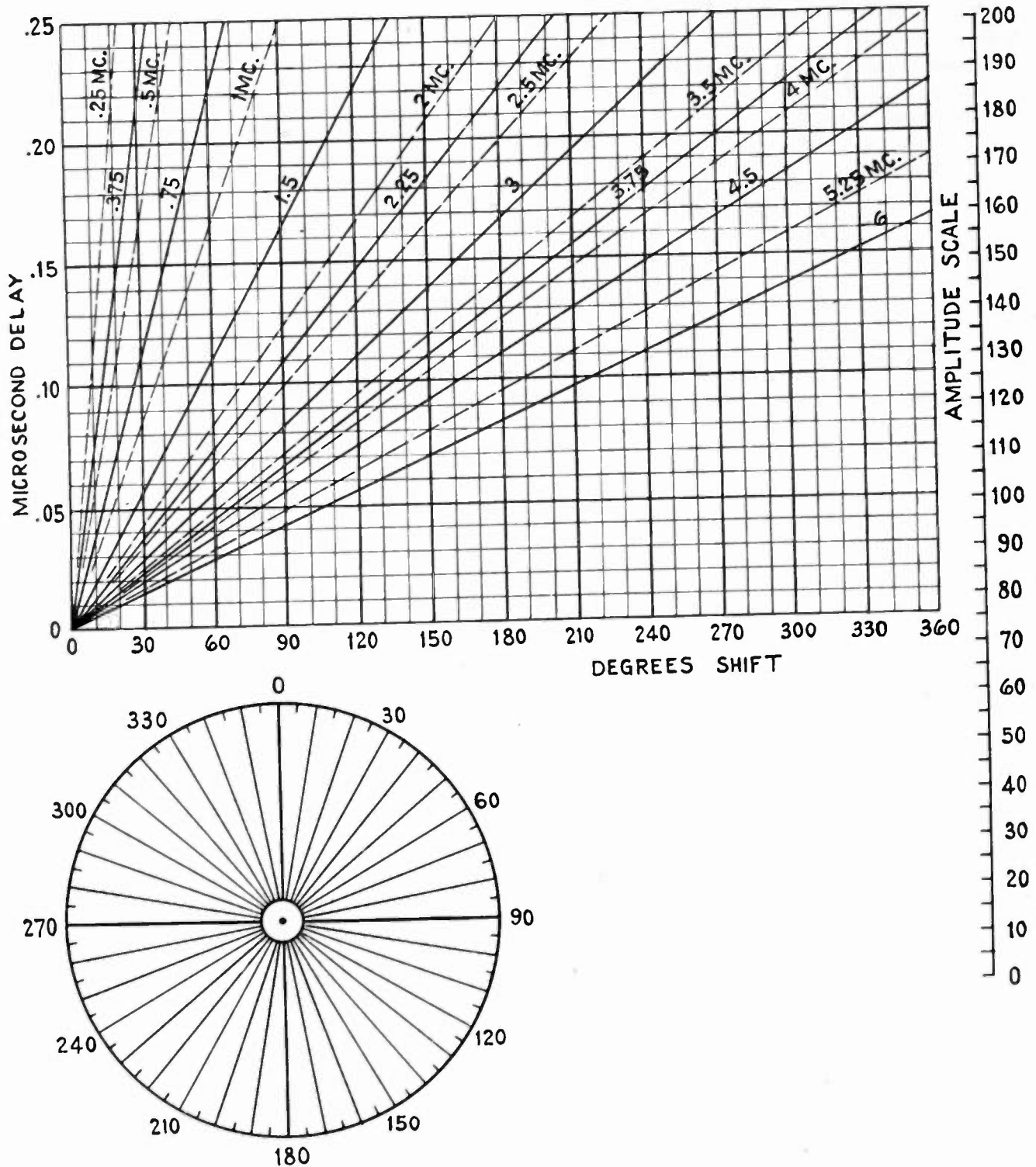

Fig. 5—Chart for square-wave analysis.

$i,$  etc., lie along the radial lines and the vectors are added as in Fig. 1(b) by manipulation of a sheet of semitransparent paper. Detailed directions for the operation of the charts are given below. The charts and directions are drawn or printed preferably on cardboard or stiff paper.

1/20-microsecond intervals (corresponding to oscillographic readings with 20-megacycle "dots" for timing) along the transient wave (Fig. 6) such as shown in column (a) of Table I. (If more accurate analysis is desired, use readings at 1/30-microsecond intervals).

Readings should begin at the zero-voltage level

before the beginning of the transient and end at a 100 per cent point where the voltage becomes uniform after the transient rise has been completed and substantial rest attained. Wave *d* of Fig. 1 is a typical plot of such a wave but plotting is not necessary for the purpose of the analysis. Compile column (b) by taking the differences in adjacent readings in column (a). These numbers represent the amplitudes of the increments in the "stairstep" wave *f*. Number the increments consecutively as in column (c).

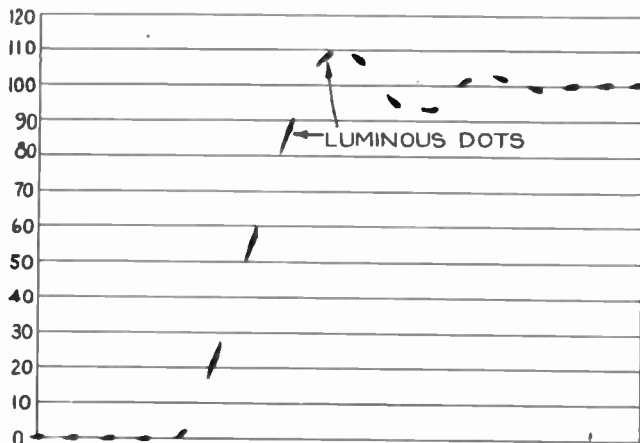

Fig. 6—Illustrative example of a square-wave response reproduced by an oscillograph showing readings at 0.05-microsecond intervals (20-megacycle dots).

Draw a horizontal *x* axis and a vertical *y* axis on a sheet of sufficiently transparent tissue paper. Place the tissue paper on Fig. 4, for example, with the origin of the *x-y* system at the center of the chart. (It will be noted that Figs. 2, 3, and 4 are for different frequencies.) Make a pencil dot on the tissue on the radial line marked "1" in circular scale (1) at a distance from the center of the chart equal to increment No. 1 in column (b). Move the tissue so that this dot coincides with the center of the chart, keeping the *x* axis parallel to the horizontal dotted lines on the chart. Make a second dot on the radial line marked "2" in circular scale (1) at a radius equal to increment No. 2. Move the tissue until the second dot is at the center of the chart and repeat the procedure for the remaining increments.

TABLE I

(a)	(b)	(c)	(a)	(b)	(c)
0	—	—	95	-13	7
2	2	1	93	-2	8
22	20	2	101	8	9
56	34	3	102	1	10
87	31	4	99	-3	11
108	21	5	100	1	12
108	0	6	100	0	13

Positive increments are plotted in the radial direction toward the increment number in circular scale (1) while negative increments are plotted in the opposite direction. Dots may be numbered to avoid errors.

Draw a vector from the *x-y* origin to the final dot located. Place the tissue on Fig. 5 and read the length of the vector on the "amplitude scale." This length is the 2.5-megacycle amplitude response in per cent.

Read the angle between the *y* axis and the final vector by using the protractor in Fig. 5. This angle<sup>4</sup> is the phase lag of the 2.5-megacycle component of wave (*d*) relative to point *P* in Fig. 1 where *P* is 1/2 a reading-interval before the second reading in column (a). The phase angles obtained for the various frequency components are correct relative to one another but the absolute time delay through the system is not obtained. The phase angles may be converted to time delay by means of the delay graph of Fig. 5. In the example given above, the amplitude response at 2.5 megacycles is 85 per cent. The relative phase angle is 103 degrees which corresponds to a time delay of 0.114 microsecond. Obtain the response at other frequencies in a similar manner by using the increments in conjunction with the other scales of Fig. 2 and the scales of other charts.

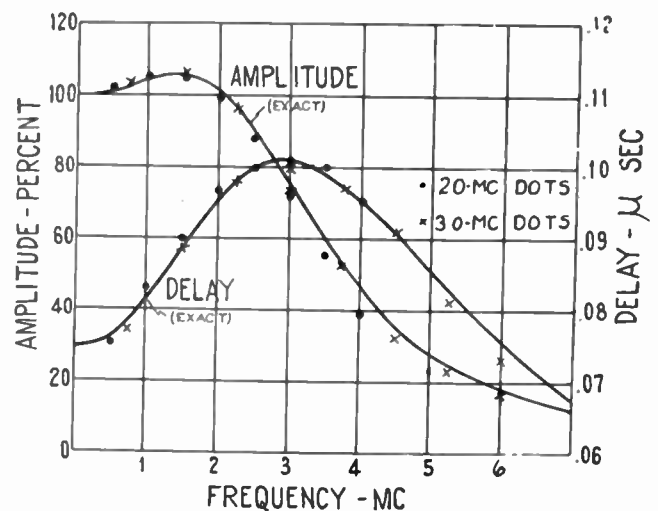

Fig. 7—Curves show exact amplitude and delay characteristics of a 2-stage compensated resistance-capacitance amplifier in which  $K = \sqrt{2}$ ,  $f_0 = 3$  megacycles. Amplitude and delay characteristics determined by chart analysis of Fig. 8 are shown by data points.

The charts may be used for other frequency ranges such as the audio range. In such applications, the time interval between successive readings on the transient-response wave will not usually correspond to 20- or 30-megacycle dots. However, the analysis charts shown in Figs. 2, 3, 4, and 5 may be employed as in the example given in Table I, when the appropriate multiplying factor for frequency is computed. This factor is equal to  $T_0/T_N$  where  $T_0$  is  $1/30 \times 10^{-6}$  or  $1/20 \times 10^{-6}$  second depending upon the original dot frequency for which the charts were designed.  $T_N$  is the new time interval in seconds.

### B. Examples of Accuracy of Chart Analysis in Specific Applications

In the instance of a compensated resistance-coupled amplifier, mathematical formulas are available for the exact calculations of the amplitude and delay.

<sup>4</sup> The angle read between the *y* axis and the vector is the phase angle for the 2.5-megacycle response of the stepped wave *f* with respect to the time of the second reading of column (a). Wave *f* lags the true-response wave *d* by one half a reading interval.

characteristics and the response to a unit function.<sup>5</sup> Hence, some conception of the accuracy of chart analysis may be gained by observing the agreement of data thus determined with the exact characteristics. Fig. 7 contains such data based on the analysis of the unit-function-response wave shown in Fig. 8. Fig. 9 contains similar data based on the response wave of Fig. 10. Since the delay characteristics determined by graphical analysis have only relative significance, the data points corresponding to 20-megacyclo-dot readings were shifted a constant amount (0.026 microsecond) in Figs. 7 and 9 so that the best correspondence with the mathematically determined delay curves was reached in order that the results of graphical and mathematical methods may be compared directly. A similar shift of 0.017 microsecond was made in the case of the 30-

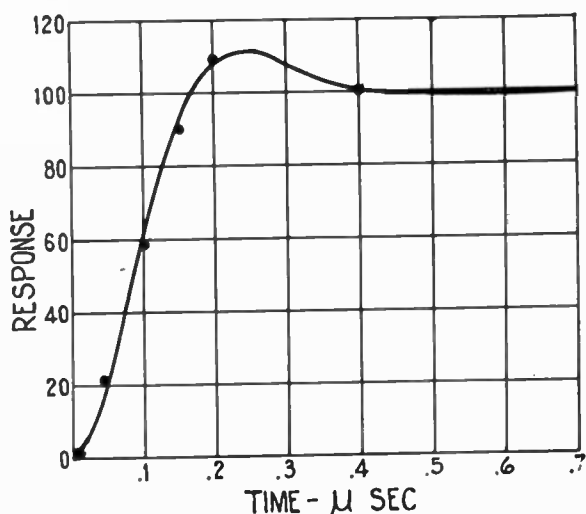

Fig. 8—Exact response to a unit function of a 2-stage compensated resistance-capacitance amplifier where  $K = \sqrt{2}$  and  $f_0 = 3$  megacycles. Points shown were obtained by synthesis from theoretical amplitude and delay characteristics in Fig. 7.

megacyclo-dot data. The deviations of the data points in Figs. 7 and 9 from the exact curves represent the degree of approximation of analysis as applied to two specific cases. For the general case, no definite limits can be set up for the error in sine-wave characteristics as determined by chart analysis. As in Fourier analysis,<sup>6</sup> the error depends upon the specific curve which is analyzed and upon the length of the time interval between readings, or in other terms, upon how well the curve is defined by the series of dots. A better approximation to the exact amplitude or delay characteristic at the higher frequencies is afforded by a solution based on 30-megacyclo-dot readings rather than on 20-megacyclo-dot readings.

It is conceivable that as a consequence of strong components of very high frequency the transient-response wave could make violent excursions between adjacent readings such that a plot of the readings

<sup>5</sup> Appendix II.

<sup>6</sup> The amplitude characteristic of a circuit, as determined graphically from the square-wave response, may be converted into the amplitude characteristic corresponding to Fourier analysis of the response of the same circuit to a square pulse. This conversion is discussed in Appendix III.

would not clearly define the wave even for the lower-frequency components. In such a case, inspection would show that analysis would be inaccurate. In

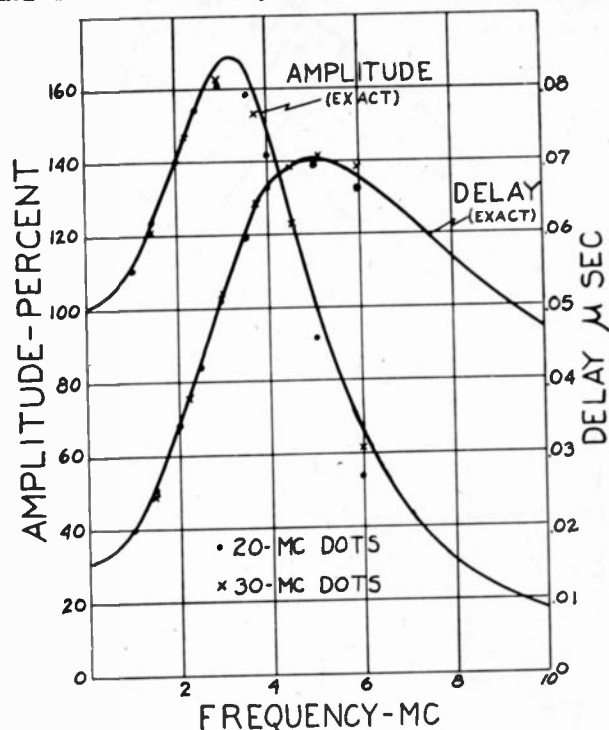

Fig. 9—Theoretical amplitude and delay characteristics of a 2-stage compensated resistance-capacitance amplifier in which  $K = 1.1$  and  $f_0 = 4$  megacycles. Amplitude and delay characteristics determined by chart analysis of Fig. 10 are shown by data points.

general, it has been found that if the 20-megacyclo timing dots trace out the square-wave response unmistakably, the 20-megacyclo dots are sufficiently accu-

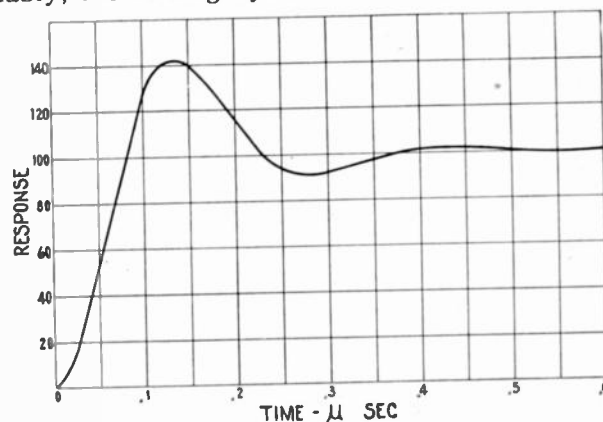

Fig. 10—Exact response to a unit function of a 2-stage compensated resistance-capacitance amplifier in which  $K = 1.1$  and  $f_0 = 4$  megacycles.

rate for analysis out to 3.5 megacycles. Under the same conditions, 30-megacyclo dots are adequate out to 5.25 megacycles.

### III. SYNTHESIS OF SQUARE-WAVE RESPONSE FROM THE SINE-WAVE CHARACTERISTICS

A closed mathematical formula<sup>7</sup> is available for the calculation of the response of a linear electrical system

<sup>7</sup> A. V. Bedford and G. L. Fredendall, "Transient response of multistage video-frequency amplifiers," Proc. I.R.E., vol. 27, pp. 277-285; April, 1939.

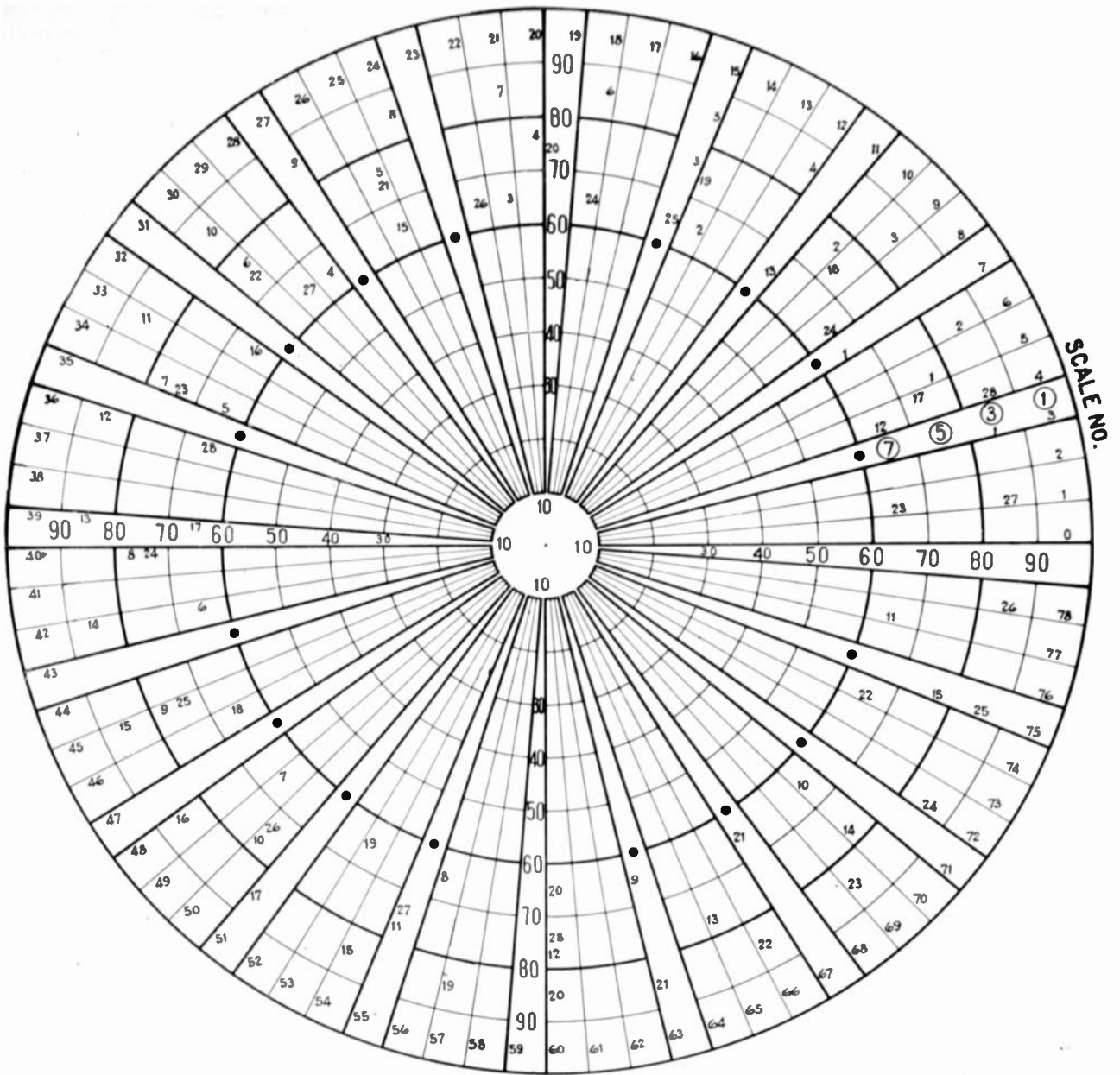

Fig. 11—Chart for square-wave synthesis.

Scale	0.05-microsecond intervals
①	0.25 Mc
②	0.75 Mc
③	1.25 Mc
④	1.75 Mc

to a unit function from the sine-wave amplitude and phase characteristics. When a numerical answer is sought, however, the formula is rarely practicable. As pointed out earlier, the solution for the response to a square wave may usually be substituted when the period required does not necessitate the computation

of many terms of the Fourier series. The period  $1/f_p$  chosen must be long enough to permit the transient response of the circuit under consideration to assume a substantially constant value between consecutive abrupt changes in the square wave.

If the square wave applied to the circuit is

$$E(t) = \frac{1}{2} + \frac{2}{\pi} (\sin 2\pi f_p t + \frac{1}{3} \sin 6\pi f_p t + \frac{1}{5} \sin 10\pi f_p t + \dots + \frac{1}{n} \sin 2\pi n f_p t + \dots) \quad (1)$$

then the response is

$$e(t) = \frac{1}{2} + \frac{2}{\pi} (A_1 \sin 2\pi f_p(t - D_1) + \frac{A_3}{3} \sin 6\pi f_p(t - D_3) + \dots + \frac{A_n}{n} \sin 2\pi n f_p(t - D_n) + \dots) \quad (2)$$

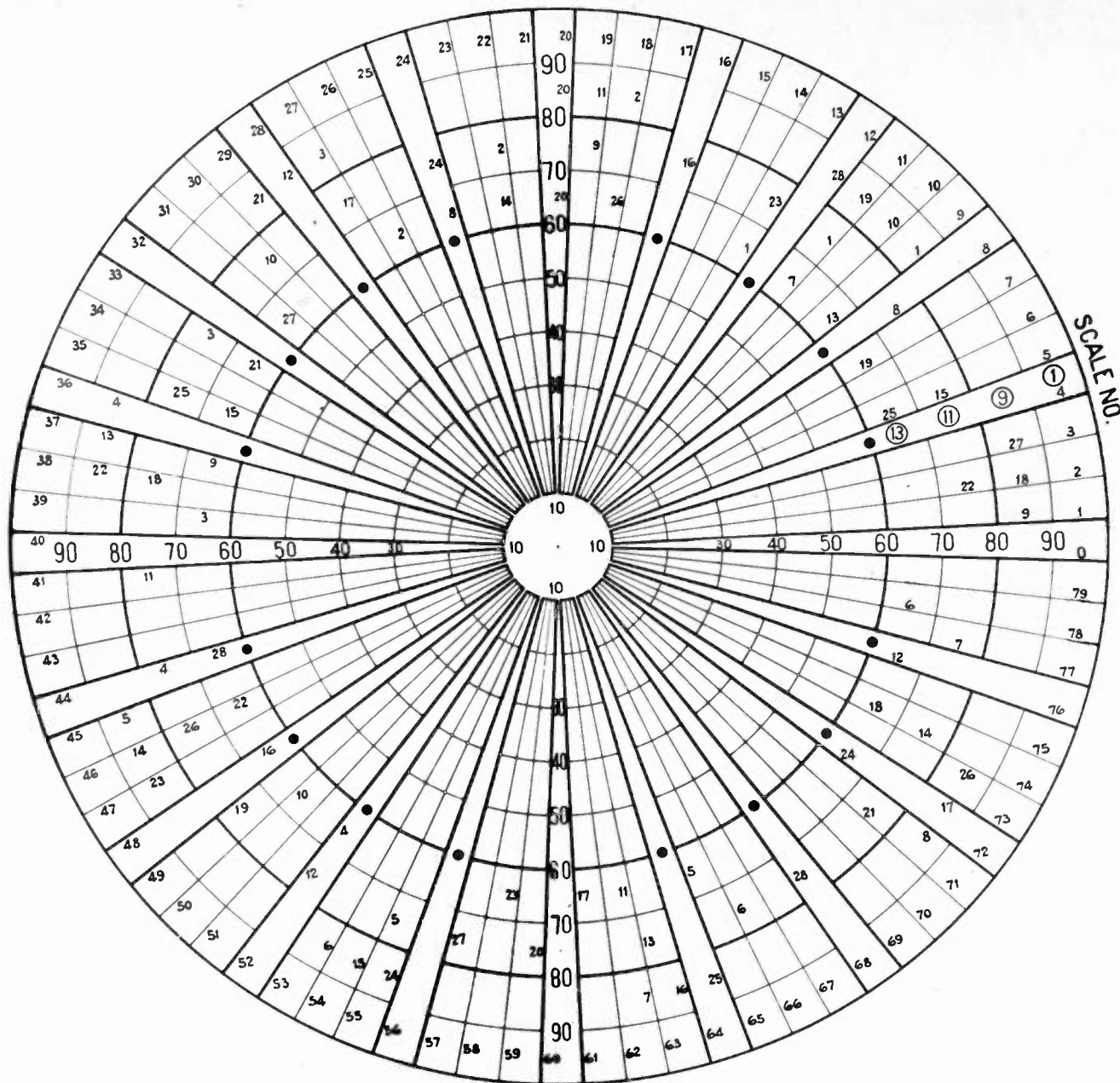

Fig. 12—Chart for square-wave synthesis.

Scale	0.05-microsecond intervals
①	0.25 Mc
⑨	2.25 Mc
⑪	2.75 Mc
⑬	3.75 Mc

where  $A_n$  and  $D_n$  are the amplitude response and delay of the circuit for the  $n$ th harmonic.  $D_n$  = phase shift in radians/ $2\pi n f_p$ .

Synthesis charts, Figs. 11, 12, and 13, were developed for the summing of the significant terms of the series (2) above. The principle of the charts is based on the vector representation of a sine function. For example, the term  $A_n/n \sin 2\pi n f_p(t - D_n)$  is represented in Fig. 14(a) by the length of the perpendicular  $AC$  to the vector  $OD$ . The value of the term may be found rapidly, for specific values of  $t$  which have been determined in advance, by dividing the circumference of a circle into a number of equal parts.

For example, if the circle in Fig. 14(b) is divided into

$N$  equal segments, then the value of the sine term may be found every  $1/Nn f_p$  second starting at  $t=0$ . It is convenient to designate a specific value of time  $t$  by one of the whole numbers between 0 and  $N$ .

A straightedge may be placed along the radial line which makes the required angle  $2\pi n f_p D_n$  with the  $x$  axis. (See Fig. 14(b)). The quantity  $2\pi n f_p D_n$  will usually be expressed in terms of the unit angular segment used in marking off the circumference of the circle. If a draftsman's triangle is moved along  $OD$ , successive values of the sine term corresponding to regular intervals of time may be read on a calibrated scale  $AC$  (marked on one leg of the triangle) by noting the points of intersection of the radial lines and an

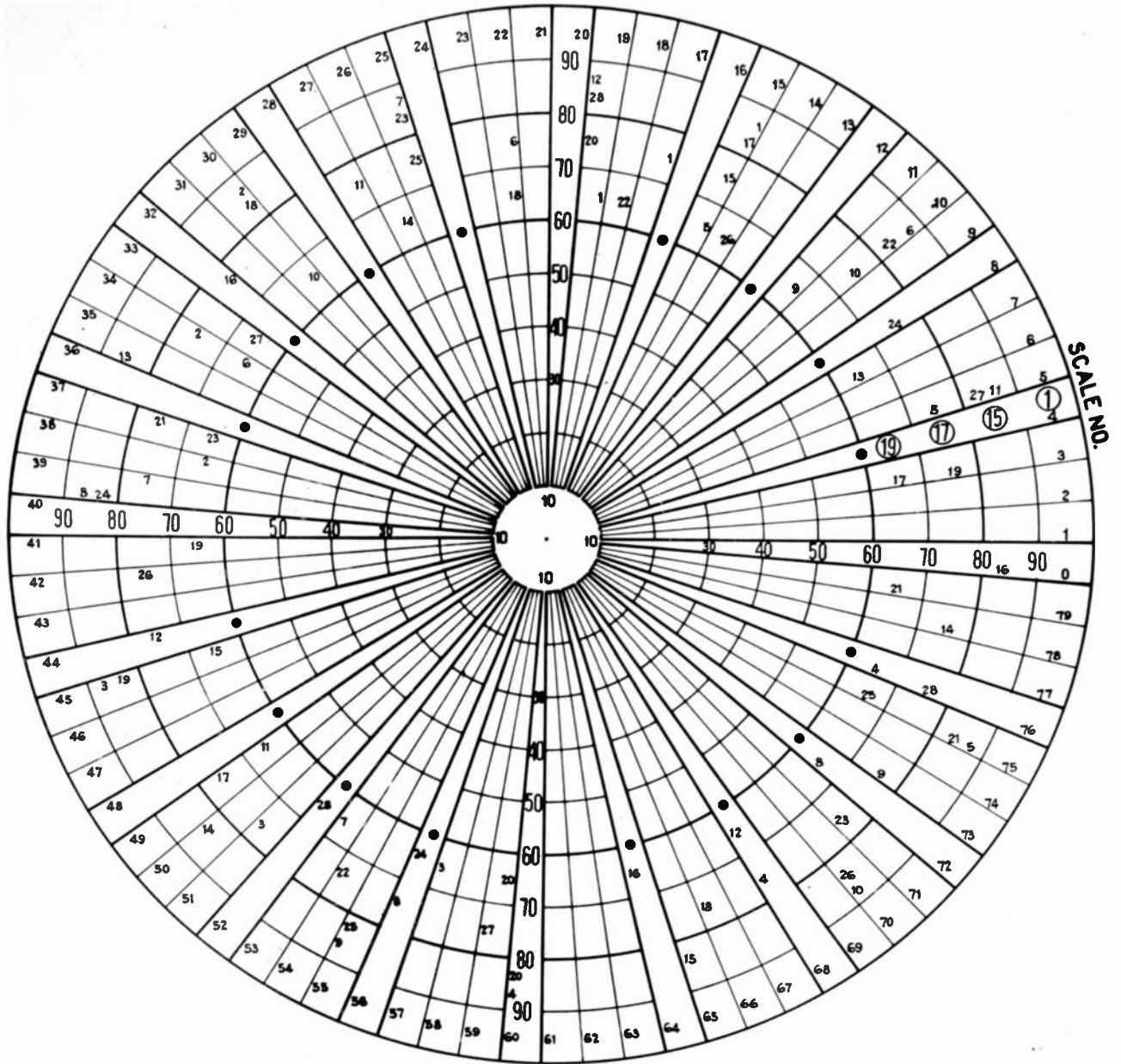

Fig. 13—Chart for square-wave synthesis.

Scale	0.05-microsecond intervals
①	0.25
②	3.75
③	4.25
④	4.75

imaginary circle having a diameter  $OA$  equal to  $A_n/n$ . The multiplying factor  $2/\pi$  in (2) may be taken into account by suitable calibration of the scale  $AC$ . A number of concentric circles permanently drawn on the chart, so as to divide the diameter of the largest circle into a convenient number of equal parts, will aid in finding the length  $OA$  as the triangle is shifted. Readings along the calibrated edge are positive above the line  $OD$  and negative below  $OD$ .

The same chart may be used for a number of different harmonic terms by simply numbering the radial lines appropriately for each term. Thus, in Fig. 14(b), if the circular scale (1) represents the fundamental term  $\sin 2\pi f_p t$ , then circular scale (3) will represent the

3rd-harmonic term  $\sin 6\pi f_p t$  in which the unit angle is 3 times the unit angle in scale (1) etc. The steps involved in finding and summing the sine terms in (2) have been systematized in a set of synthesis charts, Figs. 11, 12, and 13. The following directions have been drawn up to facilitate rapid use of the synthesis charts.

#### A. Directions for Use of Synthesis Charts

Figs. 11, 12, and 13 are used in the compilation of the response of an electric circuit to a square wave as represented by the first 10 odd harmonics (1st, 3rd, . . . , 19th) when the sine-wave, phase-delay, and amplitude characteristics of the circuit are known.

The particular characteristics of the circuit were arbitrarily



- (D) In order to find contributions of the 3rd harmonic, pass the straightedge through the number on scale (1) corresponding to the delay factor from column (d). Use scale numbers on scale (3) in order to locate the perpendicular and proceed with the measurement of its length as directed above for the fundamental frequency.

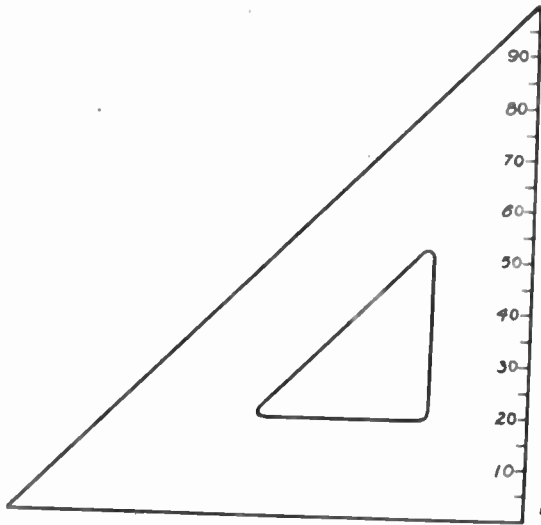

Fig. 15—Calibrated triangle<sup>8</sup> for reading contributions of harmonics from synthesis charts.

- (E) Complete the table for the other harmonics in a manner similar to the above.  
 (F) The instantaneous value of the square-wave response at  $t=0$  microseconds is found by summing column (0) and adding 50 per cent. Similarly, the response is found at other times by summing the appropriate column and adding 50 per cent.

*B. Examples of Synthesis of Square-Wave Response*

Several points on the square-wave response of a 2-stage amplifier are synthesized in Fig. 8 from the amplitude and phase characteristics in Fig. 7. Since the theoretical response is shown, a direct indication of the accuracy of the synthesis is available. The discrepancy is seen to be only a few per cent in this example.

The chart method greatly simplifies and shortens the synthesis of square-wave response in complex cases in which rigorous mathematical formulas for response are impracticable. A typical example is the response of a 32-stage amplifier which was synthesized in Fig. 16 from the theoretical amplitude and phase characteristics of Fig. 17. In this particular case, an absolute measure of the error of the synthesis is not known. The deviation of any synthesized square-wave response from the exact square-wave response is due only to

<sup>8</sup> The 100 per cent point on the radial scales of Figs. 11, 12, and 13 should coincide with the 63.6 ( $=(\pi/2)100$ ) per cent point on the calibrated triangle when the triangle is drawn to the same scale as the figures.

errors in manipulation of the charts and the neglect of contributions of harmonics beyond the limits of the charts (4.25 megacycles).

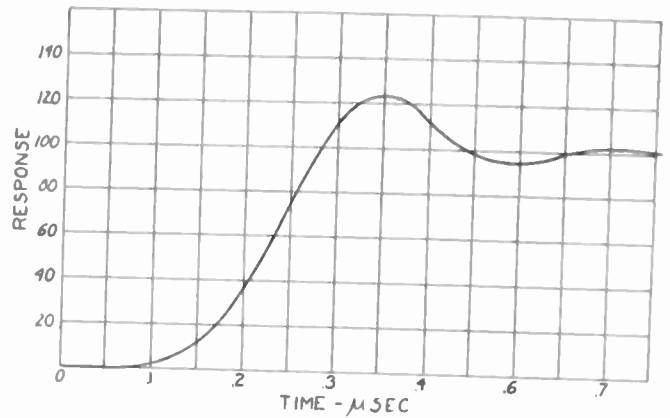

Fig. 16—Synthesis of the square-wave response of a 32-stage compensated resistance-capacitance amplifier in which  $K=1.51$  and  $f_0=7.7$  megacycles.

IV. EVALUATION OF THE SQUARE-WAVE RESPONSE

Assume that a subject containing an extensive dark area and an extensive white area with a sharp vertical junction between the two is used as a test subject for a determination of the fidelity of transmission of a television system.<sup>9</sup> An ideal scanning device in crossing the junction would generate a unit voltage which be-

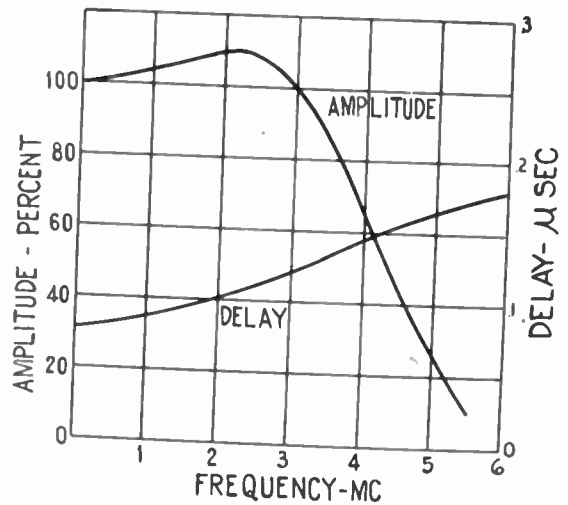

Fig. 17—Exact amplitude and delay characteristics of a 32-stage compensated resistance-capacitance amplifier in which  $K=1.51$  and  $f_0=7.7$  megacycles.

comes the input signal for a television transmission system under test. The output signal or response of the system may be symbolized in Fig. 18. The waveshape may be determined experimentally by a square-wave

<sup>9</sup> The use of a single abrupt transition from one brightness to another brightness as a test subject for measuring "resolution" in a television picture was developed by R. D. Kell, A. V. Bedford, and G. L. Fredendall in "Determination of optimum number of lines in television system," *RCA Rev.*, vol. 15, pp. 7-30; July, 1940. A test pattern consisting of several converging bars is much more commonly used in evaluating an entire television system on account of convenience. The results obtained, however, are less significant because the resolution of the individual bars is not affected by the phase fidelity, whereas it is known that phase fidelity affects the sharpness and utility of most television pictures.



oscillograph or by synthesis from known sine-wave characteristics of the system. If the test subject were reproduced by an ideal scanning device (i.e., one having negligible aperture losses), actuated by the output signal, the variation of light intensity on the screen along the scanning lines would be as shown in the figure when using for the ordinates and abscissas the light intensity and distance, respectively. The distance required for the complete change from black to white is greater than zero due to the finite rate of rise of the response curve. Upon close observation of the screen, the junction would appear blurred. Furthermore, several alternate light and gray striations following the

tion was termed the equivalent "blur" of the nonlinear transition. The blur may be specified in units of distance along the picture screen or in the corresponding units of time. Complex transition curves containing damped oscillations of sufficiently long duration are properly represented by a linear transition followed by that part of the oscillation which the eye does not include with the transition.

The comparison method of determining blur is objectionable because the labor involved is great and the evaluation of each transition depends somewhat upon the observer's judgment. A method not subject to these objections has been devised whereby the blur may be found directly from a plot of the light intensity along a transition. The steps involved in applying the method are given below in a "Generalized Statement" which defines the conditions under which a linear transition is visually equivalent to a nonlinear transition such as Fig. 18. For clarity, this "Generalized Statement" is presented in the form of a law or theorem, but we do not presume to use these terms until the statement has been proved more adequately by theory or experiment than is done in this paper.

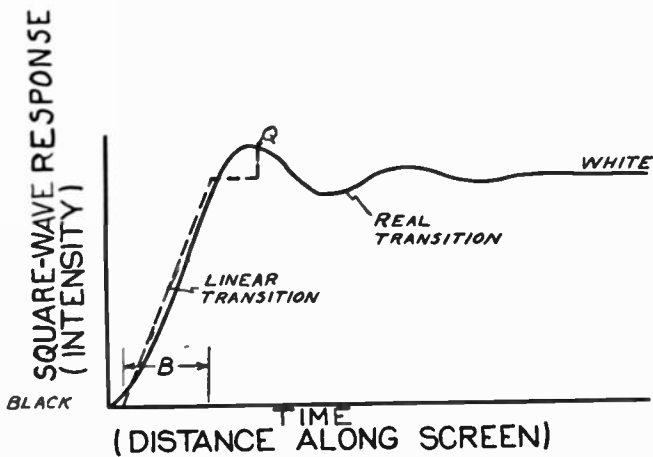

Fig. 18—Nonlinear response of a hypothetical complete television system and the equivalent linear response in terms of light along the screen surface or electrical response of the system.

Generalized Statement

A linear transition having a uniform rate of change of intensity along the surface from a first mean brightness to a second mean brightness is visually equivalent at the optimum viewing distance to any nonlinear transition

junction would be observed as a consequence of the damped oscillation in the response. The overshwing shown in Fig. 18 would not be entirely objectionable for television purposes because at the optimum viewing distance most of the overshwing is not distinguishable from the transition and the net effect would be substantially a single transition. In fact, the visual sharpness of the transition is enhanced by the overshwing in the response wave. If a quantitative measure of the sharpness were found, the response wave in Fig. 18, for example, could be compared directly with other waves having different shapes, and the relative merit of television apparatus with reference to picture sharpness could be determined.

With the object of finding such a measure of sharpness, the writers constructed several different synthetic black-white transitions with ink on cardboard using fine shading lines of variable widths to reproduce accurate half-tone values. When the transitions were viewed at a distance for which the "blur" was just discernible, that is, the optimum viewing distance it was observed that a simple linear transition similar to that shown dotted in Fig. 18 could be found for each nonlinear transition such that the observer was unable to distinguish between the nonlinear transition and its linear equivalent.

The width of the visually equivalent linear transi-

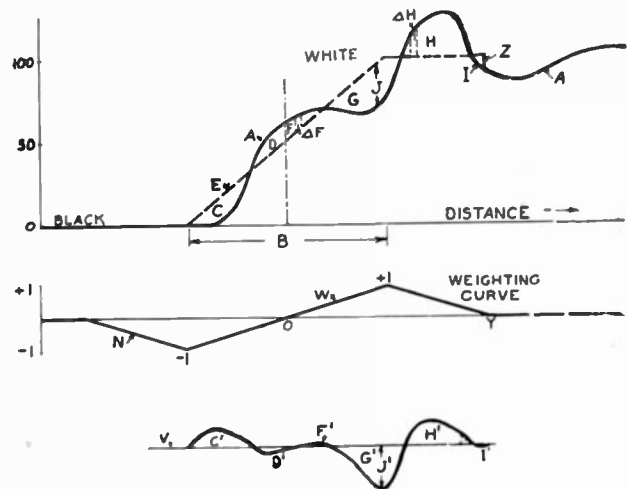

Fig. 19—Linear transition E is equivalent to A. By Condition 2, the algebraic sum of areas C, D, F, G, H, and I is zero. By condition 1, the sum of weighted areas C, D, F, etc., shown at C', D', F', etc., is zero

from the first mean brightness to the second mean brightness when conditions 1 and 2 below are fulfilled.

Condition 1—The summation of the weighted differences of the light intensities of the linear transition and of the nonlinear transition is zero, where the weighted differences are the real differences of light intensity along the transitions multiplied by a weighting factor. The weighting factor varies linearly with distance from a value of -1 at the first inflection point of the linear transition to +1 at the second inflection point; also linearly with

distance from a value of zero at a point preceding the first inflection point by half the distance between inflection points, to the  $-1$  value at the first inflection point; also linearly with distance from the  $+1$  value at the second inflection point to zero at a point following the second inflection point by half the distance between the inflection points; and is zero for all other points.

Condition 2—The summation of the differences of the light intensities along the transitions is zero, over the range where the weighting factor is not zero.

According to the generalized statement, the linear transition  $E$  in Fig. 19 is visually equivalent to the transition  $A$ . In this and other cases, it is convenient to consider the vertical dimensions  $J$  of the difference areas  $C, D, F$ , etc., as positive when  $A$  is above  $E$  and

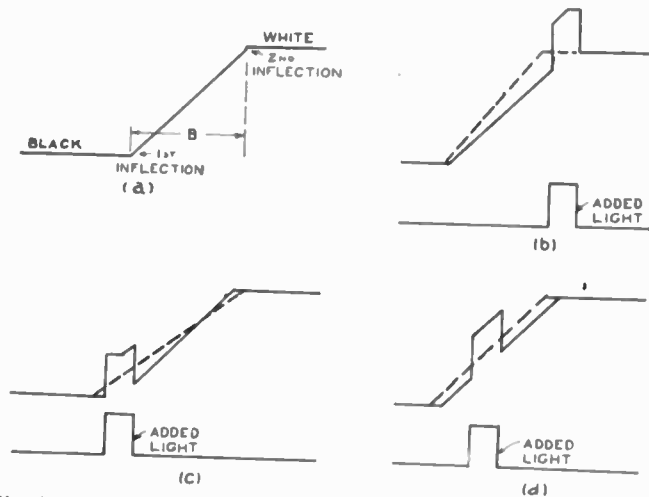

Fig. 20—Actual transitions are shown in solid lines and equivalent linear transitions are shown in dotted lines.

negative when  $A$  is below  $E$ . Then, if these dimensions are multiplied by the corresponding ordinates of the weighting curve  $N$  and plotted as at  $V$ , the positive and negative areas  $C', D', E'$ , etc., are formed. Condition 1 is fulfilled if the algebraic sum of these areas  $C', D', F'$ , etc., equals zero. Condition 2 simply requires that the algebraic sum of the positive and negative areas  $C, D, F$ , etc., equals zero.

The location of a line  $E$  that fulfills the two conditions for a particular nonuniform transition is obtained by a trial-and-error method. The equivalent blur is indicated as the distance  $B$ . Each trial curve  $E$  requires a different weighting curve  $N$  since the weighting curve is itself defined by the equivalent linear-transition curve. Such a procedure would appear to be laborious since the line  $E$  has two variable characteristics, slope and position. However, the number of trials required is much reduced by the knowledge that for small changes of slope of line  $E$  only condition 1 is affected and for small changes of position only condition 2 is affected.

Although the generalized statement for defining a linear transition which is visually equivalent to a nonlinear transition is essentially empirical, the conditions appear to be consistent with observed properties of

the eye. It is well known that the eye responds to a surface consisting of many tiny, uniformly distributed white dots on a black background (or black dots on a white background) as though the surface were uniformly white but the illumination reduced so that the total reflected light is the same. In other words, the eye responds to the average<sup>10</sup> brightness or to the total brightness. Condition 2 is consistent with this observation in that it requires equality of the total amount of light of the equivalent transition and the nonlinear transition.

The plausibility of condition 1 may be established by using the simple transitions of Fig. 20 to illustrate some basic factors which affect apparent steepness. Fig. 20(a) represents a linear change from black to white or from any half tone to another half tone. The blur by our definition is the distance  $B$ . Now assume that an extra amount of light is added near the second inflection point as shown in Fig. 20(b). As a result, the transition has been made effectively steeper so that the equivalent linear transition must also be made steeper as shown by the dotted line.

If the light were added near the first inflection point as shown in Fig. 20(c), it is apparent that the transition would be less steep as indicated by the dotted linear transition. From these two observations, it is plausible that the addition of light at the middle of the transition as in Fig. 20(d) would not alter the effective steepness. The equivalent linear transition, however, would be displaced to the left as required by condition 2.

If light were added at a point considerably ahead of the first inflection point of the linear transition or considerably after the second inflection point, it is reasonable that the effect on the steepness would be less than if the light were added near the inflection points.

Let us refer back to the example of Fig. 19, in which curve  $E$  is assumed to be the visual equivalent of the curve  $A$ . Obviously,  $E$  is identical to curve  $A$  except for the difference areas  $C, D, G$ , etc. Some of the areas such as  $C$  and  $H$  render curve  $A$  effectively steeper than the equivalent curve but other areas such as  $D$  and  $G$  detract from the steepness of curve  $A$ .

If curve  $E$  is to be the equivalent of curve  $A$ , the algebraic sum of the effects of all the aiding difference areas  $C, H$ , etc., must be canceled by the opposing areas. Condition 1 states this requirement and provides a weighting factor for determining the effectiveness of each difference area resulting from its location, as discussed in connection with Fig. 20.

A linear weighting curve has been taken arbitrarily due to the absence of evidence which would point to a specific form for the curve. A linear variation is simple and may also be considered as a mean between the various possible concave and convex forms.

It should be noted especially that in the application

<sup>10</sup> The eye also responds to the average brightness of a rapidly flickering source.

of the generalized statement to transitions which have appreciable irregularities in the region in which the weighting curve is zero (beyond  $Y$ ), the irregularities are not included in the equivalent blur. As shown in Fig. 19, the equivalent curve may be continued through  $Z$  to the actual curve  $A$ . It should be noted also that the equivalent transition defined by the statement is intended to be equivalent only when viewed at a distance for which the nonlinear transition is indistinguishable from a linear equivalent transition. At such a distance, a very definite blur may be visible without the *shape* of the transition being discernible.

The observations made in the several paragraphs above lend support to the concept of an equivalent linear blur but obviously do not place the concept on a firm physical basis. Furthermore, the physical accuracy of the particular conditions set forth in the generalized statement have not been established because of inadequate knowledge of the eye and brain. However, actual viewing tests with specific transitions lead us to believe that the application of the generalized statement is sufficiently accurate to serve a useful purpose for the evaluation of the transitions found in television.

The authors feel that such a measure of blur also can have utility in specifying the quality of many other devices related to vision, such as lens system, photographic film and processes, facsimile transmission, printing, duplicating processes, and paper.

#### V. APPLICATION OF SQUARE-WAVE METHODS IN TELEVISION

Square-wave and sine-wave measurements should be mutual aids in the solution of many television problems. In some instances, a square-wave measurement may furnish the data for analysis into amplitude and delay characteristics. In others, the evaluation of blur is indicated. In some applications, sine-wave measurement and synthesis of the square-wave response may be indicated, followed perhaps by evaluation. Most applications will not require the use of all three processes of square-wave treatment.

We know no simple satisfactory method of judging the degree of fidelity of a television system from inspection of the sine-wave characteristics. If the square-wave response of the system cannot be secured experimentally, resort must be had to synthesis from amplitude and phase data. However, acceptable tolerances in terms of sine-wave performance may be more easily determined when the amplitude and phase characteristics corresponding to a large variety of transient-response curves have been determined and cataloged.

In design work in which the characteristics of television apparatus must be determined by calculation based on circuit constants, synthesis from the sine-wave characteristics probably constitutes the only feasible means for obtaining the square-wave response. When the apparatus is susceptible to experimental

test, the most expeditious method is direct measurement of the square-wave response by oscillographic equipment such as described in a companion paper.<sup>3</sup> An analysis for amplitude and phase characteristics may then be performed in order to facilitate the design of equalizing networks if required or for any other purpose. In this connection it is significant that the experimental difficulty of phase measurements of extensive apparatus such as a complete television system including transmitter and receiver by sine-wave methods is usually so great that the attempt is not often made.<sup>11,12</sup> Notwithstanding, a reasonably linear phase shift is conceded to rank with amplitude uniformity in importance. The extreme ease with which square-wave response can be recorded with suitable equipment has been pointed out in the companion paper. The analysis of the response for delay versus frequency through the use of charts is simple and immediate.

In particular cases, square-wave measurements may provide useful data which are almost impossible to obtain by sine-wave measurements and synthesis. An example is the modulation amplifier of a television transmitter in which the output impedance may be relatively high at low frequencies, in order to permit a high output voltage, and relatively low at high frequencies such that the frequency fidelity of the stage alone is poor. Adequate equalization may be inserted in earlier stages of the system but high-frequency components may be saturated at high levels. A sine-wave characteristic of the entire amplifier taken at a low level for which saturation is negligible would indicate high fidelity. It would be almost impossible to synthesize from the low-level sine-wave data the transient response for a high level corresponding to conditions occurring in common use. Square-wave oscillographic tests, however, would indicate the transient response corresponding to any desired level. An evaluation of the square-wave response for the purpose of finding the blur corresponding to various levels would be significant but a determination of the sine-wave response at levels where saturation exists would have no meaning in the usual sense.

In general, square-wave methods have greatest usefulness (as compared with sine-wave methods) in dealing with performance of units which are likely to contribute a substantial amount of the distortion in the transmission characteristic of the system. Included in this classification are entire transmitters, entire receivers, long transmission lines, pickup chains, and any single amplifier stages which may be regarded as "bottleneck" stages. It would be rather pointless to find the square-wave response and the equivalent blur of a single stage of a video voltage amplifier of good

<sup>11</sup> B. D. Loughlin, "A phase curve tracer for television," *Proc. I.R.E.*, vol. 29, pp. 107-115; March, 1941. Loughlin describes apparatus which furnishes a direct plot of phase versus frequency on the screen of a cathode-ray tube. The complexity of the apparatus may limit its general utility.

<sup>12</sup> M. E. Strieby and J. F. Wentz, "Television transmission over wire lines," *Bell Sys. Tech. Jour.*, vol. 20, pp. 62-81; January, 1941.

fidelity in a system in which many similar stages exist. Usually the distortion of a single stage is so small that only the accumulated effect of several stages is clearly evident in the over-all square-wave response. The writers are not aware of the existence of a practicable method of combining the individual square-wave response of two or more units for the purpose of finding the over-all square-wave response. Even if a feasible method should exist, the experimental errors involved in many individual measurements would jeopardize the dependability of the calculated over-all response.

If units of good fidelity must be considered individually, it becomes expedient to determine first the sine-wave characteristics and then to combine the sine-wave characteristics so that a synthesis of the over-all square-wave response may be performed.

The accuracy of square-wave methods is more than adequate to reveal those imperfections of transmission which cause discernible effects in a television picture. Therefore, the authors hope that this paper will be a contribution to the general problem of working out electrical specifications for television transmitters and other television apparatus, giving information regarding the steepness of rise and the amplitude of over-swing of the square-wave response.

APPENDIX I

ANALYSIS OF SQUARE-WAVE RESPONSE

Let the square-wave response be approximated by a stepped wave  $f$  as shown in Fig. 1. The  $k$ th step may be approximated by the series

$$A_k \left[ \frac{1}{2} + \frac{2}{\pi} \sum_{n=1}^N \frac{1}{n} \sin n\omega_o(t - T_k) \right] \quad (3)$$

where  $N$  is very large.

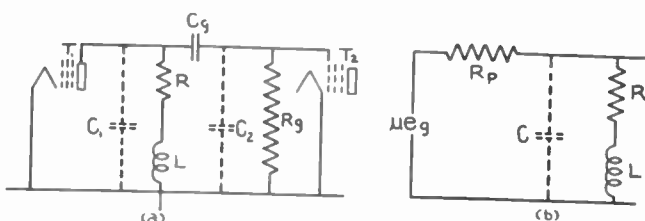

(a) Compensated resistance-capacitance amplifier. (b) Equivalent circuit for high frequencies.

Fig. 21

The sum of  $M$  steps leads to the following expression for the stepped wave

$$\sum_{m=1}^M \frac{A_m}{2} + \frac{2}{\pi} \sum_{m=1}^M \left[ A_m \sum_{n=1}^N \frac{1}{n} \sin n\omega_o(t - T_m) \right]. \quad (4)$$

The constant term in (3) is not of interest. If the order of summation of the second term is reversed, there results

$$\frac{2}{\pi} \sum_{n=1}^N \frac{1}{n} \sum_{m=1}^M \left[ A_m \sin n\omega_o(t - T_m) \right]. \quad (5)$$

The inner sum written for some specific value of  $n$  as

$N_1$  is the total  $N_1$ th harmonic content of the stepped wave. That is,

$$E_{N_1} = \frac{2}{\pi} \frac{1}{N_1} \sum_{m=1}^M A_m \sin N_1\omega_o(t - T_m) = \frac{2}{\pi} \frac{1}{N_1} B_{N_1} \sin N_1\omega_o(t - T_{N_1}). \quad (6)$$

Since the input square-wave signal may be approximated by the form

$$\frac{1}{2} + \frac{2}{\pi} \sum_{n=1}^N \frac{1}{n} \sin n\omega_o t$$

it follows that the  $N_1$  component of the input is

$$\frac{2}{\pi} \frac{1}{N_1} \sin N_1\omega_o t.$$

The amplitude response of the circuit is, therefore,  $B_{N_1}$  and the time delay is  $T_{N_1}$ . These two quantities may be found graphically as indicated in Fig. 1(a) and (b).

Since  $\omega_o$  may be allowed to approach zero, it follows that reference to a fundamental frequency is not required and the amplitude and phase corresponding to any frequency may be found.

APPENDIX II

THE COMPENSATED RESISTANCE-CAPACITANCE AMPLIFIER

A schematic diagram of the amplifier appears in Fig. 21. When  $R_p \gg Z(L, C, R)$  the response of the equivalent circuit to a unit function is expressed by the following equation:

$$e = \frac{\mu R}{R_p} \left[ 1 - e^{-\tau f_o K t} \left\{ A \sin (\Omega_1 t + \psi) + B t \sin (\Omega_1 t + \beta) \right\} \right]$$

in which

$$t = \text{time} \quad \Omega_1 = 2\pi f_o \sqrt{1 - K^2/4}$$

$$f_o = 1/(2\pi\sqrt{LC}) \quad B = \sqrt{P^2 + N^2}$$

$$A = \sqrt{1 + M^2} \quad \psi = \tan^{-1} \frac{1}{M}$$

$$K = 2\pi f_o RC$$

$$M = \frac{-3 + 3K^2 - K^4/2}{4K(1 - K^2/4)^{3/2}} \quad \beta = \tan^{-1} \frac{N}{P}$$

$$N = \frac{\pi f_o (K^2 - 1)}{K^2 \sqrt{1 - K^2/4}} \quad P = \frac{\pi f_o (3 - K^2)}{2K(1 - K^2/4)}$$

The amplitude response is

$$\text{amplitude} = \frac{\mu R}{R_p} \sqrt{\frac{1 + B^2/K^2}{B^2 K^2 + (B^2 - 1)^2}}$$

$$\text{delay} = \frac{1}{2\pi f} \tan^{-1} (1 - K^2 - B^2)B/K$$

in which

$$f = \text{frequency}$$

$$B = f/f_0$$

$$K = 2\pi f_0 RC.$$

APPENDIX III

RELATION BETWEEN SQUARE-WAVE ANALYSIS AND FOURIER ANALYSIS

Assume that the response of a linear electrical network to a unit function is represented by  $e_1(t)$  in Fig. 22(a). The response  $e_2(t)$  of the same circuit to a square pulse  $\Delta t$  seconds long is found by shifting  $e_1(t)$  to the right along the time axis by an amount  $\Delta t$  and subtracting the result from  $e_1(t)$  that is,  $e_2(t) = e_1(t) - e_1(t + \Delta t)$ . If the condition is imposed that  $e_1(t) = 1$  for  $t \geq t_q$ , then  $e_2(t) = 0$  for  $t \geq (t_q + \Delta t)$ .

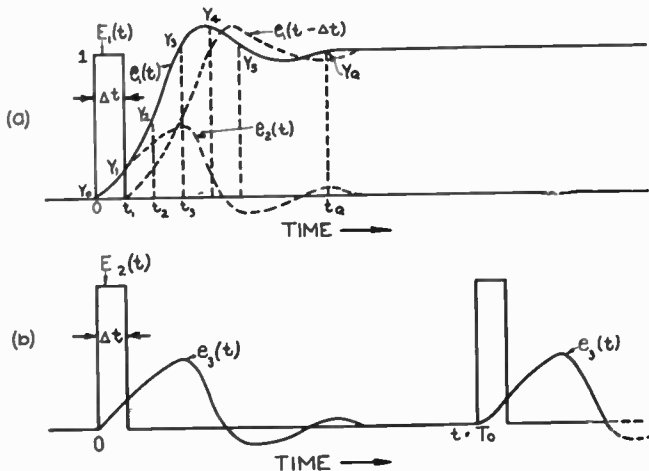

Fig. 22—Fourier analysis applied to the response of a circuit to a square pulse compared with square-wave analysis applied to the response to a unit function.

It is clear that the waveform of the response  $e_3(t)$  of the same circuit to the periodic pulse wave of Fig. 22(b) is given for each cycle by  $e_2(t)$  if  $T_0 \geq (t_q + \Delta t)$ . Hence, the coefficients of the Fourier series written for  $e_3(t)$  may be expressed in terms of the ordinate readings of  $e_1(t)$  taken at successive equal time intervals. Thus

$$e_3(t) = a_0 + a_1 \cos 2\pi f_0 t + \dots + a_k \cos K2\pi f_0 t + \dots$$

$$+ a_{n/2} \cos \frac{n}{2} 2\pi f_0 t + b_1 \sin 2\pi f_0 t + \dots$$

$$+ b_k \sin K2\pi f_0 t + \dots$$

$$+ b_{(n/2)-1} \sin \left( \frac{n}{2} - 1 \right) 2\pi f_0 t$$

where

$$a_k = 2\Delta t f_0 [(y_1 - y_0) \cos K2\pi \Delta t f_0$$

$$+ (y_2 - y_1) \cos K4\pi \Delta t f_0 + \dots$$

$$+ (y_q - y_{q-1}) \cos Kq2\pi \Delta t f_0]$$

$$= 2\Delta t f_0 A$$

and

$$b_k = 2\Delta t f_0 [(y_1 - y_0) \sin K2\pi \Delta t f_0$$

$$+ (y_2 - y_1) \sin K4\pi \Delta t f_0 + \dots$$

$$+ (y_q - y_{q-1}) \sin Kq2\pi \Delta t f_0]$$

$$= 2\Delta t f_0 B.$$

The Fourier series for  $E_2(t)$  is

$$E_2(t) = \frac{T_0}{\Delta t} + \frac{2}{\pi} \sum_K \frac{1}{k} \sin K\pi \frac{\Delta t}{T} \cos 2\pi K f_0 t.$$

Hence, the amplitude characteristic of the circuit is given by

$$R(K, f_0) = \frac{\pi \Delta t K f_0}{\sin \pi \Delta t K f} \sqrt{A^2 + B^2}$$

$$\text{or } \lim_{f_0 \rightarrow 0} R(K, f_0) = R(f) = \frac{\pi \Delta t f}{\sin \pi \Delta t f} \left[ \lim_{f_0 \rightarrow 0} \sqrt{A^2 + B^2} \right]$$

and the delay characteristic is given by

$$\lim_{f_0 \rightarrow 0} \frac{\theta(K, f_0)}{2\pi f} = \frac{1}{2\pi f} \tan^{-1} \frac{B}{A}.$$

Now  $\sqrt{A^2 + B^2}$  is the same expression which is obtained for the amplitude characteristic by the graphical method of square-wave analysis. Hence,  $\pi \Delta t f / \sin \pi \Delta t f$  may be regarded as the conversion factor which converts square-wave analysis into Fourier analysis when the latter is based on the square pulse.

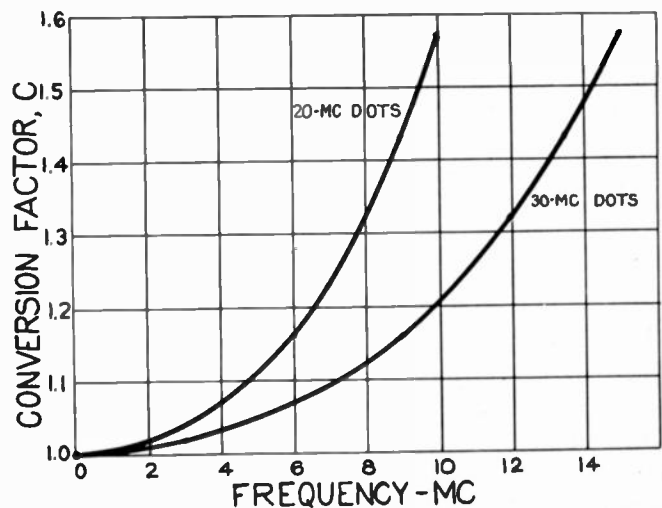

Fig. 23—Conversion factor for obtaining Fourier analysis from square-wave analysis. C times amplitude according to square-wave analysis equals amplitude according to Fourier analysis.

The magnitude of the conversion factor is shown in Fig. 23. It may be concluded that for most applications of square-wave analysis in television, the conversion factor may be taken equal to 1. The delay characteristics as determined by square-wave analysis and Fourier analysis are identical.

# A Portable High-Frequency Square-Wave Oscillograph for Television\*

R. D. KELL†, ASSOCIATE I.R.E., A. V. BEDFORD†, ASSOCIATE, I.R.E.,  
AND H. N. KOZANOWSKI†, ASSOCIATE, I.R.E.

**Summary**—A portable high-frequency oscillograph for television is described by which a square-wave (100-kilocycle) response may be viewed as a dotted wave and readily recorded as a series of readings. The dots are spaced at 1/30- (or 1/20-) microsecond intervals. No electrical connection is required between the oscillograph and the square-wave generator other than that established through the apparatus under test since the synchronous sweep and timing dots are derived from the square-wave response of the apparatus. Circuit diagrams of the square-wave generator and square-wave oscillograph are given.

## I. INTRODUCTION

THE applications of square-wave measurements in television are developed in detail in a companion paper<sup>1</sup> in which the following aspects are treated: (1) a graphical chart method for analyzing the response of a system to a square-wave input signal to obtain the sine-wave amplitude and delay characteristics; (2) a graphical chart method for synthesizing the response to a square-wave from the sine-wave amplitude and delay characteristics; (3) a method for evaluating the mean steepness of a transient-response wave in terms of the width of blur produced in a television image by a visually equivalent wave having a linear change between two reference half tones; and (4) specific applications of square-wave measurements. When an experimentally determined square-wave response is required for the execution of items (1), (3), and (4), the use of a suitable oscillograph becomes necessary. It is the purpose of the present paper to describe a portable high-frequency oscillograph and a square-wave generator by which a square-wave response may be viewed as a dotted wave and readily recorded as a series of amplitude readings separated by known equal time intervals.

## II. CHOICE OF THE FUNDAMENTAL FREQUENCY OF THE SQUARE WAVE

It can be shown that if the response of an electrical circuit to a unit-function input subsides to a substantially constant value after the transient interval as shown in Fig. 1 (A), the response of the same circuit to a square wave as shown in Fig. 1 (B) contains a transient interval or transition  $a-b$  essentially similar to that due to the unit function. In practice, the transitions may be considered identical when the period of the square wave is about 3 or more times greater than the duration of the transient interval as in Fig. 1. For most television measurements, a 100-kilocycle square

wave has been found to be adequate. Hence, the design of a square-wave oscillograph was based on this fundamental frequency. The analysis and evaluation processes mentioned in Section I presuppose that the square-wave response of the apparatus under test is

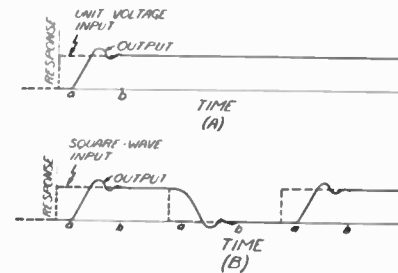

Fig. 1—(A) Response of a circuit to a unit function.  
(B) Response of the same circuit to a square wave.

essentially equivalent to the unit-function response so far as the high-frequency components are concerned.<sup>2</sup>

## III. THE ESSENTIAL COMPONENTS OF THE OSCILLOGRAPH

Fig. 2 is a block diagram of a typical test arrangement including the 100-kilocycle square-wave generator, the apparatus under test, and the square-wave oscillograph. The essential components of the oscillograph are shown as blocks within a larger block. No electrical connection is required between the oscillograph and the generator other than that established through the apparatus under test because the synchronous sweep and timing signals are derived from the square-wave output of the apparatus.<sup>3</sup> This feature contributes to convenience even in a very simple setup, but is of greatest advantage in the testing of distributed systems in which the input and the output are separated by a considerable distance as in a complete transmitter and an associated television receiver.

Fig. 3 is a photograph of the square-wave oscillograph and square-wave generator. In Fig. 4, the probe

<sup>2</sup> The use of a 60-cycle square-wave generator and an oscillograph for investigation of the behavior of a television system at low frequencies of the order of the field-scanning rate is well established. In these measurements, performance is judged by inspection of the "tilted" output wave and harmonic analysis of the wave is usually not desired. In general, a television system will have uniform response over a frequency range of many octaves in the region between the so-called "low-frequency" end and the "high-frequency" end, so that fidelity measurements at the two ends of the spectrum may be considered separately. This paper will be concerned only with the high-frequency end.

<sup>3</sup> Most previous square-wave oscillographs have depended upon a linear sweep and photography for recording. Some have required additional connections between the generator and the cathode-ray tube for timing. Such an oscillograph is described by H. E. Kallmann in "Portable equipment for observing transient response of television apparatus," Proc. I.R.E., vol. 28, pp. 351-360; August, 1940.

\* Decimal classification: R388X R583. Original manuscript received by the Institute, February 19, 1942. Presented, Summer Convention, Detroit, Michigan, June 25, 1941.

† RCA Manufacturing Company, Camden, New Jersey.

<sup>1</sup> A. V. Bedford and G. L. Fredendall, "Analysis, synthesis, and evaluation of the transient response of television apparatus," Proc. I.R.E., this issue, pp. 440-457.

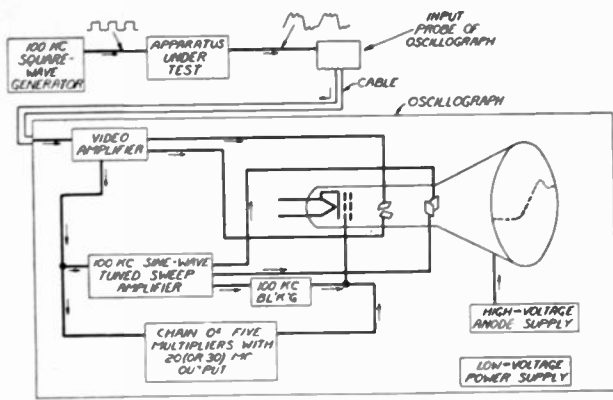

Fig. 2—Block diagram of a typical test arrangement showing the square-wave generator, apparatus under test, and the square-wave oscilloscope. Internal components of the oscilloscope also appear in block form.

and power cord have been removed from the storage compartment in front of the cathode-ray tube. The theory of operation of the various components together with certain constructional details is given below.

the video amplifier for vertical deflection of the cathode-ray tube. Rectangles enclose all external controls on the diagram. The input probe contains an

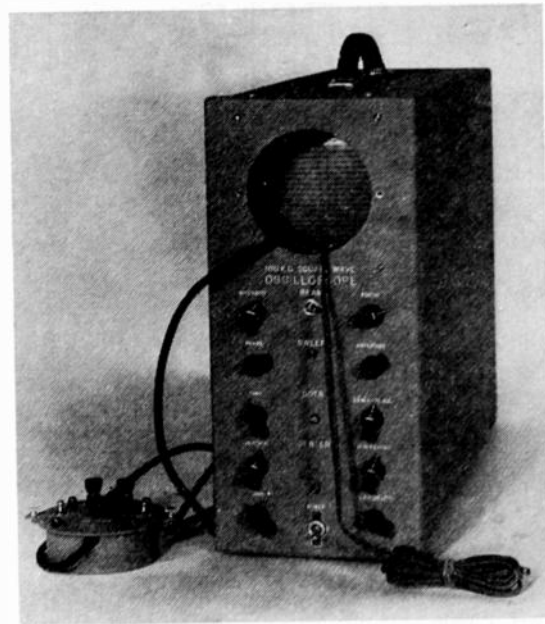

Fig. 4—Square-wave oscilloscope and probe.

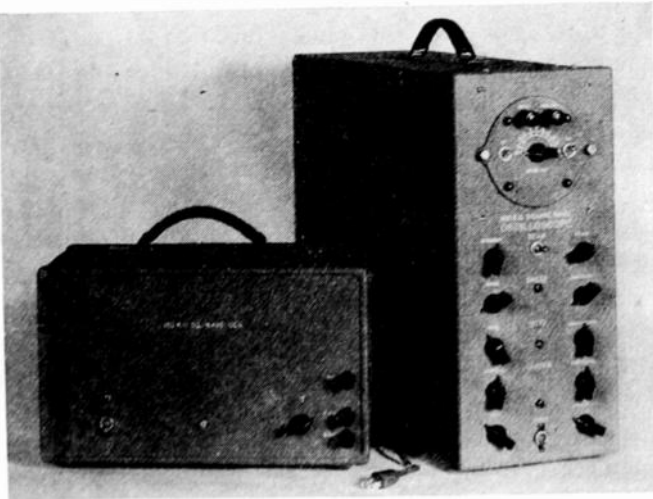

Fig. 3—Square-wave oscilloscope and square-wave generator.

A. Input Probe and Video Amplifier

Fig. 5 shows a schematic diagram of the probe and

attenuator and a control for varying the internal capacitive load across the input terminals. In order to allow convenient use with short leads from the apparatus under test, the probe is in a small metal box connected to the oscilloscope proper by a permanently shielded cable.

In experimental work, a record of the square-wave response at the grid of a tube or at the grid of a kinescope where the impedance is high is frequently desired. For such applications, the probe may be substituted for the input capacitance of the tube or kinescope and the total capacitance adjusted to the original value. A satisfactory substitution can generally be made since the minimum input capacitance of the probe is only 8 micromicrofarads. The resistive component of input impedance is negligible.

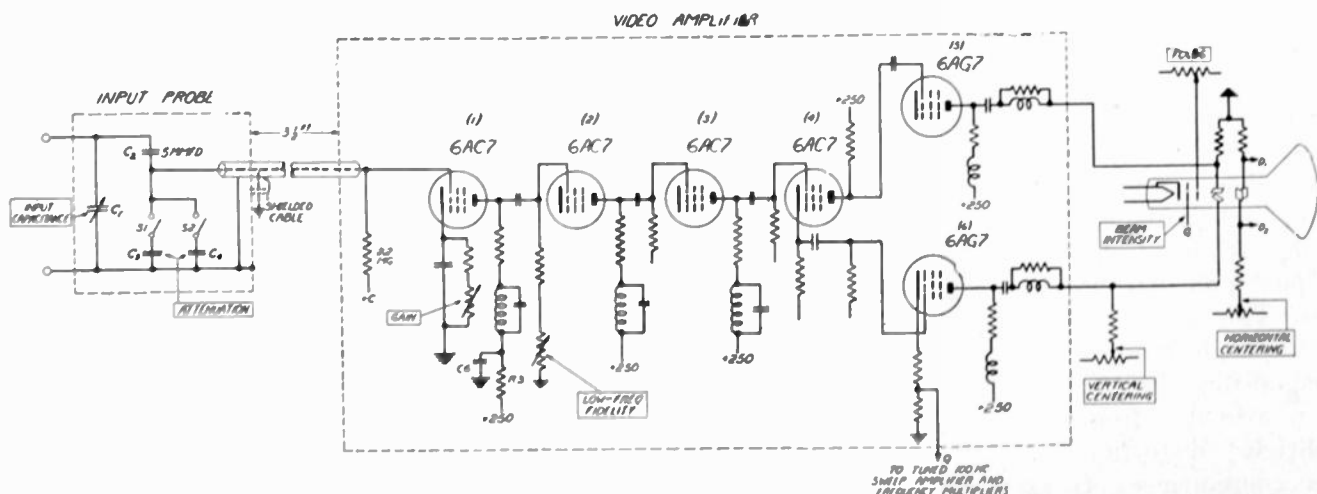
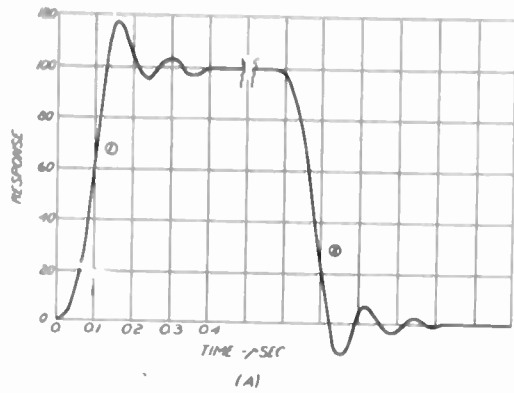
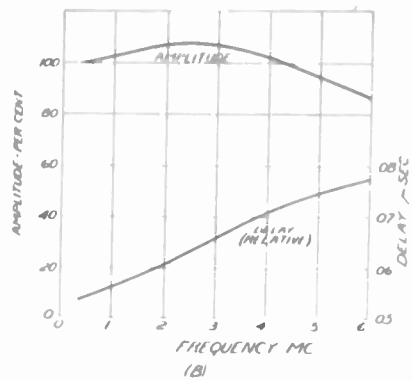

Fig. 5—Simplified circuit diagram of probe, video amplifier, and cathode-ray tube in the square-wave oscilloscope.



(A) Square-wave response of generator and oscillograph only.



(B) Combined amplitude and delay characteristics of generator and oscillograph according to chart analysis of rising trace in (A).

Fig. 6

degeneration.

Sufficient gain or attenuation control is available so that a peak-to-peak deflection of 100 units on the oscilloscope screen is possible throughout an input range of 1 to 100 volts, peak-to-peak. This range is adequate for most square-wave measurements on video apparatus in the television receiver and transmitter without the use of auxiliary amplifiers or attenuators.

When switches  $S_1$  and  $S_2$  are open, the capacitance  $C_2$  and the distributed capacitance of the probe cable comprise a capacitive potentiometer. The attenuation present when  $S_1$  and  $S_2$  are open was not purposely inserted but is incidental to the primary object of a low input capacitance. When the signal to be measured has a high voltage level, the capacitor  $C_3$  or capacitor  $C_4$  may be switched across the cable to attenuate the signal by a factor of 3 or 9 times as desired. The effect of the high-resistance grid leak of the first amplifier stage upon frequency fidelity of the capacitive potentiometer is negligible for frequencies above 250 kilocycles (lower limit used in the analysis charts). The grid-leak resistance, which is higher than commonly satisfactory for use with the 6AC7 type of tube, is low enough for stable operation in this application because the fixed portion of the cathode self-bias resistor is much higher than normal. The positive bias voltage applied to the lower end of the grid leak provides a net bias on the tube that is essentially normal, but does not interfere with the desirable automatic-control voltage generated across the high cathode resistor. The variable portion of the cathode resistor provides additional bias for fine control of the mutual conductance of the tube.

The plate circuits of the first three video stages are simple inductance-compensated stages. The fourth stage delivers cathode-output and plate-output signals for driving the push-pull output tubes. This stage requires no high-frequency equalizing circuits and is also free from amplitude distortion as a consequence of the large amount of

of the probe and amplifier is essentially flat from 100 kilocycles to 6 megacycles. A phase characteristic of the probe and amplifier is difficult to obtain independently of the phase characteristics of the square-wave generator. Fortunately, the really pertinent data are not the characteristics of the component parts but the over-all amplitude and delay characteristics of the square-wave generator and the oscillograph. Fig. 6 shows these characteristics as determined from a chart analysis of the square-wave response of the video amplifier and square-wave generator when directly connected. The amplitude characteristic is flat within  $\pm 4$  per cent out to 4.5 megacycles and the corresponding delay characteristic is flat within  $\pm 0.01$  microsecond. If interest is restricted to the usual video spectrum of 4.5 megacycles, these characteristics allow use of the equipment without corrections where only moderate accuracy is required. When corrections as indicated in Fig. 6 (B) are applied, the frequency range and the accuracy may be considerably extended.

*B. Sweep Circuit for Horizontal Deflection*

The sweep circuit is shown in Fig. 7. Tube 8 is driven by the 100-kilocycle-wave signal which exists across a part of the cathode resistor (point Q, Fig. 5)

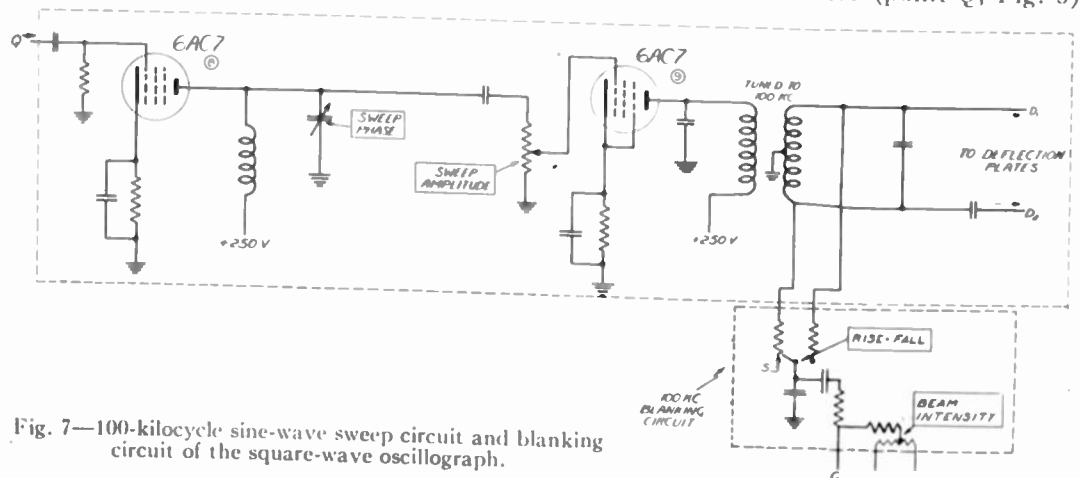

Fig. 7—100-kilocycle sine-wave sweep circuit and blanking circuit of the square-wave oscillograph.



of one output tube of the video amplifier. When the gain of the amplifier has been adjusted for a suitable vertical deflection on the cathode-ray-tube screen, the square-wave signal at point  $Q$  is also suitable for driving the sweep circuit.

The plate circuits of tubes (8) and (9) are tuned to 100 kilocycles; hence, the horizontal-deflection voltage appearing across  $D_1-D_2$  is essentially a sine wave. The voltage across  $D_1-D_2$  is used to deflect the cathode-ray tube horizontally as indicated by the similarly marked points in Fig. 5. The "sweep amplitude" is usually adjusted to several times the value which would just traverse the screen so that the visible portion of the sweep is reasonably linear. There is no need for the usual saw-tooth sweep circuit and synchronizing circuit since the use of timing dots, as explained below, obviates the necessity of a *linear* time axis. Centering of the square-wave response on the cathode-ray-tube screen is accomplished by (1) adjustment of the tuning condenser or "sweep-phase" control in the plate circuit of tube (8) and (2) by adjustment of the "horizontal-centering" control in the cathode-ray-tube circuit. The former control alters the phase relation between the sine-wave sweep signal and the square-wave signal across the vertical deflection plates. This control covers a large range and serves a very useful purpose as explained below.

### C. Cathode-Ray Keying Circuit for Timing

Almost every significant interpretation of a square-wave response curve, such as the evaluation of picture detail transmitted or the determination of amplitude and delay characteristics, depends upon the time base of the response curve as well as upon its shape. Therefore, an accurate means for measuring time along the curve appearing on the fluorescent screen of the cathode-ray tube is indispensable. The required accuracy is accomplished by a keying system which extinguishes the cathode-ray beam at either a 20- or a 30-megacycle rate as desired. The keying or "dotter" circuit shown in Fig. 8 (A) receives the amplified 100-kilocycle square wave from point  $Q$  in Fig. 5. The high-frequency keying signal which keys the beam is then generated by means of the chain of 5 frequency multipliers. Since the keying signal is synchronous with the square wave and the sweep circuit, the wave traced upon the screen consists of a dotted line in which the time interval between dots is the known time for 1 cycle of the keying signal. In order that the plate circuit of the first multiplier tube (10) shall have an

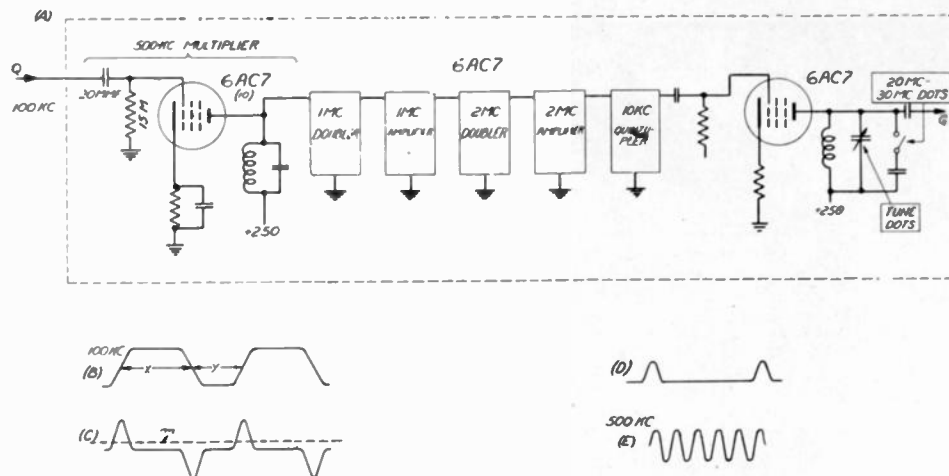

Fig. 8—(A) Dotter circuit of square-wave oscillograph.  
 (B) Square-wave signal at point  $Q$ .  
 (C) Differentiated signal at grid of 500-kilocycle multiplier tube.  
 (D) Plate current of multiplier tube.  
 (E) Output voltage of 500-kilocycle multiplier.

abundant amount of 5th-harmonic signal, independent of the ratio  $X/Y$  in the square wave shown in Fig. 8 (B), the square-wave signal from  $Q$  is effectively differentiated by the coupling condenser and grid leak and then clipped by the tube (10) as shown in Fig. 8 (C) and (D).

In an earlier arrangement, the 100-kilocycle sine-wave sweep signal was impressed on the chain of multipliers. This method was not satisfactory because small spurious changes in the video input level and in the amplification caused the amount of saturation of the first multiplier to vary, thereby changing the relative phase position of the harmonics with respect to the transition point in the square-wave test signal. Although the phase changes represented very small time changes compared with the period of the 100-kilocycle wave, the effect was great enough to cause the dots on the oscilloscope trace to move along the wave over distances comparable to the space between dots.<sup>4</sup> Since the reading and recording of the ordinates of the dots comprising the trace on the screen requires appreciable time, spurious changes in the phase of the dots seriously impaired the accuracy of recording. The improved method of deriving the dots described above provides very stable timing because the pulses of plate current shown above line  $m$  in Fig. 8 (C) are fixed with respect to the rising portion of the square wave in Fig. 8 (B).

In each unit of the chain of conventional frequency multipliers, the amplitude of the input sine wave is sufficient to cut off the tube. The proper harmonic is then selected by a parallel-tuned plate circuit. The plate circuit of the last multiplier may be tuned to either 20 or 30 megacycles depending upon the position

<sup>4</sup> This phenomenon, by which a small change in phase in an early stage of a chain of frequency multipliers causes a large phase change in the final high-frequency stage, is used to advantage in the Armstrong method of frequency modulation for sound transmission.

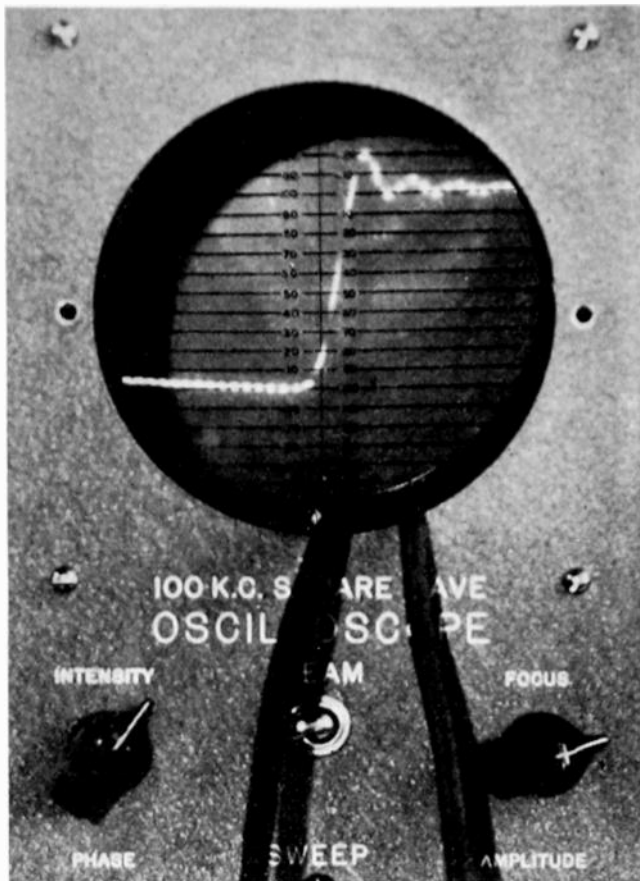

Fig. 9—Actual view of a square-wave response showing rising trace.

of the switch marked "20-Mc—30-Mc Dots." The variable condenser marked "Tune Dots" serves as a vernier. The output point G of the dotter circuit is connected to the grid of the cathode-ray-tube as shown in Fig. 5. Small and well-defined dots are obtained when the bias of the cathode-ray-tube is sufficiently negative to extinguish the beam except during positive peaks of the keying signal.

#### D. 100-Kilocycle Blanking Circuit

In order to allow easy observation of either the rising or the falling trace of the square-wave response (one at a time), a blanking circuit is provided, as shown in Fig. 7, for extinguishing the beam during the undesired trace. One trace is extinguished when the grid of the cathode-ray tube is biased by a blanking signal derived from the voltage at *one* horizontal-deflection plate and shifted nearly 90 degrees by a resistance-capacitance network. The other trace is extinguished by throwing switch  $S_3$  which applies a blanking signal derived from the voltage at the other deflecting plate and shifted by a similar resistance-capacitance network. Both traces may be viewed at the same time if the "beam-intensity" control is raised above the normal level. Fig. 9 shows only the rising trace. The output circuit at G, in Fig. 8 which connects the grid of the cathode-ray-tube, has impedance high enough not to interfere with the high-frequency keying of the grid.

#### E. Mechanical Features

The chassis of the oscillograph extends vertically along the length of the case and is fastened to the center of the front control panel as shown in Fig. 10.

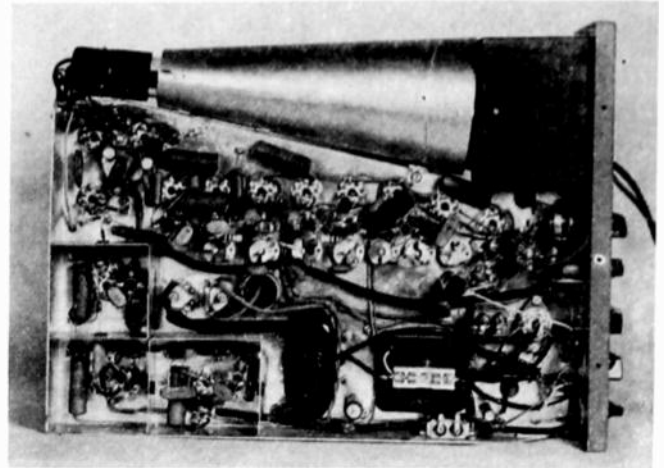

Fig. 10—Chassis of the square-wave oscillograph.

All electrical parts are mounted so that the instrument may be operated when removed from the case for servicing. All tubes are mounted on one side of the chassis and all small parts and wiring are accessible from the other side. The cathode-ray-tube is mounted with the face recessed several inches behind the viewing aperture in the control panel, thus forming an effective light shield.

Provision is made for storing the probe and the power cord in the compartment in front of the cathode-ray tube. The oscillograph weighs only 46 pounds and is readily portable.

#### IV. THE SQUARE-WAVE GENERATOR

An ideal square wave with infinite steepness contains all odd harmonics up to infinite frequency. The amplitudes of the harmonics are inversely proportional to the frequency and the phases are such that all harmonic waves pass through zero at the same time as the fundamental. High-frequency cutoff, reduction of the high-frequency components, or relative phase shift tends to reduce the steepness of rise and fall of the square wave.

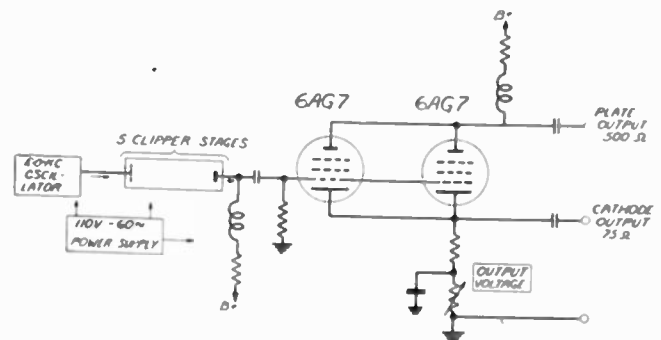

Fig. 11—Block diagram of square-wave generator.

The 100-kilocycle square-wave generator shown in the block diagram in Fig. 11 employs a sine-wave oscillator followed by several stages of limiting amplifiers which limit as a consequence of plate-current cutoff. If distributed circuit capacitance were not a controlling factor, a square wave of any prescribed steepness could be derived by repeated limiting and amplifying of a sine wave.

Since the square-wave generator for testing with the square-wave oscillograph must have good fidelity up to at least 4.5 megacycles (preferably higher), it was found necessary to provide inductance compensation for the interstage coupling between the later limiter stages. The generator has a 75-ohm output circuit supplied from the cathode of the last stage and a 500-ohm high-level output circuit supplied from the plate of the same stage. The voltage output is controlled by varying the bias on the output stage. The weight of the generator is 16 pounds.

#### V. OPERATION OF SQUARE-WAVE MEASURING EQUIPMENT

The arrangement of the square-wave measuring equipment for test is shown in Fig. 2. A choice between cathode-output and plate-output terminals of the square-wave generator is dictated by the nature of the input impedance of the apparatus under test. In instances which permit a 500-ohm source, the plate output may be used with a greater available maximum amplitude.

The probe is connected at the point in the apparatus at which the square-wave response is required. If this point has high impedance, it is desirable to disconnect some circuit element such as a tube grid and then adjust the probe capacitance to give the original total capacitance at the point as indicated by a capacitance meter. If no circuit element can be removed, the probe capacitance should be made a minimum.

Three controls may be manipulated in order to secure a full-scale square-wave response trace on the cathode-ray tube: (1) output control of the square-wave generator, (2) gain control of the oscillograph,

and (3) attenuator switches in the probe. The manner in which a full-scale deflection is obtained is dependent on the input and output voltage conditions desired for the apparatus under test. Horizontal and vertical centering controls permit centering of the trace on the calibrated scale of the cathode-ray tube. For convenience in recording data, the two constant levels of the trace, preceding and following the abrupt transition, should lie on the 0 and 100 per cent lines of the calibrated scale as shown in Fig. 12.

The choice of 20- or 30-megacycle dots is dependent upon the use to be made of the data. The use of 30-megacycle dots defines the response wave more completely so far as high-frequency components are concerned; thus allowing greater accuracy in the analysis of the response for determination of the sine-wave characteristic of the apparatus under test. However, the use of 20-megacycle dots is desirable for quick recording and analysis where less accuracy is acceptable.

A record of the response consists merely of a sequence of numbers or ordinates corresponding to the vertical positions of the dots on the trace. The first reading is 0 when the vertical centering is properly adjusted and corresponds to the dot which just precedes the beginning of the rise (or fall) of the trace. In order to obtain the second reading, the entire trace is shifted by means of the "sweep-phase" control until the next or second dot occupies a position on the calibrated vertical axis as shown in Fig. 12 (A). The corresponding ordinate is recorded. The positions of the trace for the third and the fourth readings are shown respectively by Fig. 12 (B) and Fig. 12 (C). Ordinates of subsequent dots are recorded in order by shifting the phase control in each instance until the dot falls on the vertical axis. Usually less than twenty readings are required to define the entire transition. Two ends are attained by following this procedure instead of by taking all readings with the trace in one position: (1) only a minimum amount of diligence is needed to insure recording *all* dots in the correct order and (2) errors are avoided which otherwise might be introduced as a consequence of a variation in vertical-deflection sensitivity by reason of horizontal deflection. Usually the responses for rising and for falling transitions are identical and only one need be recorded. An important exception occurs in the response of a vestigial-sideband system with high-percentage

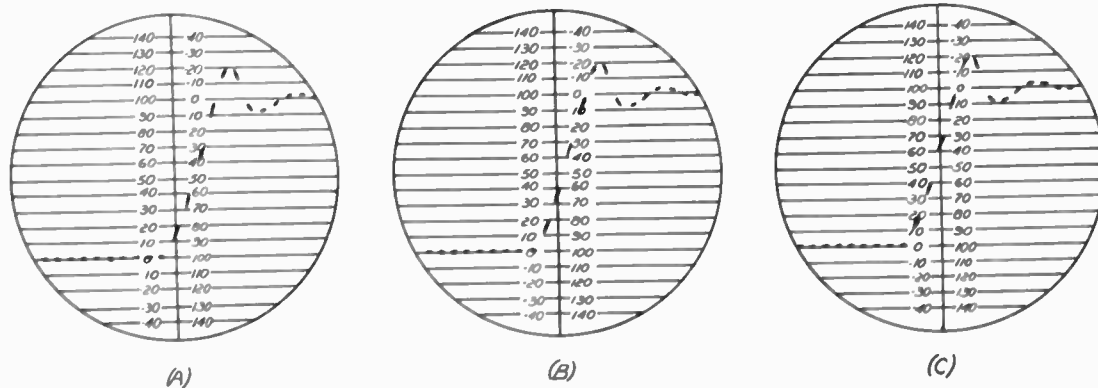

Fig. 12—(A) Position of square-wave trace for recording ordinate values of second dot. (Reading is 15.)  
 (B) Position for third dot. (Reading is 36.)  
 (C) Position for fourth dot. (Reading is 64.)

usually the responses for rising and for falling transitions are identical and only one need be recorded. An important exception occurs in the response of a vestigial-sideband system with high-percentage

modulation.<sup>6</sup> The falling transition is recorded in the same manner as the rising transition except that the readings are made on the inverted scale beginning at the top. The measuring apparatus can be calibrated or checked by recording the output of the square-wave generator directly.

It is believed that portable square-wave measuring equipment of the type described will be found useful

<sup>6</sup> R. D. Kell and G. L. Fredendall, "Selective side-band transmission in television," *RCA Rev.*, vol. 28, pp. 425-444; April, 1940.

in experimental work, in routine checking, and in determining specifications of television apparatus. The recorded data are permanent and can be filed for future reference and comparison with similar square-wave records. Reconstruction of the square-wave response on paper is obtained readily by plotting the instantaneous recorded values. The form of the data is also directly suitable for analysis by the chart method described in a companion paper.<sup>1</sup>

## A New Direct Crystal-Controlled Oscillator for Ultra-Short-Wave Frequencies\*

W. P. MASON†, FELLOW, I.R.E., AND I. E. FAIR†, ASSOCIATE, I.R.E.

*Summary*—An ultra-high-frequency crystal oscillator is described which utilizes a mechanical harmonic of an AT or BT crystal. With the oscillator frequencies as high as 197 megacycles, harmonics as high as the 23rd have been excited. Taking the second electrical harmonic of the oscillator, frequencies as high as 300 megacycles, or 1 meter have been obtained. Since a mechanical harmonic is used, the crystal can be of a practical size to handle and adjust. The harmonic vibration of the AT and BT crystals has as low a temperature coefficient as the fundamental mode, and temperature coefficients of less than two parts per million per degree centigrade are easily obtained. Stability curves for this type of oscillator are shown and the results indicate that at 120 megacycles stabilities in the same order of magnitude as for ordinary crystal oscillators can be obtained. Without temperature or voltage control it appears likely that the frequency should remain constant to  $\pm 0.0025$  per cent.

Some measurements have been made of the properties of harmonic crystals at high frequencies. It was found that the  $Q$  of a crystal is independent of the frequency but in general increases with harmonic order. The ratio of capacitances  $r$  of a crystal increases as the square of the harmonic order. It is shown that in order to obtain a positive reactance in the crystal  $Q > 2r$ . This relation will only be satisfied for harmonics of AT crystals less than the 7th. As a result oscillator circuits such as the Pierce circuit cannot be used to drive crystals at high harmonic frequencies. A discussion of oscillator circuits is given and it is shown that a capacitance-bridge oscillator circuit with the crystal in one arm is the best type to use for high-frequency harmonic crystals.

### I. INTRODUCTION

**D**URING the last several years high-frequency vacuum tubes of moderate power output<sup>1</sup> have been developed which extend the commercially usable frequency spectrum into the ultra-short-wave region. Point-to-point station transmitters working at 120 megacycles and 150-megacycle aircraft transmitters are examples of such moderate power equipment. These applications require high-frequency oscillators with stabilities of the high order of magnitudes which are attainable with crystal oscillators. This sta-

bility has been obtained in the past by using crystal oscillators working under 20 megacycles with a number of stages of harmonic generation.

It is the purpose of this paper to describe a crystal oscillator which is controlled directly by a crystal resonance as high in frequency as 197 megacycles. This resonance is a mechanical harmonic of a low-coefficient AT-cut crystal. The mechanical harmonic has the same temperature coefficient as the fundamental AT crystal which can be made under two parts per million per degree centigrade. Since a mechanical harmonic is used the crystal is considerably thicker than it would be if it had to vibrate as its fundamental in the ultra-short-wave region, and hence it can be ground and adjusted much more easily than a very thin crystal. The particular oscillator whose properties are described here uses the 15th mechanical harmonic of an AT-cut crystal and produces a frequency of 120 megacycles.

Theoretically the electromechanical coupling of a harmonic crystal varies inversely as the order of the mechanical harmonic and the ratio of capacitances in the equivalent circuit varies proportionally to the square of the order of the mechanical harmonic. It becomes increasingly difficult to excite a harmonic vibration with the ordinary oscillator circuits and in fact harmonics higher than the 5th cannot usually be excited with the Pierce circuit for example. The reason for this is that the Pierce circuit requires the crystal to have a positive reactance in order that oscillation shall take place. It is shown below that in order for a positive reactance to occur in the crystal it is necessary that  $k^2/2 > 1/Q$  or  $Q > 2r$  where  $Q$  is the ratio of reactance of the coil in the electrical representation of the crystal to its resistance,  $k$  the electromechanical coupling factor, and  $r$  the ratio of the shunt static capacitance  $C_0$  of the

\* Decimal classification: R355.65. Original manuscript received by the Institute, December 3, 1941; revised manuscript received, March 18, 1942.

† Bell Telephone Laboratories, Inc., New York, N. Y.

<sup>1</sup> A. L. Samuel and N. E. Sowers, "A power amplifier for ultra-high frequencies," *Proc. I.R.E.*, vol. 24, pp. 1464-1483; November, 1936; *Bell Sys. Tech. Jour.*, vol. 6, pp. 10-34; January, 1937.

crystal to the series capacitance  $C_1$ . The ratio of capacitances of a fundamental AT crystal as usually mounted is in the order of 1000 to 1 and hence  $2r$  for the 5th harmonic would be 50,000. The  $Q$  of a crystal is usually not much larger than this so the 5th harmonic is about the highest harmonic that can be driven by the usual oscillator circuits.

For this application the circuit used consists of a high-frequency pentode with a tuned grid and plate



Fig. 1—Equivalent electrical circuit for piezo-electric crystal.

coupled back through a capacitance bridge of which the crystal forms one arm. For this circuit the crystal impedance does not have to have a positive reactance and it has been found possible to control the frequency of an oscillator with harmonics up to the 23rd or higher.

The stability obtainable with this oscillator is about the same as can be obtained with ordinary circuits at lower frequency. The stability with plate-voltage change is in the order of 0.05 cycle per megacycle per volt. The temperature coefficients of the crystal are under two parts per million per degree centigrade. Without regulation of voltage or temperature the frequency should be stable to  $\pm 0.0025$  per cent or better. With regulation the stability can be increased.

## II. PROPERTIES OF HIGH-FREQUENCY CRYSTALS

In order that a crystal shall be useful in an ultra-high-frequency oscillator it is necessary that its  $Q$  shall remain high in the high-frequency range. Since no measurements have been published on how the  $Q$ 's of crystals vary with frequency it was thought worth while to measure the  $Q$ 's of AT-cut crystals over a

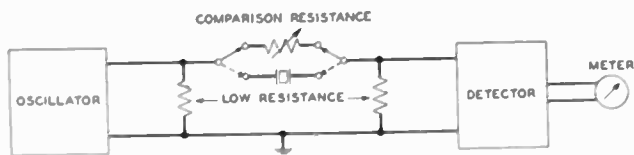

Fig. 2—Resistance method for measuring  $Q$  of crystal.

wide frequency range. For this purpose 9 crystals were obtained whose fundamentals varied in frequency from 800 kilocycles to 20 megacycles. The  $Q$  of a crystal is defined with respect to the equivalent circuit of the crystal shown in Fig. 1. Here the static capacitance of the crystal is designated by  $C_0$ , while the effect of the motional impedance of the crystal is represented by the series-resonant circuit  $L_1$ ,  $C_1$ , and  $R_1$ . The  $Q$  of the crystal is defined as the ratio  $(2\pi f_R L_1)/R_1$  where  $f_R$  is the resonant frequency.

Three independent methods were used to measure the  $Q$  of the crystals. At the lower frequencies the

method used was the one described in a former paper<sup>2</sup> and shown in Fig. 2. It consists in measuring the resonant frequency  $f_R$ , the antiresonant frequency  $f_A$ , the resistance at resonance  $R$ , and the static capacitance  $C_0$  of the crystal. From these the  $Q$  of the crystal can be calculated from the formula

$$Q = \frac{f_R^2 / (f_A^2 - f_R^2)}{2\pi f_R C_0 R} = \frac{1}{4\pi R C_0 \Delta} \text{ where } \Delta = f_A - f_R. \quad (1)$$

At higher frequencies, the measurement of resistance becomes less reliable. At these frequencies, however, the reading of vacuum-tube voltmeters is satisfactory, so the circuit of Fig. 2 was modified to that of Fig. 3,

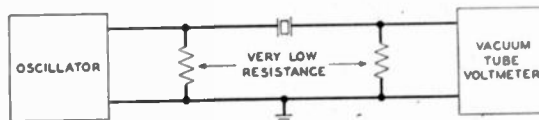

Fig. 3—Voltmeter method for measuring  $Q$  of crystal.

and the resonant and antiresonant frequencies were measured as well as the voltage across the low terminal resistance at resonance and antiresonance. It is readily shown that the  $Q$  of the crystal will be given by the formula

$$Q = \frac{f_R}{2\Delta} \sqrt{\frac{V_R}{V_A}} \text{ where } \Delta = f_A - f_R \quad (2)$$

and  $V_R$  and  $V_A$  are the voltages across the terminating resistance at the resonant and antiresonant frequencies, respectively. A third method used was to measure the voltage across the terminating resistance at antiresonance and a few cycles from antiresonance. For this case the  $Q$  of the crystal is given by

$$Q = \frac{f_A}{\Delta} \left[ \left( \frac{V_C}{V_A} \right)^2 - 1 \right] \quad (3)$$

where  $\Delta$  is the difference in frequency between the antiresonance and the frequency for which the voltage  $V_C$  is measured. All three methods were compared on several crystals and checked within a few per cent.

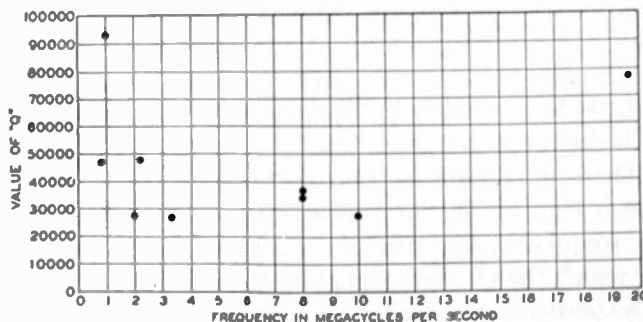

Fig. 4—Measurements of the  $Q$  of fundamental AT-cut crystals over a frequency range.

The measurement of the fundamental frequencies of the 9 crystals are shown in Fig. 4. Although the  $Q$  varies over a considerable range from crystal to crystal,

<sup>2</sup> W. P. Mason, "Electric wave filters employing crystals as elements," *Bell Sys. Tech. Jour.*, vol. 13; pp. 405-452; July, 1934.

there is no significant trend with frequency. The ratio of capacitances for the fundamental AT crystals was around 1000 to 1.

The harmonic vibrations of three of the crystals were also measured and the resulting  $Q$ 's are shown in Fig. 5. The crystal having a fundamental at 1 megacycle has a fundamental  $Q$  of 98,000 and progressively

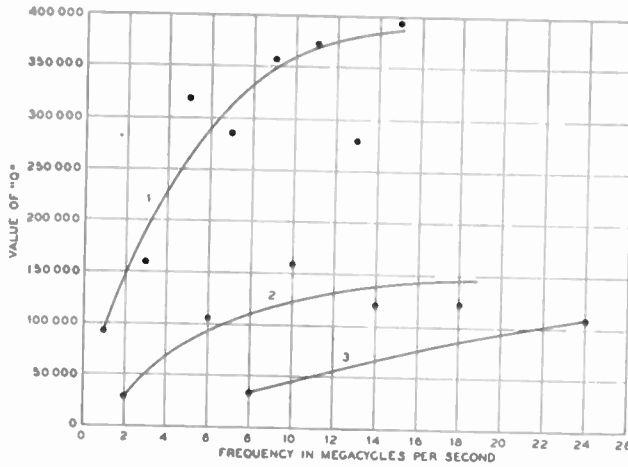

Fig. 5—Measurements of the  $Q$  of harmonic AT-cut crystals.

higher  $Q$ 's at the higher-order harmonics. The other crystals have lower initial  $Q$ 's but all show an increasing  $Q$  with harmonic order. The crystal having a fundamental of 8 megacycles is one of the crystals used in the oscillator described in this paper.

It is thought that the variation in  $Q$  of shear-vibrating crystals is due to very minute cracks on the surface which cause a small amount of rubbing when the crystal vibrates. This is borne out by the fact that etched or polished crystals usually have a higher  $Q$  than non-treated crystals. This is probably also the explanation of the higher  $Q$  in the harmonic crystals for a harmonic crystal is similar to a number of crystals in series with a number of vibrating surfaces as shown in Fig. 6. All the internal surfaces will be whole and free from cracks. If most of the resistance is associated with the outside faces it follows that a harmonic crystal with a large number of internal faces should have less dissipation than a fundamental crystal. At the high-order harmonic the  $Q$  seems to approach an asymptote of 400,000 to 500,000, which is probably the  $Q$  associated with the internal dissipation.

These data indicate that as far as internal dissipation is concerned, the  $Q$  of a crystal is independent of the frequency. If, however, one goes from a condition for which the  $Q$  is controlled by the surface dissipation to a condition where the  $Q$  is controlled by the internal dissipation, the  $Q$  will increase.

A measurement of the ratio of capacitances of the higher-order harmonics indicated that the ratio of capacitances increases about as the square of the harmonic order. This is in agreement with theory for in an odd-harmonic crystal of order  $n$ , only  $1/n$ th of the piezoelectric effect is engaged in driving the crystal at

its harmonic frequency and the other  $(n-1)/n$  parts annul each other. The electromechanical coupling factor is<sup>3</sup>

$$k = d_{20n} \sqrt{\frac{4\pi c_{66}}{K}} \quad (4)$$

where  $d_{20n}$ , the piezoelectric constant is  $d_{20}/n$ ,  $c_{66}$  is the shear elastic constant, and  $K$  the dielectric constant of the crystal. It follows that the coupling varies inversely as the harmonic order. The ratio of capacitances  $r$  being<sup>3</sup>

$$r = \frac{8}{\pi} \left( \frac{1 - k^2}{k^2} \right) \quad (5)$$

is approximately proportional to  $n^2$ .

It is a matter of interest to find how the impedance of a harmonic crystal varies with the harmonic. It has been shown previously<sup>3</sup> that the impedance of a piezoelectric crystal is given by the expression

$$Z_c = \frac{-j(1 - k^2)}{\omega C_0} \left[ \frac{1 - f^2/f_1^2 + \frac{j}{Q(1 - k^2)}}{1 - f^2/f_2^2 + j/Q} \right] \quad (6)$$

where  $C_0$  is the static capacitance of the crystal,  $f_1$  the resonant frequency, and  $f_2$  the antiresonant frequency. Also,  $f_1^2 = f_2^2(1 - k^2)$ . Inserting this value and expressing the equation in the form of a resistance and reactance we find

$$Z_c = \frac{\frac{k^2}{Q} - j \left[ 1 - k^2 - \frac{f^2}{f_2^2}(2 - k^2) + \frac{f^4}{f_2^4} + \frac{1}{Q^2} \right]}{\omega C_0 \left[ \left( 1 - \frac{f^2}{f_2^2} \right)^2 + \frac{1}{Q^2} \right]} \quad (7)$$



Fig. 6—Harmonic mode of motion.

The reactance term will have a maximum when  $f^2 = f_2^2(1 - 1/Q)$ . At that frequency the impedance of the crystal will be

$$\frac{\frac{k^2 Q}{2} + j \left( \frac{k^2 Q}{2} - 1 \right)}{\omega C_0} \quad (8)$$

<sup>3</sup> W. P. Mason, "An electromechanical representation of a piezoelectric crystal used as a transducer," PROC. I.R.E., vol. 23, pp. 1252-1264; October, 1935.

Hence, in order that the crystal shall exhibit a positive reactance

$$\frac{k^2 Q}{2} > 1 \quad \text{or} \quad k^2 > \frac{2}{Q} \quad (9)$$

But the ratio of capacitance is given by (5). Hence, the condition<sup>4</sup> for the crystal to exhibit a positive reactance is

$$Q > 2(1 + r) \doteq 2r. \quad (10)$$

If we assume that  $Q$  is in the order of 75,000 or less, which is certainly higher than can be obtained in most untreated crystals, and a ratio  $r$  of 1000 for a funda-

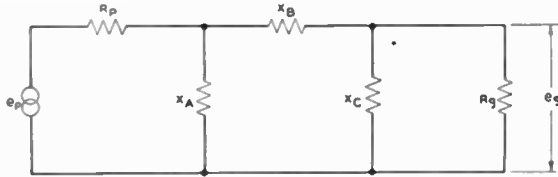

Fig. 7—Equivalent circuit of Pierce-type oscillator.

mental AT crystal, the highest-order harmonic that will show a positive reactance is the 5th harmonic for an AT-cut crystal.

### III. STANDARD OSCILLATOR CIRCUITS FOR CRYSTALS

As a consequence of the fact that high-harmonic crystals will not show a positive reactance, it follows that the standard oscillator circuits, such as the Pierce circuit, cannot be used to excite high-harmonic-order crystals. The only type of oscillator circuit which will annul the large shunt capacitance of the crystal, which prevents the crystal from having a positive reactance near the resonant frequency, is a bridge-type circuit, as discussed in Section IV. When this reactance is annulled, however, the resulting circuit reduces to a circuit similar to the Pierce circuit or to one in which the phase is reversed by the use of a phase-reversing transformer, depending on whether the crystal is in the series or lattice arm of the bridge. Since the stability of the circuit depends on which connection is used and can be evaluated from a consideration of the stability of standard oscillator circuits, it has appeared worth while to include a discussion of them.

The Pierce-type oscillator circuit consists of a  $\pi$ -network connection of reactances between the plate and grid of the tube as shown in Fig. 7. Such a circuit is required to produce a 180-degree phase shift in order to offset the 180-degree phase shift produced in the vacuum tube. The other common connection is to use a phase-reversing transformer or two tubes in tandem, so that the network itself is required to produce a zero phase shift.

If we consider a tube as represented by the circuit shown in Fig. 7, following Llewellyn,<sup>5</sup> the condition for

zero gain and zero phase shift are given by

$$\frac{R_p}{R_g} = - \left[ \frac{X_A}{X_A + X_B} \right] \left[ \mu + \frac{X_B + X_C}{X_C} \right] \quad (11)$$

and

$$R_p R_g = \frac{X_A X_B X_C}{X_A + X_B + X_C} \quad (12)$$

where  $\mu$  is the amplification factor of the tube,  $R_p$  and  $R_g$  are the plate and grid resistances of the tube, and  $X_A, X_B, X_C$  the coupling reactances which incorporate the distributed capacitances of the tubes. These formulas assume that the tube introduces a phase angle of 180 degrees. In case two tubes are used in tandem or the 180-degree phase shift is produced in a unity-coupled transformer, the sign of  $\mu$  in (11) will be reversed. For two tubes,  $\mu$  will have the significance of the ratio between the voltage applied in the plate circuit of the last tube to the voltage applied on the grid of the first tube.

For the first type circuit,  $\mu$  will ordinarily be greater than  $(X_B + X_C)/X_C$  and hence  $X_B$  will have to be of opposite sign to  $X_A$  and greater in absolute magnitude; for writing,

$$\frac{X_A}{X_A + X_B} = -m \quad \text{we have} \quad X_B = - \frac{(1 + m)}{m} X_A. \quad (13)$$

Introducing this value into (12), we have

$$R_p R_g = - \frac{X_A^2 (1 + m)}{m - \frac{X_A}{X_C}} \quad (14)$$

Since  $X_A^2$  is positive, the right-hand side of (14) can only be made positive if  $X_A$  is the same sign as  $X_C$  and

$$m X_C > X_A. \quad (15)$$

These equations show that  $X_A$  and  $X_C$  must be of the same sign and opposite to  $X_B$  while the sum of

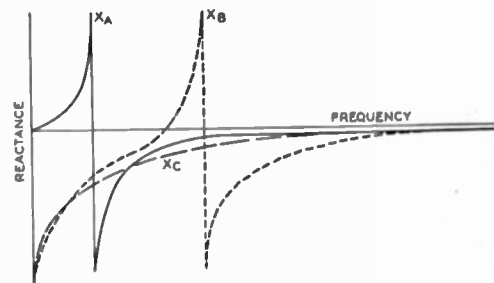

Fig. 8—Reactance curves for Pierce-type oscillator.

$X_A$  and  $X_C$  must be larger in magnitude than  $X_B$ . If  $(X_B + X_C)/X_C$  is of opposite sign to  $\mu$  and greater in magnitude it is readily shown that the resulting condition on  $X_A$  will not satisfy (13) and hence the oscillator will not oscillate under these conditions.

Since we do not know  $R_p$  and  $R_g$  explicitly, the frequency cannot be calculated definitely from these

<sup>4</sup> This condition was first derived by R. A. Sykes.

<sup>5</sup> F. B. Llewellyn, "Constant frequency oscillators," PROC. I.R.E., vol. 19, pp. 2063-2094; December, 1931.

equations unless  $R_p$ ,  $R_\theta$ , and the distributed capacitances of the tubes are evaluated as functions of the voltage and current conditions in the tube. Ways for minimizing the variation with tube and circuit conditions, however, are evident from (12). If, for example, the crystal is connected in the  $X_B$  arm, it is

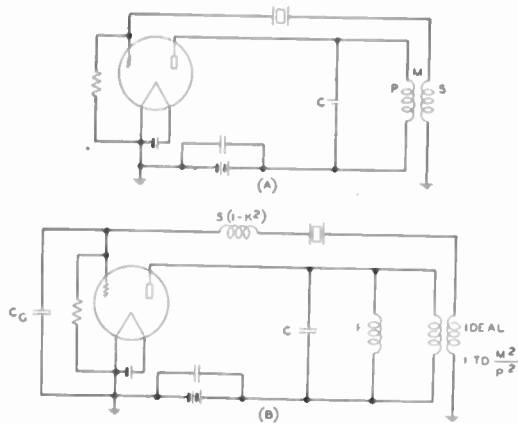

Fig. 9—Oscillator using phase-reversing transformer.

readily shown that the maximum voltage and tuning stability will occur when the  $X_A$  arm, which usually consists of a tuned circuit, is tuned for a frequency considerably lower than the crystal resonance. Under these conditions, as shown by Fig. 8,  $X_A$  is much smaller than  $X_B$  or  $X_C$ , the value of  $R_\theta$  is large, and the frequency is determined nearly by the condition that  $X_A + X_B + X_C = 0$ . A change in  $R_p R_\theta$  caused by a change in voltage will produce only a small frequency change on account of the large value already existing for the product  $R_p R_\theta$ . The maximum stability for this type of oscillator circuit occurs for a minimum output.

On the other hand, if we employ a circuit with two tubes or a phase-reversing transformer, the point of greatest voltage stability can be made to come at the highest power output. One such circuit is shown in Fig. 9(A). For a finite coupling between the two transformer windings, the equivalent network of the circuit is shown in Fig. 9(B). The leakage reactance can be combined with the crystal reactance if desired, in which case it will lower the resonant point slightly or if desired a series capacitance can be inserted to annul the leakage reactance.

The condition for oscillation for this type of circuit can be obtained from (11) and (12) by reversing the sign of  $\mu$  in (11). If we let

$$\frac{X_A}{X_A + X_B} = m_1 \text{ or } X_B = X_A(1 - m_1)/m_1 \quad (16)$$

then, in order to oscillate,  $m_1$  must be positive. If  $m_1$  is between zero and unity then

$$X_A = (m_2 - m_1)X_C \text{ where } 0 < m_2 < \frac{m_1(\mu - m_1)}{1 - m_1} \quad (17)$$

If  $m_1$  is greater than unity,

$$\frac{-m_1(\mu + m_1)}{m_1 - 1} < m_2 < 0.$$

This type of circuit will have great stability when the crystal is worked near its resonance frequency for which case  $X_B$  is a small quantity  $\Delta$ . Then, for this case,

$$\frac{R_p}{R_\theta} = \mu - 1; \quad R_p R_\theta = \Delta \left( \frac{X_A X_C}{X_A + X_C} \right) \quad (18)$$

If we let  $X_A$  and  $X_C$  antiresonate at the crystal resonant frequency  $f_R$ , the product of  $\Delta$  by the antiresonant impedance will be finite and can be made equal to  $R_p R_\theta$ . Under these conditions a large change in  $R_p R_\theta$  will not change the frequency since no phase shift requiring a shift in frequency will occur. This analysis does not take account of the change in dielectric constant with voltage for the tube capacitances entering the circuit but it has been found experimentally that this effect is small and does not alter appreciably the maximum stability conditions. Even when dissipation is associated with all of the elements, this relation is still true as can be demonstrated with reference to Figs. 10(A) and 10(B).

As shown by (18), the ratio of  $R_p/R_\theta = \mu - 1$ , which is the maximum value possible. Hence, the output will be greatest at the voltage-stabilized point also. Since  $R_\theta$  will be considerably smaller than  $R_p$  an increase in output can be obtained by making the ratio of the transformer output impedance to its input impedance

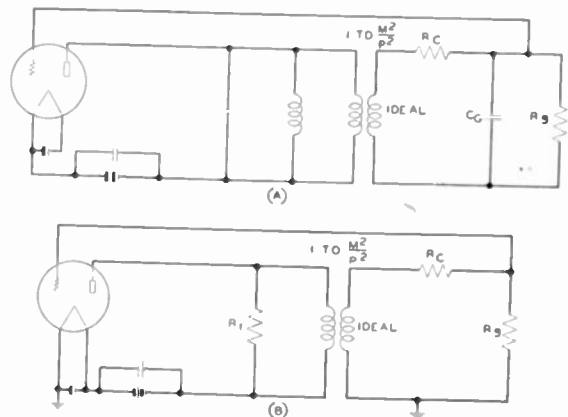

Fig. 10—Impedances at crystal resonance for phase-reversing oscillator.

less than unity. For this case the frequency and amplitude equations become

$$\frac{R_p}{R_\theta} = \frac{X_A}{\phi^2 X_A + X_B} \left[ \mu \phi - \frac{X_B + X_C}{X_C} \right]$$

$$R_p R_\theta = \frac{X_A X_B X_C}{\phi^2 X_A + X_B + X_C} \text{ or} \quad (19)$$

$$R_p R_\theta \phi^2 = \frac{X_A \phi^2 X_B X_C}{\phi^2 X_A + X_B + X_C}$$



where  $\phi^2 = \text{impedance transformation ratio} = M^2/P^2$ , where  $M$  is the mutual inductance of the transformer, and  $P$  the primary inductance. For  $X_B$  very small or for oscillations near the resonant frequency

$$\frac{R_p}{R_o} = \frac{\mu\phi - 1}{\phi^2}; \quad R_p R_o \phi^2 = \left( \frac{X_A \phi^2 X_C}{\phi^2 X_A + X_C} \right) \Delta. \quad (20)$$

Hence, the ratio of  $R_p/R_o$  will be a maximum and consequently the output will be a maximum when  $\phi = 2/\mu$ . If the resistances of the elements, as represented by

moved to the end of the lattice leaving a network of reactances. In this network the series arms are the resonance series arms of the equivalent representation of the crystal, and the shunt arms are the static capacitance of the crystal.

Suppose now that we incorporate this crystal lattice in the oscillator network shown in Fig. 12(A). Then as before we can take out the shunt capacitance of the crystal and the balancing capacitance to the ends of the network leaving the circuit shown in Fig. 12(B). Assuming perfect coupling in the transformer, the shunt capacitance  $C_B$  can be joined to  $C_0$  to tune the input coil, and  $C_B$  can be joined to  $C_2$  to tune the output coil. If we have 180-degree phase reversal in the transformer, and tune the two end coils to antiresonance at the resonant frequency of the crystal, the phase shift around the feedback path will be 360 degrees and the oscillator will oscillate at the crystal resonant frequency, which, as discussed in Section III, will result in the greatest stability at the frequency of maximum output. In case the transformer gives no change in phase, the crystal has to be put in the lattice arm to give this condition. In case the coil coupling is not unity, a small leakage-reactance coil appears. This can be annulled at the resonant frequency of the crystal by a small series capacitance. Hence, the resultant reactance at the resonant frequency will be the same as that shown in Fig. 12(B).

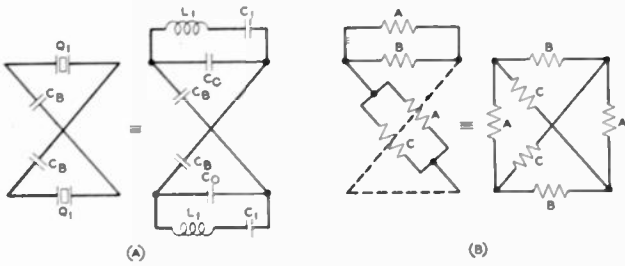

Fig. 11—Use of crystal in bridge circuit.

Fig. 10(B), are taken account of this transformation ratio for maximum output will be less. The stability with reactance tuning will also be increased by using a step-down transformer since the impedance of the crystal will effectively be increased compared to the impedance of the tuning reactance. Hence, it requires a larger change in tuning of the plate reactance to cause a given frequency change in the oscillator.

#### IV. OSCILLATOR CIRCUITS FOR USE WITH HIGH-FREQUENCY HARMONIC CRYSTALS

Neither of these two standard types of circuits can be used directly with high-harmonic-type crystals on account of the fact that the sign of the reactance does not become positive in the resonance region. They could be used to control the frequency by using the crystal as a negative reactance, but in that case it is difficult to locate the control in the resonance region. We note, however, on examining the equivalent circuit of a crystal shown in Fig. 1, that the reason the reactance does not go positive is that the series-resonant arm is shunted by a very large condenser. If this condenser could be neutralized, the remaining impedance arm would consist of a simple tuned circuit which changes from negative to positive reactance at the resonant frequency.

In crystal-filter work<sup>6</sup> it has been shown that the static capacitance of a crystal can be balanced out by incorporating the crystal in a lattice network of capacitances as shown in Fig. 11(A). The drawing shows two crystals having the same constants but they can be represented actually by a single crystal with two sets of plates. By virtue of the network theorem shown in Fig. 11(B), the static capacitances of the crystal together with the balancing condenser  $C_B$  can be re-

The crystal network as shown in Fig. 11 has two identical crystals or a crystal with two sets of plates. This is rather objectionable at high radio frequencies, since it is difficult to divide the plates for very small

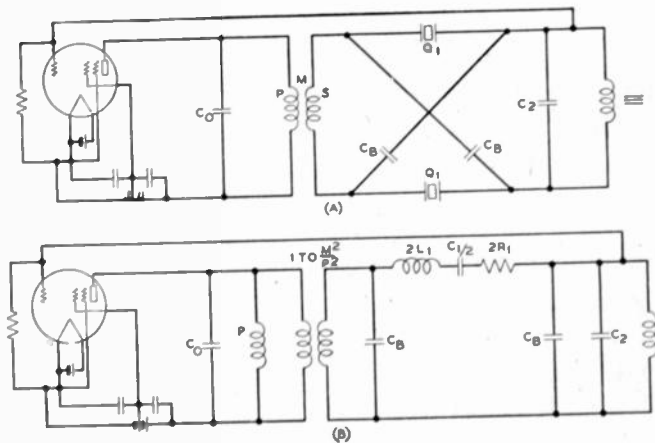

Fig. 12—Unbalanced oscillator incorporating bridge circuit with balanced crystal.

crystals. Fortunately this is not necessary for we can show that the crystal lattice with a single crystal shown in Fig. 13(A) is equivalent to the balanced lattice with two crystals. This follows from the network equivalence of Fig. 13(B), which states that the series arm of the balanced lattice is equal to

$$\frac{B(A + C) + 2AC}{2B + A + C} = D. \quad (21)$$

<sup>6</sup> See W. P. Mason, "Resistance compensated band-pass crystal filters for unbalanced circuits," *Bell Sys. Tech. Jour.*, vol. 16, pp. 423-436; October, 1937.

The crystal impedance  $C$  is given by (6) while  $A$  and  $B$  are

$$A = \frac{-j}{\omega C_A}; \quad B = \frac{-j}{\omega C_H} \quad (22)$$

Inserting these values in (21), we find the equivalent impedance  $D$  to be given by

$$D = \frac{-j(1-k'^2)}{C_0'\omega} \left[ \frac{1 - \frac{f^2}{f_2'^2(1-k'^2)} + \frac{j}{Q'(1-k'^2)}}{1 - \frac{f^2}{f_2'^2} + \frac{j}{Q'}} \right] \quad (23)$$

where

$$C_0' = \frac{C_0(2C_A + C_H) + C_A C_B}{C_0 + C_A + 2C_H} \quad (24)$$

$$f_2'^2 = f_2^2 \left[ 1 - \frac{k^2(C_A C_B)}{C_0(2C_A + C_H) + C_A C_H} \right];$$

$$Q' = Q \left[ 1 - \frac{k^2(C_A C_B)}{C_0(2C_A + C_H) + C_A C_H} \right]$$

$$k'^2 = \frac{2k^2 C_0 (C_A + C_B)^2}{(C_0 + C_A + 2C_H) [C_0(2C_A + C_H) + C_A C_H - k^2 C_A C_H]}$$

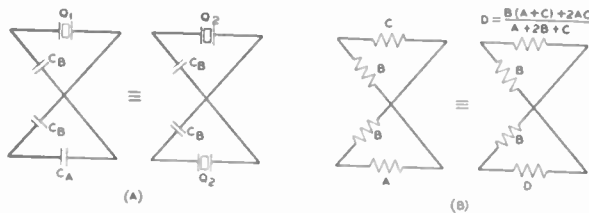

Fig. 13—Equivalence between balanced and unbalanced lattice networks.

Hence, the impedance of the  $D$  arms is that of a crystal with somewhat different constants than that for the original single crystal. If

$$C_0 C_A = C_B^2 \quad (25)$$

the values in the above equations become

$$C_0' = C_B; \quad f_2'^2 = f_2^2 \left[ 1 - \frac{k^2 C_A^2}{(C_A + C_B)^2} \right]; \quad Q' = Q \left[ 1 - \frac{k^2 C_A^2}{(C_A + C_H)^2} \right] \quad (26)$$

$$k'^2 = \frac{2k^2 C_A C_B}{(C_A + C_B)^2 - k^2 C_A^2} = \frac{2k^2 C_A C_B}{(C_A + C_H)^2}$$

If  $C_A$  is nearly equal to  $C_B$ , which will be the ordinary condition of operation,  $f_2'^2 = f_2^2(1 - k^2/4)$ ;  $Q' = Q(1 - k^2/4)$ ;  $k'^2 = k^2/2$ .

Since the shunting capacitance of the crystal  $C_0'$  is equal to  $C_B$ , all of the capacitances  $C_B$  can be removed from the lattice arms to the ends of the circuit leaving the equivalence shown in Fig. 14, in which the series-resonant arm representing the crystal impedance has four times the impedance of the single crystal used in the lattice. The oscillator shown in Fig. 14 is then

capable of driving a crystal at a high harmonic and of being controlled by the resonance characteristic of the crystal at that harmonic. A 180-degree phase shift is introduced by the transformer and the resonant circuits are tuned so that their antiresonant frequencies

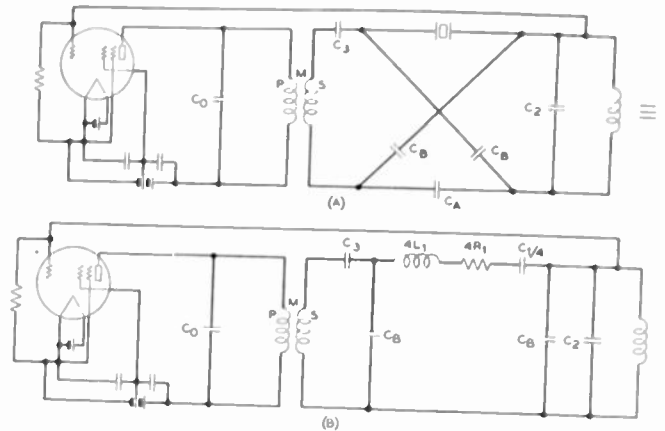

Fig. 14—Unbalanced oscillator incorporating unbalanced crystal bridge.

coincide with the resonant frequency of the crystal. An alternative arrangement is to use a transformer with no change of phase and the crystal in a lattice arm. This is the condition for maximum output and maximum stabilization against voltage changes as pointed out previously.

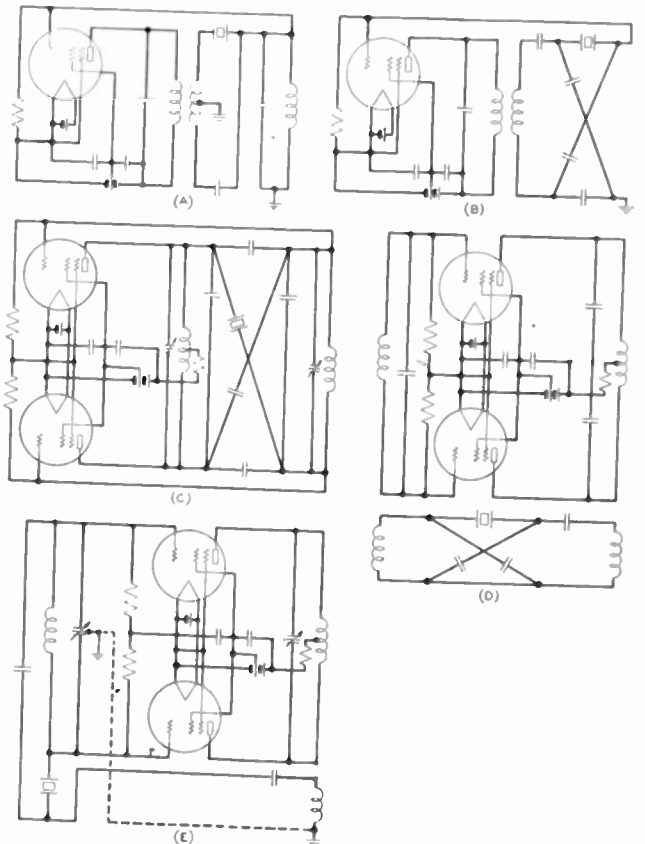

Fig. 15—Balanced and unbalanced oscillators.

Other circuits for which the same process can be applied are shown in Fig. 15. Some of these circuits are unbalanced and some balanced. At ultra-high frequencies it is often desirable to use balanced circuits

and double pentodes<sup>1</sup> such as the 240H have been developed for this purpose. For such systems it is desirable to use balanced oscillator circuits, and most of the experimental work recorded here has been done with the circuits of Fig. 15(C) and Fig. 15(E). Fig. 15(C) is especially advantageous for the crystal and all

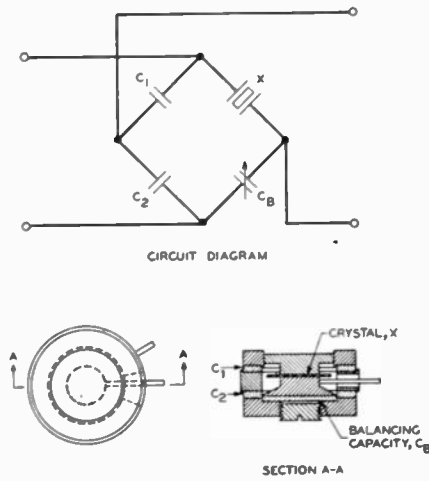

Fig. 16—Crystal bridge.

of the balancing capacitors can be put in one self-contained structure, as shown in Fig. 16, which can be enclosed in a metal vacuum-tube holder and evacuated to eliminate the effects of air damping and humidity on the crystal and bridge balance. The dielectric employed is usually fused quartz on account of its low loss and similar temperature variation of dielectric constant to that of crystalline quartz. In some cases series condensers have been placed on each side of the bridge to control the amount of feedback. The variable

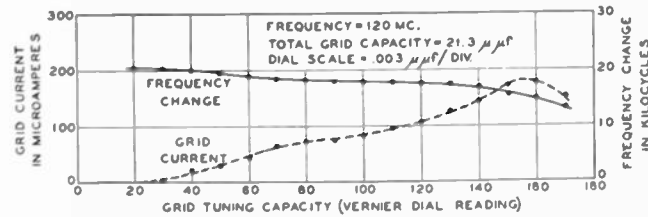

Fig. 17—Effect of grid tuning on frequency of oscillator.

tuning condensers are sometimes made with one component having a negative temperature coefficient to compensate for the positive coefficient of the metal tuning coils. This insures that the oscillator gain will remain at its maximum value over a wide temperature range.

V. EXPERIMENTAL RESULTS

In the experimental results obtained, the circuit of Fig. 15(C), with a self-contained bridge, has usually been employed since it was desirable to work the oscillator into a balanced 240H pentode amplifier. In order to make the crystal control at high radio frequencies it is necessary to employ a circuit with as much gain as possible at the high frequencies. This indicates that high-frequency pentodes should be employed; accordingly, 954 acorn pentodes were used.

With this arrangement, it was found possible to drive crystals at harmonics as high as the 23rd and frequencies as high as 197 megacycles or 1.5 meters wavelength. Furthermore, by taking the second electrical harmonic of the oscillator, a frequency of 300 megacycles or 1 meter was obtained with good output. This probably does not represent the upper limit for by using circuits with more gain the loss inserted by the crystal circuit can be overcome and the oscillator be crystal controlled to even higher frequencies.

The adjustment of this oscillator is not difficult. The crystal bridge is left unbalanced first and the oscillator will oscillate uncontrolled by the crystal. Its frequency is determined by the resonance of the coil-condenser systems on the ends. The frequency is adjusted to a somewhat lower frequency than that of the desired mode of the crystal and the coils are tuned for maxi-

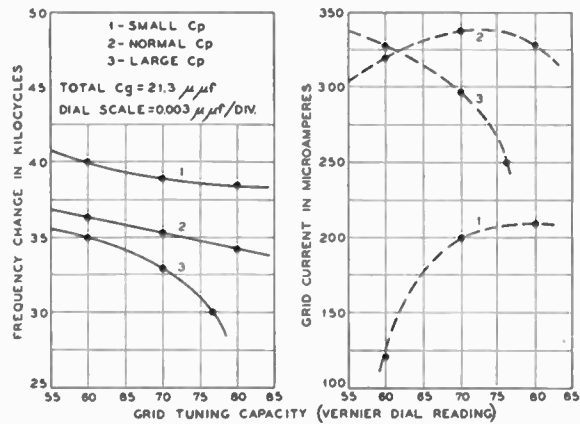

Fig. 18—Effect of grid and plate tuning on frequency of oscillator.

imum output at this frequency. The crystal bridge condenser is then adjusted towards balance and the oscillations will usually stop. The grid and plate coils are then tuned to the crystal frequency and the oscillator will then be controlled only by the crystal.

Some stability curves for such an oscillator were obtained for a frequency of 120 megacycles or 2.4 meters. The output obtained was 80 volts across the output impedance of 25,000 ohms when the plate voltage was 250 volts and the screen voltage 100 volts. The frequency variation with grid tuning for one crystal used is shown in Fig. 17. The grid current obtained is also plotted on this curve. As can be seen the maximum variation is in the order of 5 kilocycles from the point of maximum grid current to the point where oscillations ceased. The curves for plate tuning are similar to those for grid tuning. The over-all frequency change for both plate and grid tuning is shown in Fig. 18. This over-all change amounts to 10 to 12 kilocycles or about 100 parts in a million. This range represents the controllable range of the crystal and, therefore, the maximum frequency deviation which would occur for any possible combination of circuit changes unless the bridge becomes unbalanced and the circuit oscillates uncontrolled. Since in the extreme tuning positions the output is very low, the possibility of operating this far

off frequency is not great, and the usable range is probably not over one half this or  $\pm 0.0025$  per cent.

The change in frequency with plate voltage for this type of circuit is quite small for the maximum output. The reason for this is pointed out in the section on standard oscillators. When the circuit is tuned some-

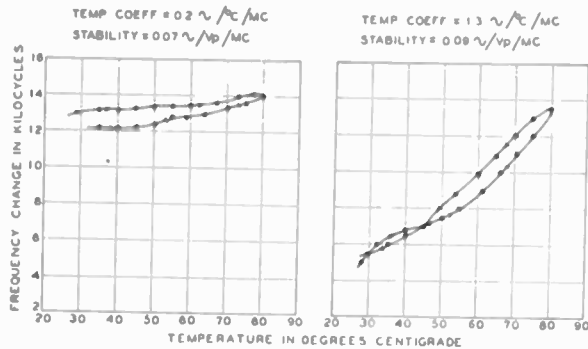

Fig. 19—Frequency change as a function of temperature.

what differently, the variations may amount to 0.05 to 0.1 cycle per megacycle per volt.

The temperature-frequency curves for two AT plates vibrating at their 15th harmonic are shown in Fig. 19. The average coefficient over a 50-degree-centigrade temperature range was 1.3 parts in  $10^6$  per degree centi-

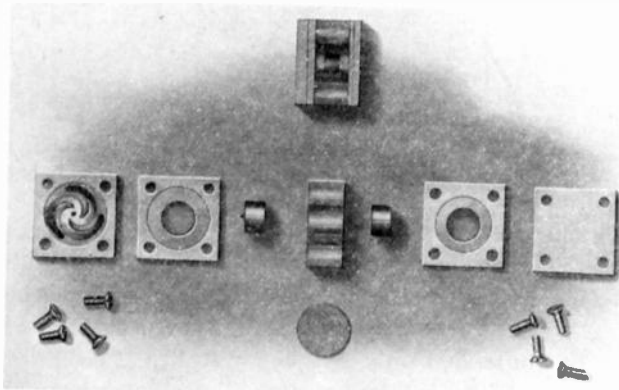

Fig. 20—Photograph of crystal and holder.

grade for one and 0.2 part for another. Five crystals were tested and all had a coefficient less than 2 parts in  $10^6$  per degree centigrade. One remarkable feature of these crystals is brought out by the temperature curves; that is, no hops in frequency were experienced in any of the temperature runs. This appears to be due to the fact that the coupling with harmonics of the low-frequency modes decreases with decreasing ratio of thickness to the diameter of the plate. This crystal was 0.21 millimeter in thickness and 12 millimeters in diameter and operated on the 15th harmonic, hence the ratio of diameter to effective thickness is 12 to 0.014 or 860 to 1, and the unwanted couplings are practically zero. Near-by frequencies may still be found if the plate is not exactly flat but they are of the same type and have the same temperature coefficient, with the result that they do not come nearer the desired

resonance and hence cause little trouble.

It is important for this work to have the crystal of uniform thickness in order to obtain a large output and a single response at the desired harmonic frequency. They are polished and the degree of flatness determined by interference fringes. A photograph of the crystal and holder is shown in Fig. 20. In this figure some interference fringes are observable which show the degree of flatness obtained. It is difficult to extend

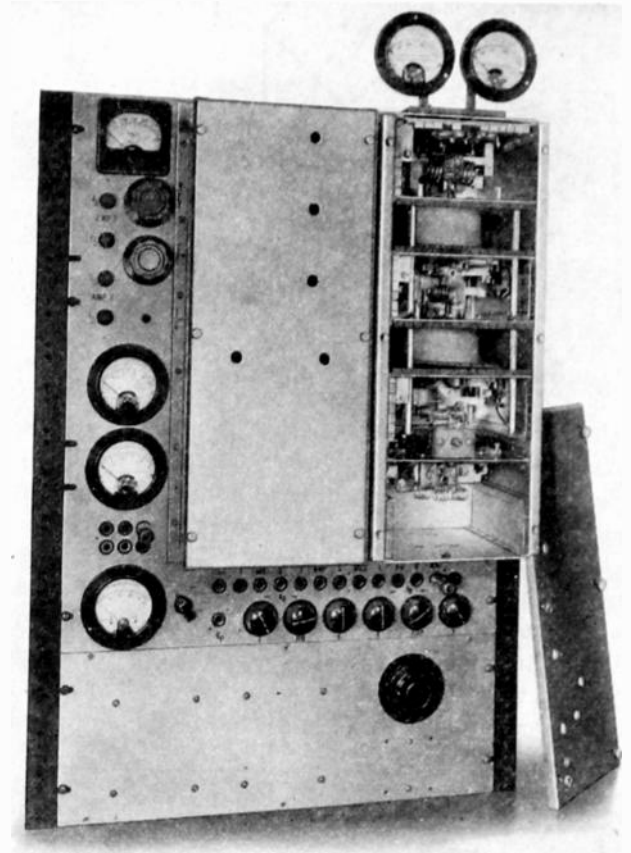

Fig. 21—Photograph of crystal oscillator and amplifier.

the flat region out to the edges since there is a tendency for the crystal to become convex. For this reason the diameter of the crystals is made twice that of the electrode area. The holder itself has very flat electrodes and is designed to center the electrodes on the crystal thus utilizing the most nearly flat portions of the crystal.

A crystal oscillator of this sort was used in conjunction with two 240H amplifying pentodes to deliver 12 watts output to the antenna at 120 megacycles. A photograph of the equipment is shown in Fig. 21. After  $5\frac{1}{2}$  hours of continuous running the frequency had changed about 800 cycles or 7 parts in  $10^6$ . Day-to-day checks indicated frequency agreement within several hundred cycles. Continuous runs indicate that the frequency variation under ordinary operating conditions should not be more than  $\pm 25$  parts in a million or  $\pm 3$  kilocycles at 120 megacycles.

# An Evaluation of Radio-Noise-Meter Performance in Terms of Listening Experience\*

CHARLES M. BURRILL†, MEMBER, I.R.E.

**Summary**—An account is given of listening tests conducted, with the co-operation of the Joint Co-ordination Committee on Radio Reception of the Edison Electric Institute, National Electrical Manufacturers Association, and Radio Manufacturers Association, for the purpose of indicating how closely instruments made in accordance with the latest radio-noise-meter specifications of the Joint Co-ordination Committee meet the objective of giving readings proportional to annoyance for all types of radio noise. Thirty people participated in the tests which involved three types of radio noise and three different radio-noise meters. Standard statistical methods are used in analyzing the results, and these methods are explained in simple fashion for the benefit of radio engineers who are unfamiliar with statistical science. The general conclusion is that the new radio-noise-meter performance is very satisfactory.

## INTRODUCTION

A MAJOR objective of radio-noise-meter design is to provide an instrument which will give, for all kinds of radio noise, indications which are proportional to the annoyance factor or nuisance capability of the noise. This annoyance factor must ultimately be determined by listening experience. Therefore, the performance of each new design should be calibrated or evaluated by means of listening tests, in which the instrument readings are compared with the judgments of a jury of listeners as to the vexatiousness of the noises measured. The general problems involved in this basic procedure of radio-noise measurement have been discussed at length elsewhere.<sup>1,2</sup> The principal purpose of the present paper is to describe a series of tests which were made to evaluate, in terms of listening experience, the performance of radio-noise meters built in accordance with the latest specifications of the Joint Co-ordination Committee on Radio Reception of the Edison Electric Institute, National Electrical Manufacturers Association, and Radio Manufacturers Association.<sup>3</sup> A further purpose is to analyze and state the results of these tests in simple, easily understood terms in conformance with standard statistical practice. The exposition will therefore serve to illustrate the application of statistical methods to a radio-engineering problem, and to suggest to radio engineers relatively unfamiliar with such methods how they might be more widely used.

The tests to be described were planned and carried out, with the co-operation of the Joint Co-ordination

\* Decimal classification: R270. Original manuscript received by the Institute, December 10, 1941. Presented, Annual Convention, New York, N. Y., January 9, 1941.

† RCA Manufacturing Co., Inc., Camden, N. J.

<sup>1</sup> C. J. Franks, "The measurement of radio noise interference," *RMA Eng.*, vol. 3, pp. 7-10; November, 1938.

<sup>2</sup> C. M. Burrill, "Progress in the development of instruments for measuring radio noise," *PROC. I.R.E.*, vol. 29, pp. 433-442; August, 1941.

<sup>3</sup> "Methods of measuring radio noise, a report of the Joint Co-ordination Committee on Radio Reception of the Edison Electric Institute, National Electrical Manufacturers Association, and Radio Manufacturers Association." Edison Electric Institute Publication No. G9, National Electrical Manufacturers Association Publication No. 107, Radio Manufacturers Association Engineering Bulletin No. 32; February, 1940.

Committee, by Dudley E. Foster at the RCA License Laboratory in New York City. Two manufacturers of radio-noise meters loaned the instruments which were used. The tests were held on the morning of May 24, 1940, preceding a regular meeting of the Joint Co-ordination Committee, so that the committee members and their guests could form the jury of listeners.

## THE RADIO-NOISE METERS

Three instruments were used, designated A, B, and C. A and B were of different manufacture but both were intended to be in accordance with the Joint Co-ordination Committee specifications.<sup>3</sup> C was similar to A, but incorporated time constants of 1 and 160 milliseconds, such as were being considered for standardization in Canada, instead of the time constants of 10 and 600 milliseconds adopted by the Joint Co-ordination Committee.

## THE RADIO-NOISE SOURCES

The noise from a direct-current commutator-type motor, that from an electric razor of the vibrator type, and the clicks from a direct-current relay were chosen for use as typical of a large percentage of radio noises encountered in broadcast reception. These noise sources covered the range from fairly continuous noise to impulse noise of repetition rates as slow as about one per second.

## THE PROGRAM SOURCE

The program of one of the National Broadcasting Company networks, obtained by direct wire from the studio, was used to modulate a standard-signal generator, which in turn was used to excite a conventional

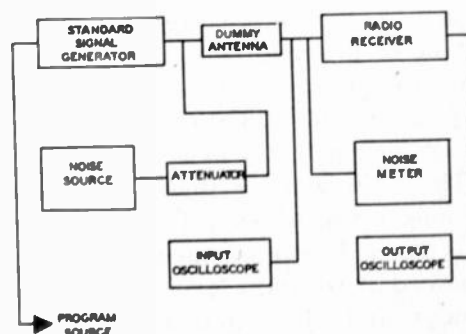

Fig. 1—Block diagram of the apparatus used in the tests.

broadcast receiver through a dummy antenna. The noise was also applied, through an attenuator, to the dummy antenna. A block diagram of the arrangement is shown in Fig. 1. The oscilloscopes were used in making preliminary adjustments and to indicate to the listeners, prior to the tests, what the noise waveforms were like. They were not used during the actual

tests. Two different receivers were used, a 13-tube console model and a 6-tube table model. The program was taken just as it came: speech, music, announcements, and all.

#### QUALITY OF RECEPTION

The quality of the program reception, with respect to noise interference, was rated by each listener in accordance with the following scale or code devised by the author some time ago:<sup>4</sup>

- A—Entirely satisfactory
- B—Very good, background unobtrusive
- C—Fairly satisfactory, background plainly evident
- D—Background very evident, but speech easily understood
- E—Speech understandable only with severe concentration
- F—Speech unintelligible

Intermediate grades were recognized, for example, B— was considered identical with C+ and half way between B and C.

This scale is a composite one, intended to be of use for programs consisting of either speech or music, whether listened to for entertainment as, for example, symphonic music, or for intelligence as, for example, news broadcasts. It is recognized that there is some loss of precision in using a single scale for all types of program. However, in the present state of the art of radio-noise measurement, the refinement of separate evaluations for different program types does not appear to be warranted. In using the present scale it is found that the three highest grades, A, B, and C are more easily differentiated when grading a musical program, while grades D, E, and F are most significant with respect to speech. Hence, if a given program sample contains both speech and music, it is readily graded, whatever its quality may happen to be.

#### SIGNAL-TO-NOISE RATIOS

The signal-to-noise ratio corresponding to each program sample or listening period was obtained before the period from the radio-noise-meter readings, first with the program-modulated carrier on and the noise stopped and then with the noise on but with the carrier off. The ratio between these two readings is the signal-to-noise ratio, which will be expressed in decibels in this paper. It was assumed that both signal and noise remained at constant levels between the time of measurement and the listening period. The noise sources were so chosen as to justify this assumption with respect to them. The program level was sensibly constant, as is usual with the type of program ordinarily broadcast in the morning hours. Signal-to-noise ratios were determined for each program sample with each of the three radio-noise meters.

<sup>4</sup>C. M. Burrill, discussion of paper by C. V. Aggers, D. E. Foster, and C. S. Young, "Instruments and methods of measuring radio noise," *Elec. Eng.*, vol. 59, pp. 178-192; March, 1940.

#### THE TESTS

Each of thirty observers, most of them untrained in listening tests, graded the "quality of reception" of twenty-four listening periods, comprising four different signal-to-noise ratios with three different kinds of noise, reproduced on two different receivers. The various signal-to-noise-ratio values were presented in random order, and the observers were not informed of these values until after the completion of all the grading. Table I gives the order of the test periods, together with the corresponding signal-to-noise-ratio values as determined with each of the three radio-noise meters.

TABLE I

Test	Noise Source	Receiver Type	Noise-Meter Signal-to-Noise Ratio—Decibels		
			A	B	C
1A	Commutator	Console	28.9	28.5	33.2
1B	Commutator	Console	19.2	19.7	25.0
1C	Commutator	Console	45.8	45.4	50.1
1D	Commutator	Console	54.8	54.4	59.1
2A	Razor	Console	40.6	40.6	50.1
2B	Razor	Console	14.6	12.6	19.2
2C	Razor	Console	48.6	48.6	58.1
2D	Razor	Console	22.9	21.2	29.3
3A	Relay	Console	34.5	36.1	46.6
3B	Relay	Console	42.5	44.1	54.6
3C	Relay	Console	19.2	18.1	28.5
3D	Relay	Console	12.0	10.1	22.1
4A	Commutator	Table	28.9	28.5	33.2
4B	Commutator	Table	45.8	45.4	50.1
4C	Commutator	Table	54.8	54.4	59.1
4D	Commutator	Table	19.2	19.7	25.0
5A	Razor	Table	40.6	40.6	50.1
5B	Razor	Table	22.9	21.2	29.3
5C	Razor	Table	14.6	12.6	19.2
5D	Razor	Table	48.6	48.6	58.1
6A	Relay	Table	12.0	10.1	22.1
6B	Relay	Table	19.2	18.1	28.5
6C	Relay	Table	34.5	36.1	46.6
6D	Relay	Table	42.5	44.1	54.6

#### THE JUDGMENTS OF THE LISTENERS

When comparisons were made of the grades given to reception with the two different receivers, for the same type of noise and the same signal-to-noise ratio, no significant differences were noted. Therefore, the data for each pair of tests with the two receivers were combined to give a total of sixty grades for each test condition.

The results for one typical test condition are shown in the form of a bar diagram in Fig. 2. Such a diagram is one way of representing what the statistician calls a frequency distribution. It indicates that a group of entities, in the present case, listeners, has been classified with respect to some specified attribute, in the present case, the grade which each gave to a particular program sample, and gives the number of the entities falling in each class. This number per class is called the frequency, indicated more specifically here as "frequency of occurrence" to distinguish it from the frequency of an alternating current.

The frequency distribution represents a considerable condensation of data, since no indication is given as to which entity falls in which class. Ordinarily this represents no loss of *useful* information, and is a great convenience. Thus, in the present instance we are not

interested in the grades given by the individual listener, but rather in the grades of the group as a whole.

Statisticians have found that nearly all frequency distributions may be grouped into a few basic types. One of the simplest of these types is so often encountered that it has been called the normal frequency distribution. As we shall see, the data plotted in Fig. 2 may be adjusted to yield a distribution of this type. The data represented by a frequency distribution may be condensed further by calculating, in a manner depending on the type of distribution, certain parameters and using these to characterize or represent the distribution itself. Two kinds of such parameters, applicable to most types of frequency distribution, are those indicating "central tendency" and those indicating "dispersion." In the language of our present example, we may represent the data for each listening test by two quantities which answer the questions, what is the convergent trend of opinion, and how much do opinions differ?

It is easy to see that the opinions trend toward about D+ for the test to which Fig. 2 applies, but the statistician requires a more precise determination of the trend or central tendency. From the number of statistical quantities useful in indicating the central tendency of such data we shall choose the simplest and the one most used—the arithmetic mean. For this purpose we must assign, somewhat arbitrarily, numerical values to the classes or grades. The data can then be

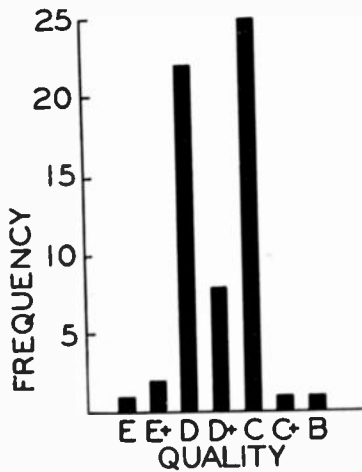

Fig. 2—The listeners' judgments for a typical test summarized in the form of a bar diagram. Noise meters A and B, commutator noise, signal-to-noise ratio = 28.7 decibels.

plotted to a continuous abscissa scale, as in Fig. 3, using the following equivalents:

F	F+	E	E+	D	D+	C	C+	B	B+	A
0.0	0.5	1.0	1.5	2.0	2.5	3.0	3.5	4.0	4.5	5.0

The arithmetic mean of all the grades may now be computed and expressed on this scale. It is found, for the data represented by Fig. 3, to be 2.51 or very nearly D+ as was to be expected.

The most commonly used statistical measure of dispersion, that is, the scattering of the data, is the standard deviation, or the root-mean-square deviation from the arithmetic mean. This is computed by

summing the squares of the deviations of each grade from the average grade and extracting the square root of the sum. The standard deviation of the data represented by Fig. 3 is 0.566 or about half a grade.

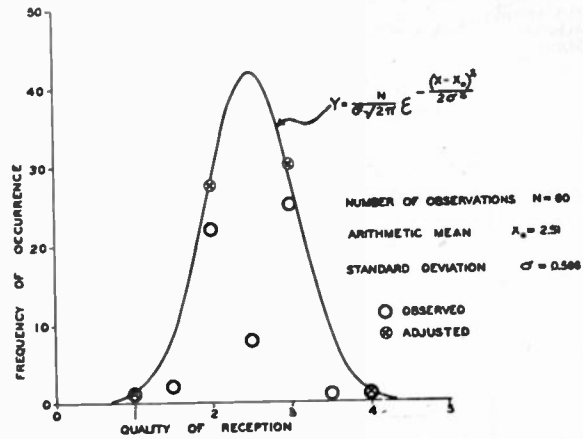

Fig. 3—The data of Fig. 2 expressed in the form of a frequency-distribution curve.

Suppose we fit a smooth curve to the points plotted on Fig. 3. Such a curve is called a frequency-distribution curve or simply a frequency curve. It must be noted that this is not at all what a radio engineer usually means by a frequency curve. Obviously many different curves could be drawn through the rather scattered points of Fig. 3. A freehand fitting would be a strain on the judgment. So we show in the figure a particular type of curve, called the normal-distribution curve, having the same arithmetic mean and standard deviation as we computed from our data. This curve corresponds to the equation

$$y = \frac{n}{\sqrt{2\pi} \cdot \sigma} \cdot e^{-\frac{(x-x_0)^2}{2\sigma^2}}$$

where  $x$  = quality of reception

$y$  = frequency of occurrence

$n = 60$  = the total number of observations

$x_0 = 2.51$  = arithmetic mean of the observations

$\sigma = 0.566$  = the standard deviation of the observations

It is noted that this theoretical distribution curve fits the observational data fairly well except for the point at quality = 2.5. The fit is close if a plausible modification is made in the data. It is evident that the listeners tended to favor the even grades A, B, C, etc., over the intermediate grades B+, C+, etc. Out of a total of 720 grades for all the tests, less than 11 per cent were intermediate grades, whereas if the listeners were not discriminating against intermediate grades one would expect about 50 per cent. If we divide up the intermediate-grade judgments between the two adjoining even grades, in proportion to the numbers of judgments for those adjacent grades, we obtain the following modified frequency tabulation:

Grade	E	D	C	B
Modified Observed Frequency	1.09	27.66	30.21	1.04
Theoretical Frequency	1.23	28.2	29.0	1.33

TABLE II

Noise Source	Noise Meter	Signal-to-Noise Ratio, Decibels	Quality of Reception				Correlation			
			Arithmetic Mean	Standard Deviation	Probable Error		Regression Coefficients		Standard Error of Estimate	Coefficient of Linear Correlation
					Single Observation	Mean of 60 Observations	a	b		
Direct-Current Commutator Motor	A & B	19.4	1.742	0.511	0.347	0.0445	0.154	0.0826	0.612	0.882
		28.7	2.508	0.566	0.385	0.0497				
		45.6	4.025	0.602	0.409	0.0524				
		54.6	4.592	0.725	0.493	0.0631				
Razor	A & B	13.6	0.842	0.566	0.382	0.0493	-0.259	0.090	0.648	0.889
		22.0	1.950	0.472	0.318	0.0411				
		40.6	3.167	0.667	0.450	0.0581				
		48.6	4.233	0.735	0.496	0.0640				
Relay	A & B	11.0	0.542	0.519	0.350	0.0452	-0.3599	0.09625	0.590	0.903
		18.6	1.683	0.533	0.360	0.0464				
		35.3	2.892	0.611	0.412	0.0532				
		43.3	3.858	0.608	0.410	0.0529				
Direct-Current Commutator Motor	C	25.0	Same as				-0.328	0.0847	0.611	0.881
		33.2								
		50.1								
		59.1								
Razor	C	19.2					-0.615	0.0807	0.646	0.890
		29.3								
		50.1								
		58.1								
Relay	C	22.1					-1.305	0.0935	0.508	0.929
		28.5								
		46.6								
		54.6								
Averages			0.593		0.401	0.0516	—	0.08796	0.6025	0.896

The closeness of this fit of our data to the theoretical normal-distribution curve permits and encourages us to make certain assumptions from which useful conclusions can be drawn. Thus we postulate a statistical population of all or a very large number of people like those who participated as listeners in our tests, and we suppose our listeners to comprise a fair sample selected at random from this population. We further assume that if the judgments of this entire population regarding a given radio-program sample could be tabulated they would turn out to be normally distributed, that is, distributed in accordance with the normal-distribution curve. It is also assumed that the arithmetic mean of the judgments of our sample group of listeners would coincide with the arithmetic mean of the judgments of the entire population.

Now, under these assumptions, we can estimate from our data the standard deviation of the entire population, in accordance with the formula

$$s \cong \sqrt{\frac{n}{n-1}} \cdot \sigma = \sqrt{\frac{60}{59}} \times 0.566 = 0.571.$$

From this value the probable error of a single judgment, and the probable error of the mean of a sample of  $n$  judgments, in each case selected at random from the population, can be calculated. Thus

probable error of a single observation =  $0.6745s = 0.6745 \sqrt{\frac{n}{n-1}} \sigma = 0.385.$

probable error of mean of  $n$  observations =  $0.6745 \frac{s}{\sqrt{n}} = 0.6745 \frac{\sigma}{\sqrt{n-1}} = 0.0497.$

The interpretation of these values is as follows:

(1) The odds are even (probability 0.5) that the judgment of a single listener chosen at random, regarding the particular program sample we have been

considering, would fall within  $\pm 0.385$  of a grade of the arithmetic mean obtained in our test.

(2) The odds are even that the arithmetic mean of the sixty judgments obtained from a second similar group of listeners chosen at random would fall within  $\pm 0.0497$  of a grade of the arithmetic mean obtained in our test.

In Table II are given the results of the grading for each of the four noise levels and for each of the three types of noise. The arithmetic mean of the grades, the probable error of this mean, and the probable error of a single grade are tabulated. It is indicated that very satisfactory reliance can be placed on these data.

### THE CORRELATION OF THE RADIO-NOISE-METER INDICATIONS

In referring to Table I it is noted that the indications of radio-noise meters A and B were very nearly alike. Therefore the readings of these two instruments were averaged for use in the subsequent analysis.

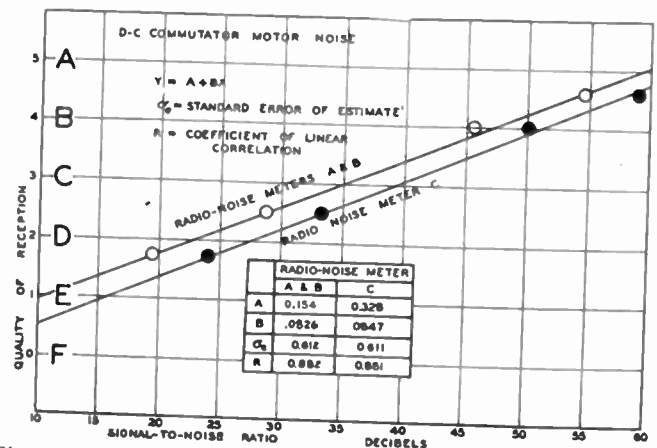

Fig. 4—Quality of reception as a function of signal-to-noise ratio, for commutator-motor noise and for two types of radio-noise meter.



Fig. 4 shows a plot of the quality of reception determined by the arithmetic mean of the listeners' judgments, as a function of the signal-to-noise ratio in decibels indicated by the radio-noise meters. It represents the tests with direct-current commutator-motor noise; similar plots for the other tests are shown in Figs. 5 and 6. It is evident that the observed points shown in Fig. 4 can be represented very well by two straight lines, one for each type of radio-noise meter. Usually such straight lines would be drawn in simply by inspection. However, in the present instance we wish to determine a numerical measure of how well these lines represent the data, and so we must be careful to obtain the "best" fit. This is obtained by the method of least squares, by which the sum of the squares of the deviations of the observational points from the line is made a minimum. The lines shown in the figure, which were obtained in this way, would be called by statisticians linear regression lines; the coefficients  $a$  and  $b$  in their algebraic expression, the regression equation  $y = a + bx$  would be called regression coefficients.

The usual measure of how well a regression line fits the data is the "standard error of prediction." It is equal to the square root of the sum of the squares of the deviations of all the values of the dependent variable—"quality of reception" in the present case—as predicted by the regression equation, from the corresponding observed values. This quantity  $\sigma_e$  which is made a minimum by the use of the method of least squares in determining the regression equation, is a measure of the error to be expected in estimating a value of  $y$  from the corresponding value of  $x$  and the regression equation.

Without any knowledge of  $x$ , the best estimate one could make of a particular value of  $y$  would be the arithmetic mean of all the  $y$  values, and the error to be expected would be measured by the square root of the sum of the squares of the deviations of all of the  $y$  values from this mean. This latter quantity is called

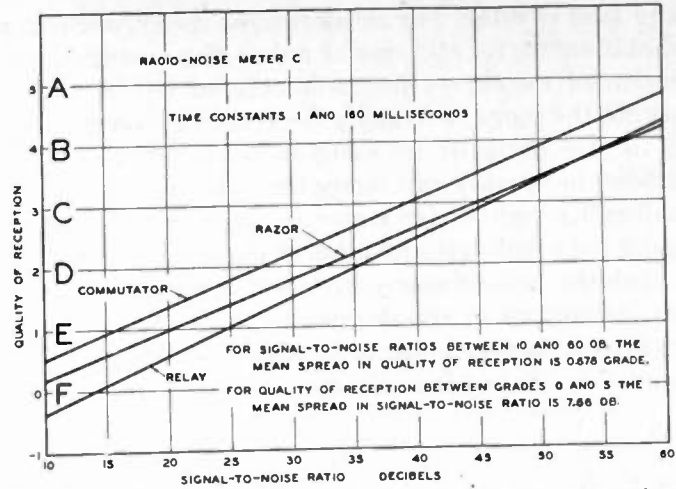

Fig. 6—Quality of reception as a function of signal-to-noise ratio as read by radio-noise meter C, for three different kinds of noise.

the standard deviation of the  $y$ 's or  $\sigma_y$ . Then the ratio  $\sigma_e/\sigma_y$  indicates how much a knowledge of the corresponding value of  $x$  reduces the error to be expected in predicting a particular value of  $y$ . The error is reduced only if  $x$  and  $y$  are correlated. The usual measure of this correlation is the coefficient of linear correlation  $r$ , given by

$$r = \sqrt{1 - (\sigma_e/\sigma_y)^2}$$

The values of the regression coefficients, the standard errors of estimate, and the coefficients of linear correlation, for the case chosen for illustration—that of direct-current commutator-motor noise—are exhibited in Fig. 4, along with plots of the mean judgments and the regression equations. The values of these parameters for all the cases are listed in Table II.

#### COMPARISON OF THE RADIO-NOISE METERS

The two types of radio-noise meter may be compared in two ways using the foregoing data. First, it is observed by comparing the standard errors of estimate given in Table II that the data for radio-noise meter C are fitted by linear regression curves a trifle more closely than are the data for radio-noise meters A and B. Second, the regression lines pertaining to radio-noise meters A and B are more nearly the same for all three types of noise than are those for radio-noise meter C. This is noted by comparing the values of signal-to-noise ratio corresponding to the different grades of quality of reception calculated from the regression equations. These values are given in Table III, and indicate an average range of variation for the different types of noise of 3.2 decibels for radio-noise meters A and B and 7.8 decibels for radio-noise meter C.

The comparison may be made graphically by means of Figs. 5 and 6, which show, respectively, the three regression lines for radio-noise meters A and B and for radio-noise meter C. These figures give what are in effect radio-noise-meter calibration curves, there being a separate curve for each type of noise meter

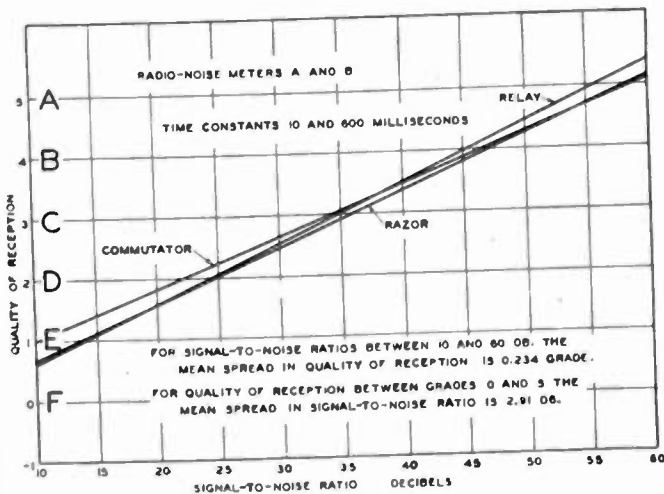

Fig. 5—Quality of reception as a function of signal-to-noise ratio as read by radio-noise meters A and B, for three different kinds of noise.

and kind of noise. For an ideal noise meter, one curve should suffice for all types of noise. The average separation of the curves for radio-noise meters A and B within the range covered by the tests, as shown in Fig. 5, is 2.9 decibels<sup>5</sup> in signal-to-noise ratio, or 0.23 grade<sup>6</sup> in quality of reception. The corresponding values for radio-noise meter C, as shown in Fig. 6, are 7.7 decibels<sup>5</sup> or 0.68 grade.<sup>6</sup> These values may be called the noise-meter correlation errors, since they are indications of the degree of failure of the instrument readings to indicate quality of reception independently of the kind of noise.

TABLE III

Quality of Reception		Signal-to-Noise Ratio in Decibels								
Grade	Numerical Scale	Noise Meters A and B				Noise Meter C				
		Commutator	Razor	Relay	Range	Commutator	Razor	Relay	Range	
A	5	58.6	58.5	55.9	2.7	62.9	69.6	67.5	6.7	
B	4	46.6	47.4	45.4	2.0	51.1	57.2	56.8	6.1	
C	3	34.4	36.2	35.0	1.8	39.3	44.8	46.1	6.8	
D	2	22.3	25.1	24.6	2.8	27.5	32.4	35.4	7.9	
E	1	10.2	14.0	14.2	4.0	15.7	20.0	24.6	8.9	
F	0	-1.8	2.9	3.8	5.6	3.9	7.6	14.0	10.1	
Average Range Decibels										7.8

#### SIGNIFICANCE OF THE OBSERVED CORRELATION ERRORS

It would be difficult for a listener to detect a 2.9-decibel change in level of a broadcast program, unless the change were made very suddenly. It is reasonable to expect that a 2.9-decibel change in signal-to-noise ratio would be at least as hard to detect.

Since the fundamental determination of quality of reception is by the judgment of listeners, the noise-meter correlation errors should be compared with the errors to be expected in the basic subjective, or listening method. Now the average, for the twelve test conditions, of the standard deviation of the listeners' judgments, was 0.593 grade (see Table II). This corresponds to a probable error, for the judgment of a single listener, of  $\pm 0.40$  grade, or a spread of 0.80 grade. Since this value is more than three times the correlation error of noise meters A and B, it may be said with assurance that these instruments are more reliable than the judgment of a single listener. In fact, it may be calculated on the same basis that radio-

<sup>5</sup> These values were obtained by finding the area bounded by the extreme calibration curves of the group and abscissas corresponding to quality grades A and F (0.0 to 5.0). They are therefore slightly different from the similar values given in Table III, which were obtained by averaging the separations at the five even grades A, B, C, D, and E.

<sup>6</sup> Obtained by finding the area bounded by the extreme calibration curves of the group and the ordinates corresponding to signal-to-noise ratios of 10 and 60 decibels.

noise meters A and B are equivalent in accuracy to a jury of twelve listeners. On the same basis, noise meter C is a little more accurate than the judgment of a single listener.

#### CONCLUSIONS

The scale of grades A, B, C, etc., used for the subjective determination of quality of reception is shown to be very satisfactory from the statistical point of view.

Radio-noise meters of either of the two types tested may be used to indicate quality of reception on this scale with reasonable accuracy, with linear calibration curves (regression lines) which do not vary greatly for different types of noise. Radio-noise meters A and B, embodying the time constants adopted by Joint Co-ordination Committee, had somewhat smaller correlation errors than radio-noise meter C employing the modification of these time constants under consideration in Canada. All three of these instruments are believed to give indications proportional to quality of reception much more uniformly for different noise waveforms than any instrument previously available, although comprehensive tests corresponding to those here reported have not been carried out for other instruments.

Finally, the adequacy of the Joint Co-ordination Committee specification is indicated by the satisfactory uniformity of performance, in these tests, of radio-noise meters A and B, built to conform to it by different manufacturers. The validity of this conclusion when noise waveforms of the types used in the present tests are concerned has not been challenged, but subsequent investigations have indicated that the Joint Co-ordination Committee specification is not entirely adequate when noise waveforms consisting of widely separated sharp peaks are involved. In the latter case the transient characteristics of the automatic-volume-control circuit play a dominant role in determining the instrument response, and it therefore appears that these characteristics should be more definitely specified. This matter has been further discussed by the author elsewhere.<sup>7</sup>

#### ACKNOWLEDGMENTS

The author expresses his thanks and appreciation to all those who assisted in the tests and to those who co-operated in the writing of the paper; especially to L. C. F. Horle for his interest and enthusiasm in sponsoring the tests, to D. E. Foster for planning and carrying them out, and to W. C. Morrison, who checked the computations.

<sup>7</sup> C. M. Burrill, "Some observations concerning the transient behavior of radio-noise meters." Presented, Rochester Fall Meeting, Rochester, N. Y., November 12, 1941.

A Symposium On  
RADIO IN THE WAR EFFORT

Rarely does the radio field, speaking as an integrated community, clearly and inspiringly express its aims and accomplishments. At the June, 1942, Convention of the Institute of Radio Engineers at Cleveland, Ohio, our membership listened as the responsible leaders of opinion in the major divisions of radio contributed to a constructive and unified discussion. The Presidents of our engineering fraternity, The Institute of Radio Engineers; of the grouped constructors of equipment, the Radio Manufacturers Association; and

of the affiliated broadcasters, the National Association of Broadcasters; conclusively proved on that occasion that, beneath the dust and turmoil of our daily activities and relationships, rests a solid foundation of common interests and mutual respect. It is fortunate that their thoughts were expressed, since the words of such speakers may well lead to closer understanding and greater cooperative effort between all portions of the radio field in the years to come.

*The Editor*

## War Contributions of Radio Manufacturing\*

PAUL V. GALVIN†, NONMEMBER, I.R.E.

I AM indeed delighted in having this opportunity to be with you this afternoon and participate in this Panel covering radio's efforts in the war.

From my observation of those on the Panel, the broadcast phase of radio is very well represented. Therefore, I shall confine my remarks to the manufacturing and apparatus phase. In my reference to engineers, I refer particularly to design and development engineers. In passing, I only wish to state in regard to broadcast that the manufacturers are very conscious of their responsibility in keeping the radio sets in the hands of the American public in a satisfactory state of repair and in operation. We are constantly concerned

with the matter of maintenance and replacement parts. Our Association maintains an active committee on this

\* Decimal classification: R560XR700. Original manuscript received by the Institute, June 29, 1942.

† President, Radio Manufacturers Association, Washington, D.C.

subject. We are even investigating the future prospects of utilizing Boy Scouts for the necessary servicing of the radio sets in the hands of the public, when the service organization as we know it has completely gone to war.



THE THREE PRESIDENTS

*Neville Miller, National Association of Broadcasters; Arthur Van Dyck, Institute of Radio Engineers, and Paul V. Galvin, Radio Manufacturers Association.*

The radio manufacturing industry was in the vanguard of those industries who recognized their responsibility in the Defense Program as launched in the summer of 1940 by President Roosevelt. We took this as the initial opening phase and chartered a course of industry in the preparation for war. Immediately following the launching of the Defense Program in 1940, discussions took place in group meetings of the Radio Manufacturers Association searching for the most intelligent

approach for industry guidance in the defense effort. Up to this time the radio industry—like all America—was primarily concerned with their peacetime pursuits. A few large companies were making some radio apparatus for war purposes.

Limited allocation of funds to our Army and Navy for the purpose of radio equipment development severely limited the activity of the Army and Navy on radio engineering and production prior to the summer of 1940. With the invasion of the lowlands in France in May and June of 1940, the importance of radio and the part it was to play in modern warfare became very apparent. The precise co-ordination of all of the service arms of the German Army was accomplished by the effective use of radio.

When wartime radio problems hit the industry in the summer of 1940, we found them in a highly amorphous state. The engineering, manufacturing, and procurement of radio apparatus needed further prescription of the broad problems we were to tackle.

In World War I, we had no radio industry as we know it today. This is the first entry of radio as an industry in a war. True, radio was used in World War I but not in the sense nor to the extent we know it today. The Navy did depend on wireless but aside from that, radio was a minor factor in the last war. Today radio is used as communication by all of the service arms. Today each tank contains an average of \$5000 worth of radio equipment. A single heavy bomber carries on the average of some \$50,000 worth of the most complete and delicate devices. The protection of ships, troops, and even our homeland is now very much involved in the use of radio. Radio also enters very materially into the all important "war of nerves." The backbone of enemy spy activity is radio. Radio also plays a very important part in maintenance of public morale.

By September, 1940, it became apparent to the radio industry that it had a big task to perform in the Defense Program. The magnitude of the job was emphasized by the projection of a radio apparatus program amounting in excess of one billion dollars. Up to this time a half-dozen companies were making the few millions of dollars worth of apparatus the Army and Navy bought.

Gradually the problems began to spread through the industry. It was impossible to show results over night. People had to become adjusted. Organizations had to become adjusted. Engineering departments of the radio industry had to become adjusted. Research and procurement divisions of the Army and Navy expanded. The engineering activity as a whole from a military standpoint had to take on a new and increased tempo. The efforts of management of the radio industry started channeling into its new defense grooves.

While this was going on during 1941 civilian production continued—and some, unfamiliar with the whole problem, advocated disruption of the civilian production organizations. But the industry leaders as well as the Army and Navy and War Production Board officials knew that the industry production organizations must be kept intact as going concerns until the engineering and procurement problems of this

whole, new vast program shook down to a state where they were in shape to go into production on a scale to utilize the production facilities of the industry. A vindication of this policy was contained in the recent report of the Senate investigation of the WPB. This Committee investigated the activities and reported on the industry. At the conclusion of the report the Senate Committee made a statement to the effect that in view of the facts presented, criticisms in regard to the radio industry were not well founded.

That war is destructive is axiomatic. The purpose of war is the destruction of enough of the assets, human and material, of the enemy to force him to give up the struggle. But war destroys not only lives and property. War causes a great alteration of ideas and habits—peacetime ideas and habits change to wartime ideas and habits. For the very best war effort we must become war minded. This means, not just idly thinking of the war or wondering who's going to win and when the war will end. We must marshal real fighting ideas and turn our works and our habits of working into the groove that will best aid in our country winning the war. Those who have not negotiated this mental bottleneck as yet haven't made the proper adjustment to where they can make their very best war effort.

Engineers too often are inclined to view their job narrowly. The engineer too often prefers to resolve his problem within well-defined limits and within a field whose structure is clearly defined. The engineer is too prone to want plenty of time to conclude a project with finality in the prescribed fashion—that's out, positively, for the duration of this war. Your problems will never be finished. You will be called upon constantly to explore new horizons in the radio and electronics field. You will be called upon for better and quicker answers. Courageous enterprise on the part of the engineer will be a major contribution to our winning the war. I might go so far as to say that without courageous enterprise on the part of our engineers, we might lose the war. We must have new and better models of everything, planes, tanks, boats, guns, and radio equipment. If we don't, our smart enemy will have better equipment and apparatus and we will be outclassed.

You are being called upon and will continue to be called upon throughout this entire war to strain to the breaking point for the deliverance of energy, effort, and brains, the like of which you have never done before. You may have thought you were very busy many times before, but this war effort calls for a personal and social readjustment and sacrifice of all engineers to where they must give complete devotion tenaciously to their task. The engineers are being relied upon to come up with intelligent answers which the manufacturers can put into production in a hurry, and thus put into the hands of the Army and Navy large quantities of material for greater and more effective striking power.

In the war effort, radio engineers have to be ready and willing at all times to tackle the problem of substitution of materials when it comes up, regardless of how annoying it may be. It is part of the game. One way to keep clear of the critical material problem as best you can is to design away from it. And in your design activity I caution you to watch this critical material problem very carefully. It will save you, your manufacturer, and the Army and Navy many headaches. The mechanical engineer and the electrical engineer in this effort, more than ever before, must have a greater spirit of co-operation, one unto the other, in quickly working out design problems. The design engineer should be more conscious of the manufacturing and tooling problems. These can be serious bottlenecks in getting apparatus through the plant in quantities, and on time.

Today the radio development and design engineer has to be more cognizant of the other fellow's problems than ever before. The effectiveness of our industry war effort depends upon the proper integration of all of our efforts—and these efforts can be so much more fruitful all along the line when broad thinking is applied to the development and design of the apparatus when it is still in the hands of the engineer.

Radio men are up against some clever engineers in the radio and electronics field in both Germany and Japan. An examination of the technical literature will show you that—and the Nazis have turned out apparatus which will command your attention and challenge. I wonder sometimes, if you men thoroughly realize the importance radio is destined to play in the winning of this war. The whole pattern of war tactics and strategy has been altered by the use of radio communication and radio direction finders. The co-ordination of land, air, and sea forces is accomplished by radio. Protection from the enemy and firing accuracy is accomplished by Radar. It has been said that in the aerial battle for Britain in the fall of 1940 radio direction finding apparatus which we, in this country, call Radar, was a prime contributing factor of the Royal Air Force's maintaining superiority in the air over the Nazis with a much smaller aggregation of flying equipment. You are alive, I am sure, to your war effort responsibilities but I implore you to do more. You must do more. We all must do more if we are to win this war.

The management group as a whole in whose hands the war production effort of this radio industry has been entrusted, are fully conscious of their very serious responsibility in this program. They have stripped their plants for necessary action and are producing apparatus in huge quantities. They realize they will be continuously pressed to do more and better. They are just now feeling the acceleration from their early efforts. They are prepared and will meet the require-

ments and beat schedules. I am fully confident the radio industry will come through for the Army and Navy on every score. It is a big order, I know, when we realize the magnitude of this vast radio and Radar program. But the radio manufacturers are used to "licking" big problems; they know their problems in this war effort and they will be solved. To you radio engineers who are "in the groove" and making your grand contribution to this great effort toward our winning the war, "Hat's off to you and keep up the good work"—and that, I am glad to say, goes for most of you. To you few who are not yet "in the groove," giving your very best and your all in this war effort—I say, "break that old mental bottleneck—dust off the cobwebs and get in there with some good intelligent licks." Your brainstorm may be the "rabbit out of the hat" that will make a most valuable contribution to this effort.

Industry, by its deeds in the war effort, is standing the business "baiter" back on his heels. The critics of reputable business seem to have had a "field day" before the war. Today their demagoguery is being answered by action. The production job being done by industry in this war effort is a vindication of the private-enterprise system. The public is, and will continue to be, very much impressed with the job industry is doing. These accomplishments of assembly, process, and method are all basically engineering. Let's be sure when these accomplishments are recorded in history, that the radio industry can proudly look back on its record.

Yesterday morning I received a communication from James S. Knowlson, Director of the Division of Industry Operations of the War Production Board in Washington, D. C. In that communication the following paragraph is of specific interest to the radio engineers:

"Of course the radio industry has a tremendous job ahead and probably a good deal of grief because the art changes so rapidly it is hard to keep up with the requirements. Certainly, if necessity is the mother of invention, we are going to see a lot of new things in the radio and Radar developments, and I imagine that when we go back to television we are going to find that most of the standards that have been made are obsolete. In the meantime, war production is the big thing, and as you say, it looks like quite a job."

Work hard during the war; your fun is coming after the war is over. With all the new materials, new tubes, and new ideas developed during the war you are going to have a picnic shaping them into playthings for commercial and civilian application. There will be no "*status quo ante bellum*" for the radio engineer.

# What Radio Broadcasting Means in the War Effort\*

NEVILLE MILLER†, NONMEMBER, I.R.E.

AMERICA is not a warlike nation. Our natural impulses are humane and charitable. We have the inborn determination which is necessary to make good warriors when forced to fight but with it all have a spirit of fairness which was evidenced by our treatment of the eight saboteurs recently caught red handed who were planning to kill and destroy. I mentioned this because what radio means today in the war effort must be interpreted in the light of our background—must be interpreted as radio developed during times of peace, and not developed to be used as a war instrument. Let us look back briefly at the twenty years between the two wars, years of disarmament conferences when men were trying to get away from war. The Army and Navy undoubtedly were making such plans as they could against obstacles. Our gold was moved to Fort Knox amid the cheers and jeers of our comedians.

I remember visiting Fort Knox in company with a Congressional Committee in 1936 and seeing, at that time, the entire tank force of our Army. Considering the importance which tanks now play in warfare, it is hard to realize that even six years ago the Army had difficulty in securing funds for experimental tanks from a reluctant Congress which was reflecting the wishes of a reluctant people.

What is the history of radio? We were granted the right by the government to use a few wavelengths. There was no government money provided for development; no appropriations, such as road appropriations or harbor appropriations; no subsidies by mail contracts and no second-class postal privileges. All that we asked was to be let alone and during the last twenty years, thanks to your engineering ability and to the salesmen and program builders and to Mr. Galvin's associates and Mr. Jett's associates we built high-

\* Decimal classification: R560. Original manuscript received by the Institute, August 24, 1942.

† President, National Association of Broadcasters, Washington, D. C.

ways into the homes of the American people. Today there are 56,000,000 sets in 85 per cent of the homes and the American people listen to the radio.

Then war came and overnight radio was able to deliver to the government without cost the greatest means of mass communication the world has ever seen. No tooling-up period was needed, no appropriation bills were passed through Congress. It was all done so rapidly and so quietly that it was taken for granted.

There are no four-minute speakers today as there were in the last war. There are no trains taking groups around the country to campaign. All that today is being done by radio. There are just as many campaigns—maybe more—campaigns of recruiting, for the sale of war bonds, salvage, rubber, and all the others with which you are so familiar. But the burden of all these campaigns is being borne cheerfully and successfully by radio.

We face many problems in a difficult age but our greatest problem is not engineering, not the procurement of equipment, not the securing of business, not Mr. Petrillo—our greatest problem is keeping our social developments abreast of our engineering development. I have every confidence that the engineering skill of America will solve all of our engineering problems, but we must realize that unless our social development is kept abreast of the engineering development, the net result may be disastrous.

The history of America is the story of a great nation. However, we have been extravagant. We have wasted our forests, our public lands, our oil. Today we have received an asset in radio equal to all of our natural assets. You and I were not parties to what has happened in the past but you and I are going to have a part in writing the chapter of the future. Let us avoid the past mistakes; let us conserve our assets. Let us see that radio is used to make America's future a brilliant future. It is a grand chapter and let us be proud of the way we write it.

## Radio Engineering in the War Effort\*

ARTHUR VAN DYCK†, FELLOW, I.R.E.

MOST analysts agree that the most important element in this war is aviation, that next most important is ordnance, and in third place is radio. Each of these elements has shared in the general

and rapid advance in technology of recent years. As a result each has developed rapidly in capability, complexity, and degree of effect on the practice of war. Just how rapid and how great that development has been is clearly seen by comparing their present capabilities with those of World War I. Aviation and radio are similar in that both had their introduction to war

\* Decimal classification: R560. Original manuscript received by the Institute, September 9, 1942.

† President, Institute of Radio Engineers, New York, N. Y.

in World War I, and then revealed clearly their enormous potentialities.

We are concerned here with radio only, and will find it interesting and helpful to compare its uses in World War I with those of today. To those now under forty years of age, and who, therefore, were under fifteen years of age when we entered World War I, the radio conditions of that time are unknown by personal experience, and must seem antediluvian. There was no broadcasting, no transmission of pictures by radio, and transoceanic radiotelegraphy was sporadic and unreliable. Practical radiotelephony had just been born. Even radiotelegraphy was only five years old, in the sense that only for that length of time had passenger vessels been required to have wireless and operators to be licensed.

What a contrast is presented by today's conditions! Now transoceanic radiotelegraphy and telephony both are giving every-day reliable service, and broadcasting covers the earth. Television and entry into the higher-frequency spectrum are repeating the conditions of new possibilities in war which were brought to the last war by the vacuum tube and radiotelephony. New and great significance results from the application of space radio principles to uses other than communication, to which radio was confined previously, such as the now well-known radio plane detectors. The work of the radio engineer would have inestimable value if radio were used only for communication purposes in ships, planes, and tanks. With other uses added, it takes on importance second only to that of the planes and guns themselves. It seems to me correct to say that never before in the history of science, has any branch had as varied, ramified, and powerful utilization as radio does today. The radio engineer of today has a right to stick out his chest and feel important, even as he has the obligation to feel and realize his responsibility to use to the fullest advantage his opportunity for unusual service in this critical time.

As this country approached war in 1941, the radio industry encountered its first war problem in the shortage of certain critical materials upon which radio apparatus had depended from its beginning. Radio engineers met that problem so successfully that in spite of shortage and substitution, more receivers were manufactured in 1941 than in any previous year.

Then came conversion from civilian home-entertainment receiver production to the manufacture of radio apparatus for war. This was really difficult, because military radio involves degrees of complexity, precision, and ruggedness not known in civilian radio. It meant changing engineering and factory practice from designs utilizing crude tolerances to ones of high precision, both mechanically and electrically. It meant changing from apparatus required to meet only the range of conditions between parlor and kitchen to apparatus capable of working reliably in the stratosphere and in the equatorial desert. The burden of this

change fell most heavily upon the radio engineers. And well have they carried it—without adequate sleep, without furloughs, without rewards, or medals, they are doing the job.

I have not recited this story just to record what has been done so far, or to pat the profession on the back. I have done so in order to silhouette what remains to be done, because if we are to continue on to the greater tasks ahead, with maximum efficiency, we must realize where we fit in the picture, and how basically vital radio is in this war. Furthermore, to advance and improve we do not need to dwell upon the good things we have done or are certain to do, but instead we need to know the bad, and to correct them.

The new mobility of attack, on land, on sea, and in the air, is possible only by use of radio communication. The companion mobility of successful defense is dependent likewise upon radio communication. In World War I, radio communication was an adjunct; in this war it is a vital necessity. In addition, we have now the applications of radio techniques to new instruments and weapons, thereby broadening the field of radio to limits not yet clearly seen. How can realization of this situation assist toward better execution of the tasks ahead?

The task ahead is not merely the invention and development of new devices, but even more important, is wise utilization of the ones we already have. Utilization of the things we have is not in the hands of engineers alone; in fact, it is mostly in the hands of others. Therefore, it devolves upon engineers to educate those others in the facts of technical life as rapidly and forcefully as possible. In peacetime we can allow the time needed for sufficient education to percolate slowly through the minds of others involved, with any amount of accompanying confusion and loss. In war we cannot with safety allow that time or that confusion and loss.

The advances in radio are but a part of the advance of technology on many fronts. In aviation, metallurgy, chemistry, and plastics, to name only a few, the advance has been so rapid that, as in radio, the nontechnical person could not understand the implications of the early stages until the final stages had been reached. So, for example, we have had various phases of aviation unappreciated until very recently, although aviation experts have understood them for many years. Unfortunately for the world, this condition did not exist in Germany. There, in Dr. Haushofer's incredible Institute, and in the German Army, was full realization of the new importance of technology and a thoroughly integrated utilization of it.

There are some examples of the kind of thing which we in radio need to do in our own industry, to improve our integration, co-ordination, and utilization of technical possibilities, and which can be mentioned in public forum. One is the utilization of the broadcasting system for public information, instruction, and control

in the event of air attack. So far this vast system has not been arranged for such use at all, in spite of its obvious availability and effectiveness. Let us examine this particular situation from the integrated technical viewpoint, which of course includes radio, military, and psychological factors, and see what conclusion would be reached.

Preparation of protection against air attack on this country has the following factors:

1. Attack will come unexpectedly.
2. Attack is almost certain to include new elements of attack (because this is past practice of the enemy in new attacks).
3. Rapid distribution of information to organized workers and the public regarding new elements of attack can mean the difference between catastrophe and successful resistance.
4. Instant calling or signaling to certain vital organized workers (such as auxiliary firemen and home guards) is necessary if they are to be of service quickly, as they must be to be effective.
5. The American people are not like Europeans with respect to news information. When anything happens they are strongly in the habit of finding out what it is—but quickly! They will not sit in ignorance. They insist upon being informed.
6. The American people are trained, as are no other people, to look to radio for quick news.
7. The American broadcasting system gives good communication into every spot in the country where people are located in any number.
8. Broadcast stations, in numbers sufficient to give adequate news dissemination, can stay on the air without giving aid to the enemy, if certain technical provisions are made, and if proper judgment is used in the information broadcast.

If these factors are correct, and every thoroughly experienced radio engineer knows that they are, why is

not the broadcast system already set up and operating as a public war communications system, now that the whole public is in the front line of war? Simply because we lack integration of knowledge and decision. We engineers have not educated others to know that we have a system available which can be used without any objection. The public was not in the front lines in the last war, and did not need quick communication. This war is different, but we have not educated old-line thinking to know that now there is advantage in radio communication to the public comparable with its advantage in communication to tanks and planes. I hope that we can find a way to convince and coordinate the various agencies involved in the use of broadcasting before there is need to use it.

In the design and manufacture of war radio apparatus we will have plenty of difficult problems. We should try to the utmost to design and build with the maximum of standardization and the maximum of reliability. The problem of maintenance of military equipment will be one of huge and increasing difficulty. The enormous quantities of apparatus, the extreme complexities of many types, the scarcity of well-trained servicing personnel, all add up to a tremendous difficulty and even military failure of operations if the apparatus is not well designed and well built.

The story of this war is being written into history. Some of it is behind us, but much more is ahead. The part which radio is playing and will play is being determined by the radio engineers. It is a vital part, and perhaps when the whole story is written it will be seen to have been a determining factor in the outcome. However it may be, we will be in there, doing our best to give all the assistance we can toward the destruction of the most barbarous organizations the world has ever known, in order that we may again proceed with peaceful, orderly development of things for the betterment of mankind.



## Correspondence

The following letter merits the close attention of the readers of the PROCEEDINGS. None will question the writer's conclusion that technology can become the handmaiden of destruction in states dominated by ambitious, impulsive, and ruthless dictators animated by an unbridled passion for self-aggrandizement. Our readers are doubtless divided into camps on the question whether the

engineer should, and could, guide or control the mode of utilization of his toil for the world's weal or woe. The views of our readers are invited, for their mutual information and benefit and as a possible broad guide to those formulating the policies of the Institute of Radio Engineers.

*The Editor*

### TO THE EDITOR:

If Mr. Van Dyck<sup>1</sup> manages to arouse even a minority of the readers of the PROCEEDINGS to a sense of responsibility in the disposal and utilization of the products of their ingenuity, he will more than have justified his tenure of the office of president, provided, the minority be sufficiently roused to take the initiative in formulating some corrective measure.

The problem however is more fundamental than would appear from Mr. Van Dyck's article. The engineer has traditionally been the servant of mankind and has cheerfully taken his orders from anyone with sufficient driving force to assume the lead, and has never demanded of his overlords any too deep an appreciation of matters technical.

This state of affairs is, I submit, inherent in the nature of man. To be a successful technician a man must be capable—indeed he must enjoy the process—of subjugating himself to his problem, rendering himself receptive to all the evidence it presents, and applying the train of logic to his findings with complete disregard of his own personal desires as to the outcome.

Your leader, director, autocrat, exploiter, dictator (call him what you will) is fundamentally the opposite of this in character. For him to succeed his ego must always dominate. He deals not with physical properties but with the shifting intangibilities of men themselves, and, operating outside of logic, deals in their emotions—fear, pride, ambition and the like. This field may yet yield to scientific method, but with mankind as it is today, the technician naturally becomes the economic servant of the director type.

To advocate the delivery of some technical sense to our leaders is hardly a solution, yet some solution must be found if our children's children are to reap where we sow. Undoubtedly the forces that are now bearing down upon us will yield by burdensome trial and painful error the rare combination in our eventual leaders of initiative and driving force coupled with scientific integrity and technological insight. But to hasten that happy day, I would advocate the deliberate cultivation of a wider range of interest in every practicing

engineer. If the majority of technicians were politically and economically well informed a body of opinion would arise whose influence could be a controlling one. If this opinion were scientifically informed it would of necessity be disinterested and act wholly for the good of the race. As initial moves toward such a condition the following might be contemplated.

(1) A campaign of education by this and all such technical societies to encourage members to interest themselves in the economic, political, artistic, and humanitarian aspects of their professional activities. To this end a special form of membership might be established to grant appropriate standing to those who, in addition to their technical abilities, have demonstrated their acquaintance with the relationship between their profession and the society in which it operates.

(2) The founding of a society of technicians to study the impingement of technical research on all phases of life, and to give the widest possible publicity to its findings among supporting technical societies. Too often the technician proceeds unperturbed along his chosen line of endeavor with no means of knowing to what final result his success may lead society.

(3) To organize a group to keep the technical man impartially advised of fundamental facts in current affairs having immediate bearing on his activities. Most of our opinions (which we flatter ourselves are as logical as our treatment of technical matters) are mere prejudices grown out of our emotional reactions to propaganda by one or other interested groups.

The emphasis in these somewhat tentative suggestions is not on any hope that change can come from the top but rather that it must originate with rank-and-file engineers, and this can only come about by their wider education in responsibility outside the present limits of their technical activities.

My salute to Mr. Van Dyck for his initiation of what I, for one, hope will prove a fundamentally important Institute activity.

L. T. BIRD  
Vice Chairman  
Montreal Section  
Institute of Radio Engineers

<sup>1</sup> PROC. I.R.E., vol. 30, pp. 305-309; July, 1942.

# Institute News and Radio Notes

## TO BE OR NOT TO BE—IN UNIFORM

Bill paid a visit the other day to the laboratory where he used to work, on leave from his post deep in the heart of Florida. He had two of those beautiful Navy gold stripes on each sleeve and one of those new pre-Pearl Harbor ribbons on his chest—he was something! He carried an aura of valor, romance, and patriotism which seemed to spell "slacker" to every civilian suit of clothes in the lab. Had he been a recruiting officer, he could have signed up the whole staff right then and there. If you are a civilian in a laboratory today, you know what I mean.

But after he left I got to wondering about what would happen to the lab, and to the Navy, if the staff did sign up, or if even but a few more members like Bill, did so. That lab is developing and engineering the production of radio equipment which the Navy uses. And the Army too. The engineers

who work there are a pretty special breed—years of training, years of experience in factory, field, and laboratory, and a teamwork which is knocking out results fast. In fact, there are fewer such fellows in the whole country than there are two strippers in the Navy.

The Navy and the Army cannot afford to have many more men leave the laboratories, if they are to keep on getting improved apparatus and new instruments until the war is won. But the men who have stuck to their jobs so far are getting restless under the lure of more direct service appeal, of uniforms and ribbons, and honors and preferments.

So, as an old timer who has been through it once, I want to appeal to the civilian radio engineers who are engaged in really vital war work, and who feel the pull of the uniformed services, to remember that their present work is vital, that

they cannot be replaced by others in less than several years, and to sacrifice those honors and preferences which come readily to the uniformed services and not so readily to civilians. Such sacrifice will be worth while if it helps to assure the safety of freedom in the world, as it will. The balance is too critical right now to take any chances with our total effort.

The Army and Navy will need more men, and undoubtedly some more engineers from civilian ranks can be spared, but each case should be weighed carefully to determine whether the national effort will be better served by transfer or by remaining on the more prosaic civilian job. Certainly it is not to the national interest to have the wholesale desertion from laboratory ranks which seems to be looming.

Arthur Van Dyck  
President

## Board of Directors

A regular meeting of the Board of Directors was held on September 2, 1942. Those present were A. F. Van Dyck, president; C. C. Chambers, I. S. Coggeshall, Alfred N. Goldsmith, O. B. Hanson, F. B. Llewellyn, Haradan Pratt, B. J. Thompson, H. M. Turner, H. A. Wheeler, L. P. Wheeler, and H. P. Westman, secretary.

George Lewis was appointed official representative of the Institute in England for the duration of the war.

The Winter Convention which would normally be held in New York City in January, 1943, was canceled.

A recommendation of the Executive Committee that a New York Section be established and the necessary procedure to do so were approved.

During the past several months, the Secretary has devoted a substantial part of his time under Institute authorization to a project sponsored by the War Production Board on the preparation of standards covering radio components for the Military Services, which project is under the administrative direction of the American

Standards Association. It was agreed by the Board that any required proportion of the Secretary's time would be made available for this work by the Institute during the next several months. This action was taken by the Board because of the vital importance of the project to the prosecution of the War.

## Executive Committee

The Executive Committee met on August 18 and those present were A. F. Van Dyck, chairman; Alfred N. Goldsmith, R. A. Heising (guest), F. B. Llewellyn, Haradan Pratt, B. J. Thompson and H. P. Westman, secretary.

At the recommendation of Advertising Manager Copp, the advertising rates for the PROCEEDINGS were revised to provide for a 15 per cent discount to the agency placing the advertisement.

Several letters of petition naming additional candidates for the office of Director were received. An insufficient number of signatures were affixed to those petitions received before August 15 to comply with the Constitutional requirements and necessarily the petition could not be received.

We were informed by the Institution of Radio Engineers (Australia) of the following resolution passed by the Council of that organization:

"That members of the Institute of Radio Engineers (United States of America) in the fighting forces, resident for the time being in Australia, be invited to become Honorary Members of the Institution of Radio Engineers (Australia) and that a suitable letter be forwarded to General MacArthur, the Institute of Radio Engineers (United States of America), and branches of this Institution advising them of the above decision of the Council."

Members of the Institute desiring to partake of these privileges may communicate directly with the Institution of Radio Engineers, Science House, 157 Gloucester Street, Sydney, N. S. W., or with any of the following division secretaries: K. L. Elliott, Brisbane Division, Box 1765 W, General Post Office, Brisbane, Queensland; R. R. Mackay, Melbourne Division, c/o Melbourne Technical College, 134 Latrobe Street, Melbourne, Victoria; and S. C. Austin, Perth Division, Box 335, General Post Office, Perth, Western Australia.

The Institute extends a cordial invita-



ROY ALEXANDER WEAGANT  
1881-1942

Roy Alexander Weagant (M'13-F'15) was born on March 29, 1881, in Morrisburg, Ontario, Canada. When he was but a few years old, his family moved to Dornby Line, Vermont.

He received a Bachelor of Science degree from McGill University in 1905. The next year was spent with the Montreal Light, Heat, and Power Company, and the following year with the Westinghouse Electric and Manufacturing Company at East Pittsburgh, Pennsylvania. In 1907, he entered the employ of the DeLaval Steam Turbine Company of Trenton, New Jersey. From 1908 to 1915 he was with the National Electric Signalling Company. He became Chief Engineer of the Marconi Wireless Telegraph Company from 1915 to 1920 and served as a Consulting Engineer for the next four years to the Radio Corporation of America which was a successor to the Marconi Company. He then served as Chief Engineer and Vice President of the DeForest Radio Company and later devoted his time to a consulting practice.

Mr. Weagant was the second recipient of the Morris Liebmann Memorial Prize which he received in 1920 for his work on methods for reducing the effects of static in the reception of radio signals.

The death of Mr. Weagant, which occurred at Newport, Vermont, on August 23, 1942, marks the passing of another of the early pioneers who contributed substantially to the new art of radio communications.

tion to all members of the Institution of Radio Engineers (Australia) who are located in the United States to attend its meetings and to avail themselves of such facilities as the Institute office can provide.

It was recommended to the Board of Directors that George Lewis, who has been recently ordered to London for the duration by the International Telephone and

Telegraph Corporation, be designated an official Institute representative in England.

It was noted that a number of conventions including the Rochester Fall Meeting for 1942 had been canceled and in view of the limited attendance and difficulties in obtaining suitable papers for the summer convention in Cleveland, it was recommended to the Board of Directors that the Winter Convention which would normally be held in New York in January, 1943, be canceled.

An invitation from the Chicago Section that the Institute convene there in June, 1943, was considered. In view of the unsettled conditions, no action was taken on it.

All members of the Executive Committee were present at a meeting held on August 26. The attendance included A. F. Van Dyck, chairman; I. S. Coggeshall, Alfred N. Goldsmith, R. A. Heising (guest), F. B. Llewellyn, Haraden Pratt, B. J. Thompson, and H. P. Westman, secretary.

Dr. Llewellyn, who is that member of the Executive Committee charged with the responsibility for overseeing the activities of our technical committees, reported on a meeting of the chairmen of the various technical committees, and, as a result, the following three actions were taken.

The terms of service of all technical committees is the calendar year at the present time. This results in two major periods of inactivity each year. One of these is during the summer months, and the other is during the first couple of months of the year when committee personnel is appointed. It was agreed that it would be desirable to start the term of service in the early summer and thus avoid the lull which occurs during the winter when the committees should be in full activity. This requires a modification of the Bylaws and Dr. Llewellyn will prepare a proposed revision for submission to the Board of Directors.

It was agreed that brief or partial standards reports may be published in order that they might appear at an earlier date than would be possible if final reports were required. The diminution in activities of committees as a result of the war effort may make it impossible to prepare complete reports in some instances.

With the exception of a few specified committees, the secretarial assistance normally provided to all Institute committees will be restricted to the preparation and mailing of notices of meetings and of duplicating and distributing minutes and reports of the meetings. This action, which applies to all technical committees and most of the administrative committees, was considered necessary in order to release the headquarters staff and the Secretary for other duties.

On September 1, A. F. Van Dyck, Chairman; Alfred N. Goldsmith, F. B. Llewellyn, Haraden Pratt, B. J. Thompson, and H. P. Westman, Secretary, attended a meeting of the Executive Committee.



MALCOLM PARKER HANSON  
1894-1942

Malcolm Parker Hanson (A'21-M'29) was born of American parents in Berlin, Germany, on October 19, 1894.

After three years at the University of Wisconsin he enrolled in the United States Naval Reserve Force in 1917 as a radio electrician. Later, he was commissioned as an Ensign and in June, 1919, he was released from active service.

In 1924, as a civilian engineer, he joined the staff of the Naval Research Laboratory, subsequently being placed in charge of the Aircraft Radio Section. He acted as technical advisor on radio matters to the Wilkins-Detroit, the Navy-MacMillan, and the Byrd Antarctic expeditions, and to the Byrd North Pole and transatlantic flights. He accompanied Admiral Byrd on his 1928-1930 expedition to the Antarctic.

On his return he was placed in charge of the technical work at the Radio Flight Test Laboratory of the Naval Air Station at Anacostia.

In 1938, he became Vice President of the Radio Navigational Instrument Corporation in New York, manufacturers of radio navigational instruments for aircraft.

In 1939, he returned to the Navy as a Lieutenant Commander and was promoted to Commander two years later.

In recognition of his work he was awarded a special gold medal by Congress in 1930; the gold medal of the Veteran Wireless Operators' Association which was awarded by radio from New York to Little America; the special gold medal from the City of New York, and the medal of the Aeronautical Chamber of Commerce.

Commander Hanson's death occurred in the line of duty in Alaska on August 9, 1942, where he was killed in an airplane accident. With his death, the radio engineering profession lost one of its keenest minds and principal authorities on all phases of aircraft radio.

Approval was granted of 94 applications for Associate, 6 for Junior, 29 for Student, and 2 for transfer to Associate grade.

The Secretary reported that under date of August 27, 1942 the PROCEEDINGS was admitted to membership in the Audit Bureau of Circulations.

It was recommended to the Board of Directors that as great a proportion as may be required of the Secretary's time be made available to the American Standards Association for activities on a Government-sponsored project to develop standards on radio components for the Military Services.

It was recommended to the Board of Directors that a New York Section be formed and a procedure to bring this about was approved.

## Summer Convention

Our summer convention for 1942 was held in Cleveland, Ohio, on June 29, 30, and July 1. The program was published in the May, 1942, issue of the PROCEEDINGS and the following papers which were not contained in that announcement were among those presented.

"Half-Wave Voltage-Doubling Rectifier Circuit," by W. D. Waidelich and C. H. Gleason of the University of Missouri, Columbia, Missouri.

"A Solution of the Problem of Adjusting Broadcast Directional Arrays With Towers of Unequal Heights," by J. M. Baldwin and G. H. Brown, KDYL, Salt Lake City, Utah, and RCA Manufacturing Company, Camden, N. J., respectively.

The paper on "Stub-Feeder Calculations," by H. A. Brown and W. J. Trijitzinsky of the University of Illinois was not presented through inability of the authors to be present.

A symposium on "What Radio Means in the War Effort" was also included in the program. The following speakers participated.

A. F. Van Dyck, President, Institute of Radio Engineers, Chairman.

Paul Galvin, President, Radio Manufacturers Association.

Neville Miller, President, National Association of Broadcasters.

E. K. Jett, Chief Engineer, Federal Communications Commission.



Dr. Schelkunoff (right) receiving from President Van Dyck the check for the Morris Liebmann Memorial Prize for 1942. The presentation was made at the Summer Convention Banquet on June 30 in recognition of Dr. Schelkunoff's contributions to the theory of electromagnetic fields in wave transmission and radiation.

E. M. Webster, Captain, United States Coast Guard.

Glen Bannerman, President of the Canadian Association of Broadcasters, was originally scheduled to speak but was unable to be present.

The material presented by the Presidents of the Institute, the Radio Manufacturers Association, and the National Association of Broadcasters appears elsewhere in this issue.

Captain Webster discussed the radio problems which face the Coast Guard in its wartime activities.

The work of the Federal Communications Commission was outlined by Mr. Jett. He discussed the problems which the advent of war had brought about in the realm of radio regulation. The problems of making greatest use of the radio spectrum for the war effort were considered and included not only the need for effective point-to-point communications but also the necessity of maintaining public morale through a continuation of broadcasting. The problems of monitoring such a large spectrum as radio now encompasses, to

prevent inimical use of radio, is a task of great proportions on account of the geographical size of the United States, the characteristics of radio waves, and the ability to carry on long-distance communications with relatively low powers. The need for full co-operation by all radio organizations and individuals will be required to give the most effective use of this important medium of communication in winning the war.

During the banquet, the Morris Liebmann Memorial Prize was presented to Dr. S. A. Schelkunoff for his contributions to the theory of electromagnetic fields in wave transmission and radiation. About 150 members and guests attended the banquet.

At the luncheon on June 30, Frazier Hunt, news reporter and correspondent, spoke on the war and the immediate probabilities which might be expected from the conditions then existing. His appearance was through the courtesy of the General Electric Company.

The registration at the Convention included 256 men and 36 women.

## INSTITUTE COMMITTEES—1942

## ADMISSIONS

H. M. Turner, *Chairman*

C. B. Aiken	D. E. Harnett
H. H. Beverage	L. C. F. Horle
I. S. Coggeshall	C. W. Horn
Melville Eastham	George Lewis
Lloyd Espenschied	G. T. Royden

## AWARDS

Ralph Bown, *Chairman*

Melville Eastham	C. B. Jolliffe
G. E. Gustafson	F. B. Llewellyn
C. M. Jansky, Jr.	F. E. Terman
H. A. Wheeler	

## BOARD OF EDITORS

Alfred N. Goldsmith, *Chairman*

R. R. Batcher	H. F. Olson
P. S. Carter	G. W. Pickard
L. M. Clement	Haraden Pratt
E. W. Engstrom	C. A. Priest
W. L. Everitt	L. J. Sivian
P. C. Goldmark	L. C. Smeby
F. W. Grover	B. J. Thompson
C. M. Jansky, Jr.	H. A. Wheeler
J. D. Kraus	L. P. Wheeler
F. B. Llewellyn	L. W. Whittemore
S. S. Mackeown	G. W. Willard
E. L. Nelson	William Wilson

C. J. Young

## CONSTITUTION AND LAWS

Austin Bailey, *Chairman*

I. S. Coggeshall	L. C. F. Horle
R. A. Heising	H. M. Turner
H. R. Zeamans	

## EXECUTIVE

A. F. Van Dyck, *Chairman*Haraden Pratt, *Vice Chairman*

I. S. Coggeshall	F. B. Llewellyn
Alfred N. Goldsmith	B. J. Thompson
H. P. Westman, <i>Secretary</i>	

## MEMBERSHIP

F. E. Terman, *Chairman*

V. J. Andrew	J. G. Kreer, Jr.
C. M. Burrill	J. P. Minton
J. M. Clayton	A. Preisman
R. I. Co'e	Bernard Salzberg
E. D. Cook	R. L. Snyder
A. V. Eastman	J. C. Stroebel
Noel Eldred	Sarkes Tarzian
W. L. Everitt	K. S. Van Dyke
D. G. Fink	H. M. Wagner
E. W. Herold	Ernst Weber
C. M. Jansky, Jr.	H. A. Wheeler
Jack Yolles	

## NEW YORK PROGRAM

Keith Henney, *Chairman*

C. B. Aiken	F. A. Hinners
Wilson Aull, Jr.	G. T. Royden
E. J. Content	B. E. Shackelford

## NOMINATIONS

H. H. Beverage, *Chairman*

Ralph Bown	J. K. Johnson
W. L. Everitt	W. W. Lindsay, Jr.
C. M. Jansky, Jr.	Haraden Pratt
L. P. Wheeler	

## PAPERS

William Wilson, *Chairman*F. B. Llewellyn, *Vice Chairman*

H. A. Affel	D. K. Martin
J. L. Callahan	Knox McIlwain
N. P. Case	H. R. Mimno
J. K. Clapp	G. G. Muller
I. S. Coggeshall	A. F. Murray
F. W. Cunningham	Benjamin Olney
R. B. Dome	H. O. Peterson
W. G. Dow	J. R. Poppele
E. B. Ferrell	Simon Ramo
F. W. Grover	F. X. Rettenmeyer
O. B. Hanson	P. C. Sandretto
J. V. L. Hogan	S. A. Schelkunoff
F. V. Hunt	D. B. Sinclair
Harley Iams	H. M. Turner
L. F. Jones	Dayton Ulrey
J. G. Kreer	W. C. White
F. R. Lack	Irving Wolff
H. C. Leuteritz	J. W. Wright

H. A. Zeamans

## PAPERS PROCUREMENT

D. D. Israel, *Chairman*W. L. Everitt, *Vice Chairman*J. R. Pierce, *Second Vice Chairman*

W. L. Barrow	D. E. Noble
E. L. Bowles	A. A. Oswald
J. E. Brown	J. R. Poppele
R. S. Burnap	P. C. Sandretto
E. L. Chaffee	W. L. Schwesinger
J. D'Agostino	B. E. Shackelford
E. T. Dickey	H. C. Sheve
A. V. Eastman	L. C. Smeby
D. E. Foster	Karl Spangenberg
Virgil M. Graham	H. M. Turner
O. B. Hanson	A. F. Van Dyck
F. V. Hunt	H. A. Wheeler
H. S. Knowles	L. P. Wheeler
H. K. Morgan	R. M. Wise

## PUBLIC RELATIONS

O. H. Caldwell, *Chairman*

E. K. Cohan	O. B. Hanson
D. G. Fink	D. D. Israel
G. W. Gilman	I. J. Kaar
George Grammer	F. X. Réttenmeyer
	R. M. Wise

## SECTIONS

R. A. Heising, *Chairman*

C. N. Anderson	L. C. F. Horle
I. S. Coggeshall	J. H. Miller
E. D. Cook	F. A. Polkinghorn
Virgil M. Graham	G. T. Royden
	L. P. Wheeler

## REGISTRATION OF ENGINEERS

H. B. Richmond, *Chairman*

J. K. Johnson	E. L. Nelson
---------------	--------------

## TELLERS

R. S. Burnap, *Chairman*

Beverly Dudley	C. E. Scholz
----------------	--------------

## TECHNICAL COMMITTEES

## ANNUAL REVIEW

L. E. Whittemore, *Chairman*

W. M. Angus	Keith Henney
W. G. Cady	I. J. Kaar
O. H. Caldwell	D. E. Noble
J. L. Callahan	E. G. Ports
J. H. Dellinger	H. A. Wheeler

## FREQUENCY MODULATION

D. E. Noble, *Chairman*

J. E. Brown	C. M. Jansky, Jr.
C. C. Chambers	V. D. Landon
W. F. Cotter	H. B. Marvin
Murray Crosby	B. E. Shackelford
W. L. Everitt	D. B. Smith
R. F. Guy	L. P. Wheeler
	Warren White

## ELECTROACOUSTICS

G. G. Muller, *Chairman*

S. J. Begun	George Nixon
F. V. Hunt	Benjamin Olney
V. N. James	H. F. Olson
Knox McIlwain	H. H. Scott
	L. J. Sivan

## PIEZOELECTRIC CRYSTALS

W. G. Cady, *Chairman*

C. F. Baldwin	W. P. Mason
W. L. Bond	J. M. Wolfskill
J. K. Clapp	K. S. Van Dyke

## ELECTRONICS

R. S. Burnap, *Chairman*

E. L. Chaffee	Ben Kievit, Jr.
H. P. Corwith	I. E. Mouromtseff
K. C. DeWalt	L. S. Nergaard
W. G. Dow	G. D. O'Neill
R. L. Freeman	H. W. Parker
T. T. Goldsmith, Jr.	H. J. Reich
L. B. Headrick	C. M. Wheeler
S. B. Ingram	J. R. Wilson

## RADIO RECEIVERS

W. M. Angus, *Chairman*

G. L. Beers	D. E. Foster
W. M. Breazeale	C. J. Franks
W. F. Cotter	David Grimes
Harry Diamond	J. K. Johnson
W. L. Dunn	Garrard Mountjoy
H. B. Fischer	H. O. Peterson
H. C. Forbes	A. E. Thiessen
	R. M. Wilmotte

## FACSIMILE

J. L. Callahan, *Chairman*

E. P. Bancroft	J. V. L. Hogan
J. C. Barnes	Paul Lefko
F. R. Brick, Jr.	P. Mertz
Brown, W. A. R.	Charles Singer
G. V. Dillenback, Jr.	L. A. Smith
John Hancock	R. J. Wise
	C. J. Young

## RADIO WAVE PROPAGATION

J. H. Dellinger, *Chairman*

S. L. Bailey	H. R. Mimno
J. L. Barnes	K. A. Norton
C. R. Burrows	H. O. Peterson
W. A. Fitch	H. P. Thomas
G. D. Gillett	Warren White

## STANDARDS

H. A. Wheeler, *Chairman*

W. M. Angus	L. C. F. Horle
C. T. Burke	I. J. Kaar
W. G. Cady	D. E. Noble
J. L. Callahan	E. G. Ports
C. C. Chambers	A. E. Thiessen
Virgil M. Graham	H. M. Turner

## SYMBOLS

H. M. Turner, *Chairman*

R. R. Batcher	E. L. Chaffee
M. R. Briggs	E. T. Dickey
C. R. Burrows	O. T. Laube
E. W. Schafer	

## TELEVISION

I. J. Kaar, *Chairman*

H. S. Baird	R. R. Batcher
-------------	---------------

J. E. Brown
A. B. DuMont
D. E. Foster
P. C. Goldmark
T. T. Goldsmith, Jr.
A. G. Jensen
L. M. Leeds

H. M. Lewis
A. V. Loughren
H. T. Lyman
A. F. Murray
R. E. Shelby
D. B. Sinclair
D. B. Smith

## TRANSMITTERS AND ANTENNAS

E. G. Ports, *Chairman*

Raymond Asserson	Ronold King
M. R. Briggs	J. F. Morrison
W. W. Brown	J. C. Schelleng
Harry Diamond	Robert Serrell
F. A. Gunther	D. B. Sinclair
Raymond Guy	Warren White
W. E. Jackson	J. E. Young

## INSTITUTE REPRESENTATIVES IN COLLEGES

Alabama Polytechnic Institute: Woodrow Darling	Manhattan College: J. F. Reintjes
Alberta, University of: J. W. Porteous	Maryland, University of: G. L. Davies
British Columbia, University of: H. J. MacLeod	Massachusetts Institute of Technology: W. H. Radford and E. Guillemin
Brooklyn, Polytechnic Institute of: F. E. Canavaciol	McGill University: F. S. Howes
California Institute of Technology: S. S. Mackeown (Alternate, William Pickering)	Michigan, University of: L. N. Holland
California, University of: L. J. Black	Minnesota, University of: H. E. Hartig
Carleton College: C. A. Culver	Montana State College: G. J. Fiedler
Carnegie Institute of Technology: R. T. Gabler	Nebraska, University of: F. W. Norris
Case School of Applied Science: P. L. Hoover	Newark College of Engineering: Solomon Fishman
Cincinnati, University of: W. C. Osterbrock	New Mexico, University of: H. L. Jones
Colorado, University of: J. M. Cage	New York College of the City of: Maxwell Henry
Columbia University: J. B. Russell	New York University: Philip Greenstein
Connecticut, University of: P. H. Nelson	North Dakota, University of: E. J. O'Brien
Cooper Union: J. B. Sherman	Northeastern University: G. E. Pihl
Cornell University: True McLean	Northwestern University: A. B. Bronwell
Drexel Institute of Technology: R. T. Zern	Notre Dame, University of: H. E. Ellithorn
Duke University: W. J. Seeley	Ohio State University: E. C. Jordan
Florida, University of: Joseph Weil	Oklahoma Agricultural and Mechanical College: H. T. Fristoe
Georgia Institute of Technology: M. A. Honnell	Pennsylvania State College: G. H. Crossley
Harvard University: E. L. Chaffee	Pennsylvania, University of: C. C. Chambers
Idaho, University of: Hubert Hatstrup	Pittsburgh, University of: R. C. Gorham
Illinois Institute of Technology: P. G. Andres	Princeton University: J. G. Barry
Illinois, University of: H. J. Reich	Purdue University: R. P. Siskind
Iowa, University of: R. C. Kent	Rensselaer Polytechnic Institute: H. D. Harris
Johns Hopkins University: Ferdinand Hamburger, Jr.	Rose Polytechnic Institute: H. A. Moench
Kansas State College: Karl Martin	Rutgers University: J. L. Potter
Kansas, University of: S. E. Clements	Southern California, University of: J. K. Nunan
Kentucky, University of: E. B. Doll	Southern Methodist University: R. E. Beam
La Plata: Jean Arnaud	Stanford University: Karl Spangenberg
Lawrence Institute of Technology: H. L. Byerlay	Stevens Institute of Technology: F. C. Stockwell
Lehigh University: H. C. Knutson	Texas, University of: E. W. Hamlin
Louisiana State University: Taintor Parkinson	Toronto, University of: B. de F. Bayly
Maine, University of: W. J. Creamer, Jr.	

Tufts College: J. L. Barnes	Wayne University: G. W. Carter
Union College: F. W. Grover	Western Ontario, University of: G. A. Woonton
United States Military Academy: E. C. Gillette, Jr.	West Virginia University: R. C. Colwell
United States Naval Academy: G. R. Giet	Wisconsin, University of: Glenn Koehler
Utah, University of: O. C. Haycock	Worcester Polytechnic Institute: H. H. Newell
Virginia Polytechnic Institute: W. A. Murray	Wyoming, University of: Carl Brown
Washington, University of: A. V. Eastman	Yale University: H. M. Turner
Washington University: R. S. Glasgow	

### INSTITUTE REPRESENTATIVES ON OTHER BODIES

A.I.E.E.—Subcommittee on Radio of the Committee on Applications to Marine Work	T. E. NIVISON AND J. L. PRESTON
American Documentation Institute	C. M. JANSKY, JR.
Committee on Applied Physics	WILLIAM WILSON
Council of the American Association for the Advancement of Science	J. C. JENSEN
Engineering Index National Committee	MELVILLE EASTHAM
Joint Co-ordination Committee on Radio Reception of the N.E.L.A., N.E.M.A., and R.M.A.	C. E. BRIGHAM
National Advisory Council on Radio in Education, Committee on Engineering Developments	LLOYD ESPENSCHIED, ALFRED N. GOLDSMITH, C. W. HORN, L. M. HULL, AND R. H. MARRIOTT
National Television Systems Committee	ALFRED N. GOLDSMITH (H. A. WHEELER, alternate)
Panel 2	ALFRED N. GOLDSMITH, chairman
Panel 4	E. G. PORTS
Panel 8	KNOX MCILWAIN
New York City Advisory Board on Industrial Education	H. P. WESTMAN
Planning Committee, National Conference on Educational Broadcasting, American Council on Education	C. M. JANSKY, JR., C. B. JOLLIFFE, AND E. L. NELSON
U.R.S.I. (International Scientific Radio Union) Executive Committee	C. M. JANSKY, JR.
U. S. National Committee, Advisers on Electrical Measuring Instruments	MELVILLE EASTHAM AND HAROLD OLESEN
U. S. National Committee, Advisers on Symbols	L. E. WHITTEMORE AND J. W. HORTON

### AMERICAN STANDARDS ASSOCIATION

Standards Council	ALFRED N. GOLDSMITH (H. P. WESTMAN, alternate)
Board of Examination	H. P. WESTMAN, chairman
Electrical Standards Committee	H. M. TURNER (H. P. WESTMAN, alternate)
Sectional Committee on Acoustical Measurements and Terminology	E. D. COOK AND H. F. OLSON
Sectional Committee on Definitions of Electrical Terms	HARADEN PRATT
Subcommittee on Vacuum Tubes	B. E. SHACKELFORD
Sectional Committee on Electric and Magnetic Magnitudes and Units	J. H. DELLINGER
Sectional Committee on Electrical Installations on Shipboard	I. F. BYRNES AND V. R. RUSS
Sectional Committee on Electrical Measuring Instruments	WILSON AULL
Sectional Committee on Graphical Symbols and Abbreviations for Use on Drawings	AUSTIN BAILEY (H. P. WESTMAN, alternate)
Subcommittee on Communication Symbols	H. M. TURNER
Sectional Committee on Letter Symbols and Abbreviations for Science and Engineering	H. M. TURNER
Subcommittee on Letter Symbols for Radio Use	H. M. TURNER
Sectional Committee on National Electrical Safety Code, Subcommittee on Article 810, Radio Broadcast Reception Equipment	E. T. DICKEY (VIRGIL M. GRAHAM, alternate)
Sectional Committee on Preferred Numbers	A. F. VAN DYCK
Sectional Committee on Radio	ALFRED N. GOLDSMITH, chairman; HARADEN PRATT, AND L. E. WHITTEMORE
Sectional Committee on Radio-Electrical Co-ordination	J. V. L. HOGAN, C. M. JANSKY, JR., AND L. E. WHITTEMORE
Sectional Committee on Specifications for Dry Cells and Batteries	H. M. TURNER
Sectional Committee on Standards for Drawings and Drafting Room Practices	AUSTIN BAILEY
Sectional Committee on Vacuum Tubes for Industrial Purposes	B. E. SHACKELFORD



# Contributors



ALDA V. BEDFORD

Alda V. Bedford (A'31) was born in Winters, Texas, on January 6, 1904. He received the B.S. degree in electrical engineering from the University of Texas in 1925. While at the University he spent one summer with the Dallas Power and Light Company, and during the latter part of his school term he was engaged as assistant in the physics department. In 1925 Mr. Bedford joined the General Electric Company, starting in the general engineering department and later transferring to the testing department and research laboratories, working on sound recording by film and disk, audio-frequency amplifiers, loudspeakers, sound printers for film, and television. While in Schenectady he obtained the M.S. degree in electrical engineering from Union College. Since 1929 he has been employed in the laboratories of the RCA Manufacturing Company, first on disk sound recording and then on television. He received a "Modern Pioneer" award from the National Association of Manufacturers in February, 1940, for inventions in television.



G. L. FREDENDALL

Charles M. Burrill (A'24-M'30) studied electrical engineering at the University of Minnesota, graduating in 1923. He then went with the General Electrical Company. Following three years of general training in the General Electric advanced course in engineering, he joined the radio engineering department, and in 1927 was placed in charge of tuned-radio-frequency receiver development. Since 1930 Mr. Burrill has been with RCA at Camden, N. J., with the exception of a year and a half in 1931-1932 spent with the Rogers-Majestic Corporation of Toronto, Canada, in charge of research. Since returning to Camden he has been engaged in general research, first in sound recording, and more recently in interference and noise suppression and in ultra-short-wave propagation. He is a member of Tau Beta Pi, Eta Kappa Nu, Sigma Xi, and the Franklin Institute.



CHARLES M. BURRILL

G. L. Fredendall (A'41) received the Ph.D. degree from the University of Wisconsin. From 1931 to 1936 he was at the University teaching electrical engineering, mathematics, and doing research work in mercury-arc phenomena. Since 1936 he has been with the RCA Manufacturing Company engaged in television research.

Irvin E. Fair (A'39) was born at Iola, Kansas, on June 30, 1907. He received the B.S. degree in electrical engineering from Iowa State College in 1929. The same year Mr. Fair entered the radio research department at the Bell Telephone Laboratories and has been engaged principally in the study of piezoelectric crystals and crystal oscillators.



MARTIAL A. HONNELL

Martial A. Honnell (A'40) was born on October 23, 1910, at Lyons, France. From 1928 to 1930 he was a shipboard radio operator with the Radiomarine Corporation of America. He received the B.S. degree in electrical engineering in 1934 and the M.S. degree in electrical engineering in 1940 from the Georgia School of Technology. Mr. Honnell was on the engineering staff of WGST from 1930 to 1936, and worked part-time for the Van Nostrand Radio Engineering Service of Atlanta in 1935. He was with the radio division of the Pan American Airways at Miami in 1936-1937. From 1937 to 1941 he was instructor of electrical engineering at the Georgia School of Technology, advancing to assistant professor in 1941, and is now head of the communication division of the electrical engineering department. He is a member of Tau Beta Pi and Eta Kappa Nu.

Ray D. Kell (A'35) received his B.S. degree in electrical engineering from the University of Illinois in 1926. From 1926 to 1930 he was engaged in television research in the radio consulting laboratory



IRVIN E. FAIR



RAY D. KELL

of the General Electric Company. From 1930 to the present time he has been a member of the research division of the RCA Manufacturing Company, where he has continued his work on various television problems. He received a "Modern Pioneer" award from the National Association of Manufacturers in February, 1940, for inventions in television. Mr. Kell is a member of Sigma Xi.



Henry N. Kozanowski (A'34), was born on August 15, 1907, at Buffalo, New York. He received the B.S. degree from the University of Buffalo in 1927; the M.A. degree in 1929; and the Ph.D. degree in physics from the University of Michigan in 1930. Dr. Kozanowski held a graduate teaching assistantship at the University of Buffalo during 1927 and 1928. He was a research assistant at the University of Michigan during 1929 and 1930. From 1930 to 1935 he was in the research laboratories, power tube section, of the Westinghouse Electric and Manufacturing Company. Since 1935 he has been in the research laboratories of the RCA Manufacturing Company. He is a member of Sigma Xi, Phi Beta Kappa, and the American Physical Society.



HENRY N. KOZANOWSKI

Warren P. Mason (A'36-F'42) was born in Colorado Springs, Colorado, on September 28, 1900. He received the B.S. degree in electrical engineering from the University of Kansas in 1921, the M.A. degree from Columbia University in 1924, and the Ph.D. degree in 1928 from Columbia. He has been a member of the research department of the Bell



WARREN P. MASON



W. E. RUDER

Telephone Laboratories since 1921. His work has been mainly with wave propagation networks, both electrical and mechanical, and with piezoelectric crystals. Dr. Mason is now head of the department investigating piezoelectric crystals. He is a member of the Physical Society and a Fellow of the Acoustical Society.



W. E. Ruder was born in Stockdale, Pennsylvania. He is a graduate of Southwestern State Normal School and of Pennsylvania State College.

Mr. Ruder has been with the General Electric Company since 1907. In 1920 he was made head of the magnetic section of the research laboratory, and has been head of the metallurgical and magnetic section since 1938. He is the holder of many patents on magnetic and metallurgical processes and products, such as calorizing, alnico magnets, resistance alloys, magnetic sheet materials, etc., and is the author of many papers on metallurgical and magnetic subjects. He is a director of the Allegheny Ludlum Steel Corporation and a member of Theta Xi Fraternity, American Iron and Steel Institute, American Society for Metals, American Association for the Advancement of Science, and the American Institute of Mining and Metallurgical Engineers.



# UNFINISHED BUSINESS...

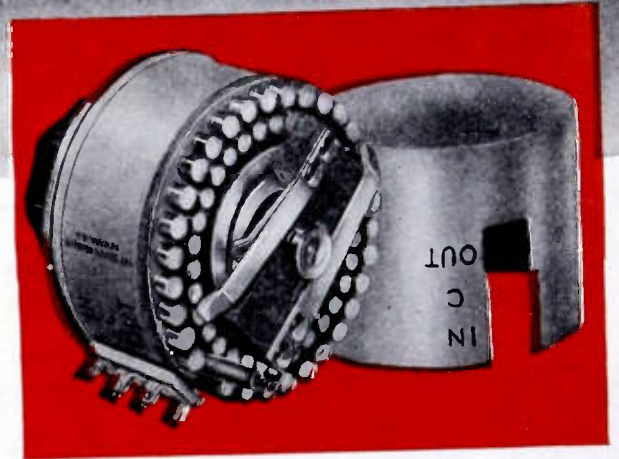

Our fighting men have undertaken to complete a job. We, in turn, are determined that they shall have the necessary tools to do so. Commercial requirements must be subordinated.

When normal conditions return, we will be proud to offer not only our most complete line of precision attenuators in the world, but many advanced types of laboratory test equipment for use in electrical, broadcast, sound picture and television fields.

# THE DAVEN COMPANY

158 SUMMIT STREET

NEWARK, NEW JERSEY

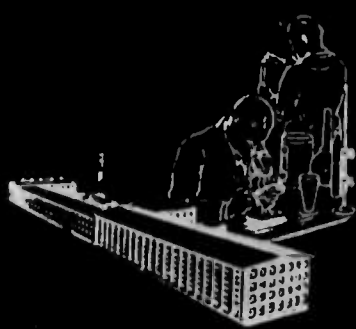

# Condenser Problems **SOLVED!**

**T**HE same engineering leadership that characterized Sprague peace-time activities has today long since been devoted exclusively—and on a greatly accelerated basis—to problems of winning the war. Following are a few of the Sprague developments which are proving helpful.

**ELECTROLYTIC CONDENSERS FOR AIR-PLANE USE**—Yes—electrolytics can fly safely and perform faithfully, even at high altitudes and resulting low temperatures. Sprague has developed a special, fully proved type for this purpose.

**PAPER CONDENSERS THAT STAND UP UNDER KILOVOLTS TO 90° C.** It's not much of a trick to make paper condensers to stand high voltages at moderate temperatures—or much more difficult to make them to stand low voltages at high temperatures. Sprague engineering, however, has produced a unique combination of the two—high-voltage condensers (from 5,000 to 15,000 volts) with ambient temperatures of the order of 90° C.!

**CONDENSERS THAT WILL STAND PULSE VOLTAGES**—Sprague engineers have made a special study of this field.

**PAPER CONDENSERS TO READ "OFF SCALE" ON MEGOHM BRIDGES**—Sprague produces a special type that reads "off scale" on megohm meters. \*

**SATISFACTORY MICA CONDENSER SUBSTITUTES**—Sprague makes them—in paper condenser types—proved beyond all question of doubt in dozens of applications where only mica units were previously used.

\* i.e. More than 200,000 megohms

**QUALITY COMPONENTS • EXPERTLY ENGINEERED • COMPETENTLY PRODUCED**

# SPRAGUE

## SPECIALTIES COMPANY

North Adams, Mass.

*Manufacturers of a complete line of radio and industrial capacitors and Koolohm Resistors.*



# Another Eimac Achievement

Illustration shows typical application of electromagnet actuating coil to Vacuum Relay. In certain installations outside flash-overs are eliminated by use of ball type connectors.

## Solves a Tough Electrical Problem

Handling 20,000 volts RF potential with this Eimac vacuum relay is as easy as turning on your living room lights.

Over two years ago Eimac engineers developed this strange looking vacuum tube which has been seeing service ever since. It is a single pole double throw relay used for many high voltage switching applications. Although the contact spacing is only .015", no arc-over is experienced inside the tube. Changes in air pressure and humidity, such as encountered in aviation, have no effect on the breakdown within the relay, because the contacts are in vacuum. Actually a flash-over will occur across the outside terminals before breaking down within. A tribute to the high degree of vacuum attained on Eimac pumps.

This development is a direct outcome of the far-reaching advancements made possible through the Eimac technique of vacuum tube construction. A typical example of why Eimac transmitting tubes are first choice of leading engineers throughout the world.

*Follow the leaders to Eimac Tubes*

# Eimac

## VACUUM RELAY

Manufactured by  
**EITEL - McCULLOUGH, INC.**  
San Bruno, California, U. S. A.

Export Agents: FRAZAR & CO., LTD., 301 Clay St., San Francisco, California, U. S. A.

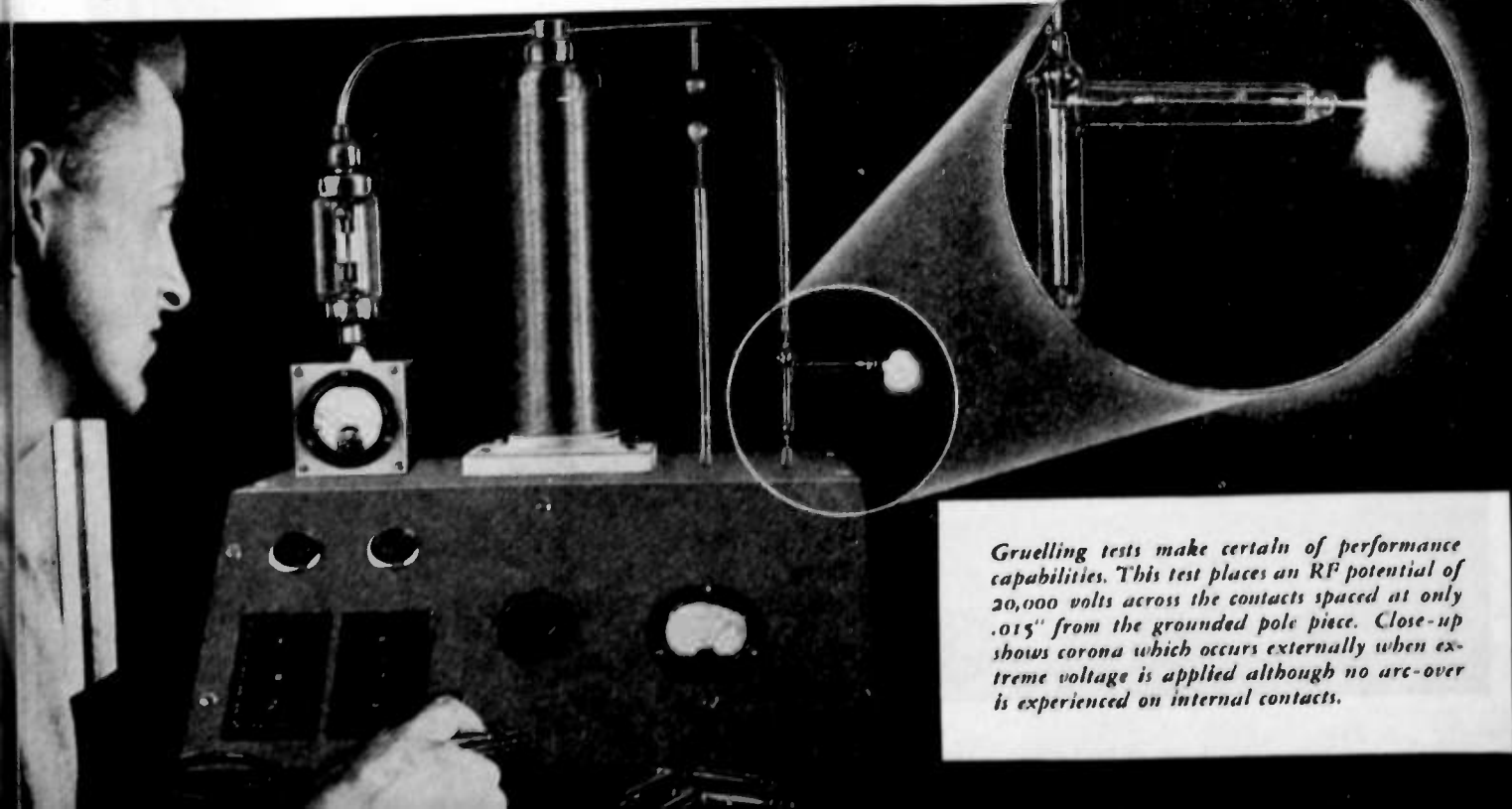

Gruelling tests make certain of performance capabilities. This test places an RF potential of 20,000 volts across the contacts spaced at only .015" from the grounded pole piece. Close-up shows corona which occurs externally when extreme voltage is applied although no arc-over is experienced on internal contacts.

# Electroneering is our business!

ELECTRONEERING is the word we have coined to symbolize the part we are playing in the conquest of the stirring new world of Electronics.

Behind the closed doors of the RAULAND laboratories, new visions, new ideas, new discoveries are unfolding themselves. Here, scores of new vacuum devices are blazing new trails in the fields of Television, Broadcasting, Communications, and Sound.

But first and foremost, we at RAULAND are at war—along with 130,000,000 other fighting Americans. All of our energies, experience, engineering ingenuity, and manufacturing resources are at work on military communications, building the vital sinews of

modern warfare. Electroneering for American victory is our main business.

We are not unmindful, however, that since 1922 we have been at the service of the radio industry. We feel, therefore, that it is our obligation to tell you something about our present activities. It is our plan to give you, from time to time, worthwhile information (within the limits of government

regulations) describing unique advances in electronic design and in techniques of manufacture that symbolize the RAULAND ideal in Electroneering.

We hope to make these messages interesting and informative—to keep you posted on the scope of RAULAND'S engineering and manufacturing activities—against the day when we can once again share these resources with you.

## Rauland

RADIO • SOUND • COMMUNICATIONS

The Rauland Corporation • Chicago, Illinois



The new laboratories and plant of the RAULAND Corporation—a superb setting for forward-looking research and precision manufacturing.

★ THE ALCO PLANT WAS ON THE FIRST LIST OF 43 AWARDS FOR EXCELLENCE IN QUALITY AND QUANTITY OF WAR PRODUCTION ★



AWARDED JULY 27, 1942  
ARMY - NAVY PRODUCTION AWARD



*I*N THE SHADOW of war-historic Lookout Mountain, within gun shot of America's bloodiest battlefield at Chickamauga, on soil hallowed by the best blood of North and South — there proudly flies the Army-Navy burgee.

Nearly a hundred years ago in the Mexican War of 1846, when Tennessee exceeded its quota by supplying 30,000 troops instead of 2,800, it earned, and has retained, its title as the "Volunteer State." Perhaps there is significance in the fact that this area was one of the first in the land to receive an Army-Navy combination award for excellence in quality and quantity of war production. A star is offered by the Army-Navy for every period of six months in which the record of high production is maintained.

Our employees, whose achievements in the production of ALSiMAG steatite ceramic insulation constitute the real glory of the award, wish to publicly record their determination to earn a Service Star every 180 days. This is not at all for our aggrandizement, but as evidence of a stern resolution: "That our brave fighting forces on the water, on the land, in the air or under the seas shall never suffer from the lack of what we can supply." That shall be our goal and our pledge. This is our slogan:

WHILE AMERICA IS AT WAR,  
AMERICAN LAVA IS AT WORK

*Excerpts from Acceptance of the joint Army-Navy Burgee by Paul J. Kruesi, President*

★ ★ ★  
**ALSiMAG**  
TRADE MARK REGISTERED U. S. PATENT OFFICE

★ ★ ★  
**AMERICAN LAVA CORPORATION**  
CHATTANOOGA, TENNESSEE

CHICAGO • CLEVELAND • NEW YORK • ST. LOUIS • LOS ANGELES • SAN FRANCISCO • BOSTON • PHILADELPHIA • WASHINGTON, D. C.

# "FIGHTING" MICROPHONES

*in the Din of Battle*



In a Flying Fortress . . . in a General Grant . . . in a battleship or a shell hole . . . when the Microphone switch is pressed — the message must get through! Millions of lives may depend on it. This is the supreme test. Microphones made by Shure Brothers are in action on fighting fronts all over the world. Shure Microphones pass this supreme test because they have survived engineering and production tests more destructive than conditions they meet in service. These "Fighting Mikes" do their part in serving the cause of Freedom.

**SHURE BROTHERS**

*Designers and Manufacturers of Microphones and Acoustic Devices*

225 West Huron Street, Chicago, U. S. A.



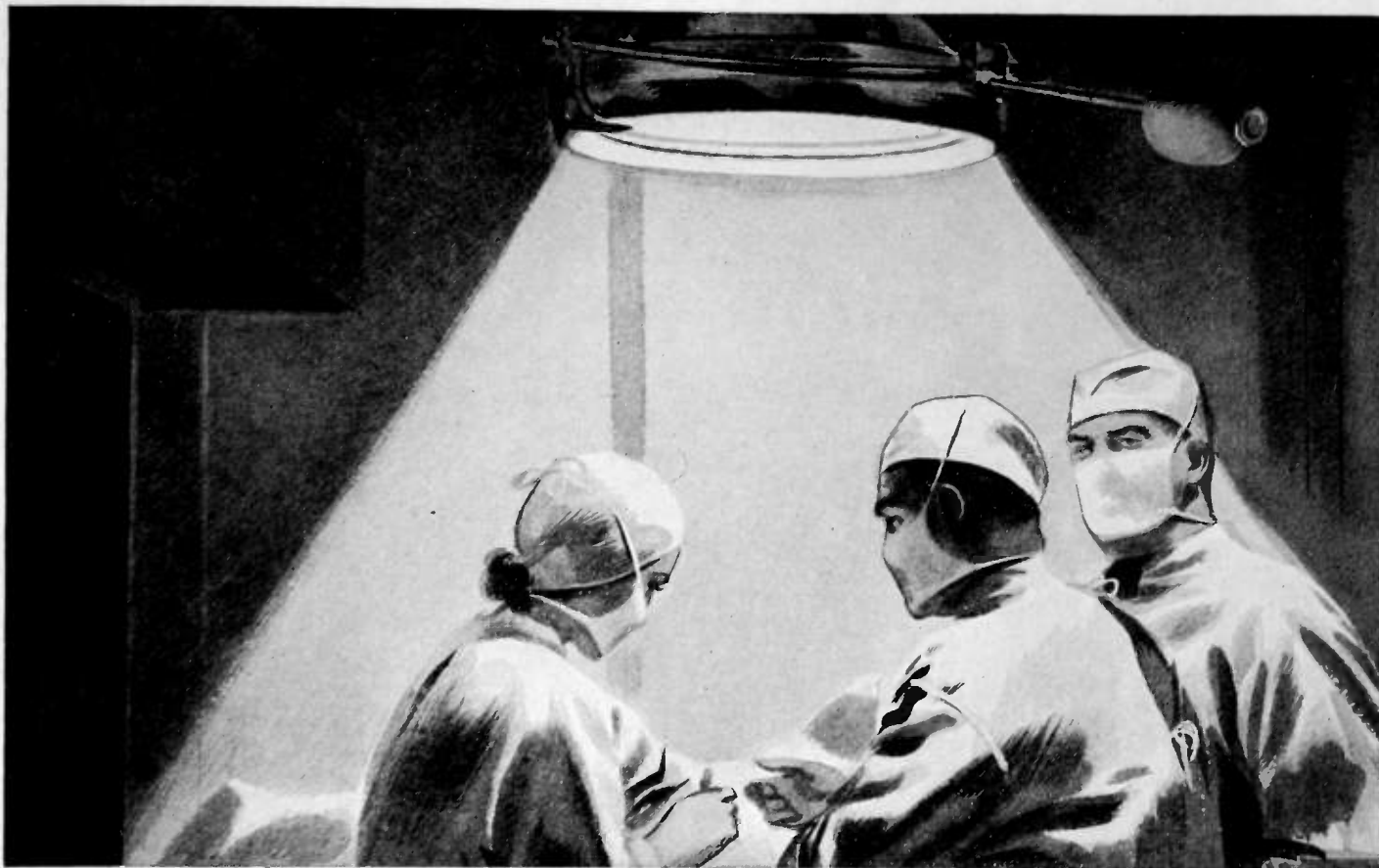

## Abandon hope . . . all Germs who enter here

**S**CIENTISTS HAVE LONG KNOWN that certain wave lengths in the ultraviolet spectrum are true "death rays" to the world of bacteria.

The rays in the narrow region of 2500-2600 Angstrom units . . . about 1/100,000 of an inch in length . . . were found to have the greatest bacteria-killing power.

The problem was to devise a practical and efficient device for transmitting selected ultraviolet radiations within a given bactericidal range.

The device must not generate a lot of heat. It should have long life. It should be inexpensive and easy to install and operate. Most of its radiation must be in the region of peak bactericidal effectiveness. It must produce only a limited amount of ozone.

Some years ago one of the scientists of the Westinghouse (Lamp Division) Re-

search Laboratory, which is under the direction of Dr. Harvey C. Rentschler, produced an ultraviolet generator meeting these difficult requirements.

Further research and patient effort brought about a commercial ultraviolet bactericidal lamp that emitted about 84% of its ultraviolet at 2537 Angstrom units . . . a lamp that was efficient and relatively cool during operation . . . that produced an amount of ozone sufficient to correct odors and protect areas not directly irradiated, but insufficient to cause taste change or detrimentally affect food products. This lamp was marketed under the trade mark, *Sterilamp*.\*

In hospitals, the *Sterilamp*\* stops air-borne infections from entering wounds and incisions . . . by providing a protective zone of sterile, bacteria-free air around

\*Trade Mark Reg. U. S. Pat. Off.

the patient on the operating table.

When properly installed in air-conditioning systems in hospitals, schools, and nurseries, the *Sterilamp*\* is the most effective agent known for reducing cross-infection . . . the spread of air-borne contagious diseases.

The commercial applications of the *Sterilamp*\* are practically endless. It is used in the "Tenderay" process for tenderizing meat . . . and in bakeries, breweries, wineries, canneries, restaurants, biological laboratories, lavatories . . . wherever air-borne bacteria must be killed or controlled.

In the *Sterilamp*\*, Westinghouse "know how" has scored a notable victory over the invisible enemies of mankind. Today, Westinghouse scientists are hard at work developing weapons that will score the same kind of victory in our war against the Axis.



# Westinghouse

WESTINGHOUSE ELECTRIC & MANUFACTURING COMPANY, PITTSBURGH, PENNSYLVANIA • PLANTS IN 25 CITIES—OFFICES EVERYWHERE

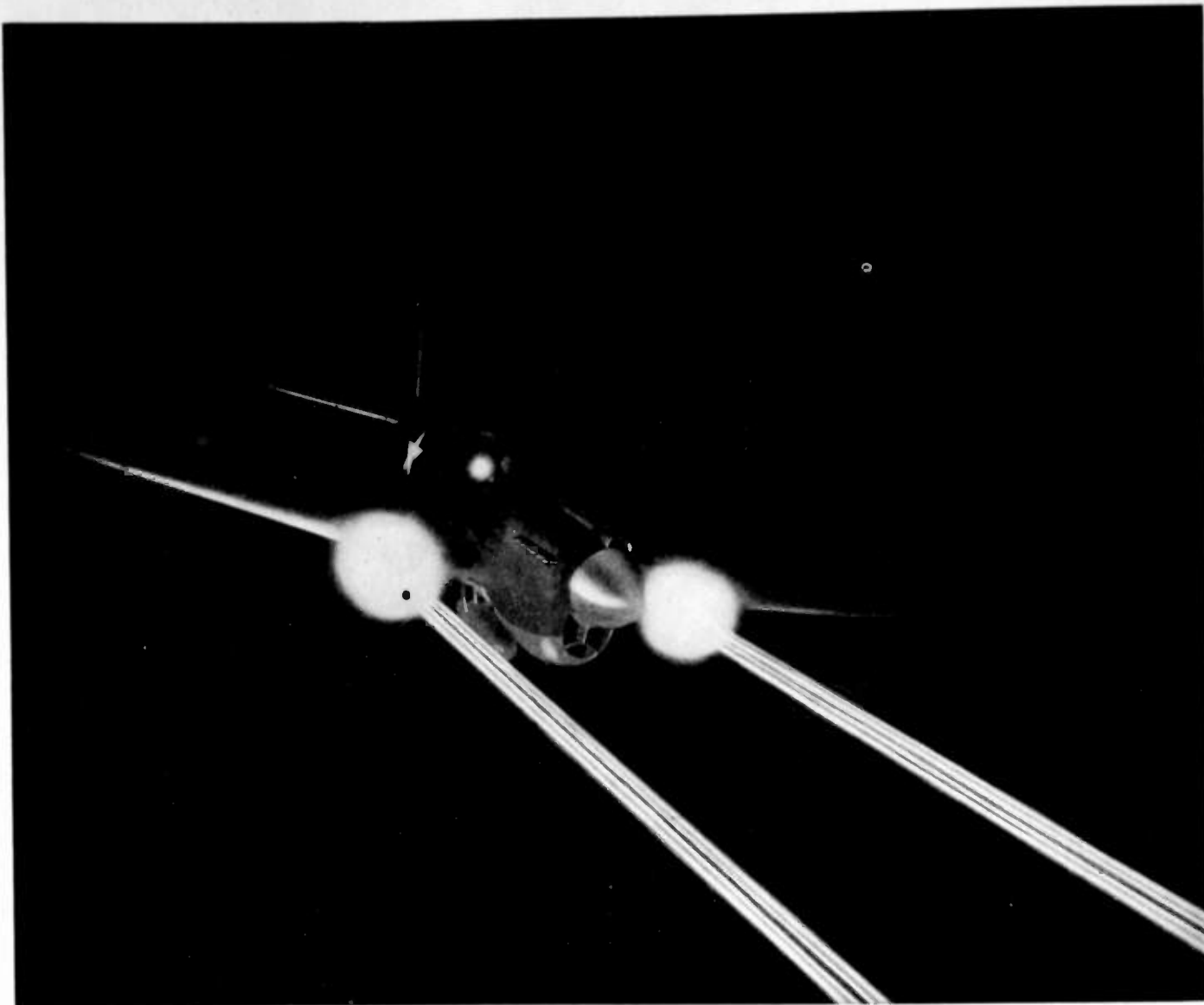

## He's firing telephone wire at a Zero!

**T**his fighter plane, with its six wing guns spitting fire, uses up enough copper every minute to make several miles of telephone line.

That's the right use for copper now — and it's the reason why we can't continue to expand our facilities to take care of the expanding Long Distance telephone traffic.

Right now, our lines are flooded with Long Distance calls. Most of them have to do with the war — they must have the right of way.

Will you help us keep the wires clear for war calls — industrial calls that send a plane down the assembly line — military calls that send it into the air against the enemy?

You can do it by keeping your own calls as few and as brief as possible. And you'll be bringing Victory that much nearer.

**Bell Telephone System**



*When Space is at a Premium*

**TRIPLET**  
*Thin Line*  
**INSTRUMENTS**



Full size of Instrument. Note deep shroud for glass protection—and "Quick-Look" Scale.

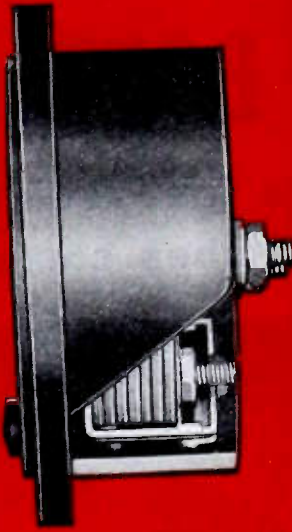

This molded case contains full size Triplet Mechanism. Rugged Construction—Compact Convenience.

**THIS IS THE INSIDE STORY**

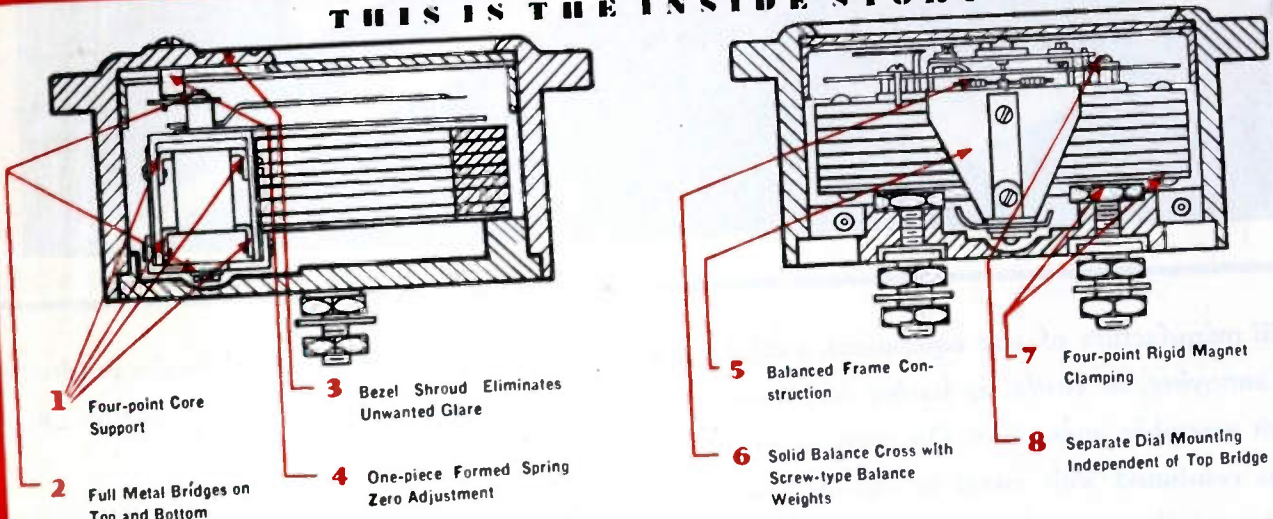

Thin-Line Instruments also have Standard Large Coil Triplet Movements. Furnished with Osmium pivots for special requirements. All these features make for greater rigidity under vibration; greater permanence of calibration; greater user satisfaction.

**TRIPLET**  
*Thin Line*

memo

FOR CIRCULATION TO...

Triplet Thin-Line Instruments meet rigid requirements for dependable performance. Though occupying minimum space they are *not* miniatures. Mechanisms are standard size with emphasis on excellent performance over long periods. Standardized installation. Made in three styles of cases — Molded, Metal Wide Rim and Metal Narrow Rim.

Triplet Thin-Line Instruments, available for many industrial applications, can be depended upon for precision performance in limited space. For full details write for "Triplet Thin-Line Bulletin".

**THE TRIPLET ELECTRICAL INSTRUMENT CO., CLEVELAND, OHIO, U. S. A.**

PLEASE INSERT INITIALS OF YOUR EXECUTIVES

✓

# MINOR ASSEMBLY OPERATIONS YOUR BOTTLENECK?

On parts that require steatite  
Isolantite furnishes complete assemblies

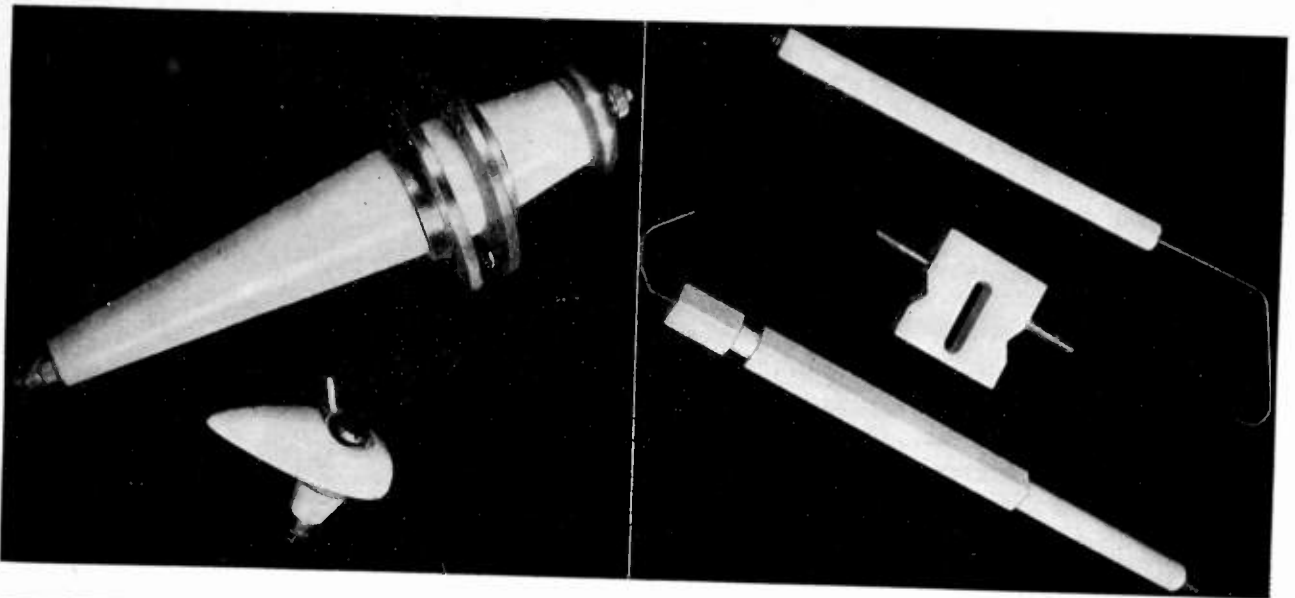

**I**N THE manufacture of war equipment, nothing is so annoying, or *costly*, as having to perform the minor assembly operations. On parts in which steatite is combined with metal in various forms, this burden can be avoided. When such assemblies are *furnished* by Isolantite Inc., it enables you to reserve your production facilities and trained personnel for major assembly tasks.

Among the insulators illustrated are several developed for aircraft. These offer convincing evidence of Isolantite's ability to supply assemblies that meet the most exacting demands. And point up a fact second in importance only to speed of production—the combination of advantages found in Isolantite\*.

Uniformity of product, high mechanical strength, electrical efficiency, non-absorption of moisture—all contribute to dependable insulation performance,

and make Isolantite's adaptability to the production of intricate shapes to accurate dimensions unusually significant.

Equipment manufacturers who can attribute their difficulties in meeting war production schedules to the necessity of performing a number of minor assembly operations may find welcome relief in Isolantite's service, and enjoy, in addition, all the advantages resulting from the use of high-grade insulation in their products.

## ISOLANTITE

**CERAMIC INSULATORS**

ISOLANTITE INC., BELLEVILLE, NEW JERSEY

\*Registered trade-name for the products of Isolantite Inc.

**THE INSTITUTE** serves those interested in radio and allied electrical communication fields through the presentation and publication of technical material.

**THE PROCEEDINGS** has been published without interruption since 1913 when the first issue appeared. The contents of each paper published in the **PROCEEDINGS** are the responsibility of the author and are not binding on the Institute or its members. Material appearing in it may be reprinted or abstracted in other publications on the express condition that specific reference shall be made to its original appearance in the **PROCEEDINGS**. Illustrations of any variety, however, may not be reproduced without specific permission from the Institute.

**STANDARDS** reports are published from time to time and are sent to each member without charge. The four current reports are on Electroacoustics, Electronics Radio Receivers, and Radio Transmitters and were published in 1938.

**MEMBERSHIP** has grown from a few dozen in 1912 to about seven thousand. Practically every country in the world in which radio engineers may be found is represented in our roster. Dues for the five grades of membership range from \$3.00 to \$10.00 per year. The **PROCEEDINGS** is sent to each member without further payment.

**SECTIONS** in twenty-six cities in the United States, Canada, and Argentina hold regular meetings. The chairmen and secretaries of these sections are listed on the page opposite the first article in this issue.

**SUBSCRIPTIONS** are accepted for the **PROCEEDINGS** at \$10.00 per year in the United States of America, its possessions, and Canada; when college and public libraries order direct from the Institute, the subscription price is \$5.00. For other countries there is an additional charge of \$1.00.

**The Institute of Radio Engineers, Inc.**  
Harold P. Westman, Secretary  
330 West 42nd Street  
New York, N.Y.

## The Institute of Radio Engineers

Incorporated

330 West 42nd Street, New York, N.Y.

To the Board of Directors

Gentlemen:

I hereby make application for ASSOCIATE membership in the Institute of Radio Engineers on the basis of my training and professional experience given herewith, and refer to the sponsors named below who are personally familiar with my work.

I certify that the statements made in the record of my training and professional experience are correct, and agree if elected, that I shall be governed by the Constitution of the Institute as long as I continue a member. Furthermore I agree to promote the objects of the Institute so far as shall be in my power.

.....  
(Sign with pen)

.....  
(Address for mail)

.....  
(City and State)

.....  
(Date)

### SPONSORS

(Signatures not required here)

Mr. ....

Address .....

City and State .....

Mr. ....

Address .....

City and State .....

Mr. ....

Address .....

City and State .....





# the resistors that knocked tradition into a cocked hat

**BY DOING THE JOBS CONVENTIONAL WIRE-WOUND RESISTORS COULDN'T HANDLE**

**T**HE unique and exclusive construction of KOOLOHM resistors has completely revolutionized previous conceptions of wire-wound resistor design. It has freed engineers from use limitations which a few years ago they regarded as "necessary evils."

KOOLOHMS are the only resistors made with wire that is ceramic insulated *BEFORE* it is wound. This one feature alone provides you with advantages that no other wire-wound resistor can give you. It furnishes absolute protection against shorts and changed values. It makes possible extremely high resistance values in amazingly small-size units. It permits the use of larger, safer wire sizes. It permits full-rated wattage dissipation regardless of resistance value. This ceramic insulation on KOOLOHM wire is heat-proof to 1000° C. It is

moisture-proof and flexible and can either be layer wound or progressively wound in high density patterns. It allows perfect Ayrton-Perry windings, thus reducing inductance to negligible values, and also permits the design of units with predetermined inductance values. It makes possible the use of an *extra* outer protection in the form of chip-proof ceramic or shock-proof sealed glass casing. Thus *doubly* protected they can be easily and cheaply mounted directly to or against metal or grounded parts with *complete* resistor circuit insulation.

Thus, KOOLOHM superiority is not a matter of hair-splitting differences—it is *conspicuously* evident in any test you care to name.

Send for free samples and catalog—today!

SPRAGUE SPECIALTIES COMPANY (Resistor Division), North Adams, Mass.



Turns can't "swim" or short, when wound with KOOLOHM ceramic-insulated wire. Insulation has a dielectric strength of 350 volts per mil at 400° C.!



KOOLOHM construction permits perfect Ayrton-Perry windings. As a result, resistors are available having negligible inductance, even at 50 to 100 Mc.!



Section of KOOLOHM wire with ceramic insulation removed to show contrast between bare and insulated wire. This flexible, heat-proof insulation is actually applied to wire at a temperature of 1000° C.!



**SPRAGUE**

**KOOLOHM**

**WIRE-WOUND RESISTORS**





# What is Your Problem?

... Development or Production Testing?

The  $-hp$ - Resistance-Tuned Audio Oscillator utilizes a resistance-capacity network to control the frequency of oscillation. The effective "Q" of this network is maintained in a high order by a negative feedback amplifier so that the frequency is stable. Fundamentally the Resistance-Tuned Oscillator is much more stable and produces less distortion than the common types of variable frequency audio oscillators on the market today. Low temperature coefficient elements in the resistance network keep thermal drift at the very minimum. Furthermore, the thermal drift is not magnified as is the case with the beat frequency oscillator.

**DIRECT READING, LOGARITHMIC SCALE • NO ZERO SETTING**

A unique balancing circuit automatically selects proper operating point for the oscillator and keeps distortion at a low level at all times. Thus no manual adjustment of operating point is necessary.

For more complete information write direct to the factory. Technical data will be furnished without obligation.  
Write today... don't delay!

**HEWLETT  PACKARD  
COMPANY**

**BOX 135 J, STATION A, PALO ALTO, CALIFORNIA**

xiv

## Section Meetings

### BALTIMORE

"Telephone Equipment for the Remote Control of Radio Apparatus," by C. J. Dorr, Engineer, Automatic Electric Sales Company, May 15.

### CINCINNATI

"Patents in the War Program and Future Possibilities," by Alden D. Redfield, Legal Department, Crosley Corporation, June 23.

### CLEVELAND

"Radio Reminiscences," by Ralph M. Heintz, Jack and Heintz, Inc., May 28.  
"K Carrier Systems," by Charles E. Dutton, American Telephone and Telegraph Company, June 18.

### DETROIT

"The Application of Inductive Tuning to Ultra High Frequencies" by B. V. K. French, Engineer, P. R. Mallory Company, May 15.  
"Air-Raid-Warning Systems," by Edwin C. Denstadt, Controller, Air Raid Control Center, Detroit, June 19.

### ST. LOUIS

"Emergency Telephone Communication Equipment," by Newton B. Fowler, American Telephone and Telegraph Company, May 15.

## Membership

The following indicated admissions and transfers of memberships have been approved by the Admissions Committee. Objections to any of these should reach the Institute office by not later than October 31, 1942.

### Transfer to Member

Atwood, John B., R.C.A. Communications, Riverhead, L. I., N. Y.  
Becker, Stewart, 611 S. Gilpin St., Denver, Colo.  
Johnson, J. F., 4316 Whitman Ave., Seattle, Wash.  
Maser, Harold T., General Electric Co., Schenectady, N. Y.  
McFarlane, Maynard D., Massachusetts Institute of Technology, Cambridge, Mass.  
Piore, E. R., 325 Central Park West, New York, N. Y.  
Wysotzky, Michael Z., 3355-16 St., N. W., Washington, D. C.

### Admission to Member

Bramhall, F. B., Western Union Telegraph Co., 60 Hudson St., New York, N. Y.  
Carpenter, D. D., 269 Somerset W., Ottawa, Ont., Canada  
Dubinin, Alexei V., 1026-17 St., N. W., Washington, D. C.

(Continued on page xvi)



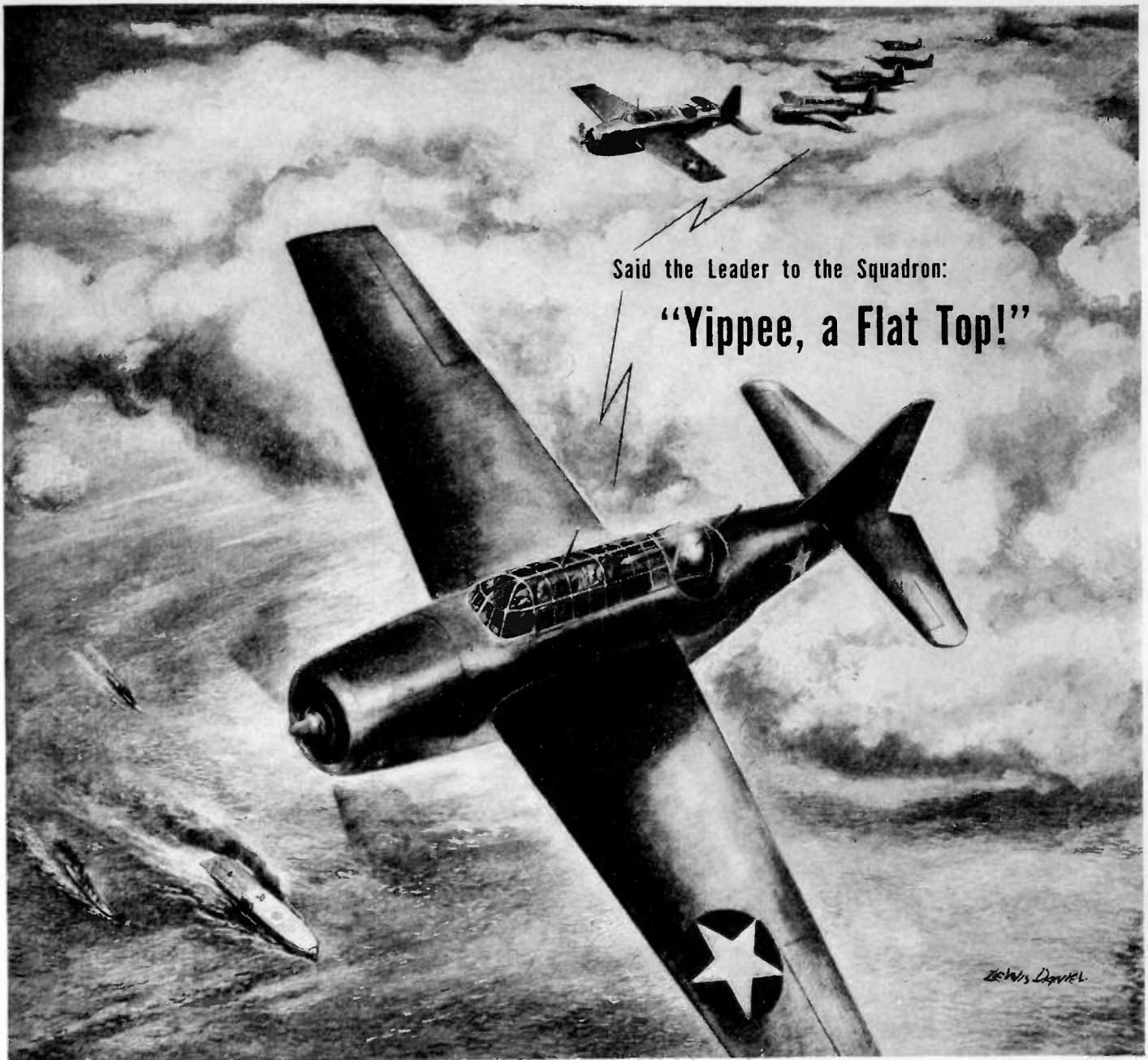

They work together better . . .  
because they can talk together

In both the Coral Sea battle  
And at Midway,  
The Japs were robbed of a sneak attack  
By scouting U. S. fliers,  
Who reported back by radio.

Then Uncle Sam's carrier-based planes,  
And land-based bombers  
With perfect team work  
Plastered the Jap task forces . . .  
Giving special attention to  
The enemy carriers.

And over the radiotelephones  
Of our planes and ships  
Came the phrase, "Scratch one flat top!"

The young American fliers  
Were telling the world  
Another Jap carrier  
Had gone to the bottom!

Modern communications equipment  
Designed and manufactured  
By I. T. & T. associate companies  
Is helping Uncle Sam  
Coordinate his fighting forces  
On land, sea and in the air.

The broad peacetime experience  
Of I. T. & T.  
In the field of communications  
Is proving its value in time of war.

INTERNATIONAL TELEPHONE AND TELEGRAPH CORPORATION 67 Broad St., New York, N. Y.

**IT&T**

*Associate Manufacturing Companies in the United States*

International Telephone & Radio Manufacturing Corporation  
Federal Telegraph Company

*From* **HEROIC  
DEFENSE..**



*...to* **Terrific  
Offense!**

Not so long ago American industry was putting up a heroic defense . . . a defense against time.

Today that picture has changed. Production "ahead of schedule" of vital equipment is making it possible for our boys to take the offensive. Thordarson is proud of the part it is playing in producing transformers so vital to our armed forces in launching a "Terrific Offense."

Official Photographs  
U. S. Marine Corps.

**THORDARSON**  
ELECTRIC MFG. CO.

500 WEST HURON STREET, CHICAGO, ILLINOIS

*Transformer Specialists Since 1895*

**Membership**

*(Continued from page xiv)*

- Marathe, D. H., Radio Electric, Ltd., Laminton Chambers, Bombay, No. 4, India
- McArthur, E. D., General Electric Co., Schenectady, N. Y.
- Neiman, M. S., 1026-17 St., N. W., Washington, D. C.
- Scully, C. T., 59 Sevenoako Way, St. Pauls Cray, Kent, England
- Simons, A. H., 54 Western Elms Ave., Reading, Berks., England
- van Dissel, G. F., 30 Fifth Ave., New York, N. Y.
- Wallis, Clifford M., University of Missouri, Columbia, Mo.

**Admission to Associate**

The following indicated admissions (or transfers where indicated as such) to Associate grade were approved on September 1, 1942.

- Albee, Charles, Lecombe Plaza, 58 and Hoffman Ave., Philadelphia, Pa.
- Anzjon, Arne E., KPFA, Helena, Mont.
- Austin, Frank M., 3103 Amherst St., Houston, Texas
- Aviles-Brunet Jesus M., Box 1331, Mayaguez, P. R.
- Barber, William H., 201 Barnsdale, Gardenville, N. Y.
- Bond, Conrad F. 7804 Linden Rd. Wyndmoor, Pa.
- Borgstrom, Howard P. M., Elcock Ave., Boonton, N. J.
- Bosman, Elmer H., 140-10 Franklin Ave., Flushing, N. Y.
- Brown, Harold A., Box 238, State College, N. M.
- Butz, A. Nelson, Jr., 7 Irving Ter., Cambridge, Mass.
- Carrillo, Efren A., 1301 D. Guerra St., C. Juarez, Chih., Mexico
- Cotty, William F., 36 Innes St., Kimberly, South Africa
- Cranger, Peter, 7285 Sunset Blvd., Hollywood, Calif.
- Curry, William F., 418 E. Bennett St., Springfield, Mo.
- Dahl, A. Donald, 215 N. Tenth St., Brainerd, Minn.
- Davids, Hugh H., 834 Hampton Ave., Schenectady, N. Y.
- Den Breems, A., 10 Rockefeller Plaza, New York, N. Y.
- Dervishian, Edward, 1440 N. Dearborn St., Chicago, Ill.
- Dougherty, Raleigh G., 786 Broad St., Newark, N. J.
- Easton, Allan, 32-15-35 St., Astoria, L. I., N. Y.
- Engh, Dick F., 5001 N. Tenth St., Tacoma, Wash.
- Ewing, Edward G., Admiralty Signal Establishment, G. P. O., London, England
- Feyerherm, Marvin P., RCA Manufacturing Co., Harrison, N. J.
- Fisher, Weston C., No. 3 Wireless School, RCAF, Winnipeg, Manit., Canada
- Fitzhugh, J. V., 1203 Breeden Ave., San Antonio, Texas
- Flockencier, Walter E., 508 N. Columbus St., Crestline, Ohio

*(Continued on page xviii)*



**"GET THE  
MESSAGE  
THROUGH"**



The troops who carry the crossed-flags-and-torch of the Signal Corps into combat are devoted to one essential task—"Get the message through!"

GAMMATRON tubes, with the same primary mission, are engineered to maintain communications under the most trying conditions.

Their sturdy mechanical construction prevents breakage from handling. Tantalum grids and plates . . . the absence of internal insulators and "getter" . . . plus improved pumping methods give positive assurance that these transmitting tubes will not fail due to accidental or intentional overload.

GAMMATRON tubes improve the efficiency of any circuit. They require a minimum of grid excitation, producing an extremely high power gain with few transmitter stages.

Today the unique performance, absolute continuity of operation, and the long life of GAMMATRON tubes are especially imperative.

Write for free booklet "13 Ways to Prolong Tube Life." It contains many helpful suggestions—and no advertising except on page 11.

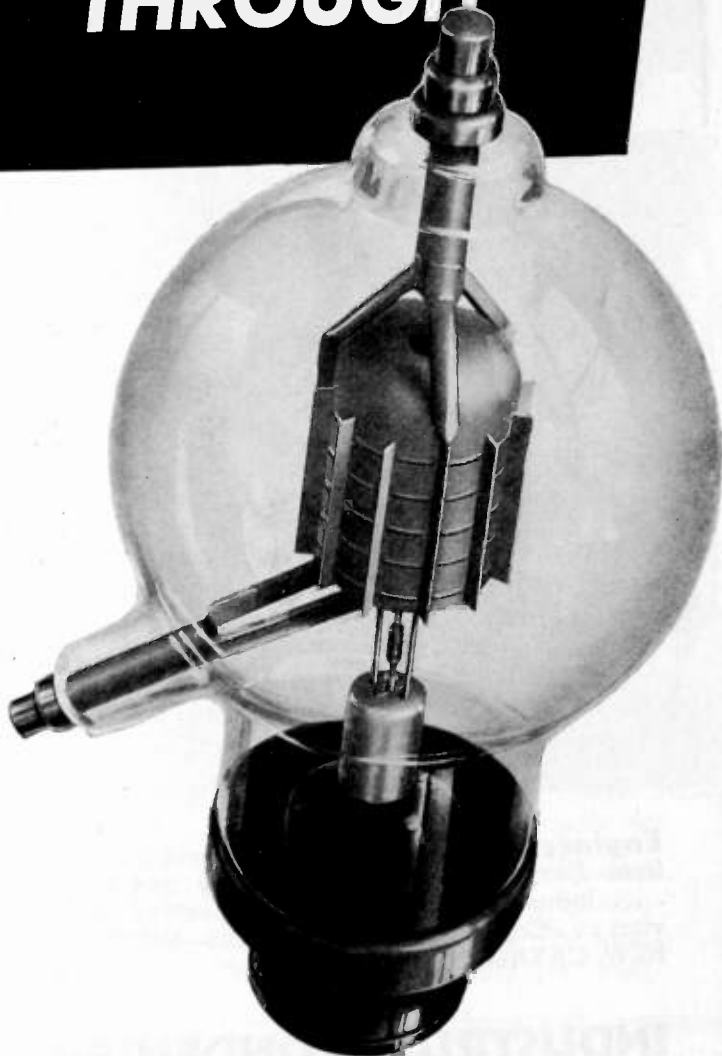

HK 1054 PLATE DISS. 750 WATTS  
MAX. POWER OUTPUT 3000 WATTS

**HEINTZ AND KAUFMAN**  
SOUTH SAN FRANCISCO LTD. CALIFORNIA U.S.A.

# GAMMATRONS OF COURSE!

# QUICK DELIVERY ON CONDENSERS!

**INDUSTRIAL CONDENSER CORP.**  
through a new distribution plan enables you to secure *small lots* of condensers locally. Contact the Industrial Condenser district office nearest you:

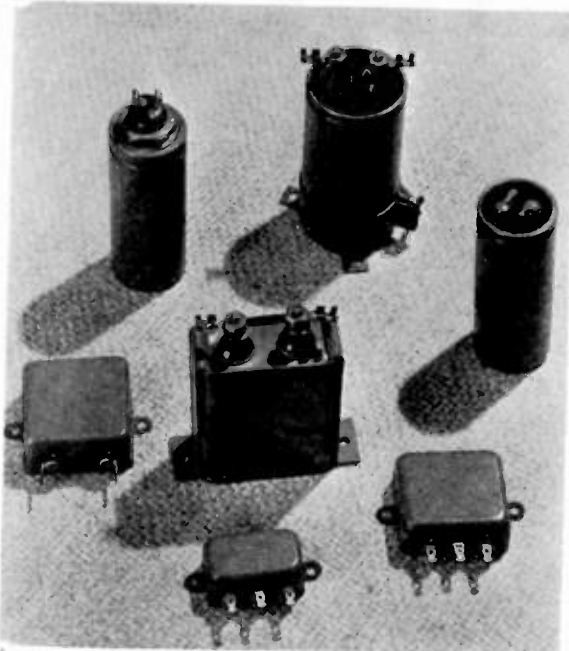

ADDRESS	TELEPHONE NO.
Box 1052 Dallas, Texas	Logan 6-1685
117 Water St. Boston, Mass.	Hancock 0200
2024 W. Eleventh St. Los Angeles, Calif.	Drexel 7163
Box 1202 Ashville, N.C.	7149-J
27 Park Place New York, N.Y.	Barclay 7-4977
Rm. 220—Medical Arts Bldg. 34th & Broadway Kansas City, Mo.	Westport 5323
1456 Waterbury Road Lakewood (Cleveland), Ohio	Academy 4932
2434 W. 22nd St. Minneapolis, Minn.	Kenwood 2833
1135 Lincoln Tower Ft. Wayne, Ind.	Anthony 5278
2016 Third Ave. Seattle, Wash.	Seneca 1088
Lutz (Tampa), Fla.	99-144
6432 Cass Ave. Detroit, Mich.	Madison 6300
401 N. Broad St. Philadelphia, Pa.	Walnut 4163

**Engineers Attention!** Condensers immediately available from distributors stocks meet Army and Navy requirements . . . Industrial Condensers are specified where precision is vital . . . Capacitors to 150,000 volts—WRITE FOR COMPLETE NEW CATALOG.

## INDUSTRIAL CONDENSER CORP.

1725 W. NORTH AVE.

CHICAGO, U.S.A.



**Manufacturers of Quality Oil, Wax and  
Electrolytic Capacitors**

## Membership

(Continued from page xvi)

- Gittelson, Frank, 118 W. 69 St., New York, N. Y.  
 Godsey, Marvin S., Box 232, Culpeper, Va.  
 Goldstein, Joseph E., 110 Belshaw Ave., Eatontown, N. J.  
 Greenough, Leighton, RCA Laboratories, Princeton, N. J.  
 Hagen, Harold M., 407 W. South St., Angola, Ind.  
 Harmon, William R., WMVA, Martinsville, Va.  
 Holbrook, R. A., 146 Lawrenceville Rd., Decatur, Ga.  
 Holmes, Leonard O., 9581 Hillhaven Ave., Tujunga, Calif.  
 Holt, Albert C., 385 Elm St., Oradell, N. J.  
 Hoover, Merle V., 302 W. Alexandria Ave., Alexandria, Va.  
 Houser, John A., 206 Park St., West Springfield, Mass.  
 Javna, Stephen L., 590 Fort Washington Ave., New York, N. Y.  
 Julian, Charles N., 4914 Holder Ave., Baltimore, Md.  
 Kennedy, William A., 517 Seventh St., Bremerton, Wash.  
 Kerr, George O., 30 Pansy Ave., Ottawa, Ont., Canada  
 Klahn, Richard H., Radio Laboratories, P.S.N.Y., Bremerton, Wash.  
 Krieger, Indore, 2201 W. 15 Ave., Gary, Ind.  
 Lebenbaum, Matthew T., Radio Research Laboratories, Harvard University, Cambridge, Mass.  
 Lee, Parkman, c/o G. & H. Taylor, 47 Mott Street, New York, N. Y.  
 Levine, Samuel, 2406 Ballentine Blvd., Norfolk, Va.  
 Liebson, Sidney H., 2005 O St., N. W., Washington, D. C.  
 Lind, David A., 1910—15 N., Seattle, Wash.  
 Madsen, R. G., Box 211, Mountain View, Calif.  
 Mellvaine, Douglas K., Box 292, Short Hills, N. J.  
 McKee, Herbert W., Naval Research Laboratory, Anacostia, D. C.  
 Meilander, Willard C., 412 W. Gilmore Ave., Angola, Ind.  
 Miller, Edward A., Acme Electric and Manufacturing Co., Cuba, N. Y.  
 Mumma, Harries A., Jr., 8 Hawthorne Rd., Bronxville, N. Y.  
 Newcomb, George O., 142 Wilmington Pl., S. E., Washington, D. C.  
 Palmes, Albert H., 5 Dutton Ave., Catonsville, Md.  
 Pang, Daniel L., 3321 Martha St., Honolulu, T. H.  
 Patterson, Thomas C., 22 Dryburn Rd., Durham Moor, Nr. Durham, England  
 Place, Roger, 212 Murray St., Ann Arbor, Mich.  
 Polster, Norman E., Leeds and Northrup Co., 4901 Stenton Ave., Philadelphia, Pa. (transfer)  
 Price, William J., 64 Ettrick Ter., Rutherford, N. J.

(Continued on page xxii)



# Centralab

## CERAMIC TUBULAR CAPACITORS

with Temperature Controlled Characteristics

Another important Centralab development in tune with our present war efforts. These parts are definitely suited to high and ultra high-frequency circuits. Your inquiries are invited for special capacity problems in which Ceramic capacitors are indicated.

### TYPE 850 High Frequency, High Voltage Unit

Capacity ranges 10MMF to 100MMF and intermediate values. Available either Zero or Max. Negative temperature coefficient. Standard tolerances as to coefficients and capacity. Size  $\frac{5}{8}$ " long. .765" diameter, exclusive of terminals.

Power Factor .05% does not increase with ageing. Voltage rating 5000 volts D.C. A.C. voltage rating varies with frequency.

Terminals available in two types; same as Type 840.

### TYPE 840 High Capacity

Available in any temperature coefficient from zero to  $-.00075 \text{ mmf/mmF/C}^\circ$ .

- (1) Zero Temperature Coefficient up to 1500 MMF.
- (2) Negative Temperature Coefficient up to 3000 MMF.

SIZE: .780" diameter Steatite tube — length varies with capacity and temperature coefficient.

- 500 MMF NTC approximately  $\frac{3}{4}$ " long.
- 1000 MMF NTC approximately 1" long.
- 500 MMF ZTC approximately  $\frac{3}{4}$ " long.
- 1000 MMF ZTC approximately  $1\frac{1}{2}$ " long.

Power factor of .05% — does not increase with ageing.

Voltage rating — 1000 volts D.C. Leakage more than 10,000 megohms.

Terminals — two types available:

- (1) Lug .030" thick threaded for 6-32 machine screw, or conventional soldering
- (2) Axial mounting post with 6-32 machine screw thread.

**CENTRALAB: Div. of Globe-Union Inc., Milwaukee, Wis., U. S. A.**

# Acoustic Design Charts

By

FRANK MASSA, B.Sc., M.Sc.  
In Charge, Acoustic Division, Brush  
Development Co., Cleveland

**T**HIS VOLUME provides a new type of handbook containing an easy to use source of quantitative information on the design of electrical, mechanical and acoustical apparatus. Several thousand hours of laborious computations are reduced to a system of accurately prepared charts giving the exact quantitative value.

The book covers the fields of electro-acoustics, sound transmission, sound proofing, loud speaker and horn design, electromagnetic and permanent magnet horn and speaker design, mechanical vibrations and isolation of vibrating machinery, electric circuit and field coil data, etc. It contains 107 full page charts with over 750 accurately plotted curves. About 100 sample problems illustrate the use of each chart.

228 Pages. \$4.00 (1942)

OLSON AND MASSA

## Applied Acoustics

2nd Edition

By H. F. OLSON and FRANK MASSA  
278 Illus. 494 Pages. \$5.50 (1939)

THE  
BLAKISTON COMPANY  
Philadelphia

Accuracy and dependability are built into every Bliley Crystal Unit. Specify **BLILEY** for assured performance.

## QUARTZ CRYSTALS

**BLILEY ELECTRIC COMPANY**  
UNION STATION BUILDING ERIE, PA.

## BINDERS FOR THE PROCEEDINGS

Protect your file of copies  
against damage and loss

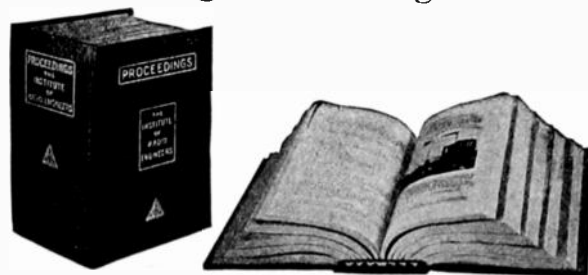

Binders are available for those who desire to protect their copies of the PROCEEDINGS with stiff covers. Each binder will accommodate the twelve monthly issues published during the year. These binders are of blue spanish grain fabricoid with gold lettering and will serve either as temporary transfers or as permanent binders. They are so constructed that each individual copy of the PROCEEDINGS will lie flat when the pages are turned. Copies can be removed from the binder in a few seconds and are not damaged by their insertion.

Available for both the old, small size, PROCEEDINGS or the new large size (1939 to date).

Price: \$1.50, either size (specify which)

You may have a volume number or your name stamped in gold for 50 cents additional

Remittance should accompany your order

THE INSTITUTE OF RADIO ENGINEERS, INC.  
330 West 42nd Street, New York, N.Y.

*Smooth, Electronic  
Control with . . .*

**OHMITE**

**Rheostats · Resistors · Tap Switches**

*M*ANY of you now engaged in vital war work have long been familiar with the dependability of Ohmite Products. Their wide use in planes, tanks and ships, in walkie-talkies and field units, in communications, test apparatus and other electronic equipment, gives you added assurance in dealing with today's resistance-control problems. It is also the best assurance for their application in the development of new devices to defeat the enemy and build for tomorrow's peace. Units produced to Government specifications or engineered for you.

BE RIGHT WITH  
**OHMITE**  
Rheostats · Resistors  
Tap Switches

**OHMITE MANUFACTURING COMPANY**  
4860 Flournoy Street • Chicago, U. S. A.

## Helpful 96-page Catalog and Manual

Write on company letterhead for complete Catalog and Engineering Manual No: 40. Helps expedite the solution to resistance problems. Gives valuable information on the selection and application of rheostats, resistors, tap switches, chokes and attenuators. Contains useful reference tables, dimensional drawings, important engineering data and a manual of resistance measurements.



*This isn't a  
One-Man job!*

Never has there been a time demanding more teamwork and cooperation—not only within one's own organization but also between consumer and supplier.

Our hearts and resources are in this job one hundred percent to a victorious finish!

Call on us for ELECTRICAL, CORROSION, and HEAT-RESISTING ALLOYS\*, also "BERALOY 25" (beryllium-copper)—and find out what teamwork really means!

\*Available in rod, wire, ribbon and strip—both hot and cold rolled.



**WILBUR B. DRIVER CO.**  
NEWARK, NEW JERSEY



Manufacturers of "TOPHET" the Nickel-Chrome Resistance Wire

TRADE MARK REG. U. S. PAT. OFF.

*Concentration  
of Skill!*

**PAR-METAL**  
*Specializes*  
IN THE MANUFACTURE OF

- CABINETS
- CHASSIS
- PANELS
- RACKS

for ELECTRONIC APPARATUS

Specialized skill — that is something you cannot specify. It's "in the blood". Par-Metal has it by virtue of years of concentration on making metal housings for sound equipment. — Send specifications; or write for our Catalog No. 41.

**PAR-METAL PRODUCTS CORP.**  
LONG ISLAND CITY, N. Y.  
32-62 — 49th STREET EXPORT DEPT: 100 VARICK ST., N. Y. C.

## Membership

(Continued from page xviii)

- Reade, Ralph B., R 3 Laboratory, International Telephone and Radio Laboratories, 67 Broad St., New York, N. Y.
- Riegger, W. Joseph, 1136 Neal St., N. E., Washington, D. C.
- Roberts, Charles E., 4235 Huntley Ave., Culver City, Calif.
- Rodenburg, John R., Midland Radio and Television Schools, Inc., Athens, Ga.
- Sastry, N. S., T. S. Adyar, Madras, India
- Saylor, William R., 119 Holden Green, Cambridge, Mass.
- Schmitz, Maurice W., 536 N. Hayworth Ave., Los Angeles, Calif.
- Shanck, Roy B., 134 Manor Rd., Douglaston, L. I., N. Y.
- Sholand, Steve O., 1422 Foster Ave., Chicago, Ill.
- Shreve, Leonard, 3217 N. E. Everett St., Portland, Ore.
- Shufer, Max, 939 Longfellow St., N. W., Washington, D. C.
- Singleton, Julius K., Seville Apt. Hotel, Sioux Falls, S. D.
- Smith, F. A. B., 4215 Alton Place, N. W., Washington, D. C.
- Stelzenmuller, G. V., Jr., Box 142, Grand Island, Neb.
- Stephens, Helen, 179 Maple Ave., Red Bank, N. J.
- Steppler, Robert V., 1122 Catalina Blvd., San Diego, Calif.
- Tague, William T., 42 Ferguson Place, Box 174, Ramsey, N. J.
- Taschner, Vern M., 6347 Ivarene Ave., Hollywood, Calif.
- Thaler, Samuel, 4933 Pulaski St., Philadelphia, Pa.
- Thompson, James F., 2423 S. 27 St., Arlington, Va.
- Thorson, Harry L., General Electric Co., Schenectady, N. Y.
- Tirrell, Clyde W., 3128 Newton Ave., San Diego, Calif.
- Travis, Edward F., 147 Sacandaga Rd., Scotia, N. Y.
- Voelpel, John, 248 E. Jamaica Ave., Valley Stream, N. Y.
- Webb, Haywood E., Jr., Box 468, Tuskegee Institute, Ala.
- Weiss, Milton L., 60 Lithgow St., Dorchester, Mass.
- Wesenberg, Corbit M., 120 N. Forest Ave., Rockville Center, L. I., N. Y.
- Whittier, Carl H., 31 Summer St., Nahant, Mass.
- Williams, Arthur D., 2725 Inglewood Ave., Baltimore, Md.
- Williams, John R., 4042 First St., N. W., Washington, D. C.
- Witt, Marcus K., Jr., 106 Cedar St., Hempstead, L. I., N. Y.
- Wright, David I., 257 Nassau St., Princeton, N. J. (transfer)
- Yelsky, Benjamin, 1004 Eastern Pkwy., Brooklyn, N. Y.
- Young, Earl S., 2908 Beaumont Rd., Louisville, Ky.
- Zimet, Burt L., 2540 E. 24 St., Brooklyn, N. Y.



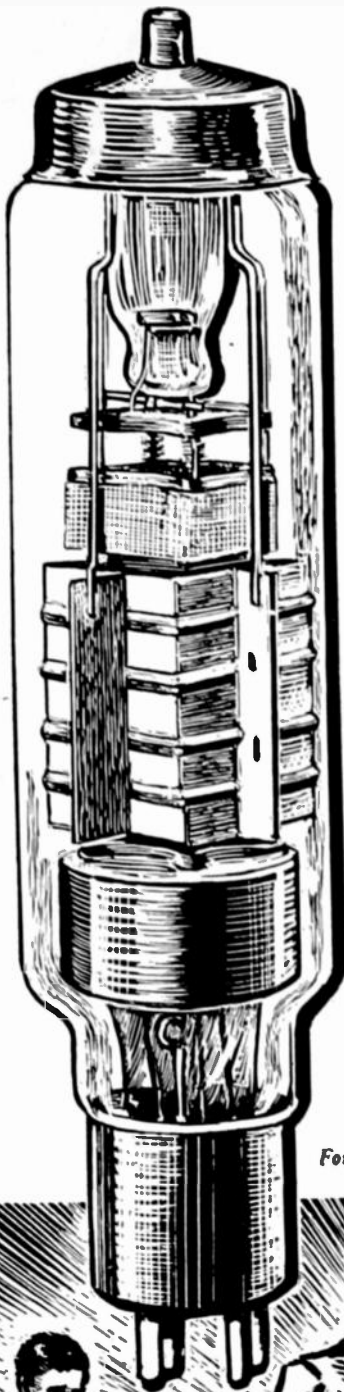

**S**ince the curtailment of civilian radio production, RAYTHEON engineers and scientists are devoting all their energies to designing and building special tubes for today's important electronic developments. It has long been the opinion of our research engineers that special electronic services required tubes designed for their individual application. RAYTHEON'S new development work is going forward with amazing speed.

This new challenge for special tubes of intricate design to meet the rapidly expanding use of electronic devices is being met by our engineers in the same manner with which we, in the past, produced tubes for civilian use.

Our laboratories will, when this conflict is past, produce the latest design in tubes, incorporating many new principles in electronic engineering.

*For military reasons, the tube shown is not a new development*



## **Raytheon Manufacturing Company**

*Waltham and Newton, Massachusetts*

**DEVOTED TO RESEARCH AND THE MANUFACTURING  
OF TUBES FOR THE NEW ERA OF ELECTRONICS**

# TELICON

*Corporation*

Design, Development and Manufacture

of

## SUPERSONIC INSTRUMENTS

*for all applications in*

Defense, Industry, Science,  
Medicine, Short Time Measurements.

*Inquiries Welcomed*

305 East 63rd Street, New York City



## TELESCOPING ADJUSTABLE ANTENNAS

**That Meet the Specifications  
Of All Branches of the  
Armed Service**

For convenience, durability and satisfactory performance under most trying conditions, Premax Telescoping Adjustable Antennas are meeting every test in the service of the Armed forces.

Standard designs and mountings or special equipment to meet specifications.

Let Premax help you with your antenna problems. Get the Bulletin of Standard Antennas and Mountings.

### Premax Products

DIVISION OF  
CHISHOLM-RYDER CO., INC.  
4301 Highland Ave., Niagara Falls, N.Y.

Proceedings of the I.R.E. October, 1942

*Quality above all..*

Solar's latest complete presentation, laid out and edited to save time for busy engineers and technicians. Your copy available upon letterhead request.

**SOLAR**

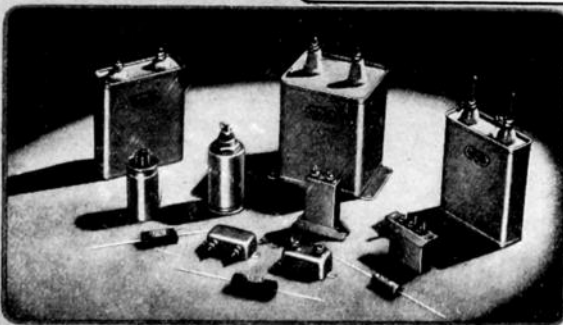

## PAPER CAPACITORS

CATALOG 12 - SECTION C

SOLAR MANUFACTURING CORP., BAYONNE, N. J.

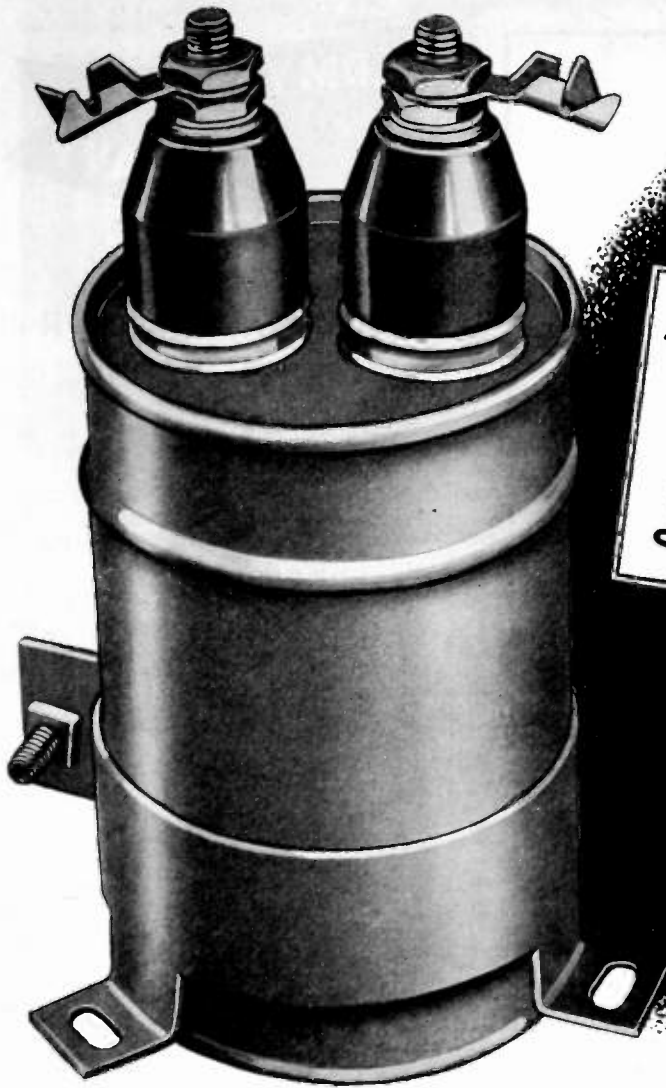

# AEROVOX "05" SERIES Oil Capacitors *In fighting togs....*

Standard units: 600, 1000, and 1500 v. D.C.W., 1 and 2 mfd. Also 2000, 2500 and 3000 v. D.C.W., 1 and 2 mfd.

Can sizes: 2, 2½ and 3" dia. by 2¾ to 5¼" tall.

Unusual requirements can be met by special types made to your particular specifications or needs.

Type 05 is one of several types of Hyvol or high-voltage oil-filled capacitors in round and rectangular containers, and in working voltages up to 7500 D.C.W.

Also the high-voltage "20" series in voltages up to 50,000 D.C.W.

● This popular round-can oil-filled transmitting capacitor has donned fighting clothes "for the duration." Gone is the shiny aluminum can, for aluminum is a premium war metal that must be conserved. In its place is the fighting touch of gray paint protecting the ribbed and reinforced steel can.

It's a still tougher capacitor, this wartime Type 05. The high-voltage ceramic insulators slip over screw-stud

assemblies including rubber bakelite washers and lock nuts for a perfect electrical and mechanical construction. The three-point support of the adjustable mounting ring means rigid upright or inverted mounting with terminals at top or bottom, any height above or below chassis. In its fighting togs this Type 05 is a tougher capacitor indeed for the toughest wartime applications. And it is typical of other Aerovox "Victory" or wartime types.

**Have you our Transmitting Capacitor Catalog listing and describing the heavy-duty types? If not, write on business stationery for your copy. Submit your capacitor problems.**

**NEW BEDFORD, MASS.,  
U. S. A.  
Sales Offices in All  
Principal Cities**

# AEROVOX

**CORPORATION**



**In Canada  
AEROVOX CANADA LTD.  
Hamilton, Ont.  
EXPORT: 100 Varick St., N. Y.  
Cable 'ARLAB'**



*To Our Gallant Men on the*  
**FIGHTING FRONTS OF FREEDOM**

The men and women of the Remler Company are greatly honored to be named in the first list of firms to receive the new Army-Navy Production Award for "high achievement in the production of war equipment." • This recognition by our War and Navy Departments is a source of inspiration and a challenge for the future. • To our armed forces on far-flung battle lines, we send this message: "We pledge ourselves to our tasks at desk and bench in order that we may be worthy of your gallant bravery on the fighting fronts of freedom."

*Announcing & Communication Equipment*  
*Electrical Plugs • Connectors • Accessories*



**REMLER**

*Company, Ltd.*

19TH AT BRYANT ST. • SAN FRANCISCO, CALIF.



**Army-Navy "E" Honor Roll**

*History of the Army-Navy "E" Award.* In 1906 the Navy instituted the "E" pennant as an award for excellence in gunnery, and later extended this to engineering and communications. Prior to Pearl Harbor the Navy gave the award to a few firms and organizations which showed excellence in producing ships, weapons and equipment for the Navy.

Since Pearl Harbor, the Army and Navy have joined together in making the award to both plants and their employees, who working as a team and given "excellent" performance in winning the production battle and thus have proven their patriotism and grim determination to serve their country.

Manufacturers serving the radio industry have ranked high in their war production effort. Sixteen of these firms have won the honored Army-Navy "E" Award, as completely as the PROCEEDINGS could compile the information up to September 14th. Following is a list of these firms, and some detail about the presentation ceremonies. We hope to be able to add to this list in another month, and will welcome information.

**American Lava Corporation** received the award flag on August 17, 1942 at Chattanooga, Tennessee. Col. Willis R. Lansford represented the Army and Navy in making the award, and Paul J. Kruesi, President, accepted the flag. Lt. Cecil F. Hackney, U. S. Navy presented the pins to each Alco employee.

**Bell Telephone Laboratories** held its ceremony in the Bell Auditorium in New York, September 16, 1942. Col. Rex V. D. Corput of the Signal Corps, Camp Evans, N. J. presented the Award Flag to President Oliver E. Buckley and Lt. John L. Lodge, U. S. Navy awarded the employee pins which were accepted by Eric Weil, President of the Bell Telephone Laboratories Employees Association, and Franklin A. Korn of the technical staff.

**Belmont Radio Corporation** received the award at Chicago, September 10, 1942 from Col. Thomas L. Clark, Chicago Signal Corps, Procurement District, and Lt. Com. J. M. Ross, Commander 4th Naval Reserve Area. W. L. Dunn accepted for the company and Raymond Kwidzinski and Albert Weise for the employees. This firm is particularly proud of the part played in winning the award by 30 physically handicapped employees who have found at Belmont that they can serve their country by energetic production.

**Bendix Radio Division of Bendix Aviation Corp.** received the coveted Army-Navy "E" at Towson, Md., August 10, 1942, from Gen. Roger B. Colton, U. S. Army and Lt. Com. George W. McCormick, U. S. Navy. Hugh Benet, Division Manager accepted this pennant, one of the first awarded communications firms. Fred Hoep-

*Proceedings of the I.R.E. October, 1942*



DeJur

## METERS \* POTENTIOMETERS \* RHEOSTATS

*New England Minute-Men Fight Again!*

These modern "minute-men" are the precision, dependable electrical instruments designed and manufactured by the DeJur-Amsco Corporation. They're serving America in our Armed Forces as well as in hundreds of factories from coast-to-coast. Full-scale production permits us to help you immediately with your war contracts.

*If you have any special problems, let us hear from you.  
Write, wire or phone for new Catalog 1-61, Dept. IR.*

DeJur-Amsco Corporation

SHELTON, CONNECTICUT



### Army-Navy "E" Honor Roll

rich and John Cole accepted for Bendix employees whose efforts have helped Bendix reach the "million dollars a day" mark in radio equipment production for the government.

Henry L. Crowley & Co., Inc. of West Orange, N. J. received the Army-Navy "E" pennant on September 4, 1942 from Brig. Gen. A. A. Farmer, Commanding Officer, Philadelphia Signal Depot. In his acceptance of the honor, Henry L. Crowley, pledged his organization to the winning of the addition of a star to the pennant by the end of the next six months "a practical token of appreciation for what our armed forces are doing on many battle fronts."

Eitel-McCullough, Inc. San Bruno, Calif. officially won the Army-Navy "E" on September 4th but the award ceremony took place September 10th, Eimac's eighth anniversary. Col. Ira H. Treest, U. S. Army made the award to the firm, and Capt. A. B. Court, U. S. Navy (Ret.) presented the employee pins. W. W. Eitel and J. A. McCullough accepted for the company. Bill Eitel now manages the new Eimac plant at Salt Lake City while Jack McCullough handles the San Bruno organization.

Galvin Manufacturing Corp., Chicago, Illinois won the Army-Navy "E" for production of radio communications equipment in excess of quota expectations. The award ceremony took place September 8, 1942 at the Motorola plant in the presence of all employees and Paul V. Galvin, President.

*(Continued on page xxx)*



## Battle Flags!

All of us at the Hallicrafters are both proud and humble to have important assignments in defeating America's enemies.

That our efforts have justified the award of the famous Army-Navy "E" flag is a great honor. We shall keep it proudly flying.

all of the hallicrafters

# An Unending Task



## CREI Courses in Practical Radio Engineering Are Under Constant Revision to Meet the Ever-New Developments of the Radio Art

There will never be a "completed" CREI home study course. We will never be content to "let well enough alone." That is why our texts are presented in loose-leaf binders for constant addition and revision. New ideas, new equipment, new methods are constantly changing the radio scene and to keep pace with this progress CREI is constantly revising and modernizing its lesson material.

This is a never-ending task for our competent staff of outstanding engineer-instructors, headed by Mr. E. H. Rietzke. Today, Mr. Rietzke is still writing new lessons and revising older ones, assisted by a highly qualified staff of radio engineering specialists. CREI training is built on a sound knowledge of modern radio engineering practice. Behind the scenes, CREI is making a constant effort to improve that which already has proven good. This is slow, exacting and arduous work, but the results are far-reaching in effect, as shown by the accomplishments of our students and graduates.

*The entire CREI home study course includes 120 complete lessons. Our schedule requires a thorough revision and new printing of all lessons at frequent intervals. Very rarely does a CREI lesson, when issued, show a copyright date older than two years. ONLY by such methods can radiomen be assured of adequate up-to-date lesson material.*

"Since 1927"

## **CAPITOL RADIO ENGINEERING INSTITUTE**

E. H. RIETZKE, *President*

*Home Study Courses in Practical Radio Engineering for Professional Self-Improvement*

**Dept. PR-10, 3224 — 16th Street, N.W.  
WASHINGTON, D.C.**

Contractors to the U. S. Signal Corps—U. S. Coast Guard

Producers of Well-Trained Technical Radiomen for Industry

## POSITIONS OPEN

The following positions of interest to I.R.E. members have been reported as open. Apply in writing, addressing reply to company mentioned or to Box No. ....



**PROCEEDINGS of the I.R.E.**  
330 West 42nd Street, New York, N.Y.

### INSTRUCTORS IN RADIO AND ELECTRICITY

50 civilian instructors needed immediately for Army Air Forces Radio Instructor School. Subjects of instruction: Direct current and alternating current electricity, vacuum tubes, standard radio receivers and transmitters; international Morse code, telegraph and radiotelephone procedure. Salaries follow Civil Service starting from \$2,000 per year. State experience, education, code speed, personal data. Positions open immediately. Saint Louis University, Army Air Forces Radio Instructor School, 221 N. Grand Boulevard, Saint Louis, Mo. A. H. Weber, Technical Director.

### PHYSICIST OR RADIO ENGINEER

Man to manage development group. Knowledge and experience in design of electrical measuring equipment particularly in ultra-high-frequency field essential. Permanent position. Write full particulars. Boonton Radio Corporation, Boonton, N.J.

### RADIO ENGINEERS

Large New York City plant has excellent opportunities and immediate employment for those who can qualify as foremen, leaders, or designers in the production of aircraft radio equipment. Electrical engineer's degree or equivalent, with experience in manufacture of electronic equipment required. Lesser positions in many other classifications available for those lacking above qualifications. Send full details to Box 277.

### COMMUNICATIONS ENGINEERS AND PHYSICISTS

The Stanolind Oil and Gas Company maintains an extensive research and development laboratory primarily devoted to the research and development of instruments and processes for geophysical prospecting. A large staff of physicists and communication engineers including men experienced in radio is provided. Recently this Laboratory has undertaken a number of defense research contracts with the National Defense Research Committee, Naval Ordnance Laboratory and other defense organizations, and is anxious to hire additional personnel in order to utilize to the full extent the facilities of the Laboratory in defense work. Men hired for this purpose will immediately devote their time to both defense and geophysical activities, although as time goes on, it is expected their work will become more and more completely defense research. Positions are available for research development and supervisory activities. The positions available will in most cases be considered permanent positions. Stanolind Oil and Gas Co., Philcade Bldg., Tulsa, Okla.

### CRYSTAL TECHNICIANS

An organization with crystal plants on the West Coast and in Middle West needs capable hard working men both experienced and unexperienced to work in making crystals. Excellent opportunity for men to become associated with a smaller concern that they will enjoy working for. Good pay. Excellent opportunities with this concern after the war. Robert E. Henry, 2335 Westwood Blvd., West Los Angeles, Calif.

\* Micro-Dimensional  
**WIRE & RIBBON**  
for  
**VACUUM TUBES**

**In a complete range of sizes and alloys for Transmitting, Receiving, Battery and Miniature Tubes**

**M**elted and worked under close supervision to assure maximum uniformity and tensile strength . . .

**WIRES**  
drawn to .0005" diameter

**RIBBON**  
rolled to .0001" thick

**SPECIAL ALLOYS**  
made to meet individual specifications

**Inquiries Invited**

*Write for list of stock alloys*

**SIGMUND COHN**

**44 GOLD ST. NEW YORK**

SINCE  1901

### NAVY LABORATORY

An activity of the United States Navy is in need of civil Junior, Assistant and Associate Radio Engineers; Assistant and Associate Physicists and Physicists for Laboratory research and development work in conjunction with the war effort program. Salaries range from \$2000.00 to \$3800.00 per annum. For further information and application for employment form write the Director, U. S. Navy Radio and Sound Laboratory, San Diego, California.

### RADAR LABORATORY

The Signal Corps Radar Laboratory has urgent need for Physicists and Engineers with Mechanical, Electrical, and Radio training. Inexperienced engineering graduates can also qualify.

Salaries range from \$2000 to \$3200 and up.

Draftsmen, Engineering Aides, Electricians, and Radio Mechanics also are wanted.

Apply in writing stating full qualifications to: Civil Service Representative, Signal Corps Radar Laboratory, Camp Evans, Belmar, New Jersey.

### CIVILIAN ORDNANCE ENGINEERS

The Naval Ordnance Laboratory of the Washington Navy Yard is seeking research and engineering men holding Ph.D. degrees or like calibre to head up new research problems—Salaries are very attractive.

Also—men with proven ability as Mechanical Engineers, Electrical Engineers, Physicists and Draftsmen are urgently needed.

An unusual opportunity as the work is among men proven leaders in their respective fields who have been loaned to the Navy by their civilian employers, and excellence of war-time work will certainly receive recognition in peacetime industry.

Only American citizens can be considered. Apply by letter—stating full experience, education and qualifications to Robert F. Moore, Naval Ordnance Laboratory, Washington, D.C.

### CRYSTAL ENGINEERS

A New England organization requires the services of a highly experienced engineer on finishing and calibrating quartz crystals. Also need several assistants. Box 272.



### Attention Employers . . .

Announcements for "Positions Open" are accepted without charge from employers offering salaried employment of engineering grade to I.R.E. members. Please supply complete information and indicate which details should be treated as confidential. Address: "POSITIONS OPEN," Institute of Radio Engineers, 330 West 42nd Street, New York, N.Y.

The Institute reserves the right to refuse any announcement without giving a reason for the refusal.

*Creators and Makers of*  
**ACCURATE RESISTORS—SWITCHES—SPECIAL EQUIPMENT AND  
SPECIAL MEASURING APPARATUS FOR PRODUCTION AND  
ROUTINE TESTING OF ELECTRICAL EQUIPMENT ON MILITARY AIR-  
CRAFT . . . SHIPS . . . VEHICLES . . . ARMAMENT . . . AND WEAPONS**

Over 40 Standard and Many Special Designs.  
. . . Resistance Range: 0.001 ohm to 10 meg-ohms. . . Accuracy: Tolerances as close as 0.05%. . . Supplied on ceramic, metal or synthetic forms. . . Inductive or Non-Inductive windings. . . Wound with the alloy you specify. . . With any insulation commercially available. . . A variety of terminals and mounting facilities. . . Impregnated against moisture and high humidity. . . Address Dept. No. 23

MEMBER  

**HALLCROSS MFG. CO.**  
**COLLINGDALE, PENNA.**

# SPECIFICATION TRANSFORMERS

for Electronic and Voltage Control Applications

Tell us what you want the transformer to do, and we'll supply a design with outstanding performance features.

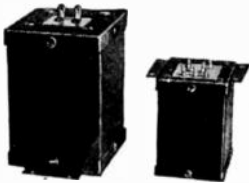

### For Example

Acme compound filled transformers for short wave communication, public address systems and

other radio applications are preferred for their serviceability under climatic variations from below zero to 120° in the shade..

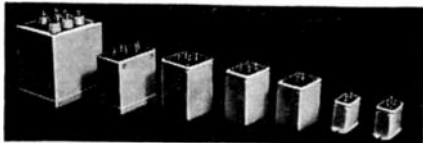

### or Maybe This Style

Here are a group of air-borne transformers. Made to Acme quality standards for operations ranging from sea level to 8 miles plus in the air. For such service there can be no compromise with quality.



### Space Saver

Long, flat and narrow. This is one of the 15 different styles of Acme fluorescent lamp ballasts. Do the physical dimensions of your needs compare with this? Write Acme.

### Heavy Duty Transformers

Where ruggedness is an asset. The Acme line of air-cooled transformer designs in a range from 1/10th to 50 KVA can be used as a basis for building your heavy duty special purpose transformers. What's your transformer problem?



THE ACME ELECTRIC & MFG. CO. 44 Water Street Cuba, New York

Acme Electric TRANSFORMERS

## Army-Navy "E" Honor Roll

(Continued from page xxvii)

Hallicrafter Company of Chicago received the Army-Navy "E" citation on September 9, 1942 at the Hallicrafters Main Plant. Col. Thomas L. Clark, Officer in Charge, Chicago Signal Depot made the award. W. J. Halligan, President accepted for the company and Dolores Yager and Robert Foss for the employees.

International Resistance Company of Philadelphia, Pa. is among the leading radio and allied organizations to whom has been awarded the coveted Army-Navy Production Award. The symbolic "Army-Navy "E" or excellence pennant, to be flown over the plant, and the lapel buttons for employees were formally presented on September 15, 1942 at ceremonies at the 103rd Engineering Armory, attended by 2000 IRC employees. Brig. Gen. A. A. Farmer, U. S. Army and Lt. Com. Joseph L. Tinney, U. S. Navy made the award.

Three Philco Corporation Plants win the Army-Navy "E." Brig. Gen. A. A. Farmer, U. S. Army, made the award at a ceremony attended by 7000 employees and their families of the Philadelphia plant. Similar awards will be made October 7th to the Storage Battery Division at Trenton, New Jersey and October 9th to the Philco plant at Sandusky, Ohio.

Remler Company, Ltd., San Francisco, Calif. was on the very first list of firms to win the Army-Navy "E." The award was made August 8th and on September 4th Remler employees took time between the day and swing shifts for a ceremony at which Lt. Com. L. L. Wardell awarded them the official "E" buttons, while Col. Ira H. Treest presented the pennant for the plant to E. G. Danielson, president. A dinner for the official guests and employees followed. The ceremony also marked the opening of a new 20,000 sq. ft. addition to the present manufacturing facilities.

Western Electric Company has received the Army-Navy "E" award for all its plants, the Hawthorne Works in Chicago, the Point Breeze Works in Baltimore, and the Kearny Works at Kearny, N. J. At a ceremony August 28th at the Point Breeze Works Maj. Gen. Roger B. Colton made the award to the workers and C. G. Stool, company president. Just 25 years before, in August 1917 Western Electric demonstrated radio two-way communication between a ground station and aeroplane at Langley Field, Va. So it was fitting that a flight of combat planes circling the plant as the pennant was raised dipped their wings in salute at a radio command given by Gen. Colton.

Westinghouse Electric and Manufacturing Co. received the Army-Navy "E" pennant for five Pittsburgh area plants. Selected to receive the awards were the Transformer Division at Sharon, Pa., and the East Pittsburgh Division which includes the porcelain plant at Derry, Pa., Nuttall Gear Works, Pittsburgh and plants at East Pittsburgh and Trafford, Pa. Rear Admiral William Carleton Watts, U. S. Navy, made the awards. The giant East Pittsburgh Division is running 60 per cent ahead of 1941. At Sharon, three 50-year veterans represented the employees in receiving the "E" buttons, Henry C. Bert, James T. Burke and James R. Stevens.

Weston Electric Instrument Co., of Newark, N. J. received the Army-Navy "E" Award at a ceremony conducted on September 29th.

## Available I. R. E. Standards

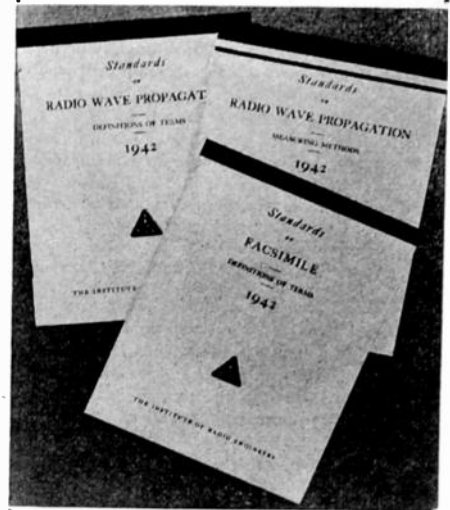

- |   | Price  |
|---|--------|
| 1) Standards on Electroacoustics, 1938 .....  | \$0.50 |
| Definitions of Terms, Letter and Graphical Symbols, Methods of Testing Loud Speakers. (vi+37 pages, 6x9 inches.)  |        |
| 3a) Standards on Transmitters and Antennas: Definitions of Terms, 1938 .....  | \$0.20 |
| A Reprint (1942) of the like-named section of "Standards on Transmitters and Antennas, 1938." (vi+8 pages, 8½x11 inches.)   |        |
| 3b) Standards on Transmitters and Antennas: Methods of Testing, 1938 .....  | \$0.50 |
| A Reprint (1942) of the like-named section of "Standards on Transmitters and Antennas, 1938." (vi+10 pages, 8½x11 inches.)  |        |
| 4a) Standards on Radio Receivers: Definitions of Terms, 1938 .....  | \$0.20 |
| A reprint (1942) of the like-named section of "Standards on Radio Receivers, 1938." (vi+6 pages, 8½x11 inches.)   |        |
| 4b) Standards on Radio Receivers: Methods of Testing Broadcast Radio Receivers, 1938 .....  | \$0.50 |
| A reprint (1942) of the like-named section of "Standards on Radio Receivers, 1938." (vi+20 pages, 8½x11 inches.)  |        |
| 5) Standards on Radio Wave Propagation: Definitions of Terms, 1942 .....  | \$0.20 |
| (vi+8 pages, 8½x11 inches.)   |        |
| 6) Standards on Radio Wave Propagation: Measuring Methods, 1942 .....   | \$0.50 |
| Methods of Measuring Radio Field Intensity, Methods of Measuring Power Radiated from an Antenna, Methods of Measuring Noise Field Intensity. (vi+16 pages, 8½x11 inches.) |        |
| 7) Standards on Facsimile: Definitions of Terms, 1942 .....   | \$0.20 |
| (vi+6 pages, 8½x11 inches.)   |        |
| <b>ASA STANDARDS</b><br>(Sponsored by the I. R. E.)   |        |
| 9) American Standard: Standard Vacuum-Tube Base and Socket Dimensions .....   | \$0.20 |
| (ASA C16.2-1939). (8 pages, 7¼x10½ inches.)   |        |
| 10) American Standard: Manufacturing Standards Applying to Broadcast Receivers .....  | \$0.20 |
| (ASA C16.3-1939). (16 pages, 7¼x10½ inches.)  |        |

Prices are net and include postage to any country. Include remittance with order and address:

THE INSTITUTE OF RADIO ENGINEERS, Inc. 330 West 42nd Street, New York, N.Y.





☆ A decade ago the cathode-ray oscillograph was a scientific curiosity. A few such costly instruments were in use, in leading laboratories, entrusted to skilled technicians.

Then came the first DuMont cathode-ray oscillograph. Simplicity, practicality, economy—those were the cardinal features. And those very features soon attracted universal attention. Thus the DuMont cathode-ray oscillograph became indispensable equipment not only in laboratories but also in factories and out in the field.

Today the DuMont name is synonymous with cathode-ray oscillography. That name is your assurance of the latest refinements in this firmly-established technique.

★ Write for literature . . .



Cable Address: Wespeclin, New York

## INDEX

Section Meetings	.....xiv
Membership	.....xiv, xvi, xviii, xxii
"E" Honor Roll	.....xxvi, xxvii, xxx
Positions Open	.....xxviii, xxix

### DISPLAY ADVERTISERS

<b>A</b>	
Acme Electric & Mfg. Company	.....xxx
Aerovox Corporation	.....xxv
American Lava Corporation	.....v
American Telephone & Telegraph Co.	.....viii
<b>B</b>	
Blakiston Company	.....xx
Bliley Electric Company	.....xx
<b>C</b>	
Capitol Radio Engineering Institute	.....xxviii
Centralab	.....xix
Sigmund Cohn	.....xxviii
Cornell-Dubilier Electric Corp.	.....Cover III
<b>D</b>	
Daven Company	.....i
DeJur-Amsco Corporation	.....xxvii
Wilbur B. Driver Company	.....xxii
Allen B. DuMont Laboratories, Inc.	.....xxxi
<b>E</b>	
Eitel-McCullough, Inc.	.....iii
<b>G</b>	
General Radio Company	.....Cover IV
<b>H</b>	
Hallicrafters Company	.....xxvii
Heintz & Kaufman, Ltd.	.....xvii
Hewlett-Packard Company	.....xiv
<b>I</b>	
Industrial Condenser Corporation	.....xviii
International Telephone & Telegraph Corp.	.....xv
Isolantite, Inc.	.....x
<b>O</b>	
Ohmite Manufacturing Company	.....xxi
<b>P</b>	
Par-Metal Products Corporation	.....xxii
Premax Products	.....xxiv
<b>R</b>	
Rauland Corporation	.....iv
Raytheon Manufacturing Company	.....xxiii
RCA Manufacturing Company, Inc.	.....xxxii
Remler Company, Ltd.	.....xxvi
<b>S</b>	
Shellcross Manufacturing Company	.....xxix
Shure Brothers	.....vi
Solar Manufacturing Corporation	.....xxiv
Sprague Specialties Company	.....ii, xiii
<b>T</b>	
Telicon Corporation	.....xxiv
Thordarson Electric Mfg. Company	.....xvi
Triplett Electrical Instrument Co.	.....ix
<b>U</b>	
United Transformer Company	.....Cover II
<b>W</b>	
Westinghouse Electric & Mfg. Co.	.....vii
John Wiley & Sons, Inc.	.....xxxi

## Are you weak on WAVES?



You don't need to be. Did you know there is a new book on the Fundamentals of Electric Waves? Make a study of this book, and you will develop a *concrete* conception of electric waves. You clear up any hazy notions, and learn the subject thoroughly so that you can apply your knowledge. Electric waves have recently become of practical importance to engineers and radio men—not only physicists. Here is one book which serves the engineers' need.

The volume is arranged for those who do not necessarily have any previous knowledge of electromagnetic theory. General college physics and mathematics through calculus are enough. It is a small book—186 pages. This is the result of rigorous elimination of non-essential material. If you want a book to give you basic ideas, and help develop your ability to work with electric waves, this is your book.

By HUGH HILDRETH SKILLING  
Professor of Electrical Engineering  
Stanford University

## FUNDAMENTALS OF ELECTRIC WAVES

JOHN WILEY & SONS, INC.  
440 Fourth Avenue, New York, N.Y.

Please send me, on ten days' approval, a copy of Skilling's FUNDAMENTALS OF ELECTRIC WAVES. At the end of that time, if I decide to keep the book, I will remit \$2.75 plus postage; otherwise I will return the book postpaid.

NAME .....

ADDRESS .....

CITY AND STATE .....

EMPLOYED BY .....

IRE 10-42



## RESTS DURING STANDBY PERIODS

### Mean Longer Life For Your Transmitting Tubes

It pays to let transmitting tubes "take it easy" during standby periods! Even though such care might not be considered normally, it now looms important in gaining the last possible hour of operation from tubes that may be difficult to replace.

**HEATER-CATHODE TYPE TUBES**—Where some operating delay can be tolerated, it is a good practice to drop the heater voltage as much as 20% during long or frequent standbys. This conserves the cathode and minimizes contamination of the grid by active material evaporated from the coating.

**TUNGSTEN AND THORIATED-TUNGSTEN-FILAMENT TYPE TUBES**—Every time a filament is turned on or off, it passes through a temperature range in which it has reduced strength. This repeated action may cause warping and, eventually, grid-filament shorts. Rather than turning off the filament during short standbys, reduction of filament voltage to 80% of normal will prevent warping, will enable the filament to come up to operating temperature quickly, and will avoid evaporation of emissive material.

During standby periods, tubes using thoriated-tungsten filaments should have their filament voltage decreased to 80% of normal provided the periods are of less than 15 minutes' duration. For longer standby periods, the filament voltage should be turned off.

Tubes using tungsten filaments should have their filament voltage decreased to 80% of normal for standby periods of less than two hours. For longer periods, the tubes should be shut down. At reduced voltage, a tungsten-filament tube will last about ten times as long as at normal voltage. Its hot filament also acts as a "getter" to maintain a high vacuum within the tube.

Care should always be taken in starting up tungsten filaments, and never should the filament current exceed, even momentarily, a value of more than 150% of normal. Wherever possible, it is wise to operate the filaments of all types of tubes on the low side—perhaps 5% down when only light loads are involved. As previously explained, even this small reduction may actually double tube life—a mark well worth shooting at these days, even at the possible cost of some slight decrease in station efficiency.



## Transmitting Tubes

# C-D's SERVE WITH THE NIGHT WATCH



**TODAY'S** C-D Capacitors Speed Victory...

**TOMORROW'S** C-D Capacitors assure more hours of use  
per dollar for **AMERICAN INDUSTRY**...

Somewhere along the Coast, "giant ears" pick up an approaching plane. A calculator fixes the plane's position. Shafts of light stab the black, spotting a perfect target for anti-aircraft gunners. Here, as in a hundred other electrical and electronic devices on critical war duty, C-D Capacitors are meeting the enemy challenge.

C-D extras — *extra stamina, extra dependability, extra long life* — have

made C-Ds the most widely used capacitors in the world. Today, cumulative war-spurred "impossible" improvements and applications promise measureless peacetime benefits; giving new and richer meaning to C-D's well-known pledge to industry of "more hours of capacitor use per dollar". Cornell-Dubilier Electric Corporation, South Plainfield, New Jersey.

★ ★ ★



## Cornell Dubilier Capacitors

MICA • PAPER • DYKANOL • WET & DRY ELECTROLYTIC CAPACITORS



**Dykanol Transmitter Capacitors**  
*copied • imitated  
but never duplicated*

Type TJ series filter capacitors are the most dependable units for use in transmitters and power supply equipment.

These units are filled with non-explosive, non-inflammable Dykanol and hermetically sealed. Conservative voltage rating permits safe operation at 10% above rated voltage. Available in DC working voltage ranges from 600 to 6000 volts.

Described in Catalog No. 160T free on request.

**MORE IN USE TODAY THAN ANY OTHER MAKE**



Photographs courtesy Pan American Airways

## Dependable Service

The maintenance of *all* types of radio communication systems requires accurate and reliable test equipment. The General Radio Company has always specialized in the design and manufacture of this type of equipment.

The accuracy and rugged construction of General Radio instruments have won for them particularly wide acceptance among airlines—including the world-wide Pan American Airways System—to whom reliable radio communication is vitally important. Wartime conditions have given the airlines an urgent and difficult transportation job, which means that test equipment must often be used "around the clock." General Radio instruments are built to stand up under these unusual demands.

General Radio standard-signal generator and output meter in use in radio test and repair shop at Pan American Airways' hangar at LaGuardia Field.



**GENERAL RADIO COMPANY • Cambridge, Massachusetts**