

VOLUME 26

JANUARY, 1938

NUMBER 1

PROCEEDINGS
of
The Institute of Radio
Engineers



Application Blank for Associate Membership on Page XV

Institute of Radio Engineers

Forthcoming Meetings

JOINT MEETING

American Section, International Scientific Radio Union
and

Institute of Radio Engineers

Washington, D. C.

April 29 and 30, 1938

CHICAGO SECTION

January 21, 1938

February 4, 1938

February 25, 1938

CLEVELAND SECTION

January 27, 1938

DETROIT SECTION

January 21, 1938

LOS ANGELES SECTION

January 18, 1938

MONTREAL SECTION

January 12, 1938

January 26, 1938

February 9, 1938

NEW YORK MEETING

January 5, 1938

February 2, 1938

PHILADELPHIA SECTION

January 6, 1938

February 3, 1938

TORONTO SECTION

January 10, 1938

WASHINGTON SECTION

January 10, 1938

The Institute of Radio Engineers

VOLUME 26

January, 1938

NUMBER 1

Board of Editors

ALFRED N. GOLDSMITH, *Chairman*

R. R. BATCHER	B. E. SHACKELFORD
P. S. CARTER	K. S. VAN DYKE
F. W. GROVER	H. P. WESTMAN, <i>ex officio</i>
J. W. HORTON	L. P. WHEELER
G. W. PICKARD	L. E. WHITTEMORE

WILLIAM WILSON

CONTENTS

PART I

Institute News and Radio Notes.....	1
December Meeting of the Board of Directors.....	1
Joint Meeting of the Institute and the American Section of the International Scientific Radio Union.....	1
Broadcast Engineering Conference.....	1
Rochester Fall Meeting.....	2
Australian Radio Convention.....	2
Committee Work.....	3
Institute Meetings.....	5
Personal Mention.....	15

PART II

Technical Papers

The Ultra-Short-Wave Guide-Ray Beacon and Its Application.....	
..... E. KRAMAR AND W. HAHNEMANN	17
Precise Measurements of Electromagnetic Fields.....	HOWARD G. SMITH 45
Time-Division Multiplex in Radiotelegraphic Practice.....	
..... J. L. CALLAHAN, R. E. MATHES, AND A. KAHN	55
The Basic Principles of Superregenerative Reception.....	FREDERICK W. FRINK 76
Note on the Frequency Behavior of Reactances.....	HANS SALINGER 107
Characteristics of the Ionosphere at Washington, D.C., November, 1937.....	T. R. GILLILAND, S. S. KIRBY, N. SMITH, AND S. E. REYMER 112
Discussion on "The Fading Characteristics of the Top-Loaded WCAU Antenna," by G. H. Brown and John G. Leitch.....	
..... K. A. NORTON AND G. H. BROWN	115
Book Review: Radio Engineering (Second Edition).....	122
..... F. E. Terman	
Reviewed by H. M. Turner	
Book Review: Servicing with Set Analyzers.....	122
..... H. G. McEntee	
Reviewed by Joseph L. Hurff	
Book Review: The International Broadcast and Sound Engineer, 1937 Year Book.....	123
..... A. L. J. Bernaert, Editor	
Reviewed by Howard A. Chinn	
Book Review: Anleitungen zum Arbeiten im Röhrenlaboratorium.....	123
..... M. Knoll	
Reviewed by B. E. Shackelford	
Contributors to This Issue.....	125

Copyright, 1938, by The Institute of Radio Engineers, Inc.

The Institute of Radio Engineers

GENERAL INFORMATION

INSTITUTE. The Institute of Radio Engineers was formed in 1912 through the amalgamation of the Society of Wireless Telegraph Engineers and the Wireless Institute. Its headquarters were established in New York City and the membership has grown from less than fifty members at the start to several thousand.

AIMS AND OBJECTS. The Institute functions solely to advance the theory and practice of radio and allied branches of engineering and of the related arts and sciences, their application to human needs, and the maintenance of a high professional standing among its members. Among the methods of accomplishing this is the publication of papers, discussions, and communications of interest to the membership.

PROCEEDINGS. The PROCEEDINGS is the official publication of the Institute and in it are published all of the papers, discussions, and communications received from the membership which are accepted for publication by the Board of Editors. Copies are sent without additional charge to all members of the Institute. The subscription price to nonmembers is \$10.00 per year, with an additional charge for postage where such is necessary.

RESPONSIBILITY. It is understood that the statements and opinions given in the PROCEEDINGS are views of the individual members to whom they are credited, and are not binding on the membership of the Institute as a whole. Papers submitted to the Institute for publication shall be regarded as no longer confidential.

REPRINTING PROCEEDINGS MATERIAL. The right to reprint portions or abstracts of the papers, discussions, or editorial notes in the PROCEEDINGS is granted on the express condition that specific reference shall be made to the source of such material. Diagrams and photographs published in the PROCEEDINGS may not be reproduced without making specific arrangements with the Institute through the Secretary.

MANUSCRIPTS. All manuscripts should be addressed to the Institute of Radio Engineers, 330 West 42nd Street, New York City. They will be examined by the Papers Committee and the Board of Editors to determine their suitability for publication in the PROCEEDINGS. Authors are advised as promptly as possible of the action taken, usually within two or three months. Manuscripts and illustrations will be destroyed immediately after publication of the paper unless the author requests their return. Information on the mechanical form in which manuscripts should be prepared may be obtained by addressing the secretary.

MAILING. Entered as second-class matter at the post office at Menasha, Wisconsin. Acceptance for mailing at special rate of postage is provided for in the act of February 28, 1925, embodied in Paragraph 4, Section 412, P. L. and R., and authorization was granted on October 26, 1927.

Published monthly by

THE INSTITUTE OF RADIO ENGINEERS, INC.

Publication office, 450-454 Ahnaip St., Menasha, Wis.

BUSINESS, EDITORIAL, AND ADVERTISING OFFICES

Harold P. Westman, *Secretary*

330 West 42nd Street, New York, N. Y.

INSTITUTE SECTIONS

- ATLANTA**—Chairman, N. B. Fowler; Secretary, G. S. Turner, Federal Communications Commission, 411 Federal Annex, Atlanta, Ga.
- BOSTON**—Chairman, H. W. Lamson; Secretary, E. B. Dallin, 64 Oakland Ave., Arlington, Mass.
- BUFFALO-NIAGARA**—Chairman, G. C. Crom, Jr.; Secretary, E. C. Waud, 235 Huntington Ave., Buffalo, N. Y.
- CHICAGO**—Chairman, J. K. Johnson; Secretary, V. J. Andrew, 7221 S. Francisco Ave., Chicago, Ill.
- CINCINNATI**—Chairman, R. J. Rockwell; Secretary, M. M. Wells, Crosley Radio Corporation, 1329 Arlington St., Cincinnati, Ohio.
- CLEVELAND**—Chairman, R. A. Fox; Secretary, R. L. Kline, Winteradio, Inc., 3014 Lorain Ave., Cleveland, Ohio.
- CONNECTICUT VALLEY**—Chairman, F. H. Scheer; Secretary, C. E. Keeler, 59 Fairfield St., Springfield, Mass.
- DETROIT**—Chairman, R. L. Davis; Secretary, H. S. Gould, 214 Tuxedo Ave., Detroit, Mich.
- EMPORIUM**—Chairman, M. I. Kahl; Secretary, M. C. Hoffman, Hygrade Sylvania Corporation, Emporium, Pa.
- INDIANAPOLIS**—Chairman, V. C. MacNabb; Secretary, I. M. Slater, 6433 E. Shelley Ave., Indianapolis, Ind.
- LOS ANGELES**—Chairman, Douglas Kennedy; Secretary, F. G. Albin, United Artists Studios, 1041 N. Formosa Ave., Los Angeles, Calif.
- MONTREAL**—Chairman, A. M. Patience; Secretary, S. Sillitoe, 1261 Shearer St., Montreal, Que., Canada.
- NEW ORLEANS**—Chairman, L. J. N. Du Treil; Secretary, G. H. Peirce, Electrical Research Products, Inc., 1631 Canal Bank Bldg., New Orleans, La.
- PHILADELPHIA**—Chairman, A. F. Murray; Secretary, R. L. Snyder, 103 Franklin Rd., Glassboro, N. J.
- PITTSBURGH**—Chairman, R. T. Gabler; Secretary, A. F. Shreve, 459 Willow Dr., Mt. Lebanon, Pittsburgh, Pa.
- ROCHESTER**—Chairman, Lee A. Du Bridge; Secretary, H. A. Brown, 89 East Ave., Rochester, N. Y.
- SAN FRANCISCO**—Chairman, V. J. Freiermuth; Secretary, C. J. Penther, 1000 Aileen St., Oakland, Calif.
- SEATTLE**—Chairman, J. W. Wallace; Secretary, R. O. Bach, Pacific Telephone and Telegraph Company, Rm. 602, Northern Life Tower, Seattle, Wash.
- TORONTO**—Chairman, W. H. Kohl; Secretary, N. Potter, Canadian National Carbon Co., Ltd., 805 Davenport Rd., Toronto, Ont., Canada.
- WASHINGTON**—Chairman, E. H. Rietzke; Secretary, L. C. Young, 12 Grove St., Hyattsville, Md.

GEOGRAPHICAL LOCATION OF MEMBERS ELECTED DECEMBER 1, 1937

Elected to the Associate Grade

California	Glendale, 646 N. Kenwood St.	Haskell, D. S.
	Oakland, 881-53rd St.	Hallikainen, K. E.
Connecticut	Waterbury, Engineering Dept., The Bristol Co.	MacLaren, F. B., Jr.
District of Columbia	Washington, Capitol Radio Engineering Inst., 14th and Park Rd.	Williams, C.
Illinois	Chicago, 6326 Kenwood Ave.	Anderson, C. W.
Maryland	Baltimore, Federal Communications Commission	Newcomb, L. A.
Massachusetts	North Quincy, 130 Billings St.	Thomas, H. C.
Missouri	Kansas City, 7552 Walnut St.	Wolfskill, R. F.
New Jersey	Oaklyn, 19 E. Cedar Ave.	Young, J. E.
New York	Brooklyn, 1135-43rd St.	Jaffe, D. L.
	Brooklyn, 2610 Newkirk Ave.	Williamson, E. J.
	Rochester, 108 Armstrong Ave.	Haupt, G. H.
	Rochester, Laboratory of Psychology, Univ. of Rochester	Wellman, B.
	Schenectady, 831 Union St.	Kenefake, E. W.
Ohio	Cleveland, 12002 Hamlen Ave.	Salay, S. G.
	Youngstown, Radio Station WKBN, Central YMCA Bldg.	Lindberg, C. L.
Pennsylvania	Bethlehem, Electrical Engineering Dept., Lehigh Univ.	Brunetti, C.
	Philadelphia, 34 Rounfort Rd.	McKay, D. S.
Washington	Bremerton, Naval Radio Station, Navy Yard.	Larson, A. C.
	Spokane, 324 E. 10th Ave.	Davis, R. F.
Wisconsin	Hurley	Pedri, J. N.
Canada	Grande Prairie, Alta., c/o CFGP	Sinclair, G.
Ceylon	Welikada, Colombo, Officer-in-Charge, Radio Station	de Silva, H. B. F.
England	Riddlesden, Nr. Keighley, Yorks., 224 Bradford Rd.	Dennison, E.
	Whetstone, London N. 20, "West View," Friern Lane	Smith, D. E.
France	Paris 18, 163 rue Belliard	Work, L.
New Zealand	Auckland S.E. 1, 2 Glenfell Rd., Epsom	Watson, D. M.
	Otago, 31 Gordon Rd., Mosgiel	Bowler, J. R. W.
Philippine Islands	Cavite, Naval Radio Laboratory	Alvendia, A.
Poland	Poznan, Dabrowskiego 82. m. 10	Rajewski, M.
South India	Tuticorin, 123 Great Cotton Rd.	Vetrivale, S.

Elected to the Junior Grade

New York	New York, 1664 Hoe Ave.	Gatkin, T. E.
Wisconsin	La Crosse, 930 Johnson St.	Pavela, P. H.

Elected to the Student Grade

Indiana	Clinton, 912 Bogart St.	Giacoletto, L. J.
New Jersey	Rutherford, 44 Daniel Ave.	Tuller, W. G.
New York	Ithaca, 109 Williams St.	Fash, R. E.



APPLICATIONS FOR MEMBERSHIP

Applications for transfer or election to the various grades of membership have been received from the persons listed below and have been approved by the Admissions Committee. Members objecting to transfer or election of any of these applicants should communicate with the Secretary on or before January 31, 1938. These applications will be considered by the Board of Directors at its meeting on February 2, 1938.

For Transfer to the Fellow Grade

New York	New York, c/o Bell Telephone Labs., Inc., 463 West St.	Kelly, M. J.
	New York, c/o Bell Telephone Labs., Inc., 463 West St.	Llewellyn, F. B.

For Transfer to the Member Grade

Connecticut	Bridgeport, 348 McKinley Ave.	Dome, R. B.
District of Columbia	Washington, 2123 Tunlaw Rd., N.W.	Norton, K. A.
	Washington, Federal Communications Commission	Webster, E. M.
Maryland	Chevy Chase, 6305 Hillcrest Pl.	Jett, E. K.
Massachusetts	Cambridge, General Radio Co., 30 State St.	Bousquet, A. G.
	Chicopee Falls, c/o Westinghouse Elec. & Mfg. Co.	Burnside, C. J.
	North Weymouth, 9 Brewster Pl.	Hollis, H. H.
New Jersey	Camden, RCA Manufacturing Co., Inc., RCA Victor Division	Engstrom, E. W.
	Camden, RCA Manufacturing Co., Inc., RCA Victor Division	Schrader, H. J.
	Deal, c/o Bell Telephone Labs., Inc.	Sterba, E. J.
	Haddonfield, 247 Merion Ave.	Trouant, V. E.
	Harrison, RCA Manufacturing Co., Inc., RCA Radiotron Division	Jams, H.
	Harrison, RCA Manufacturing Co., Inc., RCA Radiotron Division	Nergaard, L. S.
	Harrison, RCA Manufacturing Co., Inc., RCA Radiotron Division	North, D. O.
	Harrison, RCA Manufacturing Co., Inc., RCA Radiotron Division	Orth, R. T.
	Harrison, RCA Manufacturing Co., Inc., RCA Radiotron Division	Rose, G. M., Jr.
	Harrison, RCA Manufacturing Co., Inc., RCA Radiotron Division	Salzberg, B.
	Harrison, RCA Manufacturing Co., Inc., RCA Radiotron Division	Stinchfield, J. M.
	Harrison, RCA Manufacturing Co., Inc., RCA Radiotron Division	Zottu, P. D.
	Interlaken, 302 Grassmere Ave.	Burrows, C. R.
	Verona, 18 Winding Way	Spitzer, E. E.
New York	New York, Western Union Telegraph Co., 60 Hudson St.	Arnold, J. W.
	New York, General Radio Co., 90 West St.	Ireland, F.
	Port Jefferson, L.I., 108 Prospect St.	Carter, P. S.
	Riverhead, L.I., c/o RCA Communications, Inc.	Crosby, M. G.
	Riverhead, L.I., 179 Woodhull Ave.	Trevor, B.
	Schenectady, General Electric Co., 1 River Rd.	Darlington, E. S.
	Schenectady, General Electric Co., 1 River Rd.	Metcalf, G. F.
	Schenectady, 1413 Hawthorn St.	Priest, C. A.

For Election to the Associate Grade

Alabama	Leighton, Box 211	McCoy, J. H.
California	Los Angeles, 511 E. 6th St.	Schaefer, R. M.
District of Columbia	Washington, 1514 Spring Pl., N.W.	Gamwell, T. M.
	Washington, 1615 Newhampshire Ave., N.W.	Harrell, E. E.
	Washington, 4633 Davenport St., N.W.	Schleter, G. C.
Georgia	Atlanta, 976 Drewry St.	Burke, J. M., Jr.
	Atlanta, Rm. 318, 51 Ivy St., N.E.	Crowson, F. B.
Illinois	Chicago, 4442 S. Homan Ave.	Merten, D. J.
	Chicago, 1154 Merchandise Mart	Radius, C.
	Chicago, 5216 W. Monroe St.	Wright, R. W.
Iowa	Sioux City, 1921 W. 4th St.	Lien, C. E.
Maryland	Silver Spring, 1711 Bradford Rd.	Sharpless, W. R.
Massachusetts	Winchester, 54 Hemingway St.	Gaffney, F. J.
Michigan	Highland Park, 10 Eason St.	Penhollow, H. A.
Missouri	Doe Run	LeGrand, J. S.
	Kansas City, 408 1/2 W. 75th St.	Crane, E. J.
	Kansas City, 2730 Troost Ave.	Ferguson, L. T.
New Jersey	Bloomfield, 55 Monroe Pl.	Spangenberg, L.
	Jersey City, 125 Summit Ave.	Cotter, F. M.
	Plainfield, 1287 Florence Ave.	Johnson, G. D., Jr.
New York	Brooklyn, 66 Howard Ave.	Scholer, R. A.
	Endicott, International Business Machines Corp.	Palmer, R. L.
Pennsylvania	Philadelphia, 5419 Germantown Ave.	Packer, W. H.
	Philadelphia, 7866 Devon St.	Snell, P. A.

Applications for Membership

Virginia	Arlington, 1022 N. Edgewood St.	Hauber, E. N.
Canada	Montreal, Que., 204 Hospital St.	Macleod, D. N.
	Toronto, Ont., 236 Gainsborough Rd.	Hedley, C. E.
	Vancouver, B.C., 1927 Georgia St., W.	Watson, J. W.
	Winnipeg, Manit., Canadian Westinghouse Co.	Parker, H.
Cuba	Vedado, Havana, La-Voz-Del-Aire, Calle G y 25, Box 2294.	Guiral, R. L.
Czechoslovakia	Prague, Elektropopper	Horvath, A.
England	Honley, Nr. Huddersfield, Yorks., "Farcroft"	Garside, J. H.
	Worthing, Sussex, 20 Leighton Ave.	Gill, F. W.
France	Nancy, Meurthe et Moselle, 76 Ave. Foch	Lochard, J. C.
India	Bangalore, Electrical Communication Engineering Dept., Indian Institute of Science, P. O. Hebbal	Karve, K. R.
	Dacca, East Bengal, Physics Dept., Dacca University	Khastgir, S. R.
South Africa	Cradock, Union Bldgs.	Theron, C.
Straits Settlements	Singapore, W/T Transmitting Station, R.A.F. Seletar	Colbon, C. V.
	Singapore, W/T Transmitting Station, R.A.F. Seletar	Pook, B. T. T.

For Election to the Junior Grade

New York	White Plains, 70 Robertson Ave.	Locanthi, B.
New Zealand	Christchurch, 116 St. Albans St.	Lee, W. C.

For Election to the Student Grade

Indiana	West Lafayette, 238 East Cary Hall	Gibson, O. B.
Kansas	Manhattan, 723 Moro	Pfeffer, W. J.
Massachusetts	Boston, 526 Beacon St.	Ferry, J., Jr.
	Cambridge, M.I.T. Dormitories	Landy, R. B.
New York	New York, 1435 University Ave.	Lippencott, G. H.
	New York, 666 W. 188th St.	Torian, J. T.
North Carolina	Chapel Hill, 10 Pettigrew	Rockwell, P.
Virginia	Blacksburg, Route 1, Box 119-A	Martin, E. T.

OFFICERS AND BOARD OF DIRECTORS

(Terms expire January 1, 1938, except as otherwise noted)

President

H. H. BEVERAGE

Vice President

P. P. ECKERSLEY

Treasurer

MELVILLE EASTHAM

Secretary

HAROLD P. WESTMAN

Editor

ALFRED N. GOLDSMITH

Directors

STUART BALLANTINE, *Past President*

T. A. M. CRAVEN

L. C. F. HORLE

C. M. JANSKY, JR.

C. B. JOLLIFFE

A. F. MURRAY

E. L. NELSON

HARADEN PRATT

B. J. THOMPSON

L. E. WHITTEMORE

SERVING UNTIL JANUARY 1, 1939

E. H. ARMSTRONG

VIRGIL M. GRAHAM

ALAN HAZELTINE, *Past President*

SERVING UNTIL JANUARY 1, 1940

RALPH BOWN

H. M. TURNER



INSTITUTE NEWS AND RADIO NOTES

December Meeting of the Board of Directors

The December 1 meeting of the Board of Directors was held in the Institute office and attended by Haraden Pratt (president-elect and acting chairman), Ralph Bown, F. W. Cunningham (director-elect), Alfred N. Goldsmith, Virgil M. Graham, O. B. Hanson (director-elect), L. C. F. Horle, C. M. Jansky, Jr., E. L. Nelson, B. J. Thompson, H. M. Turner, L. E. Whittemore, and H. P. Westman, secretary.

Thirty-one applications for Associate grade, two for Junior, and three for Student grade were approved.

The dates of April 29 and 30, 1938 were approved for the joint meeting of the Institute and the American Section of the International Scientific Radio Union.

Standards reports on electroacoustics, transmitters and antennas, and the testing of radio receivers, were approved.

Approval was granted for holding the next Rochester Fall Meeting on November 14, 15, and 16, 1938.

Joint Meeting of the Institute and the American Section of the International Scientific Radio Union

The annual joint meeting of the Institute of Radio Engineers and the American Section of the International Scientific Radio Union will be held in Washington, D. C., on April 29 and 30, 1938. This will be a two-day meeting instead of the usual one-day meeting held in past years. This meeting is an important feature of the week which attracts to Washington every year an increasingly large number of scientists and scientific societies. Papers on the more fundamental and scientific aspects of radio will be presented. A program of titles will be published in the April PROCEEDINGS. This will necessitate the submission of titles to the Committee by February 23. It is desirable but not necessary that abstracts be submitted with the titles. A program of abstracts will be printed and mailed to those interested before the meeting. The abstracts will therefore be required by April 1. Correspondence should be addressed to S. S. Kirby, National Bureau of Standards, Washington, D. C.

Broadcast Engineering Conference

The Ohio State University at Columbus, Ohio, will conduct from February 7 to 19 a broadcast engineering conference under the direc-

tion of W. L. Everitt, professor of electrical engineering. Papers will be read by members of the staff and prominent speakers active in the field covered. The tentative program lists the following speakers and subjects. A detailed program may be obtained by addressing Professor Everitt.

"Field Strength Surveys," by J. F. Byrne, Collins Radio Company.

"Coupling Networks," by W. L. Everitt, Ohio State University.

"Studio Acoustics," by G. M. Nixon, National Broadcasting Company.

"Ultra-High-Frequency Propagation," by H. H. Beverage, RCA Communications, Inc.

"Propagation of Broadcast Frequencies at Night," by J. H. Delinger, National Bureau of Standards.

"Demonstrations of Phenomena of Interest to Radio Engineers," by W. L. Everitt, Ohio State University.

"Broadcast Antenna Design," by G. H. Brown, Godley and Brown.

"High-Power Radio-Frequency Amplifiers," by W. H. Doherty, Bell Telephone Laboratories.

"Modulation and Distortion Measurements," by A. E. Thiessen, General Radio Company.

"Indicating Instruments," by H. L. Olesen, Weston Electrical Instrument Corporation.

"Snow Static Effects on Aircraft," by H. M. Hucke, United Air Lines.

"Aeronautical Ground Radio Station Design," by P. C. Sandretto, United Air Lines.

Rochester Fall Meeting

At the Rochester Fall Meeting which was held on November 8, 9, and 10 with headquarters at the Sagamore Hotel, the attendance exceeded all previous figures and totaled 513. There were nineteen papers presented during the eight technical sessions which were held. Thirty-five commercial organizations participated in the exhibition which was part of the meeting.

Australian Radio Convention

The Institution of Radio Engineers of Australia has extended a most cordial invitation to the members of the Institute of Radio Engineers to take part in the World Radio Convention which will be held at Sydney, New South Wales, from April 4 to April 14, 1938. Sir Ernest Fisk,

President of the Australian group and Vice President of our Institute will preside at the meetings.

Twelve technical sessions as well as trips, receptions, and other social activities promise to make this Convention one of great interest. Coming as it does towards the end of the celebration of the 150th anniversary of the settling of Australia, it offers an excellent opportunity to learn much about the country.

Those interested may obtain specific program information from the secretary, O. F. Mingay, 30 Carrington Street, Sydney, N.S.W., Australia.

Committee Work

NEW YORK PROGRAM COMMITTEE

A meeting of the New York Program Committee was held in the Institute office on November 19 and attended by H. P. Westman, acting chairman and secretary; Austin Bailey, G. C. Connor, D. E. Foster, R. A. Heising, J. K. Henney, and L. G. Pacent.

Preparations were made for meetings for January, February, and March, 1938. It was agreed that in order to facilitate the rapid distribution of notices, they would hereafter be mailed as post cards rather than folded sheets.

TECHNICAL COMMITTEES

American Standards Association

Technical Committee on Electroacoustic Devices

The Technical Committee on Electroacoustic Devices of the Sectional Committee on Radio operating under the American Standards Association met in the Institute office on November 12. Those present were Julius Weinberger, chairman; E. D. Cook (representing H. B. Marvin), J. W. Fulmer, H. S. Knowles, J. D. Parker (representing W. B. Lodge), L. J. Sivian, W. F. Snyder, and H. P. Westman, secretary.

The committee reviewed the report on Electroacoustics prepared by the Technical Committee on Electroacoustics of the Institute of Radio Engineers. It did not complete its review of this report and on November 13 an additional meeting of Messrs. Cook, Knowles, and Westman was held to prepare recommendations for further action by the committee at a subsequent meeting.

Technical Committee on Electronics

A meeting of the Technical Committee on Electronics was held in the Institute office on December 10 and attended by B. J. Thompson,

chairman; J. W. Arnold, R. S. Burnap, E. L. Chaffee, Ben Kievit, F. R. Lack, A. F. Murray, G. D. O'Neill, W. B. Wells (representing A. M. Granum), secretary, J. D. Crawford, assistant secretary, and H. P. Westman.

The meeting was devoted to the editing and consolidation of a number of reports prepared by the subcommittees on developments in their fields during 1937. This report now goes to the Annual Review Committee for final action.

The following subcommittee meetings were held for the preparation of the annual review material and final action on a small amount of material which is concerned with standardization work.

Subcommittee on Cathode-Ray and Television Tubes

This committee met in the Sagamore Hotel in Rochester on November 8. Those present were A. F. Murray, chairman; R. M. Bowie, A. B. DuMont, V. H. Fraenckel, M. S. Glass, L. B. Headrick (representing H. Iams and T. B. Perkins), H. C. Hergenrother, F. S. Somers (representing P. T. Farnsworth), A. W. Vance, and H. P. Westman, secretary. The following guests also attended this meeting: R. R. Batcher, J. C. Batchelor, H. L. Byerlay, F. J. Bingley, J. R. Duncan, H. M. Lewis, I. G. Maloff, H. C. Remler, and M. P. Wilder.

Subcommittee on Electron-Beam Tubes

Ben Kievit, chairman; A. B. DuMont, V. H. Fraenckel (representing G. F. Metcalf), L. B. Headrick (representing H. M. Wagner), H. G. Hergenrother, and H. P. Westman, secretary, attended the meeting of this subcommittee which was held in the Sagamore Hotel, Rochester, N. Y. on November 8.

Subcommittee on Gas-Filled Tubes

This committee met in the Bell Telephone Laboratories on November 8 and those present were F. R. Lack, chairman; G. F. Arnott (representing W. G. Moran), C. H. Bachman, O. W. Pike, and C. M. Wheeler.

Subcommittee on High-Frequency Tubes

The following were present at the meeting of this committee which was held in the Institute office on November 29, B. J. Thompson, chairman; G. R. Kilgore, F. B. Llewellyn, A. L. Samuel, J. D. Crawford, assistant secretary, and H. P. Westman, secretary.

Subcommittee on Small High Vacuum Tubes

This committee met in the Institute office on December 6 and those present were P. T. Weeks, chairman; R. S. Burnap, H. A. Pidgeon, C. B. Upp, J. D. Crawford, assistant secretary; and H. P. Westman, secretary.

Technical Committee on Television and Facsimile

In order to prepare its report for the Annual Review Committee, the Technical Committee on Television and Facsimile met in the Institute office on December 14. Those present were J. V. L. Hogan, chairman; R. R. Batcher, K. B. Eller, (representing J. W. Milnor), E. W. Engstrom, E. F. Kingsbury, H. M. Lewis, J. D. Parker (representing E. K. Cohan), S. Simpson, Jr. (representing J. L. Callahan), L. F. Willging (representing D. D. Israel), H. C. Ressler (guest), J. E. Young, and H. P. Westman, secretary.

Institute Meetings

ATLANTA SECTION

A meeting of the Atlanta Section was held on November 18 in the Atlanta Athletic Club with N. B. Fowler, chairman, presiding. There were thirteen present.

A paper on "Carrier Current and the Power Systems" was presented by Olan Richardson, electrical engineer for the Georgia Power Company. The discussion started with a review of the more important fundamentals of carrier-current transmission which included descriptions of various types of equipment used and information on the coupling systems and frequencies best suited for this work. The use of this system for controlling the frequency of various generating stations that are connected together was also covered. Other recent adaptations of carrier-current devices included a test on the operation of water heaters during minimum load periods.

BOSTON SECTION

On October 29, H. W. Lamson, chairman, presided at a meeting of the Boston Section held at Harvard University and attended by ninety.

A paper on "Contributions of the Amateur to Radio Communication" was presented by G. W. Bailey, vice president of the American Radio Relay League. In it he presented a historical sketch of the technical contributions of the amateur to radio communications. It was pointed out that a large number of radio engineers who have achieved distinction were originally amateurs. Amateur experimental work gave

impetus to the development of high-frequency communication systems and to limited range communication at ultra-high frequencies. The military services of the amateur during the World War were discussed and the paper was closed with an outline of relief activities during major floods. The paper was discussed by Messrs. Barnes and Dallin.

BUFFALO-NIAGARA SECTION

On October 20, the annual meeting of the Buffalo-Niagara Section was held as an inspection trip to Stations WGR-WKBW of the Buffalo Broadcasting Company at Amherst, N. Y. There were forty members and guests present.

The two transmitters of five-kilowatt rating each are located in the same building and employ the same radiator. WGR operates at 550 kilocycles and WKBW at 1480 kilocycles. The antenna is a uniform cross-section tower of welded galvanized steel sections which are bolted together. Two sets of guys are attached at a third and two thirds the distance from the top of the tower which is mounted on an insulator located ten feet above ground level. Two four-wire transmission lines are curved away from each other and leave and enter the station and antenna tuning houses at right angles to each other to reduce interference between the two stations. Filters prevent each station from feeding energy to the other and isolate the 110-volt tower lighting circuit from the radio-frequency circuits. The ground system is comprised of a mat approximately forty feet square located at the base of the tower from which 600-foot conductors radiate. There are 180 of these conductors all of which are plowed into the ground.

The station building is five feet above the highest flood level of Ellicott Creek which is near it and its basement is completely waterproofed with no openings below high-water level. A forced draft system for cooling transformers and tubes is arranged to assist in heating the building in winter and cooling it in summer. Copper strips placed in the floors, roof, and walls are connected to a strip around the outside of the building and tied into the radiator ground system. The two stations operate without mutual interference. The antenna ratios are 0.6 for the high-frequency station and 0.28 for the low-frequency transmission.

A buffet lunch was served at the conclusion of the meeting.

In the election of officers, those serving for the previous year were re-elected and are George C. Crom, Jr., of the Rudolph Wurlitzer Company, chairman; K. B. Hoffman of the Buffalo Broadcasting Corporation, vice chairman; and E. C. Waud of the New York Fire Insurance Rating Organization, secretary-treasurer.

The November meeting of the section was held on the 17th with Chairman Crom presiding. The meeting was at the University of Buffalo and was attended by twenty-four.

"Some Facts Concerning the Manufacture and Use of Global Products" was presented by B. A. Bovee, chief engineer of the Carborundum Company. Experimental and commercial developments of Global elements were described. Some of the problems met in producing uniformity and permanence were explained. Operating characteristics were described and the industrial application of high temperature heating elements to furnaces and the use of low temperature coefficient resistance elements were explained.

CHICAGO SECTION

The Chicago Section met on November 5 at Fred Harvey's Union Station Restaurant. J. K. Johnson, chairman, presided and there were 118 present.

C. E. Skroder, professor of electrical engineering at the University of Illinois presented a paper on "Filter Networks." He included a discussion of the fundamental principles of ideal four-terminal filter networks; the use of reactance curves for computing attenuation and transmission bands, attenuation characteristics, improvement in sharpness of cutoff obtainable by the use of resonant circuits, and practical composite filters. Data sheets were distributed showing circuits and reactance and attenuation curves for different types of filters and a sample design for a composite high-pass filter. Additional copies of these sheets may be obtained from the author. The paper was discussed by Messrs. Baumzweiger, Gilman, Herrick, Kohler, Petrie, and Robinson.

Members of the senior engineering class of the University of Illinois were guests of the section at the meeting which was included in the itinerary of their senior inspection trip.

CINCINNATI SECTION

The University of Cincinnati was the place at which the October 19 meeting of the Cincinnati Section was held. There were thirty-five present and G. F. Platts, chairman, presided.

"Recent Developments in Radio Tests and Service Equipment" was the subject of a paper presented by Kendall Clough, president and chief engineer of the Clough-Brengle Company. After outlining the usual procedure in delineating resonance curves by means of an oscilloscope, the author described difficulties met when using a mixer system whereby any two signals are employed to obtain a third. Only the

second-order products are necessary to obtain the wanted signal with a square-law rectifier; the third and higher derivatives give rise to unwanted signals. In conclusion, he described a practical method and showed how the original frequency-modulated signal could be kept below ten microvolts in the output by means of a balanced mixing system using two tubes in push-pull.

CLEVELAND SECTION

The Cleveland Section met on September 24 in the Cleveland Photographic Society auditorium with forty-one present. R. A. Fox, chairman, presided.

H. P. Boswau, chief engineer, and D. A. Heisner, engineer in charge of operations of the Lorain Telephone Company, presented a paper on "Ship-to-Shore Telephone Equipment." Mr. Boswau first sketched the history of ship-to-shore telephone communication which started in 1934 on a frequency of 2550 kilocycles with service to a single ship. There are now fifty-five ships being served. The original transmitter which comprised a crystal oscillator, a buffer, and a plate-modulated 50-watt final stage was designed for alternating-current operation and required a converter because direct current only was available on shipboard.

Mr. Heisner described the latest equipment. Four channels are provided and selected by dialing. If the channel dialed is busy, automatic-volume-control voltage developed in the crystal-controlled receiver for that channel automatically prevents the operation of the transmitter. By means of relays, the dialing of a channel selects the frequency for the 50-watt transmitter, releases the proper receiver, and locks out all operation of the remaining three receivers. A demonstration was given of the equipment which was set up in the meeting room.

The October 28 meeting of the section was attended by twenty-five, and was also held in the Cleveland Photographic Society auditorium and presided over by Chairman Fox.

I. E. Beasley, biophysicist of the Cleveland Clinic Foundation presented a paper on "Practical Uses of Geiger Counter Tubes." The paper was opened with a brief discussion of the developments in photo-cell construction and dependability which permits light measurements over the entire spectral range from infrared to ultraviolet. These cells in combination with a Geiger-Mueller counter tube are employed to detect extremely faint radiations. The operating characteristics of the tubes were given. As a practical use, Dr. Beasley described how the minute radiation from substances not generally recognized as being

radioactive were detected. The use of the equipment in locating two supplies of radium that had accidentally been mislaid in hospitals following their use was mentioned.

CONNECTICUT VALLEY SECTION

The October meeting of the Connecticut Valley Section was held at Connecticut State College and fifty members and guests were present. D. E. Noble, chairman, presided.

H. W. Lamson, engineer for the General Radio Company, presented a paper on the "Edgerton Stroboscope." This device permits intermittent visual or photographic observations of a moving object in such a manner as apparently to reduce or stop its motion. It may be accomplished by a shutter mechanism or illuminating the object with short pulses of light. The latter method is employed in the Edgerton stroboscope, the light source being a high intensity mercury arc which is struck and extinguished in five microseconds. To indicate this order of time interval it was pointed out that a body moving at sixty miles per hour would advance the thickness of a newspaper sheet in five microseconds. The rate of flash can be controlled accurately and fundamental stroboscope synchronism can be obtained at rotational speeds as high as 10,000 revolutions per minute. Several demonstrations of these effects were given and motion pictures were projected of such phenomena as the splash of a falling drop, the take-off and flight of pigeons, the hummingbird in flight and feeding from a flower, the landing of a cat on its feet when dropped from an inverted position at a distance of a foot and a half from the floor, and the autogiro mode of flight of the mosquito. These subjects were illuminated with stroboscopic light and photographed with a camera capable of taking up to 5000 frames per second. When projected at the rate of fifteen frames per second the action is reduced in speed and details can be observed.

EMPORIUM SECTION

The following three meetings of the Emporium Section were held in the American Legion Rooms and presided over by M. I. Kahl, chairman.

The October 29 meeting was attended by thirty-eight and J. C. McNary of McNary and Chambers presented a paper on "Repeater Stations for Broadcasting." It was pointed out that existing allocations provide for three types of stations. Local stations, several dozen of which may operate on a given frequency, are limited to 250 watts, daytime, and 100 watts at night. Regional stations of which eight may occupy a given channel, employ up to 1 kilowatt at night. Clear-

channel stations are not duplicated in frequency assignment and employ the highest powers. The use of repeater or satellite stations is most effective in the first two classes. When the area to be served is oval, rather than circular, a master station with a satellite station located on its 4-millivolt contour will provide satisfactory service. To reach the limits of such an area with a single station would require more than double the combined power of the master and satellite stations. The single station would cover a large area and also produce greater interference. The paper was closed with a discussion of the physical and electrical arrangement of WBAL, operating on 1060 kilocycles, and its satellite, W3XJ. The paper was discussed by Messrs. Bachman, Bowie, and Steen.

The November 12 meeting was attended by sixty-three and two papers were presented.

"Fundamental Concepts of Cathode-Ray Television" was presented by R. M. Bowie, director of television research, Hygrade Sylvania Corporation. Dr. Bowie first defined television as a system of transmitting motion pictures through space by electrical means. Explanations of the more important terms used in television were then presented. He described existing American practices and standards and pointed out the variations found in European practice. The present allocation of channels for television is between 44 and 120 megacycles and provides channels 6 megacycles wide.

"Principles of Television Reception" was the subject of a paper by C. W. Carnahan, an engineer for the Hygrade Sylvania Corporation. The function of a receiver was the utilization of the video-frequency signal, the direct-current component, the blanking impulses, and the synchronizing signals to produce a picture. The video signals may be either positive and produce illuminated spots on the screen at maximum voltage or negative and produce minimum illumination under this condition. Similarly, there are two types of direct-current components and in one method the average carrier amplitude varies while in the other it remains constant. Blanking and synchronizing impulses may be transmitted in a number of different ways. Either amplitude or wave-shape separation may be employed for synchronizing impulses.

These papers were discussed by Messrs. Abbott, Campbell, Carter, Haas, Jones, and Stringfellow. During the discussion, Mr. Carter gave a résumé of the paper on selective ionization which was given at the Rochester Fall Meeting.

At the November 17 meeting, A. V. Loughren, engineer for the

Hazeltine Service Corporation, presented a paper on "The Fine Structure of Television Images." In it he defined scanning as a method of transmitting a large number of picture elements over a single circuit. Basic principles were first examined and indicated that the sine wave shape of the elements obtained in electronic scanning as contrasted with mechanical scanning permitted a greater tolerance for variation in the line width without seriously changing the transverse brightness of a flat field. The definition of resolution is arbitrary and depends somewhat on the picture. For the purpose of his analysis the extreme condition of a narrow bright line on a black field was chosen. From this were developed equations for the spot size and shape as well as characteristics of the electrical circuit necessary. In conclusion, it was shown by substitution how the derived formulas fit the results for the conditions of 441 lines per picture, 30 frames per second, and an aspect ratio of 4 to 3. The paper was discussed by Messrs. Bachman, Ballard, Bowie, Carnahan, Carter, Fink, Jones, and McLean.

NEW ORLEANS SECTION

A meeting of the New Orleans Section was held on August 31 in the Association of Commerce Building. L. J. N. DuTreil, chairman, presided and there were fourteen present.

A paper on "The United States Frequency Monitoring Station at Grand Island, Nebraska" was presented by W. L. Abbott, radio inspector of the Federal Communications Commission. The description was augmented by the showing of motion pictures of the station.

NEW YORK MEETING

The regular New York meeting of the Institute was held in the Engineering Societies Building on December 1. In the absence of President Beverage, the meeting was presided over by Secretary Westman. There were 450 members and guests present.

A paper on "Teledynamic Control by Selective Ionization with Application to Radio Receivers" by S. W. Seeley, H. B. Deal, and C. N. Kimball of the RCA License Laboratory was presented by Dr. Kimball. The paper described a method of remote control which may be applied to electrical devices of various sorts. It utilizes the alternating-current power line as a medium for transmission of radio-frequency control signals from the remote control unit to the device to be operated. It requires no stand-by power during times of nonoperation. A demonstration of the device showed the control of a broadcast receiver which involved turning it on and off, increasing or decreasing volume, and the selection of any one of several channels.

PHILADELPHIA SECTION

On November 4, the Philadelphia Section met at the Engineers Club. A. F. Murray, chairman, presided and there were 230 present.

"Snow Static Effects on Radio Reception" was the subject of a paper by H. M. Hucke, communications engineer of United Air Lines. It was presented by P. C. Sandretto of the same organization because Mr. Hucke was unable to be present. The paper first covered various types of transmissions employed in aeronautical radio communication. It has been found at high speed flying that snowflakes, ice crystals, dust particles, or charged raindrops striking the antenna deposit static charges of sufficient intensity to render reception poor or impossible. Experimental work under conditions causing this static indicates an enclosed loop antenna as most effective in eliminating the interference. The housing should have a pointed front to reduce the accumulation of ice as the teardrop shape of housing gathers a greater ice cap which becomes charged and has a larger effect on reception. A high speed plane will pick up a static charge of 100,000 volts and various methods have been tried to dissipate these charges. One method employs a trailing wire attached to the tail of the plane by means of a partially conductive cord. A charge of 100,000 volts on a plane produces a corona effect which creates the same type of noise as is produced by snow static. The paper was discussed by Messrs. Engstrom, Gunther, Luck, McLoughren, Snyder, West, and Wolff.

A paper on "Modern Aircraft Radio Compass Equipment" by Edward Blodgett, receiver engineer for the RCA Manufacturing Company was presented by D. S. Little. The particular device was designed for itinerant flying and may be used as an aircraft radio receiver for weather broadcasts, the standard broadcast spectrum, and the high-frequency aviation bands. A loop antenna is used for direction finding purposes and a T antenna for communication purposes. The equipment was available for inspection.

PITTSBURGH SECTION

The Pittsburgh Section held a meeting in the Carnegie Institute of Technology on November 16 with R. T. Gabler, chairman, presiding.

A paper on "Physical Causes of Critical Coupling" was presented by G. A. Scott, professor of physics at the University of Pittsburgh. The more simple and familiar formulas for the impedance and resistance of coupling coils were first presented and then developed into more complicated forms required for the design of coils and transformers to give maximum transfer of energy between coupled circuits. The paper was discussed by Messrs. Baudino, Gabler, Krause, Place, Stark, and Sutherlin.

SAN FRANCISCO SECTION

The San Francisco Section holds two meetings a month, one of which is devoted to a discussion of published papers and the other to the presentation of unpublished material. The October 6 meeting, held in the Pacific Telephone and Telegraph Company auditorium, was attended by forty and presided over by V. J. Freiermuth, chairman.

Andrew Alford, engineer of the Mackay Radio and Telegraph Company, presented a paper on "High-Frequency Transmission-Line Networks." In it he described newly developed high-frequency networks for matching impedances of antennas and transmission lines and networks for frequency discrimination. A system was described which permits the operation of two transmitters on a single antenna.

The October 20 meeting reviewed two published papers and was held in the auditorium of the Pacific Telephone and Telegraph Company. Noel Eldred, vice chairman, presided and there were thirty-six present. The first paper reviewed was "Simultaneous Radio Range and Telephone Transmission" by Jackson and Stuart which appeared in the March, 1937, *PROCEEDINGS*. H. W. McKinley of the Bureau of Air Commerce led the discussion.

The second paper on "A Multiple Unit Steerable Antenna for Short-Wave Reception" by Friis and Feldman and published in the July, 1937, *PROCEEDINGS* was discussed under the direction of Mark Sandfort of the engineering staff of the Pacific Telephone and Telegraph Company.

The November 5 meeting was held jointly with the local section of the American Institute of Electrical Engineers and presided over by Howard Lane, chairman of that section. The attendance was 250 and the meeting was held in the Pacific Gas and Electric Auditorium.

J. O. Perrine of the American Telephone and Telegraph Company presented a paper on "Waves, Words, and Wires." As part of it, Dr. Perrine demonstrated the high fidelity hill-and-dale recordings and three loud-speakers having ranges of 50 to 2000 cycles, 500 to 5000 cycles, and 2000 to 9000 cycles. Standard telephone equipment was available and used to demonstrate distortion, howling, and echo effects over distances of several hundred miles of circuit.

The meeting on the 17th was for review purposes and held at Manning's Cafe. There were ten present and C. J. Penther, secretary-treasurer, presided.

The review on "Simple Method for Observing Current Amplitude and Phase Relations in Antenna Arrays" by J. F. Morrison which ap-

peared in the PROCEEDINGS for October, 1937, was led by Lowell Hollingsworth.

W. A. McAully conducted the review of "Ground Systems as a Factor in Antenna Efficiency" by G. H. Brown, R. F. Lewis, and J. Epstein which appeared in the June, 1937, PROCEEDINGS.

SEATTLE SECTION

"Some Problems in Nuclear Structure" was the subject of a paper by E. A. Eauahling, professor of physics at the University of Washington, presented at the October 29 meeting of the Seattle Section which was held at the University of Washington. J. W. Wallace, chairman, presided and there were fifty-five present.

A historical background of nuclear theory was first presented, and it was pointed out that atomic physics really began with the work of Dalton early in the nineteenth century and followed by the notable work of such investigators as Young, Kelvin, and Crookes. The phenomena of radioactivity defeated early efforts to construct an atomic model consistent with experimental results. Planck, Bohr, and Einstein later accounted for radiation on the basis of equivalence between mass and energy and permitted the completion of a satisfying atomic model. The present knowledge of the mass of the nucleus and its components was presented and the actions believed to occur when transmutations are effected were outlined.

TORONTO SECTION

W. H. Kohl, chairman, presided at the November 22 meeting of the Toronto Section which was held at the University of Toronto.

"The Technical Operations of a 'Broadcast Network'" was the subject of a paper by E. K. Cohan, director of engineering of the Columbia Broadcasting System. The Columbia network uses 15,000 miles of telephone cable for program service and in addition maintains communication between stations by teletype. The studio construction was described and the use of theaters as large studios was discussed. New studios under construction in Hollywood were described and facilities required for broadcasting special news events were dealt with and included the use of high-frequency transmitters and receivers and their operation as mobile units both on land and in the air. A dial system whereby executives of the system in New York City dial for any desired program on the air or being auditioned in their studios was described. The paper closed with an outline of technical difficulties encountered in broadcasting from the Byrd expedition.

WASHINGTON SECTION

W. P. Burgess, chairman, presided at the November 8 meeting of the Washington Section which was attended by eighty-five and held in the Potomac Electric Power Company auditorium.

R. E. Mathes of RCA Communications, Inc., presented a paper on "Time Division Multiplex in Radiotelegraphic Practice." This paper appears elsewhere in this issue.

Personal Mention

F. M. McCarthy formerly with the Galvin Manufacturing Corporation has joined the engineering staff of the Kellogg Switchboard and Supply Company of Chicago, Ill.

Stephen Stevens has left Eastern Air Lines to become technical adviser on communications for the Trans-Canada Air Lines.

G. V. Eltgroth has joined the Research and Development Department of Bendix Radio Corporation of Chicago having previously been with Industrial Instruments, Inc.

Formerly with RCA Manufacturing Company, F. J. Friel, Jr., is now with the Oak Manufacturing Company in Chicago, Ill.

M. K. Goldstein is now with the Bureau of Commerce Radio Division, Washington, D. C., having previously been with the RCA Manufacturing Company.

Alex Gorbunoff has become an engineer for Seeburg Radio Corporation of Chicago, Ill., having formerly been with General Household Utilities Company.

Previously with Electrical Research Products, F. H. Graham has joined the staff of Bell Telephone Laboratories in New York City.

Formerly with Hazeltine Service Corporation, R. T. Hintz has become a member of the staff of Belmont Radio Corporation of Chicago, Ill.

C. F. Horne, Jr., Lieutenant, U.S.N., has been transferred from the U.S.S. *Semmes* to U.S.S. *New York*.

M. F. Kennedy previously with the Firestone Plantations Company is now with the Wireless Section of the Kenya government Posts and Telegraphs at Uganda and Tanganyika, East Africa.

W. G. McConnell of the Bendix Radio Corporation is now located at Baltimore, Md., having been transferred from Washington, D.C.

E. H. Murty is now a radio engineer in the Receiver Engineering Department of the Bendix Radio Corporation at Chicago, Ill.

W. A. Nichols has left the Northern Electric Company to become chief engineer of CBL of the Canadian Broadcasting Corporation at Hornby, Ontario.

R. J. Renton an inspector for the Federal Communications Commission has been transferred from Boston, Mass., to Grand Island, Neb.

J. W. Sanborn has joined the Transmitter Engineering Section of the RCA Manufacturing Company at Camden, N.J., having formerly been with the International Telephone and Telegraph Company.

F. H. Scheer has left F. W. Sickles Company and is now with the Colonial Radio Corporation of Buffalo, N.Y.

M. T. Smith of the General Radio Company has been transferred to Los Angeles, Calif.

B. E. Southorn has left the South African Broadcasting Corporation to join the South African Airways as a radio engineer and is located at Germiston, Transvaal.

Edward Stanko has left the Buffalo Broadcasting Corporation to become a field engineer for the RCA Manufacturing Company at Camden, N.J.

W. A. Steel formerly of the Canadian Radio Commission has opened a consulting radio engineering practice in Ottawa, Ont., Canada.

Eiiti Sugiyama, assistant chief engineer of the Bureau of Communications, has been transferred from Kyoto to Osaka, Japan.

J. D. Woodward has left United Air Lines Transport Corporation to join the staff of McNary and Chambers, Washington, D.C.



TECHNICAL PAPERS

THE ULTRA-SHORT-WAVE GUIDE-RAY BEACON
AND ITS APPLICATION*

BY

E. KRAMAR AND W. HAHNEMANN

(C. Lorenz A.G. Berlin, Germany)

Summary—Part I. Proceeding from the present state of the art of air navigation in the United States and in Germany, the ultra-short-wave instrument landing system in Europe is described. The fundamental principle and the technical improvements are mentioned and practical statements and views are given. Mention is made of the experience gained in the operation of the beacon. The conditions of inversion of the signals one into the other to avoid clicking are stated. The occurrence of split beams is dealt with. Their causes are explained and advice as to how to avoid such trouble is given. In the operation of neighboring beacons, disturbed zones will occur which, by choosing the proper frequency spacing and the proper selectivity of the receivers, may be restricted to such an extent that they will not impair the use of radio beacons in any way. These problems are discussed more in detail.

Part II. At first the propagation of ultra-short waves is treated on the basis of the theory of combining reflection and diffraction on the earth with respect to their application to long-range navigation. It results that for a fixed distance and flying height an optimum wave length range exists allowing the airplane to cover ranges of 250 kilometers and more.

The investigation of propagation results in the possibility of long-range navigation by means of ultra-short-wave beacons. The experiments made in Australia gave very encouraging results. Examples are given for producing four beams in any desired direction and for introducing the landing beacon in the long range navigation system.

Finally the properties of an ultra-short-wave system of navigation are considered in comparison with the use of long-wave beacons. It becomes evident that the ultra-short-wave system offers a number of advantages which seem to make it worth while to treat this problem earnestly.

PART I

THE ULTRA-SHORT-WAVE LANDING BEACON AND THE
PRACTICAL RESULTS OF THAT SYSTEM†

BY E. KRAMAR

INTRODUCTION

THE RISE of commercial aviation to its present high stage of development was, to a great extent, dependent on the progress of air navigation. The task of air navigation is the safe guidance of

* Decimal classification: R526.3. Original manuscript received by the Institute August 5, 1937.

† Presented before joint meeting of the American Section, U.R.S.I. and the Institute, Washington, D. C., April 30, 1937.

the aircraft to its destination, above all during nighttime and poor visibility.

Development has gone different ways in the various countries and consequently the present state of the art is different in the different countries.

In the United States, long-distance air navigation, that is, the guidance of aircraft while flying in and above the cloud ceiling, has been the object of much study. The long distances flown so regularly by the great air line operating companies require a special carefully operated system of air navigation. This has been facilitated by the creation of the long-wave radio range beacon for long distances which has overcome the influence of night error by means of the transmission-line antenna.

In European countries at the beginning of the rise of aviation the problem was less difficult because of the lower density of air traffic. Instruments and experience of maritime navigation were made use of to a wide extent and were gradually transformed in order to serve new purposes. Thus the scheme of the German flying organization was as follows: The commercial air liner is equipped with a long-wave transmitter and receiver for wireless communication. Ground stations, every one of which covers a fixed flying area, determine by means of loop direction finding receivers the position of the aircraft and give it the instructions necessary for safe operation. A great deal of responsibility is, therefore, left to the ground organization. It is primarily for its relief that the help of homing devices was recently taken up as well as the development of better landing methods by means of radio.

The problem of landing during bad visibility came to the foreground as soon as long-distance flying sufficient for the demands of air traffic in Europe had been established. The electric expedients to be employed for that purpose had to show two principal properties; i. e., first, a range restricted as much as possible, and second, freedom from all kinds of disturbances as far as possible. Examining the wave spectrum from this point of view for waves suitable for the purposes mentioned, it is found that the ultra-short waves appear to meet these conditions on the strength of the law of their propagation and because of their being little subject to disturbances, particularly of atmospheric origin. With regard to propagation, the greatly reduced reflection from the Heaviside layer is the deciding property in the use of ultra-short waves for short-distance signaling. Consequently, the range in general is well defined, extreme variations of range being encountered only on rare occasions. The properties of propagation will be discussed more in detail in PART II. For the moment it may be stated that we are able to

calculate the receiving intensity with a high degree of precision beforehand.

Fig. 1 shows a set of field strength curves corresponding to a standard 500-watt transmitter. By selecting the proper transmitter height and power the ranges may be fixed within certain limits as desired. The wave band below 10 meters thus proves to be especially suitable for simultaneous operation of a large number of transmitters on the same wave length. Even with high power it is possible to use the same wave

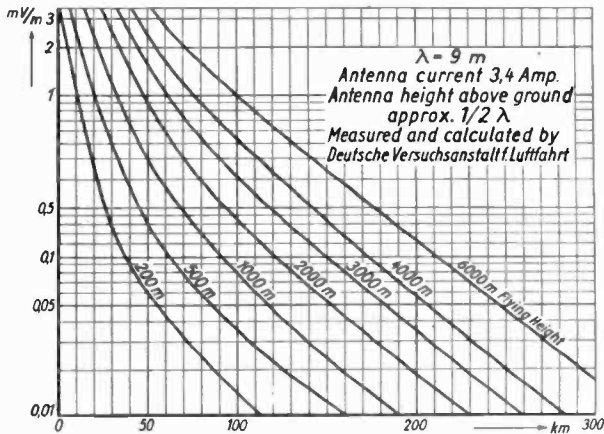

Fig. 1—Variation of field strength with flying altitude and distance based on a transmitter power of 500 watts.

length for instrument landing systems with comparatively short separating distances. This is explainable by the fact that an airplane making a landing operates near the beacon while the field strength is very much greater than that of an interfering signal that might arrive on occasions from a distant point by way of the Heaviside layer. The above considerations have led us to apply this sort of waves to the electrical instrument landing system. On the strength of these considerations and suggestions the well-known ultra-short-wave beacon of C. Lorenz A. G. was built.

THE ULTRA-SHORT-WAVE INSTRUMENT LANDING SYSTEM IN EUROPE

The beacon was first used for instrument landing purposes as planned in the original development program. Our expectations concerning the properties of propagation and freedom from disturbances have been perfectly realized. By making use of ultra-short waves, those airdromes which are most used for international traffic may be equipped with landing devices operated on the same frequency. This

eliminates tuning of the airplane receivers in addition to other advantages. Ultra-short waves also have the advantage of relative freedom from disturbances, especially of atmospheric origin. The paper by Diamond and Dunmore,¹ gave the impetus to European development in 1932. First of all it was necessary to adapt the well-known beacon principle to the ultra-short-wave range. As this subject has already been discussed in detail in earlier publications,² only the fundamental principle and more recent technical improvements will be mentioned here.

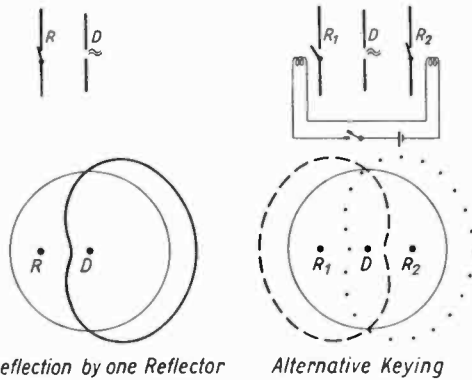

Fig. 2—Antenna and antenna keying arrangement.

(a) The Fundamental Principle

The antenna arrangement and its principle are illustrated in Fig. 2. The round diagram of a vertical dipole D is displaced by the reflector R_1 . Another reflector R_2 at the right-hand side of the dipole operating alternatively with the first produces the symmetrical diagram. The periodical alternating keying of the diagrams in a time ratio of $1/8$ to $7/8$ second produces very short dot signals on one side and long dash signals on the other side. In a central zone—the guide beam—the two signals combine into a continuous signal. This arrangement causes an electric “highway” determining the direction of approach. Two small transmitters serving as distance markers take the part of the milestones on that highway.

Fig. 3 illustrates the complete arrangement. The vertical shaded plane represents the equisignal zone, on the left-hand side is the dot

¹ H. Diamond and F. W. Dunmore, “A radio beacon and receiving system for blind landing of aircraft,” *Nat. Bur. Stand. Jour. Res.*, vol. 5, p. 897, (1930); *Proc. I.R.E.*, vol. 19, pp. 585–626; April, (1931).

² E. Kramar, “A new field of application for ultra-short waves,” *Proc. I.R.E.*, vol. 21, pp. 1519–1531; November, (1933); “The present state in the art of blind landing of airplanes using ultra-short waves in Europe,” *Proc. I.R.E.*, vol. 23, pp. 1171–1182; October, (1935).

area, on the right-hand side the dash area, and in the center the position of the radio beacon. The oval projections on the guide beam plane indicate the radiations of the outer and the inner markers both of which radiate upwards at a certain angle.

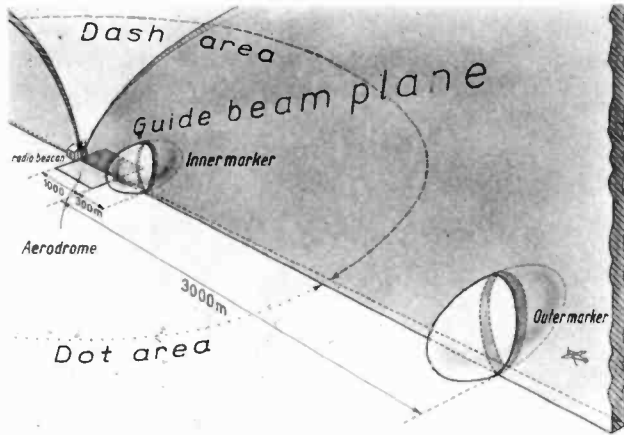

Fig. 3—Diagram illustrating the principle of Lorenz instrument landing system.

If the vertical diagram of the dipole arrangement is studied it will be observed that in the guide beam or equisignal plane, it has the same shape as that of a single vertical dipole as shown in Fig. 4. The club-

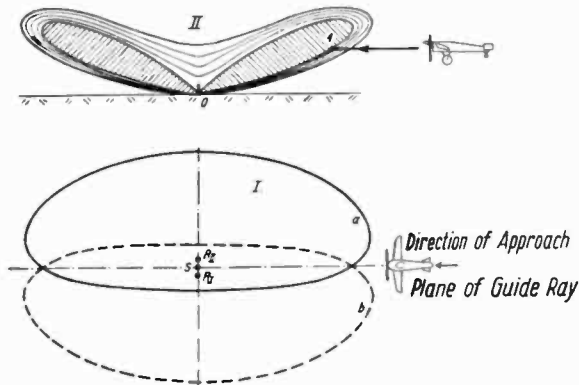

Fig. 4—Radiation pattern of the main beacon.

shaped pattern of this radiation diagram is due to the reflection of the ultra-short waves from the ground. It is shaped so that a combination of the guide beam beacon system with the glide path system of Diamond and Dunmore is possible.

The operating frequencies were selected in 1933 and 1934, and made common for European transmitters. The frequency of 33.33 megacycles was assigned to the main beacon transmitter while 38 megacycles was allocated to the marker transmitters. The use of the same frequency for the main beacon and marker beacons would seem obvious at first thought, but a number of tests of this scheme proved it to be unsatisfactory, because the exact determination of position by means of markers makes it necessary that their radiation be received

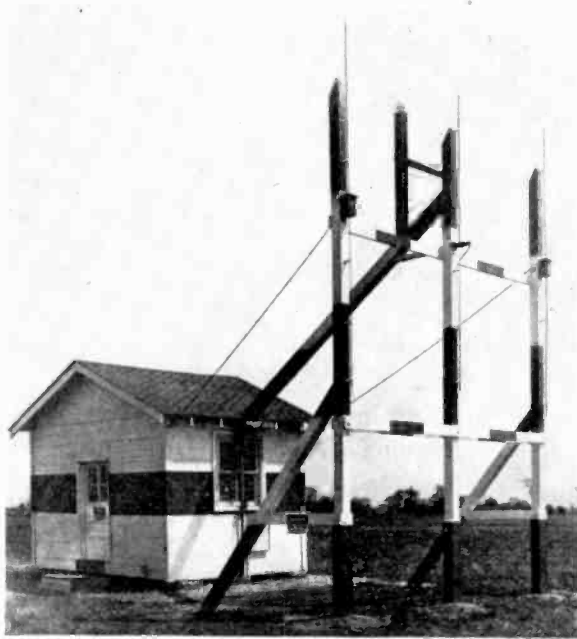

Fig. 5—Main beacon antenna system and transmitter house installed at the Indianapolis Municipal Airport.

only within a narrow vertical cone. The directional properties of the sending and receiving antennas must work together for that purpose. Both are, therefore, arranged horizontally. The metal parts of the aircraft cause the horizontal polarization of the marker beacon to be rotated so that the vertical rod antenna of the sensitive beacon receiver accepts too much of the radiation of the distance marker if the same frequency is employed. This results in some loss of directional effect.

(b) Practical Statements

A few pictures will show that the instruments in use today have already reached the form of standard equipment. Fig. 5 shows a modern arrangement of the main beacon set up for demonstration at the

Indianapolis Municipal Airport. Fig. 6 shows the main beacon transmitter and Fig. 7 the complete marker beacon; both distance markers have the same appearance but they differ in the modulation tone and in the keying rhythm of the radiated signals; Fig. 8 shows the marker beacon transmitter. Fig. 9 is the central control unit from which the

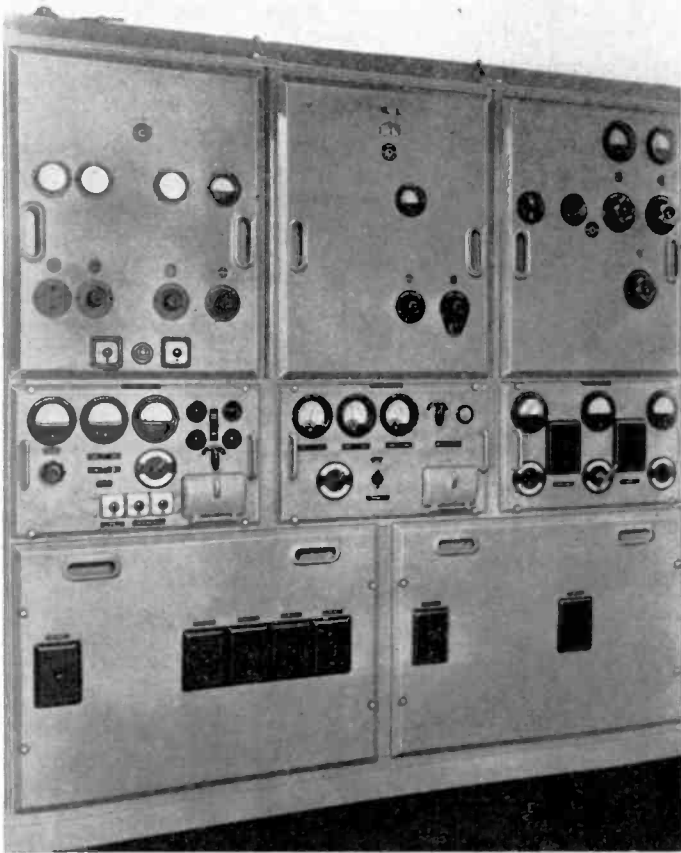

Fig. 6—Main beacon transmitter.

complete ground system is remotely operated and controlled; finally the automatic receiver and the dial instrument as they are used at present are shown in Figs. 10 and 11. A more recent type of receiver will be discussed later.

The routine of landing is accomplished in the following manner by the ordinary methods of aerial navigation: The plane proceeds to a point about 20 to 30 kilometers from the air terminal. The ultra-short-wave landing system receiving equipment is then switched into opera-

tion and by means of the characteristic signal the vertical plane of the guide beam is located. This beam is followed in a direct line until the characteristic signal and flashing of the outer marker lamp in the cockpit notifies the pilot that he is 3 kilometers from the edge of the air-

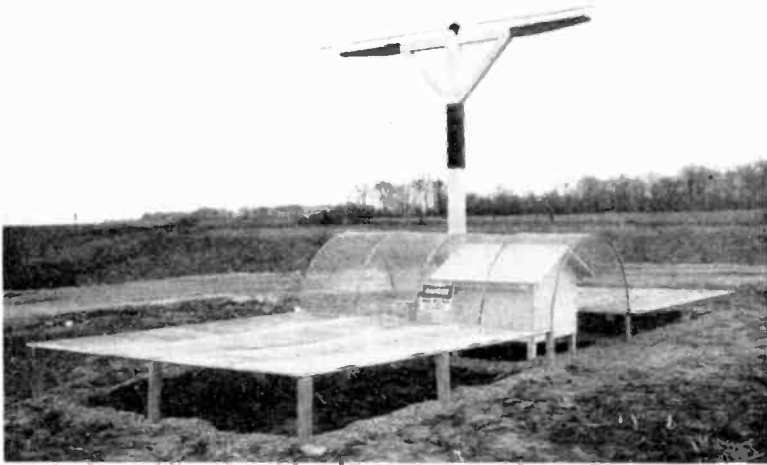

Fig. 7—Marker beacon showing horizontal dipole, counterpoise, and transmitter housing.

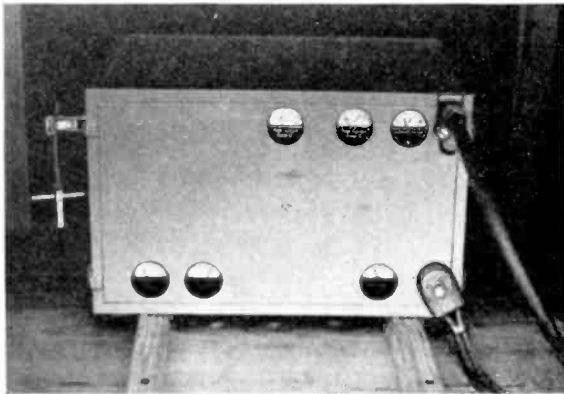

Fig. 8—Marker beacon transmitter.

drome. Using the glide beam as a guide, the pilot then causes the airplane to descend, the vertical line of descent being indicated by a visual device. At a point about 300 meters from the approach end of the runway, the flashing of the inner marker light advises the pilot that he is approaching the edge of the airdrome and is in a position to land. The



Fig. 9—Central control unit and alternating-current power supply unit.

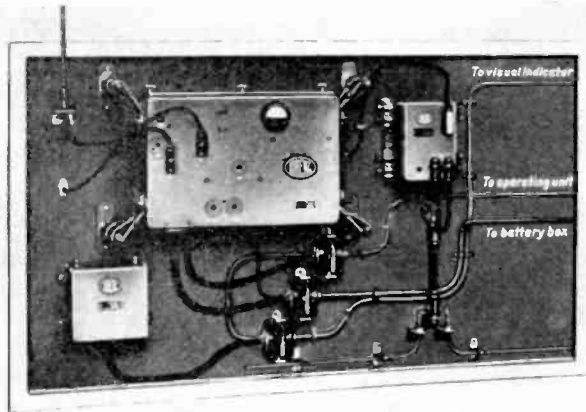

Fig. 10—Instrument landing receiving equipment consisting of a 33.33-megacycle main beacon receiver unit (top left), a 38-megacycle marker beacon receiver (top right), and an audio-frequency filter unit (lower left).

indications of the inner marker are given in a distinctive manner aurally in addition to the flashing of the inner marker light.

(c) *Practical Experience*

Because during the last few years the use of instrument landing systems in Europe and throughout the world has steadily gained

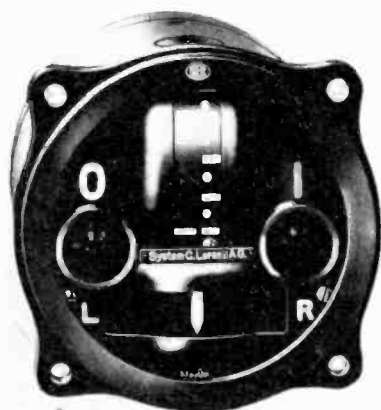

Fig. 11—Aircraft instrument landing indicator showing glide path indicator scale, the localizer right-left indicator, and the two marker beacon lamps, *O* and *I*.

ground, a number of problems have arisen, the solution of which has widely extended our experience and for that reason will be worth mentioning here.

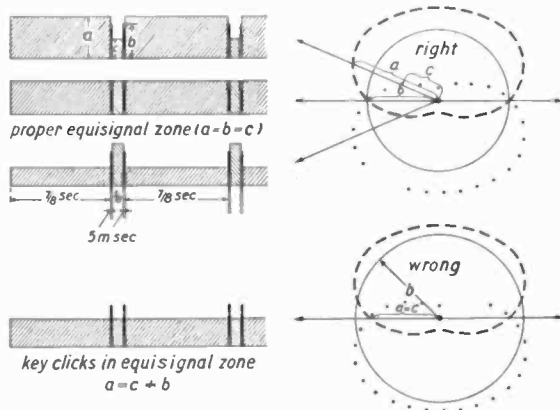

Fig. 12—Keying method designed to eliminate key clicks.

In this respect the properties of the guide beam are of interest. It is generally assumed that for the production of the beam it is sufficient to combine two complementary signals—either dash-dot or *A-N*—in an equal signal zone. However, the method of blending the signals, one

into the other is very important. The shortest interruptions of the equal signal cause clicks which destroy the continuous equal signal and make it difficult to follow the guide beam.

It is absolutely necessary that during the change-over from one directional diagram to the other in the equal-signal zone, equal field intensity be radiated. It will be seen from Fig. 12 how this is easily accomplished through the reflector principle provided a correct keying of the reflectors is carried out. During the time of about five milliseconds when the R_1 relay has already interrupted the reflector R_1 but the R_2 relay has not yet closed the reflector R_2 , the dipole fed by the transmitter radiates in a circular pattern providing the supplement

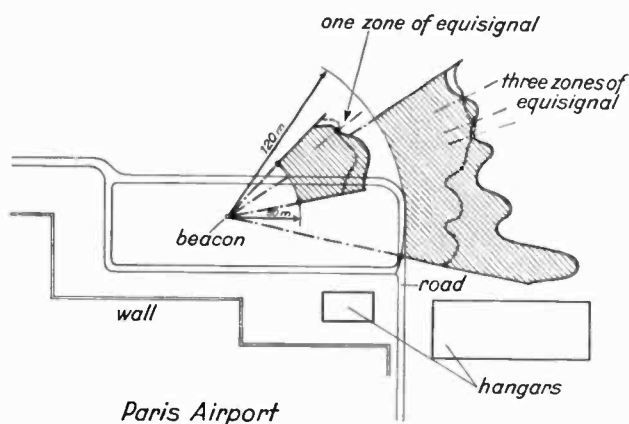

Fig. 13—False signal zones produced by reflections from hangars at the Le Bourget-Paris Airport.

needed in the equal signal zone. Only with the help of this idea can a guide beam that avoids clicking be produced. Alternate keying of larger directional antenna arrays, without attention to this detail, will, of course, give satisfactory signals on both sides of the equal signal zone but will not produce a satisfactory guide beam.

Another difficulty arose with the occurrence of split beams. After a great number of beacon arrangements had been erected without difficulty at various airports, this phenomenon was observed for the first time at Le Bourget-Paris. Fig. 13 shows the local conditions and the directional diagrams taken from different distances. It is gathered from the picture that the disturbing influence of the big metal hangars is not very great although they are quite close to the beacon. At a distance of only about 200 meters the radiation reflected by the two right-hand hangars produced such distortion that a repeated crossing of the diagram occurred. The result was the appearance of not one but three guide beams. One of them tended to disappear with increasing dis-

tance while the other two were noticed at the maximum distance. The repeated crossing of the diagrams is caused by a standing wave which starts from the hangar and is easily recognized on the picture. On account of limited space in this part of the airdrome, nothing could be done to counteract the disturbing influences. Thus it was necessary to transfer the beacon in the direction of the guide beam to the opposite side of the airdrome.

Fig. 14 once again calls special attention to the difference between an undisturbed and a disturbed guide beam. The curves indicate the intensity of the dot and dash signals compared to the total volume in the environs of the guide beam. The upper curve crosses the zero line

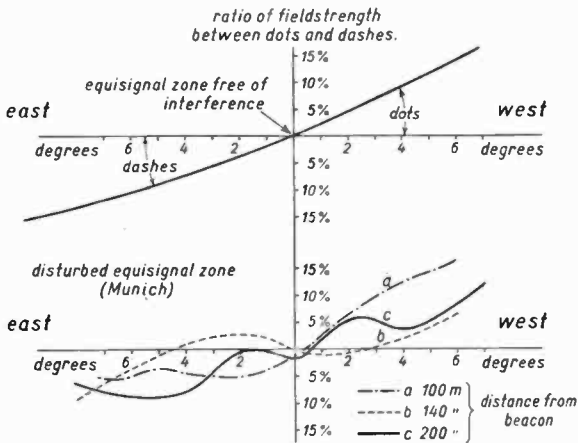

Fig. 14—Curves illustrating split beam effects produced by a near-by gas tank at the Munich airport.

once only, which means that only at one point dots and dashes combine into an equal signal. On both sides the signal strength increases continuously with increasing distance. In the lower part of the picture the irregular course with disturbed radiation is clearly seen. The values entered were taken near the beacon at three different distances. The curves repeatedly cross the zero line at various points. This means splitting and curving of the beam. The measurements were made by the German Air Ministry at the Munich airport and illustrate the influence of a near-by gas tank. Its position may be seen in Fig. 15. The curved metallic plane reflects the signals in all directions and at certain flying heights more than ten guide beams have been observed. In order to study the conditions, measurements were made at various points. It was shown that the angle of elevation of the reflecting wall taken at the transmitter defines the extent of the disturbance. At present we may

say that even large obstacles do not exercise any influence provided they are not erected above an angle of 1.5 degrees. The disturbances at Munich, therefore, were overcome by moving the beacon in the line of the guide beam away from the gas tank. The present position of the beacon is two kilometers outside the airdrome.

Of special interest is the experience with the airship hangar of sixty meters height on the airport of Frankfurt am Main. It showed that the reflections by the straight metallic sides of the hangar very accurately follow the rules of optics.

Furthermore it is worthy of notice that the disturbing influence of a reflecting surface increases with an increase in the ratio of the field

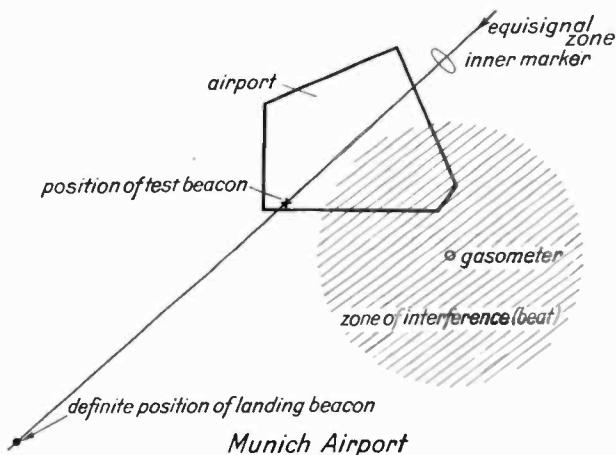

Fig. 15—Layout of the Munich airport showing position of gas tank and interference zone.

strengths of the two signals (dot-dash or A-N, respectively) at the point of reflection. Therefore, besides the angle of elevation the distance of the disturber from the guide beam is a factor determining the degree of disturbance.

The rapidly increasing use of landing beacons recently resulted in the provision of landing systems at neighboring airports. So the use of different beacon frequencies became necessary. Of course, the standard frequency of 33.33 megacycles was left unchanged at the large airports carrying international traffic. Supplementary frequencies are to be used only for emergency cases.

In the first place this development required the creation of new types of airplane receivers. In order to simplify servicing of receivers, the number of frequencies had to be limited as much as possible. Since in many cases two national wave lengths in addition to the interna-

tional one of 9 meters will be sufficient, a simple receiver for 3 wave lengths was first developed (Fig. 16). In principle it closely resembles the fixed-frequency type. Three operating frequencies between 8 and 9 meters are carefully pretuned and the selection of any frequency is readily accomplished by the pilot through the use of remote switching.

For future development a special superheterodyne receiver has been designed and built to meet three principal requirements, (1) greater selectivity, (2) additional frequencies, and (3) wider range for the application to long-range navigation as discussed later on.

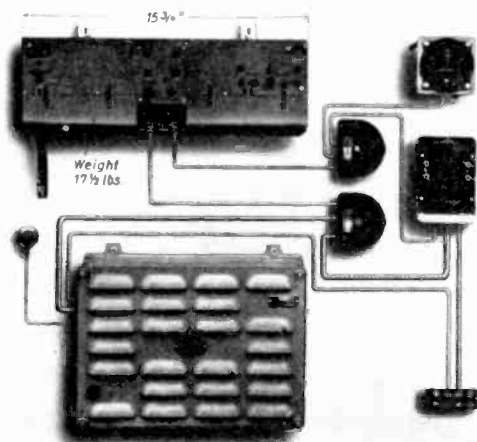

Fig. 16—Instrument landing receiving equipment for three fixed operating frequencies.

Regarding the selection and distribution of the various frequencies for ground stations, several points are important and will now be discussed. The field intensity in the vicinity of the beacon is about one thousand times the minimum required for good reception. The permissible distance separation of an undesired beacon is, therefore, dependent only on the frequency spacing and the selectivity of the receiver. We shall designate a suppression factor p , indicating the ratio of how many times greater the field intensity of a disturbing transmitter on a neighboring frequency can be in order to provide the same receiver volume as does the field intensity of the transmitter to which the receiver is tuned. Thus factor p is dependent on the selectivity of the receiver and on the frequency spacing of the transmitters and can be derived from the resonance curve of the receiver. The range of the disturbing transmitter by itself would be equal to that of a transmitter p times weaker on the frequency to which the receiver is tuned.

Consideration of cases where another beacon is located within the range of the desired beacon is of importance. Radiation of the other beacon is now being encountered. To what extent must it be suppressed by the receiver to make certain that no error is possible? These problems have been solved by accurate practical tests. It should be noted that not only the appearance of foreign keyed signals in the guide beam cause false deviations from it but beats may also interfere with reception. These would be due to the difference in modulating frequencies of the two beacons. Such beats are particularly disturbing. The interference is most severe in the twilight zones of the guide beam where, of course, keyed signals of the proper beacon are being received. As a result of the beats, inversion of the signals may occur from time to time.

Avoidance of all disturbances is only assured if the volume of the disturbing signal in the vicinity of the guide beam of the beacon to be followed nowhere exceeds $1/50$ of the volume of the proper signal. This figure is arrived at in the following manner: A volume difference of 5 per cent between dot and dash signals is distinctly perceived by the ear and, therefore, defines the limits of the guide beam. If the signals of the disturbing transmitter are received within the guide beam, their volume must be considerably less than 5 per cent; i.e., $1/20$ of the volume of the proper signals, in order not to cause confusion. A number of test flights showed no disturbances when the undesired signals had less than $1/50$ of the volume of the proper signals.

Outside the guide beam conditions are less critical but since the approach must start from the most critical zone, i.e., the direction of the guide beam, no restriction is required on the beacon because, for reasons of safety, the guide beam is likewise not allowed to touch the environs of a second airport.

The following statements will briefly explain how the areas of impaired reception of the beacon can be determined. The field intensities of two beacon transmitters are shown graphically in the vertical and horizontal planes. (Fig. 17.) The transmitters are located at *A* and *B*. The vertical diagram shows, in the form of two cones, the values of the field intensities in the neighborhood of each transmitter. The horizontal diagram indicates the useful area for a given altitude, for example, the base of the cone. Suppose airport *A* is wanted. The plane receiver is tuned to the frequency of that transmitter. As mentioned above, the disturbance will commence at the point where the volume from transmitter *A* becomes less than fifty times stronger than the volume received from *B*. For purposes of comparison the field intensity of the transmitter is plotted on a scale of $1/50$ of its normal value. The selective property of the receiver automatically weakens *B* to the value of

$1/p$. In accordance therewith the field strength above B is shown with the p th part of its value. The section line of both cones designed in this manner indicates the limits of the disturbed area. That part where the

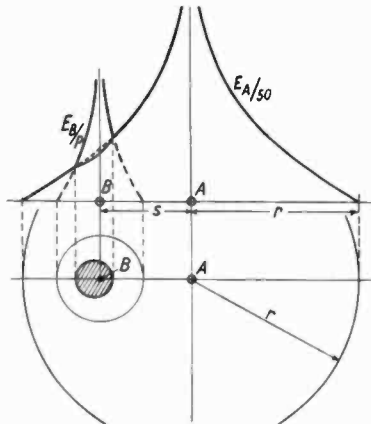

Fig. 17—Graphical method for determining interference areas between two neighboring beacon transmitters.

cone of transmitter B rises above the cone of transmitter A is to be considered disturbed. On the basic section this area is marked by cross-hatching.

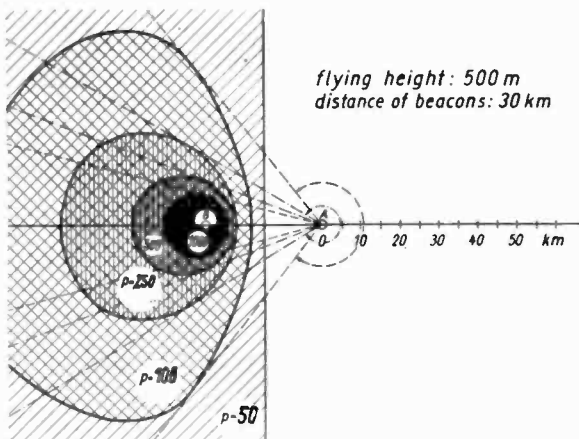

Fig. 18—Disturbing zones for different suppression factors between two beacon transmitters separated by a distance of 30 kilometers.

In a more accurate analysis of the question two surprising facts are perceived: (1) The extent of the disturbances decreases with decreasing distance between the airports and (2) a change of the flying height has

little influence on the values obtained. Both facts are explained by the steeper slope of the field strength close to the transmitter. It is, therefore, seen in a general manner that by suitably selecting the value of p no restriction of the use of the landing beacon occurs as long as its guide beam does not touch upon the neighborhood of a second radio beacon equipped airport.

In order to explain more accurately the value of p , we draw attention to the fact that the value chosen for Fig. 17 is 250 (50 decibels). This corresponds to the value obtained with the standard tuned-radio-frequency receiver at a frequency spacing of 0.5 megacycle; with the later superheterodyne type at about 100 kilocycles. Fig. 18 shows the disturbing zones with different suppression factors p , for two beacons of the same power separated by a distance of 30 kilometers. The disturbing zones demonstrate the space allowed between the guide beam corresponding to beacon *A* and beacon *B* without exceeding the disturbing ratio of 1:50. Frequency spacing of the beacons and the selectivity of the receiver are determining factors in the extent of the corresponding disturbing zone. The tangent from beacon *A* to the marked disturbing zones gives in every case the closest approach of the guide beam to the area of beacon *B*.

Summarizing it may be stated that during the operation of a large number of landing beacons it has been possible to gain considerable experience and to solve satisfactorily a number of new problems that came up in connection therewith, so that the landing beacon has now become an important aid to flying safety.

PART II

THE APPLICATION OF THE ULTRA-SHORT-WAVE GUIDE-RAY BEACON FOR LONG-RANGE AIR NAVIGATION†

By W. HAHNEMANN

INTRODUCTION

The ultra-short-wave landing beacon for poor visibility has already reached a high degree of technical development. At many airports in many countries it has proved to be very useful and has contributed to greater safety of air transportation. It is to the credit of these installations that scheduled flights on the European air routes are carried out so punctually that they may be favorably compared to the railroads. This is of particular significance in countries where weather conditions are unfavorable for flying. Fig. 19 gives an idea of the extensive use of

† Presented before Silver Anniversary Convention, New York City, May 10, 1937.

the system. Approximately 35 Lorenz ground equipments have been installed in various parts of the world, 14 of which are in Germany. About 200 receivers have been installed in planes engaged in air transportation in various countries.

The Lorenz system as used in Europe was recently brought to the United States. We know it will need modification to meet American flying conditions but we are confident that with the criticism and assistance of American pilots and radio engineers the Lorenz system can be developed to meet the special requirements of American aviation. We feel that the fundamental principles of our system are sound and will be a useful contribution to safety in air navigation in the United States.



Fig. 19—Map showing the locations of Lorenz poor-visibility instrument landing systems in Europe.

Whereas, for bad weather *landing* purposes the ultra-short waves are used as a radio means of navigation, *long-range* navigation of aircraft, that is, flying from airport to airport, is operated almost exclusively on medium wave lengths.

The use of a number of groups of frequencies naturally requires, from a technical point of view, the provision of a considerable amount of radio apparatus with added requirements for space and weight in the aircraft. It is obvious for one to inquire into the feasibility of extending the use of the ultra-short-wave band to long-range navigation. A system of ultra-short-wave beacons installed at suitable points along the airways would be a possible method of carrying out such a scheme. It should be pointed out that we are making no recommendations as to a final system at this time, but are merely setting forth our ideas and suggestions in order that they may be considered in connection with future planning and development in the air navigation field.

(a) *The Propagation of the Ultra-Short Waves*

In discussing the question of the applicability of the ultra-short-wave beacon to long-range navigation purposes we shall begin with the range problem; i.e., the conditions of propagation will be dealt with in order to determine the ranges to be expected. The laws of ultra-short-wave propagation have been the subject of much study during the last few years.

When we began with our fundamental experiments with ultra-short-waves in the years 1925 to 1928, it was first assumed that they followed optical laws and that their range was limited to the range of visual sight. However, ultra-short waves and especially the longer waves of the ultra-short-wave band proved to have a considerable effect far beyond visual sight. In this connection reference may be made to the later work of Schelleng, Burrows and Ferrell,³ of Englund, Crawford and Mumford,⁴ of Trevor and Carter,⁵ of von Handel and Pfister,⁶ and of others. The result of all these researches was as follows: Within the range of sight a number of phenomena occur tending to increase the range of ultra-short waves far beyond that of vision.

Diffraction of the rays along the spherical surface of the earth has proved to be a very important factor in extending the range of ultra-short waves. The mathematical basis of the problem assuming an infinitely conducting earth was published by Poincaré, Watson, and Laporte. Later on, the theory was extended to finite conductivity. On the supposition of complete absorption by the earth, Epstein⁷ calculated the diffraction problem of ultra-short waves according to Huyghens' principle.

The reflecting property of the earth's surface must also be considered as it has a pronounced effect on the radiation diagram of the transmitting antenna, depending on the ground constants and height of the antenna above ground. The curvature of the earth must be taken into account when studying the "interference" effect of ground reflection on propagation.

Von Handel and Pfister⁶ of the German Research Laboratory for

³ J. C. Schelleng, C. R. Burrows, and E. B. Ferrell, "Ultra-short-wave propagation," *Proc. I.R.E.*, vol. 21, pp. 427-463; March, (1933).

⁴ C. R. Englund, A. B. Crawford, and W. M. Mumford, "Some results of a study of ultra-short-wave transmission phenomena," *Proc. I.R.E.*, vol. 21, pp. 464-492; March, (1933).

⁵ B. Trevor and P. S. Carter, "Notes on propagation of waves below ten meters in length," *Proc. I.R.E.*, vol. 21, pp. 387-426; March, (1933).

⁶ P. von Handel and W. Pfister, "Die Ausbreitung der ultrakurzen Wellen längs der gekrümmten Erdoberfläche," *Hochfreq. und Elektroakustik.*, vol. 47, p. 182, (1936); "Ultra-short-wave propagation along the curved earth's surface," *Proc. I.R.E.*, vol. 25, pp. 346-363; March, (1937).

⁷ P. S. Epstein, "On the bending of electromagnetic microwaves below the horizon," *Proc. Nat. Acad. Sci.*, vol. 21, p. 62, (1935).

Air Service recently developed a theory based on the phenomena of diffraction and reflection on the surface of the earth. Other influences which may considerably modify the propagation of ultra-short waves were neglected; for example, the variation of the rate of propagation within the plane of the wave front perpendicular to the direction of radiation or the refraction or reflection of the waves from the upper layers of the atmosphere towards the surface of the earth; these conditions are variable in effect, while the influence on range of diffraction and reflection along the surface of the earth is always maintained. Other variable conditions bring about a temporary and sometimes considerable increase in range. For our purposes it seems preferable to consider the unchangeable conditions only, in order to be sure that the conclusions drawn with regard to range are valid at any time. The ranges so calculated represent very reliable minimum values.

The field strength curves calculated by von Handel and Pfister based on the distance from the transmitter, flying height of the receiver, height of the transmitting antenna, and wave length, correspond so well to those obtained by flight tests that it seems justifiable to discuss the ultra-short-wave ranges as indicated by these curves.

A few original curves of von Handel and Pfister, as published on page 352 of the PROCEEDINGS for March, 1937, will be considered. First, the curve of field intensity, especially at the limit of visual sight and beyond, plotted against the distance of the receiver from a transmitter (Fig. 5) is reviewed. The transmitting dipole antenna was erected 135 meters above the ground. A wave length of 7 meters was used. The receiving airplane was, in one case, 2000 meters and in the other, 5000 meters above the ground. The two field strength curves on which the flying heights are indicated represent the calculated values. The test figures taken by the airplane are given by the small circles. The check between test results and calculation is obvious. It should be mentioned that test values published by Trevor and George⁸ for a wave length of 73 centimeters also correspond very well to the theoretical figures of von Handel.

Now consider the curves illustrating the relation between field strength and distance, at various flying heights of the receiver and for different wave lengths in the ultra-short-wave band. (Figs. 9 to 16 inclusive of the von Handel and Pfister paper.) Here the transmitting dipole is placed 30 meters above the ground which is a height easily obtainable in practice. The field strength values correspond to an antenna power of 70 watts. Field intensities are given in microvolts per meter on a logarithmic scale while the distances in kilometers are plotted on a linear scale. Each individual curve covers only the range

⁸ B. Trevor and R. W. George, "Notes on propagation at a wave length of seventy-three centimeters," *Proc. I.R.E.*, vol. 23, pp. 461-469; May, (1935).

beyond the line of optical sight for the altitude of the ship corresponding to the particular curve. Flying heights from 50 meters to 6000 meters are assumed.

In general the following observations may be made: The decrease of field strength within the range indicated and on a logarithmic scale is almost a straight line. With the same wave length, the curves of different flying heights are almost parallel and are higher for greater flying height. The slope of the curves is steeper, the shorter the wave length.

With the help of the curves we can now determine the range obtainable for any specified minimum field intensity, flying height, transmitter power, and transmitter antenna height. Let us assume that the receiver requires a minimum field strength of 50 microvolts per meter which appears to be satisfactory for modern superheterodyne receivers,

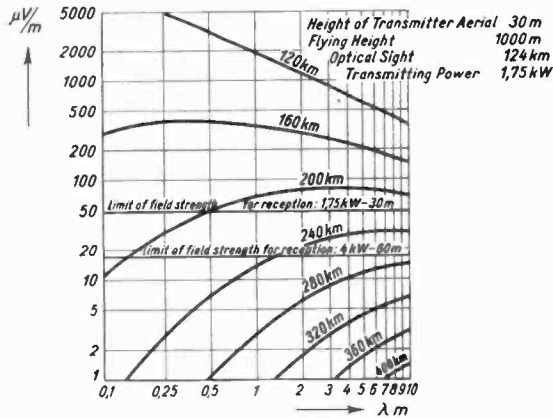

Fig. 20—Relation between field strength and wave length for certain distances suitable for long-range navigation.

and the transmitter delivers about 1.5 to 2 kilowatts power to a dipole 30 meters above the ground on a wave length of 7 meters. From these curves we obtain a distance of about 260 kilometers at a flying height of 2000 meters.

It appears, therefore, that very considerable distances can be covered at practical flying heights and with reasonable transmitting and receiving systems. For practical use the effect of wave length on the range is of great importance. For that purpose the curves of propagation will be given in a somewhat different form.

For example, in long-range navigation, flying heights between 500 and 2000 meters, a transmitting power of 1.75 kilowatts, and a dipole height of 30 meters may be assumed. The curves show the relation between field intensity and wave length for certain distances suitable for long-range navigation.

In Fig. 20, field intensities as well as wave lengths are plotted on a

logarithmic scale. The curve picture shows the remarkable fact that for distances beyond the limits of visual sight there are optimum wave lengths at which the received field intensities are maximum. With greater distances the optimum wave length becomes longer. Further investigation shows the relation between flying height and wave length. With other conditions unchanged the optimum wave length is shorter, the greater the flying height. In this connection similar results published by Schelleng, Burrows and Ferrell³ in regard to visual sight conditions should be mentioned.

These facts depend on the combination of two effects. With decreasing wave length the ratio between the transmitting dipole height

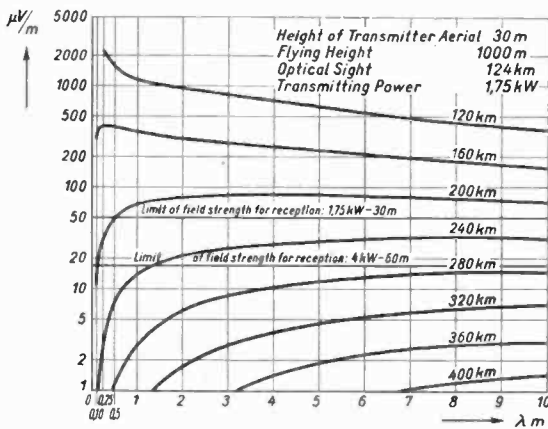

Fig. 21—Field strength curves corresponding to a flying altitude of 1000 meters.

above the ground and the wave length is more favorable for long-range operation because the angle of the lower maximum of the vertical radiation diagram decreases; on the other hand the propagation within the zone of diffraction weakens with decreasing wave length. These two effects work one against the other and for certain wave lengths produce the demonstrated optima.

With the help of the curves we can now proceed to the important question of wave length selection.

In order to simplify the study of the 1- to 10-meter band which is of special interest for our purpose the curves of field intensity are represented with linear abscissas and logarithmic ordinates in the following figures. In Fig. 21 a flying height of 1000 meters is assumed. At this height within the entire wave range of about 1 to 10 meters and at a field strength of 50 microvolts per meter (upper line) a range of about 200 to 220 kilometers is obtained. If longer ranges, for example 250 to 280 kilometers are wanted, the wave lengths between 4 and 10 meters

must be used; also the transmitting power, the transmitting dipole height, or both must be increased; if the lower line which lies at about 17 microvolts per meter in the figure is to correspond to a true value of

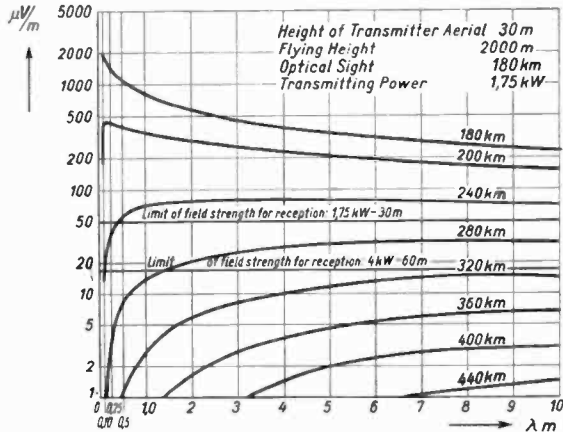

Fig. 22—Field strength curves corresponding to a flying altitude of 2000 meters.

50 microvolts per meter the transmitting power must be, for example, 4 kilowatts for a dipole height of 60 meters. To arrive at this conclusion one must take into account the fact that the field intensity for a given

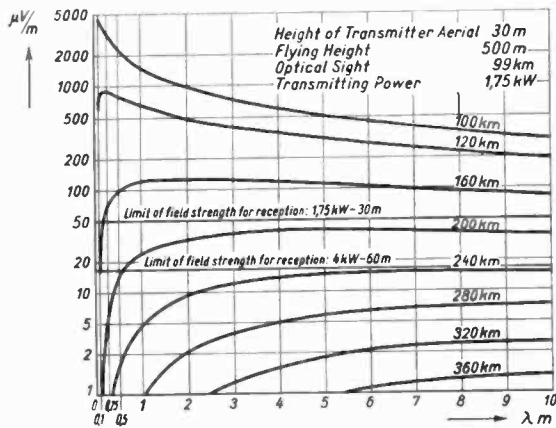

Fig. 23—Field strength curves corresponding to a flying altitude of 500 meters.

height of the transmitting dipole is proportional to the square root of the transmitting power and is also proportional to the height of the transmitting dipole.

In Fig. 22 the same group of curves is given for a flying height of 2000 meters and in Fig. 23 for 500 meters. This shows that under the

conditions assumed with a flying height of 2000 meters and one of 500 meters, ranges of 250 to 300 kilometers and 200 to 230 kilometers, respectively, can best be covered within the wave length range of about 2 to 10 meters.

Summarizing, the result of this examination is as follows: Ranges of 200 to 300 kilometers at the assumed flying heights are obtained with certainty with a transmitting power of 1.5 to 4 kilowatts and a transmitting dipole height of 30 to 60 meters within the wave length range of about 2 to 10 meters. An optimum wave length range exists for every



Fig. 24—Lorenz ultra-short-wave beacon as installed in Australia.

distance and flying height but the dependence of field intensity on the wave length within the range of 2 to 10 meters is for the most part not very considerable so that this entire wave range can be used for long range navigation over distances of 200 to 300 kilometers.

(b) Long-Range Navigation with Ultra-Short-Wave Beacons

We have seen that the obtainable ranges of the ultra-short waves would allow their utilization for long-range navigation of aircraft at suitable flying heights. Let us examine, for instance, the air navigation system of the United States. A network of about one hundred radio range beacons is spread over the whole country. The power of each radio beacon is generally a few kilowatts while the average distance between them is about 250 kilometers; therefore, a beacon having a range of about 200 kilometers will be sufficient in most cases. We learned from the laws of propagation just described that we are able with certainty to obtain such ranges in the ultra-short-wave band with the same

amount of transmitting power. Therefore, we shall now consider in what manner we can effectively supplement the long-wave beacons by ultra-short-wave beacons and indicate the advantages that would result.

For the application of ultra-short-wave beacons, practical tests have been made lately and produced very encouraging results. Such tests were made a short time ago at the airport of Essendon, Australia, in co-operation with authorities of that country.

Fig. 24 shows the transmitting station used. The antenna system was erected on a wooden tower of 30 meters height. The system con-

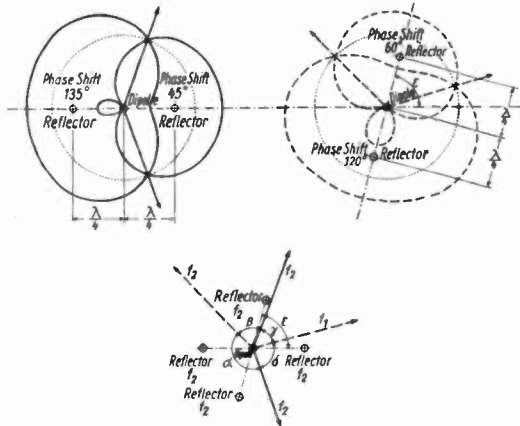

Fig. 25—Method of obtaining 4-course beacons.

sisted of the usual arrangement of one transmitting and two reflecting dipoles at the top of the tower. The 500-watt transmitter was placed at the foot of the tower and supplied the transmitting dipole through a transmission line. A wave length of 9 meters was used. With this arrangement very good reception was obtained in the aircraft up to distances of about 160 kilometers at altitudes of about 2000 to 3000 meters, using a poor-visibility landing receiver of earlier design which still required a field strength of about 300 microvolts per meter. This result corresponds in every way to the curve values shown above.

The tests proved so favorable that it was decided to consider earnestly the plan of introducing in Australia long-range navigation by means of ultra-short-wave radio beacons instead of long-wave beacons.

The next problem now becomes that of producing more beams with the ultra-short-wave beacon; for example, four, the angles of which must be arranged according to local conditions.

In this connection an arrangement similar to that illustrated in Fig. 25 may be used. Again two reflecting dipoles and one transmitting

dipole are provided in a vertical plane. The two reflectors are so arranged that two radiation diagrams of different shapes are obtained. Their intersecting points are so located that two beams are produced making any desired angle between them. Two more reflectors are arranged within another vertical plane making a predetermined angle with the first arrangement. Two more beams are thus obtained making any other desirable angle with respect to each other and with respect

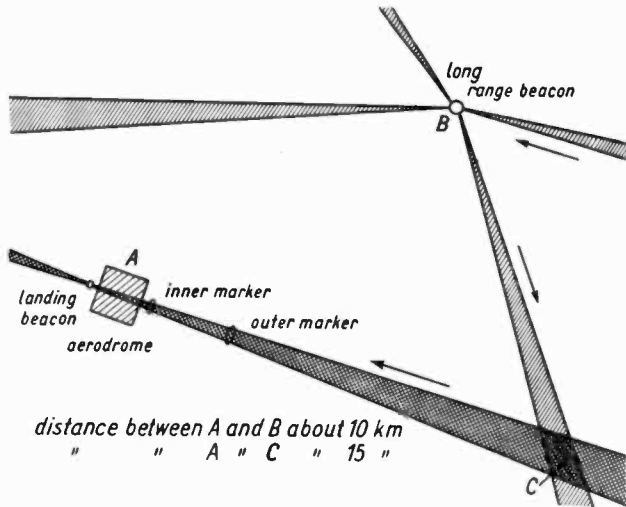

Fig. 26—Method of contacting the landing beam from the range beacon.

to the first two beams. In order to avoid interference between the two pairs of reflectors, the two systems are operated on different wave lengths. The transmitting dipole which is common for both antenna systems is fed on both wave lengths. The two systems can most easily operate alternatively at short intervals and will thus produce four guide beams making any desirable angles with respect to each other.

Finally we have to consider the transfer of the approaching airplane from the long-distance navigating beam to the landing beam. This is easily rendered possible if the airdrome is near a range beacon as will usually be the case.

An example of such a flight approach will be illustrated with the help of Fig. 26. The range beacon with four guide beams is located at point B. The ultra-short-wave landing beacon is situated near the airdrome (point A). Whatever direction the guide beam of the landing beacon may have, it will never be too far off to meet one of the guide beams of the range beacon. The aircraft following one of the legs of the range approaches until it either meets with the beam of the landing

beacon or passes the long-range beacon. In the latter case it will follow the beam that meets the guide beam of the landing beacon. From the junction point on, it follows the beam of the landing beacon and in this way safely reaches the airport. Another example with the beams arranged in another manner is shown in Fig. 27.

From the above we see that long-range navigation by means of ultra-short waves is entirely possible. If now we consider the properties of such a system of navigation in comparison with the use of long-

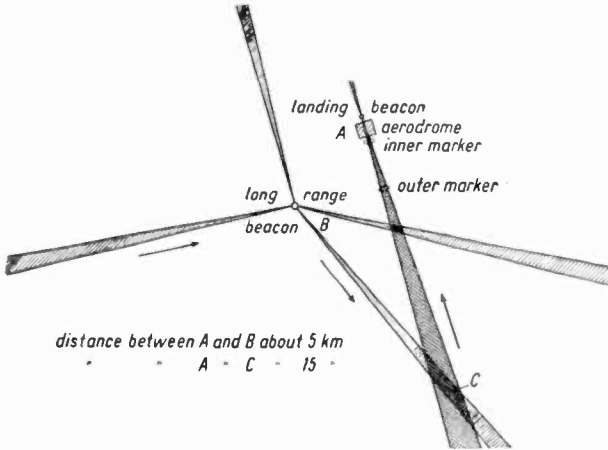

Fig. 27—Method of contacting the landing beam with another arrangement of landing and range beacons.

wave beacons the following advantages for long-range navigation are demonstrated:

1. A wave length band completely separated from that for communication purposes may be used for air navigation. The separation of communication and navigation in regard to wave length means a great simplification and increase in safety.
2. The limited and comparatively well-defined range of the ultra-short waves enables repeated assignment of the same wave lengths without fear of mutual interference.
3. Within the proposed wave length band there is sufficient space at this time for the installation of a more extensive network of airways without increasing the number of wave lengths. At the same time the medium wave range would be relieved. This would be of great advantage for the safety of traffic.
4. *Of the greatest importance is the complete absence of atmospheric disturbances, night errors, and detrimental reflections from mountains within the ultra-short-wave band. Not even heavy thunderstorms*

can hinder the proper operation of the system whereas with the long waves thunderstorms and atmospherics sometimes prove so serious that radio navigation becomes unreliable. Disturbances that may occur on ultra-short waves are of local nature (by ignition from the engine) and may be overcome effectively by careful installation of the receiver on the aircraft; furthermore these disturbances are quite independent of changing weather conditions and with adequate care are eliminated by the operating staff on the ground before flying.

5. The antenna system required for the ultra-short-wave beacon is not complicated. The small dimensions enable simple and sturdy design.
6. For reasons of flight as well as of expense great advantages can be obtained in the plane for with one ultra-short-wave receiver we can perform the functions for which quite a number of instruments are now necessary.
 - a. Long-range navigation by means of ultra-short-wave beacons,
 - b. Use of marker beacons between the landing fields,
 - c. Location of a vertical landing plane with the aid of marker beacons determines the exact position of the aircraft on the approach path,
 - d. Reception of the outer and inner marker signals and thereby preparation for safe landing,
 - e. Finally the glide path landing of Diamond and Dunmore.

As mentioned above this description of the use of ultra-short-wave beacons for long-range navigation is to be taken only as a suggested method for providing a modern radio beacon system for air traffic. Undoubtedly, before adopting such a new application of the ultra-short-wave beacon it would be necessary to carry out more extensive tests. On the other hand, the results so far obtained with ultra-short-wave radio beacons for long-range navigation are most encouraging and it would seem worth while to attack this problem earnestly. The above information is intended to be of assistance to that end.



PRECISE MEASUREMENTS OF ELECTROMAGNETIC FIELDS*

BY

HOWARD G. SMITH

(Cornell University, Ithaca, New York)

Summary—A design of field strength measuring equipment is described wherein the emphasis has been laid upon ability to secure precise measurements in a limited range rather than extreme flexibility. A consideration of the suitability of various fundamental methods for precision work is presented. A circuit design is described by which certain difficulties associated with the insertion of the standard signals into loop circuits are eliminated. An attenuator is described wherein the effects of unavoidable stray reactances are minimized. Experimental results are given indicating ability of the design to achieve accuracies to within better than one per cent at broadcast frequencies. Comparison is made with accuracies attained in the field with alternative methods.

IN RECENT years the growing interest in the field of radiation engineering, especially in the field of antenna research, has again turned attention to the problem of securing precise reliable measurements of field intensities. There have been available a number of commercial designs of measuring equipment which have achieved a high degree of flexibility of application with respect to useful intensity range and have functioned over wide frequency limits. By the use of reasonable care with such equipment it has been possible to secure measurements accurate to within ten per cent and on some of the better designs possibly five per cent. This is entirely adequate for the normal requirements of field-strength or interference surveys. However, in the field of antenna research the need has been felt for equipment capable of higher precision and reliability. One example of that need is in the experimental investigation of the effect of changing current distribution in broadcast antennas by means of top loading. While much valuable theoretical material has been produced on this subject, little is available in the way of experimental checks under normal operating conditions involving imperfectly reflecting surfaces below the radiator. For any such experiments to be significant the precision of measurement must be high since the effects which are under investigation involve small percentages of the total measured values. In practical experiments on full-sized antennas, moreover, it is usually not feasible to vary the current distribution over wide limits so that satisfaction must be had with measurements within limited

* Decimal classification: R270. Original manuscript received by the Institute, August 24, 1937.

ranges. Under such conditions, variations of the measured values by five to ten per cent due to the measuring equipment may completely obscure or falsify the results of the experiment. Equipment has been developed, the reliable absolute accuracy of which is within one per cent for measurements of field intensities greater than three millivolts per meter at broadcast frequencies. This accuracy is of the same order with which radio-frequency power input to antenna systems may be measured at these frequencies and hence is entirely adequate for the purpose described. In the course of the development work comparative data have been obtained on the limitations of accuracy of several fundamental measurement methods.

GENERAL METHOD

Almost all the designs of measuring equipment in use utilize a loop antenna of known dimensions in which the unknown field to be measured induces a voltage which may be readily calculated in terms of that field and the dimensions of the loop. The fact that this relationship is much more amenable to calculation for the loop antenna than for any other type is largely responsible for its wide acceptance in spite of the relatively small effective height. The directive properties make it indispensable in equipment designs, such as the one herein described, which require elimination of the unknown signal without disconnecting the loop during the measurement routine.

Due to the relatively low intensity of the voltages induced in a loop of reasonable dimensions, however, it is impracticable to measure such voltages directly except by the use of vacuum tube devices which introduce a serious calibration problem. Resort has usually been made to comparison of the unknown induced voltage with standard voltages produced by a local oscillator within the measuring equipment. A superheterodyne receiving set with a meter indicating the second detector plate current has had wide acceptance as a device for making such comparisons. The essential difference between the general methods in use lies in the method of making this comparison.

There are so many possibilities for the comparison receiver and detector to depart from a strictly linear relation between input signal and detector indication or even from a known nonlinear relation under field conditions that it is desirable, for precise measurements, to avoid all dependence on the characteristics of the receiver by making the comparison of the unknown and standard signals at identical levels. Systems which involve dependence upon the proportional response of the comparator are not suitable where accuracy of the order of one per cent is desired, however superior their adaptability for measure-

ments of lower precision may be. In order to achieve the full advantage of a comparison at identical levels it is imperative that the comparison be made between the standard signal and the *induced* loop voltage and not the loop terminal voltage. This avoids the highly difficult problem of precise determination of the so-called "loop gain" and thus eliminates errors associated with the routine field measurement of that ratio.

To adopt such a method of comparison, however, involves the solution of certain problems which have been avoided in commercial designs by the use of alternative methods. These problems are:

1. The production of a highly accurate standard signal at comparatively low intensities.
2. The introduction of this standard signal into the loop circuit in such a manner as to avoid inaccuracies due to changes of circuit conditions.
3. Highly effective shielding of the standard signal oscillator to prevent stray pickup into the loop circuit.

For production of precise standard signals at the carrier frequency, use is made of the familiar method of the production and measurement of the standard signal at measurable intensities and subsequent attenuation to the desired level. The use of a vacuum thermocouple type voltmeter for the signal measurement avoids many of the pitfalls inherent in vacuum tube voltmeter measurements and frees the equipment from the necessity of frequent rechecking of the calibration. The choice of attenuator is made in favor of a resistive network due to the greater stability of this type in its useful frequency range. Mutual inductance attenuators prove highly useful at higher attenuations and under precision requirements which are not as severe as those here undertaken, but for a limited intensity and frequency range the resistive network may be made more precise and less subject to changing calibration.

The problem of the insertion of this voltage into the loop circuit is closely linked with the choice of an attenuator. Some designs have used a calibrated mutual inductance as a means for inserting the standard signal into the loop circuit but if complete freedom from the effects of aging and mechanical shock are to be attained by the choice of a resistive attenuator, consistency dictates the use of a resistor inserted into the loop circuit as a means for the insertion of the standard signal.

The chief difficulty in the design of such resistive systems has been the severe requirements met in attempting to arrange the circuits so that stray reactances and admittances do not narrow the useful fre-

quency and intensity limits too severely. In common practice the attenuating network has been terminated in a small resistance inserted in the loop at its electrical center. The impedance presented to the loop by the attenuator has been made high with respect to the terminal resistor. This has made possible the assumption that the shunt admittance of the attenuator may be neglected when measuring the unknown signal.¹ However, by so doing, a severe and contradictory requirement is placed on the design of the network and terminating resistor. If the impedance of the network presented to the loop is made too high, the stray capacitive admittances narrow the useful range of the attenuator, whereas if the terminating resistor is made too small, the inductive

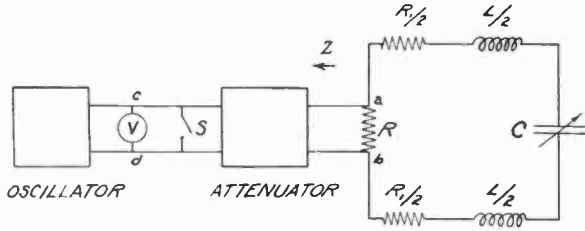

Fig. 1

reactance of the termination introduces serious errors.² An application of Thevenin's theorem to the network shown in Fig. 1, however, shows how this conflicting requirement may be avoided and the limits of the system extended.

The loop inductance and equivalent series loss resistance are shown divided equally in the two halves of the balanced loop. Let E_{ab} be the voltage existing across the terminating resistor R with the loop disconnected. Then by Thevenin's theorem, the current which will flow in the loop circuit when the standard voltage is inserted at the center of the balanced loop as shown, and the circuit tuned to resonance, is

$$I = \frac{E_{ab}}{R_1 + \frac{RZ'}{R + Z'}} \tag{1}$$

Then the voltage developed across C is

$$E_c = IX_c = \frac{E_{ab}X_c}{R_1 + \frac{RZ'}{R + Z'}} \tag{2}$$

¹ England and Friis, "Methods for the measurement of radio field strengths," *Trans. Amer. Inst. Elec. Eng.*, vol. 26, pp. 492-497; May (1927).

² A. G. Jensen, "Portable receiving sets for measuring field strengths at broadcast frequencies," *Proc. I.R.E.*, vol. 14, pp. 333-344; June, (1926).

The driver circuit connected to the input of the attenuator may be considered as an ideal generator of zero internal impedance whose voltage E_{cd} is measured by the thermocouple voltmeter V . Thus the input terminal impedance of the attenuating network when using the standard signal is zero. If the switch S is closed so as to short-circuit the input of the attenuator when the unknown signal is being received, the impedance Z' looking back into the attenuator will be unchanged from the value existing when using the standard signal. Consequently if an unknown voltage E_x is induced in the loop circuit, the current which will flow at resonance is

$$I' = \frac{E_x}{R_1 + \frac{RZ'}{R + Z'}} \quad (3)$$

The voltage developed across C is

$$E_c' = I'X_c = \frac{E_x X_c}{R_1 + \frac{RZ'}{R + Z'}} \quad (4)$$

Thus if E_c is made equal to E_c' then E_x will be equal to E_{ab} since the remaining terms of (2) and (4) are identical. E_{ab} is readily determined from the measured value of E_{cd} and the attenuation ratio of the network. By this method the comparison of the standard voltage with the unknown induced voltage is made independent of the relative values of Z' and R_1 , permitting a much greater freedom of design of the attenuating network and terminal resistor. The arrangement, moreover, maintains the circuit conditions between the loop and insertion networks undisturbed except for rotation of the loop to eliminate the unknown signal during the comparison, thus eliminating errors due to switching of these circuits. The comparison receiver is actually operated by the voltage between one side of the loop circuit and ground. However, the voltage developed in quadrature to E_c due to the resistances R and R_1 is rarely one twentieth of E_c and is usually considerably less than this. Since this voltage is developed in quadrature to the voltage E_c with both the unknown and standard signals this actually causes no difficulty.

Since the absolute accuracy of measurement with the above circuit depends almost entirely on the accuracy of the standard voltage inserted in the loop, considerable care must be given to the design of the attenuating network to insure that the effects of stray reactances and admittances at carrier frequencies are reduced to a minimum. At broadcast frequencies the calibration of a vacuum type thermocouple

voltmeter may be relied on to within one per cent, especially if the resistance of the couple is such as not to require external multipliers.³ In the attenuator itself, however, the limiting factor lies in the stray reactance of the individual cards of the network. In order to reduce further the limitations imposed by this factor the network was designed so as to balance out the effects of such reactances.

A balanced ladder type of structure was chosen because of the ability to reduce errors due to stray admittances between sections of the attenuator and the avoidance of errors due to ground-return currents which are more serious in unbalanced structures. Individual shunt arms were grounded separately to the frame at their mid-points

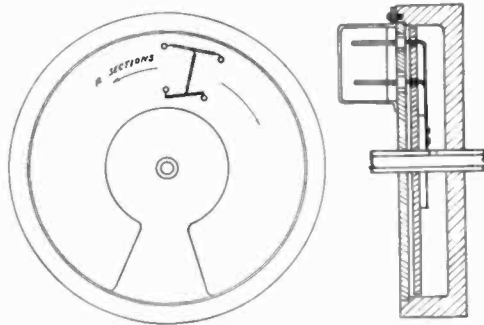

Fig. 2

to insure maintenance of the balance without producing mutual paths between the various sections and ground.

The mechanical arrangements and the shielding of the attenuator may be seen in Fig. 2, illustrating the method of arrangement of a twelve-section attenuator having an over-all attenuation of 10^6 and an equivalent surge impedance of 200 ohms. The individual cards were wound with No. 40 enameled, single silk-covered, Advance wire on thin bakelite forms in a closely spaced single-layer reversed-loop winding. Each card was approximately one centimeter wide, two centimeters long, and one millimeter in thickness. By making the series and shunt arms of approximately the same resistance, size, and form factor, cumulative errors due to stray card reactance may be reduced to a differential effect dependent on the ability to achieve identical form factors. The choice of an attenuation ratio of $\sqrt{10}$ per section and a surge impedance of 200 ohms results in individual card impedances

³ J. H. Miller, "Thermocouple ammeters for ultra-high frequencies," Proc. I.R.E., vol. 24, pp. 1567-1572; December, (1936).

of the order of 100 ohms, a value which minimizes the stray reactances of the cards themselves.⁴

The network is able to function without intersectional shielding since errors produced by stray admittances between adjacent sections are minimized by the balanced nature of the structure, the symmetry of the mechanical arrangement, and by the relatively low impedance level of the network. Errors due to over-all admittances within the shield are minimized for the same reasons and also because interven-



Fig. 3

ing attenuator sections are essentially grounded as far as these high impedance stray paths are concerned, and thus act effectively as shields. Input and output connections were made to the attenuator by means of transmission lines so as to match the terminating impedances, each line consisting of a shielded twisted pair. Checks of the input and output voltages of the terminated feeders indicated that the loss for feeders of reasonable length was negligible. The output line was terminated in a 200-ohm resistor located at the loop terminals and having a 20-ohm mid-section inserted directly into the loop circuit. Experimental checks of the accuracy of this type of attenuator verified design calculations, tests at one megacycle against attenuators of more conventional shielded types indicating less than one per cent error over an attenuation ratio of 10^6 .

⁴ Behr and Tarpley, "Design of resistors for precise high-frequency measurements," *Proc. I.R.E.*, vol. 20, pp. 1101-1113; July, (1932).

EQUIPMENT

The equipment shown in Fig. 3 was designed to make measurements by the method described above. Its essential components consist of a standard signal generator, attenuator, and a sensitive superheterodyne receiver provided with a loop antenna. Means were provided for so switching the loop circuits as to make measurements by comparison with the developed loop voltage. Circuits and calibrated resistors were provided for measurement of the loop gain by the conventional calculation from the measured loop inductance and the effect of the insertion of a known series resistance, and also by the method suggested by Taylor using series and shunt resistors.⁵

RESULTS OF TESTS

In order to assure that errors were not being made in absolute values of field intensity due to the effects of loop geometry on calculated effective height or to factors possibly overlooked in nonuniform current and voltage distributions in the loop, measurements were made using loops of different effective heights, equivalent loss resistances, and inductances. The results obtained using the direct insertion method gave excellent agreement. The following is a set of six independent readings made with two different loop antennas, the measured field being that produced by a one-kilowatt broadcast transmitter whose output was carefully watched to insure constant antenna current during the tests. The readings are entirely typical of many such groups obtained in the field.

FIELD INTENSITY IN MILLIVOLTS PER METER

Loop A	Loop B
156.5	156.5
156.5	156.0
157.0	156.5

The two loops were of the type shown in Fig. 3, one being a loop of 14 turns wound on the bakelite frame shown, and the other a loop of 10 turns wound on a paraffined maple frame of similar construction. The natural frequency of loop *B* was not far removed from the frequency of the measured signal.

The ultimate sensitivity limit imposed on this method is determined by the ability to shield the loop against stray fields from the standard signal oscillator when making comparisons with the standard voltage (with the loop crossed with respect to the unknown signal). At high signal levels, however, such as would normally be encountered in antenna efficiency measurements, this difficulty is of no importance. The

⁵ P. B. Taylor, "A compact radio field strength meter," *Proc. I.R.E.*, vol. 22, pp. 191-200; February, (1934).

maximum experimental variation up to this limit was found to be less than one per cent and the mean variation approximately one third of one per cent. Since by careful attenuator design it is possible to maintain an accuracy of the standard signal of one per cent at broadcast frequencies, the resulting measurements may be relied on within this limit.

ALTERNATIVE METHODS

At the same time that the above tests of the direct insertion method were being made, the set was also employed to make measurements of the same field by means of routines involving comparison of the developed loop voltage with the standard signal, and the measurement of loop gain. It was found that complexity of the field routine was the determining factor in the accuracy of the measurements, random variations from this cause alone being so great as to obscure the observation of errors from other sources.⁶ One of the more recent suggestions for loop gain determination by means of calibrated series and shunt resistors⁵ presents especial difficulty in this regard since the method of determination of the loop gain involves two differential measurements in which small errors may combine and produce large discrepancies in the calculated gain. Use of this method in the field gave frequent random errors of over five per cent and sometimes ranging to ten or twelve per cent. The more conventional methods involving the measurement of the loop reactance and the insertion of known series resistors in the field were found to give individual readings seldom departing more than five or six per cent from mean values. The absolute accuracy of these methods moreover depends, in addition, on the precise knowledge of circuit constants, either of the loop or of the associated calibrated measuring resistors at high frequencies—a requirement avoided entirely by the use of the direct insertion method.

The method here described has the advantage that it is neither dependent on the permanency of calibration of a vacuum tube voltmeter or mutual inductance, nor on the linearity of response of the comparison device over wide intensity limits. Thus once the thermocouple voltmeter and the attenuator have been properly calibrated, little opportunity exists for errors within the set over long time intervals and the resulting measurements are reliable without frequent recalibration. All switching of the loop circuits during the measurement is eliminated.

LIMITATIONS

Using reasonable care to shield the standard oscillator by means of double shielding and to filter plate and filament supplies adequately

⁶ "Precise measurements of high frequency electromagnetic fields," a thesis by the author on file in the library of Cornell University.

it has been found that errors due to stray field pickup by the loop may be neglected and the high precision of measurement maintained down to field intensities of approximately three millivolts per meter at broadcast frequencies. This was checked by changing the position of the equipment so as to vary the orientation of the loop relative to the local oscillator during the standard signal comparison with no observable effect on the measured value of the field intensity. At lower field intensities the error becomes more pronounced but may be minimized by orienting the equipment relative to the loop so that when the standard signal generator is in operation and the loop is crossed with respect to the unknown signal, it is also in such a position as to eliminate stray field from the oscillator. By this process measurements which are accurate to within two or three per cent may be made down to the point where difficulties due to noise level and the presence of sky-wave components are encountered.

ACKNOWLEDGMENT

The author is indebted to Assistant Professor True McLean of the School of Electrical Engineering, Cornell University, for much valuable assistance in this work and to the Westinghouse research grant by the University which made possible the construction of the equipment.



TIME-DIVISION MULTIPLEX IN RADIOTELEGRAPHIC PRACTICE*

BY

J. L. CALLAHAN, R. E. MATHES, AND A. KAHN

(RCA Communications, Inc., New York City)

Summary—The paper outlines certain methods of multiplexing telegraphic signals on a common communication channel and the factors governing the application of these methods to radio circuits. The recently developed trend toward the use of multiplex methods in radiotelegraphic service is discussed. Consideration is given to the advantages of using the time division method based on the baud, at least at the present state of the radio art. General specifications for the equipment are stated, based on practical operating requirements. Major changes from practices obtaining on wire-line multiplex systems are mentioned and the reasons therefor are given. A description of a practical system based on the above considerations and its use and effectiveness in a large radiotelegraph organization is furnished.

IN FULFILLING its allotted function in the economic scheme of commerce, both domestic and international, radiotelegraphy has, in general, followed the old established methods of central office operating procedure. This is true even though the radio circuits and equipment proper have kept fully abreast—even led—the progress of the art. Recently, several of the leading radiotelegraph operating companies of the world have been making serious efforts to improve their central office operating equipment and procedure to match the improving radio circuits. One of the most important of these improvements has been the application of multiplex systems for telegraphic code communications.

For many years now¹ the operating methods used on most of the established point-to-point radiotelegraph circuits have consisted of transmission of the continental code by means of an automatic transmitter controlled by perforated tape and reception by means of undulators or ink recorders which register the code characters on a narrow paper tape. The tape record is then transcribed on to the message blanks by an operator. As the radio circuits have improved, and as traffic has increased, it has been necessary to operate the circuits at higher speeds, which now far exceed the capabilities of a single transmitting or receiving operator. When more than one operator is used to feed a single circuit of this type, its full speed capabilities are not realized. Furthermore, possibilities of delays, mix-ups, and oc-

* Decimal classification: R460. Original manuscript received by the Institute, July 28, 1937. Presented before Silver Anniversary Convention, New York City, May 10, 1937.

¹ Numbers refer to Bibliography.

casional lost traffic are increased, the net result causing operating difficulties which do not obtain on the slower speed circuits. If, however, multiplexing could be utilized to break the circuit into channels, the speed of each of which is within the efficient capability of a single operator, over-all operating efficiency should be considerably increased.

The land-line and cable companies have appreciated the desirability of channeling and have used multiplex operation on trunk circuits for a long time.² Extenuating circumstances such as static, fading, and inherent circuit instability, have heretofore prevented the application of this procedure to radiotelegraph circuits. Within recent years, with the application of directive antennas, diversity receiving equipment,³ and a greater comprehension on the part of the operating staff of diurnal and seasonal effects and how to correct for them, the major circuits have become sufficiently reliable to warrant the application of multiplex operation.

Many proposals have been offered for multiplexing. These divide naturally into two major categories; (1) frequency division, and (2) time division. Several proposals have been advanced which combine these two divisions.

The frequency-division type of multiplexing usually contemplates that all the components of the code for each character will be sent simultaneously but at different frequencies. When this scheme is applied to a radio circuit, it means that these several frequencies must be applied as amplitude modulation to the radio-frequency carrier. This means, of course, that the equipment throughout the entire circuit must be capable of essentially linear modulation and, therefore, the average power of the radio-frequency carrier must be reduced from that permissible for simplex telegraph keying. The power available to each channel must be further reduced from the maximum permissible modulation by a factor proportional to the number of channels. This modulation requirement also prohibits the use of limiting, signal shaping, etc. This system, does however, have one great advantage in that careful synchronizing of speeds between transmitting and receiving equipment is not essential. Another method of frequency division is that of channeling a given frequency band or spectrum, usually by means of wave filters, and then operating each channel as an independent simplex circuit. This does not fall under the term "multiplexing" as usually understood in telegraph art and is not here considered.

The time-division systems are predicated on the principle of assigning the sole use of the circuit to each channel successively and for predetermined periods; viz, sequentially switching the trunk cir-

cuit to the various channels in a predetermined order. Thus, each channel functions as a normal telegraph system during its successive assignments to the circuit. This principle of switching is more fully explained later in the description of a practical system and in conjunction with Fig. 2. As applied to radio service, it is possible to modify the signals in the various fashions usually applied to the simplex radio-telegraph circuits when this type of multiplexing is adopted. Such modification includes the application of limiting, signal-shaping, simple tone-frequency conversions by means of keyers, etc. It also permits the use of telegraph type diversity reception, which is more efficacious than the telephone type.⁷ The use of pure on-and-off keying of the transmitter can utilize more power from a given transmitter because linear modulation is not required. Further, because the use of the entire circuit at a given instant is assigned to only one channel, the signal-to-noise ratio at the receiver on this channel is the same as that with simplex operation for the same total intelligence speed.

The major disadvantage of time-division multiplex as opposed to frequency division is that provision must always be made to insure accurate timing of the channel assignments. This involves synchronous drives, phasing, speed corrections, and other bothersome details at both the transmitting and receiving central office terminals. A vast number of schemes have been propounded to meet these requirements, but, unfortunately, the only practicable ones add considerable complexity to the design and operation of the system.

Other multiplex systems have been proposed which attempt to combine features of the frequency-division and time-division principles. They are notably of interest because of the simplification of the synchronizing problem. However, they all require the equivalent of linearly modulated radio systems and therefore have not as yet found favor for commercial application.

For more detailed consideration, the time-division schemes may be segregated into three sections.

- (1) Equal length character base
- (2) Baud base
- (3) Plural assignments per baud

The system designed with the equal length character as its base is intended primarily for use with channels equipped with synchronous type telegraph printers. These are almost invariably operated with a special telegraph code in which each letter or character is represented by a code of five time units. The permutations of marking and spacing within these five units identify the desired character. With printers of the above type, a time interval must be provided for the actual printing

function before the start of the next character. This is most conveniently accomplished by utilizing for this purpose the time during which the printer on another channel is assigned to the circuit.

The above system is the one in general use by most wire-line and cable telegraph companies. It has the serious disadvantage of requiring the operating equipment (such as printers) to be kept relatively near the multiplex equipment. To extend channels to local loops about a city or elsewhere requires the use of rather complex auxiliary equipment.

Another method of arranging the channel assignments is on the basis of the baud. The baud (named after Baudot, the inventor of the five-unit equal-length printer code that carries his name) is the shortest duration of a mark or space element in a given telegraphic code. All other marks or spaces comprising the code are integral multiples thereof. The baud, then, may also be taken as the interval of time for which the channels may successively be assigned to the circuit. For such a system, it is immaterial whether the codes for the different characters are of the same length or not, so long as the transmission speeds are such that the bauds of all the channels are of equal length. Such a system permits the use of continental code simultaneously with printers, either of the synchronous or start-stop type.

The third system of time division is directed toward assigning the channels successively to the circuit as before, but so rapidly that each channel will be so assigned at least several times during a baud. The expected advantage of eliminating the synchronizing problem is more than outweighed by the necessarily increased modulation band, key-click interference in adjacent radio channels, multipath effects, control line and filter requirements, etc.

Some of the systems which have been tried more or less successfully on long-distance radio circuits are the Baudot-Verdan system of the Ateliers J. Carpentier of France,⁴ the six-channel system of Siemens-Halasko of Germany, the so-called "D.C.C.C." system⁵ of Cable and Wireless, Ltd., of England, and the three-channel system of RCA Communications, Inc. Some of these have interesting features and functions other than multiplexing, but they cannot be considered here. The first two operate on an equal-length character base while the latter two operate on the baud base.

In surveying the general problem from the viewpoint of improving the service of RCA Communications, it was found that several desirable features could be realized by the use of multiplexing.

1. Raise operating efficiency and more quickly dispatch the traffic.

2. Provide an acceptable degree of privacy for purposes of commerce.
3. Conserve radio circuits and frequencies through utilizing a single radio circuit for more than one service, as well as through increased operating efficiency.
4. Provide a basis for applying automatic collation (Baudot-Verdan principle) thus minimizing static, etc.

It was also found that a system predicated on the baud base would have still other distinct advantages, thus:

1. In making the transition from simplex to multiplex, it is highly desirable that the operating methods remain essentially the same.
2. Because RCA Communications does not control the other end of the international circuits but works co-operatively with foreign administrations, it is essential that operating methods have the maximum possible flexibility.
3. Permits the use of any code based on two-element keying and utilizing the baud time units or base. Thus it can be adapted to use with special systems which may be developed by our foreign correspondents.
4. Permits the use either of synchronous type printers or start-stop printers, the latter through the medium of relatively simple storage units.

All of the above desirable features can be provided when the baud base is utilized.

Certain broad functions and operations of the following type must be performed by any satisfactory time-division multiplex system based on the baud.

1. Time division is inherently sequential switching. Thus, distributor devices must be provided at transmitting and receiving terminals.
2. At the receiving end means must be provided to elongate effectively the signals of each channel to correct for the part-time use made of the circuit by that channel. This requires a degree of "telegraphic regeneration"² and signal shaping.
3. Both terminals must operate in exact synchronism, as any asynchronous operation produces a cumulative effect which will soon cause serious errors in reception, mislocation of channels, etc. Speed discrepancies of even one part in one million will cause such errors if not compensated. This requires that sources of nearly synchronous frequencies be provided at each end and

further that they be held in exact phase by means of speed-correction systems.

4. To insure that the switching of the circuit occurs at the proper instant with respect to the channels, the transmitting equipment, at least, of the channels must be driven in synchronism with the distributor. Thus synchronous drive must be derived from the distributor and fed to such devices as auto heads, printer tape transmitters, keyboard printers, or storage devices which may be inserted between such printers and the distributor, and, in special cases, receiving recorders or printers.
5. To liberalize somewhat the otherwise extremely rigid requirements of exact speed and phase, as well as to provide for some variation in the proportions of the received signal, the principle of "telegraphic regeneration" is utilized.

In designing a multiplex system for radio circuits all of the above factors must be considered, and, in addition, it must be kept in mind that radio circuits are subject to greater fortuitous distortion than wire lines of comparable length. They are subject to noise, fading, and multipath transmission, all of which severely affect the shape or duration of the received signals. Therefore, it is essential that the multiplex equipment permit the maximum possible tolerance to the radio equipment and circuit and demand the minimum of tolerance for itself.

From this viewpoint of minimum of tolerance necessary to the multiplex equipment, a system has been developed and put in successful daily operation between New York and San Francisco by RCA Communications. It is this equipment we propose to describe specifically.

To achieve the order of accuracy which must be maintained to insure continuous commercial operation of the multiplex system, use is made of a 480-cycle frequency standard at each installation. This frequency standard consists of a temperature controlled fork which is held to a practical accuracy of approximately one part in one hundred thousand. The output of the frequency standard is led to thyatron inverters which supply power to the multiplex transmitting and receiving machine motors at frequencies which are submultiples of the 480-cycle control tone.

The transmitting and receiving machines carry commutators which perform the channeling functions and also provide means for synchronizing the automatic tape transmitters associated with the multiplex channel distributor. Commutators also provide pulses for neon lamps which act as indicators of phase and synchronism on the auto base units. It is noted from the above that the entire system is controlled,

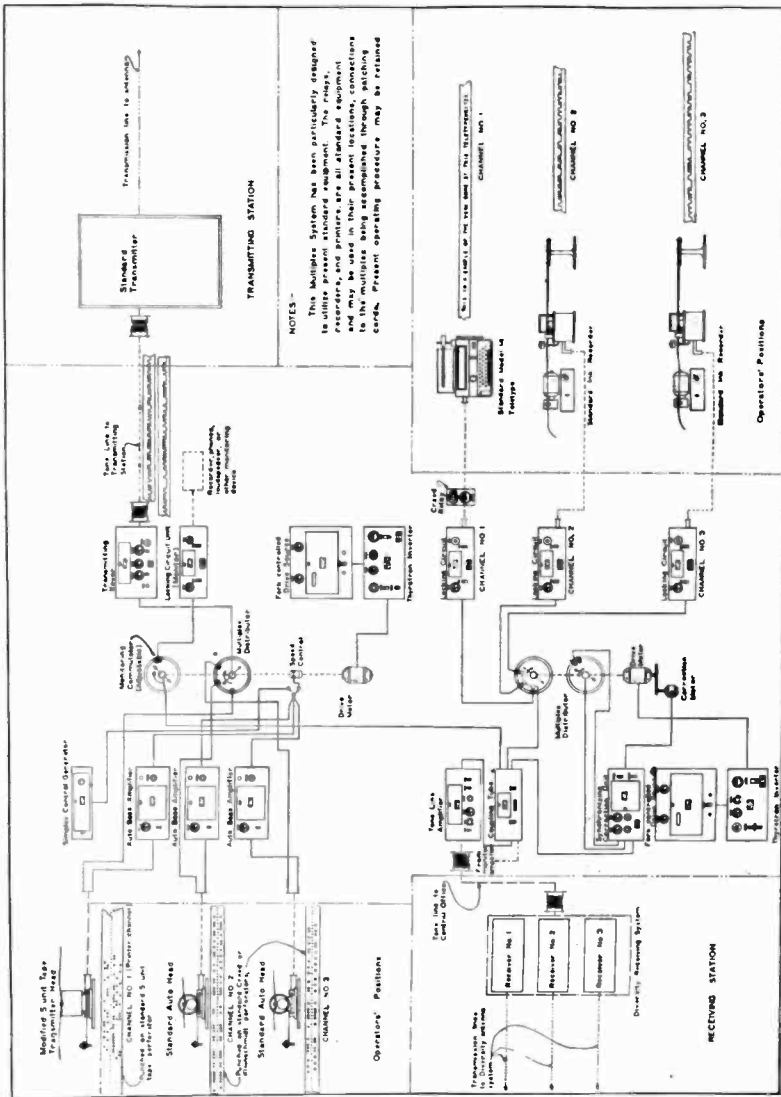

Fig. 1—Functional diagram of RCA Communications time-division multiplex system.

either directly or indirectly, by the tone supplied by the frequency standard.

To facilitate operations, one of the stations on the multiplex network is considered as a reference standard to which the frequency standards of all other terminals are adjusted. Because of the high stability of the standards, the installations operate for long periods of time without requiring readjustment. When necessary, these adjustments can be made without interfering with the service.

It will be noted that the accuracy of the frequency standard is considerably higher than that of similar devices generally used in wire-line multiplex. This greater accuracy of control frequency has been found highly desirable in the radio application of multiplex telegraphy mainly because of the lesser amount of correction required at the receiving end. Thus, longer periods of signal disturbance may be experienced without affecting the synchronism between the transmitting and receiving machines. Furthermore, it is possible to operate on a shorter active portion of the signal pulse than is required for wire-line multiplex. The use of approximately the middle eighth of a baud greatly minimizes the effect of other phenomena such as short rapid fading, sharp static clicks, and multipath effect.

The multiplex system of RCA Communications is operated, as previously mentioned, on the basis of a baud or unit dot length of a channel. Fig. 1 shows a functional diagram of this system. In order to obtain three channels, the system is so arranged that during the first third of each baud the outgoing circuit is connected to the telegraph equipment of the first channel, for the second third of the baud the outgoing circuit is connected to the telegraph equipment of the second channel, and for the third third of the baud the outgoing circuit is connected to the equipment of the third channel. Fig. 2 is a time-sequence chart showing the compositing and selecting relationships of the signals. The equipment of each channel may either be a Morse tape transmitter for continental code or a transmitter arranged to make use of equal length time unit printer codes. These automatic transmitters are mounted on "auto base" units and are driven by synchronous motors which have power supplied to them by "auto base drive amplifiers," which in turn operate from a signal originating in the auto base drive commutator located on the transmitting machine distributor shaft, thereby maintaining the tape transmitter head in synchronism with the distributor shaft. Each auto head is phased so that it will be assigned to the outgoing circuit at approximately the center of each baud transmitted from the head. This is accomplished when one of the shorting bars of the channeling commutator closes

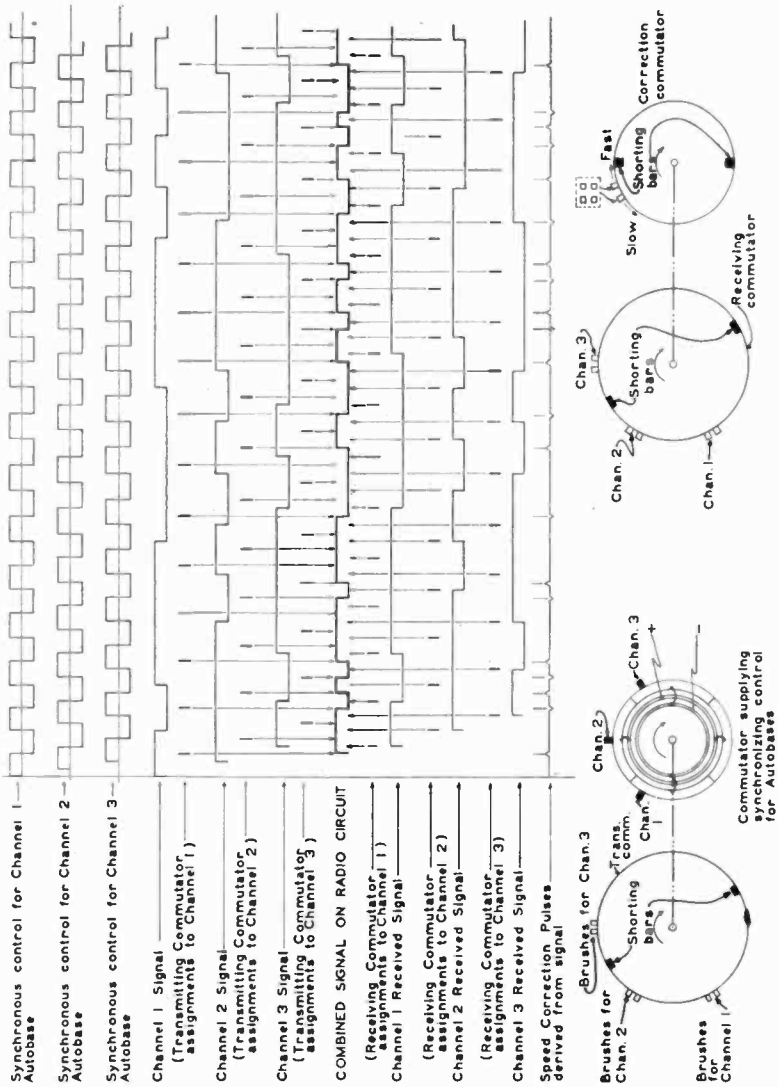

Fig. 2—Time-sequence chart for functioning of RCA Communications time-division multiplex.

the circuit from the auto head to the transmitting keyer by completing this circuit through the channel brushes. The duration of this selected part of the signal which is passed on to the transmitting keyer, is equivalent to approximately 1/25 baud.

The transmitting keyer is a trigger circuit whose characteristic it is to maintain a condition of mark or space dependent on the character of the pulse last received. In other words, the unit acts as a vacuum tube polar relay. Thus, as the channels successively operate the keyer, this unit produces a combined tone signal of the individual channels operating. The tone is then sent over the tone pair which connects the central office to the radio transmitter where the tone is rectified and control is effected in the same manner as when high speed simplex signals are being used. At the radio receiving station diversity equipment is employed as in simplex operation, and the composite multiplex signal sent to the central office over a tone pair. At the central office the incoming composite tone signal is amplified, rectified, and then passed into the multiplex receiving apparatus. The rectified signal first passes into the coupling unit and thence to the receiving distributor commutator which is a duplicate of the commutator used for transmission. The brushes mounted about the circumference of this commutator connect to three individual "locking units," which are circuits essentially the same as the transmitting keyer. The short pulses received by the locking unit are regenerated by it to produce full length characters as originally formed by the channel tape transmitter. The locking unit output may be used directly to operate an ink recorder or it may actuate either a mechanical or vacuum tube relay, which in turn will supply the current necessary to operate a printer. By means of the "correction unit," operating in conjunction with the correction commutator and the correction motor, the frame of the receiving motor is rotated, when necessary, to maintain proper speed relations between the receiving machine and the distant transmitter. A more detailed description of the several units making up the multiplex machine follows.

TRANSMITTING MACHINE

Fig. 3 is a picturization of the multiplex transmitting machine. The unit consists mainly of a 1/30-horsepower synchronous motor connected through a 20/11 gear reduction to the commutator shaft. Brushes are mounted about the circumference of these commutators to perform their several functions. The rotating parts are all mounted on a subbase which is shockproofed to prevent vibration being transmitted to other units mounted in the rack. The subbase is arranged to slide in and out on a drawer for inspection and maintenance.

Switching is provided to permit the selection of one-, two-, or three-channel operation. An auxiliary channeling commutator is provided on the transmitting machine and is used in a receiving sense with the monitor coupling unit and locking unit to permit monitoring the outgoing signal. The monitor commutator brush arrangement differs from that used with the normal receiving commutator in that a single movable brush and one fixed brush is used instead of the fixed brushes used on the channeling commutators. The movable brush permits the selection and monitoring of any single channel of the outgoing composite signal.

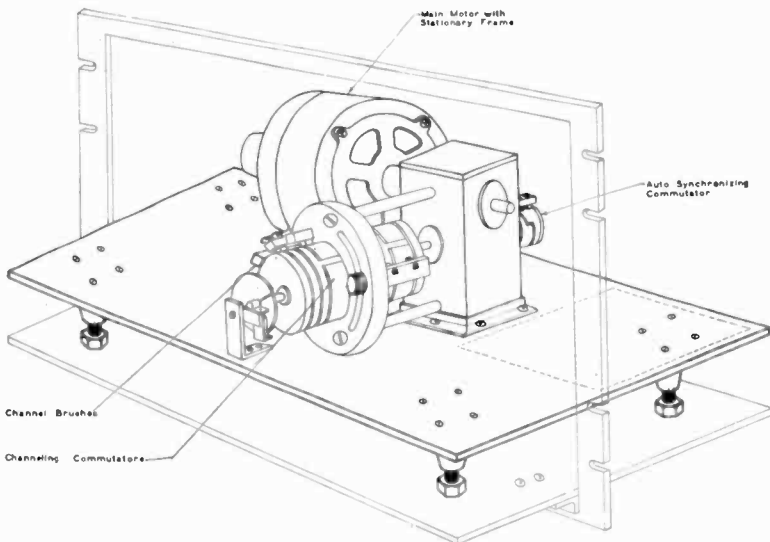

Fig. 3—Multiplex transmitting machine.

The auto base unit used in connection with the terminal includes a 1/300 horsepower synchronous motor, which drives the tape controlled auto head or transmitter. Protective resistors for the auto head contacts and all other components are contained within the base. Contacts are provided on the unit so that any one of several makes of Morse auto heads may be used with the base. Contacts and circuits are also provided to utilize the base as a drive for a five-unit transmitting head for Teletype printer signals.

Drive power for the bases is provided by individual auto base amplifiers. These are excited by the auto base drive synchronizing commutator mounted on the transmitting machine commutator shaft. The output stage of the auto base drive amplifier consists of a pair of 841 tubes in push-pull which supply power adequate to drive the

motors in synchronism over the range of speeds at which the multiplex system operates.

The auto bases may be operated on a simplex circuit by the use of a "simplex control generator," which consists of a varispeed arrangement for varying the speed of a secondary shaft upon which is mounted a commutator to perform the same functions as the auto base synchronizing commutator; that is, it provides plus and minus reversals which are led to the auto base amplifier. However, this unit operates independently of the multiplex and by its use a word speed range of

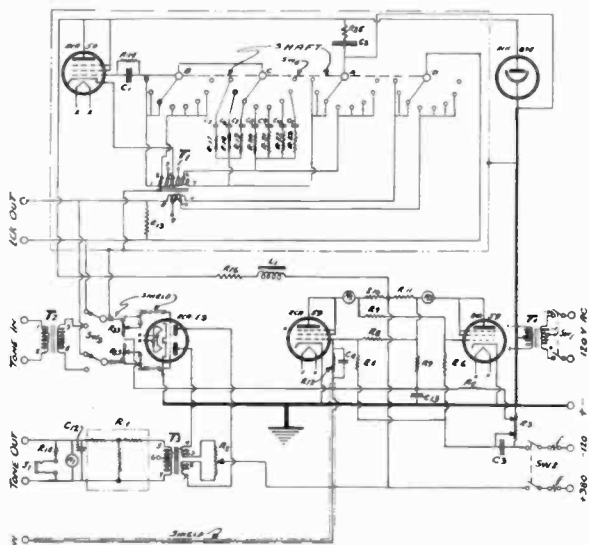

Fig. 4—Transmitting keyer.

from approximately 12 to 120 words per minute can be realized for simplex operation. This unit functions as auxiliary apparatus and is not directly essential to the operation of the multiplex system.

KEYER UNIT

The circuit of this unit as shown in Fig. 4 comprises a two-tube locking circuit similar to that used on the receiving locking circuits, a tone keying stage, and an oscillator. The oscillator provides seven different frequencies, 765, 1275, 1615, 2125, 2975, 3825, and 4675 cycles, any one of which may be selected by means of a multicontact switch. This oscillator also supplies a tone to the receiving locking circuits, which is keyed in these units and supplies an operator's headphone signal of the incoming channel. The locking circuit portion of the

keyer, by virtue of the interconnecting resistor network, operates in such a manner as to maintain a condition dependent upon the polarity of the signal pulse impressed on the grid of the input tube through the coupling capacitance. Thus if a pulse of certain polarity is received, one tube will tend to pass current and the cumulative effect of the potential changes across the locking circuit resistors will be to cut off the other tube. The changes in condition of the locking circuit tubes are caused to affect the bias of the keying tube by means of a voltage divider circuit so that this tube will pass tone on mark signal from the auto heads, and will be cut off on space signal. This is a very versatile circuit and has been used in numerous applications.

COUPLING UNIT

The principal function of this unit is to isolate the commutators from preceding circuits and thereby to insure proper operation of the receiving locking circuits. The unit consists of two separate coupling tubes with individual inputs and outputs. One of these is used for the received signals from the distant transmitter and the other is used for monitoring purposes in conjunction with the monitor locking circuit and the monitor commutator located on the transmitting machine. A low-pass filter is included in the input of each coupling tube to eliminate the residual tone component from the rectified signal.

RECEIVING MACHINE

Fig. 5 is a picturization of the receiving machine. This unit takes the interlaced composite signal as received from the coupling unit and separates it back into the several original channels. The mechanical features of the receiving machine are in general similar to those of the transmitting machine. However, in the receiver, the drive-motor stator is mounted on a bearing and is rotatable by means of the correction motor. The receiving commutator is similar in construction to the one used in the transmitter.

The incoming signal as received from the coupling unit is passed to the slip-ring portion of the receiving channeling commutator. Two short-circuiting bars, which are part of the slip ring, are spaced 180 degrees about the circumference of the commutator. As the commutator rotates, the incoming signal is passed sequentially through the shorting bars and the channel brushes and thence to the individual channel locking units where the code elements are regenerated to their original full length. The receiving commutator shaft also carries the correction commutator and the receiving neon slip rings. Switching is provided for the selection of one-, two-, or three-channel operation. A manual

phasing switch is also located on the machine base. This switch controls the correction motor and enables the attendant to phase the machine approximately and bring it within range of the correction unit.

LOCKING UNIT

This unit acts in a manner similar to the transmitting keyer in that the pulses of short duration, received from the commutator, trigger off the locking circuit which maintains its condition of marking or

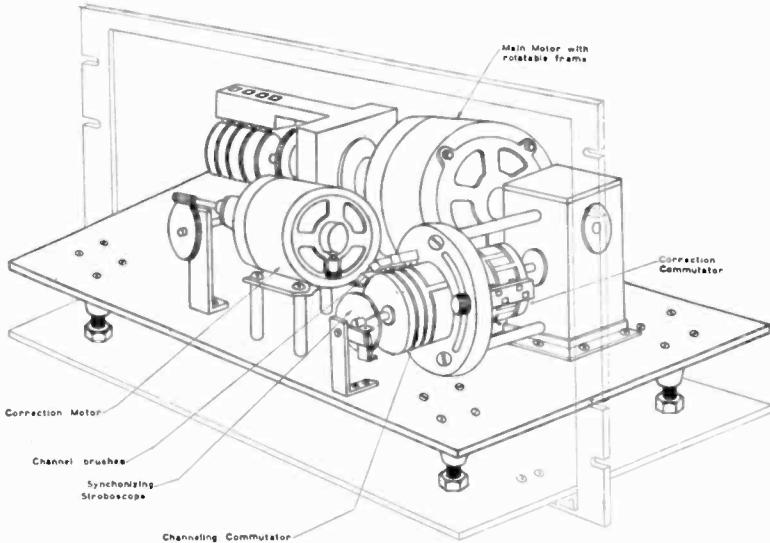

Fig. 5—Multiplex receiving machine.

spacing until a pulse of opposite sense causes it to reverse this condition. Thus, when a dot mark is sent on channel 1, for example, channel 1 locking circuit will receive a pulse which will cause the locking circuit to mark and it will continue to mark during the time impulses are being received by the locking units of channels 2 and 3 for one-half revolution of the distributor commutator. When channel 1 is again connected to the coupling unit by means of the shorting bar the incoming signal will now be on a space and channel 1 will receive a pulse in such sense as to produce a spacing signal. When a dash, which has a length of three bauds in the continental Morse code, is transmitted, the channel locking circuit will receive three mark pulses and a space pulse and will thus produce a properly formed dash signal. The output circuit of the unit is arranged to operate an ink recorder directly, or if desired, a relay, the output of which may be utilized to operate a printer.

It is seen from the foregoing that the locking unit acts as a vacuum tube telegraphic regenerator. Telegraphic regeneration is accomplished by the use of a small part of the incoming signal, selected by means of the channel distributor on the receiving machine and passed on to the locking unit, which produces perfectly formed signals of proper length.

CORRECTION UNIT

Fig. 6 is a schematic diagram of the correction unit, which is a vacuum tube arrangement used in conjunction with the correction

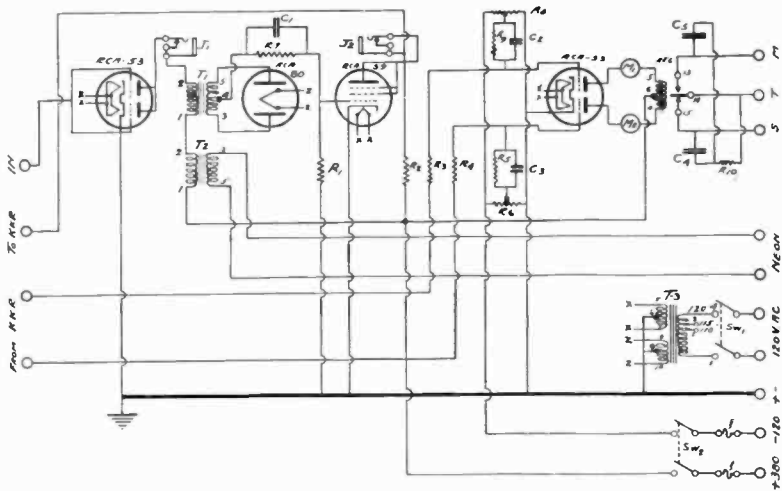

Fig. 6—Correction unit—schematic diagram.

commutator and the correction motor which are part of the receiving machine, by means of which, pulses derived from the incoming composite signal act to correct the speed of the receiving motor, either slow or fast as necessary, and thereby maintain a fixed average phase relation between the multiplex transmitter and receiver. The unit functions to perform this purpose in the following manner. The rectified signals, after passing through the low-pass filter which is part of the coupling unit, pass into the input tube of the correction unit to isolate the signal further and prevent interaction with any of the other multiplex units. This direct-current signal is passed through a transformer and produces two pulses, one for the make and one for the break of the signal. These pulses are rectified in order that they be in the same direction, and are shaped by a capacitance-resistance circuit. The resultant essentially rectangular pulses of extremely short duration are passed on to the correction commutator on the receiving

machine. This correction commutator provides a pair of shorting bars for each channel and operates in conjunction with a common brush and two brushes mounted on a holder movable about the circumference of the commutator. The two brushes are fixed with respect to each other at a distance sufficient to clear the shorting bar, so that the two brushes cannot be connected to the circuit by the shorting bars at the same time. The correction commutator and the movable correction brushes are located on the commutator shaft and with respect to the signal commutator in such a manner that when the receiving machine is in phase with the distant transmitter, a correction pulse will arrive at the common brush at a time when the shorting bar is in a position midway between the two movable correction brushes. When this condition obtains the signal shorting bar will be in position in the center of a received signal baud and will pass the signal on to the utilization circuits. Now if there is a difference in the standard fork frequencies at the two ends of the circuit the tendency will be to increase or decrease the speed of transmission slightly, as the case may be. Should the control at the receiver be slower than at the transmitter, it will result in the condition that the lagging correction brush will be in contact with the correction shorting bar at the time when the correction signal arrives, and the signal will be passed through the bar to the grid of one of the output triodes of the correction unit. However, the grid circuits of this stage are each provided with a capacitance-resistance integrating circuit so that a number of sequential pulses are required before a sufficient voltage is built up to counteract the effect of the fixed negative bias on the tube. This is done for the express purpose of minimizing the effect of fortuitous signal elongation, static, or other ether phenomena. When the voltage on the grid is such that the tube passes current it will operate the differentially connected relay in the plate circuit which in turn will supply power to the correction motor at such polarity as to produce rotation of the motor frame in a counteracting direction to overcome the effect of the speed difference. The correction circuit operates in this manner to correct the speed of the receiving motor, whether it is running slow or fast with respect to the transmitter, and will tend to hold the receiving commutator shorting bar so that the channel closure occurs in the center of each baud.

STOP-START PRINTER

The printer used in conjunction with the RCA Communications multiplex is a Model 14 Teletype with 60-cycle synchronous drive. The gearing in the printer has been changed from the standard to meet the multiplex operating speed and produces print at the rate of fifty-three

words per minute. This speed of operation has been chosen as it represents the equivalent Morse speed at which most efficient use of the circuit is realized. On extended experimental tests through the multiplex system over the New York-San Francisco radio circuit a printer margin of sixty points was consistently realized. On a basis of operations, circuit errors ran to about 0.0113 per cent, or 0.068 per cent on the basis of words.

FREQUENCY STANDARD

The frequency standard employs a Ketos steel fork which has a frequency of 480 cycles and which is mounted in a temperature-con-

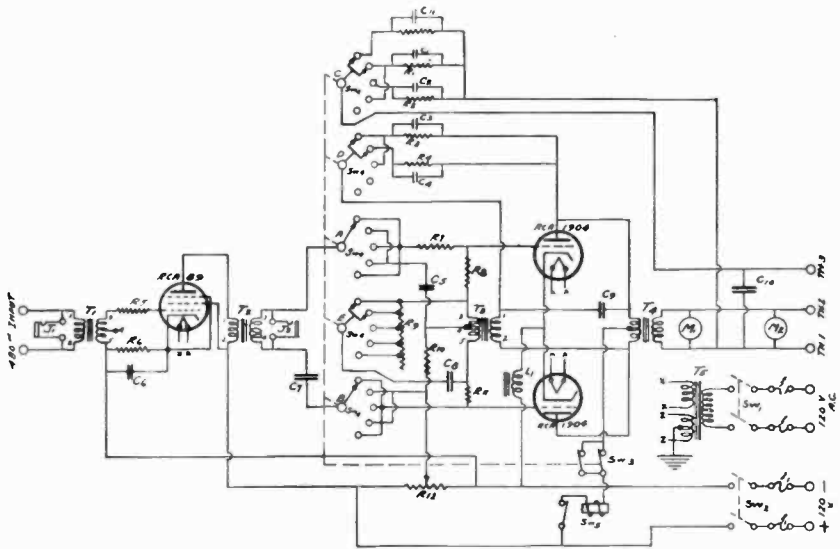

Fig. 7—Thyratron inverter—schematic diagram.

trolled oven. The standard is equipped with a mercury thermoregulator to keep the fork temperature constant. A mercury thermostat is also used as a safety device to open the heater circuit in case of failure of the thermoregulator. The fork is connected in the conventional manner to act as the coupling between the grid and plate circuits of a vacuum tube oscillator. A variable resistor is connected in the plate circuit of the fork drive tube to permit the variation of the fork amplitude and hence its frequency over a very narrow range. This means of variation of the fork frequency is used at each link of the multiplex circuit network to meet the frequency of the accepted standard station.

THYRATRON INVERTER⁶

A parallel inverter circuit, such as shown schematically in Fig. 7, utilizing a pair of RCA-1904 thyatron tubes is employed. The output of the 480-cycle frequency standard is impressed on the grids of these tubes and by the proper selection of the circuit constants of the inverter these units can be made to lock in at any one of four frequencies. These frequencies are the ninth, eighth, seventh, and sixth submultiples of the 480-cycle tone. The thyatron units therefore supply power at an accurately controlled frequency to drive the synchronous motors of the multiplex transmitting and receiving machine.

SPEEDS AVAILABLE

The following table shows the speeds at which the multiplex system operates:

MORSE CODE

Inverter frequency	Submultiple of 480-cycle control frequency	Drive motor speed r.p.m.	Distributor shaft speed r.p.m.	One Channel		Two Channels		Three Channels	
				Keying frequency in cycles	Words per minute	Keying frequency in cycles	Words per minute	Keying frequency in cycles	Words per minute
53.3	9	1600	880	14.67	36.67	29.33	73.33	44.00	110
60.0	8	1800	990	16.50	41.25	33.00	82.50	49.50	123.75
68.6	7	2057	1131.4	18.86	47.15	37.72	94.28	56.57	142.43*
80	6	2400	1320	22.00	55.00	44.00	110.00	66.00	165.00

* Printer Speed.

The inverter frequency of 68.6 cycles is used when printer operation is desired. This gives a printer speed of approximately 53 words per minute and a Morse speed of 47.15 words per minute per channel.

CENTRAL OFFICE FACILITIES

The injection of multiplex operation into the central office has in no way affected the associated terminal apparatus at either end of the circuit. Standard tone pairs and channeling filter facilities normally employed for high speed simplex operation between the central office and the radio station plant are used for multiplex operation with equally satisfactory results.

For example, on the New York-San Francisco multiplex circuit, a tone frequency of 1615 cycles, keyed by the multiplex keyer unit in accordance with the channel signals being transmitted, is passed through a high-pass filter and used on a line which carries another circuit using a tone frequency of 765 cycles. The tones are separated at the transmitting station and operate the radio transmitters by means of vacuum tube keyers.

In the near future wide band filters will be installed which will permit of a more efficient use of the control lines.

RADIO TRANSMITTERS

The transmitters employed by RCA Communications for long-distance short-wave communication have a power output of from 20 to 40 kilowatts. Crystal- or long-line-controlled oscillators and frequency doubling circuits are employed. Electromechanical relays have been replaced by a vacuum tube keying stage which is used to key one of the low power stages of the transmitter. The tank circuit of the power amplifier is coupled, either directly or through a transmission line, to the antenna. Several types of directive antennas have been developed and both horizontally and vertically polarized types are used on the various point-to-point services.¹

RADIO RECEIVERS

On the New York-San Francisco circuit as well as on all first-class radiotelegraph circuits operated by RCA Communications, space diversity receiving equipment is employed.² Here again, the technique employed in handling the multiplex signal is exactly the same as that employed in handling any high speed telegraph signal. Use is made of space diversity receivers, thereby insuring the optimum signal for any given conditions. The combined signals of the diversity receivers operate a vacuum tube keyer which provides a keyed tone for transmission to the central office over a standard tone pair.

MULTIPLEX INSTALLATION

Associated with the RCA Communications multiplex system are such standard operating position equipment as auto heads, printers, ink recorders, etc. An effort has been made in the design of the system to use standard simplex operating position equipment and technique wherever possible. This makes for minimum confusion and produces maximum efficiency where circuit conditions are not uniform.

The system has been designed as simply as possible, consistent with ruggedness, durability, and ample factors of safety at all points. It must of necessity operate continuously over long periods of time without requiring attention from the personnel. To meet these requirements, mechanisms have been held at a minimum. The electrical circuits are simple, highly stable and noncritical. Power requirements are of standard services; viz, 115 volt, 60-cycle, and 240-volt, three-wire direct current.

The equipment for a full two-way multiplex system, comprising three outgoing and three incoming channels, consists of three 19-inch racks mounted side by side. From left to right on Fig. 8 they are the frequency standards rack, the transmitting rack, and the receiving rack.

OPERATION OF NEW YORK-SAN FRANCISCO CIRCUIT

The New York-San Francisco circuit of RCA Communications has been in continuous operation for a period of two years, operating for about 12 hours daily on two or three channels, depending on traffic load and signal conditions. It has been found in practice that the multiplex will show an improvement over simplex operation at the same keying speed for conditions of sharp noise clicks or fades, because of

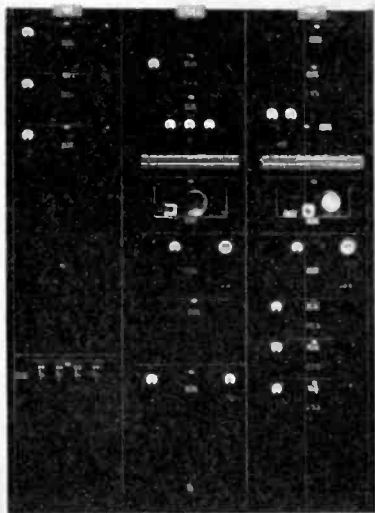

Fig. 8—Three-bay multiplex terminal—front view.

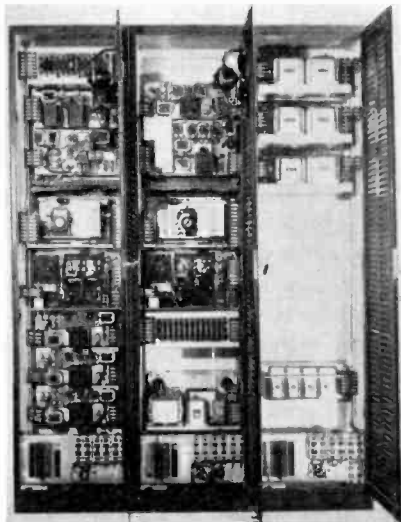

Fig. 9—Three-bay multiplex terminal—back view.

The standards rack contains the following units: 3 auto base drive amplifiers, 2 480-cycle frequency standards,* and 1 power control panel.

The transmitting rack contains: 1 monitor locking unit, 1 transmitting keyer unit, 1 jack panel, 1 transmitting machine, 1 inverter, 1 simplex control generator, and 1 main rectifier.

The receiving rack contains: 1 printer relay panel, 1 coupling unit, 1 correction unit, 1 jack panel, 1 receiving machine, 1 inverter, and 3 receiving locking units.

the utilization of only a small portion of the incoming signals and the use of telegraphic regeneration. However, in the case of long fades or long static crashes, simplex operation produces a slightly better signal.

* The frequency standard units are only supplied at installations not already provided with this equipment as only one standard is required at each terminal. The second standard is provided as a spare at each office in case of emergency. These bays are located distant from the operating positions, the latter being in no way encumbered with any of the multiplexing apparatus.

EXTENSION OF RCA COMMUNICATIONS MULTIPLEX SYSTEM

At present the New York-San Francisco link is the only one in actual commercial service. A manufacturing program which is rapidly nearing completion will provide quite a number of additional terminals for use on the domestic and international radiotelegraph circuits operated wholly or jointly by RCA Communications. Experience indicates time-division multiplex can be used successfully on first class radiotelegraph circuits and has made possible improved operating efficiency. Figs. 8 and 9 illustrate a multiplex terminal of the type described.

ACKNOWLEDGMENT

The authors wish to acknowledge the helpful suggestions and assistance supplied by the traffic department, under the direction of Mr. J. B. Rostron, during the early commercial radio circuit tests of the multiplex terminal equipment.

Acknowledgment is also due Messrs. C. H. Taylor and H. H. Beverage for their encouragement and active support.

Bibliography

- (1) H. H. Beverage, C. W. Hansell, and H. O. Peterson, "Radio plant of RCA Communications, Inc.," *Trans. Amer. Inst. Elec. Eng.*, vol. 51, p. 586; August, (1932).
- (2) H. H. Harrison, "Printing Telegraph Systems and Mechanisms," Longmans & Company.
- (3) H. H. Beverage and H. O. Peterson, "Diversity receiving system of RCA Communications, Inc., for radiotelegraphy," *Proc. I.R.E.*, vol. 19, pp. 531-561; April, (1931).
- (4) C. Verdan, U. S. Patent 1,677,062.
- (5) H. V. Higgitt, U. S. Patents 1,925,756 and 2,029,071.
- (6) F. N. Tompkins, "The parallel type of inverter," *Elec. Eng.*, vol. 52, p. 253; April, (1933).
- (7) H. O. Peterson and J. B. Moore, "Diversity telephone receiving system of RCA Communications, Inc.," *Proc. I.R.E.*, vol. 19, pp. 562-584; April, (1931).



THE BASIC PRINCIPLES OF SUPER- REGENERATIVE RECEPTION*

By

FREDERICK W. FRINK

(Yonkers, New York)

Summary—By means of cathode-ray oscillograms and mathematical analyses the principal phenomena occurring in superregenerative receivers are explained. The results verify an earlier theory that in the separately quenched detector the received signal merely causes the detector to oscillate at maximum output for a longer period during each quench cycle, without increasing the maximum amplitude of the oscillations. It is also shown that in the self-quenched detector the signal merely produces an increase in the quench frequency, without increasing the maximum amplitude reached by the oscillations. The sensitivity, selectivity, and characteristic noise of superregenerative receivers are discussed.

GENERAL

ALTHOUGH fifteen years have elapsed since Armstrong's invention of the superregenerative circuit, relatively little research work pertaining to it has been reported in engineering literature, and the principles involved in the operation of the circuit do not seem to be very thoroughly understood by most radio engineers. The principal characteristics of the circuit can, however, be explained as completely as the characteristics of many other vacuum tube circuits now in use. The following paper is intended to do this experimentally, by means of the cathode-ray oscilloscope, and theoretically with the aid of mathematics.

In a typical superregenerative receiver the regenerative coupling between the plate and grid circuits of the detector tube is great enough so that self-sustained oscillations are produced, and these oscillations are periodically quenched, by applying, between two elements of the tube, an alternating voltage having a frequency much lower than that of the oscillations. A sine wave voltage is ordinarily used for quenching, but other wave forms could be used. To facilitate our analysis and understanding of the superregenerative circuit, we shall commence by considering the operation when the wave form of the quench voltage is rectangular and later progress to the more complicated case in which a sine wave voltage is used. As will become evident from the experimental results, the characteristics of the circuit are sufficiently similar in the two cases so that the mathematical analysis developed for the rectangular wave case throws a great deal of light on the operation in the sine wave case.

* Decimal classification: R163. Original manuscript received by the Institute, June 29, 1937.

OPERATION WITH RECTANGULAR WAVE QUENCH VOLTAGE

1. Experimental Results

The superregenerative receiver shown in Fig. 1 is used as the first example, because, although it is not a typical circuit, it has simpler operating characteristics than some of the more conventional circuits. The receiver comprises a radio-frequency amplifier 1, a fixed-bias superregenerative detector 2, an audio-frequency amplifier connected to a loud-speaker, and a rectangular wave oscillator.

Plate voltage is applied to the detector and radio-frequency amplifier circuits intermittently by means of the rectangular wave oscillator,

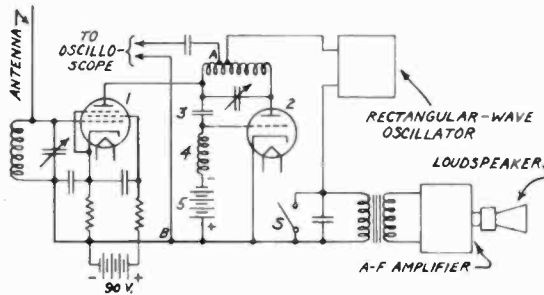

Fig. 1—Receiver with fixed-bias detector and rectangular wave quench oscillator.

at a frequency of 25 kilocycles. The wave form of the plate voltage is shown in the cathode-ray oscillogram, Fig. 2(a), which was taken with a linear sweep circuit operating at a frequency of 12.5 kilocycles. The detector plate voltage was 90 volts during each impulse, and zero between impulses.

To obtain Fig. 2(b), one of the vertical deflection plates of the oscilloscope was connected to the detector cathode and the other to a tap A on the detector tank circuit coil, so the oscillogram shows all of the 25-kilocycle voltage, together with a portion of the ultra-high-frequency voltage superimposed on the 25-kilocycle voltage. The receiver was tuned to a frequency of 60 megacycles per second, but no signal was being received when the oscillogram was taken, so the ultra-high-frequency oscillations were started by circuit noises alone. Switch S was kept closed to avoid distorting the wave shape of the 25-kilo-cycle voltage.

For Fig. 2(c) the conditions were the same as for 2(b), except that a strong unmodulated carrier wave having a frequency of 60 megacycles was being received from a laboratory oscillator very loosely coupled to the receiver. A comparison of Figs. 2(b) and 2(c) shows that

the ultra-high-frequency voltage built up to the same maximum amplitude in both cases and remained at this amplitude until quenching took place, but the maximum amplitude was reached earlier in the quench voltage cycle when the received carrier wave was present.

For Figs. 2(d) and 2(e) the conditions were the same as for 2(b) and 2(c), respectively, except that switch S was left open, thus intro-

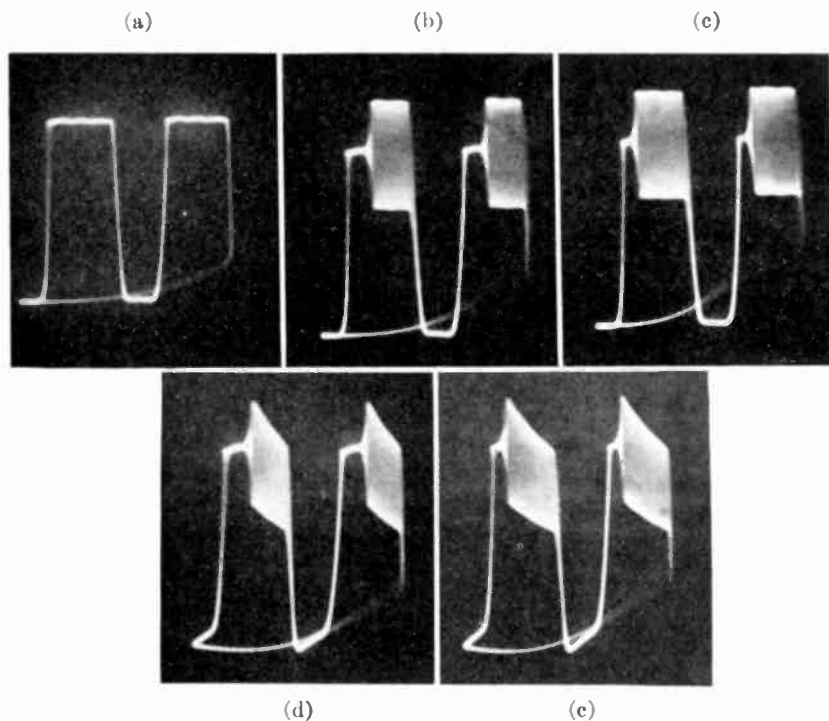

Fig. 2—(a) Rectangular wave plate voltage. (b) Voltage between points A and B of Fig. 1. Switch S is closed. No received signal. (c) Same conditions as for 2(b) except that a signal (unmodulated carrier wave) is being received. (d) Switch S is open. No received signal. (e) Switch S is open. Signal is being received.

ducing the audio-frequency transformer into the circuit. The only change in the operation was that the detector plate voltage dropped considerably after the ultra-high-frequency oscillations built up, because of the increase in detector plate current caused by the oscillations. Most of the voltage decrease took place gradually, because of the effect of the by-pass condenser across the audio-frequency transformer.

This receiver circuit and all other receiver circuits used in this investigation were tested by listening to speech signals from amateur

radio stations before they were used for obtaining oscillograms, to make certain that the recorded performance represented the behavior of receivers in such conditions of adjustment that they could be used in actual speech communication. The ability of the receiver of Fig. 1 to receive speech signals can be explained as follows: Because the detector is biased on the lower curved portion of the grid-plate characteristic, the ultra-high-frequency oscillations cause an increase in the average plate current. When a carrier wave is received, the average plate current increases further, because the ultra-high-frequency oscillations are at maximum amplitude during a greater portion of the quench-frequency cycle. If the amplitude of the carrier wave varies because of audio-frequency modulation, the duration of the maximum amplitude oscillations in the detector also varies, causing an audio-frequency variation in the detector plate current.

Ordinarily, superregenerative detectors employ grid-leak bias, rather than fixed bias and therefore function as grid-leak detectors; that is, the ultra-high-frequency voltage is rectified in the grid circuit of the tube, causing a voltage having an audio-frequency component, corresponding to the received speech, to be produced across the grid-leak resistance; and this audio-frequency voltage is amplified by the detector tube, producing an audio-frequency voltage across the detector plate circuit transformer. To obtain this type of operation, the circuits of Fig. 1 were modified by removing choke coil 4 and bias battery 5, and connecting a 25,000-ohm grid leak between the grid and the cathode of the detector tube 2. The capacitance of the grid condenser 3 was 50 micromicrofarads. Switch *S* was left open in taking the oscillograms. Figs. 3(a) and 3(b) represent, respectively, the operation with no received signal and the operation with a strong received carrier wave from the 60-megacycle laboratory oscillator. The ultra-high-frequency voltage built up to the same maximum amplitude in both cases, but reached that amplitude sooner when the received carrier wave was present. The maximum amplitude was considerably lower than in Figs. 2(b) and 2(c), because the negative bias voltage developed across the grid-leak resistor reduced the output voltage of the tube. The quench frequency for Figs. 3(a) and 3(b) was 50 instead of the 25 kilocycles previously used, and the sweep frequency was 25 instead of 12.5 kilocycles. If the difference between the quench frequencies is kept in mind, a comparison of Fig. 3(a) with Fig. 2(b) shows that the ultra-high-frequency voltage built up more rapidly in Fig. 3(a). This is due to the fact that the initial bias voltage was zero in the case of Fig. 3(a), and the tube was therefore biased on the steep portion of its static characteristic when the oscillations first started building up.

Another peculiarity of Figs. 3(a) and 3(b) is the fact that the ultra-high-frequency voltage first built up a to a maximum and then dropped down slightly. This is due to the fact that the grid condenser, which has to be charged through the finite grid resistance of the tube, did not become fully charged until an appreciable time after the ultra-high-frequency voltage had built up to maximum. When the bias voltage finally caught up with the ultra-high-frequency voltage, it caused the latter to drop down to a lower level.

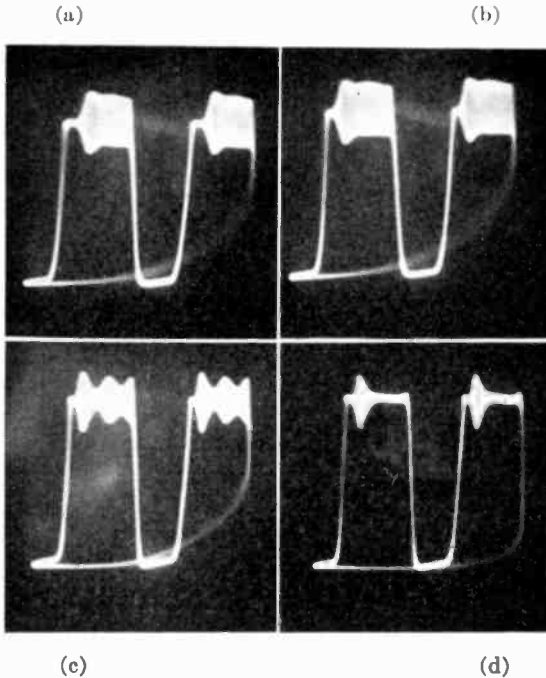

Fig. 3—(a) Operation with 25,000-ohm grid leak and no fixed bias. No signal. (b) Same as 3(a) except that signal is being received. (c) With 100,000-ohm grid leak. No signal. (d) With 250,000-ohm grid leak. No signal.

Fig. 3(c) shows the effect of increasing the grid-leak resistance to 100,000 ohms. The ultra-high-frequency voltage first outran the bias voltage and then started to drop, as in Fig. 3(a); but, because of the larger grid-leak resistance, the bias voltage was not able to decrease fast enough to stop the decay of the oscillations until the ultra-high-frequency voltage had fallen about 50 per cent. The oscillations then started building up again, and the cycle of operation was repeated. Fig. 3(d), taken with a 250,000-ohm grid leak, shows a case in which the oscillations became completely quenched before the externally

applied plate voltage started decreasing. Figs. 3(c) and 3(d) are also of interest in connection with the study of self-quenching superregenerative detectors, which will be discussed more fully in the following pages, but the main reason for presenting them here is to show that the magnitude of the grid-leak resistance can have a large effect on the behavior of a superregenerative circuit, even when an externally applied quench voltage is used.

When grid-leak bias is used, the ultra-high-frequency voltage causes a decrease, rather than an increase, in the average detector plate current, and this decrease becomes greater when a carrier wave is received. In other respects the operation is similar to that of the fixed-bias detector previously discussed.

2. *Mathematical Analysis*

Theoretical reasons will now be given for the effect of the received signal voltage on the behavior of the superregenerative detector. It is well known that the use of regeneration in a tuned vacuum tube circuit has the effect of introducing negative resistance into the tuned circuit. In the ordinary regenerative circuit, the tube introduces sufficient negative resistance so that the resultant positive resistance of the tuned circuit is relatively low, and the response to an applied signal voltage at the resonant frequency of the circuit is therefore relatively great. In the superregenerative circuit, on the other hand, the regeneration is made great enough so that the resultant resistance is negative, and self-sustained oscillations can, therefore, occur. The application of the quench voltage (between the cathode and the plate or the cathode and one of the grids) varies the negative resistance introduced by the tube, causing the resultant resistance of the tuned circuit to be alternately positive and negative. As a result, the ultra-high-frequency oscillations built up during the period of negative resistance are quenched during the period of positive resistance. If a quench voltage having a rectangular wave form is used, the resistance changes abruptly from positive to negative and vice versa.

To understand how the received signal can control the building up of the oscillations, let us consider the receiver of Fig. 1 again. Plate voltage is applied to the detector tube abruptly by the rectangular wave oscillator, thus enabling the tube to function as a regenerative amplifier, introducing negative resistance into the tuned circuit. At the same time, plate voltage is applied to the radio-frequency amplifier tube, thus causing it to apply an amplified signal voltage to the detector circuit. Fig. 4 represents the same detector circuit reduced to its basic elements, so far as the building up of the oscillatory current is

concerned. The signal voltage is represented by generator G , which produces an electromotive force $A \sin \omega t$. The effect of the quench

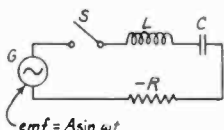

Fig. 4—Elementary representation of superregenerative receiver.

voltage is represented by switch S , which is assumed to be closed and opened periodically, at the quench frequency. When switch S is closed, the voltage equation of the circuit is

$$L \frac{di}{dt} - Ri + \frac{1}{C} \int i dt = A \sin \omega t \quad (1)$$

where,

i = current

t = time

$\omega = 2\pi f$

f = frequency.

Differentiating (1) with respect to t gives

$$L \frac{d^2i}{dt^2} - R \frac{di}{dt} + \frac{i}{C} = A \omega \cos \omega t. \quad (2)$$

Solving this linear differential equation by ordinary methods gives

$$i = K_1 \epsilon^{(a+b)t} + K_2 \epsilon^{(a-b)t} - \frac{R}{R^2 + (\omega L - 1/\omega C)^2} A \sin \omega t - \frac{(\omega L - 1/\omega C)}{R^2 + (\omega L - 1/\omega C)^2} A \cos \omega t, \quad (3)$$

or,

$$i = K_1 \epsilon^{(a+b)t} + K_2 \epsilon^{(a-b)t} - \frac{A \sin (\omega t + \phi)}{\sqrt{R^2 + (\omega L - 1/\omega C)^2}}, \quad (4)$$

where,

$$a = R/2L,$$

$$b = \sqrt{\frac{R^2}{4L^2} - \frac{1}{LC}},$$

$$\phi = \tan^{-1} \frac{(\omega L - 1/\omega C)}{R}, \quad \left(-\frac{\pi}{2} \leq \phi \leq \frac{\pi}{2} \right)$$

and K_1 and K_2 are arbitrary constants.

The constants of integration, K_1 and K_2 , may be evaluated by making use of the initial conditions,

$$i = 0 \quad \text{when } t = 0, \quad (5)$$

and,

$$L \frac{di}{dt} = A \sin \omega t = 0 \quad \text{when } t = 0. \quad (6)$$

These initial conditions are not perfectly general, because, to simplify the calculations, they are based on the assumption that switch S is closed at the instant when $t=0$, and therefore $A \sin \omega t=0$. Actually, the switch might be closed at some other time during the generator voltage cycle; however, it will be found that the analysis based on these initial conditions is sufficiently illustrative to explain the principal characteristics of the circuit.

Substituting the value of current, as given by (3), in (5) and (6), gives

$$K_1 + K_2 - \frac{A(\omega L - 1/\omega C)}{R^2 + (\omega L - 1/\omega C)^2} = 0, \quad (7)$$

and,

$$K_1(a + b) + K_2(a - b) - \frac{AR\omega}{R^2 + (\omega L - 1/\omega C)^2} = 0. \quad (8)$$

Solving (7) and (8) simultaneously gives

$$K_1 = \frac{A[R\omega - (\omega L - 1/\omega C)(a - b)]}{2b[R^2 + (\omega L - 1/\omega C)^2]}, \quad (9)$$

and,

$$K_2 = \frac{-A[R\omega - (\omega L - 1/\omega C)(a + b)]}{2b[R^2 + (\omega L - 1/\omega C)^2]}, \quad (10)$$

Substituting these values of K_1 and K_2 in (4) gives

$$\begin{aligned} i = & \frac{A[R\omega - (\omega L - 1/\omega C)(a - b)]}{2b[R^2 + (\omega L - 1/\omega C)^2]} e^{(a+b)t} \\ & - \frac{A[R\omega - (\omega L - 1/\omega C)(a + b)]}{2b[R^2 + (\omega L - 1/\omega C)^2]} e^{(a-b)t} \\ & - \frac{A \sin(\omega t + \phi)}{\sqrt{R^2 + (\omega L - 1/\omega C)^2}}. \end{aligned} \quad (11)$$

The third term of (11) represents a steady-state sine wave current, which has a constant amplitude, and a frequency the same as that of the applied signal voltage. The free oscillation which makes possible the high degree of amplification obtainable in the superregenerative receiver can be accounted for by means of the first and second terms of (11). If the quantity b , appearing in the exponential functions $e^{(a+b)t}$ and $e^{(a-b)t}$, is a real quantity or zero, the first two terms of (11) represent hyperbolic functions; but, if b is an imaginary quantity the exponential functions may be transformed into sine and cosine functions, representing an oscillatory current. Since the oscillatory case is the only case with which we are concerned in this investigation, it will be assumed that $(R^2/4L^2 - 1/LC)$ is a negative quantity thus making b an imaginary quantity. In (11) we may then make the substitution, $b = j\beta$, where,

$$\beta = \sqrt{\frac{1}{LC} - \frac{R^2}{4L^2}},$$

thus obtaining the equation,

$$i = \frac{A [R\omega - (\omega L - 1/\omega C)(a - j\beta)]}{j2\beta [R^2 + (\omega L - 1/\omega C)^2]} e^{(a+j\beta)t} - \frac{A [R\omega - (\omega L - 1/\omega C)(a + j\beta)]}{j2\beta [R^2 + (\omega L - 1/\omega C)^2]} e^{(a-j\beta)t} - \frac{A \sin(\omega t + \phi)}{\sqrt{R^2 + (\omega L - 1/\omega C)^2}}, \quad (12)$$

or,

$$i = \frac{A [R\omega - (\omega L - 1/\omega C)(a - j\beta)]}{j2\beta [R^2 + (\omega L - 1/\omega C)^2]} e^{at}(\cos \beta t + j \sin \beta t) - \frac{A [R\omega - (\omega L - 1/\omega C)(a + j\beta)]}{j2\beta [R^2 + (\omega L - 1/\omega C)^2]} e^{at}(\cos \beta t - j \sin \beta t) - \frac{A \sin(\omega t + \phi)}{\sqrt{R^2 + (\omega L - 1/\omega C)^2}}. \quad (13)$$

In analyzing the characteristics of the circuit, we are primarily interested in the effect produced by a signal voltage having a frequency the same as the resonant frequency of the circuit; that is, having a frequency, $f_r = \omega_r/2\pi$, such that the resultant reactance, $(\omega_r L - 1/\omega_r C)$, is zero. For such a frequency, (13) reduces to

$$\begin{aligned}
 i = & \frac{A\omega_r\epsilon^{\alpha t}}{j2\beta R} (\cos \beta t + j \sin \beta t) \\
 & - \frac{A\omega_r\epsilon^{\alpha t}}{j2\beta R} (\cos \beta t - j \sin \beta t) \\
 & - \frac{A \sin (\omega_r t + 0)}{R},
 \end{aligned} \tag{14}$$

or,

$$i = \frac{A\omega_r\epsilon^{(R/2L)t}}{R\beta} \sin \beta t - \frac{A \sin \omega_r t}{R}. \tag{15}$$

The second term of (15) represents the relatively unimportant steady-state current, but the first term represents an oscillatory current which increases in amplitude exponentially with respect to time. The frequency of this oscillatory current is $\beta/2\pi$, which depends on the circuit constants, and is independent of the frequency of the applied signal voltage. In a typical circuit, $R^2/4L^2$ is small compared with $1/LC$; therefore, $\beta/2\pi$ is approximately, though not exactly, equal to the resonant frequency, $1/2\pi\sqrt{LC}$, of the circuit.

The amplitude I_0 of the oscillatory current is given by the equation,

$$I_0 = \frac{A\omega_r}{R\beta} \epsilon^{(R/2L)t}, \tag{16}$$

which indicates that the initial amplitude is directly proportional to the amplitude A of the applied signal voltage. The rate at which the amplitude increases with respect to time is

$$\frac{d}{dt} (I_0) = \frac{d}{dt} \left(\frac{A\omega_r}{R\beta} \epsilon^{(R/2L)t} \right) = \frac{A\omega_r}{2L\beta} \epsilon^{(R/2L)t}, \tag{17}$$

which indicates that the rate of building up of the oscillatory current is directly proportional to the amplitude A of the applied signal voltage, and also that this rate can be increased by increasing the absolute magnitude of the negative resistance R ; in other words, by increasing the regeneration.

If the oscillatory current is allowed sufficient time for building up the amplitude will eventually reach a saturation value beyond which it cannot increase because of the limitations imposed by the tube characteristics. In a superregenerative receiver employing a quench voltage which has a rectangular wave form, there are theoretically two possible modes of operation. In what will be referred to herein as the "logarithmic mode of operation," the oscillations are allowed sufficient

time for building up to the saturation amplitude before being quenched, and the amount of time required for building up to this amplitude depends upon the amplitude of the applied signal voltage which started the oscillations. In the "linear mode of operation," on the other hand, the oscillations are always quenched before reaching the saturation amplitude, and the maximum amplitude reached before quenching takes place is dependent on the amplitude of the applied signal voltage. For reasons which will become evident, it appears that the logarithmic mode of operation is the mode ordinarily employed in practical superregenerative receivers. However, because the linear

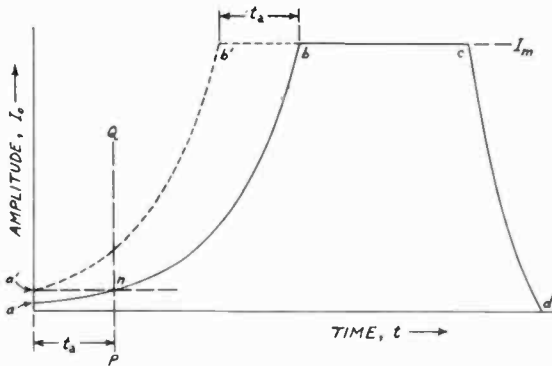

Fig. 5—Theoretical variation in amplitude ultra-high-frequency current.

mode might be preferred in some practicable application, both modes will be analyzed.

Roosenstein¹ has proved, by mathematical means, that if the ultra-high-frequency oscillations always build up exponentially to the saturation amplitude before being quenched, the rectified current produced by the detector will change by an amount proportional to the logarithm of the received signal amplitude whenever a signal is received. A proof basically the same as Roosenstein's is given below.

Fig. 5 gives theoretical curves showing how the amplitude of the oscillatory current builds up and dies down during one quench cycle. The solid curve represents the behavior for an applied signal voltage of amplitude A_1 , and the broken curve for a stronger signal voltage of amplitude A_2 . In both cases the amplitude of the oscillatory current builds up to a maximum value I_m , which is dependent on the tube characteristics, but this amplitude is reached sooner in the case of the

¹ H. O. Roosenstein, *Hochfrequenz. und Elektroakustik*, Bd. 42, p. 86: September, (1933).

stronger signal. To find the time required for building up to the maximum amplitude I_m , let us first rearrange (16) as follows:

$$\begin{aligned} e^{(R/2L)t} &= \frac{I_0 R \beta}{A \omega_r} \\ \frac{R}{2L} t &= \log_e \frac{I_0 R \beta}{A \omega_r} \\ t &= \frac{2L}{R} \log_e \frac{I_0 R \beta}{A \omega_r} \\ &= \frac{2L}{R} \log_e \frac{I_0 R \beta}{\omega_r} - \frac{2L}{R} \log_e A. \end{aligned} \quad (18)$$

If t_1 and t_2 are the lengths of time required for the oscillatory currents to build up to I_m for signal amplitudes A_1 and A_2 , respectively, then the difference between t_1 and t_2 , represented by the symbol t_a (see Fig. 5) is

$$\begin{aligned} t_a = t_1 - t_2 &= \left(\frac{2L}{R} \log_e \frac{I_m R \beta}{\omega_r} - \frac{2L}{R} \log_e A_1 \right) \\ &\quad - \left(\frac{2L}{R} \log_e \frac{I_m R \beta}{\omega_r} - \frac{2L}{R} \log_e A_2 \right) \\ &= \frac{2L}{R} (\log_e A_2 - \log_e A_1) \\ &= \frac{2L}{R} \log_e \frac{A_2}{A_1}. \end{aligned} \quad (19)$$

Thus t_a , which may be referred to as the "time of advance" due to increasing the signal voltage in the ratio A_2/A_1 , is proportional to the logarithm of the ratio of the two voltage amplitudes.

Since the frequency of the oscillatory current is the same in both cases, the curves of Fig. 5 may be considered to represent the variation in voltage across the inductance (or capacitance) of the tuned circuit. The average detector current produced by the oscillatory voltage is proportional to the area under curve $a-b-c-d$ in the case of the weaker signal and to the area under $a'-b'-c-d$ in the case of the stronger signal. If a modulated wave is being received, we are interested in the *change* in the average detector current caused by the variation in signal amplitude from A_1 to A_2 . This change in current is proportional to the area bounded by lines $a-b-b'-a'-a$. Before starting to calculate

this area, let us first consider the effect of moving the I_0 co-ordinate axis to a new position PQ which is to the right of the original position by a distance t_a . From (16), we know that the equations of curves $a'-b'$ and $a-b$ when referred to the original co-ordinate axis are, respectively,

$$I_0 = \frac{A_2 \omega_r}{R\beta} \epsilon^{(R/2L)t}, \quad (20)$$

and,

$$I_0 = \frac{A_1 \omega_r}{R\beta} \epsilon^{(R/2L)t}. \quad (21)$$

If t' is the time as measured from axis PQ , the equation of curve $a-b$ as referred to axis PQ is found by substituting $t = t' + t_a$ in (21)

$$I_0 = \frac{A_1 \omega_r}{R\beta} \epsilon^{(R/2L)(t'+t_a)} = \frac{A_1 \omega_r}{R\beta} \epsilon^{(R/2L)t'} \epsilon^{(R/2L)t_a}. \quad (22)$$

Substituting for t_a its value as given in (19), we obtain

$$\begin{aligned} I_0 &= \frac{A_1 \omega_r}{R\beta} \epsilon^{(R/2L)t'} \epsilon^{(R/2L) \cdot (2L/R) \log_e (A_2/A_1)} \\ &= \frac{A_1 \omega_r}{R\beta} \cdot \frac{A_2}{A_1} \epsilon^{(R/2L)t'} \\ &= \frac{A_2 \omega_r}{R\beta} \epsilon^{(R/2L)t'}. \end{aligned} \quad (23)$$

Equation (23), derived from (21), is exactly the same as (20), except that the time variable t' is measured from axis PQ , instead of from the original axis. Evidently, then, curve $n-b$ has exactly the same shape as curve $a'-b'$. If curve $n-b$ were moved horizontally to the left through a distance t_a , it would coincide exactly with curve $a'-b'$, and in undergoing this motion it would sweep over an area directly proportional to t_a . This area in which we are interested also includes that bounded by $a-n-a'-a$, but in a typical superregenerative circuit the initial amplitudes of the oscillatory currents are so small compared with I_m that area $a-n-a'-a$ is negligible compared with $n-b-b'-a'-n$. For this reason, we may consider that the area under the entire amplitude curve (and therefore the average detector current) undergoes a change proportional to t_a when the signal amplitude is increased from A_1 to A_2 . Therefore, if i_d is the change in the average detector current, we may write

$$i_d = K t_a = K \frac{2L}{R} \log_e \frac{A_2}{A_1},$$

where K is a constant depending on the characteristics of the detector. The logarithmic variation of detector current with respect to received signal voltage is represented in Fig. 6. It is obtainable when sine wave quenching is used, also, and accounts for the inherent automatic volume control feature of the superregenerative receiver and for its ability to discriminate against noise impulses which are stronger than the signal.

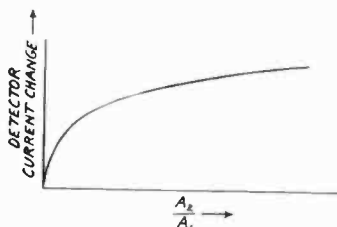

Fig. 6—Logarithmic variation of detector current change with received signal voltage.

OPERATION WITH SINE WAVE QUENCH VOLTAGE

For studying the operation with a sine wave quench voltage, the receiver shown in Fig. 7 was used. The quench voltage was inserted in series with the plate circuit, as this seemed to be the method most frequently used. Figs. 8(a) and 8(b) show the operation with no received signal and with a received carrier wave, respectively. The

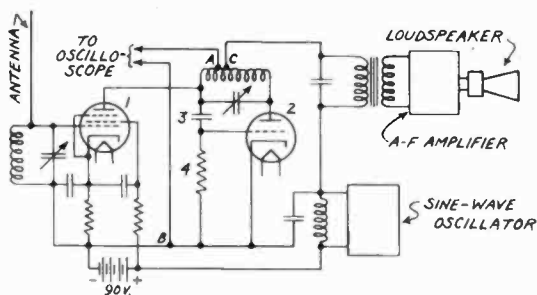

Fig. 7—Receiver with sine wave quench voltage inserted in plate circuit.

oscilloscope was connected between points A and B , so that the oscillogram would show the sum of the direct voltage (90 volts), the 50-kilocycle sine wave quench voltage, and part of the ultra-high-frequency voltage. A zero line was also recorded on the oscillogram, to represent the condition of zero plate voltage. The sweep frequency was 25 kilocycles. The horizontal line cutting across the ultra-high-frequency image was caused by the return of the cathode-ray beam. Figs. 8(c) and 8(d) are for the same conditions, but the oscilloscope plates

were connected between points *A* and *C* on the detector tank circuit coil, so that only the ultra-high-frequency voltage is shown.

A comparison of Fig. 8(c) (no signal) and Fig. 8(d) (with signal) shows that the only effect of the received carrier wave was an elongation of the ultra-high-frequency image, caused by the fact that the oscillations built up to maximum sooner when the carrier wave was being received. Figs. 8(c) and 8(d) resemble the ultra-high-frequency

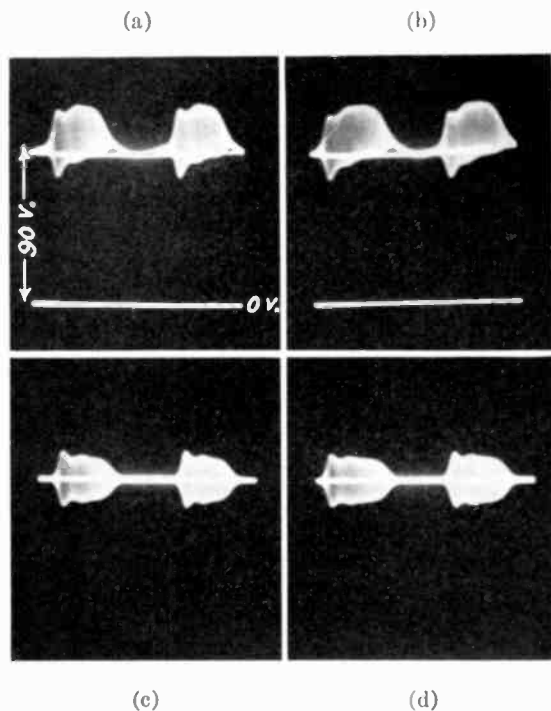

Fig. 8—(a) Voltage between points *A* and *B* of Fig. 7. No signal. (b) Operation with signal. (c) Voltage between *A* and *C*. No signal. (d) Operation with signal.

portions of Figs. 3(a) and 3(b), except that the quenching action shown in Figs. 8(c) and 8(d) is less sudden, because a sine wave voltage was used instead of a rectangular wave voltage.

The distance from the image to the zero line in Figs. 8(a) and 8(b) indicates that the amplitude of the 50-kilocycle quench voltage was small compared with the direct voltage of the plate battery. The amplitude of the quench voltage had been adjusted so that when no signal was being received the "characteristic noise" of the receiver was clearly audible but not very loud. If the quench voltage was reduced

much below that amplitude, the detector oscillated continuously and the characteristic noise disappeared entirely.

The reader may well question how it was possible to obtain quenching by means of a quench voltage having the small amplitude shown in Figs. 8(a) and 8(b). This is easily explained, however, if the constants of the circuit (Fig. 7) are considered. The grid condenser 3 had a capacitance of 50 micromicrofarads, which gives a reactance of 63,500 ohms at 50 kilocycles, and the resistance of the grid leak 4, was 100,000 ohms. From these figures it is clear that the 50-kilocycle voltage impressed across the grid leak must have been almost as great as

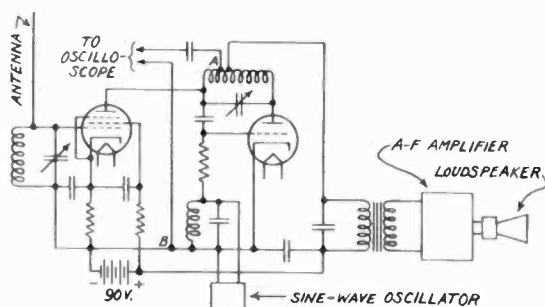
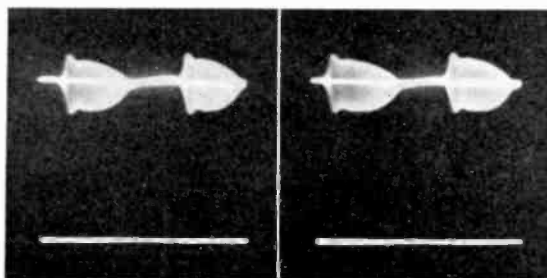

Fig. 9—Receiver with quench voltage applied in grid circuit.

the 50-kilocycle voltage between the plate and the cathode of the tube, and the quenching must have been due primarily to the 50-kilocycle voltage in the grid circuit. Evidently, the introduction of the quench voltage in series with the plate circuit, although a frequently used procedure, was merely an indirect method of obtaining a sufficient voltage in the grid circuit for quenching purposes. The capacitance of the grid condenser and the resistance of the grid leak were no greater than the values ordinarily used in superregenerative detector circuits. It is probable that in most circuits of the type shown in Fig. 7 the quenching is due primarily to the quench voltage present between the grid and the cathode of the tube. The bias voltage developed across the grid leak by the rectification of ultra-high-frequency current also assists in the quenching process, even though the resistance is not great enough to produce self-quenching.

Fig. 9 shows a receiver in which the quench voltage was applied in series with the grid-leak resistor, which was reduced to 50,000 ohms to facilitate the application of the quench voltage. The quench frequency was 50 kilocycles, and the amplitude of the quench voltage was adjusted so that the characteristic noise was distinctly audible but not very loud. The oscilloscope was connected as shown in the

diagram. Figs. 10(a) and 10(b) show the operation without, and with, a received carrier wave, respectively. The received carrier wave merely increased the effective duration of the ultra-high-frequency voltage without changing the maximum amplitude, and the ultra-high-frequency images are much the same as in Figs. 3(a) and 3(b), except that the quenching is not sudden.



(a)

(b)

Fig. 10

(a) Voltage between *A* and *B* of Fig. 9. No signal. (b) With signal.

This receiver gave good performance in receiving speech from distant stations, and the results did not disclose any reason why the quench voltage should not be introduced in this manner, instead of in series with the plate circuit as in Fig. 7. Introducing the quench voltage in the grid circuit has the advantage that it is not necessary to use an audio-frequency transformer having an electrostatic shield to keep the quench voltage out of the audio-frequency amplifier as is so frequently done when the quench voltage is applied in the plate circuit.

From the foregoing information it is evident that when a separately quenched superregenerative detector is operating in the logarithmic mode the operation passes through three distinct periods during each cycle of the quench voltage, as follows:

1. *The build-up period*, during which the amplitude of the ultra-high-frequency oscillations rises to a saturation value due to the tube characteristics. During most of this period the operation of the tube is essentially class A.

2. *The class C period*, during which the amplitude of the ultra-high-frequency oscillations is limited to a value depending on the plate voltage and the grid-bias voltage. During this period such variations as may occur in the amplitude of the ultra-high-frequency oscillations are due to variations in the plate and grid voltages, caused principally by the application of the quench voltage, and by the bias

voltage built up by the grid condenser. These variations do not contribute to the sensitivity.

3. *The inactive period*, beginning as soon as the oscillations have dropped to a negligible amplitude, and lasting until the resistance of the circuit again becomes negative.

Because of the existence of these three periods, with such widely different operating conditions, it is apparently not practicable to write a single formula expressing the variation in the amplitude of the ultra-high-frequency voltage throughout an entire quench cycle.

LINEAR MODE OF OPERATION

As previously mentioned, it is theoretically possible, when using a rectangular wave quench voltage, to adjust the receiver so that the oscillatory current is always quenched before it reaches a saturation amplitude. This can be accomplished by using a higher quench frequency, a lower degree of regeneration, or both. In Fig. 11, curve *a-b* represents the amplitude of oscillations which build up exponentially,

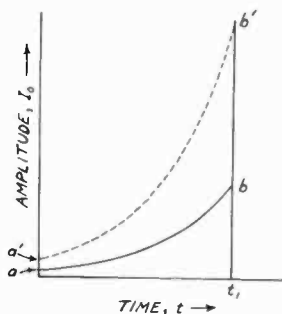

Fig. 11—Theoretical variation in amplitude of ultra-high-frequency current for linear mode of operation.

in accordance with (16), and are instantly quenched at the instant t_1 . If linear detection is used, the detector plate current change produced by the oscillations is proportional to the area under curve *a-b*. This area can be calculated by integrating I_0 between 0 and t_1 :

$$\begin{aligned} \text{Area} &= \int_0^{t_1} I_0 dt = \int_0^{t_1} \frac{A\omega_r}{R\beta} \epsilon^{(R/2L)t} dt \\ &= \frac{2A\omega_r L}{\beta R^2} (\epsilon^{(R/2L)t_1} - 1). \end{aligned} \quad (24)$$

The above expression shows that the area, and hence the detector plate current change, is directly proportional to A , the amplitude of the

impressed signal voltage. If A increases, the amplitude curve merely rises to a new position; e.g., $a'-b'$. This mode of operation does not give the automatic volume control feature, but it avoids the amplitude distortion which would be introduced by the logarithmic mode.

The use of a rectangular wave quench voltage would not be practicable in most applications of superregenerative receivers, because of

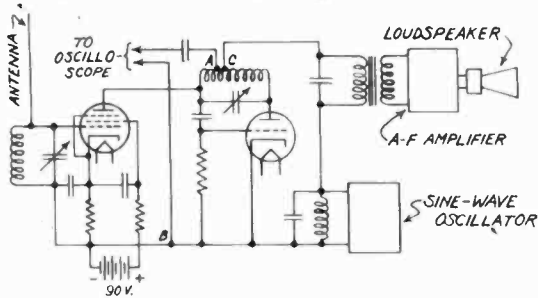

Fig. 12—Receiver with no direct plate voltage.

the complexity involved. The rectangular wave generator used in the receiver of Fig. 1 was quite complicated, and was used merely for the purpose of illustrating certain principles more clearly. However, it is possible to obtain a mode of operation resembling the linear mode just described, by using a sine wave quench voltage without any direct voltage in the plate circuit of the detector. A receiver employing this

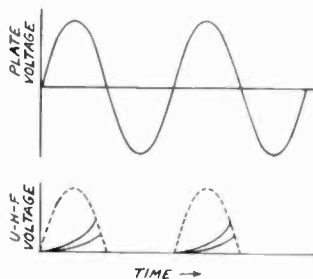

Fig. 13—Theoretical operation of receiver of Fig. 12.

method is shown in Fig. 12. The principle of operation can be understood more clearly by an examination of Fig. 13. The upper curve represents the sine wave plate voltage of the detector, and the broken curve below shows the maximum amplitude to which the ultra-high-frequency oscillations can rise at various times during the positive half of the quench voltage cycle. Two exponential curves, representing the effects of two different values of received signal strength, have also been drawn, to show that the maximum amplitude reached is greater

for the stronger signal. Since the sides of the sine wave voltage are so steep, the time required to reach the maximum amplitude is not much different for the two signals.

Figs. 14(a) and 14(b) were taken with the oscilloscope connected to points *A* and *B* in Fig. 12. The quench frequency was 75 kilocycles, and the oscilloscope sweep frequency was 37.5 kilocycles. Fig. 14(a) was taken with no received signal, and Fig. 14(b) with an unmodulated

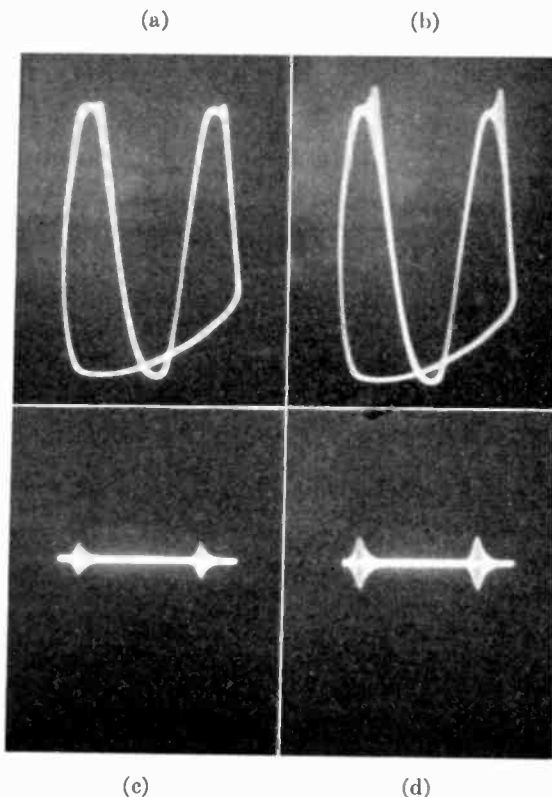

Fig. 14—(a) Voltage between *A* and *B* of Fig. 12. No signal. (b) With signal.
(c) Voltage between *A* and *C*. No signal. (d) With signal.

received carrier wave. It is evident that the ultra-high-frequency voltage was quenched by the sudden falling off of the plate voltage before the saturation amplitude was reached. Figs. 14(c) and 14(d) are for the same conditions as 14(a) and 14(b), respectively, but the oscilloscope was connected to points *A* and *C*, so that only the ultra-high-frequency voltage was recorded. It is clear that the received signal caused a rise in the maximum amplitude, not merely an advance in the time at which that amplitude was reached.

EFFECT OF QUENCH FREQUENCY ON SENSITIVITY

Experience shows that in a given design of a separately quenched superregenerative receiver there is a particular quench frequency which gives maximum sensitivity. For example, Ataka² has, by measurement, obtained curves showing the detector plate current change as a function of quench frequency for constant received signal amplitude, and these curves show that a maximum sensitivity was obtained at a particular quench frequency. A sine wave quench voltage was used.

When a rectangular wave quench voltage is used, the detector plate current change produced by the received signal is proportional to area $a-b'-a'-a$ in Fig. 5. This area also represents the change in the total quantity of electricity passing through the detector plate

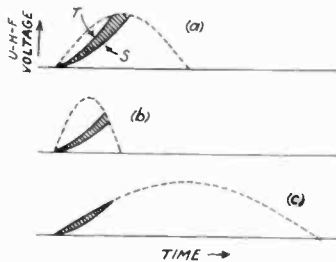

Fig. 15—Effect of varying the quench frequency.

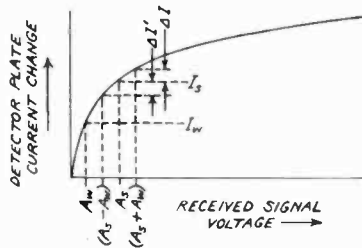

Fig. 16—Effect of a strong carrier wave on the reception of a weak signal.

during each quench cycle. Increasing the number of quench cycles per second increases the change in the average detector plate current, because the above-mentioned area remains the same while the quench frequency is increased, *provided* there is sufficient time for the ultra-high-frequency voltage to build up to the saturation value during each quench cycle. Thus, the change in the average detector plate current produced by the received signal is directly proportional to the quench frequency, until the quench frequency becomes so high that the ultra-high-frequency voltage does not have time to build up to the saturation value. After this condition is reached, a further increase in frequency causes a falling off in the sensitivity.

When a sine wave voltage is used, the quench frequency has a similar effect on the sensitivity, but the effect is complicated by the fact that the grid voltage, or the plate voltage, or both, undergo continual variation, due to the application of the quench voltage. The

² Ataka, "On superregeneration of an ultra-short-wave receiver." Proc. I.R.E., vol. 23, p. 876; August, (1935).

amplitude of the ultra-high-frequency voltage immediately after the class C condition is reached depends on how early in the quench cycle this occurs. In Fig. 15(a), the broken line indicates the maximum amplitude to which the ultra-high-frequency voltage can rise at various times during the positive half of the quench-voltage cycle. The exponential curves S and T represent the building up of the ultra-high-frequency voltage without a signal and with a signal, respectively. The area (shaded) between the two curves therefore represents the effect of the signal. Fig. 15(b) represents the results when the quench frequency is doubled. The area between the two curves has been decreased, because the quench voltage has already fallen off considerably by the time the oscillations reach the class C condition, and this prevents the maximum amplitude from being as great. If the quench frequency is increased indefinitely, the decrease in this area ultimately becomes great enough to cause a decrease in the average detector plate current change produced by the received signal, in spite of the increase in the number of quench cycles per second.

Fig. 15(c) represents the results for a lower quench frequency and shows that the area is decreased in this case also, in comparison with Fig. 15(a). Furthermore, at the frequency corresponding to Fig. 15(c) there is also a loss of sensitivity due to the smaller number of ultra-high-frequency wave trains per second.

The optimum quench frequency depends on the rate at which the ultra-high-frequency voltage builds up, which in turn depends on the ratio $-R/L$ of the particular circuit involved.

Of course, there are other considerations besides sensitivity which affect the choice of the quench frequency. Ordinarily, the quench frequency should be well above the audio-frequency range, not only to make it inaudible, but also to facilitate by-passing, and to prevent the quench voltage from entering the audio-frequency amplifier and overloading it. On the other hand, if the quench frequency is too high, interference may be caused by harmonics within the tuning range of the receiver.

SELECTIVITY

In the analysis given so far, it has been assumed that the frequency of the received signal was the same as the resonant frequency of the circuit, so that $(\omega_r L - 1/\omega_r C) = 0$, and (15) was derived from (13) on the basis of that assumption. In order to study the ability of the circuit to discriminate against signals whose frequencies differ considerably from the resonant frequency, let us consider a case in which the signal frequency is $f_n = \omega_n/2\pi$, and is far enough from the resonant frequency of the circuit so that the resultant reactance $(\omega_n L - 1/\omega_n C)$

is very much greater than the resultant negative resistance $-R$. In such a case the expression R^2 in the denominators of (13) may be disregarded. Furthermore, a study of the relative magnitudes of the various factors involved shows that the quantity $R\omega_n$ is small compared with the quantities $(\omega_n L - 1/\omega_n C) (a - j\beta)$ and $(\omega_n L - 1/\omega_n C) (a + j\beta)$. We may, therefore, disregard the expression $R\omega_n$, with slight error, under the conditions assumed for this case. By taking advantage of these simplifications when substituting ω_n in (13), we obtain the following approximate formula:

$$i = \frac{A\epsilon^{at}}{\beta(\omega_n L - 1/\omega_n C)} (-a \sin \beta t + \beta \cos \beta t) - \frac{A \sin (\omega_n t + 90^\circ)}{(\omega_n L - 1/\omega_n C)} \quad (25)$$

The second term of (25) represents the unimportant steady-state current, and will therefore be disregarded. The first term gives the oscillatory current, i_0 , which may be expressed as

$$i_0 = \frac{A\epsilon^{at}}{\beta(\omega_n L - 1/\omega_n C)} (\sqrt{a^2 + \beta^2}) \sin (\beta t + \theta_2) \quad (26)$$

where,

$$\theta_2 = \tan^{-1} \left(\frac{\beta}{-a} \right) = 90^\circ, \text{ approximately.}$$

Substituting the values of a and β in terms of the circuit constants gives

$$i_0 = \frac{A\epsilon^{(R/2L)t}}{\beta(\omega_n L - 1/\omega_n C)} \left(\frac{1}{\sqrt{LC}} \right) \sin (\beta t + 90^\circ), \quad (27)$$

but $1/\sqrt{LC} = \omega_r$, corresponding to the resonant frequency of the circuit. Then,

$$i_0 = \frac{A\omega_r \epsilon^{(R/2L)t}}{(\omega_n L - 1/\omega_n C)\beta} \sin (\beta t + 90^\circ). \quad (28)$$

The amplitude I_n of the free oscillation is, then,

$$I_n = \frac{A\omega_r}{(\omega_n L - 1/\omega_n C)\beta} \epsilon^{(R/2L)t}. \quad (29)$$

Comparison of (29) with (16), which shows the amplitude of the oscillatory current I_0 for a resonant signal, shows that

$$\frac{I_n}{I_0} = \frac{R}{(\omega_n L - 1/\omega_n C)} \quad (30)$$

It also indicates that a nonresonant signal voltage of amplitude A_n and angular frequency ω_n would produce the same oscillatory current as a resonant signal voltage of amplitude A_r and angular frequency ω_r if the ratio of the two voltages was

$$\frac{A_n}{A_r} = \frac{(\omega_n L - 1/\omega_n C)}{R} \quad (30a)$$

Equation (30a) shows that the selectivity can be increased by decreasing the absolute magnitude of the resultant negative resistance R or by increasing L .

If R were a resultant positive resistance instead of a resultant negative resistance, the above expression would give (approximately) the ratio of the signal voltages required to give steady-state currents of equal magnitude. Thus, the selectivity increases when the resultant resistance approaches zero, regardless of whether the circuit involved is a superregenerative circuit, having a resultant negative resistance, or a simple regenerative circuit, having a resultant positive resistance.

The resultant negative resistance of a superregenerative receiver can be decreased by decreasing the regenerative coupling, thus increasing the selectivity, but there is a limit to this, as too low a degree of coupling would make it impossible for the oscillatory current to build up sufficiently before quenching took place. The quench frequency cannot be lowered indefinitely, because it would ultimately fall within the audible range.

The work of Grimes and Barden³ indicates that the selectivity of an *ultra-high-frequency* superregenerative circuit can be made much higher than that of a simple tuned circuit having no regeneration of any kind. Experience with the receivers shown in Figs. 1, 7, and 9, seems to verify this conclusion, because, when signals of moderate strength were being received, it was necessary to tune the detector circuit quite precisely, using the slow-movement knob of the variable condenser.

³ "A study of superregeneration," *Electronics*, vol. 7, p. 44; February, (1934).

EFFECT OF A STRONG CARRIER WAVE
ON WEAK SIGNALS AND NOISE

When no signals are being received, the superregenerative circuit ordinarily produces a continuous noise, known as the "characteristic noise." This is evidently caused by circuit noises, such as thermal agitation, shot effect, and contact noises, which provide the impetus that starts the ultra-high-frequency oscillations in the absence of a signal. Since the circuit noises are very irregular, they do not have the same effect at the beginning of all of the build-up periods, and for this reason the detector responds as though a very irregularly modulated carrier wave were being received. When a strong carrier wave is received, this noise disappears almost entirely. A weak signal, also, can be rendered inaudible by the reception of a strong carrier wave on a frequency different from that of the weak signal. This effect can readily be explained by referring to the sensitivity characteristic represented in Fig. 16. If a carrier wave having amplitude A_w is received, the detector plate current change produced thereby is I_w . If this carrier wave is removed and a stronger carrier wave, having amplitude A_s , is substituted, the detector plate current change is I_s . Now, if both carrier waves are received simultaneously and they do not have the same frequency, we cannot find the combined effect by merely adding the two amplitudes A_w and A_s because the phase relations between the two voltages undergo a continuous change. When the two voltages are in phase, the resultant amplitude is $(A_s + A_w)$, and the detector plate current is greater by an amount ΔI than it would be if only the stronger signal were present. When the two voltages are 180 degrees out of phase, the resultant amplitude is $(A_s - A_w)$, and the detector plate current is decreased by an amount $\Delta I'$ below I_s . The detector plate current varies between the values $(I_s + \Delta I)$ and $(I_s - \Delta I')$ at a frequency equal to the difference between the signal frequencies, and if this beat frequency is above the audible range no audible effect is produced. Since ΔI is approximately equal to $\Delta I'$, the average detector plate current remains at practically the same value as though the stronger signal were present alone. Since the weaker signal does not add appreciably to the variation in the detector plate current, except at the superaudible beat frequency, it is impossible for any audio-frequency modulation present on the weaker signal to produce any appreciable audio-frequency current in the detector plate circuit.

The effect is somewhat similar to that which occurs in a linear detector when used without superregeneration. In such a detector it is possible for a strong carrier wave to change the operating conditions

in such a manner that a weaker signal, even though modulated, is unable to produce any audio-frequency current, provided the frequency difference between the two signals is above the audible range.⁴

Because of the curvature of the logarithmic characteristic shown in Fig. 16, $\Delta I'$ is not exactly equal to ΔI , and for this reason the suppression of the weaker signal is not complete. However, the curvature also tends to reduce the sensitivity to the weaker signal, because of the decrease in the slope of the curve with increasing amplitude. It is probable that the suppression of the weaker signal is due partly to the decrease in this slope with increasing amplitude, and partly to the varying phase difference between the two signals as explained above.

After considering the effect of a strong carrier wave upon the reception of a weak signal, it is easy to see how the characteristic noise can be suppressed in a similar manner. When no signal is being received, the ultra-high-frequency components of the circuit noises always cause ultra-high-frequency oscillations to be started at the beginning of each build-up period, and the phase of these oscillations makes no difference in the resulting detector current. However, when a strong carrier wave is being received the question of phase relations becomes important. At the beginning of the build-up periods, the oscillations produced by the noise voltages are sometimes aiding and sometimes opposing the oscillations produced by the received signal voltage, depending on the phase relations. As a result, the effect of the noise voltages tends to average out over a period of time long enough for producing an audio-frequency voltage.

SELF-QUENCHING SUPERREGENERATIVE DETECTORS

To avoid the necessity of providing a separate vacuum tube oscillator for generating the quench voltage, superregenerative detectors are sometimes made self-quenching, by increasing the grid-leak resistance until the bias voltage produced is great enough to cause intermittent blocking of the ultra-high-frequency oscillations without the assistance of an externally applied quench voltage. In such a case the detector plate voltage supply is direct only, and no fixed grid bias is used.

To study this type of operation, the receiver shown in Fig. 17 was used. For taking oscillograms, the detector plate voltage was obtained from a rectangular wave oscillator operating at a frequency considerably lower than the self-quenching frequency of the detector. The object of obtaining the plate voltage in this manner was to make it

⁴ F. E. Terman, "Radio Engineering," First Edition, Chap. VIII, p. 319, McGraw-Hill Book Co.

possible to obtain a stationary image of the ultra-high-frequency wave trains without the necessity of synchronizing the oscilloscope sweep circuit with the self-quenching frequency of the detector. One of the important characteristics of the self-quenching detector is the fact that the quench frequency varies greatly with the strength of the incoming signal, and it would be difficult to observe this variation if the oscilloscope sweep circuit were synchronized with the quench frequency. Applying the plate voltage intermittently by means of a rectangular wave oscillator makes it necessary for the detector to

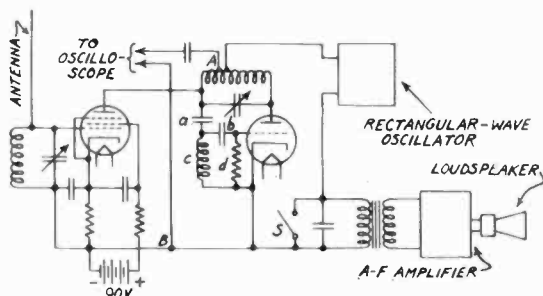

Fig. 17—Circuits for studying the self-quenching of a superregenerative detector.

start operating again under the same conditions each time the plate voltage is applied, and the only requirement necessary for obtaining a stationary image on the oscilloscope screen is that the sweep circuit be synchronized with the rectangular wave voltage. The rectangular wave generator was operated within the audio-frequency range, so that its frequency would be enough lower than the quench frequency to obtain a satisfactory image for studying the behavior of the detector.

Switch *S* in Fig. 17 was opened for tuning the receiver, and then closed for taking the oscillograms, so that the rectangular wave voltage would not be distorted by the audio-frequency transformer. Choke coil *c*, not ordinarily present in such circuits, was used for preventing the rectangular wave voltage from being applied between grid and cathode of the detector. Constants in the grid circuit were: $a=50$ micromicrofarads, $b=50$ micromicrofarads, $c=2.5$ millihenrys, $d=4$ megohms.

Fig. 18(a), obtained with the oscilloscope connected between points *A* and *B* in Fig. 17, shows the operation during a single cycle of the rectangular wave voltage, while a weak carrier wave was being received. Fig. 18(b) shows the effect of greatly increasing the strength of the carrier wave. Evidently, the ultra-high-frequency oscillations

occur in a series of wave trains which are equally spaced with respect to time, and the number of these wave trains in a given period of time (i.e., the quench frequency) increases as the strength of the incoming carrier wave is increased. The maximum amplitude reached by the ultra-high-frequency oscillations is not increased by increasing the strength of the incoming carrier wave.

The increase in the number of ultra-high-frequency wave trains causes an increase in the average grid current, thus causing an increase

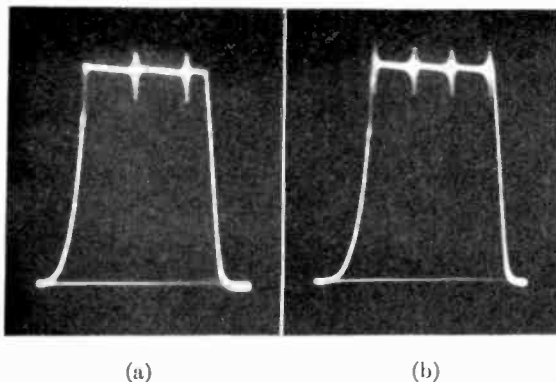

Fig. 18—(a) Voltage between *A* and *B* of Fig. 17, with weak received signal. (b) With strong signal.

in the average bias voltage across the grid leak. In this way, variations in the carrier amplitude due to modulation cause variations in the detector plate current.

It was not possible to obtain a satisfactory oscillogram when no signal was being received, as the ultra-high-frequency image became an irregular blur under this condition. Evidently, the quench frequency varied in an irregular manner because of the irregularity of the circuit noises which controlled the oscillations.

The fact that the self-quenching frequency increases when a carrier wave is received was also verified by merely increasing the resistance of the grid leak until the quench frequency came within the audible range, and could be heard in the loud-speaker. Whenever a carrier wave was received, an easily observed increase in the quench frequency took place.

The reasons for the results shown in Figs. 18(a) and 18(b) can easily be explained. The ultra-high-frequency oscillations build up at a rate dependent on the amplitude of the received signal voltage. This building up is accompanied by an increase in the absolute magnitude of the negative bias voltage produced by the grid-current flow through

the grid-leak resistor. The increase in bias voltage causes a decrease in the amplification provided by the tube, until an equilibrium condition is finally reached, in which the output power of the tube is barely great enough to furnish a grid excitation voltage of sufficient magnitude to maintain the output at a constant level. If the grid-leak resistance is relatively low, this equilibrium condition is stable, because any slight decrease in grid-excitation voltage is accompanied by a slight decrease in the bias voltage produced, which allows the output to rise to its original level. If, however, the resistance of the grid leak is very high,

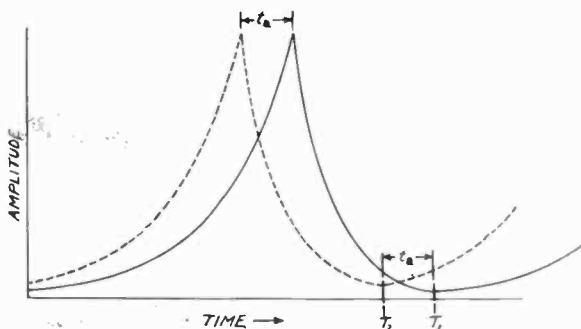

Fig. 19—Theoretical variation in amplitude of ultra-high-frequency oscillations for self-quenching operation.

the equilibrium is unstable. The slightest decrease in output power, such as might be caused by a circuit noise voltage acting in opposition to the ultra-high-frequency oscillations, causes a decrease in the grid excitation, which then causes a further decrease in output, thus tending to make the effect cumulative. The time constant of the grid condenser and grid-leak combination is great enough to prevent the bias voltage from dropping to a value which allows the oscillations to build up again, until after they have fallen to a negligible amplitude.

In Fig. 19 the solid line represents the building up and dying down of the ultra-high-frequency oscillations for a particular signal amplitude A_1 and the broken line represents the same phenomena for a greater signal amplitude A_2 . After the amplitude has risen to a maximum and then dropped to a negligible value, the charge leaks out of the grid condenser sufficiently to allow the oscillations to start building up again. This is assumed to occur at the time T_1 for the weaker signal, and T_2 for the stronger. The oscillations reach their peak value sooner by a length of time t_a for the stronger signal than for the weaker, and since the dying down occurs in the same manner for both signals, the total duration of the quench cycle is shorter by an amount t_a ; i. e., $T_1 - T_2 = t_a$.

For the weaker signal, the quench frequency is

$$f_1 = \frac{1}{T_1}, \quad (31)$$

and for the stronger signal,

$$f_2 = \frac{1}{T_2} = \frac{1}{T_1 - t_a}. \quad (32)$$

The quench-frequency increase due to increasing the signal amplitude from A_1 to A_2 is, then,

$$f_2 - f_1 = \frac{1}{T_1 - t_a} - \frac{1}{T_1} = \frac{t_a}{T_1(T_1 - t_a)}. \quad (33)$$

If t_a is small compared with T_1 , the t_a in the denominator may be neglected and the frequency change may be considered to be directly proportional to t_a . Elsewhere in this paper it has been shown that

$$t_a = \frac{2L}{R} \log_e \frac{A_2}{A_1}. \quad (34)$$

The increase in quench frequency is, therefore, proportional to the logarithm of the ratio of the signal amplitudes.

The detector plate current change produced by the ultra-high-frequency voltage depends on the area under the amplitude curves shown in Fig. 19. Theoretically, the area (for one quench cycle) does not increase when the strength of the incoming carrier wave increases, because the more rapid building up of the ultra-high-frequency voltage has the same effect as though the exponential build-up curve were merely shifted to the left by an amount t_a . The change in detector plate current due to the increase in the signal amplitude is due merely to the increase in the number of quench cycles per second and is proportional to that increase. Because the increase in the quench frequency has been shown to be proportional to $\log_e(A_2/A_1)$, the change in the detector plate current may also be assumed to be a logarithmic function of the received signal amplitude.

It may have occurred to the reader that when grid-leak bias is used, particularly in self-quenching circuits, the large variation that occurs in the grid-bias voltage may change the amplification to such an extent that the build-up curve of the oscillations is not exponential throughout its entire length. This, however, does not impair the validity of the mathematical analysis which shows that the "time of advance" t_a and the detector current change, are logarithmic func-

tions of the received signal amplitude. In Fig. 5, let us suppose that curve $a-b$ builds up exponentially from point a to point n . The horizontal distance t_a between points a' and n is, then, proportional to $\log_e(A_2/A_1)$, where A_1 and A_2 are the amplitudes of the weaker signal and the stronger signal, respectively. From n to b the curve may build up in any manner whatever and the horizontal separation from curve $a'-b'$ will remain t_a , because the shape of the curve from n to b is dependent solely on the characteristics of the circuit and these characteristics are the same for oscillations building up from n to b as for oscillations building up from a' to b' . Evidently, the foregoing mathematical analyses are valid provided the building up of the oscillations is exponential over a range of amplitudes which includes the *initial* amplitudes produced by all signal voltages received. In actual superregenerative receivers the initial amplitudes are all far too small to produce any appreciable change in the grid-bias voltage. The initial amplitudes are much smaller compared with the maximum amplitude than the proportions of Figs. 5 and 19 would indicate, because these figures were drawn for convenience of representation, rather than for quantitative accuracy.



NOTE ON THE FREQUENCY BEHAVIOR OF REACTANCES*

BY

HANS SALINGER

(Farnsworth Television, Inc., of Pennsylvania, Philadelphia, Pa.)

Summary—Some general rules stated previously by Feldtkeller but not definitely proved are shown to be a consequence of the reactance theorem. Other analogous propositions can easily be deduced by the method used here.

IN A RECENT article, R. Feldtkeller¹ showed that the following rule seems to hold for pure reactance networks:

In a network whose reactance is zero at infinite frequency and which, therefore, can be represented by Figs. 1(a) and 1(d) with the shunt capacitance C_0 , the sum of all frequency ranges in which the reactance lies between Z and $Z+dZ$ or between $-Z$ and $-Z-dZ$ equals $dZ/2\pi C_0 Z^2$; i.e., the sum of these frequency ranges is the same for the total network as for its shunt capacitance C_0 taken separately.

This proposition is, as Feldtkeller remarks, of importance in computing the fluctuation voltage in a reactive network; he also draws some conclusions from it on the possible amplification factor of a triode connected with a "constant K " filter. Moreover he states the following reciprocal rule:

In a network whose reactance is infinite at $\omega = \infty$, so that the schemes of Figs. 2(b) and 2(c) with a series inductance M_0 apply, the sum of all frequency ranges in which the reactance lies between Z and $Z+dZ$ or $-Z$ and $-Z-dZ$ is $dZ/2\pi M_0$, so that in this case the total network is equivalent to its first series inductance.

While Feldtkeller gave sufficient examples to show the validity of his propositions, no exact proof has been given. They are, however, simple inferences from Campbell² and Foster's³ reactance theorem. To show this, we divide all possible reactances iX into four classes, according to their behavior at zero and infinite frequencies; viz.,

(a) $X = \infty$ for $\omega = 0$; $X = 0$ for $\omega = \infty$. Reactances of this group are equivalent to the schemes of Figs. 1(a) or 2(a) and their general expression is

* Decimal classification: R145. Original manuscript received by the Institute, June 1, 1937.

¹ *Elekt. Nach. Tech.*, vol. 13, p. 401, (1936).

² *Bell Sys. Tech. Jour.*, vol. 1, November, (1922).

³ *Bell Sys. Tech. Jour.*, vol. 3, April, (1924).

$$X = -\frac{1}{C_0\omega} \frac{(\omega^2 - \omega_1^2) \cdots (\omega^2 - \omega_n^2)}{(\omega^2 - \omega_1'^2) \cdots (\omega^2 - \omega_n'^2)},$$

where C_0 is the value of the first shunt capacitance in Fig. 1(a) as is readily verified by forming the limiting value of X for $\omega \rightarrow \infty$. Figs. 1(a) and 2(a) are equivalent, one making evident the resonant and the other the antiresonant frequencies.

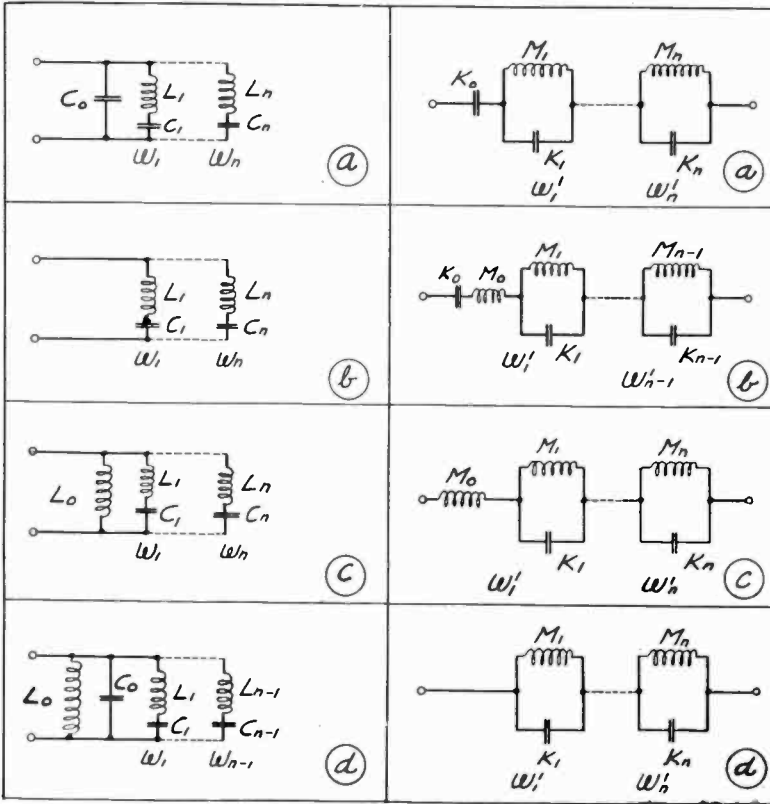

Fig. 1

Fig. 2

(b) $X = \infty$ for $\omega = 0$ and $\omega = \infty$. Here the schemes of Figs. 1(b) and 2(b) apply, and we can write

$$X = \frac{M_0}{\omega} \frac{(\omega^2 - \omega_1^2) \cdots (\omega^2 - \omega_n^2)}{(\omega^2 - \omega_1'^2) \cdots (\omega^2 - \omega_{n-1}'^2)} \tag{1b}$$

(c) $X = 0$ for $\omega = 0$, $X = \infty$ for $\omega = \infty$ (Figs. 1(c) and 2(c)).

$$X = M_0\omega \frac{(\omega^2 - \omega_1^2) \cdots (\omega^2 - \omega_n^2)}{(\omega^2 - \omega_1'^2) \cdots (\omega^2 - \omega_n'^2)} \tag{1c}$$

(d) $X=0$ for $\omega=0$ and $\omega=\infty$ (Figs. 1(d) and 2(d)).

$$X = -\frac{\omega}{C_0} \frac{(\omega^2 - \omega_1^2) \cdots (\omega^2 - \omega_{n-1}^2)}{(\omega^2 - \omega_1'^2) \cdots (\omega^2 - \omega_n'^2)}. \quad (1d)$$

If now $\Omega_1, \Omega_2, \dots$ are the frequencies at which $X=Z$ where Z is an arbitrary value, positive or negative, (1a) shows that for reactances of class (a) the Ω_i will be the solutions of an equation

$$F_{2n}(\omega) = -C_0 Z \omega G_{2n}(\omega); \quad (2)$$

F_{2n} and G_{2n} are even functions of ω , of degree $2n$, and with unity coefficient of the highest order term ω^{2n} . Therefore,

$$\sum \Omega_i = -\frac{1}{C_0 Z}. \quad (3)$$

The same result is obtained for class (d), whereas for classes (b) and (c) we find

$$\sum \Omega_i = \frac{Z}{M_0}. \quad (3')$$

From (3) we derive for a small variation dZ ,

$$d \sum \Omega_i = \frac{1}{C_0 Z^2} dZ.$$

But $d \sum \Omega_i = \sum d\Omega_i$ can also be interpreted as the sum of all frequency ranges in which X lies between Z and $Z+dZ$. Inasmuch as these frequency ranges are always considered as positive, we should write more properly

$$\sum |d\Omega_i| = \frac{1}{C_0 Z^2} |dZ|, \quad (4)$$

the substitution $|\sum d\Omega_i| = \sum |d\Omega_i|$ being permitted as by the very nature of a reactance all the $d\Omega_i$ have the same sign. Now we must remember that about half of the Ω_i are negative. As it is not customary to use negative frequencies, we rewrite (4) for the roots Ω_i' of $X = -Z$

$$\sum |d\Omega_i'| = \frac{1}{C_0 Z^2} |dZ|. \quad (5)$$

Thus, $\sum |d\Omega_i| = \sum |d\Omega_i'|$ and $\sum |d\Omega_i| + \sum |d\Omega_i'| = (2/C_0 Z^2) |dZ|$. Having in mind, that X is an odd function of ω , so that $X(-\omega) = -X(\omega)$, it may be seen that any negative Ω_i corresponds to a positive Ω_i' of the same amount and vice versa. If, therefore, we want to use only

positive frequency values, we have to divide the last result by 2, so that finally we have

$$\sum' |d\Omega_i| + \sum' |d\Omega_i'| = \frac{1}{C_0 Z^2} |dZ|, \quad (6)$$

the sign \sum' indicating that only the positive values of Ω_i and Ω_i' are to be included. In the same manner we find, starting from (3') for classes (b) and (c)

$$\sum' |d\Omega_i| + \sum' |d\Omega_i'| = \frac{|dZ|}{M_0}. \quad (6')$$

Equations (6) and (6') are Feldtkeller's results, which are thus rigorously proved. In networks of classes (a) and (d), the capacitance C_0 determines the behavior of the reactance at the very highest frequencies; so does the inductance M_0 for classes (b) and (c). It is easy to add two more rules which are based on the low-frequency properties of the reactance. If (2) is abbreviated in the form

$$C_0 Z \omega^{2n+1} + \dots + p_1 \omega + p_0 = 0, \quad (7)$$

the sum of its reciprocal roots is

$$\sum \frac{1}{\Omega_i} = \frac{-p_1}{p_0},$$

and thus upon comparison of (2) and (7) we find for class (a)

$$\sum \frac{1}{\Omega_i} = -C_0 Z \frac{\omega_1'^2 \dots \omega_n'^2 \cdot (-1)^n}{\omega_1^2 \dots \omega_n^2 \cdot (-1)^n} = -K_0 Z. \quad (8)$$

The latter part of this formula follows from 1(a) and the fact that for the lowest frequencies $X = -1/K_0 \omega$ as is seen immediately from Fig. 2(a). The same formula is found for class (b), whereas for classes (c) and (d) (8) is replaced by

$$\sum \frac{1}{\Omega_i} = \frac{L_0}{Z}. \quad (8')$$

$2\pi/\Omega_i$ is the period of oscillation; we might also say that $2\pi c/\Omega_i$ is the wave length λ_i . Therefore, the following statement may be made:

The sum of all wave length ranges, for which a given reactance lies between Z and $Z+dZ$ or $-Z$ and $-Z-dZ$, is equal to the same sum for the first series capacitance K_0 of the reactance, if it belongs to class (a) or (b); for classes (c) and (d) the sum is the same for the reactance network and for its first shunt inductance L_0 .

Perhaps the most comprehensive manner in which these results can be stated, and at the same time the most useful for practical applications, is the following one: Any integral of the form

$$\int_0^{\infty} F(X)d\omega, \quad (9)$$

F , being an even function, remains unchanged if X is replaced by $-1/C_0\omega$ or $M_0\omega$, depending on the class to which the reactance X belongs; similarly in

$$\int_0^{\infty} F(X) \frac{d\omega}{\omega^2}, \quad (9')$$

X may be replaced by $-1/K_0\omega$ or $L_0\omega$.

This form also is due to Feldtkeller; as a matter of fact it formed the starting point of his paper. As is well known, any symmetrical function of the roots of an algebraic equation can be expressed in terms of its coefficients, and thus a large number of analogous formulas may be derived, using the same method. It will, however, not be necessary to state them explicitly.



CHARACTERISTICS OF THE IONOSPHERE AT WASHINGTON, D.C., NOVEMBER, 1937*

BY T. R. GILLILAND, S. S. KIRBY, N. SMITH, AND S. E. REYMER
(National Bureau of Standards, Washington, D.C.)

FIG. 1 shows the critical frequency and virtual height data for November, 1937. The average critical frequencies of the F and F_2 layers for the undisturbed days in November, 1937, exceeded

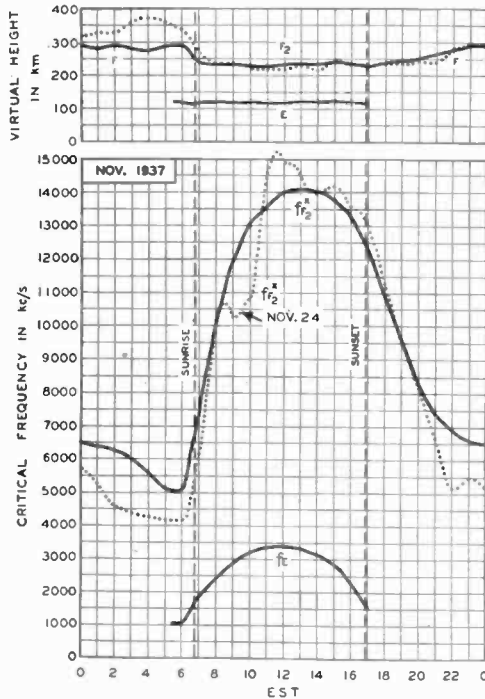

Fig. 1—Virtual heights and critical frequencies of the E, F, and F_2 layers of the ionosphere for November, 1937. Solid curve undisturbed average. Dotted curve slightly disturbed day of November 24.

those for November, 1936, by approximately the following amounts: noon f_{F_2} —700 kilocycles, midnight f_F —700 kilocycles, diurnal mini-

* Decimal classification: R113.61. Original manuscript received by the Institute, December 11, 1937. This is one of a series of reports on the characteristics of the ionosphere at Washington, D.C. For earlier publications on this subject see Proc. I.R.E., vol. 25, pp. 823-840; July, (1937), and a series of monthly reports beginning in Proc. I.R.E., vol. 25, pp. 1174-1191; September, (1937). Publication Approved by the Director of the National Bureau of Standards of the U. S. Department of Commerce.

mum (0600 local time) f_F —350 kilocycles. In November, 1937, the average noon f_E was 80 kilocycles less than in November, 1936.

The decrease of f_E and the decrease of the rate of rise of f_F was associated with a decrease of sunspot activity which is believed to be temporary, but probably indicates a slowing-down of the increase of ionization densities as the eleven-year sunspot maximum is approached.

Out of 704 hourly observations during November, strong sporadic-E reflections were present at 4400 kilocycles but not at 6200 kilocycles

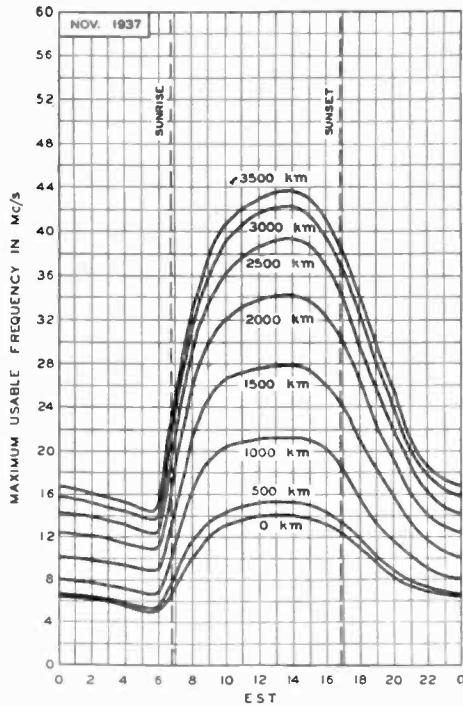

Fig. 2—Maximum usable frequencies for latitude of Washington, average for November. Time to be used is local time where the wave is reflected from the layer.

during sixteen hours, at 6200 kilocycles but not at 7700 kilocycles during six hours, and at 7700 kilocycles during two hours.

The ionosphere storms during November were comparatively mild in proportion to the associated magnetic disturbances. The ionosphere disturbances did not seriously affect radio transmission. On disturbed days the F layer critical frequencies were not appreciably lowered during most of the day and night but the f_{F2} after sunrise rose a half hour to an hour later than normal and its variations during the fore-

noon were somewhat erratic. The virtual heights were greater than average during the hours before sunrise but were normal during the day and evening. This type of ionosphere storm was reported for February 3, 1937, and is believed to be typical of winter storms, except those associated with the most severe magnetic disturbances. Thus, as previously pointed out,¹ for a magnetic disturbance of given intensity, the intensity of the associated ionosphere storm varies with the season.

In Table I the November ionosphere storms are listed approximately in the order of the severity:

TABLE I

Date	h_p before sunrise km	Min. fE_2 during day (before sunrise) kc	Max. fE_2^x during day (near noon) kc	Magnetic Character ¹	
				0000-1200 G.M.T.	1200-2400 G.M.T.
Nov. 24	352	4200	15,200	0.7	0.6
Nov. 28	328	no data	less than 13,700	0.6	0.8
Nov. 18	320	5850	13,600	0.9	1.2
Nov. 19	318	4600	13,700	0.8	1.1
Average of undisturbed days	286	5120	14,070	0.2	0.3

¹ American character figure, compiled by Department of Terrestrial Magnetism, Carnegie Institution of Washington, from data by two of their observatories and five observatories of the U.S. Coast and Geodetic Survey.

Table II shows the number of hours f_p^x differed from the November average of the undisturbed days by more than the given percentages.

TABLE II

For 439 hours of observations between 1800 and 0800 E.S.T.

Per cent	-30	-20	-10	-0	+0	+10	+20	+30
Number of hours	2	43	133	235	204	101	29	9
Disturbed hours (for days in Table I)	0	6	24	36	14	4	0	0
Undisturbed hours	2	37	109	199	190	97	29	9

Observations for 36 hours made on Wednesdays between 0900 and 1700 E.S.T. are shown in Table III.

TABLE III

Number of hours	0	0	2	21	15	1	0	0
Disturbed hours (for days in Table I)	0	0	2	4	5	0	0	0
Undisturbed hours	0	0	0	17	10	1	0	0

A sudden disturbance of the ionosphere was marked by a radio fade-out from 1908-1953 G.M.T., November 12, on transmissions from Ohio at 6060 kilocycles. The minimum field intensity was 0.1 normal.

¹ *Phys. Rev.*, vol. 51, p. 992, (1937).

DISCUSSION ON "THE FADING CHARACTERISTICS OF
 THE TOP-LOADED WCAU ANTENNA"*

G. H. BROWN AND JOHN G. LEITCH

K. A. Norton:¹ The authors give an interesting discussion of the received field intensity in the region where the sky wave and ground wave are of comparable intensity. In order to account for their experimental results, it is evident that it is *necessary* to assume that *both* the intensity and phase of the sky wave are variable. On the assumption that the intensity and phase of the sky wave are randomly distributed between the values 0 and K , and 0 and 2π , respectively, while the ground wave has unit intensity and zero phase angle, an equation and theoretical curves were given for $P_{s>x}$ the probable percentage of time that the total field s will be greater than a specified value x . The equation and one of the theoretical curves appear to be incorrect. With k and θ denoting instantaneous values of the sky-wave intensity and phase, the instantaneous total intensity may be written

$$s = \sqrt{1 + 2k \cos \theta + k^2}. \quad (1)$$

If we assume (a) k is independent of θ , (b) all values of k between 0 and K are equally likely, and (c) all values of θ between 0 and 2π are equally likely, then it is possible to determine $P_{s>x}$; this may be done most easily by sketching the surface s , defined by (1), when θ and k are allowed to vary between 0 and 2π , and 0 and K on mutually perpendicular axes (this is possible since θ and k are independent) and integrating the area on the $\theta-k$ plane defined by the projection of the curve $s=x$ on this plane. With k' and θ' denoting the values of k and θ , which satisfy (1) when $s=x$, the authors determined the value of $\int \theta' dk$, but used incorrect limits of integration. This same area is, of course, given by $\int k' d\theta$, and I have found that this integral may be expressed in terms of elliptic integrals of the first and second kind:

$$F(\alpha, \phi) = \int_0^\phi \frac{d\theta}{\sqrt{1 - \sin^2 \alpha \sin^2 \theta}} \quad (2)$$

$$E(\alpha, \phi) = \int_0^\phi \sqrt{1 - \sin^2 \alpha \sin^2 \theta} d\theta. \quad (3)$$

Whether the integral $\int \theta' dk$ or $\int k' d\theta$ is used, it does not appear to be possible to obtain a single equation which will apply for all values of x and K . Using the integral $\int k' d\theta$, I have found that the following equations are required for determining $P_{s>x}$ for arbitrary values of x and K .

$$\text{I. } x \geq 1 + K \\ P_{s>x} = 0. \quad (4)$$

$$\text{II. } 1 < x < 1 + K \text{ and } x > K - 1$$

$$P_{s>x} = \frac{100}{K\pi} [K\phi + \sin \phi - xE(\alpha, \phi)] \quad (5)$$

where,

$$\cos \phi = \frac{x^2 - 1 - K^2}{2K}$$

$$\sin \alpha = 1/x.$$

* PROC. I.R.E., vol. 25, pp. 583-611; May, (1937).

¹ Washington, D. C.

III. $1 < x < K - 1$ (i.e., $K > 2$)

$$P_{s>x} = \frac{100}{K\pi} \left[K\pi - 2xE \left(\alpha, \frac{\pi}{2} \right) \right]. \tag{6}$$

IV. $x = 1$ $K \geq 2$

$$P_{s>1} = \frac{100}{\pi} \left[\cos^{-1} \left(-\frac{K}{2} \right) + \frac{2}{K} \left\{ \sqrt{1 - K^2/4} - 1 \right\} \right]. \tag{7}$$

V. $x = 1$ $K \geq 2$

$$P_{s>1} = 100 \left[1 - \frac{2}{K\pi} \right]. \tag{8}$$

VI. $|1 - K| \leq x < 1$ (i.e., $K < 2$)

$$P_{s>x} = \frac{100}{K\pi} \left[K\phi + \sin \phi + (1 - x^2)F(\beta, \psi) - E(\beta, \psi) \right], \tag{9}$$

where,

$$\sin \psi = \frac{1}{x} \sin \phi$$

$$\sin \beta = x$$

$\phi < \pi/2$ when $K < 1$ and $\phi > \pi/2$ when $K > 1$.

VII. $x \leq 1 - K$ (i.e., $K \leq 1$)

$$P_{s>x} = 100.$$

VIII. $x < K - 1$ and $x < 1$

$$P_{s>x} = \frac{100}{K\pi} \left[K\pi + 2(1 - x^2)F \left(\beta, \frac{\pi}{2} \right) - 2E \left(\beta, \frac{\pi}{2} \right) \right]. \tag{11}$$

Convenient tables of F and E are given in Jahnke-Emde's "Tables of Functions."

Equations (7) and (8) show that $P_{s>1}$ is greater than 50 per cent for all values of K while the No. 1 curve in Fig. 14 lies below 50 per cent. Using the above equations $P_{s>x}$ has been computed for $K=0.1, 0.5, 1,$ and 3.5 . These theoretical curves are in Fig. 1 below and are in somewhat better agreement with

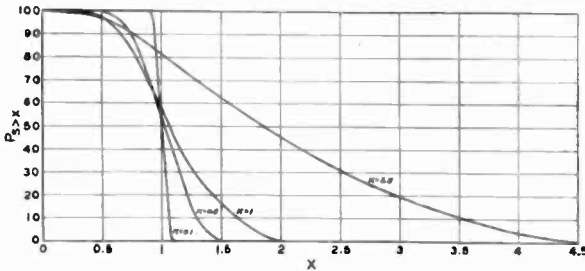

Fig. 1—Ratio of signal level to daytime signal level.

the experimental data than those of Fig. 14. The remaining discrepancy between experiment and theory may be due to several causes: (1) failure of the assumption of independence of θ and k , or of the other two assumptions, (2) insufficient data for the determination of a statistical average; this doubt might be eliminated by sampling, or (3) actual errors of measurement which could easily arise if the ground wave shifted its amplitude from day to night or the apparatus changed its calibration.

G. H. Brown:² Mr. Norton has pointed out that one of the curves of Fig. 14 in the paper under discussion is incorrect. He has further pointed out that the equation is incorrect and that incorrect limits of integration were used. That No. 1 curve of Fig. 14 is in error is true, but not for the reason stated. How the No. 1 curve was drawn as published we do not know, but later in this discussion the correct curve sheet will be shown.

Because Mr. Norton's discussion casts some doubt on the published equation, it seems appropriate to present the derivation of this equation, together with an explanation of its use.

We first consider the case of a fixed unit vector and another vector of magnitude k , related by the angle θ , as shown in Fig. 2 of this discussion. The unit

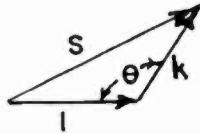

Fig. 2

vector and the vector of magnitude k add to give a sum, of magnitude s . We assume that all values of the angle θ are equally likely. Then the probability that θ lies between θ_1 and $\theta_1 + d\theta$ is

$$P_{\theta_1, \theta_1 + d\theta} = \frac{d\theta}{2\pi} \tag{1}$$

At an angle θ the vector sum of the two vectors under consideration is given by

$$s^2 = 1 + k^2 - 2k \cdot \cos \theta. \tag{2}$$

Then,

$$s \cdot ds = k \cdot \sin(\theta) d\theta. \tag{3}$$

But,

$$\sin \theta = \sqrt{1 - \frac{|s^2 - 1 - k^2|}{4k^2}} = \frac{1}{2k} \sqrt{-s^4 + 2(1 + k^2)s^2 - (1 - k^2)^2}. \tag{4}$$

Thus, for a fixed value of k , there is a sum s_1 which corresponds to an angle θ_1 and a sum $s_1 + ds$ which corresponds to an angle $\theta_1 + d\theta$. These corresponding values may be determined from (2) or (4).

The probability that the sum lies between s_1 and $s_1 + ds$ is twice the probability that the angle will lie between θ_1 and $\theta_1 + d\theta$, since there are two values of θ_1 , equal positive and negative values, that will yield the same sum. Then,

$$P_{s_1, s_1 + ds} = 2P_{\theta_1, \theta_1 + d\theta} = \frac{d\theta}{\pi} = \frac{2s \cdot ds}{\pi \sqrt{-s^4 + 2(1 + k^2)s^2 - (1 - k^2)^2}} \tag{5}$$

At this point, it should be mentioned that it is obvious that the largest value possible for s to attain is $1 + k$, so that the probability $P_{s_1, s_1 + ds}$ is zero for all values of s_1 greater than $1 + k$.

With (5) available, we wish to find the probability that the sum will exceed a certain value x . We simply sum up the probabilities of the values falling in all the infinitesimal intervals corresponding to each value of s greater than x . Then, for a fixed value of k , the probability that the sum will exceed a value x is given by

² Godley and Brown, Upper Montclair, N. J.

$$P'_{s>x} = \sum_{s=x}^{s=1+k} P_{s,s+ds} = \frac{2}{\pi} \int_{s=x}^{s=1+k} \frac{s \cdot ds}{\sqrt{-s^4 + 2(1+k^2)s^2 - (1-k^2)^2}} \quad (6)$$

This equation integrates, by formula (161), "A Short Table of Integrals," by B. O. Peirce, to give

$$P'_{s>x} = \left[0.5 + \frac{1}{\pi} \sin^{-1} \left(\frac{1+k^2-x^2}{2k} \right) \right] \quad (7)$$

Equation (7) gives the expression for the probability that the sum s will exceed a value x when all values of the angle are equally likely and the vector k is constant in magnitude.

Let us now examine the three separate conditions of x that may arise, for fixed values of k .

1. $x < 1$, $k < 1$, $k < 1-x$ ($x < 1-k$)

Since x is less than $1-k$ and since $1-k$ is the smallest value s can reach, the probability that the sum s is greater than x is unity or certainty. If a value of k less than $1-x$ is substituted in (7), the quantity $(1+k^2-x^2)/2k$ will be greater than unity. Whenever this quantity exceeds unity, we simply proceed as if the quantity were exactly unity, and obtain

$$P'_{s>x} = 0.5 + \frac{1}{\pi} \cdot \sin^{-1}(1) = 0.5 + \frac{1}{\pi} \cdot \frac{\pi}{2} = 1.0.$$

2. $k > 1+x$ ($x < k-1$). $\therefore k > 1$

Since x is less than $k-1$ and since $k-1$ is the smallest value s can reach, the probability that the sum s is greater than x is unity or certainty. If a value of k greater than $1+x$ is substituted in (7), the quantity $(1+k^2-x^2)/2k$ will be greater than unity, and we again interpret it as we did in the preceding example.

$$P'_{s>x} = 0.5 + \frac{1}{\pi} \cdot \sin^{-1}(1) = 0.5 + \frac{1}{\pi} \cdot \frac{\pi}{2} = 1.0.$$

3. $x > 1$, $k < x-1$ ($x > k+1$)

Since x is greater than $k+1$, and since $k+1$ is the largest value that s can reach, the probability that s is greater than x is zero. If a value of k less than $x-1$ is substituted in (7), the quantity $(1+k^2-x^2)/2k$ will be a negative number whose absolute value is greater than unity. We treat this quantity as if it were -1 , and obtain

$$P'_{s>x} = 0.5 + \frac{1}{\pi} \cdot \sin^{-1}(-1) = 0.5 - \frac{1}{\pi} \cdot \frac{\pi}{2} = 0.$$

From the three above conditions, we now arrive at a rule to be used in connection with (7).

- (a). When $\frac{1+k^2-x^2}{2k} > +1$, $\sin^{-1} \left\{ \frac{1+k^2-x^2}{2k} \right\} = +\frac{\pi}{2}$
 (b). When $\frac{1+k^2-x^2}{2k} < -1$, $\sin^{-1} \left\{ \frac{1+k^2-x^2}{2k} \right\} = -\frac{\pi}{2}$

Fig. 3 shows a number of curves of (7) as a function of k , for various values of x , where the conditions (a) and (b) have been applied.

Let us next turn our attention to the condition where the vector k is variable in magnitude. If all values of k between 0 and K are equally likely, the probability of the vector k having a magnitude whose value lies between k_1

and $k_1 + dk$ is dk/K . Then the probability that the vector k lies between k_1 and $k_1 + dk$, and that, at the same time, the sum s exceeds a value x is found by forming the product of (7) and dk/K . Since K is the maximum value which k can assume, the sum s can never exceed $1 + K$. We now sum up the product just formed for all values of k between 0 and K to obtain the probability that the sum s will exceed a value x when all values of k between 0 and K are equally likely, and all values of θ between 0 and 2π are equally likely. Thus,

$$P_{s>x} = \frac{1}{K} \int_{k=0}^{k=K} \left[0.5 + \frac{1}{\pi} \sin^{-1} \left(\frac{1 + k^2 - x^2}{2k} \right) \right] dk. \tag{8}$$

To accomplish the integration, for a given value of x , we simply obtain the area under the proper curve on Fig. 3, from an abscissa value of zero to a value of k equal to K , and divide the result by K . When a planimeter is used, the opera-

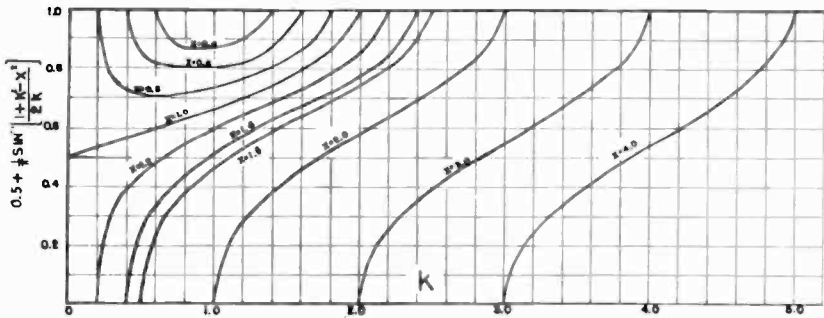

Fig. 3

tion is very simple and rapid. By way of example, let us examine the procedure in case we wish to obtain the probability value corresponding to $x=0.8$ and $K=2$. We start at the origin of co-ordinates with our planimeter and proceed upward along the vertical line to the unity ordinate, thence horizontally to $k=2$, thence downward on a vertical line to the zero ordinate, and thence horizontally to the origin of co-ordinates. The area thus obtained is the reference or unit area. We then measure a new area, using the same starting point, proceed upward to the unit ordinate, horizontally to $k=0.2$, along the $x=0.8$ curve to $k=1.8$, then along the horizontal to $k=2$, thence downward to the zero ordinate, and thence to the origin of co-ordinates. The area thus formed is divided by the reference area, and the result is $P_{s>0.8}$ when K is equal to 2. In this manner the curves of Fig. 4 are obtained. These curves are the ones that should have appeared as Fig. 14 in the original paper.

In (5) we substituted s for θ and finally obtained an integral which Mr. Norton calls $\int \theta' \cdot dk$, which is our equation (8). If, at the same point in the development, we had substituted s for k , we would have obtained $\int k' \cdot d\theta$, as Mr. Norton has done. Either procedure should yield identical results.

The authors were aware of some of the closed forms disclosed by Mr. Norton, but preferred to use the mechanical integration method because of its speed, and for the further reason that the curves of Fig. 3 had already been plotted for use in another investigation made long before the paper under discussion was written.

That the published equation is correct and that the limits as published are also correct will be demonstrated by integrating (8) for a special case.

Norton's Case IV. $x=1, K \leq 2$

$$P_{s>1} = \frac{1}{2K} \int_{k=0}^{k=K} \left[1 + \frac{2}{\pi} \cdot \sin^{-1} \left(\frac{k}{2} \right) \right] \cdot dk \tag{9}$$

or

$$\begin{aligned} P_{s>1} &= \frac{1}{2K} \left[K + \frac{2}{\pi} \int_{k=0}^{k=K} \sin^{-1} \left(\frac{k}{2} \right) \cdot dk \right] \\ &= \frac{1}{2K} \left[K + \frac{4}{\pi} \int_{u=0}^{u=K/2} \sin^{-1} (u) \cdot du \right]. \end{aligned} \tag{10}$$

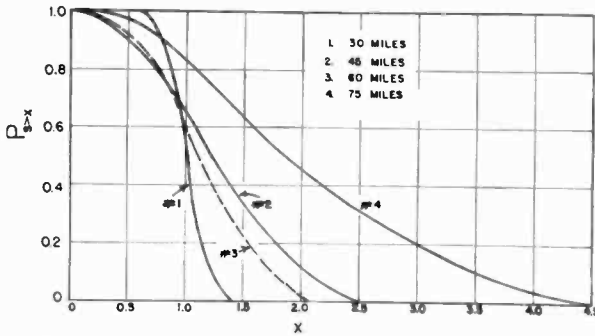

Fig. 4—Ratio of signal level to daytime signal level.

Then, by formula (380), "A Short Table of Integrals" by B. O. Peirce, (10) becomes

$$P_{s>1} = \frac{1}{2K} \left[K + \frac{4}{\pi} \left\{ u \cdot \sin^{-1} u + \sqrt{1-u^2} \right\} \Big|_{u=0}^{u=K/2} \right] \tag{11}$$

and

$$\begin{aligned} P_{s>1} &= \frac{1}{\pi} \left[\frac{\pi}{2} + \sin^{-1} \left(\frac{K}{2} \right) - \frac{2}{K} + \frac{2}{K} \sqrt{1 - \frac{K^2}{4}} \right] \\ &= \frac{1}{\pi} \left[\cos^{-1} \left(\frac{-K}{2} \right) + \frac{2}{K} \left(\sqrt{1 - \frac{K^2}{4}} - 1 \right) \right] \end{aligned} \tag{12}$$

which is in exact agreement with Norton's equation (7).

We note that, for $K=2$,

$$P_{s>1} = 1 - \frac{1}{\pi}. \tag{13}$$

Norton's Case V. $x=1, K \geq 2$

We first divide the integral as follows:

$$\begin{aligned} P_{s>1} &= \frac{1}{K} \int_{k=0}^{k=K} \left[0.5 + \frac{1}{\pi} \sin^{-1} \left(\frac{k}{2} \right) \right] dk \\ &= \frac{1}{K} \int_{k=0}^{k=2} \left[0.5 + \frac{1}{\pi} \sin^{-1} \left(\frac{k}{2} \right) \right] dk \\ &\quad + \frac{1}{K} \int_{k=2}^{k=K} \left[0.5 + \frac{1}{\pi} \sin^{-1} \left(\frac{k}{2} \right) \right] dk. \end{aligned} \tag{14}$$

From the procedure of (11), (12), and (13), we see that the first term of (14) is

$$\frac{2}{K} \left[1 - \frac{1}{\pi} \right] = \frac{2}{K} - \frac{2}{K\pi}. \quad (15)$$

Turning now to Fig. 2, we see that the second integral of (14) is simply the area of a rectangle one unit high and $K-2$ units wide. Then the area is $K-2$, and the second term of (14) is

$$\frac{K-2}{K} = 1 - \frac{2}{K}. \quad (16)$$

Adding (15) and (16),

$$P_{s>1} = 1 - \frac{2}{K\pi} \quad (17)$$

a result which is identical to Norton's equation (8).

The authors take this opportunity to point out that the angle shown as θ in Figs. 12 and 13 of the original paper should have been shown as ϕ , to conform with the text of the paper. Further, on page 601 in speaking of the hat insulators, the parenthetical expression "(this capacitance is over 0.2 microfarad)" should have read "(this capacitance is over 0.0002 microfarad)."

K. A. Norton:¹ The purpose of my discussion was to supply equations (expressed in tabled functions) which could be used for any physical case. In Dr. Brown's reply to my discussion of his paper, he shows that, with sufficient interpretation, which includes a modification of the integrand to fit the boundary conditions, his equation may be used in conjunction with graphical methods to give results in good agreement with the curves given in my discussion.

Brown and Leitch have made a real contribution in presenting such a wealth of experimental data for this important range of distances where the ground and sky waves are of comparable intensity. Their theoretical discussion is of no less importance, demonstrating, as it does, that both the intensity and phase of the sky wave must be variable in order to account for their observed experimental facts.



BOOK REVIEWS

Radio Engineering (Second Edition), by F. E. Terman. Published by McGraw-Hill Book Company, New York, N. Y., 796 pages plus 17 pages index. Price \$5.50.

One can recommend with enthusiasm this new edition of "Radio Engineering" which contains a large amount of useful material presented in an interesting and effective manner. The treatment is more quantitative than that of the first edition but with the emphasis still on the physical interpretation rather than the mathematical. This will be appreciated by many readers. The author, a frequent contributor to radio literature, has incorporated in this book his wide experience as a teacher and engineer.

Those who have the first edition will be glad to know that most of this material is still sufficiently fundamental to be retained. Much new material has been added including universal amplification curves for resistance and transformer coupled amplifiers, the analysis of the directional characteristics of radiation from a nonresonant wire in space, and high efficiency grid and suppressor grid-modulated amplifiers. Even with the 35 pages on radio measurements omitted the new edition contains approximately 125 pages more than the old.

The section on amplifiers has been considerably extended and strengthened particularly that relating to the feed-back principle, the possibilities of which are well brought out by curves. Power amplifiers are analyzed in much greater detail and represent a very definite contribution to the literature. The chapters on wave propagation and antennas have been enlarged and greatly improved. The fundamentals of television have been included, but the treatment is in no way comprehensive. The introduction of the power-series method of analyzing distortion and modulation is to be commended as it provides a means of comparing different methods of operation. The limited space devoted to quartz crystals is not in keeping with the importance of the subject. It is felt that Fig. 393 of the first edition showing the resistance and reactance of the receiver with the diaphragm free to vibrate and blocked, which was omitted, is sufficiently fundamental that it should have been retained. At the end of each chapter will be found many thought-provoking problems.

Attention is called to the fact that Fig. 22 has been reduced so much that it does not show the difference among the various windings. It is felt by the reviewer that photographs of switchboards and assembled sets, such as shown in Figs. 283a, 283b, 283c, 284a, 284b, 289a, 289b, 317, 318, 319, 320, and 321 could have been omitted with little if any loss to the reader.

*H. M. TURNER

Servicing with Set Analyzers, by H. G. McEntee. Published by Radercraft Publications, Inc., 99 Hudson Street, New York, N. Y. 64 pages. Price fifty cents.

This booklet presents an introduction to the serviceman's problem. It contains an explanation of the theory of operation of set analyzers and associated equipment and describes their proper use for servicing. A description, illustrated with circuits and photographs of 24 pieces of commercial test equipment such as all-wave oscillators and volt-ohm-milliammeters, is included in the text.

†JOSEPH L. HURFF

* Yale University, New Haven, Connecticut

† Hazeltine Service Corporation, Bayside, L.I., New York.

"The International Broadcast and Sound Engineer, 1937 Year Book", by A. L. J. Bernaert, Editor. Published by I. Davey, London, and J. Davey, Velthem, Belgium. In English, 226 pages, $5 \times 7\frac{1}{2}$ inches. Available in U. S. A. through International News Company, 131 Varick Street, N. Y. C. Price \$1.50.

This is the first volume of a proposed series of year books being published for the purpose of collecting, each year, important papers of well-known technical authors of various nationalities, in the field of broadcast and sound engineering. The year book provides a digest of contemporary progress accompanied by authoritative articles of practical value and followed by independent technical reviews of typical equipment and apparatus.

The technical digest, comprising 45 pages of the present volume, is the result of the perusal of over 100 papers published throughout the world. The high lights of numerous new developments, together with a complete bibliography, are concisely presented.

Ten full-length papers, from authorities in seven countries, comprise the second section of the year book. The subjects covered include transformer design, sound reinforcing systems, acoustical measurements, broadcast transmitters, high- and very high-frequency transmission, antennas, and television.

The third section of the year book consists of summaries in seven languages of the full-length articles mentioned above. These summaries should be of especial interest to those readers who possess only a slight knowledge of the English language.

The final section consists of a well-illustrated review of recent equipment and apparatus which reflects the general tendencies of design of broadcast and sound equipment throughout the world.

*HOWARD A. CHINN

"Anleitungen zum Arbeiten im Röhrenlaboratorium" (Instructions for Work in the Tube Laboratory), by M. Knoll. Dritter Teil der Anleitungen zum Arbeiten im elektrotechnischen Laboratorium (Third Part of Instructions for Work in the Electrotechnical Laboratory), by E. Orlich. Julius Springer, Berlin, Germany. 67 pages, 57 illustrations. Price, RM 3.

Dr. Knoll's book is a brief laboratory manual containing the theory, descriptions of apparatus, and experimental instructions for fourteen experiments dealing with pumping and characteristics of various types of electron tubes. The experiments are as follows:

1. Study of vacuum pumps and high vacuum pump arrangements.
2. Calibration of a McLeod manometer.
3. Calibration of a thermal conductivity manometer (Pirani gauge).
4. Calibration of an ionization manometer.
5. Temperature determination with the micropyrometer.
6. Measurement of filament temperature of electron tubes by means of the space current.
7. Study of gas liberation and gas "sorption" in discharge tubes.
8. Determination of the Richardson constant for the saturation current of an electron tube.
9. Pumping, out-gasing, sealing-off and testing of a high vacuum triode with tungsten filament cathode.

* Columbia Broadcasting System, New York, New York.

10. Pumping, out-gassing, sealing-off, and testing of a high vacuum triode with indirectly heated barium paste cathode.
11. Pumping, filling, and determination of the characteristics of a noble-gas lighting tube.
12. Preparation of a photocell with sodium cathode by means of glass electrolysis.
13. Field plotting and "durchgriff" determination of a model triode amplifier in the electrolytic trough.
14. Study of the electron microscope.

The illustrations are clear and the text explicit though brief. Dr. Knoll of the Telefunken staff, is perhaps best known in this country for his work on electron optics and through the book written by himself and Dr. Werner Espe entitled "Werkstoffkunde der Hochvakuumtechnik."

*B. E. SHACKELFORD

* RCA Manufacturing Company, Inc., Harrison, New Jersey.



CONTRIBUTORS TO THIS ISSUE

Callahan, John L.: Born December 9, 1898, at Minneapolis, Minnesota. U. S. Army, 1917-1919. Postgraduate course, radio engineering, Sorbonne University, Paris. Civil Service, Army Research Laboratory, 1919-1920; engineering department, Radio Corporation of America, 1920-1928; engineering department, RCA Communications, Inc., 1928 to date; division head in charge of central office research laboratory, 1930 to date. Associate member, Institute of Radio Engineers, 1921; Member, 1931.

Frink, Frederick W.: Born May 12, 1904, at Ann Arbor, Michigan. Received A. B. Degree, Stanford University, 1925; E. E. degree, 1926. Test and radio engineering department, General Electric Company, 1926-1935; independent research, 1935 to date. Member, Sigma Xi. Associate member, American Institute of Electrical Engineers. Associate Member, Institute of Radio Engineers 1929.

Gilliland, T. R.: Born March 16, 1903, at Danville, Illinois. Received B. S. degree in electrical engineering, California Institute of Technology, 1927; M.S. degree in communication engineering, Harvard University, 1931. Commercial radio operator, aboard ship for two years between 1923 and 1927; radio section, Bureau of Standards, 1928-1930, and June, 1931, to date. Associate member, Institute of Radio Engineers, 1928.

Hahnemann, Walter M.: Born May 6, 1879, at Annaberg, Saxony. Technische Hochschule, Munich, 1899-1902. Expert and engineer, A.E.G., 1903-1905; engineer, Telefunken Gesellschaft für drahtlose Telegraphie m.b.H., Berlin, 1905-1906; chief of wireless telegraphy division, C. Lorenz Aktiengesellschaft, Berlin, 1906-1909; radiotelegraph engineer, German Navy, 1909-1912; director Signal Gesellschaft m.b.H., Kiel, 1912-1925; director, C. Lorenz Aktiengesellschaft, Berlin-Tempelhof, 1925 to date. Nonmember, Institute of Radio Engineers.

Kahn, Alfred: Born March 28, 1902, at New York, New York. Marine radio operator, Independent Wireless Telegraph Company and RCA Radiomarine, 1923-1928; central office laboratory, RCA Communications, Inc., 1928 to date. Student, Cooper Union night school of electrical engineering. Associate member, Institute of Radio Engineers, 1931.

Kirby, S. S.: Born October 27, 1893, at Gandy, Nebraska. Received A.B. degree, College of Emporia, 1917; M.A. degree, University of Kansas, 1921. Signal Corps, U. S. Army, A.E.F., 1918-1919. High school teacher, 1919-1921; professor of physics, Friends University, Wichita, Kansas, 1921-1926. Assistant physicist, Bureau of Standards, 1926-1930; associate physicist, 1930 to date. Associate member, Institute of Radio Engineers, 1927.

Kramar, Ernst A. Ludwig: Technical High School, Prague, 1919-1925. Technical High School, Dresden, laboratories of Professor Barkhausen, 1925-1927. Received Dr. Ing. degree, 1927. Radio laboratories, C. Lorenz Aktiengesellschaft, Berlin-Tempelhof, 1927 to date. Nonmember, Institute of Radio Engineers.

Mathes, Richard E.: Born April 28, 1902, at Minneapolis, Minnesota. Received B.S. degree in electrical engineering, University of Minnesota, 1924. Engineering department, Radio Corporation of America, 1924-1928; engineering department, RCA Communications, Inc., 1928 to date. Junior member, Institute of Radio Engineers, 1922; Associate member, 1924.

Reymer, S. E.: Born September 21, 1905, at Ramey, Pennsylvania. Attended electrical engineering college, Cornell University, 1927-1930; assistant to Dr. L. W. Austin, radio research laboratory, Bureau of Standards, 1930-1932; wave phenomena group, radio section, National Bureau of Standards, 1932-1935; air navigation division, Bureau of Air Commerce, 1935-1936; ionosphere research, radio section, National Bureau of Standards, 1936 to date. Nonmember Institute of Radio Engineers.

Salinger, Hans W. G.: Born April 1, 1891, at Berlin, Germany. Received Ph.D. degree, University of Berlin, 1915. Research associate, Reichpostzentramt, Berlin, 1919-1929; professor, Polytechnical Institute and the Heinrich Hertz Institut für Schwingungsforschung, Berlin, 1929-1935; research engineer, Farnsworth Television, Inc., 1936 to date. Associate member, Institute of Radio Engineers, 1937.

Smith, Howard G.: Born April 9, 1910, at Brooklyn, New York. Received E.E. degree, Cornell University, 1930; M.E.E. degree, 1931; Ph.D. degree, 1937. New York Telephone Company, summers, 1928, 1930; Bell Telephone Laboratories, Inc., summer, 1929. McMullen Fellow, Cornell University, 1930-1931. Assistant, department of physics, Cornell University, 1931-1934; instructor, school of electrical engineering, Cornell University, 1934 to date. Bell Telephone Laboratories, Inc., summer, 1937. Engineering associate, Cornell University broadcast station, 1931 to date. Member, Sigma Xi. Associate member, American Institute of Electrical Engineers. Associate member, Institute of Radio Engineers, 1934.

Smith, Newbern: Born January 21, 1909, at Philadelphia, Pennsylvania. Received B.S. degree in electrical engineering, University of Pennsylvania, 1930; M.S. degree, 1931; Ph.D. degree in physics, 1935. Radio section, National Bureau of Standards, 1935 to date. Nonmember, Institute of Radio Engineers.



For the
**First
Time**



... A PRACTICAL OSCILLOSCOPE

- Exclusive Turret Type Tube Mounting for Adjusting Screen to Any Angle for Direct View . . .
- Extremely Brilliant Pattern
- Linear Sweep 15 to 20,000 Cycles

**Model 1690
In Metal Case
DEALER PRICE . . \$47.00**

- 2" Cathode Ray Tube

**MEETS EVERY REQUIREMENT OF SERVICING
ENGINEERS FOR VISUAL STUDY AND
ADJUSTMENT OF RADIO RECEIVER
CIRCUIT PROBLEMS**

ADVANTAGES

This new Triplett Oscilloscope is complete. In addition to radio servicing, it has invaluable applications in radio transmitter, sound equipment, industrial and educational fields.

The cathode ray tube with exclusive Triplett turret type mounting can be moved up or down or to either side for adjustment of the screen to an angle always in direct alignment with the user's line of vision. Adjustable shield can be pulled out to project beyond the screen for easy reading in brightest daylight.

The Oscilloscope incorporates separately controlled resistances coupled vertical and horizontal amplifiers. Vertical and horizontal plates can be either direct coupled with amplitude control, or through amplifiers with amplitude control. Can

be used with any type frequency modulated Signal Generator. 60 Cycle A.C. operated.

Linear sweep from 15 to 20,000 cycles. Sweep (either internal, external or 60 cycle) may be used through amplifier or direct with amplitude control. Positive lock. All controls on panel. No interactional controls.

Model 1690—Contained in black leatherette case (as shown above) with removable cover. Built-in compartment for accessories.

DEALER NET PRICE \$51.00

Model 1690—also furnished in black wrinkle finish metal case. (Same as above less black leatherette carrying case and cover)

DEALER NET PRICE \$47.00



A TRIPLETT DELUXE MODEL



The Triplett Elec. Instrument Co.
211 Harmon Drive, Bluffton, Ohio
—Please send me more information on Model
1690 Oscilloscope.
—Please send me Catalog New Triplett DeLuxe
Line.

Name
Address
City State

When writing to advertisers mention of the PROCEEDINGS will be mutually helpful.

MORE SERVICE FOR MORE PEOPLE



There are more Bell telephones today than ever.

More people can talk with you and you can

talk with more people. Bell telephone service

gives you more value now than ever before.

BELL TELEPHONE SYSTEM



When writing to advertisers mention of the PROCEEDINGS will be mutually helpful.

A NEW EDITION

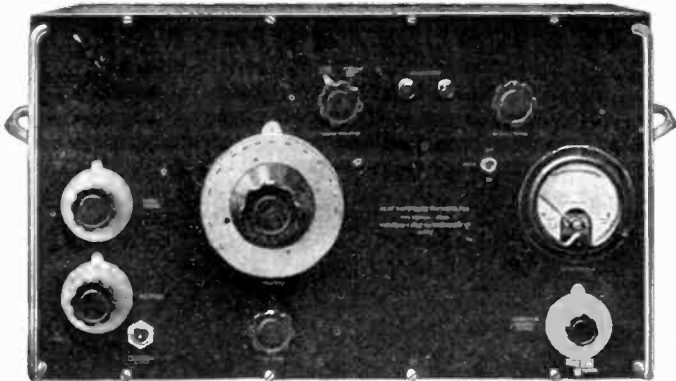

Frequency
Range
50-150,000
cycles

Output 5
microvolts-5
volts

BEAT FREQUENCY MICROVOLTER. Type T.F.336

This Microvolter has been re-designed to cover the Audio and lower Carrier frequencies. It still incorporates the essential features of the old design, but with the new and improved technique embodied in the construction of Heterodyne Oscillator. NOTE particularly the incremental dial incorporated in the frequency control giving an open scale for 1000 cycles. NOTE also the calibrated output attenuator and the provision for direct output.

BRIEF SPECIFICATION:

FREQUENCY RANGE	50-150,000 cycles with incremental dial 50-1000 cycles.
FREQUENCY CHARACTERISTIC	Constant to 1 dB from 500-100,000 cycles without resetting the output control.
OUTPUT VOLTAGE	5 Microvolts—5 volts to plus or minus 5%.
DISTORTION	Less than 2% total R.M.S. above 500 cycles.

Other instruments in this series are BEAT FREQUENCY OSCILLATOR, T.F. 195, range 10-12,000 cycles, and BEAT FREQUENCY MICROVOLTER, T.F. 410, range 1000 cycles to 3 megacycles.

MARCONI-EKCO INSTRUMENTS LTD.

Electra House, Victoria Embankment,
London, W.C. 2, England

When writing to advertisers mention of the PROCEEDINGS will be mutually helpful.

INSTITUTE SUPPLIES

EMBLEMS



Three styles of emblems are available to members of the Institute only. They are all of 14K gold with gold lettering on an enameled background, the color of which indicates the grade of membership. The approximate size of each emblem is as illustrated.

The lapel button is supplied with a screw back having jaws which fasten it securely to the coat. The price is \$2.75, postpaid, for any grade.

The pin which is provided with a safety catch may be obtained for any grade for \$3.00, postpaid.

The watch charm is handsomely finished on both sides and is equipped with a suspension ring for attaching to a watch chain or fob. Price for any grade, \$5.00, postpaid.

BINDERS



Binders are available for those who desire to protect their copies of the PROCEEDINGS with stiff covers. Each binder will accommodate the twelve monthly issues published during the year. These binders are of blue Spanish Grain Fabricoid with gold

lettering, and will serve either as temporary transfers or as permanent binders. They are so constructed that each individual copy of the

PROCEEDINGS will lie flat when the pages are turned. Copies can be removed from the binder in a few seconds and are not damaged by their insertion. They are priced at \$1.50 each, and the member's name or PROCEEDINGS Volume Number will be stamped upon the binder in gold for \$0.50 additional.

BACK ISSUES OF THE PROCEEDINGS

Complete volumes of back issues of the PROCEEDINGS are available in unbound form for the years 1918, 1921, 1922, 1923, and 1926 at \$6.75 per year (six issues) to members. Also complete unbound for 1931, 1932, 1933, 1934, and 1935 at \$7.50 per year to members. A list of the available miscellaneous copies published from 1913 on may be obtained from the Secretary. Single copies published prior to 1927 are sold to members at \$1.13 each, and those issued during and after 1927 are \$0.75 each. Foreign postage on single copies is \$0.10 per copy, making \$0.60 on unbound volumes before 1927.

Issues bound in blue buckram for 1922 (six numbers) are available at \$8.75 to members. For 1930 and 1931 they are priced at \$9.50 each to members. Foreign postage is \$1.00 additional per volume. Volumes for 1922 and 1926 bound in Morocco leather are available at \$10.25 each to members.

TWENTY-EIGHT-YEAR INDEX

An Index of the PROCEEDINGS for the years 1909-1936, inclusive, is available at \$1.00 per copy. It is extensively cross indexed. The earlier references are to the PROCEEDINGS of the Wireless Institute; the PROCEEDINGS of the Institute of Radio Engineers has been published since 1913.

When ordering any of the above, send remittance with order to the Secretary, Institute of Radio Engineers, 330 West 42nd Street, New York City.

When writing to advertisers mention of the PROCEEDINGS will be mutually helpful.

Size is an indication of something important to you as a buyer of radio components. However, we take far more pride in Sprague's consistent record of engineering supremacy than in the world's largest condenser factory which came as its natural result.

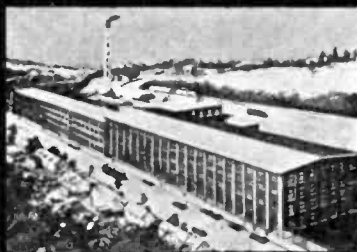

SPRAGUE

GOOD CONDENSERS—EXPERTLY ENGINEERED—
COMPETENTLY PRODUCED

SPRAGUE SPECIALTIES COMPANY, NORTH ADAMS, MASS.

When writing to advertisers mention of the PROCEEDINGS will be mutually helpful.

What **A.A.E.** means to you...

• Good condensers are usually taken for granted when dealing with a reputable manufacturer. But—how about getting the BEST condenser for that job? • That's where A. A. E.—**AEROVOX APPLICATION ENGINEERING**—comes in. • Our engineers work with you. They study your circuits, components, operating conditions, cost figures. • Result: Condenser satisfaction, maximum life, and usually, cost reduction. • Let's prove it to you!

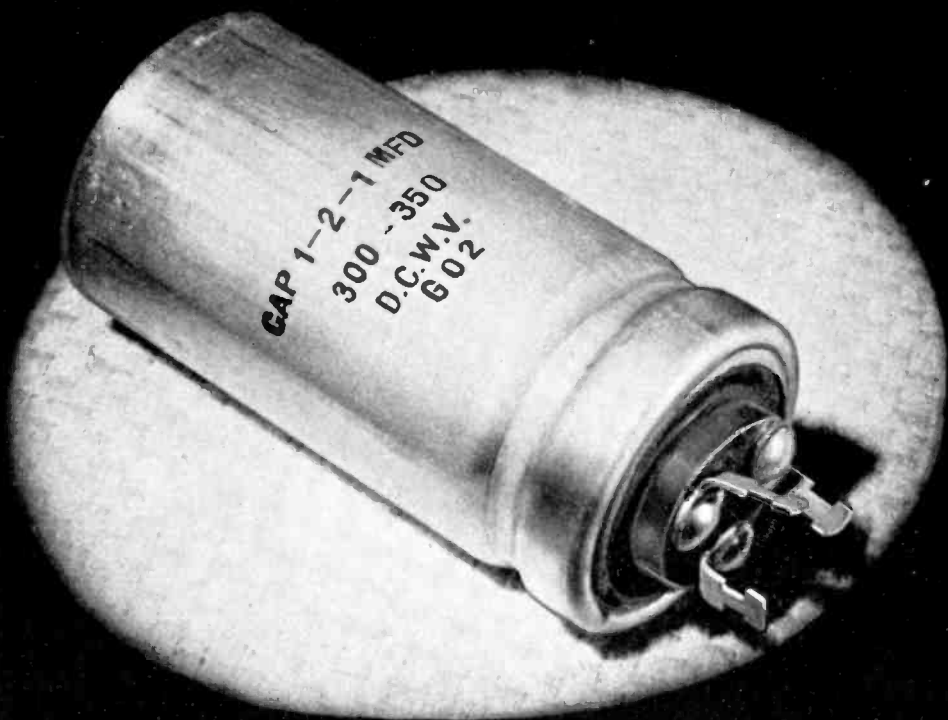

AEROVOX CORPORATION

70 WASHINGTON STREET, BROOKLYN, N. Y.



Sales Offices in All Principal Cities

The Institute of Radio Engineers

Incorporated

330 West 42nd Street, New York, N.Y.

APPLICATION FOR ASSOCIATE MEMBERSHIP

(Application forms for other grades of membership are obtainable from the Institute)

To the Board of Directors
Gentlemen:

I hereby make application for Associate membership in the Institute of Radio Engineers on the basis of my training and professional experience given herewith, and refer to the members named below who are personally familiar with my work.

I certify that the statements made in the record of my training and professional experience are correct, and agree if elected, that I will be governed by the constitution of the Institute as long as I continue a member. Furthermore I agree to promote the objects of the Institute so far as shall be in my power, and if my membership shall be discontinued will return my membership badge.

.....
(Sign with pen)

.....
(Address for mail)

.....
(Date)

.....
(City and State)

Sponsors:

(Signature of references not required here)

Mr. Mr.

Address Address

City and State City and State

Mr.

Address

City and State

The following extracts from the Constitution govern applications for admission to the Institute in the Associate grade:

ARTICLE II—MEMBERSHIP

Sec. 1: The membership of the Institute shall consist of: * * * (c) Associates, who shall be entitled to all the rights and privileges of the Institute except the right to hold any elective office specified in Article V.

Sec. 4. An Associate shall be not less than twenty-one years of age and shall be a person who is interested in and connected with the study or application of radio science or the radio arts.

ARTICLE III—ADMISSION AND EXPULSIONS

Sec. 2: * * * Applicants shall give references to members of the Institute as follows: * * * for the grade of Associate, to three Fellows, Members, or Associates; * * * Each application for admission * * * shall embody a full record of the general technical education of the applicant and of his professional career.

ARTICLE IV—ENTRANCE FEE AND DUES

Sec. 1: * * * Entrance fee for the Associate grade of membership is \$3.00 and annual dues are \$6.00.

ENTRANCE FEE SHOULD ACCOMPANY APPLICATION

Announcing



ERIE CERAMICONS

TRADE MARK REG.

CERAMIC DIELECTRIC CONDENSERS WITH UNUSUAL CHARACTERISTICS

Erie Ceramicons consist essentially of a ceramic dielectric with coated plates of pure silver. The capacity of these small fixed condensers is independent of frequency and has a definite temperature coefficient, which is either $+1.2 \times 10^{-4}$ per °C. or -6.5×10^{-4} per °C. depending on the type of dielectric used. Erie Ceramicons are available in capacities from 1 to 600 MMF. in sealed insulated types and non-insulated types.

Erie Compensating Ceramicons, consisting of either one or two Ceramicons with a definite predetermined temperature coefficient and housed in a single ceramic case, are an important contribution

to the more efficient operation of push-button tuned receivers because of their ability to compensate for reactance changes in other circuit parts.

For complete information on Erie Ceramicons and Erie Compensating Ceramicons fill in and mail the coupon below today!

Erie Resistor Corp., Erie, Pa.

Gentlemen: Please send me a copy of your bulletin giving engineering data on Erie Ceramicons and Erie Compensating Ceramicons. We are interested in using them in

NAME and TITLE _____

COMPANY _____

STREET _____

CITY & STATE _____

ERIE RESISTOR CORPORATION, Erie, Pa.

TORONTO, CANADA • LONDON, ENGLAND • PARIS, FRANCE - J. E. CANETTI CO.

RESISTORS • SUPPRESSORS • CERAMICONS • INJECTION MOLDED PLASTICS

When writing to advertisers mention of the PROCEEDINGS will be mutually helpful.

ENGINEERING DIRECTORY

QUARTZ CRYSTALS

for Standard or Special
Radio Frequency Applications

Write for Catalog

BLILEY ELECTRIC CO.
230 Union Station Bldg.
ERIE, PENNA.

**Cathode Ray Tubes
and Associated
Equipment For All
Purposes**

*Write for Complete
Technical Data*

**ALLEN B. DUMONT
LABORATORIES**
UPPER MONTCLAIR, N.J.

PRACTICAL RADIO ENGINEERING

One year Residence Course
Advanced Home Study Course
Combined Home Study-Residence
Course

Write for details

**Capitol Radio Engineering
Institute**
Washington, D.C.

"Q"—Measurements

We specialize in equipment for
the radio frequency measurement
of "Q" (X/R) of coils, condens-
ers and other radio components.

Write for Circular

BOONTON RADIO CORPORATION
BOONTON, NEW JERSEY

ALPHABETICAL INDEX TO ADVERTISEMENTS

	A	
Aerovox Corporation		XIV
American Telephone & Telegraph Co.		X
	C	
Central Radio Laboratories		Cover III
Cornell-Dubilier Electric Corp.		XX
	E	
Erie Resistor Corporation		XVII
	G	
General Radio Company		Cover IV
	M	
Marconi-Ekco Instruments Ltd.		XI
	R	
RCA Manufacturing Company, Inc.		XIX
	S	
Sprague Specialties Company		XIII
	T	
Triplett Electrical Instrument Co.		IX

When writing to advertisers mention of the PROCEEDINGS will be mutually helpful.

NEW!

RCA HIGH FREQUENCY R-F TEST OSCILLATOR

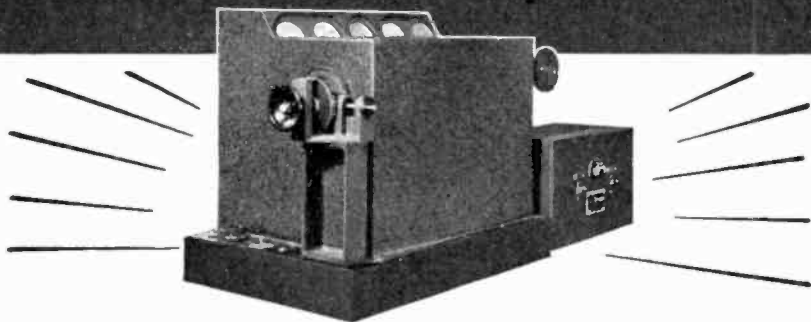

RCA announces a new ultra-high frequency Oscillator—the TMV-187-A. Covers carrier band of from 40 to 100 megacycles. Can be modulated externally over the range of 30 to 3,000,000 cycles.

This instrument is extremely useful in laboratories for ultra-high frequency circuit design—or for television receiver development. It forms a source of signal with a controllable output. Comes with internal 400 cycle oscillator for tone modulation, with a percentage modulation indicator. Other features include direct cali-

bration in frequency... direct reading logarithmic output attenuator which covers range of one microvolt to 100,000 microvolts.

Stability of TMV-187-A is guaranteed by use of a carefully designed push-pull oscillator circuit and output amplifier. It's completely shielded to prevent extraneous radiation. Designed for 110 volt AC operation. Offers uniform output over frequency band and direct calibration with single dial control.

Detailed specifications are available on request.

RCA special purpose tubes are available for every application



Test Equipment

RCA MANUFACTURING CO., INC., CAMDEN, N. J.
A SERVICE OF THE RADIO CORPORATION OF AMERICA

When writing to advertisers mention of the PROCEEDINGS will be mutually helpful.

CORNELL- **DUBILIER** *Capacitors* for broadcast transmission



When the layman thinks of radio, he thinks of personalities — famous names. But ask the broadcast engineer, who the **REAL** performers are.

He'll give you great names, but not of entertainers. He'll mention names like Cornell-Dubilier. He'll talk of the solid, in-built dependability of C-D's. And should you ask him, "Why always Cornell-Dubilier condensers?", he'll tell you that in radio there is no substitute for a reputation built on engineering experience.

When radio men specify C-D's you know they are thinking of the twenty-eight years Cornell-Dubilier has devoted exclusively to the building of condensers and of the world-wide reputation those years have won for the product behind the C-D emblem.

... take Dykanol Transmitting Capacitors for instance: impregnated and filled with non-inflammable Dykanol, these capacitors are available in a complete capacity range from 600 to 100,000 volts. ... C-D heavy duty mica capacitors are scientifically designed to operate under conditions of full load duty, abnormal temperatures and high voltages. For complete listing of C-D Capacitors, send for catalog No. 150.

WORLD'S LARGEST & OLDEST EXCLUSIVE MANUFACTURER OF CAPACITORS
DYKANOL • PAPER • MICA • WET & DRY ELECTROLYTICS

CORNELL-DUBILIER
ELECTRIC CORPORATION



1004 Hamilton Boulevard, South Plainfield, New Jersey



RIDING THE CLOUDS WITH



Along the great circle route, or across uncharted jungles, Bendix equipped ships ride the clouds . . . and in more peaceful and prosaic pursuits Bendix ground stations and beacons will make positive contact with their winged companions aloft. In these various installations CENTRALAE Volume Controls, Fixed Resistors, and Switches play a dependable part.



Centralab

DIVISION OF GLOBE-UNION INC., MILWAUKEE, WIS.

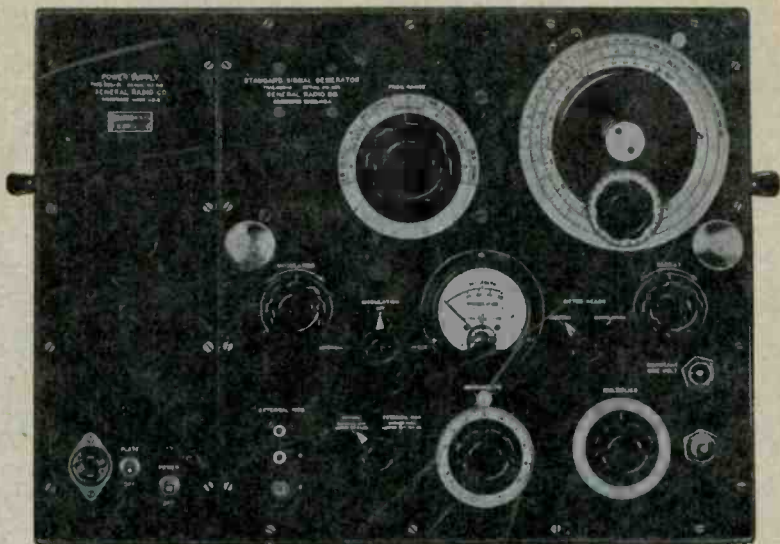

IMPROVED STANDARD-SIGNAL GENERATOR

• We announce improvements in the popular Type 605-A Standard-Signal Generator which increase its accuracy considerably, add greatly to its convenience of operation and extend its range into the ultra-high frequency range.

The new Type 605-B model incorporates these improvements:

1. GEARED SLOW-MOTION DIAL—engraved so that 1 division equals 0.1% of carrier frequency. Ideal for obtaining selectivity curves. Effective scale length is 38 feet.
2. RANGE EXTENDED TO 50 Mc—direct reading from 9.5 ke to 30 Mc; calibration curve 30 Mc to 50 Mc.
3. NEW TUNING CONDENSER—one-piece cast aluminum frame; ball bearings; four rotor spring contacts for equal-potential plates; smoother operation and lower r-f resistance.
4. CONSTANT ONE-VOLT OUTPUT—terminal on panel for one-volt output for general laboratory use, r-f bridge work, resonance tests with v-t voltmeter and measurements of conversion stage gain.
5. NEW OUTPUT CABLE—improved mechanically and electrically for more accurate r-f measurements.

This new generator is supplied in both a-c and battery powered models. The a-c model is equipped with voltage-regulated built-in power supply which assures constant output voltage over normal line voltage fluctuations.

The price for either model, complete with tubes and accessories, remains the same\$415.00.

Write for Bulletin 213 for Complete Data

GENERAL RADIO COMPANY
Cambridge, Massachusetts

New York

Los Angeles